



VICTORIA
GOVERNMENT GAZETTE.

Published by Authority.

[Registered at the General Post Office, Melbourne, for transmission by post as a newspaper.]

No. 231]

TUESDAY, APRIL 15.

[1947

GAS REGULATION ACT 1933.

PROCLAMATION

By His Excellency the Governor of the State of Victoria and its Dependencies in the Commonwealth of Australia, &c., &c., &c.

EMERGENCY POWERS UNDER THE GAS REGULATION ACT 1933
(No. 4142).

WHEREAS by section 33 of the *Gas Regulation Act 1933* it is amongst other things enacted that whenever it appears to the Governor in Council that from any cause the available supply of gas is or is likely to become less than is sufficient for the reasonable requirements of the community, the Governor in Council may from time to time exercise all or any of the powers conferred on him by or under the said provision and may from time to time by Proclamation declare that on and after the date of the publication of such Proclamation in the *Government Gazette* or a later date specified therein the provisions of section 33 of the said Act shall have effect: And whereas there exists in Victoria an acute shortage of coal for the making of gas: And whereas as a consequence of such cause it appears to the Governor in Council that the available supply of gas is less than is sufficient for the reasonable requirements of the community: Now therefore I, the Governor of the State of Victoria, by and with the advice of the Executive Council thereof, and in pursuance of the powers conferred by section 33 of the said Act do by this my Proclamation declare that on and after the date of the publication of this my Proclamation in the *Government Gazette*, the provisions of section 33 of the *Gas Regulation Act 1933* shall have effect.

Given under my hand and the Seal of the State of Victoria aforesaid, at Melbourne, this fifteenth day of April, in the year of our Lord One thousand nine hundred and forty-seven, and in the eleventh year of the reign of His Majesty King George VI.

(L.S.) WINSTON DUGAN.

By His Excellency's Command,

W. SLATER,
Chief Secretary.

GOD SAVE THE KING!

No. 231.—3680/47.

GAS REGULATION ACT 1933.

At the Executive Council Chamber, Melbourne, the
fifteenth day of April, 1947.

PRESENT:

His Excellency the Governor of Victoria.
Mr. Field | Mr. Galvin
Mr. Stoneham |

REGULATIONS.

WHEREAS by a Proclamation dated the fifteenth day of April, 1947, His Excellency the Governor of the State of Victoria, by and with the advice of the Executive Council thereof, declared that on and after the date of the publication in the *Government Gazette* of such Proclamation the provisions of section 33 of the *Gas Regulation Act 1933* should have effect: And whereas the said Proclamation was published in the *Government Gazette* of the fifteenth day of April, 1947: Now therefore His Excellency the Governor of the said State, by and with the advice of the Executive Council thereof, and in pursuance of the powers conferred by section 33 of the said Act, doth hereby make the following Regulations (that is to say):—

1. (1) These Regulations may be cited as the "Gas Regulation (Emergency Powers) Regulations (No. 42)", and shall apply to and have operation throughout the areas supplied with gas by The Metropolitan Gas Company, The Colonial Gas Association Limited (as to its Box Hill, Footscray, Frankston, and Oakleigh works), and The Brighton Gas Company Limited.
- (2) These Regulations shall take effect on the fifteenth day of April, 1947.

2. In these Regulations—

"Gas" means gas supplied by a Gas Undertaker pursuant to the provisions of the *Gas Regulation Act 1933*.

"Gas Undertaker" shall have the same meaning as "Undertaker" as defined by the *Gas Regulation Act 1933*.

3. (1) No person shall use gas on Tuesday, the fifteenth day of April, 1947, between the hours of Eight o'clock in the morning and Five-thirty o'clock in the afternoon; or between the hours of Seven o'clock in the afternoon and Midnight.

(2) No person shall use gas on Wednesday, the 16th April, 1947, except between the hours hereinafter specified—

(i) 6.30 a.m. and 8 a.m.

(ii) 12 o'clock noon and 1 p.m.

(iii) 5.30 p.m. and 7 p.m.

4. The restrictions contained in Regulation 3 shall not apply to persons using gas in connexion with the conduct of hospitals, medical services, or institutions rendering relief to the aged or infirm, or to persons using gas for pilot lights or by-pass flames on automatic appliances.

5. It shall be lawful for any inspector or other person upon producing an authority issued to him by a Gas Undertaker referred to in Regulation 1 hereof to enter any

premises to which gas is supplied by such Gas Undertaker for the purpose of determining whether the provisions of these Regulations are being observed.

6. No person shall obstruct any such inspector or other authorized person in the course of his duties.

7. A Gas Undertaker shall not, except during the hours referred to in Regulation 3 hereof, be required to supply gas in any main or in any pipe, of the pressure prescribed by the *Gas Regulation Act 1933*.

8. Any person who offends against these Regulations shall be liable to a penalty of not more than Fifty pounds (£50), and in the case of a continuing offence a further penalty of not more than Five pounds (£5) for each day on which any offence is continued after conviction or order of any court.

And the Honorable William Slater, His Majesty's Chief Secretary for the State of Victoria, shall give the necessary directions herein accordingly.

C. W. KINSMAN,
Clerk of the Executive Council.



VICTORIA
GOVERNMENT GAZETTE.

Published by Authority.

[Registered at the General Post Office, Melbourne, for transmission by post as a newspaper.]

No. 232]

WEDNESDAY, APRIL 16.

[1947

ANZAC DAY HOLIDAY.

IT is hereby notified that on—

FRIDAY, THE 25TH APRIL, 1947,

the Public Offices will be closed, such day having been appointed by the *Public Service Act 1946* to be observed as a holiday in the Public Offices throughout Victoria.

W. SLATER,
Chief Secretary.

Chief Secretary's Office,
Melbourne, 9th April, 1947.

The Game Acts.

SANCTUARY FOR NATIVE GAME AT WALWA.

PROCLAMATION

By His Excellency the Governor of the State of Victoria and its Dependencies in the Commonwealth of Australia, &c., &c., &c.

THE Governor of the State of Victoria, in the Commonwealth of Australia, by and with the advice of the Executive Council of the said State, and in pursuance of the provisions of the Game Acts and all other powers me enabling in that behalf, do by this my Proclamation revoke the Proclamation made the 25th day of January, 1917, and published in the *Government Gazette* of the 7th day of February, 1917, respecting the protection of native game at Walwa and direct that the parts of Victoria within the boundaries hereinafter described shall be localities in which from the first day of January to the thirty-first day of

December (both days inclusive) in each year, it shall be unlawful for any person to kill or destroy any native game included in the Third Schedule to the *Game Act 1928*.

PARTS OF VICTORIA REFERRED TO.

County of Benambra, Parish of Walwa.—Commencing at a point on the northern side of the main Upper Murray-road distant 430 yards in an easterly direction from the south-west corner of allotment 4 of section 4; thence easterly by the northern boundary of the said main Upper Murray-road to the south-east corner of allotment 2; thence northerly by the eastern boundary of that allotment and a line in continuation thereof to the southern bank of the Murray River; thence westerly by the southern bank of such river to a point where a line in continuation of the western boundary of allotment 1 of section 4 meets the southern bank of such river; thence southerly by that line and the western boundaries of allotments 1 and 4 to a point distant 430 yards from the south-west corner of allotment 4; thence by a direct line in an easterly direction for a distance of 430 yards; thence by a direct line in a southerly direction for a distance of 430 yards to the commencing point.

Given under my Hand and the Seal of the State of Victoria aforesaid, at Melbourne, this fifteenth day of April, in the year of our Lord One thousand nine hundred and forty-seven, and in the eleventh year of the reign of His Majesty King George VI.

(L.S.) WINSTON DUGAN.

By His Excellency's Command,

W. SLATER,
Chief Secretary.

GOD SAVE THE KING!

Land Act 1928.

AREAS OF LANDS COMPRISED IN CERTAIN CLASSES DIMINISHED OR INCREASED.

PROCLAMATION

By His Excellency the Governor of the State of Victoria and its Dependencies in the Commonwealth of Australia, &c., &c., &c.

WHEREAS by the Land Act 1928 it is amongst other things enacted that the Governor in Council may, by Proclamation to be published in the Government Gazette, at any time diminish or increase the area of land comprised in any of the classes mentioned in Part I., Division 1, section 5, of the said Land Act 1928, but that the area of lands which may be sold by auction (Class 6) shall not be increased except as in certain cases in the said Act provided: Now therefore I, the Governor of the State of Victoria, in the Commonwealth of Australia, by and with the advice of the Executive Council of the said State, and in accordance with the provisions of sections 94 and 117 of the Land Act 1928 aforesaid, do hereby diminish or increase (as the case may be) the areas of Crown lands comprised in Classes 2 and 6 respectively of the classes mentioned in section 5 of the Land Act 1928 aforesaid to the extent set forth in the subjoined Schedule (that is to say):—

Schedule referred to.

CLASSES DIMINISHED OR INCREASED.

County.	Parish.	Allotment.	Section.	Area.	Diminished.	Increased.	Description.
					Class.	Class.	
Mornington ..	Wannaesue ..	20D	..	A. R. P. 1 0 0	..	6	In south-east of parish
Buln Buln ..	Dumbalk ..	94D	..	20 2 15	2	6	In north of parish

Given under my Hand and the Seal of the State of Victoria aforesaid, at Melbourne, this fifteenth day of April, in the year of our Lord One thousand nine hundred and forty-seven, and in the eleventh year of the reign of His Majesty King George VI.

(L.S.)

WINSTON DUGAN.

By His Excellency's Command,

L. W. GALVIN,
Commissioner of Crown Lands and Survey.

GOD SAVE THE KING!

PUBLIC HIGHWAY.—SHIRE OF WODONGA.

PROCLAMATION

By His Excellency the Governor of the State of Victoria and its Dependencies in the Commonwealth of Australia, &c., &c., &c.

WHEREAS by the Local Government Act 1928 (No. 3720), section 518, it is amongst other things enacted that it shall be lawful for the Governor in Council at any time, and from time to time, upon the request of the Council of any municipality, by notice in the Government Gazette, to declare any land reserved, used, or by purchase or exchange acquired for a street, road, highway, thoroughfare, bridge, square, court, alley, or right-of-way to be a public highway, and that such land shall thereupon and thenceforth from the date of such Proclamation become and be absolutely dedicated to the public as a public highway within the meaning of any law then or thereafter in force: And whereas the Council of the Shire of Wodonga has requested that the land hereinafter mentioned, which has been used as a street by the said Council within the said shire, be so declared to be a public highway: Now therefore I, the Governor of the State of Victoria, in the Commonwealth of Australia, by and with the advice of the Executive Council of the said State, do by this Proclamation declare the land used as a street hereinafter described, and situated within the Shire of Wodonga aforesaid, to be a public highway within the meaning of the said Act, viz.:—

SHIRE OF WODONGA.—PUBLIC HIGHWAY.

All that piece and parcel of land being part of Crown allotment 3, section IX., Town of Wodonga, Parish of Wodonga, County of Bogong, commencing at a point on the southern boundary of the said allotment 3, distant 205 ft., bearing west from the south-east corner of the said allotment 3; thence north 2 deg. 17 min. east 685 ft. 4 in.; thence north 63 deg. 55 min. west 65 ft. 7 in. along the northern boundary of the said allotment 3; thence south 2 deg. 17 min. west 714 ft. 2½ in.; thence east 60 ft. 1 in. along the southern boundary of the said allotment 3 back to the point of commencement.

Given under my Hand and the Seal of the State of Victoria aforesaid, at Melbourne, this fifteenth day of April, in the year of our Lord One thousand nine hundred and forty-seven, and in the eleventh year of the reign of His Majesty King George VI.

(L.S.) WINSTON DUGAN.

By His Excellency's Command,

P. J. KENNELLY,
Commissioner of Public Works.

GOD SAVE THE KING!

PUBLIC SERVICE OF VICTORIA.—VACANCIES.

APPLICATIONS will be received by the Public Service Board up to Saturday, the 3rd May, 1947, from persons employed in the Public Service of Victoria, who are eligible and qualified, for appointment to the under-mentioned positions:—

ADMINISTRATIVE DIVISION.

Clerk, Class "C," (Cobram), Department of Water Supply.
Yearly Salary.—£449, minimum; £501, maximum.

Duties.—To supervise the collection of revenue, to keep Water Rate Books and Irrigation Registers, Meter Ledgers, Water Sales Ledgers, Cash Books and office records, to issue rate assessment notices and receive revenue, to supervise the preparation of wages sheets, returns and statements, the payment of wages and district costing work, and to have charge of all clerical work connected with the District Office.

Qualifications.—A good knowledge of the Water Acts, a knowledge of the incidence of rating and experience in rate collecting, ability to conduct negotiations and correspondence and to represent the Commission in proceedings for recovery of rates and charges, and a working knowledge of the Land and Local Government Acts.

Fee Clerk, Class "D," Stamp Duties Branch, Department of Treasurer.

Yearly Salary.—£286, minimum; £436, maximum.

Duties.—To assist in the collection of and accounting for revenue payable as fees on instruments lodged in the Office of Titles and the Registrar-General's office, and to receive payments and to issue permits for searches in such offices.

Qualifications.—A knowledge of the Stamps Acts and Regulations thereunder; a good knowledge of the instruments charitable with fees and of the schedule of charges in respect thereof.

PROFESSIONAL DIVISION.

Supervisor of Mass X-Ray Surveys, Class "A," General Health Branch, Department of Health.

Yearly Salary.—£761, minimum; £850, maximum.

Duties.—To have control and supervision of mass surveys of chests; in conjunction with allotted Radiologists to report on miniature films; and to act under the general direction of the State Director of Tuberculosis, and assist when and where required in the clinical work of the Department of Health.

Qualifications.—To be a physician under the age of 45 years experienced in the clinical and radiological aspects of diseases of the chest.

Mechanical Engineer, Grade II, Class "C2," Department of Water Supply.

Yearly Salary.—£527, minimum; £579, maximum.

Duties.—To carry out inspection and testing duties on mechanical equipment and earth moving machinery. To supervise installation of minor pumping plants and act as Relief Engineer-in-Charge of pumping stations as required.

Qualifications.—To possess a Degree or Diploma in Mechanical Engineering, Board of Trade First Class Engineers' Certificate, or other recognized qualification in Mechanical Engineering. To have had extensive practical experience in the operation of modern steam, internal combustion engine, and pumping plants. To have a knowledge of manufacturing processes and testing as governed by British and Australian standards. A knowledge of modern H. T. electrical practice is desirable.

Physicist, Class "C1," National Museum, Department of Chief Secretary.

Yearly Salary.—£449, minimum; £579, maximum.

Duties.—To plan and prepare exhibits for display and to assist generally in research and extension activities as directed.

Qualifications.—To hold a Science degree with honors which must include Physics, Part III.; or the Degree of Bachelor of Electrical Engineering, and to possess ability in scientific craftsmanship.

Draughtsman, Class "D," Department of Water Supply.

Yearly Salary.—£364, minimum; £436, maximum.

Duties.—To prepare, under direction, plans and reports on applications for the Commission's approval to the subdivision of private lands within Irrigation and Drainage Districts, and to deal with correspondence relating to compensation for land and easements acquired for Commission's works.

Qualifications.—To possess the Leaving Certificate or equivalent Technical School training; to be a competent draughtsman with experience in survey computations; to have a good working knowledge of the Commission's activities and the provisions of the Water Acts relating to lands compensation for lands acquired for works and the private subdivision of land.

TECHNICAL AND GENERAL DIVISION.

Fireman, Mental Hospital, Mont Park, Mental Hygiene Branch, Department of Health.

Yearly Salary.—£278, minimum; £317, maximum.

Duties.—To fire boilers and to assist the Engineer Mechanic.

Qualifications.—To possess Boiler Attendant's Certificate or higher qualification.

NOTE.—In addition to the salary rates quoted, a cost of living adjustment at the rate of £32 a year in the case of females and £48 a year in the case of males is payable. The rates are subject to variation in accordance with the rise or fall in the index numbers of the cost of living.

By order,
E. F. FITZGIBBON,
Secretary.

Office of the Public Service Board,
Melbourne, 15th April, 1947.

PUBLIC SERVICE (PUBLIC SERVICE BOARD)
REGULATION 36A.

NOTICE is hereby given that the Public Service Board has raised the classification of the office of Assistant Chief Draughtsman, Survey Branch, Office of Titles, Department of Law, from Class "B2" to Class "A" (£761), Professional Division, and that the Permanent Head of the Department has recommended Henry Nicholas Shea for appointment thereto.

Duties.—To act as Deputy to the Surveyor and Chief Draughtsman and to perform such executive and administrative duties as are delegated to him.

Qualifications.—To be a Licensed Surveyor, to have a thorough knowledge of the survey and transfer work of the Office of Titles and of all legislation having application to the conveyance or transfer of land, and to be competent to direct and control staff.

Appeals against such recommendation should be lodged with the Secretary to the Public Service Board not later than Saturday, the 26th April, 1947.

By order,
E. F. FITZGIBBON,
Secretary.

Office of the Public Service Board,
Melbourne, 15th April, 1947.

PUBLIC SERVICE (PUBLIC SERVICE BOARD)
REGULATION 36A.

NOTICE is hereby given that the Public Service Board has raised the classification of the office of Clerk, Administrative Division, Stamp Duties Branch, Department of Treasurer, the duties of and qualifications for which are set out below, from Class "D" to Class "C," and that the Permanent Head of the Department has recommended John Robert Fitzgerald for appointment thereto.

Duties.—To assess stamp duty chargeable on Instruments relating to transfers and conveyances of real estate, partitions, exchanges, leases, deeds of family arrangement and of settlement and gift lodged for the opinion of the Comptroller of Stamps; to interview solicitors or their representatives in regard to assessments and requisitions made in respect of the before-mentioned Instruments.

Qualifications.—A good knowledge of the Stamps Acts and Regulations and of the various legal decisions relating thereto.

Appeals against such recommendation should be lodged with the Secretary to the Public Service Board not later than Saturday, the 26th April, 1947.

By order,
E. F. FITZGIBBON,
Secretary.

Office of the Public Service Board,
Melbourne, 15th April, 1947.

Public Service Act 1946, Section 39.

REGULATIONS.—PART III.—SALARIES, INCREMENTS, AND ALLOWANCES.

THE Public Service Board, in pursuance of the powers conferred by the Public Service Act 1946, hereby amends its Regulations as shown below:—

FIRST SCHEDULE.

PROFESSIONAL DIVISION.

Offices and Rates of Salaries.

Office.	Yearly Rate of Salary.		Increments (Annual).
	Minimum.	Maximum.	
DEPARTMENT OF CHIEF SECRETARY.	£	£	
CLASS "D."			
Revoke— Assistant Museum of Applied Science	364	436	..
CLASS "C1."			
Add Physicist	449	579	..

D. D. PAINE, Chairman.
E. F. FITZGIBBON, Secretary.

Office of the Public Service Board,
Melbourne, 31st March, 1947.

Transport Regulation Acts.
TRANSPORT REGULATION BOARD.
NOTICE OF PUBLIC HEARINGS.

NOTICE is hereby given that the applications lodged by the person named below for licence to operate the commercial passenger vehicles on the route or routes, or in the manner set out opposite his name, will be heard at the offices of the Board, Exhibition Buildings, Carlton, at a quarter past Ten a.m., on Wednesday, 23rd April, 1947:—
Name of Applicant; Nature of Application.

TOMASETTI, M. C., AND E. M. HALL (trading as Warragul Bus Lines); application for variation of "A" licences to operate a picture trip each Friday night between Darnum and Warragul.

TOMASETTI, M. C., AND E. M. HALL (trading as Warragul Bus Lines); application for variation of "A" licences to operate a picture trip between Drouin and Warragul on Wednesday and Saturday nights.

NOTICE is hereby given that the applications lodged by the persons named below for licences to operate the commercial goods or passenger vehicles on the route or routes, or in the manner set out opposite their names, will be heard at a time and place to be communicated to the parties:—

FORBES, A.; 1 commercial goods vehicle (10 cwt. utility) to operate throughout Victoria for the carriage of own shearing plant, equipment, and tools, in connexion with business as "shearing contractor and wool-classer."

STOTT, J.; 1 commercial goods vehicle for the carriage of—(a) general goods 20 miles Neerim South, (b) live stock and furniture 50 miles Neerim South, (c) sand from Cranbourne to places in (a) above.

WARD, A. P.; 1 commercial goods vehicle for the carriage of road contracting plant and material throughout Victoria.

YEOMAN, J. N. L.; 1 commercial goods vehicle (15 cwt. utility) to operate throughout the Western District of Victoria for the carriage of equipment and provisions on behalf of the Country Roads Board.

ANDERSON, G.; 1 commercial passenger vehicle, with seating capacity for 14 persons, for the carriage of school children from Cobram via Katamatite to Cobram.

CAMPBELL, E. B. AND I.; application for variation of licence TA.2011 to operate under private hire conditions within 50 miles Bayswater.

APPLICATIONS for licences to operate commercial passenger vehicles, with seating capacity for 5 persons, for the carriage of passengers otherwise than at separate and distinct fares for each passenger throughout Victoria:—

BROCK, G. L. C., AND E. A. HALE (trading as Hurstbridge Motors); Hurstbridge.

FELMINGHAM, A. J. G.; Benalla.

GANGE, A. J.; Fitzroy (two vehicles).

HAAG, C. J.; Altona.

KENNEDY, J.; Hampton (to be operated from Black Rock).

MATHEWS, K. W.; Drumcondra.

WISE, L.; Skipton.

Notice of any objection should be forwarded to reach the Secretary to the Board not later than Wednesday, 30th April, 1947.

E. V. FIELD,
Secretary.

Exhibition Buildings, Rathdown-street, Carlton, 15th April, 1947.

MUNICIPAL AUDITORS BOARD.

NOTICE is hereby given that an examination of persons over the age of 25 years desirous of obtaining a certificate to exercise the office of Municipal Auditor or Inspector of Municipal Accounts will be held on Wednesday, 21st May, 1947.

Applications to appear at the examination will be received not later than 30th April.

THOS. G. KING, Secretary,
Municipal Auditors Board.
Department of Public Works, Melbourne, C.2.

FIRST MILDURA IRRIGATION TRUST.—MILDURA URBAN WATER TRUST.

PETITIONS UNDER THE MILDURA IRRIGATION AND WATER TRUSTS ACT 1928.

IN pursuance of the provisions of the *Mildura Irrigation and Water Trusts Act 1928*, the substance and prayer of petitions which have been presented to His Excellency the Governor in Council are published, viz.:—

Petitioners purporting to be the majority of the rate-payers in the areas described in the petitions, such areas being described in the schedule hereto.

Joint petitions from the First Mildura Irrigation Trust and the Mildura Urban Trust in respect of the above areas.

The petitioners pray that His Excellency the Governor in Council may be pleased to sever such areas from the District of the First Mildura Irrigation Trust, and annex the said areas to the District of the Mildura Urban Trust in accordance with the provisions of the said Act.

Copies of such petitions, together with plans showing the areas proposed to be severed and annexed, may be seen at the offices of the Mildura Urban Water Trust, Deakin-avenue, Mildura.

SCHEDULE.

Lots 4, 5, and 11, and parts of lots 8, 9, and 12 of section 31, block F, on lodged plan of subdivision numbered 2168, Parish of Mildura, County of Karkaroc.

Lots 1, 2, 5, 6, 7, and 8 of section 6, lots 4 and 8 and parts of lots 3 and 7 of section 34, lots 7 and 8 of section 63, lots 6, 10, 11, and 12 and part of lot 5 of section 74, lots 7 and 8 of section 82, all in block D on lodged plan of subdivision numbered 2144, Parish of Mildura, County of Karkaroc.

Parts of lots 13 and 14 of section 17, block E, on lodged plan of subdivision numbered 2380, Parish of Mildura, County of Karkaroc.

Lots 1 to 25 inclusive on lodged plan of subdivision numbered 16437, being part of lot 9 of section 30, block F, on lodged plan of subdivision numbered 2168, Parish of Mildura, County of Karkaroc.

L. W. GALVIN,
Minister of Water Supply.

Public Offices, Melbourne, 11th April, 1947.

CITY OF PORT MELBOURNE.

ROAD DEVIATION.

IN pursuance of the powers conferred by sections 521 and 525 of the *Local Government Act 1928*, the Council of the City of Port Melbourne doth hereby order that the land next hereinafter described shall be a public highway from and after the date of publication of this Order in the *Government Gazette*, viz.:—

All that piece of land being parts of Crown allotments 11, 12, 34, and 35 of Crown section 63, City of Port Melbourne, Parish of South Melbourne, County of Bourke—commencing at the south-east corner of Crown allotment 35; thence north 58 deg. 9 min. west 82.6 links along the north side of Ingles-street; thence north 46 deg. 11 min. east 559.5 links; thence south 49 deg. 53 min. east 80.4 links along the south side of Boundary-street; thence south 46 deg. 11 min. west 547.5 links to the point of commencement.

And the said Council doth hereby declare that the land above described shall, from and after the date of the said publication in the *Government Gazette*, be a public highway in lieu of the land hereinafter described, that is to say:—

All that piece of land being an existing road known as Quinn-street, in the said Parish and County—commencing at a point bearing south 58 deg. 9 min. east 336.3 links from the south-west angle of section 63; thence north 36 deg. 10 min. east 589.6 links, south 49 deg. 53 min. east 150.4 links along the south side of Boundary-street, south 36 deg. 10 min. west 568 links, north 58 deg. 9 min. west 150.4 links along the north side of Ingles-street to the point of commencement.

In witness whereof the Mayor, Councillors, and Citizens of the City of Port Melbourne has caused its common seal to be hereunto affixed, this 16th day of April, 1940.

The common seal of the Mayor, Councillors, and Citizens of the City of Port Melbourne was hereunto affixed, in the presence of—

(SEAL) J. P. CRICHTON, Mayor.
W. HOWE, Councillor.
S. S. ANDERSON, Town Clerk.

Confirmed by the Governor in Council,
15th April, 1947.

C. W. KINSMAN,
Clerk of the Executive Council.

Local Government Acts.

PETITION FOR ALTERATION OF BOUNDARIES OF TOWNSHIP OF TONGALA.

NOTICE is hereby given that a petition signed by not less than twenty-five ratepayers resident in the Township of Tongala has been presented to the Minister of Public Works praying that the boundaries of the Township of Tongala be altered to the following:—

Commencing at a point on the southern boundary of allotment 30A, section C, Parish of Tongala, County of Rodney, a distance of 10 chains 26 links from the south-western corner of allotment 30A; thence by a line across the road to the south-western corner of allotment 64; thence by a line bearing north 3 min. 30 sec. west along the western boundary of allotment 64, a distance of 3 chains; thence by a line bearing south 89 deg. 56 min. 30 sec. east, a distance of 45 chains 24.9 links; thence by a line bearing south 3 min. east to the southern boundary of allotment 69, section C, Parish of Tongala; thence by a line bearing west to the south-western corner of allotment 18; thence by a line bearing north 3 min. west to its intersection with the northern boundary of the Toolamba-Echuca railway on the southern boundary of allotment 30P; thence along the railway boundary to a point on a bearing south 3 min. 30 sec. east from the commencing point; thence by a line bearing north 3 min. 30 sec. west to the commencing point.

The above notice is published pursuant to the provisions of section 46 of the *Local Government Act 1928*.

P. J. KENNELLY,
Commissioner of Public Works.

Farmers' Debts Adjustment Act 1935.

CANCELLATION OF STAY ORDER.

NOTIFICATION is hereby given that the Stay Order issued to the under-mentioned farmer has been cancelled by the Farmers' Debts Adjustment Board, such cancellation to take effect on Wednesday, 16th April, 1947:—

No. of Stay Order; Name; Address.

1887; Wood, Herbert Edward, deceased; Mooroopna.

W. J. EVANS, Deputy Secretary,
Farmers' Debts Adjustment Board.

15th April, 1947.

INDUSTRIAL AND PROVIDENT SOCIETIES ACT 1928.

NOTICE is hereby given that a society called "Lake Wallace Co-operative Dairymen's Society Limited" is registered under the provisions of the above Act.

Given under my hand, this tenth day of April, 1947.

A. E. RASMUSSEN,
Registrar of Friendly Societies.

SUBJECT to any necessary excisions, &c., it is proposed to grant the following leases:—

9078, Ballarat; Andrew Oscar Paul; 41a. 2r. 6p., in Parish of Corindhap.

8191, Beechworth; Charles Ferguson Procter; 13a. 0r. 30p., in Parish of Harrietville.

9010, Castlemaine; John Bertram Ducrow and Herbert William Miller; 16a. 0r. 23p., in Parish of Castlemaine.

APPLICATIONS FOR MINING LEASES DECLARED ABANDONED.

6985, Maryborough; Victor Tasman Ekberg; 138a. 1r. 3p., in Parish of Warrenmang.

TERM OF LICENCE EXTENDED.

The term of the under-mentioned licence has been extended for a further period of one year, from the 31st March, 1947:—

128, Petroleum Prospecting Licence; The L. E. Pure Oil Co. Ltd.; 2.83 square miles, in the Parish of Colquhoun.

W. G. MCKENZIE,
Minister of Mines.

CONTRACTS ACCEPTED.—(Series 1946-47.)

VICTORIAN RAILWAYS.

150. Bluestone pitchers and spalls, at rates (Contract 55856).—C. Nash and Son Pty. Ltd. 151. Broken metal, at rates (Contract 55871).—C. Nash and Son Pty. Ltd. 152. Stationary type steam boiler, at £1,079 each (Contract 56038).—Johnsons Tyne Foundry Pty. Ltd. 153. Combined surfacing and thickening machine, at £526 each (Contract 56113).—A. E. Supplies Pty. Ltd. 154. Tea, at 2s. 9½d. lb. (Contract 56114).—Griffiths Bros. Ltd. 155. Walnut sawn timber, at rates (Contract 56129).—Romcke Pty. Ltd. 156. Superheater elements, at £263 4s. stg. per set (Contract 56157).—The Superheater Co. (Aust.) Pty. Ltd. 157. Van body, at £565 10s. each (Contract 56283).—Alf A. Mitchell Pty. Ltd. 158. Electric lamps, at rates (Contract 56310).—Noyes Bros. (Melbourne) Ltd. 159. Cocoa, at 20s. 10d. per dozen 1 lb. packets, less 12½ per cent. (Contract 56319).—Cadbury-Fry-Pascall Pty. Ltd.

By order of the Victorian Railways Commissioners,

E. C. EYERS, Secretary. 11.4.47.

GENERAL STORES.

Gazette No. 122, 5th July, 1946, Schedule No. 29, Cordage, Lines, Rope, Twine, &c.—For the rates shown opposite the following items, substitute the rates as set out hereunder, as from 31st March, 1947:—

Item No. 3, amended rate 189s. 6d. per cwt.; Item No. 4, amended rate 189s. 6d. per cwt.; Item No. 5, amended rate 189s. 6d. per cwt.; Item No. 6, amended rate 3s. 8d. per lb.; Item No. 8, amended rate 3s. 8d. per lb.; Item No. 9, amended rate 3s. 5½d. per lb.; Item No. 10 (coils), amended rate 1s. 11½d. per lb.; (reels), amended rate 2s. 0½d. per lb.; Item No. 12, amended rate 3s. 0½d. per lb.; Item No. 13, amended rate 3s. 3d. per lb.; Item No. 14, amended rate 3s. 5½d. per lb.; Item No. 16, 1 in. and up, amended rate 202s. per cwt.; ¾ in. and ⅝ in., amended rate 210s. 9d. per cwt.; under ¾ in., amended rate 234s. 9d. per cwt.; Item No. 17, 2½ in. and up, amended rate 102s. 6d. per cwt.; 1½ in. to 2¼ in., amended rate 108s. 9d. per cwt.; ¾ in. to 1½ in., amended rate 120s. 3d. per cwt.; Item No. 18, 1 in. and up, amended rate 119s. 6d. per cwt.; under 1 in., amended rate 125s. 9d. per cwt.; Item 19, 1 in. and up, amended rate 119s. 6d. per cwt.; under 1 in., amended rate 125s. 9d. per cwt.; Item No. 20, amended rate 202s. per cwt.; Item No. 21, amended rate 2s. 9½d. per lb.; Item No. 22, amended rate 2s. 9½d. per lb.; Item No. 23, amended rate 2s. 9d. per lb.; Item No. 27, amended rate 105s. 9d. per cwt.; Item No. 28, amended rate 2s. 11½d. per lb.; Item No. 29, amended rate 2s. 10½d. per lb.; Item No. 30, amended rate 5s. 4½d. per lb.; Item No. 31, amended rate 5s. 3½d. per lb.; Item No. 32, amended rate 192s. per cwt.; Item No. 34, amended rate 189s. 6d. per cwt.; Item No. 35, amended rate 2s. 9d. per lb.

Gazette No. 122, 5th July, 1946, Schedule No. 39, Sub-Schedule B, Steel Furniture—Items Nos. 41, 42, and 43, subject to a surcharge of 8 per cent. as from 27th March, 1947.

Gazette No. 269, 27th February, 1947, Schedule No. 52, Tools (General).—For the rate shown opposite item No. 196 substitute 11s. 6d. each.

W. H. RUTHERFORD, Secretary to the Tender Board. 14.4.47.

ROAD TRAFFIC ACT 1935.—SECTION 3.

At the Executive Council Chamber, Melbourne, the fifteenth day of April, 1947.

PRESENT:

His Excellency the Governor of Victoria.

Mr. Field	Mr. Galvin
Mr. Stoneham	

HIS Excellency the Governor of the State of Victoria, by and with the advice of the Executive Council thereof, and pursuant to the provisions of section 3 of the *Road Traffic Act 1935*, doth hereby make the Regulation following, that is to say:—

For the purposes of the Road Traffic Regulations 1939, that portion of High-street in the City of Malvern from Malvern-road to Essex-street is hereby designated a "major street."

And the Honorable William Slater, His Majesty's Chief Secretary for the State of Victoria, shall give the necessary directions herein accordingly.

C. W. KINSMAN,
Clerk of the Executive Council.

DEPARTMENT OF LANDS AND SURVEY.

At the Executive Council Chamber, Melbourne, the
fifteenth day of April, 1947.

PRESENT:

His Excellency the Governor of Victoria.
Mr. Field | Mr. Galvin
Mr. Stoneham

LAND TEMPORARILY RESERVED FROM SALE.

HIS Excellency the Governor of the State of Victoria, by and with the advice of the Executive Council thereof, doth hereby, in pursuance of the provisions of the *Land Act* 1928, reserve, temporarily, and also except from occupation for mining purposes under any miner's right, the land hereinafter described:—

COLLINGWOOD.—Site for Municipal Tip purposes—14 acres 3 roods 20 perches, City of Collingwood, Parish of Jika Jika, County of Bourke, as indicated by hachure on plan hereunder.—(C.366(+)) (Rs.3588).

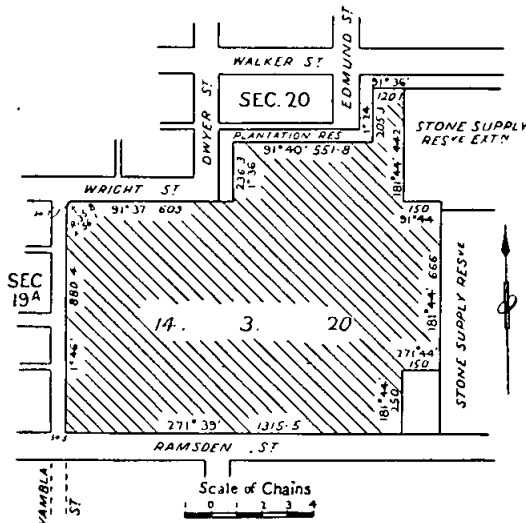

GALLA.—Site for Public Hall purposes—1 acre 0 roods 16 perches, Parish of Galla, County of Hampden, as indicated by hachure on plan hereunder.—(G.3(9)) (Rs.5950).

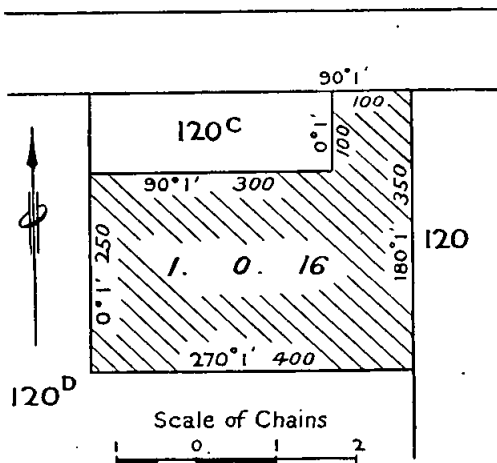

YAN YAN GURT.—Site for Recreation purposes—5 acres, more or less, Parish of Yan Yan Gurt, County of Polwarth, as indicated by hachure on plan hereunder.—(Y.49(2)) (Rs.5944).

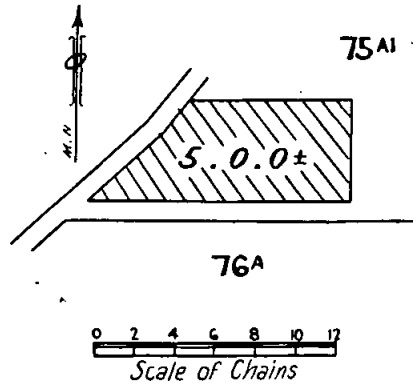

And the Honorable Leslie William Galvin, His Majesty's Commissioner of Crown Lands and Survey for the State of Victoria, shall give the necessary directions herein accordingly.

C. W. KINSMAN,
Clerk of the Executive Council.

DEPARTMENT OF LANDS AND SURVEY.

At the Executive Council Chamber, Melbourne, the
fifteenth day of April, 1947.

PRESENT:

His Excellency the Governor of Victoria.
Mr. Field | Mr. Galvin
Mr. Stoneham

UNUSED AND UNMADE ROADS CLOSED.

HIS Excellency the Governor of the State of Victoria, by and with the advice of the Executive Council thereof, doth hereby direct that, in pursuance of the provisions of section 304 of the *Land Act* 1928 (No. 3709), the unused and unmade roads referred to hereunder be closed, viz:—

Township of Birregurra, Parish of Birregurra, County of Polwarth, being the road between allotments 1, 2, 3, 4, and 5, and allotments 6, 7, 8, and 9, in section U2.—(B.396(2)) (C.90178).

Parish of Wangoom, County of Villiers, being the roads indicated by hachure on plan hereunder.—(W.98(3)) (J.27115).

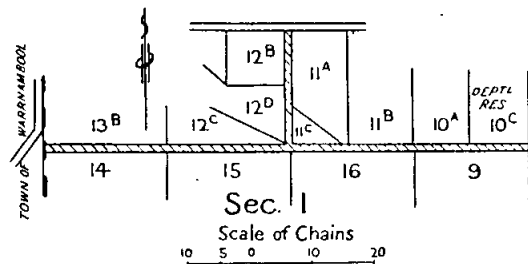

Parish of Myamyn, County of Normanby, being the road between allotment 1 and allotment 2A of section 21.—(M.417(3)) (C.89797).

And the Honorable Leslie William Galvin, His Majesty's Commissioner of Crown Lands and Survey for the State of Victoria, shall give the necessary directions herein accordingly.

C. W. KINSMAN,
Clerk of the Executive Council.

DEPARTMENT OF LANDS AND SURVEY.

At the Executive Council Chamber, Melbourne, the
fifteenth day of April, 1947.

PRESENT:

His Excellency the Governor of Victoria.
Mr. Field | Mr. Galvin
Mr. Stoneham |

REVOCATION OF TEMPORARY RESERVATION OF
LAND BY ORDER IN COUNCIL.

HIS Excellency the Governor of the State of Victoria, by and with the advice of the Executive Council thereof, doth hereby, in pursuance of the provisions of the *Land Act 1928*, revoke the temporary reservation of the land by Order in Council hereinafter referred to, viz.:—

MOYREISK.—Order in Council of 28th December, 1906, of 17 acres of land in the Parish of Moyreisk, as a site for Camping and Watering purposes, so far only as regards the portion thereof comprised within the boundaries published in the *Government Gazette* of 5th March, 1947, and containing 5 acres.—(Rs.2444.)

And the Honorable Leslie William Galvin, His Majesty's Commissioner of Crown Lands and Survey for the State of Victoria, shall give the necessary directions herein accordingly.

C. W. KINSMAN,
Clerk of the Executive Council.

COUNTRY ROADS BOARD.

At the Executive Council Chamber, Melbourne, the
fifteenth day of April, 1947.

PRESENT:

His Excellency the Governor of Victoria.
Mr. Field | Mr. Galvin
Mr. Stoneham |

ORDER APPROVING OF A DEVIATION FROM A MAIN
ROAD IN THE SHIRE OF WALPEUP.

WHEREAS the Country Roads Board constituted under the *Country Roads Act 1928* (No. 3662) has represented to His Excellency the Governor in Council that it appears to it desirable that the deviation hereinafter referred to from the existing Ouyen-Pinaroo road in the Shire of Walpeup (declared to be a main road under the said Act which declaration was confirmed by the Order in Council published in the *Government Gazette* of the 23rd December, 1914, on page 5856) should be made by the said Board: And whereas the said Board in accordance with the requirements of section 19 of the said cited Act has caused to be prepared a map plan and estimate showing the points between which and on and through what land the said deviation is proposed to be made and the cost of acquiring the land and constructing the said deviation: And whereas on an inspection of the said map and plan and a consideration of the said estimate His Excellency the Governor in Council is satisfied that there are funds legally available for acquiring the land and constructing the said deviation: Now therefore be it known by this present Order that His Excellency the Governor of the State of Victoria with the advice of the Executive Council thereof, doth hereby approve of the said road being made that is to say:—

All those pieces of land in the Parish of Walpeup, the boundaries of which are as follow:—

- (a) Commencing at the north-eastern angle of allotment 10 of the said parish; thence by lines bearing respectively 64 deg. 37½ min. 51 links, 89 deg. 45 min. 235.5 links, 244 deg. 37½ min. 1,311.7 links, 217 deg. 46 min. 930 links, 251 deg. 40 min. 4,455 links, 257 deg. 0½ min. 6,554.5 links, 0 deg. 2 min. 618.8 links, and 76 deg. 12½ min. 8,854 links; thence north-easterly by the arc of a circle of radius 10,400 links a distance of 2,102.5 links, the chord of which arc bears 70 deg. 25 min.; thence by a line bearing 64 deg. 37½ min. 1,674 links to the point of commencement.

- (b) Commencing at the north-eastern angle of allotment 8 of the said parish; thence by lines bearing respectively 180 deg. 2 min. 740 links, 280 deg. 8 min. 1,033 links, and 256 deg. 12½ min. 12,700.4 links; thence south-westerly by the arc of a circle of radius 5,500 links a distance of 1,919.8 links, the chord of which arc bears 246 deg. 13 min.; thence by lines bearing respectively 236 deg. 13 min. 12,008.2 links, 270 deg. 2 min. 539 links, and 56 deg. 13 min. 12,456 links; thence north-easterly by the arc of a circle of radius 5,800 links a distance of 2,024.6 links, the chord of which arc bears 66 deg. 13 min.; thence by a line bearing 76 deg. 12½ min. 13,821 links to the point of commencement.

- (c) Commencing at the western angle of a reserve east of the Township of Walpeup; thence by lines bearing respectively 56 deg. 13 min. 979 links, 90 deg. 2 min. 89.8 links, 236 deg. 13 min. 1,050.1 links, and 322 deg. 15 min. 50.1 links to the point of commencement—

which said pieces of land are particularly delineated and shown coloured red on survey plan numbered 4808, lodged in the office of the Country Roads Board.

And the Honorable Patrick John Kennelly, His Majesty's Commissioner of Public Works for the State of Victoria, shall give the necessary directions herein accordingly.

C. W. KINSMAN,
Clerk of the Executive Council.

COUNTRY ROADS BOARD.

At the Executive Council Chamber, Melbourne, the
fifteenth day of April, 1947.

PRESENT:

His Excellency the Governor of Victoria.
Mr. Field | Mr. Galvin
Mr. Stoneham |

ORDER APPROVING OF A NEW MAIN ROAD IN THE
SHIRE OF MANSFIELD.

WHEREAS the Country Roads Board constituted under the *Country Roads Act 1928* (No. 3662) has represented to His Excellency the Governor in Council that it appears to it desirable that the new Mansfield-road in the Shire of Mansfield should be made by the said Board: And whereas the said Board in accordance with the requirements of section 19 of the said cited Act has caused to be prepared a map plan and estimate showing the points between which and on and through what land the said new road is proposed to be made and the cost of acquiring the land and constructing the said new road: And whereas on an inspection of the said map and plan and a consideration of the said estimate His Excellency the Governor in Council is satisfied that there are funds legally available for acquiring the land and constructing the said new road: Now therefore be it known by this present Order that His Excellency the Governor of the State of Victoria, with the advice of the Executive Council thereof, doth hereby approve of the said road being made, that is to say:—

All that piece of land in the Parish of Beolite, the boundaries of which are as follow:—Commencing at a point on the northern boundary of Crown portion 22 of the said parish, distant 279 deg. 0 min. 5,234 links from the north-eastern angle of the said portion; thence by lines bearing respectively 260 deg. 34 min. 421.5 links, 56 deg. 40 min. 198 links, and 99 deg. 0 min. 253.5 links to the point of commencement—which said piece of land is particularly delineated and shown coloured red on survey plan numbered 4810, lodged in the office of the Country Roads Board.

And the Honorable Patrick John Kennelly, His Majesty's Commissioner of Public Works for the State of Victoria, shall give the necessary directions herein accordingly.

C. W. KINSMAN,
Clerk of the Executive Council.

MOTOR OMNIBUS ACT 1928 (No. 3742).

At the Executive Council Chamber, Melbourne, the
fifteenth day of April, 1947.

PRESENT:

His Excellency the Governor of Victoria.
Mr. Field | Mr. Galvin
Mr. Stoneham

AMENDMENT OF THE PRESCRIPTIONS OF CERTAIN
METROPOLITAN MOTOR OMNIBUS ROUTES.

HIS Excellency the Governor of the State of Victoria, by and with the advice of the Executive Council thereof, and in pursuance of the powers conferred by the *Motor Omnibus Act 1928* (No. 3742), doth by this Order amend, as set out hereunder, the prescriptions of certain routes within the metropolitan area along which motor omnibuses for which "regular service" licences are granted may ply for hire, viz.:—

Route No. 36A (Hampton).—Under the heading "Time-tables to be Observed," amend "15" to read "20."

Route No. 93A (Coburg-North Essendon).—Under the heading "Time-tables to be Observed," amend "12 midnight" to read "11.45 p.m."

Licensing Authority.—Pursuant to the provisions of section 15 (1) (c) of the said Act (No. 3742), the Governor in Council, by this Order, confers upon the Licensing Authority full power and authority for the carrying into effect by the said Licensing Authority of the foregoing provisions of this Order.

And the Honorable Patrick John Kennelly, His Majesty's Commissioner of Public Works for the State of Victoria, shall give the necessary directions herein accordingly.

C. W. KINSMAN,
Clerk of the Executive Council.

FACTORIES AND SHOPS ACTS.

At the Executive Council Chamber, Melbourne, the
fifteenth day of April, 1947.

PRESENT:

His Excellency the Governor of Victoria.
Mr. Field | Mr. Galvin
Mr. Stoneham

APPOINTMENT OF A VEGETABLE GROWERS' BOARD,
IN PURSUANCE OF THE "FACTORIES AND SHOPS
(WAGES BOARDS) ACT 1946," AND IN PLACE OF
THE MARKET GARDENERS' BOARD APPOINTED
ON THE 10TH DAY OF AUGUST, 1942.

WHEREAS it is by the *Factories and Shops (Wages Boards) Act 1946* enacted that, notwithstanding anything in the provisions of the *Factories and Shops Acts*, and in particular the provisions of section nine of the principal Act as amended by any Act, a Wages Board shall be appointed so as to apply to persons engaged in the trade of vegetable growers (that is to say, the growing of vegetables, including tomatoes, for sale) within the State of Victoria: And whereas the Governor in Council, by Order dated the 10th day of August, 1942, appointed a Market Gardeners' Board (now by the said Act renamed the Vegetable Growers' Board) and by the same Order defined the area or locality within which the determination of the said Board shall be operative as such portion of the State of Victoria as is within a radius of 40 miles from the post office at the corner of Bourke and Elizabeth streets, in the City of Melbourne: And whereas it is expedient to appoint a Vegetable Growers' Board to take the place of the aforesaid Board appointed by Order dated the 10th day of August, 1942: Now, therefore, His Excellency the Governor of the State of Victoria, by and with the advice of the Executive Council thereof, in pursuance of the provisions of the *Factories and Shops Acts*, doth hereby—

- (a) revoke the aforesaid Order dated the 10th day of August, 1942, insofar as it relates to a Market Gardeners' Board (now by the said Act renamed the Vegetable Growers' Board), and abolish the said Board;

- (b) order that a Wages Board, consisting of six members and a chairman, three of such members being appointed as representatives of employers and three as representatives of employees, be constituted and appointed to determine the lowest prices or rates which may be paid to persons engaged in the trade of vegetable growers (that is to say, the growing of vegetables, including tomatoes, for sale), also that such Wages Board may in any regulation, determination, order, instrument, or legal proceeding be described for all purposes as the Vegetable Growers' Board, and that the area or locality within which the determination of the said Wages Board shall be operative shall be the whole of the State of Victoria.

And the Honorable Percy James Clarey, His Majesty's Minister of Labour and Employment for the State of Victoria, shall give the necessary directions herein accordingly.

C. W. KINSMAN,
Clerk of the Executive Council.

FACTORIES AND SHOPS ACTS.

At the Executive Council Chamber, Melbourne, the
fifteenth day of April, 1947.

PRESENT:

His Excellency the Governor of Victoria.
Mr. Field | Mr. Galvin
Mr. Stoneham

APPOINTMENT OF A NURSERYMEN'S BOARD, IN
PURSUANCE OF THE "FACTORIES AND SHOPS
(WAGES BOARDS) ACT 1946," AND IN PLACE OF
THE NURSERYMEN'S BOARD APPOINTED ON THE
10TH DAY OF AUGUST, 1942.

WHEREAS it is by the *Factories and Shops (Wages Boards) Act 1946* enacted that, notwithstanding anything in the provisions of the *Factories and Shops Acts*, and in particular the provisions of section nine of the principal Act as amended by any Act, a Wages Board shall be appointed so as to apply to persons engaged in the trade of nurserymen within the State of Victoria: And whereas the Governor in Council, by Order dated the 10th day of August, 1942, appointed a Nurserymen's Board, and by the same Order defined the area or locality within which the determination of the said Board shall be operative as the Cities of Ballarat, Bendigo, Geelong and Warrnambool and such other portions of the State of Victoria as are within a radius of 40 miles from the post office at the corner of Bourke and Elizabeth streets, in the City of Melbourne: And whereas it is expedient to appoint a Nurserymen's Board to take the place of the aforesaid Board appointed by Order dated the 10th day of August, 1942: Now, therefore, His Excellency the Governor of the State of Victoria, by and with the advice of the Executive Council thereof, in pursuance of the provisions of the *Factories and Shops Acts*, doth hereby—

- (a) revoke the aforesaid Order dated the 10th day of August, 1942, insofar as it relates to a Nurserymen's Board, and abolish the said Board;
- (b) order that a Wages Board, consisting of six members and a chairman, three of such members being appointed as representatives of employers and three as representatives of employees, be constituted and appointed to determine the lowest prices or rates which may be paid to persons engaged in the trade of nurserymen. Also, that such Wages Board may in any regulation, determination, order, instrument, or legal proceeding be described for all purposes as the Nurserymen's Board, and that the area or locality within which the determination of the said Wages Board shall be operative shall be the whole of the State of Victoria.

And the Honorable Percy James Clarey, His Majesty's Minister of Labour and Employment for the State of Victoria, shall give the necessary directions herein accordingly.

C. W. KINSMAN,
Clerk of the Executive Council.

ROAD TRAFFIC ACT 1935.—SECTION 3.

At the Executive Council Chamber, Melbourne, the
fifteenth day of April, 1947.

PRESENT:

His Excellency the Governor of Victoria.

Mr. Field		Mr. Galvin
Mr. Stoneham		

HIS Excellency the Governor of the State of Victoria, by and with the advice of the Executive Council thereof, and pursuant to the provisions of section 3 of the *Road Traffic Act 1935*, doth hereby make the Regulation following, that is to say:—

The Road Traffic Regulations 1939 are hereby amended as follows:—

After clause 22 of the said Regulations there shall be inserted the clause following:—

“22A. The driver of a vehicle or horse approaching a railway level crossing shall—

(a) proceed at such rate of speed that he will be able to stop the vehicle or horse in time to avoid any danger;

(b) where a mechanical warning device is installed at the crossing and is giving a warning indication, stop the vehicle or horse before reaching the crossing.

Penalty £20.”

And the Honorable William Slater, His Majesty's Chief Secretary for the State of Victoria, shall give the necessary directions herein accordingly.

C. W. KINSMAN,
Clerk of the Executive Council.

APPROACHING LAND SALES.

SALES of Crown lands, in fee-simple, will be held at the under-mentioned places and dates, viz.:—

	No. of Gazette.
Bairnsdale.—Thursday, 24th April, 1947	.. 216
Foster.—Thursday, 17th April, 1947	.. 184
Geelong.—Thursday, 17th April, 1947	.. 184
Manangatang.—Tuesday, 6th May, 1947	.. 224
Numurkah.—Thursday, 17th April, 1947	.. 197

Lands and Survey Office, Melbourne.

PROPOSED REVOCATION OF TEMPORARY RESERVATION OF LAND BY ORDER IN COUNCIL.

IN pursuance of the provisions of the *Land Act 1928*, notice is hereby given that it is the intention of the Governor in Council to revoke the temporary reservation of land by Order in Council hereunder referred to, viz.:—

The following Notice was published 1° on the 2nd April, 1947, pursuant to Order of the 25th March, 1947.

OAKLEIGH.—The Order in Council of the 2nd September, 1889, temporarily reserving 1 acre 1 rood 25 2/10 perches of land in the Town of Oakleigh as a site for a Market is about to be revoked.—(O.1⁽²⁾) (Rs.5848).

L. W. GALVIN,
Commissioner of Crown Lands and Survey.

PROPOSED REVOCATION OF TEMPORARY RESERVATIONS OF LANDS BY ORDERS IN COUNCIL.

IN pursuance of the provisions of the *Land Act 1928*, notice is hereby given that it is the intention of the Governor in Council to revoke the temporary reservations of lands by Orders in Council hereunder referred to, viz.:—

The following Notices were published 1° on the 2nd April, 1947, pursuant to Orders of the 1st April, 1947.

DARNUM.—The Order in Council of the 21st October, 1902, temporarily reserving as a site for a Cemetery 3 acres of land in the Township of Darnum, being part of allotment 6 of section 13, is about to be revoked.—(D.189(B²)) (C.90497).

ST. KILDA, at Elwood.—The Order in Council of the 24th September, 1924, temporarily reserving 30 3/10 perches of land in the City of St. Kilda, at Elwood, as a site for a Public Hall, is about to be revoked.—(S.226(R)) (Rs.3007).

L. W. GALVIN,
Commissioner of Crown Lands and Survey.

PROPOSED REVOCATION OF TEMPORARY RESERVATION OF LAND BY ORDER IN COUNCIL.

IN pursuance of the provisions of the *Land Act 1928*, notice is hereby given that it is the intention of the Governor in Council to revoke the temporary reservation of land by Order in Council hereunder referred to, viz.:—

The following Notice was published 1° on the 16th April, 1947, pursuant to Order of the 15th April, 1947.

COBRAM.—The Order in Council of the 12th February, 1890, temporarily reserving 2 acres of land in the Parish of Cobram as a site for a Manure Depot, is about to be revoked.—(C.398⁽²⁾) (H.016586).

L. W. GALVIN,
Commissioner of Crown Lands and Survey.

Land Act 1928.

LICENCE UNDER THE LAND ACTS 1915 and 1928 DECLARED VOID.

NOTICE is hereby given that the Licence mentioned in the Schedule hereunder has been declared void by the Governor in Council for the reason specified.

District.	Corr. No.	Name of Licensee.	Section of Land Act under which Licensed.	Parish.	Allotment.	Area.	Class.	Annual Rental.	Reasons for Voiding.
Seymour ..	40/129	William Bryant McKenzie	129	Costerfield	3, 4	A. R. P. 2 3 28	Garden Site	£ s. d. 1 0 0	Non-compliance with conditions

Department of Lands and Survey,
Melbourne, 16th April, 1947.

L. W. GALVIN,
Commissioner of Crown Lands and Survey.

LAND AVAILABLE UNDER THE SOLDIER SETTLEMENT ACTS.

NOTIFICATION is hereby given, in accordance with section 16 of the *Soldier Settlement Act 1946*, that the undermentioned allotments are available or are about to become available for settlement.

Any discharged soldier who has applied to the Commission on or before 16th April, 1947, for classification in the required class or classes of primary production for which the lots are made available and whose application has not been finalized or any discharged soldier who has been classified as suitable in such class or classes of primary production may apply on the proper form for settlement on any lot or lots, indicating where he applies in respect of more than one lot, his order of preference therefor.

Application forms, plans, and further particulars may be obtained from the Enquiry Branch, Soldier Settlement Commission, State Public Offices, Melbourne, at which office completed applications for settlement should be lodged on or before the 9th May, 1947.

E. SINGLETON,
Secretary.

Soldier Settlement Commission,
Melbourne, 9th April, 1947.

SCHEDULE OF ALLOTMENTS.

Lot Number on Plan of Subdivision.	Approximate Area which is Subject to Survey.	Class of Primary Production for which Allotments are Considered to be Suitable.
Acres.		
BOURCHIER'S ESTATE.		
<i>Parish of Kellalac, County of Borung.</i>		
1	806	Wheat growing and grazing (sheep)
2	790	" " "

LAND AVAILABLE UNDER THE SOLDIER SETTLEMENT ACTS.

NOTIFICATION is hereby given, in accordance with section 16 of the *Soldier Settlement Act 1946*, that the undermentioned allotments are available or are about to become available for settlement.

Any discharged soldier who has applied to the Commission on or before 16th April, 1947, for classification in the required class or classes of primary production for which the lots are made available and whose application has not been finalized or any discharged soldier who has been classified as suitable in such class or classes of primary production may apply on the proper form for settlement on any lot or lots, indicating where he applies in respect of more than one lot, his order of preference therefor.

Application forms, plans, and further particulars may be obtained from the Enquiry Branch, Soldier Settlement Commission, State Public Offices, Melbourne, at which office completed applications for settlement should be lodged on or before the 16th May, 1947

E. SINGLETON,
Secretary.

Soldier Settlement Commission,
Melbourne, 28th March, 1947.

SCHEDULE OF ALLOTMENTS.

Lot Number on Plan of Subdivision.	Approximate Area which is Subject to Survey.	Class of Primary Production for which Allotments are Considered to be Suitable.
Acres.		
MURRAY VALLEY IRRIGATION DISTRICT.		
<i>Parish of Yarroweyah, County of Moira.</i>		
2	60	Orchard—under irrigation
2A	100	Dairying and mixed farming—under irrigation
30	95	" " "
42	140	" " "
44	109	" " "
45	103	" " "
46	118	" " "
47	115	" " "
49	103	" " "
49A	97	" " "
55	122	" " "
56	106	" " "
57	101	" " "
58	105	" " "
70	128	" " "
71	124	" " "
72	158	" " "
73	154	" " "
74	115	" " "
75	122	" " "
76	128	" " "
77	96	" " "
78	112	" " "
79	100	" " "
80	103	" " "
81	112	" " "
82	119	" " "
92	108	" " "
93	142	" " "
95	145	" " "
97	113	" " "
98	101	" " "
99	100	" " "
100	100	" " "
101	100	" " "
102	95	" " "
103 and 103A	133	" " "
104	108	" " "
105	95	" " "
108	106	" " "

Land Act 1928.

LEASES UNDER THE LAND ACTS 1915 AND 1928 DECLARED VOID.

NOTICE is hereby given that the Leases mentioned in the Schedule hereunder have been declared void by the Governor in Council for the reason specified in each case.

District.	Corr. No.	Name of Lessee.	Section of Land Act under which Leased.	Parish.	Allotment.	Area.	Class.	Annual Rental.	Reasons for Voiding.
Hamilton ..	287/44	Duncan McDougall	44	Bossiebelle ..	9	A. R. P. 130 0 27	3rd	£ s. d. 3 5 6	Non-compliance with conditions
Hamilton ..	174/44	Charles Glynn Fogdon	44	Glenaulin ..	30	574 3 18	3rd	7 3 9	Non-payment of rent

Department of Lands and Survey,
Melbourne, 15th April, 1947.

L. W. GALVIN,
Commissioner of Crown Lands and Survey.

Land Act 1928.

LEASE SURRENDERED.

NOTICE is hereby given that the Governor in Council has accepted the surrender of the Lease mentioned in the Schedule hereunder for the reason specified.

District.	Corr. No.	Name.	Section of Land Act under which Leased.	Parish.	Allotment.	Area.	Class.	Reason.
Geelong	270/44	Lister John McKay	44	Irrewillipe	47B, 47D	A. R. P. 182 1 18	3rd	Surrendered; new lease to issue

Department of Lands and Survey,
Melbourne, 15th April, 1947.

L. W. GALVIN,
Commissioner of Crown Lands and Survey.

TENDERS.

TENDERS will be received at this office until **TEN A.M.** on the days and for the purposes under mentioned.

Particulars may be learnt at this office, and also at the offices named in each instance.

The Board of Land and Works will not necessarily accept the lowest or any tender.

22nd April, 1947.

Altona.—Repairs to fences, State School No. 3923. Deposit, £4.

Avonmore.—Repairs and painting, school and residence, State School No. 1650. Particulars at Inspector of Works Office, Bendigo; Police Station, Rochester; State School, Avonmore. Preliminary deposit, £4. Final deposit, 2 per cent.

Bairnsdale.—Repairs to desks, State School No. 754. Particulars at Inspector of Works Office, Bairnsdale; Police Stations, Maffra, Sale; State School, Bairnsdale. Preliminary deposit, £4. Final deposit, 2 per cent.

Baringhup West.—Repairs and painting, State School No. 941. Particulars at Inspectors of Works Offices, Bendigo, Maryborough; Police Station, Castlemaine; State School, Baringhup West. Preliminary deposit, £3. Final deposit, 2 per cent.

Blythevale Estate (near Streatham).—Erection of eight (8) timber residences on Lots Nos. 1, 2, 3, 4, 5, 6, 7, and 8, Soldier Settlement Commission. Particulars at Inspectors of Works Offices, Ballarat, Geelong, Hamilton, Stawell. Preliminary deposit, £50. Final deposit, 2 per cent.

Burn Brae.—New out-offices and repairs, State School No. 4396. Particulars at Inspector of Works Office, Hamilton; Police Station, Peshurst; State School, Burn Brae. Deposit, £2.

Dudley.—New out-offices for boys and girls, State School No. 3674. Particulars at Inspector of Works Office, Korumburra; Police Station, Wonthaggi; State School, Dudley. Deposit, £3.

Dumbalk.—Repairs and painting, State School No. 3415. Particulars at Inspector of Works Office, Korumburra; Police Stations, Foster, Meenyan. Deposit, £2.

Fairfield.—Supply and installation of one (1) steam-heated mattress sterilizer, "Fairhaven" V.D. Hostel. Preliminary deposit, £10. Final deposit, 2 per cent.

Gala Estate (near Lismore).—Erection of five (5) timber residences on Lots Nos. 1, 2, 3, 4, and 5, Soldier Settlement Commission. Particulars at Inspectors of Works Offices, Ballarat, Geelong, Hamilton; Police Station, Colac. Preliminary deposit, £25. Final deposit, 2 per cent.

Maffra.—Repairs and painting, residence, State School No. 861. Particulars at Inspector of Works Office, Bairnsdale; Police Station, Sale; State School, Maffra. Preliminary deposit, £2. Final deposit, 2 per cent.

Mont Park.—Supply and installation of motorized hydro-extractor, Mental Hospital. Preliminary deposit, £4. Final deposit, 2 per cent.

Mont Park.—Supply and installation of domestic-type refrigerator, Mental Hospital. Preliminary deposit, £2. Final deposit, 2 per cent.

Mount Emu Estate (near Skipton).—Erection of eight (8) timber residences on Lots Nos. 1, 2, 3, 4, 5, 6, 8, and 9, Soldier Settlement Commission. Particulars at

Inspectors of Works Offices, Ballarat, Geelong, Hamilton, Stawell. Preliminary deposit, £50. Final deposit, 2 per cent.

Nar-nar-noon North.—Repairs and painting, State School No. 2914. Particulars at Police Stations, Dandenong, Warragul; State School, Nar-nar-noon North. Deposit, £3.

Ormond East.—Removal of classroom from State School No. 773, Caulfield, and re-erection, State School No. 4366. Preliminary deposit, £10. Final deposit, 2 per cent.

Ouyen.—Supply and installation of domestic-type refrigerator, Higher Elementary School. Preliminary deposit, £2. Final deposit, 2 per cent.

Preston West.—Extension of water service, State School No. 3885. Deposit, £4.

Wahgunyah.—Painting and repairs, State School No. 644. Particulars at Inspector of Works Office, Wangaratta; Police Station, Wodonga; State School, Wahgunyah. Preliminary deposit, £5. Final deposit, 2 per cent.

Warburton.—Fencing, State School No. 1485. Particulars at Police Stations, Healesville, Lilydale; State School, Warburton. Deposit, £4.

West Tarwin-road (Trida).—Removal of State School No. 3428, Doomburrim, and re-erection, State School No. 3405. Particulars at Inspector of Works Office, Korumburra; Police Stations, Foster, Leongatha, Mirboo North. Preliminary deposit, £6. Final deposit, 2 per cent.

29th April, 1947.

Armadale.—Renovations and improved lighting, State School No. 2634. Deposit, £5.

Ballarat.—Erection of brick veneer residence for clerk, Country Roads Board. Particulars at Inspectors of Works Offices, Ballarat, Geelong, Horsham. Preliminary deposit, £15. Final deposit, 2 per cent.

Ballarat.—Erection of brick veneer residence for Assistant Divisional Engineer, Country Roads Board. Particulars at Inspectors of Works Offices, Ballarat, Geelong, Horsham. Preliminary deposit, £15. Final deposit, 2 per cent.

Ballarat.—Supply and installation of electric hot-water service, Matron's Quarters, Mental Hospital. Particulars at Inspectors of Works Offices, Ballarat, Bendigo, Warrnambool. Preliminary deposit, £2. Final deposit, 2 per cent.

Ballarat.—Supply and installation of solid fuel hot-water service, Head Attendant's Quarters, Mental Hospital. Particulars at Inspectors of Works Offices, Ballarat, Bendigo, Warrnambool. Preliminary deposit, £2. Final deposit, 2 per cent.

Barkstead.—Removal of school residence from State School No. 1062, Craigie, re-erection and repairs, State School No. 985. Particulars at Inspectors of Works Offices, Ballarat, Bendigo; Police Stations, Castlemaine, Trentham; State School, Barkstead. Preliminary deposit, £10. Final deposit, 2 per cent.

Beechworth.—Connexion of sewerage system from farm piggery to the institution, sand filter, and drains, Mental Hospital. Particulars at Inspector of Works Office, Wangaratta; Police Stations, Myrtleford, Yackandandah. Preliminary deposit, £10. Final deposit, 2 per cent.

Bethanga.—Repairs and painting, &c., and provision of new garage and out-office, residence, State School No. 1883. Particulars at Inspector of Works Office, Wangaratta; Police Stations, Tallangatta, Wodonga; State School, Bethanga. Preliminary deposit, £5. Final deposit, 2 per cent.

Blackburn.—Provision of new verandah, alterations, and painting, State School No. 3850 (open air school). Particulars at State School, Blackburn. Preliminary deposit, £10. Final deposit, 2 per cent.

Boisdale.—Erection of junior and infants wings, Consolidated School. Particulars at Inspector of Works Office, Bairnsdale; Police Stations, Sale, Traralgon; Consolidated School, Boisdale. Preliminary deposit, £25. Final deposit, 2 per cent.

Buffalo.—Erection and completion of teacher's residence, State School No. 3240. Particulars at Inspector of Works Office, Korumburra; Police Stations, Warragul, Wonthaggi; State School, Buffalo. Preliminary deposit, £15. Final deposit, 2 per cent.

Burnley.—Provision of nursery frames, Horticultural Gardens. Preliminary deposit, £5. Final deposit, 2 per cent.

Calulu.—Erection and completion of teacher's residence, State School No. 1821. Particulars at Inspector of Works Office, Bairnsdale; Police Station, Sale; State School, Calulu. Preliminary deposit, £15. Final deposit, 2 per cent.

Calulu.—General repairs, painting, and provision of new tank, stand, and basin, State School No. 1821. Particulars at Inspector of Works Office, Bairnsdale; Police Stations, Orbost, Sale; State School, Calulu. Deposit, £3.

Canterbury.—Improved lavatory accommodation, State School No. 3572. Particulars at State School, Canterbury. Deposit, £4.

Dromana.—Supply and installation of an electric hot-water service, Police Station. Particulars at Police Station, Dromana. Preliminary deposit, £2. Final deposit, 2 per cent.

Eltham North.—Erection of new store-room, internal and external painting, State School No. 4212. Particulars at Police Station, Eltham; State School, Eltham North. Preliminary deposit, £4. Final deposit, 2 per cent.

Gaffney's Creek.—Re-straining of fences, repairs, and painting, State School No. 1049. Particulars at Inspector of Works Office, Benalla; Police Stations, Alexandra, Mansfield; State School, Gaffney's Creek. Deposit, £2.

Gisborne.—Repairs and painting, school and residence, State School No. 262. Particulars at Inspector of Works Office, Bendigo; Police Stations, Kyneton, Woodend; State School, Gisborne. Preliminary deposit, £5. Final deposit, 2 per cent.

Glenmaggie.—Removal of out-offices, painting, and repairs, State School No. 1576. Particulars at Inspector of Works Office, Bairnsdale; Police Stations, Moe, Morwell; State School, Glenmaggie. Preliminary deposit, £2. Final deposit, 2 per cent.

Kenmare.—Removal of timber residence from Willenabrina North, and re-erection, State School No. 3221. Particulars at Inspector of Works Office, Horsham; Police Stations, Hopetoun, Nhill, Rainbow; State School, Kenmare. Preliminary deposit, £5. Final deposit, 2 per cent.

Kew.—Supply and installation of solid fuel hot-water service, Engineer's Quarters, Mental Hospital. Preliminary deposit, £2. Final deposit, 2 per cent.

Kingsville.—Renovations and additions to out-office accommodation, State School No. 3988. Preliminary deposit, £10. Final deposit, 2 per cent.

Kyneton.—Heating of class-rooms, State School No. 343. Particulars at Inspector of Works Office, Bendigo; Police Stations, Daylesford, Trentham; State School, Kyneton. Preliminary deposit, £4. Final deposit, 2 per cent.

Lake Boga.—Repairs and painting, school and residence, State School No. 3278. Particulars at Inspector of Works Office, Swan Hill; Police Stations, Kerang, Pyramid Hill; State School, Lake Boga. Preliminary deposit, £25. Final deposit, 2 per cent.

Longerenong.—Removal and alterations of workman's cottage, Agricultural College. Particulars at Inspectors of Works Offices, Ballarat, Horsham; Agricultural College, Longerenong. Preliminary deposit, £10. Final deposit, 2 per cent.

Lower Ferntree Gully.—Removal of Army hut from Rowville Camp and re-erection, Horticultural Research Station. Particulars at Police Stations, Dandenong, Ferntree Gully. Deposit, £3.

Malmsbury.—Renovations, repairs, and painting, State School No. 1408. Particulars at Inspector of Works Office, Bendigo; Police Stations, Castlemaine, Kyneton, Woodend; State School, Malmsbury. Preliminary deposit, £4. Final deposit, 2 per cent.

Malvern.—Repairs to fencing, State School No. 2586. Deposit, £4.

Melbourne.—Provision of cool chamber, William Angliss Food Trades School. Particulars at William Angliss Food Trades School, Melbourne. Deposit, £4.

Melbourne.—Alterations, &c., City Watchhouse, Russell-street. Preliminary deposit, £10. Final deposit, 2 per cent.

Minyip.—Erection of new out-offices, fencing, repairs, and painting, State School No. 2167. Particulars at Inspector of Works Office, Horsham; Police Station, Murtoa; State School, Minyip. Preliminary deposit, £5. Final deposit, 2 per cent.

Moonee Ponds.—Repairs to fencing, &c., State School No. 3987. Particulars at State School, Moonee Ponds. Deposit, £4.

Murchison.—Supply and installation of an electric hot-water service, Police Station. Particulars at Inspectors of Works Offices, Benalla, Wangaratta, Bendigo; Police Station, Murchison. Deposit, £2.

Nandaly.—Erection of teacher's residence, State School No. 3927. Particulars at Inspectors of Works Offices, Bendigo, Swan Hill; Police Stations, Ouyen, Sea Lake, Woomelang; State School, Nandaly. Preliminary deposit, £15. Final deposit, 2 per cent.

Navigator.—Removal of school buildings from State School No. 1170, Green Hill, and re-erection, renovations, repairs, and painting, State School No. 1971. Particulars at Inspector of Works Office, Ballarat. Preliminary deposit, £5. Final deposit, 2 per cent.

Noojee.—Erection and completion of teacher's residence, State School No. 4098. Particulars at Inspector of Works Office, Bairnsdale; Police Stations, Moe, Sale; State School, Noojee. Preliminary deposit, £15. Final deposit, 2 per cent.

Northcote.—Supply and installation of an electric hot-water service, Police Station. Particulars at Police Station, Northcote. Deposit, £2.

Osborne's Flat.—Repairs to school and residence, new shelter sheds, State School No. 1463. Particulars at Inspector of Works Office, Wangaratta; Police Stations, Beechworth, Tallangatta, Yackandandah. Preliminary deposit, £5. Final deposit, 2 per cent.

Powelltown.—Provision of new bath, basin, linen press, &c., State School No. 3957. Particulars at Police Stations, Lilydale, Warburton; State School, Powelltown. Deposit, £3.

Pyalong.—Repairs and renovations, and provision of windmill and pump, &c., Police Station. Particulars at Police Stations, Kilmore, Pyalong, Seymour. Preliminary deposit, £4. Final deposit, 2 per cent.

Quambatook.—Repairs and painting, residence, State School No. 2443. Particulars at Inspectors of Works Offices, Bendigo, Swan Hill; Police Stations, Kerang, Quambatook. Preliminary deposit, £5. Final deposit, 2 per cent.

Ross Bridge.—Provision of new porch, bath-room, and laundry, repairs and painting, residence, State School No. 1069. Particulars at Inspector of Works Office, Stawell; Police Station, Ararat; State School, Ross Bridge. Deposit, £4.

Royal Park.—Supply and installation of an electric hot-water service, Engineer's Quarters, Mental Hospital. Preliminary deposit, £2. Final deposit, 2 per cent.

Sale.—General repairs, State School No. 545. Particulars at Inspector of Works Office, Bairnsdale; Police Stations, Maffra, Traralgon; State School, Sale. Preliminary deposit, £5. Final deposit, 2 per cent.

Shepparton.—Erection of new timber residence, Staff Residence No. 277, State Rivers and Water Supply Commission. Particulars at Inspectors of Works Offices, Bendigo, Shepparton; Police Stations, Echuca, Cobram, Tatura. Preliminary deposit, £15. Final deposit, 2 per cent.

Sorrento.—Supply and installation of an electric hot-water service, Police Station. Particulars at Police Station, Sorrento. Preliminary deposit, £2. Final deposit, 2 per cent.

Tahara.—Erection of teacher's residence in timber, State School No. 1378. Particulars at Inspector of Works Office, Hamilton; Police Stations, Casterton, Coleraine, Portland; State School, Tahara. Preliminary deposit, £15. Final deposit, 2 per cent.

Tolmie.—Erection and completion of teacher's residence, State School No. 2305. Particulars at Inspector of Works Office, Benalla; Police Stations, Alexandra, Mansfield; State School, Tolmie. Preliminary deposit, £15. Final deposit, 2 per cent.

Tongala.—Erection of new timber residence, Staff Residence No. 270, State Rivers and Water Supply Commission. Particulars at Inspectors of Works Offices, Bendigo, Shepparton; Police Stations, Echuca, Kyabram, Tongala. Preliminary deposit, £15. Final deposit, 2 per cent.

6th May, 1947.

Cameron's Estate.—Erection of two (2) timber residences, Soldier Settlement Commission. Particulars at Police Stations, Castlemaine, Kilmore, Kyneton, Woodend. Preliminary deposit, £20. Final deposit, 2 per cent.

Ferndale Estate (near Silvan).—Erection of four (4) new timber residences, Soldier Settlement Commission. Particulars at Police Stations, Lilydale, Warburton; State School, Seville. Preliminary deposit, £25. Final deposit, 2 per cent.

Kalkallo.—Repairs, painting, and drainage, residence, State School No. 195. Particulars at Police Station, Seymour; State School, Kalkallo. Preliminary deposit, £5. Final deposit, 2 per cent.

Mont Park.—Supply and installation of hot-water service to remodelled Nurses' Home, Mental Hospital. Preliminary deposit, £5. Final deposit, 2 per cent.

Walpeup.—Erection of two (2) timber residences, Research Station. Particulars at Inspector of Works Office, Mildura; Police Stations, Murrayville, Ouyen, Redcliffs. Preliminary deposit, £20. Final deposit, 2 per cent.

Tenders to be addressed to the Honorable the Commissioner of Public Works, and envelope containing tender marked "Tender for _____ due _____"

P. J. KENNELLY,
Commissioner of Public Works.

Melbourne, 15th April, 1947.

TENDERS FOR THE SERVICE, 1947-48.—PRINTING AND WRITING PAPERS, ENVELOPES, ETC.

TENDERS will be received until Eleven a.m. on the 6th June, 1947, from persons willing to supply, at Melbourne, Paper and Envelopes, &c., for the Victorian Government, as per Schedule No. 1, in the quantities and at the time stated therein.

The rates tendered must not include Sales Tax.

Forms of tender, conditions of tendering, schedule, conditions of contract, and samples, may be obtained from the Secretary to the Tender Board, Gisborne-street, Melbourne, C.2.

Tenders must be accompanied by the preliminary deposit, as provided in the Schedule. *Savings Bank deposit books, fixed deposit receipts, Commonwealth Treasury Bonds, or reference to securities on existing contracts will in no case be received or entertained as preliminary deposits.* Preliminary deposits will be returned within 30 days to unsuccessful tenderers on their application.

The amount and designation of the preliminary deposit enclosed must be clearly stated in the tender.

Security will be required, as provided in the tender form, either in Commonwealth Treasury Bonds, or approved bank guarantee, bank deposit receipt, Savings Bank deposit book, or non-negotiable cheque in favour of the Secretary to the Tender Board, as the tenderer may elect.

The security must be completed and the contract signed within five days of acceptance of the tender, failing which the contract may be again advertised, or another tender accepted.

The lowest or any tender will not necessarily be accepted.

In the event of tenderers withdrawing or attempting to withdraw their tenders before notification of acceptance of same, or failing to take up their accepted tenders within the prescribed period after notification of acceptance, the preliminary deposit will be forfeited, and, in addition, they may be disqualified from tendering or holding any future contracts for Government supplies for a period of twelve months, such disqualification to date from the notification of acceptance of tender. It is also stipulated that, if a tenderer be a member of a firm and such firm be interested in the contract, the tender shall be in the name of the firm and not in that of the individual and that, for a breach of this condition, the preliminary deposit will be forfeited and the tender declared informal.

Preference will be given by the Tender Board, provided the quality of the articles offered is satisfactory and the rates tendered are considered reasonable—

- (a) to tenders for articles manufactured within the Commonwealth;
- (b) to tenders for articles manufactured within any other part of the British Empire.

Rates tendered must include T.T. exchange ruling at time of tendering.

Tenders enclosed in a separate envelope, and having the words, "Tender for Supplies to the Government Printer" written thereon, must be deposited in the Tender Box at the Tender Board Offices, Gisborne-street, Melbourne, or, if sent by post, postage must be prepaid, and the tenders addressed to the Chairman of the Tender Board, Tender Board Offices, Gisborne-street, Melbourne, C.2, which office they must reach not later than by first post on the date of closing of tenders.

CONDITIONS OF CONTRACT.

1. In these conditions and in the form of contract and Schedule hereto annexed the words "Government Printer" shall include the officer bearing or acting under that title, or such other officer as the Government may from time to time appoint to perform the duty in the matter in relation to which the expression is used. The word "Storekeeper" shall mean the officer (or officers) of the Government who inspects and takes delivery of the stores. The word "Schedule" shall mean and embrace the Schedule or Schedules hereunto annexed.

2. Under no circumstances will a contractor be permitted to abandon his contract. In the event of the contractor failing to carry on the contract, the contract security money will in that case be absolutely forfeited; and, in addition, the contractor will be held liable for any loss which the Government may sustain in consequence of such failure.

3. The Government will order from the contractor those articles enumerated in the Schedule for which his tender is accepted.

4. The first delivery under this contract, equal to one-half the quantity contracted for, shall be made not later than 30th November, 1947, and the remainder shall be delivered not later than 28th February, 1948. Should the contractor so desire, the whole quantity contracted for may be delivered by the date first specified.

5. The supplies are to be in accordance with Schedule conditions where so stated, and of the particular manufacture indicated in the Schedule.

6. All packages, cases, wrappings, &c., whether bulk be broken or not, shall be considered the property of the Government, and no charges or expenses whatsoever beyond the price tendered and set out in the Schedule will be allowed to the contractor. The net weight only will be paid for. Contractors must provide, without extra charge, whatever labour, &c., may be required in the packing and delivery of the supplies.

7. All supplies shall be made to the Government Printer. The goods shall be delivered as may be directed by that officer in terms of contract. At the time of delivering the supplies, the contractor shall produce an invoice and specification showing the number and contents of each package in duplicate to the officer authorized to accept delivery, and such officer shall give an acknowledgment to the contractor of the receipt of the stores delivered by him.

8. All papers supplied, excepting Item 38, must be supplied in reams, and must be according to the specification as set out in the Schedule, and cut to the true size ordered. Each ream must contain 500 sheets, and must be supplied flat (unless otherwise specified). No creased or damaged paper will be accepted.

9. The acceptance of the supplies shall be subject to the approval of the Government Printer, whose decision shall be final. If, after the delivery of the supplies has been taken, any deficiency or defect is discovered therein, such deficient or defective stores may be returned to the contractor. All rejected goods must be removed by the contractor within forty-eight hours after notice has been given to him by the Government Printer of such rejection, and if not so removed the Government Printer is hereby empowered to send same to any store in Melbourne, there to be stored at the contractor's risk and expense, such expenses to be deducted as in clause 10. Delivery will not be deemed to have been made until the goods have been approved. In the case of the rejection or return of any supplies the contractor shall bear the whole cost of replacing the supplies rejected or returned, otherwise purchases will be effected at the contractor's risk, and the extra expense deducted as in clause 10.

10. In the event of the goods not being delivered within the time stated the Government Printer may, on giving the contractor twenty-four hours' notice, purchase the supplies, or any like supplies that are suitable for the service, at the contractor's risk, and the extra expense incurred over and above the contract price (if any) will be deducted from the contractor's account or from the security money.

11. A refusal to execute orders, irregularity in the quantity or quality of the supplies, or delay in delivering or replacing them when required, will subject the contractor, upon report from the Government Printer to the Tender Board, to such mulct, not exceeding One hundred pounds, for each and every default, as the Treasurer may direct, and the amount may be deducted as set out in clause 10. It will also be in the power of the Treasurer, upon such refusal, irregularity, or delay, to terminate the contract forthwith, and declare forfeit the whole or any portion of the security money; and, in addition, the contractor may be disqualified from tendering or holding any future contract or contracts for a period of twelve months from the date of such disqualification.

12. Contractors are not at liberty to transfer their contracts under cover of power of attorney, coupled with an interest or otherwise, and no such transfer will be recognized by the Government.

13. In the event of any alteration in the duty of Customs or Telegraphic Transfer Exchange, which may affect any of the items included in the contract, the Government or the contractor, as the case may be, will make a proportionate allowance by way of deduction from or increase of the price of the item so affected, and the contractor shall, if called upon, submit such documentary evidence as may be required by the Government to permit of the calculation of any such allowance.

14. The contractor shall not insure the material against war risk. Provided the material is consigned on a separate bill of lading to the Government of Victoria, any loss or damage in transit occasioned by any war risks to which the material may be subject whilst on board ship shall be to Victorian Government account, subject to the production by the contractor of documentary evidence satisfactory to the Tender Board.

15. Each package shall be branded "O.H.M.S., The Government of Victoria, The Government Printer, Melbourne," and numbered consecutively, and each package shall also be marked with the number of the contract and contents of same for identification purposes.

16. Every account shall be in prescribed form, setting out the contract and item numbers, and shall furnish full details of how it is made up.

17. Payment for supplies will be made in Melbourne when same have been accepted.

JOHN CAIN,
Treasurer.

The Treasury,
Melbourne, 14th April, 1947.

PRIVATE ADVERTISEMENTS.

Victoria.

ACT 391.—FIRST SCHEDULE.

I, JAMES PATRICK O'COLLINS, of The Palace, Sturt-street, Ballarat, in the State of Victoria, head or authorized representative within the Roman Catholic Diocese of Ballarat, of the denomination known as the Roman Catholic, and being the person entitled to minister in or occupy a building or buildings upon the land described in the subjoined statement of trusts, hereby apply to the Governor of the State of Victoria for leave to dispose of the said land by the means and for the purposes mentioned in the said statement of trusts, and I hereby certify that the said land was approved by the Executive Council on the 9th day of March, 1855, as a site for the purpose of the Roman Catholic Church.

That the only trustees of the said land resident in the State of Victoria are the Roman Catholic Trusts Corporation for the Diocese of Ballarat.

That there are no buildings upon the said land, and that the only persons entitled to minister in or occupy the same are myself and such persons as I may authorize to do so.

I desire that the title to the land may be made out in the name of the Roman Catholic Trusts Corporation for the Diocese of Ballarat, the office of which is at The Palace, Sturt-street, Ballarat.

Dated this 27th day of March, 1947.

JAS. P. O'COLLINS, Bishop.

We consent to this application—

The seal of the Roman Catholic Trusts Corporation for the Diocese of Ballarat was affixed hereto by its order, in the presence of—

(SEAL) JAS. P. O'COLLINS, Bishop.
E. GALLIGAN, Member.
E. GLOWREY, Member.

STATEMENT OF TRUSTS.

Description of Land.—1 acre 3 roods, Town of Portland, Parish of Portland, County of Normanby, being allotment 1 of section 22B: Commencing at a point where the northern side of Fern-street abuts on the eastern side of Blair-street; bounded thence by Blair-street bearing north 1 deg 30 min. east 400 links, by a line bearing south 88 deg. 30 min. east 359 links, by a road bearing south 39 deg. 58 min. east 137 5/10 links; thence by Palmer-street bearing south 1 deg. 30 min. west 297 links; and thence by Fern-street bearing north 88 deg. 30 min. west 450 links to the point of commencement.

Names of Trustees.—The Roman Catholic Trusts Corporation for the Diocese of Ballarat.

Powers of Disposition.—To sell, exchange, lease, or mortgage.

Purposes to which Proceeds of Disposition are to be Applied.—To such purposes of the Roman Catholic Church in the Diocese of Ballarat as a Council of such Diocese, under the provisions of the Act of the Parliament of Victoria (No. 2100), may from time to time by resolution direct.

PEARSON & MANN, solicitors, Lydiard-street, Ballarat. 12

Victoria.

ACT 391.—FIRST SCHEDULE.

I, JAMES PATRICK O'COLLINS, of The Palace, Sturt-street, Ballarat, in the State of Victoria, head or authorized representative within the Roman Catholic Diocese of Ballarat, of the denomination known as the Roman Catholic, and being the person entitled to minister in or occupy a building or buildings upon the land described in the subjoined statement of trusts, hereby apply to the Governor of the State of Victoria for leave to dispose of the said land by the means and for the purposes mentioned in the said statement of trusts, and I hereby certify that the said land was approved by the Executive Council on the 28th day of March, 1857, as a site for the purpose of the Roman Catholic Church.

That the only trustees of the said land resident in the State of Victoria are the Roman Catholic Trusts Corporation for the Diocese of Ballarat.

That there are no buildings upon the said land, and that the only persons entitled to minister in or occupy the same are myself and such persons as I may authorize to do so.

I desire that the title to the land may be made out in the name of the Roman Catholic Trusts Corporation for the Diocese of Ballarat, the office of which is at The Palace, Sturt-street, Ballarat.

Dated this 27th day of March, 1947.

JAS. P. O'COLLINS, Bishop.

We consent to this application—

The seal of the Roman Catholic Trusts Corporation for the Diocese of Ballarat was affixed hereto by its order, in the presence of—

(SEAL) JAS. P. O'COLLINS, Bishop.
E. GALLIGAN, Member.
E. GLOWREY, Member.

STATEMENT OF TRUSTS.

Description of Land.—2 acres, Town of Portland, Parish of Portland, County of Normanby, being allotment 46p of section D: Commencing at the south-west angle of the State School reserve; bounded thence by roads bearing north 83 deg. 30 min. west 400 links and north 6 deg. 15 min. east 500 links, by the south boundary of the Church of England reserve bearing south 83 deg. 30 min. east 400 links; and thence by the west boundary of the State School reserve bearing south 6 deg. 15 min. west 500 links to the point of commencement.

Names of Trustees.—The Roman Catholic Trusts Corporation for the Diocese of Ballarat.

Powers of Disposition.—To sell, exchange, lease, or mortgage.

Purposes to which Proceeds of Disposition are to be Applied.—To such purposes of the Roman Catholic Church in the Diocese of Ballarat as a Council of such Diocese, under the provisions of the Act of the Parliament of Victoria (No. 2100), may from time to time by resolution direct.

PEARSON & MANN, solicitors, Lydiard-street, Ballarat. 13

Water Act.

PROPOSED NOOJEE WATERWORKS TRUST.

NOTICE is hereby given that the Buln Buln Shire Council has made application to the Honorable the Minister of Water Supply for the constitution of a Waterworks Trust and for the proclamation of a Waterworks District at Noojee, and the construction, maintenance, and continuance of water supply works within that district under the provisions of the Water Act.

A general plan and description of the proposed works have been submitted with the application, and copies of same may be seen at Shire Office at Drouin.

Dated at Drouin, the 27th day of March, 1947.

9906

T. J. RYAN, J.P., Shire Secretary.

CITY OF BOX HILL.

LOAN 53.—ELECTRIC SUPPLY.

NOTICE is hereby given that the Council of the City of Box Hill intends to borrow the sum of £20,000 to cover normal capital expenditure in the electric supply undertaking, such loan to be repayable by half-yearly instalments, including principal and interest, at a rate not exceeding £3 6s. per annum over a period of twenty years, the relevant debentures being repayable at the E. S. & A. Bank, Box Hill.

Plans, specifications, and an estimate of the cost of such works and undertakings, together with a statement showing the proposed expenditure of the money to be borrowed, are open for inspection at the office of the Council.

A. BRUCE CURREY, Town Clerk.

10th April, 1947.

16

CITY OF HEIDELBERG.

BY-LAW No. 154.

Amending Residential Area.

A By-law of the City of Heidelberg, made and numbered 154, under the provisions of the Local Government Acts and all other powers enabling, but particularly under and with reference to sections 197-5-B and 228 of the *Local Government Act 1928*, to amend By-law 74 to prescribe a Residential Area No. 2 at Stortford-avenue, West Ivanhoe.

IN pursuance of the powers conferred by the Local Government Acts, the Mayor, Councillors, and Citizens of the City of Heidelberg, with the approval of the Governor in Council, order as follows:—

1. That all those six allotments of land fronting Stortford-avenue, West Ivanhoe, being more particularly delineated on plan of subdivision lodged in the Office of Titles, and numbered 9090, as lots numbers 6, 7, and 8 on the west side, and 13, 14, and 15 on east side, be excised from Residential Area No. 1 and added to Residential Area No. 2.

The resolution for passing this By-law was agreed to by the Council on the 18th day of June, 1946, and confirmed on the 16th day of July, 1946.

G. E. FITZGERALD, Mayor.

(SEAL)

A. NUTTALL, Councillor.

F. PHILLIPS, Town Clerk.

Approved by the Governor in Council on the 25th day of March, 1947.—C. W. KINSMAN, Clerk of the Executive Council. 21

CITY OF HEIDELBERG.

BY-LAW No. 160.

Prohibiting Riding Horses in Chelsworth Park.

A By-law of the City of Heidelberg, made under the provisions of the *Local Government Act 1928*, and particularly under and with reference to section 228, and numbered 160.

IN pursuance of the powers conferred by the Local Government Acts, the Mayor, Councillors, and Citizens of the City of Heidelberg, with the approval of the Governor in Council, order as follows:—

1. That the whole of By-law No. 147, permitting the riding of horses in that portion of Chelsworth Park between the Ivanhoe Golf Links and the River Yarra, be and is hereby repealed.

The resolution for passing this By-law was agreed to by the Council on the 12th November, 1946, and confirmed on the 4th February, 1947.

A. E. CARLYLE, Mayor.

(SEAL)

A. NUTTALL, Councillor.

F. PHILLIPS, Town Clerk.

Approved by the Governor in Council on the 18th day of March, 1947.—C. W. KINSMAN, Clerk of the Executive Council. 22

CITY OF MILDURA.

LOANS Nos. 18 AND 19.

Notice of Intention to Borrow the Sums of £25,000 and £20,000, respectively, for Permanent Works and Undertakings in the City of Mildura.

TAKE notice that the Council of the City of Mildura proposes to borrow, on the credit of the Mayor, Councillors, and Citizens of the said City, the sum of Forty-five thousand pounds (£45,000) in the separate amounts set out above, such total sum to be raised by the issue of debentures in accordance with the respective provisions of the Local Government Acts.

The maximum rate of interest that may be paid is Three pounds six shillings and three pence (£3 6s. 3d.) per centum per annum.

Such moneys shall be repayable by 40 half-yearly instalments of £1,547 9s. 7d. each, including principal and interest, by providing out of the municipal fund the said amounts on the first day of January and the first day of July in each respective year during the currency of the loans.

Such moneys shall be repayable at Melbourne, at the Commercial Banking Company of Sydney Limited, or at the Council's bankers for the time being in Melbourne.

The purposes for which the loans are to be applied are—

Loan No. 18.—Construction of roads, footpaths, and drainage	£25,000
Loan No. 19.—Electricity extensions in Mildura and district	20,000
	£45,000

The plans, specifications, and estimate of the cost of the works referred to above, and a statement showing the proposed expenditure of money to be borrowed, are open for inspection at the Town Hall, Mildura.

Dated this 16th day of April, 1947.

23

T. J. NIHILL, Town Clerk.

Local Government Act 1928, Part 18, Division 3.

CITY OF MORDIALLOC.

NOTICE OF INTENTION TO ACQUIRE LAND COMPULSORILY.
TO WHOM IT MAY CONCERN.

WHEREAS the Council of the City of Mordialloc deems it expedient to execute a certain work or undertaking, viz.:—

The provision of a park and recreational facilities at Mordialloc for the purpose whereof it is, in the opinion of the said Council, necessary and desirable that the said Council exercise its power to take certain land within its municipal district compulsorily as provided by the *Local Government Act 1928*, as amended, and the said Council has caused to be prepared specifications, maps, plans, sections, and elevations in which are expressed the nature and extent of such work or undertaking and the exact site and admeasurements thereof, and on what land the said work or undertaking is proposed to be placed, and the name of the owner of such land proposed to be taken as far as is known, and the said specifications, maps, plans, sections, and elevations so prepared have been approved by the said Council.

The Council doth hereby publish and give notice that the purport of the said specifications, maps, plans, sections, and elevations shortly described is as follows:—

"The provision of a park and recreation facilities at Mordialloc,"

and for the purpose the land which it is necessary and desirable to take compulsorily is the land containing 16 acres 3 roods 38 perches, or thereabouts, being part of Crown allotments 17, 18, 19, and 21, City and Parish of Mordialloc, County of Bourke, and more particularly described in certificate of title, volume 6822, folio 1364339, in the name of Investors Land and Finance Corporation Pty. Ltd.

The said Council doth hereby give further notice that the said specifications, maps, plans, sections, and elevations are deposited at the office of the said Council, Brindisistreet, Mentone, and are there open for inspection on all days and between the hours the said office is appointed to be open, for the space of 40 clear days from the date of publication of this notice in the *Victoria Government Gazette*, and the said Council doth hereby call upon all persons interested in or affected by the proposed work or undertaking to set forth, in writing, addressed to the said Council or the Town Clerk thereof, within 40 clear days from the date of the publication of this notice as aforesaid all objections which they may have to the said work or undertaking.

Dated this 11th day of April, 1947.

11

E. C. OWBRIDGE, Town Clerk.

BOROUGH OF PORTLAND.

LOAN No. 14.

Notice of Intention to Borrow the Sum of Three Thousand Pounds (£3,000) for Permanent Works and Undertakings in the Borough of Portland.

TAKE notice that the Council of the Borough of Portland proposes to borrow on the credit of the Mayor, Councillors, and Burgesses of the said Borough, the sum of Three thousand pounds (£3,000), such sum to be raised by the issue of debentures in accordance with the provisions of the Local Government Acts.

The rate of interest to be paid shall not exceed £3 6s. 3d. per centum per annum.

Such moneys shall be repayable by 30 half-yearly instalments, each including principal and interest, by providing out of the electric supply account on the first day of January and the first day of July in each respective year during the currency of the loan.

Such moneys shall be repayable at Portland, at the Commercial Banking Company of Sydney, or at the Council's bankers for the time being in Portland.

The purpose for which the loan is to be applied is—
Extension of plant at the existing electric supply undertaking £3,000

The plans, specifications, and estimate of cost of the works referred to above, and a statement showing the proposed expenditure of money to be borrowed, are open for inspection at the Town Hall, Portland.

Dated this 14th day of April, 1947.

20 E. NOEL T. HENRY, Town Clerk.

AMHERST UNITED BOROUGH AND GOLDFIELDS COMMON.

NOTICE is hereby given that A. W. Monk has been appointed Herdsman and Prosecuting Officer for the Amherst United Borough and Goldfields Common.

F. A. WOOD, Secretary. 30

Talbot, 30th March, 1947.

NOTICE OF DISSOLUTION OF PARTNERSHIP.

NOTICE is hereby given that the partnership heretofore subsisting between the undersigned John Cape Thompson and Geoffrey Noel, carrying on business as monumental masons at Gheringhap-street, Geelong, in the State of Victoria, under the name of Classic Memorials, has been dissolved by mutual consent as from the 1st day of February, 1947. All debts due to and owing by the said late firm will be received and paid by John Cape Thompson, who will continue to carry on the business at the same place.

Dated at Geelong, the 1st day of February, 1947.

G. NOEL.
J. THOMPSON. 15

Witness—J. A. Toy.

NOTICE is hereby given that the partnership heretofore subsisting between Frederick Northausen, Edward Northausen, James Aikenhead, and Neil Elltton James, heretofore carrying on business under the style or firm of Alpha Electric Company, at 409 Lonsdale-street, Melbourne, has been dissolved as from the 9th day of December, 1946, so far as concerns the said Neil Elltton James, who retires from the said firm.

Dated this 10th day of April, 1947.

F. NORTHAUSEN.
E. NORTHAUSEN.
J. AIKENHEAD.
N. E. JAMES.

Witness to signatures—ROBERT G. DUNLOP, solicitor, Melbourne.

R. G. Dunlop, solicitor, 108 Queen-street, Melbourne. 48

NOTICE is hereby given that the partnership heretofore subsisting between Albert Walter Borsa and Oscar Wilczer, carrying on business at Barkly Theatre, Footscray, under the name or style of Metropolitan Entertainments and Publicity, has been dissolved by mutual consent as from the 18th day of November, 1946, so far as concerns the said Oscar Wilczer, who retired from the said firm. Albert Walter Borsa continues to carry on business as aforesaid under the name of Metropolitan Entertainments and Publicity.

Dated the 19th day of March, 1947.

35 A. W. BORSA.
O. WILCZER.

No. 232.—3503/47.—2

NOTICE is hereby given that the partnership heretofore subsisting between us, the undersigned, Ronald Percival Bennett and John Augustine Burke, carrying on business as motor garage proprietors, at 35 Arthurton-road, Northcote, under the style or firm of "Arthurton Motors," has been dissolved by mutual consent as from the date hereof. All debts due to and owing by the said late firm will be received and paid respectively by the said Ronald Percival Bennett, who will continue to carry on the said business, under the name or style of "Arthurton Motors," at 35 Arthurton-road, Northcote.

Dated the 3rd day of April, 1947.

R. P. BENNETT.
J. A. BURKE.

Witness to both signatures—G. G. MASON.

Norman J. Shankly, LL.B., solicitor, 31 Queen-street, Melbourne. 59

NOTICE is hereby given that the partnership heretofore subsisting between the undersigned Kenneth Victor Radford and William Eric Rogers, carrying on business as plumbers and hardware at 217 McKinnon-road, McKinnon, under the style or firm name of "Radford and Rogers," has been dissolved by mutual consent as from the 29th day of March, 1947. All debts due to and owing by the partnership will be received and paid by Kenneth Victor Radford, who will continue to carry on the business at the same place and under the same firm name.

Dated the 3rd day of April, 1947.

K. V. RADFORD.
W. E. ROGERS.

W. E. and O. McCutcheon, solicitors, 31 Queen-street, Melbourne. 27

NOTICE is hereby given that the partnership previously subsisting between us, the undersigned Alan McDougall Glen and Ronald William Thomas Stewart, carrying on the business of a quarry, at Lysterfield, under the style or firm of Stewart's Blue Metal Quarries, has been dissolved as from the 31st day of December, 1946.

Dated the 10th day of April, 1947.

32 A. MCD. GLEN.
R. STEWART.

THE MORGAN ADVERTISING COMPANY PROPRIETARY LIMITED.

PURSUANT TO SECTION 226.

AT an Extraordinary General Meeting of the above-named company, duly convened and held at 64 Elizabeth-street, Melbourne, on Monday, the 14th day of April, 1947, the following resolution was duly passed as a special resolution:—

"That the company be wound up voluntarily."

And at such last-mentioned meeting, George Thomas Ramsay Wilby, of 31 Queen-street, Melbourne, was appointed liquidator for the purposes of the winding up.

Dated this 14th day of April, 1947.

34 VAL. MORGAN, Chairman.

The Companies Act 1938.

N. RASCH PTY. LTD. (IN LIQUIDATION).

NOTICE is hereby given, in pursuance of section 236 of the Companies Act 1938, that a General Meeting of the members of the above-named company will be held at the office of Messrs. Young and Outhwaite, 368 Collins-street, Melbourne, on Monday, the 19th day of May, 1947, at Twelve noon, for the purpose of having the account laid before them, showing the manner in which the winding up has been conducted and giving any explanations required.

Dated this 16th day of April, 1947.

24 C. A. STEWART, Liquidator.

CREDITORS, next of kin, and others having claims in respect of the estate of Harriet Ryan, late of 806 Macarthur-street, Ballarat, widow, deceased (who died on the 16th day of February, 1947), are to send the particulars of their claims to The Ballarat Trustees, Executors, and Agency Company Limited and Leslie James Barker, to the care of The Ballarat Trustees, Executors, and Agency Company Limited, of 101 Lydiard-street north, Ballarat, by the 30th day of June, 1947, after which date it and he will distribute the assets, having regard only to the claims of which it and he then have notice.

DOOLEY, SUTTON, & A. W. LONG, 38 Lydiard-street south, Ballarat, solicitors. 19

Trustee Act 1928.

NOTICE TO CLAIMANTS.

PURSUANT to the *Trustee Act 1928*, creditors, next of kin, and all other persons having claims in respect of the estate of any deceased person named below are required to send particulars thereof to the legal personal representative or representatives at the address stated below, on or before the date stated, after which date the representative or representatives will distribute the assets, having regard only to the claims of which notice has been received:—

Ealey Ebenezer Daniels, late of Auckland, in New Zealand, gentleman, deceased, died 10th day of May, 1946.—Claims to Ross Gibson Macfarlan, solicitor, the attorney under power of the executors, care of Aitken, Walker, and Strachan, 123 William-street, Melbourne, solicitors for the attorney, by the 17th day of June, 1947. 33

Mary Isabel Guthrie, late of "Coolangatta," Moorabool, in the State of Victoria, married woman, deceased, died 14th day of December, 1946.—Claims to the executors, Rupert Vance Moon, manager, of Dennys, Lascelles Limited, Geelong, in the said State, and Rutherford Campbell Guthrie, of "Warrawidgee," Linton, in the said State, grazier, care of Aitken, Walker, and Strachan, of 123 William-street, Melbourne, solicitors for the executors, by the 17th day of June, 1947. 36

Jessie Daniels, late of Auckland, in New Zealand, widow, deceased, died 14th day of July, 1946.—Claims to Ross Gibson Macfarlan, solicitor, the attorney under power of the executors, care of Aitken, Walker, and Strachan, 123 William-street, Melbourne, solicitors for the attorney, by the 17th day of June, 1947. 37

Richard Valentine Keane, late of 56 Wanda-road, Caulfield, Senator of the Parliament of the Commonwealth, deceased, died 26th day of April, 1946.—Claims to the executrices, Nancy Elizabeth Keane and Patricia Mary Keane, care of Upton, Ettelson, and Owen, 395 Collins-street, Melbourne, solicitors for the executrices, by the 18th day of June, 1947. 50

Thomas Rooke, late of Hamilton, farmer, deceased, died 25th day of November, 1944.—Claims to the executrix, Ellen Josephine Rooke, of Barenja Court, Kew, widow, care of Upton, Ettelson, and Owen, 395 Collins-street, Melbourne, solicitors for the executrix, by the 18th day of June, 1947. 62

Isobel Ferguson Biffen, late of 61 Darling-street, South Yarra, widow, deceased, died 27th day of October, 1946.—Claims to the executors, Phillip Windmiller Ettelson, of 395 Collins-street, Melbourne, solicitor, and Charles Roberts, of 223 Toorak-road, Hartwell, sworn valuer, care of Upton, Ettelson, and Owen, 395 Collins-street, Melbourne, solicitors for the executors, by the 18th day of June, 1947. 68

Ethel Carter, late of care of Bank of New South Wales, 47 Berkeley Square, London, and Belle Vue Cottage, Brading, Isle of Wight, England, gentlewoman, deceased, died 3rd day of February, 1947.—Claims to the executor, Frederick Carter Read, solicitor, care of Read and Read, solicitors, Temple Court, 422-8 Collins-street, Melbourne, by 21st day of June, 1947. 41

Florence Rennick, formerly of "Moreaki," Barker's-road, Hawthorn, but late of Peverill-street, Camberwell, widow, deceased, died 26th day of February, 1947.—Claims to the executor, Frederick Carter Read, solicitor, care of Read and Read, solicitors, Temple Court, 422-8 Collins-street, Melbourne, by 21st day of June, 1947. 42

Ellen Sheehan, late of Finlayson-street, Lane Cove, in the State of New South Wales, widow, deceased, who died on the 6th January, 1947.—Claims to the executor, Michael Joseph Mornane, solicitor, 95 Queen-street, Melbourne, by the 19th June, 1947. 45

Joseph James Eugene Feehan, late of Hotel Federal, Collins-street, Melbourne, gentleman, deceased, who died on the 20th day of February, 1947.—Claims to the executors, John Francis Feehan and Robert Chappell, care of M. Mornane, solicitor, 95 Queen-street, Melbourne, by the 19th June, 1947. 46

CREDITORS, next of kin, and others having claims in respect of the estate of Herbert James Church, late of Stradbroke-avenue, Heidelberg, machinist, deceased (who died on the 29th day of December, 1946), are to send particulars of their claims to the executor, Edith Church, care of the undersigned, on or before the 18th day of June, 1947, after which date the estate will be distributed, having regard only to the claims of which notice shall have been received.

UPTON, ETTELSON, & OWEN, solicitors, 395 Collins-street, Melbourne. 61

CREDITORS, next of kin, and others having claims in respect of the estate of David Henry Sleeth, late of 215 Queensberry-street, North Melbourne, retired railway employee, deceased (who died on the 25th day of September, 1946), are to send particulars of their claims to the executrix, Dyson Frances Sleeth, of 19 Abbotsford-street, North Melbourne, widow, care of the undersigned, on or before the 18th day of June, 1947, after which date the estate will be distributed, having regard only to the claims of which notice shall have been received.

UPTON, ETTELSON, & OWEN, solicitors, 395 Collins-street, Melbourne. 63

CREDITORS, next of kin, and others having claims in respect of the estate of Arthur Howard Swan, late of 14 Power-street, Balwyn, mechanical engineer, deceased (who died on the 27th day of October, 1946), are to send particulars of their claims to the executrix, Ethel Victoria Swan, care of the undersigned, on or before the 18th day of June, 1947, after which date the estate will be distributed, having regard only to the claims of which notice shall have been received.

UPTON, ETTELSON, & OWEN, solicitors, 395 Collins-street, Melbourne. 64

CREDITORS, next of kin, and others having claims in respect of the estate of Isabella Telford, late of 62 Tennyson-street, Moonee Ponds, spinster, deceased (who died on the 20th day of January, 1944), are to send particulars of their claims to the executor, George Telford, care of the undersigned, on or before the 18th day of June, 1947, after which date the estate will be distributed, having regard only to the claims of which notice shall have been received.

UPTON, ETTELSON, & OWEN, solicitors, 395 Collins-street, Melbourne. 65

CREDITORS, next of kin, and others having claims in respect of the estate of Margaret Jane Telford, late of 62 Tennyson-street, Moonee Ponds, spinster, deceased (who died on the 9th day of March, 1946), are to send particulars of their claims to the executor, George Telford, care of the undersigned, on or before the 18th day of June, 1947, after which date the estate will be distributed, having regard only to the claims of which notice shall have been received.

UPTON, ETTELSON, & OWEN, solicitors, 395 Collins-street, Melbourne. 66

CREDITORS, next of kin, and others having claims in respect of the estate of Francis Hampston, late of 28 The Esplanade, Brighton Beach, spinster, deceased (who died on the 23rd day of September, 1946), are to send particulars of their claims to the executrix, Daisy Maynard, care of the undersigned, on or before the 18th day of June, 1947, after which date the estate will be distributed, having regard only to the claims of which notice shall have been received.

UPTON, ETTELSON, & OWEN, solicitors, 395 Collins-street, Melbourne. 67

PURSUANT to the *Trustee Act 1928*, notice is hereby given that all persons having claims against the estate of Robert Cockerell, late of Swan Hill, coachbuilder, deceased (who died on the 5th day of December, 1943, and probate of whose will was granted on the 10th day of February, 1947, to Douglas Brydon, farmer, Clarence Henry Phylard, farmer, John Robert Cockerell, manager, all of Swan Hill, the executors appointed by the said will), are hereby required to send particulars, in writing, of such claims to the said executors, care of the undersigned, on or before the 30th day of June, 1947, after which date the said executors will distribute the said estate amongst the persons entitled thereto, having regard only to the claims of which they shall then have had notice, and the said executors will not be liable for the assets so distributed to any person of whose claim they shall not then have had notice.

DAVIES & HAYES, solicitors, Campbell-street, Swan Hill. 7

PURSUANT to the Trustee Act, notice is hereby given that all persons having claims against the estate of Clifford Donald Kennedy, late of Dandenong House, Dandenong, in the State of Victoria, gentleman, deceased (who died on the 9th day of June, 1946, and probate of whose will was granted by the Supreme Court of Victoria on the 1st day of April, 1947, to Donald Nicolson Cameron, of "Durban," Port Fairy, in the said State, grazier (hereinafter called the executor)), are hereby required to send particulars, in writing, of such claims to the executor, care of his under-mentioned solicitor, on or before the 20th day of June, 1947, after which date the executor will proceed to convey or distribute the assets of the said deceased to or among the persons entitled thereto, having regard only to the claims of which he shall then have had notice.

FRANCIS FIELD, M.A., LL.B., of 100 Queen-street, Melbourne, and at Dandenong, proctor for the executor. 25

PURSUANT to the Trustee Act 1928, notice is hereby given that all persons having claims against the estate of Francis Augustine Burke, late of "Coonara," 44 Stewart-street, East Brunswick, in the State of Victoria, temporary clerk, deceased (who died on the 19th day of January, 1947, and probate of whose will was granted by the Supreme Court of the said State, in its probate jurisdiction, on the 1st day of April, 1947, to National Trustees, Executors, and Agency Company of Australasia Limited, of 95 Queen-street, Melbourne, in the said State), are hereby required to send particulars, in writing, of such claims to the said company, at its above-mentioned address, on or before the 18th day of June, 1947, after which date the said company will proceed to distribute the assets of the said Francis Augustine Burke, deceased, which shall have come to its hands amongst the persons entitled thereto, having regard only to the claims of which it shall then have had notice; and notice is hereby further given that the said company will not be liable for the assets so distributed, or any part thereof, to any person of whose claim it shall not have had notice as aforesaid.

ROYSTON T. CAHIR, solicitor, 108 Queen-street, Melbourne. 25

CREDITORS, next of kin, and others having claims in respect of the estate of Chequetta (also known as Chequta and as Chequeta), late of Hopetoun, no occupation, deceased (who died on the 29th day of July, 1946), are requested to send particulars of their claims to the executors, Walter Clement Poulton and Ronald Poulton, in care of the under-mentioned solicitor, on or before the 30th day of June, 1947, after which date the executors will distribute the assets, having regard only to the claims of which they then have notice.

D. J. COMMONS, solicitor, Hopetoun. 28

CREDITORS, next of kin, and all others having claims against the estate of John Sturrock, late of Coonooer Bridge, farmer, deceased (who died on the 18th August, 1946), are required to send particulars to the executors, Raymond Clive Scollary and Jean Dearing, care of the undersigned, on or before the 30th day of June, 1947, after which date the executors will distribute the assets, having regard only to the claims of which they then have notice.

MITCHELL & MONOTTI, solicitors, St. Arnaud. 29

RE LUCIE AUGUSTINE OBST, late of "Lyon," Rose-street, Gardenvale, in the State of Victoria, married woman, DECEASED.

PURSUANT to the Trustee Act 1928, notice is hereby given that William John Lovell, gentleman, and Anna Teresa Lovell, married woman, both of 5 Rose-street, Gardenvale, and Jack Vincent Shallard, of 430 Little Collins-street, Melbourne, solicitor (hereinafter called "the said executors"), the executors of the will of the said Lucie Augustine Obst, deceased (who died on the 9th day of October, 1946), intend to convey or distribute the estate of the said deceased to or among the persons entitled thereto, and require all persons or creditors interested to send to the said executors, care of the undersigned, on or before the 21st day of June, 1947, particulars of their claims against the said estate, and after the said 21st day of June, 1947, the said executors may convey or distribute the said estate to or among the persons entitled thereto, having regard only to the claims, whether formal or not, of which they shall then have had notice.

Dated the 16th day of April, 1947.

J. V. SHALLARD, LL.B., 430 Little Collins-street, Melbourne, solicitor for the executors. 38

EDITH MARTHA HALLILEY, DECEASED.

CREDITORS, next of kin, and others having claims in respect of the estate of Edith Martha Halliley, late of 8 Railway-avenue, Armadale, in the State of Victoria, widow, deceased (who died on the 19th day of February, 1947), are to send the particulars of their claims to John Symons and Edith Symons, care of the under-mentioned solicitors, by the 17th day of June, 1947, after which date the said John Symons and Edith Symons will distribute the assets, having regard only to the claims of which they then have notice.

MELVILLE & McCONKEY, solicitors, 409-413 Collins-street, Melbourne. 40

PURSUANT to the Trustee Act 1928, creditors, beneficiaries, next of kin, and all other persons having claims against the estate of Isabella Marion Hannah Lambert, formerly of 2 Seaview-street, South Caulfield, but late of 100 Willis-street, Hampton, in the State of Victoria, widow, deceased (who died on the 4th February, 1947, and probate of whose will was granted by the Supreme Court of Victoria, on the 11th April, 1947, to Isabel Adeline Roberts, of 100 Willis-street, Hampton aforesaid, married woman, and Palmer Lee, of 143 Queen-street, Melbourne, solicitor), are hereby required to send particulars of their claims, in writing, to the said Palmer Lee, at his above-mentioned address, on or before the 25th June, 1947, after which date the said executors will distribute the assets of the said deceased amongst the persons entitled thereto, having regard only to the claims of which they then have had notice.

EGGLESTON, EGGLESTON, & LEE, 143 Queen-street, Melbourne, solicitors. 43

CREDITORS, next of kin, and others having claims in respect of the estate of Mary Broderick, late of 306 Albert-road, South Melbourne, widow, deceased (who died on the 23rd February, 1947), are to send the particulars of their claims to the National Trustees, Executors, and Agency Company of Australasia Limited, of 95 Queen-street, Melbourne, by the 19th June, 1947, after which date it will distribute the assets, having regard only to the claims of which it then has notice.

Dated the 16th day of April, 1947.

M. MORNANE, solicitor, 95 Queen-street, Melbourne, solicitor for the company. 44

PURSUANT to the Trustee Act 1928, all persons having claims against the property or estate of Agnes Mosely, formerly of 20 William Way, Letchworth, Hertfordshire, but late of 34 Teignmouth-road, Cricklewood, Middlesex, in England, widow, deceased (who died on the 5th day of November, 1945, and probate of whose will and codicil was granted to Westminster Bank Limited, of 41 Lothbury, in the City of London, in England, the sole executor named therein by His Majesty's High Court of Justice at Llanudno, in England, on the 11th day of March, 1946, and an application for reseat of a sealed certified photostat copy of the said probate was on the 14th day of February, 1947, granted by the Supreme Court of Victoria to Perpetual Trustee Company (Limited), of 39 Hunter-street, Sydney, in the State of New South Wales, the duly authorized attorney under power of the said executor), are hereby required to send particulars of such claims to the said Perpetual Trustee Company (Limited), on or before the 18th day of June, 1947, after which date the said Perpetual Trustee Company (Limited) will, in pursuance of section 86 of the Administration and Probate Act 1928, pay and/or hand over to the said executor the assets of the said deceased which shall have come to its hands or possession, having regard only to the claims of which it shall have had notice.

Dated this 14th day of April, 1947.

BLAKE & RIGGALL, 120 William-street, Melbourne, solicitors for the said company. 47

CREDITORS, next of kin, and others having claims in respect of the estate of Mary Brettie Cane, late of 31 Bambra-road, Caulfield, spinster, deceased (who died on the 8th day of October, 1946), are to send particulars of their claims to the Trustees, Executors, and Agency Company Limited, of 401 Collins-street, Melbourne, by the 24th day of June, 1947, after which date it will distribute the assets, having regard only to the claims of which it then has notice.

ELLISON, HEWISON, & WHITEHEAD, solicitors, 352 Collins-street, Melbourne. 49

CREDITORS, next of kin, and others having claims in respect of the estate of Frances Mary Stabb (born Whiteley), late of George-street, Rosettenville, Johannesburg, South Africa, widow, deceased, intestate (who died on the 21st day of July, 1945), are to send the particulars of their claims to The Trustees, Executors, and Agency Company Limited, whose registered office is situate at 401 Collins-street, Melbourne, in the State of Victoria, by the 20th day of June, 1947, after which date it will distribute the assets, having regard only to the claims of which it then has notice.

GILLOTT, MOIR, & AHERN, solicitors, 95 Queen-street, Melbourne. 50

CREDITORS, next of kin, and others having claims in respect of the estate of Melbourne William Frederick Excell (in the will called Frederick Melbourne William Excell), late of Kooyong-road, Caulfield, gentleman, deceased (who died on the 7th day of November, 1946), are to send particulars of their claims to The Equity Trustees, Executors, and Agency Company Limited, of 472 Bourke-street, Melbourne, by the 30th day of June, 1947, after which date it will distribute the assets, having regard only to the claims of which it then has notice.

HENDERSON & BALL, solicitors, 430 Little Collins-street, Melbourne. 51

ALL persons having claims against the estate of Alice Mary Beecroft, of 8 Somerville Gardens, Boyne Park, Tunbridge Wells, Kent, England, widow, deceased (who died on the 24th February, One thousand nine hundred and forty-six, and probate of whose will was granted by His Majesty's High Court of Justice in England to Ethel Alice Beecroft, of 8 Somerville Garden, Boyne Park, Tunbridge Wells, Kent, England, spinster, and Arthur Edward Beecroft, of Goldsmith Building, Temple, London, E.C.4, England, barrister at law, the executors therein named on the 2nd day of December, 1946, and application for reseat of which said probate has been made to the Supreme Court of Victoria by Roy James McArthur, of 46 Queen-street, Melbourne, in the said State, solicitor, the duly authorized attorney under power of the said executors), are hereby required to send particulars, in writing, of such claims to the said Roy James McArthur, in care of Malleson, Stewart, and Co., at the address below, on or before the 25th day of June, One thousand nine hundred and forty-seven, after which date the said Roy James McArthur will, in pursuance of section 86 of the *Administration and Probate Act 1928*, pay and/or hand over to the said executors the assets of the said deceased, which shall have come to his hands or possession, having regard only to the claims of which he shall have had notice.

MALLESON, STEWART, & CO., 46 Queen-street, Melbourne, C.I. 54

RE LUCIEN ANTOINE SAMUEL OBST, late of "Lyon," Rose-street, Gardenvale, in the State of Victoria, retired draper, DECEASED.

PURSUANT to the *Trustee Act 1928*, notice is hereby given that William John Lovell, gentleman, and Anna Teresa Lovell, married woman, both of 5 Rose-street, Gardenvale, and Jack Vincent Shallard, of 430 Little Collins-street, Melbourne, solicitor (hereinafter called "the said executors"), the executors of the will of the said Lucien Antoine Samuel Obst, deceased (who died on the 24th day of October, 1946), intend to convey or distribute the estate of the said deceased to or among the persons entitled thereto, and require all persons or creditors interested to send to the said executors, care of the undersigned, on or before the 21st day of June, 1947, particulars of their claims against the said estate, and after the said 21st day of June, 1947, the said executors may convey or distribute the said estate to or among the persons entitled thereto, having regard only to the claims, whether formal or not, of which they shall then have had notice.

Dated the 16th day of April, 1947.

J. V. SHALLARD, LL.B., 430 Little Collins-street, Melbourne, solicitor for the executors. 39

CREDITORS, next of kin, and others having claims in respect of the estate of Reginald Edward Forsyth, late of "Warrawee," McLaren-street, Upwey, in the State of Victoria, clerk, deceased (who died on the 1st day of January, 1947), are to send particulars of their claims to The Equity Trustees, Executors, and Agency Company Limited, at its registered office, 472 Bourke-street, Melbourne, by the 18th day of June, 1947, after which date it will distribute the assets, having regard only to the claims of which it then has notice.

PEARSON, EGGINGTON, & LEGGATT, of 191 Queen-street, Melbourne, solicitors for the said company. 57

CREDITORS, next of kin, and all others having claims in respect of the estate of Alexandra Mary Seeley, late of 54 Finch-street, East Malvern, widow, deceased (who died on the 31st December, 1946), are to send particulars of their claims to The Equity Trustees, Executors, and Agency Company Limited, of 472 Bourke-street, Melbourne, and Adolphe Henry Seeley and Geoffrey William Seeley, care of the said company, by the 25th June, 1947, after which date they will distribute the assets, having regard only to the claims of which they shall then have had notice.

MADDOCK, LONIE, & CHISHOLM, solicitors, 339 Collins-street, Melbourne. 55

CREDITORS, next of kin, and all others having claims in respect of the estate of Harold Philipson, late of Carrum Downs, in the State of Victoria, gentleman, deceased (who died on the 22nd day of November, 1946, and letters of administration of whose estate were granted to Alexander Llewellyn Wettenhall, of 357 Little Collins-street, Melbourne, solicitor), are required to send particulars, in writing, of such claims to the said Alexander Llewellyn Wettenhall, at the above address, on or before the 17th day of June, 1947, after which date the said Alexander Llewellyn Wettenhall will proceed to distribute the said estate among the persons entitled, having regard only to the claims of which he shall then have had notice.

PARKINSON, WETTENHALL, & HART, solicitors, 357 Little Collins-street, Melbourne. 56

MINING NOTICES.

AJAX SOUTH GOLD MINE NO LIABILITY.

NOTICE is hereby given that all shares forfeited for non-payment of the 18th (March) Call of Three pence per share will be sold by public auction at the Stock Exchange Hall, 428 Chancery-lane, Melbourne, at 11.50 a.m. on Wednesday, the 23rd day of April, 1947, unless redeemed on or before 5 p.m. on Tuesday, the 22nd day of April, 1947.

By order of the Board,

A. E. LLEWELLYN, Manager.

430 Little Collins-street, Melbourne, C.I., 15th April, 1947. 52

CHEWTON GOLD MINES NO LIABILITY.

NOTICE is hereby given that all shares forfeited for non-payment of the 63rd (March) Call of Three pence per share will be sold by public auction at the Stock Exchange Hall, 428 Chancery-lane, Melbourne, at a quarter to Twelve a.m. on Wednesday, the 23rd day of April, 1947, unless redeemed on or before 5 p.m. on Tuesday, the 22nd day of April, 1947.

By order of the Board,

A. E. LLEWELLYN, Manager.

430 Little Collins-street, Melbourne, C.I., 15th April, 1947. 53

NEW DON NO LIABILITY.

NOTICE.—All shares in this company (included in Nos. 1 to 60,000) on which the 42nd Call of Six pence per share remains unpaid are forfeited, and will be sold by public auction at the Stock Exchange, Bendigo, on Thursday, 24th April, 1947, at Four o'clock p.m., unless previously redeemed, as required by the *Companies Act 1938*.

J. J. STANISTREET

9 (McColl, Rankin, and Stanistreet), Manager.

EAST CLARENCE GOLD MINING COMPANY NO LIABILITY.

NOTICE.—All shares in this company (included in Nos. 1 to 50,000) on which the 52nd Call of Six pence per share remains unpaid are forfeited, and will be sold by public auction at the Stock Exchange, Bendigo, on Thursday, 24th April, 1947, at Four o'clock p.m., unless previously redeemed, as required by the *Companies Act 1938*.

J. J. STANISTREET

10 (McColl, Rankin, and Stanistreet), Manager.

Companies Act 1938.—Fifteenth Schedule.

LEAD AND NICKEL CO. (ZEEHAN) NO LIABILITY.

I, THE undersigned, hereby make application to register Lead and Nickel Co. (Zeehan) No Liability as a company, under the provisions of Part II. of the Companies Act 1938.

1. The name of the company is to be Lead and Nickel Co. (Zeehan) No Liability.
2. The place of intended operations is at Zeehan in the State of Tasmania.
3. The registered office of the company will be situate at 360 Collins-street, Melbourne.
4. The value of the company's property, including claim, leased ground, and machinery, is nil.
5. The number of shares in the company is 125,000 of 4s. each.
6. The number of shares subscribed for is 32,000, being not less than twenty-five per centum of the entire number of shares in the company.
7. The amount of the subscribed capital which is paid up is £6,400, being not less than five per centum of the subscribed capital.
8. The name of the manager is George Selth Anderson.
9. The names and addresses and occupation of at least two shareholders who have subscribed for shares in the company, and the number of shares subscribed for by each of them at this date, are as follows:—

Name, Address, Occupation.	No. of Shares.
Elinor Jean Pittman, 38 Elva-avenue, Killiard, New South Wales, domestic duties	100
Charles Joseph Hill, 47 Railway-crescent, Williamstown, manager	200

Dated this 14th day of April, 1947.
 GEORGE S. ANDERSON, Manager.
 Witness to signature—JOAN G. SUTHERLAND.

I, GEORGE SELTH ANDERSON, do solemnly and sincerely declare that—

1. I am the manager of the said intended company.
2. The above statement is, to the best of my belief and knowledge, true in every particular. And I make this solemn declaration conscientiously believing the same to be true, and by virtue of the provisions of an Act of Parliament of Victoria rendering persons making a false declaration punishable for wilful and corrupt perjury.

GEORGE S. ANDERSON.

Taken before me, at Melbourne, this 14th day of April, 1947.—R. GILLESPIE JONES, J.P. 58

IMPOUNDINGS.

CRANBOURNE.—Impounded at Cranbourne, by Ranger, from Frankston-road, Langwarrin, on 8th April, 1947.
 1 red cow, white markings underneath, single notch in lob of both ears, wide horns, no visible brand
 If not claimed and expenses paid, to be sold on 1st May, 1947.

17—5/4 F. H. CLARK, Poundkeeper.

EPPING.—Impounded at Epping.

1 dark chestnut horse, white near hind fetlock, no visible brand
 If not claimed and expenses paid, to be sold on 1st May, 1947.

18—4/8 E. WORN, Poundkeeper.

MELBOURNE.—Impounded in Arden-street Pound, by A. Thomas.

1 bay gelding, blaze, white legs, like B near shoulder, like V over 701 on off shoulder
 If not claimed and expenses paid, to be sold on 1st May, 1947.

8—5/4 D. CROWE, Poundkeeper.

WARRNAMBOOL.—Impounded at Warrnambool.

1 bay mare, few white hairs on forehead, no visible brand
 If not claimed and expenses paid, to be sold on 30th April, 1947.

31—4/ I. HILDER, Poundkeeper.

STATE ACTS, 1943.

COPIES of the following Acts of Parliament of Victoria may be obtained at the Government Printing Office, or from any bookseller, at the price set opposite to each:—

No.	Price.
	s. d.
4943. Consolidated Revenue	0 6
4944. Consolidated Revenue	0 6
4945. State Development	0 6
4946. Grain Elevators	0 6
4947. Consolidated Revenue	0 6
4948. Lunacy	0 6
4949. National Security (Emergency Powers) Continuation	0 6
4950. Commonwealth Powers	0 6
4951. Consolidated Revenue	0 6
4952. Factories and Shops (Chairman of Wages Boards)	0 6
4953. Country Roads (Forest Roads and Stock Routes)	0 6
4954. State Schools (Bush Fire Relief)	0 6
4955. Consolidated Revenue	0 6
4956. Coal Mines Regulation	0 6
4957. Petrol Pumps (Licence Fees)	0 6
4958. Superannuation (Contributions)	0 6
4959. Coal Mine Workers Pensions	0 6
4960. Forests (Exchange of Lands)	0 6
4961. Local Government (Valuations)	0 6
4962. Railway Construction (Extensions)	0 6
4963. Mental Hygiene (Mode of Citation)	0 6
4964. Administration and Probate Duties	0 6
4965. Sewerage Districts	0 6
4966. Stamps (Increased Duty Continuance)	0 6
4967. Land Tax	0 6
4968. Surplus Revenue	0 6
4969. Financial Emergency (Grants and Funds)	0 6
4970. Partially Blinded Soldiers Fund	0 6
4971. Melbourne and Metropolitan Board of Works (Contributions)	0 6
4972. Milk Pasteurization	1 0
4973. Country Roads Board Fund	0 6
4974. Workers' Compensation	0 6
4975. Public Works Loan and Application	0 6
4976. Factories and Shops (Saturday Half-holiday)	0 6
4977. Springvale Necropolis Land	0 6
4978. South Melbourne to Melbourne Tramway Construction	0 6
4979. Water Supply Loans Application	0 6
4980. Forests	0 6
4981. State Forests Loan Application	0 6
4982. Administration and Probate (War Service)	0 6
4983. Water	0 9
4984. Farmers Protection (Amendment)	0 6
4985. Stamps	0 6
4986. Railway Loan Application	0 6
4987. Farmers Debts Adjustment	0 6
4988. Ministry of Health	1 0
4989. Discharged Servicemen's Preference	1 0
4990. Instruments (Insurance Contracts)	0 6
4991. Melbourne (Widening of Streets)	0 6
4992. Mines (Petroleum)	0 6
4993. Education	0 6
4994. Land Settlement (Acquisition)	0 6
4995. Land Settlement Loan and Application	0 6
4996. Housing	1 0
4997. Milk and Dairy Supervision	1 0
4998. Appropriation of Revenue	3 9

J. J. GOURLEY,
 Government Printer.

STATE ACTS, 1944.

COPIES of the following Acts of Parliament of Victoria may be obtained at the Government Printing Office, or from any bookseller, at the price set opposite to each:—

No.	Price.
	s. d.
4999. Consolidated Revenue	0 6
5000. Local Government (Polling Booths)	0 6
5001. Police Offences (Unlawful Games)	0 6
5002. Hospitals and Charities	0 6
5003. Water (Loddon)	0 6
5004. Justices	0 6
5005. Coal Mines Regulation (Amendment)	0 6
5006. Consolidated Revenue	0 6
5007. Melbourne and Metropolitan Board of Works (Contributions)	0 6
5008. Marketing of Primary Products	0 6
5009. National Security (Emergency Powers) Continuation	0 6
5010. Outer Circle Railway (Partial Dismantling)	0 6
5011. Mines (Minerals)	0 6
5012. Goods (Textile Products)	0 6
5013. Masseurs	0 6
5014. Electoral (War Service Deaths)	0 6
5015. Cremorne Bridge	0 6
5016. Melbourne Harbor Trust	0 6
5017. Water	0 9
5018. Consolidated Revenue	0 6
5019. Mildura Irrigation and Water Trusts	0 6
5020. Farm Water Supplies Advances	0 6
5021. Sewerage Districts	0 6
5022. Trustee Companies	0 6
5023. Mildura Irrigation and Water Trusts (Superannuation)	0 6
5024. Consolidated Revenue	0 6
5025. Cemeteries	0 6
5026. Border Railways	0 6
5027. Local Government (Shire of Blackburn and Mitcham)	0 6
5028. Electoral Districts	0 6
5029. Land	0 6
5030. Land Tax	0 6
5031. Administration and Probate Duties	0 6
5032. Stock Foods (Amendment)	0 6
5033. Stamps (Increased Duty Continuance)	0 6
5034. Maribyrnong and Ashburton Lands Exchange	0 6
5035. Financial Emergency (Grants and Funds)	0 6
5036. Farmers Advances	0 6
5037. Land Settlement (Acquisition) Amendment	0 6
5038. Railways	0 6
5039. Farmers Protection (Amendment)	0 6
5040. Country Fire Authority	1 9
5041. Country Roads Board Fund	0 6
5042. Railway Loan and Application	0 6
5043. Town and Country Planning	1 0
5044. Agricultural Colleges	0 9
5045. Heatherston Sanatorium	0 6
5046. Health (Infectious Diseases Hospitals)	0 6
5047. Surplus Revenue	0 6
5048. Water Supply Loans Application	0 9
5049. State Forests Loan and Application	0 6
5050. Public Works Loan and Application	0 6
5051. Commonwealth and States Financial Agreement	1 3
5052. The Constitution Act Amendment	0 6
5053. Public Library National Gallery and Museums	0 9
5054. Drought Relief	0 6
5055. Co-operative Housing Societies	1 6
5056. Local Government	1 0
5057. Melbourne and Metropolitan Board of Works	0 9
5058. Appropriation of Revenue	3 9

J. J. GOURLEY,
Government Printer.

STATE ACTS, 1945.

COPIES of the following Acts of Parliament of Victoria may be obtained at the Government Printing Office, or from any bookseller, at the price set opposite to each:—

No.	Price.
	s. d.
5059. Mildura Irrigation and Water Trusts (Borrowing)	0 6
5060. Supreme Court (Judges)	0 6
5061. Oakleigh (Regent-street) Land	0 6
5062. Swine	0 6
5063. Drought Relief (Amendment)	0 6
5064. Unclaimed Moneys	0 6
5065. Consolidated Revenue	0 6
5066. Consolidated Revenue	0 6
5067. Agent-General's	0 6
5068. Land Surveyors (Amendment)	0 6
5069. State Development	0 6
5070. Melbourne and Metropolitan Board of Works (Borrowing Powers)	0 6
5071. Education	0 6
5072. Water	0 6
5073. National Security (Repeal)	0 6
5074. Moorabbin (Unimproved Rating Poll)	0 6
5075. Licensing (Poll)	0 6
5076. Lilydale Waterworks Trust Abolition	0 6
5077. East Melbourne Land	0 6
5078. Health (Wines)	0 6
5079. Local Government (Emergency Housing Accommodation)	0 6
5080. Law Institute	0 6
5081. Bendigo Land	0 6
5082. Consolidated Revenue	0 6
5083. Consolidated Revenue	0 6
5084. Consolidated Revenue	0 6
5085. Factories and Shops (Bread Holidays)	0 6
5086. Administration and Probate Duties	0 6
5087. Land Tax	0 6
5088. Stamps (Increased Duty Continuance)	0 6
5089. Licensing Fund	0 6
5090. Employers and Employés	0 6
5091. Farmers Advances	0 6
5092. University (Veterinary Research)	0 6
5093. Surplus Revenue	0 6
5094. State Forests Loan and Application	0 6
5095. Mines (Amendment)	0 6
5096. Farmers Protection (Amendment)	0 6
5097. Railway Loan Application	0 6
5098. Public Works Loan and Application	0 6
5099. Water Supply Loans Application	0 9
5100. Public Account Advances (Amendment)	0 6
5101. Hospital Benefits	0 6
5102. Totalizator (Amendment)	0 6
5103. Financial Emergency (Municipal Endowment)	0 6
5104. Country Roads Board Fund (Amendment)	0 6
5105. Coal Mines Regulation (Amendment)	0 6
5106. Melbourne and Metropolitan Tramways (Chairman)	0 6
5107. Soldier Settlement	1 3
5108. Appropriation of Revenue	4 0

J. J. GOURLEY,
Government Printer.

STATE ACTS, 1946.

STATE ACTS, 1946—continued.

COPIES of the following Acts of Parliament of Victoria may be obtained at the Government Printing Office, or from any bookseller, at the price set opposite to each:—

No.	Price. s. d.	No.	Price. s. d.
5109. Geelong Land	0 6	5166. Local Government (Dandenong Street Construction)	1 0
5110. Transport Regulation (Amendment)	0 6	5167. Stamps (Increased Duty Continuance)	0 6
5111. Factories and Shops (Annual Holidays)	0 9	5168. Land Tax	0 6
5112. Mornington Sewerage Authority (Validation)	0 6	5169. Cattle Breeding	0 6
5113. Local Government (Emergency Housing Accommodation) Amendment	0 6	5170. Administration and Probate Duties	0 6
5114. Housing (Commonwealth and State Agreement)	1 0	5171. Co-operative Housing Societies (Guarantees)	0 6
5115. Factories and Shops (Early Closing)	0 6	5172. Railways (Sick Leave)	0 6
5116. Building Operations and Building Materials Control	0 9	5173. Fruit and Vegetables	0 6
5117. Water (Levee Banks)	0 9	5174. Farm Water Supplies and Drainage Advances	0 6
5118. Co-operative Housing Societies	0 6	5175. State Forests Loan and Application	0 6
5119. Local Government (Municipal Rolls)	0 6	5176. Melbourne South Land	0 6
5120. Public Works Loan and Application	0 6	5177. Agricultural Colleges (Amendment)	0 6
5121. Totalizator (Charities)	0 6	5178. Drought Relief (Amendment)	0 6
5122. Drought Relief	0 6	5179. Soldier Settlement	1 9
5123. Taxation (Arrangements)	0 6	5180. Free Library Service Board	0 6
5124. Public Service	1 6	5181. Adult Education	0 6
5125. Teaching Service	1 3	5183. Evidence	0 6
5126. Police Regulation	1 0	5184. Housing (Discharged Servicemen)	0 6
5127. Railways (Long Service)	0 6	5185. Parliamentary Contributory Retirement Fund	0 6
5128. Workers' Compensation	1 6	5186. Friendly Societies	0 6
5129. Sewerage Districts (Amendment)	0 6	5187. Police Offences (Race-meetings)	0 6
5130. Factories and Shops (Bread)	0 6	5188. Railways (Mont Park Siding)	0 6
5131. Crimes (Intermediate Sentences)	0 6	5189. Land (Grazing Licences)	0 6
5132. Medical (Chemists' Apprentices)	0 6	5190. Factories and Shops (Bread Carters)	0 6
5133. Soldier Settlement (Amendment)	0 6	5191. Country Fire Authority	1 0
5134. Consolidated Revenue	0 6	5192. Supreme Court (Judges)	0 6
5135. Consolidated Revenue	0 6	5193. Railway Loan Application	0 6
5136. Apprenticeship	0 6	5194. Metropolitan Gas Company's	0 6
5137. Consolidated Revenue	0 6	5195. Railways (Temporary Employés)	0 6
5138. Consolidated Revenue	0 6	5196. Railways (State Coal Mine)	0 6
5139. Consolidated Revenue	0 6	5197. Licensing	0 6
5140. Nicholson-street Tramway Construction	0 6	5198. Town and Country Planning	0 6
5141. Burke-road Tramway Construction	0 6	5199. Public Works Loan and Application (No. 2)	0 6
5142. Ballarat Gas Company's	0 6	5201. Trotting Races	0 6
5143. Melbourne and Metropolitan Board of Works (Contributions)	0 6	5202. Economic Stability	0 6
5144. Stamps (Betting Tax)	0 6	5204. Stamps	2 3
5145. Juries (Fees)	0 6	5206. Melbourne and Metropolitan Tramways (Appeal Board)	0 6
5146. Cattle and Swine Compensation	0 6		
5147. Marine (Pilots and Pilotage Rates)	0 6		
5148. Patriotic Funds	0 6		
5149. Stock Foods (Amendment)	0 6		
5150. Municipal Endowment (Temporary Discontinuance)	0 6		
5151. Medical Practitioners' Registration	0 6		
5152. Seeds	0 6		
5153. Water	0 6		
5154. Clifton Hill Land	0 6		
5155. Tobacco Sellers	0 6		
5156. Country Roads Board Fund (Amendment)	0 6		
5157. Moorpanyal Land	0 6		
5158. Factories and Shops (Annual Holidays) Amendment	0 6		
5159. Factories and Shops (Wages Boards)	0 6		
5160. Melbourne and Metropolitan Tramways (Amendment)	0 6		
5161. Infectious Diseases Hospital (Borrowing)	0 6		
5162. University (Mildura Branch)	0 6		
5163. Farmers Protection (Amendment)	0 6		
5164. Forests (Exchange of Lands) Extension	0 6		
5165. Money Lenders (Cash Orders)	0 6		

J. J. GOURLEY,
Government Printer.

AGENTS FOR THE "VICTORIA GOVERNMENT GAZETTE."

THE following have been appointed agents to receive Advertisements and subscriptions for the *Victoria Government Gazette*:—

ARMSTRONG'S AGENCY, 143 Queen-street, Melbourne.

MESSRS. ARNALL & JACKSON, 115 Barkly-street, West Brunswick.

MESSRS. GORDON & GOTCH, News Agents, 511 Little Collins-street, Melbourne; and corner Barrack and Clarence streets, Sydney.

MESSRS. HARSTON, PARTRIDGE, & CO., 455 Little Collins-street, Melbourne.

N. V. NIXON & CO., 20 Queen-street, Melbourne.

THE PATON ADVERTISING SERVICE PTY. LTD.

ROBERTSON & MULLEN LTD., Elizabeth-street, Melbourne.

MESSRS. W. H. WADDELL and A. S. RICHARDSON, trading as the Mercantile Exchange, 380 Collins-street, Melbourne.

MR. A. J. DIGBY, News Agent, Bairnsdale.

MR. M. R. BADE, Tobacconist, Sturt-street, Ballarat.

TRIGG'S NEWS AGENCY, Hargreaves-street, Bendigo.

MR. G. H. K. PAYNE, 4 View Point, Bendigo.
 MR. C. F. LATIMER, News Agent, Casterton.
 MESSRS. HENRY FRANKS & CO., Booksellers and Stationers, Market-square, Geelong.
 MESSRS. SMITH & DUNNON, Hamilton.
 ARMSTRONG BROS., Kyneton.
 MR. WM. DAVIS, Mildura.
 PIKE'S AUTHORIZED NEWS AGENCY, Sale.
 MR. C. T. RUST, News Agent, Wangaratta.
 MR. F. T. MCCORMICK, Nunn-street, Benalla.
 F. R. & E. M. COOKE, Bridge-street, Benalla.
 W. GORDON HAMPTON, 243 Mitchell-street, Bendigo.
 R. & A. SMALLMAN, News Agents, Toora.

A copy of the Gazette filed at each place for public reference.

ALL COMMUNICATIONS should be addressed to "The Government Printer, Melbourne."

ALL DOCUMENTS illegibly written will be returned unpublished, and, where brands occur unprovided for by the ordinary letters of the alphabet, a worded explanatory description must be furnished.

THE VICTORIA GOVERNMENT GAZETTE is published on WEDNESDAY EVENING in each week, and Notices for insertion will be received by the Government Printer at or before Two p.m., at ordinary rates, and late advertisements between Two p.m. and FIVE p.m. at double rates on the day preceding the day of publication.

Single copies of the VICTORIA GOVERNMENT GAZETTE are Six pence, posted Eight pence, each.

No GAZETTES prior to January, 1936, in stock.

***ALL PAYMENTS ARE REQUIRED IN ADVANCE.—Remittances should be made by postal note, money order, or draft in favour of the Government Printer. Advertisements unaccompanied by a remittance sufficient to cover the cost of insertion will be returned unpublished.

THE "VICTORIA GOVERNMENT GAZETTE."

SUBSCRIPTIONS.—The subscription, including Postage, is £1 12s. 6d. per annum, 16s. 3d. half-yearly, or 8s. 2d. per quarter, payable in advance.

Subscriptions are required to commence and terminate with a month.

A lesser period than three months cannot be subscribed for.

Subscribers do not receive the Acts of Parliament with the GAZETTE.

ADVERTISEMENTS are charged at the rate of EIGHT PENCE per line single column, and ONE SHILLING and FOUR PENCE per line double column.

The title (£5 Reward, Dissolution of Partnership, &c.) forms one or more lines as a heading.

On an average, ten words make a line.

Every signature must likewise be counted as a line.

The final words of a paragraph, though only portion of a line must be counted as one line.

SIGNATURES (in particular) and proper names must be written very plainly in the text; ONE SIDE ONLY of each slip of paper should be WRITTEN UPON.

CONTENTS

	PAGE
Acts of Parliament on sale at the Government Printing Office	2177
Anzac Day Holiday	2157
Contracts	2161
Country Roads Board	2163
Government Notices	2160
Impoundings	2177
Lands	2165
Mining	2161, 2176
Orders in Council	2161
Private Advertisements	2171
Proclamations	2157
Public Service Notices	2158
Stay Order	2161
Tenders	2168
Transport Regulation Board—Public Hearings	2160
Waterworks Trust	2160