



VICTORIA
GOVERNMENT GAZETTE.

Published by Authority.

[Registered at the General Post Office, Melbourne, for transmission by post as a newspaper.]

No. 433]

WEDNESDAY, NOVEMBER 12.

[1947

Land Act 1928.

AREAS OF LANDS COMPRISED IN CERTAIN CLASSES DIMINISHED OR INCREASED.

PROCLAMATION

By His Excellency the Governor of the State of Victoria and its Dependencies in the Commonwealth of Australia, &c., &c., &c.

WHEREAS by the *Land Act 1928* it is amongst other things enacted that the Governor in Council may, by Proclamation to be published in the *Government Gazette*, at any time diminish or increase the area of land comprised in any of the classes mentioned in Part I., Division 1, section 5, of the said *Land Act 1928*, but that the area of lands which may be sold by auction (Class 6) shall not be increased except as in certain cases in the said Act provided: Now therefore I, the Governor of the State of Victoria, in the Commonwealth of Australia, by and with the advice of the Executive Council of the said State, and in accordance with the provisions of sections 94 and 117 of the *Land Act 1928* aforesaid, do hereby diminish or increase (as the case may be) the areas of Crown lands comprised in Classes 2, 3, 6 and 7 respectively of the classes mentioned in section 5 of the *Land Act 1928* aforesaid to the extent set forth in the subjoined Schedule (that is to say):—

Schedule referred to.

CLASSES DIMINISHED OR INCREASED.

County.	Parish.	Allotment.	Section.	Area.	Diminished.	Increased.	Description.
					Class.	Class.	
				A. R. P.			
Borong ..	Concongella ..	41C, 41D	6	18 0 0	6	3	Near centre of parish. (Z.27972)
Normanby ..	Trewalla ..	34B	9	120 0 0	3	2	In west of parish. (Z.28789)
Normanby ..	Trewalla ..	3A	11	32 3 21	3	6	In north-east of parish. (Z.29429)
Talbot ..	Creswick ..	15A	U	20 0 0	7	2	At Cabbage Tree. (182/121)

Given under my Hand and the Seal of the State of Victoria aforesaid, at Melbourne, this sixth day of November, in the year of our Lord One thousand nine hundred and forty-seven, and in the eleventh year of the reign of His Majesty King George VI.

(L.S.)

WINSTON DUGAN.

By His Excellency's Command,

L. W. GALVIN,
Commissioner of Crown Lands and Survey.

GOD SAVE THE KING!

Soldier Settlement Act 1946.

UNUSED AND UNMADE ROADS CLOSED—PARISHES OF BAANGAL AND ENUC.

PROCLAMATION

By His Excellency the Governor of the State of Victoria and its Dependencies in the Commonwealth of Australia, &c., &c., &c.

I, THE Governor of the State of Victoria, in the Commonwealth of Australia, by and with the advice of the Executive Council of the said State, and in pursuance of section 6 of the *Soldier Settlement Act 1946* (No. 5179), do by this my Proclamation direct that the unused and unmade roads as described as under, be closed, that is to say:—

Parish of Baangal, County of Ripon, being the road between subdivisions A and B of allotments 1 and 4, section 36, and subdivisions A and B of allotments 3 and 4, section 35.—(B.581⁽²⁾) (D.122).

Parish of Enuç, County of Ripon, being the roads indicated by hachure on plan herewith.—(E.90(A¹)) (D.122).

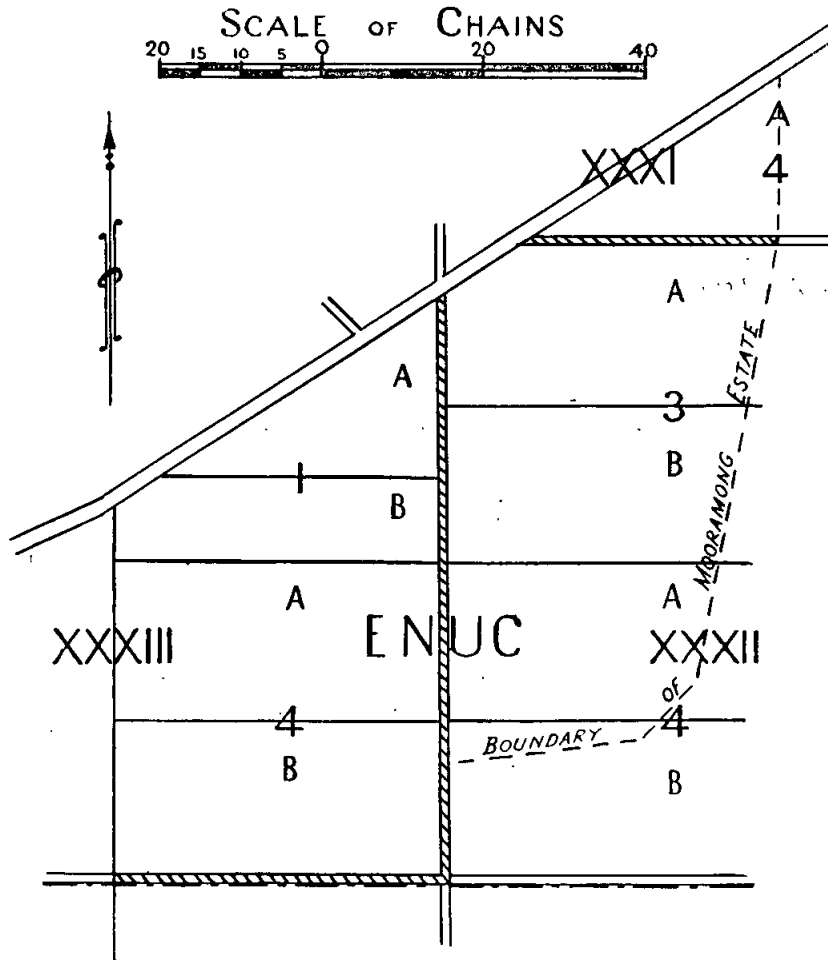

Given under my Hand and the Seal of the State of Victoria aforesaid, at Melbourne, the sixth day of November, in the year of our Lord One thousand nine hundred and forty-seven, and in the eleventh year of the reign of His Majesty King George VI.

(L.S.)

WINSTON DUGAN.

By His Excellency's Command,

L. W. GALVIN,
Commissioner of Crown Lands and Survey.

GOD SAVE THE KING!

Soldier Settlement Act 1946 (No. 5179).

UNUSED AND UNMADE ROADS CLOSED—PARISH OF WICKLIFFE SOUTH.

PROCLAMATION

By His Excellency the Governor of the State of Victoria and its Dependencies in the Commonwealth of Australia, &c., &c., &c.

I, THE Governor of the State of Victoria, in the Commonwealth of Australia, by and with the advice of the Executive Council of the said State, and in pursuance of section 6 of the *Soldier Settlement Act 1946 (No. 5179)*, do by this my Proclamation direct that the unused and unmade roads as described hereunder, be closed, that is to say:—

Parish of Wickliffe South, County of Ripon, and Parish of Towanway, County of Hampden, being the roads indicated by hachure on plan herewith.—(W.245(4) T.148(2) (D.293).

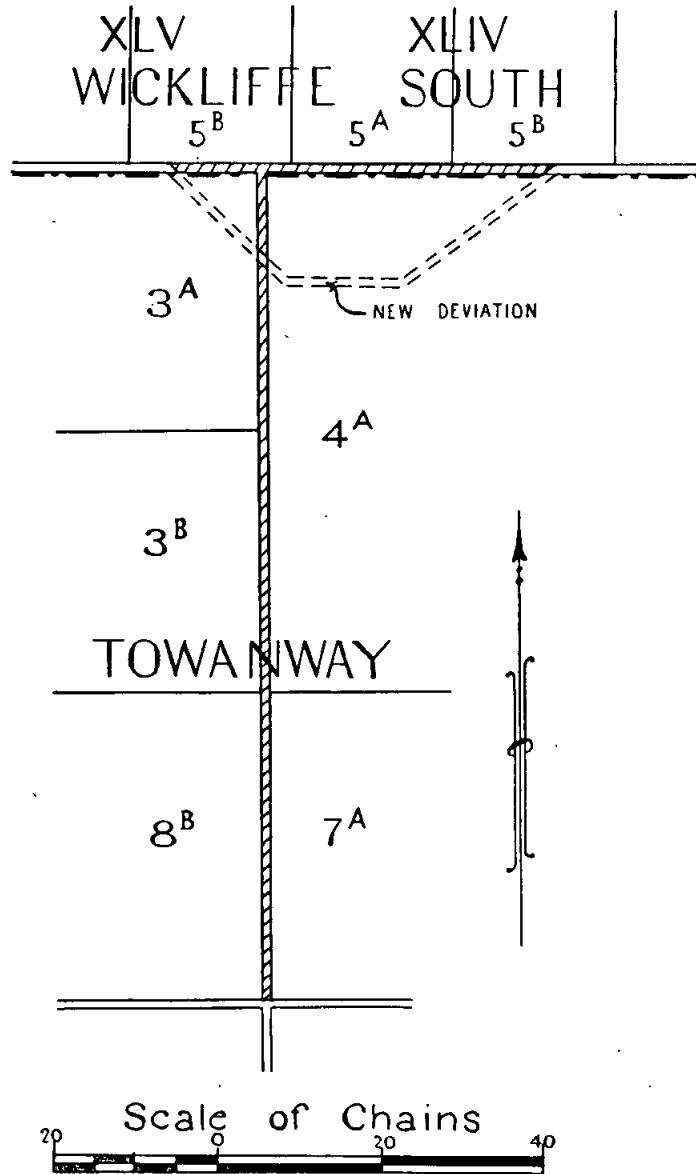

Given under my Hand and the Seal of the State of Victoria aforesaid, at Melbourne, the sixth day of November, in the year of our Lord One thousand nine hundred and forty-seven, and in the eleventh year of the reign of His Majesty King George VI.

(L.S.) WINSTON DUGAN.

By His Excellency's Command,

L. W. GALVIN,
Commissioner of Crown Lands and Survey.

GOD SAVE THE KING!

Soldier Settlement Act 1946 (No. 5179).
UNUSED AND UNMADE ROAD CLOSED—PARISH OF
WICKLIFFE SOUTH.

PROCLAMATION

By His Excellency the Governor of the State of Victoria and its Dependencies in the Commonwealth of Australia, &c., &c., &c.

I THE Governor of the State of Victoria, in the Commonwealth of Australia, by and with the advice of the Executive Council of the said State, and in pursuance of section 6 of the *Soldier Settlement Act 1946 (No. 5179)*, do by this my Proclamation direct that the unused and unmade road as described hereunder, be closed, that is to say:—

Parish of Wickliffe South, County of Ripon, being the road between allotment 6B, section 44, and allotment 5A, section 43.—(W.245(*) (D.293).

Given under my Hand and the Seal of the State of Victoria aforesaid, at Melbourne, the sixth day of November, in the year of our Lord One thousand nine hundred and forty-seven, and in the eleventh year of the reign of His Majesty King George VI.

(L.S.) WINSTON DUGAN.

By His Excellency's Command,

L. W. GALVIN,
Commissioner of Crown Lands and Survey.
GOD SAVE THE KING!

Soldier Settlement Act 1946 (No. 5179).
UNUSED AND UNMADE ROAD CLOSED—PARISH OF
WICKLIFFE SOUTH.

PROCLAMATION

By His Excellency the Governor of the State of Victoria and its Dependencies in the Commonwealth of Australia, &c., &c., &c.

I THE Governor of the State of Victoria, in the Commonwealth of Australia, by and with the advice of the Executive Council of the said State, and in pursuance of section 6 of the *Soldier Settlement Act 1946 (No. 5179)*, do by this my Proclamation direct that the unused and unmade road as described hereunder, be closed, that is to say:—

Parish of Wickliffe South, County of Ripon, being the road between allotments 2B, 4A, 4B, section 45, allotments 3A, 3B, 4A, 4B, section 44, and allotments 6A, 5A, 5B, section 45, allotments 5A, 5B, 6A, 6B, section 44.—(W.245(*) (D.293).

Given under my Hand and the Seal of the State of Victoria aforesaid, at Melbourne, the sixth day of November, in the year of our Lord One thousand nine hundred and forty-seven, and in the eleventh year of the reign of His Majesty King George VI.

(L.S.) WINSTON DUGAN.

By His Excellency's Command,

L. W. GALVIN,
Commissioner of Crown Lands and Survey.
GOD SAVE THE KING!

Soldier Settlement Act 1946 (No. 5179).
UNUSED AND UNMADE ROAD CLOSED—PARISH OF
WICKLIFFE SOUTH.

PROCLAMATION

By His Excellency the Governor of the State of Victoria and its Dependencies in the Commonwealth of Australia, &c., &c., &c.

I THE Governor of the State of Victoria, in the Commonwealth of Australia, by and with the advice of the Executive Council of the said State, and in pursuance of section 6 of the *Soldier Settlement Act 1946 (No. 5179)*, do by this my Proclamation direct that the unused and unmade road as described hereunder, be closed, that is to say:—

Parish of Wickliffe South, County of Ripon, being the road between allotment 7B, section 45, Parish of Wickliffe South, County of Ripon, and allotment 1A, Parish of Towanway, County of Hampden.—(W.245(*) (T.148(2) (D.293).

Given under my Hand and the Seal of the State of Victoria aforesaid, at Melbourne, the sixth day of November, in the year of our Lord One thousand nine hundred and forty-seven, and in the eleventh year of the reign of His Majesty King George VI.

(L.S.) WINSTON DUGAN.

By His Excellency's Command,

L. W. GALVIN,
Commissioner of Crown Lands and Survey.
GOD SAVE THE KING!

Soldier Settlement Act 1946 (No. 5179).
UNUSED AND UNMADE ROAD CLOSED—PARISH OF
WICKLIFFE SOUTH.

PROCLAMATION

By His Excellency the Governor of the State of Victoria and its Dependencies in the Commonwealth of Australia, &c., &c., &c.

I THE Governor of the State of Victoria, in the Commonwealth of Australia, by and with the advice of the Executive Council of the said State, and in pursuance of section 6 of the *Soldier Settlement Act 1946 (No. 5179)*, do by this my Proclamation direct that the unused and unmade road as described hereunder, be closed, that is to say:—

Parish of Wickliffe South, County of Ripon, being the road between allotment 1B, section 45, and allotment 7A, section 45.—(W.245(*) (D.293).

Given under my Hand and the Seal of the State of Victoria aforesaid, at Melbourne, the sixth day of November, in the year of our Lord One thousand nine hundred and forty-seven, and in the eleventh year of the reign of His Majesty King George VI.

(L.S.) WINSTON DUGAN.

By His Excellency's Command,

L. W. GALVIN,
Commissioner of Crown Lands and Survey.
GOD SAVE THE KING!

Soldier Settlement Act 1946 (No. 5179).
UNUSED AND UNMADE ROAD CLOSED—PARISH OF
BAANGAL.

PROCLAMATION

By His Excellency the Governor of the State of Victoria and its Dependencies in the Commonwealth of Australia, &c., &c., &c.

I THE Governor of the State of Victoria, in the Commonwealth of Australia, by and with the advice of the Executive Council of the said State, and in pursuance of section 6 of the *Soldier Settlement Act 1946 (No. 5179)*, do by this my Proclamation direct that the unused and unmade road as described hereunder, be closed, that is to say:—

Parish of Baangal, County of Ripon, being the road between subdivision A of allotments 1 and 4, section 37, and subdivision A of allotments 3 and 4, section 34.—(B.581(3) (D.122).

Given under my Hand and the Seal of the State of Victoria aforesaid, at Melbourne, the sixth day of November, in the year of our Lord One thousand nine hundred and forty-seven, and in the eleventh year of the reign of His Majesty King George VI.

(L.S.) WINSTON DUGAN.

By His Excellency's Command,

L. W. GALVIN,
Commissioner of Crown Lands and Survey.
GOD SAVE THE KING!

THE TERRITORY OF PAPUA DECLARED A RECIPROCATING STATE WITHIN THE MEANING OF THE MAINTENANCE ACTS.

PROCLAMATION

By His Excellency the Governor of the State of Victoria and its Dependencies in the Commonwealth of Australia, &c., &c., &c.

I THE Governor of the State of Victoria, in the Commonwealth of Australia, being satisfied that in the Territory of Papua there is in force legislation containing provisions substantially similar to the provisions contained in Part V. of the *Maintenance Act 1928* of the Parliament of Victoria (as amended by the *Maintenance Act 1933* of the said Parliament), do now, under the powers conferred by the Maintenance Acts of the Parliament of the State of Victoria, by and with the advice of the Executive Council of the said State, hereby declare the Territory of Papua to be a reciprocating State within the meaning and for the purposes of the said Maintenance Acts.

Given under my Hand and the Seal of the State of Victoria aforesaid, at Melbourne, this sixth day of November, in the year of our Lord One thousand nine hundred and forty-seven, and in the eleventh year of the reign of His Majesty King George VI.

(L.S.) WINSTON DUGAN.

By His Excellency's Command,

W. SLATER,
Attorney-General and Solicitor-General.
GOD SAVE THE KING!

DROMANA TOWN COMMON ABOLISHED.

PROCLAMATION

By His Excellency the Governor of the State of Victoria and its Dependencies in the Commonwealth of Australia, &c., &c., &c.

WHEREAS by Division 10 of Part I. of the *Land Act 1928* it is amongst other things enacted that the Governor in Council may from time to time increase, and, after one month's notice in the *Government Gazette*, diminish, alter, or abolish any common, and may from time to time re-proclaim the whole or any part of any such common for any of the purposes and subject to the provisions of the said Part of the said Act, and that nothing therein contained shall prevent the exercise of the powers conferred by the said Part of the said Act with respect to the leasing or licensing of any land comprised in any common: Now therefore I, the Governor of the State of Victoria, in the Commonwealth of Australia, by and with the advice of the Executive Council of the said State, do hereby abolish

THE DROMANA TOWN COMMON.

Given under my Hand and the Seal of the State of Victoria aforesaid, at Melbourne, this sixth day of November, in the year of our Lord One thousand nine hundred and forty-seven, and in the eleventh year of the reign of His Majesty King George VI.

(L.S.) WINSTON DUGAN.

By His Excellency's Command,

L. W. GALVIN,
Commissioner of Crown Lands and Survey.
GOD SAVE THE KING!

Vermin and Noxious Weeds Act 1928.

CERTAIN PLANT DECLARED TO BE A NOXIOUS WEED WITHIN THE SHIRE OF ORBOST.

PROCLAMATION

By His Excellency the Governor of the State of Victoria and its Dependencies in the Commonwealth of Australia, &c., &c., &c.

IN pursuance of the provisions of section 6 of the *Vermin and Noxious Weeds Act 1928* (No. 3799), I, the Governor of the State of Victoria, by and with the advice of the Executive Council of the said State, do by this my Proclamation declare the plant named hereunder to be a noxious weed for the purposes of the above Act within the Shire of Orbost, viz.:—

Carduus Marianus, L., "Spotted or Variegated Thistle."

Given under my Hand and the Seal of the State of Victoria aforesaid, at Melbourne, this sixth day of November, in the year of our Lord One thousand nine hundred and forty-seven, and in the eleventh year of the reign of His Majesty King George VI.

(L.S.) WINSTON DUGAN.

By His Excellency's Command,

L. W. GALVIN,
Commissioner of Crown Lands and Survey.
GOD SAVE THE KING!

PUBLIC HALF-HOLIDAY.

PROCLAMATION

By His Excellency the Governor of the State of Victoria and its Dependencies in the Commonwealth of Australia, &c., &c., &c.

IN pursuance of the provisions contained in Part III. of the *Public Service Act 1946* (10 Geo. VI. No. 5124), I, the Governor of the State of Victoria, in the Commonwealth of Australia, by and with the advice of the Executive Council of the said State, do by this my Proclamation appoint the day and date hereunder mentioned to be observed as a Public Half-Holiday at the place specified, viz.:—

Public Half-Holiday from the Hour of Twelve o'clock noon:—

WEDNESDAY, 26TH NOVEMBER, 1947, throughout the Borough of Sebastopol.

Given under my Hand and the Seal of the State of Victoria aforesaid, at Melbourne, this sixth day of November, in the year of our Lord One thousand nine hundred and forty-seven, and in the eleventh year of the reign of His Majesty King George VI.

(L.S.) WINSTON DUGAN.

By His Excellency's Command,

P. J. CLAREY,
for Chief Secretary.
GOD SAVE THE KING!

BANK HALF-HOLIDAYS.

PROCLAMATION

By His Excellency the Governor of the State of Victoria and its Dependencies in the Commonwealth of Australia, &c., &c., &c.

IN pursuance of the provisions contained in Part III. of the *Banks and Currency Act 1928*, I, the Governor of the State of Victoria, in the Commonwealth of Australia, do by this my proclamation appoint the days and dates named hereunder as special days to be observed as Bank Half-Holidays at the places mentioned, that is to say:—

Bank Half-Holidays from the Hour of Twelve o'clock noon:—

TUESDAY, 18TH NOVEMBER, 1947, at Kilmore.

WEDNESDAY, 12TH NOVEMBER, 1947, at Woodend.

Given under my Hand and the Seal of the State of Victoria aforesaid, at Melbourne, this sixth day of November, in the year of our Lord One thousand nine hundred and forty-seven, and in the eleventh year of the reign of His Majesty King George VI.

(L.S.) WINSTON DUGAN.

By His Excellency's Command,

W. SLATER,
Chief Secretary.

GOD SAVE THE KING!

APPOINTMENTS.

HIS Excellency the Governor of the State of Victoria, by and with the advice of the Executive Council thereof, has, by Orders made on the 6th day of November, 1947, been pleased to make the under-mentioned appointments, viz.:—

DEPARTMENT OF CHIEF SECRETARY.

Assistants to Inspector of Fisheries.

ERNEST ARTHUR FOLETTA, and

WILLIAM JOHNSON,

pursuant to the provisions of the Fisheries Acts, to be Assistants to the Inspector of Fisheries.

Officer in Charge (Acting) of Gaol.

THOMAS MORRISSEY

to be Officer in Charge (acting) of the Geelong Gaol, from the 10th November, 1947, to the 30th November, 1947, both dates inclusive, during the absence on leave of Charles James McGann.

Officer in Charge (Acting) of Prison Camp.

DANIEL MCAULEY

to be Officer in Charge (acting) of the Coorimungla Prison Camp, from the 5th November, 1947, to the 11th November, 1947, both dates inclusive, during the absence on leave of Charles Henry Roberts.

Inspector under Explosives Act.

HAROLD WILLIAM MCKELVIE,

pursuant to the provisions of section 32 of the *Explosives Act 1928*, to be an Inspector for the purposes of Part I. of the said Act, from the 20th October, 1947.

Licensing Magistrate and Chairman of Licensing Courts.

DIXON HEARDER,

pursuant to the provisions of section 57 of the *Licensing Act 1928*, to be a Licensing Magistrate and Chairman of Licensing Courts, for a period of three years, from the 18th December, 1947.

DEPARTMENT OF LANDS AND SURVEY.

Bailiff of Crown Lands.

ROBERT GEORGE HAND

to be a Bailiff of Crown Lands, without salary, in the place of Wallace John Hepburn, whose appointment is hereby revoked.

Trustees of Sites.

ALFRED EVERETT SHAW,

LESLIE VICTOR SHAW,

ROBERT ALFRED SHAW,

DORIS AMELIA SHAW,

DAVID JOHN SHAW,

CLYDE CUMMING, and

JESSIE MARSHALL CUMMING,

to be Trustees of the land permanently reserved on the 21st November, 1890, as a site for a Mechanics' Institute and Free Library at Gobur, in the place of John Hewlett, David Coghill, John Rowan, and Thomas Cumming, resigned, and William Macklin, Edward Brodie, and Thomas Doyle, deceased; and

ROY CYRIL JAMES, and
PERCY ERNEST OUTEN,

to be Trustees of the land permanently reserved on the 17th February, 1885, as a site for a Ladies' Benevolent Society, at Maryborough, in the place of Mary Eleanor Harris, deceased, and Stanley Charles Nicol, resigned.

Inspectors of Vermin and Noxious Weeds.

RONALD WALLACE FINDLAY,
GUY DANIEL GOODYEAR,
GORDON THOMAS CAMERON,
FREDRICK OSWALD COUSTLEY,
JOSEPH LINDSAY JORGENSEN,
HARRY BURGOYNE, and
HAROLD BATHOLOMEW JACKSON—

Inspectors of Land Settlement, Department of
Lands and Survey,

to be also Inspectors under the provisions of section 7 of the *Vermin and Noxious Weeds Act 1928*, without additional salary.

DEPARTMENT OF LAW.

Bailiff of County Court.

ARTHUR LESLIE BELL, Senior Constable of Police, Red Cliffs,

to be also a Bailiff of the County Court at Mildura, in the place of E. K. McCarthy, resigned, with fees.

Clerk of Children's Court, &c.

WILLIAM JOHN SUMMERS MALONEY

to be also Clerk of the Children's Court at Yarram, Foster, and Toora, during the absence on annual leave of F. L. McSweeney.

Commissioner for Taking Declarations, &c.

OSWALD SALISBURY BAKER, Sales Manager, North Western Woollen Mills, 187 Flinders-lane, Melbourne,

to be a Commissioner for taking Declarations and Affidavits, pursuant to the provisions of Division 8 of Part IV. of the *Evidence Act 1928*, to resign upon ceasing to occupy his present position;

AUBREY DAVID FORD, 144 Abbott-street, Sandringham, to be a Commissioner for taking Declarations and Affidavits, pursuant to the provisions of Division 8 of Part IV. of the *Evidence Act 1928*, to resign upon removing from the neighbourhood of the address stated—this appointment is in lieu of the appointment of John Ford contained in the Order of the 14th October, 1947, and appearing in the *Gazette* of the 22nd October, 1947;

SYDNEY POWELL PATRICK SMITH, 26 New-street, Hampton,

to be a Commissioner for taking Declarations and Affidavits, pursuant to the provisions of Division 8 of Part IV. of the *Evidence Act 1928*—this appointment is in lieu of the appointment of Sydney Powell Smith contained in the Order of the 27th September, 1943;

ALBERT EDWARD SANSOM, 70 Market-street, Essendon,
ERNEST HENRY WINTER, 15 Balmoral-avenue, Pascoe Vale South,

CHARLES WILLIAM SALTER, 106 Crookston-road, Reservoir,

BENJAMIN JOSEPH TALBOT, 10 Olive-street, Reservoir,
STANLEY JOSEPH RUSSELL, Malpas-street, Preston,
FRANK RICHARD TELFER, 13 Hawker-avenue, Preston,
ROY ALLEN JARVIS, 661 Bell-street, Preston,
SAMUEL ROBERT HARROW, 68 Regent-street, Preston,
MORRIS NOEL AUSTIN, 63 Robeson-street, Preston,
WILLIAM JAMES CANTY, 37 Kellett-street, Northcote,
JAMES OWLER CAMERON, 139 Rathgown-road, Reservoir,
VIOLET AMELIA DRAKEFORD, 46 Reynolds-parade, Pascoe Vale South,

THOMAS LEWIS BUCHAN, 25 North-terrace, Clifton Hill,
GERALD ALPHONSUS COOK, 105 Hodgkinson-street, Clifton Hill,

THOMAS FRANCIS WRIGHT, 33 Yambla-street, Clifton Hill,

FREDERIC REDFEARN, 5 Kooyong-road, Armadale,
HUGH ALFRED MCGILL, 20 George-street, Brunswick,
WILLIAM EDWARD CARLING, 15 Lowan-street, East Brunswick,

BRIDGET TERESA CROUCH, 14 Leeds-street, Footscray,
CLARICE RITA MCGRATH, 103 Victoria-street, Footscray, and

JOHN BARWICK MARSHALL, 41 Seddon-street, Seddon, to be Commissioners for taking Declarations and Affidavits, pursuant to the provisions of Division 8 of Part IV. of the *Evidence Act 1928*, to resign upon removing from the neighbourhood of the addresses stated; and

JOSEPH JAMES DELANEY, Acting Manager, Clothing Factories, Department of Supply and Shipping, Miles-street, South Melbourne, and

DONALD CLIVE COLLINS, and
FREDERICK NORMAN COPPEL—

Officers of the Taxation Office, 436 Lonsdale-street, Melbourne,

to be Commissioners for taking Declarations and Affidavits, pursuant to the provisions of Division 8 of Part IV. of the *Evidence Act 1928*, to refrain from charging fees, and to resign upon ceasing to occupy their present positions.

Magistrates.

JOHN PATRICK SMITH, 20 George-street, West Preston, and

PHILIP MCGREGOR EDWARD, Belgrave Heights,

to Keep the Peace in the Central Bailiwick of the State of Victoria;

FRANCIS MICHAEL FITZPATRICK, View Point, Eaglehawk, to Keep the Peace in the Midland Bailiwick of the State of Victoria; and

WILLIE ELLIS FINCH, Commercial Bank of Australia, Colac,

to Keep the Peace in the Southern Bailiwick of the State of Victoria.

Probation Officers.

JEAN OLIVE NORMAN, 59 Serrell-street, East Malvern, and

JOHN SYMINGTON, 7 Denman-avenue, East St. Kilda, to be Probation Officers, pursuant to the provisions of section 8 of the *Children's Court Act 1928*, for the Children's Courts as Malvern and St. Kilda respectively; and

CHARLES MULCAHY, Linton, and
HAROLD SCOTT, Linton,

to be Probation Officers, pursuant to the provisions of section 8 of the *Children's Court Act 1928*, for the Children's Court at Smythesdale.

Officers Authorized to Attest Instruments, &c.

JAMES HENRY GOETZE, of Coburg,
CEDRIC IVOR MORRISON, of Hawthorn West,
BEN GRIBBIN, of Sandringham,
CHARLES OWEN CAZALY, of Ashburton,
CARLYLE ARCHIBALD HOADLEY ADAMSON, of East Kew,
RALPH GRAY, of Mordialloc,
NORMAN FREDERICK LUNN, of 470 Spencer-street, Melbourne,

MALCOLM ROBERT BRUCE, of Thornbury,
FRANK SEBASTIAN HYDEN, of Springvale,
EDWARD STANISLAUS MULLEN, of Talbot,
ALEXANDER WILLIAM MACRAE, of Koroit, and
JACK ST. KILDA TOY, of Murrumbidgee—

Officers of The English, Scottish, and Australian Bank Limited at the places named,

pursuant to the provisions of section 191 of the *Transfer of Land Act 1928*, to attest instruments and powers of attorney under the said Act signed by any person within the limits of Victoria.

DEPARTMENT OF TREASURER.

Collector of Imposts.

ANDREW ERNEST JOHN SCOTLAND to act as Collector of Imposts, Government Statist Office, during the absence of C. Douglas, on leave.

DEPARTMENT OF WATER SUPPLY.

Waterworks Trust Commissioners.

WILLIAM LAWRENCE KRAFT

to be a Commissioner of the Drouin Waterworks Trust, and to hold office as such for a period of four years from the date hereof, subject to the provisions of the Water Acts;

SAMUEL COZENS FARRELL

to be a Commissioner of the Stratford Waterworks Trust, and to hold such position during the present term of office of Garfield Riley, J.P., as a Councillor for the East Riding of the Shire of Avon, subject to the provisions of the Water Acts;

WILLIAM FRANCIS STONER

to be a Commissioner of the Kiewa Waterworks Trust, in place of Richard Walter Ahearn, resigned, and to hold office as such from the date hereof until the 19th March, 1950, subject to the provisions of the Water Acts;

LEO REOCH COHN

to be a Commissioner of the Swan Hill Waterworks Trust, and to hold office as such for a period of four years from the date hereof, subject to the provisions of the Water Acts; and

EDMOND JOHN CORBOY

to be a Commissioner of the Seymour Waterworks Trust, and to hold office as such for a period of four years from the date hereof, subject to the provisions of the Water Acts.

C. W. KINSMAN,
Clerk of the Executive Council.

At the Executive Council Chamber,
Melbourne, the 6th November, 1947.

RESIGNATIONS.

HIS Excellency the Governor of the State of Victoria, by and with the advice of the Executive Council thereof, has, by Orders made on the 6th day of November, 1947, accepted the resignations of the persons named hereunder of the offices mentioned, viz.:—

DEPARTMENT OF CHIEF SECRETARY.

ANDREW MCKERRAL, a Licensing Inspector for each and every Licensing District in the State of Victoria, to date from and inclusive of the 5th November, 1947.

DEPARTMENT OF LAW.

JAMES CAMPBELL HOLDEN, Justice of the Peace, as a Deputy Coroner, pursuant to the provisions of the *Coroners Act 1928*, at and in the vicinity of Port Fairy.

JOHN SYMINGTON, as a Probation Officer, pursuant to the provisions of the *Children's Court Act 1928*, for the Children's Court at Castlemaine.

EDRIC KEITH MCCARTHY, of Red Cliffs, as a Bailiff of the County Court at Mildura.

C. W. KINSMAN,
Clerk of the Executive Council.

At the Executive Council Chamber,
Melbourne, the 6th November, 1947.

PUBLIC SERVICE OF VICTORIA.—VACANCIES.

APPPLICATIONS will be received by the Public Service Board up to Saturday, the 29th November, 1947, from persons employed in the Public Service of Victoria, who are eligible and qualified, for appointment to the under-mentioned positions:—

ADMINISTRATIVE DIVISION.

Clerk, Class "B1," Audit Office, Department of Premier.

Yearly Salary.—£748, minimum; £800, maximum.

Duties.—To perform the duties of an Inspector of Audit, as directed by section 50 of the *Audit Act 1928*, and to supervise other special audits and investigations, as directed by the Auditor-General.

Qualifications.—As required by section 51 of the *Audit Act 1928*.

Clerk, Class "C," Audit Office, Department of Premier. (Seven vacancies.)

Yearly Salary.—£449, minimum; £501, maximum.

Duties.—To act as Assistant Inspector of Audit, and to carry out audits and investigations as directed by the Auditor-General. Country work is essential.

Qualifications.—To be a qualified accountant. To have a thorough knowledge of the Audit Act and of the General Regulations respecting Public Accounts, and a knowledge of the various activities which the Auditor-General is required by law to audit.

Clerk, Class "C," Department of Agriculture.

Yearly Salary.—£449, minimum; £501, maximum.

Duties.—To have charge of the correspondence room of the Central Administration, and control of the recording and filing of correspondence. To supervise opening of mail, check remittances received, forward routine inward correspondence to the Division concerned, and record correspondence relating to staff matters.

Qualifications.—To have experience in classifying correspondence and registering same under the card system, and a knowledge of the activities and organization of the Department and the Acts administered, and the Public Service Act and Regulations thereunder.

PROFESSIONAL DIVISION.

Court Reporter, Class "C1," Department of Law. (Three vacancies.)

Yearly Salary.—£527, minimum; £579, maximum.

Duties.—To report cases in the Supreme and General Sessions, &c., Courts as required, to take notes for the Judges and of deputations, and to perform such other departmental shorthand reporting work as may be required.

Qualifications.—To be a licensed shorthand writer under the provisions of the *Evidence Act 1928* with sufficient experience in duties of the kind mentioned.

Plant Pathologist, Grade II, Class "C1," Department of Agriculture.

Yearly Salary.—£527, minimum; £579, maximum.

Duties.—To assist in the conduct of research into the plant pathological problems of Victoria, to survey and report on plant disease outbreaks, to diagnose plant disease specimens, to deliver lectures, and to assist in the conduct of field demonstrations on the control of plant diseases.

Qualifications.—To possess a degree in Agricultural Science, or Science, experience in the conduct of research in plant pathology, a knowledge of agricultural and horticultural practice, and capacity to lecture and write reports.

Chemist, Class "C1," Department of Mines.

Yearly Salary.—£527, minimum; £579, maximum.

Duties.—To analyse rocks, clays, minerals, oils, and other metallurgical products; to investigate metallurgical and associated problems; to take charge of the Mines Section of the laboratories during the absence of the Officer in Charge.

Qualifications.—To hold a science degree or an approved diploma with chemistry or metallurgy as a major subject, and to have had experience in metallurgical and kindred analyses. Experience in directing laboratory work and in investigating metallurgical problems is desirable.

Cadet Valuer, Class "D," Department of Water Supply. (Three vacancies.)

Yearly Salary.—£286, minimum; £436, maximum.

Duties.—To assist valuers in both field and office work in connexion with the valuation of properties for rating and land compensation purposes.

Qualifications.—To be over 21 years of age and not more than 35 years of age; to be in possession of Leaving Certificate, including the subject of Agricultural Science; or to possess a Diploma of the Dookie Agricultural College; to be a good penman, and to be able to make simple plans of buildings and farm holdings.

Draughtsman, Class "D" (Nambrok-Denison Construction Works), Department of Water Supply.

Yearly Salary.—£286, minimum; £436, maximum—successful applicant will be paid a commencing salary of £364 a year.

Duties.—To prepare plans of surveys and of civil and hydraulic structures, and to take out earthwork quantities.

Qualifications.—To have had Technical School training in Engineering or Draughtsmanship, or experience in the class of work outlined above.

TECHNICAL AND GENERAL DIVISION.

Senior Warden, Penal and Gaols Branch, Department of Chief Secretary.

Yearly Salary.—£396, minimum; £409, maximum.

Duties.—To assist in the control of a Division, and, in the absence of the Chief Warden, to act as Chief Warden, and to perform other duties as directed, including those of storekeeper, where allotted to country institutions, and officer in charge for night watches and for court escorts.

Qualifications.—To have passed the prescribed examination for promotion. To have a satisfactory record of service and display the qualities of leadership required by a senior officer in the management of staff and prisoners. To have had sufficient experience to be able readily to assume responsibility, including storekeeping, when required.

Believing Charge Attendant, Criminal and Refractory Ward, Mental Hospital, Ararat, Department of Health.

Salary.—£383 a year.

Duties.—To assist the Head Attendant in management of Criminal and Refractory Ward, to prepare leave sheets and other records. To act as Head Attendant in his absence.

Qualifications.—Ability to direct and control staff and patients, and to keep records relating thereto. To have had some experience as Acting Head Attendant. Previous experience in Criminal and Refractory Ward is desirable.

Head Water Bailiff (Tongala), Department of Water Supply.

Yearly Salary.—£331, minimum; £344, maximum.

Qualifications.—Ability to take charge of a number of water bailiffs; experience in the regulation and distribution of water; a knowledge of water requirements, crops, and grasses grown under irrigation, and of the method of preparation of land for same; and experience in channel and drain construction and maintenance.

Engine-driver of Launches, Ports and Harbors Branch, Department of Public Works.

Yearly Salary.—£312, minimum; £338, maximum.

Duties.—To have charge of the engine-room of the Diesel-engine tug-boats used for the towage of explosives, lighters, &c.; and to assist at the Ports and Harbors Dredging Depot, Williamstown.

Qualifications.—To possess a Marine Engine Driver's Certificate, Class "D" (Diesel) and a Motorboatman's Licence, to have had experience with all classes of marine motor engines, and to be familiar with floating plant used for the handling of explosives.

Overseer (Ouyen Centre), Department of Water Supply.

Yearly Salary.—£331, minimum; £344, maximum.

Duties.—To supervise rangers employed in the distribution of water and maintenance of channels in the Ouyen Centre.

Qualifications.—Experience in distribution of water for domestic and stock purposes; capacity for handling men with horse teams on sand clearing; and supervising gangs of men on channel maintenance and repairing structures. To be competent to measure up piece-work, and to perform clerical work involved in preparing time-book, &c., in connexion with works involving large expenditure, and to have a knowledge of sand-drift prevention.

Fireman, Office of the Chief Commissioner of Police, Department of Chief Secretary.

Yearly Salary.—£271, minimum; £310, maximum.

Duties.—To act as a boiler attendant at Police Headquarters, Russell-street, Melbourne.

Qualifications.—To possess a boiler attendant's certificate, or a higher certificate.

Messenger, Taxation (Land Tax) Office, Department of Treasurer.

Yearly Salary.—Juniors—according to age; adults—£273, minimum, £286, maximum.

Duties.—To act as Messenger, and to be responsible for the preparation and despatch of mail matter. To assist generally in the branch.

Qualifications.—To be active and industrious, and show expedition in the performance of the duties.

Cook (Female), Travancore Development Centre, Mental Hygiene Branch, Department of Health.

Yearly Salary.—£244, minimum; £257, maximum.

Duties.—To have charge of the kitchen, and to prepare and cook meals.

Qualifications.—A knowledge of and experience in large-quantity cooking.

Mess Room Attendant (Female), Mental Hospital, Kew, Department of Health.

Salary.—£206 a year.

Duties.—To attend Staff Mess Room, prepare tables, serve meals, clear and wash dishes, and assist cook if required.

Qualifications.—Ability to carry out above duties, and to possess an elementary knowledge of cooking.

NOTE.—In addition to the salary rates quoted, a cost of living adjustment at the rate of £27 a year in the case of minors, £36 in the case of adult females, and £54 in the case of adult males is payable. The rates are subject to variation in accordance with the rise or fall in the index numbers of the cost of living.

By order,

E. F. FITZGIBBON,
Secretary.

Office of the Public Service Board,
Melbourne, 11th November, 1947.

PUBLIC SERVICE OF VICTORIA.

TEMPORARY APPOINTMENTS.

APPLICATIONS will be received by the Public Service Board up to Saturday, the 29th November, 1947, from persons who are qualified, for appointment to the under-mentioned positions:—

Assistant Field Officer, Department of Agriculture.

Yearly Salary.—At 18 years of age, £228; at 19 years, £241; at 20 years, £254; adult, £280 minimum; £325 maximum.

Duties.—To carry out field inspections of vegetable seed crops submitted for certification or approval under Victorian Seed Certification and Approval Schemes; to supervise the cleaning and handling of harvested seed; and to carry out experimental work as required in connexion with vegetable seed production.

Qualifications.—A Diploma of an approved Agricultural College, or its equivalent, and a good general knowledge of the farming practices and machinery involved in vegetable seed production work.

Visiting Nurse, Tuberculosis Division, General Health Branch, Department of Health. (Two vacancies.)

Yearly Salary.—£292, minimum; £318, maximum.

Duties.—Under the direction of the State Director of Tuberculosis, to assist at X-ray examinations in connexion with the working of mobile X-ray units, chiefly in country centres, including keeping of records and visiting certain cases of pulmonary tuberculosis.

Qualifications.—To be a fully trained and registered nurse, preferably with experience in tuberculosis work and social service work, and to be a licensed motor driver. Further particulars can be obtained from the Tuberculosis Bureau, 364 Mint-place, Melbourne.

NOTE.—In addition to the salary rates quoted, a cost of living adjustment at the rate of £27 a year in the case of minors, £36 in the case of adult females, and £54 in the case of adult males, is payable. The rates are subject to variation in accordance with the rise or fall in the index numbers of the cost of living.

By order,

E. F. FITZGIBBON,
Secretary.

Office of the Public Service Board,
Melbourne, 11th November, 1947.

**PUBLIC SERVICE (PUBLIC SERVICE BOARD)
REGULATION 36A.**

NOTICE is hereby given that the Public Service Board has raised the classification of an office of Photographer, Technical and General Division, Department of Lands and Survey, to Senior Photographer, Technical and General Division, and that the Permanent Head of the Department has recommended David Walker for appointment thereto.

Duties.—Under direction, to have charge of the Central Photographic Laboratories; to arrange the distribution and supervision of work and the checking of the quality of output; to be responsible for the care and maintenance of equipment and the training of juniors; and to perform such other duties as may be required.

Qualifications.—To be a competent photographer of wide experience, with a knowledge of the various methods of reproduction used in the Department, and to have the personal qualities necessary for the direction of technical staff.

Appeals against such recommendation should be lodged with the Secretary to the Public Service Board not later than Saturday, the 22nd November, 1947.

By order,

E. F. FITZGIBBON,
Secretary.

Office of the Public Service Board,
Melbourne, 11th November, 1947.

No. 149. *Public Service Act 1946, Section 39.*
**REGULATIONS.—PART III.—SALARIES, INCREMENTS,
AND ALLOWANCES.**

THE Public Service Board, in pursuance of the powers conferred by the *Public Service Act 1946*, hereby amends its Regulations as shown below :—

FIRST SCHEDULE.
PROFESSIONAL DIVISION.
Offices and Rates of Salaries.

Office.	Yearly Rate of Salary.	
	Minimum.	Maximum.
DEPARTMENT OF AGRICULTURE.	£	£
CLASS " B. "		
<i>Revoke—</i> Senior Inspector of Agricultural Education	670	722
CLASS " B1. "		
<i>Add—</i> Senior Inspector of Agricultural Education	748	800

D. D. PAINE, Chairman.
E. F. FITZGIBBON, Secretary.

Office of the Public Service Board,
Melbourne, 13th October, 1947.

No. 150.

Public Service Act 1946, Section 50.

**REGULATIONS.—PART III.—SALARIES, INCREMENTS,
AND ALLOWANCES.**

THE Public Service Board, in pursuance of the powers conferred by the *Public Service Act 1946*, hereby amends its Regulations as shown below :—

FIFTH SCHEDULE.
TEMPORARY EMPLOYEES.

Designations of Positions and Rates of Salaries.

Department and Designation of Position.	Yearly Rate of Salary.	
	Minimum.	Maximum.
DEPARTMENT OF HEALTH.	£	£
MENTAL HYGIENE.		
<i>Add—</i> Carpenter, Assistant	312

D. D. PAINE, Chairman.
E. F. FITZGIBBON, Secretary.

Office of the Public Service Board,
Melbourne, 22nd October, 1947.

No. 151.

Public Service Act 1946, Section 39.

**REGULATIONS.—PART III.—SALARIES, INCREMENTS,
AND ALLOWANCES.**

THE Public Service Board, in pursuance of the powers conferred by the *Public Service Act 1946*, hereby amends its Regulations as shown below :—

FIRST SCHEDULE.
PROFESSIONAL DIVISION.
Offices and Rates of Salaries.

Office.	Yearly Rate of Salary.	
	Minimum.	Maximum.
DEPARTMENT OF HEALTH.	£	£
GENERAL HEALTH BRANCH.		
Class " B. "		
<i>Add—</i> Medical Officer (Industrial Hygiene) ..	670	722

D. D. PAINE, Chairman.
E. F. FITZGIBBON, Secretary.

Office of the Public Service Board,
Melbourne, 27th October, 1947.

No. 152.

Public Service Act 1946, Section 39.

**REGULATIONS.—PART III.—SALARIES, INCREMENTS,
AND ALLOWANCES.**

THE Public Service Board, in pursuance of the powers conferred by the *Public Service Act 1946*, hereby amends its Regulations as shown below :—

FIRST SCHEDULE.
PROFESSIONAL DIVISION.
Offices and Rates of Salaries.

Office.	Yearly Rate of Salary.	
	Minimum.	Maximum.
DEPARTMENT OF CHIEF SECRETARY.	£	£
PUBLIC LIBRARY.		
Class " C2. "		
<i>Add—</i> Secretary, Free Library Service Board ..	592	644

D. D. PAINE, Chairman.
E. F. FITZGIBBON, Secretary.

Office of the Public Service Board,
Melbourne, 29th October, 1947.

No. 153.

Public Service Act 1946, Section 39.

REGULATIONS.—PART III.—SALARIES, INCREMENTS, AND ALLOWANCES.

THE Public Service Board, in pursuance of the powers conferred by the *Public Service Act 1946*, hereby amends its Regulations as shown below:—

FIRST SCHEDULE.
PROFESSIONAL DIVISION.
Offices and Rates of Salaries.

Office.	Yearly Rate of Salary.	
	Minimum.	Maximum.
	£	£
DEPARTMENT OF WATER SUPPLY.		
CLASS "C."		
Add— Draughtsman (Cartographic)	449	501
CLASS "D."		
Add— Draughtsman (Cartographic)	286	436
Draughtsman (Computing)	286	436

D. D. PAINE, Chairman.
E. F. FITZGIBBON, Secretary.

Office of the Public Service Board,
Melbourne, 20th October, 1947.

No. 154.

Public Service Act 1946.

REGULATIONS.—PART III.—SALARIES, INCREMENTS, AND ALLOWANCES.

THE Public Service Board, in pursuance of the powers conferred by the *Public Service Act 1946*, hereby amends the Public Service (Public Service Board) Regulations as follows:—

Regulation 55 is revoked.

Sub-regulation 2 of Regulation 62 is amended by omitting the figures "55."

This Regulation shall have effect as on and from the 2nd November, 1947.

D. D. PAINE, Chairman.
E. F. FITZGIBBON, Secretary.

Office of the Public Service Board,
Melbourne, 7th November, 1947.

Health Acts.

MEAT SUPERVISION REGULATIONS 1947.

ALLOCATION OF MEAT BRANDS.

THE brand letters allotted by the Commission of Public Health to the Borough of Daylesford and the Shire of Glenlyon are "DGC," not "DCC" as notified in error in the *Government Gazette* of 15th October, 1947.

J. WHITLOCK, Secretary,
Commission of Public Health.

Department of Health,
Melbourne, 3rd November, 1947.

Stamps Act 1937.

NOTICE.

NOTICE is hereby given that the certificate appearing in *Government Gazette*, No. 389, dated 30th December, 1937, that certain companies were engaged solely or principally in the search or mining for gold, is withdrawn as from the 12th November, 1947, in respect to the under-mentioned companies.

Dated the 12th day of November, 1947.

W. E. CAMIER,
Comptroller of Stamps.

COMPANIES.

New Campbell's Creek Dredging No Liability.
Western Gold Mines No Liability.

DEPARTMENT OF LAW.—ATTORNEY-GENERAL.

CURATOR OF CONVICT'S PROPERTY.

PURSUANT to the provisions of section 576 of the *Crimes Act 1928*, His Excellency the Governor of the State of Victoria, by and with the advice of the Executive Council thereof, has, by Order made on the 6th day of November, 1947, directed that the custody and management of the property of the convict, George Frederick Pearson, be committed to Harold Edward Pearson, of 71 Buckingham-street, North Richmond, dealer, as a curator hereby appointed in that behalf by the said Order.

C. W. KINSMAN,
Clerk of the Executive Council.

At the Executive Council Chamber,
Melbourne, the 6th November, 1947.

DEPARTMENT OF LAW.—ATTORNEY-GENERAL.

CURATOR OF CONVICT'S PROPERTY.

PURSUANT to the provisions of section 576 of the *Crimes Act 1928*, His Excellency the Governor of the State of Victoria, by and with the advice of the Executive Council thereof, has, by Order made on the 6th day of November, 1947, directed that the custody and management of the property of the convict James John Slater, also known as James John O'Brien, be committed to Sybil Mavis Amor, of 286 Wellington-street, Collingwood, married woman, as a curator hereby appointed in that behalf by the said Order.

C. W. KINSMAN,
Clerk of the Executive Council.

At the Executive Council Chamber,
Melbourne, the 6th November, 1947.

DEPARTMENT OF LAW.

SITTINGS OF THE SUPREME COURT, BENDIGO.—
DAY ALTERED.

HIS Excellency the Governor of the State of Victoria, by and with the advice of the Executive Council thereof, has, by Order made on the 6th day of November, 1947, directed that the Sittings of the Supreme Court for the hearing of Criminal Trials and for the Trial of Causes appointed to be held at Bendigo, on Tuesday, the 11th November, 1947, be held on Tuesday, the 25th November, 1947.

C. W. KINSMAN,
Clerk of the Executive Council.

At the Executive Council Chamber,
Melbourne, 6th November, 1947.

DEPARTMENT OF LAW.—SOLICITOR-GENERAL.

COURTS OF PETTY SESSIONS.

ALTERATION OF DAYS AND HOURS.

HIS Excellency the Governor of the State of Victoria, by and with the advice of the Executive Council thereof, and pursuant to the provisions of section 61 of the *Justices Act 1928*, has, by Order made on the 6th day of November, 1947, directed that the days and hours heretofore appointed for the holding of Courts of Petty Sessions at the places named in the Schedule below be altered to the days and hours stated in the second column of such Schedule.

SCHEDULE.

Court.	Day and Hour Appointed.
Leongatha ..	Every Wednesday at 10 o'clock a.m., as from and inclusive of the 7th January, 1948
Wonthaggi ..	Every Tuesday and Thursday at 10 o'clock a.m., as from and inclusive of the 6th January, 1948

C. W. KINSMAN,
Clerk of the Executive Council.

At the Executive Council Chamber,
Melbourne, 6th November, 1947.

AUCTION SALES ACT 1928.

MYRTLEFORD.—Notice is hereby given that the Annual Meeting of Justices for the Licensing of Auctioneers will be held at the Court House, Myrtleford, on Tuesday, the 25th day of November, 1947, at the hour of Ten o'clock in the forenoon. Dated this 31st day of October, 1947.—
F. C. HILL, Clerk of Petty Sessions.

Transport Regulation Acts.
TRANSPORT REGULATION BOARD.

NOTICES OF PUBLIC HEARINGS.

NOTICE is hereby given that the applications made by the persons named below for licences to operate the commercial passenger vehicles on the route or routes, or in the manner set out opposite their names, will be heard at a time and place to be communicated to the parties:—

Name and Address of Applicant; Nature of Application.

ADAMS, R. W., & M. E. WILLIAMS (trading as "Adams & Williams"), "Do Drop in," corner of York and Swansea roads, Montrose; application for variation of licence to be issued to operate a picture trip from Mt. Evelyn to Croydon Picture Theatre on Wednesday and Saturday nights, with the proviso that no passengers shall be picked up and set down between Montrose and Croydon.

ANSETT MOTORS LTD., 202-212 Gray-street, Hamilton; application for variation of licence for Naracoorte, S.A.—Horsham service to include the ability to operate a daily service on the following time-table:—

Read Down.		Read Up.	
Daily.		Daily.	
Vic. Time.		Vic. Time.	
5.00 p.m.	Dep. Horsham	Arr. 11.45 a.m.	
5.30 p.m.	Dep. Natimuk	Dep. 11.20 a.m.	
6.30 p.m.	Dep. Goroke	Dep. 10.20 a.m.	
7.10 p.m.	Dep. Minimay	Dep. 9.40 a.m.	
S.A. Time.		S.A. Time.	
7.15 p.m.	Dep. Frances	Dep. 8.30 a.m.	
7.30 p.m.	Dep. Kybybolite	Dep. 8.15 a.m.	
7.45 p.m.	Dep. Hynam	Dep. 8.00 a.m.	
8.00 p.m.	Arr. Naracoorte	Dep. 7.45 a.m.	

ENEVER, N. J., Tallangatta; application for variation of licence A.2063, to include the ability to operate under private hire conditions within a 50 miles radius of Tallangatta.

FAIRWEATHER, N. A., 1424 Sturt-street, Ballarat; 1 commercial passenger vehicle, with seating capacity for 20 persons, to operate as a special service omnibus within a 20 miles radius of Ballarat, and to Daylesford, Maryborough, Avoca, Batesford, Castlemaine, Ballan, Bacchus Marsh, Macedon, Kyneton.

HANCOCK, J. J., 31 Macarthur-street, Sale; application for variation of licence A.1810, to increase present private hire radius of 50 miles of Sale to places throughout the State of Victoria.

HARBERGER, C. G., Post Office, Banyena; 1 commercial passenger vehicle, with seating capacity for 6 persons, to operate for the carriage of passengers, mails, and parcels, between Banyena Post Office and Murtoa Railway Station (subject to the cancellation of licence A.1383 now held by H. Clifford).

HOGG, J. T., Mountain Highway, Bayswater; application for variation of licence A.1949, to include the ability to operate from Bayswater Railway Station to Boronia Railway Station, via Scoresby and Boronia roads.

LITTLE, B. J. & L. (trading as "Sale Bus Service & Gippsland Service Tours"), 9 Macalister-street, Sale; application for variation of licences A.1341, A.1342, A.1195, to operate between Sale and Melbourne or alternatively between Sale and Dandenong on Mondays, Wednesdays, and Fridays of each week, via—(a) Maffra, Tinamba, Heyfield, Rosedale, Traralgon, Morwell, Yallourn, Moe, Trafalgar, Yarragon, and Warragul, (b) direct via the Prince's Highway, both vehicles meeting at Warragul and off-loading on to one, if necessary. Leave Sale, 8 a.m. Leave Dandenong, 6 p.m.

LYON, J. (trading as "Lyon Bros."), Eltham; application for variation of licence A.1793, allowing operations as substitute vehicle, to operate as an additional vehicle between Kinglake and Darebin, and under private hire conditions within a 50 miles radius of Eltham.

MACKAY, A. J., Post Office, Bambra; 1 commercial passenger vehicle, with seating capacity for 21 persons, to operate for the carriage of passengers and goods between Dean's Marsh and Geelong (subject to the cancellation of licence at present held by J. Norton).

MANSFIELD-YEA PASSENGER SERVICE PTY. LTD., 1 Empire-arcade, Melbourne; application for variation of licences A.668, A.669, A.670, A.671, and A.672, to amend present licensed route between Lilydale and Mansfield, via Yea, so as to operate to Melbourne from Mansfield on the following time-table:—

Daily, except Sunday.		Sundays.	
Depart Melbourne	8 a.m., 4 p.m.	..	4 p.m.
Depart Mansfield	8 a.m., 2 p.m.	..	2 p.m.

MAXFIELD, K. E., 7 Seymour-street, Traralgon; 1 commercial passenger vehicle, with seating capacity for 5 persons, to operate—(a) separate and distinct fares within a 5 miles radius of Traralgon Post Office, (b) under private hire conditions within a 50 miles radius of Traralgon.

CUNNINGHAM, J., K. BROWN, & C. E. RUTZOW (trading as "Mentone Bus Lines"), 250 Balcombe-road, Mentone; application for variation of licence A.1508, to extend service from corner of Station-street and Point Nepean-road, Cheltenham, to Moorabbin Railway Station, via Point Nepean-road.

PIONEER TOURIST COACHES PTY. LTD., 465 Swanston-street, Melbourne; application for variation of touring licences, to delete clause 5 of conditions relevant to touring operations to delete the following:—"With the exception of the Cities of Bendigo, Ballarat, and Warrnambool."

SHEIL, P., Macedon Transport Services, Main-road, Mt. Macedon; 1 commercial passenger vehicle, to be purchased, to operate as a stage omnibus between Mount Macedon and Melbourne. (This replaces application previously lodged by R. W. Sheil, gazetted on 20th August, 1946.)

VENTURA MOTORS, 885 Canterbury-road, Box Hill; 1 commercial passenger vehicle, with seating capacity for 25 persons, to operate as an additional unit between Box Hill and Aspendale.

WALKER, S. A., 27 Rennison-street, Mordialloc; 1 commercial passenger vehicle, with seating capacity for 5 persons, to operate—(a) separate and distinct fares within a 5 miles radius of Mordialloc, (b) under private hire conditions within 50 miles radius of Mordialloc.

WEST, A. H. (trading as "West's Motor Service"), Cowes; 1 commercial passenger vehicle, to be purchased, with approximate seating capacity for 31 passengers, to operate as an additional vehicle within licensed area.

APPLICATION for licences to operate commercial passenger vehicles, with seating capacity for 5 persons, to operate for the carriage of passengers otherwise than at separate, and distinct fares for each passenger throughout Victoria:—

BARTON, G. I., Warrnambool.

EDNEY, C., Leongatha.

CUSACK, N. A., Tatura (to operate from Castlemaine).

HARRY, I. V., Alexandra.

HUDSON, J. A., East Malvern.

O'BRIEN, G. F., Melbourne (to operate from Mentone).

PATRIKEOS, A. P., Hawthorn East (to operate from Vermont) (subject to the cancellation of licence at present held by K. A. Spear).

MCDONALD, J., Middle Brighton.

SHEIL, P., Mt. Macedon (subject to the cancellation of licence P.H.1091 at present held by R. W. Sheil).

WOODBIDGE, R. T., Tumberumba.

NOTICE is hereby given that the applications made by the persons named below for licences to operate the commercial goods vehicles on the route or routes, or in the manner set out opposite their names, will be heard at a time and place to be communicated to the parties concerned:—

Name and Address of Applicant; Nature of Application.

BILLS, R. G., Templestowe; 1 commercial goods vehicle (30 cwt.), to operate throughout the State of Victoria in the course of trade as "travelling showman"—circus equipment, &c.

GARRETT, R. L., & SONS, 106 Melville-road, West Brunswick; 1 commercial goods vehicle, to operate throughout the State of Victoria in the course of trade as earth-moving contractors—tractors, earth-moving equipment (power excavators, road rollers, graders, &c.) owned and operated by the applicant for the licence.

GLOVER, J. (on behalf of G. Glover & Sons), Brougham-place, Geelong; 1 commercial goods vehicle (50 cwt.), for the carriage of own goods in the course of trade as wool and skin merchants—(a) within 50 miles radius Geelong, (b) from and to Geelong to and from Mortlake.

GRAY BROS., Upper Ryans Creek, via Benalla; 1 commercial goods vehicle (100 cwt.), to operate throughout the State of Victoria for the carriage of road contracting plant and material.

"NU-INSUL" INSULATION Co., 121-123 Brunswick-street, Fitzroy, N.6; 1 commercial goods vehicle (12 cwt.), to operate throughout the State of Victoria for the purpose of undertaking insulation work in factories, houses, shipyards, &c.—insulating material, tools of trade, &c.

HAVEN, V. V., 16 St. Helen's-road, Hawthorn; 1 commercial goods vehicle (8 cwt.), to operate throughout the State of Victoria in the course of trade as a hawker—drapery.

JARVIS, H. T., Walwa, Victoria; 1 commercial goods vehicle, for the carriage of general goods on behalf of Mates Ltd., Albury, from and to Melbourne to and from Albury.

LOUREY, J., 16 Shadforth-street, Terang; 1 commercial goods vehicle (12 cwt.), for the carriage of goods in the course of trade as undertaker throughout the State of Victoria.

MAWSON, E. B., Cohuna; 1 commercial goods vehicle (100 cwt.), for the carriage of road contracting plant and material throughout the State of Victoria.

MEDDINGS, A. R., Sarsfield P.O., via Bairnsdale; 1 commercial goods vehicle (70 cwt.), to operate throughout the State of Victoria for the carriage of road contracting plant and material.

MILLER, H. R., 37 Garfield-street, Richmond; 3 commercial goods vehicles (70 cwt., 60 cwt., and 160 cwt.), to operate throughout the State of Victoria in the course of trade as travelling showman—merry-go-rounds, side-show equipment, &c.

PEACOCK, H. W., Stanley-street, Wodonga; 1 commercial goods vehicle (190 cwt.), for the carriage of sawn timber from Tawonga to Albury, N.S.W., on behalf of Mates Pty. Ltd.

SPRATLING & LOUDER, 1 Hope-street, West Preston; 1 commercial goods vehicle (70 cwt.), to operate within the limits of the Shire of Upper Yarra as a sanitary contractor.

TURNHAM, W. H., 6 Woodlands-avenue, Pascoe Vale South; 1 commercial goods vehicle (80 cwt.), to operate throughout the State of Victoria for the carriage of own goods in the course of trade as second-hand dealer, such goods to be consigned from nearest or most convenient railhead to Melbourne.

WHITE, E. G., Pty. Ltd., Hotham-road, Sorrento; 1 commercial goods vehicle (80 cwt.), for the carriage of general goods from and to Sorrento to and from Melbourne.

WILKE, A. H., Skipton; 3 commercial goods vehicles (60 cwt., 70 cwt., 75 cwt.), to operate throughout the State of Victoria in the course of trade as boring contractor—boring plant and equipment.

Name and Address; Present Franchise; Licence No.; Expiry Date.

WILSON, R. W., Box 75, Hopetoun; (a) general goods 20 miles radius Hopetoun, (b) furniture 100 miles radius Hopetoun; D.3110; 1st December, 1947.

Notice of any objection should be forwarded to reach the Secretary of the Board not later than Wednesday, 26th November, 1947.

E. V. FIELD,
Secretary.

Exhibition Buildings, Rathdown-street, Carlton, N.3, 11th November, 1947.

Crimes Act 1928, Section 323.
APPROVAL OF SUPERINTENDENT OF
REFORMATORY SCHOOL.

HIS Excellency the Governor of the State of Victoria, by and with the advice of the Executive Council thereof, and pursuant to the provisions of section 323 of the *Crimes Act 1928*, has, by Order made on the 6th day of November, 1947, approved of

The Reverend GABRIEL KELLY
as superintendent of the reformatory school known as the Morning Star Training Farm, Hannan Park, Mornington, during the absence on leave of the Reverend Felix Nette from the 17th October, 1947.

C. W. KINSMAN,
Clerk of the Executive Council.

At the Executive Council Chamber,
Melbourne, the 6th November, 1947.

Audit Act 1928.
CERTIFICATION OF ACCOUNTS.

HIS Excellency the Governor of the State of Victoria, by and with the advice of the Executive Council thereof, has, by Order made on the 6th day of November, 1947, pursuant to the provisions of clause 31 of the General Regulations respecting Public Accounts, authorized the Chief Bookkeeper, Railways Department, to certify Sundry Adjustments Journal Entries in connexion with expenditure accounts of the said Department.

C. W. KINSMAN,
Clerk of the Executive Council.

At the Executive Council Chamber,
Melbourne, the 6th November, 1947.

SEWERAGE AUTHORITIES.

APPOINTMENT OF AUDITORS.

HIS Excellency the Governor of the State of Victoria, by and with the advice of the Executive Council thereof, has, by an Order made on the 6th day of November, 1947, in pursuance of the provisions of the *Sewerage Districts Act 1928* (No. 3772), approved of the appointment of the persons mentioned hereunder, being Auditors holding certificates of competency from the Municipal Auditors' Board under the *Local Government Act 1946*, to audit and report upon the accounts of the Sewerage Authorities set forth opposite their respective names, for the years as shown; at the remuneration shown in the Order payable out of the general fund of the respective Authorities for such audit, including transport and maintenance expenses.

Authority.	Year Ending—	Name of Auditor.
Ballarat ..	31st December, 1948	M. Shackell, 395 Collins-street, Melbourne
Bendigo ..	30th September, 1948	W. A. Draper, Bendigo
Dandenong ..	30th September, 1948	S. B. W. Cooke, 40 Queen-street, Melbourne
Mildura ..	30th September, 1948	W. A. McDonald, 191 Queen-street, Melbourne
Mornington ..	30th September, 1948	S. B. W. Cooke, 40 Queen-street, Melbourne
Benalla ..	31st December, 1948	E. A. Kellam, 14 Queen-street, Melbourne

Authority.	Year Ended—	Name of Auditor.
Ararat ..	30th September, 1947	M. Shackell, 395 Collins-street, Melbourne
Castlemaine ..	30th September, 1947	L. J. Yeo, 331 Collins-street, Melbourne
Dimboola ..	30th September, 1947	M. J. Cohen, 44 Queen-street, Melbourne
Portland ..	30th September, 1947	R. A. Seymour, 191 Queen-street, Melbourne
Shepparton ..	30th September, 1947	D. B. Leigh, 422 Collins-street, Melbourne
Wangaratta ..	30th September, 1947	A. R. Denton, P.O. Box 18, Bright
Warracknabeal	30th September, 1947	F. C. B. Minchin, 395 Collins-street, Melbourne
Warrnambool	30th September, 1947	L. S. Digby, 14 Queen-street, Melbourne
Yarrowonga ..	30th September, 1947	N. R. Macaw, 31 Queen-street, Melbourne

Authority.	Year Ending—	Name of Auditor.
Bairnsdale ..	31st December, 1947	P. Sartori, 450 Collins-street, Melbourne
Colac ..	31st December, 1947	K. H. Vial, 83 William-street, Melbourne
Echuca ..	31st December, 1947	R. G. Ham, Bendigo
Hamilton ..	31st December, 1947	T. H. Green, 77 Wilson-street, Horsham
Horsham ..	31st December, 1947	E. A. Kellam, 14 Queen-street, Melbourne
Kerang ..	31st December, 1947	E. R. Grelis, Williamson-street, Bendigo
Kyabram ..	31st December, 1947	J. J. O'Loughlin, 118 Queen-street, Melbourne
Kyneton ..	31st December, 1947	W. A. Coghlan, 411 Collins-street, Melbourne
Morwell ..	31st December, 1947	R. M. Hatch, 379 Collins-street, Melbourne
Murtoa ..	31st December, 1947	T. H. Green, 77 Wilson-street, Horsham
Nhill ..	31st December, 1947	T. H. Green, 77 Wilson-street, Horsham
Swan Hill ..	31st December, 1947	E. F. Granger, Bendigo
Warragul ..	31st December, 1947	W. A. Betheras, 443 Little Collins-street, Melbourne

C. W. KINSMAN,
Clerk of the Executive Council.

At the Executive Council Chamber,
Melbourne, the 6th November, 1947.

SHIRE OF FERN TREE GULLY.

ORDER DECLARING A PUBLIC HIGHWAY, AND ORDER FOR DEVIATION OF HIGHWAY.

IN pursuance of the powers conferred by sections 521 and 525 of the *Local Government Act 1946*, the Council of the Shire of Fern Tree Gully do hereby order that the land next hereinafter described, which has been acquired by them, shall be a public highway from and after the date of publication of this Order in the *Government Gazette*, viz.:—

All that piece or parcel of land situate, lying, and being in the Parish of Scoresby in the County of Mornington in the State of Victoria, containing by admeasurement 13 perches more or less, and being part of Crown allotment 78 of the said parish, bounded as follows: Commencing at a point distant 1,584 links in a straight line bearing 10 deg. 59 min. and 194 links in a straight line bearing 89 deg. 51 min. from the south-western corner of the said Crown allotment 78; thence for 107 5/10 links in a straight line bearing 157 deg. 24 min. for 66 links in a straight line bearing 67 deg. 35 min. for 36 links in a straight line bearing 68 deg. 1 min. for 41 8/10 links in a straight line bearing 88 deg. 39 min. for 31 links in a straight line bearing 117 deg. 33 min. for 34 6/10 links in a straight line bearing 138 deg. 1 min. for 145 links in a straight line bearing 338 deg. 26 min. for 32 4/10 links in a straight line bearing 202 deg. 37 min. for 67 2/10 links in a straight line bearing 243 deg. 16 min. for 39 links in a straight line bearing 248 deg. 1 min. for 18 1/10 links in a straight line bearing 282 deg. 50 min. and for 60 links in a straight line bearing 306 deg. 21 min. to the point of commencement.

And the Council do hereby declare that the land above described shall, from the date of the said publication in the *Government Gazette*, be a public highway in lieu of the land hereinafter described, that is to say—

All that piece or parcel of land situate, lying, and being in the Parish of Scoresby in the County of Mornington in the State of Victoria, containing by admeasurement 1 rood 11 1/2 perches more or less, being part of a Government road bounded as follows: Commencing at a point distant 1,915 links in a straight line bearing 10 deg. 59 min. from the south-western corner of Crown allotment 78, Parish of Scoresby; thence for 323 links in a straight line bearing 10 deg. 59 min. for 185 1/10 links in a straight line bearing 338 deg. 17 min. for 323 links in a straight line bearing 190 deg. 59 min. and for 185 1/10 links in a straight line bearing 158 deg. 17 min. to the point of commencement.

In witness whereof the President, Councillors, and Ratepayers of the Shire of Fern Tree Gully have caused their common seal to be hereunto affixed, this 9th day of June, 1947—

(SEAL) VIOLET B. LAMBERT, President.
ALLEN C. TYE, Councillor.
CHAS. C. DANCE, Secretary.

The common seal of the Shire of Fern Tree Gully was hereunto affixed, in pursuance of an order of the Council made the 9th day of June, 1947, in the presence of—

(SEAL) CHAS. C. DANCE, Secretary.

Confirmed by the Governor in Council,
6th November, 1947.

C. W. KINSMAN,
Clerk of the Executive Council.

SHIRE OF HEYTESBURY.

ORDER IN COUNCIL.—ROAD DEVIATION.

IN pursuance of the power conferred by sections 521 and 526 of the *Local Government Act 1946*, the Council of the Shire of Heytesbury do hereby order that the lands next hereinafter described shall be a public highway from the date of the publication of this Order in the *Government Gazette*, that is to say—

All that piece of land, being part of Crown allotment 1c of section 11, Parish of Ecklin, County of Heytesbury, commencing at a point at the south-eastern corner of Crown allotment 1f in the section and parish above mentioned; thence by a line bearing south 89 deg. 37 min. east 2,342.5 links; thence by a line bearing south 20 deg. 26 min. east 107 links; thence by a line bearing north 89 deg. 37 min. west 2,380 links; thence by a line bearing north 0 deg. 5 min. east 100 links, home to the point of commencement, containing an area of 2 acres 1 rood 18 perches, or thereabouts.

And the said Council doth hereby declare that the lands above described shall, from the said date of publication in the *Government Gazette*, be a public highway in lieu of the land hereinafter described, that is to say—

All that piece of land, being part of the existing surveyed road, abutting partly on the said Crown allotment 1f to the north and on the said Crown allotment 1c to the north, and abutting partly to the north and east and on Crown allotment 1e of the said section, parish, and county, commencing at a point at the north-western corner of Crown allotment 1f aforesaid; thence by a line bearing north 0 deg. 5 min. east 100 links; thence by a line bearing north 89 deg. 34 min. east 906 links; thence by a line bearing south 86 deg. 44 min. east 1,417 links; thence by a line bearing south 65 deg. 13 min. east 578 links; thence by a line bearing south 20 deg. 26 min. east 424 links; thence by a line bearing north 89 deg. 37 min. west 107 links; thence by a line bearing north 20 deg. 26 min. west 344.1 links; thence by a line bearing north 65 deg. 13 min. west 468 links; thence by a line bearing north 86 deg. 44 min. west 1,395 links; thence by a line bearing south 89 deg. 34 min. west 904 links, home to the point of commencement, containing an area of 3 acres 0 roods 34 9/10 perches, or thereabouts.

Dated the 18th day of July, 1947.

The common seal of the President, Councillors, and Ratepayers of the Shire of Heytesbury was hereunto affixed, this 18th day of July, 1947, in the presence of—

(SEAL) A. T. CURRELL, President.
G. H. WILTSHIRE, Councillor.
LESLIE W. SIMPKIN, Shire Secretary.

Confirmed by the Governor in Council,
6th November, 1947.

C. W. KINSMAN,
Clerk of the Executive Council.

SHIRE OF MINHAMITE.

PETITION UNDER THE DRAINAGE AREAS ACT 1928 (No. 3668).

IN pursuance of the provisions of the *Drainage Areas Act 1928* (No. 3668), section 6, the substance and prayer of the petition presented to His Excellency the Governor in Council, in accordance with section 4 of the said Act, are published, viz.:—

The petitioners purport to be a majority of the owners of at least half the land in the area described in their petition, such area being within the Parishes of Weerangourt and Ardonachie.

The petitioners pray that His Excellency the Governor in Council may be pleased to constitute the said area a drainage area within the meaning of the said Act.

A copy of such petition, together with a plan showing the proposed drainage area and a report by the Chief Engineer of the Public Works Department with regard thereto, has been lodged at the Shire Office, Hawkesdale, and shall be open for inspection for a period of sixty (60) days from the 19th November, 1947, to the 17th January, 1948.

A counter-petition against the proposal may be forwarded to the Minister of Public Works, pursuant to the provisions of section 5 (5) of the said Act, not later than the 14th February, 1948.

T. HAYES,
for Commissioner of Public Works.

Department of Public Works (Local Government Branch), Melbourne.

MELBOURNE AND METROPOLITAN BOARD OF WORKS.

UPPER YARRA YARRA RIVER.

HENLEY-ON-YARRA.

Notice to Boatmen and Others.

BOATMEN and others are hereby notified that permission has been granted to the Melbourne Amateur Regatta Association, in connexion with the Annual Regatta, to row races on the Henley Course on the Upper Yarra on the 22nd November, 1947, and that motor and other boats permitted to be on the river during the day must observe the following Regulations, viz.:—

Boat races must not be obstructed, nor public safety or order endangered.

Every motor boat must have a supply of dry sand, with shovel or scoop, and carry—

- a bucket with rope attached; and
- an approved chemical fire extinguisher.

for fire extinguishing purposes, and no inflammable oil or spirit shall be exposed.

All non-competing boats must be kept off the course during the racing programme.

No boats (except racing boats) will be allowed to land or take up passengers at the boat stagings (south bank), or from the bank along the Henley Reserve except at the landing stage.

Passengers on any boat overcrowded or incompetently managed may be ordered to disembark.

No boat deemed by the River Officer or his Deputy to be too large or deemed to be offensive, dangerous, unsuitable, or unsightly shall remain on the river along the course or adjacent waters.

The direction of the officers in charge of the course must be strictly attended to.

All boats (except racing boats) must move up stream along the right hand (south) bank, and must move down stream along the opposite (north) bank.

No advertisement or objectionable device will be permitted to be shown on any boat.

No fireworks or firearms will be allowed to be discharged from any boat, except where permission of the River Officer or his Deputy has been given.

All motor boats shall hold a permit from the River Officer to enter or remain on that part of the River Yarra between Prince's-bridge and the Punt-road bridge, between the hours of 10 a.m. and 12 midnight on Henley Day.

No motor or other boats will be allowed to ply for hire between Prince's-bridge and Punt-road bridge between the hours of 10 a.m. and 12 midnight on Henley Day except under special permit from the Board.

All motor boats shall be moored in the positions allotted to them by 12.30 p.m., and shall remain moored until the finish of the racing programme.

All motor boats on south bank must moor bow up stream, and all motor boats on north bank must moor bow down stream.

An applicant for permit must apply at the office of the River Officer, 110 Spencer-street, Melbourne, and furnish the name and dimensions of the boat for which a permit is required; also the name and address of the owner, and of the person taking charge of the boat on Henley Day. If the boat is unnamed, some identification number must be affixed to each bow of the boat.

No permit shall be given to a motor boat exceeding a length of 35 feet from stem to stern, or with a beam exceeding 9 feet over all, unless the River Officer shall see fit to do so. It is recommended that row boats be in attendance on large motor boats for transporting passengers, also that a gangway be provided for each motor boat to enable passengers to reach the bank.

No permit shall be given for boats burning other than liquid fuel.

A permit shall not be transferable by the holder or in respect of motor boats.

A limited number of moorings will be available along the Henley Reserve, and early application to the River Officer for same is invited. An applicant must give name and dimensions of boat, and must provide his own mooring ropes. Pegs will be supplied.

Acceptance of a permit shall be a guarantee that its holder and the boat it is issued for will observe the regulations, whether general or special.

Motor boats not moored along the Henley Reserve must use the mooring pegs provided on the north or south side of the river, and must moor at post bearing same number as shown on permit.

Mooring or holding on to the booms or buoys will be strictly forbidden.

After sunset on Henley Day motor boats shall exhibit a red light and go slow in the centre of the river only. Motor boats shall not tow any boat.

On Henley Day the length of oars used by any boat, other than racing boats, between Punt-road bridge and Prince's-bridge, shall not exceed 8 feet.

The use of paddles as a means of propulsion for rowing boats is preferred.

Boats over 25 feet in length or boats with jibbooms or other objectionable projections will not be permitted on the Yarra between Prince's-bridge and Punt-road bridge between the hours of 10 a.m. and 12 midnight on Henley Day.

Rowing boats and canoes shall exhibit a white light after sunset on Henley Day.

All boats must give way to racing boats going up stream to the start of the course.

CHAS. J. W. BRIGGS, Secretary.
C. VIVIAN HORE, Acting River Officer.

110 Spencer-street, Melbourne, C.1.
11th November, 1947.

4 GEORGE VI. No. 4755, SECTION 6.

I HEREBY give notice that, on the 21st October, 1947, I filed an election to administer the following deceased persons' estates, in accordance with section 6 of the *Public Trustee Act 1940*:—

DUDGEON, ROBERT, late of 419 Liverpool-street, Darlinghurst, New South Wales, marine cook, died 21st September, 1936, intestate.

I HEREBY give notice that, on the 29th October, 1947, I filed elections to administer the following deceased persons' estates, in accordance with section 6 of the *Public Trustee Act 1940*:—

CARSWELL, ROBERT, formerly of 23 Haines-street, Mitcham, but late of Mount Royal, Royal Park, quarryman, died 25th April, 1947, intestate.

COOK, GEORGE HENRY, late of Queen Elizabeth Benevolent Home, Ballarat, pensioner, died 6th August, 1947, intestate.

*COOPER, LUCY LOUISE, also known as Lucy Louisa Cooper, formerly of Strathfieldsaye, but late of Mont Park, widow, died 1st July, 1947.

DOWN, NELLIE LAURA ALICE, late of 373 Rae-street, North Fitzroy, married woman, died 27th August, 1947, intestate.

EVANS, FRANCES, late of Mount Royal, Royal Park, pensioner, died 17th July, 1947, intestate.

FLENLEY, VINCENT, late of Victoria-street, Trentham, forestry overseer, died 13th August, 1946, intestate.

GILES, EMILY, late of Benevolent Home, Bendigo, pensioner, died 20th August, 1947, intestate.

*GLEESON, LUCY ELLEN, formerly of Tempy, but late of Broadway, Dunolly, married woman, died 4th September, 1946.

GROVES, ALEXANDER WILLIAM, late of 11B Walkley-place, North Melbourne, watchman, died 19th April, 1947, intestate.

*HANNAH, ALLAN, also known as Allen Hannah, and as Alick Earl, late of A.I.F., soldier, died 20th February, 1942.

HEWSTON, WILLIAM, late of 11 Levers-terrace, Carlton, pensioner, died 18th August, 1947, intestate.

HILL, SARAH ANN, formerly Sarah Ann Connell, formerly of 13 Station-street, Fairfield, but late of 157 Clarendon-street, Thornbury, married woman, died 12th July, 1943, intestate.

*KENDALL, ERIC ARTHUR, late of A.I.F., soldier, became missing 20th February, 1942, and is presumed dead.

MARRIOTT, EDMUND, late of 128 Park-street, St. Kilda, military pensioner, died 30th July, 1947, intestate.

OLNEY, RALPH, late of 27 Comas-grove, Thornbury, gentleman, died 11th March, 1947, intestate.

*ROBINSON, ROBERT CECIL, formerly of 492 Murray-road, West Preston, but late of Steele's Creek, motor driver, died 14th June, 1947.

* According to the provisions of the will.

I HEREBY give notice that, on the 31st October, 1947, I filed elections to administer the following deceased persons' estates, in accordance with section 6 of the *Public Trustee Act 1940*:—

COOPER, JAMES, also known as James Taylor, late of Corryong, labourer, died 24th January, 1947, intestate.

*MCKENZIE, SHERMAN GRANT, formerly of 53 Brighton-road, St. Kilda, late of 160 High-street, Ararat, gentleman, died 24th July, 1947.

* According to the provisions of the will.

C. J. GARDNER,
Public Trustee.

412 Collins-street, Melbourne, C.1, 5th November, 1947.

NOTICE.

ADMINISTRATION of the estate of each of the under-mentioned deceased persons has been granted to me, and creditors, next of kin, and all others having claims against the estate of any of the persons so mentioned are required to send particulars of their claims to the Public Trustee, No. 412 Collins-street, Melbourne, on or before the 15th January, 1948, or they will be excluded from the distribution of the estate when the assets are being distributed:—

CARSWELL, ROBERT, formerly of 23 Haines-street, Mitcham, but late of Mount Royal, Royal Park, quarryman, died 25th April, 1947, intestate.

COOK, GEORGE HENRY, late of Queen Elizabeth Benevolent Home, Ballarat, pensioner, died 6th August, 1947, intestate.

COOPER, JAMES, also known as James Taylor, late of Corryong, labourer, died 24th January, 1947, intestate.

*COOPER, LUCY LOUISE, also known as Lucy Louisa Cooper, formerly of Strathfieldsaye, but late of Mont Park, widow, died 1st July, 1947.

DOWN, NELLIE LAURA ALICE, late of 373 Rae-street, North Fitzroy, married woman, died 27th August, 1947, intestate.

DUDGEON, ROBERT, late of 419 Liverpool-street, Darlinghurst, New South Wales, marine cook, died 21st September, 1936, intestate.

EVANS, FRANCES, late of Mount Royal, Royal Park, pensioner, died 17th July, 1947, intestate.

FLENLEY, VINCENT, late of Victoria-street, Trentham, forestry overseer, died 13th August, 1946, intestate.

GILES, EMILY, late of Benevolent Home, Bendigo, pensioner, died 20th August, 1947, intestate.

*GLEESON, LUCY ELLEN, formerly of Tempy, but late of Broadway, Dunolly, married woman, died 4th September, 1946.

GROVES, ALEXANDER WILLIAM, late of 11b Walkley-place, North Melbourne, watchman, died 19th April, 1947, intestate.

*HANNAH, ALLAN, also known as Allen Hannah, and as Alick Earl, late of A.I.F., soldier, died 20th February, 1942.

HEWSTON, WILLIAM, late of 11 Ievers-terrace, Carlton, pensioner, died 18th August, 1947, intestate.

HILL, SARAH ANN, formerly Sarah Ann Connell, formerly of 18 Station-street, Fairfield, but late of 157 Clarendon-street, Thornbury, married woman, died 12th July, 1943, intestate.

†JOHNSON, JOHN GULL BICKFORD, late of Koo-wee-rup, farmer, died 25th March, 1947.

*KENDALL, ERIC ARTHUR, late of A.I.F., soldier, became missing 20th February, 1942, and is presumed dead.

MARRIOTT, EDMUND, late of 128 Park-street, St. Kilda, military pensioner, died 30th July, 1947, intestate.

†MORROW, ALICE MARY, late of 41 Highfield-road, Canterbury, widow, died 4th August, 1947.

*MCKENZIE, SHERMAN GRANT, formerly of 53 Brighton-road, St. Kilda, but late of 160 High-street, Ararat, gentleman, died 24th July, 1947.

OLNEY, RALPH, late of 27 Comas-grove, Thornbury, gentleman, died 11th March, 1947, intestate.

*ROBINSON, ROBERT CECIL, formerly of 492 Murray-road, West Preston, but late of Steele's Creek, motor driver, died 14th June, 1947.

†RYAN, ARTHUR JOHN, formerly of 132 Rathdown-street, Carlton, but late of 38 Loch-street, St. Kilda, clerk, died 4th August, 1947.

†TOGNINI, WILLIAM, late of 34 Grey-street, East Melbourne, gentleman, died 2nd August, 1947.

TUCKER, DOROTHEA CECILY, late of 86 Princess-street, Kew, retired school teacher, died 26th August, 1947, intestate.

* According to the provisions of the will.

† With the will annexed.

C. J. GARDNER,
Public Trustee.

Melbourne, 5th November, 1947.

Farmers Debts Adjustment Act 1935.

CANCELLATION OF STAY ORDERS.

NOTIFICATION is hereby given that the Stay Orders issued to the under-mentioned farmers have been cancelled by the Farmers' Debts Adjustment Board, such cancellation to take effect on Wednesday, 12th November, 1947:—

No. of Stay Order; Name; Address.

- 4213; Briggs, Clement Ewin; Cudgewa.
542; Pendlebury, Edward Joseph; Ultima.
145; O'Sullivan, William, deceased; Knowsley.
1646; Newitt, James Ernest; Brim.
4115; Burton, Thomas Montague; Carron.
4163; Newell, estate of Walter James, deceased; Berri-willock.
1347; Pill, Edwin Henry; Cottle's Bridge.
2817; Walker, Conn McGillivray and Walter John; Strathbogie, via Euroa.
2818; Walker, estate of James, deceased (James Robert Walker and Conn McGillivray as legal personal representatives); Strathbogie, via Euroa.
2197; Chenhall, Edric (legal personal representative of John Eghert Chenhall); Jack River.
1535; Chenhall, Edric; Jack River.
320; Tepper, Alfred Oscar; Box 106, Minyip.

W. J. EVANS, Deputy Secretary,
Farmers' Debts Adjustment Board.

11th November, 1947.

CONTRACTS ACCEPTED.—(Series 1947-48.)

VICTORIAN RAILWAYS.

75. Mobile crane, petrol, electric, at £3,910 each (Contract 56340).—Horrocks, Roxburgh Pty. Ltd. 76. Sawed red gum timber, at rates (Contract 56449).—F. C. Walker. 77. Bread and/or bread rolls, at rates (Contract 56482).—Owens and Dixon Pty. Ltd. 78. Wooden telegraph poles, at rates (Contract 56611).—P. J. McMahon. 79. Sewerage (house connexions) to engine shed at Ararat for £715 9s. (Contract 56612).—F. H. Davis. 80. Condensate make-up pump, motor, and starter, at rates (Contract 56621).—Harland Engineering (Aust.) Pty. Ltd. 81. Cast steel locomotive cylinders, at £350 each (Contract 56628).—The Steel Co. of Aust. Pty. Ltd. 82. Aerial survey of parts of railway property, at rates (Contract 56642).—Brown and Dureau Ltd. 83. Wooden telegraph poles, at rates (Contract 56672).—G. R. Lee.

By order of the Victorian Railways Commissioners,
BURT KELLY, Secretary. 7.11.47.

ORDER IN COUNCIL.—(Series 1946-47.)

STATE RIVERS AND WATER SUPPLY COMMISSION.
Stores Suspense Account—

2603. Supply f.o.r. Melbourne of 12 30 in. by 8 ft., 6 30 in. by 8 ft., and 30 24 in. by 4 ft. class X reinforced concrete pipes, with plain ends, £1,043 14s.—Hume Pipe Co.

Approved by the Governor in Council, 20th May, 1947.—
C. W. KINSMAN, Clerk of the Executive Council.

ORDERS IN COUNCIL.—(Series 1947-48.)

STATE RIVERS AND WATER SUPPLY COMMISSION.
Water Supply Works Depreciation Fund—

1243. Supply f.o.r. Melbourne of windmills and equipment to eleven bores specified, and transporting such equipment to site of works and carrying out repairs required to place bores in working condition, £1,729 14s. 2d.—Southern Cross Windmills and Engines Pty. Ltd.

Approved by the Governor in Council, 26th August, 1947.
—C. W. KINSMAN, Clerk of the Executive Council.

Loan—

1244. Purchase of house and land known as 7 Edward-street, Horsham, £1,300.—Sawyer and Devlin.

Approved by the Governor in Council, 9th September, 1947.—C. W. KINSMAN, Clerk of the Executive Council.

Stores Suspense Account—

1245. Supply of 100 tons $\frac{3}{4}$ in. R.M. reinforcement steel, £1,435 12s. 6d.—Broken Hill Proprietary Co. Ltd.

Approved by the Governor in Council, 7th October, 1947.
—C. W. KINSMAN, Clerk of the Executive Council.

Loan—

1246. Supply f.o.r. West Footscray of 36 in. cast-iron pipes and special fittings as specified, £4,558 8s.—Graham Campbell Ferrum Co. Pty. Ltd.

Approved by the Governor in Council, 21st October, 1947.
—C. W. KINSMAN, Clerk of the Executive Council.

LIBRARIES ACTS.

At the Executive Council Chamber, Melbourne, the sixth day of November, 1947.

PRESENT:

His Excellency the Governor of Victoria.
Mr. Clarey | Mr. Hayes.

ORDER AUTHORIZING THE TRUSTEES OF THE YACKANDANDAH ATHENAEUM TO TRANSFER CERTAIN LAND TO THE MUNICIPALITY OF YACKANDANDAH.

WHEREAS all that piece of land described hereunder, being vested in trustees in trust that the same may be used as a site for a free library and reading room at Yackandandah, is no longer required for such purposes; And whereas the trustees for the time being of such land, and the Council of the Municipality of Yackandandah, within the municipal district of which the said land is situate, have presented a petition in writing in accordance with the provisions of the *Libraries (Amendment) Act 1933* to the Governor in Council praying that authority be granted to such trustees to convey the said piece of land to the said municipality; And whereas there is no lessee, mortgagee, or other person holding any interest in or right over such land: Now therefore, in pursuance of the

powers conferred by the said Act, His Excellency the Governor of the State of Victoria, by and with the advice of the Executive Council thereof, doth hereby authorize the said trustees for the time being of such land, notwithstanding any trusts, conditions, restrictions, or limitations contained in any deed of grant or document of title concerning such land to convey the same to the municipality aforesaid.

THE LAND HEREINBEFORE REFERRED TO.

All that piece or parcel of land in the State of Victoria, situate in a County formerly unnamed, now called Bogong, Parish of Yackandandah, being a portion of allotment 21, section 2, Township of Yackandandah: Commencing at a point on the southern boundary line of said allotment 27 ft. 6 in. distant from the south-west angle of said allotment; bounded on the south of High-street bearing east 5 deg. north 38 ft. 6 in., on the east by allotment 20 bearing north 5 deg. west 165 feet, on the north by part of allotment 4 bearing west 5 deg. south 38 ft. 6 in., and on the west by other part of said allotment 21 bearing south 5 deg. east 165 feet to the commencing point, reserving for the use of the owners and occupiers of the other portion of said allotment 21 for ever hereafter the free use, ingress, egress, and regress of a right-of-way 7 ft. 6 in. in width by 165 feet in depth over and upon the western portion of the said piece of land hereby conveyed.

And the Honorable William Slater, His Majesty's Chief Secretary for the State of Victoria, shall give the necessary directions herein accordingly.

C. W. KINSMAN,
Clerk of the Executive Council.

CLOSER SETTLEMENT ACT 1938.

At the Executive Council Chamber, Melbourne, the sixth day of November, 1947.

PRESENT:

His Excellency the Governor of Victoria.
Mr. Clarey | Mr. Hayes.

RESUMPTION FOR RAILWAY PURPOSES.—PARISHES OF SEYMOUR AND TALLAROOK.—ORDER AMENDED.

HIS Excellency the Governor of the State of Victoria, by and with the advice of the Executive Council thereof, and in pursuance of the provisions of the *Closer Settlement Act 1938* and all other powers him enabling in that behalf, doth hereby amend the Order made on the seventeenth day of September, 1946, and published in the *Government Gazette* of the eighteenth day of September, 1946, page 2896, resuming for Railway purposes certain lands in the Parishes of Seymour and Tallarook, by deleting the Schedule thereto, and in lieu thereof substituting the Schedule following, that is to say:—

83 acres 3 roods 26 perches, Parishes of Seymour and Tallarook, County of Anglesey, in the two separate portions hereinafter described:—

- (1) 63 acres and 18 perches, Parish of Seymour, being part of Crown allotment 7, section W: Commencing at the south-western angle of allotment 6A; bounded thence by that allotment bearing N. 72 deg. 2 min. E. 1,319 8/10 links, by a line bearing S. 15 deg. 35 min. W. 6,046 5/10 links, by a road bearing S. 71 deg. 59 min. W. 340 1/10 links, by lines bearing respectively N. 43 deg. 47 min. E. 176 3/10 links, N. 15 deg. 35 min. E. 309 9/10 links, and S. 71 deg. 57 min. W. 1,181 8/10 links; and thence by a road bearing N. 23 deg. 17 min. E. 626 5/10 links, and N. 15 deg. 35 min. E. 5,074 links to the point of commencement.
- (2) 20 acres 3 roods 8 perches, Parish of Tallarook, being part of Crown allotment 47, section 1: Commencing at the north-western angle of the said allotment; bounded thence by a road bearing S 89 deg. 49 min. E. 1,144 5/10 links; by a line bearing S. 15 deg. 35 min. W. 1,888 links; by allotment 47A bearing N. 89 deg. 49 min. W. 1,141 1/10 links; and thence by a road bearing N. 15 deg. 29 min. E. 1,887 links to the point of commencement.—(335/12.)

And the Honorable Leslie William Galvin, His Majesty's Commissioner of Crown Lands and Survey for the State of Victoria, shall give the necessary directions herein accordingly.

C. W. KINSMAN,
Clerk of the Executive Council.

TOWN OF ARARAT WATER SUPPLY DISTRICT.

At the Executive Council Chamber, Melbourne, the sixth day of November, 1947.

PRESENT:

His Excellency the Governor of Victoria.
Mr. Clarey | Mr. Hayes.

AMENDMENT OF ORDER.

UNDER the powers conferred by the Water Acts and all other powers enabling him in that behalf, His Excellency the Governor of the State of Victoria, by and with the advice of the Executive Council of the said State, doth hereby amend, as follows, the Order in Council made on the 15th day of January, 1946, and published in the *Government Gazette* dated 23rd January, 1946, fixing the limit of the overdraft to be obtained by the Council of the Town of Ararat.

For the expression "at an amount not to exceed at any one time the sum of One thousand pounds (£1,000)" there shall be substituted the expression "at an amount not to exceed at any one time the sum of Three thousand pounds (£3,000)."

And the Honorable Leslie William Galvin, His Majesty's Minister of Water Supply for the State of Victoria, shall give the necessary directions herein accordingly.

C. W. KINSMAN,
Clerk of the Executive Council.

COUNTRY ROADS BOARD.

At the Executive Council Chamber, Melbourne, the sixth day of November, 1947.

PRESENT:

His Excellency the Governor of Victoria.
Mr. Clarey | Mr. Hayes.

ORDER APPROVING OF A NEW ROAD IN THE SHIRE OF RIPON.

WHEREAS the Country Roads Board constituted under the *Country Roads Act 1928* (No. 3662) and section 4 of the *Country Roads Act 1936* (No. 4458) has represented to His Excellency the Governor in Council that it appears to it desirable that the new Raglan-Mount Cole road in the Shire of Ripon should be made by the said Board: And whereas the said Board in accordance with the requirements of section 19 of the said cited Act has caused to be prepared a map plan and estimate showing the points between which and on and through what land the said new road is proposed to be made and the cost of acquiring the land and constructing the said new road: And whereas on an inspection of the said map and plan and a consideration of the said estimate His Excellency the Governor in Council is satisfied that there are funds legally available for acquiring the land and constructing the said new road: Now therefore be it known by this present Order that His Excellency the Governor of the State of Victoria with the advice of the Executive Council thereof doth hereby approve of the said road being made, that is to say:—

All that piece of land in the Parish of Raglan West, the boundaries of which are as follow:—Commencing at the southern angle of allotment 14A, section A, of the said parish; thence by lines bearing respectively 316 deg. 38 min. 718 ft. 10 in., 107 deg. 45 min. 78 ft. 10½ in., 136 deg. 28 min. 649 ft. 5 in., 133 deg. 35 min. 456 ft. 5 in., 119 deg. 51 min. 162 ft. 11 in., 106 deg. 7 min. 326 ft. 8½ in., 144 deg. 26 min. 376 ft. 1½ in., 123 deg. 37 min. 470 ft. 6 in., 119 deg. 19 min. 145 ft. 11 in., 115 deg. 2 min. 506 ft. 8 in., 108 deg. 11 min. 583 ft. 6 in., 85 deg. 44 min. 172 ft. 7½ in., 63 deg. 18 min. 339 ft. 10½ in., 118 deg. 4 min. 744 ft. 10 in., 147 deg. 22 min. 441 ft. 8 in., 134 deg. 34 min. 555 ft. 9 in., 122 deg. 37 min. 2,847 ft. 5 in., 116 deg. 50 min. 219 ft. 3½ in., 90 deg. 0 min. 993 ft. 11 in., 256 deg. 57 min. 630 ft. 4½ in., 276 deg. 17 min. 308 ft. 10½ in., 294 deg. 42 min. 260 feet, 302 deg. 37 min. 3,039 feet, 314 deg. 34 min. 365 ft. 10 in., 326 deg. 31 min. 424 feet, 312 deg. 32 min. 214 ft. 8 in., 298 deg. 34 min. 550 ft. 8 in., 270 deg. 56 min. 250 ft. 8½ in., 243 deg. 18 min. 284 ft. 5½ in., 288 deg. 11 min.

708 ft. 1 in., 295 deg. 2 min. 588 ft. 9 in., 303 deg. 37 min. 654 ft. 4 in., 319 deg. 30 min. 360 ft. 6 in., 286 deg. 7 min. 300 ft. 0 1/2 in., 312 deg. 4 min. 560 ft. 4 in., and 46 deg. 11 min. 40 ft. 11 in., to the point of commencement—which said piece of land is particularly delineated and shown coloured red, yellow, and blue, on survey plan numbered 4885, lodged in the office of the Country Roads Board.

JUMBUK.—Site for a Timber Reserve, 213 acres 3 roods 8 perches, Parish of Jumbuk, County of Buln Buln, as indicated by hachure on plan hereunder.—(J.49^(s)) (H.019004, H.019003).

And the Honorable Thomas Hayes, for and on behalf of His Majesty's Commissioner of Public Works for the State of Victoria, shall give the necessary directions herein accordingly.

C. W. KINSMAN,
Clerk of the Executive Council.

DEPARTMENT OF LANDS AND SURVEY.

At the Executive Council Chamber, Melbourne, the sixth day of November, 1947.

PRESENT:

His Excellency the Governor of Victoria.
Mr. Clarey | Mr. Hayes.

LANDS TEMPORARILY RESERVED FROM SALE.

HIS Excellency the Governor of the State of Victoria, by and with the advice of the Executive Council thereof, doth hereby, in pursuance of the provisions of the Land Act 1928, reserve, temporarily, and also except from occupation for mining purposes under any miner's right, the lands hereinafter described:—

CARWARP.—Site for Public Recreation, 15 acres, Parish of Carwarp, County of Karkaroc, as indicated by hachure on plan hereunder.—(C.473^(s)) (Rs.3288).

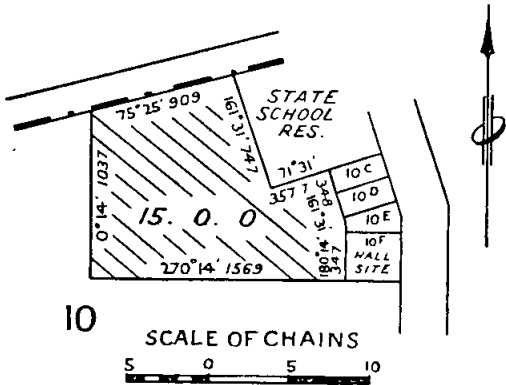

KOO-WEE-RUP.—Site for Public Recreation, in addition to and adjoining the site temporarily reserved therefor by Order in Council of the 22nd July, 1908, 2 acres 0 roods 28 perches, Parish of Koo-wee-rup, County of Mornington, as indicated by hachure on plan hereunder.—(K.118^(s)) (Rs.6052).

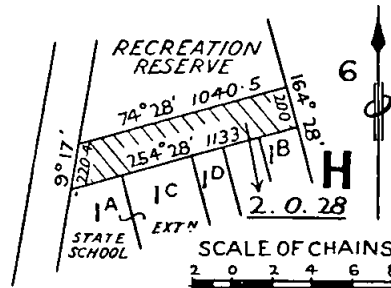

GORAE.—Site for Public Recreation, 2 roods, Parish of Gorae, County of Normanby, as indicated by hachure on plan hereunder.—(G.210⁽⁴⁾) (Rs.6065).

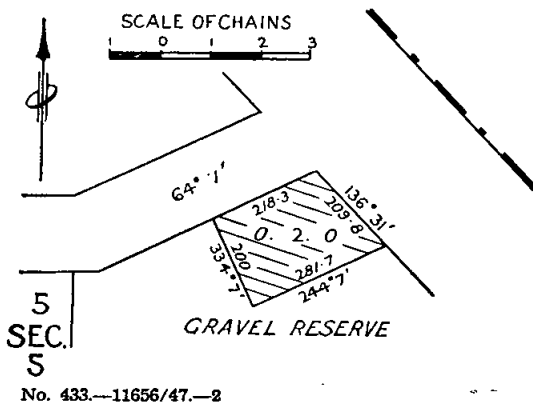

MARYBOROUGH.—Site for Government Buildings, 34 perches, Town of Maryborough, Parish of Maryborough, County of Talbot, as indicated by hachure on plan hereunder.—(M.66^(s)) (Rs.6050).

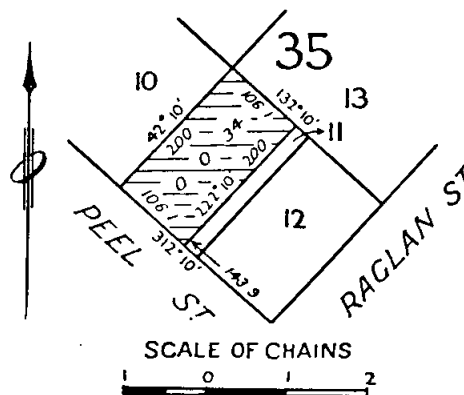

WARRANTYTE NORTH.—Site for Public purposes, 2 acres, more or less, Township of Warrandyte North, Parish of Nillumbik, County of Evelyn, as indicated by hachure on plan hereunder.—(W.25(4) (Rs.6062).

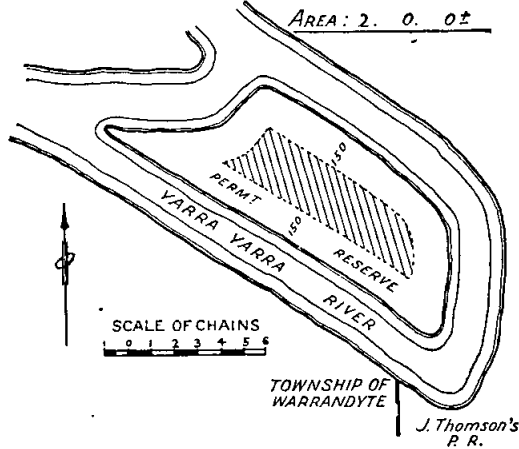

And the Honorable Leslie William Galvin, His Majesty's Commissioner of Crown Lands and Survey for the State of Victoria, shall give the necessary directions herein accordingly.

C. W. KINSMAN,
Clerk of the Executive Council.

DEPARTMENT OF LANDS AND SURVEY.

At the Executive Council Chamber, Melbourne, the sixth day of November, 1947.

PRESENT:
His Excellency the Governor of Victoria.
Mr. Clarey | Mr. Hayes.

REVOCATION OF PERMANENT RESERVATIONS OF LANDS, ETC., AT NEWSTEAD AND MARYBOROUGH.

HIS Excellency the Governor of the State of Victoria, by and with the advice of the Executive Council thereof, doth hereby:—

- (a) In pursuance of section 2 of the Land Act 1941, revoke the Order in Council of the 28th September, 1863, permanently reserving various sites for the purpose of Common Schools, so far only as regards that portion of the site reserved in the Town of Newstead containing 5 3/10 perches indicated by hachure on plan hereunder.—(N.39(1) (C.90794, C.64125).

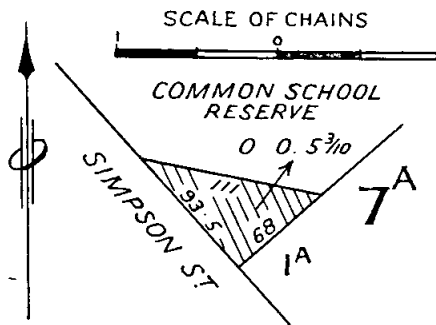

- (b) in pursuance of the provisions of the Land Act 1928, revoke the Order in Council of the 27th July, 1885, excepting from occupation for mining purposes, or for residence or business under any miner's right or business licence, and withholding from sale leasing and licensing 58 acres, more or less, of land in the Parish of Maryborough, municipal district of Maryborough

(revoked as to parts by various Orders), so far only as regards the portion containing 7 acres, more or less, indicated by hachure in plan hereunder.—(M.66(11) (W.50282).

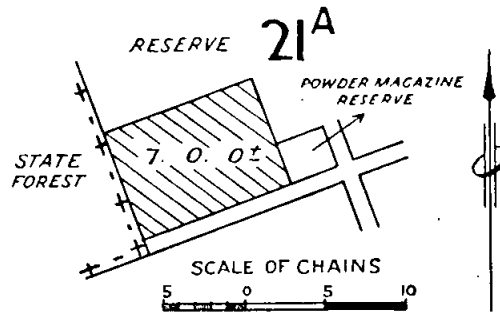

And the Honorable Leslie William Galvin, His Majesty's Commissioner of Crown Lands and Survey for the State of Victoria, shall give the necessary directions herein accordingly.

C. W. KINSMAN,
Clerk of the Executive Council.

DEPARTMENT OF LANDS AND SURVEY.

At the Executive Council Chamber, Melbourne, the sixth day of November, 1947.

PRESENT:
His Excellency the Governor of Victoria.
Mr. Clarey | Mr. Hayes.

UNUSED AND UNMADE ROADS CLOSED.

HIS Excellency the Governor of the State of Victoria, by and with the advice of the Executive Council thereof, doth hereby direct that, in pursuance of the provisions of section 304 of the Land Act 1928 (No. 3709), as amended by section 10 of the Land Act 1933, the unused and unmade roads referred to hereunder be closed, viz.:—

Parish of Berrimal, County of Gladstone, being the road between allotments 16, 19 and allotments 15, 20, section C, and the road between allotment 24 and allotment 22, section C.—(B.570A(4) (C.85192).

Parish of Dousta Galla, County of Bourke, being the road between allotment 2, section A, and the reserve for Public Recreation.—(D.85(6) (C.70374).

Town of Dunolly, Parish of Dunolly, County of Gladstone, being the road between allotment 4 and allotment 5, section C.—(D.124(8) (C.87361).

Parish of Wurruk Wurruk, County of Tanjil, being the road between allotment 6 and allotment 7, section A.—(W.225(8) (H.018483).

And the Honorable Leslie William Galvin, His Majesty's Commissioner of Crown Lands and Survey for the State of Victoria, shall give the necessary directions herein accordingly.

C. W. KINSMAN,
Clerk of the Executive Council.

DEPARTMENT OF LANDS AND SURVEY.

At the Executive Council Chamber, Melbourne, the sixth day of November, 1947.

PRESENT:
His Excellency the Governor of Victoria.
Mr. Clarey | Mr. Hayes.

REVOCATION OF TEMPORARY RESERVATIONS OF LANDS BY ORDERS IN COUNCIL.

HIS Excellency the Governor of the State of Victoria, by and with the advice of the Executive Council thereof, doth hereby, in pursuance of the provisions of the Land Act 1928, revoke the temporary reservations of the lands by Orders in Council hereinafter referred to, viz.:—

MARYBOROUGH.—Order in Council of 14th January, 1901, of 6 acres 2 roods 34 6/10 perches of land in the Municipal District of Maryborough as a site for Rubbish Depot.—(Rs.6004.)

SWANWATER.—Order in Council of 5th July, 1875, of 5 acres of land in the Parish of Swanwater as a site for State School purposes, and withholding from sale, leasing, and licensing.—(C.73792.)

And the Honorable Leslie William Galvin, His Majesty's Commissioner of Crown Lands and Survey for the State of Victoria, shall give the necessary directions herein accordingly.

C. W. KINSMAN,
Clerk of the Executive Council.

APPROACHING LAND SALES.

SALES of Crown lands, in fee-simple, will be held at the under-mentioned places and dates, viz:—

	No. of Gazette
Ararat.—Thursday, 13th November, 1947 ..	419
Bendigo.—Wednesday, 26th November, 1947 ..	427
Castlemaine.—Wednesday, 10th December, 1947 ..	433
Daylesford.—Wednesday, 10th December, 1947 ..	433
Rushworth.—Monday, 15th December, 1947 ..	433
Stanhope.—Thursday, 13th November, 1947 ..	424

SALE OF RIGHT TO LEASE.

Melbourne.—Wednesday, 5th November, 1947.. 407

SALES BY AUCTION.

The lands will be sold in fee-simple, and subject to the covenants, conditions, exceptions, and reservations directed by the Governor in Council by an Order in Council dated the 5th August, 1930, and published in the *Government Gazette* of the 8th August, 1930, varied as herein.

A deposit of at least twelve and a half per centum of the price at which each lot is sold must be paid by the purchaser at the time of sale, and all such payments shall be made in bank notes or cheques approved by the officer conducting the sale, and the residue of such price will be payable in equal instalments, in accordance with the scale hereunder, on the last day of each successive period of six months from the time of sale, or, if the purchaser choose, at any earlier time or times; such residue of the price shall bear interest at the rate of £5 per centum per annum, to be computed between the time of sale and the time when payment of such residue or instalment of such residue is made. If the residue of the price be paid within thirty days after the time of the sale no interest will be payable thereon.

The Governor in Council may allow a transfer of the purchaser's interest to an approved person at any time before the final payment of the purchase money is made. The fee for transfer shall be One pound, and such transfer will be subject to payment of stamp duty.

SCALE OF PAYMENTS OF RESIDUE.

£20 and under, 6 instalments.
Over £20, and not exceeding £50, 8 instalments.
Over £50, and not exceeding £100, 10 instalments.
Over £100, and not exceeding £200, 12 instalments.
Over £200, and not exceeding £300, 14 instalments.
Over £300, and not exceeding £400, 16 instalments.
Over £400, and not exceeding £500, 18 instalments.
Over £500, 20 instalments.

FEES, ETC.

The fees payable for Crown grant and assurance (One halfpenny for each pound of purchase price) must be paid with the balance of purchase money. The following is the scale:—

50 acres and under, £1 10s.
Over 50 acres, £2.
Where the purchase money does not exceed £5, the grant fee is £1.

Valuations of improvements (if not purchased by the owner thereof) and charges for survey must also be paid at the time of sale.

L. W. GALVIN,
Commissioner of Crown Lands and Survey.
Office of Lands and Survey,
Melbourne, 10th November, 1947.

CASTLEMAINE.—Sale (No. 10634) of Crown lands, in fee-simple, by auction, will be held at the COURT HOUSE, CASTLEMAINE, on WEDNESDAY, the 10th DECEMBER, 1947, at NINE o'clock a.m. To be conducted by H. J. HENKEL, Land Officer, Bendigo. Auctioneer: C. V. PITT.

CASTLEMAINE, PARISH OF CASTLEMAINE, COUNTY OF TALBOT.

Fronting Britton-street.

Upset price £15 the lot. Charge for survey £3 2s. 6d.

Lot 1. Area 1 rood (subject to survey), allotment 18, section 140.

Fronting Bowden-street.

Upset price £20 the lot. Charge for survey £3 2s. 6d.

Lot 2. Area 1r. 7 2/10p., allotment 19, section 110. One month allowed for removal of improvements.

Fronting Farnsworth-street.

Upset price £40 the lot. Charge for survey £3 2s. 6d.

Lot 3. Area 3r. 4 3/10p., allotment 3, section 108A. Valuation of improvements £300 (Baptist Church, Castlemaine).

MALDON, PARISH OF MALDON, COUNTY OF TALBOT.

Frontages to Reef and Evans streets.

Upset price £5 the lot. Charge for survey £3 2s. 6d.

Lot 4. Area 1r. 1 7/10p., allotment 10A, section 4c. Valuation of improvements £325 (L. R. Cox).

GREEN GULLY, PARISH OF STRANGWAYS, COUNTY OF TALBOT.

In the South of the Township.

Upset price £5 the lot. Charge for survey £4 4s.

Lot 5. Area 2a. 1r. 25 8/10p., allotment 3B, section A.

PARISH OF CASTLEMAINE, COUNTY OF TALBOT.

In the North of the Parish.

Upset price £6 the lot. Charge for survey £3 2s. 6d.

Lot 6. Area 1a. 0r. 15 8/10p., allotment 11A, section A1. Valuation of improvements £308 (D. T. Norris).

In the South of the Parish.

Upset price £20 the lot. Charge for survey £6 7s. 6d.

Lot 7. Area 4a. 3r. (subject to survey), allotments 18 and 23, section 7. Valuation of improvements £20 (Harriet M. Sheehan).

In the Mid-south of the Parish.

Upset price £8 the lot. Charge for survey £3 2s. 6d.

Lot 8. Area 2a. 1r. 29p., allotment 13, section 8a. Valuation of improvements £550 (K. Sheen).

PARISH OF CHEWTON, COUNTY OF TALBOT.

Fronting the Calder Highway.

Upset price £4 the lot. Charge for survey £3 2s. 6d.

Lot 9. Area 2 perches (subject to survey), allotment 6A, section F. One month allowed for removal of improvements.

PARISH OF WALMER, COUNTY OF TALBOT.

In the East of the Parish.

Upset price £1 the lot. Charge for survey £2 2s.

Lot 10. Area 1 acre (subject to survey), allotment 5c, section 9. One month allowed for removal of improvements.

Upset price £1 per acre. Charge for survey £3 15s.

Lot 11. Area 9 acres (subject to survey), allotment 30n, section 7.

PARISH OF TARRENGOWER, COUNTY OF TALBOT.

In the North of the Parish, near Sandy Creek.

Upset price £5 the lot. Charge for survey £3 2s. 6d.

Lot 12. Area 3r. 29p., allotment 2p, section 6. Valuation of improvements £5 (William Pitts).

DAYLESFORD.—Sale (No. 10635) of Crown lands, in fee-simple, by auction will be held at the COURT HOUSE, DAYLESFORD, on WEDNESDAY, the 10th DECEMBER, 1947, at half-past ELEVEN o'clock a.m. To be conducted by H. J. HENKEL, Land Officer, Bendigo. Auctioneers: GREENFIELDS PTY. LTD., Ballarat. Local agents: E. E. LEGGO & CO., Daylesford.

HEPBURN, PARISH OF WOMBAT, COUNTY OF TALBOT.
In the South of the Township.

Upset price £10 the lot. Charge for survey £3 2s. 6d.
Lot 1. Area 3r. 12p. (subject to survey).

DAYLESFORD, PARISH OF WOMBAT, COUNTY OF TALBOT.
Fronting Albert-lane.

Upset price £15 per lot. Charge for survey £3 2s. 6d.
Lot 2. Area 1r. 8p. (subject to survey), allotment 7, section 21.
Lot 3. Area 1r. 24p. (subject to survey), allotment 8, section 21.
Lot 4. Area 1r. 8p. (subject to survey), allotment 9, section 21.
Upset price £17 10s. the lot. Charge for survey £3 2s. 6d.
Lot 5. Area 1r. 8p. (subject to survey), allotment 10, section 21.

North of the Town.

Upset price £25 the lot. Charge for survey £1.
Lot 6. Area 2r. 10p., allotment 11, section 2d. One month allowed to remove fencing.

TOWNSHIP NEAR TIPPERARY SPRINGS, PARISH OF WOMBAT, COUNTY OF TALBOT.

In the East of the Township.

Upset price £10 the lot. Charge for survey £5 5s.
Lot 7. Area 1r. 10p. (subject to survey), allotment 13, section 25A.
Upset price £12 10s. per lot. Charge for survey £5 5s.
Lot 8. Area 1r. 20p. (subject to survey), allotment 14, section 25A.
Lot 9. Area 1r. 24p. (subject to survey), allotment 15, section 25A.
Upset price £10 the lot. Charge for survey £5 5s.
Lot 10. Area 1r. 24p. (subject to survey), allotment 16, section 25A.
Upset price £15 the lot. Charge for survey £7 7s.
Lot 11. Area 2a. 2r. (subject to survey), allotment 17, section 25A.

PARISH OF WOMBAT, COUNTY OF TALBOT.

At Blanket Flat, with frontage to Ballarat to Daylesford road.

Upset price £7 10s. the lot. Charge for survey £3 2s. 6d.
Lot 12. Area 2 roods, allotment 10, section 3A.

At Eganstown.

Upset price £7 10s. the lot. Charge for survey £3 15s.
Lot 13. Area 7a. 1r. 35p., allotment 51, section 3A. Subject to race easements.

PARISH OF YANDOIT, COUNTY OF TALBOT.

Near the Centre of the Parish, East of Jim Crow Creek.

Upset price £3 the lot. Charge for plan £1.

Lot 14. Area 2a. 3r. 5p., allotment 15A, section 2. One month allowed for removal of improvements.

Upset price £5 the lot. Charge for survey £4 5s.

Lot 15. Area 4a. 2r. 29p., allotment 15c, section 2.

RUSHWORTH.—Sale (No. 10636) of Crown lands, in fee-simple, by auction, will be held at the COURT HOUSE, RUSHWORTH, on MONDAY, the 15th DECEMBER, 1947, at half-past ONE o'clock p.m. To be conducted by H. RAMSAY, Land Officer, Seymour.

RUSHWORTH, PARISH OF MOORA, COUNTY OF RODNEY.

Fronting Public Park.

Upset price £10 per lot. Charge for survey £3 2s. 6d.
Lot 1. Area 1r. 33p. (subject to survey), allotment 10, section 16c.
Lot 2. Area 1r. 36p. (subject to survey), allotment 11, section 16c.
Lot 3. Area 1r. 39p. (subject to survey), allotment 12, section 16c.

Fronting Reed-street.

Upset price £10 the lot. Charge for survey £3 2s. 6d.
Lot 4. Area 3r. 12p. (subject to survey), allotment 18, section 16c. Subject to drainage easement 10 links wide.
Upset price £8 per lot. Charge for survey £3 2s. 6d.
Lot 5. Area 2 roods (subject to survey), allotment 21, section 16c. Subject to drainage easement 10 links wide.
Lot 6. Area 2 roods (subject to survey), allotment 22, section 16c. Subject to drainage easement 10 links wide.

Upset price £9 the lot. Charge for survey £3 2s. 6d.
Lot 7. Area 2 roods (subject to survey), allotment 23, section 16c. Subject to drainage easement 10 links wide.
Upset price £10 per lot. Charge for survey £3 2s. 6d.
Lot 8. Area 2 roods (subject to survey), allotment 24, section 16c. Subject to drainage easement 10 links wide.
Lot 9. Area 2 roods (subject to survey), allotment 25, section 16c. Subject to drainage easement 10 links wide.

Fronting Moora-road.

Upset price £20 the lot. Charge for survey £3 2s. 6d.
Lot 10. Area 1 acre, allotment 7, section A. One month allowed to remove fencing.

MOORA, PARISH OF MOORA, COUNTY OF RODNEY.

Fronting Country Roads Board road.

Upset price £30 the lot. Charge for survey £3 5s.
Lot 11. Area 5 acres, allotment 6, section 2.

Land Act 1928.

LICENCES UNDER THE LAND ACTS 1915 AND 1928 DECLARED VOID.

NOTICE is hereby given that the Licences mentioned in the Schedule hereunder have been declared void for the reason specified in each case.

District.	Corr. No.	Name of Licensee.	Section of Land Act under which Licensed.	Parish.	Allotment.	Area.	Class.	Annual Rental.	Reason for Voiding.
Stawell ..	032/129	Valentine Wortley	129	Stawell ..	19, sec. 94	A. R. P. 0 1 0	..	£ s. d. 1 15 0	Non-compliance with conditions

Department of Lands and Survey,
Melbourne, 12th November, 1947.

L. W. GALVIN,
Commissioner of Crown Lands and Survey.

LIST OF CROWN LANDS AVAILABLE.

THE under-mentioned areas are available for application as provided by various sections of the *Land Act 1928*, and all applications received on or before Wednesday, 10th December, 1947, will be deemed to have been simultaneously made, but any application lodged after such date may be considered if received in time for inclusion in the advertisement of the cases to be heard at the Local Land Board.

Applications on proper form, accompanied by 5s. duty stamp uncancelled (registration fee), may be delivered or forwarded by post to the Local Land Officer or to any Crown Lands Office in Victoria.

Applicants may obtain from Local Land Officers, or the Enquiry Office, Lands Department, Melbourne, a certificate authorizing the issue by the Railway Department of a return ticket at concession fares to enable them to inspect available areas or to attend Local Land Boards. When an applicant is granted an allotment he may, if travelling by rail, obtain reduced fares for his family and also freight concessions in regard to some of his effects.

Subject to the approval of the Minister, when the survey fee exceeds £10, a deposit of £5 may be paid, and the balance over six years in half-yearly instalments.

Marked plans of any particular area, application forms, and any further information may be obtained from the Enquiry Office, Lands Department, Melbourne, and Land Officers, Bairnsdale and Stawell.

Department of Crown Lands and Survey,
Melbourne, 12th November, 1947.

L. W. GALVIN,
Commissioner of Crown Lands and Survey.

* Improvements may be subject to re-valuation after land has been granted to an applicant.

Local Land Office.	County.	Parish.	Allotment.	Section.	Area.	How available.		Survey Fee.	Valuation of Improvements (if any).	Location of Land, &c.	Nearest Railway Station or Township and Distance in miles therefrom.	How accessible.	Water Supply.	General Description of Land—Soil, Timber, Suitability (Grazing, &c.)
						Classification.	Value per Acre.							
AVAILABLE UNDER SECTION 129, LAND ACT 1928.														
Bairnsdale R.S., 8 miles														
In Township of Sarsfield..														
To be conserved (H.018650)														
Bairnsdale (a)	Dargo	Township and Parish of Sarsfield	11	A	3 0 0	Annual rental to be fixed	3 2 6 Nil					Fronting Bruthen-road		Suitable for dwelling and garden.
Stawell (a)	Borong	Parish and Borough of Stawell	16	49A	1 3 10	"	3 0 0			Fronting Fisher-street or Albion-road	Stawell about 1 1/4 mile	Road	"	Suitable for dwelling and garden. (Z.27835)
" (a)	"	"	17	49A	2 1 10	"	3 0 0			"	"	"	"	"
" (a)	"	"	18	49A	1 3 10	"	3 0 0			"	"	"	"	"
" (a)	"	"	19	49A	1 3 20	"	3 0 0			"	"	"	"	"
" (a)	"	"	20	49A	2 2 0	"	3 0 0			"	"	"	"	"
" (a)	"	"	21	49A	2 0 20	"	3 0 0			"	"	"	"	"

(a) Subject to survey.

PROPOSED REVOCATIONS OF TEMPORARY RESERVATIONS OF LANDS BY ORDERS IN COUNCIL.

IN pursuance of the provisions of the *Land Act 1928*, notice is hereby given that it is the intention of the Governor in Council to revoke the temporary reservations of lands by Orders in Council hereunder referred to, viz.:

The following Notices were published 1° on the 29th October, 1947, pursuant to Orders of the 21st October, 1947.

GOROKE.—The Order in Council of the 17th February, 1891, temporarily reserving as a site for Show Yards 10 acres of land in the Parish of Goroce, revoked as to part by Order of the 31st March, 1930, is about to be further revoked so far only as regards the portion containing 1 acre 0 roods 5 perches indicated by hachure on plan hereunder.—(G.214(*) (Rs.4002).

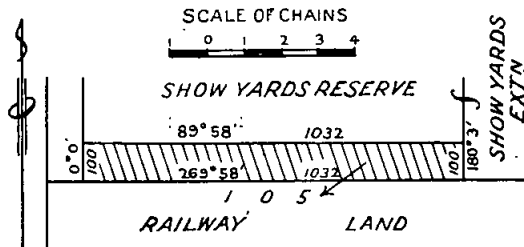

GOROKE.—The Order in Council of the 27th February, 1900, temporarily reserving 5 acres 2 roods 5 perches of land in the Parish of Goroce as a site for Show Yards, in addition to and adjoining the site temporarily reserved therefor by Order of the 17th February, 1891, revoked as to part by Order of the 31st March, 1930, is about to be further revoked so far only as regards the portion containing 32 perches indicated by hachure on plan hereunder.—(G.214(*) (Rs.4002).

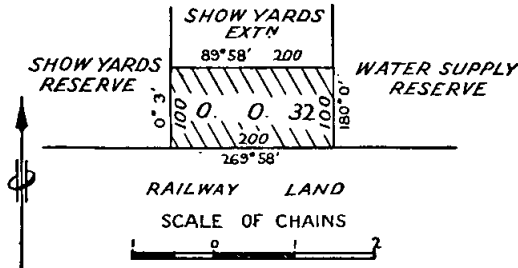

GOROKE.—The Order in Council of the 7th August, 1882, temporarily reserving as a site for Conservation of Water, and withholding from sale, leasing, and licensing, 140 acres 0 roods 24 perches of land in the Parish of Goroce, revoked as to parts by various Orders, is about to be further revoked so far only as regards the portion containing 32 acres 2 roods 39 perches indicated by hachure on plan hereunder.—(G.214(*) (Rs.1574).

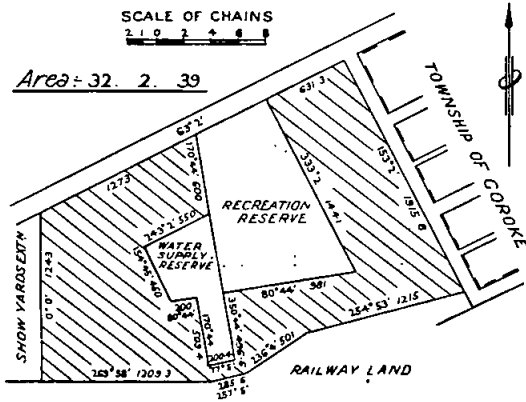

PORT MELBOURNE.—The Order in Council of the 27th July, 1874 (see *Government Gazette* of the 31st July, 1874, page 1430) temporarily reserving for Public purposes certain Crown lands indicated on a plan of Melbourne and suburbs accompanying the Order, is about to be revoked so far only as regards the portion containing 8 acres 2 roods 13 3/10 perches indicated by hachure on plan hereunder.—(M.334(15) (Rs.2357).

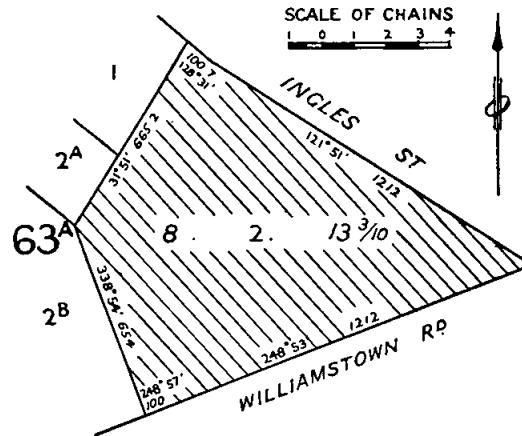

L. W. GALVIN,
Commissioner of Crown Lands and Survey.

PROPOSED REVOCATION OF TEMPORARY RESERVATION OF LAND BY ORDER IN COUNCIL.

IN pursuance of the provisions of the *Land Act 1928*, notice is hereby given that it is the intention of the Governor in Council to revoke the temporary reservation of land by Order in Council hereunder referred to, viz.:

The following Notice was published 1° on the 22nd October, 1947, pursuant to Order of the 14th October, 1947.

KORWEINGUBOORA.—The Order in Council of the 5th March, 1884, temporarily reserving as a site for a Quarry, and withholding from sale, lease, and licensing, 4 acres 2 roods 32 perches of land in the Parish of Korweinguboorra, is about to be revoked.—(K.133(*) (C.90326).

L. W. GALVIN,
Commissioner of Crown Lands and Survey.

PROPOSED REVOCATIONS OF TEMPORARY RESERVATIONS OF LANDS BY ORDERS IN COUNCIL.

IN pursuance of the provisions of the *Land Act 1928*, notice is hereby given that it is the intention of the Governor in Council to revoke the temporary reservations of lands by Orders in Council hereunder referred to, viz.:

The following Notices were published 1° on the 12th November, 1947, pursuant to Orders of the 6th November, 1947.

BUNINYONG.—The Order in Council of the 12th August, 1861 (see *Government Gazette* of the 1st October, 1861), temporarily reserving 1 rood of land in the Town of Buninyong, being part of allotment 9, section 5, as a site for a Temperance Hall, is about to be revoked.—(B.501(2) (J.25773).

GEELONG.—The Order in Council of the 17th December, 1918, temporarily reserving 2 roods 31 7/10 perches of land in the City of Geelong as a site for Police purposes, revoked as to part by Order of the 14th December, 1921, is about to be further revoked so far as regards the balance thereof containing 2 roods 21 7/10 perches.—(G.29(10) (Rs.1877).

DOUTTA GALLA.—The Order in Council of the 11th August, 1890, temporarily reserving 7 acres 1 rood 22 8/10 perches of land in the Parish of Doutta Galla, Town of Footscray, as a site for Public Recreation, is about to be revoked.—(D.85(5) (C.70374).

KORUMBURRA.—The Order in Council of the 24th September, 1907, temporarily reserving 5 acres 1 rood 32 perches of land in the Parish of Korumburra as a site for a Quarry, is about to be revoked.—(K.172(11) (Rs.5331).

PORT CAMPBELL.—The Order in Council of the 26th October, 1885, temporarily reserving 2 acres of land in the Township of Port Campbell as a site for a State School, is about to be revoked.—(P.147(2) (Rs.5968).

STAWELL.—The Order in Council of the 15th July, 1947, temporarily reserving 1 rood 1 6/10 perches, more or less, of land in the Township of Stawell as a site for Police purposes in addition to and adjoining the sites temporarily reserved therefor by Orders of the 27th April, 1868, and the 30th August, 1869, is about to be revoked so far only as regards the portion containing 20 8/10 perches, more or less, indicated by hachure on plan hereunder.—(S.329(11) (Rs.2884).

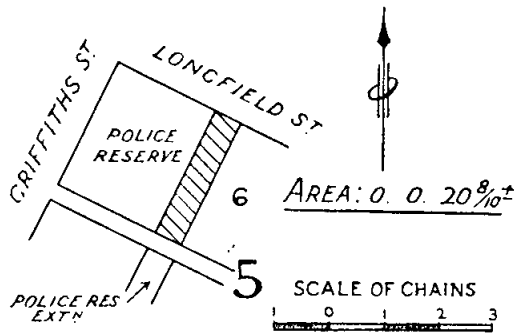

STAWELL.—The Order in Council of the 27th April, 1868, temporarily reserving 2 roods of land at Stawell for Police purposes, is about to be revoked.—(S.329(11) (Rs.2884).

L. W. GALVIN,
Commissioner of Crown Lands and Survey.

PUBLIC HEARING BY A PERSON APPOINTED UNDER THE 34TH SECTION OF THE LAND ACT 1928.

NOTICE is hereby given that, at the time and place mentioned in the Schedule hereunder, applications for leases and licences under the Land Acts, objections to such applications, objections to proposed proclamations, alterations, additions, diminutions, revocations, or unions of commons, and reasons against forfeiture of any leases or licences under the Land Acts deemed liable to forfeiture, will be publicly heard by the person whose name is set opposite such place in such Schedule, being the person appointed by me, the responsible Minister of the Crown administering the Land Acts, to hear the same and report thereon in writing to me.

L. W. GALVIN,
Commissioner of Crown Lands and Survey, and
President of the Board of Land and Works.

Department of Lands and Survey,
Melbourne, 12th November, 1947.

SCHEDULE.

COURT HOUSE, KANIVA, Wednesday, 26th November, 1947, at 10 a.m., J. A. Tipping, Land Officer.

HEARING OF REASONS AGAINST THE FORFEITURE OF CERTAIN LICENCES AND LEASES BY PERSONS APPOINTED UNDER 34TH SECTION OF THE LAND ACT 1928.

NOTICE is hereby given that reasons against the forfeiture of the licences and leases in the Schedule hereto, which are deemed liable to forfeiture under the provisions of the Land Acts, will be publicly heard by the persons appointed by me, the responsible Minister of the Crown administering the said Acts, to hear the same and report thereon in writing to me, when the persons in the said Schedule mentioned as holders of such licences and leases will be allowed to show cause against the same at the places and on the dates mentioned in the Schedule hereto.

L. W. GALVIN,
Commissioner of Crown Lands and Survey.
Department of Lands and Survey,
Melbourne, 12th November, 1947.

SCHEDULE.

LAND INSPECTOR'S OFFICE, RAINBOW, Thursday, 27th November, at 11 a.m., J. A. Tipping—
377/199, J. F. Mellington, 11 acres, Yaapeet.

COURT HOUSE, KANIVA, Wednesday, 26th November, 1947, at 11 a.m., J. A. Tipping—
560/199, G. M. Deans, 1,473 acres, Lillimur.

LAND AVAILABLE UNDER THE SOLDIER SETTLEMENT ACTS.

NOTIFICATION is hereby given, in accordance with section 1⁶ of the Soldier Settlement Act 1946, that the undermentioned allotments are available or are about to become available for settlement.

Any discharged soldier who has applied to the Commission on or before 12th November, 1947, for classification in the required class or classes of primary production for which the lots are made available, and whose application has not been finalized, or any discharged soldier who has been classified as suitable in such class or classes of primary production, may apply on the proper form for settlement on any lot or lots, indicating where he applies in respect of more than one lot, his order of preference therefor.

Application forms, plans of subdivision, and further particulars may be obtained from the Inquiry Branch, Soldier Settlement Commission, State Public Offices, Melbourne, at which office completed applications for settlement should be lodged on or before the 6th December, 1947.

E. SINGLETON,
Secretary.

Soldier Settlement Commission,
Melbourne, 7th November, 1947.

SCHEDULE OF ALLOTMENTS.

Lot Number on Plan of Subdivision.	Approximate Area in Acres (Subject to Survey).
MURRAY VALLEY IRRIGATION DISTRICT.	
PARISH OF YARROWEYAH, COUNTY OF MOIRA.	
<i>Suitable for Growing of Soft Fruits under Irrigation.</i>	
1	50
10	46
11	42
15	53
33	40
34	40
36	41
37	47
40	50
41	49
<i>Suitable for Dairying and Mixed Farming under Irrigation.</i>	
4	158
8	111
9	123
12	115
38	96
63	129
64	113
66	111
67 and 69	110
68	99
72	149

TENDERS.

TENDERS will be received at this office until TEN A.M. on the days and for the purposes under mentioned.

Particulars may be learnt at this office, and also at the offices named in each instance.

The Board of Land and Works will not necessarily accept the lowest or any tender.

18th November, 1947.

Albert Park.—Provision of new concrete floors to out-offices, State School No. 1181. Deposit, £5.

Ararat.—Supply and delivery of steam-heated manual press, Mental Hospital. Preliminary deposit, £4. Final deposit, 2 per cent.

Heatherton.—Supply and installation of three (3) electric refrigerators, second three-storey Ward, Sanatorium. Preliminary deposit, £5. Final deposit, 2 per cent.

Lake Tyers.—Repairs to Manager's Residence, skylight to office, and repairs to church spire, Aboriginal Station. Particulars at Inspector of Works Office, Bairnsdale; Police Station, Orbost. Preliminary deposit, £5. Final deposit, 2 per cent.

Malvern.—Additional lavatory accommodation, Girls' School, Tooronga-road. Deposit, £10.

Maribyrnong.—Attention to settlement of building, State School No. 3736. Deposit, £4.

Mildura.—Erection of new brick out-offices, State School No. 2915. Particulars at Inspector of Works Office, Mildura; State School, Mildura. Preliminary deposit, £10. Final deposit, 2 per cent.

Mont Park.—Supply and delivery of five (5) crockery trolleys, Gresswell Sanatorium. Preliminary deposit, £5. Final deposit, 2 per cent.

Mooney's Estate (near Moyhu).—Erection of two (2) timber-framed residences on Blocks Nos. 1 and 2, Soldier Settlement Commission. Particulars at Inspectors of Works Offices, Benalla, Wangaratta. State School, Moyhu. Preliminary deposit, £20. Final deposit, 2 per cent.

Mornington.—Supply of stone spalls, Foreshore. Particulars at Shire Office, Mornington.

Orbost.—Alterations and additions, repairs, and painting, Police Station. Particulars at Inspector of Works Office, Bairnsdale; Police Stations, Bruthen, Orbost. Preliminary deposit, £10. Final deposit, 2 per cent.

Pakenham.—Removal of State School No. 1359, Pakenham, re-erection, repairs, and painting, Junior Wing, Consolidated School. Particulars at Police Stations, Dandenong, Warragul. Deposit, £10.

Preston.—Renovations, Court House. Deposit, £10.

Tallangatta.—Repairs, alterations, &c., Police Station. Particulars at Inspector of Works Office, Wangaratta; Police Stations, Tallangatta, Wodonga. Deposit, £3.

Tottenham.—Provision of bathroom, Caretaker's Residence, State School No. 3890. Deposit, £3.

Wangaratta.—Repairs to verandahs, High School. Particulars at Inspectors of Works Offices, Benalla, Wangaratta; High School, Wangaratta. Deposit, £4.

Warragul.—Replacement of roof, Police Station. Particulars at Inspector of Works Office, Bairnsdale; Police Stations, Moe, Sale, Warragul. Deposit, £2.

White Hills.—Remodelling and repairs to teacher's residence, State School No. 1916. Particulars at Inspector of Works Office, Bendigo. Preliminary deposit, £10. Final deposit, 2 per cent.

Yarra Bend.—Renovations to staff cottage, "Fairhaven" V.D. Hostel. Deposit, £5.

Yarra Bend.—Provision of new drying room, "Fairhaven," V.D. Hostel. Deposit, £4.

25th November, 1947.

Ballarat.—Supply and delivery of electrically-heated food trolleys and warmers for Female Hospital Ward, Mental Hospital. Preliminary deposit, £5. Final deposit, 2 per cent.

Beaufort.—Erection of six (6) new timber out-offices for girls' State School No. 60. Particulars at Inspectors of Works Offices, Ballarat, Stawell; Police Station, Ararat; State School, Beaufort. Preliminary deposit, £5. Final deposit, 2 per cent.

Braeside.—Erection of new timber school building and repairs to existing out-buildings, State School No. 3910. Particulars at Police Station, Frankston; State School, Mordialloc. Preliminary deposit, £15. Final deposit, 2 per cent.

Daylesford.—Remodelling of boys' out-office block, Technical School. Particulars at Inspectors of Works Offices, Bendigo, Maryborough; Police Stations, Daylesford, Trentham. Preliminary deposit, £2. Final deposit, 2 per cent.

Dookie.—Erection of new residence for Dairy Inspector, Agricultural College. Particulars at Inspectors of Works Offices, Benalla, Shepparton, Wangaratta; Police Station, Euroa; Agricultural College, Dookie. Preliminary deposit, £15. Final deposit, 2 per cent.

Dookie.—Erection of new building for domestic staff in brick veneer, Agricultural College. Particulars at Inspectors of Works Offices, Benalla, Shepparton; Agricultural College, Dookie. Preliminary deposit, £15. Final deposit, 2 per cent.

Hawthorn.—Installation of improved lighting, Swinburne Technical College. Preliminary deposit, £15. Final deposit, 2 per cent.

Jeparit.—Installation of a solid fuel hot-water service, Police Station. Particulars at Inspectors of Works Offices, Horsham, Warrnambool; Police Station, Jeparit. Preliminary deposit, £2. Final deposit, 2 per cent.

Kew.—Renewal of water service, Mental Hospital. Preliminary deposit, £15. Final deposit, 2 per cent.

Kyneton.—Erection of Infectious Diseases Wards, District Hospital. Particulars at Inspector of Works Office, Bendigo; Police Station, Castlemaine District Hospital, Kyneton. Preliminary deposit, £50. Final deposit, 2 per cent.

Leitchville.—Removal of State School No. 2006, Terrick South, and re-erection, State School No. 2087. Particulars at Inspectors of Works Offices, Bendigo, Swan Hill; Police Station, Cohuna; State School, Leitchville. Preliminary deposit, £5. Final deposit, 2 per cent.

Longerenong.—Supply and installation of additional hot-water storage, Agricultural College. Particulars at Inspectors of Works Offices, Ballarat, Bendigo, Horsham. Preliminary deposit, £2. Final deposit, 2 per cent.

Melbourne.—Adaptation of hutment, Stamp Duties Office, Queen-street. Preliminary deposit, £10. Final deposit, 2 per cent.

Miloo East.—Purchase and removal of school buildings, State School No. 2156. Particulars at Inspector of Works Office, Bendigo; Police Stations, Elmore, Inglewood, Pyramid, Raywood, Wedderburn; State School, Miloo East. Deposit, £10.

Oakleigh.—Alterations to workshop block, Technical School. Particulars at Technical School, Oakleigh. Preliminary deposit, £5. Final deposit, 2 per cent.

Sea Lake.—Removal of building from State School No. 4282, Tyrrell Creek, and re-erection and re-conditioning, State School No. 3273. Particulars at Inspector of Works Office, Swan Hill; Police Stations, Woomelang, Wychee-proof; State School, Sea Lake. Preliminary deposit, £4. Final deposit, 2 per cent.

South Melbourne.—Installation of two (2) electric hot-water services, Police Station. Preliminary deposit, £3. Final deposit, 2 per cent.

South Yarra.—Supply and installation of central heating system, State School No. 583, Punt-road. Preliminary deposit, £15. Final deposit, 2 per cent.

Sunbury.—Renovations and alterations, Tailors, Tailoresses, and Sewing Room Block, Mental Hospital. Particulars at Police Station, Sunbury. Preliminary deposit, £15. Final deposit, 2 per cent.

Sunbury.—Erection of new police station, Police Station. Particulars at Police Stations, Kilmore, Kyneton, Sunbury. Preliminary deposit, £15. Final deposit, 2 per cent.

Wedderburn.—Removal of State School No. 4497, Salisbury North, re-erection, repairs, painting, &c., State School No. 794. Particulars at Inspectors of Works Offices, Bendigo, Maryborough; Police Station, Inglewood; State School, Wedderburn. Preliminary deposit, £4. Final deposit, 2 per cent.

Wickliffe.—Provision of new sleep-out, and repairs, painting, school and residence, State School No. 948. Particulars at Inspector of Works Offices, Hamilton, Stawell; Police Stations, Ararat, Willaura; State School, Wickliffe. Preliminary deposit, £10. Final deposit, 2 per cent.

Williamstown.—Provision of staff toilet accommodation, State School No. 1183. Particulars at State School, Williamstown. Preliminary deposit, £4. Final deposit, 2 per cent.

2nd December, 1947.

Brunswick.—Provision of new lavatory, Court House. Deposit, £4.

Heatherton.—Supply and delivery of sterilizers, water and milk urns, and plate warmers, second three-story ward, Sanatorium. Preliminary deposit, £15. Final deposit, 2 per cent.

Melbourne.—Provision of lift enclosure, Public Library. Preliminary deposit, £10. Final deposit, 2 per cent.

Melbourne.—Additions to Physics School, University. Preliminary deposit, £50. Final deposit, 2 per cent.

Moonee Ponds.—Repairs to out-offices, State School No. 3987. Deposit, £4.

Williamstown.—Additional lavatory accommodation, Court House. Preliminary deposit, £4. Final deposit, 2 per cent.

Tenders to be addressed to the Honorable the Commissioner of Public Works, and envelope containing tender marked "Tender for
due

P. J. KENNELLY,
Commissioner of Public Works.

Melbourne, 11th November, 1947.

TENDERS FOR THE SERVICE, 1947-48.
PROVISIONS—MEAT.

TENDERS will be received until Eleven o'clock a.m. on Friday, 5th December, 1947, from persons willing to furnish the under-mentioned supplies, in such quantities as may be ordered by the Victorian Government—delivery to be made at the under-mentioned places—during the three months commencing on 1st January, 1948.

The estimated quantities shown in the Schedules will be subject to variation in accordance with the requirements of any Regulations for the rationing of meat in force during the contract period.

The prices tendered must not include sales tax.

In all cases, the total cost of each item must be extended in the columns provided.

The places for which tenders will be received, the amount of the preliminary deposit, and the security required for the due fulfilment of each contract, are as follows:—

		Preliminary Deposit.	Security.
		£	£
Schedule No. 1.	Meat—Kew Mental Hospital	2	35
Melbourne District	" Pentridge Penal Establishment, Female Penitentiary, and Metropolitan Gaol, Coburg ...	2	35
	" Children's Welfare Depot, Royal Park, and Police Hospital	1	8
	" Receiving House and Mental Hospital, Royal Park ...	1	10
	Schedule No. 2.	Meat	3
Mont Park, Bundoora, Jane field, and Gresswell			
Schedule No. 3.	Meat	1	5
Rip and Dredges			
Schedule No. 4.	Meat	1	8
Teachers' College, Carlton, and Travancore, Flemington			
Schedule No. 5.	Meat	2	30
Ararat District			
Schedule No. 6.	Meat	2	35
Ballarat District			
Schedule No. 7.	Meat	2	30
Beechworth District			
Schedule No. 8.	Meat	1	5
Castlemaine District			
Schedule No. 9.	Meat	1	3
School of Forestry, Creswick			
Schedule No. 10.	Meat	1	5
McLeod Settlement, French Island			
Schedule No. 11.	Meat	1	5
Heatherton Sanatorium, Cheltenham			
Schedule No. 12.	Meat	1	7
Sanatorium, Greenvale			
Schedule No. 13.	Meat	1	4
Coorimungle Prison Camp, Heytesbury Forest			

		Preliminary Deposit.	Security.
		£	£
Schedule No. 16.	Meat	1	3
Sale Gaol			
Schedule No. 17.	Meat	1	3
Pleasant Creek Special School, Stawell			
Schedule No. 18.	Meat	2	40
Sunbury District			
Schedule No. 21.	Meat	1	5
Geelong District			

Printed forms of tender and the conditions of contract may, in all cases, be obtained from the Secretary to the Tender Board, Gisborne-street, Melbourne, by whom also any information or explanation will be afforded to persons tendering.

Tenders must be accompanied by the preliminary deposit, as shown above, preferably by non-negotiable cheque payable to the order of the Secretary to the Tender Board. The amount and designation of the preliminary deposit enclosed must be clearly stated in the tender. Savings Bank deposit books, fixed deposit receipts, Commonwealth Treasury bonds, or reference to securities on existing contracts will in no case be received or entertained as preliminary deposits. Preliminary deposits will be returned within 30 days to unsuccessful tenderers on their application.

Security will be required either in Commonwealth Treasury Bonds, or approved bank guarantee, fixed deposit receipt, Savings Bank deposit book, or non-negotiable cheque in favour of the Secretary to the Tender Board, as the tenderer may elect.

The security must be completed and the contract signed within five days of acceptance of the tender, failing which the service may be again advertised, or another tender accepted.

The lowest or any tender will not necessarily be accepted.

In the event of tenderers withdrawing or attempting to withdraw their tenders before notification of acceptance of same, or failing to take up their accepted tenders within the prescribed period after notification of acceptance, the preliminary deposit will be forfeited and, in addition, they may be disqualified from tendering or holding any future contracts for Government supplies for a period of twelve months, such disqualification to date from the notification of acceptance of tender. It is also stipulated that, if a tenderer be a member of a firm and such firm be interested in the contract, the tender shall be in the name of the firm and not in that of the individual and that, for a breach of this condition, the preliminary deposit will be forfeited and the tender declared informal.

Tenders, enclosed in a separate envelope, and having the words "Tender for at" (as the case may be) written thereon, must be deposited in the Tender-box at the Tender Board Offices, Gisborne-street, Melbourne, or, if sent by post, postage must be prepaid, and the tenders addressed to the Chairman of the Tender Board, Tender Board Offices, Gisborne-street, Melbourne, C.2, which office they must reach not later than by first post on the date of closing of tenders.

CONDITIONS OF CONTRACT.

The conditions of contract are those published in the Victoria Government Gazette, No. 240, dated 30th April, 1947, pages 2279 to 2281.

JOHN CAIN,
Treasurer.

The Treasury,
Melbourne, 7th November, 1947.

TENDERS FOR THE SERVICE, 1947-48.

GENERAL STORES.

TENDERS will be received until Eleven o'clock a.m. on Friday, the 5th December, 1947, from persons willing to supply the under-mentioned goods, in such quantities as may be ordered by the Victorian Government, during the twelve months commencing 1st February, 1948:—

Schedule No.	Preliminary Deposit
56. Motor Spirit and Kerosene	£ 3

The prices tendered must not include sales tax. Security.—Five per cent. of total amount of tender accepted, but in no case will security of less than £3 be received.

Schedules as above, with full particulars, may be obtained from the Secretary to the Tender Board, Gisborne-street, Melbourne, by whom also the samples will be shown and any information afforded to persons tendering.

In all cases the total cost of each item must be extended in the columns provided.

Tenders must be accompanied by the preliminary deposit, as shown above, preferably by non-negotiable cheque payable to the order of the Secretary to the Tender Board. The amount and designation of the preliminary deposit enclosed must be clearly stated in the tender. Savings Bank deposit books, fixed deposit receipts, Commonwealth Treasury bonds, or reference to securities on existing contracts will in no case be received or entertained as preliminary deposits. Preliminary deposits will be returned within 30 days to unsuccessful tenderers on their application.

Security will be required either in Commonwealth Treasury bonds, or approved bank guarantee, fixed deposit receipt, Savings Bank deposit book, or non-negotiable cheque in favour of the Secretary to the Tender Board, as the tenderer may elect.

The security must be completed and the contract signed within five days of acceptance of the tender, failing which the service may be again advertised, or another tender accepted.

The lowest or any tender will not necessarily be accepted. In the event of tenderers withdrawing or attempting to withdraw their tenders before notification of acceptance of same, or failing to take up their accepted tenders within the prescribed period after notification of acceptance, the preliminary deposit will be forfeited and, in addition, they may be disqualified from tendering or holding any future contracts for Government supplies for a period of twelve months, such disqualification to date from the notification of acceptance of tender. It is also stipulated that, if a tenderer be a member of a firm and such firm be interested in the contract, the tender shall be in the name of the firm and not in that of the individual and that, for a breach of this condition, the preliminary deposit will be forfeited and the tender declared informal.

Tenders enclosed in a separate envelope, and having the words "Tender for ——" (as the case may be) written thereon, must be deposited in the Tender-box at the Tender Board Offices, Gisborne-street, Melbourne, or, if sent by post, postage must be prepaid and the tenders addressed to the Chairman of the Tender Board, Tender Board Offices, Gisborne-street, Melbourne, C.2, which office they must reach not later than by first post on the date of closing of tenders.

The conditions of contract are those published in the Victoria Government Gazette, No. 184, of 12th March, 1947, pages 1677 to 1679.

JOHN CAIN,
Treasurer.

The Treasury,
Melbourne, 7th November, 1947.

PRIVATE ADVERTISEMENTS.

NOTICE is hereby given that The Trotting Control Board has applied for a lease under section 125 of the Land Acts, for a term of twenty years, from 15th December, 1947, of 20 acres, more or less, situate between the New Footscray-road, West Melbourne, and section 1A, City of Melbourne, as a site for amusement and recreation (control of trotting tests and trials). 2129

I LESLIE EDWARD JEFFORD, of 238 Post Office-place, Melbourne, in the State of Victoria, hairdresser, heretofore called and known by the name of Leslie Edward Lamb, hereby give public notice that by a deed poll dated the 28th day of October, 1947, duly executed and attested and deposited with the Registrar-General of the said State on the 5th day of November, 1947, I formally and absolutely renounced and abandoned the said surname of Lamb, and declared that I had assumed and adopted and intended thenceforth upon all occasions whatsoever to use and subscribe, the surname of Jefford instead of the said surname of Lamb, and so as to be at all times thereafter called, known, and described by the said surname of Jefford. Dated this 7th day of November, 1947.

L. E. JEFFORD.
Witness—R. H. DUNN, solicitor, Melbourne. 2390

CITY OF BENDIGO.

BY-LAW No. 67.

A By-law of the City of Bendigo, made pursuant to the Motor Omnibus Acts and numbered 67, for repealing portion of By-law No. 36, and for prescribing the fares to be charged for children passengers carried by motor omnibuses.

THAT sub-clause (c) of clause 21 of By-law No. 36 be and is hereby repealed, and the following inserted in lieu thereof:—

(c) Half Fares.—Children over four and under fourteen years of age shall be charged for at half the adult rate.

Resolution for passing this By-law agreed to by the Council of the City of Bendigo, on the 12th day of May, 1947, and confirmed on the 9th day of June, 1947.

The common seal of the Mayor, Councillors, and Citizens of the City of Bendigo was hereunto affixed, in the presence of:—

DAVID W. STREADER, Mayor.
A. TRUSCOTT, Councillor.
F. T. AMER, Town Clerk.

Approved by the Governor in Council, 14th October, 1947.
—C. W. KINSMAN, Clerk of the Executive Council. 2368

Local Government Act 1946.—Fifteenth Schedule.

CITY OF CHELSEA.

POPULOUS AND RESIDENTIAL AREA.

BY virtue of the powers conferred upon it, the Mayor, Councillors, and Citizens of the City of Chelsea do hereby declare the whole of the municipal district of the said City of Chelsea to be a populous and/or residential area within the meaning of section 42 of Part 1 of the Fifteenth Schedule of the Local Government Act 1946, which Schedule applies and operates throughout the whole of the Municipal District of the said City of Chelsea, in accordance with By-law No. 41 of this municipality.

Resolution passed this 20th day of October, 1947.

H. D. THOMAS, Mayor.
H. S. McCOLL, Councillor.
L. F. PAYNE, Councillor.
A. S. COLLINGS, Town Clerk.

2362

CITY OF ESSENDON.

LOAN No. 24.

Notice of Special Order for Borrowing £30,000.

NOTICE is hereby given that, at a meeting of the Council of the City of Essendon to be held at the Town Hall, Moonee Ponds, on Monday, 10th November, 1947, at half-past Seven p.m., the said Council agrees by Special Order to the following Resolution, that is to say:—

"That in order to carry out the works and undertakings set out in the plans and specifications and estimate of cost, dated 29th September, 1947, the Council of the City of Essendon hereby authorizes the borrowing of the sum of £30,000 (Thirty thousand pounds), by the issue of Fifty debentures, each including principal and interest amounting to £881 0s. 1d., bearing interest at the rate of £3 5s. per cent. per annum, and charged upon the security of the Municipal Fund under the provisions of the Local Government Act 1946"—

be and is hereby adopted, and that the confirmation of this Resolution be made an Order of the Day for a meeting of the Council to be held on the 8th day of December, 1947, at half-past Seven p.m. The plans, specifications, and estimate of cost of the works referred to above, and a statement showing the proposed expenditure of money to be borrowed, are open for inspection at the Town Hall, Moonee Ponds, during office hours.

Dated this 6th day of November, 1947.
N. F. WELLINGTON, Town Clerk.

2360

CITY OF MALVERN.

NOTICE is hereby given that, in pursuance of the powers conferred by the Local Government Acts, the Mayor, Councillors, and Citizens of the City of Malvern have made By-law 120 for the purpose of amending By-law 76, as amended by By-laws Nos. 85, 114, and 118, relating to "Residential Areas" (this refers to land in Malvern and Glenferrie roads).

This By-law comes into operation on the day following its publication in the *Government Gazette*.

The Resolution for passing this By-law was agreed to by the Council on the 3rd March, 1947, confirmed on the 21st April, 1947, and approved by the Governor in Council on the 17th June, 1947.

A copy of this By-law is open for inspection, free of charge, during office hours, at the office of the Council, City Hall, Malvern.

A. M. YEATMAN, Town Clerk.
City Hall, Malvern, S.E.4, 6th November, 1947. 2376

CITY OF ST. KILDA.

BY-LAW No. 136.

By-law of the City of St. Kilda, made and passed under the provisions of the Local Government Acts, No. 136, for altering By-law No. 116 (Residential Areas).

IN pursuance of the powers conferred by the Local Government Acts and of every power it thereunder enabling, the Mayor, Councillors, and Citizens of the City of St. Kilda, with the approval of the Governor in Council, orders as follows:—

1. This By-law shall be read and construed as one with By-law No. 116 of the City of St. Kilda (hereinafter referred to as the principal By-law).

2. This By-law shall come into operation on its approval by the Governor in Council immediately after its publication in the *Victoria Government Gazette*.

3. The principal By-law shall be altered as follows:—

For the area referred to in clause 2 of the principal By-law, under "Addison-street," the following shall be substituted:—

"From the south-west side of Ruskin-street to a point 162 feet north of Glenhantly-road, all the land fronting to or abutting on the east side of Addison-street to a depth of 166 feet, and from the south-east side of Dickens-street to a point 163 feet north of Glenhantly-road, all the land fronting to or abutting on the west side of Addison-street to a depth of 156 feet."

Resolution for passing this By-law agreed to by the Council the 1st day of September, 1947, and confirmed the 29th day of September, 1947.

The common seal of the Mayor, Councillors, and Citizens of the City of St. Kilda was hereto affixed the 29th day of September, 1947, in the presence of—

(SEAL) H. MORONEY, Mayor.
ARTHUR E. WATSON, Councillor.
ALFRED KELLY, Acting Town Clerk.

Approved by the Governor in Council, the 28th day of October, 1947.—C. W. KINSMAN, Clerk of the Executive Council. 2361

Sewerage Districts Acts.
BOROUGH OF STAWELL.
PROPOSED SEWERAGE AUTHORITY.

NOTICE is hereby given that the Council of the Borough of Stawell has made application to the Honorable the Minister of Water Supply for the constitution of a Sewerage Authority and for the proclamation of a Sewerage District at Stawell, and for the construction, maintenance, and continuance of sewerage works within that district under the provisions of the Sewerage Districts Acts.

A general plan and description of the proposed works have been submitted with the application, and copies may be seen at the office of the State Rivers and Water Supply Commission, 100 Exhibition-street, Melbourne, and at the Town Hall, Stawell.

W. G. SHARPLEY, F.F.I.A., F.A.I.S., Town Clerk.
Town Hall, Stawell, 3rd November, 1947. 2359

SHIRE OF DANDENONG.

NOTICE is hereby given that Aubrey Ernest Boutcher, of 8 Murrumbeena-road, Murrumbeena, has been appointed Ranger and Impounding Officer, Dog Registration Officer, and Prosecuting Officer, of the Shire of Dandenong.
2379

R. BOOTH, Shire Secretary.

SHIRE OF KEILOR.

APPOINTMENT OF CATTLE RANGER.

NOTICE is hereby given that the Council of the Shire of Keilor has appointed Robert Dixon cattle ranger to the municipality, *vice* Hugh Dempster, resigned.

Dated at Keilor, this 10th day of November, 1947.

2433 N. A. WOODS, Shire Secretary.

SHIRE OF WODONGA.

NOTICE is hereby given that Richard Saunders has been appointed Poundkeeper in the Shire of Wodonga, in place of Thomas Ardern, resigned.

2377 J. N. EDDY, Shire Secretary.

NOTICE is hereby given that the partnership heretofore subsisting between the undersigned, Albert Leonard Knight, Ronald Percival Carter, Betty Kathleen Braithwaite Knight, and Gilbert George Knight, carrying on business as grocers at Portland under the name of "Knight and Carter," has been dissolved by mutual consent as from the 11th day of October, 1947.

All debts due to and owing by the said firm will be received and paid by the said Albert Leonard Knight, Betty Kathleen Braithwaite Knight, and Gilbert George Knight, who will continue to carry on the business at the same place under the name of "A. L. Knight and Co."

Dated the 27th day of October, 1947.

A. L. KNIGHT.
RONALD P. CARTER.
B. K. KNIGHT.
G. G. KNIGHT.

Witness—JNO. S. HARRIS, solicitor, Portland. 2381

PARTNERSHIP ACT.

NOTICE is hereby given that the partnership subsisting between Cecil Arthur Crockford and Kevin William Lake, of Lockington, garage proprietors, trading under the name or style of "Lockington Motors," carrying on business in Lockington and district, will be dissolved by mutual consent as from the 1st day of November, 1947. All debts due to, and owing by, the said late firm will be received and paid by Cecil Arthur Crockford, who will continue to carry on the business at the same place.

Dated the 31st day of October, 1947.

2383 C. A. CROCKFORD.
K. W. LAKE.

NOTICE is hereby given that the partnership heretofore subsisting between the undersigned, Mary Frances Zamburro and Maria Stella Gornalle, carrying on business as general drapers at 500 Lygon-street, East Brunswick, under the name of "Zamburro and Gornalle," has been dissolved by mutual consent as from the 24th day of December, 1946. All debts due to and owing by the said late firm will be received and paid by the said Mary Frances Zamburro, who will continue to carry on business at the same place.

Dated the 18th day of August, 1947.

M. S. GORNALLE.
MARY FRANCES ZAMBURRO.
P. S. Coltman, solicitor, 443 Little Collins-street, Melbourne. 2388

NOTICE OF DISSOLUTION OF PARTNERSHIP.

NOTICE is hereby given that the partnership heretofore subsisting between the undersigned, Frances Leyton Brown and Ailee Catherine Hanna Ralph, carrying on business as caterers at 60 Champion-street, Brighton, under the name of "Marlborough Catering Service," has been dissolved by mutual consent as from the 1st day of June, 1947. All debts due to and owing by the said late firm will be received and paid by Frances Leyton Brown, who will carry on the business at "Avalon," 16 Beach-road, Hampton.

Dated at Melbourne, the 3rd day of November, 1947.

Witness—LLOYD P. GOODE. F. LEYTON BROWN.

Witness—LLOYD P. GOODE. A. RALPH. 2392

NOTICE is hereby given that the partnership heretofore existing between Alexander Jones and Robert Scott, wood merchants, at Fawkner, in the State of Victoria, under the firm name of Jones and Scott, was dissolved on the 10th day of November, 1947. The said Alexander Jones will continue to carry on the said business.

Dated the 10th day of November, 1947.

A. JONES.
Cleary, Ross, and Doherty, solicitors, 40 Queen-street, Melbourne. 2428

NOTICE is hereby given that the partnership heretofore subsisting between Abraham Samuel Leibler, Rachel Leibler, and Isaac Feiglin, carrying on the business of general importers at 231 Collins-street, Melbourne, under the style or firm name of A. S. Leibler and Company, has been dissolved by mutual consent as from the 10th day of November, 1947. All debts due to and owing by the said firm will be paid by the said Abraham Samuel Leibler and Rachel Leibler, who will continue to carry on the said business.

Dated the 10th day of November, 1947.

A. LEIBLER.
R. LEIBLER.
ISAAC FEIGLIN.

Middleton, McEacharn, and Shaw, 60 Market-street, Melbourne, solicitors. 2425

PARTNERSHIP ACT.

NOTICE is hereby given that the partnership heretofore subsisting between Laurence Harry Cainer and Barbara Ann Brent, carrying on business as manufacturers and distributors at 9 Queen-street, Melbourne, under the name of M. C. B. Manufacturing and Distributing Company, has been dissolved by mutual consent as from the 10th day of November, 1947, so far as concerns the said Laurence Harry Cainer, who retires from the said firm. All debts due and owing by the said firm will be received and paid by the said Barbara Ann Brent, and John Ashton Brent, Lionel Bernard Brodie, and Noel Graham Brodie (who enter the firm), who will continue to carry on the business at the same place.

Dated the 10th day of November, 1947.

LAURENCE H. CAINER.
BARBARA ANN BRENT.
JOHN A. BRENT.
L. B. BRODIE.
NOEL G. BRODIE.

Wm. J. Clarke and Co., solicitors, 422 Collins-street, Melbourne. 2432

NOTICE is hereby given that the partnership lately subsisting between the undersigned, Hector Lawrence Drew and Henry John Tomkins, carrying on business as carriers at Valley-road, Highton, Geelong, under the style or firm name of "Highton Transport Service," has been dissolved by mutual consent as and from the 27th day of June, 1947, so far as concerns the said Henry John Tomkins, who retires from the said firm.

Dated the 1st day of November, 1947.

H. J. TOMKINS.

Witness to signature—ANDREW R. PHILLIPS, solicitor, Geelong.

Andrew R. Phillips, LL.B., A.I.C.A., of 57A Yarra-street, Geelong, solicitor for the above-named Henry John Tomkins. 2373

Companies Act 1938.—In the matter of ALLIED MOTOR INTERESTS LIMITED (in Voluntary Liquidation).

A FIRST Return to shareholders will shortly be made in the above matter. Creditors are required to prove their claims by the 28th day of November, 1947, otherwise the return will be made without regard to such claims.

Dated this 6th day of November, 1947.

F. G. HARDING, Liquidator.

Wilson, Danby, and Giddy, chartered accountants (Aust.), 51 Queen-street, Melbourne, C.1. 2401

In the matter of the *Companies Act 1938*, and in the matter of the MORWELL INVESTMENTS PROPRIETARY LIMITED (in Voluntary Liquidation).

NOTICE is hereby given, pursuant to section 236 of the *Companies Act 1938*, that an Extraordinary General Meeting of the company will be held at the office of the liquidator, 60 Market-street, Melbourne, on Friday, the 12th day of December, 1947, at Eleven o'clock in the forenoon, for the purpose of having an account laid before the company showing the manner in which the winding up has been conducted and the property of the company disposed of, and of hearing any explanation that may be given by the liquidator.

Dated this 10th November, 1947.

2405

T. J. WHITTLE, Liquidator.

CREDITORS, next of kin, and others having claims in respect of the estate of Walter Aubrey Butler, late of Moolort, retired grazier, deceased (who died on 14th October, 1946), are to send the particulars of their claims to Agnes Grace Butler, of Moolort, widow, Jessie Nixon, of 50 Buckley-street, Morwell, married woman, and Doris May Bartlett, of Alma, married woman, care of the undersigned solicitors, by the 1st day of March, 1948, after which date they will distribute the assets, having regard only to the claims of which they then have notice.

HERRING & BATHURST, solicitors, Maryborough.

2382

NOTICE TO CREDITORS.—ELLEN ANN CHAPPLE, DECEASED.

CREDITORS, next of kin, and others having claims in respect of the estate of Ellen Ann Chapple, late of 1 Kendall-street, Elwood, in the State of Victoria, widow (who died on the 1st day of July, 1947), are to send the particulars of their claims to National Trustees, Executors, and Agency Company of Australasia Limited, of 95 Queen-street, Melbourne, by the 15th day of January, 1948, after which date it will distribute the assets, having regard only to the claims of which it then has notice.

H. H. HOARE, solicitor, 191 Queen-street, Melbourne.

2384

CREDITORS, next of kin, and others having claims in respect of the estate of Agnes Benson, late of 25 Hoddle-street, Elsternwick, in the State of Victoria, married woman, deceased (who died on the 8th day of July, 1947), are to send the particulars of their claims to the executors, care of The Perpetual Executors and Trustees Association of Australia Limited, at its registered office, 100-104 Queen-street, Melbourne, by the 14th day of January, 1948, after which date it will distribute the assets, having regard only to the claims of which it then has notice.

CORR & CORR, solicitors, 104 Queen-street, Melbourne.

2385

MARGARET DALGLISH, late of York-street, Prahran, in the State of Victoria, spinster, deceased (who died on the 22nd August, 1947), probate of whose will was granted to Joseph Lynch, of 299 Bridge-street, Richmond, solicitor.

CREDITORS, next of kin, and all others having claims against the estate of the above-named deceased are required by the said executor to send particulars thereof to the undersigned, on or before the 14th day of January, 1948, after which date the assets will be distributed, having regard only to the claims to which notice has been received.

JOSEPH LYNCH, LL.B., 299 Bridge-road, Richmond.

2403

PURSUANT to the *Trustee Act 1928*, notice is hereby given that all persons having any claim against the estate of Helen Emma Greig, late of 3 Addison Gardens, Kensington, London, England, single woman, deceased (who died on the 13th day of December, 1945, and a certified copy probate of whose will, granted by His Majesty's High Court of Justice to National Provincial Bank Limited, the executor named therein, was sealed on the 19th day of September, 1946, by the Supreme Court of Victoria, in its probate jurisdiction, on being produced by Cecil Gordon Hooper, solicitor, and Keith Vannan Rintoul, solicitor, both of 100 Queen-street, Melbourne, the duly appointed attorneys of the aforesaid executor), are hereby required to forward particulars to the undersigned, on or before the 6th day of January, 1948, after which date the said attorneys of the aforesaid executor will convey or distribute such property or estate to or amongst the persons entitled thereto, having regard only to the claims, whether formal or not, of which they shall then have had notice.

BEST, HOOPER, AND RINTOUL, solicitors, 100 Queen-street, Melbourne.

2393

CREDITORS, next of kin, and others having claims in respect of the estate of John Galates, late of 152 Melville-road, West Brunswick, fishmonger, deceased (who died on the 1st day of July, 1947), are to send particulars of their claims to The Equity Trustees, Executors, and Agency Company Limited, of 472 Bourke-street, Melbourne, by the 24th day of January, 1948, after which date it will distribute the assets, having regard only to the claims of which it then has notice.

DAVID THOMAS, of 140 Queen-street, Melbourne, solicitors for the said company.

2397

NOTICE TO CLAIMANTS.—RE JOSEPH HEYWOOD ROULSTON, DECEASED.

PURSUANT to the *Trustee Act* 1928, Emily Kate Roulston, of Gritjurk, in the State of Victoria, widow, and Herbert George Roulston, of Macarthur, in the said State, farmer, the executrix and executor of the will of Joseph Heywood Roulston, late of Gritjurk aforesaid, farmer, deceased (who died on the 3rd day of May, 1946), require all creditors, next of kin, and others having claims against the property or estate of the said deceased to send to the said executrix and executor, care of the under-mentioned solicitors, on or before the 15th day of January, 1948, particulars, in writing, of such claim, after which date the said executrix and executor intend to convey or distribute such property or estate to or among the persons entitled thereto, having regard only to the claims of which they shall have had notice.

Dated the 7th November, 1947.

FITZGERALD & NASH, Whyte-street, Coleraine, solicitors for the said executrix and executor. 2395

NOTICE TO CLAIMANTS.—RE AGNES CECIL COSTER, DECEASED.

PURSUANT to the *Trustee Act*, 1928, John Egbert Grice, of 100 Queen-street, Melbourne, in the State of Victoria, pastoral inspector, the executor in Victoria of the will of Agnes Cecil Coster, late of the City of Nelson, in the Dominion of New Zealand, widow, deceased (who died on the 30th day of October, 1945), requires all creditors, next of kin, and others having claims against the property or estate of the said deceased, to send to the said executor, care of the under-mentioned solicitors, on or before the 15th day of January, 1948, particulars, in writing, of such claims, after which date the said executor intends to convey or distribute such property or estate to or among the persons entitled thereto, having regard only to the claims of which he shall have had notice.

Dated the 7th November, 1947.

FITZGERALD & NASH, Whyte-street, Coleraine, solicitors for the said executor. 2396

CREDITORS, next of kin, and others having claims in respect of the estate of Alice Elizabeth Trowbridge, late of 28 Sudan-street, Coburg, widow (who died on the 19th July, 1947), are to send the particulars of their claims to the administratrix, Mrs. Kathleen Phyllis Hales, care of Messrs. Plante and Henty, 395 Collins-street, Melbourne, by the 17th January, 1948, after which date the administratrix will distribute the assets, having regard only to the claims of which she then has notice.

PLANTE & HENTY, 395 Collins-street, Melbourne, solicitors for the said administratrix. 2399

EMMA LAURA KING, late of 46 Brunswick-road west, Brunswick, in Victoria, gentlewoman, DECEASED (who died on the 8th June, 1947).

CREDITORS, next of kin, and all other persons having claims against the estate of the deceased are required by the executor of her will, Percy Thomas King, of 12 Ross-street, Kew, clerk, to send particulars to him, care of the under-mentioned solicitor, on or before the 16th January, 1948, after which date the said executor will distribute the assets, having regard only to the claims of which he then has notice.

M. S. MINOGUE, 243 Collins-street, Melbourne, solicitor for the executor. 2400

HAROLD HERBERT SHERLOCK, late of 43 Grange-road, Toorak, Melbourne, retired chartered accountant (Australia (who died 20th July, 1947).

CREDITORS, next of kin, and all other persons having claims against the estate of the deceased are required by the executors, to whom probate of the will was granted by the Supreme Court of Victoria, Richard Holden Sherlock, of "Roskhill," Apsley, contractor, and The Trustees, Executors, and Agency Company Limited, of 401 Collins-street, Melbourne, to send particulars to the said The Trustees, Executors, and Agency Company Limited, at its said address, on or before the 15th January, 1948, after which date the assets will be distributed, having regard only to the claims of which notice has then been received.

PLANTE & HENTY, 395 Collins-street, Melbourne, solicitors for the said executors. 2402

NOTICE is hereby given that all persons having claims against the estate of Margaret Irene Halliwell, late of "Northwood," Whittlesea, in the State of Victoria, spinster, deceased, intestate (who died on the 29th day of August, 1947, and administration of whose estate was granted by the Supreme Court of the said State, in its probate jurisdiction, on the 17th day of October, 1947, to George Lewis Halliwell, of Wallan Wallan-road, Whittlesea, in the said State, farmer), are hereby required to send particulars, in writing, to the undersigned, at their office hereunder mentioned, on or before the 23rd day of January, 1948, after which date the said George Lewis Halliwell will proceed to distribute the assets of the said Margaret Irene Halliwell, deceased, which shall have come to his hands amongst the persons entitled thereto, having regard only to the claims of which he shall then have had notice. And notice is hereby further given that the said George Lewis Halliwell will not be liable for the assets so distributed, or any part thereof, to any person of whose claim he shall not have had notice as aforesaid.

Dated this 6th day of November, 1947.

WATERS & STEWART, of 422 Collins-street, Melbourne, proctors for the said George Lewis Halliwell. 2424

IRENE LINDA MARY DUNCAN, late of 18 Barnsbury-road, Balwyn, in the State of Victoria, spinster, DECEASED (who died on the 15th day of October, 1947).

CREDITORS, next of kin, and all other persons having claims against the estate of the above-named Irene Linda Mary Duncan, deceased, are required by Francis McNab and Finlay McNab, both of 422 Collins-street, Melbourne, solicitors, the executors to whom probate of the will of the above-named deceased was granted on the 10th day of November, 1947, to send particulars of their claims to the said executors, at the office of the undersigned solicitors, on or before the 21st day of January, 1948, after which date they will distribute the assets of the said deceased among the persons entitled thereto, having regard only to the claims of which they then shall have notice, and they will not be liable to any person of whose claim they have not then received notice.

MCNAB & MCNAB, 422 Collins-street, Melbourne, and at Whittlesea and Sunbury, solicitors. 2426

PURSUANT to the *Trustee Act* 1928, all persons having claims against the estate of Clarice Evelyn Rogers, late of 29 Francis-street, West Coburg, in the State of Victoria, widow, deceased (who died on the 3rd day of October, 1947, and probate of whose will was granted by the Supreme Court of Victoria, on the 5th day of November, 1947, to Myrie Bernice Rogers and Shirley Mary Annie Rogers, both of 29 Francis-street, West Coburg aforesaid, spinsters), are hereby required to send particulars, in writing, of such claims to the said executrices, care of the undersigned, on or before the 23rd day of January, 1948, after which date the said executrices will proceed to distribute the assets of the said Clarice Evelyn Rogers, deceased, among the persons entitled thereto, having regard only to the claims of which they shall then have had notice, and the said executrices shall not be liable for the assets distributed, or any part thereof, to any person of whose claims they had not had notice as aforesaid.

OAKLEY, THOMPSON, & CO., solicitors, 443 Little Collins-street, Melbourne. 2427

NOTICE TO CLAIMANTS.

HERBERT KEITH TURNER, formerly of 4 Bank-place, Melbourne, now of 411 Collins-street, Melbourne, solicitor, and Ethel Constance Wilson, of 96 Bay-street, Brighton, grocer, the executors of the will and codicil of Amelia Ann Hinchcliffe (who died on the 16th day of January, 1947), require all creditors, next of kin, and others having claims against the property or estate of the said deceased to send to the said executors, care of Herbert Turner and Son, solicitors, of 411 Collins-street, Melbourne, on or before the 13th day of January, 1948, full particulars, in writing, of such claims, after which date the said executors intend to convey or distribute such property or estate to or among the persons entitled thereto, having regard only to the claims of which they shall have had notice.

Dated the 12th day of November, 1947.

HERBERT TURNER & SON, solicitors for the said executors. 2429

CREDITORS, next of kin, and others having claims in respect of the estate of Annie Hutchings, late of "The Farm," Bairnsdale, in the State of Victoria, widow (who died on the 26th day of June, 1947), are to send the particulars of their claims to The Equity Trustees, Executors, and Agency Company Limited, of 472 Bourke-street, Melbourne, by the 17th day of January, 1948, after which date it will distribute the assets, having regard only to the claims of which it then has notice.

HEDDERWICK, FOOKES, & ALSTON, 103 William-street, Melbourne, solicitors for the executor company.
2430

PURSUANT to the *Trustee Act* 1928, notice is hereby given that all persons having claims against the property or estate of Francis Keith Davison, late of 27 Queen's-road, Melbourne, in the State of Victoria, journalist, deceased (who died on the 15th day of October, 1946, and probate of whose will was granted by the Supreme Court of Victoria, on the 12th day of December, 1946, to Beryl Lucy Davison, of 74 Drumalbyn-road, Bellevue Hill, in the State of New South Wales, widow), are hereby required to send particulars, in writing, of such claims to the said Beryl Lucy Davison, addressed to the care of Messrs. Harwood and Pincott, of 472 Bourke-street, Melbourne aforesaid, solicitors, on or before the 19th day of January, 1948, after which date the said Beryl Lucy Davison will proceed to distribute the assets of the said Francis Keith Davison, deceased, amongst the persons entitled thereto, having regard only to the claims of which she shall then have had notice.

Dated this 7th day of November, 1947.

HARWOOD & PINCOTT, 472 Bourke-street, Melbourne, solicitors for the said Beryl Lucy Davison.
2431

CREDITORS, next of kin, and others having claims in respect of the estate of Rosaline May McDonald, late of 16 St. George's-road, Toorak, in the State of Victoria, married woman, deceased (who died on the 7th day of February, 1946), are to send the particulars of their claims to Herbert Le Poer Darvall, of 352 Collins-street, Melbourne, by the 16th day of January, 1948, after which date he will distribute the assets, having regard only to the claims of which he then has notice.

Dated the 12th day of November, 1947.

KRCROUSE, OLDHAM, & DARVALL, solicitors, 352 Collins-street, Melbourne.
2417

PURSUANT to the *Trustee Act* 1928, all persons having claims against the estate of Ada Dora Gething, late of 23 Lansdowne-street, East Melbourne, spinster, deceased (who died on the 26th day of September, 1947, and probate of whose will was granted by the Supreme Court of Victoria, on the 3rd day of November, 1947, to Violet Maud Gardner, of 12 Coppins-grove, Hawthorn, married woman, and Beatrice Fay Savage, of 368 Wattletree-road, East Malvern, married woman, the executrices appointed by the deceased's will), are hereby required to send particulars of such claims to the said Violet Maud Gardner and Beatrice Fay Savage, care of the under-mentioned solicitors, on or before the 13th day of January, 1948, after which date the said executrices will distribute the assets, having regard only to the claims of which notice has then been received.

Dated the 6th day of November, 1947.

MARTIN & MARTIN, solicitors, 37 Queen-street, Melbourne.
2418

PURSUANT to the *Trustee Act* 1928, persons having claims against the estate of John Leonard Barnes, late of 92 The Esplanade, Brighton Beach, in the State of Victoria, builder, deceased (who died on the 27th day of July, 1947, and probate of whose will (and codicil) was granted by the Supreme Court of Victoria, on the 7th day of October, 1947, to Leonard Charles Barnes, of 1 Wiltonvale-crescent, East Malvern, in the said State, builder, John Barnes, of 47 Hanby-street, Brighton, in the said State, secretary, and Horace Bruce Roberts, of 22 Fulton-street, East St. Kilda, in the said State, accountant, the executors named in the said will), are hereby required to send particulars, in writing, of such claims to the said executors, care of the undersigned solicitors, on or before the 17th day of January, 1948, after which date the said executors will proceed to convey or distribute the said estate to or among the persons entitled thereto, having regard only to the claims, whether formal or not, of which they shall then have had notice, and they will not be liable for the assets so distributed to any person of whose claim they shall not then have had notice.

PROUDFOOT, HORTON, & COX, 87 Queen-street, Melbourne, solicitors for the executors.
2419

PURSUANT to the *Trustee Act* 1928, persons having claims against the estate of Sarah Ann Ostberg, late of 417 Inkerman-road, St. Kilda, in the State of Victoria, widow, deceased (who died on the 13th day of July, 1947, and probate of whose will was granted by the Supreme Court of Victoria, on the 7th day of October, 1947, to Amy Irene Christina Ostberg, of 417 Inkerman-road, St. Kilda aforesaid, teacher, the executrix named in the said will), are hereby required to send particulars, in writing, of such claims to the said executrix, care of the undersigned solicitors, on or before the 17th day of January, 1948, after which date the said executrix will proceed to convey or distribute the said estate to or among the persons entitled thereto, having regard only to the claims, whether formal or not, of which she shall then have had notice, and she will not be liable for the assets so distributed to any person of whose claim she shall not then have had notice.

PROUDFOOT, HORTON, & COX, 87 Queen-street, Melbourne, solicitors for the executrix.
2420

PURSUANT to the *Trustee Act* 1928, notice is hereby given that all persons having claims against the estate of Edith Mabel Keir, late of 52 Cruickshank-street, Port Melbourne, married woman, deceased (who died on 27th August, 1947, probate of whose will was granted by the Supreme Court of Victoria (probate jurisdiction) to Albert Edward Hocking, of 2 O'Shannassy-street, Essendon, motor-engineer, and Edith Isabella Martha McLaverty, of 68 Barrow-street, Coburg, married woman, the executors appointed by deceased's will), are required to send particulars, in writing, of such claims to the said executors, care of the undersigned, at the address hereunder mentioned, on or before the 20th day of January, 1948, after which date the said executors will proceed to convey or distribute the assets of the said deceased to or amongst the persons entitled thereto, having regard only to the claims of which they shall then have had notice.

PROUDFOOT, HORTON, & COX, solicitors, 87 Queen-street, Melbourne.
2421

ANNIE BURNS CAMERON, DECEASED.

PURSUANT to the *Trustee Act* 1928, notice is hereby given that all persons having claims against the estate of Annie Burns Cameron, formerly of Lancefield, but late of 136 Gatehouse-street, Parkville, in the State of Victoria, married woman, deceased (who died on the 10th day of June, 1947, and probate of whose will was granted by the Supreme Court of Victoria, on the 31st day of October, 1947, to The Union Trustee Company of Australia Limited, of 333 Collins-street, Melbourne, in the said State), are hereby required to send particulars, in writing, of such claims to the said The Union Trustee Company of Australia Limited, at its above-mentioned address, on or before the 19th day of January, 1948, after which date the said The Union Trustee Company of Australia Limited will proceed to distribute the assets of the said Annie Burns Cameron, deceased, which shall have come to its hands, amongst the persons entitled thereto, having regard only to the claims of which it shall then have had notice. And notice is hereby further given that the said The Union Trustee Company of Australia Limited will not be liable for the assets so distributed, or any part thereof, to any person of whose claim it shall not have had notice as aforesaid.

Dated this 7th day of November, 1947.

RODDA, BALLARD, & VROLAND, 430 Little Collins-street, Melbourne, solicitors for the executor.
2422

PURSUANT to the *Trustee Act* 1928, notice is hereby given that all persons having claims against the estate of Jane Isabella Aikman, late of Mortlake, in the State of Victoria, spinster, deceased (who died on the 8th day of April, 1947, and probate of whose will was granted by the Supreme Court of the said State, in its probate jurisdiction, on the 30th day of October, 1947, to The Trustees, Executors, and Agency Company Limited, of No. 401 Collins-street, Melbourne, in the said State), are hereby required to send particulars, in writing, of such claims to the said company, at its above-mentioned address, on or before the 16th day of January, 1948, after which date the said company will proceed to distribute the assets of the said Jane Isabella Aikman, deceased, which shall have come to its hands amongst the persons entitled thereto, having regard only to the claims of which it shall then have had notice. And notice is hereby further given that the said company will not be liable for the assets so distributed, or any part thereof, to any person of whose claim it shall not have had notice as aforesaid.

Dated this 5th day of November, 1947.

W. L. L. ARCHER, of Dunlop-street, Mortlake, proctor for the said company.
2389

RE GEORGE MADDEN, DECEASED.

NOTICE is hereby given that all persons having claims against the property or estate of George Madden, late of "Strathire," Batesford, farmer, deceased (who died on the 14th day of September, 1947, and probate of whose will was granted to George Baker Madden, of Wycheproof, farmer, and Robert John Madden, of Bell Post Hill, Geelong, farmer), are hereby required to send, in writing, particulars of such claims to the said George Baker Madden and Robert John Madden, in the care of the under-mentioned solicitors, on or before the 15th day of January, 1948, after which date they will convey or distribute such property or estate to or among the persons entitled thereto, having regard only to the claims of which they shall then have had notice.

HARWOOD & PINCOTT, 51 Yarra-street, Geelong, solicitors for the said George Baker Madden and Robert John Madden. 2369

RE CLARA BOTT, DECEASED.

CREDITORS, next of kin, and others having claims in respect of the estate of Clara Bott, late of 11 Cintra-avenue, East St. Kilda, in the State of Victoria, spinster, deceased (who died on the 9th day of July, 1947), are to send the particulars of their claims to The Trustees, Executors, and Agency Company Limited, of 401 Collins-street, Melbourne, in the said State, by the 15th day of January, 1948, after which date it will distribute the assets, having regard only to the claims of which it then has notice.

HARGRAVE & HARGRAVE, Yarrowonga, proctors for the said company. 2363

NOTICE TO CREDITORS.

PURSUANT to the *Trustee Act* 1928, notice is hereby given that all creditors, next of kin, and others having claims against the estate of Norman Wilson, formerly of Mildura, jeweller, but late of 34 Victoria-street, Elsternwick, in the State of Victoria, gentleman, deceased (who died on the 2nd day of April, 1947), are hereby required to send particulars, in writing, of such claims to the executors, Mary Stewart Jane Wilson and Lindsay Barber, care of the undersigned solicitor, on or before the 15th day of January, 1948, after which date the executors will proceed to distribute the assets of the said deceased amongst the persons entitled thereto, having regard only to the claims of which they shall then have had notice, and will not be liable for the assets so distributed to any person of whose claim they shall not then have had notice.

Dated this 31st day of October, 1947.

KENNETH J. CLEMENTS, 29 Glenhuntly-road; Elsternwick, solicitor for the executors. 2364

NOTICE TO CREDITORS.

PURSUANT to the *Trustee Act* 1928, notice is hereby given that all creditors, next of kin, and others having claims against the estate of Herbert Russell Smith, formerly of 17, but late of 27, Regent-street, Elsternwick, in the State of Victoria, retired leather worker, deceased (who died on the 22nd day of March, 1947), are hereby required to send particulars, in writing, of such claims to the executrix of the said deceased, Mary Irene McNamara, care of the undersigned solicitor, on or before the 15th day of January, 1948, after which date the executrix will proceed to distribute the assets of the said deceased amongst the persons entitled thereto, having regard only to the claims of which she shall then have had notice, and will not be liable for the assets so distributed to any person of whose claim she shall not then have had notice.

Dated this 30th day of October, 1947.

KENNETH J. CLEMENTS, 29 Glenhuntly-road, Elsternwick, solicitor for the executrix. 2365

EDITH HELEN CROSS, formerly of 6 Clarendon-street, but late of 28 Hotham-street, Ballarat, in the State of Victoria, spinster, DECEASED (who died on the 20th day of July, 1947).

CREDITORS, next of kin, and all other persons having claims against the estate of the said deceased are required by the executor, Robert Hamilton Ramsay, of 41 Lydiard-street, Ballarat aforesaid, solicitor, to send detailed particulars of their claims in respect of the said property to the said executor, on or before the 7th day of January, 1948, after which date he will proceed to distribute the said estate, having regard only to the claims of which he then has notice.

Dated this 3rd day of November, 1947.

R. H. RAMSAY, 41 Lydiard-street, Ballarat, solicitor for the said executor. 2370

ELLEN MCRAE, late of Nhill, in the State of Victoria, spinster, DECEASED (who died on the 20th day of September, 1947).

CREDITORS, next of kin, and all other persons having claims against the estate of the said deceased are required by the executor, Robert Hamilton Ramsay, of 41 Lydiard-street, Ballarat, in the said State, solicitor, to send detailed particulars of their claims in respect of the said property to the said executor, on or before the 7th day of January, 1948, after which date he will proceed to distribute the said estate, having regard only to the claims of which he then has notice.

Dated this 3rd day of November, 1947.

R. H. RAMSAY, 41 Lydiard-street, Ballarat, solicitor for the said executor. 2371

CREDITORS, next of kin, and others having claims in respect of the estate of William Culph Sherwill, late of Benalla, fruiterer and linesman, deceased (who died on the 4th day of June, 1947), are to send particulars of their claims to THE PERPETUAL EXECUTORS AND TRUSTEES ASSOCIATION OF AUSTRALIA LIMITED, at its registered office, 100-104 Queen street, Melbourne, by the 17th day of January, 1948, after which date it will distribute the assets, having regard only to the claims of which it then has notice.

F. TRENERRY BROWN & SON, solicitors, Benalla. 2375

CREDITORS, next of kin, and others having claims in respect of the estate of Wallace Andrew Bartlett, late of 176 Orrong-road, Toorak, managing director, formerly company manager, deceased (who died on the 20th July, 1947), are to send particulars of their claims to The Trustees, Executors, and Agency Company Limited, of 401 Collins-street, Melbourne, and Marjorie Adeline Bartlett, of 176 Orrong-road, Toorak, widow, on or before the 15th January, 1948, after which date the executors will distribute the estate, having regard only to claims of which they then have notice.

MOULE, HAMILTON, & DERHAM, solicitors, 394 Collins-street, Melbourne. 2387

PURSUANT to the *Trustee Act* 1928, all persons having claims against the property or estate of Leslie Horscroft, late of 14 Sidwell-avenue, East St. Kilda, in Victoria, manufacturer, deceased (who died on the 6th day of July, 1947, and probate of whose will was granted by the Supreme Court of Victoria, on the 7th day of November, 1947, to Olive Mary Horscroft, widow, of 14 Sidwell-avenue, East St. Kilda aforesaid, and John Ralph Burt, of 120 William-street, Melbourne, solicitor, the executors named in and appointed by the said will), are hereby required to send particulars of such claims to the said executors, addressed to the care of Messieurs Blake and Riggall, 120 William-street, Melbourne, solicitors, on or before the 15th day of January, 1948, after the expiration of which time the said executors will proceed to distribute the assets of the said deceased amongst the persons entitled thereto, having regard only to the claims of which they shall have had notice.

Dated this 11th day of November, 1947.

BLAKE & RIGGALL, 120 William-street, Melbourne, solicitors for the said executors. 2406

ROBERT FULLERTON, formerly of 37 McPherson-street, Footscray, but late of 12 Jerrold-street, Footscray, in the State of Victoria, moulder, DECEASED (who died on the 1st day of September, 1947).

CREDITORS, next of kin, and all other persons having claims against the estate of the above-named deceased are required by the executrix, Mabel Cox, formerly of 37 McPherson-street, Footscray, but now of 12 Jerrold-street, Footscray aforesaid, widow, to send particulars to her, care of the undersigned, on or before the 15th day of January, 1948, after which date she will distribute the assets, having regard only to the claims of which she then has notice.

W. H. JONES & KENNEDY, solicitors, 214 Nicholson-street, Footscray. 2416

CREDITORS, next of kin, and others having claims in respect of the estate of Henry Jenner, late of Cowes, Phillip Island, gentleman, deceased (who died on the 10th September, 1947), are to send particulars of their claims to Frederick Jenner, of Cowes, Phillip Island, farmer, care of the undersigned, by 20th January, 1948, after which date the executor will distribute the assets, having regard only to the claims of which he then has notice.

HENDERSON & BALL, solicitors, 430 Little Collins-street, Melbourne. 2415

NOTICE TO CLAIMANTS.—*RE* PATRICK PHYLAND,
DECEASED.

THE PERPETUAL EXECUTORS AND TRUSTEES ASSOCIATION OF AUSTRALIA LIMITED, whose registered office is situate at 100-104 Queen-street, Melbourne, the executor of the will of Patrick Phyland, formerly of 6 Budd-street, North Brighton, but late of 22 Fallon-street, Caulfield, in the State of Victoria, retired farmer, deceased (who died on the 28th September, 1947), requires all creditors, next of kin, and others having claims against the property or estate of the said deceased, to send to the said company, on or before the 13th day of January, 1948, particulars, in writing, of such claims, after which date the said company intends to convey or distribute such property or estate to or among the persons entitled thereto, having regard only to the claims of which it shall have had notice.

H. S. W. LAWSON & CO., solicitors; 314 Collins-street, Melbourne. 2391

PURSUANT to the *Trustee Act* 1928, all persons having claims against the property or estate of Elizabeth Ada Opie, late of 351 Royal-parade, Parkville, in Victoria, married woman, deceased (who died on the 8th day of June, 1947, and probate of whose will was granted by the Supreme Court of Victoria, on the 6th day of November, 1947, to Thomas Walter Opie, grazier, of "Milton Hall," Greta, near Wangaratta, and Bernard Gore Brett, solicitor, of 120 William-street, Melbourne, both in Victoria, the executors named in and appointed by the said will), are hereby required to send particulars of such claims to the said executors, addressed to the care of Messieurs Blake and Riggall, 120 William-street, Melbourne, solicitors, on or before the 15th day of January, 1948, after the expiration of which time the said executors will proceed to distribute the assets of the said deceased amongst the persons entitled thereto, having regard only to the claims of which they shall have had notice.

Dated this 11th day of November, 1947.

BLAKE & RIGGALL, 120 William-street, Melbourne, solicitors for the said executors. 2407

PURSUANT to the *Trustee Act* 1928, all persons having claims against the property or estate of Ruby Mabel Gayer, late of 14 Rockley-road, South Yarra, in Victoria, spinster, deceased (who died on the 19th day of July, 1947, and probate of whose will was granted by the Supreme Court of Victoria, on the 7th day of November, 1947, to John Ralph Burt and Hubert Silvers Black, both of 120 William-street, Melbourne, in Victoria, solicitors, the executors named in and appointed by the said will), are hereby required to send particulars of such claims to the said executors, addressed to the care of Messieurs Blake and Riggall, 120 William-street, Melbourne, solicitors, on or before the 15th day of January, 1948, after the expiration of which time the said executors will proceed to distribute the assets of the said deceased amongst the persons entitled thereto, having regard only to the claims of which they shall have had notice.

Dated this 11th day of November, 1947.

BLAKE & RIGGALL, 120 William-street, Melbourne, solicitors for the said executors. 2408

CREDITORS, next of kin, and others having claims in respect of the estate of John Tonkyn Williams, late of 26 Kneen-street, North Fitzroy, in the State of Victoria, gentleman, deceased (who died on the 3rd day of June, 1947), are to send particulars of their claims to The Perpetual Executors and Trustees Association of Australia Limited, of 100-104 Queen-street, Melbourne, by the 27th day of January, 1948, after which date it will distribute the assets, having regard only to the claims of which it then has notice.

HENDERSON & BALL, solicitors, 430 Little Collins-street, Melbourne. 2414

NOTICE TO CLAIMANTS.

THE PERPETUAL EXECUTORS AND TRUSTEES ASSOCIATION OF AUSTRALIA LIMITED, of 100-104 Queen-street, Melbourne, and Minnie Louisa Stevenson, of Benalla, widow, the executors of the will of John Sykes Stevenson, late of Carrier-street, Benalla, storekeeper (who died on the 17th day of July, 1947), require all creditors, next of kin, and others having claims against the property or estate of the said deceased to send to the said executors, care of the said association, on or before the 6th day of January, 1947, particulars, in writing, of such claims, after which date the said executors intend to convey or distribute such property or estate to or among the persons entitled thereto, having regard only to the claims of which they shall have had notice.

Dated the 1st day of November, 1947.

HAMILTON CLARKE & CLARKE, Nunn-street, Benalla, proctors for the said executors. 2374

Trustee Act 1928.

NOTICE TO CLAIMANTS.

PURSUANT to the *Trustee Act* 1928, creditors, next of kin, and all other persons having claims in respect of the estate of any deceased person named below are required to send particulars thereof to the legal personal representative or representatives at the address stated below, on or before the date stated, after which date the representative or representatives will distribute the assets, having regard only to the claims of which notice has been received:—

Leo Frederick Kosseck, late of Torquay-road, Belmont, in the State of Victoria, farmer, died 7th August, 1947.—Claims to Leonard Julius Kosseck and Frieda Wilhelmina Kosseck, both of Torquay-road, Belmont, care of Doyle and Kerr, solicitors, Little Malop-street, Geelong, by the 14th January, 1948. 2372

Albert Edward Read, late of 57 William-street, Newport, greengrocer, deceased, died 13th September, 1947.—Claims to the executor, Leslie Barton, of 37 William-street, Newport, carpenter, care of John F. Carroll, solicitor, 4 Paisley-street, Footscray, by 15th January, 1948. John F. Carroll, LL.B., solicitor, 4 Paisley-street, Footscray. 2394

Amelia Sloss (sometimes called Amy Sloss), formerly of 101 Creeves-street, Fitzroy, but late of 15 Byrne-avenue, Elwood, married woman, deceased, died 8th day of September, 1947.—Claims to the executors, Edward William Howard Sloss, of 4 Addison-street, Elwood, purchasing officer, and Frederick Carter Read, of Temple Court, 422-8 Collins-street, Melbourne, solicitor, care of Read and Read, solicitors, Temple Court, 422-8 Collins-street, Melbourne aforesaid, by the 17th day of January, 1948. 2386

Elsie Victoria Thornley, late of "Pen-y-byrn," Natimuk-road, Horsham, married woman, deceased, died 4th November, 1946.—Claims to the executors, The Trustees, Executors, and Agency Company Limited, of 401 Collins-street, Melbourne, and Wilfred John Thornley, of Natimuk-road, Horsham, care of The Trustees, Executors, and Agency Company Limited, by 15th February, 1948. 2404

MINING NOTICES.

ARGUS HILL CHEWTON GOLD NO LIABILITY.

FORFEITURE NOTICE.

NOTICE is hereby given that all shares forfeited for non-payment of No. 48 (October) Call of Three pence per share will be sold by public auction in the vestibule of the Stock Exchange, 428 Chancery-lane, Melbourne, on Friday, 21st November, 1947, at a quarter to Twelve a.m., unless shares are previously redeemed.

By order of the Board,

FRANK COOPER, Manager.

422 Collins-street, Melbourne, C.1.

2409

NEW CHUM SYNCLINE GOLD MINE NO LIABILITY.

FORFEITURE NOTICE.

NOTICE is hereby given that all shares forfeited for non-payment of No. 88 (October) Call of Three pence per share will be sold by public auction in the vestibule of the Stock Exchange, 428 Chancery-lane, Melbourne, on Wednesday, 19th November, 1947, at a quarter to Twelve a.m., unless shares are previously redeemed.

By order of the Board,

FRANK COOPER, Manager.

422 Collins-street, Melbourne, C.1.

2410

SOUTH DEBORAH GOLD MINES NO LIABILITY.

NOTICE.—All shares in this company (included in Nos. 1 to 60,000) on which the 22nd Call of Six pence per share remains unpaid are forfeited, and will be sold by public auction at the Stock Exchange, Bendigo, on Friday, 21st November, 1947, at Four o'clock p.m., unless previously redeemed, as required by the *Companies Act 1938*.

J. J. STANISTREET
2366 (McColl, Rankin, and Stanistreet), Manager.

CENTRAL NELL GWYNNE GOLD MINING COMPANY NO LIABILITY.

NOTICE.—All shares in this company (included in Nos. 1 to 100,000) on which the 37th Call of Six pence per share remains unpaid are forfeited, and will be sold by public auction at the Stock Exchange, Bendigo, on Friday, 21st November, 1947, at Four o'clock p.m., unless previously redeemed, as required by the *Companies Act 1938*.

J. J. STANISTREET
2367 (McColl, Rankin, and Stanistreet), Manager.

NEW BUTLER'S TIN MINES NO LIABILITY.

NOTICE is hereby given that the transfer books of the above-named company will be closed on Saturday, 22nd November, 1947, at Twelve noon, for the purpose of determining shareholders entitled to participate in rights of the new issue offered to registered shareholders in the proportion of one new share for each share held.

By order of the Board,
FRANK COOPER, Manager.
422 Collins-street, Melbourne, C.1. 2411

NEW BUTLER'S TIN MINES NO LIABILITY.

NOTICE is hereby given that the capital of the above-named company has been increased from £18,000 to £72,000 by creating 36,000 new shares of Twenty shillings each and by raising the value of the existing 36,000 shares of Ten shillings to Twenty shillings each.

By order of the Board,
FRANK COOPER, Manager.
422 Collins-street, Melbourne, C.1. 2412

MOUNT TODD GOLD MINE NO LIABILITY.

NOTICE is hereby given that the capital of the above-named company has been increased from £31,250 to £62,500, by raising the value of the existing 125,000 shares of Five shillings each to Ten shillings each.

By order of the Board,
FRANK COOPER, Manager.
422 Collins-street, Melbourne, C.1. 2413

Companies Act 1938.

FIFTEENTH SCHEDULE.—PART A.

I. THE undersigned, hereby make application to register Northern Star Gold Mines as a company, under the provisions of Part II. of the *Companies Act 1938*.

1. The name of the company is to be Northern Star Gold Mines No Liability.
2. The place of operations is at Kevington.
3. The registered office of the company will be situate at 140 Queen-street, Melbourne.
4. The value of the company's property, including leased ground, is £5,100.
5. The number of shares in the company is 60,000, of Ten shillings each.
6. The number of shares subscribed for is 40,000, being not less than 25 per centum of the entire number of shares in the company.
7. The amount of the subscribed capital which is paid up is £1,500, being not less than 5 per centum of the subscribed capital.
8. The name of the manager is Frederick Leopold Smyth.

No. 433.—11656/47.—3

9. The names and addresses and occupations of at least two shareholders who have subscribed for shares in the company, and the number of shares subscribed for by each of them at this date, are as follows:—

Name, Address, Occupation.	No. of Shares.
Henry Fox, 44 Wills-street, Glen Iris, secretary	300
John Roberts, 46 Alfred-road, Essendon North, retired civil servant	300
Frank Joseph Trainor, House of Commons Hotel, Melbourne, hotel proprietor	300

F. L. SMYTH, Manager.
Dated this 10th day of November, 1947.

Witness to signature—A. S. RICHARDSON, J.P.

I, FREDERICK LEOPOLD SMYTH, do solemnly and sincerely declare that—

1. I am the manager of the said intended company.
2. The above statement is to the best of my belief and knowledge true in every particular. And I make this solemn declaration conscientiously believing the same to be true, and by virtue of the provisions of an Act of the Parliament of Victoria rendering persons making a false declaration punishable for wilful and corrupt perjury.

F. L. SMYTH,
Taken before me, this 10th day of November, 1947.—
A. S. RICHARDSON, J.P. 2423

IMPOUNDINGS.

COLAC.—Impounded in Colac Pound.

- 1 draught bay mare, three white legs, white blaze on face, no visible brand
 - 1 dark Jersey heifer, like JL off rump
 - 1 black and white heifer, no visible brand
- If not claimed and expenses paid, to be sold on 13th November, 1947.

2358—6/
JAMES MCCONNELL,
Poundkeeper.

DANDENONG.—Impounded at Dandenong, from Mr. Young's property, at Scoresby.

- 1 brown draught gelding, white face, white front feet, unshod, no visible brand
- If not claimed and expenses paid, to be sold on 27th November, 1947.

2380—5/4
A. WALKER,
Poundkeeper.

JUNG.—Impounded at Jung.

- 1 black steer, no visible brand
- 1 red steer, no visible brand
- 2 black and white steers, no visible brand
- 3 red and white steers, no visible brand

If not claimed and expenses paid, to be sold on 6th December, 1947.

2398—6/
H. PHILLIPS,
Poundkeeper.

PAKENHAM.—Impounded in Pakenham Pound.

- 1 brown draught gelding, hind feet and one fore foot white, lame near front foot, blaze, no visible brand
- If not claimed and expenses paid, to be sold on 28th November, 1947.

2378—4/3
JAMES J. AHERN,
Poundkeeper.

STATE ACTS, 1944.

COPIES of the following Acts of Parliament of Victoria may be obtained at the Government Printing Office, or from any bookseller, at the price set opposite to each:—

No.	Price. s. d.
4999. Consolidated Revenue	0 6
5000. Local Government (Polling Booths) .. .	0 6
5001. Police Offences (Unlawful Games) .. .	0 6
5002. Hospitals and Charities	0 6
5003. Water (Loddon)	0 6
5004. Justices	0 6
5005. Coal Mines Regulation (Amendment) .. .	0 6
5006. Consolidated Revenue	0 6
5007. Melbourne and Metropolitan Board of Works (Contributions)	0 6
5008. Marketing of Primary Products	0 6
5009. National Security (Emergency Powers) Con- tinuation	0 6
5010. Outer Circle Railway (Partial Dismantling)	0 6
5011. Mines (Minerals)	0 6
5012. Goods (Textile Products)	0 6
5013. Masseurs	0 6
5014. Electoral (War Service Deaths)	0 6
5015. Cremorne Bridge	0 6
5016. Melbourne Harbor Trust	0 6
5017. Water	0 9
5018. Consolidated Revenue	0 6
5019. Mildura Irrigation and Water Trusts .. .	0 6
5020. Farm Water Supplies Advances	0 6
5021. Sewerage Districts	0 6
5022. Trustee Companies	0 6
5023. Mildura Irrigation and Water Trusts (Super- annuation)	0 6
5024. Consolidated Revenue	0 6
5025. Cemeteries	0 6
5026. Border Railways	0 6
5027. Local Government (Shire of Blackburn and Mitcham)	0 6
5028. Electoral Districts	0 6
5029. Land	0 6
5030. Land Tax	0 6
5031. Administration and Probate Duties .. .	0 6
5032. Stock Foods (Amendment)	0 6
5033. Stamps (Increased Duty Continuance) .. .	0 6
5034. Maribyrnong and Ashburton Lands Exchange	0 6
5035. Financial Emergency (Grants and Funds) .. .	0 6
5036. Farmers Advances	0 6
5037. Land Settlement (Acquisition) Amendment	0 6
5038. Railways	0 6
5039. Farmers Protection (Amendment)	0 6
5040. Country Fire Authority	1 9
5041. Country Roads Board Fund	0 6
5042. Railway Loan and Application	0 6
5043. Town and Country Planning	1 0
5044. Agricultural Colleges	0 9
5045. Heatherton Sanatorium	0 6
5046. Health (Infectious Diseases Hospitals)	0 6
5047. Surplus Revenue	0 6
5048. Water Supply Loans Application	0 9
5049. State Forests Loan and Application .. .	0 6
5050. Public Works Loan and Application .. .	0 6
5051. Commonwealth and States Financial Agree- ment	1 3
5052. The Constitution Act Amendment	0 6
5053. Public Library National Gallery and Museums	0 9
5054. Drought Relief	0 6
5055. Co-operative Housing Societies	1 6
5056. Local Government	1 0
5057. Melbourne and Metropolitan Board of Works	0 9
5058. Appropriation of Revenue	3 9

J. J. GOURLEY,
Government Printer.

STATE ACTS, 1945.

COPIES of the following Acts of Parliament of Victoria may be obtained at the Government Printing Office, or from any bookseller, at the price set opposite to each:—

No.	Price. s. d.
5059. Mildura Irrigation and Water Trusts (Borrow- ing)	0 6
5060. Supreme Court (Judges)	0 6
5061. Oakleigh (Regent-street) Land	0 6
5062. Swine	0 6
5063. Drought Relief (Amendment)	0 6
5064. Unclaimed Moneys	0 6
5065. Consolidated Revenue	0 6
5066. Consolidated Revenue	0 6
5067. Agent-General's	0 6
5068. Land Surveyors (Amendment)	0 6
5069. State Development	0 6
5070. Melbourne and Metropolitan Board of Works (Borrowing Powers)	0 6
5071. Education	0 6
5072. Water	0 6
5073. National Security (Repeal)	0 6
5074. Moorabbin (Unimproved Rating Poll) .. .	0 6
5075. Licensing (Poll)	0 6
5076. Lilydale Waterworks Trust Abolition .. .	0 6
5077. East Melbourne Land	0 6
5078. Health (Wines)	0 6
5079. Local Government (Emergency Housing Accommodation)	0 6
5080. Law Institute	0 6
5081. Bendigo Land	0 6
5082. Consolidated Revenue	0 6
5083. Consolidated Revenue	0 6
5084. Consolidated Revenue	0 6
5085. Factories and Shops (Bread Holidays) .. .	0 6
5086. Administration and Probate Duties .. .	0 6
5087. Land Tax	0 6
5088. Stamps (Increased Duty Continuance) .. .	0 6
5089. Licensing Fund	0 6
5090. Employers and Employés	0 6
5091. Farmers Advances	0 6
5092. University (Veterinary Research)	0 6
5093. Surplus Revenue	0 6
5094. State Forests Loan and Application .. .	0 6
5095. Mines (Amendment)	0 6
5096. Farmers Protection (Amendment)	0 6
5097. Railway Loan Application	0 6
5098. Public Works Loan and Application .. .	0 6
5099. Water Supply Loans Application	0 9
5100. Public Account Advances (Amendment) .. .	0 6
5101. Hospital Benefits	0 6
5102. Totalizator (Amendment)	0 6
5103. Financial Emergency (Municipal Endowment)	0 6
5104. Country Roads Board Fund (Amendment) .. .	0 6
5105. Coal Mines Regulation (Amendment) .. .	0 6
5106. Melbourne and Metropolitan Tramways (Chair- man)	0 6
5107. Soldier Settlement	1 3
5108. Appropriation of Revenue	4 0

J. J. GOURLEY,
Government Printer

STATE ACTS, 1946.

COPIES of the following Acts of Parliament of Victoria may be obtained at the Government Printing Office, or from any bookseller, at the price set opposite to each:—

No.	Price.
	s. d.
5109. Geelong Land	0 6
5110. Transport Regulation (Amendment)	0 6
5111. Factories and Shops (Annual Holidays)	0 9
5112. Mornington Sewerage Authority (Validation)	0 6
5113. Local Government (Emergency Housing Accommodation) Amendment	0 6
5114. Housing (Commonwealth and State Agreement)	1 0
5115. Factories and Shops (Early Closing)	0 6
5116. Building Operations and Building Materials Control	0 9
5117. Water (Levee Banks)	0 9
5118. Co-operative Housing Societies	0 6
5119. Local Government (Municipal Rolls)	0 6
5120. Public Works Loan and Application	0 6
5121. Totalizator (Charities)	0 6
5122. Drought Relief	0 6
5123. Taxation (Arrangements)	0 6
5124. Public Service	1 6
5125. Teaching Service	1 3
5126. Police Regulation	1 0
5127. Railways (Long Service)	0 6
5128. Workers' Compensation	1 6
5129. Sewerage Districts (Amendment)	0 6
5130. Factories and Shops (Bread)	0 6
5131. Crimes (Intermediate Sentences)	0 6
5132. Medical (Chemists' Apprentices)	0 6
5133. Soldier Settlement (Amendment)	0 6
5134. Consolidated Revenue	0 6
5135. Consolidated Revenue	0 6
5136. Apprenticeship	0 6
5137. Consolidated Revenue	0 6
5138. Consolidated Revenue	0 6
5139. Consolidated Revenue	0 6
5140. Nicholson-street Tramway Construction	0 6
5141. Burke-road Tramway Construction	0 6
5142. Ballaarat Gas Company's	0 6
5143. Melbourne and Metropolitan Board of Works (Contributions)	0 6
5144. Stamps (Betting Tax)	0 6
5145. Juries (Fees)	0 6
5146. Cattle and Swine Compensation	0 6
5147. Marine (Pilots and Pilotage Rates)	0 6
5148. Patriotic Funds	0 6
5149. Stock Foods (Amendment)	0 6
5150. Municipal Endowment (Temporary Discontinuance)	0 6
5151. Medical Practitioners' Registration	0 6
5152. Seeds	0 6
5153. Water	0 6
5154. Clifton Hill Land	0 6
5155. Tobacco Sellers	0 6
5156. Country Roads Board Fund (Amendment)	0 6
5157. Moorpanyal Land	0 6
5158. Factories and Shops (Annual Holidays) Amendment	0 6
5159. Factories and Shops (Wages Boards)	0 6
5160. Melbourne and Metropolitan Tramways (Amendment)	0 6
5161. Infectious Diseases Hospital (Borrowing)	0 6
5162. University (Mildura Branch)	0 6
5163. Farmers Protection (Amendment)	0 6
5164. Forests (Exchange of Lands) Extension	0 6
5165. Money Lenders (Cash Orders)	0 6
5166. Local Government (Dandenong Street Construction)	1 0

STATE ACTS, 1946—continued.

No.	Price.
	s. d.
5167. Stamps (Increased Duty Continuance)	0 6
5168. Land Tax	0 6
5169. Cattle Breeding	0 6
5170. Administration and Probate Duties	0 6
5171. Co-operative Housing Societies (Guarantees)	0 6
5172. Railways (Sick Leave)	0 6
5173. Fruit and Vegetables	0 6
5174. Farm Water Supplies and Drainage Advances	0 6
5175. State Forests Loan and Application	0 6
5176. Melbourne South Land	0 6
5177. Agricultural Colleges (Amendment)	0 6
5178. Drought Relief (Amendment)	0 6
5179. Soldier Settlement	1 9
5180. Free Library Service Board	0 6
5181. Adult Education	0 6
5183. Evidence	0 6
5184. Housing (Discharged Servicemen)	0 6
5185. Parliamentary Contributory Retirement Fund	0 6
5186. Friendly Societies	0 6
5187. Police Offences (Race-meetings)	0 6
5188. Railways (Mont Park Siding)	0 6
5189. Land (Grazing Licences)	0 6
5190. Factories and Shops (Bread Carters)	0 6
5191. Country Fire Authority	1 0
5192. Supreme Court (Judges)	0 6
5193. Railway Loan Application	0 6
5194. Metropolitan Gas Company's	0 6
5195. Railways (Temporary Employés)	0 6
5196. Railways (State Coal Mine)	0 6
5197. Licensing	0 6
5198. Town and Country Planning	0 6
5199. Public Works Loan and Application (No. 2)	0 6
5201. Trotting Races	0 6
5202. Economic Stability	0 6
5204. Stamps	2 3
5206. Melbourne and Metropolitan Tramways (Appeal Board)	0 6

J. J. GOURLEY,
Government Printer.

STATE ACTS, 1947.

COPIES of the following Acts of Parliament of Victoria may be obtained at the Government Printing Office, or from any bookseller, at the price set opposite to each:—

No.	Price.
	s. d.
5207. Consolidated Revenue	0 6
5208. Custodian Trustee	0 6
5209. Revocation and Excision of Crown Reservations	0 9
5210. Farmers Advances (Amendment)	0 6
5211. Private Bill Committees	0 6
5212. Health (Amendment)	0 6
5213. Wills (Amendment)	0 6
5214. Old Colonists' Association	0 6
5215. Consolidated Revenue	0 6
5216. Local Authorities Superannuation	1 0
5217. Statute Law Revision	0 6
5218. Motor Car (Registration Fees)	0 6
5219. State Electricity Commission (Yallourn Area)	0 6
5220. Transport Regulation (Licences and Fees)	0 6
5221. Local Government (Private Street Construction)	0 6
5222. State Development (Amendment)	0 6
5223. Coal Mine Workers Pensions	0 6
5224. State Savings Bank	0 9
5225. Drought Relief	0 6
5226. Soil Conservation and Land Utilization	1 0

J. J. GOURLEY,
Government Printer.

AGENTS FOR THE "VICTORIA GOVERNMENT GAZETTE."

THE following have been appointed agents to receive Advertisements and subscriptions for the *Victoria Government Gazette*:—

- ARMSTRONG'S AGENCY, 143 Queen-street, Melbourne.
- MESSRS. ARNALL & JACKSON, 115 Barkly-street, West Brunswick.
- MESSRS. GORDON & GOTCH, News Agents, 511 Little Collins-street, Melbourne; and corner Barrack and Clarence streets, Sydney.
- MESSRS. HARSTON, PARTRIDGE, & CO., 455 Little Collins-street, Melbourne.
- N. V. NIXON & CO., 20 Queen-street, Melbourne.
- THE PATON ADVERTISING SERVICE PTY. LTD.
- ROBERTSON & MULLENS LTD., Elizabeth-street, Melbourne.
- MESSRS. W. H. WADDELL and A. S. RICHARDSON, trading as the Mercantile Exchange, 380 Collins-street, Melbourne.
- MR. A. J. DIGBY, News Agent, Bairnsdale.
- MR. M. R. BADE, Tobacconist, Sturt-street, Ballarat.
- TRIGG'S NEWS AGENCY, Hargreaves-street, Bendigo.
- MR. G. H. K. PAYNE, 4 View Point, Bendigo.
- MR. C. F. LATIMER, News Agent, Casterton.
- MESSRS. HENRY FRANKS & CO., Booksellers and Stationers, Market-square, Geelong.
- MESSRS. SMITH & DUNNON, Hamilton.
- ARMSTRONG BROS., Kyneton.
- MR. WM. DAVIS, Mildura.
- PIKE'S AUTHORIZED NEWS AGENCY, Sale.
- MR. C. T. RUST, News Agent, Wangaratta.
- MR. F. T. MCCORMICK, Nunn-street, Benalla.
- W. GORDON HAMPTON, 243 Mitchell-street, Bendigo.
- R. & A. SMALLMAN, News Agents, Toora.

A copy of the *Gazette* filed at each place for public reference.

THE "VICTORIA GOVERNMENT GAZETTE."

SUBSCRIPTIONS.—*The subscription, including Postage, is £1 12s. 6d. per annum, 16s. 3d. half-yearly, or 8s. 2d. per quarter, payable in advance.*

Subscriptions are required to commence and terminate with a month.

A lesser period than three months cannot be subscribed for.

Subscribers do not receive the Acts of Parliament with the GAZETTE.

ADVERTISEMENTS are charged at the rate of EIGHT PENCE per line single column, and ONE SHILLING and FOUR PENCE per line double column.

The title (£5 Reward, Dissolution of Partnership, &c.) forms one or more lines as a heading.

On an average, ten words make a line.

Every signature must likewise be counted as a line.

The final words of a paragraph, though only portion of a line, must be counted as one line.

SIGNATURES (in particular) and proper names must be written very plainly in the text; ONE SIDE ONLY of each slip of paper should be WRITTEN UPON.

ALL COMMUNICATIONS should be addressed to "The Government Printer, Melbourne."

ALL DOCUMENTS illegibly written will be returned unpublished, and, where brands occur unprovided for by the ordinary letters of the alphabet, a worded explanatory description must be furnished.

THE VICTORIA GOVERNMENT GAZETTE is published on WEDNESDAY EVENING in each week, and Notices for insertion will be received by the Government Printer at or before Two p.m., at ordinary rates, and late advertisements between Two p.m. and FIVE p.m. at double rates on the day preceding the day of publication.

Single copies of the VICTORIA GOVERNMENT GAZETTE are Six pence, posted Eight pence, each.

No GAZETTES prior to January, 1936, in stock.

***ALL PAYMENTS ARE REQUIRED IN ADVANCE.—Remittances should be made by postal note, money order, or draft in favour of the Government Printer. Advertisements unaccompanied by a remittance sufficient to cover the cost of insertion will be returned unpublished.

CONTENTS

	PAGE.
Acts of Parliament on sale at the Government Printing Office	5696
Appointments	5667
Auction Sales Act	5672
Bank Half-holidays	5667
Contracts	5677
Country Roads Board	5678
Courts	5672
Estates of Deceased Persons	5676
Government Notices	5672
Impoundings	5695
Lands	5681
Mining	5694
Orders in Council	5677
Private Advertisements	5688
Proclamations	5663
Public Half-Holiday	5667
Public Service Notices	5669
Resignations	5669
Stay Orders	5677
Tenders	5685
Transport Regulation Board—Public Hearings	5673