



VICTORIA  
GOVERNMENT GAZETTE.

Published by Authority.

[Registered at the General Post Office, Melbourne, for transmission by post as a newspaper.]

No. 1053]

WEDNESDAY, NOVEMBER 10.

[1948

GAS REGULATION ACT 1933.

PROCLAMATION

By His Excellency the Governor of the State of Victoria and its Dependencies in the Commonwealth of Australia, &c., &c., &c.

**I**N pursuance of the powers conferred by the provisions of the *Gas Regulation Act 1933, I*, the Governor of the State of Victoria, by and with the advice of the Executive Council thereof, do by this my Proclamation revoke, as from the eleventh day of November, 1948, a Proclamation which was made on the fifth day of November, 1948, by virtue of and in accordance with the provisions contained in section 33 of the *Gas Regulation Act 1933*, and which was published in the *Government Gazette* of the said fifth day of November, 1948.

Given under my Hand and the Seal of the State of Victoria aforesaid, at Melbourne, this ninth day of November, in the year of our Lord One thousand nine hundred and forty-eight, and in the twelfth year of the reign of His Majesty King George VI.

(L.S.)

WINSTON DUGAN.

By His Excellency's Command,

K. DODGSHUN,  
Chief Secretary.

GOD SAVE THE KING!

The Fisheries Acts.

**PROHIBITION OF ALL FISHING IN OR THE TAKING OF FISH FROM PORTION OF BIRCH'S OR BULLAROOK CREEK UNTIL 31st AUGUST, 1950 (INCLUSIVE).**

PROCLAMATION

By His Excellency the Governor of the State of Victoria and its Dependencies in the Commonwealth of Australia, &c., &c., &c.

**I**, THE Governor of the State of Victoria, in the Commonwealth of Australia, by and with the advice of the Executive Council of the said State, and in pursuance of the provisions of the Fisheries Acts and all other powers me enabling in that behalf, do by this my Proclamation prohibit all fishing in or the taking of fish from the Birch's or Bullarook Creek below or downstream from the western side of the road forming the eastern boundary of allotment 66, Parish of Spring Hill, to the eastern side of Cosgrove's-lane which forms the western boundary of allotment 67, Parish of Spring Hill, until the 31st day of August, 1950 (inclusive).

Given under my Hand and the Seal of the State of Victoria aforesaid, at Melbourne, this first day of November, in the year of our Lord One thousand nine hundred and forty-eight, and in the twelfth year of the reign of His Majesty King George VI.

(L.S.)

WINSTON DUGAN.

By His Excellency's Command,

K. DODGSHUN,  
Chief Secretary.

GOD SAVE THE KING!

The Game Acts.  
SANCTUARY FOR NATIVE GAME AT  
"KOORAWEEERA," NEAR CAMPERDOWN.

## PROCLAMATION

By His Excellency the Governor of the State of Victoria and its Dependencies in the Commonwealth of Australia, &c., &c., &c.

I, THE Governor of the State of Victoria, in the Commonwealth of Australia, by and with the advice of the Executive Council of the said State, and in pursuance of the provisions of the Game Acts and all other powers me enabling in that behalf, do by this Proclamation direct that the part of Victoria hereunder described shall be a locality in which from the first day of January to the thirty-first day of December (both days inclusive) in each year, it shall be unlawful for any person to kill or destroy any native game included in the Third Schedule to the *Game Act 1928*.

## PART OF VICTORIA REFERRED TO.

Crown allotments 49A, 49B, and 60, Parish of Taaraak, County of Hampden, containing 437 acres 3 roods more or less, and being portion of the property known as "Kooraweera."

Given under my Hand and the Seal of the State of Victoria aforesaid, at Melbourne, this first day of November, in the year of our Lord One thousand nine hundred and forty-eight, and in the twelfth year of the reign of His Majesty King George VI.

(L.S.) WINSTON DUGAN.

By His Excellency's Command,

K. DODGSHUN,  
Chief Secretary.

GOD SAVE THE KING!

The Game Acts.  
SANCTUARY FOR NATIVE GAME NEAR  
TYRENDARRA.

## PROCLAMATION

By His Excellency the Governor of the State of Victoria and its Dependencies in the Commonwealth of Australia, &c., &c., &c.

I, THE Governor of the State of Victoria, in the Commonwealth of Australia, by and with the advice of the Executive Council of the said State, and in pursuance of the provisions of the Game Acts and all other powers me enabling in that behalf, do by this my Proclamation direct that the parts of Victoria within the boundaries hereinafter described shall be localities in which from the first day of January to the thirty-first day of December (both days inclusive) in each year, it shall be unlawful for any person to kill or destroy any native game included in the Third Schedule to the *Game Act 1928*.

## PARTS OF VICTORIA REFERRED TO.

1. 536 acres 3 roods 19 perches or thereabouts, being Crown allotments 1, 1A, 2, 29A, 29D, 63, 63A, and 63B, Parish of Bessiebelle, County of Normanby, together with the road between allotments 1 and 29D.

2. 996 acres or thereabouts, being Crown allotments 140, 141, 142, 143, 144, 156, 157, and 158B, Parish of Homerton, County of Normanby, together with the road between allotments 142 and 143 and the road between allotments 144 and 156.

3. The Darlot's Creek, together with all Government reserves on either bank of such creek, between an imaginary line across such creek in continuation of the northern boundary of Crown allotment 140, Parish of Homerton, and an imaginary line across such creek in continuation of the southern boundary of Crown allotment 158B, Parish of Homerton.

Given under my Hand and the Seal of the State of Victoria aforesaid, at Melbourne, this first day of November, in the year of our Lord One thousand nine hundred and forty-eight, and in the twelfth year of the reign of His Majesty King George VI.

(L.S.) WINSTON DUGAN.

By His Excellency's Command,

K. DODGSHUN,  
Chief Secretary.  
GOD SAVE THE KING!

The Game Acts.  
SANCTUARY FOR NATIVE GAME AT ARARAT.

## PROCLAMATION

By His Excellency the Governor of the State of Victoria and its Dependencies in the Commonwealth of Australia, &c., &c., &c.

I, THE Governor of the State of Victoria, in the Commonwealth of Australia, by and with the advice of the Executive Council of the said State, and in pursuance of the provisions of the Game Acts and all other powers me enabling in that behalf, do by this my Proclamation direct that the part of Victoria within the boundaries hereinafter described shall be a locality in which from the first day of January to the thirty-first day of December (both days inclusive) in each year, it shall be unlawful for any person to kill or destroy any native game included in the Third Schedule to the *Game Act 1928*.

## PART OF VICTORIA REFERRED TO.

Allotments 1A, 1B, 1C, and 1D of section 16, Parish of Ararat, County of Ripon, containing 75 acres 2 roods 14 perches more or less.

Given under my Hand and the Seal of the State of Victoria aforesaid, at Melbourne, this first day of November, in the year of our Lord One thousand nine hundred and forty-eight, and in the twelfth year of the reign of His Majesty King George VI.

(L.S.) WINSTON DUGAN.

By His Excellency's Command,

K. DODGSHUN,  
Chief Secretary.

GOD SAVE THE KING!

## BANK HALF-HOLIDAYS.

## PROCLAMATION

By His Excellency the Governor of the State of Victoria and its Dependencies in the Commonwealth of Australia, &c., &c., &c.

I, IN pursuance of the provisions contained in Part III. of the *Banks and Currency Act 1928*, I, the Governor of the State of Victoria, in the Commonwealth of Australia, do by this my Proclamation appoint the days and dates named hereunder special days to be observed as Bank Half-Holidays at the places mentioned, that is to say:—

*Bank Half-Holidays from the Hour of Twelve o'clock noon:—*

WEDNESDAY, 10TH NOVEMBER, 1948, at Heathcote.

THURSDAY, 11TH NOVEMBER, 1948, at Linton.

THURSDAY, 18TH NOVEMBER, 1948, at Kilmore.

WEDNESDAY, 17TH NOVEMBER, 1948, at Omeo.

WEDNESDAY, 24TH NOVEMBER, 1948, at Yarram.

Given under my Hand and the Seal of the State of Victoria aforesaid, at Melbourne, this ninth day of November, in the year of our Lord One thousand nine hundred and forty-eight, and in the twelfth year of the reign of His Majesty King George VI.

(L.S.) WINSTON DUGAN.

By His Excellency's Command,

K. DODGSHUN,  
Chief Secretary.

GOD SAVE THE KING!

## PUBLIC HOLIDAYS.

## PROCLAMATION

By His Excellency the Governor of the State of Victoria and its Dependencies in the Commonwealth of Australia, &c., &c., &c.

I, IN pursuance of the provisions contained in Part III. of the *Public Service Act 1946* (10 Geo. VI. No. 5124), I, the Governor of the State of Victoria, in the Commonwealth of Australia, by and with the advice of the Executive Council of the said State, do by this my Proclamation appoint the days and dates hereunder mentioned to be observed as Public Holidays or Public Half-Holidays (as the case may be) at the places respectively specified, viz.:—

*Public Holidays:—*

\*THURSDAY, 11TH NOVEMBER, 1948, throughout the Shire of Bungaree.

WEDNESDAY, 10TH NOVEMBER, 1948, throughout the Townships of Kangaroo Flat, Marong, Maiden Gully, and Wilson's Reef, in the Shire of Marong.

*Public Half-Holidays from the Hour of Twelve o'clock noon:—*

WEDNESDAY, 24TH NOVEMBER, 1948, throughout the Shire of Bungaree.

THURSDAY, 2ND DECEMBER, 1948, throughout the Shire of Bungaree.

WEDNESDAY, 17TH NOVEMBER, 1948, throughout the Borough of Eaglehawk.

\* Agricultural Show.

Given under my Hand and the Seal of the State of Victoria aforesaid, at Melbourne, this ninth day of November, in the year of our Lord One thousand nine hundred and forty-eight, and in the twelfth year of the reign of His Majesty King George VI.

(L.S.) WINSTON DUGAN.

By His Excellency's Command,  
K. DODGSHUN,  
Chief Secretary.

GOD SAVE THE KING!

## PUBLIC HIGHWAY.—SHIRE OF CRANBOURNE.

## PROCLAMATION

By His Excellency the Governor of the State of Victoria and its Dependencies in the Commonwealth of Australia, &c., &c., &c.

WHEREAS by the *Local Government Act 1946* (No. 5203), section 518, it is amongst other things enacted that it shall be lawful for the Governor in Council at any time, and from time to time, upon the request of the council of any municipality, by notice in the *Government Gazette*, to declare any land reserved, used, or by purchase or exchange acquired for a street, road, highway, thoroughfare, bridge, square, court, alley, or right-of-way to be a public highway, and that such land shall thereupon and thenceforth from the date of such Proclamation become and be absolutely dedicated to the public as a public highway within the meaning of any law then or thereafter in force: And whereas the Council of the Shire of Cranbourne has requested that the land hereinafter mentioned, which has been used as a street within the said shire, be so declared to be a public highway: Now therefore I, the Governor of the State of Victoria, in the Commonwealth of Australia, by and with the advice of the Executive Council of the said State, do by this Proclamation declare the land used as a street hereinafter described, and situated within the Shire of Cranbourne aforesaid, to be a public highway within the meaning of the said Act, viz:—

## PUBLIC HIGHWAY.—SHIRE OF CRANBOURNE.

*Right-of-way.*

(a) All that piece or parcel of land commencing at a point on a line bearing N. 43 deg. 22 min. W. 165 feet from the south-eastern corner of Crown allotment 5, Parish of Lang Lang, County of Mornington; thence bounded by lines bearing N. 62 deg. 40 min. E. 287 ft. 2 in., N. 43 deg. 22 min. W. 12 ft. 6 in., S. 62 deg. 40 min. W. 287 ft. 2 in., S. 43 deg. 22 min. E. 12 ft. 6 in. to the commencing point; also

(b) All that piece or parcel of land commencing at a point on a line bearing N. 43 deg. 22 min. W. 165 feet, N. 62 deg. 40 min. E. 355 ft. 10 in. from the south-eastern corner of Crown allotment 5, Parish of Lang Lang, County of Mornington; thence bounded by lines bearing N. 62 deg. 40 min. E. 287 ft. 2 in., N. 43 deg. 22 min. W. 12 ft. 6 in., S. 62 deg. 40 min. W. 287 ft. 2 in., S. 43 deg. 22 min. E. 12 ft. 6 in. to the commencing point; also

(c) All that piece or parcel of land commencing at a point on a line bearing N. 43 deg. 22 min. W. 165 feet, N. 62 deg. 40 min. E. 711 ft. 8 in. from the south-eastern corner of Crown allotment 5, Parish of Lang Lang, County of Mornington; thence bounded by lines bearing N. 62 deg. 40 min. E. 287 ft. 2 in., N. 43 deg. 22 min. W. 12 ft. 6 in., S. 62 deg. 40 min. W. 287 ft. 2 in., S. 43 deg. 22 min. E. 12 ft. 6 in., to the commencing point.

Given under my Hand and the Seal of the State of Victoria aforesaid, at Melbourne, this first day of November, in the year of our Lord One thousand nine hundred and forty-eight, and in the twelfth year of the reign of His Majesty King George VI.

(L.S.) WINSTON DUGAN.

By His Excellency's Command,  
J. A. KENNEDY,  
Commissioner of Public Works.  
GOD SAVE THE KING!

## APPOINTMENTS.

HIS Excellency the Governor of the State of Victoria, by and with the advice of the Executive Council thereof, has, by Orders made on the 1st day of November, 1948, been pleased to make the under-mentioned appointments, viz:—

## DEPARTMENT OF CHIEF SECRETARY.

*Assistant to Inspector of Fisheries.*

ROBERT McDONALD MOODIE,  
pursuant to the provisions of the Fisheries Acts, to be an Assistant to the Inspector of Fisheries.

*Electoral Registrars (Acting).*

GEORGE ALEXANDER MORGAN  
to be Electoral Registrar (Acting) for the Benalla, Euroa, Moyhu, Ovens, and Violet Town Subdivisions of the Electoral District of Benalla; for the Beechworth, Chiltern, Corryong, Tallangatta, Wodonga, and Yackandandah Subdivisions of the Electoral District of Benambra; for the Nagambie Subdivision of the Electoral District of Goulburn; for the Cobram, Nathalia, Numurkah, Rutherglen, Tungamah, Wangaratta, and Yarrawonga Subdivisions of the Electoral District of Murray Valley; and for the Kyabram, Shepparton, and Tatura Subdivisions of the Electoral District of Shepparton, to take effect on and from 9th December, 1948, during the absence on leave of John Thomas McPherson; and

PERCY BASIL ROBIN  
to be Electoral Registrar (Acting) for the Drysdale, Newtown and Chilwell, and Queenscliff Subdivisions of the Electoral District of Barwon; for the Fawkner Subdivision of the Electoral District of Coburg; for the Essendon North Subdivision of the Electoral District of Essendon; for the Geelong and Geelong West Subdivisions of the Electoral District of Geelong; for the Geelong North, Sunbury, and Werribee Subdivisions of the Electoral District of Grant; for the Broadmeadows and Gisborne Subdivisions of the Electoral District of Mernda; for the Sunshine Subdivision of the Electoral District of Sunshine; and for the Altona Subdivision of the Electoral District of Williamstown, to take effect on and from 25th October, 1948, during the absence on leave of Michael Francis McSherry.

*Local Guardian of Aborigines.*

KENNETH ROWE, First Constable of Police, No. 8441, pursuant to the provisions of section 8 of the *Aborigines Act 1928*, to be Local Guardian of Aborigines at the Framlingham Aboriginal Reserve, from date of appointment, *vice* First Constable O. M. Taylor, resigned.

*Registrars of Births and Deaths.*

ROBERT HARVEY MARTINDALE,  
pursuant to the provisions of section 4 of the *Registration of Births Deaths and Marriages Act 1928*, to be Registrar of Births and Deaths at Dimboola, to date from commencement of duty, with fees, *vice* Peter Martindale, deceased; and

JOHN LARRY BRADY,  
pursuant to the provisions of section 4 of the *Registration of Births Deaths and Marriages Act 1928*, to be Registrar of Births and Deaths at Minyip, to date from commencement of duty, with fees, *vice* George Andrew Farrell, resigned.

## DEPARTMENT OF HEALTH.

*Trustees of Cemeteries.*

DANIEL HASSETT and  
GEORGE HASSELL  
to be Trustees of the Caramut Public Cemetery, *vice* N. Hyde;  
THOMAS BOCK  
to be a Trustee of the Toolamba Public Cemetery, *vice* B. A. Cummins, resigned;  
ALBERT REGINALD NIOA  
to be a Trustee of the Inglewood Public Cemetery, *vice* K. Simons;  
ARTHUR JOHN BETT,  
MATHEW MORRISON, and  
THOMAS CAREY  
to be Trustees of the Yea Public Cemetery;  
LESLIE THOMAS WOODWARD  
to be a Trustee of the Barrabool Hills Public Cemetery, *vice* R. Lamble, left district;  
JAMES KENNETT and  
CYRIL CARDWELL  
to be Trustees of the Mitta Mitta Public Cemetery; and  
JOHN GILLESPIE  
to be a Trustee of the Kingower Public Cemetery.

## DEPARTMENT OF LANDS AND SURVEY.

*Trustee of Site.*

CARLO SARTORI  
to be a Trustee of the land permanently reserved on the 19th February, 1889, as a site for a Mechanics' Institute and Free Library at Yandoit, in the place of Peter John Righetti, deceased.

## DEPARTMENT OF LAW.

*Bailiff of County Court.*

KENNETH ROWE, First Constable of Police, Dennington, to be also a Bailiff of the County Court at Warrnambool, in the place of O. M. Taylor, resigned, with fees.

*Commissioners for Taking Declarations, &c.*

ARTHUR STANLEY THORPE, Mansfield, and  
ANDREW LIVINGSTON BIRD, 70 Westbury-street, East St. Kilda,  
to be Commissioners for taking Declarations and Affidavits, pursuant to the provisions of Division 8 of Part IV. of the *Evidence Act 1928*, to resign upon removing from the neighbourhood of the addresses stated.

*Magistrates.*

FELIX RUSSO, 24 Ormond-road, Elwood,  
RONALD WALTER LANCASHIRE, 499 Bourke-street, Melbourne,  
VINCENT SAMUEL RANKIN, 358 Collins-street, Melbourne,  
HAROLD WIGHTMAN LILLY, 465 Collins-street, Melbourne  
VIOLET BARRY LAMBERT, Lysterfield, and  
CHARLES HENRY MASTERS, 23 Thomas-street, Dandenong,  
to Keep the Peace in the Central Bailiwick of the State of Victoria; and  
JOHN HERBERT JENKIN, Daylesford, and  
RUBY EMILY MCKENZIE, Woodend,  
to Keep the Peace in the Midland Bailiwick of the State of Victoria.

*Sheriff's Bailiff, &c.*

THOMAS STEPHEN HARTLEY, First Constable of Police, Beeac,  
to be a Sheriff's Bailiff and a Bailiff of the County Court at Geelong, in the place of W. Cain, resigned, with fees.

## DEPARTMENT OF MINES.

*Mining Registrar.*

KEVIN JOHN O'CONNOR  
to act as Mining Registrar for the Ararat Division and District Mining Registrar for the Ararat Mining District, *vice* G. Leahy, transferred, fees received to be the only remuneration.

## DEPARTMENT OF TREASURER.

*Receiver and Paymaster (Acting).*

WILLIAM HENRY BREEN  
to act temporarily as Receiver and Paymaster, Melbourne, during the absence of L. E. Turner on leave.

## DEPARTMENT OF WATER SUPPLY.

*Waterworks Trust Commissioner.*

ALFRED EDWIN LINTON  
to be a Commissioner of the Foster Waterworks Trust, *vice* Fred Fisher, resigned, and to hold office as such from the date hereof until the 5th March, 1949, subject to the provisions of the Water Acts.

J. C. MACGIBBON,  
Acting Clerk of the Executive Council.

At the Executive Council Chamber,  
Melbourne, 1st November, 1948.

## RESIGNATIONS.

HIS Excellency the Governor of the State of Victoria, by and with the advice of the Executive Council thereof, has, by Orders made on the 1st day of November, 1948, accepted the resignations of the persons named hereunder of the offices mentioned, *viz.*:—

## DEPARTMENT OF CHIEF SECRETARY.

GEORGE ANDREW FARRELL, as Registrar of Births and Deaths at Minyip.

## DEPARTMENT OF LAW.

ALEXANDER ROY MCKENZIE, late of Kyabram, from the Commission of the Peace for the Midland Bailiwick of Victoria.  
WILLIAM CAIN, as a Sheriff's Bailiff and a Bailiff of the County Court at Geelong.  
OSWALD MURRAY TAYLOR, as a Sheriff's Bailiff and a Bailiff of the County Court at Warrnambool.

J. C. MACGIBBON,  
Acting Clerk of the Executive Council.

At the Executive Council Chamber,  
Melbourne, 1st November, 1948.

## PUBLIC SERVICE OF VICTORIA.—VACANCIES.

APPLICATIONS will be received by the Public Service Board up to Saturday, the 27th November, 1948, from persons employed in the Public Service of Victoria, who are eligible and qualified for appointment to the under-mentioned positions:—

## ADMINISTRATIVE DIVISION.

Assistant Research Officer (Economics), Class "C,"  
Department of Water Supply.

*Yearly Salary.*—£449, minimum; £501, maximum.

*Duties.*—Under the direction of the Chief Irrigation Officer, to compile and keep statistics of the extent of irrigation of the various types of vegetation grown and stock carried under irrigation and of the quantity and value of production from irrigation. In conjunction with other officers to investigate and estimate the future production from areas to be developed with increased supplies of water and the effects on production of restricted water supplies. To assist in farm management and land utilization studies in irrigation areas.

*Qualifications.*—A degree in Arts or Commerce with Honours in Economics and Statistics, together with evidence of interest in rural economics and ability to pursue investigations of agricultural problems.

## PROFESSIONAL DIVISION.

Assistant Surveyor-General, Class "A," Department of Lands and Survey.

*Yearly Salary.*—£900, minimum; £950, maximum.

*Duties.*—To assist the Surveyor-General in the administration of the Survey Branch and of the Survey Co-ordination Act; to inspect, classify and value Crown lands; to report upon applications for disposal of Crown lands; to prepare designs for subdivision.

*Qualifications.*—To be a licensed surveyor with extensive experience in the classification, valuation and survey of Crown lands; to have an intimate knowledge of the Land Acts, Survey Co-ordination Act, and any other Act relating to the disposal of land, and the Regulations thereunder.

Engineer, Class "B1," Department of Public Works.

*Yearly Salary.*—£748, minimum; £800, maximum, commencing salary according to qualifications and experience.

*Duties.*—To act as deputy to the Chief Mechanical and Electrical Engineer as required. To prepare and supervise reports, schemes, contract plans, specifications, and estimates for mechanical plant and installations in all types of Government Buildings and Hospitals.

*Qualifications.*—To possess a Degree or Diploma of Mechanical Engineering of a recognized University or Technical School, and to have had extensive practical experience in the design, operation, and testing of modern mechanical equipment in large buildings and hospitals. To possess experience in the control and direction of staff engaged on above duties. Some general training and experience in electrical installation work is desirable.

Buildings Inspector, Class "D," Department of Health.

*Yearly Salary.*—£364, minimum; £436, maximum.

*Duties.*—To inspect and report on public and other buildings; to inspect public buildings during occupation to ensure compliance with Regulations affecting public safety; to give evidence in Court as to breaches of Regulations; and to carry out such other duties as may be directed.

**Qualifications.**—To have a thorough knowledge of building materials and of the construction, lighting and ventilation of buildings. To be capable of preparing accurate sketch plans and of writing clear and concise reports. Preferably to be the holder of a Technical College Diploma in Building Construction or its equivalent.

TECHNICAL AND GENERAL DIVISION.

**Mechanical Assistant, Grade I, Department of Water Supply.**

**Yearly Salary.**—£357, minimum; £396, maximum.

**Duties.**—To be responsible, under direction of the Engineer in Charge, for the operation and maintenance of two Diesel-engined re-lift pumping installations at Robinvale.

**Qualifications.**—To be a competent mechanic in the operation and maintenance of small pumping plants, with particular reference to a knowledge of and experience with modern high-speed Diesel engines.

**Inspector, Grade I. (Bendigo), Department of Water Supply.**

**Yearly Salary.**—£357, minimum; £383, maximum.

**Duties.**—To regulate the supply of water in the urban districts of Eaglehawk, Marong, Raywood, and Sebastian; to supervise the repair and maintenance of mains, valves, fire plugs, and small service basins. To tap mains and to inspect all plumbing connected with the water supply of these towns.

**Qualifications.**—To possess a good general knowledge of the location of all water mains, meters, and services in the district; to have ability to handle men engaged on repair and maintenance and the laying of all classes of water mains; to be able to manipulate the various valves in the reticulations so as to obtain the maximum efficiency of the system, and to have a practical knowledge of the relevant provisions of the Commission's By-laws.

**Charge Attendant, Children's Welfare Branch, Department of Chief Secretary.**

**Yearly Salary.**—£364, minimum; £377, maximum.

**Duties.**—Under the direction of the Officer in Charge, to supervise the staff and inmates of the Senior Boys' Section. To be responsible for the general cleanliness and order of the Senior Boys' building and grounds. To have charge of stocks of clothing, &c. To relieve the Officer in Charge.

**Qualifications.**—Ability to supervise a male staff, to control youths (including delinquents) over school age, and to keep records, and a general knowledge of the institutions connected with the Children's Welfare Branch and of Children's Court procedure.

**Typist (Female), Grade I, Government Printing Office, Department of Treasurer.**

**Yearly Salary.**—£221, minimum; £234, maximum.

**Qualifications.**—To be a competent typist.

**NOTE.**—In addition to the salary rates quoted, a cost of living adjustment (£72 a year for adult males and £48 a year for adult females), which varies in accordance with the rise or fall in the index number of the cost of living, is payable.

By order,

E. F. FITZGIBBON,

Secretary.

Office of the Public Service Board,  
Melbourne, 8th November, 1948.

PUBLIC SERVICE OF VICTORIA.

TEMPORARY APPOINTMENTS.

**APPLICATIONS** will be received by the Public Service Board up to Saturday, the 27th November, 1948, from persons, who are qualified, for appointment to the under-mentioned positions:—

**Draughtsmen, Department of Public Works.**

**Senior Draughtsmen.**

**Yearly Salary.**—£501, minimum; £553, maximum. Commencing salary in accordance with experience and qualifications.

*Architectural.*

**Duties.**—To prepare preliminary sketches, contract plans, details, and specifications for modern buildings.

**Qualifications.**—To be a registered architect or to possess equivalent qualifications, to be fully qualified in the subject of building construction and experience in the draughtsmanship as applied to at least one of the following types of buildings:—Schools, Public Hospitals, Sanatoria, Police Stations, Law Courts, Penal Establishments, Offices, or other major structures for State purposes.

*Mechanical.*

**Duties.**—To prepare, under direction, plans, specifications, and estimates of mechanical installations, and services in all types of public buildings, and to be capable of checking work of other draughtsmen.

**Qualifications.**—To have completed a Technical School Diploma Course in Mechanical Engineering, or possess other approved qualifications; to possess engineering workshop and general drawing office experience; also wide experience in the design of heating, ventilation, and hot-water systems, air-conditioning, refrigeration, steam plant lay-out.

*Electrical.*

**Duties.**—To prepare, under direction, plans, specifications, and estimates of electrical installations and services in all types of public buildings, and to be capable of checking work of other draughtsmen.

**Qualifications.**—To have completed a Technical School Diploma Course in Electrical Engineering or possess other approved qualifications; to have had good practical and outside drawing office experience in electrical installations, and wide experience in the design and lay-out of electric light and power installations, including illumination design of all types, both office and industrial.

**Draughtsmen.**

**Yearly Salary.**—£364, minimum; £475, maximum. Commencing salary in accordance with experience and qualifications.

*Architectural.*

**Duties.**—To prepare preliminary sketches, contract plans, details, and specifications for modern buildings.

**Qualifications.**—To be fully qualified in building construction and widely experienced in architectural draughtsmanship in connexion with the planning and detailing of major departmental structures or institutional buildings.

*Mechanical.*

**Duties.**—To prepare, under direction, plans, specifications, and estimates of mechanical installations and services in all types of public buildings.

**Qualifications.**—To have had approved technical training in Mechanical Engineering, preferably to Technical School Diploma standard; to possess engineering workshop and drawing office experience, and a good general knowledge of mechanical engineering, especially in relation to heating, hot-water supply, air conditioning, refrigeration, and steam plant lay-out, and calculations pertaining thereto.

*Electrical.*

**Duties.**—To prepare, under direction, plans, specifications, and estimates of electrical installations and services in all types of public buildings.

**Qualifications.**—To have had approved technical training in Electrical Engineering, preferably to Technical School Diploma standard; to have had a wide practical outside and drawing office experience in electrical light and power, and to possess a good knowledge of the design and layout of electric light and power installations, including illumination design of all types, both office and industrial.

**Field Officer, Department of Agriculture.** (Two vacancies.)  
*Yearly Salary.*—£358, minimum; £423, maximum.

*Position No. 1.*

**Duties.**—To assist generally in the conduct of potato experimental plots; to inspect potato crops for purity and freedom from diseases, pests, &c., in accordance with the provisions of the Seed Potato Certification Scheme; to assist generally as required.

**Qualifications.**—Diploma of an Agricultural College or its equivalent; knowledge of potato varieties and culture, grade standards and marketing methods; experience in the identification of diseases and pests in potatoes.

*Position No. 2.*

**Duties.**—To assist in the conduct of experimental plots with cereals and other crops, to maintain records, and assist generally in the work of the Field Branch.

**Qualifications.**—A Diploma or Certificate of an Agricultural College and experience in the laying out, maintenance, and harvesting of experimental plots. To be at least 21 years of age.

**NOTE.**—In addition to the salary rates quoted, a cost of living adjustment (at present £72 a year), which varies in accordance with the rise or fall in the index numbers of the cost of living, is payable.

By order,

E. F. FITZGIBBON,  
 Secretary.

Office of the Public Service Board,  
 Melbourne, 8th November, 1948.

No. 360.

*Public Service Act 1946, Section 39.*

**REGULATIONS—PART III.—SALARIES, INCREMENTS, AND ALLOWANCES.**

THE Public Service Board, in pursuance of the powers conferred by the *Public Service Act 1946*, hereby amends its Regulations as shown below:—

**FIRST SCHEDULE.**  
**PROFESSIONAL DIVISION.**  
*Offices and Rates of Salaries.*

Office.	Yearly Rate of Salary.	
	Minimum.	Maximum.
DEPARTMENT OF HEALTH. MENTAL HYGIENE BRANCH.	£	£
<i>Delete—</i> CLASS "C."		
Pharmaceutical Chemist .. ..	449	501*
<i>Add—</i> CLASS "C1."		
Pharmaceutical Chemist .. ..	527	579†

\* Subject to a charge of £50 a year for quarters and allowances.  
 † Subject to a charge of 10 per cent. of total emolument payable by way of salary for quarters and allowances.

*This Regulation shall have effect as on and from the 17th October, 1948.*

D. D. PAINE, Chairman.  
 E. F. FITZGIBBON, Secretary.

Office of the Public Service Board,  
 Melbourne, 18th October, 1948.

No. 359.

*Public Service Act 1946, Section 50.*

**REGULATIONS—PART III.—SALARIES, INCREMENTS, AND ALLOWANCES.**

THE Public Service Board, in pursuance of the powers conferred by the *Public Service Act 1946*, hereby amends its Regulations as shown below:—

**SIXTH SCHEDULE.**  
**TEMPORARY EMPLOYEES.**  
*Designations of Positions and Rates of Salaries.*

Department and Designation of Position.	Yearly Rate of Salary.		Increments (Annual).
	Minimum.	Maximum.	
DEPARTMENT OF WATER SUPPLY.	£	£	
<i>Add—</i> Accounting Officer* .. ..	449	501	2 of £26

\* Employees must be certificated accountants.

D. D. PAINE, Chairman.  
 E. F. FITZGIBBON, Secretary.

Office of the Public Service Board,  
 Melbourne, 19th October, 1948.

No. 361.

*Public Service Act 1946, Section 39.*

**REGULATIONS—PART III.—SALARIES, INCREMENTS, AND ALLOWANCES.**

THE Public Service Board, in pursuance of the powers conferred by the *Public Service Act 1946*, hereby amends its Regulations as shown below:—

**FIRST SCHEDULE.**  
**PROFESSIONAL DIVISION.**  
*Offices and Rates of Salaries.*

Office.	Yearly Rate of Salary.	
	Minimum.	Maximum.
DEPARTMENT OF LAW. CLASS "A1."	£	£
<i>Delete—</i> Senior Metropolitan Police Magistrate and Chairman of the Bench of Metropolitan and Suburban Magistrates .. ..	1,150	1,200
Metropolitan Police Magistrate .. ..	..	1,100
<i>Add—</i> Chief Stipendiary Magistrate .. ..	1,150	1,200
Metropolitan Stipendiary Magistrate .. ..	..	1,100
CLASSES "A" AND "A1."		
<i>Delete—</i> Police Magistrate, Grade I. (Suburban, Bendigo, Ballarat, Geelong, City Coroner, and Relieving) .. ..	900	1,050
<i>Add—</i> Stipendiary Magistrate, Grade I. (Suburban, Bendigo, Ballarat, Geelong, City Coroner, Relieving, and Children's Court) .. ..	900	1,050
CLASSES "B1" AND "A."		
<i>Delete—</i> Police Magistrate, Grade II. (Country and Children's Court) .. ..	800	1,000
<i>Add—</i> Stipendiary Magistrate, Grade II. (Country) .. ..	800	1,000

D. D. PAINE, Chairman.  
 E. F. FITZGIBBON, Secretary.

Office of the Public Service Board,  
 Melbourne, 18th October, 1948.

No. 363.

*Public Service Act 1946, Section 50.*

REGULATIONS—PART III.—SALARIES, INCREMENTS, AND ALLOWANCES.

THE Public Service Board, in pursuance of the powers conferred by the *Public Service Act 1946*, hereby amends its Regulations as shown below:—

SECOND SCHEDULE.  
TECHNICAL AND GENERAL DIVISION.  
*Offices and Rates of Salaries.*

Department and Office.	Yearly Rate of Salary.		Increments (Annual).
	Minimum.	Maximum.	
DEPARTMENT OF HEALTH. GENERAL HEALTH. State Sanatoria.	£	£	
Add— Fireman .. .. .	315	328*	..

\* Less deduction of £45 a year for board and lodging.

D. D. PAINE, Chairman.  
E. F. FITZGIBBON, Secretary.

Office of the Public Service Board,  
Melbourne, 18th October, 1948.

No. 367.

*Public Service Act 1946, Section 39.*

REGULATIONS—PART III.—SALARIES, INCREMENTS, AND ALLOWANCES.

THE Public Service Board, in pursuance of the powers conferred by the *Public Service Act 1946*, hereby amends its Regulations as shown below:—

FIRST SCHEDULE.  
PROFESSIONAL DIVISION.  
*Offices and Rates of Salaries.*

Office.	Yearly Rate of Salary.		Increments (Annual).
	Minimum.	Maximum.	
DEPARTMENT OF CHIEF SECRETARY. CLASS "C."	£	£	
Delete— Claims Clerk, State Motor Car Insurance Office .. .. .	449	501	..
Add— Claims Clerk, State Motor Car Insurance Office .. .. .	527	579	..
DEPARTMENT OF TREASURER. CLASS "C2."			
Delete— Assistant Estates Officer, Housing Commission .. .. .	592	644	..
Add— Assistant Estates Officer, Housing Commission .. .. .	670	722	..
DEPARTMENT OF WATER SUPPLY. CLASS "C2."			
Delete— Senior Electrical Engineer .. .. .	592	644	..
Add— Senior Electrical Engineer .. .. .	670	722	..

D. D. PAINE, Chairman.  
E. F. FITZGIBBON, Secretary.

Office of the Public Service Board,  
Melbourne, 18th October, 1948.

No. 362.

*Public Service Act 1946, Section 50.*

REGULATIONS—PART III.—SALARIES, INCREMENTS, AND ALLOWANCES.

THE Public Service Board, in pursuance of the powers conferred by the *Public Service Act 1946*, hereby amends its Regulations as shown below:—

SIXTH SCHEDULE.  
TEMPORARY EMPLOYEES.  
*Designations of Positions and Rates of Salaries.*

Department and Designation of Position.	Yearly Rate of Salary.		Increments (Annual).
	Minimum.	Maximum.	
DEPARTMENT OF TREASURER. HOUSING COMMISSION.	£	£	
Delete— Engineer Manager, Holmesglen Concrete House Factory .. .. .	..	1,000	..
Add— Chief Engineer .. .. . Manager, Holmesglen Concrete House Factory .. .. .	..	1,200 900	.. ..

*This Regulation shall have effect as on and from the 1st November, 1948.*

D. D. PAINE, Chairman.  
E. F. FITZGIBBON, Secretary.

Office of the Public Service Board,  
Melbourne, 22nd October, 1948.

No. 370.

*Public Service Act 1946, Section 50.*

REGULATIONS—PART III.—SALARIES, INCREMENTS, AND ALLOWANCES.

THE Public Service Board, in pursuance of the powers conferred by the *Public Service Act 1946*, hereby amends its Regulations as shown below:—

SIXTH SCHEDULE.  
TEMPORARY EMPLOYEES.  
*Designations of Positions and Rates of Salaries.*

Department and Designation of Position.	Yearly Rate of Salary.		Increments (Annual).
	Minimum.	Maximum.	
DEPARTMENT OF TREASURER. GOVERNMENT PRINTING OFFICE.	£	£	
Delete— Binder, Quarter (Female) .. .. . Book Folder (Female) .. .. . Book Folder and Sewer (Female) .. .. . Embossor (Female) .. .. . Feeder (Female) .. .. . Indexer (Female) .. .. . Machinist, Envelope (Female) .. .. . Reader's Assistant (Female) .. .. . Dining Room Assistant .. .. .	..	186 174 186 186 174 188 186 174 146	.. .. .. .. .. .. .. .. ..
Add— Binder, Quarter (Female) .. .. . Book Folder (Female) .. .. . Book Folder and Sewer (Female) .. .. . Embossor (Female) .. .. . Feeder (Female) .. .. . Indexer (Female) .. .. . Machinist, Envelope (Female) .. .. . Reader's Assistant (Female) .. .. . Dining Room Assistant .. .. .	..	194 183 194 194 183 194 183 153	.. .. .. .. .. .. .. ..

*This Regulation shall have effect as on and from the 4th July, 1948.*

D. D. PAINE, Chairman.  
E. F. FITZGIBBON, Secretary.

Office of the Public Service Board,  
Melbourne, 25th October, 1948.

No. 365.

*Public Service Act 1946, Section 39.*

REGULATIONS—PART III.—SALARIES, INCREMENTS, AND ALLOWANCES.

THE Public Service Board, in pursuance of the powers conferred by the *Public Service Act 1946*, hereby amends its Regulations as shown below :—

FIRST SCHEDULE.  
PROFESSIONAL DIVISION.  
*Offices and Rates of Salaries.*

Office.	Yearly Rate of Salary.	
	Minimum.	Maximum.
DEPARTMENT OF AGRICULTURE.	£	£
CLASS "D."		
Add— Live Stock Research Officer (Female) ..	364	436

*This Regulation shall have effect as on and from the 1st November, 1948.*

D. D. PAINE, Chairman.  
E. F. FITZGIBBON, Secretary.

Office of the Public Service Board,  
Melbourne, 27th October, 1948.

No. 366.

*Public Service Act 1946, Section 50.*

REGULATIONS—PART III.—SALARIES, INCREMENTS, AND ALLOWANCES.

THE Public Service Board, in pursuance of the powers conferred by the *Public Service Act 1946*, hereby amends its Regulations as shown below :—

SECOND SCHEDULE.  
TECHNICAL AND GENERAL DIVISION.  
*Offices and Rates of Salaries.*

Department and Office.	Yearly Rate of Salary.		Increments (Annual).
	Minimum.	Maximum.	
DEPARTMENT OF TREASURER.	£	£	
HOUSING COMMISSION.			
Add— Rental Officer, Senior (Male) ..	..	427	..

*This Regulation shall have effect as on and from the 31st October, 1948.*

D. D. PAINE, Chairman.  
E. F. FITZGIBBON, Secretary.

Office of the Public Service Board,  
Melbourne, 25th October, 1948.

No. 371.

*Public Service Act 1946, Section 50.*

REGULATIONS—PART III.—SALARIES, INCREMENTS, AND ALLOWANCES.

THE Public Service Board, in pursuance of the powers conferred by the *Public Service Act 1946*, hereby amends its Regulations as shown below :—

SIXTH SCHEDULE.  
TEMPORARY EMPLOYEES.  
*Designations of Positions and Rates of Salaries.*

Department and Designation of Position.	Yearly Rate of Salary.		Increments (Annual).
	Minimum.	Maximum.	
DEPARTMENT OF PUBLIC WORKS.	£	£	
Add— Storekeeper ..	312	351	

D. D. PAINE, Chairman.  
E. F. FITZGIBBON, Secretary.

Office of the Public Service Board,  
Melbourne, 25th October, 1948.

No. 364.

*Public Service Act 1946, Section 50.*

REGULATIONS—PART III.—SALARIES, INCREMENTS, AND ALLOWANCES.

THE Public Service Board, in pursuance of the powers conferred by the *Public Service Act 1946*, hereby amends its Regulations as shown below :—

SIXTH SCHEDULE.  
TEMPORARY EMPLOYEES.

*Designations of Positions and Rates of Salaries.*

Department and Designation of Position.	Yearly Rate of Salary.		Increments (Annual).
	Minimum.	Maximum.	
DEPARTMENT OF PREMIER.	£	£	
Add— AUDIT.			
Audit Clerk* ..	449	501	2 of £26

\* Employees must be certificated accountants.

*This Regulation shall have effect as on and from the 19th October, 1948.*

D. D. PAINE, Chairman.

E. F. FITZGIBBON, Secretary.

Office of the Public Service Board,  
Melbourne, 22nd October, 1948.

No. 369.

*Public Service Act 1946, Section 50.*

REGULATIONS—PART III.—SALARIES, INCREMENTS, AND ALLOWANCES.

THE Public Service Board, in pursuance of the powers conferred by the *Public Service Act 1946*, hereby amends its Regulations as shown below :—

SECOND SCHEDULE.  
TECHNICAL AND GENERAL DIVISION.  
*Offices and Rates of Salaries.*

Department and Office.	Yearly Rate of Salary.
DEPARTMENT OF TREASURER.	£
GOVERNMENT PRINTING OFFICE.	
Delete—	
Binder, Quarter (Female) ..	199
Binding, Forewoman (Quarter) ..	240
Book Folder and Sewer, Forewoman ..	269
Book Folder (Female) ..	187
Book Folder and Sewer (Female) ..	199
Embossor (Female) ..	199
Feeder (Female) ..	187
Indexer (Female) ..	199
Machinist, Envelope (Female) ..	199
Reader's Assistant (Female) ..	187
Add—	
Binder, Quarter (Female) ..	207
Binding, Forewoman (Quarter) ..	250
Book Folder and Sewer, Forewoman ..	279
Book Folder (Female) ..	196
Book Folder and Sewer (Female) ..	207
Embossor (Female) ..	207
Feeder (Female) ..	196
Indexer (Female) ..	207
Machinist, Envelope (Female) ..	207
Reader's Assistant (Female) ..	196

*This Regulation shall have effect as on and from the 4th July, 1948.*

D. D. PAINE, Chairman.

E. F. FITZGIBBON, Secretary.

Office of the Public Service Board,  
Melbourne, 25th October, 1948.



No. 372.

*Public Service Act 1946, Section 39.*  
REGULATIONS—PART III.—SALARIES, INCREMENTS,  
AND ALLOWANCES.

THE Public Service Board, in pursuance of the powers conferred by the *Public Service Act 1946*, hereby amends the Public Service (Public Service Board) Regulations by revoking that part of the First Schedule thereto which relates to the Department of Public Works and by inserting the following in lieu thereof:—

Office.	Yearly Rate of Salary.	
	Minimum.	Maximum.
DEPARTMENT OF PUBLIC WORKS.		
CLASS "A1."		
Chief Architect .. .. .	1,300	1,500
Chief Engineer and Engineer, Ports and Harbours .. .. .	1,200	1,350
CLASSES "A" AND "A1."		
Assistant Chief Architect (Design) .. .. .	1,000	1,100
Assistant Chief Architect (Maintenance) .. .. .	1,000	1,100
Assistant Chief Engineer .. .. .	1,000	1,100
Senior District Architect .. .. .	1,000	1,050
CLASS "A."		
Chief Mechanical and Electrical Engineer .. .. .	950	1,000
Senior Engineer .. .. .	900	1,000
District Architect .. .. .	900	950
Marine Surveyor .. .. .	900	950
Superintendent of Floating Plant .. .. .	900	950
Senior Architect .. .. .	850	900
CLASS "B1."		
Chief Quantity Surveyor .. .. .	748	800
Chief Structural Engineer .. .. .	748	800
District Architect .. .. .	748	800
Engineer .. .. .	748	800
Senior Architect .. .. .	748	800
CLASS "B."		
Architect .. .. .	670	722
Assistant District Architect .. .. .	670	722
Assistant Marine Surveyor .. .. .	670	722
Engineer .. .. .	670	722
Technical Stores Officer .. .. .	670	722
CLASS "C2."		
Assistant Engineer .. .. .	592	644
Engineering Surveyor .. .. .	592	644
Senior Draughtsman .. .. .	592	644
Supervisor of Works .. .. .	592	644
CLASS "C1."		
Assistant Engineer .. .. .	527	579
Assistant Technical Stores Officer .. .. .	527	579
Senior Draughtsman .. .. .	527	579
Senior Inspector of Works .. .. .	527	579
CLASS "C."		
Assistant to Marine Surveyor .. .. .	449	501
Draughtsman .. .. .	449	501
Engineering Assistant .. .. .	449	501
Inspector of Works .. .. .	449	501
Pilot and Harbour Master, Portland .. .. .	449	501
Senior Draughtswoman .. .. .	449	501
CLASS "D."		
Inspector of Works .. .. .	364	436
Pilot and Harbour Master, Warmambool .. .. .	364	436*
Draughtsman .. .. .	312	436
Draughtswoman .. .. .	312	364
CLASS "E."		
Draughtsman .. .. .	143	286

\* Subject to a charge of 10 per cent. of total emolument payable by way of salary for quarters.

*This Regulation shall have effect as on and from the 31st October, 1948.*

D. D. PAINE, Chairman.  
E. F. FITZGIBBON, Secretary.  
Office of the Public Service Board,  
Melbourne, 25th October, 1948.

No. 368.

*Public Service Act 1946, Section 50.*  
REGULATIONS—PART III.—SALARIES, INCREMENTS,  
AND ALLOWANCES.

THE Public Service Board, in pursuance of the powers conferred by the *Public Service Act 1946*, hereby amends its Regulations as shown below:—

SIXTH SCHEDULE.

TEMPORARY EMPLOYEES.

*Designations of Positions and Rates of Salaries.*

Department and Designation of Position.	Yearly Rate of Salary.		Increments (Annual).
	Minimum.	Maximum.	
DEPARTMENT OF TREASURER.			
HOUSING COMMISSION.			
Add— Housing Inspector, Senior .. .. .	..	527	..

*This Regulation shall have effect as on and from the 31st October, 1948.*

D. D. PAINE, Chairman.

E. F. FITZGIBBON, Secretary.

Office of the Public Service Board,  
Melbourne, 25th October, 1948.

No. 380.

*Public Service Act 1946, Section 50.*  
REGULATIONS—PART III.—SALARIES, INCREMENTS,  
AND ALLOWANCES.

THE Public Service Board, in pursuance of the powers conferred by the *Public Service Act 1946*, hereby amends its Regulations as shown below:—

SIXTH SCHEDULE.

TEMPORARY EMPLOYEES.

*Designation of Positions and Rates of Salaries.*

Department and Designation of Position.	Yearly Rate of Salary.		Increments (Annual).
	Minimum.	Maximum.	
DEPARTMENT OF TREASURER.			
HOUSING COMMISSION.			
Add— Valuer .. .. .	527	579	2 of £26

D. D. PAINE, Chairman.

E. F. FITZGIBBON, Secretary.

Office of the Public Service Board,  
Melbourne, 25th October, 1948.

No. 377.

PUBLIC SERVICE ACT 1946.

THE Public Service Board, in pursuance of the powers conferred by the *Public Service Act 1946*, hereby amends the Public Service (Public Service Board) Regulations as follows:—

PART V.—TRAVELLING EXPENSES.

DIVISION I.—REIMBURSEMENT OF PERSONAL EXPENSES.

Items (ii) and (iii) of the scale of allowances set out under (b) of Regulation 84 are deleted, and the following item is inserted in lieu thereof:—

	Full Rate (less than one week).	One Week but not more than Three Weeks at the Same Place.	More than Three Weeks at the Same Place.
(ii) Officers whose salaries are not more than £900 a year .. .. .	s. d. 17 0	s. d. 14 6	s. d. 11 0

*This Regulation shall have effect as on and from the 1st November, 1948.*

D. D. PAINE, Chairman.

E. F. FITZGIBBON, Secretary.

Office of the Public Service Board,  
Melbourne, 25th October, 1948.

No. 375.

Public Service Act 1946.

REGULATIONS—PART III.—SALARIES, INCREMENTS,  
AND ALLOWANCES.

THE Public Service Board, in pursuance of the powers conferred by the Public Service Act 1946, hereby amends the Public Service (Public Service Board) Regulations as follows:—

The Fourth Schedule to these Regulations is hereby revoked, and the following Schedule is inserted in lieu thereof:—

FOURTH SCHEDULE.  
ADMINISTRATIVE DIVISION.

Amount or Range of Salary Assigned to Offices in Class "A1,"  
Classes "A" and "A1," Class "A" and Classes "B1" and "A."

Office.	Yearly Rate of Salary.		Salary Payable to the Occupant of Each Office on 31st October, 1948.
	Minimum.	Maximum.	
DEPARTMENT OF PREMIER.			
CLASS "A1."			
Chief Clerk, Audit Office .. .. .	..	1,250	1,250
Public Service Inspector .. .. .	..	1,250	1,250
CLASS "A."			
Secretary to the Public Service Board .. .. .	850	1,000	1,000
DEPARTMENT OF CHIEF SECRETARY.			
CLASS "A1."			
Secretary and Inspector, Children's Welfare Branch .. .. .	..	1,250	1,250
CLASSES "A" AND "A1."			
Chief Clerk, Chief Secretary's Office	1,000	1,100	1,100
CLASS "A."			
Officer in Charge, Motor Registration Branch .. .. .	850	950	900
Secretary, Office of the Chief Commissioner of Police .. .. .	850	950	950
Chief Electoral Officer .. .. .	850	950	900
DEPARTMENT OF TREASURER.			
CLASS "A1."			
Chief Clerk, Treasury .. .. .	..	1,250	1,250
Accountant to the Treasury .. .. .	..	1,250	1,250
CLASS "A."			
Comptroller of Stamps .. .. .	850	1,000	950
Chief Clerk, Land Tax Office .. .. .	850	900	..
Chief Clerk, Probate Duties Office	850	1,000	950
Assistant Accountant to the Treasury .. .. .	850	900	850
Secretary, Housing Commission .. .. .	850	1,000	950
Accountant, Housing Commission	850	950	950
DEPARTMENT OF PUBLIC INSTRUCTION.			
CLASSES "A" AND "A1."			
Secretary .. .. .	950	1,050	1,050
CLASS "A."			
Accountant .. .. .	850	950	950

FOURTH SCHEDULE.—ADMINISTRATIVE DIVISION—continued.

Office.	Yearly Rate of Salary.		Salary Payable to the Occupant of Each Office on 31st October, 1948.
	Minimum.	Maximum.	
DEPARTMENT OF LAW.			
CLASSES "A" AND "A1."			
Chief Clerk .. .. .	1,000	1,100	..
CLASS "A."			
Deputy Registrar-General and Assistant Registrar of Titles .. .. .	850	950	950
DEPARTMENT OF LANDS AND SURVEY.			
CLASSES "A" AND "A1."			
Under Secretary for Lands .. .. .	1,000	1,150	1,100
CLASS "A."			
Accountant .. .. .	850	1,000	1,000
Chief Clerk .. .. .	850	950	950
Senior Divisional Officer .. .. .	850	950	950
DEPARTMENT OF PUBLIC WORKS.			
CLASS "A."			
Accountant .. .. .	850	950	900
Chief Clerk .. .. .	850	950	900
DEPARTMENT OF HEALTH.			
CLASSES "B1" AND "A."			
Chief Clerk and Accountant, Mental Hygiene Branch .. .. .	800	900	850
DEPARTMENT OF AGRICULTURE.			
CLASS "A."			
Secretary .. .. .	850	1,000	1,000
Accountant .. .. .	850	900	900
DEPARTMENT OF LABOUR.			
CLASS "A."			
Chief Inspector of Factories and Shops .. .. .	850	900	900
DEPARTMENT OF STATE FORESTS.			
CLASS "A."			
Accountant .. .. .	850	1,000	1,000
Secretary .. .. .	850	1,000	1,000
Chief Clerk .. .. .	850	950	950
DEPARTMENT OF WATER SUPPLY.			
CLASS "A1."			
Chief Finance Officer .. .. .	..	1,050	1,050
CLASS "A."			
Secretary .. .. .	850	950	950
CLASSES "B1" AND "A."			
Officer in Charge, Stores Branch	748	850	850
Accountant .. .. .	748	850	850
Staff and Industrial Officer .. .. .	748	850	850

This Regulation shall have effect as on and from the 31st October, 1948.

D. D. PAINE, Chairman.

E. F. FITZGIBBON, Secretary.

Office of the Public Service Board,  
Melbourne, 1st November, 1948.

No. 373.

*Public Service Act 1946, Section 50.*

**REGULATIONS—PART III.—SALARIES, INCREMENTS, AND ALLOWANCES.**

THE Public Service Board, in pursuance of the powers conferred by the *Public Service Act 1946*, hereby amends its Regulations as shown below:—

**SECOND SCHEDULE.**  
**TECHNICAL AND GENERAL DIVISION.**  
*Offices and Rates of Salaries.*

Department and Office.	Yearly Rate of Salary.	
	Minimum.	Maximum.
DEPARTMENT OF HEALTH.	£	£
GENERAL HEALTH.		
Venereal Diseases Clinic.		
<i>Delete—</i>		
Attendant, Senior .. .. .	312	338
Attendant .. .. .	273	299
<i>Add—</i>		
Attendant, Senior .. .. .	..	377
Attendant .. .. .	..	351

*This Regulation shall have effect as on and from the 31st October, 1948.*  
D. D. PAINE, Chairman.  
E. F. FITZGIBBON, Secretary.  
Office of the Public Service Board,  
Melbourne, 25th October, 1948.

No. 374.

*Public Service Act 1946, Section 50.*

**REGULATIONS—PART III.—SALARIES, INCREMENTS, AND ALLOWANCES.**

THE Public Service Board, in pursuance of the powers conferred by the *Public Service Act 1946*, hereby amends its Regulations as shown below:—

**SIXTH SCHEDULE.**  
**TEMPORARY EMPLOYEES.**  
*Designations of Positions and Rates of Salaries.*

Department and Designation of Position.	Yearly Rate of Salary.		Increments (Annual).
	Minimum.	Maximum.	
DEPARTMENT OF HEALTH.	£	£	
GENERAL HEALTH.			
<i>Delete—</i>			
Attendant, Venereal Diseases Clinic .. .. .	273	299	..
<i>Add—</i>			
Attendant, Venereal Diseases Clinic .. .. .	..	351	..

*This Regulation shall have effect as on and from the 31st October, 1948.*  
D. D. PAINE, Chairman.  
E. F. FITZGIBBON, Secretary.  
Office of the Public Service Board,  
Melbourne, 25th October, 1948.

No. 376.

**PUBLIC SERVICE ACT 1946.**

THE Public Service Board, in pursuance of the powers conferred by the *Public Service Act 1946*, hereby amends the Public Service (Public Service Board) Regulations as follows:—

**PART III.—SALARIES, INCREMENTS, AND ALLOWANCES.**

Sub-regulation 3 of Regulation 48A is revoked, and the following sub-regulation is inserted in lieu thereof:—

48A. (3) The annual amount or range of salary assigned to each office classified in Classes "A1," "A" and "A1," "A," or "B1" and "A" of the Administrative Division shall be that entered opposite the

name thereof in the Fourth Schedule to these Regulations. The occupant of each such office on the 31st October, 1948, shall be paid the appropriate sum specified in the last column of such Schedule.

*This Regulation shall have effect as on and from the 31st October, 1948.*

D. D. PAINE, Chairman  
E. F. FITZGIBBON, Secretary.

Office of the Public Service Board,  
Melbourne, C.2, 1st November, 1948.

No. 378.

*Public Service Act 1946, Section 50.*

**REGULATIONS—PART III.—SALARIES, INCREMENTS, AND ALLOWANCES.**

THE Public Service Board, in pursuance of the powers conferred by the *Public Service Act 1946*, hereby amends its Regulations as shown below:—

**SIXTH SCHEDULE.**  
**TEMPORARY EMPLOYEES.**  
*Designations of Positions and Rates of Salaries.*

Department and Designation of Position.	Yearly Rate of Salary.		Increments (Annual).
	Minimum.	Maximum.	
DEPARTMENT OF CHIEF SECRETARY.	£	£	
OFFICE OF THE CHIEF COMMISSIONER OF POLICE.			
<i>Add—</i>			
Police Hospital—			
Matron .. .. .	383	396*	..
Sister .. .. .	318	344†	..
Housemaid .. .. .	..	232†	..
Cook .. .. .	..	282†	..
Wardsman .. .. .	..	318	..

\* Less deduction of £55 a year for quarters and rations.  
† Less deduction of £45 a year for board and lodging.

*This Regulation shall have effect as on and from 14th November, 1948.*

D. D. PAINE, Chairman.  
E. F. FITZGIBBON, Secretary.

Office of the Public Service Board,  
Melbourne, 25th October, 1948.

No. 379.

*Public Service Act 1946, Section 39.*

**REGULATIONS—PART III.—SALARIES, INCREMENTS, AND ALLOWANCES.**

THE Public Service Board, in pursuance of the powers conferred by the *Public Service Act 1946*, hereby amends its Regulations as shown below:—

**FIRST SCHEDULE.**  
**PROFESSIONAL DIVISION.**  
*Offices and Rates of Salaries.*

Office.	Yearly Rate of Salary.	
	Minimum.	Maximum.
DEPARTMENT OF HEALTH.	£	£
GENERAL HEALTH BRANCH.		
<i>Delete—</i>		
CLASSES "A" AND "A1."		
Tuberculosis Officer .. .. .	1,000	1,050
CLASS "A1."		
<i>Add—</i>		
Tuberculosis Officer .. .. .	1,050	1,100

*This Regulation shall have effect as on and from the 31st October, 1948.*

D. D. PAINE, Chairman.  
E. F. FITZGIBBON, Secretary.

Office of the Public Service Board,  
Melbourne, 25th October, 1948.

## PUBLIC SERVICE (PUBLIC SERVICE BOARD) REGULATION 36A.

NOTICE is hereby given that the Public Service Board has raised the classification of the under-mentioned offices, as shown, and that the Permanent Heads of the Departments in which such offices are classified have recommended the officers named for appointment.

Present Office and Classification.	Revised Classification.	Duties.	Qualifications.	Name of Person Recommended.
<b>ADMINISTRATIVE DIVISION.</b>				
<b>DEPARTMENT OF TREASURER.</b>				
<i>Housing Commission.</i>				
Clerk, Class "C" ..	Clerk, Class "C1"	To have charge of the Correspondence and Records Branch	To possess experience in the practice and procedure of the Commission, a thorough knowledge of the Acts administered by the Commission, ability to conduct correspondence, and experience in dealing with the public	Lalor, J.
<b>DEPARTMENT OF AGRICULTURE.</b>				
Clerk, Class "C" ..	Clerk, Class "C1"	To act as sub-editor and prepare for publication the <i>Journal of Agriculture</i> , departmental bulletins, and pamphlets	Experience in editing technical writings on agricultural subjects, in literary and press work, and in the compilation of technical publications	Lewis, V. C. G.
<b>TECHNICAL AND GENERAL DIVISION.</b>				
<b>DEPARTMENT OF TREASURER.</b>				
<i>Housing Commission.</i>				
Rental Officer (Male)	Senior Rental Officer (Male)	To assist with the organization and supervision of Rental Officers engaged upon collection of metropolitan rents	To have administrative ability and to have an intimate knowledge of the metropolitan estates of the Housing Commission and of the system of rent collection thereon	Ashmore, W. A.

Appeals against such recommendations should be lodged with the Secretary to the Public Service Board not later than Saturday, the 20th November, 1948.

By order,

E. F. FITZGIBBON,  
Secretary.

Office of the Public Service Board,  
Melbourne, 8th November, 1948.

*Dried Fruits Act 1938.*

## GENERAL ELECTION OF MEMBERS OF THE VICTORIAN DRIED FRUITS BOARD.

NOTICE is hereby given, in accordance with the Dried Fruits Regulations, that the under-mentioned persons have been nominated for election as representatives of growers on the Victorian Dried Fruits Board for the areas specified in paragraphs (b), (c), and (d), respectively, of sub-section (3) of section 5 of the *Dried Fruits Act 1938*, viz.:—

*The Area Comprised by the Municipal Districts of the Shire of Mildura and the City of Mildura.*

HENRY VICTOR DAVEY, Block 554, Red Cliffs, horticulturist.

STEPHEN ROBERT MANSELL, 181 9th-street, Mildura, horticulturist.

ALFRED RAWLINGS, Merbein, horticulturist.

*The Area Comprised by the Municipal Districts of the Shires of Kerang and Swan Hill (also the Borough of Swan Hill).*

DAVID ARTHUR COCKROFT, Woorinen, fruitgrower.

*That Part of the State of Victoria Not within the Area Comprised by the Municipal Districts of the Shires of Mildura, Kerang and Swan Hill (and the Borough of Swan Hill) and the City of Mildura.*

DONALD EDWARD BARRY WOOD, "Hawthorne," Tongala East, orchardist.

As only the required number of candidates has been nominated for each area, I declare the above-named persons to be duly elected as representatives of growers on the Victorian Dried Fruits Board for the respective areas for which they have been nominated.

J. L. EABRY, Returning Officer,  
Victorian Dried Fruits Board Elections.

Chief Secretary's Office,  
Melbourne, 5th November, 1948.

*Railways Act 1928.*

## VICTORIAN RAILWAYS.

THE Victorian Railways Commissioners, in the exercise of the powers conferred on them by sub-section 2 (b) of section 160 of the *Railways Act 1928*, do hereby nominate—

LESLIE GEORGE DAVID, an officer in the Railway Service, to be their representative on the Board of Discipline, constituted as provided in the above-mentioned Act.

In witness whereof the common seal of the Victorian Railways Commissioners was hereunto affixed this twenty-seventh day of October, One thousand nine hundred and forty-eight.

(SEAL) M. J. CANNY } Victorian Railways  
R. G. WISHART } Commissioners.

*Railways Act 1928.*

## VICTORIAN RAILWAYS.

THE Victorian Railways Commissioners, in the exercise of the powers conferred on them by sub-section 2 of section 161 of the *Railways Act 1928*, do hereby nominate—

WILLIAM STEWART, an officer in the Railway Service, to act as the deputy of Leslie George David, the Commissioners' representative on the Board of Discipline, constituted as provided in the above-mentioned Act, during the hearing of any charge made against or appeal brought by an officer or employee other than in the Way and Works Branch of the Railway Service, in the event of the temporary absence of the said Leslie George David.

In witness whereof the common seal of the Victorian Railways Commissioners was hereunto affixed this twenty-seventh day of October, One thousand nine hundred and forty-eight.

(SEAL) M. J. CANNY } Victorian Railways  
R. G. WISHART } Commissioners.

Transport Regulation Acts.  
TRANSPORT REGULATION BOARD.

## NOTICES OF PUBLIC HEARINGS.

NOTICE is hereby given that the applications made by the persons named below for licences to operate the commercial passenger vehicles on the route or routes, or in the manner set out opposite their names, will be heard at a time and place to be communicated to the parties:—

*Name of Applicant; Nature of Application.*

ADAMS, D. M., Branjee-road, Euroa; 1 utility vehicle, with seating capacity for 1 person, to operate for the carriage of passengers, mails, and parcels between Euroa and Ruffy. Depart Euroa, 12 noon; depart Ruffy, 3 p.m.—subject to the cancellation of licence No. A.2355, at present held by H. H. Wheeler, Euroa.

ADAMS, R. W., & M. E. WILLIAMS, corner of York and Swansea roads, Montrose; application for variation of licence No. A.2286 to include the ability to operate a picture trip between the corner of York and Birmingham roads, Mt. Evelyn, and Croydon Theatre, via York and Oxford roads, on Wednesday and Saturday nights. Fare: 2s. return.

ADAMS, R. W., & M. E. WILLIAMS, corner of York and Swansea roads, Montrose; application for variation of licence No. A.2286 to include the ability to operate a picture trip between the corner of York and Birmingham roads, Mt. Evelyn, and Croydon Theatre, via York-road, Railway-parade, Birmingham-road, Swansea-road, Hereford-road, Anderson-street, Jones-street, and Castella-street, on Tuesday and Saturday nights. Fare: 1s. return.

ADAMS, R. W., & M. E. WILLIAMS, corner of York and Swansea roads, Montrose; application for variation of licence No. A.2286 to include the ability to deviate from licensed route so as to operate from Mt. Evelyn Railway Station along York and Birmingham roads to railway crossing, thence to the corner of Birmingham-road and Railway-parade.

ANSETT MOTORS PTY. LTD., 64 Percy-street, Portland; application for variation of "A" licences in course of transfer from R. J. Westlake, Portland, to operate to and from Warrnambool Railway Station and the border of South Australia *en route* to and from Mt. Gambier, South Australia, via Port Fairy, Portland, Heywood, Lyons, Greenwald, Winnap, and Dartmoor, instead of to and from Port Fairy Railway Station—with the proviso that passengers shall not be taken up and set down between and including Port Fairy and Warrnambool.

(This replaces application previously gazetted in the name of R. J. Westlake on 7th July, 1948.)

BLACK & PRICE, Clarke-road, Springvale; application for renewal of licence No. A.1773, expiring 23rd December, 1948, allowing operations as follows:—(a) On a round route commencing and terminating at Springvale Railway Station, (b) corner of Princes Highway East-Edithvale Railway Station, (c) Springvale Railway Station-Mordialloc Railway Station.

CAMPBELL, E. B. & I. (trading as E. Campbell's Bus Service), The Basin; 1 commercial passenger vehicle, to be purchased, to operate between Upper Ferntree Gully and Bayswater Railway Station via Burwood-road, Ringwood-road, and Mountain Highway.

(This replaces application previously gazetted on 3rd November, 1948.)

EASTERN ROADLINES PTY. LTD., 494 Olive-street, Albury; application for variation of "A" licences to delete present conditions on route between Albury and the Hume Weir, and instead to operate from Albury and Wodonga to the Hume Weir via Murray Valley Highway and Hume Weir-road, returning via the same route. Fare: 5s.

FERGUSON, S. V., 151 Raymond-street, Sale; application for variation of licence No. A.174 to operate additional trips between Sale and Maffra as follows:—

*Tuesdays, Fridays, and Saturdays only.*

Depart Sale, 9 a.m.  
Depart Stratford, 9.20 a.m.  
Arrive Maffra, 9.25 a.m.  
Depart Maffra, 9.45 a.m.  
Depart Bundalaguah, 9.55 a.m.  
Arrive Sale, 10.10 a.m.

STAUNTON, A. E., R. D. C. PLANE, P. J. QUINLAN, & F. R. STORER (trading as Green Bus Lines), 326 Tooronga-road, Glen Iris; application for variation of licences Nos. A.2342, A.2341, A.2340, and A.2382, to include the ability to deviate only on each alternate trip between

Beaumaris and Heatherton Sanatorium, from the corner of Jellicoe-street and Chesterfield-road via Chesterfield-road, Bernard-street, and thence via licensed route to Heatherton Sanatorium.

HARDY, P. A., 510 Main-street, Mordialloc; 1 commercial passenger vehicle, to be purchased, with seating capacity for 5 persons, to operate as follows:—(a) Separate and distinct fares within a 5 miles radius of Bayswater, (b) private hire within a 50 miles radius of Bayswater.

(This replaces application previously gazetted on the 4th August to operate as a substitute vehicle on all licensed routes.)

Hoy, E. M., Box 66, Wangaratta; application for variation of "A" licences to include the ability to operate as follows:—(a) As and when required on the Bogong-Wangaratta and Harrietville-Wangaratta daily services, in addition to the normal time-tables, (b) as and when required between Bright and Harrietville, in addition to the normal time-tables, (c) to deviate via Everton and Gapsted roads on route between Wangaratta and Bogong.

Hoy, E. M., Box 66, Wangaratta; application for variation of "A" licences to include the ability to operate the following tours:—

	Fare.	
	£	s. d.
<i>One-day tours from Wangaratta.</i>		
(1) Wangaratta to Shepparton and return	0	15 6
(2) Wangaratta to Albury	0	11 6
(3) Wangaratta to Hume Weir via Albury	0	16 0
(4) Wangaratta to Yarrawonga	0	10 0
(5) Wangaratta to Echuca via Shepparton	1	6 0
or via Cobram and Nathalia	1	11 9
(6) Wangaratta to Nathalia	1	3 6
(7) Wangaratta to Cobram	0	16 0
(8) Wangaratta to border of New South Wales <i>en route</i> Corowa	0	11 6
(9) Wangaratta to Benalla	0	6 0
(10) Wangaratta to Mansfield via Benalla or Tolmie	0	16 0
(11) Wangaratta to Mt. Buller	1	1 6
(12) Wangaratta to Whitfield	0	7 6
(13) Wangaratta to Whitlands	0	11 6
(14) Wangaratta to Euroa	0	12 6
(15) Wangaratta to Tallangatta	1	0 0
(16) Wangaratta to Mt. Buffalo	0	15 0
(17) Wangaratta to Mt. Hotham	1	10 0
(18) Wangaratta to Beechworth	0	5 6
(19) Wangaratta to Stanley	0	6 0
(20) Wangaratta to Yackandandah	0	9 0

*Two-days tour from Wangaratta.*

Wangaratta to Tawonga-Bogong via Happy Valley, thence via Tawonga Gap to Bright to Harrietville. Harrietville to Wandiligong, Mt. Buffalo, Wangaratta. Fare: £2 2s.

*Three-days tour from Wangaratta.*

Wangaratta to Tallangatta via Wodonga and Albury, Mitta Mitta, Omeo, Mt. Hotham, Harrietville, Wangaratta. Fare: £2 15s.

*Five-days tour from Wangaratta.*

(a) Wangaratta to Omeo via Mt. Hotham, Ensay, Bairnsdale, Lakes Entrance, and return. Fare: £3.

(b) Wangaratta to Tallangatta via Albury, Hume Weir, Corryong via Jingellic, thence to Tallangatta via Cudgewa, Mitta Mitta, Omeo, Mt. Hotham, Harrietville, Wangaratta. Fare: £3 15s.

KELLY, J. J. (trading as Illawarra Motor and Tourist Services), Kembla-street, Wollongong, New South Wales; 1 commercial passenger vehicle, with seating capacity for 20 persons, to operate as a touring omnibus on an 11-day tour from Wollongong, New South Wales, to Melbourne, as follows:—

1st day—overnight, Bega.  
2nd day—overnight, Bairnsdale.  
3rd day—Bairnsdale.  
4th day—overnight, Melbourne.  
5th day—Melbourne.  
6th day—Melbourne.  
7th day—Melbourne.  
8th day—overnight, Wangaratta.  
9th day—overnight, Wagga Wagga.  
10th day—overnight, Goulburn.  
11th day—tour terminates.

Fare: £20.

KELLY, J. J. (trading as Illawarra Motor and Tourist Services), Kembla-street, Wollongong, New South Wales; 1 commercial passenger vehicle, with seating capacity for 20 persons, to operate as a touring omnibus on an 18-day tour from Wollongong, New South Wales, to Adelaide, South Australia, as follows:—

- 1st day—overnight, Gundagai.
- 2nd day—overnight, Yarrawonga.
- 3rd day—overnight, Swan Hill.
- 4th day—overnight, Mildura.
- 5th day—Mildura.
- 6th day—overnight, Adelaide.
- 7th day—Adelaide.
- 8th day—Adelaide.
- 9th day—Adelaide.
- 10th day—overnight, Nhill.
- 11th day—overnight, Ballarat.
- 12th day—overnight, Melbourne.
- 13th day—Melbourne.
- 14th day—Melbourne.
- 15th day—overnight, Bairnsdale.
- 16th day—Bairnsdale.
- 17th day—overnight, Bega.
- 18th day—tour terminates.

Fare: £34.

KLIPPEL, O. M., 490 Parkinson-street, Albury; application for renewal of licence No. A.11, expiring 31st December, 1948, allowing operations as follows:—(a) Corryong-border of New South Wales en route to Albury, New South Wales, (b) specified day tours, (c) charter conditions within a 20 miles radius of Wodonga Post Office, and to Tallangatta, Beechworth, Rutherglen, Yarrawonga, Myrtleford, Bright, and border of New South Wales en route to Corowa, New South Wales.

LATROBE VALLEY BUS LINES PTY. LTD., 66-68 Princes-street, Traralgon; 18 commercial passenger vehicles, with seating capacity for 25, 30, 34, 27, 34, 34, 29, 36, 60, 29, 60, 25, 29, 25, 29, 29, 60, and 60 persons, respectively, to operate in the same terms and conditions as licences held by Traralgon Bus Service—subject to the cancellation of licences Nos. A.934, A.130, A.975, A.1770, A.799, A.1643, A.800, A.812, A.900, A.974, A.1800, A.2458, A.2459, A.2462, A.1801, A.2466, A.2461, and A.913, at present held by Traralgon Bus Service, Traralgon.

LATROBE VALLEY BUS LINES PTY. LTD., 66-68 Princes-street, Traralgon; application for variation of licences applied for to include the ability to operate a daily service between Morwell and Mirboo North via Yinnar and Boolarra. Depart Morwell, 11.30 a.m.; depart Mirboo North, 1.30 p.m.

	Single.		Return.	
	s.	d.	s.	d.
Morwell-Yinnar	1	0	2	0
Morwell-Boolarra	2	0	3	6
Morwell-Mirboo North	2	6	4	6

LATROBE VALLEY BUS LINES PTY. LTD., 66-68 Princes-street, Traralgon; 1 commercial passenger vehicle, with seating capacity for 34 persons, to operate as an additional vehicle on all licensed routes.

MONTI, T. L., 35 View-street, Bendigo; application for variation of licence No. A.2405 to include the ability to operate under charter conditions within a 25 miles radius of Bendigo, and to Maryborough, Rochester, Dingle, Vaughan Springs, Daylesford, Elmore, Inglewood, Bridgewater, Seymour, Nagambie, Echuca, and Shepparton.

MONTI, T. L., 35 View-street, Bendigo; application for variation of licences No. A.518 and A.979 to include the ability to operate under charter conditions within a 20 miles radius of Bendigo, and to Maryborough, Macedon, Vaughan Springs, Daylesford, Rochester, Shepparton, Seymour, and Nagambie.

FRASER, A. J. & K. H., & I. BLACKLEY (trading as Point Cook Passenger Service), Laverton; 1 commercial passenger vehicle, with seating capacity for 27 persons, to operate as an additional vehicle in accordance with the same terms and conditions as the other "A" licences at present held by the applicants.

SCOTT, R. W., 63 Forest-street, Castlemaine; 1 commercial passenger vehicle, with seating capacity for 26 persons, to operate on all licensed routes as and when required.

SQUIRES, C. T. & M. C., Faraday-street, Avoca; 1 commercial passenger vehicle, with seating capacity for 20 persons, to operate as a substitute vehicle on licensed route between Avoca and Ballarat.

SMALE, B. M., N. A. LUCAS, I. R. EVANS, T. EASTICK, & C. A. J. VEDMORE (trading as Warrnambool Bus Lines), Raglan-parade, Warrnambool; application for renewal of licence No. A.248, expiring 23rd December, 1948, allowing operations as follows:—(a) Separate and distinct fares within a 5 miles radius of Koroit, (b) private hire within a 50 miles radius of Koroit, (c) Koroit to racecourses at Warrnambool, Port Fairy, Terang, Camperdown, and Mortlake, on race days and show days.

WATSON, A. J., Tidal River, via Foster; 1 commercial passenger vehicle, with seating capacity for 5 persons, to operate for the carriage of passengers, mails, and parcels between Tidal River and Foster, and under private hire conditions within a 50 miles radius of Tidal River.

WILLIAMSON, G. R., 56 Patrick-street, Stawell; application for variation of licence No. A.1331 to include the ability to operate at separate and distinct fares within a 5 miles radius of Stawell.

ROBERTS, A. T. A. & R. W. WOOLLEY (trading as Walker's Hire Cars), 257 Charman-road, Cheltenham; 1 commercial passenger vehicle, with seating capacity for 5 persons, to operate as follows:—(a) Separate and distinct fares within a 5 miles radius of Cheltenham, (b) private hire within a 50 miles radius of Cheltenham—subject to the cancellation of licence No. A.2348, at present held by the late W. A. Quince, Murrumbena.

WATKINS, D. P., 106 McLeod-street, Bairnsdale; 2 commercial passenger vehicles, with seating capacity for 5 persons, to operate as follows:—(a) Separate and distinct fares within a 5 miles radius of Bairnsdale, (b) private hire within a 50 miles radius of Bairnsdale—subject to the cancellation of licences Nos. A.164 and A.1492, at present held by A. Balfour, Bairnsdale.

DAVIS, H. A., MOTOR SERVICE PTY. LTD., Ballarat; application for variation of licences Nos. C.133, C.134, and C.137, to include the ability to operate under charter conditions from Ballarat to Ararat, Amphitheatre, Avoca, Buangor, Blackwood, Beac, Beaufort, Bacchus Marsh, Colac, Castlemaine, Cressy, Dunolly, Elmhurst, Geelong, Gisborne, Harcourt, Kyneton, Lake Bolac, Lancefield, Lismore, Maryborough, Maldon, Mt. Macedon, Macedon, Meredith, Melton, Sunbury, Streatham, Skipton, Woodend, Winchelsea, Willaura, Westmere, and Werribee.

WILKINS, A. W., Ballarat; application for variation of licences Nos. C.135 and C.217 to include the ability to operate under charter conditions from Ballarat to the same-named places as set forth in the above application by H. A. Davis Motor Service Pty. Ltd., Ballarat.

MARK, A. E., Ballarat; application for variation of licence No. A.2352 to include the ability to operate under charter conditions within a 25 miles radius of Ballarat, and to the same-named places as set forth in the above application by H. A. Davis Motor Service Pty. Ltd., Ballarat.

MARK, A. E., Ballarat; 1 commercial passenger vehicle, with seating capacity for 31 persons, to operate as follows:—(a) As an additional vehicle on the Ballarat-Snake Valley-Skipton route, (b) under charter conditions within a 25 miles radius of Ballarat, and to the same-named places as set forth in the above application by H. A. Davis Motor Service Pty. Ltd., Ballarat, (c) under charter conditions within a 25 miles radius of Snake Valley and Linton, and to Ararat, Amphitheatre, Avoca, Buangor, Blackwood, Beac, Bacchus Marsh, Colac, Castlemaine, Cressy, Dunolly, Elmhurst, Geelong, Gisborne, Harcourt, Kyneton, Lake Bolac, Lancefield, Lismore, Maryborough, Maldon, Mt. Macedon, Macedon, Meredith, Melton, Sunbury, Streatham, Woodend, Winchelsea, Willaura, Westmere, and Werribee, (d) interchangeably with any other licensed vehicle of the applicant.

**A**PPPLICATION for licences to operate commercial passenger vehicles, with seating capacity for 5 persons, to operate for the carriage of passengers otherwise than at separate and distinct fares for each passenger throughout Victoria:—

COON, H. G., Ballarat.

FULLER, S., East Brighton.

GANGE, A., Fitzroy (two vehicles).

HEFFER, I. J., Kerang.

ROBERTS, A. T. A., & R. W. WOOLLEY (trading as Walker's Hire Cars), Cheltenham—3 vehicles, subject to the cancellation of licences Nos. PH.839, PH.840, and PH.845, at present held by the late W. A. Quince, Murrumbena.

**N**OTICE is hereby given that the applications made by the persons named below for licences to operate the commercial goods vehicles on the route or routes, or in a manner set out opposite their names, will be heard at a time and place to be communicated to the parties concerned:—

*Name and Address; Nature of Application.*

BELMAN, J., Drouin; 1 commercial goods vehicle (18 cwt.) for the carriage of own goods in the course of business as "logging and clearing contractor" throughout the State of Victoria.

- BRAMALL, G., & Co., Geelong-road, West Footscray; 1 commercial goods vehicle (65 cwt.) for the carriage of highly inflammable solution in drums and unassembled coats from Melbourne to the decentralized factory of the applicants situate at Yarrowonga, returning to Melbourne with finished products.
- BRINGS, R. W., Montague-street, Glen Iris; 1 commercial goods vehicle (8 cwt.) for the carriage of materials and tools of trade in the course of business as "sign-writer" throughout the State of Victoria.
- COOKSON, W. H., Kent-street, Sebastopol; 1 commercial goods vehicle (80 cwt.) for the carriage of road contracting plant and material throughout the State of Victoria.
- LENNON, P. J., King-street, Melbourne; 1 commercial goods vehicle (75 cwt.) for the carriage of—(a) own goods in connexion with business as "caterer" throughout the State of Victoria, (b) staff required and actually employed by the applicant at the meeting to which the vehicle will be operated.
- LEURY BROS., 12 Burnell-street, West Brunswick; 1 commercial goods vehicle (110 cwt.) for the carriage of—(a) general goods within a 25 miles radius of Melbourne, (b) bricks, tiles, and sewerage pipes within a 40 miles radius of Melbourne.
- LOMAX, R. F. W., Glenfern-road, Ferntree Gully; 1 commercial goods vehicle (100 cwt.) for the carriage of—(a) general goods within a 20 miles radius of Ferntree Gully, (b) live stock within a 50 miles radius of Ferntree Gully.
- RODDA, S. N., PTY. LTD., 65 Beach-street, Port Melbourne; 1 commercial goods vehicle (170 cwt.) for the carriage of—(a) own earth-moving equipment throughout the State of Victoria, (b) mineral earth from places of excavation to the nearest or most convenient railway siding for consignment to Melbourne—when vehicle returns to Melbourne, one pay load to be carried.
- STAFF, G., 10 McArthur-place, Carlton; 1 commercial goods vehicle (20 cwt.) for the carriage of second-hand bags and sacks in the course of business as "bag dealer" throughout the State of Victoria.
- STAUDINGER, W. F., Croxton East; 1 commercial goods vehicle (50 cwt.) for the carriage of own plant and equipment in the course of business as "boring contractor" throughout the State of Victoria.
- VAUGHAN, J., 34 Harrow-street, Box Hill; 1 commercial goods vehicle (6 cwt.) for the carriage of spare parts and tools of trade required for the servicing and maintenance of refrigeration equipment throughout the State of Victoria.
- NOTICE** is hereby given that the applications made by the persons named below for renewal of licences to operate the commercial goods vehicles in the manner set out hereunder, the numbers of which are also set out in each case, will be heard at a time and place to be communicated to the parties concerned:—
- Name and Address; Present Franchise; Licence No.; Date of Expiry.*
- THE BARKLY BRICK CO. PTY. LTD., 32 Weston-street, Brunswick; bricks within a radius of 50 miles from the premises of the holder of this licence and carried in course of trade as "brick manufacturers"; D.3851; 23rd December, 1948.
- BERRY, A. H., 28 Urquhart-street, Horsham; mails and parcels—(a) between Horsham and Brimpaen, (b) between Horsham and Drung Drung; D.3461; 13th December, 1948.
- WHITEHEAD, W. E., "The Border Wool Company," Kiewa-street, Albury; in the course of business as "wool scourers and fellmongers" on the following routes:—(a) Wodonga to the border of N.S.W., en route to Albury, N.S.W., and thence from the Victorian-N.S.W. border to Tangambalanga, Tawonga, Bright, Myrtleford, and Yackandandah, (b) Wodonga, Beechworth, Moyhu, Milawa—purchasing and picking up new skins and carrying same to own wool scour stores situate at Wodonga; D.3817; 16th December, 1948.
- BRIEN BROS., Main-street, Croydon; (a) general goods within a 20 miles radius of Croydon, (b) furniture within a 50 miles radius of Croydon; D.1976; 1st December, 1948.
- BROWN'S DRY CLEANING COY. LTD., 75 Camberwell-road, Upper Hawthorn; articles for cleaning or dyeing, or having been cleaned or dyed, between Melbourne and Geelong; D.3819; 16th December, 1948.
- BURCOMBE, H. T., Wangaratta P.O.; general goods within a 25 miles radius of Wangaratta; D.1257; 13th December, 1948.
- BURNHAM, W. H., 61 Herbert-street, Mordialloc; (a) general goods within a 20 miles radius of Parkdale, (b) furniture within a 50 miles radius of Parkdale; D.2447; 1st December, 1948.
- CANNY, W., & SON, Roy-street, Wangaratta; (a) general goods within a 20 miles radius of Wangaratta, (b) furniture within a 50 miles radius of Wangaratta; D.2424, D.2425; 1st December, 1948.
- CLEMENS, J. R., Loch-street, Beechworth; (a) general goods within a 20 miles radius of Beechworth, (b) aerated waters on behalf of Murray Breweries within a 40 miles radius of Beechworth, and to Mansfield, Benalla, Corryong, and Yarrowonga; D.3824; 16th December, 1948.
- COLES, G. J., & Co. LTD., 282 Little Collins-street, Melbourne; building maintenance material, tools, &c., required in connexion with the maintenance of own stores from and to the City of Melbourne to and from branch stores operated by the holder of this licence throughout the State of Victoria; D.3875; 10th March, 1949.
- COUTTS, J. D., 59 Milan-street, Mentone; (a) general goods within a 20 miles radius of Mentone, (b) furniture within a 50 miles radius of Mentone; D.2072; 1st December, 1948.
- CUNNINGHAM, A. W., 40 Manifold-street, Colac; (a) general goods within a 20 miles radius of Colac, (b) cream only to Colac from places situate on the direct route between Beech Forest and Princetown, (c) mails between Colac and Lower Gellibrand—two passengers may be carried on the route between Colac and Princetown; D.2325; 8th January, 1949.
- CURL, G., 252 Station-street, Chelsea; (a) general goods within a 20 miles radius of Chelsea, (b) furniture within a 50 miles radius of Chelsea; D.2193; 1st December, 1948.
- DAVEY, W. F., Minyip; (a) general goods within a 20 miles radius of Minyip, (b) furniture within a 50 miles radius of Minyip; D.1883; 1st December, 1948.
- DOBNEY, G. T., 73 Templeton-street, Castlemaine; (a) general goods within a 20 miles radius of Castlemaine, (b) furniture within a 50 miles radius of Castlemaine; D.2215, D.2216; 1st December, 1948.
- DYSON, A. V., Macarthur; (a) general goods within a 20 miles radius of Macarthur, (b) general goods from and to a 10 miles radius of Macarthur to and from railway towns between Warrnambool and Port Fairy, Warrnambool and Hamilton, and Portland and Hamilton, (c) live stock from and to a 10 miles radius of Macarthur to and from a 50 miles radius of Macarthur; D.3826; 16th December, 1948.
- ELKIN, J. R., 7 McLeod-street, Wonthaggi; (a) general goods within a 20 miles radius of Wonthaggi, (b) mining timber from Darlimurla to State Coal Mine at Wonthaggi; D.3837; 16th December, 1948.
- FINLAYSON, J. R., & SONS, 87 Wawunna-road, Horsham; road-making material throughout the State of Victoria; D.3828; 16th December, 1948.
- FREYER, C., Bethanga; (a) general goods within a 20 miles radius of Bethanga, (b) general goods from and to Wodonga to and from places on or most conveniently reached from the Murray Valley Highway between Wodonga and a point 12 miles west of Walwa and not to any place beyond this point; D.123; 31st December, 1948.
- COGGER BROS., Mt. Macedon; (a) general goods within a 20 miles radius of Upper Macedon, (b) furniture within a 50 miles radius of Upper Macedon; D.2407; 1st December, 1948.
- GLADMAN, G. G., Serpentine; (a) general goods within a 20 miles radius of Serpentine, (b) general goods from and to places within a 12 miles radius of Serpentine to and from Bendigo, (c) furniture within a 50 miles radius of Serpentine, (d) live stock from and to places in (a) to and from Bendigo, except to places within 5 miles of Mitiamo; D.3840; 16th December, 1948.
- GLEGHORN, L. J., The Patch-road, Kallista; (a) general goods within a 25 miles radius of Kallista, (b) road contracting plant and material within a 50 miles radius of Kallista; D.1758; 15th December, 1948.
- GUEST, J. E., 55 Elgin-street, Sale; (a) general goods within a 20 miles radius of Sale, (b) furniture within a 50 miles radius of Sale, (c) live stock within a 50 miles radius of Sale; D.2200; 1st December, 1948.
- HAINSON, L., 146 Mitford-street, Elwood; drapery in course of business as "hawker" throughout the State of Victoria; D.3845; 23rd December, 1948.
- HARRIS, A. J., Willan-street, Eaglehawk; (a) general goods within a 25 miles radius of Bendigo, (b) furniture within a 50 miles radius of Bendigo; D.1991; 1st December, 1948.
- HINE, L. J., Rowsley; general goods within a 24 miles radius of Rowsley; D.1256; 13th December, 1948.
- HULM, P. J., Koroit; (a) general goods within a 20 miles radius of Koroit, (b) milk on behalf of Nestles between Penshurst and Koroit; D.2102; 1st December, 1948.

- JOHNSTON, W., Belmore-street, Yarrowonga; (a) general goods within a 20 miles radius of Yarrowonga, (b) furniture within 50 miles radius of Yarrowonga; D.2128; 1st December, 1948.
- LA FONTAINE, L. W., Mitta Mitta; (a) general goods within a 20 miles radius of Mitta Mitta, (b) general goods from and to places in (a) to and from Tallangatta, (c) live stock from and to places in (a) to and from Wodonga; D.160; 31st December, 1948.
- LARSON, A. A., Carlisle River; (a) general goods within a 20 miles radius of Carlisle River, (b) furniture within a 50 miles radius of Carlisle River, (c) two (2) passengers between Kennedy's Creek and Colac; D.2095; 1st December, 1948.
- MARSHALL, N., Beremboke, via Ballan; (a) general goods within a 20 miles radius of Beremboke, (b) farm produce and firewood from an 8 miles radius of Beremboke to Geelong, (c) farm requirements from Geelong to area as defined in paragraph (b); D.3834; 16th December, 1948.
- MATTHEWS, A. A., 22 Fairy-street, Warrnambool; (a) general goods within a 20 miles radius of Warrnambool, (b) firewood within a 30 miles radius of Warrnambool, and to Glenormiston; D.1259; 13th December, 1948.
- MILLETT, W., 55 Foster-street, Dandenong; (a) general goods within a 20 miles radius of Dandenong, (b) furniture within a 50 miles radius of Dandenong; D.2000; 1st December, 1948.
- MILLMAN, J. W., Avonmore; (a) general goods within a 20 miles radius of Avonmore, (b) live stock from and to places in (a) to and from Bendigo; D.2120; 1st December, 1948.
- MONTAGUE, B. E., 2 Miller-street, East Brunswick; (a) second-hand furniture throughout the State of Victoria, (b) coursing greyhounds and owners and trainers from Melbourne to coursing meetings at Gracedale Park, on behalf of Gracedale Park Speed Coursing Club; D.3849; 23rd December, 1948.
- MURPHY, J. V., Murrayville; within the districts of Murrayville and Ouyen in course of trade as "sanitary contractor"; D.3835; 16th December, 1948.
- MCKENZIE'S MARYVILLE TRANSPORT SERVICE, Nicholson-street, Healesville; (a) from and to the City of Melbourne to and from places situate on or reached from the road between the Township of Fernshaw and a point 1 mile south of the Post Office at the Township of Buxton, via Marysville—general goods, excluding wool, (b) from and to the Township of Healesville to and from places situate on or reached from the road between the Township of Fernshaw and a point 1 mile south of the Post Office at the Township of Buxton, via Marysville—general goods; D.3861; 23rd December, 1948.
- NELSON, L. G., Weering; (a) general goods within a 20 miles radius of Weering, (b) general goods from and to places in (a) to and from Colac; D.2025; 1st December, 1948.
- LEO OWENS PTY. LTD., Pyramid Hill; (a) general goods within 20 miles radius of Pyramid Hill; (b) general goods from and to places within a 12 miles radius of Pyramid Hill to and from Bendigo, (c) furniture within a 50 miles radius of Pyramid Hill, (d) live stock from and to places within a 20 miles radius of Pyramid Hill to and from Echuca, Charlton, Boort, Wycheproof, Kerang, and Cohuna, (e) live stock from and to places within a 12 miles radius of Pyramid Hill to and from Bendigo; D.3843; 16th December, 1948.
- PAYDON, A. A., 7 Clow-street, Dandenong; (a) general goods within a 20 miles radius of Dandenong, (b) furniture within a 50 miles radius of Dandenong; D.2005, D.2421, D.2006; 1st December, 1948.
- PEART, R. E., 5 Evans-street, Belmont, via Geelong; (a) general goods within a 25 miles radius of Geelong, (b) furniture within a 50 miles radius of Geelong, (c) pedigree dogs and their owners to and from shows and exhibitions throughout the State of Victoria; D.2086; 1st December, 1948.
- PICKLES, R. R., Private Bag, Mitiamo; (a) general goods within a 20 miles radius of Calivil, (b) general goods from and to a 10 miles radius of Calivil to and from Bendigo, excluding areas within a 2 miles radius of any railway station; D.3844; 16th December, 1948.
- RAE, R. J., 145 Woodland-street, Essendon; (a) general goods within a 25 miles radius of Melbourne, (b) road contracting plant and material within a 50 miles radius of Melbourne; D.1774; 5th December, 1948.

Notice of any objection should be forwarded to reach the Secretary of the Board not later than Wednesday, 24th November, 1948.

E. V. FIELD,  
Secretary.

Exhibition Buildings, Rathdown-street, Carlton, N:3, 9th November, 1948.

*Town and Country Planning Act 1944.*

BOROUGH OF SHEPPARTON.

INTERIM DEVELOPMENT ORDER.

WHEREAS by virtue of the powers conferred by the *Town and Country Planning Act 1944* and every other power enabling them in that behalf, the preparation of a planning scheme in accordance with the said Act has been commenced by the Council of the Borough of Shepparton (hereinafter referred to as the "Responsible Authority"), which hereby makes the following Interim Development Order:—

1. The development of all land referred to in the Schedule, and the erection, construction and carrying out of any buildings, roads, or other works on any of the said land is hereby prohibited.

2. Any person may apply to the Responsible Authority for permission to develop, subdivide, or otherwise use any land, or erect or construct any buildings, roads, or other works during the operation of this Order.

3. Any application for permission to develop, subdivide, or otherwise use any land, or erect or construct any building, roads, or other works, may be granted by the Responsible Authority, subject to such conditions as are specified in the permit, or may be refused.

4. Any owner of any land who, after the publication of a copy of this Order, contravenes any of the provisions contained herein, shall, when directed by notice, in writing, remove, pull down, take up, or alter any building, road, or other works, and, if any owner fails to do so within the time specified by the notice, the Responsible Authority may carry out all or any of such works, and recover all expenses incurred, after due notice has been given to the owner, lessee, and/or occupier in accordance with the provisions of section 12, sub-section 3, of the Act.

5. None of the provisions of this Order shall prohibit the continuance of the use of any land or buildings for the purpose for which it was used immediately before the coming into operation of this Order.

6. This Order shall remain in operation until the approval of the planning scheme, in accordance with the *Town and Country Planning Act 1944*, or until this Interim Development Order is revoked by the Governor in Council.

7. Schedule of land affected:—

(a) All that land being allotments 3 and 4 of plan of subdivision 9379, being part of Crown allotment 78, Parish of Shepparton.

(b) All that land within the following boundary, viz.:—  
Commencing at the north-west angle of Crown allotment 5, section M, Township of Shepparton; thence east 250 links; thence south 600 links to Fryers-street; thence west 250 links to the south-west angle of Crown allotment 10 of the said section; thence north 600 links to the commencing point.

(c) All that land within the following boundary, viz.:—  
Commencing at the north-west angle of Crown allotment 1, section L, Township of Shepparton; thence south 200 links; thence east 250 links; thence south 300 links to the south boundary of Crown allotment 5 of the said section; thence west 250 links; thence south-easterly and southerly along the west boundary of allotments 7, 8, and 10 of the said section to Fryers-street; thence east 120 links; thence north 1,000 links to the north-east angle of Crown allotment 2 of the said section; thence west 500 links to the commencing point.

(d) All that land within the following boundary, viz.:—  
Commencing at the north-west angle of Crown allotment 1, section A, Township of Shepparton; thence east 197 links; thence south 286 links; thence west 197 links to Welsford-street; thence north 286 links to the commencing point.

The common seal of the Mayor, Councillors, and Burgesses of the Borough of Shepparton was hereto affixed, pursuant to a Resolution of the Council, dated the eleventh day of October, 1948, in the presence of—

(SEAL) ANDREW W. FAIRLEY, Mayor.  
V. E. VIBERT, Councillor.  
R. WEST, Town Clerk.

Report by the Town and Country Planning Board on the twenty-seventh day of October, 1948. Recommended for approval.—J. S. GAWLER, Chairman.

Approved by the Governor in Council,  
9th November, 1948.

J. C. MACGIBBON,  
Acting Clerk of the Executive Council.



*Prices Regulation Act 1948.*

## ORDER EXEMPTING CERTAIN LAND FROM THE OPERATION OF THE PROVISIONS OF PART III. OF THE ACT.

I, TREVOR DONALD OLDHAM, His Majesty's Attorney-General in Victoria, and for the State of Victoria and the responsible Minister of the Crown for the time being administering the *Prices Regulation Act 1948*, in pursuance of the powers conferred by section 40 thereof, do hereby unconditionally exempt from the application of the whole of the provisions of Part III. of the said Act, all those pieces of land in the Parish of Mordialloc, County of Bourke, more particularly described in the Schedule hereto, and being the whole of the land now comprised in the certificates of title therein set out.

## SCHEDULE.

Lot Number.	Lodged Plan Number.	Crown Allotment Number.	Section Number.	Volume.	Folio.
1. .. ..	.. ..	Part of 3 .. ..	17	5145	1028845
2. 43, section C	2701	Part of 3 .. ..	17	5447	1028846
3. .. ..	.. ..	Part of 4 .. ..	17	3610	1089225
4. .. ..	.. ..	Parts of 17, 19, 20, 21, and 22 .. ..	at Mentone	3774	721900
5. 135, 136, and 137	7123	Part of 17 .. ..	.. ..	5229	754663
6. 133 .. ..	7123	Part of 17 .. ..	.. ..	4885	1045750
7. 132 .. ..	7123	Part of 17 .. ..	.. ..	4885	976888
8. 130 and 131	7123	Part of 17 .. ..	.. ..	5271	976887
9. 119 .. ..	7123	Part of 17 .. ..	.. ..	5314	1054170
10. 118 .. ..	7123	Part of 17 .. ..	.. ..	5217	1062771
11. 116 and 117	7123	Part of 17 .. ..	.. ..	5262	1043205
12. 134 .. ..	7123	Part of 17 .. ..	.. ..	4711	1052380
13. 115 .. ..	7123	Part of 17 .. ..	.. ..	4968	942093
14. 8 .. ..	11593	Part of 21, City of Mordialloc .. ..	.. ..	6162	993494
15. 16 .. ..	11593	Part of 21, City of Mordialloc .. ..	.. ..	6162	1232300
16. 17 .. ..	11593	Part of 21, City of Mordialloc .. ..	.. ..	6162	1232299
17. .. ..	.. ..	Parts of 17 and 21 .. ..	.. ..	5326	1232298
18. .. ..	.. ..	Part of 17 .. ..	.. ..	5225	1065022
19. .. ..	.. ..	Parts of 17, 19, and 21, City of Mordialloc .. ..	.. ..	6167	1044915
					1233326

Given under my hand at Melbourne in the State of Victoria, the 4th day of November, 1948.

T. D. OLDHAM,  
Attorney-General.

Crown Law Offices,  
459 Lonsdale-street, Melbourne.

*Prices Regulation Act 1948.*

## ORDER DECLARING LAND SUITABLE FOR WAR SERVICE LAND SETTLEMENT.

I, TREVOR DONALD OLDHAM, His Majesty's Attorney-General in Victoria, and for the State of Victoria and the responsible Minister of the Crown for the time being administering the *Prices Regulation Act 1948*, in pursuance of the powers conferred upon me by section 41 thereof do hereby declare the country land specified in the Schedule to this Order, to be land suitable for settlement by former members of the Defence Force.

## SCHEDULE.

All that piece of land containing 299 acres 3 roods 32 perches being Crown allotments 1B<sup>1</sup> and 1C, section 46, Crown allotment 5, and parts of Crown allotments 4A and 4B, section 36, all in the Parish of Moyhu, County of Delatite, being the land more particularly described in certificates of title, volume 4890, folio 977884, and volume 5823, folio 1164474.

Given under my hand at Melbourne, the tenth day of November, 1948.

T. D. OLDHAM,  
Attorney-General.

DEPARTMENT OF LAW—SOLICITOR-GENERAL.  
COURTS OF PETTY SESSIONS.  
ALTERATION OF DAYS AND HOURS.

HIS Excellency the Governor of the State of Victoria, by and with the advice of the Executive Council thereof, and pursuant to the provisions of section 61 of the *Justices Act 1928*, has, by Order made on the 1st day of November, 1948, directed that the days and hours appointed for the holding of Courts of Petty Sessions at the places named in the Schedule below be altered to the days and hours contained in the second column of such Schedule—to take effect as from and inclusive of the 1st January, 1949.

SCHEDULE.

Place.	Days and Hours.
Caulfield ..	Every Tuesday, Thursday, and Friday, at 10 o'clock a.m.
South Melbourne	Every Monday, Wednesday, and Friday, at 10 o'clock a.m.
North Melbourne	Every Monday and Wednesday, at 10 o'clock a.m.
Ringwood ..	Every Tuesday, at 10 o'clock a.m.
Lilydale ..	Every Tuesday, at 10 o'clock a.m.

J. C. MACGIBBON,  
Acting Clerk of the Executive Council.

At the Executive Council Chamber,  
Melbourne, 1st November, 1948.

DEPARTMENT OF LAW—SOLICITOR-GENERAL.  
COURTS OF PETTY SESSIONS.  
ALTERATION OF DAYS AND HOURS.

HIS Excellency the Governor of the State of Victoria, by and with the advice of the Executive Council thereof, and pursuant to the provisions of section 61 of the *Justices Act 1928*, has, by Order made on the 1st day of November, 1948, directed that the days and hours appointed for the holding of Courts of Petty Sessions at the places named in the Schedule below be altered to the days and hours contained in the second column of such Schedule.

SCHEDULE.

Place.	Days and Hours.
Mirboo North ..	Alternate Tuesdays at 10 o'clock a.m., as from and inclusive of the 11th January, 1949
Morwell ..	Every Friday at 10 o'clock a.m., as from and inclusive of the 7th January, 1949
Traralgon ..	Every Monday at 10 o'clock a.m., as from and inclusive of the 3rd January, 1949

J. C. MACGIBBON,  
Acting Clerk of the Executive Council.

At the Executive Council Chamber,  
Melbourne, 1st November, 1948.

*Farmers' Debts Adjustment Act 1935.*

ISSUE OF STAY ORDERS.

NOTIFICATION is hereby given that Stay Orders have been issued to the under-mentioned persons, such Stay Orders to take effect on and from 3rd November, 1948:—

Name; Address.

Craigen, William; Tempy.  
Craigen, Florence Ellen; Tempy.

J. E. GLASSBOROW, Deputy Secretary,  
Farmers' Debts Adjustment Board.

9th November, 1948.

SUBJECT to any necessary excisions, &c., it is proposed to grant the following leases:—  
5524, Gippsland; Roger Blackmore, Joseph Alenzo Attridge, Frederick Charles Schreiber, and George Bernard Sommer; 128a. 0r. 22p., in the Parish of Hotham.  
7076, Mineral; Colin Emery West; 44a. 2r. 18p., in the Parish of Allambee East.  
7112, Mineral; Melba Ada Mavis Illingworth; 13a. 2r. 6p., in the Parish of Bungal.

APPLICATION FOR MINING LEASE DECLARED ABANDONED.

7129, Mineral; William Thomas and Keith Donald Thomas; 5 acres, in the Parish of Faraday.

TAILINGS LICENCE EXPIRED.

1812, Tailings Licence; Edward Sampson O'Halloran; 4a. 3r. 1p., in the Parish of Nerring.

J. H. LIENHOP,  
Minister of Mines.

DECLARING VOID AS TO PART A MINING LEASE.

In pursuance of the powers conferred by sections 113 and 90 of the *Mines Act 1928* (No. 3737), the Governor in Council has, by Order made on the 1st November, 1948, declared void Mining Lease No. 8572, Castlemaine, as to such part of the land and mine as is indicated by green colour on the plan annexed to the said Order, and containing 182 acres 0 roods 33 perches, more or less, and has fixed the rental of the said lease at One hundred and two pounds and ten shillings per annum. The said lease is entered in the register book at the Office of Titles, volume 315, folio 34817.

GEO. BROWN,  
Secretary for Mines.

Cemeteries Acts.

SCALE OF FEES OF THE YALLOURN PUBLIC CEMETERY.

IN pursuance of the powers conferred by the *Cemeteries Act 1928*, the Trustees of the Yallourn Public Cemetery hereby make the following scale of fees, which will come into operation upon publication in the *Government Gazette*, and from and after such publication any scale of fees heretofore made by the said Trustees shall be and is hereby rescinded to the extent to which it conflicts with this scale:—

Sinking a grave, any depth .. .. £2 15 0

P. J. HARRY, Trustee.  
J. COLLINS, Trustee.  
JAS. C. CULLEN, Trustee.

Approved by the Governor in Council,  
1st November, 1948.

J. C. MACGIBBON,  
Acting Clerk of the Executive Council.

Cemeteries Acts.

SCALE OF FEES OF THE BURWOOD GENERAL CEMETERY.

IN pursuance of the powers conferred by the *Cemeteries Act 1928*, the Trustees of the Burwood General Cemetery hereby make the following scale of fees, which will come into operation upon publication in the *Government Gazette*, and from and after such publication any scale of fees heretofore made by the said Trustees shall be and is hereby rescinded to the extent to which it conflicts with this scale:—

Sinking—	£ s. d.
7 feet deep .. ..	2 12 6
8 feet deep .. ..	3 12 0
9 feet deep .. ..	4 12 6
Re-opening .. ..	2 12 6
Any additions, alterations, or amendments to graves, extra .. ..	1 1 0
Cutting additional inscription, extra .. ..	0 5 0

JOHN HARRISON, Trustee.  
THOMAS T. SCOTT, Trustee.  
ALLAN W. LEWIS, Trustee.  
HERBERT HORE, Trustee.

Approved by the Governor in Council,  
1st November, 1948.

J. C. MACGIBBON,  
Acting Clerk of the Executive Council.

## NOTICE PURSUANT TO SECTION 24 OF THE MILK BOARD ACTS.

AFTER inquiry, conducted in the manner prescribed by the Milk Board Acts and Regulations made thereunder, the Milk Board doth, by this notice, amend the notice published in the *Government Gazette*, No. 390, of the 17th September, 1947, as follows:—

## SECOND SCHEDULE.

Specified Dairies from which Milk may be Distributed in Defined Areas.	Areas Defined by Numbers in the First Schedule to Notice published in <i>Government Gazette</i> , No. 390, of the 17th September, 1947, in which Milk may be Distributed from the Dairies described in Column 1.
<i>Municipal District—Brighton.</i>	
14 Ferguson-street, Brighton	Add Moorabbin 9A.
<i>Municipal District—Camberwell.</i>	
24 Power-street, Balwyn	Add Camberwell 3B.
<i>Municipal District—Caulfield.</i>	
10 Elster-avenue, Elsternwick	Add Brighton 2.
<i>Municipal District—Coburg.</i>	
27 Shorts-road, North Coburg	Add Broadmeadows 4.
31 Nicholson-street, East Coburg	Add Coburg 16.
63 Mashoubra-street, Merlynston	Add Broadmeadows 4.
<i>Municipal District—Collingwood.</i>	
71 Hotham-street, Collingwood	Add Collingwood 2b, 3.
<i>Municipal District—Essendon.</i>	
1 York-street, Moonee Ponds	Add Essendon 7.
37 Keilor-road, Essendon	Add Essendon 1B.
307 Maribyrnong-road, Ascot Vale	Add Braybrook 6.
70 Lincoln-road, Essendon	Add Essendon 1A.
<i>Municipal District—Fitzroy.</i>	
45 Moor-street, Fitzroy	Add Melbourne 16B.
<i>Municipal District—Footscray.</i>	
117 Cowper-street, Footscray	Add Footscray 16B.
34 Walter-street, Footscray	Add Footscray 12B.
10 Schild-street, Yarraville	Add Footscray 11A.
36 Clive-street, West Footscray	Add Footscray 4A.
<i>Municipal District—Hawthorn.</i>	
284 Barkers-road, Glenferrie	Add Hawthorn 5.
20 Victoria-road, Auburn	Add Kew 7.
<i>Municipal District—Kew.</i>	
80 Pakington-street, Kew	Add Hawthorn 2A, Kew 7.
<i>Municipal District—Malvern.</i>	
1495 Malvern-road, Glen Iris	Add Malvern 1.
60 Belgrave-road, East Malvern	Add Camberwell 20B.
<i>Municipal District—Melbourne.</i>	
155 Capel-street, North Melbourne	Add Melbourne 12.
<i>Municipal District—Moorabbin.</i>	
863 Pt. Nepean-road, Moorabbin	Add Moorabbin 9A.
<i>Municipal District—Mulgrave.</i>	
High Street-road (near War-rigal-road, Burwood)	Add Oakleigh 7.
<i>Municipal District—Northcote.</i>	
176 St. George's-road, Northcote	Add Northcote 9.

## SECOND SCHEDULE—continued.

Specified Dairies from which Milk may be Distributed in Defined Areas.	Areas Defined by Numbers in the First Schedule to Notice published in <i>Government Gazette</i> , No. 390, of the 17th September, 1947, in which Milk may be Distributed from the Dairies described in Column 1.
<i>Municipal District—Prahran.</i>	
29 Howitt-street, Hawksburn	Add Prahran 8.
236 Toorak-road, South Yarra	Add Prahran 1C.
50 Alexandra-street, South Yarra	Add Melbourne 18.
745 Malvern-road, Toorak	Add Prahran 7.
24 Wright-street, Prahran	Add Prahran 23.
<i>Municipal District—Richmond.</i>	
85 Richmond-terrace, Richmond	Add Melbourne 16B.
<i>Municipal District—Williamstown.</i>	
89 Thompson-street, Williamstown	Add Williamstown 5.
28 Station-road, Williamstown	Add Williamstown 8.

By order of the Milk Board,  
M. H. RANKIN,  
Secretary.

## ORDER EXEMPTING A REGISTERED CLUB FROM THE OPERATION OF CERTAIN PROVISIONS OF THE LICENSING ACT.

CITY AND OVERSEAS CLUB, IN THE LICENSING DISTRICT OF MELBOURNE, SITUATE AT 164 FLINDERS-STREET, MELBOURNE.

THE Licencing Court for the above-mentioned Licensing District, sitting at Melbourne this day, application having been duly made on behalf of the above-mentioned registered club by Neville Gardner Whitehead, the secretary thereof, such club having been formed before the first day of July, One thousand nine hundred and six, doth hereby order that the said club be exempt from the operation of the provision of section 202 of the *Licensing Act 1928*.

Given under the seal of the said Court, this twenty-fifth day of October, 1948—

(SEAL) H. MCALISTER,  
Registrar of the said Court.

## 4 GEORGE VI. No. 4755, SECTION 6.

I HEREBY give notice that on the 28th October, 1948, I filed an election to administer the following deceased person's estate, in accordance with section 6 of the *Public Trustee Act 1940*:—

TREEBY, HENLEY, late of Melbourne Benevolent Asylum, Cheltenham, pensioner, died 16th May, 1948, intestate.

C. J. GARDNER,  
Public Trustee.

412 Collins-street, Melbourne, C.1, 3rd November, 1948.

## NOTICE.

ADMINISTRATION of the estate of each of the under-mentioned deceased persons has been granted to me, and creditors, next of kin, and all others having claims against the estate of any of the persons so mentioned are required to send particulars of their claims to the Public Trustee, No. 412 Collins-street, Melbourne, on or before the 12th January, 1949, or they will be excluded from the distribution of the estate when the assets are being distributed:—

CAMPBELL, MARY ELLEN, late of 22 Gillman-street, Hawthorn East, married woman, died 10th June, 1948, intestate.  
\*CHEYNE, ANN MARGARET, late of 19 Mount Hobson-road, Remuera, Auckland, New Zealand, spinster, died 31st October, 1947.

\*HAY, DAVID, late of Christchurch, New Zealand, retired, died on or about 17th October, 1945.

\*STURT, CHARLOTTE THERESA JANE, formerly of Dorset-road, Croydon, but late of 41 Hawker-street, Ivanhoe, spinster, died 11th February, 1941.

TREEBY, HENLEY, late of Melbourne Benevolent Asylum, Cheltenham, pensioner, died 16th May, 1948, intestate.

\* With the will annexed.

C. J. GARDNER,  
Public Trustee.

Melbourne, 3rd November, 1948.

MELBOURNE AND METROPOLITAN BOARD OF WORKS.  
UPPER YARRA YARRA RIVER.  
HENLEY-ON-YARRA.

*Notice to Boatmen and Others.*

**B**OATMEN and others are hereby notified that permission has been granted to the Melbourne Amateur Regatta Association, in connexion with the Annual Regatta, to row races from Como Park downstream on the Upper Yarra on the 20th November, 1948, and that motor and other boats permitted to be on the river during the day must observe the following Regulations, viz.:—

Boat races must not be obstructed, nor public safety or order endangered.

Every motor boat must have a supply of dry sand, with shovel or scoop, and carry—

- (a) a bucket with rope attached; and
- (b) an approved chemical fire extinguisher

for fire extinguishing purposes, and no inflammable oil or spirit shall be exposed.

All non-competing boats must be kept off the course during the racing programme.

No boats (except racing boats) will be allowed to land or take up passengers at the boat stagings (south bank), or from the bank along the course except at the landing stage.

Passengers on any boat overcrowded or incompetently managed may be ordered to disembark.

No boat deemed by the River Officer or his Deputy to be too large or deemed to be offensive, dangerous, unsuitable, or unsightly shall remain on the river along the course or adjacent waters.

The direction of the officers in charge of the course must be strictly attended to.

All boats (except racing boats) must move up stream along the right hand (south) bank, and must move down stream along the opposite (north) bank.

No advertisement or objectionable device will be permitted to be shown on any boat.

No fireworks or firearms will be allowed to be discharged from any boat, except where permission of the River Officer or his Deputy has been given.

All motor boats shall hold a permit from the River Officer to enter or remain on that part of the River Yarra between Prince's-bridge and Como Park, between the hours of 10 a.m. and 6 p.m. on Henley Day.

No motor or other boats will be allowed to ply for hire between Prince's-bridge and Como Park between the hours of 10 a.m. and 6 p.m. on Henley Day except under special permit from the Board.

All motor boats shall be moored in the positions allotted to them by 12.30 p.m., and shall remain moored until the finish of the racing programme.

All motor boats on south bank must moor bow up stream, and all motor boats on north bank must moor bow down stream.

An applicant for permit must apply at the office of the River Officer, 110 Spencer-street, Melbourne, and furnish the name and dimensions of the boat for which a permit is required; also the name and address of the owner, and of the person taking charge of the boat on Henley Day. If the boat is unnamed, some identification number must be affixed to each bow of the boat.

No permit shall be given to a motor boat exceeding a length of 35 feet from stem to stern, or with a beam exceeding 9 feet over all, unless the River Officer shall see fit to do so. It is recommended that row boats be in attendance on large motor boats for transporting passengers, also that a gangway be provided for each motor boat to enable passengers to reach the bank.

No permit shall be given for boats burning other than liquid fuel.

A permit shall not be transferable by the holder or in respect of motor boats.

An applicant must give name and dimensions of boat, and must provide his own mooring ropes and anchors. Mooring posts will not be provided.

Acceptance of a permit shall be a guarantee that its holder and the boat it is issued for will observe the regulations, whether general or special.

Motor boats must moor at the position bearing same number as shown on permit.

Mooring or holding on to the booms or buoys will be strictly forbidden.

After sunset on Henley Day motor boats shall exhibit a red light and go slow in the centre of the river only. Motor boats shall not tow any boat.

On Henley Day the length of oars used by any boat, other than racing boats, between Como Park and Prince's-bridge, shall not exceed 8 feet.

The use of paddles as a means of propulsion for rowing boats is preferred.

Boats over 25 feet in length or boats with jib-booms or other objectionable projections will not be permitted on the Yarra between Prince's-bridge and Como Park between the hours of 10 a.m. and 6 p.m. on Henley Day.

Bowing boats and canoes shall exhibit a white light after sunset on Henley Day.

All boats must give way to racing boats going up stream to the start of the course.

CHAS. J. W. BRIGGS, Secretary.  
G. W. WILSON, Acting River Officer.

110 Spencer-street, Melbourne, C.1,  
3rd November, 1948.

SHIRE OF DUNDAS.

ORDER DECLARING PUBLIC HIGHWAY CONFIRMED BY GOVERNOR  
IN COUNCIL.

**I**N pursuance of the powers conferred by sections 521 and 525 of the *Local Government Act 1946*, the Council of the Shire of Dundas doth hereby order that the two parcels of land next hereinafter described shall be a public highway from the date of the publication of this Order in the *Government Gazette*, that is to say:—

All that piece of land containing 5 acres 2 roods 11 6/10 perches, or thereabouts, being part of allotments 2 and 4, section 1, Parish of Yatchaw West, County of Normanby, commencing at the north-east corner or angle of said allotment 4; thence bounded on the east by a Government road bearing south 23 min. east 1 chain 2 links; thence on the south by other parts of said allotments 4 and 2 bearing south 78 deg. 9 min. west 52 chains 3 links; thence again on the south by another part of said allotment 2 bearing south 64 deg. 56 min. west 4 chains 59 6/10 links; thence on the west by a Government road bearing north 40 deg. 45 min. east 2 chains 44 1/10 links; thence on the north-west by another part of said allotment 2 bearing north 64 deg. 56 min. east 2 chains 48 5/10 links; thence on the north by other parts of said allotments 2 and 4 bearing north 78 deg. 9 min. east 52 chains 34 links to the commencing point. And, also, all that piece of land containing 11 2/10 perches, or thereabouts, being part of allotment 3, section 10, Parish of Yatchaw West, County of Normanby, commencing at a point on a Government road distant south 64 deg. 56 min. west 2 chains 44 1/10 links from the north-westerly corner or angle of the land lastly hereinbefore described; thence bounded on the south-east by such Government road bearing south 40 deg. 45 min. west 1 chain 50 links; thence on the south-west by other part of the said Government road bearing north 81 deg. 16 min. west 1 chain 10 1/2 links; thence on the north by other part of said allotment 3 bearing north 64 deg. 56 min. east 2 chains 28 7/10 links to the commencing point.

And the said Council doth hereby declare that the pieces of land above described shall from the said date of publication in the *Government Gazette* be a public highway, in lieu of the land hereinafter described, that is to say:—

All that piece of land containing 7 acres 2 roods 33 6/10 perches, or thereabouts, situate in the Parish of Yatchaw West, County of Normanby, being part of a Government road commencing at the north-east angle of allotment 5, section 1, in the said parish; thence along the south side of a Government road north 56 deg. 10 min. west 8 chains 41 links; thence south 52 deg. 37 min. west 13 chains 2 links; thence south 19 deg. 6 min. west 15 chains 46 links; thence south 47 deg. 58 min. west 11 chains 62 links; thence north 74 deg. 57 min. west 9 chains 16 links; thence south 55 deg. 33 min. west 10 chains 16 links; thence south 40 deg. 45 min. west 7 chains 79 9/10 links; thence south 64 deg. 56 min. west 2 chains 44 1/10 links; thence north 40 deg. 45 min. east 10 chains 15 links; thence north 55 deg. 33 min. east 10 chains 75 links; thence south 74 deg. 57 min. east 9 chains 8 links; thence north 47 deg. 58 min. east 10 chains 82 links; thence north 19 deg. 6 min. east 15 chains 49 links; thence north 52 deg. 37 min. east 14 chains 3 links; thence south 56 deg. 10 min. east 8 chains 26 links; thence south 7 deg. 4 min. east 1 chain 32 links to the commencing point. And, also, all that piece of land containing 16 9/10 perches, or thereabouts, being part of a Government road situate in the Parish of Yatchaw West, County of Normanby, commencing at the south-west corner or angle of the land firstly hereinbefore described; thence bounded on the south-east by part of allotment 2, section 1, in the said parish bearing south 40 deg. 45 min. west 1 chain 84 links; thence on the south-west by other part of said allotment 2 bearing north 81 deg. 16 min. west 1 chain

35 5/10 links; thence on the north by part of the said Government road bearing north 64 deg. 56 min. east 2 chains 80 4/10 links to the commencing point.

Dated the third day of June, One thousand nine hundred and forty-eight.

The common seal of the Body Corporate, incorporated under the name of the President, Councillors, and Ratepayers of the Shire of Dundas, was hereunto affixed by the secretary of the said shire by order of the Council of the said shire, made at a meeting of the said Council on the third day of June, One thousand nine hundred and forty-eight.

(SEAL) R. A. CHRISTIE, President.  
E. V. WALTER, Member of the said Council present at the said meeting.  
L. KIRKWOOD, Member of the said Council present at the said meeting.  
L. C. SMITH, Secretary.

Confirmed by the Governor in Council,  
1st November, 1948.

J. C. MACGIBBON,  
Acting Clerk of the Executive Council.

#### ORDERS IN COUNCIL.—(Series 1948-49.)

##### STATE ELECTRICITY COMMISSION.

1468. The supply of 25 self-discharging overburden trucks, Morwell Open Cut.—A. Goldsmith.

1469. The supply of 940 cartridges for high rupturing capacity fuses, to Quotation No. 1524.—English Electric Co. Ltd.

1470. The supply of 1,629 tons structural steel, Yallourn, to Quotation No. 771.—Broken Hill Pty. Co. Ltd.

1471. The supply of 11,000 single grey blankets, Kiewa and Yallourn Hostels, to Quotation No. 1126.—Auslaine Trading Co.

1472. The supply of galvanized steel strand and wire rope for a period of twelve months, to Specification No. 48-49/9.—Australian Wire and Rope Works Pty. Ltd.

1473. The supply of five D7 tractors with power control units and dozers, Kiewa Hydro-Electric Scheme, to Quotation No. 1977.—Department of Works and Housing.

1474.—The erection of mess building, cubicle, and ablution blocks, Rubicon, to Specification No. 48-49/50.—O. D. Fyfe.

1475. The supply of 1,000 round wooden poles.—S. Mitchell.

1476. The erection of additional sanitary facilities, Transport Workshops, South Melbourne, to Quotation No. 1976.—W. J. Townsend.

1477. The supply of air cooler section turbo-generator, Newport Generating Station, to Quotation No. 385.—Williams, Adams, and Co. Ltd.

1478. The supply of two Vauxhall 14-h.p. sedan cars, to Quotation No. 1688.—S. A. Cheney Pty. Ltd.

1479. The supply of 420 track bushes and 420 track pins, to Quotation No. 1239.—Tutt, Bryant Pty. Ltd.

1480. The supply of briquette-fired hot-water system, Yallourn North, to Quotation No. 816.—Gardner and Naylor Pty. Ltd.

1481. The fixing and maintenance of fibre-cement roofing, Yallourn Main Store, to Quotation No. 535.—Wunderlich Ltd.

1482. The supply of 15,000 feet canvas fire hose, to Quotation No. 1443.—Thomas Evans Pty. Ltd.

1483.—The supply of 8,000 feet fire hose, Yallourn, to Quotation No. 1378.—Thomas Evans Pty. Ltd.

Approved by the Governor in Council, 1st November, 1948.—J. C. MACGIBBON, Acting Clerk of the Executive Council.

#### PATRIOTIC FUNDS ACTS.

*At the Executive Council Chamber, Melbourne, the twenty-sixth day of October, 1948.*

##### PRESENT:

The Lieutenant-Governor, as Deputy for His Excellency the Governor of Victoria.

Mr. Kennedy | Mr. Byrnes.

#### TRANSFER OF CERTAIN PATRIOTIC FUNDS TO THE PATRIOTIC FUNDS COUNCIL OF VICTORIA.

WHEREAS it is provided, *inter alia*, by the Patriotic Funds Acts that the Governor in Council, on the recommendation of the Patriotic Funds Council of Victoria, may by Order published in the *Government Gazette*, vest in the said Council any patriotic fund on being

satisfied that there has been failure of administration of such fund: And whereas His Excellency the Governor in Council is satisfied that there has been failure of administration of the patriotic fund known as the Lysterfield and Rowville United Services Association Patriotic Fund: Now therefore, in pursuance of the powers conferred by the said Acts, the Lieutenant-Governor, as Deputy for His Excellency the Governor of the State of Victoria, by and with the advice of the Executive Council thereof, and upon the recommendation of the Patriotic Funds Council of Victoria, doth by this Order vest in the said Council the patriotic fund known as—

Lysterfield and Rowville United Services Association Patriotic Fund,

as from the publication of this Order in the *Government Gazette*.

And the Honorable John Gladstone Black McDonald, for and on behalf of His Majesty's Premier for the State of Victoria, shall give the necessary directions herein accordingly.

J. C. MACGIBBON,  
Acting Clerk of the Executive Council.

#### MARKETING OF PRIMARY PRODUCTS ACT 1935 (No. 4337).

*At the Executive Council Chamber, Melbourne, the first day of November, 1948.*

##### PRESENT:

His Excellency the Governor of Victoria.  
Mr. McDonald | Mr. Dodgshun.  
Mr. Oldham | Sir Albert Dunstan.

#### REGULATIONS.

IN pursuance of the powers conferred by sections 23 (1) and 43 (1) of the *Marketing of Primary Products Act 1935* (No. 4337), His Excellency the Governor of the State of Victoria, by and with the advice of the Executive Council thereof, and on the recommendation of the Onion Marketing Board, doth hereby make the following Regulation (that is to say):—

The thirty-seventh period of time in respect of which the computation of or accounting for the net proceeds of the sale of onions may be made by the Onion Marketing Board shall be from the 16th November, 1947, to the 15th November, 1948 (both dates inclusive).

And the Honorable Alexander Henry Dennett, His Majesty's Minister of Agriculture for the State of Victoria, shall give the necessary directions herein accordingly.

J. C. MACGIBBON,  
Acting Clerk of the Executive Council.

#### LOCAL GOVERNMENT ACT 1946.

*At the Executive Council Chamber, Melbourne, the first day of November, 1948.*

##### PRESENT:

His Excellency the Governor of Victoria.  
Mr. McDonald | Mr. Dodgshun.  
Mr. Oldham | Sir Albert Dunstan.

#### HOURS OF POLLING—SHIRE OF FRANKSTON AND HASTINGS.

IN pursuance of the provisions of section 134 of the *Local Government Act 1946*, His Excellency the Governor of the State of Victoria, by and with the advice of the Executive Council thereof, and in compliance with a petition presented by the Council of the Shire of Frankston and Hastings, dated the 10th September, 1948, doth by this Order declare that the hour for closing the poll at municipal elections for the said shire shall be Eight (8) o'clock in the afternoon.

And the Honorable James Arthur Kennedy, His Majesty's Commissioner of Public Works for the State of Victoria, shall give the necessary directions herein accordingly.

J. C. MACGIBBON,  
Acting Clerk of the Executive Council.

DEPARTMENT OF LANDS AND SURVEY.

At the Executive Council Chamber, Melbourne, the first day of November, 1948.

PRESENT:

His Excellency the Governor of Victoria.  
 Mr. McDonald | Mr. Dodgshun  
 Mr. Oldham | Sir Albert Dunstan.

LANDS TEMPORARILY RESERVED FROM SALE.

HIS Excellency the Governor of the State of Victoria, by and with the advice of the Executive Council thereof, doth hereby, in pursuance of the provisions of the Land Act 1928, reserve, temporarily, and also except from occupation for mining purposes under any miner's right, the lands hereinafter described:—

FORREST.—Site for Police purposes, 3 roods 7 3/10 perches, Township of Forrest, Parish of Yaughar, County of Polwarth, as indicated by hachure on plan hereunder.—(F.104) (Rs.6234).

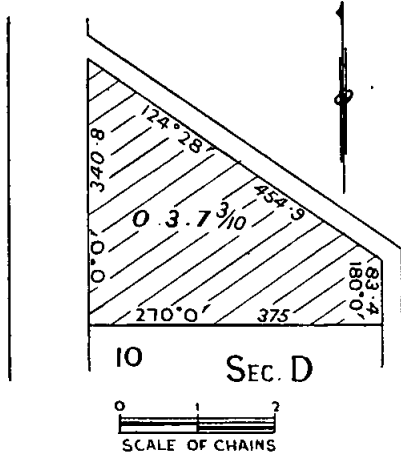

LYNDHURST.—Site for Public Recreation, 4 acres 3 roods, more or less, Parish of Lyndhurst, County of Mornington, as indicated by hachure on plan hereunder.—(L.101<sup>(5)</sup>) (Rs.6262).

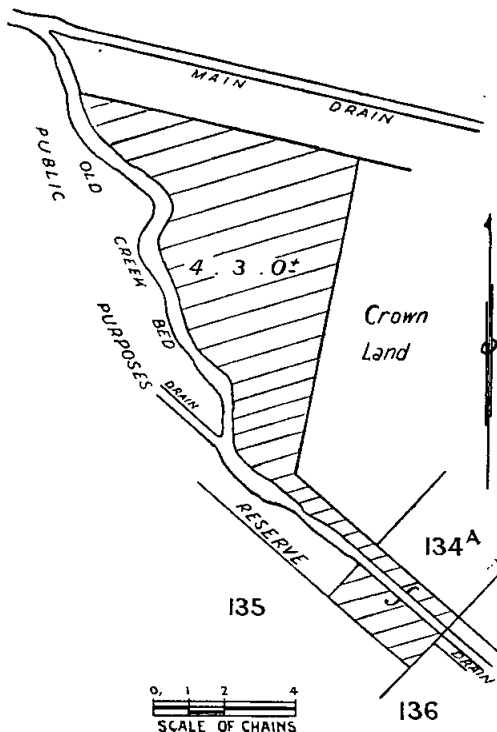

NULLAWIL.—Site for Public Recreation, 11 acres 3 roods 31 perches, Parish of Nullawil, County of Tatchera, as indicated by hachure on plan hereunder.—(N.160<sup>(2)</sup>) (Rs.6276).

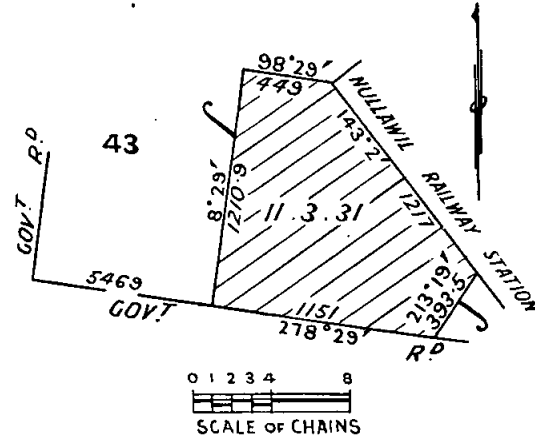

FOSTER.—Site for a State School, in addition to and adjoining the site temporarily reserved therefor by Order in Council of the 24th November, 1925, 1 acre, Township of Foster, Parish of Wonga Wonga South, County of Buln Buln, as indicated by hachure on plan hereunder.—(F.100<sup>(3)</sup>) (Rs.1275).

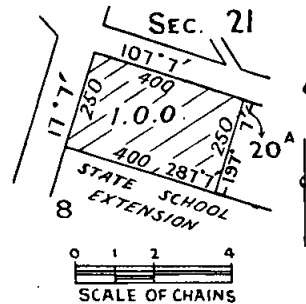

FOSTER.—Site for a State School, in addition to the sites temporarily reserved therefor by Orders in Council of the 3rd March, 1890, 13th October, 1903, 7th August, 1917, and 24th November, 1925, 1 acre 1 rood 1 perch, Township of Foster, Parish of Wonga Wonga South, County of Buln Buln, as indicated by hachure on plan hereunder.—(F.100<sup>(3)</sup>) (Rs.1275).

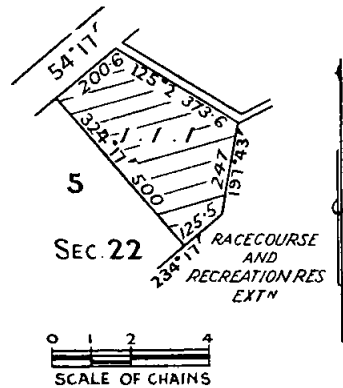

And the Honorable Percy Thomas Byrnes, for and on behalf of His Majesty's Commissioner of Crown Lands and Survey for the State of Victoria, shall give the necessary directions herein accordingly.

J. C. MACGIBBON,  
 Acting Clerk of the Executive Council.

DEPARTMENT OF LANDS AND SURVEY.

At the Executive Council Chamber, Melbourne, the first day of November, 1948.

PRESENT:

His Excellency the Governor of Victoria.  
 Mr. McDonald | Mr. Dodgshun  
 Mr. Oldham | Sir Albert Dunstan.

REVOCATION OF TEMPORARY RESERVATIONS OF LANDS BY ORDERS IN COUNCIL.

HIS Excellency the Governor of the State of Victoria, by and with the advice of the Executive Council thereof, doth hereby, in pursuance of the provisions of the Land Act 1928, revoke the temporary reservations of the lands by Orders in Council hereinafter referred to, viz.:

ARARAT.—Order in Council of 2nd March, 1891, of 2 acres 1 rood of land in the municipal district of Ararat as a site for Plantation and Drainage purposes, so far only as regards the portion thereof comprised within the boundaries published in the Government Gazette of 6th October, 1948, and containing 1 rood.—(Rs.6205.)

CORRYONG.—Order in Council of 22nd September, 1902, of 2 roods of land in the Township of Corryong, as a site for watering purposes.—(Rs.6251.)

And the Honorable Percy Thomas Byrnes, for and on behalf of His Majesty's Commissioner of Crown Lands and Survey for the State of Victoria, shall give the necessary directions herein accordingly.

J. C. MACGIBBON,  
 Acting Clerk of the Executive Council.

DEPARTMENT OF LANDS AND SURVEY.

At the Executive Council Chamber, Melbourne, the first day of November, 1948.

PRESENT:

His Excellency the Governor of Victoria.  
 Mr. McDonald | Mr. Dodgshun  
 Mr. Oldham | Sir Albert Dunstan.

UNUSED AND UNMADE ROADS CLOSED.

HIS Excellency the Governor of the State of Victoria, by and with the advice of the Executive Council thereof, doth hereby direct that, in pursuance of the provisions of section 304 of the Land Act 1928 (No. 3709), the unused and unmade roads referred to hereunder be closed, viz.:

Parish of Warrong, County of Villiers, being the road in section Q between allotment 6B and allotment 5.—(W.91(4) (Z.29861).

Parish of Harcourt, County of Talbot, being the road indicated by hachure on plan hereunder.—(H.16(4) (W.63653).

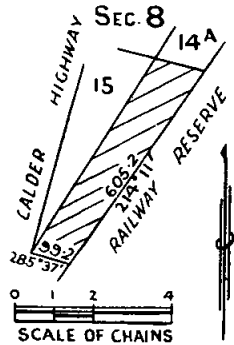

And the Honorable Percy Thomas Byrnes, for and on behalf of His Majesty's Commissioner of Crown Lands and Survey for the State of Victoria, shall give the necessary directions herein accordingly.

J. C. MACGIBBON,  
 Acting Clerk of the Executive Council.

HOSPITALS AND CHARITIES ACT 1928 (No. 3699).—  
 HOSPITALS AND CHARITIES ACT 1941 (No. 4846).

At the Executive Council Chamber, Melbourne, the first day of November, 1948.

PRESENT:

His Excellency the Governor of Victoria.  
 Mr. McDonald | Mr. Dodgshun  
 Mr. Oldham | Sir Albert Dunstan.

THE QUEEN VICTORIA MEMORIAL HOSPITAL.—  
 EXTENSION OF OBJECTS OR PURPOSES.

WHEREAS the Queen Victoria Memorial Hospital is a hospital incorporated under the Hospitals and Charities Act 1928 (No. 3699): And whereas the Committee of Management of the said hospital desires to extend the objects or purposes of such hospital: And whereas the Charities Board of Victoria after inquiry recommends the extension desired by the aforesaid Committee: And whereas the Governor in Council may under the powers conferred by section 3 of the Hospitals and Charities Act 1941 (No. 4846) order such extension:

Now therefore His Excellency the Governor of the State of Victoria, by and with the advice of the Executive Council thereof, doth hereby order that the objects or purposes of the Queen Victoria Memorial Hospital shall be extended to read:—

- (a) To afford to women and children the opportunity of obtaining medical and surgical treatment, and to women of obtaining obstetrical treatment, by qualified women practitioners.
- (b) To assist in the education and training of women medical students.
- (c) To provide facilities for the training of women as nurses, midwives, dietitians, physiotherapists, and almoners.
- (d) To provide facilities for the treatment of private and intermediate patients, or either, who shall be treated by their own doctors in a section of the hospital which shall be known as the "Jessie McPherson Community Hospital."
- (e) To provide facilities for scientific investigation and research.

And the Honorable Sir Albert Arthur Dunstan, His Majesty's Minister of Health for the State of Victoria, shall give the necessary directions herein accordingly.

J. C. MACGIBBON,  
 Acting Clerk of the Executive Council.

HOSPITALS AND CHARITIES ACT 1928 (No. 3699).

At the Executive Council Chamber, Melbourne, the first day of November, 1948.

PRESENT:

His Excellency the Governor of Victoria.  
 Mr. McDonald | Mr. Dodgshun  
 Mr. Oldham | Sir Albert Dunstan.

WONTHAGGI AND DISTRICT HOSPITAL.

WHEREAS a petition signed by not less than twenty-five contributors to the Wonthaggi and District Hospital, an institution capable of incorporation under the Hospitals and Charities Act 1928 (No. 3699), praying that the said hospital be incorporated has been forwarded to the Charities Board of Victoria in accordance with the provisions of section 50 of the said Act:

And whereas the substance of the prayer of the said petition has been published in the Government Gazette and no counter petition has been lodged with the Charities Board of Victoria within one month after the date of such publication:

Now therefore His Excellency the Governor of the State of Victoria, by and with the advice of the Executive Council thereof, doth by this present Order declare the contributors for the time being to the hospital aforesaid to be a body corporate by the name of the Wonthaggi and District Hospital.

And the Honorable Sir Albert Arthur Dunstan, His Majesty's Minister of Health for the State of Victoria, shall give the necessary directions herein accordingly.

J. C. MACGIBBON,  
 Acting Clerk of the Executive Council.

MOTOR OMNIBUS ACT 1928 (No. 3742).

At the Executive Council Chamber, Melbourne, the first day of November, 1948.

PRESENT:

His Excellency the Governor of Victoria.
Mr. McDonald | Mr. Dodgshun
Mr. Oldham | Sir Albert Dunstan.

AMENDMENT OF PRESCRIPTION OF METROPOLITAN MOTOR OMNIBUS ROUTE No. 26A (GLEN IRIS-ASHBURTON).

HIS Excellency the Governor of the State of Victoria, by and with the advice of the Executive Council thereof, and in pursuance of the powers conferred by the Motor Omnibus Act 1928 (No. 3742), doth by this Order amend, as set out hereunder, the prescription of a certain route, i.e., No. 26A, within the metropolitan area, along which motor omnibuses for which "regular service" licences are granted may ply for hire, viz.:-

Under the heading "Description of Route, including Commencing and Terminal Points" add—"Return trips to Glen Iris to terminate at corner of Kialla-avenue and High-street."

Licensing Authority.—Pursuant to the provisions of section 15 (1) (c) of the said Act (No. 3742), the Governor in Council by this Order confers upon the Licensing Authority full power and authority for the carrying into effect by the said Licensing Authority of the foregoing provisions of this Order.

And the Honorable James Arthur Kennedy, His Majesty's Commissioner of Public Works for the State of Victoria, shall give the necessary directions herein accordingly.

J. C. MACGIBBON, Acting Clerk of the Executive Council.

SUPREME COURT ACT 1928.

At the Executive Council Chamber, Melbourne, the first day of November, 1948.

PRESENT:

His Excellency the Governor of Victoria.
Mr. McDonald | Mr. Dodgshun
Mr. Oldham | Sir Albert Dunstan.

NOMINATION OF TWO PERSONS FOR THE PURPOSE OF DIVISION 10 OF PART VII. OF THE SAID ACT.

WHEREAS under the provisions of Division 10 of Part VII. of the Supreme Court Act 1928 it is enacted that two persons nominated by the Governor in Council in conjunction with the Chief Justice or any other Judge of the Supreme Court nominated by him, and two members of the Council of the Law Institute of Victoria to be nominated by the said Council, may from time to time exercise the powers set forth in the said Division:

Now I, the Governor of the State of Victoria, by and with the advice of the Executive Council thereof, in pursuance of the powers conferred by the said Division, do hereby nominate—

ERIC SMITH VANCE, Master-in-Equity under the Supreme Court Act 1928, and
LOUIS LUCAS OLIVER, Taxing Master under the said Act,
as persons empowered to exercise the powers aforesaid.

And the Honorable Trevor Donald Oldham, His Majesty's Attorney-General for the State of Victoria, shall give the necessary directions herein accordingly.

J. C. MACGIBBON, Acting Clerk of the Executive Council.

FIRST MILDURA IRRIGATION TRUST.—MILDURA URBAN WATER TRUST.

At the Executive Council Chamber, Melbourne, the first day of November, 1948.

PRESENT:

His Excellency the Governor of Victoria.
Mr. McDonald | Mr. Dodgshun
Mr. Oldham | Sir Albert Dunstan.

APPORTIONMENT OF LIABILITIES.

UNDER the powers conferred by the Mildura Irrigation and Water Trusts Acts and all other powers enabling him in that behalf, His Excellency the Governor of the State of Victoria, by and with the advice of the Executive Council of the said State, doth hereby declare, order, and direct as follows:—

That in respect of the portions severed from the District of the First Mildura Irrigation Trust and annexed to the District of the Mildura Urban Water Trust by Order in Council of even date there shall, as on and from the 1st January, 1949, be transferred in the books of the Treasury Department, Melbourne, from the liabilities of the said First Mildura Irrigation Trust to the said Mildura Urban Water Trust the sum of Ninety-seven pounds seven shillings and eight pence (£97 7s. 8d.).

And the Honorable John Gladstone Black McDonald, His Majesty's Minister of Water Supply for the State of Victoria, shall give the necessary directions herein accordingly.

J. C. MACGIBBON, Acting Clerk of the Executive Council.

FIRST MILDURA IRRIGATION TRUST.—MILDURA URBAN WATER TRUST.

At the Executive Council Chamber, Melbourne, the first day of November, 1948.

PRESENT:

His Excellency the Governor of Victoria.
Mr. McDonald | Mr. Dodgshun
Mr. Oldham | Sir Albert Dunstan.

SEVERANCE OF PORTIONS OF THE FIRST MILDURA IRRIGATION TRUST DISTRICT AND ANNEXATION THEREOF TO THE MILDURA URBAN WATER TRUST DISTRICT.

UNDER the powers conferred by the Mildura Irrigation and Water Trusts Acts and all powers enabling him in that behalf, His Excellency the Governor of the State of Victoria, by and with the advice of the Executive Council of the said State, doth hereby declare, order, and direct as follows:—

That on and from the 1st January, 1949, the areas set out and described in the Schedule hereto, being portions of the district of the First Mildura Irrigation Trust, be severed therefrom, and that such areas be annexed to the district of the Mildura Urban Water Trust.

SCHEDULE.

Portion I.

Commencing at the most northerly angle of lot 4, section 82, Block D, on lodged plan of subdivision numbered 2144, Parish of Mildura, County of Karkaroc; thence south-easterly along the north-eastern boundary of the said lot 4 to its most easterly angle; thence south-westerly along the south-eastern boundaries of lots 4 and 10 to the most southerly angle of the said lot 10; thence north-westerly along the south-western boundary of the said lot 10 to its most westerly angle; thence north-easterly along the north-western boundaries of lots 10 and 4 to the point of commencement.

Portion II.

Commencing at the most southerly angle of lot 9, section 17, Block E, on lodged plan of subdivision numbered 2380, Parish of Mildura, County of Karkaroc; thence north-westerly along the south-western boundary of the said lot 9 a distance of 669 ft. 10 1/2 in.; thence by a line bearing north 45 deg. 16 min. east through lot 9 a distance of 329 ft. 4 in.; thence by a line bearing south 44 deg. 44 min. east through lot 9 a distance of 669 ft. 10 1/2 in. to a point on its south-eastern boundary; thence south-westerly along the said south-eastern boundary of lot 9 to the point of commencement.



*Portion III.*

Commencing at the most easterly angle of lot 8, section 17, Block E, on lodged plan of subdivision numbered 2380, Parish of Mildura, County of Karkaroc; thence south-westerly along the south-eastern boundaries of lots 8 and 9 to a point distant 106 ft. 3½ in. south-westerly from the most easterly angle of the said lot 9; thence by a line bearing north 44 deg. 44 min. west through lot 9 a distance of 669 ft. 10½ in.; thence by a line bearing south 45 deg. 16 min. west through lot 9 to a point on its south-western boundary; thence north-westerly along the said south-western boundary of lot 9 to its most westerly angle; thence south-westerly along the south-eastern boundaries of lots 3 and 4 to the most southerly angle of the said lot 4; thence north-westerly along the south-western boundary of the said lot 4 a distance of 42 ft. 3 in.; thence across lots 4 and 3 by lines bearing north 6 deg. 16 min. 30 sec. east a distance of 207 ft. 6½ in., north 29 deg. 31 min. 30 sec. east a distance of 444 ft. 8½ in., north 23 deg. 18 min. east a distance of 202 ft. 4½ in., north 30 deg. 19 min. east a distance of 100 ft. 5½ in. to a point on the south-western boundary of lot 2; thence north-westerly along the said south-western boundary of lot 2 a

distance of 7 ft. 8 in.; thence across the said lot 2 by lines bearing north 30 deg. 43 min. east a distance of 339 ft. 6½ in., north 22 deg. 24 min. east a distance of 116 ft. 2 in. to a point on the south-western boundary of lot 1; thence south-easterly along the said south-western boundary of lot 1 a distance of 8 ft. 10½ in.; thence across lot 1 by a line bearing north 21 deg. 53 min. east a distance of 244 ft. 5½ in. to a point on the north-eastern boundary of the said lot 1; thence south-easterly along the north-eastern boundaries of lots 1 and 8 to the point of commencement.

The areas described in the foregoing Schedule are shown on plans marked A, B, and C approved by the Governor in Council, and deposited in the office of the State Rivers and Water Supply Commission, Melbourne.

And the Honorable John Gladstone Black McDonald, His Majesty's Minister of Water Supply for the State of Victoria, shall give the necessary directions herein accordingly.

J. C. MACGIBBON,  
Acting Clerk of the Executive Council.

## MILK AND DAIRY SUPERVISION ACT 1928 (No. 3736).

*At the Executive Council Chamber, Melbourne, the first day of November, 1948.*

## PRESENT:

His Excellency the Governor of Victoria.

Mr. McDonald  
Mr. Oldham

Mr. Dodgshun  
Sir Albert Dunstan.

## ORDER IN COUNCIL PROHIBITING THE KEEPING GRAZING OR MILKING OF COWS WITHIN A SPECIFIED AREA OF THE MUNICIPAL DISTRICT OF THE CITY OF MOORABBIN.

WHEREAS by section 67 of the *Milk and Dairy Supervision Act* 1928 (No. 3736) the Governor in Council is empowered on the application of the Council of any municipal district whether wholly or partly within a milk area or not, if approved by the Minister, to prohibit any person keeping grazing or milking cows on any part or parts or in any part of such area or district: And whereas the Council of the municipal district of the City of Moorabbin has applied to the Governor in Council to prohibit any person keeping grazing or milking cows in the following specified area of such municipality, that is to say:—

“Commencing at the south-east corner of McKinnon and Jasper roads; thence easterly along McKinnon-road to the west building line of Tucker-road; thence southerly along Tucker-road to the south-west corner of Tucker and Centre roads; thence easterly along Centre-road to the west building line of East Boundary-road; thence southerly along East Boundary-road to the north building line of South-road; thence westerly along South-road to the north-east building line of the Nepean Highway; thence north-westerly along the Nepean Highway to the south building line of Patterson-road; thence easterly along Patterson-road to the south-east corner of Patterson and Jasper roads; thence northerly along Jasper-road to the commencing point.”

And whereas the Minister administering for the time being the *Milk and Dairy Supervision Act* 1928 (No. 3736) has approved of such application to prohibit as aforesaid.

Now, therefore, His Excellency the Governor of the State of Victoria, by and with the advice of the Executive Council of the State of Victoria, doth by this Order prohibit any person keeping, grazing, or milking cows on any part or parts or in any part of such area of the municipal district of the City of Moorabbin aforesaid.

And the Honorable Alexander Henry Dennett, His Majesty's Minister of Agriculture for the State of Victoria, shall give the necessary directions herein accordingly.

J. C. MACGIBBON,  
Acting Clerk of the Executive Council.

## PRICES REGULATION ACT 1948.

*At the Executive Council Chamber, Melbourne, the first day of November, 1948.*

PRESENT:

His Excellency the Governor of Victoria.

Mr. McDonald  
Mr. OldhamMr. Dodgshun  
Sir Albert Dunstan.

## NOTICE OF REVOCATION OF DECLARATION OF CERTAIN GOODS AS DECLARED GOODS FOR THE PURPOSES OF PART II. OF THE PRICES REGULATION ACT 1948.

IN pursuance to the powers conferred upon him by the *Prices Regulation Act 1948*, His Excellency the Governor of Victoria, by and with the advice of the Executive Council thereof, doth hereby revoke the declarations heretofore made under the said Act of the following goods as declared goods for the purposes of Part II. of the said Act, that is to say:—

Fish, fresh and frozen, other than scallops.

Fish, other than scallops, which is cooked and which is not fish which is served as a meal or a part thereof.

And the Honorable Trevor Donald Oldham, His Majesty's Attorney-General in and for the State of Victoria, shall give the necessary directions herein accordingly.

J. C. MACGIBBON,  
Acting Clerk of the Executive Council.

## WORKERS' COMPENSATION ACTS.

*At the Executive Council Chamber, Melbourne, the ninth day of November, 1948.*

PRESENT:

His Excellency the Governor of Victoria.

Mr. Kennedy | Mr. Byrnes.

PURSUANT to the provisions of the Workers' Compensation Acts, His Excellency the Governor of the State of Victoria, by and with the advice of the Executive Council thereof, doth hereby make the Regulations following (that is to say):—

The "Workers Compensation Board Regulations (No. 1)" are hereby amended as follows:—

Clauses nine and eleven of the said Regulations, as inserted by Regulations made on the twenty-fourth day of February, 1947, and published in the *Government Gazette* of the twenty-sixth day of February, 1947, are hereby revoked, and the following substituted therefor:—

"9. The salary of each member of the Workers Compensation Board (other than the Chairman) shall be the sum of One thousand and twenty pounds per annum.

11. The remuneration of the deputy of each member of the Workers Compensation Board (other than the Chairman) while acting shall be at the rate of One thousand and twenty pounds per annum."

And the Honorable Keith Dodgshun, His Majesty's Chief Secretary for the State of Victoria, shall give the necessary directions herein accordingly.

J. C. MACGIBBON,  
Acting Clerk of the Executive Council.

## APPROACHING LAND SALES.

SALES of Crown lands, in fee-simple, will be held at the under-mentioned places and dates. viz.:—

	No. of Gazette.
Benalla.—Tuesday, 23rd November, 1948 ..	960
Bendigo.—Thursday, 2nd December, 1948 ..	997
Leongatha.—Thursday, 18th November, 1948 ..	960
Red Cliffs.—Thursday, 11th November, 1948 ..	950
Shepparton.—Thursday, 9th December, 1948 ..	1053
Terang.—Tuesday, 7th December, 1948 ..	997
Warrnambool.—Wednesday, 8th December, 1948 ..	1053
Woodside.—Wednesday, 17th November, 1948 ..	950

## SALE OF CROWN LANDS BY AUCTION.

The lands will be sold in fee-simple, and subject to the covenants, conditions, exceptions, and reservations directed by the Governor in Council by an Order in Council dated the 5th August, 1930, and published in the *Government Gazette* of the 8th August, 1930, varied as herein.

A deposit of at least twelve and a half per centum of the price at which each lot is sold must be paid by the purchaser at the time of sale, and all such payments shall be made in bank notes or cheques approved by the officer conducting the sale, and the residue of such price will be payable in equal instalments, in accordance with the scale hereunder, on the last day of each successive period of six months from the time of sale, or, if the purchaser choose, at any earlier time or times; such residue of the price shall bear interest at the rate of 5 per centum per annum, to be computed between the time of sale and the time when payment of such residue or instalment of such residue is made. If the residue of the price be paid within thirty days after the time of the sale no interest will be payable thereon.

The Governor in Council may allow a transfer of the purchaser's interest to an approved person at any time before the final payment of the purchase money is made. The fee for transfer shall be One pound, and such transfer will be subject to payment of stamp duty.

## SCALE OF PAYMENTS OF RESIDUE.

£20 and under, 6 instalments.
Over £20, and not exceeding £50, 8 instalments.
Over £50, and not exceeding £100, 10 instalments.
Over £100, and not exceeding £200, 12 instalments.
Over £200, and not exceeding £300, 14 instalments.
Over £300, and not exceeding £400, 16 instalments.
Over £400, and not exceeding £500, 18 instalments.
Over £500, 20 instalments.

## FEES, ETC.

The fees payable for Crown grant and assurance (One halfpenny for each pound of purchase price) must be paid with the balance of purchase money. The following is the scale:—

50 acres and under, £1 10s.

Over 50 acres, £2.

Where the purchase money does not exceed £5, the grant fee is £1.

Valuations of improvements (if not purchased by the owner thereof), and charges for survey, must also be paid at the time of sale.

JOHN G. B. McDONALD,  
Commissioner of Crown Lands and Survey.  
Office of Lands and Survey.  
Melbourne, 8th November, 1948.

**WARRNAMBOOL.**—Sale (No. 10701) of Crown lands, in fee-simple, by auction, will be held at the COURT HOUSE, WARRNAMBOOL, on WEDNESDAY, the 8th DECEMBER, 1948, at TEN o'clock a.m. To be conducted by the LAND OFFICER, GEELONG. Auctioneer: N. K. MORRIS, 93 Kepler-street, Warrnambool.

CITY OF WARRNAMBOOL, PARISH OF WANGOOM, COUNTY OF VILLIERS.

*Fronting Hotham-street.*

Upset price £100 per lot. Charge for survey £2 15s. per lot.

- Lot 1. Area 28 8/10 perches, allotment 6 of section 48.
- Lot 2. Area 28 8/10 perches, allotment 7 of section 48.
- Lot 3. Area 28 8/10 perches, allotment 8 of section 48.
- Lot 4. Area 28 8/10 perches, allotment 9 of section 48.
- Lot 5. Area 28 7/10 perches, allotment 9a of section 48.

PARISH OF WANGOOM, COUNTY OF VILLIERS.

*In South of Parish.*

Upset price £224 the lot. Charge for survey £10 10s.

Lot 6. Area 13a. 3r. 39p., allotment 10c of section 1. Valuation of improvements, £3 10s. (H. F. Drake).

**SHEPPARTON.**—Sale (No. 10702) of Crown lands, in fee-simple, by auction, will be held at the COURT HOUSE, SHEPPARTON, on THURSDAY, the 9th DECEMBER, 1948, at TWO o'clock p.m. To be conducted by C. A. GOURLAY, Land Officer, Benalla.

PARISH OF SHEPPARTON, COUNTY OF MOIRA.

*About 5 miles North-west of Shepparton Railway Station.*

Upset price £1 5s. per acre. Charge for survey £9 10s.

Lot 1. Area 20 acres (subject to survey), allotment 50 of section A.

KIALLA, PARISH OF KIALLA, COUNTY OF MOIRA.

*Fronting Shepparton-road.*

Upset price £15 the lot. Charge for survey £6 6s.

Lot 2. Area 2r. 32p. (subject to survey), allotment 5.

*Closer Settlement Act 1938.*

**SALE BY AUCTION.**

**SHEPPARTON.**—A Sale of the under-mentioned land, in fee-simple, by auction, will be held at the COURT HOUSE, SHEPPARTON, on THURSDAY, the 9th DECEMBER, 1948, at half-past TWO o'clock p.m. To be conducted by C. A. GOURLAY, Land Officer, Benalla.

AT KATANDRA WEST, PARISH OF KATANDRA, COUNTY OF MOIRA.

*Opposite Katandra West School.*

Charge for survey £1 10s.

Area 38 6/10 perches, allotment 31 of section 8. One month allowed for removal of fencing.

**TERMS AND CONDITIONS.**

Deposit to be paid at sale, 25 per cent. of purchase price. Balance payable by ten equal half-yearly instalments, with interest computed at the rate of 4½ per cent. per annum on the unpaid balance.

The Board of Land and Works may allow a transfer of the purchaser's interests to an approved person at any time before the final payment is made (fee, £1). The registration of the transfer may be subject to payment of such further sum as the Board may require in reduction of the outstanding balance.

Purchaser may pay balance and fees at any time prior to the due date.

Crown grant will be prepared and issued as soon as practicable after payment of purchase money in full.

(Fee for Crown grant, £1 10s. Contribution to Assurance Fund, ½d. per £1 of purchase money.)

Improvements to be maintained and insured with the Board of Land and Works.

JOHN G. B. McDONALD,  
Commissioner of Crown Lands and Survey.

Melbourne, 8th November, 1948.

**RETIREMENT AND APPOINTMENT OF MANAGERS OF COMMONS.**

IT is hereby notified for the information of all persons entitled to depasture stock on commons that successors to the individual managers thereof, who will retire on the 31st December, 1948, should be elected before the close of the year by the persons interested at public meetings duly convened for the purpose by the president of

the shire. The names, in full, of the gentleman who may be elected for either one (1), two (2), or three (3) years, should be forwarded to the Department of Lands and Survey.

P. T. BYRNES,  
Acting Commissioner of Crown Lands and Survey.

Department of Lands and Survey,  
Melbourne, 27th October, 1948.

**HORSHAM BOTANIC GARDENS AND PUBLIC RECREATION RESERVES.**

**RESCISSON OF REGULATIONS.**

THE Board of Land and Works, in pursuance of the powers conferred on it, doth hereby rescind the Regulations made on the 31st May, 1932, for the care, protection, and management of the above-named Reserves.

This rescission is in lieu of that appearing in the *Government Gazette* of the 22nd September, 1948, page 5861.—(Rs.2496, Rs.4161.)

In witness hereof the common seal of the Board of Land and Works was hereunto affixed this 29th day of October, 1948, in the presence of—

(SEAL) JOHN G. B. McDONALD, President.  
W. McILROY, Member.

**PROPOSED REVOCATIONS OF TEMPORARY RESERVATIONS OF LANDS BY ORDERS IN COUNCIL.**

IN pursuance of the provisions of the *Land Act 1928*, notice is hereby given that it is the intention of the Governor in Council to revoke the temporary reservations of lands by Orders in Council hereunder referred to, viz.:—  
*The following Notices were published 1° on the 27th October, 1948, pursuant to Orders of the 19th October, 1948.*

**ARARAT.**—The temporary reservation, by Order in Council of the 11th August, 1936, of 2 roods 17 perches of land in the Town of Ararat, as a site for Plantation purposes, is about to be revoked.—(A.148<sup>(a)</sup>) (Rs.4605).

**CAMPERDOWN.**—The temporary reservation as a site for Recreation, and the withholding from sale, leasing, and licensing, by Order in Council of the 11th November, 1875, of 12 acres 1 rood 22 perches of land in the Township of Camperdown, being sections A and B, is about to be revoked so far only as regards section A, containing 3 acres 3 roods 7 perches.—(C.165<sup>(2)</sup>) (Rs.370).

**CASTERTON.**—The temporary reservation as a site for the use of the Railway Department (Drainage), and the withholding from sale, leasing, and licensing, by Order in Council of the 23rd June, 1884, of 23 perches of land in the Town of Casterton, is about to be revoked.—(C.177<sup>(2)</sup>) (C.91283).

**WOODEND.**—The temporary reservation, by Order in Council of the 25th November, 1918, of 1 acre 3 roods 4 4/10 perches of land in the Town of Woodend, as a site for Public Park and Gardens, is about to be revoked so far only as regards the portion containing 20 perches, more or less, indicated by hachure on plan hereunder.—(W.199<sup>(2)</sup>) (Rs.112).

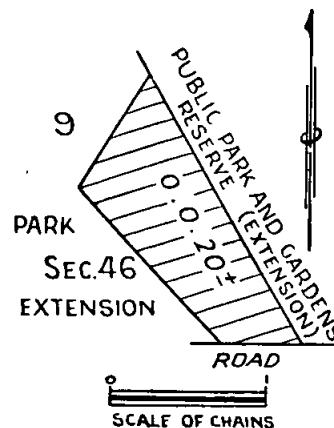

WOODEND.—The temporary reservation, by Order in Council of the 8th November, 1922, of 4 acres 0 roods 12 perches of land in the Town of Woodend, as a site for Public Park and Gardens, is about to be revoked so far only as regards the portion containing 1 rood 30 perches, more or less, indicated by hachure on plan hereunder.—(W.199<sup>(\*)</sup>) (Rs.112).

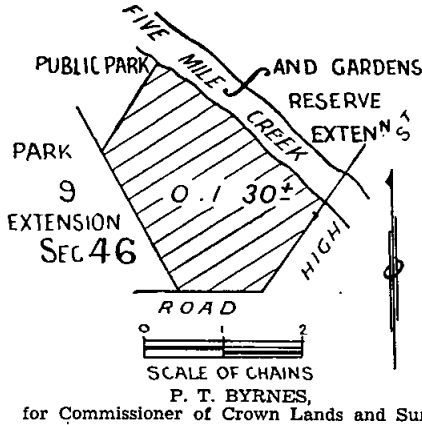

P. T. BYRNES,  
for Commissioner of Crown Lands and Survey.

**PROPOSED REVOCATIONS OF TEMPORARY RESERVATIONS OF LANDS BY ORDERS IN COUNCIL.**

IN pursuance of the provisions of the *Land Act 1928*, notice is hereby given that it is the intention of the Governor in Council to revoke the temporary reservations of lands by Orders in Council hereunder referred to, viz.:

The following Notices were published 1<sup>o</sup> on the 3rd November, 1948, pursuant to Orders of the 26th October, 1948.

BARWO.—The temporary reservation as a site for Public purposes (State School), and the withholding from sale, leasing, and licensing, by Order in Council of the 10th May, 1880, of 4 acres 3 roods 39 perches of land in the Parish of Barwo, situate in section F, is about to be revoked.—(B.690(A<sup>2</sup>)) (C.77592).

BOHO.—The temporary reservation, by Order in Council of the 31st March, 1885, of 1 acre of land in the Parish of Boho, as a site for a Mechanics' Institute, is about to be revoked.—(B.431<sup>(\*)</sup>) (Rs.852).

P. T. BYRNES,  
for Commissioner of Crown Lands and Survey.

**PROPOSED REVOCATION OF ORDER IN COUNCIL SETTING APART CERTAIN LAND.**

IN pursuance of the provisions of the *Land Act 1928*, notice is hereby given that it is the intention of the Governor in Council to revoke the setting apart of certain land by Order in Council hereunder referred to, viz.:

The following Notice was published 1<sup>o</sup> on the 3rd November, 1948, pursuant to Order of the 26th October, 1948.

PORTARLINGTON.—The setting apart, by Order in Council of the 19th March, 1860, of 1 rood of land in the Township of Portarlington, being part of allotment 1, section 22A, as a site for a Mechanics' Institute, is about to be revoked.—(P.37<sup>(\*)</sup>) (C.91433).

P. T. BYRNES,  
for Commissioner of Crown Lands and Survey.

**PROPOSED REVOCATIONS OF TEMPORARY RESERVATIONS OF LANDS BY ORDERS IN COUNCIL.**

IN pursuance of the provisions of the *Land Act 1928*, notice is hereby given that it is the intention of the Governor in Council to revoke the temporary reservations of lands by Orders in Council hereunder referred to, viz.:

The following Notices were published 1<sup>o</sup> on the 10th November, 1948, pursuant to Orders of the 1st November, 1948.

SARSFIELD.—The temporary reservation by Order in Council of the 30th January, 1894 (see *Government Gazette* of the 2nd February, 1894, page 629), of 52 acres 2 roods of land in the Township of Sarsfield, as a site for Camping and Watering purposes, is about to be revoked so far only as regards the portion containing 3 acres 1 rood 32 perches, indicated by hachure on plan hereunder.—(S.245<sup>(1)</sup>) (86/129).

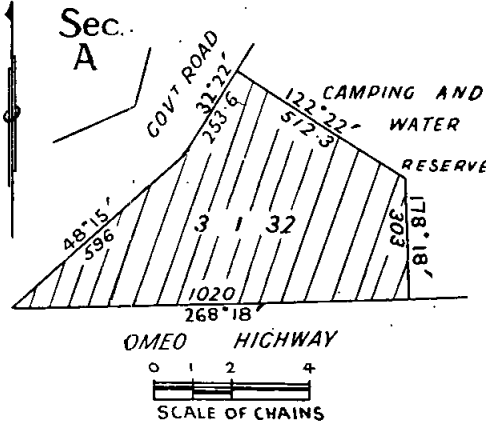

GRETA.—The temporary reservation by Order in Council of the 9th March, 1937, of 17 acres 2 roods 6 perches of land in section 32 in the Parish of Greta, as a site for Watering purposes, is about to be revoked so far only as regards the portion containing 2 acres, more or less, indicated by hachure on plan hereunder.—(G.131<sup>(\*)</sup>) (Rs.4649).

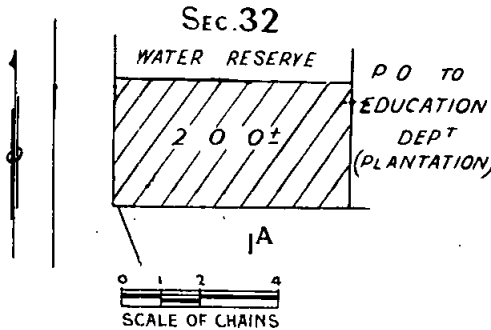

P. T. BYRNES,  
for Commissioner of Crown Lands and Survey.

*Land Act 1928.*

**LICENCES UNDER THE LAND ACTS 1915 AND 1928 DECLARED VOID.**

NOTICE is hereby given that the Licences in the Schedule hereunder have been declared void for the reason specified in each case.

District.	Corr. No.	Name of Licensee.	Section of Land Act under which Licensed.	Parish.	Allotment.	Section.	Area.	Annual Rental.	Reasons for Voiding.
Castlemaine	0688/86	Bertha Claudine Foulter	86	Chewton	78	F	A. B. P. 11 0 0	£ s. d. 0 11 0	Surrendered at licensee's request
Beechworth	247/129	William Henry Hayes	129	Township and Parish of Bright	11	5	2 2 6	1 0 0	Expired

Department of Lands and Survey,  
Melbourne, 10th November, 1948.

JOHN G. B. McDONALD,  
Commissioner of Crown Lands and Survey.

LIST OF CROWN LANDS AVAILABLE.

THE under-mentioned areas are available for application as provided by various sections of the Land Act 1928, and all applications received on or before Wednesday, 8th December, 1948, will be deemed to have been simultaneously made, but any application lodged after such date may be considered if received in time for inclusion in the advertisement of the cases to be heard at the Local Land Board.

Applications on proper form, accompanied by 5s. duty stamp uncancelled (registration fee), may be delivered or forwarded by post to the Local Land Officer or to any Crown Lands Office in Victoria. Applicants may obtain from Local Land Officers, or the Enquiry Office, Lands Department, Melbourne, a certificate authorizing the issue by the Railway Department of a return ticket at concession fares to enable them to inspect available areas or to attend Local Land Boards. When an applicant is granted an allotment he may, if travelling by rail, obtain reduced fares for his family and also freight concessions in regard to some of his effects.

Subject to the approval of the Secretary for Lands, when the survey fee exceeds £25 but does not exceed £50, a deposit of £25 may be paid, and when the fee exceeds £50, a deposit of 50 per cent. of the fee, the balance in either case being payable over six years in half-yearly instalments.

Marked plans of any particular area, application forms, and any further information may be obtained from the Enquiry Office, Lands Department, Melbourne, and Land Officers, Bairnsdale, Ballarat, and Stawell.

Department of Crown Lands and Survey,  
Melbourne, 10th November, 1948.

JOHN G. B. McDONALD,  
Commissioner of Crown Lands and Survey.

\* Improvements may be subject to re-valuation after land has been granted to an applicant.

Local Land Office.	County.	Parish.	Allotment.	Bedden.	Area.	How available.		Survey Fee.	Valuation of Improvements (if any).	Location of Land, &c.	Nearest Railway Station or Township and Distance in Mile therefrom.	How accessible.	Water Supply.	General Description of Land—Soil, Timber, Suitability (Grazing, &c.)	
						Classification.	Value Actn.								
		A. B. F.		F. S. D.		F. S. D.		F. S. D.							
Bairnsdale (a)	Tambo ..	Buchan ..	9A	C	52 0 0	3rd	1 0 0	10 10 0	Nil	In west of parish	Buchan (town), 2½ miles	By road ..	To be conserved	Steep, with stony soil; peppermint and messmate; suitable for grazing. (H.018028)	
Bairnsdale	Dargo ..	Township and Parish of Sarsfield	8	3	0 2 0	Residence	Annual rental to be fixed	3 2 6	To be valued	In north-west of township	In township of Sarsfield	By road ..	To be conserved	Suitable for a residence. (93/129)	
Melbourne (b)	Bulu Bulu	Narraean..	16	C	0 0 32	Residence and Garden	"	3 7 6	Nil	Adjoining railway line at Herne's Oak	Yalourm, 1½ mile	By road ..	To be conserved	Suitable for residence and garden. Not more than one residence or other building with the exception of outhouses shall be erected on the licensed area. (92440/129)	
Stawell ..	Borong ..	Parish and Borough of Stawell	16	108	0 0 37	Garden Dwelling	"	3 0 0	To be valued	Fronting Lilian-street ..	Stawell, 1 mile	By road ..	To be conserved	Suitable for a dwelling. (070/129)	
Ballarat ..	Grant ..	Bungal ..	1C	B	2 1 0	Residence	"	6 2 6	To be valued	In north-west of parish ..	Egerton township, ½ mile	Gravelled road	By conservation	Suitable for a garden site. (134/121)	

AVAILABLE UNDER SECTION 129, LAND ACT 1928.

AGRICULTURAL AND GRAZING LANDS—SELECTION PURCHASE ALLOTMENTS.

DIVISION 4, PART I, LAND ACT 1928.

(a) Subject to survey.—(b) Subject to drainage easement 15 links wide.

**LAND AVAILABLE UNDER THE SOLDIER SETTLEMENT ACTS.**

NOTIFICATION is hereby given, in accordance with section 16 of the *Soldier Settlement Act 1946*, that the under-mentioned lots are available or are about to become available for settlement.

Any discharged soldier who has applied to the Commission on or before the 10th November, 1948, for classification in the required class or classes of primary production for which the lots are made available, and whose application has not been finalized, or any discharged soldier who has been classified as suitable in such class or classes of primary production may apply on the proper form for settlement on any lot or lots, indicating where he applies in respect of more than one lot his order of preference therefor.

Application forms, plans, and further particulars may be obtained from the Inquiry Branch, Soldier Settlement Commission, State Public Offices, Melbourne, at which office completed applications for settlement should be lodged on or before the 6th December, 1948.

E. SINGLETON,  
Secretary.

Soldier Settlement Commission,  
Melbourne, 5th November, 1948.

**SCHEDULE OF ALLOTMENTS.**

**SUBDIVISION OF PORTION OF "LIMA" ESTATE.**

PARISH OF SAMARIA.—COUNTY OF DELATITE.  
*Suitable for Dairying and Mixed Farming or Grazing (Sheep) and Mixed Farming.*

Lot Number on Plan of Subdivision.	Approximate Area in Acres (Subject to Survey).
1	390
2	360
3	340
4	340
5	350
6	340
7	370
8	1,080

**SUBDIVISION OF "MUNDARRA" ESTATE.**

PARISH OF MURRANDARRA.—COUNTY OF LOWAN.  
*Suitable for Grazing (Sheep) and Cropping.*

Lot Number on Plan of Subdivision.	Approximate Area in Acres (Subject to Survey).
1	1,170
2	734
3	965
4	965
5	725
6	745
7	993
8	965
9	700
10	700

**PORTION OF "NARRAPUMELAP SOUTH" ESTATE.**

PARISHES OF BUCKERAN YARRACK, TOWANWAY, AND CHATSWORTH WEST.—COUNTIES OF VILLIERS AND HAMPDEN.  
*Suitable for Grazing (Sheep).*

Lot Number on Plan.	Approximate Area in Acres (Subject to Survey).
31	801

**PORTION OF "WOODHOUSE" ESTATE.**

PARISHES OF COREA, BILPAH, POM POM, AND YALIMBA EAST.—COUNTY OF VILLIERS.  
*Suitable for Grazing (Sheep) and Mixed Farming.*

Lot Number on Plan.	Approximate Area in Acres (Subject to Survey).
8	496

**REGULATIONS FOR THE CARE, PROTECTION, AND MANAGEMENT OF THE "J. L. MURPHY RECREATION RESERVE," PORT MELBOURNE.**

WHEREAS by section 181 of the *Land Act 1928*, as re-enacted by section 9 of the *Land Act 1941*, power is given to the Board of Land and Works to make Regulations in respect of the care, protection, and management of any Crown land which has been reserved under the Land Acts for any public purpose whatsoever, and which has not been conveyed to or vested in trustees, and for the further purposes as enacted: Now therefore the Board of Land and Works, in pursuance of the powers conferred as aforesaid, doth hereby make the following Regulations in respect of the land temporarily reserved by Order in Council dated 15th April, 1940, as a site for Public Park and Recreation in the City of Port Melbourne, Parish of Melbourne South, and known as the "J. L. Murphy Recreation Reserve," hereinafter referred to as the "Reserve."

**REGULATIONS.**

1. The Reserve shall be open to the public from sunrise to sunset, free of charge, excepting on such days as the Reserve may be set apart for cricket, football, golf, tennis, fêtes, sports, or holiday amusements, on any of which occasions a sum not exceeding Two shillings and six pence may be charged and taken for the admission of every adult to the Reserve.
2. No person shall enter or remain in the Reserve who may offend against decency as regards dress, language, or conduct.
3. No person shall damage in any way the trees, shrubs, or flowers in the Reserve, nor shall fires be lighted therein, excepting in the places provided for the purpose by the Committee of Management.
4. No person shall climb or jump over the gates or fences in or around the Reserve, stick bills thereon, or cut names on, or in any way damage or injure any of the buildings, gates, fences, seats, or trees in the Reserve, nor leave or deposit any glass, paper, or rubbish, nor roll or throw stones or any missiles of any kind therein.
5. No person shall put in the Reserve any cattle, horses, sheep, goats, or other animals without the permission, in writing, of the Committee of Management first obtained.
6. The Committee of Management may debar any person from bringing into the Reserve any dog, unless such dog is controlled by a chain or cord.
7. No person shall camp in the Reserve.
8. No person shall erect in the Reserve any structure for the purpose of offering for sale any article without the permission, in writing, of the Committee of Management first obtained.
9. No person shall take part in any public meeting, nor shall any band perform in the Reserve, without the permission, in writing, of the Committee of Management first obtained.
10. No person shall bet publicly in any part of the Reserve, and every person infringing this Regulation shall be liable to expulsion from the enclosures and Reserve.
11. No person shall hawk or offer for sale in the Reserve any goods, chattels, articles, or provisions of any description without the permission, in writing, of the Committee of Management first obtained.
12. No person, not being a player or official, shall trespass on the playing arena during the progress of any football or cricket match, or any sports gathering, nor wilfully obstruct nor interrupt, or in any way interfere with, any servant of the Committee of Management in the proper execution of his work or duty.
13. No person shall cross or trespass on the playing ground during any cricket or football match, or sports, show, &c., or during practise at football or cricket, when any such crossing or trespassing would be injurious to, or cause undue interference with, the progress of the aforesaid sports, football, or cricket, &c.
14. No person shall in the Reserve wilfully obstruct, disturb, or annoy any other person in the proper use of the Reserve, or any part thereof, or wilfully obstruct or interrupt any servant of the Committee of Management in the proper execution of his duty or work.
15. Persons renting or hiring any stand, building, erection, or enclosure on the occasions of any fêtes, matches, sports, or holiday amusements may be required to deposit any sum which the Committee of Management may at any time determine, not exceeding Ten pounds, by way of guarantee that due care shall be taken of such stand, building, erection, or enclosure, and such Committee of Management, in its absolute discretion, may make good any damage or injury sustained by such stand, building, erection, or enclosure, or anything contained therein, during such occupancy or hiring, and deduct the cost of making good such loss or damage from the sum of money deposited by way of guarantee, and all persons so renting or hiring shall abide by these Regulations, and by any order given by the Committee of Management.

16. Persons renting or hiring the Reserve for any purpose whatsoever, and who make any charge to the public for admission to the Reserve, shall pay to the Committee of Management a fee for the use of the Reserve, such fee to be fixed by the Committee of Management.

17. No person, except labourers or workmen employed in the Reserve, shall enter any plots therein which may be enclosed for plantations of young trees or shrubs.

18. No person shall park motor cars or other vehicles within the Reserve, excepting at such places as are set apart by the Committee of Management for that purpose, and the Committee of Management may charge and take a fee not exceeding One shilling per motor car or other vehicle per day for use of such area on such days as a charge for admission is being made, as provided hereinbefore in clause 1.

19. The Committee of Management may set apart any portion of the Reserve for the purpose of any lawful game, or sports, or picnics, and from time to time grant any club or association or clubs, upon such terms and conditions as the Committee of Management may deem to be consistent with these Regulations, the use of the grounds so set apart.

20. No person shall dig or remove any sand, gravel, soil, or other material in or from the Reserve.

21. No person shall remove or displace any board, plate, fitting, or written notice for the exhibition of any Regulations, or any notice fixed or set up by the Committee of Management of the Reserve.

Every person who contravenes or fails to comply with these Regulations shall, in accordance with the provisions of section 181 of the *Land Act 1928*, as re-enacted by section 9 of the *Land Act 1941*, for each offence be liable to a penalty of not more than Five pounds (£5), and every person who contravenes or fails to comply with any such Regulation and who, after he has been warned by any bailiff of Crown lands, or by any member of the Police Force, does not desist therefrom may be forthwith apprehended by such bailiff or member of the Police Force and taken before some justice to be dealt with according to law, and shall be liable to a penalty of not more than Ten pounds (£10).

The common seal of the Board of Land and Works was hereunto affixed this 29th day of October, 1948, in the presence of—

(SEAL) JOHN G. B. McDONALD, President.  
W. McILROY, Member.

The Reserve has been placed under the control of the Council of the City of Port Melbourne as the Committee of Management thereof, with power and authority to enforce the foregoing Regulations.—(Rs.5031.)

#### REGULATIONS FOR THE CARE, PROTECTION, AND MANAGEMENT OF THE RESERVES FOR PUBLIC RECREATION IN THE PARISH OF MILDURA, KNOWN AS "SANDALONG PARK."

WHEREAS by section 181 of the *Land Act 1928*, as re-enacted by section 9 of the *Land Act 1941*, power is given to the Board of Land and Works to make Regulations in respect of the care, protection, and management of any Crown land which has been reserved under the *Land Acts* for any public purpose whatsoever, and which has not been conveyed to or vested in trustees, and for the further purposes as enacted, and whereas by subsection (1) (e) of the said section 181 of the *Land Act 1928*, power is given to the Board of Land and Works to apply all or any of the Regulations so made to any other land reserved as aforesaid and not conveyed to or vested in trustees, in any case where the persons, council, or body comprising the Committee of Management of such first-mentioned land are or is also appointed to be the Committee of Management of such other land: Now therefore the Board of Land and Works, in pursuance of the powers conferred, doth hereby make the following Regulation:—

"The Regulations made by the Board on the 26th August, 1937, as notified in the *Government Gazette* of 1st September, 1937, for the care, protection, and management of the lands temporarily reserved by the Governor in Council on the 10th October, 1932, and 18th November, 1935, as sites for Public Recreation in the Parish of Mildura, known as "Sandalong Park," are hereby applied to the land reserved by the Governor in Council on 26th July, 1948."

This reservation is in addition to and adjoining the first-mentioned Reserve.

The common seal of the Board of Land and Works was hereunto affixed this 29th day of October, 1948, in the presence of—

(SEAL) JOHN G. B. McDONALD, President.  
W. McILROY, Member.

(Rs.4244.)

#### REGULATIONS FOR THE CARE, PROTECTION, AND MANAGEMENT OF "LOCHIEL PARK."

WHEREAS by section 181 of the *Land Act 1928*, as re-enacted by section 9 of the *Land Act 1941*, power is given to the Board of Land and Works to make Regulations in respect of the care, protection, and management of any Crown land which has been reserved under the *Land Acts* for any public purpose whatsoever, and which has not been conveyed to or vested in trustees, and for the further purposes as enacted: Now, therefore, the Board of Land and Works, in pursuance of the powers conferred as aforesaid, doth hereby make the following Regulations in respect of the land permanently reserved by Order in Council of 25th May, 1948, as a site for Public Park and Recreation purposes in the Parish of Orbst, and known as "Lochiel Park," hereinafter referred to as the "Reserve."

#### REGULATIONS.

1. The Reserve shall be open to the public free of charge from sunrise to sunset, except on such days (not exceeding thirty in any one year) as the Reserve may be set apart for cricket or football matches, athletic, cycling, or other sports or holiday amusements, on any of which occasions a charge not exceeding Three shillings may be made for admission of each adult person to the Reserve.

2. No person shall enter or remain in the Reserve who offends against decency as regards dress, language, or conduct.

3. No person shall damage in any way any buildings, fences, gates, seats, asphalt, netting, posts, play devices, trees, shrubs, flowers, tracks, pitches, courts, water pipes, water taps, drainage pipes, erections, enclosures, or fittings in the Reserve, and no person shall light or tend any fire therein, except in the fireplaces provided for that purpose.

4. No person shall climb or jump over the fences or gates, stick bills thereon, or in any way injure or disfigure any of the fences, gates, seats, buildings, erections, or fittings in the Reserve, nor leave or deposit any glass, paper, fruit peel, or rubbish, nor roll or throw stones or any missiles therein.

5. No person shall put into the Reserve any cattle, horses, sheep, goats, pigs, or any other animals, without the permission, in writing, of the Committee of Management first obtained.

6. No person shall bring into the Reserve any dog, unless led by a chain or cord, without the permission, in writing, of the Committee of Management first obtained.

7. No person shall camp in the Reserve or erect therein any building or any booth for the purpose of offering for sale any article, without the permission, in writing, of the Committee of Management first obtained.

8. No person shall spit or expectorate on the paths, tracks, or any structure or erection in the Reserve.

9. No person shall play, practise, or engage in any organized sport, including tennis, football, cricket, foot-racing, or any other game, except in the portions of the Reserve set apart for that purpose, and then only subject to such terms and conditions as the Committee of Management may determine.

10. No person shall take part in any public entertainment of any sort in the Reserve without the permission, in writing, of the Committee of Management first obtained.

11. No person, except a labourer or workman employed in the Reserve, shall enter any plots therein, which may be enclosed for plantations of young trees or shrubs.

12. No person shall obstruct, disturb, interrupt, or annoy any officer or employee of the Committee of Management in the proper execution of his work and duty.

13. Every person or club using the tracks, pitches, courts, yards, seats, buildings, rooms, erections, enclosures, and conveniences provided and erected in the Reserve may be charged such fees and rents for the use thereof as the Committee of Management may from time to time consider reasonable and consistent with these Regulations. The moneys received in fees and rents shall be expended on the maintenance and improvement of the Reserve, and a statement thereof shall be forwarded annually to the Board of Land and Works.

14. Persons renting or hiring any site, stand, building, erection, or enclosure on the occasions of any fête, games, sports, or holiday amusements may be required to deposit any sum which the Committee of Management may determine, not exceeding Ten pounds (£10), by way of guarantee that due care shall be taken of such site, stand, building, erection, or enclosure, and such Committee in its absolute discretion may make good any damage or injury sustained by such site, stand, building, erection, or enclosure, or anything contained therein, during such occupancy or hiring, and deduct the cost of making good

such loss or damage from the sum of money deposited by way of guarantee. All persons so renting or hiring shall abide by these Regulations, and by any order given by the Committee of Management.

15. No person shall publicly address any assembly or assemble with any other person or persons for the purpose of hearing any public address within the Reserve without the permission, in writing, of the Committee of Management first obtained.

16. No male person shall enter or use any place, room, or building set apart for the use of females, and no female person shall enter or use any place, room, or building set apart for the use of males. The provisions of this clause shall not apply to a male person under the age of seven years.

17. No person shall intrude or enter upon any playground or oval within the Reserve while any organized game or sport is being played or conducted thereon. The provisions of this clause shall not apply to any player, competitor, or official actually taking part, competing, or assisting in the conduct of any organized game or sport.

18. Any person committing in any part of the Reserve, or in any of the buildings, structures, or erections for the time being thereon, any of the following shall be guilty of an offence against these Regulations:—

- (a) Assaulting any other person.
- (b) Being drunk.
- (c) Crossing or trespassing on the playing ground during any cricket match, football match, cycling race, or sports, or during practise at football, cricket, cycling, or sports.
- (d) Using profane, indecent, or obscene language.
- (e) Using any threatening, abusive, or insulting words.
- (f) Behaving improperly or riotously.
- (g) Improperly interfering with or interrupting any cricket match, football match, cycling race, or any athletic or other sports or holiday amusements, or any practise thereat.
- (h) Obtaining admission to any part of the Reserve when not entitled to such admission under these Regulations.

19. No person shall hawk or offer for sale in the Reserve any goods or articles of any description without permission, in writing, of the Committee of Management.

20. Any person, club, or society, having obtained permission of the Committee of Management to use any dressing-shed, pavilion, or other structure, shall maintain and leave the same in a clean and tidy condition. No water tap or shower shall be left running, nor shall any room or enclosure be left unlocked after use.

21. No person shall force open any locked gate or door to any enclosure, room, or building in the Reserve, nor shall any person use any unauthorized key to open any lock on such gates or doors.

22. Should any person receive from any member, officer, or employee of the Committee of Management any key or keys for the unlocking of any doors or gates in the Reserve, he shall return such key or keys in good order and condition.

23. All keys shall be returned to the caretaker of the Reserve, or to the Shire Secretary of the Shire of Orbost, before sunset of the day on which such keys were received, unless otherwise allowed or directed by the Committee of Management.

The Reserve has been placed under the control of the Council of the Shire of Orbost, as a Committee of Management, with power and authority to enforce the foregoing Regulations.

Every person who contravenes or fails to comply with these Regulations shall, in accordance with the provisions of section 181 of the *Land Act 1928*, as re-enacted by section 9 of the *Land Act 1941*, for each offence be liable to a penalty of not more than Five pounds, and every person who contravenes or fails to comply with any such Regulation, and who, after he has been warned by any bailiff of Crown Lands or by any member of the Police Force, does not desist therefrom, may be forthwith apprehended by such bailiff or member of the Police Force and taken before some justice to be dealt with according to law, and shall be liable to a penalty of not more than Ten pounds.

The common seal of the Board of Land and Works was hereunto affixed this 29th day of October, 1948, in the presence of—

(SEAL) JOHN G. B. McDONALD, President.  
W. McILROY, Member.  
(Rs.1212.)

#### REGULATIONS FOR THE CARE, PROTECTION, AND MANAGEMENT OF THE "WEST BRUNSWICK CHILDREN'S PLAYGROUND RESERVE."

WHEREAS by section 181 of the *Land Act 1928*, as re-enacted by section 9 of the *Land Act 1941*, power is given to the Board of Land and Works to make Regulations in respect of the care, protection, and management of any Crown land which has been reserved under the *Land Acts* for any public purpose whatsoever, and which has not been conveyed to or vested in trustees, and for further purposes as enacted: Now, therefore, the Board of Land and Works, in pursuance of the powers conferred as aforesaid, doth hereby make the following Regulations in respect of the land reserved by Order in Council of 26th July, 1948, as a site for Children's Playground in the City of Brunswick, Parish of Jika Jika, hereinafter referred to as the "Reserve," such Reserve having been placed under the control of a Committee of Management, hereinafter referred to as the "Committee."

#### REGULATIONS.

1. The Reserve shall be open daily from 8 o'clock a.m. until half an hour after sunset.

2. No person above the age of fourteen years shall use the Reserve or use any of the swings, fixtures, or other appliances erected or provided thereon; provided, however, that parents or other adults in charge of children shall be at liberty to enter the Reserve to watch over children who are in their charge.

3. Any person found within the Reserve except during the hours the same is open to the public shall be guilty of an offence against these Regulations.

4. The swings or other appliances erected in the Reserve shall not be used by the same child or children for a longer period than five minutes if any other child or children is or are waiting to use them.

5. No child shall use any of the swings or other appliances in the Reserve except for the purposes for which they are respectively provided.

6. No person shall play cricket or football in the Reserve.

7. All papers, fruit peel, and other litter shall be placed in the baskets or bins provided by the Committee for the purpose.

8. Every person in the Reserve shall obey the lawful directions of any officer of the Committee in respect of his or her conduct therein.

9. The Committee shall not be responsible for any accident arising from the use of any of the swings or other appliances in the Reserve.

10. Any bailiff of Crown lands, member of the Police Force, or duly appointed officer or servant of the Committee shall have the right (in addition to any other penalty provided under these Regulations) to remove or exclude from the Reserve any person who commits a breach of these Regulations, or who wilfully damages any of the swings or other appliances or property in the Reserve.

11. No person shall ride or drive any bicycle in any part of the Reserve.

12. No person shall be permitted to bring any animal into the Reserve.

The Reserve has been placed under the control of the Council of the City of Brunswick as Committee of Management with power and authority to enforce the foregoing Regulations.

Every person who contravenes or fails to comply with these Regulations shall, in accordance with the provisions of section 181 of the *Land Act 1928*, as re-enacted by section 9 of the *Land Act 1941*, for each offence be liable to a penalty of not more than Five pounds (£5), and every person who contravenes or fails to comply with any such Regulation and who, after he has been warned by any bailiff of Crown Lands or by any member of the Police Force, does not desist therefrom may be forthwith apprehended by such bailiff or member of the Police Force and taken before some justice to be dealt with according to law, and shall be liable to a penalty of not more than Ten pounds (£10).

The common seal of the Board of Land and Works was hereunto affixed this 29th day of October, 1948, in the presence of—

(SEAL) JOHN G. B. McDONALD, President.  
W. McILROY, Member.  
(Rs.6198.)



## COMMITTEES OF MANAGEMENT OF RESERVES.

## APPOINTMENTS.

WHEREAS by section 184 of the *Land Act* 1928 it is provided that it shall be lawful for the Governor in Council or the Board of Land and Works to appoint and remove any number of persons, not less than three, or any municipal council, or the governing body of any corporation, to be a Committee of Management of any specified Crown land reserved either temporarily or permanently for any of the purposes set out in section 14 of the *Land Act* 1928, and not conveyed to or vested in trustees: Now therefore the Board of Land and Works doth hereby appoint the under-mentioned persons to be members of the Committee of Management of the Reserves named:—

## "RAINBOW SWIMMING POOL RESERVE."

The Council of the Shire of Dimboola as the Committee of Management of the land temporarily reserved by Order in Council dated 31st August, 1948, for Swimming Pool in the Township of Rainbow, Parish of Werrap, and known as the "Rainbow Swimming Pool Reserve."—(Corres. Rs.6240.)

## "SWAN REACH RECREATION RESERVE."

George James Gilmore, Robert Liddel Cunningham, Clarence Rupert Cunningham, Lionel Henry Whelan, and Leo Walter Howlett as a Committee of Management for a period of three (3) years from 29th September, 1948, of the land temporarily reserved by Order in Council dated 2nd December, 1895, as a site for Public Recreation in the Parish of Bumberrah, and known as the "Swan Reach Recreation Reserve."—(Corres. Rs.5094.)

## "LANDSBOROUGH MEMORIAL PARK RESERVE."

Maurice Gilbert Davies as a member of the Committee of Management for the period ending the 9th January, 1951, of the land temporarily reserved by Order in Council dated the 23rd August, 1875, as a site for Recreation purposes in the Township of Landsborough, now known as the "Landsborough Memorial Park."—(Corres. Rs.1230.)

This appointment is in lieu of that of Henry Percy Vendy, deceased.

## "COLBINABBIN RECREATION RESERVE."

Alfred Edward Rathjen, Leslie Murray Weeks, David Thomas Wright, David Robert Andrew, Edward Caldwell Hill, Clement Bertrand Hill, John Henry Pook, Joseph Percival Oliver Johnson, and Alexander Brown as the Committee of Management for a period of three (3) years of the land temporarily reserved by Order in Council dated 16th December, 1907, as a site for Public Recreation in the Parish of Colbinabbin, and known as the "Colbinabbin Recreation Reserve."—(Corres. Rs.660.)

## "BET BET RECREATION RESERVE."

William H. Freemantle, John Harris Alderson, Charles Chiswell, and Donald James McKenzie as the Committee of Management for a period of three (3) years of the lands temporarily reserved by Order in Council dated 12th May, 1924, as sites for Public Recreation in the Parish of Bet Bet, and known as the "Bet Bet Recreation Reserve."—(Corres. Rs.2933.)

## "HOWITT PARK," AT LUCKNOW.

Alexander James Flett, Nicholas Ernest Lind, Frank Holloway, Clement Roy Sandman, and George Albert Marshall for a period of three (3) years from 1st July, 1948, and Councillors Donald McIlwraith Cameron, William Harry Dumaresq, and Frank Burne for so long only as they continue to be Councillors and the elect of the Shire of Bairnsdale, as a Committee of Management of the land temporarily reserved by Order in Council dated 26th November, 1928, as a site for Public Park, Recreation, and Public purposes in the Parish of Wy Yung, and known as "Howitt Park," at Lucknow.—(Corres. Rs.3789.)

This appointment is in lieu of all previous appointments.

## "WYPERFELD NATIONAL PARK."

Harold Edgar Tarr, in the place of Charles Leslie Barrett, resigned, as a member of the Committee of Management of the lands permanently reserved by Orders in Council dated 13th September, 1921, 9th February, 1922, 1st July, 1930, 5th December, 1938, 6th May, 1941, and 1st June, 1948, as sites for a National Park in the Parishes of Ginap, Wyperfeld, Baring, and Yallum, and in the County of Weeah, and known as "Wyperfeld National Park."—(Corres. Rs.1128.)

No. 1053.—11545/48.—3

## "DUNDONNELL PUBLIC HALL RESERVE."

Trevor Owen Smith, Charles Mortimer Luckock, Laurie William Grant, James S. Rowland Grant, and James Malcolm Small as a Committee of Management for a period of three (3) years from 30th August, 1948, of the land temporarily reserved by Order in Council dated 26th June, 1945, in the Parish of Terrinallum as a site for a Public Hall, and known as the "Dundonnell Public Hall Reserve."—(Corres. Rs.5676.)

## "GLENROWAN WATER AND CAMPING RESERVE."

William Henry Neville, Reginald Michael Egan, James Walter Taylor, William Thomas Woodsell, Harry Stewart Keir, Vincent Gavan Egan, Kenneth Leslie Graham, Norman Roy Montgomery, Robert John McMonigle, Gordon Robert Twamley, and Leslie B. Goodwin as a Committee of Management for a period of three (3) years from 13th August, 1948, of the land temporarily reserved by Order in Council dated 4th July, 1932, as a site for Water and Camping purposes in the Parish and Township of Glenrowan, and known as the "Glenrowan Water and Camping Reserve."—(Corres. Rs.4220.)

## "CORACK EAST RACECOURSE AND RECREATION RESERVE."

Dennis Harty, Norval Keith Madder, Joseph Martin Gleeson, Donald Edward McCallum, and Archibald John Barbour Louttit as the Committee of Management for a period of three (3) years from the 1st September, 1948, of the land temporarily reserved by Order in Council dated 9th January, 1884, as a site for a Racecourse and other purposes of Public Recreation in the Parish of Corack East, and known as the "Corack East Racecourse and Recreation Reserve."—(Corres. Rs.411.)

## "SALE CRICKET AND RECREATION RESERVE."

Kenneth Gillard, Murray Hutchinson, Charles Augustus Willaby Smith, Leslie John Bailey, Bertie Hudson Warren, Hugh Richard Murnane, and Joseph Patrick Loughnan as a Committee of Management for a period of three (3) years from 30th August, 1948, of the Reserve for the purposes of Cricket and Public Recreation at Sale, and known as the "Sale Cricket and Recreation Reserve."—(Corres. Rs.1072.)

## "SHIRE HALL AND MUNICIPAL DEPOT RESERVE," AT MOONAMBEL.

The Council of the Shire of Avoca as the Committee of Management of the land temporarily reserved by Order in Council of the 28th September, 1948, as a site for Shire Hall and Municipal Depot in the Township of Moonambel, Parish of Warrenmang.—(Corres. Rs.6259.)

## "GLENROWAN PUBLIC PARK RESERVE."

William Henry Neville, Reginald Michael Egan, James Walter Taylor, William Thomas Woodsell, Harry Stewart Keir, Vincent Gavan Egan, Kenneth Leslie Graham, Norman Roy Montgomery, Robert John McMonigle, Gordon Robert Twamley, and Leslie B. Goodwin as a Committee of Management for a period of three (3) years from 13th August, 1948, of the land temporarily reserved by Orders in Council dated 24th February, 1891, and 28th June, 1933, as a site for a Public Park in the Township of Glenrowan, and known as the "Glenrowan Public Park Reserve."—(Corres. Rs.1065.)

## "YANDOIT PUBLIC PARK AND RECREATION RESERVE."

Carlo Sartori, Ernest Charles Schroeder, Edgar Morrison, George William Sartori, Stanley James Giovanetti, Henry Matthew Lee, and George Donald Hird as the Committee of Management for a period of three (3) years from the 21st September, 1948, of the land temporarily reserved by Orders in Council dated the 16th November, 1908, and the 1st December, 1924, as a site for a Public Park and for the additional purposes of Public Recreation in the Township of Yandoit, and known as the "Yandoit Public Park and Recreation Reserve."—(Corres. Rs.3012.)

## "WARNEET PUBLIC HALL RESERVE."

Oscar Adolf Granowski, Albert C. Taunton, George Charles Whitworth, Reginald N. Thompson, William Burns, Leslie William Crouch, and Solly Friedman as the Committee of Management for a period of three (3) years of the land temporarily reserved on 7th September, 1948, as a site for Public Hall in the Township of Warneet, Parish of Sherwood, and known as the "Warneet Public Hall Reserve."—(Corres. Rs.6229.)

**"MANANGATANG RECREATION RESERVE."**

Edwin Edward Huggett, Owen Thomas Jones, Clarence Edgar Hicks, Donald Frederick Plant, C. John Plant, Herbert Ross Blair, and William Thompson as the Committee of Management for a period of three (3) years of the land temporarily reserved by Order in Council of the 2nd March, 1922, as a site for Recreation purposes, and the adjoining land temporarily reserved by Order in Council of the 13th November, 1924, as a site for Public Recreation, both sites being in the Parish of Manangatang, and together known as the "Manangatang Recreation Reserve."—(Corres. Rs.2469.)

**"ARARAT CHILDREN'S PLAYGROUND RESERVE."**

The Council of the Town of Ararat as the Committee of Management of the land temporarily reserved by Order in Council of 5th October, 1948, as a site for Children's Playground in the Township of Ararat, known as "Ararat Children's Playground Reserve."—(Corres. Rs.6242.)

**"ARARAT PLANTATION RESERVE."**

The Council of the Town of Ararat as the Committee of Management of the land temporarily reserved by Order in Council of 17th August, 1948, as a site for Plantation and Public purposes in the Township of Ararat, known as "Ararat Plantation Reserve."—(Corres. Rs.6218.)

**"HOPWOOD GARDENS RESERVE," ECHUCA.**

The Council of the Borough of Echuca as the Committee of Management of the land temporarily reserved by Order in Council dated the 3rd August, 1948, as a site for Public Gardens in the Town of Echuca, Parish of Echuca North, and known as the "Hopwood Gardens Reserve."—(Corres. Rs.6215.)

**"KALORAMA PEACE MEMORIAL RESERVE."**

Harriet Baker Hand, Daisy Jeeves, Eric Lancelot Singleton, Walter Thomas Jeeves, and Hubert Ellis Jeeves as a Committee of Management for a period of three (3) years from 20th September, 1948, of the land temporarily reserved by Order in Council dated 18th November, 1935, as a site for a Peace Memorial in the Parish of Mooroolbark, at Kalorama, and known as the "Kalorama Peace Memorial Reserve."—(Corres. Rs.4493.)

**"QUEENSLIFF RECREATION RESERVE."**

Alfred James Barber, John Andrew Monahan, and William James Field (for so long only as each shall continue to be a Councillor and the elect of the Council of the Borough of Queenscliffe), Harry Smith (for so long as he fills the position of Commanding Officer of the Military Forces at Queenscliff), Ernest Baden Pinney, William Dundas Welsh, Robert Harley Goodall (for a period ending 3rd October, 1951) as a Committee of Management of the land permanently reserved by Order in Council of 30th March, 1931, as a site for Recreation of the people in the Parish of Paywit, Town of Queenscliff, and known as the "Queenscliff Recreation Reserve."—(Corres. Rs. 4111.)

This appointment is in lieu of all previous appointments.

**"WHITTLESEA PUBLIC PARK RESERVE."**

John Downie as a member of the Committee of Management, in the place of Ken McPhee, of that portion of the land reserved as a site for a Public Park in the Parish of Toorourrong, at Whittlesea, and that portion of the permanent reservation along the Plenty River, both of which are indicated in yellow and blue colours respectively on plan marked W.A./3.8.39 attached to Lands Department correspondence Rs.2111, and known as the "Whittlesea Public Park Reserve": Provided however that the said John Downie shall hold office as a member of such Committee for so long only as he shall continue to be a Councillor and the elect of the Council of the Shire of Whittlesea.—(Corres. Rs.2111.)

**"LORQUON RECREATION RESERVE."**

Frederick Walter Effrett, Thomas George Marshall, Edwin Albert Schuller, Oscar Edward Reichelt, Alwin Adolph Wedding, Carsten Howard Roediger, and Victor Herman Deckert as the Committee of Management for the period of three (3) years from the 18th October, 1948, of the land temporarily reserved by Order in Council of the 9th April, 1923, as a site for Recreation purposes in the Township of Lorquon, and known as the "Lorquon Recreation Reserve."—(Corres. Rs.2183.)

**"NETHERBY RECREATION RESERVE."**

Alfred Carolus Duffty, Harry Sydney Nottle, Gustav John Launer, Harold Ernest James Stephens, Stanley Gordon Nottle, William John Chilton, Percival Norman Wilksch, Alfred Norman Cramer, and Ronald John Smith as the Committee of Management for the period of three (3) years from the 2nd October, 1948, of the land temporarily reserved by Order in Council of the 29th June, 1948, as a site for Public Recreation in the Township of Netherby, Parish of Warraquil, and known as the "Netherby Recreation Reserve."—(Corres. Rs.6193.)

**"SEAFORD FORESHORE RESERVE."**

Frederick James Reardon as a member of the Committee of Management for so long only as he continues to be a Councillor and the elect of the Council of the Shire of Frankston and Hastings of such portion of the land reserved for Public purposes in the Parish of Frankston as is indicated by red colour on plan marked S/29.4.37 attached to Lands Department correspondence Rs.4674, together with the land between high and low water mark bordering such area, all of which is known as the "Seaford Foreshore Reserve."—(Corres. Rs.4674.)

This appointment is in lieu of that of Raoul Fortescue Miles, who has ceased to hold office as a Councillor of Shire of Frankston and Hastings.

**"HAWKESDALE RECREATION RESERVE."**

Leslie Sault, William Carlin, Lawson Evered Glare, Robert Williams, and James William Waters as a Committee of Management for a period of three (3) years from 21st September, 1948, of the land temporarily reserved by Order in Council dated 1st May, 1923, as a site for Recreation purposes in the Township of Hawkesdale, and known as the "Hawkesdale Recreation Reserve."—(Corres. Rs.2285.)

**"MORNINGTON FORESHORE RESERVE" AND "MT. MARTHA CAMPING RESERVE."**

Donald Rutherford Morell as a member of the Committee of Management for so long only as he shall continue to be a Councillor and the elect of the Council of the Shire of Mornington of the reserved Crown lands in the Town of Mornington and Parish of Moorooduc as are indicated by red colour on plans marked M/27.4.31 and M/22.4.36 with Lands Department correspondence C.68905, and the land temporarily reserved by Order in Council dated 22nd December, 1938, as a site for Camping purposes in the Parish of Moorooduc, and known as the "Mornington Foreshore Reserve" and "Mt. Martha Camping Reserve" respectively.—(Corres. Rs.5207, Rs.4898.)

Such appointment being in the place of Edward Albert Berry, who has ceased to hold office as a Councillor of such Shire.

**"MOORNGAG PUBLIC HALL AND RECREATION RESERVE."**

George Ginnivan, Dennis Keith McCauley, Daniel E. Ginnivan, William John Burns, John Thomas Duffty, Frederick J. Horsburgh, Leslie V. Smith, Reginald Francis McCauley, Patrick Francis Burns, and James Reginald Patterson as a Committee of Management for the period ending 3rd July, 1950, of the land temporarily reserved by Order in Council dated 21st November, 1887, as a site for Public Recreation, and by Order in Council dated 7th September, 1948, as a site for the additional purpose of a Public Hall in the Parish of Rothesay, and known as the "Moornag Public Hall and Recreation Reserve."—(Corres. Rs.2741.)

This appointment is in lieu of all previous appointments.

**"ST. VINCENT PUBLIC GARDENS" AT SOUTH MELBOURNE.**

The Council of the City of South Melbourne as the Committee of Management of the lands permanently reserved by Orders in Council of the 13th January, 1873, and 1st December, 1873, as sites for Public Gardens in the Borough of Emerald Hill (now City of South Melbourne) and of the land temporarily reserved by Order in Council of 14th September, 1948, as a site for Public Gardens in the City of South Melbourne, Parish of Melbourne South, which lands are known as the "St. Vincent Public Gardens."—(Corres. Rs.2033.)

## "KORUMBURRA RECREATION RESERVE."

Councillors Leslie Maurice Tolson and Cyril Henry Janson as members of the Committee of Management, for so long only as they continue to be Councillors and the elect of the Council of the Shire of Korumburra, of the land temporarily reserved by Order in Council of 19th August, 1895, as a site for Public Recreation in the Township of Korumburra.—(Corres. Rs.757.)

This appointment is in lieu of that of Messrs. Peter Hudson and Alfred Norman Alp, who have ceased to hold office as Councillors of the Council of the Shire of Korumburra.

## "BANGERANG RECREATION RESERVE."

Arthur Hawkrige Hewitt, Eric Wilfred Parkinson, Ernest John Koschitzke, Francis Leslie Parsons, Phillip Emil Koschitzke, Harold Vaughan, and Hugh Alexander McLean as the Committee of Management for a period of three (3) years from the 20th September, 1948, of the land temporarily reserved by Order in Council of 21st November, 1927, as a site for Public Recreation in the Township and Parish of Bangerang, and known as the "Bangerang Recreation Reserve."—(Corres. Rs.3576.)

## "BENAMBRA HALL RESERVE."

Herbert Nicholas, Kingsley Joseph Pendergast, Claud Cornelius Matthews, Charles John Pendergast, John Miles Poulson, Alan Young McKenzie, and Gerard Alexander Paterson as a Committee of Management for a period of three (3) years from 19th September, 1948, of the land permanently reserved by Order in Council dated 8th November, 1886, as a site for a Public Hall and Library in the Township of Benambra, and known as "Benambra Hall Reserve."—(Corres. Rs.3029.)

## "WILBY PUBLIC PARK."

Bernard Darcy, Horrie Robert Prescott, William Robert Hargreaves, Allan Richard Wakefield, Stanley Rider Hargreaves, Arthur William Hargreaves, and Thomas J. Lewis as the Committee of Management for a period of three (3) years of the land temporarily reserved by Order in Council dated the 28th August, 1906, as a site for a Public Park and other purposes of Public Recreation in the Parish of Pelluebla, and known as "Wilby Public Park."—(Corres. Rs.1464.)

## "MERBEIN WEST RECREATION RESERVE."

John Little Avery, Frederick George Mackenzie, Ernest Keith Hudson, Stephen Francis McCarthy, Henry Phillip Castleman, Stephen Richard Goetz, George William Ashdown, and Charles Berry as the Committee of Management for the period ending the 7th November, 1949, of the land temporarily reserved by Order in Council of the 3rd August, 1948, as a site for Public Recreation in the Parish of Merbein, in addition to and adjoining the site temporarily reserved therefor by Order of the 7th December, 1936, and known as "Merbein West Recreation Reserve."—(Corres. Rs.4640.)

## "LAKE PURRUMBETE RESERVE."

Herbert Smith, F. E. Bartlett, A. R. Smith, R. Rippon, C. H. Smith, and E. Place as a Committee of Management for a period of three (3) years from 30th August, 1948, of such portion of the frontage to Lake Purrumbete as is indicated by pink tint on plan marked P/23.7.31 attached to Lands Department correspondence C.30169, and known as "Lake Purrumbete Reserve."—(Corres. C.30169.)

## "GREGSON PARK," MINYIP.

John Gustave Gormann, David Robertson, John William Hewitt, George Albert Keating, John Hugh Brady, Archibald Duncan McGillp, and William Mackenzie, as the Committee of Management for a period of three (3) years from 22nd October, 1948, of the land temporarily reserved by Order in Council of 22nd July, 1902, as a site for Public Recreation in the Township of Minyip, and known as "Gregson Park."—(Corres. Rs.566.)

## "WINCHELSEA CRICKET GROUND."

David Scott Warner, William Wilson Westhorpe, William Mortimer Nash, John Stanley Caldwell, and Edmund Michael Hole as a Committee of Management for a period of three (3) years from 22nd October, 1948, of the land set apart on the 6th June, 1859, as a site for Cricket Ground and for purposes of Public Recreation generally at Winchelsea, and known as the "Winchelsea Cricket Ground."—(Corres. Rs.2462.)

## "CHETWYND RECREATION RESERVE."

Ernest James Wicker, Thomas James Howlett, Thaddeus William Griffith, Alfred Edward Howlett, and John Cyril Gartlan as a Committee of Management for a period of three (3) years from 9th October, 1948, of the land temporarily reserved by Order in Council of the 24th August, 1948, as a site for Public Recreation in the Town of Chetwynd.—(Corres. Rs.664.)

In witness whereof the common seal of the Board of Land and Works was hereunto affixed, this twentieth day of October, One thousand nine hundred and forty-eight, in the presence of—

(SEAL) JOHN G. B. McDONALD, President.  
W. McILROY, Member.

## TENDERS.

TENDERS will be received at this office until **TEN A.M.** on the days and for the purposes under mentioned. Particulars may be learnt at this office, and also at the offices named in each instance. The Board of Land and Works will not necessarily accept the lowest or any tender.

16th November, 1948.

Ballarat.—Supply and delivery of one (1) 50 K.V.A. 3-phase arc-welding transformer, complete with condenser, School of Mines. Preliminary deposit, £10. Final deposit, 2 per cent.

Ballarat.—Supply and delivery of electric mixer, Mental Hospital. P.D., £5. F.D., 2 per cent.

Burnewang Estate (near Elmore).—Additions to residence on Block No. 3, Soldier Settlement Commission. (W.O., Bendigo; P.S., Elmore, Rochester.) P.D., £10. F.D., 2 per cent.

Balmoral.—Painting and repairs to teacher's residence, S.S. No. 29. (W.O., Horsham; H.E.S., Edenhope; S.S., Balmoral.) Deposit, £4.

Beaac.—Erection of new police station, residence, office, &c., P.S. (W.O., Geelong; P.S., Beaac, Colac.) Preliminary deposit, £20. Final deposit, 2 per cent.

Brighton.—Adaptation of huts, T.S. (T.S., Brighton.) Preliminary deposit, £15. Final deposit, 2 per cent.

Brunswick South.—External painting and repairs, S.S. No. 2743. (S.S., Brunswick South.) Preliminary deposit, £5. Final deposit, 2 per cent.

Bruthen.—Repairs and painting, school and residence, S.S. No. 1141. (W.O., Bairnsdale; P.S., Orbost, Sale; S.S., Bruthen.) Preliminary deposit, £15. Final deposit, 2 per cent.

Camperdown.—External and internal renovations and repairs, Court House. (W.O., Warrnambool; P.S., Colac; Court House, Camperdown.) Deposit, £4.

Chillingollah.—Repairs and painting, S.S. No. 3697. (W.O., Swan Hill; P.S., Sea Lake, Manangatang, Ultima; S.S., Chillingollah.) Deposit, £3.

Chiltern.—Erection and completion of new timber residence, office, laundry, &c., P.S. (W.O., Benalla, Wangaratta; P.S., Chiltern, Tallangatta, Wodonga.) Preliminary deposit, £15. Final deposit, 2 per cent.

Coburg.—Supply and installation of dust blower on dresser machine, Pentridge. Preliminary deposit, £3. Final deposit, 2 per cent.

Dumbalk East.—Repairs and painting, S.S. No. 3172. (W.O., Korumburra; P.S., Foster, Leongatha; S.S., Dumbalk East.) Deposit, £5.

Foster.—Fencing, teacher's residence, S.S. No. 1172. (W.O., Korumburra; P.S., Leongatha, Yarram; S.S., Foster.) Deposit, £4.

Hodde's Creek.—Repairs, painting, and new tank, S.S. No. 2541. (P.S., Lilydale, Warburton; S.S., Hodde's Creek.) Preliminary deposit, £4. Final deposit, 2 per cent.

Kaniva.—Alterations and renovations, P.S. (W.O., Horsham; P.S., Kaniva, Nhill.) Preliminary deposit, £10. Final deposit, 2 per cent.

Kerang East.—Internal repairs and painting, S.S. No. 2346. (W.O., Bendigo, Swan Hill; P.S., Cohuna, Pyramid, Quambatook; S.S., Kerang East.) Deposit, £2.

Korumburra.—General repairs, renovations, &c., new wireless mast, and new lino, P.S. (W.O., Korumburra; P.S., Leongatha.) Preliminary deposit, £10. Final deposit, 2 per cent.

Lake Moodemere.—Repairs and painting, S.S. No. 1557. (W.O., Wangaratta; P.S., Rutherglen; S.S., Lake Moodemere.) Deposit, £4.

- Lance Creek.—Painting and repairs, S.S. No. 3715. (W.O., Korumburra; P.S., Leongatha, Loch; S.S., Lance Creek.) Preliminary deposit, £5. Final deposit, 2 per cent.
- Macorna.—Internal and external repairs and painting and provision of soakage pit, S.S. No. 2909. (W.O., Bendigo, Swan Hill; P.S., Cohuna, Kerang, Pyramid; S.S., Macorna.) Deposit, £4.
- Melbourne.—Sewerage installation, State Offices Annexe, 179 Queen-street. Preliminary deposit, £20. Final deposit, 2 per cent.
- Melbourne.—Renovation of room on second floor, Department of Lands, 107 Russell-street. Deposit, £4.
- Melbourne.—Supply and installation of oil-firing equipment for boiler, State Accident Insurance Office, 412 Collins-street. Preliminary deposit, £5. Final deposit, 2 per cent.
- Melbourne.—Installation of wiring to master and slave clocks, Law Courts, 459 Lonsdale-street. P.D., £5. F.D., 2 per cent.
- Melbourne.—Electrical installation, State Offices Annexe, 179-183 Queen-street. P.D., £20. F.D., 2 per cent.
- Melbourne.—Supply and installation of cold cathode fluorescent lighting equipment, State Offices Annexe, 179-183 Queen-street. P.D., £20. F.D., 2 per cent.
- Melbourne.—Supply and installation of central-heating and hot-water systems, State Offices Annexe, 179-183 Queen-street. P.D., £20. F.D., 2 per cent. (Amended specification.)
- Merbein.—External painting and provision of fly-wire doors and window screens, S.S. No. 3687. (W.O., Mildura; P.S., Ouyen, Redcliffs, Sea Lake, Werrimul; S.S., Merbein.) Deposit, £4.
- Merino.—General repairs, internal and external renovations, Court House. (W.O., Hamilton; P.S., Casterton, Coleraine; Court House, Merino.) Deposit, £4.
- Modella.—Repairs and painting, new storeroom, woodshed, &c., S.S. No. 3456. (P.S., Dandenong, Warragul; S.S., Modella.) Deposit, £10.
- Nathalia.—Conversion of Army hut into two (2) classrooms, S.S. No. 2060. (W.O., Shepparton; P.S., Numurkah; S.S., Nathalia.) P.D., £10. F.D., 2 per cent.
- Newtown.—Provision of sleep-out, re-blocking scullery floor, repairs to fences, and painting to caretaker's quarters, S.S. No. 1887. (W.O., Geelong; S.S., Newtown.) Deposit, £4.
- North Melbourne.—Internal renovations, Printing Trades School, Queensberry-street. (Printing Trades School, Queensberry-street.) Preliminary deposit, £10. Final deposit, 2 per cent.
- Portland.—Renovations to Jury Room, Court House. (W.O., Hamilton; P.S., Portland, Heywood.) Deposit, £3.
- Quantong.—Repairs and painting, S.S. No. 3194. (W.O., Horsham; P.S., Nhill; S.S., Kewell North, Quantong.) Deposit, £3.
- Quarry Hill.—Provision of cupboards under blackboards, removal of platforms, new hyloplates, display boards, and general repairs and painting, S.S. No. 1165. (W.O., Bendigo; S.S., Quarry Hill.) Preliminary deposit, £10. Final deposit, 2 per cent.
- Red Cliffs.—Alterations, renovations and painting, &c., school and residence, S.S. No. 4057. (W.O., Mildura; P.S., Ouyen, Werrimul; S.S., Red Cliffs.) Preliminary deposit, £10. Final deposit, 2 per cent.
- Rutherglen.—Repairs and painting, residence, and provision of display boards, H.E.S. No. 522. (W.O., Benalla, Wangaratta; P.S., Wodonga; H.E.S., Rutherglen.) Preliminary deposit, £10. Final deposit, 2 per cent.
- Rutherglen.—Provision of bathrooms, alterations, &c., Research Farm. (W.O., Wangaratta; P.S., Rutherglen, Tallangatta.) Preliminary deposit, £5. Final deposit, 2 per cent.
- Sea Lake.—Repairs, renovations, &c., of Tyrrell Creek School Buildings, S.S. No. 3273. (W.O., Swan Hill; P.S., Woomelang, Wycheproof; S.S., Sea Lake.) Deposit, £3.
- South Melbourne.—External repairs and painting of steel windows and doors, MacRobertson Girls' High School. (MacRobertson Girls' High School, South Melbourne.) Preliminary deposit, £15. Final deposit, 2 per cent.
- Strathkellar.—Repairs to teacher's residence, out-office and wash house, new surround to blackboards, and external painting to residence, S.S. No. 3536. (W.O., Hamilton; S.S., Strathkellar.) Deposit, £4.
- Sunshine East.—Erection of new brick school, S.S. No. 4909. Preliminary deposit, £50. Final deposit, 2 per cent.
- The Sisters.—Painting and repairs, S.S. No. 3252. (W.O., Warrnambool; P.S., Camperdown; S.S., The Sisters.) Deposit, £4.
- Tongio.—Repairs, painting, &c., S.S. No. 2545. (W.O., Bairnsdale; P.S., Orbost; S.S., Tongio.) Preliminary deposit, £2. Final deposit, 2 per cent.
- Tyrrell Downs.—Repairs and painting, S.S. No. 3394. (W.O., Swan Hill; P.S., Culgoa, Ultima, Woomelang; S.S., Tyrrell Downs.) Deposit, £2.
- Walwa.—Erection of timber residence and standard office, P.S. (W.O., Wangaratta; P.S., Tallangatta, Walwa.) Preliminary deposit, £15. Final deposit, 2 per cent.
- Warragul.—Installation of water service to school and residence, S.S. No. 2104. (W.O., Bairnsdale; P.S., Moe, Sale; S.S., Warragul.) Deposit, £2.
- Willow Grove.—Repairs, new tank stand and painting, S.S. No. 2520. (W.O., Bairnsdale; P.S., Moe, Warragul; S.S., Willow Grove.) Preliminary deposit, £5. Final deposit, 2 per cent. (Amended specification.)
- Wycheproof.—Repairs and painting, S.S. No. 1757. (W.O., Bendigo; P.S., Charlton, Inglewood; S.S., Wycheproof.) P.D., £15. F.D., 2 per cent.
- Yea.—Erection of tank stands, new blackboard, general repairs and external painting, &c., S.S. No. 699. (P.S., Kilmore, Seymour; S.S., Yea.) Preliminary deposit, £5. Final deposit, 2 per cent.

23rd November, 1948.

- Baranduda.—Erection and completion of teacher's residence (labour only), S.S. No. 2222. (W.O., Wangaratta; P.S., Tallangatta, Wodonga; S.S., Baranduda.) P.D., £10. F.D., 2 per cent.
- Bookar.—Repairs and renovations, S.S. No. 3578. (W.O., Warrnambool; P.S., Camperdown; S.S., Bookar.) Deposit, £3.
- Boolarra South.—Erection of new sleep-out, teacher's residence, S.S. No. 3670. (W.O., Korumburra; P.S., Morwell, Mirboo North; S.S., Boolarra South.) P.D., £3. F.D., 2 per cent.
- Boorhaman.—Erection and completion of new teacher's residence, S.S. No. 1996. (W.O., Benalla, Wangaratta; P.S., Wahgunyah; S.S., Boorhaman.) P.D., £15. F.D., 2 per cent.
- Brunswick.—External painting and repairs, Girls' School. (Girls' School, Brunswick.) P.D., £10. F.D., 2 per cent.
- Burndale.—Repairs, painting, and re-blocking, S.S. No. 4249. (W.O., Korumburra; P.S., Leongatha; S.S., Burndale.) P.D., £3. F.D., 2 per cent.
- Cheltenham.—Repairs and painting to school buildings and provision of new fencing, S.S. No. 84. (S.S., Cheltenham.) P.D., £15. F.D., 2 per cent.
- Club Terrace.—Repairs and renovations, S.S. No. 3343. (W.O., Bairnsdale; P.S., Orbost; S.S., Club Terrace.) Deposit, £4.
- Cowes.—Repairs and painting, S.S. No. 1282. (P.S., Frankston; S.S., Cowes.) P.D., £5. F.D., 2 per cent.
- Dimboola.—Adaptation of Army hut into classrooms, H.S. (W.O., Horsham; P.S., Nhill; H.S., Dimboola.) P.D., £10. F.D., 2 per cent.
- Donald.—Erection of new building, District Hospital. (W.O., Ballarat, Bendigo, Maryborough; District Hospital, Donald.) P.D., £50. F.D., 2 per cent. (Quantities available at Public Works Department.)
- Donald.—Supply and installation of mechanical services and equipment, District Hospital. (W.O., Ballarat, Bendigo; P.S., Donald.) P.D., £50. F.D., 2 per cent.
- Donald.—Electrical installation, District Hospital. (P.S., Donald, St. Arnaud.) P.D., £15. F.D., 2 per cent.
- Donald.—Supply and delivery of electric over-bed assemblies, District Hospital. P.D., £5. F.D., 2 per cent.
- Hamilton.—Provision of new fire-escape stairs, H.S. (W.O., Hamilton, Ararat, Warrnambool; P.S., Portland; H.S., Hamilton.) P.D., £5. F.D., 2 per cent.
- Horsham.—Adaptation of Army hut into classrooms, H.S. (W.O., Ararat, Horsham; P.S., Nhill; H.S., Horsham.) P.D., £5. F.D., 2 per cent.
- Kalkallo.—Repairs and painting and fencing, S.S. No. 195. (P.S., Eroadford, Kilmore, Seymour; S.S., Kalkallo.) P.D., £4. F.D., 2 per cent.
- Koo-wee-rup.—Conversion of Army hut into two (2) classrooms, H.E.S. No. 2629. (P.S., Dandenong; H.E.S., Koo-wee-rup.) P.D., £15. F.D., 2 per cent.
- Leongatha North.—Repairs and painting, S.S. No. 4181. (W.O., Korumburra; P.S., Foster; S.S., Leongatha North.) P.D., £4. F.D., 2 per cent.
- Meatian West.—Repairs and painting, S.S. No. 3464. (W.O., Swan Hill; P.S., Kerang, Sea Lake, Ultima; S.S., Meatian West.) Deposit, £2.
- Melbourne.—Repairs to shutters and mechanism, Strong Room, Titles Office. P.D., £5; F.D., 2 per cent.
- Melbourne.—Conversion of basement rooms to office accommodation, Old Treasury Building, Spring-street. Deposit, £4.
- Moonee Ponds.—Alterations, P.S. Deposit, £4.
- Murtoa.—Provision of fibrous plaster lining and internal painting of residence, external painting and repairs and provisions of sun shades to school, S.S. No. 1549. (W.O., Ararat, Horsham; P.S., Warracknabeal; S.S., Murtoa.) Deposit, £4.
- Noorongong.—Erection and completion of teacher's residence (labour only), S.S. No. 3073. (W.O., Wangaratta; P.S., Tallangatta, Wodonga; S.S., Noorongong.) P.D., £10. F.D., 2 per cent.

North Richmond.—Renovations, S.S. No. 2798. (S.S., North Richmond.) P.D., £10. F.D., 2 per cent.

Orford.—Alterations, repairs and painting, school and residence, S.S. No. 1858. (W.O., Warrnambool; P.S., Koroit, Port Fairy; S.S., Orford.) Deposit, £4.

Red Hill.—Sinking of a bore for water supply, Consolidated School. Deposit, £10.

Rutherglen.—Purchase and removal of old house, S.S. No. 522. (W.O., Wangaratta; P.S., Wodonga; S.S., Rutherglen.) P.D., £5. F.D., full amount of purchase money.

Speed.—Supply and installation and testing of fuel hot-water service, P.S. (W.O., Mildura; P.S., Speed.) P.D., £2. F.D., 2 per cent.

Tatura.—Excavations and concrete foundations for new P.S., Hogan-street. (W.O., Bendigo, Shepparton; P.S., Echuca, Tatura.) Deposit, £3.

Templestowe.—Repairs, painting, and, new sky-lights, S.S. No. 1395. (S.S., Templestowe.) P.D., £5. F.D., 2 per cent.

Upwey.—Conversion of Army hut into two (2) classrooms and cloakroom, H.S. (H.S., Upwey.) P.D., £10. F.D., 2 per cent.

Yarram.—Painting and repairs to school, out-buildings, and residence, S.S. No. 693. (W.O., Korumburra; P.S., Foster, Leongatha; S.S., Yarram.) P.D., £15. F.D., 2 per cent.

Yarra Park.—Repairs and painting, S.S. No. 1406. Preliminary deposit, £10. Final deposit, 2 per cent.

30th November, 1948.

Agnes.—Repairs and painting, S.S. No. 3043. (W.O., Korumburra; P.S., Leongatha, Yarram; S.S., Agnes.) P.D., £4. F.D., 2 per cent.

Barnawartha.—Erection of new verandah, repairs and painting, and new tanks, S.S. No. 1489. (W.O., Wangaratta; P.S., Wodonga; S.S., Barnawartha.) P.D., £10. F.D., 2 per cent.

Belmont (Geelong).—Erection of police station and residence, P.S. (W.O., Geelong.) P.D., £15. F.D., 2 per cent.

Blackburn.—Replacements to fencing, S.S. No. 2923. (S.S., Blackburn.) P.D., £5. F.D., 2 per cent.

Box Hill.—Internal renovations of school buildings and caretaker's quarters, Boys' H.S. (Boys' H.S., Box Hill.) P.D., £15. F.D., 2 per cent.

Broadford.—Repairs, &c., S.S. No. 1125. (P.S., Kilmore, Seymour; S.S., Broadford.) P.D., £5. F.D., 2 per cent.

Burramine South.—Repairs and painting, S.S. No. 2203. (W.O., Benalla; P.S., Katamatite, Tungamah, Yarrowonga; S.S., Burramine South.) Deposit, £3.

Carrum North.—Repairs and painting and new sky-lights, S.S. No. 3341. (P.S., Frankston, Mornington; S.S., Carrum North.) Deposit, £4.

Catani.—Erection of new laundry and fittings, bathroom fittings, kitchen sink and cupboard, tank and stands, repairs and painting, residence, S.S. No. 4154. (P.S., Dandenong, Warragul; S.S., Catani.) P.D., £5. F.D., 2 per cent.

Everton Upper.—Re-blocking, repairs and internal and external painting, S.S. No. 1198. (W.O., Benalla, Wangaratta; S.S., Everton Upper.) Deposit, £4.

Kew.—Alterations for installation of new electric goods lift, Mental Hospital. Deposit, £4.

Kilcunda.—Repairs and painting, S.S. No. 2307. (W.O., Korumburra; P.S., Nyora, Wonthaggi; S.S., Kilcunda.) Deposit, £4.

Lardner.—Improved lighting to classroom, repairs and painting to school and residence, S.S. No. 1711. (W.O., Bairnsdale, Korumburra; P.S., Warragul; S.S., Lardner.) P.D., £10. F.D., 2 per cent.

Lucknow.—Repairs, painting, &c., S.S. No. 1231. (W.O., Bairnsdale; P.S., Orbost, Sale; S.S., Lucknow.) P.D., £10. F.D., 2 per cent.

Mardan South.—Painting and repairs, S.S. No. 3166. (W.O., Korumburra; P.S., Leongatha, Mirboo North; S.S., Mardan South.) Deposit, £4.

Molesworth.—Erection of new sleep-out to residence, repairs and painting to school and residence, S.S. No. 2233. (W.O., Benalla; P.S., Euroa, Seymour; S.S., Molesworth.) Deposit, £4. (Amended specification.)

Mornington.—Repairs and renovations, P.S. (P.S., Frankston, Mornington.) P.D., £5. F.D., 2 per cent.

Nariel North.—Removal, re-erection and renovations, &c., S.S. No. 4633. (W.O., Benalla, Wangaratta; P.S., Corryong; S.S., Nariel North.) P.D., £10. F.D., 2 per cent.

Neerim.—Repairs, painting, minor extensions and new blackboards, S.S. No. 2666. (W.O., Bairnsdale; P.S., Moe, Traralgon, Warragul; S.S., Neerim.) P.D., £10. F.D., 2 per cent.

Ripplebrook.—Repairs and painting, improved lighting and erection of new shed, S.S. No. 2129. (W.O., Korumburra; P.S., Warragul; S.S., Ripplebrook.) P.D., £10. F.D., 2 per cent.

Sandringham.—Erection of new premises, P.S. P.D., £25. F.D., 2 per cent.

Tetoora-road.—Painting and repairs, school and residence, S.S. No. 3860. (W.O., Korumburra; P.S., Warragul; S.S., Tetoora-road.) P.D., £5. F.D., 2 per cent.

7th December, 1948.

Melbourne.—Supply and installation of central heating, mechanical ventilation and exhaust ventilation, Chemistry School, Technical College, P.D., £25. F.D., 2 per cent.

Tenders to be addressed to the Honorable the Commissioner of Public Works, and envelope containing tender marked "Tender for \_\_\_\_\_"

J. A. KENNEDY,  
Commissioner of Public Works.

Melbourne, 9th November, 1948.

#### TENDERS FOR THE SERVICE, 1948-49.

##### GENERAL STORES.

TENDERS will be received until Eleven o'clock a.m. on Friday, the 3rd December, 1948, from persons willing to supply the under-mentioned goods, in such quantities as may be ordered by the Victorian Government, during the twelve months commencing 1st February, 1948:—

Schedule No.	Preliminary Deposit.
	£
56. Motor Spirit and Kerosene	3

The prices tendered must not include sales tax.

Security.—Five per cent. of total amount of tender accepted, but in no case will security of less than £3 be received.

Schedules as above, with full particulars, may be obtained from the Secretary to the Tender Board, Gisborne-street, Melbourne, by whom also the samples will be shown and any information afforded to persons tendering.

In all cases the total cost of each item must be extended in the columns provided.

Tenders must be accompanied by the preliminary deposit, as shown above, preferably by non-negotiable cheque payable to the order of the Secretary to the Tender Board. The amount and designation of the preliminary deposit enclosed must be clearly stated in the tender. Savings Bank deposit books, fixed deposit receipts, Commonwealth Treasury bonds, or reference to securities on existing contracts will in no case be received or entertained as preliminary deposits. Preliminary deposits will be returned within 30 days to unsuccessful tenderers on their application.

Security will be required either in Commonwealth Treasury bonds, or approved bank guarantee, fixed deposit receipt, Savings Bank deposit book, or non-negotiable cheque in favour of the Secretary to the Tender Board, as the tenderer may elect.

The security must be completed and the contract signed within five days of acceptance of the tender, failing which the service may be again advertised, or another tender accepted.

The lowest or any tender will not necessarily be accepted.

In the event of tenderers withdrawing or attempting to withdraw their tenders before notification of acceptance of same, or failing to take up their accepted tenders within the prescribed period after notification of acceptance, the preliminary deposit will be forfeited and, in addition, they may be disqualified from tendering or holding any future contracts for Government supplies for a period of twelve months, such disqualification to date from the notification of acceptance of tender. It is also stipulated that, if a tenderer be a member of a firm and such firm be interested in the contract, the tender shall be in the name of the firm and not in that of the individual and that, for a breach of this condition, the preliminary deposit will be forfeited and the tender declared informal.

Tenders enclosed in a separate envelope, and having the words "Tender for \_\_\_\_\_" (as the case may be) written thereon, must be deposited in the Tender-box at the Tender Board Offices, Gisborne-street, Melbourne, or, if sent by post, postage must be prepaid and the tenders addressed to the Chairman of the Tender Board, Tender Board Offices, Gisborne-street, Melbourne, C.2, which office they must reach not later than by first post on the date of closing of tenders.

The conditions of contract are those published in the Victoria Government Gazette, No. 155, of 17th March, 1948, pages 1528 to 1529.

J. G. B. McDONALD,  
Acting Treasurer.

The Treasury,  
Melbourne, 8th November, 1948.

TENDERS FOR THE SERVICE, 1948.  
PROVISIONS—MEAT.

TENDERS will be received until Eleven o'clock a.m. on Friday, 3rd December, 1948, from persons willing to furnish the under-mentioned supplies, in such quantities as may be ordered by the Victorian Government—delivery to be made at the under-mentioned places—during the three months commencing on 1st January, 1948.

The estimated quantities shown in the Schedules will be subject to variation in accordance with the requirements of any Regulations for the rationing of meat in force during the contract period.

The prices tendered must not include sales tax.

In all cases, the total cost of each item must be extended in the columns provided.

The places for which tenders will be received, the amount of the preliminary deposit, and the security required for the due fulfilment of each contract, are as follows:—

	Preliminary Deposit.	Security.
	£	£
Schedule No. 1.—Melbourne District—		
Meat—Kew Mental Hospital .. .. .	2	35
„ Pentridge Penal Establishment, Female Penitentiary, and Metropolitan Gaol, Coburg .. .. .	2	35
„ Children's Welfare Depot, Royal Park, and Police Hospital .. .. .	1	8
„ Receiving House and Mental Hospital, Royal Park .. .. .	1	10
Schedule No. 2.—Mont Park, Bundoora, Janefield, and Gresswell—		
Meat .. .. .	3	50
Schedule No. 3.—s.s. Rip and Dredges—		
Meat .. .. .	1	5
Schedule No. 4.—Teachers' College, Carlton, and Travancore, Flemington—		
Meat .. .. .	1	8
Schedule No. 5.—Ararat District—		
Meat .. .. .	2	30
Schedule No. 6.—Ballarat District—		
Meat .. .. .	2	35
Schedule No. 7.—Beechworth District—		
Meat .. .. .	2	30
Schedule No. 8.—Castlemaine District—		
Meat .. .. .	1	5
Schedule No. 9.—School of Forestry, Creswick—		
Meat .. .. .	1	3
Schedule No. 10.—McLeod Settlement, French Island—		
Meat .. .. .	1	5
Schedule No. 11.—Heatherton Sanatorium, Cheltenham—		
Meat .. .. .	1	5
Schedule No. 12.—Sanatorium, Groenvale—		
Meat .. .. .	1	7
Schedule No. 13.—Coorimungie Prison Camp, Heytesbury Forest—		
Meat .. .. .	1	4
Schedule No. 16.—Sale Gaol—		
Meat .. .. .	1	3
Schedule No. 17.—Pleasant Creek Special School, Stawell—		
Meat .. .. .	1	3
Schedule No. 18.—Sunbury District—		
Meat .. .. .	2	40
Schedule No. 21.—Geelong District—		
Meat .. .. .	1	5

Printed forms of tender and the conditions of contract may, in all cases, be obtained from the Secretary to the Tender Board, Gisborne-street, Melbourne, by whom also any information or explanation will be afforded to persons tendering.

Tenders must be accompanied by the preliminary deposit, as shown above, preferably by non-negotiable cheque payable to the order of the Secretary to the Tender Board. The amount and designation of the preliminary deposit

enclosed must be clearly stated in the tender. Savings Bank deposit books, fixed deposit receipts, Commonwealth Treasury bonds, or reference to securities on existing contracts will in no case be received or entertained as preliminary deposits. Preliminary deposits will be returned within 30 days to unsuccessful tenderers on their application.

Security will be required either in Commonwealth Treasury Bonds, or approved bank guarantee, fixed deposit receipt, Savings Bank deposit book, or non-negotiable cheque in favour of the Secretary to the Tender Board, as the tenderer may elect.

The security must be completed and the contract signed within five days of acceptance of the tender, failing which the service may be again advertised, or another tender accepted.

The lowest or any tender will not necessarily be accepted.

In the event of tenderers withdrawing or attempting to withdraw their tenders before notification of acceptance of same, or failing to take up their accepted tenders within the prescribed period after notification of acceptance, the preliminary deposit will be forfeited and, in addition, they may be disqualified from tendering or holding any future contracts for Government supplies for a period of twelve months, such disqualification to date from the notification of acceptance of tender. It is also stipulated that, if a tenderer be a member of a firm and such firm be interested in the contract, the tender shall be in the name of the firm and not in that of the individual and that, for a breach of this condition, the preliminary deposit will be forfeited and the tender declared informal.

Tenders, enclosed in a separate envelope, and having the words "Tender for .. .. ." (as the case may be) written thereon, must be deposited in the Tender-box at the Tender Board Offices, Gisborne-street, Melbourne, or, if sent by post, postage must be prepaid, and the tenders addressed to the Chairman of the Tender Board, Tender Board Offices, Gisborne-street, Melbourne, C.2, which office they must reach not later than by first post on the date of closing of tenders.

CONDITIONS OF CONTRACT.

The conditions of contract are those published in the Victoria Government Gazette, No. 406, dated 5th May, 1948, pages 2882 to 2884.

J. G. B. McDONALD,  
Acting Treasurer.

The Treasury,  
Melbourne, 8th November, 1948.

PRIVATE ADVERTISEMENTS.

I, DOROTHY DURRANCE, of 242 Ryrie-street, Geelong, stenographer, a spinster, heretofore called and known by the name of Dorothy Finnel, hereby give notice that by a deed poll dated 23rd October, 1948, duly executed, attested, and deposited with the Registrar-General of the State of Victoria on the 29th October, 1948, I formally and absolutely renounced and abandoned the surname of Finnel, and declared that I had assumed and adopted, and intended henceforth upon all occasions whatsoever to use and subscribe the surname of Durrance instead of the said surname of Finnel, and so to be at all times thereafter called and known and described by the name of Dorothy Durrance.

Dated the 4th day of November, 1948.

DOROTHY DURRANCE.

Witness—ALEX. D. HOLLYHOKE, solicitor, Geelong. 6467

DIOCESE OF WANGARATTA.  
DIOCESAN SYNOD.

NOTICE is hereby given that the Bishop of Wangaratta has convened the Diocesan Synod for Tuesday, 23rd day of November, 1948, at half-past Two p.m., at the Parish Hall, Wangaratta.

6468 GEORGE W. CARTER, Registrar.

Local Government Act 1946.  
CITY OF HEIDELBERG.

NOTICE TO ALL WHOM IT MAY CONCERN.

WHEREAS the Council of the municipality of the City of Heidelberg, in the State of Victoria, deems it expedient to execute a certain work or undertaking for the purpose of providing a place of public resort and

recreation for the purposes whereof it is, in the opinion of the said Council, necessary and desirable that the said Council exercise its power of taking land compulsorily within the municipal district of the said Council, as provided by the *Local Government Act 1946*, and the said Council has caused its surveyor to prepare such specifications, maps, plans, sections, and elevations of the said work or undertaking as are necessary, and in which are expressed the nature and extent of such work or undertaking and the exact site and admeasurements thereof, and on and through what land the said work or undertaking is proposed to be placed, and the names of the owners or reputed owners, lessees or reputed lessees, and the occupiers of such land so proposed to be taken so far as known, and the said specifications, maps, plans, sections, and elevations so prepared have been approved by the said Council.

In pursuance of the provisions of the *Local Government Act 1946*, the said Council doth hereby publish and give notice that the description shortly of the purport of the said work or undertaking, and of the said specifications, maps, plans, sections, and elevations is as follows:—

The providing of a place of public resort and recreation at corner The Boulevard and Vasey-street, Ivanhoe.

And the said Council doth hereby give further notice that the said specifications, maps, plans, sections, and elevations are deposited at the office of the said Council, Town Hall, Upper Heidelberg-road, Ivanhoe, and are there open for inspection and perusal on all the days and between the hours the municipal office is appointed to be open, for the space of 40 clear days from the date of the publication of this notice in the *Government Gazette*. And the said Council doth hereby call upon all persons interested in or affected by the said proposed work or undertaking to set forth, in writing addressed to the said Council, or the Town Clerk thereof, at the Town Hall, Upper Heidelberg-road, Ivanhoe, within 40 clear days from the date of the publication of this notice as aforesaid, all objections which they may have to the said work or undertaking.

Dated this 27th day of October, 1948.

The common seal of the Mayor, Councillors, and Citizens of the City of Heidelberg was hereto affixed, by me—

F. PHILLIPS, Town Clerk.

In the presence of—

(SEAL) H. T. SPARKS, Mayor.  
A. NUTTALL, Councillor.

6437

#### CITY OF MORDIALLOC.

##### BY-LAW No. 94.

NOTICE is hereby given that, in pursuance of the powers conferred by the *Local Government Act 1946*, the Mayor, Councillors, and Citizens of the City of Mordialloc has made a By-law, numbered 94, for prescribing areas within the municipal district as residential areas, and prohibiting or regulating within the whole or any part of any such residential areas, the use of any land or the erection (including adaptation for use), or the use of any building for the purpose of all classes of trade, industries, manufactures, or public amusements.

In particular the By-law provides for:—

- (a) The repeal of all former By-laws as far as they relate to matters and things provided for in this By-law.
- (b) The areas within the boundaries set out in Schedules 1 and 2 as residential areas.
- (c) The prohibition of the use of the land or the erection (including adaptation for use), or the use of any building within the areas set out in Schedule 1 for the purpose of all classes of trade, industries, manufactures, businesses, or public amusements.
- (d) The prohibition of the use of the land, or the erection (including adaptation for use), or the use of any building within the areas set out in Schedule 2 for the purpose of all classes of trades, industries, manufactures and businesses other than businesses of a class or nature usually carried on in a shop.

Notice is also hereby given that a copy of the said By-law is open for inspection, free of charge, during office hours at the Council Chambers, Mentone.

The Resolution for adopting the said By-law was passed by the Council, on the 10th May, 1948, confirmed on the 15th June, 1948, and approved by the Governor in Council, on the 26th October, 1948.

6469 E. C. OWBRIDGE, Town Clerk.

#### SHIRE OF AVON.

NOTICE is hereby given that Thomas Richard Galway has been appointed Poundkeeper of the Stratford Pound as from 8th November, 1948, in the place of E. C. Bock, resigned.

J. G. W. CECIL SHORT, Shire Secretary and Engineer.  
6459

#### SHIRE OF BROADFORD.

##### LOAN No. 9.

*Notice of Intention to Borrow the Sum of Two Thousand Pounds (£2,000) for Permanent Works and Undertakings in the Shire of Broadford.*

TAKE notice that the Council of the Shire of Broadford proposes to borrow, on the credit of the President, Councillors, and Ratepayers of the said shire, the sum of Two thousand pounds (£2,000), such sum to be raised by the issue of debentures in accordance with the provisions of the *Local Government Acts*.

The maximum rate of interest that may be paid is £3 5s. (3½ per cent.) per centum per annum.

Such moneys shall be repayable by twenty equal half-yearly instalments, each including principal and interest, by providing out of the municipal fund such sums on the 1st day of February and the 1st day of August in each respective year during the currency of the loan.

Such moneys shall be repayable at Melbourne, at the Commercial Banking Company of Sydney, or at the Council's bankers for the time being in Melbourne.

The purpose for which the loan is to be applied is for—

“For the purchase of a power grader,” £2,000.

The plans, specifications, and estimate of the cost of the works referred to above, and a statement showing the proposed expenditure of money to be borrowed, are open for inspection at the Shire Office, Broadford.

Dated this 8th day of November, 1948.

6501

H. L. POLGLASE, Shire Secretary.

#### SHIRE OF DANDENONG.

##### BY-LAW No. 94.

A By-law of the Shire of Dandenong, made under section 197 of the *Local Government Act 1946*, and numbered 94, for the adoption of provisions of the Fifteenth Schedule of the said Act.

IN pursuance of the powers conferred by the *Local Government Act 1946*, the President, Councillors, and Ratepayers order as follows:—

1. By-law No. 31 and all previous By-laws adopting all or any provisions of the Thirteenth Schedule of the *Local Government Act 1915*, or of the Thirteenth Schedule of the *Local Government Act 1928*, are hereby repealed.

2. The whole of the provisions of the Fifteenth Schedule of the *Local Government Act 1946* are hereby adopted, with the exception of the following:—

- (a) The reading of the minutes of the proceedings at the preceding meeting, as provided in clause 2 of Part XI. of the said Schedule, and
- (b) the reading of the rough minutes of the proceedings of the Council at any meeting at the close of such meeting, as provided in clause 2 of Part XI. of the said Schedule.

3. This By-law shall apply to and have operation throughout the whole of the municipal district of the Shire of Dandenong.

Resolution for passing this By-law, No. 94, agreed to by the Council the 30th day of August, 1948; confirmed the 1st day of November, 1948.

The common seal of the President, Councillors, and Ratepayers of the Shire of Dandenong was hereto affixed this 1st day of November, 1948, in the presence of—

(SEAL) WINWOOD L. PODMORE, Shire President.  
E. C. SMITH, Councillor.  
C. W. BAKER, Councillor.  
R. BOOTH, Shire Secretary.

6454

## SHIRE OF DANDENONG.

BY-LAW No. 95.

A By-law of the Shire of Dandenong, made under section 197, and numbered 95, for—

- (a) Prohibiting or regulating the use of private property situate at the junction of streets or roads for the growing of trees, shrubs, or hedges abutting on any such street or road, or within 10 feet thereof.
- (b) Requiring the removal or lopping of trees, shrubs, or hedges (whether planted before or after the commencement of the *Local Government Act 1946*) from or on private property so situate where such trees, shrubs, or hedges abut or are within 10 feet of such street or road.
- (c) Requiring the reduction to a height not exceeding 3 ft. 6 in. of any portion of a fence within 10 feet of the junction of any streets or roads, and
  - (a) Authorizing the Council, at the expense of the owner—
    - (1) To remove or lop trees, shrubs, or hedges growing or being on private property so situate which are not removed or lopped as required by or under this By-law.
    - (2) To reduce in height any portion of a fence which is not reduced in height as required by or under this By-law.

IN pursuance of the powers conferred by the *Local Government Act 1946*, the President, Councillors, and Ratepayers of the Shire of Dandenong order as follows:—

1. The use of private property situate at the junction of streets or roads for the growing of trees, shrubs, or hedges abutting on any such streets or roads, or within 10 feet of such junction, to a greater height than 3 ft. 6 in. above the level of the footpath is prohibited.
2. Trees, shrubs, or hedges (whether planted before or after the commencement of the *Local Government Act 1946*) growing on private property situate at the junction of streets or roads and abutting on any such streets or roads within 10 feet from such junction, or within 10 feet of any such streets or roads for a distance of 10 feet from such junction, shall be removed or lopped to a height not exceeding 3 ft. 6 in. above the level of the footpath.
3. Any portion of a fence on private property situate at the junction of streets or roads within 10 feet of such junction shall be reduced to a height not exceeding 3 ft. 6 in. above the level of the footpath.
4. The Council, at the expense of the owner (the amount of which expense may be recovered by the Council in a Court of Petty Sessions as a civil debt recoverable summarily), is hereby authorized—

- (1) To remove or lop trees or shrubs or hedges growing or being on private property so situate which are not removed or lopped as required by or under this By-law.
- (2) To reduce in height any portion of a fence which is not reduced in height as required by or under this By-law.

5. Any wilful contravention of the foregoing provisions by act or omission shall be an offence against this By-law, and any person guilty of an offence against this By-law shall be liable to a penalty of not less than Two pounds or more than Twenty pounds. In the case of a continuing offence, to a further daily penalty of not more than Five pounds for each day on which an offence against this By-law is continued after a conviction by any court.

6. This By-law shall apply to and have operation throughout the whole of the municipal district of the Shire of Dandenong.

Resolution for passing this By-law, No. 95, agreed to by the Council on the 30th day of August, 1948, and confirmed on the 1st day of November, 1948.

The common seal of the President, Councillors, and Ratepayers of the Shire of Dandenong was hereunto affixed by order of the Council this 1st day of November, 1948, in the presence of—

(SEAL) WINWOOD L. PODMORE, Shire President.  
ARTHUR F. MARSHALL, Councillor.  
ANDREW ERICKSEN, Councillor.  
6455 R. BOOTH, Shire Secretary.

## SHIRE OF GORDON.

NOTICE is hereby given that First Constable Charles Briant has been appointed Prosecuting Officer for the Township of Boort, *vice* Jonathan W. Ogden, resigned.  
6458 ROSS M. GRAHAM, Shire Secretary.

NOTICE is hereby given that the partnership heretofore subsisting between the undersigned, Frederick Thomas Sutherland and Clarence Percival Prouse, carrying on business as poultry farmers, at Jell's-road, Mulgrave, under the name of Sutherland and Prouse, has been dissolved by mutual consent as from the 31st day of July, 1948, and the business has been discontinued.

Dated at Melbourne, the 5th day of November, 1948.

YVONNE E. STANTON, 924 Burke-road, Balwyn, solicitor for the said Frederick Thomas Sutherland.

HERBERT TURNER & SON, 411 Collins-street, Melbourne, solicitors for the said Clarence Percival Prouse.

6451

NOTICE is hereby given that the partnership heretofore subsisting between Leonard Edward Hoult, John Verence Hoult, and Phyllis Mary Bushnell, carrying on business as steel and machinery merchants, under the firm name of N. Durance and Company, at 221 King-street, Melbourne, in the State of Victoria, has been altered by mutual consent as from the 30th day of June, 1948. Phyllis Mary Bushnell has retired from the partnership. All debts due and owing to the said firm will be received and paid respectively by Leonard Edward Hoult and John Verence Hoult, who will in future carry on the business in partnership under the said firm name of "N. Durance and Company."

Dated the 25th day of October, 1948.

L. E. HOULT.

Witness—MICHAEL NIALL.

J. V. HOULT.

Witness—JAMES JOHNSTONE, J.P.

P. M. BUSHNELL.

Witness—BRIAN LANNOCK.

Michael Niall and Co., solicitors, Melbourne.

6450

NOTICE is hereby given that the partnership heretofore subsisting between Edward Francis Kane and Frederick John Phillips, carrying on business as pastry-cooks, at 329 Johnston-street, Abbotsford, under the name of "Peters Pikelets," has been dissolved by mutual consent as from the 30th day of June, 1948. All debts due to and owing by the said late firm will be received and paid by the said Frederick John Phillips, who will continue to carry on the business at the same address.

F. J. PHILLIPS.  
E. KANE.

Keith Hercules, LL.B., solicitor, 443 Little Collins-street, Melbourne.

6447

## NOTICE OF DISSOLUTION OF PARTNERSHIP.

NOTICE is hereby given that the partnership heretofore subsisting between the undersigned, Chan Yee and Chan Fai, carrying on business as café proprietors at the San Sang Café, at 247 Smith-street, Fitzroy, has been dissolved by mutual consent as from the 31st day of October, 1948. All debts due to and owing by the said late firm will be received and paid by Chan Fai, who will continue to carry on the business at the same place.

Dated the 3rd day of November, 1948.

CHAN YEE.  
CHAN FAI.

6446

NOTICE is hereby given that the partnership heretofore subsisting between Arnold Stiller, Izak Einhorn-Bodzechowski, and Stanley Ross, carrying on business as textile manufacturers at 14 Queen-street, Melbourne, under the style or firm name of Woodlands Textile Mills, has been dissolved as from the date hereof.

Dated the 14th day of October, 1948.

STANLEY ROSS.  
IZAK EINHORN-BODZECZOWSKI.  
ARNOLD STILLER.

6445

NOTICE is hereby given that the partnership heretofore subsisting between the undersigned Arthur Sloughton Clarke Bloomfield and George Barclay Dicker, carrying on the business of chartered accountants (Australia) at 84-88 William-street, Melbourne, under the name of A. S. Bloomfield and Co., has been dissolved by mutual consent as from the 1st day of October, 1948. All debts due to and owing by the said firm will be received and paid by the said George Barclay Dicker, who will continue to carry on the said business under the same name and at the same address as aforesaid, in partnership with Alan Reid Pitts.

Dated this 29th day of October, 1948.

A. S. BLOOMFIELD.  
G. B. DICKER.

6502



## NOTICE OF CHANGE IN PARTNERSHIP.

NOTICE is hereby given that on 29th October, 1948, Frederick James Musicka retired from the partnership heretofore subsisting between him and George Frederick Lyngcoln and Archibald Edward Hawkins, carrying on business at Richmond Abattoirs, Burnley, under the name of G. Lincoln and Company. The said George Frederick Lyngcoln and Archibald Edward Hawkins will continue to carry on in partnership under the same name, and all debts due and owing by the partnership will be received and paid by them.

F. J. MUSICKA.  
G. L. LYNGCOLN.  
A. E. HAWKINS.

Moule, Hamilton, and Derham, solicitors, 394 Collins-street, Melbourne. 6444

## NOTICE OF DISSOLUTION OF PARTNERSHIP.

NOTICE is hereby given that the partnership heretofore subsisting between the undersigned William Francis McKenzie and Ian David Rich, carrying on business as designers, builders, and contractors at 56 Abbeygate-street, Oakleigh, under the name of McKenzie and Rich, has been dissolved by mutual consent as from the 30th day of June, 1948. All debts due to and owing by the said late firm will be received and paid by William Francis McKenzie, who will carry on the business at 56 Abbeygate-street, Oakleigh.

Dated at Melbourne, the 5th day of November, 1948.

W. F. MCKENZIE.

Witness—LLOYD P. GOODE.

IAN RICH.

Witness—LLOYD P. GOODE.

6512

NOTICE is hereby given that the partnership heretofore subsisting between the undersigned Maurice Louis Bryan Bellgrove and Alfred Robert Russell Sterry, heretofore carrying on the business of builders, under the style or firm name of "Sterry and Bellgrove," has been dissolved by mutual consent as and from the 20th day of June, 1948. All debts due to and owing by the said late firm will be received and paid by the said Alfred Robert Russell Sterry, who will continue to carry on the said business at the same place as and from the said 20th day of June, 1948.

A. STERRY.

Witness—JOHN B. PLANT, solicitor, Melbourne.

M. L. B. BELLGROVE.

Witness—ROBERT G. DUNLOP, solicitor, Melbourne.

John B. Plant, LL.B., of 368 Collins-street, Melbourne. 6515

## NOTICE OF DISSOLUTION OF PARTNERSHIP.

NOTICE is hereby given that the partnership heretofore subsisting between the undersigned Morry Wald and Aron Siemaychki, carrying on business as manufacturers at 188 Princes-street, North Carlton, in the State of Victoria, under the firm name of "Vendome Fashions," has been dissolved by mutual consent as from the 3rd day of November, 1948. All debts due to and owing by the said firm will be received and paid by Morry Wald, who will continue to carry on business at the same place.

Dated the 3rd day of November, 1948.

M. WALD.

A. SIEMAYCHKI.

Witness—RALPH FREADMAN.

Leslie Cohen and Freadman, solicitors, 141A Chapel-street, St. Kilda, S.2. 6473

## PARTNERSHIP ACT 1928.

NOTICE is hereby given that the partnership formerly carried on by Heriot Bedwell Anderson, Ellen Clarke, and Margaret Kuhn, under the firm name "Melanda Modes," at 244 Collins-street, Melbourne, has been dissolved by mutual consent as from the 27th day of October, 1948.

H. B. ANDERSON.  
E. CLARKE.  
M. KUHN.

Boothby and Boothby, solicitors, 408 Collins-street, Melbourne. 6476

## PARTNERSHIP ACT.

NOTICE is hereby given that the partnership heretofore subsisting between Arthur Ernest Nicholas and John McKellar, carrying on business as general carriers at 114 Wyndham-street, Shepparton, under the style or firm name of "Goulburn Valley Transport Service," has been dissolved as from the 30th day of June, 1948.

Dated the 30th day of October, 1948.

A. E. NICHOLAS.

Maxwell Brown, public accountant, Shepparton. 6434

No. of Company 22454.

Form No. 40.

Companies Act 1938.

## AUSTRALIAN JEWISH WELFARE SOCIETY.

COPY RESOLUTION OR AGREEMENT, PURSUANT TO SECTION 118.

At a General Meeting of the members of Australian Jewish Welfare Society, duly convened and held at 443 Little Collins-street, Melbourne, on the 5th day of November, 1948, the following Special Resolution was duly passed:—

"That the Australian Jewish Welfare Society be wound up voluntarily."

Dated this 8th day of November, 1948.

L. FINK, Director.

J. Okno, LL.B., solicitor, 100 Queen-street, Melbourne. 6489

Companies Act 1938.

## THE AUSTRALIAN JEWISH WELFARE AND RELIEF SOCIETY.

NOTICE OF INTENTION TO APPLY TO ATTORNEY-GENERAL FOR LICENCE, PURSUANT TO SECTION 18 (1).

THE AUSTRALIAN JEWISH WELFARE AND RELIEF SOCIETY, being an association formed for the purpose of rendering charity, hereby gives notice of intention to apply to the Attorney-General for a licence directing that the said association be registered as a company with limited liability, without the addition of the word "limited" to the name.

Dated this 10th day of November, 1948.

6488

L. FINK, Director.

TAKE notice that Douglas Sidebottom has retired from the firm S.M.S. Builders, which firm will continue to be carried on by Arthur Marshall Schaeche and James Edward Mackie at 12 Gavan-street, Burwood.

6496

A. M. SCHAECHÉ.

SARNIA PACKING PROPRIETARY LIMITED  
(IN VOLUNTARY LIQUIDATION).

NOTICE is hereby given, in pursuance of section 236 of the Companies Act 1938, that a General Meeting of the members of the above-named company will be held at 257 Collins-street, Melbourne, on Thursday, the 16th day of December, 1948, at half-past Two o'clock in the afternoon, for the purpose of having an account laid before them showing the manner in which the winding up has been conducted and the property of the company disposed of, and of hearing any explanation that may be given by the liquidator.

Dated the 25th day of October, 1948.

R. SWALE, Liquidator.

Moule, Hamilton, and Derham, 394-6 Collins-street, Melbourne, solicitors for the liquidator. 6449

VICTORIA NYANZA SUGAR COMPANY LIMITED  
(IN LIQUIDATION).

NOTICE is hereby given, in pursuance of section 245 of the Companies Act 1938, that a General Meeting of the members of the above-named company will be held at the office of the liquidator, 4 Bank-place, Melbourne, on Monday, the 13th day of December, 1948, at Twelve o'clock noon, for the purpose of having an account laid before them showing the manner in which the winding up has been conducted and the property of the company disposed of, and of hearing any explanation that may be given by the liquidator.

Dated the 9th day of November, 1948.

R. W. TOVELL, Liquidator.

Arthur Phillips and Just, Equity Chambers, 472 Bourke-street, Melbourne, solicitors for the liquidator. 6490

## TRADAIR PROPRIETARY LIMITED.

MEETING OF CREDITORS, PURSUANT TO SECTION 238, VICTORIAN COMPANIES ACT.

NOTICE is hereby given that an Extraordinary General Meeting of the above-named company has been convened for the purpose of considering and, if thought fit, of passing a resolution to wind up the company voluntarily, and that a meeting of creditors will be held at the meeting room of the Chamber of Manufactures, 312 Flinders-street, Melbourne, C.I., on Tuesday, 16th November, 1948, at half-past Two o'clock in the afternoon.

## Business:

- (1) To receive a statement of the position of the company's affairs.
- (2) To nominate a liquidator.
- (3) To appoint (if thought fit) a committee of inspection.

Proxies desired to be used at the meeting must be lodged at the registered office of the company, 365 Elizabeth-street, Melbourne, C.I., not later than Twelve noon on Monday, 15th November, 1948.

Dated this 3rd day of November, 1948.

By order of the Board,

6485

G. S. MOFFAT, Secretary.

In the matter of the *Companies Act 1938*, and in the matter of EDEN FISHERIES PROPRIETARY LIMITED (in Liquidation).  
—Notice to Creditors.

THE creditors of the above-named company are required, on or before the 10th day of December, 1948, to send their names and addresses, and the particulars of their debts or claims, and the names and addresses of their solicitors, if any, to A. J. Quaine, of 358 Collins-street, Melbourne, the liquidator of the said company, and, if so required by notice in writing from the said liquidator, are by their solicitors or otherwise to come in and prove their said debts or claims at such time and place as shall be specified in such notice, or in default thereof they will be excluded from the benefit of any distribution made before such debts or claims are proved.

Dated this 8th day of November, 1948.

6453

A. J. QUAIN, Liquidator.

EVENDEN ANCHOR NAIL PROPRIETARY LIMITED  
(IN LIQUIDATION).

NOTICE CONVENING FINAL MEETING, PURSUANT TO SECTION 236.

NOTICE is hereby given, in pursuance of section 236 of the *Companies Act 1938*, that a General Meeting of the members of the above-named company will be held at Pope-street, East Brunswick, on Friday, the 10th day of December, 1948, at Two o'clock in the afternoon, for the purpose of having an account laid before them showing the manner in which the winding up has been conducted and the property of the company disposed of, and of hearing any explanation that may be given by the liquidator.

Dated at Melbourne, this 9th day of November, 1948.

6495

L. G. HUNTER, Liquidator.

The *Companies Act 1938*.COUNTRY MASTER BAKERS CO. LTD.  
(IN LIQUIDATION).

NOTICE is hereby given that a Final Meeting of the members will be held at the office of the liquidator on 16th December, 1948, at Twelve o'clock noon, for the purposes set out in section 245 of the *Companies Act 1938*.

Dated this 3rd day of November, 1948.

M. R. M. SMITH, Liquidator.

M. R. M. Smith, Peacock, and Henshaw, 59 Queen-street, Melbourne. 6498

*Companies Act 1948*, Section 245.EDWARDS COMMERCIAL COMMODITIES CO.  
PTY. LTD. (IN LIQUIDATION).

NOTICE is hereby given that a General Meeting of creditors of the above-named company, will be held on Friday, 10th December, at Two p.m., at Temple Court, 422 Collins-street, Melbourne, for the purpose of laying before the meeting an account of the realization of the property of the company, and the disposal of the proceeds of such realization. 6517

## M. &amp; S. SUPPLIES PTY. LTD.

AT an Extraordinary General Meeting of the above-named company, duly convened and held at 401 Collins-street, Melbourne, at half-past Nine a.m., on 27th October, 1948, the following Resolution was duly passed as a Special Resolution, formal notice of meeting having been dispensed with:—

"That the company be wound up voluntarily, and that Kenneth Conway Keown, of York-street, Eltham, chartered accountant (Aust.), be appointed liquidator for the purposes of the winding up."

Dated this 28th day of October, 1948.

6516

C. H. STIRLING, Chairman.

LILY MAUD HODGSON, late of Darkbonee, in Victoria, spinster, DECEASED.

CREDITORS, next of kin, and others having claims in respect of the estate of the deceased (who died on the 27th November, 1947) are to send particulars of their claims to the Ballarat Trustees, Executors, and Agency Company Limited, of 101 Lydiard-street north, Ballarat, and Colin Morrison, of Wycheproof, and Sydney Montague Davies, of Darkbonee, both farmers and graziers, care of the said company, by the 12th January, 1949, after which date it and they will distribute the assets, having regard only to the claims of which it and they then have notice.

MITCHELL &amp; MONOTTI, solicitors, St. Arnaud. 6438

## NOTICE TO CLAIMANTS.

CREDITORS, next of kin, and others having claims in respect of the estate of Sussannah Herminia Oliver, late of Waggarrandall, in the State of Victoria, widow, deceased (who died on the 16th day of January, 1948), are to send the particulars of their claims to the Equity Trustees, Executors, and Agency Company Limited, at the registered office of the said company, at 472 Bourke-street, Melbourne, in the said State, by the 17th day of January, 1949, after which date it will distribute the assets, having regard only to the claims of which it then has notice.

Dated the 1st day of November, 1948.

HARGRAVE &amp; HARGRAVE, Yarrowonga, proctors for the said executor. 6439

## NOTICE TO CREDITORS.

PURSUANT to the *Trustee Act 1928*, notice is hereby given that all creditors, next of kin, and others having claims against the estate of Stanley James Harrison Taylor, late of 267 Balaclava-road, Caulfield, estate agent, deceased (who died on the 8th day of March, 1948), are hereby required to send particulars, in writing, of such claims to the administratrix, Mrs. Martha Maude Taylor, care of the undersigned solicitor, on or before the 1st day of February, 1949, after which date the administratrix will proceed to distribute the assets of the said deceased amongst the persons entitled thereto, having regard only to the claims of which she shall then have had notice, and will not be liable for the assets so distributed to any person of whose claim she shall not then have had notice.

Dated this 4th day of November, 1948.

KENNETH J. CLEMENTS, 29 Glenhuntly-road, Elsternwick, solicitor for the administratrix. 6440

CREDITORS, next of kin, and others having claims in respect of the estate of Wilhelm Albert Luhrs, late of Inverleigh, in the State of Victoria, farmer, deceased (who died on the 26th day of August, 1948), are to send the particulars of their claims to The Ballarat Trustees, Executors, and Agency Company Limited, of Malop-street, Geelong, by the 14th day of January, 1949, after which date it will distribute the assets, having regard only to the claims of which it then has notice.

WHYTE, JUST, &amp; MOORE, solicitors, 27 Malop-street, Geelong. 6465

**CREDITORS**, next of kin, and all persons having claims in respect of the estate of Hilda Daisy Warwick-Paul, late of "Kapunda," 7 Abbot-grove, Clifton Hill, widow, deceased (who died on the 27th day of July, 1948), are required by the executrix, Irene Ellen Grimby, to send particulars of their claims to her, care of Sylvia Rothstadt, solicitor, 243 Collins-street, Melbourne, by the 14th day of January, 1949, after which date she will distribute the assets, having regard only to the claims of which she then has notice.

Dated the 8th day of November, 1948.

SYLVIA ROTHSTADT, M.A., LL.B., solicitor, 243 Collins-street, Melbourne. 6462

**CREDITORS**, next of kin, and all others having claims against the estate of Kathleen Josephine Coughlan, late of 25 Epping-street, East Malvern, in the State of Victoria, registry office proprietor, deceased, intestate (who died on the 5th day of July, 1948), are to send particulars of their claims to Annie Amelia Coughlan, the administratrix, care of Sylvia Rothstadt, solicitor, 243 Collins-street, Melbourne, on or before the 14th day of January, 1949, after which date the said Annie Amelia Coughlan will distribute the assets, having regard only to the claims of which she then has notice.

Dated the 8th day of November, 1948.

SYLVIA ROTHSTADT, M.A., LL.B., solicitor, 243 Collins-street, Melbourne. 6461

**CREDITORS**, next of kin, and others having claims in respect of the estate of Sarah Kay, late of 23 Blessington-street, St. Kilda, in the State of Victoria, married woman, deceased, intestate (who died on the 11th day of July, 1948, and letters of administration of whose estate were granted to The Ballarat, Trustees, Executors, and Agency Company Limited, of 101 Lydiard-street north, Ballarat), are to send particulars, in writing, of their claims to the said company, at its above-mentioned address, on or before the 14th day of January, 1949, after which date it will distribute the assets, having regard only to the claims of which it then has notice.

Dated the 8th day of November, 1948.

SYLVIA ROTHSTADT, M.A., LL.B., 243 Collins-street, Melbourne, solicitor for the said company. 6460

**RE MARY ANN LEAH MOORFOOT, DECEASED.**

**NOTICE** is hereby given that all persons having claims against the property or estate of Mary Ann Leah Moorfoot, late of 3 Crofton-street, Geelong west, widow, deceased (who died on the 29th day of July, 1948, and letters of administration of whose estate were granted to Ada Ethel Rosina Harvey, of 60 Villamanta-street, Geelong West, widow), are hereby required to send, in writing, particulars of such claims to the said administratrix, on or before the 13th day of January, 1949, after which date she will convey or distribute such property or estate to or among the persons entitled thereto, having regard only to the claims of which she shall then have had notice.

HARWOOD & PINCOTT, solicitors, 51 Yarra-street, Geelong, and 472 Bourke-street, Melbourne. 6456

HARRIET ANN MOORE, late of 78 Story-street, Parkville, widow (who died on 17th September, 1948).

**CREDITORS** and all other persons having claims against the estate of the deceased are required by the executrices of the will, Pearl Clara Amelia Schmidt and Edith Jane Costigan, both of Park-court, 283 Royal-parade, Parkville, in the State of Victoria, gentlewomen, to send particulars to the undersigned, on or before 12th January, 1949, after which date the assets will be distributed, having regard only to the claims of which notice has then been received.

PLANTE & HENTY, 395 Collins-street, Melbourne, solicitors for the executrices. 6475

**CREDITORS**, next of kin, and others having claims in respect of the estate of Mary Ellen de Silva, formerly of 53 Greville-street, Prahran, but late of 23 Irving-avenue, East Prahran, home duties, deceased, intestate (who died 14th September, 1948), are to send particulars of their claims to Randolph Arthur de Silva, care of the undersigned, by 7th January, 1949, after which date he will distribute the assets, having regard only to the claims of which he then has notice.

JAMES P. OGGE, LL.B., solicitor, &c., 165 Greville-street, Prahran. 6481

**CREDITORS**, next of kin, and all persons having claims in respect of the estate of Frances Ellen Armstrong, late of 106 Bennett-street, North Fitzroy, spinster, deceased (who died on the 27th day of May, 1948), are to send particulars of their claims to Florence Armstrong, Amy Maud Moorhead, and Garnet Beaumont Frost, care of Messrs. Middleton, McEacharn, and Shaw, solicitors, 60 Market-street, Melbourne, by the 12th day of January, 1949, after which date the said Florence Armstrong, Amy Maud Moorhead, and Garnet Beaumont Frost will distribute the assets of the estate of the said deceased, having regard only to the claims of which they then have notice.

Dated the 8th day of November, 1948.

MIDDLETON, MCEACHARN, & SHAW, solicitors, 60 Market-street, Melbourne. 6486

**CREDITORS**, next of kin, and others having claims in respect of the estate of Andrew John Byrne, late of 23 Loch-street, St. Kilda, investor, deceased (who died 17th July, 1948), are to send particulars of their claims to National Trustees, Executors, and Agency Company of Australasia Limited, of 95 Queen-street, Melbourne, by the 7th January, 1949, after which date they will distribute the assets, having regard only to the claims of which it then has notice.

JAMES P. OGGE, LL.B., solicitor, 165 Greville-street, Prahran. 6482

**CREDITORS**, next of kin, and others having claims in respect of the estate of Alfred Edward Doran, late of Nathalia, in the State of Victoria, bootmaker, deceased (who died on the 3rd day of June, 1948), are to send the particulars of their claims to The Perpetual Executors and Trustees Association of Australia Limited, of 100-104 Queen-street, Melbourne, by the 1st day of February, 1949, after which date it will distribute the assets, having regard only to the claims of which it then has notice.

S. W. STIFE & KEOGH, solicitors, Nathalia. 6472

**PURSUANT** to the provisions of the *Trustee Act 1928*, notice is hereby given that all persons having claims against the estate of May Osborne, formerly of 53 Jackson-street, St. Kilda, in the State of Victoria, but late of 29 Thames Promenade, Chelsea, in the said State, spinster, deceased (who died on the 17th September, 1948, and probate of whose will was on the 29th October, 1948, granted by the Supreme Court of Victoria to Roy James McArthur and Richard Francis Maplestone Clark, both of 46 Queen-street, Melbourne, in the said State, solicitors, the executors appointed thereby), are hereby required to send particulars, in writing, of such claims to the said Roy James McArthur and Richard Francis Maplestone Clark, to care of Malleon, Stewart, and Co., at the address below, on or before the 18th January, 1949, after which date the said executors will proceed to convey or distribute the said estate to or among the persons entitled thereto, having regard only to the claims, whether formal or not, of which they shall then have had notice, and will not be liable for the assets so distributed to any person of whose claim they shall not then have had notice.

MALLESON, STEWART, & CO., solicitors, 46 Queen-street, Melbourne, C.I. 6511

**CREDITORS**, next of kin, and others having claims in respect of the estate of Agnes Carrick, late of 19 Mangarra-road, East Camberwell, widow, deceased (who died on the 11th August, 1948), are to send the particulars of their claims to The Perpetual Executors and Trustees Association of Australia Limited, at its registered office, situate at 100-104 Queen-street, Melbourne, by the 12th day of January, 1949, after which date it will distribute the assets, having regard only to the claims of which it then has notice.

FREDK. W. COX, solicitor, 87 Queen-street, Melbourne. 6506

**CREDITORS** and next of kin and others having claims in respect of the estate of John Maxwell, late of 3 Hartwell-road, Camberwell, retired carpenter, deceased (who died on the 7th day of June, 1948), are to send the particulars of their claims to The Trustees, Executors, and Agency Company Limited, at its registered office, 401 Collins-street, Melbourne, by the 13th day of January, 1949, after which date it will distribute the assets, having regard only to the claims of which it then has notice.

KEITH A. NESS, solicitor, 411 Collins-street, Melbourne. 6514

JOHN JAMES WILLIAMS, late of 21 Melcombe-road, Ivanhoe, in the State of Victoria, secretary, DECEASED (who died on the 17th day of July, 1948).

CREDITORS, next of kin, or all other persons having claims against the estate of the above-named John James Williams, deceased, are required by National Trustees, Executors, and Agency Company of Australasia Limited, Rose Priscilla Williams, and Rose Mary Page, the executor and executrices to whom probate of the will of the said deceased was granted, on the 3rd day of November, 1948, to send particulars of their claims to the said executor and executrices, at the registered office of the said company, at 95 Queen-street, Melbourne, on or before the 12th day of January, 1949, after which date the said executor and executrices will distribute the assets of the said deceased among the persons entitled thereto, having regard only to the claims of which they then have notice, and they will not be liable to any persons of whose claims they have not then received notice.

ARTHUR J. DOWNING, LL.B., solicitor, 84 William-street, Melbourne. 6507

RE HUGH CHARLES WILSON, DECEASED.

PURSUANT to the *Trustee Act 1928*, all persons having claims against the estate of Hugh Charles Wilson, formerly of The Manse, Marine-parade, Lorne, in the State of Victoria, but late of Bulla, in the said State, minister of religion, deceased (who died on the 3rd day of June, 1948, and probate of whose will was granted by the Supreme Court of Victoria to The Ballarat Trustees, Executors, and Agency Company Limited, of 101 Lydiard-street north, Ballarat, on the 8th day of September, 1948, the executor named in such will), are required to send in particulars of such claims, in writing, to the said The Ballarat Trustees, Executors, and Agency Company Limited, on or before the 10th day of January, 1949, after which date the said executor will proceed to distribute the assets amongst the persons entitled thereto, having regard only to the claims of which it shall then have had notice.

NORMAN MILLER & DONALDSON, of 100 Queen-street, Melbourne, solicitors for the executor. 6509

PURSUANT to the provisions of the *Trustee Act 1928*, notice is hereby given that all persons having claims against the estate of Norman Sutherland, late of "Carrick," No. 78 Walpole-street, Kew, in the State of Victoria, manufacturer, deceased (who died on the 8th September, 1948, and probate of whose will was, on the 29th October, 1948, granted by the Supreme Court of Victoria to Rachel Maud Sutherland, of "Carrick," No. 78 Walpole-street, Kew aforesaid, widow, the executrix appointed thereby), are hereby required to send particulars, in writing, of such claims to the said Rachel Maud Sutherland, to care of Malleon, Stewart, and Co., at the address below, on or before the 18th January, 1949, after which date the said executrix will proceed to convey or distribute the said estate to or among the persons entitled thereto, having regard only to the claims, whether formal or not, of which she shall then have had notice, and will not be liable for the assets so distributed to any person of whose claim she shall not then have had notice.

MALLESON, STEWART, & CO., solicitors, 46 Queen-street, Melbourne, C.I. 6510

CREDITORS, next of kin, and all others having claims against the estate of William Kay Noble, formerly of 560 Barkers-road, Hawthorn, late of 29 Herbert-street, St. Kilda, retired farmer, deceased (who died on the 26th day of May, 1948), are required to send particulars of their claims to The Equity Trustees, Executors, and Agency Company Limited, of 472 Bourke-street, Melbourne (the executor to whom probate of the will of the said William Kay Noble, deceased, was granted on the 27th day of October, 1948), on or before the 14th day of January, 1949, after which date the said company will distribute the assets of the said deceased, having regard only to the claims of which it then has had notice.

JOHN W. MCCOMAS & CO., solicitors, 450 Collins-street, Melbourne. 6513

CREDITORS, next of kin, and others having claims in respect of the estate of Lillian Agnes O'Connell, late of Anglers' Rest, in the State of Victoria, married woman, deceased, intestate (who died on the 12th day of September, 1943), are to send particulars of their claims to the National Trustees, Executors, and Agency Company of Australasia Limited, of 95 Queen-street, Melbourne, in the said State, by the 15th day of January, 1949, after which date it will distribute the assets, having regard only to the claims of which it then has notice.

H. T. LUMSDEN, solicitor, Omeo. 6491

CREDITORS, next of kin, and all persons having claims in respect of the estate of Mary Jane Dealey, late of 8 Pembroke-road, Balwyn, spinster, deceased (who died on the 22nd day of July, 1948), are to send particulars of their claims to Alexander Joseph Cathro, care of Messrs. Middleton, McEacharn, and Shaw, solicitors, 60 Market-street, Melbourne, by the 12th day of January, 1949, after which date the said Alexander Joseph Cathro will distribute the assets of the estate of the said deceased, having regard only to the claims of which he then has notice.

Dated the 8th day of November, 1948.

MIDDLETON, MCEACHARN, & SHAW, solicitors, 60 Market-street, Melbourne. 6487

CREDITORS, next of kin, and others having claims in respect of the estate of Clara Phoebe Durling, late of 50 Burlington-street, Oakleigh, spinster, deceased (who died on the 18th August, 1948), are to send particulars of their claims to the National Trustees, Executors, and Agency Company of Australasia Limited, the registered office of which is situate at 95 Queen-street, Melbourne, by the 12th January, 1949, after which date it will distribute the assets, having regard only to the claims of which it then has notice.

RODDA, BALLARD, & VROLAND, solicitors, 430 Little Collins-street, Melbourne, C.I. 6497

CREDITORS, next of kin, and others having claims in respect of the estate of Mary Frances Mathieson, late of 113 Wellington-street, Collingwood, in the State of Victoria, married woman, deceased (who died on the 25th day of February, 1948), are to send the particulars of their claims to the National Trustees, Executors, and Agency Company of Australasia Limited, the registered office of which is situated at 95 Queen-street, Melbourne, by the 18th day of January, 1949, after which date it will distribute the assets, having regard only to the claims of which it then has notice.

D. CONDON, 469 Little Collins-street, Melbourne, solicitor. 6499

CREDITORS, next of kin, and others having claims in respect of the estate of Emma de Marbaix Burgess (sometimes known as Emma Burgess), formerly of 242 Toorak-road, South Yarra, in the State of Victoria, but late of Merbein, in the said State, widow, deceased (who died on the 30th day of July, 1948), are to send particulars of their claims to Elsie Burgess and National Trustees, Executors, and Agency Company of Australasia Limited, care of the said company, at its registered office at 95 Queen-street, Melbourne, by the 20th day of January, 1949, after which date they will distribute the assets, having regard only to the claims of which they then have notice.

F. L. BIRCH, solicitor, 411 Collins-street, Melbourne. 6503

NOTICE TO CLAIMANTS—RE KENNETH MCWHAE, DECEASED.

MARGARET ALICE MCWHAE, of 12 Marne-street, South Yarra, in the State of Victoria, spinster, and Hector Joseph Richard Clayton, of 136 Liverpool-street, Sydney, New South Wales, solicitor, the executors to whom probate of the will of Kenneth McWhae, late of 314 Collins-street, Melbourne, in the State of Victoria, grazier, deceased, was granted by the Supreme Court of Victoria, on the 25th day of August, 1947, require all creditors, next of kin, and others having claims against the property or estate of the said deceased to send to the said executors, care of the undersigned, on or before the 18th day of January, 1949, particulars, in writing, of such claims, after which date the said executors intend to convey or distribute such property or estate to or among the persons entitled thereto, having regard only to the claims of which they shall have had notice.

H. S. W. LAWSON & CO., 314 Collins-street, Melbourne, solicitors for the executors. 6452

CREDITORS, next of kin, and others having claims in respect of the estate of John Horatio Carr, formerly of 40 Burke-road, East Malvern, but late of 3A Mount Ida-avenue, Hawthorn, in the State of Victoria, retired dentist, deceased (who died on the 2nd day of August, 1948), are to send the particulars of their claims to The Equity Trustees, Executors, and Agency Company Limited, whose registered office is situate at 472 Bourke-street, Melbourne, in the said State, by the 14th day of January, 1949, after which date it will distribute the assets, having regard only to the claims of which it then has notice.

HEDDERWICK, FOKES, & ALSTON, 103 William-street, Melbourne, solicitors for the executor. 6441

NOTICE TO CREDITORS.—*RE* ARTHUR LLOYD,  
DECEASED.

PURSUANT to the provisions of the *Trustee Act 1928* (Victoria), and the *Wills Probate Administration Act 1898-1940*, the *Public Trustee Act 1913-1942*, the *Testators' Family Maintenance and Guardianship of Infants Act 1916-1938*, and the *Trustee Act 1925-1942* (New South Wales), notice is hereby given that all persons having claims against the property or estate of Arthur Lloyd, late of Mosman, in the State of New South Wales, gentleman, deceased (who died on the 21st day of August, 1947, and probate of whose will and codicil was granted to the Public Trustee of the State of New South Wales, the executor named therein by the Supreme Court of New South Wales, on the 15th day of January, 1948, and application for reseal of an exemplification of which said probate was granted by the Supreme Court of Victoria, on the 13th day of October, 1948, to the Public Trustee of the State of New South Wales (hereinafter called the "executor")), are hereby required to send particulars, in writing, of such claims to the said executor, care of the under-mentioned solicitor, on or before the 18th day of January, 1949, after which date the said executor will proceed to distribute the assets of the said deceased which shall have come to his hands amongst the persons entitled thereto, having regard only to the claims of which he shall then have had notice. And notice is hereby further given that the said executor will not be liable for the assets so paid out and/or handed over, or any part thereof, to any person of whose claim he shall not have had notice as aforesaid.

Dated this 3rd day of November, 1948.

J. & S. SHATIN, of 408 Collins-street, Melbourne, solicitors for the above-named executor. 6448

*Trustee Act 1928.*  
NOTICE TO CLAIMANTS.

PURSUANT to the *Trustee Act 1928*, creditors, next of kin, and all other persons having claims in respect of the estate of any deceased person named below are required to send particulars thereof to the legal personal representative or representatives at the address stated below, on or before the date stated, after which date the representative or representatives will distribute the assets, having regard only to the claims of which notice has been received:—

William Connell, late of West-street, Daylesford, labourer, deceased, who died 15th August, 1948.—Claims to the executors, George Francis Jubilee Roberts, retired butcher, and Mary Roberts, married woman, both of West-street, Daylesford, care of Wighton and McDonald, solicitors, 53 Yarra-street, Geelong, by 13th January, 1949. 6463

William Matthews, late of Grandview-grove, Drumcondra, Geelong West, commercial traveller, died 7th August, 1948.—Claims to the applicant for probate, Mabel Alice Matthews, of Grandview-grove, Drumcondra, Geelong West, widow, care of Wighton and McDonald, solicitors, 53 Yarra-street, Geelong, by 12th January, 1949. 6464

William Margrave Lerew, formerly of 70 Armstrong-street, Middle Park, in the State of Victoria, but late of 6 Reginald-street, Cottesloe, in the State of Western Australia, veterinary officer, deceased, who died on the 15th day of May, 1948.—Claims to the executrix, Loris Margaret Lerew, on or before 13th January, 1949, care of Francis James Corder, of 108 Queen-street, Melbourne, solicitor. 6443

Mary Rees, formerly of 32 Longroyd-street, Mount Lawley, in the State of Western Australia, but late of 13 Kendall-street, Elwood, in the State of Victoria, widow, who died on 7th July, 1948.—Claims to the executrix, Yvonne Mary McMillan, of 13 Kendall-street, Elwood aforesaid, married woman, by 14th January, 1949. Hedderwick, Fookes, and Alston, 103 William-street, Melbourne, solicitors for the executrix. 6442

William George Harris, late of 14 Gordon-street, Footscray, storeman, deceased, died 30th September, 1948.—Claims to the executrix, Julia Mary Harris, of 14 Gordon-street, Footscray, widow, care of John F. Carroll, solicitor, 4 Paisley-street, Footscray, by 13th January, 1949. John F. Carroll, LL.B., solicitor, 4 Paisley-street, Footscray. 6471

Jessie Irene Evans, late of 83-5 Hornby-street, Windsor, in the State of Victoria, married woman, deceased, intestate, died 14th September, 1948.—Claims to the administrator, Henry Austin Evans, of 83-5 Hornby-street, Windsor, in the State of Victoria, sheet-metal worker, care of J. W. Glover, solicitor, of 422 Collins-street, Melbourne, by 12th January, 1949. J. W. Glover, LL.B., solicitor, 422 Collins-street, Melbourne. 6479

John Tuach MacKenzie, late of Horsham, retired farmer, who died on the 24th July, 1948.—Claims to executors, care of Messrs. J. Weldon Power and Bennett, solicitors, of Horsham, by the 15th day of January, 1949. 6478

Mary Gwladis Ronald, late of "Koo-man-goo-nong," Pakenham East, in Victoria, widow, deceased, who died on the 25th day of August, 1948.—Claims to the executors, Peter Bruce Ronald, grazier, and Michael William Bruce Ronald, railway officer, both of "Koo-man-goo-nong," Pakenham East, care of Aitken, Walker, and Strachan, 123 William-street, Melbourne, solicitors of the said executors, by the 11th day of January, 1949. 6480

George Ernest Guest, late of 17 Anderson-street, Geelong West, estate agent, died 17th June, 1946.—Claims to the executors, Charles Thomas Seeley, of Pollock-street, Colac, retired law clerk, Cyril Stanley Moorfoot, of Guthrie-avenue, Geelong West, insurance inspector, and Ronald Percival Wood, of Villamanta-street, Geelong West, butcher, by 10th January, 1949. Sewell and Sewell, solicitors, Colac. 6483

Albert Coulson, late of 11 Laura-street, Moonee Ponds, in the State of Victoria, retired customs official, deceased.—Claims by the 12th day of January, 1949, to the executor, The Equity Trustees, Executors, and Agency Company Limited, of 472 Bourke-street, Melbourne, which is its address for service of notices. Dated this 4th day of November, 1948. Kiddle, Briggs, and Willox, solicitors, 15 Queen-street, Melbourne. 6508

Kathleen Gilmore Gurner, late of 217 Cotham-road, Kew, in the State of Victoria, spinster, who died on 3rd April, 1948.—Claims to the executors, Thomas Cauvine Alston and James Alexander Forrest, both of 103 William-street, Melbourne, solicitors, by 14th January, 1949. Hedderwick, Fookes, and Alston, 103 William-street, Melbourne, solicitors for the executors. 6519

In the Supreme Court of the State of Victoria.—*Fi. Fa.*

NOTICE is hereby given that, under and by virtue of certain process issued out of the Supreme Court of the State of Victoria, and directed to the Sheriff, requiring him to levy certain moneys of the real and personal estate of Edward Thomas Bayne, of Virginia-street, Springvale, cartage contractor, the said Sheriff will, on Friday, the 10th day of December, 1948, at the hour of Eleven o'clock in the forenoon, cause to be sold at Police Station, Springvale (unless the said process shall have been previously satisfied or the said Sheriff be otherwise stayed):—

All the right, title, estate, and interest (if any) of the said Edward Thomas Bayne, in and to all that piece of land, being lot 58 on plan of subdivision No. 8873, lodged in the Office of Titles, and being part of Crown portion 10, Parish of Dandenong, County of Bourke, and being the whole of the land comprised in certificate of title volume 6924, folio 1384700.

N.B.—Terms: Cash. No cheques taken.

Dated at Melbourne, this 29th day of October, 1948.

6477 JOSEPH H. BURLING, Sheriff's Officer.

MINING NOTICES.

HILLSBOROUGH GOLD MINING COMPANY NO  
LIABILITY.

NOTICE is hereby given that an Extraordinary Meeting of shareholders will be held at the registered office, 140 Queen-street, Melbourne, on Friday, 26th November, 1948, at half-past Two o'clock p.m. Business: To increase the capital of the company by raising the amount of each of the 44,000 shares existing in the company from Two shillings and six pence to Five shillings. To confirm the minutes of the meeting.

By order of the Board,

F. L. SMYTH, Manager.

Melbourne, 9th November, 1948.

6500

## NEW CHUM SYNCLINE GOLD MINE NO LIABILITY.

NOTICE is hereby given that all shares forfeited for non-payment of No. 100 (October) Call of Three pence per share will be sold by public auction in the vestibule of the Stock Exchange, 428 Chancery-lane, Melbourne, on Tuesday, 23rd November, 1948, at a quarter to Twelve a.m., unless shares are previously redeemed.

By order of the Board,  
FRANK COOPER, Manager.  
422 Collins-street, Melbourne, C.I. 6493

## MOUNT TODD GOLD MINE NO LIABILITY.

NOTICE is hereby given that all shares forfeited for non-payment of No. 7 (October) Call of Six pence per share will be sold by public auction in the vestibule of the Stock Exchange, 428 Chancery-lane, Melbourne, on Thursday, 18th November, 1948, at a quarter to Twelve a.m., unless shares are previously redeemed.

By order of the Board,  
FRANK COOPER, Manager.  
422 Collins-street, Melbourne, C.I. 6494

## ARGUS HILL CHEWTON GOLD NO LIABILITY.

NOTICE is hereby given that all shares forfeited for non-payment of No. 60 (October) Call of Three pence per share will be sold by public auction in the vestibule of the Stock Exchange, 428 Chancery-lane, Melbourne, on Friday, 19th November, 1948, at a quarter to Twelve a.m., unless shares are previously redeemed.

By order of the Board,  
FRANK COOPER, Manager.  
422 Collins-street, Melbourne, C.I. 6492

## MAXWELL CONSOLIDATED NO LIABILITY.

NOTICE is hereby given that all shares in default of Call No. 41 of Two pence per share are forfeited, and will be sold by public auction at the vestibule, Stock Exchange, Little Collins-street, Melbourne, on Wednesday, 24th November, 1948, at a quarter to Twelve o'clock a.m., unless previously paid.

By order of the Board,  
HADDON A. SMITH, Manager.  
360 Collins-street, Melbourne, 10th November, 1948. 6504

## ROMA BLOCKS OIL COMPANY NO LIABILITY.

NOTICE is hereby given that all shares in default of Call No. 55 of Two pence per share are forfeited, and will be sold by public auction at the vestibule, Stock Exchange, Little Collins-street, Melbourne, on Wednesday, 24th November, 1948, at a quarter to Twelve o'clock a.m., unless previously paid.

By order of the Board,  
L. B. TOMLINS, Manager.  
360 Collins-street, Melbourne, 10th November, 1948. 6505

## CENTRAL NELL GWYNNE GOLD MINING COMPANY NO LIABILITY.

NOTICE.—All shares in this company (included in Nos. 1 to 100,000) on which the 44th Call of Six pence per share remains unpaid are forfeited, and will be sold by public auction at the Stock Exchange, Bendigo, on Thursday, 18th November, 1948, at Four o'clock p.m., unless previously redeemed as required by the *Companies Act 1938*.

J. J. STANISTREET  
6434 (McColl, Rankin, and Stanistreet), Manager.

## SOUTH DEBORAH GOLD MINES NO LIABILITY.

NOTICE.—All shares in this company (included in Nos. 1 to 60,000) on which the 26th Call of Six pence per share remains unpaid are forfeited, and will be sold by public auction at the Stock Exchange, Bendigo, on Thursday, 18th November, 1948, at Four o'clock p.m., unless previously redeemed as required by the *Companies Act 1938*.

J. J. STANISTREET  
6435 (McColl, Rankin, and Stanistreet), Manager.

## DEBORAH GOLD MINES NO LIABILITY.

NOTICE.—All shares in this company (included in Nos. 1 to 61,000) on which the 49th Call of Six pence per share remains unpaid are forfeited, and will be sold by public auction at the Stock Exchange, Bendigo, on Thursday, 18th November, 1948, at Four o'clock p.m., unless previously redeemed as required by the *Companies Act 1938*.

J. J. STANISTREET  
6436 (McColl, Rankin, and Stanistreet), Manager.

## IMPOUNDINGS.

CAMPERDOWN.—Impounded at Camperdown on 4th November (off Darlington-road).

1 Ayrshire heifer, about sixteen months, piece off top near ear, nick out of bottom off ear

If not claimed and expenses paid, to be sold on 23rd November, 1948.

J. ROBB,  
6470—6/8 Poundkeeper.

FERNTREE GULLY.—Impounded at Ferntree Gully, by Shire Ranger.

1 light medium chestnut mare, white stockings, star and small streak, T near shoulder, chain around neck  
1 bay gelding hack, white front and near hind feet, few white hairs on forehead, white patch near hind between stifle and hip, F6 near shoulder

If not claimed and expenses paid, to be sold on 25th November, 1948.

A. DINSDALE,  
6520—9/2 Poundkeeper.

HORSHAM.—Impounded at Horsham.

1 Hereford bull, no visible brand

If not claimed and expenses paid, to be sold on 27th November, 1948.

A. G. FRASER,  
6474—5/ Poundkeeper.

ROCHESTER.—Impounded from Rochester West, by Shire Ranger.

1 medium draught bay gelding, dull white blaze, white feet, shod (one shoe off), like S on near shoulder

If not claimed and expenses paid, to be sold on 19th November, 1948.

L. WALLIS,  
6457—6/8 Poundkeeper.

WANGARATTA.—Impounded at Wangaratta.

1 bay draught mare, aged, collar and saddle marked, white feet, white blaze face, slit in top of near ear

If not claimed and expenses paid, to be sold on 18th November, 1948.

J. McDONNELL,  
6466—5/10 Poundkeeper.

YARRA JUNCTION.—Impounded at Yarra Junction.

1 bay draught gelding, blaze face, hind white legs, front coronets white, white streak near front leg from coronet to knee, no visible brand

If not claimed and expenses paid, to be sold on 20th November, 1948.

M. BERUDE,  
6433—6/8 Poundkeeper.

## STATE ACTS, 1947.

COPIES of the following Acts of Parliament of Victoria may be obtained at the Government Printing Office, or from any bookseller, at the price set opposite to each:—

No.		Price.	
		s.	d.
5207.	Consolidated Revenue .. .. .	0	6
5208.	Custodian Trustee .. .. .	0	6
5209.	Revocation and Excision of Crown Reservations .. .. .	0	9
5210.	Farmers Advances (Amendment) .. .. .	0	6
5211.	Private Bill Committees .. .. .	0	6
5212.	Health (Amendment) .. .. .	0	6
5213.	Wills (Amendment) .. .. .	0	6
5214.	Old Colonists' Association .. .. .	0	6
5215.	Consolidated Revenue .. .. .	0	6
5216.	Local Authorities Superannuation .. .. .	1	0
5217.	Statute Law Revision .. .. .	0	6
5218.	Motor Car (Registration Fees) .. .. .	0	6
5219.	State Electricity Commission (Yallourn Area) .. .. .	0	6
5220.	Transport Regulation (Licences and Fees) .. .. .	0	6
5221.	Local Government (Private Street Construction) .. .. .	0	6
5222.	State Development (Amendment) .. .. .	0	6
5223.	Coal Mine Workers Pensions .. .. .	0	6
5224.	State Savings Bank .. .. .	0	9
5225.	Drought Relief .. .. .	0	6
5226.	Soil Conservation and Land Utilization .. .. .	1	0
5227.	Consolidated Revenue .. .. .	0	6
5228.	Consolidated Revenue .. .. .	0	6
5229.	Consolidated Revenue .. .. .	0	6
5230.	Municipal Endowment (Temporary Discontinuance) .. .. .	0	6
5231.	Forests (Commissioners) .. .. .	0	6
5232.	State Forests Loan and Application .. .. .	0	6
5233.	Melbourne and Metropolitan Tramways (Amendment) .. .. .	0	6
5234.	Auditor-General's Salary .. .. .	0	6
5235.	Drought Relief (Amendment) .. .. .	0	6
5236.	Wheat Marketing (Winding Up) Amendment .. .. .	0	6
5237.	University (Mildura Branch) .. .. .	0	6
5238.	Factories and Shops (Bread) .. .. .	0	6
5239.	Water Supply Loan and Application .. .. .	1	3
5240.	Public Works Loan and Application .. .. .	0	6
5241.	Administration and Probate Duties .. .. .	0	6
5242.	Land Tax .. .. .	0	6
5243.	Country Roads Board Fund (Amendment) .. .. .	0	6
5244.	Ballaarat Land .. .. .	0	9
5245.	Stamps (Increased Duty Continuance) .. .. .	0	6
5246.	Railway Loan Application .. .. .	0	9
5247.	Sewerage Districts (Amendment) .. .. .	0	6
5248.	State Electricity Commission (Financial) .. .. .	0	6
5249.	Public Account Advances (Amendment) .. .. .	0	6
5250.	Infectious Diseases Hospital (Amendment) .. .. .	0	6
5251.	Public Works Loan and Application (Amendment) .. .. .	0	6
5252.	Officials in Parliament .. .. .	0	6
5253.	Water .. .. .	0	6
5254.	Supreme Court (Judges Salaries) .. .. .	0	6
5255.	Superannuation .. .. .	0	9
5256.	Country Sewerage Loan and Application .. .. .	0	6
5257.	Melbourne and Metropolitan Board of Works (Contributions) .. .. .	0	6
5258.	Vegetation Diseases (Fruit Fly) .. .. .	0	6
5259.	Building Operations and Building Materials Control (Amendment) .. .. .	0	6
5260.	Police Regulation (Amendment) .. .. .	0	6
5261.	Factories and Shops (Determinations) .. .. .	0	6
5262.	Appropriation of Revenue .. .. .	5	3

J. J. GOURLEY,  
Government Printer.

## STATE ACTS, 1948.

COPIES of the following Acts of Parliament of Victoria may be obtained at the Government Printing Office, or from any bookseller, at the price set opposite to each:—

No.		Price.	
		s.	d.
5263.	Essential Services .. .. .	0	9
5264.	Landlord and Tenant .. .. .	2	6
5265.	Public Works Committee .. .. .	0	6
5266.	Midwives (Amendment) .. .. .	0	6
5267.	Carriers and Innkeepers .. .. .	0	6
5268.	Camberwell Lands .. .. .	0	9
5269.	Consolidated Revenue .. .. .	0	6
5270.	Miners' Phthisis (Treasury Allowances) Amendment .. .. .	0	6
5271.	Building Operations and Building Materials Control (Amendment) .. .. .	0	6
5272.	State Electricity Commission .. .. .	0	9
5273.	Town and Country Planning .. .. .	0	6
5274.	Coranderrk Lands .. .. .	0	9
5275.	Coroners (Medical Witnesses) .. .. .	0	6
5276.	Vegetation Diseases (Fruit Fly) .. .. .	0	6
5277.	Administration and Probate (Amendment) .. .. .	0	9
5278.	Country Roads (Permanent Works) .. .. .	0	6
5279.	Shrine of Remembrance Trustees .. .. .	0	6
5280.	Non-Contributory State Pensions .. .. .	0	6
5281.	Closer Settlement (Disposal of Land) .. .. .	0	6
5282.	Melbourne North Land .. .. .	0	6
5283.	Melbourne Harbor Trust (Chairman's Salary) .. .. .	0	6
5284.	Police Offences (Race-meetings) .. .. .	1	0
5285.	Statute Law Revision Committee .. .. .	0	9
5286.	Public Trustee .. .. .	1	3
5287.	Horse Breeding (Amendment) .. .. .	0	6
5288.	Building Operations Control (Amendment) .. .. .	0	6
5289.	Local Government (Streets) .. .. .	1	3
5290.	Country Roads .. .. .	0	6
5291.	Landlord and Tenant (Amendment) .. .. .	1	3
5292.	Hepburn Springs Land .. .. .	0	6
5293.	Gas Regulation (Amendment) .. .. .	0	6
5294.	Commonwealth Transferred Officers .. .. .	0	6
5295.	Forests (Amendment) .. .. .	0	6
5296.	Parliamentary Salaries and Allowances .. .. .	0	9
5297.	Farmers Debts Adjustment (Board) .. .. .	0	6
5298.	Justices (Courts) .. .. .	0	6
5299.	Local Authorities Superannuation (Amendment) .. .. .	0	6
5300.	Hospitals and Charities .. .. .	2	3
5301.	Health (Hospitals) .. .. .	0	9
5302.	River Improvement .. .. .	1	9
5303.	Geelong Harbor Trust (Land) .. .. .	0	6
5304.	Stipendiary Magistrates .. .. .	0	6
5305.	Consolidated Revenue .. .. .	0	6
5306.	Consolidated Revenue .. .. .	0	6
5307.	Local Government (Footscray Street Construction) .. .. .	0	6
5308.	Teaching Service (Application of Enactments) .. .. .	0	6
5309.	Parliamentary Contributory Retirement Fund .. .. .	0	6
5310.	Prices Regulation .. .. .	2	0
5311.	Marine (Pilotage Rates) .. .. .	0	6
5312.	State Savings Bank .. .. .	0	6
5313.	Coal Mine Workers Pensions .. .. .	0	9
5314.	Transfer of Land (Acquisitions) .. .. .	0	6
5315.	Workers' Compensation (Police Force) .. .. .	0	6
5316.	Fire Brigades (Borrowing and Salaries) .. .. .	0	6
5317.	Public Officers Salaries .. .. .	0	6
5318.	Mildura Irrigation and Water Trusts (Amendment) .. .. .	0	6

## STATE ACTS, 1948—continued.

No.	Price.
	s. d.
5319. Thornbury Land .. .. .	1 0
5320. Barley Marketing .. .. .	1 0
5321. North-West Mallee Settlement Areas ..	1 0
5322. Latrobe-street Tramway Construction ..	0 6
5323. Gippsland Railway (Duplication and Regrading)	0 6

J. J. GOURLEY,  
Government Printer.

## AGENTS FOR THE "VICTORIA GOVERNMENT GAZETTE."

THE following have been appointed agents to receive Advertisements and subscriptions for the *Victoria Government Gazette*:—

- ARMSTRONG'S AGENCY, 143 Queen-street, Melbourne.  
 MESSRS. ARNALL & JACKSON, 115 Barkly-street, West Brunswick.  
 MESSRS. GORDON & GOTCH, News Agents, 511 Little Collins-street, Melbourne; and corner Barrack and Clarence streets, Sydney.  
 MESSRS. HARSTON, PARTRIDGE, & CO., 455 Little Collins-street, Melbourne.  
 ROBERTSON & MULLENS LTD., Elizabeth-street, Melbourne.  
 MESSRS. A. S. RICHARDSON and T. C. GARDNER, trading as The Mercantile Exchange, 380 Collins-street, Melbourne.  
 A. J. DIGBY (B. S. and N. W. CASH), Main-street, Bairnsdale.  
 MR. M. R. BADE, Tobacconist, Sturt-street, Jallarat.  
 EDGAR'S NEWS AGENCY, Hargreaves-street, Bendigo.  
 MESSRS. H. PAYNE & R. N. LOWE, 4 View Point, Bendigo.  
 MR. C. F. LATIMER, News Agent, Casterton.  
 MESSRS. HENRY FRANKS & CO., Booksellers and Stationers, Market-square, Geelong.  
 MESSRS. SMITH & DUNNON, Hamilton.  
 ARMSTRONG BROS., Kyneton.  
 MR. WM. DAVIS, Mildura.  
 PIKE'S AUTHORIZED NEWS AGENCY, Sale.  
 MR. C. T. RUST, News Agent, Wangaratta.  
 MR. F. T. McCORMICK, Nunn-street, Benalla.  
 W. GORDON HAMPTON, 243 Mitchell-street, Bendigo.  
 R. & A. SMALLMAN, News Agents, Toora.  
 TRAINOR & McBRIDE, 246 Wyndham-street, Shepparton.  
 A copy of the *Gazette* filed at each place for public reference.

## THE "VICTORIA GOVERNMENT GAZETTE."

SUBSCRIPTIONS.—*The subscription, including Postage, is £1 12s. 6d. per annum, 16s. 3d. half-yearly, or 8s. 2d. per quarter, payable in advance.*

*Subscriptions are required to commence and terminate with a month.*

*A lesser period than three months cannot be subscribed for.*

Subscribers do not receive the Acts of Parliament with the GAZETTE.

ADVERTISEMENTS are charged at the rate of TEN PENCE per line single column, and ONE SHILLING and EIGHT PENCE per line double column.

The title (£5 Reward, Dissolution of Partnership, &c.) forms one or more lines as a heading.

On an average, ten words make a line.

Every signature must likewise be counted as a line.

The final words of a paragraph, though only portion of line must be counted as one line.

SIGNATURES (in particular) and proper names must be written very plainly in the text; ONE SIDE ONLY of each slip of paper should be WRITTEN UPON.

ALL COMMUNICATIONS should be addressed to "The Government Printer, Melbourne."

ALL DOCUMENTS illegibly written will be returned unpublished, and, where brands occur unprovided for by the ordinary letters of the alphabet, a worded explanatory description must be furnished.

THE VICTORIA GOVERNMENT GAZETTE is published on WEDNESDAY EVENING in each week, and Notices for insertion will be received by the Government Printer at or before Two p.m. at ordinary rates, and late advertisements between Two p.m. and Five p.m. at double rates on the day preceding the day of publication.

Single copies of the VICTORIA GOVERNMENT GAZETTE are Six pence, posted Eight pence, each.

No GAZETTES prior to January, 1938, in stock.

\*\*\*ALL PAYMENTS ARE REQUIRED IN ADVANCE.—Remittances should be made by postal note, money order, or draft in favour of the Government Printer. Advertisements unaccompanied by a remittance sufficient to cover the cost of insertion will be returned unpublished.

## CONTENTS.

	PAGE.
Acts of Parliament on sale at the Government Printing Office .. .. .	6713
Appointments .. .. .	6669
Bank Half-holidays .. .. .	6668
Cemeteries—Scale of Fees .. .. .	6684
Contracts .. .. .	6687
Courts .. .. .	6684
Estates of Deceased Persons .. .. .	6685
Government Notices .. .. .	6678
Impoundings .. .. .	6712
Lands .. .. .	6692
Mining .. .. .	6684, 6711
Orders in Council .. .. .	6687
Private Advertisements .. .. .	6704
Proclamations .. .. .	6667
Public Holidays .. .. .	6668
Public Service Notices .. .. .	6670
Resignations .. .. .	6670
Stay Orders .. .. .	6684
Tenders .. .. .	6701
Transport Regulation Board—Public Hearings ..	6679