



# VICTORIA GOVERNMENT GAZETTE.

Published by Authority.

[Registered at the General Post Office, Melbourne, for transmission by post as a newspaper.]

No. 1196]

WEDNESDAY, DECEMBER 8.

[1948

LOCAL AUTHORITIES SUPERANNUATION ACT 1947.

## PROCLAMATION

By His Excellency the Governor of the State of Victoria and its Dependencies in the Commonwealth of Australia, &c., &c., &c.

I, THE Governor of the State of Victoria, by and with the advice of the Executive Council thereof, and in pursuance of the powers conferred by section 2 of the *Local Authorities Superannuation Act 1947*, do by this my Proclamation declare each of the under-mentioned bodies to be an Authority for the purposes of the said Act:—

Committee of Management of "Albert Park" in the Cities of South Melbourne and St. Kilda.  
Committee of Management of the St. Kilda Foreshore Reserves.  
Western Metropolitan Market Trust.

Given under my Hand and the Seal of the State of Victoria aforesaid, at Melbourne, this thirtieth day of November, in the year of our Lord one thousand nine hundred and forty-eight, and in the twelfth year of the reign of His Majesty King George VI.

(L.S.) WINSTON DUGAN.

By His Excellency's Command,

J. A. KENNEDY,  
Commissioner of Public Works.  
GOD SAVE THE KING!

COOK ISLANDS DECLARED A RECIPROCATING STATE WITHIN THE MEANING OF THE MAINTENANCE ACTS.

## PROCLAMATION

By His Excellency the Governor of the State of Victoria and its Dependencies in the Commonwealth of Australia, &c., &c., &c.

I, THE Governor of the State of Victoria, in the Commonwealth of Australia, being satisfied that in Cook Islands there is in force legislation containing provisions substantially similar to the provisions contained in Part V. of the *Maintenance Act 1928* of the Parliament of Victoria (as amended by the *Maintenance Act 1933* of the said

Parliament), do now, under the powers conferred by the Maintenance Acts of the Parliament of the State of Victoria, by and with the advice of the Executive Council of the said State, hereby declare Cook Islands to be a reciprocating State within the meaning and for the purposes of the said Maintenance Acts.

Given under my Hand and the Seal of the State of Victoria aforesaid, at Melbourne, this thirtieth day of November, in the year of our Lord One thousand nine hundred and forty-eight, and in the twelfth year of the reign of His Majesty King George VI.

(L.S.) WINSTON DUGAN.

By His Excellency's Command,

T. D. OLDHAM,  
Attorney-General and Solicitor-General.  
GOD SAVE THE KING!

## Water Acts.

DATE OF COMING INTO OPERATION OF THE RIVER IMPROVEMENT ACT 1948 (No. 5302).

## PROCLAMATION

By His Excellency the Governor of the State of Victoria and its Dependencies in the Commonwealth of Australia, &c., &c., &c.

WHEREAS by the *River Improvement Act 1948* (No. 5302), it is provided that the Act shall come into operation on a day to be fixed by proclamation of the Governor in Council.

Now therefore I, the Governor of the State of Victoria, in the Commonwealth of Australia, by and with the advice of the Executive Council of the said State, do by this my Proclamation fix Saturday, the first day of January, 1949, as the day on which the said Act shall come into operation.

Given under my Hand and the Seal of the State of Victoria aforesaid, at Melbourne, this thirtieth day of November, in the year of our Lord One thousand nine hundred and forty-eight, and in the twelfth year of the reign of His Majesty King George VI.

(L.S.) WINSTON DUGAN.

By His Excellency's Command,

JOHN G. B. McDONALD,  
Minister of Water Supply.

GOD SAVE THE KING!

## PUBLIC HIGHWAY.—CITY OF SANDRINGHAM.

## PROCLAMATION

By His Excellency the Governor of the State of Victoria and its Dependencies in the Commonwealth of Australia, &c., &c., &c.

WHEREAS by the *Local Government Act 1946* (No. 5203), section 518, it is amongst other things enacted that it shall be lawful for the Governor in Council at any time, and from time to time, upon the request of the council of any municipality, by notice in the *Government Gazette*, to declare any land reserved, used, or by purchase or exchange acquired for a street, road, highway, thoroughfare, bridge, square, court, alley, or right-of-way to be a public highway, and that such land shall thereupon and thenceforth from the date of such Proclamation become and be absolutely dedicated to the public as a public highway within the meaning of any law then or thereafter in force: And whereas the Council of the City of Sandringham has requested that the land hereinafter mentioned, which has been reserved as a street within the said city, be so declared to be a public highway: Now therefore I, the Governor of the State of Victoria, in the Commonwealth of Australia, by and with the advice of the Executive Council of the said State, do by this Proclamation declare the land reserved as a street hereinafter described, and situated within the City of Sandringham aforesaid, to be a public highway within the meaning of the said Act, viz:—

## PUBLIC HIGHWAY.—CITY OF SANDRINGHAM.

*Swyer-street.*

All that piece of land being part of Crown portion 19, Parish of Moorabbin, County of Bourke, commencing at a point on the south building line of Nell-street, being 376 ft. 10 in. west from the west building line of Bluff-road bounded by a line 657 ft. 11½ in. in length bearing 179 deg. 38 min.; thence by a line 50 feet in length bearing 270 deg. 22 min. along the north building line of Hightt-road; thence by a line 655 feet in length bearing 359 deg. 38 min.; thence by a line 50 feet in length bearing 90 deg. 6 min. to the commencing point.

Given under my Hand and the Seal of the State of Victoria aforesaid, at Melbourne, this thirtieth day of November, in the year of our Lord One thousand nine hundred and forty-eight, and in the twelfth year of the reign of His Majesty King George VI.

(L.S.)

WINSTON DUGAN.

By His Excellency's Command,

J. A. KENNEDY,  
Commissioner of Public Works.

GOD SAVE THE KING!

## Country Fire Authority Acts.

## SUMMER PERIOD IN RESPECT OF SPECIFIED PARTS OF THE COUNTRY AREA OF VICTORIA.

## PROCLAMATION

By His Excellency the Governor of the State of Victoria and its Dependencies in the Commonwealth of Australia, &c., &c., &c.

WHEREAS by sub-section two of section four of the *Country Fire Authority Act 1944*, it is enacted that the Governor in Council, after consultation by the Chief Secretary of Victoria with the Minister of Forests, may from time to time by Proclamation published in the *Government Gazette* proclaim any period as the summer period in respect of the country area of Victoria or any specified part or parts thereof and, without affecting the generality of the foregoing, may proclaim different summer periods in respect of different parts of the said country area:

And whereas the said Chief Secretary and the said Minister have consulted accordingly:

Now therefore I, the Governor of the State of Victoria, in the Commonwealth of Australia, by and with the advice of the Executive Council of the said State and in pursuance of the powers conferred by the *Country Fire Authority Act 1944*, do by this my Proclamation proclaim the period commencing on the eighth day of December, 1948, and ending on the thirty-first day of March next following to be the summer period in respect of the parts hereinafter specified of the country area of Victoria, that is to say:—

Those portions of the Eleventh Fire Control Region comprised by the municipal districts of the Shires of Bairnsdale and Tambo;

those portions of the Fourteenth Fire Control Region comprised by the municipal districts of the Shires of Bulla, Broadford, and Melton, and those portions of the municipal district of the Shire of Keilor which lie outside the Metropolitan Fire District;

those portions of the Sixteenth Fire Control Region comprised by the municipal districts of the Borough of Stawell and the Shires of Stawell and Avoca;

those portions of the Seventeenth Fire Control Region comprised by the municipal districts of the Town of Horsham and the Shires of Dimboola, Dunmunkle, Kaniva, Lowan, Warracknabeal, and Wimmera; and

those portions of the Nineteenth Fire Control Region comprised by the municipal districts of the Borough of Inglewood and the Shire of Bet Bet.

Given under my Hand and the Seal of the State of Victoria aforesaid, at Melbourne, this third day of December, in the year of our Lord One thousand nine hundred and forty-eight, and in the twelfth year of the reign of His Majesty King George VI.

(L.S.)

WINSTON DUGAN.

By His Excellency's Command,

K. DODGSHUN,

Chief Secretary.

GOD SAVE THE KING!

*Vermin and Noxious Weeds Act 1928.*

## CERTAIN PLANT DECLARED TO BE A NOXIOUS WEED WITHIN CERTAIN MUNICIPALITIES.

## PROCLAMATION

By His Excellency the Governor of the State of Victoria and its Dependencies in the Commonwealth of Australia, &c., &c., &c.

IN pursuance of the provisions of section 6 of the *Vermin and Noxious Weeds Act 1928* (No. 3799), I, the Governor of the State of Victoria, by and with the advice of the Executive Council of the said State, do by this my Proclamation declare the plant named hereunder to be a noxious weed for the purposes of the above Act within the City of Bendigo, the Borough of Daylesford, the Borough of Eaglehawk, the Shires of Bet Bet, Cohuna, Glenlyon, Huntly, Kara Kara, Strathfieldsaye, and Talbot:—

*Bassia Quinquedispis*, F.V.M., "Five Spined Saltbush."

Given under my Hand and the Seal of the State of Victoria aforesaid, at Melbourne, this third day of December, in the year of our Lord One thousand nine hundred and forty-eight, and in the twelfth year of the reign of His Majesty King George VI.

(L.S.)

WINSTON DUGAN.

By His Excellency's Command,

JOHN G. B. McDONALD,

Commissioner of Crown Lands and Survey.

GOD SAVE THE KING!

## CHRISTMAS AND NEW YEAR HOLIDAYS.

IT is hereby notified that on—

SATURDAY, THE 25TH DECEMBER, 1948,

MONDAY, THE 27TH DECEMBER, 1948,

TUESDAY, THE 28TH DECEMBER, 1948,

and on

SATURDAY, THE 1ST JANUARY, 1949, and

MONDAY, THE 3RD JANUARY, 1949,

the Public Offices will be closed, the 25th and 27th December, 1948, and the 1st January, 1949, being appointed by the *Public Service Act 1946* to be observed as holidays in the Public Service, and the 28th December, 1948, and the 3rd January, 1949, having been proclaimed by the Governor in Council (see *Victoria Government Gazette* of 13th October, 1948, page 6118) under the powers conferred by the said Act to be observed as such.

K. DODGSHUN,

Chief Secretary.

Chief Secretary's Office,

Melbourne, 18th November, 1948.

## PUBLICATION OF THE "GOVERNMENT GAZETTE."

IT is hereby notified that, owing to the Proclamation of Christmas and New Year Holidays, the *Victoria Government Gazette* will be published on—

FRIDAY, THE 31ST DECEMBER, 1948, and

FRIDAY, THE 7TH JANUARY, 1949,

instead of the ordinary days of publication.

J. J. GOURLEY,

Government Printer.

## APPOINTMENTS.

HIS Excellency the Governor of the State of Victoria, by and with the advice of the Executive Council thereof, has, by Orders made on the 30th day of November, 1948, been pleased to make the under-mentioned appointments, viz.:

DEPARTMENT OF CHIEF SECRETARY.  
*Registrar of Births and Deaths.*

JOHANNA MADELINE BELL,  
pursuant to the provisions of section 4 of the *Registration of Births Deaths and Marriages Act 1928*, to be Registrar of Births and Deaths at Tallangatta, to date from commencement of duty, with fees, *vice* Alice May Gibson, resigned.

*Superintendent (Acting) of Reformatory Prison.*

RONALD JOHN REDRUP,  
pursuant to the provisions of the *Crimes Act 1928*, to be Superintendent (Acting) of the Reformatory Prison at French Island, from the 26th November, 1948, to the 9th December, 1948, both dates inclusive, during the absence on leave of William George Wilson.

*Licensing Inspector.*

KENNETH PHILLIP HOLT, Sub-Inspector of Police, pursuant to the provisions of the Licensing Acts, to be a Licensing Inspector for each and every Licensing District in the State of Victoria, from the 28th October, 1948, *vice* Richard Trewarne, resigned.

*Electoral Registrars (Acting).*

WILLIAM REGINALD BUCHANAN  
to be Electoral Registrar (Acting) for the Alphington, Fitzroy North, and Westgarth Subdivisions of the Electoral District of Clifton Hill; for the Preston East Subdivision of the Electoral District of Ivanhoe; for the Northcote Subdivision of the Electoral District of Northcote; and for the Preston Subdivision of the Electoral District of Preston, to take effect on and from 10th December, 1948, during the absence on leave of Laurence McMahon;

HERBERT WILLIAM HODGSON  
to be Electoral Registrar (Acting) for the Dimboola, Horsham, and Murtoa Subdivisions of the Electoral District of Borung; for the Casterton, Goroke, Hamilton, and Harrow Subdivisions of the Electoral District of Dundas; for the Branxholme, Koroit, Port Fairy, and Portland Subdivisions of the Electoral District of Portland; for the Jeparit, Kaniva, and Nhill Subdivisions of the Electoral District of Rainbow; and for the Horsham South and Stawell Subdivisions of the Electoral District of Ripon, to take effect on and from 9th December, 1948, during the absence on leave of Archibald James Milligan MacPherson; and

WILLIAM DAVID MILLAR  
to be Electoral Registrar (Acting) for the Brighton Subdivision of the Electoral District of Brighton; for the Caulfield Subdivision of the Electoral District of Caulfield; for the Elsternwick Subdivision of the Electoral District of Elsternwick; and for the St. Kilda Subdivision of the Electoral District of St. Kilda, to take effect on and from 21st December, 1948, during the absence on leave of Isaac Harold Kenney.

## DEPARTMENT OF HEALTH.

*Trustees of Cemetery.*

RALPH DAVIDSON, and  
WILLIAM MCKENZIE  
to be Trustees of the Bruthen Public Cemetery, *vice* W. J. Davidson, deceased, and J. Coleman, left district, respectively.

## DEPARTMENT OF LANDS AND SURVEY.

*Committee of Management of Reserves.*

EDWIN EDGAR LEGGO, and  
WILLIAM MACDONALD  
for so long only as they shall continue to be Councillors and the elect of the Council of the Shire of Glenlyon (in the place of James Samuel Gooch and Israel King Gamble, who have ceased to be Councillors of the Shire of Glenlyon); and

JAMES LANCE COATES,  
HAROLD LAVER, and  
THOMAS ALEXANDER WHITELEY  
for so long only as they shall continue to be Councillors and the elect of the Borough of Daylesford (in the place of John Paul Crockett, Lomas Holmes, and John Bush Jackson, who have ceased to be Councillors of the Borough of Daylesford), in pursuance of section 183 of the *Land Act 1928* to be appointed to the Committee of Management of the Reserves at Hepburn, in the Parish of Wombat, in

respect of which Crown grants have issued to the Board of Land and Works, the President, Councillors, and Rate-payers of the Shire of Mt. Franklin (now Glenlyon), and the Mayor, Councillors, and Burgesses of the Borough of Daylesford, and known as the "Hepburn Mineral Springs."

## DEPARTMENT OF LAW.

*Clerk of the Peace, &c.*

GERALD LEAHY  
as Clerk of the Peace and Registrar of the County Court at Shepparton, to be appointed by virtue of section 92 of the *Juries Act 1928* to do and perform with respect to the Courts at that place, in the place and stead of the Sheriff, all such acts and things as the Sheriff is, by the said Act, authorized or required to do or perform, during the absence on annual leave of L. S. Galagher.

*Commissioners for Taking Declarations, &c.*

FRANCIS MICHAEL LYONS, Trust Officer, Office of the Public Trustee, Melbourne,  
to be a Commissioner for taking Declarations and Affidavits, pursuant to the provisions of Division 8 of Part IV. of the *Evidence Act 1928*, to refrain from charging fees and to resign upon ceasing to occupy his present position;  
HECTOR ADOLPHUS CARR SPROSTON, 221 Glen Eira-road, East St. Kilda,  
EDNA GERTRUDE LOADER, 18 Aberdeen-street, Newtown, Geelong,  
LESLIE ERNEST ALOYSIUS CHADWICK, 15 Skipton-road, Oakleigh, and  
WILLIAM HENRY LOUCH, 75 Moonya-road, Murrumbidgee,  
to be Commissioners for taking Declarations and Affidavits, pursuant to the provisions of Division 8 of Part IV. of the *Evidence Act 1928*, to resign upon removing from the neighbourhood of the addresses stated.

*Magistrates.*

DONALD COUCHE FORBES, Yarrowonga, and  
WILLIAM EDGAR MARTIN, Wilby,  
to Keep the Peace in the Northern Bailiwick of the State of Victoria; and  
ARTHUR HILTON MITCHEM, Secretary, Athenaeum Club, 83 Collins-street, Melbourne,  
VICTOR WILLIAM HENDERSON, Salvation Army Headquarters, 69 Bourke-street, Melbourne,  
ERNEST THOMAS ASHWORTH HARRISON, Rockbank,  
WILLIAM JOHN RATFORD, Clyde, and  
HENRY FOLLETT CLARKE, Commercial Bank of Australia Limited, 337 Collins-street, Melbourne,  
to Keep the Peace in the Central Bailiwick of the State of Victoria.

## DEPARTMENT OF MINES.

*Mining Registrar.*

THOMAS STEPHEN HARTLEY, First Constable of Police, to act as Mining Registrar for the Avoca Division of the Maryborough Mining District, *vice* First Constable J. I. O'Shea, transferred, fees received to be the only remuneration.

## DEPARTMENT OF PUBLIC WORKS.

*Wharf Manager.*

First Constable ALLAN COWDEN, No. 6963,  
to be Wharf Manager at Portarlinton, to carry out that portion of Part II. of the *Marine Act 1928*, which relates to the management of Public Wharfs, and to be an officer under section 19 of such Act to levy and collect wharfage rates thereat.

## DEPARTMENT OF TREASURER.

*Collectors of Imposts (Acting).*

HENRY WALKER THOMPSON  
to act temporarily as Collector of Imposts, Department of Law, during the absence of W. H. Kift, on leave; and  
ALFRED ERNEST MANN  
to act temporarily as Collector of Imposts, Country Roads Board, during the absence of G. C. Griffiths, on leave.

*Collector of Imposts.*

THOMAS STEPHEN HARTLEY  
to be Collector of Imposts, Avoca, for the purpose of collecting fees payable for the issue of Miners' Rights, *vice* J. I. J. M. O'Shea (with a commission of 10 per cent. on all collections made as issuer).

J. C. MACGIBBON,  
Acting Clerk of the Executive Council,  
At the Executive Council Chamber,  
Melbourne, 30th November, 1948.

## APPOINTMENTS.

HIS Excellency the Governor of the State of Victoria, by and with the advice of the Executive Council thereof, has, by Orders made on the 3rd day of December, 1948, been pleased to make the under-mentioned appointments, viz.:—

## DEPARTMENT OF CHIEF SECRETARY.

*Electoral Registrar (Acting).*

CHARLES EDWARDS  
to be Electoral Registrar (Acting) for the Bendigo, Eaglehawk, Golden Square, and Sandhurst East Subdivisions of the Electoral District of Bendigo; for the Heathcote Subdivision of the Electoral District of Goulburn; for the Charlton, Dunolly, Inglewood, Marong, Raywood, and Wedderburn Subdivisions of the Electoral District of Korong; for the Lancefield Subdivision of the Electoral District of Mernda; for the Strathfieldsaye Subdivision of the Electoral District of Midlands; for the Cohuna, Echuca, Elmore, Mitiamo, Pyramid Hill, Rochester, and Rushworth Subdivisions of the Electoral District of Rodney; and for the Murchison Subdivision of the Electoral District of Shepparton, to take effect on and from 23rd December, 1948, during the absence on leave of Gilbert Finlay Boyle.

*Probation Officer.*

WILLIAM ROBERT WALWORTH KNIGHT  
pursuant to the provisions of section 536 of the *Crimes Act 1928*, to be a Probation Officer for the purposes of the said Act in Melbourne and suburbs.

J. C. MACGIBBON,  
Acting Clerk of the Executive Council.

At the Executive Council Chamber,  
Melbourne, 3rd December, 1948.

## RESIGNATIONS.

HIS Excellency the Governor of the State of Victoria, by and with the advice of the Executive Council thereof, has, by Orders made on the 30th day of November, 1948, accepted the resignations of the persons named hereunder of the offices mentioned, viz.:—

## DEPARTMENT OF CHIEF SECRETARY.

MICHAEL CANNY, as a Licensing Inspector for each and every Licensing District in the State of Victoria, to date from and inclusive of the 18th October, 1948.

ERIC GEORGE REEDER, as Deputy Electoral Registrar for the Drouin and Warragul Divisions of the Gippsland Province; for the Dandenong North, Mulgrave, and Scoresby Divisions of the Southern Province; and for the Berwick, Chelsea, Cranbourne, Dandenong, Flinders, Mordialloc, Mornington, and Western Port Divisions of the South-eastern Province, to date from and inclusive of the 17th November, 1948.

ALICE MAY GIBSON, as Registrar of Births and Deaths at Tallangatta, to date from and inclusive of the 31st August, 1948.

## DEPARTMENT OF LAW.

EDITH WARREN, J.P., as a Special Magistrate, pursuant to the provisions of the *Children's Court Act 1928*, for the Petty Sessions District of Hawthorn.

J. C. MACGIBBON,  
Acting Clerk of the Executive Council.

At the Executive Council Chamber,  
Melbourne, 30th November, 1948.

## RESIGNATION.

HIS Excellency the Governor of the State of Victoria, by and with the advice of the Executive Council thereof, has, by Order made on the 3rd day of December, 1948, accepted the resignation of the person named hereunder of the office mentioned, viz.:—

## DEPARTMENT OF CHIEF SECRETARY.

FREDERICK A. WHITE, as Registrar of Births and Deaths at Romsey.

J. C. MACGIBBON,  
Acting Clerk of the Executive Council.

At the Executive Council Chamber,  
Melbourne, 3rd December, 1948.

## PUBLIC SERVICE OF VICTORIA.—VACANCIES.

APPLICATIONS will be received by the Public Service Board up to Wednesday, the 29th December, 1948, from persons employed in the Public Service of Victoria, who are eligible and qualified, for appointment to the under-mentioned positions:—

## PROFESSIONAL DIVISION.

Chief Health Officer, Class "A1," General Health Branch, Department of Health.

*Yearly Salary.*—£1,350, minimum; £1,400, maximum.

*Duties.*—To have charge of the administration of the General Health Branch, to perform such duties as are imposed by the Health Acts, and to act as Chairman of the Commission of Public Health and Chairman of the Food Standards Committee.

*Qualifications.*—To be a legally qualified medical practitioner, an expert in sanitary science, and to hold a qualification in Public Health.

Senior District Architect, Classes "A" and "A1," Department of Public Works.

*Yearly Salary.*—£1,000, minimum; £1,050, maximum.

*Duties.*—Under the Chief Architect, to organize and direct the construction of departmental day labour building projects.

*Qualifications.*—To be a qualified and experienced architect possessing initiative, energy, and proven organizing ability, and the capacity to undertake departmental day labour building projects.

District Architect, Class "A," Department of Public Works.

*Yearly Salary.*—£900, minimum; £950, maximum.

*Duties.*—To prepare and have general supervision, under the Chief Architect, of the draughting of preliminary and contract plans, details, specifications, reports, and estimates, and to have general supervision of building works within a specified district.

*Qualifications.*—To be a qualified and experienced architect, competent to practise sound and efficient methods in architectural and structural design.

Assistant District Architect, Class "B," Department of Public Works.

*Yearly Salary.*—£670, minimum; £722, maximum.

*Duties.*—To prepare schemes, estimates, reports, contract plans, details, and specifications; to supervise and advise staff under the direction of the District Architect; to represent the District Architect in his absence.

*Qualifications.*—To be a qualified and experienced architect, competent to practise sound and efficient methods in planning, construction, and design.

Assistant District Architect, Class "B," Department of Public Works.

(One vacancy at Warrnambool.)

(One vacancy at Horsham.)

(One vacancy at Bendigo.)

(One vacancy at Wangaratta.)

(One vacancy at Bairnsdale.)

*Yearly Salary.*—£670, minimum; £722, maximum.

*Duties.*—To represent the Architectural Branch of the Public Works Department at one of the above centres; to assist the District Architect generally, and to prepare preliminary plans, contract drawings, specifications, and details for works nominated; to exercise general supervision over selected inspectorates and nominated projects therein.

*Qualifications.*—To be a registered architect, or equivalent standard, or to hold a recognized degree or diploma of architecture; to have had at least 10 years experience as an architectural draughtsman, and to be capable of preparing designs, structural computations, estimates, working drawings, details, specifications, and reports of architectural projects and structural conditions of buildings.

NOTE.—Successful applicants will be required to reside at one of the centres indicated; a departmental residence will be provided as soon as possible—rental, 10 per cent. of total emolument.

**Inspector of Works, Class "C," Department of Public Works.**

- (One vacancy at Hamilton.)
- (One vacancy at Ararat.)
- (One vacancy at Bendigo.)
- (One vacancy at Warracknabeal.)
- (One vacancy at Camperdown.)
- (One vacancy at Alexandra.)
- (One vacancy at Traralgon.)

*Yearly Salary.*—£449, minimum; £501, maximum.  
*Duties.*—General inspection of public buildings and supervision of works carried out by the Public Works Department, and the preparation of reports in connexion therewith.

*Qualifications.*—To possess ability to make reports; to prepare estimates of costs of works and to make sketch plans when required; to have a comprehensive knowledge of building trades and suitable technical qualifications.

*NOTE.*—Successful applicants will be required to reside at one of the centres indicated; a departmental residence will be provided as soon as possible—rental, 10 per cent. of total emolument.

**TECHNICAL AND GENERAL DIVISION.**

**Library Attendant, Grade II., Public Library Branch, Department of Chief Secretary. (Six vacancies.)**

*Yearly Salary.*—£312, minimum; £338, maximum.  
*Duties.*—To perform the general duties of an attendant in the Public Library, collating and preparing books for the shelves, arranging books on shelves, and obtaining books from the stacks, &c.

*Qualifications.*—Good appearance and suitability for attending to the public, educated either up to Proficiency Certificate, or to the Merit Certificate with library experience.

**Nurse, Grade I, Mental Hospital, Sunbury, Department of Health.**

*Salary.*—£310 a year.  
*Duties.*—To be in charge or sub-charge of a ward in a mental hospital.

*Qualifications.*—To possess the Mental Hygiene Nursing Certificate and experience as a Nurse, Grade II. in a mental hospital.

**Typist (Female), Grade I, Government Printing Office, Department of Treasurer.**

*Yearly Salary.*—£221, minimum; £234, maximum.  
*Qualifications.*—To be a competent typist.

*NOTE.*—In addition to the salary rates quoted a cost of living adjustment (£72 a year for adult males and £48 a year for adult females), which varies in accordance with the rise or fall in the index number of the cost of living, is payable.

By order,

E. F. FITZGIBBON,  
 Secretary.

Office of the Public Service Board,  
 Melbourne, 6th December, 1948.

**PUBLIC SERVICE (PUBLIC SERVICE BOARD) REGULATION 36A.**

**NOTICE** is hereby given that the Public Service Board has raised the classifications of the under-mentioned offices, as shown, and that the Permanent Heads of the Departments in which such offices are classified have recommended the officers named for appointment.

Present Office and Classification.	Revised Classification.	Duties.	Qualifications.	Name of Person Recommended.
------------------------------------	-------------------------	---------	-----------------	-----------------------------

**ADMINISTRATIVE DIVISION.**

**DEPARTMENT OF AGRICULTURE.**

Clerk, Class "D"	Clerk, Class "C"	To have sub-charge of Dairy Farm Permit and Expenditure Section	A sound knowledge of accounting principles, the Regulations affecting Public Accounts and the Milk and Dairy Supervision Acts, experience in departmental procedure, and ability to control staff and conduct correspondence	Harris, D. L.
------------------	------------------	---	--	---------------

**PROFESSIONAL DIVISION.**

**DEPARTMENT OF MINES.**

Superintending Draughtsman, Class "B"	Superintending Draughtsman, Class "B1"	To have charge of the computing, draughting, cartographic, and lithographic work in connexion with the preparation of geological maps and plans	To have a thorough knowledge of all sections of the work prepared by the draughting staff, the administrative ability and personal qualities necessary for the control of varied technical staff	Kennedy, A. E.
Senior Draughtsman (Lithographic), Class "C2"	Senior Draughtsman, Class "B"	To compile geological and topographical maps for reproduction, to do the work necessary in the preparation of geological plans by lithography, and to take charge in the absence of the Chief Draughtsman	To have a full knowledge of lithography as applied to the preparation of maps and plans and be a competent survey draughtsman	McCann, R. M.
Draughtsman, Class "C" (two positions)	Draughtsman, Class "C1," (two positions)	To examine plans and field notes by licensed surveyors; to make the necessary computations relative to dealings under the Transfer of Land Act; to be responsible for the upkeep of lease plans	To have sufficient survey and mathematical knowledge to deal with survey computations, and to have a knowledge of the Land Acts and Titles Office procedure with relation to mining leases	Collie, J. A.
		To compile geological and topographical maps and plans for reproduction, compile underground plans from geologists' field notes, and check lease plans	To be a good penman; to have a thorough knowledge of the preparation of plans and maps for reproduction; to be able to compile underground plans from geologists' field notes	Windsor, N. M.

Appeals against such recommendations should be lodged with the Secretary to the Public Service Board not later than Saturday, the 18th December, 1948.

By order,

E. F. FITZGIBBON,  
 Secretary.

Office of the Public Service Board,  
 Melbourne, 6th December, 1948.

No. 404.

Public Service Act 1946, Section 50.

REGULATIONS—PART III.—SALARIES, INCREMENTS, AND ALLOWANCES.

THE Public Service Board, in pursuance of the powers conferred by the Public Service Act 1946, hereby amends its Regulations as shown below :—

SECOND SCHEDULE.

TECHNICAL AND GENERAL DIVISION.  
Offices and Rates of Salaries.

Department and Office.	Yearly Rate of Salary.		Increments (Annual).
	Minimum.	Maximum.	
DEPARTMENT OF CHIEF SECRETARY.	£	£	
<i>Delete—</i> Probation Officer, Indeterminate Sentences Board .. .. .	383	409	1 of £26
<i>Add—</i> Probation Officer, Indeterminate Sentences Board .. .. .	383	422	1 of £26 and 1 of £13
PENAL AND GAOLS.			
<i>Delete—</i> Engineer Mechanic, Pentridge ..	357	409*	2 of £26
Hospital Attendant .. .. .	383	409*	1 of £26
Overseer (Brush and Broom Making) .. .. .	357	409*	2 of £26
Overseer of Cookhouse .. .. .	357	409*	2 of £26
Overseer of Farm .. .. .	357	409*	2 of £26
Overseer (Matting and Mat Making) .. .. .	357	409*	2 of £26
Overseer of Shoemakers .. .. .	357	409*	2 of £26
Overseer, Assistant, Wire Netting Factory .. .. .	357	409*	2 of £26
Photographer and Overseer of Printers .. .. .	357	409*	2 of £26
Warder, Senior .. .. .	396	409*	..
<i>Add—</i> Engineer Mechanic, Pentridge ..	357	422*	2 of £26 and 1 of £13
Hospital Attendant .. .. .	383	422*	1 of £26 and 1 of £13
Overseer (Brush and Broom Making) .. .. .	357	422*	2 of £26 and 1 of £13
Overseer of Cookhouse .. .. .	357	422*	2 of £26 and 1 of £13
Overseer of Farm .. .. .	357	422*	2 of £26 and 1 of £13
Overseer (Matting and Mat Making) .. .. .	357	422*	2 of £26 and 1 of £13
Overseer of Shoemakers .. .. .	357	422*	2 of £26 and 1 of £13
Overseer, Assistant, Wire Netting Factory .. .. .	357	422*	2 of £26 and 1 of £13
Photographer and Overseer of Printers .. .. .	357	422*	2 of £26 and 1 of £13
Warder, Senior .. .. .	396	422*	1 of £26
DEPARTMENT OF LAW.			
<i>Delete—</i> Crier .. .. .	286	312	..
Superintendent, Law Courts ..	299	364	..
<i>Add—</i> Crier .. .. .	299	351	..
Superintendent, Law Courts ..	364	416	2 of £26

\* Less deduction for quarters, where provided, as determined by the Board.  
This Regulation shall have effect as on and from the 28th November, 1948.

D. D. PAINE, Chairman.  
E. F. FITZGIBBON, Secretary.

Office of the Public Service Board,  
Melbourne, 26th November, 1948.

No. 406.

Public Service Act 1946, Section 39.

REGULATIONS—PART III.—SALARIES, INCREMENTS, AND ALLOWANCES.

THE Public Service Board, in pursuance of the powers conferred by the Public Service Act 1946, hereby amends its Regulations as shown below :—

FIRST SCHEDULE.

PROFESSIONAL DIVISION.  
Offices and Rates of Salaries.

Office.	Yearly Rate of Salary.	
	Minimum.	Maximum.
DEPARTMENT OF LANDS AND SURVEY.	£	£
CLASS "A."		
<i>Delete—</i> Chief Photogrammetrist and Survey Research Officer .. .. .	..	850
CLASS "B."		
<i>Add—</i> Superintending Photogrammetrist ..	670	722

This Regulation shall have effect as on and from the 6th December, 1948.

D. D. PAINE, Chairman.  
E. F. FITZGIBBON, Secretary.

Office of the Public Service Board,  
Melbourne, 29th November, 1948.

No. 407.

Public Service Act 1946, Section 50.

REGULATIONS—PART III.—SALARIES, INCREMENTS, AND ALLOWANCES.

THE Public Service Board, in pursuance of the powers conferred by the Public Service Act 1946, hereby amends its Regulations as shown below :—

SECOND SCHEDULE.

TECHNICAL AND GENERAL DIVISION.  
Offices and Rates of Salaries.

Department and Office.	Yearly Rate of Salary.		Increments* (Annual).
	Minimum.	Maximum.	
DEPARTMENT OF HEALTH.	£	£	
GENERAL HEALTH.			
<i>Delete—</i> X-ray Technician, Tuberculosis Bureau .. .. .	312	351	..
X-ray Technician (Female) ..	247	286	..
<i>Add—</i> X-ray Technician, Grade I., Tuberculosis Bureau .. .. .	..	416	..
X-ray Technician, Grade II., Tuberculosis Bureau .. .. .	..	390	..
X-ray Technician (Female), Tuberculosis Bureau .. .. .	..	320	..

This Regulation shall have effect as on and from the 28th November, 1948.

D. D. PAINE, Chairman.  
E. F. FITZGIBBON, Secretary.

Office of the Public Service Board,  
Melbourne, 29th November, 1948.

No. 405.

*Public Service Act 1946, Section 39.*  
REGULATIONS—PART III.—SALARIES, INCREMENTS,  
AND ALLOWANCES.

THE Public Service Board, in pursuance of the powers conferred by the *Public Service Act 1946*, hereby amends its Regulations as shown below:—

FIRST SCHEDULE.  
PROFESSIONAL DIVISION.  
*Offices and Rates of Salaries.*

Office.	Yearly Rate of Salary.	
	Minimum.	Maximum.
	£	£
DEPARTMENT OF WATER SUPPLY. CLASS "B."		
Add— Superintending Surveyor .. .. .	670	722

D. D. PAINE, Chairman.  
E. F. FITZGIBBON, Secretary.

Office of the Public Service Board,  
Melbourne, 29th November, 1948.

No. 408.

*Public Service Act 1946, Section 50.*  
REGULATIONS—PART III.—SALARIES, INCREMENTS,  
AND ALLOWANCES.

THE Public Service Board, in pursuance of the powers conferred by the *Public Service Act 1946*, hereby amends its Regulations as shown below:—

SIXTH SCHEDULE.  
TEMPORARY EMPLOYEES.  
*Designations of Positions and Rates of Salaries.*

Department and Designation of Position.	Yearly Rate of Salary.		Increments (Annual).
	Minimum.	Maximum.	
	£	£	
DEPARTMENT OF HEALTH. GENERAL HEALTH.			
Delete—			
X-ray Technician .. .. .	312	351	..
X-ray Technician (Female) .. .. .	247	286	..
Add—			
X-ray Technician, Grade I. .. .. .	..	416	..
X-ray Technician, Grade II. .. .. .	..	390	..
X-ray Technician (Female) .. .. .	..	320	..

*This Regulation shall have effect as on and from the 28th November, 1948.*

D. D. PAINE, Chairman.  
E. F. FITZGIBBON, Secretary.

Office of the Public Service Board,  
Melbourne, 29th November, 1948.

DEPARTMENT OF LAW.—SOLICITOR—GENERAL.  
CHILDREN'S COURT, CAULFIELD.—ALTERATION OF  
DAYS AND HOURS.

HIS Excellency the Governor of the State of Victoria, by and with the advice of the Executive Council thereof, doth, by Order made on the 30th day of November, 1948, pursuant to the provisions of section 12 of the *Children's Court Act 1928*, hereby direct that the day and hour heretofore appointed for the holding of the Children's Court at Caulfield be altered to every second Monday at Two o'clock p.m., as from and inclusive of the 10th January, 1949.

J. C. MACGIBBON,  
Acting Clerk of the Executive Council,  
At the Executive Council Chamber,  
Melbourne, the 30th November, 1948.

DEPARTMENT OF LAW.—SOLICITOR—GENERAL.  
CHILDREN'S COURT, RINGWOOD.—ALTERATION OF  
DAYS AND HOURS.

HIS Excellency the Governor of the State of Victoria, by and with the advice of the Executive Council thereof, doth, by Order made on the 30th day of November, 1948, pursuant to the provisions of section 12 of the *Children's Court Act 1928*, hereby direct that the day and hour heretofore appointed for the holding of the Children's Court at Ringwood be altered to every second Tuesday at Two o'clock p.m., as from and inclusive of the 11th January, 1949.

J. C. MACGIBBON,  
Acting Clerk of the Executive Council,  
At the Executive Council Chamber,  
Melbourne, the 30th November, 1948.

DEPARTMENT OF LAW.—SOLICITOR—GENERAL.  
CHILDREN'S COURT AT NORTH MELBOURNE.—  
ALTERATION OF DAYS AND HOURS.

HIS Excellency the Governor of the State of Victoria, by and with the advice of the Executive Council thereof, doth, by Order made on the 30th day of November, 1948, pursuant to the provisions of section 12 of the *Children's Court Act 1928*, hereby direct that the day and hour heretofore appointed for the holding of the Children's Court at North Melbourne be altered to every second Tuesday at Two p.m., as from and inclusive of the 11th January, 1949.

J. C. MACGIBBON,  
Acting Clerk of the Executive Council,  
At the Executive Council Chamber,  
Melbourne, the 30th November, 1948.

DEPARTMENT OF LAW.—ATTORNEY—GENERAL.  
*Administration and Probate Act 1928.*  
COMPANY APPROVED.

HIS Excellency the Governor of the State of Victoria, by and with the advice of the Executive Council thereof, doth, by Order made on the 7th day of September, 1948, approve of the Eagle Star Insurance Company Limited, under the provisions of section 51 of the *Administration and Probate Act 1928*.

C. W. KINSMAN,  
Clerk of the Executive Council,  
At the Executive Council Chamber,  
Melbourne, 7th September, 1948.

DEPARTMENT OF PUBLIC WORKS.  
*Melbourne and Metropolitan Tramways Act 1928.*  
FIXING PERIOD OF APPOINTMENT, ETC., OF  
CHAIRMAN OF THE MELBOURNE AND METRO-  
POLITAN TRAMWAYS BOARD, AND APPOINTING  
A MEMBER AND CHAIRMAN OF THE MELBOURNE  
AND METROPOLITAN TRAMWAYS BOARD.

HIS Excellency the Governor of the State of Victoria, by and with the advice of the Executive Council thereof, has, by Order made on the 30th day of November, 1948, under the powers conferred by the *Melbourne and Metropolitan Tramways Act 1928*, directed that the term of office of the person to be appointed chairman of the Melbourne and Metropolitan Tramways Board shall be six months, from and inclusive of the first day of January, One thousand nine hundred and forty-nine, at the salary prescribed in such Order, and that Hector Hercules Bell shall be a member and chairman of the said Melbourne and Metropolitan Tramways Board for the term specified.

J. C. MACGIBBON,  
Acting Clerk of the Executive Council,  
At the Executive Council Chamber,  
Melbourne, the 30th November, 1948.

DEPARTMENT OF PUBLIC WORKS.  
*Melbourne and Metropolitan Tramways Act 1928*  
(No. 3732).  
FIXING TERM OF OFFICE OF AND APPOINTMENT  
OF MEMBERS OF THE MELBOURNE AND METRO-  
POLITAN TRAMWAYS BOARD.

HIS Excellency the Governor of the State of Victoria, by and with the advice of the Executive Council thereof, has, by Order made on the 30th day of November, 1948, under the powers conferred by the *Melbourne and Metropolitan Tramways Act 1928*, directed that the term of office of the persons mentioned hereunder, who are hereby

appointed members of the Melbourne and Metropolitan Tramways Board, shall be six months from and inclusive of the first day of January, One thousand nine hundred and forty-nine:—

JAMES VINCENT O'CONNOR,  
WILLIAM KENNEDY PARK,  
BURNETT GRAY,  
ARTHUR MCKENZIE HISLOP,  
WILLIAM JOHN MCGRATH, and  
ROBERT HENRY SOLLY.

J. C. MACGIBBON,  
Acting Clerk of the Executive Council.

At the Executive Council Chamber,  
Melbourne, the 30th November, 1948.

*Hospitals and Charities Act 1948 (No. 5300).*  
PETITION TO INCORPORATE THE COBRAM  
DISTRICT HOSPITAL.

IT is hereby notified, in accordance with the provisions of section 46 (2) of the *Hospitals and Charities Act 1948 (No. 5300)*, that the Hospitals and Charities Commission of Victoria has received a petition signed by not less than twenty-five contributors to the Cobram District Hospital, an institution capable of incorporation under the provisions of the said Act, praying that the said hospital be incorporated, and that if no counter-petition, signed by an equal or greater number of contributors is lodged with the said Commission within one month after the publication of this notice, the Governor in Council may, by Order published in the *Government Gazette*, declare the contributors for the time being to the said institution to be a body corporate, pursuant to the provisions of the *Hospitals and Charities Acts*.

Dated, at Melbourne, this sixth day of December, 1948.

T. D. OLDHAM,  
Minister of Health.

*Land Act 1928.*  
ORDER ACCEPTING SURRENDER OF LEASE  
AMENDED.

HIS Excellency the Governor of the State of Victoria, by and with the advice of the Executive Council thereof, and in pursuance of the provisions of the *Land Act 1928*, doth hereby amend the Order made on the 9th day of June, 1948, accepting the surrender of certain leases, details of which were published in the *Victoria Government Gazette* of the 16th June, 1948, at page 4000, by deleting from such Order and *Gazette* notice all reference to the lease held by Ernest Phillip La Fontaine.

J. C. MACGIBBON,  
Acting Clerk of the Executive Council.

At the Executive Council Chamber,  
Melbourne, the 30th November, 1948.

APPLICATION FOR MINING LEASE REFUSED.  
11250, Bendigo; William Elliot Scanlan; 18,000 acres, at Eaglehawk.

APPLICATIONS FOR MINING LEASES DECLARED  
ABANDONED.

- 8208, Beechworth; Edward Anketell Henderson; 37a. 2r. 30p., in the Parish of Carlyle.  
11246, Bendigo; James Browne and George Sayer; 40 acres, at Whipstick.  
11247, Bendigo; James Browne and George Sayer; 40 acres, at Whipstick.  
11248, Bendigo; James Browne and George Sayer; 40 acres, at Whipstick.  
11249, Bendigo; James Browne and George Sayer; 40 acres, at Neilborough.

J. H. LIENHOP,  
Minister of Mines.

POLICE SALE.  
PUBLIC NOTICE.

AN Auction Sale of confiscated and unclaimed liquor in the possession of the police will be held at the Police Licensing Branch, 43 Little Bourke-street, Melbourne, on Monday, the 20th December, 1948, at One p.m.

ALEX. M. DUNCAN,  
Chief Commissioner.

*Licensing Act 1928.*

REGISTRATION OF A BREWER.

CARLTON AND UNITED BREWERIES LIMITED has this day caused to be registered its name and a particular description of the premises situate at 1 Smith-street, Bairnsdale, wherein it proposes to carry on the business of a brewer during the year 1949.

Dated at Bairnsdale, this 20th day of November, 1948.

M. L. KILLEEN,  
Clerk of the Licensing Court for the  
Licensing District of Gippsland East.

The Licensing Acts.

REGISTRATION OF A BREWER.

GIPPSLAND BREWERY PROPRIETARY LIMITED has this day caused to be registered its name and a particular description of its premises situate at York-street, Sale, wherein it proposes to carry on the business of a brewer during the year 1949.

Dated at Sale, this 3rd day of December, 1948.

N. J. SCANNELL,  
Clerk of the Licensing Court for the  
Licensing District of Gippsland South.

AUCTION SALES ACT 1928.

NOTICE is hereby given that a Special Meeting of Justices for the Licensing of Auctioneers will be held at the Court House, at Swan Hill, on Thursday, the 23rd day of December, 1948, at the hour of Ten o'clock in the forenoon, to consider an application by Graham Ernest Oliver, of Swan Hill, for an auctioneer's licence. Dated at Swan Hill, this 26th day of November, 1948.—J. W. HAYES, Clerk of Petty Sessions.

SHIRE OF YACKANDANDAH.

ROAD DEVIATION.

Order in Council.

IN pursuance of the powers conferred by sections 521 and 525 of the *Local Government Act 1946*, the Council of the Shire of Yackandandah doth hereby order that the lands next hereinafter described shall be a public highway from the date of the publication of this Order in the *Government Gazette*, that is to say:—

*Firstly*.—All that piece or parcel of land being part of Crown allotment 14A, section XV., Parish of Tangambalanga, County of Bogong; Commencing at a point situated east 836.5 links from the south-west corner of Crown allotment 14A; thence bounded on the west by part of Crown allotment 14A, bearing north 327 deg. 21 min. west 432 links; thence north 338 deg. 16 min. west 745 links; thence north 328 deg. 26 min. west 571 links; thence north 301 deg. 8 min. west 99.5 links; thence north 277 deg. 45 min. west 370 links; thence south 259 deg. 9 min. west 449.5 links; thence north 280 deg. 26 min. west 289.5 links to a Government road; thence bearing north 352 deg. 26 min. west 90 links along the said Government road; thence along the boundary of Crown allotment 14A, bearing north 82 deg. 26 min. east 180.5 links; thence south 115 deg. 3 min. east 144.5 links; thence north 79 deg. 9 min. east 433.5 links; thence south 97 deg. 45 min. east 407 links; thence south 121 deg. 8 min. east 144.5 links; thence south 148 deg. 26 min. east 603.5 links; thence south 158 deg. 16 min. east 744 links; thence south 147 deg. 21 min. east 419 links; thence south 143 deg. 45 min. east 70 links to the south boundary of Crown allotment 14A; thence bearing west 124 links to the point of commencement, containing an area of 3 acres 0 roods and 16 perches, or thereabouts.

*Secondly*.—All that piece or parcel of land being part of Crown allotment 14c, section XV., Parish of Tangambalanga, County of Bogong; Commencing at a point situated east 836.5 links from the south-west corner of Crown allotment 14A; thence east 124 links; thence south 143 deg. 45 min. east 347.2 links; thence west 124 links; thence north 323 deg. 45 min. west 347.2 links to point of commencement, containing an area of 1 rood and 15.6 perches, or thereabouts.

And the said Council doth hereby further order that the lands above described shall from the said date of publication in the said *Government Gazette*, be a public highway in lieu of the following piece or parcel of land, that is to say:—

All that piece or parcel of land being a former Government road in the Parish of Tangambalanga, County of Bogong; Commencing at the south-west corner of Crown allotment 14A; thence west 158 links; thence north 18 deg. 7 min. east 190.5 links; thence north 356 deg. 58 min. west



625 links; thence north 325 deg. 14 min. west 183 links; thence north 276 deg. 23 min. west 269.5 links; thence north 270 deg. 50 min. west 535 links to the east boundary of Crown allotment 14; thence along the east boundary of Crown allotments 14 and 14b, bearing north 334 deg. 29 min. west 727 links; thence south 100 deg. 26 min. east 207 links; thence south 172 deg. 26 min. east 57 links; thence south 154 deg. 29 min. east 458 links; thence south 90 deg. 50 min. east 449 links; thence south 96 deg. 23 min. east 345 links; thence south 145 deg. 14 min. east 294 links; thence south 176 deg. 58 min. east 696 links; thence south 198 deg. 7 min. west 169 links to the point of commencement, containing an area of 3 acres 3 roods and 2 perches, or thereabouts.

Dated the seventh day of October, 1948.

The common seal of the President, Councillors, and Ratepayers of the Shire of Yackandandah was hereunto affixed, in the presence of—

(SEAL) MARK COULSTON, Councillor.  
MATTHEW MEEHAN, Councillor.  
L. KRUTLI, Secretary.

Confirmed by the Governor in Council,  
the 30th day of November, 1948.

J. C. MACGIBBON,  
Acting Clerk of the Executive Council.

#### THE BALLARAT WATER COMMISSIONERS.

RATING BY-LAW FOR YEAR 1949, No. 52.

THE Ballarat Water Commissioners, pursuant to and in exercise and execution of the powers and authorities conferred on it by the Water Acts, and in exercise and execution of any other powers and authorities in any wise enabling it in that behalf, doth hereby make the By-law following:—

1. The following rates are hereby made and shall be levied for the supply of water for domestic purposes upon the occupiers or owners of lands and tenements liable to be rated by it within the Ballarat Water Supply District:—

- (a) Of any tenements (other than land on which there is no building) the annual municipal valuation whereof does not exceed Twelve pounds fifteen shillings per annum.
- (b) Of any such tenement the annual municipal valuation whereof exceeds Twelve pounds, a rate of One shilling and two pence in the pound on the net annual municipal value.
- (c) Of lands on which there is no building, a rate of One shilling and two pence in the pound on the net annual municipal value.

2. Such rates are made and shall be levied upon the occupiers or owners of the said lands and tenements for the year beginning the 1st day of January, 1949, and ending the 31st day of December, 1949, and shall be payable on the 31st day of January, 1949, at the office of the Water Commissioners, Ballarat.

3. The maximum quantity of water to be supplied in any one year without further charge to any property rated by the Commissioners is hereby fixed at the quantity which at a charge of One shilling per 1,000 gallons would produce an amount equal to the amount of the rate levied on such property for the said year.

4. The charge for water supplied by measure to any property rated by the Commissioners in excess of such maximum quantity computed as in the last preceding clause is hereby fixed at One shilling per 1,000 gallons.

5. The charge for water supplied by measure shall be payable, on demand, at the office of the Commissioners.

6. Such person or persons as The Ballarat Water Commissioners may from time to time appoint for the purpose, shall be and is, or are hereby authorized to demand, receive, collect, and recover such rates and charges.

The foregoing By-law was made by The Ballarat Water Commissioners, and the common seal of the said Commissioners was hereunto affixed this eleventh day of November, 1948, in the presence of—

(SEAL) ALF. J. PITTARD, Chairman.  
F. C. WRAY, Commissioner.  
CHAS. H. CLAMP, Secretary.

Approved by the Governor in Council,  
the 30th day of November, 1948.

J. C. MACGIBBON,  
Acting Clerk of the Executive Council.

#### Transport Regulation Acts.

#### TRANSPORT REGULATION BOARD.

#### NOTICES OF PUBLIC HEARINGS.

NOTICE is hereby given that the applications made by the persons named below for licences to operate the commercial goods vehicles on the route or routes, or in a manner set out opposite their names, will be heard at a time and place to be communicated to the parties concerned:—

#### Name of Applicant; Nature of Application.

BENNETT, R. L., 38 Mason-street, Warragul; 1 commercial goods vehicle (80 cwt.) for the carriage of—(a) all types of marine goods in the course of business as "marine dealer" from and to Warragul, to and from Traralgon, Korumburra, Noojee, and Pakenham areas, (b) bottles, second-hand bags, and copper metals from the applicant's premises at Warragul to Melbourne.

BROCK, F. A., Garden-street, Benalla; 1 commercial goods vehicle (15 cwt.) for the carriage of building materials and tools of trade in the course of business as "building contractor" within an area in Victoria east of a line joining Melbourne and Echuca.

CUTHELL BROS., 4 Gilmartin-street, Colac; 1 commercial goods vehicle (motor cycle and box) for the carriage of goods in the course of business as "electro-platers" within 50 miles radius of Colac.

HACKETT, T., 191 Raymond-street, Sale; 1 commercial goods vehicle (22 cwt.) for the carriage of—(a) general goods within 20 miles radius of Sale, (b) garments to be cleaned or having been cleaned and carried in the course of business as "dry cleaners" from and to Sale, to and from Bairnsdale and Yallourn.

MASON, C. J., 55 William-street, Preston; 1 commercial goods vehicle (30 cwt.) for the carriage of brushware and kitchen supplies in the course of business as "hawker" throughout the State of Victoria.

MILLER, H. C., & SON, Forrest; 1 commercial goods vehicle (60 cwt.) for the carriage of—(a) general goods within 20 miles radius of Forrest, (b) timber from sawmills in the Forrest district to Geelong, (c) perishable goods from Geelong to Forrest.

NAIRN, W., Buangor; 1 commercial goods vehicle (107 cwt.) for the carriage of—(a) general goods within 20 miles radius of Buangor, (b) posts under contract to the Soldier Settlement Commission from Buangor to Glen-thompson.

PREMIER REFRIGERATION SERVICE Co., Williamstown-road, Port Melbourne; 1 commercial goods vehicle (15 cwt.) for the carriage of spare parts, tools of trade, and replacement units carried in connexion with the carrying out of servicing work to food preservation equipment at hospitals, hotels, shops, &c., throughout the State of Victoria.

STOTT, F. W., 189 Allingham-street, Golden Square, via Bendigo; 1 commercial goods vehicle (80 cwt.) for the carriage of road contracting plant and material throughout the State of Victoria.

NOTICE is hereby given that the applications made by the persons named below for renewal of licences to operate the commercial goods vehicles in the manner set out hereunder, the numbers of which are also set out in each case, will be heard at a time and place to be communicated to the parties concerned:—

#### Name and Address; Present Franchise; Licence No.; Date of Expiry.

DRAKE, Mrs. M. M., Skene-street, Warrnambool; (a) general goods within a radius of 20 miles of Warrnambool, (b) general goods from and to the area as defined in paragraph (a) above, to and from Portland, (c) live stock within an area of 50 miles of Warrnambool, (d) timber from mills in Heywood and Portland districts to area as defined in paragraph (a) above; D.3854; 23rd December, 1948.

MITCHELL, E. W., 101 Severn-street, Box Hill; own goods in the course of trade—foodstuffs, cakes, shortbreads, and sponges as follows:—(a) within a radius of 50 miles of Melbourne, (b) from Melbourne to Sale, Maffra, Benalla, Wangaratta, Yarrawonga, and Tocumwal; D.3886; 10th March, 1949.

SMALES, R., 40 Edgar-street, Glen Iris; bricks within a radius of 40 miles of the premises of Glen Iris Brick, Tile, and Terra Cotta Coy. Pty. Ltd., Thornbury; D.3848; 23rd December, 1948.

**NOTICE** is hereby given that the application made by the person named below for renewal of the licence with variation to operate the commercial goods vehicle in the manner set out hereunder, the number of which is set out, will be heard at a time and place to be communicated to the party concerned:—

*Name of Applicant; Present Rights; Nature of Application; Licence No.; Date of Expiry.*

SUTTON, K. J., Strathmerton; (a) general goods within 20 miles radius of Bearii, (b) cream from places in (a) to the Borough of Shepparton, (c) live stock and second-hand household furniture within 50 miles radius of Bearii, (d) fruit from Cobram district to Shepparton, (e) firewood from places situate within 25 miles radius of Bearii to Shepparton, (f) building materials from Shepparton to places in (a); to delete the present conditions and obtain—(a) general goods within 20 miles radius of Strathmerton, (b) cream from places in (a) to the Borough of Shepparton, (c) live stock and second-hand household furniture within 50 miles radius of Strathmerton, (d) fruit from Cobram district to Shepparton, (e) firewood from places situate within 25 miles radius of Strathmerton to Shepparton, (f) building materials from Shepparton to places in (a); D.2264; 1st December, 1948.

**NOTICE** is hereby given that the applications made by the persons named below for licences to operate the commercial passenger vehicles, on the route or routes, or in the manner set out opposite their names, will be heard at a time and place to be communicated to the parties:—

*Name of Applicant; Nature of Application.*

ANSETT MOTORS LTD., 210 Gray-street, Hamilton; application for variation of licences numbered A.2010 and A.2011, to include the ability to operate as follows:—

(a) Under charter conditions within a 20 miles radius of Camperdown Post Office and to Mailors Flat, Lake Bolac, Skipton, Cressy, Lorne, Apollo Bay, Port Campbell, Princetown, Peterborough, Naringal, Darlington, Derrinalum, Lismore, Nalingal, and Warrnambool, via Glenfyne.

(b) On the following day tours:—

1. Camperdown—The Grampians.
2. Camperdown—Daylesford.
3. Camperdown—Portland.
4. Camperdown—Apollo Bay and Lorne.

BOLTON, G. E., 245 Princes Highway, Morwell; 1 commercial passenger vehicle, with seating capacity for 5 persons, to operate as follows:—(a) Separate and distinct fares within a 5 miles radius of Morwell, (b) private hire within a 50 miles radius of Morwell (subject to the cancellation of licence numbered A.2430, at present held by D. F. McKenzie, Morwell).

BROWN, H. W., 84 Beveridge-street, Swan Hill; 1 commercial passenger vehicle to be purchased, with approximate seating capacity for 11 persons, to operate between Swan Hill and Melbourne, via Kerang, Serpentine, and Kyneton, on Sundays, with the proviso that passengers shall only be picked up and set down at Swan Hill.

BURGESS, R. S. W., 1 Yarra-street, Echuca; 1 commercial passenger vehicle, with seating capacity for 5 persons, to operate as follows:—(a) Separate and distinct fares within a 5 miles radius of Echuca, (b) private hire within a 50 miles radius of Echuca (subject to the cancellation of licence numbered A.2178, at present held by G. R. C. McLeod, Echuca).

COOK, R., Central Garage, High-street, Maldon; application for renewal of licence numbered P.H.622 (expiring 27th December, 1948), allowing operations at otherwise than at separate and distinct fares from Maldon to places throughout Victoria.

CROCOMBE, R. E., Wonga, via Foster; application for variation of licence numbered A.2119, to include the ability to operate as follows:—(a) Separate and distinct fares within a 5 miles radius of Foster, (b) private hire within a 50 miles radius of Foster.

CROCOMBE, R. E., Wonga, via Foster; application for variation of licence numbered A.1532, to include the ability to operate at separate and distinct fares within a 20 miles radius of Foster.

DREW, H. L., Valley-road, Highton; 2 commercial passenger vehicles, with seating capacity for 27 and 29 persons respectively, to operate as a special service omnibus (charter conditions) within a 30 miles radius of Geelong.

GOODMAN, R., 10 Connor-street, East Geelong; 2 commercial passenger vehicles, with seating capacity for 27 and 29 persons respectively, to operate as additional vehicles on licensed route between Geelong and Ballarat.

HARRINGTON, M. L. & E., Fosterville Post Office; 3 commercial passenger vehicles, with seating capacity for 26, 29, and 17 persons respectively, to operate as follows:—(a) Boronia Railway Station and the corner of Mountain Highway and Toorak-avenue, via Boronia-road, Forest-road, and Mountain Highway, passing through The Basin, (b) Boronia Railway Station and The Basin, via Ringwood-road and Mountain Highway, (c) parcels may be carried up to a total weight of 14 lb., (d) day tour from The Basin, thence via Lower Ferntree Gully, Upper Ferntree Gully, Upwey, Tecoma, Belgrave, Kallista, Nathania Springs, Kallista, Sherbrooke, and Sassafras, (e) under charter conditions within a 20 miles radius of The Basin Post Office and to Frankston, Mornington, Rosebud, Sorrento, Portsea, Marysville, and Warburton (subject to the cancellation of licences numbered A.1974, A.1976, and A.1978, at present held by E. B. and I. Campbell, The Basin).

HEFFER, L. F., 32 Wyndham-street, Kerang; application for renewal of licence numbered A.1792 (expiring 23rd December, 1948), allowing operations as follows:—(a) Separate and distinct fares within a 5 miles radius of Kerang Post Office, (b) private hire within a 50 miles radius of Kerang Post Office.

JOHNSTON, W., corner Main-street and South-parade, Blackburn; application for renewal of licence numbered A.1855 (expiring 23rd December, 1948), allowing operations as follows:—(a) Separate and distinct fares within a 5 miles radius of Blackburn Railway Station, (b) private hire within a 50 miles radius of Blackburn Railway Station.

MANSFIELD-YEA PASSENGER SERVICES PTY. LTD., 1 Empire-arcade, Princes-street, Melbourne; 5 commercial passenger vehicles, with seating capacity for 32, 32, 11, 30, and 14 persons respectively, to operate as follows:—(a) Lilydale Railway Station—Mansfield, (b) Flowerdale Post Office—Yea Higher Elementary School (school service), (c) A.668 and A.672—under charter conditions within a 20 miles radius of Mansfield Post Office and to The Chalet, Merton, Whitfield, Alexandra, Woods Point, and Benalla, (d) A.671—under charter conditions within a 20 miles radius of Flowerdale Post Office, (e) Mansfield to Melbourne, via Yea and Lilydale (subject to the cancellation of licences numbered A.668, A.669, A.670, A.671, and A.672, at present held by the applicants).

MANSFIELD-YEA PASSENGER SERVICE PTY. LTD., 1 Empire-arcade, Flinders-street, Melbourne; 1 commercial passenger vehicle, with seating capacity for 32 persons, to operate as follows:—(a) As an additional vehicle on licensed route between Lilydale Railway Station and Mansfield, on Saturdays, Sundays, public holidays, or as and when required, (b) Mansfield—Melbourne, via Yea and Lilydale (subject to the cancellation of licence numbered A.1923, at present held by the applicant).

MAYBERRY, J. C., High-street, Broadford; 1 commercial passenger vehicle, with seating capacity for 5 persons, to operate as follows:—(a) Separate and distinct fares within a 5 miles radius of Broadford, (b) private hire within a 50 miles radius of Broadford (subject to the cancellation of licence numbered P.H.17, at present held by the applicant).

MACNAMARA, P. J. (trading as MacNamara's Motors), Nicholson-street, Healesville; 5 commercial passenger vehicles, with seating capacity for 11, 5, 22, 27, and 27 persons respectively, to operate as follows:—(a) Maroondah Lake Hotel-Lilydale Railway Station, (b) Healesville-Lilydale Higher Elementary School (school service), (c) Healesville-Toolangi, (d) Healesville-Sir Colin McKenzie Sanctuary (Badger Creek), (e) parcels may be carried on routes (a), (c), and (d) up to a total weight of 28 lb., (f) A.265—separate and distinct fares within a 5 miles radius of Healesville Post Office, (g) A.258, A.260, A.261, and A.632—under charter conditions within a 20 miles radius of Healesville Post Office and Lilydale Post Office, (h) Maroondah Hotel to Melbourne, via Healesville and Lilydale, with the ability to pick up and set down passengers at guest-houses within a 5 miles radius of Healesville and in a northerly direction to Toolangi (subject to the cancellation of licences numbered A.258, A.260, A.261, A.265, and A.632).

OCEAN-ROAD PASSENGER SERVICES PTY. LTD., 29 Gheringhap-street, Geelong; 4 commercial passenger vehicles, each with seating capacity for 25 persons, to operate as additional vehicles on all licensed routes.

RICARDO, F. (trading as Powelltown Bus Service), Powelltown; 3 commercial passenger vehicles, with seating capacity for 32, 32, and 5 persons respectively, to operate as follows:—(a) Lilydale Railway Station-Noojee, (b) Powelltown-Bayook West, (c) Goodwood-Powelltown, (d) parcels may be carried up to a total weight of 56 lb., (e) on round tours from Powelltown to Mt. Donna Buang, Marysville, Healesville, and Warragul, (f) A.1351—at otherwise than at separate and distinct fares within a 20 miles radius of Powelltown Post Office, (g) A.1350 and A.1352—under charter conditions within a 20 miles radius of Powelltown Post Office, (h) Powelltown-Melbourne, via Lilydale (subject to the cancellation of licences numbered A.1350, A.1351, and A.1352, at present held by the applicant).

PROVINCIAL MOTORS PTY. LTD., 123 High-street, Bendigo; 1 commercial passenger vehicle, to be purchased, to operate as follows:—(a) between Hepburn Springs and Malmsbury via Daylesford, (b) mails may be carried, (c) parcels up to 56 lb. (subject to the cancellation of licence numbered A.1405 at present held by R. H. McKinnon, trading as Hepburn Spa Motors, Hepburn Springs).

RICHARDS, S. L., 344 Barkly-street, Footscray; 1 commercial passenger vehicle, with seating capacity for 19 persons, to operate as a special service omnibus (charter conditions) within a 25 miles radius of the G.P.O., Melbourne.

ROBINSON, J. H., 21 Collins-street, Morwell; 1 commercial passenger vehicle, to be purchased, with approximate seating capacity for 5 persons, to operate at separate and distinct fares within a 5 miles radius of Morwell Post Office.

ROWLAND, E. M., Kinglake West; application for renewal of licences numbered A.1895 and A.1896 (expiring 23rd December, 1948) allowing operations as follows:—(a) Kinglake-Whittlesea Railway Station, (b) Kinglake West-Flowerdale Hotel, (c) Kinglake-Reservoir Railway Station, (d) goods may be carried on routes (a) and (b) up to 1 cwt.

SANDLANT, H. I., Landsborough; 1 commercial passenger vehicle, with seating capacity for 31 persons, to operate as follows:—(a) as an additional vehicle on all licensed routes, (b) interchangeably to all licensed vehicles. This replaces application previously gazetted on 14th July, 1948.

SHORTHOUSE, A. H., 23 Normanby-street, Warragul; application for variation of "A" licence applied for to include the ability to operate under charter conditions within a 20 miles radius of Warragul, and to include the ability to operate interchangeably to licence numbered A.2215.

SHORTHOUSE, A. H., 23 Normanby-street, Warragul; application for variation of licence numbered A.2215 to include the ability to operate under charter conditions within a 20 miles radius of Warragul, and as an additional vehicle to licence applied for to operate between Warragul and Buln Buln Post Office.

STEWART, E., Thanet-street, Ringwood; 1 commercial passenger vehicle, with seating capacity for 20 persons, to operate as an additional vehicle on all licensed routes.

WANNENMACHER, G. P., Tocumwal-road, Numurkah; 1 commercial passenger vehicle, to be purchased, to operate as an additional vehicle on all licensed routes and under charter conditions within a 25 miles radius of Numurkah Post Office.

WEDGE, D. E., Curdie-street, Cobden; application for variation of licence numbered A.2351 to delete that portion of the route between Cobden and Colac from South Purrumbete Factory to Carpendeit Hall on Tuesdays, Thursdays, and Saturdays, and instead to operate on the Cobden and Colac route from South Purrumbete Factory along Neils-road to Carpendeit Hall on Tuesdays, Thursdays, and Saturdays.

WEDGE, D. E., Curdie-street, Cobden, 1 commercial passenger vehicle, to be purchased, to operate a town bus service at Camperdown as follows:—

*Sundays only.*

Commencing at corner of Prince's Highway and Micklejohn-street, thence via Micklejohn-street, Thornton-street, and Church-street to the Clock Tower on Prince's Highway, thence Pike-street, Longmore-street, Cressy-street, Prince's Highway, Adeney-street, Barkly-street, Leura-street, Brooke-street, Henderson-street to the Catholic Church. Returning via same route to commencing point.

Depart corner Prince's Highway and Micklejohn-street at 8 a.m. and 10.30 a.m.

Depart Church on return trips at 9.30 a.m. and 12 noon.

*Tuesdays, Wednesdays, Fridays, and Saturdays.*

Commencing at Clock Tower in Prince's Highway, thence along Highway to Adeney-street, Barkly-street, Leura-street to corner of Leura-street and Errey-street, thence Brooke-street, McKinnon-street, Wall-street to Robinson-street, thence Bowen-street, Hope-toun-street, Wall-street, Micklejohn-street, Thornton-street, Church-street, and terminating at the Clock Tower in Prince's Highway.

Tuesday.—Depart Clock Tower at 11 a.m., 12 noon, 1 p.m., 1.30 p.m., 2 p.m., 2.45 p.m., 4 p.m., and 5 p.m.

Wednesday.—\*7.15 p.m. and 11 p.m.

Friday.—Depart Clock Tower 1.30 p.m., 2 p.m., 2.45 p.m., 4 p.m., and 5 p.m.

Saturday.—Depart Clock Tower 9.30 a.m., 10 a.m., 10.30 a.m., 11 a.m., 11.30 a.m., 12.15 p.m., 7 p.m., 7.30 p.m., 11 p.m., and 12.10 a.m.

\* This trip to commence and terminate at the local picture theatre in Prince's Highway near Clock Tower.

WITHERS, A. P., 50 Riversdale-road, Camberwell; application for renewal of licences numbered PH.1117 and PH.1123 (expiring 23rd December, 1948) allowing operations at otherwise than at separate and distinct fares from the metropolitan area to places throughout Victoria.

O'RILEY, W. J., 163 Lime-avenue, Mildura; 1 commercial passenger vehicle, with seating capacity for 3 persons, to operate for the carriage of passengers, mails, and parcels between Mildura Post Office and Billabong Post Office via 15th-street, Irymple, and between Mildura Post Office and Mildura Railway Station.

**A**PPPLICATION for licences to operate commercial passenger vehicles, with seating capacity for five persons, to operate for the carriage of passengers otherwise than at separate and distinct fares for each passenger throughout Victoria:—

LANG, J., Bright.  
WHEELDON, R. J., East Kew.

Notices of any objection should be forwarded to reach the Secretary to the Board not later than Wednesday, the 22nd December, 1948.

E. V. FIELD,  
Secretary.

Exhibition Buildings, Rathdown-street, Carlton, N.3,  
7th December, 1948.

## BOX HILL GENERAL CEMETERY.

Cemetery-avenue, Whitehorse-road, Box Hill, E.11.

## RULES AND REGULATIONS.

IN pursuance of the powers vested in them by the Cemeteries Acts, the trustees of the Box Hill General Cemetery hereby rescind the Rules and Regulations previously published in the *Government Gazette* and make the following Rules and Regulations, that is to say:—

1. That any person desiring ground in the cemetery for a private grave, vault, tomb, monument, cenotaph or tombstone, or for any other purpose shall apply to the trustees therefor. If approved, the trustees, on payment of the required fees, shall issue to such person so applying a certificate of right of burial in the form specified in Schedule A.

2. That all fees and charges payable to the trustees shall be paid when applications are made or orders given.

3. That any person desiring to construct, add to, alter, or amend a brick grave, vault, or tomb, or to erect, add to, alter, or amend a monument, tombstone, cenotaph, wall, fence, or any other construction or erection, or to place any inscription, epitaph, writing, or drawing in any part of the cemetery, shall apply, in writing, to the trustees for permission to do so, and at the same time submit, in writing, a statement, plan, design, or drawing of the same with full particulars, and, on payment of fees, shall obtain such permission, in writing, before proceeding with the work.

Any person violating the provisions of this Regulation shall be liable to the penalties imposed by law for so doing and to be further dealt with as a trespasser.

4. That all applications for interment shall be made at the office of the cemetery at least eight working hours prior to the time fixed for the burial, otherwise an extra charge shall be made.

5. That the name, age, late place of residence, probable cause of death of the deceased, and other particulars mentioned in Schedule B shall be furnished at the time of giving the order.

6. That the trustees may cause all ordinary graves to be dug; but any person wanting a brick grave or vault shall be permitted to construct the same, if approved and under directions of the officer in charge, on payment of the required fees, and every coffin placed therein shall be bricked in and covered by a slab of stone or slate and properly cemented.

7. That every coffin shall have on the lid a lead, copper, or other approved plate with the name of the deceased distinctly stamped or engraved thereon.

8. That every grave shall be at least 7 feet deep and of no greater depth than 9 feet, except with special approval, and no interment shall be allowed in any grave with a less depth than 4 feet from the top of the coffin to the original surface of the ground after such interment.

9. That no interment shall be permitted in any private grave or vault without the production of the certificate of right of burial or other satisfactory evidence that the person desiring to bury therein is entitled to do so, except as provided for in the next Regulation.

10. That in case of an application for interment in any private grave or vault to which during life the deceased person had no claim, the written consent of the owner of the certificate of right of burial shall be given with the application.

11. No burial shall take place in the cemetery until a permit to bury has been signed by the secretary or officer in charge after the undertaker or other person conducting the burial has produced the registrar's certificate, medical practitioner's notice, coroner's or justice's order, or statutory declaration, as required by the *Cemeteries Act 1944*.

12. That the regular hours fixed for burials shall be as follows:—

On week days	.. .. .	9 a.m. to 4 p.m.
On Saturdays and holidays (when allowed)	.. .. .	9 a.m. to 11 a.m.
On Sundays (when allowed)	.. .. .	9 a.m. to 11 a.m.

No interment shall be allowed on a Sunday except when it is certified in writing by the officer of health of the district or by a police magistrate that for sanitary reasons it is necessary that the burial take place on that day. (Christmas Day and Good Friday shall be observed as Sundays.)

13. That no burial shall be allowed to take place between the hours of 6 p.m. and 9 a.m. except by special permission of the officer in charge.

14. That the time fixed for any burial shall be the time when the funeral is to be at the cemetery, and the same shall be punctually observed.

15. That every funeral shall enter the cemetery by the principal entrance. No vehicles except hearses and mourning coaches shall be permitted to enter or stand opposite the entrance gates, save for the purpose of with all due despatch driving away after loading or unloading. Breaking out of the procession after passing the gates is forbidden.

No motor vehicle shall be driven within the cemetery at a faster rate than 15 miles per hour, and no horse faster than at a walking pace.

16. That every grave, vault, tomb, monument, tombstone, cenotaph, wall, fence, or any other erection shall be maintained and kept in thorough repair and proper condition by or at the expense of the owner.

17. That all monumental work shall be placed on proper and substantial foundations, and shall comply with the Regulations authorized by the trustees. No soft stone shall be allowed to be used in any work. All refuse and other rubbish remaining after any work is completed shall be removed at once from the cemetery or to an appointed place by and at the expense of the person causing the same.

18. That all materials required in the completion of any stone or other work shall be fully prepared before being taken into the cemetery, and shall be admitted only at the prescribed entrance, and all vehicles conveying any such materials shall have tires not less than 4 inches broad.

19. That no catacomb shall be allowed.

20. That no wooden erection shall be allowed.

21. Exhumations.—The provisions of section 46 of the *Cemeteries Act 1928*, as follows, shall apply:—

“ (1) Except in pursuance of a warrant to exhume a body for the purpose of an inquest as provided by the *Coroners Act 1928*, no person shall remove any body or the remains of any body interred in any cemetery burial ground or place of burial—

(a) without licence under the hand of a law officer;

(b) without observing such precautions as such law officer prescribes as the condition of such licence.

(ii) Every person who acts in contravention of any of the provisions of this section shall be liable to a penalty of not more than Ten pounds.”

If found necessary, the coffin shall be enclosed in a second and airtight coffin after exhumation and prior to removal to another grave vault or mausoleum.

22. That any workman or other employee, whether employed by the trustees or by any other person, shall at all times while in the cemetery be subject to the supervision directions and control of the officer in charge and shall obey all such directions, and upon any breach of the Regulations shall be subject to the penalty prescribed by section 10 of the *Cemeteries Act 1928*.

23. That any person taking any part in dressing or attending to any grave shall comply with the following rules, viz.:—

*First.*—No rubbish clay or other material removed in dressing a grave shall be placed on any other grave, and if placed on any adjoining ground shall be removed immediately after the completion of the work.

*Second.*—No loam shall be taken from any portion of the cemetery for the purpose of dressing any grave except by permission of the officer in charge.

*Third.*—No grave shall be dressed in wet weather, except by special permission of the officer in charge, nor shall any materials be wheeled or carted along any path or road while the surface is soft from rain or otherwise.

*Fourth.*—Work in all cases is to be carried out with due despatch, and only during the regular working hours of the cemetery employees. No such work shall be carried out on holidays.

24. Unless otherwise ordered, the entrances to the cemetery shall be open daily throughout the year from 8 a.m. to 5 p.m., except that the opening time for all entrances on Sundays shall be 9 a.m.

25. That no dogs shall be admitted into the cemetery unless on a leash.

26. That no person in the cemetery or its approaches shall commit any nuisance or trespass or be guilty of any breach of decorum or cut, pluck, gather, or take out of the cemetery any flower, plant, shrub, or tree, or any part thereof, or do any injury whatsoever thereto, or to any grass, plot, border, railing, fence, or any other erection or road therein, or remove or interfere in any way with anything laid, built, or placed on, or in any grave or burying place.

27. That no person shall promote or advertise or carry on within the cemetery, or at or near any gateway thereof or any approach thereto, any trade business or calling, either by solicitation, distribution of circulars or cards, or otherwise, or by any other system of advertisement whatsoever.

28. Touting for business within the cemetery area is strictly forbidden, and cemetery employees are not allowed to act as agents for monumental masons, directly or indirectly, or to receive gratuities or commissions of any kind. Any employee of the trust not complying with this Regulation will be subject to summary dismissal.

29. That no person employed by the trustees shall be permitted to accept any gratuity whatever in discharge of his duty, nor shall he be allowed to be pecuniarily interested in any work in the cemetery other than that for which he receives payment from the trustees.

30. That any person employed by the trustees accepting any such gratuity or being pecuniarily interested in any such work shall be liable to be summarily dismissed.

31. That any person committing any breach of any of these Rules or Regulations, or of any other Rules, Regulations, By-laws lawfully made under the authority of any Act relating to cemeteries, may be proceeded against accordingly under section 10 and section 40 of the *Cemeteries Act 1928*.

32. In these Rules and Regulations the expression "Officer in Charge" includes the secretary, the foreman, and any other employee authorized (either generally or in any particular case) to act for the secretary or the foreman. An officer in charge shall, subject to the trustees, exercise a general supervision and control over all matters pertaining to the cemetery and to the carrying out and enforcement of these Rules and Regulations, and subject to the provisions of the *Cemeteries Acts*, the direction of such person shall in all such matters and for all such purposes be presumed to be and to have been the direction of the trustees.

33. That in all cases (other than those the subject of a special agreement or contract) the period of employment of cemetery employees shall be "during the pleasure of the trustees," but all employees shall retire at the age of 65 years unless, in any specific case where it is considered to be necessary or desirable in the particular circumstances, the trustees by resolution extend the term.

34. That a plan of the cemetery, showing the distribution of the land, compartments, situations and numbers of the graves, and a registry of all certificates of right of burial, shall be kept at the office.

(SEAL) L. E. SCOTT, Chairman.  
FRANK CLOTA, Trustee.  
F. W. YOUNG, Trustee.  
H. HARVEY, Trustee.  
H. J. BAKER, Trustee.  
JOHN H. PATTERSON, Trustee.  
A. L. MCFARLANE, Trustee.  
A. R. ALLINGHAM, Trustee.  
R. A. WORTH, Trustee.  
J. WILSON (Miss), Secretary.

20th August, 1948.

Approved by the Governor in Council,  
30th November, 1948.  
J. C. MACGIBBON,  
Acting Clerk of the Executive Council.

SCHEDULE A.

CERTIFICATE OF RIGHT OF BURIAL IN BOX HILL GENERAL CEMETERY.

On the application of \_\_\_\_\_ and upon the payment of the sum of \_\_\_\_\_ pounds \_\_\_\_\_ shillings the trustees of the Box Hill General Cemetery, in terms of and as authorized by the Cemeteries Acts, have agreed to grant; and do hereby grant, unto the said \_\_\_\_\_ or \_\_\_\_\_ heirs or representatives permission to dig or make a grave or vault on that piece of ground \_\_\_\_\_ feet long by \_\_\_\_\_ feet broad, lying within the portion of the said cemetery appropriated for \_\_\_\_\_ burials and marked section \_\_\_\_\_ No. \_\_\_\_\_ Compartment \_\_\_\_\_ on the map or plan of the said cemetery, kept by the said trustees, with permission to erect or place on the said piece of ground a monument or tombstone, on payment of such charges as may from time to time be established, and shall be entitled to have, maintain or keep up such vault, monument or tombstone, according to the terms of this permission, provided always, and it is hereby declared, that this grant is made subject to the terms and conditions following, viz.:—

*First.*—That the said piece of ground shall be kept and used solely as a burying place, and that no other use shall be made thereof.

*Second.*—That no enclosing kerb, monument or tombstone shall be erected or placed on said piece of ground, until a plan thereof shall have been exhibited to the said trustees, and their authority given for the erection thereof.

*Third.*—That the said grave or vault, and the said kerb, monument or tombstone shall be maintained and kept up by the said \_\_\_\_\_ and \_\_\_\_\_ heirs or representatives, in proper repair to the satisfaction of the said trustees.

*Fourth.*—That the owner shall, in the use of the said piece of ground, and access thereto, be subject in every respect to such Rules and Regulations as the said trustees of the said cemetery may from time to time make, and shall not be entitled to exercise the right to bury or inter therein, except on payment of such charges as may from time to time be established by the said trustees.

Given under our Hands at Box Hill, in the State of Victoria, this day \_\_\_\_\_ A.D. 19 \_\_\_\_\_

Trustees of the Box Hill General Cemetery.

Signed by the above trustees, in the presence of—

Secretary.

Register Nos.	Date.	Page.	Compartment.	Section No.	Grave No.

This certificate must be produced when a burial is required.

SCHEDULE B.

INSTRUCTIONS FOR GRAVE—BOX HILL CEMETERY.

- |  |      |    |
|--|------|----|
| 1. Name of deceased                    | Date | 19 |
| 2. Age                                 |      |    |
| 3. Residence                           |      |    |
| 4. Denomination                        |      |    |
| 5. Section                             | No.  |    |
| 6. Size of grave                       |      |    |
| 7. Cause of death                      |      |    |
| 8. It is the first interment?          |      |    |
| 9. If not, date of last interment      |      |    |
| 10. Day of burial                      |      |    |
| 11. Hour of burial                     |      |    |
| 12. Is it a public funeral?            |      |    |
| 13. Signature of undertaker            |      |    |
| 14. Name in full for title certificate |      |    |

Address \_\_\_\_\_

NOTE.—The certificate for this grave must be produced at the cemetery office at the time of burial. If certificate is not available, this order must be signed by the owner of the certificate or his or her representative authorizing the grave to be opened.

Signature of person giving authority \_\_\_\_\_

Address \_\_\_\_\_

(If not owner of certificate, state relationship to owner).

## SCHEDULE C.

No. ....

## THE COLUMBARIUM IN THE BOX HILL GENERAL CEMETERY.

The trustees of the Box Hill General Cemetery, in the State of Victoria, do hereby acknowledge to have received the sum of \_\_\_\_\_ pounds  
shillings from \_\_\_\_\_

of \_\_\_\_\_  
in consideration whereof such trustees do hereby upon the conditions herein-  
after stated grant the use of space No. \_\_\_\_\_ (on  
the plan kept in the office of the trustees) in the \_\_\_\_\_ section  
of the Columbarium, situate in the said cemetery as a repository for a  
metal urn or other casket for the reception of the ashes of the late  
for affixing a memorial tablet.

Conditions hereinbefore referred to:—

1. Access to such space may be had only at the times provided by the cemetery Regulations.
2. The urn or casket may be bolted to the shelf upon which the same is placed.
3. Every urn, casket or tablet must be approved by the trustees before being placed in position.
4. The trustees incur no liability whatever should any urn, casket or tablet be removed or in any way injured or interfered with.

Given under our Hands at Box Hill, in the State of Victoria, this  
day of \_\_\_\_\_ A.D.

Trustees of the Box Hill General Cemetery.

Signed by the said trustees, in the presence of—

Secretary.

Ledger No. \_\_\_\_\_ Section \_\_\_\_\_ No. \_\_\_\_\_

## SCHEDULE D.

## NOTICE TO ALL MONUMENTAL MASONS, ETC., PURSUANT TO THE RULES AND REGULATIONS OF THE BOX HILL CEMETERY TRUST.

On and after the 8th December, 1948, the trustees do hereby order that the following specifications shall be observed in the erection of all monumental work in the Box Hill Cemetery:—

1. All stone work shall be fully prepared before conveyance to the cemetery, and shall only be admitted at the appointed entrance, and no material shall be permitted to enter the cemetery in vehicles with iron wheels having less than 4-in. tires.

Materials must be placed where directed, and at the conclusion of all work, surplus clay and other material must be removed, and iron numbers replaced in their proper positions adjoining monuments, grave sites, paths, roads, &c.

Monumental work will not be permitted in wet weather, or outside the working hours of the cemetery trust.

2. No work on any kerb or monument shall be commenced until foundations are approved by cemetery trust authority.

Kerbs and monuments, including any projections, must be definitely within the area of the grave site, and in line plumb and level.

The base of all stone work to follow the natural surface line. No brick or cement facing will be allowed under stone work. No headstone will be allowed unless the grave is surrounded by a kerb.

3. Foundations for 8 ft. x 4 ft. single kerb shall consist of a 12 in. x 9 in. concrete pier at each corner, having a depth of 2 feet or deeper as directed.

For 8 ft. x 8 ft. single kerb not less than 18 in. x 9 in. concrete pier at each corner, having a depth of 2 feet or deeper as directed.

All foundations to be connected with an arch of reinforced concrete from each top and bottom corner, 6 in. x 6 in. just below ground level.

For double kerbs or other heavy work, proper foundations of reinforced concrete must go to full depth of grave excavation when considered necessary by the cemetery authority.

Concrete ledgers must be properly reinforced. The concrete shall in all cases be a 4, 2 and 1 mixture. Aggregates shall be clean, derived from hard durable rock and graded. Maximum size ¾-in.

The concrete shall be comparable to the Australian standard specifications. Reinforcements shall be not less than 3 sets of ¾-in. clean steel.

4. Vaults and mausoleums must be of specially approved specification.

5. Reinforced concrete kerbs 6 inches wide shall not exceed 18½ inches from ground level, over 7 inches wide not to exceed 24 inches in height. Concrete reinforced head stones shall not exceed 36 inches from the socket or base.

Monumental kerbs and foundations must be so placed as to give the maximum clearance for grave excavation.



6. Passes will not be issued for brick, glass, soft stone, or brick and cement work, decorated mounds, tiles, wood or spawls borders.

7. Faulty construction or workmanship will not be allowed. Monumental work of any kind must have the approval of the trustees or the officer in charge. All crevices must be filled with cement concrete between newly constructed work and adjoining masonry.

8. No existing monumental work of any kind shall be removed without trustees' authority.

9. Applications for permits must be forwarded to the secretary, and work shall not be commenced until approved and prescribed fees paid.

10. Attention is again drawn to clauses 28, 29, 30, 31, and 32 of the Box Hill Cemetery Trust's Rules and Regulations, e.g., 28—

Touting for business within the cemetery area is strictly forbidden and cemetery employees are not allowed to act as agents for monumental masons, directly or indirectly, or to receive gratuities or commissions of any kind. Any employee of the trust not complying with this Regulation will be subject to summary dismissal.

By order of the trustees,

J. WILSON,  
Secretary.

SCHEDULE E.

TO THE TRUSTEES, BOX HILL GENERAL CEMETERY.

I/we hereby apply for permission to fix \_\_\_\_\_  
 in the \_\_\_\_\_ compartment, section \_\_\_\_\_  
 plot No. \_\_\_\_\_ for the owner \_\_\_\_\_  
 address \_\_\_\_\_ in accordance  
 with the following plan, design, and specification (including inscriptions,  
 if any):—

I/we hereby certify that the value of the construction referred to in this application is to the full value of £ : : and that the consent of the owner of certificate for the above-mentioned grave has been given, for the sanction of the work described, and I/we hereby bind and pledge myself/ourselves (in the event of this application being granted), to comply with all the Rules, Regulations, By-laws, and Resolutions relative to such permission.

Signature

Trade

Address

All plans, designs, and specifications submitted for approval to be carefully prepared with dimensions and inscriptions fully described.

SCALE OF FEES AND CHARGES PAYABLE.

IN pursuance of the powers vested in them by the Cemeteries Acts, the trustees of the Box Hill General Cemetery hereby rescind the scales of fees and charges previously published in the *Government Gazette*, and make the following scale of fees and charges, viz.:—

LAND FOR PRIVATE GRAVES.	£ s. d.
Plots other than corner plots or plots on drives or plantations—	
8 ft. x 4 ft. .. .. .	8 10 0
8 ft. x 8 ft. .. .. .	17 0 0
Corner plots not on drives or plantations—	
8 ft. x 4 ft. .. .. .	9 10 0
8 ft. x 8 ft. .. .. .	20 0 0
Plots on drives or plantations—	
8 ft. x 4 ft. (where allowed) .. .. .	12 10 0
8 ft. x 8 ft. .. .. .	25 0 0
Special sites, as per plan—8 ft. x 16 ft. .. .. .	60 0 0
Plots specially selected—extra charges—	
8 ft. x 4 ft., extra .. .. .	2 0 0
8 ft. x 8 ft., extra .. .. .	4 0 0
8 ft. x 16 ft., extra .. .. .	8 0 0

NOTE.—The scale of plots to any one person is restricted to four plots, 8 ft. x 4 ft., or other plots of equivalent total area, except by special permission of the trustees.

ADDITIONAL CHARGES.		£ s. d.
Sinking graves, standard measurements, 2 ft. 3 in. wide at shoulders—		
7 feet deep .. .. .		2 15 0
8 feet deep .. .. .		3 10 0
9 feet deep (when allowed) .. .. .		4 10 0
Sinking grave, over standard width (when allowed)—		
Over 2 ft. 3 in. at shoulders, extra .. .. .		1 10 0
For square caskets, extra .. .. .		2 2 0
Re-opening grave, any compartment .. .. .		2 10 0
Iron numbers, each .. .. .		0 5 0
Permission to construct a brick grave .. .. .		1 0 0
Interment in private grave—extra charges—		
Without due notice, extra .. .. .		1 7 6
Not in usual hours, extra .. .. .		1 0 0
Late arrival of funeral, extra .. .. .		0 10 6
On a Saturday (when allowed), extra .. .. .		2 2 0
On a Sunday (when allowed), extra .. .. .		3 3 0
On a gazetted holiday (when allowed), extra .. .. .		2 2 0
Interment in private grave of ashes of deceased person .. .. .		1 7 6
Cancellation of order for burial .. .. .		1 0 0
Exhumation (when authorized) plus the amount required by the Wages Board determination to be paid to the cemetery employees engaged in connexion with the exhumation .. .. .		6 6 0
Transfer of duplicate of certificate of right of burial .. .. .		0 10 6

NOTE.—Where a monument or marble slab is placed on a grave, arrangements for removal and replacement must be made with a monumental mason prior to the opening of the grave.

#### FEES FOR SPACES IN COLUMBARIUM AS PER PLAN.

	£ s. d.
Urn space, west wing .. .. .	10 0 0
Urn space, all other wings .. .. .	7 10 0
Urn space, for casket under floor .. .. .	5 0 0
Tablet space, each 18 in. x 12 in. .. .. .	2 10 0
Fee for further deposit of ashes in any urn or casket .. .. .	1 0 0

#### CHARGES FOR MAINTENANCE OF GRAVES

	£ s. d.
(1) Removal of clay, dressing with loam, planting with shrubs, and maintenance for the first year—	
8 ft. x 4 ft. grave, planted with two shrubs .. .. .	2 0 0
8 ft. x 8 ft. grave, planted with four shrubs .. .. .	4 0 0
(2) Maintenance each succeeding year—	
8 ft. x 4 ft. grave .. .. .	1 0 0
8 ft. x 8 ft. grave .. .. .	2 0 0

NOTES.—When a grave has been re-opened the charge to re-establish it shall be the same as shown in (1) above.

When maintenance orders have been discontinued and subsequently renewed the charge to re-establish a grave shall be the same as shown in (1) above.

A charge of 15s. shall be made each time for additional loam or shrubs.

The charges for maintenance and re-establishment of special sites shall be as determined by the trustees from time to time according to the circumstances of each case.

FEEs FOR ERECTION OF MONUMENTS, HEADSTONES, KERBINGS,  
DECORATIONS, ETC., AS PER REGULATIONS.

	£	s.	d.
Value £15 or under .. .. .	1	1	0
Value over £15 up to £50 .. .. .	2	2	0
Value over £50 up to £150 .. .. .	3	3	0
Value over £150 up to £250 .. .. .	4	4	0
Value over £250—for each additional £100 or part thereof	1	1	0
For additional inscriptions (if approved) .. .. .	0	10	0

The fee, in the case of vaults and mausoleums, shall be as decided by the trustees from time to time according to the circumstances of each case.

NOTE.—All cemetery fees and charges are payable in advance.

(SEAL) L. E. SCOTT, Chairman.  
FRANK CLOTA, Trustee.  
F. W. YOUNG, Trustee.  
H. HARVEY, Trustee.  
H. J. BAKER, Trustee.  
JOHN H. PATTERSON, Trustee.  
A. L. MCFARLANE, Trustee.  
A. R. ALLINGHAM, Trustee.  
R. A. WORTH, Trustee.  
J. WILSON (Miss), Secretary.

20th August, 1948.

Approved by the Governor in Council,  
30th November, 1948.

J. C. MACGIBBON,  
Acting Clerk of the Executive Council.

VICTORIAN RAILWAYS.

VICTORIAN RAILWAYS COMMISSIONERS.

BY-LAW No. 357.

THE Victorian Railways Commissioners, in the exercise of the powers conferred in that behalf by the Railways Acts, do hereby make the following By-law, and do hereby repeal so much of the provisions of all previous By-laws as conflicts therewith.

1. INTER-SYSTEM FARES.

(A) The fares between the under-mentioned stations shall be as follows:—

	Single.		Ordinary Return.	
	1st Class.	2nd Class.	1st Class.	2nd Class.
	£ s. d.	£ s. d.	£ s. d.	£ s. d.

Victoria and New South Wales via Albury.

Between Melbourne and—				
Sydney .. .. .	4 13 0	3 10 0	7 2 9	5 3 9
Canberra .. .. .	4 14 0	3 10 6	6 11 1	4 15 6
Queanbeyan .. .. .	4 13 0	3 10 0	6 9 8	4 14 5
Circular—Melbourne to Melbourne via Adelaide, Broken Hill and Sydney, or vice versa .. .. .	13 6 0	10 0 0	..	..

1. INTER-SYSTEM FARES—continued.

	Single.		Ordinary Return.	
	1st Class.	2nd Class.	1st Class.	2nd Class.
	£ s. d.	£ s. d.	£ s. d.	£ s. d.

Victoria and Queensland via Albury and Kyogle.

Between Melbourne and—				
Brisbane .. .. .	7 16 0	5 17 0	12 14 6	9 1 0
Bowen .. .. .	12 15 6	9 12 0	..	..
Bundaberg .. .. .	9 4 6	6 18 6	..	..
Cairns .. .. .	14 12 6	10 8 5	..	..
Charters Towers .. .. .	13 12 0	10 1 2	..	..
Cloncurry .. .. .	15 9 0	11 3 6	..	..
Cunnamulla .. .. .	12 19 6	9 7 2	..	..
Gladstone .. .. .	9 11 6	7 4 0	..	..
Gympie .. .. .	8 13 0	6 10 0	..	..
Hughenden .. .. .	14 6 0	10 9 6	..	..
Innisfail .. .. .	14 12 0	10 6 0	..	..
Ipswich .. .. .	8 0 6	6 0 6	..	..
Longreach .. .. .	13 15 6	9 17 11	..	..
Mackay .. .. .	11 15 6	8 17 0	..	..
Maryborough .. .. .	8 19 0	6 14 6	..	..
Mount Isa .. .. .	16 15 6	11 10 9	..	..
Rockhampton .. .. .	10 1 0	7 11 0	..	..
Toowoomba .. .. .	8 17 6	6 12 11	..	..
Townsville .. .. .	13 5 6	9 17 11	..	..

Victoria and Queensland via Albury and Wallangarra.

Between Melbourne and—				
Brisbane .. .. .	7 16 0	5 17 0	..	..
Cunnamulla .. .. .	10 14 0	8 0 6	..	..
Goondiwindi .. .. .	7 16 0	5 17 0	..	..

Victoria and South Australia via Serviceton.

Between Melbourne and—				
Adelaide .. .. .	3 13 6	2 15 6	5 11 9	4 9 4
Millicent .. .. .	3 9 2	2 15 6	5 0 3	4 1 4

New South Wales and South Australia via Albury and Serviceton.

Between Sydney and—				
Adelaide .. .. .	6 11 6	4 19 0	11 15 2	8 17 8
Mt. Gambier .. .. .	6 11 6	4 19 0	10 17 8	8 3 8
Between Canberra and Adelaide .. .. .	6 12 6	4 19 6	11 3 6	8 9 5

South Australia and Queensland via Serviceton and Albury.

Between Adelaide and—				
Brisbane via Kyogle .. .. .	10 2 6	7 12 0	17 6 11	12 14 11
Toowoomba via Kyogle .. .. .	11 4 0	8 7 11	..	..
Brisbane via Wallangarra .. .. .	10 2 6	7 12 0	..	..

Victoria and Western Australia via Serviceton.

Between Melbourne and—				
Kalgoorlie .. .. .	12 10 0	8 7 0	25 0 0	16 14 0
Perth .. .. .	13 2 6	8 15 0	26 5 0	17 10 0
Fremantle .. .. .	13 2 6	8 15 0	26 5 0	17 10 0

New South Wales and Western Australia via Albury and Serviceton.

Between Sydney and—				
Kalgoorlie .. .. .	15 17 6	10 12 0	31 15 0	21 4 0
Perth .. .. .	16 10 0	11 0 0	33 0 0	22 0 0
Fremantle .. .. .	16 10 0	11 0 0	33 0 0	22 0 0
Between Newcastle and—				
Kalgoorlie .. .. .	16 13 6	11 3 6	33 7 0	22 7 0
Perth .. .. .	17 6 0	11 11 6	34 12 0	23 3 0
Fremantle .. .. .	17 6 0	11 11 6	34 12 0	23 3 0
Between Canberra and—				
Kalgoorlie .. .. .	15 19 0	10 12 6	31 18 0	21 5 0
Perth .. .. .	16 11 6	11 1 0	33 3 0	22 2 0
Fremantle .. .. .	16 11 6	11 1 0	33 3 0	22 2 0

Queensland and Western Australia via either Wallangarra or Kyogle, and Albury and Serviceton.

Between Brisbane and—				
Kalgoorlie .. .. .	19 16 6	14 1 6	39 13 0	28 3 0
Perth .. .. .	20 9 0	14 9 6	40 18 0	28 19 0
Fremantle .. .. .	20 9 0	14 9 6	40 18 0	28 19 0

(B) The fares between other stations on the Victorian Railways System and stations on other Railway Systems or between other stations on other Railway Systems via the Victorian Railways System shall be the sum of the mileage fares on each Railway System concerned unless it is cheaper to charge as under—

(i) The fares shown between stations in sub-clause (A) shall apply as maximum fares between intermediate stations and the stations specified.

(ii) For other stations for which the route is via an intermediate junction station or beyond the stations specified in sub-clause (A) the sum of the appropriate fares shown in that clause and the local fare shall be charged.

(C) In addition to the rail fares shown in sub-clause (A) the fees for reserved seats, meals, and sleeping berths which are prescribed as compulsory on the Railways Systems concerned shall be charged.

2. INTER-SYSTEM GOODS RATES.

(A) The rates for the carriage of goods between the following stations shall be as shown hereunder—

Between—	Class Rates per Ton.					Minimum Charge per Consignment.
	"A."	"B."	"C."	"1."	"2."	
	£ s. d.	£ s. d.	£ s. d.	£ s. d.	£ s. d.	£ s. d.
Melbourne or Geelong and Adelaide ..	3 13 6	4 15 6	6 16 0	7 8 6	9 9 6	0 9 6
Melbourne and Sydney ..	4 12 0	5 18 0	7 17 0	8 17 6	10 10 0	0 8 0
Melbourne and Newcastle ..	5 3 6	6 15 0	9 0 0	10 3 0	12 0 6	0 9 6
Melbourne and Brisbane ..	..	..	15 1 0	17 10 6	20 10 0	0 17 6
Adelaide and Sydney ..	8 1 6	10 2 6	12 18 0	14 18 0	17 8 6	0 17 0
Adelaide and Brisbane ..	..	..	20 8 0	23 5 0	27 11 6	1 6 0

—	Class Rates per Ton.							Minimum Charge per Consignment.
	Grain.	"M."	"A."	"B."	"C."	"1."	"2."	
	£ s. d.	£ s. d.	£ s. d.	£ s. d.	£ s. d.	£ s. d.	£ s. d.	£ s. d.
Melbourne or Geelong and Kalgoorlie ..	5 7 6	6 5 0	9 7 6	11 17 6	14 7 6	18 13 6	23 16 0	1 0 0
Melbourne or Geelong and Perth ..	6 16 0	7 12 0	11 5 0	14 2 6	16 17 6	22 13 6	28 14 0	1 0 0

(B) The classification of goods into class rates with the minimum tonnage applicable thereto and other conditions of carriage on each Railway System concerned shall apply to such System's proportion of the Inter-system rates.

(C) The sum of the local rates and the conditions on each System shall apply where cheaper than the Inter-system rates shown above.

The provisions of this By-law shall become effective as on and from the first day of December, 1948.

In witness whereof the common seal of the Victorian Railways Commissioners was affixed hereto this ninth day of November in the year of Our Lord One thousand nine hundred and forty-eight, in the presence of—

(SEAL) N. C. HARRIS } Victorian  
M. J. CANNY } Railways  
R. G. WISHART } Commissioners.

Approved by the Governor in Council,  
30th November, 1948.

J. C. MACGIBBON,  
Acting Clerk of the Executive Council.

## COMPANIES ACT 1938.

NOTICE is hereby given that, in pursuance of section 295 (5) of the *Companies Act 1938*, the names of the companies referred to below have been struck off the register, and on the publication of this notice in the *Government Gazette* the said companies will be dissolved.

Dated this twenty-ninth day of November, 1948.

Registrar-General's Office,  
Melbourne.

J. QUINLIVAN,  
Deputy Registrar-General.

## COMPANIES ABOVE REFERRED TO.

Name of Company.	Date of Registration.	Number of Registration.
Johnson & Sons Proprietary Limited .. .. .	21st March, 1901 .. .. .	3455
The Maldon Brewing Co. Proprietary Limited .. .. .	15th November, 1907 .. .. .	4221
The Australian Prudential Association Proprietary Limited .. .. .	16th April, 1908 .. .. .	4263, folio 7432
Australian Farms Limited .. .. .	3rd December, 1912 .. .. .	5247, folio 7794
Old Mildura Estate Proprietary Limited .. .. .	7th December, 1916 .. .. .	6272
T. W. Cotton Proprietary Limited .. .. .	19th December, 1916 .. .. .	6277
Egerton Hosiery Mills Proprietary Limited .. .. .	15th September, 1920 .. .. .	7414
The Dandy Preserves Proprietary Limited .. .. .	30th March, 1921 .. .. .	7695
J. C. Hutton (Australasia) Proprietary Limited .. .. .	30th June, 1921 .. .. .	7833
J. Morell Proprietary Limited .. .. .	24th January, 1922 .. .. .	8167
Arkaringa Land Company Proprietary Limited .. .. .	13th August, 1923 .. .. .	9252
Murrong Lands Proprietary Limited .. .. .	27th August, 1923 .. .. .	9292
Bennetts' (Cohuna) Proprietary Limited .. .. .	12th August, 1924 .. .. .	10091
Malabar Proprietary Limited .. .. .	29th September, 1925 .. .. .	11010
A. E. Lydford Proprietary Limited .. .. .	2nd March, 1926 .. .. .	11354
Nixon and Co. Proprietary Limited .. .. .	14th September, 1926 .. .. .	11925
William Drum & Son Proprietary Limited .. .. .	16th November, 1926 .. .. .	12120
Mildura Steam Laundry and Dry Cleaning Company Proprietary Limited .. .. .	28th September, 1927 .. .. .	13021
M. & N. J. Rodda Proprietary Limited .. .. .	17th August, 1928 .. .. .	13874
Specialty Investments Proprietary Limited .. .. .	16th May, 1929 .. .. .	14545
House & Baskett Proprietary Limited .. .. .	29th June, 1929 .. .. .	14644
Mont Victor Wine Company Proprietary Limited .. .. .	29th November, 1929 .. .. .	15092
Hydro Manufacturing Company Proprietary Limited .. .. .	20th January, 1930 .. .. .	15203
Jack Cato Proprietary Limited .. .. .	3rd February, 1930 .. .. .	15235
James G. S. Stewart Associates Proprietary Limited .. .. .	5th May, 1930 .. .. .	15436
L. H. Tadich Proprietary Limited .. .. .	10th May, 1930 .. .. .	15453
Secret Cash Recorder Proprietary Limited .. .. .	16th May, 1930 .. .. .	15464
R. Wood Dairy Company Proprietary Limited .. .. .	23rd December, 1930 .. .. .	16002
Glen Iris Building Company Proprietary Limited .. .. .	2nd July, 1932 .. .. .	17063
B. G. Nicholls Proprietary Limited .. .. .	8th November, 1932 .. .. .	17358
Waroon Proprietary Limited .. .. .	5th October, 1933 .. .. .	18074
F. H. Waters Proprietary Limited .. .. .	9th November, 1933 .. .. .	18143
The Lobster Pot Proprietary Limited .. .. .	22nd January, 1934 .. .. .	18292
The Dee Trading Company Proprietary Limited .. .. .	24th January, 1934 .. .. .	18300
Newmarket Contract Slaughtering Co. Proprietary Limited .. .. .	12th February, 1934 .. .. .	18339
Avalon Basket Shoes Proprietary Limited .. .. .	14th March, 1934 .. .. .	18405
Millson & Magnus Proprietary Limited .. .. .	20th March, 1934 .. .. .	18424
Austin Friars Proprietary Limited .. .. .	26th April, 1935 .. .. .	19219
F. G. Bevan & Co. Proprietary Limited .. .. .	23rd August, 1935 .. .. .	19484
Machin Bros. Proprietary Limited .. .. .	16th August, 1935 .. .. .	19488
Solo Import Company Proprietary Limited .. .. .	11th December, 1935 .. .. .	19595
Sea Flights Proprietary Limited .. .. .	3rd July, 1936 .. .. .	20186
Robert Swinton Proprietary Limited .. .. .	1st December, 1936 .. .. .	20500
Edric Laboratories Proprietary Limited .. .. .	29th September, 1937 .. .. .	21156
Derwent Builders Proprietary Limited .. .. .	4th December, 1937 .. .. .	21299
Corfield Proprietary Limited .. .. .	24th December, 1937 .. .. .	21361
Students Matriculation Academy Proprietary Limited .. .. .	18th March, 1938 .. .. .	21505
Universal Air Conditioners Proprietary Limited .. .. .	11th May, 1938 .. .. .	21619
Aviation Schools Proprietary Limited .. .. .	3rd June, 1938 .. .. .	21665
L. G. & R. E. Bland Proprietary Limited .. .. .	8th June, 1938 .. .. .	21673
Parking Meters Company of Australia Proprietary Limited .. .. .	16th December, 1938 .. .. .	22075
G. E. Toll Proprietary Limited .. .. .	6th January, 1939 .. .. .	22099
C. & D. Brown Proprietary Limited .. .. .	22nd March, 1939 .. .. .	22251
Western Coursing Association Proprietary Limited .. .. .	28th April, 1939 .. .. .	22383
Austar Industrial Development Proprietary Limited .. .. .	28th April, 1939 .. .. .	22385
Creditors Rating Service Proprietary Limited .. .. .	29th July, 1939 .. .. .	22473
Millawa Estates Proprietary Limited .. .. .	26th October, 1939 .. .. .	22563
Selkirk Bros. Proprietary Limited .. .. .	9th March, 1940 .. .. .	22685
Ivan S. Young Proprietary Limited .. .. .	6th May, 1940 .. .. .	22737
J. P. Strathmore Proprietary Limited .. .. .	16th September, 1940 .. .. .	22835
Essendon Community Centre Limited .. .. .	23rd December, 1940 .. .. .	22929
K. P. H. Metals Limited .. .. .	5th July, 1946 .. .. .	23721
Australian Straits and Far Eastern Trading Company Limited .. .. .	4th September, 1946 .. .. .	23866
Warrnambool Legion Housing Company Proprietary Limited .. .. .	22nd November, 1946 .. .. .	24068
The Hotstream Heater Company Pty. Limited .. .. .	9th December, 1946 .. .. .	24117
Stiltona and Investments Proprietary Limited .. .. .	28th May, 1947 .. .. .	24476
Morley Products Proprietary Limited .. .. .	1st July, 1947 .. .. .	24631
Yarradale Limited .. .. .	17th September, 1947 .. .. .	24839
Pacific Entertainments Proprietary Limited .. .. .	5th November, 1947 .. .. .	24949
American Bias Blinding Company Proprietary Limited .. .. .	23rd December, 1947 .. .. .	25078
North Byron Reef Company No Liability .. .. .	4th March, 1901 .. .. .	M.7008
Dark River Proprietary Gold Mining Syndicate No Liability .. .. .	23rd March, 1901 .. .. .	M.7022

## COMPANIES ABOVE REFERRED TO—continued.

Name of Company.	Date of Registration.	Number of Registration.
Axedale Gold Mining Company No Liability .. ..	6th February, 1908 .. ..	M.8177
Ballararat Prospecting Company No Liability .. ..	7th February, 1908 .. ..	M.8178
Ballararat City Gold Mining Company No Liability .. ..	6th September, 1909 .. ..	M.8328
Star of Remu Gold Mining Company No Liability .. ..	11th December, 1909 .. ..	M.8337
Mount Balfour Copper Mines No Liability .. ..	16th December, 1909 .. ..	M.8338
Toombon Gold Mining Company No Liability .. ..	9th October, 1934 .. ..	M.9999
Epic Gold Prospecting Syndicate No Liability .. ..	22nd January, 1941 .. ..	Pros. 5
Gem Gold Prospecting Syndicate No Liability .. ..	18th February, 1942 .. ..	Pros. 6
Fuel Prospecting Syndicate No Liability .. ..	25th January, 1946 .. ..	Pros. 7
B. Q. Prospecting Syndicate No Liability .. ..	9th July, 1946 .. ..	Pros. 9

## 4 GEORGE VI. No. 4755, SECTION 6.

I HEREBY give notice that on the 26th November, 1948, I filed elections to administer the following deceased persons' estates, in accordance with section 6 of the *Public Trustee Act 1940*:—

ARMSTRONG, FRANCIS ANDREW, also known as Frank Andrew Armstrong, late of Bundoora Repatriation Hospital, pensioner, died 26th June, 1948, intestate.

BARRETT, BERTRAM, late of 38 Wellington-parade, East Melbourne, steward, died 28th September, 1948, intestate.

BARRETT, SYDNEY, late of 41 Lyle-street, Brunswick, pensioner, died 16th July, 1948, intestate.

\*BERRILL, EMILY HANNAH, late of 15 Baldwin-street, Armadale, dressmaker, died 2nd July, 1948.

BROWNE, RICHARD ARTHUR, late of 1 Bendigo-street, Prahran, electrician, died 3rd July, 1948, intestate.

CHADWICK, WILLIAM EDWARD, late of 187 Stokes-street, Port Melbourne, pensioner, died 6th October, 1948, intestate.

CONNAUGHTON, WILLIAM JAMES, late of Melbourne Benevolent Asylum, Cheltenham, pensioner, died 3rd October, 1948, intestate.

CORKE, MARY, late of Melbourne Benevolent Asylum, Cheltenham, pensioner, died 15th July, 1948, intestate.

DAWSON, CHRISTINA ANN, late of Sorrento, married woman, died 16th August, 1948, intestate.

\*DRAKE, CARL DUDLEY, late of Drysdale, farmer, died 4th August, 1948.

FERRIS, EVA CAROLINE, late of 102 Ascot-street, Ballarat, widow, died 28th April, 1948, intestate.

\*LOWE, NICHOLAS HARRISON, formerly of 185 Highett-street, Richmond, and Middleborough-road, Box Hill, but late of Royal Park, gentleman, died 17th July, 1948.

\* According to the provisions of the will

I HEREBY give notice that on the 30th November, 1948, I filed elections to administer the following deceased persons' estates, in accordance with section 6 of the *Public Trustee Act 1940*:—

\*BOTTLE, ALFRED ERNEST, late of 81 Anderson-road, Sunshine, pensioner, died 11th October, 1948.

CARMODY, FLORA FRANCES, late of 43A Fitzroy-street, St. Kilda, widow, died 17th September, 1948, intestate.

DAVILL, FREDERICK, late of Dare-street, Golden Square, Bendigo, shoe maker, died 15th September, 1948, intestate.

GODDARD, JOSEPH SAMUEL, formerly of Spring Gully-road, Bendigo, pensioner, died 24th June, 1948, intestate.

GROSSMAN, WILLIAM CHARLES, also known as William Grossman, late of 111 Keon-street, Thornbury, boiler attendant, died 3rd October, 1948, intestate.

MCKENNA, FRANCIS JOSEPH, late of Booth Memorial Home, 462 Little Lonsdale-street, Melbourne, labourer, died 27th August, 1948, intestate.

SHAY, MARGARET, late of 26 Thistlewaite-street, South Melbourne, widow, died 17th August, 1948, intestate.

\*SUTTON, MARY, late of 160 Knight-street, Shepparton, widow, died 15th July, 1948.

TREBILCOCK, ELIZABETH, late of Purinium-road, Reservoir, spinster, died 9th September, 1948, intestate.

TROTMAN, JOHN, late of Hamilton, New South Wales, farmer, died 20th May, 1946, intestate.

\* According to the provisions of the will.

C. J. GARDNER,  
Public Trustee.

412 Collins-street, Melbourne, C.1, 1st December, 1948.

## NOTICE.

ADMINISTRATION of the estate of each of the under-mentioned deceased persons has been granted to me, and creditors, next of kin, and all others having claims against the estate of any of the persons so mentioned are required to send particulars of their claims to the Public Trustee, No. 412 Collins-street, Melbourne, on or before

the 10th February, 1949, or they will be excluded from the distribution of the estate when the assets are being distributed:—

ARMSTRONG, FRANCIS ANDREW, also known as Frank Andrew Armstrong, late of Bundoora Repatriation Hospital, pensioner, died 26th June, 1948, intestate.

BARRETT, BERTRAM, late of 38 Wellington-parade, East Melbourne, steward, died 28th September, 1948, intestate.

BARRETT, SYDNEY, late of 41 Lyle-street, Brunswick, pensioner, died 16th July, 1948, intestate.

\*BERRILL, EMILY HANNAH, late of 15 Baldwin-street, Armadale, dressmaker, died 2nd July, 1948.

\*BOTTLE, ALFRED ERNEST, late of 81 Anderson-road, Sunshine, pensioner, died 11th October, 1948.

BROWNE, RICHARD ARTHUR, late of 1 Bendigo-street, Prahran, electrician, died 3rd July, 1948, intestate.

CARMODY, FLORA FRANCES, late of 43A Fitzroy-street, St. Kilda, widow, died 17th September, 1948, intestate.

CHADWICK, WILLIAM EDWARD, late of 187 Stokes-street, Port Melbourne, pensioner, died 6th October, 1948, intestate.

CONNAUGHTON, WILLIAM JAMES, late of Melbourne Benevolent Asylum, Cheltenham, pensioner, died 3rd October, 1948, intestate.

CORKE, MARY, late of Melbourne Benevolent Asylum, Cheltenham, pensioner, died 15th July, 1948, intestate.

DAVILL, FREDERICK, late of Dare-street, Golden Square, Bendigo, shoe maker, died 15th September, 1948, intestate.

DAWSON, CHRISTINA ANN, late of Sorrento, married woman, died 16th August, 1948, intestate.

\*DRAKE, CARL DUDLEY, late of Drysdale, farmer, died 4th August, 1948.

EGAN, KIERAN, late of Korweinguboorra, farmer, died 9th September, 1948, intestate.

FERRIS, EVA CAROLINE, late of 102 Ascot-street, Ballarat, widow, died 28th April, 1948, intestate.

GODDARD, JOSEPH SAMUEL, formerly of Spring Gully-road, Bendigo, but late of Bendigo Benevolent Home, Bendigo, pensioner, died 24th June, 1948, intestate.

GROSSMAN, WILLIAM CHARLES, also known as William Grossman, late of 111 Keon-street, Thornbury, boiler attendant, died 3rd October, 1948, intestate.

\*LOWE, NICHOLAS HARRISON, formerly of 185 Highett-street, Richmond, and Middleborough-road, Box Hill, but late of Royal Park, gentleman, died 17th July, 1948.

MILES, FRANK, late of 70 Vine-street, Windsor, watchman, died 29th September, 1948, intestate.

MORRISSEY, WILLIAM JOHN, formerly of 38 Dunn-street, Wonthaggi, but late of Mont Park, miner, died 3rd March, 1925, intestate.

MCKENNA, FRANCIS JOSEPH, late of Booth Memorial Home, 462 Little Lonsdale-street, Melbourne, labourer, died 27th August, 1948, intestate.

†NEWBY, MARGARET EMMA, late of 29 Clarence-street, East Malvern, spinster, died 16th January, 1942.

†PURSER, MARGARET CAMPBELL, late of 111A Mitchell-street, East Brunswick, widow, died 2nd October, 1948.

SHAY, MARGARET, late of 26 Thistlewaite-street, South Melbourne, widow, died 17th August, 1948, intestate.

STEPHENS, FRANCIS JOHN, formerly of Queenscliff, but late of Mont Park, fisherman, died 13th October, 1948, intestate.

\*SUTTON, MARY, late of 160 Knight-street, Shepparton, widow, died 15th July, 1948.

TREBILCOCK, ELIZABETH, late of Purinium-road, Reservoir, spinster, died 9th September, 1948, intestate.

TROTMAN, JOHN, late of Hamilton, New South Wales, farmer, died 20th May, 1946, intestate.

†WEBSTER, JOSEPH JOHN, formerly of 41 Glenhuntly-road, Elsternwick, but late of "Dunhelen," Greenvale, retired timber merchant, died 25th August, 1948.

†WITTON, HECTOR STANLEY, late of 59 Claremont-avenue, Malvern, retired, died 1st October, 1948.

\* According to the provisions of the will.

† With the will annexed.

C. J. GARDNER,  
Public Trustee.

Melbourne, 1st December, 1948.

## RULES OF THE SUPREME COURT.

IN pursuance of the powers conferred by the Supreme Court Acts and all other powers hereunto enabling, the following rules are made, and shall take effect from the first day of December, 1948:—

1. Order LIV. Rule 4c of the Rules of the Supreme Court is amended by the deletion of the words "if served on Saturday not later than Twelve o'clock," and the substitution therefor of the words "in the case of any such summons attendable on a Monday not later than Two o'clock in the afternoon of the preceding Friday".

2. Rule 8 of Order LXIV. of the said Rules is deleted and the following rule is substituted therefor:—

"8. Service of pleadings notices summonses orders rules and other proceedings shall be effected not later than the hour of Four in the afternoon on week-days except Saturdays, provided however that service effected after the hour of four in the afternoon on any week-day except Friday or Saturday shall for the purpose of computing any period of time subsequent to such service be deemed to have been effected on the following day, and that for such purpose service effected after the hour of Four on Friday and service effected on Saturday shall be deemed to have been effected on the following Monday."

Dated this twenty-ninth day of November, 1948, Judges' Chambers, Supreme Court, Melbourne.

E. F. HERRING, C.J.  
J. R. MACFARLAN, J.  
CHARLES J. LOWE, J.  
C. GAVAN DUFFY, J.  
RUSSELL MARTIN, J.  
NORMAN O'BRYAN, J.  
W. K. FULLAGAR, J.  
JOHN V. BARRY, J.

Judges' Chambers,  
Melbourne.

## CONTRACTS ACCEPTED.—(Series 1948-49.)

## VICTORIAN RAILWAYS.

77. Power units, at £2,235 2s. 3d. per set (Contract 56152).—Coates and Co. Pty. Ltd. 78. Weldless mild steel angle rings, at £8 3s. 11d. each (Contract 57041).—Commonwealth Steel Co. Ltd. 79. Weldless mild steel angle rings, at rates (Contract 57204).—Commonwealth Steel Co. Ltd. 80. Cast steel wheel centres, at rates (Contract 57281).—Thompson's (Castlemaine) Ltd. 81. Weldless mild steel angle rings, at £9 1s. 6d. each (Contract 57321).—Thompson's (Castlemaine) Ltd. 82. Cast steel wheel centres, at rates (Contract 57341).—The Steel Co. of Aust. Pty. Ltd.

## CORRIGENDUM.

Serial 17, *Gazette* 834 of 11th August, 1948, amended rate 10s. from 25th September, 1948.

Serial 181, *Gazette* 651 of 16th June, 1948, additional service for £150.

By order of the Victorian Railways Commissioners,

B. KELLY, Secretary. 3.12.48.

## GENERAL STORES.

*Gazette* No. 708, 16th July, 1948, Schedule No. 5.—Flannels, Serges, &c.—For Items Nos. 7 and 8 substitute 11s. 8d. and 14s. 11d. per yard, as from 4th October, 1948, and for Items Nos. 6, 7, 8, 12 and 14 substitute 10s. 6d., 13s. 1d., 16s. 6d., 6s. 4d., and 10s. 5d. per yard, as from 15th November, 1948.

*Gazette* No. 708, 16th July, 1948, Schedule No. 19.—Bricks, Cement, &c.—Items Nos. 10 and 11.—Cement supplied by Cement Distributors Pty. Ltd. subject to additional surcharge of 5d. per bag. Rate 4s. 10d. per bag, as from 8th November, 1948.

*Gazette* No. 708, 16th July, 1948, Schedule No. 28.—Coppers, &c.—For Items Nos. 12 and 13 substitute £7 6s. 6d. and £9 each respectively, as from 18th November, 1948.

*Gazette* No. 708, 16th July, 1948, Schedule No. 46.—India-rubber Goods.—For Item No. 25 substitute 4s. 6d. per lb. for 1/32-in.; 3s. per lb. for 1/16-in.; 2s. 9d. per lb. for 3/32-in.; 1-in., 3/16-in., and 1-in. thicknesses, as from 11th November, 1948.

*Gazette* No. 708, 16th July, 1948, Schedule No. 54.—Metals.—For Item No. 1 substitute 1s. 6d. per lb., as from 5th November, 1948.

W. H. RUTHERFORD, Secretary to the Tender Board. 6.12.48.

## PUBLIC WORKS.

1633. (1) Allansford, Police Station, installation of septic tank and drainage system, £125.—L. Baker.

1634. (1) Ascot, State School No. 2507, repairs and painting, £256.—James and Rooney.

1635. (2) Ashburton, State School No. 4317, conversion of hutment to classroom, £1,095.—B. C. Stevenson.

1636. (2) Bald Hills, State School No. 2027, renovations, £163 1s.—James and Rooney.

1637. (2) Ballan, Police Station, new building, &c., £1,589.—P. Kinsella.

1638. (1) Ballarat, Mental Hospital, provision of flywire doors and screens, £128.—J. H. Brown and Son Pty. Ltd.

1639. (1) Beechworth, State School No. 1560, renovations, £185 10s.—T. E. McGeehan.

1640. (2) Beechworth, Mental Hospital, supply and installation of completely renewed main hot-water service, £3,194 12s.—Ross's Pty. Ltd.

1641. (3) Bembidge, State School No. 4557, renovations, £157 10s.—M. J. L. Clota.

1642. (2) Boundary Bend, State School No. 4089, renovations, £140 10s.—Tillig and Sons.

1643. (1) Buffalo, State School No. 3240, renovations, £485.—F. W. Carlsson.

1644. (3) Eltham, Higher Elementary School, conversion of army hut into classroom, £1,096.—F. W. Basing.

1645. (1) French Island, Reformatory Prison, supply and fix malthoid to concrete roofs, £320 10s.—J. Murray More Pty. Ltd.

1646. (3) Geelong North, Police Station, new building, &c., £4,620.—W. McF. Russell.

1647. (2) Glenferrie, Swinburne Technical School, supply and installation of fume hood ductwork, £276 10s.—Triplett and Prentice.

1648. (1) Island Road, State School No. 3952, renovations, £373 10s.—H. S. Bolger, jun.

1649. (2) Ivanhoe East, State School No. 4386, adaptation of hutments, £1,161.—G. S. Gay.



1650. (1) Kew, Mental Hospital, renewal of G.C.I. roof, £195 12s.—W. R. Jackson.
1651. (1) Kew, Mental Hospital, erection of lavatory conveniences, Children's Cottages, £332 8s.—T. I. and K. A. Vaughan Bros.
1652. (2) Kew, Mental Hospital, renovations to lavatories, £372.—T. I. and K. A. Vaughan Bros.
1653. (3) Kew, Mental Hospital, electrical reticulation and installation of distribution and section boards, £2,984 11s.—H. W. Templeton.
1654. (3) Kew, Mental Hospital, supply and installation of belt-driven washing machine for laundry, £392 11s. 6d.—Robert Bryce and Co. Pty. Ltd.
1655. (2) Maffra, State School No. 861, renovations, £313 10s. 6d.—T. A. Duck.
1656. (2) Melbourne, Council of Adult Education, supply and installation of cold cathode fluorescent lighting, £144.—Neon Electric Signs Ltd.
1657. (2) Melbourne, Emily McPherson College of Domestic Economy, supply and installation of fluorescent lighting, £179 16s. 6d.—Claude Neon Lights (Victoria) Ltd.
1658. (2) Melbourne, Public Offices, painting, second floor, £1,128.—John R. and E. Secull Pty. Ltd.
1659. (1) Melbourne, Public Works Department, painting and decorating new partitions, £1,220 10s.—John R. and E. Secull Pty. Ltd.
1660. (2) Melbourne, Central Tuberculosis Bureau, external and internal painting and repairs, £794.—H. C. Goldberg.
1661. (1) Mildura, High School, supply and installation of fuel hot-water service, £299.—Howie Bros.
1662. (1) Mildura, High School, installation of electric light and power, £180.—C. F. Russell.
1663. (3) Mildura West, State School No. 3983, renovations, £266 15s.—Berton Bros.
1664. (2) Mincha, State School No. 3628, repairs, £143.—Saunders and Ross.
1665. (1) Mirboo North, State School No. 2383, conversion of army hut to classrooms, £1,170.—J. P. Carter.
1666. (2) Mont Park, Mental Hospital, supply and installation of ventilation system in staff kitchen, £437 10s.—J. Wilson.
1667. (1) Mont Park, Mental Hospital, alterations, additions, repairs, and painting, £20,150.—J. Viney Construction Co.
1668. (3) Moonee Ponds Central, State School No. 3987, alterations and repairs to stairs, £117 10s.—John Graham Building Constructions.
1669. (2) Mont Park, Gresswell Sanatorium, extension of kitchen scullery, alterations to servery, £1,689.—J. Viney Construction Co.
1670. (1) Mont Park, Gresswell Sanatorium, fencing, £453 18s.—Burrows and Hardy Pty. Ltd.
1671. (2) Mysia, State School No. 1899, repairs, £171 5s.—W. Chalmers.
1672. (2) Naroghid, State School No. 1502, removal and re-erection of sleep-out, repairs, &c., £138 10s. 6d.—J. H. Pyke.
1673. (1) Pakenham, Consolidated School, erection of junior wing, £12,742.—Keith G. Hooker and Co.
1674. (1) Port Fairy, State School No. 1188, new residence, £1,675 1s. 3d.—J. J. McLaren.
1675. (4) Port Melbourne, State School No. 2932, renovations, £335.—Ford and Ross.
1676. (1) Prahran, Technical School, renovations, £570.—D. Tincknell.
1677. (4) Preston, State School No. 1494, renovations, £816.—E. J. Lewis.
1678. (3) Richmond, State School No. 1396, renovations, £855 17s.—Lewis and Davis.
1679. (3) Richmond, Technical School, supply and installation of electric light and power, £1,736.—Sutherland and Green Pty. Ltd.
1680. (2) Richmond, Technical School, supply and installation of cold cathode fluorescent lighting equipment, £1,980.—Neon Electric Signs Limited.
1681. (1) Rosebud, State School No. 2627, conversion of army hut, £1,012.—H. A. Bucher and Son.
1682. (1) Rosebud, State School No. 2627, provision of new closet and repairs, &c., £157.—H. A. Bucher and Son.
1683. (3) Royal Park, Mental Hospital, supply and installation of motorized hydro extractor, £240.—Robert Lilley and Co. Pty. Ltd.
1684. (1) St. James, Police Station, internal renovations, £158 6s. 6d.—R. A. O'Donnell.
1685. (2) Sale, High School, completion of painting, &c., £525.—D. Maher.
1686. (1) Scarsdale, State School No. 980, construction of laundry, £175 3s.—F. N. Wilson.
1687. (3) Scotsburn, State School No. 2176, renovations, £299 10s.—J. H. Brown and Son Pty. Ltd.
1688. (2) Sorrento, State School No. 1090, renovations, £334.—V. V. Fazio.
1689. (5) South Melbourne, Public Works Storeyard, new residence, £1,717.—R. B. Hallett.
1690. (4) South Yarra, State School No. 583, installation of electric light and power, £575.—Colmax Electric Pty. Ltd.
1691. (1) Stawell, Pleasant Creek Special School, supply and delivery of electric mixer for kitchen, £353 10s.—Brice Scale and Slicer Co.
1692. (1) Stawell, Pleasant Creek Special School, repairs to seven fireplaces, £104.—R. Brayshaw.
1693. (2) Sunbury, Mental Hospital, supply and installation of refrigeration equipment, £970.—Rickards Bros. Pty. Ltd.
1694. (1) Sunbury, Mental Hospital, supply and installation of electric meat mincer for main kitchen, £140.—Butcher's Service Eng. Co.
1695. (4) Surrey Hills, State School No. 2778, renovations, £777.—R. Bryant.
1696. (1) Swan Hill, State School No. 1142, remodelling, £1,129.—Drummond Bros.
1697. (1) Tallangatta, State School No. 1365, renovations, £183.—J. Davis.
1698. (1) Tongala, State School No. 3776, renovations, £355.—L. A. Skelton.
1699. (2) Toorak, State School No. 3016, renovations, £1,565.—D. Tincknell.
1700. (2) Trafalgar East, State School No. 3499, new flooring, re-blocking, &c., £148.—A. K. McCrabb.
1701. (1) Traralgon, State School No. 3584, conversion of army hut into classrooms, £1,179.—A. F. Angus.
1702. (4) Tunstall, State School No. 4190, renovations, £160.—Netherton and Hughes.
1703. (1) Tynong North, State School No. 4464, renovations, £347.—Keith G. Hooker and Co.
1704. (9) Upper Ferntree Gully, State School No. 3926, renovations, £208.—C. W. Grant.
1705. (2) Wandin Yallock, State School No. 1033, repairs to roof, re-blocking residence, &c., £468.—D. Tincknell.
1706. (1) Wangaratta, Technical School, additional workshops by adding new floor to existing workshop block, £13,090 9s. 10d.—R. J. Lowe.
1707. (1) Wangaratta South, State School No. 1580, repairs, £269 14s. 6d.—W. A. Meldrum.
1708. (1) Warracknabeal, High School, renovations, £103 10s.—A. Carter and C. W. Taylor.
1709. (2) Waurin Ponds, State School No. 1040, renovations, £335.—J. C. Morland.
1710. (3) Weering, State School No. 904, renovations, £138.—F. Jones.
1711. (3) Westbreen, State School No. 4158, new porch, £127 10s.—H. S. Bolger, jun.
1712. (3) Wilby, State School No. 2288, renovations, £281 4s. 6d.—R. A. O'Donnell.
1713. (2) Woomelang, State School No. 3373, renovations, £256.—D. Moore.
1714. (2) Yallock, State School No. 3420, renovations, £595.—D. Tincknell.
1715. (3) Yallock, State School No. 3420, fencing, £115 10s.—H. S. Bolger, jun.
1716. (1) Yallourn, High School, painting and repairs, £865 15s. 6d.—W. and D. Pitts and Son.
1717. (2) Yallourn, High School, supply and installation of refrigerator, £169.—Rickards Bros. Pty. Ltd.
1718. (1) Yallourn, High School, conversion of army hut, £1,283.—Keith G. Hooker and Co.
1719. (1) Yan Yean, State School No. 697, renovations, £314.—Netherton and Hughes.
1720. (2) Keysborough, State School No. 1466, renovations, £312 2s.—H. S. Bolger, jun.
1721. (1) Ballarat, Mental Hospital, supply and lay rubber flooring, £377 14s. 7d.—Dunlop Rubber (Aust.) Ltd.
1722. (1) Maffra, High School, supply of gravel, £154 13s. 4d.—C. F. Henderson.
1723. (1) Melbourne, Agricultural Department, washing walls, £186.—Utility Cleaning Co.
1724. (3) Royal Park, Zoological Gardens, supply of café fountain, £132 10s.—Toledo-Berkel Pty. Ltd.
1725. (2) Royal Park, Zoological Gardens, supply of sinks, £320.—L. J. Morgan.
1726. (1) Greenvale, Sanatorium, supply of linoleum, £723 9s. 6d.—Michael Nairn and Co. (Aust.) Pty. Ltd.
1727. (16) Heatherton, Sanatorium, furniture and fittings, £639.—Latex Products Pty. Ltd.
1728. (16) Heatherton, Sanatorium, furniture and fittings, £767 5s.—C. Mott.
1729. (16) Heatherton, Sanatorium, furniture and fittings, £107 2s.—Mutual Store Ltd.
1730. (16) Heatherton, Sanatorium, furniture and fittings, £331 19s.—G. A. Whiting.
1731. (16) Heatherton, Sanatorium, furniture and fittings, £294.—United Furnishers.
1732. (16) Heatherton, Sanatorium, furniture and fittings, £200.—C. E. Wilkes and Co.

1733. (16) Heatherton, Sanatorium, furniture and fittings, £558 9s. 7d.—K. G. Luke Pty. Ltd.
1734. (16) Heatherton, Sanatorium, furniture and fittings, £259 15s. 7d.—Lincot Pty. Ltd.
1735. (1) Greenvale, Sanatorium, supply of pillows, £475 4s.—The Myer Emporium Ltd.
1736. (1) Heatherton, Sanatorium, supply of pillows, £462.—The Myer Emporium Ltd.
1737. (3) Williamstown, High School, repairs to out-offices, £117.—R. B. Hallett.
1738. (2) Portland, Harbour Works, supply of drill, £1,095.—Goldfields Diamond Drilling Co. Pty. Ltd.
1739. (3) Melbourne, State Rivers and Water Supply Commission, supply of ten (10) plan presses, £377 15s.—Dandy Woodware Pty. Ltd.
1740. (1) Carlton, Education Department, Furniture Depot, supply of 1,500 sanitary pans, £1,162 10s.—A. G. Way and Co. Pty. Ltd.
1741. (1) Melbourne, various Police Stations, supply of coat racks, £112 2s. 6d.—The Myer Emporium Ltd.
1742. (4) Melbourne, various Police Stations, supply of cabinets and desks, £794 11s.—Johnstone and Morrison.
1743. (4) Melbourne, various Police Stations, supply of six safes, £109 5s. 6d.—Victoria Safe Co. Pty. Ltd.
1744. (4) Melbourne, various Police Stations, supply of nine cabinets, £193 10s.—B. E. Purnell.
1745. (3) Kensington, State School No. 2374, repairs to roof, £155.—R. B. Hallett.
1746. (1) Williamstown, installation of bend to laundry pipes, £139 10s.—Johnsons Tyne Foundry Pty. Ltd.
1747. (1) Dandenong, High School, supply of cupboard, &c., £124 19s.—Dandy Woodware Pty. Ltd.
1748. (2) Springvale, Crematorium, supply of four fans, £180.—British General Electric Co. Pty. Ltd.
1749. (5) Caulfield, Technical School, furniture and fittings, £171 10s.—Pollard Bros.
1750. (5) Caulfield, Technical School, furniture and fittings, £145 10s.—B. E. Purnell.
1751. (5) Caulfield, Technical School, furniture and fittings, £471 10s.—Johnston's Pty. Ltd.
1752. (1) Koo-wee-rup, Police Station, supply and fix plaster, £171 7s.—Liddy Classic Fibrous Plaster Pty. Ltd.
1753. (2) Murrumbidgee, State School No. 4119, renovations, £156.—C. G. Tillig and Sons.
1754. (1) Nhill, High School, repairs to ceilings, £139.—G. Lange.
1755. (1) Mont Park, Mental Hospital, supply of six oeds, £128 4s. 4d.—C. Mott.
1756. (2) Richmond, State School No. 2084, renovations to infants' room, £115.—D. Tincknell.
1757. (2) Greenvale, Sanatorium, supply of refrigerators, £476.—Rickards Bros. Pty. Ltd.
1758. (2) Bendigo, Teachers' College, supply of steel chairs, £237.—Stewarts and Lloyds (Aust.) Pty. Ltd.
1759. (2) North Melbourne, Police Station, renovations, £182 10s.—F. T. Pulling.
1760. (1) Melbourne, Government House, supply and lay carpet, £415.—N. Nixon.
1761. (5) Hampton, Breakwater, supply of spalls, £3,386 9s. 2d.—J. Starbuck and Sons.
1762. (5) Hampton, Breakwater, supply of spalls, £3,386 9s. 2d.—G. H. Reid and Sons.
1763. (3) Heatherton, Sanatorium, supply of refrigerators, £357.—Rickards Bros. Pty. Ltd.
1764. (2) Royal Park, Mental Hospital, supply of chairs, £234.—D. F. Cowan.
1765. (1) Mildura, State School No. 2915, repairs to brickwork, £125.—O. H. Wynne.
1766. (1) Greenvale, Sanatorium, erecting storeroom shelves, £197 10s.—B. Fellows.
1767. (1) South Yarra, Migrants' Camp, shelving, £146 15s.—Brooklyn Cabinet Works.
1768. Extras on Contract, Serial No. 1330/47-48, £241 11s.
1769. Extras on Contract, Serial No. 745/48-49, £34 4s. 9d.
1770. Extras on Contract, Serial No. 620/48-49, £9 15s.
1771. Extras on Contract, Serial No. 1540/46-47, £21 15s.
1772. Extras on Contract, Serial No. 1053/48-49, £12 10s.
1773. Extras on Contract, Serial No. 722/46-47, £79 19s. 3d.
1774. Extras on Contract, Serial No. 2157/47-48, £305 1s. 5d.
1775. Extras on Contract, Serial No. 1854/46-47, £23 19s. 1d.
1776. Extras on Contract, Serial No. 2499/47-48, £13 1s. 6d.
1777. Extras on Contract, Serial No. 2368/47-48, £64.
1778. Extras on Contract, Serial No. 927/46-47, £176 14s.
- J. A. KENNEDY, Commissioner of Public Works.  
6.12.48.

## ORDERS IN COUNCIL.—(Series 1948-49.)

## DEPARTMENT OF EDUCATION.

1597. One only "John Heine" 36-in. treadle guillotine shear, for Castlemaine Technical School, £106 8s.—McPherson's Pty. Ltd., Melbourne.  
(This is in lieu of Order in Council approved on 3rd August, 1948.)

Approved by the Governor in Council, 12th October, 1948.—J. C. MACGIBBON, Acting Clerk of the Executive Council.

## STATE ELECTRICITY COMMISSION.

1598. The supply of 60 forged silicon chrome steel moulds, Yallourn, to Quotation No. 1603.—H. V. Hampton.

1599. The erection of concrete telephone exchange room, Traralgon office, to Quotation No. 184A.—K. G. Hooker and Co.

Approved by the Governor in Council, 23rd November, 1948.—J. C. MACGIBBON, Acting Clerk of the Executive Council.

1600. The supply of one mobile X-ray plant, Kiewa, to Quotation No. 3305A.—Watson Victor Ltd.

1601. The supply of 23,534 super. feet Tuart hardwood.—Millars Timber and Trading Co. Ltd.

1602. The supply of iron castings and fittings for a period of twelve months, to Quotation No. 1151.—Hanks Bros.

1603. The supply of six 10-cwt. Bedford coupe utilities, to Quotation No. 2032.—S. A. Cheney Pty. Ltd.

1604. The supply of 7,712 lb. fabric moulding powder, to Quotation No. 223.—Electronic Industries Ltd.

1605. The supply of three electrically-operated stiff-legged derrick cranes, Yallourn, to Specification No. 48-49/101.—Horrocks, Roxburgh Pty. Ltd.

1606. The supply of spare parts for Cummins Diesel engines, to Quotation No. 892.—Tutt, Bryant (Vic.) Pty. Ltd.

1607. The supply of 116,500 porcelain insulators.—Japanese Board of Trade (Boeki Cho).

1608. The supply of two double-deck steam cookers, Yallourn North Hostel, to Quotation No. 1553.—A. E. Atherton and Sons Pty. Ltd.

1609. The supply of fourteen door locks and fourteen door checks for lifts, Yallourn Generating Station, to Quotation No. 1729.—Edmiston and O'Neill Pty. Ltd.

1610. The supply of 3,750 feet steel for track shoe nuts, to Quotation No. 1138.—Commonwealth Steel Co. Ltd.

1611. The supply of black carbon and drilling crystals, to Quotation No. 1150.—Rene Vanderkelen.

1612. The supply of 1,850 universal air hose couplings, Kiewa Hydro-Electric Scheme, to Quotation No. 1926.—McPherson's Ltd.

1613. The supply and fitting of one power control unit and angledozer to International tractor, Yallourn, to Quotation No. 1297.—Victorian Industrial Sales and Service Pty. Ltd.

1614. The supply of steel storage bin components, Kiewa Hydro-Electric Scheme, to Quotation No. 2119.—E. T. Brown Ltd.

1615. The electrical wiring installation, Richmond office, to Specification No. 48-49/81.—W. Cumming and Co. Pty. Ltd.

1616. The installation of automatic thermostatic fire alarm system, Richmond office, to Quotation No. 1637.—May, Oatway Fire Alarms Pty. Ltd.

1617. The supply of ten pneumatic portable hand saws, Kiewa Hydro-Electric Scheme, to Quotation No. 2570.—Rusden, Birrell, and Co.

1618. The supply of four 800-gallon hot-water systems, Kiewa Hydro-Electric Scheme, to Specification No. 48-49/80.—Gardner and Naylor Pty. Ltd.

1619. The supply of one 800-gallon hot-water system, Kiewa Hydro-Electric Scheme, to Specification No. 48-49/80.—Noyes Bros. (Melb.) Ltd.

1620. The supply of two 800-gallon hot-water systems, Kiewa Hydro-Electric Scheme, to Specification No. 48-49/80.—Charles E. Guy and Co.

1621. The supply of 75 items of lighting equipment, to Quotation No. 2415.—British General Electric Co. Pty. Ltd.

1622. The supply of six Austin A40 coupe utilities, to Quotation No. 2543.—Austin Distributors Ltd.

1623. The supply of 19,800 gallons creosote oil, to Quotation No. 576.—Timbrol Ltd.

1624. The supply of 20,250 gallons creosote oil, to Quotation No. 576.—Ajax Oil Refineries (Aust.) Pty. Ltd.

1625. The supply of 4,000 yards insulated cable, to Quotation No. 1648.—Gilbert Lodge and Co. Pty. Ltd.

1626. The supply of 17 tons hollow rock drill steel, Kiewa Hydro-Electric Scheme, to Quotation No. 1475.—Commonwealth Steel Co. Ltd.

1627. The supply of 10-ton Lorain mobile crane and attachments, Kiewa Hydro-Electric Scheme, to Quotation No. 2585.—Frank J. Hodgson Pty. Ltd.

1628. The supply of electrical equipment for 1,066 bucket wheel dredger, Yallourn, to Quotation No. 2526.—Garbe Lahmeyer, through the Joint Export/Import Agency (U.K./U.S.).

1629. The supply of 25-ton erection crane, Yallourn Open Cut, to Quotation No. 2527.—Lubecker Maschinenbau Gesellschaft, through the Joint Export/Import Agency (U.K./U.S.).

1630. The supply of additional electrical equipment for DS650 Stahlbau dredger, Yallourn, to Quotation No. 2528.—Garbe Lahmeyer, through the Joint Export/Import Agency (U.K./U.S.).

1631. The cancellation of the contract approved on 13th July, 1948, for the supply of 244,560 super. feet sawn blue gum timber.—Neville Smith and Co. Pty. Ltd.

Approved by the Governor in Council, 30th November, 1948.—J. C. MACGIBBON, Acting Clerk of the Executive Council.

#### FORESTS COMMISSION.

Loan Act No. 5232, Item 8—

1632. To the purchase of allotment 51, section A, Parish of Wyalangta, comprising 174 acres 2 roods 16 perches for Forest purposes, £349 4s.—Dr. C. G. Godfrey, M.D., Bay-street, Brighton.

Approved by the Governor in Council, 16th November, 1948.—J. C. MACGIBBON, Acting Clerk of the Executive Council.

#### LANDLORD AND TENANT ACTS.

*At the Executive Council Chamber, Melbourne, the thirtieth day of November, 1948.*

PRESENT:

His Excellency the Governor of Victoria.  
Lieut.-Col. Dennett | Mr. Byrnes.

ORDER EXCLUDING CERTAIN PREMISES FROM THE OPERATION OF PART III. OF THE "LANDLORD AND TENANT ACT 1948."

IN pursuance of the powers conferred upon him by the *Landlord and Tenant Act 1948*, as amended by the *Landlord and Tenant (Amendment) Act 1948*, His Excellency the Governor of Victoria, by and with the advice of the Executive Council thereof, doth hereby declare that the premises situated upon all that piece of land, being Crown allotment 6, section A, at Royal Park, Parish of Jika Jika, County of Bourke, shall be excluded from the operation of the whole of the provisions contained in Part III. of the *Landlord and Tenant Act 1948*.

And the Honorable Trevor Donald Oldham, His Majesty's Attorney-General in and for the State of Victoria, shall give the necessary directions herein accordingly.

J. C. MACGIBBON,  
Acting Clerk of the Executive Council.

#### DEPARTMENT OF LANDS AND SURVEY.

*At the Executive Council Chamber, Melbourne, the thirtieth day of November, 1948.*

PRESENT:

His Excellency the Governor of Victoria.  
Lieut.-Col. Dennett | Mr. Byrnes.

#### UNUSED AND UNMADE ROAD CLOSED.

HIS Excellency the Governor of the State of Victoria, by and with the advice of the Executive Council thereof, doth hereby direct that, in pursuance of the provisions of section 304 of the *Land Act 1928* (No. 3709), the unused and unmade road referred to hereunder be closed, viz.:

Parish of Drumborg, County of Normanby, being the road between the reserve for a State School and the reserves for a Public Hall and, for Public Recreation.—(D.106<sup>(\*)</sup>) (Rs.1702).

And the Honorable Percy Thomas Byrnes, for and on behalf of His Majesty's Commissioner of Crown Lands and Survey for the State of Victoria, shall give the necessary directions herein accordingly.

J. C. MACGIBBON,  
Acting Clerk of the Executive Council.

#### DEPARTMENT OF LANDS AND SURVEY.

*At the Executive Council Chamber, Melbourne, the thirtieth day of November, 1948.*

PRESENT:

His Excellency the Governor of Victoria.  
Lieut.-Col. Dennett | Mr. Byrnes.

#### REVOCATION OF TEMPORARY RESERVATIONS OF LANDS BY ORDERS IN COUNCIL.

HIS Excellency the Governor of the State of Victoria, by and with the advice of the Executive Council thereof, doth hereby, in pursuance of the provisions of the *Land Act 1928*, revoke the temporary reservations of the lands by Orders in Council hereinafter referred to, viz.:

BARWO.—Order in Council of 10th May, 1880, of 4 acres 3 roods 39 perches of land in the Parish of Barwo, as a site for Public purposes (State School).—(C.77592.)

BOHO.—Order in Council of 31st March, 1885, of 1 acre of land in the Parish of Boho, as a site for a Mechanics' Institute.—(Rs.852.)

PORTARLINGTON.—Order in Council of 19th March, 1860, of 1 rood of land in the Township of Portarlington, as a site for a Mechanics' Institute.—(C.91433.)

And the Honorable Percy Thomas Byrnes, for and on behalf of His Majesty's Commissioner of Crown Lands and Survey for the State of Victoria, shall give the necessary directions herein accordingly.

J. C. MACGIBBON,  
Acting Clerk of the Executive Council.

#### DEPARTMENT OF LANDS AND SURVEY.

*At the Executive Council Chamber, Melbourne, the thirtieth day of November, 1948.*

PRESENT:

His Excellency the Governor of Victoria.  
Lieut.-Col. Dennett | Mr. Byrnes.

#### LANDS TEMPORARILY RESERVED FROM SALE.

HIS Excellency the Governor of the State of Victoria, by and with the advice of the Executive Council thereof, doth hereby, in pursuance of the provisions of the *Land Act 1928*, reserve, temporarily, and also except from occupation for mining purposes under any miner's right, the lands hereinafter described:—

BLACKWOOD.—Site for Mineral Springs and Tourist Camp purposes, 14 acres, more or less, Parish of Blackwood, County of Bourke, in the two portions indicated by hachure on plan hereunder.—(B.405<sup>(\*)</sup>) (Rs.1588).

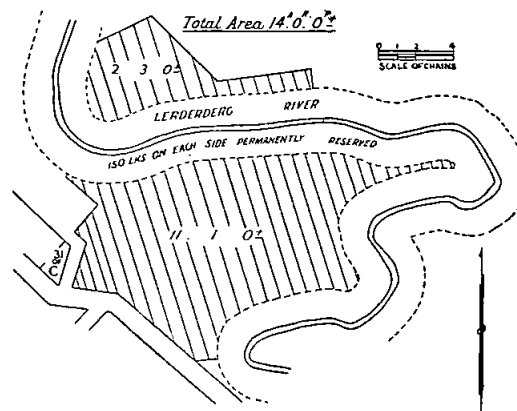

DRUMBORG.—Site for Public Recreation, in addition to and adjoining the site temporarily reserved therefor by Order in Council of the 6th February, 1903, 2 roods 20 perches, more or less, Parish of Drumborg, County of Normanby, as indicated by hachure on plan hereunder.—(D.106(\*) (Rs.1702).

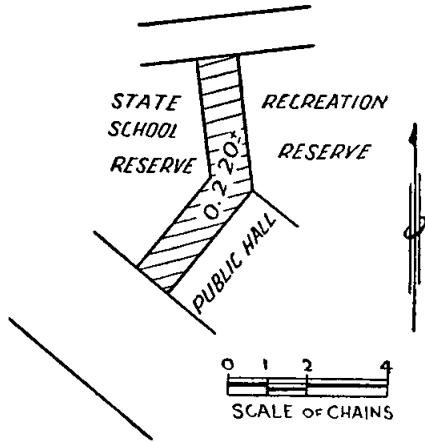

FRANKSTON.—Site for Public Recreation, 10 acres 3 roods 20 perches, Parish of Frankston, County of Mornington, as indicated by hachure on plan hereunder.—(F.87(\*) (Rs.3128).

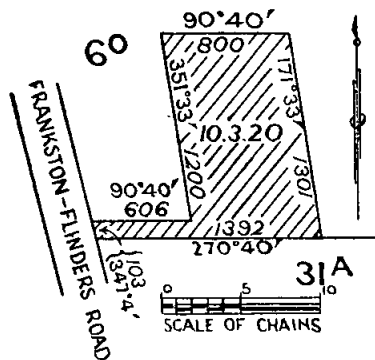

OXLEY.—Site for an Ornamental Plantation and a Soldiers' Memorial, 3 roods 9 perches, Township of Oxley, Parish of Oxley, County of Delatite, as indicated by hachure on plan hereunder.—(O.16(\*) (Rs.6297).

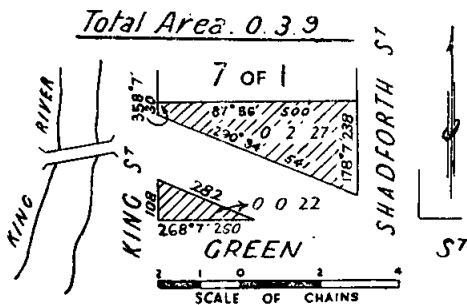

And the Honorable Percy Thomas Byrnes, for and on behalf of His Majesty's Commissioner of Crown Lands and Survey for the State of Victoria, shall give the necessary directions herein accordingly.

J. C. MACGIBBON,  
Acting Clerk of the Executive Council.

STATE RIVERS AND WATER SUPPLY COMMISSION.

At the Executive Council Chamber, Melbourne, the thirtieth day of November, 1948.

PRESENT:

His Excellency the Governor of Victoria.  
Lieut.-Col. Dennett | Mr. Byrnes.

SPRINGVALE AND NOBLE PARK SEWERAGE AUTHORITY.

SEWERAGE DISTRICT PROCLAIMED AND AUTHORITY CONSTITUTED.

UNDER the powers conferred by the Sewerage District Acts and all other powers enabling him in that behalf, His Excellency the Governor of the State of Victoria, by and with the advice of the Executive Council of the said State, doth hereby approve of the application of the Dandenong Shire Council for the proclamation of a Sewerage District and for the constitution of a Sewerage Authority to carry out works for the sewerage of Springvale and Noble Park, in accordance with the provisions of the said Acts, and doth hereby appoint as follows:—

- (a) That the amount of loan moneys which may be borrowed by such Sewerage Authority shall be One hundred and forty thousand pounds (£140,000), and the amount which may be borrowed by way of overdraft shall be Three thousand pounds (£3,000).
- (b) That the principal works to be constructed or carried out by the Sewerage Authority shall consist of reticulation and branch sewers, main sewers, and outfall sewer.
- (c) That the limits of the land within which the said Sewerage Authority shall have authority shall be those within the following boundaries.

SCHEDULE.

Portion I. (Noble Park).

Commencing at a point in the Parish of Dandenong, County of Bourke, such point being the most northerly angle of Crown portion 16; thence southerly along its western boundary to its south-western angle; thence southerly by a line across a road to the north-western angle of Crown portion 21; thence southerly along its western boundary to a point on the north-eastern boundary of the Eastern Railway Reserve; thence by a line being a continuation thereof across the Eastern Railway Reserve to a point on its south-western boundary; thence southerly along the western boundary of Crown portion 21 to a point distant 771 links, or thereabouts, north from the north-western angle of Crown portion 21A; thence westerly by a line across a road to a point on the eastern boundary of Crown portion 22, such point being distant 974 links, or thereabouts, north from the north-eastern angle of Crown portion 22A; thence westerly by a line parallel to the southern boundary of Crown portion 22, across portion of Crown portion 22 for a distance of 4,103 links, or thereabouts; thence southerly by a line parallel to the eastern boundary of Crown portion 22 for a distance of 496.4 links, or thereabouts; thence westerly across portion of Crown portion 22 by a line being parallel to its southern boundary to a point on its western boundary; thence westerly by a line being a continuation thereof across a road to a point on the eastern boundary of Crown allotment D, section 23; thence northerly along the eastern boundary of Crown allotment D to a point distant 1,330 links, or thereabouts, south from the north-eastern angle of Crown allotment D; thence westerly by a line parallel to the northern boundary of Crown allotment D to a point distant 1,334 links, or thereabouts, from the eastern boundary of Crown allotment D; thence northerly a distance of 360 links, or thereabouts, to a point distant 1,335 links, or thereabouts, west from the eastern boundary of Crown allotment D; thence easterly by a line parallel to the northern boundary of Crown allotment D for a distance of 40 links, or thereabouts; thence northerly by a line across portion of Crown allotment D, across Crown allotment B, across a road, and across portion of Crown allotment D, section 12, to a point on the south-western boundary of the Eastern Railway Reserve, such point being 1,595½ links, or thereabouts, north-westerly from the intersection of the south-western boundary of the Eastern Railway Reserve and the eastern boundary of Crown allotment D, section 12; thence north-westerly along the south-western boundary of the Eastern Railway Reserve for a distance of 895 links, or thereabouts; thence north-easterly across the Eastern Railway Reserve

to a point on its north-eastern boundary, such point being distant 2,240.2 links, or thereabouts, north-westerly from the intersection of the north-eastern boundary of the Eastern Railway Reserve and the eastern boundary of Crown allotment D; thence easterly across portion of Crown allotment D to a point on its eastern boundary 939 links, or thereabouts, south from its north-eastern angle; thence northerly along the eastern boundaries of Crown allotments D and B to the north-eastern angle of Crown allotment B; thence easterly along the southern boundary of Crown portion 11 to its most easterly angle; thence by a line being a continuation thereof across the Prince's Highway to a point on its north-eastern boundary; thence south-easterly along the north-eastern boundary of the Prince's Highway to a point in line with the western boundary of Crown portion 16; thence southerly by a line across the Prince's Highway to the point of commencement.

*Portion II. (Springvale).*

Commencing at a point in the Parish of Mordialloc, County of Bourke, such point being the south-western angle of Crown allotment 2, section 5; thence easterly along the southern boundary of Crown allotment 2 to its south-eastern angle; thence north-easterly by a line across a road to a point on the western boundary of Crown portion 10, Parish of Dandenong, such point being distant 3,754½ links, or thereabouts, south of the most northerly angle of Crown portion 10; thence easterly by a line being parallel to the southern boundary of Crown portion 10, through portion of Crown portion 10, for a distance of 1,775 links, or thereabouts; thence southerly by a line being parallel to the western boundary of Crown portion 10, through portion of Crown portion 10, for a distance of 1,558½ links, or thereabouts; thence easterly by a line across portion of Crown portion 10 to a point on its eastern boundary, distant 1,908 links, or thereabouts, south from its north-eastern angle; thence southerly along the eastern boundary of Crown portion 10 to a point on the north-eastern boundary of Mile Creek; thence south-easterly along the north-eastern boundary of Mile Creek, across the Cemetery Railway Reserve to a point on its south-eastern boundary; thence south-westerly along the south-eastern boundary of the Cemetery Railway Reserve to a point on the eastern boundary of Crown allotment A, section 12; thence southerly along the eastern boundary of Crown allotment A to a point on the north-eastern boundary of the Eastern Railway Reserve; thence southerly by a line being a continuation thereof across the Eastern Railway Reserve to a point on its south-western boundary; thence southerly along the eastern boundaries of Crown allotments A and C to a point distant 1,935 links, or thereabouts, north from the south-eastern angle of Crown allotment C; thence westerly by a line being parallel to the southern boundary of Crown allotment C, across Crown allotment C, to a point on its western boundary; thence northerly along the western boundary of Crown allotment C for a distance of 258 links, or thereabouts; thence westerly by a line being parallel to the southern boundary of Crown allotment 3, section 12, Parish of Mordialloc, across a road to a point on the eastern boundary of Crown allotment 3; thence westerly by a line being a continuation thereof, across portion of Crown allotment 3 to a point distant 1,558 links, or thereabouts, from its eastern boundary; thence northerly by a line across portion of Crown allotment 3 to a point on its northern boundary, such point being distant 1,571 links, or thereabouts, from its north-eastern angle; thence westerly along the northern boundary of Crown allotment 3 to its north-western angle; thence by a line being a continuation thereof across portion of Crown allotment 1A for a distance of 1,000 links, or thereabouts; thence northerly by a line parallel to the eastern boundary of Crown allotment 1, across portion of Crown allotment 1A, portion of Crown allotment 1, and portion of Crown allotment 1, section 5, to a point on the south-western boundary of the Eastern Railway Reserve; thence by a line being a continuation thereof across the Eastern Railway Reserve to a point on its north-eastern boundary; thence north-westerly along the north-eastern boundary of the Eastern Railway Reserve to a point distant 2,828 links, or thereabouts, from the intersection of the eastern boundary of Crown allotment 1 and the north-eastern boundary of the Eastern Railway Reserve; thence northerly by a line through portion of Crown allotment 1 to a point being distant 3,250 links, or thereabouts, south from the northern boundary of Crown allotment 1 and distant 2,322 links, or thereabouts, west from its eastern boundary; thence westerly by a line parallel to the northern boundary of Crown allotment 1 to a point on its eastern boundary; thence southerly along the western boundary of Crown allotment 2 to the point of commencement.

All of which boundaries are shown on a plan approved by the Governor in Council, and deposited in the office of the State Rivers and Water Supply Commission, Melbourne.—(Corres. 48/19250.)

- (d) That the councillors for the time being of the North and South Ridings of the Shire of Dandenong, and one other person, shall be the members of the Sewerage Authority.
- (e) That the name of the Authority shall be Springvale and Noble Park Sewerage Authority.

And the Honorable John Gladstone Black McDonald, His Majesty's Minister of Water Supply for the State of Victoria, shall give the necessary directions herein accordingly.

J. C. MACGIBBON,  
Acting Clerk of the Executive Council.

Water Acts.

STATE RIVERS AND WATER SUPPLY COMMISSION.

*At the Executive Council Chamber, Melbourne, the thirtieth day of November, 1948.*

PRESENT:

His Excellency the Governor of Victoria.  
Lieut.-Col. Dennett | Mr. Byrnes.

MORNINGTON PENINSULA WATERWORKS DISTRICT.—CHELSEA-FRANKSTON URBAN DISTRICT.—PORTION EXCISED.

UNDER the powers conferred by the Water Acts and all other powers enabling him in that behalf, His Excellency the Governor of the State of Victoria, with the advice of the Executive Council of the said State, on the recommendation of the State Rivers and Water Supply Commission, doth hereby declare, order, and direct as follows:—

That there shall be excised from the Chelsea-Frankston Urban District of the Mornington Peninsula Waterworks District that portion of the same set out and described in the Schedule hereto, which portion, as on and from the date of this Order, shall be deemed to be excised accordingly.

SCHEDULE.

All that land, comprising lots 8 to 45 inclusive, on lodged plan of subdivision No. 11532, Parish of Frankston, County of Mornington, that portion of Summit-road forming the northern boundaries of lot 10 and lots 13 to 29 inclusive, that portion of Sebroke-street forming the western boundary of lot 37, and that portion of Yuille-street forming the western boundaries of lots 10, 11, and 12, all on said lodged plan of subdivision No. 11532.

The portion set out and described in the foregoing Schedule is shown on a plan approved by the Governor in Council, and deposited in the office of the State Rivers and Water Supply Commission, Melbourne.—(Corres. 48/16933.)

And the Honorable John Gladstone Black McDonald, His Majesty's Minister of Water Supply for the State of Victoria, shall give the necessary directions herein accordingly.

J. C. MACGIBBON,  
Acting Clerk of the Executive Council.

Water Acts.

STATE RIVERS AND WATER SUPPLY COMMISSION.

*At the Executive Council Chamber, Melbourne, the thirtieth day of November, 1948.*

PRESENT:

His Excellency the Governor of Victoria.  
Lieut.-Col. Dennett | Mr. Byrnes.

ROCHESTER IRRIGATION AND WATER SUPPLY DISTRICT.—LOCKINGTON URBAN DIVISION.—DIVISION EXTENDED.

UNDER the powers conferred by the Water Acts and all other powers enabling him in that behalf, His Excellency the Governor of the State of Victoria, with the advice of the Executive Council of the said State, on

the recommendation of the State Rivers and Water Supply Commission, doth hereby declare, order, and direct as follows:—

That the Lockington Urban Division of the Rochester Irrigation and Water Supply District be extended by adding to the same the land set out and described in the Schedule hereto, and as on and from the date of this Order such urban division shall be deemed to be so extended.

SCHEDULE.

All that piece of land, comprising portion of Crown allotment 112, Parish of Bamawm, County of Rochester, being the land more particularly described in certificate of title, volume 5422, folio 1084400.

The land described in the foregoing Schedule is shown on a plan approved by the Governor in Council, and deposited in the office of the State Rivers and Water Supply Commission, Melbourne.—(Corres. 48/21709.)

And the Honorable John Gladstone Black McDonald, His Majesty's Minister of Water Supply for the State of Victoria, shall give the necessary directions herein accordingly.

J. C. MACGIBBON,  
Acting Clerk of the Executive Council.

Water Acts.

STATE RIVERS AND WATER SUPPLY COMMISSION.

*At the Executive Council Chamber, Melbourne, the thirtieth day of November, 1948.*

PRESENT:

His Excellency the Governor of Victoria.  
Lieut.-Col. Dennett | Mr. Byrnes.

SHEPPARTON IRRIGATION AND WATER SUPPLY DISTRICT—ORDER EXCISING PORTIONS OF DISTRICT AMENDED.

UNDER the powers conferred by the Water Acts and all other powers enabling him in that behalf, His Excellency the Governor of the State of Victoria, with the advice of the Executive Council of the said State, on the recommendation of the State Rivers and Water Supply Commission, doth hereby declare, order, and direct as follows:—

That there shall be substituted for portion 1 in the Schedule to Order of the Governor in Council, dated the 13th day of April, 1948, excising portion of the Shepparton Irrigation and Water Supply District, the following:—

Portion 1.—Commencing at the south-eastern angle of lot 4 on lodged plan of subdivision No. 9379, Parish of Shepparton; thence westerly by the southern boundary of the said lot to a point in line with the western boundary of lot 1 on lodged plan of subdivision No. 18246; thence northerly by a line, the western boundaries of lots 1 to 6 inclusive, on the said lodged plan of subdivision No. 18246, and a line connecting those boundaries to the north-western angle of the last-mentioned lot; thence easterly and northerly by the southern and eastern boundaries of lot 3 on lodged plan of subdivision No. 9379 to a point in line with the northern boundary of the land described in certificate of title, volume 4312, folio 862332; thence easterly by a line and the last-mentioned boundary, southerly by the eastern boundary and westerly by the southern boundary of the land described in the said certificate of title to the south-western angle thereof; thence north-westerly by a line to the point of commencement—

and the said Order of the Governor in Council shall be deemed to be amended accordingly.

The boundaries described above are shown on a plan approved by the Governor in Council, and deposited in the office of the State Rivers and Water Supply Commission, Melbourne.—(Corres. 48/22456.)

And the Honorable John Gladstone Black McDonald, His Majesty's Minister of Water Supply for the State of Victoria, shall give the necessary directions herein accordingly.

J. C. MACGIBBON,  
Acting Clerk of the Executive Council.

Water Acts.

SHEPPARTON URBAN WATERWORKS TRUST.

*At the Executive Council Chamber, Melbourne, the thirtieth day of November, 1948.*

PRESENT:

His Excellency the Governor of Victoria.  
Lieut.-Col. Dennett | Mr. Byrnes.

ORDER INCREASING EXTENT OF DISTRICT AMENDED.

UNDER the powers conferred by the Water Acts and all other powers enabling him in that behalf, His Excellency the Governor of the State of Victoria, with the advice of the Executive Council of the said State, doth hereby declare, order, and direct as follows:—

That there shall be substituted for paragraph 1 of the Schedule to Order of the Governor in Council, dated 13th day of April, 1948, increasing the extent of the Waterworks District of the Shepparton Urban Waterworks Trust, the following:—

1.—Commencing at the south-eastern angle of lot 4 on lodged plan of subdivision No. 9379, Parish of Shepparton; thence westerly by the southern boundary of the said lot to a point in line with the western boundary of lot 1 on lodged plan of subdivision No. 18246; thence northerly by a line, the western boundaries of lots 1 to 6 inclusive on the said lodged plan of subdivision No. 18246, and a line connecting those boundaries to the north-western angle of the last-mentioned lot; thence easterly and northerly by the southern and eastern boundaries of lot 3 on lodged plan of subdivision No. 9379 to a point in line with the northern boundary of the land described in certificate of title, volume 4312, folio 862332; thence easterly by a line and the last-mentioned boundary, southerly by the eastern boundary and westerly by the southern boundary of the land described in the said certificate of title to the south-western angle thereof; thence north-westerly by a line to the point of commencement—

and the said Order of the Governor in Council shall be deemed to be amended accordingly.

The boundaries described above are shown on a plan approved by the Governor in Council, and deposited in the office of the State Rivers and Water Supply Commission, Melbourne.—(Corres. 48/22456.)

And the Honorable John Gladstone Black McDonald, His Majesty's Minister of Water Supply for the State of Victoria, shall give the necessary directions herein accordingly.

J. C. MACGIBBON,  
Acting Clerk of the Executive Council.

LANCEFIELD WATERWORKS TRUST.

*At the Executive Council Chamber, Melbourne, the thirtieth day of November, 1948.*

PRESENT:

His Excellency the Governor of Victoria.  
Lieut.-Col. Dennett | Mr. Byrnes.

ADDITIONAL LOAN OF £4,000.

UNDER the powers conferred by the Water Acts and all other powers enabling him in that behalf, His Excellency the Governor of the State of Victoria, by and with the advice of the Executive Council of the said State, doth hereby grant an additional loan of Four thousand pounds (£4,000) to the Lancefield Waterworks Trust for purchase and installation of water meters and construction of pipe mains and new storage as set forth in the detailed statement bearing the date of 19th November, 1948, and verified under the seal of the State Rivers and Water Supply Commission.

The loan hereby granted shall be subject to the provisions of the Water Acts.

And the Honorable John Gladstone Black McDonald, His Majesty's Minister of Water Supply for the State of Victoria, shall give the necessary directions herein accordingly.

J. C. MACGIBBON,  
Acting Clerk of the Executive Council.

## ARARAT SEWERAGE AUTHORITY.

At the Executive Council Chamber, Melbourne, the thirtieth day of November, 1948.

PRESENT:

His Excellency the Governor of Victoria.  
Lieut.-Col. Dennett | Mr. Byrnes.

CONSENT TO BORROWING £7,000.

UNDER the powers conferred by the Sewerage Districts Acts and all other powers enabling him in that behalf, His Excellency the Governor of the State of Victoria, by and with the advice of the Executive Council of the said State, doth hereby consent to the Ararat Sewerage Authority borrowing by the issue of debentures a further sum of Seven thousand pounds (£7,000) for sewer reticulation extensions as set forth in the detailed statement bearing the date the 22nd November, 1948.

And the Honorable John Gladstone Black McDonald, His Majesty's Minister of Water Supply for the State of Victoria, shall give the necessary directions herein accordingly.

J. C. MACGIBBON,  
Acting Clerk of the Executive Council.

## COUNTRY ROADS BOARD.

At the Executive Council Chamber, Melbourne, the thirtieth day of November, 1948.

PRESENT:

His Excellency the Governor of Victoria.  
Lieut.-Col. Dennett | Mr. Byrnes.

## ORDER APPROVING OF A NEW MAIN ROAD IN THE SHIRE OF KARA KARA.

WHEREAS the Country Roads Board constituted under the *Country Roads Act 1928* (No. 3662) has represented to His Excellency the Governor in Council that it appears to it desirable that the new Marnoo-St. Arnaud road in the Shire of Kara Kara should be made by the said Board: And whereas the said Board in accordance with the requirements of section 19 of the said cited Act has caused to be prepared a map plan and estimate showing the points between which and on and through what land the said new road is proposed to be made and the cost of acquiring the land and constructing the said new road: And whereas on an inspection of the said map and plan and a consideration of the said estimate His Excellency the Governor in Council is satisfied that there are funds legally available for acquiring the land and constructing the said new road: Now therefore be it known by this present Order that His Excellency the Governor of the State of Victoria with the advice of the Executive Council thereof doth hereby approve of the said road being made, that is to say:—

All those pieces of land in the Parish of St. Arnaud, the boundaries of which are as follow:—

- (a) Commencing at the south-western angle of allotment C10, section C, of the said parish; thence by lines bearing respectively 359 deg. 54 min. 273 links, 121 deg. 34 min. 425.2 links, 89 deg. 56 min. 1,884.8 links, 90 deg. 4 min. 4,083.5 links, 90 deg. 0 min. 1,918 links, 33 deg. 44 min. 180.3 links, 180 deg. 3 min. 200 links, 270 deg. 0 min. 2,018 links, 270 deg. 4 min. 4,083.5 links, and 269 deg. 56 min. 2,246.6 links to the point of commencement.
- (b) Commencing at the north-western angle of allotment C9, section C, of the said parish; thence by lines bearing respectively 89 deg. 56 min. 2,246.3 links, 90 deg. 4 min. 4,083.5 links, 90 deg. 0 min. 2,018 links, 180 deg. 0 min. 100 links, 270 deg. 0 min. 2,018 links, 270 deg. 4 min. 4,083.5 links, 269 deg. 56 min. 2,246 links, and 359 deg. 54 min. 100 links to the point of commencement—

which said pieces of land are particularly delineated and shown coloured red and yellow on survey plan numbered 5001, lodged in the office of the Country Roads Board.

And the Honorable James Arthur Kennedy, His Majesty's Commissioner of Public Works for the State of Victoria, shall give the necessary directions herein accordingly.

J. C. MACGIBBON,  
Acting Clerk of the Executive Council.

## COUNTRY ROADS BOARD.

At the Executive Council Chamber, Melbourne, the thirtieth day of November, 1948.

PRESENT:

His Excellency the Governor of Victoria.  
Lieut.-Col. Dennett | Mr. Byrnes.

## ORDER APPROVING OF A NEW MAIN ROAD IN THE CITY OF BRIGHTON.

WHEREAS the Country Roads Board constituted under the *Country Roads Act 1928* (No. 3662) has represented to His Excellency the Governor in Council that it appears to it desirable that the new Cummins-road in the City of Brighton should be made by the said Board: And whereas the said Board in accordance with the requirements of section 19 of the said cited Act has caused to be prepared a map plan and estimate showing the points between which and on and through what land the said new road is proposed to be made and the cost of acquiring the land and constructing the said new road: And whereas on an inspection of the said map and plan and a consideration of the said estimate His Excellency the Governor in Council is satisfied that there are funds legally available for acquiring the land and constructing the said new road: Now therefore be it known by this present Order that His Excellency the Governor of the State of Victoria with the advice of the Executive Council thereof doth hereby approve of the said road being made, that is to say:—

All those pieces of land in the Parish of Moorabbin, and being parts of Dendy's Crown special survey, the boundaries of which are as follow:—

- (a) Commencing at the northern angle of lot 1 on plan of subdivision numbered 9347, lodged in the Office of Titles, and being part of the said special survey; thence by lines bearing respectively 135 deg. 42½ min. 69 ft. 4 in., 226 deg. 12 min. 64 ft. 10 in., 180 deg. 0 min. 107 ft. 8½ in., 315 deg. 42½ min. 22 ft. 11½ in., 360 deg. 0 min. 171 ft. 10 in., and 45 deg. 42 min. 20 feet to the point of commencement.
- (b) Commencing at the northern angle of lot 27 on plan of subdivision numbered 9347, lodged in the Office of Titles, and being part of the said special survey; thence by lines bearing respectively 135 deg. 42½ min. 33 ft. 11½ in., 260 deg. 10 min. 7 ft. 10 in., 180 deg. 0 min. 316 ft. 4½ in., 135 deg. 24 min. 14 ft. 4½ in., 271 deg. 59½ min. 16 feet, 315 deg. 24 min. 14 ft. 4½ in., and 360 deg. 0 min. 341 ft. 5½ in. to the point of commencement.
- (c) Commencing at the more northerly of the north-western angles of lot 32 on plan of subdivision numbered 9347, lodged in the Office of Titles, and being part of the said special survey; thence by lines bearing respectively 91 deg. 59½ min. 16 feet, 225 deg. 24 min. 13 ft. 10½ in., 180 deg. 0 min. 281 ft. 10 in., 136 deg. 25 min. 11 ft. 8 in., 271 deg. 59½ min. 14 ft. 0½ in., 315 deg. 24 min. 14 ft. 4½ in., 360 deg. 0 min. 280 feet, and 45 deg. 24 min. 13 ft. 10½ in. to the point of commencement.
- (d) Commencing at the south-western angle of lot 40 on plan of subdivision numbered 9347, lodged in the Office of Titles, and being part of the said special survey; thence by lines bearing respectively 360 deg. 0 min. 140 feet, 45 deg. 24 min. 13 ft. 10½ in., 91 deg. 59½ min. 16 feet, 225 deg. 24 min. 13 ft. 10½ in., 180 deg. 0 min. 140 feet, 181 deg. 29 min. 678 ft. 3½ in., 137 deg. 0 min. 14 ft. 3 in., 272 deg. 31½ min. 34 ft. 6 in., 1 deg. 29 min. 688 ft. 3½ in., and 91 deg. 59½ min. 8 ft. 6 in. to the point of commencement.
- (e) Commencing at the more northerly of the north-western angles of lot 31 on plan of subdivision numbered 11769, lodged in the Office of Titles, and being part of the said special survey; thence by lines bearing respectively 92 deg. 31½ min. 15 ft. 11½ in., 227 deg. 2 min. 14 ft. 0½ in., 181 deg. 29 min. 279 ft. 74 in., 137 deg. 3 min. 14 ft. 3 in., 272 deg. 32 min. 20 sec. 16 ft. 1 in., 317 deg. 3 min. 14 ft. 3 in., 1 deg. 30½ min. 279 ft. 7 in., and 47 deg. 2 min. 14 ft. 0½ in. to the point of commencement.

(f) Commencing at the south-western angle of lot 9 on plan of subdivision numbered 11980, lodged in the Office of Titles, and being part of the said special survey; thence by lines bearing respectively 1 deg. 32 min. 61 ft. 3 in., 47 deg. 2 min. 14 feet, 92 deg. 32 min. 20 sec. 16 feet, 227 deg. 2 min. 14 feet, 181 deg. 29 min. 226 ft. 2½ in., 136 deg. 56 min. 14 ft. 3 in., 272 deg. 22 min. 35 feet, 1 deg. 32 min. 175 feet, and 92 deg. 22 min. 8 ft. 9 in. to the point of commencement.

(g) Commencing at the north-eastern angle of lot 48 on plan of subdivision numbered 12684, lodged in the Office of Titles, and being part of the said special survey; thence by lines bearing respectively 181 deg. 33½ min. 32 ft. 4½ in., 360 deg. 0 min. 1,144 ft. 8½ in., 338 deg. 42½ min. 93 ft. 2 in., 137 deg. 25 min. 62 ft. 7 in., 179 deg. 57 min. 1,153 ft. 4 in., and 271 deg. 42½ min. 8 ft. 6 in. to the point of commencement—

which said pieces of land are particularly delineated and shown coloured red on survey plan numbered 4998, lodged in the office of the Country Roads Board.

And the Honorable James Arthur Kennedy, His Majesty's Commissioner of Public Works for the State of Victoria, shall give the necessary directions herein accordingly.

J. C. MACGIBBON,  
Acting Clerk of the Executive Council.

#### COUNTRY ROADS BOARD.

*At the Executive Council Chamber, Melbourne, the thirtieth day of November, 1948.*

##### PRESENT:

His Excellency the Governor of Victoria.  
Lieut.-Col. Dennett | Mr. Byrnes.

#### ORDER APPROVING OF A DEVIATION FROM A MAIN ROAD IN THE SHIRE OF LEXTON.

WHEREAS the Country Roads Board constituted under the *Country Roads Act* 1928 (No. 3662) has represented to His Excellency the Governor in Council that it appears to it desirable that the deviation hereinafter referred to from the existing Beaufort-Amphitheatre road in the Shire of Lexton (declared to be a main road under the said Act which declaration was confirmed by the Order in Council published in the *Government Gazette* of the 16th July, 1947, on pages 3851-5) should be made by the said Board: And whereas the said Board in accordance with the requirements of section 19 of the said cited Act has caused to be prepared a map plan and estimate showing the points between which and on and through what land the said deviation is proposed to be made and the cost of acquiring the land and constructing the said deviation: And whereas on an inspection of the said map and plan and a consideration of the said estimate His Excellency the Governor in Council is satisfied that there are funds legally available for acquiring the land and constructing the said deviation: Now therefore be it known by this present Order that His Excellency the Governor of the State of Victoria with the advice of the Executive Council thereof doth hereby approve of the said road being made, that is to say:—

All that piece of land in the Parish of Glenlogie, the boundaries of which are as follow:—Commencing at the southern angle of allotment 8, section 2, of the said parish; thence by lines bearing respectively 345 deg. 46 min. 750 links, 148 deg. 9 min. 1,283.4 links, 305 deg. 27 min. 512.6 links, and 311 deg. 11 min. 100 links to the point of commencement—which said piece of land is particularly delineated and shown coloured red on survey plan numbered 5004, lodged in the office of the Country Roads Board.

And the Honorable James Arthur Kennedy, His Majesty's Commissioner of Public Works for the State of Victoria, shall give the necessary directions herein accordingly.

J. C. MACGIBBON,  
Acting Clerk of the Executive Council.

#### COUNTRY ROADS BOARD:

*At the Executive Council Chamber, Melbourne, the third day of December, 1948.*

##### PRESENT:

His Excellency the Governor of Victoria.  
Mr. Hollway | Lieut.-Colonel Dennett  
Colonel Kent Hughes | Mr. Kennedy  
Mr. Oldham | Mr. Warner.

#### DECLARATION OF THE NEW KOO-WEE-RUP-LONGWARRY ROAD IN THE SHIRE OF CRANBOURNE.

WHEREAS by section 21 of the *Country Roads Act* 1928 (No. 3662) it is amongst other things enacted that when the Country Roads Board under the provisions of the Country Roads Act has taken the land necessary for constructing a road or deviation it shall as soon as it thinks such road or deviation is fit to be used as a public highway by Resolution declare the road or deviation to be a main road or part thereof and that upon publication in the *Government Gazette* of the Order of the Governor in Council confirming such Resolution such road or deviation shall thereupon be a main road or part thereof within the meaning of the said Act: And whereas the said Board has by Resolution declared the road on the land described in the Schedule to such Resolution to be part of a main road: Now therefore His Excellency the Governor of the State of Victoria by and with the advice of the Executive Council thereof doth hereby confirm the said Resolution.

#### Resolution for Declaration of a New Main Road under the Country Roads Act.

Whereas the land the site the road the course of which is below set out was taken by the Board under the provisions of the Country Roads Act for the purpose of constructing such new road which new road has now been laid out and formed on the same: And whereas the said Board (being the Country Roads Board incorporated under the said Act) thinks that the road aforesaid is fit to be used as part of a public highway such Board at a meeting now holden doth by this Resolution hereby declare the said new road the course of which is described in the Schedule hereto with the commencing and terminating points thereof respectively specified to be part of a main road within the meaning and for the purposes of the Country Roads Act.

##### SCHEDULE.

#### Shire of Cranbourne.

6. *Koo-wee-rup-Longwarry road* (3906).—All those pieces of land in the Parish of Yallock, the boundaries of which are as follow:—

- Commencing at the northern angle of Crown section 4 of the said parish; thence by lines bearing respectively 87 deg. 54 min. 389.3 links, 261 deg. 7 min. 362 links, 240 deg. 50 min. 376.5 links, and 52 deg. 54 min. 373 links to the point of commencement.
- Commencing at a point on the southern boundary of allotment 5A of the said parish distant 97 deg. 40 min. 1,510.5 links from the south-western angle of the said allotment; thence by lines bearing respectively 89 deg. 36 min. 353 links, 70 deg. 44 min. 353 links, 242 deg. 40 min. 365 links, and 277 deg. 40 min. 365 links to the point of commencement—

which said pieces of land are particularly delineated and shown coloured red on survey plan numbered 4802, lodged in the office of the Country Roads Board.

The common seal of the Country Roads Board was hereto affixed, at Melbourne, this twenty-fifth day of November, One thousand nine hundred and forty-eight, in the presence of—

(SEAL) W. L. DALE, Chairman.  
F. M. CORRIGAN, Member.  
R. JANSEN, Secretary.

And the Honorable James Arthur Kennedy, His Majesty's Commissioner of Public Works for the State of Victoria, shall give the necessary directions herein accordingly.

J. C. MACGIBBON,  
Acting Clerk of the Executive Council.



## COUNTRY ROADS BOARD.

*At the Executive Council Chamber, Melbourne, the third day of December, 1948.*

## PRESENT:

His Excellency the Governor of Victoria.  
 Mr. Hollway | Lieut.-Colonel Dennett  
 Colonel Kent Hughes | Mr. Kennedy  
 Mr. Oldham | Mr. Warner.

## DECLARATION OF THE NEW WONTHAGGI-LOCH ROAD IN THE SHIRE OF BASS.

**WHEREAS** by section 21 of the *Country Roads Act* 1928 (No. 3662) it is amongst other things enacted that when the Country Roads Board under the provisions of the Country Roads Act has taken the land necessary for constructing a road or deviation it shall as soon as it thinks such road or deviation is fit to be used as a public highway by Resolution declare the road or deviation to be a main road or part thereof and that upon publication in the *Government Gazette* of the Order of the Governor in Council confirming such Resolution such road or deviation shall thereupon be a main road or part thereof within the meaning of the said Act: And whereas the said Board has by Resolution declared the road on the land described in the Schedule to such Resolution to be part of a main road: Now therefore His Excellency the Governor of the State of Victoria by and with the advice of the Executive Council thereof doth hereby confirm the said Resolution.

*Resolution for Declaration of a New Main Road under the Country Roads Act.*

Whereas the land the site the road the course of which is below set out was taken by the Board under the provisions of the Country Roads Act for the purpose of constructing such new road which new road has now been laid out and formed on the same: And whereas the said Board (being the Country Roads Board incorporated under the said Act) thinks that the road aforesaid is fit to be used as part of a public highway such Board at a meeting now holden doth by this Resolution hereby declare the said new road the course of which is described in the Schedule hereto with the commencing and terminating points thereof respectively specified to be part of a main road within the meaning and for the purposes of the Country Roads Act.

## SCHEDULE.

*Shire of Bass.*

1. *Wonthaggi-Loch road* (801).—All that piece of land in the Parish of Wonthaggi North, the boundaries of which are as follow:—Commencing at the south-western angle of allotment 90 of the said parish; thence by lines bearing respectively 29 deg. 2 min. 90 links, 190 deg. 220 min. 170.5 links, and 351 deg. 42 min. 90 links to the point of commencement—which said piece of land is particularly delineated and shown coloured red on survey plan numbered 4754, lodged in the office of the Country Roads Board.

The common seal of the Country Roads Board was hereto affixed, at Melbourne, this twenty-fifth day of November, One thousand nine hundred and forty-eight, in the presence of—

(SEAL) W. L. DALE, Chairman.  
 F. M. CORRIGAN, Member.  
 R. JANSEN, Secretary.

And the Honorable James Arthur Kennedy, His Majesty's Commissioner of Public Works for the State of Victoria, shall give the necessary directions herein accordingly.

J. C. MACGIBBON,  
 Acting Clerk of the Executive Council.

## COUNTRY ROADS BOARD.

*At the Executive Council Chamber, Melbourne, the third day of December, 1948.*

## PRESENT:

His Excellency the Governor of Victoria.  
 Mr. Hollway | Lieut.-Colonel Dennett  
 Colonel Kent Hughes | Mr. Kennedy  
 Mr. Oldham | Mr. Warner.

## DECLARATION OF THE NEW STUD-ROAD IN THE SHIRE OF FERNTREE GULLY.

**WHEREAS** by section 21 of the *Country Roads Act* 1928 (No. 3662) it is amongst other things enacted that when the Country Roads Board under the provisions

of the Country Roads Act has taken the land necessary for constructing a road or deviation it shall as soon as it thinks such road or deviation is fit to be used as a public highway by Resolution declare the road or deviation to be a main road or part thereof and that upon publication in the *Government Gazette* of the Order of the Governor in Council confirming such Resolution such road or deviation shall thereupon be a main road or part thereof within the meaning of the said Act: And whereas the said Board has by Resolution declared the road on the land described in the Schedule to such Resolution to be part of a main road: Now therefore His Excellency the Governor of the State of Victoria by and with the advice of the Executive Council thereof doth hereby confirm the said Resolution.

*Resolution for Declaration of a New Main Road under the Country Roads Act.*

Whereas the land the site the road the course of which is below set out was taken by the Board under the provisions of the Country Roads Act for the purpose of constructing such new road which new road has now been laid out and formed on the same: And whereas the said Board (being the Country Roads Board incorporated under the said Act) thinks that the road aforesaid is fit to be used as part of a public highway such Board at a meeting now holden doth by this Resolution hereby declare the said new road the course of which is described in the Schedule hereto with the commencing and terminating points thereof respectively specified to be part of a main road within the meaning and for the purposes of the Country Roads Act.

## SCHEDULE.

*Shire of Ferntree Gully.*

8. *Stud-road* (5908).—All the piece of land in the Parish of Scoresby, the boundaries of which are as follow:—Commencing at the north-western angle of lot 21 on plan of subdivision numbered 8723, lodged in the Office of Titles, and being part of allotment 43 of the said parish; thence by lines bearing respectively 43 deg. 58 min. 150 links, 201 deg. 59 min. 278.2 links, and 360 deg. 0 min. 150 links to the point of commencement—which said piece of land is particularly delineated and shown coloured red on survey plan numbered 4717, lodged in the office of the Country Roads Board.

The common seal of the Country Roads Board was hereto affixed, at Melbourne, this twenty-second day of November, One thousand nine hundred and forty-eight, in the presence of—

(SEAL) W. L. DALE, Chairman.  
 F. M. CORRIGAN, Member.  
 R. JANSEN, Secretary.

And the Honorable James Arthur Kennedy, His Majesty's Commissioner of Public Works for the State of Victoria, shall give the necessary directions herein accordingly.

J. C. MACGIBBON,  
 Acting Clerk of the Executive Council.

## COUNTRY ROADS BOARD.

*At the Executive Council Chamber, Melbourne, the third day of December, 1948.*

## PRESENT:

His Excellency the Governor of Victoria.  
 Mr. Hollway | Lieut.-Colonel Dennett  
 Colonel Kent Hughes | Mr. Kennedy  
 Mr. Oldham | Mr. Warner.

## DECLARATION OF THE NEW HENTY HIGHWAY IN THE SHIRE OF KARKAROC.

**WHEREAS** by sections 21 and 74 of the *Country Roads Act* 1928 (No. 3662) it is amongst other things enacted that when the Country Roads Board under the provisions of the Country Roads Act has taken the land necessary for constructing a road or deviation it shall as soon as it thinks such road or deviation is fit to be used as a public highway by Resolution declare the road or deviation to be a State highway or part thereof and that upon publication in the *Government Gazette* of the Order of the Governor in

Council confirming such Resolution such road or deviation shall thereupon be a State highway or part thereof within the meaning of the said Act: And whereas the said Board has by Resolution declared the road on the land described in the Schedule to such Resolution to be part of a State highway: Now therefore His Excellency the Governor of the State of Victoria by and with the advice of the Executive Council thereof doth hereby confirm the said Resolution.

*Resolution for Declaration of a New State Highway under the Country Roads Act.*

Whereas the land the site the road the course of which is below set out was taken by the Board under the provisions of the Country Roads Act for the purpose of constructing such new road which new road has now been laid out and formed on the same: And whereas the said Board (being the Country Roads Board incorporated under the said Act) thinks that the road aforesaid is fit to be used as a public highway such Board at a meeting now holden acting under the authority conferred upon it by sections 21 and 74 of the *Country Roads Act 1928* doth hereby declare the said new road the course of which is described in the Schedule hereto with the commencing and terminating points thereof respectively specified to be part of a State highway within the meaning and for the purposes of the Country Roads Act.

SCHEDULE.

*Shire of Karkaroc.*

12. *Henty Highway*.—All that piece of land in the Parish of Wiall, the boundaries of which are as follow:— Commencing at a point on the western boundary of allotment 30 of the said parish, distant 32 deg. 17 min. 4,613 links from the south-western angle of the said allotment; thence by lines bearing respectively 32 deg. 17 min. 150 links, 69 deg. 57 min. 150 links, and 231 deg. 7 min. 283.9 links to the point of commencement—which said piece of land is particularly delineated and shown coloured red on survey plan numbered 4959, lodged in the office of the Country Roads Board.

The common seal of the Country Roads Board was hereto affixed, at Melbourne, this twenty-second day of November, One thousand nine hundred and forty-eight, in the presence of—

(SEAL) W. L. DALE, Chairman.  
F. M. CORRIGAN, Member.  
R. JANSEN, Secretary.

And the Honorable James Arthur Kennedy, His Majesty's Commissioner of Public Works for the State of Victoria, shall give the necessary directions herein accordingly.

J. C. MACGIBBON,  
Acting Clerk of the Executive Council.

THE CONSTITUTION ACT AMENDMENT ACTS.

*At the Executive Council Chamber, Melbourne, the third day of December, 1948.*

PRESENT:

His Excellency the Governor of Victoria.	
Mr. Hollway	Lieut.-Colonel Dennett
Colonel Kent Hughes	Mr. Kennedy
Mr. Oldham	Mr. Warner.

APPOINTMENT OF POLLING PLACE FOR THE SOUTH-WESTERN PROVINCE.

IN pursuance of the provisions contained in The Constitution Act Amendment Acts, His Excellency the Governor of the State of Victoria, by and with the advice of the Executive Council thereof, doth hereby appoint—

GEELONG CENTRAL

as a Polling Place within and for the Geelong Division of the South-Western Province.

And the Honorable Keith Dodgshun, His Majesty's Chief Secretary for the State of Victoria, shall give the necessary directions herein accordingly.

J. C. MACGIBBON,  
Acting Clerk of the Executive Council.

POLICE REGULATION ACTS.

*At the Executive Council Chamber, Melbourne, the third day of December, 1948.*

PRESENT:

His Excellency the Governor of Victoria.	
Mr. Hollway	Lieut.-Colonel Dennett
Colonel Kent Hughes	Mr. Kennedy
Mr. Oldham	Mr. Warner.

HIS Excellency the Governor of the State of Victoria, by and with the advice of the Executive Council thereof, and in pursuance of the provisions of the Police Regulation Acts, doth hereby make the Regulations following (that is to say):—

The "Police Regulations", made by the Governor in Council on the fifth day of August, 1947, and published in the *Government Gazette* of the seventh day of August, 1947, are hereby amended as follows:—

Clause eleven of Chapter seventeen of the said Regulations is hereby amended as follows:—

- (a) in sub-clause (1) thereof, for the expression—  
"12s. per day as an in-patient"  
there shall be substituted the expression—  
"14s. per day as an in-patient"; and
- (b) in sub-clause (2) thereof, for the expression—  
"18s. per day as an in-patient"  
there shall be substituted the expression—  
"£1 per day as an in-patient".

And the Honorable Keith Dodgshun, His Majesty's Chief Secretary for the State of Victoria, shall give the necessary directions herein accordingly.

J. C. MACGIBBON,  
Acting Clerk of the Executive Council.

DEPARTMENT OF LANDS AND SURVEY.

At the Executive Council Chamber, Melbourne, the third day of December, 1948.

PRESENT:

His Excellency the Governor of Victoria.	
Mr. Hollway	Lieut.-Colonel Dennett
Colonel Kent Hughes	Mr. Kennedy
Mr. Oldham	Mr. Warner.

UNUSED AND UNMADE ROAD CLOSED.

HIS Excellency the Governor of the State of Victoria, by and with the advice of the Executive Council thereof, doth hereby direct that, in pursuance of the provisions of section 304 of the *Land Act 1928* (No. 3709), the unused and unmade road referred to hereunder be closed, viz.:-

Township of Meringur, Parish of Meringur, County of Millewa, being the road between allotments 16 and 1, section J, and the State School Reserve; and the road between allotments 9, 8, and 7, section A, and the State School Reserve Extension.—(M.594B(1) (Rs.3449).

And the Honorable John Gladstone Black McDonald, His Majesty's Commissioner of Crown Lands and Survey for the State of Victoria, shall give the necessary directions herein accordingly.

J. C. MACGIBBON,  
Acting Clerk of the Executive Council.

DEPARTMENT OF LANDS AND SURVEY.

At the Executive Council Chamber, Melbourne, the third day of December, 1948.

PRESENT:

His Excellency the Governor of Victoria.	
Mr. Hollway	Lieut.-Colonel Dennett
Colonel Kent Hughes	Mr. Kennedy
Mr. Oldham	Mr. Warner.

LANDS TEMPORARILY RESERVED.

HIS Excellency the Governor of the State of Victoria, by and with the advice of the Executive Council thereof, doth hereby, in pursuance of the provisions of the *Land Act 1928*, reserve, temporarily, and also except from occupation for mining purposes under any miner's right, the lands hereinafter described:-

MERINGUR.—Site for State School purposes, in addition to and adjoining the site temporarily reserved therefor by Order in Council of the 27th March, 1945, 25 perches, more or less, Township of Meringur, Parish of Meringur, County of Millewa, as indicated by hachure on plan hereunder.—(M.594B(1) (Rs.3449).

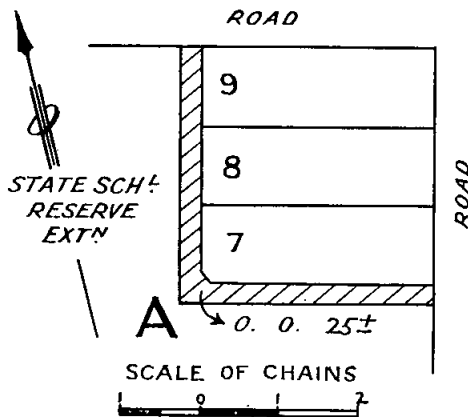

MERINGUR.—Site for State School purposes, in addition to and adjoining the site temporarily reserved therefor by Order in Council of the 4th May, 1927, 3 acres 3 roods,

more or less, Township of Meringur, Parish of Meringur, County of Millewa, as indicated by hachure on plan hereunder.—(M.594B(1) (Rs.3449).

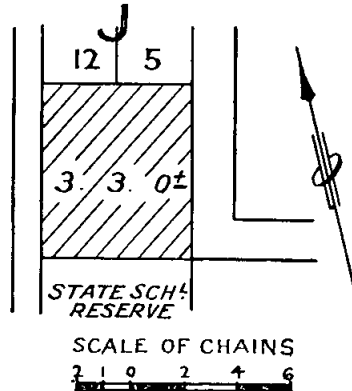

CORRYONG.—Site for Public purposes, 2 roods, Town of Corryong, Parish of Towong, County of Benambra, as indicated by hachure on plan hereunder.—(C.427(1) (Rs.6251).

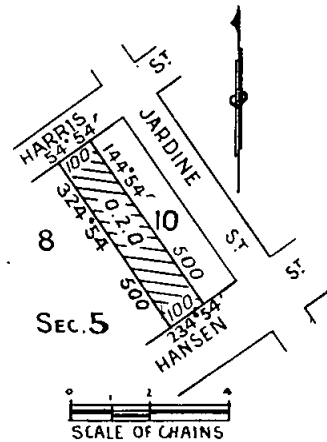

And the Honorable John Gladstone Black McDonald, His Majesty's Commissioner of Crown Lands and Survey for the State of Victoria, shall give the necessary directions herein accordingly.

J. C. MACGIBBON,  
Acting Clerk of the Executive Council.

DEPARTMENT OF LANDS AND SURVEY.

At the Executive Council Chamber, Melbourne, the third day of December, 1948.

PRESENT:

His Excellency the Governor of Victoria.	
Mr. Hollway	Lieut.-Colonel Dennett
Colonel Kent Hughes	Mr. Kennedy
Mr. Oldham	Mr. Warner.

REVOCATION OF TEMPORARY RESERVATION OF LAND BY ORDER IN COUNCIL.

HIS Excellency the Governor of the State of Victoria, by and with the advice of the Executive Council thereof, doth hereby, in pursuance of the provisions of the *Land Act 1928*, revoke the temporary reservation of the land by Order in Council hereinafter referred to, viz.:-

GRETA.—Order in Council of 9th March, 1937, of 17 acres 2 roods 6 perches of land in the Parish of Greta as a site for Watering purposes so far only as regards the portion thereof comprised within the boundaries published in the *Government Gazette* of 10th November, 1948, and containing 2 acres.—(Rs.4649.)

And the Honorable John Gladstone Black McDonald, His Majesty's Commissioner of Crown Lands and Survey for the State of Victoria, shall give the necessary directions herein accordingly.

J. C. MACGIBBON,  
Acting Clerk of the Executive Council.

MOTOR OMNIBUS ACT 1928 (No. 3742).

At the Executive Council Chamber, Melbourne, the seventh day of December, 1948.

PRESENT:

His Excellency the Governor of Victoria.	
Mr. Hollway	Colonel Kent Hughes
Mr. Oldham	Lieut.-Colonel Dennett
Mr. Kennedy	Mr. Warner.

AMENDMENT OF METROPOLITAN MOTOR OMNIBUS ROUTE No. 1A (THORNBURY-RESERVOIR-REGENT).

HIS Excellency the Governor of the State of Victoria, by and with the advice of the Executive Council thereof, and in pursuance of the powers conferred by the *Motor Omnibus Act 1928* (No. 3742), doth by this Order amend, as set out hereunder, the prescription of a certain route, viz., No. 1A, within the metropolitan area, along which motor omnibuses for which "regular service" licences are granted may ply for hire, viz.:—

Under the heading "Description of Route, including Commencing and Terminal Points" delete the sub-heading "Thornbury-Reservoir-Regent," and in place thereof insert "Thornbury-Edwardes Park, West Reservoir." Also delete "returning via Clarence, Regent, and Spring streets, &c.," and in place thereof insert "thence via Clarence, Regent, and High streets to Dundas-street."

Under the heading "Sections on Route" in section (2) add "or to Regent Railway Station."

Under the heading "Fares to be Charged" delete "through fare, 6d.," and in place thereof insert "through fare to Edwardes Park-via Reservoir, 5d.; via Spring-street, &c., 5d."

Under the heading "Time-tables to be Observed" add "Trips may be operated to and from Edwardes Park, via Reservoir or via Spring-street, alternately, and in both directions."

*Licensing Authority.*—Pursuant to the provisions of section 15 (1) (c) of the said Act (No. 3742), the Governor in Council by this Order confers upon the Licensing Authority full power and authority for the carrying into effect by the said Licensing Authority of the foregoing provisions of this Order.

And the Honorable James Arthur Kennedy, His Majesty's Commissioner of Public Works for the State of Victoria, shall give the necessary directions herein accordingly.

J. C. MACGIBBON,  
Acting Clerk of the Executive Council.

MOTOR OMNIBUS ACT 1928 (No. 3742).

At the Executive Council Chamber, Melbourne, the seventh day of December, 1948.

PRESENT:

His Excellency the Governor of Victoria.	
Mr. Hollway	Colonel Kent Hughes
Mr. Oldham	Lieut.-Colonel Dennett
Mr. Kennedy	Mr. Warner.

AMENDMENT OF THE GENERAL CONDITIONS IN RESPECT OF THE METROPOLITAN MOTOR OMNIBUS ROUTES.

HIS Excellency the Governor of the State of Victoria by and with the advice of the Executive Council thereof, and in pursuance of the powers conferred by the *Motor Omnibus Act 1928* (No. 3742), doth by this Order amend, as set out hereunder, the general conditions in respect of the metropolitan motor omnibus routes, viz.:—

Immediately after "nearest lower penny" add "Provided, however, that on 'all night' routes fares at the same rates as for adults shall be charged for children under fourteen years of age (other than one child under four years of age carried on passenger's lap) who shall be carried free."

Pursuant to the provisions of the said Act, the Governor in Council also by this Order confers upon the Licensing Authority full power and authority, and grants consent to the Melbourne and Metropolitan Tramways Board, for

the carrying into effect by the said Licensing Authority and by the said Board, so far as they are respectively concerned, of the foregoing provisions of this Order.

And the Honorable James Arthur Kennedy, His Majesty's Commissioner of Public Works for the State of Victoria, shall give the necessary directions herein accordingly.

J. C. MACGIBBON,  
Acting Clerk of the Executive Council.

MOTOR OMNIBUS ACT 1928 (No. 3742).

At the Executive Council Chamber, Melbourne, the seventh day of December, 1948.

PRESENT:

His Excellency the Governor of Victoria.	
Mr. Hollway	Colonel Kent Hughes
Mr. Oldham	Lieut.-Colonel Dennett
Mr. Kennedy	Mr. Warner.

EXTENSION OF THE ELSTERNWICK-NORTH BRIGHTON "ALL-NIGHT" MOTOR OMNIBUS ROUTE TO SANDRINGHAM RAILWAY STATION.

HIS Excellency the Governor of the State of Victoria, by and with the advice of the Executive Council thereof, and in pursuance of the powers conferred by the *Motor Omnibus Act 1928* (No. 3742), doth by this Order amend, as set out hereunder, the prescription of the Elsternwick-North Brighton "All-Night" Motor Omnibus Route, and doth grant consent to the Melbourne and Metropolitan Tramways Board to use motor omnibuses to ply for hire along the said route as so extended, viz.:—

Under the heading "Description of Route, including Commencing and Terminal Points," amend the sub-heading "Elsternwick-North Brighton" to read "Elsternwick-Sandringham"; also delete "street, to corner of New and Bay streets, North Brighton," and in place thereof insert "Bay, Hampton, Thomas, and Sargood streets, Higgitt-road, Nelson-street, and Bay-road, to Sandringham Railway Station."

Under the heading "Sections on Route" delete the existing particulars, and in place thereof insert (1) Elsternwick Railway Station to corner of New and Bay streets; (2) corner of New and Bay streets to Dendy-street; (3) Dendy-street to Hampton Railway Station; (4) Hampton Railway Station to Sandringham Railway Station.

Under the heading "Fares to be Charged," delete the existing particulars, and in place thereof insert "Any one or two sections, 4d.; three or four sections, 8d.; through fare, 8d."

And the Honorable James Arthur Kennedy, His Majesty's Commissioner of Public Works for the State of Victoria, shall give the necessary directions herein accordingly.

J. C. MACGIBBON,  
Acting Clerk of the Executive Council.

APPROACHING LAND SALES.

SALES of Crown lands, in fee-simple, will be held at the under-mentioned places and dates, viz.:—

	No. of Gazette.
Ararat.—Thursday, 16th December, 1948	1100
Ballarat.—Wednesday, 15th December, 1948	1100
Shepparton.—Thursday, 9th December, 1948	1053

Local Government Act 1946, Part 48.

RENEWAL OF UNUSED ROAD AND WATER FRONTAGE LICENCES.

ALL unused road and water frontage licences expiring on 31st December, 1948 (excepting those cancelled or terminated), are hereby renewed for a further term of three years.

JOHN G. B. McDONALD,  
Minister of Lands.

Department of Lands and Survey,  
Melbourne, 3rd December, 1948.

LAND AVAILABLE UNDER THE SOLDIER SETTLEMENT ACTS.

NOTIFICATION is hereby given, in accordance with section 16 of the *Soldier Settlement Act 1946*, that the under-mentioned lots are available or are about to become available for settlement.

Any discharged soldier who has applied to the Commission on or before the 8th December, 1948, for classification in the required class or classes of primary production for which the lots are made available, and whose application has not been finalized, or any discharged soldier who has been classified as suitable in such class or classes of primary production may apply on the proper form for settlement on any lot or lots, indicating where he applies in respect of more than one lot, his order of preference therefor.

Application forms, plans, and further particulars may be obtained from the Enquiry Branch, Soldier Settlement Commission, State Public Offices, Melbourne, at which office completed applications for settlement should be lodged on or before the date mentioned hereunder on the respective estates.

E. SINGLETON,  
Secretary.

Soldier Settlement Commission,  
Melbourne, 3rd December, 1948.

SCHEDULE OF ALLOTMENTS.

SUBDIVISION OF THIRD PORTION OF "LANGI KAL" ESTATE.

PARISH OF LIVINGSTONE.—COUNTY OF RIPON.  
*Suitable for Grazing (Sheep) and Mixed Farming.*  
Closing Date—4th January, 1949.

Lot Number on Plan of Subdivision.	Approximate Area in Acres (Subject to Survey).
27	905
28	905
29	625
30	767
31	830

SUBDIVISION OF "SPRINGFIELD" ESTATE.

PARISHES OF WOODSTOCK AND MARONG.—COUNTY OF BENDIGO.  
*Suitable for Grazing (Sheep) and Cereal Growing.*  
Closing Date—4th January, 1949.

Lot Number on Plan of Subdivision.	Approximate Area in Acres (Subject to Survey).
1	896
2	815
3	881

SUBDIVISION OF "STOKIE'S" ESTATE.

PARISH OF DARLINGTON WEST.—COUNTY OF HAMPDEN.  
*Suitable for Grazing (Sheep) and Mixed Farming.*  
Closing Date—4th January, 1949.

Lot Number on Plan of Subdivision.	Approximate Area in Acres (Subject to Survey).
1	738
2	698

SUBDIVISION OF "GOYNES" ESTATE.

PARISHES OF KAMAROOKA, MINTO, AND WARRAGAMBA.—COUNTY OF BENDIGO.  
*Suitable for Cereal Growing and Grazing (Sheep).*  
Closing Date—4th January, 1949.

Lot Number on Plan of Subdivision.	Approximate Area in Acres (Subject to Survey).
1	1,017
2	870

PORTION OF "LIMA" ESTATE.

PARISH OF SAMARIA.—COUNTY OF DELATITE.  
*Suitable for Grazing (Sheep) and Mixed Farming.*  
Closing Date—29th December, 1948.

Lot Number on Plan.	Approximate Area in Acres (Subject to Survey).
9	740

PROPOSED REVOCATIONS OF TEMPORARY RESERVATIONS OF LANDS BY ORDERS IN COUNCIL.

IN pursuance of the provisions of the *Land Act 1928*, notice is hereby given that it is the intention of the Governor in Council to revoke the temporary reservations of lands by Orders in Council hereunder referred to, viz.:—  
*The following Notices were published 1° on the 17th November, 1948, pursuant to Orders of the 9th November, 1948.*

FRANKSTON.—The temporary reservation, by Order in Council of the 30th March, 1886, of 1 acre 2 roods 29 perches of land, being part of original allotment 10 of section C in the Parish of Frankston, as a site for a road, is about to be revoked.—(F.86(2)) (Rs.6231).

COWANGIE.—The temporary reservation, by Order in Council of the 12th October, 1915, of 1 acre of land in the Township of Cowangie, as a site for Water Supply purposes, is about to be revoked so far only as regards the portion containing 32 perches indicated by hachure on plan hereunder.—(C.478(2)) (Rs.838).

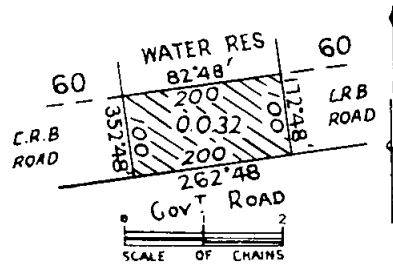

FRANKSTON.—The temporary reservation as a site for the use of the Railway Department, and the withholding from sale, leasing, and licensing, by Order in Council of the 4th December, 1882, of 5 acres 0 roods 12 perches of land, being part of suburban allotment 10, section C, in the town of Frankston, is about to be revoked so far only as regards the portion containing 3 roods 3 4/10 perches, indicated by hachure on plan hereunder.—(F.86(2)) (Rs.6232).

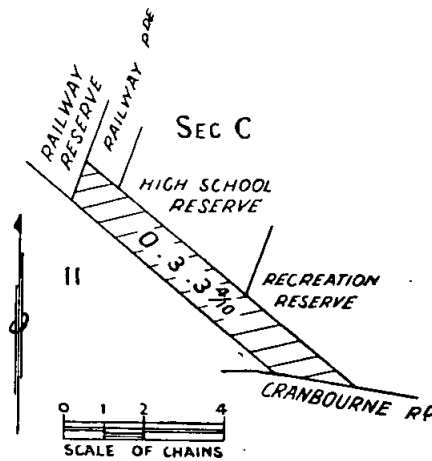

CARINA.—The temporary reservation, by Order in Council of the 28th April, 1936, of 9 acres 3 roods 19 perches of land in the Parish of Carina as a site for Public Recreation, is about to be revoked so far only as regards the portion containing 3 roods 8 perches, indicated by hachure on plan hereunder.—(C.477(3)) (Rs.4657).

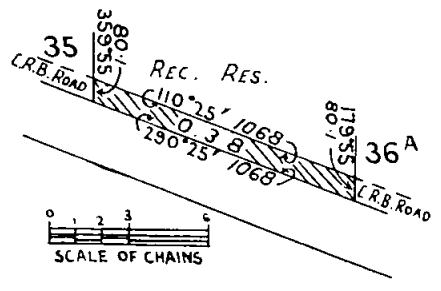

TYALLA.—The temporary reservation, by Order in Council of the 3rd July, 1918, of 13 acres 2 roods 8 perches of land in the Parish of Tutye, now in the Parish of Tyalla, as a site for Recreation purposes, revoked as to part by Order of the 7th September, 1925, is about to be further revoked so far only as regards the portion containing 2 acres 3 roods 3 perches indicated by hachure on plan hereunder.—(T.251(2) (Rs.1796).

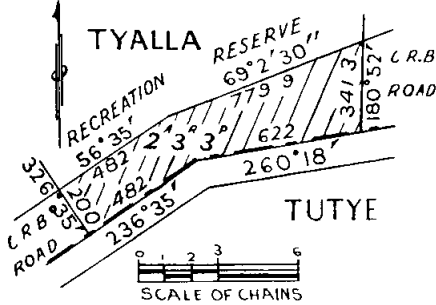

TYALLA.—The temporary reservation, by Order in Council of the 23rd November, 1920, of 68 acres 2 roods 6 perches of land in the Parish of Tyalla as a site for Recreation and Show Ground, is about to be revoked so far only as regards 2 acres 1 rood 35 perches in the two separate portions containing 2 acres 0 roods 4 perches and 1 rood 31 perches, respectively, indicated by hachure on plan hereunder.—(T.251(2) (Rs.2240).

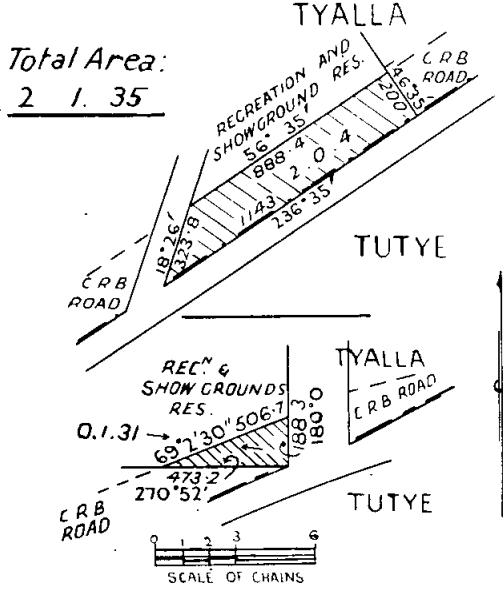

Total Area:  
2 1 35

P. T. BYRNES,  
for Commissioner of Crown Lands and Survey.

PROPOSED REVOCATIONS OF TEMPORARY RESERVATIONS OF LANDS BY ORDERS IN COUNCIL.

IN pursuance of the provisions of the Land Act 1928, notice is hereby given that it is the intention of the Governor in Council to revoke the temporary reservations of lands by Orders in Council hereunder referred to, viz.:—  
The following Notices were published 1° on the 24th November, 1948, pursuant to Orders of the 16th November, 1948.

MIRBOO NORTH.—The temporary reservation, by Order in Council of the 29th April, 1908, of 2 acres 3 roods 28 perches of land in the Township of Mirboo North, as a site for the Supply of Gravel, is about to be revoked.—(M.517(12) (C.33509).

SPEED.—The temporary reservation, by Order in Council of the 25th October, 1927, of 12 acres 0 roods 2 perches of land in the Township of Speed, as a site for Public Recreation, is about to be revoked.—(S.458(3) (Rs.210).

SPEED.—The temporary reservation, by Order in Council of the 20th October, 1914, of 6 acres 0 roods 248/10 perches of land in the Township of Speed, as a site for Public Recreation, is about to be revoked.—(S.458(4) (Rs.210).

P. T. BYRNES,  
for Commissioner of Crown Lands and Survey.

PROPOSED REVOCATION OF TEMPORARY RESERVATION OF LAND BY ORDER IN COUNCIL.

IN pursuance of the provisions of the Land Act 1928, notice is hereby given that it is the intention of the Governor in Council to revoke the temporary reservation of land by Order in Council hereunder referred to, viz.:—

The following Notice was published 1° on the 1st December, 1948, pursuant to Order of the 23rd November, 1948.

BALLAARAT (at Ballaarat East).—The temporary reservation, by Order in Council of the 7th September, 1948, of 1 acre 2 roods 14 5/10 perches of land at Ballaarat East, in the City of Ballaarat, as a site for Public Gardens, is about to be revoked.—(B.128(18) (Rs.6129).

P. T. BYRNES,  
for Commissioner of Crown Lands and Survey.

PROPOSED REVOCATIONS OF TEMPORARY RESERVATIONS OF LANDS BY ORDERS IN COUNCIL.

IN pursuance of the provisions of the Land Act 1928, notice is hereby given that it is the intention of the Governor in Council to revoke the temporary reservations of lands by Orders in Council hereunder referred to, viz.:—

The following Notices were published 1° on the 8th December, 1948, pursuant to Orders of the 30th November, 1948.

WARBURTON.—The temporary reservation, by Order in Council of the 22nd July, 1908, of 20 acres of land in the Parish of Warburton, being allotment 203, as a site for a Night-soil Depot, is about to be revoked so far only as regards the portion containing 2 roods, more or less, indicated by hachure on plan hereunder.—(W.348(9) (C.39169).

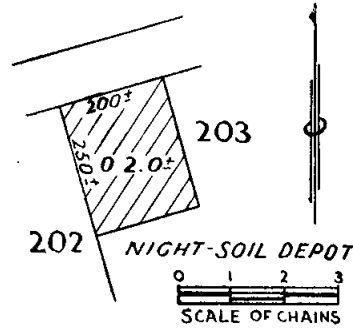

SWANWATER.—The temporary reservation as a site for a Quarry and the withholding from sale, leasing, and licensing, by Order in Council of the 17th October, 1881, of 57 acres 0 roods 34 perches of land in the Parish of Swanwater, situate in section E, revoked as to part by Order of the 17th November, 1885, is about to be further revoked so far only as regards the portion containing 4 acres 1 rood 20 perches, more or less, indicated by hachure on plan hereunder.—(S.367(7) (Rs.6284).

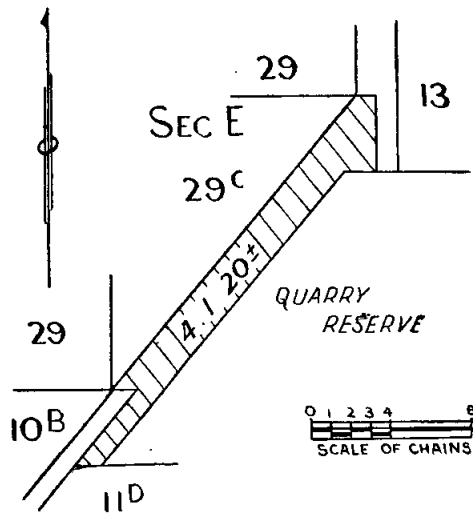

ARARAT.—The temporary reservation, by Order in Council of the 17th July, 1945, of 1 acre 2 roods 23 perches of land in the Town of Ararat, as a site for Public purposes, is about to be revoked so far only as regards the portion containing 1 rood 24 perches, more or less, indicated by hachure on plan hereunder.—(A.148<sup>(6)</sup>) (Rs.5675).

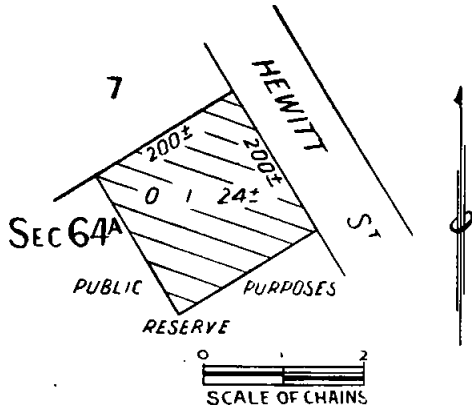

SANDHURST.—The temporary reservation, by Order in Council of the 28th July, 1941, of 85 acres, more or less, of land in the Parish of Sandhurst, as a site for a Boys' Training Farm, is about to be revoked.—(S.371<sup>(19)</sup>) (Rs.5197).

P. T. BYRNES,  
for Commissioner of Crown Lands and Survey.

LAND PROPOSED TO BE PERMANENTLY RESERVED.

IN pursuance of the provisions of the Land Act 1928, notice is hereby given that it is the intention of the Governor in Council to permanently reserve for the purpose mentioned the land hereunder described:—

The following Notice was published 1\* on the 1st December, 1948, pursuant to Order of the 23rd November, 1948.

BALLAARAT (at Ballaarat East).—Land to be permanently reserved as a site for a Public Library, 37 perches, at Ballaarat East, City of Ballaarat, Parish of Ballaarat, County of Grant, as indicated by hachure on plan hereunder.—(B.128<sup>(18)</sup>) (Rs.6127).

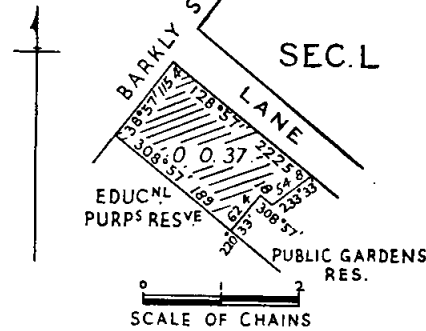

P. T. BYRNES,  
for Commissioner of Crown Lands and Survey.

Land Act 1928.

LICENCES UNDER THE LAND ACTS 1915 AND 1928 DECLARED VOID.

NOTICE is hereby given that the Licences in the Schedule hereunder have been declared void for the reason specified in each case

District.	Corr. No.	Name of Licensee.	Section of Land Act under which Licensed.	Parish.	Allotment.	Section.	Area.	Annual Rental.	Reasons for Voiding.
Bendigo ..	0729/129	Albert Sidney Carlyon	129	City of Bendigo, Parish of Sandhurst	..	43A	A. R. P. 0 0 20	£ s. d. 2 0 0	Abandoned
Ballarat ..	12/86	James Michael Kennedy	86	Kerrit Baret	1D	14	19 3 29	1 0 0	Non-compliance with the conditions
Ballarat ..	23/86	James Daniel Judd..	86	Scarsdale ..	27	46	19 3 39	1 0 0	Non-compliance with the conditions
Bendigo ..	0523/129	Thomas Joseph Crowe	129	City of Bendigo, Parish of Sandhurst	..	45B	3 0 0	1 0 0	Non-compliance with the conditions

Department of Lands and Survey,  
Melbourne, 3rd December, 1948.

JOHN G. B. McDONALD,  
Commissioner of Crown Lands and Survey.

THE CLOSER SETTLEMENT ACT 1938.

THE Farm Allotment mentioned in the Schedule hereunder is hereby proclaimed available for application, and may be taken up under Closer Settlement Lease (Section 27).

Parish.	Allotment.	Section.	Area	Monetary Liability.	Deposit, including Lease and Registration Fees.	Term of Lease.	Remarks.
Berwick ..	3	1	A. R. P. 21 2 0	£ s. d. 1,137 0 0*	£ s. d. 228 5 0*	35 1/2 years ..	Quarterly instalments of £12 10s. 3d.

\* This sum does not include present occupant's improvements to the value of £584, which sum must be paid in cash, in addition to deposit and fees.

Department of Lands and Survey,  
Melbourne, 3rd December, 1948.

JOHN G. B. McDONALD,  
Commissioner of Crown Lands and Survey

## TENDERS.

TENDERS will be received at this office until **TEN A.M.** on the days and for the purposes under mentioned.

Particulars may be learnt at this Office and also at places shown in parenthesis.

W.O. means Inspector of Works Office; P.S.—Police Station; T.S.—Technical School; H.E.S.—Higher Elementary School; S.S.—State School; H.S.—High School; P.D.—Preliminary deposit; F.D.—Final deposit.

The Board of Land and Works will not necessarily accept the lowest or any tender.

14th December, 1948.

Aberfeldie.—Renovations, Caretaker's Quarters, S.S. No. 4220. (S.S., Aberfeldie.) P.D., £4. F.D., 2 per cent.

Balmoral.—Painting and repairs to teacher's residence, S.S. No. 29. (W.O., Horsham; H.E.S., Edenhope; S.S., Balmoral.) Deposit, £4.

Ballarat.—Supply and delivery of six (6) electrically-heated plate warmers for female wards, Mental Hospital. P.D., £5. F.D., 2 per cent.

Benalla.—Repairs and renovations, school and residence, S.S. No. 31. (W.O., Benalla, Wangaratta; P.S., Seymour; S.S., Benalla.) P.D., £10. F.D., 2 per cent.

Bendigo.—Renewal of flooring, provision of display boards and cupboards, minor repairs and internal painting, Girls' School. (W.O., Bendigo; P.S., Castlemaine, Elmore, Inglewood.) P.D., £5. F.D., 2 per cent.

Bookar.—Repairs and renovations, S.S. No. 3578. (W.O., Warrnambool; P.S., Camperdown; S.S., Bookar.) Deposit, £3.

Brunswick.—Alterations and renovations, T.S. (T.S., Brunswick.) P.D., £4. F.D., 2 per cent.

Bruthen.—Repairs and painting, school and residence, S.S. No. 1141. (W.O., Bairnsdale; P.S., Orbost, Sale; S.S., Bruthen.) P.D., £15. F.D., 2 per cent.

Croydon.—Conversion of 60-ft. army hut into two (2) classrooms, S.S. No. 2900. (P.S., Healesville; S.S., Croydon.) P.D., £15. F.D., 2 per cent.

East Coburg.—Adaptation of Army hut, S.S. No. 4260. P.D., £10. F.D., 2 per cent.

Erica.—Repairs and painting, school and residence, S.S. No. 2437. (W.O., Bairnsdale; P.S., Warragul, Moe, Traralgon; S.S., Erica.) P.D., £10. F.D., 2 per cent.

Glenrowan.—Repairs and painting, residence, S.S. No. 1742. (W.O., Benalla, Wangaratta; S.S., Glenrowan.) P.D., £3. F.D., 2 per cent.

Korumburra.—General repairs, renovations, &c., new wireless mast, and new lino, Police Station. (W.O., Korumburra; P.S., Leongatha.) P.D., £10. F.D., 2 per cent.

Lake Moodemere.—Repairs and painting, S.S. No. 1557. (W.O., Wangaratta; P.S., Rutherglen; S.S., Lake Moodemere.) Deposit, £4.

Meenyan.—Renovations, &c., to school buildings and residence, S.S. No. 3165. (W.O., Korumburra; P.S., Leongatha, Wonthaggi; S.S., Meenyan.) P.D., £10. F.D., 2 per cent.

Melbourne.—Renovation of room on second floor, Lands Department, State Offices Annexe, 107 Russell-street. Deposit, £4.

Melbourne.—Supply and delivery of two (2) only 3-4 ton and alternatively 4-5 ton trucks with about 12 ft. by 7 ft. tray body with drop sides and tail, and with rack, Public Works Department. (Delivery date to be quoted with tender.)

Modella.—Repairs and painting, new storeroom, woodshed, &c., S.S. No. 3456. (P.S., Warragul, Dandenong; S.S., Modella.) Deposit, £10.

Mont Park.—Provision of laundry facilities at Men's Hostel, Mental Hospital. Deposit, £4.

Mont Park.—Supply and installation of central heating and hot-water services, Mental Hospital. P.D., £25. F.D., 2 per cent.

North Brunswick.—Renovations, Caretaker's Quarters, S.S. No. 3585. (S.S., North Brunswick.) P.D., £4. F.D., 2 per cent.

Northcote.—Alterations, caretaker's residence, S.S. No. 1401. (S.S., Northcote.) P.D., £10. F.D., 2 per cent.

Pirron Yallock.—Painting and repairs, S.S. No. 1242. (W.O., Geelong, Warrnambool; P.S., Colac, Camperdown; S.S., Pirron Yallock.) P.D., £5. F.D., 2 per cent.

Quambatook.—Alterations, additions, repairs, and painting, residence, S.S. No. 2443. (W.O., Swan Hill, Bendigo; P.S., Kerang, Wycheproof, Sea Lake; S.S., Quambatook.) P.D., £10. F.D., 2 per cent.

Red Hill.—Electrical installation, Junior Wing, Consolidated School. P.D., £5. F.D., 2 per cent.

Richmond.—Renovations, Girls' School. P.D., £5. F.D., 2 per cent.

Rutherglen.—Provision of bathrooms, alterations, &c., Department of Agriculture, Research Farm. (W.O., Wangaratta; P.S., Rutherglen, Tallangatta.) P.D., £5. F.D., 2 per cent.

Sea Lake.—Repairs, renovations, &c., of Tyrrell Creek School Buildings, S.S. No. 3273. (W.O., Swan Hill; P.S., Woomeyang, Wycheproof; S.S., Sea Lake.) Deposit, £3.

The Sisters.—Painting and repairs, S.S. No. 3252. (W.O., Warrnambool; P.S., Camperdown; S.S., The Sisters.) Deposit, £4.

Thorpdale.—Repairs and painting, S.S. No. 2966. (W.O., Korumburra; P.S., Warragul, Moe; S.S., Thorpdale.) Deposit, £4.

Tongio.—Repairs, painting, &c., S.S. No. 2545. (W.O., Bairnsdale; P.S., Orbost; S.S., Tongio.) P.D., £2. F.D., 2 per cent.

Warragul.—Installation of water service to school and residence, S.S. No. 2104. (W.O., Bairnsdale; P.S., Sale, Moe; S.S., Warragul.) Deposit, £2.

Warrnambool.—Alterations, repairs, and painting, Police Station. (W.O., Warrnambool; P.S., Warrnambool.) Deposit, £4.

Williamstown.—Roof renewals, High School. P.D., £10. F.D., 2 per cent.

Yea.—Erection of tank stands, new blackboard, general repairs and external painting, &c., S.S. No. 699. (P.S., Seymour, Kilmore; S.S., Yea.) P.D., £5. F.D., 2 per cent.

21st December, 1948.

Ararat.—Supply of food containers, Mental Hospital. Deposit, £2.

Ballarat.—Renewal of interior lining of copper-jacketted pans with stainless steel and supply of new equipment for main kitchen, Mental Hospital. P.D., £15. F.D., 2 per cent.

Barwidgee Creek.—Repairs and renovations, S.S. No. 1577. (W.O., Wangaratta; P.S., Myrtleford; S.S., Barwidgee Creek.) P.D., £3. F.D., 2 per cent.

Beac.—Erection of new police station, residence, office, &c., P.S. (W.O., Geelong; P.S., Beac, Colac.) P.D., £20. F.D., 2 per cent.

Belmont (Geelong).—Erection of P.S. and residence, P.S. (W.O., Geelong.) P.D., £15. F.D., 2 per cent. (Amended specification.)

Bena.—Repairs, painting, and new bath, residence, S.S. No. 3062. (W.O., Korumburra; P.S., Nyora; S.S., Bena.) Deposit, £3.

Cheltenham.—Supply and installation of one (1) electric passenger lift in Nurses' Quarters, Heatherton Sanatorium. P.D., £20. F.D., 2 per cent.

Cheltenham.—Repairs and painting to school buildings and provision of new fencing, S.S. No. 84. (S.S., Cheltenham.) P.D., £15. F.D., 2 per cent.

Coburg.—Supply and installation of motor-driven washing machine, Pentridge. P.D., £5. F.D., 2 per cent.

Coburg.—Supply only of one (1) 8-in. all-gear head motorized lathe, Pentridge. P.D., £10. F.D., 2 per cent.

Coburg.—Supply, delivery, and erection of one (1) private automatic telephone system, Pentridge. P.D., £25. F.D., 2 per cent.

Cowes.—Repairs and painting, S.S. No. 1282. (P.S., Frankston; S.S., Cowes.) P.D., £5. F.D., 2 per cent.

Greenvale.—Supply and installation of motor-driven single roll ironing machine, Laundry, Sanatorium. P.D., £5. F.D., 2 per cent.

Hamilton.—Painting and repairs to two (2) classrooms and corridor, S.S. No. 295. (W.O., Hamilton; S.S., Hamilton.) Deposit, £3.

Hamilton.—Provision of new fire escape stairs, H.S. (W.O., Ararat, Hamilton, Warrnambool; P.S., Portland; H.S., Hamilton.) P.D., £5. F.D., 2 per cent.

Horsham.—Adaptation of Army hut into classrooms, H.S. (W.O., Ararat, Horsham; P.S., Nhill; H.S., Horsham.) P.D., £5. F.D., 2 per cent.

Kalkallo.—Repairs and painting and fencing, S.S. No. 195. (P.S., Broadford, Kilmore, Seymour; S.S., Kalkallo.) P.D., £4. F.D., 2 per cent.

Kalimna West.—Repairs and painting and new incinerator, S.S. No. 3364. (W.O., Bairnsdale; P.S., Lakes Entrance; S.S., Kalimna West.) P.D., £3. F.D., 2 per cent.

Learmonth.—Supply and installation of electric hot-water service, residence, P.S. (W.O., Ballarat; P.S., Learmonth.) Deposit, £2.

Malvern.—Provision of laboratory for female teachers, S.S. No. 1604. (S.S., Malvern.) P.D., £4. F.D., 2 per cent.

Marnoo East.—Repairs and painting, new porch, blackboard, and chimney, S.S. No. 2951. (W.O., Ararat, Horsham; P.S., Rupanyup; S.S., Marnoo East.) Deposit, £4.



Melbourne.—Supply and installation of electric hot-water service, State Accident Insurance Office, 412 Collins-street. P.D., £5. F.D., 2 per cent.

Melbourne.—Supply and installation of electric hot-water service, caretaker's residence, rear Old Treasury Building. Deposit, £2.

Melbourne.—Installation of improved lighting, Crown Law Offices, Lonsdale-street. P.D., £10. F.D., 2 per cent.

Murtoa.—Provision of fibrous plaster lining and internal painting of residence, external painting and repairs and provision of sun shades to school, S.S. No. 1549. (W.O., Ararat, Horsham; P.S., Warracknabeal; S.S., Murtoa.) Deposit, £4.

North Melbourne.—Repairs to roof, S.S. No. 2566. Deposit, £3.

North Richmond.—Renovations, S.S. No. 2798. (S.S., North Richmond.) P.D., £10. F.D., 2 per cent.

Ocean Grove.—Supply and installation of an electric hot-water service, teacher's residence, S.S. No. 3100. (W.O., Geelong; S.S., Ocean Grove.) Deposit, £2.

Orford.—Alterations, repairs, and painting, school and residence, S.S. No. 1858. (W.O., Warrnambool; P.S., Koroit, Port Fairy; S.S., Orford.) Deposit, £4.

Ouyen.—Supply and installation of a solid fuel hot-water service, P.S. (W.O., Bendigo, Mildura, Swan Hill; P.S., Ouyen.) Deposit, £2.

Prahran.—Renovations, S.S. No. 3774, Deaf and Dumb Institute, St. Kilda-road. P.D., £10. F.D., 2 per cent.

Pyramid.—Remodelling of residence, P.S. (W.O., Bendigo; P.S., Cohuna, Echuca, Elmore, Pyramid.) P.D., £10. F.D., 2 per cent.

Richmond.—Supply and installation of electric hot-water services to new workshops, T.S. P.D., £5. F.D., 2 per cent.

Royal Park.—Supply and installation of stainless steel steam-heated pans for main kitchen, Mental Hospital. P.D., £10. F.D., 2 per cent.

Royal Park.—Supply and installation of refrigeration equipment, Zoological Gardens. P.D., £10. F.D., 2 per cent.

Sunbury.—Renewal of interior lining of copper-jacketed pans with stainless steel and supply of new equipment for main kitchen, Mental Hospital. P.D., £15. F.D., 2 per cent.

Templestowe.—Repairs, painting, and new skylights, S.S. No. 1395. (S.S., Templestowe.) P.D., £5. F.D., 2 per cent.

Upwey.—Improvement of water service, S.S. No. 4530. (S.S., Upwey.) Deposit, £4.

Violet Town.—Supply and installation of electric hot-water service, residence, S.S. No. 640. (W.O., Benalla, Wangaratta; P.S., Violet Town.) Deposit, £2.

Walpeup.—Installation of hot-water services to two (2) residences, Research Station. Deposit, £3.

Winton.—Additions and repairs to residence and school, S.S. No. 1870. (W.O., Benalla, Wangaratta; S.S., Winton.) P.D., £5. F.D., 2 per cent.

Yallourn.—Additional staff room accommodation, H.S. (W.O., Bairnsdale; P.S., Sale, Warragul; H.S., Yallourn.) P.D., £10. F.D., 2 per cent.

28th December, 1948.

Barnawartha.—Erection of new verandah, repairs, and painting, and new tanks, S.S. No. 1489. (W.O., Wangaratta; P.S., Wodonga; S.S., Barnawartha.) P.D., £10. F.D., 2 per cent.

Broadford.—Repairs and painting, S.S. No. 1125. (P.S., Kilmore, Seymour; S.S., Broadford.) P.D., £5. F.D., 2 per cent.

Carpentait.—Painting and repairs, S.S. No. 1500. (W.O., Warrnambool; P.S., Camperdown, Colac; S.S., Carpentait.) Deposit, £3.

Catani.—Erection of new laundry and fittings, bathroom fittings, kitchen sink and cupboard, tank and stands, repairs and painting, residence, S.S. No. 4154. (P.S., Dandenong, Warragul; S.S., Catani.) P.D., £5. F.D., 2 per cent.

Cobram.—Repairs, painting, and internal renovations, P.S. (W.O., Shepparton; P.S., Cobram, Tatura, Numurkah.) P.D., £3. F.D., 2 per cent.

Cohuna.—Repairs, painting, and internal renovations, Court House. (W.O., Bendigo, Swan Hill; P.S., Cohuna.) P.D., £4. F.D., 2 per cent.

Cohuna.—Removal of residence and outbuildings from S.S. No. 3721, Burke's Bridge, and re-erection, Consolidated School. (W.O., Bendigo; P.S., Echuca, Rochester; Consolidated School, Cohuna.) P.D., £10. F.D., 2 per cent.

Dhurringile.—Erection of new teacher's residence, S.S. No. 3944. (W.O., Shepparton; P.S., Elmore, Nagambie, Numurkah, Tongala; S.S., Dhurringile.) P.D., £15. F.D., 2 per cent.

Dreite.—Repairs and painting, S.S. No. 3915. (W.O., Geelong; P.S., Colac; S.S., Dreite.) Deposit, £3.

Foster.—(a) Repairs and painting, (b) fencing and paths, P.S. W.O., Korumburra; P.S., Foster, Leongatha, Yarram.) (a) P.D., £4. F.D., 2 per cent. (b) P.D., £2. F.D., 2 per cent.

Glenth Estate (near Wycheproof).—Erection of six (6) timber residences, Soldier Settlement Commission. (W.O., Bendigo, Swan Hill; P.S., Charlton, Inglewood, Wycheproof.) P.D., £50. F.D., 2 per cent.

Glennaggie.—Erection of new fences and external painting, residence, S.S. No. 1576. (W.O., Bairnsdale; P.S., Sale, Traralgon; S.S., Glennaggie.) Deposit, £5.

Healesville.—Repairs and painting, residence, S.S. No. 849. (P.S., Lilydale; S.S., Healesville.) Deposit, £3.

Jumburra.—Repairs and painting, S.S. No. 2954. (W.O., Korumburra; P.S., Dandenong, Leongatha; S.S., Jumburra.) P.D., £4. F.D., 2 per cent.

Koo-wee-rup.—Conversion of Army hut into two (2) classrooms, H.E.S. No. 2629. (P.S., Dandenong; H.E.S., Koo-wee-rup.) P.D., £15. F.D., 2 per cent.

Kyabram.—Removal of school building from S.S. No. 1558, Cooma, and re-erection, S.S. No. 2902. (W.O., Shepparton; P.S., Echuca, Tatura; S.S., Kyabram.) P.D., £3. F.D., 2 per cent.

Lardner.—Improved lighting to classroom, repairs and painting to school and residence, S.S. No. 1711. (W.O., Bairnsdale, Korumburra. P.S., Warragul; S.S., Lardner.) P.D., £10. F.D., 2 per cent.

Lucknow.—Repairs and painting, &c., S.S. No. 1231. (W.O., Bairnsdale; P.S., Orbost, Sale; S.S., Lucknow.) P.D., £10. F.D., 2 per cent.

Mandurang South.—Repairs and painting, S.S. No. 1628. (W.O., Bendigo; P.S., Castlemaine, Elmore, Inglewood, Raywood; S.S., Mandurang South.) P.D., £5. F.D., 2 per cent.

Molesworth.—Erection of new sleep-out to residence, repairs, and painting to school and residence, S.S. No. 2233. (W.O., Benalla; P.S., Euroa, Seymour; S.S., Molesworth.) Deposit, £4.

Mornington.—Repairs and renovations, P.S. (P.S., Frankston, Mornington.) P.D., £5. F.D., 2 per cent.

Murrayville.—Internal and external painting and repairs, Court House. (W.O., Mildura; P.S., Murrayville, Ouyen.) P.D., £4. F.D., 2 per cent.

Nariel North.—Removal, re-erection, and renovations, &c., S.S. No. 4633. (W.O., Benalla, Wangaratta; P.S., Corryong; S.S., Nariel North.) P.D., £10. F.D., 2 per cent.

Neerim.—Repairs, painting, minor extensions, and new blackboards, S.S. No. 2666. (W.O., Bairnsdale; P.S., Moe, Traralgon, Warragul; S.S., Neerim.) P.D., £10. F.D., 2 per cent.

Porepunkah.—Repairs and painting, &c., to residence, and fencing to school, S.S. No. 1144. (W.O., Wangaratta; P.S., Myrtleford, Yackandandah; S.S., Porepunkah.) Deposit, £4.

Preston.—Improvements to electrical installation in main block, T.S. P.D., £15. F.D., 2 per cent.

Preston.—Supply and installation of cold cathode fluorescent lighting equipment in main block, T.S. P.D., £5. F.D., 2 per cent.

Ripplebrook.—Repairs and painting, improved lighting, and erection of new shed, S.S. No. 2129. (W.O., Korumburra; P.S., Warragul; S.S., Ripplebrook.) P.D., £10. F.D., 2 per cent.

Tongala.—Erection of timber residence, Soldier Settlement Commission. (W.O., Bendigo, Shepparton; P.S., Echuca, Tongala.) P.D., £15. F.D., 2 per cent.

Warburton East.—Painting, repairs, &c., school and residence, S.S. No. 2764. (P.S., Healesville, Lilydale; S.S., Warburton East.) P.D., £10. F.D., 2 per cent.

Willaura.—Internal and external repairs and painting, P.S. (W.O., Ararat; P.S., Willaura.) Deposit, £4.

Tenders to be addressed to the Honorable the Commissioner of Public Works, and envelope containing tender marked "Tender for due

J. A. KENNEDY,

Commissioner of Public Works.

Melbourne, 7th December, 1948.

#### TENDERS FOR THE RIGHT TO REMOVE SALT.

TENDERS will be received up to Noon on Wednesday, 29th December, 1948, for the exclusive right to collect and remove salt from the area described below for a period of eleven months from 1st January, 1949. The licence will be renewable annually for four years from 1st December, 1949, and the amount tendered for the eleven-month period will be treated as the annual rental for such renewal.

The successful tenderer will be required to preserve the bottom of the lake or lakes or collecting grounds from injury, in accordance with instructions from any officer authorized by the Minister of Lands.

No tender will be received unless the total amount of fee offered for the period as stated, and Ten shillings (10s.) fee for preparation of licence, are enclosed. The licence is subject to a royalty charge of Two shillings and six pence (2s. 6d.) per ton on all salt collected or removed. Sworn declarations must be furnished to the Secretary for Lands by the licensee when required, setting out the quantity removed.

Plans of all buildings or other structures proposed to be erected on the licensed area must be submitted to and approved of by the Secretary for Lands, who reserves the right of entry for inspection by any officer authorized by him.

The licensee shall not assign, sublet, or part with his interest in the area, or any portion thereof, without the consent of the Minister of Lands.

The licence will be cancelled for non-payment of any annual fees or any royalty charges or breach of any conditions thereof, or if the licensee shall, for a period of twelve (12) months, fail to use the land bona fide for the purposes for which a licence has been issued.

The Governor in Council reserves the right to resume the area, or any part thereof, for public purposes.

Tenderers must forward full name and address and fee for the right to remove salt for the period and fee for the preparation of licence (10s.) to Secretary for Lands, Treasury Buildings, Melbourne, C.2, endorsed "Tender for the right to remove salt."

Plans may be seen and all information obtained at Lands Department, Melbourne.

The highest or any tender not necessarily accepted.

T. T. HOLLWAY,  
Commissioner of Crown Lands and Survey.

Office of Lands and Survey,  
Melbourne, 6th December, 1948.

*Description.*—The salt lake in the Parish of Toolongrook known as White Lake. Formerly held by James McIntyre Salt Pty. Ltd. Period of occupation, eleven months from 1st January, 1949, renewable annually for four years from 1st December, 1949, at the same rental.

**PRIVATE ADVERTISEMENTS.**

**BRITISH AUSTRALIAN LEAD MANUFACTURERS  
PTY. LTD.**

NOTICE is hereby given that British Australian Lead Manufacturers Proprietary Limited has applied for a lease, under section 125, *Land Act 1928*, for a term of 45 years from 18th January, 1949, of allotment 1, section 67n, City of Port Melbourne, as a site for stores, factories, and general engineering works.

For and on behalf of British Australian Lead  
Manufacturers Pty. Ltd.,

6536

R. C. WALLACE.

**I** MARIE FLORENCE PRIEST, of Wangaratta, in the State of Victoria, trained nurse (heretofore called and known by the name of Marie Florence Pollock), hereby give public notice that by a deed poll dated the 19th day of November, 1948, duly executed and attested and deposited with the Registrar-General of the said State on the 25th day of November, 1948, I formally and absolutely renounced and abandoned the name of Marie Florence Pollock and declared that I had assumed and adopted and intended thenceforth on all occasions to use and subscribe the name of Marie Florence Priest, instead of the name of Marie Florence Pollock, and so as to be at all times thereafter called, known, and subscribed by the name of Marie Florence Priest.

Dated this 29th day of November, 1948.

M. F. PRIEST.

Witness—J. C. MCKENZIE-MCHARG, solicitor, Wodonga.  
6886

**CITY OF HEIDELBERG.**

**BY-LAW No. 167.**

*Restricting the Importation of Second-hand Houses to  
Certain Districts Within the City.*

**A** BY-LAW of the City of Heidelberg, made under the provision of the Local Government Acts and particularly under and with reference to the *Local Government Act 1946*, sections 198 (1) (a) and 228, and numbered 167, for restricting the removal of houses from other municipal districts and their re-erection within the City of Heidelberg.

(1) That By-law 81, Part XII., clause 3, be further amended by inserting a new sub-clause 135 (a) 3K in By-law 118, as follows:—

135 (a) 3K. Any such building shall only be re-erected in those areas within the City of Heidelberg where dwelling houses having a floor area of between 600 and 800 square feet are permitted to be erected.

The Resolution for passing this By-law was agreed to by the Council on the 21st June, 1948, and confirmed on the 26th July, 1948.

A. NUTTALL, Mayor.  
W. C. ELWERS, Councillor.  
F. PHILLIPS, Town Clerk.

(SEAL)

Approved by the Governor in Council on the 16th day of November, 1948.—J. C. MACGIBBON, Acting Clerk of the Executive Council. 6852

**CITY OF MELBOURNE.**

**BY-LAW No. 292.**

A By-law of the City of Melbourne, made under the Carriages Acts and the *Motor Car Act 1928*, and numbered 292, to amend or add to By-law No. 249.

**T**HE Council of the City of Melbourne doth hereby, in pursuance of the powers conferred by the Carriages Acts and the *Motor Car Act 1928* and by every other Act or power enabling it in that behalf, order as follows:—

1. This By-law shall from and after the date of the same coming into operation be read and construed as one with By-law No. 249 intitled "A By-law to provide for licensing, regulating, and limiting the number of motor cars used as hackney carriages plying, kept, or let out for hire within the City of Melbourne and within the distance of eight miles from the corporate limits of the said city, and the owners and drivers of such motor cars and for or with respect to the cancellation, revocation, or suspension of such licences and any By-laws amending the same."

2. By-law No. 249, as amended by By-laws Nos. 270 and 282, is hereby amended as follows:—

(a) By substituting for clause 85 thereof the following clause:—

"(i) No child of or under three years of age carried in the lap of any passenger shall be charged for, but not more than one child with any one passenger shall be so exempt. Children between three years and twelve years of age shall be charged for at half fare.

(ii) The provisions of sub-clause (i) shall not be applicable to motor cabs running on fixed routes."

(b) By omitting in sub-paragraph (a) of clause 86 the words and figures—

	£	s.	d.
"For one-third of a mile, or any part thereof	0	1	8
For each additional one-third of a mile, or any part thereof	0	0	5"

and substituting therefor the words and figures—

	£	s.	d.
"For one-third of a mile, or any part thereof	0	2	0
For each additional one-third of a mile, or any part thereof	0	0	6."

(c) By omitting in sub-paragraph (c) of clause 86, after the word "Detention", the words and figures—

	£	s.	d.
"For each five minutes or part thereof	0	0	8"

and substituting therefor the words and figures—

	£	s.	d.
"For each five minutes or part thereof	0	0	6."

(d) By omitting in Schedule C thereto, after the words "Fares for motor cabs running on fixed routes", the words and figures—

	£	s.	d.
"First section	0	0	2
Every subsequent section	0	0	1
No section to be less than one mile"			

and substituting therefor the words and figures—

“Adults—

For the first mile, or part thereof . . . . . 0 0 2  
 For any subsequent mile, or part thereof . . . . . 0 0 1½  
 Children under 14 years of age—Half adult fare, to the nearest lower half-penny.  
 Children up to 4 years of age, if carried on passenger's lap—Free.”

Resolution for passing this By-law agreed to by the Council of the City of Melbourne on the 9th day of November, 1948, and confirmed on the 6th day of December, 1948.

(SEAL) JAMES S. DISNEY, Lord Mayor.  
 6851 H. S. WOOTTON, Town Clerk.

CITY OF ST. KILDA.

NOTICE OF INTENTION TO BORROW THE SUM OF FIFTY-ONE THOUSAND POUNDS (£51,000) FOR PERMANENT WORKS AND UNDERTAKINGS IN THE CITY OF ST. KILDA.

NOTICE is hereby given that the Council of the City of St. Kilda proposes to borrow, on the credit of the Mayor, Councillors, and Citizens of the said City, the sum of Fifty-one thousand pounds (£51,000), such sum to be raised by the issue of debentures in accordance with the provisions of the *Local Government Act 1946*.

The rate of interest to be paid shall be Three pounds five shillings per centum per annum.

The period of the loan shall be thirty years.

The loan shall be liquidated by 60 equal half-yearly instalments of £1,337 0s. 9d. (to be provided out of the Municipal Fund), which shall cover principal and interest, payable on the 1st day of April and the 1st day of October in each year during the currency of the loan at the Commercial Bank, Melbourne, or at the Melbourne office of the Council's bankers for the time being.

The permanent works and undertakings upon which such loan is to be expended are:—

Work or Undertaking.	Estimated Cost.
1. Improvements, Elwood reserves and foreshore, including Point Ormond plantations and Treetree Reserve, Elwood . . . . .	£9,000
2. Completion of construction of a new refuse destructor . . . . .	25,000
3. Purchase of three motorized refuse collectors . . . . .	9,300
4. Miscellaneous drainage works . . . . .	5,000
5. Elwood Baby Health Centre (completion) . . . . .	1,000
6. Clarke-street Reserve, improvements and playground . . . . .	1,200
7. Jacoby Reserve playground . . . . .	500
Total . . . . .	£51,000

The plans, specifications, and estimates of the cost of such works and undertakings, and a statement showing the intended expenditure of the money to be borrowed, are open for inspection at the Town Clerk's Office, Town Hall, St. Kilda, during office hours.

By order,

W. H. GREAVES, Town Clerk.

Town Hall, St. Kilda, 7th December, 1948. 6893

SHIRE OF CHARLTON.

LOAN No. 6.

Notice of Intention to Borrow the Sum of Two Thousand Pounds (£2,000) for Permanent Works and Undertakings in the Shire of Charlton.

TAKE notice that the Council of the Shire of Charlton proposes to borrow, on the credit of the municipal revenues of the President, Councillors, and Ratepayers of the said shire, the sum of Two thousand pounds (£2,000), such sum to be raised by the issue of debentures in accordance with the provisions of the *Local Government Act 1946*.

The period of the loan shall be ten years. The maximum rate of interest that may be paid is £3 5s. (3½ per cent.) per centum per annum.

Such moneys shall be repayable by twenty half-yearly instalments of approximately £118, each including principal and interest, by providing out of the municipal fund such amounts on the 1st day of March and on the 1st day of September in each respective year during the currency of the loan. The first instalment shall be payable on the 1st day of September, 1949.

Such moneys shall be repayable at Melbourne, at the Commercial Banking Company of Sydney Limited, or at the Council's bankers for the time being in Melbourne.

The purpose for which this loan is to be applied is:—

The purchase of a power grader.

The plans, specifications, and estimate of the cost of the works referred to above, and a statement showing the proposed expenditure of money to be borrowed, are open for inspection at the Shire Office, Charlton.

Dated this 29th day of November, 1948.

6843 A. BEANLAND, Shire Secretary.

SHIRE OF DONCASTER AND TEMPLESTOWE.

LOAN No. 14.

NOTICE is hereby given that the Council of the Shire of Doncaster and Templestowe intends to borrow, on the credit of the President, Councillors, and Ratepayers of the said Shire, the sum of £5,000, such sum to be raised by the issue of debentures, in accordance with the provisions of the *Local Government Act 1946*.

The maximum rate of interest that may be paid shall be Three pounds five shillings (£3 5s.) per centum per annum.

The money borrowed shall be repayable, together with and including interest, at the English, Scottish, and Australasian Bank, Melbourne, or at the Council's bankers for the time being in Melbourne, in 20 consecutive half-yearly instalments of principal and interest of approximately £295, on the 1st day of March and the 1st day of September in each year during the currency of the loan. The first payment shall be made on the 1st September, 1949.

The purpose for which the loan is to be applied shall be the reconstruction of roads within the municipality.

The loan shall be liquidated by provision out of the municipal fund each half year during the currency of the loan of the instalments set out above.

The plans, specifications, and estimate of the cost of works referred to above, and a statement showing the proposed expenditure of the money to be borrowed, are open for inspection at the Municipal Offices, Doncaster.

Dated this 6th day of December, 1948.  
 6849 J. W. THOMSON, Shire Secretary.

SHIRE OF ORBOST.

LOAN No. 7.

Notice of Intention to Borrow the Sum of Two Thousand Five Hundred Pounds (£2,500) for Permanent Works and Undertakings.

NOTICE is hereby given that the Council of the Shire of Orbost proposes to borrow the sum of Two thousand five hundred pounds (£2,500), on the credit of the President, Councillors, and Ratepayers of the Shire of Orbost, by the issue of debentures in accordance with the provisions of Part XV. of the *Local Government Act 1946*.

It is further proposed that—

1. The period of the loan shall be twenty years.  
 2. The maximum rate of interest to be paid shall be £3 5s. per centum per annum.

3. The money borrowed shall be repayable by providing out of the municipal fund 40 half-yearly instalments of approximately £85 10s. each, including principal and interest, on the 1st day of February and the 1st day of August in each year during the currency of the loan. The first instalment shall be payable on the 1st day of August, 1949.

4. The money borrowed, and the interest thereon, shall be payable at the Commercial Bank of Australia Ltd., Melbourne, or at the Council's bankers for the time being in the City of Melbourne.

5. The purpose for which the loan is to be applied is for the construction of a residence for use of a Council officer.

6. The plans and specifications and estimate of the cost of the residence referred to, with a statement of the proposed expenditure of the money to be borrowed, are open for inspection at the Shire Office, Orbost, during office hours.

Dated this 29th day of November, 1948.

6825 H. MCK. SILKE, Shire Secretary.

NOTICE is hereby given that the partnership heretofore subsisting between the undersigned, William George Bartlett and Alma May Bartlett, carrying on a mixed business at No. 108 Poath-road, Hughesdale, under the name of "W. G. and A. M. Bartlett," has been dissolved by mutual consent.

Dated the 6th day of December, 1948.

Witness—R. G. B. SKINNER. W. G. BARTLETT.

A. M. BARTLETT.

Witness—E. ASTON LLOYD. 6868

## NOTICE OF DISSOLUTION OF PARTNERSHIP.

NOTICE is hereby given that the partnership heretofore subsisting between Lionel William Douglas Beacall and Alexander Archibald Jones, carrying on business as nursery furniture manufacturers at 91-93 Denmark-street, Kew, under the style or firm of "Beacall and Jones," has been dissolved by mutual consent as from the 29th day of September, 1948. All debts due to and owing by the said late firm will be received and paid respectively by Lionel William Douglas Beacall, who will continue to carry on the said business at the same place.

Dated the 27th day of November, 1948.

L. W. D. BEACALL.  
A. JONES.

Cornwell, Stodart, and Co., 47 Queen-street, Melbourne, solicitors. 6829

## NOTICE OF DISSOLUTION OF PARTNERSHIP.

NOTICE is hereby given that the partnership heretofore subsisting between George Alexander McWhinney and John Walker, carrying on business as manufacturers, at 573 Swanston-street, Carlton, under the style or firm of "Walker Products," has been dissolved by mutual consent as from the 14th day of October, 1948. All debts due to and owing by the said late firm will be received and paid respectively by George Alexander McWhinney, who will continue to carry on the said business at the same place.

Dated the 30th day of November, 1948.

GEORGE McWHINNEY.  
J. WALKER.

Cornwall, Stodart, & Co., 47 Queen-street, Melbourne, solicitors. 6840

TAKE notice that the partnership hereto carried on by Leslie William Priestly, George Silbert Cadman, and Alan Dunlop, under the name of D.P.C. Cleaning Service, will, as from the date hereof, be carried on by the said Leslie William Priestly, George Silbert Cadman, and Alan Smallacombe, the said Alan Dunlop having retired from the business and the said Alan Smallacombe having taken his place thereon. All debts of the business will be paid by the present partners.

Dated the 9th day of November, 1948.

L. W. PRIESTLY.  
A. DUNLOP.  
G. S. CADMAN.

Hoad and Bonella, of 101 Queen-street, Melbourne, solicitors for partnership. 6834

NOTICE is hereby given that the partnership heretofore subsisting between Horace William James Hankin, Alfred Leslie Green, and Robert James Thomas, carrying on business as mechanical and electrical engineers and manufacturers of liquid porcelain, at 14 Little William-street, Melbourne, under the style or firm of Hankin Electric Company, has been dissolved as from the 30th day of November, 1948. Any persons having claims against the said partnership are required to send in particulars of their claim to McLaughlin, Eaves, and Johnston, of 343 Little Collins-street, Melbourne, not later than the 15th day of January, 1949.

Dated the 2nd day of December, 1948.

H. W. J. HANKIN.  
A. L. GREEN.  
R. J. THOMAS.

McLaughlin, Eaves, and Johnston, solicitors, 343 Little Collins-street, Melbourne. 6836

NOTICE is hereby given that the partnership heretofore subsisting between Theodore Bruce Anderson and Georg Sharpe, carrying on business as bakers and pastry-cooks at 5 McCrae-street, Swan Hill, under the style or firm of Anderson's Cake Kitchen, has been dissolved by mutual consent as from the 1st December, 1948. Such business will henceforth be carried on solely by the said Theodore Bruce Anderson.

T. B. ANDERSON.  
G. SHARPE.

Gerald E. Delany, LL.B., solicitor, 63 Campbell-street, Swan Hill. 6860

NOTICE is hereby given that the partnership heretofore subsisting between Frederick John Gates and Glyn Jones, carrying on a radio sales and service business at 109 Bay-street, Port Melbourne, under the name of Graham Radio and Sewing Machines, has been dissolved by mutual consent as from the 16th day of November, 1948. The said

business will be carried on by the said Frederick John Gates, under the same name, at the same address, and all debts due to and owing by the partnership will be received and paid by him.

Dated this 1st day of December, 1948.

F. J. GATES.  
G. JONES.

Witness to both signatures—J. W. GLOVER.  
J. W. Glover, LL.B., solicitor, 422 Collins-street, Melbourne. 6861

## Companies Act 1938.

## FRED. WATSON PROPRIETARY LIMITED.

NOTICE OF SPECIAL RESOLUTION TO WIND UP, PURSUANT TO SECTION 226 (1).

AT an Extraordinary General Meeting of the above-named company, duly convened and held at 175 Scott-street, Warracknabeal, on Wednesday, the 1st day of December, 1948, the following Resolution was duly passed as a Special Resolution:—

"That the company be wound up voluntarily."

And at such last-mentioned meeting Joseph Sims, of 12 Woolcock-street, Warracknabeal, accountant, was appointed liquidator for the purposes of the winding up.

Dated the 1st day of December, 1948.

6830 F. A. WATSON, Governing Director.

## Companies Act 1938.

## TRADAIR PROPRIETARY LIMITED.

AT an Extraordinary General Meeting of the members of Tradair Proprietary Limited, duly convened and held at the Board Room, Chamber of Manufacturers, Flinders-street, Melbourne, on the 16th day of November, 1948, the following Extraordinary Resolution was duly passed:—

"That it has been proved to the satisfaction of this meeting that the company cannot by reason of its liabilities continue its business, and that it is advisable to wind up the same, and accordingly that the company be wound up voluntarily, and that John Kenneth Hall, of Hall and Rose, chartered accountants (Aust.), be nominated as liquidator."

Dated this 25th day of November, 1948.

6873 F. H. EARLE, Director.

## M. &amp; S. SUPPLIES PTY. LTD.

NOTICE is hereby given that the creditors of the above-named company, which is being voluntarily wound up, are required on or before the 1st day of February, 1949, being the day for that purpose fixed by me, the undersigned, the liquidator of the company, to send their names and addresses and the particulars of their debts or claims to the undersigned, and if so required by notice, in writing, from me are to come in and prove their said debts and claims at such time and place as shall be specified in such notice, or in default thereof they will be excluded from the benefit of any distribution made before such debts are proved.

Dated this 1st day of December, 1948.

York-street, Eltham. K. C. KEOWN, Liquidator. 6882

NOTICE TO CREDITORS.—*RE* CATHERINE CHATHAM, DECEASED.

PURSUANT to the provisions of the *Trustee Act 1928*, notice is hereby given that all persons having claims against the estate of Catherine Chatham, late of Napoleons, in the State of Victoria, spinster, deceased (who died on the 6th day of September, 1948, letters of administration of whose estate was granted to The Ballarat Trustees, Executors, and Agency Company Limited, of 101 Lydiard-street north, Ballarat), are hereby required to send particulars, in writing, of such claims, on or before the 6th day of February, 1949, to the said administrator, care of the undersigned. And notice is hereby given that after the said date the said administrator will proceed to distribute the assets of the said deceased which shall have come to its hands or possession amongst the persons entitled thereto, having regard only to the claims of which the said administrator may then have had notice, and the said administrator will not then be liable for the assets, or any part thereof, so distributed to any person of whose claim it shall not then have had notice.

Dated this 30th day of November, 1948.

F. RUSSELL COLDHAM & CO., 32 Lydiard-street, Ballarat, proctors for the said administrator. 6844

NOTICE TO CREDITORS.—JOHN JAMES CONLON,  
DECEASED.

CREDITORS, next of kin, and others having claims in respect of the estate of John James Conlon, formerly of 30 Cameron-street, Coburg, but late of Mena House, Simpson-street, East Melbourne, in the State of Victoria, retired signalman, deceased (who died on the 1st day of June, 1948), are to send particulars of their claims to the National Trustees, Executors, and Agency Company of Australasia Limited, the executor named in the will of the said deceased, at their registered office, 95 Queen-street, Melbourne, by the 9th day of February, 1949, after which date it will distribute the assets, having regard only to the claims of which it then has notice.

Dated the 2nd day of December, 1948.

FRANK BRENNAN & CO., 20 Queen-street, Melbourne,  
solicitors for the applicants. 6880

JOSEPH RANCE DOUIE, DECEASED.

CREDITORS, next of kin, and others having claims in respect of the estate of Joseph Rance Douie, late of 653 Brunswick-street, North Fitzroy, retired estate agent, deceased (who died on the 31st day of July, 1948), are to send the particulars of their claims to National Trustees, Executors, and Agency Company of Australasia Limited, the registered office of which is at 95 Queen-street, Melbourne (the applicant for letters of administration of the estate of the said deceased with the will annexed), by the 18th day of February, 1949, after which date it will distribute the assets, having regard only to the claims of which it then has notice.

COLE & O'HEARE, solicitors, 465 Collins-street, Mel-  
bourne. 6871

CREDITORS, next of kin, and others having claims in respect of the estate of John McLean, late of Invercargill, in the Dominion of New Zealand, retired boat builder, deceased (who died on the 9th September, 1947), are to send particulars of their claims to the executor in Victoria, Robert John Ball, care of the undersigned, by the 14th day of February, 1949, after which date the executor will distribute the assets, having regard only to claims of which he then has notice.

HENDERSON & BALL, solicitors, 430 Little Collins-  
street, Melbourne. 6883

NOTICE TO CREDITORS.—HENRY KIRWAN, DECEASED.

CREDITORS, next of kin, and others having claims in respect of the estate of Henry Kirwan, late of 4 Portland-street, Richmond, in the State of Victoria, retired bootmaker, deceased (who died on the 18th day of July, 1948), are to send the particulars of their claims to National Trustees, Executors, and Agency Company of Australasia Limited, of 95 Queen-street, Melbourne, by the 19th day of February, 1949, after which date it will distribute the assets, having regard only to the claims of which it then has notice.

H. H. HOARE, 191 Queen-street, Melbourne, solicitor  
for the said company. 6870

CREDITORS, next of kin, and others having claims in respect of the estate of John Thomas Cox, formerly of 2 Webb-street, Footscray, but late of 14 Federal-street, Footscray, in the State of Victoria, retired coppersmith, deceased (who died on the 16th day of August, 1948), are to send particulars of their claims to the National Trustees, Executors, and Agency Company of Australasia Limited, whose registered office is situate at No. 95 Queen-street, Melbourne, by the 11th day of February, 1949, after which date it will distribute the assets, having regard only to the claims of which it then has notice.

W. H. JONES & KENNEDY, 214 Nicholson-street,  
Footscray, solicitors for the company. 6884

CREDITORS, next of kin, and others having claims in respect of the estate of Frances Cato, late of "Kawarau," Toorong-road, Hawthorn, in the State of Victoria, widow, deceased (who died on the 20th day of August, 1948), are to send particulars of their claims to the personal representatives, care of the under-mentioned solicitors, on or before the 15th day of February, 1949, after which date they will distribute the assets, having regard only to the claims of which they then have notice.

E. P. JOHNSON & DAVIES, 339 Collins-street, Mel-  
bourne. 6885

WILLIAM BECKLEY GILLON, late of 5 Buxton-street, Elsternwick, mechanic (who died on the 31st day of July, 1948).

CREDITORS, next of kin, and all other persons having claims against the estate of the deceased are required by the administratrix of the estate, Jean Mary Gillard, of 20 Asling-street, North Brighton, married woman, to send particulars to her, care of the undersigned, on or before the 10th day of February, 1949, after which date she will distribute the assets, having regard only to the claims of which she then has notice.

MOLOMBY & MOLOMBY, solicitors, 99 Queen-street,  
Melbourne. 6887

CATHERINE ELLEN WALKER, formerly of 5 Rowan-street, Bendigo, in the State of Victoria, but late of Yalleroi Convalescent Home, 3 Bennett-street, Wentworthville, in the State of New South Wales, widow, DECEASED (who died on the 17th day of July, 1948).

CREDITORS, next of kin, and all persons having claims against the estate of the above deceased are requested by Farmers and Citizens Trustees Company Bendigo Limited, of Charing Cross, Bendigo, the executor of the will of the said deceased, to send particulars to the said company, on or before the 9th day of February, 1949, after which date the said company will distribute the assets, having regard only to the claims of which it shall then have had notice.

COHEN, KIRBY, & CO., solicitors, 117 Pall Mall,  
Bendigo. 6824

BLANCHE BILL, late of Lincoln-road, Croydon, in the State of Victoria, widow, DECEASED.

CREDITORS, next of kin, and all other persons having claims against the estate of the said deceased are required by Sandhurst and Northern District Trustees, Executors, and Agency Company Limited, of View-street, Bendigo, the executor of the will of the said deceased, to send particulars thereof, in writing, to the said company, on or before the 15th day of February, 1949, after which date the said company will proceed to distribute the assets of the said deceased, having regard only to the claims of which it then has notice.

Dated the 2nd day of December, 1948.

T. M. WILLIAMS, WATSON, & JAMES, of Bull-street,  
Bendigo, solicitors for the executor. 6823

MARY ANN MURNANE, late of Avoca, widow, DECEASED.

CREDITORS, next of kin, and others having claims in respect of the estate of the deceased (who died on the 9th May, 1948), are required by the executors of her will, James Alphonse Murnane, of Ouyen, farmer, and John Joseph Murnane, of Rochester, farmer, to send particulars of their claims to the said executors, care of the undersigned, on or before the 15th February, 1949, after which date the executors will distribute the assets, having regard only to the claims of which they then have notice.

MITCHELL & MONOTTI, solicitors, St. Arnaud. 6831

WILLIAM JOHN PILGRIM, late of St. Arnaud, retired farmer, DECEASED.

CREDITORS, next of kin, and others having claims in respect of the estate of the deceased (who died on 23rd November, 1925), are required to send particulars of their claims to the executors, Peter Glen William Pilgrim, of 21 Victoria-road, Northcote, council employee, and Albert George Berry Pilgrim, of 36 Wakanui-street, Northcote, council employee, care of the undersigned, on or before 15th February, 1949, after which date they will distribute the assets, having regard only to the claims of which they then have notice.

MITCHELL & MONOTTI, solicitors, St. Arnaud. 6832

ELLEN PILGRIM, formerly of St. Arnaud, but late of 91 Carlisle-street, St. Kilda, widow, DECEASED

CREDITORS, next of kin, and others having claims in respect of the estate of the deceased (who died on 19th October, 1945), are required to send particulars of their claims to the executors, Peter Glen William Pilgrim, of 21 Victoria-road, Northcote, council employee, and Albert George Berry Pilgrim, of 36 Wakanui-street, Northcote, council employee, care of the undersigned, on or before the 15th February, 1949, after which date they will distribute the assets, having regard only to the claims of which they then have notice.

MITCHELL & MONOTTI, solicitors, St. Arnaud. 6833

ELIZABETH BAILLIE, late of 47 Auburn-road, Auburn, widow, DECEASED.

CREDITORS, next of kin, and all other persons having claims against the estate of the deceased are required by the executor of the will, John Clifton Baillie, of 47 Auburn-road, Auburn, hairdresser, to send particulars to him, care of the undersigned, on or before 9th February, 1949, after which date he will distribute the assets, having regard only to the claims of which he then has notice.

WISEWOULD & DUNCAN, solicitors, of 408 Collins-street, Melbourne. 6837

THE PERPETUAL EXECUTORS AND TRUSTEES ASSOCIATION OF AUSTRALIA LIMITED, whose registered office is situate at Nos. 100-104 Queen-street, Melbourne, in the State of Victoria, and Florence Adelaide Ledger, widow, Laurence Herbert Ledger, stock and station agent, Alexander Halliburton Wann, stock and station agent, all of Benalla, in the said State, and James Clarence Beattie, of 3 Power-avenue, Toorak, in the said State, investor, the executors and executrix respectively of the will of Herbert Ledger, late of Church-street, Benalla aforesaid, stock and station agent, deceased (who died on the 24th day of August, 1947), require all creditors, next of kin, and others having claims against the property or estate of the said deceased, to send to the said executors, in the care of the said association, on or before the 15th day of February, 1949, particulars, in writing, of such claims, after which date the said executors intend to convey or distribute such property or estate to or among the persons entitled thereto, having regard only to the claims of which they shall have had notice.

Dated the 1st day of December, 1948.

CORR & CORR, of 104 Queen-street, Melbourne, solicitors for the said association. 6835

ALBERT HENRY GAYDON, late of Bunyip, farmer (who died 14th August, 1948).

CREDITORS, next of kin, and all other persons having claims against the estate of the deceased are required by the executor, National Trustees, Executors, and Agency Company of Australasia Limited, whose registered office is at 95 Queen-street, Melbourne, to send particulars, in writing, to the said company, at its registered office aforesaid, on or before 11th February, 1949, after which date it will distribute the assets, having regard only to the claims of which it then has notice.

HAMILTON & TELFORD, solicitors, Drouin. 6828

JOSEPH ALFRED BUDD, late of Bona Vista Farm, labourer, DECEASED.

CREDITORS, next of kin, and all other persons having claims against the estate of the above-named Joseph Alfred Budd, deceased, are required to send particulars thereof to the undersigned solicitors for the executor, Frederick James Budd, of Bona Vista aforesaid, farmer, on or before the 15th day of February, 1949, after which date the said executor will proceed to distribute the assets among the persons entitled thereto, having regard only to claims of which they shall then have had notice.

GRAY, FRIEND, & MOONIE, solicitors, Warragul. 6820

NOTICE TO CREDITORS IN THE ESTATE OF ELIZABETH ANN WARD, DECEASED.

CREDITORS, next of kin, and others having claims in respect of the estate of Elizabeth Ann Ward, late of Lucknow, near Bairnsdale, spinster, deceased, intestate (who died on the 18th day of July, 1947), are requested to forward particulars of their claims to Charles Henry Kennedy, of Granite Rock, near Bairnsdale, farmer, the administrator of the estate of the said Elizabeth Ann Ward, deceased, intestate, by sending such particulars to him, care of the undersigned solicitors, by the 15th day of February, 1949, after which date the said Charles Henry Kennedy will distribute the assets of the said deceased, having regard only to the claims of which he then has notice.

WARREN & THOMSON, Bailey-street, Bairnsdale, solicitors for the administrator. 6821

CREDITORS, next of kin, and all others having claims in respect of the estate of Allan James Harmer, late of Hopetoun, in the State of Victoria, farmer, deceased (who died on the 8th day of September, 1948), are to send particulars of their claims to the executors, Lionel John Afford and Earle Richard Harmer, care of the undersigned, on or before the 15th day of February, 1949, after which date they will distribute the assets, having regard only to the claims of which they then have notice.

D. J. COMMONS, solicitor, Hopetoun. 6857

NOTICE TO CLAIMANTS.

THE PERPETUAL EXECUTORS AND TRUSTEES ASSOCIATION OF AUSTRALIA LIMITED, whose registered office is situate at Nos. 100-104 Queen-street, Melbourne, in the State of Victoria, and Charles Arthur Sims, of Johnsonville, in the said State, the executors of the will of John Sims, late of 96 Pyke-street, Bairnsdale, in Victoria, retired licensed victualler (who died on the 19th day of June, 1948), require all creditors, next of kin, and others having claims against the property or estate of the said deceased to send to the said executors, in the care of the said association, on or before the 23rd day of February, 1949, particulars, in writing, of such claims, after which date the said executors intend to convey or distribute such property or estate to or among the persons entitled thereto, having regard only to the claims of which they shall have had notice.

Dated the 30th day of November, 1948.

J. I. LANFRANCHI, of Bairnsdale, solicitor for the executors. 6822

CREDITORS, next of kin, and others having claims in respect of the estate of Maurice Allan Rice, formerly of 137 Beach-road, Sandringham, but late of 92 Mentone-parade, Mentone, both in the State of Victoria, retired postal employee, deceased (who died on the 25th day of June, 1948), are to send the particulars of their claims to National Trustees, Executors, and Agency Company of Australasia Limited, at its registered office, 95 Queen-street, Melbourne, in the said State, by the 10th day of February, 1949, after which date it will distribute the assets, having regard only to the claims of which it then has notice.

ARTHUR F. RICE & CO., solicitors, Johnson-street, Maffra. 6848

ELIZABETH ZOE MACFIE, DECEASED.

PURSUANT to the *Trustee Act* 1928, notice is hereby given that all persons having any claims against the property or estate of Elizabeth Zoe Macfie, formerly of "Oronsay," 6 Epping-street, East Malvern, but late of Stratherne Presbyterian Girls' School, Power-street, Hawthorn, in the State of Victoria, spinster, deceased (who died on the 16th day of July, 1948, and probate of whose will was granted by the Supreme Court of Victoria to The Trustees, Executors, and Agency Company Limited, of 401 Collins-street, Melbourne, in the said State, the executor appointed by the said will), are hereby required to send to the said company, on or before the 10th day of February, 1949, particulars, in writing, of such claims, after which last-mentioned date the said company intends to convey or distribute such property or estate to or among the persons entitled thereto, having regard only to the claims of which they shall have had notice.

PEARCE & WEBSTER, solicitors, 191 Queen-street, Melbourne. 6839

NOTICE TO CLAIMANTS.—*RE* WILLIAM ALBERT HAIGH BROWN, late of 2 Baker-street, St. Kilda, retired plumber, DECEASED.

CREDITORS and others having claims in respect of the estate of the above-named deceased (who died on the 5th day of June, 1948), are required to send particulars of their claims to the Union Trustee Company of Australia Limited, of 333 Collins-street, Melbourne, on or before the 12th day of February, 1949, after which date the company will distribute the assets, having regard only to the claims of which it then has notice.

CORNWALL, STODART & CO., solicitors, 47 Queen-street, Melbourne. 6841

PURSUANT to the *Trustee Act* 1928, all persons having claims against the estate of Edward Joseph Wood, late of 29 Waiora-parade, West Footscray, fitter, deceased (who died on the 9th day of October, 1948, and probate of whose will was granted by the Supreme Court of Victoria on the 1st day of December, 1948, to Lillian Alice Hirst, of 14 Carlyle-street, Maidstone, household duties, the executrix appointed by deceased's will), are hereby required to send particulars of such claims to the said Lillian Alice Hirst, care of the under-mentioned solicitors, on or before the 9th day of February, 1949, after which date the said executrix will distribute the assets, having regard only to the claims of which notice has then been received.

MARTIN & MARTIN, solicitors, 37 Queen-street, Melbourne. 6890

## ALBERT NIXON, DECEASED.

PURSUANT to the *Trustee Act* 1928, notice is hereby given that all persons having claims, whether as creditors, next of kin, beneficiaries, or otherwise, against the estate of Albert Nixon, late of 218 Buckley-street, Essendon, in the State of Victoria, pastrycook, deceased (who died on the 8th day of July, 1948, and letters of administration of whose estate were granted by the Supreme Court of Victoria on the 7th day of September, 1948, to Lilian Nixon, of 218 Buckley-street, Essendon aforesaid, widow), are hereby required to send particulars, in writing, to the said administratrix, care of the undersigned solicitors, on or before the 17th day of February, 1949, after which date the said administratrix will proceed to distribute the estate of the said deceased which shall then have come to her hands amongst the persons entitled thereto, having regard only to the claims of which she shall then have had notice; and the said administratrix will not be liable for the assets so distributed, or any part thereof, to any person of whose claim she shall not have had notice as aforesaid.

ABBOTT, BECKETT, STILLMAN & GRAY, solicitors,  
422 Little Collins-street, Melbourne. 688

CREDITORS, next of kin, and others having claims in respect of the estate of Gertrude Mabel Poulton, late of Hopetoun, married woman, deceased (who died on the 20th day of July, 1948), are to send particulars of their claims to the executor, Evered Poulton, care of the undersigned, by the 15th day of February, 1949, after which date he will distribute the assets, having regard only to the claims of which he then has notice.

D. J. COMMONS, solicitor, Hopetoun. 6855

CREDITORS, next of kin, and all others having claims in respect of the estate of Ernest William Lynch, late of Patchewollock, in the State of Victoria, farmer, deceased (who died on the 9th day of October, 1948), are to send particulars of their claims to the executor, Ernest Robert Lynch, care of the undersigned, on or before the 15th day of February, 1949, after which date he will distribute the assets, having regard only to the claims of which he then has notice.

D. J. COMMONS, solicitor, Hopetoun. 6856

CREDITORS, next of kin, and others having claims in respect of the estate of Robert Arthur Edmanson, formerly of Majestic Mansions, Fitzroy-street, St. Kilda, but late of No. 16 Hill-street, Toorak, valuer (who died on the 17th August, 1948), are to send particulars of their claims to George Arthur Edmanson and The Union Trustee-Company of Australia Limited, at 333 Collins-street, Melbourne, by the 15th day of March, 1949, after which date they will distribute the assets, having regard only to the claims of which they then have notice.

WEIGALL & CROWTHER, solicitors, 459 Chancery-lane, Melbourne. 6857

AUGUSTUS JOHN ROSSITER, late of Yarram, journalist (who died on the 27th June, 1948).

CREDITORS, next of kin, and all other persons having claims against the estate of the said deceased are required by Kenneth Mortimer Cox, of Yarram, public accountant, the executor of the will and codicil thereto of the said deceased, to send particulars of such claims to him, at his address aforesaid, on or before the 18th day of February, 1949, after which date he will distribute the assets, having regard only to the claims of which he then has notice.

SKINNER & HART, solicitors, Yarram. 6859

ALICE JANE DAVIES, late of Hornsby, in the State of New South Wales, married woman (who died on 11th September, 1948).

CREDITORS and all other persons having claims against the estate of the deceased are required by the administrator with the will annexed of the estate, the Public Trustee in and for the State of New South Wales, of 19 O'Connell-street, Sydney, in the said State, to send particulars of such claims to him, in writing, on or before 11th February, 1949, after which date the assets will be distributed, having regard only to the claims of which notice has then been received.

PLANTE & HENTY, 395 Collins-street, Melbourne, solicitors for the administrator, c.t.a. 6863

CREDITORS, next of kin, and others having claims in respect of the estate of Margaret Cottell, late of 65 Highfield-road, Canterbury, widow, deceased (who died 4th July, 1948), are to send particulars of their claims to James Patrick Ogge, care of the undersigned, by the 28th February, 1949, after which date he will distribute the assets, having regard only to the claims of which he then has notice.

JAMES P. OGGE, LL.B., solicitor, 165 Greville-street, Prahran. 6866

ARTHUR VINCENT CARD, late of 262 Beach-road, Black Rock, salesman (who died on 31st August, 1948).

CREDITORS and all other persons having claims against the estate of the deceased are required by the administratrix, with the will annexed, Gwendolyn Ethel Card, of 262 Beach-road, Black Rock aforesaid, to send particulars of such claims, in writing, to the undersigned, on or before 11th February, 1949, after which date the assets will be distributed, having regard only to the claims of which notice has then been received.

PLANTE & HENTY, 395 Collins-street, Melbourne, solicitors for the administratrix, c.t.a. 6862

CECELIA MARY AGNES PEAT, late of 1 Inverness-street, East Brunswick, taxi cab proprietress (who died on the 3rd day of November, 1948).

CREDITORS, next of kin, and all other persons having claims against the estate of the deceased are required by the executrix of the will, Catherine Sadie Buddle, of 275 Victoria-street, Abbotsford, home duties, to send particulars to her, care of the undersigned, on or before the 10th day of February, 1949, after which date she will distribute the assets, having regard only to the claims of which she then has notice.

MOLOMBY & MOLOMBY, solicitors, 99 Queen-street, Melbourne. 6889

WILLIAM GIBBINS, late of 805 Sydney-road, Coburg, retired public servant, DECEASED.

CREDITORS, next of kin, and all other persons having claims against the estate of the said deceased are required by the executor of the will, Francis William Edmund Gibbins, of 779 Sydney-road, Coburg, civil servant, to send particulars to him, care of the undersigned, on or before the 18th February, 1949, after which date he will distribute the assets, having regard only to the claims of which he then has notice.

P. J. RIDGEWAY & PEARCE, solicitors, 379 Collins-street, Melbourne. 6891

RE JOHN ALFRED THOMAS BUCHANAN, DECEASED.

PURSUANT to the *Trustee Act* 1928, notice is hereby given that James Martin Spring, of Romsey, farmer, and James Fulton Jordan, of 6 Albert-avenue, Oakleigh, timber foreman, executors of the will of the above-named John Alfred Thomas Buchanan, late of Launching Place, farmer, deceased (who died on the 30th day of March, 1948), intend to convey or distribute the estate of the said deceased to or among the persons entitled thereto, and require all persons and creditors interested to send to them, care of the under-mentioned solicitors, on or before the 16th day of February, 1949, particulars, in writing, of their claims against the said estate, after which date the executors may convey or distribute the said estate to or among the persons entitled thereto, having regard only to the claims, whether formal or not, of which they shall then have had notice.

RIGBY & FIELDING, 60 Market-street, Melbourne, solicitors for the executors. 6892

THE PERPETUAL EXECUTORS AND TRUSTEES ASSOCIATION OF AUSTRALIA LIMITED, whose registered office is situate at Nos. 100-104 Queen-street, Melbourne, in the State of Victoria, and Ernest William Smith, of Merbein, in the said State, the executors of the will of Joseph Nicholson, late of Merbein, horticulturist, deceased (who died on the 20th day of July, 1948), require all creditors, next of kin, and others having claims against the property or estate of the said deceased to send to the said association, on or before the 3rd day of February, 1949, particulars, in writing, of such claims, after which date the said executors intend to convey or distribute such property or estate to or among the persons entitled thereto, having regard only to the claims of which they shall have had notice.

Dated this 29th day of November, 1948.

PERCY T. PARK & HILLARD, solicitors, Deakin-avenue, Mildura. 6826



SARAH GILLON, late of 5 Buxton-street, Elsternwick, married woman (who died on the 20th day of July, 1948).

**CREDITORS**, next of kin, and all other persons having claims against the estate of the deceased are required by the executrix of the will, Jean Mary Gillard, of 20 Asling-street, North Brighton, married woman, to send particulars to her, care of the undersigned, on or before the 10th day of February, 1949, after which date she will distribute the assets, having regard only to the claims of which she then has notice.

MOLOMBY & MOLOMBY, solicitors, 99 Queen-street, Melbourne. 6888

**CREDITORS**, next of kin, and all persons having claims in respect of the estate of Sidney William Ernest Styles, late of Harlington-street, Clayton, carpenter, deceased, intestate (who died on the 21st day of August, 1948), are to send particulars of their claims to Gladys Caroline Styles, care of Messrs. H. S. W. Lawson and Co., solicitors, 314 Collins-street, Melbourne, by the 9th February, 1949, after which date she will distribute the assets, having regard only to the claims of which she then has notice.

H. S. W. LAWSON & CO., solicitors, 314 Collins-street, Melbourne. 6869

**NOTICE TO CREDITORS.—RE JAMES TREMBATH, DECEASED.**

**PURSUANT** to the *Trustee Act 1928*, notice is hereby given that all persons having claims against the estate of James Trembath, farmer, deceased (who died on the 22nd day of May, 1948, letters of administration of whose estate were granted to Lavinia Mary Trembath, Tyer's-road, Traralgon aforesaid, widow), are required to send particulars, in writing, of such claims, on or before the 9th day of February, 1949, to the said administratrix, care of the undersigned; and notice is hereby given that after the said date the said administratrix will proceed to distribute the assets of the said deceased which shall have come to her hands or possession amongst the persons entitled thereto, having regard only to the claims of which the said administratrix may then have had notice, and the said administratrix will not then be liable for the assets, or any part thereof, so distributed to any person of whose claim she shall not then have had notice.

Dated the 6th day of December, 1948.

AKEHURST, FRIEND, & HAACK, 405 Collins-street, Melbourne, solicitors for the administratrix. 6878

**NOTICE TO CREDITORS.—RE NANCY ELIZABETH LYNCH, DECEASED.**

**PURSUANT** to the *Trustee Act 1928*, notice is hereby given that all persons having claims against the estate of Nancy Elizabeth Lynch, late of 16 Essex-road, Surrey Hills, in the State of Victoria, spinster, deceased (who died on the 15th day of July, 1948, letters of administration of whose estate were granted to Jane Harvey Lynch, of 16 Essex-road, Surrey Hills aforesaid, widow), are required to send particulars, in writing, of such claims, on or before the 9th day of February, 1949, to the said administratrix, care of the undersigned; and notice is hereby given that after the said date the said administratrix will proceed to distribute the assets of the said deceased which shall have come to her hands or possession amongst the persons entitled thereto, having regard only to the claims of which the said administratrix may then have had notice, and the said administratrix will not then be liable for the assets, or any part thereof, so distributed to any person of whose claim she shall not then have had notice.

Dated the 3rd day of December, 1948.

AKEHURST, FRIEND, & HAACK, 405 Collins-street, Melbourne, solicitors for the administratrix. 6879

**CREDITORS**, next of kin, and others having claims in respect of the estate of Ernest William Pooley, formerly of 51 Vincent-street, Malvern, but late of 25 Paxton-street, East Malvern, retired railway employee, deceased, intestate (who died on the 25th day of May, 1948), are to send particulars of their claims to Catherine Judith Pooley, care of her solicitors, at their address set out below, by the 11th day of February, 1949, after which date she will distribute the assets, having regard only to the claims of which she then has notice.

J. P. MINOGUE, CAREY, & MORAN, 20 Queen-street, Melbourne, solicitors for the said Catherine Judith Pooley. 6877

**CREDITORS**, next of kin, and others having claims in respect of the estate of John McKillop, late of 501 Malvern-road, Hawksburn, baker, deceased (who died 29th May, 1948), are to send particulars of their claims to The Equity Trustees, Executors, and Agency Company Limited, of 472 Bourke-street, Melbourne, by the 28th February, 1949, after which date it will distribute the assets, having regard only to the claims of which it then has notice.

JAMES P. OGDGE, LL.B., solicitor, &c., 165 Greville-street, Prahran. 6867

*Trustee Act 1928.*

**NOTICE TO CLAIMANTS.**

**PURSUANT** to the *Trustee Act 1928*, creditors, next of kin, and all other persons having claims in respect of the estate of any deceased person named below are required to send particulars thereof to the legal personal representative or representatives at the address stated below, on or before the date stated, after which date the representative or representatives will distribute the assets, having regard only to the claims of which notice has been received:—

John Thomas Harry, late of Lorne, tobacconist, died 12th July, 1948.—Claims to the applicants for probate, Annie Harry, of Lorne, widow, and Norman Henry Harry, of 14 Corris-street, Yarraville, State school teacher, care of Wighton and McDonald, solicitors, 53 Yarra-street, Geelong, by 10th February, 1949. 6842

Elizabeth Jane Piper, formerly of Hopetoun, but late of Point Lonsdale, married woman, deceased, died 23rd August, 1948.—Claims to executor, Allan Lindsay Jenkins, of Hopetoun, care of D. J. Commons, solicitor, Hopetoun, by 15th February, 1949. 6854

Henry William Simpkin, late of Weering, farmer, died 14th October, 1948.—Claims to the executors, Joseph Henry Simpkin, of Meeroo Meadow, via Nowra, in New South Wales, and Stanley Donald Simpkin, of Weering, in Victoria, farmers, by 8th February, 1949. Sewell and Sewell, solicitors, Colac. 6864

Catherine Bannerman, late of Sutherland-street, Helmsdale, Sutherland, Scotland, spinster, died 17th May, 1924.—Claims to the administrator, The Ballarat Trustees, Executors, and Agency Company Limited, of 101 Lydiard-street north, Ballarat, by 8th February, 1949. Sewell and Sewell, solicitors, Colac. 6865

Victor Norman Jame, late of 42 Hedderwick-street, Essendon, in the State of Victoria, departmental manager, who died on 3rd March, 1948.—Claims to the executrix, Iris Madge Jame, of 11 Erewster-street, Essendon, widow, by 11th February, 1949. Hedderwick, Fookes, and Alston, 103 William-street, Melbourne, solicitors for the executrix. 6872

**MINING NOTICES.**

**TOOLLEEN GOLD MINING CO. N. L.**

**NOTICE** is hereby given that a Call (the 31st) of One penny per share (making shares 19s. 5d. paid up) has been made on all contributing shares in the company, due and payable at the registered office, 340 Little Collins-street, Melbourne, on Wednesday, 12th January, 1949.

By order of the Board,

E. C. CANDY, Legal Manager.

E. C. Candy and Co., 340 Little Collins-street, Melbourne, C.I. 6881

**AJAX SOUTH GOLD MINE NO LIABILITY.**

**NOTICE** is hereby given that all shares forfeited for non-payment of the 34th (November) Call of Three pence per share will be sold by public auction at the Stock Exchange Hall, 428 Chancery-lane, Melbourne, at a quarter to Twelve a.m., on Thursday, the 16th day of December, 1948, unless redeemed on or before Five p.m. on Wednesday, the 15th day of December, 1948.

By order of the Board,

A. E. LLEWELLYN, Manager.

6875



**NEW CHUM SYNCLINE GOLD MINE NO LIABILITY.**

**NOTICE** is hereby given that all shares forfeited for non-payment of No. 101 (November) Call of Three pence per share will be sold by public auction in the vestibule of the Stock Exchange, 428 Chancery-lane, Melbourne, on Thursday, 16th December, 1948, at a quarter to Twelve a.m., unless shares are previously redeemed.

By order of the Board,

FRANK COOPER, Manager.

422 Collins-street, Melbourne, C.1. 6876

**ARGUS HILL CHEWTON GOLD NO LIABILITY.**

**NOTICE** is hereby given that all shares forfeited for non-payment of No. 61 (November) Call of Three pence per share will be sold by public auction in the vestibule of the Stock Exchange, 428 Chancery-lane, Melbourne, on Friday, 17th December, 1948, at a quarter to Twelve a.m., unless shares are previously redeemed.

By order of the Board,

FRANK COOPER, Manager.

422 Collins-street, Melbourne, C.1. 6877

**NORTH VIRGINIA GOLD MINING COMPANY NO LIABILITY.**

**NOTICE.**—All shares in this company (included in Nos. 1 to 90,000), on which the 81st Call of Six pence per share remains unpaid are forfeited, and will be sold by public auction at the Stock Exchange, Bendigo, on Thursday, 16th December, 1948, at Four o'clock p.m., unless previously redeemed, as required by the *Companies Act 1938*.

J. J. STANISTREET

6845 (McColl, Rankin, and Stanistreet), Manager.

**DEBORAH GOLD MINES NO LIABILITY.**

**NOTICE.**—All shares in this company (included in Nos. 1 to 61,000), on which the 50th Call of Six pence per share remains unpaid are forfeited, and will be sold by public auction at the Stock Exchange, Bendigo, on Thursday, 16th December, 1948, at Four o'clock p.m., unless previously redeemed, as required by the *Companies Act 1938*.

J. J. STANISTREET

6846 (McColl, Rankin, and Stanistreet), Manager.

**NELL GWYNNE REEF NO LIABILITY.**

**NOTICE.**—All shares in this company (included in Nos. 1 to 150,000), on which the 11th Call of Six pence per share remains unpaid are forfeited, and will be sold by public auction at the Stock Exchange, Bendigo, on Thursday, 16th December, 1948, at Four o'clock p.m., unless previously redeemed, as required by the *Companies Act 1938*.

J. J. STANISTREET

6847 (McColl, Rankin, and Stanistreet), Manager.

**FERN TREE GULLY.**—Impounded at Fern Tree Gully, by Shire Ranger.

- 1 bay mare, light medium sort, hind feet and near front foot white, white face, no visible brand
- 1 light bay mare, heavy delivery sort, white streak, little white on near front foot and near hind foot, 3 near shoulder
- 1 bay gelding, light delivery sort, black points, white on nose, 3 near shoulder

If not claimed and expenses paid, to be sold on 23rd December, 1948.

A. DINSDALE,

6898—10/10 Poundkeeper.

**LAKE BENETOOK.**—Impounded at Lake Benetook (Mildura).

- 1 chestnut heavy draught gelding, white feet, blazed face, no visible brand

If not claimed and expenses paid, to be sold on 16th December, 1948.

S. C. JESSOP,

6827—6/8 Poundkeeper.

**ST. ARNAUD.**—Impounded at St. Arnaud.

- 1 bay draught gelding, 8 years, white legs, blaze face, no visible brand

If not claimed and expenses paid, to be sold on 27th December, 1948.

C. E. CONSTABLE,

6894—5/10 Poundkeeper.

**STANHOPE.**—Impounded at Stanhope.

- 1 black draught mare, aged, white blaze on face, white hind feet, no visible brand

If not claimed and expenses paid, to be sold on 23rd December, 1948.

L. J. SPENCE,

6896—5/10 Poundkeeper.

**TRARALGON.**—Impounded at Traralgon, by Road Ranger, from Shire road, on 2nd December, 1948.

- 1 black draught gelding, aged, three white feet, blaze face, no visible brand

If not claimed and expenses paid, to be sold on 27th December, 1948

ADAM WILSON,

6895—6/8 Poundkeeper.

**IMPOUNDINGS.**

**BOX HILL.**—Impounded at Box Hill, by E. J. Charles.

- 1 white mare, unshod

If not claimed and expenses paid, to be sold on 23rd December, 1948.

H. J. BARRETT,

6853—5/ Poundkeeper.

**BROADMEADOWS.**—Impounded at Campbellfield.

- 1 brown delivery gelding, white face, near hind foot white, JH near shoulder
- 1 bay delivery mare, white face, white legs, rope on neck

If not claimed and expenses paid, to be sold on 23rd December, 1948.

A. OLIVER,

6850—6/8 Poundkeeper.

**COLAC.**—Impounded in Colac Pound.

- 1 spotted roan shorthorn bull, lump near knee, like VR on off rump

If not claimed and expenses paid, to be sold on 16th December, 1948.

JAMES McCONNELL,

6897—5/10 Poundkeeper.

**STATE ACTS, 1946.**

**COPIES** of the following Acts of Parliament of Victoria may be obtained at the Government Printing Office, or from any bookseller, at the price set opposite to each:—

No.	Price.
	s. d.
5109. Geelong Land .. .. .	0 6
5110. Transport Regulation (Amendment) .. .. .	0 6
5111. Factories and Shops (Annual Holidays) .. .. .	0 9
5112. Mornington Sewerage Authority (Validation) .. .. .	0 6
5113. Local Government (Emergency Housing Accommodation) Amendment .. .. .	0 6
5114. Housing (Commonwealth and State Agreement) .. .. .	1 0
5115. Factories and Shops (Early Closing) .. .. .	0 6
5116. Building Operations and Building Materials Control .. .. .	0 9
5117. Water (Levee Banks) .. .. .	0 9
5118. Co-operative Housing Societies .. .. .	0 6
5119. Local Government (Municipal Rolls) .. .. .	0 6
5120. Public Works Loan and Application .. .. .	0 6
5121. Totalizator (Charities) .. .. .	0 6
5122. Drought Relief .. .. .	0 6

STATE ACTS, 1946—continued.

No.	Description	Price.	
		s.	d.
5123.	Taxation (Arrangements) .. ..	0	6
5124.	Public Service .. ..	1	6
5125.	Teaching Service .. ..	1	3
5126.	Police Regulation .. ..	1	0
5127.	Railways (Long Service) .. ..	0	6
5128.	Workers' Compensation .. ..	1	6
5129.	Sewerage Districts (Amendment) ..	0	6
5130.	Factories and Shops (Bread) .. ..	0	6
5131.	Crimes (Intermediate Sentences) ..	0	6
5132.	Medical (Chemists' Apprentices) ..	0	6
5133.	Soldier Settlement (Amendment) ..	0	6
5134.	Consolidated Revenue .. ..	0	6
5135.	Consolidated Revenue .. ..	0	6
5136.	Apprenticeship .. ..	0	6
5137.	Consolidated Revenue .. ..	0	6
5138.	Consolidated Revenue .. ..	0	6
5139.	Consolidated Revenue .. ..	0	6
5140.	Nicholson-street Tramway Construction	0	6
5141.	Burke-road Tramway Construction ..	0	6
5142.	Ballaarat Gas Company's .. ..	0	6
5143.	Melbourne and Metropolitan Board of Works (Contributions) .. ..	0	6
5144.	Stamps (Betting Tax) .. ..	0	6
5145.	Juries (Fees) .. ..	0	6
5146.	Cattle and Swine Compensation .. ..	0	6
5147.	Marine (Pilots and Pilotage Rates) ..	0	6
5148.	Patriotic Funds .. ..	0	6
5149.	Stock Foods (Amendment) .. ..	0	6
5150.	Municipal Endowment (Temporary Discon- tinuance) .. ..	0	6
5151.	Medical Practitioners' Registration ..	0	6
5152.	Seeds .. ..	0	6
5153.	Water .. ..	0	6
5154.	Clifton Hill Land .. ..	0	6
5155.	Tobacco Sellers .. ..	0	6
5156.	Country Roads Board Fund (Amendment) ..	0	6
5157.	Moorpanyal Land .. ..	0	6
5158.	Factories and Shops (Annual Holidays) Amendment .. ..	0	6
5159.	Factories and Shops (Wages Boards) ..	0	6
5160.	Melbourne and Metropolitan Tramways (Amendment) .. ..	0	6
5161.	Infectious Diseases Hospital (Borrowing) ..	0	6
5162.	University (Mildura Branch) .. ..	0	6
5163.	Farmers Protection (Amendment) .. ..	0	6
5164.	Forests (Exchange of Lands) Extension ..	0	6
5165.	Money Lenders (Cash Orders) .. ..	0	6
5166.	Local Government (Dandenong Street Con- struction) .. ..	1	0
5167.	Stamps (Increased Duty Continuance) ..	0	6
5168.	Land Tax .. ..	0	6
5169.	Cattle Breeding .. ..	0	6
5170.	Administration and Probate Duties ..	0	6
5171.	Co-operative Housing Societies (Guarantees)	0	6
5172.	Railways (Sick Leave) .. ..	0	6
5173.	Fruit and Vegetables .. ..	0	6
5174.	Farm Water Supplies and Drainage Advances	0	6
5175.	State Forests Loan and Application ..	0	6
5176.	Melbourne South Land .. ..	0	6
5177.	Agricultural Colleges (Amendment) ..	0	6
5178.	Drought Relief (Amendment) .. ..	0	6
5179.	Soldier Settlement .. ..	1	9
5180.	Free Library Service Board .. ..	0	6
5181.	Adult Education .. ..	0	6
5183.	Evidence .. ..	0	6
5184.	Housing (Discharged Servicemen) .. ..	0	6
5185.	Parliamentary Contributory Retirement Fund	0	6
5186.	Friendly Societies .. ..	0	6
5187.	Police Offences (Race-meetings) .. ..	0	6

STATE ACTS, 1946—continued.

No.	Description	Price.	
		s.	d.
5188.	Railways (Mont Park Siding) .. ..	0	6
5189.	Land (Grazing Licences) .. ..	0	6
5190.	Factories and Shops (Bread Carters) ..	0	6
5191.	Country Fire Authority .. ..	1	0
5192.	Supreme Court (Judges) .. ..	0	6
5193.	Railway Loan Application .. ..	1	6
5194.	Metropolitan Gas Company's .. ..	0	6
5195.	Railways (Temporary Employés) .. ..	0	6
5196.	Railways (State Coal Mine) .. ..	0	6
5197.	Licensing .. ..	0	6
5198.	Town and Country Planning .. ..	0	6
5199.	Public Works Loan and Application (No. 2) ..	0	6
5201.	Trotting Races .. ..	0	6
5202.	Economic Stability .. ..	0	6
5204.	Stamps .. ..	2	3
5206.	Melbourne and Metropolitan Tramways (Appeal Board) .. ..	0	6

J. J. GOURLEY,  
Government Printer.

STATE ACTS, 1947.

COPIES of the following Acts of Parliament of Victoria may be obtained at the Government Printing Office, or from any bookseller, at the price set opposite to each:—

No.	Description	Price.	
		s.	d.
5207.	Consolidated Revenue .. ..	0	6
5208.	Custodian Trustee .. ..	0	6
5209.	Revocation and Excision of Crown Reserva- tions .. ..	0	9
5210.	Farmers Advances (Amendment) .. ..	0	6
5211.	Private Bill Committees .. ..	0	6
5212.	Health (Amendment) .. ..	0	6
5213.	Wills (Amendment) .. ..	0	6
5214.	Old Colonists' Association .. ..	0	6
5215.	Consolidated Revenue .. ..	0	6
5216.	Local Authorities Superannuation .. ..	1	0
5217.	Statute Law Revision .. ..	0	6
5218.	Motor Car (Registration Fees) .. ..	0	6
5219.	State Electricity Commission (Yallourn Area)	0	6
5220.	Transport Regulation (Licences and Fees) ..	0	6
5221.	Local Government (Private Street Construc- tion) .. ..	0	6
5222.	State Development (Amendment) .. ..	0	6
5223.	Coal Mine Workers Pensions .. ..	0	6
5224.	State Savings Bank .. ..	0	9
5225.	Drought Relief .. ..	0	6
5226.	Soil Conservation and Land Utilization ..	1	0
5227.	Consolidated Revenue .. ..	0	6
5228.	Consolidated Revenue .. ..	0	6
5229.	Consolidated Revenue .. ..	0	6
5230.	Municipal Endowment (Temporary Discon- tinuance) .. ..	0	6
5231.	Forests (Commissioners) .. ..	0	6
5232.	State Forests Loan and Application .. ..	0	6
5233.	Melbourne and Metropolitan Tramways (Amendment) .. ..	0	6
5234.	Auditor-General's Salary .. ..	0	6
5235.	Drought Relief (Amendment) .. ..	0	6
5236.	Wheat Marketing (Winding Up) Amendment	0	6
5237.	University (Mildura Branch) .. ..	0	6
5238.	Factories and Shops (Bread) .. ..	0	6
5239.	Water Supply Loan and Application .. ..	1	3
5240.	Public Works Loan and Application .. ..	0	6
5241.	Administration and Probate Duties .. ..	0	6
5242.	Land Tax .. ..	0	6

## STATE ACTS, 1947—continued.

No.	Description	Price.	
		s.	d.
5243.	Country Roads Board Fund (Amendment)	0	6
5244.	Ballaarat Land	0	9
5245.	Stamps (Increased Duty Continuance)	0	6
5246.	Railway Loan Application	0	9
5247.	Sewerage Districts (Amendment)	0	6
5248.	State Electricity Commission (Financial)	0	6
5249.	Public Account Advances (Amendment)	0	6
5250.	Infectious Diseases Hospital (Amendment)	0	6
5251.	Public Works Loan and Application (Amendment)	0	6
5252.	Officials in Parliament	0	6
5253.	Water	0	6
5254.	Supreme Court (Judges Salaries)	0	6
5255.	Superannuation	0	9
5256.	Country Sewerage Loan and Application	0	6
5257.	Melbourne and Metropolitan Board of Works (Contributions)	0	6
5258.	Vegetation Diseases (Fruit Fly)	0	6
5259.	Building Operations and Building Materials Control (Amendment)	0	6
5260.	Police Regulation (Amendment)	0	6
5261.	Factories and Shops (Determinations)	0	6
5262.	Appropriation of Revenue	5	3

J. J. GOURLEY,  
Government Printer.

## STATE ACTS, 1948.

COPIES of the following Acts of Parliament of Victoria may be obtained at the Government Printing Office, or from any bookseller, at the price set opposite to each:—

No.	Description	Price.	
		s.	d.
5263.	Essential Services	0	9
5264.	Landlord and Tenant	2	6
5265.	Public Works Committee	0	6
5266.	Midwives (Amendment)	0	6
5267.	Carriers and Innkeepers	0	6
5268.	Camberwell Lands	0	9
5269.	Consolidated Revenue	0	6
5270.	Miners' Phthisis (Treasury Allowances) Amendment	0	6
5271.	Building Operations and Building Materials Control (Amendment)	0	6
5272.	State Electricity Commission	0	9
5273.	Town and Country Planning	0	6
5274.	Coranderrk Lands	0	9
5275.	Coroners (Medical Witnesses)	0	6
5276.	Vegetation Diseases (Fruit Fly)	0	6
5277.	Administration and Probate (Amendment)	0	9
5278.	Country Roads (Permanent Works)	0	6
5279.	Shrine of Remembrance Trustees	0	6
5280.	Non-Contributory State Pensions	0	6
5281.	Closer Settlement (Disposal of Land)	0	6
5282.	Melbourne North Land	0	6
5283.	Melbourne Harbor Trust (Chairman's Salary)	0	6
5284.	Police Offences (Race-meetings)	1	0
5285.	Statute Law Revision Committee	0	9
5286.	Public Trustee	1	3
5287.	Horse Breeding (Amendment)	0	6
5288.	Building Operations Control (Amendment)	0	6
5289.	Local Government (Streets)	1	3
5290.	Country Roads	0	6
5291.	Landlord and Tenant (Amendment)	1	3
5292.	Heppburn Springs Land	0	6
5293.	Gas Regulation (Amendment)	0	6

## STATE ACTS, 1948—continued.

No.	Description	Price.	
		s.	d.
5294.	Commonwealth Transferred Officers	0	6
5295.	Forests (Amendment)	0	6
5296.	Parliamentary Salaries and Allowances	0	9
5297.	Farmers Debts Adjustment (Board)	0	6
5298.	Justices (Courts)	0	6
5299.	Local Authorities Superannuation (Amendment)	0	6
5300.	Hospitals and Charities	2	3
5301.	Health (Hospitals)	0	9
5302.	River Improvement	1	9
5303.	Geelong Harbor Trust (Land)	0	6
5304.	Stipendiary Magistrates	0	6
5305.	Consolidated Revenue	0	6
5306.	Consolidated Revenue	0	6
5307.	Local Government (Footscray Street Construction)	0	6
5308.	Teaching Service (Application of Enactments)	0	6
5309.	Parliamentary Contributory Retirement Fund	0	6
5310.	Prices Regulation	2	0
5311.	Marine (Pilotage Rates)	0	6
5312.	State Savings Bank	0	6
5313.	Coal Mine Workers Pensions	0	9
5314.	Transfer of Land (Acquisitions)	0	6
5315.	Workers' Compensation (Police Force)	0	6
5316.	Fire Brigades (Borrowing and Salaries)	0	6
5317.	Public Officers Salaries	0	6
5318.	Mildura Irrigation and Water Trusts (Amendment)	0	6
5319.	Thornbury Land	1	0
5320.	Barley Marketing	1	0
5321.	North-West Mallee Settlement Areas	1	0
5322.	Latrobe-street Tramway Construction	0	6
5323.	Gippsland Railway (Duplication and Regrading)	0	6

J. J. GOURLEY,  
Government Printer.

## AGENTS FOR THE "VICTORIA GOVERNMENT GAZETTE."

THE following have been appointed agents to receive advertisements and subscriptions for the *Victoria Government Gazette*:—

- ARMSTRONG'S AGENCY, 143 Queen-street, Melbourne.
- MESSRS. ARNALL & JACKSON, 115 Barkly-street, West Brunswick.
- MESSRS. GORDON & GOTCH, News Agents, 511 Little Collins-street, Melbourne; and corner Barrack and Clarence streets, Sydney.
- MESSRS. HARSTON, PARTRIDGE, & CO., 455 Little Collins-street, Melbourne.
- ROBERTSON & MULLENS LTD., Elizabeth-street, Melbourne.
- MESSRS. A. S. RICHARDSON and T. C. GARDNER, trading as The Mercantile Exchange, 380 Collins-street, Melbourne.
- A. J. DIGBY (E. S. and N. W. CASH), Main-street, Bairnsdale.
- MR M R BADE, Tobacconist, Sturt-street, Ballarat.
- EDGAR'S NEWS AGENCY, Hargreaves-street, Bendigo.
- MESSRS. H. PAYNE & R. N. LOWE, 4 View Point, Bendigo.
- MR C F LATIMER, News Agent, Casterton.
- MESSRS HENRY FRANKS & CO., Booksellers and Stationers, Market-square, Geelong.

MESSRS. SMITH & DUNNON, Hamilton.  
 ARMSTRONG BROS., Kyneton.  
 MR. WM. DAVIS, Mildura.  
 PIKE'S AUTHORIZED NEWS AGENCY, Sale.  
 MR. C. T. RUST, News Agent, Wangaratta.  
 MR. F. T. MCCORMICK, Nunn-street, Benalla.  
 W. GORDON HAMPTON, 243 Mitchell-street, Bendigo.  
 R. & A. SMALLMAN, News Agents, Toora.  
 TRAINOR & MCBRIDE, 246 Wyndham-street, Shepparton.  
 E. W. B. WELSH, Hogan-street, Tatura.

A copy of the Gazette filed at each place for public reference.

THE VICTORIA GOVERNMENT GAZETTE is published on WEDNESDAY EVENING in each week, and Notices for insertion will be received by the Government Printer at or before Two p.m., at ordinary rates, and late advertisements between Two p.m. and FIVE p.m. at double rates on the day preceding the day of publication.

Single copies of the VICTORIA GOVERNMENT GAZETTE are Six pence, posted Eight pence, each.

No GAZETTES prior to January, 1938, in stock.

\*\*\*ALL PAYMENTS ARE REQUIRED IN ADVANCE.—Remittances should be made by postal note, money order, or draft in favour of the Government Printer. Advertisements unaccompanied by a remittance sufficient to cover the cost of insertion will be returned unpublished.

THE "VICTORIA GOVERNMENT GAZETTE."

SUBSCRIPTIONS.—The subscription, including postage, is £1 12s. 6d. per annum, 16s. 3d. half-yearly, or 8s. 2d. per quarter, payable in advance.

Subscriptions are required to commence and terminate with a month.

A lesser period than three months cannot be subscribed for.

Subscribers do not receive the Acts of Parliament with the GAZETTE.

ADVERTISEMENTS are charged at the rate of TEN PENCE per line single column, and ONE SHILLING and EIGHT PENCE per line double column.

The title (15 Reward, Dissolution of Partnership, &c.) forms one or more lines as a heading.

On an average, ten words make a line.

Every signature must likewise be counted as a line.

The final words of a paragraph, though only portion of a line must be counted as one line.

SIGNATURES (in particular) and proper names must be written very plainly in the text; ONE SIDE ONLY of each slip of paper should be WRITTEN UPON.

ALL COMMUNICATIONS should be addressed to "The Government Printer, Melbourne."

ALL DOCUMENTS illegibly written will be returned unpublished, and, where brands occur unprovided for by the ordinary letters of the alphabet, a worded explanatory description must be furnished.

CONTENTS.

	PAGE.
Acts of Parliament on sale at the Government Printing Office .. .. .	7393
Appointments .. .. .	7347
Auction Sales Act .. .. .	7352
Cemetery—Rules and Regulations and Scale of Fees	7356
Christmas and New Year Holidays .. .. .	7346
Companies Act 1938—Notice .. .. .	7366
Contracts .. .. .	7368
Country Roads Board .. .. .	7375
Courts .. .. .	7351
Estates of Deceased Persons .. .. .	7367
Government Notices .. .. .	7351
Impoundings .. .. .	7393
Lands .. .. .	7380
Mining .. .. .	7352, 7392
Orders in Council .. .. .	7371
Police Sale .. .. .	7352
Private Advertisements .. .. .	7386
Proclamations .. .. .	7345
Publication of the Government Gazette .. .. .	7346
Public Service Notices .. .. .	7348
Resignations .. .. .	7348
Rules of the Supreme Court .. .. .	7368
Tenders .. .. .	7384
Transport Regulation Board—Public Hearings ..	7353