



VICTORIA  
GOVERNMENT GAZETTE.

Published by Authority.

[Registered at the General Post Office, Melbourne, for transmission by post as a newspaper.]

No. 19]

WEDNESDAY, JANUARY 21.

[1948

## ACT OF PARLIAMENT.

## PROCLAMATION

By the Lieutenant-Governor, as Deputy for His Excellency the Governor of the State of Victoria and its Dependencies in the Commonwealth of Australia, &c., &c., &c.

I, THE Lieutenant-Governor, as Deputy for the Governor of the State of Victoria, in the Commonwealth of Australia, do hereby declare that I have this day assented, in His Majesty's name, to the Bill passed by the Parliament of the said State, the title whereof is hereunder set forth, that is to say:—

No. 5263. "An Act to make provision with respect to the Protection of the Community against the Interruption or Dislocation of Essential Services."

Given under my Hand and the Seal of the State of Victoria aforesaid, at Melbourne, this twentieth day of January, in the year of our Lord One thousand nine hundred and forty-eight, and in the twelfth year of the reign of His Majesty King George VI.

(L.S.)

E. F. HERRING.

By His Excellency's Command,

T. T. HOLLWAY.

GOD SAVE THE KING!

## COUNTRY ROADS (FOREST ROADS AND STOCK ROUTES) ACT 1943 (No. 4953).

## PROCLAMATION OF FOREST ROAD

By the Lieutenant-Governor, as Deputy for His Excellency the Governor of the State of Victoria and its Dependencies in the Commonwealth of Australia, &c., &c., &c.

WHEREAS by section 3 (1) of the *Country Roads (Forest Roads and Stock Routes) Act 1943* it is provided that the Governor in Council may, on the recommendation of the Country Roads Board made after consultation with the Minister of Forests and the Commissioner of Crown Lands and Survey, and on the recommendation of the Commissioner of Public Works by Proclamation published in the *Government Gazette*, proclaim any road or any part of any road to be a forest road for the purposes of the said Act: And whereas the Country Roads Board (after consultation with the Minister of Forests and the Commissioner of Crown Lands and Survey) and the Commissioner

of Public Works have recommended that the roads described in the Schedule hereunder be so proclaimed: Now therefore the Lieutenant-Governor, as Deputy for His Excellency the Governor of the State of Victoria, by and with the advice of the Executive Council thereof, doth hereby proclaim the said roads to be forest roads for the purposes of the said Act.

## SCHEDULE.

*Shire of Otway.*

*Forrest-Apollo Bay-road.*—Commencing at its junction with the Beech Forest-Mount Sabine road at a point on the eastern boundary of the Experimental Farm Reserve, Parish of Olangolah, distant 4 chains, more or less, north-easterly from the intersection of the old Government road through that reserve and the said eastern boundary; thence south-westerly and south-easterly to and through State forest to the north-western angle of allotment 16A, Parish of Wongarra (S.P. 300); thence south-easterly and south-westerly to its junction with Skene's Creek road near the northern angle of allotment 59A, Parish of Olangolah.

*Shires of Healesville and Upper Yarra.*

*Reefton Spur-road.*—Commencing at a point on the western boundary of allotment 2A, Parish of Brimbonga, distant 175 deg. 33 min. 585.4 links from the north-western angle of that allotment, at its junction with the Woods Point-road; thence westerly to and across the bridge over the Yarra River to the eastern boundary of allotment 9, Parish of Manango; thence generally north-westerly and north-easterly through the allotment last named to an angle in the said eastern boundary distant 217 deg. 50 min. 51 links from the north-eastern angle of that allotment (S.P. 4761); thence north-easterly and north-westerly through State forest to its junction with the Marysville-Woods Point road (tourists') at a point distant 120 chains generally south-easterly from the crossing of that road over the Cumberland Creek.

Given under my Hand and the Seal of the State of Victoria aforesaid, at Melbourne, this thirteenth day of January, in the year of our Lord One thousand nine hundred and forty-eight, and in the twelfth year of the reign of His Majesty King George VI.

(L.S.)

E. F. HERRING.

By His Excellency's Command,

J. A. KENNEDY,  
Commissioner of Public Works.

GOD SAVE THE KING!

Health Acts.  
MARYBOROUGH MEAT AREA EXTENDED.

## PROCLAMATION

By the Lieutenant-Governor, as Deputy for His Excellency the Governor of the State of Victoria and its Dependencies in the Commonwealth of Australia, &c., &c., &c.

BY virtue of the powers conferred by the Health Acts, I, the Lieutenant-Governor, as Deputy for His Excellency the Governor of the State of Victoria, in the Commonwealth of Australia, on the recommendation of the Commission of Public Health, and by and with the advice of the Executive Council of the said State, do by this my Proclamation extend the limits of the Maryborough Meat Area to include the Borough of Maryborough and those parts of the Shire of Tullaroop within a distance of six miles from the Maryborough Town Hall.

Given under my Hand and the Seal of the State of Victoria aforesaid, at Melbourne, this thirteenth day of January, in the year of our Lord One thousand nine hundred and forty-eight, and in the twelfth year of the reign of His Majesty King George VI.

(L.S.)

E. F. HERRING.

By His Excellency's Command,

A. A. DUNSTAN,

Minister of Health.

GOD SAVE THE KING!

## PUBLIC HOLIDAYS.

## PROCLAMATION

By the Lieutenant-Governor, as Deputy for His Excellency the Governor of the State of Victoria and its Dependencies in the Commonwealth of Australia, &c., &c., &c.

IN pursuance of the provisions contained in Part III. of the *Public Service Act 1946* (10 Geo. VI. No. 5124), I, the Lieutenant-Governor, as Deputy for the Governor of the State of Victoria, in the Commonwealth of Australia, and by and with the advice of the Executive Council of the said State, do by this my Proclamation appoint the days and dates hereunder mentioned to be observed as Public Holidays or Public Half-Holidays (as the case may be) at the places respectively specified, viz.:—

*Public Holidays:—*

\*SATURDAY, 21ST FEBRUARY, 1948, throughout the Shire of Mirboo.

WEDNESDAY, 4TH FEBRUARY, 1948, throughout the Shire of Healesville.

*Public Half-Holidays from the Hour of Twelve o'clock noon:—*

THURSDAY, 22ND JANUARY, 1948, throughout the Borough of Koroit.

WEDNESDAY, 11TH FEBRUARY, 1948, throughout the Shire of Colac.

WEDNESDAY, 11TH FEBRUARY, 1948, throughout the Borough of Colac.

## \* Agricultural show.

Given under my Hand and the Seal of the State of Victoria aforesaid, at Melbourne, this twenty-first day of January, in the year of our Lord One thousand nine hundred and forty-eight, and in the twelfth year of the reign of His Majesty King George VI.

(L.S.)

E. F. HERRING.

By His Excellency's Command,

K. DODGSHUN,

Chief Secretary.

GOD SAVE THE KING!

## PUBLIC HOLIDAY.—AUSTRALIA DAY.

IT is hereby notified that on—

MONDAY, THE 26TH DAY OF JANUARY, 1948,

the Public Offices will be closed, that day being appointed by the *Public Service Act 1946* to be observed as a holiday in the Public Offices throughout Victoria.

K. DODGSHUN,

Chief Secretary.

Chief Secretary's Office,  
Melbourne, 6th January, 1948.

## APPOINTMENTS.

THE Lieutenant-Governor, as Deputy for His Excellency the Governor of the State of Victoria, by and with the advice of the Executive Council thereof, has, by Orders made on the 13th day of January, 1948, been pleased to make the under-mentioned appointments, viz.:—

## DEPARTMENT OF CHIEF SECRETARY.

*Registrars of Births and Deaths.*

JOHN HERBERT CANAVAN,

pursuant to the provisions of section 4 of the *Registration of Births Deaths and Marriages Act 1928*, to be Registrar of Births and Deaths at Orbost, to date from commencement of duty, with fees, *vice* William Godfrey Robinson, resigned;

DONALD HAROLD GUDE,

pursuant to the provisions of section 4 of the *Registration of Births Deaths and Marriages Act 1928*, to be Registrar of Births and Deaths at Kyneton, to date from commencement of duty, *vice* Gregory Daniel O'Sullivan, resigned; and

MARGARET ANNIE LUNN,

pursuant to the provisions of section 4 of the *Registration of Births Deaths and Marriages Act 1928*, to be Registrar of Births and Deaths at Mildura, to date from commencement of duty, with fees, *vice* Doreen May O'Brien, resigned.

*Officer in Charge of Gaol.*

REGINALD JOHN SOUTER,

pursuant to the provisions of the *Gaols Act 1928*, to be Officer in Charge of the Ballarat Gaol, from and inclusive of the 24th December, 1947, *vice* George Carey, retired.

*Inspector-General of Penal Establishments (Acting).*

JAMES EDWARDS,

pursuant to the provisions of the *Gaols Act 1928*, to be Inspector-General of Penal Establishments (acting), from the 11th January, 1948, to the 31st January, 1948, both dates inclusive, during the absence on leave of Alexander Russel Whatmore.

*Members of Indeterminate Sentences Board.*

RAYMOND TENNYSON ALLAN, M.B., B.S.,  
ROBERT KENNETH BAZLEY, and  
LESLIE LEIDER WEBSTER,

pursuant to the provisions of section 531 of the *Crimes Act 1928*, to be Members of the Indeterminate Sentences Board, for a period of one year from the 1st January, 1948.

*Member of Free Library Service Board.*

ERNEST RICHARD GLENISTER SHEIL, B.Sc., M.B., B.S.,

pursuant to the provisions of the *Free Library Service Board Act 1946*, to be a Member of the Free Library Service Board, for the period ending on the 1st May, 1950, *vice* Robert Miller.

*Electoral Registrars (Acting).*

LEONARD FOSTER MURRAYLEE

to be Electoral Registrar (acting) for the Canterbury Subdivision of the Electoral District of Box Hill; for the Camberwell Subdivision of the Electoral District of Camberwell; for the Glen Iris Subdivision of the Electoral District of Glen Iris; for the Auburn Subdivision of the Electoral District of Hawthorn; for the Balwyn and Kew North Subdivisions of the Electoral District of Ivanhoe; and for the Deepdene and Kew Subdivisions of the Electoral District of Kew, to take effect on and from 12th January, 1948, during the absence on leave of Daniel Fogarty;

LEONARD FOSTER MURRAYLEE

to be Electoral Registrar (acting) for the Albert Park and St. Kilda West Subdivisions of the Electoral District of Albert Park; for the Port Melbourne and South Melbourne Subdivisions of the Electoral District of Port Melbourne; and for the Newport and Williamstown Subdivisions of the Electoral District of Williamstown, to take effect on and from 23rd January, 1948, during the absence on leave of William Wade;

CHARLES CECIL WILLIAMS

to be Electoral Registrar (acting) for the Box Hill, Mitcham, Ringwood, and Surrey Hills Subdivisions of the Electoral District of Box Hill; for the Box Hill South Subdivision of the Electoral District of Camberwell; for the Croydon, Healesville, Lilydale, and Warburton Subdivisions of the Electoral District of Evelyn; for the Alexandra, Avenel, Kilmore, Mansfield, Seymour, and Yea

Subdivisions of the Electoral District of Goulburn; for the Heidelberg and Ivanhoe Subdivisions of the Electoral District of Ivanhoe; and for the Diamond Creek, Doncaster, and Kangaroo Ground Subdivisions of the Electoral District of Mernda, to take effect on and from 12th January, 1948, during the absence on leave of Keith Maxwell Campbell;

**LEONARD FOSTER MURRAYLEE**

to be Electoral Registrar (acting) for the Clifton Hill Subdivision of the Electoral District of Clifton Hill; for the Abbotsford and Collingwood Subdivisions of the Electoral District of Collingwood; for the Hawthorn Subdivision of the Electoral District of Hawthorn; and for the Richmond Subdivision of the Electoral District of Richmond, to take effect on and from 22nd January, 1948, during the absence on leave of Sydney Allan Wilkes;

**PERCY BASIL ROBIN**

to be Electoral Registrar (acting) for the Essendon Subdivision of the Electoral District of Essendon; for the Footscray and Footscray South Subdivisions of the Electoral District of Footscray; for the Ascot Vale and Moonee Ponds Subdivisions of the Electoral District of Moonee Ponds; for the Footscray North and Kingsville Subdivisions of the Electoral District of Sunshine; and for the Yarraville Subdivision of the Electoral District of Williamstown, to take effect on and from 27th January, 1948, during the absence on leave of Henry Charles Louis Giles; and

**WILLIAM EWART DUNSTAN**

to be Electoral Registrar (acting) for the Clunes Subdivision of the Electoral District of Allendale; for the Bannockburn, Beac, Camperdown, Linton, and Smythesdale Subdivisions of the Electoral District of Hampden; for the Avoca, Carisbrook, Maldon, and Maryborough Subdivisions of the Electoral District of Midlands; for the Beech Forest, Birregurra, Cobden, Colac, Krambruk, and Port Campbell Subdivisions of the Electoral District of Polwarth; for the Penshurst Subdivision of the Electoral District of Portland; for the Ararat, Beaufort, Landsborough, and Willaura Subdivisions of the Electoral District of Ripon; and for the Allansford, Mortlake, and Terang Subdivisions of the Electoral District of Warrnambool, to take effect on and from 22nd December, 1947, during the absence on leave of William Edward Ball.

*Deputy Electoral Registrar.*

**ROY CHARLES HINGSTON**

to be Deputy Electoral Registrar for the Hawthorn Division of the East Yarra Province; for the Abbotsford, Collingwood, and Richmond Divisions of the Melbourne Province; and for the Clifton Hill Division of the Melbourne North Province, to take effect on and from 3rd January, 1948, *vice* Herbert Leslie Spargo, resigned.

*Electoral Registrar.*

**DANIEL FOGARTY**

to be Electoral Registrar for the Auburn, Camberwell, Camberwell North-East, Camberwell North-West, Camberwell South, and Kew Divisions of the East Yarra Province, to take effect on and from 7th January, 1948, *vice* Jules Samuel Gascard, resigned.

*Probation Officer.*

**GEOFFREY REGINALD WESTBROOK,**

pursuant to the provisions of section 536 of the *Crimes Act 1928*, to be a Probation Officer for the purposes of the said Act in Melbourne and suburbs.

DEPARTMENT OF HEALTH.

*Acting Medical Superintendents.*

**Dr. HERBERT HARDING HENSHALL**

to be Acting Medical Superintendent of the Mental Hospital, Beechworth, from the 22nd December, 1947, *vice* Dr. Harold Crowcombe Stone, on leave; and

**Dr. LYAL LONGHURST LOVETT**

to be Acting Medical Superintendent of the Mental Hospital, Ararat, from the 29th December, 1947, *vice* Dr. Horace Joseph Carlyle Edmonds, on leave.

*Acting Clerks of Mental Hospitals.*

**ERNEST HENRY GUPPY**

to be Acting Clerk of the Mental Hospital, Beechworth, from the 7th December, 1947, *vice* Francis Joseph Walsh, on leave; and

**KELVIN CHARLES TURNER**

to be Acting Clerk of the Mental Hospital, Ararat, from the 5th January, 1948, *vice* Alexander Hele Riley, on leave.

*Government Representatives on Hospital Committees.*

**JOHN BUSH JACKSON**

to be Government Representative on the Committee of Management of the Daylesford District Hospital for a further period to 10th December, 1950;

**EDWIN JAMES LEWIS**

to be Government Representative on the Committee of Management of the Gippsland Hospital (Sale), *vice* C. J. Shellew, retired; and

**GEORGE HERRIOTT**

to be Government Representative on the Committee of Management of the Alexandra District Hospital, *vice* J. W. Whittaker, retired.

DEPARTMENT OF LANDS AND SURVEY.

*Committees of Management.*

THE COUNCIL OF THE CITY OF RICHMOND,

in pursuance of section 183 of the *Land Act 1928*, to be a Committee of Management of that portion of the land reserved in the City of Richmond as a site for Public Park and Recreation, and known as Richmond Park, in respect of which a Crown grant has been issued to the Board of Land and Works, and the Mayor, Councillors, and Citizens of the City of Richmond; and

**WALTER GEORGE THOMAS ROSE,**

in pursuance of section 183 of the *Land Act 1928*, to be a Member of the Committee of Management of the land permanently reserved by Order in Council of 30th July, 1894, as a site for Watering purposes and for Public Recreation in the Parish of Moorabbin, at Cheltenham, for the period ending 11th August, 1950, in the place of William Percy Fairlam, deceased.

*Managers of Commons.*

The Honorable **ALFRED JAMES PITTARD, C.B.E., M.L.C.**, to be a Manager of the Ballarat West Town Common for a period ending 31st December, 1949;

**ALBERT ALFRED DAHLITZ,  
JOSEPH RICHARD PRICE,  
HENRY EDWARDS, and  
ABEDI ALFRED BOURKE**

to be Managers of the Branxholme Town Common for a period of three (3) years, from the 1st January, 1948; and

**ARCHIBALD VICTOR McNEIL,  
JAMES HENRY SLATTERY, and  
SYDNEY JAMES GILES**

to be Managers of the Caramut Town Common for a period of three (3) years, from 1st January, 1948.

*Bailiffs of Crown Lands.*

**NORMAN GEORGE ROESZLER, and  
ALFRED THOMAS OPIE**

to be Bailiffs of Crown Lands, without salary.

DEPARTMENT OF LAW.

*Magistrates.*

**MARY ELIZABETH CREELEY, 573 Bourke-street, Melbourne,  
RICHARD LEO PURCELL, 147 Miller-street, Thornbury,  
JOHN FREDERICK CALLAHAN, 164-170 Flinders-street, Melbourne,  
ALEXANDER ELMORE POYNTON, 11 Howard-street, Box Hill,**

**GEORGE ANDREW FOX, 3 Sherwood-street, Glen Iris,  
LESLEY GEORGE LEE, 8 Iris-road, South Camberwell,  
CHANDOS KINGSLEY BLACKER, 140 Union-road, Surrey Hills, and**

**ALBERT HENRY HACKING, 619 Nepean-road, Carrum,**

to Keep the Peace in the Central Bailiwick of the State of Victoria;

**HERBERT AIKMAN KEELE, Bamawm,  
WILLIAM RUTHERFORD CHILDS, Hunter, and  
JOHN THOMAS MUIR, Sailors Falls,**

to Keep the Peace in the Midland Bailiwick of the State of Victoria; and

**LESLIE BASIL CARLYLE CARTER, Goroke, and  
ALFRED CHARLES HARRIS, Birchip,**

to Keep the Peace in the Western Bailiwick of the State of Victoria.

*Bailiff of County Court.*

**JOHN WILLIAM MAY, First Constable of Police, Elmore,** to be also a Bailiff of the County Court at Bendigo in the place of L. McKenna, resigned, with fees.

*Clerks of Petty Sessions, &c.*

JOHN MALCOLM HODGSON, First Constable of Police, Cowes,

to be also Clerk of Petty Sessions (acting), and Clerk of the Children's Court (acting) at Cowes, for the period during which he shall continue to act as First Constable at Cowes in the place of C. G. Grummisch, resigned; and

JAMES GEORGE GOFF

to be also Clerk of Petty Sessions and Clerk of the Metropolitan Industrial Court at Melbourne during the absence on annual leave of F. C. P. Hill, and to be also Collector for Interstate Destitute Persons, pursuant to the provisions of section 69 of the *Maintenance Act 1928* during the absence on annual leave of F. C. P. Hill.

*Clerks of Children's Courts.*

DAVID KENNETH DAVIES

to be also Clerk of the Children's Court at Ferntree Gully during the absence on annual leave of H. A. Bennett;

KEVIN ALOYSIUS McDONALD

to be also Clerk of the Children's Court at Wodonga, Chiltern, and Rutherglen, in the place of E. L. McConvill, relieved; and

EDWARD LEO MCCONVILL

to be also Clerk of the Children's Court at St. Arnaud, Birchip, and Donald, in the place of A. E. O'Connell, transferred.

*Deputy Prothonotary, &c.*

HARRY WILLIAM PASCOE

to be also Deputy Prothonotary and Clerk of the Children's Court at Bendigo during the absence on annual leave of W. P. Walsh, and as Clerk of the Peace and Registrar of the County Court at Bendigo, to be appointed by virtue of section 92 of the *Juries Act 1928* to do and perform with respect to the Courts at that place in the place and stead of the Sheriff, all such acts and things as the Sheriff is, by the said Act, authorized or required to do or perform during the absence on annual leave of W. P. Walsh.

*Commissioner for Taking Declarations, &c.*

EDWARD ALFRED HAINS, 46 Breen-street, Bendigo,

to be a Commissioner for taking Declarations and Affidavits, pursuant to the provisions of Division 8 of Part IV. of the *Evidence Act 1928*, to resign upon removing from the neighbourhood of the address stated.

*Probation Officers.*

ALBERT EDWARD BELLAMY, The Rectory, 8 Mostyn-street, Castlemaine, and

JAMES TOWNSEND, St. Matthew's Vicarage, 48 The Avenue, Windsor,

to be Probation Officers, pursuant to the provisions of section 8 of the *Children's Court Act 1928*, for the Children's Court at Castlemaine and Prahran respectively; and

JOHN WILLIAM HEWITT, Minyip, and

ERNEST SIMPSON, 2 Austin-street, Oakleigh,

to be Probation Officers, pursuant to the provisions of section 8 of the *Children's Court Act 1928*, for the Children's Court at Minyip and Oakleigh respectively.

*Sworn Valuers.*

LAURENCE IRWIN JONES, 397 Murray-road, Preston, to be a Sworn Valuator, pursuant to the provisions of section 14 of the *Transfer of Land Act 1928*, for the County of Bourke; and

ARTHUR FREDERICK TRICKS, care of State Rivers and Water Supply Commission, Numurkah,

to be a Sworn Valuator, pursuant to the provisions of section 14 of the *Transfer of Land Act 1928*, for the Counties of Bendigo and Rodney.

## DEPARTMENT OF MINES.

*Mining Registrar.*

WILLIAM JOHN MCMASTER

to act as Mining Registrar for the Smythesdale Division of the Ballarat Mining District, *vice* W. H. Hockridge, resigned, fees received to be the only remuneration.

## DEPARTMENT OF PUBLIC WORKS.

*Wharf Manager, &c.*

First Constable JOHN MALCOLM HODGSON, No. 7021, as Wharf Manager at Cowes, Tankerton, and Rhyll, to carry out that portion of Part II. of the *Marine Act 1928* which relates to the management of public wharfs, and to be an officer under section 19 of such Act to levy and collect wharfage rates thereat.

## DEPARTMENT OF TREASURER.

*Member of Tender Board.*

HERBERT WILLIAM CARLTON, Architect (Furniture and Fittings), Class "B1," Professional Division, Department of Public Works, to be a Member of the Tender Board, *vice* J. M. Dooley, retired.

*Receivers of Revenue.*

KEVIN ALOYSIUS McDONALD

to act as Receiver of Revenue at St. Arnaud and Wodonga, *vice* A. E. O'Connell and E. L. McConvill, respectively;

EDWARD LEO MCCONVILL

to act as Receiver of Revenue, St. Arnaud, *vice* K. A. McDonald;

HARRY WILLIAM PASCOE

to act as Receiver of Revenue, Bendigo, during the absence of W. P. Walsh on leave; and

JOHN REGINALD KENT

to act as Receiver of Revenue, Stamp Duties Office, during the absence of W. E. Camier on leave.

*Collectors of Imposts.*

WILLIAM HENRY KIFT

to act as Collector of Imposts, Law Department, *vice* M. E. Blair;

FREDERICK ROYAL MELROSE RICHARDS

to act as Collector of Imposts, Police Department, during the absence of R. R. Greenwood on leave; and

RAYMOND DIXON HOWELLS

to act as Collector of Imposts, Lands Department, during the absence of R. R. Neal on leave.

## DEPARTMENT OF WATER SUPPLY.

*Waterworks Trust Commissioners.*

CHARLES ROBERTS

to be a Commissioner of the Orbost Waterworks Trust, *vice* James MacKinnon, resigned, and to hold office as such from the date hereof until the 3rd September, 1951, subject to the provisions of the Water Acts; and

JOHN ALEXANDER MILLERICK

to be a Commissioner of the Cobram Waterworks Trust, and to hold office as such for a period of four (4) years from the date hereof, subject to the provisions of the Water Acts.

C. W. KINSMAN,

Clerk of the Executive Council.

At the Executive Council Chamber,  
Melbourne, the 13th January, 1948.

## RESIGNATIONS.

THE Lieutenant-Governor, as Deputy for His Excellency the Governor of the State of Victoria, by and with the advice of the Executive Council thereof, has, by Orders made on the 13th day of January, 1948, accepted the resignations of the persons named hereunder of the offices mentioned, *viz.*—

## DEPARTMENT OF CHIEF SECRETARY.

WILLIAM GODFREY ROBINSON, as Registrar of Births and Deaths at Orbost.

WILLIAM JOHN TOPE, as an Assistant to the Inspector of Fisheries.

GREGORY DANIEL O'SULLIVAN, as Registrar of Births and Deaths at Kyneton, to date from and inclusive of the 4th December, 1947.

DOREEN MAY O'BRIEN, as Registrar of Births and Deaths at Mildura, to date from and inclusive of the 17th November, 1947.

HERBERT LESLIE SPARGO, as Deputy Electoral Registrar for the Hawthorn Division of the East Yarra Province; for the Abbotsford, Collingwood, and Richmond Divisions of the Melbourne Province; and for the Clifton Hill Division of the Melbourne North Province, to date from and inclusive of 3rd January, 1948.

JULES SAMUEL GASCARD, as Electoral Registrar for the Auburn, Camberwell, Camberwell North-east, Camberwell North-west, Camberwell South, and Kew Divisions of the East Yarra Province, to date from and inclusive of 7th January, 1948.

## DEPARTMENT OF LAW.

LEO MCKENNA, as a Bailiff of the County Court at Bendigo.

JAMES TOWNSEND, as a Probation Officer, pursuant to the provisions of the Children's Court Act, for the Children's Court at Werribee.

C. W. KINSMAN,

Clerk of the Executive Council.

At the Executive Council Chamber,  
Melbourne, the 13th January, 1948.

## PUBLIC SERVICE OF VICTORIA.—VACANCIES.

APPLICATIONS will be received by the Public Service Board up to Saturday, the 7th February, 1948, from persons employed in the Public Service of Victoria, who are eligible and qualified, for appointment to the under-mentioned positions:—

## ADMINISTRATIVE DIVISION.

**Clerk (Revenue Officer), Class "C1," Murtoa Centre, Department of Water Supply.**

*Yearly Salary.*—£527, minimum; £579, maximum.

*Duties.*—To supervise the collection of revenue; to keep Water Rate Books, Meter Ledgers, Water Sales Ledgers, Cash Books, and office records; to issue Rate Assessment Notices and receive revenue; to supervise the preparation of wages sheets, returns and statements, the payment of wages and District costing work; and to have charge of all clerical work connected with a District office.

*Qualifications.*—A good knowledge of the Water Acts, a knowledge of the incidence of rating, and experience in rate collecting; ability to conduct negotiations and correspondence and to represent the Commission in proceedings for recovery of rates and charges. A working knowledge of the Land and Local Government Acts and the possession of municipal clerkship or accountancy qualifications are desirable.

## PROFESSIONAL DIVISION.

**Court Reporter, Class "C1," Department of Law. (Two vacancies.)**

*Yearly Salary.*—£527, minimum; £579, maximum.

*Duties.*—To report cases in the Supreme and General Sessions, &c., Courts as required; to take notes for the Judges and of deputations; and to perform such other departmental shorthand reporting work as may be required.

*Qualifications.*—To be a licensed shorthand writer under the provisions of the *Evidence Act 1928*, with sufficient experience in duties of the kind mentioned.

**Assistant Engineer, Class "C" or Class "C1," Department of Water Supply. (Four vacancies.)**

*Yearly Salary.*—Class "C"—£449, minimum; £501, maximum. Class "C1"—£527, minimum; £579, maximum.

Investigations and Designs Branch .. Two vacancies.

*Duties.*—To report on schemes for the development of water resources, and to prepare designs and estimates for hydraulic structures, dams, and channels.

*Qualifications.*—To possess a University Degree in Civil Engineering or equivalent qualification, and to have had experience in the work set out above.

Murray Valley Construction .. One vacancy.

Robinvale .. .. . One vacancy.

*Duties.*—To prepare designs and estimates for hydraulic structures, dams and channels, and to supervise construction of works of this nature.

*Qualifications.*—To possess a University Degree in Civil Engineering or other recognized engineering qualification. Some experience in construction work is desirable.

**Staff Surveyor, Class "C," Department of State Forests.**

*Yearly Salary.*—£449, minimum; £501, maximum.

*Duties.*—To carry out surveys under Transfer of Land Act; to make base line, internal subdivisions, and trigonometrical surveys for the preparation of forest assessment maps; to locate and survey road and tramway routes for forest extraction; and to prepare plans, sections, and estimates for road and tramway construction.

*Qualifications.*—To be a licensed surveyor.

**Mechanical Engineer (Red Cliffs), Grade IV., Class "C," Department of Water Supply.**

*Yearly Salary.*—£449, minimum; £501, maximum.

*Duties.*—To be responsible to the Engineer-in-Charge for the maintenance and efficient operation of all electrical equipment at the pumping and power stations.

*Qualifications.*—To possess a University Degree or Diploma in Mechanical or Electrical Engineering, and to have had approved practical experience in electrical generation and distribution.

## TECHNICAL AND GENERAL DIVISION.

**Warder, Penal and Gaols Branch, Department of Chief Secretary. (Nine vacancies.)**

*Yearly Salary.*—£305, minimum; £370, maximum.

*Duties.*—To perform duties as required in connexion with the control and supervision of male prisoners.

*Qualifications.*—As required by Regulation 29 of the Public Service (Public Service Board) Regulations 1946.

**Inspector, Grade II. (Mornington Peninsula District), Department of Water Supply. (Three vacancies.)**

*Yearly Salary.*—£305, minimum; £344, maximum.

*Duties.*—To attend to the reticulation, tapping, and scouring of mains; to affix and read water meters and to keep accurate records thereof, and to supervise the work of licensed plumbers; to control the supply to storage basins connected with the Mornington Peninsula Scheme, and to repair and do necessary tappings to main pipe lines; to carry out the duties of turncock when required.

*Qualifications.*—To be competent to do minor repairs to wood stave, steel, fibrolite, and concrete mains, and to be able to tap same. To have had experience in plumbing work associated with water supply installations, and to be capable of driving a truck. Possession of an Intermediate Technical School Certificate is desirable.

**Channel Foreman, Werrimull Centre, Department of Water Supply.**

*Yearly Salary.*—£305, minimum; £331, maximum.

*Duties.*—Supervision of distribution of water, and maintenance of channels in an area adjacent to Werrimull.

*Qualifications.*—Experience in distribution of water for domestic and stock purposes; capacity for handling men with horse teams on sand clearing, and supervising gangs of men on channel maintenance and repairing structures. To be competent to measure up piecework, and to perform clerical work involved in preparing time book, &c.

**Nurse, Grade I., Mental Hospital, Kew, Department of Health.**

*Salary.*—£291 a year.

*Duties.*—To take charge or sub-charge of a ward in a Mental Hospital.

*Qualifications.*—To possess the Mental Hygiene Nursing Certificate, and experience as a Nurse, Grade II., in a Mental Hospital.

**Shorthand Writer and Typist (Female), Grade III., Department of Water Supply. (Two vacancies.)**

*Yearly Salary.*—£260, minimum; £273, maximum.

*Position No. 1—*

*Duties.*—To act as typist and stenographer to the Commissioners; to report deputations when required; and to supervise the work of other typists.

*Qualifications.*—To be a competent typist and shorthand writer, capable of reporting deputations, and with ability to set out special reports.

*Position No. 2—*

*Duties.*—To carry out the duties of typist and stenographer, and to supervise the work of other typists; to report deputations when required.

*Qualifications.*—To be a competent typist and shorthand writer, with ability to set out reports, and to be capable of organizing and controlling the work of other typists.

**Cook (Female), Repatriation Mental Hospital, Bundoora, Department of Health.**

*Yearly Salary.*—£244, minimum; £257, maximum.

*Qualifications.*—A knowledge of and experience in large quantity cooking.

NOTE.—In addition to the salary rates quoted, a cost of living adjustment at the rate of £36 a year in the case of females and £54 a year in the case of males is payable. The rates are subject to variation in accordance with the rise or fall in the index numbers of the cost of living.

By order,

G. V. STAFFORD,

Acting Secretary.

Office of the Public Service Board,

Melbourne, 19th January, 1947.

*Public Service Act 1946.*PUBLIC SERVICE (GOVERNOR IN COUNCIL)  
REGULATION 53 (1) (f).

THE Public Service Board hereby recommends that it be determined by the Governor in Council that, for the purposes of Regulation 52 of the Public Service (Governor in Council) Regulations "service" of an officer or employee shall include any period or periods of service or employment under the Council of a Technical School.

D. D. PAINE, Chairman.  
E. F. FITZGIBBON, Secretary.

Office of the Public Service Board,  
Melbourne, 9th September, 1947.

Approved by the Governor in Council,  
30th September, 1947.

C. W. KINSMAN,  
Clerk of the Executive Council.

*Public Service Act 1946.*PUBLIC SERVICE (GOVERNOR IN COUNCIL)  
REGULATION 53 (1) (f).

THE Public Service Board hereby recommends that it be determined by the Governor in Council that, for the purposes of Regulation 52 of the Public Service (Governor in Council) Regulations "service" of an officer or employee shall include any period or periods of service or employment of persons appointed by the Governor in Council under—

- (a) the *Milk and Dairy Supervision Act 1928* or any corresponding previous enactment; and  
(b) the *Vermin and Noxious Weeds Act 1928* or any corresponding previous enactment.

D. D. PAINE, Chairman.  
E. F. FITZGIBBON, Secretary.

Office of the Public Service Board,  
Melbourne, 9th October, 1947.

Approved by the Governor in Council,  
13th November, 1947.

C. W. KINSMAN,  
Clerk of the Executive Council.

No. 174.

*Public Service Act 1946.*REGULATIONS—PART II.—PROMOTIONS AND  
TRANSFERS.

THE Public Service Board, in pursuance of the powers conferred by the *Public Service Act 1946*, hereby amends the Public Service (Public Service Board) Regulations as follows:—

*Regulation 42.*

From Sub-regulation (1) (a) (1) delete the Class "C" and insert in lieu thereof the Class "C1."

From Sub-regulation (2) delete—

- (a) Introduction to Legal Method;  
(b) The Law of Contract;  
(c) Mercantile Law;  
(d) Law of Wrongs (Civil and Criminal);  
(e) Law of Evidence—

and insert in lieu thereof—

- (a) Introduction to Legal Method;  
(b) Principles of Contract;  
(c) Mercantile Law;  
(d) Tort;  
(e) Criminal Law and Procedure;  
(f) Law of Evidence.

*This Regulation shall have effect as on and from the 24th December, 1947.*

D. D. PAINE, Chairman.  
G. V. STAFFORD, Acting Secretary.

Office of the Public Service Board,  
Melbourne, 8th January, 1948.

## CITY OF PORT MELBOURNE.

## ROAD DEVIATION.

IN pursuance of the powers conferred by sections 521 and 525 of the *Local Government Act 1946*, the Council of the City of Port Melbourne doth hereby order that the land next hereinafter described shall be a public highway from and after the date of publication of this Order in the *Government Gazette*, viz:—

All that piece of land being part of Crown allotments 11, 12, 34, 35, and 36 of the Crown section 63, City of Port Melbourne, Parish of South Melbourne, County of Bourke, commencing at the south-east corner of Crown allotment 35; thence north 58 deg. 9 min. west 82.6 links along the north side of Ingles-street; thence north 46 deg. 11 min. east 559.5 links; thence south 49 deg. 53 min. east 80.4 links along the south side of Boundary-street; thence south 46 deg. 11 min. west 547.6 links to the point of commencement.

And the said Council doth hereby declare that the land above described shall, from and after the date of the said publication in the *Government Gazette*, be a public highway in lieu of the land hereinafter described, that is to say:—

All that piece of land being an existing road known as Quinn-street, in the said parish and county, commencing at a point bearing south 58 deg. 9 min. east 336.3 links from the south-west angle of section 63; thence north 36 deg. 10 min. east 589.6 links, south 49 deg. 53 min. east 150.4 links along the south side of Boundary-street, south 36 deg. 10 min. west 568 links, north 58 deg. 9 min. west 150.4 links along the north side of Ingles-street to the point of commencement.

In witness whereof, the Mayor, Councillors, and Citizens of the City of Port Melbourne have caused its common seal to be hereunto affixed, this 17th day of December, 1947.

The common seal of the Mayor Councillors, and Citizens of the City of Port Melbourne was hereunto affixed, in the presence of—

(SEAL) M. H. FENNELL, Mayor.  
J. P. CRICHTON, Councillor.  
S. S. ANDERSON, Town Clerk.

This Order is in lieu of Order confirmed by the Governor in Council on the 15th April, 1947, and published in the *Government Gazette* of the 16th April, 1947.

Confirmed by the Governor in Council,  
13th January, 1948.

C. W. KINSMAN,  
Clerk of the Executive Council.

HEALTH ACTS.—PLUMBERS AND GASFITTERS  
REGULATIONS.APPOINTMENT OF MEMBER OF THE PLUMBERS AND GASFITTERS  
BOARD.

IN pursuance of the powers contained in the Plumbers and Gasfitters Regulations 1936, I hereby appoint—  
GEORGE EDWARD BARROW

to be a member of the Plumbers and Gasfitters Board, representing The National Gas Association, *vice* G. W. Wales (resigned), for the period ending 15th February, 1949.

A. A. DUNSTAN,

Minister of Health.

Melbourne, 5th December, 1947.

## STAMPS ACT 1946.

IN pursuance of the powers contained in the *Stamps Act 1946*, I hereby certify, until further notice, that Northern Star Gold Mines No Liability, is engaged solely or principally in the search or mining for gold.

Dated the 21st day of January, 1948.

W. E. CAMIER,  
Comptroller of Stamps.

*Country Fire Authority Act 1944.*

## COUNTRY FIRE AUTHORITY.

## PERMISSION TO HOLD FIRE BRIGADE DEMONSTRATIONS.

IN pursuance with the provisions of section 79 (1) and (2) of the *Country Fire Authority Act 1944*, the Country Fire Authority has granted permission to hold fire brigade demonstrations at Warragul, on Monday, 29th March, 1948.

G. G. SINCLAIR,  
Secretary.

60 Market-street, Melbourne, C.1, 14th January, 1948.

## Transport Regulation Acts.

## TRANSPORT REGULATION BOARD.

## NOTICES OF PUBLIC HEARINGS.

NOTICE is hereby given that the applications made by the persons named below for licences to operate the commercial passenger vehicles, on the route or routes, or in the manner set out opposite their names, will be heard at a time and place to be communicated to the parties:—

*Name of Applicant; Nature of Application.*

- AUSSIE TOURS PTY. LTD., 278 Lonsdale-street, Melbourne; 5 commercial passenger vehicles, with seating capacity for 11, 18, 18, 18, and 11 persons respectively, to operate as additional vehicles over the routes and for the tours in respect of which the applicant is already licensed to operate.
- AUSTRALIAN NATIONAL AIRWAYS PTY. LTD., Deakin-avenue, Mildura; 1 commercial passenger vehicle, with seating capacity for 24 persons, to operate between the offices of R. H. Chaffey and Co., Deakin-avenue, Mildura, and the Mildura Aerodrome.
- BENNETT, O. L., & G. GREENAWAY, Box 175, Horsham; 1 commercial passenger vehicle, with seating capacity for 27 persons, to operate as follows:—(a) Town bus service at Dimboola via Lloyd-street, Hope-street, Ellermann-street, Horsham-road, High-street, returning to Lloyd-street. Service to commence and terminate at National Bank corner. Fares: Adults, 6d.; children, 3d. Weekly tickets: Adults, 3s.; children, 2s. Time-table: 8.40 a.m., 10 a.m., 12.15 p.m., 2.15 p.m., 4.10 p.m., 5.15 p.m. daily (Mondays to Fridays), Saturday, 7 p.m., 11 p.m., (b) under charter conditions within a 25 miles radius of Dimboola, and to Murtoa, Minyip, Rupanyup, Stawell, Ararat, and Goroke, (c) day tours from Dimboola to Hall's Gap, fare, 15s. return, and Dimboola to Wartook and Zumsteins, via Horsham, fare 10s. return.
- HUBBARD, F. R., Hepburn Springs; application for variation of licence A.197 to include the ability to operate to and from the Daylesford Railway Station on the Daylesford-Hepburn service.
- HUBBARD, F. R., Hepburn Springs; 1 commercial passenger vehicle, to be purchased, with approximate seating capacity for 27 persons, to operate as a substitute unit to all licences vehicles.
- HUBBARD, F. R., Hepburn Springs; application for variation of licence applied for on transfer from W. R. Street to include the ability to operate from the Daylesford Railway Station to guest houses within the Daylesford district.
- HUBBARD, F. R., Hepburn Springs; application for variation of licence A.1953 to include the ability to operate as a substitute vehicle to licence operating on Daylesford-Hepburn service.
- HUBBARD, F. R., Hepburn Springs; 1 commercial passenger vehicle, with seating capacity for 20 persons, to operate as follows:—(a) Between Daylesford and Ballarat on Wednesdays and Fridays only, (b) for the carriage only of school children from Daylesford via Egans-town, Blampied, Kingston, Newlyn North, Blampied, and Eganstown, (c) charter within a 20 miles radius of Daylesford, (d) specified day tours. (Subject to cancellation of licence A.194, at present held by W. R. Street.)
- HASTY, A. J., Quambatook; 1 commercial passenger vehicle, with seating capacity for 19 persons, to operate as follows:—(a) For the carriage of school children between Talgitcha and Quambatook, (b) charter within a 20 miles radius of Quambatook, and to Ultima, Swan Hill, Kerang, Boort, Wycheproof, Birchip, Donald, Charlton, Sea Lake, and Wedderburn.
- KEANE, P. V., Fish Creek, South Gippsland; 1 commercial passenger vehicle, with seating capacity for 7 persons, to operate—(a) Fish Creek-Fish Creek North on Tuesdays, Thursdays, and Saturdays, (b) Fish Creek-Sandy Point and Walkerville on Tuesdays, Thursdays, and Saturdays.
- McKINNON, H. C., Hepburn Springs; 1 commercial passenger vehicle, with seating capacity for 7 persons, to operate as a substitute vehicle to licensed vehicles TA.1442 and TA.1443.
- McPHERSON, L. G., Myrtle-street, Myrtleford; 1 commercial passenger vehicle, with seating capacity for 29 persons, to operate for the carriage of school children between Myrtleford and Dondangadale.
- PEARCE, C. J., 5 Kerford-street, Coburg; 1 commercial passenger vehicle, with seating capacity for 7 persons, to operate—(a) Mentone Railway Station-Mentone Racecourse, (b) Mentone Railway Station-Epsom Racecourse.

RONKE, F. H., Whitlands Post Office; 1 commercial passenger vehicle, with seating capacity for 3 persons, to operate for the carriage of passengers, mails, and parcels between Mason's turn-off and Mansfield, via Gears, Tolmie Post Office, and Barwite Post Office.

SOUTER, E. W., 46 Neerim-road, Caulfield; 1 commercial passenger vehicle, with seating capacity for 5 persons, and 1 commercial passenger vehicle, to be purchased, to operate as additional vehicles between Melbourne and Daylesford.

STEPHENSON, J. F. & T. H. (trading as "Gippsland, Manaro, and A.C.T. Motor Service"), Cann River; application for variation of licence to extend the Canberra-Bombala-Cann River-Orbost service from Orbost to Bairnsdale on Tuesdays, and return on Thursdays, with the proviso that passengers shall not be picked up and set down between Bairnsdale and the border of New South Wales.

APPLICATION for licences to operate commercial passenger vehicles, with seating capacity for 5 persons, to operate for the carriage of passengers otherwise than at separate and distinct fares for each passenger throughout Victoria:—

BALFOUR'S MOTORS PTY. LTD., Geelong.

BARNES, J. F., Brunswick.

BOYD, A. J., Sunshine.

DUNN, S. M., Kew.

HAMLEY, E. R., Bendigo.

HARVEY, J. E., Elwood.

KENDALL, C. G., Tallangatta (subject to the cancellation of licence PH.1102, at present held by J. Conway).

LOHREY, E. H. J. (trading as "Hurstbridge Private Hire Service"), Hurstbridge.

RALPH, M. G., Malvern.

ROWE, J. M., Box Hill.

RUSSELL, H., Elwood.

TAYLOR, E., Northcote.

McBURNIE, W., North Balwyn.

NOTICE is hereby given that the applications made by the persons named below for licences to operate the commercial goods vehicles on the route or routes, or in the manner set out opposite their names, will be heard at a time and place to be communicated to the parties concerned:—

*Name of Applicant; Nature of Application.*

- WALKINGTON, R. H. (trading as "Dalzell and Walkington"), 87 Wellington-street, Kerang; 1 commercial goods vehicle (170 cwt.) for the carriage of—(a) general goods 20 miles radius Kerang, (b) live stock within 50 miles radius Kerang, and to and from Echuca.
- HARRIS, HUGH, Box 7, Werrimull; 1 commercial goods vehicle (80 cwt.) for the carriage of—(a) fruit and vegetables from Mildura and South Australian border en route from Renmark, South Australia, to the applicant's shops situate at Meringur and Werrimull, (b) pine posts and poles from Meringur and Werrimull to properties in the Mildura district, and to the South Australian border en route to Renmark, South Australia.
- HOWE, GEORGE, 35 Hartington-street, Northcote; 1 commercial goods vehicle (15 cwt.) to operate throughout the State of Victoria for the carriage of clothing, Manchester, &c., in the course of business as "hawker."
- MAHONEY BROS., Coragulac, via Colac; 1 commercial goods vehicle (40 cwt.) for the carriage of road contracting plant and materials throughout the State of Victoria.
- MATTHEWS, W. T., William-street, Castlemaine; 1 commercial goods vehicle (60 cwt.) for the carriage of—(a) general goods 20 miles radius Castlemaine, (b) live stock from and to (a) to and from the City of Bendigo.
- REYNOLDS, KENNETH, 209 Toorak-road, South Yarra; 1 commercial goods vehicle (67 cwt.) to operate as a cash van for the purpose of selling and distributing confectionery, cordials, ice cream cones, and ice block mixtures, such goods being the property of the applicant, and carried in the course of business as distributor of same throughout an area east of a line bounded by Echuca, Rochester, Bendigo, Kyneton, Woodend, and Melbourne, such area to comprise Central and Southern Gippsland, North-eastern and Central Victoria.
- STUART, THOMAS, Box 162, Red Cliffs; 1 commercial goods vehicle (100 cwt.) for the carriage of—(a) general goods within 20 miles radius Red Cliffs, (b) firewood from the State forest at Hattah to Red Cliffs.

NOTICE is hereby given that the application made by the person named below for renewal of licence to operate the commercial goods vehicle in the manner set out hereunder, the number of which is also set out, will be heard at a time and place to be communicated to the party concerned:—

*Name and Address; Present Franchise; Licence No.; Expiry Date.*

McINTYRE, N., Compton-street, Mt. Gambier, South Australia; timber from Dartmoor to the border of South Australia en route to Mt. Gambier, South Australia; D.3419; 10th March, 1948.

Notice of any objection should be forwarded to reach the Secretary of the Board not later than Wednesday, 4th February, 1948.

E. V. FIELD,  
Secretary.

Exhibition Buildings, Rathdown-street, Carlton, N.3, 20th January, 1948.

#### FORESTS COMMISSION OF VICTORIA.

PURSUANT to the provisions of section 7 of the *Forests Act* 1939, as amended by section 3 of the *Forests Act* 1942 and section 2 of the *Forests Act* 1943, whereby the Minister of Forests is empowered by notice published in the *Government Gazette* to specify the names of forest officers for the purposes of the said section, whereupon every forest officer so specified shall be authorized, in any case where he is of opinion that a condition of acute fire danger exists in any district under his control, by notice to direct any person who is engaged within any fire protected area in any of the operations of felling, logging, snagging, skidding, sledging, or other like operation, or in the operation of driving any steam engine or steam locomotive, to suspend or cause to be suspended all or any such operations until such time as such suspension is revoked by such officer by a like notice: Now therefore I, Alexander Henry Dennett, His Majesty's Minister of Forests for the State of Victoria, do hereby specify the names of the following forest officers for the purpose of the said section:—

DOUGLAS MACGREGOR CAMPBELL.  
GEORGE HENRY JENNINGS.  
JAMES ANDREW MCKINTY.  
LAURENCE KENNETH MOORE.  
ROBERT THOMAS SEATON.  
CYRIL VERNON WYLLIE.

A. H. DENNETT,  
Minister of Forests.

8th January, 1948.

#### *Companies Act* 1938.

#### CONSENT TO THE USE OF THE WORD "CO-OPERATIVE."

THE Lieutenant-Governor, as Deputy for His Excellency the Governor of the State of Victoria, by and with the advice of the Executive Council thereof, doth by Order made on the 13th day of January, 1948, pursuant to the provisions of section 17 of the *Companies Act* 1938, consent to the use of the word "Co-operative" in the name of the company known as "The New South Wales Co-operative Wholesale Society Limited," and which it is desired shall be registered in that name.

C. W. KINSMAN,  
Clerk of the Executive Council.

At the Executive Council Chamber,  
Melbourne, the 13th January, 1948.

#### *Companies Act* 1938.

#### CONSENT TO THE USE OF THE WORD "CO-OPERATIVE."

THE Lieutenant-Governor, as Deputy for His Excellency the Governor of the State of Victoria, by and with the advice of the Executive Council thereof, doth by Order made on the 13th day of January, 1948, pursuant to the provisions of section 17 of the *Companies Act* 1938, consent to the use of the word "Co-operative" in the name of the company known as "National Co-operative Insurance Society Limited," and which it is desired shall be registered in that name.

C. W. KINSMAN,  
Clerk of the Executive Council.

At the Executive Council Chamber,  
Melbourne, the 13th January, 1948.

#### NOTICE.

ADMINISTRATION of the estate of each of the under-mentioned deceased persons has been granted to me, and creditors, next of kin, and all others having claims against the estate of any of the persons so mentioned are required to send particulars of their claims to the Public Trustee, No. 412 Collins-street, Melbourne, on or before the 23rd March, 1948, or they will be excluded from the distribution of the estate when the assets are being distributed:—

BLANDFORD, EDGAR LESLIE THEODORE, late of 2A Victoria-road, Malvern, motor trimmer, died 13th May, 1947, intestate.

BOAK, THOMAS PEARSON, late of Piangil, pensioner, died between 25th September, 1947, and 3rd October, 1947, intestate.

\*BROADMEAD, GEORGE, late of 55 Foote-street, Albert Park, retired club steward, died 31st October, 1947.

CARAGON, ANTONIO, late of 29 Wreckyn-street, North Melbourne, of no occupation, died 6th October, 1947, intestate.

CATLIN, HELENA MARION, also known as Lena Catlin, late of Ouyen, married woman, died 15th June, 1935, intestate.

†CLAGUE, THOMAS, late of 107 Melrose-street, North Melbourne, painter and decorator, died 14th October, 1947.

\*DAVIS, MARY ANN, late of 90 Brunswick-road, West Brunswick, widow, died 29th October, 1947.

DICKINS, STANLEY, late of 195 Tyler-street, Preston, labourer, died 25th September, 1947, intestate.

FORSTER, PHOEBE, late of Melbourne Benevolent Asylum, Cheltenham, pensioner, died 10th September, 1946, intestate.

FRY, RALPH SAMUEL, also known as Ralph Fry, late of 513 Upper Heidelberg-road, Heidelberg, painter, died 31st October, 1947, intestate.

HENDRY, STANLEY, late of Benevolent Home, Bendigo, pensioner, died 14th November, 1947, intestate.

HERDSMAN, FREDERICK, also known as Frederick Daley, late of 7 Autumn-street, Geelong West, labourer, died 3rd November, 1947, intestate.

HOLMES, JAMES GEORGE, late of Bendigo Benevolent Home, Bendigo, pensioner, died 12th October, 1947, intestate.

†LAWRENCE, EUSTACE BRITON, late of 403 Glenferrie-road, Hawthorn, merchant, died 28th September, 1947.

MCLEAN, MARGARET, late of "The Hill," Sale-road, Maffra, spinster, died 4th December, 1911, intestate.

O'SULLIVAN, CONOR, late of Greystone, Kilmihill, County Clare, Eire, farmer, died 24th May, 1929, intestate.

O'SULLIVAN, GEORGE, late of Kilmihill, County Clare, Eire, publican, died 18th July, 1930, intestate.

O'SULLIVAN, PETER, late of Tiermallane, Ennis, County Clare, Eire, blacksmith, died 4th August, 1930, intestate.

†PALLISER, WILFRID, formerly of Strezlecki, but late of Yallourn, storekeeper, died 19th July, 1939, intestate.

POYNTON, JULIA MARY, late of 20 Henry-street, Abbotsford, married woman, died 4th November, 1947, intestate.

REED, CHARLES THOMAS JAMESON, also known as Charles Thomas Jamieson Reed, late of Red Cliffs, retired blacksmith, died 10th September, 1947, intestate.

ROBAS, HARRY, formerly of Old Dandenong-road, Heather-ton, but late of 340 George-street, Fitzroy, poultry dealer, died 19th November, 1947, intestate.

RUMSEY, ROBERT, late of Westall-road, Spring Vale, labourer, died 29th October, 1947, intestate.

\*YOUNGMAN, THOMAS RAYMOND, late of Fire Station, Williamstown-road, Port Melbourne, station officer, died 31st July, 1947.

\* According to the provisions of the will.  
† With the will annexed.

C. J. GARDNER,  
Public Trustee.

Melbourne, 14th January, 1948.

#### 4 GEORGE VI. No. 4755, SECTION 6.

I HEREBY give notice that on the 13th January, 1948, I filed elections to administer the following deceased persons' estates, in accordance with section 6 of the *Public Trustee Act* 1940:—

BLANDFORD, EDGAR LESLIE THEODORE, late of 2A Victoria-road, Malvern, motor trimmer, died 13th May, 1947, intestate.

BOAK, THOMAS PEARSON, late of Piangil, pensioner, died between 25th September, 1947, and 3rd October, 1947, intestate.

\*BROADMEAD, GEORGE, late of 55 Foote-street, Albert Park, retired club steward, died 31st October, 1947.

CARAGON, ANTONIO, late of 29 Wreckyn-street, North Melbourne, of no occupation, died 6th October, 1947, intestate.

CATLIN, HELENA MARION, also known as Lena Catlin, late of Ouyen, married woman, died 15th June, 1935, intestate.



\*DAVIS, MARY ANN, late of 90 Brunswick-road, West Brunswick, widow, died 29th October, 1947.

DICKINS, STANLEY, late of 195 Tyler-street, Preston, labourer, died 25th September, 1947, intestate.

FORSYER, PHEBE, late of Melbourne Benevolent Asylum, Cheltenham, pensioner, died 10th September, 1946, intestate.

FRY, RALPH SAMUEL, also known as Ralph Fry, late of 513 Upper Heidelberg-road, Heidelberg, painter, died 31st October, 1947, intestate.

HENDRY, STANLEY, late of Benevolent Home, Bendigo, pensioner, died 14th November, 1947, intestate.

HERDSMAN, FREDERICK, also known as Frederick Daley, late of 7 Autumn-street, Geelong West, labourer, died 3rd November, 1947, intestate.

HOLMES, JAMES GEORGE, late of Bendigo Benevolent Home, Bendigo, pensioner, died 12th October, 1947, intestate.

MCLEAN, MARGARET, late of "The Hill," Sale-road, Maffra, spinster, died 4th December, 1911, intestate.

O'SULLIVAN, CONOR, late of Greystone, Kilmihill, County Clare, Eire, farmer, died 24th May, 1929, intestate.

O'SULLIVAN, GEORGE, late of Kilmihill, County Clare, Eire, publican, died 18th July, 1930, intestate.

O'SULLIVAN, PETER, late of Tiernallane, Ennis, County Clare, Eire, blacksmith, died 4th August, 1930, intestate.

PALLISER, WILFRID, formerly of Strezlecki, but late of Yallourn, storekeeper, died 19th July, 1939, intestate.

POYNTON, JULIA MARY, late of 20 Henry-street, Abbotsford, married woman, died 4th November, 1947, intestate.

REED, CHARLES THOMAS JAMESON, also known as Charles Thomas Jamieson Reed, late of Red Cliffs, retired blacksmith, died 10th September, 1947, intestate.

ROBAS, HARRY, formerly of Old Dandenong-road, Heather-ton, but late of 340 George-street, Fitzroy, poultry dealer, died 19th November, 1947, intestate.

RUMSEY, ROBERT, late of Westall-road, Spring Vale, labourer, died 29th October, 1947, intestate.

\*YOUNGMAN, THOMAS RAYMOND, late of Fire Station, Williamstown-road, Port Melbourne, station officer, died 31st July, 1947.

\* According to the provisions of the will.

C. J. GARDNER,  
Public Trustee.

412 Collins-street, Melbourne, C.1, 14th January, 1948.

#### APPLICATION FOR MINING LEASE DECLARED ABANDONED.

7025, Maryborough; Gold Mines of Australia Limited;  
1,850 acres, in the Parishes of Avoca and Yehrip.

#### TAILINGS LICENCE EXPIRED.

1989, Tailings Licence; Stawell Brick Company Pty. Ltd.

J. H. LIENHOP,  
Minister of Mines.

#### Farmers' Debts Adjustment Act 1935.

#### CANCELLATION OF STAY ORDERS.

NOTIFICATION is hereby given that the Stay Orders issued to the under-mentioned farmers have been cancelled by the Farmers' Debts Adjustment Board, such cancellation to take effect on Wednesday, 21st January, 1948:—

*No. of Stay Order; Name; Address.*

3276; Henseleit, Albert Gustav; Woorak.  
3975; Witney, Susan; Jeparit.  
3417; Schnaars, Benjamin Franz; Netherby.  
1415; De Forest, Gilbert (now deceased); Longwarry.  
3788; Green, Gordon Vincent and William Alexis; Vervale.

W. J. EVANS, Deputy Secretary,  
Farmers' Debts Adjustment Board.

20th January, 1948.

#### THE BALLARAT SEWERAGE AUTHORITY.

#### RATING BY-LAW No. 27.

#### The Ballarat Sewerage District.

THE Ballarat Sewerage Authority, in pursuance and exercise of the powers conferred by the Sewerage Districts Acts, doth hereby make the following By-law:—

The following sewerage rate is hereby made under the provisions of the Sewerage Districts Acts, and shall be levied upon the net annual value of all rateable sewered properties within the Ballarat Sewerage District:—

1. Of any land or tenement situate within the Ballarat Sewerage District, a sewerage rate of One shilling and six pence in the pound of the net annual value of all rateable "sewered property" within the said district.

2. Such rate is made and shall be levied for the year beginning with the first day of January, 1948, and ending with the thirty-first day of December, 1948, and shall be payable on the thirty-first day of March, 1948, at the office of the Authority, situate at the Water and Sewerage Offices, Ballarat.

3. If any rateable property which is unsewered at the time of the making of the aforesaid rate becomes during the year 1948 a "sewered property," there shall be levied upon such property a proportionate part of the sewerage rate for the portion of the year after it has become a sewered property, and such property shall be deemed to have been lawfully rated accordingly.

4. For making and levying such rate the valuation for the time being of such lands and tenements for the municipal rate of the municipality in the municipal district of which such lands and tenements are situate shall be deemed and taken to be the valuation of such lands and tenements respectively; but if any such lands and tenements are not included in a valuation in force for the municipality in whose district they are situate, or if there is no such valuation, the net annual value thereof may for all purposes of such rate be determined in the manner provided in the Sewerage Districts Acts.

5. Such person or persons as The Ballarat Sewerage Authority may from time to time appoint for that purpose shall be and is or are hereby authorized to demand, receive, collect, and recover the said rate and charges.

The resolution for passing the foregoing By-law was agreed to by The Ballarat Sewerage Authority on the twenty-seventh day of November, 1947, and was confirmed by the said Authority on the eighteenth day of December, 1947.

The common seal of The Ballarat Sewerage Authority was affixed hereto on the eighteenth day of December, 1947—

(SEAL) ALF. J. PITTARD, Chairman.  
ALEX. M. KING, Member.  
CHAS. H. CLAMP, Secretary.

Approved by the Governor in Council,  
13th January, 1948.

C. W. KINSMAN,  
Clerk of the Executive Council.

#### MARIBYRNONG RIVER.

#### HENLEY ON THE MARIBYRNONG.

#### Notice to Boatmen and Others.

BOATMEN and others are hereby notified that Henley on the Maribyrnong will be held on Saturday, 7th February, 1948, and that persons in charge of motor and other boats permitted to be on the river during the day and night shall observe the following Regulations, viz.:—

Boat races must not be obstructed, nor public safety or order endangered.

Every motor boat must have a supply of dry sand and carry a bucket for fire-extinguishing purposes, and no inflammable oil or spirit shall be exposed. An approved chemical fire extinguisher shall be carried.

All non-competing boats shall be kept off the course during the racing programme, and the direction of the officers in charge of the course must be strictly complied with.

Passengers on any boat overcrowded or incompetently managed may be ordered to disembark, and no boat deemed by the River Officer, or his deputy, to be too large, or deemed to be offensive, dangerous, unsuitable, or unsightly, shall remain on the river along the course or adjacent waters.

No fireworks or firearms are to be discharged from any boats unless permission of the River Officer or his deputy has been given for so doing.

After sunset, motor boats shall have a red light exhibited, and shall not travel faster than two miles per hour.

Motor boats shall not tow any boat.

After sunset, rowing boats shall have a white light exhibited.

All boats must give way to racing boats going upstream to the start of the course.

CHAS. J. W. BRIGGS,  
Secretary.

Melbourne and Metropolitan Board of Works, 110  
Spencer-street, Melbourne, 19th January, 1948.

## STATE RIVERS AND WATER SUPPLY COMMISSION.

## SALE OF CERTAIN LAND APPROVED.

**T**HE Lieutenant-Governor, as Deputy for His Excellency the Governor of the State of Victoria, by and with the advice of the Executive Council thereof, and in pursuance of the provisions of the *Water Act 1928*, doth by Order made on the 13th day of January, 1948, approve the sale of an area of 1 rood 25½ perches, being allotment 1, section 1, Township of Stanhope, Parish of Girgarre, County of Rodney, and being part of the land described in Crown grant, volume 6400, folio 1279976, which land was purchased by or vested in the said Commission.

C. W. KINSMAN,  
Clerk of the Executive Council.

At the Executive Council Chamber,  
Melbourne, the 13th day of January, 1948.

## APOLLO BAY WATERWORKS TRUST.

## RATING BY-LAW FOR THE YEAR 1948.

**T**HE Apollo Bay Waterworks Trust, in pursuance and exercise of the powers conferred by the *Water Acts*, doth hereby make a rate for the supply of water for domestic purposes of One shilling and six pence (1s. 6d.) in the pound of the annual municipal valuation of lands and tenements liable to be rated within the Apollo Bay Urban District.

Provided that in no case shall the amount of rate payable per annum in respect of any tenement (other than land on which there is no building) be less than Twenty-six shillings and eight pence (26s. 8d.), and in respect of any land on which there is no building less than Ten shillings (10s.).

Such rates are made and shall be levied upon the occupiers or owners of the said lands and tenements for the year commencing the 1st day of January, 1948, and shall be payable on the 1st day of February, 1948, at the office of the said Trust.

The maximum quantity of water to be supplied in any one year without further charge to any property rated by the said Trust is hereby fixed at the quantity which, at a charge of One shilling and six pence (1s. 6d.) per 1,000 gallons, would produce an amount equal to the amount of the rate levied on such property for the said year.

The charge for water supplied by measure to any property rated by the Trust in excess of such maximum quantity, computed as in the last preceding clause, is hereby fixed at One shilling and six pence (1s. 6d.) per 1,000 gallons.

Water supplied to cricket, tennis, or bowling clubs, and to Government Departments, showgrounds, and similar properties shall be charged for at the rate of One shilling and six pence (1s. 6d.) per 1,000 gallons, provided that the minimum quantity to be charged for shall not be less than 15,000 gallons.

The charge for water by measure shall be payable, on demand, at the office of the Trust.

Passed this 15th day of December, 1947.

(SEAL) R. M. WHELAN, Chairman.  
W. O. CORKE, Secretary.

Approved by the Governor in Council,  
13th January, 1948.

C. W. KINSMAN,  
Clerk of the Executive Council.

## BAIRNSDALE WATERWORKS TRUST.

## RATING BY-LAW, 1948.

**T**HE Bairnsdale Waterworks Trust, in pursuance and exercise of the powers conferred by the *Water Acts*, doth hereby make a rate for the supply of water for domestic purposes of One shilling in the pound of the annual municipal valuation of lands and tenements liable to be rated within the Bairnsdale Urban District.

Provided that in no case shall the amount of rate payable per annum in respect of any tenement (other than land on which there is no building) be less than Twenty-five shillings, and in respect of any land on which there is no building less than Five shillings.

Such rate is made for the year commencing on the first day of January, 1948, and shall be payable on the second day of February, 1948, at the office of the Trust, Nicholson-street, Bairnsdale.

Made this eighteenth day of December, 1947.

(SEAL) PHIL. C. KING, Chairman.  
H. G. HEATH, Commissioner.  
H. F. HOLLOWAY, Secretary.

Approved by the Governor in Council,  
13th January, 1948.

C. W. KINSMAN,  
Clerk of the Executive Council.

## CARISBROOK WATERWORKS TRUST.

## RATING BY-LAW FOR 1948.

**T**HE Commissioners of the Carisbrook Waterworks Trust, the waterworks district which has been proclaimed an urban district, in pursuance and in exercise of the powers conferred by the *Water Acts*, doth hereby make a rate for the supply of water for domestic purposes only of Two shillings and six pence in the pound on the annual municipal valuation of lands and tenements liable to be rated within the Carisbrook Urban District.

Provided that in no case shall the amount of the rate payable in respect of any land or tenement be less than Forty shillings.

Such rates are made and shall be levied upon the occupiers or owners of the said lands and tenements for the year commencing on the 1st day of January, 1948, and shall be payable on the 1st day of March, 1948, at the office of the Trust.

For water supplied by the Trust by measurement a charge of Five shillings per 1,000 gallons shall be paid. The charge for water supplied by measurement shall be paid on demand.

Such person or persons as the Trust from time to time may appoint for that purpose shall be authorized to demand, receive, collect, and recover the said rates and charges.

Passed this 11th day of December, 1947.

(SEAL) H. W. HINKS, Chairman.  
R. F. MACGUGAN, Secretary.

Approved by the Governor in Council,  
13th January, 1948.

C. W. KINSMAN,  
Clerk of the Executive Council.

## COLAC WATERWORKS TRUST.

## RATING BY-LAW FOR THE YEAR 1948.

**T**HE Colac Waterworks Trust, in pursuance and exercise of the powers conferred by the *Water Acts*, doth hereby make a rate for the supply of water for domestic purposes of One shilling and two pence in the pound of the annual municipal valuation of lands and tenements liable to be rated within the Colac Urban District.

Provided that in no case shall the amount of rate payable per annum in respect of any tenement (other than land on which there is no building) be less than Twenty shillings, and in respect of any land on which there is no building less than Ten shillings.

Such rates are made and shall be levied upon the occupiers or owners of the said lands and tenements for the year commencing on the 1st day of January, 1948, and shall be payable on the 17th day of May, 1948, at the office of the said Trust.

Water supplied to cricket, bowling, or tennis clubs, and to Government Departments, mechanics' institutes, churches, showgrounds, and similar properties shall be charged for by measurement at Six pence per 1,000 gallons, provided that the minimum quantity to be charged for shall not be less than 40,000 gallons per annum.

The maximum quantity of water to be supplied in any one year without further charge to any property rated by the Trust is hereby fixed at the quantity which, at a charge of One shilling and two pence per 1,000 gallons, would produce an amount equal to the amount of the rate levied on such property for the said year.

The charge for water supplied by measure to any property rated by the said Trust in excess of such maximum quantity, computed as in the last preceding clause, is hereby fixed at One shilling per 1,000 gallons.

The charge for water supplied by measure shall be payable, on demand, at the office of the Trust.

Passed this 22nd day of December, 1947.

(SEAL) J. S. BROWN, Chairman.  
ALLAN MCKENZIE, Secretary.

Approved by the Governor in Council,  
13th January, 1948.

C. W. KINSMAN,  
Clerk of the Executive Council.

#### BOROUGH OF DAYLESFORD WATERWORKS TRUST.

##### RATING BY-LAW FOR THE YEAR 1948.

THE Borough of Daylesford Waterworks Trust, in pursuance and exercise of the powers conferred by the Water Acts, doth hereby make the following rates for the supply of water for domestic purposes of lands and tenements liable to be rated within the waterworks districts of the Trust:—

(1) On such lands and tenements, a rate of One shilling in the pound of the annual municipal valuation not exceeding £200 and eleven pence in the pound of the amount of the valuation exceeding £200, provided that the minimum amount to be payable shall be Twenty-one shillings on land on which there is a building, and Ten shillings on land on which there is no building.

(2) Such rates are made and shall be levied upon the occupiers or owners of the said lands and tenements for the year commencing on the 1st day of January, 1948, and shall be payable on the 10th day of April, 1948, at the office of the said Trust.

(3) (a) The maximum quantity of water to be supplied in any one year without further charge to any property rated by the Trust is hereby fixed at the quantity which, at a charge of One shilling and six pence per 1,000 gallons would produce an amount equal to the amount of the rate levied on such property for the said year.

(b) The charge for water supplied by measure to any property rated by the Trust in excess of such maximum quantity, computed as in the last preceding clause, is hereby fixed at One shilling and three pence per 1,000 gallons up to 20,000 gallons, and over 20,000 gallons at the rate of One shilling per 1,000 gallons.

(c) The charge for water supplied by measure to any property not rated by the Trust is hereby fixed at One shilling and six pence per 1,000 gallons, and the minimum quantity of water to be charged for in cases where water is so supplied is hereby fixed at 7,000 gallons.

(d) For water supplied to buildings in course of erection the charge of Twenty shillings per cent. on the amount of the contract for brickwork, stone, or plastering, or should the Trust require a meter to be put on the rate shall be One shilling and six pence per 1,000 gallons, none being allowed without charge.

(e) The charge for water supplied by measure shall be payable, on demand, at the office of the Trust.

(4) Such person or persons as the Trust may appoint for the purpose are hereby authorized to demand, receive, collect, and recover the said rates and charges.

(5) A charge for water for industrial purpose in excess of such maximum quantity allowed shall be charged for at the rate of Six pence per 1,000 gallons.

Dated this fifteenth day of December, 1947.

(SEAL) A. D. ANSON, Chairman.  
E. R. MARCHANT, Secretary.

Approved by the Governor in Council,  
13th January, 1948.

C. W. KINSMAN,  
Clerk of the Executive Council.

#### TOWN OF HORSHAM WATERWORKS TRUST.

##### RATING BY-LAW FOR YEAR 1948.

THE Commissioners of the Town of Horsham Waterworks Trust do hereby make the following By-law, in pursuance of the provisions of the Water Acts:—

1. That the water rate for the year 1948 on all lands and tenements within the Town of Horsham Waterworks Trust District shall be One shilling and two pence in the pound on the municipal valuation of the Town of Horsham

for the year 1947-48, with a minimum of One pound (£1) upon all tenements valued at or under Seventeen pounds (£17), and upon which a building is erected, except such as are entitled to the provisions of section 237 of the *Water Act 1928*.

2. (a) The maximum quantity of water to be supplied in any one year without further charge to any property rated by the Trust is hereby fixed at the quantity which, at a charge of One shilling and two pence per 1,000 gallons, would produce an amount equal to the amount of the rate levied on such property for the said year.

(b) The charge for water supplied by measure to any property rated by the Trust in excess of such maximum quantity, computed as in the last preceding clause, is hereby fixed at Nine pence per 1,000 gallons.

(c) The charge for water supplied by measure to any property not rated by the Trust is hereby fixed at Nine pence per 1,000 gallons, and the minimum quantity of water to be charged for in cases where water is so supplied is hereby fixed at 27,000 gallons.

(d) The charge for water supplied by measure shall be payable, on demand, at the office of the Trust.

3. All water rates shall be payable on the 31st day of January, 1948, at the office of the Trust, Wilson-street, Horsham, where payments will be received during office hours.

4. Such officers as the Trust may from time to time appoint for the purpose are hereby authorized to demand, receive, and recover the said charges.

The foregoing By-law was passed by the Commissioners of the Town of Horsham Waterworks Trust on the fifteenth day of December, 1947, and the common seal hereunder affixed in the presence of—

(SEAL) IAN T. BENNETT, Chairman.  
W. W. COOK, Commissioner.  
A. J. WATTS, Secretary.

Approved by the Governor in Council,  
13th January, 1948.

C. W. KINSMAN,  
Clerk of the Executive Council.

#### KERANG WATERWORKS TRUST.

##### RATING BY-LAW FOR THE YEAR 1948.

THE Kerang Waterworks Trust, in pursuance and exercise of the powers conferred by the Water Acts, doth hereby make a rate for the supply of water for domestic purposes of One shilling and two pence in the pound of the annual municipal valuation of lands and tenements liable to be rated within the Kerang Urban District.

Provided that in no case shall the amount of the rate payable per annum in respect of any tenement be less than Twenty shillings.

Such rates are made and shall be levied upon the occupiers or owners of the said lands and tenements for the year commencing on the 1st day of January, 1948, and shall be payable on the 1st day of May, 1948, at the office of the said Trust.

The maximum quantity of water to be supplied in any one year without further charge to any property rated by the Trust is hereby fixed at the quantity which, at a charge of One shilling per 1,000 gallons, would produce an amount equal to the amount of the rate levied on such property for the said year.

The charge for water supplied by measure to any property rated by the Trust in excess of such maximum quantity, computed as in the last preceding clause, is hereby fixed at One shilling per 1,000 gallons.

The charge for water supplied by measure shall be payable, on demand, at the office of the Trust.

Passed this 19th day of December, 1947.

(SEAL) NEVILLE H. BISHOP, Chairman.  
A. K. LYALL, Secretary.

Approved by the Governor in Council,  
13th January, 1948.

C. W. KINSMAN,  
Clerk of the Executive Council.

## LANCEFELD WATERWORKS TRUST.

RATING BY-LAW FOR THE YEAR 1948.

**T**HE Lancefield Waterworks Trust, in pursuance and exercise of the powers conferred by the Water Acts, doth hereby make a rate for the supply of water for domestic purposes of Two shillings and six pence in the pound of the annual municipal valuation of lands and tenements liable to be rated within the Lancefield Urban District.

Provided that in no case shall the amount of rate payable per annum in respect of any tenement (other than land on which there is no building) be less than Thirty-five shillings, and in respect of any land on which there is no building less than Ten shillings.

Such rates are made and shall be levied upon the occupiers or owners of the said lands and tenements for the year commencing the first day of January, 1948, and shall be payable in two moieties on the 31st day of January, 1948, and on the 1st day of July, 1948, at the office of the said Trust.

Dated this 16th day of December, 1947.

(SEAL) GEO. HALL, Chairman.  
J. S. RUMMING, Secretary.

Approved by the Governor in Council,  
13th January, 1948.

C. W. KINSMAN,  
Clerk of the Executive Council.

## LEONGATHA WATERWORKS TRUST.

RATING BY-LAW FOR THE YEAR 1948 (No. 48).

**T**HE Leongatha Waterworks Trust, in pursuance and exercise of the powers conferred by the Water Acts, doth hereby make a rate for the supply of water for domestic purposes of One shilling and four pence in the pound on the net annual valuation of lands and tenements liable to be rated within the Leongatha Urban District.

Provided that in no case shall the amount of the rate payable per annum in respect of any tenement (other than land on which there is no building) be less than Fifteen shillings, and in respect of any land where there is no building less than Ten shillings.

Such rates are made and shall be levied upon the occupiers or owners of the said lands and tenements for the year commencing on the first day of January, 1948, and shall be due and payable on the first day of February, 1948, at the office of the Trust.

The maximum quantity of water to be supplied in any one year without further charge to any property rated by the Trust is hereby fixed at the quantity which, at a charge of Two shillings per 1,000 gallons, would produce an amount equal to the amount of rate levied on such property for the said year.

The charge for water supplied by measure to any property rated by the Trust in excess of such maximum quantity, computed as in the last preceding clause, is hereby fixed at Two shillings per 1,000 gallons.

The charge for water supplied by measure shall be payable, on demand, at the office of the Trust.

Passed this 18th day of December, 1947.

(SEAL) C. A. S. BOND, Chairman.  
J. CONWAY, Commissioner.  
JOHN W. POUNDER, Commissioner.  
C. H. LYON, Secretary.

Approved by the Governor in Council,  
13th January, 1948.

C. W. KINSMAN,  
Clerk of the Executive Council.

## MANSFIELD WATERWORKS TRUST.

RATING BY-LAW FOR 1948.

**T**HE Mansfield Waterworks Trust, in pursuance and exercise of the powers conferred by the Water Acts, doth hereby make a rate for the supply of water for domestic purposes of One shilling and nine pence in the pound on the annual municipal valuation of lands and tenements liable to be rated within the Mansfield Urban District.

Provided that in no case shall the amount of the rate payable per annum in respect of any tenement (other than land on which there is no building) be less than Fifteen shillings.

Such rates are made and shall be levied upon the occupiers or owners of the said lands and tenements for the year commencing on the 1st day of January, 1948, and ending on the 31st day of December, 1948, and shall be payable on the 1st day of February, 1948, at the office of the said Trust.

Passed this 11th day of December, 1948.

(SEAL) D. P. BEGLEY, Chairman.  
A. WOMERSLEY, Secretary.

Approved by the Governor in Council,  
13th January, 1948.

C. W. KINSMAN,  
Clerk of the Executive Council.

## MARYSVILLE WATERWORKS TRUST.

RATING BY-LAW FOR THE YEAR 1948.

**T**HE Marysville Waterworks Trust, in pursuance and exercise of the powers conferred by the Water Acts, doth hereby make a rate for the supply of water for domestic purposes of One shilling and eight pence in the pound of the annual municipal valuation of the land and tenements liable to be rated within the Marysville Urban District, provided that in no case shall the amount of rate payable per annum in respect of any tenement (other than land on which there is no building) be less than One pound, and in respect of any land on which there is no building less than Ten shillings.

Such rates are made and levied upon the occupiers or owners of the said land or tenements for the year commencing on the first day of January, 1948, and shall be payable on the sixteenth day of February, 1948, at the office of the said Trust.

Passed this sixteenth day of December, 1947.

(SEAL) F. J. BARTON, Chairman.  
W. MASSEY, Secretary.

Approved by the Governor in Council,  
13th January, 1948.

C. W. KINSMAN,  
Clerk of the Executive Council.

## MOE WATERWORKS TRUST.

RATING BY-LAW FOR THE YEAR 1948.

**T**HE Moe Waterworks Trust, in pursuance and exercise of powers conferred by the Water Acts, doth hereby make a rate for the supply of water for domestic purposes of One shilling and four pence in the pound of the net annual valuation (municipal) of lands and tenements liable to be rated within the Moe Urban Districts.

Provided that in no case shall the amount of the rate payable per annum in respect of any tenement (other than land on which there is no building) be less than Twenty-six shillings and eight pence, and in respect of any land on which there is no building less than Ten shillings.

Such rates are made and shall be levied upon the occupiers or owners of the said lands and tenements for the year commencing the 1st day of January, 1948, and shall be payable on the 1st day of February, 1948, at the office of the said Trust.

The maximum quantity of water to be supplied in any one year without further charge to any property rated by the Trust is hereby fixed at the quantity which, at a charge of One shilling per 1,000 gallons, would produce an amount equal to the amount of the rate levied on such property for the said year.

The charge for water supplied by measure to any property rated by the Trust in excess of such maximum quantity, computed as in the preceding clause, is hereby fixed at Three pence per 1,000 gallons.

The charge for water supplied by measure shall be payable, on demand, at the office of the Trust.

Passed this 19th day of December, 1947.

(SEAL) GEO. C. PURVIS, Chairman.  
J. S. TABUTEAU, Commissioner.  
J. G. SAXTON, Commissioner.  
W. H. BURRAGE, JUNR., Secretary.

Approved by the Governor in Council,  
13th January, 1948.

C. W. KINSMAN,  
Clerk of the Executive Council.

## MURTOA WATERWORKS TRUST.

## RATING BY-LAW FOR THE YEAR 1948.

THE Murtoa Waterworks Trust, in pursuance and exercise of the powers conferred by the Water Acts, doth hereby make a rate for the supply of water for domestic purposes of Sixteen pence in the pound of the annual municipal valuation of lands and tenements liable to be rated within the Murtoa Urban District.

Provided that in no case shall the amount of rate payable per annum in respect of any tenement (other than land on which there is no building) be less than Fifteen shillings, and in respect of any land on which there is no building less than Seven shillings and six pence.

Such rates are made and shall be levied upon the occupiers or owners of the said land and tenements for the year commencing the 1st day of January, 1948, and shall be payable on the 1st day of February, 1948, at the office of the said Trust.

The maximum quantity of water to be supplied in any one year without further charge to any property rated by the Trust is hereby fixed at the quantity which, at a charge of Sixteen pence per 1,000 gallons, would produce an amount equal to the amount of the rate levied on such property for the said year.

The charge for water supplied by measure to any property rated by the Trust in excess of such maximum quantity, computed as in the last preceding clause, is hereby fixed at Nine pence per 1,000 gallons.

The charge for water supplied by measure shall be payable, on demand, at the office of the Trust.

Dated this 22nd day of December, 1947.

(SEAL) HAROLD H. EVANS, Chairman.  
VICTOR RABL, Commissioner.  
A. J. NEWTON, Commissioner.  
H. G. CRAM, Secretary.

Approved by the Governor in Council,  
13th January, 1948.

C. W. KINSMAN,  
Clerk of the Executive Council.

## RIDDELL'S CREEK WATERWORKS TRUST.

## RATING BY-LAW FOR 1948.

THE Riddell's Creek Waterworks Trust, in pursuance and exercise of the powers conferred by the Water Acts, doth hereby make a rate for the supply of water for domestic purposes of Two shillings and nine pence in the pound of the annual municipal valuation of lands and tenements liable to be rated within the Riddell's Creek Urban District.

Provided that in no case shall the amount of rate payable per annum in respect of any tenement (other than land on which there is no building) be less than Two pounds fifteen shillings, and in respect of land on which there is no building less than One pound.

Such rates are made and shall be levied upon the occupiers or owners of the said lands and tenements for the year commencing the 1st day of January, 1948, and shall be payable on the 1st day of February, 1948, at the office of the said Trust.

(a) The maximum quantity of water to be supplied in any one year without further charge to any property rated by the Trust is hereby fixed at the quantity which, at a charge of One shilling per 1,000 gallons, would produce an amount equal to the amount of the rate levied on the property for the said year.

(b) The charge for water supplied by measure to any property rated by the Trust in excess of such maximum quantity, computed as in the last preceding clause, is hereby fixed at One shilling and six pence per 1,000 gallons.

The charge for water supplied by measure shall be payable, on demand, at the office of the Trust.

Passed this 17th day of December, 1947.

(SEAL) J. R. BOLITHO, Chairman.  
UNA I. WRIGHT, Secretary.

Approved by the Governor in Council,  
13th January, 1948.

C. W. KINSMAN,  
Clerk of the Executive Council.

## ROMSEY WATERWORKS TRUST.

## RATING BY-LAW FOR THE YEAR 1948.

THE Romsey Waterworks Trust, in pursuance and exercise of the powers conferred by the Water Acts, doth hereby make a rate for the supply of water for domestic purposes of One shilling and six pence in the pound of the annual municipal valuation of lands and tenements liable to be rated within the Romsey Urban District.

Provided that in no case shall the amount of rate payable per annum in respect of any tenement (other than land on which there is no building) be less than One pound two shillings and six pence, and in respect of any land on which there is no building less than Ten shillings.

Such rates are made and shall be levied upon the occupiers or owners of the said lands and tenements for the year commencing the first day of January, 1948, and shall be payable on the first day of February, 1948, at the office of the collector of the said Trust, at Romsey.

Passed this 22nd day of December, 1947.

(SEAL) A. M. BUCHANAN, Chairman.  
H. M. WHITE, Secretary.

Approved by the Governor in Council,  
13th January, 1948.

C. W. KINSMAN,  
Clerk of the Executive Council.

## RUSHWORTH WATERWORKS TRUST.

## RATING BY-LAW FOR YEAR ENDED 1948.

THE Rushworth Waterworks Trust, in pursuance and exercise of the powers conferred by the Water Acts, doth hereby make a rate for the supply of water for domestic purposes of Two shillings in the pound of the annual municipal valuation of lands and tenements liable to be rated within the Rushworth Urban District.

Provided that in no case shall the amount of rate payable in respect of any tenement (other than land on which there is no building) be less than Two pounds, and in respect of any land on which there is no building less than One pound.

Such rates are made and shall be levied upon the occupiers or owners of the said lands and tenements for the year commencing the 1st day of January, 1948, and shall be payable on the 1st day of February, 1948, at the office of the said Trust.

The maximum quantity of water to be supplied in any one year without further charge to any property rated by the Trust is hereby fixed at the quantity which, at a charge of One shilling per 1,000 gallons, would produce an amount equal to the amount of rate levied on such property for the said year.

The charge for water supplied by measure to any property rated by the Trust in excess of such maximum quantity, computed as in the last preceding clause, is hereby fixed at One shilling per 1,000 gallons.

The charge for water supplied by measure shall be payable on demand.

Dated 23rd December, 1947.

(SEAL) F. V. HAMMOND, Chairman.  
A. WILSON, Secretary.

Approved by the Governor in Council,  
13th January, 1948.

C. W. KINSMAN,  
Clerk of the Executive Council.

## ST. ARNAUD BOROUGH WATERWORKS TRUST.

## RATING BY-LAW FOR THE YEAR 1948.

THE St. Arnaud Borough Waterworks Trust, in pursuance and exercise of the powers conferred by the Water Acts, doth hereby make a rate for the supply of water for domestic purposes of Three shillings and six pence in the pound of the annual municipal valuation of the lands and tenements liable to be rated within the St. Arnaud Borough Waterworks Trust Urban District.

Provided that in no case shall the rate per annum in respect of any tenement (other than land on which there is no building) be less than Three pounds, and in respect of land on which there is no building less than Ten shillings.

Such rates are made and shall be levied upon the occupiers or owners of the said lands and tenements for the year commencing the 1st day of January, 1948, and shall be payable on the 17th day of February, 1948, at the offices of the said Trust, Town Hall, St. Arnaud.

The maximum quantity of water to be supplied in any one year without further charge to any property rated by the Trust is hereby fixed at a quantity which, at a charge of One shilling and six pence per 1,000 gallons, would produce an amount equal to the amount of the rate levied on such property for the said year.

The charge for water supplied by measure to any property rated by the Trust in excess of such maximum quantity, computed as in the last preceding clause, is hereby fixed at One shilling and six pence per 1,000 gallons.

The charge for water supplied by measure shall be payable, on demand, at the offices of the Trust.

Passed this 22nd day of December, 1947.

(SEAL) FRANK A. DUFF, Chairman.  
C. G. MORISON, Secretary.

Approved by the Governor in Council,  
13th January, 1948.

C. W. KINSMAN,  
Clerk of the Executive Council.

#### STRATFORD WATERWORKS TRUST.

##### RATING BY-LAW FOR THE YEAR 1948.

THE Stratford Waterworks Trust, in pursuance and exercise of the powers conferred by the Water Acts, doth hereby make a rate for the supply of water for domestic purposes of One shilling and ten pence in the pound of the annual municipal valuation of lands and tenements within the Stratford Waterworks Urban District.

Provided that in no case shall the amount of rate payable per annum in respect of any tenement (other than land on which there is no building) be less than Two pounds, and in respect of any land on which there is no building less than Three shillings and eight pence.

Such rate is made for the year commencing on the 1st day of January, 1948, and shall be payable on the 1st day of May, 1948, at the office of the said Trust.

The maximum quantity of water to be supplied in any one year without further charge to any property rated by the Trust is hereby fixed at the quantity which, at a charge of Ten pence per 1,000 gallons, would produce an amount equal to the amount of the rate levied on such property for the said year.

The charge for water supplied by measure to any property rated by the Trust in excess of such maximum quantity, computed as in the last preceding clause, is hereby fixed at One shilling per 1,000 gallons.

The charge for water supplied by measure shall be payable, on demand, at the office of the Trust.

Passed this 30th day of October, 1947.

(SEAL) KEITH DAVIDSON, Chairman.  
L. H. WEBB, Commissioner.  
J. W. BARTLETT, Commissioner.  
F. NORDEN, Commissioner.  
E. C. BOCK, Secretary.

Approved by the Governor in Council,  
13th January, 1948.

C. W. KINSMAN,  
Clerk of the Executive Council.

#### TONGALA WATERWORKS TRUST.

##### RATING BY-LAW FOR THE YEAR 1948.

THE Tongala Waterworks Trust, in pursuance and exercise of the powers conferred by the Water Acts, doth hereby make a rate for the supply of water for domestic purposes of One shilling and three pence in the pound of the annual municipal valuation of lands and tenements liable to be rated within the Tongala Urban District.

Provided that in no case shall the amount of rate payable per annum in respect of any tenement (other than land on which there is no building) be less than One pound four shillings (£1 4s.), and in respect of any land on which there is no building less than Ten shillings.

Such rates are made and shall be levied upon the occupiers or owners of the said lands and tenements for the year commencing the 1st day of January, 1948, and shall be payable on the 1st day of February, 1948, at the office of the said Trust.

The maximum quantity of water to be supplied in any one year without further charge to any property rated by the Trust is hereby fixed at the quantity which, at a

charge of One shilling and three pence per 1,000 gallons, would produce an amount equal to the amount of the rate levied on such property for the said year.

The charge for water supplied by measure to any property rated by the Trust in excess of such maximum quantity, computed as in the last preceding clause, is hereby fixed at One shilling per 1,000 gallons.

The charge for water supplied by measure shall be payable, on demand, at the office of the Trust.

The charge for the supply for watering gardens shall be One pound per tenement.

For water supplied from standpipe or hydrant, the charge for every 1,000 gallons, or portion of same, to be at the rate of Two shillings and six pence per 1,000 gallons, with a minimum of Six pence for any one tank or load.

Notwithstanding the payment of any charge by any owner or occupier, the Trust reserves the right to cut off the supply of water from any premises if such owner or occupier shall wilfully or negligently allow water to run to waste, or who uses it in an unauthorized manner.

When the water is cut off from any premises the owner or occupier must pay the sum of One pound to be re-connected to the main.

Water must not be used for gardens between the hours of 8 o'clock p.m. and 6 o'clock a.m.

Such person or persons as the Commissioners of the said Trust may from time to time appoint for the purposes are hereby authorized to collect and recover the said rates and charges.

The foregoing By-law was made by the Tongala Waterworks Trust, and passed this 22nd day of December, 1947.

(SEAL) H. K. SLADE, Chairman.  
K. C. GRAHAM, Secretary.

Approved by the Governor in Council,  
13th January, 1948.

C. W. KINSMAN,  
Clerk of the Executive Council.

#### TOORA WATERWORKS TRUST.

##### RATING BY-LAW FOR THE YEAR 1948.

THE Toora Waterworks Trust, in pursuance and exercise of the powers conferred by the Water Acts, doth hereby make the following rates for the supply of water for domestic purposes on lands and tenements liable to be rated within the Toora Urban District:—

On such lands and tenements a rate of One shilling and six pence in the pound of the annual municipal valuation not exceeding Seventy-five pounds, and where the annual municipal valuation exceeds Seventy-five pounds, a rate of One shilling and six pence in the pound for the first Seventy-five pounds and One shilling and four pence in the pound for every pound exceeding Seventy-five pounds of such valuation.

Provided that in no case shall the amount of rate payable in respect of any tenement (other than land on which there is no building) be less than One pound six shillings and eight pence, and in respect of any land on which there is no building less than Ten shillings.

Such rates are made and shall be levied upon the occupiers or owners of such lands and tenements for the year commencing on the first day of January, 1948, and shall be payable on the first day of February, 1948, at the office of the said Trust.

The maximum quantity of water to be supplied in any one year without further charge to any property rated by the Trust is hereby fixed at the quantity which, at a charge of Two shillings per 1,000 gallons, would produce an amount equal to the amount of the rate levied on such property for the said year.

The charge for water supplied by measure to any property rated by the Trust in excess of such maximum quantity, computed as in the last preceding clause, is hereby fixed at Two shillings per 1,000 gallons.

The charge for water supplied by measure to any property not rated by the Trust is hereby fixed at Two shillings per 1,000 gallons, and the minimum quantity of water to be charged for in cases where water is so supplied is hereby fixed at 5,000 gallons.

The charge for water supplied by measure shall be payable, on demand, at the office of the Trust.

Passed this 20th day of December, 1947.

(SEAL) WALTER IRELAND, Chairman.  
W. F. GIBBS, Secretary.

Approved by the Governor in Council,  
13th January, 1948.

C. W. KINSMAN,  
Clerk of the Executive Council.

## WARBURTON WATERWORKS TRUST.

## RATING BY-LAW FOR YEAR 1948.

THE Warburton Waterworks Trust, in pursuance and exercise of the powers conferred by the Water Acts, doth hereby make a rate for the supply of water for domestic purposes of One shilling in the pound of the annual valuation of lands and tenements liable to be rated in the Warburton Urban District.

Provided that in no case shall the amount of rate payable per annum in respect of any tenement (other than land on which there is no building) be less than Sixteen shillings and eight pence, and on land on which there is no building less than Seven shillings and six pence.

Such rates are made and shall be levied upon the occupiers or owners of the said lands and tenements for the year commencing the 1st day of January, 1948, and shall be payable on the 1st day of February, 1948, at the office of the said Trust.

The maximum quantity of water to be supplied in any one year without further charge to any property rated by the Trust is hereby fixed at the quantity which, at a charge of One shilling per 1,000 gallons, would produce an amount equal to the amount of rate levied on such property for the said year.

The charge for water supplied, by measure to any property rated by the Trust in excess of such maximum quantity, computed as in the last preceding clause, is hereby fixed at One shilling per 1,000 gallons.

The charge for water supplied by measure shall be payable, on demand, at the office of the Trust.

Passed this 18th day of December, 1947.

(SEAL) W. J. BESSELL, Chairman.  
R. CHISHOLM, Secretary.

Approved by the Governor in Council,  
13th January, 1948.

C. W. KINSMAN,  
Clerk of the Executive Council.

## YARRA JUNCTION WATERWORKS TRUST.

## RATING BY-LAW No. 24.

THE Yarra Junction Waterworks Trust, in pursuance and exercise of the powers conferred by the Water Acts, doth hereby make a rate for the supply of water for domestic purposes of One shilling and eight pence in the pound on the annual municipal valuation of lands and tenements within the Yarra Junction Urban District.

Provided that in no case shall the amount of rate payable per annum in respect of any tenement (other than land on which there is no building) be less than Twenty-six shillings and eight pence, and in respect of land on which there is no building less than Ten shillings.

Such rate is made for the year commencing the 1st day of January, 1948, and shall be payable on the 1st day of February, 1948, at the office of the said Trust.

Such person or persons as the Trust may appoint for the purpose are hereby authorized to demand, receive, collect, and recover the said rates and charges.

Passed this 19th day of December, 1947.

(SEAL) H. PIETSCH, Chairman.  
E. H. WELCH, Secretary.

Approved by the Governor in Council,  
13th January, 1948.

C. W. KINSMAN,  
Clerk of the Executive Council.

## YARRAM WATERWORKS TRUST.

## RATING BY-LAW FOR THE YEAR 1948.

THE Yarram Waterworks Trust, in pursuance and exercise of the powers conferred by the Water Acts, doth hereby make a rate for the supply of water for domestic purposes of One shilling and two pence in the pound of the annual municipal valuation of lands and tenements liable to be rated within the Yarram Urban District.

Provided that in no case shall the amount of rate payable per annum in respect of any tenement (other than land on which there is no building) be less than Twenty shillings, and in respect of any land on which there is no building less than Ten shillings.

Such rates are made and shall be levied upon the occupiers or owners of the said lands and tenements for the year commencing on the 1st day of January, 1948, and shall be payable on the 1st day of July, 1948, at the office of the said Trust.

The maximum quantity of water to be supplied in any one year without further charge to any property rated by the Trust is hereby fixed at the quantity which, at the charge of One shilling and three pence per 1,000 gallons, would produce an amount equal to the amount of the rate levied on such property for the said year.

The charge for water supplied by measure to any property rated by the Trust in excess of such maximum quantity, computed as in the last preceding clause, is hereby fixed at One shilling per 1,000 gallons.

The charge for water supplied by measure shall be payable, on demand, at the office of the Trust.

Dated this 11th day of December, 1947.

(SEAL) R. P. NICOL, Chairman.  
A. W. CURRY, Secretary.

Approved by the Governor in Council,

13th January, 1948.

C. W. KINSMAN,  
Clerk of the Executive Council.

## YATCHAW WATERWORKS TRUST.

## RATING BY-LAW No. 42 FOR THE YEAR 1948.

THE Yatchaw Waterworks Trust, in pursuance of its powers by the Water Acts, doth hereby make a rate of Four shillings in the pound on the value of all rateable property, according to the value for the time being of all lands and tenements for the municipalities of the Shires of Dundas and Mount Rouse.

Such rate is made for the year commencing the 1st day of January, 1948, and shall be payable on the 31st day of January, 1948.

Passed on the 19th day of December, 1947.

(SEAL) J. H. CARTER, Chairman.  
EDGAR A. NAGORCKA, Commissioner.  
J. W. TULLOCH, Secretary.

Approved by the Governor in Council,  
13th January, 1948.

C. W. KINSMAN,  
Clerk of the Executive Council.

## CONTRACTS ACCEPTED.—(Series 1947-48.)

## PROVISIONS.

Gazette No. 287, 27th June, 1947, Schedule No. 10—Provisions, McLeod Settlement, French Island: Sub-Schedule No. 2. Item No. 1—Butter. Rate 1s. 11d. per lb. as from 1st December, 1947.

## GENERAL STORES.

Gazette No. 284, 26th June, 1947, Schedule No. 43—Haberdashery.—For the rates shown opposite the following items, substitute the rates as set out hereunder as from 8th December, 1947:—Item No. 13, 11s. 9d. per dozen cogs; Item No. 15, black, No. 36, £1 0s. 2d.; black, No. 40, 19s. 9d.; white, No. 24, 19s. 9d.; white, No. 36, 19s. 4d.; white, No. 40, 19s.; black, No. 24, £1 0s. 4d. per dozen cogs; Item No. 48, No. 50, unbleached, 12s. 1d.; No. 50, black, 12s. 4d.; No. 50, colours, 13s. 9d.; No. 60, unbleached, 14s. 1d.; No. 60, black, 14s. 3d.; No. 60, colours, 16s. 2d.; Nos. 10 and 25, unbleached, 10s. 11d.; Nos. 10 and 25, black, 11s. 2d.; No. 25, colours, 12s. 6d. per lb.

W. H. RUTHERFORD, Secretary to the Tender Board.  
19.1.48.

CONTRACTS ACCEPTED.—(Series 1947-48.)

GENERAL STORES.

Schedule No. 52.

TOOLS (GENERAL).

Contract from 1st January, 1948, to 31st December, 1948.

1947/1960—McPherson's Ltd. . . . .	..	..	Security, £100.
1947/1961—Scott and Son Pty. Ltd. . . . .	..	..	Security, £76.
1947/1962—John Perry Pty. Ltd. . . . .	..	..	Security, £26.
1947/1963—Thos. Mitchell and Co. Pty. Ltd. . . . .	..	..	Security, £17.
1947/1964—John Sharp and Sons Pty. Ltd. . . . .	..	..	Security, £61.

ADJUSTMENT OF RATES, ETC.

The rates marked † are subject to adjustment in accordance with the special conditions of the respective contracts. Supplies are subject to availability of stocks.

AGREEMENTS.

Where the name of the supplier opposite any item is shown in italics, with the sign (A), no contract has been executed nor security lodged: requirements of such items are to be purchased from the supplier named, under Tender Board Agreement.

All items marked thus (\*) to samples at Tender Board Offices.

Item No.	Description of Articles.	Rate.		Name of Contractor.
		£	s. d.	
*1	Adzes—Carpenters', square polled, size 2 .. each	† 0	8 0	McPherson's Ltd.
2	" " pin polled, sizes 2 and 3 .. ..	..	..	
3	Augers—Screw { 1/2 in. } "Ridgway's" .. { per doz. } ..	..	..	Purchase (Clause 62)
	{ 3/8 in. } .. { " " } ..	..	..	
	{ 1/2 in. } .. { " " } ..	..	..	
4	" " all sizes over 1 in. to 2 in. .. per inch diameter	..	..	
5	Awls—Brad, handled, all sizes .. per doz.	..	..	
6	" Pad, Preston's patent, complete with 9 bits each	..	..	
*7	Axes—American pattern, handled, 4 1/2 lb., "Hyttest" ..	† 0	16 0	McPherson's Ltd.
8	Bevels—Sliding, 10-in. .. ..	..	..	
9	Bits—Brace, auger, 1/2-in., "Ridgway's" .. per doz.	..	..	Purchase (Clause 62)
10	" " auger { 3/8 in. } "Ridgway's" .. { " " } ..	..	..	
	{ 1/2 in. } .. { " " } ..	..	..	
	{ 1 in. } .. { " " } ..	..	..	
11	" " expansion, 1/2-in. to 1 1/2-in., "Union" .. each	..	..	
12	" " expansion, 3/8-in. to 3-in., "Union" .. ..	..	..	
13	" " centre { 1 in. } .. per doz. ..	..	..	Purchase (Clause 62)
	{ 1 1/2 in. } .. .. ..	..	..	
14	" " nail, German pattern, any size or number .. each	..	..	
15	" " turnscrew .. ..	..	..	
16	" " rinder, half-round, square, or hexagon .. ..	..	..	
17	" " countersinks, snail .. ..	..	..	
18	" " gimlets, 1/8" .. ..	..	..	
19	" " Copper soldering, handled, 10-oz., No. 137 ..	† 0	3 3	Scott and Son Pty. Ltd.
	" " " " " " 12-oz. .. ..	† 0	2 7	McPherson's Ltd.
	" " " " " " 16-oz. .. ..	† 0	3 1	
20	" " " " " " 20-oz., No. 137 ..	† 0	5 2	Scott and Son Pty. Ltd.
21	" " for Preston's patent tool, in boxes of 9 .. per box	Not required	..	
22	Blades—Brad-awl, assorted sizes .. per doz.	..	..	Purchase (Clause 62)
23	" Saw, bow, 12-in. .. .. each	..	..	
24	" " keyhole, "Disston" .. ..	..	..	
25	" " pad, any size .. ..	Not required	..	
26	" " hack, "Elk," 8-in. .. per doz.	† 0	2 4	Thos. Mitchell and Co. Pty. Ltd.
	" " " " " " 10-in. .. ..	† 0	2 6	
	" " " " " " 12-in. .. ..	† 0	2 10	
27	" Scythe, riveted, 30-in., 33-in. or 36-in. each	..	..	Purchase (Clause 62)
28	" " bramble, 24-in. or 26-in., "Tyzacks" .. ..	..	..	
29	Braces—Iron, 8-in. or 10-in. sweep .. ..	..	..	
30	" " 12-in. sweep .. ..	..	..	



CONTRACTS ACCEPTED—continued.

Item No.	Description of Articles.	Rate.	Name of Contractor.
31	Braces—Iron, ratchet, ball-bearing, 10-in. sweep, each "Silex" No. 100	£ s. d. † 1 7 9	John Sharp and Sons Pty. Ltd.
32	" " ratchet, ball-bearing, 12-in. sweep, " "Silex" No. 100	† 1 9 0	
*33	Brushes—Tube, steel wire, 1-in. to 1½-in. .. per doz.	† 1 13 0	Thos. Mitchell and Co. Pty. Ltd.
	" " " " 2-in. to 2½-in. .. "	† 1 16 0	
	" " " " 3-in. .. "	† 1 19 0	
	" " " " 3½-in. to 4-in. .. "	† 2 2 0	
*34	Buttons—Boxwood, for planes .. .. .	..	Purchase (Clause 62)
35	Callipers—Steel, 6-in. outside, firm joint (Moore and Wright) or equal	† 0 2 6	McPherson's Ltd.
*36	Cans—Joiner's oil, ½-pint .. .. .	..	Purchase (Clause 62)
37	Chisels—Cold, all steel { ¼-in. } "Gregsteel" .. } per doz.	† 0 9 0	McPherson's Ltd.
		† 0 12 0	
		† 0 14 0	
		† 0 17 9	
38	" Firmer, handled, "Titan" { ¼-in. } .. each	† 0 2 9	McPherson's Ltd.
		† 0 2 9	
		† 0 2 11	
		† 0 3 1	
39	" " " " { ½-in. } .. "	† 0 3 4	McPherson's Ltd.
		† 0 3 8	
40	" " " " over 1-in. to 2-in., "Taylors" .. "	..	Purchase (Clause 62)
41	" " " bevelled edge, ½-in. to ¾-in. .. "	..	
42	" " " bevelled edge, ¾-in. to 1-in. .. "	..	Purchase (Clause 62)
43	" " " bevelled edge, over 1-in. to 2-in., "Marples" .. "	..	
44	" " Reg. Handled, ¼-in. } .. "	† 0 3 1	McPherson's Ltd.
		† 0 3 1	
		† 0 3 2	
		† 0 3 4	
45	" " " " { ½-in. } "Titan" .. "	† 0 3 8	McPherson's Ltd.
		† 0 4 0	
46	" " " " over 1-in. to 2-in., "Taylors" .. "	..	Purchase (Clause 62)
47	" Socket, handled, ¼-in. to ½-in., "Marples" .. "	..	
48	" " " ¾-in. to 1-in., "Marples" per ½-in. of width	..	Purchase (Clause 62)
49	" " " over 1-in. to 2-in., "Marples" .. "	..	
50	Clippers—Horse, "Martin's" .. .. .	† 0 16 10	McPherson's Ltd.
51	Compasses—Carpenters' wing, 6-in. to 8-in. .. per doz.	..	Purchase (Clause 62)
52	Cork Rubbers, 4-in. x 2½-in. x ¾-in. .. .. .	† 0 5 6	McPherson's Ltd.
53	Cramps—Joiners' { 3-ft. } .. each	† 0 17 3	McPherson's Ltd.
		† 0 17 9	
		† 0 18 5	
		† 0 19 0	
		† 0 19 8	
		† 1 0 3	
54	Cultivators—Hand, 5-prong, 4-ft., "Trojan," No. 63	† 0 6 2	Scott and Son Pty. Ltd.
55	Cutters—Pipe, steel, 3-wheel, No. 1 } "Fairfax" { ..	† 0 15 6	McPherson's Ltd.
56	" " " " No. 2 } ..	† 1 2 7	
57	" " " " No. 3 .. .. .	..	Purchase (Clause 62)

CONTRACTS ACCEPTED—continued.

Item No.	Description of Articles.	Rate.	Name of Contractor.
58	Drills—Brest, ½-in., "Sillex," No. 50 .. each	£ s. d. ‡ 1 11 3	McPherson's Ltd.
59	Drills—Twist, carbon steel— Taper shank (high speed only) .. .. at % off Trade List	Patience and Nicholson Ltd. ‡List Price less 10%	
60	Jobbers (high speed only) .. .. "		
61	Longset or taper length (high speed only) .. .. "		
62	Prentice short, ½-in., round shank .. .. "		Purchase (Clause 62)
63	Coes, ⅝-in., round shank .. .. "		
64	Bitstock .. .. "		
65	Ratchet .. .. "		
*66	File Carding, cut to size, best .. per lin. ft.	‡ 0 0 7	McPherson's Ltd.
67	Files of every description, except watchmakers', at % on or and warding. "Wiltshire," Regular off Trade Half Round List	‡ List Price, less 7½% ‡ List price, plus 25%	
68	" warding, sizes as ordered .. .. "	‡ List Price, less 7½%	
69	" "Dreadnought" .. .. "	..	Purchase (Clause 62)
	Forks, Digging—		
70	" D.H., strapped, socket, 4 prongs, "Trojan" No. 14 .. each	‡ 0 11 6	Scott and Son Pty. Ltd.
71	" D.H., strapped, socket, 4 prongs, Border .. .. "	..	Purchase (Clause 62)
72	" D.H., strapped, socket, 5 prongs .. .. "	..	
*73	" Hay, 6-ft. length, 3 prongs, { straight .. .. " "Trojan" { bent .. .. "	‡ 0 8 4 ‡ 0 8 8	
	Manure—		
74	" D.H., strapped, socket, 4 prongs, "Trojan" No. 18 .. .. "	‡ 0 13 9	Scott and Son Pty. Ltd.
75	" D.H., strapped, socket, 5 prongs, "Trojan" No. 16 .. .. "	‡ 0 16 4	
76	" Spading— D.H., strapped, socket, 4 prongs, "Trojan" No. 24 .. .. "	‡ 0 14 9	
77	" D.H., strapped, socket, 5 prongs, "Trojan" No. 26 .. .. "	‡ 0 16 4	
78	" Stone, 10 prongs, T.D. "Dreadnought" .. .. "	..	Purchase (Clause 62)
79	" Weeding, twisted, 4 prong, 6½" handle, "Trojan" No. 78 .. .. "	‡ 0 1 2	Scott and Son Pty. Ltd.
	Gauges—Rosewood—		
80	Cutting .. .. "	..	Purchase (Clause 62)
81	Marking, plated, No. 66 "Sillex" .. .. per doz.	‡ 1 19 6	John Sharp and Sons Pty. Ltd.
82	Mortise, with brass thumbscrews, No. 90, "Sillex" .. each	‡ 0 5 7	
83	Pressure, iron back, 5-in. diameter face, 200 lb. .. .. "	..	
84	Gimlets, twist, large, medium and small, "Marples" .. .. "	..	
	Glasses, Gauge—		
85	Opal-lined, size and length as ordered .. .. "	..	Purchase (Clause 62)
86	Moncrieff's, size and length as ordered .. .. "	..	
87	Glue, best, fine, joiners', pearls or cake, "Davis" per lb.	..	
88	" liquid, 4-oz. tins, "Hammers" .. per tin	..	
	Gauges—Handled—		
89	Firmer, any size, ¼-in. to ½-in. .. .. each	..	Purchase (Clause 62)
90	" ⅝-in. to 2-in. .. .. per ½-in. across blade	..	
	Grindstones—Unmounted, best Newcastle—		
91	Any size up to 24-in., 4-in. face "Pymont" per in. diam.	‡ 0 1 0	McPherson's Ltd.
92	Over 24-in. up to 36-in., 6-in. face .. .. "	‡ 0 1 0	Purchase (Clause 62)
93	Iron mountings, 17½" and 20" .. .. each	..	
	Hammers—		
94	Blacksmiths', hand, "Plumb" 7 lb. and 10 lb. per lb.	‡ 0 1 3½	McPherson's Ltd.
*95	Carpenters', claw, handled, "Service," 20 oz. each	‡ 0 6 6½	John Sharp and Sons Pty. Ltd.

§ Rate less 30 per cent. discount.

CONTRACTS ACCEPTED—continued.

Item No.	Description of Articles.	Rate.	Name of Contractor.
96	Hammers— Carpenters', steel handled, "Warrington pattern," 12-oz., "White-house"	each £ s. d. ..	Purchase (Clause 62)
97	Engineers' Ballpein, handled { ½-lb. .. per doz. ¾-lb. .. " 1-lb. .. "	† 2 5 0 † 2 8 6 † 3 5 0	McPherson's Ltd.
98	" " " { 1¼-lb. .. " 1½-lb. .. " 1¾-lb. .. " 2-lb. .. "	† 3 7 6 † 3 16 0 † 4 5 9 † 4 11 0	
99	" chipping .. .. "	..	
100	Riveting, small, handled, Ballpein or Cross-pein, 4-oz. .. .. "	..	
101	Sledge, spalling { 7 to 10 lb. "Hytest" .. per lb. 12 lb. .. " 14 lb. .. "	† 0 1 8½ † 0 1 5 † 0 1 3½	John Sharp and Sons Pty. Ltd.
102	" drill or quartz, "Plumb" .. .. each	..	Purchase (Clause 62)
103	Handles— Adze, hickory, No. 1 .. .. per doz.	..	Purchase under Item 104
*104	Adze, Commonwealth timber, Spotted Gum, "Gumleaf" .. .. per doz.	† 0 18 6†	John Perry Pty. Ltd.
105	Handles— Axe, hickory, No. 1—32-in. .. .. per doz.	..	Purchase under Item 106
*106	" Commonwealth timber, Spotted Gum, "Gumleaf" .. .. "	† 1 1 0†	John Perry Pty. Ltd.
*107	Broom, hardwood, 4-ft. .. .. "	† 0 6 0	Thos. Mitchell and Co. Pty. Ltd.
108	Chisel, ferruled, Firmer, any size .. .. "	..	Purchase (Clause 62)
109	" " socket, any size .. .. "	..	
110	File, ferruled, 4-in. to 6-in. .. .. "	† 0 3 0	McPherson's Ltd.
111	Fork, bent, "D" top, Spotted Gum, not ferruled .. .. "	† 1 17 4†	John Perry Pty. Ltd.
112	" hay, Mountain Ash, { 5-ft. 6-in. .. " " " " { 6-ft. .. "	† 1 3 9† † 1 6 0†	
*113	{ Hammer, hand, Spotted Gum, { 14-in. .. " " " " { 16-in. .. " " " " { 18-in. .. "	† 0 5 3† † 0 6 0† † 0 6 9†	
*114	{ " claw, Spotted Gum .. .. " " for Warrington hammers, Spotted Gum, 12-in., "Gumleaf" .. .. "	† 0 6 9† † 0 4 9†	
115	{ Hoe, 4-ft. 6-in. { 1½-in. Mountain Ash { .. " " " " { 2-in. " " " { .. " " " 5-ft. x 1¼-in. .. .. " " " { .. "	† 0 19 2† † 1 11 0† † 1 5 9†	
116	Mop, ferruled .. .. "	..	Purchase (Clause 62)
117	Pick or mattock, hickory, No. 1 .. .. "	..	Purchase under Item 118
*118	" Commonwealth timber, Spotted Gum, 36-in. .. .. "	† 1 6 0†	John Perry Pty. Ltd.
119	Plane, beech, jack, or trying .. .. "	..	Purchase (Clause 62)
120	" beech, jack, technical .. .. "	..	
*121	Rake { 5-ft. .. .. " 5-ft. 6-in. .. .. " 6-ft. .. .. "	† 0 14 0† † 0 15 0† † 0 16 3†	John Perry Pty. Ltd.
122	Scythe, complete, metal .. .. each	† 0 12 9	John Sharp and Sons Pty. Ltd.
*123	Slasher, 42-in., oval, "Blue Mountain" .. .. per doz.	..	Purchase (Clause 62)
*124	" 36-in., oval .. .. "	..	John Perry Pty. Ltd.
*125	" 42-in. x 1¼-in. round, Fernhook, Spotted Gum or Mountain Ash, "Gumleaf" .. .. "	† 1 0 0†	
*126	" 36-in., round .. .. "	Not required	
*127	{ Spade, straight, "D," Spotted Gum, "Gumleaf" .. .. " Shovel, single bend, "D," .. .. "	† 1 15 0† † 1 16 6†	John Perry Pty. Ltd.
*128	Spade or Shovel, long, hardwood .. .. "	† 1 4 6	Thos. Mitchell and Co. Pty. Ltd.
129	Sledge, Striking, or Spalling, 30-in. hickory .. .. "	..	Purchase under Item 131
130	" " " 36-in. hickory .. .. "	..	Purchase under Item 132
*131	Sledge, Striking, or Spalling, 30-in. Commonwealth timber, { .. .. " " " " Spotted Gum, { .. .. "	† 0 12 6†	John Perry Pty. Ltd.
*132	Sledge, Striking, or Spalling, 36-in. "Gumleaf" { .. .. "	† 0 16 0†	
133	Hatchets—Shingling, sizes 2 and 3 .. .. each	..	Purchase (Clause 62)

† Rate plus 20 per cent. less 5 per cent. discount.

¶ Rate less 27½% discount.

CONTRACTS ACCEPTED—continued.

Item No.	Description of Articles.	Rate.	Name of Contractor.
		£ s. d.	
	Hoes—		
*134	Dutch, steel, riveted, blade 5-in. to 8-in., "Trojan" No. 309	each † 0 5 0	} Scott and Son Pty. Ltd.
135	{ Garden, 6-in., "Trojan" No. 58—Pressed steel, not handled	" † 0 1 3	
	{ " 6-in. to 8-in., swan neck, forged steel—handled, No. 54	" † 0 4 3	
*136	Field, swan neck, 6-in., handled, "Trojan" No. 56	" † 0 6 3	
137	Pickeye, grubbing, handled, 4-lb. weight, "Hyttest"	" ..	} Purchase (Clause 62)
138	Thistle .. .. .	" ..	
*139	Holdfasts—Joiners' .. .. .	" ..	
140	Hooks—Bill .. .. .	Not required	
141	" Bagging, No. 143/5 .. .. .	" ..	} Scott and Son Pty. Ltd.
142	" Fern, No. 1010, "Trojan" .. .. .	† 0 6 8	
143	" " No. 1012, "Trojan" .. .. .	† 0 7 0	
144	" Furze, 10-in. .. .. .	Not required	
145	" Gippsland, No. 142, "Trojan" .. .. .	† 0 7 2	Scott and Sons Pty. Ltd.
146	" " No. 292c, "Trojan" .. .. .	Not required	
147	" No. 159/2, sharp point, single cutter .. .. .	" ..	
148	Irons—Plane, single cut .. .. . at per in. in width	..	} Purchase (Clause 62)
149	" " Technical, jack, 1½-in. .. .. . per doz.	..	
150	" " Combined technical and back technical, jack, 1½-in. .. .. .	..	
151	Knives—Drawing, 8-in. .. .. . each	† 0 4 6	McPherson's Ltd.
*152	" Sloyd .. .. . per doz.	..	} Purchase (Clause 62)
153	" " Commonwealth manufacture .. .. .	..	
154	Levels, spirit, brass mounted, with brass tips—12-in. .. .. . each	..	
155	24-in., with plumb, "Hunt" .. .. .	† 0 13 9	} John Sharp and Sons Pty. Ltd.
156	30-in. " " .. .. .	† 0 15 0	
157	Mallets—Carpenters', beech, square head, 6-in. .. .. .	† 0 4 6	McPherson's Ltd.
*158	Mattocks—without handles, { 4½-lb. } "Hyttest" { per doz.	" † 7 9 0§	} John Sharp and Sons Pty. Ltd.
		" † 7 14 0§	
		" † 8 2 0§	
159	Oilstones—Arkansas, 7-in. x 2-in. x 1-in., "Norton" .. .. . each	† 1 9 2	McPherson's Ltd.
160	" Gem, 7-in. x 2-in. x 1-in., "Carbosil," No. 81109 .. .. .	† 0 7 2	} General Abrasives Pty. Ltd. (A)
161	" India quality, "Aluminox," 8-in. x 2-in. x 1-in., medium, fine, or coarse, as ordered .. .. .	† 0 7 2	
162	" Slips, Washita No. 1, "Norton," { L.S. 3 } .. .. .	† 0 2 6	} McPherson's Ltd.
	{ L.S. 4 } .. .. .	† 0 3 4	
	{ L.S. 5 } .. .. .	† 0 4 2	
	Pencils, Carpenters'—		
163	Red and Black } "Cumberland" { .. .. . per doz.	..	} Purchase (Clause 62)
164	Cedar, oval, 7½-in. } .. .. .	..	
*165	Picks—Single, miners', 3½-lb., with handles .. .. . each	..	
*166	" Double, steel end, 7-lb., "Hyttest" .. .. . per doz.	† 6 19 0§	John Sharp and Sons Pty. Ltd.
167	Pincers—Carpenters', 6-in. to 8-in. .. .. . each	..	} Purchase (Clause 62)
168	Planes—iron, complete—Router, open throat .. .. .	..	
169	" " " smoothing, 2-in., iron, "Pope" .. .. .	† 1 5 5	McPherson's Ltd.
	Planes—wood, beech, complete, sizes as ordered—		
170	Beading .. .. .	..	} Purchase (Clause 62)
171	Fillister, sash .. .. .	..	
172	" side .. .. .	..	
173	Grooving or trenching .. .. .	..	
174	Jack (red label) .. .. .	..	} McPherson's Ltd.
175	" technical, 14-in. long, 1½-in. iron No. 5, "Pope" .. .. .	† 1 9 4	

§ Rate less 27½ per cent. discount. || Rate less 2½ per cent. discount.

CONTRACTS ACCEPTED—continued.

Item No.	Description of Articles.	Rate.	Name of Contractor.
	Planes—	£ s. d.	
176	Ovolo .. .. . each	..	}
177	Ogee .. .. . "	..	
178	Plough—Iron Body .. .. . "	..	
179	Quirked bead, $\frac{3}{16}$ -in. .. .. . "	..	
180	Rabate, skew-mouth, $\frac{1}{4}$ -in. to $\frac{3}{8}$ -in. } Mathieson { .. .. . "	..	
181	Smoothing .. .. . }	..	
182	Trying .. .. . }	..	
	Pliers—		
183	Bellhangers', 5-in. to 7-in. .. .. . "	..	} Purchase (Clause 62)
184	Round nose, 5-in. to 7-in. .. .. . "	..	
185	Side cutting, { 6-in. .. .. . "	..	
	{ 7-in. .. .. . "	..	
186	Long nose, round or flat, 5-in. to 7-in. .. .. . "	..	
187	Gas, 7-in. or 8-in. .. .. . "	..	
188	Netting fastener .. .. . "	..	} McPherson's Ltd.
189	Punches, leather, engineers', $\frac{1}{4}$ -in. to 1-in. .. .. . "	..	
190	" nail, round .. .. . "	† 0 1 3	
	Rakes, garden, unhandled—		
*191	Iron, wrought, "Trojan" No. 64, 14 tooth .. per tooth	† 0 0 1 $\frac{1}{2}$	} Scott and Son Pty. Ltd.
*192	Steel, wrought, "Trojan" No. 66, 16 tooth .. .. . "	† 0 0 4	
*193	Cast steel, bow, handled, "Trojan" No. 67, 14 tooth .. .. . "	† 0 0 6	
194	Rasps—of any description ordered .. .. per inch	..	Purchase (Clause 62)
195	Rega knapsack spray pump, } Double cyclone } each	† 5 19 4	} A. W. Wells & Co. (A)
	L.C., fitted with auto-pop } nozzle } valve and special fittings } (90 only)		
196	Rega Continuous Atomizer—Solid brass (26 only) .. .. . "	† 0 9 6	
	Rules—		
197	Boxwood, four-fold, $1\frac{1}{8}$ " width, 2-ft., Rabone's No. 1377 .. .. . per doz.	..	} Purchase (Clause 62)
198	" four-fold, $1\frac{1}{8}$ " width, 3-ft., Rabone's No. 1377 .. .. . "	..	
199	Steel, two-fold, "Rabones" No. 1667 .. .. . "	..	
	Saws—		
200	Butchers', 14-in., "Gregory" .. .. . each	..	} Purchase (Clause 62)
201	Bow, wood frame, 12-in. to 14-in., "Marples" .. .. . "	..	
202	Bow, wood frame, 16-in. to 24-in. .. .. . "	..	
203	Crosscut, "M" tooth, 5-ft. to 6 $\frac{1}{2}$ -ft. .. per ft.	..	} Thos. Mitchell and Co. Pty. Ltd.
204	Hack, Pistol Model "B," adjustable frames, per doz.	† 2 11 3	
205	Hand, to 26-in., hollow or straight back .. .. . "	..	
206	Keyhole, compass, and pruning, nests of 3, per nest "Tricut" .. .. . "	† 0 10 4	John Sharp and Sons Pty. Ltd.
207	Dove tail, brass back, 8-in. .. .. . each	..	} Purchase (Clause 62)
208	Panel, hollow or straight back .. .. . "	..	
209	Pruning, curved .. .. . "	..	
210	Rip, up to 23-in., hollow back .. .. . "	..	
211	Tenon, 8-in., iron back .. .. . "	..	
212	" 12-in., iron back .. .. . "	..	
213	" 14-in., brass back .. .. . "	..	
214	" 16-in., brass back .. .. . "	..	
215	Scrapers—Cabinet, oval or rectangular, any size each	..	
	Screw-drivers—		
*216	Flat or spindle, beech handled, "Moseley's" .. per inch length of blade	..	} John Sharp and Sons Pty. Ltd.
217	Ratchet, "Turner" { 4-in. .. .. . per doz.	† 2 4 8	
	{ 6-in. .. .. . "	† 2 10 6	
	{ 8-in. .. .. . "	† 2 14 8	
*218	Screws—Bench, vice, wrought steel, 1-in., "Webster" .. .. . each	..	} Purchase (Clause 62)
219	" boxwood, for gauges .. .. . per doz.	..	
220	Sets—Saw, hand .. .. . each	..	
221	" Saw, hand, crosscut No. 8, Disston .. .. . "	..	} John Sharp and Sons Pty. Ltd.
222	Shears—Border, long handled, with or without wheel, any size, as ordered .. .. . per pair	..	
223	" Grass, 7-in., M.E.M. .. .. . "	† 0 9 9 $\frac{1}{2}$	
224	" Hedge, 10-in., "Sunray" .. .. . "	† 0 13 4	} Purchase (Clause 62)
225	" Hedge, 12-in. .. .. . "	..	
226	" Sheep, 7 $\frac{1}{2}$ -in., "Ward and Payne" .. per doz.	† 6 5 4	

§ Rate less 30% discount.

CONTRACTS ACCEPTED—continued.

Item No.	Description of Articles.	Rate.	Name of Contractor.
	Shovels—	£ s. d.	Purchase (Clause 62)
*227	Fire, wood handle .. .. . each	.. .. .	} Scott and Son Pty. Ltd.
*228	D.H., R.M., socketed, No. 3, "Trojan" .. .. .	† 0 7 6	
229	D.H., S.M., socketed, No. 3, "Trojan" .. .. .	† 0 7 6	
*230	L.H., R.M., socketed, No. 2, "Trojan" .. .. .	† 0 7 2	
231	L.H., R.M., socketed, No. 3, "Trojan" .. .. .	† 0 7 4	
232	L.H., S.M., socketed, No. 2 .. .. .	† 0 7 2	
*233	L.H., S.M., socketed, No. 3, "Trojan" .. .. .	† 0 7 4	
234	Special rabbiters, L.H., with ring lock on handle socket .. .. .	† 0 7 5	
235	Stokers', D.H., riveted back, No. 4 .. .. .	† 0 7 9	
236	Stokers', D.H., riveted back, No. 5 .. .. .	† 0 7 11	
	Slashers—		
237	Double-bladed, handled, 10 in. .. .. .	† 0 12 9	} Purchase (Clause 62)
238	Double-bladed, handled, 11 in., No. 217 B.A., "Trojan" .. .. .	† 0 12 9	
239	Double-bladed, handled, 12 in. .. .. .	.. .. .	} Purchase (Clause 62)
240	Single-bladed, handled, 10 in. .. .. .	.. .. .	
241	Single-bladed, handled, 11 in., No. 213A, "Trojan" .. .. .	Not required	} Purchase (Clause 62)
242	Single-bladed, handled, 12 in. .. .. .	.. .. .	
243	Mallec, fishtail, 10 in. unhandled, "Trojan" .. .. .	† 0 9 5	Scott and Son Pty. Ltd.
	Snips, Tinsmiths'—		McPherson's Ltd.
244	Cast steel, straight blade, 10 in. M.E.M. per pair	† 0 7 9	Purchase (Clause 62)
245	Cast steel, bent blade, 8 in. to 14 in. .. .. .	.. .. .	
	Spades—		
246	M.T.D.H., black socket, treaded, No. 270, "Trojan" No. 0 .. .. . each	† 0 7 0	} Scott and Son Pty. Ltd.
247	M.T.D.H., black socket, treaded, No. 270, "Trojan" No. 1 .. .. .	† 0 7 1	
*248	M.T.D.H., black socket, treaded, No. 270, "Trojan" No. 2 .. .. .	† 0 7 3	
249	Malleable Tee, black socket, treaded, No. 3 .. .. .	.. .. .	
250	Spanners—double ended, dropped forged, in sets of 4, "Macson" $\left. \begin{matrix} \frac{1}{2} \times \frac{15}{16} \\ \frac{3}{8} \times \frac{7}{8} \\ \frac{1}{2} \times \frac{3}{4} \\ \frac{3}{4} \times \frac{1}{2} \end{matrix} \right\}$ per set	.. .. .	Purchase (Clause 62)
251	Spanners, Clyburn, 8 in. to 16 in. .. .. . per inch	.. .. .	} Purchase (Clause 62)
	Spokeshaves—Any size—		
252	Plated, beech .. .. . length per inch of blade	.. .. .	
253	Iron "Pope" .. .. . each	† 0 4 6	McPherson's Ltd.
	Squares—rosewood—		
254	} Brass-plated, "Lovatt" $\left. \begin{matrix} 6\text{-in.} \\ 9\text{-in.} \\ 12\text{-in.} \end{matrix} \right\}$ per doz.	† 3 10 4	} John Sharp and Sons Pty. Ltd.
255		† 4 19 2	
		† 5 19 8	
*256	Stamps—Steel, branded "E. & D." .. .. .	.. .. .	Purchase (Clause 62)
257	Stones—Scythe, round, No. 191A .. .. .	† 1 1 0	} John Sharp and Sons Pty. Ltd.
258	Scythe, "Carborundum," No. 190 .. .. .	.. .. .	
259	Straight edges—Steel, polished, from 2 ft. long and upwards, bevelled per inch	.. .. .	
260	Strickles—Scythe, 12 in. .. .. . each	.. .. .	
	Tapes, measuring, leather cases, with flush handles, in decimals of yards and feet, or in links and feet, as ordered, "Rabone," No. 251—		
261	Metallic, $\frac{3}{8}$ in. wide, 33 ft. .. .. .	.. .. .	} Purchase (Clause 62)
262	Metallic, $\frac{3}{8}$ in. wide, 66 ft. .. .. .	.. .. .	
263	Metallic, $\frac{3}{8}$ in. wide, 100 ft. .. .. .	.. .. .	
	Tapes, measuring, steel, leather cases with flush handles, "Rabone's" No. 418—		
264	$\frac{1}{2}$ in. wide, 33 ft. .. .. . feet and links {	.. .. .	} Purchase (Clause 62)
265	$\frac{1}{2}$ in. wide, 66 ft. .. .. .	.. .. .	
	Tapes, steel, measuring, in steel cases, detachable—"Rabone's" No. 438—		
266	$\frac{1}{2}$ in. wide, 66 ft. .. .. . feet and links {	.. .. .	} Purchase (Clause 62)
267	$\frac{1}{2}$ in. wide, 100 ft. .. .. .	.. .. .	
	Tapes, measuring, on winding frame—		
268	Steel, links, $\frac{3}{8}$ in. wide, 66 ft., "Rabone's" No. 638 .. .. .	.. .. .	} Purchase (Clause 62)
269	Steel, links, $\frac{1}{2}$ in. wide, 66 ft., "Rabone's" .. .. .	.. .. .	
270	Steel, feet, $\frac{1}{2}$ in. wide, 100 ft., "Rabone's" No. 639 .. .. .	.. .. .	



1940. For the supply of single-phase A.C. kilowatt-hour meters for a period of twelve months, to Specification No. 47-48/82.—Electricity Meter Manufacturing Co. Pty. Ltd.

1941. For the supply of 2,000 single-phase kilowatt-hour meters, to Specification No. 47-48/82.—Warburton Franki (Melb.) Ltd.

1942. For the supply of copper conductors, jointing sleeves, and trolley wire, for a period of twelve months, to Specification No. 47-48/116.—British Insulated Callenders Cables Ltd.

1943. For the supply of 7½ tons steel sections and plates for tipping and winch trucks, to Quotation No. 2288.—Broken Hill Pty. Co. Ltd.

1944. For the supply of 200 cubic yards ready mixed concrete, to Quotation No. 1841.—Ready Mixed Concrete (Vic.) Pty. Ltd.

1945. For the supply of 61 tons of structural steelwork for Newport "C" Generating Station, to Quotation No. 2488.—Johns and Waygood Ltd.

1946. For the supply of 1,150 fuse cartridges, handles, &c., for high rupturing capacity fuse gear, to Quotation No. 2256.—English Electric Co. Ltd.

1947. For the supply of spare parts for bucket wheel excavator, Yallourn, ex Lübecker Maschinenbau Gesellschaft.—Control Commission for Germany.

1948. For the supply of 82 tables for dining rooms, Yallourn, to Quotation Nos. 1537, 1537A, and 1537B.—J. Walsh.

1949. For the supply of eighteen 400-volt motor starters for pumps, Yallourn, to Quotation No. 742.—W. H. Lowe and Co. Pty. Ltd.

1950. For the erection of office and change house at Camberwell Briquette Depot, to Specification No. 47-48/12.—W. J. Townsend.

1951. For the conversion of cooling equipment on two 20 MVA transformers for Malvern Terminal Station, to Quotation No. 1053.—Australian General Electric Pty. Ltd.

1952. For the supply of one portable Diesel-driven air-compressor unit, to Quotation No. 2143.—Knox Schlapp Pty. Ltd.

1953. For the supply of 12,500 yards cable for consumers' services, to Quotation No. 2301.—Gilbert Lodge and Co.

1954. For equipping and wiring of a control panel, installation and alterations to control cables, at Waratah-place Sub-station, to Quotation No. 2642.—The Corporation of the City of Melbourne.

1955. For the supply of 7,000 feet of fire hose for Yallourn, to Quotation No. 2180.—Thomas Evans Pty. Ltd.

1956. For the supply of one 40-50-h.p. Diesel engine for Kiewa Hydro-Electric Scheme, to Quotation No. 2540.—Ronaldson Bros. and Tippett Pty. Ltd.

1957. For the supply of four electric motor-driven fuel oil pumps, Newport Generating Station, to Quotation No. 1788.—Ebs-Ray Pumps Pty. Ltd.

1958. For the supply of galvanized structural steelwork, to Quotation No. 2655.—A. Challingsworth Pty. Ltd.

1959. For the purchase by the Commission of land in Grant and Bayley streets, Alexandra.—Returned Sailors, Soldiers, and Airmen's Imperial League of Australia (Alexandra Branch).

Approved by the Governor in Council, 13th January, 1948.—C. W. KINSMAN, Clerk of the Executive Council.

#### COUNTRY ROADS BOARD.

At the Executive Council Chamber, Melbourne, the thirteenth day of January, 1948.

#### PRESENT:

The Lieutenant-Governor, as Deputy for His Excellency the Governor of Victoria.

Mr. Hollway | Mr. Byrnes.

#### DECLARATION OF THE MAROONDAH HIGHWAY IN THE CITIES OF CAMBERWELL, BOX HILL, NUNAWADING, BOROUGH OF RINGWOOD, SHIRES OF LILLYDALE, HEALESVILLE, ALEXANDRA, AND MANSFIELD.

WHEREAS by the Resolution set out below and dated the twenty-second day of December One thousand nine hundred and forty-seven the Country Roads Board incorporated under the *Country Roads Act 1928* (No. 3662) being of opinion that the highway in the State of Victoria set out or described in the Schedule to the same is of sufficient importance to be a State highway and acting under the powers in that behalf conferred upon it by the said Act declared such highway to be a State highway within the meaning and for the purposes of the Act aforesaid: And whereas the said Act amongst other things provides that the Governor in Council may by Order

published in the *Government Gazette* confirm such Resolution whereupon any road mentioned in such Resolution shall be a State highway: And whereas it is deemed desirable to confirm the Resolution so made and passed by the said Country Roads Board: Now therefore the Lieutenant-Governor as Deputy for His Excellency the Governor of the State of Victoria by and with the advice of the Executive Council thereof doth hereby confirm such Resolution and declare upon the publication of this Order in the *Government Gazette* the road mentioned in the Schedule to such Resolution of the Country Roads Board a State highway within the meaning and for the purposes of the *Country Roads Act 1928*.

#### Resolution for Declaration of a State Highway under the Country Roads Act.

The Country Roads Board incorporated by the *Country Roads Act 1928* (No. 3662) at a meeting now holden being of opinion that the highway within the State of Victoria set out or described in the Schedule hereunder written is of sufficient importance to be a State highway acting under the powers in that behalf conferred upon it by the said Act doth by this Resolution hereby declare such highway to be a State highway within the meaning and for the purposes of the said *Country Roads Act 1928*.

#### SCHEDULE.

Cities of Camberwell, Box Hill, Nunawading, Borough of Ringwood, Shires of Lillydale, Healesville, Alexandra, and Mansfield.

22. *Maroondah Highway*.—Commencing at the western boundary of Union-road at the intersection of that road with Whitehorse-road, in the Parish of Boroondara; thence easterly to the north-eastern angle of allotment 24A (being a school reserve) in the Parish of Nunawading; thence generally north-easterly and easterly to the north-western angle of allotment 3, Parish of Ringwood; thence easterly and north-easterly to and through the Township of Ringwood, Parish of Ringwood, and including the Country Roads Board road deviation adjoining allotments 19, 20a, 20c, 20d, 20e, 20f, and 20g of the parish last named (S.P. 488), and continuing north-easterly and northerly to the north-western angle of allotment 2, section 22, Hamlet of Brushy Creek, Parish of Warrandyte; thence northerly, north-easterly, and generally easterly to the north-eastern angle of allotment 16, section A, Parish of Mooroolbark, and including the Country Roads Board road deviations through allotments 2a, 2f, and 16A, section A, and allotment 1, section 2, of the parish last named (S.P.'s 277 and 2691); thence easterly and north-easterly to and through allotment 1, section 30, Parish of Yering, to the north-eastern angle of that allotment (S.P.'s 2256, 2760, 2761, and 2766); thence south-easterly and north-easterly, through the Township of Lillydale, Parish of Yering, to the north-eastern angle of allotment 12, section 29, of the parish last named; thence continuing north-easterly under a railway bridge and further north-easterly to the north-eastern angle of allotment 4 of the said section 29; thence northerly, north-westerly and north-easterly through section 24 of the Parish of Yering to the north-western angle of section 25 of the parish last named (S.P.'s 4292 and 2260); thence northerly and north-easterly to and through sections 17, 14, 15, and 8, Parish of Yering, to a point on the eastern boundary of the section last mentioned, distant 8 deg. 23 min. 71 chains, more or less, from the south-eastern angle thereof (S.P.'s 2592, 2593, and R.36); thence northerly and north-easterly to and through allotment 105, Parish of Gruyere, to the northern boundary of that allotment; thence easterly, south-easterly, and north-easterly to and through allotments 96, 95, 119, and 120 to and across the bridge over the River Yarra on the eastern boundary of the allotment last named (S.P. 595); thence easterly and generally north-easterly through a public reserve and Coranderrk Aboriginal Reserve to the north-western angle of section 1, Township of Healesville, Parish of Gracedale; thence north-westerly and north-easterly through the said township, and including the Country Roads Board road deviations through the said township (S.P.'s 2285 and 2982), to the bridge over Graceburn near a point on the northern boundary of a recreation reserve in that township, distant 62 deg. 57 min. 572 links from the north-western angle of the said reserve; thence generally north-easterly to the north-western angle of allotment 31, section 2, of the parish last named, and including the road deviation through allotments 16, 15, and 4, section 2, Parish of Gracedale; thence generally south-easterly along the boundary between the Parishes of Monda and Gracedale to the north-eastern angle of allotment 35, section 2, of the parish last named, on the boundary of the Watts River watershed reserve.



Also, commencing at a point on the northern boundary of the Watts River watershed reserve, Parish of Glenwatts, the said point being distant by a line bearing approximately 144 deg. 15 min. 1,000 feet from the south-eastern angle of allotment 69, Parish of Nar-be-thong; thence north-easterly across a road reserve, north-easterly and north-westerly through the State forest, and north-westerly through a reserve for public purposes to its junction with the existing Government road at or near the north-eastern angle of allotment 71 of the parish last named (S.P. 3549); thence generally north-westerly and north-easterly along the boundary of that public reserve to the north-western angle thereof; thence generally north-easterly, northerly, and again north-easterly to and through the Township of Nar-be-thong to the north-western angle of allotment 14C, section A, Parish of Granton, at St. Fillans; thence generally northerly and north-easterly along the valley of Acheron River to and across the bridge over the Steavenson River at Buxton, and including the Country Roads Board deviations through allotment 2, section A, and allotments 19 and 7, Parish of Granton, and allotments 11b and 9, Parish of Buxton (S.P.'s 3111, 3112, 3113, 2557, 3554, and 1521); thence north-easterly through allotment 9, Parish of Buxton, to a point on the north-eastern boundary of that allotment, distant 133 deg. 34 min. 210 links from the northern angle thereof (S.P. 2697); thence north-westerly through allotment 6A of the parish last named to the eastern boundary thereof; thence generally northerly along the valley of the Acheron River to and across the bridges over Little River and Acheron River, in the Township of Taggerty, Parish of Taggerty; thence north-westerly, generally northerly, and north-westerly to the north-western angle of allotment 29, Parish of Acheron, and including the Country Roads Board road deviations through allotment 6A, section 6, Parish of Taggerty, and allotments 24, 25B, 27A, 27B, and section H, Parish of Acheron (S.P.'s 4231, 3828, 3829, and 2745); thence north-westerly, northerly, and easterly to and across the bridge over River Goulburn near the western angle of allotment 35A3, Parish of Alexandra, and including the Country Roads Board road deviations through allotments 33b, 33A, 33c, and 38, Parish of Acheron (S.P.'s 3546, 4547, 1475, 1476, and 3830); thence generally north-easterly to and through the Township of Alexandra, Parish of Alexandra, to the north-western angle of section 4 of that township; thence generally north-westerly through the said township and parish to the south-eastern angle of allotment 84, Parish of Alexandra; thence further north-westerly across the railway, west of Koriella Railway Station, and Spring Creek, to and along the boundary between the Parishes of Molesworth and Yarck, and across the railway to the western angle of allotment 5b of the parish last named; thence north-easterly to and through the Township of Yarck and further north-easterly to a point on the western boundary of allotment 77, Parish of Merton, distant 32 deg. 28 min. 3,141.9 links from the south-western angle of that allotment; thence north-easterly and generally northerly through allotments 77 and 77A of the parish last named, to and across the railway at the northern angle of the said allotment 77A (S.P.'s 1485 and 4535); thence generally northerly and north-easterly to and through section 1, Town of Merton, Parish of Merton, to the north-western angle of section 4 of the said town (S.P.'s 1917 and 3461); thence generally south-easterly to the north-western angle of allotment 60A, section B, Parish of Brankeet; thence south-easterly, north-easterly, and easterly to and through the Township of Doon, in the Parishes of Brankeet and Doolam, to the north-eastern angle of section 5 of that township, Parish of Doolam; thence south-easterly, crossing and recrossing the railway in the Township of Maindample, Parish of Doolam, and further south-easterly through the Parishes of Doolam and Maindample, to the north-western angle of section 1, Town of Mansfield, Parish of Mansfield.

The common seal of the Country Roads Board was hereto affixed, at Melbourne, this twenty-fourth day of December, One thousand nine hundred and forty-seven, in the presence of—

(SEAL) W. L. DALE, Chairman.  
F. M. CORRIGAN, Member.  
R. JANSEN, Secretary.

And the Honorable James Arthur Kennedy, His Majesty's Commissioner of Public Works for the State of Victoria, shall give the necessary directions herein accordingly.

C. W. KINSMAN,  
Clerk of the Executive Council.

#### COUNTRY ROADS BOARD.

*At the Executive Council Chamber, Melbourne, the thirteenth day of January, 1948.*

PRESENT:

The Lieutenant-Governor, as Deputy for His Excellency the Governor of Victoria.

Mr. Hollway | Mr. Byrnes.

#### ORDER APPROVING OF A NEW MAIN ROAD IN THE SHIRE OF BRIGHT.

WHEREAS the Country Roads Board constituted under the *Country Roads Act 1928* (No. 3662) has represented to His Excellency the Governor in Council that it appears to it desirable that the new Kiewa Valley-road in the Shire of Bright should be made by the said Board: And whereas the said Board in accordance with the requirements of section 19 of the said cited Act has caused to be prepared a map plan and estimate showing the points between which and on and through what land the said new road is proposed to be made and the cost of acquiring the land and constructing the said new road: And whereas on an inspection of the said map and plan and a consideration of the said estimate His Excellency the Governor in Council is satisfied that there are funds legally available for acquiring the land and constructing the said new road: Now therefore be it known by this present Order that the Lieutenant-Governor as Deputy for His Excellency the Governor of the State of Victoria with the advice of the Executive Council thereof doth hereby approve of the said road being made, that is to say:—

All that piece of land in the Parish of Mullindolingong, the boundaries of which are as follow:—Commencing at a point on the western boundary of allotment 7A of the said parish, distant 844.3 links from the north-western angle of that allotment; thence by lines bearing respectively 152 deg. 32 min. 447.8 links, 148 deg. 53 min. 630.9 links, 320 deg. 39 min. 433.5 links, and 340 deg. 15 min. 458 links to the point of commencement—which said piece of land is particularly delineated and shown coloured red and blue on survey plan numbered 4904, lodged in the office of the Country Roads Board.

And the Honorable James Arthur Kennedy, His Majesty's Commissioner of Public Works for the State of Victoria, shall give the necessary directions herein accordingly.

C. W. KINSMAN,  
Clerk of the Executive Council.

#### COUNTRY ROADS BOARD.

*At the Executive Council Chamber, Melbourne, the thirteenth day of January, 1948.*

PRESENT:

The Lieutenant-Governor, as Deputy for His Excellency the Governor of Victoria.

Mr. Hollway | Mr. Byrnes.

#### DECLARATION OF THE CUMMINS-ROAD IN THE CITY OF BRIGHTON.

WHEREAS by the Resolution set out below and dated the twenty-second day of December One thousand nine hundred and forty-seven the Country Roads Board incorporated under the *Country Roads Act 1928* (No. 3662) being of opinion that the highway in the State of Victoria set out or described in the Schedule to the same is of sufficient importance to be a main road and acting under the powers in that behalf conferred upon it by the said Act declared such highway to be a main road within the meaning and for the purposes of the Act aforesaid: And whereas the said Act amongst other things provides that the Governor in Council may by Order published in the *Government Gazette* confirm such Resolution whereupon any road mentioned in such Resolution shall be a main road: And whereas it is deemed desirable to confirm the Resolution so made and passed by the said Country Roads Board: Now therefore the Lieutenant-Governor as Deputy for His Excellency the Governor of the State of Victoria by and with the advice of the Executive Council thereof doth hereby confirm such Resolution and declare upon the publication of this Order in the *Government Gazette* the road mentioned in the Schedule to such Resolution of the Country Roads Board a main road within the meaning and for the purposes of the *Country Roads Act 1928*.

*Resolution for Declaration of a Main Road under the  
Country Roads Act.*

The Country Roads Board incorporated under the *Country Roads Act 1928* (No. 3662) at a meeting now holden being of opinion that the highway within the State of Victoria set out or described in the Schedule hereunder written is of sufficient importance to be a main road acting under the powers conferred upon it by the said Act doth by this Resolution hereby declare such highway to be a main road within the meaning and for the purposes of the said *Country Roads Act 1928*.

SCHEDULE.

*City of Brighton.*

3. *Cummins-road* (19303).—Commencing at its junction with the Nepean Highway on the eastern boundary of the city near the northern angle of lot 1 on plan of subdivision numbered 9347, lodged in the Office of Titles, and being part of Dendy's Crown special survey, Parish of Moorabbin; thence southerly to its junction with South-road at the south-western angle of the land comprised in certificate of title entered in the register book, volume 5161, folio 1032162, and being part of the said special survey on the southern boundary of the city.

The common seal of the Country Roads Board was hereto affixed, at Melbourne, this twenty-fourth day of December, One thousand nine hundred and forty-seven, in the presence of—

(SEAL) W. L. DALE, Chairman.  
F. M. CORRIGAN, Member.  
R. JANSEN, Secretary.

And the Honorable James Arthur Kennedy, His Majesty's Commissioner of Public Works for the State of Victoria, shall give the necessary directions herein accordingly.

C. W. KINSMAN,  
Clerk of the Executive Council.

COUNTRY ROADS BOARD.

*At the Executive Council Chamber, Melbourne, the  
thirteenth day of January, 1948.*

PRESENT:

The Lieutenant-Governor, as Deputy for His Excellency the Governor of Victoria.

Mr. Hollway | Mr. Byrnes.

ORDER APPROVING OF A DEVIATION FROM A MAIN  
ROAD IN THE SHIRE OF WANNON.

WHEREAS the Country Roads Board constituted under the *Country Roads Act 1928* (No. 3662) has represented to His Excellency the Governor in Council that it appears to it desirable that the deviation hereinafter referred to from the existing Wannon Bridge-road in the Shire of Wannon (declared to be a main road under the said Act which declaration was confirmed by the Order in Council published in the *Government Gazette* of the 9th December, 1914, on page 5530) should be made by the said Board: And whereas the said Board in accordance with the requirements of section 19 of the said cited Act has caused to be prepared a map plan and estimate showing the points between which and on and through what land the said deviation is proposed to be made and the cost of acquiring the land and constructing the said deviation: And whereas on an inspection of the said map and plan and a consideration of the said estimate His Excellency the Governor in Council is satisfied that there are funds legally available for acquiring the land and constructing the said deviation: Now therefore be it known by this present Order that the Lieutenant-Governor as Deputy for His Excellency the Governor of the State of Victoria with the advice of the Executive Council thereof doth hereby approve of the said road being made, that is to say:—

All that piece of land in the Parish of Hilgay, the boundaries of which are as follow:—Commencing at the north-eastern angle of allotment 10A, section 2, of the said parish; thence by lines bearing respectively 206 deg. 58 min. 117.5 links, 234 deg. 59 min. 818 links, 31 deg. 49 min. 1,122.1 links, 47 deg. 49 min. 813.2 links, and 206 deg. 58 min. 1,038.4 links to the point of commencement—which said piece of land is particularly delineated and shown coloured red and yellow on survey plan numbered 4901, lodged in the office of the Country Roads Board.

And the Honorable James Arthur Kennedy, His Majesty's Commissioner of Public Works for the State of Victoria, shall give the necessary directions herein accordingly.

C. W. KINSMAN,  
Clerk of the Executive Council.

COUNTRY ROADS BOARD.

*At the Executive Council Chamber, Melbourne, the  
thirteenth day of January, 1948.*

PRESENT:

The Lieutenant-Governor, as Deputy for His Excellency the Governor of Victoria.

Mr. Hollway | Mr. Byrnes.

DECLARATION OF THE BASS HIGHWAY IN THE SHIRES OF BASS AND CRANBOURNE, BOROUGH OF WONTHAGGI, NORTH-WESTERN HIGHWAY IN THE BOROUGH OF ST. ARNAUD, SHIRES OF BALLAARAT, LEXTON, AVOCA, KARA, KARA, DONALD, AND BIRCHIP, BORUNG HIGHWAY IN THE SHIRES OF WARRACKNABEAL, DONALD, AND CHARLTON.

WHEREAS by the Resolution set out below and dated the fifth day of November One thousand nine hundred and forty-seven the Country Roads Board incorporated under the *Country Roads Act 1928* (No. 3662) being of opinion that the highways in the State of Victoria set out or described in the Schedule to the same are of sufficient importance to be State highways and acting under the powers in that behalf conferred upon it by the said Act declared such highways to be State highways within the meaning and for the purposes of the Act aforesaid: And whereas the said Act amongst other things provides that the Governor in Council may by Order published in the *Government Gazette* confirm such Resolution whereupon any roads mentioned in such Resolution shall be State highways: And whereas it is deemed desirable to confirm the Resolution so made and passed by the said Country Roads Board: Now therefore the Lieutenant-Governor as Deputy for His Excellency the Governor of the State of Victoria by and with the advice of the Executive Council thereof doth hereby confirm such Resolution and declare upon the publication of this Order in the *Government Gazette* the roads mentioned in the Schedule to such Resolution of the Country Roads Board State highways within the meaning and for the purposes of the *Country Roads Act 1928*.

*Resolution for Declaration of State Highways under the  
Country Roads Act.*

The Country Roads Board incorporated by the *Country Roads Act 1928* (No. 3662) at a meeting now holden being of opinion that the highways within the State of Victoria set out or described in the Schedule hereunder written are of sufficient importance to be State highways acting under the powers in that behalf conferred upon it by the said Act doth by this Resolution hereby declare such highways to be State highways within the meaning and for the purposes of the said *Country Roads Act 1928*.

SCHEDULE.

*Shires of Bass and Cranbourne, Borough of Wonthaggi.*

21. *Bass Highway*.—Commencing at its junction with the South Gippsland Highway near the south-western angle of allotment 19A, Parish of Lang Lang; thence southerly to a point on the western boundary of allotment 28A of the said parish, distant 849.2 links from the south-western angle of the allotment last named; thence south-easterly through that allotment, across a Government road, and through allotments 39A and 84A to the south-western boundary of the allotment last named (S.P. 4796); thence south-easterly and south-westerly to the south-western angle of allotment 213B, Parish of Corinella; thence generally southerly and south-westerly to the south-eastern angle of allotment 2, section 1, Township of Woolamai; thence south-easterly to and across the bridge over the Bass River, and continuing south-easterly, south-westerly, and southerly to a point on the northern boundary of Crown portion 25, Parish of Woolamai, distant 35 links from the north-western angle thereof; thence southerly and south-westerly through the said Crown portion and Crown portion 26 to the western boundary of the Crown portion last named (S.P. 3376); thence southerly to a point on the western boundary of Crown portion 7 of the parish last named, distant 556.4 links from the south-western angle thereof; thence south-easterly through that Crown portion, across a Government road, and through allotment 12 to the north-eastern boundary of the allotment last named (S.P.'s 3579 and 2945); thence south-easterly to the south-western boundary of allotment 14, Parish of Woolamai; thence south-easterly through that allotment to the south-eastern angle thereof (S.P. 4358); thence generally south-easterly and easterly to the north-eastern angle of the southern portion of allotment 76 of the parish last named; thence generally southerly to and across the bridge over the Powlett River, and south-easterly

to a point on the northern boundary of allotment 2, Parish of Wonthaggi, distant 517.1 links from the north-eastern angle thereof; thence south-easterly through that allotment and allotment 3 to the north-eastern boundary of the allotment last named (S.P. 1752); thence south-easterly to its junction with the Wonthaggi-Inverloch and Graham roads near the south-eastern angle of allotment 25, section 1, Township of Wonthaggi, Parish of Wonthaggi.

*Borough of St. Arnaud, Shires of Ballaarat, Lexton, Avoca, Kara Kara, Donald, and Birchip.*

20. *North-Western Highway.*—Commencing at its junction with the Ballaarat-Creswick road at the north-eastern angle of allotment 20, section A, Township of Ballaarat North, Parish of Ballaarat; thence westerly, north-westerly, and northerly to the north-eastern angle of allotment 72, Parish of Dowling Forest; thence generally north-westerly to and through the Town of Learmonth in the Parish of Burrumbeet to the south-eastern angle of allotment 16, Parish of Glendaruel; thence generally north-westerly to and through the Parish of Addington, and continuing north-westerly to the north-western angle of allotment 57 of the parish last named; thence generally north-westerly through the Township of Waubra, Parish of Ercildoun, to the northern angle of allotment 2, section 28, of the parish last named; thence south-westerly and generally north-westerly to the northern angle of section 20, Township of Lexton, Parish of Lexton; thence north-westerly through that township to the north-eastern angle of allotment 1 of the parish last named; thence north-easterly and north-westerly to the north-eastern angle of allotment D23, Parish of Caralulup; thence north-easterly to and across the Bet Bet Creek near the south-eastern angle of allotment 20A, Parish of Yalong, and including the Country Roads Board road deviation through allotment D3, Parish of Caralulup (S.P. 4137); thence northerly and north-easterly to a point on the western boundary of allotment 21B, section 1, Parish of Yalong, distant 22 deg. 15 min. 529 links from the south-eastern angle of that allotment; thence north-westerly through that allotment to the north-eastern boundary thereof (S.P. 3918), and further north-westerly to and through the Parish of Glenmona to the south-eastern angle of section 33, Town of Avoca, Parish of Avoca; thence north-westerly through the town and parish last named and the Parish of Yehrip to the south-eastern angle of allotment 38, section 1, Parish of Warrenmang; thence north-westerly to the south-eastern angle of section 6, Township of Redbank, Parish of Redbank, and including the Country Roads Board road deviation through allotments 68 and 68A, section 1, Parish of Warrenmang (S.P. 3671); thence north-westerly and north-easterly through the township last named to the south-eastern angle of allotment 7N, being a quarry reserve, Parish of Redbank, and including the deviation through allotments 15, 16, and 17, section 8, of that township (S.P. 3487); thence north-westerly and north-easterly to and through allotment 5B, section E, Parish of Boola Boloke, to a point on the eastern boundary thereof, distant 180 deg. 27 min. 919 links, and 179 deg. 19 min. 560.4 links from the north-eastern angle of that allotment; thence northerly to and through allotments 5, 4A, and 4, section E, parish last named, to the eastern boundary of the said allotment 4, section E (S.P. 4518); thence generally north-westerly to a point on the northern boundary of the Township of Stuart Mill, distant 89 deg. 53 min. 403 links from the north-western angle of that township and including the Country Roads Board road deviations through allotments A8 and A8A, section C, Parish of Moyreisk, allotments 23, 21, A28, section C, and allotment 29K, section A, Parish of Boola Boloke (S.P.'s 4519, 4520, and 4521); thence north-westerly through a State forest (S.P. 2504), and further north-westerly to an angle in the eastern boundary of allotment 48, section A, Parish of Carapooee West, distant 179 deg. 42 min. 1,367 links from the north-eastern angle of that allotment; thence north-easterly along the boundary between the Parishes of Carapooee and Carapooee West to the north-eastern angle of allotment 37A, section A, of the parish last named, and further north-easterly and north-westerly through the Parish of Moolerr to the south-eastern angle of allotment 26A, section A1, Parish of St. Arnaud; thence northerly to the north-eastern angle of section T2, Town of St. Arnaud, Parish of St. Arnaud, and north-westerly through the said town to the eastern angle of section 2 thereof; thence generally westerly and north-westerly to and through the Parish of Darkbonee to the north-eastern angle of allotment 4, section A, Parish of Swanwater, and further north-westerly through the parish last named and the Parishes of Donald and Banyenong to its junction with the Borung Highway near the eastern angle of section 1B, Township of Donald, in the parish last named; thence north-westerly across the Avon River, and further north-westerly to and across the railway reserve near the north-eastern angle of Lake Buloke Railway Station grounds,

Parish of Witchipool; thence north-westerly to its junction with the Borung Highway on the western boundary of allotment 1, section 1, of the parish last named; thence generally northerly along the boundary between the Parishes of Carron and Witchipool and the Parishes of Corack and Watchem to the north-western angle of allotment 34A, Parish of Corack; thence westerly across the railway reserve at the northern end of Massey Station grounds to the north-eastern angle of allotment 10A, Parish of Watchem; thence northerly, north-easterly, and northerly to and along the western boundary of the Village of Watchem, and further northerly and north-easterly to the north-eastern angle of allotment 34, Parish of Warmur; thence north-westerly and north-easterly to the south-eastern angle of allotment 97B of the parish last named; thence generally northerly to the north-eastern angle of allotment 16A, Parish of Wirmbirchip.

*Shires of Warracknabeal, Donald, and Charlton.*

19. *Borung Highway.*—Commencing at its junction with the Henty Highway at the north-western angle of a race-course and recreation reserve, Township of Warracknabeal, Parish of Werrigar; thence easterly through the Parishes of Werrigar and Bangerang to the north-eastern angle of allotment 77, Parish of Areegra; thence south-easterly to the eastern angle of allotment 36 of the parish last named, and generally north-easterly to the north-western angle of allotment 106, Parish of Carron; thence easterly and south-easterly to the north-eastern angle of allotment 27 of the parish last named; thence north-easterly to and across a railway to its junction with the North-western Highway near the western end of Litchfield Station grounds, on the western boundary of allotment 1, section 1, Parish of Witchipool.

Also, commencing at its junction with the North-western Highway at the western angle of section 1, Town of Donald, Parish of Banyenong; thence generally north-easterly through the town last named to the north-western angle of allotment 1, section 14, Parish of Banyenong; thence north-westerly and north-easterly to the north-western angle of allotment 2, section 4, of the parish last named; thence easterly, north-easterly, and easterly to the north-eastern angle of allotment 4C, Parish of Banyenong; thence south-easterly to and through allotment 4B of the parish last named to a point on the southern boundary of that allotment, distant 269 deg. 55 min. 5,100 links from the south-eastern angle thereof; thence easterly and south-easterly to the north-western angle of allotment 66, Parish of Jeffcott; thence generally north-easterly through the parish last named to the north-western angle of allotment 86, Parish of Wooronook; thence north-easterly along the boundary between the Parishes of Charlton West and Wooronook to the north-eastern angle of allotment 67B of the parish last named; thence easterly, south-easterly, north-easterly, and easterly along the said parish boundary to its junction with the Calder Highway at the north-eastern angle of allotment 10C, Township of Charlton, Parish of Wooronook.

The common seal of the Country Roads Board was hereto affixed, at Melbourne, this twenty-fourth day of December, One thousand nine hundred and forty-seven, in the presence of—

(SEAL) W. L. DALE, Chairman.  
F. M. CORRIGAN, Member.  
R. JANSEN, Secretary.

And the Honorable James Arthur Kennedy, His Majesty's Commissioner of Public Works for the State of Victoria, shall give the necessary directions herein accordingly.

C. W. KINSMAN,  
Clerk of the Executive Council.

#### COUNTRY ROADS BOARD.

*At the Executive Council Chamber, Melbourne, the thirteenth day of January, 1948.*

PRESENT:

The Lieutenant-Governor, as Deputy for His Excellency the Governor of Victoria.

Mr. Hollway | Mr. Byrnes.

DECLARATION OF THE WELLINGTON-ROAD, EMERALD-MONBULK ROAD, IN THE SHIRE OF FERN TREE GULLY, EMERALD-MONBULK ROAD IN THE SHIRE OF LILLYDALE, OUYEN-PIANGIL ROAD, ROBINVALE-ROAD, IN THE SHIRE OF SWAN HILL, OUYEN-PIANGIL ROAD IN THE SHIRE OF WALPEUP.

WHEREAS by the Resolution set out below and dated the fifth day of January One thousand nine hundred and forty-eight the Country Roads Board incorporated under the *Country Roads Act 1928* (No. 3662) being of

opinion that the highways in the State of Victoria set out or described in the Schedule to the same are of sufficient importance to be main roads and acting under the powers in that behalf conferred upon it by the said Act declared such highways to be main roads within the meaning and for the purposes of the Act aforesaid: And whereas the said Act amongst other things provides that the Governor in Council may by Order published in the *Government Gazette* confirm such Resolution whereupon any roads mentioned in such Resolution shall be main roads: And whereas it is deemed desirable to confirm the Resolution so made and passed by the said Country Roads Board: Now therefore the Lieutenant-Governor as Deputy for His Excellency the Governor of the State of Victoria by and with the advice of the Executive Council thereof doth hereby confirm such Resolution and declare upon the publication of this Order in the *Government Gazette* the roads mentioned in the Schedule to such Resolution of the Country Roads Board main roads within the meaning and for the purposes of the *Country Roads Act 1928*.

*Resolution for Declaration of Main Roads under the  
Country Roads Act.*

The Country Roads Board incorporated under the *Country Roads Act 1928* (No. 3662) at a meeting now holden being of opinion that the highways within the State of Victoria set out or described in the Schedule hereunder written are of sufficient importance to be main roads acting under the powers conferred upon it by the said Act doth by this Resolution hereby declare such highways to be main roads within the meaning and for the purposes of the said *Country Roads Act 1928*.

SCHEDULE.

*Shire of Fern Tree Gully.*

10. *Wellington-road* (5910).—Commencing at its junction with Belgrave-Hallam road at the south-western angle of allotment 43r, Parish of Narree Worrnan; thence south-easterly and north-easterly to and across Cardinia Creek, near the southern angle of allotment 108b of the said parish; thence northerly and generally north-easterly to its junction with Belgrave-Emerald road at the eastern angle of allotment 43, Parish of Narree Worrnan.

15. *Emerald-Monbulk road* (5915).—Commencing at its junction with Emerald-road at the most eastern angle of allotment 8, section A, Township of Emerald, Parish of Gembrook; thence north-westerly and north-easterly to the most eastern angle of allotment 54 of the parish last named; thence north-westerly and generally northerly through the Parish of Mangana to and across Menzies Creek near the north-eastern angle of allotment 46a, section A, Parish of Narree Worrnan; thence north-westerly and south-westerly along the Woori Yallock Creek Reserve to and across the bridge over that creek at Fairy Dell, near the south-western angle of allotment 24, section L, Parish of Monbulk; thence north-westerly along the Sassafras Creek Reserve, and through allotments 35, 37, and 38, section K, of the parish last named (S.P.'s 1243 and 1244); thence further north-westerly along the said reserve and the north-eastern boundary of allotments 39, 40, 41, 42, and 43 of the said section, and further north-easterly to and through allotment 44, section K, to the north-eastern angle thereof (S.P. 1242); thence northerly and north-westerly through allotment 47, section K, Parish of Monbulk, and the Creek Reserve aforementioned to and crossing Sassafras Creek near the northern angle of allotment 45, section K, of the parish last named (S.P. 1241); thence north-westerly and south-westerly through the creek reserve to the southern boundary of allotment 1, section L, Parish of Monbulk; thence south-westerly and north-westerly through that allotment to a point on its western boundary, distant 320.8 links from the south-western angle thereof; thence north-westerly across a Government road and further north-westerly and north-easterly through allotments 81, 80, 79, and 77 of section C, Parish of Monbulk, and allotments 5, 4, and 1 of section I of the parish last named to a point on the north-western boundary of the allotment last named, distant 356 links from the northern angle thereof (S.P.'s 1240, 1239, 1238, 1237, 1236, and 1235); thence north-westerly, north-easterly, and northerly through allotment 77, section C, aforementioned, along a Government road and through allotment 74, section C, to a point on the north-eastern boundary of the allotment last named, distant 150 links from the eastern angle thereof (S.P.'s 1233 and 1234); thence north-westerly along the boundary between the Shires of Fern Tree Gully and Lillydale to its junction

with Monbulk-road near the western angle of allotment 87, section A, Parish of Monbulk, on the northern boundary of the shire.

*Shire of Lillydale.*

14. *Emerald-Monbulk road* (9414).—*Note.*—The route of the portion of this road between the Shires of Fern Tree Gully and Lillydale is set out in the description of the road route in the Shire of Fern Tree Gully.

*Shire of Swan Hill.*

10. *Ouyen-Piangil road* (15910).—Commencing at the south-eastern angle of allotment 42, Parish of Wagant, on the western boundary of the shire; thence easterly and north-easterly along the boundary between the Shires of Walpeup and Swan Hill to the north-eastern angle of allotment 27 of the said parish; thence generally north-easterly to the northern angle of allotment 10, Parish of Larundel; thence generally south-easterly, southerly, and south-easterly to and through allotment 22 of the parish last named to a point on the western boundary of allotment 22A, Parish of Manangatang, distant 0 deg. 2 min. 1,075 links from the south-western angle of the said allotment; thence south-easterly through that allotment to the southern boundary thereof; thence generally easterly and north-easterly to the north-western angle of allotment 28, Parish of Manangatang.

Also, commencing at the railway crossing at the northern end of the Piangil Station Ground south of allotment 140, Parish of Piangil; thence north-easterly and easterly to its junction with the Murray Valley Highway at the south-eastern angle of the northern portion of allotment 147b of the said parish.

*NOTE.*—The above description is in lieu of the description of the Ouyen-Manangatang road published in the *Government Gazette* of 6th August, 1947, on pages 4204 and 4205, and the description of the Piangil Station-road, published in the *Government Gazette* of 12th September, 1917, on page 2831.

15. *Robinvale-road* (15915).—Commencing at its junction with the Murray Valley Highway at the eastern angle of allotment 15, Parish of Toitoli; thence generally north-westerly to the northern angle of allotment 28 of the said parish.

*NOTE.*—The above description is in lieu of portion of the description of the Euston-road published in the *Government Gazette* of 24th March, 1915, on page 1101.

*Shire of Walpeup.*

5. *Ouyen-Piangil road* (17305).—Commencing at its junction with the Calder Highway at the south-western angle of allotment 1, section 5, Township of Ouyen, Parish of Ouyen; thence generally easterly to an angle in the northern boundary of allotment 7, Parish of Boorongie, distant 2,456 links from the north-western angle thereof; thence easterly through that allotment (S.P. 4774) and continuing generally easterly and north-easterly to a point on the western boundary of allotment 28, Parish of Wagant, distant 1,369 links from the north-western angle of the allotment last named; thence north-easterly through that allotment to the northern boundary thereof (S.P. 4773); thence north-easterly and easterly to the south-eastern angle of allotment 42, Parish of Wagant, on the eastern boundary of the shire.

*NOTE.*—The route of the portion of this road between the Shires of Walpeup and Swan Hill is set out in the description of the road route in the Shire of Swan Hill, and the above description is in lieu of the description of the Ouyen-Manangatang road published in the *Government Gazette* of 2nd August, 1939, on page 2773, and 9th July, 1947, on pages 3628 and 3629.

The common seal of the Country Roads Board was hereto affixed, at Melbourne, this eighth day of January, One thousand nine hundred and forty-eight, in the presence of—

(SEAL)      W. L. DALE, Chairman.  
D. V. DARWIN, Member.  
R. JANSEN, Secretary.

And the Honorable James Arthur Kennedy, His Majesty's Commissioner of Public Works for the State of Victoria, shall give the necessary directions herein accordingly.

C. W. KINSMAN,  
Clerk of the Executive Council.

CO-OPERATIVE HOUSING SOCIETIES ACT 1944  
(No. 5055).

*At the Executive Council Chamber, Melbourne, the  
thirteenth day of January, 1948.*

PRESENT:

The Lieutenant-Governor, as Deputy for His Excellency  
the Governor of Victoria.

Mr. Hollway | Mr. Byrnes.

APPOINTMENT OF DEPUTY REGISTRAR OF  
CO-OPERATIVE HOUSING SOCIETIES.

IN accordance with the provisions of section 48 (6) of  
the *Co-operative Housing Societies Act 1944* (No.  
5055), the Lieutenant-Governor, as Deputy for His Ex-  
cellency the Governor of the State of Victoria, by and  
with the advice of the Executive Council thereof, doth by  
this Order appoint—

EDWARD THEODORE ERBELS, Deputy Registrar of  
Co-operative Housing Societies,

during the absence of the Registrar, for the periods 7th  
January, 1948, to 13th January, 1948, and 27th January,  
1948, to 9th February, 1948, all dates inclusive.

And the Honorable Thomas Tuke Hollway, His Majesty's  
Treasurer for the State of Victoria, shall give the necessary  
directions herein accordingly.

C. W. KINSMAN,  
Clerk of the Executive Council.

## STATE SAVINGS BANK ACT 1928 (No. 3777).

*At the Executive Council Chamber, Melbourne, the  
thirteenth day of January, 1948.*

PRESENT:

The Lieutenant-Governor, as Deputy for His Excellency  
the Governor of Victoria.

Mr. Hollway | Mr. Byrnes.

APPOINTMENT OF CHAIRMAN OF COMMISSIONERS,  
STATE SAVINGS BANK.

IN accordance with the provisions of the *State Savings  
Bank Act 1928* (No. 3777), the Lieutenant-Governor,  
as Deputy for His Excellency the Governor of the State  
of Victoria, by and with the advice of the Executive  
Council thereof, doth by this Order hereby appoint—

WILLIAM WARREN KERR, C.M.G., C.B.E.,

to be Chairman of the Commissioners of the State Savings  
Bank of Victoria for the year commencing on the 1st  
January, 1948.

And the Honorable Thomas Tuke Hollway, His Majesty's  
Treasurer for the State of Victoria, shall give the necessary  
directions herein accordingly.

C. W. KINSMAN,  
Clerk of the Executive Council.

FRUIT AND VEGETABLES ACTS 1928 (No. 3687), 1936 (No. 4421),  
AND 1946 (No. 5173).

*At the Executive Council Chamber, Melbourne, the  
thirteenth day of January, 1948.*

PRESENT:

The Lieutenant-Governor, as Deputy for His Excellency  
the Governor of Victoria.

Mr. Hollway | Mr. Byrnes.

## REGULATIONS.

IN pursuance of the powers conferred by the *Fruit and Vegetables  
Acts 1928* (No. 3687), 1936 (No. 4421), and 1946 (No. 5173), the  
Lieutenant-Governor, as Deputy for His Excellency the Governor of  
the State of Victoria, by and with the advice of the Executive Council  
thereof, doth hereby amend the Regulations made under the provisions  
of the said Acts on 11th November, 1935, as follows, that is to say:—

In Regulation 4—(Part 1—Definitions), after the definition of  
"Falsely packed" insert the following definition:—

"'Firm' when used in relation to tomatoes means that the  
tomato is not broken, puffy, shrivelled, soft, water soaked or  
affected by leaky cracks."

and after the definition of "Immature" when used in relation to  
potatoes, insert the following definition:—

"'Immature' when used in relation to tomatoes means  
immature in the opinion of an Inspector or that the fruit has  
not attained its full growth and that the skin has not changed  
from dull green to a bright-green colour and the flesh surround-  
ing the seeds has not changed from a light-green colour to a deep-  
amber or to an amber tinged with pink."

In Regulation 19—(Sixth Schedule—Grade Standards for  
Tomatoes) in paragraph (c) after the word "of" in the first line  
insert the word "firm" and in paragraph (d) after the word "of" in  
the first line insert the word "firm" and in place of paragraph (e)  
substitute the following paragraph:—

"(e) Tomatoes described as "green" shall consist of firm  
tomatoes which are green to greenish-yellow in colour  
and which are sound and free from disease. Such  
tomatoes shall not be immature."

and after paragraph (e) add the following paragraph:—

"(f) The sale of tomatoes described as "green" is prohibited  
during the months of November, December and January."

And the Honorable Alexander Henry Dennett, His Majesty's  
Minister of Agriculture for the State of Victoria, shall give the  
necessary directions herein accordingly.

C. W. KINSMAN,  
Clerk of the Executive Council.

LAND ACTS.

At the Executive Council Chamber, Melbourne, the thirteenth day of January, 1948.

PRESENT:

The Lieutenant-Governor, as Deputy for His Excellency the Governor of Victoria.  
 Mr. Hollway | Mr. Byrnes.

REGULATIONS ALTERED AND AMENDED.

THE Lieutenant-Governor, as Deputy for His Excellency the Governor of Victoria, by and with the advice of the Executive Council thereof and in pursuance of the Land Acts, doth hereby approve the following alterations and amendments to the Regulations under the Land Act 1928 which appeared in the Government Gazettes of 8th August 1930 and 28th September, 1932.

In Schedule 49 (licences which do not confer any exclusive right to enter on Crown lands) for the portion of such Schedule appearing on page 2114 of the Government Gazette of 8th August 1930 amended as shown in the Government Gazette of 28th September, 1932 relating to the removal of sand and loam from unappropriated Crown lands at Sandridge Bend and Port Melbourne there shall be substituted the following:—

Purpose of Licence.	Fee to be Paid.	Right to be Conferred by Licence.
For removal of sand from unappropriated Crown land in the City of Port Melbourne	Three shillings (3s.) per cubic yard for the full capacity of the vehicle in which the sand is removed, provided a quantity of approved filling material at least equal to the sand removed is brought to the area and deposited where required by the Officer in Charge  In any case where for good reason, authority is given for sand to be obtained without insistence on the requirement to provide approved filling material, the fee for each cubic yard shall be increased by three shillings (3s.)	1. Sand shall be removed only from the area set apart for that purpose, which area is hereinafter referred to as the "Sand Ground." 2. Every person wishing to remove sand shall, on entering the Sand Ground, pay to the Officer in Charge the prescribed fee and shall receive a "sand permit" for each load. 3. The Officer in Charge shall endorse on such "sand permit" the name of the sand-carter by whom the same is to be used, as well as the date and hour of issue. 4. Sand shall be removed only between the hours of 7.30 a.m. and 4 p.m. on days when the Sand Ground is open for business. 5. No sand permit shall be applied for after the hour of 3 p.m. 6. The Sand Ground will not be open for business on Saturdays, Sundays, or proclaimed public holidays. 7. Every person loading or moving sand within the sand ground shall produce his permit to any bailiff of Crown lands when called upon so to do. 8. Every such person shall, before departure from the Sand Ground, surrender his "sand permit" to the Officer in Charge or his deputy. 9. Any person found loading or moving sand from the Sand Ground without a "sand permit," or any person found loading or moving sand from Crown lands outside the Sand Ground with or without a "sand permit," shall be summoned by any bailiff of Crown lands or any member of the Police Force to appear before justices of the peace to answer for such offence. 10. The Officer in Charge shall decline to issue a "sand permit" to any person who may be guilty of any breach of these Regulations. 11. Any person convicted of illegally procuring sand from Crown lands shall be excluded from the Sand Ground for the periods set forth hereunder, as the case may require:— 1st offence, one (1) month; 2nd offence, three (3) months; 3rd offence, six (6) months. The conditions for the removal of loam shall be similar to those provided for the removal of sand.
For removal of loam from unappropriated Crown lands in the City of Port Melbourne	Two shillings (2s.) per cubic yard on the terms provided for the removal of sand	

And the Honorable John Gladstone Black McDonald, His Majesty's Commissioner of Crown Lands and Survey for the State of Victoria, shall give the necessary directions herein accordingly.

C. W. KINSMAN,  
 Clerk of the Executive Council.

## TEACHING SERVICE ACT 1946.

At the Executive Council Chamber, Melbourne, the  
thirteenth day of January, 1948.

## PRESENT:

The Lieutenant-Governor, as Deputy for His Excellency  
the Governor of Victoria.  
Mr. Hollway | Mr. Byrnes.

TEACHING SERVICE (GOVERNOR IN COUNCIL) REGULATIONS  
AMENDED.

THE Lieutenant-Governor, as Deputy for His Excellency the Governor of the State of Victoria, by and with the advice of the Executive Council thereof and in pursuance of the powers conferred by the *Teaching Service Act* 1946 doth hereby amend Regulation 5 of the Teaching Service (Governor in Council) Regulations made on the twenty-ninth day of October 1946 and published in the *Government Gazette* of the thirtieth day of October 1946 in the manner following, that is to say:—

To the heading of the Regulation after the words "in the Armed Forces" there shall be added the words "and for War Widows."

Revoke clause 6 and substitute therefor the following clause:—

"6. A person honourably discharged after having served in the armed forces in connexion with the war commencing in the year One thousand nine hundred and thirty-nine, or a war widow eligible for training under the Commonwealth Reconstruction Training Scheme, and who, prior to the commencement of such war, was not a classified teacher or a student teacher, may be awarded a studentship—

- (a) for the Trained Primary Teacher's Certificate, provided that he has served as a temporary teacher for a period approved by the Director and that he possesses the following qualifications:—
- (i) the applicant shall be not less than eighteen years of age and not more than thirty-five years of age, and shall be of suitable character and personality;
  - (ii) he shall have passed the School Leaving examination of the University of Melbourne, or shall hold an approved equivalent or higher qualification;
- (b) for the Trained Secondary Teacher's Certificate or for the Trained Commercial Teacher's Certificate or for the Trained Manual Arts Teacher's Certificate or for the Trained Domestic Arts Teacher's Certificate provided that he possesses the following qualifications:—
- (i) the applicant shall be not less than eighteen years of age and not more than thirty-five years of age and shall be of suitable character and personality;
  - (ii) he shall have passed the examinations prescribed for entry to his particular course in Regulation 12 of the Teaching Service (Teachers Tribunal) Regulations, or shall hold an approved equivalent or higher qualification.

Holders of studentships under the provisions of this clause shall, during the course of training, be paid allowances at the rates of salary for the time being payable to adult temporary teachers male or female as the case may be and in addition the appropriate adult cost of living allowance."

Revoke clause 7 and substitute therefor the following clause:—

"7. The holder of a studentship under clause 6 of this Regulation shall on completion of his course be placed in the subdivision prescribed for his particular course in clause 23 of Regulation 12 of the Teaching Service (Teachers Tribunal) Regulations."

And the Honorable Wilfred Selwyn Kent Hughes, His Majesty's Minister of Public Instruction for the State of Victoria, shall give the necessary directions herein accordingly.

C. W. KINSMAN,  
Clerk of the Executive Council.

Apprenticeship Acts.  
APPRENTICESHIP COMMISSION OF VICTORIA.

At the Executive Council Chamber, Melbourne, the  
thirteenth day of January, 1948.

## PRESENT:

The Lieutenant-Governor, as Deputy for His Excellency  
the Governor of Victoria.

Mr. Hollway | Mr. Byrnes.

AMENDMENT OF BREAD MAKING AND BAKING  
TRADE REGULATIONS (No. 1).

IN pursuance of the powers conferred by the Apprenticeship Acts and the Acts Interpretation Acts, the Lieutenant-Governor, as Deputy for His Excellency the Governor of the State of Victoria, by and with the advice of the Executive Council thereof, doth hereby make the following Regulations (that is to say):—

1. Regulation 10 of the Bread Making and Baking Trade Regulations (No. 1) shall be and the same is hereby rescinded as from the beginning of the first pay period to commence in January, 1948.

2. Such rescission shall not affect any right accrued or accruing to any person or any liability of any person under the said rescinded Regulation before the commencement of these Regulations.

3. For the said rescinded Regulation substitute the following:—

"10. The minimum rates of pay to be paid as wages to apprentices in the said trade in each year of their apprenticeship course shall be as follows as from the beginning of the first pay period to commence in January, 1948, on, from, and after which date all indentures of apprenticeship heretofore executed, under the provisions of the Acts and Regulations made in respect of the aforesaid trade shall be deemed to be amended accordingly:—

(a) With respect to the term of apprenticeship of five years—

1st year—

1st six months—at the rate of 33s. per week.  
2nd six months—at the rate of 33s. 10d.  
per week.

2nd year—

1st six months—at the rate of 36s. 4d. per  
week.  
2nd six months—at the rate of 40s. 9d. per  
week.

3rd year—

1st six months—at the rate of 46s. 5d. per  
week.  
2nd six months—at the rate of 54s. 9d. per  
week.

4th year—

1st six months—at the rate of 64s. per week.  
2nd six months—at the rate of 74s. 11d.  
per week.

5th year—

1st six months—at the rate of 88s. 1d. per  
week.  
2nd six months—at the rate of 102s. 10d.  
per week.

(b) With respect to the term of apprenticeship of four years—

1st year—

1st six months—at the rate of 36s. 4d. per  
week.  
2nd six months—at the rate of 40s. 9d. per  
week.

2nd year—

1st six months—at the rate of 46s. 5d. per  
week.  
2nd six months—at the rate of 54s. 9d. per  
week.

3rd year—

1st six months—at the rate of 64s. per week.  
2nd six months—at the rate of 74s. 11d.  
per week.

4th year—

1st six months—at the rate of 88s. 1d. per  
week.  
2nd six months—at the rate of 102s. 10d.  
per week."

And the Honorable Herbert John Thornhill Hyland, His Majesty's Minister of Labour for the State of Victoria, shall give the necessary directions herein accordingly.

C. W. KINSMAN,  
Clerk of the Executive Council.

Apprenticeship Acts.  
APPRENTICESHIP COMMISSION OF VICTORIA.

At the Executive Council Chamber, Melbourne, the  
thirteenth day of January, 1948.

## PRESENT:

The Lieutenant-Governor, as Deputy for His Excellency  
the Governor of Victoria.

Mr. Hollway | Mr. Byrnes.

AMENDMENT OF CARPENTRY AND JOINERY  
TRADES REGULATIONS.

IN pursuance of the powers conferred by the Apprenticeship Acts and the Acts Interpretation Acts, the Lieutenant-Governor, as Deputy for His Excellency the Governor of the State of Victoria, by and with the advice of the Executive Council thereof, doth hereby make the following Regulations, that is to say:—

1. The Carpentry and Joinery Regulations (Nos. 1 and 2) shall be and the same are hereby rescinded as from 1st day of January, 1948.

2. Such rescission shall not affect any right accrued or accruing to any person or any liability of any person under the said rescinded Regulations before the commencement of these Regulations.

3. For the said rescinded Regulations substitute the following:—

## SHORT TITLE.

1. These Regulations may be cited as the "Carpentry and Joinery Regulations (No. 1)."

## INTERPRETATION.

2. In these Regulations—

"Acts" mean the Apprenticeship Acts.

"Applicant" means an applicant for apprenticeship employed on probation.

"Commission" means the Apprenticeship Commission of Victoria.

"Registrar" means the Registrar of Apprenticeship.

"Secretary" means the Secretary to the Commission.

## APPLICATION OF REGULATIONS.

3. These Regulations shall apply only with respect to the apprenticeship trades of Carpentry and/or Joinery.

## APPLICANTS FOR APPRENTICESHIP TO APPLY FOR CERTIFICATE.

4. Applications by persons desiring to become apprentices in the said trades shall be in the form contained in the Third Schedule to General Regulations (No. 1) made under the Acts.

## APPLICANTS MAY BE EXAMINED.

5. Applicants for apprenticeship in the said trades may be required to submit themselves for examination at the time and place determined by the Commission to prove that they possess the preparatory educational qualifications required for entry into apprenticeship in such trades. Provided that any such applicant shall be exempted from such examination—

## Exemptions.

(a) If he possesses any one of the following educational qualifications, or, in the opinion of the Commission the equivalent thereof—

(i) The Intermediate Technical or Junior Technical Certificates of the Education Department of Victoria, the School Intermediate Certificate, or equivalent qualifications approved by the Commission.

(ii) The satisfactory completion, as certified by the school authority and approved by the Commission, of a three years' course of study in a Junior Technical School or equivalent qualifications approved by the Commission.

(b) If he satisfies the Commission, in accordance with sub-section (2) of section 18 of the Act, that he has not had sufficient opportunity to obtain the preparatory educational qualifications prescribed for entry into the said trades.

## MINIMUM AGE FOR ENTRY INTO APPRENTICESHIP.

6. The minimum age at which persons shall enter the said trades as apprentices or applicants for apprenticeship on probation shall be fifteen years.



## TERM OF APRENTICESHIP.

7. The term of apprenticeship in the said trades shall be five years.

## FORM OF INDENTURES OF APRENTICESHIP—GENERAL FORM.

8. The standard form of indentures of apprenticeship in each of the said trades, and the terms, covenants, and conditions thereof, shall be in the form contained in the Second Schedule to General Regulations (No. 2) made under the Acts with the following additions thereto:—

*Additional Covenants, &c., to General Form of Indentures of Apprenticeship.**Employer's Covenants.*

At the end of paragraph (c) (i) add the following proviso:—

Provided that where he is temporarily unable to provide such work as will keep the apprentice fully employed during any ordinary working week or month, he may, with the approval of the Commission, employ the apprentice for such less time in any such week or month as may, on the application of such employer, be determined by the said Commission, at wages proportionate to those which he is required, under the provisions of this paragraph, to pay to the apprentice when employed during the whole of any ordinary working week or month—

(c) (iii) Make no deduction from the wages of the apprentice in respect of any time lost by reason of compulsory attendance at classes for instruction in subjects of the apprenticeship course.

(c) (iv) In the event of the employer being unable, owing to lack of orders, or through financial difficulties, to find employment and training for the apprentice, or to arrange for the transfer of the apprentice to another employer as provided for under the Acts, the Commission may on application made in that behalf by the employer, and after satisfying itself that the circumstances justify such action, arrange for the suspension of the indentures for such period as it determines, or for the cancellation of the indentures.

(f) Not require or allow the apprentice while under the age of eighteen years to attend winches, sling timber, or work power-driven machinery.

(g) Not hold the apprentice responsible for any faulty work or for any damage or injury done to material, work or machinery, tools or plant, other than wilful damage or injury, during the course of his work.

(h) In the event of the apprentice, while in his service, having his clothes or tools spoilt by acid, sulphur, or other deleterious substances, recompense the apprentice to the value of the loss sustained, unless such loss was occasioned by the carelessness or neglect of the apprentice.

(i) Not keep more than one day's pay in hand.

*Apprentice and Parent or Guardian's Covenants.*

(c) At all times while in the employment of the employer conduct himself in a courteous, obedient, and proper manner.

*Mutual Agreements.*

At the end of paragraph (3), add the following provisos:—

Provided further—

(i) That where the apprentice is required under the provisions of the proviso to paragraph (c) (i) hereof to work for less time than full time in any ordinary working week or month; or

(ii) that where the indentures of any apprentice are suspended for any period by the Commission,

the total period of time not served by the apprentice by reason of either of the above-mentioned provisions shall, at the option of the apprentice, be included in the term of his apprenticeship, or be added to the term of his apprenticeship. In the event of such period being added to the term of his apprenticeship, the apprentice shall be paid for such period at the wages rates prescribed in respect of the last year of his apprenticeship.

(10) That the apprentice shall be paid the same allowances as are from time to time paid by the employer to journeymen in the same trade for meal money, fares, travelling time, country work, and other matters, or, where

such allowances are proportionate to the rates of pay received by journeymen, the apprentice shall be paid only such proportion thereof as the rates of pay of the apprentice bear to such journeymen's minimum rates of pay.

(11) That in the event of the employer's premises being destroyed or partly destroyed by fire, preventing for a period the proper tuition of the apprentice in the said trades, he may, with the approval of the Commission, be employed during such period on the performance of such other work for the employer as may be agreed upon between the employer and the said Commission.

## RATES OF PAY OF APRENTICES.

9. The minimum rates of pay to be paid as wages to apprentices in each year of their apprenticeship course shall be as follows:—

- 1st year—at the rate of 31s. 6d. per week.
- 2nd year—at the rate of 42s. per week.
- 3rd year—at the rate of 58s. per week.
- 4th year—at the rate of 81s. per week.
- 5th year—at the rate of 106s. per week.

## TOOL ALLOWANCE.

10. A tool allowance of 2s. per week shall be payable to apprentices in their third, fourth, and fifth years of apprenticeship.

## RATES FOR OVERTIME WORKED.

11. Where overtime (i.e., work done on Sundays and public holidays or outside ordinary working hours) is worked, the apprentice shall be paid by the employer additional wages for such overtime at the rate of time and a half, double time, or at such other rate (as the case may be) as the employer may for the time being be obliged to pay to journeymen employed by him in the same trade.

## STANDARD OF AND INCREASED RATES OF PAY FOR PROFICIENCY.

12. Should the apprentice in the first year pass in the subjects prescribed for that year of the apprenticeship course and attain a standard of proficiency as certified by the Commission of not less than an average of 70 per cent. of the possible marks allotted to such subjects at the annual examinations, he shall for the second year of the apprenticeship course be paid the sum of 5s. per week in addition to the prescribed weekly wage, and should the apprentice attain the aforesaid standard of proficiency in any year (other than the first year) in the subjects prescribed for that year of the apprenticeship course, he shall for the next succeeding year be paid the sum of 2s. 6d. per week in addition to the prescribed weekly wage.

## PROPORTION OF APRENTICES TO JOURNEMEN.

13. The number of apprentices who may be employed by any employer at any time in the said trades shall not exceed the proportion of one apprentice to every three journeymen or fraction of three journeymen employed by such employer, except in the case of joinery mills or joinery workshops, where the number of apprentices who may be employed by any employer at any time in the said trades shall not exceed the proportion of two apprentices to every three journeymen or fraction of three journeymen employed by such employer.

For the purposes of this Regulation an employer working at the trades shall be deemed to be a journeyman, and the number of journeymen employed at any time shall be deemed to be the average per working day of the number of journeymen employed in the said trades by such employer during the period of six months immediately preceding such time.

## APRENTICESHIP COURSE—CLASSES FOR INSTRUCTION.

14. (a) The classes for instruction in the subjects of the apprenticeship course for the said trades shall be as set out in the Schedule hereto, but any apprentice or applicant who has the necessary qualifications may, subject to the approval of the Commission, be permitted to enter the classes prescribed for any year of the said course.

## STANDARD OF EDUCATION TO BE ATTAINED BY AN APRENTICE.

(b) The standard of education to be attained by an apprentice—

- (i) in the subjects of the first, second, and third years of his apprenticeship course in order that he may qualify to proceed to the classes for instruction prescribed for the next succeeding year, and
- (ii) in the subjects of the fourth year of the apprenticeship course in order that he may qualify in respect to education for the "final certificate" of the Commission,

shall be not less than 50 per cent. of the possible marks at the annual examinations approved by the Commission in each of the subjects prescribed for such year of the said

course, or such average percentage of marks in all of the said subjects deemed by the Commission to be equivalent thereto.

#### TRADE EXPERIENCE REQUIRED OF AN APPRENTICE.

15. The trade experience to be obtained by an apprentice in his apprenticeship course shall include gradual and complete instruction, to the satisfaction of the Commission, in the following processes (as the case may be):—

##### Carpentry—

All phases of the trade, including the correct methods of using all tools commonly used in connexion with the carpentry trade.

The construction, erection, alteration, and repair of the timber framework and timber coverings of buildings; form building, framing, and timber construction work in connexion with concrete, brickwork, plaster, and other commonly used building materials; the erection of interior woodwork of buildings; and the making of such woodwork where made on the job.

The fixing of floors, doors, window frames and sashes, skirtings, mouldings, panelling, stairs, mantles, cases and built-in fixtures, and the fixing of building hardware and fittings as generally carried out by the carpenter.

##### Joinery—

All phases of the trade, including the correct methods of using all tools commonly used in the joinery trade.

The preparation of timber, and the making and repair of timber fittings used in connexion with buildings, including doors, door frames, window sashes and frames, cupboards, stairs, panelling, metal shop fronts, and fittings.

##### Carpentry and Joinery—

All phases of each trade as above prescribed—and the employer shall, by the best means in his power, teach and instruct, or cause to be taught and instructed, the apprentice in the said processes.

#### PAYMENT OF SCHOOL FEES.

16. The school fees of apprentices or applicants for attendance at the prescribed classes for instruction for the first, second, and third years of their apprenticeship course shall be paid by such apprentices or applicants, but on the receipt by the employer of a report from the Commission that any such apprentice or applicant has secured during the period covered by the report a record of not less than 80 per cent. of the possible attendances at the prescribed day and evening classes respectively, the employer shall refund to the apprentice or applicant the school fees so paid by him for such period of instruction.

The school fees of apprentices for attendance at the classes for instruction prescribed for the fourth year of the apprenticeship course shall be paid by such apprentices.

In cases where the apprentice or applicant is prevented on occasions from attendance at the said classes through illness or accident, such occasions shall not be included as possible attendances in determining the aforesaid percentage, provided that the employer may demand a medical certificate from the apprentice or applicant as proof of such illness or accident.

#### INCORPORATION OF GENERAL REGULATIONS.

17. The provisions of the following General Regulations, made under the Acts, shall apply in the said trades:—

General Regulations (No. 1), approved by the Governor in Council on the 18th day of September, 1928, and published in the *Victoria Government Gazette* on the 19th day of September, 1928.

General Regulations (No. 2), approved by the Governor in Council on the 26th day of October, 1928, and published in the *Victoria Government Gazette* on the 31st day of October, 1928.

General Regulations (No. 3), approved by the Governor in Council on the 10th day of December, 1928, and published in the *Victoria Government Gazette* on the 12th day of December, 1928.

General Regulations (No. 4), approved by the Governor in Council on the 24th day of December, 1931, and published in the *Victoria Government Gazette* on the 30th day of December, 1931.

General Regulations (No. 5), approved by the Governor in Council on the 9th day of December, 1932, and published in the *Victoria Government Gazette* on the 4th day of January, 1933.

General Regulations (No. 6), approved by the Governor in Council on the 17th day of May, 1943, and published in the *Victoria Government Gazette* on the 19th day of May, 1943.

General Regulations (No. 7), approved by the Governor in Council on the 29th day of July, 1947, and published in the *Victoria Government Gazette* on the 6th day of August, 1947.

#### SCHEDULE.

*Classes for Instruction in the Subjects of the Apprenticeship Course for the Carpentry and/or Joinery Trades.*

		Hours per week.
<i>First Year—</i>		
Trade Theory and Drawing ..	Grade I. ..	2
Trade Practice .. ..	Grade I. ..	4
Trade Mathematics .. ..	Grade I. ..	1
Geometrical Drawing (applied) ..	Grade I. ..	1
<i>Second Year—</i>		
Trade Theory and Drawing ..	Grade II. ..	2
Trade Practice .. ..	Grade II. ..	4
Trade Mathematics .. ..	Grade II. ..	1
Geometrical Drawing (applied) ..	Grade II. ..	1
<i>Third Year—</i>		
Trade Theory, Drawing, and Mathematics .. ..	Grade III. ..	2
Trade Practice .. ..	Grade III. ..	2
Additional Theory and/or Practice optional at evening classes.		
<i>Fourth Year—</i>		
Trade Theory, Drawing, and Mathematics .. ..	Grade IV. ..	2
Trade Practice .. ..	Grade IV. ..	2
Additional Theory and/or Practice optional at evening classes.		

The detailed syllabus of the above-mentioned subjects shall be as determined by the Commission from time to time.

And the Honorable Herbert John Thornhill Hyland, His Majesty's Minister of Labour for the State of Victoria, shall give the necessary directions herein accordingly.

C. W. KINSMAN,  
Clerk of the Executive Council.

#### Apprenticeship Acts.

#### APPRENTICESHIP COMMISSION OF VICTORIA.

*At the Executive Council Chamber, Melbourne, the thirteenth day of January, 1948.*

#### PRESENT:

The Lieutenant-Governor, as Deputy for His Excellency the Governor of Victoria.

Mr. Hollway | Mr. Byrnes.

#### ELECTROPLATING TRADE REGULATIONS (No. 1).

WHEREAS by section 39 of the *Apprenticeship Act 1928* (No. 3636), it is amongst other things enacted that the Governor in Council may make Regulations for or with respect to providing for any matters which are or may be the subject of draft Regulations submitted by the Apprenticeship Commission of Victoria: And whereas the said Commission has prepared and submitted to His Excellency the Governor in Council draft Regulations for or with respect to the matters hereinafter set out: Now, therefore, the Lieutenant-Governor, as Deputy for His Excellency the Governor of the State of Victoria, by and with the advice of the Executive Council thereof, doth hereby make the Regulations following, that is to say:—

#### SHORT TITLE.

1. These Regulations may be cited as the "Electroplating Trade Regulations (No. 1)."

#### INTERPRETATION.

2. In these Regulations—

"Acts" mean the Apprenticeship Acts.

"Applicant" means an applicant for apprenticeship employed on probation.

"Commission" means the Apprenticeship Commission of Victoria.

"Registrar" means the Registrar of Apprenticeship.

"Secretary" means the Secretary to the Commission.

#### APPLICATION OF REGULATIONS.

3. These Regulations shall apply only with respect to the following apprenticeship trade, viz:—

Electroplater—First Class.

APPLICANTS FOR APPRENTICESHIP TO APPLY FOR CERTIFICATE.

4. Applications by persons desiring to become apprentices in the said trade shall be in the form contained in the Third Schedule to General Regulations (No. 1) made under the Acts.

APPLICANTS MAY BE EXAMINED.

5. Applicants for apprenticeship in the said trade may be required to submit themselves for examination at the time and place determined by the Commission to prove that they possess the preparatory educational qualifications required for entry into apprenticeship in such trade. Provided that any such applicant shall be exempted from such examination—

*Exemptions.*

- (a) If he possesses any one of the following educational qualifications, or, in the opinion of the Commission, the equivalent thereof—
- (i) The Intermediate Technical or Junior Technical Certificates of the Education Department of Victoria, the School Intermediate Certificate, or equivalent qualifications approved by the Commission.
  - (ii) The satisfactory completion, as certified by the school authority and approved by the Commission, of a three years' course of study in a Junior Technical School or equivalent qualifications approved by the Commission.
- (b) If he satisfies the Commission, in accordance with sub-section (2) of section 18 of the Act, that he has not had sufficient opportunity to obtain the preparatory educational qualifications prescribed for entry into the said trades.

MINIMUM AGE FOR ENTRY INTO APPRENTICESHIP.

6. The minimum age at which persons shall enter the said trade as apprentices or applicants for apprenticeship on probation shall be fifteen years.

TERM OF APPRENTICESHIP.

7. The term of apprenticeship in the said trade shall be as follows:—

- (a) In the case of persons entering the said trade under the age of seventeen years, a term of five years.
- (b) In the case of persons entering the said trade at or above the age of seventeen years, a term of four or five years, at the option of the contracting parties.

FORM OF INDENTURES OF APPRENTICESHIP—GENERAL FORM.

8. The standard form of indentures of apprenticeship in the said trade, and the terms, covenants, and conditions thereof shall be in the form contained in the Second Schedule to General Regulations (No. 2) made under the Acts, with the following additions thereto:—

*Additional Covenants, &c., to General Form of Indentures of Apprenticeship.*

*Employer's Covenants.*

At the end of paragraph (c) (i), add the following proviso:—

Provided that where he is temporarily unable to provide such work as will keep the apprentice fully employed during any ordinary working week or month, he may, with the approval of the Commission, employ the apprentice for such less time in any such week or month as may, on the application of such employer, be determined by the said Commission, at wages proportionate to those which he is required, under the provisions of this paragraph, to pay to the apprentice when employed during the whole of any ordinary working week or month—

- (c) (iii) Make no deduction from the wages of the apprentice in respect of any time lost by reason of compulsory attendance at classes for instruction in subjects of the apprenticeship course.
- (c) (iv) In the event of the employer being unable, owing to lack of orders or through financial difficulties, to find employment and training for the apprentice, or to arrange for the transfer of the apprentice to another employer as provided for under the Acts, the Commission may on application made in that behalf by the employer, and after satisfying itself that the circumstances justify such action, arrange for the suspension of the indentures for such period as it determines, or for the cancellation of the indentures.
- (f) Not hold the apprentice responsible for any damage or injury done to materials, machinery, tools, or plant, other than wilful damage or damage due to carelessness.
- (g) Not require the apprentice to work on any holiday without his consent.

- (h) Not require the apprentice while under the age of eighteen years to work overtime or shift work unless he so desires.
- (i) Not require the apprentice, except in an emergency, to work overtime or shift work at times which would prevent his attendance at technical school as required by the Regulations.
- (j) Provide the apprentice with all tools necessary for carrying out his work.

*Apprentice and Parent or Guardian's Covenants.*

- (c) At all times while in the employment of the employer conduct himself in a courteous, obedient, and proper manner.

*Mutual Agreements.*

(3) At the end of paragraph (3) add the following provisos:—

Provided further—

- (i) that where the apprentice is required under the provisions of the proviso to paragraph (c) (i) hereof to work for less time than full time in any ordinary working week or month; or
- (ii) that where the indentures of any apprentice are suspended for any period by the Commission, the total period of time not served by the apprentice by reason of either of the above-mentioned provisions shall, at the option of the apprentice, be included in the term of his apprenticeship or be added to the term of his apprenticeship. In the event of such period being added to the term of his apprenticeship the apprentice shall be paid for such period at the wages rates prescribed in respect of the last year of his apprenticeship.

(10) That the apprentice shall be paid the same allowances as are from time to time paid by the employer to journeymen in the same trade for meal money, fares, travelling time, country work, and other matters, or, where such allowances are proportionate to the rates of pay received by journeymen, the apprentice shall be paid only such proportion thereof as the rates of pay of the apprentice bear to such journeymen's minimum rates of pay.

(11) That the apprentice will replace any of the tools supplied for his use as hereinbefore provided if lost or broken through his own carelessness.

*Rates of Pay of Apprentices.*

9. The minimum rates of pay to be paid as wages to apprentices in the said trades in each year of their apprenticeship course shall be as follows:—

- (a) With respect to the term of apprenticeship of five years—
 

1st year—	at the rate of	26s. 6d. per week.
2nd year—	at the rate of	36s. 0d. per week.
3rd year—	at the rate of	54s. 6d. per week.
4th year—	at the rate of	89s. 6d. per week.
5th year—	at the rate of	114s. 0d. per week.
- (b) With respect to the term of apprenticeship of four years—
 

1st year—	at the rate of	30s. 6d. per week.
2nd year—	at the rate of	54s. 0d. per week.
3rd year—	at the rate of	89s. 6d. per week.
4th year—	at the rate of	114s. 0d. per week.

*Rates for Overtime Worked.*

10. Where overtime (i.e., work done on Sundays and Public Holidays or outside ordinary working hours) is worked, the apprentice shall be paid by the employer wages for such overtime at the rate of time and a half, double time, or at such other rates (as the case may be) as the employer may for the time being be obliged to pay to the journeymen employed by him in the same trade, provided that the rate shall not be less than 1s. 6d. per hour.

*Standard of Proficiency.*

11. Should the apprentice in any year pass in the subjects prescribed for that year of his apprenticeship course and attain a standard as certified by the Commission of not less than an average of 75 per cent. of the possible marks allotted at the annual examinations approved by the Commission to the subjects of Trade Theory and Practice prescribed for that year of such course, he shall be deemed to have attained the standard of proficiency for such year.

*Increased Rates of Pay for Proficiency.*

12. When an apprentice attains in any year the standard of proficiency prescribed for that year of his apprenticeship course he shall—

- (a) for the first occasion on which he attains such standard be paid for the next succeeding year the sum of Two shillings per week in addition to the prescribed weekly wage;

- (b) for the second occasion on which he attains such standard be paid for the next succeeding year the sum of Two shillings and six pence per week in addition to the prescribed weekly wage;
- (c) for the third and/or fourth occasion on which he attains such standard be paid for the next succeeding year the sum of Three shillings per week in addition to the prescribed weekly wage.

*Proportion of Apprentices to Journeymen.*

13. The number of apprentices who may be employed by any employer at any time in the said trades shall not exceed the proportion of one apprentice to every three journeymen, or fraction of three journeymen, employed by such employer in such trade.

For the purposes of this Regulation an employer working at the trade shall be deemed to be a journeyman, and the number of journeymen employed at any time shall be deemed to be the average per working day of the number of journeymen employed in the said trade by such employer during the period of six months immediately preceding such time.

*Apprenticeship Course—Classes for Instruction.*

14. (a) The classes for instruction in the subjects of the apprenticeship course for the said trade shall be as set out in the Schedule hereto, but any apprentice or applicant who has the necessary qualifications may, subject to the approval of the Commission, be permitted to enter the classes prescribed for any year of the said course.

*Standard of Education to be Attained by an Apprentice.*

(b) The standard of education to be attained by an apprentice—

- (i) in the subjects of the first, second, and third years of his apprenticeship course in order that he may qualify to proceed to the classes for instruction prescribed for the next succeeding year, and
- (ii) in the subjects of the fourth year of the apprenticeship course in order that he may qualify in respect to education for the "final certificate" of the Commission—

shall be not less than 50 per cent. of the possible marks allotted at the annual examinations approved by the Commission in each year of the subjects prescribed for such year of the said course, or such average percentage of marks in all the said subjects deemed by the Commission to be equivalent thereto.

*Payment of School Fees.*

17 (a) The school fees of apprentices or applicants for attendance at the prescribed classes for instruction shall be paid by such apprentices or applicants, but on the receipt by the employer of a report from the Commission that any such apprentice or applicant has secured during the period covered by the report a record of not less than 80 per cent. of the possible attendances at the prescribed day and evening classes respectively, the employer shall refund to the apprentice or applicant the school fees paid by him for such period of instruction.

(b) In cases where the apprentice or applicant is prevented on occasions from attendance at the said classes through illness or accident, such occasions shall not be included as possible attendances in determining the aforesaid percentage provided that the employer may demand a medical certificate from the apprentice or applicant as proof of such illness or accident.

*Trade Experience Required of an Apprentice.*

18. The trade experience to be obtained by an apprentice in his apprenticeship course shall include gradual and complete instruction to the satisfaction of the Commission in the following processes:—

All classes of Electroplating and all things incidental thereto, including—

- (a) the preparation after polishing of materials for electroplating;
- (b) the electroplating of ware by electrolytic means;
- (c) the preparation, analysis and maintenance of solutions used;
- (d) in such establishments where electroplating is carried out, the colouring of metal and metallised surfaces; and
- (e) where the facilities exist, such instruction in polishing and finishing (not exceeding the period of six months) as will enable the apprentice to improve his knowledge of the trade of electroplating.

*Incorporation of General Regulations.*

19. The provisions of the following General Regulations made under the Acts shall apply in the said trade:—

General Regulations (No. 1), approved by the Governor in Council on the 18th day of September, 1928, and published in the *Victoria Government Gazette* on the 19th day of September, 1928.

General Regulations (No. 2), approved by the Governor in Council on the 26th day of October, 1928, and published in the *Victoria Government Gazette* on the 31st day of October, 1928.

General Regulations (No. 3), approved by the Governor in Council on the 10th day of December, 1928, and published in the *Victoria Government Gazette* on the 12th day of December, 1928.

General Regulations (No. 4), approved by the Governor in Council on the 24th day of December, 1931, and published in the *Victoria Government Gazette* on the 30th day of December, 1931.

General Regulations (No. 5), approved by the Governor in Council on the 9th day of December, 1932, and published in the *Victoria Government Gazette* on the 4th day of January, 1933.

General Regulations (No. 6), approved by the Governor in Council on the 17th day of May, 1943, and published in the *Victoria Government Gazette* on the 19th day of May, 1943.

General Regulations (No. 7), approved by the Governor in Council on the 29th day of July, 1947, and published in the *Victoria Government Gazette* on the 6th day of August, 1947.

*Schedule.*

Classes for Instruction in the Subjects of the Apprenticeship Course for the Trade of Electroplating.

First Year—	Hours Per Week.
Trade Theory .. Grade I.	2
Trade Practice .. Grade I.	4
Trade Mathematics .. Grade I.	1
Trade Science (Special Course)	1
<i>Second Year—</i>	
Trade Theory .. Grade II.	2
Trade Practice .. Grade II.	2
Trade Chemistry (Special Course)	2
Electricity and Magnetism (Special Course)	2
<i>Third Year—</i>	
Trade Theory .. Grade III.}	6
Trade Practice .. Grade III.}	
<i>Fourth Year—</i>	
Trade Theory .. Grade IV.}	6
Trade Practice .. Grade IV.}	

The detailed syllabus of the above-mentioned subjects shall be as determined by the Commission from time to time.

And the Honorable Herbert John Thornhill Hyland, His Majesty's Minister of Labour for the State of Victoria, shall give the necessary directions herein accordingly.

C. W. KINSMAN,  
Clerk of the Executive Council.

SHIRE OF NUMURKAH WATERWORKS TRUST.

At the Executive Council Chamber, Melbourne, the thirteenth day of January, 1948.

PRESENT:

The Lieutenant-Governor, as Deputy for His Excellency the Governor of Victoria.

Mr. Hollway | Mr. Byrnes.

EXTENT OF DISTRICT INCREASED.

UNDER the powers conferred by the Water Acts and all other powers enabling him in that behalf, the Lieutenant-Governor, as Deputy for His Excellency the Governor of the State of Victoria, by and with the advice of the Executive Council of the said State, doth hereby declare, order, and direct as follows:—

That the extent of the Waterworks District of the Shire of Numurkah Waterworks Trust be increased by adding thereto the lands set out and described in the Schedule hereto, and as on and from the date hereof the extent of such district shall be deemed to be increased accordingly.

## SCHEDULE.

Commencing at the south-eastern angle of Crown allotment 1A, section A, Parish of Picola, County of Moira; thence northerly along the eastern boundary of Crown allotment 1A to its north-eastern angle; thence westerly along the northern boundary of the said Crown allotment 1A to its north-western angle; thence westerly along the northern boundary of a road to a point on the eastern boundary of Crown allotment 3, section A; thence northerly along the eastern boundary of Crown allotment 3 to a point 1,100 links northerly from the south-eastern angle of that allotment; thence westerly by a line parallel to the southern boundary of Crown allotment 3 and by a line to a point in Crown allotment 5, distant 500 links westerly from the eastern boundary of the last-mentioned allotment; thence southerly by a line parallel to the eastern boundary of said Crown allotment 5 to the southern boundary of that allotment; thence westerly by the southern boundary of the last-mentioned allotment to a point distant 2,486.5 links westerly from the south-eastern angle of said Crown allotment 5; thence southerly by a line bearing south 0° 5' west, a distance of 615 links; thence easterly by a line parallel to the northern boundary of Crown allotment 2, section 2, Parish of Narioka, County of Moira, to a point distant 500 links from the eastern boundary of the last-mentioned allotment; thence southerly a distance of 735 links by a line parallel to the eastern boundary of Crown allotment 2; thence by a line bearing east 850 links; thence northerly by a line parallel to the western boundary of Crown allotment 3, section 2, in the said Parish of Narioka to the southern boundary of the Picola Railway Station Reserve; thence by a line bearing east 2,336 links (being the southern boundary of the Picola Railway Station Reserve); thence northerly along the eastern boundary of the said Railway Station Reserve to its intersection with the northern boundary of the Picola and Numurkah Railway Reserve; thence generally easterly along the northern boundary of the last-mentioned Railway Reserve to its intersection with the eastern boundary of Crown allotment 3; thence northerly along the eastern boundary of Crown allotment 3 to a point distant 450 links south from the northern boundary of the last-mentioned allotment; thence easterly by a line across Crown allotment 4, section 2, to a point in line with the eastern boundary of Crown allotment 1A, section A; thence northerly by a line across Crown allotment 4 and across a road to the point of commencement.

The lands set out and described in the foregoing Schedule are shown on a plan approved by the Governor in Council and deposited in the office of the State Rivers and Water Supply Commission, Melbourne.

And the Honorable John Gladstone Black McDonald, His Majesty's Minister of Water Supply for the State of Victoria, shall give the necessary directions herein accordingly.

C. W. KINSMAN,  
Clerk of the Executive Council.

## REVOCATION AND EXCISION OF CROWN RESERVATIONS ACT 1947.

*At the Executive Council Chamber, Melbourne, the thirteenth day of January, 1948.*

## PRESENT:

The Lieutenant-Governor, as Deputy for His Excellency the Governor of Victoria.

Mr. Hollway | Mr. Byrnes.

## REVOCATION OF RESERVATION OF CERTAIN LAND IN THE TOWN OF EMERALD HILL (NOW CITY OF SOUTH MELBOURNE).

IN pursuance of the provisions of section 2 (1) of the *Revocation and Excision of Crown Reservations Act 1947* (No. 5209), the Lieutenant-Governor, as Deputy for His Excellency the Governor of the State of Victoria, by and with the advice of the Executive Council of the said State, doth hereby revoke the permanent reservation by Order of 24th November, 1973, of an area of 1 acre 0 roods 3 perches of land in the Town of Emerald Hill (now City of South Melbourne) as a site for a Public Garden, as notified on pages 2088 and 2089 of the *Government Gazette* of 28th November, 1873.—(Rs.5669.)

And the Honorable John Gladstone Black McDonald, His Majesty's Commissioner of Crown Lands and Survey for the State of Victoria, shall give the necessary directions herein accordingly.

C. W. KINSMAN,  
Clerk of the Executive Council.

## DEPARTMENT OF LANDS AND SURVEY.

*At the Executive Council Chamber, Melbourne, the thirteenth day of January, 1948.*

## PRESENT:

The Lieutenant-Governor, as Deputy for His Excellency the Governor of Victoria.

Mr. Hollway | Mr. Byrnes.

## REVOCATION OF TEMPORARY RESERVATIONS OF LANDS BY ORDERS IN COUNCIL.

THE Lieutenant-Governor, as Deputy for his Excellency the Governor of the State of Victoria, by and with the advice of the Executive Council thereof, doth hereby, in pursuance of the provisions of the *Land Act 1928* revoke the temporary reservations of the lands by Orders in Council hereinafter referred to, viz.:

GOORAMADDA.—Order in Council of 25th August, 1911, of 2 acres of land in the Parish of Gooramadda, as a site for a State School.—(C.55676.)

KOO-WEE-RUP.—Order in Council of 23rd April, 1894, of 2 acres of land in the Parish of Koo-wee-rup, as a site for a State School, so far only as regards the portion thereof comprised within the boundaries published in the *Government Gazette* of 19th November, 1947, and containing 2 roods 32 perches.—(C.55304.)

NOWA NOWA.—Order in Council of 11th November, 1929, of 1 acre 0 roods 22 perches of land in the Township of Nowa Nowa, as a site for a State School, so far only as regards the portion thereof comprised within the boundaries published in the *Government Gazette* of 10th December, 1947, and containing 3 roods 12 perches.—(Rs.3926.)

YEA.—Order in Council of 23rd May, 1923, of 3 acres 3 roods 15 perches of land in the Township of Yea, as a site for Educational (playground), so far only as regards the portion thereof comprised within the boundaries published in the *Government Gazette* of 3rd December, 1947, and containing 2 roods 21 perches.—(Rs.2729.)

And the Honorable John Gladstone Black McDonald, His Majesty's Commissioner of Crown Lands and Survey for the State of Victoria, shall give the necessary directions herein accordingly.

C. W. KINSMAN,  
Clerk of the Executive Council.

## DEPARTMENT OF LANDS AND SURVEY.

*At the Executive Council Chamber, Melbourne, the thirteenth day of January, 1948.*

## PRESENT:

The Lieutenant-Governor, as Deputy for His Excellency the Governor of Victoria.

Mr. Hollway | Mr. Byrnes.

## UNUSED AND UNMADE ROADS CLOSED.

THE Lieutenant-Governor, as Deputy for His Excellency the Governor of the State of Victoria, by and with the advice of the Executive Council thereof, doth hereby direct that, in pursuance of the provisions of section 304 of the *Land Act 1928* (No. 3709), the unused and unmade roads referred to hereunder be closed, viz.:

Parish of Concongella, County of Borung, being the road in section 3, between allotments 6A, 7A and 8B, and allotment 7.—(C.371<sup>(6)</sup>) (C.90250).

City of Richmond, Parish of Jika Jika, County of Bourke, being that portion of Murphy-street between allotment 1 of section 33, and allotments B and C.—(R.19<sup>(3)</sup>) (C.90822).

Parish of Yarpurk, County of Villiers, being the road between the Recreation Reserve and allotments 2 and 1, section 24.—(Y.54<sup>(3)</sup>) (Rs.4671).

Parish of Noorinbee, County of Croajingolong, being the road lying between allotment 14, section A, and allotment 15, section A.—(N.156<sup>(3)</sup>) (H.018722).

And the Honorable John Gladstone Black McDonald, His Majesty's Commissioner of Crown Lands and Survey for the State of Victoria, shall give the necessary directions herein accordingly.

C. W. KINSMAN,  
Clerk of the Executive Council.

DEPARTMENT OF LANDS AND SURVEY.

At the Executive Council Chamber, Melbourne, the thirteenth day of January, 1948.

PRESENT:

The Lieutenant-Governor, as Deputy for His Excellency the Governor of Victoria.

Mr. Hollway | Mr. Byrnes.

LANDS TEMPORARILY RESERVED FROM SALE.

THE Lieutenant-Governor, as Deputy for His Excellency the Governor of the State of Victoria, by and with the advice of the Executive Council thereof, doth hereby, in pursuance of the provisions of the Land Act 1928, reserve, temporarily, and also except from occupation for mining purposes under any miner's right, the lands hereinafter described:—

**BUNINYONG.**—Site for the Supply of gravel, 106 acres, more or less, Parish of Buninyong, County of Grant, as indicated by hachure on plan hereunder.—(B.489<sup>(8)</sup>) (Rs.6098).

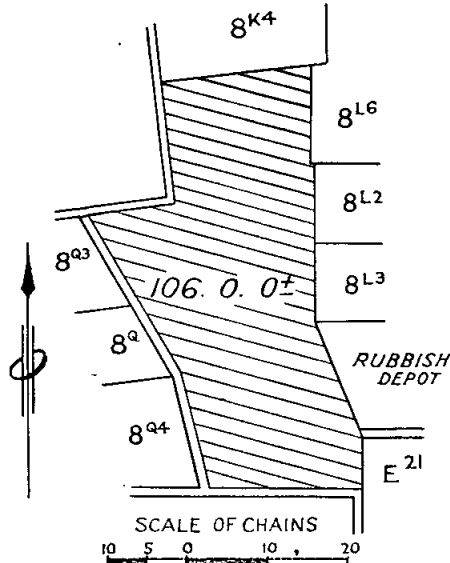

**COHUNA.**—Site for State School purposes, in addition to and adjoining the site temporarily reserved therefor by Order in Council of the 30th September, 1941, 3 roods 2 perches, Village of Cohuna, Parish of Cohuna, in the two separate portions as indicated by hachure on plan hereunder.—(C.424<sup>(6)</sup>) (Rs.5164).

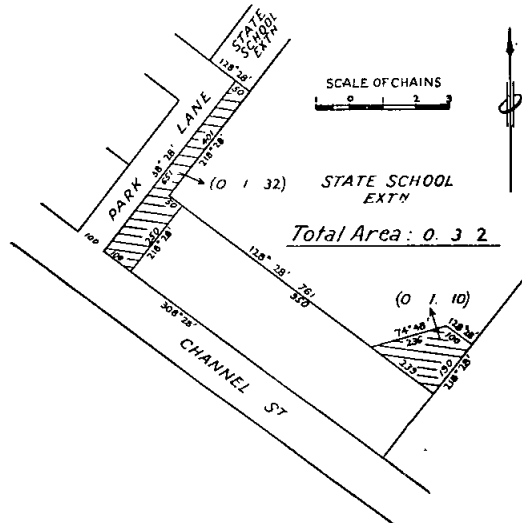

**HAMILTON.**—Site for Children's Playground, in addition to and adjoining the site temporarily reserved therefor by Order in Council of the 11th December, 1944, 3 perches, more or less, Town of Hamilton, Parish of North Hamilton, County of Dundas, as indicated by hachure on plan hereunder.—(H.45<sup>(2)</sup>) (Rs.5534).

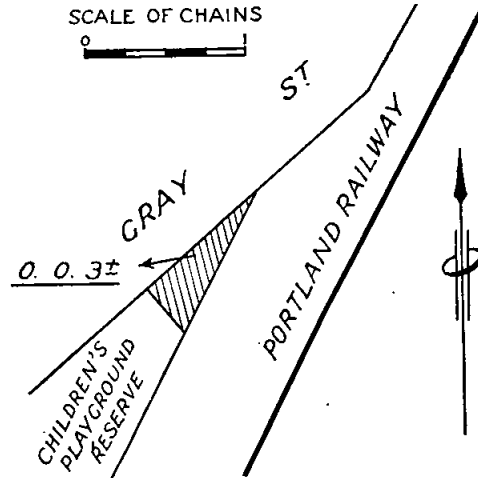

**ST. LEONARDS.**—Site for Public Recreation, 7 acres, more or less, Township of St. Leonards, Parish of Paywit, County of Grant, as indicated by hachure on plan hereunder.—(S.449<sup>(3)</sup>) (Rs.6096).

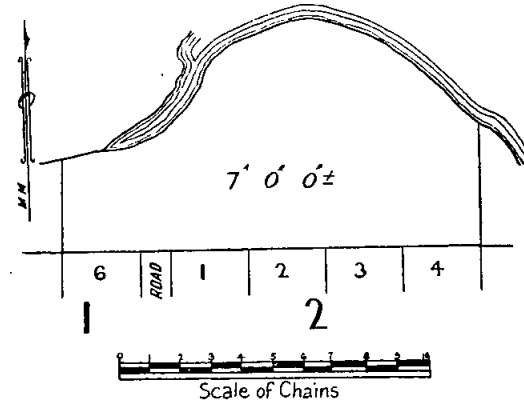

**POMPAPIEL.**—Site for Public Recreation, in addition to and adjoining the site temporarily reserved therefor by Order in Council of the 24th June, 1902, 11 acres, more or less, Parish of Pompapiel, County of Bendigo, as indicated by hachure on plan hereunder.—(P.120(A<sup>1</sup>)) (Rs.3851).

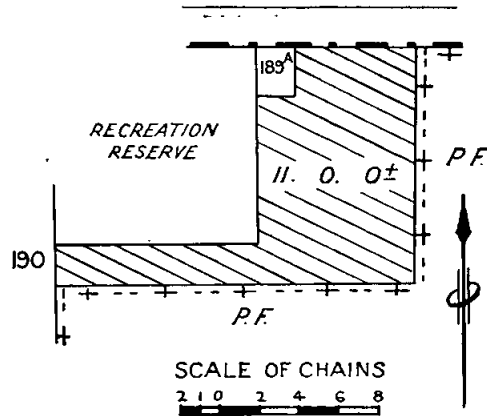

PRAHRAN (AT CAULFIELD).—Site for Police purposes, 1 rood 32 5/10 perches, Parish of Prahran (at Caulfield), County of Bourke, as indicated by hachure on plan hereunder.—(P.81(11) (Rs.6083).

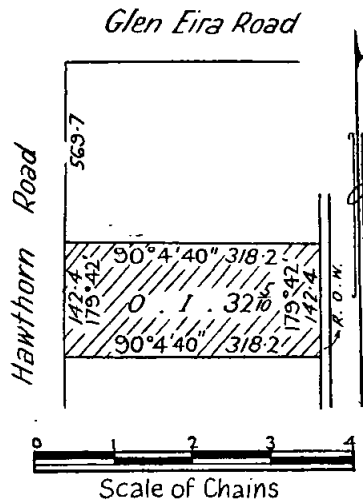

Annual Sittings of the Licensing Courts for the Licensing Districts shown below appointed to be held on the dates indicated, be extended by a period not exceeding two months from the 31st December, 1947 (section 87 of Act No. 3717).

*Licensing District; Date of Sittings.*

- Swan Hill; 6th November, 1947.
- Gippsland West; 19th November, 1947.
- Hawthorn; 19th November, 1947.
- Ivanhoe; 19th November, 1947.
- Wonthaggi; 5th November, 1947.
- Glen Iris; 19th November, 1947.
- Brighton; 19th November, 1947.
- Polwarth; 27th November, 1947.
- Murray Valley; 13th November, 1947.
- St. Kilda; 19th November, 1947.
- Port Melbourne; 19th November, 1947.
- Oakleigh; 19th November, 1947.

And the Honorable Trevor Donald Oldham, His Majesty's Attorney-General for the State of Victoria, shall give the necessary directions herein accordingly.

C. W. KINSMAN,  
Clerk of the Executive Council.

APPROACHING LAND SALES.

SALES of Crown lands, in fee-simple, will be held at the under-mentioned places and dates, viz.:—

	No. of Gazette.
Ballarat.—Tuesday, 17th February, 1948 ..	9
Benalla.—Tuesday, 17th February, 1948 ..	9
Bendigo.—Wednesday, 28th January, 1948 ..	485
Kyabram.—Thursday, 26th February, 1948 ..	19
Melbourne.—Thursday, 22nd January, 1948 ..	485
Sale.—Friday, 20th February, 1948 ..	19
Stanhope.—Thursday, 26th February, 1948 ..	19
Tatura.—Thursday, 26th February, 1948 ..	19
Tongala.—Thursday, 26th February, 1948 ..	19
Warracknabeal.—Thursday, 26th February, 1948 ..	19
Wonthaggi.—Wednesday, 28th January, 1948 ..	486

SALE OF RIGHT TO LEASE.

Melbourne.—Thursday, 22nd January, 1948 ..	485
--	-----

SALES BY AUCTION.

The lands will be sold in fee-simple, and subject to the covenants, conditions, exceptions, and reservations directed by the Governor in Council by an Order in Council dated the 5th August, 1930, and published in the *Government Gazette* of the 8th August, 1930, varied as herein.

A deposit of at least twelve and a half per centum of the price at which each lot is sold must be paid by the purchaser at the time of sale, and all such payments shall be made in bank notes or cheques approved by the officer conducting the sale, and the residue of such price will be payable in equal instalments, in accordance with the scale hereunder, on the last day of each successive period of six months from the time of sale, or, if the purchaser choose, at any earlier time or times; such residue of the price shall bear interest at the rate of £5 per centum per annum, to be computed between the time of sale and the time when payment of such residue or instalment of such residue is made. If the residue of the price be paid within thirty days after the time of the sale no interest will be payable thereon.

The Governor in Council may allow a transfer of the purchaser's interest to an approved person at any time before the final payment of the purchase money is made. The fee for transfer shall be One pound, and such transfer will be subject to payment of stamp duty.

SCALE OF PAYMENTS OF RESIDUE.

- £20 and under, 6 instalments.
- Over £20, and not exceeding £50, 8 instalments.
- Over £50, and not exceeding £100, 10 instalments.
- Over £100, and not exceeding £200, 12 instalments.
- Over £200, and not exceeding £300, 14 instalments.
- Over £300, and not exceeding £400, 16 instalments.
- Over £400, and not exceeding £500, 18 instalments.
- Over £500, 20 instalments.

ST. ARNAUD.—Site for Water Supply purposes, 5 acres, more or less, Parish of St. Arnaud, County of Kara Kara, as indicated by hachure on plan hereunder.—(S.366(5) Rs.6099).

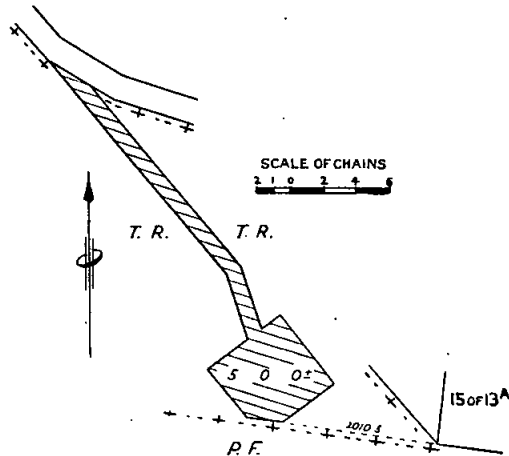

And the Honorable John Gladstone Black McDonald, His Majesty's Commissioner of Crown Lands and Survey for the State of Victoria, shall give the necessary directions herein accordingly.

C. W. KINSMAN,  
Clerk of the Executive Council.

LICENSING ACT 1928.

At the Executive Council Chamber, Melbourne, the thirteenth day of January, 1948.

PRESENT:

The Lieutenant-Governor, as Deputy for His Excellency the Governor of Victoria.  
Mr. Hollway | Mr. Eyrnes.

TIMES FOR HOLDING LICENSING COURTS EXTENDED.

THE Lieutenant-Governor, as Deputy for His Excellency the Governor of the State of Victoria, by and with the advice of the Executive Council thereof, doth by this Order direct that the times for holding the

## FEES, ETC.

The fees payable for Crown grant and assurance (One halfpenny for each pound of purchase price) must be paid with the balance of purchase money. The following is the scale:—

50 acres and under, £1 10s.  
Over 50 acres, £2.

Where the purchase money does not exceed £5, the grant fee is £1.

Valuations of improvements (if not purchased by the owner thereof), and charges for survey, must also be paid at the time of sale.

JOHN G. B. McDONALD,

Commissioner of Crown Lands and Survey.

Office of Lands and Survey.

Melbourne, 19th January, 1948.

**SALE.**—Sale (No. 10645) of Crown lands, in fee-simple, by auction will be held at the OFFICES of A. McLEAN AND COY., Raymond-street, SALE, on FRIDAY, the 20th FEBRUARY, 1948, at FOUR o'clock p.m. To be conducted by R. A. WALKER, Land Officer, Sale. Auctioneers: A. McLEAN AND COY.

LOWNGERUT, PARISH OF YEERUNG, COUNTY OF TANJIL.

*North-west of Munro Railway Station.*

Upset price £5 per lot. Charge for survey £3 per lot.

Lot 1. Area 2r. 0 2/10p. (subject to survey), allotment 7 of section 7.

Lot 2. Area 2r. 0 2/10p. (subject to survey), allotment 8 of section 7.

Lot 3. Area 2r. 0 2/10p. (subject to survey), allotment 9 of section 7.

Lot 4. Area 2r. 0 2/10p. (subject to survey), allotment 10 of section 7.

Lot 5. Area 2r. 0 2/10p. (subject to survey), allotment 11 of section 7.

Upset price £6 the lot. Charge for survey £3.

Lot 6. Area 2r. 39 6/10p. (subject to survey), allotment 12 of section 7.

PARISH OF GLENCOE, COUNTY OF BULN BULN.

*In the West of the Parish.*

Upset price £8 the lot. Charge for survey £6 6s.

Lot 7. Area 7a. 1r. 22p., allotment 41A.

**WARRACKNABEAL.**—Sale (No. 10646) of Crown lands, in fee-simple, will be held at the COURT HOUSE, WARRACKNABEAL, on THURSDAY, the 26th FEBRUARY, 1948, at half-past ELEVEN o'clock a.m. To be conducted by J. TIPPING, Land Officer, Horsham.

BRIM, PARISH OF BATCHICA, COUNTY OF BORUNG.

*In the South-east of the Township.*

Upset price £20 per lot. Charge for survey £3 per lot.

Lot 1. Area 1 rood, allotment 12 of section 11. One month allowed to remove improvements.

Lot 2. Area 1 rood, allotment 13 of section 11. One month allowed to remove improvements.

BEULAH, PARISH OF GALAQUIL, COUNTY OF KARKAROOC.

*Fronting Phillips-street.*

Upset price £40 per lot. Charge for survey £5 5s. per lot.

Lot 3. Area 39 6/10 perches (subject to survey), allotment 4 of section 3.

Lot 4. Area 39 6/10 perches (subject to survey), allotment 5 of section 3.

*Fronting Bell-street.*

Upset price £30 per lot. Charge for survey £5 5s. per lot.

Lot 5. Area 1 rood (subject to survey), allotments 5 and 6 of section 2.

*Corner of Bell and Phillips streets.*

Lot 6. Area 1 rood (subject to survey), allotment 7 of section 2.

Also, to be offered, under the provisions of the *Transfer of Land Act 1928*, for and on behalf of the Honorable the Minister of the Crown administering the Education Acts:—

PARISH OF WARRACKNABEAL, COUNTY OF BORUNG.

*Batchica School Site.*

Upset price £23 the lot.

Area 3 acres, allotment 63A, and being the area more particularly described in Crown grant, volume 5575, folio 1114949. Value of fencing sold with land.

Sale is subject to the following conditions:—

(a) The purchaser shall pay the purchase money in full at the sale.

(b) The preparation and registration of the transfer, under the *Transfer of Land Act*, shall be attended to by the purchaser or his solicitor, and all costs relating thereto shall be borne by the purchaser.

**TATURA.**—Sale (No. 10647) of Crown lands, in fee-simple, by auction will be held at the COURT HOUSE, TATURA, on THURSDAY, the 26th FEBRUARY, 1948, at half-past TWO o'clock p.m. To be conducted by H. J. HENKEL, Land Officer, Bendigo.

PARISH OF TOOLAMBA, COUNTY OF RODNEY.

*West of Toolamba Railway Station.*

Upset price £10 per lot. Charge for survey £3 2s. 6d. per lot.

Lot 1. Area 1r. 20 6/10p., subdivision 46 of allotment 135.

Lot 2. Area 1r. 20 4/10p., subdivision 47 of allotment 135.

**TONGALA.**—Sale by auction, under the provisions of the *Transfer of Land Act 1928*, for and on behalf of the Minister of the Crown administering the Education Acts, will be held at the LAND INSPECTOR'S OFFICE, TONGALA, on THURSDAY, the 26th FEBRUARY, 1948, at TWELVE o'clock noon. To be conducted by H. J. HENKEL, Land Officer, Bendigo.

PARISH OF TONGALA, COUNTY OF RODNEY.

*In the North-east of the Parish, and being a former State School Site.*

Upset price £20 the lot.

Area 2 acres, part of allotment 37, being the land more particularly described in freehold certificate of title, volume 3249, folio 649691.

Sale is subject to the following conditions:—

(a) The purchaser shall pay the purchase money in full at the sale.

(b) The preparation and registration of the transfer, under the *Transfer of Land Act*, shall be attended to by the purchaser or his solicitor, and all costs relating thereto shall be borne by the purchaser.

**KYABRAM.**—Sale by auction, under the provisions of the *Transfer of Land Act 1928*, for and on behalf of the Minister of the Crown administering the Education Acts, will be held at the LAND INSPECTOR'S OFFICE, KYABRAM, on THURSDAY, the 26th FEBRUARY, 1948, at ONE o'clock p.m. To be conducted by H. J. HENKEL, Land Officer, Bendigo.

PARISH OF KYABRAM, COUNTY OF RODNEY.

*At the South-east corner of allotment 118.*

Upset price £11 10s. the lot.

Area 1 acre, part of allotment 118, being the land more particularly described in freehold certificate of title, volume 2835, folio 566996.

Sale is subject to the following conditions:—

(a) The purchaser shall pay the purchase money in full at the sale.

(b) The preparation and registration of the transfer, under the *Transfer of Land Act*, shall be attended to by the purchaser or his solicitor, and all costs relating thereto shall be borne by the purchaser.

*Closer Settlement Act 1938.*

SALE BY AUCTION.

**WARRACKNABEAL.**—A sale of the under-mentioned land, in fee-simple, by auction will be held at the COURT HOUSE, WARRACKNABEAL, on THURSDAY, the 26th FEBRUARY, 1948, at ELEVEN o'clock a.m. To be conducted by J. TIPPING, Land Officer, Horsham.

TERMS AND CONDITIONS.

Deposit to be paid at sale, 15 per cent. of purchase price. Balance payable by twenty equal half-yearly instalments, with interest computed at the rate of 4½ per cent. per annum on the unpaid balance.

The Board of Land and Works may allow a transfer of the purchaser's interests to an approved person at any time before the final payment is made (fee, £1). The registration of the transfer may be subject to payment of such further sum as the Board may require in reduction of the outstanding balance.



Purchaser may pay balance and fees at any time prior to the due date.

Crown grant will be prepared and issued as soon as practicable after payment of purchase money in full.

Improvements to be maintained and insured with the Board of Land and Works.

JOHN G. B. McDONALD,  
Commissioner of Crown Lands and Survey.  
Melbourne, 19th January, 1948.

PARISH OF KELLALAC, COUNTY OF BORUNG.  
*In the South-eastern Corner of the Parish.*

Formerly leased to H. H. Krause.  
Area 97a. Or. 39p., allotment 62c.

The Board of Land and Works may allow a transfer of the purchaser's interests to an approved person at any time before the final payment is made (fee, £1). The registration of the transfer may be subject to payment of such further sum as the Board may require in reduction of the outstanding balance.

Purchaser may pay balance and fees at any time prior to the due date.

Crown grant will be prepared and issued as soon as practicable after payment of purchase money in full.

Improvements to be maintained and insured with the Board of Land and Works.

JOHN G. B. McDONALD,  
Commissioner of Crown Lands and Survey.  
Melbourne, 19th January, 1948.

*Closer Settlement Act 1938.*

SALE BY AUCTION.

STANHOPE.—A sale of the under-mentioned land, in fee-simple, by auction will be held at the PUBLIC HALL, STANHOPE, on THURSDAY, the 26th FEBRUARY, 1948, at TEN o'clock a.m. To be conducted by H. J. HENKEL, Land Officer, Bendigo. Auctioneer: A. F. McDONALD, Stanhope.

TERMS AND CONDITIONS.

Deposit to be paid at sale, 25 per cent. of purchase price. Balance payable by four equal half-yearly instalments, with interest computed at the rate of 4½ per cent. per annum on the unpaid balance.

STANHOPE, PARISH OF GIRGARRE, COUNTY OF RODNEY.

*Fronting Birdwood-street.*

Survey fee £1 10s. per lot.

- Lot 1. Area 20 1/10 perches, allotment 11 of section 4.
- Lot 2. Area 29 7/10 perches, allotment 12 of section 4.
- Lot 3. Area 26 perches, allotment 13 of section 4.
- Lot 4. Area 26 perches, allotment 14 of section 4.
- Lot 5. Area 34 5/10 perches, allotment 16 of section 4.
- Lot 6. Area 30 perches, allotment 17 of section 4.
- Lot 7. Area 30 perches, allotment 18 of section 4.

*Land Act 1928.*

LEASES UNDER THE LAND ACTS 1915 AND 1928 DECLARED VOID.

NOTICE is hereby given that the Leases mentioned in the Schedule hereunder have been declared void by the Governor in Council for the reason specified in each case.

District.	Corr. No.	Name of Lessee.	Section of Land Act under which Leased.	Parish.	Allotment.	Area.	Class.	Annual Rental.	Reasons for Voiding.
						A. R. P.		£ s. d.	
Geelong ..	286/44	John Simper ..	44	Cooriejong	61B	157 1 8	3rd	3 19 0	Non-compliance with conditions New lease to issue
Melbourne	0418/125	Johnsons Tyne Foundry Proprietary Ltd.	125	Melbourne South	81	1 3 39 <sup>1</sup> / <sub>10</sub>	..	..	

Department of Lands and Survey,  
Melbourne, 14th January, 1948.

JOHN G. B. McDONALD,  
Commissioner of Crown Lands and Survey.

*Land Act 1928.*

LICENCE UNDER THE LAND ACTS 1915 AND 1928 DECLARED VOID.

NOTICE is hereby given that the Licence mentioned in the Schedule hereunder has been declared void for the reason specified.

District.	Corr. No.	Name of Licensee.	Section of Land Act under which Licensed.	Parish.	Allotment.	Area.	Class.	Annual Rental.	Reasons for Voiding.
								£ s. d.	
Bairnsdale	0190/129	William Ray ..	129	Bairnsdale	Net rack site	..	..	0 10 0	Non-payment of rents

Department of Lands and Survey,  
Melbourne, 21st January, 1948.

JOHN G. B. McDONALD,  
Commissioner of Crown Lands and Survey.

**PROPOSED REVOCATIONS OF TEMPORARY RESERVATIONS OF LANDS BY ORDERS IN COUNCIL.**

IN pursuance of the provisions of the *Land Act 1928*, notice is hereby given that it is the intention of the Governor in Council to revoke the temporary reservations of lands by Orders in Council hereunder referred to, viz.:-

The following Notices were published 1<sup>o</sup> on the 21st January, 1948, pursuant to Orders of the 13th January, 1948.

**CLUB TERRACE.**—The Order in Council of the 24th April, 1899, temporarily reserving 1 rood 39 4/10 perches of land as a site for Public purposes in the Township of Club Terrace, being allotment 6 of section 3, is about to be revoked.—(C.457(1) (Rs.4718).

**MALMSBURY.**—The Order in Council of the 19th October, 1937, temporarily reserving 1 acre 3 roods 28 1/10 perches of land in the Town of Malmsbury as a site for Police purposes is about to be revoked so far only as regards the portion indicated by hachure on plan hereunder.—(M.65(4) (Rs.4717).

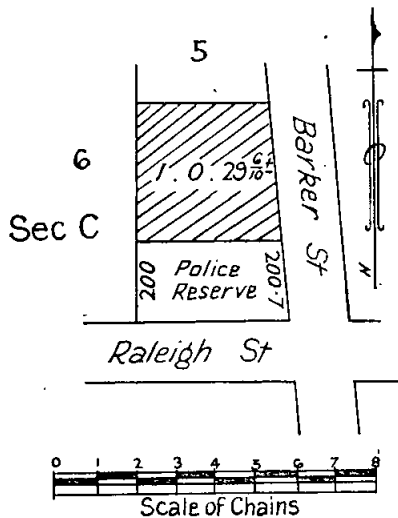

**MAMENGOROOK.**—The Order in Council of the 13th July, 1925, temporarily reserving as a site for Public purposes 4.617 acres, more or less, of land in the Parish of Mamengorook, is about to be revoked so far only as regards the portion containing 48 acres, more or less, indicated by hachure on plan hereunder.—(M.578(4) (Rs.3144).

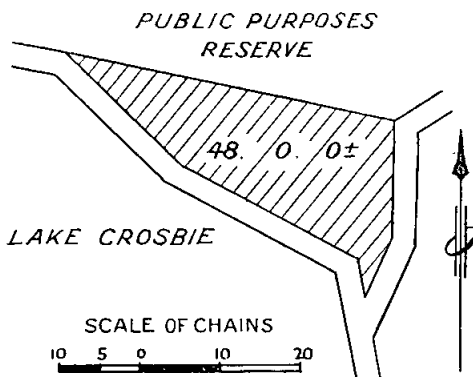

**MOKOAN.**—The Order in Council of the 15th May, 1888 (see *Government Gazette* of the 18th May, 1888, page 1509), temporarily reserving 27 acres 2 roods 25 perches of land as a site for Water Supply purposes in the Parish of Mokoan, is about to be revoked.—(M.463(5) (H.018741).

**HAMILTON.**—The Order in Council of the 20th December, 1872, temporarily reserving 3 roods 22 1/2 perches of land in the Town of Hamilton, being portion of section 11, as

a site for Police purposes, is about to be revoked so far only as regards the portion indicated by hachure on plan hereunder.—(H.45(2) (Rs.359).

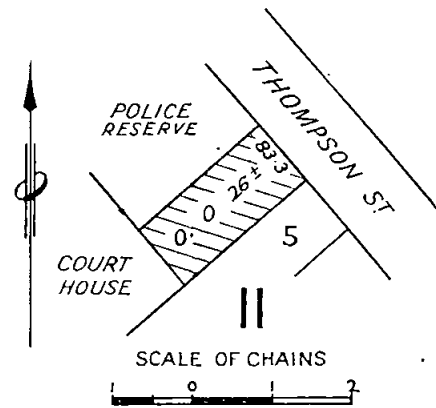

**SANDHURST.**—The Order in Council of the 9th August, 1881 (see *Government Gazette* of the 12th August, 1881, page 2338), temporarily reserving as a site for Rifle ranges, and withholding from sale, leasing, and licensing 15 acres of land in the Parish of Sandhurst, revoked as to part by Order of the 4th December, 1929 (see *Government Gazette* of the 11th December, 1929, page 4172), is about to be further revoked as regards the balance thereof containing 5 acres 1 rood 19 perches.—(S.371(18) (W.61186).

**WITCHIPOOL.**—The Order in Council of the 27th February, 1865 (see *Government Gazette*, 7th March, 1865, page 571), temporarily reserving 1 acre of land, more or less, at Banyenong West, now Parish of Witchipool, as a site for Presbyterian Church purposes, is about to be revoked.—(W.299(4) (C.91028).

JOHN G. B. McDONALD,  
Commissioner of Crown Lands and Survey.

**"NOLEN'S PARK," BOORT.**

**RESCISSION OF REGULATIONS.**

THE Board of Land and Works, in pursuance of the powers conferred on it, doth hereby rescind the Regulations made on the 28th July, 1931, for the care, protection, and management of the land temporarily reserved as a site for a Public Park and Garden in the Township and Parish of Boort, and known as "Nolen's Park."—(Rs.440.)

As witness thereof the common seal of the Board of Land and Works was hereunto affixed this sixteenth day of January, 1948, in the presence of—

(SEAL) JOHN G. B. McDONALD, President.  
J. E. HUNTER, Member.

**REGULATIONS FOR THE CARE, PROTECTION, AND MANAGEMENT OF THE "MARYBOROUGH BOTANICAL GARDENS RESERVE."**

WHEREAS by section 181 of the *Land Act 1928*, as re-enacted by section 9 of the *Land Act 1941*, power is given to the Board of Land and Works to make Regulations in respect of the care, protection, and management of any Crown land which has been reserved under the Land Acts for any public purpose whatsoever, and which has not been conveyed to or vested in trustees, and for the further purposes as enacted: Now therefore the Board of Land and Works, in pursuance of the powers conferred as aforesaid, doth hereby make the following Regulations in respect of the land temporarily reserved by Order in Council of 22nd April, 1879, as a site for park and garden, and for dam and reservoir purposes, in the municipal district of Maryborough, and known as the "Maryborough Botanical Gardens Reserve," hereinafter referred to as the "Reserve."

**REGULATIONS.**

1. The Reserve shall be open to the public from sunrise to sunset, free of charge, except as hereinafter provided.
2. No person shall enter or remain in the Reserve who may offend against decency as regards dress, language, or conduct, and no society, club, picnic party, or other combined body shall be allowed to use the Reserve, without permission, in writing, of the Committee of Management first obtained.

3. No person shall climb or jump over the fences or gates, stick bills thereon, or cut names in the fences, trees, seats, or in any way damage or deface any of the buildings, fences, gates, seats, paving, or any property in or enclosing the Reserve, or leave or roll stones therein, or enter or pollute any water in the Reserve, or remove therefrom any soil, sand, or manure.

4. No person shall interfere with or remove any trees, shrubs, plants, fish, birds, or other property in the Reserve, or throw any stones or other missiles, or commit any nuisance, or leave therein any glass, paper, or other litter, except in receptacles that may be provided for the purpose.

5. No person shall make or cause to be made any violent outcry, noise, disturbance, or sound, or shall play upon any musical or noisy instrument, or sing, in the Reserve, nor shall any person preach or declaim, harangue, or deliver any address of any kind to the members of the public in the Reserve, without the permission, in writing, of the Committee of Management first obtained.

6. No person shall spit or expectorate on the paths or on any structure or erection in or enclosing the Reserve.

7. No person shall bet publicly in any part of the Reserve, and any person infringing this Regulation shall be liable to expulsion from the Reserve.

8. No person shall play, practise, or engage in any game or sport within the Reserve.

9. No person shall bring or allow to remain in the Reserve any cattle, sheep, pigs, goats, fowls, or other animals, and any such found therein shall be liable to be destroyed.

10. No person shall camp or light a fire in the Reserve.

11. No booth, tent, or other structure shall be erected in the Reserve, without the consent, in writing, of the Committee of Management first obtained.

12. No person shall offer for sale within the Reserve any article or articles, without the permission, in writing, of the Committee of Management first obtained.

13. No person shall take part in any public entertainment of any sort in the Reserve, without the permission, in writing, of the Committee of Management first obtained.

14. No person shall remove or displace any board, plate, or tablet, or any support, fastening, or fitting, used or constructed or adapted to be used for the exhibition of any Regulations or notice, and fixed or set by the Committee of Management in the Reserve.

15. No person shall bring into the Reserve any dog, unless controlled by a chain or cord.

16. No children under five (5) years of age shall be allowed in the Reserve, unless in charge of a parent or guardian.

17. No person shall carry or use firearms or fishing tackle in the Reserve, without the consent, in writing, of the Committee of Management first obtained.

18. No person shall in any part of the Reserve wilfully obstruct, disturb, interrupt, or annoy any other person in the proper use of the Reserve, or wilfully obstruct in the execution of his duty, or insult, or neglect to obey the lawful directions of any curator or other servant of the Committee of Management thereof.

19. No person, except those in the employ of or authorized by the Committee of Management thereof, shall ride or drive any horse or any bicycle or motor vehicle in the Reserve.

Every person who contravenes or fails to comply with these Regulations shall, in accordance with the provisions of section 181 of the *Land Act* 1928, as re-enacted by section 9 of the *Land Act* 1941, for each offence be liable to a penalty of not more than Five pounds, and every person who contravenes or fails to comply with any such Regulation, and who, after he has been warned by any bailiff of Crown lands or member of the Police Force, does not desist therefrom, may be forthwith apprehended by such bailiff or member of the Police Force and taken before some justice to be dealt with according to law, and shall be liable to a penalty of not more than Ten pounds.

The common seal of the Board of Land and Works was hereunto affixed this sixteenth day of January, 1948, in the presence of—

(SEAL) JOHN G. B. McDONALD, President.  
J. E. HUNTER, Member.

The Council of the Borough of Maryborough has been appointed a Committee of Management, with power and authority to enforce the foregoing Regulations.—(Rs.851.)

## COMMITTEES OF MANAGEMENT OF RESERVES.

### APPOINTMENTS.

WHEREAS by section 184 of the *Land Act* 1928 it is provided that it shall be lawful for the Governor in Council or the Board of Land and Works to appoint and remove any number of persons, not less than three, or any municipal council, or the governing body of any corporation, to be a Committee of Management of any specified Crown land reserved either temporarily or permanently for any of the purposes set out in section 14 of the *Land Act* 1928, and not conveyed to or vested in trustees: Now therefore the Board of Land and Works doth hereby appoint the under-mentioned persons to be members of the Committee of Management of the Reserves named:—

#### "TOORONGO VALLEY RESERVE."

Cyril Norman Blackwood and William John Beck as members of the Committee of Management for the period ending 1st July, 1949, of the Reserves for Public Purposes in the Parishes of Neerim and Noojee East (Toorong Valley, &c.) as is indicated by pink tint on plan marked N.E.5/10/22 attached to Lands Department correspondence Rs.2952 and known as the "Toorong Valley Reserve," in the place of Hedley A. Heighway and Leo O'Donohue, who have left the district.—(Corres. Rs.2952.)

#### "SALE TEMPERANCE HALL SITE."

Samuel Lauchlan Lacey, John Kenneth Gregg, James Brown Campbell, Robert Guest, and George Henry Field as a Committee of Management for a period of three (3) years of the land temporarily reserved by Order in Council dated 16th August, 1937, as a site for Temperance Hall Purposes in the Parish of Sale, and known as the "Sale Temperance Hall Reserve."—(Corres. Rs.4710.)

#### "OFFICER PUBLIC HALL AND LIBRARY RESERVE."

Percy Charles Brown, John Campbell Cunningham, Frederick George Baker, Rosie M. Swift, Basil Alcuin Dodd, Errol Gordon Robinson, Peter McMullen, Isaac Amos Wright, and Thomas Clair Whiteside as a Committee of Management for a period of twelve (12) months from 1st January, 1948, of the land temporarily reserved by Order in Council dated the 9th September, 1940, as a site for a Public Hall and Library in the Parish of Pakenham at Officer, and known as the "Officer Public Hall and Library Reserve."—(Corres. Rs.5088.)

#### "RUPANYUP RACECOURSE AND RECREATION RESERVE."

George Lendrum Cromie, Archibald George Swan, Percy James Gissing, Gordon Herbert Hemphill, and Harry Johnston as the Committee of Management for a period of three (3) years from the 26th September, 1947, of the land temporarily reserved by Order in Council dated the 23rd December, 1936, as a site for Public Park, Racecourse and Recreation Purposes in the Parish of Lallat, and known as the "Rupanyup Racecourse and Recreation Reserve."—(Corres. Rs.1848.)

#### "MURTOA SHOW YARDS RESERVE."

Herman Heinrich Holtkamp, Daniel Alphonsus Tobin, Roderick Mark Delahunty, Rupert Vivian Bates, Jack Rudolph Anders, Arthur Edward Sprake, and Victor Rahl as the Committee of Management for a period of three (3) years from the 10th January, 1948, of the land temporarily reserved by Order in Council dated the 14th May, 1895, as a site for Show Yards in the Parish of Ashens, and known as the "Murtoa Show Yards Reserve."—(Corres. Rs.2627.)

#### "NUMURKAH SHOW GROUNDS RESERVE."

William G. Hooper, William Prentice, John D. Hendy, Ernest C. Watters, and Thomas A. Morris as a Committee of Management for a period of three (3) years from 21st December, 1947, of the land permanently reserved by Order in Council dated 7th March, 1933, as a site for Show Yards in the Township of Numurkah, and known as "Numurkah Show Yards Reserve."—(Corres. Rs.1294.)

#### "RECREATION RESERVE IN HAVILAH-ROAD, CITY OF BENDIGO."

The Council of the City of Bendigo as the Committee of Management of the land temporarily reserved by Order in Council of the 16th September, 1947, as a site for Public Recreation in the City of Bendigo.—(Corres. Rs.6053.)

"LORNE FORESHORE AND OTHER RESERVES."

Theophilus William Joseph Grace in the place of Frank E. Richardson, resigned, as a representative of the Board of Land and Works on the Committee of Management of those portions of the reserved Crown lands in the Township and Parish of Lorne, as is indicated in red colour on the plan marked L/8.5.42 attached to Lands Department correspondence Rs.1690, and known as the "Lorne Fore-shore and other Reserves."—(Corres. Rs.1690.)

"GREAT WESTERN RECREATION RESERVE."

Colin T. Preece, Donald J. McKay, Warren Taylor, Ian F. Kilpatrick, and Louis G. Grellet as a Committee of Management for a period of three (3) years from 3rd January, 1948, of the land temporarily reserved by Order in Council dated the 13th May, 1867, as a site for Racing and General Recreative Purposes at Great Western, and known as the "Great Western Recreation Reserve."—(Corres. Rs.2903.)

"CRESWICK RACECOURSE AND RECREATION RESERVE."

John Thomas Mullins, Leonard Moore, Robert Anderson, John Patrick Slattery, and Daniel Benedict Moore as a Committee of Management for a period of three (3) years from 20th December, 1947, of the land temporarily reserved as a site for Racing and other purposes of Public Recreation in the Parish of Tourella, and known as the "Creswick Racecourse and Recreation Reserve."—(Corres. Rs.697.)

"EXTENSION OF A QUARRY RESERVE IN THE CITY AND PARISH OF BALLAARAT."

The Council of the City of Ballarat as a Committee of Management of the land temporarily reserved by Order in Council of the 18th December, 1947, as an extension of a site for a Quarry in the City and Parish of Ballarat.—(Corres. Rs.3712.)

EXTENSION OF THE "NYORA SHOW YARDS RESERVE."

William Henry Forster, John William Grundy, William Charles Hutchinson, Henry William Dart, James Horsburgh, William Bellingham, and John Duncan Mitchell as a Committee of Management for the period ending 12th February, 1949, of the land temporarily reserved by Order in Council dated 9th December, 1947, as a site for Showyards in the Parish of Lang Lang East.—(Corres. Rs.493.)

"NEWBRIDGE RECREATION RESERVE."

William Metelman, George Bartlett, Leslie Holland, Dominic Charles Bravo, William Leslie Stewart, John William Ramsay, and Edward John Hennessy as the Committee of Management for a period of three (3) years from the 6th December, 1947, of the land temporarily reserved by Order in Council dated the 17th May, 1865, for purposes of Public Recreation at Newbridge.—(Corres. Rs.1428.)

"MAJORCA VICTORIA PARK AND PUBLIC GARDENS RESERVE."

Arthur John Gibbs, James Johnson Young, Alfred Charles Hemley, David Wilson Bilton, Archibald John Mason, Harold Osborn Gibbs, and William John Nisbet as the Committee of Management for a period of three (3) years from the 17th November, 1947, of the land temporarily reserved by Order in Council dated the 28th February, 1876, as a site for Public Gardens at Majorca, and the lands temporarily reserved for Racecourse, Recreation Purposes, and Public Park at Majorca, Parish of Craigie, and known as "Victoria Park."—(Corres. Rs.572.)

ADDITION TO THE "OAKLEIGH PUBLIC PARK AND GARDENS RESERVE."

The Council of the City of Oakleigh, as a Committee of Management of the land temporarily reserved by Order in Council dated 2nd December, 1947, as a site for Public Park and Recreation purposes, in addition to the present site known as the "Oakleigh Public Park and Gardens Reserve."—(Corres. Rs.1121.)

"LEEOR-SERVICETON RECREATION RESERVE."

John Ronald King, Laurie Fryar, Allan Edward Earl, Alexander John Charles, Herbert Harrow Farrow, William Copeman, and Arthur William Parsons, as the Committee of Management, for a period of three (3) years, of the land

temporarily reserved by Order in Council dated the 24th April, 1928, as a site for Public Recreation in the Parish of Leeor, and known as the "Leeor-Serviceton Recreation Reserve."—(Corres. Rs.3643.)

"DIMBOOLA RECREATION RESERVE."

The Council of the Shire of Dimboola, as the Committee of Management of the land temporarily reserved by Order in Council dated the 7th February, 1881, as a site for Public Gardens and other purposes of Public Recreation in the Town of Dimboola, and known as the "Dimboola Recreation Reserve."—(Corres. Rs.2260.)

This appointment is in lieu of all previous appointments, which are hereby revoked.

"GERANG GERUNG RECREATION RESERVE."

Frederick Klinge, as a member of the Committee of Management in the place of Percy Arnold Collins, who has resigned, for a period ending 6th June, 1949, of the lands temporarily reserved by Orders in Council dated 18th February, 1890, and 6th July, 1915, as sites for Public Recreation in the Parish of Gerang Gerung, and known as the "Gerang Gerung Recreation Reserve."—(Corres. Rs.106.)

"HEATHCOTE MUNICIPAL PURPOSES RESERVE."

The Council of the Shire of McIvor, as a Committee of Management of the lands temporarily reserved by Orders in Council dated 6th May, 1913, and 13th November, 1947, as a site for Municipal purposes in the Town and Parish of Heathcote.—(Corres. Rs.1395.)

"MURRAYVILLE RECREATION AND SHOW GROUNDS RESERVE."

Charles Frederick Lackmann, to be a member and the chairman of the Committee of Management of the lands temporarily reserved by Orders in Council dated 5th August, 1912, 3rd August, 1920, 9th April, 1923, and 24th October, 1932, for Recreation purposes and Show Grounds in the Township of Murrayville, Parish of Danyo, for so long only as he shall continue to be a Councillor and the elect of the Council of the Shire of Waipau, in the place of Wilhelm Henry Kruse, who has ceased to hold office as a Councillor of such Shire.—(Corres. Rs.2072.)

"BARKER'S CREEK RECREATION RESERVE."

Edward Frank Pritchard, Alfred James Peeler, and Clifford Norris, as the Committee of Management, for a period of three (3) years from the 20th November, 1947, of the land temporarily reserved by Order in Council dated the 29th January, 1889, as a site for Cricket and other purposes of Public Recreation in the Parish of Castlemaine, and known as the "Barker's Creek Recreation Reserve."—(Corres. Rs.3082.)

"CASHMORE RECREATION RESERVE."

George Fredrick Kerr, Vincent Albert Antony, John Joseph Antony, Oliver Charles Lang, and Richard Ernest Goldby, as a Committee of Management, for a period of three (3) years from the 8th December, 1947, of the land temporarily reserved by Order in Council dated 16th October, 1934, as a site for Public Recreation in the Parish of Trewalla, and known as the "Cashmore Recreation Reserve."—(Corres. Rs.4408.)

"CASTERTON RACECOURSE RESERVE."

Lawrence Theyre O'Neill, Joseph Henry McCombe, Frederick Osborne, William Henry Mitchell, Herbert David Mitchell, James Richmond Bryan, John Riddell Carter, Percy Quarles Pinnell, Frederick Martin, and Norman Clifton McClelland, as a Committee of Management, for a period of three (3) years from 1st January, 1948, of the land permanently reserved by Order in Council dated the 17th September, 1883, as a site for a Racecourse in the Parish of Casterton, and known as the "Casterton Racecourse Reserve."—(Corres. Rs.1771.)

"SHELFORD MECHANICS' INSTITUTE RESERVE."

Roy Gillett, James William Simpson, John Richard Heard, John Alexander McKenzie, John Andrew Simpson, and Frederick Thomas Challis, as a Committee of Management, for a period of three (3) years from the 6th December, 1947, of the land temporarily reserved by Orders in Council dated 1st August, 1864, and 23rd October, 1945, as a site for a Mechanics' Institute in the Township of Shelford, and known as the "Shelford Hall."—(Corres. Rs.2561.)

"CASHMORE PUBLIC HALL RESERVE."

Vincent Albert Antony, John Joseph Antony, and Oliver Charles Lang, as a Committee of Management, for a period of three (3) years from the 8th December, 1947, of the land temporarily reserved by Order in Council dated 23rd March, 1914, as a site for a Public Hall in the Parish of Trewalla, and known as the "Cashmore Public Hall Reserve."—(Corres. Rs.734.)

"GOOLENGOOK CAMPING RESERVE," WENDON PARK.

Dougald McIntyre, Henry Farmer, John Burton Clay, Philip Henry Farmer, Walter John Gray, and Hugh Alpherson Royal McDonald, as a Committee of Management, for a period of three (3) years, of the land temporarily reserved by Order in Council dated 18th December, 1947, together with the adjoining permanent reservation along the Bemm River, as shown coloured red and blue on plan "G," 8th December, 1947, attached to Lands Department Correspondence Rs.6087, as a site for Tourist Camping purposes in the Parish of Goolengook, and known as "Wendon Park."—(Corres. Rs.6087.)

"VOLCANO WATER RESERVE," IN THE PARISH OF SWANWATER.

The St. Arnaud Borough Waterworks Trust, as a Committee of Management of the land temporarily reserved by Order in Council of the 16th December, 1947, as a site for Affording Access to Water and for other Public purposes in the Parish of Swanwater, and known, together with the land permanently reserved for such purposes by Order of the 8th November, 1880, as the "Volcano Water Reserve."—(Corres. Rs.3824.)

"DROMANA SOLDIERS' MEMORIAL HALL RESERVE."

Reuben Moorehead, John Brown, Jack Maynard Cornish, James Clwydd Osborne, Arthur Frederick Johnson, Ronald Anson Hipwell, and John Pritchard Wallace, as a Committee of Management for a period of three (3) years from 15th December, 1947, of the land temporarily reserved by Order in Council dated the 25th October, 1921, as a site for a Public Hall in the Parish of Kangerong, at Dromana, and known as the "Dromana Soldiers' Memorial Hall Reserve."—(Corres. Rs.2405.)

"MARYBOROUGH RECREATION RESERVE."

The Council of the Borough of Maryborough; as the Committee of Management of the land temporarily reserved by Order in Council of the 13th November, 1947, as a site for Public Recreation and Drainage purposes in the Town of Maryborough.—(Corres. Rs.6079.)

"WOLLONABY (GLEN VALLEY) PUBLIC HALL RESERVE."

John George Barker, Victor Charles Hulme, and Thomas Prendergast, as a Committee of Management for a period of three (3) years from 5th November, 1947, of the land temporarily reserved by Order in Council dated 30th June, 1941, as a site for a Public Hall in the Parish of Wollonaby, and known as the "Wollonaby Public Hall Reserve."—(Corres. Rs.4627.)

"COLAC PUBLIC PARK AND RECREATION RESERVE."

The Council of the Borough of Colac as a Committee of Management of the land temporarily reserved by Order in Council of 13th November, 1947, as a site for Public Park and Public Recreation in the Town of Colac.—(Corres. Rs.6073.)

"FENTON'S CREEK RECREATION RESERVE."

Ronald Dudley Stephenson, Thomas Stephenson, John Sutton, Charles Henry Finch, and Arthur Charles E. Finch, as a Committee of Management for a period of three (3) years of the land temporarily reserved by Order in Council dated the 27th October, 1910, as a site for Public Recreation in the Parish of Berrimal, and known as "Fenton's Creek Recreation Reserve."—(Corres. Rs.23.)

"BOORT RACECOURSE AND RECREATION RESERVE."

James Augustus Lackmann, Eric William Boyle, and Frederick Henry McClelland, as the Committee of Management for a period of three (3) years of the land permanently reserved by Order in Council dated the 13th October, 1931, as a site for a Racecourse and other purposes of Public Recreation in the Parish of Boort, and known as the "Boort Racecourse and Recreation Reserve."—(Corres. Rs.650.)

"WHOROULY EAST RECREATION RESERVE."

Leslie George Rae, James D. Roche, Abraham Phillips, Herbert J. Newton, William Paul Williamson, James Enock Phillips, and Edmond Comerford, as a Committee of Management for a period of three (3) years of the land temporarily reserved by Orders in Council dated 6th July, 1910, and 28th September, 1915, as a site for Public Recreation in the Parish of Whorouly, and known as the "Whorouly East Recreation Reserve."—(Corres. Rs.946.)

"FRANKSTON AND MOUNT ELIZA FORESHORE RESERVE."

Frank Archibald John Morris, Edward Kerr, and John Arthur Gloury, as representatives of the public for a period of three (3) years from 27th November, 1947, and Frank Henry Wells, John Leslie Pratt, John Egbert Grice, Melville Charles Tomasetti, Gerald Vardy Hirst, and Donald Horsley Fowler, for so long only as they continue to be councillors and the elect of the Council of the Shire of Frankston and Hastings, as a Committee of Management of such portion of the reserved Crown lands in the Parish of Frankston as is indicated in pink tint on plan marked F/19.5.1937, attached to Lands Department correspondence Rs.3203, and known as the "Frankston and Mount Eliza Foreshore Reserve."—(Corres. Rs.3203.)

This appointment is in lieu of all previous appointments, which are hereby revoked.

"GLEN IRIS MECHANICS' INSTITUTE RESERVE."

James Prowse, David Hay, William Alexander Norman Hamilton, Thomas Pountney Edwards, Arthur Hamilton Pearcey, William Charles Riley, and Wilfred Ernest Painter, as a Committee of Management for a period of three (3) years from 6th December, 1947, of the land temporarily reserved by Order in Council dated the 23rd March, 1926, as a site for a Mechanics' Institute in the Parish of Boroondara, at Glen Iris, and known as the "Glen Iris Mechanics' Institute Reserve."—(Corres. Rs.3249.)

"NOOJEE RECREATION RESERVE."

Cyril Norman Blackwood and William John Beck as members of the Committee of Management for the period ending 1st July, 1949, of the lands temporarily reserved by Orders in Council dated 20th January, 1923, as a site for Recreation purposes, and 20th May, 1927, as a site for Public Recreation in the Township of Noojee, Parish of Neerim, and known as the "Noojee Recreation Reserve," in the place of Hedley A. Heighway and Leo O'Donohue, who have left the district.—(Corres. Rs.2660.)

"ALBERTON RECREATION RESERVE."

Albert Emerson Coulthard, Stanley Johnstone Finlay, George Finlay, Kenneth Ross Bell, Harold Douglas Mowat, John Neils Christensen, and Charles Tuckey, as a Committee of Management for a period of three (3) years from 3rd January, 1948, of the land temporarily reserved by Order in Council dated 17th March, 1891, as a site for Public Recreation in the Township of Alberton, and known as the "Alberton Recreation Reserve."—(Corres. Rs.942.)

"WATCHEM RACECOURSE AND RECREATION RESERVE."

Gustave Fredrick Zimmer, James Augustine Colbert, Samuel William Fielding, Thomas Patrick Connellan, Lucien Belleville, Alfred Edward Richmond, John F. McErvale, and Alfred H. S. Chalk, as the Committee of Management for a period of three (3) years from the 4th December, 1947, of the land temporarily reserved by Order in Council dated the 8th December, 1931, as a site for a Racecourse and Public Recreation in the Village and Parish of Watchem, and known as the "Watchem Racecourse and Recreation Reserve."—(Corres. Rs.4160.)

"KENNEDY'S CREEK PUBLIC HALL RESERVE."

Thomas Edward Elliott, Robert Roberts, Albert Arthur Atwell, Donald Wilson, and Thomas Finning, as a Committee of Management for a period of three (3) years from 13th December, 1947, of the land temporarily reserved by Order in Council dated 28th December, 1906, as a site for a Public Hall and other Public purposes in the Parish of Wirridjil, and known as "Kennedy's Creek Public Hall Reserve."—(Corres. Rs.4877.)

In witness whereof the common seal of the Board of Land and Works was hereunto affixed, this sixteenth day of January, One thousand nine hundred and forty-eight, in the presence of—

(SEAL) JOHN G. B. McDONALD, President.  
J. E. HUNTER, Member.

REGULATIONS FOR THE CARE, PROTECTION, AND MANAGEMENT OF THE YAN YAN GURT RECREATION RESERVE.

WHEREAS by section 181 of the *Land Act* 1928, as re-enacted by section 9 of the *Land Act* 1941, power is given to the Board of Land and Works to make Regulations in respect of the care, protection, and management of any Crown land, which has been reserved under the Land Acts for any public purpose whatsoever, and which has not been conveyed to or vested in trustees and for the further purposes as enacted: Now therefore the Board of Land and Works, in pursuance of the powers conferred as aforesaid, doth hereby make the following Regulations in respect of the land temporarily reserved by Order in Council of the 15th April, 1947, as a site for Recreation purposes in the Parish of Yan Yan Gurt, and known as the "Bambra Recreation Reserve," hereinafter referred to as the "Reserve," such reservation having been placed under the control of a Committee of Management, hereinafter referred to as the "Committee."

REGULATIONS.

1. The Reserve shall be open to the public free of charge from sunrise to sunset, except on such days, not exceeding fifty-two (52) in any one year, as the Reserve may be set apart for cricket, football, or other matches, shows, sports, fêtes, musical performances, outdoor gatherings, or holiday amusements, on any of which occasions a sum not exceeding Five shillings (5s.) may be charged and taken for the admission of each adult person to the Reserve, but no person shall be permitted to enter any of the buildings on the Reserve on days on which fees for admission are not being charged without the permission, in writing, of the Committee first obtained.

2. No person shall—

- (a) Enter or remain in the Reserve who may offend against decency as regards dress, language, or conduct, or who may behave in a disorderly, unseemly, or offensive manner, or create or take part in any disturbance.
- (b) Enter or remain in the Reserve whilst in a state of intoxication.
- (c) Use indecent or offensive language in the Reserve.
- (d) Bring any intoxicating liquor on to the Reserve without the consent of the Committee first obtained.
- (e) Obstruct, hinder, or interfere with any person under authority from the Committee or employed by it at the Reserve in the execution of his lawful duties.
- (f) Exercise or train any horse or pony on the Reserve, or on any part thereof, without the consent of the Committee first obtained.

3. The Committee shall have power to hold entertainments, shows, or performances on the Reserve, and to make a charge for admission thereto as hereinbefore provided.

4. The Committee shall have power to let any portion of the Reserve to any club, association, person, or society for the purpose of holding entertainments, performances, shows, or sports, subject to the payment of such fees and on such terms as it may deem to be reasonable and consistent with these Regulations, and to authorize any club, association, society, or person to make a charge for admission thereto, as hereinbefore provided in these Regulations.

5. No club, association, society, or person shall hold any sport, entertainment, performance, show, or ceremony on any part of the Reserve without the authority of the Committee first obtained.

6. No person, except the Committee or its officers or employees on duty, shall enter any part of the Reserve on an occasion when a charge is made for admission thereto without first paying the fees chargeable for such admission.

7. No person shall park a motor car, vehicle, or motor cycle in the Reserve, except at such places as are set apart for that purpose by the Committee, who reserve the right to make a parking charge not exceeding 2s. for each vehicle.

8. No person shall take part in any games, sports, or entertainments of any kind in the Reserve at any time, without the permission of the Committee first obtained.

9. No person, club, or other body using the Reserve shall damage any building thereon or the fittings of such building, and in the event of such damage occurring during their occupancy thereof, such person, club, or other body

shall be responsible for such damage, and shall pay to the Committee the cost of making good and repairing such building or fittings.

10. No person shall, in the Reserve, interfere with or break or damage any of the trees, plants, or shrubs, or pluck any flowers, or climb, jump, or get over or under any of the fences, gates, seats, or other structures therein, or roll or throw stones or other missiles, or leave any bottles, broken glass, paper, orange peel, banana skins, or any refuse or rubbish whatever therein, or post bills or advertisements on any of the fences, gates, seats, or other structures therein.

11. No person shall remove any wood or timber from the Reserve unless with the consent of the Committee first obtained and then only on such terms and conditions as shall be determined by the said Committee and approved of by the Board of Land and Works.

12. No person shall light a fire in the Reserve, except at such places as are set apart for that purpose by the Committee.

13. No person shall put in the Reserve any cattle, horses, pigs, goats, or other animals without the permission of the Committee first obtained.

14. No person shall camp in the Reserve or erect therein any building or any other structure without the consent of the Committee first obtained.

15. No person shall sell or offer for sale any article in the Reserve without the permission of the Committee first had and obtained, and then only subject to such conditions as such Committee may determine.

16. No person, club, or other body shall, without the consent of the Committee first obtained, grade or scrape the ground off, or cut or burn any grass growing on any part of the Reserve.

Every person who contravenes or fails to comply with these Regulations shall in accordance with the provisions of section 181 of the *Land Act* 1928, as re-enacted by section 9 of the *Land Act* 1941, for each offence be liable to a penalty of not more than Five pounds, and every person who contravenes or fails to comply with any such Regulation and who, after he has been warned by any bailiff of Crown lands or by any member of the Police Force, does not desist therefrom, may be forthwith apprehended by such bailiff or member of the Police Force and taken before some justice to be dealt with according to law, and shall be liable to a penalty of not more than Ten pounds.

The common seal of the Board of Land and Works was hereunto affixed, this 16th day of January, 1948, in the presence of—

(SEAL) JOHN G. B. McDONALD, President.  
J. E. HUNTER, Member.

(Rs.5944.)

REGULATIONS FOR THE CARE, PROTECTION, AND MANAGEMENT OF THE HEATHCOTE RECREATION RESERVES.

WHEREAS by section 181 of the *Land Act* 1928, as re-enacted by section 9 of the *Land Act* 1941, power is given to the Board of Land and Works to make Regulations in respect of the care, protection, and management of any Crown land which has been reserved under the Land Acts for any public purpose whatsoever, and which has not been conveyed to or vested in trustees, and for the further purposes as enacted: Now therefore the Board of Land and Works, in pursuance of the powers conferred as aforesaid, doth hereby make the following Regulations in respect of the under-mentioned lands in the Town of Heathcote, hereinafter referred to as the "Reserves," such reservations having been placed under a Committee of Management, hereinafter referred to as the "Committee":—

- (a) The land temporarily reserved by Order in Council of 31st March, 1913, as a site for General Recreation purposes in the Town of Heathcote.
- (b) The remaining portion of the lands temporarily reserved by Orders in Council of 7th July, 1873, and 5th April, 1887, as sites for Public Recreation in the municipal district of Heathcote.

REGULATIONS.

1. The Reserves shall be open to the public, free of charge, from sunrise to sunset, except on such days as the Reserves may be set apart for cricket or football matches, fêtes, sports, or holiday amusements, on any of which occasions a sum not exceeding Three shillings may be charged and taken for the admission of every adult to the Reserves.

2. (a) No person shall enter or remain in the Reserves who may offend against decency as regards dress, language, or conduct, and for maintaining good order in the Reserves the Committee or its employees may refuse any person admission to the Reserves or any structure therein.

(b) Climb or jump over the gates, fences, seats, tables, signboards, building equipment, notices, fittings, or other improvements in or around the Reserves, nor stick therein or thereon any bills, or in any way injure, damage, deface, write, or paint on or otherwise mark any rocks, gates, fences, seats, tables, buildings, equipment, notices, signboards, or other improvements, structure, or fittings therein or thereon, nor leave or deposit any glass, paper, or rubbish nor roll or throw stones or any missiles of any kind therein.

(c) Remove or displace any board, plate, or fitting, or written or printed notice for the exhibition of any Regulations or notice, fixed or set up by the Committee in the Reserves.

3. Every person shall exercise reasonable and proper care in the use of any portion of the Reserves' dressing rooms, conveniences, or appurtenances therein.

4. No person shall, without the consent of the Committee, light any fire in the Reserves, except in a place set apart by the Committee or as indicated by the curator for the purpose. No such fire shall be left burning or unattended, and before lighting such fire such person shall make provision for extinguishing the same either by water or loose earth. Every person whilst in the Reserves shall take special precautions against the risk of fire.

5. No person shall play, practise, or engage in any game or sport in the Reserves at any time, without the consent, in writing, of the Committee first obtained, and then only subject to such conditions as the Committee thinks fit.

6. All fees prescribed herein shall be paid to the secretary of the Committee, or other specially authorized officer, on demand.

7. No person shall play on the tennis court in the Reserves, except with the permission of the Committee, and then only by payment of such fees as may be fixed from time to time by the Committee.

8. No person shall enter the Reserves on any day set apart for cricket or football matches, cycling, sports, fêtes, or holiday amusements, except on production of a ticket issued by the Committee, or any club, association, or person authorized to issue such ticket of admission, or by any club, association, or person renting the Reserves, or any part thereof, duly authorizing the admission of such person, and no such ticket of admission shall be of any avail except on the date or during the period provided thereon, and every such ticket shall be produced and, if for one day only, surrendered, on demand, to the gate-keeper or other person authorized to collect the same.

9. Upon application to the Committee, any club, association, or person may be granted the exclusive use of the Reserves for the holding of cricket or football matches, shows, sports, fêtes, bicycle races, or other amusements, and may charge for admission thereto of persons, subject to the provisions of these Regulations, and shall pay to the Committee such charges as the Committee may deem to be reasonable and consistent with these Regulations.

10. Persons renting or hiring any stand, building, erection, or enclosure on the occasions of any cricket or football matches, horse races, fêtes, coursing, sports, or holiday amusements may be required to deposit any sum which the Committee may at the time determine, not exceeding Ten pounds, by way of guarantee that due care shall be taken of such stand, building, erection, or enclosure, and such Committee, in its absolute discretion, may make good any damage or injury sustained by such stand, building, erection, or enclosure, or any thing contained therein, during such occupancy or hiring, and deduct the cost of making good such loss or damage from the sum of money deposited by way of guarantee, and all persons so renting or hiring shall abide by these Regulations and by any order given by the Committee.

11. No fête, concert, carnival, or aquatic display shall be held on the Reserves, without the consent of the Committee, nor shall fees for admission to the Reserves on days on which fêtes, concerts, or carnival be charged, without the consent of such Committee.

12. No assemblies for the purpose of public worship, preaching, or public speaking of any kind, or meetings of a like character, shall take place in the Reserves, without the permission, in writing, of the Committee first obtained.

13. No person shall offer for sale within the Reserves, or deliver therein, any article or commodity, without the consent, in writing, of the Committee being first obtained.

14. No person shall spit or expectorate on the paths or any structure or erections in the Reserves.

15. No unauthorized person shall interfere with, damage, or in any way destroy or have in his possession in the Reserves, or take away therefrom, any animal, bird, bird's egg or nest, or any live or dead or dressed timber, or any vegetation, tree, shrub, fern, plant, or flower.

16. No person shall bring into or have in his possession or discharge in the Reserves any rifle, firearm, sporting gun, or airgun, without the permission, in writing, of the Committee.

17. No person shall permit or suffer any cattle, horses, sheep, goats, or other animals belonging to him or under his care or control to be at large in the Reserves, or to graze or wander over the same, without the permission, in writing, of the Committee first obtained, and upon payment of such fees as may be fixed by such Committee.

18. No person shall bring or allow any dog belonging to him or under his care or control to enter or remain in the Reserves, unless controlled by a leash, cord, or chain, and all dogs found swimming in any water or wandering in the Reserves shall be liable to be destroyed.

19. No person, except workmen employed in the Reserves, shall enter any plots therein which may be enclosed for plantations of young trees or shrubs, without the consent of the Committee first obtained, nor shall any person, without lawful excuse, enter any area made for the purpose in the Reserves.

20. No person shall drive any motor car or other vehicle of any kind, or ride any bicycle, motor cycle, or horse, except on a road or parking area made for the purpose, in the Reserves, and then only as near as practicable to the left-hand side of such road.

21. All persons using the conveniences provided by the Committee shall pay such charges for the use of same as shall be fixed from time to time by the said Committee.

22. No person shall park any motor car, cycle, or other vehicle or tether any horse within the Reserves, excepting at such area as is set apart by the Committee for the purpose, and any person using any such area shall obey any order given by the said Committee, the curator, or other employee of such Committee, and shall pay, on demand, a fee not exceeding Two shillings per day or Five shillings per week for use of such parking area.

23. No person shall drive any motor car or other vehicle of any kind, or ride any bicycle, motor cycle, or horse, within the Reserves, or in any parking area or along any road therein, recklessly or at a speed or in a manner which is dangerous to the public, having regard to all the circumstances of the case, including the nature and to the amount of traffic which actually is at the time or which might reasonably be expected to be on any such road, parking area, or in the Reserves.

24. The Committee may at its discretion on such conditions and terms and at such times as it may from time to time permit persons, clubs, or association to use part or parts of the Reserves.

25. The Committee shall not be responsible for any accident arising from the use of the swings or other appliances in the children's playground, nor from any cause howsoever arising within the Reserves.

26. No person shall camp in the Reserves or erect therein any building or any other structure, without the consent of the Committee first obtained.

Every person who contravenes or fails to comply with these Regulations shall, in accordance with the provisions of section 181 of the *Land Act 1928*, as re-enacted by section 9 of the *Land Act 1941*, for each offence be liable to a penalty of not more than Five pounds, and every person who contravenes or fails to comply with any such Regulation and who, after he has been warned by any bailiff of Crown lands, or by any member of the Police Force, does not desist therefrom, may be forthwith apprehended by such bailiff or member of the Police Force and taken before some justice to be dealt with according to law, and shall be liable to a penalty of not more than Ten pounds.

The common seal of the Board of Land and Works was hereunto affixed this sixteenth day of January, 1948, in the presence of—

(SEAL) JOHN G. B. McDONALD, President.  
J. E. HUNTER, Member.

(Rs.626, Rs.627.)

LAND AVAILABLE UNDER THE SOLDIER SETTLEMENT ACTS.

NOTIFICATION is hereby given, in accordance with section 16 of the *Soldier Settlement Act 1946*, that the undermentioned lots are available or are about to become available for settlement.

Any discharged soldier who has applied to the Commission on or before the 21st January, 1948, for classification in the required class or classes of primary production for which the lots are made available, and whose application has not been finalised, or any discharged soldier who has been classified as suitable in such class or classes of primary production, may apply on the proper form for settlement on any lot or lots, indicating where he applies in respect of more than one lot, his order of preference therefor.

Application forms, plans, and further particulars may be obtained from the Inquiry Branch, Soldier Settlement Commission, State Public Offices, Melbourne, at which office completed applications for settlement should be lodged on or before the 9th February, 1948.

E. SINGLETON,  
Secretary.

Soldier Settlement Commission,  
Melbourne, 16th January, 1948.

SCHEDULE OF ALLOTMENTS.

Lot Number on Plan of Subdivision.	Approximate Area in Acres (Subject to Survey).
------------------------------------	--

PORTION OF ROBINVALE IRRIGATION SETTLEMENT.

PARISHES OF BUMBANG AND TOLTOL.—COUNTY OF KARRAROOC.

*Suitable for Dried Fruits mainly, with some Citrus.*

15	26.3
16	28.9
18	23.4
19	26.1
20	22.9
22	27.5
26	27.4
27	23.9
28	25.4
29	23.6
30	28.8
31	23.4
34	28.4
35	27.4
36	23.8
45	26.1
46	27.5
47	24.2
51	24.3
52	26.5
53	28.5
54	24.5
57	27.5
58	30.0
61	24.8
62	30.2
69	36.0
70	22.6
71	26.2
79	25.4

TENDERS.

TENDERS will be received at this office until **TEN A.M.** on the days and for the purposes under mentioned.

Particulars may be learnt at this office, and also at the offices named in each instance.

The Board of Land and Works will not necessarily accept the lowest or any tender.

Plans and Specifications will not be shown at school buildings from the 19th December, 1947, to the 3rd February, 1948.

27th January, 1948.

Beechworth.—Completion of tiling of existing slate roof and repairs, State School No. 1560. Particulars at Inspectors of Works Offices, Benalla, Wangaratta; Police Stations, Beechworth, Wodonga. Preliminary deposit, £15. Final deposit, 2 per cent.

Boolarra.—Erection and completion of new timber residence, office, garage, stable, wood shed, &c., radio masts, paths and fencing, Police Station. Particulars at Inspector of Works Office, Korumburra; Police Stations, Boolarra, Morwell, Sale. Preliminary deposit, £15. Final deposit, 2 per cent.

Bungaree.—Demolition of one timber residence and erection of two (2) new timber residences, former Ballarat Water Commission land, Soldier Settlement Commission. Particulars at Inspector of Works Office, Ballarat; Police Station, Bungaree. Preliminary deposit, £15. Final deposit, 2 per cent.

Cardinia.—Painting and repairs, State School No. 3689. Particulars at Police Stations, Dandenong, Frankston. Deposit, £4.

Carlton.—Extension of boiler room, Country Roads Board, Exhibition Building. Preliminary deposit, £20. Final deposit, 2 per cent.

Cheltenham.—Supply, delivery, and erection of a coal elevator, Boiler House, Heatherton Sanatorium. Preliminary deposit, £15. Final deposit, 2 per cent.

Cheltenham.—Supply and installation of two (2) steam boilers, complete with mechanical stokers, Heatherton Sanatorium. Particulars at Inspector of Works Office, Ballarat. Preliminary deposit, £25. Final deposit, 2 per cent.

Cockbill's Estate (near Kotta).—Erection of new timber residence on Block No. 2, Soldier Settlement Commission. Particulars at Inspectors of Works Offices, Bendigo, Shepparton; Police Stations, Echuca, Elmore, Cohuna. Preliminary deposit, £15. Final deposit, 2 per cent.

Cowwarr.—Repairs and renovations to school and residence, State School No. 1967. Particulars at Inspector of Works Office, Bairnsdale; Police Stations, Sale, Traralgon. Preliminary deposit, £10. Final deposit, 2 per cent.

Digby.—Repairs and renovations and new out-offices, State School No. 2047. Particulars at Inspector of Works Office, Hamilton; Police Stations, Coleraine, Portland. Preliminary deposit, £5. Final deposit, 2 per cent.

Dimboola.—Removal of State School No. 2880, Lochiel Bridge, and re-erection and re-conditioning, High School. Particulars at Inspector of Works Office, Horsham; Police Station, Stawell. Deposit, £4.

Forest Tank.—Repairs and external and internal painting, State School No. 3808. Particulars at Inspectors of Works Offices, Bendigo, Swan Hill; Police Station, Culgoa. Deposit, £3.

Geelong.—External painting, Gordon Institute of Technology. Particulars at Inspector of Works Office, Geelong. Preliminary deposit, £15. Final deposit, 2 per cent.

Gooramadda.—Purchase and removal of school building and out-offices, State School No. 1948. Particulars at Inspector of Works Office, Wangaratta; Police Stations, Rutherglen, Wodonga. Preliminary deposit, £5. Final deposit, full amount of purchase money.

Hamilton.—Erection of new residence for Inspector of Works, Department of Public Works. Particulars at Inspectors of Works Offices, Hamilton, Warrnambool; Police Stations, Portland, Stawell. Preliminary deposit, £15. Final deposit, 2 per cent.

Hansonville.—Repairs, renovations, and painting, &c., State School No. 1584. Particulars at Inspectors of Works Offices, Benalla, Wangaratta; Police Station, Euroa. Preliminary deposit, £4. Final deposit, 2 per cent.

Heatherton.—Electrical installation in new Nurses' Home, Sanatorium. Preliminary deposit, £15. Final deposit, 2 per cent.

Horsham.—Erection of residence for Inspector of Works, Department of Public Works. Particulars at Inspector of Works Offices, Ararat, Ballarat, Hamilton, Horsham; Police Station, Nhill. Preliminary deposit, £15. Final deposit, 2 per cent.

Horsham.—Erection of five (5) brick veneer residences, Country Roads Board. Particulars at Inspectors of Works Offices, Ararat, Horsham. Preliminary deposit, £50. Final deposit, 2 per cent.

Koorlong.—Repairs and painting and erection of two (2) new out-offices and new cyclone field gate, State School No. 3470. Particulars at Inspector of Works Office, Mildura; Police Stations, Merbein, Redcliffs. Preliminary deposit, £3. Final deposit, 2 per cent.

Koroit.—Repairs and painting, Court House. Particulars at Inspector of Works Office, Warrnambool; Police Station, Koroit. Deposit, £3.



Learmonth.—Conversion of stable to garage and additions to residence, Police Station. Particulars at Inspector of Works Office, Ballarat; Police Station, Learmonth. Deposit, £4.

Leongatha.—Renewal of blackboards, fencing, repairs and painting, State School No. 2981. Particulars at Inspector of Works Office, Korumburra; Police Station, Wonthaggi. Preliminary deposit, £10. Final deposit, 2 per cent.

Melbourne.—Additions and alterations to Caretaker's Quarters, Old Treasury Building. Preliminary deposit, £15. Final deposit, 2 per cent.

Melbourne.—Supply and installation of one (1) electric passenger lift, new building, Department of Agriculture, Treasury Place. Preliminary deposit, £25. Final deposit, 2 per cent.

Mildura.—Provision of heating facilities in classrooms, High School. Particulars at Inspector of Works Office, Mildura; Police Station, Red Cliffs. Deposit, £3.

Nathalia.—Renewal of fencing, State School No. 2060. Particulars at Inspector of Works Office, Shepparton; Police Stations, Echuca, Kyabram, Numurkah, Strathmerton. Preliminary deposit, £5. Final deposit, 2 per cent.

Nhill.—Repairs, renovations and fencing, Police Station. Particulars at Inspector of Works Office, Horsham; Police Station, Nhill. Deposit, £4.

Omeo Valley.—Erection of new out-offices, painting and repairs, State School No. 3328. Particulars at Inspector of Works Office, Bairnsdale; Police Stations, Bruthen, Omeo, Orbost. Preliminary deposit, £5. Final deposit, 2 per cent.

Preston East.—Overhaul and repairs to spoutings and downpipes, State School No. 4316. Deposit, £2.

Rutherglen.—Provision of new concrete floor to barn, paving and new steps to main building, Research Station. Particulars at Inspector of Works Office, Wangaratta; Police Station, Wodonga; Research Station, Rutherglen. Preliminary deposit, £5. Final deposit, 2 per cent.

Teesdale.—Provision of new bedroom and drainage, State School No. 2065. Particulars at Inspector of Works Office, Geelong; Police Station, Colac. Deposit, £2.

Terang.—External painting to both school buildings, out-offices, Art Block, cycle and shelter sheds, and minor repairs and new fence, Higher Elementary School and State School No. 617. Particulars at Inspectors of Works Offices, Geelong, Warrnambool; Police Station, Camperdown. Preliminary deposit, £5. Final deposit, 2 per cent.

Toongabbie.—Painting and repairs to school and moving kitchen of teacher's residence, State School No. 856. Particulars at Inspector of Works Office, Bairnsdale; Police Station, Sale. Preliminary deposit, £5. Final deposit, 2 per cent.

Underbool.—Repairs and painting, State School No. 3819. Particulars at Inspector of Works Office, Mildura; Police Stations, Ouyen, Woomelang. Deposit, £3.

Walwa.—Erection of timber residence on Walwa land, near Walwa, for Soldier Settlement Commission. Particulars at Inspector of Works Office, Wangaratta; Police Stations, Corryong, Tallangatta, Walwa, Wodonga. Preliminary deposit, £15. Final deposit, 2 per cent.

Warracknabeal.—Erection of Nurses Home, District Hospital. Particulars at Inspectors of Works Offices, Ballarat, Horsham; Police Stations, Dimboola, Warracknabeal; District Hospital, Warracknabeal. Preliminary deposit, £25. Final deposit, 2 per cent.

Warracknabeal.—Supply and installation of hot-water and heating services, New Nurses' Home, I.D. Block, &c., District Hospital. Particulars at Inspectors of Works Offices, Ballarat, Bendigo, Horsham; Police Station, Warracknabeal. Preliminary deposit, £15. Final deposit, 2 per cent.

Warracknabeal.—Electrical installation, Nurses' Home, District Hospital. Particulars at Inspectors of Works Offices, Ararat, Ballarat, Bendigo, Horsham, Stawell; Police Station, Warracknabeal. Preliminary deposit, £10. Final deposit, 2 per cent.

Werribee.—Erection of one (1) new residence, State Research Farm. Particulars at Inspector of Works Office, Geelong; State Research Farm, Werribee. Preliminary deposit, £15. Final deposit, 2 per cent.

White Hills.—Remodelling and repairs to teacher's residence, State School No. 1916. Particulars at Inspector of Works Office, Bendigo. Preliminary deposit, £10. Final deposit, 2 per cent.

Wycheproof.—Repairs and painting, State School No. 1757. Particulars at Inspector of Works Office, Bendigo; Police Stations, Charlton, Inglewood. Preliminary deposit, £5. Final deposit, 2 per cent.

Yallourn.—Repairs and renovations to desks, State School No. 4085. Particulars at Inspector of Works Office, Bairnsdale; Police Stations, Moe, Warragul, Yallourn. Deposit, £4.

3rd February, 1948.

Ballarat.—Supply and installation of central heating system, Teachers' College Hostel. Particulars at Inspector of Works Office, Ballarat. Preliminary deposit, £10. Final deposit, 2 per cent.

Barmah.—Repairs, renovations and new wood shed, school and residence, State School No. 3260. Particulars at Inspector of Works Office, Shepparton; Police Stations, Echuca, Numurkah. Preliminary deposit, £5. Final deposit, 2 per cent.

Bendigo.—Erection of four (4) residences in brick or brick veneer, Country Roads Board, Lansell-street. Particulars at Inspector of Works Office, Bendigo. Preliminary deposit, £50. Final deposit, 2 per cent.

Brunswick North-west.—Provision of cupboards and display boards, State School No. 4399. Deposit, £5.

Caldermeade.—Erection and completion of teacher's residence, State School No. 4271. Particulars at Police Station, Dandenong. Preliminary deposit, £15. Final deposit, 2 per cent.

Carlton.—Extensions to central heating system, Country Roads Board, Exhibition Building. Preliminary deposit, £20. Final deposit, 2 per cent.

Cohuna.—Removal of school buildings from State School No. 4137, Daltons Bridge, State School No. 3904, Keely, State School No. 1829, McMillans, State School No. 3844, Cohuna Estate, State School No. 2993, Horfield, State School No. 1959, Gannawarra, and re-erection, State School No. 2502. Particulars at Inspector of Works Office, Bendigo; Police Stations, Echuca, Elmore, Kerang. Preliminary deposit, £15. Final deposit, 2 per cent.

Corryong.—Additional accommodation, repairs and painting to existing buildings, Court House. Particulars at Inspector of Works Office, Wangaratta; Police Stations, Corryong, Tallangatta, Wodonga. Preliminary deposit, £5. Final deposit, 2 per cent.

Deepdene.—Re-erection of hutment, State School No. 3680. Deposit, £3.

Geelong.—Supply and installation of electric hot-water service in Senior Warder's Quarters, Gaol. Particulars at Inspector of Works Office, Geelong. Deposit, £2.

Golden Point.—Alterations to classrooms and heating of classrooms, State School No. 1493. Particulars at Inspector of Works Office, Ballarat. Deposit, £4.

Kew.—Provision of bathroom at staff quarters, Mental Hospital. Preliminary deposit, £4. Final deposit, 2 per cent.

Lake Tyers.—Additions to staff cottage, Aboriginal Station. Particulars at Inspector of Works Office, Bairnsdale; Police Station, Orbost; Aboriginal Station, Lake Tyers. Preliminary deposit, £10. Final deposit, 2 per cent.

Mansfield.—Repairs and painting, &c., Police Station. Particulars at Inspector of Works Office, Benalla; Police Stations, Euroa, Mansfield, Seymour. Preliminary deposit, £5. Final deposit, 2 per cent.

Melbourne.—Replacement of roof, William Angliss Food Trades School. Preliminary deposit, £10. Final deposit, 2 per cent.

Melbourne.—Improved lighting, Public Service Board, State Public Offices. Preliminary deposit, £3. Final deposit, 2 per cent.

Merino.—Repairs, &c., and painting and provision of new out-office, teacher's residence, State School No. 2115. Particulars at Inspector of Works Office, Hamilton; Police Stations, Casterton, Coleraine. Deposit, £4.

Mildura.—Supply and installation of electric hot-water service in teacher's residence, High School. Particulars at Inspectors of Works Offices, Bendigo, Mildura. Deposit, £2.

Mincha West.—Repairs, internal and external painting, State School No. 1931. Particulars at Inspector of Works Office, Bendigo; Police Stations, Echuca, Kerang, Pyramid. Deposit, £3.

Mooney's Estate (near Moyhu).—Erection of two (2) timber-framed residences on Blocks Nos. 1 and 2, Soldier Settlement Commission. Particulars at Inspectors of Works Offices, Benalla, Wangaratta. Preliminary deposit, £20. Final deposit, 2 per cent.

Omeo.—Painting and repairs, Police Station. Particulars at Inspector of Works Office, Bairnsdale; Police Stations, Omeo, Orbost. Preliminary deposit, £5. Final deposit, 2 per cent.

Orbost.—Alterations and additions, repairs and painting, Police Station. Particulars at Inspector of Works Office, Bairnsdale; Police Stations, Bruthen, Orbost. Preliminary deposit, £10. Final deposit, 2 per cent.

Port Fairy.—Repairs and renovations, State School No. 1188. Particulars at Inspector of Works Office, Warrnambool; Police Station, Port Fairy. Preliminary deposit, £5. Final deposit, 2 per cent.

Sorrento.—Painting and repairs, Police Station. Particulars at Police Stations, Frankston, Sorrento. Preliminary deposit, £5. Final deposit, 2 per cent.

Springvale.—Erection of external lavatories, Necropolis. Particulars at Police Stations, Dandenong, Oakleigh; Necropolis, Springvale. Preliminary deposit, £15. Final deposit, 2 per cent.

Sunbury.—Supply and installation of electric hot-water service, Head Attendant's Quarters, Mental Hospital. Deposit, £2.

Sunbury.—Supply and installation of electric hot-water service in Pharmaceutical Chemist's Quarters, Mental Hospital. Deposit, £2.

Sunbury.—New Police Station, Police Station. Particulars at Police Stations, Kilmore, Kyneton, Sunbury. Preliminary deposit, £15. Final deposit, 2 per cent.

Swan Hill.—Repairs and painting, Inspector's Residence. Particulars at Inspector of Works Office, Swan Hill. Deposit, £4.

Toolamba.—Removal of State School No. 2298, Wakiti Creek, re-erection, repairs and painting to both schools, State School No. 1455. Particulars at Inspector of Works Office, Shepparton; Police Stations, Murchison, Tatura. Preliminary deposit, £5. Final deposit, 2 per cent.

Traralgon.—Provision of new cupboard, repairs and painting, &c., State School No. 3584. Particulars at Inspector of Works Office, Bairnsdale; Police Stations, Morwell, Sale, Traralgon. Preliminary deposit, £3. Final deposit, 2 per cent.

Ventnor.—Painting and repairs, State School No. 3895. Particulars at Police Stations, Cowes, Frankston. Deposit, £4.

Warragul.—Infectious Diseases Block, West Gippsland Hospital. Particulars at Inspector of Works Office, Bairnsdale; Police Stations, Moe, Sale, Warragul; West Gippsland Hospital, Warragul. Preliminary deposit, £50. Final deposit, 2 per cent.

Yarragon.—Repairs and renovations, Police Quarters and Office, Police Station. Particulars at Inspector of Works Office, Bairnsdale; Police Stations, Trafalgar, Warragul, Yarragon. Preliminary deposit, £10. Final deposit, 2 per cent.

Yarrowalla and Mologa Estates.—New timber residence (labour only), Soldier Settlement Commission. Particulars at Inspectors of Works Offices, Bendigo, Swan Hill; Police Stations, Echuca, Kerang, Pyramid. Preliminary deposit, £10. Final deposit, 2 per cent.

10th February, 1948.

Eagle Point.—Repairs, painting, &c., State School No. 3215. Particulars at Inspector of Works Office, Bairnsdale; Police Station, Sale. Deposit, £4.

Melbourne.—Supply and installation of a ventilating system, Photographic Annexe, 107 Russell-street. Preliminary deposit, £4. Final deposit, 2 per cent.

Melbourne.—Supply and installation of ventilation equipment in new kitchen, Emily McPherson College. Preliminary deposit, £4. Final deposit, 2 per cent.

Pender's Grove (Thornbury).—Provision of window and counter, and new bicycle shed, State School No. 3806. Preliminary deposit, £5. Final deposit, 2 per cent.

Port Welshpool.—Repairs and painting, State School No. 3375. Particulars at Inspector of Works Office, Korumburra; Police Station, Yarram. Deposit, £4.

Stawell.—Supply and installation of electric hot-water service at Rehabilitation Training Unit, Technical School. Particulars at Inspectors of Works Offices, Ballarat, Bendigo, Ararat, Warrnambool. Deposit, £2.

Tyabb.—Repairs, painting, fencing, &c., to school and residence, State School No. 3544. Particulars at Police Stations, Frankston, Mornington, Tyabb. Preliminary deposit, £5. Final deposit, 2 per cent.

Williamstown.—Painting and repairs, Court House. Preliminary deposit, £10. Final deposit, 2 per cent.

Williamstown.—Additional lavatory accommodation, Court House. Preliminary deposit, £4. Final deposit, 2 per cent.

Tenders to be addressed to the Honorable the Commissioner of Public Works, and envelope containing tender marked "Tender for

J. A. KENNEDY,  
Commissioner of Public Works.

Melbourne, 20th January, 1948.

## PRIVATE ADVERTISEMENTS.

**I** ERINA GLADYS GARTLAN, of 33 Duke-street, Richmond, in the State of Victoria, spinster, heretofore called and known by the name of Erina Gladys Ford, hereby give public notice that by deed poll dated the 7th day of January, 1948, and registered in the office of the Registrar-General of the State of Victoria, I formally and absolutely renounced, relinquished, and abandoned the use of my said surname of Ford, and then assumed and adopted, and determined thenceforth on all occasions whatsoever to use and subscribe the name of Erina Gladys Gartlan instead of the name of Erina Gladys Ford.

Dated this 16th day of January, 1948.

3123

ERINA GLADYS GARTLAN.

**NOTICE OF INTENTION TO APPLY FOR A LICENCE TO DIVERT WATER AND CUT RACES FROM THE MURRAY RIVER AT A POINT DUE EAST OF THE NORTH-EAST CORNER OF ALLOTMENT 12, TOWNSHIP OF BUMBANG, PARISH OF BUMBANG, COUNTY OF KARKAROO, AND ALSO AT A POINT OPPOSITE THE SOUTH-EAST CORNER OF ALLOTMENT 32 (SAME TOWNSHIP, PARISH, AND COUNTY), AND IN A LINE WITH THE SOUTH-EAST BOUNDARY OF THE SAID ALLOTMENT.**

**I** HEREBY give notice that I intend to apply for a licence empowering me to divert water for a term of five years to the extent of 50 acre-feet per annum at a maximum rate of 1 acre-foot per day of 24 hours for irrigation purposes, and to occupy certain Crown lands for works of storage and diversion, and to cut a race thereon.

Any objection to such application must be forwarded, in writing, to the State Rivers and Water Supply Commission, Melbourne, within 30 days of the date hereof.

JOHN VICTOR ALFRED WILLIAMS.

Robinvale, 19th January, 1948.

3159

### Water Acts.

**NOTICE OF INTENTION TO APPLY FOR A LICENCE TO DIVERT WATER AND CUT RACES FROM THE MURRAY RIVER AT A POINT OPPOSITE THE SOUTHERN BOUNDARY OF ALLOTMENTS 2 AND 3, PARISH OF BUMBANG, COUNTY OF KARKAROO.**

**WE** hereby given notice that we intend to apply for a licence empowering us to divert water for a term of fifteen years to the extent of 200 acre-feet per annum at a maximum rate of 5 acre-feet per day of 24 hours for irrigation purposes, and to occupy certain Crown lands for works of storage and diversion, and to cut a race thereon.

Any objection to such application must be forwarded, in writing, to the State Rivers and Water Supply Commission, Melbourne, within 30 days of the date hereof.

MICHELANGELO SICURA.  
GIUSEPPE SICURA.  
ANGELO SICURA.

Robinvale, 19th January, 1948.

3160

### OPTICIANS' REGISTRATION ACT 1935.

**L**IST of alterations, additions, and removals made in the Register of Certified Opticians during the year 1947:—

#### 1. Additions to the Register.

Clemens, Ewen Dale; Wales Building, Mollison-street, Kyneton; F.V.O.A.; 21st April, 1947; 375.  
Sainken, Benjamin; care of Metropole Hotel, Bourke-street, Melbourne; F.V.O.A.; 19th May, 1947; 376.

#### 2. Restorations to the Register.

Bailey, Harold Edwin; 328 Flinders-street, Melbourne; 377.  
Flint, Frank Leighton; 100 Glenferrie-road, Malvern; 374.  
Hastings, Joseph Wallis; 80 Swanston-street, Melbourne; 239.

#### 3. Removals from the Register.

Bursill, Gilbert Acaon; 9 Cookson-street, Camberwell; 64.  
Bucklow, Alexander Brown; Ballan; 308.  
Caddy, Clarence Victor; 182 Collins-street, Melbourne; 116.  
Dwyer, Brian Stanway; 338 Collins-street, Melbourne; 341.  
Landry, Joseph James; "Shirwell," Inverloch, South Gippsland; 241.  
Wastell, Brian Henry; 46 Sturt-street, Ballarat; 353.

WM. J. CLARKE, Registrar.

Opticians' Registration Board, Melbourne, 15th January, 1948.

3170

## CITY OF GEELONG WEST.

NOTICE is hereby given that the Council of the City of Geelong West has, under the provisions of the *Local Government Act 1946*, altered the names of the streets within the municipality, as set forth in the subjoined schedule:—

*New Name; Old Name; Situation; Ward.*

1. Calder-street; Mary-street; extending from West Melbourne-road to Minerva-road in Crown allotment 1, section 9, Parish of Moorpanyal; West.

2. Edinburgh-avenue; George-street; extending north from Fyansford-road to the north boundary of Crown allotment 11 in Crown allotments 11 and 12, section 13, Parish of Moorpanyal; West.

3. Rix-street; Andrews-street; extending east from Minerva-road to railway reserve in Crown allotment 6, section 13, Parish of Moorpanyal; West.

By order,

H. R. FRENCH, Town Clerk.

19th January, 1948.

3166

## CITY OF MELBOURNE.

## BY-LAW No. 281.

A By-law of the City of Melbourne, made under Part VII., Division 1, of the *Local Government Act 1946*, and numbered 281, to amend By-law No. 250.

THE Council of the City of Melbourne doth hereby, in pursuance of the powers conferred by the *Local Government Act 1946* and by every other Act or power in that behalf, order as follows:—

1. This By-law shall from and after the date of the same coming into operation be read and construed as one with By-law No. 250 intitled "A By-law of the City of Melbourne, made under Part VII., Division 1, of the *Local Government Act 1928*, and numbered 250, to amend and consolidate the by-laws with reference to street traffic and for suppressing nuisances," and any by-laws amending the same.

2. The following paragraph shall be inserted after paragraph (c) of sub-clause (1) of clause 28 of By-law No. 250:—

"(d) In a southerly direction—along any part of Downie-street at any time."

Resolution for passing this By-law agreed to by the Council of the City of Melbourne the 24th day of November, 1947, and confirmed the 19th day of January, 1948.

(L.S.) F. R. CONNELLY, Lord Mayor.  
H. S. WOOTTON, Town Clerk.

3156

## CITY OF MELBOURNE.

## REGULATIONS.

Regulations made by the Council of the City of Melbourne, in pursuance of the provisions of section 6 of the *Police Offences Act 1928*, to amend the Regulations made by the Council on the 21st day of April, 1941, to amend and consolidate the Regulations made by the Council for the route to be observed by all carriages, carts, vehicles, and persons, and for keeping order in the carriage and footways and other public places, and for preventing any obstruction thereof.

THE Council of the City of Melbourne doth hereby, in pursuance of the powers conferred by the provisions of section 6 of the *Police Offences Act 1928* and by every other Act or power enabling it in that behalf, order as follows:—

1. These Regulations shall from and after the date of the same coming into operation be read and construed as one with the Regulations (hereinafter called "the principal Regulations") made by the Council on the 21st day of April, 1941, intitled "Regulations made by the Council of the City of Melbourne, in pursuance of the provisions of section 6 of the *Police Offences Act 1928*, to amend and consolidate the Regulations made by the Council for the route to be observed by all carriages, carts, vehicles, and persons, and for keeping order in the carriage and footways and other public places, and for preventing any obstruction thereof," and any Regulations amending the same.

2. The following paragraph shall be inserted after paragraph (c) of sub-clause (1) of clause 25 of the principal Regulations:—

"(d) In a southerly direction—along any part of Downie-street at any time."

Resolution for passing these Regulations agreed to by the Council of the City of Melbourne the 24th day of November, 1947, and confirmed the 19th day of January, 1948.

(L.S.) F. R. CONNELLY, Lord Mayor.  
H. S. WOOTTON, Town Clerk.

3157

## TOWN OF HORSHAM.

## NOTICE OF INTENTION TO BORROW £5,500.

NOTICE is hereby given that the Council of the Town of Horsham proposes to borrow the sum of £5,500, on the credit of the Mayor, Councillors, and Burgesses of the Town, such sum to be raised by the issue of debentures in accordance with the provisions of the *Local Government Act*.

1. Period of the loan will be 20 years.

2. Maximum rate of interest, 3½ per cent.

3. Money borrowed will be repayable by providing out of Municipal Fund forty half-yearly instalments covering principal and interest, at the Melbourne office of the Council's bankers for the time being.

4. Purpose for which the loan is to be applied is construction of roads, footpaths, and drainage.

The plans, specifications, and estimate of the cost of works referred to above, and a statement showing the proposed expenditure of money to be borrowed, are open for inspection at the Town Hall, Horsham.

Dated this 14th day of January, 1948.

3136

A. J. WATTS, Town Clerk.

## SHIRE OF ALEXANDRA.

## NOTICE OF INTENTION TO BORROW THE SUM OF £5,000.

NOTICE is hereby given that the Council of the Shire of Alexandra proposes to borrow the sum of Five thousand pounds, on the credit of the President, Councillors, and Ratepayers of the said Shire, such sum to be raised by the issue of debentures in accordance with the provisions of the *Local Government Act 1946*.

1. The maximum rate of interest that may be paid is 3½ per cent. per annum.

2. The purposes for which the loan is to be applied are:—

Construction of drains, Alexandra .. .. £2,542

Construction of drains, Thornton .. .. 550

Additions to Health Centre, Alexandra .. .. 500

Park improvement, Alexandra .. .. 800

Contingencies for materials and labour .. .. 608

3. The period of the loan shall be 20 years.

4. The loan shall be repayable by providing out of the municipal fund half-yearly, on the 1st day of April and the 1st day of October during the currency of the loan, instalments of principal and interest, commencing on the 1st day of October, 1948.

5. Such moneys shall be repayable at the National Bank of Australasia, Melbourne, or at the Council's bankers for the time being in Melbourne.

The plans and specifications, and the estimate of the cost of the proposed works, are open for inspection at the Shire Office, Alexandra.

3138

J. W. HALL, Shire Secretary.

## SHIRE OF MOUNT ROUSE.

## NOTICE OF INTENTION TO BORROW MONEY FOR PERMANENT WORKS AND UNDERTAKINGS.

NOTICE is hereby given that the Council of the Shire of Mount Rouse proposes to borrow the sum of Two thousand pounds (£2,000), on the credit of the President, Councillors, and Ratepayers of the said Shire, by the issue of debentures, in accordance with the provisions of the *Local Government Act 1946*.

It is further proposed that the maximum rate of interest that may be paid will be Three pounds five shillings per cent. per annum.

The loan shall be liquidated by providing out of the municipal fund 40 half-yearly instalments, each including principal and interest, payable at the National Bank of Australasia Limited, Penhurst.

The purpose for which the loan is to be applied is to erect a dwelling for a Council officer.

A plan and specifications of the building to be erected is open for inspection at the Shire Office, Penhurst.

3140

H. S. MASON, Secretary.

## SHIRE OF NUMURKAH.

## BY-LAW No. 49.

A By-law of the Shire of Numurkah, numbered 49, made under section 197 of the *Local Government Act 1946*, and also as Rules and Regulations under section VI. of the *Police Offences Act 1928*, for the regulation of street traffic and the enforcement of one-way traffic through Blake-street, in the Township of Nathalia.

IN pursuance of the powers conferred by the *Local Government Act 1946* and by every other Act and power enabling it in that behalf, the President, Councillors, and Ratepayers of the Shire of Numurkah order as follows:—

1. In this By-law, unless the context otherwise requires—

"Driver" means any person in charge of a vehicle or motor car or traction engine.

"Motor car" means any conveyance propelled by mechanical power, and includes a motor cycle.

"Vehicle" means any conveyance drawn or propelled by human or animal power.

"Reserve" means the whole of the plantation area in Blake-street, whether wholly or partially enclosed by a fence or not, bounded on the northern end by a fence at the War Memorial, at the intersection of Blake-street and Bromley-street, and Blake-street and Weir-street, and at the southern end by the division of the road at the end of the plantation south of the water tower.

"Rider" means any person in charge of a horse or other animal.

"Street" shall refer to Blake-street.

2. The driver of a vehicle or motor car or traction engine, or the rider of any horse or other animal shall, when travelling in a northerly direction over the whole or part of the roadway adjoining the said reserve, proceed by the roadway on the left hand or western side of the said reserve. Likewise, the driver of a vehicle or motor car or traction engine, or the rider of any horse or other animal shall, when travelling in a southerly direction over the whole or any part of the road adjoining the said reserve, proceed by the roadway on the left hand or eastern side of the said reserve.

3. Any person committing offence against this By-law shall be liable to a penalty not exceeding Twenty pounds.

The Resolution for passing this By-law was agreed to by the Council on the 16th day of November, 1947, and confirmed by the Council on the 12th day of January, 1948.

The common seal of the President, Councillors, and Ratepayers of the Shire of Numurkah was hereunto affixed, in the presence of—

(SEAL)  
P. T. NASE, President.  
S. GARONNE, Councillor.  
W. G. HOOPER, Councillor.  
J. K. DANCOCKS, Secretary.

3126

## SHIRE OF SWAN HILL.

## REGULATION No. 5.

NOTICE is hereby given that, in pursuance of the powers conferred by the *Local Government Act 1946*, the President, Councillors, and Ratepayers of the Shire of Swan Hill have made Regulation No. 5, under section 4 of Part VI. of the Fifteenth Schedule to the *Local Government Act 1946*, in force in the Shire by virtue of a By-law of the Shire numbered 41 for appointing the times and hours during or at which respectively any hall or other building used for public meetings, or of any building or ground in which public amusements are conducted shall be used for the purpose for which it is registered or shall be closed.

Notice is also given that a copy of this Regulation is open for inspection, free of charge, during office hours at the office of the Council, the Town Hall, Swan Hill.

3132

L. C. FREEMAN, Shire Secretary.

## SHIRE OF WANNON.

NOTICE is hereby given that First Constable Thomas R. Patterson, No. 964, has been appointed Inspector of Nuisances for the Balmoral Police District in the Shire of Wannon, in place of First Constable George Henry Tucker, transferred.

V. WHARTON, Shire Secretary.  
Coleraine, 15th January, 1948. 3129

## NOTICE OF DISSOLUTION OF PARTNERSHIP.

NOTICE is hereby given that the partnership heretofore subsisting between Lloyd William Gribben and Francis Selwyn Gribben, trading as "Gribbens Motor Cycles," has been dissolved as from Wednesday, the 24th day of December, 1947.

Dated this 24th day of December, 1947.

LLOYD W. GRIBBEN.  
F. S. GRIBBEN.

Witness—H. KENNEDY, F.C.C.A., accountant, Shepparton. 3128

## PARTNERSHIP ACT 1928.

THE partnership heretofore subsisting between Fred Sewell Stevens, of 5 Higinbotham-street, Brighton, in the State of Victoria, Alfred Loring Sullivan, of Narre Warren North, in the said State, and Frederick George Billings, of 149 Tooronga-road, Glen Iris, in the said State, under the style or firm name of "S.S.B. Manufacturing Company," has been dissolved as from the 15th day of December, 1947.

FORD, ASPINWALL, & DE GRUCHY, 104 Queen-street, Melbourne, solicitors for the said firm. 3178

NOTICE is hereby given that the partnership heretofore subsisting between Jules Geoffrey Joubert, Thelma Annie Joubert, and Beryl Mary Zeusche, carrying on business as bakers and pastrycooks, at 1418 Malvern-road, Glen Iris, under the name of "Oslo and Tooronga Bakeries," has been dissolved by mutual consent. All debts due to and owing by the said late firm will be received and paid by the said Beryl Mary Zeusche, who will continue to carry on business at the same place.

J. G. JOUBERT.  
T. A. JOUBERT.  
B. M. ZEUSCHE.

Morgan, Fyffe, and Mulkearns, 108 Queen-street, Melbourne, solicitors for the said Jules Geoffrey Joubert and Thelma Annie Joubert, and C. L. Barbour, 89 Queen-street, Melbourne, solicitor for the said Beryl Mary Zeusche. 3180

NOTICE is hereby given that the partnership heretofore subsisting between the undersigned, John Hildebrand and Henry James Docter, carrying on business as radio and electrical dealers at 911 High-street, Thornbury, under the several trade names of "M. G. Radio Services," and "Sky Chief Radio," has been dissolved by mutual consent as from the 19th day of January, 1948. All debts due to and owing by the said late firm will be received and paid by the said John Hildebrand, who will continue to carry on the business at the same place.

Dated this 19th day of January, 1948.

J. HILDEBRAND.

Signed by the said John Hildebrand, in the presence of—ALAN WAINWRIGHT, solicitor, Melbourne.

H. J. DOCTER.

Signed by the said Henry James Docter, in the presence of—ARTHUR D. PEARCE, solicitor, Melbourne. 3189

NOTICE is hereby given that the partnership heretofore subsisting between the undersigned Stavros Phillipo and Dimitrios Yoanu Phillipo, carrying on the business of cafe proprietors, at 376 Clarendon-street, South Melbourne, under the style or firm name of "Swan Cafe," has been dissolved by mutual consent as from the 12th day of January, 1948. All debts due and owing by the late partnership will be received and paid by Dimitrios Yoanu Phillipo, of 376 Clarendon-street, South Melbourne, who will solely carry on the business of the said partnership at 376 Clarendon-street, South Melbourne.

Dated at Melbourne, the 16th day of January, 1948.

D. Y. FILLIPO.  
STAVROS PHILLIPOU.

Witness—B. M. KENNY.

E. Edgar Davies and Co., solicitors, 11 Bank-place, Melbourne. 3142

*Companies Act 1938.*

## VICTORIAN ANIMAL AID TRUST.

NOTICE OF INTENTION TO APPLY TO ATTORNEY-GENERAL FOR LICENCE, PURSUANT TO SECTION 18 (1).

VICTORIAN ANIMAL AID TRUST, formed for the purpose of constructing and maintaining animal aid centres, hereby gives notice of intention to apply to the Attorney-General for a licence directing that the said association be registered as a company with limited liability without the addition of the word "limited" to its name.

Dated this 31st day of December, 1947.

ALEXANDER HUGH GRIERSON,  
3153 a Member of the Committee of the said Association.

## RE LITTLE, KENT, &amp; CO. PTY. LTD.

NOTICE is hereby given that, on the 12th day of January, 1948, the above-named company resolved, by Special Resolution, that the company be wound up voluntarily.

Dated this 13th day of January, 1948.

3137 B. M. KENT, Director.

*Companies Act 1938.*—In the matter of the MALVERN TYRE CO. PTY. LTD. (in Voluntary Liquidation).—Notice of Final Meeting.

NOTICE is hereby given that, pursuant to sections 235 and 236 of the *Companies Act 1938*, a General Meeting of the members of the above-named company will be held at 397 Little Collins-street, Melbourne, on Monday, the 23rd day of February, 1948, at Three o'clock in the afternoon, for the purpose of having an account laid before them showing the manner in which the winding up has been conducted and the property of the company disposed of, and of hearing any explanation that may be given by the liquidator.

Dated this 16th day of January, 1948.

3183 H. N. EVANS, Liquidator.

DUNLOP RUBBER AUSTRALIA LIMITED.

REGISTER of Unclaimed Money held by Dunlop Rubber Australia Limited, 108 Flinders-street, Melbourne.  
WAGES YEAR ENDING DECEMBER, 1941.

DUNLOP RUBBER AUSTRALIA LIMITED—continued.

Wages Year ending December, 1941—continued.

Name and Address.	Amount.	Name and Address.	Amount.
	£ s. d.		£ s. d.
Allen, May, 70 Simpson-street, Yarraville ..	0 0 9	Footo, George Clifford, 23 Hoddle-street, Port Melbourne ..	0 9 4
Appleby, Thelma, 67 Powell-street, Regent ..	0 6 7	Floody, Leslie Thomas, 7 Admiral-street, West Footscray ..	0 17 8
Adair, Edith Christina, 75 Bastings-street, Northcote ..	0 3 10	Greenwood, David, 104 Hope-street, West Brunswick ..	0 10 3
Allison, Ormond John, 10 Buckley-street, Footscray ..	0 9 3	Guy, Ada Lilian, 30 York-street, South Melbourne ..	0 11 4
Andrews, Nell, 42 Koroit Creek-road, North Williams-town ..	0 9 0	Greaves, Richard, 5 Stafford-street, West Footscray ..	5 3 0
Andrews, Nell, 42 Koroit Creek-road, North Williams-town ..	1 8 6	Gray, Albert James, 14 Albion-street, West Brunswick ..	0 6 5
Alexander, Elizabeth Jean, 472 Bay-street, Port Melbourne ..	0 7 8	Greaves, Richard, 5 Stafford-street, West Footscray ..	0 13 10
Aarons, Alfred, 103 George-street, Fitzroy ..	0 18 2	Graham, Leonard, 16 Gordon-crescent, Black Rock ..	1 15 7
Adair, Edith Christina, 75 Bastings-street, Northcote ..	0 9 11	George, Gwen Louise, 251 Barker's-road, Kew ..	0 1 1
Arnold, Leslie George, 17 Alma-terrace, Newport ..	0 17 6	Goldsmith, Olive Madeline, 44 Blandford-street, West Footscray ..	0 0 6
Booth, Desmond, 16 Chain-street, Windsor ..	0 1 2	Gooby, Gwendoline Jean, 6 Tennis-grove, Caulfield ..	0 12 10
Baker, Vera Eileen, 22A Ellis-street, South Yarra ..	0 6 2	Gardner, Edward Hayden, 18 Croxford-street, Port Melbourne ..	0 13 1
Bradley, John Albert, 61 O'Grady-street, Albert Park ..	1 7 5	Gay, Joan, 178 Princess-street, Port Melbourne ..	0 7 7
Brennan, Herbert Vincent, 154 Charles-street, Abbotsford ..	0 0 4	Good, Robert James, 84 Brook-street, Albert Park ..	0 0 5
Bailey, Ralph, 52 Ferrars-place, Albert Park ..	0 19 6	Gardner, Thomas Joseph, 24 David-road, Hampton ..	0 1 4
Bellehambers, Allan Raymond, 2 Montague-place, South Melbourne ..	2 2 2	Gray, Albert James, 14 Albion-street, West Brunswick ..	0 0 10
Brown, Arthur John, 25 Lewisham-road, Windsor ..	0 1 11	Garlopp, Freda, 33 St. Vincent-street, Albert Park ..	0 9 10
Bradley, Henry, 50 Clyde-street, St. Kilda ..	1 13 6	Harrington, Nellie Veronica, 24 Napier-street, Footscray ..	0 4 10
Brady, Kathleen, 45 Beach-street, Port Melbourne ..	0 9 4	Hartney, Shirley Kathleen, 42 Darling-street, South Yarra ..	0 4 11
Brown, Joan Elizabeth, 42 Donaldson-street, Footscray ..	0 0 4	Hocking, Ernest Phillip, 178 High-street, St. Kilda ..	0 3 7
Beasley, Florence, 22 Newman-street, West Brunswick ..	0 14 2	Hawking, Douglas, 31 Austin-avenue, Preston ..	1 4 3
Blackford, Walter Charles, 301 George-street, Fitzroy ..	0 2 6	Higgins, John Ernest, 3 Brixton-street, Flemington ..	0 16 2
Boote, Cyril Alfred, 222 William-road, Toorak ..	1 10 6	Hands, Kevin Ronald, 126 Williamstown-road, Port Melbourne ..	0 3 7
Betts, James Edward, 18 Sycamore-street, Carnegie ..	1 15 1	Hore, William Charles, 87 Cartisle-street, St. Kilda ..	0 3 7
Benson, Beryl Valerie, 12 Hudson-street, Coburg ..	0 14 5	Horwood, Maurice Joseph, 4 Dalgety-street, Preston ..	0 1 1
Bailey, Ralph, 32 Ferrars-place, Albert Park ..	0 9 6	Hammett, John 37 Perth-street, Prahran ..	0 7 2
Breeze, Mary Ellen, 3 Lyle-street, South Melbourne ..	0 9 8	Helliar, Fred Charles, 44 Wheatland-grove, Malvern ..	0 2 5
Bettie, James Arthur, 15 Princess-street, Seddon ..	0 0 5	Hammond, Kevin John, 39 Aaron-street, Richmond ..	0 15 0
Bodley, Jean, 3 Auburn-grove, Armadale ..	0 2 11	Hossack, Arthur, Kitchener-road, Croydon ..	0 8 6
Cowman, Jean Lydia, 82 Kerr-street, Footscray ..	0 4 7	Hollowell, Bessie, 6 Rowell-avenue, Camberwell ..	1 9 8
Conway, Ella May, 135 Ross-street, Port Melbourne ..	0 2 0	Hall, Margaret Rose, 233 Clarendon-street, South Melbourne ..	0 15 8
Chadwick, Shirley Margaret, 104 Commercial-road, Footscray ..	0 1 1	Hall, Margaret Rose, 233 Clarendon-street, South Melbourne ..	0 6 7
Caldwell, Shirley, 135 Ross-street, Port Melbourne ..	0 1 10	Horgan, John Robert, 91 St. Leonards-road, Ascot Vale ..	2 3 3
Cain, May Robina, 123 Bridge-street, Port Melbourne ..	0 2 1	Heeps, Norman, 260 Esplanade East, Port Melbourne ..	0 2 9
Carrington, John Douglas, 99 Hoddle-street, North Richmond ..	0 7 8	Horgan, John Robert, 91 St. Leonards-road, Ascot Vale ..	1 6 3
Caldwell, Patricia, 135 Ross-street, Port Melbourne ..	0 3 10	Hopwood, Harold John, 129 Queensberry-street, North Melbourne ..	0 19 0
Cumberland, Alan Frederick, 103 Ruskin-street, Elwood ..	0 14 1	Ingie, John Percival, 6 Willison-road, Oakleigh ..	1 13 0
Clarke, Rex Harold, 282 Ascot Vale-road, Moonee Ponds ..	0 1 0	Irving, Kevin James, 488 Bay-street, Montague ..	0 0 2
Croft, Leslie Roy, 151 North-road, Reservoir ..	0 6 9	Ingram, Clarence, Howe-crescent, South Melbourne ..	0 6 6
Cooke, Nancy June, 15 Staniland-grove, Elsternwick ..	0 3 1	Jones, Keith, 72 Napier-street, South Melbourne ..	1 11 6
Carmen, Margaret Ellen, 96 Hotham-street, East Melbourne ..	0 6 6	Jacobsen, Olive Blanche, 50 Raglan-street, South Melbourne ..	0 9 6
Cargill, Albert, 105 Pickle-street, Port Melbourne ..	0 5 1	Jubb, Anne, 853 Mouhray-street, Albert Park ..	0 16 10
Coff, Mabel Margaret, 276 Dorcas-street, South Melbourne ..	0 7 6	J Jarvis, Lily May, 121 Blyth-street, Brunswick ..	0 5 2
Campbell, Violet, 16 Hobb-street, Seddon ..	0 5 4	Judd, Edward Archers, 6 Willis-street, Richmond ..	0 12 4
Condon, Brendon Thomas, 73 Chatsworth-road, Prahran ..	0 10 3	Jowett, Joseph Patrick, 22 Reid-street, Northcote ..	0 10 5
Caldar, Thomas, 46 George-street, Fitzroy ..	0 4 0	Kerrison, Thomas, 42 Glenferrie-road, Hawthorn ..	0 19 8
Clarke, Rex Harold, 282 Ascot Vale-road, Ascot Vale ..	0 3 11	King, Florence Dawn, 270 Ross-street, Port Melbourne ..	0 14 6
Dunn, Nancy Rene, 8 Brighton-road, St. Kilda ..	0 0 6	Keating, Douglas Percival, 22 Ardoyen-street, Black Rock ..	1 7 3
Durham, George Alfred, 25 O'Hea-street, Coburg ..	1 19 4	Kelly, Maurice, 46 Grant-street, Clifton Hill ..	0 14 9
Dalton, Sarah, 212 Station-street, Port Melbourne ..	0 5 8	Kinsman, Melva, 126 Pascoe Vale-road, Moonee Ponds ..	2 9 9
Dalgleish, Bruce Alex., 144 Darford-street, Richmond ..	0 3 6	Kannergressor, Joan Elizabeth, 22 Newman-street, Brunswick ..	0 14 2
Danaher, William, 65 Brunswick-street, Fitzroy ..	1 13 6	Kearns, Dennis, 555 Little Lonsdale-street, Melbourne ..	0 6 4
Davis, William, 10 Little Page-street, Middle Park ..	0 0 2	King, William Ernest, 16 Carlton-street, Carlton ..	0 1 1
Dean, Alice Lillian, 97 Graham-street, Albert Park ..	0 0 6	Kelly, Leonard, 169 Barkly-street, East Brunswick ..	1 6 9
Draw, Dudley, 23 Reed-street, Albert Park ..	0 0 4	Liddecoat, Richard John, 45 Dinsdale-street, Albert Park ..	0 5 2
Dickman, Lydia Ellen, 32 Ferrars-place, South Melbourne ..	0 1 0	Le Vier, Lorraine, 156 Thistlewaite-street, South Melbourne ..	1 17 2
Dinsdale, Margaret Noble, 7 Ashley-street, Tottenham ..	0 0 6	Legg, Ronald Victor, 6 Allie-street, Surrey Hills ..	0 0 4
Dunlop, John, Henry-street, Eltham ..	0 1 0	Lynch, Jack Richard, 283 Coppin-street, Richmond ..	1 6 1
Dodds, Agnes, 289 Amess-street, North Carlton ..	0 6 11	Lewis, Jean Dorothy, 33 Buckhurst-street, South Melbourne ..	0 5 3
Drennen, Betty Bertha, 332 Clarendon-street, South Melbourne ..	0 1 0	Lynch, Dorean Olive, 72 Smith-street, Kensington ..	1 12 6
Dunn, Keith, 377 Latrobe-street, Melbourne ..	0 1 8	Lewis, Freda May, 203 Montague-street, South Melbourne ..	0 19 0
Doyle, James Stephen, 35 South-street, Ascot Vale ..	1 6 0	Lowry, George, 66 Lang-street, South Yarra ..	0 0 4
Edwards, Marjorie, 406 Church-street, Richmond ..	0 6 4	Little, Frank Kevin, 67 Crockford-street, Port Melbourne ..	1 18 6
Fennessy, Francis Edward, 48 Myrtle-street, Clifton Hill ..	0 4 0	Leyden, Maurice, 123 Farrell-street, Port Melbourne ..	0 11 4
Fennessy, Tilly, 71 Clifford-street, Albert Park ..	1 6 2	Maher, Freda, 2 Nelson-road, South Melbourne ..	0 3 7
Foley, Thomas Michael, 154 Cecil-street, North Melbourne ..	2 6 4	Maskell, Leslie Alan, 24 Dalgety-street, St. Kilda ..	1 2 6
Fair, Ivy, 2 Wolsely-street, South Melbourne ..	0 2 7	Marks, Cecil Ronald, 14 Roxburgh-street, Preston ..	0 9 9
Floody, Leslie Thomas, 7 Admiral-street, West Footscray ..	3 13 11	Machin, Edith Muriel, 33 Amelia-road, North Essendon ..	0 19 7
Fenning, William Albert, 118 Bendigo-street, Prahran ..	0 5 9	Martin, George, 86 Fraser-street, Burnley ..	0 0 2
Fowler, Dorothy, 246 Dorcas-street, South Melbourne ..	1 17 2		
Flegg, Raymond John, 199 Greville-street, Prahran ..	0 3 9		
Footo, George Clifford, 23 Hoddle-street, Port Melbourne ..	0 9 4		

DUNLOP RUBBER AUSTRALIA LIMITED—continued.

Wages Year ending December, 1941—continued.

Name and Address.	Amount.
Marks, William James, Mt. Waverley Post Office ..	£ s. d. 2 13 4
Maskell, Leslie Alan, 24 Dalgety-street, St. Kilda ..	4 1 1
Morris, Donald William, 97 Gibbs-street, East Melbourne ..	0 3 8
Murtagh, Leslie Ivan, 14 Watsonia-street, Oakleigh ..	0 0 7
Maye, Keith Thomas, 7 Francis-grove, Northcote ..	0 8 1
Maggs, Russell Ian, 24 Chappel-street, Windsor ..	0 12 8
Moreland, Duncan, 45 Linda-street, Coburg ..	0 2 6
Moody, George, 31 Raglan-street, Port Melbourne ..	0 14 9
Mangin, Laurence, 148 Johnstone-street, Fitzroy ..	0 8 6
Mason, Patricia, 44 Seddon-street, Seddon ..	0 19 8
Musgrove, Lange, 68 Westhorn-road, Kensington ..	0 4 8
McLaughlin, Leo John, 294 Ross-street, Port Melbourne ..	0 6 3
McMahon, Cyril Frederick, 21 Fergie-street, North Fitzroy ..	0 1 6
McRedmond, Kevin, 222 Esplanade West, Port Melbourne ..	4 4 0
McGrory, Raymond Hugh, 9 Herbert-place, Albert Park ..	0 6 6
McEwan, Harold George, Salvation Army Home, Little Lonsdale-street, Melbourne ..	0 4 0
McKenzie, James Andrew, 12 Tyrone-street, South Yarra ..	0 3 10
McPherson, Jean Kathleen, 11 Southward-avenue, Port Melbourne ..	0 9 5
McNamara, Hector, 18 Lothian-street, North Melbourne ..	0 0 9
McDougall, William, 37 Vincent-street, Coburg ..	0 4 1
McNamara, John Robert, McLean-road, Boronia ..	0 8 8
McGory, William Leslie, 91 Johnson-street, Collingwood ..	0 16 2
McKenna, Basil Hewett, 22 Union-street, Westgarth ..	1 5 0
McAuley, Albert Edward, 8 Pyne-street, South Caulfield ..	1 2 1
Nugent, William Harold, 22 Nicholson-street, Fitzroy ..	3 4 9
North, Leslie Edward, 16 Jellicoe-street, Cheltenham ..	0 2 7
Noyce, Sydney Percy, 15 Robert-street, Essendon ..	0 7 4
Neil, Joyce, 602 City-road, South Melbourne ..	0 5 10
Nembs, Phyllis Mary, 52 Brooke-street, Albert Park ..	0 2 6
Owens, Mary, 270 Williamstown-road, Yarraville ..	1 13 6
Ogden, Ruth, 6 Wilson-street, North Carlton ..	0 7 1
O'Halloran, Thomas Henry, 13 Coronation-street, West Footscray ..	0 3 7
O'Donnell, Martin, 172 Victoria-parade, East Melbourne ..	0 16 9
O'Riley, Jack, 246 Grango-road, Fairfield Park ..	0 13 7
O'Connor, Marie Antoinette, 45 Church-street, South Melbourne ..	0 0 2
Powell, Ellis Humphrey, 10 Bayview-terrace, Kensington ..	0 0 2
Power, Joyce, 1 Walters-avenue, Port Melbourne ..	0 7 3
Perryman, Lila, 223 Page-street, Middle Park ..	0 1 5
Paul, Rowland Ernest, 7 McRae-street, Elwood ..	1 7 3
Parker, Arthur, Sydney-road, Fawkner ..	0 1 8
Powell, James Baden, 119 Droop-street, Footscray ..	0 1 10
Peterson, Norman Henry, Yarra-road, Croydon ..	1 7 3
Porter, John Frances, 185 Inkerman-street, St. Kilda ..	1 5 8
Porrain, Robert John, 81 Walter-street, Footscray ..	0 5 9
Porter, Edward, 199 Victoria-parade, Fitzroy ..	1 2 2
Pocock, George William, 1 Hambleton-street, Albert Park ..	1 1 6
Ponton, Eileen Audrey, 52 Nightingale-street, Balaclava ..	0 4 1
Pulford, Leonard Alfred, Henry-street, Eltham ..	0 0 9
Philpot, Stanley Robert, 12 Young-street, East St. Kilda ..	0 8 10
Page, Jean Gwendoline, 157 Page-street, Port Melbourne ..	0 0 5
Pinches, Edward, 1 Barwon-street, Prahran ..	1 0 0
Power, Cecil Leslie, 34 Ewin-street, East Brunswick ..	0 0 5
Palmer, John Raymond, 39 Barry-street, South Yarra ..	0 9 3
Peel, Norman Ellen, 66 Ascot Vale-road, Flemington ..	1 0 2
Raschke, Mervyn Lloyd, 6 River-street, South Yarra ..	0 6 1
Reid, Francis Joseph, 463 Glenferrie-road, Kooyong ..	0 11 9
Rohan, Veronica Mary, 234 Ferris-street, South Melbourne ..	0 7 4
Rundle, Robert, 93 Yarra-street, Abbotsford ..	0 0 4
Robertson, Sydney John, Henry-street, Eltham ..	1 13 3
Rennie, Margaret Amelia, 192 Heath-street, Port Melbourne ..	1 5 5
Rich, Dennis Arthur, 168 Nicholson-street, Fitzroy ..	0 16 7
Ryan, Kathleen, 206 Cecil-street, South Melbourne ..	0 0 7
Robinson, Albert William, 12 Federation-street, Ascot Vale ..	2 14 6
Rundle, Robert, 93 Yarra-street, Abbotsford ..	4 12 6
Raymond, Daisy, 220 Esplanade East, Port Melbourne ..	2 7 6
Simmons, Millic, 391 Graham-street, Port Melbourne ..	0 1 10
Spooner, Nancy, 38 Draper-street, South Melbourne ..	0 7 2
Shannon, Mabel Lorraine, 104 Bridport-street, Albert Park ..	0 16 2
Sharpe, Reginald Andrew, 200 Ferris-street, South Melbourne ..	0 6 9

DUNLOP RUBBER AUSTRALIA LIMITED—continued.

Wages Year ending December, 1941—continued.

Name and Address.	Amount.
Sager, Rose Francis, 266 Dorcas-street, South Melbourne ..	£ s. d. 0 3 2
Spencer, Gordon Arthur, 7 Washington-avenue, East Malvern ..	0 12 0
Smith, Charles William, 84A Inkerman-street, St. Kilda ..	0 14 9
Spencer, Gordon Arthur, 7 Washington-avenue, East Malvern ..	0 4 11
Sticker, Alton, 186 Cochrane-street, Elsternwick ..	0 19 3
Sommers, Harold Herbert, 99 Marton-street, Richmond ..	1 12 11
Stone, Robert Clive, 34 Gold-street, Brunswick ..	0 2 10
Spencer, Mavis Ida, 4 Washington-avenue, East Malvern ..	0 13 2
Smith, Stella Winifred, 210 Heath-street, Port Melbourne ..	0 0 6
Siggins, Cyril, 182 Arden-street, North Melbourne ..	0 0 1
Sandersons, William George, 15 Service-crescent, South Melbourne ..	0 13 6
Stephens, Lillian Grace, Noble-street, Noble Park ..	2 6 4
Smith, Joyce Lorraine, 20 Darling-street, South Yarra ..	0 0 7
Smith, Daisy May, 341 Richardson-street, Middle Park ..	0 6 3
Sommers, Charles Thomas, 16 Rivers-street, Collingwood ..	1 1 5
Smith, Edward, 97 Mitchell-street, Northcote ..	0 0 7
Spencer, Norma Janet, 87 Beaucamp-street, Preston ..	1 8 6
Stickland, —, address unknown ..	0 5 11
Taylor, Minnie, 76 Cobden-street, South Melbourne ..	0 1 1
Turpie, Edward Stanley, 61 O'Grady-street, Albert Park ..	0 4 1
Tennant, Leslie Alfred, 90 Chatsworth-road, East Prahran ..	0 5 3
Tucker, Margaret Elizabeth, 3 St. Vincent's-place, Albert Park ..	0 4 7
Thackrah, Robert Arthur, 131 Ferrell-street, Port Melbourne ..	0 5 1
Tasdale, Thomas, 28 Wattle-grove, Coburg ..	0 3 7
Thomas, Edna Irene, 4 York-street, Moonee Ponds ..	0 0 2
Thompson, Nancy Louise, 72 Brook-street, Albert Park ..	0 10 6
Tripp, Noel, 184 Nelson-road, South Melbourne ..	0 10 4
Thomas, Frederick, 32 Grove-street, Middle Park ..	1 3 6
Thompson, Beryl Jean, Siddeley-street, V. Melbourne ..	0 19 6
Tucker, Bonita, 14 Owen-street, West Brunswick ..	0 0 1
Tonkin, Donald Francis, 211 Beaconsfield-parade, Albert Park ..	1 11 3
Turner, William, 53 Cumberland-street, West Brunswick ..	0 2 7
Taylor, Doreen May, 38 Park-street, St. Kilda ..	0 9 9
Utdley, Andrew Johnson, 90 Raglan-street, Port Melbourne ..	0 4 0
Van Uden, Charles Edward, 71 Dunstan-parade, Port Melbourne ..	0 5 11
Veal, Douglas John, 107 Ekadale-road, Caulfield ..	1 18 10
Waldron, Frank, 142 Albert-street, Port Melbourne ..	0 1 9
Webb, Mavis Veronica, 4 Tucker-avenue, Garden City ..	0 0 5
Wild, Arthur John, 25 Hambeldon-street, Albert Park ..	0 12 6
Whitehouse, Audrey Mavis, 17 Henry-street, Kensington ..	0 6 8
Wilkinson, Tom Andrew, 103 Fisher's-parade, Ascot Vale ..	0 6 3
Whelan, George Henry, 16 Young-street, Albert Park ..	0 4 7
Webb, Patrick, 13 Fink-street, Kensington ..	0 4 1
Weatherhead, Thelma Eileen, 23 Abbotsford-street, North Melbourne ..	0 18 5
Windberg, Harold John, Monbulk Post Office, Victoria ..	0 1 10
Wythe, Alan William, 15 Bay-street, Port Melbourne ..	0 8 10
Wilson, James Bryant, 163 Drummond-street, Carlton ..	0 3 0
Wood, Fredrick George, 38 Wright-street, Carlton ..	0 2 0
Watson, Amy Parker, 38 Park-street, St. Kilda ..	1 9 0
Williams, Margaret, 4 Naismith-street, Footscray ..	0 0 3
172 3 9	
WAR SAVINGS CERTIFICATES. YEAR ENDING DECEMBER, 1941.	
2nd Series.	
Black, Alec Beament, 9 Davies-street, East Brighton ..	0 11 0
Croft, Leslie Roy Carr, 151 North-road, Reservoir ..	0 14 0
Chant, Marjorie (Miss), 22 Loch-street, Coburg ..	0 12 0
Robinson, Hope H., 18 Gilmour-street, Coburg ..	0 12 0
Stewart, James Hadley, 15 Finsbury-street, Newmarket ..	0 10 0
Thomas, Joyce Mary (Miss), 24 Hammer-street, Williamstown ..	0 3 0
Tucker, Blanche (Miss), 182 Pickle-street, Port Melbourne ..	0 14 0
Torney, John Arthur, 50 Shiel-street, North Melbourne ..	0 12 0
Wells, John Paul, 82 Lewisham-road, Prahran ..	0 7 0
Whincup, Reginald, 16 Athelstane-grove, Ivanhoe ..	4 12 0
West, James Leslie, 330 Richardson-street, Middle Park ..	0 8 0
9 15 0	

DUNLOP RUBBER AUSTRALIA LIMITED—continued.  
War Savings Certificates Year ending December, 1941—continued.

Name and Address.	Amount.
<i>3rd Series.</i>	
Bradley, Henry, 50 Clyde-street, St. Kilda ..	0 10 0
Marshall, Plazzy Edna (Mrs.), 48 Swan-street, Richmond ..	0 12 0
Appleby, Thelma (Miss), 67 Powell-street, Regent ..	0 1 0
McKay, Ann Louisa (Miss), 55 Mary-street, St. Kilda ..	0 10 0
Adams, Harold George, 198 Albert-street, Port Melbourne ..	0 2 0
Helliar, Frederick Charles, 44 Westland-grove, Malvern ..	0 2 0
Richardson, Gertrude Elizabeth (Miss) 9 Raglan-place, South Melbourne ..	0 15 0
Garrett, Roland James, 75 Southern Hay-street, Regent ..	0 5 0
Cain, Patrick Joseph, 8 Clarendon-street, South Melbourne ..	0 4 0
Waddell, Alexander, 12 Westgarth-street, Oakleigh ..	0 3 0
Beaumont, John Patrick, 100 Gordon-street, West Coburg ..	0 10 0
Goldsworthy, William Thomas, 69 Munro-street, Ascot Vale ..	0 5 0
Guthrie, Clarence Joseph, 150 Collins-street, Thornbury ..	0 4 0
Scott, J. (address unknown) ..	0 3 0
Green, William Edward, Croydon-road, Croydon ..	0 10 0
Pierce (address unknown) ..	0 8 0
Buckland, Bruce, 12 Westbourne-street, Prahran ..	0 12 0
Wilson, Eileen Elizabeth (Mrs.), 163 Drummond-street, Carlton ..	0 1 0
Aron, Alfred, 25-Octavia-street, St. Kilda ..	0 10 0
Gee, George Rock, 12 Gould-street (Box 13), Frankston ..	0 1 0
	6 8 0
<i>4th Series.</i>	
Phillips, Andrew Christian, 5 Somner-street, East Brunswick ..	0 10 0
Burns, John Hamilton, 2 Manalick-street, Brunswick ..	0 5 0
Andrews (address unknown) ..	0 5 0
Baker, Thomas Raymond, 4 Tennyson-street, Moonee Ponds ..	0 4 0
Bettie, J. (address unknown) ..	0 8 0
Croft, Leslie Roy Carr, 151 North-road, Reservoir ..	0 7 0
Callick, Pearl May (Miss), 95 Cruickshank-street, Port Melbourne ..	0 4 0
Barton, Ronald, 48 Byron-street, Footscray ..	0 2 0
Woodhead, Veronica (Mrs.), 28 Talbot-street, West Brunswick ..	0 4 0
Scott, James Malcolm, 2 Packington-street, Kew ..	0 3 0
McCallum, Athol Ernest, Henry-street, Clayton ..	0 9 0
McDonald, Alexander, 112 Hawke-street, West Melbourne ..	0 12 0
Davenport, Dorothy (Miss), 94 Evans-street, Port Melbourne ..	0 4 0
Hayden, Elsie (Miss), 348 Ascot Vale-road, Moonee Ponds ..	0 4 0
Holland, Laurel, 184 Hanna-street, South Melbourne ..	0 5 0
Bowler, Agnes (Miss), 42 Connell-street, Hawthorn ..	0 14 0
Sheldon, Dorothy (Miss), 27 St. Vincent-place, Albert Park ..	0 2 0
Good (Miss) (address unknown) ..	0 6 0
Powell, Kathleen (Miss), 87 Inkerman-street, St. Kilda ..	0 1 0
Lee, James, 559 Victoria-street, Abbotsford ..	0 1 0
O'Neill, Evelyn Mary (Miss), 407 Dorcas-street, South Melbourne ..	0 6 0
Davis, Hazel (Miss), 30 Blyth-street, Brunswick ..	0 2 0
MacDonald, Kenneth John, 18 Malakoff-street, Caulfield ..	0 4 0
Simpson, Beryl May (Miss), 8 Beckley-street, East Coburg ..	0 10 0
	6 12 0

3130

Companies Act 1938.  
MASONIC CLUB HOUSE COMPANY OF VICTORIA LIMITED.

REGISTER of Unclaimed Moneys held by Masonic Club House Company of Victoria Limited.

Name of Owner on Books.	Total Amount Due to Owner.	Description of Unclaimed Money.	Date of Last Claim.
	£ s. d.		
John T. Anderson ..	1 0 0	14th dividend (paid 15th September, 1941)	Sept., 1930
James N. Baker (deceased) ..	0 1 0	" "	Sept., 1935
Edward Betts ..	0 5 0	" "	Sept., 1936
Douglas G. Blair ..	0 10 0	" "	Sept., 1934
Harold A. Bruce ..	0 5 0	" "	Sept., 1938
Alfred E. Burton (deceased) ..	0 5 0	" "	Sept., 1940
Andrew S. Chisholm ..	0 5 0	" "	Sept., 1938
William Collie ..	0 5 0	" "	Sept., 1935
David Cooper (deceased) ..	0 5 0	" "	Sept., 1939
Albert C. Dungey ..	0 15 0	" "	Sept., 1939
George Dunse ..	0 5 0	" "	Sept., 1939
Henry P. Foster ..	0 5 0	" "	Sept., 1932
Simeon G. Gibson ..	0 5 0	" "	Sept., 1940
Otto Goetz ..	1 5 0	" "	Sept., 1938
Ernest W. Goodrich ..	0 5 0	" "	Sept., 1929
Frederick H. Gross (deceased) ..	0 5 0	" "	Sept., 1939
Archibald Hamilton ..	1 0 0	" "	Sept., 1939
James Hamilton (deceased) ..	2 10 0	" "	Sept., 1939
Leslie T. Hurley ..	0 10 0	" "	Sept., 1940
Albert E. Johnston ..	0 10 0	" "	Sept., 1940
Robert Lindsay (deceased) ..	0 15 0	" "	Sept., 1930
Percival C. McHutchison ..	0 10 0	" "	Sept., 1934
John W. McKnight ..	0 5 0	" "	Sept., 1938
George S. Moffett ..	0 5 0	" "	Sept., 1934
Walter Nichol ..	1 0 0	" "	Sept., 1938
Richard H. North ..	0 15 0	" "	Sept., 1940
Walter K. Onslow ..	0 5 0	" "	Sept., 1934
Edward B. Parker ..	0 10 0	" "	Sept., 1939
William W. V. Parsons ..	0 2 0	" "	Sept., 1934
Cecil W. Rashleigh ..	0 5 0	" "	Sept., 1939
Edward R. Rogers ..	0 2 0	" "	Sept., 1940
Gilbert E. Selby (deceased) ..	0 10 0	" "	Sept., 1935
Frederick J. Smye ..	0 5 0	" "	Sept., 1936
John W. Stimson ..	0 4 0	" "	Sept., 1937
Ernest F. Stirett ..	0 14 0	" "	Sept., 1938
Henry W. Surrah ..	0 5 0	" "	Sept., 1935
W. M., J. J., and A. Trickey ..	0 15 0	" "	Sept., 1940

3182

PIONEER PERMANENT BUILDING SOCIETY.

REGISTER of Unclaimed Money held by Pioneer Permanent Building Society at 1st January, 1948.

Name of Owner on Books.	Total Amount Due to Owner.	Description of Unclaimed Money.	Date of Last Claim.
	£ s. d.		
Mary Ripper (deceased) ..	2 5 0	Dividend ..	Last claim, 1931

49 Elizabeth-street, Melbourne.

3174

REGISTER of Unclaimed Moneys held by John Connell & Co. Ltd., 578 Bourke-street, Melbourne.

Name of Owner on Books.	Total Amount Due to Owner.	Description of Unclaimed Money.	Date of Last Claim.
	£ s. d.		
Names unknown, records destroyed in London Air Raid, May, 1941 ..	29 11 6	Dividends on preference shares	No claim made
Miss Florence Roberts, 37 Richmond-terrace, Liverpool, England ..	1 7 6	Preference dividend paid 1st October, 1941	"

F. T. KNOX, Secretary.

Melbourne, 15th January, 1948.

3146

## THE WARRNAMBOOL WOOLLEN MILL COMPANY LIMITED

REGISTER of Unclaimed Money held by the Warrnambool Woollen Mill Co. Ltd., for year ended 31st December, 1947.

Name of Owner on Books and Last Known Address.	Total Amount Due to Owner.	Description of Unclaimed Money.	Date of Last Claim.
	£ s. d.		
Estate of late Wm. Henry Johnson, c/o Albert E. Johnson, 10 Victoria-avenue, Elsternwick ..	0 15 6	Dividend declared Nov., '26 .. .. .	No claim
Mrs. Esther M. McDonald .. .. .	0 5 0	Dividend declared Dec., '29 .. .. .	No claim
Estate of late Wm. Alfred Tayler .. .. .	1 18 7	Dividend declared Dec., '29, May, '40, May, '41, Dec., '41	No claim
Edward A. Thompson, Swinton's-lane, Warrnambool	1 12 6	Dividend declared Nov., '32, Nov., '35, May, '36, May, '37, Nov., '37, May, '38, Dec., '39, May, '40, Nov., '40, May, '41, Dec. '41	No claim
C. J. Kenny, Treseo, Victoria .. .. .	0 13 6	Dividend declared Nov., '35, May, '39, May, '40, May, '41, Dec., '41	No claim
Morton V. Mitchell, 14 Munro-street, Armadale	0 15 0	Dividend declared Nov., '32 .. .. .	No claim
William B. Richie, junr., c/o Mrs. Elizabeth Richie, 145 Brunswick-street, West Brunswick	3 18 0	Dividend declared May, '33, Dec., '39, May, '40, May, '41, Dec., '41	No claim
Sidney W. Thomas, 30 Wanda-road, Caulfield ..	9 12 0	Dividend declared Nov., '32, May, '33, Nov., '33, May, '34, Nov., '34, May, '35, Nov., '35, May, '36, Nov., '36, May, '37, Nov., '37, May, '38, Nov., '38, May, '39, Dec., '39, May, '40, Nov., '40, May, '41, Dec., '41	No claim
Mrs. Elizabeth Jane Tyers (deceased), Raglan-parade, Warrnambool	0 8 0	Dividend declared May, '21 .. .. .	No claim

3179

E. M. DEMPSTER, Secretary.

## BROKEN HILL SOUTH LIMITED.

REGISTER of Unclaimed Money as at 31st December, 1947.

Name of Owner on Books.	Address.	Total Amount Due to Owner.	Description of Unclaimed Money.	Date of Last Claim.
		£ s. d.		
<i>London Register.</i>				
Abraham Bennett .. .. .	Dudlow-lane, Liverpool, England ..	1 10 2	Dividend No. 72 .. .. .	.. .. .
Clive A. Brewster .. .. .	Suva, Fiji .. .. .	12 1 1	Dividend No. 72 .. .. .	.. .. .
Lillias C. Guthrie .. .. .	44 Princes-court, Queensway, London	3 0 5	Dividend No. 72 .. .. .	.. .. .
Lewis M. Wilkins .. .. .	Telegraph-street, London .. .. .	12 6 1	Dividend No. 71-72 .. .. .	.. .. .
<i>Australian Register.</i>				
Clare S. Broughton .. .. .	28 Kent-road, Rose Bay, New South Wales	8 0 0	Dividend No. 72 .. .. .	.. .. .
Eleanor A. Giblin .. .. .	Queens Club, Sydney .. .. .	5 0 0	Dividend No. 72 .. .. .	.. .. .
William Shipham .. .. .	35 Wilton-street, Surry Hills, New South Wales	15 17 2	Dividend No. 71-72 .. .. .	.. .. .
Milly Waye .. .. .	Willunga, South Australia .. .. .	12 5 9	Dividend No. 72 .. .. .	.. .. .
		70 0 8		

Registered office: 360 Collins-street, Melbourne, 15th January, 1948.

3181

## DALGETY AND COMPANY LIMITED.

REGISTER of Unclaimed Moneys held by Dalgety and Company Limited at 1st January, 1948.

Name of Owner on Books.	Total Amount Due to Owner.	Description.	Date of Last Claim.
	£ s. d.		
Howell and Knight .. .. .	10 0 0	Shipping passage deposit .. .. .	3.10.39
Rosenbaum, M. .. .. .	2 0 0	Marine claim .. .. .	30.5.40
Rosenbaum, D. .. .. .	3 0 0	Marine claim .. .. .	30.5.40
Dowling, — .. .. .	5 0 0	Shipping passage deposit .. .. .	21.6.40
<i>Geelong Branch Account—</i>			
Colac Account, Unknown owner .. .. .	2 12 6	Proceeds 3 pigs .. .. .	24.9.40
Mortlake Account, Unknown owner .. .. .	0 15 7	Proceeds stock .. .. .	17.1.41
Ingram, A. G. .. .. .	0 7 6	Cash received .. .. .	5.3.41
<i>Geelong Branch Account—</i>			
Horsham Account, Unknown owner .. .. .	0 14 11	Proceeds stock .. .. .	26.6.41
Sandy, D. D. .. .. .	4 15 6	Cash received .. .. .	29.7.41
Knight, Messrs. .. .. .	0 1 11	Cash returned .. .. .	18.11.41
Lewkowich, — .. .. .	2 10 0	Shipping passage deposit .. .. .	2.12.41
	31 17 11		

Melbourne, 15th January, 1948.

L. Y. BUTLER, Accountant.

3186



COUNTY OF BOURKE PERMANENT BUILDING AND INVESTMENT SOCIETY.

REGISTER of Unclaimed Money held by County of Bourke Permanent Building and Investment Society.

Name of Owner on Books.	Total Amount Due to Owner.	Description of Unclaimed Money.	Date of Last Claim.
	£ s. d.		
Brady, Ernest, Prahran .. .. .	0 5 6	Dividend on ordinary shares	No claim
Fisher, Edgar Henry, 77 Osborne-street, South Yarra .. .. .	0 4 2	" " "	"
Magnus, Miss Mary, 182 Danks-street, Albert Park .. .. .	0 14 0	" " "	"
Evans, Mrs. Mary, c/o Mrs. Freeman, 18 St. George's-road, North Fitzroy	62 3 5	Surplus following sale of property	"
	63 7 1		

3141

Companies Act 1938.—Thirty-second Schedule.

SWALLOW AND ARIELL LIMITED.

REGISTER of Unclaimed Money held by Swallow and Ariell Limited.

Name.	Address of Owner on Books.	Total Amount Due to Owner.	Description of Unclaimed Money.	Date of Last Claim.
		£ s. d.		
Bridge, James .. .. .	57 Autumn-street, Geelong West	2 0 0	Dividend on Ordinary Shares	No claim has been made in respect of such money
Cross, John .. .. .	Hopkins-street, Footscray .. .. .	1 0 0	" " " "	" " "
Dando, Henry (deceased)	159 Graham-street, Port Melbourne	0 5 0	" " " "	" " "
Mueller, Bertha (deceased)	Burwood-road, Hawthorn .. .. .	0 10 0	" " " "	" " "

3121

E. T. BOREHAM, Secretary.

POOL PETROLEUM PROPRIETARY LIMITED.

AT an Extraordinary General Meeting of the above-named company, duly convened and held at 163 William-street, Melbourne, on Wednesday, the 14th day of January, 1948, the following Resolution was duly passed as a Special Resolution:—

"That the company be wound up voluntarily, and that John David Clifford Kellock, of 163 William-street, Melbourne, be and is hereby appointed liquidator for the purposes of such winding up."

Dated the 16th day of January, 1948.

M. T. LLOYD, Chairman.

Malleon, Stewart, and Co., 46 Queen-street, Melbourne, solicitors. 3187

PURSUANT to the *Trustee Act* 1928, notice is hereby given that all creditors, next of kin, and others having claims against the property or estate of Alfred Sanderson, late of 3 Dean-avenue, East St. Kilda, engineer, deceased (who died on the 13th day of November, 1947, and probate of whose will was granted by the Supreme Court of Victoria to the executors, Alfred Eric Sanderson, of 3 Dean-avenue, East St. Kilda, law clerk, and Allan George Sanderson, of 17 Courtney-street, Newtown, in the State of Tasmania, instrument tester), are hereby required to forward particulars, in writing, of their claims to the said executors, in care of the undersigned solicitors, on or before the 21st day of March, 1948, after which date the said executors will convey or distribute such property or estate to or amongst the persons entitled, having regard only to those claims of which they shall then have had notice.

W. H. FLOOD & PERMEZEL, 379 Collins-street, Melbourne, solicitors for the said executors. 3148

CREDITORS, next of kin, and others having claims in respect of the estate of Malcolm Boyd, late of 40 Laurel Bank-parade, Newtown, Geelong, in the State of Victoria, retired farmer, deceased (who died on the 13th day of October, 1947), are to send the particulars of their claims to the executor, The Ballarat Trustees, Executors, and Agency Company Limited, at their branch office, Malop-street, Geelong, by the 29th day of March, 1948, after which date it will distribute the assets, having regard only to the claims of which it then has notice.

NEIL M. FREEMAN, 57 Yarra-street, Geelong, solicitor for the said executor. 3139

EDWARD FINDLEY, DECEASED.

PURSUANT to the *Trustee Act* 1928, notice is hereby given that all persons having claims against the estate of Edward Findley, formerly of 23 Heatherbrae-avenue, Caulfield, senator of the Commonwealth Parliament, but late of 45 Neerim-road, Caulfield aforesaid, gentleman, deceased (who died on the 26th day of October, 1947), are hereby required to send particulars, in writing, of such claims to Lilian Findley, of 45 Neerim-road aforesaid, widow, the executrix appointed by the deceased's will, care of the under-mentioned solicitors, on or before the 26th day of March, 1948, after which date the said executrix will proceed to distribute the assets of the said deceased amongst the persons entitled thereto, having regard only to the claims of which she shall have had notice.

Dated this 13th day of January, 1948.

MORGAN, FYFFE, & MULKEARNS, Vaughan House, 108 Queen-street, Melbourne, solicitors for the said executrix. 3151

CREDITORS, next of kin, and others having claims in respect of the estate of John Joseph Sexton, late of Swan Marsh, dairy farmer, deceased (who died on the 9th day of April, 1947), are to send the particulars of their claims to the executors of the said John Joseph Sexton, namely, The Perpetual Executors and Trustees Association of Australia Limited and Mary Anne Sexton, care of The Perpetual Executors and Trustees Association of Australia Limited, at 100-104 Queen-street, Melbourne, by the 25th day of March, 1948, after which date the said executors will distribute the assets, having regard only to the claims of which they then have notice.

P. ARUNDELL, Colac, proctor for the executors. 3175

JOHN JOSEPH PURTELL, late of 62 Pender-street, Preston, retired (who died on the 7th day of November, 1947).

CREDITORS, next of kin, and all other persons having claims against the estate of the deceased are required by the executor of the will, Frederick Storer, of 297 Burke-road, Malvern, secretary, to send particulars to him, the said Frederick Storer, care of the undersigned, Gray and Gray, on or before the 31st day of March, 1948, after which date he will distribute the assets, having regard only to the claims of which he then has notice.

GRAY & GRAY, solicitors, 340 Collins-street, Melbourne. 3177

ALL persons having claims against the estate of William Thomas Hazlett, late of Invercargill, in the Dominion of New Zealand, merchant, deceased (who died on the 2nd day of May, 1947, and probate of whose will was granted by the Supreme Court of New Zealand, Otago and Southland District, Invercargill Registry, to William Edgar Hazlett, of Invercargill aforesaid, sheep farmer, James Luke Hazlett, of Oreti, in the County of Southland in the said Dominion, sheep farmer, and Agnes Laura Cunningham, of Dipton, in the County of Southland aforesaid, wife of William Leslie Cunningham, of the same place, sheep farmer, the executors named therein, on the 9th day of May, 1947, and application for reseat of an exemplification of which said probate has been made to the Supreme Court of Victoria by Richard Francis Maplestone Clark, of 46 Queen-street, Melbourne, in the State of Victoria, solicitor, the duly authorized attorney under power of the said executors, are hereby required to send particulars, in writing, of such claims to the said Richard Francis Maplestone Clark, in care of Malleson, Stewart, and Co., at the address below, on or before the 25th day of March, 1948, after which date the said Richard Francis Maplestone Clark will, in pursuance of section 86 of the *Administration and Probate Act 1928*, pay and/or hand over to the said executors the assets of the said deceased which shall have come to his hands or possession, having regard only to the claims of which he shall then have had notice.

MALLESON, STEWART, & CO., solicitors, 46 Queen-street, Melbourne. 3184

JACK STANLEY HUEGE-DE-SERVILLE, late of 15 Manor-street, Brighton (who died 11th September, 1947).

CREDITORS, next of kin, and all other persons having claims against the estate of the deceased are required by Eleanor Louise Duffield, the administratrix of his estate, to send written particulars to her, care of the undersigned, on or before 22nd March, 1948, after which date she will distribute the assets, having regard only to the claims of which she then has notice.

KIDDLE, BRIGGS, & WILLOX, solicitors, 15 Queen-street, Melbourne. 3188

ANNIE ELIZA McMAHON, late of 473 Gore-street, Fitzroy, widow, DECEASED (who died on 15th day of October, 1947).

CREDITORS, next of kin, and all other persons having claims against the estate of the said deceased are required to send particulars of their claims to National Trustees, Executors, and Agency Company of Australasia Limited, at its registered office at 95 Queen-street, Melbourne, on or before the 22nd day of March, 1948, after which date it will distribute the assets of the said deceased, having regard only to the claims of which it shall then have had notice.

JOHN T. RYAN, LL.B., solicitor, 263 Smith-street, Fitzroy. 3127

CREDITORS, next of kin, and others having claims in respect of the estate of Ivo Robert Norman Lucas, late of Rochester, in the State of Victoria, farmer, deceased, intestate (who died on the 12th day of May, 1947), are to send the particulars of their claims to Farmers and Citizens Trustees Company Bendigo Limited, of Charing Cross, Bendigo, in the said State, by the 29th day of March, 1948, after which date it will distribute the assets, having regard only to the claims of which it then has notice.

Dated the 13th day of January, 1948.

MILES O'NEILL, Gillies-street, Rochester, solicitor for the said company. 3179

PURSUANT to the *Trustee Act 1928*, notice is hereby given that Beatrice Elizabeth Forster, of "Nangunyah," Ninth-street, Mildura, in the State of Victoria, married woman, and Arthur James Smith, of Buronga, in the State of New South Wales, truck driver, the executrix and executor respectively of the will of Clarence John Smith, late of Rochester, in the State of Victoria, postal official, deceased (who died on the 16th day of July, 1947), intend to convey or distribute the estate of the said deceased to or among the persons entitled thereto, and require all persons and creditors interested to send to the said executrix and executor, in care of the under-mentioned solicitor, on or before the 29th day of March, 1948, particulars, in writing, of their claims against the said estate, after which date the said executrix and executor may convey or distribute the said estate to or among the persons entitled thereto, having regard only to the claims, whether formal or not, of which they shall then have had notice.

Dated the 13th day of January, 1948.

MILES O'NEIL, Gillies-street, Rochester, solicitor for the said executrix and executor. 3120

WILLIAM ROBERT FERGUSON, late of Tresco and Tempy, orchardist, DECEASED (who died on the 18th November, 1947).

CREDITORS, next of kin, and all other persons having claims against the estate of the said deceased are required by the executor of the will of the said deceased, George Albert Waters, of Tresco, labourer, to send particulars to him, in care of the undersigned, on or before the 31st March, 1948, after which date he will distribute the assets, having regard only to the claims of which he then has notice.

GERALD E. DELANY, LL.B., solicitor, 63 Campbell-street, Swan Hill. 3168

ROBERT GORDON BLAIR RICHARDS, late of Mount Best, retired farmer, DECEASED, intestate (who died on or about 28th August, 1947).

CREDITORS, next of kin, and all other persons having claims against the estate of the deceased are required by Edith Howlett Richards, of Corowa, New South Wales, widow (who has applied for letters of administration thereof), to send particulars, in writing, to her, in care of the undersigned solicitors, on or before 31st March, 1948, after which date she will distribute the assets, having regard only to the claims of which she then has notice.

SKINNER & HART, solicitors, Commercial-road, Yarram. 3171

CREDITORS, next of kin, and others having claims against the estate of Anne Jane Dainty, formerly of 45 John-street, East Brunswick, in Victoria, but late of 50 Laneast-street, Malvern, in the said State, widow, deceased (who died on the 2nd August, 1947, probate of whose will was granted to the executor, Frederick Dainty, of 19 Orient-grove, West Preston, in the said State, tramway employee), are hereby required to send in particulars, in writing, of such claims to the said executor, at his address aforesaid, on or before the 29th day of March, 1948, after which date he will proceed to convey or distribute the said estate, or any part thereof, to or among the persons entitled thereto, having regard only to the claims, whether formal or not, of which he shall have then had notice.

Dated the 15th day of January, 1948.

A. LESLIE ANDERSON, 405 Collins-street, Melbourne, solicitor for the said executor. 3172

ARTHUR ERNEST DOWLING, also known as Harry Dowling, late of 3 Bank-street, Box Hill, in the State of Victoria, tobacconist, DECEASED (who died on the 4th October, 1947, probate of whose will was granted to Mabel Irene Williams, of 123 Wright-street, Middle Park, widow).

CREDITORS, next of kin, and all others having claims against the estate of the above-named deceased are required by the executrix to send particulars thereof to the undersigned, on or before the 30th day of March, 1948, after which date the assets will be distributed, having regard only to the claims of which notice has been received.

JOSEPH LYNCH, LL.B., 299 Bridge-road, Richmond. 3173

CREDITORS, next of kin, and others having claims in respect of the estate of Frank John Godier, late of Koyuga, in the State of Victoria, retired grazier, deceased (who died on the 8th day of August, 1947), are to send the particulars of their claims to The Perpetual Executors and Trustees Association of Australia Limited, of 100-104 Queen-street, Melbourne, in the said State, by the 24th day of March, 1948, after which date it will distribute the assets, having regard only to the claims of which it then has notice.

STEWART & DONOHUE, solicitors, 175 High-street, Echuca. 3158

CHARLOTTE MARIA FREW, late of Barkly-place, Bendigo, widow, DECEASED.

CREDITORS, next of kin, and all other persons having claims against the estate of the deceased are required by Sandhurst and Northern District Trustees, Executors, and Agency Company Limited, of View-street, Bendigo, the executor of the will, to send particulars to the said company, care of the under-mentioned solicitors, on or before the 21st day of March, 1948, after which date the said company will distribute the assets, having regard only to the claims of which the said company shall then have notice.

Dated this 20th day of January, 1948.

T. M. WILLIAMS, WATSON, & JAMES, solicitors, 16 View-street, Bendigo. 3122

WILLIAM HENRY MORGAN, late of "Kinross," Terry's-avenue, Belgrave, retired builder, DECEASED (who died on 7th November, 1947).

**CREDITORS**, next of kin, and all other persons having claims against the estate of the deceased are required by the executor, Donald McGaw Addison, of 9 Oтира-road, Caulfield, police magistrate, to send particulars of their claims to him, care of the undersigned, on or before the 23rd March, 1948, after which date he will distribute the assets of the deceased, having regard only to the claims of which he shall then have had notice.

R. C. H. BEATTIE, solicitor, 422 Little Collins-street, Melbourne. 3190

NOTICE TO CLAIMANTS.

**PERCIVAL JENKINS O'DONNELL**, of Benalla, salesman, the sole executor of the will of Charles Lynch McDonald, late of Benalla, retired farmer, deceased (who died on the 6th day of November, 1947), requires all creditors, next of kin, and others having claims against the property or estate of the said deceased, to send to the said executor, care of Hamilton Clarke and Clarke, Nunn-street, Benalla, on or before the 22nd day of March, 1948, particulars, in writing, of such claims, after which date the said executor intends to convey or distribute such property or estate to or among the persons entitled thereto, having regard only to the claims of which he shall then have had notice.

Dated this 19th day of January, 1948.

HAMILTON CLARKE & CLARKE, Nunn-street, Benalla, proctors for the said executor. 3165

**CREDITORS**, next of kin, and others having claims in respect of the estate of Benjamin Walker, late of Newbridge, farmer, deceased (who died on the 30th day of August, 1947), are to send particulars of their claims to Harriett Walker, of Newbridge, spinster, care of the undersigned solicitors, by the 28th day of March, 1948, after which date she will distribute the assets, having regard only to the claims of which she then has notice.

HERRING & BATHURST, solicitors, Maryborough.

3118

MARGARET DARROCH, DECEASED.

**PURSUANT** to the *Trustee Act 1928*, notice is hereby given that all persons having claims, whether as creditors, next of kin, beneficiaries, or otherwise, against the estate of Margaret Darroch, late of No. 10 Jackson-street, Toorak, in the State of Victoria, spinster, deceased (who died on the 18th day of October, 1947, and probate of whose will was granted by the Supreme Court of Victoria, on the 29th day of December, 1947, to THE UNION TRUSTEE COMPANY OF AUSTRALIA LIMITED, of 333 Collins-street, Melbourne, in the said State), are hereby required to send particulars, in writing, of such claims to the said executor, at its said address, on or before the 31st day of March, 1948, after which date the said executor will proceed to distribute the estate of the said deceased which shall then have come to its hands amongst the persons entitled thereto, having regard only to the claims of which it shall then have had notice, and the said executor will not be liable for the assets so distributed, or any part thereof, to any person of whose claim it shall not have had notice as aforesaid.

TIETYENS, ANGEL, & JACKLING, solicitors, 40 Queen-street, Melbourne. 3144

ADA MARY CANNING, DECEASED.

**PURSUANT** to the *Trustee Act 1928*, notice is hereby given that all persons having claims, whether as creditors, next of kin, beneficiaries, or otherwise, against the estate of Ada Mary Canning, formerly of "Narbehong," Church-street, Brighton, in the State of Victoria, but late of 300 St. Kilda-street, Brighton aforesaid, widow, deceased (who died on the 13th day of December, 1947, and letters of administration of whose estate, with the will annexed, were granted by the Supreme Court of Victoria, on the 9th day of January, 1948, to William Spencer Canning, of 54 Almond-street, Caulfield, in the said State, insurance inspector), are hereby required to send particulars, in writing, of such claims to the said administrator, in the care of the undersigned solicitors, on or before the 30th day of March, 1948, after which date the said administrator will proceed to distribute the estate of the said deceased which shall then have come to his hands amongst the persons entitled thereto, having regard only to the claims of which he shall then have had notice, and the said administrator will not be liable for the assets so distributed, or any part thereof, to any person of whose claim he shall not have had notice as aforesaid.

ABBOTT, BECKETT, STILLMAN, & GRAY, solicitors, 422 Little Collins-street, Melbourne. 3149

WALTER PETER HEINZ, late of 411 Lydiard-street north, Ballarat, manager, deceased (who died on 18th October, 1947).

**CREDITORS**, next of kin, and all other persons having claims against the estate of the deceased are required by the executrix and executors, Muriel Emily Heinz, of 411 Lydiard-street north, Ballarat, widow, John Handford Heinz, of Sturt-street, Ballarat, accountant, and Walter Henry Heinz, of 411 Lydiard-street north, Ballarat, solicitor, to send particulars to them, care of the undersigned, on or before 25th March, 1948, after which date they will distribute the assets, having regard only to the claims of which they then have notice.

R. J. GRIBBLE, HOLLWAY, & HEINZ, solicitors, 22 Lydiard-street south, and 99 Bridge-street, Ballarat. 3131

**CREDITORS**, next of kin, and others having claims in respect of the estate of Patrick Cremin, late of Iona, in the State of Victoria, parish priest, deceased (who died on the 30th day of August, 1947), are to send particulars of their claims to the National Trustees, Executors, and Agency Company of Australasia Limited, the registered office of which is situated at 95 Queen-street, Melbourne, by the 26th day of March, 1948, after which date it will distribute the assets, having regard only to the claims of which it then has notice.

Dated this 12th day of January, 1948.

MORGAN, FYFFE, & MULKEARNS, Vaughan House, 108 Queen-street, Melbourne, solicitors for the said company. 3150

MARY COSGROVE, DECEASED.

**PURSUANT** to the *Trustee Act 1928*, notice is hereby given that all persons having claims against the estate of Mary Cosgrove, late of 36 Glenlyon-road, Brunswick, in the State of Victoria, widow, deceased (who died on the 30th day of October, 1947), are hereby required to send particulars, in writing, of such claims to Annie Kelly and Bridget Kelly, both of 191 Albert-street, West Brunswick, in the said State, spinsters, the executrices appointed by the deceased's will, care of the under-mentioned solicitors, on or before the 26th day of March, 1948, after which date the said executrices will proceed to distribute the assets of the said deceased amongst the persons entitled thereto, having regard only to the claims of which they shall have had notice.

Dated this 12th day of January, 1948.

MORGAN, FYFFE, & MULKEARNS, Vaughan House, 108 Queen-street, Melbourne, solicitors for the said executrices. 3152

**PURSUANT** to the *Trustee Act 1928*, notice is hereby given that Andrew William Shugg, executor of the will of Ada Grace Vermish, also known as Ada Grace Bruton, formerly of Ventnor, but late of Cowes, Phillip Island, guest house proprietress, deceased (who died on 12th November, 1947), intends to convey or distribute the estate of deceased to or among the persons entitled thereto, and requires all persons interested to send to the executor, A. W. Shugg, 105 Bruce-street, Preston, on or before 31st March, 1948, particulars, in writing, of their claims against the said estate, after which date the said executor may convey or distribute the said estate to or among the persons entitled thereto, having regard only to the claims of which he then has notice.

G. A. HILFORD, solicitor, 19 Queen-street, Melbourne. 3154

**NOTICE TO CLAIMANTS.—RE MICHAEL JOHN CANNY**, late of 28 Highbury-grove, East Prahran, retired Senior Constable of Police, DECEASED (who died on the 6th day of October, 1947).

**CREDITORS**, next of kin, and all other persons having claims against the estate of the above-named deceased are required by the executors, Margaret Frances Canny, of 28 Highbury-grove, East Prahran aforesaid, and The Trustees, Executors, and Agency Company Limited, of 401 Collins-street, Melbourne, to send particulars thereof, in writing, to them, care of the said company, on or before the 23rd day of March, 1948, after which date the said executors will proceed to distribute the assets, having regard only to the claims, whether formal or not, of which notice has then been received.

Dated this 16th day of January, 1948.

E. K. O'DONNELL, solicitor, of 411 Collins-street, Melbourne, C.1. 3145

Trustee Act 1928.

NOTICE TO CLAIMANTS.

PURSUANT to the Trustee Act 1928, creditors, next of kin, and all other persons having claims in respect of the estate of any deceased person named below are required to send particulars thereof to the legal personal representative or representatives at the address stated below, on or before the date stated, after which date the representative or representatives will distribute the assets, having regard only to the claims of which notice has been received:—

Charles Wilkinson, late of 38 Myrtle-street, Bendigo, Victoria, photographer, deceased, intestate (who died on the 8th day of October, 1947.—Claims to the administrator, Alice Maud Wilkinson, of the above address, widow, in care of the undersigned solicitors, by the 19th day of March, 1948. Tatchell, Dunlop, Smalley, and Balmer, solicitors, Bendigo. 3124

Clement James Condon, late of 147 Victoria-parade, Fitzroy, died 29th June, 1946.—Claims to Annie Mary Condon, care of Walter Kemp and Townsend, 340 Collins-street, Melbourne, solicitors, by the 23rd day of March, 1948. 3143

Thomas Skyrme, late of 42 Scott-grove, East Malvern, gentleman, who died on the 18th September, 1947.—Claims to the executors, The Trustees, Executors, and Agency Company Limited and Charles Richard Brough, addressed to them at 401 Collins-street, Melbourne, by 31st March, 1948. Davies, Campbell, and Piesse, 401 Collins-street, Melbourne. 3147

Harold Michael Rymer, late of Wonga, via Foster, farmer, died 30th March, 1947.—Claims to the administrator, Edward William Rymer, of 40 Bowen-street, South Oakleigh, bricklayer, care of P. J. Wilson, M.A., LL.B., solicitor, Foster, by 25th March, 1948. 3167

Emily Hannen, late of 7 St. Vincent-place, Albert Park, widow, deceased, died 23rd November, 1947.—Claims to the executrix, Sylvia Viola Elizabeth Stackpoole, of 30 Ferguson-street, Williamstown, married woman, care of John F. Carroll, solicitor, 4 Paisley-street, Footscray, by 24th March, 1948. John F. Carroll, LL.B., solicitor, 4 Paisley-street, Footscray. 3169

Robert Wilson (otherwise known as Robert Peter Wilson), late of 100 Hanover-street, Fitzroy, gardener, died 1st October, 1947.—Claims to the executor, The Trustees, Executors, and Agency Company Limited, 401 Collins-street, Melbourne, by 23rd March, 1948. 3176

Christina Chisholm Warren, late of 109 Anderson-street, Yarraville, widow, died 30th July, 1947.—Claims to the executors, Richard Harold Warren, of 9 Orlando-street, Hampton, clerk, and Annie Linda Taylor, of 16 Gardenvale-road, Caulfield, married woman, care of Maddock, Lonie, and Chisholm, solicitors, 339 Collins-street, Melbourne, by the 29th March, 1948. 3185

MINING NOTICES.

CENTRAL NELL GWYNNE GOLD MINING COMPANY NO LIABILITY.

NOTICE.—A Call (the 39th) of Six pence per share has been made on the capital of this company, due and payable at the company's office, Charing Cross, Bendigo, on Wednesday, 11th February, 1948.

J. J. STANISTREET  
3133 (McColl, Rankin, and Stanistreet), Manager.

NELL GWYNNE REEF NO LIABILITY.

NOTICE.—A Call (the 8th) of Six pence per share has been made on the capital of this company, due and payable at the company's office, Charing Cross, Bendigo, on Wednesday, 11th February, 1948.

J. J. STANISTREET  
3134 (McColl, Rankin, and Stanistreet), Manager.

SOUTH DEBORAH GOLD MINES NO LIABILITY.

NOTICE.—A Call (the 23rd) of Six pence per share has been made on the capital of this company, due and payable at the company's office, Charing Cross, Bendigo, on Wednesday, 11th February, 1948.

J. J. STANISTREET  
3135 (McColl, Rankin, and Stanistreet), Manager.

IMPOUNDINGS.

CARISBROOK.—Impounded at Carisbrook, by B. J. Duncombe.  
3 lambs, V bottom of right ear, branded SD  
9 lambs, V bottom of left ear and point of right ear, branded SD  
1 lamb, V bottom of each ear, branded SD  
If not claimed and expenses paid, to be sold on 12th February, 1948.  
T. CHURCH,  
3155—6/8 Poundkeeper.

DANDENONG.—Impounded at Dandenong, by Shire Ranger A. Boutcher, from Dandenong Market.  
1 black and white Friesian heifer, no visible brand  
If not claimed and expenses paid, to be sold on 5th February, 1948.  
A. WALKER,  
3161—4/8 Poundkeeper.

LILYDALE.—Impounded at Lilydale.  
1 bay pacer delivery gelding, off hind foot white, leather head stall, no visible brand  
If not claimed and expenses paid, to be sold on 7th February, 1948.  
E. E. MASON,  
3162—4/8 Poundkeeper.

NUMURKAH.—Impounded at Numurkah, by the Soldiers' Settlement Commission.  
1 bay draught gelding, star on face, white feet, snip out of offside ear, saddle scar, no visible brand  
1 bay draught gelding, near hind foot white, blaze face, no visible brand  
1 bay draught gelding, near front foot white, hind socks white, blaze face, no visible brand  
1 bay draught mare, near front foot white, hind socks white, blaze face, no visible brand  
1 draught bay mare, hind socks white, blaze face, M near-side front shoulder  
If not claimed and expenses paid, to be sold on 6th February, 1948.  
J. T. BROWN,  
3125—10/8 Poundkeeper.

TATURA.—Impounded at Tatura, by Shire Ranger, on 16th January, 1948.  
1 bay pony mare, aged, few white hairs on forehead, scar on shoulder  
If not claimed and expenses paid, to be sold on 5th February, 1948.  
L. THORNTON,  
3164—5/4 Poundkeeper.

TRAFALGAR.—Impounded in Trafalgar Pound.  
1 bay pony mare, hind foot white, like K near shoulder  
If not claimed and expenses paid, to be sold on 2nd February, 1948.  
E. MILLS,  
3163—4/ Poundkeeper.

CONTENTS

	PAGE.
Act of Parliament .. .. .	337
Appointments .. .. .	338
Australia Day Holiday .. .. .	338
Contracts .. .. .	351
Country Roads Board .. .. .	360
Estates of Deceased Persons .. .. .	344
Government Notices .. .. .	342
Impoundings .. .. .	396
Lands .. .. .	375
Mining .. .. .	345, 396
Orders in Council .. .. .	360
Private Advertisements .. .. .	386
Proclamations .. .. .	337
Public Holidays .. .. .	338
Public Service Notices .. .. .	341
Resignations .. .. .	340
State Rivers and Water Supply Commission .. .. .	346
Stay Orders .. .. .	345
Tenders .. .. .	384
Transport Regulation Board—Public Hearings .. .. .	343
Waterworks Trusts .. .. .	346