



# VICTORIA GOVERNMENT GAZETTE.

Published by Authority.

[Registered at the General Post Office, Melbourne, for transmission by post as a newspaper.]

No. 20]

WEDNESDAY, JANUARY 28.

[1948

## APPOINTMENTS.

THE Lieutenant-Governor, as Deputy for His Excellency the Governor of the State of Victoria, by and with the advice of the Executive Council thereof, has, by Orders made on the 20th day of January, 1948, been pleased to make the under-mentioned appointments, viz.:—

### DEPARTMENT OF AGRICULTURE.

*Inspectors under Vegetation and Vine Diseases Act and Fruit and Vegetables Act.*

GODFREY RALPH WATERS, Orchard Supervisor,  
JACK ROY DAVID JONES, Orchard Inspector,  
JOHN ALEXANDER MACDONALD, Orchard Inspector,  
CARL ADOLPH JOHN PILTZ, Orchard Inspector,  
REGINALD DAVID SIMPSON, Orchard Inspector, and  
THOMAS EDWARD WRIGHT, Orchard Inspector,

to be also Inspectors under the provisions of the *Vegetation and Vine Diseases Act 1928*, and the *Fruit and Vegetables Act 1928*, without additional salary.

### DEPARTMENT OF CHIEF SECRETARY.

*Assistants to the Inspector of Fisheries.*

JOHN MALCOLM HODGSON, First Constable of Police,  
No. 7021,

ORMAND PATRICK BLEAZBY,  
ALEXANDER JAMES WATSON,  
LESLIE EDWARD DETTMAN,  
HERBERT ANDERSON,  
JOHN GEORGE GRAY, and  
ARTHUR WILLIAM ALDRIDGE,

pursuant to the provisions of the Fisheries Acts, to be Assistants to the Inspector of Fisheries.

### *Electoral Registrar.*

JULES SAMUEL GASCARD

to be Electoral Registrar for the Carlton, Flemington, and Parkville Divisions of the Doutta Galla Province; for the Carlton South, Fitzroy, Melbourne East, Melbourne West, and North Melbourne Divisions of the Melbourne Province, to take effect on and from 13th January, 1948, *vice* Percy Basil Robin, resigned.

### *Deputy Electoral Registrar.*

KEITH HOWLETT

to be Deputy Electoral Registrar for the Carlton, Flemington, and Parkville Divisions of the Doutta Galla Province; for the Carlton South, Fitzroy, Melbourne East, Melbourne West, and North Melbourne Divisions of the Melbourne Province, to take effect on and from 8th January, 1948, *vice* George Livie Prosser, resigned.

## DEPARTMENT OF LANDS AND SURVEY.

### *Land Officer.*

CLARENCE EDWARD RICE, Clerk, Class "C2," Administrative Division, Department of Lands and Survey, to be a Land Officer in and for the State of Victoria, and to be appointed as provided in section 6 of the *Land (Residence Areas) Act 1935*, as a duly authorized person to grant to an applicant a right to occupy, as a residence area under the said Act, any Crown lands.

### DEPARTMENT OF LAW.

### *Clerk of the Children's Court.*

HENRY VICTOR BOARDER

to be also Clerk of the Children's Court at Tungamah, during the absence on annual leave of G. N. Grose.

### *Commissioners for Taking Declarations, &c.*

JAMES THOMAS CROMWELL HURLEY, Officer of the Australian Mutual Provident Society, Sale,

to be a Commissioner for taking Declarations and Affidavits, pursuant to the provisions of Division 8 of Part IV. of the *Evidence Act 1928*, to resign upon ceasing to occupy his present position; and

JAMES WILLIAM ANGUS JOHNSTONE, Mt. Richmond,  
MARK JOSEPH CALLINAN, 4 Avenue Athol, Canterbury,  
and  
ALBERT FREDERICK STAINES, 578 Bourke-street, Melbourne,

to be Commissioners for taking Declarations and Affidavits, pursuant to the provisions of Division 8 of Part IV. of the *Evidence Act 1928*, to resign upon removing from the neighbourhood of the addresses stated.

### *Magistrates.*

DONALD CLAUDE CAMERON, Cobden, and  
EDWARD AUSTIN PEARCE, North Creswick,

to Keep the Peace in the Southern Bailiwick of the State of Victoria;

JOHN MOLESWORTH FFLOYD CHOMLEY, Connemirricoo,  
and  
HERBERT GEORGE CRAM, Murtoa,

to Keep the Peace in the Western Bailiwick of the State of Victoria;

JOSEPH CLARENCE BULL, Metung, and  
EDGAR GEORGE MILLARD, Metung,

to Keep the Peace in the Eastern Bailiwick of the State of Victoria; and

THOMAS SCANLON, 11 Hoffman-street, West Brunswick,  
BARBARA LYELL HUNT, 3 Leslie-grove, Brighton,  
FREDERICK WILLIAM BENJAMIN OLSEN, 3 Noble-avenue,  
Strathmore,  
HUBERT LEON JOELSON, 4 Adrian-street, Burwood, and  
EDWARD THOMAS CHARLES MARTIN, 34 Watt-street, South  
Kingsville,

to Keep the Peace in the Central Bailiwick of the State  
of Victoria.

*Probation Officer.*

GEORGE THEXTON MORPHET, Woodend,  
to be a Probation Officer, pursuant to the provisions of  
section 8 of the *Children's Court Act 1928*, for the Children's  
Court at Woodend.

*Sheriff's Bailiff, &c.*

VINCENT JAMES ALFRED CONDON, First Constable of  
Police, Ouyen,

to be also a Sheriff's Bailiff and a Bailiff of the County  
Court at Mildura, in the place of H. Stafford, resigned,  
with fees.

*Sworn Valuators.*

GEORGE McNAUGHT HUME, Manchester Unity Buildings,  
corner of Collins and Swanston streets, Melbourne.  
ALAN CROWNSON SALEK, 281 Collins-street, Melbourne,  
ALAN CUNNINGHAM NEEDHAM, 281 Collins-street, Mel-  
bourne, and  
ERIC CHARLES JACK, Town Hall, Ivanhoe,

to be Sworn Valuators, pursuant to the provisions of  
section 14 of the *Transfer of Land Act 1928*, for the  
Counties of Bourke, Bourke, Bourke, and Bourke and  
Evelyn, respectively.

C. W. KINSMAN,

Clerk of the Executive Council.

At the Executive Council Chamber,  
Melbourne, the 20th January, 1948.

REVOCATION OF APPOINTMENT.

THE Lieutenant-Governor, as Deputy for His Excellency  
the Governor of the State of Victoria, by and with  
the advice of the Executive Council thereof, has, by Order  
made on the 20th day of January, 1948, revoked the  
following appointment:—

DEPARTMENT OF LANDS AND SURVEY.

HERBERT ANDREW HUTTON, as a Bailiff of Crown Lands.

C. W. KINSMAN,  
Clerk of the Executive Council.

At the Executive Council Chamber,  
Melbourne, 20th January, 1948.

RESIGNATIONS.

THE Lieutenant-Governor, as Deputy for His Excellency  
the Governor of the State of Victoria, by and with  
the advice of the Executive Council thereof, has, by Orders  
made on the 20th day of January, 1948, accepted the resi-  
gnations of the persons named hereunder of the offices  
mentioned, viz.:—

DEPARTMENT OF CHIEF SECRETARY.

PERCY BASIL ROBIN, as Electoral Registrar for the  
Carlton, Flemington, and Parkville Divisions of  
the Doutta Galla Province; for the Carlton South,  
Fitzroy, Melbourne East, Melbourne West, and  
North Melbourne Divisions of the Melbourne  
Province, to date from and inclusive of 13th  
January, 1948.

GEORGE LIVIE PROSSER, as Deputy Electoral Registrar  
for the Carlton, Flemington, and Parkville Divi-  
sions of the Doutta Galla Province; for the Carlton  
South, Fitzroy, Melbourne East, Melbourne West,  
and North Melbourne Divisions of the Melbourne  
Province, to date from and inclusive of 8th January,  
1948.

DEPARTMENT OF LAW.

LAURENCE RICHARD QUAYLE and CHARLES MATTHEW  
CHAMBERLAIN, as Commissioners for taking Declara-  
tions and Affidavits under the provisions of the  
*Evidence Act 1928*.

HENRY STAFFORD, as a Sheriff's Bailiff and a Bailiff of  
the County Court at Mildura.

C. W. KINSMAN,  
Clerk of the Executive Council.

At the Executive Council Chamber,  
Melbourne, the 20th January, 1948.

PUBLIC SERVICE OF VICTORIA.—VACANCIES.

APPLICATIONS will be received by the Public Service  
Board up to Saturday, the 14th February, 1948, from  
persons employed in the Public Service of Victoria, who  
are eligible and qualified, for appointment to the under-  
mentioned positions:—

PROFESSIONAL DIVISION.

**Mechanical Engineer, Grade II., Class "C2," Department  
of Water Supply.**

*Yearly Salary.*—£592, minimum; £644, maximum.

*Duties.*—To be responsible, under the Manager,  
Bendigo Central Plant Depot, for the detailed  
operation and administration of the machine and  
repair shops, and to maintain records of the cost  
of repairs to plant and vehicles.

*Qualifications.*—A University Degree or Diploma of  
Mechanical or Automotive Engineering, or a recog-  
nized equivalent qualification, and approved  
experience in the detailed operation and adminis-  
tration of machine shops carrying out repairs to  
mechanical equipment and motor vehicles.

TECHNICAL AND GENERAL DIVISION.

**Inspector, Grade II. (Ouyen), Department of Water Supply.**

*Yearly Salary.*—£305, minimum; £344, maximum.

*Duties.*—To be responsible for the maintenance of  
windmills and bores in the Walpeup West District.

*Qualifications.*—To possess a general knowledge of  
machinery and plumbing, and to be able and  
prepared to climb and work in windmill towers  
of considerable heights.

NOTE.—In addition to the salary rates quoted, a cost of  
living adjustment (at present £54 a year), which varies in  
accordance with the rise or fall in the index numbers of  
the cost of living, is payable.

By order,

E. F. FITZGIBBON,  
Secretary.

Office of the Public Service Board,  
Melbourne, 27th January, 1948.

No. 177.

*Public Service Act 1946.*

REGULATIONS—PART I.—APPOINTMENTS TO THE  
ADMINISTRATIVE, PROFESSIONAL, AND TECHNICAL  
AND GENERAL DIVISIONS.

THE Public Service Board, in pursuance of the powers  
conferred by the *Public Service Act 1946*, hereby  
amends the Public Service (Public Service Board)  
Regulations as follows:—

PROFESSIONAL DIVISION.

*Revoke*—  
Regulation No. 22A.

*Add*—  
22A. Candidates for appointment as Draughtsmen in  
the Professional Division, Class "E," shall be required  
to enter for competitive examination in English  
Expression, Practical Mathematics, General Intelli-  
gence, and General Knowledge.

*This Regulation shall have effect as on and from the 24th  
December, 1947.*

D. D. PAINE, Chairman.  
G. V. STAFFORD, Acting Secretary.

Office of the Public Service Board,  
Melbourne, 21st January, 1948.

No. 176.

*Public Service Act 1946, Section 39.*

REGULATIONS—PART III.—SALARIES, INCREMENTS,  
AND ALLOWANCES.

THE Public Service Board, in pursuance of the powers  
conferred by the *Public Service Act 1946*, hereby amends  
its Regulations as shown below:—

FIRST SCHEDULE.

PROFESSIONAL DIVISION.  
*Offices and Rates of Salaries.*

Office.	Yearly Rate of Salary.	
	Minimum.	Maximum.
DEPARTMENT OF AGRICULTURE.		
CLASS "B."		
<i>Add</i> — Senior District Agricultural Officer ..	£ 670	£ 722

D. D. PAINE, Chairman.  
G. V. STAFFORD, Acting Secretary.

Office of the Public Service Board,  
Melbourne, 14th January, 1948.

No. 175.

Public Service Act 1946, Section 50.

REGULATIONS—PART III.—SALARIES, INCREMENTS, AND ALLOWANCES.

THE Public Service Board, in pursuance of the powers conferred by the Public Service Act 1946, hereby amends its Regulations as shown below:—

SECOND SCHEDULE.

TECHNICAL AND GENERAL DIVISION.

Offices and Rates of Salaries.

Officers while acting in higher classified positions or performing certain specified duties shall be paid allowances at the following rates, viz:—

	Rate per Hour.	
	For—	Read—
DEPARTMENT OF TREASURER.		
GOVERNMENT PRINTING OFFICE.	d.	d.
Folder and Sewer acting as Forewoman ..	4 <sup>10</sup> / <sub>11</sub>	5 <sup>2</sup> / <sub>5</sub>
Lithographic Printer employed on Rotary Machine ..	2 <sup>7</sup> / <sub>22</sub>	2 <sup>11</sup> / <sub>20</sub>
Compositor acting as Linotype or Monotype Operator ..	2 <sup>5</sup> / <sub>11</sub>	2 <sup>7</sup> / <sub>10</sub>
Compositor Reader acting as Linotype or Monotype Operator ..	1 <sup>7</sup> / <sub>11</sub>	1 <sup>4</sup> / <sub>5</sub>
Compositor acting as Reader ..	9 <sup>1</sup> / <sub>11</sub>	9 <sup>1</sup> / <sub>10</sub>
Head Machineman and Night Foreman acting as Day Foreman Machineman ..	3 <sup>3</sup> / <sub>11</sub>	3 <sup>2</sup> / <sub>5</sub>
Machineman acting as Head Machineman and Night Foreman ..	3 <sup>3</sup> / <sub>11</sub>	4 <sup>1</sup> / <sub>5</sub>
Head Binder or Head Finisher acting as Foreman ..	5 <sup>9</sup> / <sub>11</sub>	6 <sup>2</sup> / <sub>10</sub>
Folder and Sewer acting as Forewoman ..	5 <sup>12</sup> / <sub>22</sub>	6 <sup>9</sup> / <sub>20</sub>
Folder acting as Folder and Sewer ..	1 <sup>5</sup> / <sub>22</sub>	1 <sup>7</sup> / <sub>20</sub>
Clicker acting as Foreman ..	7 <sup>4</sup> / <sub>11</sub>	8 <sup>1</sup> / <sub>10</sub>
Reader acting as Foreman ..	7 <sup>12</sup> / <sub>22</sub>	8 <sup>11</sup> / <sub>20</sub>
Linotype or Monotype Operator acting as Foreman ..	6 <sup>9</sup> / <sub>11</sub>	7 <sup>1</sup> / <sub>2</sub>
Lithographic Printer acting as Foreman ..	9 <sup>3</sup> / <sub>22</sub>	10 <sup>1</sup> / <sub>20</sub>
Lithographic Printer employed on a Rotary Machine ..	2 <sup>7</sup> / <sub>22</sub>	2 <sup>11</sup> / <sub>20</sub>
Assistant Lithographic Printer employed in preparing Plates ..	2 <sup>2</sup> / <sub>11</sub>	2 <sup>2</sup> / <sub>5</sub>
Paper Ruler acting as Foreman ..	6 <sup>22</sup> / <sub>22</sub>	7 <sup>12</sup> / <sub>20</sub>
Compositor Reader acting as Press Reviser ..	9 <sup>1</sup> / <sub>11</sub>	9 <sup>3</sup> / <sub>5</sub>
Senior Assistant Ticket Printer acting as Foreman ..	9 <sup>3</sup> / <sub>22</sub>	10 <sup>1</sup> / <sub>20</sub>
Assistant Warehouseman acting as Warehouseman ..	2 <sup>19</sup> / <sub>22</sub>	3 <sup>2</sup> / <sub>20</sub>
Linotype Attendant or Monotype Caster acting as Mechanic in Charge ..	4 <sup>1</sup> / <sub>11</sub>	4 <sup>1</sup> / <sub>2</sub>
Officer acting as Leading Hand in the Periodical Railway Ticket, Stereotyping, or Ruling Sections ..	9 <sup>1</sup> / <sub>11</sub>	9 <sup>1</sup> / <sub>10</sub>
Linotype and Monotype Foremen and Operators employed on night work ..	6	6 <sup>2</sup> / <sub>5</sub>
Machineman while in charge of Rotary Magazine Press or L. & M. Perfection Press ..	4	4 <sup>2</sup> / <sub>5</sub>
Leather Cutter acting as Foreman ..	4 <sup>1</sup> / <sub>2</sub>	4 <sup>19</sup> / <sub>20</sub>
Delete—		
Clicker acting as Foreman ..	4 <sup>10</sup> / <sub>11</sub>	..

This Regulation shall have effect as on and from the 11th January, 1948.

D. D. PAINE, Chairman.  
G. V. STAFFORD, Acting Secretary.

Office of the Public Service Board,  
Melbourne, 9th January, 1948.

PUBLIC SERVICE (PUBLIC SERVICE BOARD) REGULATION 36A.

NOTICE is hereby given that the Public Service Board has raised the classification of an office of Assistant Mechanic, Janefield Colony, Technical and General Division, Mental Hygiene Branch, Department of Health, to Engineer Mechanic, Grade II. (£373), Technical and General Division, and that the Permanent Head of the Department has recommended John Clow for appointment thereto.

Duties.—To have charge of engineering plant, including steam boilers, hot and cold water service, cooking appliances, and electric installation.

Qualifications.—To possess a Boiler Attendant's Certificate, or higher qualifications, to have served an engineering apprenticeship, and to have a good knowledge of plumbing.

Appeals against such recommendation should be lodged with the Secretary to the Public Service Board not later than Saturday, the 7th February, 1948.

By order,

E. F. FITZGIBBON,  
Secretary.

Office of the Public Service Board,  
Melbourne, 27th January, 1948.

DEPARTMENT OF LAW.—ATTORNEY-GENERAL.  
CURATOR OF CONVICT'S PROPERTY.

THE Lieutenant-Governor, as Deputy for His Excellency the Governor of the State of Victoria, by and with the advice of the Executive Council thereof, has, by Order made on the 20th day of January, 1948, pursuant to the provisions of section 576 of the Crimes Act 1928, directed that the custody and management of the property of the convict, Frederick John Quinn, be committed to his brother, Raymond Harold Quinn, of 57 Park-street, St. Kilda, wood merchant, as a curator, hereby appointed in that behalf.

C. W. KINSMAN,  
Clerk of the Executive Council.

At the Executive Council Chamber,  
Melbourne, the 20th January, 1948.

LAW DEPARTMENT.—SOLICITOR-GENERAL.  
HAWKERS' AND PEDLERS' LICENCES—DAYS ALTERED.

THE Lieutenant-Governor, as Deputy for His Excellency the Governor of the State of Victoria, by and with the advice of the Executive Council thereof, has by Order made on the 20th day of January, 1948, pursuant to the provisions of section 6 of the Hawkers and Pedlers Act 1928, in lieu of the days heretofore appointed, appointed the day and hour set forth in the third column of the Schedule below for holding General Meetings of Justices for the special purpose of taking into consideration applications for hawkers' and pedlers' licences at the Court named in the first column of such Schedule in the Police District indicated, to take effect as from and inclusive of the date shown.

SCHEDULE.

Court.	Police District.	Day Appointed.	Date of Commencement.
Violet Town	North-Eastern	Every Wednesday at 10.30 o'clock a.m.	4th February, 1948

C. W. KINSMAN,

Clerk of the Executive Council.

At the Executive Council Chamber,  
Melbourne, the 20th January, 1948.

DISCHARGED SERVICEMEN'S EMPLOYMENT BOARD.

INVESTIGATING OFFICER.

APPLICATIONS, together with copies of testimonials and particulars of war service, addressed to the Secretary, Discharged Servicemen's Employment Board, 358 Lonsdale-street, Melbourne, will be received for the above-mentioned position until Saturday, 31st January, 1948, at a commencing salary of £450 per annum.

Duties.—To interview discharged servicemen contemplating the purchase of retail and other types of businesses, and investigate books, returns, and general features of such businesses.

Qualifications.—A practical knowledge of accountancy, business principles and practice. Experience in the conduct of investigations and furnishing of reports.

NOTE.—In addition to the salary quoted, a cost of living adjustment (at present £54 a year), which varies in accordance with the rise or fall in the index numbers of the cost of living, is payable.

W. M. SOMERVILLE,  
Secretary.

Transport Regulation Acts.  
TRANSPORT REGULATION BOARD.  
NOTICE OF PUBLIC HEARINGS.

NOTICE is hereby given that the applications made by the persons named below for licences to operate the commercial goods vehicles on the route or routes, or in the manner set out opposite their names, will be heard at a time and place to be communicated to the parties concerned:—

*Name of Applicant; Nature of Application.*

- ANDERSON HOSIERY MILLS PTY. LTD., McDonald-street, Coburg; 1 commercial goods vehicle (15 cwt.) for the carriage of—(a) goods in the course of trade as hosiery manufacturer within 50 miles radius Melbourne, (b) ladies' hose and children's socks, knitting machines, and machine parts from and to the applicant's factory at Coburg to and from the decentralized factories of the applicant situate at Bridgewater, Charlton, and Donald.
- BELL, R. D., 29 Scott-street, Camperdown; 1 commercial goods vehicle (50 cwt.) for the carriage of liquor and foodstuffs and goods in the course of business as "caterer" to various shows, race meetings, and football matches throughout the State of Victoria.
- CARLILE BROS., Strickland-road, Bendigo East; 1 commercial goods vehicle (60 cwt.) for the carriage of skins, wool, hides, and tallow, such goods being the property of the applicants and carried in the course of business as "wool and skin merchants"—(a) within 50 miles radius Bendigo, (b) from and to (a) to and from Charlton, St. Arnaud, Donald, Kerang, and Melbourne.
- DIXON, W. F. & C. E., Dandenong-road, Clayton North; 1 commercial goods vehicle (90 cwt.) to operate throughout the State of Victoria for the carriage of road contracting plant and material.
- KELLER, H., 17 Canterbury-road, Camberwell; 1 commercial goods vehicle (10 cwt.) for the carriage of ladies' and children's wear, plastics, &c., in the course of business as "hawker" throughout the State of Victoria.
- MCDONALD, E. R., Witt-street, Yarrowonga; 1 commercial goods vehicle (90 cwt.) for the carriage of road contracting plant and material throughout the State of Victoria.
- WARNER, L., 154 Murray-road, East Preston; 1 commercial goods vehicle (27 cwt.) to operate throughout the State of Victoria for the carriage of new and reconditioned sewing machines, electric motors, cabinets, tools of trade, and duplicate parts, such goods carried in the course of the applicant's business of "selling, reconditioning, and servicing sewing machines."
- WARNER, A., 154 Murray-road, Preston; 1 commercial goods vehicle (8 cwt.) to operate throughout the State of Victoria for the carriage of new and reconditioned sewing machines, electric motors, cabinets, tools of trade, and duplicate parts, such goods carried in the course of the applicant's business of "selling, reconditioning, and servicing sewing machines."
- WEBB, G. A., 2 Field-street, Hampton; 1 commercial goods vehicle (30 cwt.) to operate throughout the State of Victoria for the carriage of gear and equipment being the property of the applicant and to be carried in connexion with business of "travelling showman."

NOTICE is hereby given that the applications made by the persons named below for licences to operate the commercial passenger vehicles on the route or routes, or in the manner set out opposite their names, will be heard at a time and place to be communicated to the parties:—

*Name of Applicant; Nature of Application.*

- ALL WEATHER SCENIC COACHES PTY. LTD., corner of New-street and Point Nepean-road, Elsternwick; 4 commercial passenger vehicles, with seating capacity for 23, 30, 33, and 29 persons respectively, to operate as special service omnibuses within a 25 miles radius of G.P.O., Melbourne.
- BOYD, A. J., 80 Monash-street, Sunshine; 1 commercial passenger vehicle, to be purchased, to operate as a special service omnibus within a 25 miles radius of G.P.O., Melbourne.
- CHEESEMAN, R. H., & H. E. KERR, Tucker-road, East Ormond; application for variation of licence A.2173 to operate as an additional vehicle instead of as a substitute vehicle between Mordialloc and Clayton and between Mordialloc and the Harley Motor Cycle Race Track.
- CORRY, C. C. W., 11 Dorcas-street, South Melbourne; 1 commercial passenger vehicle, with seating capacity for 30 persons, to operate as a special omnibus within a 50 miles radius of the G.P.O., Melbourne.

DANIELS, N. C. E., Box 155, Warracknabeal; application for variation of licences to include the ability to operate tours as follows:—

1. (a) From Warracknabeal to The Grampians, via Rupanyup and Stawell and return via Horsham. One day—22s. 6d.
  - (b) From Warracknabeal to Portland, via Rupanyup and Hamilton and return via the same route. Two days—50s.
  - (c) From Warracknabeal to Naracoorte, via Horsham, Natimuk, and Edenhope and return via the same route. Two days—50s.
  - (d) From Warracknabeal to Mildura, via Hopetoun and Calder Highway and return via the same route. Two days—60s.
  - (e) From Warracknabeal to Warrnambool, via Stawell, Ararat, Lake Bolac, Mortlake and return via the same route. Two days—50s.
2. Under charter conditions from Warracknabeal to The Grampians, Hopetoun, Horsham, Dimboola, Jeparit, Murtoa, Stawell, Donald, Watchem.

DICK, R., & J. TORRANCE, Box 56, Tongala; application for renewal of licences A.1388 and A.1389, expiring on the 4th March, 1948, allowing operations as follows:—

- (a) Tongala-Echuca (school service), (b) charter within a 20 miles radius of Tongala.

ELSTON, G. F., 22 Ludstone-street, Hampton; 1 commercial passenger vehicle, with seating capacity for 16 persons, to operate as a substitute vehicle to all licensed vehicles.

FERGUSON, E. O. J., 151 Raymond-street, Sale; application for renewal of licences A.203 and A.735, expiring on the 19th April, 1947, allowing operations as follows:—

- A.203—(a) Heyfield-Sale High and Technical Schools (school service), (b) Heyfield-Sale Speed Coursing Ground, (c) Heyfield-Sale, (d) goods may be carried on route (c) up to a total weight of 5 cwt.
- A.735—(a) Munro-Sale High and Technical Schools (school service), (b) on a round route, commencing in the Township of Sale, thence via Myrtlebank, Bundalagwah, Montgomery, Airlie, Clydebank, Somerton Park, Cobain's Estate, returning to Sale.

FOLEY, H. J., Lakes Entrance; application for renewal of licence A.1426, expiring on 8th February, 1948, allowing operations as follows:—(a) Bairnsdale Railway Station-Lakes Entrance, (b) specified round tours, (c) tours within a 20 miles radius of Lakes Entrance and to Buchan, Orbost, Marlo, Lindenow, Ensay, Swift's Creek, Stafford, and Sale.

FOWLER, G. G. R., 36 Grey-street, East Melbourne; 1 commercial passenger vehicle, with seating capacity for 29 persons, to operate as a special service omnibus within a 25 miles radius of the G.P.O., Melbourne.

GAINGER, A. R. & L. G. (trading as "Gainger Bros."), Beeac and Colac; 2 commercial passenger vehicles, with approximate seating capacity for 31 persons, to operate as substitute vehicles to all licensed vehicles.

GAINGER, A. R. & L. G. (trading as "Gainger Bros."), Beeac and Colac; application for variation of licences to include the ability to operate all vehicles interchangeably.

GRASKE, W. E., 27 Banksia-street, Yallourn; 1 commercial passenger vehicle, with seating capacity for 5 persons, to operate—(a) separate and distinct fares within a 5 miles radius of Yallourn Railway Station, (b) private hire within a 50 miles radius of Yallourn Railway Station. Subject to the cancellation of licence PH.1251 at present held by applicant.

HUBBARD, F. R., Hepburn Springs; application for variation of licence to include the ability to carry school children on a round route as follows:—Daylesford, Eganstown, Blampied, Kingston, Newlyn North, Blampied, and Eganstown.

MATTHEWS, E. (trading as "Matthews Bus Service Pty. Ltd."), Nicol-street, Yarram; application for variation of licence A.1825 to include the ability to extend the present Sale-Yarram service to Port Albert for the carriage of mail, newspapers, passengers, and parcels. Leave Yarram 5.30 p.m. daily. Leave Port Albert 6 p.m. daily.

MARTYN'S SERVICE PTY. LTD., Vincent-street, Daylesford; 1 commercial passenger vehicle, with seating capacity for 19 persons, to operate—(a) as a stage omnibus on a town bus route and within the Borough of Daylesford, (b) charter conditions within a 25 miles radius of Daylesford. This replaces application gazetted on the 22nd October, 1947.

MORRISON, J. J. & M. D., 70 Ruskin-street, Elwood; 1 commercial passenger vehicle, to be purchased, to operate as a special service omnibus within a 15 miles radius of Elwood.

McKENZIES MARYSVILLE TRANSPORT SERVICE, 53 Barker's-road, Kew; application for variation of licences to include the ability to operate five vehicles as special service omnibuses within a 25 miles radius of G.P.O., Melbourne.

NATHALIA-MELBOURNE PASSENGER SERVICE PTY. LTD., 922 High-street, Reservoir; application for variation of licence TA.938, to include the ability to operate as a special service omnibus within a 25 miles radius of Reservoir, and to Frankston, Kinglake, Woodend, Healesville, and Bacchus Marsh.

NEWBOLD, M. C., 635 Lygon-street, North Carlton; 1 commercial passenger vehicle, to be purchased, to operate as a special service omnibus throughout the State of Victoria.

RAMADGE, R. W., 28 Larnoo-avenue, East Brunswick; 1 commercial passenger vehicle, to be purchased, to operate as a special service omnibus throughout the State of Victoria, and to operate to and from race meetings as set out in the Victoria Racing Club's calendar and speed coursing meetings.

REID, D., 252 St. George's-road, Northcote; 4 commercial passenger vehicles, with seating capacity for 27 persons, to operate as special service omnibuses within a 25 miles radius of the G.P.O., Melbourne.

REYNOLDS, D. W. J., 307 Geelong-road, West Footscray; 3 commercial passenger vehicles, with seating capacity for 25, 25, and 27 persons respectively, to operate as special service omnibuses within a 25 miles radius of the G.P.O., Melbourne, on alternate Sundays only when vehicles are not required on applicant's metropolitan omnibus service.

ROBERTS, J., 2 Gillies-street, Fairfield; 1 commercial passenger service, to be purchased, with approximate seating capacity for 11 persons, to operate between Bulga Park and Melbourne daily. Depart Bulga Park 7 a.m. Depart Melbourne 4 p.m.

STOLL, G. M., Drouin; 1 commercial passenger vehicle, to be purchased, to operate as a substitute unit to all licensed vehicles.

THOMPSON, B. W., Main-street, Koondrook; 1 commercial passenger vehicle, with seating capacity for 19 persons, to operate as a special omnibus within a 50 miles radius of Koondrook.

WARRANDYTE TRANSPORT SERVICE PTY. LTD., 244 Nicholson-street, Fitzroy; application for variation of licences A.434, A.436, A.437, A.438, and A.636 to include the ability to operate as special service omnibuses within a 25 miles radius of G.P.O., Melbourne.

WILKINSON, J. H., Rupert-street, Orbost; 1 commercial passenger vehicle, with seating capacity for 5 persons, to operate—(a) separate and distinct fares within a 5 miles radius of Orbost Railway Station, (b) private hire within a 50 miles radius of Orbost Railway Station.

**A**PPPLICATIONS for licences to operate commercial passenger vehicles, with seating capacity for 5 persons, to operate for the carriage of passengers otherwise than at separate and distinct fares for each passenger throughout Victoria:—

EDWARDS, R. W., St. Kilda.

FORD, R. J., Nyora.

HIGGINS, F. W. E., Parkville.

MITCHELL, A. J. R., St. Kilda.

RODNEY MOTORS PTY. LTD., Kyabram (subject to the cancellation of licence PH.88 held by Bilson's Garage).

WARD, E. J., Carlton.

Notices of any objection should be forwarded to reach the Secretary to the Board not later than Wednesday, the 11th February, 1948.

E. V. FIELD,  
Secretary.

Exhibition Buildings, Rathdown-street, Carlton, 27th January, 1948.

*State Savings Bank Act 1928, Section 31.*

#### THE STATE SAVINGS BANK OF VICTORIA.

##### ESTABLISHMENT OF BRANCH.

**T**HE Commissioners of the State Savings Bank of Victoria hereby give notice of their intention to establish a branch of the bank at Moe, on Monday, 16th February, 1948.

N. S. WHITE,  
Assistant General Manager.

22nd January, 1948.

#### FARMERS PROTECTION ACT 1941.

**N**OTIFICATION is hereby given that the Farmers' Debts Adjustment Board, pursuant to the powers conferred by the *Farmers Protection Act 1941*, cancelled the following Limited Stay Orders:—

*No; Farmer; Address; Debt; Creditor; Address; Date of Cancellation.*

408; Fisher, Robert John; Pimpinio; £4,734 10s.; Richard Humphreys; Bowden-street, Horsham; 22nd January, 1948.

397; Tepper, Alfred Oscar; Minyip; £3,850; Trustees, Executors, and Agency Co. Ltd.; 401 Collins-street, Melbourne; 22nd January, 1948.

W. J. EVANS, Deputy Secretary,  
Farmers' Debts Adjustment Board.

27th January, 1948.

#### *Farmers Debts Adjustment Act 1935.*

##### CANCELLATION OF STAY ORDERS.

**N**OTIFICATION is hereby given that the Stay Orders issued to the under-mentioned farmers have been cancelled by the Farmers' Debts Adjustment Board, such cancellation to take effect on Wednesday, 28th January, 1948:—

*No. of Stay Order; Name; Address.*

3230; Henderson, John and Elizabeth May; Baulkamaugh North.

3866; Creed, Sidney Stephen F.; Donnybrook.

3573; Pollock, estate of Robert Sinclair, deceased; Talbot.

4046; McGee, Ellen Theresa (executrix of the estate of John Edward McGee, deceased); Beulah.

4047; McGee, Patrick Edward and William Bernard; Beulah.

4415; Byron, Herbert Ernest; Woomelang.

W. J. EVANS, Deputy Secretary,  
Farmers' Debts Adjustment Board.

27th January, 1948.

**S**UBJECT to any necessary excisions, &c., it is proposed to grant the following lease:—

9029, Castlemaine; Hubert Rodriguez Meiklejohn Faneco and Ruby Faneco; 23a. 2r. 18p., in the Parish of Greensborough.

#### APPLICATIONS FOR MINING LEASES DECLARED ABANDONED.

11196, Bendigo; James Henry Laurie; 40 acres, north-west of abandoned Lady Barkly Mine.

11202, Bendigo; Universal Gold Development N. L.; 90 acres, in the Parish of Sandhurst.

11238, Bendigo; Alec Ray Dodson; 40 acres, at Long Gully. 9021, Castlemaine; Michael Duhan Garretty; 240 acres, at Maldon.

9039, Castlemaine; Southern Minerals Pty. Ltd.; 236 acres, at Hoddle's Creek.

7045, Mineral; John Henry Haddon Barnes; 750 acres, at Toora North.

J. H. LIENHOP,  
Minister of Mines.

#### NOTICE.

**A**DMINISTRATION of the estate of each of the under-mentioned deceased persons has been granted to me, and creditors, next of kin, and all others having claims against the estate of any of the persons so mentioned are required to send particulars of their claims to the Public Trustee, No. 412 Collins-street, Melbourne, on or before the 30th March, 1948, or they will be excluded from the distribution of the estate when the assets are being distributed:—

BRYANT, LESLIE, late of O'Shannassy Weir, via Warburton, labourer, died 23rd or 24th November, 1947, intestate.

CHRISTIE, ALBERTA MARY, also known as Berta Price, late of 374 St. Kilda-road, Melbourne, process worker, died 29th September, 1947, intestate.

CONNELL, ARTHUR PHIPPS, late of 34 Carrier-street, Benalla, pensioner, died 5th November, 1947, intestate.

DALE, OLIVE JANE, formerly of 96 Canning-street, Carlton, but late of Royal Park, domestic duties, died 14th November, 1947, intestate.

DAVIDSON, GEORGE, late of 21 Eastern-road, South Melbourne, labourer, died 16th September, 1947, intestate.

FERGUSON, ROBERT MACKENZIE, late of 88 Ireland-street, West Melbourne, tinsmith, died 4th October, 1947, intestate.

FETTLING, ANNIE, late of 3 Keppel-street, Carlton, dress-maker, died 14th March, 1947, intestate.

HODGES, GEORGE, late of 49 Stephenson-street, Richmond, labourer, died 6th October, 1947, intestate.

HUNTER, JANE, late of Melbourne Benevolent Home, Cheltenham, pensioner, died 12th November, 1947, intestate.  
LOVEGROVE, FRANCES IRENE, late of 30 Station-street, Carlton, married woman, died 14th May, 1946, intestate.

LUMSDEN, JOHN PROUDFOOT, late of 3 Sharpe-street, Benalla, road foreman, died 25th July, 1947, intestate.

LUNGHUSEN, BESSIE HELEN MITCHELL, also known as Bessie Linghusen, Elizabeth Lunghusen, and Bessie Lunghusen, late of Gippsland Benevolent Home, Bairnsdale, widow, died 31st July, 1947, intestate.

LYFIELD, MARY ANN, late of Gloucester-avenue, Woome- lang, widow, died 14th July, 1946, intestate.

\*MUMFORD, EDITH ALLEYNE, late of 27 Kireep-road, Balwyn, married woman, died 15th November, 1947.

\*RUSSELL, ISABELLA, late of 20 Smith-street, West Brun- swick, married woman, died 10th December, 1922.

SCHWEDEE, ERICH THEODOR, late of Eildon Weir, pensioner, died 12th November, 1947, intestate.

SPIERS, SYDNEY ALBERT, late of 107 Young-street, Fitzroy, pensioner, died 20th November, 1947, intestate.

THATER, JOHANN BAHNE, late of Bendigo, pensioner, died 5th August, 1946, intestate.

WILLIAMS, EDWARD, formerly of Sorrento, but late of Royal Park, pensioner, died 12th July, 1936, intestate.

†WINTON, EDITH VICTORIA, late of 29 Fairholm-grove, Camberwell, milliner, died 23rd October, 1947.

\*WOODWARD, FREDERICK WILLIAM, late of Christchurch, New Zealand, retired tobacconist, died 26th July, 1947.

YOUNG, WILLIAM PATRICK, late of Benevolent Home, Cheltenham, pensioner, died 1st October, 1947, intestate.

\* With the will annexed.

† According to the provisions of the will.

C. J. GARDNER,  
Public Trustee.

Melbourne, 21st January, 1948.

4 GEORGE VI. No. 4755, SECTION 6.

I HEREBY give notice that on the 23rd December, 1947, I filed an election to administer the following deceased person's estate, in accordance with section 6 of the *Public Trustee Act 1940*:—

LYFIELD, MARY ANN, late of Gloucester-avenue, Woome- lang, widow, died 14th July, 1946, intestate.

I HEREBY give notice that on the 15th January, 1948, I filed elections to administer the following deceased persons' estates, in accordance with section 6 of the *Public Trustee Act 1940*:—

BRYANT, LESLIE, late of O'Shannassy Weir, via War- burton, labourer, died 23rd or 24th November, 1947, intestate.

CHRISTIE, ALBERTA MARY, also known as Berta Price, late of 374 St. Kilda-road, Melbourne, process worker, died 29th September, 1947, intestate.

CONNELL, ARTHUR PHIPPS, late of 34 Carrier-street, Benalla, pensioner, died 5th November, 1947, intestate.

DAVISON, GEORGE, late of 21 Eastern-road, South Mel- bourne, labourer, died 16th September, 1947, intestate.

FERGUSON, ROBERT MACKENZIE, late of 88 Ireland-street, West Melbourne, tinsmith, died 4th October, 1947, intestate.

LUMSDEN, JOHN PROUDFOOT, late of 3 Sharpe-street, Benalla, road foreman, died 25th July, 1947, intestate.

LUNGHUSEN, BESSIE HELEN MITCHELL, also known as Bessie Linghusen, Elizabeth Lunghusen, and Bessie Lung- husen, late of Gippsland Benevolent Home, Bairnsdale, widow, died 31st July, 1947, intestate.

WILLIAMS, EDWARD, formerly of Sorrento, but late of Royal Park, pensioner, died 12th July, 1936, intestate.

\*WINTON, EDITH VICTORIA, late of 29 Fairholm-grove, Camberwell, milliner, died 23rd October, 1947.

YOUNG, WILLIAM PATRICK, late of Benevolent Home, Cheltenham, pensioner, died 1st October, 1947, intestate.

\* According to the provisions of the will.

I HEREBY give notice that on the 19th January, 1948, I filed elections to administer the following deceased persons' estates, in accordance with section 6 of the *Public Trustee Act 1940*:—

HONGES, GEORGE, late of 49 Stephenson-street, Richmond, labourer, died 6th October, 1947, intestate.

HUNTER, JANE, late of Melbourne Benevolent Home, Cheltenham, pensioner, died 12th November, 1947, intestate.

SCHWEDEE, ERICH THEODOR, late of Eildon Weir, pensioner, died 12th November, 1947, intestate.

SPIERS, SYDNEY ALBERT, late of 107 Young-street, Fitzroy, pensioner, died 20th November, 1947, intestate.

THATER, JOHANN BAHNE, late of Bendigo, pensioner, died 5th August, 1946, intestate.

C. J. GARDNER,  
Public Trustee.

412 Collins-street, Melbourne, C.1, 21st January, 1948.

AUCTION SALES ACT 1928.

KYNETON.—Notice is hereby given that a Special Meeting of Justices will be held at the Court House, Kyneton, on Tuesday, the 24th day of February, 1948, at Ten o'clock in the forenoon, to consider an application by Dennis James Hughes, of Carlsruhe, for an auctioneer's licence. Dated at Kyneton this 23rd day of January, 1948.—D. H. GUDE, Clerk of Petty Sessions.

Dairy Products Acts.

QUOTAS FOR BUTTER AND CHEESE.

BUTTER QUOTA.

I, ALEXANDER HENRY DENNETT, Minister of Agri- culture in the State of Victoria, after consultation with the Victorian Dairy Products Board, and after ascertaining that the supply and distribution of butter at reasonable prices to consumers thereof in Victoria will be ensured, hereby determine a quota for butter as follows:—

The proportion shall be forty-four point nought seven per cent.

The period for which this quota is to operate shall be the month of February, 1948.

CHEESE QUOTA.

I, ALEXANDER HENRY DENNETT, Minister of Agri- culture in the State of Victoria, after consultation with the Victorian Dairy Products Board, and after ascertaining that the supply and distribution of cheese at reasonable prices to consumers thereof in Victoria will be ensured, hereby determine a quota for cheese as follows:—

The proportion shall be forty-four point one two per cent.

The period for which this quota is to operate shall be the month of February, 1948.

A. H. DENNETT,  
Minister of Agriculture.

20th January, 1948.

Water Acts.

STATE RIVERS AND WATER SUPPLY COMMISSION.

ALLANSFORD, TORQUAY AND BARWON HEADS AND OCEAN GROVE URBAN DISTRICTS.

NOTICE to owners of tenements in the under-mentioned streets in the above-mentioned urban districts, and the private streets, lanes, courts, and alleys opening thereto:—

Allansford Urban District.

Catherine-street, from Frank-street to Maria-street.  
Maria-street, from Catherine-street to a point opposite lot 59, about 3½ chains westerly.

Torquay Urban District.

Felix-crescent, from Beach-street to a point opposite lot 2 on lodged plan of subdivision No. 2379, about 3 chains north-easterly, and from Cowrie-road to a point opposite lot 25, about 4½ chains north-easterly.

Barwon Heads and Ocean Grove Urban District.

Barwon Heads.

Margate-street, from end of existing main opposite lot 7 to a point opposite lot 12 on lodged plan of subdivision No. 9338, about 1½ chain southerly.

Ocean Grove.

The Avenue, from Eggleston-street to a point opposite lot 237, Block B, on lodged plan of subdivision No. 1855, about 7½ chains westerly.

The Parade, from end of existing main opposite lot 192 on lodged plan of subdivision No. 1854 to Tuckfield-street.

The main pipe in the said streets being laid down, the owners of all tenements situated as above are hereby required, on or before the 28th day of February next, to cause proper pipes and stop cocks to be laid so as to supply water within such tenements from the main pipe.

L. DUGGAN, Secretary,  
State Rivers and Water Supply Commission.  
Melbourne, 21st January, 1948.

## NOTICE TO MARINERS.

[No. 1 of 1948.]

## AUSTRALIA.—VICTORIA.

PORT PHILLIP.—WEST AND COLES CHANNELS.

(1) *Establishment of Leading Lights.*

Date.—23rd January, 1948.

Former Notice.—No. 7 of 1947; in force.

(2) *Alteration in Sectors of Lights.*

Position.—(a) Rear light—high light, Queenscliff. Lat. 38 deg. 16 min. 25 sec. S. Long. 144 deg. 39 min. 44 sec. E. (approx.).

Alteration.—An additional white sector now shows from 224 deg. to 228 deg.

Position.—(b) Rear light—Monash. Lat. 38 deg. 19 min. 06 sec. S. Long. 144 deg. 40 min. 44 sec. E. (approx.).

Alteration.—The sector is now white from 135 deg. through south to 245 deg., obscured elsewhere.

D. STEVENSON,  
Port Officer.

Ports and Harbours Branch,  
Department of Public Works,  
Melbourne, C.2, 19th January, 1948.

## CARISBROOK WATERWORKS TRUST.

AUTHORITY TO OBTAIN A BANK OVERDRAFT.

THE Lieutenant-Governor, as Deputy for His Excellency the Governor of the State of Victoria, by and with the advice of the Executive Council thereof, doth hereby authorize the Carisbrook Waterworks Trust to obtain, in pursuance of the provisions of section 271 of the *Water Act 1928* (No. 3801), an advance or advances during the year 1948 from the English, Scottish, and Australian Bank Limited, Maryborough, by overdraft of the Trust's current account thereat, such overdraft not to exceed at any one time the sum of Eighty pounds (£80).

C. W. KINSMAN,  
Clerk of the Executive Council.

At the Executive Council Chamber,  
Melbourne, the 20th January, 1948.

## BENALLA WATERWORKS TRUST.

RATING BY-LAW FOR THE YEAR 1948.

THE Benalla Waterworks Trust, in pursuance and exercise of the powers conferred by the Water Acts, doth hereby make a rate for the supply of water for domestic purposes of One shilling and three pence in the pound on the annual municipal valuation of lands and tenements liable to be rated within the Benalla Urban District.

Provided that in no case shall the amount of rate payable per annum in respect of any tenement (other than land on which there is no building) be less than Twenty-five shillings, and in respect of land on which there is no building, less than Fifteen shillings.

Such rates are made and shall be levied upon the occupiers or owners of the said lands and tenements for the year commencing the 1st day of January, 1948, and shall be payable in one sum on the 31st day of January, 1948, at the office of the said Trust.

The maximum quantity of water to be supplied in any one year without further charge to any property rated by the Trust is hereby fixed at the quantity which, at a charge of One shilling per 1,000 gallons, would produce an amount equal to the amount of the rate levied on such property for the said year.

The charge for water supplied by measure to any property rated by the Trust in excess of such maximum quantity, computed as in the last preceding clause, is hereby fixed at One shilling per 1,000 gallons.

The charge for water supplied by measure to any property shall be payable, on demand, at the office of the said Trust.

Signed and sealed this 15th day of December, 1947.

(SEAL) W. McCALL SAY, Chairman.  
GEORGE L. OLIVER, Commissioner.  
E. C. BATES, Secretary.

Approved by the Governor in Council,  
20th January, 1948.

C. W. KINSMAN,  
Clerk of the Executive Council.

## BRIDGEWATER WATERWORKS TRUST.

RATING BY-LAW FOR YEAR 1948.

THE Bridgewater Waterworks Trust, in pursuance and exercise of the powers conferred by the Water Acts, doth hereby make a rate for the supply of water for domestic purposes of Sixteen pence in the pound of the annual municipal valuation of lands and tenements liable to be rated within the Bridgewater Urban District.

Provided that in no case shall the amount of rate payable per annum in respect of any tenement (other than lands on which there is no building) be less than Fifty-three shillings and four pence, and in respect of any land on which there is no building be less than Ten shillings.

Such rates are made and shall be levied upon the occupiers or owners of the said lands and tenements for the year commencing the 1st day of January, 1948, and shall be payable on the 1st day of February, 1948, at the office of the said Trust.

The maximum quantity of water to be supplied in any one year without further charge to any property rated by the Trust is hereby fixed at the quantity which, at a charge of Twelve pence per 1,000 gallons, would produce an amount equal to the amount of the rate levied on such property for the said year.

The charge for water supplied by measure to any property rated by the Trust in excess of such maximum quantity, computed as in the last preceding clause, is hereby fixed at One shilling per 1,000 gallons.

The charge for water supplied by measure to any property not rated by the Trust is hereby fixed at One shilling and three pence per 1,000 gallons, and the minimum quantity of water to be charged for in cases where water is so supplied is hereby fixed at 10,000 gallons.

The charge for water supplied by measure shall be payable, on demand, at the office of the Trust.

Passed this 9th day of December, 1947.

(SEAL) A. D. SCHOLDS, Chairman.  
R. L. LUCAS, Commissioner.  
CLAUDE BURGE, Secretary.

Approved by the Governor in Council,  
20th January, 1948.

C. W. KINSMAN,  
Clerk of the Executive Council.

## BROADFORD WATERWORKS TRUST.

RATING BY-LAW FOR THE YEAR 1948.

THE Broadford Waterworks Trust, in pursuance and exercise of the powers conferred by the Water Acts, doth hereby make a rate for the supply of water for domestic purposes, otherwise than by measure, of Two shillings and eight pence in the pound on the annual municipal valuation of land and tenements liable to be rated within the Broadford Urban District.

Provided that in no case shall the amount of rate payable per annum in respect of any tenement (other than land on which there is no building) be less than Forty-seven shillings, and in respect of any land on which there is no building, less than Seventeen shillings.

Such rates are made and shall be levied upon the occupiers or owners of the said lands and tenements for the year commencing on the 1st day of January, 1948, and shall be payable in one amount on the 1st day of March, 1948, at the office of the said Trust.

Dated this 8th day of January, 1948.

(SEAL) A. M. ZWAR, Chairman.  
H. L. POLGLASE, Secretary.

Approved by the Governor in Council,  
20th January, 1948.

C. W. KINSMAN,  
Clerk of the Executive Council.

## ROCHESTER WATERWORKS TRUST.

RATING BY-LAW FOR THE YEAR 1948.

THE Rochester Waterworks Trust, in pursuance and exercise of the powers conferred by the Water Acts, doth hereby make a rate for the supply of water for domestic purposes of One shilling and three pence in the pound of the annual municipal valuation of lands and tenements liable to be rated within the Rochester Urban District.

Provided that in no case shall the amount of rate payable per annum in respect of any tenement (other than land on which there is no building) be less than Fifty shillings, and in respect of any land on which there is no building less than Seven shillings and six pence.

Such rates are made and shall be levied upon the occupiers or owners of the said lands and tenements for the year commencing the 1st day of January, 1948, and shall be payable on the 1st day of February, 1948, at the office of the said Trust.

The maximum quantity of water to be supplied in any one year without further charge to any property rated by the Trust is hereby fixed at the quantity which, at a charge of One shilling and three pence per 1,000 gallons, would produce an amount equal to the amount of the rate levied on such property for the said year.

The charge for water supplied by measure to any property rated by the Trust in excess of such maximum quantity, computed as in the last preceding clause, is hereby fixed at One shilling per 1,000 gallons.

The charge for water supplied by measure shall be payable, on demand, at the office of the Trust.

Passed this 16th day of December, 1947.

(SEAL) J. G. HART, Chairman.  
A. G. FULLER, Secretary.

Approved by the Governor in Council,  
20th January, 1948.

C. W. KINSMAN,  
Clerk of the Executive Council.

**SHEPPARTON URBAN WATERWORKS TRUST.**

**RATING BY-LAW FOR THE YEAR 1948.**

THE Shepparton Urban Waterworks Trust, in pursuance and exercise of the powers conferred by the Water Acts, doth hereby make a rate for the supply of water for domestic purposes of Ten and one-half pence in the pound of the annual municipal valuation of lands and tenements liable to be rated within the Shepparton Urban District.

Provided that in no case shall the amount of rate payable per annum in respect of any tenement (other than land on which there is no building) be less than Twenty shillings, and in respect of any land on which there is no building less than Ten shillings.

Such rates are made and shall be levied upon the occupiers or owners of the said lands and tenements for the year commencing on the 1st day of January, 1948, and shall be payable on the 15th day of May, 1948, at the office of the said Trust.

The maximum quantity of water to be supplied in any one year without further charge to any property rated by the Trust is hereby fixed at the quantity which, at a charge of Nine pence per 1,000 gallons, would produce an amount equal to the amount of the rate levied on such property for the said year.

The charge for water supplied by measure to any property rated by the Trust in excess of such maximum quantity, computed as in the last preceding clause, is hereby fixed at Nine pence per 1,000 gallons.

The charge for water supplied by measure to any property not rated by the Trust is hereby fixed at Nine pence per 1,000 gallons, and the minimum quantity of water to be charged for in cases where water is so supplied is hereby fixed at 50,000 gallons.

The charge for water supplied by measure shall be payable, on demand, at the office of the Trust.

Passed this 13th day of January, 1948.

(SEAL) A. McC. DUNCAN, Chairman.  
A. W. KNEE, Secretary.

Approved by the Governor in Council,  
20th January, 1948.

C. W. KINSMAN,  
Clerk of the Executive Council.

**YACKANDANDAH WATERWORKS TRUST.**

**RATING BY-LAW FOR THE YEAR 1948.**

THE Commissioners of the Yackandandah Waterworks Trust do hereby, pursuant to and in exercise of the powers and authorities conferred by the Water Acts, make the following By-law, viz.:-

1. General Rate.—A rate of One shilling and ten pence in the pound is hereby made for the year 1948 upon all property liable to be rated within the waterworks district of the Trust, and such rates shall be based on the annual municipal valuation of the Shire of Yackandandah.

2. The minimum rate payable shall be Thirty-one shillings and two pence.

The foregoing rates shall be due and payable in one amount, in advance, on the 1st day of March, 1948.

Such person or persons as may from time to time be employed by the Trust for that purpose shall be authorized to demand, collect, sue for, and recover the rates hereby made.

Passed on the 8th day of January, 1948.

(SEAL) E. I. ARNOLD, Chairman.  
A. R. MCKIBBIN, Commissioner.  
Y. PERMEZEL, Secretary.

Approved by the Governor in Council,  
20th January, 1948.

C. W. KINSMAN,  
Clerk of the Executive Council.

**BUSINESS AGENTS ACT 1930.**

IN accordance with the provisions of the above-mentioned Act, the following is published for general information:—

*(a) Supplementary List of Business Agents' Licences issued during the months of November and December, 1947.*

Name.	Principal Place of Business (Registered Office).	Name of Firm or Partnership.	Date from which Licence is Effective.
Cummins, H. A. .. ..	702b Whitehorse-road, Mitcham .. ..	Pugh and Cummins .. ..	24.11.47
*Gilchrist, D. G. .. ..	High-street, Woodend .. ..	.. ..	11.11.47
McAdie, I. W. .. ..	169 Barkly-street, Ararat .. ..	.. ..	12.11.47
†W. Bolton Paxton and Co. (nominee, C. Power)	89 Queen-street, Melbourne .. ..	.. ..	22.12.47
Phillips, G. E. .. ..	423 Swan-street, Richmond .. ..	James Ewins .. ..	28.11.47

\* By transfer from J. F. Gilchrist. † By transfer from previous nominee, T. R. Walton.

*(b) Supplementary List of Business Sub-Agents' Licences issued during the months of November and December, 1947.*

Name.	Registered Address.	Date from which Licence is Effective.	Name.	Registered Address.	Date from which Licence is Effective.
Bentick, R. N. ..	458 Waverley-road, East Malvern ..	5.11.47	McVean, A. G. ..	"The Hermitage," 11-15 Palmer-street, Jolimont	15.12.47
Blackburn, J. H. ..	15 Benjamin-street, Parkville ..	14.11.47	Matthews, F. A. ..	Frankston-road, Carrum Downs	24.11.47
Bottoms, W. A. ..	53 Blessington-street, St. Kilda ..	7.11.47	Moloney, A. H. J. ..	105 Osborne-street, South Yarra	12.12.47
Callister, J. ..	High-street, Woodend ..	11.11.47	Racca, O. J. ..	87 Barkers-road, Kew ..	19.11.47
Dwyer, J. ..	Lancefield ..	21.11.47			
J. P. Jones Pty. Ltd. (nominee, J. P. Jones)	209 Swanston-street, Melbourne	15.12.47			

The Treasury,  
Melbourne, 20th January, 1948.

R. STAFFORD,  
Registrar.



## AUCTION SALES ACT 1928.

**S**UPPLEMENTARY List of Persons to whom Auctioneers' Licences have been issued for the months of November and December, 1947.

Name.	Address.	Date of Issue.
Cumming, E. J. D. . . . .	South-road, Warragul . . . . .	4.11.47
Cooper, C. . . . .	526 Bourke-street, Melbourne . . . . .	10.11.47
Ferguson, C. H. . . . .	114 Wellington-street, St. Kilda . . . . .	8.12.47
Jennings, R. M. . . . .	c/o N. Z. L. & M. Agency Co. Ltd., 538 Collins-street, Melbourne	24.11.47
Young, R. A. . . . .	Gray-street, Hamilton . . . . .	3.11.47

The Treasury,  
Melbourne, 20th January, 1948.

A. T. SMITHERS,  
Director of Finance.

## REAL ESTATE AGENTS ACTS.

**I**N accordance with the provisions of the above-mentioned Acts, the following is published for general information:—

(a) *Supplementary List of Real Estate Agents' Licences issued and transferred during the months of November and December, 1947.*

Name.	Principal Place of Business (Registered Office).	Name of Firm or Partnership.	Date from which Licence is Effective.
Cummins, H. A. . . . .	702B Whitehorse-road, Mitcham . . . . .	Pugh and Cummins . . . . .	24.11.47
*Gilchrist, D. G. . . . .	High-street, Woodend . . . . .	. . . . .	11.11.47
McAdie, Ian Wm. . . . .	169 Barkly-street, Ararat . . . . .	W. McAdie . . . . .	12.11.47
Mayall, R. T. . . . .	Drouin West . . . . .	. . . . .	21.11.47
†W. Bolton Paxton and Co. Pty. Ltd. (nominee, C. Power)	89 Queen-street, Melbourne . . . . .	. . . . .	22.12.47
Ramage, R. J. . . . .	Vernon-road, Wangaratta . . . . .	. . . . .	25.11.47
Vary, N. . . . .	3 Fitzroy-avenue, Frankston . . . . .	The Long Island Estate Agency . . . . .	18.12.47
Woodruff, H. . . . .	Traralgon . . . . .	T. G. Haynes . . . . .	5.12.47

\* By transfer from J. F. Gilchrist. † By transfer from previous nominee, T. R. Walton.

(b) *Supplementary List of Real Estate Sub-Agents' Licences issued during the months of November and December, 1947.*

Name.	Registered Address.	Date from which Licence is Effective.	Name.	Registered Address.	Date from which Licence is Effective.
Bailey, I. H. . . . .	341 Collins-street, Melbourne . . . . .	12.11.47	MacDonald, A. L. . . . .	45 Park-street, South Yarra . . . . .	22.11.47
Bartlett, L. G. . . . .	25-43 Moorabool-street, Geelong . . . . .	11.11.47	MaoRac, M. C. . . . .	110 William-street, Melbourne . . . . .	20.11.47
Blackburn, J. H. . . . .	15 Benjamin-street, Parkville . . . . .	14.11.47	McVean, A. G. . . . .	"The Hermitage," 11-15 Palmer-street, Jolimont . . . . .	15.12.47
Callister, J. . . . .	High-street, Woodend . . . . .	11.11.47	Quinsey, B. I. . . . .	128 Eighth-street, Mildura . . . . .	24.11.47
Daniels, G. E. . . . .	35 Grandview-terrace, North Kew . . . . .	3.11.47	Ryan, G. . . . .	Main-street, Lilydale . . . . .	5.12.47
Duffield, A. G. . . . .	25-43 Moorabool-street, Geelong . . . . .	11.11.47	Stuart, A. M. . . . .	Dorothy-grove, Ferntree Gully . . . . .	12.12.47
Hutchinson, G. F. . . . .	8 Newbury-avenue, Bonbeach . . . . .	3.11.47	Swift, R. W. . . . .	Oxford-road, Croydon . . . . .	5.12.47
Hutchinson, John Allan	Ninth-street, Mildura . . . . .	24.11.47	Tilson, D. J. . . . .	Myrtleford . . . . .	24.11.47

The Treasury,  
Melbourne, 20th January, 1948.

R. STAFFORD,  
Registrar.

## CONTRACTS ACCEPTED.—(Series 1947-48.)

## VICTORIAN RAILWAYS.

108. Rectifier Units at rates (Contract 55852).—Gibson Battle (Melb.) Pty. Ltd. 109. Sawn red gum timber at rates (Contract 56455).—A. B. Rowe and Son. 110. Supply, Delivery, and Erection of Coal Handling Plant for £3,496 (Contract 56473).—Gibson Battle (Melb.) Pty. Ltd. 111. Electric light poles at rates (Contract 56638).—F. Radford. 112. Cold Sawing Machine at £1,161 10s. each (Contract 56644).—Gilbert Lodge and Co. Pty. Ltd. 113. Supply and delivery of General Stores as ordered during the period 1st July, 1947, to 30th June, 1949, as per attached annex.

By order of the Victorian Railways Commissioners,  
BURT KELLY, Secretary. 23.1.48.

## ORDERS IN COUNCIL.—(Series 1947-48.)

## STATE ELECTRICITY COMMISSION.

1965. The supply of ball and roller bearings for motor vehicles.—Ministry of Munitions.  
1966. The supply of twenty tires for motor vehicles and tractors, to Quotation No. 2470.—General Tyre and Rubber Co. Pty. Ltd.  
1967. The supply of 168 tires for motor vehicles and tractors, to Quotation No. 2470.—Goodyear Tyre and Rubber Co. (Aust.) Ltd.

1968. The supply of two portable Diesel engine powered air compressors for Kiewa Hydro-Electric Scheme, to Quotation No. 2376.—McPherson's Ltd.

1969. The supply of 16.95 tons of rock drill steel for Kiewa Hydro-Electric Scheme, to Quotation No. 1849.—Noyes Bros. (Melb.) Ltd.

1970. The supply of 25,000 shackle insulators, to Quotation No. 1443.—John Shorter Pty. Ltd.

1971. The supply of 2,200-volt metal-clad switchgear for Brunswick Terminal Station, to Specification No. 47-48/41.—Australian General Electric Pty. Ltd.

1972. The supply of one steel-framed building, 200 ft. x 100 ft., Yallourn, to Quotation No. 2102.—Tydarch Pty. Ltd.

1973. The supply of a briquette-fired hot-water service, Yallourn North Hostel, to Specification No. 46-47/173.—T. W. Futcher and Sons Pty. Ltd.

1974. The supply of four portable Diesel engine powered air compressors for Kiewa Hydro-Electric Scheme, to Quotation No. 2376.—Knox Schlapp Pty. Ltd.

1975. The supply of spare parts for Allis Chalmers Tractors.—Commonwealth Disposals Commission.

1976. The supply and delivery of two prefabricated houses, Kyabram and Wodonga.—Housing Commission, Victoria.

Approved by the Governor in Council, 20th January, 1948.—C. W. KINSMAN, Clerk of the Executive Council.

CONTRACTS ACCEPTED.—(Series 1947-48.)

Contract No.	Particulars.	Amount.	Name of Contractor.	Charge against Vote or Fund.
1977	GENERAL STORES— Supply of Motor Spirit and Kerosene, in such quantities as may be ordered from 1st February, 1948, to 31st January, 1949	Rates as per annex	The Shell Co. of Australia Ltd.	Contingencies, 1947-48, 1948-49
1978	" " " " " " " "	"	The Vacuum Oil Co. Pty. Ltd.	
1979	" " " " " " " "	"	The Commonwealth Oil Refineries Ltd.	
1980	" " " " " " " "	"	The Alba Petroleum Co. of Aust. Pty. Ltd.	
1981	" " " " " " " "	"	Neptune Oil Co. Pty. Ltd. . .	

Approved—T. T. HOLLWAY, Treasurer. 22.1.48.

ANNEX TO CONTRACTS NOS. 1947/1977 TO 1947/1981.

Schedule No. 50.

MOTOR SPIRIT AND KEROSENE.

CONTRACT FROM 1ST FEBRUARY, 1948, TO 31ST JANUARY, 1949.

1947/1977.—*The Shell Co. of Australia Ltd.* Security, £1,020.

1947/1978.—*The Vacuum Oil Co. Pty. Ltd.* Security, £765.

1947/1979.—*The Commonwealth Oil Refineries Ltd.* Security, £370.

1947/1980.—*The Alba Petroleum Co. of Aust. Pty. Ltd.* Security £390.

1947/1981.—*Neptune Oil Co. Pty. Ltd.* Security £375.

DISTRIBUTION OF ORDERS.

Orders for supplies of Item 2 are to be issued on the respective contractors as follows :—

The Shell Co. of Australia Ltd.—Public Works Department and Forests Commission as to one-half of requirements.

The Alba Petroleum Co. of Aust. Pty. Ltd.—Public Works Department and Forests Commission as to one-half of requirements.

The Commonwealth Oil Refineries Ltd.—All other Departments.

Orders for supplies of Item 3 are to be issued on the respective contractors as follows :—

The Shell Co. of Australia Ltd.—Police Department, Public Works Department, and Department of Agriculture as to one-half of requirements; Education Department and Forests Commission as to one-third of requirements.

The Vacuum Oil Co. Pty. Ltd.—Police Department, Public Works Department, and Department of Agriculture as to one-half of requirements; Education Department as to one-third of requirements; Forests Commission as to two-thirds of requirements.

The Commonwealth Oil Refineries Ltd.—Education Department as to one-third of requirements.

The rates shown are F.O.R. Melbourne, and cover delivery within the Metropolitan Free Delivery Area; for supplies outside that area, other than those forwarded on Stores and Transport Consignment Notes, freight differentials in accordance with the Contractors' differential lists are to be added. Contractors to supply copies of current differential lists to Departments requiring same.

All rates, including freight differentials, are subject to alteration as authorized by the Commonwealth Prices Commissioner. Tins and cases become the property of the Government. Drums will be charged at—Heavy, £2 10s.; Light, £1 each—to be credited on return.

Officers are required to return drums in good order and condition to the point of delivery within a reasonable time.

In addition to standard grade spirit, alcohol blend will be supplied in bulk, in the declared selling zone which, at present, is approximately within a radius of 10 miles from the G.P.O., Melbourne.

Item No.	Description of Articles.	Rate.	Name of Contractor.
1	Motor Spirit, Standard Grade—in 4-gallon drums .. .. per drum	£ s. d. 0 10 4	The Commonwealth Oil Refineries Ltd. The Shell Co. of Australia Ltd. The Alba Petroleum Co. of Aust. Pty. Ltd. The Commonwealth Oil Refineries Ltd. The Shell Co. of Australia Ltd. The Vacuum Oil Co. Pty. Ltd. The Commonwealth Oil Refineries Ltd. The Alba Petroleum Co. of Aust. Pty. Ltd.
2	" " " " in 44-gallon drums .. .. per gal.	0 2 0	
3	" " " " in bulk into Bowsers .. .. per gal.	0 1 11	
4	Kerosene, 150 test—in tins and cases .. .. per case	0 17 0	
5	" " " " in 44-gallon drums .. .. per gal.	0 1 4½	
6	" " Power—in tins and cases .. .. per case	0 16 4	
7	" " " " in 44-gallon drums .. .. per gal.	0 1 3½	

## TEACHING SERVICE ACT 1946.

*At the Executive Council Chamber, Melbourne, the  
twentieth day of January, 1948.*

## PRESENT:

The Lieutenant-Governor, as Deputy for His Excellency the  
Governor of Victoria.

Mr. Dodgshun

| Mr. Kennedy.

DEFINITION OF SCHOOL WORK AND SCHOOLS.—SCHEDULES  
AMENDED.

PURSUANT to the powers conferred by the *Teachers Service Act* 1946, the Lieutenant-Governor, as Deputy for His Excellency the Governor of the State of Victoria, by and with the advice of the Executive Council thereof, doth amend the Order in Council made on the 29th day of October, 1946, and published in the *Government Gazette* of the 30th idem—Definition of School Work and Schools—in the manner following, that is to say:—

1. Schedule I. is hereby revoked and a new Schedule I. as hereunder is substituted therefor.
2. Schedule II. is hereby revoked and a new Schedule II. as hereunder is substituted therefor.

## SCHEDULE I.

*Teachers' College.*

MEMORANDUM OF AGREEMENT made the \_\_\_\_\_ day  
of \_\_\_\_\_ One thousand nine hundred and \_\_\_\_\_  
between \_\_\_\_\_ now a  
student at the Teachers' College at \_\_\_\_\_ in the  
State of Victoria (hereinafter called "the Student") of the first  
part  
of  
in the said State (hereinafter called "the Surety") of the second  
part and the Honorable \_\_\_\_\_ in his  
capacity as the responsible Minister of the Crown for the time being  
administering the Education Acts of the said State (hereinafter called  
"the Minister") of the third part: Whereas under and subject to  
the provisions of the *Teaching Service Act* 1946 and the Regulations  
made thereunder the student has been awarded a studentship in a  
course of training at the Teachers' College at \_\_\_\_\_  
in the said State: And whereas it is provided by the said Regulations  
that the holder of such a studentship may in certain circumstances have his  
studentship extended by the Director of Education: And  
whereas it is provided amongst other things by an Order made by the  
Governor in Council pursuant to and in accordance with the said Act  
that the Minister is authorized to enter into agreements with holders  
of studentships and sureties approved by him: And whereas the  
Minister has approved of the party hereto of the second part as such  
surety as aforesaid: And whereas the student and the surety have  
requested the Minister to pay on behalf of the student the tuition fees  
(if any) that may become payable during the currency of the said  
studentship or of any extension thereof as aforesaid and to make to  
the student the allowances and advances (if any) to which he may  
be or may become entitled under the provisions of the aforesaid  
Regulations or any amendment thereof in connexion with his  
studentship or any extension thereof: And whereas the Minister has  
agreed to pay such fees and to make allowances and advances as  
aforesaid: And whereas it has been mutually agreed upon by and  
between the parties hereto that the studentship or any extension  
thereof may be suspended by the Minister for such period and for  
such reason as he may in his discretion determine and may be  
cancelled by the Minister if he is satisfied that the conduct or progress  
of the student is not satisfactory during the currency of the said  
studentship or of any extension thereof: Now these presents witness  
that in consideration of the premises the student and the surety do  
hereby for themselves their executors and administrators and also as

separate covenants each of them doth hereby for h self h executors and administrators covenant with the Minister in manner following, that is to say:—

1. That the student will observe the conditions of tenure of h studentship or any extension thereof as provided in any Statute Regulation or Order for the time being in force relating to studentships and will in the course of h training in connexion with the said studentship or any extension thereof make satisfactory progress and conduct h self in a satisfactory manner.

2. That the student will not relinquish or discontinue h course of training and study under or in connexion with the said studentship or any extension thereof without the permission in writing of the Minister first had and obtained.

3. That the student will for and throughout the period of three and one-half years next after the termination of h said course of training and study teach in any school to which he may be appointed by the Minister or under and in pursuance of any Act or Regulations for the time being in force governing or relating to the appointment or employment of State school teachers: Provided that the beginning of such period of three and one-half years may be deferred by the Minister for such reason and for such time as he may think fit: And provided also that in computing the said period of three and one-half years any leave of absence granted to the student at any time or times after the commencement of such period shall not reckoned as part thereof.

4. That all moneys advanced to the student shall be repaid to the Minister by the student and the surety or either of them within two years next after the completion of the said studentship or any extension thereof by such instalments and at such time as the Minister may in his discretion determine.

5. That in the event of—

- (a) the dismissal of the student pursuant to the provisions of the *Teaching Service Act 1946* or any amendment thereto;
- (b) the cancellation by the Minister of the said studentship or any extension thereof on the ground that the student has failed to make satisfactory progress or that h conduct has not been satisfactory;
- (c) the termination of the services of the student as a teacher after the expiration of the studentship and any extension thereof but before the expiration of the period of three and one-half years aforesaid by any cause whatever other than death; or
- (d) any breach or non-observance by the student of any term other than clause 4 of this agreement—

the student and the surety or one of them will forthwith on demand pay or cause to be paid to the Minister an amount of Thirty pounds in respect of each year or portion of a year of the student's tenure of h studentship and any extension thereof and will in addition pay or cause to be paid to the Minister an amount equal to the total amount of all outstanding advances which the student has received and of all allowances other than allowances made under clause 22 of Regulation 12 of the *Teaching Service (Teachers Tribunal) Regulations* which the student has received and of all tuition fees the benefit of which the student has received during and by virtue of h tenure of h studentship and any extension thereof.

Provided however that if the matters referred to in paragraph (c) or (d) arise the total amount payable by the student to the Minister under this clause other than the amount of any advances may with the approval of the Minister be proportionately reduced in consideration of each completed period of three months' service as a teacher and if the student is a female who after commencing service as a teacher resigns or retires in order to marry she shall if the Minister so directs be deemed for the purpose of this proviso to have completed an additional period of six months' service as a teacher: And provided further that if the student is a female who either before the expiration of the studentship or after the expiration thereof but before commencing service as a teacher resigns or retires in order to marry the sum other than the amount of any advances payable by such student to the Minister under this clause shall if the Minister so directs be reduced by an amount equal to one-seventh part of such sum.



3. That the student instructor will for and throughout the period of three years next after the termination of his said course of training and study teach in any school to which he may be appointed by the Minister or under and in pursuance of any Act or Regulations for the time being in force governing or relating to the appointment or employment of teachers or instructors in technical schools: Provided that in computing the said period of three years any leave of absence granted to the student instructor at any time or times after the commencement of such period shall not be reckoned as part thereof.

4. That in the event of the extension by the Minister of the said studentship for the purpose of a further course of training prescribed by the Chief Inspector of Technical Schools the period of three years mentioned in the last preceding clause hereof shall begin from the date of the completion or discontinuance by the student instructor of such further course of training.

5. That in the event (a) of the dismissal of the student pursuant to the provisions of the *Teaching Service Act* 1946 or any amendment thereto or (b) of the cancellation by the Minister of the said studentship or any extension thereof on the ground that the student has failed to make satisfactory progress or that his conduct has not been satisfactory or (c) of the termination of the services of the student instructor as a teacher after the expiration of the studentship and any extension thereof but before the expiration of the period of three years aforesaid by any cause except the death of the student or (d) of any breach or non-observance by the student instructor of any one or more of the terms of this agreement the student instructor and the surety or one of them his executors or administrators will forthwith on demand pay or cause to be paid to the Minister an amount of Thirty pounds in respect of each year or portion of a year of the student instructor's tenure of his studentship and any extension thereof and will in addition pay or cause to be paid to the Minister the amount of all tuition fees the benefit of which the student instructor has received during and by virtue of such tenure: Provided however that in the event of the termination of the services of the student instructor as a teacher by any cause except the death of the student or of a breach or non-observance by the student of this agreement at any time subsequent to the completion of the course of training and study aforesaid but during the period of three years aforesaid the total amount payable by the student to the Minister under this clause may with the approval of the Minister be proportionately reduced in consideration of each completed period of three months' service as a teacher.

6. That the liability of the surety his executors or administrators hereunder shall not be in any way released or discharged by reason of any time or other indulgence which the Minister may in his absolute discretion grant to the student instructor whereby the time or mode of payment by the student of the whole or any portion of the moneys referred to in clause 5 of this agreement may be extended or altered.

In witness whereof the parties hereto have hereunto set their hands and seals on the day and year first above written—

Signed, sealed, and delivered by the  
said Student, in the presence of—

(Signature of witness)  
(Address)

Signed, sealed, and delivered by the  
said Surety, in the presence of—

(Signature of witness)  
(Address)

Signed, sealed, and delivered by the  
said Minister, in the presence of—

And the Honorable Wilfred Selwyn Kent Hughes, His Majesty's Minister of Public Instruction for the State of Victoria, shall give the necessary directions herein accordingly.

C. W. KINSMAN,  
Clerk of the Executive Council.

DEPARTMENT OF LANDS AND SURVEY.

At the Executive Council Chamber, Melbourne, the twentieth day of January, 1948.

PRESENT:

The Lieutenant-Governor, as Deputy for His Excellency the Governor of Victoria.  
Mr. Dodgshun | Mr. Kennedy.

UNUSED AND UNMADE ROADS CLOSED.

THE Lieutenant-Governor, as Deputy for His Excellency the Governor of the State of Victoria, by and with the advice of the Executive Council thereof, doth hereby direct that, in pursuance of the provisions of section 304 of the Land Act 1928 (No. 3709), the unused and unmade roads referred to hereunder be closed, viz.:—

Parish of Heywood, County of Normanby, being the road in section A between allotments 4, 2A, and 3, and allotment 18.—(H.87<sup>(s)</sup>) (C.90040).  
Town of Pakenham, Parish of Nar Nar Goon, County of Mornington, being the road indicated by hachure on plan hereunder.—(P.5<sup>(h)</sup>) (Misc. 2235).

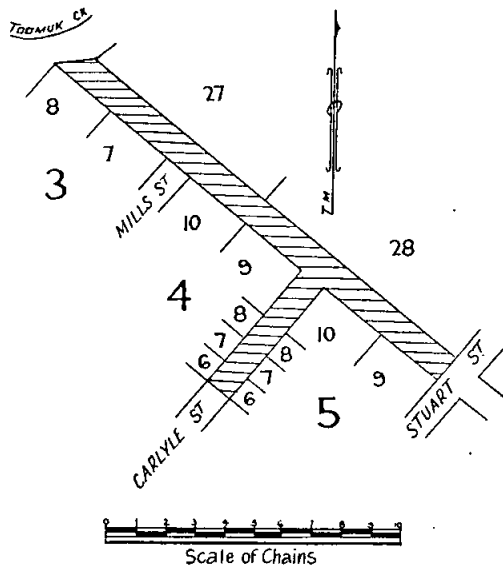

And the Honorable John Gladstone Black McDonald, His Majesty's Commissioner of Crown Lands and Survey for the State of Victoria, shall give the necessary directions herein accordingly.

C. W. KINSMAN,  
Clerk of the Executive Council.

DEPARTMENT OF LANDS AND SURVEY.

At the Executive Council Chamber, Melbourne, the twentieth day of January, 1948.

PRESENT:

The Lieutenant-Governor, as Deputy for His Excellency the Governor of Victoria.  
Mr. Dodgshun | Mr. Kennedy.

REVOCATION OF TEMPORARY RESERVATIONS OF LANDS BY ORDERS IN COUNCIL.

THE Lieutenant-Governor, as Deputy for His Excellency the Governor of the State of Victoria, by and with the advice of the Executive Council thereof, doth hereby, in pursuance of the provisions of the Land Act 1928, revoke the temporary reservations of the lands by Orders in Council hereinafter referred to, viz.:—

DROUIN.—Order in Council of 12th January, 1900, of 1 rood 28 perches of land in the Town of Drouin as a site for Road purposes, so far only as regards the portion

thereof comprised within the boundaries published in the Government Gazette of 17th December, 1947, and containing 1 9/10 perches.—(Rs.1606.)

SANDHURST.—Order in Council of 11th September, 1871, of 1 rood 30 perches of land in the City of Sandhurst (now City of Bendigo) as a site for Water Supply purposes.—(C.90978.)

WARTOOK.—Order in Council of 23rd May, 1887, of 149 acres 1 rood 32 perches of land in the Parish of Wartook as a site for Water Supply purposes.—(Rs.5938.)

WARTOOK.—Order in Council of 23rd May, 1887, of 399 acres 3 roods 27 perches of land in the Parish of Wartook as a site for Water Supply purposes.—(Rs.5939.)

And the Honorable John Gladstone Black McDonald, His Majesty's Commissioner of Crown Lands and Survey for the State of Victoria, shall give the necessary directions herein accordingly.

C. W. KINSMAN,  
Clerk of the Executive Council.

DEPARTMENT OF LANDS AND SURVEY.

At the Executive Council Chamber, Melbourne, the twentieth day of January, 1948.

PRESENT:

The Lieutenant-Governor, as Deputy for His Excellency the Governor of Victoria.  
Mr. Dodgshun | Mr. Kennedy.

LAND TEMPORARILY RESERVED FROM SALE.

THE Lieutenant-Governor, as Deputy for His Excellency the Governor of the State of Victoria, by and with the advice of the Executive Council thereof, doth hereby, in pursuance of the provisions of the Land Act 1928, reserve, temporarily, and also except from occupation for mining purposes under any miner's right, the land hereinafter described:—

MIRBOO NORTH.—Site for Public Baths, in addition to the site temporarily reserved therefor by Order in Council of the 13th August, 1907, 4 acres 2 roods 4 perches, Township of Mirboo North, Parish of Mirboo, County of Buln Buln, as indicated by hachure on plan hereunder.—(M.517<sup>(12)</sup>) (Rs.3430).

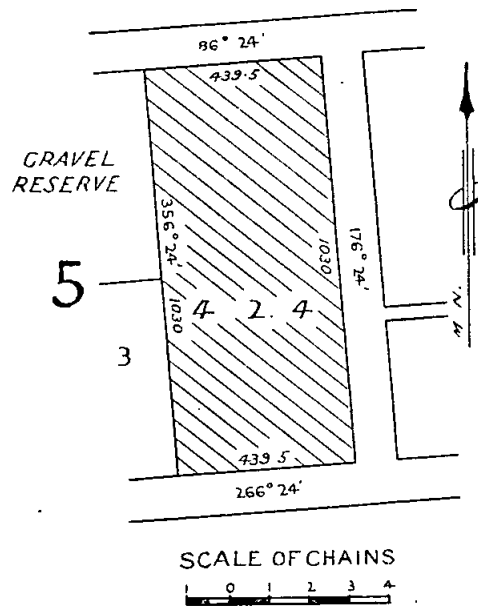

And the Honorable John Gladstone Black McDonald, His Majesty's Commissioner of Crown Lands and Survey for the State of Victoria, shall give the necessary directions herein accordingly.

C. W. KINSMAN,  
Clerk of the Executive Council.

## DEPARTMENT OF LANDS AND SURVEY.

At the Executive Council Chamber, Melbourne, the  
twentieth day of January, 1948.

## PRESENT:

The Lieutenant-Governor, as Deputy for His  
Excellency the Governor of Victoria.  
Mr. Dodgshun | Mr. Kennedy.

## LAND PERMANENTLY RESERVED.

**T**HE Lieutenant-Governor, as Deputy for His Excellency the Governor of the State of Victoria, by and with the advice of the Executive Council thereof, doth hereby, in pursuance of the provisions of the *Land Act 1928*, permanently reserve and except from occupation for mining purposes under any miner's right, the land hereinafter referred to, viz.:—

Township and Parish of Wonthaggi, as a site for Municipal purposes, 3 roods 10 3/10 perches of land, comprised within the boundaries as defined by technical description published in the *Government Gazette* of 17th December, 1947.—(Rs.6085.)

And the Honorable John Gladstone Black McDonald, His Majesty's Commissioner of Crown Lands and Survey for the State of Victoria, shall give the necessary directions herein accordingly.

C. W. KINSMAN,  
Clerk of the Executive Council.

## COUNTRY ROADS BOARD.

At the Executive Council Chamber, Melbourne, the  
twentieth day of January, 1948.

## PRESENT:

The Lieutenant-Governor, as Deputy for His Excellency the Governor of Victoria.  
Mr. Dodgshun | Mr. Kennedy.

## DECLARATION OF THE WARRACKNABEAL—RAINBOW ROAD IN THE SHIRES OF DIMBOOLA AND WARRACKNABEAL.

**W**HEREAS by the Resolution set out below and dated the twelfth day of January One thousand nine hundred and forty-eight the Country Roads Board incorporated under the *Country Roads Act 1928* (No. 3662) being of opinion that the highway in the State of Victoria set out or described in the Schedule to the same is of sufficient importance to be a main road and acting under the powers in that behalf conferred upon it by the said Act declared such highway to be a main road within the meaning and for the purposes of the Act aforesaid: And whereas the said Act amongst other things provides that the Governor in Council may by Order published in the *Government Gazette* confirm such Resolution whereupon any road mentioned in such Resolution shall be a main road: And whereas it is deemed desirable to confirm the Resolution so made and passed by the said Country Roads Board: Now therefore the Lieutenant-Governor as Deputy for His Excellency the Governor of the State of Victoria by and with the advice of the Executive Council thereof doth hereby confirm such Resolution and declare upon the publication of this Order in the *Government Gazette* the road mentioned in the Schedule to such Resolution of the Country Roads Board a main road within the meaning and for the purposes of the *Country Roads Act 1928*.

## Resolution for Declaration of a Main Road under the Country Roads Act.

The Country Roads Board incorporated under the *Country Roads Act 1928* (No. 3662) at a meeting now holden being of opinion that the highway within the State of Victoria set out or described in the Schedule hereunder written is of sufficient importance to be a main road acting under the powers conferred upon it by the said Act doth by this Resolution hereby declare such highway to be a main road within the meaning and for the purposes of the said *Country Roads Act 1928*.

## SCHEDULE.

## Shire of Dimboola.

10. *Warracknabeal-Rainbow road* (4610).—Commencing at the north-western angle of allotment 6, Parish of Joop, on the eastern boundary of the shire; thence westerly to the south-eastern angle of allotment 36, Parish of Wirmbool; thence northerly, westerly, and northerly to its junction with the *Rainbow-Beulah-Birchip road* at the north-eastern angle of allotment 13 of the parish last named.

**NOTE.**—The route of the portion of this road between the Shires of Dimboola and Warracknabeal is set out in the description of the road route in the Shire of Warracknabeal.

## Shire of Warracknabeal.

4. *Warracknabeal-Rainbow road* (17204).—Commencing at its junction with the *Hopetoun-road* at a point on the southern boundary of allotment 1, Parish of Werrigar, distant 89 deg. 52 min. 22.7 links from the south-western angle of the said allotment; thence north-westerly through that allotment to the western boundary thereof (S.P. 809); thence northerly, north-westerly, and westerly to a point on the eastern boundary of allotment 2 of the said parish, distant 55 links from the north-eastern angle thereof; thence westerly through that allotment, north-westerly through allotment 25 of the said parish, northerly through allotments 24, 22, 20, and 130, northerly, north-westerly, and westerly through allotment 129, north-westerly through allotment 161A, and northerly, north-westerly, and westerly through allotment 136 of the said parish to the western boundary of the allotment last named (S.P.'s 527, 482, 483, 484, 485, 3453, 3454, 3455, and 3456); thence westerly to and through allotment 165, Parish of Cannum, and north-westerly across a Government road and through allotments 81A, 73A, 73B, and 71, Parish of Yellangip, to the northern boundary of the allotment last named (S.P.'s 3457, 3458, 3459, and 3460); thence north-westerly and northerly to the north-eastern angle of allotment 2, Parish of Willenabrina; thence westerly and northerly to the north-eastern angle of allotment 58 of the parish last named on the northern boundary of the shire; thence westerly along the boundary between the Shires of Warracknabeal and Dimboola to the north-western angle of allotment 6, Parish of Joop, at the north-western angle of the Shire of Warracknabeal.

**NOTE.**—Portion of the above description is in lieu of the description of the *Rainbow-road* published in the *Government Gazette* of 9th April, 1915, on page 1314, and amended in the *Government Gazette* of 5th July, 1916, on page 2425.

The common seal of the Country Roads Board was hereto affixed, at Melbourne, this fifteenth day of January, One thousand nine hundred and forty-eight, in the presence of—

(SEAL) W. L. DALE, Chairman.  
F. M. CORRIGAN, Member.  
R. JANSEN, Secretary.

And the Honorable James Arthur Kennedy, His Majesty's Commissioner of Public Works for the State of Victoria, shall give the necessary directions herein accordingly.

C. W. KINSMAN,  
Clerk of the Executive Council.

## THE CONSTITUTION ACT AMENDMENT ACTS.

At the Executive Council Chamber, Melbourne, the  
twentieth day of January, 1948.

## PRESENT:

The Lieutenant-Governor, as Deputy for His Excellency the Governor of Victoria.  
Mr. Dodgshun | Mr. Kennedy.

## REVOCATION OF APPOINTMENT OF A POLLING PLACE FOR THE ELECTORAL DISTRICT OF IVANHOE.

**I**N pursuance of the provisions contained in The Constitution Act Amendment Acts, the Lieutenant-Governor, as Deputy for His Excellency the Governor of the State of Victoria, by and with the advice of the Executive Council thereof, doth hereby revoke the appointment of the under-mentioned polling place:—

LARUNDEL  
as a Polling Place within and for the Preston East Subdivision of the Electoral District of Ivanhoe.

And the Honorable Keith Dodgshun, His Majesty's Chief Secretary for the State of Victoria, shall give the necessary directions herein accordingly.

C. W. KINSMAN,  
Clerk of the Executive Council.



## AVOCA TOWNSHIP WATERWORKS TRUST.

*At the Executive Council Chamber, Melbourne, the twentieth day of January, 1948.*

PRESENT:

The Lieutenant-Governor, as Deputy for His Excellency the Governor of Victoria.

Mr. Dodgshun | Mr. Kennedy.

## ADDITIONAL LOAN OF £7,000.

UNDER the powers conferred by the Water Acts and all other powers enabling him in that behalf, the Lieutenant-Governor, as Deputy for His Excellency the Governor of the State of Victoria, by and with the advice of the Executive Council of the said State, doth hereby grant an additional loan of Seven thousand pounds (£7,000) to the Avoca Township Waterworks Trust for the enlargement of reservoirs and for new mains, as set forth in the detailed statement bearing the date the 14th January, 1948, and verified under the seal of the State Rivers and Water Supply Commission.

The loan hereby granted shall be subject to the provisions of the Water Acts.

And the Honorable John Gladstone Black McDonald, His Majesty's Minister of Water Supply for the State of Victoria, shall give the necessary directions herein accordingly.

C. W. KINSMAN,  
Clerk of the Executive Council.

## BENALLA WATERWORKS TRUST.

*At the Executive Council Chamber, Melbourne, the twentieth day of January, 1948.*

PRESENT:

The Lieutenant-Governor, as Deputy for His Excellency the Governor of Victoria.

Mr. Dodgshun | Mr. Kennedy.

## AMENDMENT OF ORDER FIXING THE LIMIT OF THE OVERDRAFT TO BE OBTAINED BY THE BENALLA WATERWORKS TRUST.

UNDER the powers conferred by the Water Acts and all other powers enabling him in that behalf, the Lieutenant-Governor, as Deputy for His Excellency the Governor of the State of Victoria, by and with the advice of the Executive Council of the said State, doth hereby amend as follows the Order in Council made on the 23rd day of January, 1945, as amended by Orders in Council made on the 2nd day of October, 1945, and 5th day of November, 1945, and published in the *Government Gazette* dated 24th January, 1945, the 10th October, 1945, and the 14th November, 1945, respectively.

For the expression "at an amount not to exceed at any one time the sum of Two thousand five hundred pounds (£2,500)" there shall be substituted the expression "at an amount not to exceed at any one time the sum of Ten thousand pounds (£10,000)."

And the Honorable John Gladstone Black McDonald, His Majesty's Minister of Water Supply for the State of Victoria, shall give the necessary directions herein accordingly.

C. W. KINSMAN,  
Clerk of the Executive Council.

## HAMILTON WATERWORKS TRUST.

*At the Executive Council Chamber, Melbourne, the twentieth day of January, 1948.*

PRESENT:

The Lieutenant-Governor, as Deputy for His Excellency the Governor of Victoria.

Mr. Dodgshun | Mr. Kennedy.

## ADDITIONAL LOAN OF £12,300.

UNDER the powers conferred by the Water Acts and all other powers enabling him in that behalf, the Lieutenant-Governor, as Deputy for His Excellency the Governor of the State of Victoria, by and with the advice of the Executive Council of the said State, doth hereby grant an additional loan of Twelve thousand three

hundred pounds (£12,300) to the Hamilton Waterworks Trust for construction of an additional storage reservoir and purchase of meters, as set forth in the detailed statement bearing date the 14th January, 1948, and verified under the seal of the State Rivers and Water Supply Commission.

The loan hereby granted shall be subject to the provisions of the Water Acts.

And the Honorable John Gladstone Black McDonald, His Majesty's Minister of Water Supply for the State of Victoria, shall give the necessary directions herein accordingly.

C. W. KINSMAN,  
Clerk of the Executive Council.

## APPROACHING LAND SALES.

SALES of Crown lands, in fee-simple, will be held at the under-mentioned places and dates, viz.:-

	No. of Gazette.
Ballarat.—Tuesday, 17th February, 1948	9
Benalla.—Tuesday, 17th February, 1948	9
Kyabram.—Thursday, 26th February, 1948	19
Leongatha.—Wednesday, 3rd March, 1948	20
Portland.—Thursday, 26th February, 1948	20
Sale.—Friday, 20th February, 1948	19
Stanhope.—Thursday, 26th February, 1948	19
Tatura.—Thursday, 26th February, 1948	19
Tongala.—Thursday, 26th February, 1948	19
Warracknabeal.—Thursday, 26th February, 1948	19
Yarrowonga.—Thursday, 19th February, 1948	20

## SALES BY AUCTION.

The lands will be sold in fee-simple, and subject to the covenants, conditions, exceptions, and reservations directed by the Governor in Council by an Order in Council dated the 5th August, 1930, and published in the *Government Gazette* of the 8th August, 1930, varied as herein.

A deposit of at least twelve and a half per centum of the price at which each lot is sold must be paid by the purchaser at the time of sale, and all such payments shall be made in bank notes or cheques approved by the officer conducting the sale, and the residue of such price will be payable in equal instalments, in accordance with the scale hereunder, on the last day of each successive period of six months from the time of sale, or, if the purchaser choose, at any earlier time or times; such residue of the price shall bear interest at the rate of 5 per centum per annum, to be computed between the time of sale and the time when payment of such residue or instalment of such residue is made. If the residue of the price be paid within thirty days after the time of the sale no interest will be payable thereon.

The Governor in Council may allow a transfer of the purchaser's interest to an approved person at any time before the final payment of the purchase money is made. The fee for transfer shall be One pound, and such transfer will be subject to payment of stamp duty.

## SCALE OF PAYMENTS OF RESIDUE.

£20 and under, 6 instalments.
Over £20, and not exceeding £50, 8 instalments.
Over £50, and not exceeding £100, 10 instalments.
Over £100, and not exceeding £200, 12 instalments.
Over £200, and not exceeding £300, 14 instalments.
Over £300, and not exceeding £400, 16 instalments.
Over £400, and not exceeding £500, 18 instalments.
Over £500, 20 instalments.

## FEES, ETC.

The fees payable for Crown grant and assurance (One halfpenny for each pound of purchase price) must be paid with the balance of purchase money. The following is the scale:—

50 acres and under, £1 10s.

Over 50 acres, £2.

Where the purchase money does not exceed £5, the grant fee is £1.

Valuations of improvements (if not purchased by the owner thereof) and charges for survey, must also be paid at the time of sale.

J. G. B. McDONALD,  
Commissioner of Crown Lands and Survey.

Office of Lands and Survey,  
Melbourne, 23rd January, 1948.

**PORTLAND.**—Sale (No. 10648) of Crown lands, in fee-simple, by auction, will be held at the COURT HOUSE, PORTLAND, on THURSDAY, the 26th FEBRUARY, 1948, at THREE o'clock p.m. To be conducted by H. E. MICHELL, Land Officer, Hamilton.

PORTLAND, PARISH OF PORTLAND, COUNTY OF NORMANBY.  
*Fronting Townsend-street.*

Upset price £40 per lot. Charge for survey £3 per lot.  
Lot 1. Area 34 5/10 perches (subject to survey), allotment 2 of section 24B.  
Lot 2. Area 34 5/10 perches (subject to survey), allotment 6 of section 24B.

*Fronting Kennedy-street.*

Upset price £350 the lot. Charge for survey £10 10s.  
Lot 3. Area 2a. 0r. 27p. (subject to survey), allotment 10 of section 23A.

MACARTHUR, PARISH OF MACARTHUR, COUNTY OF NORMANBY.  
*Being the South-east portion of the Departmental Reserve with a Frontage of 50 feet to Heckfield-street, and a depth of 90 feet, approximately.*

Upset price £50 the lot. Charge for survey £6 6s.  
Lot 4. Area 17 perches (subject to survey), allotment 4A of section 2. Valuation of improvements (fencing) £3 (Crown). The purchaser will be required to remove the gates and re-erect them to provide access to the Court House site.

PARISH OF TREWALLA, COUNTY OF NORMANBY.

*In North-east of Parish, about 4 miles from Portland.*

Upset price £1 per acre. Charge for survey £12.  
Lot 5. Area 32a. 3r. 21p. (subject to survey), allotment 3A of section 11.

**LEONGATHA.**—Sale (No. 10649) of Crown lands, in fee-simple, by auction, will be held at the COURT HOUSE, LEONGATHA, on WEDNESDAY, the 3rd MARCH, 1948, at ONE o'clock p.m. To be conducted by C. E. RICE, Land Officer, Melbourne.

KOONWARRA, PARISH OF LEONGATHA, COUNTY OF BULN BULN.  
*In South-west of Township.*

Upset price £38 the lot. Charge for survey £4 12s. 6d.  
Lot 1. Area 18a. 3r. 39p., allotment 22 of section 2.

*In West of Township.*

Upset price £26 the lot. Charge for survey £3 15s.  
Lot 2. Area 6a. 1r. 12p., allotment 10 of section 2.  
Upset price £22 the lot. Charge for survey £3 15s.  
Lot 3. Area 5a. 1r. 33p., allotment 12 of section 2.  
Upset price £9 the lot. Charge for survey £3 2s. 6d.  
Lot 4. Area 2a. 0r. 36 7/10p., allotment 13 of section 2.  
Upset price £12 the lot. Charge for survey £3 2s. 6d.  
Lot 5. Area 2a. 3r. 7 5/10p., allotment 14 of section 2.

MIRBOO NORTH, PARISH OF MIRBOO, COUNTY OF BULN BULN.  
*In Centre of Township.*

Upset price £7 the lot. Charge for survey £3 15s.  
Lot 6. Area 1a. 3r. 6p., allotment 5 of section 7. One month allowed to remove improvements (fencing).

MEENIYAN, PARISH OF NERRENA, COUNTY OF BULN BULN.  
*About 1/2 mile South of Meeniyon Railway Station.*

Upset price £7 per lot. Charge for survey £2 2s. per lot.  
Lot 7. Area 3r. 8 3/10p., allotment 24 of section 5.  
Lot 8. Area 3r. 8p., allotment 25 of section 5.  
Lot 9. Area 3r. 8p., allotment 26 of section 5.

PARISH OF KORUMBURRA, COUNTY OF BULN BULN.  
*About 2 miles South-east of Kardella Railway Station.*

Upset price £44 the lot. Charge for survey £7 7s.  
Lot 10. Area 5a. 1r. 32p. (subject to adjustment after survey), allotment 33A of section 1. Sold to a depth of 30 feet only. Valuation of improvements £45 (A. E. Wynne).

PARISH OF DRUMBLEMARA, COUNTY OF BULN BULN.  
*In South of Parish, former gravel reserve.*

Upset price £7 the lot. Charge for survey £3 5s.  
Lot 11. Area 3a. 0r. 24p., allotment 83A. One month allowed to remove fencing on road frontage.

PARISH OF DUMBALK, COUNTY OF BULN BULN.  
*About 7 miles North-east of Meeniyon Railway Station.*

Upset price £60 the lot. Charge for survey £8 5s.  
Lot 12. Area 20a. 2r. 15p. (subject to adjustment after survey), allotment 94B.

*Closer Settlement Act 1938.*

SALE BY AUCTION.

**YARRAWONGA.**—A sale of the under-mentioned land, in fee-simple, by auction, will be held at the LAND INSPECTOR'S OFFICE, YARRAWONGA, on THURSDAY, the 19th FEBRUARY, 1948, at half-past TWO o'clock p.m. To be conducted by W. EDMENDS, Lands Department, Melbourne.

TERMS AND CONDITIONS.

Deposit to be paid at sale, 20 per cent. of purchase price. Balance payable by forty equal half-yearly instalments, with interest computed at the rate of 4 1/2 per cent. per annum on the unpaid balance.

The Board of Land and Works may allow a transfer of the purchaser's interests to an approved person at any time before the final payment is made (fee, £1). The registration of the transfer may be subject to payment of such further sum as the Board may require in reduction of the outstanding balance.

Purchaser may pay balance and fees at any time prior to the due date.

Crown grant will be prepared and issued as soon as practicable after payment of purchase money in full.

Improvements to be maintained and insured with the Board of Land and Works.

JOHN G. B. McDONALD,  
Commissioner of Crown Lands and Survey.

Melbourne, 23rd January, 1948.

PARISH OF BOOSEY, COUNTY OF MOIRA.

*7 miles from Katamatite Railway Station.*

Recently leased to P. G. O'Dwyer.

Area 312 acres, allotment 111. Improvements included in sale are house, outbuildings, windmill frame, and fencing.

PROPOSED REVOCATIONS OF TEMPORARY RESERVATIONS OF LANDS BY ORDERS IN COUNCIL.

IN pursuance of the provisions of the Land Act 1928, notice is hereby given that it is the intention of the Governor in Council to revoke the temporary reservations of lands by Orders in Council hereunder referred to, viz.:

*The following Notices were published 1° on the 21st January, 1948, pursuant to Orders of the 13th January, 1948.*

CLUB TERRACE.—The Order in Council of the 24th April, 1899, temporarily reserving 1 rood 39 4/10 perches of land as a site for Public purposes in the Township of Club Terrace, being allotment 6 of section 3, is about to be revoked.—(C.457(1) (Rs.4718).

MALMSBURY.—The Order in Council of the 19th October, 1937, temporarily reserving 1 acre 3 roods 23 1/10 perches of land in the Town of Malmsbury as a site for Police purposes is about to be revoked so far only as regards the portion indicated by hachure on plan hereunder.—(M.65(4) (Rs.4717).

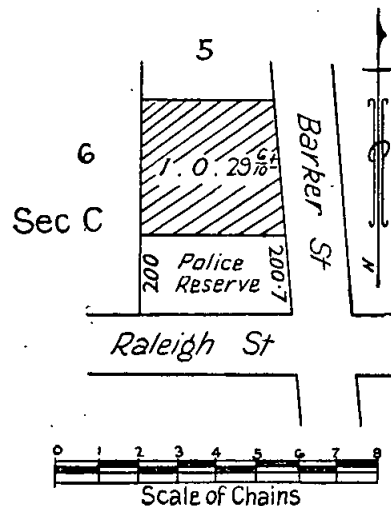

MAMENGOROOCK.—The Order in Council of the 13th July, 1925, temporarily reserving a site for Public purposes 4,617 acres, more or less, of land in the Parish of Mamen-gorooch, is about to be revoked so far only as regards the portion containing 48 acres, more or less, indicated by hachure on plan hereunder.—(M.578(\*) (Rs.3144).

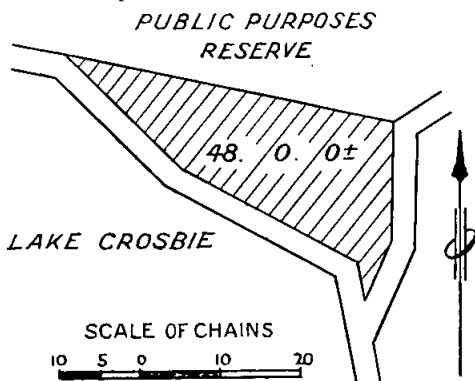

MOKOAN.—The Order in Council of the 15th May, 1888 (see *Government Gazette* of the 18th May, 1888, page 1509), temporarily reserving 27 acres 2 roods 25 perches of land as a site for Water Supply purposes in the Parish of Mokoan, is about to be revoked.—(M.463(\*) (H.018741).

HAMILTON.—The Order in Council of the 20th December, 1872, temporarily reserving 3 roods 22½ perches of land in the Town of Hamilton, being portion of section 11, as a site for Police purposes, is about to be revoked so far only as regards the portion indicated by hachure on plan hereunder.—(H.45(\*) (Rs.359).

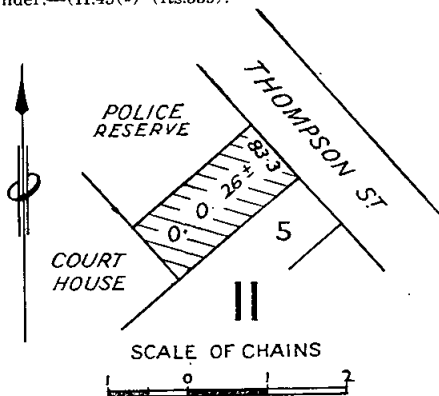

SANDHURST.—The Order in Council of the 9th August, 1881 (see *Government Gazette* of the 12th August, 1881, page 2338), temporarily reserving as a site for Rifle ranges, and withholding from sale, leasing, and licensing 15 acres of land in the Parish of Sandhurst, revoked as to part by Order of the 4th December, 1929 (see *Government Gazette* of the 11th December, 1929, page 4172), is about to be further revoked as regards the balance thereof containing 5 acres 1 rood 19 perches.—(S.371(\*) (W.61186).

WITCHPOOL.—The Order in Council of the 27th February, 1865 (see *Government Gazette*, 7th March, 1865, page 571), temporarily reserving 1 acre of land, more or less, at Banyenong West, now Parish of Witchpool, as a site for Presbyterian Church purposes, is about to be revoked.—(W.299(\*) (C.91028).

JOHN G. B. McDONALD,  
Commissioner of Crown Lands and Survey.

**PROPOSED REVOCATION OF TEMPORARY  
RESERVATION OF LAND BY ORDER IN COUNCIL.**

IN pursuance of the provisions of the *Land Act* 1928, notice is hereby given that it is the intention of the Governor in Council to revoke the temporary reservation of land by Order in Council hereunder referred to, viz.:—*The following Notice was published 1<sup>o</sup> on the 28th January, 1948, pursuant to Order of the 20th January, 1948.*

BEULAH.—The Order in Council of the 6th June, 1893, temporarily reserving 2 roods of land in the Township of Beulah as a site for Police purposes, revoked as to part by Order of the 28th January, 1910, is about to be further revoked so far as regards the balance thereof, containing 1 rood.—(B.729(\*) (Rs.6020).

JOHN G. B. McDONALD,  
Commissioner of Crown Lands and Survey.

**PUBLIC HEARINGS BY PERSONS APPOINTED  
UNDER THE 34TH SECTION OF THE LAND ACT  
1928.**

NOTICE is hereby given that at the times and places mentioned in the Schedule hereunder, applications for leases and licences under the Land Acts, objections to such applications, objections to proposed proclamations, alterations, additions, diminutions, revocations, or unions of commons, and reasons against forfeiture of any leases or licences under the Land Acts deemed liable to forfeiture, will be publicly heard by the persons whose names are set opposite such places respectively in such Schedule, being persons appointed by me, the responsible Minister of the Crown administering the Land Acts, to hear the same and report thereon in writing to me.

JOHN G. B. McDONALD,  
Commissioner of Crown Lands and Survey.

Department of Lands and Survey,  
Melbourne, 28th January, 1948.

SCHEDULE.

LAND INSPECTOR'S OFFICE, PORTLAND, Thursday, 26th February, 1948, at 9 a.m.—H. E. Michell, Land Officer.

LAND OFFICE, HAMILTON, Friday, 20th February, 1948, at 9 a.m.—H. E. Michell, Land Officer.

**HEARING OF REASONS AGAINST THE FORFEITURE  
OF CERTAIN LICENCES AND LEASES BY A  
PERSON APPOINTED UNDER 34TH SECTION OF  
THE LAND ACT 1928.**

NOTICE is hereby given that reasons against the forfeiture of the licences and leases in the Schedule hereto, which are deemed liable to forfeiture under the provisions of the Land Acts, will be publicly heard by the person appointed by me, the responsible Minister of the Crown administering the said Acts, to hear the same and report thereon in writing to me, when the person in the said Schedule mentioned as the holder of such licences and leases will be allowed to show cause against the same at the place and on the date mentioned in the Schedule hereto.

JOHN G. B. McDONALD,  
Commissioner of Crown Lands and Survey.

Department of Lands and Survey,  
Melbourne, 28th January, 1948.

SCHEDULE.

LAND OFFICE, HAMILTON, Friday, 20th February.—  
H. E. Michell—

404/44, J. Edge, 81 acres, Winyayung.

**HEARING OF REASONS AGAINST THE FORFEITURE  
OF CERTAIN LICENCES AND LEASES BY A PERSON  
APPOINTED UNDER 34TH SECTION OF THE LAND  
ACT 1928.**

NOTICE is hereby given that reasons against the forfeiture of the licences and leases in the Schedule hereto, which are deemed liable to forfeiture under the provisions of the Land Acts, will be publicly heard by the person appointed by me, the responsible Minister of the Crown administering the said Acts, to hear the same and report thereon in writing to me, when the persons in the said Schedule mentioned as holders of such licences and leases will be allowed to show cause against the same at the place and on the date mentioned in the Schedule hereto.

JOHN G. B. McDONALD,  
Commissioner of Crown Lands and Survey.

Department of Lands and Survey,  
Melbourne, 28th January, 1948.

SCHEDULE.

LAND INSPECTOR'S OFFICE, COBDEN, 11th February, 1948, at 1 p.m., A. L. Reah, Land Officer—

262/44, J. A. Knight, 150a. 0r. 1p., Coradjil; 302/44,  
J. Fenton, 243a. 2r. 13p., Cooriejong.

LIST OF CROWN LANDS AVAILABLE.

THE under-mentioned areas are available for application as provided by various sections of the Land Act 1928, and all applications received on or before Wednesday, 25th February, 1948, will be deemed to have been simultaneously made, but any application lodged after such date may be considered if received in time for inclusion in the advertisement of the cases to be heard at the Local Land Board. Applications on proper form, accompanied by 5s. duty stamp uncancelled (registration fee), may be delivered or forwarded by post to the Local Land Officer or to any Crown Lands Office in Victoria. Applicants may obtain from Local Land Officers, or the Enquiry Office, Lands Department, Melbourne, a certificate authorizing the issue by the Railway Department of a return ticket at concession fares to enable them to inspect available areas or to attend Local Land Boards. When an applicant is granted an allotment he may, if travelling by rail, obtain reduced fares for his family and also freight concessions in regard to some of his effects.

Subject to the approval of the Minister, when the survey fee exceeds £10, a deposit of £5 may be paid, and the balance over six years in half-yearly instalments.

Marked plans of any particular area, application forms, and any further information may be obtained from the Enquiry Office, Lands Department, Melbourne, and Land Officers, St. Arnaud and Stawell.

Department of Crown Lands and Survey, Melbourne, 28th January, 1948.

JOHN G. B. McDONALD,

Commissioner of Crown Lands and Survey.

\* Improvements may be subject to re-valuation after land has been granted to an applicant.

Local Land Office.	County.	Parish.	Allotment.	Section.	Area.	How available.			Valuation of Improvements (if any).	Location of Land, &c.	Nearest Railway Station or Township and Distance in miles therefrom.	How accessible.	Water supply.	General Description of Land—Soil, Timber, Suitability (Grazing, &c.)
						(Classification)	Value per Acre.	Survey Fee.						
						A.	B.	P.	£	s.	d.			
St. Arnaud (a)	Talbot	Amherst	12r	9A	9 0 5	1st	2 0 0	3 15 0	0	In east of parish and east of Ballarat-Maryborough railway line	Daisy Hill, 1 mile	By road	To be conserved	Soil poor and gravelly, with some fair loam in the gully; scattered grey and yellow box timber; suitable for residence and poultry farming. (W.59063)
						2nd	0 10 0	0 10 0	0					
St. Arnaud	Karkaroc	Patches-woollock	52A	..	44 2 5	3rd	0 10 0	0 10 0	0	In south of parish	Willia R.S., 1½ mile	By road	To be conserved	Light sandy loam; Mallee; suitable for grazing. (05938/198.)
						4th	0 10 0	0 10 0	0					
Bendigo (b, c)	Bendigo	Sandhurst, City of Bendigo	493b	A	0 1 0	Garden or Residence	Annual rental to be fixed.	3 2 6	Nil	Fronting the south side of Creoth-street	Bendigo, 2 miles	By road	To be conserved	Low-lying, broken ground; suitable for garden or residence. (W.63688)
						Dwelling.	..	..	..					
Stawell (b)	Borong	Township and Parish of Stawell	10	5	0 0 34	Dwelling.	..	3 0 0	0	Formerly part of a reserve for police purposes, fronting Longfield-street	Stawell, about ¾ mile	By road	To be conserved	Suitable for a dwelling. (Z.28409)
						..	..	..	..					
Stawell (b)	Borong	Township and Parish of Stawell	11	5	0 0 34	..	..	3 0 0	0	Formerly part of a reserve for police purposes, fronting Longfield-street	Stawell, about ¾ mile	By road	To be conserved	Suitable for a dwelling. (Z.28409)
						..	..	..	..					

AGRICULTURAL AND GRAZING LANDS—SELECTION PURCHASE ALLOTMENTS.

DIVISION 4, PART I, LAND ACT 1928.

DIVISION 1, PART II, LAND ACT 1928 (MALLEE LANDS).

AVAILABLE UNDER SECTION 129, LAND ACT 1928.

LIST OF CROWN LANDS AVAILABLE—continued.

\* Improvements may be subject to re-valuation after land has been granted to an applicant.

Local Land Office.	County.	Parish.	Allotment.	Section.	Area.	How available.		Valuation of improvement (if any).	Location of Land, &c.	Nearest Railway Station or Township and Distance in miles therefrom.	How accessible.	Water Supply.	General Description of Land—Bod. Timber. Suitability (Grassg. &c.)
						Classification.	Value per Acre.						
AVAILABLE UNDER SECTION 129, LAND ACT 1928—continued.													
£ s. d.													
Stawell (b)	Rorung ..	Township and Parish of Stawell	12	5	0 0 34	Dwelling	Annual rental to be fixed.	3 0 0	Formerly part of a reserve for police purposes, fronting Longfold-street	Stawell, about 3/4 mile	By road ..	To be con-served	Suitable for a dwelling. (Z.28409)
Stawell (b)	Rorung ..	Borough and Parish of Stawell	21	94	0 1 9	..	..	3 0 0	Corner of Little Rickard and Henderson streets	Stawell R.S., about 1 1/4 mile	By road ..	To be con-served	Suitable for a dwelling. (Z.28791)
Stawell (b)	Rorung ..	Township and Parish of Stawell	16	D	1 3 0	..	..	3 0 0	Near junction of Sloane-street and C.R.B. road	Stawell, about 1 mile	By road ..	To be con-served	Suitable for a dwelling. (Z.27164)
Stawell (b)	Rorung ..	Township and Parish of Stawell	17	D	2 0 0	..	..	3 0 0	Near junction of Sloane-street and C.R.B. road	Stawell, about 1 mile	By road ..	To be con-served	Suitable for a dwelling. (Z.27164)
Stawell (b)	Rorung ..	Township and Parish of Stawell	18	D	2 1 0	..	..	3 0 0	Near junction of Sloane-street and C.R.B. road	Stawell, about 1 mile	By road ..	To be con-served	Suitable for a dwelling. (Z.27164)
Stawell (c)	Rorung ..	Township and Parish of Stawell	19	D	2 1 0	..	..	3 0 0	Near junction of Sloane-street and C.R.B. road	Stawell, about 1 mile	By road ..	To be con-served	Suitable for a dwelling. (Z.27164)
Stawell (b)	Rorung ..	Township and Parish of Stawell	20	D	1 3 0	..	..	3 0 0	Near junction of Sloane-street and C.R.B. road	Stawell, about 1 mile	By road ..	To be con-served	Suitable for a dwelling. (Z.27164)

(a) Subject to mining condition.—(b) Subject to survey.—(c) Subject to race and pipe-line easements.

LAND AVAILABLE UNDER THE SOLDIER SETTLEMENT ACTS.

NOTIFICATION is hereby given, in accordance with section 16 of the *Soldier Settlement Act 1946*, that the undermentioned lots are available or are about to become available for settlement. Any discharged soldier who has applied to the Commission on or before the 28th day of January, 1948, for classification in the required class or classes of primary production for which the lots are made available and whose application has not been finalized, or any discharged soldier who has been classified as suitable in such class or classes of primary production, may apply on the proper form for settlement on any lot or lots, indicating, where he applies in respect of more than one lot, his order of preference therefor. Application forms, plans, and further particulars may be obtained from the Enquiry Branch, Soldier Settlement Commission, State Public Offices, Melbourne, at which office completed applications for settlement should be lodged on or before the 1st March, 1948.

E. SINGLETON,  
Secretary.

Soldier Settlement Commission,  
Melbourne, 23rd January, 1948.

SCHEDULE OF ALLOTMENTS.  
PORTION OF "NORTH STATION" ESTATE.  
PARISH OF TOORAK.—COUNTY OF HAMPDEN.  
*Suitable for Grazing (Sheep) and Some Mixed Farming.*

Lot Number on Plan of Subdivision.	Approximate Area in Acres (Subject to Survey).
1	710
2	609
3	610
4	594
5	594
6	598
7	582
8	689
9	661

"CHAMALLAK" ESTATE.  
PARISH OF KOLORA.—COUNTY OF HAMPDEN.  
*Suitable for Dairying and Mixed Farming.*

Lot Number on Plan of Subdivision.	Approximate Area in Acres (Subject to Survey).
1	350
2	325
3	315
4	315
5	245
6	250
7	255

PORTION OF "LARRA" ESTATE.  
PARISHES OF GEELENGLA AND ETRICK.—COUNTY OF HAMPDEN.  
*Suitable for Dairying and Mixed Farming.*

Lot Number on Plan of Subdivision.	Approximate Area in Acres (Subject to Survey).
12	422
13	424
14	420

TENDERS.

TENDERS will be received at this office until TEN A.M. on the days and for the purposes under mentioned. Particulars may be learnt at this office, and also at the offices named in each instance. The Board of Land and Works will not necessarily accept the lowest or any tender. Plans and Specifications will not be shown at school buildings from the 19th December, 1947, to the 3rd February, 1948.

3rd February, 1948.

Ballarat.—Supply and installation of central heating system, Teachers' College Hostel. Particulars at Inspector of Works Office, Ballarat. Preliminary deposit, £10. Final deposit, 2 per cent.

Barmah.—Repairs, renovations and new wood shed, school and residence, State School No. 3260. Particulars at Inspector of Works Office, Shepparton; Police Stations, Echuca, Numurkah. Preliminary deposit, £5. Final deposit, 2 per cent.

Bendigo.—Erection of four (4) residences in brick or brick veneer, Country Roads Board, Lansell-street. Particulars at Inspector of Works Office, Bendigo. Preliminary deposit, £50. Final deposit, 2 per cent.

Brunswick North-west.—Provision of cupboards and display boards, State School No. 4399. Deposit, £5.

Caldermeade.—Erection and completion of teacher's residence, State School No. 4271. Particulars at Police Station, Dandenong. Preliminary deposit, £15. Final deposit, 2 per cent.

Carlton.—Extensions to central heating system, Country Roads Board, Exhibition Building. Preliminary deposit, £20. Final deposit, 2 per cent.

Cohuna.—Removal of school buildings from State School No. 4137, Daltons Bridge, State School No. 3904, Keely, State School No. 1829, McMillans, State School No. 3844, Cohuna Estate, State School No. 2993, Horfield, State School No. 1959, Gannawarra, and re-erection, State School No. 2502. Particulars at Inspector of Works Office, Bendigo; Police Stations, Echuca, Elmore, Kerang. Preliminary deposit, £15. Final deposit, 2 per cent.

Corryong.—Additional accommodation, repairs and painting to existing buildings, Court House. Particulars at Inspector of Works Office, Wangaratta; Police Stations, Corryong, Tallangatta, Wodonga. Preliminary deposit, £5. Final deposit, 2 per cent.

Deepdene.—Re-erection of hutment, State School No. 3680. Deposit, £3.

Geelong.—Supply and installation of electric hot-water service in Senior Warder's Quarters, Gaol. Particulars at Inspector of Works Office, Geelong. Deposit, £2.

Golden Point.—Alterations to classrooms and heating of classrooms, State School No. 1493. Particulars at Inspector of Works Office, Ballarat. Deposit, £4.

Kew.—Provision of bathroom at staff quarters, Mental Hospital. Preliminary deposit, £4. Final deposit, 2 per cent.

Lake Tyers.—Additions to staff cottage, Aboriginal Station. Particulars at Inspector of Works Office, Bairnsdale; Police Station, Orbost; Aboriginal Station, Lake Tyers. Preliminary deposit, £10. Final deposit, 2 per cent.

Mansfield.—Repairs and painting, &c., Police Station. Particulars at Inspector of Works Office, Benalla; Police Stations, Euroa, Mansfield, Seymour. Preliminary deposit, £5. Final deposit, 2 per cent.

Melbourne.—Replacement of roof, William Angliss Food Trades School. Preliminary deposit, £10. Final deposit, 2 per cent.

Melbourne.—Improved lighting, Public Service Board, State Public Offices. Preliminary deposit, £3. Final deposit, 2 per cent.

Merino.—Repairs, &c., and painting and provision of new out-office, teacher's residence, State School No. 2115. Particulars at Inspector of Works Office, Hamilton; Police Stations, Casterton, Coleraine. Deposit, £4.

Mildura.—Supply and installation of electric hot-water service in teacher's residence, High School. Particulars at Inspectors of Works Offices, Bendigo, Mildura. Deposit, £2.

Mincha West.—Repairs, internal and external painting, State School No. 1931. Particulars at Inspector of Works Office, Bendigo; Police Stations, Echuca, Kerang, Pyramid. Deposit, £3.

Mooney's Estate (near Moyhu).—Erection of two (2) timber-framed residences on Blocks Nos. 1 and 2, Soldier Settlement Commission. Particulars at Inspectors of Works Offices, Benalla, Wangaratta. Preliminary deposit, £20. Final deposit, 2 per cent.

Omeo.—Painting and repairs, Police Station. Particulars at Inspector of Works Office, Bairnsdale; Police Stations, Omeo, Orbost. Preliminary deposit, £5. Final deposit, 2 per cent.

Orbost.—Alterations and additions, repairs and painting, Police Station. Particulars at Inspector of Works Office, Bairnsdale; Police Stations, Bruthen, Orbost. Preliminary deposit, £10. Final deposit, 2 per cent.

Port Fairy.—Repairs and renovations, State School No. 1188. Particulars at Inspector of Works Office, Warrnambool; Police Station, Port Fairy. Preliminary deposit, £5. Final deposit, 2 per cent.

Sorrento.—Painting and repairs, Police Station. Particulars at Police Stations, Frankston, Sorrento. Preliminary deposit, £5. Final deposit, 2 per cent.

Springvale.—Erection of external lavatories, Necropolis. Particulars at Police Stations, Dandenong, Oakleigh; Necropolis, Springvale. Preliminary deposit, £15. Final deposit, 2 per cent.

Sunbury.—Supply and installation of electric hot-water service, Head Attendant's Quarters, Mental Hospital. Deposit, £2.

Sunbury.—Supply and installation of electric hot-water service in Pharmaceutical Chemist's Quarters, Mental Hospital. Deposit, £2.

Sunbury.—New Police Station, Police Station. Particulars at Police Stations, Kilmore, Kyneton, Sunbury. Preliminary deposit, £15. Final deposit, 2 per cent.

Swan Hill.—Repairs and painting, Inspector's Residence. Particulars at Inspector of Works Office, Swan Hill. Deposit, £4.

Toolamba.—Removal of State School No. 2298, Wakiti Creek, re-erection, repairs and painting to both schools, State School No. 1455. Particulars at Inspector of Works Office, Shepparton; Police Stations, Murchison, Tatura. Preliminary deposit, £5. Final deposit, 2 per cent.

Traralgon.—Provision of new cupboard, repairs and painting, &c., State School No. 3584. Particulars at Inspector of Works Office, Bairnsdale; Police Stations, Morwell, Sale, Traralgon. Preliminary deposit, £3. Final deposit, 2 per cent.

Ventnor.—Painting and repairs, State School No. 3895. Particulars at Police Stations, Cowes, Frankston. Deposit, £4.

Warragul.—Infectious Diseases Block, West Gippsland Hospital. Particulars at Inspector of Works Office, Bairnsdale; Police Stations, Moe, Sale, Warragul; West Gippsland Hospital, Warragul. Preliminary deposit, £50. Final deposit, 2 per cent.

Yarragon.—Repairs and renovations, Police Quarters and Office, Police Station. Particulars at Inspector of Works Office, Bairnsdale; Police Stations, Trafalgar, Warragul, Yarragon. Preliminary deposit, £10. Final deposit, 2 per cent.

Yarrowalla and Mologa Estates.—New timber residence (labour only), Soldier Settlement Commission. Particulars at Inspectors of Works Offices, Bendigo, Swan Hill; Police Stations, Echuca, Kerang, Pyramid. Preliminary deposit, £10. Final deposit, 2 per cent.

#### 10th February, 1948.

Eagle Point.—Repairs, painting, &c., State School No. 3215. Particulars at Inspector of Works Office, Bairnsdale; Police Station, Sale. Deposit, £4.

Harrow.—Provision of new sleep-out, new skylight, and repairs and painting, school and residence, State School No. 2049. Particulars at Inspectors of Works Offices, Hamilton, Horsham; Police Stations, Nhill, Stawell; State School, Harrow. Preliminary deposit, £5. Final deposit, 2 per cent.

Marysville.—Restoration of existing classroom, repairs and addition of new classroom, State School No. 1273. Particulars at Police Stations, Healesville, Lilydale. Preliminary deposit, £15. Final deposit, 2 per cent.

Melbourne.—Supply and installation of a ventilating system, Photographic Annexe, 107 Russell-street. Preliminary deposit, £4. Final deposit, 2 per cent.

Melbourne.—Supply and installation of ventilation equipment in new kitchen, Emily McPherson College. Preliminary deposit, £4. Final deposit, 2 per cent.

Pender's Grove (Thornbury).—Provision of window and counter, and new bicycle shed, State School No. 3806. Preliminary deposit, £5. Final deposit, 2 per cent.

Port Campbell.—Repairs and painting, Police Station. Particulars at Inspector of Works Office, Warrnambool; Police Stations, Camperdown, Cobden, Port Campbell. Deposit, £4.

Port Fairy.—Provision of new tile roof, repairs, &c., and painting, Court House. Particulars at Inspector of Works Office, Warrnambool; Police Station, Port Fairy. Preliminary deposit, £10. Final deposit, 2 per cent.

Port Welshpool.—Repairs and painting, State School No. 3375. Particulars at Inspector of Works Office, Korumburra; Police Station, Yarram. Deposit, £4.

Snake Valley.—Painting and repairs to school, teacher's residence, out-offices, and shelter shed, State School No. 574. Particulars at Inspector of Works Office, Ballarat; State School, Snake Valley. Preliminary deposit, £10. Final deposit, 2 per cent.

Stawell.—Supply and installation of electric hot-water service at Rehabilitation Training Unit, Technical School. Particulars at Inspectors of Works Offices, Ballarat, Bendigo, Ararat, Warrnambool. Deposit, £2.

Stawell.—Supply and installation of two (2) solid fuel hot-water services in residences, Pleasant Creek Special School. Particulars at Inspectors of Works Offices, Ararat, Ballarat, Bendigo, Warrnambool. Deposit, £4.

Tyabb.—Repairs, painting, fencing, &c., to school and residence, State School No. 3544. Particulars at Police Stations, Frankston, Mornington, Tyabb. Preliminary deposit, £5. Final deposit, 2 per cent.

Westmere.—Repairs to spouting and verandah floor, provision of a linen cupboard, and new tank and stand, State School No. 3833. Particulars at Inspectors of Works Offices, Ararat, Ballarat, Hamilton; State School, Westmere. Deposit, £4.

Williamstown.—Painting and repairs, Court House. Preliminary deposit, £10. Final deposit, 2 per cent.

Williamstown.—Additional lavatory accommodation, Court House. Preliminary deposit, £4. Final deposit, 2 per cent.

#### 17th February, 1948.

Bairnsdale.—Additional residence and office accommodation, Police Station. (Tenders are invited for sections Nos. 1 and 2 only, at present, comprising No. 1—excavator, concreter, and bricklayer; No. 2—carpenter and joiner). Particulars at Inspector of Works Office, Bairnsdale; Police Stations, Orbost, Sale, Traralgon. Preliminary deposit, £15. Final deposit, 2 per cent. in both cases.

Brunswick.—Repairs and painting, Girls' School. Preliminary deposit, £10. Final deposit, 2 per cent.

Fawkner.—Erection of new brick lavatories, State School No. 3590. Preliminary deposit, £10. Final deposit, 2 per cent.

Footscray.—Installation of forges and the supply and installation of blast air and exhaust ventilation systems, Technical School, Ballarat-road. Preliminary deposit, £4. Final deposit, 2 per cent.

Kew.—Erection of new timber shelter shed, Mental Hospital. Preliminary deposit, £10. Final deposit, 2 per cent.

Mordialloc-Chelsea.—Repairs, painting, &c., High School. Particulars at Police Station, Mordialloc. Deposit, £3.

Sunshine.—Fencing, Technical School. Deposit, £10.

Tongala.—Erection of junior wing, Consolidated School. Particulars at Inspectors of Works Offices, Bendigo, Shepparton; Police Station, Echuca. Preliminary deposit, £25. Final deposit, 2 per cent.

Youarang.—Painting and repairs, State School No. 1923. Particulars at Inspector of Works Office, Benalla; Police Station, Yarrowonga; State School, Youarang. Deposit, £4.

Tenders to be addressed to the Honorable the Commissioner of Public Works, and envelope containing tender marked "Tender for  
due

J. A. KENNEDY,  
Commissioner of Public Works.

Melbourne, 27th January, 1948.

## PRIVATE ADVERTISEMENTS.

### TRARALGON WATERWORKS TRUST.

NOTICE to owners of tenements situated in the following streets, and the private streets, lanes, courts, and alleys opening thereto:—

Moore, Gordon, Byron, Burns, Park-avenue, Anderson, Pax-road, Foxlease, Gilwell, Somers, Mafeking, Chenhall, Ryan, Kay (Old Melbourne), Cumberland, Broadford-court, La Fayette, Garibaldi, Fairview, Cromwell, Neville, Brookes, Dennison, Banks, Swanston, Morrison, Mason, Liddiard's-road.

The main pipe in the above streets being laid down, the owners of all tenements situated as above are hereby required, on or before the 30th of April next, to cause a proper pipe and stop cock to be laid, so as to supply water within such tenements from the main pipe.

JAMES THOMAS RILEY, Chairman,  
Traralgon Waterworks Trust.

**NOTICE OF INTENTION TO APPLY FOR A LICENCE TO DIVERT WATER AND CUT RACES FROM THE LODDON RIVER AT LOWER LODDON, KERANG.**

I HEREBY give notice that I intend to apply for a licence empowering me to divert water for a term of fifteen years to the extent of 130 acre-feet per annum at a maximum rate of 8 acre-feet per day of 24 hours for irrigation purposes, and to occupy certain Crown lands for works of storage and diversion, and to cut a race thereon.

Any objection to such application must be forwarded, in writing, to the State Rivers and Water Supply Commission, Melbourne, within 30 days of the date hereof.

ROBERT JAMES HAMPTON.

Fairley, 12th December, 1947.

3191

**TOWN OF ARARAT.**

**NOTICE OF INTENTION TO BORROW THE SUM OF £3,500 FOR PERMANENT WORKS AND UNDERTAKINGS.**

NOTICE is given that it is the intention of the Council to borrow, on the credit of the Mayor, Councillors, and Burgesses of the Town of Ararat, the sum of £3,500, such sum to be raised by the issue of debentures in accordance with the provisions of the Local Government Act.

1. It is proposed that the rate of interest shall not exceed £3 5s. per cent.

2. That moneys borrowed, together with interest due from time to time, shall be repayable in twenty half-yearly instalments, to be paid on the 1st day of March and the 1st day of September in each year, the first payment to be made on the 1st day of March, 1949.

3. The above instalments will be paid at the E. S. and A. Bank Ltd., Ararat, or the Council's bankers for the time being, in equal half-yearly instalments of the principal and interest.

4. The loan shall be for the purchase of road making plant, additions to hot-water service at municipal abattoirs, and for constructing roads.

Plans and specifications and an estimate of the cost are available for inspection at the Town Hall, Ararat, during office hours.

3206

C. C. MURRAY, Town Clerk.

**BOROUGH OF CLUNES.**

**NOTICE OF INTENTION TO BORROW £750.**

NOTICE is hereby given that the Council of the Borough of Clunes proposes to borrow, on the credit of the Mayor, Councillors, and Burgesses of the Borough of Clunes, the sum of £750, such sum to be raised by the issue of debentures in accordance with the provisions of the Local Government Act 1946.

The rate of interest to be paid shall be Three pounds five shillings per centum per annum. The period of the loan shall be fifteen years. The loan shall be liquidated by providing out of the municipal fund, half-yearly on the 1st day of March and the 1st day of September during the currency of the loan, instalments of principal and interest, commencing on the 1st day of September, 1948. Such moneys shall be repayable at the Union Bank of Australia Limited, Melbourne, or at the Council's bankers for the time being in Melbourne.

The purposes for which the loan is to be applied are—

- Road construction (Fraser-street).
- Construction of kerbs and channels.

The plans, specifications, and estimate of the cost of the above works, and statement showing the proposed expenditure of the money to be borrowed, are open for inspection at the Town Hall, Clunes.

Dated this 12th day of January, 1948.

3198

W. L. MOUNTJOY, Town Clerk.

Dog Act 1936 (No. 4447).

**SHIRE OF LILLYDALE.**

**SHOPPING AREAS.**

TAKE notice that on the 22nd day of December, 1947, the Council of the Shire of Lillydale passed an order specifying the roads or sections of roads set out in the Schedule hereunder to be shopping areas under the above Act, which provides, *inter alia*:—

1. The owner of any dog (other than a dog being used in the droving of stock)—

- (a) which is found in any municipal district in or on any shopping area or bathing beach specified for the purposes of this section by order of the Council of that municipality, published in the Government Gazette and in some newspaper circulating in the municipal district; and

- (b) which is not under the effective control of some person by means of a chain or cord or leash,

shall be liable for a first offence to a penalty of not more than Two pounds, and for a second or any subsequent offence to a penalty of not more than Five pounds.

2. Any dogs so found may be seized by the police or by the officers of the municipality duly authorized in that behalf, and dealt with as if it had been seized under section thirteen or section fourteen (as the case requires) of the principal Act.

**SCHEDULE.**

Mount Evelyn.—Railway-crescent, between York-road and Birmingham-road.

3196

E. WINTERBOTTOM, Shire Secretary.

**SHIRE OF WINCHELSEA.**

**BY-LAW No. 39.**

A By-law of the Shire of Winchelsea, made under section 228 of the Local Government Act 1946, and numbered 39, for repealing part of By-law No. 31.

IN pursuance of the powers conferred by the Local Government Act 1946, the President, Councillors, and Ratepayers of the Shire of Winchelsea order as follows:—

In sub-clause (1) of clause 18 of By-law No. 31 of the Shire all the words therein after the word "road" where first occurring shall be and the same are hereby repealed.

Resolution for passing this By-law was agreed to by the Council on the 8th day of October, 1947, and confirmed on the 12th day of November, 1947.

J. S. MATHISON, President.

(SEAL)

HENRY W. HOPKINS, Councillor.

W. W. WESTHORPE, Shire Secretary.

Approved by the Governor in Council this 23rd day of December, 1947.—C. W. KINSMAN, Clerk of the Executive Council.

3205

NOTICE is hereby given that the partnership lately existing between Irving Leonard Jones and Christopher Laurence Harper, carrying on business of dyers and dry cleaners and a laundry at Castlemaine, in the State of Victoria, under the name or style of "Maine Dry Cleaning Co.," has been dissolved by mutual agreement as from the 31st day of December, 1947. The said Irving Leonard Jones will continue to carry on the said business at Castlemaine, under the name of Maine Dry Cleaning Co., and will receive and pay all debts due to and by the said firm.

Dated the 24th day of January, 1948.

I. L. JONES.

C. L. HARPER.

H. S. W. Lawson and Co., solicitors, Castlemaine.

3203

NOTICE is hereby given that the partnership subsisting and carried on between the undersigned Allan Taranto and Albert Saba, under the style or business name of "Double A," at 4 Puckle-street, Moonee Ponds, has been dissolved as from the 14th day of January, 1948. All debts due to and owing by the said firm will be received and paid by the said Allan Taranto, who will carry on the said business on his own behalf, under the same name and at the same premises.

Dated at Melbourne, this 14th day of January, 1948.

A. SABA.

A. TARANTO.

J. J. Carroll, 191 Queen-street, Melbourne, solicitor for the said Albert Saba.

F. J. Corder, 108 Queen-street, Melbourne, solicitor for the said Allan Taranto.

3215

TAKE notice that the partnership heretofore existing between Daisy Rebecca Lasky, of 48 Charles-street, East Brighton, and Solomon Joseph Abadee, of 672 Station-street, North Carlton, trading under the firm name of Lingerie Fair, at 361 High-street, Preston, is hereby dissolved by mutual consent as from the 17th January, 1948. All debts due to and owing by the said firm will be received and paid in the ordinary course of business by Daisy Rebecca Lasky, who will continue to carry on the business under the same trade name and at the same address.

Dated at Melbourne, 21st January, 1948.

D. LASKY.

S. ABADEE.

Witness to signatures—L. LASKY.

3224



**NOTICE** is hereby given that the partnership heretofore subsisting between William John Ross, Daniel Armen Schneider, and George Archibold Ross, carrying on the business of boot manufacturers, under the style or firm of Poplar Shoes; has been dissolved by mutual consent as from the 29th day of November, 1947, the said William John Ross and George Archibold Ross having retired from the firm, and all debts due and owing by the firm will be received and paid respectively by the said Daniel Armen Schneider, who will continue to carry on the business under the style or firm of Poplar Shoes, at 2 Easey-street, Collingwood.

Dated the 21st day of January, 1948.

W. J. ROSS.  
G. A. ROSS.

Witness to the signatures of William John Ross and George Archibold Ross—L. A. CHISHOLM, solicitor, Melbourne.

DANIEL SCHNEIDER.

Witness to the signature of Daniel Armen Schneider—R. KENNEDY, solicitor, Melbourne.

Russell Kennedy and Cook, of 401 Collins-street, Melbourne, solicitors for the said Daniel Armen Schneider.

Maddock, Lonie, and Chisholm, of 339 Collins-street, Melbourne, solicitors for the said William John Ross and George Archibold Ross. 3222

**NOTICE** is hereby given that the partnership heretofore subsisting between the undersigned, Michael Fitzgerald Healy and Brian Blayney Walpole, carrying on business as manufacturers, wholesalers, and representatives, at 443 Little Collins-street, Melbourne, under the name of Healy and Walpole, has been dissolved by mutual consent as from the 9th day of January, 1948.

Dated at Melbourne, the 19th day of January, 1948.

MICHAEL F. HEALY.  
BRIAN WALPOLE.

Witness—E. V. CASH.

3234

Form No. 52.

ST. CLEM'S ORCHARD PROPRIETARY LIMITED  
(IN VOLUNTARY LIQUIDATION).

NOTICE CONVENING FINAL MEETING, PURSUANT TO SECTION 236.

**NOTICE** is hereby given, in pursuance of section 236 of the Companies Act 1938, that a General Meeting of members of the above-named company will be held on Monday, the 15th day of March, 1948, at half-past Eleven o'clock in the morning, for the purpose of having an account laid before them showing the manner in which the winding up has been conducted and the property of the company disposed of, and of hearing any explanation that may be given by the liquidator.

Dated this 16th day of January, 1948.

S. B. HOLDER, Liquidator.

360 Collins-street, Melbourne.

3244

Companies Act 1938.

G.E.S. PTY. LTD. (IN VOLUNTARY LIQUIDATION).

NOTICE OF FINAL MEETING.

**A** GENERAL Meeting of the shareholders of the above-named company will be held, pursuant to section 236, at 238 Dudley-street, West Melbourne, on Monday, 1st March, 1948, at Five p.m., for the purpose of laying before the shareholders of the company the account of the liquidation, and giving any explanation thereof.

Dated 16th January, 1948.

3199

FREDERICK CLYNE, Liquidator.

Form No. 52.

BATMAN EXPLORATION COMPANY PROPRIETARY LIMITED (IN VOLUNTARY LIQUIDATION).

NOTICE CONVENING FINAL MEETING, PURSUANT TO SECTION 236.

**NOTICE** is hereby given, in pursuance of section 236 of the Companies Act 1938, that a General Meeting of members of the above-named company will be held on Monday, the 15th day of March, 1948, at Eleven o'clock in the morning, for the purpose of having an account laid before them showing the manner in which the winding up has been conducted and the property of the company disposed of, and of hearing any explanation that may be given by the liquidator.

Dated this 16th day of January, 1948.

S. B. HOLDER, Liquidator.

360 Collins-street, Melbourne.

3245

Companies Act 1938.

THE CASTLEMAINE BREWERY COMPANY MELBOURNE LIMITED.

**R**EGISTER of Unclaimed Moneys held by above Company on 1st January, 1948.

Name of Owner on Books.	Total Amount due to Owner.	Description of Unclaimed Moneys.
Blake, T. (deceased), address unknown	£ s. d. 4 7 0	Dividend, 1941
Donovan, H., address unknown ..	0 15 0	Dividend, 1941
Edwards, J. H., address unknown ..	8 17 0	Dividend, 1941

3241

AUSTRALIAN MERCANTILE LAND AND FINANCE CO. LTD.

**L**IST of Unpresented Cheques and Unclaimed Moneys for period 1st January, 1941, to 31st December, 1941.

Cheque Number.	Date.	Amount.	Payee.	Address.
		£ s. d.		
4685	11.7.41	2 1 11	W. McCulloch .. .. .	Tumborumba, New South Wales
482	19.7.41	0 8 0	R. Douglas .. .. .	339 Park-street, Carlton
846	29.7.41	4 4 8	Private H. Hicks .. .. .	No. 4 Camp, Tatura
3007	10.9.41	6 4 3	C. Nunn .. .. .	Scotts Creek
3527	17.9.41	0 8 3	W. O. Smith .. .. .	Morwell
4792	23.9.41	1 2 8	Geo. Coburn .. .. .	Melton
7554	1.12.41	2 14 1	W. Travers .. .. .	Monomeith
Cash	27.5.41	0 8 8	H. Hicks .. .. .	Tatura
Cash	31.7.41	0 7 3	J. Kuhl .. .. .	Murchison
Cash	31.7.41	0 7 8	J. Simpson .. .. .	Beaufort
Cash	31.7.41	0 2 10	J. Miller .. .. .	Middle Creek
Cash	31.7.41	0 7 7	W. McCulloch .. .. .	Wodonga
		18 17 10		

THE BALLARAT WOOLLEN AND WORSTED COMPANY LIMITED.

DIVIDEND ACCOUNT, 1946—£95 14s. 6d.

REGISTER of Unclaimed Moneys held by The Ballarat Woollen and Worsted Company Limited, Hill-street, Ballarat, 1946.

Name and Address of Owner on Books.	Total Amount Due to Owner.	Description of Unclaimed Money.	Date of Last Claim.
	£ s. d.		
Anderson, Mary Ann (estate of), "Blackwood Estate," Smythesdale ..	0 14 5	Ninth dividend on 9 shares	No claim has been made in respect of such claim
Armstrong, William (estate of), Whiting and Aitken, solicitors, Melbourne	0 8 0	" " 5 "	" "
Andoe, Mrs. Elsey A., 5 Barnard-grove, North Kew ..	0 3 3	" " 2 "	" "
Baker, James C. (estate of), c/o W. T. Baker, Barkly-street, Footscray	0 8 0	" " 5 "	" "
Barr, Robert (estate of), John Barr, Kanyapella ..	0 8 0	" " 5 "	" "
Bennett, Henry G. (estate of), 50 Highway, Nedlands, Western Australia	0 4 10	" " 3 "	" "
Blythe, Helen (estate of), Downing and Downing, solicitors, 39 St. George's-terrace, Perth, Western Australia	0 9 7	" " 6 "	" "
Brooks, Mrs. Helen F., Hoskins-street, Temora, New South Wales ..	0 3 2	" " 2 "	" "
Budden, Mrs. Emma, Kedron Park-road, Woolowin, Brisbane, Queensland	0 12 10	" " 8 "	" "
Callaway, Julia (estate of), c/o National Bank, Bairnsdale ..	1 2 5	" " 14 "	" "
Cannon, Mrs. Catherine, 6 Nelson-street, Windsor ..	0 4 10	" " 3 "	" "
Carey, Mrs. Bridget A., 2 King-street south, Ballarat East ..	0 4 10	" " 3 "	" "
Cattanach, Mary (estate of), Miss Margaret A. Cattanach, Campbell's Forest	0 4 10	" " 3 "	" "
Charles, Andrew, Eastern View, Grovedale, via Geelong ..	0 4 10	" " 3 "	" "
Clark, Lyndon, 196 Victoria-street, Ballarat East ..	0 16 0	" " 10 "	" "
Clancy, Patrick, o/o H. G. Curtis, 252 Tooronga-road, East Malvern ..	0 9 8	" " 6 "	" "
Cohen, Coleman H., 250 High-street, St. Kilda ..	0 4 10	" " 3 "	" "
Cook, Percy P., Collins House, 360 Collins-street, Melbourne ..	0 6 4	" " 4 "	" "
Costello, Mrs. Ellen, 107 Rowena-street, Richmond ..	1 0 10	" " 13 "	" "
Crowther, Miss Edith M., 19 Clyde-street, Glen Iris ..	0 4 10	" " 3 "	" "
Chisholm, John, Miner's Rest ..	0 3 2	" " 2 "	" "
Davies, Miss Jane, 59 Phillips-street, Coburg ..	3 16 10	" " 48 "	" "
De Ravin, Mrs. Eunice E., 19 Selborne-road, Toorak ..	2 17 7	" " 36 "	" "
Davies, George F., 360 Collins-street, Melbourne ..	0 4 10	" " 3 "	" "
Bett, Frank W., 360 Collins-street, Melbourne ..	0 4 10	" " 3 "	" "
Evans, Mrs. Dulcie B., 15 Mills-street, Hampton ..	0 4 10	" " 3 "	" "
Figgis, Mrs. Zillah A., c/o Price and Chamberlin, Chancery-lane, Melbourne	0 4 10	" " 3 "	" "
George, Thomas J., 133 Shaftesbury-parade, Croxton ..	0 4 10	" " 3 "	" "
Germon, William (estate of), W. J. Germon, 26 Pearson-street, Brighton	0 6 5	" " 4 "	" "
Grey, Robert H. (estate of), Cuthbert, Morrow, Must, and Shaw, Lydiard-street south, Ballarat	0 19 2	" " 12 "	" "
Hanlon, Mrs. Kathleen, "Braemar," Allansford ..	1 4 0	" " 15 "	" "
Hepburn, Miss Elaine M., c/o N. Macegeorge, Fairy Hills, Riverside-road, Ivanhoe	0 4 10	" " 3 "	" "
Hicks, Louisa (estate of), James Hicks, Westgarth-street, Fairfield	0 4 10	" " 3 "	" "
Hayman-Joyce, Mrs. Irene M., c/o Lloyd's Bank Ltd., Godalming, Surrey, England	0 19 2	" " 12 "	" "
Hosken, James T., 9 Brougham-street, Ballarat ..	0 6 5	" " 4 "	" "
Ingleman, Alfred G., c/o Western Hotel, Sturt-street, Ballarat ..	9 15 2	" " 122 "	" "
James, Edwin H., Wandin Yallock ..	0 4 10	" " 3 "	" "
Jenkin, A. P., State School, Kilcunda, South Gippsland ..	0 4 10	" " 3 "	" "
Keats, Jessie E. (estate of), Aitken, Walker, and Strachan, 123-5 William-street, Melbourne	1 4 0	" " 15 "	" "
Kean, Miss Kate, Leigh Creek ..	0 3 2	" " 2 "	" "
Kerr, Miss Martha C., Victoria-street, Kerang ..	0 6 5	" " 4 "	" "
Lamont, Charles (estate of), J. Lamont, 13 Talbot-street north, Ballarat	0 6 5	" " 4 "	" "
Lang, Mrs. Janet, 8 Kangerong-road, Box Hill ..	0 4 10	" " 3 "	" "
Lang, Robert I. (estate of), Morton Hercules, Godfrey-street, Boort ..	0 9 7	" " 6 "	" "
Lang, David, Barellan, New South Wales ..	0 9 7	" " 6 "	" "
Lawrence, Mrs. Amelia, Drummond-street south, Ballarat ..	0 3 2	" " 2 "	" "
Levy, Rose (estate of), Ballarat Trustees & Extrs. Co., Ballarat ..	0 4 10	" " 3 "	" "
Long, Rev. Robert G., The Rectory, Bright ..	0 4 10	" " 3 "	" "
Marshall, Joseph (estate of), Mrs. M. Marshall, 1 Donald-street, Prahran	0 4 10	" " 3 "	" "
Marshall, William, Ouyen ..	0 4 10	" " 3 "	" "
Merritt, Miss Dorothy M., 65 Albany-road, Toorak ..	1 18 5	" " 24 "	" "
Merze, Wilbur M., Hanna-street P.O., South Melbourne ..	18 14 5	" " 234 "	" "
Mildred, Lindsay, 60 Queen-street, Melbourne ..	0 9 7	" " 6 "	" "
Ludbrook, Miss Julia, 9 Chamberlain-street, Ballarat East ..	0 3 2	" " 2 "	" "
Mills, Miss Clara W., 469 Chancery-lane, Melbourne ..	1 18 5	" " 24 shares	No claim has been made in respect of such moneys
Mills, George P., 469 Chancery-lane, Melbourne ..	4 16 0	" " 60 "	" "
Osmond, Stanley, 293 Collins-street, Melbourne ..	9 12 0	" " 120 "	" "
Plummer, Frederick R., Box 172, Haymarket P.O., Sydney, New South Wales	0 6 5	" " 4 "	" "
Phillips, Miss Linda H. J., 26 Blaxland-road, Bellevue Hill, New South Wales	1 5 7	" " 16 "	" "
Radley, W. D. (estate of), the Executors, Moore-street, Ararat ..	0 17 7	" " 11 "	" "
Rainbow, Mrs. Matilda, 32 Dendy-street, Middle Brighton ..	0 4 10	" " 3 "	" "
Rainbow, Joseph (estate of), J. J. Rainbow, 630 Bell-street, Preston ..	0 4 10	" " 3 "	" "
Ramage, Misses Ruth and Ella, "Hollywood," Lang-street, Croydon, New South Wales	0 3 2	" " 2 "	" "
Reid, William H. (estate of), W. L. Reid, 50 Peel-street south, Ballarat	4 16 0	" " 60 "	" "
Reynolds, Alfred, 205 Mont Albert-road, Surrey Hills ..	1 2 5	" " 14 "	" "
Rothacker, Mrs. Ellen J., "Kelvins Grove," Woodvale ..	0 4 10	" " 3 "	" "
Rowlands, Owen, Sebastopol P.O. ..	0 3 2	" " 2 "	" "
Sayle, Miss Eliza J., Chinaman's Flat, Maryborough ..	0 3 2	" " 2 "	" "
Scarfe, Jeremiah F., 12 Clota-avenue, Box Hill ..	0 4 10	" " 3 "	" "

UNCLAIMED MONEYS—THE BALLARAT WOOLLEN AND WORSTED COMPANY LIMITED—*continued.*

Name and Address of Owner on Books.	Total Amount Due to Owner.	Description of Unclaimed Money.	Date of Last Claim.
Settle, Harold W., c/o Mrs. B. Settle, 16 Banole-avenue, East Prahran	£ s. d. 0 8 0	Ninth dividend on 5 shares	No claim has been made in respect of such moneys
Sherry, John C., 1 Story-street, Parkville .. .. .	0 14 5	" " 9 "	" "
Smith, Agnes (estate of), Ballarat Trustees, & Executors Co., Ballarat	0 3 2	" " 2 "	" "
Stillman, Christina M. (estate of), Cohen Kirby and Co., 117 Pall Mall, Bendigo	0 17 7	" " 11 "	" "
Summerscales, Mary A. (estate of), 47 Matlock-street, Canterbury ..	0 4 10	" " 3 "	" "
Stephenson, Harold G., 100 Linacre-road, Hampton .. .. .	0 19 2	" " 12 "	" "
Tait, George W., 210 Union-road, Ascot Vale .. .. .	0 6 5	" " 4 "	" "
Thomas, Miss Elizabeth, 407 Urquhart-street, Ballarat .. .. .	0 14 5	" " 9 "	" "
Tonkin, Mrs. Mary E., 10 Oak-street, Hawthorn .. .. .	0 19 2	" " 12 "	" "
Varcoe, Benjamin (estate of), Philip W. Must, Lydiard-street, Ballarat	0 4 10	" " 3 "	" "
Walters, Mary E. (estate of), W. A. Walters, St. Mary's Vicarage, 233 Tyler-street, Preston	0 4 10	" " 3 "	" "
Wise, John M., c/o Mrs. J. McRae, 327 Marmion-street, North Cottesloe, Western Australia	0 8 0	" " 5 "	" "
White, Mrs. Marion E., Biggs-street, St. Albans .. .. .	0 3 2	" " 2 "	" "
Young, James (estate of), Union Trustee Co. Ltd., Melbourne ..	0 3 2	" " 2 "	" "
Sundry shareholders (79 in number), particulars of whose names, &c., may be inspected at the registered office of the company, whose individual amounts are 1s. 7d.	6 5 1	" " 79 "	" "

3193

CALTEX OIL (AUSTRALIA) PTY. LTD.

REGISTER of Unclaimed Moneys held by Caltex Oil (Australia) Pty. Limited, Melbourne, Victoria.

Name and Address.	Total Amount Due to Owner.	Description of Unclaimed Money.	Date of Last Claim.
Atherton, W., Oakleigh .. .. .	£ s. d. 0 10 0	Unclaimed credit balance .. .. .	30.4.41
Bottger, E. T., Kooloonong .. .. .	0 0 6	" " " " .. .. .	30.6.41
Coltish, L., Brucknell .. .. .	0 10 0	" " " " .. .. .	7.8.41
Collyer, A. V., Leongatha .. .. .	0 1 10	" " " " .. .. .	22.10.41
Ford, H. C., Bayles .. .. .	2 0 0	" " " " .. .. .	30.4.41
Glen Iris Motors, Glen Iris .. .. .	0 15 10	" " " " .. .. .	30.4.41
Levins, A., Castlemaine .. .. .	0 4 0	" " " " .. .. .	31.12.41
Law, C., North Melbourne .. .. .	0 10 0	" " " " .. .. .	31.12.41
Langley, H., Port Campbell .. .. .	0 10 0	" " " " .. .. .	7.8.41
Luxford, T., Munro .. .. .	0 1 8	" " " " .. .. .	31.12.41
Leven, A., Castlemaine .. .. .	0 1 6	" " " " .. .. .	31.12.41
Marine Garage, Camberwell .. .. .	0 1 11	" " " " .. .. .	30.4.41
Mitchell, F., Ebdon .. .. .	0 10 0	" " " " .. .. .	15.10.41
McMillan, A. J., Sale .. .. .	0 2 3	" " " " .. .. .	30.6.41
Police Department, Lilydale .. .. .	0 10 0	" " " " .. .. .	19.8.41
Reddie, C. F., Cressy .. .. .	1 0 0	" " " " .. .. .	30.4.41
Reeve, G. W., Geelong .. .. .	1 1 3	" " " " .. .. .	30.4.41
Thompson, A. M., Morwell .. .. .	0 10 0	" " " " .. .. .	30.6.41
Whiteman, M., Drysdale .. .. .	1 10 0	" " " " .. .. .	30.4.41
Wilson, W. J., Bethanga .. .. .	0 8 2	" " " " .. .. .	16.10.41

3219

THE LANGRIDGE MUTUAL PERMANENT BUILDING SOCIETY.

REGISTER of Unclaimed Moneys held by The Langridge Mutual Permanent Building Society.

Name of Owner on the Books.	Total Amount Due to Owner.	Description of Unclaimed Moneys.	Date of Last Claim.
William Murray, Jordan-street, Malvern ..	£ s. d. 7 0 0	Dividend on 20 £5 shares, payable May, 1941 (£3 10s.), and October, 1941 (£3 10s.)	Probably November, 1891
Walter Emery Loveland, 117 Compton-street, Ballarat	0 7 0	Dividend on 1 £5 share, payable May, 1941 (3s. 6d.), and October, 1941 (3s. 6d.)	October, 1907
Harry Dempster, 42 St. George's-terrace, Perth, Western Australia	2 2 0	Dividend on 6 £5 shares, payable May, 1941 (£1 1s.), and October, 1941 (£1 1s.)	April, 1929
John Jordison, Spreyton, Tasmania ..	1 8 0	Dividend on 4 £5 shares, payable May, 1941 (14s.), and October, 1941 (14s.)	November, 1934
	10 17 0		

3247

Companies Act 1938.  
COMMONWEALTH AIRCRAFT CORPORATION PTY. LTD.

REGISTER of Unclaimed Money held by Commonwealth Aircraft Corporation Pty. Ltd.

Name of Owner on Books.	Last Known Address.	Total Amount Due to Owner.	Description of Unclaimed Money.	Date of Last Claim.
		£ s. d.		
A. W. Hunter .. .. .	2 Mulgrave-street, Elsternwick .. .. .	1 11 8	Unclaimed wages ..	No claim
W. Crowe .. .. .	1 Berry-street, Richmond .. .. .	0 18 5	" .. .. .	" .. .. .
R. W. Evans .. .. .	3 Dunstan-avenue, East Brunswick .. .. .	0 3 4	" .. .. .	" .. .. .
T. W. Place .. .. .	15 Princess-parade, St. Kilda-road, Melbourne .. .. .	0 6 10	" .. .. .	" .. .. .
L. E. Drummond .. .. .	102 Buckingham-street, Richmond .. .. .	0 1 6	" .. .. .	" .. .. .
W. Borthwick .. .. .	26 Fielding-street, Yarraville .. .. .	0 19 1	" .. .. .	" .. .. .
A. E. Hanks .. .. .	32 Martin-street, South Melbourne .. .. .	0 11 2	" .. .. .	" .. .. .
T. G. Ruby .. .. .	31 Raglan-street, South Melbourne .. .. .	0 19 3	" .. .. .	" .. .. .
G. Hamilton .. .. .	17 Hornby-street, Windsor .. .. .	0 18 9	" .. .. .	" .. .. .
W. L. Brown .. .. .	102 Carlton-street, Carlton .. .. .	2 1 7	" .. .. .	" .. .. .
A. V. Allie .. .. .	34 Gladstone-street, Windsor .. .. .	0 4 8	" .. .. .	" .. .. .
R. G. C. Balmer .. .. .	9 Reeves-street, Clifton Hill .. .. .	0 2 2	" .. .. .	" .. .. .
R. A. Allen .. .. .	Sargood-street, Altona .. .. .	0 5 11	" .. .. .	" .. .. .
W. R. Hobson .. .. .	1 Crane-street, South Melbourne .. .. .	0 5 7	" .. .. .	" .. .. .
E. F. Kimber .. .. .	5 Selwyn-street, Canterbury .. .. .	0 16 8	" .. .. .	" .. .. .
L. V. Malee .. .. .	11A Darlington-grove, East Coburg .. .. .	0 7 1	" .. .. .	" .. .. .
R. Nicholson .. .. .	203 Montague-street, South Melbourne .. .. .	0 2 2	" .. .. .	" .. .. .
H. W. Dawson .. .. .	56 Banks-street, Ascot Vale .. .. .	0 6 1	" .. .. .	" .. .. .
R. N. Granger .. .. .	22 The Strand, Williamstown .. .. .	1 12 6	" .. .. .	" .. .. .
C. L. Bowen .. .. .	335 Bell-street, Preston .. .. .	0 6 10	" .. .. .	" .. .. .
R. F. Bridgland .. .. .	c/o Post Office, Mt. Dandenong .. .. .	1 3 2	" .. .. .	" .. .. .
W. H. E. Jewell .. .. .	10 Hamilton-street, Gardenvale .. .. .	0 5 1	" .. .. .	" .. .. .
W. J. Robb .. .. .	146 St. Leonards-road, Ascot Vale .. .. .	1 0 11	" .. .. .	" .. .. .
R. H. Poulter .. .. .	21 Sea View-crescent, Black Rock .. .. .	1 6 2	" .. .. .	" .. .. .
J. C. Parlett .. .. .	19 Abbotsford-grove, Ivanhoe .. .. .	2 2 2	" .. .. .	" .. .. .
E. Bryceland .. .. .	12 Canterbury-road, Albert Park .. .. .	1 17 6	" .. .. .	" .. .. .
R. L. Wallish .. .. .	4 Glenmark-avenue, St. Kilda .. .. .	0 16 3	" .. .. .	" .. .. .
R. H. M. Ford .. .. .	2 Moorhouse-street, Armadale .. .. .	1 6 10	" .. .. .	" .. .. .
W. G. Riddle .. .. .	26 Oak-grove, East St. Kilda .. .. .	1 14 4	" .. .. .	" .. .. .
F. D. Brill .. .. .	55 Roslyn-street, Middle Brighton .. .. .	0 10 1	" .. .. .	" .. .. .
W. L. Parris .. .. .	51 Argyle-street, St. Kilda .. .. .	0 4 3	" .. .. .	" .. .. .
M. T. Smith .. .. .	372 Albert-road, Albert Park .. .. .	1 18 8	" .. .. .	" .. .. .
W. Carter .. .. .	114 King-street, Melbourne .. .. .	2 10 11	" .. .. .	" .. .. .
J. A. Ferguson .. .. .	352 Fitzroy-street, Fitzroy .. .. .	0 19 4	" .. .. .	" .. .. .
A. H. Bradshaw .. .. .	191 Richardson-street, Albert Park .. .. .	1 0 9	" .. .. .	" .. .. .
D. J. Traill .. .. .	42 Beacon-road, Port Melbourne .. .. .	4 18 11	" .. .. .	" .. .. .
H. J. Quiney .. .. .	158 Hawthorn-road, Caulfield .. .. .	1 1 1	" .. .. .	" .. .. .
H. Buchan .. .. .	12 Mellwick-street, Windsor .. .. .	1 15 0	" .. .. .	" .. .. .
E. Wilkinson .. .. .	63 Hoddle-street, North Richmond .. .. .	1 7 8	" .. .. .	" .. .. .
N. M. Searle .. .. .	5 Hillard-street, East Malvern .. .. .	0 4 4	" .. .. .	" .. .. .
G. R. Pope .. .. .	4 Cameron-street, West Brunswick .. .. .	1 2 6	" .. .. .	" .. .. .
A. J. Harris .. .. .	41 Barrett-street, Albert Park .. .. .	0 6 0	" .. .. .	" .. .. .
R. G. Edwards .. .. .	Chapel-street, Wedderburn .. .. .	3 19 1	" .. .. .	" .. .. .
A. Marsh .. .. .	c/o Masonic Club, Flinders-street, Melbourne .. .. .	2 8 3	" .. .. .	" .. .. .
A. L. Hewett .. .. .	83 Canterbury-road, Middle Park .. .. .	1 5 6	" .. .. .	" .. .. .
E. Weston .. .. .	51 Stanley-street, West Melbourne .. .. .	0 9 2	" .. .. .	" .. .. .
N. R. Robertson .. .. .	14 Little Mountain-street, South Melbourne .. .. .	0 8 8	" .. .. .	" .. .. .
J. L. T. Edwards .. .. .	31 Murphy-street, Gardenvale .. .. .	1 15 4	" .. .. .	" .. .. .
R. T. Smith .. .. .	9 Elder-parade, Essendon .. .. .	0 2 2	" .. .. .	" .. .. .
B. H. Bonnor .. .. .	Flat 4, Barkly-street, St. Kilda .. .. .	2 17 4	" .. .. .	" .. .. .
R. T. Smith .. .. .	9 Elder-parade, Essendon .. .. .	0 4 11	" .. .. .	" .. .. .
T. A. J. Ray .. .. .	1 Cardigan-place, Albert Park .. .. .	1 3 7	" .. .. .	" .. .. .
L. S. Bell .. .. .	26 Garnett-street, Brunswick .. .. .	0 10 2	" .. .. .	" .. .. .
H. B. Cooper .. .. .	Leigh-avenue, Yarraman Park, Dandenong .. .. .	1 17 2	" .. .. .	" .. .. .
H. Gamble .. .. .	13 Service-crescent, Albert Park .. .. .	2 3 6	" .. .. .	" .. .. .
D. H. House .. .. .	64 Barkers-road, Hawthorn .. .. .	0 13 11	" .. .. .	" .. .. .
L. R. D. Landers .. .. .	High-street, Glen Waverley .. .. .	5 7 3	" .. .. .	" .. .. .
C. C. Kealy .. .. .	235 Princess-street, Port Melbourne .. .. .	1 19 10	" .. .. .	" .. .. .
E. V. C. Nugent .. .. .	124 Ross-street, Port Melbourne .. .. .	1 15 0	" .. .. .	" .. .. .
F. Gilbert .. .. .	172 Beavers-road, Northcote .. .. .	2 9 9	" .. .. .	" .. .. .
J. C. Baker .. .. .	11 Park-street, St. Kilda .. .. .	2 3 5	" .. .. .	" .. .. .
S. B. Finnin .. .. .	" Lismore," Lennon-street, Parkville West .. .. .	0 13 8	" .. .. .	" .. .. .
A. L. Niner .. .. .	18 Little Bourke-street, Melbourne .. .. .	2 2 11	" .. .. .	" .. .. .
E. Hutchison .. .. .	4 York-street, Glenferrie .. .. .	1 5 2	" .. .. .	" .. .. .
W. B. Campbell .. .. .	12 Lyndhurst-crescent, Auburn .. .. .	1 1 11	" .. .. .	" .. .. .
R. J. Box .. .. .	189 Osborne-street, Williamstown .. .. .	0 8 8	" .. .. .	" .. .. .
M. Darveniza .. .. .	117 Kerford-road, Albert Park .. .. .	1 12 0	" .. .. .	" .. .. .
H. W. James .. .. .	32 Regent-street, Oakleigh .. .. .	1 10 6	" .. .. .	" .. .. .
V. Heagerty .. .. .	12 Little Mountain-street, South Melbourne .. .. .	0 7 4	" .. .. .	" .. .. .
W. E. Pollock .. .. .	9 Angle-road, Balwyn .. .. .	6 17 10	" .. .. .	" .. .. .
A. J. Clough .. .. .	52 Burlington-street, Oakleigh .. .. .	1 7 10	" .. .. .	" .. .. .
R. S. Glennon .. .. .	28 Drake-street, Elwood .. .. .	6 10 4	" .. .. .	" .. .. .
W. E. McKenzie .. .. .	36 St. Vincent's-place, Albert Park .. .. .	0 9 10	" .. .. .	" .. .. .
W. G. Densley .. .. .	165 High-street, Northcote .. .. .	0 9 10	" .. .. .	" .. .. .
W. Sweetnam .. .. .	7 Kingsley-street, East Camberwell .. .. .	1 0 5	" .. .. .	" .. .. .
J. Casey .. .. .	43 Riversdale-road, Hawthorn .. .. .	0 14 0	" .. .. .	" .. .. .
C. E. Hatfield .. .. .	15 Curran-street, North Melbourne .. .. .	1 3 10	" .. .. .	" .. .. .
C. P. Nissen .. .. .	59 Sutherland-street, Brunswick .. .. .	0 18 6	" .. .. .	" .. .. .
C. J. Cheeseman .. .. .	37 Chestnut-street, Richmond .. .. .	2 8 0	" .. .. .	" .. .. .
W. N. Cooke .. .. .	241 High-street, Prahran .. .. .	3 12 0	" .. .. .	" .. .. .
A. H. Smith .. .. .	121 Buckingham-street, Richmond .. .. .	1 3 1	" .. .. .	" .. .. .
E. W. Hawksford .. .. .	3 Howard-street, Glen Iris .. .. .	1 3 8	" .. .. .	" .. .. .
C. E. Stewart .. .. .	173 Barkley-street, St. Kilda .. .. .	1 4 3	" .. .. .	" .. .. .
T. J. Taylor .. .. .	18 Bell-street, Seddon .. .. .	2 7 1	" .. .. .	" .. .. .
W. R. Hodgkin .. .. .	54 Harold-street, Thornbury .. .. .	3 8 7	" .. .. .	" .. .. .

COMMONWEALTH AIRCRAFT CORPORATION PTY. LTD.—UNCLAIMED MONEY—continued.

Name of Owner on Books.	Last Known Address.	Total Amount Due to Owner.	Description of Unclaimed Money.	Date of Last Claim.
		£ s. d.		
E. L. Wilson ..	75 Kingsville-street, Footscray ..	0 4 6	Unclaimed wages ..	No claim
A. V. Stranger ..	23 Winfield-street, Footscray ..	1 8 4	" ..	" ..
M. W. G. Murray ..	13 Selworthy-avenue, Oakleigh South ..	0 0 11	" ..	" ..
J. A. MacKenzie ..	73 Finch-street, East Malvern ..	2 18 6	" ..	" ..
F. W. Lacey ..	80 Gray-street, St. Kilda ..	2 18 5	" ..	" ..
J. A. Lawler ..	67 Mitford-street, Elwood ..	0 9 5	" ..	" ..
L. H. Moulden ..	36 Beach-road, Hampton ..	1 5 1	" ..	" ..
C. P. Boland ..	155 Nicholson-street, Abbotsford ..	0 5 6	" ..	" ..
C. R. Skerman ..	39 Beaconsfield-parade, Albert Park ..	2 2 2	" ..	" ..
R. P. Aubert ..	3 Lock-street, St. Kilda ..	1 4 0	" ..	" ..
J. P. Robertson ..	10 York-street, Surrey Hills ..	1 12 3	" ..	" ..
W. F. McKenzie ..	36 St. Vincent's place, Albert Park ..	1 0 9	" ..	" ..
R. N. Granger ..	22 The Strand, Williamstown ..	0 16 11	" ..	" ..
B. Clempson ..	162 Toorak-road, South Camberwell ..	0 7 9	" ..	" ..
K. A. Harris ..	299 Wattletree-road, East Malvern ..	1 2 0	" ..	" ..
H. L. Morley ..	18 Neil-street, West Footscray ..	1 15 8	" ..	" ..
D. R. McMillan ..	32 Madden-avenue, Carnegie ..	4 8 6	" ..	" ..
J. Mole ..	3 Seymour-grove, Brighton Beach ..	2 15 3	" ..	" ..
L. H. Moulden ..	36 Beach-road, Hampton ..	5 3 0	" ..	" ..
F. H. Biggs ..	79 Keon-street, Thornbury ..	1 8 4	" ..	" ..
P. Greaves ..	11 Fitzgibbons-street, Parkville ..	1 4 6	" ..	" ..
L. H. Vinin ..	226 Richardson-street, Middle Park ..	1 7 5	" ..	" ..
F. Augustine ..	837 Rathdown-street, North Carlton ..	5 3 3	" ..	" ..
R. E. Heupt ..	245 Stawell-street, Burnley ..	0 11 1	" ..	" ..
F. W. Rate ..	11 Elman-road, Cheltenham ..	0 4 9	" ..	" ..
H. G. Oldfield ..	149 Kerford-road, Albert Park ..	4 2 2	" ..	" ..
H. C. Courtney ..	27 Fisher-street, East Malvern ..	2 6 5	" ..	" ..
C. F. Taggart ..	53 Ackland-street, St. Kilda ..	1 6 1	" ..	" ..
M. J. O'Hehir ..	220 Hope-street, West Brunswick ..	4 8 3	" ..	" ..
J. W. H. Cushen ..	29 Prentice-street, Elsternwick ..	0 17 0	" ..	" ..
R. J. McIntosh ..	17 Ti-Tree-grove, Parkdale ..	3 2 3	" ..	" ..
W. Carlson ..	132 Albert-street, East Brunswick ..	2 8 11	" ..	" ..
F. J. Reid ..	8 Griffiths-grove, East Brighton ..	1 9 6	" ..	" ..
B. N. McKay ..	76 Swan-street, Richmond ..	2 17 7	" ..	" ..
K. O. Thompson ..	96 Albion-road, Glen Iris ..	0 13 9	" ..	" ..
E. F. Milne ..	240 Canterbury-road, Canterbury ..	0 11 6	" ..	" ..
H. G. Crump ..	406 Dryburgh-street, North Melbourne ..	2 19 3	" ..	" ..
R. K. White ..	6 Canning-street, North Melbourne ..	0 19 1	" ..	" ..
E. E. Brooks ..	7 Stanley-parade, Caulfield ..	1 9 4	" ..	" ..
D. Doyle ..	137 Gladstone-street, Montague ..	0 6 9	" ..	" ..
R. E. Lark ..	16 Lofty-avenue, East Camberwell ..	1 14 9	" ..	" ..
B. F. Smallman ..	10 Grant-street, East Brighton ..	0 17 6	" ..	" ..
M. R. Montgomery ..	177 Charles-street, Footscray ..	1 3 5	" ..	" ..
M. A. McMahon ..	537 Main-street, Mordialloc ..	0 18 6	" ..	" ..
P. J. Rollason ..	26 Simpson's-road, Box Hill ..	0 1 0	" ..	" ..
A. F. Wilson ..	13 Service-crescent, Albert Park ..	3 12 6	" ..	" ..
P. L. Thomas ..	31 Carramar-avenue, Camberwell ..	1 2 6	" ..	" ..
R. R. Rogers ..	194 Dorcas-street, South Melbourne ..	0 10 11	" ..	" ..
M. A. McMahon ..	537 Main-street, Mordialloc ..	0 10 2	" ..	" ..
J. A. Gillies ..	21 Stirling-street, Footscray ..	1 4 10	" ..	" ..
W. B. Treweek ..	187 Barkley-street, Brunswick ..	4 19 0	" ..	" ..
J. R. Graham ..	19 Ivy-street, Prahran ..	0 2 3	" ..	" ..
W. W. Pritchard ..	14 Gibbon-street, Burnley ..	1 2 9	" ..	" ..
W. L. Hinchcliffe ..	2A Warburton-street, East Brunswick ..	0 19 8	" ..	" ..
S. G. Palmer ..	24 Collins-street, Melbourne ..	1 5 2	" ..	" ..
W. P. Evans ..	22 Macquarie-street, Williamstown ..	0 13 1	" ..	" ..
F. J. Reid ..	8 Griffith's-grove, East Brighton ..	3 11 7	" ..	" ..
R. S. McVitty ..	126 Bluff-road, Black Rock ..	1 0 6	" ..	" ..
D. J. Traill ..	42 Beacon-road, Port Melbourne ..	5 7 3	" ..	" ..
W. P. Evans ..	22 MacQuarie-street, Williamstown ..	0 5 3	" ..	" ..
J. F. O'Brien ..	73 Ormond-street, Kensington ..	3 3 9	" ..	" ..
K. W. Croxson ..	38 Wellington-street, St. Kilda ..	0 7 6	" ..	" ..
J. A. Fazio ..	3 Spring-street, Frankston ..	0 13 6	" ..	" ..
J. Hall ..	260 Williams-road, Toorak ..	1 8 0	" ..	" ..
D. J. Traill ..	42 Beacon-road, Port Melbourne ..	1 7 5	" ..	" ..
M. D. K. Ross ..	20 Glass-street, Glenborvie ..	1 5 11	" ..	" ..
M. I. Roberts ..	383 Church-street, Richmond ..	1 15 7	" ..	" ..
J. A. Hailey ..	1 Ford-street, Brunswick ..	0 18 10	" ..	" ..
W. D. Daley ..	113 Evans-street, East Brunswick ..	0 16 4	" ..	" ..
G. E. Clark ..	21 Louvain-street, West Coburg ..	0 10 5	" ..	" ..
R. G. Trevail ..	80 Iffla-street, South Melbourne ..	1 3 3	" ..	" ..
R. W. Vincent ..	132 Edward-street, East Brunswick ..	2 2 8	" ..	" ..
D. M. McPherson ..	Werona Post Office, via Smeaton, Victoria ..	2 3 2	" ..	" ..
C. J. Nugent ..	13 Laver-street, Kew ..	2 2 8	" ..	" ..
R. L. Galley ..	Hunt-street, East Doncaster ..	1 3 10	" ..	" ..
		244 9 11		

Dated at Melbourne this twentieth day of January, 1948.

A. G. BROWN, Secretary.

ORBOST BUTTER AND PRODUCE COMPANY LIMITED.  
**R**EGISTER of Unclaimed Moneys held by the Orbest Butter and Produce Company Limited.

Name of Owner on Books.	Total Amount Due to Owner.	Description of Unclaimed Money.	Date of Last Claim.
	£ s. d.		
Hooper, C. H., address unknown	2 4 9	Unclaimed dividends	No claim made
Mooney, J., address unknown	1 2 5	"	"
Richardson, Jos., address unknown	4 9 7	"	"

3208 E. H. D. WHITE, Secretary.

Companies Act.—32nd Schedule.

THE AUSTRALASIAN TEMPERENCE AND GENERAL MUTUAL LIFE ASSURANCE SOCIETY LIMITED.  
 Corner Collins and Russell streets, Melbourne, C.I.

**R**EGISTER of Unclaimed Money held by The Australasian Temperence and General Mutual Life Assurance Society Limited, at 31st December, 1947.

Name of Owner on Books.	Total Amount due to Owner.	Description of Unclaimed Money.	Date of Last Claim.
	£ s. d.		
Farrell, J. G.	1 0 0	Deposit on incomplete proposal	28.7.41
Harman, W. L.	1 7 0	Deposit on incomplete proposal	28.7.41
Jetson, H. W.	0 10 0	Deposit on incomplete proposal	28.7.41
Jetson, H. W.	0 13 0	Deposit on incomplete proposal	11.8.41
Pappas, G. . .	1 14 0	Deposit on incomplete proposal	21.4.41
Vance, R. . .	5 8 0	Deposit on incomplete proposal	26.5.41
Cleghorn, F. B.	0 6 0	Proceeds of I.D. death claim under Policy No. 5646853	26.9.32
Pritchard, H.	1 3 6	Proceeds of I.D. death claim under Policy No. 5654757	7.11.32
Smith, D. H. M.	10 0 4	Proceeds of maturity claim under O.D. Policy No. 122419	13.6.32
Fry, C. R. . .	1 8 3	Premium paid after date of lapse of Policy No. 774509	24.2.41
Roberts, F. E.	1 3 6	Premium paid after date of lapse of Policy No. 774397	3.3.41

3204

Re Real Estate and Business Agent, named GEOFFREY SCOTT BROMLEY (trading as Bromley's Agency), formerly of 64 Elizabeth-street, Melbourne.

**P**ERSONS having claims against the fidelity bond issued under the provisions of the Real Estate Agents Acts in connexion with the real estate and business agents licences of the above-named Geoffrey Scott Bromley, are required to forward full particulars and proof thereof to the Registrar under the Real Estate Agents Acts, at the State Treasury, Melbourne, not later than the 20th day of February, 1948. Claims will not be considered unless they arise from the activities of the said Geoffrey Scott Bromley as a licensed real estate and business agent during the currency of the said licence, i.e., from 24th April, 1946, to 31st December, 1946.

R. E. STAFFORD, Registrar.  
 State Treasury, Melbourne, 20th January, 1948. 3201

**C**REDITORS, next of kin, and others having claims in respect of the estate of Gertrude Elizabeth Margaret Wallace (sometimes known as Gertrude Alston Wallace), late of 21 Tivoli-place, South Yarra, in the State of Victoria, married woman, deceased, intestate (who died on the 28th September, 1947), are to send the particulars of their claims to The Equity Trustees, Executors, and Agency Company Limited, of 472 Bourke-street, Melbourne, in the said State, by the 31st day of March, 1948, after which date it will distribute the assets, having regard only to the claims of which it then has notice.

HEDDERWICK, FOKES, & ALSTON, 103 William-street, Melbourne, solicitors for the administrator company. 3218

**P**URSUANT to the *Trustee Act* 1928, all persons having claims against the estate of Catherine Devine Goodwin, formerly of 396 Punt-road, South Yarra, but late of Belmont Hotel, Thomastown, widow, deceased (who died on the 2nd day of December, 1945, and probate of whose will was granted by the Supreme Court of Victoria, on the 14th day of November, 1946, to Francis Wallace Landy, of 312 High-street, Northcote, bank manager, and Thomas Anthony Goodwin, of Thomastown, licensed victualler), are required to send particulars, in writing, of such claims to the said executors, care of the under-mentioned solicitor, on or before the 30th day of March, 1948, after which date the said executors will proceed to distribute the estate of the said deceased amongst the persons entitled thereto, having regard only to claims of which they shall then have had notice, and the said executors will not be liable for the assets so distributed, or any part thereof, to any person of whose claim they shall not then have had notice.

ROYSTON T. CAHIR, solicitor, 108 Queen-street, Melbourne. 3220

**P**URSUANT to the *Trustee Act* 1928, notice is hereby given that all persons having claims against the estate of John Towyn Davies (also known as John Davies), formerly of Mt. Eliza, in the State of Victoria, but late of 9 Ronald-street, Dandenong, in the said State, retired master mariner, deceased (who died on the 10th day of April, 1946, and probate of whose will has been granted to Robert Caradoc Hughes, of 4 Spray-street, Elwood, in the said State, minister of religion, William James McLean, of 512 Melbourne-road, Frankston, in the said State, estate agent, and Lily Beatrice Bassett, of 9 Ronald-street, Dandenong, in the said State, married woman), are hereby required to send particulars, in writing, of such claims to the said executors, care of E. W. Olley, at the address below, on or before the 1st day of April, 1948, after which date the said executors will proceed to distribute the estate of the said deceased amongst the persons entitled thereto, having regard only to the claims, whether formal or not, of which it shall then have had notice, and will not be liable for the assets so distributed, or any part thereof, to any person of whose claims it shall not have had notice.

Dated the 28th day of January, 1948.

E. W. OLLEY, solicitor, 431 Bourke-street, Melbourne. 3236

RE KATHLEEN MARY JOSEPHINE DEVINE, DECEASED.

**N**OTICE is hereby given that all persons having claims against the property or estate of Kathleen Mary Josephine Devine, formerly of 45 Church-street, West Footscray, but late of Barwon Heads, infant welfare nurse, deceased (who died on the 2nd day of November, 1947, and probate of whose will was granted to Anthony Aloysius Devine, of Warwick Lodge, Caroline-street, South Yarra, civil servant), are hereby required to send, in writing, particulars of such claims to the said Anthony Aloysius Devine, in the care of the under-mentioned solicitors, on or before the 1st day of April, 1948, after which date he will convey or distribute such property or estate to or among the persons entitled thereto, having regard only to the claims of which he shall then have had notice.

HARWOOD & PINCOTT, 51 Yarra-street, Geelong, solicitors for the said Anthony Aloysius Devine. 3192

HERBERT HILL, late of Bona Vista, Warragul, in the State of Victoria, retired farmer, DECEASED (who died on the 19th day of December, 1947).

**C**REDITORS, next of kin, and all others having claims against the property or estate of above-named deceased are required by the executors, Norman Herbert Hill, of Hopetoun-street, Camperdown, in the said State, painter, and George Leslie Hill, of Manifold-street, Camperdown aforesaid, electrical contractor, to send particulars thereof to them, care of the under-mentioned solicitors, on or before the 18th day of March, 1948, after which date the executors will distribute the property and estate of said deceased, having regard only to the claims of which they shall then have had notice.

GRAY, FRIEND, & MOONIE, solicitors, Warragul. 3194

**C**REDITORS, next of kin, and all other persons having claims in respect of the estate of Ellen Amies, late of 206 St. Kilda-street, Middle Brighton, spinster (who died on the 27th August, 1947), are to send particulars of their claims to The Union Trustee Company of Australia Limited, of 333 Collins-street, Melbourne, by the 7th April, 1948, after which date the company will distribute the assets, having regard only to the claims of which the company shall then have had notice.

MADDOCK, LONIE, AND CHISHOLM, 339 Collins-street, Melbourne, solicitors. 3249

**NOTICE TO CREDITORS.**—*RE* MINNIE HARGREAVES, late of 1071 Dandenong-road, East Malvern, in Victoria, widow, DECEASED.

PURSUANT to the provisions of the *Trustee Act 1928*, notice is hereby given that the National Trustees, Executors, and Agency Company of Australasia Limited, whose registered office is situated at 95 Queen-street, Melbourne, in Victoria, the executor of the will of the above-named deceased (who died on the 27th day of August, 1947, and probate of whose will was granted to the said executor by the Supreme Court of Victoria, in its probate jurisdiction, on the 19th day of January, 1948), intends to convey or distribute the estate of the said deceased to or amongst the persons entitled thereto, and all persons interested or having any claims against the estate of the deceased are hereby required to send to the said National Trustees, Executors, and Agency Company of Australasia Limited, at its registered office, 95 Queen-street, Melbourne aforesaid, full particulars, in writing, of their claims against the said estate, on or before the 2nd day of April, 1948, and at the expiration of that time the said executor will convey or distribute the estate of the said deceased to or amongst the persons entitled thereto, having regard only to the claims of which it shall then have had notice.

Dated 23rd day of January, 1948.

MCINERNEY, WILLIAMS, & CURTAIN, of 90 Queen-street, Melbourne, solicitors for the executor. 3252

**CREDITORS**, next of kin, and others having claims in respect of the following estates:—

(a) Samuel Macdonald, formerly of 4 Jessie-street, Preston, but late of 116 Point Nepean-road, Gardenvale, railway employee, deceased (who died on the 2nd day of October, 1947);

(b) Hildred Leslie Macdonald, late of 4 Jessie-street, Preston, married woman, deceased (who died on the 5th day of August, 1947);

are to send the particulars of their claims to the executors of the respective wills, Archibald James Norris and William George Coates, care of the undersigned solicitors, by the 30th day of March, 1948, after which date they will distribute the respective assets, having regard only to the claims to which they then have notice.

NORRIS & NORRIS, solicitors, of 422 Collins-street, Melbourne. 3253

**CREDITORS**, next of kin, and all others having claims against the estate of William Stewart, late of "Clovelly," 270 Hawthorn-road, Caulfield, in Victoria, hotel proprietor, deceased (who died on the 1st day of August, 1947), are requested by the executors of his will, Olive Inez Wheller, of 270 Hawthorn-road, Caulfield, married woman, and Frederick Dower, of St. Arnaud, retired, to send particulars thereof to the said executors, care of the undersigned, on or before 5th April, 1948, after which date the said executors will distribute the assets, having regard only to the claims of which they then have notice.

MITCHELL & MONOTTI, solicitors, Napier-street, St. Arnaud. 3256

**CREDITORS**, next of kin, and others having claims in respect of the estate of George Stewart, late of Sydney, New South Wales, and latterly temporarily resident at 34 Hatton-place, Edinburgh, Scotland, gentleman, deceased (who died on 22nd September, 1945), are to send the particulars of their claims to The Trustees, Executors, and Agency Company Limited, of Nos. 401-403 Collins-street, Melbourne, by the 1st day of April, 1948, after which date it will distribute the assets, having regard only to the claims of which it then has notice.

W. H. FLOOD & PERMEZEL, solicitors, 379 Collins-street, Melbourne. 3235

**CREDITORS**, next of kin, and others having claims in respect of the estate of Constanza Carrasco, late of 789 Punt-road, South Yarra, in the State of Victoria, spinster, deceased (who died on the 8th day of November, 1947), are to send the particulars of their claims to The Trustees, Executors, and Agency Company Limited, of 401 Collins-street, Melbourne, in the said State, by the 31st day of March, 1948, after which date it will distribute the assets, having regard only to the claims of which it then has notice.

HEDDERWICK, FOOKES, & ALSTON, 103 William-street, Melbourne, solicitors for the executor company. 3217

FLORENCE PIDGEON, late of Salthaven, Belmont, Geelong, in the State of Victoria, married woman, DECEASED (who died on 30th July, 1947).

**CREDITORS**, next of kin, and other persons having claims against the estate of the said deceased are required by The Union Trustee Company of Australasia Limited, of 333 Collins-street, Melbourne, in the said State, and Arthur Hose Bullivant, of 12 Marne-street, South Yarra, in the said State, gentleman, the executors of the will of the said deceased, to send particulars of claims, in writing, to the said The Union Trustee Company of Australasia Limited, at its address aforesaid, on or before the 31st day of March, 1948, after which date the said executors will distribute the assets, having regard only to the claims of which they shall then have had notice.

MADDEN, BUTLER, ELDER, & GRAHAM, 406 Collins-street, Melbourne. 3248

PURSUANT to the *Trustee Act 1928*, all persons having claims against the estate of Louisa Govan, late of 520 Barkly-street, Footscray, widow, deceased (who died on the 9th day of October, 1947, and probate of whose will was granted by the Supreme Court of Victoria, on the 17th day of December, 1947, to Colin Gaskell, of 487 Barkly-street, Footscray, toolmaker, the executor appointed by deceased's will), are hereby required to send particulars, in writing, of such claims to the said Colin Gaskell, care of the under-mentioned solicitors, on or before the 29th day of March, 1948, after which date the said executor will distribute the assets, having regard only to the claims of which notice has then been received.

MARTIN & MARTIN, solicitors, 37 Queen-street, Melbourne. 3250

PURSUANT to the provisions of the *Trustee Act 1928*, notice is hereby given that all persons having claims against the estate of Lillie Walker, late of "Krangibahtoo," The Island, Frankton, in the State of Victoria, spinster, deceased (who died on the 28th July, 1947, and probate of whose will was on the 20th January, 1948, granted by the Supreme Court of Victoria to Tom Compson Trumble, of 46 Queen-street, Melbourne, in the said State, solicitor, one of the executors appointed thereby), are hereby required to send particulars, in writing, of such claims to the said Tom Compson Trumble, to care of Malleon, Stewart, and Co., at the address below, on or before the 5th April, 1948, after which date the said executor will proceed to convey or distribute the said estate to or among the persons entitled thereto, having regard only to the claims, whether formal or not, of which he shall then have had notice, and will not be liable for the assets so distributed to any person of whose claim he shall not then have had notice.

MALLESON, STEWART, & CO., solicitors, 46 Queen-street, Melbourne. 3251

PURSUANT to the *Trustee Act 1928*, all persons having claims against the estate of Jane Monica Cleary, late of 14 Caroline-street, Clifton Hill, widow, deceased, intestate (who died on the 6th day of October, 1947, and letters of administration of whose estate was granted by the Supreme Court of Victoria, on the 18th day of December, 1947, to Bridget Josephine Ashton, of 52 Birch-street, Preston, married woman), are required to send particulars, in writing, of such claims to the said administratrix, care of the under-mentioned solicitor, on or before the 30th day of March, 1948, after which date the said administratrix will proceed to distribute the estate of the said deceased amongst the persons entitled thereto, having regard only to claims of which she shall then have had notice, and the said administratrix will not be liable for the assets so distributed, or any part thereof, to any person of whose claim she shall not then have had notice.

ROYSTON T. CAHIR, solicitor, 108 Queen-street, Melbourne. 3221

ANNIE BLACKLEY, late of 4 Lord-street, Glenhuntly, in the State of Victoria, married woman, DECEASED, intestate (who died on the 27th day of November, 1947).

**CREDITORS**, next of kin, and all other persons having claims against the estate of the above-named Annie Blackley, deceased, are required by Philomena Mary Coughlan, of 189 Hotham-street, East Melbourne, in the said State, spinster, the administratrix to whom letters of administration of the estate of the above-named deceased were granted, on the 14th day of January, 1948, to send particulars of their claims to her, at the office of the under-mentioned solicitors, on or before the 29th day of March, 1948, after which date she will distribute the assets of the said deceased among the persons entitled thereto, having regard only to the claims of which she then shall have notice, and she will not be liable to any person of whose claim she has not then received notice.

J. P. MINOGUE, CAREY, & MORAN, solicitors, 20 Queen-street, Melbourne. 3225

**CREDITORS**, next of kin, and others having claims in respect of the estate of Jean Miller Mercer, late of 126 Kooyong-road, Armadale, registered school teacher, deceased (who died on the 15th day of November, 1947), are to send the particulars of their claims to The Trustees, Executors, and Agency Company Limited, of 401 Collins-street, Melbourne, by the 1st day of April, 1948, after which date it will distribute the assets, having regard only to the claims of which it then has notice.

DAVID THOMAS, of 140 Queen-street, Melbourne, solicitors for the said company. 3226

**CREDITORS**, next of kin, and others having claims in respect of the estate of Fanny Johnson Gibb Jeffrey, formerly of Camp-street, Kangaroo Flat, but late of 172 Wattle-street, Bendigo, married woman, deceased (who died on 6th October, 1947), are to send the particulars of their claims to the executors, The Perpetual Executors and Trustees Association of Australia Limited, of 100 Queen-street, Melbourne, and Cecil Henry Trethowan Jeffrey, of 172 Wattle-street, Bendigo, care of the said company, by the 30th day of March, 1948, after which date they will distribute the assets, having regard only to the claims of which they then have notice.

Dated the 21st day of January, 1948.

HYETT & HYETT, solicitors, 51 Bull-street, Bendigo. 3202

**CREDITORS**, next of kin, and others having claims against the estate of Theodore Christian Hansen Holst (also known as Theodore Christian Hasen Holst), late of 159 Williamstown-road, West Footscray, gentleman, deceased (who died on the 3rd day of September, 1947, and probate of whose will was granted on the 14th January, 1948, to Rose Dorothy Holst, of 159 Williamstown-road, West Footscray, the executrix appointed by the deceased's will), are required to send particulars of their claims to the said Rose Dorothy Holst, care of John Ginnane, solicitor, 422 Collins-street, Melbourne, on or before the 9th day of April, 1948, after which date the said Rose Dorothy Holst will distribute the assets, having regard only to the claims of which she then has had notice.

JOHN GINNANE, solicitor, 422 Collins-street, Melbourne, and 74 Nicholson-street, Footscray. 3214

FLORENCE SARAH BLAKE, late of Bunnaloo, in the State of New South Wales, widow, DECEASED.

**CREDITORS**, next of kin, and all other persons having claims against the estate of the deceased are required by Geoffrey Robert Blake, of Bunnaloo aforesaid, farmer, the executor to whom probate of the will of the said deceased was granted to send particulars to him, care of the under-mentioned solicitors, on or before the 28th day of March, 1948, after which date he will distribute the assets, having regard only to the claims of which he shall then have notice.

Dated this 28th day of January, 1948.

T. M. WILLIAMS, WATSON, & JAMES, solicitors, 16 View-street, Bendigo. 3209

JAMES ELFORD, formerly of Keen-street, Caulfield, but late of Beverin-street, Sebastopol, in the State of Victoria, retired farmer, DECEASED (who died on the 14th day of April, 1947).

**CREDITORS**, next of kin, and all other persons having claims against the estate of the deceased are required by the executors, Francis Gordon Elford, formerly of the Teachers' Training College, Grattan-street, Carlton, but now of 76 New-street, Brighton, in the State of Victoria, school teacher, and Stanley Elford, formerly of Magpie, but now of Albert-street, Sebastopol, in the said State, farmer, to send particulars to them, care of this office, on or before the 30th day of April, 1948, after which date they will distribute the assets, having regard only to the claims of which they then have notice.

Dated the 20th day of January, 1948.

T. E. BYRNE & CO., solicitors, Ballarat. 3210

**CREDITORS**, next of kin, and others having claims in respect of the estate of Samuel Lewers, late of Linton, in the State of Victoria, retired grazier, deceased (who died on the 5th day of September, 1947), are to send particulars of their claims to the executor, The Ballarat Trustees, Executors, and Agency Company Limited, of 101 Lydiard-street north, Ballarat, in the said State, by the 7th day of April, 1948, after which date it will distribute the assets, having regard only to the claims of which it then has notice.

CUTHBERT, MORROW, MUST, & SHAW, solicitors, Ballarat. 3211

**PURSUANT** to the *Trustee Act* 1928, creditors, beneficiaries, next of kin, and all other persons having claims against the estate of Agnes Mary Hunt, late of 84 Blessington-street, St. Kilda, in the State of Victoria, widow, deceased (who died on the 20th day of October, 1947, and probate of whose will was granted by the Supreme Court of Victoria on the 19th day of January, 1948, to The Trustees, Executors, and Agency Company Limited, of 401 Collins-street, Melbourne, the executor appointed by the said will), are hereby required to send particulars, in writing, of such claims to the said executor, at its above address, on or before the 14th of April, 1948, after which date the said executor will distribute the said estate amongst the persons entitled thereto, having regard only to the claims of which it shall then have had notice, and the said executor will not be liable for the assets so distributed to any person of whose claim it shall not then have had notice.

DAVIES & HAYES, solicitors, 113 Campbell-street, Swan Hill. 3207

**PURSUANT** to the *Trustee Act* 1928, all persons having claims against the property or estate of Annie Eveline Duncan, formerly of Oxford Chambers, Bourke-street, Melbourne, but late of "Elenara," 2 Fitzroy-street, St. Kilda, in Victoria, widow, deceased (who died on the 24th day of October, 1947, and probate of whose will and codicil was granted by the Supreme Court of Victoria on the 21st day of January, 1948, to Bernard Gore Brett, of 120 William-street, Melbourne, in Victoria, solicitor, one of the executors named in and appointed by the said will), are hereby required to send particulars of such claims to the said executor, addressed to the care of Messieurs Blake and Riggall, 120 William-street, Melbourne, solicitors, on or before the 31st day of March, 1948, after the expiration of which time the said executor will proceed to distribute the assets of the said deceased amongst the persons entitled thereto, having regard only to the claims of which he shall have had notice.

Dated this 22nd day of January, 1948.

BLAKE & RIGGALL, 120 William-street, Melbourne, solicitors for the said executor. 3238

**CREDITORS**, next of kin, and others having claims in respect of the estate of William John Hall, formerly of Doutta Galla, via Tullamarine, but late of 29 Norfolk-road, Essendon, farmer, deceased (who died on the 19th day of August, 1947), are to send particulars of their claims to The Ballarat Trustees, Executors, and Agency Company Limited, of 101 Lydiard-street, Ballarat, by the 31st day of March, 1948, after which date it will distribute the assets, having regard only to claims of which it then has notice.

WILLIAM S. COOK & McCALLUM, solicitors, 422 Collins-street, Melbourne. 3239

**PURSUANT** to the provisions of the *Trustee Act* 1928, notice is hereby given that all persons having claims against the estate of Speros Marados, late of 290 Little Lonsdale-street, Melbourne, in the State of Victoria, cook, deceased (who died on the 3rd day of April, 1947, and letters of administration were granted by the Supreme Court of Victoria to The National Trustees, Executors, and Agency Company of Australasia Limited, of 95 Queen-street, Melbourne, the administrators therein), are hereby required to send particulars, in writing, of such claims to the said company, at the above address, on or before the 7th day of April, 1948, after which date the said administrators will proceed to convey or distribute the said estate to or among the persons entitled thereto, having regard only to the claims, whether formal or not, of which it shall then have had notice, and will not be liable for the assets so distributed to any person of whose claim he shall not then have had notice.

D. CONDON, solicitor, 469 Little Collins-street, Melbourne. 3242

BARTHOLOMEW JAMES DONOVAN, DECEASED.

**CREDITORS**, next of kin, and others having claims in respect of the estate of Bartholomew James Donovan, late of 4 Crimea-street, Caulfield, in the State of Victoria, retired farmer, deceased (who died on the 23rd day of October, 1947), are to send the particulars of their claims to The Union Trustee Company of Australia Limited, of 333 Collins-street, Melbourne, in the said State, by the 29th day of March, 1948, after which date it will distribute the assets, having regard only to the claims of which it then has notice.

MELVILLE & McCONKEY, solicitors, 409-413 Collins-street, Melbourne. 3227



**CREDITORS**, next of kin, and others having claims in respect of the estate of Doris Muriel Dagmar Greene Kelly, late of Myrnong Close, 204 Orrong-road, Toorak, in the State of Victoria, widow, deceased (who died on the 25th day of June, 1947, and probate of whose will was granted by the Supreme Court of Victoria on the 21st day of January, 1948, to The Union Trustee Company of Australia Limited, of 333 Collins-street, Melbourne, the executor named in the said will), are to send particulars of their claims to the said company, at its address above mentioned, by the 31st day of March, 1948, after which date it will distribute the assets, having regard only to the claims of which it then has notice.

Dated this 22nd day of January, 1948.

BLAKE & RIGGALL, 120 William-street, Melbourne, solicitors for the said executors. 3237

**CREDITORS**, next of kin, and others having claims against the estate of Mary Elizabeth Donne, late of 93 The Strand, Newport, widow (who died on the 18th day of June, 1947), are to send particulars of their claims to the executor, Leon Ernest Gerald Donne, care of the undersigned, by the 3rd day of April, 1948, after which date he will distribute the assets, having regard only to the claims of which he then has notice.

HENDERSON & BALL, solicitors, 430 Little Collins-street, Melbourne. 3246

**PURSUANT** to the provisions of the *Trustee Act 1928*, notice is hereby given that all persons having claims against the estate of Victor Peacock, late of Wallan, in the State of Victoria, farmer, deceased (who died on the 15th day of August, 1947, and letters of administration were granted by the Supreme Court of Victoria to Florence Catherine Peacock, of Wallan, in the said State, widow, the administratrix therein), are hereby required to send particulars, in writing, of such claims to the said administratrix, care of the address below; on or before the 7th day of April, 1948, after which date the said administratrix will proceed to convey or distribute the said estate to or among the persons entitled thereto, having regard only to the claims, whether formal or not, of which it shall then have had notice, and will not be liable for the assets so distributed to any person of whose claim she shall not then have had notice.

D. CONDON, solicitor, 469 Little Collins-street, Melbourne. 3243

ELIZABETH LYONS, late of 7 Muir-street, Hawthorn, in Victoria, widow, DECEASED.

**CREDITORS**, next of kin, and all other persons having claims against the estate of the above-named Elizabeth Lyons, deceased, are required by her executors, Albert Burns, reporter, and Eileen Burns, married woman, both of 95 York-street, Richmond aforesaid, to send particulars of such claims to the executors, in care of the under-mentioned solicitors, on or before the 16th day of April, 1948, after which date the said executors will distribute the assets of the estate, having regard only to the claims of which they shall then have had notice.

Dated this 21st day of January, 1948.

L'ESTRANGE & KENNEDY, solicitors, 291 Bridge-road, Richmond. 3232

**PURSUANT** to the *Trustee Act 1928*, notice is hereby given that all creditors, next of kin, and others having claims against the property or estate of Nancy Rose Rose, late of "Fairview," Woodend, formerly of "Penarth," Redesdale, in the State of Victoria, married woman, deceased (who died on the 23rd day of August, 1944, and probate of whose will was granted by the Supreme Court of Victoria, in its probate jurisdiction, on the 15th day of May, 1945, to Hugh Strathnairn Rose, of "Fairview," Woodend aforesaid, grazier, and Stanley William Byrne, of 101 William-street, Melbourne, in the said State, solicitor), are hereby required to send particulars, in writing, of such claims to the said executors, addressed to 101 William-street, Melbourne aforesaid, on or before the 30th day of March, 1948, after which date the said executors will proceed to distribute the assets of the said deceased amongst the persons entitled thereto, having regard only to the claims of which they shall then have had notice. And notice is hereby further given that the said executors will not be liable for the assets, or any part thereof, so distributed to any person of whose claim they shall not then have had notice.

Dated this 22nd day of January, 1948.

WHITING & BYRNE, of 101 William-street, Melbourne, solicitors for the executors. 3233

**CREDITORS**, next of kin, and others having claims in respect of the estate of Francis Edward Price, late of 1233 Howitt-street, Wendouree, in Victoria, mental hospital attendant, deceased (who died on the 16th day of August, 1947), are to send the particulars of their claims to the Ballarat Trustees, Executors, and Agency Co. Ltd., by the 31st day of March, 1948, after which date it will distribute the assets, having regard only to the claims of which it then has notice.

R. W. SHELLARD & SON, Albert-street, Daylesford, proctors. 3231

**PURSUANT** to the *Trustee Act 1928*, all persons having claims against the property or estate of Helen Kestell Le Roux, formerly of Martindale, Barnawartha, but late of Moorooduc, in the State of Victoria, married woman, deceased (who died on the eleventh day of October, 1947, and probate of whose will was granted by the Supreme Court of Victoria, on the 30th day of December, 1947, to Henry Reeve Le Roux, of Moorooduc aforesaid, farmer and grazier, the executor named in and appointed by the said will), are hereby required to send particulars of such claims to the said executor, addressed to the care of Frank B. Lethbridge, of Rutherglen, solicitor, on or before the 31st day of March, 1948, after the expiration of which time the said executor will proceed to distribute the assets of the said deceased amongst the persons entitled thereto, having regard only to the claims of which he will then have had notice.

Dated the 20th day of January, 1948.

FRANK B. LETHBRIDGE, of Rutherglen, solicitor for the said executor. 3229

#### *Trustee Act 1928.*

#### NOTICE TO CLAIMANTS.

**PURSUANT** to the *Trustee Act 1928*, creditors, next of kin, and all other persons having claims in respect of the estate of any deceased person named below are required to send particulars thereof to the legal personal representative or representatives at the address stated below, on or before the date stated, after which date the representative or representatives will distribute the assets, having regard only to the claims of which notice has been received:—

Alexander James Hurtle Casey, formerly of Wallington, poultry farmer, but late of Bailey-street, Belmont, Geelong, retired farmer, died 25th October, 1947.—Claims to the applicants for probate, Alma Isabel Farrell, of Bailey-street, Belmont, Geelong, married woman, and Loris Esma Mallard, of 27 Station-street, Mortdale, Sydney, married woman, care of Wighton and McDonald, solicitors, 53 Yarra-street, Geelong, by 30th March, 1948. 3212

Alice Lewis, late of 6 Heath-street, Sandringham, spinster, deceased, died 25th November, 1947.—Claims to the executors, Frederick Smith Kendall, of 10 Paywit-street, Preston, engineer, and Jack Whitehead Powling, of Port Fairy, solicitor, care of the said J. W. Powling, by 2nd April, 1948. 3213

Anthony Mifsud, formerly of Albion Quarries, Sunshine, in the State of Victoria, but late No. V502750, Australian Military Forces, deceased, died 12th December, 1944.—Claims to the administrator, National Trustees, Executors, and Agency Company of Australasia Limited, whose registered office is situate at 95 Queen-street, Melbourne, before 30th March, 1948. F. J. Corder, solicitor, 108 Queen-street, Melbourne. 3216

Robert Grace Christoferson, late of Cape Everard, assistant lighthouse-keeper, deceased, who is presumed to have died on the 3rd day of April, 1947.—Claims to the administratrix, Gladys Lillian Christoferson, care of J. McD. Jones, solicitor, 421 Bourke-street, Melbourne, by the 31st day of March, 1948. 3223

#### MINING NOTICES.

##### HERCULES GOLD MINING COMPANY NO LIABILITY.

**ALL** contributing shares (Nos. 1 to 60,000), upon which the 64th Call of Three pence per share (due and payable on 14th January, 1948) remains unpaid, will be sold by public auction at the Stock Exchange, Melbourne, on Tuesday, 10th February, 1948, at a quarter to Twelve o'clock a.m., unless the call be previously paid.

H. L. STEWART

(J. G. Stanfield and Stewart), Manager.

379 Collins-street, Melbourne.

3254

**IRONBARK GOLD MINING COMPANY NO LIABILITY.**

ALL contributing shares (Nos. 1 to 60,000), upon which the 107th Call of Three pence per share (due and payable on 14th January, 1948) remains unpaid, will be sold by public auction at the Stock Exchange, Melbourne, on Tuesday, 10th February, 1948, at a quarter to Twelve o'clock a.m., unless the call be previously paid.

H. L. STEWART  
(J. G. Stanfield and Stewart), Manager.  
379 Collins-street, Melbourne. 3255

**IMPOUNDINGS.**

**COBDEN.**—Impounded in Cobden Pound.

- 1 red and white bull calf, no visible brand
- 1 black and white bull calf, stumpy tail, piece out of top near ear, branded T
- 1 red and white brindle heifer calf, piece out of top near ear, branded T
- 1 dark-brown heifer calf, piece out of top near ear, branded T
- 1 red and white heifer calf, piece out of top near ear, branded T
- 1 black Jersey heifer calf, piece out of top near ear, branded T
- 1 light-red heifer calf, piece out of top near ear, branded T
- 1 light-red heifer calf, piece out of top near ear, no visible brand

If not claimed and expenses paid, to be sold on 6th February, 1948.

J. S. BRADD,  
Poundkeeper.  
3257—12/8

**COLERAINE.**—Impounded at Coleraine, off road, by Mrs. J. Spong.

- 1 bay mare, blaze down face, white feet and docked tail, no visible brand

If not claimed and expenses paid, to be sold on 7th February, 1948.

S. R. DOLMAN,  
Poundkeeper.  
3200—5/4

**ROSEDALE.**—Impounded at Rosedale.

- 1 black gelding, white front feet, no visible brand
- 1 bay mare, star on forehead, one white off hind foot, no visible brand
- 1 bay draught gelding, white face, white hind feet, like ? over half-circle on near shoulder

If not claimed and expenses paid, to be sold on 4th March, 1948.

G. FARLEY,  
Poundkeeper.  
3228—6/8

**WARRNAMBOOL.**—Impounded at Warrnambool.

- 1 brown Jersey cow, notch bottom of off ear, like EE on off side rump
- 1 yellow heifer calf, branded like EE
- 1 yellow heifer calf, like EE on both rumps
- 1 dark Jersey heifer calf, like EE on near side rump

If not claimed and expenses paid, to be sold on 4th February, 1948.

I. HILDER,  
Poundkeeper.  
3230—6/8

**THE "VICTORIA GOVERNMENT GAZETTE."**

SUBSCRIPTIONS.—The subscription, including Postage, is £1 12s. 6d. per annum, 16s. 3d. half-yearly, or 8s. 2d. per quarter, payable in advance.

Subscriptions are required to commence and terminate with a month.

A lesser period than three months cannot be subscribed for.

Subscribers do not receive the Acts of Parliament with the GAZETTE.

ADVERTISEMENTS are charged at the rate of EIGHT PENCE per line single column, and ONE SHILLING and FOUR PENCE per line double column.

The title (£5 Reward, Dissolution of Partnership, &c.) forms one or more lines as a heading.

On an average, ten words make a line.

Every signature must likewise be counted as a line.

The final words of a paragraph, though only portion of a line must be counted as one line.

SIGNATURES (in particular) and proper names must be written very plainly in the text; ONE SIDE ONLY of each slip of paper should be WRITTEN UPON.

ALL COMMUNICATIONS should be addressed to "The Government Printer, Melbourne."

ALL DOCUMENTS illegibly written will be returned unpublished, and, where brands occur unprovided for by the ordinary letters of the alphabet, a worded explanatory description must be furnished.

THE VICTORIA GOVERNMENT GAZETTE is published on WEDNESDAY EVENING in each week, and Notices for insertion will be received by the Government Printer at or before Two p.m., at ordinary rates, and late advertisements between Two p.m. and Five p.m. at double rates on the day preceding the day of publication.

Single copies of the VICTORIA GOVERNMENT GAZETTE are Six pence, posted Eight pence, each.

No GAZETTES prior to January, 1936, in stock.

\*\*\*ALL PAYMENTS ARE REQUIRED IN ADVANCE.—Remittances should be made by postal note, money order, or draft in favour of the Government Printer. Advertisements unaccompanied by a remittance sufficient to cover the cost of insertion will be returned unpublished.

**CONTENTS**

	PAGE.
Appointments .. .. .	397
Auction Sales Act .. .. .	402, 405
Business Agents Act 1930—Supplementary List ..	404
Contracts .. .. .	405
Country Roads Board .. .. .	412
Courts .. .. .	399
Estates of Deceased Persons .. .. .	401
Government Notices .. .. .	399
Impoundings .. .. .	430
Lands .. .. .	413
Mining .. .. .	401, 429
Notice to Mariners .. .. .	403
Orders in Council .. .. .	407
Private Advertisements .. .. .	419
Public Service Notices .. .. .	398
Real Estate Agents Act—Supplementary List ..	405
Resignations .. .. .	398
State Rivers and Water Supply Commission ..	402
Stay Orders .. .. .	401
Tenders .. .. .	418
Transport Regulation Board—Public Hearings ..	400
Waterworks Trusts .. .. .	403