



VICTORIA  
GOVERNMENT GAZETTE.

Published by Authority.

[Registered at the General Post Office, Melbourne, for transmission by post as a newspaper.]

No. 351]

WEDNESDAY, APRIL 21.

[1948

*Water Act 1947 (No. 5253).*

AMENDMENT OF PUBLIC ACCOUNT ADVANCES ACT  
1924 (No. 3341) AS AMENDED.

PROCLAMATION

By His Excellency the Governor of the State of Victoria  
and its Dependencies in the Commonwealth of Australia,  
&c., &c., &c.

WHEREAS by sub-section 5 of section three of *Water Act 1947 (No. 5253)* it is amongst other things enacted that section eight of *Public Account Advances Act 1924* shall as from a date to be fixed by proclamation be amended as provided in the said sub-section: Now therefore I, the Governor of the State of Victoria, by and with the advice of the Executive Council thereof, do by this my Proclamation fix the 21st day of April, 1948, as the said date.

Given under my Hand and the Seal of the State of Victoria aforesaid, at Melbourne, this twentieth day of April in the year of our Lord One thousand nine hundred and forty-eight, and in the twelfth year of the reign of His Majesty King George VI.

(L.S.)

WINSTON DUGAN.

By His Excellency's Command,

A. A. DUNSTAN,  
for Minister of Water Supply.

GOD SAVE THE KING!

*Vermin and Noxious Weeds Act 1928.*

CERTAIN PLANT DECLARED TO BE A NOXIOUS  
WEED WITHIN THE SHIRE OF ROCHESTER.

PROCLAMATION

By His Excellency the Governor of the State of Victoria  
and its Dependencies in the Commonwealth of Australia,  
&c., &c., &c.

IN pursuance of the provisions of section 6 of the *Vermin and Noxious Weeds Act 1928 (No. 3799)*, I, the Governor of the State of Victoria, by and with the advice of the Executive Council of the said State, do by this my Proclamation declare the plant named hereunder to be a noxious weed for the purposes of the above Act within the Shire of Rochester, viz.:—

*Juncus Acutus*, "Spiny Rush."

Given under my Hand and the Seal of the State of Victoria aforesaid, at Melbourne, this thirteenth day of April, in the year of our Lord One thousand nine hundred and forty-eight, and in the twelfth year of the reign of His Majesty King George VI.

(L.S.)

WINSTON DUGAN.

By His Excellency's Command,

J. G. B. McDONALD,  
Commissioner of Crown Lands and Survey.

GOD SAVE THE KING!

PUBLIC HIGHWAY.—CITY OF OAKLEIGH.

PROCLAMATION

By His Excellency the Governor of the State of Victoria and its Dependencies in the Commonwealth of Australia, &c., &c., &c.

WHEREAS by the *Local Government Act 1946* (No. 5203), section 518, it is amongst other things enacted that it shall be lawful for the Governor in Council at any time, and from time to time, upon the request of the council of any municipality, by notice in the *Government Gazette*, to declare any land reserved, used or by purchase or exchange acquired for a street, road, highway, thoroughfare, bridge, square, court, alley or right-of-way to be a public highway, and that such land shall thereupon and thenceforth from the date of such Proclamation become and be absolutely dedicated to the public as a public highway within the meaning of any law then or thereafter in force: And whereas the Council of the City of Oakleigh has requested that the land hereinafter mentioned, which has been used as a street within the said city, be so declared to be a public highway: Now therefore I, the Governor of the State of Victoria, in the Commonwealth of Australia, by and with the advice of the Executive Council of the said State, do by this Proclamation declare that all that piece of land used as a street and being parts of Crown allotments 4 and 5, section 1, Parish of Mordialloc, County of Bourke, and indicated by hachure on the plan hereunder, shall be a public highway within the meaning of the said Act, viz.:—

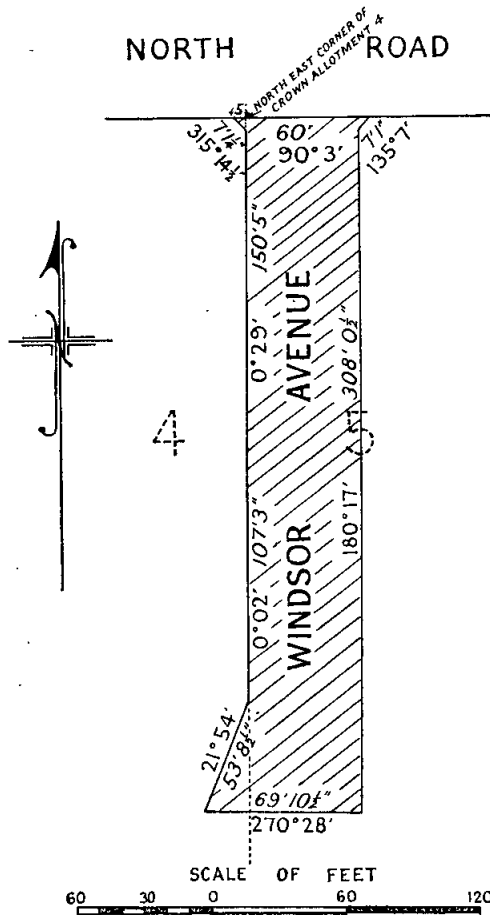

Given under my Hand and the Seal of the State of Victoria aforesaid, at Melbourne, this thirteenth day of April, in the year of our Lord One thousand nine hundred and forty-eight, and in the twelfth year of the reign of His Majesty King George VI.

(L.S.) WINSTON DUGAN.

By His Excellency's Command,  
J. A. KENNEDY,  
Commissioner of Public Works.  
GOD SAVE THE KING!

LABOUR DAY HOLIDAY.

IT is hereby notified that—

MONDAY, THE 26TH APRIL, 1948,

will be observed as a Holiday in the Public Offices throughout the State of Victoria, with the exception of those situated within the following areas:—

The City of Bendigo; the Boroughs of Castlemaine, Eaglehawk, Echuca, Inglewood, and Maryborough; and the Shires of Bet Bet, Deakin, East Loddon, Gordon, Huntly, Korong, Kyneton, McIvor, Maldon, Marong, Metcalfe, Newstead and Mount Alexander, Rochester, Strathfieldsaye, Tullaroop, and Waranga.

K. DODGSHUN,  
Chief Secretary.

Chief Secretary's Office,  
Melbourne, 2nd April, 1948.

APPOINTMENTS.

HIS Excellency the Governor of the State of Victoria, by and with the advice of the Executive Council thereof, has, by Orders made on the 13th day of April, 1948, been pleased to make the under-mentioned appointments, viz.:—

DEPARTMENT OF CHIEF SECRETARY.

*Registrar of Births and Deaths.*

STANLEY MAXWELL JONES,  
pursuant to the provisions of section 4 of the *Registration of Births Deaths and Marriages Act 1928*, to be Registrar of Births and Deaths at Trafalgar, to date from commencement of duty, with fees, *vice* Frank H. Dineen, resigned.

*Assistant to Inspector of Fisheries.*

LESLIE RUDOLPH WERNER,  
pursuant to the provisions of the Fisheries Acts, to be an Assistant to the Inspector of Fisheries.

DEPARTMENT OF HEALTH.

*Trustees of Cemeteries.*

LESLIE DRISCOLL  
to be a Trustee of the Barkly Public Cemetery, *vice* R. Herd, resigned;

HORACE EMERSON  
to be a Trustee of the Barkly Public Cemetery;  
ALVIN WILLIAM THOMAS COLE  
to be a Trustee of the Kiata Public Cemetery, *vice* P. A. Collins, deceased;

FREDERICK JOHN BECK  
to be a Trustee of the Korong Vale Public Cemetery, *vice* F. J. Bohan, deceased;

CHARLES CUNNINGHAM  
to be a Trustee of the Landsborough Public Cemetery, *vice* M. M. Wright;

HOWARD COX  
to be a Trustee of the Miners' Rest Public Cemetery, *vice* Miss H. Wilson, resigned;

VICTOR RICHARD McNAB  
to be a Trustee of the Mooroopna Public Cemetery, *vice* H. Turnbull, deceased;

PERCIVAL PLACE MARLOW  
to be a Trustee of the Pompapeli Public Cemetery, *vice* N. Kirwan, left district;

JAMES CROFTON LEE  
to be a Trustee of the Sale Public Cemetery, *vice* J. Ronchi, deceased;

THOMAS ERIL  
to be a Trustee of the Seymour Public Cemetery, *vice* J. P. O'Sullivan, deceased; and

WILLIAM EDWARD GRIFFITHS VAUGHAN  
to be a Trustee of the Warracknabeal Public Cemetery.

*Acting Clerks of Mental Hospitals.*

WILLIAM JOHN ALEXANDER RAE  
to be Acting Clerk of the Mental Hospital, Kew, from the 13th April, 1948, *vice* William Clement Ball, on leave;

MERVIN JOHN HANDLEY  
to be Acting Clerk of the Repatriation Mental Hospital, Bundoora, from the 5th April, 1948, *vice* Norman Francis Wilkinson, on leave; and

KENNETH MELTON BAIRD  
to be Acting Clerk of the Receiving House and Mental Hospital, Royal Park, from the 9th April, 1948, *vice* Harold Francis Simmons, on sick leave.

*President of Dental Board.*

GEORGE FINDLAY  
to be President of the Dental Board of Victoria, for the period ending 28th February, 1949, pursuant to the provisions of section 38 of the *Medical Act 1928*.

*Government Representative on Hospital Committee.*

CHARLES IAN MURRAY MILNER  
to be Government Representative on Committee of Management of the Frankston Community Hospital, from the 23rd March, 1948, *vice* Charles Ian Murray.

## DEPARTMENT OF LANDS AND SURVEY.

*Trustees of Site.*

WILLIAM EADIE HEMPHILL,  
NOEL THOMAS GEORGE NAPIER, and  
ROBERT JAMES SIMPSON,  
to be Trustees of the land permanently reserved on the 7th January, 1890, as a site for a Mechanics' Institute and Free Library at Alexandra, in the room of Arthur Kidd, deceased, George David Leckie, deceased, and Harry Wood, resigned.

## DEPARTMENT OF LAW.

*Clerk of Petty Sessions (Acting), &c.*

ALFRED JAMES O'KEEFE, First Constable of Police, Cowes,  
to be also Clerk of Petty Sessions (acting) and Clerk of the Children's Court (acting) at Cowes, during the period during which he acted as such First Constable at Cowes, from the 9th to the 31st December, 1947.

*Commissioners for Taking Declarations, &c.*

DAVID CHARLES KIMPTON, 12 Chesterfield-avenue, Malvern, and  
ALBERT JOHN BOYD, 80 Monash-street, Sunshine,  
to be Commissioners for taking Declarations and Affidavits, pursuant to the provisions of Division 8 of Part IV. of the *Evidence Act 1928*, to resign upon removing from the neighbourhood of the addresses stated; and

EDWARD CHARLES TOY,  
THOMAS LEWIS HICKEY,  
LESLIE ARTHUR CHEONG, and  
EDWYN PIPER,

Officers of the Chamber of Manufacturers Insurance Limited, 312 Flinders-street, Melbourne,  
to be Commissioners for taking Declarations and Affidavits, pursuant to the provisions of Division 8 of Part IV. of the *Evidence Act 1928*, to resign upon ceasing to occupy their present positions.

*Magistrates.*

LYELL MAY KELLY, 1018 Malvern-road, Armadale,  
FRANK ERNEST PAICE, 28 Fuchsia-street, Blackburn, and  
ROBERT HAYWARD BARBER, 51 Shooobra-road, Elsternwick,  
to Keep the Peace in the Central Bailiwick of the State of Victoria;

ALLAN GEOFFREY BRANSDON, 30 Reid-street, Wangaratta,  
to Keep the Peace in the Northern Bailiwick of the State of Victoria;

SYDNEY THOMAS JOYCE, 92 Bent-street, Northcote,  
LORIS CECILIE ROSENBLUM, 6A Seymour-avenue, Malvern,  
NEVILLE GARDNER WHITEHEAD, 164 Flinders-street, Melbourne,

ALBERT WILLIAM GOLDSTONE, Traffic Superintendent, (Melbourne Branch), Trans Australian Air Lines, 339 Swanston-street, Melbourne,

REGINALD EDWARD GREGORY, Secretary, Myer Emporium Limited, Bourke-street, Melbourne,

RICHARD ALBERT HUTCHINGS, 12 York-street, Bonbeach,  
LESLIE NELSON MEIER, 364 Clarke-street, Northcote,  
WILLIAM HENRY TREYVAUD PULLEN, 32 Sussex-street, Middle Brighton,

ERIC STEVENS PURBRICK, Chateau Tabilk, Tabilk,  
PERCY EVANS, 5 Howitt-street, Glen Iris,  
HENRY FREDERICK PROT, 9 Glencairn-avenue, Coburg, and

COLUMBUS LEIGH PRICE, 48 Darling-road, East Malvern,  
to Keep the Peace in the Central Bailiwick of the State of Victoria.

*Probation Officer.*

GRAHAM ALEXANDER CONNAN, 138 Lord-street, Richmond,

to be a Probation Officer, pursuant to the provisions of section 8 of the *Children's Court Act 1928*, for the Children's Court at Richmond.

## DEPARTMENT OF PUBLIC WORKS.

*Wharf Managers, &c.*

First Constable LAWRENCE JOSEPH RYAN, No. 8937,  
as Wharf Manager at Mildura, to carry out that portion of Part II. of the *Marine Act 1928* which relates to the management of public wharfs, and to be an officer under section 19 of such Act to levy and collect wharfage rates thereat, without remuneration;

First Constable RONALD ALBERT NARROWAY KIRK, No. 8499,

as Wharf Manager at Port Campbell, to carry out that portion of Part II. of the *Marine Act 1928* which relates to the management of public wharfs, and to be an officer under section 19 of such Act to levy and collect wharfage rates thereat; and

Senior Constable JAMES LEWIS MCCOLL, No. 7501,  
as Wharf Manager at Sale, to carry out that portion of Part II. of the *Marine Act 1928* which relates to the management of public wharfs, and to be an officer under section 19 of such Act to levy and collect wharfage rates thereat.

*Members of the Architects Registration Board of Victoria.*

ALEC STANLEY EGGLESTON and  
STANLEY THOMAS PARKES,  
nominated by the Registered Architects,  
ARTHUR CEDRIC LEITH,  
nominated jointly by the governing bodies referred to in paragraph (a) of sub-section (1) of section 4 of the aforesaid Act; and  
BRIAN BANNATYNE LEWIS,  
nominated by the University of Melbourne,  
to be Members of the Architects Registration Board of Victoria for a period of two years from the 9th April, 1948, pursuant to section 5 of the *Architects Act 1928* (No. 3638).

C. W. KINSMAN,

Clerk of the Executive Council.

At the Executive Council Chamber,  
Melbourne, 13th April, 1948.

## RESIGNATIONS.

HIS Excellency the Governor of the State of Victoria, by and with the advice of the Executive Council thereof, has, by Orders made on the 13th day of April, 1948, accepted the resignations of the persons named hereunder of the offices mentioned, *viz.*:—

## DEPARTMENT OF CHIEF SECRETARY.

FRANK H. DINEEN, as Registrar of Births and Deaths at Trafalgar.

ALBERT JOSEPH MOYLAN, as a Licensing Inspector for each and every Licensing District in the State of Victoria, from and inclusive of the 12th April, 1948.

## DEPARTMENT OF LAW.

TOM AUSTIN SYMONS, as a Commissioner for taking Declarations and Affidavits, pursuant to the provisions of the *Evidence Act 1928*.

IAN AUSTIN STRINGER, as a Commissioner for taking Declarations and Affidavits, pursuant to the provisions of the *Evidence Act 1928*.

PATRICK JOSEPH BUSHELL, as a Probation Officer, pursuant to the provisions of the *Children's Court Act 1928*, from the Children's Court at Mildura.

C. W. KINSMAN,

Clerk of the Executive Council.

At the Executive Council Chamber,  
Melbourne, 13th April, 1948.

## PUBLIC SERVICE OF VICTORIA.—VACANCIES.

APPLICATIONS will be received by the Public Service Board up to Saturday, the 8th May, 1948, from persons employed in the Public Service of Victoria, who are eligible and qualified for appointment to the under-mentioned positions:—

## ADMINISTRATIVE DIVISION.

Clerk, Class "C," Department of Premier. (Two vacancies.)

*Yearly Salary.*—£449, minimum; £501, maximum.

*Duties.*—To act as Statistical Research Officer, Central Planning Authority; to undertake the collation and preparation of statistical information for the purposes of regional resources surveys; to maintain liaison with Regional Committees and assist such Committees in carrying out resources surveys; and to assist in the preparation of reports on the completed surveys.

*Qualifications.*—To have had experience in statistical work and be capable of interpreting statistics collated; possession of a degree or diploma in Economics or Commerce is desirable.

## PROFESSIONAL DIVISION.

Chief Engineer, Class "B1," Department of State Forests.

*Yearly Salary.*—£748, minimum; £800, maximum.

*Duties.*—To supervise the Engineering Branch of the Department; to advise the Commission on all technical, and practical aspects related to location of forest roads, tramways, water storages and

other works of a forests engineering character; to be responsible for determination of design, purchase and maintenance of engineering equipment.

**Qualifications.**—To be the holder of a University degree in Civil Engineering or a certificate of Qualification issued by the Municipal Engineers' Board or a recognized equivalent.

**Deputy Inspector-General of Penal Establishments, Class "B," Department of Chief Secretary.**

**Yearly Salary.**—£670, minimum; £722, maximum.

**Duties.**—To assist the Inspector-General in the administration of the Penal Department.

**Qualifications.**—To possess good educational qualifications, with preferably, a degree in Arts, Commerce or Law or equivalent qualifications, and to be experienced in the handling of men.

**Assistant District Engineer, Class "C1" (Murtoa), Department of Water Supply.**

**Yearly Salary.**—£527, minimum; £579, maximum.

**Duties.**—Under the direction of the District Engineer, to assist with the supervision and control of all rural and urban water supplies, works and expenditure for the Districts administered from Murtoa. To make surveys, prepare plans, specifications, estimates and reports in regard to works within the District and to assist with the supervision of construction and maintenance works throughout the district.

**Qualifications.**—To possess a University Degree or Technical School Diploma of Civil Engineering or equivalent qualifications; to be competent to carry out surveys, to supervise water distribution and to organize and control the work of large numbers of men and teams on Water Supply works; to have had experience in the design, construction and maintenance of channels and structures and Water Supply works.

**Senior Draughtsman, Grade II., Class "C1," Department of Water Supply.**

**Yearly Salary.**—£527, minimum; £579, maximum.

**Duties.**—To prepare under direction routine and detailed designs, estimates and plans of mechanical plant and installations and to prepare specifications for such plant.

**Qualifications.**—To possess a Technical School Diploma in Mechanical Engineering or Draughtsman's Expert Certificate or equivalent qualification, and to have had at least five years' practical experience in design of mechanical plant and installations; or alternatively to have had approved training as a Mechanical Draughtsman, and at least ten years of practical experience as above.

**Analyst, Grade I., Class "C," or Grade II., Class "D," Department of Agriculture.**

**Yearly Salary.**—Grade I., Class "C"—£449, minimum; £501, maximum. Grade II., Class "D"—£364, minimum; £436, maximum.

**Duties.**—To carry out soil surveying in the field under direction; to undertake analyses of agricultural products generally, and particularly of soils.

**Qualifications.**—To hold a University degree or approved diploma, with chemistry as a major subject, with preferably some analytical or soils experience.

The successful applicant will be graded in accordance with experience and qualifications.

TECHNICAL AND GENERAL DIVISION.

**Matron, His Majesty's Gaol, Pentridge, Penal and Gaols Branch, Department of Chief Secretary.**

**Yearly Salary.**—£331, minimum; £344, maximum.

**Duties.**—Under the direction of the Governor to control and administer the Female Division of Penal Establishment, Pentridge.

**Qualifications.**—Experience in institutional and staff management with ability to study and apply modern methods of treatment of delinquent females.

Successful applicant will be required to live in quarters for which a reduction of 5 per cent. of salary will be made.

**Ministerial Chauffeur, Department of Public Works.**

**Yearly Salary.**—£299, minimum; £351, maximum.

**Duties.**—To act as Chauffeur to the Minister and to transport senior officials as required; to keep such records as may be required.

**Qualifications.**—To be an experienced motor driver possessing a good mechanical knowledge of motor cars with ability to effect necessary minor repairs; to have a good knowledge of the roads of the State.

**Hall Porter, Mental Hospital, Sunbury, Department of Health.**

**Yearly Salary.**—£286, minimum; £312, maximum.

**Duties.**—To be responsible for cleanliness of Administrative offices; to attend to patients' visitors; to control Institutional switchboard and attend to public telephone; and to be responsible for the collection and distribution of inwards and outwards mail.

**Qualifications.**—Experience in dealing with the public; a good knowledge of the routine and organization of a Mental Hospital; and to be a good telephonist.

**NOTE.**—In addition to the salary rates quoted a cost of living adjustment (at present £40 a year for females, and £60 a year for males), which varies in accordance with the rise or fall in the index numbers of the cost of living, is payable.

By order,

E. F. FITZGIBBON,  
Secretary.

Office of the Public Service Board,  
Melbourne, 19th April, 1948.

Public Service of Victoria.

COMPETITIVE EXAMINATION FOR ADMISSION TO  
THE PUBLIC SERVICE.

(ADMINISTRATIVE DIVISION.)

**AN** examination of male candidates for appointment to Administrative Division of the Public Service of Victoria will be held on the 26th and 28th June, 1948.

The examination is open to persons who are recorded by the University of Melbourne as having passed the School Leaving examination or the School Intermediate examination or such other examination as may be deemed by the Board as equivalent thereto, and who—

- (a) on the 26th June, 1948, are between the ages of 15 and 22 years at last birthday; or
- (b) on the 3rd September, 1939, were under the age of 22 years, and who, having served in the Naval, Military, or Air Forces of the Commonwealth, the United Kingdom, or any other part of the British Dominions, were discharged from such Forces subsequent to the 28th June, 1945; or
- (c) are officers of the Technical and General Division of the Public Service.

A candidate will be required to enter for competitive examination in English, Mathematics, General Intelligence, General Knowledge, and Handwriting.

Two hundred candidates will be appointed.

Entries for the examination, accompanied by a fee of 5s., must be lodged at the office of the Public Service Board, Public Offices, Treasury-place, Melbourne, C.2 (where the prescribed forms are obtainable) on or before Saturday, the 5th June, 1948.

Provision is made on the entry form for candidates to state the centre in which they desire to sit for the examination.

By order,

E. F. FITZGIBBON,  
Secretary.

Office of the Public Service Board,  
Melbourne, 20th April, 1948.

**NOTIFICATION** is hereby given that the Permanent Head of the Department of Agriculture has recommended to the Public Service Board that a position of Field Agrostologist, Grade II., Class "C," Professional Division, Department of Agriculture, be filled by Rex J. Newman.

**Duties.**—To assist in the conduct of field experiments in the establishment and management of grasses, clovers, and other herbage plants; to carry out advisory work; to assist in the conduct of demonstrations and field days; to undertake the judging of pasture competitions, and deliver lectures.

**Qualifications.**—To possess a Degree in Agricultural Science, experience in the conduct of field pasture experiments and in the interpretation of results, and ability to prepare articles for publication and deliver lectures.

Appeals against such recommendation should be lodged with the Secretary to the Public Service Board not later than Saturday, the 1st May, 1948.

By order,

E. F. FITZGIBBON,  
Secretary.

Office of the Public Service Board,  
Melbourne, 19th April, 1948.

No. 235.

*Public Service Act 1946.*REGULATIONS.—PART III.—SALARIES, INCREMENTS,  
AND ALLOWANCES.

THE Public Service Board, in pursuance of the powers conferred by the *Public Service Act 1946*, hereby amends the Public Service (Public Service Board) Regulations as follows:—

The Seventh Schedule to these Regulations is hereby revoked and the following Schedule inserted in lieu thereof:—

## SEVENTH SCHEDULE.

## TECHNICAL AND GENERAL DIVISION.

## DEPARTMENT OF HEALTH.

## MENTAL HYGIENE.

*Offices and Rates of Salaries.*

Office.	Yearly Rate of Salary.		Increments (Annual).
	Minimum.	Maximum.	
<i>Criminal and Refractory Ward.</i>			
Attendant, Head .. .. .	£	£	..
Attendant, Relieving Charge .. .. .	..	436*	..
	..	403	..
<i>General Staff—Males.</i>			
Assistant, Travancore Developmental Centre .. .. .	291	351	..
Attendant, Assistant Head .. .. .	..	403	..
Attendant, Charge .. .. .	..	403	..
Attendant, Head, Grade I. .. .. .	..	462*	..
Attendant, Head, Grade II. .. .. .	..	436*	..
Attendant, Hospital .. .. .	..	403	..
Curator of Gardens .. .. .	364	403†	1 of £26 and 1 of £13
Dental Mechanic .. .. .	364	377	..
Engineer Mechanic, Grade I. .. .. .	..	417*	..
Engineer Mechanic, Grade II. .. .. .	..	393*	..
Engineer Mechanic, Senior .. .. .	436	462	1 of £26
Farm Manager (Mont Park) .. .. .	436	462*	1 of £26
Farm Manager, Grade I. .. .. .	410	423*	..
Farm Manager, Grade II. .. .. .	371	397*	1 of £26
Farm Manager, Assistant .. .. .	..	339	..
Hall Porter .. .. .	286	312	..
Laboratory Attendant .. .. .	338	377	1 of £13 and 1 of £26
Mechanic, Assistant .. .. .	338	351	..
<i>General Staff—Females.</i>			
Dental Attendant .. .. .	240	266	..
Guidance Kindergarten, Travancore Developmental Centre .. .. .	274	313	..
Housekeeper .. .. .	..	338‡	..
Nurse, Principal Chief (Mont Park) .. .. .	..	409‡	..
Nurse, Senior Chief (Kew, Beechworth, Sunbury, Ballarat) .. .. .	..	390‡	..
Nurse, Chief (Ararat, Royal Park, Kew Cottages, Stawell, Janefield) .. .. .	..	364‡	..
Nurse, Chief, Receiving House, Ballarat .. .. .	..	351‡	..
Nurse, Assistant Chief .. .. .	..	325	..
Nurse, Chief, Travancore Developmental Centre .. .. .	..	351*	..
Nurse, Hospital .. .. .	..	325	..
Nurse, Psychiatric Clinic, Travancore Developmental Centre .. .. .	311	350	..
Therapist, Organizing .. .. .	..	359	..
Therapist, Senior .. .. .	..	323	..
Therapist .. .. .	297	310	..
<i>Artisans and Servants—Males.</i>			
Blacksmith .. .. .	351	364	..
Bricklayer .. .. .	351	364	..
Carpenter, Senior .. .. .	351	364	..
Carpenter .. .. .	..	339	..
Carter .. .. .	286	325	..
Cook, Senior .. .. .	354	367	..
Cook .. .. .	..	341	..
Electrical Mechanic .. .. .	367	380	..
Motor Mechanic .. .. .	351	364	..
Fireman .. .. .	307	333	..
Gardener, Senior .. .. .	341	354*	..

\* Less deductions for quarters and allowances.  
† Subject to a charge of £50 for quarters and allowances.  
‡ Less deductions for quarters, allowances, and rations.

SEVENTH SCHEDULE—*continued.*

Office.	Yearly Rate of Salary.		Increments (Annual).
	Minimum.	Maximum.	
<i>DEPARTMENT OF HEALTH—continued.</i>			
<i>MENTAL HYGIENE—continued.</i>			
<i>Artisans and Servants—Males—continued.</i>			
Gardener .. .. .	..	329	..
Laundry Foreman .. .. .	367	380	..
Laundryman .. .. .	299	338	..
Painter, Senior .. .. .	351	364	..
Painter .. .. .	..	339	..
Plumber .. .. .	351	364	..
Shoemaker, Senior .. .. .	341	354	..
Shoemaker .. .. .	..	329	..
Soapmaker .. .. .	341	354	..
Storeman, Grade I. .. .. .	354	393	1 of £26 and 1 of £13
Storeman, Grade II. .. .. .	341	367	..
Stores Assistant .. .. .	315	328	..
Tailor, Senior .. .. .	341	354	..
Tailor .. .. .	..	329	..
Tinsmith .. .. .	341	354	..
Upholsterer, Senior .. .. .	351	364	..
Upholsterer .. .. .	..	339	..
Watchman .. .. .	286	325	..
<i>Artisans and Servants—Females.</i>			
Cook, Head .. .. .	289	302	..
Cook .. .. .	263	276	..
Female Reliever .. .. .	237	250	..
Laundress, Senior .. .. .	271	284	..
Laundress .. .. .	245	258	..
Mess Room Attendant .. .. .	..	225	..
Seamstress, Senior .. .. .	271	284	..
Seamstress .. .. .	245	258	..
Tailoress .. .. .	271	284	..
<i>Attendants.</i>			
Grade I. (in charge of large wards, Relieving Attendants in large hospital wards, and Senior Night Attendant in each hospital) .. .. .	364	377	..
Grade II. (relieving Attendants in large wards, in charge of small wards, and other special duties)	338	351§	..
Grade III. .. .. .	286	325¶	..
<i>Nurses.</i>			
Grade I. (in charge of large wards, Relieving Nurses in large hospital wards, and Senior Night Nurse in each hospital) .. .. .	..	310	..
Grade II. (Relieving Nurses in large wards, in charge of small wards, and other special duties)	284	297§	..
Grade III. .. .. .	232	271¶	..

§ An allowance of £13 a year may be paid to Grade II. Attendants or Nurses who have completed six years' service in Grade II.

¶ An allowance of £13 a year may be paid to officers who have completed four years' service as Attendants or Nurses and have passed the Third Examination.

*Note.*—When an officer is required to reside at the institution, a charge of £45 a year will be made (except where otherwise specified in these Regulations) for quarters and rations.

Chief Nurses, Housekeepers, Nurses, Cooks, and Laundresses will be provided with uniforms.

Attendants will be provided with one tunic and two pairs of trousers annually, and caps and helmets as required.

*Salaries of Officers residing in Separate Quarters in the Reserves of the various Mental Institutions.*

Deductions will be made from the salaries of these officers in accordance with the schedule hereunder:—

Rent .. .. .	..	As fixed
Fuel .. .. .	..	£12 a year
Light .. .. .	..	£6 a year
Water .. .. .	..	£2 a year
Vegetables .. .. .	..	£8 a year
Milk .. .. .	..	£4 a year
Laundry .. .. .	..	£6 a year

The Chief Nurses and Housekeepers will be charged £45 a year for rations and allowances other than quarters.

SEVENTH SCHEDULE.—*continued.*  
DEPARTMENT OF HEALTH—*continued.*  
MENTAL HYGIENE—*continued.*

Rent for quarters will be charged as under:—

For quarters occupied by—	
Head Attendants .. .. .	£20 a year
Farm Managers .. .. .	£20 a year
Mechanics .. .. .	£20 a year
Gardeners .. .. .	£20 a year
Chief Nurses .. .. .	£16 a year
Housekeepers .. .. .	£16 a year

Officers who are allowed Quarters for themselves only and Rations.—

Deductions will be made from the salaries of these officers as under:—	
Rent and allowances .. .. .	£18 a year
Rations .. .. .	£27 a year

*These Regulations shall have effect as on and from the 18th April, 1948.*

D. D. PAINE, Chairman.  
E. F. FITZGIBBON, Secretary.

Office of the Public Service Board,  
Melbourne, 13th April, 1948.

No. 236.

*Public Service Act 1946.*

REGULATIONS.—PART III.—SALARIES, INCREMENTS,  
AND ALLOWANCES.

THE Public Service Board, in pursuance of the powers conferred by the *Public Service Act 1946*, hereby amends the Public Service (Public Service Board) Regulations as follows:—

The Fifth Schedule to these Regulations is hereby revoked, and the following Schedule inserted in lieu thereof:—

FIFTH SCHEDULE.

TEMPORARY EMPLOYEES.

DEPARTMENT OF HEALTH.  
MENTAL HYGIENE.

*Designations of Positions and Rates of Salaries.*

Designation of Position.	Yearly Rate of Salary.	
	Minimum.	Maximum.
Attendant .. .. .	£	£
Carpenter .. .. .	..	286
Carter .. .. .	..	339
Cleaner and Labourer .. .. .	286	312
Cook (Male) .. .. .	286	299
Cook (Female) .. .. .	..	341
Female Reliever .. .. .	..	263
Firesman .. .. .	..	237
General Assistant .. .. .	307	320
Hairdresser (Female) .. .. .	..	299
Kitchen Maid .. .. .	..	291
Kitchen and Wardsmaid .. .. .	..	201
Laboratory Attendant .. .. .	..	201
Laundress .. .. .	338	364
Messroom Attendant .. .. .	..	245
Nurse .. .. .	..	225
Nurse, Chief (Bundoora) .. .. .	..	232
Nurse, Hospital .. .. .	..	364
Nurse, Psychiatric Clinic, Travancore Development Centre .. .. .	311	325
Painter .. .. .	..	337
Plumber .. .. .	..	339
Seamstress .. .. .	..	351
Supervisor, Moorakynne Hostel .. .. .	..	245
Supervisor, Assistant, Moorakynne Hostel .. .. .	..	297
Tailoress .. .. .	..	284
Therapist, Organizing (Female) .. .. .	..	271
	..	359

The relevant provisions contained in the footnote to the Seventh Schedule to these Regulations shall be deemed to be included in this Schedule.

*These Regulations shall have effect as on and from the 18th April, 1948.*

D. D. PAINE, Chairman.  
E. F. FITZGIBBON, Secretary.

Office of the Public Service Board,  
Melbourne, 13th April, 1948.

No. 226. *Public Service Act 1946, Section 50.*

REGULATIONS—PART III.—SALARIES, INCREMENTS, AND ALLOWANCES.

THE Public Service Board, in pursuance of the powers conferred by the *Public Service Act 1946*, hereby amends its Regulations as shown below :—

SIXTH SCHEDULE.  
TEMPORARY EMPLOYEES.

*Designations of Positions and Rates of Salaries.*

Department and Designation of Position.	Yearly Rate of Salary.		Increments (Annual).
	Minimum.	Maximum.	
DEPARTMENT OF HEALTH.	£	£	
GENERAL HEALTH.			
<i>Add—</i> Director of Tuberculosis .. .. .	..	1,150	..

*This Regulation shall have effect as on and from the 28th May, 1948.*

D. D. PAINE, Chairman.  
E. F. FITZGIBBON, Secretary.

Office of the Public Service Board,  
Melbourne, 31st March, 1948.

No. 227. *Public Service Act 1946, Section 50.*

REGULATIONS—PART III.—SALARIES, INCREMENTS, AND ALLOWANCES.

THE Public Service Board, in pursuance of the powers conferred by the *Public Service Act 1946*, hereby amends its Regulations as shown below :—

SECOND SCHEDULE.  
TECHNICAL AND GENERAL DIVISION.  
*Offices and Rates of Salaries.*

Department and Office.	Yearly Rate of Salary.		Increments (Annual).
	Minimum.	Maximum.	
GENERAL.	£	£	
<i>Delete—</i> Typist and Assistant (Male) ..	236	364	..
<i>Add—</i> Typist and Assistant (Male), Grade I .. .. .	364	390	..
Typist and Assistant (Male), Grade II .. .. .	286	364	..

D. D. PAINE, Chairman.  
E. F. FITZGIBBON, Secretary.

Office of the Public Service Board,  
Melbourne, 5th April, 1948.

No. 234. *Public Service Act 1946, Section 50.*

REGULATIONS—PART III.—SALARIES, INCREMENTS, AND ALLOWANCES.

THE Public Service Board, in pursuance of the powers conferred by the *Public Service Act 1946*, hereby amends its Regulations as shown below :—

SIXTH SCHEDULE.  
TEMPORARY EMPLOYEES.

*Designations of Positions and Rates of Salaries.*

Department and Designation of Position.	Yearly Rate of Salary.		Increments (Annual).
	Minimum.	Maximum.	
DEPARTMENT OF STATE FORESTS.	£	£	
<i>Add—</i> Firewood Machinery Officer .. .. .	..	390	..

*This Regulation shall have effect as on and from the 1st April, 1948.*

D. D. PAINE, Chairman.  
E. F. FITZGIBBON, Secretary.

Office of the Public Service Board,  
Melbourne, 5th April, 1948.

No. 228.

*Public Service Act 1946, Section 50.*

REGULATIONS—PART III.—SALARIES, INCREMENTS, AND ALLOWANCES.

THE Public Service Board, in pursuance of the powers conferred by the *Public Service Act 1946*, hereby amends its Regulations as shown below :—

SECOND SCHEDULE.

TECHNICAL AND GENERAL DIVISION.  
*Offices and Rates of Salaries.*

Department and Office.	Yearly Rate of Salary.		Increments (Annual).
	Minimum.	Maximum.	
DEPARTMENT OF PUBLIC WORKS.	£	£	
PORTS AND HARBOURS.			
<i>Delete—</i> Engine Driver of Launches .. .. .	312	338	..
Engine Driver, Marine .. .. .	312	338†	..
Engineer, Chief of Dredges, &c. .. .. .	..	438†	..
Engineer, Second .. .. .	..	386†	..
Engineer, Third .. .. .	..	360†	..
Master of Launches .. .. .	312	338	..
Master, Dredges, &c. .. .. .	..	438†	..
Mate, First, Dredges, &c. .. .. .	..	386†	..
Mate, Second, Dredges, &c. .. .. .	..	360†	..
<i>Add—</i> Engine Driver of Launches .. .. .	..	*	..
Engine Driver, Marine .. .. .	..	*†	..
Engineer, Chief of Dredges, &c. .. .. .	..	*†	..
Engineer, Second .. .. .	..	*†	..
Engineer, Third .. .. .	..	*†	..
Master of Launches .. .. .	..	*	..
Master, Dredges, &c. .. .. .	..	*†	..
Mate, First, Dredges, &c. .. .. .	..	*†	..
Mate, Second, Dredges, &c. .. .. .	..	*†	..

\* Rates in accordance with the Merchant Service Guild of Australia Award.

† With rations when required to live on the vessel.

*This Regulation shall have effect as on and from the 11th January, 1948.*

D. D. PAINE, Chairman.  
E. F. FITZGIBBON, Secretary.

Office of the Public Service Board,  
Melbourne, 5th April, 1948.

No. 230. *Public Service Act 1946, Section 39.*

REGULATIONS—PART III.—SALARIES, INCREMENTS, AND ALLOWANCES.

THE Public Service Board, in pursuance of the powers conferred by the *Public Service Act 1946*, hereby amends its Regulations as shown below :—

FIRST SCHEDULE.  
PROFESSIONAL DIVISION.  
*Offices and Rates of Salaries.*

Office.	Yearly Rate of Salary.	
	Minimum.	Maximum.
DEPARTMENT OF HEALTH.	£	£
GENERAL HEALTH BRANCH.		
CLASS "C."		
<i>Delete—</i> Building Surveyor .. .. .	449	501
CLASS "D."		
<i>Delete—</i> Building Surveyor .. .. .	364	436

D. D. PAINE, Chairman.  
E. F. FITZGIBBON, Secretary.

Office of the Public Service Board,  
Melbourne, 5th April, 1948.



No. 231.

Public Service Act 1946, Section 50.

REGULATIONS.—PART III.—SALARIES, INCREMENTS, AND ALLOWANCES.

THE Public Service Board, in pursuance of the powers conferred by the Public Service Act 1946, hereby amends its Regulations as shown below:—

SECOND SCHEDULE.

TECHNICAL AND GENERAL DIVISION.

Offices and Rates of Salaries.

Department and Office.	Yearly Rate of Salary.		Increments (Annual).
	Minimum.	Maximum.	
	£	£	
<b>DEPARTMENT OF CHIEF SECRETARY.</b>			
<b>PENAL AND GAOLS.</b>			
<i>Delete—</i>			
Deputy Governor, Pentridge ..	559	611*	2 of £26
Engineer, Pentridge ..	475	527†	2 of £26
Engineer Mechanic, Pentridge ..	357	409	2 of £26
Hospital Attendant ..	383	409‡	1 of £26
Hospital Attendant, Senior ..	422	448	1 of £26
Overseer of Woollen Manufactures ..	..	534	..
Overseer of Woollen Manufactures, Assistant ..	344	396	2 of £26
Overseer of Works and Buildings ..	396	448	2 of £26
Overseer of Works and Buildings, Assistant ..	344	396	2 of £26
Overseer (Brush and Broom Making) ..	357	409	2 of £26
Overseer of Cookhouse ..	357	409	2 of £26
Overseer of Farm ..	357	409	2 of £26
Overseer (Matting and Mat Making) ..	357	409	2 of £26
Overseer of Shoemakers ..	357	409	2 of £26
Overseer of Tailors ..	396	448	2 of £26
Overseer of Tailors, Assistant ..	344	396	2 of £26
Overseer, Wire Netting Factory ..	396	448	2 of £26
Overseer, Assistant, Wire Netting Factory ..	357	409	2 of £26
Photographer and Overseer of Printers ..	357	409	2 of £26
Superintendent, Beechworth Reformatory ..	422	448	1 of £26
Superintendent, Castlemaine Reformatory ..	494	533	1 of £26 and 1 of £13
Superintendent, French Island Reformatory ..	494	533‡	1 of £26 and 1 of £13
Warder, Senior Chief ..	461	474‡	..
Warder, Chief ..	435	448‡	..
Warder, Senior ..	396	409‡	..
Warder ..	305	370§	..
Warder, Watchman, Pentridge ..	305	370§	..
Matron ..	331	344*	..
Sub-Matron and Nurse ..	305	318*	..
Warder, Grade I. (Female) ..	..	262	..
Warder, Grade II. (Female) ..	..	249	..
Warder, Grade III. (Female) ..	210	236	..
<i>Add—</i>			
Deputy Governor, Pentridge ..	559	611	2 of £26
Engineer, Pentridge ..	475	527	2 of £26
Engineer Mechanic, Pentridge ..	357	409	2 of £26
Hospital Attendant ..	383	409	1 of £26
Hospital Attendant, Senior ..	422	448	1 of £26
Overseer of Woollen Manufactures ..	..	534	..
Overseer of Woollen Manufactures, Assistant ..	344	396	2 of £26
Overseer of Works and Buildings ..	396	448	2 of £26
Overseer of Works and Buildings, Assistant ..	344	396	2 of £26
Overseer (Brush and Broom Making) ..	357	409	2 of £26
Overseer of Cookhouse ..	357	409	2 of £26
Overseer of Farm ..	357	409	2 of £26
Overseer (Matting and Mat Making) ..	357	409	2 of £26
Overseer of Shoemakers ..	357	409	2 of £26
Overseer of Tailors ..	396	448	2 of £26
Overseer of Tailors, Assistant ..	344	396	2 of £26
Overseer, Wire Netting Factory ..	396	448	2 of £26

TECHNICAL AND GENERAL DIVISION—continued.

Department and Office.	Yearly Rate of Salary.		Increments (Annual).
	Minimum.	Maximum.	
	£	£	
<b>DEPARTMENT OF CHIEF SECRETARY—continued.</b>			
<b>PENAL AND GAOLS—continued.</b>			
Overseer, Assistant, Wire Netting Factory ..	357	409	2 of £26
Photographer and Overseer of Printers ..	357	409	2 of £26
Superintendent, Beechworth Reformatory ..	422	448	1 of £26
Superintendent, Castlemaine Reformatory ..	494	533	1 of £26 and 1 of £13
Superintendent, French Island Reformatory ..	494	533	1 of £26 and 1 of £13
Warder, Senior Chief ..	461	474	..
Warder, Chief ..	435	448	..
Warder, Senior ..	396	409	..
Warder ..	305	370  §	..
Warder, Watchman, Pentridge ..	305	370  §	..
Matron ..	331	344	..
Sub-Matron and Nurse ..	305	318	..
Warder, Grade I. (Female) ..	..	262	..
Warder, Grade II. (Female) ..	..	249	..
Warder, Grade III. (Female) ..	210	236	..

\* Subject to a charge of 7½ per cent. of total emolument payable by way of salary for quarters.  
 † Subject to a charge of 5 per cent. of total emolument payable by way of salary for quarters.  
 ‡ With quarters when required to reside on premises.  
 § An allowance at the rate of £13 a year may be paid to officers who have completed 13 years' service as Warder.  
 || Less deduction for quarters, where provided, as determined by the Board.

This Regulation shall have effect as on and from the 4th April, 1948.  
 D. D. PAINE, Chairman.  
 E. F. FITZGIBBON, Secretary.  
 Office of the Public Service Board,  
 Melbourne, 31st March, 1948.

No. 232.

Public Service Act 1946, Section 39.

REGULATIONS.—PART III.—SALARIES, INCREMENTS, AND ALLOWANCES.

THE Public Service Board, in pursuance of the powers conferred by the Public Service Act 1946, hereby amends its Regulations as shown below:—

FIRST SCHEDULE.

PROFESSIONAL DIVISION.

Offices and Rates of Salaries.

Office.	Yearly Rate of Salary.	
	Minimum.	Maximum.
	£	£
<b>DEPARTMENT OF CHIEF SECRETARY.</b>		
<b>CLASS "C2."</b>		
<i>Delete—</i>		
Governor, Pentridge ..	592	644*
<i>Add—</i>		
Governor, Pentridge ..	592	644†

\* Subject to a charge of 7½ per cent. of total emolument payable by way of salary for quarters.  
 † Less deduction for quarters, where provided, as determined by the Board.

This Regulation shall have effect as on and from the 4th April, 1948.  
 D. D. PAINE, Chairman.  
 E. F. FITZGIBBON, Secretary.  
 Office of the Public Service Board,  
 Melbourne, 31st March, 1948.

No. 229. *Public Service Act 1946, Section 50.*

REGULATIONS—PART III.—SALARIES, INCREMENTS, AND ALLOWANCES.

THE Public Service Board, in pursuance of the powers conferred by the *Public Service Act 1946*, hereby amends its Regulations as shown below :—

SIXTH SCHEDULE.  
TEMPORARY EMPLOYEES.

*Designations of Positions and Rates of Salaries.*

Department and Designation of Position.	Yearly Rate of Salary.		Increments (Annual).
	Minimum.	Maximum.	
	£	£	
DEPARTMENT OF PUBLIC WORKS.			
PORTS AND HARBOURS.			
<i>Delete—</i>			
Engineer, Chief of Dredges, &c.	..	438†	..
Engineer, Second of Dredges, &c.	..	386†	..
Engineer, Third of Dredges, &c.	..	360†	..
Engine Driver of Launches	..	325	..
Master, Dredges, &c.	..	438†	..
Mate, First, of Dredges, &c.	..	386†	..
Mate, Second, of Dredges, &c.	..	360†	..
		0	
<i>Add—</i>			
Engineer, Chief of Dredges, &c.	..	* †	..
Engineer, Second of Dredges, &c.	..	* †	..
Engineer, Third of Dredges, &c.	..	* †	..
Engine Driver of Launches	..	*	..
Master, Dredges, &c.	..	* †	..
Mate, First of Dredges, &c.	..	* †	..
Mate, Second of Dredges, &c.	..	* †	..

\* Rates in accordance with the Merchant Service Guild of Australia Award.

† With rations when required to live on the vessel.

*This Regulation shall have effect as on and from the 11th January, 1948.*

D. D. PAINE, Chairman.  
E. F. FITZGIBBON, Secretary.

Office of the Public Service Board,  
Melbourne, 5th April, 1948.

No. 233. *Public Service Act 1946, Section 50.*

REGULATIONS—PART III.—SALARIES, INCREMENTS, AND ALLOWANCES.

THE Public Service Board, in pursuance of the powers conferred by the *Public Service Act 1946*, hereby amends its Regulations as shown below :—

SIXTH SCHEDULE.  
TEMPORARY EMPLOYEES.

*Designations of Positions and Rates of Salaries.*

Department and Designation of Position.	Yearly Rate of Salary.		Increments (Annual).
	Minimum.	Maximum.	
	£	£	
DEPARTMENT OF CHIEF SECRETARY.			
PENAL AND GAOLS			
<i>Delete—</i>			
Assistant Overseer, Wire Netting Factory, Pentridge	..	357	409
Warder	..	305	357
Warder (Female)	..	210	223
<i>Add—</i>			
Assistant Overseer, Wire Netting Factory, Pentridge	..	357	409*
Warder	..	305	357*
Warder (Female)	..	210	223*

\* Less deduction for quarters, where provided, as determined by the Board.

*This Regulation shall have effect as on and from the 4th April, 1948.*

D. D. PAINE, Chairman.  
E. F. FITZGIBBON, Secretary.

Office of the Public Service Board,  
Melbourne, 31st March, 1948.

SUBJECT to any necessary excisions, &c., it is proposed to grant the following leases:—

- 8200, Beechworth; John Frederick Easdown; 18a. 2r. 16p., in the Parish of Flowerdale.
- 8201, Beechworth; John Frederick Easdown; 20a. 0r. 39p., in the Parish of Flowerdale.
- 8204, Beechworth; Roland William Easdown and Lloyd Robert Easdown; 25a. 3r. 13p., in the Parish of Flowerdale.

APPLICATION FOR MINING LEASE REFUSED.

9040, Castlemaine; W. J. Doran; 300 acres, at Hoddles Creek.

J. H. LIENHOP,  
Minister of Mines.

MINING LEASES DECLARED VOID.

- 9047, Ballarat; William Appleyard; 9a. 3r. 12p., in the Parish of Kerrit Baret.
- 8698, Castlemaine; Charles William Leonard; 32a. 2r. 5p., in the Parishes of Chewton and Castlemaine.
- 8981, Castlemaine; John McKenzie and Dugald McInness Cameron; 18a. 2r. 32p., in the Parish of Campbelltown.
- 5057, Gippsland; Toombon Gold Mining Co. N.L.; 109a. 3r. 2p., in the Parish of Butgulla.
- 6750, Maryborough; Mark Wanlace the elder, Mark Wanlace the younger, Joseph Wanlace, and Rowland Cooke; 18a. 1r. 26p., in the Parish of Craigie.
- 6912, Mineral; John Harold Richards; 30 acres, in the Parish of Croajingolong.
- 6913, Mineral; John Harold Richards; 22a. 3r. 25p., in the Parish of Bendock.

GEO. BROWN,  
Secretary for Mines.

*Dried Fruits Act 1938 and Regulations.*

VICTORIAN DRIED FRUITS BOARD.

IT is hereby notified, in accordance with the provisions of the *Dried Fruits Act 1938*, and Regulations thereunder, that, with respect to the year ending the 31st December, 1948, the amount of contribution payable by every person in whose name a packinghouse is registered is four shillings and three pence per ton, computed from the quantity of 1948 season's dried fruits sold from such packinghouse, and from the quantity of dried fruits forwarded therefrom for the purposes of trade and sale.

PARKER J. MOLONEY, Chairman,  
Victorian Dried Fruits Board.  
19th April, 1948.

STAWELL SEWERAGE AUTHORITY.

ANNUAL BALANCE.

HIS Excellency the Governor of the State of Victoria, by and with the advice of the Executive Council thereof, and in pursuance of the provisions of the *Sewerage Districts Act 1928* (No. 3772), doth, by Order made on the 13th day of April, 1948, hereby fix the 30th day of September in each year as being the day to which the accounts of the Stawell Sewerage Authority shall be balanced.

C. W. KINSMAN,  
Clerk of the Executive Council.

At the Executive Council Chamber,  
Melbourne, the 13th April, 1948.

INDUSTRIAL AND PROVIDENT SOCIETIES ACT 1928.

NOTICE is hereby given that a society called "The Consumers Co-operative Fisheries Limited" is registered under the provisions of the above Act.

Given under my hand this 19th day of March, 1948.

A. E. RASMUSSEN,  
Registrar of Friendly Societies.

Transport Regulation Acts.  
TRANSPORT REGULATION BOARD.

NOTICES OF PUBLIC HEARINGS.

NOTICE is hereby given that the applications made by the persons named below for licences to operate the commercial passenger vehicles on the route or routes, or in the manner set out opposite their names, will be heard at a time and place to be communicated to the parties:—

*Name and Address of Applicant; Nature of Application.*

- BAILEY, R. A., Maldon; 1 commercial passenger vehicle, with seating capacity for 27 persons, to operate as an additional vehicle on all licensed routes, and under charter conditions within a 20 miles radius of Maldon.
- BENNETT, O. L., 10 Millar-street, Horsham; application for renewal of private hire licence No. PH.803 (expired January, 1948), allowing operations at otherwise than at separate and distinct fares from Horsham.
- LAMBORN, W. H., King Edward-street, Cohuna; 1 commercial passenger vehicle, to be purchased, to operate for the carriage of school children, under contract to the Education Department, from Horefield to Cohuna Consolidated School.
- LITTLEHALES, R. M., 340 Humfray-street north, Ballarat; 1 commercial passenger vehicle, with seating capacity for 29 persons, to operate for the carriage of school children, under contract to the Education Department, from Eraldooone to Ballarat, via Windemere.
- SHERRY, F. P., 96 McCrae-street, Dandenong; 1 commercial passenger vehicle, with seating capacity for 25 persons, to operate for the carriage of school children from Delmore, Koo-wee-rup, to Dandenong, and under charter conditions within a 20 miles radius of Koo-wee-rup, and to Mount Donna Buang, Healesville, and Cowes.

This replaces application gazetted 25th February, 1948.

- SHERRY, F. P., 96 McCrae-street, Dandenong; application for renewal of licence No. A.1434 (expired 16th April, 1948), allowing operations as follows:—From Dandenong Railway Station to West Dandenong State School, and thence to Forest Hill Golf Course.
- SHERRY, F. P., 96 McCrae-street, Dandenong; application for renewal of licence No. A.100 (expired 20th September, 1947), allowing operations as follows:—(a) Yannathan-Dandenong Railway Station, subject to limiting conditions *re* picking up and setting down passengers, (b) specified parcels may be carried *en route*.
- STANTON, G. F., Cohuna; application for variation of licences Nos. A.186 and A.1285, to amend present school service between Gunbower and Cohuna Consolidated School, to operate instead as follows:—(a) Cohuna to Martin's Lane, Randall's Lane, to Leechfield, thence to Gunbower, returning direct via the Murray Valley Highway, via Wee-wee-rup, for the carriage only of school children, (b) for the carriage of school children, under contract to the Education Department, from Holms Bridge to Cohuna Consolidated School.
- YALLOURN PASSENGER SERVICE PTY. LTD., 1 Southend-road, Yallourn; 1 commercial passenger vehicle, to operate as a prime mover on all licensed routes.

APPLICATIONS for licences to operate commercial passenger vehicles, with seating capacity for five persons, to operate for the carriage of passengers otherwise than at separate and distinct fares for each passenger throughout Victoria:—

- HARLING, J. H. T., Mitcham (two vehicles, subject to cancellation of private hire licences Nos. PH.1222 and PH.954, at present held by Harling and Wright).
- MCLEOD, W. W., St. Kilda.
- WANNEMACHER, V. G., Numurkah (subject to the cancellation of licence No. A.1585, at present held by the applicant).
- WHYTE, A. J., Glenhantly.

NOTICE is hereby given that the applications made by the persons named below for licences to operate the commercial goods vehicles on the route or routes, or in the manner set out opposite their names, will be heard at a time and place to be communicated to the parties concerned:—

*Name and Address of Applicant; Nature of Application.*

- BLACK, W. H., 26 Brunswick-road, West Brunswick; 1 commercial goods vehicle (90 cwt.) for the carriage of—(a) general goods within 25 miles radius of Melbourne, (b) bricks and tiles within 40 miles radius of Melbourne.

CHEGWIN, R. P., 235 Pascoe Vale-road, Essendon; 1 commercial goods vehicle (105 cwt.) for the carriage of brown coal only from Bacchus Marsh to the cities of Melbourne, Ballarat, and Geelong.

CLAY, A., 14 Brook-street, Hawthorn; 1 commercial goods vehicle (90 cwt.) for the carriage of brown coal only from Bacchus Marsh to Melbourne and the metropolitan area.

CLEARY, J. A., 16 Merrydale-street, Maffra; 1 commercial goods vehicle (100 cwt.) for the carriage of—(a) general goods within 20 miles radius of Maffra, (b) bricks on behalf of the Maffra Brick Works within 100 miles radius of Maffra.

DESAILLY, H. V., Melton South; 1 commercial goods vehicle (70 cwt.) for the carriage of brown coal only from Bacchus Marsh to Melbourne and the metropolitan area.

DEVONDALE CREAM Co., 242 Dryburgh-street, North Melbourne; 1 commercial goods vehicle (15 cwt.) for the carriage of—(a) own goods within 50 miles radius of Melbourne, (b) confectionery, being the property of the applicants and carried in the course of business as distributing agent for the Silverstream Manufacturing Co. Pty. Ltd., such confectionery to be delivered to retail stores on the following route:—From Melbourne to Kyabram, Shepparton, Benalla, Mansfield, and Alexandra (one trip per month).

DOWLING, N. G., Lot 312, Bluff-road, Hampton; 1 commercial goods vehicle (100 cwt.) for the carriage of brown coal only from Bacchus Marsh to Melbourne and the metropolitan area.

RODDA, P. F. & B. A. (trading as "Gippsland Tile Works"), corner of Stawell and Darling streets, Sale; 1 commercial goods vehicle (80 cwt.) for the carriage of—(a) own goods in the course of business as "cement tile manufacturers" within 50 miles radius of Sale, (b) cement tiles within 100 miles radius of Sale.

HUNT, M. J., Apsley; 1 commercial goods vehicle (200 cwt.) for the carriage of general goods within an area bounded as follows:—(a) On the west by the South Australian border, (b) on the north by the road running from Horsham, via Natimuk and Goroke, to the border of South Australia *en route* to Frances, South Australia, (c) on the east by the road running from Horsham, via Noradjuha, Jalumba, Kanagulk, and Balmoral, to Hamilton, (d) on the south by the road running from Hamilton, via Coleraine and Casterton, to the border of South Australia *en route* to Penola, South Australia.

RYAN, J., Delegate, New South Wales; 1 commercial goods vehicle for the carriage of—(a) general goods from and to Orbest to and from the border of New South Wales *en route* to Delegate and Bombala, New South Wales, (b) live stock from and to the border of New South Wales *en route* from Delegate, New South Wales, to Bairnsdale.

SHILKIN, P., care of Waverley Hotel, corner of Newry and Drummond streets, Carlton; 1 commercial goods vehicle (8 cwt.) to operate throughout the State of Victoria for the carriage of softgoods in the course of business as "hawker."

SMITH, A. R., PTY. LTD., Box 19, Beulah; 1 commercial goods vehicle (15 cwt.) for the carriage of—(a) general goods within 20 miles radius of Beulah, (b) mails, bread, cream, and parcels between Beulah and Rainbow, thence to Pijick, Kurnbrunn, and Pella, returning to Beulah, via Wheatlands and Kenmare.

Notice of any objection should be forwarded to reach the Secretary of the Board not later than Wednesday, 5th May, 1948.

E. V. FIELD,  
Secretary.

Exhibition Buildings, Rathdown-street, Carlton, N.3, 20th April, 1948.

Country Fire Authority Act 1944.

COUNTRY FIRE AUTHORITY.

IN pursuance with the provisions of section 79 (1) and (2) of the *Country Fire Authority Act 1944*, the Country Fire Authority has granted permission to hold a Fire Brigade Demonstration at Ararat, on Saturday, 27th November, 1948, and at North Geelong, on Saturday, 4th December, 1948.

G. G. SINCLAIR,  
Secretary.

60 Market-street, Melbourne, C.1., 13th April, 1948.

## Water Acts.

STATE RIVERS AND WATER SUPPLY COMMISSION.  
BIRREGURRA URBAN DISTRICT.

NOTICE to owners of tenements in the under-mentioned streets in the Birregurra Urban District, and the private streets, lanes, courts, and alleys opening thereto:—

Austin-street, from Main-street to Skene-street.  
Barry-street, from Roadknight-street to Strachan-street.  
Beal-street, from Main-street to Prime-street.  
Ennis-street, from Main-street to Skene-street.  
Hopkins-street, from Strachan-street to a point opposite allotment 9, section T, about 3 chains north-westerly.  
Jenner-street, from Austin-street to a point opposite allotment 5, section J, about 3½ chains north-westerly; from Austin-street to a point opposite allotment 5, section I, about 4 chains south-easterly; from Beal-street to a point opposite allotment 7, section F, about 3 chains north-westerly; and from Beal-street to a point opposite allotment 9, section C, about 8 chains south-easterly.

Main-street, from Ennis-street to Barwon-street.  
Prime-street, from Strachan-street to Beal-street.  
Roadknight-street, from Main-street to a point about 46½ chains northerly.

Skene-street, from Ennis-street to Austin-street.  
Sladen-street, from Beal-street to a point opposite allotment 6, section O, about 4 chains north-westerly.  
Strachan-street, from Main-street to a point opposite allotment 2, section K, about 21 chains north-easterly; and from Main-street to a point opposite allotment 10, section U, about 36½ chains south-westerly.

The main pipe in the said streets being laid down, the owners of all tenements situated as above are hereby required, on or before the 1st day of June next, to cause proper pipes and stop cocks to be laid, so as to supply water within such tenements from the main pipe.

L. DUGGAN, Secretary,  
State Rivers and Water Supply Commission.

Melbourne, 7th April, 1948.

BALLAN WATERWORKS TRUST (URBAN DISTRICT).  
RATING BY-LAW FOR THE YEAR 1948.

THE Ballan Waterworks Trust, in pursuance and exercise of powers conferred by the Water Acts, doth hereby make the following rates for the supply of water for domestic purposes on lands and tenements liable to be rated within the Ballan Urban District.

On such lands and tenements a rate of One shilling and four pence in the pound on the amount of the annual municipal valuation not exceeding Seventy-five pounds (£75), and One shilling in the pound on the amount of the annual municipal valuation exceeding Seventy-five pounds (£75).

Provided that in no case shall the amount of rate payable in respect of any tenement (other than land on which there is no building) be less than One pound two shillings (£1 2s.), and in respect of any land on which there is no building less than Ten shillings.

Such rates are made and shall be levied upon the occupiers or owners of the said lands and tenements for the year commencing on the 1st day of January, 1948, and shall be payable in two instalments, the first instalment due and payable on the 21st day of April, and the second instalment on the 1st day of October, 1948, at the office of the said Trust.

The maximum quantity of water to be supplied in any one year without further charge to any property rated by the Trust is hereby fixed at the quantity which, at a charge of One shilling and nine pence (1s. 9d.) per 1,000 gallons, would produce an amount equal to the amount of the rate levied on such property for the said year.

The charge for water supplied by measure to any property rated by the Trust in excess of such maximum quantity, computed as in the last preceding clause, is hereby fixed at One shilling and nine pence (1s. 9d.) per 1,000 gallons.

The charge for water supplied by measure to any property not rated by the Trust is hereby fixed at One shilling and nine pence (1s. 9d.) per 1,000 gallons, and the minimum quantity of water to be charged for in cases where water is so supplied is hereby fixed at 1,000 gallons.

The charge for water supplied by measure shall be payable, on demand, at the office of the Trust.

Dated this 20th day of March, 1948.

(SEAL) C. F. MYERS, Chairman.  
JOHN V. PORTER, Secretary.

Approved by the Governor in Council,  
13th April, 1948.  
C. W. KINSMAN,  
Clerk of the Executive Council.

## CHILTERN WATERWORKS TRUST.

## RATING BY-LAW FOR THE YEAR 1948.

THE Chiltern Waterworks Trust, in pursuance and exercise of the powers conferred by the Water Acts, doth hereby make a rate for the supply of water for domestic purposes of Two shillings and six pence in the pound on the annual municipal valuation of lands and tenements liable to be rated within the Chiltern Urban District.

Provided that in no case shall the amount of rate payable per annum in respect of any tenement (other than land on which there is no building) be less than Two pounds, and in respect of land on which there is no building less than Twelve shillings and six pence.

Such rates are made and shall be levied upon the occupiers or owners of the said lands and tenements for the year commencing 1st January and ending 31st December, 1948, and shall be payable on the 22nd day of April, 1948, at the office of the said Trust.

The maximum quantity of water to be supplied for the year without further charge to any property rated by the Trust is hereby fixed at the quantity which, at a charge of Two shillings and four pence per 1,000 gallons, would produce an amount equal to the amount of the rate levied on such property for the said year.

The charge for water supplied by measure to any property rated by the Trust in excess of such maximum quantity, computed as in the last preceding clause, is hereby fixed at Two shillings and four pence per 1,000 gallons.

The charge for water supplied by measure to any property not rated by the Trust is hereby fixed at Two shillings and four pence per 1,000 gallons, and the minimum quantity of water to be charged for in cases where water is so supplied is hereby fixed at 1,000 gallons.

The charge for water supplied by measure shall be payable, on demand, at the office of the Trust, Chiltern.

Passed this 10th day of February, 1948.

(SEAL) J. R. DOW, Chairman.  
R. SCOTT, Commissioner.  
R. G. HATFIELD, Secretary.

Approved by the Governor in Council,  
13th April, 1948.

C. W. KINSMAN,  
Clerk of the Executive Council.

## ROMSEY WATERWORKS TRUST.

## FIXING THE LIMIT OF A BANK OVERDRAFT.

HIS Excellency the Governor of the State of Victoria, by and with the advice of the Executive Council thereof, doth, by Order made on the 13th day of April, 1948, in pursuance of the provisions of section 273 of the *Water Act 1928* (No. 3801), hereby fix the limit of the overdraft to be obtained by the Romsey Waterworks Trust from the National Bank of Australasia Limited, Romsey, at an amount not to exceed at any one time the sum of Five hundred pounds (£500).

C. W. KINSMAN,  
Clerk of the Executive Council.

At the Executive Council Chamber,  
Melbourne, the 13th April, 1948.

## SWAN HILL WATERWORKS TRUST.

## AUTHORITY TO OBTAIN A BANK OVERDRAFT.

HIS Excellency the Governor of the State of Victoria, by and with the advice of the Executive Council thereof, doth, by Order made on the 13th day of April, 1948, hereby authorize the Swan Hill Waterworks Trust to obtain, in pursuance of the provisions of section 271 of the *Water Act 1928* (No. 3801), an advance or advances during the year 1948 from the English, Scottish, and Australian Bank Limited, Swan Hill, by overdraft of the Trust's current account thereat, such overdraft not to exceed at any time the sum of One thousand pounds (£1,000).

C. W. KINSMAN,  
Clerk of the Executive Council.

At the Executive Council Chamber,  
Melbourne, the 13th April, 1948.

FARMERS' PROTECTION ACT 1941.

NOTIFICATION is hereby given that the Farmers' Debts Adjustment Board pursuant to the powers conferred by the *Farmers' Protection Act 1941* cancelled the following Limited Stay Order:—

No.	Farmer.	Address.	Debt.	Creditor.	Address.	Date of Cancellation.
426	Tuohey, Patrick ..	Colbinabbin ..	£ s. d. 6,337 15 8	Estate of Grace Doherty (deceased)	c/o Farmers and Citizens Trustees Co. Bendigo Ltd., Charing Cross, Bendigo	13.4.48

20th April, 1948.

W. J. EVANS,  
Deputy Secretary, Farmers' Debts Adjustment Board.

RULES UNDER THE JUSTICES ACTS.

SELECTION BY A LAW OFFICER OF A PLACE AND THE DAYS AND HOURS FOR HOLDING COURTS (WITHIN THE MEANING OF THE SAID RULES).

I, THE undersigned, Trevor Donald Oldham, a Law Officer of the State of Victoria, in pursuance of the powers conferred upon me by Rule 2 of the *Justices Act Rules 1936* (No. 2), do hereby select for the remainder of the year 1948 from the places appointed by the Governor in Council for holding the Courts of Petty Sessions referred to in Rule 1 of the said Rules, the place named below as a place for holding Courts within the meaning of the said Rule 2: And I do hereby with respect to such place from the days and hours appointed by the Governor in Council for holding Courts of Petty Sessions, further select the days and hours set forth hereunder as the days and hours at which the said Courts shall be held.

SCHEDULE.

Court.	Day.	Hour.	May.	June.	July.	August.	September.	October.	November.	December.
Nagambie .. ..	Friday	9 a.m.	14	..	9	..	3	29	..	24

Signed at Melbourne, this 15th day of April, 1948.

T. D. OLDHAM,  
Law Officer.

DEPARTMENT OF LAW.

SITTINGS OF THE SUPREME COURT.—  
WARRNAMBOOL.

HIS Excellency the Governor of the State of Victoria, by and with the advice of the Executive Council thereof, has, by Order made on the 13th day of April, 1948, appointed Wednesday, the 5th May, 1948, a day for the Sittings of the Supreme Court for the Trial of Divorce and Matrimonial Causes at Warrnambool.

C. W. KINSMAN,  
Clerk of the Executive Council.

At the Executive Council Chamber,  
Melbourne, the 13th April, 1948.

MELBOURNE AND METROPOLITAN BOARD OF WORKS.

NOTICE TO THE OWNERS OF TENEMENTS IN THE UNDERMENTIONED STREETS, AND THE PRIVATE STREETS, LANES, COURTS, AND ALLEYS OPENING THERETO.

THE main pipe in the said streets being laid down, the owners of all tenements situated as under are hereby required, on or before the 24th May, 1948, to cause a proper pipe and stop cocks to be laid, so as to supply water within such tenements from the main pipe.

CHAS. J. W. BRIGGS,  
Secretary.

13th April, 1948.

STREET AND POSITION.  
Box Hill.

Naples-street, from 2½ chains east of Elgar-road eastwards 4½ chains.

Burwood-road, from 25½ chains west of Station-street to McComas-street.

McComas-street, from Burwood-road southwards 4½ chains.

Braybrook.

Maylands-street, from Wyalong-street to Ballarat-road.

York-street, from Maylands-street eastwards 5½ chains.

Camberwell.

Munro-avenue, from Dent-street southwards 21 chains.

Duncombe-avenue, from Orford-road to Baker-parade.

Gloucester-road, from High-street to Victory Boulevard.

Victory Boulevard, from Gloucester-road to Ramu-grove.

Ramu-grove, from Victory Boulevard northwards 4 chains.

Warner-avenue, from Victory Boulevard to High-street.

Wewak-road, from Warner-avenue to Gona-court.

Lae-court, from Wewak-road northwards 3½ chains.

Crete-avenue, from Warner-avenue to Alamein-avenue.

Alamein-avenue, from Gloucester-road westwards 19½ chains.

Benghazi-avenue, from Warner-avenue to Derna-road.

Derna-road, from Warner-avenue to Gloucester-road.

Tobruk-road, from Warner-avenue to Gloucester-road.

Bardia-avenue, from Warner-avenue to Tobruk-road.

Baker-parade, from Duncombe-avenue to Warrigal-road.

Mountain View-road, from 15½ chains north of Riverview-road northwards 15½ chains.

Yerrin-street, from Belmore-road to Winmalee-road.

Vears-road, from Fakenham-road to Cyril-street.

Poulter-street, from Vears-road to Cyril-street.

Cyril-street, from Poulter-street to High-street.

Glennuss-street, from Belmore-road to Burroughs-street.

Belmore-road, from Yerrin-street to Jacka-street.

Coburg.

Gould-street, from Spry-street northwards 5½ chains

Treloar-street, from Spry-street to Shorts-road.

Eltham.

Hillside-avenue, from Pitt-street to Dalton-street.

Essendon.

Madden-street, from Kerferd-street north-eastwards 2 chains.

Footscray.

Cross-street, from Geelong-road to Hocking-street.

Heidelberg.

Altona-street, from Dresden-street eastwards 3 chains.

Leicester-street, from St. Hellier-street northwards 3½ chains.

Ellesmere-parade, from 12 chains north of Invermay-grove northwards 6 chains.

Moorabbin.

Warrigal-road, from Claronga-street southwards 6½ chains.

Rudyard-street, from Warrigal-road westwards 3½ chains.

Warrigal-road, from Old Dandenong-road to Kershaw-street.

Goodrich-street, from Mackie-road eastwards 21 chains.

Hallow-street, from Goodrich-street northwards 3 chains.

Mordialloc.

Point Nepean-road, from Lower Dandenong-road to Olive-grove.

Long-street, from Point Nepean-road northwards 4½ chains.

Nunawading.

Heather-grove, from Mount Pleasant-road westwards 6½ chains.

*Oakleigh.*

Paget-street, from 1½ chains east of Poath-road eastwards 3½ chains.

*Sandringham.*

Hudson-street, from Willis-street southwards 5½ chains.  
Garnet Leary-avenue, from Fern-street northwards 10½ chains.

*Williamstown.*

Wood-street, from Challis-street to Bradley-street.  
Monmouth-street, from Challis-street westwards 9 chains.  
Champion-road, from Challis-street westwards 9½ chains.  
Maddox-street, from Champion-road northwards 2½ chains.  
Maddox-street, from Wood-street southwards 3 chains.

## 4 GEORGE VI. No. 4755, SECTION 6.

I HEREBY give notice that on the 7th April, 1948, I filed elections to administer the following deceased persons' estates, in accordance with section 6 of the *Public Trustee Act 1940*:—

PICKERING, LAVINIA MARY, late of Barnard-street, Bendigo, pensioner, died 18th November, 1944, intestate.

REIDY, DANIEL FRANCIS, late of Mount Royal, Royal Park, labourer, died 2nd February, 1948, intestate.

I HEREBY give notice that on the 8th April, 1948, I filed elections to administer the following deceased persons' estates, in accordance with section 6 of the *Public Trustee Act 1940*:—

BUSSELL, FREDERICK WALTER, late of Bendigo Benevolent Home, Bendigo, farm labourer, died 8th September, 1947, intestate.

\*MACKENZIE, JOHN, late of 361 Coventry-street, South Melbourne, labourer, died 18th November, 1947.

NICHOLSON, ROBERT, late of Bendigo Benevolent Home, Bendigo, pensioner, died 28th October, 1947, intestate.

\* According to the provisions of the will.

I HEREBY give notice that on the 9th April, 1948, I filed elections to administer the following deceased persons' estates, in accordance with section 6 of the *Public Trustee Act 1940*:—

DOWNWARD, RAY JAMES DALTON, otherwise known as Raymond Henry Dalton Downward and as Ray Henry Dalton, late of Charlton, signwriter, died 14th November, 1947, intestate.

WILLIAMS, MORRIS, late of Daylesford, no occupation, died 7th March, 1948, intestate.

\*WILLIAMSON, CHARLOTTE, late of 246 Punt-road, Prahran, widow, died 18th February, 1948.

WORT, ELIZABETH MATILDA, late of 45 North-street, Ascot Vale, pensioner, died 28th December, 1947, intestate.

\* According to the provisions of the will.

I HEREBY give notice that on the 12th April, 1948, I filed elections to administer the following deceased persons' estates, in accordance with section 6 of the *Public Trustee Act 1940*:—

JACKSON, JONATHON, late of Bendigo, pensioner, died 10th January, 1948, intestate.

JACKSON, THOMAS, late of 5 Yarra-place, South Melbourne, french polisher, died 22nd January, 1948, intestate.

JONSSON, NILS, late of Bendigo Benevolent Home, Bendigo, pensioner, died 4th January, 1948, intestate.

\*KILLURY, MARY SHIELDS, late of 32 Munster-terrace, North Melbourne, widow, died 29th October, 1947.

LEACH, THOMAS, sometimes known as George Hilton Leach, late of 102 Barkly-street, St. Kilda, painter, died 30th October, 1947, intestate.

\* According to the provisions of the will.

H. C. CHIPMAN,  
Acting Public Trustee.

412 Collins-street, Melbourne, C.1, 14th April, 1948.

## NOTICE.

ADMINISTRATION of the estate of each of the under-mentioned deceased persons has been granted to me, and creditors, next of kin, and all others having claims against the estate of any of the persons so mentioned are required to send particulars of their claims to the Public Trustee, No. 412 Collins-street, Melbourne, on or before the 23rd June, 1948, or they will be excluded from the distribution of the estate when the assets are being distributed:—

BUSSELL, FREDERICK WALTER, late of Bendigo Benevolent Home, Bendigo, farm labourer, died 8th September, 1947, intestate.

COCKREM, EDWIN ARTHUR, late of 9 Nepean-street, Glen Iris, gentleman, died 6th February, 1948, intestate.

DOWNWARD, RAY JAMES DALTON, otherwise known as Raymond Henry Dalton Downward and as Ray Henry Dalton, late of Charlton, signwriter, died 14th November, 1947, intestate.

\*GAY, LESLIE GILES, formerly of Midland Highway, Welshpool, but late of Glenloth, farmer, died 20th February, 1948.

\*HA RIGAN, CATHERINE, formerly of 64 Edinburgh-street, Flemington, but late of 177 Blyth-street, East Brunswick, widow, died 9th February, 1948.

HUTCHINSON, ELIZABETH GRAHAM, late of 43 Spencer-street, Northcote, home duties, died 11th December, 1947, intestate.

\*INGRAM, MARY BARMBY, late of 80 Clowes-street, South Yarra, spinster, died 16th December, 1942.

JACKSON, JONATHON, late of Bendigo, pensioner, died 10th January, 1948, intestate.

JACKSON, THOMAS, late of 5 Yarra-place, South Melbourne, french polisher, died 22nd January, 1948, intestate.

JONSSON, NILS, late of Bendigo Benevolent Home, Bendigo, pensioner, died 4th January, 1948, intestate.

\*KILLURY, MARY SHIELDS, late of 32 Munster-terrace, North Melbourne, widow, died 29th October, 1947.

\*KITCHIN, BERTHA ELLEN, formerly of Kitchwood Park, via Launching Place, but late of St. Margaret's Convalescent Home, 316 Wattletree-road, East Malvern, widow, died 23rd February, 1948.

\*LACEY, THOMAS LAURENCE, late of 16 Imbros-street, Hampton, foreman, died 12th December, 1947.

LANE, ETHEL ELLEN SOPHIA, late of 15 Bayswater-road, Kensington, widow, died 14th January, 1948, intestate.

LEACH, THOMAS, sometimes known as George Hilton Leach, late of 102 Barkly-street, St. Kilda, painter, died 30th October, 1947, intestate.

\*MACKENZIE, JOHN, late of 361 Coventry-street, South Melbourne, labourer, died 18th November, 1947.

NICHOLSON, ROBERT, late of Bendigo Benevolent Home, Bendigo, pensioner, died 28th October, 1947, intestate.

PICKERING, LAVINIA MARY, late of Barnard-street, Bendigo, pensioner, died 18th November, 1944, intestate.

REIDY, DANIEL FRANCIS, late of Mount Royal, Royal Park, labourer, died 2nd February, 1948, intestate.

WILLIAMS, MORRIS, late of Daylesford, no occupation, died 7th March, 1948, intestate.

\*WILLIAMSON, CHARLOTTE, late of 246 Punt-road, Prahran, widow, died 18th February, 1948.

WORT, ELIZABETH MATILDA, late of 45 North-street, Ascot Vale, pensioner, died 28th December, 1947, intestate.

\* With the will annexed.

† According to the provisions of the will.

H. C. CHIPMAN,

Acting Public Trustee.

Melbourne, 14th April, 1948.

*Town and Country Planning Act 1944.*

## SHIRE OF FRANKSTON AND HASTINGS.

## INTERIM DEVELOPMENT ORDER.

WHEREAS by virtue of the powers conferred by the *Town and Country Planning Act 1944* and every other power enabling in that behalf, the preparation of a planning scheme in accordance with the said Act has been commenced by the Council of the municipality of the Shire of Frankston and Hastings (hereinafter referred to as the "Responsible Authority"), which hereby makes the following Interim Development Order:—

1. The development of all land referred to in the Schedule, and the erection, construction, and carrying out of any buildings, roads, or other works on any of the said land, is hereby prohibited.

2. Any person may apply to the Responsible Authority for permission to develop, subdivide, or otherwise use any land, or erect or construct any buildings, roads, or other works, during the operation of this Order.

3. Any application for permission to develop, subdivide, or otherwise use any land, or erect or construct any building, roads, or other works, may be granted by the Responsible Authority, subject to such conditions as are specified in the permit, or may be refused.

4. Any owner of any land who, after the service of a copy of this Order, contravenes any of the provisions contained herein, shall, when directed by notice, in writing, remove, pull down, take up, or alter any building, road, or other works, and, if any owner fails to do so within the time specified by the notice, the Responsible Authority may carry out all or any of such works, and recover all expenses incurred, after due notice has been given to the owner, lessee, and/or occupier in accordance with the provisions of section 12, sub-section 3, of the Act.

5. None of the provisions of this Order shall prohibit the continuance of the use of any land or buildings for the purpose for which it was used immediately before the coming into operation of this Order.

6. This Order shall remain in operation until the approval of the Planning Scheme, in accordance with the *Town and Country Planning Act 1944*, or until this Interim Development Order, is revoked by the Governor in Council.

7. Schedule of land affected:—All that area comprised in the Frankston, Mount Eliza, and Seaford Ridings of the Shire of Frankston and Hastings as at present constituted, being all that land contained within the area commencing at a point on the foreshore of Port Phillip Bay, being the south-western angle of Crown allotment 1A in the Parish of Lyndhurst; thence easterly by the southern boundary of the said Crown allotment 1A produced across the Nepean Highway to a point on the western boundary of Crown allotment 90; thence northerly by the western boundary of the said Crown allotment 90 produced across the railway reserve to a point on the centre line of Eel Race-road as depicted on the Parish of Lyndhurst plan; thence easterly by the centre lines of the said Eel Race-road and a Government road to a point on the western boundary of Crown allotment 95; thence southerly by the western boundary of the said Crown allotment 95 to the south-western corner of Crown allotment 95; thence easterly by the southern boundary of Crown allotment 95 to the south-eastern corner of Crown allotment 95; thence northerly by the eastern boundary of Crown allotment 95 produced to a point on the centre line of a Government road on the northern boundaries of Crown allotments 56 and 55; thence easterly by the centre line of the said Government road produced to its intersection with the centre line of the Country Roads Board main Frankston-Dandenong road; thence southerly by the centre line of the said Frankston-Dandenong road to its intersection with the northerly production of the eastern boundary of Crown allotment 72c; thence southerly by a line to the northern-most angle of the said Crown allotment 72c; thence southerly by the western boundaries of Crown allotments 72c, 72b, and 72a produced for 50 links to a point on the centre line of a Government road, known as Bullarto-road; thence easterly by the centre line of the said Bullarto-road to a point on the eastern boundary of the Parish of Frankston; thence southerly by the eastern boundary of the said Parish of Frankston to the north-eastern angle of Crown allotment 9B1; thence south-easterly by the boundary of the Parish of Frankston to a point on the centre line of a Government road forming the southern boundary of Crown allotment 29f; thence westerly by the centre line of the said Government road produced to its intersection with the centre line of a Government road, known as Sages-road, and forming the southern boundary of the Baxter Flat Reserve; thence south-westerly and westerly by the centre line of the said Sages-road produced to its intersection with the centre line of the Country Roads Board main Moorooduc-road; thence south-westerly by the centre line of the said Moorooduc-road to its intersection with the south-easterly production of the centre line of a Government road forming the south-western boundary of section V of the Parish of Frankston; thence north-westerly by the centre line of the said Government road produced to a point on the foreshore of Port Phillip Bay; thence northerly by the foreshore of Port Phillip Bay to the point of commencement.

(SEAL) K. H. WEBB, President.  
F. H. WELLS, Councillor.  
L. C. FREEMAN, Shire Secretary.

Report by the Town and Country Planning Board on the seventh day of April, 1948, recommended for approval.—J. S. CAWLER, Chairman.

Approved by the Governor in Council,  
13th April, 1948.

C. W. KINSMAN,  
Clerk of the Executive Council.

#### SHIRE OF MIRBOO.

##### ROAD DEVIATION.

##### Order in Council.

IN pursuance of the powers conferred by sections 521 and 525 of the *Local Government Act 1946*, the Council of the Shire of Mirboo doth hereby Order that the lands next hereinafter described shall be a public highway from the date of the publication of this Order in the *Government Gazette*, that is to say:—

All that piece of land, being part of allotments 75 and 76, Parish of Mirboo, County of Buln Buln, commencing at a point distant south 380.5 links from the north-east angle of the said allotment 76; thence north 45 deg. 10 min. west 540.7 links; thence north 33 deg. 12 min. west 107 links; thence north 20 deg. 47 min. west 203 links; thence north 6 deg. 16 min. east 167.2 links; thence north 32 deg. 11 min. east 455.2 links; thence north 23 deg. 10 min. east 642.5 links; thence north 835.4 links; thence south 18 deg.

45 min. west 1,080.2 links; thence south 27 deg. 54 min. west 488.8 links; thence south 16 deg. 39 min. west 466 links; thence south 1 deg. 43 min. west 133.5 links; thence south 32 deg. 40 min. east 209.7 links; thence south 38 deg. 41 min. east 58.1 links; thence south 38 deg. 41 min. east 633.4 links; thence south 62 deg. 57 min. east 189.1 links; thence in a straight line north 199.1 links to the commencing point.

And the said Council doth hereby declare that the lands above described shall from the said date of publication in the *Government Gazette* be a public highway, in lieu of the land hereinafter described, that is to say:—

All that piece of land, being part of allotments 75 and 76, Parish of Mirboo, County of Buln Buln, commencing at a point distant south 239.5 links from the most north-easterly corner or angle of the said allotment 76; thence by a line bearing north 45 deg. 10 min. west 411 links; thence by a line bearing north 11 deg. 26 min. west 302.1 links; thence by a line bearing north 23 deg. 10 min. east 884.2 links; thence by a line bearing north 254.2 links; thence by a line bearing south 23 deg. 10 min. west 1,159 links; thence by a line bearing south 11 deg. 26 min. east 363.5 links; thence by a line bearing south 45 deg. 10 min. east 540.7 links; thence by a line bearing north 141 links home to the point of commencement, containing an area of 1 acre 3 roods 7 perches, or thereabouts.

Dated the 3rd day of March, 1948.

The common seal of the President, Councillors, and Ratepayers of the Shire of Mirboo was hereunto affixed, in the presence of—

(SEAL) B. T. DROWLEY, Councillor.  
ALEC. MCPHIE, Councillor.  
J. SUMMERS, Secretary.

Confirmed by the Governor in Council,  
13th April, 1948.

C. W. KINSMAN,  
Clerk of the Executive Council.

#### CONTRACTS ACCEPTED.—(Series 1947-48.)

##### GENERAL STORES.

*Gazette* No. 234, 26th June, 1947, Schedule No. 64, Polishes, Dusters, &c.—For Item 4, substitute £2 6s. 9d. per dozen as from 9th April, 1948.

*Gazette* No. 437, 19th November, 1947, Schedule No. 69, Stationery, General.—For Item No. 89, substitute "Dupered" Erasers at 21s. 2d. per gross, less 2½ per cent. settlement discount, as from 30th March, 1948. Items Nos. 119, 120, and 121 not now available.

*Gazette* No. 19, 21st January, 1948, Schedule No. 52, Tools (General).—For Item No. 166, substitute £7 9s. per dozen, less 27½ per cent. discount, as from 23rd September, 1947.

W. H. RUTHERFORD, Secretary to the Tender Board.  
19.4.48.

#### ORDERS IN COUNCIL.—(Series 1947-48.)

##### DEPARTMENT OF EDUCATION.

2313. One only 4-ft. Brown and Sharpe cast iron straight edge, 48 in. by 2 in.; one only 24-in. by 1½-in. capacity upright drill, for Preston Technical School, £191.—McPherson's Pty. Ltd., Melbourne.

Approved by the Governor in Council, 13th April, 1948.—C. W. KINSMAN, Clerk of the Executive Council.

##### FORESTS COMMISSION.

Loan Act, No. 5232, Item 8—

2314. To the purchase of portion of allotment 10, section C, Parish of Tildesley West, County of Tambo, comprising 3 acres, for Forest purposes, £120.—Mrs. L. McMahon, Maffra.

Approved by the Governor in Council, 2nd December, 1948.—C. W. KINSMAN, Clerk of the Executive Council.

##### STATE ELECTRICITY COMMISSION.

2315. The supply of twelve gable bottom 20-ton coal trucks, Yallourn Open Cut, to Specification No. 47-48/92.—Thompson's (Castlemaine) Ltd.

2316. The supply of one 10-ton and five 5-ton derrick cranes and spare parts for Kiewa Hydro-Electric Scheme, to Specification No. 47-48/55.—W. A. Hodkinson and Co. Pty. Ltd.

2317. The supply of 85,000 braces and 2,100 brackets for transmission lines, to Quotation No. 2855.—F. L. Kirkby and Co. Pty. Ltd.

2318. The supply of 60,000 washers and 2,000 braces for transmission lines, to Quotation No. 2855.—McPherson's Ltd.

2319. The supply of two frequency modulated radio transmitters and receivers, auxiliary apparatus, and spare parts, Kiwa Hydro-Electric Scheme, to Specification No. 47-48/37.—Standard Telephones and Cables Pty. Ltd.

2320. The supply of 25,000 linear feet Baltic flooring, to Quotation No. 3514.—John Sharp and Sons Pty. Ltd.

2321. The supply of 70,000 linear feet Baltic weatherboards, and 20,000 linear feet Baltic flooring, to Quotation No. 3514.—Neville Smith and Co. Pty. Ltd.

2322. The supply of two power control units for Allis-Chalmers H.D.14 tractors, to Quotation No. 3300.—Tutt Bryant Pty. Ltd.

2323. The erection of shop fronts, tiling, &c., Yallourn, to Quotation No. 3160.—Silverwood and Beck Pty. Ltd.

2324. The supply and fitting of one double drum power control unit, and one front end loader to caterpillar tractor.—Tutt Bryant Pty. Ltd.

2325. The supply of 5,000 feet victualic piping, Yallourn Open Cut, to Quotation No. 3357.—Stewarts and Lloyds (Aust.) Pty. Ltd.

2326. The erection of staff accommodation house at Mt. Beauty, Kiwa Hydro-Electric Scheme, to Specification No. 47-48/147.—F. W. Rittwag.

Approved by the Governor in Council, 13th April, 1948.—C. W. KINSMAN, Clerk of the Executive Council.

Apprenticeship Acts.

APPRENTICESHIP COMMISSION OF VICTORIA.

At the Executive Council Chamber, Melbourne, the thirteenth day of April, 1948.

PRESENT:

His Excellency the Governor of Victoria.

Mr. Kennedy | Mr. Byrnes.  
Mr. Warner

AMENDMENT OF ELECTRICAL TRADES REGULATIONS (No. 3).

IN pursuance of the powers conferred by the Apprenticeship Acts and the Acts Interpretation Acts, His Excellency the Governor of the State of Victoria, by and with the advice of the Executive Council thereof, doth hereby make the following amendment to the Electrical Trades Regulations (No. 3), that is to say—

For the Schedule of the said Electrical Trades Regulations (No. 3), the following Schedule shall be substituted:—

SCHEDULE.

Course "A."

Classes for instruction in the subjects of the Apprenticeship Course for the trade of Electrical Fitting.

	<i>Hours per week.</i>
<i>First Year—</i>	
Trade Mathematics .. Grade I. ..	2
Trade Drawing .. Grade I. ..	2
Electricity and Magnetism (special course) ..	2
Trade Theory and Practice Grade I. ..	2
<i>Second Year—</i>	
Trade Theory and Practice Grade II. ..	4
Trade Drawing .. Grade II. ..	2
Electrical Technology and Testing .. Grade I. ..	2
<i>Third Year—</i>	
Trade Theory and Practice Grade III. ..	4
<i>Fourth Year—</i>	
Trade Theory (Electrical Technology and Testing, Grade II.) ..	Grade IV. .. 2
Trade Practice ..	Grade IV. .. 2
Safety First Principles	

*Fifth Year—*

Trade Theory and Practice (Armature Winding, Grade I.) ..	Grade V. .. 4
Safety First Principles	

The detailed syllabus of the above-mentioned subjects shall be as determined by the Apprenticeship Commission of Victoria from time to time.

Course "B."

Classes for instruction in the subjects of the Apprenticeship Course for the trade of Electrical Fitting and Armature Winding.

	<i>Hours per week.</i>
<i>First Year—</i>	
Trade Mathematics .. Grade I. ..	2
Trade Drawing .. Grade I. ..	2
Electricity and Magnetism (special course) ..	2
Trade Theory and Practice (Electrical Fitting, Grade I.) ..	Grade I. .. 2
<i>Second Year—</i>	
Trade Theory and Practice (Electrical Fitting, Grade II.) ..	Grade II. .. 4
Trade Drawing ..	Grade II. .. 2
Electrical Technology and Testing ..	Grade I. .. 2
<i>Third Year—</i>	
Trade Theory and Practice (Electrical Fitting, Grade III.) ..	Grade III. .. 4
<i>Fourth Year—</i>	
Electrical Technology and Testing ..	Grade II. .. 2
Trade Theory and Practice (Armature Winding, Grade I.) ..	Grade IV. .. 2
Safety First Principles	
<i>Fifth Year—</i>	
Trade Theory and Practice (Armature Winding, Grade II.) ..	Grade V. .. 4
Safety First Principles	

*Third Year—*

Trade Theory and Practice (Electrical Fitting, Grade III.) ..	Grade III. .. 4
---	-----------------

*Fourth Year—*

Electrical Technology and Testing ..	Grade II. .. 2
Trade Theory and Practice (Armature Winding, Grade I.) ..	Grade IV. .. 2
Safety First Principles	

*Fifth Year—*

Trade Theory and Practice (Armature Winding, Grade II.) ..	Grade V. .. 4
Safety First Principles	

The detailed syllabus of the above-mentioned subjects shall be as determined by the Apprenticeship Commission of Victoria from time to time.

Course "C."

Classes for instruction in the subjects of the Apprenticeship Course for the trade of Armature Winding.

	<i>Hours per week.</i>
<i>First Year—</i>	
Trade Mathematics .. Grade I. ..	2
Trade Drawing .. Grade I. ..	2
Electricity and Magnetism (special course) ..	2
Trade Theory and Practice (Electrical Fitting, Grade I.) ..	Grade I. .. 2
<i>Second Year—</i>	
Trade Theory and Practice (Electrical Fitting, Grade II.) ..	Grade II. .. 4
Trade Drawing ..	Grade II. .. 2
Electrical Technology and Testing ..	Grade I. .. 2
<i>Third Year—</i>	
Trade Theory and Practice (Armature Winding, Grade I.) ..	Grade III. .. 4
<i>Fourth Year—</i>	
Electrical Technology and Testing ..	Grade II. .. 2
Trade Theory and Practice (Armature Winding, Grade II.) ..	Grade IV. .. 2
Safety First Principles	



*Fifth Year—*

Trade Theory and Practice (Armature Winding, Grade III.) .. .. .	Grade V. .. .	4
Safety First Principles		

The detailed syllabus of the above-mentioned subjects shall be as determined by the Apprenticeship Commission of Victoria from time to time.

*Course "D."*

Classes for instruction in the subjects for the trades of Electrical Fitting and/or Armature Winding as carried on in connexion with motor vehicles.

		<i>Hours per week.</i>
<i>First Year—</i>		
Trade Mathematics .. .. .	Grade I. .. .	2
Trade Drawing .. .. .	Grade I. .. .	2
Electricity and Magnetism (special course) .. .. .		2
Trade Theory and Practice (Electrical Fitting, Grade I.) .. .. .	Grade I. .. .	2
<i>Second Year—</i>		
Trade Theory and Practice (Electrical Fitting, Grade II.) .. .. .	Grade II. .. .	4
Trade Drawing .. .. .	Grade II. .. .	2
Electrical Technology and Testing .. .. .	Grade I. .. .	2
<i>Third Year—</i>		
Trade Theory and Practice (Armature Winding, Grade I.) .. .. .	Grade III. .. .	4
<i>Fourth Year—</i>		
Trade Theory and Practice (Electrical Principles and Testing (Auto), Grade I.)	Grade IV. .. .	4
Safety First Principles		
<i>Fifth Year—</i>		
Trade Theory and Practice (Electrical Principles and Testing (Auto), Grade II.)	Grade V. .. .	4
Safety First Principles		

The detailed syllabus of the above-mentioned subjects shall be as determined by the Apprenticeship Commission of Victoria from time to time.

*Course "E."*

Classes for instruction in the subjects of the trade of Electrical-Mechanics and Electrical Wiring.

		<i>Hours per week.</i>
<i>First Year—</i>		
Trade Mathematics .. .. .	Grade I. .. .	2
Trade Drawing .. .. .	Grade I. .. .	2
Trade Theory and Practice (preliminary) .. .. .		4
<i>Second Year—</i>		
Trade Theory and Practice	Grade I. .. .	4
Trade Drawing .. .. .	Grade II. .. .	2
Electrical Fitting (Theory and Practice) .. .. .	Grade I. .. .	2
<i>Third Year—</i>		
Trade Theory and Practice	Grade II. .. .	4
<i>Fourth Year—</i>		
Trade Theory and Practice	Grade III. .. .	4
Safety First Principles		
<i>Fifth Year—</i>		
Trade Theory and Practice	Grade IV. .. .	4
Safety First Principles		

The detailed syllabus of the above-mentioned subjects shall be as determined by the Apprenticeship Commission of Victoria from time to time.

And the Honorable Herbert John Thornhill Hyland, His Majesty's Minister of Labour for the State of Victoria, shall give the necessary directions herein accordingly.

C. W. KINSMAN,  
Clerk of the Executive Council.

Apprenticeship Acts.  
APPRENTICESHIP COMMISSION OF VICTORIA.

*At the Executive Council Chamber, Melbourne, the  
thirteenth day of April, 1948.*

PRESENT:

His Excellency the Governor of Victoria.  
Mr. Kennedy | Mr. Byrnes.  
Mr. Warner |

AMENDMENT OF ENGINEERING TRADES  
REGULATIONS (No. 3).

IN pursuance of the powers conferred by the Apprenticeship Acts and the Acts Interpretation Acts, His Excellency the Governor of the State of Victoria, by and with the advice of the Executive Council thereof, doth hereby make the following amendment to the Engineering Trades Regulations (No. 3), that is to say:—

For the First, Second, Third, Fourth, and Fifth Schedules of the said Engineering Trades Regulations (No. 3), the following Schedules shall be substituted:—

FIRST SCHEDULE.

Classes for instruction in the subjects of the apprenticeship course for the trades of Fitting and/or Turning and Machinist.

		<i>Hours per week.</i>
<i>First Year—</i>		
Trade Mathematics .. .. .	Grade I. .. .	1
Trade Drawing .. .. .	Grade I. .. .	2
Trade Science .. .. .	Grade I. .. .	1
Trade Theory .. .. .	Grade I. .. .	1
Trade Practice .. .. .	Grade I. .. .	3
<i>Second Year—</i>		
Trade Drawing .. .. .	Grade II. .. .	2
Trade Science .. .. .	Grade II. .. .	1
Trade Metallurgy .. .. .	Grade I. .. .	1
Trade Theory and Calcula- tions .. .. .	Grade II. .. .	1
Trade Practice .. .. .	Grade II. .. .	3
Additional Trade Drawing (optional at evening classes) .. .. .	Grade II. .. .	
<i>Third Year—</i>		
Trade Theory and Calcula- tions .. .. .	Grade III. .. .	1
Trade Practice .. .. .	Grade III. .. .	2
Trade Metallurgy .. .. .	Grade II. .. .	1
Additional Trade Practice (optional at evening classes) .. .. .	Grade III. .. .	
<i>Fourth Year (for apprentice Fitters)—</i>		
Trade Theory and Calcula- tions (Fitting and Welding)	Grade IV. } .. .	4
Trade Practice (Fitting) ..	Grade IV. }	
Trade Metallurgy (optional at evening classes) .. .. .	Grade III. .. .	
Additional Trade Practice (optional at evening classes) .. .. .	Grade IV. .. .	
<i>Fourth Year (for apprentice Fitters and Turners, Turners, and Machinists)—</i>		
Trade Theory and Calcula- tions .. .. .	Grade IV. } .. .	4
Trade Practice .. .. .	Grade IV. }	
Trade Metallurgy (optional at evening classes) .. .. .	Grade III. .. .	
Additional Trade Practice (optional at evening classes) .. .. .	Grade IV. .. .	

The detailed syllabus of the above-mentioned subjects shall be as determined by the Apprenticeship Commission of Victoria from time to time.

SECOND SCHEDULE.

Classes for instruction in the subjects of the Apprenticeship course for the trade of Pattern-making—

		<i>Hours per week.</i>
<i>First Year—</i>		
Trade Mathematics .. .. .	Grade I. .. .	1
Trade Drawing .. .. .	Grade I. .. .	2
Trade Science .. .. .	Grade I. .. .	1
Trade Theory .. .. .	Grade I. .. .	1
Trade Practice .. .. .	Grade I. .. .	3

*Second Year—*

Trade Drawing .. ..	Grade II.	.. 2
Trade Theory and Calculations .. ..	Grade II.	.. 1
Trade Practice .. ..	Grade II.	.. 3
Foundry Theory and Practice .. ..	Special Course	.. 2

*Third Year—*

Trade Theory and Calculations .. ..	Grade III.	.. 2
Trade Practice .. ..	Grade III.	.. 2

*Fourth Year—*

Trade Theory and Calculations .. ..	Grade IV.	.. 2
Trade Practice .. ..	Grade IV.	.. 2

The detailed syllabus of the above-mentioned subjects shall be as determined by the Apprenticeship Commission of Victoria from time to time.

THIRD SCHEDULE.

Classes for instruction in the subjects of the Apprenticeship course for the trade of Brassfinishing—

		Hours per week.
<i>First Year—</i>		
Trade Mathematics .. ..	Grade I.	.. 1
Trade Drawing .. ..	Grade I.	.. 2
Trade Science .. ..	Grade I.	.. 1
Trade Theory .. ..	Grade I.	.. 1
Trade Practice .. ..	Grade I.	.. 3

*Second Year—*

Trade Drawing .. ..	Grade II.	.. 2
Trade Science .. ..	Grade II.	.. 2
Trade Theory and Calculations .. ..	Grade II.	.. 1
Trade Practice .. ..	Grade II.	.. 3

*Third Year—*

Trade Theory and Calculations .. ..	Grade III.	} .. 4
Trade Practice .. ..	Grade III.	
Foundry Practice (optional at evening classes) .. ..		
Additional Trade Practice (optional at evening classes) .. ..	Grade III.	

*Fourth Year—*

Trade Theory and Calculations .. ..	Grade IV.	} .. 4
Trade Practice .. ..	Grade IV.	
Additional Trade Practice (optional at evening classes) .. ..	Grade IV.	
Welding (optional at evening classes) .. ..	Grade IV.	

The detailed syllabus of the above-mentioned subjects shall be as determined by the Apprenticeship Commission of Victoria from time to time.

FOURTH SCHEDULE.

Classes for instruction in the subjects of the Apprenticeship course for the trade of Blacksmithing—

		Hours per week.
<i>First Year—</i>		
Trade Mathematics .. ..	Grade I.	.. 1
Trade Drawing .. ..	Grade I.	.. 2
Trade Science .. ..	Grade I.	.. 1
Trade Theory .. ..	Grade I.	.. 1
Trade Practice .. ..	Grade I.	.. 3

*Second Year—*

Trade Drawing .. ..	Grade II.	.. 2
Trade Science .. ..	Grade II.	.. 1
Trade Theory and Calculations .. ..	Grade II.	.. 1
Trade Practice .. ..	Grade II.	.. 4

*Third Year—*

Trade Science .. ..	Grade III.	.. 1
Trade Theory and Calculations .. ..	Grade III.	.. 1
Trade Practice .. ..	Grade III.	.. 2
Additional Trade Practice (optional at evening classes) .. ..	Grade III.	

*Fourth Year—*

Trade Theory .. ..	Grade IV.	} .. 4
Trade Practice .. ..	Grade IV.	
Trade Science (optional at evening classes) .. ..	Grade IV.	

The detailed syllabus of the above-mentioned subjects shall be as determined by the Apprenticeship Commission of Victoria.

FIFTH SCHEDULE.

Classes for instruction in the subjects of the Apprenticeship course for the trades of Copper and/or Brass-smithing—

		Hours per week.
<i>First Year—</i>		
Trade Mathematics .. ..	Grade I.	.. 1
Trade Drawing .. ..	Grade I.	.. 2
Trade Science .. ..	Grade I.	.. 1
Trade Theory .. ..	Grade I.	.. 1
Trade Practice .. ..	Grade I.	.. 3

*Second Year—*

Trade Mathematics .. ..	Grade II.	.. 1
Trade Drawing .. ..	Grade II.	.. 2
Trade Theory .. ..	Grade II.	.. 1
Trade Practice .. ..	Grade II.	.. 4

*Third Year—*

Trade Theory, Calculations, and Drawing .. ..	Grade III.	} .. 4
Trade Practice .. ..	Grade III.	
Additional Trade Practice (optional at evening classes) .. ..	Grade III.	

*Fourth Year—*

Trade Theory and Practice .. ..	Grade IV.	.. 2
Welding .. ..		.. 2
Additional Trade Practice (optional at evening classes) .. ..	Grade IV.	

The detailed syllabus of the above-mentioned subjects shall be as determined by the Apprenticeship Commission of Victoria from time to time.

And the Honorable Herbert John Thornhill Hyland, His Majesty's Minister of Labour for the State of Victoria, shall give the necessary directions herein accordingly.

C. W. KINSMAN,  
Clerk of the Executive Council.

MARKETING OF PRIMARY PRODUCTS ACT 1935 (No. 4337).

At the Executive Council Chamber, Melbourne, the thirteenth day of April, 1948.

PRESENT:

His Excellency the Governor of Victoria.  
Mr. Kennedy | Mr. Byrnes.  
Mr. Warner |

APPOINTMENT OF MEMBERS OF THE CHICORY MARKETING BOARD.

IN pursuance of the powers conferred by the *Marketing of Primary Products Act 1935* and all other powers enabling him in that behalf, His Excellency the Governor of the State of Victoria, by and with the advice of the Executive Council thereof, doth by this Order—

- (1) Appoint ALFRED HENRY JOHNSON as a member of the Chicory Marketing Board constituted under the said Act, to hold office for a period of two (2) years, from and inclusive of the 16th April, 1948; and
- (2) Appoint RUPERT TREGONNING HARRIS and JOHN RATFORD as members of the Chicory Marketing Board for a period of two (2) years, from and inclusive of the 16th April, 1948; the said Rupert Tregonning Harris and John Ratford having been elected by the producers of chicory as elective members of such Board, pursuant to and in accordance with the said Act.

And the Honorable Alexander Henry Dennett, His Majesty's Minister of Agriculture for the State of Victoria, shall give the necessary directions herein accordingly.

C. W. KINSMAN,  
Clerk of the Executive Council.

Water Acts.  
SHEPPARTON URBAN WATERWORKS TRUST.

At the Executive Council Chamber, Melbourne, the  
thirteenth day of April, 1948.

PRESENT:

His Excellency the Governor of Victoria.  
Mr. Kennedy | Mr. Byrnes.  
Mr. Warner

EXTENT OF DISTRICT INCREASED.

UNDER the powers conferred by the Water Acts and all other powers enabling him in that behalf, His Excellency the Governor of the State of Victoria, with the advice of the Executive Council of the said State, doth hereby declare, order, and direct as follows:—

That the extent of the Waterworks District of the Shepparton Urban Waterworks Trust be increased by adding to the same the lands set out and described in the Schedule hereto, and as on and from the date of this Order such district shall be deemed to be increased accordingly.

SCHEDULE.

1. Commencing at a point on the southern boundary of Crown allotment 78, Parish of Shepparton, County of Moira, being the north-western angle of the intersection of the Goulburn Valley Highway and Cemetery-road; thence westerly by the said southern boundary a distance of 2 chains 12-1/10 links; thence northerly by a line parallel to the said Goulburn Valley Highway to a point in line with the northern boundary of the land described in Certificate of Title, volume 4312, folio 862332; thence easterly by a line and the last-mentioned boundary and southerly and westerly by the eastern and southern boundaries of the land described in the said Certificate of Title to the south-western angle thereon; thence north-westerly by a line to the point of commencement.

2. Commencing at the south-eastern angle of lot 21 on lodged plan of subdivision No. 3297, Parish of Shepparton, County of Moira; thence northerly by the eastern boundaries of the said lot 21 and lots 22, 23, and 25 to a point distant 3 chains southerly from the northern boundary of lot 25; thence east by a line to the eastern boundary of lot 26; thence southerly by the last-mentioned boundary and a line in continuation thereof to a point in the southern boundary of MacIntosh-street; thence westerly by the last-mentioned boundary to a point in line with the eastern boundary of said lot 21; thence northerly by a line to the point of commencement.

3. All that piece of land comprising lot 1 on lodged plan of subdivision No. 15507, Parish of Shepparton, County of Moira.

The lands described in the foregoing Schedule are shown on a plan approved by the Governor in Council and deposited in the office of the State Rivers and Water Supply Commission, Melbourne.—(Corres. 47/28604.)

And the Honorable John Gladstone Black McDonald, His Majesty's Minister of Water Supply for the State of Victoria, shall give the necessary directions herein accordingly.

C. W. KINSMAN,  
Clerk of the Executive Council.

Water Acts.  
STATE RIVERS AND WATER SUPPLY COMMISSION.

At the Executive Council Chamber, Melbourne, the  
thirteenth day of April, 1948.

PRESENT:

His Excellency the Governor of Victoria.  
Mr. Kennedy | Mr. Byrnes.  
Mr. Warner

SHEPPARTON IRRIGATION AND WATER SUPPLY DISTRICT.—PORTIONS EXCISED.

UNDER the powers conferred by the Water Acts and all other powers enabling him in that behalf, His Excellency the Governor of the State of Victoria, with the advice of the Executive Council of the said State, on the recommendation of the State Rivers and Water Supply Commission, doth hereby declare, order, and direct as follows:—

That there shall be excised from the Shepparton Irrigation and Water Supply District those portions of the same set out and described in the schedule thereto, which portions as on and from the date of this Order shall be deemed to be excised accordingly.

SCHEDULE.

Portion 1.—Commencing at a point on the southern boundary of Crown allotment 78, Parish of Shepparton, County of Moira, being the north-western angle of the intersection of the Goulburn Valley Highway and Cemetery-road; thence westerly by the said southern boundary a distance of 2 chains 12-1/10 links; thence northerly by a line parallel to the said Goulburn Valley Highway to a point in line with the northern boundary of the land described in Certificate of Title, volume 4312, folio 862332; thence easterly by a line and the last-mentioned boundary and southerly and westerly by the eastern and southern boundaries of the land described in the said Certificate of Title to the south-western angle thereof; thence north-westerly by a line to the point of commencement.

Portion 2.—Commencing at the south-eastern angle of lot 21 on lodged plan of subdivision No. 3297, Parish of Shepparton, County of Moira; thence northerly by the eastern boundaries of the said lot 21 and lots 22, 23, and 25 to a point distant 3 chains southerly from the northern boundary of lot 25; thence east by a line to the eastern boundary of lot 26; thence southerly by the last-mentioned boundary and a line in continuation thereof to a point in the southern boundary of MacIntosh-street; thence westerly by the last-mentioned boundary to a point in line with the eastern boundary of said lot 21; thence northerly by a line to the point of commencement.

Portion 3.—All that piece of land comprising lot 1 on lodged plan of subdivision No. 15507, Parish of Shepparton, County of Moira.

The portions described in the foregoing Schedule are shown on a plan approved by the Governor in Council and deposited in the office of the State Rivers and Water Supply Commission, Melbourne.—(Corres. 47/28604.)

And the Honorable John Gladstone Black McDonald, His Majesty's Minister of Water Supply for the State of Victoria, shall give the necessary directions herein accordingly.

C. W. KINSMAN,  
Clerk of the Executive Council.

SHIRE OF ARARAT WATERWORKS TRUST.

At the Executive Council Chamber, Melbourne, the  
thirteenth day of April, 1948.

PRESENT:

His Excellency the Governor of Victoria.  
Mr. Kennedy | Mr. Byrnes.  
Mr. Warner

AMENDMENT OF ORDER FIXING THE LIMIT OF THE OVERDRAFT TO BE OBTAINED BY THE SHIRE OF ARARAT WATERWORKS TRUST.

UNDER the powers conferred by the Water Acts and all other powers enabling him in that behalf, His Excellency the Governor of the State of Victoria, by and with the advice of the Executive Council of the said State, doth hereby amend as follows the Order in Council made on the 3rd day of September, 1946, as amended by Order in Council made on the 13th day of November, 1947, and published in the *Government Gazette* dated 11th September, 1946, and 19th November, 1947, respectively, fixing the limit of the overdraft to be obtained by the Shire of Ararat Waterworks Trust:—

For the expression "at an amount not to exceed at any one time the sum of Four thousand pounds (£4,000)," there shall be substituted the expression "at an amount not to exceed at any one time the sum of Six thousand pounds (£6,000)."

And the Honorable John Gladstone Black McDonald, His Majesty's Minister of Water Supply for the State of Victoria, shall give the necessary directions herein accordingly.

C. W. KINSMAN,  
Clerk of the Executive Council.

COUNTRY ROADS BOARD.

At the Executive Council Chamber, Melbourne, the  
thirteenth day of April, 1948.

PRESENT:

His Excellency the Governor of Victoria.  
Mr. Kennedy | Mr. Byrnes.  
Mr. Warner

ORDER APPROVING OF A DEVIATION FROM A MAIN ROAD IN THE SHIRE OF CHARLTON.

WHEREAS the Country Roads Board constituted under the *Country Roads Act* 1928 (No. 3662) has represented to His Excellency the Governor in Council that it

appears to it desirable that the deviation hereinafter referred to from the existing Charlton-Durham Ox road in the Shire of Charlton (declared to be a main road under the said Act which declaration was confirmed by the Order in Council published in the *Government Gazette* of the 20th July, 1938, on page 2174) should be made by the said Board: And whereas the said Board in accordance with the requirements of section 19 of the said cited Act has caused to be prepared a map plan and estimate showing the points between which and on and through what land the said deviation is proposed to be made and the cost of acquiring the land and constructing the said deviation: And whereas on an inspection of the said map and plan and a consideration of the said estimate His Excellency the Governor in Council is satisfied that there are funds legally available for acquiring the land and constructing the said deviation: Now therefore be it known by this present Order that His Excellency the Governor of the State of Victoria with the advice of the Executive Council thereof doth hereby approve of the said road being made, that is to say:—

All that piece of land in the Parish of Charlton East, the boundaries of which are as follow:—Commencing at the north-eastern angle of allotment 18, section A, of the said parish; thence by lines bearing respectively 242 deg. 11 min. 1,534 links, 226 deg. 14 min. 482.5 links, 216 deg. 17 min. 480 links, 207 deg. 33 min. 407.5 links, 198 deg. 36 min. 446.5 links, 191 deg. 15 min. 340 links, 182 deg. 53 min. 329 links, 354 deg. 38 min. 1,065.2 links, 18 deg. 36 min. 150.6 links, 27 deg. 33 min. 453.8 links, 36 deg. 17 min. 529 links, 46 deg. 14 min. 550.6 links, 62 deg. 11 min. 1,007.5 links, and 90 deg. 0 min. 642.8 links to the point of commencement.

Also, all that piece of land in the Parish of Narrewillock, the boundaries of which are as follow:—Commencing at the south-eastern angle of allotment A of the said parish; thence by lines bearing respectively 270 deg. 0 min. 1,476.3 links, 59 deg. 23 min. 365 links, 50 deg. 25 min. 634.4 links, 36 deg. 29 min. 603 links, 26 deg. 6 min. 444.4 links, 18 deg. 9 min. 378.9 links, and 179 deg. 58 min. 1,834 links to the point of commencement—which said pieces of land are particularly delineated and shown coloured red on survey plans numbered 4925 and 4926, lodged in the office of the Country Roads Board.

And the Honorable James Arthur Kennedy, His Majesty's Commissioner of Public Works for the State of Victoria, shall give the necessary directions herein accordingly.

C. W. KINSMAN,  
Clerk of the Executive Council.

#### COUNTRY ROADS BOARD.

*At the Executive Council Chamber, Melbourne, the thirteenth day of April, 1948.*

PRESENT:

His Excellency the Governor of Victoria.  
Mr. Kennedy | Mr. Byrnes.  
Mr. Warner

#### ORDER APPROVING OF A NEW MAIN ROAD IN THE SHIRE OF BULN BULN.

WHEREAS the Country Roads Board constituted under the *Country Roads Act* 1928 (No. 3662) has represented to His Excellency the Governor in Council that it appears to it desirable that the main Neerim-road in the Shire of Buln Buln should be made by the said Board: And whereas the said Board in accordance with the requirements of section 19 of the said cited Act has caused to be prepared a map plan and estimate showing the points between which and on and through what land the said new road is proposed to be made and the cost of acquiring the land and constructing the said new road: And whereas on an inspection of the said map and plan and a consideration of the said estimate His Excellency the Governor in Council is satisfied that there are funds legally available for acquiring the land and constructing the said new road: Now therefore be it known by this present Order that His Excellency the Governor of the State of Victoria with the advice of the Executive Council thereof, doth hereby approve of the said road being made, that is to say:—

All that piece of land in the Parish of Neerim, the boundaries of which are as follow:—

Commencing at a point on the western boundary of allotment A3 of the said parish, distant 217 deg. 15 min. 756.9 links from the north-western angle of the said allotment; thence by lines

bearing respectively 206 deg. 10 min. 148.3 links, 353 deg. 26 min. 41.2 links, and 37 deg. 15 min. 115.8 links to the point of commencement—

which said piece of land is particularly delineated and shown red on survey plan numbered 4938, lodged in the office of the Country Roads Board.

And the Honorable James Arthur Kennedy, His Majesty's Commissioner of Public Works for the State of Victoria, shall give the necessary directions herein accordingly.

C. W. KINSMAN,  
Clerk of the Executive Council.

#### COUNTRY ROADS BOARD.

*At the Executive Council Chamber, Melbourne, the thirteenth day of April, 1948.*

PRESENT:

His Excellency the Governor of Victoria.  
Mr. Kennedy | Mr. Byrnes.  
Mr. Warner

#### DECLARATION OF A DEVIATION FROM THE WITHERDEN-ROAD IN THE SHIRE OF KORUMBURRA.

WHEREAS by section 58 of the *Country Roads Act* 1928 (No. 3662) it is amongst other things enacted that when the Country Roads Board under the provisions of the *Country Roads Act* has by resolution declared a deviation to be a road the said Board may also declare that such deviation shall be in lieu of any existing road or part thereof named in such resolution and that on publication in the *Government Gazette* of the Order confirming such resolution the existing road or part thereof shall cease to be a road or be discontinued as provided in the resolution: And whereas the said Board has by resolution declared the deviation on the land described in the First Schedule to such resolution to be a road and has also declared that such deviation shall be in lieu of the part of the existing road being the land described in the Second Schedule to the said resolution and that such part of the said existing road shall be discontinued: Now therefore His Excellency the Governor of the State of Victoria by and with the advice of the Executive Council thereof doth hereby confirm the said resolution.

#### Resolution for declaration of a deviation under the Country Roads Act.

Whereas the land the site of the road the course of which is below set out was taken by the Board under the provisions of the *Country Roads Act* 1928 for the purpose of constructing such road deviation which road deviation has now been laid out and formed on the same: And whereas the said Board (being the Country Roads Board incorporated under the said Act) thinks that the road aforesaid is fit to be used as a public highway such Board at a meeting now holden acting under the authority conferred upon it by section 58 of the said Act doth by this present resolution hereby declare the said road deviation the course of which is described in the First Schedule hereto with the commencing and terminating points thereof respectively specified to be part of a road within the meaning and for the purposes of the *Country Roads Act* 1928: And the said Board doth also declare that such deviation shall be in lieu of the existing road or part thereof described in the Second Schedule hereto, and that such part of the said existing road shall be discontinued.

#### FIRST SCHEDULE.

##### Shire of Korumburra.

17. *Witherden-road* (9067).—All those pieces of land in the Parish of Allambee, the boundaries of which are as follow:—

- (a) Commencing at a point on the eastern boundary of allotment 84B, of the said parish, distant 188 deg. 42 min. 3,067.1 links from the north-eastern angle of that allotment; thence by lines bearing respectively 230 deg. 9 min. 86.8 links, 326 deg. 14 min. 135.7 links, 104 deg. 37 min. 41.5 links, 43 deg. 49 min. 37.7 links, 31 deg. 44 min. 221 links, and 188 deg. 42 min. 265.3 links to the point of commencement.

- (b) Commencing at a point on the northern boundary of allotment 84c, of the said parish, distant 326 deg. 14 min. 295.7 links from the north-eastern angle of that allotment; thence by lines bearing respectively 284 deg. 23 min. 237.7 links, 258 deg. 1 min. 244.3 links, 254 deg. 2 min. 582.2 links, 294 deg. 32 min. 208.3 links, 88 deg. 17 min. 213.1 links, 75 deg. 12 min. 532 links, 70 deg. 11 min. 204.9 links, 77 deg. 55 min. 69 links, 104 deg. 37 min. 154.6 links, and 146 deg. 14 min. 147 links to the point of commencement.
- (c) Commencing at the south-western angle of allotment 84c of the said parish; thence by lines bearing respectively 42 deg. 47 min. 332 links, 88 deg. 17 min. 398.7 links, 268 deg. 4 min. 395 links, 221 deg. 27 min. 325.9 links, and 278 deg. 35 min. 13.8 links to the point of commencement—

which said pieces of land are particularly delineated and shown coloured red on survey plan numbered 3477B, lodged in the office of the Country Roads Board.

## SECOND SCHEDULE.

## Shire of Korumburra.

17. *Witherden-road*.—All those pieces of land in the Parish of Allambee, the boundaries of which are as follow:—

- (a) Commencing at the north-eastern angle of allotment 84c of the said parish; thence by lines bearing respectively, 326 deg. 14 min. 295.7 links, 104 deg. 23 min. 137.5 links, 50 deg. 9 min. 8.2 links, 146 deg. 14 min. 85.2 links, and 188 deg. 42 min. 148.1 links to the point of commencement.
- (b) Commencing at a point on the northern boundary of allotment 84c of the said parish, distant 8 deg. 42 min. 395 links, and 326 deg. 14 min. 442.7 links from the south-eastern angle of that allotment; thence by lines bearing respectively 326 deg. 14 min. 99.3 links, 250 deg. 11 min. 172.1 links, 257 deg. 55 min. 202.3 links, 253 deg. 59 min. 545.1 links, 294 deg. 22 min. 193.7 links, 268 deg. 17 min. 580 links, 221 deg. 33 min. 434.3 links, 278 deg. 35 min. 14.9 links, 42 deg. 47 min. 442 links, 88 deg. 17 min. 759 links, 75 deg. 12 min. 516 links, 70 deg. 11 min. 451 links, 146 deg. 14 min. 289.8 links, and 284 deg. 37 min. 150.5 links to the point of commencement—

which said pieces of land are particularly delineated and shown coloured blue on survey plan numbered 3477B, lodged in the office of the Country Roads Board.

The common seal of the Country Roads Board was hereto affixed at Melbourne, this eighth day of April, One thousand nine hundred and forty-eight, in the presence of—

(SEAL) F. M. CORRIGAN, Member.  
D. V. DARWIN, Member.  
R. JANSEN, Secretary.

And the Honorable James Arthur Kennedy, His Majesty's Commissioner of Public Works for the State of Victoria, shall give the necessary directions herein accordingly.

C. W. KINSMAN,  
Clerk of the Executive Council.

## HEALTH ACTS.

*At the Executive Council Chamber, Melbourne, the thirteenth day of April, 1948.*

## PRESENT:

His Excellency the Governor of Victoria.  
Mr. Kennedy | Mr. Byrnes.  
Mr. Warner

## APPOINTMENT OF HEALTH INSPECTORS.

HIS Excellency the Governor of the State of Victoria, by and with the advice of the Executive Council thereof, has been pleased to appoint, under section 335 (1) of the *Health Act 1928*, without additional pay, the under-mentioned officers of the Department of Agriculture to execute the powers and fulfil the duties of Health

Inspectors of the Department of Health, insofar as such powers and duties relate to the positions held by them in the Department of Agriculture, and only for such time as they continue to hold such positions:—

*Name of Officer; Position Held.*

LEONARD PONSFORD; Dairy Produce Inspector.  
CHARLES HAROLD CHAMBERLAIN; Dairy Supervisor.  
JOHN WILLIAM WOODBURN; Dairy Supervisor.  
CHARLES HARRY FOSTER; Dairy Supervisor.  
EDGAR GEORGE VIAL; Dairy Supervisor.  
MAX HENRY INGRAM; Dairy Supervisor.  
VICTOR GEORGE BROOM; Dairy Supervisor.

And the Honorable Albert Arthur Dunstan, His Majesty's Minister of Health for the State of Victoria, shall give the necessary directions herein accordingly.

C. W. KINSMAN,  
Clerk of the Executive Council.

## MENTAL HYGIENE ACT 1928.

*At the Executive Council Chamber, Melbourne, the thirteenth day of April, 1948.*

## PRESENT:

His Excellency the Governor of Victoria.  
Mr. Kennedy | Mr. Byrnes.  
Mr. Warner

## REGULATIONS PRESCRIBING FEES PAYABLE TO MEDICAL PRACTITIONERS FOR EXAMINING PERSONS CHARGED WITH LUNACY.

WHEREAS by section 257 of the *Mental Hygiene Act 1928* it is amongst other things enacted that the Governor in Council may from time to time make such Regulations as to him shall seem meet for fixing the fees to be charged and paid in all or any proceedings in lunacy: Now therefore His Excellency the Governor of the State of Victoria, with the advice of the Executive Council of the said State, doth hereby make the following Regulations fixing the fees to be paid to medical practitioners ordered by justices to examine persons charged with lunacy under the provisions of Part II. of the said Act, that is to say:—

1. These Regulations shall come into operation on publication in the *Government Gazette*.
2. All Regulations heretofore made relating to matters herein are hereby repealed.
3. The fee for examining any person charged with lunacy, and for giving the necessary evidence and certificate, shall be £2.
4. When more than one examination is necessary to determine the question of insanity, the fee for each such additional examination shall be £1: Provided that the total fees payable for additional examinations shall not exceed £2 2s.

The fees above prescribed shall not include any allowance payable for travelling expenses of medical witnesses under any Regulations that are now or may hereafter be in force.

And the Honorable Albert Arthur Dunstan, His Majesty's Minister of Health for the State of Victoria, shall give the necessary directions herein accordingly.

C. W. KINSMAN,  
Clerk of the Executive Council.

## MOTOR OMNIBUS ACT 1928 (No. 3742).

*At the Executive Council Chamber, Melbourne, the thirteenth day of April, 1948.*

## PRESENT:

His Excellency the Governor of Victoria.  
Mr. Kennedy | Mr. Byrnes.  
Mr. Warner

## AMENDMENT OF PRESCRIPTION OF METROPOLITAN MOTOR OMNIBUS ROUTE No. 36 (MOONEE PONDS-FOOTSCRAY).

HIS Excellency the Governor of the State of Victoria, by and with the advice of the Executive Council thereof, and in pursuance of the powers conferred by the *Motor Omnibus Act 1928* (No. 3742), doth by this Order amend,

as set out hereunder, the prescription of a certain route, viz., No. 36, within the metropolitan area, along which motor omnibuses for which "regular service" licences are granted may ply for hire, viz.:—

Under the heading "Description of Route, including Commencing and Terminal Points," delete "commencing in Ascot Vale-road, Moonee Ponds, 50 yards south from Mount Alexander-road, via," and in place thereof insert "commencing at Central Parking Area, Mount Alexander-road (opposite the Town Hall), Moonee Ponds; thence via Mount Alexander-road."

**Licensing Authority.**—Pursuant to the provisions of section 15 (1 (c)) of the said Act (No. 3742), the Governor in Council by this Order confers upon the Licensing Authority full power and authority for the carrying into effect by the said Licensing Authority of the foregoing provisions of this Order.

And the Honorable James Arthur Kennedy, His Majesty's Commissioner of Public Works for the State of Victoria, shall give the necessary directions herein accordingly.

C. W. KINSMAN,  
Clerk of the Executive Council.

LOCAL GOVERNMENT ACT 1946.

At the Executive Council Chamber, Melbourne, the thirteenth day of April, 1948.

PRESENT:

His Excellency the Governor of Victoria.  
Mr. Kennedy | Mr. Byrnes.  
Mr. Warner

SALARY TO BE PAID INSPECTOR OF MUNICIPAL ACCOUNTS.

HIS Excellency the Governor of the State of Victoria, by and with the advice of the Executive Council thereof, under the powers conferred by section 489 of the *Local Government Act 1946*, doth by this Order determine that the scale of salary to be paid to Leslie Edward Stringer, Inspector of Municipal Accounts, shall be, minimum £748 (standard) per annum and maximum £800 (standard) per annum, and that he be paid at the rate of £774 (standard) per annum from and inclusive of the 5th October, 1947, and at the rate of £800 (standard) per annum from and inclusive of the 5th October, 1948.

And the Honorable James Arthur Kennedy, His Majesty's Commissioner of Public Works for the State of Victoria, shall give the necessary directions herein accordingly.

C. W. KINSMAN,  
Clerk of the Executive Council.

MONEY LENDERS ACT 1938.

At the Executive Council Chamber, Melbourne, the thirteenth day of April, 1948.

PRESENT:

His Excellency the Governor of Victoria.  
Mr. Kennedy | Mr. Byrnes.  
Mr. Warner

EXEMPTION FROM TAKING OUT LICENCE.

UNDER the powers conferred by section 3 (1) (e) of the *Money Lenders Act 1938* (No. 4625), as amended by section 2 of the *Statute Law Revision Act 1939* (No. 4636), His Excellency the Governor of the State of Victoria, by and with the advice of the Executive Council thereof, doth hereby exempt Mary Cecilia O'Neill, of 24 Adams-street, Castlemaine (trading as Loddon Investments), from taking out a licence under the provisions of the *Money Lenders Act 1938* (No. 4625).

And the Honorable Wilfred Selwyn Kent Hughes, for and on behalf of His Majesty's Treasurer for the State of Victoria, shall give the necessary directions herein accordingly.

C. W. KINSMAN,  
Clerk of the Executive Council.

DEPARTMENT OF LANDS AND SURVEY.

At the Executive Council Chamber, Melbourne, the thirteenth day of April, 1948.

PRESENT:

His Excellency the Governor of Victoria.  
Mr. Kennedy | Mr. Byrnes.  
Mr. Warner

LAND TEMPORARILY RESERVED FROM SALE.

HIS Excellency the Governor of the State of Victoria, by and with the advice of the Executive Council thereof, doth hereby, in pursuance of the provisions of the *Land Act 1928*, reserve, temporarily, and also except from occupation for mining purposes under any miner's right, the land hereinafter described:—

STAWELL.—Site for Police purposes—1 rood 0 5/10 perches, Borough of Stawell, Parish of Stawell, County of Borung, as indicated by hachure on plan hereunder.—(S.329<sup>(\*)</sup>) (Rs.6152).

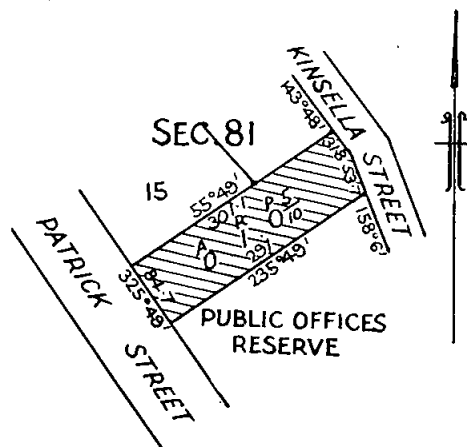

And the Honorable John Gladstone Black McDonald, His Majesty's Commissioner of Crown Lands and Survey for the State of Victoria, shall give the necessary directions herein accordingly.

C. W. KINSMAN,  
Clerk of the Executive Council.

DEPARTMENT OF LANDS AND SURVEY.

At the Executive Council Chamber, Melbourne, the thirteenth day of April, 1948.

PRESENT:

His Excellency the Governor of Victoria.  
Mr. Kennedy | Mr. Byrnes.  
Mr. Warner

UNUSED AND UNMADE ROAD CLOSED.

HIS Excellency the Governor of the State of Victoria, by and with the advice of the Executive Council thereof, doth hereby direct that, in pursuance of the provisions of section 304 of the *Land Act 1928* (No. 3709), the unused and unmade road referred to hereunder be closed, viz.:— Parish of Ballark, County of Grant, being the road as indicated by hachure on plan hereunder.—(B.29<sup>(\*)</sup>) (J.27314).

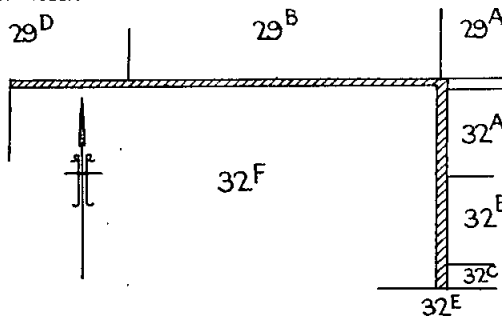

And the Honorable John Gladstone Black McDonald, His Majesty's Commissioner of Crown Lands and Survey for the State of Victoria, shall give the necessary directions herein accordingly.

C. W. KINSMAN,  
Clerk of the Executive Council.

## WORKERS' COMPENSATION ACTS.

At the Executive Council Chamber, Melbourne, the  
twentieth day of April, 1948.

## PRESENT:

His Excellency the Governor of Victoria.  
Colonel Kent Hughes | Mr. Dunstan  
Mr. Dodgshun | Mr. Lienhop.

## REGULATIONS.

IN pursuance of the powers conferred by the Workers' Compensation Acts and all other powers enabling him in that behalf, His Excellency the Governor of the State of Victoria, in the Commonwealth of Australia, by and with the advice of the Executive Council of the said State, doth hereby make the Regulations following (that is to say):—

1. (a) These Regulations shall come into operation on the first day of June, 1948.

(b) The rates of premium herein prescribed shall apply in respect of policies of insurance effected on and after the said first day of June, 1948, and existing policies renewed on and after that date.

2. The "Workers' Compensation Regulations 1942" as amended by Regulations made by the Governor in Council on the 20th day of October, 1944, and published in the *Government Gazette* of the 1st day of November, 1944, and further amended by Regulations made by the Governor in Council on the 24th day of September, 1946, and published in the *Government Gazette* of the 25th day of September, 1946, are hereby amended as follows:—

(1) In clause 11 of the said Regulations the Schedule of Trades and Rates is hereby revoked and the following substituted therefor:—

Trade.	Rate per cent.			
	s.	d.	s.	d.
Agricultural, Pastoral, and Horticultural ..	24	6	to	123 9
Aircraft .. .. .	45	0	to	150 0
Amusements, Halls, &c. .. .. .	4	9	to	93 0
Caretakers .. .. .	10	6	to	68 6
Clerical .. .. .	2	0		
Clothing .. .. .	4	9	to	48 0
Textile .. .. .	4	9	to	25 0
Clubs, Light .. .. .	16	0	to	31 0
Clubs, Heavy .. .. .	9	6	to	131 3
Constructional .. .. .	8	6	to	309 6
Delivery and Transport .. .. .	9	6	to	154 9
Glass Trades .. .. .	38	6	to	53 6
Horses and Live Stock .. .. .	9	6	to	247 6
Hotels and Catering .. .. .	21	9	to	58 3
Householders (rate <i>per capita</i> ) .. .. .	4	9	to	18 9
Importers, Warehouses, and Wholesalers ..	6	3	to	77 6
Leather Trades .. .. .	10	0	to	49 6
Light, Heating, and Power Supplies .. ..	9	6	to	54 3
Manufacturers, Foodstuffs (other than Meat)	14	3	to	77 6
Manufacturers, Light (excluding Foodstuffs)	4	9	to	62 0
Manufacturers, Heavy (excluding Foodstuffs)	18	9	to	247 6
Meat Trades .. .. .	14	3	to	87 3
Metal (Base) Trades .. .. .	12	3	to	206 3
Mining, excluding Metal and Coal .. ..	25	6	to	247 6
Mining, Metal and Coal .. .. .	18	9	to	244 9
Motor and Cycle Trades .. .. .	25	6	to	112 6
Municipalities and Public Authorities ..	18	9	to	61 0
Oil Trades .. .. .	25	0	to	61 0
Printers and Stationers .. .. .	15	9	to	27 3
Professional .. .. .	3	6	to	62 0
Public Institutions .. .. .	7	3	to	46 9
Ships and Shipping .. .. .	18	9	to	278 6
Shops and Retail Distributors .. .. .	6	3	to	31 0
Timber Trades and Workers in Wood,				
Primary Industries .. .. .	46	9	to	247 6
Timber Trades and Workers in Wood,				
Secondary Industries .. .. .	14	3	to	247 6
Travellers .. .. .	9	6	to	46 9

(2) In paragraph (c) of clause 12 of the said Regulations for the expression—

“be less than 3s. 9d.”

there shall be substituted the expression—

“be less than 4s. 9d.”

(3) Clause 16 of the said Regulations is hereby amended as follows:—

(a) In paragraph (1) of the said clause, for the expression—

“(a) Underground workers—

Coal .. 185s. 9d. per cent.  
Gold, &c. .. 117s. 6d. per cent.

(b) Aboveground workers—

Coal .. 75s. 0d. per cent.  
Gold, &c. .. 56s. 3d. per cent.”

there shall be substituted the following expression:—

“(a) Underground workers—

Coal .. 232s. 3d. per cent.  
Gold, &c. .. 147s. 0d. per cent.

(b) Aboveground workers—

Coal .. 93s. 9d. per cent.  
Gold, &c. .. 70s. 3d. per cent.”

(b) In paragraph (3) of the said clause, for the expression—

“Coal .. 75s. 0d. per cent. } Minimum  
Gold, &c. 56s. 3d. per cent. } Premium, £4 10s.”

there shall be substituted the following expression:—

“Coal .. 93s. 9d. per cent. } Minimum  
Gold, &c. 70s. 3d. per cent. } Premium, £4 10s.”

And the Honorable Keith Dodgshun, His Majesty's Chief Secretary for the State of Victoria, shall give the necessary directions herein accordingly.

C. W. KINSMAN,  
Clerk of the Executive Council.

**APPROACHING LAND SALES**

SALES of Crown lands, in fee-simple, will be held at the under-mentioned places and dates, viz.:—

	No. of Gazette.
Corryong.—Thursday, 20th May, 1948	.. 233
Manangatang.—Tuesday, 4th May, 1948	.. 224
Maryborough.—Friday, 23rd April, 1948	.. 155
Stanhope.—Thursday, 29th April, 1948	.. 233
Swan Hill.—Monday, 17th May, 1948	.. 224

Market 1 acre 0 roods 34 8/10 perches of land in the Parish of Warragul, at Waterloo (now Township of Yarragon), is about to be revoked.—(W.335(1) (Rs.6148).

DONALD.—The Order in Council of the 23rd December, 1874, temporarily reserving as a site for Recreation purposes, and withholding from sale, leasing, and licensing, 68 acres 3 roods 36 perches of land in the Town of Donald (revoked as to part by various Orders), is about to be further revoked so far only as regards the portion thereof, containing 1 acre 2 roods 37 7/10 perches, indicated by hachure on plan hereunder.—(D.168(L<sup>3</sup>) (Rs.3088).

**PROPOSED REVOCATIONS OF TEMPORARY RESERVATIONS OF LANDS BY ORDERS IN COUNCIL.**

IN pursuance of the provisions of the Land Act 1928, notice is hereby given that it is the intention of the Governor in Council to revoke the temporary reservations of lands by Orders in Council hereunder referred to, viz.:—

The following Notices were published 1<sup>o</sup> on the 14th April, 1948, pursuant to Orders of the 6th April, 1948.

IRREWARRA.—The Order in Council of the 4th August, 1873, temporarily reserving 4 acres of land in the Parish of Irrewarra as a site whence stone may be procured, is about to be revoked.—(I.12(3) (34/121).

KADNOOK.—The Order in Council of the 5th June, 1906, temporarily reserving 5 acres of land in the Parish of Kadnook as a site for a Hospital or Place for isolating persons suffering from small-pox, cholera, or other dangerous, infectious, or contagious disease, is about to be revoked.—(K.128(4) (C.32367).

YARRAGON.—The Order in Council of the 18th March, 1879 (see *Government Gazette* of the 21st March, 1879, page 617), temporarily reserving as a site for General

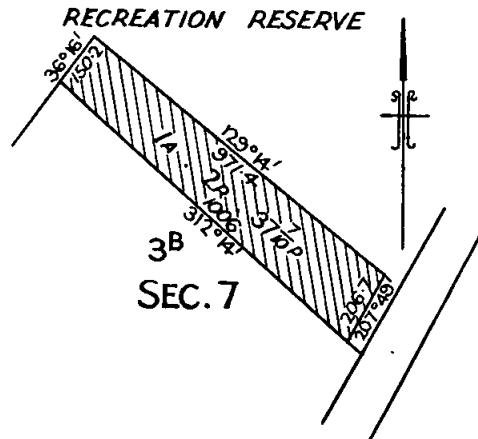

JOHN G. B. McDONALD,  
Commissioner of Crown Lands and Survey.



**PROPOSED REVOCATIONS OF TEMPORARY RESERVATIONS OF LANDS BY ORDERS IN COUNCIL.**

IN pursuance of the provisions of the *Land Act 1928*, notice is hereby given that it is the intention of the Governor in Council to revoke the temporary reservations of lands by Orders in Council hereunder referred to, viz.:—  
*The following Notices were published 1° on the 21st April, 1948, pursuant to Orders of the 13th April, 1948.*

**WINDHAM.**—The Order in Council of the 28th July, 1884, temporarily reserving as a site for the Use of the Railway Department, and withholding from sale, leasing, or licensing, 20 acres 0 roods 30 perches of land in the Parish of Windham, is about to be revoked.—(W.149(3)) (C.91328).

**UPOTIPOPON.**—The Order in Council of the 1st March, 1887, temporarily reserving 2 acres of land in the Parish of Upotipotpon, as a site for a State School, being part of allotment 23, is about to be revoked.—(U.53(2)) (C.90647).

**THALIA.**—The Order in Council of the 15th April, 1878, temporarily reserving as a site for Public purposes (State School), and withholding from sale, leasing, and licensing, 5 acres of land in the Parish of Thalia, is about to be revoked.—(T.204(2)) (C.90714).

JOHN G. B. McDONALD,  
 Commissioner of Crown Lands and Survey.

**LAND PROPOSED TO BE PERMANENTLY RESERVED.**

IN pursuance of the provisions of the *Land Act 1928*, notice is hereby given that it is the intention of the Governor in Council to permanently reserve for the purpose mentioned the land hereunder described:—  
*The following Notice was published 1° on the 2nd April, 1948, pursuant to an Order of the 23rd March, 1948.*

**ST. ARNAUD.**—Land to be permanently reserved as a site for a Town Hall in addition to and adjoining the site

permanently reserved therefor by Order in Council of the 19th September, 1870, also excepted from occupation for mining purposes under any miner's right. 19 1/10 perches, Town of St. Arnaud, Parish of St. Arnaud, County of Kara Kara, as indicated by hachure on plan hereunder.—S.206(7) (Rs.237).

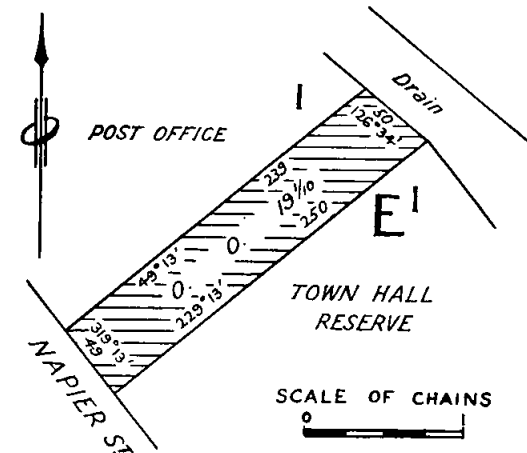

JOHN G. B. McDONALD,  
 Commissioner of Crown Lands and Survey.

*Land Act 1928.*

**LEASES SURRENDERED.**

NOTICE is hereby given that the Governor in Council has accepted the surrender of the Lease mentioned in the Schedule hereunder for the reason specified.

District.	Corr. No.	Name.	Section of Land Act under which Leased.	Parish.	Allotment.	Area.	Class.	Reason.
Mallee ..	W1772/217	John Trewin Runnalls	217	Bourka ..	36 and 36A	A. R. P. 7 0 36	3rd	Formal surrender—area acquired for railway purposes

Department of Lands and Survey,  
 Melbourne, 14th April, 1948.

JOHN G. B. McDONALD,  
 Commissioner of Crown Lands and Survey.

*Land Act 1928.*

**LICENCES UNDER THE LAND ACTS 1915 AND 1928 DECLARED VOID.**

NOTICE is hereby given that the Licences in the Schedule hereunder have been declared void for the reason specified in each case.

District.	Corr. No.	Name of Licensee.	Section of Land Act under which Licensed.	Parish.	Allotment.	Section.	Area.	Annual Rental.	Reasons for Voiding.
Ballarat ..	0566/86	Richard Svanosio ..	86	Spring Hill..	45L	..	A. R. P. 19 3 38	£ s. d. 1 0 0	Non-compliance with conditions
Ballarat ..	0997/86	Leslie Bertram Camm	86	Dereel ..	A28E	..	20 0 0	1 0 0	Non-compliance with conditions.

Department of Lands and Survey,  
 Melbourne, 21st April, 1948.

JOHN G. B. McDONALD,  
 Commissioner of Crown Lands and Survey.

LIST OF CROWN LANDS AVAILABLE.

THE under-mentioned areas are available for application as provided by various sections of the *Land Act 1928*, and all applications received on or before Wednesday, 19th May, 1948, will be deemed to have been simultaneously made, but any application lodged after such date may be considered if received in time for inclusion in the advertisement of the cases to be heard at the Local Land Board.

Applications on proper form, accompanied by 5s. duty stamp uncancelled (registration fee), may be delivered or forwarded by post to the Local Land Officer or to any Crown Lands Office in Victoria. Applicants may obtain from Local Land Officers, or the Enquiry Office, Melbourne, a certificate authorizing the issue by the Railway Department of a return ticket at concession fares to enable them to inspect available areas or to attend Local Land Boards. When an applicant is granted an allotment he may, if travelling by rail, obtain reduced fares for his family and also freight concessions in regard to some of his effects.

Subject to the approval of the Minister, when the survey fee exceeds £10, a deposit of £5 may be paid, and the balance over six years in half-yearly instalments.

Marked plans of any particular area, application forms, and any further information may be obtained from the Enquiry Office, Lands Department, Melbourne, and Land Officer, Bairnsdale.

Department of Crown Lands and Survey,

Melbourne, 21st April, 1948.

JOHN G. B. McDONALD,

Commissioner of Crown Lands and Survey.

\* Improvements may be subject to re-valuation after land has been granted to an applicant.

Local Land Office.	County.	Parish.	Allotment.	Section.	Area.	How available.		Survey Fee.	Valuation of Improvements (if any).	Location of Land, A.C.	Nearest Railway Station or Township and Distance in miles, thence in direction.	How accessible.	Water Supply.	General Description of Land—Soil, Timber, Suitability (Grazing, &c.).
						Value per Acre.	Instalment.							
A. B. P. £ s. d. £ s. d.														
Bairnsdale (a, b, c)	Tambo	Woongulmerang East	7c	A	320 0 0	4th	0 7 6	18 15 0	To be valued	In the north of parish	Nowa Nowa, 40 miles	By Snowy River road	To be conserved	Undulating; light grey loam; parts poor and stony; snow gum; suitable for grazing. (H.019061)
Bairnsdale (a)	Dargo	WY-Yung	16b	4	3 0 0	Residence.	Annual rental to be fixed	3 0 0	To be valued	In the north-east of parish	Bairnsdale, approximately 10 miles	By road	To be conserved	Suitable for a residence. (H.019265)

AGRICULTURAL AND GRAZING LANDS—SELECTION PURCHASE ALLOTMENTS.

DIVISION 4, PART I., LAND ACT 1928.

AVAILABLE UNDER SECTION 129, LAND ACT 1928.

(a) Subject to survey. (b) Subject to mining condition. (c) Subject to soil erosion prevention condition.

## TENDERS.

TENDERS will be received at this office until **TEN A.M.** on the days and for the purposes under mentioned.

Particulars may be learnt at this office, and also at the offices named in each instance.

The Board of Land and Works will not necessarily accept the lowest or any tender.

27th April, 1948.

Alfredton.—Repairs, painting and internal renovations, State School No. 1091. Particulars at Inspector of Works Office, Ballarat; State School, Alfredton. Deposit, £3.

Areegra.—Removal of State School No. 2262, Bangerang, and re-erection and alterations, State School No. 2314. Particulars at Inspector of Works Office, Horsham; Police Stations, Hopetoun, Nhill, Warracknabeal. Preliminary deposit, £10. Final deposit, 2 per cent.

Avenel.—Repairs and painting, Police Station. Particulars at Inspectors of Works Offices, Benalla, Wangaratta; Police Stations, Avenel, Euroa. Deposit, £4.

Ballarat.—Provision of new fibro-plaster ceilings and wall basins, Mental Hospital. Particulars at Inspector of Works Office, Ballarat. Deposit, £3.

Ballarat.—Repairs and renovations, Kitchen Block, Mental Hospital. Particulars at Inspectors of Works Offices, Ballarat, Geelong. Preliminary deposit, £5. Final deposit, 2 per cent.

Ballarat.—Supply of one (1) steam-heated mattress sterilizer, Mental Hospital. Preliminary deposit, £10. Final deposit, 2 per cent.

Ballarat.—Supply and installation of heat storage cooker for Staff Mess Kitchen, Mental Hospital. Preliminary deposit, £15. Final deposit, 2 per cent.

Bayles.—Erection and completion of teacher's residence, State School No. 4374. Particulars at State School, Bayles. Preliminary deposit, £15. Final deposit, 2 per cent. (Amended Specification).

Benalla.—Internal alterations, High School. Particulars at Inspectors of Works Offices, Benalla, Wangaratta; Police Station, Euroa. Preliminary deposit, £4. Final deposit, 2 per cent.

Bright.—Erection and completion of new timber residence, office, garage, loose box, wood shed, &c., Police Station. Particulars at Inspector of Works Office, Wangaratta; Police Stations, Bright, Myrtleford, Yackandandah. Preliminary deposit, £15. Final deposit, 2 per cent.

Brim East.—Remodelling, repairs, and painting to residence, laundry, &c., State School No. 3733. Particulars at Inspector of Works Office, Horsham; Police Stations, Hopetoun, Nhill, Warracknabeal; State School, Brim East. Preliminary deposit, £10. Final deposit, 2 per cent.

Clarinda.—Provision of display boards and repairs, State School No. 3336. Particulars at State School, Clarinda. Deposit, £4.

Cockbill's Estate.—Removal, re-erection, and remodelling of timber-framed residences on Blocks Nos. 3 and 4, Soldier Settlement Commission. Particulars at Inspectors of Works Offices, Bendigo, Shepparton. Police Stations, Cohuna, Echuca, Elmore. Preliminary deposit, £15. Final deposit, 2 per cent.

Corryong.—Additional accommodation, repairs and painting to existing buildings, Court House. Particulars at Inspector of Works Office, Wangaratta; Police Stations, Corryong, Tallangatta, Wodonga. Preliminary deposit, £5. Final deposit, 2 per cent.

Cressy.—Repairs and renovations, school and teacher's residence, State School No. 731. Particulars at Inspectors of Works Office, Geelong; Police Stations, Colac, Cressy. Preliminary deposit, £5. Final deposit, 2 per cent.

Crossover.—Repairs, painting, &c., State School No. 3131. Particulars at Inspector of Works Office, Bairnsdale; Police Stations, Moe, Warragul; State School, Crossover. Preliminary deposit, £5. Final deposit, 2 per cent.

Durham Ox.—Repairs and painting, State School No. 1483. Particulars at Inspector of Works Office, Bendigo; Police Stations, Charlton, Inglewood; State School, Durham Ox. Deposit, £3.

Echuca.—Internal and external repairs, residence, State School No. 208. Particulars at Inspector of Works Office, Shepparton; Police Station, Echuca; State School, Echuca. Preliminary deposit, £3. Final deposit, 2 per cent.

Foxhow.—External renovation and fibro-plaster lining for two (2) front rooms, State School No. 1600. Particulars at Inspectors of Works Offices, Ballarat, Geelong; Police Station, Cressy; State School, Foxhow. Deposit, £4.

Frankston.—Removal of fittings, provision of new floor, and internal painting, High School. Particulars at High School, Frankston. Deposit, £3.

Gapstead.—New fencing, State School No. 2240. Particulars at Inspector of Works Office, Wangaratta; Police Station, Myrtleford; State School, Gapstead. Deposit, £4.

Geelong.—Removal of two (2) huts from High School, Geelong, and re-erection and adaptation into classrooms, Matthew Flinders Girls' School. Particulars at Inspector of Works Office, Geelong; Matthew Flinders Girls' School, Geelong. Preliminary deposit, £15. Final deposit, 2 per cent.

Gherang Gherang.—Removal of timber residence from Buckley, re-erection and remodelling, Farm, Soldier Settlement Commission. Particulars at Inspector of Works Office, Geelong; Police Stations, Colac, Winchelsea. Preliminary deposit, £10. Final deposit, 2 per cent.

Glen Park.—Repairs and renovations to school, out-office, and shelter shed, State School No. 1135. Particulars at Inspector of Works Office, Ballarat; State School, Glen Park. Deposit, £4.

Glenthompson.—Repairs and renovations, school and residence, State School No. 947. Particulars at Inspectors of Works Offices, Ararat, Hamilton; State School, Glenthompson. Preliminary deposit, £10. Final deposit, 2 per cent.

Gonn Crossing.—Erection of teacher's residence, State School No. 4566. Particulars at Inspectors of Works Offices, Bendigo, Swan Hill; Police Station, Kerang; State School, Gonn Crossing. Preliminary deposit, £15. Final deposit, 2 per cent.

Hamilton.—Erection of paling fence in playing area, High School. Particulars at Inspector of Works Office, Hamilton; Police Station, Hamilton; High School, Hamilton. Deposit, £3.

Harrow.—Repairs and painting, new septic tank, new bore and mill and high stand, Inspector's Residence, Lands Department. Particulars at Inspectors of Works Offices, Hamilton, Horsham; Police Station, Nhill. Preliminary deposit, £10. Final deposit, 2 per cent.

Lal Lal.—Painting and repairs, State School No. 863. Particulars at Inspectors of Works Offices, Ballarat, Geelong; Police Station, Ballan; State School, Lal Lal. Preliminary deposit, £5. Final deposit, 2 per cent.

Liesfield's Estate (near Rainbow).—Erection of four (4) timber farm houses on Blocks Nos. 1, 2, 3, and 4, Soldier Settlement Commission. Particulars at Inspector of Works Office, Horsham; Police Stations, Hopetoun, Nhill, Rainbow. Preliminary deposit, £25. Final deposit, 2 per cent.

Marysville.—Restoration of existing classroom, repairs and addition of new classroom, State School No. 1273. Particulars at Police Stations, Healesville, Lilydale, Marysville. Preliminary deposit, £15. Final deposit, 2 per cent.

Melbourne.—Installation of electric light and power, New Chemistry School, Technical College. Preliminary deposit, £25. Final deposit, 2 per cent.

Melbourne.—External painting and repairs, Titles Office, Queen-street. Preliminary deposit, £20. Final deposit, 2 per cent.

Mirboo North.—Additional out-office accommodation for girls, and repairs and painting to out-offices, State School No. 2383. Particulars at Inspector of Works Office, Korumburra; Police Stations, Moe, Morwell; State School, Mirboo North. Deposit, £3.

Mont Park.—Erection of new dairy and milking sheds, Mental Hospital. Preliminary deposit, £25. Final deposit, 2 per cent.

Murtoa.—Repairs and renovations to residence, erection of new "A" type office, Police Station. Particulars at Inspector of Works Office, Horsham; Police Stations, Murtoa, Nhill, Stawell. Preliminary deposit, £15. Final deposit, 2 per cent.

Myola East.—Repairs, painting, and display boards, State School No. 2407. Particulars at Inspectors of Works Offices, Bendigo, Shepparton; Police Station, Echuca; State School, Myola East. Deposit, £2.

Neerim South.—Painting, repairs to school and residence, State School No. 2432. Particulars at Inspector of Works Office, Bairnsdale; Police Stations, Moe, Warragul; State School, Neerim South. Preliminary deposit, £10. Final deposit, 2 per cent.

North Fitzroy.—Provision of sleep-out, caretaker's residence, State School No. 3918. Deposit, £4.

Port Fairy.—Provision of new tile roof, repairs, &c., and painting, Court House. Particulars at Inspector of Works Office, Warrnambool; Police Station, Port Fairy. Preliminary deposit, £10. Final deposit, 2 per cent.

Port Melbourne.—Supply and delivery of three (3) only combustion end loader and cranes on pneumatic tires; about ½ yd. cap. loader and 2-ton crane on about 30 horse-power tractor, Public Works Department Depot, Salmon-street.

Port Welshpool.—Supply of piles, Jetty. Deposit, £5.

Ronald's Estate.—Demolition of one (1) timber residence, and erection of three (3) timber residences on Blocks Nos. 1, 2 and 3, Soldier Settlement Commission. Particulars at Inspector of Works Office, Korumburra; Police Stations, Boolarra, Moe, Morwell. Preliminary deposit, £25. Final deposit, 2 per cent.

Royal Park.—Supply and installation of electric hot-water service, Head Attendant's Quarters, Mental Hospital. Deposit, £2.

San Remo.—Removal and re-erection of school building, State School No. 1369. Particulars at Inspector of Works Office, Korumburra; Police Station, Dandenong; State School, San Remo. Preliminary deposit, £10. Final deposit, 2 per cent.

Shelbourne.—Repairs and renovations and painting, State School No. 950. Particulars at Inspectors of Works Offices, Bendigo, Maryborough; Police Stations, Castlemaine, Tarnagulla; State School, Shelbourne. Deposit, £4.

Smeaton.—Alterations, repairs, and painting, State School No. 552. Particulars at Inspector of Works Office, Ballarat; Police Station, Learmonth; State School, Smeaton. Deposit, £3.

South Melbourne.—Additions to out-offices, J. H. Boyd Domestic College. Preliminary deposit, £10. Final deposit, 2 per cent.

Sunbury.—Repairs and alterations to milking sheds and stable blocks, Mental Hospital. Particulars at Inspectors of Works Offices, Bendigo, Kyneton; Police Stations, Sunbury, Woodend. Preliminary deposit, £15. Final deposit, 2 per cent.

Timboon.—Supply and delivery of kitchen equipment, Consolidated School. Preliminary deposit, £4. Final deposit, 2 per cent.

Timboon.—Supply and installation of refrigeration equipment, Consolidated School. Preliminary deposit, £5. Final deposit, 2 per cent.

Timboon.—Supply and delivery of electric mixer for kitchen, Consolidated School. Preliminary deposit, £5. Final deposit, 2 per cent.

Walwa.—Erection of timber residence, standard office, garage, &c., Police Station. Particulars at Inspector of Works Office, Wangaratta; Police Stations, Corryong, Tallangatta, Walwa, Woodonga. Preliminary deposit, £15. Final deposit, 2 per cent.

Warragul.—Repairs and renovations, new bicycle shed and extensions to girl's out-office, High School. Particulars at Inspector of Works Office, Bairnsdale; Police Stations, Morwell, Sale, Warragul. Preliminary deposit, £20. Final deposit, 2 per cent.

Weatherboard Hill.—Repairs, renovations, and painting, school and residence, &c., State School No. 656. Particulars at Inspector of Works Office, Ballarat; Police Station, Clunes; State School, Weatherboard Hill. Preliminary deposit, £5. Final deposit, 2 per cent.

Werribee.—Supply and installation of hot-water service, manager's residence, Research Farm. Particulars at Inspector of Works Office, Geelong. Preliminary deposit, £2. Final deposit, 2 per cent.

Werribee.—Removal, re-erection, and adaptation of army hut as library-classroom, State School No. 649. Particulars at Inspector of Works Office, Geelong; Police Station, Werribee. Preliminary deposit, £10. Final deposit, 2 per cent.

Wilson's Reef.—Repairs, renovations, and painting, school and residence, State School No. 1437. Particulars at Inspector of Works Office, Bendigo; Police Stations, Bridgewater, Wedderburn; State School, Wilson's Reef. Deposit, £4.

Wonthaggi.—General repairs and painting to out-offices, repairs to boundary fences, State School No. 3650. Particulars at Inspector of Works Office, Korumburra; Police Station, Loch; State School, Wonthaggi. Preliminary deposit, £10. Final deposit, 2 per cent.

Woolsthorpe.—Painting and repairs, residence and school building, State School No. 688. Particulars at Inspectors of Works Offices, Hamilton, Warrnambool; Police Station, Port Fairy; State School, Woolsthorpe. Preliminary deposit, £5. Final deposit, 2 per cent.

Wycheproof.—Removal of school building from State School No. 2204, Narrewillock, and re-erection, State School No. 1757. Particulars at Inspector of Works Office, Bendigo; Police Stations, Boort, Charlton; State School, Wycheproof. Deposit, £3.

Wycheproof South.—Repairs and painting, State School No. 3114. Particulars at Inspectors of Works Offices, Bendigo; Swan Hill; Police Stations, Charlton, Kerang; State School, Wycheproof South. Deposit, £4.

Yallock.—Additions to teacher's residence, painting and repairs to school, State School No. 3420. Particulars at Police Station, Dandenong. Preliminary deposit, £5. Final deposit, 2 per cent.

Yulungah.—Repairs and painting, &c., State School No. 3413. Particulars at Inspector of Works Office, Bairnsdale; Police Stations, Moe, Trafalgar; State School, Yulungah. Preliminary deposit, £5. Final deposit, 2 per cent.

4th May, 1948.

Ballarat.—Supply and installation of electric hot-water service, Clerk's residence, Country Roads Board. Particulars at Inspector of Works Office, Ballarat. Preliminary deposit, £2. Final deposit, 2 per cent.

Ballarat.—External renovations and minor repairs, State Offices. Particulars at Inspector of Works Office, Ballarat. Preliminary deposit, £10. Final deposit, 2 per cent.

Bolinda.—Extension of classroom, State School No. 1070. Particulars at Inspectors of Works Offices, Bendigo, Kyneton; Police Station, Woodend; State School, Bolinda. Preliminary deposit, £4. Final deposit, 2 per cent.

Brighton.—Renovations of residence, Technical School. Deposit, £10.

Coburg North.—Conversion of military hutment to classrooms, State School No. 4543. Particulars at State School, Coburg North. Preliminary deposit, £10. Final deposit, 2 per cent.

Cocks and Runnall's Estate.—Erection of timber farm house on lot No. 1, Soldier Settlement Commission. Particulars at Inspector of Works Office, Swan Hill; Police Stations, Birchip, Sealake, Woomelang. Preliminary deposit, £15. Final deposit, 2 per cent.

Coleraine.—Repairs and renovations, State School No. 2118. Particulars at Inspector of Works Office, Hamilton; Police Stations, Casterton, Coleraine; State School, Coleraine. Preliminary deposit, £10. Final deposit, 2 per cent.

Emerald.—Additional accommodation, State School No. 3381. Particulars at State School, Emerald. Preliminary deposit, £15. Final deposit, 2 per cent.

Flemington.—Additional lavatory basins, Girls' School. Particulars at Girls' School, Flemington. Deposit, £3.

Healesville.—Alterations to bathroom, kitchen, &c., Police Station. Particulars at Police Stations, Healesville, Lilydale, Warburton. Deposit, £4.

Kerang.—Repairs and painting, School Inspector's residence, Education Department. Particulars at Inspectors of Works Offices, Bendigo, Swan Hill; Police Station, Kerang. Preliminary deposit, £5. Final deposit, 2 per cent.

Kew.—Extensions to laundry, Mental Hospital. Preliminary deposit, £10. Final deposit, 2 per cent.

Mack's Creek.—Repairs, painting, &c., State School No. 3357. Particulars at Inspector of Works Office, Korumburra; Police Station, Yarram; State School, Mack's Creek. Preliminary deposit, £4. Final deposit, 2 per cent.

Melbourne.—Supply and delivery of two (2) steam-heated sterilizers, Tuberculosis Bureau, Mint-place Annexe. Deposit, £3.

Melbourne.—Renovations, 9th floor, State Accident Insurance Office, 412 Collins-street. Preliminary deposit, £4. Final deposit, 2 per cent.

Middle Brighton.—Supply and delivery of squared timber, Jetty. Preliminary deposit, £5. Final deposit, 2 per cent.

Middle Brighton.—Supply and delivery of piles, Jetty. Preliminary deposit, £5. Final deposit, 2 per cent.

Montague.—Repairs and painting, State School No. 2784. Particulars at State School, Montague. Preliminary deposit, £5. Final deposit, 2 per cent.

Mont Park.—Supply and installation of three (3) electric hot-water services, one in each of three residences (second lot), Gresswell Sanatorium. Deposit, £4.

Murchison.—Repairs, painting, and re-blocking to residence, State School No. 1126. Particulars at Inspector of Works Office, Shepparton; Police Stations, Nagambie, Kyabram; State School, Murchison. Deposit, £4.

Nhill.—Repairs and renovations and new fencing, Court House. Particulars at Inspector of Works Office, Horsham; Police Station, Nhill. Deposit, £4.

Omeo.—Painting and repairs, Police Station. Particulars at Inspector of Works Office, Bairnsdale; Police Stations, Omeo, Orbost. Preliminary deposit, £5. Final deposit, 2 per cent.

Ouyen.—Repairs and painting to school and residence, State School No. 3615. Particulars at Inspectors of Works Offices, Maryborough, Mildura; Police Station, Birchip; State School, Ouyen. Preliminary deposit, £15. Final deposit, 2 per cent.

Pascoe Vale.—Erection of new wash-house, State School No. 3081. Particulars at State School, Pascoe Vale. Deposit, £3.

Pomborneit North.—Supply and installation of electric hot-water service, State School No. 3898. Particulars at Inspectors of Works Offices, Geelong, Warrnambool. Preliminary deposit, £2. Final deposit, 2 per cent.

Port Melbourne.—Supply and delivery of two (2) only portable chain saws operated by petrol engine, complete with spare saw to each machine, Public Works Department Depot, Salmon-street. (Full specification to be supplied by tenderer.)

Rocklyn.—Repairs and painting, school and residence, State School No. 785. Particulars at Inspector of Works Office, Kyneton; Police Stations, Castlemaine, Daylesford; State School, Rocklyn. Deposit, £4.

Stawell.—Provision of new flywire screens, Pleasant Creek Special School. Particulars at Inspectors of Works Offices, Ararat, Horsham; Police Station, Stawell. Preliminary deposit, £5. Final deposit, 2 per cent.

Swan Hill.—Repairs and painting, Inspector's residence, Education Department. Particulars at Inspector of Works Office, Swan Hill. Deposit, £4.

Tarnagulla.—Repairs and painting, State School No. 1023. Particulars at Inspectors of Works Offices, Bendigo, Maryborough; Police Stations, Castlemaine, Inglewood; State School, Tarnagulla. Preliminary deposit, £5. Final deposit, 2 per cent.

Toora.—Supply and installation of electric hot-water service, Police Station. Particulars at Inspector of Works Office, Korumburra; Police Station, Yarram. Preliminary deposit, £2. Final deposit, 2 per cent.

Toolleen.—Repairs and painting, school and residence, State School No. 1336. Particulars at Inspector of Works Office, Bendigo; Police Stations, Castlemaine, Elmore; State School, Toolleen. Preliminary deposit, £5. Final deposit, 2 per cent.

Wattle Glen.—Re-blocking, repairs, and painting, State School No. 4060. Particulars at Police Station, Lilydale; State School, Wattle Glen. Preliminary deposit, £4. Final deposit, 2 per cent.

Williamstown.—Renovations to classrooms, Domestic Arts School. Particulars at Domestic Arts School, Williamstown. Preliminary deposit, £3. Final deposit, 2 per cent.

Yinnar.—Repairs to fencing, State School No. 2419. Particulars at Inspector of Works Office, Korumburra; Police Stations, Sale, Traralgon; State School, Yinnar. Preliminary deposit, £4. Final deposit, 2 per cent.

11th May, 1948.

Katamatite.—Erection of new Police Station. Particulars at Inspectors of Works Offices, Benalla, Wangaratta; Police Stations, Euroa, Katamatite. Preliminary deposit, £20. Final deposit, 2 per cent.

Kew.—Supply and installation of renewed steam line to Dairy and Soap Works, Mental Hospital. Preliminary deposit, £10. Final deposit, 2 per cent.

Lilydale.—Enclosure of verandah, State School No. 876. Particulars at Police Station, Healesville; State School, Lilydale. Deposit, £3.

Pakenham.—Fencing, Police Station. Particulars at Police Stations, Berwick, Pakenham. Deposit, £3.

Warragul.—Infectious Diseases Block, West Gippsland Hospital. Particulars at Inspector of Works Office, Bairnsdale; Police Stations, Moe, Sale; West Gippsland Hospital, Warragul. Preliminary deposit, £50. Final deposit, 2 per cent. (Amended specification.)

Yinnar.—Repairs, painting, and attention to fencing, State School No. 2419. Particulars at Inspector of Works Office, Korumburra; Police Stations, Moe, Morwell; State School, Yinnar. Preliminary deposit, £10. Final deposit, 2 per cent.

Tenders to be addressed to the Honorable the Commissioner of Public Works, and envelope containing tender marked "Tender for \_\_\_\_\_ due \_\_\_\_\_."

J. A. KENNEDY,  
Commissioner of Public Works.

Melbourne, 20th April, 1948.

## PRIVATE ADVERTISEMENTS.

I, NORMAN VINCENT ANTONIE, of McEacharn-street, East Bairnsdale, in the State of Victoria, patrolman, heretofore called and known by the name of Norman Vincent Rodrigues, hereby give public notice that by a deed poll dated the 7th day of April, 1948, duly executed, attested, and deposited with the Registrar-General of the said State, on the 9th day of April, 1948, I formally and absolutely renounced and abandoned the said surname of Rodrigues and declared that I had assumed and adopted and intended thenceforth upon all occasions whatsoever to use and subscribe the surname of Antonie instead of the said surname of Rodrigues, and so as to be at all times thereafter called, known, and described by the said surname of Antonie.

Dated the 21st day of April, 1948.

NORMAN VINCENT ANTONIE.

A. P. Agg and Engel, Bairnsdale, solicitors for the said Norman Vincent Antonie. 4163

NOTICE is hereby given that J. S. Lee and Sons (Melbourne) Pty. Ltd. has applied for a lease under section 125 of the Land Acts for a term of 25 years from 2nd June, 1948, of allotment 56A, City of South Melbourne, containing 1 rood 15 perches, as a site for factories, stores, and warehouses. 3921

NOTICE is hereby given that the Castlemaine Tennis Club has applied for a lease, under section 125 of the Land Act 1928, for a term of ten years, of certain land in section 85, Township of Castlemaine, containing 3 acres 2 roods 39 perches, as a site for tennis courts. 4060

### MARYBOROUGH WATERWORKS TRUST.

NOTICE TO THE OWNERS OF TENEMENTS IN BRASSEY-STREET, AND THE PRIVATE STREETS, LANES, COURTS, AND ALLEYS OPENING THERETO.

THE main pipe in the said street being laid down, the owners of all tenements situated as above are hereby required, on or before the 1st day of June next, to cause a proper pipe and stop cocks to be laid, so as to supply water within such tenements from the main pipe.

4129

R. F. MACGUGAN, Acting Secretary.

### CITY OF OAKLEIGH.

BY-LAW No. 77.

A By-law of the City of Oakleigh, made under the provisions of the *Local Government Act* 1946, and numbered 77, for the purpose of regulating the use of lands within prescribed residential areas within the municipal district for the respective purposes specified in this By-law.

IN pursuance of the powers conferred by the *Local Government Act* 1946, the Mayor, Councillors, and Citizens of the City of Oakleigh order as follows:—

1. Notwithstanding anything contained in By-law No. 24, as amended by By-law No. 36, the areas of lands within the municipal district described in the Schedules hereto, being in prescribed residential areas, may be used for the purposes mentioned in such Schedules.

2. If the said lands or any of them shall be wilfully used by any person otherwise than in accordance with this By-law, such person shall be guilty of an offence against this By-law.

3. Any person wilfully offending against this By-law shall be liable to a penalty not exceeding Twenty pounds, and to a further penalty of not more than Ten pounds for each day on which an offence against this By-law is continued after notice has been given by the Council to the offender of the commission of the offence, or after a conviction or order of any court in respect of such offence.

#### First Schedule.

All that land, being part of Crown portion three, near Oakleigh, Parish of Mulgrave, County of Bourke, described in certificate of title, volume 5098, folio 1019592.

The purposes for which the land may be used are the erection of a memorial hall and/or clubrooms, and the use thereof by (a) the Oakleigh Sub-Branch of the Australian Legion of ex-Servicemen and Women, or (b) any other organization or body of persons authorized by the Council, in writing, so to do in the event of the use of such memorial hall and/or clubrooms by the Oakleigh Sub-Branch of the Australian Legion of ex-Servicemen and Women being terminated.

*Second Schedule.*

All that land having a frontage of 60 feet to the west side of Atkinson-street by a depth of 150 feet, and being part of Crown allotment 5, section 3, Town of Oakleigh, Parish of Mulgrave, County of Bourke, described in certificate of title, volume 1425, folio 284835.

The purposes for which the land may be used are the erection of a recreation hall, and the use thereof by (a) the Fourth Oakleigh Group of the Boy Scouts' Association, or (b) any other organization or body of persons authorized by the Council, in writing, so to do in the event of the use of such recreation hall by the Fourth Oakleigh Group of the Boy Scouts' Association being terminated.

*Third Schedule.*

All that land, being part of Crown portion three, Parish of Mulgrave, County of Bourke, described in certificate of title, volume 6781, folio 1356183.

The purposes for which the land may be used are the erection of a recreation hall, and the use thereof by (a) the Oakleigh Boys' Club, or (b) any other organization or body of persons authorized by the Council, in writing, so to do in the event of the use of such recreation hall by the Oakleigh Boys' Club being terminated.

*Fourth Schedule.*

All the land being that described in Memorial Book 312, No. 898.

The purposes for which the land may be used are the erection of recreation halls, and the use thereof by (a) the Hughesdale Community Centre Committee, or (b) any other organization or body of persons authorized by the Council, in writing, so to do in the event of the use of such recreation halls by the Hughesdale Community Centre Committee being terminated.

The Resolution for making and passing this By-law was agreed to by the Council at a meeting held on the 15th day of December, 1947, and confirmed at a meeting held on the 2nd day of February, 1948.

In witness whereof the common seal of the Mayor, Councillors, and Citizens of the City of Oakleigh was hereunto affixed this 3rd day of February, 1948.

(SEAL) J. V. HUGHES, Mayor.  
L. R. FORD, Councillor.  
J. A. PRICE, Town Clerk.

Approved by the Governor in Council, 6th April, 1948.—  
C. W. KINSMAN, Clerk of the Executive Council. 4127

**BOROUGH OF ECHUCA.***By-Law No. 35.*

**A** BY-LAW of the Borough of Echuca, made under section 292 of the *Health Act 1928*, and numbered 35, for the regulation and management of the meat area within the municipal district of the said Borough, and for—

- (a) Prescribing the conditions on which animals may be received into or supplied or removed from the abattoirs therein situate.
- (b) Fixing the rates of fees or dues payable to the Council of the said Borough under Part XIII. of the *Health Act 1928*.
- (c) Prescribing the times for selling and for slaughtering animals, and for selling carcasses or meat at the said abattoirs.
- (d) The feeding, watering and tending, and the preventing of cruelty to and overcrowding of animals in the said abattoirs, and
- (e) Stopping temporarily the manufacture of and the sale of small goods in circumstances in which danger to the consumer is apprehended owing to uncleanness or to the presence of infection on or about the premises where such manufacture or sale is carried on.

Resolution for passing this By-law was agreed to by the Council of the Borough of Echuca on the 8th day of December, 1947, and confirmed on the 12th day of January, 1948.

The common seal of the Mayor, Councillors, and Burgesses of the Borough of Echuca was affixed hereto, in the presence of—

(SEAL) F. C. McCARTNEY, Mayor.  
S. L. McDONALD, Councillor.  
F. WALSHE, Town Clerk.

Approved by the Governor in Council, the 2nd day of March, 1948.—J. C. MACCIBBON, Acting Clerk of the Executive Council. 4161

**SHIRE OF ARAPILES.***Loan No. 8.*

**NOTICE** is hereby given that the Council of the Shire of Arapiles proposes to borrow on the credit of the municipality the sum of Three thousand pounds (£3,000), to be raised by the issue of debentures, in accordance with the provisions of the *Local Government Act 1946*.

The amount of the principal moneys proposed to be borrowed is £3,000.

The maximum rate of interest that may be paid is £3 5s. per cent. per annum.

The loan will be liquidated by twenty equal half-yearly repayments of the principal, together with interest from time to time accruing on so much of the amount of the loan as is unpaid, and to be payable at the Melbourne office of the Council's bankers for the time being.

The purposes of the loan are—

1. Purchase of road-making plant .. £1,700
2. Construction of roads .. .. £1,300

Plans and specifications and estimate of cost of works referred to, and statement showing expenditure of the moneys to be borrowed, may be inspected at the Shire Offices, Noradjuha.

4162 WILLIAM J. SINCLAIR, Shire Secretary.

**SHIRE OF BAIRNSDALE.***By-Law No. 61.*

**A** By-law of the Shire of Bairnsdale made under the Local Government Acts and the Uniform Building Regulations Victoria, and numbered 61, for determining, applying, dispensing with or regulating such matters or things as are left to be determined, applied, dispensed with or regulated by the Council of the said Shire of Bairnsdale under the Uniform Building Regulations Victoria.

**I**N pursuance of the powers conferred by the Local Government Acts and the Uniform Building Regulations Victoria, and of any and every other power enabling it in that behalf, the President and Councillors and Rate-payers of the Shire of Bairnsdale order as follows:—

*Brick Areas.*

1. The areas set out and described in the First Schedule hereto are hereby prescribed as brick areas, and no person shall, in any such area, construct or cause to be constructed any building, the external walls of which are of material other than brick, stone, or concrete.

*Minimum Area, Depth, and Width of Frontage.*

2. The minimum area, depth, and width of frontage specified in column three (3) of table eight hundred and three (803) of the Uniform Building Regulations Victoria (hereinafter called the Regulations), are hereby adopted as the minimum area, depth, and width of frontage of land on which a building shall be constructed throughout those portions of the municipal district set out and described in the Second Schedule hereto.

*Distance from Street Alignment.*

3. The minimum distance measured horizontally from the outermost projection from the exterior wall of any building of Classes I. or II. occupancy as defined in the Regulations, from the front street alignment of any land, is hereby specified as twenty (20) feet, and this clause shall have application throughout those portions of the municipal district set out and described in the Second Schedule hereto.

*Sites Below Minimum Requirements.*

4. Notwithstanding anything contained in the Regulations, but subject to Regulations made pursuant to section 17 of the Slum Reclamation and Housing Act, any person may—

- (a) construct a building of Class I. occupancy as defined in the Regulations on land having a lesser area, depth, width, or frontage, or at a lesser distance from the boundaries than those specified in column three (3) of table 803 of the Regulations, and clause three (3) of this By-law, or
- (b) construct a building of Class III., V., VI., VII., or VIII. occupancy, or a building to which a building of Class IV. occupancy is attached, on land having an area, depth, or width of frontage less than that prescribed in clause 809 of the Regulations,

in any case where on the date of commencement of the Regulations such land existed as a separate allotment and has not since been reduced in area, or is shown on any plan of subdivision approved by the Council, and lodged in the Office of Titles.

5. By-laws Nos. 49, 52, 54, and 57 are hereby repealed.

## SCHEDULE 1.

(a) Main-street, Township of Bairnsdale, both sides for a depth of 2½ chains, extending from McCulloch and Macarthur streets easterly to the Mitchell River.

(b) Nicholson-street, Township of Bairnsdale, both sides for a depth of 2½ chains, extending from Pyke-street easterly to Riverine-street.

(c) Macleod-street, Township of Bairnsdale, both sides for a depth of 2½ chains, extending from Macarthur-street easterly to Park-street.

## SCHEDULE 2.

(a) The Centre Riding.

(b) Township of Lucknow, in the Parish of Wy Yung, together with Crown allotments 27B, portion of Crown allotments 28 and 29B west of the 3-chain road, 29A, 30A, 30B, 30C, 30D, and 30E.

(c) Township of Lucknow, in the Parish of Coongulmerang.

(d) Crown allotments 131A, 131B, 131C, 131D, 131E, 162, 162A, and 162B in the Parish of Coongulmerang.

(e) All that piece of land (including the Township of Paynesville), commencing at the south-east corner of Crown allotment 138A, Parish of Bairnsdale, County of Tanjil; thence westerly along the northern boundary of a 1-chain road to the south-west corner; thence 359 deg. 20 min. 2,105 links, 89 deg. 20 min. 2,954 links to the north-east corner of Crown allotment 138B; thence northerly by the eastern boundary of a 1-chain Government road to the north-west corner of Crown allotment 143A; thence by the coast generally in an easterly, southerly, and westerly direction to the point of commencement.

(f) The whole of the island known as Raymond Island, within the Parish of Bairnsdale.

The resolution for passing this By-law was agreed to by the Council of the Shire of Bairnsdale on the 10th day of November, 1947, and was confirmed by the said Council on the 14th day of January, 1948.

(SEAL) T. H. PEART, President.  
A. H. MORRISON, Councillor.  
E. LLOYD BRINDLEY, Secretary.

Approved by the Governor in Council, on the 6th day of April, 1948.—C. W. KINSMAN, Clerk of the Executive Council. 4153

## SHIRE OF MANSFIELD.

NOTICE OF INTENTION TO BORROW THE SUM OF THREE THOUSAND FIVE HUNDRED POUNDS (£3,500) FOR PERMANENT WORKS AND UNDERTAKINGS IN THE SHIRE OF MANSFIELD.

TAKE notice that the Council of the Shire of Mansfield proposes to borrow, on the credit of the President, Councillors, and Ratepayers of the said shire, the sum of Three thousand five hundred pounds (£3,500), such sum to be raised by the issue of debentures in accordance with the provisions of the *Local Government Act 1946*.

The maximum rate of interest that may be paid is £3 5s. per centum per annum.

Such moneys shall be repayable by twenty equal half-yearly instalments, each including principal and interest, by providing out of the municipal fund such amounts on the 1st day of September and the 1st day of March in each respective year, during the currency of the loan.

Such moneys shall be repayable at Melbourne, at the Bank of New South Wales, or at the Council's bankers for the time being in Melbourne.

The purposes for which the loan is to be applied are—

The purchase of a bulldozer and winch, motor mower, and construction of workshop.

The plans and specifications and estimate of the cost of the works referred to above, and a statement showing the proposed expenditure of money to be borrowed, are open for inspection at the Shire Office, Mansfield.

Dated this 15th day of April, 1948.

4126 R. WOMERSLEY, Shire Secretary.

## SHIRE OF MORWELL.

NOTICE is hereby given that the Council of the Shire of Morwell has appointed Senior Constable Thomas Malachi Nally as prosecuting officer for the shire, *vice* First Constable Bertie Stanton, resigned.

W. K. MATHISON, Shire Secretary.  
12th April, 1948. 4128

## NOTICE OF DISSOLUTION OF PARTNERSHIP.

NOTICE is hereby given that the partnership heretofore subsisting between the undersigned, Strathis Verginis, of 14 Bourke-street, Melbourne, and George Vlahos, of 114 Elizabeth-street, Melbourne, carrying on business as cafe proprietors, under the name of "Central Cafe," at 114 Elizabeth-street, Melbourne, has been dissolved by mutual consent as from the 12th day of April, 1948.

S. VIRGINIS.  
G. VLAHOS.

Witness to both signatures—D. CONDON, solicitor, Melbourne. 4134

NOTICE is hereby given that the partnership heretofore subsisting between Garnet Henry Gahan and Leslie James Cargill, carrying on business as roofing tile manufacturers, at 184 Point Nepean-road, Gardenvale, in the State of Victoria, under the name of Gahan and Cargill, has been dissolved by mutual consent as from the 23rd day of January, 1948. Dated at Melbourne the 16th day of April, 1948.

G. H. GAHAN.  
L. J. CARGILL.

Cleverdon, Reid, and Finlay, solicitors, 89 Queen-street, Melbourne. 4141

NOTICE is hereby given that the partnership heretofore subsisting between Garnet Henry Gahan and Archibald A. Ingram, carrying on business as painters and decorators, at 228 Glenhuntly-road, Elwood, in the State of Victoria, under the name of G. H. Gahan and A. Ingram, was dissolved by mutual consent as from the 1st day of April, 1946.

Dated at Melbourne the 16th day of April, 1948.

G. H. GAHAN.

Cleverdon, Reid, and Finlay, solicitors, 89 Queen-street, Melbourne. 4142

## NOTICE OF DISSOLUTION OF PARTNERSHIP.

NOTICE is hereby given that the partnership heretofore subsisting between the undersigned, Grace Mary White and Percy Norman Dunstan, carrying on business as cafe proprietors, at 23 McCallum-street, Swan Hill, under the name of "Rendex-vous Cafe, P. Dunstan and G. White, Proprietors," has been dissolved by mutual consent as from the 1st day of April, 1948. All debts due and owing by the said late firm will be received and paid by Grace Mary White, who will continue to carry on the business at the same place in partnership with Murray Robert White.

Dated at Swan Hill the 5th day of April, 1948.

G. M. WHITE.  
P. DUNSTAN.

Witness—J. J. McPHERSON, clerk to Davies and Hayes, solicitors, Swan Hill. 4164

NOTICE is hereby given that the partnership hitherto existing between the undersigned, Leslie John Westacott and Jack Charles Laver, carrying on business as surgeons and medical practitioners at High-street, Terang, has been dissolved by mutual consent as from the 31st day of March, 1948. The said Jack Charles Laver has retired from the partnership and the said business will henceforth be carried on by the said Leslie John Westacott, solely upon his own account and under his name. All claims against the said partnership will be discharged by, and all accounts should be paid to the said Leslie John Westacott.

Dated this 10th day of April, 1948.

LESLIE J. WESTACOTT.  
J. C. LAVER.

Witness to the above signatures—DAVID E. TRICKETT, solicitor, Terang. 4165

NOTICE is hereby given that the partnership formerly subsisting between William Francis Foster, Gerard Noall, Percival Albert Young, and Noel Larritt, carrying on business as stock and sharebrokers at 422 Little Collins-street, Melbourne, in Victoria, under the style or firm of Wm. Noall and Son, has been dissolved as from the 1st day of January, 1948, so far as concerns the said William Francis Foster, who has retired from the said firm. The business will be carried on by the said Gerard Noall, Percival Albert Young, and Noel Larritt, under the same firm name and at the same address, to which all communications may be addressed.

Dated the 13th day of April, 1948.

G. NOALL.

Aitken, Walker, and Strachan, solicitors for the above firm. 4168

NOTICE is hereby given that the partnership heretofore subsisting between the undersigned Richard George Winter, Thomas Turnbull Winter, and Elisabeth Turnbull Winter, merchants at 562 Bourke-street, Melbourne, under the firm name of "Geo. T. Winter and Son," has, by mutual consent, been dissolved so far as the said Thomas Turnbull Winter is concerned as from the 30th day of June, 1947. All debts due and owing by the said firm will be received and paid by the said Richard George Winter and Elisabeth Turnbull Winter, who will continue on the business at the same place under the firm name of "Geo. T. Winter and Son."

Dated the 14th day of April, 1948.

R. G. WINTER.  
T. T. WINTER.  
E. T. WINTER.

Oswald Burt and Co., 394 Collins-street, Melbourne, solicitors for the said Richard George Winter and Elisabeth Turnbull Winter.

Patrick H. Kearney, 116 Queen-street, Melbourne, solicitor for the said Thomas Turnbull Winter. 4184

NOTICE is hereby given that the partnership heretofore subsisting between the undersigned Francis James Beers and Reuben George Fielding, carrying on business as mattress manufacturers at 2a Hill-street, Thornbury, under the name of Beers and Fielding, has been dissolved by mutual consent as from the 23rd day of March, 1948. All debts due to and owing by the said late firm will be received and paid by Francis James Beers, who will continue to carry on the business at the same place.

Dated at Melbourne, the 1st day of April, 1948.

R. G. FIELDING.  
F. J. BEERS.

Witness—OSWALD R. CHARLTON, 473 Bourke-street, Melbourne. 4130

DOYLE AND MCCARTHY PTY. LTD. (IN LIQUIDATION).  
NOTICE CONVENING FINAL MEETING, PURSUANT TO SECTION 236.

NOTICE is hereby given, in pursuance to section 236 of the *Companies Act 1938*, that a General Meeting of the members of the above-named company will be held at the office of the liquidator, T. F. Bourke, chartered accountant, 317 Collins-street, Melbourne, on Friday, 21st May, 1948, at half-past Two o'clock in the afternoon, for the purpose of having an account laid before them, showing the manner in which the winding up has been conducted and the property of the company disposed of, and of hearing any explanation that may be given by the liquidator. 4167

THOS. F. BOURKE.

*Companies Act 1938.*

TOORAK COLLEGE LIMITED.

NOTICE OF INTENTION TO APPLY TO ATTORNEY-GENERAL FOR LICENCE, PURSUANT TO SECTION 18 (1).

TOORAK COLLEGE LIMITED, the registered office of which is situate at 51 Queen-street, Melbourne, being an association formed as a limited company for the purpose of promoting a useful object, namely, the taking over of the institution known as Toorak College, and the development and extension of the same, and for the provisions of tuition board and lodging necessaries and conveniences for pupils attending the said college, hereby gives notice of intention to apply to the Attorney-General for a licence directing that the said association may be registered as a company with limited liability without the addition of the word "Limited" to its name.

Dated this 12th day of April, 1948.

G. B. McINDOE, Secretary, Toorak College Limited.  
Whiting & Byrne, 101 William-street, Melbourne, solicitors for the said Toorak College Limited. 4171

*Companies Act 1938.*

In the matter of HENRY REGINALD GOORST, of Bentleigh, contractor.

A SIXTH Dividend is intended to be declared. Creditors who have not proved their debts before the 5th day of May, 1948, will be excluded.

Dated this 13th day of April, 1948.

HERBERT M. KENNEDY, Trustee.

Kennedy, Small, and Middlemiss, accountants, 31 Queen-street, Melbourne. 4172

*Companies Act 1938.*

In the matter of RODNEY JACKSON LEE, of Tintalra, storekeeper.

A FIRST Dividend is intended to be declared. Creditors who have not proved their debts before the 5th day of May, 1948, will be excluded.

Dated this 13th day of April, 1948.

HERBERT M. KENNEDY, Trustee.

Kennedy, Small, and Middlemiss, accountants, 31 Queen-street, Melbourne. 4173

*Companies Act 1938.*

J. H. CAMERON PROPRIETARY LIMITED  
(IN VOLUNTARY LIQUIDATION).

NOTICE is hereby given that pursuant to section 236 of the *Companies Act 1938*, a General Meeting of J. H. Cameron Proprietary Limited (in voluntary liquidation) will be held at 26 Flinders-street, Melbourne, on Friday, 23rd May, 1948, at 12.30 p.m., for the purpose of laying before it an account of the winding-up, showing how the winding-up has been conducted and the property of the company has been disposed of, and of hearing any explanation that may be given by the liquidator.

J. G. MUIR, Liquidator.

Hedderwick, Fookes, and Alston, solicitors, 103 William-street, Melbourne. 4138

*Companies Act 1938.*

STEPHENS & GUTHRIDGE PROPRIETARY LIMITED (IN VOLUNTARY LIQUIDATION).

NOTICE is hereby given that pursuant to section 236 of the *Companies Act 1938*, a General Meeting of Stephens & Guthridge Proprietary Limited (in voluntary liquidation) will be held at 26 Flinders-street, Melbourne, on Friday, 28th May, 1948, at 12 o'clock noon, for the purpose of laying before it an account of the winding-up, showing how the winding-up has been conducted and the property of the company has been disposed of, and of hearing any explanation that may be given by the liquidator.

J. G. MUIR, Liquidator.

Hedderwick, Fookes, and Alston, solicitors, 103 William-street, Melbourne. 4139

PASSILA FRUIT PRODUCTS PROPRIETARY LIMITED (IN VOLUNTARY LIQUIDATION).

NOTICE is hereby given in pursuance of section 245 (1) of the *Companies Act 1938*, that a General Meeting of the members of the above-named company will be held at 488 Collins-street, Melbourne, on Monday, the 24th day of May, 1948, at half-past Ten o'clock in the forenoon, for the purpose of receiving the liquidator's account showing how the winding-up has been conducted and the company's property disposed of.

Dated this 16th day of April, 1948.

4143 RONALD B. FORBES, Liquidator.

TRENTHAM CO-OPERATIVE SOCIETY LIMITED.

TAKE notice that at an Extraordinary General Meeting of the shareholders of the above-named society, held on the 17th day of April, 1948, the following Resolutions were passed as Special Resolutions:—

1. That The Trentham Co-operative Society Limited be voluntarily wound-up.
2. That Martin Tressider, of Trentham, farmer, be appointed liquidator.

MARTIN TRESSIDER, junior, Chairman of Directors.

4154

*Companies Act 1938.*

EDUCATION IN MUSIC AND DRAMATIC ARTS SOCIETY.

NOTICE OF INTENTION TO APPLY TO ATTORNEY-GENERAL FOR LICENCE, PURSUANT TO SECTION 18 (1).

ERNEST BARKLEY EDWARDS, of 422 Little Collins-street Melbourne, on behalf of Education in Music and Dramatic Arts Society, about to be formed for the purposes of—

- (i) the propagation of the arts of music, the drama, and the ballet;
- (ii) education in the proper appreciation of music, drama, and ballet;
- (iii) the provision of education and experience for persons practising the arts of music, drama, and ballet, or any of them—

hereby give notice of intention to apply to the Attorney-General for a licence, directing that the said society be registered as a company with limited liability, without the addition of the word "Limited" to its name.

Dated this 19th day of April, 1948.

4182 E. B. EDWARDS, Director.



ULONGA PASTORAL COMPANY PROPRIETARY  
LIMITED.

AT an Extraordinary General Meeting of the above-named company, duly convened and held at 127 William-street, Melbourne, on the 15th day of April, 1948, the following Resolution was duly passed as a Special Resolution:—

RESOLUTION.

That the company be wound up voluntarily, and that Charles Augustine Stewart, of 368 Collins-street, Melbourne, be appointed as liquidator for the purposes of such winding-up, with full power to such liquidator, at the expense of the company, to do all things he may consider necessary in connexion with the winding-up, including the employment and remuneration of servants and agents.

Dated the 15th day of April, 1948.

VERA MACKENZIE, Secretary.  
Blake and Riggall, 120 William-street, Melbourne. 4181

ROSE BUILDERS PTY. LTD.

(IN VOLUNTARY LIQUIDATION).

Pursuant to section 236 (3) *Victorian Companies Act 1938*.

NOTICE is hereby given that the Final Meeting of the shareholders of Rose Builders Proprietary Limited (in voluntary liquidation) will be held at the registered office of the company, 31 Collins-street, Melbourne, on 31st May, 1948, at 1.45 p.m., for the purpose of having an account laid before it, showing how the winding-up of the company has been conducted and the property of the company has been disposed of.

4187 CLIFFORD L. ROSEFIELD, Liquidator.

CREDITORS, next of kin, and others having claims in respect of the estate of Margaret Elizabeth Jeffries, late of "The Minnories," 99 Broadway, East Camberwell, widow, deceased (who died on the 12th day of February, 1948), are to send particulars of their claims to National Trustees, Executors, and Agency Company of Australasia Limited, whose registered office is situate at 95 Queen-street, Melbourne, by the 28th day of June, 1948, after which date it will distribute the assets, having regard only to the claims of which it then has notice.

LEACH & THOMSON, solicitors, 472 Bourke-street, Melbourne. 4146

CREDITORS, next of kin, and others having claims in respect of the estate of Mary Pollock, formerly of Moyarra, but late of Korumburra, spinster, deceased (who died on the 21st day of January, 1948), are to send particulars of their claims to The Equity Trustees, Executors, and Agency Company Limited, of 472 Bourke-street, Melbourne, by the 30th day of June, 1948, after which date it will distribute the assets, having regard only to the claims of which it then has notice.

SHEGOG & BIRCH, solicitors, Korumburra. 4147

CREDITORS, next of kin, and others having claims in respect of the estate of Thomas Walter Lord, late of Yarram, in the State of Victoria, pharmaceutical chemist, deceased (who died on the 13th day of November, 1947), are to send particulars of their claims to The Ballarat Trustees, Executors, and Agency Company Limited, and Lillian Mary Lord, the executor and executrix respectively of the will of the said deceased, care of the said company, whose registered office is at 101 Lydiard-street north, Ballarat, by the 30th day of June, 1948, after which date the said executors will distribute the assets, having regard only to the claims of which the said executors then have notice.

SKINNER & HART, solicitors, Commercial-road, Yarram. 4148

RE ELIZABETH ANN TARR, DECEASED.

NOTICE is hereby given that all persons having claims against the property or estate of Elizabeth Ann Tarr, late of 321 Pakington-street, Geelong, married woman, deceased (who died on the 6th day of February, 1948), and probate of whose will was granted to Reginald Walter Cook, of 63 St. Elmo-road, Ivanhoe, public servant, and Gilbert Edward Cook, of 7 Marshall-street, Chilwell, Geelong, motor body builder, are hereby required to send, in writing, particulars of such claims to the said Reginald Walter Cook and Gilbert Edward Cook, in the care of the under-mentioned solicitors, on or before the 23rd day of June, 1948, after which date they will convey or distribute such property or estate to or among the persons entitled thereto, having regard only to the claims of which they shall then have had notice.

HARWOOD & PINCOTT, 51 Yarra-street, Geelong, and 472 Bourke-street, Melbourne, solicitors for the said executors. 4155

No. 351.—3997.—3

PURSUANT to the *Trustee Act 1928*, creditors, next of kin, and all other persons having claims in respect of the estate of Ivy Lavinia Palm, late of Nhill, in Victoria, widow, deceased (who died on the 13th day of February, 1948), are required to send particulars to the executors, The Ballarat Trustees, Executors, and Agency Company Limited, of Lydiard-street, Ballarat, and James Robert Palm, of Nhill, in Victoria, mechanic, care of the said company, on or before the 23rd day of June, 1948, after which date the said executors will distribute the assets, having regard only to the claims of which notice has been received.

TRUMBLE & PALMER, Nhill, estate solicitors. 4156

NOTICE is hereby given that all persons having claims against the estate of William John Lynn, late of Pine Park, Bamawm, in the State of Victoria, orchardist, deceased (who died on the 4th day of July, 1947), and probate of whose will was granted by the Supreme Court of Victoria on the 27th day of February, 1948, to Farmers and Citizens Trustees Company Bendigo Limited, whose registered office is situated at Charing Cross, Bendigo, in the said State), are hereby required to send particulars, in writing, of such claims to the said company on or before the 17th day of June, 1948, after which date the company will proceed to convey or distribute the said estate or any part thereof to or among the persons entitled thereto, having regard only to the claims, whether formal or not, of which it shall then have had notice. And notice is further given that it will not be liable to any person of whose claim it shall not have had such notice as aforesaid.

H. W. RALEIGH & ROBERTS, solicitors, Rochester. 4157

FREDERICK ERNEST ELLIS, late of 140 Douglas-parade, Williamstown, in the State of Victoria, garage proprietor, DECEASED (who died on the 1st November, 1947).

CREDITORS, next of kin, and all other persons having claims against the estate of the above-named deceased are required by the executor, Alexander Charles Macfarlane, formerly of 70 The Strand, Newport, life assurance superintendent, but now of British Hotel, Creswick, in the said State, licensed victualler, to send particulars to him, care of the undersigned, on or before the 22nd day of June, 1948, after which date he will distribute the assets, having regard only to the claims of which he then has notice.

W. H. JONES & KENNEDY, solicitors, 214 Nicholson-street, Footscray. 4192

RE JOHN PATRICK O'SULLIVAN, DECEASED.

PURSUANT to the *Trustee Act 1928*, notice is hereby given that all creditors, next of kin and other persons having claims against the estate of John Patrick O'Sullivan, late of Seymour, in the State of Victoria, grazier, deceased (who died on the 3rd day of February, 1948), and probate of whose will was granted by the Supreme Court of the said State, on the 7th day of April, 1948, to Margaret Mary O'Sullivan, of Seymour, widow, are hereby required to send particulars of such claims to the said executrix, in care of the undersigned, at his address hereunder set out, on or before the 22nd day of June, 1948, after which date the said executrix will proceed to distribute the assets of the said deceased amongst the persons entitled thereto, having regard only to the claims of which she shall then have had notice.

W. J. OSBORNE, LL.B., solicitor, Station-street, Seymour. 4131

PURSUANT to the *Trustee Act 1928*, notice is hereby given that all persons having claims against the estate of Thomas Everett, late of Rokewood, farmer, deceased (who died on the 5th day of December, 1947), and probate of whose will is being applied for by The Ballarat Trustees, Executors, and Agency Company Limited, of 101 Lydiard-street north, Ballarat, and James Francis Everett, of Rokewood, farmer, are hereby required to send particulars, in writing, of such claims to the said company, at its above-mentioned address, on or before the 1st day of July, 1948, after which date the said executors will proceed to distribute the assets of the testator amongst the persons entitled thereto, having regard only to the claims of which they shall then have had notice, and will not be liable for the assets so distributed, or any part thereof, to any person of whose claim they shall not then have had notice.

Dated the 14th day of April, 1948.

NEVETT, NEVETT, & GLENN, 11 Lydiard-street, Ballarat, proctors for the said executors. 4125

## NOTICE TO CLAIMANTS AND OTHERS.

PURSUANT to the *Trustee Act* 1928, all persons having claims against the estate of Eva Minna Margaret Peck, formerly of 314 New-street, Gardenvale, and 214 Glenhunting-road, Elsternwick, but late of 41 Prentice-street, Elsternwick, spinster, deceased (who died on the 10th day of January, 1948, and probate of whose will was granted by the Supreme Court of Victoria, on the 26th day of February, 1948, to Alan Stuart Riach, of 14 Blackwood-street, Murrumbeena, auctioneer, and Doris Eileen McClure, of 5 Normanby-avenue, Caulfield, gentlewoman), are required to send particulars, in writing, of such claims to the said executors, care of the under-mentioned solicitors, on or before the 30th day of June, 1948, after which date the said executors will proceed to distribute the assets of the said deceased among the persons entitled thereto, having regard only to the claims of which they shall then have had notice.

MAURICE BLACKBURN & CO., solicitors, 431 Bourke-street, Melbourne. 4140

MARGARET CORDER, late of 16 Waterloo-street, Camberwell, in the State of Victoria, widow, DECEASED (who died on the 13th day of January, 1948).

CLAIMS to the executrix, Elsie McClelland, and the executor, National Trustees, Executors, and Agency Company of Australasia Limited, care of National Trustees, Executors, and Agency Company of Australasia Limited, whose registered office is at 95 Queen-street, Melbourne, in the said State, on or before the 30th day of June, 1948.

F. J. CORDER, solicitor, 108 Queen-street, Melbourne. 4137

ELIZABETH DOLEAN DUMBLETON, late of 67 Francis-street, Yarraville, spinster, DECEASED (who died on the 29th day of January, 1948).

CREDITORS, next of kin, and all other persons having claims against the estate of the deceased are required to send particulars of their claims to The Equity Trustees, Executors, and Agency Company Limited, of 472 Bourke-street, Melbourne, by the 30th day of June, 1948, after which date the said company will distribute the assets, having regard only to the claims of which it then has notice.

WM. BROCKET, solicitor, 108 Queen-street, Melbourne. 4144

CREDITORS, next of kin, and others having claims in respect of the estate of Alice Mary Ellen Wilson, late of 4 Randolph-street, Hawthorn, widow (who died on the 11th October, 1947), are to send the particulars of their claims to The Perpetual Executors and Trustees Association of Australia Limited, of 100-104 Queen-street, Melbourne, by the 30th day of June, 1948, after which date it will distribute the assets, having regard only to the claims of which it then has notice.

JOHN P. RHODEN, 376 Collins-street, Melbourne, solicitor for the applicant. 4177

RICHARD NORMAN EXELBY, late of 39 St. George's-road, Preston, in the State of Victoria, commercial traveller, DECEASED (who died on the 1st day of January, 1948).

CREDITORS, next of kin, and all other persons having claims against the estate of the deceased are required by the executor of the will, Leslie Richard Thomas Exelby, of 10 Feodore-street, Caulfield, in the said State, softgoods wholesaler, to send particulars to him, care of the undersigned, on or before the 23rd day of June, 1948, after which date he will distribute the assets, having regard only to the claims of which he then has notice.

MOLOMBY & ASTLEY, solicitors, 99 Queen-street, Melbourne. 4175

CREDITORS, next of kin, and others having claims in respect of the estate of David Hughes, formerly of Flinders-street, Melbourne, in the State of Victoria, but late of Luthermuir, Kincardineshire, near Montrose, Scotland, retired commercial traveller, deceased (who died on the 7th day of October, 1947), are to send the particulars of their claims to the Trustees, Executors, and Agency Company Limited, of 401 Collins-street, Melbourne, by the 25th day of June, 1948, after which date it will distribute the assets, having regard only to the claims of which it then has notice.

Dated the 21st day of April, 1948.

DARVALL & HAMBLETON, solicitors, 352 Collins-street, Melbourne. 4189

ALICE EMILY SCOTT, formerly of "Aratula," Tocumwal, in the State of New South Wales, but late of "Ardoch," 226 Dandenong-road, East St. Kilda, in the State of Victoria, widow, DECEASED (who died on 10th day of November, 1947).

CREDITORS, next of kin, and all other persons having claims against the estate of the said deceased are required by Alexander Clark Scott, of "Yantara," Tocumwal, in the State of New South Wales, grazier, Stewart James Scott, of 79 Burke-road, East Malvern, in the State of Victoria, auctioneer, and Ella Kathleen Scott, of 79 Stanhope-street, Malvern, in the State of Victoria, spinster, the executors to whom probate of her will was granted by the Supreme Court of Victoria, in its probate jurisdiction, to send particulars to them, care of the undersigned solicitors, on or before the 1st day of July, 1948, after which date the said executors will distribute the assets of the said estate, having regard only for the claims of which they then have had notice.

Dated the 19th day of April, 1948.

McLAUGHLIN, EAVES, & JOHNSTON, solicitors, 343 Little Collins-street, Melbourne. 4132

## STATUTORY NOTICE TO CREDITORS, BENEFICIARIES, AND OTHERS.

ALL persons having any claims against the estate of Ivy Gladys Stockdale, late of 69 Pascoe-crescent, Essendon, in the State of Victoria, married woman, deceased (who died on the 7th July, 1947, and letters of administration of whose estate were granted by the Supreme Court of Victoria, on the 13th November, 1947, to Gregory Stockdale, of 69 Pascoe-crescent, Essendon, sales manager), are hereby required to send particulars, in writing, of such claims to Eggleston, Lee, and Clifton-Jones, of 143 Queen-street, Melbourne, solicitors, on or before the 25th June, 1948, after which date the said administrator will proceed to distribute the assets of the said deceased which shall have come to his hands among the persons entitled thereto, having regard only to the claims of which he shall then have had notice, and he will not be liable for the assets so distributed, or any part thereof, to any person of whose claim he shall not have had notice as aforesaid.

EGGLESTON, LEE, AND CLIFTON-JONES, of 143 Queen-street, Melbourne, solicitors. 4133

PURSUANT to the *Trustee Act* 1928, notice is hereby given that all creditors, next of kin, and others having claims against the property or estate of Clara Bartlett, late of 494 Dandenong-road, Carnegie, widow, deceased, intestate (who died on 31st August, 1947, and letters of administration of whose estate were granted by the Supreme Court of Victoria to Clara Mary May Webster, of 1219 Dandenong-road, East Malvern, widow), are hereby required to forward particulars, in writing, of their claims to the said administratrix, in care of the undersigned solicitors, on or before the 30th day of June, 1948, after which date the said administratrix will convey and distribute such property or estate to or amongst the persons entitled thereto, having regard only to those claims of which they shall then have had notice.

W. H. FLOOD & PERMEZEL, 379 Collins-street, Melbourne, solicitors for the said administratrix. 4135

HUGH STANES BAYFORD, late of 67 The Boulevard, Hawthorn, motor garage proprietor, DECEASED.

CREDITORS, next of kin, and all other persons having claims against the estate of the said deceased are required by the executors of the will, Milton Melville Bayford, of Sycamore-street, Caulfield, clerk, and Alwin Livingston Bayford, of 14 Bourne-road, Glen Iris, motor garage proprietor, to send particulars to them, care of the undersigned, on or before 23rd June, 1948, after which date they will distribute the assets, having regard only to the claims of which they then have notice.

WISEWOULD & DUNCAN, solicitors, 408 Collins-street, Melbourne. 4136

CREDITORS, next of kin, and others having claims in respect of the estate of Karl Saarinen, late of 11 Lansell-crescent, Camberwell, builder (who died on the 5th day of February, 1948), are to send the particulars of their claims to the Perpetual Executors and Trustees Association of Australia Limited, 100-104 Queen-street, Melbourne, by the 21st day of June, 1948, after which date it will distribute the assets, having regard only to the claims of which it then has notice.

RYLAH & RYLAH, solicitors, 349 Collins-street, Melbourne. 4179

MARY JANE WILKINS, late of 62 Wattle-street, Bendigo, widow, DECEASED (who died on the 21st day of October, 1947).

CREDITORS, next of kin, and all other persons having claims against the estate of the above-named deceased are required by the executor, Sandhurst and Northern District Trustees, Executors, and Agency Company Limited, of View-street, Bendigo, to send particulars to it, care of the said company, on or before the 24th day of June, 1948, after which date it will distribute the assets, having regard only to the claims of which it then has notice.

Dated the 19th day of April, 1948.

HYETT, WILLIS, & HYETT, 51 Bull-street, Bendigo, solicitors for the executor. 4158

CREDITORS, next of kin, and all other persons having claims against the estate of Ethel Box, late of Tucker-road, Bentleigh, widow, deceased (who died on the 2nd day of December, 1947), are required to send particulars of their claims, in writing, to Raymond Arthur Brewster, of 24 Barkly-terrace, Mitcham, motor mechanic, the executor to whom probate of the will of the said deceased was granted, care of the solicitors named hereunder, on or before the 26th day of June, 1948, after which date he will distribute the assets of the said deceased, having regard only to the claims of which he then has notice.

Dated the 14th day of April, 1948.

HOME, WILKINSON, & LOWRY, solicitors, 401 Collins-street, Melbourne. 4191

CREDITORS, next of kin, and others having claims in respect of the estate of John William Middleton, late of 502 Ascot-street south, Ballarat, gentleman, deceased (who died on 4th March, 1948), are to send particulars of their claims to the executor, The Ballarat Trustees, Executors, and Agency Company Limited, of 101 Lydiard-street north, Ballarat, by 24th June, 1948, after which date it will distribute the assets, having regard only to the claims of which it then has notice.

R. J. GRIBBLE, HOLLWAY, & HEINZ, solicitors, 22 Lydiard-street south and 99 Bridge-street, Ballarat. 4124

PURSUANT to the provisions of the *Trustee Act 1928*, notice is hereby given that all persons having claims against the estate of Blanche Sara Burkitt, late of Donaldson-street, Corinda, Brisbane, in the State of Queensland, spinster, deceased (who died on the 22nd day of June, 1947, and probate of whose will was, on the 16th day of December, 1947, granted by the Supreme Court of Queensland to Jane Teresa Burkitt and Olive Bridget Fleetwood Burkitt, both of Donaldson-street, Corinda, Brisbane aforesaid, spinsters, and which said probate was, on the 14th day of April, 1948, sealed with the seal of the Supreme Court of Victoria), are hereby required to send particulars, in writing, of such claims, on or before the 22nd day of June, 1948, to the said executrices, care of the undersigned, after which date the said Jane Teresa Burkitt and Olive Bridget Fleetwood Burkitt will convey or distribute the estate and assets of the said Blanche Sara Burkitt, deceased, which shall have come to their hands or possession amongst the persons entitled thereto, having regard only to those claims of which they shall have then had notice, and the said executrices will not be liable for the estate so distributed, or any part thereof, to any person of whose claim they shall not then have had notice.

W. H. JONES & KENNEDY, solicitors, 214 Nicholson-street, Footscray, solicitors, for the executrices. 4193

PURSUANT to the *Trustee Act 1928*, all persons having claims against the estate of George Clarence Tickell, formerly of 151 Charles-street, Footscray, but late of 6 Rippon-street, Footscray, manufacturer, deceased (who died on the 22nd day of April, 1947, and probate of whose will and codicil was granted by the Supreme Court of Victoria on the 7th day of April, 1948, to Ethel Tickell, of 6 Rippon-street, Footscray, widow, and Ronald Edmund Tickell, of 6 Ripon-street, Footscray, french polisher, the executrix and executor appointed by deceased's will and codicil), are hereby required to send particulars of such claims to the said Ethel Tickell and Ronald Edmund Tickell, care of the under-mentioned solicitors, on or before the 21st day of June, 1948, after which date the said executrix and executor will distribute the assets, having regard only to the claims of which notice has then been received.

MARTIN & MARTIN, solicitors, 37 Queen-street, Melbourne. 4174

KATHLEEN BRIDGET RYAN, DECEASED.

CREDITORS, next of kin, and others having claims in respect of the estate of Kathleen Bridget Ryan (also known as Catherine Bridget Ryan), late of 79 Rose-street, Armadale, married woman, deceased (who died on 18th January, 1948), are required by John Patrick Molloy, of 23 Arthur-street, Ponsonby, Auckland, New Zealand, gentleman, the executor of the will of the said deceased, to send particulars of their claims to him, care of the under-mentioned solicitors, on or before the 30th day of June, 1948, after which date he will distribute the assets, having regard only to the claims of which he then has notice.

P. J. RIDGEWAY & PEARCE, solicitors, 379 Collins-street, Melbourne. 4178

PURSUANT to the *Trustee Act 1928*, notice is hereby given that all persons having claims against the estate of Arthur Mitchell Wilson, late of "Wanawong," 380 Toorak-road, South Yarra, in the State of Victoria, medical practitioner, deceased (who died on the 19th day of December, 1947, and application for a grant of representation of whose estate has been made to the Registrar of Probates by the Equity Trustees, Executors, and Agency Company Limited, whose registered office is situate at 472 Bourke-street, Melbourne, in the said State, Sarah Marguerita Wilson, of "Wanawong," 380 Toorak-road, South Yarra aforesaid, widow, and Alan John Moir, of 95 Queen-street, Melbourne, in the said State, solicitor, the executors appointed by the will and two codicils thereto of the said deceased), are hereby required to send particulars, in writing, of such claims to the said executors, care of the said company, at its registered office aforesaid, on or before the 25th day of June, 1948, after which date the said executors will proceed to convey or distribute the said estate, or any part thereof, amongst the persons entitled thereto, having regard only to the claims, whether formal or not, of which they shall then have had notice; and notice is hereby further given that they will not, as respects the property so conveyed or distributed, be liable to any person of whose claim they shall not have had notice.

GILLOTT, MOIR, & AHERN, 95 Queen-street, Melbourne, solicitors for the said executors. 4180

PURSUANT to the *Trustee Act 1928*, all persons having claims against the estate of Arthur Herbert Olsson, late of 30 Deepdene-road, Balwyn, gentleman, deceased (who died on the 20th day of September, 1947, and probate of whose will was granted by the Supreme Court of Victoria, on the 19th day of February, 1948, to the Equity Trustees, Executors, and Agency Company Limited, of 472 Bourke-street, Melbourne, and Jennie Olsson, of 30 Deepdene-road, Balwyn, widow), are hereby required to send particulars, in writing, of such claims to the said executors, care of the above-named company, at its address above appearing, on or before the 1st day of July, 1948, after which time the said executors will distribute the assets of the said deceased amongst the persons entitled thereto, having regard only to the claims of which it shall then have had notice.

Dated this 13th day of April, 1948.

RUPERT F. BULLEN, of 20 Queen-street, Melbourne, solicitor for the executors. 4183

CREDITORS, next of kin, and others having claims in respect of the estate of Sarah Nelis, late of 41 Hanover-street, Fitzroy, in the State of Victoria, spinster, deceased (who died on the 25th day of December, 1947), are to send particulars of their claims to the executor, National Trustees, Executors, and Agency Company of Australasia Limited, of 95 Queen-street, Melbourne, in the said State, by the 24th of June, 1948, after which date the said company will distribute the assets, having regard only to the claims of which it shall then have had notice.

M. MORNANE, solicitor, 95 Queen-street, Melbourne. 4194

CREDITORS, next of kin, and all others having claims against the estate of Edna May Varker, late of 46 St. John's-avenue, Camberwell, in the State of Victoria, factory employee, deceased (who died on the 13th day of August, 1947), are requested to send particulars thereof to the administrator, John Bamber, care of the under-named, on or before the 30th day of June, 1948, after which date the administrator will proceed to distribute the assets, having regard only to the claims of which he then has notice.

J. A. REDMOND & CO., of 358 Collins-street, Melbourne, solicitors for the administrator. 4176

**CREDITORS**, next of kin, and others having claims against the estate of Emily Noy, late of 67 Thompson-street, Williamstown, married woman (who died on the 3rd day of May, 1947), are to send particulars of their claims to the administrator, Walter William Noy, of 67 Thompson-street, Williamstown, by the 30th day of June, 1948, after which date the administrator will distribute the assets, having regard only to the claims of which he then has notice.

HENDERSON & BALL, solicitors, 430 Little Collins-street, Melbourne. 4190

*Trustee Act 1928.*

**NOTICE TO CLAIMANTS.**

**PURSUANT** to the *Trustee Act 1928*, creditors, next of kin, and all other persons having claims in respect of the estate of any deceased persons named below are required to send particulars thereof to the legal personal representative or representatives at the address stated below, on or before the date stated, after which date the representative or representatives will distribute the assets, having regard only to the claims of which notice has been received:—

Janet Gardiner, formerly of 4 Watkins-street, McKinnon, but late of 24 Albion-street East Brunswick, widow, deceased, died 1st November, 1947.—Claims to the executors, National Trustees, Executors, and Agency Company of Australasia Limited, whose registered office is situate at 95 Queen-street, Melbourne, and Marsden Gardiner, of 10 Marden-street, Canterbury, constable of police, care of the said company, on or before the 28th June, 1948. Leach and Thomson, solicitors, 472 Bourke-street, Melbourne. 4145

Hermann (sometimes spelt Herman) Gilbert Gale, formerly of Jeparit, but late of Parwan, retired railway employee, died 24th December, 1947.—Claims to the executor, The Ballarat Trustees, Executors, and Agency Company Limited, of 101 Lydiard-street north, Ballarat, by 19th day of June, 1948. Miller and Tartakover, solicitors, Dimboola. 4166

Alice Gorton Aitken, late of Westbury-street, East St. Kilda, in Victoria, widow, deceased.—Claims to the executors, James Burt Aitken, of 120 William-street, Melbourne, in Victoria, solicitor, and James Ford Strachan, of 123 William-street, Melbourne, aforesaid, solicitor, care of Aitken, Walker, and Strachan, of 123 William-street, Melbourne, in Victoria, solicitors for the said executors, by the 22nd day of June, 1948. Aitken, Walker, and Strachan, 123 William-street, Melbourne, solicitors for the applicants. 4169

Alma Joan Bell, late of "Murrnong," Albury, in New South Wales, spinster, deceased.—Claims to the executors, James Marius Bell, of "Deep Lagoon," Daysdale, in New South Wales, grazier, and Lewis Bell, of "Alma," Booligal, in the said State, grazier, care of Aitken, Walker, and Strachan, of 123 William-street, Melbourne, in Victoria, solicitors for the said executors, by the 22nd day of June, 1948. Aitken, Walker, and Strachan, 123 William-street, Melbourne, solicitors for the applicants. 4170

Elsie Mary Elizabeth Cuthbert, late of No. 11, Ladbrooke Gardens, Kensington, in the County of London, England, spinster, deceased, who died on the 28th October, 1947.—Claims to the executor, Bertie Harris, of 103 William-street, Melbourne, in the State of Victoria, accountant, by 23rd June, 1948. Hedderwick, Fookes, and Alston, 103 William-street, Melbourne, solicitors for the executor. 4195

**MINING NOTICES.**

**NEW CHUM SYNCLINE GOLD MINE NO LIABILITY.**  
**FORFEITURE NOTICE.**

**NOTICE** is hereby given that all shares forfeited for non-payment of No. 93 (March) Call of Three pence per share will be sold by public auction in the vestibule of the Stock Exchange, 428 Chancery-lane, Melbourne, on Friday, 30th April, 1948, at a quarter to Twelve a.m., unless shares are previously redeemed.

By order of the Board,  
FRANK COOPER, Manager.

422 Collins-street, Melbourne, C.1. 4185

**ARGUS HILL CHEWTON GOLD NO LIABILITY.**

**FORFEITURE NOTICE.**

**NOTICE** is hereby given that all shares forfeited for non-payment of No. 53 (March) Call of Three pence per share will be sold by public auction in the vestibule of the Stock Exchange, 428 Chancery-lane, Melbourne, on Thursday, 29th April, 1948, at a quarter to Twelve a.m., unless shares are previously redeemed.

By order of the Board,  
FRANK COOPER, Manager.

422 Collins-street, Melbourne, C.1. 4186

**NEW CHUM SYNCLINE GOLD MINE NO LIABILITY.**

**NOTICE** is hereby given that the capital of the above-named company has been increased by raising the value of the existing 55,000 shares of £1 10s. each to £2 each, thus making the capital of the company £110,000.

By order of the Board,  
FRANK COOPER, Manager.

422 Collins-street, Melbourne, C.1. 4188

**IMPOUNDINGS.**

**ARARAT.**—Impounded at Wickliffe Pound, on 14th April, 1948.

1 long-tailed crossbred ram, no visible brand  
If not claimed and expenses paid, to be sold on 6th May, 1948.

C. W. R. GRIMMER,  
Poundkeeper.

4160—4/8

**BROADMEADOWS.**—Impounded at Campbellfield.

1 black yearling heifer, no visible brand  
If not claimed and expenses paid, to be sold on 6th May, 1948.

A. OLIVER,  
Poundkeeper.

4151—4/

**DANDENONG.**—Impounded at Dandenong, by E. M. Sutton, Shire Ranger, from Market Sale Yards.

1 blue-roan delivery type gelding, white face, off side front foot white, near side hind foot white, no visible brand  
If not claimed and expenses paid, to be sold on 6th May, 1948.

A. WALKER,  
Poundkeeper.

4150—5/4

**MAFFRA.**—Impounded at Maffra, by C. A. Hibbins.

1 light Jersey heifer, nick out and slit off ear, slit point near ear, no visible brand  
If not claimed and expenses paid, to be sold on 7th May, 1948.

C. H. CAMERON,  
Poundkeeper.

4149—4/8

**MILDURA.**—Impounded at Lake Benetook (Mildura).

1 brown mare, light draught type, white strip on face, white hind feet, like N near shoulder  
If not claimed and expenses paid, to be sold on 6th May, 1948.

S. C. JESSOP,  
Poundkeeper.

4196—4/8

**ROSEDALE.**—Impounded at Rosedale.

1 brown draught mare, aged, blaze face, three white feet, indistinct brand on near shoulder  
If not claimed and expenses paid, to be sold on 6th May, 1948.

G. FARLEY,  
Poundkeeper.

4159—4/8

**ORBOST.**—Impounded in Orbost Shire Pound.

1 Jersey heifer, bottom quarter out of near ear, A on near rump  
If not claimed and expenses paid, to be sold after fourteen days.

H. DOMINEY,  
Poundkeeper.

4197—4/8

**WANGARATTA.**—Impounded at Wangaratta.

1 red brindle cow, aged, big frame, diamond hole torn out off ear, white under udder  
If not claimed and expenses paid, to be sold on 6th May, 1948.

J. McDONNELL,  
Poundkeeper.

4152—4/8

## STATE ACTS, 1943.

COPIES of the following Acts of Parliament of Victoria may be obtained at the Government Printing Office, or from any bookseller, at the price set opposite to each:—

No.	Description	Price.	
		s.	d.
4943.	Consolidated Revenue .. ..	0	6
4944.	Consolidated Revenue .. ..	0	6
4945.	State Development .. ..	0	6
4946.	Grain Elevators .. ..	0	6
4947.	Consolidated Revenue .. ..	0	6
4948.	Lunacy .. ..	0	6
4949.	National Security (Emergency Powers) Con- tinuation .. ..	0	6
4950.	Commonwealth Powers .. ..	0	6
4951.	Consolidated Revenue .. ..	0	6
4952.	Factories and Shops (Chairman of Wages Boards) .. ..	0	6
4953.	Country Roads (Forest Roads and Stock Routes) .. ..	0	6
4954.	State Schools (Bush Fire Relief) .. ..	0	6
4955.	Consolidated Revenue .. ..	0	6
4956.	Coal Mines Regulation .. ..	0	6
4957.	Petrol Pumps (Licence Fees) .. ..	0	6
4958.	Superannuation (Contributions) .. ..	0	6
4959.	Coal Mine Workers Pensions .. ..	0	6
4960.	Forests (Exchange of Lands) .. ..	0	6
4961.	Local Government (Valuations) .. ..	0	6
4962.	Railway Construction (Extensions) .. ..	0	6
4963.	Mental Hygiene (Mode of Citation) .. ..	0	6
4964.	Administration and Probate Duties .. ..	0	6
4965.	Sewerage Districts .. ..	0	6
4966.	Stamps (Increased Duty Continuance) .. ..	0	6
4967.	Land Tax .. ..	0	6
4968.	Surplus Revenue .. ..	0	6
4969.	Financial Emergency (Grants and Funds) .. ..	0	6
4970.	Partially Blinded Soldiers Fund .. ..	0	6
4971.	Melbourne and Metropolitan Board of Works (Contributions) .. ..	0	6
4972.	Milk Pasteurization .. ..	1	0
4973.	Country Roads Board Fund .. ..	0	6
4974.	Workers' Compensation .. ..	0	6
4975.	Public Works Loan and Application .. ..	0	6
4976.	Factories and Shops (Saturday Half-holiday) .. ..	0	6
4977.	Springvale Necropolis Land .. ..	0	6
4978.	South Melbourne to Melbourne Tramway Con- struction .. ..	0	6
4979.	Water Supply Loans Application .. ..	0	6
4980.	Forests .. ..	0	6
4981.	State Forests Loan Application .. ..	0	6
4982.	Administration and Probate (War Service) .. ..	0	6
4983.	Water .. ..	0	9
4984.	Farmers Protection (Amendment) .. ..	0	6
4985.	Stamps .. ..	0	6
4986.	Railway Loan Application .. ..	0	6
4987.	Farmers Debts Adjustment .. ..	0	6
4988.	Ministry of Health .. ..	1	0
4989.	Discharged Servicemen's Preference .. ..	1	0
4990.	Instruments (Insurance Contracts) .. ..	0	6
4991.	Melbourne (Widening of Streets) .. ..	0	6
4992.	Mines (Petroleum) .. ..	0	6
4993.	Education .. ..	0	6
4994.	Land Settlement (Acquisition) .. ..	0	6
4995.	Land Settlement Loan and Application .. ..	0	6
4996.	Housing .. ..	1	0
4997.	Milk and Dairy Supervision .. ..	1	0
4998.	Appropriation of Revenue .. ..	3	9

J. J. GOURLEY,  
Government Printer.

## STATE ACTS, 1944.

COPIES of the following Acts of Parliament of Victoria may be obtained at the Government Printing Office, or from any bookseller, at the price set opposite to each:—

No.	Description	Price.	
		s.	d.
4999.	Consolidated Revenue .. ..	0	6
5000.	Local Government (Polling Booths) .. ..	0	6
5001.	Police Offences (Unlawful Games) .. ..	0	6
5002.	Hospitals and Charities .. ..	0	6
5003.	Water (Loddon) .. ..	0	6
5004.	Justices .. ..	0	6
5005.	Coal Mines Regulation (Amendment) .. ..	0	6
5006.	Consolidated Revenue .. ..	0	6
5007.	Melbourne and Metropolitan Board of Works (Contributions) .. ..	0	6
5008.	Marketing of Primary Products .. ..	0	6
5009.	National Security (Emergency Powers) Con- tinuation .. ..	0	6
5010.	Outer Circle Railway (Partial Dismantling) .. ..	0	6
5011.	Mines (Minerals) .. ..	0	6
5012.	Goods (Textile Products) .. ..	0	6
5013.	Masseurs .. ..	0	6
5014.	Electoral (War Service Deaths) .. ..	0	6
5015.	Cremorne Bridge .. ..	0	6
5016.	Melbourne Harbor Trust .. ..	0	6
5017.	Water .. ..	0	9
5018.	Consolidated Revenue .. ..	0	6
5019.	Mildura Irrigation and Water Trusts .. ..	0	6
5020.	Farm Water Supplies Advances .. ..	0	6
5021.	Sewerage Districts .. ..	0	6
5022.	Trustee Companies .. ..	0	6
5023.	Mildura Irrigation and Water Trusts (Super- annuation) .. ..	0	6
5024.	Consolidated Revenue .. ..	0	6
5025.	Cemeteries .. ..	0	6
5026.	Border Railways .. ..	0	6
5027.	Local Government (Shire of Blackburn and Mitcham) .. ..	0	6
5028.	Electoral Districts .. ..	0	6
5029.	Land .. ..	0	5
5030.	Land Tax .. ..	0	6
5031.	Administration and Probate Duties .. ..	0	6
5032.	Stock Foods (Amendment) .. ..	0	6
5033.	Stamps (Increased Duty Continuance) .. ..	0	6
5034.	Marlbyrnong and Ashburton Lands Exchange .. ..	0	6
5035.	Financial Emergency (Grants and Funds) .. ..	0	6
5036.	Farmers Advances .. ..	0	6
5037.	Land Settlement (Acquisition) Amendment .. ..	0	6
5038.	Railways .. ..	0	6
5039.	Farmers Protection (Amendment) .. ..	0	6
5040.	Country Fire Authority .. ..	1	9
5041.	Country Roads Board Fund .. ..	0	6
5042.	Railway Loan and Application .. ..	0	6
5043.	Town and Country Planning .. ..	1	0
5044.	Agricultural Colleges .. ..	0	9
5045.	Heatherton Sanatorium .. ..	0	6
5046.	Health (Infectious Diseases Hospitals) .. ..	0	6
5047.	Surplus Revenue .. ..	0	6
5048.	Water Supply Loans Application .. ..	0	9
5049.	State Forests Loan and Application .. ..	0	6
5050.	Public Works Loan and Application .. ..	0	6
5051.	Commonwealth and States Financial Agree- ment .. ..	1	3
5052.	The Constitution Act Amendment .. ..	0	6
5053.	Public Library National Gallery and Museums .. ..	0	9
5054.	Drought Relief .. ..	0	6
5055.	Co-operative Housing Societies .. ..	1	6
5056.	Local Government .. ..	1	0
5057.	Melbourne and Metropolitan Board of Works .. ..	0	9
5058.	Appropriation of Revenue .. ..	3	9

J. J. GOURLEY,  
Government Printer.

## STATE ACTS, 1945.

COPIES of the following Acts of Parliament of Victoria may be obtained at the Government Printing Office, or from any bookseller, at the price set opposite to each:—

No.	Price.	
	s.	d.
5059. Mildura Irrigation and Water Trusts (Borrowing)	0	6
5060. Supreme Court (Judges)	0	6
5061. Oakleigh (Regent-street) Land	0	6
5062. Swine	0	6
5063. Drought Relief (Amendment)	0	6
5064. Unclaimed Moneys	0	6
5065. Consolidated Revenue	0	6
5066. Consolidated Revenue	0	6
5067. Agent-General's	0	6
5068. Land Surveyors (Amendment)	0	6
5069. State Development	0	6
5070. Melbourne and Metropolitan Board of Works (Borrowing Powers)	0	6
5071. Education	0	6
5072. Water	0	6
5073. National Security (Repeal)	0	6
5074. Moorabbin (Unimproved Rating Poll)	0	6
5075. Licensing (Poll)	0	6
5076. Lilydale Waterworks Trust Abolition	0	6
5077. East Melbourne Land	0	6
5078. Health (Wines)	0	6
5079. Local Government (Emergency Housing Accommodation)	0	6
5080. Law Institute	0	6
5081. Bendigo Land	0	6
5082. Consolidated Revenue	0	6
5083. Consolidated Revenue	0	6
5084. Consolidated Revenue	0	6
5085. Factories and Shops (Bread Holidays)	0	6
5086. Administration and Probate Duties	0	6
5087. Land Tax	0	6
5088. Stamps (Increased Duty Continuance)	0	6
5089. Licensing Fund	0	6
5090. Employers and Employés	0	6
5091. Farmers Advances	0	6
5092. University (Veterinary Research)	0	6
5093. Surplus Revenue	0	6
5094. State Forests Loan and Application	0	6
5095. Mines (Amendment)	0	6
5096. Farmers Protection (Amendment)	0	6
5097. Railway Loan Application	0	6
5098. Public Works Loan and Application	0	6
5099. Water Supply Loans Application	0	9
5100. Public Account Advances (Amendment)	0	6
5101. Hospital Benefits	0	6
5102. Totalizator (Amendment)	0	6
5103. Financial Emergency (Municipal Endowment)	0	6
5104. Country Roads Board Fund (Amendment)	0	6
5105. Coal Mines Regulation (Amendment)	0	6
5106. Melbourne and Metropolitan Tramways (Chairman)	0	6
5107. Soldier Settlement	1	3
5108. Appropriation of Revenue	4	0

J. J. GOURLEY,

Government Printer

## STATE ACTS, 1946.

COPIES of the following Acts of Parliament of Victoria may be obtained at the Government Printing Office, or from any bookseller, at the price set opposite to each:—

No.	Price.	
	s.	d.
5109. Geelong Land	0	6
5110. Transport Regulation (Amendment)	0	6
5111. Factories and Shops (Annual Holidays)	0	9
5112. Mornington Sewerage Authority (Validation)	0	6
5113. Local Government (Emergency Housing Accommodation) Amendment	0	6
5114. Housing (Commonwealth and State Agreement)	1	0
5115. Factories and Shops (Early Closing)	0	6
5116. Building Operations and Building Materials Control	0	9
5117. Water (Levee Banks)	0	9
5118. Co-operative Housing Societies	0	6
5119. Local Government (Municipal Rolls)	0	6
5120. Public Works Loan and Application	0	6
5121. Totalizator (Charities)	0	6
5122. Drought Relief	0	6
5123. Taxation (Arrangements)	0	6
5124. Public Service	1	6
5125. Teaching Service	1	3
5126. Police Regulation	1	0
5127. Railways (Long Service)	0	6
5128. Workers' Compensation	1	6
5129. Sewerage Districts (Amendment)	0	6
5130. Factories and Shops (Bread)	0	6
5131. Crimes (Intermediate Sentences)	0	6
5132. Medical (Chemists' Apprentices)	0	6
5133. Soldier Settlement (Amendment)	0	6
5134. Consolidated Revenue	0	6
5135. Consolidated Revenue	0	6
5136. Apprenticeship	0	6
5137. Consolidated Revenue	0	6
5138. Consolidated Revenue	0	6
5139. Consolidated Revenue	0	6
5140. Nicholson-street Tramway Construction	0	6
5141. Burke-road Tramway Construction	0	6
5142. Ballaarat Gas Company's	0	6
5143. Melbourne and Metropolitan Board of Works (Contributions)	0	6
5144. Stamps (Betting Tax)	0	6
5145. Juries (Fees)	0	6
5146. Cattle and Swine Compensation	0	6
5147. Marine (Pilots and Pilotage Rates)	0	6
5148. Patriotic Funds	0	6
5149. Stock Foods (Amendment)	0	6
5150. Municipal Endowment (Temporary Discontinuance)	0	6
5151. Medical Practitioners' Registration	0	6
5152. Seeds	0	6
5153. Water	0	6
5154. Clifton Hill Land	0	6
5155. Tobacco Sellers	0	6
5156. Country Roads Board Fund (Amendment)	0	6
5157. Moorpanyal Land	0	6
5158. Factories and Shops (Annual Holidays) Amendment	0	6
5159. Factories and Shops (Wages Boards)	0	6
5160. Melbourne and Metropolitan Tramways (Amendment)	0	6
5161. Infectious Diseases Hospital (Borrowing)	0	6

STATE ACTS, 1946—*continued.*

No.	Price.
	s. d.
5162. University (Mildura Branch) .. ..	0 6
5163. Farmers Protection (Amendment) .. ..	0 6
5164. Forests (Exchange of Lands) Extension .. ..	0 6
5165. Money Lenders (Cash Orders) .. ..	0 6
5166. Local Government (Dandenong Street Construction) .. ..	1 0
5167. Stamps (Increased Duty Continuance) .. ..	0 6
5168. Land Tax .. ..	0 6
5169. Cattle Breeding .. ..	0 6
5170. Administration and Probate Duties .. ..	0 6
5171. Co-operative Housing Societies (Guarantees) .. ..	0 6
5172. Railways (Sick Leave) .. ..	0 6
5173. Fruit and Vegetables .. ..	0 6
5174. Farm Water Supplies and Drainage Advances .. ..	0 6
5175. State Forests Loan and Application .. ..	0 6
5176. Melbourne South Land .. ..	0 6
5177. Agricultural Colleges (Amendment) .. ..	0 6
5178. Drought Relief (Amendment) .. ..	0 6
5179. Soldier Settlement .. ..	1 9
5180. Free Library Service Board .. ..	0 6
5181. Adult Education .. ..	0 6
5183. Evidence .. ..	0 6
5184. Housing (Discharged Servicemen) .. ..	0 6
5185. Parliamentary Contributory Retirement Fund .. ..	0 6
5186. Friendly Societies .. ..	0 6
5187. Police Offences (Race-meetings) .. ..	0 6
5188. Railways (Mont Park Siding) .. ..	0 6
5189. Land (Grazing Licences) .. ..	0 6
5190. Factories and Shops (Bread Carters) .. ..	0 6
5191. Country Fire Authority .. ..	1 0
5192. Supreme Court (Judges) .. ..	0 6
5193. Railway Loan Application .. ..	0 6
5194. Metropolitan Gas Company's .. ..	0 6
5195. Railways (Temporary Employés) .. ..	0 6
5196. Railways (State Coal Mine) .. ..	0 6
5197. Licensing .. ..	0 6
5198. Town and Country Planning .. ..	0 6
5199. Public Works Loan and Application (No. 2) .. ..	0 6
5201. Trotting Races .. ..	0 6
5202. Economic Stability .. ..	0 6
5204. Stamps .. ..	2 3
5206. Melbourne and Metropolitan Tramways (Appeal Board) .. ..	0 6

J. J. GOURLEY,  
Government Printer.

## STATE ACTS, 1947.

COPIES of the following Acts of Parliament of Victoria may be obtained at the Government Printing Office, or from any bookseller, at the price set opposite to each:—

No.	Price.
	s. d.
5207. Consolidated Revenue .. ..	0 6
5208. Custodian Trustee .. ..	0 6
5209. Revocation and Excision of Crown Reservations .. ..	0 9
5210. Farmers Advances (Amendment) .. ..	0 6
5211. Private Bill Committees .. ..	0 6

STATE ACTS, 1947—*continued.*

No.	Price.
	s. d.
5212. Health (Amendment) .. ..	0 6
5213. Wills (Amendment) .. ..	0 6
5214. Old Colonists' Association .. ..	0 6
5215. Consolidated Revenue .. ..	0 6
5216. Local Authorities Superannuation .. ..	1 0
5217. Statute Law Revision .. ..	0 6
5218. Motor Car (Registration Fees) .. ..	0 6
5219. State Electricity Commission (Yallourn Area) .. ..	0 6
5220. Transport Regulation (Licences and Fees) .. ..	0 6
5221. Local Government (Private Street Construction) .. ..	0 6
5222. State Development (Amendment) .. ..	0 6
5223. Coal Mine Workers Pensions .. ..	0 6
5224. State Savings Bank .. ..	0 9
5225. Drought Relief .. ..	0 6
5226. Soil Conservation and Land Utilization .. ..	1 0
5227. Consolidated Revenue .. ..	0 6
5228. Consolidated Revenue .. ..	0 6
5229. Consolidated Revenue .. ..	0 6
5230. Municipal Endowment (Temporary Discontinuance) .. ..	0 6
5231. Forests (Commissioners) .. ..	0 6
5232. State Forests Loan and Application .. ..	0 6
5233. Melbourne and Metropolitan Tramways (Amendment) .. ..	0 6
5234. Auditor-General's Salary .. ..	0 6
5235. Drought Relief (Amendment) .. ..	0 6
5236. Wheat Marketing (Winding Up) Amendment .. ..	0 6
5237. University (Mildura Branch) .. ..	0 6
5238. Factories and Shops (Bread) .. ..	0 6
5239. Water Supply Loan and Application .. ..	1 3
5240. Public Works Loan and Application .. ..	0 6
5241. Administration and Probate Duties .. ..	0 6
5242. Land Tax .. ..	0 6
5243. Country Roads Board Fund (Amendment) .. ..	0 6
5244. Ballarat Land .. ..	0 9
5245. Stamps (Increased Duty Continuance) .. ..	0 6
5246. Railway Loan Application .. ..	0 9
5247. Sewerage Districts (Amendment) .. ..	0 6
5248. State Electricity Commission (Financial) .. ..	0 6
5249. Public Account Advances (Amendment) .. ..	0 6
5250. Infectious Diseases Hospital (Amendment) .. ..	0 6
5251. Public Works Loan and Application (Amendment) .. ..	0 6
5252. Officials in Parliament .. ..	0 6
5253. Water .. ..	0 6
5254. Supreme Court (Judges Salaries) .. ..	0 6
5255. Superannuation .. ..	0 9
5256. Country Sewerage Loan and Application .. ..	0 6
5257. Melbourne and Metropolitan Board of Works (Contributions) .. ..	0 6
5258. Vegetation Diseases (Fruit Fly) .. ..	0 6
5259. Building Operations and Building Materials Control (Amendment) .. ..	0 6
5260. Police Regulation (Amendment) .. ..	0 6
5261. Factories and Shops (Determinations) .. ..	0 6

J. J. GOURLEY,  
Government Printer.

## AGENTS FOR THE "VICTORIA GOVERNMENT GAZETTE."

THE following have been appointed agents to receive Advertisements and subscriptions for the *Victoria Government Gazette*:—

- ARMSTRONG'S AGENCY, 143 Queen-street, Melbourne.  
 MESSRS. ARNALL & JACKSON, 115 Barkly-street, West Brunswick.  
 MESSRS. GORDON & GOTCH, News Agents, 511 Little Collins-street, Melbourne; and corner Barrack and Clarence streets, Sydney.  
 MESSRS. HARSTON, PARTRIDGE, & CO., 455 Little Collins-street, Melbourne.  
 NIXON & CO., 20 Queen-street, Melbourne.  
 THE PATON ADVERTISING SERVICE PTY. LTD.  
 ROBERTSON & MULLENS LTD., Elizabeth-street, Melbourne.  
 MESSRS. A. S. RICHARDSON and T. C. GARDNER, trading as The Mercantile Exchange, 380 Collins-street, Melbourne.  
 MR. A. J. DIGBY, News Agent, Bairnsdale.  
 MR. M. R. BADE, Tobacconist, Sturt-street, Ballarat.  
 FRIGG'S NEWS AGENCY, Hargreaves-street, Bendigo.  
 MR. G. H. K. PAYNE, 4 View Point, Bendigo.  
 MR. C. F. LATIMER, News Agent, Casterton.  
 MESSRS. HENRY FRANKS & CO., Booksellers and Stationers, Market-square, Geelong.  
 MESSRS. SMITH & DUNNON, Hamilton.  
 ARMSTRONG BROS., Kyneton.  
 MR. WM. DAVIS, Mildura.  
 PIKE'S AUTHORIZED NEWS AGENCY, Sale.  
 MR. C. T. RUST, News Agent, Wangaratta.  
 MR. F. T. McCORMICK, Nunn-street, Benalla.  
 W. GORDON HAMPTON, 243 Mitchell-street, Bendigo.  
 R. & A. SMALLMAN, News Agents, Toora.

A copy of the *Gazette* filed at each place for public reference.

## THE "VICTORIA GOVERNMENT GAZETTE."

SUBSCRIPTIONS.—*The subscription, including Postage, is £1 12s. 6d. per annum, 16s. 3d. half-yearly, or 8s. 2d. per quarter, payable in advance.*

*Subscriptions are required to commence and terminate with a month.*

*A lesser period than three months cannot be subscribed for.*

*Subscribers do not receive the Acts of Parliament with the GAZETTE.*

ADVERTISEMENTS are charged at the rate of EIGHT PENCE per line single column, and ONE SHILLING and FOUR PENCE per line double column.

*The title (£5 Reward, Dissolution of Partnership, &c.) forms one or more lines as a heading.*

*On an average, ten words make a line.*

*Every signature must likewise be counted as a line.*

*The final words of a paragraph, though only portion of a line must be counted as one line.*

SIGNATURES (in particular) and proper names must be written very plainly in the text; ONE SIDE ONLY of each slip of paper should be WRITTEN UPON.

ALL COMMUNICATIONS should be addressed to "The Government Printer, Melbourne."

ALL DOCUMENTS illegibly written will be returned unpublished, and, where brands occur unprovided for by the ordinary letters of the alphabet, a worded explanatory description must be furnished.

THE VICTORIA GOVERNMENT GAZETTE is published on WEDNESDAY EVENING in each week, and Notices for insertion will be received by the Government Printer at or before TWO p.m., at ordinary rates, and late advertisements between TWO p.m. and FIVE p.m. at double rates on the day preceding the day of publication.

Single copies of the VICTORIA GOVERNMENT GAZETTE are Six pence, posted Eight pence, each.

No GAZETTES prior to January, 1936, in stock.

\*\*\*ALL PAYMENTS ARE REQUIRED IN ADVANCE.—Remittances should be made by postal note, money order, or draft in favour of the Government Printer. Advertisements unaccompanied by a remittance sufficient to cover the cost of insertion will be returned unpublished.

## CONTENTS

	PAGE.
Acts of Parliament on sale at the Government Printing Office .. .. .	2629
Appointments .. .. .	2594
Contracts .. .. .	2607
Country Roads Board .. .. .	2611
Courts .. .. .	2605
Estates of Deceased Persons .. .. .	2606
Government Notices .. .. .	2602
Impoundings .. .. .	2628
Labour Day Holiday .. .. .	2594
Lands .. .. .	2616
Melbourne and Metropolitan Board of Works— Notices .. .. .	2605
Mining .. .. .	2602, 2628
Orders in Council .. .. .	2608
Private Advertisements .. .. .	2621
Proclamations .. .. .	2593
Public Service Notices .. .. .	2595
Resignations .. .. .	2595
State Rivers and Water Supply Commission .. .. .	2604
Tenders .. .. .	2619
Transport Regulation Board—Public Hearings .. .. .	2603
Waterworks Trusts .. .. .	2604