



VICTORIA GOVERNMENT GAZETTE.

Published by Authority.

[Registered at the General Post Office, Melbourne, for transmission by post as a newspaper.]

No. 691]

WEDNESDAY, JULY 7.

[1948

ACTS OF PARLIAMENT.

PROCLAMATION

By His Excellency the Governor of the State of Victoria and its Dependencies in the Commonwealth of Australia, &c., &c., &c.

I, THE Governor of the State of Victoria, in the Commonwealth of Australia, do hereby declare that I have this day assented, in His Majesty's name, to the Bills passed by the Parliament of the said State, the titles whereof are hereunder set forth, that is to say:—

No. 5268. "An Act to provide, upon the Transfer and Surrender to His Majesty of certain Land at Burwood, for the Reservation of that Land as a Site for a Public Park and Children's Playground, for the Excision of a Part of certain Land at Camberwell permanently reserved as a Site for Public Gardens and for the Reservation of the Land so excised, together with the Land forming the existing Town Hall Site at Camberwell, as a Site for a Town Hall and for Municipal Purposes."

No. 5269. "An Act to apply out of the Consolidated Revenue the sum of Five million four hundred and thirty-seven thousand three hundred and seventeen pounds to the service of the year One thousand nine hundred and forty-eight and One thousand nine hundred and forty-nine."

No. 5270. "An Act to amend the *Miners' Phthisis (Treasury Allowances) Act 1938.*"

No. 5271. "An Act to amend the Building Operations and Building Materials Control Acts."

Given under my Hand and the Seal of the State of Victoria aforesaid, at Melbourne, this thirtieth day of June, in the year of our Lord One thousand nine hundred and forty-eight, and in the twelfth year of the reign of His Majesty King George VI.

(L.S.)

WINSTON DUGAN.

By His Excellency's Command,

JOHN G. B. McDONALD,
for Premier.

GOD SAVE THE KING!

Milk and Dairy Supervision Act 1928 (No. 3736).

DECLARING A MUNICIPAL DISTRICT TO BE SUBJECT TO PART II. OF ACT.

PROCLAMATION

By His Excellency the Governor of the State of Victoria and its Dependencies in the Commonwealth of Australia, &c., &c., &c.

WHEREAS by paragraph (c) of section 40 of the *Milk and Dairy Supervision Act 1928* it is provided that Part II. of the said Act shall have effect as regards any municipal district outside any milk area on such date as such district is proclaimed by the Governor in Council to be subject to the provisions of Part II. of the said Act: Now, therefore, I, the Governor of the State of Victoria by and with the advice of the Executive Council thereof do by this my Proclamation declare the municipal district of the Shire of Chiltern to be subject to the provisions of Part II. of the aforesaid Act on and from the first day of July, 1948, on which date Part II. of the said Act and all Regulations and Orders now in force or which may from time to time be made under Part II. of the said Act shall come into operation and be of full force and effect in such municipal district.

Given under my Hand and the Seal of the State of Victoria aforesaid, at Melbourne, this sixth day of July, in the year of our Lord One thousand nine hundred and forty-eight, and in the twelfth year of the reign of His Majesty King George VI.

(L.S.)

WINSTON DUGAN.

By His Excellency's Command,

A. H. DENNETT,
Minister of Agriculture.

GOD SAVE THE KING!

APPOINTMENTS.

HIS Excellency the Governor has made the following appointments to his Personal Staff for duty in connexion with arrangements prior to and during the visit to Victoria next year of Their Majesties the King and Queen and Her Royal Highness The Princess Margaret:—

Chief of Staff:

Major-General CHARLES HARVEY MILLER, C.B., C.B.E., D.S.O.

Personal Assistant:

Rear-Admiral Sir LEIGHTON SEYMOUR BRACE-GIRDLE, K.C.V.O., C.M.G., D.S.O.

By His Excellency's Command,

C. W. KINSMAN,
Official Secretary.

The Governor's Office,
Melbourne, 6th July, 1948.

APPOINTMENTS.

HIS Excellency the Governor of the State of Victoria, by and with the advice of the Executive Council thereof, has, by Orders made on the 29th day of June, 1948, been pleased to make the under-mentioned appointments, viz.:—

DEPARTMENT OF CHIEF SECRETARY.

Officer in Charge of Gaol.

THOMAS MORRISSEY,
pursuant to the provisions of the *Gaols Act 1928*, to be Officer in Charge (acting) of the Geelong Gaol, from the 5th July, 1948, to the 26th July, 1948, both dates inclusive, during the absence on leave of Charles James McGann.

Assistant to the Inspector of Fisheries.

DENNIS FREDERICK PUFFETT,
pursuant to the provisions of the Fisheries Acts, to be an Assistant to the Inspector of Fisheries.

Chaplain to Reformatory Prison.

KENNETH BRANDRETH ESLINGTON RAFF (The Reverend) to be Church of England Chaplain to the Reformatory Prison at French Island, as from the 3rd February, 1948, *vice* George Walter Edwards (The Reverend), resigned.

DEPARTMENT OF LAW.

Magistrates.

GEORGE THOMPSON ALBAN ATKINSON, 1 Kingsley-crescent, Mont Albert,
FREDERICK SHELDON, 158 Victoria-street, West Brunswick,
LESLIE GLOSTER HOLDER, 10 Hornsby-street, Malvern,
JAMES HENRY ROBERTS, Seymour,
JOHN THOMAS TAIT HALLIGAN, Yarck,
HUGH BLAYNEY HAMILTON, 286 Queensberry-street, North Melbourne,
JOHN JAMIESON, Catering Manager, Parliament House, Spring-street, Melbourne,
WILLIAM KEITH MCKINNON, 40 St. Johns-avenue, Springvale,
ANDREW AMMEL ERICKSEN, 16-18 Springvale-road, Springvale, and
HAROLD HARLEY MACKAY, Woolamai,
to Keep the Peace in the Central Bailiwick of the State of Victoria;
HAROLD CLARENCE WICKETT, Cabbage Tree Creek,
GEORGE STANLEY EVANS, Morwell, and
ERIC WALTER BATTEN, Moe,
to Keep the Peace in the Eastern Bailiwick of the State of Victoria;
DANIEL BERNARD POWELL, Clarks Hill,
to Keep the Peace in the Southern Bailiwick of the State of Victoria;
GEORGE ALEXANDER CROSS, Toolamba, and
FRANK ALAN POGUE, Toolamba,
to Keep the Peace in the Midland Bailiwick of the State of Victoria; and
DONALD CLIVE COLLINS, Chief Clerk, Taxation Office, 436 Lonsdale-street, Melbourne,
to Keep the Peace in the Central, Northern, Southern, Eastern, Western, and Midland Bailiwicks of the State of Victoria.

Bailiffs of the County Court.

GEORGE SPENCER BOCK, First Constable of Police, Beulah,
to be also a Bailiff of the County Court at Horsham, in the place of J. R. Gray, resigned, with fees; and
ARTHUR LAWRENCE FREEMAN, First Constable of Police, Nyah West,
to be also a Bailiff of the County Court at Kerang, in the place of T. E. W. Yuill, resigned, with fees.

Clerks of the Children's Court.

THOMAS JOHN ALEXANDER MAYBERRY
to be also Clerk of the Children's Court at Lismore, in the place of G. N. Hornsby, resigned; and

NORMAN JOHN FITZPATRICK
to be also Clerk of the Children's Court at Wedderburn, in the place of G. S. Boal, resigned.

Commissioner for Taking Declarations, &c.

WILLIAM JOHN MCLENNAN, 35 McCracken-street, Kensington,
to be a Commissioner for taking Declarations and Affidavits, pursuant to the provisions of Division 8 of Part IV. of the *Evidence Act 1928*, to resign upon removing from the neighbourhood of the address stated.

Probation Officer.

FRANCIS ELLERKER LEWIN, The Vicarage, Ringwood,
to be a Probation Officer, pursuant to the provisions of section 8 of the *Children's Court Act 1928*, for the Children's Court at Ringwood.

DEPARTMENT OF PUBLIC WORKS.

Court of Marine Inquiry.

CLIFTON WILFRID PALMER (Class I., Sailing Ships),
CLIFTON WILFRID PALMER, ROBERT JOBLING, and ALAN SIDNEY JOHNSON (Class II., Steamships),
FRANK CUMMING HALL (Class III., Engineers),
CLIFTON WILFRID PALMER (Class IV., Pilots and Exempt Masters), and
JOHN PATRICK LARKIN and EDWIN CLAUDE TODNER (Class V., Scientific),
to be skilled members of the Court of Marine Inquiry, pursuant to the provisions of section 184 of the *Marine Act 1928*, for the twelve months ending 30th June, 1949.

DEPARTMENT OF WATER SUPPLY.

Waterworks Trust Commissioner.

ERNEST ALEXANDER RIED
to be a Commissioner of the Tallangatta Waterworks Trust, *vice* James Ronan, resigned, and to hold office as such from the date hereof until the 13th August, 1948, subject to the provisions of the Water Acts.

C. W. KINSMAN,

Clerk of the Executive Council.
At the Executive Council Chamber,
Melbourne, 29th June, 1948.

REVOCATION OF APPOINTMENTS.

HIS Excellency the Governor of the State of Victoria, by and with the advice of the Executive Council thereof, has, by Order made on the 29th day of June, 1948, revoked the following appointments:—

DEPARTMENT OF LANDS AND SURVEY.

WALTER LEO SIMPSON and ALEXANDER JAMES STEELE, as Bailiffs of Crown Lands, without salary.

C. W. KINSMAN,

Clerk of the Executive Council.
At the Executive Council Chamber,
Melbourne, 29th June, 1948.

RESIGNATIONS.

HIS Excellency the Governor of the State of Victoria, by and with the advice of the Executive Council thereof, has, by Orders made on the 29th day of June, 1948, accepted the resignations of the persons named hereunder of the offices mentioned, viz.:—

DEPARTMENT OF CHIEF SECRETARY.

GEORGE WALTER EDWARDS (The Reverend), as Church of England Chaplain to the Reformatory Prison at French Island, to date from and inclusive of the 3rd February, 1948.

DEPARTMENT OF LAW.

GEOFFREY THOMAS BOAL, as the Clerk of Petty Sessions (acting) and Clerk of the Children's Court (acting) at Wedderburn.
THOMAS EDMONSTON WILLIAM YUILL, as a Bailiff of the County Court at Kerang.
ALBERT RICHARDS WOODS, late of Boweya, from the Commission of the Peace for the Northern Bailiwick of Victoria.
GEORGE NORMAN HORNSBY, as Clerk of Petty Sessions (acting) and Clerk of the Children's Court (acting) at Lismore.
JOSHUA ROBERT GRAY, as a Bailiff of the County Court at Horsham.

C. W. KINSMAN,

Clerk of the Executive Council.
At the Executive Council Chamber,
Melbourne, 29th June, 1948.

PUBLIC SERVICE OF VICTORIA.—VACANCIES.

APPLICATIONS will be received by the Public Service Board up to Saturday, the 24th July, 1948, from persons employed in the Public Service of Victoria, who are eligible and qualified, for appointment to the under-mentioned positions:—

ADMINISTRATIVE DIVISION.

Clerk, Class "C," Office of the Housing Commission, Department of Treasurer.

Yearly Salary.—£449, minimum; £501, maximum.

Duties.—To inspect contract accounts in the metropolitan and country areas, to undertake special investigations and duties when required, and to compile financial statistical returns.

Qualifications.—To be capable of conducting investigations of accounts, and to have a sound knowledge of the law relating to contracts. To be a qualified accountant.

PROFESSIONAL DIVISION.

District Engineer, Grade I, Class "B1," Murray Valley Irrigation District, Department of Water Supply.

Yearly Salary.—£748, minimum; £800, maximum.

Duties.—To supervise and control all rural and urban water supplies, drainage and other works, and expenditure within the Murray Valley Irrigation District. To direct surveys and to prepare plans, specifications, estimates, and reports in regard to works within the district, to supervise construction and maintenance of works, and to control water distribution within this area.

Qualifications.—To possess a University Degree or Technical School Diploma of Civil Engineering or equivalent qualifications; to be competent to carry out surveys and to supervise water distribution; to be well versed in modern engineering practice, and in the design, construction, and maintenance of channels and structures and water supply works. Experience in an irrigation district is essential. To be conversant with the control of water and with land values, and to have a thorough knowledge of the provisions of the Water Acts.

Field Geologist, Class "C1," Department of Mines.

Yearly Salary.—£527, minimum; £579, maximum.

Duties.—To perform geological, topographical, and underground surveys.

Qualifications.—To have completed a satisfactory course of training in geology and related subjects; to have an intimate knowledge of the geology and mines of the Bendigo goldfield; to be competent to carry out surface and underground surveys, to identify rocks, minerals and fossils, and to prepare geological reports.

Horticultural Instructor, Class "C1," Department of Agriculture.

Yearly Salary.—£527, minimum; £579, maximum.

Duties.—To instruct orchardists and vegetable growers in the application of the results of horticultural research, and to undertake investigational work as required.

Qualifications.—Degree of Bachelor of Agricultural Science or its equivalent, experience in modern methods of experimentation as applied to horticulture, and in the interpretation of results, sound knowledge of modern horticultural practice under Victorian conditions.

TECHNICAL AND GENERAL DIVISION.

Laundry Foreman, Mental Hospital, Mont Park Mental Hygiene Branch, Department of Health.

Yearly Salary.—£367, minimum; £380, maximum.

Duties.—To be responsible for all departments of the laundry, the correct counting in of articles from the wards, &c., and for their despatch properly laundered.

Qualifications.—To have had experience in the use of all laundry equipment; ability to direct laundry staff and patients employed, and a knowledge of modern laundry processes.

Assistant (Male), Grade II, Stamp Duties Office, Department of Treasurer.

Yearly Salary.—£299, minimum; £364, maximum.

Duties.—To act as a checking officer in Betting Tax Section, and perform duties generally as directed.

Qualifications.—To be quick and accurate at figures, and preferably, to possess the School Intermediate Certificate.

Inspector, Grade II, Fisheries and Game Branch, Department of Chief Secretary.

Yearly Salary.—£279, minimum; £331, maximum.

Duties.—Under the direction of the Chief Inspector, to enforce the provisions of the Fisheries and Game Acts and Regulations thereunder, and generally to assist in the outside work of the Branch in such district as is allotted to him.

Qualifications.—To be strong, healthy, and active, and able to drive a motor vehicle and manage a motor boat. To have a good knowledge of and ability to effect running repairs to motor vehicles and marine engines. A knowledge of all classes of fish and native game and the methods of fishermen and shooters is essential. Education to Intermediate standard is desirable.

Carter, Mental Hospital, Kew, Mental Hygiene Branch, Department of Health.

Yearly Salary.—£286, minimum; £325, maximum.

Duties.—To assist in all farm work.

Qualifications.—Ability to carry out all ordinary farm work. To possess a motor driver's licence.

Nurse and Attendant, Children's Welfare Branch, Department of Chief Secretary.

Yearly Salary.—£283, minimum; £309, maximum; less deduction of £45 a year for board and lodging.

Duties.—Under the direction of the Medical Superintendent, to supervise children's wards and to attend to sick patients at the Children's Welfare Receiving Depot, Royal Park, and to take charge of the Girls' Depot when on night duty.

Qualifications.—To be a certificated nurse with ability to supervise a small staff. Experience in children's nursing is desirable.

Water Bailiff (Rochester), Department of Water Supply.

Yearly Salary.—£279, minimum; £292, maximum.

Qualifications.—Ability to control and regulate the supply of water to irrigators, and to keep the necessary records and make arithmetical computations in connexion therewith; a knowledge of water requirements for crop and grasses grown under irrigation, the methods of preparation of land for same, and method of channel and drain construction and maintenance.

Labourer, Law Courts, Department of Law.

Yearly Salary.—£260, minimum; £273, maximum.

Shorthand Writer and Typist (Female), Grade III, Survey Branch, Office of Titles, Department of Law.

Yearly Salary.—£260, minimum; £273, maximum.

Duties.—To have charge of the keeping of records and indexing of all dealings in the Survey Branch. To supply relevant information to the public. To carry out any secretarial duties required and supervise general typing.

Qualifications.—To be an experienced typist and stenographer, with a knowledge of filing and recording. To be able to control a small staff.

Attendant (Female), Children's Welfare Branch, Department of Chief Secretary. (Seven vacancies.)

Yearly Salary.—£224, minimum; £250, maximum; less £45 a year for board and lodging. An allowance of £13 a year may be paid to an officer who holds a Certificate of Competency as a Mothercraft Nurse.

Duties.—To assist in the care of children at the Children's Welfare Receiving Depot, and to perform such domestic and other duties as may be directed by the Medical Superintendent.

Qualifications.—To be of sound health, and possess an aptitude for work amongst babies, toddlers, and school children. Experience in caring for children and in the general routine of a children's institution is desirable.

NOTE.—In addition to the salary rates quoted, a cost of living adjustment (at present £60 a year for adult males and £40 a year for adult females), which varies in accordance with the rise or fall in the index numbers of the cost of living, is payable.

By order,

E. F. FITZGIBBON,
Secretary.

Office of the Public Service Board,
Melbourne, 5th July, 1948.

COOK (MALE), MENTAL HOSPITAL, ROYAL PARK, MENTAL HYGIENE BRANCH, DEPARTMENT OF HEALTH.

TEMPORARY APPOINTMENT.

APPLICATIONS will be received by the Public Service Board up to Saturday, the 24th July, 1948, from persons who are qualified, for appointment to the above-mentioned position.

Salary.—£341 a year, plus £60 cost of living adjustment. The rate is subject to variation in accordance with the rise or fall in the index numbers of the cost of living.

Duties.—To assist in preparation, cooking, and serving of meals for patients and staff, and in maintenance and cleanliness of kitchen.

Qualifications.—A knowledge of and experience in large-quantity cooking.

By order,

E. F. FITZGIBBON,
Secretary.

Office of the Public Service Board,
Melbourne, 5th July, 1948.

EXAMINATION FOR LICENCE AS SHORTHAND WRITER.

IT is hereby notified that the under-mentioned persons passed the examination held on the 26th June, 1948, for licence as shorthand writer under the *Evidence Act 1928*:-

DENT, DORIS HELEN.
HEGARTY, LORNA BEATRICE.
VEREY, GWENDOLYN.

By order,

E. F. FITZGIBBON,
Secretary.

Office of the Public Service Board,
Melbourne, 2nd July, 1948.

No. 291.

Public Service Act 1946, Section 50.

REGULATIONS.—PART III.—SALARIES, INCREMENTS, AND ALLOWANCES.

THE Public Service Board, in pursuance of the powers conferred by the *Public Service Act 1946*, hereby amends its Regulations as shown below:-

SECOND SCHEDULE.

TECHNICAL AND GENERAL DIVISION.

Offices and Rates of Salaries.

Department and Office.	Yearly Rate of Salary.		Increments (Annual).
	Minimum.	Maximum.	
DEPARTMENT OF WATER SUPPLY.	£	£	
<i>Delete</i> — District Supervisor	397	436	1 of £26 and 1 of £13
<i>Add</i> — District Supervisor	436	488	2 of £26

This Regulation shall have effect as on and from the 1st July, 1948.

D. D. PAINE, Chairman.
E. F. FITZGIBBON, Secretary.

Office of the Public Service Board,
Melbourne, 30th June, 1948.

No. 288.

Public Service Act 1946, Section 39.

REGULATIONS.—PART III.—SALARIES, INCREMENTS, AND ALLOWANCES.

THE Public Service Board, in pursuance of the powers conferred by the *Public Service Act 1946*, hereby amends its Regulations as shown below:-

FIRST SCHEDULE.

PROFESSIONAL DIVISION.

Offices and Rates of Salaries.

Office.	Yearly Rate of Salary.	
	Minimum.	Maximum.
DEPARTMENT OF CHIEF SECRETARY.	£	£
CLASS "A."		
<i>Add</i> — Director, National Museum	850	900
CLASSES "B1" and "A."		
<i>Delete</i> — Director, National Museum	748	850
CLASS "C2."		
<i>Add</i> — Entomologist, National Museum Senior Assistant, Museum of Applied Science	592 592	644 644
CLASS "C1."		
<i>Delete</i> — Entomologist, National Museum Senior Assistant, Museum of Applied Science	527 527	579 579
<i>Add</i> — Physicist, Museum of Applied Science ..	527	579
CLASS "C."		
<i>Delete</i> — Physicist, Museum of Applied Science ..	449	501
<i>Add</i> — Conchologist (Female), National Museum Mineralogist (Female), National Museum	449 449	501 501
CLASS "D."		
<i>Delete</i> — Conchologist (Female), National Museum Mineralogist (Female), National Museum	364 364	436 436

This Regulation shall have effect as on and from the 1st July, 1948.

D. D. PAINE, Chairman.
E. F. FITZGIBBON, Secretary.

Office of the Public Service Board,
Melbourne, 25th June, 1948.

No. 292.

Public Service Act 1946, Section 50.

REGULATIONS.—PART III.—SALARIES, INCREMENTS, AND ALLOWANCES.

THE Public Service Board, in pursuance of the powers conferred by the *Public Service Act 1946*, hereby amends its Regulations as shown below:-

SIXTH SCHEDULE.

TEMPORARY EMPLOYEES.

Designations of Positions and Rates of Salaries.

Department and Designation of Position.	Yearly Rate of Salary.		Increments (Annual).
	Minimum.	Maximum.	
DEPARTMENT OF WATER SUPPLY.	£	£	
<i>Add</i> — Materials Procurement Officer ..	449	475	1 of £26

D. D. PAINE, Chairman.
E. F. FITZGIBBON, Secretary.

Office of the Public Service Board,
Melbourne, 2nd July, 1948.

No. 289.

Public Service Act 1946, Section 50.

REGULATIONS.—PART III.—SALARIES, INCREMENTS, AND ALLOWANCES.

THE Public Service Board in pursuance of the powers conferred by the Public Service Act 1946, hereby amends its Regulations as shown below:—

SECOND SCHEDULE.

TECHNICAL AND GENERAL DIVISION.
Offices and Rates of Salaries.

Department and Office.	Yearly Rate of Salary.		Increments (Annual).
	Minimum.	Maximum.	
	£	£	
DEPARTMENT OF CHIEF SECRETARY.			
PENAL AND GAOLS.			
<i>Delete</i> — Superintendent, Beechworth Reformatory	422	448*	1 of £26
<i>Add</i> — Superintendent, Beechworth Reformatory	435	448*	..
DEPARTMENT OF HEALTH.			
GENERAL HEALTH.			
<i>Delete</i> — Inspector, Tuberculosis Division	410	475	2 of £26 and 1 of £13
<i>Add</i> — Inspector, Tuberculosis Division	449	527	3 of £26

* Less deduction for quarters, where provided, as determined by the Board.

This Regulation shall have effect as on and from the 1st July, 1948.

D. D. PAINE, Chairman.
E. F. FITZGIBBON, Secretary.

Office of the Public Service Board,
Melbourne, 25th June, 1948.

No. 290.

Public Service Act 1946, Section 39.

REGULATIONS.—PART III.—SALARIES, INCREMENTS, AND ALLOWANCES.

THE Public Service Board, in pursuance of the powers conferred by the Public Service Act 1946, hereby amends its Regulations as shown below:—

FIRST SCHEDULE.

PROFESSIONAL DIVISION.
Offices and Rates of Salaries.

Office.	Yearly Rate of Salary.	
	Minimum.	Maximum.
	£	£
DEPARTMENT OF TREASURER.		
CLASS "B."		
<i>Delete</i> — Estates Officer, Housing Commission ..	670	722
<i>Add</i> — CLASS "B1."		
Estates Officer, Housing Commission ..	748	800

This Regulation shall have effect as on and from the 21st May, 1948.

D. D. PAINE, Chairman.
E. F. FITZGIBBON, Secretary.

Office of the Public Service Board,
Melbourne, 25th June, 1948.

No. 293.

Public Service Act 1946, Section 50.

REGULATIONS.—PART III.—SALARIES, INCREMENTS, AND ALLOWANCES.

THE Public Service Board, in pursuance of the powers conferred by the Public Service Act 1946, hereby amends its Regulations as shown below:—

SIXTH SCHEDULE.

TEMPORARY EMPLOYEES.

Designations of Positions and Rates of Salaries.

Department and Designation of Position.	Yearly Rate of Salary.		Increments (Annual).
	Minimum.	Maximum.	
	£	£	
DEPARTMENT OF MINES.			
<i>Delete</i> — Geologist, Assistant Field ..	338	364	1 of £26
<i>Add</i> — Geologist, Assistant Field ..	338	416	3 of £26

This Regulation shall have effect as on and from the 1st July, 1948.

D. D. PAINE, Chairman.
E. F. FITZGIBBON, Secretary.

Office of the Public Service Board,
Melbourne, 5th July, 1948.

Children's Welfare Act 1928, Section 62.

APPROVAL OF MANAGER OF INSTITUTION.

HIS Excellency the Governor of the State of Victoria, by and with the advice of the Executive Council thereof, has, by Order made on the 29th day of June, 1948, pursuant to the provisions of section 62 of the Children's Welfare Act 1928, approved of Edward Hezekiah Price as Manager of The Menzies Home for Boys, vice Henry Ingleby Thomas, resigned.

C. W. KINSMAN,
Clerk of the Executive Council.

At the Executive Council Chamber,
Melbourne, the 29th June, 1948.

SUBJECT to any necessary excisions, &c., it is proposed to grant the following leases:—

- 5521, Gippsland; David Alexander Cook; 36a. 3r. 11p., in the Parish of Tanjil.
- 7116, Mineral; Peter Lambert Alkemade, Theodore Arthur Alkemade, and Herbert Lancelot Alkemade; 183 acres, in the Parish of Barongarook.

APPLICATION FOR TAILINGS LICENCE CANCELLED.

2067, Tailings Licence; E. A. Waller.

TAILINGS LICENCE EXPIRED.

2008, Tailings Licence; Victor Deschamp.

PETROLEUM PROSPECTING LICENCE EXPIRED.

68, Petroleum Prospecting Licence; Gippsland Oil Company Limited; 10,227 acres, in the Parish of Bumberrah.

J. H. LIENHOP,
Minister of Mines.

MINING LEASES DECLARED VOID.

- 8120, Beechworth; A.1 Extended Gold N. L.; 29a. 2r. 33p., in the Parish of Lauraville.
- 11187, Bendigo; Herbert Jackson Leed; 117a. 0r. 22p., in the Parish of Sandhurst.

GEO. BROWN,
Secretary for Mines.

Teaching Service Act 1946.

TEACHING SERVICE (CLASSIFICATION, SALARIES AND ALLOWANCES) REGULATIONS.

THE Teachers' Tribunal, in pursuance of the powers conferred by the *Teaching Service Act 1946*, hereby amends the Teaching Service (Classification, Salaries and Allowances) Regulations made on the nineteenth day of December 1946 and published in the *Government Gazette* of the twenty-ninth day of December 1946 in the manner following, that is to say:—

After clause 33 there shall be inserted a new clause as follows:—

“33A. No member of the Teaching Service shall be paid more than one of the allowances prescribed in Part IX. of these Regulations except with the special permission of the Tribunal.”

(To take effect from and inclusive of the 1st July, 1948.)

W. H. ELLWOOD, Chairman.
E. V. HIGGINS, Acting Secretary.

Office of the Teachers' Tribunal,
Melbourne, 30th June, 1948.

Transport Regulation Acts.
TRANSPORT REGULATION BOARD.
NOTICE OF PUBLIC HEARINGS.

NOTICE is hereby given that the applications made by the persons named below for licences to operate the commercial goods vehicles on the route or routes, or in the manner set out opposite their names, will be heard at a time and place to be communicated to the parties concerned:—

Name of Applicant; Nature of Application.

- BROWN, G. W.**, 2A Louisa-street, Brunswick; 1 commercial goods vehicle (160 cwt.) for the carriage of own bulldozer and equipment throughout the State of Victoria in the course of business as agricultural and land-clearing contractor.
- CAMPBELL, C. D.**, Murray-street, Cobram; 1 commercial goods vehicle (100 cwt.) to operate throughout the State of Victoria for the carriage of road contracting plant and material.
- COLLINS, K. T.**, Peterborough-road, Timboon; 1 commercial goods vehicle (100 cwt.) for the carriage of—
(a) general goods within a 20 miles radius of Timboon,
(b) live stock from and to Timboon to and from Colac, Warrnambool, and Camperdown.
- GRIFFITHS, K. W.**, Robinvale; 2 commercial goods vehicles (100 and 160 cwt. respectively) for the carriage of general goods—(a) between Robinvale and Mildura,
(b) between Robinvale and Swan Hill, (c) within a radius of 20 miles of Robinvale.
- THE JAY LAUNDRY PTY. LTD.**, 181 Fairy-street, Warrnambool; 1 commercial goods vehicle (8 cwt.) for the carriage of goods to be laundered, or having been laundered, between Warrnambool and Portland, Warrnambool and Terang, and Warrnambool and Hamilton.
- JOY, M.**, 14 Cunningham-street, Benalla; 1 commercial goods vehicle (90 cwt.) for the carriage of—
(a) general goods within a 20 miles radius of Benalla,
(b) road contracting plant and material within a 50 miles radius of Benalla.
- MANNEQUIN MODES PTY. LTD.**, 440 Bourke-street, Melbourne; 1 commercial goods vehicle (6 cwt.) for the carriage of—(a) own goods in the course of business as “fashion specialists” within a 50 miles radius of Melbourne, (b) ladies' coats, frocks, &c., from and to (a) to and from applicant's shops, situate at Warragul, Morwell, and Sale.
- MAXWELL, C. S.**, 23 Nixon-street, Benalla; 1 commercial goods vehicle (160 cwt.) for the carriage of—
(a) general goods within a 20 miles radius of Benalla,
(b) live stock within a 50 miles radius of Benalla.
- MOON, E. C.**, 2 Sydney-avenue, Geelong; 1 commercial goods vehicle (99 cwt.) for the carriage of—
(a) general goods within a 25 miles radius of Geelong,
(b) market garden and orchard produce from places situate within an 8 miles radius of Drysdale to Melbourne, (c) fish from St. Leonards and Portarlington to Melbourne, returning with fish boxes.
- This is an application for a licence previously held by G. A. Hood, St. Leonards.

- REPPER, J. L.**, Deep Lead; 1 commercial goods vehicle (60 cwt.) for the carriage of shearing plant and equipment throughout the State of Victoria in the course of business as “shearing contractor.”
- ROCHE BROS. PTY. LTD.**, 22 Dynon-road, South Kensington; 1 commercial goods vehicle (80 cwt.) for the carriage of—(a) earth, stone, or other materials actually excavated from place of excavation to place of disposal throughout the State of Victoria, (b) own plant and equipment throughout the State of Victoria.
- SARTORI, R. T.**, Yandoit; 1 commercial goods vehicle (140 cwt.) for the carriage of—(a) general goods within a 20 miles radius of Yandoit, (b) road contracting plant and materials within a 50 miles radius of Yandoit.
- SPROULE, O. L.**, 229 High-street, Northcote; 1 commercial goods vehicle (12 cwt.) for the carriage of fishermen's requisites and general drapery throughout the State of Victoria in the course of business as “hawker.”
- STOUT, S. A.** (trading as “J. H. Stout & Son”), Clunes-road, Creswick; 1 commercial goods vehicle (15 cwt.) for the carriage of stone, cement, gravel, and tools of trade throughout the State of Victoria in the course of business as “monumental masons.”
- WARD, M. A.**, Meadow Bank, Horsham; 1 commercial goods vehicle (50 cwt.) for the carriage of materials and equipment, such materials being steel, cement, gravel, concrete pipes, sand, firewood, chaff, and timber, used in connexion with constructional works being undertaken by the State Rivers and Water Supply Commission within a 50 miles radius of Horsham.

NOTICE is hereby given that the applications made by the persons named below for renewal of the licences, with variation, to operate the commercial goods vehicles in the manner set out hereunder, the numbers of which are also set out in each case, will be heard at a time and place to be communicated to the parties concerned:—

Name and Address; Present Rights; Nature of Application; Licence No.; Date of Expiry.

- CHARLES, L.** (trading as “Horsham Used Auto Spares”), 67-69 Pynsent-street, Horsham; as a towing vehicle within a 50 miles radius of holder's business at Horsham; to delete present conditions and substitute the following rights:—As a towing vehicle—(a) towing wrecked or disabled vehicles for repair within a 25 miles radius of Horsham, (b) towing vehicles purchased by the applicants for the purpose of wrecking same throughout the State of Victoria; D.3440; 19th August, 1948.
- WAKELING, M.**, Corindhap; (a) general goods within a 20 miles radius of Corindhap, (b) live stock from (a) to Ballarat, (c) general goods (except beer), and weight of goods must exceed 1 cwt., from and to Ballarat to and from Corindhap on Tuesday and Friday only of each week; to delete paragraph (c) and include right to carry general goods from and to Corindhap to and from Ballarat; D.3643; 24th June, 1948.

NOTICE is hereby given that the applications made by the persons named below for renewal of licences to operate the commercial goods vehicles in the manner set out hereunder, the numbers of which are also set out in each case, will be heard at a time and place to be communicated to the parties concerned:—

Name and Address; Present Franchise; Licence No.; Date of Expiry.

BENNETT, G., 34 Nelson-road, South Melbourne; (a) general goods within 25 miles radius of Melbourne, (b) road contracting plant and material within 50 miles radius of Melbourne; D.3703; 19th August, 1948.

CONBOY, J. H., Willaura; (a) general goods within 20 miles radius of Willaura, (b) own firewood within 50 miles radius of Willaura; D.3707; 19th August, 1948.

CUNNINGHAM, A. W., 40 Manifold-street, Colac; (a) general goods within 25 miles radius of Colac, but not to places on the roads between Colac and Camperdown and Colac and Winchelsea, (b) general goods between Colac and Apollo Bay and Colac and Hordern Vale, (c) mails between Colac and Lower Gellibrand, (d) cream from places on the route between Beech Forest and Princetown to Colac, (e) two passengers on the route between Colac and Princetown; D.753, D.754; 26th July, 1948.

DOOLAN, F. A., 15 Grace-street, Malvern; (a) bricks within 40 miles radius of Melbourne, (b) sling vans of furniture from wharves and rail heads in Melbourne to the premises of Wridgway Bros. Pty. Ltd., Auburn; D.3642; 24th June, 1948.

EGERTON, R., Box 20, Sandford; (a) general goods within 20 miles radius of Sandford, (b) road contracting plant and material within 50 miles of Sandford; D.3711; 19th August, 1948.

GODING, J. H., 10 William-street, Oakleigh; bricks within 40 miles radius of the premises of the Oakleigh Brick Co., at Oakleigh; D.3709; 19th August, 1948.

GOLDING, A. E., Kotupna; (a) general goods within 20 miles radius of Kotupna, (b) road contracting plant and material within 50 miles radius of Kotupna; D.1106; 16th August, 1948.

HAIGH, F. J., 77 Wilcox-street, Mt. Gambier; (a) general goods within 25 miles radius of Melbourne, (b) coursing greyhounds, owners, and trainers from and to Melbourne to and from speed coursing clubs within the metropolitan area; D.3722; 19th August, 1948.

THE HOFFMAN BRICK & POTTERIES PTY. LTD., Dawson-street, Brunswick; (a) own products within 40 miles radius from the Post Office, Melbourne, (b) clay and raw materials used in manufacture of own products within 40 miles radius of Melbourne; D.3437; 13th August, 1948.

JARVIS, H. T., Walwa; (a) general goods within 20 miles radius of Walwa, (b) general goods to and from Walwa from and to Wodonga; D.3715; 19th August, 1948.

JOHNSON, W. H., Maroona-road, Glenhuntly; (a) general goods within 25 miles radius of Melbourne, (b) cement tiles on behalf of the Globe Cement Tile Works within 60 miles radius of Melbourne; D.1691; 19th August, 1948.

JOLLY, W. F., Anakie; (a) general goods within 25 miles radius of Geelong, (b) primary produce, live stock, and wattle bark from places situate within a radius of 5 miles from Anakie to Melbourne, (c) goods required by graziers, farmers, and not otherwise, from Melbourne to places situate within 5 miles radius of Anakie; D.1124; 23rd August, 1948.

KINMAN, A. E., Waterloo-road, Trafalgar; as a sanitary contractor throughout the Gippsland district; D.3627, D.3628, D.3123, D.3629, D.2698; 24th June, 1948.

LOWE, L. H. C., Church-road, Yarram; (a) general goods within 20 miles radius of Yarram, (b) general goods from Yarram to Sale, (c) furniture from and to places within 20 miles radius of Yarram and to and from places situate within 50 miles radius of Yarram, (d) beet sugar from Maffra to places within 20 miles radius of Yarram; D.1670; 4th August, 1948.

NATIONAL BANK OF AUST. LTD., 271 Collins-street, Melbourne; building materials required for maintenance of own premises throughout the State of Victoria; D.3719; 19th August, 1948.

PELCHEN, W., Park-street, Hamilton; (a) general goods within a 20 miles radius of Hamilton, (b) sawn timber from Portland, Mount Richmond, and Heywood districts to places within 20 miles radius of Hamilton; D.3436; 12th August, 1948.

PILCHER, W. A., Toolamba; (a) general goods within 20 miles radius of Toolamba, (b) oats between Strathbogie and Euroa Railway Station; D.705; 24th June, 1948.

ROBSON, G. H., 2 Main-street, Stawell; memorial stones, tools, and equipment for erection—to cemeteries within an area bounded as follows:—(a) by a line from the Township of Beaufort through Lake Bolac, Willaura, Balmoral, Harrow, Apsley, Serviceton, Rainbow, Hope-toun, Sea Lake, Donald, St. Arnaud, to Avoca, (b) from the Townships of Stawell, Warracknabeal, and from railway stations most convenient to such cemeteries; D.3727; 19th August, 1948.

ROCHE BROS. PTY. LTD., 22 Dynon-road, South Kensington; throughout the State of Victoria earth-moving equipment (power excavators, tractors, road rollers, graders, &c.), owned and operated by the holders of the licence and on behalf of the Forests Commission and Country Roads Board; D.3730; 19th August, 1948.

ROCHE BROS. PTY. LTD., 22 Dynon-road, South Kensington; (a) from site of excavation throughout the State of Victoria to the place of disposal—earth, stone, or materials actually excavated, (b) throughout the State of Victoria—plant and equipment owned by the holders of the licence and actually used in connexion with excavation work being carried out by the said licence holders; D.3731; 19th August, 1948.

STOREY, A., Caramut; (a) general goods within 20 miles radius of Caramut, (b) general goods between the Town of Caramut and the City of Warrnambool via Koroit; D.3734; 19th August, 1948.

TOOLE, Mrs. A. L., High-street, Wodonga; as repair and towing vehicle within 50 miles radius of Wodonga; D.3430; 9th August, 1948.

WARTZELHAM, J. J., Young-street, Albury; monumental masonry and granite for erection of memorials from Albury, New South Wales, to cemeteries within an area bounded as follows:—(a) on the north by the River Murray, (b) on the west by the railway line from Wahgunyah through Rutherglen and Springhurst to Bowser, (c) on the south-west by the railway from Bowser to Bright, (d) on the south-east by a line from Bright through Mitta Mitta and Corryong to Tintaldra; D.3736; 19th August, 1948.

WILLIAMS, J. V., Box 65, Swan Hill; road-contracting plant, materials, and equipment in the Shire of Swan Hill; D.3738; 19th August, 1948.

NOTICE is hereby given that the applications made by the persons named below for licences to operate the commercial passenger vehicles on the route or routes, or in the manner set out opposite their names, will be heard at a time and place to be communicated to the parties:—

Name of Applicant; Nature of Application.

BAKER, H. E., 131 Splatt-street, Swan Hill; 1 commercial passenger vehicle, with seating capacity for 12 persons, to operate for the carriage only of school children between Nowie North and Pira.

DALGLIESH, A. S. (trading as City Omnibuses), 666 Banff-avenue, Albury, New South Wales; 1 commercial passenger vehicle, with seating capacity for 29 persons, to operate as a touring omnibus on the following route:—Albury-Mt. Buffalo or Mt. Hotham, via Yackandandah or Beechworth, Myrtleford and Bright. Leave Albury 8.30 a.m., arrive Albury 8.30 p.m.—fare 30s., including meals.

CLARKE, B. H., 107 Grey-street, Terang; application for variation of licence No. A.1368, to include the ability to operate a shopping trip between the Soldiers Settlement, Boorcan, and Terang, via Glenormiston and Noorat, on Mondays only of each week. Depart Boorcan 10.45 a.m., depart Terang 2.45 p.m.

POPE, T., & SON (trading as Consolidated Bus Lines), Timboon; 1 commercial passenger vehicle, with seating capacity for 29 persons, to operate as follows:—(a) For the carriage only of school children between Scott's Creek and Timboon, via Digby's Creek, (b) charter conditions within a 20 miles radius of Timboon.

POPE, T., & SON (trading as Consolidated Bus Lines), Timboon; 1 commercial passenger vehicle, with seating capacity for 33 persons, to operate as follows:—(a) For the carriage only of school children between Carpender-road and Timboon, (b) charter conditions within a 20 miles radius of Timboon.

DAVEY, E. A. V. (trading as Boronia Hire Car Taxi Service), Ringwood-road, Boronia; 1 commercial passenger vehicle, with seating capacity for 5 persons, to operate as follows:—(a) Separate and distinct fares within a 5 miles radius of Boronia Railway Station, (b) private hire within a 50 miles radius of Boronia Railway Station (subject to the cancellation of licence No. P.H.1194, at present held by the applicant).

FLETCHERS MOTOR SERVICES PTY. LTD., 29 Gheringhap-street, Geelong; application for variation of "A" licences, to include the ability to operate a round tour from Geelong to Lorne, via Great Ocean-road, and return via Deans Marsh and Winchelsea, or alternatively in the opposite direction.

GREYDA, G. F., 3B Warrigal-road, Oakleigh; 1 commercial passenger vehicle, to be purchased, with approximate seating capacity for 31 persons, to operate as an additional vehicle on all licensed routes, and under charter condition within a 20 miles radius of Dandenong.

GODDARD, L. E., Olinda-street, Beaufort; 1 commercial passenger vehicle, with seating capacity for 4 persons, to operate as follows:—(a) As a stage omnibus on a round route commencing and terminating at Beaufort, via Skipton Junction, Mena Park, Mooramong, Stoneleigh, and Mawallock, (b) mails and parcels to be carried (subject to the cancellation of licence No. A.1682, held by E. Charles, Beaufort).

MONTI, S. A., 83 Rae-street, Shepparton; application for variation of licence No. A.758, to allow operations between Shepparton and Melbourne on Sundays only. Depart Shepparton 7.30 a.m., depart Melbourne 6 p.m.

CUNNINGHAM, J. & M., K. BROWN, & C. RUTZOU (trading as Mentone Bus Lines), 250 Balcombe-road, Mentone; application for variation of licences Nos. A.1508 and A.2110, to extend the present licensed route from Mordialloc Railway Station to Mordialloc High School, twice daily.

McHENRY, H. E., Davies-street, Woodend; 1 commercial passenger vehicle, to be purchased, to operate as follows:—(a) For the carriage of passengers and mails between Woodend-Woodend North and Carlisle, (b) separate and distinct fares within a 5 miles radius of Woodend, (c) private hire within a 50 miles radius of Woodend.

PARKER BROS., 45 Hope-street, Maryborough; 1 commercial passenger vehicle, to be purchased, with approximate seating capacity for 29 persons, to operate as an additional vehicle on all licensed routes, and under charter conditions within a 20 miles radius of Maryborough.

PIONEER TOURIST COACHES PTY. LTD., 465 Swanston-street, Melbourne; application for renewal of licences allowing operations on specified interstate and intrastate tours, B.121, B.122, B.123, B.124, B.125, B.126, B.127, B.128, B.129, B.130, B.131, B.132, B.133, B.134, B.119, B.120 (expired 24th June, 1948).

This replaces applications previous gazetted on 26th May, 1948.

DOUGLASS, W. J., & J. I. D. REID (trading as "Ian Reid's Motor Service"), Post Office, Box 1, Bendigo; application for variation of licence No. A.2165, allowing operations between Bendigo and Cohuna to extend on to Barham, via Koondrook.

RODGER BROS., 75 Broome-crescent, Wonthaggi; 1 commercial passenger vehicle, with seating capacity for 20 persons, to operate as a substitute vehicle to all licensed vehicles, and under charter conditions within a 20 miles radius of Wonthaggi.

SHERRY, F. P., 96 McCrae-street, Dandenong; application for variation of licence No. A.100, to include the ability to operate between Poowong and Melbourne, via Dandenong, on Saturdays and Sundays only of each week. Depart Poowong 6.45 a.m., depart Melbourne 6 p.m.

TRARALGON BUS SERVICE, 66-68 Princes-street, Traralgon; 1 commercial passenger vehicle, with seating capacity for 34 persons, to operate as an additional vehicle on all licensed routes.

WEDGE, D. E., Curdie-street, Cobden; 1 commercial passenger vehicle, with seating capacity for 29 persons, to operate for the carriage only of school children between Missens-road and Timboon, via Brucknell.

WESTLAKE, R. J., 64 Percy-street, Portland; application for variation of licences Nos. A.220, A.229, A.233, A.231, and A.317, to delete the present conditions relating to operations between Port Fairy Railway Station and the border of South Australia, *en route* to and from Mt. Gambier, S.A., and instead to allow operations as between Warrnambool Railway Station and the border of South Australia, *en route* to and from Mt. Gambier, via Port Fairy, Portland, Heywood, Lyons, Greenwald, Winnap, and Dartmoor, as follows:—Depart Warrnambool 2 p.m., Mon. to Sat., depart Mt. Gambier 10.15 a.m., Mon. to Sat.

GROSE, H. W., Mandurang, Victoria; 1 commercial passenger vehicle, to be purchased, to operate between Maryborough and Castlemaine on Sundays only of each week to connect with Sunday trains, or, alternatively, buses operating to Melbourne, and return.

APPLICATIONS for licences to operate commercial passenger vehicles, with seating capacity for 5 persons, to operate for the carriage of passengers otherwise than at separate and distinct fares for each passenger throughout the State of Victoria:—

DALTON, G. B., Northcote.

GANGE, A. J., Fitzroy—two vehicles.

GILMORE, F. A., Ormeo.

HOWARD, E. R., Moorabbin.

LOH, E. A., Koroit.

MCDONALD, F. M., Sandringham.

ROWE, J., St. Kilda.

WANNENMACHER, V. G., Numurkah (subject to the cancellation of licence No. A.1585, at present held by the applicant).

WARD, J. A., Corowa, New South Wales.

Notices of any objection should be forwarded to reach the Secretary to the Board not later than Wednesday, 21st July, 1948.

E. V. FIELD,
Secretary.

Exhibition Buildings, Rathdown-street, Carlton, 6th July, 1948.

ABORIGINES BOARD.

MANAGER AND MATRON, LAKES TYERS ABORIGINAL STATION.

APPLICATIONS are invited from married couples for the positions of Manager and Matron of the Lake Tyers Aboriginal Station:—

Joint Salary.—£500 per annum, plus cost of living allowance, which at present is £60 for men and £40 for women. This allowance is subject to variation in accordance with the rise and fall in the index numbers of the cost of living. Rations and unfurnished quarters are provided.

Duties.—Manager to have general control over resident natives, buildings, plant, stock, &c., and to assist in and supervise the erection of and repairs to buildings, fencing, &c., and the cultivation of the land, and to be responsible for the good order and conduct of the Station.

Matron to exercise general supervision over the welfare of the women and children, and to nurse and attend residents requiring such care.

Qualifications.—Manager to have knowledge of farm management, storekeeping, bookkeeping, correspondence, and to possess proved administrative ability. It would be of advantage if the Matron possessed nursing qualifications.

Applications, with particulars of age, experience, testimonials, and war service (if any), should be lodged with the secretary, Aborigines Board, Old Treasury Building, Spring-street, Melbourne, C.1, not later than the 24th July, 1948.

For General Regulations as to duties, see *Government Gazette* of 13th May, 1931, or apply to Aborigines Board.

N. GARNET,
Secretary.

DEPARTMENT OF LAW.—ATTORNEY-GENERAL.

HIS Excellency the Governor of the State of Victoria, by and with the advice of the Executive Council thereof, doth, by Order made on the 29th day of June, 1948, hereby consent, in terms of section 21 of the *Business Names Act 1928*, to the use of the word "Empire" in the name of the firm to be known as "Empire Cycle and Hardware Store," and which it is desired shall be registered in that name.

C. W. KINSMAN,
Clerk of the Executive Council.

At the Executive Council Chamber,
Melbourne, the 29th June, 1948.

COMPANIES ACT 1938.

STATEMENT of the Registrar-General, in pursuance of section 302 of the *Companies Act 1938*, showing moneys received and amounts paid into the Supreme Court, Melbourne and the particular companies out of whose estate such amounts have been derived.

Date.	Name of Company.	Amount Received.	Costs, &c., Paid.	Amount Paid into Supreme Court.
		£ s. d.	£ s. d.	£ s. d.
22nd March, 1948 ..	John Carew and Company Proprietary Limited ..	87 10 0	0 9 0	87 1 0
9th June, 1948 ..	Barlow Motors Proprietary Limited	32 19 10	0 9 0	32 10 10
9th June, 1948 ..	Arthur Manufacturing Proprietary Limited ..	15 2 8	0 9 0	14 13 8

Dated this twenty-eighth day of June, 1948.

A. P. SUTHERLAND,
Registrar-General for Victoria.

Local Government Act 1928, Part 42, Section 858.

LICENCES TO OCCUPY WATER FRONTAGES.

NOTICE is hereby given that licences to occupy Water Frontages have been issued to the following approved applicants, and that the Licence Fee specified in each case has been received by the Accountant, Lands Department, Melbourne, C.2.

Number of Licence.	Name and Address of Licensee.	Municipality.	Parish.	Abutting on— Allotments and Sections.	Fee for Licence.	Date of Issue of Licence.	Date of Expiry of Licence.
					£ s. d.		
22021	Muller, Leonard Hickman, "Tremore," Yea	Yea ..	Billian ..	8, section A	0 2 6	1.1.48	31.12.50
22022	Gardiner, A. M., "Loch Brae," Kerrisdale	Yea ..	Windham ..	Goulburn River, 11 and part of Island between 11 and 25	0 2 6	1.1.47	31.12.49
22023	Henshaw, Eric, Highlands, via Seymour	Yea ..	Dropmore ..	1b, section D	0 3 6	1.1.48	31.12.50
22024	Tattersson, Muriel (Mrs.), Baird-street, Violet Town	Violet Town..	Town of Violet Town	Honeysuckle Creek, part 1, section 25 and 4 and 5, section 22	0 10 6	1.1.48	31.12.50
22025	Wells, Lionel Austin, Mooroopna	Shepparton ..	Kialla ..	1A, 1B, and 1C	0 6 9	1.1.48	31.12.50
22026	Fisher, John Henry Percival, "Roselea," East Wangaratta	Wangaratta ..	Wangaratta North	Ovens River, 1r, 1c1, 1d, 1e, and eastern most 49 3 links of 1a	0 18 0	1.1.48	31.12.50
22027	Gray, Albert, Box 68, Morwell ..	Rosedale ..	Rosedale ..	307a and 307c	0 7 3	1.1.48	31.12.50
22028	Lock, Ewan Mack, Orbost ..	Orbost ..	Orbost ..	Snowy River, 1r, 46b, 46c	0 15 0	1.1.48	31.12.50
22029	Lock, Ewan Mack, Orbost ..	Orbost ..	Orbost ..	Snowy River, 45a, section A	0 18 0	1.1.48	31.12.50
22030	Bourke, John James, Shamrock Park, Omeo Valley, Omeo	Omeo ..	Bingo Munjic North and Hinnomunjic	3 and 6, section 6, Parish of Bingo Munjic North; 1, section 7, Parish of Hinnomunjic	2 17 0	1.1.48	31.12.50
22051	Harkness, John, Stradbroke ..	Rosedale ..	Stradbroke ..	Merriman's Creek, 10, section A	0 4 0	1.1.48	31.12.50
22052	Harkness, John, Stradbroke ..	Rosedale ..	Coolungoolun	Merriman's Creek, 4, section B	0 5 0	1.1.48	31.12.50
22053	O'Meara, W. H., Toongabbie ..	Rosedale ..	Township of Toongabbie	Toongabbie Creek, south of 5, section 14, and north of 104c	0 10 0	1.1.48	31.12.50
22054	Loneragan, G. T. and Mrs. M. C., Sandy Creek, via Huon	Yaakandandah	Tangambalanga	Sandy Creek, 1, section 6	0 2 6	1.1.48	31.12.50
22055	Barfield, W. G., "Sylvandale," Katamatite	Tungamah ..	Youanmite ..	18, 19, and 20A, section D, with the exception of the most easterly 6 chains	4 1 0	1.1.48	31.12.50
22056	Gay, James Phillip, Stradbroke ..	Rosedale ..	Coolungoolun	Merriman's Creek, 1A, section B	0 2 6	1.1.48	31.12.50
22057	Earl of Essex, Woodi Yallock, Jamieson	Mansfield ..	Jamieson ..	Jamieson River, 3, 4, 8, 9, 10, 11, and 12, section D and 1 and 2, section G	0 14 0	1.1.48	31.12.50
22058	Fiske, R. D., Buxton ..	Healesville ..	Buxton ..	Acheron River, 5 ..	0 10 0	1.1.48	31.12.50
22059	Shields, M. V., Seymour ..	Yea ..	Windham ..	South of Carver's Creek and between King Parrot Creek and Government-road	0 8 0	1.1.48	31.12.50
22060	Cooper, Lucy Ada, Hazeldene ..	Broadford ..	Flowerdale ..	King Parrot Creek, 46 ..	0 4 6	1.1.48	31.12.50

JOHN G. B. McDONALD,
Commissioner of Crown Lands and Survey.

Department of Lands and Survey (Unused Roads and Water Frontages Branch),
Melbourne, 7th July, 1948.

Local Government Act 1928, Part 42, Section 358.

LICENCES TO OCCUPY UNUSED ROADS.

NOTICE is hereby given that Licences to occupy Unused Roads have been issued to the following approved applicants, and that the Licence Fee specified in each case has been received by the Accountant, Lands Department, Melbourne, C.2.

Number of Licence.	Name and Address of Licensee.	Municipality.	Parish.	Abutting— Allotments and Sections.	Area.	Fee for Licence.			Date of Issue of Licence.	Date of Expiry of Licence.
						£	s.	d.		
35161	Crocker, John M., "Ashcombe," Violet Town	Violet Town	Boho ..	Between 52c and 52D ..	A. R. P. 10 0 0	£	s.	d.	1.1.46	31.12.48
35162	McNamara, J. M. G., Cobungra, via Omeo	Omeo ..	Bundara Munjie	Between 23, 23E, and 23A, 23D, 23C; between 23A and 23B, 23C; between 23B and 23C	16 0 0	0	8	0	1.1.46	31.12.48
35163	Campbell, William D., Tallan- gatta Valley	Towong ..	Wyebooboo ..	North of 14, section 3 ..	6 2 0	0	9	9	1.1.46	31.12.48
35164	Coster, Joseph Thomas, Sars- field	Tambo ..	Township and Parish of Sarsfield	Between 6 and 9, of A and B and C, Township of Sarsfield	2 0 0	0	3	6	1.1.46	31.12.48
35165	Hill, F. R., Beechworth ..	Beechworth	Stanley ..	Between 1A, section 9, and 10B, section 11	1 0 0	0	2	6	1.1.46	31.12.48
35166	Warner, Roy Thomas, Beech- worth	Beechworth	Murmungee	Between 1, section C, and 13, section B; between 1 and 3, section C	5 0 0	0	5	0	1.1.48	31.12.50
35167	Johnston, A. A., Orbost ..	Orbost ..	Bete Bolong South	Between 1b and 2 ..	4 0 0	0	16	0	1.1.46	31.12.48
35168	Williams, Nina A., Cann River	Orbost ..	Noorinbee..	South of part 14 ..	1 2 0	0	12	0	1.1.46	31.12.48
35169	McCauley, R. F., Moorngag P.O., via Benalla	Benalla ..	Rothesay ..	North, south, and west of 43D	10 3 0	0	10	9	1.1.46	31.12.48
35170	Connley, J., Omeo ..	Omeo ..	Cobungra ..	Between 15 and 16, section 3; between 8 and 6, 7, section 3	19 0 0	2	17	0	1.1.46	31.12.48
35521	Bryant, Arthur Thomas, Homewood	Yea ..	Windham ..	East of 32, 32A, and 35A	5 0 0	1	5	0	1.1.48	31.12.50
35522	Conroy, Michael, Peechelba	Wangaratta	Killawarra	Eastern half of road between 44B and Greenvale P.R.; road north-west of 46A	4 2 0	0	18	0	1.1.48	31.12.50
35523	Howes, Thomas, Chiltern ..	Chiltern ..	Chiltern ..	West of 1, section J1, Township of Chiltern	1 3 0	0	17	6	1.1.48	31.12.50
35524	Shanahan, Timothy, Nooron- gong	Towong ..	Noorongong	Between 19 and 1c ..	2 0 0	0	4	6	1.1.48	31.12.50
35525	McGill, David Strain, c/o Lander, Rogers, and Glen, Mansfield	Mansfield ..	Nillahcootie	South of 159B ..	5 0 0	0	5	0	1.1.48	31.12.50
35526	Kugelmann, Donald, "The Pines," Metung-road, John- sonville	Tambo ..	Bumberrah	West of 74 ..	5 2 0	8	3	0	1.1.48	31.12.50
35527	Huggins, James, "Willowee," Wodonga	Yackan- dandah	Yackan- dandah	Between 202 and 8, of section A9; between 202 and 205	9 0 0	0	18	0	1.1.48	31.12.50
35528	MacDonald, James C., "Flowerdale," Bundalong South	Yarrowonga	Bundalong	Between 104 and 104A, between 99B, 100A, and 101	9 1 33	1	7	0	1.1.48	31.12.50
35529	Oliver, Kenneth Alan, "Blackheath," Main- dample	Mansfield ..	Maindample	West of 90A ..	2 2 0	0	5	0	1.1.48	31.12.50
35530	Oliver, Kenneth Alan, "Blackheath," Main- dample	Mansfield ..	Nillahcootie	Between 176A and 177	2 3 0	0	6	0	1.1.48	31.12.50

JOHN G. B. McDONALD,
Commissioner of Crown Lands and Survey.

Department of Lands and Survey (Unused Roads and Water Frontages Branch),
Melbourne, 7th July, 1948.

Water Acts.

STATE RIVERS AND WATER SUPPLY COMMISSION.
DANDENONG-SPRINGVALE AND SOMERVILLE URBAN DISTRICTS.

NOTICE to owners of tenements in the under-mentioned streets in the above-mentioned urban districts, and the private streets, lanes, courts, and alleys opening thereto:—

DANDENONG-SPRINGVALE URBAN DISTRICT.

Dandenong.

High-street.

SOMERVILLE URBAN DISTRICT.

Grant-road, from Eramosa-road to a point in line with the northern boundary of lot 18 on lodged plan of subdivision No. 1129 about 23 chains north-easterly.

Jones-road, from Station-street to a point in line with the southern boundary of allotment 57, Parish of Moorooduc, about 30½ chains south-westerly.

The main pipe in the said streets being laid down, the owners of all tenements situated as above are hereby required, on or before the 7th day of August next, to cause proper pipes and stop cocks to be laid, so as to supply water within such tenements from the main pipe.

L. DUGGAN,
Secretary.

State Rivers and Water Supply Commission,
Melbourne, 30th June, 1948.

STAMPS ACT 1946.

IN pursuance of the powers contained in the *Stamps Act* 1946, I hereby certify, until further notice, that Skipper Gold Mine No Liability is engaged solely or principally in the search or mining for gold.

Dated the 7th day of July, 1948.

W. E. CAMIER,
Comptroller of Stamps.

NOTICE PURSUANT TO SECTION 24 OF THE MILK BOARD ACTS.

AFTER inquiry, conducted in the manner prescribed by the Milk Board Acts and Regulations made thereunder, the Milk Board doth, by this notice, amend the notice published in the *Government Gazette*, No. 390, of the 17th September, 1947, as follows:—

FIRST SCHEDULE.

Delete Area No. 1 Keilor.

SECOND SCHEDULE.

Specified Dairies from which Milk may be Distributed in Defined Areas.	Areas Defined by Numbers in the First Schedule to Notice published in <i>Government Gazette</i> , No. 390, of the 17th September, 1947, in which Milk may be Distributed from the Dairies described in Column 1.
<i>Municipal District—Brighton.</i>	
11 Moffatt-street, Brighton	Brighton 12, 13b, 13c, 14, 16. Sandringham 1.
<i>Municipal District—Broadmeadows.</i>	
148 Pascoe Vale-road, Pascoe Vale	Broadmeadows 1, 2, 5A, 5B, 6A, 7. Coburg 2, 3c.
<i>Municipal District—Brunswick.</i>	
Delete 162 Edward-street east, Brunswick 87 Barkly-street east, Brunswick	Brunswick 16, 17, 18, 21B, 23, 24. Melbourne 4, 5, 7.
<i>Municipal District—Camberwell.</i>	
Delete 5 Wills-street, Deepdene Add 116 Whitehorse-road, Deepdene	Camberwell 1, 2A, 3A, 3B, 3c, 4B, 7B, 9, 10B, 12B; Kew 2, 4c, 5.
<i>Municipal District—Caulfield.</i>	
Delete 67 Grange-road, Glenhuntly 6 Queen's-avenue, Carnegie	Caulfield 5, 6, 7, 10A, 10B, 11, 12, 20, 28, 29; Malvern 7B, 9A, 10, 11; Moorabbin 3, 4, 6, 7. For St. Kilda 11A, substitute St. Kilda 11B.
<i>Municipal District—Coburg.</i>	
160 Gaffney-street, North Coburg	Delete Broadmeadows 8.
<i>Municipal District—Essendon.</i>	
Delete 371 Buckley-street, Essendon 255 Union-road, Moonee Ponds 200 Keilor-road, North Essendon 209 Buckley-street, Essendon 70 Lincoln-road, Essendon	For Melbourne 23, substitute Melbourne 2a. Delete Keilor 1. Add Essendon 1b, 1c. Add Essendon 9A.
<i>Municipal District—Frankston.</i>	
170 Point Nepean-road, Frankston 30 Playne-street, Frankston Station-street, Séafood Hastings-road, Baxter Fulton-road, Baxter	Frankston 1, 2, 3, 4, 5, 6, 7, 8. Frankston 1, 2, 3, 4, 5, 6, 7, 8. Frankston 1, 2, 3, 4, 5, 6, 7, 8. Frankston 1, 2, 3, 4, 5, 6, 7, 8. Frankston 1, 2, 3, 4, 5, 6, 7, 8.
9 Dandenong-road, East Frankston	Frankston 1, 2, 3, 4, 5, 6, 7, 8.
<i>Municipal District—Hawthorn.</i>	
Delete 31 Bell-street, Hawthorn	Delete areas shown.
<i>Municipal District—Keilor.</i>	
Delete 7 Devonshire-parade, North Essendon	
<i>Municipal District—Kew.</i>	
131-3 Cotham-road, Kew	Add Hawthorn 3.
<i>Municipal District—Moorabbin.</i>	
Delete 41 Wheeler-street, Ormond	
<i>Municipal District—Port Melbourne.</i>	
199 Graham-street, Port Melbourne	Add Port Melbourne 1; South Melbourne 2c.

SECOND SCHEDULE—continued.

Specified Dairies from which Milk may be Distributed in Defined Areas.	Areas Defined by Numbers in the First Schedule to Notice published in <i>Government Gazette</i> , No. 390, of the 17th September, 1947, in which Milk may be Distributed from the Dairies described in Column 1.
<i>Municipal District—Preston.</i>	
220 Gower-street, Preston Delete 239 Plenty-road, Preston Add 647 Gilbert-road, West Preston	Add Preston 7A, 12, 13A. Preston 1, 2, 3, 4A, 6A, 6B.
<i>Municipal District—Richmond.</i>	
609 Bridge-road, Richmond 140 Elizabeth-street, Richmond 107 Coppin-street, Richmond 497 Bridge-road, Richmond 85 Richmond-terrace, Richmond	Add Richmond 1A, 4, 5B. Add Richmond 3A. Add Richmond 3A. Add Richmond 1B, 2A, 2B, 3A, 3B. For Melbourne 17, substitute Melbourne 17A. Add Richmond 4, 5B.
356 Highett-street, Richmond	
<i>Municipal District—Sandringham.</i>	
2 Edinburgh-street, Hampton	Add Sandringham 1.
<i>Municipal District—South Melbourne.</i>	
341 Moray-street, South Melbourne 161 Eastern-road, South Melbourne	Add South Melbourne 2A. Add South Melbourne 2A.
<i>Municipal District—Williamstown.</i>	
24 Robert-street, Spotswood	For Footscray 15, substitute Footscray 15A.

By order of the Milk Board,
M. H. RANKIN,
Secretary.

SUMMONING OFFICERS.

I HEREBY appoint the under-mentioned persons, under section 31 of the *Education Act 1928*, to summon parents within the State of Victoria:—

- Senior Constable DAVID GEORGE McMILLAN, No. 8025.
- Senior Constable WILLIAM PATRICK HOARE, No. 8327.
- First Constable A. V. MOLLER, No. 9043.

W. S. KENT HUGHES,
Minister of Public Instruction.

Education Department,
Melbourne, C.2, 23rd June, 1948.

4 GEORGE VI. No. 4755, SECTION 6.

I HEREBY give notice that on the 24th June, 1948, I filed elections to administer the following deceased persons' estates, in accordance with section 6 of the *Public Trustee Act 1940*:—

- BARROW, MABEL BESSIE, late of 16 Candy-street, Westgarth, widow, died 16th March, 1948, intestate.
- BENNETT, ALBERT VICTOR, late of Lakes Entrance, labourer, died 7th March, 1935, intestate.
- DAVIES, FLORENCE, late of Melbourne Benevolent Asylum, Cheltenham, spinster, died 6th April, 1948, intestate.
- DICKSON, HERBERT, late of River Bank, Robinvale, labourer, died 26th January, 1948, intestate.
- GARRETT, SARAH JANE, late of 14th-street and Orland-avenue, Mildura, pensioner, died 22nd August, 1947, intestate.
- *LINEHAN, FRANCIS LEO, late of Lancaster, via Kyabram, farmer, died 6th June, 1947.
- MCCAFFREY, TIMOTHY JAMES, late of 11 Queensberry-street, North Melbourne, retired engine-driver, died 8th May, 1948, intestate.
- *MCLAREN, JAMES IAN, formerly of 76 Evans-street, Brunswick, but late of Collier-street, Woodend, clerk, died 4th April, 1948.
- *RYAN, DANIEL, late of St. Aidan's Orphanage, Bendigo, gardener, died 17th August, 1942.
- TAGGART, HARRY GEORGE, late of Welshpool, pensioner, died 30th April, 1948, intestate.
- WISEMAN, JAMES ARTHUR, late of 11 Hosking-street, North Williamstown, process worker, died 14th April, 1948, intestate.

* According to the provisions of the will.

C. J. GARDNER,

Public Trustee.
412 Collins-street, Melbourne, C.1, 30th June, 1948.

NOTICE.

ADMINISTRATION of the estate of each of the under-mentioned deceased persons has been granted to me, and creditors, next of kin, and all others having claims against the estate of any of the persons so mentioned are required to send particulars of their claims to the Public Trustee, No. 412 Collins-street, Melbourne, on or before the 9th September, 1948, or they will be excluded from the distribution of the estate when the assets are being distributed:—

BARROW, MABEL BESSIE, late of 16 Candy-street, Westgarth, widow, died 16th March, 1948, intestate.

BENNETT, ALBERT VICTOR, late of Lakes Entrance, labourer, died 7th March, 1935, intestate.

†DALY, ELLEN, late of 60 Rennie-street, Coburg, married woman, died 12th May, 1932.

DAVIES, FLORENCE, late of Melbourne Benevolent Asylum, Cheltenham, spinster, died 6th April, 1948, intestate.

DAVIS, ISOBEL, otherwise known as Isobel Duff, late of 1 Labassa-grove, Caulfield, widow, died 11th March, 1948, intestate.

DICKSON, HERBERT, late of River Bank, Robinvale, labourer, died 26th January, 1948, intestate.

GARRETT, SARAH JANE, late of 14th-street and Orland-avenue, Mildura, pensioner, died 22nd August, 1947, intestate.

†GUY, ARCHIBALD JARMEN, late of 16 Empress-street, West Footscray, analyst, died 20th March, 1948.

KENNEDY, MARY CATHERINE, also known as May Catherine Kennedy, formerly of 75 Claremont-avenue, Malvern, but late of Kew, widow, died 18th January, 1948, intestate.

KIN, ELI, late of Shields-street, Flemington, labourer, died 10th January, 1948, intestate.

*LINEHAN, FRANCIS LEO, late of Lancaster, via Kyabram, farmer, died 6th June, 1947.

MCCAFFREY, TIMOTHY JAMES, late of 11 Queensberry-street, North Melbourne, retired engine-driver, died 8th May, 1948, intestate.

*MCLAREN, JAMES IAN, formerly of 76 Evans-street, Brunswick, but late of Collier-street, Woodend, clerk, died 4th April, 1948.

†OGSTON, EVA, late of Christchurch, in New Zealand, married woman, died 25th December, 1947.

*RYAN, DANIEL, late of St. Aidan's Orphanage, Bendigo, gardener, died 17th August, 1942.

TAGGART, HARRY GEORGE, late of Welshpool, pensioner, died 30th April, 1948, intestate.

TROTSMAN, ALICE, late of St. Vidgons-place, Reservoir, pensioner, died 9th April, 1948, intestate.

WISEMAN, JAMES ARTHUR, late of 11 Hosking-street, North Williamstown, process worker, died 14th April, 1948, intestate.

* According to the provisions of the will.

† With the will annexed.

C. J. GARDNER,

Public Trustee.

Melbourne, 30th June, 1948.

ORDERS IN COUNCIL.—(Series 1947-48.)

STATE RIVERS AND WATER SUPPLY COMMISSION.

Water Supply Stores Suspense Account—

3025. Supply of 182 13 ft. x 2 ft. 11 in. and 1,788 7 ft. x 6 ft. floor board sections, £1,477 10s.—Commonwealth Government.

Approved by the Governor in Council, 23rd December, 1947.—C. W. KINSMAN, Clerk of the Executive Council.

Loan—

3026. Supply f.o.r. Melbourne of 1,080 lineal feet of 37-in. diameter reinforced concrete pipes, with spigot and faucet joints suitable for a working head of 55 feet, £1,800.—Rocla Ltd.

Approved by the Governor in Council, 20th April, 1948.—C. W. KINSMAN, Clerk of the Executive Council.

Loan—

3027. Supply f.o.r. Sydney of one Barber-Greene model 522 bucket loader, complete with four-cylinder petrol engine and pneumatic tires, £2,500.—Tutt, Bryant Pty. Ltd.

Approved by the Governor in Council, 4th May, 1948.—C. W. KINSMAN, Clerk of the Executive Council.

Water Supply Stores Suspense Account—

3028. Extension to approval dated 17th February, 1948, to provide for the purchase of additional fittings and wrought iron pipes, £206.—Commonwealth Government.

3029. Supply f.o.r. Maryborough of 64,000 super. feet of sawn hardwood timber in various sizes, £1,400.—W. Phelan and Sons Pty. Ltd.

Approved by the Governor in Council, 18th May, 1948.—C. W. KINSMAN, Clerk of the Executive Council.

Water Supply Stores Suspense Account—

3030. Supply f.o.r. Melbourne of 10,000 feet of 1-in., 5,000 feet of 1½-in., 25,000 feet of 2-in., and 5,000 feet of 3-in. wrought iron galvanized piping, £2,350.—Stewarts and Lloyds (Aust.) Pty. Ltd.

3031. Supply of spare parts for Le Tourneau earth-moving plant, £1,800.—Commonwealth Government.

Approved by the Governor in Council, 25th May, 1948.—C. W. KINSMAN, Clerk of the Executive Council.

Loan—

3032. Extension of contract with S. J. Hopkins, approval for which was given on 20th May, 1947, to provide for the payment of an additional amount of £292 10s.—S. J. Hopkins.

Water Supply Stores Suspense Account—

3033. Supply f.o.r. Brooklyn of 12,000 feet of 4-in., 9,000 feet of 6-in., and 2,000 feet of 8-in. medium pressure socketed A.C. pipes, and 66,000 feet of 3-in., 145,000 feet of 4-in., 60,000 feet of 6-in., and 2,000 feet of 9-in. high pressure socketed A.C. pipes, £32,200.—James Hardie and Co. Pty. Ltd.

Approved by the Governor in Council, 1st June, 1948.—C. W. KINSMAN, Clerk of the Executive Council.

Water Supply Stores Suspense Account—

3034. Supply f.o.r. Fyansford of 5,000 tons of "Arc" brand Portland cement, £20,100.—Australian Cement Ltd.

Approved by the Governor in Council, 9th June, 1948.—C. W. KINSMAN, Clerk of the Executive Council.

Loan—

3035. Supply ex works of one model D.2 "Caterpillar" Diesel crawler tractor, £1,500.—William Adams and Co.

3036. Supply f.o.r. Brisbane of seven type T.R.2 tamping rollers at £1,475 each, plus 10 per cent. provision, subject to any approved price variation, £11,357 10s.—Queensland Machinery Co. Ltd.

3037. Supply ex works of two model T.D.6 "International" diesel crawler tractors, £3,000.—Victorian Industrial Sales and Service Pty. Ltd.

3038. Supply f.o.b. Sydney of one 40 ft. x 150 ft. long Armco Pres-steel framework, plus extra equipment as specified, £1,800.—Bunbury Pty. Ltd.

3039. Purchase of allotments 1, 2, and 3, section D, Township of Werrimull, being the site of the Werrimull Bush Nursing Hospital, together with the buildings and improvements situated thereon, £1,100.—Victorian Bush Nursing Association.

Approved by the Governor in Council, 15th June, 1948.—C. W. KINSMAN, Clerk of the Executive Council.

Water Supply Stores Suspense Account—

3040. Supply of quantity of spare parts for Allis-Chalmers and Farmall tractors, £1,100.—Lane's Motors Pty. Ltd.

Approved by the Governor in Council, 22nd June, 1948.—C. W. KINSMAN, Clerk of the Executive Council.

STATE ELECTRICITY COMMISSION.

3041. The supply of 216 tons (approximately) black coal, Newport Generating Station.—Melbourne Steamship Co. Ltd.

3042. The supply of 1,002 tons (approximately) black coal, Newport Generating Station.—Melbourne Steamship Co. Ltd.

3043. The supply of 350 water screen brass wire panels, Yallourn Generating Station, to Quotation No. 3384.—Premior Wire Works Pty. Ltd.

3044. The erection of brick sub-station, Eastern-road Hostel, Yallourn, to Quotation No. 4092.—T. R. and L. Cockram Pty. Ltd.

3045. The supply of electrical equipment for mess kitchen, Kiewa Hydro-Electric Scheme, to Quotation No. 3384.—A. E. Atherton and Sons Pty. Ltd.

3046. The supply of electrical equipment for four mess kitchens, Kiewa Hydro-Electric Scheme, to Quotation No. 3384.—A. E. Atherton and Sons Pty. Ltd.

3047. The erection of five brick garages, Yallourn, to Specification No. 47-48/29.—Keith G. Hooker and Co.

- 3048.—The supply of 31,000 super. feet oregon, to Quotation No. 4504.—John Sharp and Sons Pty. Ltd.
- 3049. The supply of 25,000 super. feet oregon, to Quotation No. 4504.—J. Wright and Sons.
- 3050. The supply of 11,000 super. feet oregon, to Quotation No. 4504.—Bowen and Pomeroy Pty. Ltd.
- 3051. The supply of 11,000 super. feet oregon, to Quotation No. 4504.—H. Beecham and Co. Ltd.
- 3052. The supply of 11,000 super. feet oregon, to Quotation No. 4504.—Wm. Cook Pty. Ltd.
- 3053. The supply of 11,000 super. feet oregon, to Quotation No. 4504.—Millar's Timber and Trading Co. Ltd.
- 3054. The supply of 147 tires and 60 tubes for motor vehicles, to Quotation No. 3821.—Olympic Tyre and Rubber Co. Ltd.
- 3055. The supply of 122 tires for motor vehicles, to Quotation No. 3821.—Goodyear Tyre and Rubber Co. (Aust.) Ltd.
- 3056. The supply of 126 tires and 6 tubes for motor vehicles, to Quotations Nos. 3821, 4061, and 4231.—Dunlop Rubber Australia Ltd.
- 3057. The supply of 95 wire racks, baskets, stands, &c., for kitchen and mess, Western Hostel, Yallourn, to Quotation No. 4430.—Cyclone Company of Australia Ltd.
- 3058. The supply of 3,380 lineal feet case-hardening steel for tractor maintenance, to Quotation No. 4307.—Commonwealth Steel Co. Ltd.
- 3059. The supply of 110 bridge chairs for Fairfield-avenue Hostel, Yallourn, to Quotation No. 4200.—Kennett Bros. and Rayner Pty. Ltd.
- 3060. The supply of six pneumatic-tired tool and equipment trailers, to Quotation No. 4333.—McGrath Trailer Equipment Pty. Ltd.
- 3061. The supply of nails, staples, &c., for a period of twelve months, to Specification No. 47-48/207.—Titan Nail and Wire Pty. Ltd.

Approved by the Governor in Council, 29th June, 1948.—
C. W. KINSMAN, Clerk of the Executive Council.

DEPARTMENT OF LANDS AND SURVEY.

At the Executive Council Chamber, Melbourne, the
twenty-ninth day of June, 1948.

PRESENT:

His Excellency the Governor of Victoria.
Mr. Lienhop | Mr. Byrnes.

UNUSED AND UNMADE ROADS CLOSED.

HIS Excellency the Governor of the State of Victoria, by and with the advice of the Executive Council thereof, doth hereby direct that, in pursuance of the provisions of section 304 of the *Land Act 1928* (No. 3709), the unused and unmade roads referred to hereunder be closed, viz.:—
Township of Netherby, Parish of Warraquil, County of Lowan, being the roads indicated by hachure on plan hereunder.—(N.143) (Rs.6193).

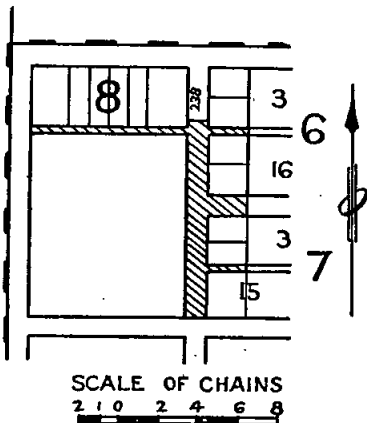

Parish of Commeralghip, County of Grenville, being the road between allotment 103 and allotment 102A.—(C.264^(a)) (J.27339).

And the Honorable John Gladstone Black McDonald, His Majesty's Commissioner of Crown Lands and Survey for the State of Victoria, shall give the necessary directions herein accordingly.

C. W. KINSMAN,
Clerk of the Executive Council.

DEPARTMENT OF LANDS AND SURVEY.

At the Executive Council Chamber, Melbourne, the
twenty-ninth day of June, 1948.

PRESENT:

His Excellency the Governor of Victoria.
Mr. Lienhop | Mr. Byrnes.

LANDS TEMPORARILY RESERVED FROM SALE.

HIS Excellency the Governor of the State of Victoria, by and with the advice of the Executive Council thereof, doth hereby, in pursuance of the provisions of the *Land Act 1928*, reserve, temporarily, and also except from occupation for mining purposes under any miner's right, the lands hereinafter described:—

BUNGALALLY (HAVEN).—Site for a Public Hall, 1 acre, more or less, Parish of Bungalally, County of Borung, as indicated by hachure on plan hereunder.—(B.93^(a)) (Rs.6195).

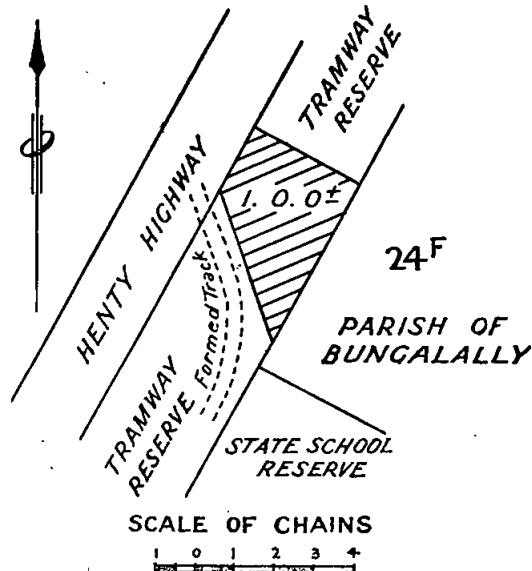

HAMILTON.—Site for a Public Park, 1 rood, more or less, Town of Hamilton, Parish of North Hamilton, County of Dundas, as indicated by hachure on plan hereunder.—(H.45⁽²⁾) (Rs.6181).

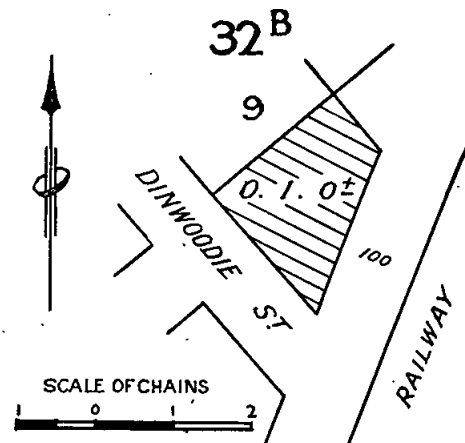

TERANG.—Site for a Cemetery, in addition to and adjoining the site previously set apart therefor, 2 acres, Parish of Terang, County of Hampden, as indicated by hachure on plan hereunder.—(T.86(3) (Rs.6160).

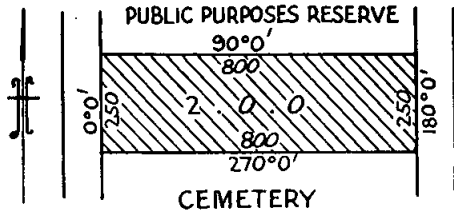

NETHERBY.—Site for Public Recreation, 11 acres, more or less, Township of Netherby, Parish of Warraquil, County of Lowan, as indicated by hachure on plan hereunder.—(N.143) (Rs.6193).

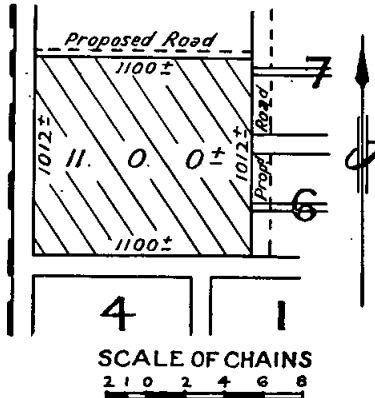

And the Honorable John Gladstone Black McDonald, His Majesty's Commissioner of Crown Lands and Survey for the State of Victoria, shall give the necessary directions herein accordingly.

C. W. KINSMAN,
Clerk of the Executive Council.

Water Acts.
STATE RIVERS AND WATER SUPPLY COMMISSION.

At the Executive Council Chamber, Melbourne, the twenty-ninth day of June, 1948.

PRESENT:
His Excellency the Governor of Victoria.
Mr. Lienhop | Mr. Byrnes.

KERANG IRRIGATION AND WATER SUPPLY DISTRICT.—PORTION EXCISED.

UNDER the powers conferred by the Water Acts and all other powers enabling him in that behalf, His Excellency the Governor of the State of Victoria, with the advice of the Executive Council of the said State, on the recommendation of the State Rivers and Water Supply Commission, doth hereby declare, order, and direct as follows:—

That there shall be excised from the Kerang Irrigation and Water Supply District that portion of the same set out and described in the Schedule hereto, which portion, as from the 2nd of February, 1948, shall be deemed to be excised accordingly.

SCHEDULE.

Commencing at the south-eastern angle of Crown allotment 3, section 1, Parish of Kerang, County of Tatchera; thence easterly by a line to the south-western angle of Crown allotment 6 of said section 1; thence north-westerly by the south-western boundaries of said Crown allotment 6 and Crown allotment 7 of said section 1 to the north-western angle of the last-mentioned Crown allotment; thence easterly by the northern boundary of the last-mentioned Crown allotment and a line in continuation

thereof to the western boundary of Crown allotment 7A of said section 1; thence northerly by the last-mentioned boundary to the southern boundary of a road forming the northern boundary of said Crown allotment 7A; thence easterly by the said road boundary to the north-western angle of the land described in certificate of title, volume 6717, folio 1343393; thence by lines bearing south 20 deg. 58 min. east 3 chains 94 links, south 47 deg. 40 min. east 1 chain 87 5/10 links, south 20 deg. 58 min. east 2 chains 48 8/10 links, south 47 deg. 40 min. east 2 chains 12 links, north 89 deg. 50 min. east 8 chains 3 links, south 20 deg. 58 min. east 20 chains 49 links, and south 69 deg. 2 min. west to the south-western boundary of the Bendigo and Swan Hill Railway Reserve; thence south-easterly by the last-mentioned boundary to the southern boundary of Dilys-street; thence westerly by the last-mentioned boundary to the eastern boundary of a channel easement 10 chains 7 links easterly from the western boundary of said Crown allotment 7A; thence southerly by the said easement boundary to the northern boundary of the land described in certificate of title, volume 6354, folio 1270763; thence westerly by the last-mentioned boundary and a line in continuation thereof to the eastern boundary of Crown allotment 9 of said section 1; thence northerly by the last-mentioned boundary to the southern boundary of a road forming the northern boundary of said Crown allotment 9; thence westerly by the said road boundary and a line in continuation thereof to the south-western boundary of a road forming the north-eastern boundary of Crown allotment 4 of said section 1; thence north-westerly by the last-mentioned road boundary to the point of commencement.

The portion described in the foregoing Schedule is shown on a plan approved by the Governor in Council, and deposited in the office of the State Rivers and Water Supply Commission, Melbourne.—(Corres. 47/27018.)

And the Honorable John Gladstone Black McDonald, His Majesty's Minister of Water Supply for the State of Victoria, shall give the necessary directions herein accordingly.

C. W. KINSMAN,
Clerk of the Executive Council.

Water Acts.
STATE RIVERS AND WATER SUPPLY COMMISSION.

At the Executive Council Chamber, Melbourne, the twenty-ninth day of June, 1948.

PRESENT:
His Excellency the Governor of Victoria.
Mr. Lienhop | Mr. Byrnes.

ROCHESTER IRRIGATION AND WATER SUPPLY DISTRICT.—LOCKINGTON URBAN DIVISION—DIVISION EXTENDED.

UNDER the powers conferred by the Water Acts and all other powers enabling him in that behalf, His Excellency the Governor of the State of Victoria, with the advice of the Executive Council of the said State, on the recommendation of the State Rivers and Water Supply Commission, doth hereby declare, order, and direct as follows:—

That the Lockington Urban Division of the Rochester Irrigation and Water Supply District be extended by adding to the same the lands set out and described in the Schedule hereto, and as on and from the first day of July, 1948, such urban division shall be deemed to be so extended.

SCHEDULE.

Commencing at a point in the western boundary of Crown allotment 171, distant 6 chains southerly from the northern boundary of said Crown allotment 171, Parish of Bamawm, County of Bendigo; thence southerly 877 ft. 2 in. by the said western boundary of Crown allotment 171 to a point in that boundary; thence by a line bearing north 89 deg. 58 min. west to the western boundary of Prairie-road; thence northerly by the last-mentioned boundary to the southern boundary of James-street; thence westerly by the last-mentioned boundary to the eastern boundary of the Elmore and Cohuna Railway Reserve; thence north-easterly by the last-mentioned boundary to the southern boundary of the Pannoo-road; thence easterly by the last-mentioned boundary to a point in that boundary 2 chains 50 links west from the western boundary of said Prairie-road; thence by lines

bearing south 4 chains and east 2 chains 50 links to the said western boundary of the Prairie-road; thence southerly by the last-mentioned boundary to a point in that boundary in line with the southern boundary of the land described in certificate of title, volume 6950, folio 1389875; thence easterly by a line and easterly and northerly by the southern and eastern boundaries of the land described in the said certificate of title, volume 6950, folio 1389875, to the southern boundary of Archibald-street; thence easterly by the last-mentioned boundary to the point of commencement.

The land described in the foregoing Schedule is shown on a plan approved by the Governor in Council, and deposited in the office of the State Rivers and Water Supply Commission, Melbourne.—(Corres. 48/8238, 48/10030.)

And the Honorable John Gladstone Black McDonald, His Majesty's Minister of Water Supply for the State of Victoria, shall give the necessary directions herein accordingly.

C. W. KINSMAN,
Clerk of the Executive Council.

Water Acts.

STATE RIVERS AND WATER SUPPLY COMMISSION.

At the Executive Council Chamber, Melbourne, the twenty-ninth day of June, 1948.

PRESENT:

His Excellency the Governor of Victoria.
Mr. Lienhop | Mr. Byrnes.

BACCHUS MARSH IRRIGATION AND WATER SUPPLY DISTRICT.—BACCHUS MARSH URBAN DIVISION—DIVISION EXTENDED.

UNDER the powers conferred by the Water Acts and all other powers enabling him in that behalf, His Excellency the Governor of the State of Victoria, with the advice of the Executive Council of the said State, on the recommendation of the State Rivers and Water Supply Commission, doth hereby declare, order, and direct as follows:—

That the Bacchus Marsh Urban Division of the Bacchus Marsh Irrigation and Water Supply District be extended by adding to the same the lands set out and described in the Schedule hereto, and as on and from the first day of July, 1948, such Division shall be deemed to be so extended.

SCHEDULE.

1. Commencing at the south-western angle of lot 1 on Lodged Plan of Subdivision No. 8499, Township of Bacchus Marsh, Parish of Korkuperrimul, County of Bourke; thence easterly by the southern boundary of said lot 1 to the south-eastern angle thereof; thence southerly 700 ft. 10 in. by the western boundary of a road forming the eastern boundary of said lot 1 to a point in the said road boundary; thence by a line bearing north 88 deg. 58 min. 30 sec. west to the south-eastern boundary of the Darley Channel Reserve; thence generally north-easterly and northerly by the last-mentioned boundary to the point of commencement.

2. Commencing at a point being the intersection of the southern boundary of the Western Highway and the western boundary of Crown portion 10, Township of Bacchus Marsh, Parish of Korkuperrimul, County of Bourke; thence easterly 481 ft. 6 in. by the said highway boundary to a point in the last-mentioned boundary; thence by lines bearing south 0 deg. 45 min. west, 164 ft. 8 in., and north 83 deg. 18 min. west to the said western boundary of Crown portion 10; thence northerly by the last-mentioned boundary to the point of commencement.

The lands described in the foregoing Schedule are shown on a plan approved by the Governor in Council, and deposited in the office of the State Rivers and Water Supply Commission, Melbourne.—(Corres. 47/27446, 48/1065, and 48/1066.)

And the Honorable John Gladstone Black McDonald, His Majesty's Minister of Water Supply for the State of Victoria, shall give the necessary directions herein accordingly.

C. W. KINSMAN,
Clerk of the Executive Council.

Water Acts.

STATE RIVERS AND WATER SUPPLY COMMISSION.

At the Executive Council Chamber, Melbourne, the twenty-ninth day of June, 1948.

PRESENT:

His Excellency the Governor of Victoria.
Mr. Lienhop | Mr. Byrnes.

WERRIBEE DRAINAGE DISTRICT.—DISTRICT EXTENDED—PORTIONS EXCISED.

UNDER the powers conferred by the Water Acts and all other powers enabling him in that behalf, His Excellency the Governor of the State of Victoria, with the advice of the Executive Council of the said State, on the recommendation of the State Rivers and Water Supply Commission, doth hereby declare, order, and direct as follows:—

Firstly, that the Werribee Drainage District be extended by adding to the same the lands set out and described in the First Schedule hereto and as on and from the first day of July, 1948, the said Werribee Drainage District shall be deemed to be so extended.

Secondly, that there shall be excised from the Werribee Drainage District those portions of the same set out and described in the Second Schedule hereto, which portions as on and from the first day of July, 1948, shall be deemed to be excised accordingly.

SCHEDULE 1.

1. That land comprising the whole of Crown allotment 20, section XVI., Parish of Deutgam, County of Bourke.

SCHEDULE 2.

Portion 1.—Commencing at the north-eastern angle of Crown allotment 17A, section E, Parish of Deutgam, County of Bourke; thence southerly by the eastern boundary of said Crown allotment 17A to a point in line with the southern boundary of Crown allotment 2B of said section E; thence westerly by a line to the south-eastern angle of said Crown allotment 2B; thence northerly by the eastern boundary of said Crown allotment 2B and a line in continuation thereof to the northern boundary of said Crown allotment 17A; thence easterly by the last-mentioned boundary to the point of commencement.

Portion 2.—Commencing at the north-eastern angle of Crown allotment 17F, section E, Parish of Deutgam, County of Bourke; thence southerly by the eastern boundary of said Crown allotment 17F and a line in continuation thereof to the north-eastern boundary of Crown allotment 18A of said section E; thence north-westerly by the north-eastern boundaries of said Crown allotment 18A and Crown allotment 18B of said section E and a line connecting those boundaries to the eastern boundary of the Town of Werribee; thence northerly by the last-mentioned boundary to a point in line with the southern boundary of Crown allotment 17C of said section E; thence easterly by a line and the last-mentioned boundary to the south-eastern angle of said Crown allotment 17C; thence southerly by a line in continuation of the eastern boundary of said Crown allotment 17C to the northern boundary of said Crown allotment 17F; thence easterly by the last-mentioned boundary to the point of commencement.

Portion 3.—Commencing at the north-eastern angle of Crown allotment 24F, section G, Parish of Deutgam; thence northerly by the western boundary of a road forming the eastern boundary of said Crown allotment 24F to the south-eastern angle of Crown allotment 24E of said section G; thence westerly by the southern boundary of said Crown allotment 24E to the south-western angle thereof; thence northerly by the western boundaries of said Crown allotment 24E and Crown allotments 24D, 24C, and 24B of said section G to the north-western angle of said Crown allotment 24B; thence easterly by the northern boundary of the last-mentioned Crown allotment and a line in continuation thereof to the western boundary of Crown allotment 92A, section D; thence southerly by the last-mentioned boundary to a point in line with the northern boundary of said Crown allotment 24F; thence westerly by a line to the point of commencement.

Portion 4.—Those lands comprising the whole of Crown allotments 93E, 93F, 93G, 93H, 93J, and 93K and that portion of a Channel Reserve adjoining the northern boundary of said Crown allotment 93E, all of section D, Parish of Deutgam, County of Bourke.

Portion 5.—Those lands comprising the whole of Crown allotments 94p, 94q, and 94r and that portion of a Channel Reserve adjoining the northern boundaries of the said Crown allotments 94p, 94q, and 94r, all of section D, Parish of Deutgam, County of Bourke.

The lands set out and described in the first of the foregoing schedules, and the portions set out and described in the Second Schedule, are shown on a plan approved by the Governor in Council, and deposited in the office of the State Rivers and Water Supply Commission, Melbourne.—(Corres. 48/6718.)

And the Honorable John Gladstone Black McDonald, His Majesty's Minister of Water Supply for the State of Victoria, shall give the necessary directions herein accordingly.

C. W. KINSMAN,
Clerk of the Executive Council.

Water Acts.

STATE RIVERS AND WATER SUPPLY COMMISSION.

At the Executive Council Chamber, Melbourne, the twenty-ninth day of June, 1948.

PRESENT:

His Excellency the Governor of Victoria.
Mr. Lienhop | Mr. Byrnes.

LODDON WATERWORKS DISTRICT.—PORTION EXCISED.

UNDER the powers conferred by the Water Acts and all other powers enabling him in that behalf, His Excellency the Governor of the State of Victoria, with the advice of the Executive Council of the said State, on the recommendation of the State Rivers and Water Supply Commission, doth hereby declare, order, and direct as follows:—

That there shall be excised from the Loddon Waterworks District that portion of the same set out and described in the Schedule hereto, which portion, as from the 1st day of July, 1948, shall be deemed to be excised accordingly.

SCHEDULE.

Commencing at the most southerly angle of section 17, Town of Bridgewater, Parish of Bridgewater, County of Bendigo; thence by a line bearing north 58 deg. 43 min. west to the right bank of the Loddon River; thence generally north-easterly by the said right bank of the Loddon River to the most northerly angle of the land described in certificate of title, volume 2077, folio 415386; thence by a line bearing south 2 deg. 45 min. west to the southern boundary of Crown allotment 84; thence easterly by the last-mentioned boundary to a point in line with the north-western boundary of Crown allotment 25A; thence south-westerly by a line and the last-mentioned boundary to the most westerly angle of the last-mentioned Crown allotment; thence easterly 10 chains 24 5/10 links by the southern boundary of said Crown allotment 25A to a point in the last-mentioned boundary; thence by a line bearing south 55 deg. 34 min. west to the southern boundary of Crown allotment 24b; thence westerly by the last-mentioned boundary to the north-western boundary of a road forming the south-eastern boundary of said section 17; thence generally south-westerly by the last-mentioned road boundary to the point of commencement.

The portion set out and described in the foregoing Schedule is shown on a plan approved by the Governor in Council, and deposited in the office of the State Rivers and Water Supply Commission, Melbourne.—(Corres. 48/5361.)

And the Honorable John Gladstone Black McDonald, His Majesty's Minister of Water Supply for the State of Victoria, shall give the necessary directions herein accordingly.

C. W. KINSMAN,
Clerk of the Executive Council.

Water Acts.

STATE RIVERS AND WATER SUPPLY COMMISSION.

At the Executive Council Chamber, Melbourne, the twenty-ninth day of June, 1948.

PRESENT:

His Excellency the Governor of Victoria.
Mr. Lienhop | Mr. Byrnes.

WERRIBEE IRRIGATION AND WATER SUPPLY DISTRICT.—PORTIONS EXCISED.

UNDER the powers conferred by the Water Acts and all other powers enabling him in that behalf, His Excellency the Governor of the State of Victoria, with the advice of the Executive Council of the said State, on the recommendation of the State Rivers and Water Supply Commission, doth hereby declare, order, and direct as follows:—

That there shall be excised from the Werribee Irrigation and Water Supply District those portions of the same set out and described in the Schedule thereto, which portions as on and from the first day of July, 1948, shall be deemed to be excised accordingly.

SCHEDULE.

Portion 1.—Commencing at the most northerly angle of Crown allotment 2, section C, Parish of Deutgam, County of Bourke; thence south-easterly by the north-eastern boundary of said Crown allotment 2 to the north-eastern angle thereof; thence southerly by the western boundary of a road forming the eastern boundary of said Crown allotment 2 to the southern boundary of a road forming the northern boundary of Crown allotment 22 of said section C; thence westerly by the last-mentioned road boundary and by a line in continuation thereof to the south-eastern boundary of Crown allotment 50; thence north-easterly and north-westerly by the south-eastern and north-eastern boundaries of the last-mentioned Crown allotment to the most northerly angle thereof; thence north-easterly by a line to the most westerly angle of Crown allotment 3 of said section C; thence generally north-easterly by the north-western boundaries of said Crown allotments 3 and 2 to the point of commencement.

Portion 2.—Commencing at the north-eastern angle of Crown allotment 17A, section E, Parish of Deutgam, County of Bourke; thence southerly by the eastern boundary of said Crown allotment 17A to a point in line with the southern boundary of Crown allotment 2b of said section E; thence westerly by a line to the south-eastern angle of the last-mentioned Crown allotment; thence northerly by the eastern boundary of said Crown allotment 2b and a line in continuation thereof to the northern boundary of said Crown allotment 17A; thence easterly by the last-mentioned boundary to the point of commencement.

Portion 3.—Commencing at the north-eastern angle of Crown allotment 17f, section E, Parish of Deutgam, County of Bourke; thence southerly by the eastern boundary of said Crown allotment 17f and a line in continuation thereof to the north-eastern boundary of Crown allotment 18A of said section E; thence north-westerly by the north-eastern boundaries of said Crown allotment 18A and Crown allotment 18B of said section E and a line connecting those boundaries to the eastern boundary of the Town of Werribee; thence northerly by the last-mentioned boundary to a point in line with the southern boundary of Crown allotment 17c of said section E; thence easterly by a line and the last-mentioned boundary to the south-eastern angle of said Crown allotment 17c; thence southerly by a line in continuation of the eastern boundary of the last-mentioned Crown allotment to the northern boundary of said Crown allotment 17f; thence easterly by the last-mentioned boundary to the point of commencement.

Portion 4.—Commencing at the most southerly angle of Crown allotment 93n, section D, Parish of Deutgam, County of Bourke; thence by a line bearing south to the shore of the Port Phillip Bay; thence generally north-westerly by the said shore and the left bank of the Werribee River to a point in line with the western boundary of a road forming the eastern boundary of Crown allotment 24M, section D; thence northerly by a line and the last-mentioned road boundary to the south-eastern angle of said Crown allotment 24M; thence westerly, northerly, and easterly by the southern, western, and northern

boundaries of the last-mentioned Crown allotment to the said road boundary; thence northerly by the last-mentioned boundary to the south-eastern angle of Crown allotment 24c of said section G; thence westerly and northerly by the southern and western boundaries of said Crown allotment 24g and northerly and easterly by the western and northern boundaries of Crown allotment 24f of said section G to the said road boundary; thence northerly by the last-mentioned boundary to the south-eastern angle of Crown allotment 24e of said section G; thence westerly by the southern boundary of the last-mentioned Crown allotment to the south-western angle thereof; thence northerly by the western boundaries of said Crown allotment 24e and Crown allotments 24b, 24c, and 24d, of said section G, to the north-western angle of the last-mentioned Crown allotment; thence easterly by the northern boundary of the last-mentioned Crown allotment and a line in continuation thereof to the western boundary of a Channel Reserve forming the eastern boundary of the said road; thence southerly, south-easterly, and north-easterly by the western, south-western, and south-eastern boundaries of the said Channel Reserve to the north-western angle of Crown allotment 94p of said section D; thence southerly by the western boundary of the last-mentioned Crown allotment to the south-western angle thereof; thence south-easterly by the south-western boundaries of said Crown allotment 94p and Crown allotments 94q, 94r, and 94s, of said section D, to the most southerly angle of the last-mentioned Crown allotment; thence southerly by the western boundaries of Crown allotments 94r, 94u, and 94v, of said section D, to the south-western angle of the last-mentioned Crown allotment; thence south-westerly, southerly, and south-easterly by the north-western, western, and south-western boundaries of Crown allotment 93b, of said section D, to the point of commencement.

The portions described in the foregoing Schedule are shown on a plan approved by the Governor in Council, and deposited in the office of the State Rivers and Water Supply Commission, Melbourne.—(Corres. 48/6718.)

And the Honorable John Gladstone Black McDonald, His Majesty's Minister of Water Supply for the State of Victoria, shall give the necessary directions herein accordingly.

C. W. KINSMAN,
Clerk of the Executive Council.

Water Acts.

STATE RIVERS AND WATER SUPPLY COMMISSION.

At the Executive Council Chamber, Melbourne, the twenty-ninth day of June, 1948.

PRESENT:

His Excellency the Governor of Victoria.
Mr. Lienhop | Mr. Byrnes.

WERRIBEE WATERWORKS DISTRICT.—DISTRICT EXTENDED.—PORTION EXCISED.

UNDER the powers conferred by the Water Acts and all other powers enabling him in that behalf, His Excellency the Governor of the State of Victoria, with the advice of the Executive Council of the said State, on the recommendation of the State Rivers and Water Supply Commission, doth hereby declare, order, and direct as follows:—

Firstly, that the Werribee Waterworks District be extended by adding to the same the lands set out and described in the First Schedule hereto, and as on and from the first day of July, 1948, the said Werribee Waterworks District shall be deemed to be so extended.

Secondly, that there shall be excised from the Werribee Waterworks District that portion of the same set out and described in the Second Schedule hereto, which portion, as from the thirtieth day of June, 1948, shall be deemed to be excised accordingly.

FIRST SCHEDULE.

Commencing at the most northerly angle of Crown allotment 2, section C, Parish of Deutgam, County of Bourke; thence south-easterly by the north-eastern boundary of said Crown allotment 2 to the western boundary of a road forming the eastern boundary of said Crown allotment 2; thence southerly by the said road boundary to the southern boundary of a road forming the northern boundary of Crown allotment 22 of said section C; thence

westerly by the last-mentioned road boundary and by a line in continuation thereof to the south-eastern boundary of Crown allotment 50 of section E; thence north-easterly and north-westerly by the south-eastern and north-eastern boundaries of the last-mentioned Crown allotment to the most northerly angle thereof; thence north-easterly by a line to the most westerly angle of Crown allotment 3; thence generally north-easterly by the north-western boundaries of said Crown allotments 3 and 2 to the point of commencement.

SECOND SCHEDULE.

That land comprising the whole of Crown allotment 1, section 3, Parish of Truganina, County of Bourke, and that portion of the Skeleton Water Holes Creek adjoining the south-western boundary of said Crown allotment 1.

The lands described in the foregoing Schedules are shown on a plan approved by the Governor in Council, and deposited in the office of the State Rivers and Water Supply Commission, Melbourne.—(Corres. 48/6718 and 48/8248.)

And the Honorable John Gladstone Black McDonald, His Majesty's Minister of Water Supply for the State of Victoria, shall give the necessary directions herein accordingly.

C. W. KINSMAN,
Clerk of the Executive Council.

MOTOR OMNIBUS ACT 1928 (No. 3742).

At the Executive Council Chamber, Melbourne, the twenty-ninth day of June, 1948.

PRESENT:

His Excellency the Governor of Victoria.
Mr. Lienhop | Mr. Byrnes.

EXTENSION OF (ALL-NIGHT) METROPOLITAN MOTOR OMNIBUS ROUTE No. 27 (MELBOURNE-WILLIAMSTOWN).

HIS Excellency the Governor of the State of Victoria, by and with the advice of the Executive Council thereof, and in pursuance of the powers conferred by the *Motor Omnibus Act 1928* (No. 3742), doth by this Order amend, as set out hereunder, the prescription of a certain route, viz., No. 27, within the metropolitan area, along which motor omnibuses for which "regular service" licences are granted may ply for hire, viz.:—

Under the heading "Description of Route, including Commencing and Terminal Points," (a) delete "North Williamstown" from the sub-heading and in place thereof insert "Williamstown"; (b) delete "to corner of Melbourne-road and Ferguson-street, North Williamstown," and in place thereof insert "Electra, Hanmer, and Morris streets, to the entrance to the Naval Dockyard Reserve, Williamstown, returning via Nelson-place and Ferguson-street, Melbourne-road, &c."

Under the heading "Sections on Route" delete "Ferguson-street" and in place thereof insert "Naval Dockyard Reserve."

Under the heading "Fares to be Charged" delete "Ferguson-street" and in place thereof insert "Naval Dockyard Reserve."

Under the heading "Time-tables to be Observed" delete "Ferguson-street" and in place thereof insert "Naval Dockyard Reserve."

Licensing Authority.—Pursuant to the provisions of section 15 (1) (c) of the said Act (No. 3742), the Governor in Council by this Order confers upon the Licensing Authority full power and authority for the carrying into effect by the said Licensing Authority of the foregoing provisions of this Order.

And the Honorable James Arthur Kennedy, His Majesty's Commissioner of Public Works for the State of Victoria, shall give the necessary directions herein accordingly.

C. W. KINSMAN,
Clerk of the Executive Council.

MOTOR OMNIBUS ACT 1928 (No. 3742).

At the Executive Council Chamber, Melbourne, the
twenty-ninth day of June, 1948.

PRESENT:

His Excellency the Governor of Victoria.
Mr. Lienhop | Mr. Byrnes.

AMENDMENT OF PRESCRIPTION OF METRO-
POLITAN MOTOR OMNIBUS ROUTE No. 119A
(GARDINER-BURWOOD).

HIS Excellency the Governor of the State of Victoria, by and with the advice of the Executive Council thereof, and in pursuance of the powers conferred by the *Motor Omnibus Act 1928* (No. 3742), doth by this Order amend, as set out hereunder, the prescription of a certain route, i.e., No. 119A, within the metropolitan area, along which motor omnibuses for which "regular service" licences are granted may ply for hire, viz.:—

Under the heading "Description of Route, including Commencing and Terminal Points," immediately after "and Wills-street" insert " (to be approached via Kyarra-road and Burke-road)."

Licensing Authority.—Pursuant to the provisions of section 15 (1) (c) of the said Act (No. 3742), the Governor in Council by this Order confers upon the Licensing Authority full power and authority for the carrying into effect by the said Licensing Authority of the foregoing provisions of this Order.

And the Honorable James Arthur Kennedy, His Majesty's Commissioner of Public Works for the State of Victoria, shall give the necessary directions herein accordingly.

C. W. KINSMAN,
Clerk of the Executive Council.

DEPARTMENT OF PUBLIC WORKS.

At the Executive Council Chamber, Melbourne, the
twenty-ninth day of June, 1948.

PRESENT:

His Excellency the Governor of Victoria.
Mr. Lienhop | Mr. Byrnes.

ORDER FOR VARIATION OF SPECIFICATION FOR
SCHEME OF PRIVATE STREET CONSTRUCTION,
CITY OF BOX HILL.

IN pursuance of the provisions of the *Local Government (Private Street Construction) Act 1947*, His Excellency the Governor of the State of Victoria, being satisfied that owing to shortages in supplies of cement or other required materials the works provided for in the scheme adopted by the Council of the City of Box Hill for the construction of Sweetland-road, Box Hill, being a private street within the municipal district of the said city, which works were commenced prior to the commencement of the said Act, cannot be satisfactorily executed in accordance with the specifications, maps, plans, sections, and elevations in the scheme, pursuant to which the works were commenced, doth by this Order, by and with the advice of the Executive Council of the said State, authorize the Council of the City of Box Hill to execute the works with the following variations of the said specifications, viz.:—

On the apportionment sheet, in lieu of—
"Paving.—Quantity 1,580 sq. yds. Estimated rate
8s. 3d. per sq. yd. Estimated amount £651 15s."
there shall be substituted—
"Paving (bituminous).—Quantity 1,580 sq. yds.
Estimated rate 6s. 6d. per sq. yd. Estimated
amount £513 10s."

And the Honorable James Arthur Kennedy, His Majesty's Commissioner of Public Works for the State of Victoria, shall give the necessary directions herein accordingly.

C. W. KINSMAN,
Clerk of the Executive Council.

CO-OPERATIVE HOUSING SOCIETIES ACTS.

At the Executive Council Chamber, Melbourne, the
twenty-ninth day of June, 1948.

PRESENT:

His Excellency the Governor of Victoria.
Mr. Lienhop | Mr. Byrnes.

CO-OPERATIVE HOUSING SOCIETIES (GENERAL)
REGULATIONS No. 5.

PURSUANT to the powers conferred by the Co-operative Housing Societies Acts and the *Acts Interpretation Act 1928*, His Excellency the Governor of the State of Victoria, by and with the advice of the Executive Council thereof, doth hereby make the following Regulations, that is to say:—

Citation.

1. These Regulations may be cited as the Co-operative Housing Societies (General) Regulations No. 5.

Amendment.

2. Regulation 2 of the Co-operative Housing Societies (General) Regulations No. 3 is hereby amended as follows:—

- (a) In sub-regulation (1) and sub-regulation (2), for the words "No person" there shall be substituted the expression "Except with the permission of the Registrar, no person"; and
(b) In sub-regulation (2), for the word "ten" there shall be substituted the word "five".

Amendment of
Co-operative
Housing
Societies
(General)
Regulations
No. 3.
G.G. 20.3.46.

And the Honorable John Herman Lienhop, for and on behalf of His Majesty's Treasurer for the State of Victoria, shall give the necessary directions herein accordingly.

C. W. KINSMAN,
Clerk of the Executive Council.

MINISTRY OF HEALTH ACT 1943 (No. 4988).

At the Executive Council Chamber, Melbourne, the
twenty-ninth day of June, 1948.

PRESENT:

His Excellency the Governor of Victoria.
Mr. Lienhop | Mr. Byrnes.

TRANSFER OF FUNCTIONS, POWERS, AND DUTIES FROM THE MATERNAL AND CHILD HYGIENE BRANCH TO THE MENTAL HYGIENE BRANCH OF THE DEPARTMENT OF HEALTH.

WHEREAS by Order of the Governor in Council dated the twenty-seventh day of June, One thousand nine hundred and forty-four, it is provided that the Maternal and Child Hygiene Branch of the Department of Health shall carry out functions, powers, and duties relating to—
the Children's Court Clinic; and
the Child Psychiatric Clinic:

And whereas by the *Ministry of Health Act 1943* (No. 4988), the Governor in Council by Order may transfer any functions, powers, and duties for any branch to any other branch: Now therefore, His Excellency the Governor of the State of Victoria, by and with the advice of the Executive Council thereof, doth order that the functions, powers, and duties relating to—

the Children's Court Clinic; and
the Child Psychiatric Clinic—

shall be and are hereby transferred from the Maternal and Child Hygiene Branch of the Department of Health to the Mental Hygiene Branch of the said Department, and doth further order that such transfer shall take effect from the first day of July, One thousand nine hundred and forty-eight.

And the Honorable Sir Albert Arthur Dunstan, His Majesty's Minister of Health for the State of Victoria, shall give the necessary directions herein accordingly.

C. W. KINSMAN,
Clerk of the Executive Council.

STATE DEVELOPMENT ACTS.

At the Executive Council Chamber, Melbourne, the
thirtieth day of June, 1948.

PRESENT:

His Excellency the Governor of Victoria.
Mr. Warner | Mr. Byrnes.

APPOINTMENT OF CHAIRMAN OF THE STATE DEVELOPMENT COMMITTEE.

WHEREAS by an Order in Council made on the eighteenth day of December, 1947, the Governor in Council, pursuant to the State Development Acts, appointed Brigadier Raymond Walter Tovell, C.B.E., D.S.O., E.D., M.L.A., to be Chairman of the State Development Committee until the thirtieth day of June, 1948: Now therefore, His Excellency the Governor of the State of Victoria, by and with the advice of the Executive Council thereof, and in pursuance of the powers conferred by the State Development Acts, doth by this Order appoint—

Lieutenant-Colonel JOHN ALEXANDER HIPWORTH, E.D.,
M.L.A.,

to be Chairman of the said Committee from the first day of July to the thirty-first day of December, 1948.

And the Honorable John Gladstone Black McDonald, for and on behalf of His Majesty's Premier of the State of Victoria, shall give the necessary directions herein accordingly.

C. W. KINSMAN,
Clerk of the Executive Council.

APPRENTICESHIP ACTS.

At the Executive Council Chamber, Melbourne, the
sixth day of July, 1948.

PRESENT:

His Excellency the Governor of Victoria.
Lieut.-Colonel Dennett | Mr. Byrnes.
Mr. Hyland

APPRENTICESHIP COMMISSION OF VICTORIA.

IN pursuance of the provisions of the Apprenticeship Acts, His Excellency the Governor of the State of Victoria, by and with the advice of the Executive Council thereof, doth by this order appoint—

DANIEL SCOTT, a person nominated by the body known as the Victorian Chamber of Manufactures, to be a member of the Apprenticeship Commission of Victoria, *vice* David Duncan, resigned, for the remainder of the term of three years for which the said David Duncan was appointed.

And the Honorable Herbert John Thornhill Hyland, His Majesty's Minister of Labour for the State of Victoria, shall give the necessary directions herein accordingly.

C. W. KINSMAN,
Clerk of the Executive Council.

APPROACHING LAND SALES.

SALES of Crown lands, in fee-simple, will be held at the under-mentioned places and dates, viz.:—

	No. of Gazette.
Beechworth.—Friday, 23rd July, 1948	670
Camperdown.—Wednesday, 28th July, 1948	691
Stawell.—Tuesday, 3rd August, 1948	678
Wonthaggi.—Thursday, 22nd July, 1948	670

Closer Settlement Act 1938.

SALE BY AUCTION.

CAMPERDOWN.—A sale of the under-mentioned land in fee-simple, by auction, will be held at the LAND INSPECTOR'S OFFICE, CAMPERDOWN, on WEDNESDAY, the 28th JULY, 1948, at ONE o'clock p.m. To be conducted by A. L. REAH, Land Officer, Geelong.

PARISH OF GEELENGLA, COUNTY OF HAMPDEN.

2½ Miles from Derrinallum Township.

Area 12 acres, allotment 4A of section A. Possession on the 2nd August, 1948.

TERMS AND CONDITIONS.

Deposit to be paid at sale 20 per cent. of purchase price. Balance payable by ten equal half-yearly instalments, with interest computed at the rate of 4½ per cent. per annum on the unpaid balance.

The Board of Land and Works may allow a transfer of the purchaser's interests to an approved person at any time before the final payment is made (fee, £1). The registration of the transfer may be subject to payment of such further sum as the Board may require in reduction of the outstanding balance.

Purchaser may pay balance and fees at any time prior to the due date.

Crown grant will be prepared and issued as soon as practicable after payment of purchase money in full.

Improvements to be maintained and insured with the Board of Land and Works.

JOHN G. B. McDONALD,
Commissioner of Crown Lands and Survey.
Melbourne, 5th July, 1948.

COMMONS ABOUT TO BE ABOLISHED.

IN pursuance of the provisions contained in Division 10 of Part I. of the *Land Act 1928* (No. 3709), notice is hereby given that it is the intention of the Governor in Council to abolish the commons hereinafter mentioned, viz.:—

The following Notices were published 1° on the 30th June, 1948, pursuant to Orders of the 22nd June, 1948.

SCHEDULE OF COMMONS TO BE ABOLISHED.

Locality; Type; Date of Proclamation.

- Blackwood; Gold Fields Common; 28th January, 1861.
- Bonang; Goldfield Common; 8th August, 1870.
- Boorolite; Common; 6th February, 1883.
- Chiltern; Common; 14th December, 1915.
- Dabyninga; Town Common; 16th December, 1862.
- Darlingford; Gold Field Common; 18th February, 1867.
- Faraday; Farmers' Common; 18th March, 1861, and 27th January, 1868.
- Longwood; Town Common; 23rd November, 1868, and 7th February, 1876.
- Macedon; Town Common; 14th December, 1863.
- Nicholson and Boggy Creek; Gold Fields Common; 28th January, 1861.
- Oxley; Agricultural Area Common; 11th November, 1868.
- Panmure; Town Common; 8th February, 1869, and 10th January, 1876.
- Rutherglen; Municipal Common; 31st August, 1863.
- Waranga; United Common; 17th December, 1901.

K. DODGSHUN,

for Commissioner of Crown Lands and Survey.

1943, is about to be further revoked so far only as regards the portion, containing 27 perches, more or less, indicated by hachure on plan hereunder.—(O.1(2) (Rs.1121).

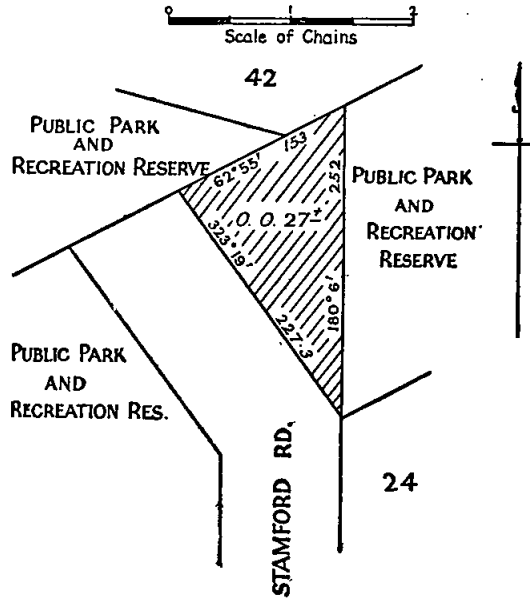

KATYIL.—The Order in Council of the 8th April, 1909, temporarily reserving as a site for Public Recreation and for Water Supply purposes 45 acres 2 roods 16 perches of land in the Parish of Katyil, revoked as to part by Order of the 18th March, 1919, is about to be further revoked so far only as regards the two separate portions, containing 3 acres 1 rood 22 perches, indicated by hachure on plan hereunder.—(K.142(6) (Rs.1237).

PROPOSED REVOCATIONS OF TEMPORARY RESERVATIONS OF LANDS BY ORDERS IN COUNCIL.

IN pursuance of the provisions of the *Land Act 1928*, notice is hereby given that it is the intention of the Governor in Council to revoke the temporary reservations of lands by Orders in Council hereunder referred to, viz.:—

The following Notices were published 1° on the 16th June, 1948, pursuant to Orders of the 9th June, 1948.

DOUTTA GALLA.—The Order in Council of the 14th January, 1879 (see *Government Gazette* of the 17th January, 1879, page 162), temporarily reserving as a site for Public purposes 878 acres, more or less, of land at Melbourne, Hotham, Footscray, and Doutta Galla, revoked as to part by various Orders, is about to be further revoked so far only as regards the four separate portions, containing 300 acres, more or less, indicated by hachure on plan hereunder.—(D.85(5) (C.70374).

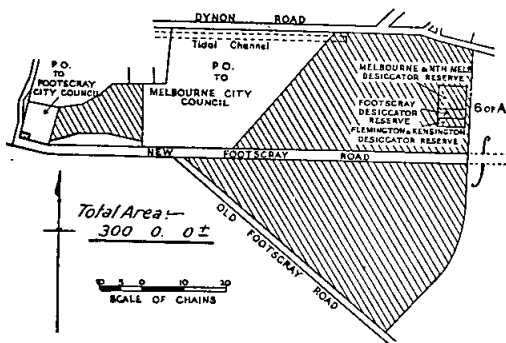

OAKLEIGH.—The Order in Council of the 21st October, 1940, temporarily reserving as a site for Public Park and Recreation 44 acres, more or less, of land in the City of Oakleigh, revoked as to part by Order of the 5th April,

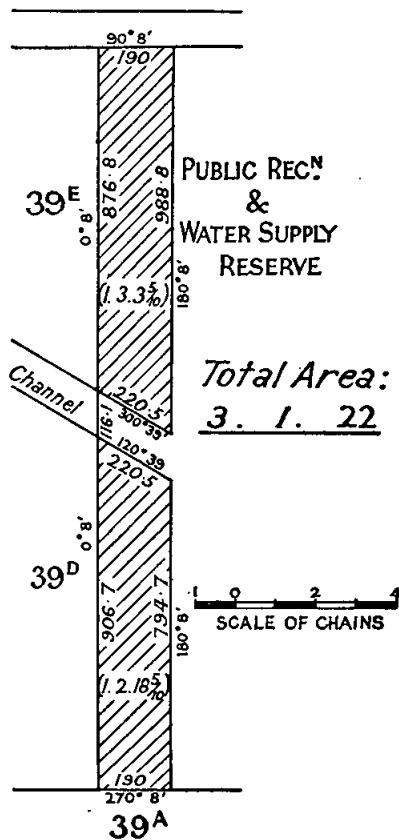

ARARAT.—The Order in Council of the 28th October, 1889, temporarily reserving as a site for the Supply of Gravel for roadmaking 18 acres, more or less, of land in the municipal district of Ararat, revoked as to part by various Orders, is about to be further revoked so far only as regards the two separate portions, containing 1 acre 3 roods, indicated by hachure on plan hereunder.—(A.148^(s)) (Rs.2346).

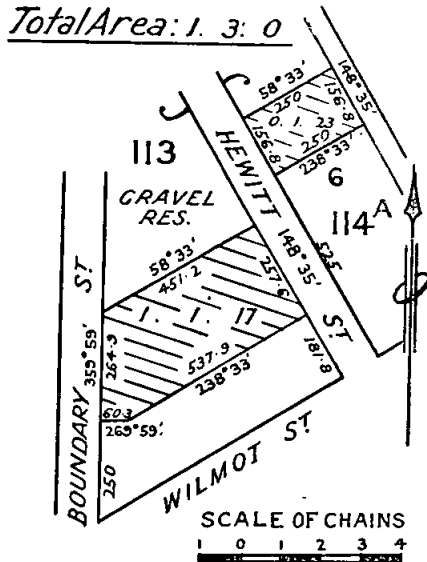

INGLEWOOD.—The Order in Council of the 12th October, 1909, temporarily reserving as a site for the Supply of Gravel 5 acres of land situate in section 6 in the Parish of Inglewood, is about to be revoked.—(I.5^(s)) (C.43092).

JOHN G. B. McDONALD,
Commissioner of Crown Lands and Survey.

PROPOSED REVOCATIONS OF TEMPORARY RESERVATIONS OF LANDS BY ORDERS IN COUNCIL.

IN pursuance of the provisions of the Land Act 1928, notice is hereby given that it is the intention of the Governor in Council to revoke the temporary reservations of lands by Orders in Council hereunder referred to, viz.:

The following Notices were published 1^o on the 23rd June, 1948, pursuant to Orders of the 15th June, 1948

EAGLEHAWK.—The Order in Council of the 11th August, 1879, temporarily reserving 7 acres 1 rood 30 perches of land in the municipal district of Eaglehawk as a site for a Cemetery, and withholding from sale, leasing, and licensing (revoked as to part by various Orders), is about to be further revoked so far only as regards the portion thereof containing 2 roods 6 perches, more or less, indicated by hachure on plan hereunder.—(E.116^(s)) (Rs.6168).

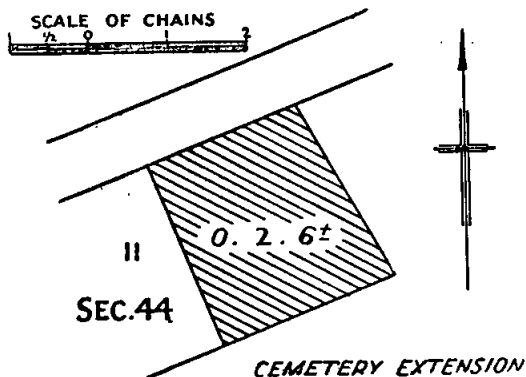

STANHOPE.—The Order in Council of the 7th December, 1936, temporarily reserving 3 roods 29 8/10 perches of land, being allotment 5, section 3, Township of Stanhope, Parish of Girgarre, as a site for Police purposes, is about to be revoked.—(S.462^(s)) (Rs.4643).

MORTLAKE.—The Order in Council of the 26th May, 1925, temporarily reserving 2 roods 10 perches of land in the Town of Mortlake as a site for Municipal purposes, is about to be revoked.—(M.210^(s)) (Rs.3107).

TRAWALLA.—The Order in Council of the 14th July, 1879, temporarily reserving as a site for Public purposes (State School), and withholding from sale, leasing, and licensing, 2 acres 0 roods 4 perches of land, being part of original allotment 41, in the Parish of Trawalla, is about to be revoked.—(T.140^(s)) (C.91220).

WARRNAMBOOL.—The Order in Council of the 23rd February, 1863 (see Government Gazette of the 6th March, 1863, page 535), temporarily reserving as a site for Public Recreation 29 acres 3 roods 35 perches of land in the Town of Warrnambool, revoked as to parts by various Orders, is about to be further revoked so far only as regards the two separate portions containing 3 roods 20 perches, more or less, as indicated by hachure on plan hereunder.—(W.99^(s)) (Rs.267).

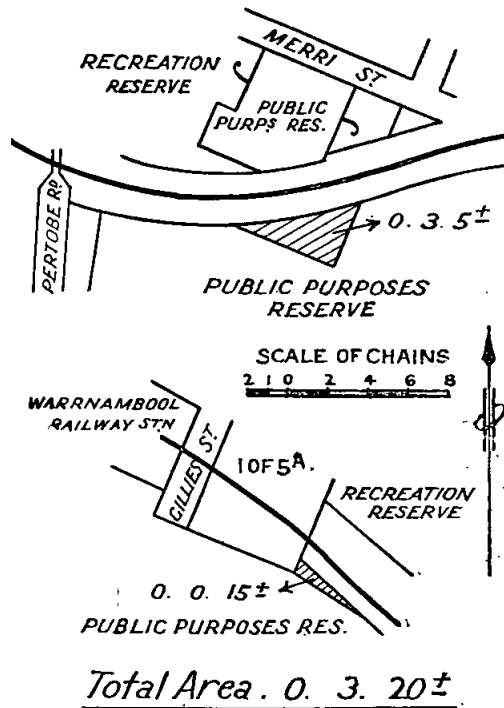

WARRNAMBOOL.—The Order in Council of the 2nd August, 1875, temporarily reserving as a site for Public purposes, and withholding from sale, leasing, and licensing, 194 acres, more or less, of land in the Town of Warrnambool, revoked as to parts by various Orders, is about to be further revoked so far as regards the balance thereof containing 180 acres, more or less.—(W.99^(s)) (Rs.284).

WARRNAMBOOL.—The Order in Council of the 5th October, 1936, temporarily reserving as a site for Public purposes 225 acres 2 roods 2 perches of land in the City of Warrnambool, is about to be revoked so far only as regards the

four separate portions containing 196 acres 1 rood 2 perches, as indicated by hachure on plan hereunder.—(W.99⁽⁶⁾) (C.78148).

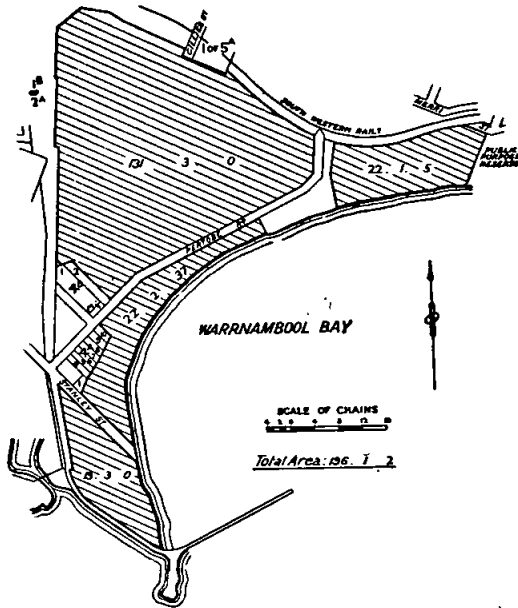

WARRNAMBOOL.—The Order in Council of the 26th July, 1910, temporarily reserving as a site for Public purposes 33 acres of land in the Town of Warrnambool, is about to be revoked.—(W.99⁽⁶⁾) (Rs.632).

JOHN G. B. McDONALD,
Commissioner of Crown Lands and Survey.

PROPOSED REVOCATIONS OF TEMPORARY RESERVATIONS OF LANDS BY ORDERS IN COUNCIL.

IN pursuance of the provisions of the *Land Act 1928*, notice is hereby given that it is the intention of the Governor in Council to revoke the temporary reservations of lands by Orders in Council hereunder referred to, viz.:

The following Notices were published 1^o on the 30th June, 1948, pursuant to Orders of the 22nd June, 1948.

NERRENA.—The temporary reservation by Order in Council of the 1st May, 1871, of 1 acre of land being portion of section AA at Little Bendigo (now Nerrena), Parish of Ballaarat, as a site for Wesleyan Place of Public Worship, is about to be revoked.—(B.127^(c)) (C.52882).

CANNUM.—The temporary reservation as a site for Public purposes (State School) and the withholding from sale, leasing, and licensing by Order in Council of the 10th December, 1883 (see *Government Gazette* of the 14th December, 1883, page 3055), of 5 acres of land, being part of allotment 65 in the Parish of Cannum, is about to be revoked.—(C.417^(e)) (C.91088).

K. DODGSHUN,
for Commissioner of Crown Lands and Survey.

PROPOSED REVOCATIONS OF TEMPORARY RESERVATIONS OF LANDS BY ORDERS IN COUNCIL.

IN pursuance of the provisions of the *Land Act 1928*, notice is hereby given that it is the intention of the Governor in Council to revoke the temporary reservations of lands by Orders in Council hereunder referred to, viz.:

The following Notices were published 1^o on the 7th July, 1948, pursuant to Orders of the 29th June, 1948.

DOBOOBETIC.—The temporary reservation by Order in Council of the 6th July, 1910, of 3 acres of land in the Parish of Doboobetic, as a site for a State School, is about to be revoked.—(D.170⁽¹⁾) (C.44981).

DOUTTA GALLA.—The temporary reservation by Order in Council of the 10th February, 1891 (see *Government Gazette* of the 13th February, 1891, page 867), of 1 acre 2 roods of land in the Parish of Douтта Galla, as a site for the erection of desiccators for the use of the Corporation of the Town of Footscray, is about to be revoked.—(D.85⁽⁶⁾) (G.57180).

DOUTTA GALLA.—The temporary reservation by Order in Council of the 10th February, 1891 (see *Government Gazette* of the 13th February, 1891, page 867), of 1 acre 2 roods of land in the Parish of Douтта Galla, as a site for the erection of desiccators for the use of the Corporation of the Borough of Flemington and Kensington, is about to be revoked.—(D.85⁽⁶⁾) (G.57180).

NETHERBY.—The temporary reservation by Order in Council of the 13th February, 1893, of 9 acres of land in the Township of Netherby as a site for Public Recreation, revoked as to part by Order of the 5th October, 1926, is about to be further revoked so far as regards the balance thereof containing 6 acres 3 roods 8 perches.—(N.143) (Rs.3124).

JOHN G. B. McDONALD,
Commissioner of Crown Lands and Survey.

LAND AVAILABLE UNDER THE SOLDIER SETTLEMENT ACTS.

NOTIFICATION is hereby given, in accordance with section 16 of the *Soldier Settlement Act 1946*, that the under-mentioned lots are available or are about to become available for settlement.

Any discharged soldier who has applied to the Commission on or before the 7th July, 1948, for classification in the required class or classes of primary production for which the lots are made available, and whose application has not been finalized, or any discharged soldier who has been classified as suitable in such class or classes of primary production, may apply on the proper form for settlement on any lot or lots, indicating where he applies in respect of more than one lot, his order of preference therefor.

Application forms, plans, and further particulars may be obtained from the Inquiry Branch, Soldier Settlement Commission, State Public Offices, Melbourne, at which office completed applications for settlement should be lodged on or before the 2nd August, 1948.

E. SINGLETON,
Secretary.

Soldier Settlement Commission,
Melbourne, 2nd July, 1948.

SCHEDULE OF ALLOTMENTS.

PORTION OF "EDGARLEY" ESTATE.

PARISHES OF KIORA AND WILLAURA.—COUNTY OF RIPON.
Suitable for Grazing (Sheep), Mixed Farming, and Cereal Growing.

Lot Number on Plan of Subdivision.	Approximate Area in Acres (Subject to Survey).
1	680
2	776
3	562
4	578
5	719
6	598
7	605
8	583

PORTION OF "YALLA-Y-POORA" ESTATE.

PARISHES OF YALLA-Y-POORA, WONGAN, AND WALLA WALLA.—COUNTY OF RIPON.
Suitable for Grazing (Sheep) and Mixed Farming.

Lot Number on Plan.	Approximate Area in Acres (Subject to Survey).
13	998

PORTION OF "TALISKER" ESTATE.

PARISH OF MERINO.—COUNTY OF NORMANBY.
Suitable for Dairying.

Lot Number on Plan.	Approximate Area in Acres (Subject to Survey).
1	170

LIST OF CROWN LANDS AVAILABLE.

THE under-mentioned areas are available for application as provided by various sections of the Land Act 1928, and all applications received on or before Wednesday, 4th August, 1948, will be deemed to have been simultaneously made, but any application lodged after such date may be considered if received in time for inclusion in the advertisement of the cases to be heard at the Local Land Board.

Applications on proper form, accompanied by 5s. duty stamp uncancelled (registration fee), may be delivered or forwarded by post to the Local Land Officer or to any Crown Lands Office in Victoria. Applicants may obtain from Local Land Officers, or the Enquiry Office, Lands Department, Melbourne, a certificate authorizing the issue by the Railway Department of a return ticket at concession fares to enable them to inspect available areas or to attend Local Land Boards. When an applicant is granted an allotment he may, if travelling by rail, obtain reduced fares for his family and also freight concessions in regard to some of his effects.

Subject to the approval of the Minister, when the survey fee exceeds £10, a deposit of £5 may be paid, and the balance over six years in half-yearly instalments.

Marked plans of any particular area, application forms, and any further information may be obtained from the Enquiry Office, Lands Department, Melbourne, and Land Officers, Geelong, Ballarat, and Hamilton.

Department of Crown Lands and Survey,
Melbourne, 7th July, 1948.

JOHN G. B. McDONALD,
Commissioner of Crown Lands and Survey.

* Improvements may be subject to re-valuation after land has been granted to an applicant.

Local Land Office.	County.	Parish.	Allotment.	Section.	Area.	How available.		Survey Fee.	Valuation of Improvements (if any).	Location of Land, &c.	Nearest Railway Station or Township and Distance in miles therefrom.	How accessible.	Water Supply.	General Description of Land—Soil, Timber, Suitability (Grazing, &c.).	
						Classification.	Value Acrc.								
						A.	B.	C.	D.						
Geelong	Heytesbury	Paaratte	17	4	160 0 0	2nd	0 15 0	10 7 6	Nil	In east of parish	Tumboon R.S., 6 miles	Made road	Cowley's Creek	Undulating; grey, loamy soil; mesquite and gum; suitable for dairying and general farming. (J.21647)	
Hamilton (a)	Normanby	Trewalla	17	11	176 0 3	3rd	0 10 0	8 12 6	To be valued	In north-west corner of parish	Portland, about 10 miles.	By road ..	To be conserved	Slightly undulating; sandy soil; covered with dense smallgrass tree, small scrub, honeyaukile, ti-tree, and heath; suitable for grazing. (Z.26647)	
DIVISION 4, PART I, LAND ACT 1928.															
AVAILABLE UNDER SECTION 129, LAND ACT 1928.															
Ballarat	Talbot	Town of Creswick	4	50	0 1 8 1/10	Dwellings	Annual rental to be fixed	3 0 0	Nil	Fronting Ford-street	In Creswick ..	By Ford-street	By conservation	Suitable for a dwelling. (J.27442)	
Hamilton (b)	Normanby	Glenaulin, Town of Lyons	1	2	1 1 0	"	"	3 2 6	Nil	Adjoining Lyons State School	Lyons, 1/4 mile..	By road ..	To be conserved	Suitable for a dwelling. (Z.23493)	

(a) Subject to drainage condition. (b) Subject to survey.

PUBLIC HEARING BY A PERSON APPOINTED UNDER THE 34TH SECTION OF THE LAND ACT 1928.

NOTICE is hereby given that at the time and place mentioned in the Schedule hereunder, applications for leases and licences under the Land Acts, objections to such applications, objections to proposed proclamations, alterations, additions, diminutions, revocations, or unions of commons; and reasons against forfeiture of any leases or licences under the Land Acts deemed liable to forfeiture, will be publicly heard by the person whose name is set opposite such place respectively in such Schedule, being a person appointed by me, the responsible Minister of the Crown administering the Land Acts, to hear the same and report thereon in writing to me.

JOHN G. B. McDONALD,
Commissioner of Crown Lands and Survey, and
President of the Board of Land and Works.

Department of Lands and Survey,
Melbourne, 7th July, 1948.

SCHEDULE.

COURT HOUSE, WONTHAGGI, Thursday, 22nd July, 1948,
at 1.30 p.m., C. E. Rice, Land Officer.

COMMITTEES OF MANAGEMENT OF RESERVES.

APPOINTMENTS.

WHEREAS by section 184 of the Land Act 1928 it is provided that it shall be lawful for the Governor in Council or the Board of Land and Works to appoint and remove any number of persons, not less than three, or any municipal council, or the governing body of any corporation, to be a Committee of Management of any specified Crown land reserved either temporarily or permanently for any of the purposes set out in section 14 of the Land Act 1928, and not conveyed to or vested in trustees: Now therefore the Board of Land and Works doth hereby appoint the under-mentioned persons to be members of the Committee of Management of the Reserves named:—

"AIREY'S INLET RESERVE."

George Samuel Ritchie, Albert Glazier Suters, Eric Selby Hart, George Osbert Cutler, James Henry Mann, Florence Alice Suters, and Ethel Daphene Hart, as a Committee of Management, for a period of three (3) years, from 1st June, 1948, of the land permanently reserved by Order in Council dated 12th June, 1888, as a site for Public purposes in the Parish of Angahook, and known as the "Airey's Inlet Reserve."—(Corres. Rs.5369.)

"CARDROSS LAKE RESERVE."

John Dunbeth Lang (representative of the State Rivers and Water Supply Commission), Bertram Crump, Jack Samuel Harris, William James Lingenburg, Donald William MacKay, Leslie Bruce Midgley, Peter Claude Stubbings, and John Lloyd Price, as the Committee of Management, for a period of three (3) years, of that portion of the land temporarily reserved by Order in Council dated 22nd April, 1938, as a site for Water Supply purposes in the Parish of Mildura, as is indicated in red colour on plan marked M/14.3.45 attached to Lands Department file No. Rs.4801, and known as the "Cardross Lake Reserve."—(Corres. Rs.4801.)

"NULLAWIL MECHANICS' INSTITUTE RESERVE."

William Henry Bennett, Jack Donald Cobham McLean, John Thomas Gordon Clarke, George Deloraine Mills, George Percy Cobham McLean, John Ryan, and Terrence Joseph Smith, as the Committee of Management, for a period of three (3) years, of the land temporarily reserved by Order in Council of the 17th May, 1898, as a site for a Mechanics' Institute and Free Library in the Township of Nullawil, and known as the "Nullawil Mechanics' Institute Reserve."—(Corres. Rs.352.)

"WANALTA RECREATION RESERVE."

Phillip Charles Ryan, Jordon Rodérick Reid, Samuel Barlow, William Haglus Pepperell, Robert Henry Beale, Arthur William Heath, Daniel Vincent Kane, and Victor Samuel Barlow, as the Committee of Management, for a period of three (3) years, of the land temporarily reserved by Order in Council dated 26th June, 1917, as a site for Public Recreation in the Parish of Wanalta, and known as the "Wanalta Recreation Reserve."—(Corres. Rs.1612.)

"EDENHOPE SHOW GROUNDS RESERVE."

Aloysius Ernest Neagle, Gemmell Rankin Donaldson, Aubrey George Osborne, John Thomas Norris, and Walter Thomas Moore, as a Committee of Management, for a period of three (3) years, from the 6th June, 1948, of the land temporarily reserved by Orders in Council dated the 21st October, 1901, and 30th September, 1935, as sites for Show Grounds in the Parish of Edenhope, and known as the "Edenhope Show Grounds Reserve."—(Corres. Rs.1546.)

"YALLOCK MECHANICS' INSTITUTE RESERVE."

Burton James Cox, Frederick William Ashby, George Hugh Light, Thomas Alfred Hatty, Harold William Cox, Eric John Cox, and Lewis Wilhelm Finck, as a Committee of Management, for a period of three (3) years from 31st May, 1948, of the land temporarily reserved by Order in Council dated 13th October, 1903, as a site for a Mechanics' Institute in the Parish of Yallock, and known as the "Yallock Mechanics' Institute Reserve."—(Corres. Rs.4911.)

"BAGSHOT RECREATION RESERVE."

Richard Hayhurst, Matthew John Brown, Cyril Henry Peatling, Morris James Clay, and Leslie Griffiths Campbell, as the Committee of Management, for a period of three (3) years from the 31st May, 1948, of the land temporarily reserved by Order in Council dated 6th June, 1922, as a site for Public Recreation in the Parish of Bagshot, and known as "Bagshot Recreation Reserve."—(Corres. Rs.2364.)

"BOWENVALE PUBLIC HALL SITE."

Thomas Patrick Chifford, Percy Edward Wade, George William Henderson, Patrick Joseph McKinley, Henry Ballantine, and Cornelius Hickey, as the Committee of Management, for a period of three (3) years from 13th June, 1948, of the land temporarily reserved by Order in Council dated 20th April, 1885, as a site for a Free Library in the Parish of Maryborough, and known as the "Bowenvale Public Hall Site."—(Corres. Rs.4884.)

"YENDON RECREATION RESERVE."

Norman Thomas Carbury, Roy William Harrison, Alexander John Walker, Leslie Herbert Trigg, Bernard Vincent Challis, John Harold Spruce, and George J. Ryan, as a Committee of Management, for a period of three (3) years, of the land temporarily reserved by Order in Council dated the 21st October, 1872, as a site for Recreation purposes and Cricket Ground in the Town of Buninyong East (now Township of Yendon), and known as the "Yendon Recreation Reserve."—(Corres. Rs.5326.)

"LARA RECREATION RESERVE."

Alfred John Spalding, Samuel Gibbs, Abraham Alexander McClelland, William Lorimer Orr, Robert Lloyd Grills, Donald Frank Walker, and Allan William Mathieson, as a Committee of Management, for a period of three (3) years from 28th April, 1948, of the land temporarily reserved for Cricket and other purposes of Public Recreation in the Town of Lara, and known as the "Lara Recreation Reserve."—(Corres. Rs.2307.)

In witness whereof the common seal of the Board of Land and Works was hereunto affixed, this second day of July, One thousand nine hundred and forty-eight, in the presence of—

(SEAL) JOHN G. B. McDONALD, President.
W. McILROY, Member.

TENDERS.

TENDERS will be received at this office until **TEN A.M.** on the days and for the purposes under mentioned. Particulars may be learnt at this office, and also at the offices named in each instance.

The Board of Land and Works will not necessarily accept the lowest or any tender.

13th July, 1948.

Bacchus Marsh.—Repairs, painting and internal renovations, Police Station. Particulars at Inspector of Works Office, Ballarat; Police Station, Bacchus Marsh. Preliminary deposit, £10. Final deposit, 2 per cent.

Bendigo.—Supply and installation of four (4) electric hot-water services, Lots 1, 2, 3 and 4, Lansell-street, Country Roads Board residences. Particulars at Inspector of Works Office, Bendigo. Preliminary deposit, £5. Final deposit, 2 per cent.

Bendigo.—Supply and installation of central heating system, Public Offices. Particulars at Inspectors of Works Offices, Ballarat, Bendigo. Preliminary deposit, £15. Final deposit, 2 per cent.

Blackburn.—Replacements to fencing, State School No. 2923. Particulars at State School, Blackburn. Preliminary deposit, £5. Final deposit, 2 per cent.

Brim East.—Remodelling, repairs, and painting to residence, laundry, &c., State School No. 3733. Particulars at Inspector of Works Office, Horsham; Police Stations, Hope-toun, Nhill, Warracknabeal; State School, Brim East. Preliminary deposit, £10. Final deposit, 2 per cent.

Buffalo.—Repairs, renewals, and painting, State School No. 3240. Particulars at Inspector of Works Office, Korumburra; Police Stations, Leongatha, Yarram; State School, Buffalo. Preliminary deposit, £5. Final deposit, 2 per cent.

Camberwell East.—Sewerage connexions to science fittings, Girls' School. Deposit, £3.

Dixie.—Repairs, renovations, &c., school and residence, State School No. 891. Particulars at Inspector of Works Office, Warrnambool; State School, Dixie. Preliminary deposit, £5. Final deposit, 2 per cent.

Dromana.—Repairs, painting, &c., school and residence, State School No. 184. Particulars at Police Stations, Frankston, Mornington; State School, Dromana. Preliminary deposit, £5. Final deposit, 2 per cent.

Footscray.—External and internal painting and repairs to all buildings, Technical School. Particulars at Technical School, Footscray. Preliminary deposit, £10. Final deposit, 2 per cent.

Foster.—Conversion of R.A.A.F. hut (80 feet) into classrooms, Higher Elementary School No. 1172. Particulars at Inspector of Works Office, Korumburra; Police Stations, Leongatha, Toora; Higher Elementary School, Foster. Preliminary deposit, £10. Final deposit, 2 per cent.

Glenloch Estate (near Wycheproof).—Erection of six (6) timber residences, Soldier Settlement Commission. Particulars at Inspectors of Works Offices, Bendigo, Swan Hill; Police Stations, Charlton, Inglewood, Wycheproof. Preliminary deposit, £50. Final deposit, 2 per cent.

Glenthompson.—Repairs and renovations, school and residence, State School No. 947. Particulars at Inspectors of Works Offices, Ararat, Hamilton; State School, Glenthompson. Preliminary deposit, £10. Final deposit, 2 per cent.

Harrow.—Repairs and painting, new septic tank, new bore, and mill and high stand, inspector's residence (Lands Department). Particulars at Inspectors of Works Offices, Hamilton, Horsham; Police Station, Nhill. Preliminary deposit, £10. Final deposit, 2 per cent.

Kialla West.—Repairs, remodelling, and painting, school and residence, State School No. 1727. Particulars at Inspector of Works Office, Shepparton; Police Stations, Echuca, Elmore, Kyabram; State School, Kialla West. Preliminary deposit, £5. Final deposit, 2 per cent.

Korrine.—Erection of new teacher's residence and out-buildings, State School No. 4558. Particulars at Inspector of Works Office, Korumburra; Police Stations, Leongatha, Wonthaggi; State School, Korrine. Preliminary deposit, £15. Final deposit, 2 per cent.

Lancefield.—Repairs and renovations to residence and erection of new garage, Police Station. Particulars at Inspector of Works Office, Kyneton; Police Stations, Castlemaine, Lancefield, Sunbury. Deposit, £4.

Melbourne.—Replacement of roof, William Angliss Food Trades School. Preliminary deposit, £10. Final deposit, 2 per cent.

Mont Park.—Alterations, additions, repairs, and painting, Hospital Block, Mental Hospital. Preliminary deposit, £50. Final deposit, 2 per cent.

Murtoa.—Repairs and renovations to residence, erection of new "A" type office, Police Station. Particulars at Inspector of Works Office, Horsham; Police Stations, Nhill, Stawell, Murtoa. Preliminary deposit, £15. Final deposit, 2 per cent.

Nar-nar-goon South.—Extension of school, State School No. 4554. Particulars at Police Stations, Dandenong, Warragul; State School, Nar-nar-goon South. Deposit, £4.

Oakleigh.—Painting and repairs to shelter shed, State School No. 1601. Particulars at State School, Oakleigh. Preliminary deposit, £4. Final deposit, 2 per cent.

Orbost.—Electrical installation, Higher Elementary School No. 2744. Particulars at Inspector of Works Office, Bairnsdale; Police Station, Orbost. Preliminary deposit, £5. Final deposit, 2 per cent.

Richmond.—Renewal of sewerage system and internal and external painting of out-offices, Girls' School. Particulars at Girls' School, Richmond. Preliminary deposit, £5. Final deposit, 2 per cent.

Seymour.—Repairs and renewals to fencing, Police Station. Particulars at Police Stations, Euroa, Kilmore, Seymour. Preliminary deposit, £5. Final deposit, 2 per cent.

Tarraville.—Repairs and painting to teacher's residence, State School No. 615. Particulars at Inspector of Works Office, Korumburra; Police Stations, Yarram, Leongatha; State School, Tarraville. Deposit, £4.

The Heart.—Purchase and removal of school buildings, State School No. 1617. Particulars at Inspector of Works Office, Bairnsdale; Police Stations, Sale, Maffra. Preliminary deposit, £5. Final deposit, full amount of purchase money.

Trafalgar East.—Repairs to chimney, new floor, &c., State School No. 3499. Particulars at Inspector of Works Office, Bairnsdale; Police Station, Moe; State School, Trafalgar East. Preliminary deposit, £3. Final deposit, 2 per cent.

Wangaratta.—Additional workshops by adding new floor to existing workshop block, Technical School. Particulars at Inspectors of Works Offices, Benalla, Wangaratta; Police Station, Wodonga; Technical School, Wangaratta. Preliminary deposit, £25. Final deposit, 2 per cent.

Warburton.—Erection and completion of teacher's residence, State School No. 1485. Particulars at Police Stations, Healesville, Lilydale; State School, Warburton. Preliminary deposit, £15. Final deposit, 2 per cent.

Werribee.—Supply of fittings, repairs, and renovations, Research Farm. Particulars at Inspector of Works Office, Geelong; Police Station, Werribee. Preliminary deposit, £5. Final deposit, 2 per cent.

Whittlesea.—Alterations, repairs, and painting, &c., State School No. 2090. Particulars at State School, Whittlesea. Preliminary deposit, £4. Final deposit, 2 per cent.

Yallourn.—Repairs, painting, &c., High School. Particulars at Inspector of Works Office, Bairnsdale; Police Stations, Moe, Morwell, Traralgon; High School, Yallourn. Preliminary deposit, £10. Final deposit, 2 per cent.

Yarra Glen.—Repairs, painting, fencing, &c., to school and residence, State School No. 956. Particulars at Police Stations, Healesville, Lilydale; State School, Yarra Glen. Preliminary deposit, £5. Final deposit, 2 per cent.

Yinnar South.—Repairs, painting, and provision of new tank, State School No. 2730. Particulars at Inspector of Works Office, Korumburra; Police Stations, Mirboo North, Morwell; State School, Yinnar South. Preliminary deposit, £4. Final deposit, 2 per cent.

20th July, 1948.

Albion.—Additions, general repairs, and painting, State School No. 4265. Particulars at State School, Albion. Preliminary deposit, £10. Final deposit, 2 per cent.

Apollo Bay.—Supply of forged centre post for five (5) ton crane. Wharf. Preliminary deposit, £3. Final deposit, 2 per cent.

Bayles.—Erection and completion of teacher's residence, State School No. 4374. Particulars at State School, Bayles. Preliminary deposit, £15. Final deposit, 2 per cent.

Beaconsfield.—General repairs and renovations, additional out-office accommodation, and new cupboards, State School No. 3033. Particulars at Police Stations, Berwick, Dandenong, Pakenham; State School, Beaconsfield. Preliminary deposit, £4. Final deposit, 2 per cent.

Bembridge.—Repairs, painting, and concreting, State School No. 4557. Particulars at Police Stations, Frankston, Hastings; State School, Bembridge. Preliminary deposit, £4. Final deposit, 2 per cent.

Bright.—Erection and completion of new timber residence, office, garage, loose box, woodshed, &c., Police Station. Particulars at Inspector of Works Office, Wangaratta; Police Stations, Bright, Myrtleford, Yackandandah. Preliminary deposit, £15. Final deposit, 2 per cent.

Brighton.—Installation of fire service mains, Technical School. Preliminary deposit, £10. Final deposit, 2 per cent.

Cheltenham.—Purchase for removal of one (1) second-hand Werner (unbranded) $\frac{3}{4}$ ton vertical belt-driven ammonia compressor, Heatherton Sanatorium.

Chiltern.—Erection and completion of new timber residence, office, laundry, garage, &c., Police Station. Particulars at Inspectors of Works Offices, Benalla, Wangaratta; Police Stations, Chiltern, Tallangatta, Wodonga. Preliminary deposit, £15. Final deposit, 2 per cent.

Eltham.—Conversion of Army hut into classrooms, Higher Elementary School. Particulars at Higher Elementary School, Eltham. Preliminary deposit, £10. Final deposit, 2 per cent.

Grassmere.—Painting and repairs to school and out-buildings, State School No. 1817. Particulars at Inspector of Works Office, Warrnambool; State School, Grassmere. Preliminary deposit, £5. Final deposit, 2 per cent.

Island Road.—Alterations, repairs, and painting, State School No. 3952. Particulars at Police Stations, Dandenong, Koo-wee-rup. Preliminary deposit, £10. Final deposit, 2 per cent.

Kew.—Alterations to bath-room, &c., ward B.1, Mental Hospital. Preliminary deposit, £10. Final deposit, 2 per cent.

Kew.—Renovations to lavatories, Mental Hospital. Preliminary deposit, £5. Final deposit, 2 per cent.

Lake Tyers.—Additions to staff cottage, Aboriginal Station. Particulars at Inspector of Works Office, Bairnsdale; Police Station, Orbost; Aboriginal Station, Lake Tyers. Preliminary deposit, £10. Final deposit, 2 per cent.

Longerenong.—Erection of new timber residence for Research Officer, Agricultural College. Particulars at Inspectors of Works Offices, Ararat, Horsham; Police Stations, Dimboola, Nhill, Stawell. Preliminary deposit, £15. Final deposit, 2 per cent.

Melbourne.—Internal renovation and painting of library dome, Law Courts. Preliminary deposit, £20. Final deposit, 2 per cent.

Mont Park.—Supply and installation of ventilation system in Staff Kitchen, Chronic Block, Mental Hospital. Preliminary deposit, £5. Final deposit, 2 per cent.

Parwan.—Repairs and painting, State School No. 916. Particulars at Inspector of Works Office, Ballarat; State School, Parwan. Deposit, £4.

Port Fairy.—Erection of new teacher's residence in timber, State School No. 1188. Particulars at Inspectors of Works Offices, Hamilton, Warrnambool; State School, Port Fairy. Preliminary deposit, £15. Final deposit, 2 per cent.

Speed.—Erection of new teacher's residence, Type "E.4.R.," State School No. 3861. Particulars at Inspectors of Works Offices, Mildura, Swan Hill; Police Stations, Birchip, Ouyen, Sea Lake; State School, Speed. Preliminary deposit, £15. Final deposit, 2 per cent.

Swinburne.—Supply and installation of fume hood duct-work, New Chemistry School, Technical School. Preliminary deposit, £4. Final deposit, 2 per cent.

Tongala East.—Repairs and painting, residence, State School No. 1851. Particulars at Inspector of Works Office, Shepparton; Police Station, Echuca; State School, Tongala East. Deposit, £3.

Traralgon.—Conversion of R.A.A.F. hut into classrooms, State School No. 3584. Particulars at Inspector of Works Office, Bairnsdale; Police Stations, Morwell, Sale; State School, Traralgon. Preliminary deposit, £15. Final deposit, 2 per cent.

Tawonga.—Erection and completion of teacher's residence, State School No. 2282. Particulars at Inspector of Works Office, Wangaratta; Police Stations, Myrtleford, Tallangatta; State School, Tawonga. Preliminary deposit, £15. Final deposit, 2 per cent.

Warrnambool.—Erection of a sleep-out to caretaker's quarters, State School No. 1743. Particulars at Inspector of Works Office, Warrnambool; State School, Warrnambool. Deposit, £3.

Wesburn.—Installation of electric light and power, residence, State School No. 3466. Particulars at Police Stations, Warburton, Yarra Junction.

Wonthaggi.—General repairs and painting to out-offices, repairs to boundary fences, State School No. 3650. Particulars at Inspector of Works Office, Korumburra; Police Station, Loch; State School, Wonthaggi. Preliminary deposit, £10. Final deposit, 2 per cent.

27th July, 1948.

Ballan.—Erection of new office and additions and renovations to residence, Police Station. Particulars at Inspector of Works Office, Ballarat; Police Station, Ballan. Preliminary deposit, £15. Final deposit, 2 per cent.

Barwon Downs.—Removal of teacher's residence from State School No. 2173, Garibaldi, and re-erection, State School No. 2866. Particulars at Inspectors of Works Offices, Ballarat, Geelong; Police Station, Colac; State School, Barwon Downs. Preliminary deposit, £5. Final deposit, 2 per cent.

Benalla.—Internal alterations, High School. Particulars at Inspectors of Works Offices, Benalla, Wangaratta; Police Station, Euroa. Preliminary deposit, £4. Final deposit, 2 per cent.

Box Hill South.—Adaptation of hutment for classrooms, State School No. 4138. Particulars at State School, Box Hill South. Preliminary deposit, £15. Final deposit, 2 per cent.

Casterton.—Alterations, repairs and painting, State School No. 2058. Particulars at Inspectors of Works Offices, Ararat, Hamilton; Police Station, Coleraine. Preliminary deposit, £15. Final deposit, 2 per cent.

Darling East.—Erection of new Infants' School. Preliminary deposit, £50. Final deposit, 2 per cent.

Heyfield.—Repairs and painting, &c., school and residence, State School No. 1108. Particulars at Inspector of Works Office, Bairnsdale; Police Stations, Maffra, Sale; State School, Heyfield. Preliminary deposit, £15. Final deposit, 2 per cent.

Hughesdale.—Installation of new water services, State Schools' Nursery No. 4214. Particulars at State Schools' Nursery, Hughesdale. Preliminary deposit, £5. Final deposit, 2 per cent.

Kew.—Extensions to shelter shed, Children's Cottages, Mental Hospital. Preliminary deposit, £10. Final deposit, 2 per cent.

Kew.—Erection of nurses' hostel in timber, one building only, Mental Hospital. Preliminary deposit, £50. Final deposit, 2 per cent.

Kinglake West.—Erection and completion of new teacher's residence and out-buildings, State School No. 3255. Particulars at Police Stations, Broadford, Kilmore; State School, Kinglake West. Preliminary deposit, £15. Final deposit, 2 per cent.

Manangatang.—Alterations and additions, District Hospital. Particulars at Inspector of Works Office, Swan Hill; Police Stations, Kerang, Manangatang, Piangil. Preliminary deposit, £20. Final deposit, 2 per cent.

Melbourne.—Renovation of external covering of dome, Public Library. Preliminary deposit, £20. Final deposit, 2 per cent.

Melbourne.—Supply and installation of mechanical ventilation system, National Museum. Preliminary deposit, £10. Final deposit, 2 per cent.

Oakleigh.—Erection of brick veneer caretaker's residence, Technical School. Preliminary deposit, £20. Final deposit, 2 per cent.

Sunshine.—Erection of Caretaker's Quarters, Technical School. Preliminary deposit, £20. Final deposit, 2 per cent.

Toolangi.—Supply and installation of two (2) solid fuel hot-water services in new residences, Potato Farm. Particulars at Police Station, Healesville. Preliminary deposit, £2. Final deposit, 2 per cent.

Toongabbie North.—Erection of timber residence, Soldier Settlement Commission. Particulars at Inspector of Works Office, Bairnsdale; Police Stations, Heyfield, Sale, Traralgon. Preliminary deposit, £15. Final deposit, 2 per cent.

Upwey.—Adaptation of Army hut into classrooms, High School. Particulars at Police Station, Ferntree Gully; High School, Upwey. Preliminary deposit, £10. Final deposit, 2 per cent.

Wandin Yallock.—Re-blocking teacher's residence, repairs to roof, and external and internal painting, State School No. 1033. Particulars at Police Stations, Healesville, Lilydale; State School, Wandin Yallock. Deposit, £4.

Warracknabeal.—Alterations and extensions to hot-water services and supply and installation of central heating system, new nurses' quarters, &c., District Hospital. Particulars at Inspectors of Works Offices, Ballarat, Bendigo, Horsham; Police Station, Warracknabeal. Preliminary deposit, £15. Final deposit, 2 per cent.

Tenders to be addressed to the Honorable the Commissioner of Public Works, and envelope containing tender marked "Tender for due . . ."

J. A. KENNEDY,
Commissioner of Public Works.

Melbourne, 6th July, 1948.

PRIVATE ADVERTISEMENTS.

I, FREDERICK CHARLES BALLANGER, of Mallacoota, in the State of Victoria, farm labourer, heretofore called and known by the name of Ian Smith, hereby give public notice that by a deed poll dated 21st June, 1948, duly executed and attested and deposited with the Registrar-General of the said State on the 28th day of June, 1948, and numbered 20100, I formally and absolutely renounced and abandoned the said name of Ian Smith, and declared that I had assumed and adopted, and intended thenceforth upon all occasions whatsoever to use and subscribe the name of Frederick Charles Ballanger instead of the said name of Ian Smith, and so as to be at all times thereafter called, known, and described by the said name of Frederick Charles Ballanger.

Dated the 1st day of July, 1948.

FREDERICK C. BALLANGER.

Witness—W. F. MADDISON, J.P. 4983

CITY OF GEELONG WEST.

BY-LAW No. 64.

A By-law of the City of Geelong West, made under Part XXXV. of the *Local Government Act 1946*, and numbered 64, prescribing Regulations for the care, protection, and management of the Western Foreshore Park.

IN pursuance of the powers conferred by Part XXXV. of the *Local Government Act 1946*, the Council of the City of Geelong West doth hereby make the following Regulations for the care, protection, control, and management of the Western Foreshore Park (hereinafter called the Park) which comprises all those the areas containing in all 9 acres 1 rood 31 6/10 perches, or thereabouts, and being:—

- (a) the land indicated by cross hachure on the plan annexed hereto, and thereon designated as "Rippleside";
- (b) the land indicated by hachure and cross hachure on the said plan, and thereon designated as "Western Foreshore," and which said Western Foreshore area extends in a northerly direction from a line drawn parallel to the northern boundary of allotment 1, section 42, City of Geelong, and situated 2 chains northerly therefrom to a line, being a prolongation of the southern side of Bell-parade and extending from the western boundary of that part of the Western Foreshore so vested in or acquired by the Commissioners easterly to high water mark.

Regulations.

1. In the construction and for the purpose of these Regulations, the following definitions shall apply:—

"The Council" shall mean the Council of the City of Geelong West.

"Vehicle" shall, where the context admits, mean any conveyance drawn or propelled by human or animal power.

"Motor car" shall mean any conveyance propelled by mechanical power, and includes a motor cycle.

2. The Park shall be open to the public at all times free of charge.

3. No person shall enter or remain in the Park who may offend against decency as regards dress, language, or conduct.

4. No society, club, picnic party, or other combined body shall use the Park without the consent, in writing, of the Council.

5. No person shall climb or jump over the fences or gates, stick bills thereon, cut names on fences, trees, or seats, or in any way damage any of the buildings, gates, fences, or other property in or around the Park, or pollute any water therein, or remove therefrom any soil, sand, or manures, or any other property.

6. No person shall place any advertisement, bill, poster, or any other like sign in any part of the Park nor give out or distribute any hand-bills, placards, notices, advertisements, books, pamphlets, or papers in the Park, or shall litter the same by scattering or throwing down hand-bills, placards, notices, advertisements, books, pamphlets, or papers.

7. No person shall interfere with the trees, shrubs, or other property in the Park or commit any nuisance, or leave in the Park any bottles, paper, cast-off clothing, or other litter, except in such places as may from time to time be set apart by the Council.

8. No person shall erect in the Park any building, booth, tent, table, or other structure for the purpose of offering for sale any article, or for the purpose of any game or amusement, or hawk or offer for sale therein any goods or articles of any description without the permission, in writing, of the Council and then only subject to the payment of such fees and on such conditions as the Council may determine.

9. No person shall light any fire in the Park or do any act which may cause or be likely to cause damage by fire to anything growing or being therein.

10. No person, except workmen employed in the Park, shall walk upon any flower bed or enter plots therein which may be enclosed or used for plantations for young trees, shrubs, or flowers.

11. No person shall bring into the Park any dog, or allow any dog on any of the lawns in the Park, and all dogs, goats, and poultry found wandering in the Park shall be liable to be destroyed.

12. No person shall put any cattle, horses, sheep, goats, pigs, or other animals in the Park.

13. The Council shall have full authority and power to impound any cattle found trespassing in the Park and shall be taken to be the occupier of the Park (with all power incidental to that status) within the meaning of any law for the time being in force relating to the impounding of cattle. For the purpose of this clause "cattle" shall mean cattle as interpreted by section 3 of the *Pounds Act 1928*.

14. No person shall, without the written consent of the Council, engage in any organized game or sport or dancing in the Park on Sunday, Christmas Day, or Good Friday.

15. No person shall play any unlawful game, or make any wager for money, or by unseemly conduct interfere with the comfort and enjoyment of others within the Park, or wilfully obstruct in the execution of his duty or insult or neglect to obey the lawful directions of any keeper or other servant of the Council.

16. No person shall play any musical instrument, preach, deliver any address, or take part in any public entertainment of any sort in the Park without the permission, in writing, of the Council being first obtained.

17. No person shall camp in the Park.

18. No person shall throw or cause to be thrown any stone, missile, or any hard substance in the Park, and no person shall play at cricket, hockey, football, golf, rounders, tennis, or any other game in the Park without the consent, in writing, of the Council.

19. No person shall spit or expectorate on the drives, paths, seats, or on any structure or erection in the Park.

20. No person shall drive any vehicle or motor car on any portion of the Park, except on the drives (if any) specially set apart for that purpose.

Every person by wilful act or default offending against this By-law shall for each offence be liable to a penalty of not more than Ten pounds (£10).

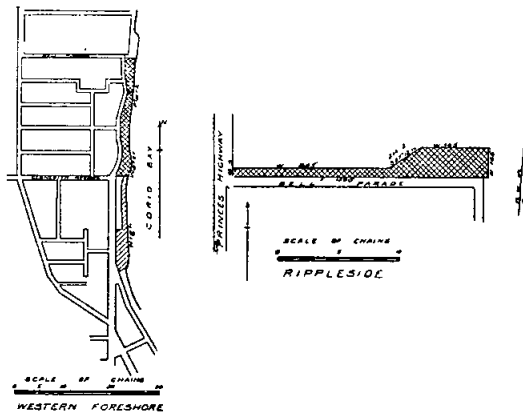

Resolution for passing this By-law agreed to by the Council, the 31st day of March, 1948.

Confirmed the 28th day of April, 1948.

The common seal of the Mayor, Councillors, and Citizens of the City of Geelong West was hereto affixed this 28th day of April, 1948, in the presence of—

(SEAL) V. C. STRADLING, Mayor.
F. C. WALKER, Councillor.
H. R. FRENCH, Town Clerk.

Approved by the Geelong Harbor Trust Commissioners on the 6th day of May, 1948.—By order, R. R. PHILLIPS, Secretary.

Approved by the Governor in Council, the 15th day of June, 1948.—C. W. KINSMAN, Clerk of the Executive Council.

CITY OF MELBOURNE.

BY-LAW No. 284.

A By-law of the City of Melbourne, made under Part VII., Division 1, of the *Local Government Act 1946*, and numbered 284, to amend or add to By-law No. 250.

THE Council of the City of Melbourne doth hereby, in pursuance of the powers conferred by the *Local Government Act 1946* and by every other Act or power in that behalf order as follows:—

1. This By-law shall, as from and after the date of the same coming into operation, be read and construed as one with By-law No. 250, intituled "A By-law of the City of Melbourne, made under Part VII., Division 1, of the *Local Government Act 1928*, and numbered 250, to amend and consolidate the By-laws with reference to street traffic, and for suppressing nuisances," and any By-laws amending the same.

2. Part 1 of the Second Schedule to By-law No. 250 shall be amended by omitting therefrom the following:—

Lonsdale-street, Central Area between Queen-street and Elizabeth-street.

That part of the carriageway of Lonsdale-street commencing at a point distant 9 feet south-easterly from the centre line of the said carriageway and 30 feet south-westerly from the prolongation north-westerly of the western boundary of Elizabeth-street; bounded thence by a line bearing south-westerly parallel to the said centre line 601 ft. 3 in.; thence by a line bearing north-westerly at right angles to the said centre line 18 feet; thence by a line bearing north-easterly parallel to the said centre line 601 ft. 3 in.; and thence by a line bearing south-easterly at right angles to the said centre line 18 feet to the commencing point.

3. Part 2 of the Second Schedule to By-law No. 250 shall be amended by adding thereto the following:—

Lonsdale-street, Central Area between Queen-street and Elizabeth-street.

That part of the carriageway of Lonsdale-street commencing at a point distant 9 feet south-easterly from the centre line of the said carriageway and 30 feet south-westerly from the prolongation north-westerly of the western boundary of Elizabeth-street; bounded thence by a line bearing south-westerly parallel to the said centre line 601 ft. 3 in.; thence by a line bearing north-westerly at right angles to the said centre line 18 feet; thence by a line bearing north-easterly parallel to the said centre line 601 ft. 3 in.; and thence by a line bearing south-easterly at right angles to the said centre line 18 feet to the commencing point.

Resolution for passing this By-law agreed to by the Council of the City of Melbourne the 10th day of May, 1948, and confirmed the 7th day of June, 1948.

In the absence of the Lord Mayor, under authority of the Council of 10th May, 1948—

(L.S.) T. S. NETTLEFOLD, Chairman.
H. S. WOOTTON, Town Clerk.

Approved by the Governor in Council, the 22nd day of June, 1948.—C. W. KINSMAN, Clerk of the Executive Council. 4963

CITY OF MOORABBIN.

ORDER CHANGING NAME OF STREET.

NOTICE is hereby given that at a meeting of the Council of the City of Moorabbin, held on the 21st day of June, 1948, the said Council, in pursuance of the provisions of the *Local Government Act 1946*, did make an order changing the name of the street set out hereunder, that is to say:—

Old name—Wards-grove.
New name—Margaretta-street.
Location—Off Centre and East Boundary roads, Bentleigh East.

WILSON B. THOMAS, Town Clerk.

Municipal Offices, Moorabbin, S.20, 28th June, 1948. 4959

SHIRE OF SHEPPARTON.

NOTICE is hereby given that Victor Clive Smith has been appointed Ranger for this Shire, in lieu of Roy Wheller, resigned.

K. LITTLE, Shire-Secretary.

Shire Hall, Shepparton. 4960

SHIRE OF TULLAROOP.

LOAN No. 4.

NOTICE is hereby given that the Council of the Shire of Tullaroop proposes to borrow the sum of £1,000, on the credit of the President, Councillors, and Ratepayers of the said shire, by the issue of debentures, in accordance with the provisions of the *Local Government Act 1946*.

The maximum rate of interest that may be paid is £3 7s. 6d. per centum per annum.

The money borrowed will be repayable, together with and including interest, at the Melbourne office of the Council's bankers for the time being, in half-yearly sums of £59 6s. 7d. each, on the 1st day of January and the 1st day of July in each year, the loan to have a currency of ten years.

The loan is to be applied for the purposes of (a) purchase of motor truck, and (b) erection of conveniences at Carisbrook Recreation Reserve.

The plans, specifications, and estimate of the cost of works referred to above, and a statement showing the proposed expenditure of money to be borrowed, are open for inspection at the Shire Office, Maryborough, during office hours.

Dated this 6th day of July, 1948.

4978 R. F. MACGUGAN, Shire Secretary.

SHIRE OF WINCHELSEA.

NOTICE is hereby given that, on the 12th day of May, 1948, John James Berry was appointed Poundkeeper at Birregurra, in lieu of Jack Ryan, junior, resigned.

4966 W. W. WESTHORPE, Shire Secretary.

THE BALLARAT SEWERAGE AUTHORITY.

PURSUANT to section 115 (2) of *Sewerage Districts Act 1928* (No. 3772), notice is hereby given of the intention to extend reticulation sewers within the area bounded approximately by the Ballarat-Maryborough and Melbourne-Adelaide railway lines, Gregory-street to Burnbank-street, Burnbank-street from Gregory-street north-west to the Melbourne-Adelaide railway line; thence by a line in a north-easterly direction to No. 845 Howitt-street, easterly along Howitt-street to Brinkley-avenue, northerly along Brinkley-avenue approximately 150 feet, easterly to the west boundary of the Show Grounds, northerly along the Show Grounds western boundary a distance of approximately 500 feet, south-easterly across the Show Grounds to the intersection of Howitt-street and Creswick-road, easterly along Howitt-street to the Ballarat-Maryborough railway line, more particularly as shown on map, and map thereof is open for inspection at this office between the hours of 9 a.m. and 4 p.m., Mondays to Fridays inclusive.

C. H. CLAMP, Secretary.

Water and Sewerage Offices, Ballarat, 2nd July, 1948.

4971

NOTICE is hereby given that the partnership heretofore subsisting between Reuben William Mann and Merle Esther Mann, at 46 Murray-street, McKinnon, under the name of "R. W. Mann," was dissolved by mutual consent on the 30th day of June, 1948. All debts due by and moneys due to the late firm will be paid or received by the said Reuben William Mann at 46 Murray-street, McKinnon.

Dated this 30th day of June, 1948.

R. W. MANN.

M. E. MANN.

Rodda, Ballard, and Vroland, solicitors, 430 Little Collins-street, Melbourne. 5034

NOTICE OF RETIREMENT.

NOTICE is hereby given that the partnership heretofore subsisting between John Aloysius Frewen, Annie Mary Frewen, Monica Clark (formerly Dowd), and Henry Michael Dowd, carrying on business as cafe proprietors at 457 Mount Alexander-road, Moonee Ponds, under the style or firm of "Alexander Cafe," has been dissolved as from the 30th day of June, 1948, so far as concerns the said Henry Michael Dowd, who retires from the said firm. The remaining partners will continue to carry on the said business.

Dated this 1st day of July, 1948.

J. A. FREWEN.

A. M. FREWEN.

M. CLARK.

H. M. DOWD.

5007

NOTICE is hereby given that the partnership heretofore subsisting between the undersigned William Charles Jasper and George Harris, carrying on business of manufacturing and selling ladies' wearing apparel, at 308 Little Flinders-street, Melbourne, under the name of "Harris and Jasper," has been dissolved by mutual consent as from the 30th day of June, 1948.

Dated this 30th day of June, 1948.

W. C. JASPER.
GEORGE HARRIS.

Witness—C. J. MERRICK.

5012

NOTICE is hereby given that the partnership heretofore subsisting between Thomas Forrest Marshall and William Wallace Gordon, carrying on business as estate and business agents at 303-9 Collins-street, Melbourne, under the style or firm name of "Gordon and Co.," has been dissolved as from the 30th day of June, 1948.

Dated the 1st day of July, 1948.

T. MARSHALL.

L. J. Murphy and Son, solicitors, 307 Collins-street, Melbourne.

5011

NOTICE is hereby given that the partnership formerly subsisting between Olof Emmanuel Johanson and Pauline Rita Grose, carrying on business as weavers at 1029 High-street, Malvern, has been dissolved by mutual consent as from the 1st day of March, 1948. All debts due to or owing by the partnership will be received and paid by the said Pauline Rita Grose.

Dated this 29th day of June, 1948.

PAULINE RITA GROSE.

R. McCallum, solicitor, Melbourne.

5024

NOTICE is hereby given that the partnership heretofore subsisting between William Sutherland Peden, Alexander James Peden, and Thomas Ian Peden, carrying on business as builders, contractors, undertakers, iron-mongers, sawmillers, furnishers, and radio salesmen at Henty-street, Casterton, under the style or firm of W. J. Peden and Sons, has been dissolved by mutual consent as from the 30th day of June, 1948, so far as concerns the said Thomas Ian Peden, who retired from the said firm. All debts due to and owing by the said late firm will be received and paid respectively by the said William Sutherland Peden and the said Alexander James Peden, who will carry on the said business in partnership under the style or firm of W. J. Peden and Sons.

Dated the 1st day of July, 1948.

W. S. PEDEN.
A. J. PEDEN.
T. I. PEDEN.

Silvester and Silvester, solicitors, Casterton.

4967

NOTICE is hereby given that the partnership heretofore subsisting between the undersigned Harold Vincent Blakeley, Ellen Jane Elizabeth Patterson, and Kenneth James Blakeley, carrying on a business as brass moulders and brass founders at 54 Clarke-street, South Melbourne, under the name of "Bronzite Brass Foundry," has been dissolved by mutual consent as and from the 31st day of March, 1948. All debts due to and owing by the said late firm will be received and paid by the said Harold Vincent Blakeley.

Dated this 30th day of June, 1948.

H. V. BLAKELEY.
E. J. E. PATTERSON.
KENNETH J. BLAKELEY.

Witness—L. CHISHOLM, solicitor, Melbourne.

Maddock, Lonie, and Chisholm, solicitors, 339 Collins-street, Melbourne.

5010

NOTICE is hereby given that the partnership heretofore subsisting between the undersigned Walter William Whitford and Grace Catherine Quinn, carrying on a home-made cake business under the style or firm name of "Quinn's Cookery," at 214a Glenferrie-road, Glenferrie, 1 Church-street, Hawthorn, and 219 Auburn-road, Hawthorn, has been dissolved as from the 1st day of July, 1948, the said Walter William Whitford having sold his interest in the said business to the said Grace Catherine Quinn, who will carry on the said business as from the said 1st day of July, 1948.

Dated at Hawthorn, the 30th day of June, 1948.

W. W. WHITFORD.
G. C. QUINN.

4996

PARTNERSHIP ACT.

NOTICE is hereby given that the partnership hitherto subsisting between Walter McGregor and Alexander McGregor, of Rochester, carrying on business as farmers under the name or style of "W. and A. McGregor Bros.," has been dissolved by mutual consent as from the 1st day of July, 1948.

Dated the 1st day of July, 1948.

WALTER MCGREGOR.
ALEXANDER MCGREGOR.

H. W. Raleigh and Roberts, solicitors, Rochester. 4986

Companies Act 1938.

J. H. ABBOTT & CO. PROPRIETARY LIMITED.

AT an Extraordinary General Meeting of the above-named company, duly convened and held at 105 Pall Mall, Bendigo, on Wednesday, the 30th day of June, 1948, the following Resolution was passed as a Special Resolution:—

"That the company be wound up voluntarily."

And at such last-mentioned meeting Reginald Garnet Booth, of 18 View-street, Bendigo, was appointed liquidator for the purposes of the winding up.

Dated the 30th day of June, 1948.

4957

L. A. ABBOTT, Chairman.

COLLINS AND SWANSTON STREETS PROPERTY PROPRIETARY LIMITED.

NOTICE is hereby given, in pursuance of section 236 of the Companies Act 1938, that a General Meeting of the members of the above-named company will be held at the office of Secretariat Proprietary Limited, 360 Collins-street, Melbourne, on Monday, the 9th day of August, 1948, at Ten o'clock in the forenoon, for the purpose of having an account laid before them showing the manner in which the winding up has been conducted and the property of the company disposed of, and of hearing any explanation that may be given by the liquidator.

Dated this 6th day of July, 1948.

V. T. BOLDEMAN, Liquidator.

Messrs. Pavey, Wilson, Cohen, and Carter, of 360 Collins-street, Melbourne, solicitors for the liquidator. 5015

Companies Act 1938.

C. & R. STEEL PRODUCTS PROPRIETARY LIMITED.

NOTICE OF SPECIAL RESOLUTION TO WIND UP, PURSUANT TO SECTION 226.

AT an Extraordinary General Meeting of the above-named company, duly convened and held at 2 Collins-street, Melbourne, on Wednesday, the 30th day of June, 1948, the following Resolution was duly passed as a Special Resolution:—"That the company be wound up voluntarily." And at such last-mentioned meeting Henry Cosmos Broderick, of 340 Collins-street, Melbourne, was appointed liquidator for the purposes of the winding up.

Dated the 5th day of July, 1948.

5000

L. F. REVILL, Chairman.

Companies Act 1938.

PRESENTATION SISTERS PROPERTY ASSOCIATION.

NOTICE OF INTENTION TO APPLY TO ATTORNEY-GENERAL FOR LICENCE, PURSUANT TO SECTION 18 (1).

I, ADELA LARDI, of O'Neill College, Nagle-avenue, Elsternwick, in the State of Victoria, on behalf of the Presentation Sisters Property Association about to be formed for the purposes of religion and education, hereby give notice of intention to apply to the Attorney-General for a licence directing that the said Association be registered as a company with limited liability, without the addition of the word "Limited" to its name.

Dated this 1st day of July, 1948.

4984

ADELA LARDI, Mother General.

CYRIL ROFE, late of 27 Martin-street, Elwood, in the State of Victoria, chief enquiry officer, DECEASED, intestate.

CREDITORS, next of kin, and others having claims against the estate of the above-named deceased are required by the administrator of his estate, Enid Margaret Rofe, to send particulars to her, at the under-mentioned address, on or before the 7th day of September, 1948, after which date she will distribute the assets, having regard only to the claims of which she then has notice.

RODDA, BALLARD, & VROLAND, solicitors, 430 Little Collins-street, Melbourne. 5033

NOTICE TO CREDITORS AND OTHERS.—*RE ELIZA LOUISA PAULO, DECEASED.*

PURSUANT to the *Trustee Act 1928*, notice is hereby given that all persons having claims against the estate of Eliza Louisa Paulo, formerly of 116 Magnolia-street, Mildura, married woman, but late of 5 Linsey-street, Coburg, widow, deceased (who died on the 30th day of March, 1948, and probate of whose will was granted by the Supreme Court of Victoria on the 4th day of June, 1948, to the executrix, Phyllis Burland Black), are hereby required to send particulars, in writing, of such claims to the said executrix, care of the under-mentioned solicitors, on or before the 17th day of September, 1948, after which date the said executrix will proceed to distribute the assets of the said deceased which shall have come to her hands amongst the persons entitled thereto, having regard only to the claims of which she shall then have had notice, and the said executrix will not be liable for the assets so distributed, or any part thereof, to any person of whose claim she shall not have had notice as aforesaid.

Dated this 18th day of July, 1948.

ARTHUR ROBINSON & CO., 360 Collins-street, Melbourne, solicitors for the said executrix. 5035

PURSUANT to the *Trustee Act 1928*, notice is hereby given that all persons having any claim against the estate of Rhoda Jane Bunworth, late of "Beaufort Park," Dresden-street, Heidelberg, in the State of Victoria, widow, deceased (who died on the 23rd November, 1947, and probate of whose will was on the 16th December, 1947, granted by the Supreme Court to Thomas Cole, of 18 Noel-street, Ivanhoe, clerk in holy orders, and Harry Tolhurst McKean, of 84 William-street, Melbourne, solicitor, the executors appointed by the said will), are hereby required to send particulars, in writing, of such claims to the said executors, at the office of McKean and Park, 84 William-street, Melbourne, on or before the 8th September, 1948, after which date the said executors will proceed to distribute the assets of the said deceased which have come to their hands among the persons entitled thereto, having regard only to the claims of which they shall then have had notice.

McKEAN & PARK, solicitors, 84 William-street, Melbourne. 4989

CREDITORS, next of kin, and all others having claims against the estate of Arthur Alfred Bryant, late of Stanhope, in the State of Victoria, farmer, deceased (who died on the 13th day of August, 1946), are requested by Lawrence Archibald Bryant, of Stanhope, farmer (to whom letters of administration with the will annexed of the said deceased have been duly granted), to send particulars of all claims to him, in care of the undersigned solicitors, on or before the 1st day of August, 1948, after which date he will distribute the assets of the estate, having regard only to the claims of which he shall then have had notice.

GALLOWAY STEWART & O'TOOLE, solicitors, Tatura. 4988

RE JANET COE, DECEASED.

NOTICE is hereby given that all persons having claims against the property or estate of Janet Coe, late of Wilson-street, Geelong, widow, deceased (who died on the 6th day of May, 1948, and letters of administration of whose estate were granted to Emma Laird, of 12 Vista-street, Sans Souci, in the State of New South Wales, spinster), are hereby required to send, in writing, particulars of such claims to the said Emma Laird, in the care of the under-mentioned solicitors, on or before the 9th day of September, 1948, after which date she will convey or distribute such property or estate to or among the persons entitled thereto, having regard only to the claims of which she shall then have had notice.

HARWOOD & PINCOTT, 51 Yarra-street, Geelong, and 472 Bourke-street, Melbourne, solicitors for the said Emma Laird. 4955

CREDITORS, next of kin, and others having claims against the estate of Keith Baragwanath Ramsay, late of 101 Greeves-street, Fitzroy, in the State of Victoria, builder, deceased (who died on the 10th February, 1948), are to send particulars of their claims to Allan Percival Ramsay, the administrator of the estate of the deceased, at the address of his solicitors hereinafter named, on or before the 11th September, 1948, after which date he will distribute the assets, having regard only to claims of which he then has notice.

WEIGALL & CROWTHER, solicitors, 459 Chancery-lane, Melbourne. 5004

PURSUANT to the *Trustee Act 1928*, all persons having claims against the property or estate of Helen Kestell Le Roux, formerly of Martindale, Barnawartha, in the State of Victoria, but late of Moorooduc, in the State of Victoria, married woman, deceased (who died on the 11th day of October, 1947, and probate of whose will was granted by the Supreme Court of Victoria, on the 30th day of December, 1947, to Henry Reeve Le Roux, of Moorooduc aforesaid, farmer and grazier, the executor named in and appointed by the said will), are hereby required to send particulars of such claims to the said executor, addressed to the care of Frank B. Lethbridge, solicitor, Rutherglen, on or before the 8th day of August, 1948, after the expiration of which time the said executor will proceed to distribute the assets of the said deceased amongst the persons entitled thereto, having regard only to the claims of which he shall have then had notice.

Dated the 30th day of June, 1948.

FRANK B. LETHBRIDGE, of Main-street, Rutherglen, solicitor for the executor. 4981

WILLIAM VENING, late of Alberton, retired farmer, DECEASED.

PURSUANT to the *Trustee Act 1928*, creditors, next of kin, and all others having claims against the estate of the above-named deceased (who died on the 15th day of January, 1948), are required by the executors, George Greer Vening and Eliza Jane Hodgson, to whom probate of deceased's will has been granted, to send particulars of such claims to the executors, care of the undersigned solicitors, on or before the 18th day of September, 1948, after which date the executors will distribute the assets of the deceased, having regard only to the claims of which they then have had notice.

SKINNER & HART, solicitors, Yarram. 4980

PURSUANT to the *Trustee Act 1928*, creditors, next of kin, and all other persons having claims against the estate of Joseph Roy Coleston, late of 36 Disraeli-grove, Pascoe Vale South, in the State of Victoria, timber worker, deceased, intestate (who died on the 26th day of April, 1948), are required by the administrator, Joseph Hoy, to whom letters of administration of the estate of the said deceased were granted, to send particulars, in writing, of such claims to the administrator, care of the under-mentioned solicitor, on or before the 1st day of October, 1948, after which date the administrator will proceed to distribute the estate of the said deceased to or among the persons entitled thereto, having regard only to the claims of which he shall then have had notice.

T. D. ARMSTRONG, solicitor, 422 Collins-street, Melbourne. 4997

CREDITORS, next of kin, and others having claims against the estate of Annie Emma Birrell, late of 39 Mary-street, Hawthorn, in the State of Victoria, widow, deceased, are to send particulars of their claims to The Union Trustee Company of Australia Limited, of 333 Collins-street, Melbourne, by the 11th September, 1948, after which date it will distribute the assets, having regard only to claims of which it then has notice.

WEIGALL & CROWTHER, solicitors, 459 Chancery-lane, Melbourne. 5003

PURSUANT to the provisions of the *Trustee Act 1928*, notice is hereby given that all persons having claims against the estate of Douglas Daniel Swaffer, late of 22 Ruskin-street, Elwood, in the State of Victoria, retired grazier, deceased (who died on the 3rd of April, 1948, and probate of whose will was on the 25th June, 1948, granted by the Supreme Court of Victoria to Percy Edward Swaffer of 16 Hardinge-street, Deniliquin, in the State of New South Wales, agricultural field officer, and Cyril Charles Brown, of 1 Lara-street, Malvern, in the State of Victoria aforesaid, manager, the executors appointed thereby), are hereby required to send particulars, in writing, of such claims to the said Percy Edward Swaffer and Cyril Charles Brown, to care of Malleison, Stewart, and Co., at the address below, on or before the 15th September, 1948, after which date the said executors will proceed to convey or distribute the said estate to or among the persons entitled thereto, having regard only to the claims, whether formal or not, of which they shall then have had notice, and will not be liable for the assets so distributed to any person of whose claim they shall not then have had notice.

MALLEISON, STEWART, & CO., solicitors, 46 Queen-street, Melbourne. 5029

CREDITORS, next of kin, and others having claims in respect of the estate of Hilda Eyre Crowe, late of 4 Grange-road, Kew, married woman, deceased (who died on the 29th day of December, 1947), are required to send the particulars of their claims to The Union Trustee Company of Australia Limited, of 333 Collins-street, Melbourne (and of 398 Queen-street, Brisbane, in the State of Queensland), by the 15th day of September, 1948, after which date it will distribute the assets, having regard only to the claims of which it then has notice.

G. W. S. ANDERSON, SEWELL & SEWELL, solicitors,
422 Collins-street, Melbourne, C.1. 5013

CREDITORS, next of kin, and others having claims in respect of the estate of Francis Watson, formerly of Marshlands, near Blenheim, New Zealand, but late of Dunedin, New Zealand, station cook, deceased (who died on or about the 28th December, 1947), are to send particulars of their claims to The Trustees, Executors, and Agency Company Limited, of 401-403 Collins-street, Melbourne, by the 9th day of September, 1948, after which date the said company will distribute the assets, having regard only to the claims of which it then has notice.

WEIGALL & CROWTHER, solicitors, 459 Chancery-lane, Melbourne. 5014

CREDITORS, next of kin, and all others having claims against the estate of Mabel Florence Robertson, late of 1 Emo-road, East Malvern, in the State of Victoria, widow, deceased (who died on the 6th day of March, 1948), are required to send particulars of their claims to William Blakiston Hodgson, care of Hodgson and Finlayson, solicitors, 360 Collins-street, Melbourne, by the 15th day of September, 1948, after which date the said William Blakiston Hodgson will distribute the assets in the estate of the said deceased, having regard only to the claims of which he then has notice.

HODGSON & FINLAYSON, 360 Collins-street, Melbourne, solicitors. 4993

CREDITORS, next of kin, and others having claims in respect of the estate of John Vincent Drew, late of 2 Queens-street, East St. Kilda, in the State of Victoria, retired guesthouse proprietor, deceased (who died on the 4th day of March, 1948), are to send the particulars of their claims to the Union Trustee Company of Australia Limited, whose registered office is at 333 Collins-street, Melbourne, in the said State, by the 9th day of September, 1948, after which date it will distribute the assets, having regard only to the claims of which it then has notice.

Dated the 2nd day of July, 1948.

J. M. SMITH & EMMERTON, 480 Bourke-street, Melbourne, solicitors. 4990

ALL persons having claims against the estate of Nellie Elizabeth Davidson, late of Clairnell, 10 Arthur-street, Malvern, Victoria, spinster, deceased (letters of administration of whose estate were granted with the will annexed by the Supreme Court of Victoria, on the 4th day of February, 1948, to Helen Ogilvie Davidson, of 136 King-street, Mascot, in the State of New South Wales, widow), are required to send particulars, in writing, of such claims to the said administratrix, or to the under-mentioned solicitors, on or before the 10th day of September, 1948, after which date the administratrix will proceed to distribute the assets of the deceased amongst the persons entitled thereto, having regard only to claims of which she shall have had notice.

Dated the 3rd day of July, 1948.

R. E. LEWIS & SON, 379 Collins-street, Melbourne, solicitors for the administratrix. 4991

ALL persons having claims against the estate of Thomas John Francis Reilly, late of 209 Adelaide-terrace, Perth, in the State of Western Australia, retired mercer, deceased (who died 20th October, 1946, and a reseal of the exemplification of the probate of whose will has been granted to Francis Reilly, of 104 Wellington-street, Bondi, in the State of New South Wales, civil servant, the surviving executor therein named), are hereby required to send particulars, in writing, of such claims to the said executor, care of his solicitor, Francis William Reilly, at 79 Elizabeth-street, Sydney, in the State of New South Wales, on or before the 20th day of September, 1948, after which last-mentioned date the said executor will proceed to distribute the assets of the said deceased amongst the persons entitled thereto, having regard only to the claims of which he shall then have had notice, and will not be liable for the assets so distributed to any person of whose claim he shall not have had notice as aforesaid.

BERNARD NOLAN, 408 Collins-street, Melbourne, solicitor. 4999

PURSUANT to the *Trustee Act 1928*, all persons having claims against the estate of Elizabeth Mary Driscoll, late of 76 Campbell-road, Upper Hawthorn, in the State of Victoria, widow, deceased (who died on the 2nd day of February, 1948, and probate of whose will and codicil was granted by the Supreme Court of Victoria, on the 1st day of July, 1948, to National Trustees, Executors and Agency Company of Australasia Limited, the registered office of which is situate at 95 Queen-street, Melbourne, in the said State, and Robert Francis Driscoll, formerly of 263 Moreland-road, West Coburg, but now of One Tree Hill Hotel, Spring Gully, Bendigo, in the said State, licensed victualler, the executors appointed by the said will and codicil), are hereby required to send particulars, in writing, of such claims to the said company, at its above-mentioned address, on or before the 14th day of September, 1948, after which date the said executors will proceed to distribute the assets of the said deceased amongst the persons entitled thereto, having regard only to the claims of which they shall then have had notice; and notice is hereby given that the executors will not be liable for the assets so distributed, or any part thereof, to any person of whose claim they shall not then have had notice.

Dated the 5th day of July, 1948.

RYMER, LANGFORD, & RITCHIE, solicitors, 128 William-street, Melbourne. 4995

CREDITORS, next of kin, and others having claims in respect of the estate of Richard Morton Hoare, late of 3 Flat, Wallace Court, Wallace-avenue, Toorak, gentleman, deceased (who died on the 20th day of January, 1948), are to send particulars of their claims to the executrix, Nellie Isabel McGrath, to the care of the undersigned, by the 10th day of September, 1948, after which date the executrix will distribute the assets, having regard only to the claims of which she then has notice.

NIGAN, HENNESSY, & CO., solicitors, 175 Greville-street, Prahran. 4979

CREDITORS, next of kin, and others having claims in respect of the estate of Dorothy MacCarthy, late of 6 John-street, East Malvern, married woman, deceased (who died on the 13th day of April, 1948), are to send particulars of their claims to Peter McCallum, the executor, care of the undersigned, by the 10th day of September, 1948, after which date he will distribute the assets, having regard only to claims of which he then has notice.

WILLIAM S. COOK & MCCALLUM, solicitors, 422 Collins-street, Melbourne. 5023

HARRIET COBBLEDICK, DECEASED.

CREDITORS, next of kin, and others having claims in respect of the estate of Harriet Cobbledick, late of No. 8 Rosemont-avenue, Caulfield, widow, deceased (who died on the 1st April, 1948), are to send particulars of their claims to the Trustees, Executors, and Agency Company Limited, of No. 401 Collins-street, Melbourne, in the State of Victoria, by the 10th September, 1948 (to which said company probate of the will of the said deceased was granted by the Supreme Court of the said State), after which date the said company will distribute the assets of the said estate, having regard only to the claims of which it shall then have notice.

ALEXR. GRANT, DICKSON, & KING, solicitors, 119 William-street, Melbourne. 4994

THOMAS BENJAMIN DENSLEY, late of Ballan, labourer, DECEASED, intestate.

CREDITORS, next of kin, and all others having claims against the estate of the said deceased (who died on the 1st day of May, 1948), are required to send particulars of their claims to Walter John Densley, the administrator of the said estate, in the care of his solicitors, whose name and address appears hereunder, by the 9th day of September, 1948, after which date the said Walter John Densley will distribute the assets in the estate of the said deceased, having regard only to the claims of which he then has notice.

DUGDALE, SIMMONS, & STEVENS, of 486 Bourke-street, Melbourne, solicitors. 5002

PURSUANT to the *Trustee Act 1928*, creditors, next of kin, and all other persons having claims in respect of the estate of Walter Charles Jones, late of 4 Stirling-street, Footscray, gentleman (who died on the 6th day of February, 1948), are required by the executor, William Mascotte Bracken, to whom probate of the deceased's will has been granted, to send particulars of such claims to the executor, care of the under-mentioned solicitor, on or before the 15th day of September, after which date the executor will distribute the assets, having regard only to the claims of which he then has notice.

JOHN GINNANE, 422 Collins-street, Melbourne, and 74 Nicholson-street, Footscray, solicitor. 5001

CREDITORS, next of kin, and those having claims in respect of the estate of Agnes Dorothy Hay, late of 7 Queen's Gate-terrace, Kensington, in the City of London, England, spinster, deceased (who died on the 18th day of March, 1947), are to send particulars of their claims to Permanent Trustee Company of New South Wales Limited, of 25 O'Connell-street, Sydney, New South Wales, by the 11th day of September, 1948, after which date it will distribute the assets, having regard only to the claims of which it then has notice.

OAKLEY, THOMPSON & CO., solicitors, 443 Little Collins-street, Melbourne. 4998

CREDITORS, next of kin, and others having claims in respect of the estate of Doreen Cecilia Curtaigne, late of 11 Linda-crescent, Hawthorn, in the State of Victoria, married woman (who died on the 23rd day of April, 1948), are to send the particulars of their claims to The Perpetual Executors and Trustees Association of Australia Limited, of 100-104 Queen-street, Melbourne, in the said State, by the 8th day of September, 1948, after which date it will distribute the assets, having regard only to the claims of which it then has notice.

PURVES & PURVES, solicitors, 448 Collins-street, Melbourne. 5032

JOHN JAMES LISTON, late of 192 Wellington-parade, East Melbourne, secretary DECEASED, intestate (who died on the 25th day of April, 1944).

CREDITORS, next of kin, and all persons having claims against the estate of the above-named deceased are requested by the administrator, John Ernest Liston, formerly of 192 The Avenue, Parkville, but now of "Mount Royal," Upper Ferntree Gully, secretary, to send particulars thereof to such administrator, care of the undersigned, on or before the 1st day of October, 1948, after which date the administrator will proceed to distribute the assets of the deceased, having regard only to the claims of which he then shall have notice.

MAHONY, O'BRIEN, & DUGGAN, 20 Queen-street, Melbourne, solicitors. 5030

CREDITORS, next of kin, and others having claims in respect of the estate of William Edwin Flanagan, late of "Co-Wabee," 470 St. Kilda-road, Melbourne, gentleman, deceased (who died on the 17th day of January, 1948), are to send particulars of their claims to National Trustees, Executors, and Agency Company of Australasia Limited, whose registered office is situate at 95 Queen-street, Melbourne, by the 10th day of September, 1948, after which date it will distribute the assets, having regard only to the claims of which it then has notice.

GILLOTT, MOIR, & AHERN, solicitors, 95 Queen-street, Melbourne. 5027

THOMAS MCFARLANE, late of Swan Hill, in the State of Victoria, farmer, DECEASED (who died on the 1st day of December, 1947).

CREDITORS, next of kin, and all other persons having claims against the estate of the deceased are required by the executors of the will, Glen Alan McFarlane, of Swan Hill aforesaid, carrier, and Charles Arthur Bruce McFarlane, of Beauchamp, in the State of Victoria, farmer, to send particulars to them, care of the undersigned, on or before the 21st day of September, 1948, after which date they will distribute the assets, having regard only to the claims of which they then have notice.

Dated the 21st day of June, 1948.

ALAN GARDEN & GREEN, solicitors, 29 McCallum-street, Swan Hill. 4985

PURSUANT to the *Trustee Act* 1928, notice is hereby given that all persons having claims against the estate of John Edward Power, late of Whyte-street, Clunes, storekeeper, deceased (who died on the 8th day of May, 1946, and probate of whose will is being applied for by The Ballarat Trustees, Executors, and Agency Company Limited, of 101 Lydiard-street north, Ballarat), are hereby required to send particulars, in writing, of such claims to the said company, at its above-mentioned address, on or before the 17th September, 1948, after which date the said executor will proceed to distribute the assets of the testator amongst the persons entitled thereto, having regard only to the claims of which it shall then have had notice, and will not be liable for the assets so distributed to any person of whose claim it shall not then have had notice.

Dated the 5th day of July, 1948.

NEVETT, NEVETT, & GLENN, 11 Lydiard-street south, Ballarat, proctors for the said executor. 4977

ELIZABETH CAROLINE PETERSEN, late of Sherriff-street, Stawell, in Victoria, widow, DECEASED.

PURSUANT to the *Trustee Act* 1928, creditors, next of kin, and all others having claims against the estate of the above-named deceased (who died on the 25th day of March, 1948), are required by the executor, Harry Passfield, to whom probate of the deceased's will has been granted, to send particulars of such claims to the executor, care of the under-mentioned solicitors, on or before the 15th day of September, 1948, after which date the executor will distribute the assets of the deceased, having regard only to the claims of which he then has notice.

J. ALLAN ANDERSON & WEBB, solicitors, Stawell. 4987

CREDITORS, next of kin, and others having claims in respect of the estate of Daniel McLeod, formerly of Fish Creek, but late of 56 Point Nepean-road, Elsternwick, retired grazier (who died on the 19th day of February, 1948), are to send the particulars of their claims to The Equity Trustees, Executors, and Agency Company Limited, of 472 Bourke-street, Melbourne, by the 10th day of September, 1948, after which date it will distribute the assets, having regard only to the claims of which it then has notice.

SKINNER & HART, solicitors, Commercial-road, Yarram. 4982

PURSUANT to the *Trustee Act* 1928, all persons having claims against the property or estate of Mary Macvean, late of Auckland, in the Dominion of New Zealand, spinster, deceased (who died on the 13th day of November, 1947, and probate of whose will and codicil was granted to The Guardian Trust and Executors Company of New Zealand Limited and David Macvean, the executors named therein, by the Supreme Court of New Zealand, on the 26th day of January, 1948, and an application for reseat of an exemplification of which said probate was on the 29th day of June, 1948, granted by the Supreme Court of Victoria to Cyril Quinton Wilkinson, of Melbourne, manager of the South British Insurance Company Limited, the duly authorized attorney under power of the said executors), are hereby required to send in particulars, in writing, of such claims to the said Cyril Quinton Wilkinson, on or before the 10th day of September, 1948, after which date the said Cyril Quinton Wilkinson will, in pursuance of section 86 of the *Administration and Probate Act* 1928, pay, and/or hand over to the said executors the assets of the said deceased, which shall have come to his hands or possession, having regard only to the claims of which he shall have had notice.

Dated this 1st day of July, 1948.

DUDLEY A. TREGENT, B.A., LL.M., 422 Collins-street, Melbourne, solicitor for the said attorney. 5009

CREDITORS, next of kin, and others having claims in respect of the estate of Maria Jane Smith, late of Barringo Creek, New Gisborne, in the State of Victoria, spinster, deceased (who died on the 10th April, 1948), are to send particulars of their claims to National Trustees, Executors, and Agency Company of Australasia Limited, whose registered office is at 95 Queen-street, Melbourne, by the 11th September, 1948, after which date it will distribute the assets, having regard only to claims of which it then has notice.

WEIGALL & CROWTHER, solicitors, 459 Chancery-lane, Melbourne. 5008

CREDITORS, next of kin, and others having claims in respect of the estate of Hannah Jane Sharp, late of Garden-street, Portland, in the State of Victoria, spinster, deceased (who died on the 9th day of February, 1948), are to send particulars of their claims to Stephen Arthur Sharp, care of the undersigned, by the 10th day of September, 1948, after which date he will distribute the assets, having regard only to the claims of which he then has notice.

E. L. MORAN, solicitor, 281 Collins-street, Melbourne. 5006

CREDITORS, next of kin, and others having claims in respect of the estate of Harold Gibling Behan, late of 24 Power-street, Hawthorn, retired bank manager (who died on 20th March, 1948), are to send the particulars of their claims to the Equity Trustees, Executors, and Agency Company Limited, of 472 Bourke-street, Melbourne, by the 14th day of September, 1948, after which date it will distribute the assets, having regard only to the claims of which it has notice.

NEWMAN, WINGROVE, & BOUGHTON, solicitors, 100 Queen-street, Melbourne. 5005

JOHN MEYER, late of Lismore, in the State of Victoria, grazier, DECEASED (who died on the 31st day of October, 1947).

CREDITORS, next of kin, and all other persons having claims against the estate of the said deceased are required by the executors, John Edward Meyer, of Lismore, grazier, and Gladys McLean, of Rennie-street, Coburg, married woman, to send detailed particulars of their claims in respect of the said property to them, care of the undersigned, on or before the 11th day of September, 1948, after which date they will proceed to distribute the said estate, having regard only to the claims of which they then have notice.

Dated this 1st day of July, 1948.

R. H. RAMSAY, 41 Lydiard-street, Ballarat, solicitor for the said executors. 4970

CREDITORS, next of kin, and others having claims in respect of the estate of Martha Walker, late of Scarsdale, spinster, deceased (who died on the 26th day of May, 1948), are to send the particulars of their claims to the Ballarat Trustees, Executors, and Agency Company Limited, of 101 Lydiard-street north, Ballarat, by the 10th day of September, 1948, after which date it will distribute the assets, having regard only to the claims of which it then has notice.

DOOLEY, SUTTON, & A. W. LONG, 38 Lydiard-street south, Ballarat, solicitors. 4969

GEORGE EDWARD ROY KILPATRICK, late of Swan Hill, in the State of Victoria, woodcutter, DECEASED (who died on the 22nd day of February, 1948).

CREDITORS, next of kin, and all other persons having claims against the estate of the deceased are required by the executrix of the will, Emmeline Eliza Kilpatrick, of Swan Hill aforesaid, widow, to send particulars to her, care of the undersigned, on or before the 2nd day of October, 1948, after which date she will distribute the assets, having regard only to the claims of which she then has notice.

Dated the 2nd day of July, 1948.

ALAN GARDEN & GREEN, solicitors, 29 McCallum-street, Swan Hill. 4961

Trustee Act 1928.

NOTICE TO CLAIMANTS.

PURSUANT to the *Trustee Act 1928*, creditors, next of kin, and all other persons having claims in respect of the estate of any deceased persons named below are required to send particulars thereof to the legal personal representative or representatives at the address stated below, on or before the date stated, after which date the representative or representatives will distribute the assets, having regard only to the claims of which notice has been received:—

Thomas Learmonth, late of Bridgewater, Victoria, farmer, deceased, who died on the 14th day of April, 1948.—Claims to the executors, Thomas Gilbert Learmonth, of Bridgewater, Victoria, farmer, and Kenneth Stuart Smalley, of Williamson-street, Bendigo, solicitor, in care of the undersigned solicitors, by the 12th day of September, 1948. Tatchell, Dunlop, Smalley, and Balmer, solicitors, Williamson-street, Bendigo. 4976

Robert Mahood, late of Wangoom, farmer, deceased, intestate, died 13th December, 1947.—Claims to the administrators, Lillian Isabel Mary Mahood, of Wangoom, widow, and John Edwin Mahood, of Purnim, farmer, in the care of Messieurs Mackay and Taylor, of Kepler-street, Warrnambool, by the 8th September, 1948. Mackay and Taylor, Kepler-street, Warrnambool, solicitors to the administrators. 4992

MINING NOTICES.

SOUTH COSTERFIELD ANTIMONY AND GOLD MINING COMPANY NO LIABILITY.

CALL NOTICE.

A CALL (the 4th) of Three pence per share has been made on the capital of this company, due and payable at the company's office, 16 View-street, Bendigo, on Wednesday, 14th July, 1948.

4956

N. McLAREN YOUNG, Manager.

No. 691.—6875/48.—3

KALIMNA OIL COMPANY NO LIABILITY.

NOTICE is hereby given that a Call (the 37th) of One penny per share on all the issued contributing shares in the capital of the company (making 4s. 7½d. paid up) has been made, due and payable at the registered office of the company, 360 Collins-street, Melbourne, on Wednesday, 14th July, 1948.

By order of the Board,

L. B. TOMLINS, Legal Manager.

360 Collins-street, Melbourne, 7th July, 1948. 5025

NEW COOLGARDIE GOLD MINES NO LIABILITY.

NOTICE is hereby given that a Call (the 5th) of One shilling (1s.) per share on all the issued contributing shares in the capital of the company (making such shares paid to 6s. each) has been made, due and payable to the manager at the registered office of the company, 360 Collins-street, Melbourne, on Wednesday, the 14th day of July, 1948.

By order of the Board,

L. EDWARDS, Manager.

360 Collins-street, Melbourne, 7th July, 1948. 5044

HERCULES GOLD MINING COMPANY NO LIABILITY.

A CALL (the 70th) of Three pence per share has been made on the capital of the company (making the shares paid to 20s. each), due and payable at the company's registered office, 379 Collins-street, Melbourne, on Wednesday, 14th July, 1948.

H. L. STEWART

5040

(J. G. Stanfield and Stewart), Manager.

IRONBARK GOLD MINING COMPANY NO LIABILITY.

A CALL (the 108th) of Three pence per shares has been made on the capital of the company (making the shares paid to 28s. each), due and payable at the company's registered office, 379 Collins-street, Melbourne, on Wednesday, 14th July, 1948.

H. L. STEWART

5041

(J. G. Stanfield and Stewart), Manager.

IRONBARK SOUTH GOLD MINING COMPANY NO LIABILITY.

A CALL (the 87th) of Three pence per share has been made on the capital of the company (making the shares paid to 25s. 3d. each), due and payable at the company's registered office, 379 Collins-street, Melbourne, on Wednesday, 14th July, 1948.

H. L. STEWART

5042

(J. G. Stanfield and Stewart), Manager.

VICTORY TIN NO LIABILITY.

NOTICE is hereby given that a Call (No. 2) of One pound per share (making shares paid up to £4) has been made on contributing shares in the above company, due and payable to me at the registered office, Temple Court, 422 Collins-street, Melbourne, on Wednesday, 14th July, 1948.

By order of the Board,

JAMES L. MOORE, Manager.

Temple Court, 422 Collins-street, Melbourne, C.1, 5th July, 1948. 5031

AJAX SOUTH GOLD MINE N. L.

NOTICE is hereby given that a Call (the 32nd) of Three pence per share (making shares 9s. paid up) has been made upon the capital of the company, due and payable at the registered office of the company, 430 Little Collins-street, Melbourne, on Wednesday, the 14th day of July, 1948.

By order of the Board,

A. E. LLEWELLYN, Manager.

430 Little Collins-street, Melbourne, C.1, 6th July, 1948. 5028

NORTH NELL GWYNNE GOLD MINES NO LIABILITY.

NOTICE is hereby given that a Call (the 81st) of Three pence per share has been made on all shares in the company, numbered 1 to 60,000 (making such shares paid up to 29s. 3d. each), due and payable at the registered office of the company, 46 Queen-street, Melbourne, on Wednesday, 14th July, 1948.

By order of the Board,

F. H. TADGELL, Manager.

Dickenson and Tadgell, chartered accountants (Aust.),
46 Queen-street, Melbourne, C.I. 5026

MOUNT TODD GOLD MINE NO LIABILITY.**CALL NOTICE.**

NOTICE is hereby given that a Call (No. 5) of Six pence per share (making shares paid up to 8s.) has been made, and is due and payable to me, at the registered office, 422 Collins-street, Melbourne, on Wednesday, 14th July, 1948.

By order of the Board,

FRANK COOPER, Manager.

422 Collins-street, Melbourne, C.I. 5021

NEW CHUM SYNCLINE GOLD MINE NO LIABILITY.**CALL NOTICE.**

NOTICE is hereby given that a Call (No. 97) of Three pence per share (making shares paid up to 30s.) has been made, and is due and payable to me, at the registered office, 422 Collins-street, Melbourne, on Wednesday, 14th July, 1948.

By order of the Board,

FRANK COOPER, Manager.

422 Collins-street, Melbourne, C.I. 5020

ARGUS HILL CHEWTON GOLD NO LIABILITY.

NOTICE is hereby given that a Call (No. 57) of Three pence per share (making shares paid up to 16s. 7½d.) has been made, and is due and payable to me, at the registered office, 422 Collins-street, Melbourne, on Wednesday, 14th July, 1948.

By order of the Board,

FRANK COOPER, Manager.

422 Collins-street, Melbourne, C.I. 5018

**SOUTH VIRGINIA GOLD MINING COMPANY.
NO LIABILITY.**

NOTICE is hereby given that a Call (the 39th) of Three pence per share has been made upon all the shares in the company, due and payable to the manager, at the registered office, 140 Queen-street, Melbourne, on Wednesday, 14th July, 1948.

5039

F. L. SMYTH, Manager.

NORTHERN STAR GOLD MINES NO LIABILITY.

NOTICE is hereby given that a Call (the 3rd) of Three pence per share has been made upon all the contributing shares in the company, due and payable to the manager, at the registered office, 140 Queen-street, Melbourne, on Wednesday, 14th July, 1948.

5037

F. L. SMYTH, Manager.

NEW COOLGARDIE GOLD MINES NO LIABILITY.

NOTICE is hereby given that all shares in New Coolgardie Gold Mines No Liability, forfeited for non-payment of the 4th Call of One shilling per share (which was due and payable on 9th June, 1948), will be sold by public auction in the vestibule of the Stock Exchange of Melbourne, on Wednesday, the 21st July, 1948, at a quarter to Twelve a.m., if not redeemed by payment of the above call on or before the day previous to the day of sale.

By order of the Board,

L. EDWARDS, Manager.

360 Collins-street, Melbourne, 7th July, 1948. 5043

**SOUTH VIRGINIA GOLD MINING COMPANY
NO LIABILITY.**

NOTICE is hereby given that all shares forfeited for non-payment of the 38th (June) Call of Three pence per share will be sold by public auction at the Stock Exchange Hall, 428 Little Collins-street, Melbourne, on Thursday, 15th July, 1948, at a quarter to Twelve o'clock a.m., unless the shares be previously redeemed.

F. L. SMYTH, Manager.

Registered office: 140 Queen-street, Melbourne. 5038

NORTHERN STAR GOLD MINES NO LIABILITY.

NOTICE is hereby given that all shares forfeited for non-payment of the 2nd (June) Call of Three pence per share will be sold by public auction at the Stock Exchange Hall, 428 Little Collins-street, Melbourne, on Thursday, 15th July, 1948, at a quarter to Twelve o'clock a.m., unless the shares be previously redeemed.

F. L. SMYTH, Manager.

Registered office: 140 Queen-street, Melbourne. 5036

MAXWELL CONSOLIDATED NO LIABILITY.

NOTICE is hereby given that all shares in default of Call No. 39 of Three pence per share are forfeited, and will be sold by public auction at the vestibule, Stock Exchange, Little Collins-street, Melbourne, on Wednesday, 21st July, 1948, at a quarter to Twelve o'clock a.m., unless previously paid.

By order of the Board,

HADDON A. SMITH, Legal Manager.

360 Collins-street, Melbourne, 7th July, 1948. 5022

NEW CHUM SYNCLINE GOLD MINE NO LIABILITY.

NOTICE is hereby given that all shares forfeited for non-payment of No. 96 (June) Call of Three pence per share will be sold by public auction in the vestibule of the Stock Exchange, 428 Chancery-lane, Melbourne, on Tuesday, 20th July, 1948, at a quarter to Twelve a.m., unless shares are previously redeemed.

By order of the Board,

FRANK COOPER, Manager.

422 Collins-street, Melbourne, C.I. 5019

ARGUS HILL CHEWTON GOLD NO LIABILITY.

NOTICE is hereby given that all shares forfeited for non-payment of No. 56 (June) Call of Three pence per share, or any previous call, will be sold by public auction in the vestibule of the Stock Exchange, 428 Chancery-lane, Melbourne, on Wednesday, 14th July, 1948, at a quarter to Twelve a.m., unless shares are previously redeemed.

By order of the Board,

FRANK COOPER, Manager.

422 Collins-street, Melbourne, C.I. 5017

NEW BUTLER'S TIN MINES NO LIABILITY.

NOTICE is hereby given that all shares forfeited for non-payment of No. 3 (June) Call of One shilling per share will be sold by public auction in the vestibule of the Stock Exchange, 428 Chancery-lane, Melbourne, on Friday, 16th July, 1948, at a quarter to Twelve a.m., unless shares are previously redeemed.

By order of the Board,

FRANK COOPER, Manager.

422 Collins-street, Melbourne, C.I. 5016

IMPOUNDINGS.**COLAC.—Impounded in Colac Pound.**

1 black and white poley heifer, notch near ear, no visible brand

If not claimed and expenses paid, to be sold on 15th July, 1948.

4973—5/10

JAMES McCONNELL,

Poundkeeper.

COLERAINE.—Impounded at Coleraine, by the Herdsman, on 23rd June, 1948.

1 black cow, notch in off ear
1 black heifer, about two years, no visible brand
1 yellow heifer, about two years, no visible brand
1 fawn yearling heifer, no visible brand

If not claimed and expenses paid, to be sold on 17th July, 1948.

4965—8/4

S. R. DOLMAN,

Poundkeeper.

DANDENONG.—Impounded at Dandenong, by Shire Ranger E. Sutton, from Council Yard, Phillip-street, Dandenong.

1 poley Jersey milker, no visible brand; chain round neck
If not claimed and expenses paid, to be sold on 22nd July, 1948.

5045—6/8
A. WALKER,
Poundkeeper.

FERNTREE GULLY.—Impounded at Ferntree Gully, by Shire Ranger.

1 yellow and white Guernsey heifer, indistinct brand near rump

1 yellow and white Guernsey heifer, indistinct brand near rump

1 light Jersey cow, no visible brand

1 light Jersey cow, both ears marked, indistinct brand near rump

1 black Jersey cow, no visible brand

1 brown and white heifer, no visible brand

1 black cow, white on tail, white on forehead, tar mark on loins, no visible brand

If not claimed and expenses paid, to be sold on 22nd July, 1948.

5046—14/2
A. DINSDALE,
Poundkeeper.

FOSTER.—Impounded at Foster, from O'Grady's Ridge.

1 bay horse, blaze face, no visible brand

If not claimed and expenses paid, to be sold on 23rd July, 1948.

4974—5/
I. MORRIS,
Poundkeeper.

GREENSBOROUGH.—Impounded at Greensborough.

3 roan semi-draught horses, no visible brand

1 light Jersey cow, no visible brand

If not claimed and expenses paid, to be sold on 21st July, 1948.

4975—5/10
S. THOMPSON,
Poundkeeper.

MELBOURNE.—Impounded in Arden-street Pound, by A. Thomas.

1 black or brown gelding, small star, near hind coronet white, no visible brand

If not claimed and expenses paid, to be sold on 22nd July, 1948.

4962—6/8
D. CROWE,
Poundkeeper.

ORBOST.—Impounded in Orbost Pound.

1 Jersey cow, HS over bar near rump

If not claimed and expenses paid, to be sold after fourteen days.

4958—5/
H. DOMINEY,
Poundkeeper.

STRATFORD.—Impounded at Stratford, by J. D. Richardson, Impounding Officer.

1 Jersey cow, dehorned, top off near ear, indescribable brand near rump

If not claimed and expenses paid, to be sold on 26th July, 1948.

4964—6/8
E. C. BOCK,
Poundkeeper.

WERRIBEE.—Impounded at Werribee, from Mt. Cottrell, by R. B. Bell, on 29th June, 1948.

1 bay draught mare, hog mane with forelock, white face, three white stockings, white on off hind pastern, no visible brand

1 dark bay gelding, star and snip, hind feet white, short tail, no visible brand

If not claimed and expenses paid, to be sold on 22nd July, 1948.

4972—9/2
TIMOTHY MAHER,
Poundkeeper.

STATE ACTS, 1947.

COPIES of the following Acts of Parliament of Victoria may be obtained at the Government Printing Office, or from any bookseller, at the price set opposite to each:—

No.	Price. s. d.
5207. Consolidated Revenue	0 6
5208. Custodian Trustee	0 6
5209. Revocation and Excision of Crown Reservations	0 9
5210. Farmers Advances (Amendment)	0 6
5211. Private Bill Committees	0 6
5212. Health (Amendment)	0 6
5213. Wills (Amendment)	0 6
5214. Old Colonists' Association	0 6
5215. Consolidated Revenue	0 6
5216. Local Authorities Superannuation	1 0
5217. Statute Law Revision	0 6
5218. Motor Car (Registration Fees)	0 6
5219. State Electricity Commission (Yallourn Area)	0 6
5220. Transport Regulation (Licences and Fees) ..	0 6
5221. Local Government (Private Street Construction)	0 6
5222. State Development (Amendment)	0 6
5223. Coal Mine Workers Pensions	0 6
5224. State Savings Bank	0 9
5225. Drought Relief	0 6
5226. Soil Conservation and Land Utilization ..	1 0
5227. Consolidated Revenue	0 6
5228. Consolidated Revenue	0 6
5229. Consolidated Revenue	0 6
5230. Municipal Endowment (Temporary Discontinuance)	0 6
5231. Forests (Commissioners)	0 6
5232. State Forests Loan and Application	0 6
5233. Melbourne and Metropolitan Tramways (Amendment)	0 6
5234. Auditor-General's Salary	0 6
5235. Drought Relief (Amendment)	0 6
5236. Wheat Marketing (Winding Up) Amendment	0 6
5237. University (Mildura Branch)	0 6
5238. Factories and Shops (Bread)	0 6
5239. Water Supply Loan and Application	1 3
5240. Public Works Loan and Application	0 6
5241. Administration and Probate Duties	0 6
5242. Land Tax	0 6
5243. Country Roads Board Fund (Amendment) ..	0 6
5244. Ballaarat Land	0 9
5245. Stamps (Increased Duty Continuance)	0 6
5246. Railway Loan Application	0 9
5247. Sewerage Districts (Amendment)	0 6
5248. State Electricity Commission (Financial) ..	0 6
5249. Public Account Advances (Amendment)	0 6
5250. Infectious Diseases Hospital (Amendment) ..	0 6
5251. Public Works Loan and Application (Amendment)	0 6
5252. Officials in Parliament	0 6

STATE ACTS, 1947—continued.

No.	Price.
	s. d.
5253. Water	0 6
5254. Supreme Court (Judges Salaries)	0 6
5255. Superannuation	0 9
5256. Country Sewerage Loan and Application	0 6
5257. Melbourne and Metropolitan Board of Works (Contributions)	0 6
5258. Vegetation Diseases (Fruit Fly)	0 6
5259. Building Operations and Building Materials Control (Amendment)	0 6
5260. Police Regulation (Amendment)	0 6
5261. Factories and Shops (Determinations)	0 6

J. J. GOURLEY,
Government Printer.

AGENTS FOR THE "VICTORIA GOVERNMENT GAZETTE."

THE following have been appointed agents to receive Advertisements and subscriptions for the *Victoria Government Gazette*:—

- ARMSTRONG'S AGENCY, 143 Queen-street, Melbourne.
- MESSRS. ARNALL & JACKSON, 115 Barkly-street, West Brunswick.
- MESSRS. GORDON & GOTCH, News Agents, 511 Little Collins-street, Melbourne; and corner Barrack and Clarence streets, Sydney.
- MESSRS. HARSTON, PARTIDGE, & CO., 455 Little Collins-street, Melbourne.
- N. V. NIXON & CO., 20 Queen-street, Melbourne.
- THE PATON ADVERTISING SERVICE PTY. LTD.
- ROBERTSON & MULLENS LTD., Elizaoeth-street, Melbourne.
- MESSRS. A. S. RICHARDSON and T. C. GARDNER, trading as The Mercantile Exchange, 380 Collins-street, Melbourne.
- MR. A. J. DIGBY, News Agent, Bairnsdale.
- MR. M. R. BADE, Tobacconist, Sturt-street, Ballarat.
- TRIGG'S NEWS AGENCY, Hargreaves-street, Bendigo.
- MR. G. H. K. PAYNE, 4 View Point, Bendigo.
- MR. C. F. LATIMER, News Agent, Casterton.
- MESSRS. HENRY FRANKS & CO., Booksellers and Stationers, Market-square, Geelong.
- MESSRS. SMITH & DUNNON, Hamilton.
- ARMSTRONG BROS., Kyneton.
- MR. WM. DAVIS, Mildura.
- PIKE'S AUTHORIZED NEWS AGENCY, Sale.
- MR. C. T. RUST, News Agent, Wangaratta.
- MR. F. T. MCCORMICK, Nunn-street, Benalla.
- W. GORDON HAMPTON, 243 Mitchell-street, Bendigo.
- R. & A. SMALLMAN, News Agents, Toora.

A copy of the *Gazette* filed at each place for public reference.

THE "VICTORIA GOVERNMENT GAZETTE."

SUBSCRIPTIONS.—The subscription, including Postage, is £1 12s. 6d. per annum, 16s. 3d. half-yearly, or 8s. 2d. per quarter, payable in advance.

Subscriptions are required to commence and terminate with a month.

A lesser period than three months cannot be subscribed for.

Subscribers do not receive the Acts of Parliament with the GAZETTE.

ADVERTISEMENTS are charged at the rate of TEN PENCE per line single column, and ONE SHILLING and EIGHT PENCE per line double column.

The title (£5 Reward, Dissolution of Partnership, &c.) forms one or more lines as a heading.

On an average, ten words make a line.

Every signature must likewise be counted as a line.

The final words of a paragraph, though only portion of a line must be counted as one line.

SIGNATURES (in particular) and proper names must be written very plainly in the text; ONE SIDE ONLY of each slip of paper should be WRITTEN UPON.

ALL COMMUNICATIONS should be addressed to "The Government Printer, Melbourne."

ALL DOCUMENTS illegibly written will be returned unpublished, and, where brands occur unprovided for by the ordinary letters of the alphabet, a worded explanatory description must be furnished.

THE VICTORIA GOVERNMENT GAZETTE is published on WEDNESDAY EVENING in each week, and Notices for insertion will be received by the Government Printer at or before Two p.m., at ordinary rates, and late advertisements between Two p.m. and Five p.m. at double rates on the day preceding the day of publication.

Single copies of the VICTORIA GOVERNMENT GAZETTE are Six pence, posted Eight pence, each.

No GAZETTES prior to January, 1938, in stock.

***ALL PAYMENTS ARE REQUIRED IN ADVANCE.—Remittances should be made by postal note, money order, or draft in favour of the Government Printer. Advertisements unaccompanied by a remittance sufficient to cover the cost of insertion will be returned unpublished.

CONTENTS

	PAGE.
Acts of Parliament	4389
Acts of Parliament on sale at the Government Printing Office	4423
Appointments	4390
Companies Act 1938—Statement	4397
Contracts	4400
Estates of Deceased Persons	4399
Government Notices	4393
Impoundings	4422
Lands	4407
Licenses to Occupy Unused Roads	4398
Licences to Occupy Water Frontages	4397
Mining	4393, 4421
Orders in Council	4401
Private Advertisements	4414
Proclamations	4389
Public Service Notices	4391
Resignations	4390
State Rivers and Water Supply Commission	4398
Tenders	4412
Transport Regulation Board—Public Hearings	4394