



VICTORIA GOVERNMENT GAZETTE.

Published by Authority.

[Registered at the General Post Office, Melbourne, for transmission by post as a newspaper.]

No. 142]

WEDNESDAY, FEBRUARY 22.

[1950

STATE ELECTRICITY COMMISSION ACTS.

At the Executive Council Chamber, Melbourne, this fourteenth day of February, 1950.

PRESENT:

His Excellency the Governor of Victoria.

Lieut.-Colonel Leggatt

Mr. Gartside.

REGULATIONS

for or with respect to

Prescribing the Quality of Materials, Fittings, and Apparatus to be used in or for purposes of or for connexion to Electrical Installations, and the methods to be followed in carrying out Electrical Wiring Work and in installing such Materials, Fittings, and Apparatus and for or with respect to Inspections of Installations.

PURSUANT to the powers in that behalf conferred by the State Electricity Commission Acts, His Excellency the Governor of the State of Victoria, acting by and with the advice of the Executive Council of that State, doth hereby, on the recommendation of the State Electricity Commission of Victoria, make the following Regulations for or with respect to prescribing the quality of materials, fittings, and apparatus to be used in or for purposes of or for connexion to electrical installations and the methods to be followed in carrying out electrical wiring work and in installing such materials, fittings, and apparatus and for or with respect to inspections of installations, that is to say:—

PRELIMINARY.

1. These Regulations may be cited as the Wiring Regulations 1950.

2. These Regulations are divided into Parts and Sections as follows:—

Introductory and General.

Part I.—Methods.

Section 1.—General Requirements—Testing of Installations.

Section 2.—Arrangement and Control.

Section 3.—Installation of Wiring.

No. 142.—1525/50.—Price 2s.

Section 4.—Installation of Apparatus and Appliances.

Section 5.—Earthing.

Section 6.—Special Situations.

Section 7.—High and Extra High Pressure Installations—Extra Low Pressure Installations.

Part II.—Materials, including Fittings, Accessories, Appliances, and Apparatus.

Section 1.—Scope—General Requirements.

Section 2.—Control Equipment—Composition Switchboard Panels.

Section 3.—Cables, Flexible Cords, and Protective Coverings.

Section 4.—Apparatus and Appliances.

Section 5.—Earthing—Earth Clips.

3. The Regulations made on the 22nd day of May, 1934, and the 4th day of December, 1934, and the 20th day of December, 1937, respectively, and published in the *Government Gazette*, No. 92, dated 23rd day of May, 1934, and No. 96, dated 12th day of December, 1934, and No. 385, dated 22nd day of December, 1937, are hereby repealed: Provided that this repeal shall not affect any right acquired, or any liability incurred, or any act, matter, or thing done or suffered under the said repealed Regulations or any of them before the commencement of these Regulations; and any approval, permit, sanction, or authority given or expressed, and any requirement or prohibition made under the repealed regulations shall be deemed to have been given, expressed, or made respectively under the corresponding provisions of these Regulations.

4. These Regulations shall come into operation on the 1st March, 1950.

INTRODUCTORY AND GENERAL.

Application of and Exemptions from Regulations— Wiring Permits—Notices—Switchboard Label— Supply Connexions and Conditions—Offences— Definitions.

Application of Regulations.

1. (a) These Regulations shall apply to all installations which are connected or are intended to be connected to supply mains.

(b) Every addition to, or alteration of, an existing installation shall be deemed to be a new installation, and all the relevant provisions of these Regulations shall apply to such alteration or addition.

2. The Regulations of Part II. (Materials, &c.) shall be read as one with the Regulations of Part I. (Methods), and no person shall install as part of or in connexion with an installation any wire, cable, material, fitting, apparatus, or appliance which conflicts with the requirements of the said Part II.

3. (a) Except as provided to the contrary in or pursuant to these Regulations, no person shall use or connect to any supply main, and no supply authority shall connect or permit to be connected to its electric lines any wiring, cables, materials, fittings, apparatus, or appliances forming part of any installation unless the said wiring, cables, materials, fittings, apparatus, or appliances, and all other things which form part of the said installation, and have been installed, fixed, or fitted after the date of coming into operation of these Regulations, comply with the requirements of these Regulations and have satisfactorily passed the tests specified in these Regulations.

(b) Notwithstanding the provisions of clause (a) of this regulation, the supply authority may, in case of urgency, on the recommendation of its installation inspector, permit an installation to be temporarily connected to its supply mains although one or more of the requirements of these Regulations have not been satisfied: Provided that no such permission shall be granted unless the installation otherwise generally complies with the requirements of these Regulations and is, in the opinion of the said inspector, reasonably free from electrical hazard. Such permission shall be for a period not exceeding one month, except that, on the recommendation of the supply authority, the Chief Electrical Inspector, Victoria, may extend such period beyond one month.

On the expiration of the period or extended period as aforesaid for which temporary connexion has been so permitted, the installation shall be disconnected from the source of supply, unless before such expiration the provisions of clause (a) of this regulation have been fully complied with.

(c) The connexion of an installation to supply mains shall not relieve the owner or occupier of any premises from the obligation to bring any installation into conformity with these Regulations if on any inspection any defect is discovered which renders such installation electrically hazardous.

(d) No person shall connect, and no consumer shall permit to be or to remain connected to an installation, any wires, cables, fittings, apparatus, appliances, or accessories which are in an unsafe condition. The occupier of any premises shall cause to be completely disconnected from the supply mains all disused portions of an installation thereon, and shall cause such disconnected portions to be dismantled entirely or to a sufficient extent to make it clear on a casual examination that they no longer form part of the installation.

Exemptions and Modifications.

4. For a period of six months (or such longer period as the Commission may decide in the case of any material, accessory, or apparatus of a specific class or type) after these Regulations are published in the *Government Gazette*, the use of materials, accessories, fittings, or apparatus which comply with the Regulations hereby repealed, will be permitted in lieu of materials, accessories, fittings or apparatus which are prescribed by these Regulations.

5. Where a supply authority changes from one voltage or system to another, the Commission may, by notice published in the *Government Gazette*, make such modification as may be specified in such notice of these Regulations and their application to the reconditioning of installations for the purpose of such change-over.

6. In any case where the Chief Electrical Inspector, Victoria, upon application being made to him, in writing, by any person proposing to make any installation, is satisfied that strict compliance with these Regulations would involve expenditure out of proportion to the degree of freedom from electrical hazard to be secured by such compliance, the Chief Electrical Inspector, Victoria, may excuse compliance with any requirements of these Regulations, with or without conditions, and in such case subject to the observance of those conditions, the non-compliance shall not be an offence.

Every such application shall be accompanied by a full statement of the reasons why such modification is desired and of the nature thereof, and by a certificate by the supply authority's engineer that the application is a reasonable one, and that, in his opinion, such modification will not lead to serious increase in the electrical hazard.

Wiring Permits, Notices, and Procedure.

11. (a) Temporary wiring, that is wiring installed in the manner referred to in regulation 361, shall not be commenced until a written permit therefor has been obtained from the supply authority. No such permit shall be granted for a period exceeding one month from the date of connexion to supply mains.

(b) On the expiration of the period for which a permit for temporary wiring is granted, renewals for such permit for further periods of not longer than one month at a time may be granted from time to time.

(c) A permit for temporary wiring shall not be renewed until the supply authority has satisfied itself by inspection, testing, or otherwise that the wiring and all apparatus connected thereto are in a safe and satisfactory condition.

(d) Temporary wiring shall be disconnected and entirely dismantled immediately after the expiry or sooner determination of the period of the permit.

12. (a) No electrical mechanic shall carry out or cause to be carried out or take charge of the carrying out of any electric wiring unless the holder of an "A" Grade (or, as the case may be, a "B1" Grade) licence granted or renewed under Regulations for the time being in force made under section 11 of the *State Electricity Commission Act 1934*, who is in charge of the work, has given to the supply authority, so as to be received by it before the commencement of any alteration or addition to an installation or at least 48 hours before the commencement of a new installation, notice in writing which states:

- (i) that the said work is intended to be carried out; and
- (ii) the nature (as ascertained from the person requiring the work) of the apparatus to be supplied by the said wires, fittings, devices, apparatus; and
- (iii) the size and capacity of the apparatus to be installed; and
- (iv) the maximum demand of the intended installation; and
- (v) the number of heating, lighting, and power points respectively which are to be installed.

(b) No installation shall be connected to supply mains until the supply authority has satisfied itself by testing and examination that the installation complies with the requirements of these Regulations.

(c) On completion of an installation, the "A" Grade or "B1" Grade electrical mechanic in charge of the work shall attach to the main switchboard a label giving the following particulars:—

- (i) The name of the firm, company, or person who undertook to carry out the installation work.
- (ii) The number of lighting points, power points, motors, and other apparatus installed and/or other particulars of work done.
- (iii) The date of completion.
- (iv) Signature of the said electrical mechanic.

The label shall be a printed label not smaller than 5 inches long by 2½ inches wide, and shall be ruled and set out in the manner shown in the diagram below.

NOT TO BE REMOVED EXCEPT BY AN AUTHORIZED INSTALLATION INSPECTOR.

Name and Address of Person or Firm by whom work of installation is undertaken: _____

• New Installation at _____
 • Extension _____
 • Alteration _____

* Delete if not applicable.

PARTICULARS OF WORK CARRIED OUT				
Lighting Points No.	Power Points No.	Motors		Other Apparatus.
		No.	Total h.p.	

Electrical Mechanic _____ Licence No. _____
 Electrical Mechanic in Charge _____ Licence No. _____
 Signature of Electrical Mechanic in Charge _____
 Date of Completion _____

This label shall be removed from the switchboard only by an inspector authorized by the Commission or the supply authority, by whom it shall be kept available for future reference.

(d) Where a Supply Authority itself contracts to carry out any installation for a consumer and any temporary wiring is to be connected to the supply mains, the Chief Electrical Inspector, Victoria, shall be notified, but a permit as required by regulation 11 shall not be necessary.

Supply Connections.

14. (a) The supply authority will determine the point of attachment for the overhead service line or the point of entry for the underground service line, as the case may be, and also the position for the location of the service cut-out or cut-outs, supply meters, and any other apparatus of the supply authority.

In the case of any doubt as to what position or point has been determined in any case, the electrical mechanic in charge of the work shall ascertain from the supply authority what has actually been determined, and the points and positions so determined shall be observed by all electrical mechanics.

b) Sufficient length of cables shall be provided at these points and positions for connexion to the supply authority's service line, service cut-outs, meters, and other devices.

15. No person other than a person authorized by the supply authority to carry out such work shall fix the service cut-out or cut-outs, or insert a fuse-link therein, make or dismantle any connexion to the supply authority's apparatus, or install the wiring between the point of entry of an underground service line and the service cut-out or cut-outs.

16. Consumer's control or protective apparatus situated on the supply side of a meter shall be metal-clad and suitable for sealing with the supply authority's seal.

Supply Conditions.

21. Except where the multiple earthed neutral system is used, no conductor normally carrying current in an installation shall be connected to earth. Where the multiple earthed neutral system is used, no earth connexions shall be made to the conductors of the installation other than those specified in regulation 262.

22. Unless special permission is given in writing by the authorities concerned prior to the commencement of work, the circuits of any electric traction system employing an earthed return shall under no circumstances be taken into, on, or through any building for light or power purposes, save in the case of the power and car houses or other buildings forming part of the system.

23. (1) Except as provided for in clause (2) of this regulation—

(a) No motor, the starting current of which, as measured by a damped ammeter, exceeds the current given in the following table shall be connected in an installation.

TABLE REFERRED TO ABOVE.

<i>Three-phase Motors.</i>		400 Volts.
Motors not exceeding 2-brake horse-power	13 amperes	
Motors exceeding 2-brake horse-power but not exceeding 8-brake horse-power	6.5 amperes per brake horse-power	
Motors exceeding 8-brake horse-power	33 amperes plus 2.5 amperes per brake horse-power.	
<i>Single-phase Motors.</i>		200/230 Volts. 400 Volts.
Motors not exceeding 2-brake horse-power	20 amperes 15 amperes	
Motors exceeding 2-brake horse-power, but not exceeding 5-brake horse-power	7.5 amperes per brake horse-power	
Motors exceeding 5-brake horse-power	13 amperes plus 5 amperes per brake horse-power	

The above table is based on a working pressure of 400 volts for three-phase motors, and 200 or 230 volts and 400 volts for single-phase motors. For other pressures the maximum permissible starting current shall be varied in inverse ratio to the pressure.

(b) No alternating current motor shall be connected in an installation unless its power factor at full load is at least that given below for a motor of corresponding speed and horse-power:—

H.P.	Speed.				
	Not Exceeding 500 r.p.m.	Exceeding 500 r.p.m. but not 750 r.p.m.	Exceeding 750 r.p.m. but not 1,000 r.p.m.	Exceeding 1,000 r.p.m. but not 1,500 r.p.m.	Exceeding 1,500 r.p.m.
(i) As to three-phase motors—					
Exceeding ½ h.p. but not exceeding 1 h.p.62	.68	.80
Exceeding 1 h.p. but not exceeding 2 h.p.	..	.64	.66	.70	.81
Exceeding 2 h.p. but not exceeding 5 h.p.	.65	.68	.70	.75	.825
Exceeding 5 h.p. but not exceeding 8 h.p.	.73	.75	.77	.82	.85
Exceeding 8 h.p. but not exceeding 15 h.p.	.75	.77	.81	.84	.865
Exceeding 15 h.p. but not exceeding 30 h.p.	.775	.80	.83	.86	.88
Over 30 h.p.	.80	.83	.85	.88	.90
(ii) As to single-phase motors—					
Exceeding ½ h.p. but not exceeding 1 h.p.70	.77
Exceeding 1 h.p. but not exceeding 2 h.p.	..	.50	.61	.72	.80
Exceeding 2 h.p. but not exceeding 5 h.p.	.55	.59	.65	.75	.83
Exceeding 5 h.p. but not exceeding 8 h.p.	.61	.65	.68	.81	.85
Exceeding 8 h.p. but not exceeding 15 h.p.	.65	.68	.70	.82	.86
Exceeding 15 h.p. but not exceeding 30 h.p.	.68	.71	.75	.84	.87
Over 30 h.p.	.70	.73	.77	.84	.88

(c) No welding apparatus shall be connected in an installation unless its power factor is at least 0.5 at the beginning of the operation, and at least 0.7 throughout the remainder of the operation.

(d) No lighting or illumination device, apparatus, or sign shall be connected in an installation unless its power factor is at least 0.85 when in full operation

(e) No person shall install or use in any private residence, or any separate flat, or any office, or any premises used as a domestic residence, or any outbuilding thereof, or in or to be used for any bathroom which is used in connexion with any such residence, flat, or premises—

(a) Any water-heater of which the capacity of the elements exceeds 3 kilowatts, unless it is so installed that electricity cannot be supplied to elements of a capacity of more than 3 kilowatts during any hours other than such hours of the night as are prescribed by the supply authority; or

(b) any water-heater, water-heaters, or water-heating apparatus of which the total capacity of the elements exceeds 5 kilowatts.

(2) Notwithstanding the provisions of clause (1) of this regulation, the supply authority may, at its discretion, permit, either generally or in any particular case, the connexion in an installation of motors with greater starting currents, or of motors welding apparatus or luminous discharge tube lighting systems with lower power factors.

26. Every portion of a service line which is on the consumer's side of a service cut-out, and which is installed within a building, shall comply with the provisions of regulation 212.

Balancing.

27. (a) In the following cases, unless the consent of the supply authority has been obtained to the contrary, the load shall be balanced as set out hereunder and to the satisfaction of the supply authority:—

(i) Where the maximum current demand exceeds 15 amperes and electricity is supplied through a service line consisting of two actives and a neutral, the load shall be divided as evenly as possible between the two actives.

(ii) Where the maximum current demand exceeds 30 amperes and electricity is supplied through a service line consisting of three actives and a neutral, the load shall be divided as evenly as possible between the three actives.

(b) Notwithstanding the provisions of clause (a) of this regulation, individual motors not exceeding 2 brake horse-power if single phase, or 3 brake horse-power if continuous current, may be connected between an active conductor and the neutral.

(c) Every individual appliance of any description having a maximum demand more than 15 amperes and which is connected to the neutral shall be balanced as laid down in clause (a) of this regulation, unless permission is obtained from the supply authority to connect it between one active and the neutral.

Safety Measures.

28. (a) Before any repairs or alterations are commenced, the circuits which are to be handled shall be entirely disconnected from the source of supply, unless other adequate precautions are taken to prevent electric shock.

(b) Any obvious defect likely to be a source of danger in an installation which is being altered or extended shall be reported by the "A" Grade or "B1" Grade electrical mechanic in charge of the work to the supply authority's inspector.

Offences.

41. In regulations 42 to 46 inclusive, "wires" shall include cables and conductors; "apparatus" shall include accessories, fittings, devices, appliances, electrical machines, and equipment.

42. No person shall—

(1) run, lay, fix, or install any wires, materials, or apparatus for conveying, controlling, or utilizing electricity supplied or to be supplied by any supply authority, whether such wires, materials, or apparatus are or are not an addition or extension to other such wires, materials, or apparatus already run, laid, fixed, or installed for the like or any other purpose—

(a) unless such wires be wires of the relevant resistance and of the relevant size specified for the purpose of these Regulations and the tables and appendix therein referred to; or

(b) unless such wires, materials, or apparatus are designed, constructed, insulated, and protected in the manner and by the devices which are, either specifically or generically, by these Regulations and the said tables and appendix prescribed to ensure against the leakage of electricity from, or to ensure the safe and economical use, conveyance, transmission, or control of electricity in or by such wires, materials, or apparatus; or

(c) for any purpose referred to in these Regulations or the said tables and appendix unless such wires, materials, or apparatus conform to any requirements of these Regulations or the said tables or appendix relating to wires, materials, or apparatus intended to be used for that purpose; or

(d) for any purpose in a manner which will permit of their being used for another purpose for which these Regulations prohibit the use of wires, materials, or apparatus run, laid, fixed, or installed for the first-mentioned purpose; or

(e) for any purpose referred to in these Regulations in a manner which is contrary to the manner by these Regulations prescribed for running, laying, fixing, fitting, or installing wires, materials, or apparatus for any such purpose; or

(f) in any position referred to in these Regulations or the said tables and appendix, unless such wires, materials, or apparatus, and the manner of running, laying, fixing, fitting, and installing the same conform to any requirements of these Regulations or the said tables or appendix relating to wires, materials, or apparatus placed in such a position, or to the running, laying, fixing, fitting, or installing thereof; or

(g) in a manner which does not conform to the requirements of these Regulations as to balancing of installations, or as to other matters affecting the economical, effective, regular, or continuous distributing and supplying of electricity by a supply authority; or

(h) in a manner which does not conform to all relevant requirements of these Regulations as to the manner of conveying, transmitting, controlling, or using of electricity by means of any wires, materials, or apparatus, or as to the protection of any wires, materials, or apparatus against outside interference, injury, damage, deterioration, or the leakage of electricity therefrom; or

(i) in a manner which fails to ensure that the supply of electricity to, and the conveyance, transmission, control, and utilization of electricity by means of any such wires, materials, or apparatus is controlled in the relevant manner prescribed in these Regulations, or that the means whereby such control is ensured are accessible as by these Regulations required; or

(j) in a manner which will permit of such wires, materials, or apparatus being used for a purpose which contravenes any provisions of these Regulations; or

(k) in any position or in any manner which is forbidden by these Regulations; or

(l) which wires, materials, or apparatus are of a kind, or quality, or capacity forbidden by these Regulations to be run, laid, fixed, or installed for the purpose for which such wires, materials, or apparatus are run, laid, fixed, or installed; or

(m) otherwise than in conformity with any relevant conditions by these Regulations specified; or

(2) join or connect in any manner other than a manner prescribed by these Regulations, or in any manner forbidden by these Regulations, any wires which convey or transmit, or are intended to convey or transmit electricity, or serve or are intended to serve, as a medium for the conveying or transmitting of electricity; or

(3) supply, take or use, convey or transmit electricity from the circuits of any electric traction system in a manner forbidden by regulation 22; or

(4) fix or install any apparatus so that it may be supplied with or use any apparatus supplied with electricity by a supply authority of which apparatus the maximum starting current exceeds, or the power factor is less than, the relevant quantity or ratio indicated by these Regulations for apparatus of that type or description.

43. Any electrical mechanic who shall run, lay, fix, or install any wires, materials, or apparatus for conveying, transmitting, controlling, or using electricity supplied or to be supplied by a supply authority shall be guilty of an infringement of these Regulations unless the holder of an "A" Grade licence or permit granted or renewed under Regulations for the time being in force made under section 11 of the *State Electricity Commission Act 1934*, or (where the installation or work is of such a nature that it need not be performed under the supervision of a holder of an "A" Grade licence) the holder of a "B1" Grade licence—

(a) has given the supply authority notice of the work in the manner and within the period required under regulation 12 (a);

(b) where a permit for the installing of electric wiring is required by these Regulations—
(i) has obtained from the supply authority a written permit therefor.

44. Any electrical mechanic who shall run, lay, fix, or install in any premises any wires, materials, or apparatus for conveying, transmitting, controlling, or using electricity supplied or to be supplied by a supply authority shall be guilty of an infringement of these Regulations unless—

the holder of an "A" Grade licence or permit, or (as the case requires) a "B1" Grade licence granted or renewed under Regulations for the time being in force made under section 11 of the *State Electricity Commission Act 1934*, who signed the notice to the supply authority under regulation 12 (a) either is present during the carrying out of the whole of the work or has for the purpose of such work inspected and approved of as conforming to the requirements of the work and of these Regulations the said wires, materials and apparatus, and has approved, after a careful inspection of the premises concerned, of a specification and/or plans showing—

- (a) a general arrangement of the installation and the approximate position of the switchboard or switchboards and switches, and of all lighting and/or power points proposed to be installed, and the purpose for which each such point is intended to be used; and
- (b) to what extent and by what method or arrangement (if at all) the installation will be divided into separate circuits pursuant to these Regulations; and
- (c) the proposed means of connecting any portion of the installation to earth; and
- (d) what (if any) incandescent lamps, heaters, and cooking devices are proposed to be used, and the means proposed to ensure that the same will be laid, fixed, or installed in compliance with these Regulations; and
- (e) any special precautions necessary in the circumstances of the particular case—
and has ascertained from the supply authority the point of attachment and positions for its meters and/or other equipment.

45. Without prejudice to any other provision of these Regulations, any holder of an "A" Grade licence or permit, or of a "B1" Grade licence, who has signed a notice to the supply authority that such work or installation is to be carried out who fails to ensure that—

- (a) the said work or installation is not connected to the mains of the supply authority until all requirements of these Regulations are fulfilled and the installation has been inspected and approved by the supply authority as conforming to the requirements of these Regulations;

(b) before the said work or installation is connected to the mains of the supply authority, any work which has been done in contravention of these Regulations, and any material or thing which has been laid, run, fixed, or installed in contravention of these Regulations is removed, amended, or replaced; and

(c) before the said work or installation is connected to the mains of the supply authority, any act or thing which has, in contravention of these Regulations, been omitted from the work or installation is done;

(d) that none of these Regulations are infringed by any person who performs any part of the work or installation;

(e) that any approval, sanction, or authority of any body which is by these Regulations required is in due course obtained;

(f) any obvious defect in an installation which is being altered or extended is reported to the supply authority's inspector in accordance with the requirements of regulation 28 (a)—

shall be guilty of an infringement of these Regulations.

46. Any person, whether or not he is the holder of a licence granted or renewed under Regulations for the time being in force made under section 11 of the *State Electricity Commission Act 1934*, who commits a breach or is guilty of an infringement of any of these Regulations, shall be liable to a penalty not exceeding £20.

50. The Commission, or any officer appointed in writing by the Chairman under his hand to represent the Commission in proceedings before Justices or in any Court of Petty Sessions may take proceedings in a Court of Petty Sessions to enforce any penalty for breach of these Regulations.

DEFINITIONS.

51. Throughout these Regulations, unless the context otherwise requires, the following terms shall have the meanings given to them hereunder in this regulation:—

- "Accessory" means any device, other than a lighting fitting, lamp or appliance, which is used, or is intended for use, in association with cables and their protective coverings as an integral portion of an installation; for example, a switch, fuse carrier, plug, or similar device.
- "Active Conductor" or "Active" means a conductor which is or may be maintained at a difference of potential from the neutral conductor of the supply system, or from earth. Where the supply system does not include a neutral or earthed conductor, all conductors, other than earthing conductors, shall be considered to be active conductors.
- "Aerial Conductor" means any bare or insulated conductor, which is supported by insulators above the ground in the open air without mechanical protection.
- "Appliance" means a consuming device (other than a lamp) in which electrical energy is converted into heat or other form of energy for performing a service.
- "Approved" means approved by the State Electricity Commission of Victoria, or, in the case of work, means approved by the officer appointed by the State Electricity Commission of Victoria for the purpose of giving or withholding approval of such work.
- "Authorized Inspector" means the inspecting officer authorized by or under authority of the Commission to inspect installations.
- "Bunched" (cables) means not separated one from another. All cables enclosed in a single conduit, pipe, or groove of a wood casing shall be deemed to be bunched.
- "Busbar" means a conductor forming a common junction between two or more circuits each connected thereto.
- "Cable" means an insulated solid or stranded conductor, or two or more such conductors laid up together, and each provided with its own insulation. The insulated conductor or conductors may or may not be provided with an overall protective covering.
- "Cable, Armoured," means a cable provided with a wrapping of metal (usually tapes or wires), primarily for the purpose of mechanical protection.

- "Cable, Flexible," means a cable, the conductors, insulation, and covering of which are such as to afford flexibility.
- "Chief Electrical Inspector, Victoria," means the Chief Electrical Inspector, Victoria, appointed by the State Electricity Commission of Victoria.
- "Circuit Breaker" means a switch suitable for opening a circuit automatically under predetermined conditions such as those of over current or under voltage, or by some form of external control.
- "Commission" means State Electricity Commission of Victoria.
- "Conductor" means a wire, cable, or other form of metal suitable for carrying current, but shall not include wires, cables, or other metallic parts directly employed in converting electrical energy into another form of energy.
- "Conductor, Bare," means a conductor not covered with insulating material.
- "Conductor, Uninsulated" means a conductor in which no provision is made for its insulation from earth or adjacent conducting material.
- "Consumer's mains" means those cables included in the portion of the electrical circuit between the consumer's terminals and the main switch-board.
- "Consumer's terminals" means the ends of the conductors situated upon any consumer's premises at which the supply of energy is delivered from the service line.
- "Cord, Flexible" means a flexible cable no conductor of which exceeds .007 sq. in. in cross-section.
- "Core" (of a Cable) means the conductor with its insulation but not including any mechanical protective covering.
- "Cut-out" (Fusible cut-out) means a device for opening a circuit in the event of over current, by the fusion of a specially designed part thereof. It comprises all the parts which, together with their mounting, base, and containing case or cover (if any) form the complete device.
- "Damp situation" means a situation in which moisture is either permanently present or intermittently present to such an extent as to be likely to impair the effectiveness and/or safety of an installation which conforms to the requirements of these Regulations for installations not subject to the presence of moisture as aforesaid.
- "Distribution board" means a suitably mounted assembly of cut-outs, with or without a switch or switches, arranged for the distribution of electricity to, and for the protection and/or control of, sub-mains or final sub-circuits.
- "Earthed" means connected to the general mass of earth in a manner that will ensure at all times an immediate and safe discharge of electricity. Where these Regulations require that any portion of an installation or apparatus connected thereto shall be earthed, such portion shall be earthed in the manner laid down by these Regulations for the earthing of such portion.
- "Earthing conductor" means a conductor connecting any portion of the earthing system to the portion of the installation or apparatus required to be earthed, or to any other portion of the earthing.
- "Earthed situation."—Any situation is an earthed situation if there is a reasonable chance of a person who is touching electrical apparatus, a fitting or appliance there being in touch with or coming into touch with a conductive medium such as metal piping, structural metalwork, earthen, concrete, tile, or brickwork flooring, telephone wiring, or permanent dampness, so as to make an electrical connexion between his body and the general mass of earth. All parts of a bathroom, lavatory, kitchen, or a washing room of a laundry, all places in proximity to metal piping or structural metalwork, everywhere external to buildings, and all rooms or places having concrete, tiled, or other conductive floors shall be deemed to be earthed situations, and, moreover, in the case of a plug socket used or to be used for the connexion of a portable fitting or appliance which is by these Regulations required to be earthed, the plug socket shall be deemed to be in an earthed situation.
- "Earthing system" means all those cables and other conductors, clamps, earth clips and earth plates or pipes which are installed and/or used for the purpose of maintaining any portion or portions of an electrical installation at earth potential, and shall include any metallic piping system to which such cables and other conductors, clamps, or clips are connected.
- "Fitting" means any device for supporting one or more lamps, together with lampholders, shades, and reflectors; for example, a bracket, pendant and ceiling rose, electrolier, or portable standard.
- "Fuse link" means that part of a cut-out which is designed to melt and thus open the circuit. It comprises the fusible metal and any end connexions forming part thereof.
- "Fuse switch" means a switch in which one or more fuse links are included in the portion which, in its closed position, forms the connexion through the switch.
- "Installation" means all the electric wiring, control and protective gear, accessories, consuming devices and other apparatus connected to the wiring, situated on a consumer's premises. The installation shall be deemed to commence at the consumer's terminals.
- "Insulated" means surrounded by non-conducting material or air space, in either case offering permanently sufficient resistance to the passage of current or disruptive discharge to prevent injurious leakage of current.
- "Insulation, Double" means that the insulating material intervenes not only between the conductor and its surrounding envelope (in the case of a cable), or its immediate support (in the case of a bare conductor), but also between the envelope or the support, as the case may be, and earth.
- "Live" (Alive).—An object is said to be live (alive) when a difference of potential exists or may normally exist between it and earth. With the exception of earthing conductors, and neutral busbars in installations where the multiple earthed neutral system is employed, all metal connected to the neutral conductor of the supply system, even if such neutral be earthed at the source of supply, shall be deemed to be alive for the purpose of these Regulations.
- "Loop-in system" means a system of wiring in which joints are avoided by connecting conductors together in the terminals of switches, ceiling roses, plug sockets, and like accessories at switching and outlet points.
- "Master switch" means a switch controlling a complete installation, or a self-contained portion of an installation, or a switch controlling or limiting the operation of a group of switches.
- "Multiple earthed neutral system" (M.E.N. system) means a low or medium pressure alternating current system, the neutral conductor of which is earthed without the insertion of a current limiting resistance, a cut-out or a circuit-breaker at the source of supply, and at one or more points along the distribution lines, service lines, and/or in consumers' installations.
- "Neutral" (Neutral conductor) means that conductor of a 3-wire or multi-wire system which is maintained at an intermediate and approximately uniform potential in regard to the active conductors.
- "Point" (Outlet) means the termination of wiring for attachment to a consuming device or to a fitting for one or more lamps.
- "Point of attachment" means the point at which an overhead service line terminates on a consumer's building or structure.
- "Point of entry" means the point at which the service line or the consumer's mains enter a building. For the purpose of this definition, open verandahs shall not be considered as part of the building.
- "Polyphase" or "Multiphase" means 3-phase unless otherwise stated.
- "Pressure" means difference of potential between conductors at the consumer's terminals.
- "Extra low pressure" means pressure normally not exceeding 32 volts alternating current, or 115 volts direct current.
- "Low pressure" means pressure normally exceeding 32 volts alternating current or 115 volts direct current, but not exceeding 250 volts in either case.
- "Medium pressure" means pressure normally exceeding 250 volts, but not exceeding 650 volts.

- "High pressure" means pressure normally exceeding 650 volts, but not exceeding 6,600 volts.
- "Extra high pressure" means pressure normally exceeding 6,600 volts.
- "Service cut-out" means a cut-out or other device installed by the supply authority for automatically interrupting the supply to an installation in the case of excessive current or earth leakage.
- "Service line" means any conductor or group of conductors through which electrical energy may be supplied, or is intended to be supplied, by the supply authority to a consumer, either from any supply main or directly from the premises of the supply authority.
- "Source of supply" means, where used in relation to any installation, the generator, converter or transformer (or group of generators, converters, or transformers) to which the supply mains conveying electricity to that particular installation are connected, and which generates, converts or transforms the electrical energy so supplied to that installation.
- "Sub-circuit, Final," means a branch circuit originating at a distribution board or other distributing centre and to which circuit lamps and/or other consuming devices are directly connected.
- "Sub-mains" means those cables included in that portion of an installation between the main switchboard and any distribution board.
- "Supply main" means an electric line of any supply authority.
- "Switchboard" means an assemblage of switchgear with or without instruments, and includes distribution board, but does not include a group of switches in final sub-circuits where each switch has its own insulating base and protective covering.
- "Switchboard, Main," means the switchboard from which the whole supply to an installation or to an independently metered portion of an installation, is controlled, and at which sub-mains or final sub-circuits originate.
- "Switch, Single-pole," means a switch suitable for making or breaking a circuit on one pole (or phase) only.
- "Switch, Double-pole," means a switch suitable for making or breaking a circuit on two poles (or phases) simultaneously.
- "Switch Multi-pole," means a switch suitable for making or breaking a circuit on two or more poles (phases) simultaneously.
- "Switchgear" means apparatus for controlling the distribution of electrical energy, or for controlling and/or protecting circuits, machines, transformers, and/or other apparatus.
- "Switches, Linked," means switches linked together mechanically so as to operate simultaneously or in definite sequence.
- "Supply authority" means and includes the State Electricity Commission of Victoria, or any council, company, or person who, by an Order in Council under the *Electric Light and Power Act 1928*, or any corresponding previous enactment is authorized to supply electricity within any area.
- "2-wire" means comprising two conductors between which the load may be connected.
- "3-wire" means comprising a neutral conductor and two actives.
- "3-wire 3-phase" means comprising three active conductors each connected to a different phase conductor of a 3-phase system of supply.
- "3-phase 4-wire" means comprising a neutral conductor in addition to the active conductors as in 3-phase 3-wire.

STATE ELECTRICITY COMMISSION OF VICTORIA.

WIRING REGULATIONS.—PART I.

SECTION 1. WORKMANSHIP AND GENERAL REQUIREMENTS.

101. All electrical wiring work and the installation and connexion of all electrical apparatus shall be carried out in a thoroughly workmanlike manner to conform to the requirements of these Regulations, and otherwise in accordance with the generally

accepted requirements for sound and safe practice and construction where specific methods are not laid down.

102. All fixings, fastenings, and supports shall be of adequate strength to ensure, throughout the normal life of the installation, against mechanical failure under the ordinary conditions of use, wear and tear, and any other factors which can be reasonably anticipated.

103. All cables, materials, fittings, appliances, and apparatus used in an installation shall comply with the requirements for such cables, materials, fittings, appliances and apparatus specified in these Regulations, and, where a method (or methods) of installing is laid down in these Regulations, shall not be installed in any other manner.

104. No material, cable, fitting, or apparatus which is defective, either mechanically or electrically, shall be used in any installation.

105. Every reasonable precaution shall be taken to prevent, during installing, interference with the installation and parts thereof by unauthorized persons.

106. No alteration, addition, or extension to an installation shall be made which will cause any conductor, accessory, apparatus, or any portion of the original installation to carry currents in excess of those permitted by these Regulations, or to be used for any purpose or in any manner that is not in accordance with these Regulations.

SAFETY PRECAUTIONS.

111. All live parts and all connexions thereto shall be so made and/or arranged that loosening of contacts or overheating cannot take place, and so made, arranged and/or shielded by non-ignitable material that short circuit or arcing, either between conductors or between conductors and a metal case, fixing screws, or other conductive material, cannot occur, and, except where installed in a room or building which is inaccessible to unauthorized persons, all live parts shall be so placed, arranged, and/or protected that no person can accidentally make contact therewith.

112. Where cable ends are soldered or secured to sockets or terminals—

(a) The insulating material shall not be removed farther than is necessary to allow each conductor to enter and extend to the full length of the hole in the socket or terminal, and to be properly soldered or connected.

Insulating material damaged by heat during the process of soldering shall be cut away, and that or any other portion of bare conductor shall be covered with insulation equivalent to the original.

(b) The braid, lead, or other covering over the insulating material, including the tape in contact therewith, shall be cut back well clear from the end of the insulation.

(c) In the case of paper insulated cables, the exposed conductor and insulating material shall be sealed with insulating compound.

113. Every joint or connexion shall be, at least, equal in conductivity to and have insulation equivalent to that of the conductors connected.

114. All cables and conductors (other than earthing conductors and insulated cables conforming to the requirements of regulation 2304) and all live parts shall be insulated by being carried on or supported by insulators or insulating material suitable for the purpose. The nature of such insulation and support shall be such that no live part can come into contact with any conductive material exposed to personal contact and such that the requirements of these Regulations with regard to pressure test and insulation resistance are complied with.

115. (a) All cables and conductors shall be so connected, supported, and/or attached that there is no undue strain on any connecting terminal, connexion, or joint.

(b) Every flexible cord shall be so supported and/or clamped that its connexion to terminals or internal conductors is entirely relieved of any pull on the cord.

116. Every cable passing through metal, unless so supported that it cannot come within 3 inches thereof, shall pass through conduit or be separated from such metal by means of a substantial non-conductive bushing, tube, sleeve, or duct securely fixed in position.

117. (a) All connexions shall be made either at terminals or by means of joints or connexions in the manner required by regulation 326.

(b) Soldered joints shall not be used either in conductors or in any part of the installation where the temperature rise of the joint can exceed 86° F. (48° C.).

(c) Corrosive fluxes shall not be used in making soldered joints.

PROTECTION AGAINST DAMAGE.

121. Every part of an installation shall be protected by its position or otherwise from injury or damage from water, steam, oil, excessive temperature, chemical fumes, and/or mechanical or other causes which may reasonably be anticipated under the conditions of use.

122. All cables other than armoured cables and earthing conductors, unless otherwise adequately protected from damage by their position, shall be enclosed in metal conduits, substantial ducts, or coverings wherever they are within 4 ft. 6 in. above a floor and in other places where they are liable to mechanical injury. Metal conduits or ducts so used shall be bushed at all cable outlets to prevent injury to the cable covering, and, if accessible, shall be earthed.

123. Metal conduits and armoured cables run on the surface of a floor shall be protected by being enclosed in substantial iron piping or by a substantial wooden or other durable covering.

124. Switches, plugs, and other accessories mounted within 6 inches above a floor shall be suitably protected against mechanical damage, and switches of the tumbler type shall be so arranged that they cannot be accidentally switched on in the process of sweeping and cleaning.

Clearances.

125. (a) Conductors not enclosed in a protective covering shall be so spaced that adequate clearance is maintained between the conductors themselves and between each conductor and any material other than its immediate connexions and supporting insulators. In the case of bare conductors used as span wires, this clearance shall be not less than 3 inches.

(b) Conductors, cables, metallic sheathings and conduits shall be supported and/or fixed so that, except at crossings, a permanent clearance of not less than 1 inch is maintained between them and gas or sprinkler pipes, telephone, bell, or other cables or metal conduits not forming part of the installation. In the case of crossings, unless a clearance of 1 inch as aforesaid is provided, an insulating crossing specially approved for the purpose or a durable non-conductive distance piece not less than 1/4-in thick shall be securely fixed between the two, and this distance piece shall extend beyond pipes, cables, and/or conduits at least 1 inch in all directions at the crossing.

Protection.

126. In all places which are not inside buildings, all fittings, accessories, appliances, and apparatus, unless completely protected by a verandah or weatherproof structure, shall be of weatherproof type, and conduit, joints, and all parts of the installation in such places shall be made watertight.

127. In all places which are exposed to excessive dampness, all fittings, accessories, appliances, and apparatus, and all parts of the installation, unless watertight, shall be effectively protected against the entry of moisture.

128. All apparatus shall be so fixed and arranged that live parts are adequately protected against the accumulation of dust and moisture.

PROTECTION AGAINST FIRE.

141. Wiring and all apparatus shall, as far as practicable, be kept clear of inflammable materials, and electrical equipment shall be mounted or fixed in such a manner that no part which will attain a temperature exceeding 212° F. (100° C.) is in direct contact with any combustible material.

142. (a) The clearances given in the table hereunder shall be maintained between apparatus and woodwork or other ignitable material which is not covered by—

- (i) sheet metal not less than No. 20 S.W.G. thick; or

- (ii) asbestos not less than 1-16 inch thick; or
- (iii) fibro-cement panel not less than 3-16 inch thick.

Apparatus.	Clearance Measured Vertically above Apparatus.	Clearance Measured Vertically below Apparatus.	Clearance in all other Directions.
	Inches.	Inches.	Inches.
Resistances the energy consumption of which exceeds 60 watts	24	12	6
Transformers other than oil-immersed transformers and transformers not exceeding 1.2 kVA. incorporated in portable appliances and apparatus	24	12	6
Static rectifiers exceeding 1.2 kVA. (unless of fireproof construction)	24	12	6
Motors and generators exceeding 1/2 h.p. other than totally enclosed, flameproof or pipe-ventilated types	48	48	12 (except in the case of hardwood bearers on which the motor or generator is mounted)
Any other apparatus the exposed parts of which during normal operation will attain a temperature in excess of 212° F. (100° C.)	24	12	6

(b) A metal plate or tray extending 12 inches beyond the base of the machine shall be placed under every motor, generator, or converting machine which has an open commutator or slip rings, and which is mounted on or within 48 inches above a floor consisting of wood or other combustible material.

143. (a) Motors, generators, resistances, control gear, protective equipment, transformers, and rectifiers, unless of flameproof construction, shall be installed only in well ventilated spaces in which inflammable or explosive dust or gases cannot normally be present under conditions capable of causing or contributing to an explosion.

(b) Where explosive gas or dust is liable to be present, all apparatus shall be of flameproof construction and type.

(c) Where liable to collect an excessive amount of inflammable dust, motors of other than enclosed types shall be protected by a case or cover which will exclude the dust but will not prevent the circulation of air necessary for effective cooling of the motor. Portions of such cases or covers which are not made of fire-proof material shall be lined with sheet asbestos not less than 1-16 inch in thickness.

144. Where passing through party walls or fire-resisting floors or partitions, conduits and other protective coverings of cables shall be close fitting around the cables, and the holes through which they pass shall be plugged with cement, fireclay, or other similar non-ignitable material, so that no space through which fire might spread is left around the protective covering.

PROTECTION AGAINST RISK OF ELECTRIC SHOCK.

151. No fitting, accessory, appliance, or apparatus shall be connected direct to a circuit operating at a pressure more than 15% above the operating pressure for which it is manufactured unless the sanction, in writing, of the supply authority for such connexion has previously been obtained. No such permission shall be given in the case of medical or dental appliances, radio-receiving equipment, or electrically operated toys.

152. In earthed situations—

- (a) tumbler and rotary switches shall be of the all-insulated type. All other switches shall also, where practicable, be of the all-insulated type, but if of another type, all exposed metal parts of such switches shall be earthed.
- (b) lampholders supported on cables or flexible cords within 8 feet above a conductive floor or any metal on which a person is likely to stand, shall be of the all-insulated type.
- (c) exposed metal parts of all other accessories, appliances, apparatus, and portions of an installation shall be earthed.

154. No addition or extension to an installation shall be made which will create an earthed situation where any accessory, fitting, appliance, apparatus, or other portion of the installation does not comply with the requirements of these Regulations for such accessory, fitting, appliance, apparatus, or other portion of an installation, in an earthed situation.

TESTING OF INSTALLATIONS.

161. Every installation shall be capable of satisfactorily passing the following tests:—

- (1) of insulation resistance as described in regulation 162, clause (a);
- (2) of the insulation resistance of apparatus as described in regulation 162, clause (b);
- (3) of continuity of conduit and/or metallic sheathings as described in regulation 162, clause (c); and
- (4) of correct connexion of single-pole switches and neutral link or bar as described in regulation 162, clause (d).

162. (a) (i) The insulation resistance between conductors and earth shall be tested with all fuse links and lamps in place, and all switches in the "on" position. The insulation resistance between conductors shall be tested with all fuse links in place, with all switches in the "on" position, but with lamps removed.

These tests shall be deemed to be satisfied if the insulation resistance is not less than megohms than the result of dividing the number 30 by the number of points under test. Appliances and consuming devices may be disconnected during the tests.

(ii) Notwithstanding the provisions of the foregoing sub-clause (i), no final sub-circuit shall be required to have an insulation resistance greater than 1 megohm.

(b) The insulation resistance between the case, frame, or exposed metal parts and every live part of each generator, motor, control gear, or other apparatus or appliance (other than a contact water-heater) shall be tested.

This test shall be deemed to be satisfied if the insulation resistance is not less than 1 megohm.

(c) Metal conduits, metallic cable sheathings, and their earth connexions shall be tested for electrical continuity.

This test shall be deemed to be satisfied if the resistance between any and every point on the conduit or sheathing and earth is low enough to permit the passage of the current necessary to operate the cut-out, circuit breaker, or earth-leakage device protecting the circuit, but does not, in any case, exceed 2 ohms.

(d) (i) A test shall be made to verify that all single-pole switches operate in active conductors and all multi-pole switches operate in all the active conductors of the circuit in which they are inserted, and that no switch is inserted in a neutral conductor unless it is linked to a corresponding switch or switches operating in every active conductor of the same circuit.

(ii) A test shall be made to verify that every neutral link or bar is connected to the neutral conductor of the supply mains.

PART I.—SECTION 2.
ARRANGEMENT AND CONTROL.
SIZE OF CABLES.

201. (a) The sizes of cables and conductors used as aerial cables, bare conductors, and for other purposes where continuous support is not practicable, shall comply with the requirements of these Regulations where minimum sizes are laid down for specific

purposes, and in other cases shall be such as to provide adequate mechanical strength and rigidity.

The sizes of all conductors shall be such that the following conditions are complied with:—

(b) The fall in pressure from the consumer's terminals to any and every point in the installation shall not exceed one volt plus 4 per cent. of the pressure at the said terminals when the cables are carrying their full load current. In the case of cables in which allowance for diversity is permitted in accordance with the provisions of regulation 204, the full load current shall be taken to be that current which corresponds to the maximum demand determined in accordance with the provisions of regulation 205.

(c) The current carried or to be carried by a cable shall in no case exceed that given in Tables A(II.) and A(III.) pages 1200, 1201, for that particular size and type of cable. Such current, in the case of cables in which allowance for diversity is permitted, shall be taken as the full load current determined as in the preceding clause (b) of this regulation.

(d) No rubber insulated cable shall be installed in any situation where the ambient temperature exceeds 120°F. (48.9°C.).

Where the ambient temperature is likely to exceed 100°F. (37.8°C.) the maximum current to be carried by the cable shall be reduced to a value below the limits specified in Table A(II.), page 1200, such that the heating effect of the current cannot increase the temperature of the cable to more than 120°F. (48.9°C.) for sustained periods, or to more than 140°F. (60°C.) at any time.

Note.—Table A(II.) is intended to be applied only in situations where the ambient temperature does not exceed 100°F. (37.8°C.) so that with the normal maximum temperature rise of 20°F. (11.1°C.) the normal maximum working temperature will not exceed 120°F. (48.9°C.).

(e) No paper insulated cable shall be installed in any situation where the ambient temperature exceeds 150°F. (65.5°C.).

Where the ambient temperature is likely to exceed 100°F. (37.8°C.) the maximum current to be carried by the cable shall be reduced to a value below the limits specified in Table A(III.), page 1201, such that the heating effect of the current cannot increase the temperature of the cable to more than 150°F. (65.5°C.) for sustained periods, or to more than 160°F. (71.1°C.) at any time.

Note.—Table A(III.) is intended to be applied only in situations where the ambient temperature does not exceed 100°F. (37.8°C.), so that with the normal maximum temperature rise of 50°F. (27.8°C.) the normal maximum working temperature will not exceed 150°F. (65.5°C.).

MAXIMUM DEMAND.

203. Main and sub-main cables and main control gear and all switchgear and apparatus inserted therein shall be capable of carrying the maximum demand of the installation, or of that portion of the installation supplied through them. The maximum demand shall be determined as provided for in regulation 205.

204. No diversity shall be allowed in final sub-circuits, except that in domestic installations—

- (i) the maximum demand of a cooking stove may be taken as the full connected load up to 10 amperes, plus one-half the load in excess of 10 amperes;
- (ii) general purpose outlets (1,000 watts each) may be connected in parallel on a power circuit as under:—

Minimum Size of Conductor.	Number of Outlets in Parallel.
7/.029	5
1/.064	4
3/.036	4

205. For the purpose of determining the size and/or carrying capacity of consumer's mains, sub-mains, and all switchgear and apparatus inserted therein, the maximum demand shall be computed in one of the following ways, namely:—

- (i) By calculation according to the manner laid down in regulation 206; or

- (ii) By assessment, as provided for under regulation 207; or
- (iii) By indicator or recorder, as set out in regulation 208.

206. Calculation of the maximum demand shall be made from the following:—

(a) *Individual Domestic Installations, including the Individual Flats of a Block—*

- (i) Lighting.—Two-thirds of connected load.
- (ii) Fixed heating, cooking, and power, other than water heaters.—Full connected load up to 10 amperes, plus one-half of the load in excess of this amount.
- (iii) General purpose outlets.—Full capacity of highest rated outlet, plus two-fifths of capacity of other outlets.

(b) *Blocks of Residential Flats—*

- (i) Lighting.—*Up to and including Two Flats:* Two-thirds of connected load. *Remaining Flats:* One half of connected load.
- (ii) Fixed heating, cooking, and power, other than water heaters.—As in (a) (ii) above for highest rated appliance, plus one-third full load of remaining appliances.
- (iii) General purpose outlets.—Full capacity of highest rated outlet, plus one-fifth of capacity of other outlets.

(c) *Hotels, Boarding Houses, Accommodation Houses—*

- (i) Lighting.—Three-quarters of connected load.
- (ii) Fixed heating, other than water heaters.—Full connected load of highest rated appliance, plus one-half of full load of remaining appliances.
- (iii) General purpose outlets.—Full capacity of highest rated outlet, plus one-half of capacity of all outlets in main rooms, such as dining rooms, lounges, billiard rooms, offices, &c., plus two-fifths of capacity of other outlets.
- (iv) Motors (other than lift motors).—Full load current of highest rated motor, plus one-half full load current of all other motors.

(d) *Shops, Stores, Offices, and Business Premises, other than Factories—*

The supply authority may require that the maximum demand be taken as the full connected load, or any lower figure which shall be not less than the following:—

- (i) Lighting.—Nine-tenths of connected load.
- (ii) Fixed cooking appliances.—Full connected load of highest rated appliance, plus three-quarters full load of second appliance, plus one-half full load of remaining appliances.
- (iii) Fixed heating and power appliances, other than motors, cookers, and water heaters.—Full connected load of highest rated appliance, plus three-quarters of full load of remaining appliances.
- (iv) General purpose outlets and special purpose outlets.—Full capacity of highest rated outlet, plus three-quarters of capacity of other outlets.
- (v) Motors (other than lift motors).—Full load current of highest rated motor, plus three-quarters of full load current of second motor plus one-half of full load current of all other motors.

(e) *Lifts—*

First lift motor.—Full load current.
Second lift motor.—Half full load current.
Additional motors.—One-quarter full load current.

(f) *Water Heaters—*

- (i) *Instantaneous and Booster Elements.—* Residential premises (including flats, hotels, boarding houses, &c.).—Full load current of first and second heaters, plus one-quarter full load current of all remaining heaters.

Other Premises.—To be assessed by supply authority.

- (ii) *Continuous Elements.*—Full load current in all cases.

- (iii) *Off Peak Elements.*—Two-thirds full load current where the remainder of the connected load is not less than that of the off peak element. Full load current in all other cases.

(g) *Order of Calculation.*—In calculating the maximum demands as above, lamps, outlets, and permanently connected appliances shall be rated in accordance with the requirements of regulation 217, and shall be taken in order of rating, the highest first.

(h) *Electricity Used for more than One Purpose.*—When electricity is used for more than one purpose, the maximum demand shall be computed by adding together the figures obtained from calculations made as above in regard to each such purpose.

207. The supply authority may, from its knowledge of the operations to be carried on, assess the maximum demand of a factory installation, but in no case shall the maximum demand be assessed at less than one-half of the full connected load. Where the assessment is less than would be obtained by the application of clause (d) of regulation 206, provision shall be made in the mains for the insertion of shunts or current transformers so that the assessment may be checked at any time.

208. Where a maximum demand indicator or recorder calibrated to the satisfaction of the supply authority is installed, the maximum demand shall be the highest averaged rate of consumption of electricity indicated or recorded over any quarter-hourly period by this instrument. Where such an indicator or recorder is not installed, the consumer may install and maintain an automatic overload circuit-breaker which has been tested and calibrated to the satisfaction of the supply authority, and which shall be enclosed in a case or box sealed by and solely under the control of the supply authority. Such a circuit-breaker may have a thirty second time lag at its determined setting, and the load setting of this circuit-breaker shall be assumed to be the maximum demand of the installation.

SERVICE CUT-OUTS.

211. (a) Where placed within a building, service cut-outs shall in no case be fixed between an uppermost ceiling and the roof, or in any other position difficult of access. They shall not be fixed in a position where they are likely to be in close proximity to inflammable gas or material.

(b) The service cut-outs for public buildings shall be arranged to conform to the requirements of regulation 601 with respect to service cut-outs.

(c) Where supply is given from an underground service line, the service cut-out or cut-outs, if fixed within the building, shall be fixed not more than 10 feet from the termination of the supply authority's underground cable.

(d) Where supply is given from an overhead service line, unless the service cut-outs are placed on the distribution pole nearest to the premises, or on a service line pole, they shall be fixed on the outside of the consumer's building or structure as close as possible to the point of attachment, or, alternatively, at a point inside the premises not more than 10 feet from the point of entry.

(e) In multi-circuit domestic installations in premises used as a boarding-house, or in premises intended for and used by not more than one family, if the service cut-out or cut-outs are fixed at or in the consumer's premises, or on a service line pole, or distribution pole adjacent thereto, the main cut-out or cut-outs referred to in regulation 222 shall not be required.

CONSUMER'S MAINS.

212. (a) Cables connecting the service line or underground service cable to the consumer's main switchboard shall in no case be smaller than 7/036 inch.

(b) Where supply is given from a neutral and two or more active conductors, the neutral main shall be of sufficient capacity to carry the maximum current under the extreme out of balance conditions which may obtain in the installation, and in no case shall it be smaller than 7/036", or its carrying capacity be less than one-third that of the largest active conductor.

(c) Unless the supply authority has given approval for other means to be adopted, consumer's mains on the supply side of meters shall be insulated cables enclosed in steel conduits, or in compound filled troughing or fireproof ducts containing no other cables.

(d) Where consumer's mains between the point of entry and the point of attachment are exposed to the weather, they shall be weatherproof cables.

Where the service cut-outs are outside the premises, and the distance between either the point of attachment or the service cut-outs and the point of entry exceeds 2 feet, the consumer's mains between these points shall be enclosed in screwed water-tight metal conduits, or fixed on outdoor type insulators in such a manner that any unsupported length does not exceed 2 feet.

Where, however, the service cut-outs are within the premises, and the length of consumer's mains between either the point of attachment or point of entry and the service cut-outs exceeds 2 feet, the consumer's mains shall not be enclosed in metal conduit, but shall be—

- (i) enclosed by non-conductive, non-inflammable conduits or casings; or
- (ii) supported on insulating racks or suitable insulators; or
- (iii) where exposed to the weather, supported on out-door type insulators,

in such a manner that any unsupported length shall not exceed 2 feet.

ARRANGEMENT OF SUB-MAINS AND SUB-CIRCUITS.

213. (a) Every sub-main and every final sub-circuit shall commence at the main switchboard or at a distribution board.

(b) Where the neutral is earthed at the source of supply through a circuit-breaker, cut-out, or current limiting resistance, no circuit other than a two-wire circuit shall be taken from the main switchboard, except that for lifts a neutral return may be used for the motor control gear circuits. In such case, a cut-out located on the control panel shall be inserted in the active conductor of the control circuit.

(c) Except as provided for in regulation 218, there shall be no break of gauge in the wiring of any final sub-circuit.

(d) Where a sub-main feeds more than one circuit or distribution board, there shall be no break of gauge throughout the entire length of such sub-main except in the following cases, that is to say—

- (i) where a distribution board is fed either from the sub-main through connecting links with cut-outs or over-current switches, or through short open conductors teed off from the sub-mains behind such distribution board.
- (ii) where the supply authority's service is taken to a central distribution board in a building, and separate portions of the installation within the building are supplied through cables which are protected by cut-outs or by switches with earth leakage or over-current releases on such distribution board. Such cables shall be deemed to be sub-mains for the purpose of this clause (d).

(e) The wiring and control and protective gear for all lifts which may convey passengers shall be kept entirely separate from every other portion of an installation. Consumer's mains supplying such lifts shall be taken independently from the supply side of the main switch.

LOADING OF CIRCUITS.

216. (a) (i) Except as provided in clause (b) of this regulation, and in regulation 607 (Public Buildings—Stage Lighting) the number of points that may be installed in parallel on a final sub-circuit shall be as follows:—

Where the total rating of the points supplied from a sub-circuit does not exceed 10 amperes, 10 points; 15 amperes, 4 points; 20 amperes, 3 points.

(ii) Each lamp or low-pressure appliance rated at more than 10 amperes, and each medium-pressure appliance other than motors not exceeding 1-h.p., shall be supplied by a separate and distinct final sub-circuit.

(iii) In calculating the loading of final sub-circuits where multi-way switching is employed, the number of points allowed shall be determined from the current to be carried as required under sub-clauses (i) and (ii) hereof by taking the greatest number of points and the greatest load that can be connected at any one time.

(b) Notwithstanding the provisions of sub-clause (a) (i) of this regulation:—

- (i) The number of permanently connected low-pressure appliances, apparatus, or lamps on a final sub-circuit supplying only electric clocks, relays, signalling lamps and the like, any one of which does not consume more than 25 watts, shall be limited only to 50, provided, however, that the total load on the circuit shall not exceed 500 watts.
- (ii) Where the load on a final sub-circuit for temporary lighting (general illumination) does not exceed 10 amperes, the number of lamps shall be limited only to 50, and where temporary lighting circuits are installed for sign, outline, or decorative lighting, the number of lamps shall be limited only by the total load on the circuit, which load, however, shall not exceed 15 amperes.
- (iii) For permanent sign, outline, or decorative lighting, the number of points shall not exceed that laid down in sub-clause (a) (i) of this regulation, except that the number of points on an indoor circuit, the connected load of which does not exceed 5 amperes, or on any outdoor circuit, shall be limited only by its connected load. In the case of outdoor circuits for permanent sign, outline, or decorative lighting, however, the load shall not exceed 15 amperes.

The provisions of this sub-clause shall not apply to sub-circuits supplying concealed lamps for general illumination purposes.

For the purposes of this sub-clause, a circuit shall be deemed to be an outdoor circuit only if it supplies two or more lamps, all external to the building, and all wiring between such lamps is external to the building.

- (iv) Where long outdoor runs of cable from distribution centres are necessary (as for sports grounds, wharfs, jetties, storage, and loading yards and the like) a lighting sub-circuit running independently in one direction may be so wired that the total number of points on the sub-circuit is limited only by the load on the circuit, which load, however, shall not exceed 15 amperes.

Where long outdoor runs of cable from distribution centres are necessary for the use of one portable appliance only or one portable power device only (such as a lawn mower, a truck loading device or a portable tool), a low or medium pressure power circuit may be so wired that the number of outlets is limited only by the load which, however, shall not exceed 15 amperes unless each outlet is individually controlled by a linked switch operating in all active conductors and protected by a corresponding circuit-breaker with over-current releases in each active conductor.

(v) See regulation 607.

(vi) See regulation 625.

217. (a) For the purpose of calculating the loading of sub-circuits, every lampholder installed for general illumination purposes shall be rated at 60 watts or the actual wattage of the lamp to be installed, whichever is the greater, and every general purpose outlet shall be rated at the wattage of the highest rated appliance to be connected or at 1,000 watts whichever is the greater, but in the case of domestic installations, diversity may be allowed for general purpose outlets rated at 1,000 watts, in accordance with the provisions of regulation 204.

(b) Every outlet installed for the purpose of connecting one special appliance only shall be rated at the actual wattage of such appliance, but in no case shall any such outlet be rated at less than 100 watts.

In order that such an outlet shall not be used for any purpose other than that of connecting the special appliance aforesaid, it shall not be capable of accommodating a plug, adaptor, or connector which can be connected to the installation of any lampholder, any general purpose outlet, or any special purpose outlet of higher rating.

Every outlet other than a general purpose outlet shall be approved for the purpose, and shall have permanently marked on it the wattage at which it is rated for the purpose of calculating the loading of the sub-circuit.

218. The minimum size of flexible cords connected to or forming a portion of a final sub-circuit shall be in accordance with the following table:—

Rating of Final Sub-circuit.	Minimum Size Flexible Cord.	
	Not Tough Rubber Covered.	Tough Rubber Covered.
Not exceeding 5 amps. . .	23/-0076	9/-012
Not exceeding 10 amps. . .	40/-0076	16/-012
Not exceeding 15 amps. . .	70/-0076	28/-012
Not exceeding 20 amps. . .	110/-0076	44/-012

In no case shall any flexible cord have a current-carrying capacity less than the maximum current loading of the apparatus or lamp it connects.

CONTROL OF MAIN SUPPLY AND OUTGOING CIRCUITS.

221. (a) (1) The main switchboard for every installation shall be located in a readily accessible position, and every switchboard at which the supply of electricity to a consumer is independently controlled shall be under the control of such consumer.

(2) Where supply is given from—

(i) a system operating with a circuit-breaker, cut-out, or current-limiting resistance in the earth connexion of the neutral at the source of supply; or

(ii) a system with all conductors insulated from earth at the source of supply,

or where more than one consumer is supplied through a single-service cut-out (or single group of service cut-outs in the case of supply through more than one active conductor), the main switchboard shall be placed as near as practicable to the service cut-outs if such are placed inside the premises, or as near as practicable to the point of entry if the service cut-outs are placed outside the premises.

(b) Where the maximum demand of any circuit, (as laid down in regulations 206 and 207) exceeds 250 amperes, or the full load current in any motor circuit exceeds 100 amperes, cut-outs shall not be used in such circuit, but circuit-breakers with over-current releases shall be installed.

(c) Where the main supply is controlled by an enclosed type circuit-breaker, a disconnecting switch (or links) shall be provided in order that the circuit-breaker may be entirely disconnected from the source of supply.

Control Equipment.

222. (a) Where the neutral conductor is earthed at the source of supply without a circuit-breaker, cut-out, or current-limiting resistance in the earth connexion—

(i) The main supply to every independently metered portion of an installation shall be controlled and protected on the main switchboard by the insertion in each active conductor of a switch and a cut-out or an over-current release operating such switch, and every circuit outgoing from any switchboard shall be controlled and protected on such switchboard in a like manner.

(ii) The incoming and outgoing neutral conductors at any switchboard shall be connected at a neutral busbar (see regulation 262) where the M.E.N. system is used, or at a covered neutral link on the switchboard (or at a neutral busbar where 30-in. spacing is provided for access to the back of the board) where the neutral is not multiply earthed.

(iii) No cut-out or unlinked switch shall be inserted in a neutral conductor.

(b) Where the neutral conductor is earthed at the source of supply through a circuit-breaker, cut-out, or current-limiting resistance, or where no conductor is earthed at the source of supply—

(i) The main supply to every independently metered portion of an installation shall be controlled and protected on the main switchboard by inserting in each conductor a switch, and in each active conductor a cut-out or an over-current release operating such switch. Every circuit outgoing from a switchboard shall be controlled on such switchboard in a like manner, and protected in each conductor by a cut-out or an over-current release operating the control switch.

(ii) No unlinked switch shall be inserted in a neutral conductor or in a negative conductor of an installation connected to a 2-wire d.c. system of supply.

(c) Where switches are required under the preceding clauses (a) and (b) in more than one conductor of a circuit, the corresponding switches in each conductor shall be linked switches, and shall operate simultaneously in all active conductors.

(d) Except in a lift circuit, the switches specified in clauses (a) and (b) of this regulation for the control of circuits outgoing from switchboards shall not be required in the case of any outgoing circuit of less than 100 amperes connected load.

(e) Nothing in this regulation shall prevent the insertion of a switch in any neutral conductor, provided it is linked with corresponding switches in all active conductors of the circuit.

MASTER SWITCHES.

227. Where premises other than those constructed for and used solely as single family dwellings are supplied with electricity through an underground service cable—

(a) A master switch capable of interrupting all active conductors supplying the installation (with the exception of any conductors supplying lifts and/or apparatus referred to in clause (g) of this regulation) shall be installed in a position proximate to and easily accessible from a main entrance to such premises.

(b) The master switch shall be clearly identified by the words "MASTER SWITCH" in prominent letters.

(c) The supply of electricity to lifts shall be controlled independently of the master switch required under clause (a) hereof by a separate master switch capable of interrupting all active conductors of the lifts circuit and installed immediately adjacent to the switch marked "Master Switch". This switch shall be known as a "lifts control switch," and shall be clearly identified by the word "LIFTS" in prominent lettering.

(d) All master switches installed as provided for under clauses (a) and (c) of this regulation shall be arranged for hand operation.

(e) Notwithstanding the foregoing provisions as to place of installation, where the complete layout of an installation has been submitted to and approved by the authorized inspector, he may authorize the installation of master switches as required under the preceding clauses of this regulation, in specified positions remote from a main entrance, provided that they can be operated at a main entrance by a remote control switch.

(f) Provided that the main switches required under regulations 222 and 431 (i) are in a position proximate to and easily accessible from a main entrance, and are identified by lettering as required for master switches installed in accordance with the requirements of this regulation, no additional master switch need be installed.

- (g) Notwithstanding the foregoing provisions of this regulation, all electrically operated fire-protection apparatus shall be connected to an independent circuit or circuits supplied from the service side of the master switch. Every such circuit shall be protected by a cut-out in each active conductor.

SWITCHBOARDS.

251. (a) Switchboard panels shall consist wholly of durable non-ignitable, non-hygroscopic materials which, unless all live parts of apparatus mounted on or in contact with the panels are adequately insulated therefrom, shall also be insulating materials of permanently high electric strength and insulation resistance.

Marble and slate panels shall be used only provided all conducting parts to be mounted thereon are insulated from the panel by a coating of suitable varnish or other non-hygroscopic insulating material. All insulating switchboard panels other than marble and slate panels shall conform to the requirements of regulation 2251.

(b) All material other than metal used as a switchboard panel shall have a thickness of not less than $\frac{1}{4}$ inch.

(c) Any switchboard panel less than $\frac{1}{4}$ inch in thickness, unless the material of which it is constructed will withstand a mechanical loading at least 100% in excess of that specified in regulation 2251 (a), shall be supported all round its edges by a grooved or beaded frame.

(d) The minimum allowable thickness of switchboard panels of material other than metal shall be in accordance with such one of the requirements of the table hereunder respecting current and area as specifies the greater thickness. Should, however, greater mechanical strength be required on account of the distance between supports, dimensions of panels, and/or nature of apparatus to be mounted thereon, panels of greater thickness shall be used.

THICKNESS OF SWITCHBOARD PANELS.

Maximum Current taken to Board.	Minimum Thickness of Panel.	Maximum Area of Switchboard Panel.
	Inches	
Not exceeding 20 amperes	$\frac{1}{4}$	2½ square feet
Exceeding 20 amperes, but not exceeding 50 amperes	$\frac{3}{8}$	6 square feet
Over 50 amperes	$\frac{1}{2}$	Not limited where the distance between supports does not exceed 2 feet, otherwise 6 square feet
Where any switch or circuit-breaker exceeds 100 amperes	$\frac{3}{8}$	Not limited where the distance between supports does not exceed 2 feet, otherwise 6 square feet

252. (a) All apparatus mounted on a switchboard shall be attached thereto by means of bolts, studs, or screws having metal threads which engage in nuts or suitably threaded holes in metal, and shall be so arranged that all parts thereof and all connexions thereto are readily accessible, and so that the course of all conductors to all instruments and apparatus can be readily traced.

Where a switchboard panel is constructed of insulating material, no apparatus shall be mounted within 1 inch of any edge of the panel, and no hole, other than holes by means of which such panel is fixed, shall be drilled closer than 1½ inches from the edge of the panel.

All nuts used at the back of a switchboard for the connexion of current-carrying parts shall be effectively locked.

(b) (i) Except in so far as it is necessary to alter such order to comply with the requirements of regulation 402 (b), all apparatus shall be mounted on a switchboard panel as far as practicable in the correct order of its insertion in the circuit or circuits connected to the panel, commencing either from the top or from the bottom of such panel.

(ii) The apparatus protecting and controlling circuits shall be arranged in such a manner as to avoid unnecessary crossings of conductors, and shall be so

grouped on the switchboard that the apparatus protecting and/or controlling each type of circuit (such as 200-300 volt circuits, 400-460 volt circuits, lighting circuits, power circuits, water-heating circuits) is kept in a distinct zone and can be readily identified. Where possible, the apparatus within each such zone shall be grouped according to the phase or polarity of the conductor in which it is inserted.

(iii) All apparatus shall be so placed on a switchboard that there is ample room for its safe and effective operation, and for the safe handling of all such apparatus which requires handling.

(iv) Unless they are effectively screened by substantial barriers of non-hygroscopic, non-ignitable insulating material, the unenclosed live metal parts of switches and cut-outs shall be so arranged and placed that no such live part can come within 2½ inches of any other live part or any exposed metal at different potential where the potential difference does not exceed 250 volts, or within 3½ inches of any other live part or any exposed metal where the potential difference exceeds 250 volts.

The foregoing provisions of this clause, however, shall not apply to those parts of fixing and/or connecting screws and studs which project through the panel on the side reverse to that on which the switches or cut-outs are fixed.

(v) Cut-outs shall be fixed in a vertical position, and be spaced so as to permit the safe and easy withdrawal of the fuse carriers.

(vi) Where practicable the wiring for connexions on switchboards shall be run at the back of the board, and where it is necessary for cables to be brought through the switchboard panel to the front of the board, they shall be brought through close-fitting holes as near as possible to the terminals to which they are to be connected.

(c) Switches and cut-outs, or the zones in which they are mounted, shall be labelled so as readily to indicate the consuming devices or circuits which they control.

(d) Busbars carrying alternating current shall be so arranged as to conform in all respects to Australian Standard Specification No. C.13 "Australian Standard Marking for Switchboard Busbars and Connexions".

(e) All bare live conductors shall be rigidly fixed in such a manner that a clearance of at least 1 inch is maintained between conductors of opposite polarity or phase and between the conductors and any other exposed metal.

(f) No cut-out other than a cut-out in an instrument circuit shall be fixed on the back of or behind a switchboard.

(g) Every main switch and every single-pole switch controlling a circuit outgoing from a switchboard shall be so connected at such board that no corresponding circuit cut-out is alive when the switch is in the "off" position.

(h) The connecting conductors to every voltmeter and its pilot lamp (if any), and to every earth lamp, shall be protected by a cut-out in each active conductor.

253. (a) Switchboards shall be so arranged as to prevent access of acid fumes, and, unless of a waterproof type, shall be placed only in dry and well-ventilated places.

(b) Switchboards, unless encased or erected in positions not accessible to unauthorized persons, shall not be erected within 4 feet above a floor. They shall not be erected above or in the immediate vicinity of gas stoves or gas meters, or in bathrooms, lavatories, or the washing-rooms of laundries, or in freezing-rooms or cooling chambers.

(c) Unless placed in an engine-room or in a compartment specially arranged for the purpose, every switchboard either shall be enclosed in a protecting case or all current-carrying parts mounted on the switchboard (except the neutral bar in the case of M.E.N. systems) shall be permanently covered and protected from personal contact.

(d) Where a switchboard is placed within 6 inches of a wooden wall or 18 inches of a wooden ceiling, unless the switchboard is completely encased or all apparatus on the switchboard is metal clad, such wall or ceiling shall be protected by a sheet of asbestos not less than 1-16 inch in thickness, or by a sheet of fibro-cement not less than 3-16 inch in thickness.

(e) Where a switchboard is sunk into a wall or partition not built entirely of non-ignitable material, the back shall be enclosed in a case constructed either of—

- (i) metal not less than No. 20 S.W.G.; or
- (ii) hardwood lined with asbestos sheet not less than 1-16 inch in thickness; or
- (iii) hardwood lined with fibro-cement not less than 3-16 inch in thickness; or
- (iv) non-ignitable insulating materials.

(f) Glass fronts of switchboard cases shall be clear of all live parts by not less than 1 inch.

254. (a) (1) Where it is necessary to have access to the back of a switchboard for wiring purposes, or where any exposed live metal is mounted on the back of a switchboard, the switchboard shall be so placed that there is a space between the back of the board and any wall or immovable structure behind the board. Provision shall be made for easy access to such space, and the minimum distance from the back of the board to such wall or immovable structure shall be as shown below. Should any live metal project from the back of the board, the minimum distance of the board from the wall or immovable structure shall be greater than that shown below by the greatest distance any such metal projects from the back of the board—

- (i) 1 inch in the case of a board carrying not more than two circuits, the total loading of which does not exceed 10 amperes, and the greatest dimension of which does not exceed 15 inches, and 3 inches in the case of all other boards the greatest dimension of which does not exceed 15 inches.
- (ii) 4 inches where either the height or the width of the board does not exceed 24 inches but one of these dimensions exceeds 15 inches.
- (iii) 12 inches where both the height and the width of the board exceed 24 inches but neither of these dimensions exceeds 4 feet, and, in addition, the back of the board is accessible from both sides or from both top and bottom. If the board is not accessible as aforesaid, the minimum distance shall be 30 inches.
- (iv) 30 inches where both the height and the width of the board exceed 4 feet. In such cases, all stays and conductors shall be so arranged as to allow a clearance above floor-level over the space behind the board and not less than 6 feet for stays and insulated conductors, and 6 ft. 6 in. for bare conductors.

(2) Except as provided for in sub-clause (3) hereunder, for the purpose of this clause (a), if a switchboard panel is mounted more than 12 inches from any other panel, it shall be deemed to be a separate switchboard, but if a panel is mounted within 12 inches of any other panel, such panels shall be deemed to be one switchboard. Where further panels are required because of additions, alterations or extensions to an installation, and any such panel is mounted within 12 inches of an existing switchboard or within 12 inches of any other such panel, the existing switchboard and new panels shall be deemed to be one switchboard if their combined height and combined width exceed 24 inches.

(3) Where a switchboard consists of panels which are hinged or can be independently removed so that in either case all wiring and all back connexions thereto are completely accessible without disturbing other panels, wiring, or connexions, the space behind the switchboard need not exceed that required under sub-clause (1) above for a switchboard of the same dimensions as the largest hinged or removable panel.

(b) Unless such switchboard is situated in a room accessible only to authorized attendants, the space behind every switchboard which is required to be spaced 30 inches from a wall or immovable structure shall be enclosed so as to make it inaccessible to any but authorized attendants, and access to such space shall be provided by a door or doors each not less than 18 inches wide and of a height permitting easy access. Such door or doors shall be kept locked when not open for access, but shall at all times be capable of being opened outwards from the inside without the use of a key.

Where passage room is provided behind a board which is more than 6 feet in length, an access door as described above shall be provided at each end of the board.

(c) Clear space shall be provided and maintained in front of every switchboard ample for the purpose of safely and effectively operating and adjusting all equipment mounted thereon. In the case of switchboards 6 feet or more in length, such space shall be not less than 4 feet wide, measured from the switchboard panels.

255. When any work done or to be done to an installation requires the alteration or extension of any switchboard or any addition to be made thereto—

- (i) If such switchboard, in the opinion of the authorized inspector, is in a position unsuitable for the safe and effective control of the circuits and apparatus to be connected thereto or supplied therefrom, it shall be removed to a position approved by the authorized inspector as conforming with the requirements of these Regulations.
- (ii) If, in the opinion of the authorized inspector, the apparatus comprising the switchboard or the layout or arrangement of the switchboard does not provide for the safe and effective control of the circuits and apparatus to be connected thereto or supplied therefrom, it shall be replaced by a switchboard conforming to the requirements of these Regulations or, if he so requires, shall be reconstructed and rearranged so as to provide, in accordance with the requirements of these Regulations, for the safe and effective control of the circuits and apparatus.

MULTIPLE EARTHED NEUTRAL SYSTEM.

261. The multiple earthed neutral system shall be installed and employed in such new installations as the Commission may direct by giving notice to the supply authority.

As to installations connected prior to the coming into operation of these Regulations, to alternating current supply mains one conductor of which is earthed at the source of supply, the Commission may, by notice published in the *Government Gazette*, direct that when any alteration, addition, or extension of any specified kind or of any kind whatever is made to installations generally, or to any installation supplied by a specified undertaking, or from a specified transformer, or to any installation located in a named district or area, the multiple earthed neutral system is to be installed and employed throughout such installations or installation.

Before any alteration, addition or extension of a kind specified in any such notice is made and completed in any installation to which such notice relates, the person carrying out the alteration, addition, or extension shall, as required by such notice, install the multiple earthed neutral system throughout the whole installation in accordance with these Regulations, and where alterations, additions, or extensions are carried out by more than one person at different times, the person carrying out that portion of the alterations, additions, or extensions which brings the installation under the operation of this regulation as amplified by any notice published in the *Government Gazette* shall be responsible that the multiple earthed neutral system is so installed. Any such notice, so far as it relates to installations in places where the Commission is not the supply authority, shall be forwarded by the Commission to the supply authority.

262. Where the multiple earthed neutral system is used—

- (a) A neutral busbar shall be provided on the main switchboard, and to this busbar shall be connected the neutral main, the main earthing conductor, and the neutral conductors of all circuits outgoing from the switchboard. Apart from these, no conductor shall be directly connected to this busbar. Should, however, the supply authority's neutral main be arranged for division at a connecting bar or link, the main earthing conductor may be soldered into a cable socket and connected to this bar or link instead of to the neutral busbar on the main switchboard, in which case the connexion shall be made in such a manner that the opening of the link will not disconnect the earthing conductor from the installation.

- (b) The neutral busbar shall be made of copper or highly conductive copper alloy. Its current-carrying capacity shall be not less than that of the neutral main, and its size not smaller than $\frac{3}{8}$ inch wide by 5-16 inch thick. It shall be visible at all times, and shall be mounted on the front of the switchboard, except that where a space of 30 inches is provided for access to the back of the board in accordance with clause (a) of regulation 254, it may be mounted behind the switchboard.
- (c) (i) Except as provided for in sub-clause (ii) hereunder, the main earthing conductor and the neutral main shall be soldered into cable sockets, and the main earthing conductor shall be connected to a terminal at one extremity of the neutral busbar and the neutral main to the next adjacent terminal thereon, or the main earthing conductor and the neutral main may be connected in any position on the neutral busbar, provided such connexions are permanently marked or labelled.
- (ii) Where any main earthing conductor or neutral main is of a form unsuitable for connexion to the neutral busbar by means of a cable socket and terminal as set out in the preceding sub-clause (i), it shall be connected thereto by means of a bolt or bolts or a suitable clamp. The position on the neutral busbar of any such connexion shall be that required under sub-clause (i) aforesaid for the main earthing conductor and neutral main respectively.
- (d) At every switchboard and distribution board other than the main switchboard, a neutral busbar as described in clause (b) of this regulation shall be provided and mounted in the manner described in the said clause (b). The carrying capacity of this busbar shall be not less than that of the neutral conductor of the sub-mains supplying the switchboard. The incoming neutral conductor and the neutral conductors of all circuits outgoing from such switchboard shall be connected to this busbar. Apart from these, no conductor shall be connected to this busbar, except neutral conductors for sub-main metering and bonding conductors, in the cases provided for under sub-clause (2) of clause (f) and clause (g) of this regulation.

The incoming neutral conductor shall be soldered into a cable socket and connected to a terminal on the neutral busbar.

Earthing and/or bonding conductors (if any) shall be soldered into cable sockets and connected to terminals on the neutral busbar on one side of the incoming neutral conductor. The neutral conductors of all circuits outgoing from such switchboard shall be connected to terminals on the neutral busbar on one side of the incoming neutral conductor, which shall be the side remote from that on which earthing and/or bonding conductors (if any) are connected.

- (e) The main earthing conductor shall in all cases be taken from the neutral busbar on the main switchboard (or from the supply authority's connecting bar or link) directly and without a break to an effective earth.
- (f) Where the main earthing conductor is taken to a water supply system—
- (1) All subsidiary earthing conductors connected to the same water supply system shall be considered to be effectively connected to each other and to the main earthing conductor by the piping of such water supply system. No subsidiary earthing conductor connected to this water supply system shall be connected or bonded to any neutral busbar.

(2) Every subsidiary earthing conductor connected to an independent earth plate or pipe shall be connected to the neutral conductor by a bonding conductor, which shall comply with the requirements of regulations 515 and 516 for earthing conductors, and which shall be taken from such earth plate or pipe, or from the subsidiary earthing conductor directly to either—

- (i) the neutral busbar of a sub-distribution board; or
- (ii) the main earthing conductor.
- (g) Where the main earthing conductor is connected to an earth plate or pipe—
- Every subsidiary earthing conductor, unless it is directly connected to the main earth plate or pipe, or to the main earthing conductor, shall be connected to an effective earth, and shall also be connected by a bonding conductor (which shall comply with the requirements of regulations 515 and 516 for earthing conductors)—
- (i) to the main earth plate or pipe; or
- (ii) to the main earthing conductor; or
- (iii) to the neutral busbar on a sub-distribution board.
- (h) Subsidiary earthing conductors and bonding conductors shall be connected to the main earthing conductor only by means of soldered joints or suitable approved clamps or clips, which shall be readily accessible for inspection.
- (i) Except as provided for in clauses (c), (e), (f), and (g) of this regulation, no direct connexion shall be made between the earthing system and the neutral conductor of an installation.
- (j) Where the multiple earthed neutral system is employed in an installation, no cut-out or unlinked switch shall be inserted in any neutral conductor, but this shall not preclude the provision of a bolted isolating link for testing purposes.

PART I.—SECTION 3. INSTALLATION OF WIRING. CONDUCTORS.

Distinguishing Colours or Forms of Cables and Flexible Cords—

301. (a) Where braided rubber insulated cables are used—

- (i) black braided cables shall be used for all neutral cables and the negative cables of 2 wire d.c. systems;
- (ii) green braided cables shall be used for insulated earthing conductors;
- (iii) cables with red or other distinctive coloured braiding (not being black or green) shall be used for all other cables.

(b) Where rubber insulated cables (flexible cords excepted) are not identified by impregnated colouring of the rubber corresponding to the colouring of braided cables, under clause (a) of this regulation, the cables of circular section having plain exterior surfaces shall be used as active cables (or positive cables in the case of 2 wire d.c. systems) and those of other section shall be used as neutral cables (or negative cables in the case of 2 wire d.c. systems).

(c) Distinguishing colouring of the current carrying conductors of flexible cords shall not be required, but only a conductor identified by green colouring (or other approved means) shall be used as an earthing conductor.

302. No cable having a conductor of a nominal sectional area less than 0.0015 square inch (1/044 inch diameter) shall be used, except for the wiring of fittings, for which a conductor of nominal sectional area not smaller than 0.001 square inch (1/036 inch diameter) may be used.

303. Except in the case of busbars, battery connexions, and trolley wires, standard cable shall be used where the nominal sectional area of the conductor exceeds 0.0032 square inch (1/064 inch diameter).

304. Except in cases where it is expressly provided that bare cables may be used, cables shall be of a type approved or listed under regulation 2304, and shall comply with those requirements of regulations 2304-2315 which are applicable to that type of cable.

INSTALLATION.

321. Of the types of cables specified in regulation 2304, the following shall not be used for alternating current:—

- (a) single cables armoured with steel wire or tape or encased in a ferrous sheath;
- (b) single cables having a conductor of nominal sectional area greater than 0.25 square inch which are encased in a metal sheathing.

Where cables of the types referred to in paragraph (b) above having a nominal sectional area of 0.25 square inch or less are used for alternating current, the lead and return shall be placed as near as possible to each other.

Bunching of Cables.

322. (a) Cables shall not be bunched in wood casing unless of the same polarity or phase.

(b) The number of cables bunched in wood casing shall not exceed six if the sectional area of any cable exceeds 0.007 square inch (7/036 inch), or ten if no cable has a sectional area greater than 0.007 square inch.

(c) The casing used shall be of sufficient size to accommodate the cables without injury, but shall not be larger than is necessary to accommodate the maximum number of cables which it is permissible to bunch.

(d) Where installed in or protected by metal conduits, wood troughing, or insulating or fireproof ducts, cables carrying direct current may be bunched whatever their polarity, but if carrying alternating current, the lead and return cables of a single-phase circuit and all phase wires with the neutral wire (if any) of a poly-phase circuit shall be bunched, except as is otherwise provided in regulation 2453 in the case of cables conveying high pressure current to luminous discharge tube signs.

(e) Notwithstanding anything in clause (d) of this regulation, cables energized through separate service lines or separate groups of service cut-outs or energized from different sources of supply shall not be bunched under any circumstances.

(f) Notwithstanding the foregoing provisions of this regulation, consumer's mains on the supply side of meters shall not be installed in conduits containing other cables, nor shall they be installed in troughings or ducts containing other cables, unless they are either armoured cables or are permanently and effectively separated from other cables.

Access to Wiring.

324. (a) No wiring shall be installed between a roof and an uppermost ceiling in a space which is sufficient to permit of access unless there is a convenient means of access thereto available. No aperture, unless it contains a rectangular space not less than 16 inches by 14 inches, shall be deemed a convenient means of access.

(b) Inspection conduit fittings and conduit draw-in boxes shall be installed only in positions where they will be at all times readily accessible for inspection. Traps in flooring boards shall be deemed a sufficient means of access to such fittings and boxes if fastened down by means of screws.

Joints and Connexions.

326. (a) All connexions between cables, whether made by means of connectors or joints, shall be accessible for inspection or repair, and shall be mechanically and electrically sound.

Except where they are made in open wiring, all joints shall be enclosed in readily accessible joint boxes of adequate size to accommodate freely the whole of the joints without rendering them liable to damage.

(b) Sub-circuit wiring, where the cables are rubber insulated cables not larger in area than 0.0032 square inch (1/064 inch diameter) shall be carried out on the loop-in system. In all other cases, the loop-in system shall be employed where practicable, and where this is not practicable, connexions

between cables shall be made either by soldered joints or by mechanical connectors in a manner complying with the appropriate requirements of this regulation.

(c) Joints between rubber insulated cables, unless insulated and protected in some other approved manner, shall be lapped with rubber tape to a thickness not less than that of the insulating material, and the joints so insulated shall be covered with waterproofed tape so as to render them moisture-proof.

(d) Except in the case of temporary wiring for sign, decorative, or outline lighting and connexions enclosed within appliances and apparatus, connexions between cables and flexible cords shall be made only by means of a plug and socket, a ceiling rose, or other connecting device in which the conductors of the cables and flexible cords are rigidly clamped between metal surfaces, and which is approved for the purpose.

Connexions between flexible cords and conductors within fittings, appliances or apparatus shall be soldered connexions only if they are completely relieved of strain.

(e) Every joint in paper-insulated cables and in armoured cables of all types shall be made in either—

- (i) an approved joint box, the protective covering of the cable being maintained intact up to a point inside the box; or
- (ii) in a lead sleeve wiped on to the cable sheathings in place of a joint box.

In either case the joint shall be suitably insulated (in the case of paper-insulated cables, with impregnated tapes) and the joint box filled with an insulating compound impervious to moisture.

(f) Cable connectors shall be enclosed in boxes constructed wholly of durable, non-ignitable, non-absorbent materials, and shall be supported by durable, non-ignitable, non-hygroscopic insulating material in such a manner that contact between metal parts at different potentials or between live metal parts and surrounding conducting material is not possible.

(g) Joint boxes shall be so installed that they maintain the electrical conductivity of the conduits, cable sheathings, and/or armourings in which they are inserted.

(h) At terminal connexions every cable except flexible cables and those having fewer than seven strands shall be either—

- (i) soldered into a cable socket of such a size that all strands of the conductor can enter the socket simultaneously; or
- (ii) clamped in a terminal or binding post; or
- (iii) terminated in an approved solderless tag or terminating device; or
- (iv) made solid by soldering and securely clamped under a clamping screw or between metal surfaces.

(i) Cables shall be connected to a common terminal only by soldered lugs unless the terminal is of such a form that all cables are securely clamped at the terminal between metal contacts without the cutting away of any cable strands. If a single terminal is insufficient to accommodate all the conductors, multiple terminals or contacts with sufficient clamping devices to clamp the conductors securely shall be used.

Any common terminal or multiple terminal used for the connexion of more than one installation shall be of such a form that any conductor can be removed or replaced without interrupting the supply of electricity to any other installation.

AERIAL CONDUCTORS.

331. (a) Every cable installed as an aerial conductor shall consist of not less than 7 strands, and where the length of an aerial line does not exceed 75 feet the minimum size of conductor shall be 7/036 inch. If the length is greater, each cable shall be not smaller than 7/044 inch. The maximum distance between points of support shall not exceed 135 feet, except in the case of bare cables erected in accordance with the provisions of clause (1) of this regulation.

(b) Aerial cables complying with the requirements of regulation 2312 shall be used for aerial conductors, except that—

- (i) for spans not exceeding 75 feet, hard-drawn, weather-proof, rubber insulated, copper cables may be used;
- (ii) for spans not exceeding 30 feet, soft-drawn, weather-proof, rubber insulated, copper cables may be used;
- (iii) where the multiple earthed neutral system is used, the neutral conductor shall be bare copper, and shall be hard drawn if the span exceeds 30 feet;
- (iv) bare conductors may be used where erected in accordance with the provisions of clause (i) of this regulation.

(c) Every aerial conductor shall be erected in a manner that will prevent, as far as is reasonably possible, any part thereof coming within 10 feet of the ground, or lower than 15 feet above any part of premises used by vehicles of any description other than private passenger motor cars.

(d) Aerial conductors shall be suitably supported on outdoor type insulators. Bobbin insulators less than 2 inches in depth or 2½ inches in diameter shall not be used for this purpose. Conductors shall be terminated on shackle, strain, or other approved types of terminating insulators.

Pin-type insulators shall not be used for supporting aerial conductors where the pull tends to lift or otherwise separate the conductors from the insulators.

(e) Cables connecting aerial conductors to other wiring shall be stranded cables not smaller than 3/029 inches, and, unless the connexions between such cables and the aerial conductors are made by means of mechanical connectors, they shall be soldered to the aerial conductors away from those parts in tension.

(f) No aerial conductor shall be capable of coming within 9 feet above any part of any roof which is accessible for traffic or resort, or, except in the immediate vicinity of a ridge on which outdoor type insulators supporting the conductors are mounted, within 4 feet above any other roof.

(g) No aerial line shall pass within 3 feet of any window which can be opened, any accessible balcony, or any similar place of resort, unless it is protected in such a manner as to prevent accidental contact therewith.

(h) Aerial conductors shall not be erected over, or under, or in close proximity to any wireless aerial or any stay wire used in connexion therewith, or be in such a position that it is possible for them to make contact with a wireless aerial or stay wire, or for any person to touch simultaneously any such aerial conductor and a wireless aerial or stay wire.

(i) Stranded, hard-drawn bare, copper conductors not smaller than 7/036 inch in spans not exceeding 100 feet, or not smaller than 7/044 inch in spans not exceeding 150 feet, or not smaller than 7/064 inch in spans not exceeding 200 feet, may be used as aerial conductors, provided they are erected according to the provisions of clauses (a), (d), (e), and (h) of this regulation, and, in addition, are maintained at a distance not less than 18 feet above the ground, 9 feet above any part of a roof which is accessible for traffic or resort, and 7 feet from all other portions of buildings.

(j) In places where lightning storms are prevalent, aerial conductors likely to be affected by lightning discharge shall be fitted with lightning arresters (on each pole or phase) placed external to all buildings.

(k) Aerial lines shall be erected in a manner that will prevent, as far as is reasonably possible, any part thereof coming within 2 feet of any telegraph or telephone line.

(l) Portions of the supply authority's service line attached to and within 7 feet of the consumer's building shall comply with and be erected according to the provisions of clauses (a), (b), (c), (d), (f), (g), (h), and (k) of this regulation, except that the neutral conductor of the service line may be bare in all cases.

BARE CONDUCTORS.

332. (a) Bare conductors shall be used only with the sanction, in writing, of the authorized inspector, except where they are used as aerial conductors, earthing conductors, switchboard connexions, battery connexions, or trolley wires for travelling cranes or similar appliances.

Except where they are used as earthing conductors, they shall be used only in positions not ordinarily accessible to unauthorized persons.

If they are intended to be used as aerial conductors, they shall comply with the provisions of clause (i) of regulation 331, and if they are intended to be used as earthing conductors, they shall comply with and be erected in accordance with the relevant regulations of Section 5 (Earthing). In all other cases they shall comply with and be erected in accordance with the requirements of the following clauses (b) to (e) inclusive.

(b) Where adjustment of the strain of conductors is required, suitable insulating and straining gear shall be provided at each straining point.

(c) Except where used as switchboard connexions or as secondary battery connexions, bare conductors shall be controlled and protected either by a suitable circuit-breaker or by a suitable switch and cut-out (or cut-outs) which comply with the requirements of regulations 221 and 222 for the control and protection of similar circuits outgoing from switchboards. Such circuit-breaker or switch and cut-out or cut-outs shall be fixed at a convenient accessible position adjacent to the bare conductors, and the provision of the circuit-breaker or switch and cut-out or cut-outs shall not affect the requirements of these Regulations as to controlling and/or protecting devices on switchboards.

(d) Bare conductors shall in no case be smaller than 0.01 square inches in sectional area, and where used as collector or trolley wires shall be not smaller than the sizes laid down in the Australian Standards Association's Code for Cranes and Hoists.

(e) Where they are fixed within buildings (other than in battery rooms and switch rooms), suitably worded danger notices shall be placed in prominent positions proximate to the conductors at each termination, and in each room not more than 50 feet apart along the run of the conductors.

OPEN WIRING.

333. (a) Taped and braided cables and braided rubber compound insulated cables, such as are specified in regulation 2304 (d) (2), and (d) (9), shall be used without the further protection of conduit or casing only in cases for which the previous sanction, in writing, of an authorized inspector has been obtained, and subject to compliance with the following requirements:—

(b) They shall be open to view throughout their length, except where protected in accordance with the requirements of clauses (d) and (h) of this regulation.

(c) They shall be maintained at a distance not less than ½ inch from walls, ceiling joists, and other non-metallic structures, not less than 3 inches above any portion of a structure over which they pass and on which they are not directly supported, not less than 1½ inch below metal ceilings, and 3 inches from all other metalwork except the conduits required to protect them under clauses (d) and (h) of this regulation.

(d) In any position in which they are liable to mechanical damage, and wherever they are within 6 feet above a floor, they shall be adequately protected by metal conduits or non-conducting casing or ducts.

(e) They shall be supported on insulators or secured by porcelain cleats or by insulating clips, saddles, or clamps having smooth or rounded edges which will not indent or damage the braiding, and which are fashioned of non-absorbent, non-inflammable, insulating material sufficiently robust to preclude the liability of mechanical failure. Where the cables are not secured throughout their length at intervals of 10 feet or less, shackle or other suitable strain insulators shall be used for terminations of cable runs exceeding 50 feet.

(f) The distance between supports shall not exceed that set out in the following table for the relevant size of cable, means of support, and arrangement of cables:—

Size of Cable.	Means of Support.	Distance between Supports.	
		Cables approx. Horizontal.	Cables approx. Vertical.
		Feet.	Feet.
Single wire conductor	Saddles, cleats, clips, or insulators	5	6
3-strand cable not larger than 3/036	Saddles, cleats, or clips	7	10
	Insulators	15	15
7-strand cable not larger than 7/064	Saddles, cleats, or clips	7	10
	Insulators	30	30
Stranded cables larger than 7/064	Saddles, cleats, or clips	7	10
	Insulators	40	40

The above table gives the maximum allowable distances between supports for clear runs, such as in open roofs and along walls. Where additional support is necessary to provide clearances from the building structure, pipework, or other features, or for any other purposes, additional supporting saddles, cleats, clips, or insulators shall be provided.

(g) Unenclosed cables shall be spaced sufficiently far apart to prevent contact with one another.

(h) Where passing through floors, partitions, ceilings, or walls, cables shall be—

(i) protected by conduits or ducts; or

(ii) (except in the case of fire-resisting floors, partitions, ceilings, or walls, as provided for in regulation 144) supported in such a manner that not less than 2 inches clearance is maintained between cables and non-conductive material, and 3 inches between cables and metal.

METAL SHEATHED CABLES.

334. Metal sheathed cables, such as are described in regulation 2304 (d) (3), shall be used without the further protection of conduit or casing only provided that the following requirements are complied with:—

(a) They shall be run only in dry situations, and shall in no case come in contact with damp brickwork or plaster. Where buried in concrete, brickwork, or plaster, they shall be protected by steel coverings or conduits.

(b) They shall be secured by clips, saddles, or clamps of non-rusting material that will not set up electrolytic action with the sheathing and having smooth or rounded edges which will not indent or damage the sheathing. The spacing of the clips, saddles, or clamps shall be such as to prevent appreciable sagging of the cable, and shall not exceed 12 inches, except in the cases specified in clauses (c), (d), and (e) of this regulation.

(c) Where inaccessible, as in dry hollow walls, a vertical length of cable not exceeding 10 feet will be allowed between the supports. In such cases, the upper support shall firmly grip the cable.

(d) (1) Where the cable is laid between the floor of an upper room and the ceiling of a lower room, and does not run parallel with the joists, unless it is protected at each joist by a steel plate not less than 0.04 inch thick overlapping the cable on both sides at least 1 inch throughout the width of the joist, and securely fixed thereto, it shall pass from joist to joist through holes in and approximately at right angles to the joists, and not less than 2 inches from the underside of the floor boards. If the distance between such holes exceeds 2 feet, the cable shall be supported at intervals not exceeding 2 feet.

(2) Where running parallel with the joists, the cable—

(i) shall be attached to the side of the joists not less than 2 inches below the underside of the floorboards by clips fixed not more than 2 feet apart; or

(ii) shall be laid directly on the ceiling without further support, provided, however, that if this method be adopted, the metal sheathing of the cable shall not come in contact with metal structural work or metal ceilings.

(e) Where run in roofs across the ceiling joists, they shall be attached to the sides of wooden battens not smaller than 1 inch square, and where laid parallel with the joists they shall be attached to the sides of the joists. In neither case shall the clips, saddles, or clamps be more than 2 feet apart.

(f) Where there is a change of direction, the cable shall follow an easy bend of a radius not less than six times the length of the axis of the exterior of the cable sheathing measured in the plane of the cable.

(g) The metal sheathing of the cable shall be earthed and made electrically continuous throughout by means of—

(i) wiped joints; or

(ii) approved bonding clamps of non-rusting material that will not set up electrolytic action with the sheathing, and of such a form that they will not damage the sheathing.

Metal conduits or ducts required under regulation 122 for the protection of the cable shall be bonded to the sheathing or otherwise earthed.

(h) The provisions of clause (b) of regulation 326 shall be deemed to be complied with if connexions between cables are made within suitable junction boxes forming part of a lead-covered system of wiring.

(i) Cables with metal sheathing not less than 0.06 inch in thickness shall be installed in such a manner as to comply with the requirements of this regulation in so far as they are applicable and appropriate.

TOUGH RUBBER COMPOUND COVERED CABLES.

335. (a) Vulcanized rubber insulated cables covered with tough rubber compound, as described in regulation 2304 (d) (6), shall be used without the further protection of conduit or casing only, provided they are installed in positions where they are not likely to be damaged by rodents and in accordance with the requirements of this regulation and of clauses (a), (c), (d), (e), and (f) of regulation 334.

(b) They shall be secured by clips, saddles, or clamps of non-rusting material that will not set up chemical action with the rubber covering and having smooth or rounded edges which will not indent or damage the rubber covering. The spacing of such clips, saddles, or clamps shall be such as to prevent appreciable sagging of the cable, and shall not exceed 12 inches, except in those cases referred to in clauses (c), (d), and (e), of regulation 334.

(c) Where two or more cables of this description are joined together by a web, the clips, saddles, or clamps securing such cables shall be of such a form as to prevent the screws or nails used therewith for fixing from damaging the cable covering, and the radius of every bend shall be sufficiently great to permit of the conductors lying in one plane without kinking or bulging.

(d) The provisions of clause (b) of regulation 326 shall be deemed to be complied with if connexions between cables are made within suitable junction boxes forming part of an all-insulated system of wiring.

RUBBER COMPOUND INSULATED CABLES.

336. Rubber compound insulated cables, as described in regulation 2304 (d) (9), shall be used without the further protection of conduit or casing only provided they are installed in compliance with

the requirements of regulation 333. Where, however, the thickness of the rubber compound insulation is not less than that required for vulcanized rubber insulated cables plus that required for the tough rubber compound covering of cables, such cables may be installed in the manner prescribed in regulation 335 for tough rubber compound covered cables.

ARMoured CABLES.

337. (a) Armoured cables, as described in regulation 2304 (d) (4), (5), and (8), may be used without further mechanical protection, only if they are installed in compliance with the requirements of this regulation.

(b) Unless buried or covered, they shall be securely fixed and/or supported by suitable supports, clips, saddles, or clamps, which shall be spaced so as to prevent any appreciable sagging of the cable, and where the run of cables is not horizontal, they shall be secured in a manner which will adequately support the weight of the cable, and in no case shall the distance between supports or fixing be more than 10 feet.

(c) No armoured cable shall be bent to a radius less than twelve times its external diameter.

(d) The electrical continuity of lead sheathing and metal armouring shall be maintained across all junction boxes and throughout the entire length of the cable run.

ENCLOSED WIRING.

341. Except as may otherwise be permitted in respect of cable of any particular class by the provisions of regulations 331 to 337 inclusive, insulated cables, as referred to in regulation 304, shall be encased in one of the following protective coverings, according to the respective manner required by regulations 343 to 350 inclusive, governing the installation of these several coverings, that is to say:—

- (i) Steel conduits with screw-grip fittings.
- (ii) Steel conduits with screwed fittings or piping with screwed fittings.
- (iii) Wood casing.
- (iv) Wood troughing, with or without compound filling.
- (v) Insulating ducts.
- (vi) Fireproof ducts.

The protective coverings listed under (iv), (v), and (vi) above shall not be used for cables other than lead-covered or lead-covered and armoured cables, except with the previous sanction, in writing, of the authorized inspector.

342. (a) When more than one type of protective covering is used in an installation, any change from one type of covering to another shall be made only at a distribution board or switchboard, or at an approved junction box or fitting which provides on both sides for the complete protection of the conductor insulation and for the continuity of any metallic coverings and sheathings.

(b) Notwithstanding the provisions of the above preceding clause (a) of this regulation, however, the wiring of final sub-circuits for fixed water-heaters, stoves, motors, and other fixed appliances may be protected by a covering which terminates at a suitable terminating box or switch adjacent to such appliance, the wiring from such box or switch to the appliance being protected by flexible conduit or wire-braided armouring, which, in either case, shall be securely supported and clamped at the box or switch and at the appliance.

STEEL CONDUITS.

343. (a) The number of V.I.R. insulated cables of any one size enclosed in any section of steel conduit shall not exceed that laid down in Table A (VII.), page 1203, for the respective cable and size and class of conduit.

In the case of V.I.R. insulated cables of different sizes or of any cables or conductors of different types, the number of cables and conductors shall not exceed that which will permit of easy drawing in and withdrawing of any one cable or conductor from the conduit.

(b) Conduit shall not be bent or set in a manner which will appreciably distort the walls from their original circular section, or open a seam, joint, or weld in the conduit. Where enamel or other protective coating of the conduit is damaged by bending or

setting, the effectiveness of the original covering shall be restored by paint or other suitable protective covering.

(c) Where erected in positions exposed to the weather or dampness, all conduit shall be completely painted after erection, and shall also be protected in any other necessary manner against corrosion.

(d) Where exposed to the action of corrosive fumes or liquids, conduits and the fittings for same shall be galvanized, sherardized, or otherwise treated by a process which will provide protection against corrosion under the conditions of use, and, in addition, they shall be coated with acid-resisting paint after erection. In all cases where galvanized conduit is used, the threads where the galvanizing has been removed shall be adequately protected by painting with white lead, red lead, or graphite jointing compound before being screwed into the fittings.

(e) Conduits shall enclose the conductors throughout their entire length, except where the conductors of a final sub-circuit pass from the ceiling to a switch or to a lighting or power point not less than 12 inches above the floor level, through a rigid non-conducting hollow partition the interior of which is inaccessible for the fixing of conduit.

(f) (i) The ends of conduit terminating at a switch, lighting, or power point shall be provided with metal outlet boxes, or, in dry situations, shall terminate in a wooden block or wooden or fire-resisting receptacle so arranged as to prevent the end of the conduit from damaging the insulation of the conductors. Where, however, conduit is run down hollow partitions, behind skirting boards, or above ceilings to a switch, lighting, or power point, terminating fittings referred to above may be dispensed with, provided that each conduit termination is fitted with an approved bell-mouth, flange, or bushing in such a manner that abrasion of the covering of the cables emerging therefrom will not take place.

(ii) The ends of conduits terminating at apparatus, appliances, and metal-clad gear shall be screwed or otherwise securely clamped thereto, or clamped to substantial rubber hose enclosing the conductors to the apparatus or appliance. Such rubber hose shall be as short as practicable, and shall be securely clamped to the apparatus or appliance. Where, however, it is impracticable to comply with the above requirements, the conduit end shall be bushed and the cables shall be adequately protected to the satisfaction of the authorized inspector against mechanical injury and the accumulation of dust.

(g) All conduits shall be securely fixed at least every 6 feet, provided, however, where the supports to which conduit is to be fixed are placed more than 6 feet apart, the authorized inspector may permit them to be run if they are securely fixed to his satisfaction. All conduits shall be securely fixed by means of—

- (1) Metal saddles.
- (2) Clips, where the conduit is run in an angle. The clips shall be fixed with screws.
- (3) Pipe hooks driven into solid woodwork.
- (4) Nails, where the conduit is run in slots cut in joints. The nails shall be fixed in such a manner that they will not indent the conduit.

(h) Metal conduit enclosing conductors shall not pass through a metal roof or metal wall where this is avoidable, but where this is unavoidable the conduit—

- (i) shall be separated from the structural metal by some durable, non-conducting bushing effectively secured in position; or
- (ii) may be in contact with such roof or wall, provided that every piece of metal conduit passing through or in contact with the metal of such roof or wall is connected to earth by a direct earthing conductor secured to the conduit by an earth clip on each side of the roof or wall.

(i) Where liable to severe mechanical damage, conduits shall be adequately protected by a substantial covering. (See also regulation 123.)

(j) Conduits shall be mechanically rigid and mechanically and electrically continuous across all joints therein. (See also regulation 515.)

Steel Conduits Not Screwed.

344. The sections of a run of conduit which are not screwed into fittings shall be joined together by screw-grip fittings.

Screwed Conduit.

345. (a) Steel conduit shall be of heavy gauge and screwed where used as protective covering for cables in the following positions, namely:—

- (i) Where external to buildings or exposed to the weather.
- (ii) In damp positions.
- (iii) Where exposed to the action of corrosive fumes or liquids.
- (iv) Where exposed to severe mechanical injury.
- (v) Where embedded in concrete.
- (vi) Where explosive dust or gas is likely to be present.
- (vii) Where installed in lift or hoist shafts.
- (viii) Where enclosing conductors any one of which carries or is intended to carry current exceeding 50 amps.

(b) In the place of screwed steel conduit, galvanized or black iron or steel piping may be used, provided that—

- (i) The internal diameter of such piping is equivalent to that required for screwed steel conduit.
- (ii) The walls of such piping are not thinner or of lower mechanical strength than the walls of the appropriate screwed steel conduit.
- (iii) Such piping and fittings therefor are freed from all internal burrs and other projections.
- (iv) It is installed in accordance with all other requirements under these Regulations for the installation of screwed conduit.

346. Where screwed conduit is used for the enclosure of cables—

(a) Either—

- (i) the conduits of each circuit shall be erected complete before the cables are drawn in, in which case an adequate number of inspection fittings and draw-in boxes shall be provided to ensure the safe and easy drawing-in of the cables, and all draw-in boxes shall have apertures sufficiently large to ensure against damage to the cables to be drawn in; or
- (ii) sections of conduits which contain no fittings other than bends shall be completed by running threads after the cables are drawn in, and in such case sufficient running threads shall be provided to permit of the replacement of any cable contained therein.

(b) All elbows and tees shall be of the inspection type and no bends having a radius less than 2½ times the outside diameter of the conduit shall be used, except that—

- (1) at the end of conduits immediately behind or adjacent to accessories or lighting fittings, non-inspection conduit fittings may be used;
- (2) in surface wiring where the conduit turns to pass through a wall, a non-inspection elbow may be used if the conditions are such that the use of an inspection elbow or normal bend would be impracticable;
- (3) in an inaccessible position, such as in a hollow partition or where conduit is to be buried in concrete, a non-inspection elbow may be used if it is impracticable to use a normal bend.

(c) Where conductors emerge from metal conduits for attachment to outside conductors, apparatus, or appliances, the conduit shall be set downward at an angle not less than 45 degrees at its exposed extremity, and there shall be provided with an insulating bellmouth so arranged as to prevent the entry of rain into the conduit.

(d) Where taper male threads and/or locknuts are used with heavy gauge conduit, the length of the thread on the conduit shall be sufficient only to engage all the threads of the fittings or locknuts.

(e) In all cases where there is a liability to excessive condensation, drip outlets shall be provided at the lowest point of each section of the conduit to ensure satisfactory draining of all moisture. Such drip outlets shall not exceed ¾ inch in diameter, or be less than ¼ inch in diameter. The provision of such drip outlets shall not, however, be required in the case of underground wiring installed in accordance with the provisions of regulation 353.

WOOD CASING.

347. (a) Rubber insulated cables and rubber compound insulated cables shall be enclosed in wood casing only if such casing is installed in compliance with the requirements of this regulation.

(b) It shall be used only in dry situations where it is not exposed to rough usage or wear and tear. In positions subject to occasional condensation, such as bathrooms and washhouses in domestic installations, casing and capping, provided they are painted over with water-resisting paint after erection, may be used on the surface of walls and partitions.

(c) Except between a roof and the uppermost ceiling, where it is accessible for inspection, it shall be exposed to view throughout its entire length.

(d) Where continuously supported, it shall be fixed to the support or structure at intervals of not more than 5 feet, and where not continuously supported, it shall be fixed at intervals of not more than 2 ft. 6 in.

(e) Capping shall be secured by round headed screws to the centre fillet of the casing at all ends and between ends, at intervals not exceeding 2 feet.

(f) Ready access shall be provided to all cables contained within wood casing.

(g) Casing and capping shall enclose conductors throughout their entire length, except where the conductors of final sub-circuits pass through a non-conductive hollow partition to a switch or a lighting or power point not less than 12 inches above floor level. In such cases, the casing and capping shall terminate by being securely fixed to the wooden wall plate through which the conductors pass.

(h) Wood casing—

- (i) shall not be used where the pressure between conductors exceeds 250 volts, or where any conductor carries more than 50 amperes, unless the previous sanction, in writing, of the authorized inspector has been obtained;
- (ii) shall not be used in lift wells, hoist ways, or in positions where it is likely to be damaged by rodents. In no case shall it be used within 12 inches above a floor;
- (iii) shall not be in contact with gas or water pipes, or run continuously below water pipes.

WOOD TROUGHING.

348. (a) Wood troughing shall be used for the protection of cables only where the use of steel conduit or wood casing is impracticable, and then only with the previous consent, in writing, of the authorized inspector. Wood troughing shall be constructed and installed in compliance with the requirements of this regulation.

(b) Wood troughing shall be built up or cut from jarrah, tallowwood, blackwood, or other approved hardwood boards. The thickness of the cover, bottom, and sides of any troughing shall be not less than that shown in the table below for troughing of the respective internal dimensions listed:—

Internal width or depth of troughing.	Minimum thickness of cover, bottom, and sides.
Not more than 4 inches	¼ inch
Not more than 8 inches	½ inch
Not more than 12 inches	1 inch
Not more than 18 inches	1½ inches
Above 18 inches	1¾ inches

(c) It shall be V shaped or rectangular, and shall be so constructed that the cover fits over and is fastened down to the sides.

(d) If troughing is to be filled with compound, the cables shall be separated and supported by non-conducting spacers before the compound is poured in.

(e) Troughing shall be used underground for the protection of live conductors only if it is filled with solid insulating compound.

INSULATING DUCTS.

349. (a) Insulating ducts used for the protection of cables shall be formed or built up of mechanically strong fire-resisting material, impervious to moisture, and so arranged that no appreciable condensation of moisture can occur, and no water can lie within the ducts.

(b) Insulating ducts shall be of ample dimensions for the drawing in and withdrawing of the cable without damage to such cable, and shall be provided with such draw-in boxes or covered apertures as are necessary for this purpose. All cable outlets shall be sufficiently smooth or rounded to prevent abrasion of the conductor insulation.

(c) In addition to the foregoing requirements, insulating ducts shall comply with any special requirements prescribed by the authorized inspector.

FIREPROOF DUCTS.

350. (a) Fireproof ducts shall be used only for the protection of tough rubber covered cables, rubber compound insulated cables, lead covered cables, lead covered and armoured cables, or of cables of other types which are further protected by steel conduits, wood troughing, or insulating ducts.

(b) Fireproof ducts shall be constructed of fire-resisting materials, shall be continuous throughout their entire length, and shall have closed ends. They shall be effectively drained to prevent the accumulation of water.

(c) The minimum thickness of the walls, closures, and cover plates of fireproof ducts shall be—

- 4½ inches in the case of brickwork or concrete;
- 3 inches in the case of reinforced concrete;
- ½ inch in the case of steel plates,

or, alternatively, earthenware pipes embedded in at least 2 inches of concrete may be used.

(d) The installation of cables within fireproof ducts shall be carried out to conform to the methods prescribed in these Regulations for the respective type of cable, and to any special requirements by the authorized inspector.

FLEXIBLE CORDS.

351. (a) No flexible cord shall be used unless it is one of the types specified in regulation 2351 and complies with the requirements of that regulation for the respective type of cord used.

(b) Twisted flexible cords without overall braiding shall be used only for pendants and wiring of fixed fittings. In all other positions, and for all other purposes, only tough rubber covered flexible cords or flexible cords made up to a circular or oval section and braided overall shall be used.

(c) (i) Except as provided for in sub-clause (ii) hereof, no flexible cord shall be used in which the nominal sectional area of the conductor is smaller than 0.001 square inch (23/0076 inch). (See also regulation 218—Minimum size of flexible cords in sub-circuits.)

(ii) Where the use of the smallest size of flexible cord permitted under the preceding sub-clause (i) is impracticable, flexible cord not smaller than 14/0076 inch may be used for such purposes only as may from time to time be approved.

(d) The maximum current carried or to be carried by a flexible cord shall in no case exceed that given in Table A (V.), page 1202, for the respective size of conductor.

(e) Except for portions of flexible cords which are enclosed in fittings or appliances, flexible cords shall be open to view throughout their entire length, and, except as provided in clause (f) of this regulation, they shall not be enclosed in conduit, casing, troughing, or any similar covering medium.

(f) Where a flexible cord from a fitting unavoidably passes into a ceiling, it may be enclosed in conduit, but it shall terminate in a junction box fitted as near as possible to the point of entry to the ceiling.

(g) A flexible cord shall not be fixed in position through a doorway, window, wall, or partition beyond the room in which such flexible cord is connected to the permanent wiring, and where a flexible cord passes through a partition within a room or other space, the hole through which it passes shall be bushed with porcelain tubing.

(h) No flexible cord shall be taken more than 9 feet across a ceiling. Any flexible cord taken across a ceiling shall be supported by an insulated hook or insulated hooks fixed to the ceiling.

(i) Unarmoured flexible pendants and flexible cords in shop windows and show cases shall be kept clear of shop fixtures and fittings, goods, and materials, and all slack conductors in such positions shall be placed only where they are not likely to be damaged.

In no case shall flexible cord be used to support anything other than the electrical fittings associated with it.

(j) In all premises such as butchers', confectioners', fish, and fruit shops, stables, hide and tallow stores, hotel bars, public dining-rooms and kitchens associated therewith, where flexible cords are likely to be exposed to the action of flies or other insects, they shall be protected by tough rubber covering or other approved means.

(k) No joint shall be made in flexible cords. Connexions between flexible cords shall be made only by means of approved cord connectors with sliding contacts, or by means of approved connectors provided for the purpose within multiple branch fittings. Connexions between flexible cords and fixed or portable fittings, appliances, or apparatus shall be soldered connexions only if relieved of strain, otherwise they shall be made only at terminals in which the conductors of the flexible cords are rigidly clamped between metal surfaces.

(l) (i) The maximum weight carried by a twin flexible cord shall not exceed the following:—

Number and Diameter of Wires comprising Conductors.	Maximum Permissible Weight.
23/0076	lb. 3
40/0076	6

The weights given above may be increased by 50 per cent. for each additional conductor of equal cross-section.

(ii) Where the weight of a fitting exceeds the maximum permissible under sub-clause (i) hereof, some other suitable support, such as a metal chain, shall be provided.

(m) Flexible pendants shall not be used under verandahs, in front of exterior doorways, or in any place exposed to the weather. In all such positions rigid fittings shall be used.

(n) Flexible cords shall be held in position only by means of substantial insulated clamps, hooks, or screw-eyes. Insulated staples shall not be used for the purpose.

352. (a) The table hereunder sets out the type of covering and type of insulation that shall be used where flexible cords are put to the uses listed in the table, but cords with coverings referred to therein under headings (a), (b), (c), and (d) shall not be used where the cable or cord is liable to the risk of mechanical damage, and those with coverings referred to under heading (e) and having pure rubber insulation, and those referred to under heading (g), shall not be used in damp places:—

Use.	Heading under which Type of Covering is referred to in Rule 2352.	Type of Insulation referred to in Rule 2351.
Pendants in dry places (domestic)	(a), (b), (c), (d), or (f)	A or B
Pendants in damp places ..	(f) ..	A
Pendants carrying lamps 200 watts or over (in dry places)	(c) ..	A
Pendants in kitchens (other than domestic), shops, dining rooms, stables, hide and tallow works, and all places where flies or other insects are prevalent	or (a) or (b) ..	B
Portable lamps and standards in dry places	(f) or (g) ..	A
Portable lamps and standards in damp places or over conductive floors	(a), (b), (c), (d), (e), (f), or (g)	A
Portable appliances in dry places (domestic or offices)	(e) or (f) ..	A
Portable appliances in damp places or over conductive floors	(a), (b), (c), (d), (e), (f), or (g)	A or B
Portable appliances where cord is subject to rough usage	(c) or (f) ..	A
Trailing cables for lifts ..	(e), (f), or (g)	A
	(f) in damp places and other types specially approved in dry places	A

Summary of Classification of Coverings under Regulation 2352 for Reference.

- (a) Natural or self-extinguishing artificial silk braiding.
- (b) Glace cotton braiding.
- (c) Fire-resisting braiding.
- (d) Compound hemp, cotton or jute braiding.
- (e) Wire armouring.
- (f) Tough rubber covering.
- (g) Hard cord braiding.

Summary of Types of Insulation under Regulation 2351 for Reference.

Type A—High insulation. Type B—Fire-resisting.

- (b) Where flexible cord with protective covering of the type referred to under heading (e) of regulation 2352 is used for wiring of a portable fitting, appliance, or apparatus in an earthed situation, the wire armouring, in addition to the earthing conductor of the flexible cord, shall be electrically connected at one end to the earthing pin of the plug, and at the other end to the exposed metal (if any) of the fitting, appliance, or apparatus.

UNDERGROUND WIRING.

353. (a) For wiring in the ground or on the ground under floors, paved areas external to buildings, roadways, pavements, or tracks, cables of one of the following classes shall be used:—

- (i) Hard rubber covered or rubber compound insulated cables enclosed in galvanized iron water piping.
- (ii) Lead covered cables, which shall be enclosed in galvanized iron water piping or compound filled troughing unless the thickness of the lead sheathing is at least 0.06 inch.
- (iii) Lead covered cables the lead sheathing of which is at least 0.06 inch in thickness, or armoured lead covered cables, either laid directly in the ground or enclosed in or protected by conduit, piping, or troughing.

(b) All joints in water piping required under sub-clauses (i) and (ii) of clause (a) hereof for the protection of cables shall be made watertight.

(c) Where installed under roadways, pavements, or tracks, the cables shall be stranded cables not smaller than 3/036 inch, and shall be laid not less than 1 foot below footpaths or tracks, and not less than 2 feet below roads or ways used by heavy vehicles. Un-armoured cables not enclosed in galvanized iron water piping shall be protected under roadways, footpaths, and tracks by a slab of durable hardwood timber at least 1 inch thick laid directly over them, and overlapping them at least 1½ inches on each side.

(d) All underground wiring and metallic coverings enclosing underground wiring shall be sufficiently spaced from underground telegraph and telephone cables or structures to ensure prevention of mechanical or electrical interference therewith.

TEMPORARY WIRING.

361. Unless installed in a manner complying with the method laid down in these Regulations for permanent wiring, temporary wiring shall be installed in accordance with any special conditions endorsed by the supply authority on the permit granted for it, and in compliance with the following:—

- (a) All cables used for temporary wiring shall be stranded rubber or rubber compound insulated cables, and shall be supported clear of all structural work on porcelain cleats, knob insulators, or in such other manner as may be approved in any particular case by the supply authority.
- (b) Joints of opposite polarity shall be kept at least 6 inches apart.
- (c) All lampholders and all tumbler switches used in temporary wiring shall be of the all-insulated type.
- (d) Temporary wiring shall be connected to permanent wiring only at a switchboard or at a permanent outlet provided for the purpose and controlled by an adjacent switch and protected by suitable cut-outs. Where connected at a switchboard, the temporary wiring shall be controlled by a linked switch opening all conductors, and be protected by a cut-out in each active conductor.

(e) Except as provided under sub-clause (f) of this regulation, a final sub-circuit for lighting shall not carry more than 10 amperes, and shall not supply more than 60 lamps. Each final sub-circuit shall be protected by a cut-out in each active conductor, and shall be controlled by a linked switch opening all conductors.

(f) Where temporary wiring is installed for sign, outline and decorative lighting, festooning and the like, joints between cables and the conductors running to individual lampholders need not be soldered, but shall be adequately insulated, and the loading of a final sub-circuit shall not be limited as laid down in clause (e) of this regulation, but shall not exceed 15 amperes, irrespective of the number of points.

(g) Temporary wiring shall not be connected with the source of supply until the supply authority is satisfied that it is installed in accordance with the requirements of this regulation and of the permit.

PART I.—SECTION 4.

SWITCHES AND CIRCUIT-BREAKERS.

401. (a) In all cases where a switch or circuit breaker is provided with a worded or other device to indicate whether the switch contacts are open or closed, the switch or circuit breaker shall be so erected or fitted that the indicating device is visible and correct in its indication.

Where tumbler switches are so erected that the tumbler knob is in the raised position when the switch is off, and in the depressed position when on, this shall be deemed to be a sufficient indicating device within the meaning of this regulation and of regulation 2401 (c).

(b) No switch or circuit breaker shall be fixed in a manner or position such that the hand of the operator can accidentally touch live metal, or be injured by an arc from the switch or the melting of an adjacent fuse link. Where a switch or circuit breaker is enclosed, its handle shall not operate through a slot in the enclosing case unless adequate protection is provided for the operator.

(c) No multipole switch or circuit breaker shall connect any active conductor before the neutral conductor is connected, or open the neutral conductor before all active conductors have been opened.

SWITCHES.

402. (a) Where switches are not fixed on a switchboard, the live parts shall be enclosed or protected in an approved manner by rigid metal, or non-conducting, non-ignitable material, excepting, however, where a switch is mounted on or sunk into a wall built entirely of non-ignitable material, the live parts may be enclosed in a case of wood, provided that where the switch is required to interrupt currents exceeding 10 amperes, such case is lined with asbestos not less than 1-16 inch in thickness.

(b) Switches shall be so arranged that their blades or other moving parts are not alive when the switch is in the "off" position unless this is impracticable, in which case the arrangement shall be subject to the approval of the authorized inspector.

(c) Pendant switches shall not be used.

(d) Lampholders containing switches may be used only if they have no exposed metal parts, and provided they are fixed on rigid supports. Lamps controlled by switches in lampholders shall, in addition, be controlled by a wall or ceiling switch in the same room.

(e) Except in the case of switches incorporated in appliances, switches in earthed situations and in damp situations shall be either all-insulated switches, or switches of a type for which special approval has been obtained for their use in such situations.

CIRCUIT-BREAKERS.

403. Every circuit-breaker shall be so arranged and placed that no inflammable material is endangered by its operation, and so that no resulting arc can damage any object or material which is not part of the circuit-breaker.

**THERMAL CIRCUIT OPENING DEVICES
(OTHER THAN CUT-OUTS).**

404. Except where they fully comply with all the requirements of regulation 2404, thermal circuit-opening devices shall be used only in series with fusible cut-outs or over current releases on circuit-breakers.

FUSIBLE CUT-OUTS.

405. (a) The circuit contacts and terminals of cut-outs shall be so spaced and/or shielded that an arc cannot be maintained when a fuse link melts.

(b) Every cut-out which is not mounted on a switchboard or distribution board shall be enclosed in a rigid metal case, or in a case robustly constructed of non-hygroscopic, non-ignitable insulating material so arranged that neither the case nor any of its surroundings can be damaged by the operation of the fuse link.

Every metal-clad cut-out shall be so erected that the cover cannot accidentally open or come apart at the hinges, and so that every cover can be fully opened.

(c) Every cut-out shall be fixed vertically.

(d) Cut-outs shall not be located in ceiling roses, in switches other than fuse switches, or in plugs or plug sockets. Where practicable, they shall be grouped together on switchboards.

(e) The fuse link shall be of such size that it would be melted in one minute or less (two minutes or less in case of a lead-tin alloy fuse link), by a current equal to twice the maximum permissible current (as given by Tables A (II.) and A (III.), pages 1200, 1201) of the smallest cable protected by it; provided that no fuse link rated to melt at less than 10 amperes need be inserted in any final sub-circuit other than those supplying small transformers, such as bell transformers and those used in connexion with luminous discharge tube installations. (See also Fusing Currents, Table A (VI).)

406. No cut-out marked "AC" shall be used in a direct current circuit, and no cut-out shall be used in any circuit in which the pressure or current exceeds the pressure or current rating marked on the cut-out, and for which pressure and current the cut-out has been approved as satisfying the requirements of regulation 2405 (a).

FITTINGS AND ACCESSORIES.

411. (a) If disused gas fittings be adapted for electric light, they shall be entirely disconnected from the gas pipes, and shall be cleared of metal borings and sharp edges before wiring. Combined gas and electric fittings shall not be used.

(b) No joint shall be made within a fitting, and no connexion shall be made within a fitting, except in a special receptacle incorporated therein for the purpose.

(c) Every fitting and accessory shall be mounted on an approved base block, except as set out hereunder, namely:—

- (i) A fitting or accessory mounted on a switchboard panel or metal conduit box;
- (ii) A fitting or accessory completely enclosed in metallic casing;
- (iii) A tumbler switch mounted on a flat architrave which is not overlapped by the base of the switch;
- (iv) A cut-out;
- (v) A flush-plug socket or flush switch.

413. (a) (i) In situations where explosive or inflammable dust or gas is likely to be present, all lighting fittings shall be gas-tight fittings, and in such situations where they are liable to mechanical injury shall be guarded gas-tight fittings.

(ii) In places where highly inflammable goods are stored, gas-tight fittings shall be used.

(iii) Every lamp which is near to inflammable material, and is not in an enclosed-type fitting, shall be suitably protected by a shade or guard.

(iv) Inflammable shades shall not be used in such a manner that they are liable to come in contact with any lamp. Lamp shades or candle tubes made of celluloid shall not be used in close proximity to any lamp.

(b) Where lamp fittings (including arc lamps) are suspended from pulleys so as to be lowered at intervals for the purpose of cleaning, re-carboning, or renewal of lamps, all conductors connected to the fitting shall be stranded conductors.

CEILING ROSES.

414. (a) No ceiling rose shall be used—

- (i) In a position in which it is not open to view;
- (ii) For a pressure exceeding 250 volts between terminals; or
- (iii) For the attachment of more than two flexible cords, unless it is specially designed for multiple pendants.

(b) A metal cover shall be securely fixed over every ceiling rose which is installed in a position where it is liable to mechanical damage.

LAMP HOLDERS.

415. (a) No lampholder shall be used for a pressure exceeding 250 volts between terminals.

(b) Lampholders shall not be used for a higher wattage lamp or current greater than that specified hereunder:—

Type of Lampholder.	Maximum Wattage for Lamp.	Maximum Current where any apparatus other than a Lamp is connected.
	watts.	amps.
Miniature Standard Bayonet (M.B.C.)	40	0.5
Miniature Edison Screw (M.E.S.)	100	1
Standard Bayonet (B.C.)	250	3
Edison Screw (E.S.)	600	5
Goliath Edison Screw (G.E.S.)	10

In every case the lampholder used shall be of such construction that there is no excessive heating of the contacts or adjacent wiring.

(c) See regulation 402 (d).

LAMP HOLDER ADAPTORS.

416. No lampholder adaptor shall be used except for attachment to pendants or fittings normally used for lighting purposes, and which are controlled by an adjacent switch, and no lampholder adaptor shall be used for a current greater than that specified under regulation 415 for a lampholder of corresponding type.

PLUGS AND SOCKETS.

421. (a) No plug socket installed in domestic premises shall be rated at less than 5 amperes. (See regulation 217 (a) and (b) regarding the minimum rating of general and special purpose outlets, and regulation 2421 (a) and (c) regarding the carrying capacity and marking of sockets.)

(b) No plug socket other than a socket of an approved type, and conforming to the requirements of regulation 2421 (c), shall be fixed in or on a floor. Plug sockets of other types may be fixed on supports projecting above a floor, provided that no portion of the socket (or its controlling switch) is less than 3 inches above floor level.

(c) No plug socket shall be installed in any earthed situation unless it is fitted with an earthing terminal. The earthing terminal of every plug socket installed in an earthed situation shall be effectively earthed.

(d) No fitting or appliance having exposed metal parts shall be connected to any plug socket which is installed in an earthed situation unless it is connected thereto by means of a flexible cord or cable containing an earthing conductor which is connected at one end to the earthing terminal of the plug, and at the other end to the exposed metal of the fitting or appliance in the manner set out in regulation 513 (b).

(e) (i) Except as specified in sub-clause (ii) hereof, every plug socket shall be independently controlled by a fixed switch in a convenient and easily accessible position within 5 feet of the socket.

(ii) Where used on low pressures, plug sockets approved as complying with the provisions of regulation 2421 (d) may be used without the control switch specified in the preceding sub-clause (i) hereof.

(f) Every switch controlling a plug socket shall have a current rating (at its operating voltage) not less than—

- (i) 5 amperes in the case of sockets rated at not more than 2.5 amperes;
- (ii) 10 amperes, or the rated capacity of the socket, whichever is the greater, in the case of all sockets rated at more than 2.5 amperes.

MOTORS.

431. (a) (1) In the case of fixed motors (including motors secured to slide rails) where conductors are run in conduit, or where metal-sheathed cables are used:—

- (i) The conduit or metal sheathing, as the case may be, shall be terminated at and be properly secured either to the terminal box of the motor, or, if the motor is not provided with a terminal box, to the frame of the motor; or
- (ii) Conduit may be terminated adjacent to the motor, and the conductors enclosed in flexible conduit or heavy rubber hose secured in a rigid and workmanlike manner to the conduit at one end, and at the other to the terminal box, or, if no terminal box is provided, to the frame of the motor.

(2) Notwithstanding the provisions of the foregoing sub-clause (1), the circuit wiring for motors not exceeding ½-h.p. which are fixed in positions where the wiring thereto will not be liable to mechanical injury, may be terminated at a connecting box, or other suitable connecting device, from which the connexion to the motor shall be made by flexible cable or flexible cord.

(3) Portable motors shall be connected to permanent wiring only by means of a suitable flexible cable or cord, which shall be secured at one end to the motor in such a manner that there is no strain on the terminals or connexions. Where the full load current of the motor does not exceed 15 amperes, such flexible cable or cord shall be connected to the permanent wiring by means of a plug and socket, and, where the full load current of the motor exceeds 15 amperes, such connexion shall be made either by means of a plug and socket or at a switchboard.

(b) Every motor shall be provided with a suitable control switch or circuit-breaker for starting and stopping, either so placed that a person operating the switch will have an uninterrupted view of the motor, or capable of being operated manually or by mechanical or electrical means from a position convenient for the control and operation of the motor.

(c) Readily accessible means for switching off the motor shall be provided at every machine driven by such motor if there is no proper mechanical means provided for stopping the machine.

(d) Where a motor is installed in a position remote from or not visible from the control switch, an isolating switch capable of entirely disconnecting the motor from the supply mains shall be inserted in the motor circuit adjacent to the motor.

(e) (1) Every shunt or compound wound continuous current motor over ½-h.p. shall be controlled by a starting switch fitted with an under-voltage release, and a series starting resistance. The shunt circuit shall be so connected that the field shall be fully excited before any portion of the starting resistance is cut out.

(2) Every series wound continuous current motor exceeding 5-h.p. rated output shall be controlled by a starting switch fitted with an under-voltage release, and a series starting resistance shall be provided to limit the starting current to that required by the supply authority. Series wound continuous current motors not exceeding 5-h.p. rated output may be connected to the supply without a series starting resistance, provided the starting current does not exceed three times full load current.

(3) Where the starting current of the motor would otherwise exceed the maximum starting current permitted by the supply authority, every alternating current motor shall be provided with a suitable starter for limiting the current to the maximum so permitted.

Every alternating current motor installation of 3-h.p. and over shall be protected against under-voltage in the following manner:—

- (i) In the case of each motor of 100-h.p. or over, by an under-voltage release fitted to the starter or circuit-breaker of the motor.
- (ii) In the case of motors each less than 100-h.p., by an under-voltage release fitted either to the starter or circuit-breaker of each motor, or to a circuit-breaker controlling a group of motors, all of which are easily accessible and visible from the circuit breaker.

For the purpose of this regulation, an under-voltage release shall ensure that the circuit-breaker will open all the active conductors of the circuit supplying the motor simultaneously in the event of the voltage falling to 50 per cent. or less of its normal value.

(f) Automatic re-closing circuit-breakers shall not be installed except for the control of lifts, automatic refrigerating or pumping plants, or protected fans, without the previous consent in writing of the authorized inspector.

(g) All polyphase motors that may be required to run unattended shall be protected against under-voltage in accordance with clause (c) (3) of this regulation, and, in addition, shall be fully protected against damage from single-phase running by thermal cut-outs in at least two active conductors, or by one or more thermal relays or equivalent devices.

(h) For the purposes of this regulation, a rotary converter or a motor converter shall, in respect of its operation as a motor, be deemed to be a motor.

(i) Every electrically operated lift which is intended to convey passengers shall be supplied by a circuit which is independent of any other portion of the installation, and which is controlled and protected by a main switch and cut-outs (or circuit-breaker), which are independent of all other switches and cut-outs (or circuit-breakers). (See regulation 227 (c)—Master switch.)

(j) Every motor exceeding 10-h.p. rated output which operates a lift, hoist, or conveyor, shall be controlled and protected by an over-current circuit-breaker, which will simultaneously open all active conductors in the event of a predetermined overload. Groups of such motors may be protected by one such circuit-breaker, provided each motor is separately controlled and protected as required under this regulation.

(k) See regulation 221 (b)—Circuit-breakers for motor circuits.

CAPACITORS (STATIC CONDENSERS).

432. (a) Where a capacitor is installed in conjunction with more than one appliance, it shall be controlled and protected by a circuit-breaker fitted with over-current releases, also auxiliary contacts and discharge resistors, unless permanently connected discharge resistors are incorporated in the capacitor. Cut-outs shall not be inserted in the conductors between the circuit-breaker and the capacitor.

(b) Unless connected and controlled in the manner set out in clause (a) of this regulation for a capacitor installed in conjunction with a group of appliances, a capacitor installed in conjunction with an individual appliance—

(i) shall be controlled and protected by the switch and cut-outs (or over-current circuit-breaker) which control and protect such appliance; and

(ii) the conductors by which it is connected shall be of a current-carrying capacity equal to or greater than that of the conductors through which the appliance is supplied, and shall be looped from the terminals of the appliance, or from the outgoing side of the cut-outs or circuit-breaker.

(c) Notwithstanding the provisions of clauses (a) and (b) of this regulation, capacitors not rated at more than 1 kVA. may be controlled by a switch operating in all active conductors with a cut-out in each active conductor, provided the requirements of sub-clause (b) (ii) are complied with where the capacitor is not independently controlled and protected.

APPLIANCES.

441. (a) In premises used for residential and/or domestic purposes, no appliance other than a cooking stove, a fixed water heater, or a motor which is fixed in position or forms part of a fixed appliance, shall be connected to any circuit other than a low pressure circuit.

(b) No appliance shall be connected to a circuit in which the pressure differs by more than 15 per cent. from the pressure at which the appliance is rated, and for which it was designed and manufactured, except through an approved transformer or converting equipment complying with the requirements of, and installed in accordance with, these Regulations.

(c) Every appliance shall be connected to the circuit wiring either—

- (i) by conductors, the protective covering of which shall terminate in and be properly secured to the terminal box of the appliance; or
- (ii) by a flexible cord or cable terminating in a suitable connecting device, or a plug or adaptor suitable for connexion to a plug socket or other outlet.

HEATING AND COOKING APPLIANCES.

442. (a) (i) Except as specified in sub-clause (iii) hereof, cables supplying every stove and fixed heating or cooking device shall be carried in metal conduit to the connexion box of the appliance to which the conduit shall be secured by screwing or by a suitable clip or arrangement of locknuts.

(ii) Where a stove is required to be moved within narrow limits for cleaning, or where the position of the connecting box on a stove or fixed heating or cooking appliance is not suitably placed for the attachment of rigid conduit, a sufficient length of flexible conduit may be used if secured by suitable clips or locknuts to the appliance and to the termination of the rigid conduit.

(iii) Unless connected in the manner specified in the preceding sub-clauses (i) and/or (ii) of this regulation, the permanent wiring to a stove or fixed heating or cooking appliance shall terminate at a suitable plug socket or multipole switch immediately adjacent to the appliance. Connexion between the socket or switch and the appliance shall be made by means of a flexible cable or cord containing the required number of conductors of suitable carrying capacity including an earthing conductor, if one is required, and having a protecting covering of wire braid which shall be securely fixed in position at both ends.

If a plug socket is used, it shall be of a type which will permit of the insertion of the plug in one position only, and the connexions shall be so arranged that the active, neutral, and earthing conductors at the socket are connected to the correct terminals of the appliance.

(b) Except in domestic installations, electric irons and similar non-luminous portable heating appliances shall be protected by some form of approved automatic cut-off, which will operate in the event of the appliance exceeding the maximum safe temperature, or an approved indicator, such as a red pilot lamp or audible indicator, shall be connected in circuit therewith. All lampholders used for pilot lamps shall be adequately shielded if fixed within 8 feet above the floor.

(c) Each separate hotplate, and each group of oven elements, shall be controlled by a single-pole quick-break switch of approved form inserted in the active conductor, or in cases where heating elements operating at medium pressure are permitted under these Regulations, by linked switches inserted in each active conductor. (See also regulation 2442 (g).)

WATER HEATERS.

443. (a) Water heaters in which the water is heated by the passage of current between electrodes immersed therein, shall not be installed unless they are fixed in position, and the previous sanction, in writing, of the supply authority has been obtained for the installation in each particular case. (See also regulation 2443 (d).)

Portable water heaters of the electrode type shall not be connected to supply mains.

(b) Conduit protecting conductors near a water heater shall be so fixed that, if the heater became defective, the water flowing therefrom could not enter the conduit.

(c) (i) Every electric geyser or bath heater shall be permanently connected to the installation, and, if water is supplied to it from a metal pipe system, shall also be permanently connected by metal piping to such pipe system.

(ii) Except in so far as such connexion is inconsistent with the preceding sub-clause (i) hereof, and with clause (d) of this regulation, connexion to fixed water heaters shall be made in the manner laid down in regulation 442 (a) for stoves and fixed heating or cooking devices; provided, however, that where the heater is installed in a roof space, a cupboard, or other position where such connexion is not likely to be damaged, hard rubber-covered flexible cord or

cable may be used instead of wire-braided cord or cable as laid down in sub-clause (a) (iii) of the said regulation 442.

(d) Conductors in which appreciable heating due to their proximity to a water heater is likely to occur shall be enclosed in metal conduit, but where the conductors are subject to temperatures exceeding those specified in regulation 201, such conduit shall terminate in an approved junction box fixed in an accessible position near the heater. Approved heat-resisting conductors shall be used between such junction box and the heater.

(e) All external metal portions of a fixed water heater shall be earthed.

(f) Every water heater shall be controlled by a multipole switch or switches fixed in an accessible position near the heater, or by a multipole switch incorporated in the heater structure. Such switches shall open all conductors connected to the elements of the water heater.

Where a water heater is installed in a roof or other similar remote place, an isolating switch or switches capable of opening all conductors connected to the elements shall be installed immediately adjacent to the heater if the control switch referred to in the preceding paragraph hereof does not comply with this requirement as to position.

ARC LAMPS.

446. (a) Lamps with exposed arcs shall be used only where this is essential for the work required (such as photographic work). In such cases, the floor immediately underneath the lamp, if of combustible material, shall be protected from falling particles of carbon by non-ignitable trays.

(b) Arc lamps shall not be installed in positions where inflammable or explosive dust or gas is likely to be present under normal conditions.

(c) See regulation 413 (b).

ELECTRIC SIGNS.

447. (a) Every sign shall be readily accessible for inspection and attention.

(b) Where luminous discharge tubes are used in conjunction with signs employing incandescent lamps, the wiring for the tubes and the lamps shall be identified by permanent labels or other permanent markings.

(c) Mechanical switching or flashing apparatus shall be installed in a non-ignitable enclosure.

(d) The exposed metal of every sign which is in an earthed situation shall be earthed.

(e) The loading of circuits shall not exceed the limits laid down in regulation 216 (b) (ii) for temporary signs, and regulation 216 (b) (iii) for permanent signs.

LIFTS.

451. (a) Every lift installation shall comply with the provisions of the Standards Association of Australia Lift Code (S.A.A. Publication No. C.A. 3) and the requirements of these Regulations.

(b) See regulation 628.

(c) See regulation 213 (e).

(d) See regulations 227 (c) and 431 (f), (i), and (j).

RADIO EQUIPMENT.

452. (a) This regulation shall apply to all radio receiving and transmitting equipment. The provisions of clauses (b), (c), and (d) shall also apply to all electro-acoustic equipment and to all rectifying apparatus not exceeding 1,200 volt amperes rated input which is to be used for charging storage batteries and similar purposes, and for the purposes of these clauses the term radio equipment shall be deemed to include electro-acoustic equipment and such rectifying apparatus. (See also regulation 2452.)

(b) Electricity from supply mains shall be conveyed to radio equipment only through permanent wiring or through an outlet, such as a plug socket or other connecting device, complying with the requirements of these Regulations.

(c) Every exposed part (including earth connexions and connexions to external speakers) shall be completely isolated from the supply mains by suitable insulation, condensers, or transformers.

(d) In all earthed situations, exposed metal containing cases, covers, and frames (including transformer frames) shall be effectively connected to earth through suitable terminals provided on the case, cover, or frame for that purpose. Such terminals shall be distinctly marked "Earth."

Except where the earthing of the radio equipment is carried out in a manner which complies with the requirements of regulation 513 (b), earthing conductors shall be of stranded copper not smaller than 7/029 inch (7/22 S.W.G.), and shall comply in all respects with the requirements of the relevant clauses of regulations 511-517 inclusive, except that where they are exposed to personal contact within buildings they shall be covered with insulation of not less than 250 volt grade.

(e) Antennae within buildings shall be so placed and constructed that they cannot come into contact with wires or apparatus (other than the radio equipment) connected to supply mains.

(f) Both inside and outside of buildings, a distance of not less than 12 inches shall be maintained between antennae or leading-in wires and electric light and power conductors unless a continuous and firmly fixed non-conductor maintains permanent separation between them. This non-conductor shall be in addition to any insulation on the conductors.

(g) Antennae and leading-in wires shall be covered with insulation of not less than 250 volt grade—

(i) within buildings; and

(ii) within a distance of 6 feet from radio equipment where they are external to buildings.

(h) Leading-in wires shall be brought into a building through a non-combustible, non-absorptive, insulating bushing, so arranged as to prevent the entry of moisture. Each leading-in wire shall be provided with a lightning protective device (lightning arrester) of approved pattern, which shall be fixed outside the building near the point where such wire is brought into the building. The protective device shall be mounted on a non-combustible base away from inflammable material, and shall include an air gap not exceeding 0.005 inch between aerial and earth connexions.

(i) The use of an antenna earthing switch shall not obviate the necessity for the protective device required by clause (h) of this regulation. If such a switch is installed, it shall form, in its closed position, a shunt round the protective device. If separate from the protective device, it may be placed within the building. Where situated within reach of the radio apparatus, such earthing switch shall be of the all-insulated type.

(j) Any cut-out inserted in the antenna circuit shall be placed so that it cannot interrupt the circuit from the antenna to ground.

LUMINOUS DISCHARGE TUBE LIGHTING SYSTEMS.

453. (a) Every luminous discharge tube lighting system operating at a pressure in excess of 650 volts (unless the system is to operate at high frequency) shall comply with the appropriate general requirements of these Regulations, with regulation 2453 with respect to the construction and assembly of the equipment, and with the following special requirements with regard to the installation thereof:—

(b) A control switch capable of entirely disconnecting the step-up transformer, transformers, or other pressure increasing equipment from the supply mains shall be fixed in an easily accessible position immediately adjacent to such transformer, transformers, or equipment. This switch shall be permanently marked "Sign Control Switch," and shall not be contained in the same case as the pressure increasing equipment or high-tension cables or apparatus.

(c) A suitably worded danger notice, consisting of red lettering on a white ground, shall be fixed in a prominent position adjacent to the transformer or transformers and control switch. This notice shall have the word "DANGER" printed in bold letters as a heading, and shall contain a warning that the system operates at a dangerous electrical pressure, and that no portion of the system shall be touched unless the system is disconnected from the supply mains by means of the control switch.

SECONDARY BATTERIES.

456. (a) Where electricity is supplied to apparatus from secondary batteries, the apparatus and all connexions thereto shall comply with the provisions of these Regulations, and the work of connecting such apparatus to the batteries shall be carried out in a manner prescribed in these Regulations for similar work where electricity is obtained from generators or supply mains at the same pressure.

(b) A battery shall be installed only in a room which is thoroughly ventilated, particularly at the ceiling level, and in which the ventilating system is in direct connexion with the open air, and so arranged that gases or fumes from the accumulators cannot penetrate to any other portion of the building.

(c) Every battery shall be so arranged that unless adequate protection between cells is provided the potential differences between adjacent cells does not exceed 50 volts, and that each cell is readily accessible from the top and at least on one side for the purposes of examination, refilling, and removal.

Where the battery pressure exceeds 50 volts, the container of each cell shall stand on insulators. In the case of glass cells, the centres of the supporting insulators shall be not more than 15 inches apart.

(d) All battery connexions shall be rigidly supported, suitable insulators being used where necessary.

(e) The battery connecting bolts, unless of the non-corrosive type, shall be covered with protective jelly or compound where acid is used as an electrolyte.

(f) All portable leads in battery rooms shall be circular type flexible cords with tough rubber coverings as defined in regulation 2310.

Lampholders on portable leads shall be of the all-insulated type or entirely protected by an insulating guard.

TRANSFORMERS.

457. (a) The installation of every transformer other than an instrument transformer, a bell transformer, or a transformer not exceeding 1,200 volt amperes input rating incorporated in radio equipment, a battery charging rectifier, or luminous discharge tube lighting system, shall be carried out in accordance with the requirements of this regulation.

(b) High or extra high pressure connexions of a transformer used for transforming energy from low or medium pressure to high or extra high pressure shall conform to the appropriate requirements of Section 7 of these Regulations.

(c) Where a step-up transformer is used to raise the pressure above that at which electricity is supplied at the consumer's terminals, no connexion other than that made by an earthing conductor shall be made between the primary and secondary windings. Unless all wiring and terminals at the higher pressure are enclosed by an insulating or earthed metal cover, such transformers shall be installed only in places inaccessible to unauthorized persons.

(d) No auto-transformer shall be used to reduce to low or extra low pressure the pressure of electricity to be conveyed through the general wiring in buildings, or to any circuit or apparatus in which, or connected to which, there is live metal exposed to personal contact.

(e) Unless encased, transformers shall be carried on supports of incombustible material.

(f) Every protecting case or enclosure containing a transformer shall be of incombustible material.

(g) Every transformer shall be so installed that personal contact cannot be made accidentally by unauthorized persons with any part of windings other than extra low pressure windings.

(h) Every transformer or bank of interconnected transformers shall be supplied through an independent circuit controlled by a multipole circuit-breaker with an over-current release in each active, or by linked switches with a cut-out in each active.

(i) If the secondary pressure is low or medium, the wiring on the secondary side of the transformer shall be protected by a cut-out in each active conductor, or by a circuit-breaker with an over-current release in each active conductor.

CHOKE COILS.

458. (a) The expression "transformer" in clauses (e), (f), and (g) of regulation 457 shall be deemed to include also choke coil and any resistance other than a resistance used for the control of a motor or generator.

(b) Choke coils and resistances shall not be used for reducing the pressure to portable appliances, battery chargers with exposed live terminals, medical or dental appliances, or electrically operated toys and other appliances which are liable to be handled in normal use.

STATIC RECTIFIERS.

459. Static rectifiers installed in rooms used for purposes other than the housing of the rectifying equipment shall be so installed that any injurious glare from the valves is shielded from view.

BELL AND SIGNALLING CIRCUITS.

460. Bell and signalling circuits (except telephone circuits) may be operated from supply mains only if—

- (a) they are connected to the secondary side of transformers having a secondary pressure not exceeding 12 volts;
- (b) each transformer is mounted on a distribution board or on an independent fire-resisting base in an easily accessible position;
- (c) the conductors of the secondary circuit are either—
 - (i) approved insulated cables as defined in regulation 2304 (d); or
 - (ii) tinned copper conductors not smaller than 1/036-in. diameter (No. 20 S.W.G.) insulated with vulcanized indiarubber insulation of not less than 300 megohm grade; or
 - (iii) (if the circuit is operated by a transformer which is capable of withstanding satisfactorily the test specified in regulation 2460 (b)) rubber or enamel insulated double cotton covered copper bell wire not smaller than 1/036-in. diameter (No. 20 S.W.G.).

PART I.—SECTION 5.**EARTHING.****SPECIFYING WHAT SHALL BE EARTHED.**

501. The following shall be effectively earthed in accordance with the Regulations of this Section and to the satisfaction of the authorized inspector:—

- (a) The metal sheathing and metallic armouring of cables and all metal boxes and accessories forming part of the wiring system.
- (b) Metal conduits enclosing conductors of any type, except that isolated lengths of conduit which are neither connected to any other length of conduit nor in any part accessible to personal contact need not be earthed.
- (c) The bedplates and frames of all electric generators.
- (d) The frames of all motors of $\frac{1}{2}$ horse-power or over and their starters and/or controlling resistances and, in earthed situations, the frames of all motors under $\frac{1}{2}$ horse-power and their starters and/or controlling resistances.
- (e) All exposed metal cores, cases, frames, and/or enclosures of transformers, choke coils, resistance units, and fixed rectifiers.
- (f) One point of the secondary winding of transformers used in connexion with extra low pressure circuits.
- (g) Metal cases and metal framework (if any) of metal-clad switchgear and exposed metal frames of switchboards in earthed situations.
- (h) The ironclad elements and frames of all electric cooking stoves.

- (i) The exposed metal framework of electric signs which are installed in earthed situations.
- (j) The exposed metal case, cover, and/or handle of any switch if such switch is—
 - (i) in an earthed situation; or
 - (ii) within 6 feet of the metal case, cover, or handle of any switch which is inserted in a conductor of different phase or polarity.
- (k) All exposed metal parts (other than nameplates, screwheads, covers, or plates which are supported on and/or attached to and/or in contact with substantial non-conductive material only, and in such a manner that they cannot become alive in the event of failure of the insulation of live parts) of appliances and apparatus in bathrooms, and in all other earthed situations.
- (l) Where electrical apparatus is mounted on machinery, e.g., cranes and lifts, the metal covers and frames of such apparatus, and the metal conduits or sheathings of the conductors, shall be connected to the machinery which shall itself be earthed. In the case of cranes, transporters, and the like, metal wheels and metal rails on which they run shall be deemed to constitute a part of the machinery.
- (m) All exposed metal liable to become alive from any cause when such metal is in a damp situation or in any earthed situation.
- (n) The earthing terminal of all plug sockets in earthed situations.

METHODS OF EARTHING.

511. (a) Runs of cable sheathings and envelopes and metal conduits which run to or from switchboards shall be earthed at the ends adjacent to such switchboards. At these boards all such sheathings, envelopes, and conduits leading to or away from the board shall be bonded together and bonded to an earthing conductor complying with regulation 516. Each separate run of metallic conduit, sheathing, or envelope in an installation shall be so connected to earth that no conduit, sheathing, or envelope of one run shall be used as the earthing medium for another run of conduit, sheathing, or envelope.

All other metal to be earthed shall be connected to earth by an earthing conductor conforming to the requirements of regulation 516.

No length of conduit, or cable sheathing, or envelope shall be used as an earthing conductor.

(b) In buildings containing steel construction, earthed metal forming part of the installation shall be earthed independently of the structural steelwork, but may be secured to it, provided that such steelwork is itself earthed. Where structural steelwork is not earthed, metal which is not earthed and which is liable to become alive should the insulation become defective shall be separated from the structure by durable non-conducting material.

(c) The neutral conductor of any installation shall not be used as an earthing conductor, but the neutral conductor of the submains between switchboards may be used, as laid down in regulation 262 (f) and (g), as a bond between earth pipes or plates where the M.E.N. system is used.

512. (a) Every main earthing conductor shall be connected to an effective earth plate or plates, earth pipe or pipes, or other suitable metallic device or metallic piping system in direct contact with the general mass of earth, and every subsidiary earthing conductor which is not earthed in the manner provided for the earthing of the main earthing conductor shall be clamped or soldered to the main earthing conductor or to another subsidiary earthing conductor which is so earthed.

If connected to the piping of a water supply system, the main earthing conductor shall be connected as close as practicable to the point of entry of the water supply system into the building, and, where practicable, within the building, to a section of water pipe of sufficient size to carry the maximum current likely to flow to earth under extreme fault conditions. Where connexion of an earthing conductor is made to a pipe or plate outside a building, such connexion shall be adequately protected from the effects of weather by a sealing compound or paint which will prevent corrosion of the contact surfaces.

Where an effectively earthed water supply system is not available, a galvanized-iron water pipe or pipes, as required by the authorized inspector, each of not less than $\frac{3}{4}$ inch internal diameter, shall be driven vertically at least 4 feet into the ground, or to such greater depth as will ensure adequate contact with the moist sub-soil. Not less than 4 feet of each such pipe shall be buried under the ground. Alternatively, an earth plate or plates approved by the authorized inspector shall be used.

(b) Earth pipes and plates shall be installed, where possible, in permanently damp places. Where installed in positions that are likely to become dry, provision shall be made for watering. Where more than one earth pipe or plate is installed, they shall be spaced not less than 6 feet apart.

If more than one earth pipe or plate, or if a piping system and one or more earth plates or pipes are employed in the earthing system of an installation, they shall be effectively and permanently connected together by a bonding conductor or conductors. Every bonding conductor shall comply with the requirements of regulation 516 for earthing conductors.

Where the multiple earthed neutral system is employed and the bonding of conductors is carried out in accordance with the provisions of regulation 262 (f) and (g), the neutral conductor between neutral busbars on switchboards shall be considered to be an effective bonding conductor for the purposes of the preceding paragraph hereof.

(c) Earthing conductors shall be so protected or fixed or placed in such positions and be attached to the pipes or plates in such a manner that they cannot be accidentally damaged or cut.

(d) Where an earthing conductor is buried, it shall be protected from mechanical injury in the same manner as insulated cables installed under similar conditions, except that wood troughing laid underground for the protection of earthing conductors need not be filled with compound.

(e) All connexions of earthing conductors to the installation and to the earth plate or pipe shall be readily accessible.

(f) Sprinkler pipes or pipes conveying gas, hot water, or an inflammable liquid shall not be used as part of any earthing system.

(g) Where the metal cases of switches, distribution boards, or other apparatus are required to be earthed, any special precautions required by the authorized inspector shall be taken to guard against the risk of shock or burning to any one working on live conductors in or adjacent to such apparatus.

EARTHING OF APPLIANCES.

513 (a) Exposed metal parts of every fixed appliance which is used in an earthed situation shall be earthed by an earthing conductor which complies in all respects with and is connected in accordance with the relevant clauses of regulation 511 to 517 inclusive.

(b) All exposed metal parts of a portable fitting or appliance used in an earthed situation shall be connected to earth by means of an earthing conductor contained within the flexible cord. This earthing conductor shall be connected at one end to the earthing pin on the plug, and at the other end shall be connected either to the earthing contact of the inlet plug of an apparatus connector as described in regulation 2422 or, if the current-carrying conductors of the flexible cord are fixed to terminals on the fitting or appliance, to the earthing terminal on the fitting or appliance.

In all cases where a portable fitting or appliance is earthed, the connexion to earth of the frame of the fitting or appliance shall be made automatically when the plug is connected to the supply, or (in the case of a fitting or appliance provided with an apparatus connector) when the plug is connected to the supply and the inlet plug of the apparatus connector is fitted in position in the inlet socket. The connexion to earth aforesaid shall be broken automatically when the plug is disconnected from the supply, or (in the case of a fitting or appliance provided with an apparatus connector) when the plug is disconnected from the supply or the inlet plug of the apparatus connector is withdrawn from the inlet socket.

(c) Where the flexible cord has metal armouring, such armouring, in addition to the earthing conductor, shall be effectively connected electrically at

one end to the metal frame of the fitting or appliance, and at the other end to the earthing terminal of the plug.

514. Where the multiple earthed neutral system is used, the main earthing conductor shall be taken from the neutral busbar of the main switchboard (or from the supply authority's connecting bar or link) without a break to an effective earth, and all conduits, sheathings, and envelopes of cables leading to or from this switchboard shall be bonded together and bonded by an earthing conductor to the main earthing conductor. The earthing throughout the installation shall be carried out to comply with regulation 262.

REQUIREMENTS OF EARTHING SYSTEM.

515. (a) (i) The combined resistance of the conduit, metallic sheathing, or envelope of cables and the earthing system shall be low enough to permit, in conjunction with the earthing connexion at the source of supply, the passage of the current necessary to operate the fuse link or the over-current or earth leakage release of the circuit-breaker protecting the circuit. The total resistance between any point on the conduit or metallic sheathing or envelope of cables and any point on the earthing system shall not exceed 2 ohms.

(ii) Every joint in conduit, cable sheathing, or envelope shall be so made that the current-carrying capacity of the joint is not less than that of the earthing conductor required under regulation 516 for earthing such conduit, cable sheathing, or envelope.

(b) Earthing conductors shall be as short as practicable.

EARTHING CONDUCTORS.

516. (a) (i) Except as provided in sub-clauses (ii) and (iii) of this clause (a), every earthing conductor shall be of high conductivity copper and shall be bare. Where exposed to excessive dampness or to corrosion, it shall be protected by tinning, painting, or other means which will effectively prevent corrosion under the conditions of use.

(ii) Galvanized solid iron or steel wire or rod, the conductivity of which is not less than that of the copper earthing conductor required under these Regulations and not smaller than No. 5 S.W.G., may be used for earthing conductors under the ground or immediately adjacent to the ground.

(iii) Earthing conductors for radio equipment shall comply with the requirements of regulation 452, and earthing conductors contained within a flexible cord may be insulated or covered.

(b) Copper earthing conductors shall be—

(i) stranded cables; or

(ii) flat strip not less than $\frac{3}{4}$ inch wide by No. 18 gauge; or

(iii) circular or rectangular bar not smaller than 0.15 square inch in cross-section.

Except as provided in clause (c) of this regulation, the minimum cross-sectional area of any stranded earthing conductor shall be 0.0045 square inch (7/029 inch) which shall be deemed sufficient for installations not exceeding 50 amperes connected load. Where the connected load of an installation exceeds 50 amperes, the carrying capacity of any earthing conductor (as determined from Table A (II), page 1200, for a cable of equivalent cross-sectional area) shall be not less than one-third of the carrying capacity of the largest conductor to be protected thereby, and not less than one-third of the full load current of any motor, fitting, or appliance earthed thereby, and, where the multiple earthed neutral system is employed, the cross-sectional area of the main earthing conductor shall be not less than half that of the main neutral conductor.

(c) If the cross-sectional area of the largest live conductor of a flexible cord used with a portable appliance is smaller than 0.0045 square inch, the cross-sectional area of the earthing conductor in the flexible cord shall be not less than that of such live conductor.

(d) The ends of all earthing conductors which are not connected to earth clips complying with regulation 2517 and which have seven or more strands shall be soldered into cable sockets or (except in the case of earthing and/or bonding conductors connected to neutral busbars where the M.E.N. system is employed) be otherwise connected in accordance with regulation 326 (h).

EARTH CLIPS.

517. (a) Where an earthing conductor is connected to a pipe, conduit, cable sheath, armouring, or other cylindrical metal section, a substantial earth clip, which firmly grips and makes good contact with both the metal section and the earthing conductor, shall be used.

(b) Paint, enamel, compound, and other non-conducting material shall be removed from the surface of the metal section to which the earth clip is attached to permit of effective contact between the clip and such surface.

(c) Earth clips of the minimum dimensions specified in clause (b) of regulation 2517 shall be used only for connecting to cylindrical sections earthing conductors not larger than 7/064 inch if the clips are made of copper or highly conductive copper alloy, or not larger than 7/044 inch if the clips are made of other metal. For the connexion of an earthing conductor larger than those above mentioned, a clip of such material and cross-section that the conductivity of the clip is not less than that of the earthing conductor shall be used.

(d) Earth clips connected to the armouring of armoured cables shall firmly grip all the wires or strips of the armouring without damage to the lead sheathing (if any), but where connected to lead-sheathed armoured cables, the principal contact shall be with the lead sheathing.

EARTH-LEAKAGE CIRCUIT-BREAKERS.

521. An earth-leakage circuit-breaker or circuit-breakers (as the case may require) complying with the requirements of regulation 2522 shall be installed as provided for hereinafter in regulations 522, 523, 524 as part of and for the protection of every installation unless at the direction of the supply authority all exposed metal, which forms a part of the wires and fittings at the installation or is used in association therewith, and which, in the event of a leakage, would be likely to become charged with electricity, is prevented, by one or other of the following methods, from acquiring a dangerous potential, viz:—

- (1) by direct connexion to an earthing medium, which is effective for the purpose (direct earthing); or
- (2) by connexion to the neutral conductor of a multiple earthed neutral system of distribution.

522. Subject to any proviso, modification, or special requirement contained in regulation 523 or 524:—

Purpose of Earth Leakage Circuit-breaker.

(a) Every earth leakage circuit-breaker shall be so installed and connected that, in the event of any exposed metal part of the installation (including any part of the installation required to be earthed under regulation 501) reaching a pressure of or exceeding 26 volts from earth potential, it will cause the installation to be disconnected from all incoming active conductors.

Position.

(b) Every earth leakage circuit-breaker required to be installed by these Regulations shall be installed in a position determined by the supply authority either on the main switchboard or at some readily accessible point in the consumer's mains.

Direct Earthing.

(c) The installation of the earth leakage circuit-breaker or circuit-breakers required under regulation 521 shall be a requirement in addition to and not in lieu of any other requirements as to the earthing of the installation contained in section 5 of these Regulations.

Connexion.

(d) One end of the tripping coil of the earth leakage circuit-breaker shall be connected by means of a stranded bare copper conductor not smaller than 7/029 inch to the metal to be earthed, and the other end shall be connected by means of a vulcanized rubber insulated 250 volt grade cable not smaller than 7/029 inch which, where exposed to the weather, shall be weatherproof cable, to an independent earthing electrode such as an earth pipe as described in the third paragraph of clause (a) of regulation 512, which shall be installed as set forth in the said paragraph of the said regulation, and shall be used solely for the purpose of such connexion. Such electrode shall be established in a place

at least 6 inches distant from any gas, water, or other metal pipe above ground and at least 6 feet distant from any cable, or gas, water, or other metal pipe on or in the ground. The resistance between any such earthing electrode and the general mass of earth shall not exceed 200 ohms. As far as practicable the insulated earthing conductor throughout its entire length shall be so placed that it is not liable to damage, but where its position is such that it is liable to damage it shall be protected by a suitable covering, and where a metallic covering is used for this purpose it shall be installed so that neither by contact nor through its supports or fixings can it be or become in electrical connexion with any metal other than clamps or clips used to fix it in position. Any connexion in the earthing conductor shall be a soldered joint which shall be insulated and covered with waterproofed tape in accordance with the requirements of clause (c) of regulation 326 of these Regulations.

Testing Notice.

(e) Every earth leakage circuit-breaker installed in any installation shall have the following words plainly and indelibly marked either on the circuit-breaker cover or on an approved durable label not smaller than 2½ inches x 1½ inches, which shall be securely fixed in a prominent position immediately adjacent to the circuit-breaker, and such marking or label shall be placed in such a position that it can be read easily when the circuit-breaker is mounted in position:—

"This switch must be tested every month by the consumer. Press the test button (or turn the test key in the direction indicated). If the switch does not open, either the switch or its connexion is defective, in which case the supply authority must be notified".

Provided that the words "Press the test button or" may be omitted in the case of an earth leakage circuit-breaker in which the test circuit is operated by a test key and the words "(or turn the test key in the direction indicated)" may be omitted in the case of an earth leakage circuit-breaker in which the test circuit is operated by a test button.

As Main Switch.

(f) If an earth leakage circuit-breaker or circuit-breakers as the case may require be installed to comply in all respects with the requirements of regulation 222 in so far as they apply to the control of the main supply to every independently metered portion of an installation by a switch or switches, no other switch to control such main supply shall be required under the said regulation 222.

If the distance between an earth leakage circuit-breaker and the main switchboard does not exceed 30 feet along a route which is not obstructed except by doors and which is at all times readily accessible to the consumer and is confined to the one story of the premises—

- (i) such earth leakage circuit-breaker shall be deemed to comply with the requirements of regulation 222 as to position; and
- (ii) no further switch shall be required under regulation 222 for the control of the main supply to any independently metered portion of the installation provided such earth leakage circuit-breaker controls the whole of the supply to the installation.

As Control Switch.

(g) If an earth leakage circuit-breaker be installed to comply in all respects with a specific requirement of these Regulations for a switch for the control of a stated appliance, apparatus, or outlet, no other control switch need be installed under such requirement in respect of such appliance, apparatus, or outlet.

SELECTIVE PROTECTION.

523. Notwithstanding the requirements of regulation 522:—

Installations Supplying not more than Six Consumers.

(a) Where an installation is installed or divided so as to comprise more than one but not more than six sections so as to be suitable for the use of electricity by a separate consumer from each such section either—

Selectivity as between Consumers.

- (1) a sufficient number of earth leakage circuit-breakers shall be installed and the installation shall be arranged to ensure that a

failure of insulation in a section supplying one consumer or in any connexion thereto will not result in the disconnexion of the supply of electricity to any other section supplying another consumer; or

Selectivity as between Specified Portions of an Installation.

(2) an earth leakage circuit-breaker shall be installed for the protection of each of the portions of the installation comprising the parts described in paragraphs (i) and (ii) hereunder, and the installation shall be arranged to ensure that a failure of insulation in any one such portion described in paragraph (i) will not cause the opening of a circuit-breaker controlling the supply of electricity to any other portion, and that a failure of insulation in any such portion described in paragraph (ii) will disconnect the supply of electricity from the whole installation, that is to say:—

- (i) all appliances and outlets within any one section which include parts required under section 5 of these Regulations to be earthed;
- (ii) all metal conduits and metal sheathings throughout the installation which are required under these Regulations to be earthed and the conductors enclosed therein.

Selectivity in an Installation Supplying more than Six Consumers.

(b) Where an installation is installed or divided so as to comprise more than six sections so as to be suitable for the use of electricity by a separate consumer from each such section the number of earth leakage circuit-breakers to be installed and the arrangement of the installation shall be such as to conform to the requirements of clause (a) of this regulation:

Provided however the installing or alteration of the installation shall not be proceeded with unless and until the electrical contractor who has undertaken the work or the electrical mechanic in charge of such work has obtained the approval in writing of the supply authority to the steps he proposes to take to secure compliance with clause (a) of this regulation. Any such electrical contractor or electrical mechanic who has failed or neglected to obtain such approval prior to such work being proceeded with shall be guilty of an infringement of this regulation.

Additional Selectivity may be Provided where Selectivity Required is not Interfered with.

(c) In addition to the earth leakage circuit-breaker or (as the case may require) earth leakage circuit-breakers required to be installed under these Regulations, additional earth leakage circuit-breakers may, if desired, be installed in any installation for the protection of any portions of such installation provided that the express provisions of these Regulations are not thereby infringed.

Purpose of Earth Leakage Circuit-breaker where Protection is Selective.

(d) Where a section or portion of an installation is protected by an earth leakage circuit-breaker in the manner provided for in clauses (a) or (b) of this regulation—

- (i) In the event of any exposed metal part of such section or portion (including any part thereof required to be earthed under regulation 501) reaching a pressure of or exceeding 26 volts from earth potential, the disconnexion required under clause (a) of regulation 522 or under clause (a) or clause (b) of regulation 524 shall be confined and apply only to the supply of electricity to such section or portion of the installation.

Direct Earthing of Certain Portions Prohibited.

- (ii) With the exception of the metal conduits and metallic sheathings referred to under paragraph (ii) of sub-clause (2) of clause (a) of this regulation, no such section or portion shall be connected to earth except through the tripping coil of such earth leakage circuit-breaker.

Connexion.

- (iii) The connexion required under clause (d) of regulation 522 shall be made as follows:—

One end of the tripping coil of the earth leakage circuit-breaker shall be connected to the metal to be earthed by means of a vulcanized rubber insulated 250 volt grade cable not smaller than 7/029 inch and coloured green or, if enclosed within the conduit with or within the sheathings of the supply conductors of such section or portion, by means of a vulcanized rubber insulated 250 volt grade cable not smaller than 3/029 inch and coloured green. The other end of the tripping coil shall be connected to an independent earthing electrode in the manner provided for in clause (d) of regulation 522.

Where Supply Authority Specifies Selectivity.

(e) Provided always that where, on application being made to it, the supply authority has by notice in writing required that some number of earth leakage circuit-breakers other than that provided for in clause (a) hereof be installed and that the arrangement of the installation for securing any specified protection by or any specified independence or interdependence of operation of such earth leakage circuit-breakers be other than that provided for in the foregoing clauses (a), (b), (c), and (d) of this regulation it shall not be an infringement of this regulation if the installation is carried out strictly in accordance with such specified requirements of the supply authority.

SPECIAL CASES.

Earth Leakage Circuit-breaker may open Relay Circuit.

524. (a) Where an installation or section or portion thereof is controlled by a contactor or circuit-breaker which complies with the requirements of these Regulations, the disconnexion referred to in clause (a) of regulation 522 or in sub-clause (i) of clause (d) of regulation 523 may be effected by the insertion of an earth leakage circuit-breaker in the relay circuit of the contactor or circuit-breaker.

Disconnexion of Neutral or Negative Conductor.

(b) Where an installation is supplied from a system in which a current limiting device is inserted in the earthing conductor at the source of supply, the earth leakage circuit-breaker shall be so installed and connected that by its operation as specified in clause (a) of regulation 522 or, as the case may be, in sub-clause (i) of clause (d) of regulation 523, the installation or, as the case may be, the section or portion thereof, shall also be disconnected from the incoming neutral conductor; and where an installation is supplied from a system in which no conductor is earthed at the source of supply, the earth leakage circuit-breaker shall be so installed and connected that by its operation as specified in the said clause (a) or sub-clause (i) of clause (d) the installation or, as the case may be, the section or portion thereof, shall be disconnected from all incoming conductors.

CONSUMER'S MAINS.

Special Provisions where Earth Leakage Circuit-breaker is Required.

525. (a) Notwithstanding anything to the contrary contained in clause (c) of regulation 212, where an earth leakage circuit-breaker is required under these Regulations to be installed, the consumer's mains between the point of entry and such earth leakage circuit-breaker shall be one of the following types of cable and shall be installed according to the method laid down hereunder in respect of such cable, that is to say:—

- (i) *Tough rubber compound covered vulcanized rubber insulated cables* complying with the requirements of paragraph (6) of clause (d) of regulation 2304.

The cables shall be enclosed in steel conduit and shall terminate in a junction box at the point of entry.

- (ii) *Rubber compound insulated cables* complying with the requirements of paragraph (9) of clause (d) of regulation 2304: Provided that where such cables are used the thickness of the rubber compound insulation shall be not less than that required for

vulcanized rubber insulated cables of the same conductor size plus the thickness of tough rubber compound covering required for tough rubber compound covered cables. The insulation and covering of such cables may be separately applied or applied in one process.

The cables shall be installed in the manner specified in paragraph (i) above.

- (iii) *Vulcanized rubber insulated and braided cables* complying with the requirements of paragraph (2) of clause (d) of regulation 2304.

The cables shall be enclosed in insulating conduit or in internally insulated steel conduit and conduit fittings, all of which shall be approved for the purpose, and shall terminate in a junction box at the point of entry.

- (iv) *Cables* in which the neutral conductor is in the form of a tape or close fitting wires helically arranged external to all active conductors and covered with insulation as required for 250 volt cables of the types listed under clause (d) of regulation 2304. Such cables shall be braided overall or tough rubber sheathed and shall not be used for this purpose unless approved therefor in writing.

The cables shall be protected by enclosure in conduit or casing where liable to mechanical damage, but otherwise may be installed without such protection. They shall terminate in a suitable junction box at the point of entry.

- (v) *Vulcanized rubber insulated weatherproof cables* complying with the requirements of regulation 2311: Provided that such cables shall not be used unless they be enclosed in a duct formed within a brick or concrete wall of a building and having a porcelain or earthenware outlet as hereinafter described.

The duct shall be approximately vertical and uniform in section and shall be partitioned off from any other cavity by barriers of durable material not less than 1 inch in thickness. It shall be of suitable form and of sufficient size to permit of easy withdrawal and replacement of the cables and shall be not smaller than 2 inches wide by 1½ inches deep.

The porcelain or earthenware outlet above mentioned shall be arranged to prevent the entry of moisture and to prevent abrasion of the cable insulation, and shall be fixed at the exterior extremity of the duct.

Where the length of the cables within the duct exceeds 12 feet they shall be supported at intervals not exceeding 12 feet by supports which are accessible for the release and adjustment of the cables and which will not damage the cable insulation.

- (vi) *Cables* that may from time to time be approved in writing for the purpose. Such approval may be either general or may be given in respect of a specified installation or installations.

The cables shall be installed in accordance with the appropriate requirements of these Regulations in respect of such cable, with any modifications thereof or requirements additional thereto that may be set out by the Commission in the writing expressing the relevant approval.

Conduit not to be Earthed.

(b) Notwithstanding the provisions of regulation 501 and paragraph (ii) of clause (h) of regulation 343 steel conduit which encloses consumer's mains installed between the point of entry and the earth leakage circuit-breaker in the manner set out in sub-clause (i), (ii), or (iii) of clause (a) hereof shall not be connected to earth either directly or through the tripping coil of an earth leakage circuit-breaker. Such conduit, unless internally insulated, shall be separated from all structural and other metal by some durable non-conducting material.

Junction Box.

(c) The junction box referred to in clause (a) hereof shall be of a type approved for the purpose. The consumer's mains between such junction box at the point of entry and the consumer's terminals shall be vulcanized rubber insulated weatherproof cables installed as required by clause (d) of regulation 212.

PART I.—SECTION 6.

SPECIAL SITUATIONS.

PUBLIC BUILDINGS.

Note.—Attention is directed to the Public Health Commission's Building Regulations (Part III.—Lighting—and Part IV., Division IV., Regulation 164—Electric Light and Power (Cinematograph Projector Cabins)) and to any modifications or amendments or additions to such Regulations.

Extract from Public Health Commission's Building Regulations—Part III.:

" 95. (1) Before the installation in any building of any system of lighting or warming therefor or of power installation therein or of any work or apparatus in connexion therewith and before any alterations to an existing installation are commenced the approval of the Commission* for what is proposed to be done shall be obtained.

For this purpose plans and specifications together with full particulars of the work it is proposed to carry out including drawings of proposed switchboards shall be forwarded to the Secretary* to whom also record copies of the drawings as approved shall on demand be supplied on completion of the work.

(2) A copy of the approved drawings showing the arrangement of all switchboards and a key to the layout of the wiring and the positions of all switchboards shall be posted as soon as practicable after approval in a prominent and approved position on such premises, and kept therein in good order and condition.

(3) In all cases in which it is intended to install temporary lighting sufficient notice in writing of such intention shall be given to the Commission* and its approval shall be obtained before the work of installation is commenced."

REGULATIONS.

601. Every electrical installation in a public building shall be carried out in accordance with the requirements of these Regulations, subject to any modification thereof by regulations 602 to 613 inclusive.

Mains and Service Cut-outs.

602. No service line, service cut-out, or consumer's mains for any public building shall be used for the supply of electricity to any other electrical installation.

603. (a) Where required by the Public Health Commission, not less than three separate sets of service cut-outs shall be provided—

A for the stage and power purposes;

B and C for the auditorium, passages, exits, and all parts of the premises open to the public; and each of the groups of circuits for A, B, and C respectively shall be kept separate and distinct throughout the installation.

Where a three-wire or four-wire service is given, the groups of circuits A, B, and C shall be balanced to the satisfaction of the Public Health Commission and the supply authority.

(b) Each group of circuits under clause (a) hereof shall be supplied from a separate service cut-out or cut-outs, and, where practicable, from a separate set of supply mains. Such service cut-out or cut-outs shall be effectually sealed, and such seals shall be broken only by an authorized officer of the supply authority.

(c) The groups of circuits B and C shall be so arranged that approximately half the lights in each division of the auditorium and half those in each passage, exit, and other place open to the public, shall be connected to circuits of group B, and the other half to circuits of group C, and, as far as practicable, the lights shall be connected on circuits of group B and group C alternately. In no case

*Public Health Commission.

shall any portion of a circuit of one group be combined in one fitting with or enclosed in the same box, conduit, casing, or other enclosure as any portion of a circuit of another group.

Switchboards.

604. (a) Main switchboards shall be placed in positions approved by the authorized inspector. Every theatre switchboard shall be installed in a compartment of fire-resisting construction, which shall be properly lighted and ventilated and used solely for that purpose.

(b) Change-over switches shall be used only if approved for the purpose.

(c) Switchboards shall be fixed in readily accessible positions, but not so as to obstruct passage-ways or exit-ways.

Where a switchboard is placed in an exposed position, it shall be wholly enclosed in a fire-resisting lock-up case.

Each switch and cut-out shall be permanently labelled in an approved manner or identified by figuring or lettering painted in an approved manner on the board to show the circuit controlled thereby.

The switchboard used for the control of signal light or other circuits shall be kept clear of bells, telephone, and similar apparatus.

(d) The groups A, B, and C, shall be controlled by separate main switches and cut-outs.

Sub-circuits.

605. (a) Circuits for power or heating purposes shall be kept distinct and separate from lighting circuits.

(b) Exit and entrance lighting circuits shall be controlled solely at the main switchboard.

(c) The general lighting of the auditorium shall, under no circumstances, be controlled solely from within any cinematograph cabin.

Where switches to control the whole of the auditorium lighting are placed in any such cabin, the switches controlling a sufficient number of lights to illuminate effectively the whole of each division of the auditorium shall be wired in parallel with switches on the main switchboard, or on a switchboard in an approved position near the main entrance door to the stalls.

Conductors and Insulation—Fixing, Support, and Protection.

606. (a) The approval of the Public Health Commission shall be obtained for the use of any means of insulation of conductors other than that permitted under these Regulations.

(b) Flexible conductors shall be insulated with pure and vulcanized indiarubber, and shall be protected on the outside by a stout braiding and rubber tube where necessary, or they shall be protected by means of tough rubber compound or other suitable covering which will resist abrasion or other injury.

(c) No joints shall be made between flexible conductors.

(d) Where necessary, special precautions shall be taken to protect conductors from chemical and other injury.

(e) Conductors and cables covered with lead, tough rubber, or other soft or easily fused material, shall not be used unless protected by external armour of iron or steel, or enclosed in substantial iron or steel tubing, or other approved covering, up to a height of not less than 8 feet from the floor.

(f) Approval shall be obtained from the Public Health Commission for the use of any means of fixing or protecting conductors which is not permitted under these Regulations.

(g) If wood casing or wood troughing be used, it shall be constructed of jarrah, or other approved hardwood, and shall be run in such a manner that it is open to view throughout its entire length. Conductors contained therein shall be always accessible.

In no circumstances shall conductors of opposite polarity be laid in the same groove in wood troughing, nor shall the conductors of the same polarity belonging to the different groups of circuits A, B, and C described in regulation 603, be laid in the same groove of wood casing or wood troughing.

(h) Except where sanction in writing has been obtained from the Public Health Commission to run open conductors on insulators external to buildings, all conductors external to buildings (other than underground cables) shall be enclosed in iron piping or steel conduit protected where necessary from mechanical injury and securely fixed and supported. Such conduit shall be run in such a manner that any condensation will automatically drain therefrom.

(i) Underground wiring shall consist of stranded cables and shall be carried out in accordance with the requirements of regulation 353.

Stage Lighting and Switchboards.

607. (a) A switchboard fitted with all switches, cut-outs, and other fittings necessary for the control and regulation of the stage lighting shall be fixed in an approved position from which the operator can overlook the stage or in some other approved position provided that the controls are so placed that the operator can see all parts of the stage. This switchboard shall be so arranged that a fire occurring on it cannot readily spread therefrom. The stage lighting final sub-circuits shall be controlled solely by the apparatus on this switchboard.

(b) A metal hood extending the full length of the board shall be fitted at the top of the switchboard to protect it effectively from falling objects.

(c) Except where remote control is used, a platform with suitable means of access to the switchboard shall be provided for the switchboard operator. The platform shall be of fire-resisting material, with a hardwood or other non-conducting floor. The handrail of the platform shall be constructed of jarrah or other approved hardwood.

Where the stage lighting is controlled from any position other than the stage lighting switchboard, the control panel shall be in an approved position and accessible only to authorized persons.

(d) The circuits for the auditorium lighting shall be so arranged that it is not possible to control the whole of the auditorium lighting from the switchboard platform or control panel referred to in clause (c) above.

(e) Lamps on footlights or battens, proscenium lights and when required by the Public Health Commission other lamps shall be protected by stiff wire guards so arranged that no inflammable material can come in contact with any such lamp or light. No readily combustible material shall be placed in such proximity to any lamp as to entail risk of such material becoming ignited.

(f) Every lamp consuming more than 200 watts shall, when used for stage lighting, be securely supported in a suitable non-combustible fitting attached to an adequately secured metallic fixture.

(g) In the case of any temporary installation used for stage purposes, all connexions with the permanent installation shall be removed immediately after each performance unless the permission of the Public Health Commission for their retention has first been obtained.

(h) (i) Stage sockets or wells shall be of a type approved by the Public Health Commission and shall be substantially constructed of marble, slate, hardwood, or other material approved by that Commission, and shall each be protected by a pair of cut-outs having a maximum capacity of 20 amperes.

(ii) Stage sockets or wells shall be installed in such a manner that dirt and dust cannot accumulate in the socket or well, and so that the contact surfaces cannot readily be short-circuited.

(i) Plugging boxes shall be constructed of hardwood or other approved material, and shall be so used that no live metal is exposed.

(j) (i) The conductors to bunch lights, portable arc lamps, battens, movable lengths, or portable strips, shall be suitably insulated and protected particularly at the points where they adjoin the fittings.

Sufficient length shall be allowed to prevent the conductors receiving any injury through movement of the fittings, and all conductors shall be protected from mechanical injury by means of leather or stout waterproof canvas hose or other covering approved by the Public Health Commission.

(ii) Cables connecting suspended battens shall be of one of the following classes of cable, namely:—

(1) Flexible cables covered with tough rubber compound.

- (2) Vulcanized rubber insulated cables containing not less than seven strands for each conductor and enclosed in canvas hose.
- (3) Insulated flexible cables covered with slow-burning braiding.
- (4) Insulated flexible cables covered with asbestos or fire-resisting braiding.
- (5) Insulated flexible cables covered with hard cord braiding.

(iii) Cables connecting suspended battens shall be supported in such a manner that no pull can be applied by the conductors to any terminals to which they are connected.

(iv) Each batten shall be suspended by means of wire ropes attached to insulators on the battens to the satisfaction of the Public Health Commission.

(k) Incandescent stage lighting, including foot-lights, border lights, and proscenium side lights, shall be so wired that the maximum current on each circuit does not exceed the limits laid down in regulation 216, except that the number of points on any final sub-circuit of 10 amperes or less shall be limited only by the loading.

(l) No electric fitting, apparatus, or appliance of any description shall be so fixed or arranged that it can in any circumstances become damaged by the lowering of the proscenium curtain or of the safety curtain of the proscenium opening of the stage.

Arc Lamps.

608. Arc lamps shall not be used without the permission of the Public Health Commission.

Where an arc lamp is used, it shall be—

- (i) provided with an approved double-pole switch placed within easy reach of the operator, and the conductors within a distance of 2 feet from the lamp shall be covered with a fire-resisting material. In no case shall such a lamp be suspended by the conductors.
- (ii) enclosed in a suitable cover or box substantially constructed of metal not less than No. 20 S.W.G. (0.036 inch) so designed as to provide proper ventilation and prevent sparks or heated particles of carbon being emitted therefrom and so arranged that live parts of the lamp cannot come into contact therewith.

Every frame for holding a coloured medium and every masking shutter shall be of metal.

Resistances and Choke Coils.

609. (a) Resistances and choke coils for regulating the pressure for lights or motors, or for other purposes, shall be mounted on incombustible bases. They shall be so protected and placed at such a distance from any combustible material that no part of the resistance or choke coil, if broken, can fall on such material, or vice versa.

(b) Resistances for arc lamps shall be placed in approved permanent positions and wired with their connecting terminals on the underside.

(c) Liquid resistances shall be placed in a fire-proof room reserved for the purpose. Liquid resistances with side or bottom connexions shall be mounted on frames and shall be provided with effective trays.

(d) All dimmer resistances shall be connected in the active conductor of the circuit, and a suitable control switch for interrupting the current shall be connected on the supply side of the dimmer. All dimmers shall be suitably insulated, and where two or more dimmers are installed in close proximity on different or active conductors, they shall be of the all-insulated type or shall have all exposed metal parts bonded together and connected to earth.

Where, however, the previous consent in writing of the Commission has been obtained, dimmers may be installed in the neutral conductor of the circuit, provided such dimmers are of a type which will not open the circuit, and a double-pole switch is inserted in the conductors of the circuit on the supply side of, and in close proximity to, the dimmers.

All metal work of dimmer frames shall be effectively connected to earth.

No. 142.—1525/50.—3

Switches.

610. The minimum distance between live metal parts of opposite polarity shall be 2½ inches, unless such parts are separated and screened by insulating material to the satisfaction of the Public Health Commission.

Fittings.

611. All electric fittings shall be suspended or fixed in a manner approved by the Public Health Commission.

Transformers.

612. Transformers shall be placed only in positions approved by the Public Health Commission.

Cinematograph Cabins.

Note.—The approval of the Public Health Commission must be obtained for the installation of any electrical resistance within a cinematograph cabin, and an electrical resistance installed outside a cinematograph cabin must be installed in a position approved by that Commission.

613. (a) Resistances installed within any cinematograph cabin shall be so designed and arranged that the maximum temperature of any part does not exceed 212° F. (100° C.).

They shall be so arranged that the heat radiated shall not injuriously or inconveniently affect the operator.

(b) The general lighting of the auditorium shall not, under any circumstances, be controlled solely from a cinematograph cabin.

Switches controlling auditorium lighting may be placed in the cinematograph cabin, provided that where the whole of the auditorium lighting is controlled by switches in such cabin, the switches controlling a sufficient number of lights to illuminate effectively the whole of each division of the auditorium are wired in parallel with switches on the main switchboard, or on a switchboard in an approved position near the main entrance to the stalls.

No switches or cut-outs, except those required by the operator during a performance, shall be installed within a cinematograph cabin.

(c) Every switchboard, circuit-breaker, motor generator, rotary converter, and all other apparatus installed in a cinematograph cabin, shall be so safeguarded as to protect effectively the projecting apparatus and the film from the effects of short circuits, electrical earths, and other electrical faults.

(d) Every electric fan used exclusively for ventilating a cinematograph cabin shall be controlled by a switch placed within the cinematograph cabin and near the entrance door thereof.

(e) All cables in a cinematograph cabin shall be enclosed in steel conduit. Such conduit shall not be laid on the surface of the floor of the cabin.

(f) The conductors supplying electricity for cinematograph projectors and accessories shall be taken as a separate circuit from the motor generator, rotary converter, or transformer terminals, or from some other suitable source of supply. Switches and cut-outs suitable for controlling and protecting such circuit shall be inserted at the point from which the supply is taken, and, in addition, a double-pole switch shall be fitted in the circuit within the cinematograph cabin.

(g) Each final sub-circuit supplying a motor driving any portion of the cinematograph apparatus shall be protected by the cut-outs (or other apparatus) required under regulations 221 and 222 for the protection of similar circuits.

(h) Portable lamps on flexible cords shall not be used in any cinematograph cabin.

(i) Lampholders on pendant flexible conductors shall be of the all-insulated pattern.

OUT-DOOR LIGHTING.

621. Where long out-door runs of cable from distribution centres are necessary (as for sports grounds, wharfs, jetties, storage and loading yards, and the like), lighting and power circuits may be loaded in accordance with the provisions of sub-clause (iv) of regulation 216 (b).

HAZARDOUS LOCATIONS.

622. (a) Outside buildings:—

- (i) Screwed conduit only shall be used and where exposed to excessive moisture the conduit system shall be made watertight.
 - (ii) Plugs and sockets shall be of the weather-proof type and shall be provided with effective means for keeping the socket weatherproof when the plug is removed.
- (b) Rigid fittings only shall be used under verandahs and in any places exposed to weather or wind.
- (c) Where conduit is used on wharfs, jetties, and other places where it is liable to be corroded by the action of sea water, it shall be treated by galvanizing or other means to prevent corrosion.

Damp Situations.

623. The following requirements shall apply in situations in which there is excessive dampness, and shall be observed in addition to those requirements under these regulations relating to earthed situations:—

- (a) Except where completely enclosed in a watertight non-hygroscopic casing, no switch, ceiling rose, plug socket, or other accessory or fitting, shall be mounted, either directly or on a wooden block, upon any surface likely to become excessively damp. Switches, ceiling roses, and other accessories mounted in the basement of brick or concrete buildings, or in any other positions subject to a degree of dampness, but where the use of water-tight fittings is not required, shall be mounted on blocks of durable non-hygroscopic materials.
- (b) The covers and knobs of all wall switches which are installed in a bathroom or other damp situation and are used to control lighting points, continuous bath-heater elements or plug sockets shall be made of mechanically strong insulating material. For other purposes in such situations, metal-clad switches with earthed cases, or other switches forming part of appliances whose exposed metal parts are effectively earthed, may be used.
- (c) Plug sockets installed in bathrooms or in other places where the floor is likely to become wet shall be fixed not less than 1 foot above the floor.
- (d) Every lampholder installed in a bathroom or other damp situation shall be of the all-insulated type or of other approved type which will preclude the possibility of any external metal portion becoming electrically charged.
- (e) The lampholder of a flexible pendant in a bathroom or other damp situation shall be at least 8 feet from the floor, and, wherever practicable, shall be out of reach of a person standing on or in a bath.
- (f) No flexible cord shall be used in a bathroom or other damp situation unless it be made up to a circular or oval section by the use of non-hygroscopic material. Such flexible cord shall be of a type approved for use in such situations. (See regulation 352.)
- (g) In butchers' chopping rooms, dairies, breweries, stables, and all other places where the conduit is likely to become wet through hoisting or any other cause, screwed conduit only shall be used.
- (h) Where internal condensation is likely to take place effective drainage of conduit shall be provided. (See regulation 346 (e).)

INFLAMMABLE AND EXPLOSIVE SURROUNDINGS.

624. (a) Distribution boards, switches, circuit-breakers, motors, starters, and resistances in situations where inflammable materials are stored or worked (such as timber yards, wood-working shops) shall be provided with covers constructed of or lined with non-ignitable material.

(b) In explosive factories and places where highly explosive dusts, vapours, or gases, are likely to be present all apparatus shall be of flameproof construction. Where plugs and sockets are used, each plug shall be interlocked fully with and controlled by a flame-proof switch.

(c) In places where inflammable or explosive dust or gas is liable to be present, incandescent lamps, together with their holders and wiring, shall be enclosed in gas-tight fittings.

PETROL SERVICE PUMPS, ETC.

625. The electrical equipment of petrol pumps, and of closed-in buildings accommodating petrol service pumps, shall comply with the requirements of this regulation.

- (a) (i) Flame-proof fittings shall be used in every room or enclosed part of a building in which a pump is installed. In all other places, flame-proof fittings or ventilated fittings of a type approved for the purpose shall be used.
- (ii) Where inflammable or explosive gas is likely to be present, or where the side lamps are enclosed in the pump casing when the pump is closed, gas-tight fittings shall be used.
- (b) Where the pumps are situated in a building in which inflammable or explosive gas is likely to be present, all conduit and fittings shall be made gas-tight.
- (c) Where the metal nozzle at the end of the filling hose is likely, under normal conditions, to come in contact with a lamp when the nozzle is being replaced in the holding-up clip, the lamp shall be protected against breakage either by means of a heavy glass outer globe or by a metal guard.
- (d) A separate lighting circuit shall be run to pumps exposed to the weather.
- (e) Several pumps may be connected to one circuit, provided the maximum number of points therein does not exceed that laid down in regulation 216, and in applying regulation 216, each pump may be regarded as one point.
- (f) The wiring inside the pump and to the lamps on the pump shall be enclosed in screwed conduit or piping. The whole of the conduit and fittings shall be gas-tight.
- (g) In cases where the conductors in the pump are joined to the conductors from the switchboard, they shall be joined by means of soldered joints, or by means of a socket and plug within the pump. Such socket and plug shall be of a type approved for the purpose.
- (h) No switches other than flame-proof switches shall be used in or on petrol pumps.

SPRAY-PAINTING BOOTHS.

626. The requirements of this regulation shall be observed in spray booths and rooms where pyroxylin and similar highly inflammable paints and finishes are used or stored otherwise than in gas-tight containers:—

- (a) No electrical appliance shall be used unless all current-carrying parts thereof are completely enclosed within a gas-tight metal casing sufficiently strong to resist internal gas explosions.
- (b) All conductors shall be completely enclosed in screwed metal conduit right up to the appliance to which the conduit shall be rigidly attached by being screwed into the connexion box of the appliance.
- (c) Switches, resistances, and other control gear shall be completely enclosed in gas-tight metal cases which shall be sufficiently strong to resist internal gas explosions, and which shall be secured to the conduit enclosing conductors in the manner described in clause (b) of this regulation.

- (d) Lamps shall be of the incandescent type only, and the fittings used in connexion therewith shall be of strong construction having air-tight external globes of thick glass capable of withstanding temperatures likely to arise when the lamp is in use. Where any such fitting is in a position exposed to mechanical injury, it shall be protected by a substantial wire guard.
- (e) Every electric motor shall be of the totally enclosed type or pipe-ventilated type with piping so arranged that both inlet and exhaust are external to the building.
- (f) No cut-out, generator, arc lamp, mercury vapour lamp, portable appliance, or plug and socket shall be used or installed either inside or within 10 feet of the entrance to the booth or room.

OTHER SITUATIONS.

627. No conductors, other than those required for the supply and use of current therein, shall be taken through or be installed in freezing chambers or cool stores, and switches which control lights or appliances in such places shall be grouped outside of and adjacent to a door. Switchboards shall not be fixed in freezing or cooling chambers. Where cables can be adequately protected by other means, conduit and casing shall not be used for enclosing wiring in freezing and cooling chambers.

628. Except in special cases, such as chemical works and cold stores, all cables in lifts and hoist shafts (except trailing cables) shall be armoured or shall be enclosed in screwed metal conduit. In the special cases referred to above, the cables shall be run in a manner approved by the authorized inspector.

629. No switch or plug socket, unless of the flame-proof type, shall be placed at a height less than 4 feet from the floor in commercial garages or similar places where petrol-driven conveyances are stored or operated.

PART I.—SECTION 7.

HIGH, EXTRA HIGH, AND EXTRA LOW PRESSURE INSTALLATIONS.

HIGH AND EXTRA HIGH PRESSURE INSTALLATIONS.

701. (a) Installations which are to be connected to high or extra high pressure supply mains shall comply with the following regulations 701-727, inclusive, and, subject thereto, with such provisions and requirements of the foregoing sections of these Regulations as are appropriate and do not conflict with good and safe practice. (See regulation 706.)

(b) No lighting system operating at high or extra high pressure, other than a luminous discharge tube lighting system, shall be installed within a building or be attached to the walls of a building without the previous sanction, in writing, of the authorized inspector.

(c) Unless the system is to operate at high frequency, every luminous discharge tube lighting system operating at a pressure in excess of 650 volts shall be installed in compliance with the requirements of regulation 453.

(d) Circuits operating at pressures in excess of 22,000 volts between conductors shall not be installed in buildings other than generating stations, substations, and other premises used solely by supply authorities for or for purposes incidental to the generation, transformation, control, and/or distribution of electricity.

706. At least seven days before the commencement of the work of installing any high or extra high pressure wiring (or any extension or alteration thereto), in any premises, notice, in writing, shall be given to the supply authority. Such notice shall be accompanied by plans, drawings, and particulars completely describing the layout, arrangement, and operating conditions of the installation (or of the extension or addition, as the case may be), and work shall not be commenced until the supply authority has given permission, in writing, for the work to be proceeded with. The supply authority may require any alteration in the proposed work as shown on the plans, drawings, and particulars submitted. Any party aggrieved or affected by such requirement of the supply authority may appeal to the Commission for its decision as to the manner in which the work is to be carried out, and the Commission may decide

finally whether the requirement of the supply authority is to be insisted on, and may also, if it thinks fit, alter any other portion of the plans, drawings, or particulars.

Except pursuant to a decision of the Commission, no high or extra high pressure wiring shall be carried out unless it be in conformity with plans, drawings, and particulars approved by the supply authority. If the Commission has required any alteration in plans, drawings, or particulars as aforesaid, the work shall be carried out only in conformity with plans, drawings, and particulars as so altered.

WIRING.

711. (a) In all premises, other than those set out in regulation 701 (d), all conduits or ducts enclosing high or extra high pressure conductors shall be brought into and be secured to the housings covering the terminals of the motor, generator, or other machine or apparatus to which the conductors are connected.

(b) In all places, other than the premises set out in regulation 701 (d), or in generator, transformer, switching, or motor rooms, all cables used in high or extra high pressure installations shall consist of multiple conductor metal-sheathed cables approved for the purpose. Cable will be approved only if it is of a class and size listed in Australian Standard Specification No. C. 50 for use at the pressure of the circuit for which it is required, and complies with the requirements of that specification relating to cables of that size and class. Such cables shall be armoured or be enclosed in suitable cableways or ducts, or shall be carried on racks or brackets, and otherwise effectively protected against mechanical damage.

(c) Joints between cables shall be made at suitable junction boxes, which will ensure electrical continuity of the metal sheathing and armouring, if any, and provide for effective and permanent insulation of conductors contained therein, and for the exclusion of moisture.

(d) All connexions shall be made by means of cable sockets and/or rigid mechanical clamps. Where a cable emerges from its sheath, the insulation of the several conductors shall be thoroughly protected from moisture and mechanical injury by a cable end box or equivalent device.

(e) Open wiring and open busbar connexions of suitable mechanical rigidity and current-carrying capacity supported on glass or porcelain insulators may be used instead of insulated cables in situations accessible only to authorized persons, provided that—

- (i) they are so placed, arranged, and protected as to avoid risk of accidental contact to the person or persons normally having access to those situations; and
- (ii) suitable protection is provided which will prevent the access of vermin thereto.

When open wiring is used, the clearances shown in the table below for the respective pressures shall be maintained, except at apparatus and devices:—

CLEARANCES.

Pressure.	Minimum Distance between Conductors.	Minimum Distance between Conductor and any Surface.
	Inches.	Inches.
Not exceeding 3,300 volts ..	6	3
Not exceeding 11,000 volts ..	9	4½
Exceeding 11,000 volts ..	12	6

714. Where an overhead service line enters a building, either the conductors shall be carried on insulators in an aperture protected against the entry of rain, or each conductor shall be brought through a separate waterproof insulating tube or bushing. In both cases, the conductors shall be inclined downwards from the building so that water cannot run along the conductors into the building.

Conductors passing from a service line into a building shall be one of the following:—

- (a) Insulated conductors, which shall be brought into the building in the manner described above. In such cases, effective drip loops shall be provided in the conductors where there is a space surrounding them through which water could enter.

- (b) Insulated cables, which shall be enclosed in screwed conduit, all external joints in which shall be made waterproof.

- (c) Conductors of a lead sheathed cable.

The termination of the conduit or lead sheathed cable outside the building shall be equipped with a suitable fitting or end box filled with insulating compound.

715. Where the pressure exceeds 3,300 volts between conductors, underground service cables shall terminate in suitable end boxes, which shall be filled with insulating compound.

TRANSFORMERS.

721. Transformers and high or extra high pressure apparatus on consumer's premises (including capacitors, but excluding transformers used exclusively to supply current to switchboard instruments and control circuits) shall be installed in accordance with the requirements of this regulation:—

- (a) Transformers and apparatus shall be located as near as practicable to the point at which the high or extra high pressure conductors enter the building.
- (b) Air-cooled transformers shall be installed in enclosures of incombustible material, and an air space of at least 6 inches above and on all sides of the transformer shall be provided. All such enclosures shall be thoroughly ventilated, preferably through chimneys, flues, or vents to the outside air.
- (c) Transformers immersed in inflammable liquids shall be enclosed in fireproof chambers constructed of concrete not less than 6 inches thick, of reinforced concrete not less than 5 inches thick, of brick not less than 9 inches thick, or of other material equally robust and of an equally fire-resisting nature and approved by the authorized inspector.

The chambers shall be provided with means of ventilation which will prevent the development of ambient temperatures in excess of those at which the transformers may be safely operated. All ventilating openings, except those in external walls or those connecting with chimneys or flues, shall be provided with automatic or manually controlled dampers to prevent the emission of smoke and fire. Such dampers, if manually operated, shall be controlled from a point outside the chamber. All doorways to the chamber, other than those opening from the outside of the building, shall be fitted with tight-fitting fire-doors.

Where practicable, a suitable drain shall be provided which will carry off all the oil and water which may, under any conditions, accumulate in the chamber. The floor and drain shall have a pitch not less than $\frac{1}{4}$ inch per foot for drainage purposes. Where such a drain is not constructed, means shall be provided to prevent effectively the escape of oil from the chamber.

CONTROL AND PROTECTIVE EQUIPMENT.

722. (a) Every installation operating at a high or extra high pressure shall be equipped with an oil-immersed main circuit-breaker, which shall be installed as close as practicable to the point of entry, and which shall be of a type and rupturing capacity approved by the supply authority, and fitted with protective devices which shall be adjusted only by the supply authority.

Such circuit-breakers shall be manually operated from a point which is readily accessible. They shall be of a type which cannot be held in the closed position under overload conditions, and shall incorporate a device indicating clearly whether they are open or closed.

(b) In addition, an air-break disconnecting switch or air-break disconnecting links, in either case fitted with automatic safety catches to prevent opening under conditions of overload, shall be provided on the supply side of the circuit-breaker, as close as possible to the point where the service line or conductors therefrom enter into the building. These disconnecting links shall at all times be accessible only to qualified attendants.

(c) Where required by the supply authority, an approved type of lightning arrester shall be installed on each conductor of an overhead service line on the supply side of all other service equipment.

723. Every motor and every other device operating at high or extra-high pressure shall be controlled by an automatic, oil-immersed, circuit-breaker fitted with inverse time-current releases, which shall open within three seconds all active conductors in the event of the current in any one active conductor exceeding 150 per cent. of the full load current of the motor or device. This circuit-breaker shall be manually operated from an accessible position adjacent to the motor or device it controls, and shall be of a type that cannot be held in its closed position under the above conditions of overload.

Where only one motor or consuming device is installed, the circuit-breaker described in regulation 722 may be used as the controlling circuit-breaker for the motor or device, provided it is installed in such a position as to comply with the requirements of this regulation and regulation 722.

Where a capacitor is installed in parallel connexion with a motor or other consuming device, no separate circuit-breaker shall be required for the capacitor.

724. The supply authority's connexions to a transformer supplied from an alternating current network system (solid system) shall be exempt from the requirements of regulations 722 and 723, provided that, in the opinion of the authorized inspector, ample protection is assured by the apparatus included in the network system.

725. All live parts, including conductors which are connected to circuits operating at high or extra high pressure shall be enclosed or isolated so as to be accessible only to authorized persons. The enclosures, if of metal, shall be effectively earthed.

Generator, switch, transformer, and motor rooms shall be kept securely locked, except while a qualified operator is present in charge.

726. Conspicuous danger notices, which shall be permanently maintained in a legible condition, shall be erected in the vicinity of all high tension apparatus. Every such notice shall contain the word "DANGER" in bold letters, and shall state the pressure at which the apparatus operates.

OUTDOOR SUB-STATIONS.

727. (a) Every transformer sub-station located on a consumer's premises out of doors shall be so placed that it will not interfere with operations of firemen, and shall be so constructed that it is inaccessible to unauthorized persons.

(b) Unless isolated by elevation, it shall be surrounded by an earthed metal or strong permanent wooden fence extending from the floor or ground to a height of at least 7 feet. No aperture in this fence shall exceed $1\frac{1}{2}$ inch in width unless it be closed by a door or a slide, which shall be kept locked.

(c) Access to the sub-station by climbing shall be obstructed by suitably placed barbed wire or other effective means and warning notices indicating the highest operating pressure shall be fixed to the fence on all sides in such positions as to be easily readable.

(d) Suitable arrangements shall be made for draining away from adjacent buildings and combustible materials any oil which may overflow.

EXTRA LOW PRESSURE INSTALLATIONS.

751. (a) An installation which is intended to operate at extra low pressure shall be supplied with electrical energy from supply mains only by medium of a transformer (or transformers) with independent primary and secondary windings, a rotary converter or static rectifier used in conjunction with such a transformer (or transformers), or by means of a motor generator.

(b) Where the pressure exceeds 50 volts, extra-low pressure installations shall be carried out in accordance with the requirements of Sections 1 to 6, inclusive, of Part I. of these Regulations. Where the pressure does not exceed 50 volts, low pressure installations shall be carried out in accordance with the requirements of the above-mentioned sections of these Regulations, except in so far as they are modified by regulation 752.

752. Conductors in dry places may be fixed with cleats or they may be fixed to insulators, provided that no insulator (other than a multiple-way cleat

or multiple-way insulator) shall carry more than one conductor. In all cases they shall be fixed at least $\frac{1}{2}$ inch clear of brick, cement, or ironwork and all damp surfaces. Conductors which may be subjected to mechanical damage shall be provided with additional protection to the satisfaction of the authorized inspector.

STATE ELECTRICITY COMMISSION OF VICTORIA.

WIRING REGULATIONS.—PART II

MATERIALS, INCLUDING FITTINGS, ACCESSORIES, APPLIANCES, AND APPARATUS.

SECTION 1.

SCOPE.

2101. Regulations under this Part, which shall be read together with the regulations of Part I., set out the requirements for or with respect to materials, fittings, appliances, and apparatus of classes and types which are used in or in connexion with, or are intended to be used in or in connexion with, electrical installations, and, in so far as they relate thereto, shall apply to materials, fittings, appliances, and apparatus used in or in connexion with any electrical installation which is connected or is to be connected to supply mains.

GENERAL REQUIREMENTS.

2102. In the construction of all electrical fittings, accessories, appliances, and apparatus, all materials shall be selected and/or formed, and all fittings, accessories, appliances, and apparatus, and all parts thereof, shall be constructed, secured, placed, and proportioned in a manner that will ensure, as far as is reasonably possible, against mechanical or electrical failure of the material, fitting, accessory, appliance, or apparatus, or any part thereof, under normal conditions of wear and tear, and any other depreciating factors which can reasonably be anticipated. The fabrication and construction shall be carried out in a thoroughly workmanlike fashion conforming to the appropriate requirements of these Regulations, and the generally accepted principles of sound and reliable practice.

2104. The Commission may require that any kind of material, fitting, accessory, appliance, or apparatus, before it is used in or in connexion with an electrical installation, be approved as complying with the requirements of these Regulations.

Where approval as aforesaid is required, or where approval for a specific purpose is required by these Regulations, written application therefor shall be made to the Commission.

Application for approval shall be accompanied by—

- (i) samples sufficient, in the opinion of the Commission, for examination and/or testing purposes;
- (ii) a sufficient description of the kind of material, fitting, accessory, appliance, or apparatus;
- (iii) a report from a recognized testing authority (such as the National Physical Laboratory) in the case of any cable submitted, as to the behaviour, properties, and life of the insulating materials employed, and, in the case of any other material, fitting, accessory, appliance, or apparatus, a detailed report from an authority as aforesaid where such is available;

and the Commission may, after such examination and testing as it thinks desirable, and after alteration, if it so requires, of the description, grant or refuse the application. Approval may be provisional or not provisional, and may be limited to use during a stated period.

In the case of approval being given, the Commission may lay down such conditions with regard to the use of the material, fitting, accessory, appliance,

or apparatus, as it may think fit, and any such conditions shall be fulfilled and observed. No approval shall be deemed to have been given unless it is in writing signed by the Chief Electrical Inspector, Victoria.

2111. All terminals, contacts, and other live parts shall be so arranged that short circuit or injurious arcing, either between live parts or between any live part and other conductive material, cannot take place, and so that no part other than an easily replaceable contact can be appreciably damaged by an arc or overheating arising from the normal operation of the apparatus. Holes for fixing screws shall be so placed that no such short circuit or arcing can occur when the screws are in position.

2112. (a) Except in the case of motors and appliances to which the connecting flexible cable or cord is permanently attached, terminals suitable for connexion to conductors, or contact pins suitable for connexion by means of a connector, shall be provided on each appliance or apparatus.

All terminals and pins shall be of such material, form, and proportions that a connexion made thereto will not slacken off or overheat under the normal conditions of use.

(b) Every appliance or apparatus with exposed metal parts (other than name plates, screw heads, and metal covers or plates which are only supported on and/or attached and/or connected to substantial non-conductive material in such a manner that they cannot become alive in the event of failure of the insulation of live parts) shall be provided with means for the connexion of any earthing conductor which may be required under these Regulations, in one of the forms following, that is to say:—

- (1) in the case of appliances to which connexion is to be made by an apparatus connector, an inlet socket as described in regulation 2422 (d); or
- (2) in the case of other appliances and apparatus, a terminal suitable for the connexion of such earthing conductor. This terminal shall be in effective electrical connexion with all exposed metal parts of the appliance or apparatus, other than those parts above mentioned.

In the case of electrical machines, a substantial screw or bolt, or nut on a bolt or stud, shall be deemed a suitable earthing terminal, provided it can be slackened off without affecting the assembly or fixing of any portion of the machine.

2114. (a) All conductors and live parts, unless they are—

- (i) busbars;
- (ii) battery connexions not requiring insulation or further supports; or
- (iii) cables of an approved type;

shall be insulated by being carried on or supported by suitable insulators or insulating material. Such insulating material shall be non-hygroscopic, except in the case of insulating supports for heating elements and resistances, and shall be incombustible, except in the case of material for switchboard panels conforming to the requirements of regulation 2251.

The nature of the support and insulation shall be such that no live part can make contact with any conductive part exposed to personal contact, and such that the requirements of these Regulations with regard to pressure test and insulation resistance are complied with. (See regulations 2161 and 2162—Insulation Resistance and Pressure Test.)

(b) All-insulated accessories shall be of such construction that, under the conditions of use, all conductive parts are completely covered by non-hygroscopic incombustible insulating material. In the case of all-insulated accessories with removable covers, however, the metal heads of fixing screws may be exposed, provided the screws engage in threads in the insulating material of the base, or metal inserts therein, and are not in contact with any other internal metal.

2115. (a) Unless a suitable means of clamping the cables is provided on an accessory, fitting, appliance, or apparatus, all terminals intended for the connexion of cables shall be of adequate mechanical strength to withstand the pull of the conductors to be connected.

(b) Every accessory, fitting, appliance, or apparatus intended for connexion by means of a flexible cord or flexible cable shall be provided with a clamp or grip which will effectively relieve the connexion of any pull on the cord or cable.

2116. Every cable, flexible cord, or conductor passing through the metal frame, or through any structural metal part of an appliance or apparatus, shall be separated therefrom by a substantial non-conductive bushing, tube, or sleeve securely fixed in position.

2117. (a) Every joint or connexion shall be at least equal in conductivity to, and shall have insulation equivalent to, that of the conductors connected.

(b) Where soldered joints are used, they shall be made without the use of fluxes containing corrosive substances.

Soft soldered joints and soft soldering shall not be used for the connexion of conductors, or in the construction of any apparatus (other than containers for heating liquids) where the temperature rise of the joint or soldered part can exceed 86°F. (48°C.).

2118. Every electrical appliance and apparatus shall be so designed, constructed, and/or arranged, that its normal operation will not give rise to avoidable interference with radio reception.

In the case of any appliance or apparatus which, in its normal operation causes or is capable of causing radio interference to such a degree as to constitute a source of annoyance to the legitimate users of radio receiving apparatus, the Commission may require that it be modified or reconstructed or fitted with an interference suppressing device, or may prohibit its use.

PROTECTION AGAINST DAMAGE.

2121. Materials, accessories, appliances, and apparatus shall be of such type, design, and/or construction as will provide adequate protection against mechanical and electrical failure which may reasonably be anticipated to result from mechanical injury, weather, water, or excessive dampness, corrosive fumes, dust, steam, oil, high temperatures, or any other conditions to which they will be exposed under the circumstances of their use.

2123. (a) Except in the case of insulation of cables, those portions of every fitting, accessory, appliance, or apparatus which are in contact with, or immediately surround live parts, shall be made of durable non-ignitable material.

(b) Cut-outs and (except for their operating handles) switches and circuit breakers, and close-fitting containing cases therefor, shall be constructed entirely of non-ignitable, non-hygroscopic material which will not readily carbonize.

2124. All motors, generators, and fully enclosed metal-clad apparatus shall be provided with suitable glands, screwed apertures, or clamps for securing thereto the protective covering of the connecting cables or with suitably bushed apertures for the entry of conductors.

2126. (a) Every fitting, appliance, or apparatus of the weatherproof type shall be constructed entirely of non-hygroscopic materials, and shall be of such form and construction that when fixed in a position exposed to the weather it will effectively prevent the entry of moisture into the conduit or cable to which it is attached. Screwed apertures or watertight glands suitable for the attachment of the apparatus to conduit or cable shall be incorporated in the fitting, appliance, or apparatus.

(b) Weatherproof plug sockets shall be provided with an effective means for keeping the socket weatherproof when the plug is removed.

2129. Where the rated current is sufficiently large to cause damage to contacts, or any other portions of apparatus, suitable arrangement shall be made for the easy replacement of the parts which are likely to be damaged by arcing or other effects of the current.

PROTECTION AGAINST FIRE.

2141. (a) All apparatus shall be so designed, proportioned, and constructed that it will carry its rated loading at all times without heating to an extent which will cause risk of fire or breakdown of insulation.

(b) Where practicable, materials used in the construction of any accessory, fitting, appliance, or apparatus shall be non-ignitable. Where the use of ignitable material is necessary, such material shall not come in contact with any part the temperature of which exceeds 212°F. (100°C.), and unless adequately separated therefrom by fire-resisting

material, shall be maintained at a distance from all parts in which this temperature is exceeded sufficient to avoid any risk of fire.

(c) Resistances, control gear, and all apparatus, other than apparatus designed and intended for heating and cooking purposes, shall be so arranged that in normal operation no accessible part of the enclosing case can rise to a temperature exceeding 176°F. (80°C.).

(d) The connecting terminals of every apparatus in which heat is generated shall be so arranged that connecting cables are not exposed to temperatures in excess of those permitted under these Regulations for the class of insulation to be used, the terminals being situated to facilitate the connecting conductors entering from below where this is necessary to avoid exposure to any such excess temperatures.

2143. Every flameproof fitting, accessory, appliance, or apparatus shall be fully enclosed, and the enclosing case shall be capable of—

(i) withstanding, without injury, any explosion which may occur within it under the conditions of operation within the rating of such fitting, accessory, appliance, or apparatus, and recognized overloads, if any, associated therewith; and

(ii) preventing the transmission of flame such as would ignite any inflammable mixture which may be present in the surrounding atmosphere.

PROTECTION AGAINST RISK FROM ELECTRIC SHOCK.

2151. Every electrical fitting, accessory, appliance, and apparatus shall be constructed so that by its normal operation the user, or any other person, is not exposed to risk of injury, and, except in the case of apparatus intended for use only in a position which is not accessible to unauthorized persons, so that when in position and/or in normal operation, it is not possible for any person accidentally to come in contact with any live part.

TESTS.

2161. (a) The insulation resistance between any live part of apparatus (other than a water-heating device in which the element is in direct contact with the water) and the case, frame, or exposed metal of the apparatus or earth, shall be not less than 1 megohm. In the case of heating appliances in which the element is mounted on hygroscopic material, the insulation resistance shall be measured after the element and insulating material have cooled down subsequent to its connexion to the supply for one minute.

(b) The resistance between the element or electrodes of any water-heating device in which the element or any electrode is in contact with the water, and any exposed metal or earth, shall be not less than 25,000 ohms.

(c) For the purposes of the foregoing clauses (a) and (b) of this regulation, the insulation resistance shall be measured at a pressure of 1,000 volts d.c.

2162. (a) Except in the case of fractional h.p. motors, and the isolating condensers of radio and similar equipment, all appliances and apparatus shall satisfactorily withstand for two minutes the application of a pressure of 1,500 volts a.c. between any live part and exposed metal or earth.

(b) Fractional h.p. motors shall satisfactorily withstand the test set out in sub-clause (a) hereof, except that the pressure applied shall be 750 volts a.c.

(c) Condensers used for the isolation of live parts of radio and electro-acoustic equipment shall satisfactorily withstand for two minutes the application of a pressure of 1,500 volts d.c., and, for one hour, the application of a pressure, at 50 cycles, equal to 1.5 times the supply pressure, across the condensers.

2163. Every fitting, accessory, appliance, or apparatus having exposed metal parts (other than name plates, screw heads, and metal covers or plates which are only supported on and/or attached and/or connected to substantial non-conductive material in such a manner that they cannot become alive in the event of failure of the insulation of live parts) shall be tested to ensure that all such exposed metal parts are directly connected without appreciable resistance to the earthing conductor, terminal, or contact.

2164. Whether the tests described in regulations 2315 and 2351 (c) have or have not been carried out by or at the instance of the manufacturer on any cable or flexible cord, the Commission may carry out such tests in respect of any such cable or cord, and for this purpose the person proposing the use of any such cable or cord shall supply to the Commission, on demand and free of cost to the Commission, samples which shall, in its opinion, be ample for the proper carrying out of the aforesaid tests in respect of such cable or cord.

STANDARD SPECIFICATIONS.

2171. All materials, wires, fittings, accessories, and apparatus of a type for which a Standard Specification has been drawn up by the Standards Association of Australia, or, failing this, by the British Engineering Standards Association, shall conform to the requirements of such specification, except as modified by these Regulations.

The following table shows the Standard Specification with which the items listed shall comply:—

Item.	Specification.
Busbars and connexions—	
Standard marking	A.S.S. No. C.13
Construction	A.S.S. No. C.52
Cable soldering sockets	A.S.S. No. C.56
Cables (see conductors)	
Circuit breakers—	
For voltages not exceeding 660 volts:	
Air-break	A.S.S. No. C.24
Air-break flameproof	A.S.S. No. C.26
Air-break totally enclosed	A.S.S. No. C.27
Oil-immersed switches and Circuit breakers for A.C.	B.S.S. No. 116
Conductors—Insulated annealed copper	A.S.S. No. C.50
Conduits and fittings (steel)	A.S.S. No. C. 66 or B.S.S. No. 31
Controllers (see resistances).	
Cut-outs—Type O	B.S.S. No. 88 as modified by these regulations
Enclosures—Flameproof, and tests ..	B.S.S. No. 229
Fittings—Watertight, for incandescent lamps	B.S.S. No. 97
Insulating materials—	
Moulded insulating materials	B.S.S. No. 488
Slate slabs	A.S.S. No. C. 19
Lamps—Tungsten filament	B.S.S. No. 161
Lamp caps and lampholders—	
For voltages not exceeding 250 volts:	
Bayonet	B.S.S. No. 52
Goliath	B.S.S. No. 98
Motors and Generators—	
Industrial, with class A insulation, Performance of	A.S.S. No. C.34
Resistances—	
Controllers, and resistances for use therewith, for motors (D.C. and A.C. slip ring)—	
Contactor (excluding controllers for traction purposes)	A.S.S. No. C.32
Drum	A.S.S. No. C.30
Face plate	A.S.S. No. C.31
Rheostats—	
Field, for Generators, Motors, Synchronous Converters and Balancers	B.S.S. No. 280
Rotary converters—	
(Continuous rating permitting overloads, performance of	B.S.S. No. 172
Starters—	
Auto-transformer (hand operated) for motors (A.C. induction without slip rings)	B.S.S. No. 167
For motors (D.C. and A.C. 3-phase induction with slip rings)—	
Contactor	A.S.S. No. C.49
Drum	A.S.S. No. C.33
Liquid	A.S.S. No. C.46
Switches—	
Air-break, for voltages not exceeding 660 volts:	
Knife and Laminated Brush	A.S.S. No. C.23
Flameproof	A.S.S. No. C.25
Totally enclosed	A.S.S. No. C.28
Transformers—	
For power lighting	A.S.S. No. C.61
For X-ray purposes	B.S.S. No. 326

Every material, wire, fitting, accessory, or apparatus to which there is no Standard Specification applicable shall be so designed, made, formed, and/or constructed as to comply with the accepted requirements of sound and safe practice, and shall not be used if any defect or feature exists therein which, in the opinion of the Chief Electrical Inspector, Victoria, would render it unsafe or liable to cause interference with supply to other consumers.

MARKING.

2181. Where marking is required under these Regulations, it shall be legibly and indelibly formed, stamped, embossed, engraved, or imprinted either on the material or apparatus itself, or on a marking plate permanently secured to the material or apparatus. Such marking shall be visible at all times, except in cases where it is specifically stated that visibility of the marking at all times is not required.

2182. Except that danger notices for radio receiving equipment may be plates or permanent labels marked in the manner specified in the preceding regulation 2181, danger notices shall be either enamelled plates, or shall be painted on a suitable board or other surface. Danger notices shall include the word "DANGER," which, except in the case of radio receiving equipment, shall be in white lettering not smaller than 3 inches high on a red background.

PART II.—SECTION 2.

COMPOSITION SWITCHBOARD PANELS.

2251. Composition switchboard panels shall be of uniform thickness, with smooth even surfaces. The material of which they are made shall be capable of satisfactorily passing the following tests:—

- (a) A strip 1 inch wide, supported on V edges 10 inches apart, shall withstand, without fracture, excessive bending or permanent distortion, the central loading given below:—
 - 15 lb. in the case of a strip $\frac{1}{4}$ inch thick;
 - 60 lb. in the case of a strip $\frac{1}{2}$ inch thick;
 - or
 - 135 lb. in the case of a strip $\frac{3}{4}$ inch thick.
- (b) (i) There shall not be any appreciable expulsion of the binding matter when a sample is heated to 130° F., and the foundation material shall not carbonize at a temperature lower than 300° F.
- (ii) A $\frac{1}{2}$ -in. x $\frac{1}{2}$ -in. sample of the material shall not ignite when held in a candle flame for fifteen seconds.
- (c) The water absorption shall not exceed .5 per cent. by weight after 48 hours' immersion in water at 60° F.
- (d) The absorption of raw linseed oil shall not exceed .5 per cent. by weight after 48 hours' immersion in such oil at 60° F.
- (e) The resistance between point contacts on opposite faces of $\frac{1}{4}$ -in. material when measured at 1,000 volts d.c. with the material in a dry state, and also immediately following each of the absorption tests required under clauses (c) and (d) hereof, shall be not less than 100 megohms.
- (f) The material shall satisfactorily withstand in its dry state a pressure test of 20,000 volts a.c. (80 volts a.c. per mil) between points on opposite faces of a sample $\frac{1}{4}$ inch thick and a pressure test of 15,000 volts a.c. (60 volts a.c. per mil) immediately following the above water and oil-absorption tests.
- (g) The cleaned surface of the dry material shall satisfactorily withstand for 30 seconds a surface leakage test of 10,000 volts a.c. between point electrodes 1 inch apart.

PART II.—SECTION 3.

CABLES, FLEXIBLE CORDS, AND PROTECTIVE COVERINGS.

DISTINGUISHING COLOURS OR FORMS OF CABLES AND FLEXIBLE CORDS.

2301. (a) Braided rubber insulated cables shall be so coloured by impregnation of the braiding that active and neutral cables may be distinguished in the manner provided for in regulation 301 (a), that is to say, black for all neutral cables and negative cables connected to two-wire d.c. systems, and red or other distinctive colour (other than black) for all other active cables.

(b) Unless identified by impregnated colouring of the rubber corresponding to that provided for under clause (a) above, rubber insulated cables without braiding shall have their outer surfaces shaped or formed in a manner approved as sufficient to provide distinction between active and neutral cables (or positive and negative cables in the case of two-wire d.c. systems) and the overall section of cables to be used as active cables (or as positive cables in the case of two-wire d.c. systems) shall be circular, and the external surface plain, except for figuring and/or lettering, and the overall section of cables to be used as neutral cables (or as negative cables in the case of two-wire d.c. systems) shall be of another form readily distinguishable from circular unless the word "neutral" or "negative," as the case may be, is formed on the outer surface continuously along the length of the cable.

(c) The coverings of the current-carrying conductors of flexible cords may be coloured identically throughout, but the covering of the earthing conductor of a multicore flexible cord shall be distinctively coloured green by impregnation or by a cotton wrapping or other approved means.

CABLE SPECIFICATION.

2304. (a) All types of cables which have copper conductors shall conform to Australian Standard Specification No. C.50 in so far as it applies to copper cables generally and/or to the particular type of cable.

(b) Except in the case of bare conductors, annealed copper cables only shall be used for internal wiring.

(c) Where the conductor is immediately surrounded by insulation containing sulphur, each strand shall be so protected with a uniform coating of tin free from all impurities that it will withstand satisfactorily the following tinning test:—

Samples of the tinned wire taken from the stranded conductor either before or after vulcanization, shall be selected and bent into loops, the radius of the loops being not less than twelve and not more than fifteen times the diameter of the wire. After cleaning by immersion in benzine and rubbing with a pad of clean cotton wool or filter paper to remove any grease, the samples shall be dried in air, and the part to be immersed in the test solution shall not be handled.

Each sample shall then be immersed for one minute in hydrochloric acid having a specific gravity at 60° F. (15.6° C.) of 1.09. The sample shall then be washed in clean water, wiped dry, and immersed for half a minute in a solution of sodium polysulphide having a specific gravity at 60° F. of 1.14, and again washed in clean water and wiped dry. This cycle of operations shall be performed three times.

The sample shall then be examined under a hand lens to ascertain if copper exposed through openings in the tin coating has been blackened by the action of the sodium polysulphide. The sample shall be considered to have failed if exposed copper is revealed by any such blackening.

In the event of only one sample of a group giving results widely dissimilar from the remaining samples, this sample may be disregarded at the discretion of the Chief Electrical Inspector, Victoria.

In carrying out the above-mentioned test, a portion of hydrochloric acid solution having a volume of 180 c.c. shall be considered exhausted when there have been immersed in it the number of test samples as shown in the following table:—

Diameter of Wire.	Maximum number to be tested in 180 c.c. of acid solution.
Up to and including 0.048 inch	20
Above 0.048 inch, up to and including 0.080 inch	12
Above 0.080 inch	8

The sodium polysulphide shall be made up by dissolving about 25 grammes of pure sodium sulphide crystals ($\text{Na}_2\text{S}\cdot 9\text{H}_2\text{O}$) in distilled water and making up to 100 c.c., and boiling for about 1 hour with occasional stirring. The solution shall then be cooled, and filtered, and diluted with distilled water to a specific gravity of 1.14 at 60° F.

Solution which has been stored shall be tested before use to ensure that it will thoroughly blacken a piece of clean untinned copper in five seconds.

(d) Except where the Commission has approved of the use of a type of cable for any specific purpose (with or without restrictions as to such use and/or as to the methods of its installation), no insulated cable shall be used unless it is insulated and/or covered as set out hereunder for the respective type of cable. Every cable so insulated and/or covered shall be subject to any provision of these Regulations requiring or prohibiting its use in any particular circumstances:—

- (1) Insulated and taped as specified in regulation 2306 and compounded.
- (2) Insulated and taped as specified in regulation 2306 and braided.
- (3) Insulated and taped as specified in regulation 2306 and sheathed with a closely fitting seamless covering containing not less than 95 per cent. of commercially pure lead and of uniform radial thickness and having a smooth exterior surface.
- (4) Insulated and taped as specified in regulation 2306, and lead covered as in (3) above, and bedded and armoured, with or without serving or braiding over the armour.
- (5) Insulated and taped as specified in regulation 2306, and bedded and armoured, with or without serving or braiding over the armour.
- (6) Insulated as specified in regulation 2306, and covered with tough rubber compound, as specified in regulation 2310.
- (7) Insulated as specified in regulation 2308, and sheathed with a closely fitting seamless covering containing not less than 95 per cent. commercially pure lead and of uniform radial thickness and having a smooth exterior surface.
- (8) Insulated as specified in regulation 2308, and lead covered as in paragraph (7) above, and bedded and armoured, with or without serving or braiding over the armour.
- (9) Insulated as specified in regulation 2309, either with or without tape and/or braiding.

2305. The name of the manufacturer and the grade or class of insulation shall be legibly and continuously printed on the tape surrounding the dielectric of vulcanized rubber insulated taped cables. In the case of cables having an outer protective covering of tough rubber in accordance with regulation 2310, where the tape is omitted, the name of the manufacturer and the grade or class of insulation shall be clearly marked on the cable at intervals not exceeding 3 feet.

2306. Vulcanized rubber insulated (V.I.R.) cables shall be insulated either—

- (a) with a layer of pure rubber next to the conductor, an intermediate layer of vulcanizing rubber, and an outer layer of vulcanizing rubber; or
- (b) provided that the quality of the tinning is such that there is no corrosion of the tinning in the finished cable, and that the tinned conductor of the finished cable will withstand the tinning test given in clause (c) of regulation 2304, with homogeneous vulcanized rubber applied in one or more layers.

The insulating material shall be surrounded by a layer of tape, and the whole shall be vulcanized together, provided that in the case of cables having an outer protective covering of tough rubber conforming with regulation 2310, the tape may be omitted.

2307. Braided cables shall have an exterior braiding of hemp, cotton, or jute, thoroughly impregnated with a protective compound of a nature that will not have any deleterious action on the rubber or armouring, as the case may be, and the finish of the braiding shall be smooth and uniform.

2308. Paper insulated cables shall be insulated with a covering of paper impregnated with a chemically neutral insulating compound.

2309. Rubber compound insulated cables shall be insulated with one or more layers of homogeneous rubber compound of high tensile strength and dielectric resistance, and capable of offering a high degree of resistance to abrasion, acids, oils, and alkalis. The radial thickness of this insulation shall be not less than that specified in Australian Standard Specification No. C.50 for rubber insulated cables.

2310. Where the protective covering of vulcanized rubber insulated cables or flexible cords is tough rubber compound, this compound shall form a closely fitting sheath filling the external irregularities of the laid-up cores of multi-core cables, and concentric with the conductors of single-core cables, and shall be capable of offering a high degree of resistance to abrasion, acids, oils, and alkalis.

2311. Weatherproof cables shall be rubber or rubber compound insulated cables complying with the requirements of Australian Standard Specification No. C.50 for rubber insulated cables, and shall be covered with impregnated material in such a manner that the cables will not be affected to an appreciable extent by exposure to the weather. (See tests for Weatherproof Cables, regulation 2315 (e).)

2312. Aerial cable shall consist of seven or more strands of hard-drawn copper, which shall be either—

- (a) covered by three braidings of two-fold cotton complying with the following table as to the thickness of braiding and size of cotton:—

Size of Conductor.	Thickness of each Braid.	Size of Cotton.
	Mils.	
7/.036 inch	20	2/22
Above 7/.036 inch up to and including 7/.064 inch	20	2/14
Above 7/.064 inch up to and including 19/.064 inch	25	2/14
Above 19/.064 inch	30	2/12

Each braiding shall be thoroughly impregnated with a dense moisture-resisting and preservative compound which will not crack or exude under extremes of temperature, and the whole shall have an external finish of special weather-resisting compound not less than 5 mils in thickness, and with a smooth surface; or

- (b) insulated and/or covered in such a manner as may from time to time be approved by the Commission.

TESTS OF CABLES.

2315. (a) Cables insulated with vulcanized rubber or impregnated paper shall be capable of withstanding the voltage test and other tests specified in Australian Standard Specification No. C.50 for the respective class of cable, and such of the other tests hereunder in this regulation described as are applicable to the class of cable to be tested.

(b) Subsequent to the above voltage test, and whilst the cable is still immersed in water, the insulation resistance at a temperature of 60° F. (15.6° C.) after one minute's electrification at a pressure of at least 500 volts shall be not less than that given in Table A (IV.), page 1201, for the respective class of cable.

The insulation resistance of each insulated conductor of a multi-core cable, measured to earth or sheathing and between cores, shall be that required for single conductors of the same sectional area, and that of the dielectric separating any conductor of a concentric cable from any other conductor or from metal sheathing or earth shall be that required for single conductors having the same overall diameter as the inner conductor.

(c) A sample of the vulcanized rubber, not less than 4 inches in length, shall be removed from the cable in tubular form. Marks shall be placed on the sample 2 inches apart. The sample shall be stretched until the marks are 6 inches apart, and then immediately released. One minute after such release, the distance between marks shall not exceed 2½ inches. The sample shall then be stretched, and shall not break before the marks are at least 9 inches apart.

(d) In addition to the tests described in clause (b) hereof, rubber compound insulated cables shall be capable of withstanding the voltage test and other tests specified in Australian Standard Specification No. C.50 for vulcanized rubber insulated cables.

(e) In addition to the tests described in clause (b) hereof, weatherproof cables shall be capable of withstanding the voltage test and other tests specified in Australian Standard Specification No. C.50 for rubber insulated cables, and the following tests:—

- (i) The longitudinal insulation resistance of a length of 6 inches between bare wire lappings round the outer covering (the cable conductor being used as a guard wire) shall be not less than 8,000 megohms at a test pressure of 500 volts from a battery. The wire lappings shall consist of three turns of No. 36 S.W.G. under a tension of 1 oz.
- (ii) After the cable has been immersed in water for 24 hours and the surface moisture removed with a dry cloth, the insulation shall give a minimum resistance of not less than 10 megohms when tested in the manner indicated in sub-clause (i).
- (iii) The cable shall be subjected to a heat test in air at 180° F. for five days. After heating, the insulation shall show no signs of cracking or softening, and the outer covering shall have a smooth hard surface, and show no signs of disintegration, and the sample shall be generally in such a condition as will indicate the suitability of the cable to withstand exposure to weather without excessive deterioration.
- (iv) After the heat test required under (iii) hereof has been carried out, the insulation resistance test described in clause (b) of this regulation shall be repeated, and, on application of the test pressure, the insulation resistance shall be not less than two-thirds of that given in Table A (IV.), page 1201, for the respective class of cable.

CABLE CONNECTORS, JOINT BOXES, AND TERMINALS.

2326. (a) Cable connectors shall be of an approved type, in which the cables can be rigidly and effectively clamped between metal contacts. Such contacts shall be supported on durable, non-ignitable, non-hygroscopic, insulating material, so fashioned that contact between metal parts and surrounding conducting material is not possible.

(b) Joint boxes shall be constructed wholly of mechanically strong, non-ignitable, non-absorbent materials, and shall be of such a form as to enclose completely the joint or joints. The insulating material used in joint boxes shall be of permanently high electric strength and insulation resistance.

Every joint box, which is intended to be used for the connexion of cables having metallic coverings, shall be provided with adequate means for maintaining the electrical conductivity of the conduits, coverings, or cable sheathings, in which it is to be inserted.

(c) Terminals and binding posts shall be constructed of highly conductive metal, and where used with cables containing seven or more strands, shall be of a form in which the conductor can be clamped either in a cylindrical hole by means of a suitable binding screw or screws, or between the cheese head of a screw and a base provided with walls or projections which will prevent the conductor from slipping or spreading.

(d) Solderless tags shall be constructed entirely of metal, and shall be of a form which will prevent spreading of the strands of the conductor. They shall be suitable for clamping under the head of the screw used for the purpose.

STEEL CONDUITS.

2343. All steel conduits and conduit fittings, including saddles, clips, and pipe hooks, shall comply with Australian Standard Specification No. C.66. In the case of fittings made of steel stampings, the minimum thickness shall be that given in the above-mentioned specification for fittings made out of tube.

Every screw-grip fitting shall be of a type which will securely grip the conduit in such a manner as will ensure mechanical rigidity and electrical continuity without damage to the conduit or distortion of the conduit from its circular section, and shall be provided with a stop which will prevent the conduit projecting into the fittings sufficiently far to damage the covering of conductors enclosed therein.

Clamping screws shall be of steel not less than 5-32 inch diameter, with Whitworth Standard threads, and shall be provided with snap or cheese heads with a suitable slot for turning. Those portions of clamping screws which come into contact with cables contained within the fitting shall not be threaded.

2345. The walls of galvanized or black iron or steel piping used in place of steel conduit shall be not less in thickness and mechanical strength than that required for screwed steel conduit of the same internal diameter, and all fittings to be used with such piping shall have radii of curvature not less than those set out in the Standard Specification cited for similar conduit fittings.

2346. Every insulating bellmouth shall be of approved type and dimensions, and shall be made of or lined with durable non-hygroscopic insulating material so as to prevent abrasion of the conductor insulation resulting in contact between the conductor and the metal conduit or any metal portion of the bellmouth

Every bellmouth constructed solely of hard-moulded insulating material shall conform to the dimensions given in the drawing and the table hereunder for each respective size:—

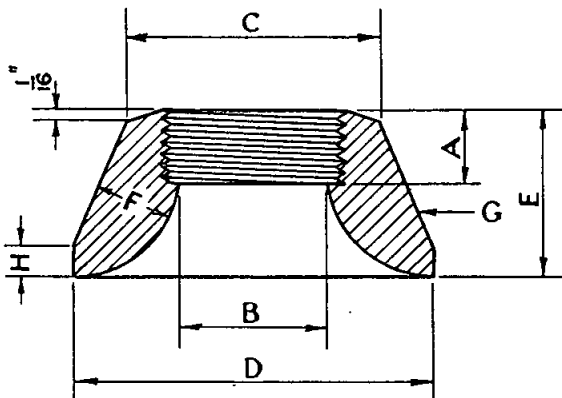

Outside Diam. Cond.	Threads per Inch.	A Min.	B Max.	C Min.	D Min.	E Min.	F Min.	G	H Min.
inch.		inch.	inch.	inch.	inch.	inch.	inch.		inch.
1/2	18	9/32	.38	7/8	1 1/4	3/4	1/2	Straight or Convex.	5/32
5/8	18	1/8	.49	1	1 1/2	7/8	5/8		3/16
3/4	16	11/32	.60	1 1/8	1 5/8	7/8	11/32		5/32
1	16	3/8	.85	1 3/8	1 3/4	7/8	3/8		3/16
1 1/4	16	1/2	1.10	1 3/4	2 1/4	1 1/2	1/2		3/16
1 1/2	14	5/8	1.25	2	2 3/4	1 1/2	5/8		3/16
2	14	3/4	1.80	2 3/8	3 1/2	1 1/2	3/4	3/16	

WOOD CASING.

2347. Wood casing shall be made of well-seasoned, straight, fine-grained timber of a non-resinous nature, free from shakes, knots, and other flaws.

It shall be so constructed that each fillet between grooves is at least 1/4 inch wide and the outside walls of the casing are at least 1/4 inch in thickness.

The thickness of capping shall in no case be less than 1/4 inch, except at mouldings, where the minimum thickness shall be not less than 3-16 inch.

FLEXIBLE CORDS.

2351. (a) The conductors of flexible cords shall be stranded copper wires (or in the case of flexible cords covered with tough rubber compound, stranded copper and steel wires) complying with the requirements for such conductors of Australian Standard Specification No. C.50.

(b) Flexible cords shall be one of the following types, and shall comply with the requirements of this regulation as to cords of that type, i.e. :—

- (i) Type A.—High Insulation Type.
- (ii) Type B.—Fire-resisting Type.

Type A.

(1) If each conductor is composed of plain copper wires, it shall be lapped with cotton, insulated with pure rubber not less than .024 inch in radial thickness, applied in two layers, and overlapped with cotton; otherwise

(2) The wires of each conductor shall be effectively and uniformly coated with tin free from all impurities, and each conductor shall be insulated with one layer of pure rubber and two layers of vulcanizing rubber. The radial thickness of such rubber insulation shall be not less than is shown in Column 4, Table A (V.) page 1202, Flexible Cords, Dimensions.

Type B.

The conductors of flexible cords of the fire-resisting type shall be insulated as for Type A under (1) above for plain copper wires, or as under (2) above for tinned copper wires, except that the radial thickness of the rubber insulation shall be not less than .020 inch in the case of pure rubber insulation, or than that shown in Column 6, Table A (V.), page 1202, Flexible Cords, Dimensions, in the case of pure and vulcanizing rubber insulation. In the latter case, the vulcanizing rubber may be applied in one layer. This insulation shall, in addition, be immediately surrounded by a continuous woven sleeve or wrapping of asbestos or other approved fire-resisting covering of a thickness not less than .025 inch.

The foregoing requirements of this regulation with respect to insulation and fire-resisting covering shall apply only to those conductors of a flexible cord which are normally intended to carry current. An earthing conductor contained within a flexible cord, if not so insulated or covered, shall be covered by a wrapping of cotton or other material in a manner which will prevent the adhesion of rubber and deterioration of the tinning (if any).

(c) Flexible cords shall be capable of withstanding the tests specified hereunder for the particular class of cord.

The insulation of multi-core flexible cords, except in the case of high insulation (Type A) cords with vulcanized rubber insulation, shall withstand for 15 minutes the application between conductors of 1,500 volts alternating pressure at 50 cycles, the flexible cord being in a dry state at the time of test.

The insulation of high insulation (Type A) cords with vulcanized rubber insulation shall be tested during immersion in water, which shall have continued for at least 24 hours at the time of test, and shall withstand for 15 minutes the application between each conductor and earth of 1,000 volts alternating pressure at 50 cycles, the conductor or conductors not under test being earthed.

Subsequent to such voltage test, the insulation resistance between conductors of flexible cords, at a temperature of 60°F. (15.6°C.) after one minute's electrification at 500 volts, shall be not less than that given in the table below for the respective size and type of cord. In the case of high insulation (Type A) cords with vulcanized rubber insulation, this test shall be made between each conductor and earth whilst still immersed in water, the conductor or conductors not under test being earthed.

Insulation Resistance per Mile at 60°F. (15.6°C.).

Conductor.	Type A Megohms.	Type B Megohms.
23/-0076 or 11/-012	1,250	300
40/-0076 or 16/-012	1,250	300
70/-0076 or 28/-012	1,250	300
110/-0076 or 44/-012	1,250	300
162/-0076 or 65/-012	900	300

2352. Flexible cables and cords shall be provided with one or other of the following protective coverings fitting closely over the insulation:—

- (a) Natural or self-extinguishing artificial silk braiding.
- (b) Glace cotton braiding.
- (c) Approved asbestos or fire-resisting braiding.
- (d) Hemp, cotton, or jute braiding thoroughly compounded.
- (e) Wire armouring, comprising a flexible braiding of galvanized steel or phosphor bronze wire, in addition to a thoroughly compounded braiding of hemp, cotton, or jute.
- (f) Tough rubber compound, in accordance with regulation 2310, applied directly to the insulated core, or to two or more such cores laid up together.
- (g) Hard cord braiding, in addition to a thoroughly compounded braiding of hemp, cotton, or jute.

PART II.—SECTION 4.

SWITCHES AND CIRCUIT BREAKERS.

2401. All switches (including fuse switches, except in regard to their operation as fuses) shall comply with the requirements of this regulation, and of regulation 2402.

All circuit-breakers shall comply with the requirements of this regulation, and of regulation 2403.

(a) All contacts shall be so formed, and all parts shall be so proportioned that when the normal working current flows through the contacts continuously, their temperature shall not rise above that of the surrounding air more than 36°F. (20°C.) in the case of switches rated below 100 amperes, and 54°F. (30°C.) in the case of switches rated at 100 amperes or above.

(b) Every switch and circuit-breaker shall be so constructed and arranged that it cannot accidentally be left in partial contact, and so that, when placed in the "off" position, it cannot accidentally be moved sufficiently to close the circuit.

Every multipole switch or circuit-breaker which includes a switch in the neutral shall be so constructed that it will not connect any active conductor before the neutral, or open the neutral before all active conductors have been opened.

(c) Except in the case of ceiling switches and multiple way switches, or where the contacts of a switch or circuit-breaker are visible, a specially worded device, indicating clearly whether the switch or circuit-breaker is on or off, shall be provided if the position of the operating handle does not indicate whether such switch or circuit-breaker is on or off, and no switch or circuit-breaker shall be so constructed that it can remain in either the "on" or "off" position unless the worded device or the position of the handle correctly indicates the position of the switch.

(d) The maximum working current and voltage at which it is intended to operate shall be marked on every switch and circuit-breaker in such a position that the marking shall be legible when the switch or circuit-breaker is fixed or mounted in position. This requirement shall be deemed to be satisfied in the case of switches marked 20 amperes or less if the marking is visible only when the cover is removed, provided that there is some form of external marking or branding on the switch sufficient for the identification of its type and make.

2402. (a) Air-break knife switches and laminated brush switches shall conform to Australian Standard Specification No. C.23, flame-proof air-break switches to Australian Standard Specification No. C.25, and totally enclosed air-break switches to Australian Standard Specification No. C.28.

(b) Switches incorporated in appliances which can be used on alternating current circuits only, and are marked accordingly, shall be capable of interrupting at 10 per cent. excess pressure alternating currents 50 per cent. in excess of their rating. All other switches shall be capable of interrupting at 10 per cent. excess pressure direct currents in a non-inductive circuit 50 per cent. in excess of their rating.

Switches shall withstand a mechanical test of 2,000 consecutive operations, each consisting of closing and opening the switch, and, in addition, shall operate satisfactorily under the tests for breaking laid down in the previous paragraph of this regulation 100 times consecutively within a period of ten minutes without the formation of a sustained arc, and without appreciable damage to the contacts.

No double-pole, triple-pole, or four-pole switch shall be used for making or breaking two or more separate circuits unless it will successfully withstand, under the actual conditions of use, the breaking and endurance tests set out in this regulation.

(c) Unless other effective means is provided to prevent partial contact or arcing which will result in burning of contacts under the conditions of use, every switch intended to be used for opening a circuit shall open with a rapid action independent of the rate of movement of the operating knob or lever, and every switch rated at not more than 30 amperes, unless it is an open knife switch mounted on a switchboard, shall close with a rapid action independent of the rate of movement of the operating knob or lever.

(d) Metal-covered switches of rating greater than 5 amperes shall be fitted with an effective insulating lining unless the covers are effectively earthed. Such lining shall be securely attached to the cover, and shall be clear of all live parts and all internal mechanism.

(e) Switch covers shall not be held in position by the switch operating knob unless this is so fitted that operation of the knob in either direction will not release the cover.

(f) Every metal-clad switch with a removable or hinged cover shall be so constructed that the cover cannot be removed or opened when the switch is in the closed position.

(g) Time switches, automatic sign switches, and similar apparatus, shall be of approved type, and shall be enclosed in robust cases made of non-ignitable insulating material or metal.

(h) Mercury tube switches shall comply with the requirements of clause (b) of this regulation, and where incorporated in appliances or apparatus, they shall be enclosed in or completely protected by substantial non-ignitable coverings, and shall be operated by mechanism suitable for the purpose.

CIRCUIT-BREAKERS.

2403. (a) Air-break circuit-breakers shall conform to Australian Standard Specification No. C.24, flame-proof air-break circuit-breakers to Australian Standard Specification No. C.26, totally enclosed air-break circuit-breakers to Australian Standard Specification No. C.27, and oil-immersed circuit-breakers for alternating currents to British Standard Specification No. 116.

(b) Every circuit-breaker shall be capable of complying with the interrupting tests for cut-outs operating under similar conditions, and, in addition, shall be capable of withstanding the tests specified in Australian Standard Specification No. C.24, C.26, C.27, or British Standard Specification No. 116, whichever is applicable and appropriate to the particular type of circuit-breaker.

(c) Every over-current circuit-breaker shall be provided with suitable means of adjustment and indication for determining and indicating, within the range of such adjustment, the current at which it shall open automatically, and shall be so made that it cannot remain in the closed position when this current flows. The maximum setting of the adjustment of any circuit-breaker shall not exceed its rated current-carrying capacity by more than 100 per cent.

(d) Every circuit-breaker shall open with a rapid action independent of the rate of movement of the operating knob or lever.

THERMAL CIRCUIT OPENING DEVICES.

2404. (a) Every thermal over-current time-lag circuit opening device (other than a cut-out) shall comply with the requirements of this regulation, and also, in so far as they are applicable and appropriate, with the requirements of regulations 2401, 2402, and 2403.

(b) If the circuit opening device—

- (i) does not incorporate an over-current release which will open the circuit immediately on short circuit, or within one minute when 100 per cent. excess current flows; or
- (ii) will not satisfactorily withstand the breaking capacity test specified in regulation 2406 for the corresponding type of ordinary duty cut-out,

such device shall be used only in series with the cut-out or over-current release specified in regulation 222 for a circuit of the type in which it is to be used.

(c) Any portions of any such device in which the temperature rise exceeds 54°F. (30°C.) shall be protected in such a manner that no risk of fire is liable to arise.

FUSIBLE CUT-OUTS.

2405. (a) Every fusible cut-out shall conform to the requirements of British Standard Specification No. 88, except that—

- (i) the ambient temperature for temperature rise tests may exceed 26°C.;
- (ii) a cut-out intended for use in a circuit in which the pressure between conductors exceeds 250 volts shall conform to the requirements of regulation 2406 (a) as to marking and breaking capacity;
- (iii) a cut-out shall not be required to pass the breaking capacity test specified in clauses 12 and 15 of the above-mentioned specification, provided that it is to be used on alternating current circuits only, is marked "AC," and is capable of passing the test laid down in regulation 2406 (b) if of ordinary duty type, or that laid down in regulation 2406 (d) (i) if of heavy duty type.

(b) Every cut-out shall be rated at and marked with the current rating of the circuit in which it is to be used, except that where there is no standard size of cut-out of the same rating as the circuit, the cut-out shall be rated and marked at the next higher standard rating.

All marking of cut-outs required under Section V., clause 17 (a) of the above-mentioned specification, or under the provisions of these Regulations, shall be plainly and indelibly marked on both base and carrier in such positions that it will be legible when the cut-out is fixed or mounted in position.

(c) The carrier for the fuse link shall be easily removable for fuse link replacement, and the cut-out shall be so made that the blowing of the fuse link during replacement of the carrier will not result in personal injury.

(d) Ironclad cut-outs shall be so constructed that the covers cannot accidentally open or come apart at the hinges, and so that the bushings for the protection of conductors remain fixed in position when the cover is open.

2406. (a) Every cut-out intended for use in a circuit in which the pressure between conductors exceeds 250 volts shall be marked 500 V. instead of 250 V., as required by clause 17 (a) of the Standard Specification aforesaid. It shall be tested for breaking capacity in the manner specified for cut-outs of its type, but the test voltage shall be not less than 500 volts, and the metal case (if any) shall be connected through a resistance not exceeding .5 ohm to the midpoint of the test battery or to the neutral point of the test transformer.

(b) Every ordinary duty cut-out intended for use in alternating current circuits only shall be plainly and permanently marked "AC," and shall be capable of passing a breaking capacity test identical with that specified in clauses 12 and 15 of British Standard Specification No. 88, except that the source of energy shall be a transformer not smaller than 100 kVA. capable of giving the short circuit current required. The test shall be carried out at a frequency of 50 cycles.

(c) Every ordinary duty cut-out not so marked or intended for use in other than alternating current circuits, shall be capable of passing the breaking capacity test as laid down in the above-mentioned Standard Specification.

(d) Every heavy duty cut-out shall be marked "Heavy Duty," and—

- (i) if intended for use in alternating current circuits only, shall be plainly and permanently marked "AC," and shall be capable of passing the breaking capacity test specified in clause (b) hereof, except that the series resistance in the circuit shall be sufficient only to limit the current to 3,000 amperes in the case of 250-volt cut-outs, or to 6,000 amperes in the case of 500-volt cut-outs.
- (ii) if not marked "AC," and intended for use on circuits other than alternating current circuits, shall be capable of passing a breaking capacity test identical with that laid down in British Standard Specification No. 88, except that the series resistance in the circuit shall be sufficient only to limit the current to 3,000 amperes in the case of 250-volt cut-outs, or to 6,000 amperes in the case of 500-volt cut-outs.

LIGHTING FITTINGS—GENERAL.

2411. (a) Where conductors are to be threaded through tubes or channels formed in the metal work of fittings, such tubes or channels shall be of ample size, and shall have no sharp angles or projecting edges which would be liable to damage the insulating material of a conductor. Open ends through which conductors pass shall be bushed.

(b) No joint shall be made within a fitting, and no connexion shall be made within a fitting except in a special receptacle incorporated therein for the purpose.

(c) Inflammable shades shall not be used in such a manner that they are liable to come in contact with any lamp. Lampshades or candle tubes made of celluloid shall not be used in close proximity to any lamp.

HANDLAMPS.

2412. Every handlamp shall be so constructed that the lamp cap, the metal parts of the lampholder, and any metal in contact therewith are shrouded by insulating material, which will prevent contact between any such metal and any other metal or any person holding or handling the handlamp. In addition, every handlamp shall have a substantial guard, which, if of metal, shall be insulated from metal parts of the lampholder and metal parts in contact therewith.

The handle of every handlamp shall be made of treated wood or of some suitable non-ignitable composite insulating material capable of withstanding rough usage in service.

SPECIAL LIGHTING FITTINGS.

2413. (a) Gas-tight fittings shall be of substantial construction, and shall be fitted with external globes of thick glass bedded on gaskets in such a manner as to ensure against entry of air from without.

(b) Guarded gas-tight fittings shall, in addition, be fitted with substantial guards which will adequately protect the glass against breakage.

(c) Enclosed fittings shall be provided with a removable glass receptacle, so arranged as to enclose the lamp completely, and of such size and/or construction as not to cause excessive heating of the lamp, of any part of the fitting, or of any conductor within or adjacent to the fitting.

CEILING ROSES.

2414. (a) The bases of ceiling roses shall be of non-hygroscopic non-ignitable insulating material. The covers of ceiling roses may be of rigid metal, provided they have a clearance of not less than $\frac{1}{4}$ inch from all live parts; otherwise they shall be constructed of non-hygroscopic, non-ignitable insulating material.

(b) Terminals and contacts shall be permanently fixed, and shall be so arranged that the flexible cord or cords can be removed from the ceiling rose without disturbing the connexion of any other conductor which is connected at the ceiling rose.

LAMP HOLDERS.

2415. Lampholders shall be of one of the following forms, namely:—

- (i) Cord grip, for direct attachment to flexible cords;
- (ii) Batten holder (or backplate) for fixing to plane surfaces;
- (iii) Screwed, for direct coupling to fittings, screwed conduits, or piping;

and of the type required in the following table for use with lamps of the wattage given. They shall be constructed entirely of non-ignitable non-hygroscopic materials which will not readily carbonize.

Size of Lamp.	Type of Lampholder Required Therewith.
Not exceeding 40 watts ..	Miniature Standard Bayonet (M.B.C.) Standard Bayonet (B.C.) Miniature Edison Screw (M.E.S.): or Edison Screw (E.S.)
Exceeding 40 watts but not exceeding 250 watts	Standard Bayonet (B.C.) or Edison Screw (E.S.)
Exceeding 250 watts but not exceeding 600 watts	Edison Screw (E.S.) or Goliath (G.E.S.)
Exceeding 600 watts ..	Goliath (G.E.S.)

(b) Lampholders containing switches shall be of the all-insulated type, and shall be screwed or provided with back plates for fixing to rigid supports.

LAMP HOLDER ADAPTORS.

2416. Lampholder adaptors shall be robustly constructed of durable insulating material which will not readily carbonize, and which completely encloses all terminals and metal, other than the contacts and catch pins.

PLUGS AND SOCKETS.

2421. (a) Plugs and sockets rated at or above 10 amperes shall be capable of carrying continuously currents 50 per cent. in excess of those for which they are intended without the temperature rise in any part exceeding 36° F. (20° C.) Plugs and sockets rated at less than 10 amperes shall be capable of carrying in a like manner 100 per cent. continuous overload current.

(b) The clearances between conductive parts shall be such that an arc cannot be maintained if the plug is withdrawn while carrying the overload currents stated in the above preceding clause (a) in a non-inductive circuit at 50 per cent. excess pressure. This test shall be carried out with direct current.

(c) Every plug socket to be used as a general purpose power outlet shall be rated at and marked in amperes or watts with the rating to be used for the purpose of calculation of the loading of the sub-circuit to which it is to be connected, and, in such marking, 5 amperes shall be deemed to be the equivalent of 1,000 watts, and any multiple of 5 amperes the equivalent of the same multiple of 1,000 watts.

Every special purpose plug and/or socket shall be rated at not less than 100 watts, and the socket shall have permanently marked thereon the wattage at which it is to be rated for the purpose of calculating the loading of the sub-circuit.

The marking required under the preceding paragraphs of this regulation shall be so placed that it is visible when the socket is fixed in position.

(d) Switch plugs shall be so arranged and constructed that the action of inserting the plug or removing the plug from the socket automatically (by means of a spring control or otherwise) makes or breaks the circuit with a definite and rapid action, operates a switch in the active conductor or (by some definite means when the plug is inserted in and withdrawn from the socket) prevents the formation of an arc or confines the extent of any arc formed, so that risk of fire or shock is eliminated and damage to the contacts will not result from its continued use. They shall be capable of satisfactorily withstanding the tests specified in these Regulations for switches and for plugs and sockets for corresponding uses.

(e) Every floor socket shall be fitted with a strong, hinged, incombustible, close-fitting cover, which shall be capable of withstanding rough usage. This cover shall be so arranged that it will automatically close over the contacts when the plug is withdrawn from the socket. In addition, the socket shall be so arranged that no dust or water can accumulate therein.

(f) A plug and socket provided with an earthing contact shall be so constructed that the connexion of the earthing pin with the earthing socket is made not later than the connexion of the live pins, and is not broken before the disconnexion of the live pins.

The earthing terminal and/or contact on a plug or socket shall be marked "earth."

APPARATUS CONNECTORS.

2422. (a) Every connector used for making a detachable connexion between a flexible cord and an appliance or apparatus having exposed metal parts shall consist of an inlet plug attached to the cord and an inlet socket fixed to the appliance or apparatus.

(b) The inlet plug shall be of a form in which the live conductors are connected to spring contact tubes enclosed in a robust body of non-ignitable insulating material, which is provided with an effective cord grip and means for keeping the conductors of the flexible cord separate from one another throughout those portions likely to attain a temperature exceeding 120° F. (48.9° C.).

A spring metal guard shall be fitted over the flexible cord where it enters the inlet plug in such a manner as to prevent the cord from being bent at a sharp angle. This guard shall be so formed, and at one end so secured to the inlet plug, as to prevent abrasion of conductor insulation. At the other end, the guard shall be provided with a suitably fixed durable non-combustible insulating bush which will prevent contact between the guard at this point and the conductors of the flexible cord should their insulation become defective. This spring guard shall be in metallic connexion with the earthing contacts (if any) of the inlet plug.

(c) Where the inlet plug is to be used for the connexion of an appliance or apparatus in an earthed situation, it shall be provided with external rubbing or sliding contacts, which will make effective connexion with the hood of the inlet socket when the plug is inserted in the socket in any position, before contact is made between the live contacts of the plug and the pins of the socket. Effective means shall be provided for the connexion of the earthing conductor of the flexible cord to such rubbing or sliding contacts.

(d) The inlet socket on the appliance or apparatus shall contain, for the connexion of the live conductors, two brass contact pins, each 3-16 inch diameter by $\frac{1}{2}$ inch long, and spaced $\frac{1}{2}$ inch apart between

centres. These contact pins shall be centrally spaced within a surrounding hood of the internal dimensions given in the following drawing:—

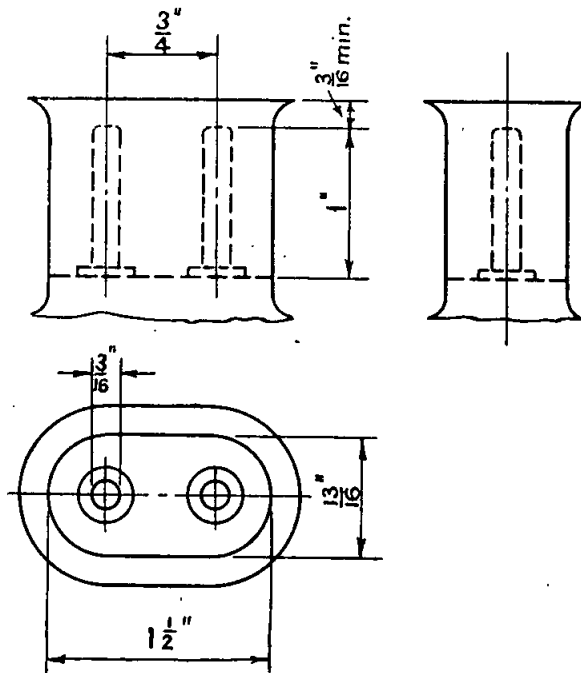

APPLIANCE INLET SOCKET.

The hood shall be made of metal not less in thickness than No. 24 S.W.G. if of tubular form, and not less than No. 20 S.W.G. if split. The metal shall be adequately protected against corrosion, and shall be securely fastened to the case of the appliance or apparatus, and in effective electrical connexion with all exposed metal parts of the appliance or apparatus, except with labels and screws, which are secured solely to substantial insulating portions of the appliance or apparatus.

(c) Where connectors are used for the connexion of appliances having no exposed metal parts—such as electric boiling jugs—the inlet plug shall be of the form described in clause (b) hereof, except that the spring guard shall be omitted. Contact pins 3-16 inch in diameter, and spacing not less than 3/4 inch apart between centres shall be provided on the appliance, and the inlet socket hood shall be omitted.

The contact pins shall not exceed 3/8 inch in length unless they are mounted on a recessed portion of the appliance in such a manner that a person using the appliance cannot touch a live contact pin when it is in connexion with a contact of the plug.

MOTORS.

2431. (a) Every motor of a type and output covered by Australian Standard Specification No. C.34 shall conform to that specification, or shall be of such design and construction that it will, in the opinion of the Chief Electrical Inspector, Victoria, perform, under the conditions of its use, in a manner not less satisfactory than a motor of the same type which complies with the said specification.

(b) Every motor, unless it be provided with connecting terminals mounted on a suitable terminal board or boards, and protected against accidental contact by a suitable cover or housing, shall be provided with connecting cables brought out in a manner complying with the appropriate requirements of these Regulations, and which will permit of connexion to the installation by a means prescribed in these Regulations.

APPLIANCES.

2441. (a) Every electrical appliance shall be constructed in a manner which will ensure, as far as practicable, freedom from electrical failure, and shall be of adequate mechanical strength to withstand the conditions of use and treatment to which such an appliance is normally subjected.

(b) The current-carrying parts shall be so arranged that they are not more exposed to personal contact than is necessary for their efficient working, and, where possible all live parts shall be protected and/or shielded so that it is impossible for the person using the appliance to touch them or make contact with them accidentally.

(c) Every electrical appliance shall be marked with the information set out below. The items shall be grouped either on the nameplate or, if the marking be made on the appliance, on a portion of the appliance reserved for such marking:—

- (i) The name of the manufacturer.
- (ii) The maker's designation number or catalogue number.
- (iii) The pressure at which the appliance is intended to operate.
- (iv) The consumption of the appliance in watts or kilowatts, or the full load current of the appliance in amperes.

There shall also be provided on the nameplate or portion aforesaid of the appliance a clear space, not smaller than 1/2 inch x 1/2 inch, suitable for any branding or marking which may be required by any approvals authority.

(d) (1) A baking oven or cooking stove shall be connected to a medium pressure sub-circuit only if each individual hotplate and each individual group of oven elements operates at low pressure and is protected by an independent cut-out inserted in the active conductor and mounted on such oven or stove. The grouping of the elements of an oven or stove so connected shall be arranged in such a manner that neither two groups of elements in one oven nor the elements of any two hotplates on one cooking hob are connected to different active conductors unless such elements are completely enclosed by substantial metal containers which are securely screwed or bolted to the framework of the oven or stove in such a manner that no difference of potential can exist between such containers and framework.

(2) In premises used for residential and/or domestic purposes—

- (i) every fixed water heater and every motor which is fixed in position or forms a portion of a fixed appliance shall operate at low or medium pressure;
- (ii) every electrical appliance other than those provided for under the preceding sub-clause (i) and under sub-clause (1) above shall operate at low pressure.

(e) (i) No portable appliance, battery charger with exposed live terminals, medical or dental appliance, or electrically operated toy shall operate from supply mains through a resistance, auto-transformer, or any apparatus for reducing the pressure, other than a transformer with independent primary and secondary windings.

(ii) Woven contact mats and electric tablecloths shall operate only at extra low pressure.

(f) Where single-pole switches are fitted on any fixed appliance, the terminal or contact to which the active conductor is to be connected shall be marked "Active."

HEATING AND COOKING APPLIANCES.

2442. (a) The elements of heating and cooking appliances shall be so arranged that they can be readily replaced.

(b) As far as practicable, every heating and cooking appliance shall be so constructed and/or mounted that its supports and those parts which are handled in the operation of such appliance cannot normally become heated to a temperature exceeding 130°F. (54°C.).

(c) The junction between the elements and other conductors or switches shall be effected without solder by connectors or terminals of approved type, which shall be so placed that their temperature cannot rise above 176°F. (80°C.).

(d) All connexions between elements and all connecting conductors, unless self-supporting or rigidly fixed in position, shall be continuously insulated with suitable non-ignitable material or beads.

(e) Except where contained in an enclosure provided with an interlocking device which prevents access to live elements, the elements shall be adequately guarded for the prevention of accidental

contact. In the case of hotplates (whether incorporated in stoves or otherwise), horizontal toasters, grillers, and similar cooking appliances, the guards shall be of such construction that cooking utensils cannot be accidentally brought into contact with the elements.

Apertures in element guards for such appliances shall not be larger than $\frac{3}{4}$ -in. mesh. In the case of elements fitted at the tops of ovens, apertures in guards shall be not larger than $\frac{3}{4}$ -in. mesh.

(f) Each hotplate or group of oven elements shall be controlled by a single-pole quick-break switch of approved form inserted in the active conductor, or, in cases where heating elements operating at medium pressure are permitted under these Regulations, by linked switches inserted in each active conductor.

(g) Every cooking stove rated at more than 2 kW. shall have a cut-out inserted in the active conductor to each separate hotplate or group of oven elements. All cut-outs on a cooking stove shall be conveniently located together.

(h) The electrically operated portion of a combined gas and electric cooking appliance shall be separated from the gas-burning portion by substantial non-ignitable insulating material not less than $\frac{1}{4}$ inch thick.

(i) Every electrically heated warming pad, cushion, or blanket shall be so designed and constructed that—

- (i) if wrapped in white paper and entirely enclosed in blankets for a period of twelve hours while connected to the supply with the thermostat (if any) short-circuited it will not char the paper;
- (ii) a possible breakdown or short-circuit in the heating element will not cause the appliance to overheat or fail to comply with the requirement of the preceding sub-clause (i);
- (iii) if the outer covering of the appliance is damped with saline matter, it shall not be possible for a person in an earthed situation to receive an electric shock from any part of such covering when the appliance is connected to a low-pressure a.c. circuit with one conductor earthed.

WATER HEATERS.

2443. (a) Every water heater shall be so arranged that the water cannot enter into it or issue from it at a potential difference from earth exceeding 1 volt.

(b) Where water heating elements are in direct contact with the water, the resistance between the elements and the water entering or leaving the heater shall be not less than 25,000 ohms.

(c) All water heaters for general use, and all portable water heaters, shall have elements of the resistance type.

(d) Water heaters in which the water is heated by the passage of current between electrodes immersed therein shall be constructed to meet the requirements of the supply authority from which permission for the use of this type of heater has been obtained in each particular case.

(e) Where a portable water heater (such as an electric jug) has an insulating container, the material of such insulating container shall be of such a nature that the potential difference between the outer surface of any such container and earth shall not exceed 30 volts when measured with a voltmeter of 50,000 ohms resistance. The design shall be such that it shall be impossible for a person to make contact with the water or any live part of the appliance while the current is flowing, and the material, construction, and mechanical strength of all parts of the appliance shall be such as will ensure compliance with this requirement at all times.

Where porcelain is used for containers, it shall be vitreous porcelain, and glazing shall not be relied upon to prevent absorption of water.

(f) Every electric geyser or bath heater shall be arranged for permanent connexion to the installation, and if water is to be supplied to it from a metal pipe system, shall also be arranged for permanent connexion by metal piping to such pipe system. In every case where there is external metal, an earthing terminal connected to such metal shall be provided.

(g) Conductors within or proximate to water heaters, where they are subject to temperatures exceeding those specified in regulation 201 (d), shall be an approved heat-resisting type.

INCANDESCENT LAMPS.

2444. (a) Lamp caps of the bayonet and Goliath Edison Screw types, shall be of the dimensions specified in British Standard Specification No. 161, "Tungsten Filament Electric Lamps," Appendices II. and III.

(b) Manually operated switches shall not be fitted in lamp caps.

MERCURY VAPOUR LAMPS.

2445. The resistance and solenoid of every mercury vapour lamp shall be completely enclosed in a metal case, and apertures in the case for ventilating, if any, shall be on the sides only, and shall be covered with strong wire gauze of fine mesh.

ARC LAMPS.

2446. (a) Arc lamps shall have the whole of their live parts insulated from the frame or case.

(b) Except where an exposed arc is essential for a particular purpose, every arc lamp to be used directly over a floor of inflammable material, or in a position where falling particles might constitute a danger to persons walking underneath, shall be provided with a globe or lantern arranged to intercept falling particles. Globes of 12-in. diameter and over shall be contained within wire netting of a mesh not greater than 3 inches, and so arranged as to prevent pieces of broken glass falling therefrom.

(c) Every open inverted arc lamp which is to be used where inflammable material is located shall have a metal reflector rigidly attached beneath the arc, which at all times shall be below the level of the upper edge of such reflector. This reflector shall project radially at least 15 inches, and in hazardous risks 21 inches, measured horizontally beyond the arc.

ELECTRIC SIGNS.

2447. (a) Every electric sign shall be so constructed that all parts likely to require attention are accessible.

(b) The loading of sub-circuits shall not exceed the limits laid down in regulation 216.

(c) Automatic switches shall conform to the requirements of regulation 2402 (g).

(d) All portions of an outdoor electric sign which contain or carry electric wiring, fittings, lamps, or apparatus, shall be constructed wholly of non-ignitable materials, except that for letters and designs approved hardwoods may be used.

LIFTS.

2451. See regulation 213 (e).

Every electrically operated lift shall comply with the requirements of these regulations, subject to any modification or amplification thereof hereunder:—

(a) (i) All electrical connexions to the lift car shall be made through trailing cables, which shall be installed in such a manner that there is no undue mechanical strain on the conductors. Trailing cables shall be of such a length that they will not come in contact with the bottom of the lift-well, when the lift car is at the lowest point of its over-run.

(ii) Each core of a lift trailing cable shall be flexible, and not less than .0017 square inch in cross-section.

(iii) Separate trailing cables shall be provided for the lighting, power, and indicator circuits in the lift car.

(b) Notwithstanding the provisions of regulation 222, under-voltage protection shall not be required—

- (i) where a lift is controlled by a car switch, except in cases where a motor generator supplies electricity to the lift motor. In such cases, under-voltage protection shall be provided for the motor of the motor generator.

- (ii) for the motor of an automatic lift, provided that neither the lift motor nor the motor generator (if any) will start prior to the pressing of any operating button subsequent to restoration of supply.

RADIO AND ELECTRO-ACOUSTIC EQUIPMENT AND SMALL RECTIFYING APPARATUS.

2452. (a) The provisions of this regulation shall apply to every rectifying apparatus not exceeding 1,200 volt amperes rated input, which is to be used for charging storage batteries and similar purposes, and to all radio receiving or transmitting and electro-acoustic equipment connected or to be connected to supply mains.

(b) Live parts connected to supply mains shall be isolated by means of—

- (i) insulation; or
- (ii) one or more condensers; or
- (iii) one or more transformers having independent primary and secondary windings,

from all exposed metal, and from metal which is not completely covered by insulating material adequate to withstand satisfactorily, at all times, the supply pressure.

(c) Where isolation as required by clause (b) hereof is obtained by means of insulation or transformers, the apparatus shall be capable of satisfactorily withstanding for two minutes the application of a pressure of 1,500 volts a.c. between the supply connexions and any exposed or inadequately insulated metal, and where such isolation is obtained by means of condensers, the apparatus shall be capable of satisfactorily withstanding for two minutes a d.c. pressure of 1,500 volts, and, for one hour, an a.c. pressure at 50 cycles, equal to 1.5 times the supply pressure, the pressure in each case being applied as aforesaid.

(d) Where a metal chassis or framework is to be at any time in connexion with a supply main, it shall be enclosed within a non-conducting case of such construction that personal contact cannot be made with the chassis or framework while the apparatus is connected to such supply main.

(e) Where the maximum voltage at any terminals exceeds 100, such terminals shall be of the insulated pattern, and shall have the extreme voltage distinctly marked thereat. All live terminals directly connected to supply mains, or energized directly or indirectly from supply mains to a pressure exceeding 100 volts, shall either be enclosed or be protected by a cover.

(f) All radio equipment shall be provided with a suitably worded danger notice, which shall be permanently fixed on the inside of the lid, cover, or door by which access is obtained to the interior of the radio equipment. This notice shall contain the heading "DANGER" in bold letters, and the words, "This equipment operates at a dangerous electrical pressure. No adjustment to the interior apparatus is to be made unless disconnected from the supply mains."

(g) Where a terminal is provided for the connexion of any portion of the apparatus to earth, it shall be distinctly marked "Earth."

LUMINOUS DISCHARGE TUBE LIGHTING SYSTEMS (L.D. SIGNS).

2453. See regulation 453.
See regulation 216.
See regulation 453.

Every luminous discharge tube lighting system operating at a pressure in excess of 650 volts shall comply with the requirements of this regulation—

(a) Transformers used to increase the electrical pressure for luminous discharge tubes shall have independent primary and secondary windings with suitable high insulation between windings. These windings shall not be inter-connected. The transformer secondary open circuit voltage shall not exceed 15,000 volts. Where the secondary open circuit voltage exceeds 7,500, the mid-point of the secondary winding shall be connected to earth. Transformers, and all other high voltage equipment, unless of weather-proof construction, shall either be enclosed in approved cabinets or be placed within metal enclosures

provided for the complete assembly. Each transformer shall bear a name plate showing the manufacturer's name and address, the primary rating in volts, amperes, and kilovolt-amperes, and the secondary operating voltage and milli-ampere.

(b) Other voltage-increasing devices, such as combinations of choke coils and condensers, shall operate at a pressure not exceeding 7,500 volts from earth potential, and shall comply with the provisions of the preceding clause (a) with respect to enclosure and name plate.

(c) The connexions to luminous discharge tubes shall be made at approved connectors, and all current-carrying metal parts throughout the system shall be suitably insulated or otherwise protected against personal contact.

(d) Conductors connecting transformers with luminous discharge tubes shall be either approved insulated high-tension cables which comply with the requirements of sub-clause (1) below, and are installed as required by sub-clause (2) below, or bare or insulated conductors installed as required under sub-clause (3) below :—

High Tension Cables.

(1) (i) The conductors of high tension cables, shall be tinned high conductivity copper not smaller than 19/0.012 inch if stranded, or 1/0.083 inch if single wire, and shall be insulated with pure and vulcanized rubber, vulcanized rubber, or rubber compound, the insulation for cables for 2,000 volts and above being protected from the effects of ozone.

(ii) Cables shall be finished in one of the following ways:—

- (aa) Insulated as required by the preceding sub-clause (i) hereof, without further protection.
- (bb) Braided and compounded.
- (cc) Proofed taped, braided, and compounded.
- (dd) Metal sheathed.
- (ee) Proofed taped and metal sheathed.
- (ff) Braided and compounded, and wire braided.
- (gg) Proofed taped, braided and compounded, and wire braided.

(iii) The working voltage to earth, the radial thickness of the insulation and of the metal sheath, and the size of the braiding wire, shall be in accordance with the following table :—

Nominal Working Voltage to Earth R.M.S. Values.	Minimum Radial Thickness of Insulation (Excluding Tape).	Minimum Thickness of Metal Sheath.	Size of Braiding Wire.
Volts.	Inches.	Inches.	Inches.
Not exceeding—			
1,000 ..	.070	.05	.010
1,500 ..	.085	.06	.010
2,000 ..	.10	.06	.010
4,000 ..	.14	.06	.010
6,000 ..	.17	.07	.012
Exceeding 6,000	.21	.07	.012

(iv) Every cable shall be capable of satisfactorily withstanding the following tests, i.e. :—

(A) The application for five minutes between the conductor of each core and earth of three times the working pressure, the test being carried out with alternating current of approximately sine wave form at a frequency between 25 and 100 periods per second during immersion in water, which shall have continued for at least 24 hours at the time of test.

(B) In the case of cables other than metal sheathed and bare rubber cables—

- (aa) no compound shall drip from a 10-in sample suspended vertically for one hour in an oven maintained at a temperature of 156° F. (69° C.); and
- (bb) flame shall not spread on a sample of the cable supported horizontally on supports 8 inches apart, more than 2 inches on either side of a point midway between supports, and to which point the 5-in. flame of a 3/4-in. bunsen burner with a 1 1/2-in. blue cone has been applied for 30 seconds.

(2) High tension cables which are not metal sheathed or wire braided shall be used only as inter-connexions between sections of tube unless they are contained in the metal case enclosing the complete sign equipment, or are enclosed in screwed conduit or metallic coverings or ducts which are effectively connected to earth. Where cables are enclosed in metal conduits, separate conduits shall be used for the high tension circuits originating from each transformer.

(3) Bare or insulated conductors (other than high tension cables which conform to the requirements of sub-clauses (1) and (2) hereof with respect to insulation, construction, and installation) shall be adequately supported on suitable insulators in such a manner that there is a space of at least 4 inches between conductors of opposite polarity, and of at least 2 inches between conductors and all metal or earthed surfaces. They shall also be so enclosed or protected that accidental personal contact therewith is not possible.

(e) Tubes shall be substantially supported at a sufficient distance from the sign face to ensure against arcing from the tube to any other portion of the sign, and shall be so installed as to be free from contact with inflammable material unless such material is so isolated as to prevent risk of fire. They shall not be unduly exposed to mechanical injury.

TRANSFORMERS.

2457. Except in the case of instrument transformers, bell transformers, transformers incorporated in luminous discharge tube lighting systems, and transformers not exceeding 1,200 volt amperes input rating incorporated in radio-receiving equipment or battery-charging rectifiers, every transformer installed on the consumer's side of the consumer's terminals shall—

- (i) comply with the requirements of Australian Standard Specification No. 61;
- (ii) have primary and secondary windings which are entirely separate (except for any common earth connexion) if the transformer is to be used for raising or reducing the pressure more than 15 per cent. from that at which it is supplied at the consumer's terminals.

BELL TRANSFORMERS.

2460. (a) Transformers to be used for the operation of bell and signalling circuits—

- (i) shall operate at a secondary pressure not exceeding 12 volts;
- (ii) shall have independent primary and secondary windings, and shall be provided with terminals by means of which one point of the secondary winding and all exposed metal can be earthed;
- (iii) shall have those terminals which are in direct connexion with supply mains covered by a shield of insulating material or metal.

(b) The maximum possible input of such of the above transformers as are to be used in connexion with secondary circuits consisting of rubber or enamel insulated double cotton-covered bell wire,

shall not exceed 50 watts, and every such transformer shall be capable of satisfactorily withstanding the following test, namely:—

The primary winding of the transformer shall be energized from supply mains at the rated operating voltage, and the secondary terminals shall be connected to one another through 20 feet of 1/036 inch rubber or enamel insulated double cotton-covered copper bell wire, and when such connexion is maintained indefinitely, neither the bell wire nor the transformer shall attain a temperature which will damage its insulation or give rise to risk of fire.

PART II.—SECTION 5.

EARTH CLIPS.

2517. (a) Earth clips, unless made of metal which will not readily corrode, shall be tinned or galvanized in a manner which will effectively protect them against corrosion under the conditions of use.

(b) Earth clips for connexion to cylindrical metal surfaces shall be not less than No. 18 S.W.G. in thickness, and if made in one piece, shall be not less than 3/4 inch wide, and if made in two pieces, shall be not less than 1 inch wide.

Earth clips of the above dimensions shall be deemed to be suitable for connecting to cylindrical metal sections, earthing conductors not larger than 7/064 inch if such clips are of copper or highly conductive copper alloy. If the clips are of other metals, they shall not be used for connecting earthing conductors larger than 7/044 inch. Any earth clip to be used for the connexion of an earthing conductor larger than those above-mentioned shall be of such material, and of such cross-sectional area and form, that the conductivity of the clip and of its contact with the cylindrical metal section is not less than that of the earthing conductor to which it is to be connected.

(c) Earth clips to be used with metal sheathed cable shall be of a type which will not damage the cable sheathing, and shall be at least equal in conductivity to the sheathing or the earthing conductor with which they are used, whichever is the lower.

For armoured cables, earth clips shall be so made as to grip firmly the whole of the wires of the armouring without damage to the insulation.

For lead sheathed armoured cables, the principal contact of earth clips shall be with the lead, but the clip shall be so made as to grip the armouring firmly without damage to the lead.

EARTH-LEAKAGE CIRCUIT-BREAKERS.

Compliance with Regulation.

2522. (1) Except as provided for in clause (2) hereof, every earth-leakage circuit-breaker shall comply with the requirements of the Standards Association of Australia Approval and Test Specification No. C.110, 1940, for earth-leakage circuit-breakers or any subsequent amendment.

(2) Every earth-leakage circuit-breaker intended for use in accordance with the provisions of clause (a) of regulation 524 for the insertion of the relay circuit of a contactor or circuit-breaker shall be rated at not less than 5 amperes and shall comply, with the exception of clauses 9 and 23 and the additional breaking capacity test in clause 24, in all respects to the requirements of the Standards Association of Australia Approval and Test Specification C.100, 1940, earth-leakage circuit-breakers or any subsequent amendment.

APPENDIX.
Tables.

TABLE A (I).
DIMENSIONS, WEIGHT AND RESISTANCE OF SOLID AND STRANDED CIRCULAR CONDUCTORS.*

1.	2.	3.	4.	5.	6.	7.
Nominal Area.	Old Standard S.W.G. (Nearest).	Effective Area.	Number and Diameter of Wires Comprising Standard Conductor.	Overall Diameter of Conductor.	Standard Weight per 1,000 yards of Conductor.	Standard Resistance per 1,000 yards at 60° F. (15-6° C.)
Square Inch.		Square Inch.	Inches.	Inches.	lb.	Ohms.
0-0010	1/20	0-001018	1/-036	0-086	11-77	23-59
0-0015	1/18	0-001521	1/-044	0-044	17-58	15-79
0-0020	3/22	0-001943	3/-029	0-062	23-37	12-36
0-0030	3/20	0-002994	3/-036	0-078	36-02	8-019
0-0030	1/16	0-003217	1/-064	0-064	37-20	7-463
0-0045	7/22	0-004546	7/-029	0-087	54-39	5-281
0-0070	7/20	0-007005	7/-036	0-108	83-81	3-427
0-0100	7/18	0-01046	7/-044	0-132	125-2	2-294
0-0145	7/17	0-01462	7/-052	0-156	174-9	1-643
0-0225	7/16	0-02214	7/-064	0-192	264-9	1-084
0-0300	7/14	0-02840	19/-044	0-220	340-4	0-8468
0-0400	19/17	0-03960	19/-052	0-260	475-5	0-6063
0-0600	19/16	0-05999	19/-064	0-320	720-3	0-4002
0-0750	19/15	0-07592	19/-072	0-360	911-6	0-3162
0-1000	19/14	0-1009	19/-083	0-415	1211-0	0-2380
0-1200	37/16	0-1168	37/-064	0-448	1403-0	0-2056
0-1500	37/15	0-1478	37/-072	0-504	1776-0	0-1625
0-2000	37/14	0-1964	37/-083	0-581	2360-0	0-1223
0-2500	37/13	0-2465	37/-093	0-651	2963-0	0-09738
0-3000	37/12	0-3024	37/-103	0-721	3635-0	0-07939
0-4000	61/13	0-4064	61/-093	0-837	4886-0	0-05908
0-5000	61/12	0-4985	61/-103	0-927	5994-0	0-04816
0-6000	61/-112	0-6062	91/-093	1-023	7290-0	0-03961
0-7500	91/-101	0-7435	91/-103	1-133	8942-0	0-03229
0-8500	..	0-8459	127/-093	1-209	10175-0	0-02838
1-0000	127/-101	1-0376	127/-103	1-339	12481-0	0-02314

* See Australian Standard Specification No. C.50.

TABLE A (II).
CURRENT CARRYING CAPACITY (SUBJECT TO VOLTAGE DROP) AND CORRESPONDING FALL IN PRESSURE.
Vulcanized Rubber Cables.

1.	2.	3.	4.
Nominal Area of Conductor.	Number and Diameter of Wires Comprising Conductor.	Normal Current Rating (2).	Approximate Total Length in Circuit (Lead and Return) for 1-volt Drop with Maximum Permissible Current. (Column 3) (1).
Square Inch.	Inches.	Amperes.	Feet.
0-0010	1/-036	4-1	30
0-0015	1/-044	7-0	25
0-0020	3/-029	10-0	23
0-0030	3/-036	15-0	23
0-0030	1/-064	15-0	24
0-0045	7/-029	20-0	25
0-0070	7/-036	30-0	26
0-0100	7/-044	35-0	34
0-0145	7/-052	45-0	36
0-0225	7/-064	55-0	45
0-0300	19/-044	65-0	49
0-0400	19/-052	75-0	59
0-0600	19/-064	100-0	67
0-0750	19/-072	115-0	73
0-1000	19/-083	140-0	80
0-1200	37/-064	155-0	82
0-1500	37/-072	180-0	85
0-2000	37/-083	220-0	86
0-2500	37/-093	255-0	85
0-3000	37/-103	285-0	84
0-4000	61/-093	345-0	79
0-5000	61/-103	395-0	72
0-6000	91/-093	460-0	63
0-7500	91/-103	550-0	54
0-8500	127/-093	600-0	50
1-0000	127/-103	700-0	44

NOTE.—See Regulation 201, particularly with regard to limitation of the capacity of conductors by the permissible drop in volts.

(1) This is for single-phase circuits. For balanced three-phase circuits, to obtain the length of circuit for 1-volt drop between phase conductors the figures shown in this column shall be divided by 1-73; this is actual length of circuit, not lead and return.

(2) For sizes 7/-036 and larger these ratings apply only where the number of conductors does not exceed four per conduit or cable. If the number exceeds four the ratings given in this table shall be reduced by 12-5 per cent.

TABLE A (III).
CURRENT CARRYING CAPACITY (SUBJECT TO VOLTAGE DROP) AND
CORRESPONDING FALL IN PRESSURE.

Impregnated Paper and Lead-covered Cables.

1.	2.	3.	4.	5.	6.
Nominal Area of Conductor.	Number and Diameter of Wires Comprising Conductor.	Single Cables run in Pairs.	Concentric or Twin Cable.	Three-core Cable.	Approximate Total Length in Circuit (Lead and Return) for 1-volt Drop with Maximum Permissible Current (Column 3).
Square Inch.	Inches.	Amperes.	Amperes.	Amperes.	Feet.
0.0010	1/.036	4.1	4.1	4.1	30
0.0015	1/.044	6.1	6.1	6.1	30
0.0020	3/.029	7.8	7.8	7.8	30
0.0030	3/.036	12.0	12.0	12.0	29
0.0030	1/.064	12.0	12.0	12.0	29
0.0045	7/.029	18.2	18.0	18.0	28
0.0070	7/.036	28.0	25.0	23.0	27
0.0100	7/.044	42.0	35.0	31.5	27
0.0145	7/.052	57.0	45.0	41.0	28
0.0225	7/.064	75.0	60.0	56.0	32
0.0300	19/.044	87.0	71.0	66.0	35
0.0400	19/.052	104.0	85.0	78.0	41
0.0600	19/.064	135.0	114.0	101.0	48
0.0750	19/.072	157.0	130.0	117.0	52
0.1000	19/.083	191.0	157.0	142.0	57
0.1200	37/.064	210.0	174.0	161.0	60
0.1500	37/.072	246.0	200.0	186.0	65
0.2000	37/.083	296.0	242.0	227.0	72
0.2500	37/.093	343.0	280.0	265.0	78
0.3000	37/.103	385.0	322.0	304.0	85
0.4000	61/.093	464.0	394.0	..	95
0.5000	61/.103	540.0	457.0	..	100
0.6000	91/.093	624.0	105
0.7500	91/.103	738.0	109
0.8500	127/.093	815.0	116
1.0000	127/.103	932.0	121

NOTE.—See Regulation 201, concerning the limitations of capacities in certain circumstances.

TABLE A (IV).
INSULATION RESISTANCE OF CABLES.

1.	2.	3.	4.	5.
Conductor.	Minimum Insulation Resistance, Megohms for a Mile Length at 60° F. (15.6° C.).			
Nominal Area of Cable.	Number and Diameter of Wires.	Rubber Insulated for Pressures.		Paper Insulated Cables.
		Up to 250 volts.	Up to 650 volts 650-volt Grade.	
Square Inch.	Inches.	Megohms.	Megohms.	Megohms.
0.0010	1/.036	2,000	5,000	140
0.0015	1/.044	2,000	5,000	140
0.0020	3/.029	1,250	4,500	140
0.0030	3/.036	1,250	4,500	140
0.0030	1/.064	2,000	5,000	140
0.0045	7/.029	1,250	4,500	140
0.0070	7/.036	900	4,000	140
0.0100	7/.044	900	4,000	140
0.0145	7/.052	900	4,000	140
0.0225	7/.064	900	3,500	130
0.0300	19/.044	750	3,500	125
0.0400	19/.052	750	3,000	115
0.0600	19/.064	750	3,000	100
0.0750	19/.072	600	3,000	85
0.1000	19/.083	600	3,000	80
0.1200	37/.064	600	3,000	75
0.1500	37/.072	600	3,000	60
0.2000	37/.083	600	2,500	55
0.2500	37/.093	600	2,500	50
0.3000	37/.103	600	2,500	50
0.4000	61/.093	600	2,500	50
0.5000	61/.103	600	2,500	45
0.6000	91/.093	600	2,500	40
0.7500	91/.103	600	2,500	40
0.8500	127/.093	600	2,500	35
1.0000	127/.103	600	2,500	35

TABLE A (V.).
FLEXIBLE CORDS.
Dimensions.

1.	2.	3.	4.	5.	6.	7.	8.	9.	10.
Nominal Area of Conductor.	Ordinary Flexible Cords.					Flexible Cords with Tough Sheathing of a Minimum Thickness of 0.05 inch.			Maximum Permissible Current (Subject to Voltage Drop).
	Number and Diameter (Inches) of Wires Comprising Conductor.	Minimum Thickness of Dielectric.				Number and Diameter (Inches) of Wires Comprising Conductor.	Overall Diameter.		
		High Insulation Type.		Insulated and Fire-Resisting Type.			250 Volts.	660 Volts.	
		Class.		Class.					
	A.1.	A.2.	B.1.	B.2.					
Sq. Inch.		Inch.	Inch.	Inch.	Inch.		Inch.	Inch.	Amperes.
0.001	23/0076	0.024	0.034	0.020	0.028	9/012	0.216	0.258	5.0
0.0017	40/0076	0.024	0.035	0.020	0.030	16/012	0.227	0.269	7.5
0.003	70/0076	0.024	0.036	0.020	0.031	28/012	0.248	0.290	12.5
0.0048	110/0076	0.024	0.038	0.020	0.032	44/012	0.268	0.308	20.0
0.007	162/0076	0.024	0.039	0.020	0.032	65/012	0.290	0.330	25.0

For resistance see Table A (I.) for conductors of the same nominal area.

TABLE A. (VI.)
APPROXIMATE FUSING DATA FOR COPPER, LEAD-TIN ALLOY AND PURE TIN FUSE WIRES.

Size.		Copper.		Lead-Tin Alloy (Lead 75%, Tin 25%).		Pure Tin.
Diameter.	Equivalent Gauge.	Fusing Point (approx.)	Maximum Safe Working Current.	Fusing Point (approx.)	Maximum Safe Working Current.	Fusing Point (approx.)
Inch.	S.W.G.	Amperes.	Amperes.	Amperes.	Amperes.	Amperes.
0.0076	36	1.09
0.0092	34	8.6	4.3	1.45
0.010	33	9.8	4.9
0.0108	32	11.0	5.5	1.84
0.0120	..	12.8	6.4
0.0124	30	13.5	6.8	2.27
0.0148	28	17	8.6	2.96
0.018	26	22	11	3.97
0.020	25	26	13	3	2.0	5.00
0.022	24	30	15	3.5	2.3	5.36
0.024	23	34	17	4	2.6	..
0.028	22	41	21	5	3.3	7.69
0.029	..	43	22
0.032	21	60	30	6	4.1	10.00
0.036	20	62	31	7	4.8	11.21
0.040	19	73	37	15.0
0.044	..	86	43
0.048	18	98	49	10	7	17.26
0.052	..	111	56	20.00
0.056	17	125	63
0.064	16	156	78	16	11.0	26
0.072	15	191	96	30
0.080	14	229	115	37
0.104	12	55
0.128	10	75
0.160	8	117

Note.—Table A. (VI.) refers to wires in free air and of the following lengths:—Copper, 2½ to 3½ in. for wires up to 0.018 in. diameter, and not less than 4 in. for larger wires. Lead-tin Alloy and Tin, 2½ to 3½ in.

The values given in the table may be taken to be correct where the fuse wire passes through an asbestos tube and does not closely touch the tube, but they do not apply where a substantial length of the wire is in contact with a porcelain holder. The tendency of the latter design is to increase the working capacity of the fuse, i.e., more current is required to melt the fuse, and if greater accuracy is required the fusing current should be determined for the fuse-holder in question.

For copper wires, the values of the currents given in the table are those necessary to fuse the wire in one minute, and are not appreciably different for other periods (the current required to fuse the wire in two hours being, in general, over 90 per cent. of that required to melt the wire in one minute).

For the lead-tin alloy, the currents given in the table are those necessary to fuse the wire in two minutes.

In every case the relation between the fusing current and the maximum safe running current is based on values which will not produce an excessive temperature under normal running conditions. The actual temperature rise at the hottest part of the fuse wire will be from 100° to 150° C. for copper, and 50° to 75° C. for the lead-tin alloy.

TABLE A (VII).
MAXIMUM NUMBER OF V.I.R. CABLES PERMITTED IN CONDUITS.

Size of Con- ductors, (New Standard).	External Diameter of Conduit.													
	½ Inch.		¾ Inch.		1 Inch.		1¼ Inch.		1½ Inch.		2 Inch.			
	Class.		Class.		Class.		Class.		Class.		Class.			
	A.	B.	A.	B.	A.	B.	A.	B.	A.	B.	A.	B.		
1/·044	3	..	5	4	7	6	12	10	20	16	30	26	50	46
1/·064	2	..	4	3	6	4	10	8	16	14	24	20	40	36
3/·029	2	..	4	3	6	5	12	10	20	16	30	26	50	46
3/·036	2	..	3	2	4	4	8	6	14	12	20	16	32	30
7/·029	1	..	2	2	4	3	8	6	12	10	16	14	24	22
7/·036	1	..	1*	1	3	2*	6	5	10	8	14	12	18	16
7/·044	1	..	1	1	2*	1	4	3	6	6	8	7	12	10
7/·052	1	..	1	1	2*	2*	4	4	6	5	9	8
7/·064	1	..	1	1	2*	2*	4	4	6	5	9	8
19/·044	1	1	1*	1	3	3	5	4	8	6
19/·052	1	1	1*	1	3	3	5	4	8	6
19/·064	1	1	1	1	2*	2*	4	4
19/·072	1	1	1	1	2	2	4	4
19/·083	1	1	1	1	2*	1	4	4

NOTE.—The external diameter is that by which the size of the conduit is known. For wires having radial dielectric thickness of 62 mils, take one size larger up to and including 7/·052.
* In these cases two additional conductors may be inserted, provided the external diameter does not exceed one-half the diameter of the conductors mentioned in the Table.

And the Honorable John Alexander Hipworth, for and on behalf of His Majesty's Minister in Charge of Electrical Undertakings for the State of Victoria, shall give the necessary directions herein accordingly.

A. G. COULTHARD,
Acting Clerk of the Executive Council.

