



# VICTORIA GOVERNMENT GAZETTE.

Published by Authority.

[Registered at the General Post Office, Melbourne, for transmission by post as a newspaper.]

No. 1020]

WEDNESDAY, OCTOBER 17.

[1951

## ACTS OF PARLIAMENT.

### PROCLAMATION

By His Excellency the Governor of the State of Victoria and its Dependencies in the Commonwealth of Australia, &c., &c., &c.

I, THE Governor of the State of Victoria, in the Commonwealth of Australia, do hereby declare that I have this day assented, in His Majesty's name, to the Bills passed by the Parliament of the said State, the titles whereof are hereunder set forth, that is to say:—

No. 5563. "An Act to amend the *Imported Materials Loan and Application Act 1949.*"

No. 5564. "An Act to amend the *Co-operative Housing Societies Acts*, and for other purposes."

Given under my Hand and the Seal of the State of Victoria aforesaid, at Melbourne, this sixteenth day of October, in the year of our Lord One thousand nine hundred and fifty-one, and in the fifteenth year of the reign of His Majesty King George VI.

(L.S.)

DALLAS BROOKS.

By His Excellency's Command,

JOHN G. B. McDONALD,  
Premier.

GOD SAVE THE KING!

*Survey Co-ordination Act 1940.*  
PROCLAIMED SURVEY AREA.

### PROCLAMATION

By His Excellency the Governor of the State of Victoria and its Dependencies in the Commonwealth of Australia, &c., &c., &c.

WHEREAS by an Act of Parliament of the State of Victoria passed in the fourth year of the reign of His present Majesty King George VI., intituled the *Survey Co-ordination Act 1940*, it is amongst other things enacted that the Governor in Council may from time to time by Proclamation published in the *Government Gazette* proclaim certain areas of land as survey areas for the purpose of the aforesaid Act: Now therefore I, the Governor

of the State of Victoria, acting by and with the advice of the Executive Council thereof do, by this my Proclamation declare that the land hereinafter described be proclaimed a Survey Area for the purposes of section 12 (2) of the aforesaid Act (that is to say):—

**BENDIGO.**—Approximately 3,000 acres, Parish of Sandhurst, part City of Bendigo, and part Borough of Eaglehawk, County of Bendigo, as indicated on plan hereunder. (Proclaimed survey area No. 2), (S.372<sup>(30, 31, 32, 33, 34, 35)</sup>, (E.116<sup>(2, 3)</sup>) (C.O.S.3214).

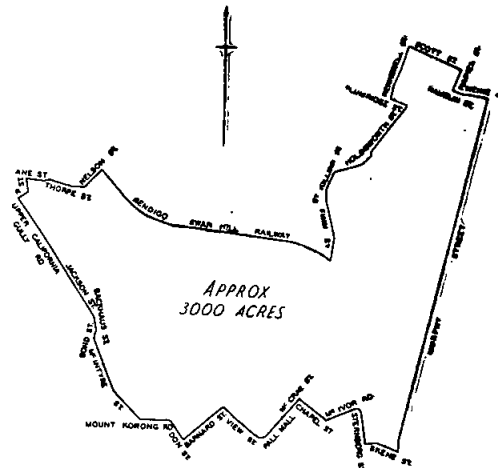

Given under my Hand and the Seal of the State of Victoria aforesaid, at Melbourne, this ninth day of October, in the year of our Lord One thousand nine hundred and fifty-one, and in the fifteenth year of the reign of His Majesty King George VI.

(L.S.)

DALLAS BROOKS.

By His Excellency's Command,

A. E. LIND,  
Commissioner of Crown Lands and Survey.

GOD SAVE THE KING!

Land Act 1928, Section 25, as amended by Land Act 1933, Section 2.

**ORDER REVOKED, PROCLAMATION RESCINDED AS TO PART AND TOWNSHIP OF BARNAWARTHA PROCLAIMED.**

**PROCLAMATION**

By His Excellency the Governor of the State of Victoria and its Dependencies in the Commonwealth of Australia, &c., &c., &c.

I THE Governor of the State of Victoria, in the Commonwealth of Australia, by and with the advice of the Executive Council of the said State, and in pursuance of the provisions contained in section 25 of the Land Act 1928, as amended by section 2 of the Land Act 1933, do by this notice revoke the Order dated 14th December, 1857, fixing the site for a Township at Barnawartha on the Indigo Creek (see Government Gazette 1857, page 2449), and rescind the Proclamation dated 18th February, 1861, defining certain areas of land as Towns insofar as it refers to the Town of Barnawartha (see Government Gazette 1861, page 401), and in lieu thereof do proclaim as a Township under the designation of Barnawartha the area of land in the Parish of Barnawartha South, County of Bogong, within the boundaries indicated by conventional township sign on the plan hereunder.—(B.55(2), (B.56(2), (C.93375).

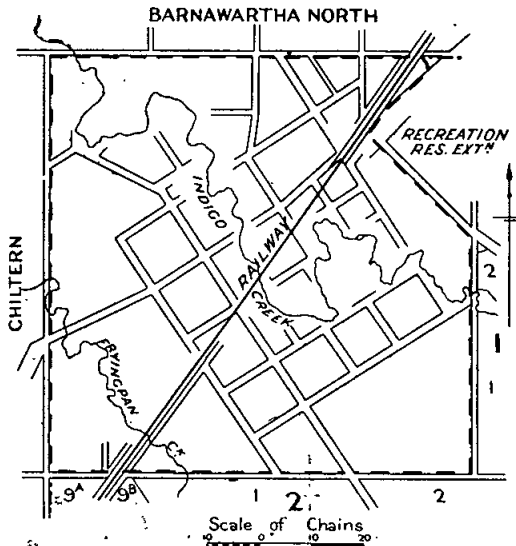

Given under my Hand and the Seal of the State of Victoria aforesaid, at Melbourne, this ninth day of October, in the year of our Lord One thousand nine hundred and fifty-one, and in the fifteenth year of the reign of His Majesty King George VI.

(L.S.) DALLAS BROOKS.

By His Excellency's Command,  
A. E. LIND,  
Commissioner of Crown Lands and Survey.  
GOD SAVE THE KING!

Land Act 1928, Section 25, as amended by Land Act 1933, Section 2.

**ORDERS REVOKED AND TOWN OF DARLINGTON ALTERED TO TOWNSHIP OF DARLINGTON.**

**PROCLAMATION**

By His Excellency the Governor of the State of Victoria and its Dependencies in the Commonwealth of Australia, &c., &c., &c.

I THE Governor of the State of Victoria, in the Commonwealth of Australia, by and with the advice of the Executive Council of the said State, and in pursuance of the provisions contained in section 25 of the Land Act 1928, as amended by section 2 of the Land Act 1933, do by this notice revoke the Order dated 29th July, 1852, fixing a site for a Village at Darlington, at Elephant Bridge, on

the Emu Creek (see Government Gazette 1852, page 801), and the Order dated 15th October, 1852, fixing a site for a Township at Darlington, at Elephant Bridge, on the Emu Creek (see Government Gazette 1852, page 1173), and substitute the designation Township of Darlington for the designation Town of Darlington of the area defined by the Proclamation dated 18th February, 1861, as the Town of Darlington (see Government Gazette 1861, page 403).—(D.5(4) (C.93372).

Given under my Hand and the Seal of the State of Victoria aforesaid, at Melbourne, this ninth day of October, in the year of our Lord One thousand nine hundred and fifty-one, and in the fifteenth year of the reign of His Majesty King George VI.

(L.S.) DALLAS BROOKS.

By His Excellency's Command,  
A. E. LIND,  
Commissioner of Crown Lands and Survey.  
GOD SAVE THE KING!

Land Act 1928, Section 25.

**PROCLAMATION OF TOWNSHIP OF HEYWOOD.**

**PROCLAMATION**

By His Excellency the Governor of the State of Victoria and its Dependencies in the Commonwealth of Australia, &c., &c., &c.

I THE Governor of the State of Victoria, in the Commonwealth of Australia, by and with the advice of the Executive Council of the said State, and in pursuance of the provisions contained in section 25 of the Land Act 1928, do hereby proclaim as a Township under the designation of Heywood the area of land in the Parishes of Drumborg and Heywood, County of Normanby, within the boundaries indicated by conventional township sign on the plan hereunder.—(D.106(2) (H.86(2) (H.87(2) (C.93358).

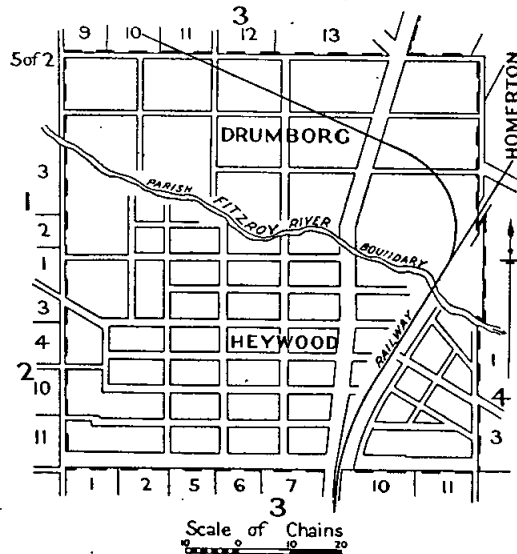

Given under my Hand and the Seal of the State of Victoria aforesaid, at Melbourne, this ninth day of October, in the year of our Lord One thousand nine hundred and fifty-one, and in the fifteenth year of the reign of His Majesty King George VI.

(L.S.) DALLAS BROOKS.

By His Excellency's Command,  
A. E. LIND,  
Commissioner of Crown Lands and Survey.  
GOD SAVE THE KING!

## PUBLIC HIGHWAY.—SHIRE OF FERN TREE GULLY.

## PROCLAMATION

By His Excellency the Governor of the State of Victoria and its Dependencies in the Commonwealth of Australia, &c., &c., &c.

**WHEREAS** by the *Local Government Act 1946* (No. 5203), section 518, it is amongst other things enacted that it shall be lawful for the Governor in Council at any time and from time to time, upon the request of the council of any municipality, by notice in the *Government Gazette*, to declare any land reserved, used, or by purchase or exchange acquired for a street, road, highway, thoroughfare, bridge, square, court, alley, or right of way, to be a public highway, and that such land shall thereupon and thenceforth from the date of such Proclamation become and be absolutely dedicated to the public as a public highway within the meaning of any law then or thereafter in force: And whereas the Council of the Shire of Fern Tree Gully has requested that the land hereinafter mentioned which has been used as a street within the said shire, be so declared to be a public highway: Now therefore I, the Governor of the State of Victoria, in the Commonwealth of Australia, by and with the advice of the Executive Council of the said State, do, by this Proclamation, declare that all that piece of land used as a street and described hereunder shall be a public highway within the meaning of the said Act, viz.:—

All that piece of land shown as Harcourt-road and coloured brown on plan of subdivision No. 12272, lodged in the Office of Titles, being part of Crown allotment 70b, Parish of Scoresby, County of Mornington, commencing at a point on the northern boundary of Forest-road distant 487 ft. 9 in. on a bearing of 262 deg. 14 min. from the eastern corner of Crown allotment 70b; thence by bearings and distances 57 deg. 24 min., 22 ft. 8 in.; 2 deg. 26 min., 276 ft. 5 in.; 321 deg. 30 min., 690 ft. 10 in.; 265 deg. 36 min., 16 ft. 10 in. to Moncoe-street; thence in line with the south-eastern boundary of Moncoe-street, bearing 29 deg. 42 min., 68 ft. 10 in.; thence 141 deg. 30 min., 744 ft. 6 in.; 182 deg. 26 min., 285 ft. 9 in.; 132 deg. 20 min., 12 ft. 10 in. to the northern boundary of Forest-road; thence 262 deg. 14 min., 79 ft. 8 in. to the point of commencement.

Given under my Hand and the Seal of the State of Victoria aforesaid, at Melbourne, this ninth day of October, in the year of our Lord One thousand nine hundred and fifty-one, and in the fifteenth year of the reign of His Majesty King George VI.

(L.S.) DALLAS BROOKS.

By His Excellency's Command,  
P. T. BYRNES,  
Commissioner of Public Works.

GOD SAVE THE KING!

## PUBLIC HIGHWAY.—SHIRE OF MELTON.

## PROCLAMATION

By His Excellency the Governor of the State of Victoria and its Dependencies in the Commonwealth of Australia, &c., &c., &c.

**WHEREAS** by the *Local Government Act 1946* (No. 5203), section 518, it is amongst other things enacted that it shall be lawful for the Governor in Council at any time and from time to time, upon the request of the council of any municipality, by notice in the *Government Gazette*, to declare any land reserved, used, or by purchase or exchange acquired for a street, road, highway, thoroughfare, bridge, square, court, alley, or right of way, to be a public highway, and that such land shall thereupon and thenceforth from the date of such Proclamation become and be absolutely dedicated to the public as a public highway within the meaning of any law then or thereafter in force: And whereas the Council of the Shire of Melton has requested that the land hereinafter mentioned which has been used as a street within the said shire, be so declared to be a public highway: Now therefore I, the Governor of the State of Victoria, in the Commonwealth of Australia, by and with the advice of the Executive Council of the said State, do, by this Proclamation, declare that all that piece of land described hereunder shall be a public highway within the meaning of the said Act, viz.:—

*Toolern-street.*

All that piece of land situate in the Parish of Djerriwarrh, County of Bourke, being part of Crown allotment A, section IV., commencing at a point on the east boundary of Exford-road, distant 5 chains south from the south

boundary of Creek-street; thence by lines bearing north 89 deg. 59½ min., east 1,755 links, south 0 deg. 4½ min., east 80 links, and south 89 deg. 59½ min., west 1,755 links; and thence along the east boundary of Exford-road, bearing north 0 deg. 4½ min., west to the commencing point, and being Toolern-street coloured brown on plan of subdivision No. 5904 lodged in the Office of Titles.

Given under my Hand and the Seal of the State of Victoria aforesaid, at Melbourne, this ninth day of October, in the year of our Lord One thousand nine hundred and fifty-one, and in the fifteenth year of the reign of His Majesty King George VI.

(L.S.) DALLAS BROOKS.

By His Excellency's Command,  
P. T. BYRNES,  
Commissioner of Public Works.  
GOD SAVE THE KING!

## SHIRE OF TRARALGON.

## PUBLIC HIGHWAY.—JANETTE STREET.

## PROCLAMATION

By His Excellency the Governor of the State of Victoria and its Dependencies in the Commonwealth of Australia, &c., &c., &c.

**WHEREAS** by the *Local Government Act 1946* (No. 5203), section 518, it is amongst other things enacted that it shall be lawful for the Governor in Council at any time and from time to time, upon the request of the council of any municipality, by notice in the *Government Gazette*, to declare any land reserved, used, or by purchase or exchange acquired for a street, road, highway, thoroughfare, bridge, square, court, alley, or right-of-way to be a public highway, and that such land shall thereupon and thenceforth from the date of such Proclamation become and be absolutely dedicated to the public as a public highway within the meaning of any law then or thereafter in force: And whereas the Council of the Shire of Traralgon has requested that the land hereinafter mentioned, which has been used as a street within the said Shire, be so declared to be a public highway: Now therefore, I, the Governor of the State of Victoria, in the Commonwealth of Australia, by and with the advice of the Executive Council of the said State, do by this Proclamation declare that all that piece of land used as a street, commencing at a point distant 176 deg. 58 min. 356.8 links from the south-west corner of allotment 81, Township of Traralgon, Parish of Traralgon; thence by lines bearing respectively 86 deg. 38 min. 1,695.6 links; 176 deg. 38 min. 68.2 links; 266 deg. 38 min. 1,695.7 links; 356 deg. 58 min. 68.2 links to the point of commencement, and known as Janette-street, Traralgon, shall be a public highway within the meaning of the said Act.

Given under my Hand and the Seal of the State of Victoria aforesaid, at Melbourne, this ninth day of October, in the year of our Lord One thousand nine hundred and fifty-one, and in the fifteenth year of the reign of His Majesty King George VI.

(L.S.) DALLAS BROOKS.

By His Excellency's Command,  
P. T. BYRNES,  
Commissioner of Public Works.  
GOD SAVE THE KING!

*North-West Mallee Settlement Areas Act 1948.*  
NORTH-WEST MALLEE SETTLEMENT AREA.—  
CARWARP (EXTENDED).

## PROCLAMATION

By His Excellency the Governor of the State of Victoria and its Dependencies in the Commonwealth of Australia, &c., &c., &c.

**WHEREAS** by an Act of Parliament of the State of Victoria passed in the twelfth year of the reign of His present Majesty King George VI., intitled the *North-West Mallee Settlement Areas Act 1948*, it is amongst other things enacted that the Governor in Council may from time to time by Proclamation published in the *Government Gazette* declare any area of land in the North-West Mallee to be a North-West Mallee Settlement Area for the purposes of the aforesaid Act, and whereas by Proclamation dated the thirty-first day of January, 1951, certain areas in the County of Karkaroc were declared to be a North-West Mallee Settlement Area to be known as the Carwarp Settlement Area: Now

therefore, I, the Governor of the State of Victoria, acting by and with the advice of the Executive Council thereof, do, by this my Proclamation, declare that the said Carwarp Settlement Area is hereby extended by the addition thereto of allotment 8A, Parish of Ginguam; allotment 37, Parish of Carwarp West; and allotments 33, 38, 38A, 39, 42, 43, 43A, 43B, 44, 52, 53, and 54, Parish of Yatpool, County of Karkaroc.—(X.122).

Given under my Hand and the Seal of the State of Victoria aforesaid, at Melbourne, this ninth day of October in the year of our Lord One thousand nine hundred and fifty-one, and in the fifteenth year of the reign of His Majesty King George VI.

(L.S.) DALLAS BROOKS.

By His Excellency's Command,  
A. E. LIND,  
Commissioner of Crown Lands and Survey.

GOD SAVE THE KING!

*North-West Mallee Settlement Areas Act 1948.*  
NORTH-WEST MALLEE SETTLEMENT AREA.—  
ANNUELLO-KOOLONONG (FURTHER EXTENDED).

#### PROCLAMATION

By His Excellency the Governor of the State of Victoria and its Dependencies in the Commonwealth of Australia, &c., &c., &c.

WHEREAS by an Act of Parliament of the State of Victoria passed in the twelfth year of the reign of His present Majesty King George VI., intitled the *North-West Mallee Settlement Areas Act 1948*, it is amongst other things enacted that the Governor in Council may from time to time by Proclamation published in the *Government Gazette* declare any area of land in the North-West Mallee to be a North-West Mallee Settlement Area for the purpose of the aforesaid Act, and whereas by Proclamation dated the twentieth day of September, 1949, certain areas in the Counties of Karkaroc and Tatchera were declared to be a North-West Mallee Settlement Area, to be known as the Annuello-Kooloonong Settlement Area, and whereas by Proclamation dated the twenty-first day of March, 1950, such Annuello-Kooloonong Settlement Area was extended: Now therefore, I, the Governor of the State of Victoria, acting by and with the advice of the Executive Council thereof, do, by this my Proclamation, declare that the Annuello-Kooloonong Settlement Area is hereby extended further by the addition thereto of allotments 1, 2, and 3, Parish of Myall, County of Karkaroc, allotments 10 and 11, Parish of Burra, and allotment 1A, Parish of Narrung, County of Tatchera.—(X.122).

Given under my Hand and the Seal of the State of Victoria aforesaid, at Melbourne, this ninth day of October in the year of our Lord One thousand nine hundred and fifty-one, and in the fifteenth year of the reign of His Majesty King George VI.

(L.S.) DALLAS BROOKS.

By His Excellency's Command,  
A. E. LIND,  
Commissioner of Crown Lands and Survey.

GOD SAVE THE KING!

#### PUBLIC HOLIDAYS.

##### PROCLAMATION

By His Excellency the Governor of the State of Victoria and its Dependencies in the Commonwealth of Australia, &c., &c., &c.

IN pursuance of the provisions contained in Part III. of the *Public Service Act 1946*, I, the Governor of the State of Victoria, in the Commonwealth of Australia, by and with the advice of the Executive Council of the said State, do by this my Proclamation appoint the days and dates hereunder mentioned to be observed as Public Holidays or Public Half-Holidays (as the case may be) at the places respectively specified, viz.:—

##### Public Holidays:—

WEDNESDAY, THE 31ST DAY OF OCTOBER, 1951, throughout the Dookie and South Ridings of the Shire of Shepparton\*.

SATURDAY, THE 1ST DAY OF DECEMBER, 1951, throughout the Shire of Mortlake\*.

##### Public Holidays from the Hour of Eleven o'clock in the Forenoon:—

THURSDAY, THE 18TH DAY OF OCTOBER, 1951, throughout the North and Tyrrell Ridings of the Shire of Wycheproof\*, and throughout the Township of Culgoa in the Shire of Wycheproof\*.

WEDNESDAY, THE 24TH DAY OF OCTOBER, 1951, throughout the South Riding of the Shire of Wycheproof\*, and throughout the Township of Nullawit in the Shire of Wycheproof\*.

##### Public Half-Holidays from the Hour of Twelve o'clock noon:—

TUESDAY, THE 16TH DAY OF OCTOBER, 1951, throughout the Shire of Creswick.

WEDNESDAY, THE 24TH DAY OF OCTOBER, 1951, throughout the City of Geelong and the City of Geelong West.

WEDNESDAY, THE 7TH DAY OF NOVEMBER, 1951, throughout the Kyneton Riding of the Shire of Kyneton.

\* Agricultural Show.

Given under my Hand and the Seal of the State of Victoria aforesaid, at Melbourne, this sixteenth day of October, in the year of our Lord One thousand nine hundred and fifty-one, and in the fifteenth year of the reign of His Majesty King George VI.

(L.S.) DALLAS BROOKS.

By His Excellency's Command,  
K. DODGSHUN,  
Chief Secretary.

GOD SAVE THE KING!

#### PUBLIC HOLIDAY.

(Victorian Centenary Celebrations.)

NOTICE is hereby given that on—

TUESDAY, THE 13TH NOVEMBER, 1951,

the Public Offices will be closed, that day having been proclaimed by the Governor in Council, under the powers conferred by the *Public Service Act 1946*, to be observed as a holiday in the Public Offices throughout the State, to mark the Centenary of the Government of Victoria.

This Notice relates only to the closing of the State Public Offices. All inquiries regarding holidays in other offices and in shops and industry should be directed to the Department of Labour, Old Treasury Building, Spring-street, Melbourne, C.1. (Telephone F0234, Extension 266 or 882).

K. DODGSHUN,  
Chief Secretary.

Chief Secretary's Office,  
Melbourne, C.1, 18th September, 1951.

#### MELBOURNE CUP HOLIDAY.

NOTICE is hereby given that on—

TUESDAY, THE 6TH NOVEMBER, 1951,

the Public Offices in the municipalities hereunder will be closed, that day having been proclaimed by the Governor in Council, under the powers conferred by the *Public Service Act 1946*, to be observed as a holiday in the Public Offices:—

Bacchus Marsh, Berwick, Box Hill, Brighton, Broadmeadows, Brunswick, Bulla, Camberwell, Caulfield, Chelsea, Coburg, Collingwood, Cranbourne, Dandenong, Doncaster and Templestowe, Eltham, Essendon, Ferntree Gully, Fitzroy, Footscray, Frankston and Hastings, Gisborne, Hawthorn, Heidelberg, Keilor, Kew, Lillydale, Malvern, Melbourne, Melton, Moorabbin, Mordialloc, Mornington, Mulgrave, Northcote, Nunawading, Oakleigh, Port Melbourne, Prahran, Preston, Richmond, Ringwood, Romsey, Sandringham, St. Kilda, South Melbourne, Sunshine, Werribee, Whittlesea, and Williamstown.

This Notice relates only to the closing of the State Public Offices. All inquiries regarding holidays in other offices and in shops and industry should be directed to the Department of Labour, Old Treasury Building, Spring-street, Melbourne, C.1. (Telephone F0234, Extension 266 or 882).

K. DODGSHUN,  
Chief Secretary.

Chief Secretary's Office,  
Melbourne, C.1, 18th September, 1951.

VICTORIA GOVERNMENT GAZETTES  
OF WEDNESDAY, 7TH NOVEMBER, 1951, AND  
WEDNESDAY, THE 14TH NOVEMBER, 1951.

PUBLICATION OF OFFICIAL MATTER.

IT is hereby notified for general information that, owing to the proclamation of public holidays on Tuesdays, the 6th and 13th November, 1951, all official matter for publication in the above-mentioned issues of the *Victoria Government Gazette* should be lodged with the *Gazette* Officer, Chief Secretary's Department, not later than 10.30 a.m. on Monday, the 5th, and Monday, the 12th November, 1951, respectively.

APPOINTMENTS.

HIS Excellency the Governor of the State of Victoria, by and with the advice of the Executive Council thereof, has, by Orders made on the 9th day of October, 1951, been pleased to make the under-mentioned appointments, viz.:—

CHIEF SECRETARY'S DEPARTMENT.

Registrars of Births and Deaths.

REGINALD NORTHCOTE DAWBORN,

pursuant to the provisions of section 4 of the *Registration of Births Deaths and Marriages Act 1928*, to be Registrar of Births and Deaths at Romsey, to date from commencement of duty, with fees; and

ALAN MELVILLE BLAKE,

pursuant to the provisions of section 4 of the *Registration of Births Deaths and Marriages Act 1928*, to be Registrar of Births and Deaths at Cobden, to date from commencement of duty, with fees, *vice* Lillian Elizabeth Jones, resigned.

Licensing Inspector.

ALEXANDER TAYLOR MARTIN, Superintendent of Police, pursuant to the provisions of the Licensing Acts, to be a Licensing Inspector for each and every Licensing District in the State of Victoria, *vice* Samuel James Williams, retired.

Inspector of Totalizators.

ERIC LAWRENCE RICHARDSON,

pursuant to the provisions of the Totalizator Acts, to be an Inspector for the purposes of the said Acts.

Officer in Charge (Acting) of Training Prison.

ELLIS MICHAEL OWENS,

pursuant to the provisions of the *Gaols Act 1928*, to be Officer in Charge (Acting) of the Beechworth Training Prison, from the 15th October, 1951, to the 28th October, 1951, both dates inclusive, during the absence on leave of William Callaghan.

Officer in Charge (Acting) of Gaol.

IAN GORDON GRINDLAY,

pursuant to the provisions of the *Gaols Act 1928*, to be Officer in Charge (Acting) of the Ballarat Gaol, from the 9th November, 1951, to the 26th November, 1951, both dates inclusive, during the absence on leave of John Duggan.

DEPARTMENT OF HEALTH.

Government Representatives on Hospital Committees.

KEITH STIRLING STEVENSON

to be Government Representative on the Committee of Management of the Frankston Community Hospital, pursuant to the provisions of section 48 of the *Hospitals and Charities Act 1948* (No. 5300), for a term of three years as from the 26th October, 1951;

FRANCIS JOSEPH LYONS

to be Government Representative on the Committee of Management of the Kilmore Hospital, pursuant to the provisions of section 48 of the *Hospitals and Charities Act 1948* (No. 5300), for a term of three years as from the 26th October, 1951; and

ROY BERESFORD McDONALD

to be Government Representative on the Committee of Management of the Port Fairy Hospital, pursuant to the provisions of section 48 of the *Hospitals and Charities Act 1948* (No. 5300), for a term of three years, *vice* H. J. Porter, deceased.

Official Visitor.

DAVID HERBERT MONTGOMERY, J.P.,

to be Official Visitor to the Mental Hospital, Ararat, pursuant to the provisions of section 74 of the *Mental Hygiene Act 1928* (No. 3721).

Member of Staff of Hospitals and Charities Commission.

RAYMOND FRANCIS WORCESTER

to be a Member of the staff of the Hospitals and Charities Commission, pursuant to the provisions of section 14 of the *Hospitals and Charities Act 1948* (No. 5300), as from the 5th October, 1951, *vice* Eric Baird, resigned.

LAW DEPARTMENT.

Bailiff of County Court.

NEIL THOMAS BRADLEY, Senior Constable of Police, Wodonga,

to be also a Bailiff of the County Court at Wangaratta, during the absence on leave of J. E. Wilson, with fees.

Commissioner of Titles.

ALFRED ERNEST RASMUSSEN

to be Commissioner of Titles, pursuant to the provisions of the *Transfer of Land Act 1928* (No. 3791), *vice* F. W. W. Betts, for a period of two months as on and from the 12th October, 1951.

Commissioners for Taking Declarations, &c.

FRANK HAMPSON LANSELL, and

FRANK JEFFERSON GOOLD,

Officers of the State Electricity Commission of Victoria, Yallourn,

to be Commissioners for taking Declarations and Affidavits, pursuant to the provisions of Division 8 of Part IV. of the *Evidence Act 1928*, to refrain from charging fees and to resign upon ceasing to occupy their present positions; and

JACK KENNETH WELSH, 701A Eyre-street, Ballarat, to be a Commissioner for taking Declarations and Affidavits, pursuant to the provisions of Division 8 of Part IV. of the *Evidence Act 1928*, to resign upon removing from the neighbourhood of the address stated.

Deputy Coroners.

ALBERT HAROLD TREBLE, J.P., Dunolly,

to be a Deputy Coroner, pursuant to the provisions of the *Coroners Act 1928*, to act and have jurisdiction for and during the absence of the Coroner at and in the vicinity of Dunolly; and

GEORGE WILLIAM TREWHELLA, J.P., Trentham,

to be a Deputy Coroner, pursuant to the provisions of the *Coroners Act 1928*, to act and have jurisdiction for and during the absence of the Coroner at and in the vicinity of Trentham.

Magistrates.

WILLIAM ALFRED JUPP, 9A Clarke-street, Abbotsford, to Keep the Peace in the Central Bailiwick of the State of Victoria;

JOHN HERBERT BEAN, Yandoit,

to Keep the Peace in the Midland Bailiwick of the State of Victoria; and

CHARLES STANLEY THOMAS PLUMMER, Hitchcock-avenue, Barwon Heads,

to Keep the Peace in the Southern Bailiwick of the State of Victoria.

DEPARTMENT OF STATE FORESTS.

Poundkeepers.

SYDNEY ERNEST RYAN, Forester,

to be Poundkeeper of Alberton West Forest Pound, Parish of Alberton, and Won Wron Forest Pound, Parish of Won Wron, *vice* G. H. Jennings, transferred;

HAROLD HEINRICH BEER, Forester,

to be Poundkeeper of Burramine Forest Pound, Parish of Burramine, Killawarra Forest Pound, Parish of Killawarra, Dick's Bend Forest Pound, Parish of Cobram, and Murray River Forest Pound, Parish of Cobram, *vice* W. J. C. Dempsey, transferred;

JAMES CAMPBELL WESTCOTT, Chief Forester,

to be Poundkeeper of Boonderoot Forest Pound, Parish of Boonderoot, and Enano Forest Pound, Parish of Enano, *vice* D. D. Beale, resigned;

ALAN JOHN THREADER, Forester,

to be Poundkeeper of Clonbinane Forest Pound, Parish of Clonbinane, *vice* E. D. Gill, transferred;

KINGSLEY MELBOURNE GIBSON, Forester,

to be Poundkeeper of Changue Forest Pound, Parish of Changue, and Merrijig Forest Pound, Parish of Merrijig, *vice* J. C. Westcott, transferred;

DONALD MURRAY THOMPSON, Forester,

to be Poundkeeper of Gooramadda Forest Pound, Parish of Gooramadda, *vice* D. K. Parnaby, transferred;

VALENTINE PERCY CLEARY, Forester,

to be Poundkeeper of Elliott River Forest Pound, Parish of Krambruk, *vice* A. J. Leslie, resigned;

JOHN HILBERT COSSTICK, Forester,

to be Poundkeeper of Upper Acheron Forest Pound, Parish

of Narbethong, and Rubicon Forest Pound, Parish of Banyarmbite, *vice* H. R. Parke, transferred;

DAVID KINGSLEY PARNABY, Forester, to be Poundkeeper of Cann Valley Forest Pound, Parish of Noorinbee, *vice* C. W. Elsey, transferred;

JOHN PHILIP NEWBY, Chief Forester, to be Poundkeeper of Crooked Creek Forest Pound, Parish of Warburton, *vice* J. H. Cosstick, transferred;

GEOFFREY KILFEDER TRELOAR, Assistant Forester, to be Poundkeeper of Bet Bet Forest Pound, Parish of Havelock, *vice* R. Ingle, transferred; and

WILLIAM JAMES CAMPBELL DEMPSEY, Forest Supervisor, to be Poundkeeper of Dargile Forest Pound, Parish of Dargile, *vice* H. H. Beer, transferred—in pursuance of the provisions of section 84 of the *Forests Act 1928*.

#### DEPARTMENT OF WATER SUPPLY.

##### *River Improvement Trust Commissioner.*

ERIC JOHN JOSEPH LEE to be a Commissioner of the Avon River Improvement Trust for a period of four years from the date hereof, subject to the provisions of the Water Acts.

##### *Waterworks Trust Commissioner.*

DAVID GRANT MACCUBBIN to be a Commissioner of the Traralgon Waterworks Trust for a period of four years from the date hereof, subject to the provisions of the Water Acts.

A. MAHLSTEDT,  
Clerk of the Executive Council.

At the Executive Council Chamber,  
Melbourne, 9th October, 1951.

#### RESIGNATIONS.

HIS Excellency the Governor of the State of Victoria, by and with the advice of the Executive Council thereof, has, by Orders made on the 9th day of October, 1951, accepted the resignations of the persons named hereunder of the offices mentioned, *viz.*—

#### CHIEF SECRETARY'S DEPARTMENT.

LILIAN ELIZABETH JONES, as Registrar of Births and Deaths at Cobden.

SARAH M. GLENNY, as Registrar of Births and Deaths at Glenlyon.

A. MAHLSTEDT,  
Clerk of the Executive Council.

At the Executive Council Chamber,  
Melbourne, 9th October, 1951.

#### VEGETATION AND VINE DISEASES ACT 1928.

THE undersigned George Colin Moss, being the responsible Minister of the Crown for the time being administering the *Vegetation and Vine Diseases Act 1928*, in pursuance of the powers conferred upon me under the provisions of section 9 of the said Act, do hereby appoint William Gillespie Morce to exercise with respect to any land whatsoever in that part of Victoria which lies within the limits of the Eastern, Western, Midland, Northern, and Southern Bailiwicks of the Supreme Court of Victoria as defined in the Third Schedule to the *Supreme Court Act 1928*, the following powers, that is to say, to enter upon any such land whatsoever at any time, with or without assistants, to search for diseased trees, plants, or vegetables, and to remain thereon so long as may be reasonable for such purpose.

Given under my hand, at Melbourne, the 5th day of October, 1951.

GEORGE C. MOSS,  
Minister of Agriculture.

#### VEGETATION AND VINE DISEASES ACT 1928.

THE undersigned George Colin Moss, being the responsible Minister of the Crown for the time being administering the *Vegetation and Vine Diseases Act 1928*, in pursuance of the powers conferred upon me under the provisions of section 9 of the said Act, do hereby appoint William Gillespie Morce to exercise with respect to any land whatsoever in that part of Victoria which lies within the limits of the Central Bailiwick of the Supreme Court of Victoria as defined by the *Supreme Court Act 1928*, the following powers, that is to say, to enter upon any such land whatsoever at any time, with or without assistants, to search for diseased trees, plants, or vegetables, and to remain thereon so long as may be reasonable for such purpose.

Given under my hand, at Melbourne, the 5th day of October, 1951.

GEORGE C. MOSS,  
Minister of Agriculture.

#### ORDERS IN COUNCIL.—(Series 1950-51.)

##### STATE ELECTRICITY COMMISSION.

5280. The supply of 840 tons of mild steel plate, for construction works, to Quotation No. 6802, £76,610.—F. W. Green and Co. Pty. Ltd.

Approved by the Governor in Council, 17th April, 1951.—A. MAHLSTEDT, Clerk of the Executive Council.

#### ORDERS IN COUNCIL.—(Series 1951-52.)

##### STATE ELECTRICITY COMMISSION.

1672. The supply of 4,263 tons of mild steel plates for new construction and extensions, to Quotation No. 2183, £255,780.—F. W. Green and Co. Pty. Ltd. (as agents for Bethlehem Steel Export Corporation).

1673. The supply of 4,235 tons of mild steel plates for new construction and extensions, to Quotation No. 2183A, £254,100.—N. W. Hutchinson and Sons Pty. Ltd. (as agents for United States Steel Export Co.).

Approved by the Governor in Council, 2nd October, 1951.—A. MAHLSTEDT, Clerk of the Executive Council.

#### EDUCATION DEPARTMENT.

1622. One only 1935 model 6-cylinder Terraplane Sedan, for Wonthaggi Technical School, £220.—J. Collins, Rodgers-street, Yarram.

1623. One only Universal grinding machine, model BK.3, Zbrojoka, for Castlemaine Technical School, £2,350.—Demco Machinery Co. Pty. Ltd.

1624. Two only cylinder stud removers, £6; one only cylinder ridge remover, £7 18s. 6d.; one only flaring tool, £1 0s. 2d.; two only bolt tension wrenches, £10 8s.; two only valve refacers, £172 10s. 4d.; one only valve seat cutter, £11 19s. 5d.; two only honing machines, £106 2s. 8d.; two only micro head, £15 9s. 6d.; two only No. 1 hone seat, £38 5s. 6d.; two only No. 2 hone seat, £54 5s. 8d.; one only piston ring groover cleaner, 5s. 5d.; one only tire pressure gauge, 8s. 8d.; one only valve cutter pliers, 15s. 1d.; one only pliers (head light bulbs), 3s. 10d.; for Technical Sections, High Schools.—£425 12s. 9d.—E. A. Machin, Melbourne.

1625. One only valve grinder, £6 5s. 9d.; two only connecting rod aligners, £13 10s.; two only piston pin vice, £1 13s. 4d.; two only valve spring compressors, £5 18s. 10d.; one only metal pot and running equipment, £19 14s. 3d.; one only metal bearing casting plates, £47 5s.; one only Universal line boring machine, £162; two only engine stands, £63 10s.; for the equipment of Technical Schools.—£319 17s. 2d.—Recco Pty. Ltd.

1626. One only wheel and gear puller, £7 0s. 5d.; two valve seat hones and pilots, £63; two only Truebore boring machines, £265 10s.; one only cylinder honing machine, £19 17s. 10d.; one only valve guide cleaning brush, 19s. 10d.; for the equipment of Technical Schools.—£356 8s. 1d.—Brooklands Accessories Pty. Ltd.

Approved by the Governor in Council, 9th October, 1951.—A. MAHLSTEDT, Clerk of the Executive Council.

#### CONTRACTS ACCEPTED.—(Series 1951-52.)

##### PUBLIC WORKS.

1627. (1) Balwyn North, State School No. (M.A.), supply and installation of central heating to aluminium prefabricated class-rooms, £855.—W. E. Tuck.

1628. (1) Balwyn North, State School No. 4638, provision of new concrete stair on ramp on west wing, £265.—G. A. Hurse.

1629. (1) Ballarat, State School No. 33, replacement of chalk-boards, £119 12s.—H. R. Dobbin.

1630. (2) Ballarat, Teachers' College, 2 Beaufort-avenue, erection of garage at residence, £168 14s.—H. R. Dobbin.

1631. (1) Barnawatha, State School No. 1489, garage and alterations to gates and posts, £180.—J. Law and Son.

1632. (1) Beechworth, Mental Hospital, repairs and clearance of fire-damaged building, Male Block, £11,000.—J. Law and Son.

1633. (1) Bayswater, State School No. 2163, supplying and fixing wardrobes, display boards, &c., "Bristol" prefabricated class-rooms, £248.—F. T. Pulling.

1634. (2) Box Hill, Technical School, supply and installation and testing of central heating to Wood and Metal Trades Workshops and alterations to boiler-room equipment, £3,265.—W. E. Tuck.

1635. (3) Burnley, Plan Research Laboratory, supply and installation of compressed air lines, £216 5s.—W. E. Tuck.

1636. (1) Cobram, Consolidated School, erection of cookery wing, £19,847.—Keith G. Hooker Pty. Ltd.

1637. (3) Collingwood, Police Station, alteration to office accommodation, £174.—E. G. Kennedy.

1638. (4) Collingwood, Girls' School, Vere-street, internal renovations, £410.—E. G. Kennedy.
1639. (2) Collingwood, Court House, repairs and painting, £210.—E. G. Kennedy.
1640. (2) Carlton, Secondary Teachers' Training Centre, provision for drain, basins, and sink, &c., £786 15s.—A. Crewther and Son.
1641. (3) Malvern East, Chadstone Park State School No. 4930, supply and installation of a central heating system, £1,185.—W. E. Tuck.
1642. (1) Coburg, Pentridge, re-arrangement of electrical services, covering reticulation in Metropolitan and Female Divisions, £2,080.—H. W. Templeton.
1643. (1) Dingley, State School No. 4257, extending office and provision of stainless steel sink and cupboards, £198.—D. Tincknell.
1644. (3) Footscray, State School No. 253, external repairs and painting to three detached class-rooms, £287.—J. Connell.
1645. (2) Frankston, State School No. 1464, external repairs and painting, £1,085.—C. M. Wilson and Co.
1646. (1) Geelong West, Police Station, gas hot-water service, residence, £145.—Geelong Gas Co.
1647. (1) Healesville, State School No. 849, Recreation-road, erection of out-office block for prefabricated school, £898.—D. Tincknell.
1648. (1) Inglewood, State School No. 1052, removal of residence from Kurting and re-erection (including re-erection of existing tanks and stands), £555 13s.—A. F. J. Whitehead.
1649. (1) Kiewa Valley, Consolidated School, sewerage and sanitary plumbing, Cookery and Administration Wings, £4,498.—Keith G. Hooker Pty. Ltd.
1650. (1) Kaniwa, Consolidated School, extension of central heating and hot-water service, Cookery Wing, £1,171.—Keith G. Hooker Pty. Ltd.
1651. (2) Leongatha, State School No. 2981, erection of new lavatory and store at new site, £790.—D. Tincknell.
1652. (1) Lavers Hill, State School No. 3569, erection of teacher's residence (labour only), £840.—Pyers Bros.
1653. (1) Melbourne, Mental Hygiene Authority Building, 300 Queen-street, installation of central heating and hot-water services, £2,720.—W. R. Davis.
1654. (3) Melbourne, Mental Hygiene Authority Building, 300 Queen-street, repairs to roof, £447 10s.—A. Crewther and Son.
1655. (4) Melbourne, Department of Health, 300 Queen-street, supply and installation of hot cathode fluorescent light fitting, £421 10s. 3d.—Sunray Fluorescent (Vic.) Pty. Ltd.
1656. (4) Melbourne, Police Headquarters, Russell-street, hot cathode installation, C.I. Branch, £159 8s. 3d.—Sunray Fluorescent (Vic.) Pty. Ltd.
1657. (1) Northcote, State School No. 1401, internal painting, £1,795.—T. H. Pennant.
1658. (1) Nandaly, State School No. 3927, repairs and painting, £270.—C. R. Lyons.
1659. (1) Prahran, Technical School, external repairs and painting to property No. 142, new stainless steel sink to 132a High-street, £445.—Kirsten and Wigg.
1660. (1) Pakenham, Consolidated School, extension to fuel room, Administrative Offices, £363.—Keith G. Hooker and Co.
1661. (1) Richmond, State School No. 1567, fixing and supplying of cupboards under blackboards, £228.—F. T. Pulling.
1662. (1) Reservoir East, State School No. 4686, supply, erection and completion, &c., of new school in Hills, "Presweld" component parts, £33,800.—G. A. Hurse.
1663. (1) Roslyn, State School No. 4663, construction of additional class-room, £1,729 14s.—Morison Bros. Pty. Ltd.
1664. (3) Royal Park, Mental Hospital, electrical installation, Receiving Home, £232 10s.—L. W. Buchanan.
1665. (1) Sunbury, Mental Hospital, installation of main switchboard, £125 17s. 6d.—W. Cumming and Co. Pty. Ltd.
1666. (1) Tongala, Consolidated School, erection of senior wing, £19,633.—Keith G. Hooker and Co.
1667. (1) Tongala, Consolidated School, supply and installation of central heating, £2,363.—Keith G. Hooker and Co.
1668. (1) Woolsthorpe, State School No. 688, provision of partition and heaters, £243 10s.—A. R. Greed.
1669. (2) Yea, State School No. 699, repairs, painting, and paperhanging, non-party fencing, residence, £1,195.—D. Tincknell.
1670. (1) Yarra Junction, State School No. 3216, supply and fix No. 3 skylights, £225.—D. Tincknell.
1671. (1) Yarram, State School No. 693, supply and installation of kerosene hot-water service, teacher's residence, Union-street, £170.—L. F. Scott and A. C. Callander.
- P. T. BYRNES, Commissioner of Public Works. 10.10.51.
1674. (1) Melbourne, Government House, floodlighting tower, £298 3s. 6d.—W. Cumming and Co. Pty. Ltd.
1675. (1) Box Hill South, State School No. 4318, extension of sewer reticulation, £445 2s. 3d.—Melbourne and Metropolitan Board of Works.
1676. (1) East Loddon, Consolidated School, supply of sisalkraft, £169 17s. 6d.—R. Thompson.
1677. (1) Buchan Caves, Lands Department, supply and fixing fibrous plaster, residence, £325 2s.—Derite Fibrous Plaster Co. Pty. Ltd.
1678. (1) Heatherton, Sanatorium, supply and delivery of one 10-quart electric food mixer for kitchen, £110.—Brice Scale and Slicer Co.
1679. (3) Sandringham, Technical School, supply of a storage rack and eight drawing benches, £261.—McCabe and Pomeroy.
1680. (1) Langwarrin North, State School No. 3531, concrete paving, approximately 225 sq. yards (Department to supply cement), £180.—Werribee Paving Co.
1681. (1) Toorak, Secondary Male Students' Hostel, corner of Toorak-road and Walsh-street, purchase of "Schwichteir" piano, £150.—C. L. Howden.
1682. (1) Wando Vale, State School No. 3397, purchase of home lighting plant, residence, £110.—F. A. Duffy.
1683. (1) Port Melbourne, Public Works Department Storeyard, Salmon-street, supply of 225 galvanized garbage bins for Education Department, £219 7s. 6d.—A. G. Way and Co. Pty. Ltd.
1684. (1) Maryborough, Technical School, provide labour and materials (excepting cement) and build into position 260 sq. yards of concrete paving, £162 10s.—A. E. Black.
1685. (1) Speewa, State School No. 4200, supplying and fixing fibrous plaster, residence, £318.—Picton Hopkins and Son Pty. Ltd.
1686. (1) Melbourne, Hospital and Charities Commission, 61 Spring-street, electrical installation, £1,243.—F. L. Catterall.
1687. (1) Pentridge, Penal and Gaols Department, overhaul, repairs, and reconditioning weft-winding machine, woollen mill, £255 9s. 9d.—Simpson Textile Machine Pty. Ltd.
1688. (1) Beechworth, Mental Hospital, overhaul and repair electric wiring, connect temporary lighting, fire-damaged building, £115.—Garland Electric Service.
1689. (2) Coburg, Pentridge Gaol, provision of refrigerator, Female Section, £320.—Brooks, Robinson Ltd.
1690. (2) Port Melbourne, Public Works Department Depot, provision of 40 plan presses, 4 ft. 6 in. x 3 feet x 3 feet; provision of 40 plan presses, 3 ft. 6 in. x 3 feet x 3 feet, £3,360.—Brooklyn Cabinet Works Pty. Ltd.
1691. (1) Kew, "Glendonald" Deaf and Dumb School, supply of weatherboards, £156 1s. 6d.—John Sharp and Sons Pty. Ltd.
1692. (1) Various, Piers, Cowes, Stony Point, and Port-arlington, supply hardwood, £218 6s. 4d.—N. F. Gordon.
1693. (1) Portarlington, Pier, supply hardwood, £103 17s. 6d.—N. F. Gordon.
1694. (1) Stony Point and Middle Brighton, Jetties, supply hardwood, £179 3s. 9d.—N. F. Gordon.
1695. (1) Flemington, Government Pavillion, Show-grounds, supply of oregon, lining, and cover strip, £134 1s. 2d.—Charles Rouch Pty. Ltd.
1696. (1) Hamilton, High School, concrete paving, £175.—John Keen.
1697. (1) Kew, Mental Hospital, renewal of ten lavatory pans, &c., £213 16s.—A. Duncan.
1698. (1) Moe, Multi-purpose School, professional services, £4,000.—Robert Marsh, Bennie, and Barry.
1699. (1) Lindenow, State School No. 1120, erection of display boards, &c., £221.—A. J. Warry.
1700. (1) South Melbourne, Public Works Department Storeyard (teachers' residences), supply of oregon timber, £826 2s. 8d.—Millars Timber and Trading Co.
1701. (1) Tallangatta Valley, State School No. 2337, supply and fixing of fibrous plaster, £264 12s. 6d.—J. Winzer.
1702. (1) South Melbourne, Public Works Department Storeyard (teachers' residences), supply of redgum, £365.—H. Beecham and Co. Ltd.
1703. (1) South Melbourne, Public Works Department Storeyard, supply of masonite, £116 11s. 11d.—H. Beecham and Co. Ltd.
1704. (1) Werribee, State Research Farm, painting and repairs, No. 1 Grain Shed, £580.—L. W. Friezer.
1705. (1) Ballarat, Teachers' Training College, provision of bore for drainage purposes, £262 10s.—Watermore Boring Co.
1706. (1) French Island, McLeod Settlement, Reformatory, supply of doors, £135 4s.—W. S. Neelands Pty. Ltd.
1707. (1) South Melbourne, Public Works Department Storeyard (Sunbury Police Station and teachers' residences), supply of joinery, £375 5s. 3d.—The Caulfield Timber Co. Pty. Ltd.
- P. T. BYRNES, Commissioner of Public Works. 15.10.51.

## Transport Regulation Acts.

## TRANSPORT REGULATION BOARD.

## NOTICES OF PUBLIC HEARINGS.

NOTICE is hereby given that the applications made by the persons named below for licences to operate the commercial goods vehicles on the route or routes, or in the manner set out opposite their names, will be heard at a time and place to be communicated to the parties concerned:—

*Name and Address; Nature of Application.*

- ALLARDICE, I. T., 16 Burt-crescent, Moorabbin; 1 commercial goods vehicle (40 cwt.) for the carriage of marine stores in the course of business as "marine dealer" throughout the State of Victoria.
- ALLEN, R. L. & E., 10 Beatty-street; Regent; 1 commercial goods vehicle (107 cwt.) for the carriage of sawn red gum timber *en route* from McDougall's mill at Deniliquin to Case's timber yard at Sandringham and Prosser's timber yard at McKinnon.
- BELL, J. J., Tolmie; 1 commercial goods vehicle (187 cwt.) for the carriage of—(a) logs from any forest landing in the Tolmie area to Bell and Son's sawmills at Tolmie and the D.S.M.'s sawmills at Mansfield, (b) sawn timber from Bell and Son's sawmills and Menaghini's sawmills at Tolmie to timber yards at Albury, Kyabram, and Echuca.
- BOWEN, L. D., S.S. 1004, Heskett, via Woodend; 1 commercial goods vehicle (220 cwt.) for the carriage of—(a) logs from forest landings in the Woodend area to Johnson and Reillu's sawmills at Keilor, (b) sawn timber from H. Patterson's sawmills at Woodend to Gynge Bros' timber yards at Moorabbin and Ascot Vale, and to building sites in the metropolitan area (in house lots only).
- BROWN, H. S., 31 Bond-street, Ringwood; 1 commercial goods vehicle (100 cwt.) for the carriage of—(a) general goods within a radius of 20 miles of Ringwood, (b) firewood within a radius of 50 miles of Ringwood, (c) soil, stone, screenings, and sand within a radius of 50 miles of Ringwood.
- BUCK, A. J., 35 Greenwood-street, Pascoe Vale; 1 commercial goods vehicle (80 cwt.) for the carriage of seasoned hardwood from Strahan and Davies's timber yards at Aden-street, North Melbourne, to J. Trenchgrove, joinery manufacturer, at Geelong.
- BURN, D. A., 74 Story-street, Parkville; 1 commercial goods vehicle (120 cwt.) for the carriage of sawn timber from E. J. Frith's sawmills at Lyonsville to Housing Commission building sites in the metropolitan area, and to consignees at Clunes and Bendigo.
- ECLIPSE APPLIANCES PTY. LTD., 225 Mair-street, Ballarat; 1 commercial goods vehicle (10 cwt.) for the carriage of spare parts, material, and tools of trade incidental to the installation and servicing of refrigerators throughout the State of Victoria.
- GILBERT & BARKER MFG. CO. (AUST.) PTY. LTD., 21 Moray-street, South Melbourne; 1 commercial goods vehicle (15 cwt.) for the carriage of spare parts, fittings, and tools of trade incidental to the installation and maintenance of petrol pumps throughout the State of Victoria.
- HIBBERT, A. W., Westall-road, Springvale; 1 commercial goods vehicle (255 cwt.) for the carriage of sawn timber from W. Ogden's sawmills at Daylesford to building sites in the metropolitan area.
- JOHNS, J. H., Buxton; 1 commercial goods vehicle (182 cwt.) for the carriage of—(a) logs from any forest landing in the Buxton area to the Edithvale timber mills at Edithvale and Crawley's sawmill at Croydon, (b) sawn timber from Barrett and Beard's sawmill at Buxton to Millard's timber yards at Mt. Evelyn and Baxter Bros' timber yards at Richmond.
- JOHNSON, T. I., & A. H. RIELLY, Keilor-road, Keilor; 1 commercial goods vehicle (100 cwt.) for the carriage of—(a) logs from any forest landing in the Lancefield and Woodend areas to own mill at Keilor, (b) sawn timber from mills at Lancefield to own yard at Keilor, (c) sawn timber from own mill at Keilor to consignees within a radius of 25 miles of the G.P.O., Melbourne.
- KAIN & SHELTON LTD., Mt. Gambier; 1 commercial goods vehicle (300 cwt.) for the carriage of cheese and commodities listed in the Third Schedule of the *Transport Regulation Act 1933* between the Victorian-South Australian border, *en route* to and from Mt. Gambier, and Melbourne.
- KEY, L. A. J., 1A Candy-street, Northcote; 1 commercial goods vehicle (108 cwt.) for the carriage of—(a) general goods within a radius of 25 miles of Melbourne, (b) bricks within a radius of 40 miles of Melbourne, and to Geelong.
- LANCASHIRE, R. H., PTY. LTD., 94-98 Bridge-street, Ballarat; 1 commercial goods vehicle (60 cwt.) for the carriage of hardware and household goods in the course of business as "hawker"—(a) from Ballarat to Mildura, via Bendigo, on the forward journey and returning via Ararat—householders *en route*, (b) from Ballarat to Casterton, via Horsham, returning via Portland—householders *en route*. (This is an application for licence No. D.5040, at present held by J. E. Rodda.)
- LEECH, C. E., MacLise-street, Castlemaine; 3 commercial goods vehicles (100, 184, and 189 cwt.) for the carriage of red gum logs from the Cairn Curran Reservoir area at Baringhup to Smith Bros' sawmill at River-street, South Yarra.
- MEULEMAN, R. J. & K. D., 2 View-street, Footscray; 1 commercial goods vehicle (120 cwt.) for the carriage of brown coal from Bacchus Marsh to Melbourne.
- MILKINS, ST. C. O., 253 King-street, Bendigo; 1 commercial goods vehicle (100 cwt.) for the carriage of road-making plant and materials throughout the State of Victoria.
- NEWITT, K. E., 47 McDonald-street, Mordialloc; 1 commercial goods vehicle (20 cwt.) to operate throughout the State of Victoria as a display van, for the demonstration and sale of toys to resellers.
- RODGERS, G., Railway Yards, Shepparton; 1 commercial goods vehicle (200 cwt.) for the carriage of general merchandise and produce in the course of business as "general wholesale merchant" within a radius of 50 miles of Shepparton, and to Melbourne.
- SHEPPARD, R. B., 1107 Lydiard-street north, Ballarat; 3 commercial goods vehicles (80, 80, and 82 cwt.) for the carriage of brown coal from Bacchus Marsh to Ballarat, Geelong, and Melbourne.
- WALKER, W. C., Buxton-road, Marysville; 1 commercial goods vehicle (180 cwt.) for the carriage of logs from any forest landing in the Niagaroon and Upper Yarra forestry districts and the North Big River area—(a) to the railway stations at Warburton and/or Yarra Junction, and to any mill or dump which is located within a radius of 20 miles of such landing or of the railway stations at Warburton or Yarra Junction, (b) to any mill or yard situated within a radius of 25 miles of the G.P.O., Melbourne.

NOTICE is hereby given that the applications made by the persons named below for licences to operate the commercial passenger vehicles on the route or routes, or in the manner set out opposite their names, will be heard at a time and place to be communicated to the parties:—

*Name of Applicant; Nature of Application.*

- BAKER, A. A., O'Shannassy-street, Sunbury; application for variation of licence No. A.54 to include the ability to operate for the carriage of passengers at separate and distinct fares for each passenger between Sunbury and Gisborne, Riddell, Romsey, and Lancefield, between the hours of 6 p.m. and 8 a.m. only.
- DANIELS, N. C. E., Box 155, Warracknabeal; 1 commercial passenger vehicle, with seating capacity for 29 persons, to operate as follows:—(a) for the carriage only of school children between Antwerp and Dimboola, in accordance with the terms of a contract entered into with the Education Department, (b) as a special service omnibus (charter conditions) within a radius of 20 miles from the post office at Warracknabeal, and from Warracknabeal to Hopetoun, Horsham, Dimboola, Jeparit, Nhill, Donald, Watchem, and Rupanyup, (c) as a touring omnibus to Grampians and return, (d) interchangeably with all other "A" licensed vehicles.
- GREENAWAY, G., Dimboola; application for variation of licence No. T.A.5634, to include the ability to operate under charter conditions for the carriage only of pupils attending the Horsham High School to sports meetings and geographical excursions within a radius of 50 miles of the Horsham Post Office as and when authorized by the headmaster of the said school.
- JOHNS, M. J. (trading as "Sale Taxi Service"), 28 Foster-street, Sale; 1 commercial passenger vehicle, with seating capacity for five persons, to operate as follows:—(a) At separate and distinct fares within a radius of 5 miles of Sale, (b) under private hire conditions within a radius of 50 miles of Sale (subject to the cancellation of licence No. A.208, at present held by M. Johns and A. J. Hawkins, Sale).



KERR, H. E., Lillian-street, Clayton; application for variation of licence No. A.2809, to include the ability to operate at separate and distinct fares between the Clayton Railway Station and the Melbourne Showgrounds on nights only when trotting meetings are held thereat.

(This replaces application gazetted on 19th September, 1951.)

LANE, A. L. (trading as "South-Western Roadways"), 159 Raglan-parade, Warrnambool; application for variation of licences Nos. T.A.3689, T.A.3450, T.A.3449, and T.A.4308, to increase the present charter radius from 20 miles to 50 miles from Terang, Oxford, Yambuk, and Lismore.

LANE, A. L. (trading as "South-Western Roadways"), 159 Raglan-parade, Warrnambool; application for variation of licence No. A.2533 to include the ability to operate as follows:—(a) As a special service omnibus (charter conditions) within a radius of 50 miles of Port Campbell, (b) for the carriage of school children only from the Timboon Consolidated School to sports meetings and educational excursions within a radius of 50 miles from the said school as and when required by the headmaster of the aforesaid school.

LANE, A. L. (trading as "South-Western Roadways"), 159 Raglan-parade, Warrnambool; application for variation of licence No. T.A.3448, to include the ability to operate as a special service omnibus (charter conditions) within a radius of 50 miles of Port Fairy.

LIMITED CHARTER GROUP, Melbourne; application for variation of "C" licences to delete the present restrictions limiting operation under charter conditions on Saturdays, Sundays, and Public Holidays only, and instead to operate from Monday to Sunday inclusive.

MARTYR, H. J., Main-street, Warburton; application for variation of all large-seating-capacity vehicles operated between Warburton-Melbourne, to include the ability to operate under charter conditions to and from Melbourne, from and to any place served by the Warburton-Melbourne stage omnibus service.

(This replaces application gazetted on 6th September, 1950.)

MOLONEY, V. A., 32 Drysdale-street, Wonthaggi; 2 commercial passenger vehicles, with seating capacity for 31 and 11 persons respectively, to operate as follows:—

(a) Between Inverloch and Dandenong Railway Stations, via Wonthaggi, Ryanston, Archies Creek, Kilcunda, and Anderson, subject to the condition that on journeys to Dandenong Railway Station passengers shall not be picked up nearer to Dandenong than half a mile on the Wonthaggi side of the turn-off to San Remo at Anderson, and on journeys to Inverloch passengers shall not be set down nearer to Dandenong than half a mile on the Wonthaggi side of the turn-off to San Remo at Anderson, on the following time-table:—

Leave Inverloch	7.45 a.m. Fridays
	2.00 p.m. Saturdays
	3.30 p.m. Sundays.

Leave Dandenong Railway Station 7.15 p.m. Fridays and Saturdays.

(b) Between Inverloch and Melbourne, via the route set out above and with the same limiting conditions, on the following time-table:—

Leave Inverloch	7.45 a.m. Saturdays.
Leave Melbourne	6.30 p.m. Sundays.

(Subject to the cancellation of licences Nos. A.2638 and T.A.2801, held by the applicant.)

NOTE.—(1) On Saturday evenings the vehicle will run empty from Melbourne to Dandenong to be in position to leave Dandenong at 7.15 p.m. (2) On Sundays the vehicle will run empty between Dandenong and Melbourne to be in position to leave Melbourne at 6.30 p.m.

OAKLEY, L. H., 211 Clyde-street, Ballarat; 1 commercial passenger vehicle, with seating capacity for four persons, to operate as follows:—(a) For the carriage of passengers, mails, and parcels between Ballarat and Westmere, (b) under private hire conditions from Ballarat to places throughout Victoria (subject to the cancellation of licence No. P.H.1959, held by the applicant).

SEYMOUR PASSENGER SERVICES PTY. LTD., 14 Tallarook-street, Seymour; 1 commercial passenger vehicle, with seating capacity for five persons, to operate for the carriage only of school children between Northwood Park and Seymour State School, in accordance with the terms of a contract entered into with the Education Department.

WILLIAMSON, G. R., 56 Patrick-street, Stawell; 1 commercial passenger vehicle, with seating capacity for 33 persons, to be purchased, to operate as follows:—(a) A shoppers' service between Pomonal and Ararat, via Moyston, on Tuesdays and Fridays only of each week.

## TIME-TABLE.

Read Down.		Read Up.
Depart 9.30 a.m.	Pomonal	Arrive 6.15 p.m.
Depart 10.20 a.m.	Moyston	Depart 5.30 p.m.
Arrive 10.45 a.m.	Ararat	Depart 5.00 p.m.

## FARES.

	Single.	Return.
Pomonal-Ararat	9s.	12s. 6d.
Moyston-Ararat	5s.	8s. 0d.

(b) A picture service between Pomonal and Ararat, via Moyston, on Wednesday and Saturdays nights only of each week.

## TIME-TABLE.

Read Down.		Read Up.
Depart 6.15 p.m.	Pomonal	Arrive 1.15 a.m.
Depart 6.50 p.m.	Moyston	Depart 12.25 a.m.
Arrive 7.15 p.m.	Ararat	Depart 11.30 p.m.

## FARES.

Pomonal-Ararat	—6s. return.
Moyston-Ararat	—4s. return.

WILSON, I. D., Forest-road, The Basin, via Bayswater; application for variation of all "A" licences to include the ability to operate as follows:—(a) Between the Boronia Railway Station and Scoresby-road, via Ringwood, Cypress-avenue, Stonehaven-avenue, Woodvale-road, and Boronia-road, and return via the same route.

## TIME-TABLE.

Monday To Friday Inclusive.	Depart Boronia Railway Station.	Depart Scoresby- road.	Saturday-Sunday Only.
	10.05 a.m.	9.00 a.m.	As and when required.
	11.05 a.m.	10.20 a.m.	
	2.10 p.m.	11.20 a.m.	
	4.00 p.m.	2.25 p.m.	
	5.00 p.m.	4.30 p.m.	
		5.15 p.m.	

(b) Between the Boronia Railway Station and Boronia-road, via Ringwood-road, Oak-avenue, Range View-road, Elsie-street, Albert-avenue, thence return via Albert-avenue, Olive-grove, Brown-street, Girdwood-road, and Ringwood-road.

## TIME-TABLE.

Monday To Friday Inclusive.	Depart Boronia Railway Station.	Depart Boronia- road.	Saturday-Sunday Only.
	9.45 a.m.	9.55 a.m.	As and when required.
	12.15 p.m.	1.55 p.m.	
	3.15 p.m.	3.30 p.m.	

(c) Between Boronia Railway Station and Hutton-avenue via Ringwood-road, Williamson-road to Lower Ferntree Gully Railway Station, thence via Forest-road to Hutton-avenue, and return via same route.

## TIME-TABLE.

Monday To Friday Inclusive.	Depart Boronia Railway Station.	Depart Hutton- avenue.	Saturday-Sunday Only.
	10.40 a.m.	11.00 a.m.	As and when required.
	11.45 a.m.	12.05 a.m.	

APPLICATIONS for licences to operate commercial passenger vehicles, with seating capacity for five persons, for the carriage of passengers throughout Victoria otherwise than at separate and distinct fares for each passenger:—

FRANCIS, E. W., and R. H. GRAY, 26 Guava-street, Red Cliffs (subject to the cancellation of licence in course of issue to R. H. Gray).

HODKINSON, R. J., Stevens-street, Hurstbridge.

JAMIESON, D. A., 7 Parkside-street, Blackburn (subject to the cancellation of licence No. P.H.1249, at present held by F. W. Guest, Blackburn).

JOHNS, M. J. (trading as "Sale Taxi Service"), 28 Foster-street, Sale.

SEIVER, F., Junr., Dunlop-street, Mortlake.

WILSON, C. P., High-street, Ararat.

**A**PPPLICATIONS for renewal of private hire licence expiring in December, 1951, and February, 1952.

MARSHALL, M. I., Main-road, Research; P.H.211.  
KING, J. F., Walter-street, Port Melbourne; P.H.656.

Notice of any objection should be forwarded to reach the Secretary to the Board not later than Wednesday, 31st October, 1951.

E. V. FIELD,  
Secretary.

Exhibition Buildings, Rathdown-street, Carlton, N.3,  
17th October, 1951.

#### Apprenticeship Acts.

#### APPRENTICESHIP COMMISSION OF VICTORIA.

**W**HEREAS on the 20th day of June, 1951, the Apprenticeship Commission of Victoria published in the *Victoria Government Gazette* notice of its intention to recommend to the Minister that the trade of—

“Radio Tradesman”

(except so far as it is carried on in connexion with the manufacture of radio equipment, or parts thereof, by repetition processes)

be proclaimed an apprenticeship trade: And whereas no such recommendation has in fact been made by the said Commission: Now, therefore, I, the Minister of Labour, pursuant to the provisions of sub-paragraph (ii) of paragraph (a) of sub-section (1) of section 31 of the *Apprenticeship Act 1928*, do hereby notify the 18th day of October, 1951, as the date required to be notified by the said sub-paragraph.

TREVOR HARVEY,  
Minister of Labour.

Department of Labour,  
Melbourne.

#### 4 GEORGE VI. No. 4755, SECTION 6.

**I** HEREBY give notice that on the 5th October, 1951, I filed elections to administer the following deceased persons' estates, in accordance with section 6 of the *Public Trustee Act 1940*—

BROWN, DORA MATILDA, late of 36 Sturt-street, Echuca, pensioner, died 21st July, 1951, intestate.

DUDEK, VLASTIMIL, late of 35 Alma-street, West Footscray, labourer, died 3rd May, 1951, intestate.

DUNNING, HARRY, late of Whitlands, via Whitfield, mail carrier, died 5th June, 1938, intestate.

HALLOWS, ROBERT, late of Levuka-street, Seaford, railway employee, died 10th November, 1950, intestate.

KELSON, JOHN HENRY, late of Healesville, slaughterman, died 15th October, 1949, intestate.

LYDON, WILLIAM, formerly of 172 Gatehouse-street, Parkville, but late of Mount Royal, Parkville, labourer, died 23rd July, 1951, intestate.

\*MASTERS, ALAN LESLIE, late of 66 Auburn-road, Auburn, inspector clock maker, died 13th August, 1951.

MURRAY, BERNARD FITZROY, late of 3 Michael-street, West Brunswick, labourer, died on or about 27th October, 1951, intestate.

\*MCARTHUR, JAMES DONALDSON, better known as James Donaldson MacArthur, formerly of Wandong, but late of Heathcote Junction, retired painter and decorator, died 17th August, 1951.

MCCARTHY, PATRICK, late of State Electricity Camp, Yalourn, fireman, died 26th July, 1950, intestate.

MACDOUGALL, DONALD, late of Harrietville, pensioner, died 17th May, 1951, intestate.

MCINTOSH, JAMES DAVID, formerly of 28 Banksia-street, Heidelberg, but late of Brougham-street, Eltham, retired carpenter, died on or about 28th May, 1951, intestate.

NUGENT, MARGARET, late of 143 Kerferd-road, Albert Park, spinster, died 13th June, 1951, intestate.

RACOVITIS, TRAECHÉ, also known as Traico Racovitis, late of 111 Gertrude-street, Fitzroy, labourer, died 12th February, 1951, intestate.

ROPER, CECILIA MARGARET, late of Melbourne Home and Hospital for the Aged, Cheltenham, pensioner, died 6th August, 1951, intestate.

SCOTT, HECTOR WILLIAM, late of Sea Lake, pensioner, died 11th July, 1951, intestate.

START, WILLIAM, late of 61 Station-street, Aspendale, pensioner, died 8th August, 1951, intestate.

\*WILLIAMSON, SARAH ANNETTE, also known as Sarah Williamson, late of 21 Neptune-street, Richmond, widow, died 19th August, 1951.

\* According to the provisions of the will.

C. J. GARDNER,  
Public Trustee.

412 Collins-street, Melbourne, C.1, 10th October, 1951.

#### NOTICE.

**A**DMINISTRATION of the estate of each of the under-mentioned deceased persons has been granted to me, and creditors, next of kin, and all others having claims against the estate of any of the persons so mentioned are required to send particulars of their claims to the Public Trustee, No. 412 Collins-street, Melbourne, on or before the 19th December, 1951, or they will be excluded from the distribution of the estate when the assets are being distributed:—

\*ALLAN, ADELAIDE, late of 203 Talbot-street, South Balarat, married woman, died 6th April, 1951.

BAYFIELD, EDWIN HENRY, late of 33 Pickett-street, Footscray, retired railway employee, died 15th August, 1951, intestate.

BOULCOTT, HERMAN CHARLES SUMNER, late of Wellington, New Zealand, clerk, died 10th April, 1951, intestate.

\*BROSNAN, JAMES DEEN, late of Wellington, New Zealand, barrister and solicitor, died 16th November, 1950.

BROWN, DORA MATILDA, late of 36 Sturt-street, Echuca, pensioner, died 21st July, 1951, intestate.

DUDEK, VLASTIMIL, late of 35 Alma-street, West Footscray, labourer, died 3rd May, 1951, intestate.

DUNNING, HARRY, late of Whitlands, via Whitfield, mail carrier, died 5th June, 1938, intestate.

\*FRY, LAWRENCE BRUCE, formerly of Bessemer-street, Springvale, but late of Royal Australian Navy, and 2 Bourke-crescent, Geelong, engine-room artificer, died 13th June, 1951.

\*GIBBONS, ERINA MAUDE, late of 270 Albert-road, South Melbourne, spinster, died 29th April, 1951.

HALLOWS, ROBERT, late of Levuka-street, Seaford, railway employee, died 10th November, 1950, intestate.

JOHNSON, LEILA MAUD, late of 9 Kangaroo-road, Murrumbeena, married woman, died 23rd January, 1941, intestate.

KELSON, JOHN HENRY, late of Healesville, slaughterman, died 15th October, 1949, intestate.

LYDON, WILLIAM, formerly of 172 Gatehouse-street, Parkville, but late of Mount Royal, Parkville, labourer, died 23rd July, 1951, intestate.

†MASTERS, ALAN LESLIE, late of 66 Auburn-road, Auburn, inspector clock maker, died 13th August, 1951.

MURRAY, BERNARD FITZROY, late of 3 Michael-street, West Brunswick, labourer, died on or about 27th October, 1951, intestate.

†MCARTHUR, JAMES DONALDSON, better known as James Donaldson MacArthur, formerly of Wandong, but late of Heathcote Junction, retired painter and decorator, died 17th August, 1951.

MCCARTHY, PATRICK, late of State Electricity Camp, Yalourn, fireman, died 26th July, 1950, intestate.

\*MCDONALD, FLORENCE EDNA, formerly of 63 Green-street, Windsor, Victoria, but late of Wakool Hotel, Kyalite, New South Wales, hotel proprietress, died 3rd June, 1951.

MACDOUGALL, DONALD, late of Harrietville, pensioner, died 17th May, 1951, intestate.

MCINTOSH, JAMES DAVID, formerly of 28 Banksia-street, Heidelberg, but late of Brougham-street, Eltham, retired carpenter, died on or about 28th May, 1951, intestate.

NUGENT, MARGARET, late of 143 Kerferd-road, Albert Park, spinster, died 13th June, 1951, intestate.

\*PARRY, CHARLES GEORGE JOHN, late of 2 Turner-street, Pascoe Vale South, retired railway employee, died 25th July, 1951.

RACOVITIS, TRAECHÉ, also known as Traico Racovitis, late of 111 Gertrude-street, Fitzroy, labourer, died 12th February, 1951, intestate.

ROPER, CECILIA MARGARET, late of Melbourne Home and Hospital for the Aged, Cheltenham, pensioner, died 6th August, 1951, intestate.

SCOTT, HECTOR WILLIAM, late of Sea Lake, pensioner, died 11th July, 1951, intestate.

START, WILLIAM, late of 61 Station-street, Aspendale, pensioner, died 8th August, 1951, intestate.

\*TEVENDALE, CATHERINE, late of 6 Fairbairn-road, Toorak, widow, died 16th August, 1951.

\*TINSON, AGNES LOUISA, formerly of 11 Kingswood-grove, Moorgate, Acomb, York, England, but late of 43 a'Beckett-street, North Coburg, widow, died 19th January, 1951.

†WILLIAMSON, SARAH ANNETTE, also known as Sarah Williamson, late of 21 Neptune-street, Richmond, widow, died 19th August, 1951.

\*WRIGHT, HENRY, formerly of 12 Leveson-street, North Melbourne, but late of 2 Leveson-street, North Melbourne, retired coach builder, died 20th August, 1951.

\* With the will annexed.

† According to the provisions of the will.

C. J. GARDNER,  
Public Trustee.

Melbourne, 10th October, 1951.

COUNTY COURTS.

NOTICE is hereby given that County Courts will be held during the year 1952 at the under-mentioned places on the days hereunder mentioned:—

ARARAT .. ..	Tuesday, 22nd April. Tuesday, 12th August. Tuesday, 11th November.	MARYBOROUGH ..	Tuesday, 8th April. Tuesday, 26th August. Thursday, 6th November.
BAIRNSDALE ..	Tuesday, 18th March. Tuesday, 24th June. Tuesday, 21st October.	MELBOURNE ..	Friday, 1st February. Monday, 3rd March. Tuesday, 1st April. Thursday, 1st May. Monday, 2nd June. Tuesday, 1st July. Friday, 1st August. Monday, 1st September. Wednesday, 1st October. Monday, 3rd November. Monday, 1st December.
BALLARAT ..	Tuesday, 19th February. Tuesday, 1st April. Tuesday, 6th May. Tuesday, 17th June. Tuesday, 5th August. Tuesday, 7th October. Tuesday, 18th November. Tuesday, 16th December.	MILDURA ..	Tuesday, 25th March. Tuesday, 5th August. Tuesday, 18th November.
BENDIGO ..	Tuesday, 4th March. Tuesday, 13th May. Tuesday, 15th July. Tuesday, 16th September. Tuesday, 2nd December.	SALE ..	Tuesday, 26th February. Wednesday, 11th June. Tuesday, 9th September. Tuesday, 2nd December.
COLAC ..	Tuesday, 18th March. Tuesday, 17th June. Tuesday, 9th September.	SEYMOUR ..	Tuesday, 8th April. Tuesday, 19th August. Thursday, 6th November.
GEELONG ..	Tuesday, 19th February. Wednesday, 12th March. Tuesday, 1st April. Tuesday, 20th May. Tuesday, 3rd June. Tuesday, 22nd July. Tuesday, 19th August. Tuesday, 16th September. Tuesday, 14th October. Tuesday, 25th November. Tuesday, 16th December.	SHEPPARTON ..	Tuesday, 12th February. Tuesday, 13th May. Tuesday, 12th August. Tuesday, 28th October. Tuesday, 9th December.
HAMILTON ..	Tuesday, 5th February. Tuesday, 6th May. Tuesday, 7th October.	WANGARATTA ..	Tuesday, 25th March. Tuesday, 22nd April. Tuesday, 3rd June. Tuesday, 22nd July. Tuesday, 14th October. Tuesday, 25th November.
HORSHAM ..	Tuesday, 26th February. Tuesday, 27th May. Tuesday, 28th October.	WARRAGUL ..	Tuesday, 5th February. Tuesday, 20th May. Tuesday, 26th August. Tuesday, 11th November.
KERANG ..	Wednesday, 12th March. Wednesday, 11th June. Tuesday, 21st October.	WARRNAMBOOL ..	Tuesday, 12th February. Tuesday, 15th July. Tuesday, 2nd September.
KORUMBURRA ..	Tuesday, 4th March. Tuesday, 24th June. Tuesday, 2nd September. Tuesday, 9th December.		
KYNETON ..	Tuesday, 27th May. Tuesday, 23rd September.		

Except at Melbourne, Courts of Insolvency and Courts of Mines will be held on the days above mentioned at such of the above-mentioned places as have been appointed for holding such Courts.

By order of the Judges,

C. BRUMBY,  
Registrar, County Court, Melbourne.

(This notice is in lieu of the notice published in the *Government Gazette*, dated 5th September, 1951, at page 6276.)

AUCTION SALES ACT 1928.

LIST of Persons to whom Auctioneers' Licences have been issued during the month of August, 1951, and prior months.

Name.	Address.	Date of Issue.
Baker, W. L. .. ..	35 Frederick-street, Horsham .. ..	5.9.51
Davies, D. L. .. ..	12 Muir-avenue, Kerang .. ..	14.9.51
Dwyer, J. P. .. ..	473 Bourke-street, Melbourne .. ..	19.9.51
Fisher, F. .. ..	54 Railway-road, Blackburn .. ..	14.9.51
Haase, A. .. ..	Coleraine .. ..	20.9.51
MacFarlane, C. R. ..	13 Emo-road, East Malvern .. ..	26.9.51
Meyland, A. H. .. ..	5 Harper-street, Wangaratta .. ..	17.9.51
Muir, J. W. .. ..	Wellington-street, Kerang .. ..	28.9.51
Richards, K. L. .. ..	25 Kendall-street, Essendon .. ..	11.9.51
Robertson, H. C. ..	Trafalgar .. ..	25.9.51
Thomson, J. B. .. ..	7 Cradley-avenue, Kew .. ..	6.9.51
Westaway, J. H. ..	31 Clarke-street, Elwood .. ..	7.9.51
*Woods, F. K. .. ..	875 Burke-road, Camberwell .. ..	7.9.51

\* By transfer from F. G. Woods.

The Treasury,  
Melbourne, 10th October, 1951.

A. T. SMITHERS,  
Director of Finance.

## AUCTION SALES ACT 1928.

**ARARAT.**—Notice is hereby given that the Annual Meeting of Justices for the Licensing of Auctioneers will be held at the Court House, at Ararat, at Ten a.m., on Tuesday, the 27th day of November, 1951. Dated at Ararat, this 11th day of October, 1951.—KEVIN J. O'CONNOR, Clerk of Petty Sessions at Ararat.

**BALLARAT.**—Notice is hereby given that the Annual Meeting of Justices for the Licensing of Auctioneers will be held at the Court House, Ballarat, on Tuesday, the 27th day of November, 1951, at Ten o'clock in the forenoon. Dated this 10th day of October, 1951.—K. A. McDONALD, Clerk of Petty Sessions.

**BENALLA.**—Notice is hereby given that a Special Meeting of Justices for the Licensing of Auctioneers will be held in the Court House, at Benalla, on Thursday, the 1st day of November, 1951, at the hour of Ten o'clock in the forenoon to consider an application by Norman Bruce Davey for an auctioneer's licence.—A. PROPOSCH, Clerk of Petty Sessions.

**CHARLTON.**—Notice is hereby given that the Annual Meeting of Justices for the Licensing of Auctioneers will be held at the Court House, Charlton, on Tuesday, the 27th day of November, 1951, at the hour of Ten o'clock in the forenoon. Dated this 12th day of October, 1951.—N. J. FITZPATRICK, Clerk of Petty Sessions.

**COLAC.**—Notice is hereby given that the Annual Meeting of Justices for the Licensing of Auctioneers will be held at the Court House, at Colac, on Tuesday, the 27th day of November, 1951, at Ten o'clock in the forenoon.—A. R. PENFOLD, Clerk of Petty Sessions.

**GEELONG.**—Notice is hereby given that the Annual Meeting of Justices for the Licensing of Auctioneers will be held at the Court House, Little Malop-street, Geelong, on Tuesday, the 27th day of November, 1951, at Ten o'clock in the forenoon. Dated this 11th day of October, 1951.—A. G. GLASSON, Clerk of Petty Sessions.

**HAMILTON.**—The Annual Meeting of Justices to consider applications for Auctioneers' Licences will be held at the Court House, Hamilton, on Tuesday, the 27th day of November, 1951, at Ten o'clock in the forenoon. Dated at Hamilton, this 8th day of October, 1951.—J. L. MCARDLE, Clerk of Petty Sessions.

**KERANG.**—Notice is hereby given that the Annual Meeting of Justices for the Licensing of Auctioneers will be held at the Court House, Kerang, on Tuesday, the 27th day of November, 1951, at the hour of Ten o'clock in the forenoon. Dated this 12th day of October, 1951.—D. H. GUDS, Clerk of Petty Sessions.

**KYNETON.**—Notice is hereby given that the Annual Meeting of Justices for the Licensing of Auctioneers will be held at the Court House, at Kyneton, on Tuesday, the 27th day of November, 1951, at the hour of Ten o'clock in the forenoon. Dated this 11th day of October, 1951.—J. F. RYAN, Clerk of Petty Sessions.

**KORUMBURRA.**—Notice is hereby given that the Annual Meeting of Justices for the Licensing of Auctioneers will be held at the Court House, Korumburra, on Tuesday, the 27th day of November, 1951, at Ten o'clock in the forenoon. Dated this 11th day of October, 1951.—A. L. BOCK, Clerk of Petty Sessions.

**MARYBOROUGH.**—The Annual Meeting of Justices for the Licensing of Auctioneers will be held at the Court House, Maryborough, on Tuesday, the 27th day of November, 1951, at Ten o'clock in the forenoon.—J. W. EGAN, Clerk of Petty Sessions.

**MILDURA.**—The Annual Meeting of Justices for the Licensing of Auctioneers will be held at the Law Courts, Mildura, on Tuesday, the 27th day of November, 1951, at Ten o'clock in the forenoon. Dated this 10th day of October, 1951.—G. D. O'SULLIVAN, Clerk of Petty Sessions.

**MORWELL.**—The Annual Meeting of Justices for the Licensing of Auctioneers will be held at the Court House, at Morwell, on Tuesday, the 27th day of November, 1951, at the hour of Ten o'clock in the forenoon.—M. A. TUOHY, Clerk of Petty Sessions.

**NUMURKAH.**—Notice is hereby given that the Annual Meeting of Justices for the Licensing of Auctioneers will be held at the Court House, Numurkah, on Tuesday, the 27th day of November, 1951, at the hour of Ten o'clock in the forenoon. Dated this 12th day of October, 1951.—J. L. COLLINS, Clerk of Petty Sessions.

**OUYEN.**—Notice is hereby given that the Annual Meeting of Justices for the Licensing of Auctioneers will be held at the Court House, at Ouyen, on Tuesday, the 27th day of November, 1951, at Ten o'clock in the forenoon. Dated this 12th day of October, 1951.—J. E. KEAN, Clerk of Petty Sessions.

**ROSEDALE.**—The Annual Meeting of Justices for the Licensing of Auctioneers will be held at the Court House, at Rosedale, on Tuesday, the 27th day of November, 1951, at the hour of Ten o'clock in the forenoon.—M. A. TUOHY, Clerk of Petty Sessions.

**STAWELL.**—Notice is hereby given that the Annual Meeting of Justices for the Licensing of Auctioneers will be held at the Court House, Stawell, on Tuesday, the 27th day of November, 1951, at the hour of Ten o'clock in the forenoon. Dated this 11th day of October, 1951.—J. F. O'HARA, Clerk of Petty Sessions.

**TRARALGON.**—The Annual Meeting of Justices for the Licensing of Auctioneers will be held at the Court House, at Traralgon, on Tuesday, the 27th day of November, 1951, at the hour of Ten o'clock in the forenoon.—M. A. TUOHY, Clerk of Petty Sessions.

**WANGARATTA.**—Notice is hereby given that the Annual Meeting of Justices for the Licensing of Auctioneers will be held at the Court House, Wangaratta, on Tuesday, the 27th day of November, 1951, at Ten o'clock in the forenoon. Dated this 10th day of October, 1951.—J. MILLS, Clerk of Petty Sessions.

**WARRACKNABEAL.**—Notice is hereby given that the Annual Meeting of Justices for the Licensing of Auctioneers will be held at the Court House, Warracknabeal, on Tuesday, the 27th day of November, 1951, at the hour of Ten o'clock in the forenoon.—L. FROUDE, Clerk of Petty Sessions.

**WARRAGUL.**—Notice is hereby given that the Annual Meeting of Justices for the Licensing of Auctioneers will be held at the Court House, Warragul, on Tuesday, the 27th day of November, 1951, at the hour of Ten o'clock in the forenoon. Dated this 15th day of October, 1951.—R. V. DAVIS, Clerk of Petty Sessions.

**WONTHAGGI.**—Notice is hereby given that the Annual Meeting of Justices for the Licensing of Auctioneers will be held at the Court House, Wonthaggi, on Tuesday, the 27th day of November, 1951, at the hour of Ten o'clock in the forenoon. Dated this 10th day of October, 1951.—D. L. STOTT, Clerk of Petty Sessions.

**YARRAM.**—Notice is hereby given that the Annual Meeting of Justices for the Licensing of Auctioneers will be held at the Court House, at Yarram, on Tuesday, the 27th day of November, 1951, at Ten o'clock in the forenoon. Dated this 12th day of October, 1951.—E. MCCONVILL, Clerk of Petty Sessions.

**YARRAWONGA.**—Notice is hereby given that the Annual Meeting of Justices for the Licensing of Auctioneers will be held at the Court House, Yarrowonga, on Tuesday, the 27th day of November, 1951, at Ten o'clock in the forenoon. Dated this 10th day of October, 1951.—J. MILLS, Clerk of Petty Sessions.

Local Government Act 1946, Part 48, Section 876.  
LICENCES TO OCCUPY UNUSED ROADS.

NOTICE is hereby given that Licences to occupy Unused Roads have been issued to the following approved applicants, and that the Licence Fee specified in each case has been received by the Accountant, Lands Department, Melbourne, C.2.

Number of Licence.	Name and Address of Licensee.	Municipality.	Parish.	Abutting— Allotments and Sections.	Area.	Fee for Licence.	Date of Issue of Licence.	Date of Expiry of Licence.
36672	I. M. E. Gammon, Ardno East	Glenelg	Ardno	North and east of 9A; north of 45, 45A; east of 17	27 1 0	2 15 6	1.1.50	31.12.52
36673	W. Storie, Sandford	Glenelg	Sandford	Bet. parts Bb and C	1 2 0	0 2 6	1.1.50	31.12.52
36674	A. Blake, Stawell	Stawell	Riachella	East of 220B and 229B	11 0 0	0 16 6	1.1.50	31.12.52
36675	A. G. Gready, Wal Wal	Stawell	Warranook	East of 68 and south of 59 and 62	16 0 0	1 4 0	1.1.50	31.12.52
36676	A. E. Davies and Sons, Kadnook	Kowree	Kadnook	West of 34	5 2 0	0 2 9	1.1.50	31.12.52
36677	{ C. E. Gardiner, Coleraine } { J. C. Kenna, Hamilton }	Dundas	Monivae	Through Monivae P.R.	4 0 0	0 16 0	1.1.50	31.12.52
36678	T. W. O'Rourke, Glenorchy	Stawell	Riachella	East of 107 and 108	11 0 0	0 11 0	1.1.50	31.12.52
36679	A. W. and M. E. McKay, Ararat	Stawell	Bulgana	South 16, 16A, 4 and 4B, bet. 4 and 16	13 3 0	0 13 9	1.1.50	31.12.52
36680	O. S. Outtram, Digby	Portland	Wataepoolan	Bet. 45B and 46A	7 1 0	0 7 3	1.1.50	31.12.52
36681	A. J. Williams, Lillimur	Glenelg	Dergholm	North, east, and west of 83	13 0 0	0 3 3	1.1.50	31.12.52
36682	A. F. Keiller, Allestree	Portland	Bolwarra	South of 7 and 1	4 2 0	0 4 6	1.1.50	31.12.52
36683	L. A. P. Saligari, Cavendish	Dundas	Cavendish	West of 1 and part 1A, section 18	4 3 23	0 13 6	1.1.50	31.12.52
36684	J. Young, Hamilton	Dundas	Bochara	South of 3 and 4 and east of 3, section 9	13 1 31	2 13 9	1.1.50	31.12.52
36685	E. V. Petersen, Heathmere	Portland	Heywood	South of part 8e, section 6	2 0 0	0 2 6	1.1.48	31.12.50
36686	M. McClure, Lake Karnak	Kowree	Karnak	North and west 63A, west and south 64A and 64B	27 0 0	0 6 9	1.1.50	31.12.52
36687	E. H. and E. S. Pendlebury, Telangatuk East	Arapiles	Connangorah	East of 72	11 2 16	0 3 0	1.1.50	31.12.52
36688	A. B. Dufty, Gymbowen	Kowree	Gymbowen	Between 37 and 52	7 0 0	0 3 6	1.1.50	31.12.52
36689	A. R. Storer, Digby	Glenelg	Town of Digby	North of 40	1 0 0	0 8 0	1.1.50	31.12.52
36690	John McWilliams, Lakeside, Murtoa	Dunmunkle	Township of Murtoa, Parish of Ashens	West of 5 and 6, section 14A	0 0 24	0 4 6	1.1.50	31.12.52
36771	Mrs. W. H. Malseed, Branxholme	Portland	Branxholme	North 3, section 6A, north 1, section 4, south 3, section 6A, south 1, section 4	5 0 0	0 15 0	1.1.50	31.12.52
36772	H. N. Fraser, Glenorchy	Stawell	Wirchilleba	East 57 and 102	4 0 0	1 4 0	1.1.50	31.12.52
36773	R. Myer, Edenhope	Kowree	Edenhope	Town 63B	4 2 0	0 2 9	1.1.49	31.12.51
36774	W. Schultz, Mountajup	Portland	Heywood	North 8 and 8A, section 6	4 3 0	0 2 6	1.1.48	31.12.50
36775	D. Cameron, Harrow	Kowree	Harrow	North 5, and western part of road north of 17	16 2 0	2 6 8	1.1.50	31.12.52
36776	E. G. Waldron, Stawell	Stawell	Ilawarra	North, 105, 108, 112	3 2 0	0 3 6	1.1.50	31.12.52
36777	H. Robertson, Edenhope	Kowree	Edenhope	South 6B	4 2 0	0 2 6	1.1.50	31.12.52
36778	A. M. Reading, Wallaloo	Stawell	Wallaloo	Bet. 34A, 34C, and 57	7 1 0	0 11 0	1.1.50	31.12.52
36779	G. H. Fischer, Horsham	Wimmera	Drung Drung	Bet. 44 and 80	4 0 0	1 4 0	1.1.50	31.12.52
36780	T. A. Brinkmann, South Hamilton	Dundas	Monivae	Surrounding 8 section 2; bet. 5, section 3, and Monivae P.R., west of 1, section 3	23 2 0	4 14 0	1.1.50	31.12.52
36781	J. C. Cunningham, Glenorchy	Wimmera	Ledcourt	South 195 and 197	12 0 0	0 18 0	1.1.50	31.12.52
36782	J. C. Cunningham, Glenorchy	Stawell	Ledcourt	South 222, east 222, 223	14 0 0	0 14 0	1.1.50	31.12.52
36783	N. Curtis, Wonwondah South	Arapiles	Wonwondah	West 47	7 0 0	0 10 6	1.1.50	31.12.52
36784	C. R. Liddle, Heywood	Portland	Drik Drik	North 3, section 5	4 2 0	1 7 0	1.1.50	31.12.52
36785	G. W. Start, Jr., Crowlands	Stawell	Joel Joel	West 169, 169A, &c.	33 0 0	1 13 0	1.1.49	31.12.51
36786	W. R. Martin, Stawell	Stawell	Watta Wella	East 7B	4 2 0	0 4 6	1.1.50	31.12.52
36787	S. M. McGregor, Penshurst	Mt. Rouse	Town of Penshurst	Bet. 9, 10, section 44 and Railway Reserve	0 2 0	0 2 6	1.1.50	31.12.52
36788	R. G. L. Taylor, Hamilton	Wannon	Carrak	North 6A	7 3 0	1 11 0	1.1.50	31.12.52
36789	Exors. J. P. Monaghan, Stawell	Stawell	Glynwylln	North 122A, 122B, east 81B	7 0 0	0 7 0	1.1.50	31.12.52
36790	W. R. Satchell, Condah	Portland	Bramburra	1A, 4A, &c., section 27	27 2 0	4 4 6	1.1.50	31.12.52
36791	B. and M. Cook, Penshurst	Mt. Rouse	Boramboram	East F. and K.; south L. and K., section 12	5 0 0	2 16 3	1.1.50	31.12.52
36792	J. L. Stewart, Campbell's Bridge	Stawell	Callawadda	North 238A1, 238A2, 237A2, 237A3, west 237A2, 237B, 226	32 0 0	3 4 0	1.1.50	31.12.52
36793	M. B. and F. P. Delahunty, Murtoa	Dunmunkle	Jung Jung	Bet. 2, 82A, 81, 272	14 1 0	1 8 6	1.1.50	31.12.52
36794	Indar Sondhu, Harrow	Kowree	Harrow	North 4	4 1 0	0 10 1	1.1.50	31.12.52
36795	H. F. Roper, Dergholm	Glenelg	Dergholm	South part 37, 38, part 79, east 11	17 2 0	1 2 6	1.1.49	31.12.51
36796	H. S. Williamson, Stawell	Stawell	Joel Joel	South 160B, 160C	4 0 0	0 6 0	1.1.50	31.12.52
36797	A. E. Hall, Stawell	Stawell	Watta Wella	East 61 and 90	3 1 0	0 4 10	1.1.50	31.12.52
36798	L. W. Hyslop, Campbell's Bridge	Stawell	Joel Joel	North 170, 171, east 171	16 0 0	1 4 0	1.1.50	31.12.52
36799	E. T. Rudolph, Glenorchy	Stawell	Ledcourt	South 235, west 245	9 0 0	0 9 0	1.1.50	31.12.52
36800	R. T. Whitehead, Edenhope	Kowree	Kadnook	East 63	1 2 0	0 2 6	1.1.50	31.12.52
36801	R. Kindred, Green's Creek	Stawell	Glynwylln	South-east 77B, 79C	8 1 0	0 8 3	1.1.50	31.12.52
36802	H. P. L. and E. C. Gaussen, Vasey	Wannon	Bil-Bil-Wyt	West 116; between 116, 117	18 1 20	1 8 0	1.1.50	31.12.52

## LICENCES TO OCCUPY UNUSED ROADS—continued.

Number of Licence.	Name and Address of Licensee.	Municipality.	Parish.	Abutting— Allotments and Sections.	Area.	Fee for Licence.	Date of Issue of Licence.	Date of Expiry of Licence.
					A. R. P.	£ s. d.		
36803	G. A. and F. Kuhne, Horsham	Dundas ..	Napier ..	North 2, 1A, A4, east 1, section A	16 2 0	2 9 6	1.1.50	31.12.52
36804	S. D. and D. E. Brain, Stawell	Stawell ..	Joel Joel, Bulgana	Parish of Joel Joel:—west of allotments 191, 207A; south-west of allotments 195, 192, 206, 207A; east of allotments 205, 205A; west of allotment 204; west of Gravel Reserve, allotments 194A, 195, 196; north of allotments 203, 203A, 204, 205A, 206, 207A Parish of Bulgana:—West of allotment 31B	70 0 0	5 0 4	1.1.50	31.12.52
36805	C. H. R. Ridler, Harrow ..	Kowree ..	Charam ..	North-east, 19 and 20	29 1 29	1 9 6	1.1.46	31.12.48
36806	B. Henty-Anderson, Henty	Glenselg ..	Sandford ..	South 1, 2, and 3, section 4	6 0 0	3 0 0	1.1.49	31.12.51
36807	T. W. Ridler, Goroke ..	Kowree ..	Charam ..	North and north-east of 9	16 0 0	0 16 0	1.1.46	31.12.48
36808	T. and R. M. Thomas, Stawell	Stawell ..	Joel Joel ..	South 158 and 159; west 159 and 160B	24 2 0	1 16 9	1.1.50	31.12.52
36809	U. R. Perrier, Stawell ..	Borough of Stawell	Borough of Stawell	Between 4 and 7, section 90B and 13 and 14, section 89	1 0 0	0 10 0	1.1.50	31.12.52
36810	N. L. Nicholson, Great Western	Stawell ..	Mokepilly ..	South-east 36, section Y	14 0 0	0 7 0	1.1.50	31.12.52
37441	P. McDonnell, Culla, via Harrow	Wannon ..	Wytwallan	East 59, 60A, 60B1, 60B2, 64A1; south 64A1, 73A, 73B1	24 0 0	2 4 0	1.1.50	31.12.52
37442	J. Young, Hamilton ..	Dundas ..	Jerrywarook	North 1, section 1 ..	5 0 30	0 14 3	1.1.50	31.12.52
37443	J. M. Florence, Rupanyup ..	Dunmunkle	Lallat ..	Between 37 and 38 ..	8 0 0	2 0 0	1.1.51	31.12.53
37444	H. I. Schneider, Dimboola ..	Portland ..	Heywood ..	West of 24, 26, section A	7 2 0	0 11 3	1.1.51	31.12.53
37445	M. G. Donaldson, Edenhope	Kowree ..	Kadnook ..	Between 4A and 59A ..	4 0 0	0 6 0	1.1.50	31.12.52
37446	A. W. Baker, Jung ..	Wimmera	Jung Jung	East, half between 156 and 209	3 0 0	0 15 0	1.1.51	31.12.53
37447	F. A. Baker, Jung ..	Wimmera	Jung Jung	West, half between 156 and 209	3 0 0	0 15 0	1.1.51	31.12.53
37448	H. R. Queale, Horsham ..	Arapiles ..	Mockinya ..	North allotment 19, bet. 21A, 21B, west 9B, 21C	29 1 36	1 9 6	1.1.51	31.12.53
37449	E. H. Zerst, Brimpaen ..	Arapiles ..	Mockinya ..	South of 60A ..	11 1 0	0 8 7	1.1.51	31.12.53
37450	C. W. E. Tiekner, Rupanyup	Dunmunkle	Lallat ..	North of allotment 114	7 1 0	1 16 3	1.1.51	31.12.53
37451	S. F. Bannam, and H. A. Ayres, Milltown	Portland ..	Myamyn ..	North of west part of 2A, section 19	6 2 0	0 6 6	1.1.51	31.12.53
37452	S. C. Turner, Dergholm ..	Glenselg ..	Dergholm ..	Bet. parts 79, 41 ..	2 0 0	0 2 6	1.1.49	31.12.51
37453	M. A. Coustley, Milltown ..	Portland ..	Dunmore ..	North and south of allotment 1A3	20 2 0	1 0 6	1.1.51	31.12.53
37454	J. C. Campbell, Stawell ..	Stawell ..	Wirchilleba	Bet. 74B and 72A, east of 74A	7 1 0	0 18 0	1.1.50	31.12.52
37455	M. McD. Kelso, Coleraine ..	Wannon ..	Hilgay ..	Bet. 2 of 20 and 2 of 21, east of 7 and south of 7 and 8 of 21	16 2 0	2 1 3	1.1.51	31.12.53
37456	D. E. Rankin, Hamilton ..	Hamilton City	N. Hamilton, Town of Hamilton	1, 2, 3, 4, 5, 6, 7, section 51A	2 1 0	1 0 0	1.1.51	31.12.53
37457	H. J. Millard, Byaduk ..	Dundas ..	Napier ..	4A, 4B, 5A, 6A, 6B, 7A, section A	13 0 0	1 19 0	1.1.51	31.12.53
37458	Lady E. O. Smyth, Portland	Portland ..	Portland ..	Allotment D, section 2	4 2 0	0 4 6	1.1.51	31.12.53
37459	H. L. Hanlon, Heywood ..	Portland ..	Dunmore ..	Between 1A and 1A1 ..	2 0 0	0 2 6	1.1.51	31.12.53
37460	D. McL. Moffatt, Portland	Portland ..	Portland ..	North of allotment 3, section 8	5 0 0	0 2 6	1.1.51	31.12.53
37461	L. D. and V. D. Milgate, Hamilton	Dundas ..	Yulecart ..	7A, section 28, 3, 7, 8, section 31, 3A, section 35, 2, 3, 4A, 4B, section 30	34 0 0	4 16 0	1.1.51	31.12.53
37462	J. F. D. Beeson, Hamilton	Dundas ..	Audley ..	East of 2A, 2B, 3A, 3B, section 7	8 0 0	1 12 0	1.1.51	31.12.53
37463	R. M. McLennan, Charam	Kowree ..	Konnepra	West of allotment 2 ..	8 0 0	3 4 0	1.1.51	31.12.53
37464	R. K. McLennan, Charam	Kowree ..	Konnepra	North 22, 25, 26, west 25, east 22	19 2 0	7 16 0	1.1.51	31.12.53
37465	H. G. Phillips, Myamyn ..	Portland ..	Myamyn ..	North of east portion of 2A, section 19	2 1 0	0 2 6	1.1.51	31.12.53
37466	Millard Bros., Tyrendarra ..	Portland ..	Dunmore ..	East 1A1 ..	2 0 0	0 2 6	1.1.51	31.12.53
37467	T. E. Dunn, Macarthur ..	Portland ..	Ardonachie	West part 4A, section 4	2 2 0	0 5 0	1.1.51	31.12.53
37468	J. J. Wallis, Condah ..	Minhamite	Ardonachie	West part 4A, section 4	2 2 0	0 5 0	1.1.51	31.12.53
37469	J. A. McDonald, Hotspur ..	Portland ..	Hotspur ..	West of allotment 4, section 3	2 0 0	0 4 0	1.1.51	31.12.53
37470	R. R. Blair, Hamilton ..	Dundas ..	Audley ..	2B, 4, section 1 ..	1 0 38	0 5 0	1.1.51	31.12.53
37471	A. E. Heffernan, Charam	Kowree ..	Konnepra	23, 24, 31 ..	9 0 0	3 12 0	1.1.51	31.12.53
37472	J. S. Hutton, Hamilton ..	Dundas ..	Bochara ..	West of allotment 1, Section 3A	3 3 6	0 15 0	1.1.51	31.12.53
37473	J. S. Hutton, Hamilton ..	Dundas ..	Bochara ..	North of allotment 2A, section 5A	4 2 12	0 12 7	1.1.51	31.12.53
37474	R. B. Taylor, Stawell ..	Stawell ..	Wirchilleba	North of allotment 179	3 0 0	0 4 6	1.1.51	31.12.53

## LICENCES TO OCCUPY UNUSED ROADS—continued.

Number of Licence.	Name and Address of Licensee.	Municipality.	Parish.	Abutting— Allotments and Sections.	Area.	Fee for Licence.		Date of Issue of Licence.	Date of Expiry of Licence.
						A. R. P.	£ s. d.		
37475	R. B. Taylor, Stawell ..	Stawell ..	Wirrohilleba	West of allotment 184	4 0 0	0 6 0	1.1.51	31.12.53	
37477	A. Kosch, Caramut ..	Warrnambool	South	North 1A, 1B, 2A, 2B, west 1A, section 5	12 2 0	2 10 0	1.1.51	31.12.53	
37478	E. G. Phelan, Harrow ..	Kowree ..	Turandurey	South of allotment 8 ..	2 2 0	0 6 3	1.1.51	31.12.53	
37479	J. J. Kingston, Stawell ..	Stawell ..	Kirkella ..	North of reserve, North of allotment 134	2 0 0	0 6 0	1.1.51	31.12.53	
37480	L. P. Burger, Penshurst ..	Warrnambool	South Caramut	Part 1B, section 6 ..	2 0 0	0 8 0	1.1.51	31.12.53	
37641	L. A. Cornish, Coleraine ..	Wannon ..	Hilgay ..	West of 4A, 4B, 5A, 5B	10 0 0	2 10 0	1.1.51	31.12.53	
37642	N. L. and A. L. Hobbs, Douglas	Kowree ..	Toolondo ..	North of 144 and 145	8 0 0	0 12 9	1.1.51	31.12.53	
37643	R. Anson, Harrow ..	Kowree ..	Turandurey	Bet. 21 and 26A ..	8 0 0	1 12 0	1.1.51	31.12.53	
37644	{ Forsyth, L. M., Cavendish Philp, P. M., Branzholme }	Portland ..	Branzholme	North 8 and 9, east 9, section 19, east 2, sec- tion 18	17 0 0	2 11 0	1.1.51	31.12.53	
37645	B. G. Wurm, Penola, S.A.	Glenelg ..	Mageppa ..	Between 27 and 31 ..	5 3 36	0 9 0	1.1.51	31.12.53	
37646	E. E. Davis, Branzholme ..	Portland ..	Branzholme	East and south of part Audley Pre-emptive Right	8 2 0	1 5 6	1.1.51	31.12.53	
37647	D. M. Chisholm, Branzholme	Portland	{ Branzholme Byambynee Lambruk ..	East 6, section 19 and part Audley P.R. North 7 and 4, section 1 North and east allotment 1	{ 24 0 0 15 0 0	{ 3 12 0 0 19 6	{ 1.1.51 1.1.51	{ 31.12.53 31.12.53	
37648	L. M. T. Brooksby, Harrow	Dundas	Bepcha ..	North allotment 1	6 0 0	1 4 0	1.1.51	31.12.53	
37649	R. M. Barr, Lyons ..	Portland ..	Glenaulin ..	Various in town of Lyons	4 1 0	1 2 0	1.1.51	31.12.53	
37650	W. A., C. A., N. J. Mitchell, Tyrendarra	Portland ..	Tyrendarra	3, 43r ..	4 1 0	1 2 0	1.1.51	31.12.53	
37651	W. A. Hateley, Mitre ..	Arapiles ..	Arapiles ..	East of 101 ..	2 1 20	0 2 6	1.1.51	31.12.53	
37652	J. McWilliams, Murtoa ..	Dunmunkle	Ashens, Township of Murtoa	Bet. 5, section 14A and 2, section 28	0 0 30	0 2 6	1.1.51	31.12.53	
37653	B. Pearce, Dooen ..	Wimmera	Kewell West	South of allotment 9 ..	4 0 0	1 16 0	1.1.51	31.12.53	
37654	L. A. Brown, Gritjurk ..	Wannon ..	Gritjurk ..	North 3, section 4 ..	4 1 16	1 1 9	1.1.51	31.12.53	
37655	A. J. McInnes, Macarthur ..	Minhamite	Macarthur ..	North 5A, 7D, section 8	5 2 0	1 13 0	1.1.52	31.12.54	
37656	C. F. A. Schmidt, Nypo ..	Wannon ..	Pawbymbyr	West half bet. 5 and 15 and 6 and 15	6 2 16	0 6 6	1.1.51	31.12.53	
37657	R. J. Parry, Greens Creek ..	Stawell ..	Joel Joel ..	East 2 ..	4 0 0	0 6 0	1.1.51	31.12.53	
37658	R. V. Quick, Brim ..	Warrackna- beal	Willenabrina	Bet. 91 and 33 ..	5 0 0	0 15 0	1.1.51	31.12.53	
37659	C. Peacock, Landsborough	Avoca ..	Landsborough	North-east of X37, X38, X39	2 2 0	0 2 6	1.1.50	31.12.52	
37660	J. B. Forster, Horsham ..	Kowree ..	Edenhope	West 26 ..	4 0 0	0 2 6	1.1.51	31.12.53	
37661	D. Holmes, Tyrendarra ..	Portland ..	Tyrendarra	North and west of 6A ..	4 0 0	0 4 0	1.1.51	31.12.53	
37662	A. E. Howlett, Chetwynd ..	Glenelg ..	Ganoo Ganoo	West 14C, section A ..	4 0 0	0 14 6	1.1.51	31.12.53	
37663	G. J. Masterson, Hamilton	Mt. Rouse	Bilpah ..	North 61A ..	4 0 0	0 14 0	1.1.51	31.12.53	
37664	J. Masterson, Hamilton ..	Mt. Rouse	Bilpah ..	South 7B, 8B, 8A ..	8 0 0	1 8 0	1.1.51	31.12.53	
37665	M. E. T. Masterson, Hamilton	Mt. Rouse	Bilpah ..	West 41A, 41B, 44A, 44B	8 0 0	1 8 0	1.1.51	31.12.53	
37666	A. F. Morgan, Cavendish ..	Dundas ..	Mokanger	West 15A, 15B, 23, section 23	18 0 0	4 10 0	1.1.51	31.12.53	
37667	J. C. Johnson, Heywood ..	Portland ..	Drik Drik ..	Bet. 2 and 7, section A	1 2 0	0 6 0	1.1.51	31.12.53	
37668	J. N. and M. Spittle, Euston	Portland ..	Heywood ..	South and east allotment 4, section 6	13 0 0	0 6 6	1.1.51	31.12.53	
37669	J. L. H. Hindson, Henty ..	Glenelg	{ Merino .. Mocamboro	South 9A, section 16 .. East 1 and part 2, section 3	{ 7 0 0	{ 4 2 0	{ 1.1.51	{ 31.12.53	
37670	J. H. Hindson, Henty ..	Glenelg	{ Sandford .. Merino .. Mocamboro	East part 14, section 9 Bet. 13 and 14, section 16 South 3, section 3	{ 8 2 0	{ 4 11 0	{ 1.1.51	{ 31.12.53	
37671	J. Grant, Casterton ..	Glenelg ..	Merino ..	Various ..	17 2 0	14 0 0	1.1.51	31.12.53	
37672	A. S. McLellan and others, Burwood	Portland ..	Curra curt ..	West 25A ..	3 3 0	0 2 6	1.1.50	31.12.52	
37673	R. H. Glare, Heywood ..	Portland ..	Curra curt ..	West 22A ..	8 0 0	0 4 0	1.1.50	31.12.52	
37674	W. E. Wilkens, Glenthompson	Mt. Rouse	Pom Pom ..	East part 9, section 12	5 0 0	1 17 6	1.1.51	31.12.53	
37675	Coomete Pty Ltd., Koroit ..	Minhamite	Willatook ..	South section 33 ..	16 0 0	5 12 0	1.1.50	31.12.52	
37676	J. J. Nicol, Koroit ..	Minhamite	Willatook ..	West 4A, section 26 ..	4 0 0	0 14 0	1.1.50	31.12.52	
37677	W. M. Threlfall, Koroit ..	Minhamite	Warrong and Willatook	Part north 1, section S, south section 35	20 3 0	7 5 3	1.1.51	31.12.53	
37678	F. Yeomans, Coleraine ..	Wannon ..	Brit Brit ..	North 1, 2, section 9 ..	3 2 0	0 7 0	1.1.51	31.12.53	
37679	A. J. Price, Cavendish ..	Dundas ..	Mooralla ..	North 3, section 8, south half E 3, section 8	8 1 0	0 16 6	1.1.51	31.12.53	
37680	J. H. Price, Hamilton ..	Dundas ..	Mooralla ..	North 3, section C, bet. 9 and 3, south part bet. 4 and 3, section C	15 3 0	1 11 6	1.1.51	31.12.53	

A. E. LIND,  
Minister of Lands.Department of Crown Lands and Survey (Unused Roads and Water Frontages Branch),  
Melbourne, 10th October, 1951.

## REAL ESTATE AGENTS ACTS.

IN accordance with the provisions of the above-mentioned Acts, the following is published for general information:—

(a) List of Real Estate Agents' Licences issued during the month of September, 1951, and prior months.

Name.	Principal Place of Business (Registered Office).	Name of Firm or Partnership.	Date from which Licence is Effective.
Baldock, C. C.	14 Hunter-street, West Brunswick		19.9.51
Bell, R. J.	41 Nolan-street, Maryborough		28.9.51
Brabender, L. C.	"Chester," Flat 1, Finchley Court, Hawthorn	Ascot Real Estate	5.9.51
Butcher, W. H.	112 Lygon-street, East Brunswick	Daygrove Metropolitan Real Estate Co.	5.9.51
Carew, E. D.	365 Murray-road, Preston	Regent Real Estate	19.9.51
Davies, C. H. A.	Kemp-street, East Ringwood		11.9.51
Dean, M. R.	Main-street, Greensborough		26.9.51
Dean, R. H.	Main-street, Greensborough		5.9.51
Delbridge, E. L.	14 Hennessy-avenue, Elwood		24.9.51
Doherty, K. A.	26 Gillies-street, Fairfield		30.8.51
Dowling, G. T.	4 Victoria-road, Camberwell		13.9.51
Doyle, S. A.	247 High-street, Bendigo		12.9.51
Drummond, A. B.	Walwa		24.9.51
Dunn, J. T.	365 Murray-road, Preston	Regent Real Estate	12.9.51
Hay, A. G.	379 Beach-road, Beaumaris		5.9.51
Johnson, T.	12 Townsend-street, Ivanhoe	Johnson's R. E. and Business Agency	13.9.51
Jolly, H. C.	Contingent-street, Trafalgar	R. R. and H. C. Jolly	13.9.51
Kay, L.	84 Ross-street, Coburg	Kay's Estate Agency	6.9.51
Little, L. R.	Bridport-street, Daylesford		11.9.51
Lord, I. M.	485 North-road, Ormond	H. Lord and Son	25.9.51
Lord, W. L.	485 North-road, Ormond	H. Lord and Son	25.9.51
Millbrook, K.	135 Osborne-street, South Yarra		11.9.51
Miller, A. F.	41 Hesse-street, Queenscliff		24.9.51
Musselwhite, L. J.	Were-street, Montmorency		30.8.51
Newman, K. S.	Gillies-street, Rochester	S. G. Newman and Son	21.9.51
Oakleigh Estate Agency (R. G. McKenzie, nominee)	7 Haughton-road, Oakleigh		24.9.51
Parker, S. W.	18 St. James-avenue, Mont Albert		20.9.51
Payne, G. W.	300 King-street, Melbourne	Embassy Real Estate	31.8.51
Rutherford, J. R.	530 Collins-street, Melbourne	All Properties R. E. and B. Agency	5.9.51
Simpkins, W. A.	Alexander-street, Montmorency	Simpkins and Hocking	12.9.51
Stanhill Pty. Ltd. (I. K. Redpath, nominee)	339 Collins-street, Melbourne		12.9.51
Warren, A. T.	High-street, Heathcote		7.9.51
Winfield Lewis Estates Pty. Ltd. (J. L. Weir, nominee)	330 Flinders-lane, Melbourne		12.9.51
Zinner, F. C.	31 Smith-street, Warragul	H. W. Jones and F. C. Zinner	27.9.51

(b) List of Real Estate Sub-agents' Licences issued during the month of September, 1951, and prior months.

Name.	Registered Address.	Date from which Licence is Effective.	Name.	Registered Address.	Date from which Licence is Effective.
Aarons, A. S.	13 Cole-street, Elwood	20.9.51	Hunt, A. W.	Flat 17, "Sylvan," 545 St. Kilda-road, Melbourne	21.9.51
Ashley, F. A.	14 Laura-street, Caulfield	5.9.51	Jenkins, M. G.	118 Skene-street, Newtown, Geelong	25.9.51
Blackham, A. M.	11 Brunswick-road, East Brunswick	12.9.51	Lempriere, K. R.	8 Mansfield-street, Thornbury	14.9.51
Butchers, T. L.	Point Lonsdale	26.9.51	Linney-Barber, G.	1871 Malvern-road, East Malvern	26.9.51
Butler, W. P.	28 Acheron-avenue, Camberwell	17.9.51	McConchie, N. R.	18 Wellington-road, Box Hill	25.9.51
Byrne, H.	Gembrook	21.9.51	McGregor, G. H.	59 Maude-street, Shepparton	6.9.51
Carpenter, J. P.	59 King-street, Queenscliff	10.9.51	McKellar, J. S. G.	70 Beaver-street, East Malvern	12.9.51
Cowan, V. E.	176 Bamba-road, Caulfield	4.9.51	McNamara, M. J.	Shamrock Hotel, Numurkah	18.9.51
Dickinson, V.	22 Andrew-street, Oakleigh	24.9.51	Manuel, M.	32 Morang-road, Hawthorn	19.9.51
Donald, A. F.	c/o P.O., Woodend	12.9.51	Marshman, G. A.	Hitchcock-avenue, Barwon Heads	18.9.51
Essery, G. S.	32 Wanda-road, Caulfield	18.9.51	O'Brien, P.	12 Gore-street, Fitzroy	14.9.51
Ettershank, J. E.	35 Baroda-street, Ascot Vale	5.9.51	Reade, G. F.	14 Crotonhurst-avenue, Caulfield	28.8.51
Fortune, H. D.	30 Washington-street, Toorak	6.9.51	Robinson, H. E.	9 Naroo-street, Balwyn	24.9.51
Frith, J. F.	55 Union-street, East Brighton	18.9.51	Sommer, A. F.	Goulburn-street, Seymour	10.9.51
Gibbs, H. D.	177 Williams-road, Hawksburn	6.9.51	Stanway, G. C.	21 Park-street, South Yarra	5.9.51
Gilchrist, D.	545 Rathdown-street, Carlton	24.9.51	Stewart, J. S.	169 Barkly-street, Ararat	21.9.51
Glett, O.	33 Gurner-street, St. Kilda	17.9.51	Tulloch, N. J.	105 Mathoura-road, Toorak	6.9.51
Hall, J. R.	53 Alexander-street, East St. Kilda	28.9.51	Walker, A. H.	Cavendish	21.9.51
Hobson, B.	Yarram	20.9.51	Wladyslaw, F.	Flat 7, 202 Lower Heidelberg-road, Ivanhoe	9.8.51
Hopkins, A. T.	Flat 9, 44 Fitzroy-street, St. Kilda	8.9.51	Wrigley, V. R.	14 Gray-street, Yarraville	6.9.51
Horn, O. (Mrs.)	North-road, Lilydale	11.9.51			
Horwood, R. J.	Merricks North	28.9.51			

R. E. STAFFORD,  
Registrar.

The Treasury,  
Melbourne, 10th October, 1951.



Local Government Act 1946, Part 48, Section 876.  
LICENCES TO OCCUPY WATER FRONTAGES.

NOTICE is hereby given that Licences to occupy Water Frontages have been issued to the following approved applicants, and that the Licence Fee specified in each case has been received by the Accountant, Lands Department, Melbourne, C.2.

Number of Licence.	Name and Address of Licensee.	Municipality.	Parish.	Abutting on— Allotments and Sections.	Fee for Licence.	Date of Issue of Licence.	Date of Expiry of Licence.
					£ s. d.		
22513	L. L. Wangler, Cavendish ..	Dundas ..	Urangara ..	Pt. 23, section B ..	0 13 6	1.1.50	31.12.52
22514	E. McLean, Hotspur ..	Portland ..	Hotspur ..	1, section 3 ..	0 18 0	1.1.50	31.12.52
22515	J. A. McDonald, Hotspur ..	Portland ..	Hotspur ..	2 and 3, section 3 ..	0 10 0	1.1.50	31.12.52
22516	W. Harrison, Chetwynd ..	Glenelg ..	Town of Chetwynd ..	5, 6, 7, 8, 11, 12, 13, 14, 15, 16, 18, section 12 ..	0 17 6	1.1.50	31.12.52
22517	A. E. Hodgetts, Wattle Creek ..	Avoca ..	Landsborough ..	Southern half of 1N and 5J, section 5 ..	3 0 0	1.1.50	31.12.52
22518	P. S. Peters, Warracknabeal ..	Warracknabeal ..	Werrigar ..	58, 58B ..	2 5 0	1.1.50	31.12.52
22519	Estate of D. Williams, Stawell ..	Stawell ..	Warranook ..	133A, 133B ..	3 12 6	1.1.50	31.12.52
22520	R. M. Herring, Hilgay ..	Wannon ..	Coleraine ..	25 ..	1 5 0	1.1.50	31.12.52
22521	A. R. Storer, Digby ..	Glenelg ..	Town of Digby ..	40, 37, 38 and 39 ..	1 1 0	1.1.50	31.12.52
22522	E. G. Waldron, Stawell ..	Stawell ..	Illawarra ..	110, 110A ..	0 8 0	1.1.50	31.12.52
22523	J. M. Leslie, Noradjuha ..	Arapiles ..	Lowan ..	Bet. 84 and 84A, 85 ..	0 15 0	1.1.50	31.12.52
22524	G. A. Williamson, Stawell ..	Stawell ..	Mokepilly and Bellellen ..	Bet: 67, 68 and bet. 39, 40 ..	1 17 4	1.1.50	31.12.52
22525	H. V. and E. W. L. MacLeod, Portland ..	Portland ..	Homerton ..	4, section B ..	2 5 0	1.1.50	31.12.52
22526	A. E. Cooper, Stawell ..	Stawell ..	Boroka ..	A2 ..	2 0 0	1.1.50	31.12.52
22527	W. Crute, Lubck ..	Stawell ..	Warranook ..	134 ..	3 0 0	1.1.50	31.12.52
22528	S. D. and D. E. Brain, Stawell ..	Stawell ..	Joel Joel ..	192, 193, 194A, 194B, 195, 196, 204, 205A, 205B ..	5 0 0	1.1.50	31.12.52
22529	A. C., M. S., and M. A. Reading, Wallaloo East ..	Kara Kara ..	Morril Morrill ..	14, 14A, 14B, section 2 ..	0 9 3	1.1.50	31.12.52
22530	R. Launder, Stawell ..	Stawell ..	Boroka ..	19, 35A, 35B, 35C, 35D ..	2 18 4	1.1.50	31.12.52
22531	H. R. Queale, Horsham ..	Arapiles ..	Mockinya ..	21, 21A, 21B ..	40 0 0	1.1.51	31.12.53
22532	D. A. Zippel, Horsham ..	Belfast ..	Eumeralla ..	1A ..	4 15 0	1.1.51	31.12.53
22533	M. D. and J. H. McCarthy, Myamyn ..	Portland ..	Condah ..	1 and 4 ..	1 6 8	1.1.51	31.12.53
22534	A. I. and A. M. J. Tyrie, Green's Creek ..	Stawell ..	Glynwylln and Malakoff ..	116A, 117, 118, 110/26, part 31, 32B, 34 ..	2 16 6	1.1.51	31.12.53
22535	M. T. Sullivan, Dartmoor ..	Glenelg ..	Myaring ..	2, 4, 5, section B ..	0 16 6	1.1.51	31.12.53
22536	Sullivan Brothers, P. and P., Dartmoor ..	Glenelg ..	Werrikoo ..	20A ..	0 15 9	1.1.51	31.12.53
22537	J. S. Hutton, Hamilton ..	Dundas ..	Bochara ..	1A, section 4A, and 1A, section 5A ..	1 2 0	1.1.51	31.12.53
22538	R. B. Taylor, Stawell ..	Stawell ..	Wirchilleba ..	137, 170, 171, 172, 173, 178, 179, 180, 181, 182 ..	5 0 0	1.1.51	31.12.53
22539	F. Arnold, Tyrendarra ..	Portland ..	Homerton ..	159B ..	0 9 0	1.1.51	31.12.53
22540	W. A., C. A., N. J., Mitchell, Tyrendarra ..	Portland ..	Homerton ..	1 and 2, section B ..	0 18 0	1.1.51	31.12.53
22891	P. G. Addinsall, Macarthur ..	Minhamite ..	Banangal ..	1, section A ..	3 0 0	1.1.51	31.12.53
22892	R. G. Tonkin, Telangatak E. ..	Kowree ..	Telangatak ..	126, 127 ..	2 0 0	1.1.51	31.12.53
22893	W. G. Wisdom, Quantong ..	Wimmera ..	Quantong ..	1, 2, 3, section 4, Town of Vectis ..	0 2 6	1.1.51	31.12.53
22894	L. A. Brown, Gritjurk ..	Wannon ..	Gritjurk ..	2A1, section 7 ..	0 4 6	1.1.51	31.12.53
22895	Sheridan, M. A., Donald ..	Dunmunkle ..	Dunmunkle ..	117, 118 ..	1 14 0	1.1.51	31.12.53
22596	A. J. McInnes, Macarthur ..	Minhamite ..	Macarthur ..	7D, section 8 ..	1 4 0	1.1.52	31.12.54
22597	A. C. McInnes, Macarthur ..	Minhamite ..	Macarthur ..	7C, 8C, section 8 ..	1 0 0	1.1.52	31.12.54
22898	A. E. Howlett, Chetwynd ..	Glenelg ..	Ganoo Ganoo ..	14A, 14B, section A ..	0 10 0	1.1.51	31.12.53
22899	J. H. Hindson, Henty ..	Glenelg ..	Merino ..	14, section 16 ..	1 16 0	1.1.51	31.12.53
22900	Coomete Pty. Ltd., Koroit ..	Minhamite ..	Willatook ..	Sections 28, part 29, part 30 ..	5 5 0	1.1.50	31.12.52
22901	J. J. Nicol, Koroit ..	Minhamite ..	Willatook and Warrong ..	Sections 33, 31, part 29, 41, 40, 39, 32, part 30. Allots. 1, 2, 7, section S ..	9 18 9	1.1.50	31.12.52
22902	Threlfall, W. H., Koroit ..	Minhamite ..	Willatook ..	Sections 35, 36, 37, 38, 38A ..	6 8 0	1.1.51	31.12.53
22903	N. Todd, Strathdownie ..	Glenelg ..	Wilkin ..	1, 4, 4A, 4B, 5, 10 ..	1 8 6	1.1.51	31.12.53
22904	G. C. Hemley, Callawadda ..	Stawell ..	Callawadda ..	202A, 202B ..	1 2 0	1.1.51	31.12.53
22905	R. S. Forrest, Wannon ..	Wannon ..	Township of Redruth ..	16 ..	0 7 6	1.1.51	31.12.53

Department of Crown Lands and Survey (Unused Roads and Water Frontages Branch), Melbourne, 10th October, 1951.

A. E. LIND,  
Commissioner of Crown Lands and Survey.

MONEY LENDERS ACT 1938.

IN accordance with the provisions of the above-mentioned Act, the following is published for general information:—

Supplementary List of Persons to whom Money Lenders' Licences have been issued for the year ending 30th June, 1952.

Name.	Authorized Name.	Authorized Address.	Date of Issue.
The Towns Supply Co. Pty. Ltd. (R. G. Pinsent, appointee)	The Towns Supply Co. Pty. Ltd. ..	761 Burke-road, Camberwell ..	25.9.51

The Treasury,  
Melbourne, 10th October, 1951.  
No. 1020.—9886/51.—2

R. E. STAFFORD,  
Registrar.

## BUSINESS AGENTS ACT 1930.

IN accordance with the provisions of the above-mentioned Act, the following is published for general information:—

(a) List of Business Agents' Licences issued during the month of September, 1951, and prior months.

Name.	Principal Place of Business (Registered Office).	Name of Firm or Partnership.	Date from which Licence is Effective.
Barwood, C. F.	118 Wellington-street, Windsor		20.9.51
Bell, R. J.	41 Nolan-street, Maryborough		28.9.51
Dean, R. H.	Main-street, Greensborough		26.9.51
Delbridge, E. L.	14 Hennessy-avenue, Elwood		24.9.51
Doherty, K. A.	26 Gillies-street, Fairfield		30.8.51
Dowling, G. T.	4 Victoria-road, Camberwell		13.9.51
Hay, A. G.	379 Beach-road, Beaumaris		5.9.51
Johnson, T.	12 Townsend-street, Ivanhoe		20.9.51
Jolly, H. C.	Contingent-street, Trafalgar	R. R. and H. C. Jolly	13.9.51
Little, L. R.	Bridport-street, Daylesford		11.9.51
Millbrook, K.	135 Osborne-street, South Yarra		11.9.51
Miller, A. F.	41 Hesse-street, Queenscliff		24.9.51
Newman, K. S.	Gillies-street, Rochester	S. G. Newman and Son	21.9.51
Parker, S. W.	18 St. James-avenue, Mont Albert		20.9.51
Payne, G. W.	300 King-street, Melbourne	Embassy Real Estate	31.8.51
Rutherford, J. R.	530 Collins-street, Melbourne	All Properties R. E. and Business Agents	5.9.51
Simpkins, W. A.	Alexander-street, Montmorency	Simpkins and Hocking	19.9.51
Warren, A. T.	High-street, Heathcote		7.9.51
Winfield Lewis Estates Pty. Ltd. (J. L. Weir, nominee)	330 Flinders-lane, Melbourne		12.9.51

(b) List of Business Sub-agents' Licences issued during the month of September, 1951, and prior months.

Name.	Registered Address.	Date from which Licence is Effective.	Name.	Registered Address.	Date from which Licence is Effective.
Ashley, F. A.	14 Laura-street, Caulfield	5.9.51	Hall, J. R.	53 Alexander-street, East St. Kilda	28.9.51
Blackham, A. M.	11 Brunswick-road, East Brunswick	12.9.51	Hopkins, A.	Flat 9, 44 Fitzroy-street, St. Kilda	8.9.51
Clarke, L.	5 Wallen-road, Carnegie	30.8.51	Linney-Barber, G.	1871 Malvern-road, East Malvern	26.9.51
Court, F. M.	10 Grange-road, Sandringham	5.9.51	McGregor, G. H.	59 Maude-street, Shepparton	6.9.51
Dickinson, V.	22 Andrew-street, Oakleigh	24.9.51	McNamara, M. J.	Shamrock Hotel, Numurkah	18.9.51
Donald, A. F.	P.O., Woodend	12.9.51	O'Brien, P.	12 Gore-street, Fitzroy	14.9.51
Essery, G. S.	32 Wanda-road, Caulfield	18.9.51	Robinson, H. E.	9 Naroo-street, Balwyn	24.9.51
Frith, J. F.	55 Union-street, East Brighton	18.9.51	Stewart, J. S.	169 Barkly-street, Ararat	21.9.51
Gibbs, H. D.	177 Williams-road, Hawksburn	6.9.51	Wrigley, V. R.	14 Gray-street, Yarraville	6.9.51
Glett, O.	33 Gurner-street, St. Kilda	17.9.51			

R. E. STAFFORD,  
Registrar.

The Treasury,  
Melbourne, 10th October, 1951.

## Marriage Act 1928.

## MINISTERS OF RELIGION REGISTERED TO CELEBRATE MARRIAGES IN VICTORIA.

IT is hereby notified that, in pursuance of the provisions of the Marriage Act 1928, 19 Geo. V. No. 3726, Section 11, the under-mentioned Officiating Ministers of Religion have been registered at this Office for the celebration of marriages in Victoria:—

Number in Register.	Name.	Designation.	Denomination.	Residence.	Date of Registration.
10468	Winter, Allen Ernest	Bishop	Church of England	Christ Church, St. Arnaud	2.8.51
10469	Miller, Alfred Theodore	Minister	Evan. Lutheran	St. Peter's, Dimboola	7.8.51
10470	Smith, Leonard Eugene	Priest	Roman Catholic	Sacred Heart, Carlton	13.8.51
10471	Traeger, Rudolph Hermann	Pastor	Evan. Lutheran	Presbyterian Church, Murrayville	8.8.51
10472	Hülley, Charles Edward	Priest	Church of England	All Saints, Bendigo	16.8.51
10473	Bongiorno, Ambrose Sylvester	Priest	Roman Catholic	St. Patrick's, Melbourne	17.8.51
10474	Roberts, John David	Minister	Congregational	Congregational Church, Glenhuntly	15.8.51
10475	Schmidt, Louis James	Minister	Presbyterian	St. Andrew's, Charlton	14.8.51
10476	Thomson, Colin William	Minister	Presbyterian	331 Holyrood-street, Hampton	21.8.51
10477	Allman, John Patrick	Priest	Roman Catholic	The Cathedral, Sale	31.8.51
10478	Westerman, John William Robert	Minister	Methodist	Newtown, Geelong	22.7.51
10479	Wilhelms, Alfred Kenneth	Minister	Methodist	Cudgewa	31.8.51
10480	Rocchi, Luciano	Priest	Roman Catholic	Capuchin Chapel, Hawthorn	14.9.51
10481	Creeley, Aloysius Bruce	Priest	Roman Catholic	St. Francis, Lonsdale-street, Melbourne	17.9.51
10482	Geursen, Marius Willem Jan	Minister	Presbyterian	Erskine Church, Carlton	19.9.51
10483	Thomson, Wilkie Jas.	Minister	Churches of Christ	Malvern-Caulfield Church of Christ	18.9.51
10484	Wilson, Ronald	Minister	Churches of Christ	Drumcondra Church of Christ	19.9.51
10485	Woods, Asa Bramwell	Major	Salvation Army	Bourke-street, Melbourne	20.9.51

Office of the Government Statist,  
Melbourne, 10th October, 1951.

O. GAWLER,  
Government Statist.

## MELBOURNE AND METROPOLITAN BOARD OF WORKS.

NOTICE TO THE OWNERS OF TENEMENTS IN THE UNDER-MENTIONED STREETS, AND THE PRIVATE STREETS, LANES, COURTS, AND ALLEYS OPENING THERETO.

THE main pipe in the said streets being laid down, the owners of all tenements situated as under are hereby required, on or before the 19th November, 1951, to cause a proper pipe and stop cocks to be laid, so as to supply water within such tenements from the main pipe.

C. F. TRATHAN,  
Secretary.

9th October, 1951.

*Box Hill.*

Cumming-street, from Burwood-road to Highbury-road.  
Corrigan-street, from Cumming-street westward 2½ chains.  
McComas-grove, from 4½ chains south of Burwood-road southwards 15½ chains.

Glendale-street, from 5½ chains south of Chester-street to Riversdale-road.  
Riversdale-road, from Glendale-street westwards 1½ chain.  
Boisdale-street, from Glendale-street westwards 3 chains.

*Brighton.*

Noel-street, from 5 chains east of Landcox-street southwards and eastwards 11 chains.

*Camberwell.*

Palmer-avenue, from Naroo-street westwards 8½ chains.  
Grieve-street, from 7½ chains south-west of Madden-street to Hosken-street.

Hosken-street, from Grieve-street south-eastwards 1½ chain.

Jacka-street, from Hosken-street southwards 8 chains.  
Boorahman-street, from Dight-avenue westwards 3½ chains.  
Ropley-avenue, from Palmer-avenue southwards 5½ chains.  
Alandale-avenue, from Belmore-road southwards 6 chains.

*Caulfield.*

Bent-street, from Elizabeth-street to Gordon-street.  
Gordon-street, from Bent-street southwards 7½ chains.

*Coburg.*

Landells-road, from Gaffney-street to Oakbank-grove.  
Oakbank-grove, from Landells-road to Derby-street.

*Dandenong.*

Grace-street, from Police-road southwards 17 chains.  
Hillside-road, from Police-road southwards 20½ chains.

*Heidelberg.*

Finlayson-street, from Pyalong-avenue to Golf-avenue.  
Golf-avenue, from Finlayson-street to Lower Plenty-road.  
St. Andrew's-avenue, from Golf-avenue north-eastwards 19½ chains.

Liberty-parade, from Ebony-parade to Carbeena-parade.

*Moorabbin.*

Crozier-court, from Whitmuir-road westwards 5½ chains.

*Nunawading.*

Aberdeen-street, from Highfield-avenue to Agnew-street.

*Sunshine.*

Barwon-avenue, from McIntyre-road westwards 8½ chains.  
Cranwell-street, from Errol-street to Butler-street.  
Butler-street, from Cranwell-street to Ballarat-road.  
Gilbert-street, from Butler-street to Errol-street.

## DEPARTMENT OF PUBLIC WORKS.

## ORDER CONFIRMED.

THE Minister of the Crown administering the *Local Government Act 1946*, on the 9th day of October, 1951, confirmed the Order hereinafter referred to in pursuance of section 513 of the said Act, viz.:—

An Order of the Council of the Shire of Numurkah, made on the 18th June, 1951, for the purpose of providing a gravel pit and for acquiring for such purpose all that piece of land, being part of Crown allotment 7, section 2, Parish of Narioka, County of Moira, commencing at a point on a Government road forming the western boundary of the said Crown allotment, and being the north-west corner of the said Crown allotment; and being a line bearing north 89 deg. 58 min. east and distant 1,000 links; thence south 0 deg. 10 min. west 450 links; thence south 89 deg. 58 min. west 1,000 links; thence north 0 deg. 10 min. east 450 links to the point of commencement, and being land within the municipal district of the said municipality.

P. T. BYRNES,  
Commissioner of Public Works.

## SHIRE OF MANSFIELD.

## ROAD DEVIATION.

IN pursuance of the powers conferred by sections 518 and 523 of the *Local Government Act 1946*, the Council of the Shire of Mansfield doth hereby order that the lands hereinafter described shall be a public highway from and after the publication of this Order in the *Government Gazette*, namely:—

All that piece of land being part of Crown allotment 39, section A, Parish of Dueran, County of Delatite, containing 1 acre 1 rood and 4 perches or thereabouts, commencing at a point on the southern boundary of said Crown allotment distant 1,211 links easterly from the south-west corner or angle of the said Crown allotment; thence northerly 349 deg. 36 min. for 1,227 links; thence north-easterly 36 deg. 51 min. for 136 links and 2/10ths of a link; thence southerly 169 deg. 36 min. for 1,329 links; thence westerly 264 deg. 57 min. for 100 links and 4/10ths of a link to the point of commencement.

And the said Council doth hereby further declare that the land above described shall from the date of publication in the said *Government Gazette* be a public highway in lieu of the following piece of land, namely:—

All that piece of land being part of a former Government road adjoining said Crown allotment 39 of section A, Parish of Dueran, commencing at the south-west corner or angle of said Crown allotment; thence westerly 264 deg. 57 min. for 134 links and 3/10th of a link; thence north-easterly 36 deg. 51 min. for 1,823 links; thence southerly 169 deg. 36 min. for 136 links and 2/10ths of a link; thence south-westerly 216 deg. 51 min. for 1,641 links to the point of commencement.

Dated the 20th day of December, 1950.

The common seal of the President, Councillors, and Ratepayers of the Shire of Mansfield was hereto affixed, in the presence of—

(SEAL) T. SHANKS, Councillor.  
W. J. REDFERN, Councillor.  
R. WOMERSLEY, Secretary.

Approved by the Governor in Council,  
9th October, 1951.

A. MAHLSTEDT,  
Clerk of the Executive Council.

*Hospitals and Charities Act 1928* (No. 5300), Section 46.

## PETITION TO INCORPORATE KERANG AND DISTRICT HOSPITAL.

IT is hereby notified, in accordance with the provisions of section 46 (2) of Act No. 5300, that the Hospitals and Charities Commission of Victoria has received a petition signed by not less than 25 contributors to Kerang and District Hospital, an institution capable of incorporation under the provisions of the said Act, praying that the said hospital be incorporated.

If a counter petition signed by an equal or greater number of contributors is not lodged with the aforesaid Commission within one month after the publication of this notice, the Governor in Council may by Order made pursuant to Act No. 5300, and published in the *Government Gazette*, declare the contributors for the time being to the said institution to be a body corporate by the name set forth in such Order.

W. O. FULTON,  
Minister of Health.

THE MELBOURNE HARBOR TRUST COMMISSIONERS.

IN pursuance of *The Melbourne Harbor Trust Act 1928*, the Melbourne Harbor Trust Commissioners make the following Regulations:—

1. The Regulations made by the Commissioners on the 21st February, 1951, approved by the Governor in Council on 16th March, 1951, and published in the *Government Gazette* on the 28th May, 1951, and any amendment thereto, are hereinafter referred to as "the Principal Regulations."

2. Sub-regulations Nos. (b) (i) and (ii) of Regulation No. 54 are amended as follows:—

In Sub-regulation (b) (i), for the words "occulting red" where appearing, substitute the words "occulting green", and in Sub-regulation (b) (ii), for the words "occulting green" substitute the words "occulting red."

3. In the heading to Regulations 230 to 233 inclusive, for the words "Wharf Cranes" therein appearing, substitute the words "Wharf Cranes and Mechanical Appliances."

4. Regulations Nos. 230 to 233 inclusive are repealed, and the following Regulations substituted therefor:—

**WHARF CRANES AND MECHANICAL APPLIANCES.**

230. Every person desiring to use any crane or any mobile cargo-handling plant of the Commissioners shall make application on the prescribed form therefor to the Commissioners, who may grant permission to use the same on payment of the fee which they may from time to time appoint.

231. The hirer of a crane or any mobile cargo-handling plant shall see that all the working parts thereof have been carefully oiled before using it, and must not lift a greater weight with it than that indicated on the crane or the plant as the maximum lift thereof, and must not use any such crane or plant for dragging out cargo, or for any other purpose than lifting and landing.

232. The hirer of any crane or any mobile cargo-handling plant shall be responsible therefor, and shall make good any damage sustained by such crane or plant when in his use.

233. The Commissioners shall be under no responsibility for any crane or any mobile cargo-handling plant when in use by any hirer thereof, and the persons using such crane or plant when hired on behalf of the hirer, are to be deemed servants of the latter, and not of the Commissioners. The hirer shall indemnify and keep indemnified the Commissioners from and against all actions, claims, and demands whatsoever arising out of the operation or use of such crane or plant during the period of hiring (except claims made by an employee of the Commissioners for workers' compensation under the Workers' Compensation Acts of the State of Victoria, or any amendment thereof for the time being in force, where the injury was not due to the negligence of the hirer).

5. After Regulation No. 304 of the Principal Regulations, the following Regulation is inserted:—

304A. The master, owner, or agent of a vessel requiring the use of any berth at Station Pier or Princes Pier, Port Melbourne, shall pay to the Commissioners for the use of such berth for the storage of cargo, in addition to the charges provided in Regulation No. 316, the following charges:—

(a) For the storage of outward cargo prior to the berthing of the vessel by which it is intended to be shipped, from the time when such wharf is set apart until the berthing of the vessel—

At Station Pier, the sum of £5 7s. 9d. for each quarter of a day.

At Princes Pier, the sum of £3 6s. 6d. for each quarter of a day.

(b) For the storage of any cargo remaining on the wharf after departure of the vessel, whether such cargo was intended for shipment or was landed from the vessel, from time of departure of the vessel until the whole of such cargo has been removed, the sum of £1 5s. per quarter of a day.

Provided always that the charge for any part of a day or less than six hours shall be that specified for a quarter of a day.

The granting of the use of any portions of the piers for the storage of outward cargo shall be at the discretion of the Commissioners and any such grant may be revoked.

The provisions of Regulation No. 304 shall not apply to Station Pier or Princes Pier, Port Melbourne.

Dated at Melbourne, this 20th day of September, 1951.

The common seal of the The Melbourne Harbor Trust Commissioners was hereunto affixed, by order of the Commissioners, in the presence of—

(SEAL) A. D. MACKENZIE, Chairman.  
H. M. GIBBONS, Commissioner.  
A. C. COOK, Secretary.

Approved by the Governor in Council,  
9th October, 1951.

A. MAHLSTEDT,  
Clerk of the Executive Council.

**Housing Acts (Section 40 of Act 4996).**

**GENERAL NOTICE TO PARTIES EMPOWERED BY THE "LANDS COMPENSATION ACT 1928" TO SELL AND CONVEY OR GRANT AND RELEASE, PURSUANT TO PARAGRAPH (b) OF SECTION 40 OF ACT 4996.**

**GENERAL NOTICE TO TREAT FOR LAND AT CORIO.**

No. 18.

IN pursuance of the provisions contained in the *Housing Act 1943* (No. 4996) and the *Lands Compensation Act 1928* (No. 3711), the Housing Commission (hereinafter referred to as "the Commission"), hereby doth give notice that the lands, tenements, and hereditaments described in the Schedule hereto are required for the purpose of the Housing Acts, and that the Commission is authorized by consent of the Treasurer, as required by paragraph (a) of sub-section (1) of section 4 of Act 4996, to purchase or take compulsorily the said lands.

And the Commission accordingly hereby gives notice to all the parties interested in such land and to all the persons empowered by the *Lands Compensation Act 1928* to sell and convey or grant and release the land so required, that it requires to take and purchase the land referred to in the said Schedule hereto, and that it is willing to treat with such parties or persons for the purchase thereof and as to the compensation to be made and for the damage that may be sustained by reason of the execution of the works.

And further, the Commission hereby requires such parties or persons on or before the expiration of twenty-one days from the fifteenth day of October, 1951, to deliver to the offices of the Commission at 179 Queen-street, Melbourne, a statement in writing of the particulars of the estate and interest in the said land, tenements, and hereditaments, and of the claims made in respect thereof.

Dated the second day of October, 1951.

By order of the Commission,

J. H. DAVEY,  
Secretary.

**SCHEDULE.**

Firstly, all that land within the Shire of Corio, being Crown allotments 61, 62, 72, 73, 74, and portions 1 to 6 (both inclusive) of Crown allotment 75, all in the Parish of Moranghurk, County of Grant.

Secondly, all that land within the Shire of Corio, being Crown allotments 148 to 172 (both inclusive) of no section, Parish of Moonpanyal, County of Grant.

**MELBOURNE AND METROPOLITAN TRAMWAYS BOARD.**

**NOTICE OF APPROVAL OF BY-LAW FIXING TOLLS, FARES, AND CHARGES.**

PURSUANT to section 110 of the *Melbourne and Metropolitan Tramways Act 1928*, it is hereby notified for public information that His Excellency the Governor of the State of Victoria, by and with the advice of the Executive Council thereof, has this day, in accordance with the provisions of the Melbourne and Metropolitan Tramways Acts, approved the following By-law made by the Melbourne and Metropolitan Tramways Board:—

Title of By-law.—No. 13, tolls, fares, and charges.

General Purport of By-law.—Rescinding By-law No. 10 of the Melbourne and Metropolitan Tramways Board, and prescribing tolls, fares, and charges which may be demanded and taken by the Board for the conveyance of passengers on its tramways, or any part thereof, or on any omnibus of the Board.

A. MAHLSTEDT,  
Clerk of the Executive Council.

At the Executive Council Chamber,  
Melbourne, the 16th October, 1951.

*Midwives Act 1928* (No. 3734).

**MIDWIVES REGULATIONS 1951.**

**CORRIGENDUM** to page 6564 of the *Victoria Government Gazette*, No. 964, of the 14th September, 1951:—

For the signatures appearing at the end of the *Midwives Regulations 1951* there shall be substituted the signatures—

JOHN B. PLANT, Chairman } Nurses  
K. E. KEY, Registrar } Board.

W. L. ROWE, Secretary,  
Health Department.

SUPPLEMENTARY LIST OF FERTILIZERS REGISTERED AT THE OFFICE OF THE DIRECTOR OF AGRICULTURE UNDER THE FERTILIZERS ACT 1923 (No. 3680) FOR THE YEAR 1951.

Description of Fertilizer.	Brand.	Nitrogen.			Phosphoric Acid.				Price asked per ton.*	Where Obtainable.
		As Blood.	As Blood and Bone.	Total.	As Water Soluble.	As Citrate Soluble.	As Citrate Insoluble.	Total.		
		%	%	%	%	%	%	%	£ s. d.	
Ground Phosphate	Siekle in diamond 80 per cent.	..	..	..	..	..	36.65	36.65	8 10 6	Commonwealth Fertilizers and Chemicals Ltd., 65 William-street, Melbourne Thos. Borthwick and Sons (A'sia) Ltd., 84 William-street, Melbourne Thos. Borthwick and Sons (A'sia) Ltd., 84 William-street, Melbourne
Dried Blood	T.B. and S. Yahl	12.0	..	12.0	..	..	..	..	18 15 0	
Blood and Bone	T.B. and S. Yahl	..	4.75	4.75	..	4.0	15.0	19.0	15 5 0	

Description of Fertilizer.	Brand.	Nitrogen as Bone.	Phosphoric Acid.	Mechanical Condition.		Price asked per ton.*	Where Obtainable.
				Fine Bone.	Coarse Bone.		
		%	%	%	%	£ s. d.	
Bonedust	Bendigonian	3.75	23.16	62.0	38.0	11 0 0	Bendigo Fertilizers, Bendigo East
Bonedust	Prospex	2.57	26.92	58.0	42.0	11 0 0	G. McL. Holt, Marong-road, Maiden Gully, via Bendigo

\* F.O.R. at Melbourne or Railway Station nearest place of manufacture.

Melbourne, 3rd October, 1951.

W. R. JEWELL, M.Sc., F.R.I.C.,  
Chemist for Agriculture.

Stamps Act 1946.  
NOTICE.

IN pursuance of the powers contained in the *Stamps Act 1946*, I hereby declare, by this notice, that transfers of stock in Gold Mines of Kalgoorlie (Aust.) Limited held by Gold Mines of Kalgoorlie Limited (in Liquidation) and transferred by the liquidators thereof to stock holders of the last-mentioned company who are entitled thereto by way of a distribution in specie in consequence of the winding up of the said last-mentioned company, are not chargeable with any stamp duty.

Dated the 11th day of October, 1951.

W. E. CAMIER,  
Comptroller of Stamps.

COUNTRY ROADS BOARD.

At the Executive Council Chamber, Melbourne, the ninth day of October, 1951.

PRESENT:

His Excellency the Governor of Victoria.

Mr. Brose  
Mr. White

Mr. Harvey.

ORDER APPROVING OF A NEW MAIN ROAD IN THE SHIRE OF LEXTON.

WHEREAS the Country Roads Board constituted under the *Country Roads Act 1928* (No. 3662) has represented to His Excellency the Governor in Council that it appears to it desirable that the new Beaufort-Lexton-road in the Shire of Lexton should be made by the said Board: And whereas the said Board in accordance with the requirements of section 19 of the said cited Act has caused to be prepared a map plan and estimate showing the points between which and on and through what land the said new road is proposed to be made and the cost of acquiring the land and constructing the said new road: And whereas on an inspection of the said map and plan and a consideration of the said estimate His Excellency the Governor in Council is satisfied that there are funds legally available for acquiring the land and constructing the said new road: Now therefore be it known by this present Order that His Excellency the Governor of the State of Victoria with the advice of the Executive Council thereof doth hereby approve of the said road being made, that is to say:—

All that piece of land in the Parish of Lexton, the boundaries of which are as follow:—Commencing at a point on the north-western boundary of allotment 1, section D, of the said parish, distant 244 deg. 46 min. 3,676 links from the northern angle of the said allotment; thence by lines bearing respectively 224 deg. 4 min. 729.7 links, 23 deg. 22 min. 390 links, and 64 deg. 46 min. 390 links to the point of commencement—which said piece of land is particularly delineated and shown coloured red on survey plan numbered 5375, lodged in the office of the Country Roads Board.

And the Honorable Percy Thomas Byrnes, His Majesty's Commissioner of Public Works for the State of Victoria, shall give the necessary directions herein accordingly.

A. MAHLSTEDT,  
Clerk of the Executive Council.

Country Fire Authority Acts.

PERMISSION TO HOLD A FIRE-BRIGADES DEMONSTRATION.

IN pursuance with the provisions of section 79 (1) and (2) of the *Country Fire Authority Act 1944*, the Country Fire Authority has granted permission for the holding of a fire brigade demonstration as under—

Rural Fire Brigades.

At Natimuk, on Tuesday, 6th November, 1951.

G. G. SINCLAIR, Secretary.

9th October, 1951.

SUMMONING OFFICER.

I HEREBY appoint the under-mentioned person, under section 31 of the *Education Act 1928*, to summon parents within the State of Victoria:—

Senior Constable WALTER DOUGLAS GREAVES, No. 8540.

P. P. INCHBOLD,  
Minister of Education.

Education Department,  
Melbourne, 11th October, 1951.

SUMMONING OFFICER.

I HEREBY appoint the under-mentioned person, under section 31 of the *Education Act 1928*, to summon parents within the State of Victoria:—

First Constable AUBREY DOUGLAS HAMMOND, No. 9384.

P. P. INCHBOLD,  
Minister of Education.

Education Department,  
Melbourne, 11th October, 1951.

## COUNTRY ROADS BOARD.

At the Executive Council Chamber, Melbourne, the  
ninth day of October, 1951.

## PRESENT:

His Excellency the Governor of Victoria.  
Mr. Brose | Mr. Harvey.  
Mr. White

ORDER APPROVING OF A DEVIATION FROM A  
MAIN ROAD IN THE SHIRE OF LEXTON.

WHEREAS the Country Roads Board constituted under the *Country Roads Act 1928* (No. 3662) has represented to His Excellency the Governor in Council that it appears to it desirable that the deviation hereinafter referred to from the existing Beaufort-Amphitheatre-road in the Shire of Lexton (declared to be a Main Road under the said Act which declaration was confirmed by the Order in Council published in the *Government Gazette* of the 16th July, 1947, on pages 3851-5) should be made by the said Board: And whereas the said Board in accordance with the requirements of section 19 of the said cited Act has caused to be prepared a map plan and estimate showing the points between which and on and through what land the said deviation is proposed to be made and the cost of acquiring the land and constructing the said deviation: And whereas on an inspection of the said map and plan and a consideration of the said estimate His Excellency the Governor in Council is satisfied that there are funds legally available for acquiring the land and constructing the said deviation: Now therefore be it known by this present Order that His Excellency the Governor of the State of Victoria with the advice of the Executive Council thereof doth hereby approve of the said road being made, that is to say:—

All those pieces of land in the Parish of Amphitheatre, the boundaries of which are as follow:—

- (a) Commencing at the eastern angle of allotment 5, section Z, of the said parish; thence by lines bearing respectively 237 deg. 30 min. 1,386.7 links, 41 deg. 13½ min. 1,818 links, and 182 deg. 38 min. 623 links to the point of commencement.
- (b) Commencing at a point on the southern boundary of allotment 5, section Z, of the said parish, distant 78 deg. 20 min. 1,871 links from the south-western angle of the said allotment; thence by lines bearing respectively 41 deg. 13½ min. 1,895 links, 177 deg. 37 min. 538.7 links, and 235 deg. 5 min. 1,550 links to the point of commencement.
- (c) Commencing at a point on the western boundary of allotment 1A, section A, of the said parish, distant 357 deg. 37 min. 567.9 links from the south-western angle of the said allotment; thence by lines bearing respectively 357 deg. 37 min. 77.1 links, 57 deg. 31 min. 189.7 links, and 221 deg. 14 min. 237.9 links to the point of commencement—

which said pieces of land are particularly delineated and shown coloured red on survey plan numbered 4996A, lodged in the office of the Country Roads Board.

And the Honorable Percy Thomas Byrnes, His Majesty's Commissioner of Public Works for the State of Victoria, shall give the necessary directions herein accordingly.

A. MAHLSTEDT,  
Clerk of the Executive Council.

## COUNTRY ROADS BOARD.

At the Executive Council Chamber, Melbourne, the  
ninth day of October, 1951.

## PRESENT:

His Excellency the Governor of Victoria.  
Mr. Brose | Mr. Harvey.  
Mr. White

ORDER APPROVING OF A NEW ROAD IN THE CITY  
OF MOORABBIN AND SHIRE OF DANDENONG.

WHEREAS the Country Roads Board constituted under the *Country Roads Act 1928* (No. 3662) has represented to His Excellency the Governor in Council that it appears to it desirable that the new South-road in

the City of Moorabbin and Shire of Dandenong should be made by the said Board: And whereas the said Board in accordance with the requirements of section 19 of the said cited Act has caused to be prepared a map plan and estimate showing the points between which and on and through what land the said new road is proposed to be made and the cost of acquiring the land and constructing the said new road: And whereas on an inspection of the said map and plan and a consideration of the said estimate His Excellency the Governor in Council is satisfied that there are funds legally available for acquiring the land and constructing the said new road: Now therefore be it known by this present Order that His Excellency the Governor of the State of Victoria with the advice of the Executive Council thereof doth hereby approve of the said road being made, that is to say:—

All those pieces of land in the Parish of Mordialloc, the boundaries of which are as follow:—

- (a) Commencing at a point on the western boundary of allotment 2, section 8, of the said parish, the said point being at the south-eastern angle of the land comprised in certificate of title entered in the Register Book, volume 6099, folio 1219720; thence by lines bearing respectively 359 deg. 38 min. 430.6 links, 164 deg. 41 min. 234.4 links, 134 deg. 49 min. 234.4 links, 104 deg. 56 min. 141.1 links, and 269 deg. 39 min. 364.5 links to the point of commencement.
- (b) Commencing at a point on the western boundary of allotment 1, section 9, of the said parish, the said point being at the north-western angle of the land comprised in certificate of title entered in the Register Book, volume 6666, folio 1333038; thence by lines bearing respectively 89 deg. 47 min. 3,854.5 links, 179 deg. 39 min. 213.8 links, 272 deg. 40 min. 523.3 links, 270 deg. 0 min. 3,271.5 links, 224 deg. 45 min. 84.5 links, and 359 deg. 30 min. 235 links to the point of commencement.
- (c) Commencing at a point on the western boundary of allotment 3, section 9, of the said parish, the said point being distant 359 deg. 39 min. 669 links from the south-western angle of the land comprised in certificate of title entered in the Register Book, volume 2656, folio 531195; thence by lines bearing respectively 359 deg. 39 min. 200.3 links, 89 deg. 47 min. 31.2 links, 97 deg. 59 min. 648.8 links, 103 deg. 18 min. 408.9 links, 148 deg. 1 min. 284.3 links, 283 deg. 18 min. 601.7 links, 277 deg. 59 min. 630.2 links, and 272 deg. 40 min. 11.4 links to the point of commencement.
- (d) Commencing at the north-eastern angle of lot 1 on plan of subdivision numbered 20657, lodged in the Office of Titles, and being part of allotment 5, section 9, of the said parish; thence by lines bearing respectively 179 deg. 30½ min. 255.3 links, 315 deg. 12 min. 119.7 links, 309 deg. 53 min. 630.2 links, 304 deg. 34 min. 630.2 links, 299 deg. 15 min. 630.2 links, 293 deg. 56 min. 630.2 links, 288 deg. 37 min. 502.5 links, 328 deg. 34 min. 298.1 links, 103 deg. 18 min. 91.9 links, 108 deg. 37 min. 648.8 links, 113 deg. 56 min. 648.8 links, 119 deg. 15 min. 648.8 links, 124 deg. 34 min. 648.8 links, 129 deg. 53 min. 579.1 links, and 179 deg. 30½ min. 21.8 links to the point of commencement.
- (e) Commencing at the south-western angle of lot 3A on plan of subdivision numbered 4685, lodged in the Office of Titles, and being part of allotment 1, section 10, of the said parish; thence by lines bearing respectively 359 deg. 30½ min. 85.5 links, 135 deg. 12 min. 616 links, 140 deg. 31 min. 648.8 links, 145 deg. 50 min. 648.8 links, 151 deg. 19 min. 648.8 links, 153 deg. 50½ min. 227.4 links, 269 deg. 45 min. 222.3 links, 333 deg. 50½ min. 125.9 links, 331 deg. 19 min. 634.8 links, 325 deg. 50 min. 629.9 links, 320 deg. 31 min. 630.2 links, 315 deg. 12 min. 401.8 links, and 359 deg. 30½ min. 1,200.9 links to the point of commencement.
- (f) Commencing at a point on the northern boundary of lot 1 on plan of subdivision numbered 4685, lodged in the Office of Titles, and being part of allotment 2, section 10, of the said parish, the said point being distant 89 deg. 45 min. 691.1 links from the north-western angle of the said lot; thence by lines bearing respectively 89 deg. 45 min. 222.3 links, 153 deg. 50½ min. 3,507.7 links, 151 deg. 42 min. 594.6 links, 140

deg. 53 min. 250.1 links, 269 deg. 40 min. 278.5 links, 320 deg. 57 min. 123.7 links, and 333 deg. 50½ min. 4,201.1 links to the point of commencement.

- (g) Commencing at a point on the northern boundary of allotment 4A, section 15, of the said parish, distant 89 deg. 43 min. 1,087 links from the north-western angle of the said allotment; thence by lines bearing respectively 89 deg. 43 min. 278.9 links, 140 deg. 53 min. 191.4 links, 128 deg. 11 min. 570.8 links, 115 deg. 25 min. 570.8 links, 102 deg. 43 min. 570.8 links, 91 deg. 54 min. 594.6 links, 89 deg. 46 min. 1,626.8 links, 179 deg. 34 min. 200 links, 269 deg. 46 min. 2,223.5 links, 282 deg. 39 min. 643.2 links, 295 deg. 25 min. 619.6 links, 308 deg. 11 min. 619.6 links, and 320 deg. 57 min. 390 links to the point of commencement.
- (h) Commencing at a point on the western boundary of allotment 1, section 14, of the said parish, distant 179 deg. 33 min. 905.3 links from the north-western angle of the said allotment; thence by lines bearing respectively 89 deg. 46 min. 2,454 links, 179 deg. 33 min. 200 links, 269 deg. 46 min. 2,454 links, and 359 deg. 33 min. 200 links to the point of commencement.
- (i) Commencing at a point in allotment 1, section 14, of the said parish, distant 179 deg. 37½ min. 909.5 links from the north-western angle of the land comprised in certificate of title entered in the Register Book, volume 3687, folio 737223; thence by lines bearing respectively 89 deg. 46 min. 5,055.3 links, 101 deg. 38 min. 170.6 links, 200 deg. 37 min. 220.8 links, 281 deg. 38 min. 76.2 links, 272 deg. 15 min. 594.2 links, 269 deg. 46 min. 4,475 links, and 359 deg. 37½ min. 200 links to the point of commencement.
- (j) Commencing at the south-western angle of lot 2 on plan of subdivision numbered 16626, lodged in the Office of Titles, and being part of allotment 1, section 13, of the said parish; thence by lines bearing respectively 20 deg. 36 min. 245.4 links, 101 deg. 38 min. 288 links, 112 deg. 22 min. 520.8 links, 123 deg. 6 min. 520.8 links, 133 deg. 50 min. 550.2 links, 145 deg. 42 min. 2,592.6 links, 231 deg. 58 min. 17.2 links, 141 deg. 58 min. 100 links, 51 deg. 58 min. 10.7 links, 145 deg. 42 min. 490.9 links, 241 deg. 56 min. 201.2 links, 325 deg. 42 min. 2,582.1 links, 323 deg. 13 min. 594.2 links, 313 deg. 50 min. 479.8 links, 303 deg. 6 min. 479.8 links, 292 deg. 22 min. 479.8 links, 281 deg. 38 min. 209.7 links, and 267 deg. 22 min. 98.9 links to the point of commencement.
- (k) Commencing at the northern angle of lot 86 on plan of subdivision numbered 4681, lodged in the Office of Titles, and being part of allotment 2, section 13, of the said parish; thence by lines bearing respectively 145 deg. 42 min. 4,525.2 links, 319 deg. 20 min. 2,093.6 links, 240 deg. 48 min. 233.3 links, 325 deg. 42 min. 257.7 links, 319 deg. 20 min. 1,802.3 links, 325 deg. 42 min. 4,558.2 links, and 61 deg. 57 min. 201.2 links to the point of commencement.
- (l) Commencing at the south-eastern angle of lot 54 on plan of subdivision numbered 4681, lodged in the Office of Titles, and being part of allotment 2, section 20, of the said parish; thence by lines bearing respectively 275 deg. 7 min. 84.6 links, 357 deg. 52 min. 690.1 links, 355 deg. 36 min. 219.1 links, 352 deg. 46 min. 160.3 links, 340 deg. 14 min. 188.9 links, 331 deg. 33 min. 282.9 links, 323 deg. 25 min. 282.9 links, 319 deg. 20 min. 1,730.3 links, 60 deg. 48 min. 204.1 links, 139 deg. 20 min. 1,933.1 links, 89 deg. 32 min. 197 links, and 179 deg. 32 min. 1,898 links to the point of commencement—

which said pieces of land are particularly delineated and shown coloured red on survey plans numbered 5352, 5353, 5354, and 5355, lodged in the office of the Country Roads Board.

And the Honorable Percy Thomas Byrnes, His Majesty's Commissioner of Public Works for the State of Victoria, shall give the necessary directions herein accordingly.

A. MAHLSTEDT,  
Clerk of the Executive Council,

HOSPITALS AND CHARITIES ACT 1948 (No. 5300).—  
SECTION 46.

At the Executive Council Chamber, Melbourne, the  
ninth day of October, 1951.

PRESENT:

His Excellency the Governor of Victoria.  
Mr. Brose | Mr. Harvey.  
Mr. White

COHUNA DISTRICT HOSPITAL.

WHEREAS a petition signed by not less than twenty-five contributors to Cohuna District Hospital, an institution capable of incorporation under the *Hospitals and Charities Act 1948* (No. 5300), praying that the said hospital be incorporated has been forwarded to the Hospitals and Charities Commission in accordance with the provisions of section 46 of the said Act: And whereas the substance of the prayer of the said petition has been published in the *Government Gazette*: And whereas no counter-petition has been lodged with the Hospitals and Charities Commission within one month after such publication: Now therefore His Excellency the Governor of the State of Victoria, by and with the advice of the Executive Council of the said State, does by this present Order declare the contributors for the time being to the hospital aforesaid to be a body corporate by the name of Cohuna District Hospital.

And the Honorable William Oliver Fulton, His Majesty's Minister of Health for the State of Victoria, shall give the necessary directions herein accordingly.

A. MAHLSTEDT,  
Clerk of the Executive Council.

MOTOR OMNIBUS ACT 1928 (No. 3742).

At the Executive Council Chamber, Melbourne, the  
ninth day of October, 1951.

PRESENT:

His Excellency the Governor of Victoria.  
Mr. Brose | Mr. Harvey.  
Mr. White

AMENDMENTS OF PRESCRIPTIONS OF CERTAIN  
METROPOLITAN MOTOR OMNIBUS ROUTES.

HIS Excellency the Governor of the State of Victoria, by and with the advice of the Executive Council thereof, and in pursuance of the powers conferred by the *Motor Omnibus Act 1928* (No. 3742), doth by this Order amend, as from and inclusive of the 22nd day of October, 1951, and as set out hereunder, the prescriptions of certain routes within the metropolitan area, along which motor omnibuses for which "regular service" licences are granted may ply for hire, viz.:—

*Route 31A (Brighton South—Middle Brighton).*—Under the heading "Fares to be charged", amend "3d." to read "4d." and "6d." to read "7d."

*Route 34A (North Brighton—Hampton).*—Under the heading "Fares to be charged", amend "3d." to read "4d." and "5d." to read "6d."

*Route 44A (Brighton Beach—Moorabbin).*—Under the heading "Fares to be charged", amend "3d." to read "4d." and "6d." to read "7d."

*Route 74A (Williamstown Beach—Footscray—Moonee Ponds—Small Arms Factory).*—Under the heading "Fares to be charged", amend "3d." to read "4d." and "1s." to read "1s. 1d."

*Licensing Authority.*—Pursuant to the provisions of section 15 (1) (c) of the said Act (No. 3742), the Governor in Council by this Order confers upon the Licensing Authority full power and authority for the carrying into effect by the said Licensing Authority of the foregoing provisions of this Order.

And the Honorable Percy Thomas Byrnes, His Majesty's Commissioner of Public Works for the State of Victoria, shall give the necessary directions herein accordingly.

A. MAHLSTEDT,  
Clerk of the Executive Council.

## REGULATIONS UNDER THE LAND ACT 1928.

At the Executive Council Chamber, Melbourne, the  
ninth day of October, 1951.

## PRESENT:

His Excellency the Governor of Victoria.

Mr. Brose		Mr. Harvey.
Mr. White		

**H**IS Excellency the Governor of Victoria, by and with the advice of the Executive Council thereof, and in pursuance of the provisions of the *Land Act* 1928 and all other powers him thereunto enabling, doth hereby amend the Regulations under the *Land Act* 1928, made on the 14th August, 1951, and published in the *Government Gazette* of 22nd August, 1951, No. 844, page 5977.

## CHAPTER IV.—SURVEY.

## SCHEDULE OF FEES.

*Part I.*

The figures "7.0.0" are substituted for the figures "7.17.6" appearing in the Third Scale opposite the expression "2 acres".

And the Honorable Sir Albert Eli Lind, His Majesty's Commissioner of Crown Lands and Survey, shall give the necessary directions herein accordingly.

A. MAHLSTEDT,  
Clerk of the Executive Council.

## MARKETING OF PRIMARY PRODUCTS ACT 1935 (No. 4337).

At the Executive Council Chamber, Melbourne, the  
ninth day of October, 1951.

## PRESENT:

His Excellency the Governor of Victoria.

Mr. Brose		Mr. Harvey.
Mr. White		

## REGULATIONS.

**I**N pursuance of the powers conferred by the *Marketing of Primary Products Act* 1935 (No. 4337), His Excellency the Governor of the State of Victoria, by and with the advice of the Executive Council thereof and on the recommendation of the Egg and Egg Pulp Marketing Board, doth hereby amend the Egg and Egg Pulp Marketing Board Regulations 1941 made under the said Act on the 13th May, 1941, as follows (that is to say):—

After clause (d) of Regulation 47, the following proviso shall be inserted:—

Provided that paragraphs (b) and (c) shall not apply where pulp is prepared by use of a mechanically operated machine approved by the Board.

And the Honorable George Colin Moss, His Majesty's Minister of Agriculture for the State of Victoria, shall give the necessary directions herein accordingly.

A. MAHLSTEDT,  
Clerk of the Executive Council.



DEPARTMENT OF CROWN LANDS AND SURVEY.

At the Executive Council Chamber, Melbourne, the ninth day of October, 1951.

PRESENT:

His Excellency the Governor of Victoria.  
Mr. Brose | Mr. Harvey.  
Mr. White

REVOCATION OF TEMPORARY RESERVATIONS OF LANDS BY ORDERS IN COUNCIL.

HIS Excellency the Governor of the State of Victoria, by and with the advice of the Executive Council thereof, doth hereby, in pursuance of the provisions of the *Land Act 1928*, revoke the temporary reservations of the lands by Orders in Council hereinafter referred to, viz.:

**BENDIGO.**—Order in Council of 21st January, 1931, of 2 acres 1 rood 17 perches of land in the City of Bendigo as a site for Recreation purposes, so far only as regards the portion thereof comprised within the boundaries published in the *Government Gazette* of 12th September, 1951, and containing 22 perches.—(Rs.4088.)

**WARMUR.**—Order in Council of 24th September, 1924, of 3 acres of land in the Parish of Warmur, as a site for a State School.—(Rs.3003.)

And the Honorable Sir Albert Eli Lind, His Majesty's Commissioner of Crown Lands and Survey for the State of Victoria, shall give the necessary directions herein accordingly.

A. MAHLSTEDT,  
Clerk of the Executive Council.

Parish of Gorong, County of Grant, being the road indicated by hachure on plan hereunder.—(G.105<sup>(s)</sup>) (J.27648).

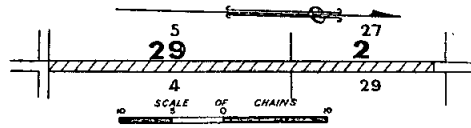

And the Honorable Sir Albert Eli Lind, His Majesty's Commissioner of Crown Lands and Survey for the State of Victoria, shall give the necessary directions herein accordingly.

A. MAHLSTEDT,  
Clerk of the Executive Council.

KILMORE WATERWORKS TRUST.

At the Executive Council Chamber, Melbourne, the ninth day of October, 1951.

PRESENT:

His Excellency the Governor of Victoria.  
Mr. Brose | Mr. Harvey.  
Mr. White

ADDITIONAL LOAN OF £4,674.

UNDER the powers conferred by the Water Acts and all other powers enabling him in that behalf, His Excellency the Governor of the State of Victoria, by and with the advice of the Executive Council of the said State, doth hereby grant an additional loan of Four thousand six hundred and seventy-four pounds (£4,674) to the Killmore Waterworks Trust for the completion of pipe mains and the purchase and installation of meters, as set forth in the detailed statement bearing date the 1st October, 1951, and verified under the seal of the State Rivers and Water Supply Commission.

The loan hereby granted shall be subject to the provisions of the Water Acts.

And the Honorable Richard Keats Brose, His Majesty's Minister of Water Supply for the State of Victoria, shall give the necessary directions herein accordingly.

A. MAHLSTEDT,  
Clerk of the Executive Council.

DEPARTMENT OF CROWN LANDS AND SURVEY.

At the Executive Council Chamber, Melbourne, the ninth day of October, 1951.

PRESENT:

His Excellency the Governor of Victoria.  
Mr. Brose | Mr. Harvey.  
Mr. White

UNUSED AND UNMADE ROADS CLOSED.

HIS Excellency the Governor of the State of Victoria, by and with the advice of the Executive Council thereof, doth hereby direct that, in pursuance of the provisions of section 304 of the *Land Act 1928* (No. 3709), the unused and unmade roads referred to hereunder be closed, viz.:

Parish of Killingworth, County of Anglesey, being the road indicated by hachure on plan hereunder.—(K.55<sup>(2)</sup>) (H.020665).

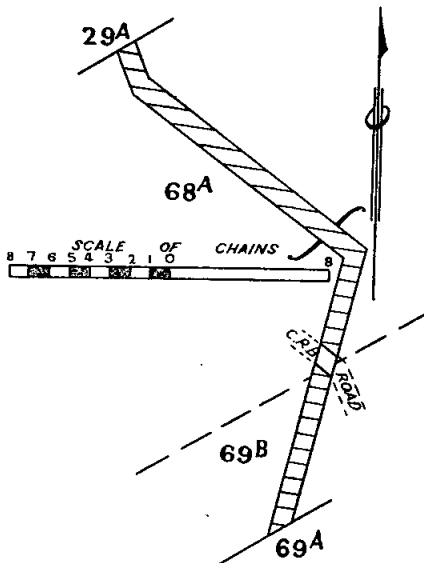

CITY OF WARRNAMBOOL.—WATER SUPPLY DISTRICT.

At the Executive Council Chamber, Melbourne, the ninth day of October, 1951.

PRESENT:

His Excellency the Governor of Victoria.  
Mr. Brose | Mr. Harvey.  
Mr. White

ADDITIONAL LOAN OF £18,736.

UNDER the powers conferred by the Water Acts and all other powers enabling him in that behalf, His Excellency the Governor of the State of Victoria, by and with the advice of the Executive Council of the said State, doth hereby grant an additional loan of Eighteen thousand seven hundred and thirty-six pounds (£18,736) to the Mayor, Councillors, and Citizens of the City of Warrnambool for the construction of pipe mains and purchase and installation of meters, as set forth in the detailed statement bearing date the 1st October, 1951, and verified under the seal of the State Rivers and Water Supply Commission.

The loan hereby granted shall be subject to the provisions of the Water Acts.

And the Honorable Richard Keats Brose, His Majesty's Minister of Water Supply for the State of Victoria, shall give the necessary directions herein accordingly.

A. MAHLSTEDT,  
Clerk of the Executive Council.

Water Acts.  
STATE RIVERS AND WATER SUPPLY COMMISSION.

*At the Executive Council Chamber, Melbourne, the  
ninth day of October, 1951.*

PRESENT:

His Excellency the Governor of Victoria.	
Mr. Brose	Mr. Harvey.
Mr. White	

RED CLIFFS-MERBEIN IRRIGATION AND WATER  
SUPPLY DISTRICT.—DISTRICT EXTENDED.

UNDER the powers conferred by the Water Acts and all other powers enabling him in that behalf, His Excellency the Governor of the State of Victoria, with the advice of the Executive Council of the said State, on the recommendation of the State Rivers and Water Supply Commission, doth hereby declare, order, and direct as follows:—

That the Red Cliffs-Merbein Irrigation and Water Supply District be extended by adding to the same the lands set out and described in the Schedule hereto, and as on and from the date of this Order such district shall be deemed to be so extended.

SCHEDULE.

Those lands comprising the whole of allotment 95A, section A, Parish of Mildura, County of Karkaroc.

The lands described in the foregoing Schedule are shown on a plan approved by the Governor in Council, and deposited in the office of the State Rivers and Water Supply Commission, Melbourne.—(Corres. 51/15375.)

And the Honorable Richard Keats Brose, His Majesty's Minister of Water Supply for the State of Victoria, shall give the necessary directions herein accordingly.

A. MAHLSTEDT,  
Clerk of the Executive Council.

MARKETING OF PRIMARY PRODUCTS ACT 1935  
(No. 4337).

*At the Executive Council Chamber, Melbourne, the  
ninth day of October, 1951.*

PRESENT:

His Excellency the Governor of Victoria.	
Mr. Brose	Mr. Harvey.
Mr. White	

APPOINTMENT OF A MEMBER OF THE CHICORY  
MARKETING BOARD.

IN pursuance of the powers conferred by the *Marketing of Primary Products Act 1935* and all other powers enabling him in that behalf, His Excellency the Governor of the State of Victoria, by and with the advice of the Executive Council thereof, doth by this Order appoint—

WILLIAM BETTS RICHARDSON  
as a member of the Chicory Marketing Board constituted under the said Act, to hold office until the 15th April, 1952.

And the Honorable George Colin Moss, His Majesty's Minister of Agriculture for the State of Victoria, shall give the necessary directions herein accordingly.

A. MAHLSTEDT,  
Clerk of the Executive Council.

KERANG WATERWORKS TRUST.

*At the Executive Council Chamber, Melbourne, the  
sixteenth day of October, 1951.*

PRESENT:

His Excellency the Governor of Victoria.	
Mr. Brose	Mr. Mitchell.
Mr. Harvey	

ADDITIONAL LOAN OF £8,000.

UNDER the powers conferred by the Water Acts and all other powers enabling him in that behalf, His Excellency the Governor of the State of Victoria, by and with the advice of the Executive Council of the said State, doth hereby grant an additional loan of Eight thousand pounds (£8,000) to the Kerang Waterworks Trust for the construction of pipe mains, as set forth in the detailed state-

ment bearing date the 5th day of October, 1951, and verified under the seal of the State Rivers and Water Supply Commission.

The loan hereby granted shall be subject to the provisions of the Water Acts.

And the Honorable Richard Keats Brose, His Majesty's Minister of Water Supply for the State of Victoria, shall give the necessary directions herein accordingly.

A. MAHLSTEDT,  
Clerk of the Executive Council.

MOE WATERWORKS TRUST.

*At the Executive Council Chamber, Melbourne, the  
sixteenth day of October, 1951.*

PRESENT:

His Excellency the Governor of Victoria.	
Mr. Brose	Mr. Mitchell.
Mr. Harvey	

ADDITIONAL LOAN OF £10,000.

UNDER the powers conferred by the Water Acts and all other powers enabling him in that behalf, His Excellency the Governor of the State of Victoria, by and with the advice of the Executive Council of the said State, doth hereby grant an additional loan of Ten thousand pounds (£10,000) to the Moe Waterworks Trust for the construction of offtake works, reservoir, and pipe mains and the purchase and installation of meters, as set forth in the detailed statement bearing date the 10th October, 1951, and verified under the seal of the State Rivers and Water Supply Commission.

The loan hereby granted shall be subject to the provisions of the Water Acts.

And the Honorable Richard Keats Brose, His Majesty's Minister of Water Supply for the State of Victoria, shall give the necessary directions herein accordingly.

A. MAHLSTEDT,  
Clerk of the Executive Council.

COUNTRY FIRE AUTHORITY ACTS.

*At the Executive Council Chamber, Melbourne, the  
sixteenth day of October, 1951.*

PRESENT:

His Excellency the Governor of Victoria.	
Mr. Brose	Mr. Mitchell.
Mr. Harvey	

CONSENT TO THE BORROWING OF FIFTY  
THOUSAND POUNDS BY THE COUNTRY FIRE  
AUTHORITY.

WHEREAS, by section 58 of the *Country Fire Authority Act 1944*, it is enacted that the Country Fire Authority, with the consent of the Governor in Council, may from time to time borrow such moneys as it deems necessary in order to enable it to carry out and perform the powers, authorities, and duties vested in or conferred or imposed upon it by the said Act:

And whereas the Country Fire Authority deems it necessary to borrow the sum of Fifty thousand pounds for the purposes aforesaid:

Now therefore His Excellency the Governor of the State of Victoria, in the Commonwealth of Australia, by and with the advice of the Executive Council of the said State, and in pursuance of the powers conferred by the said section 58 of the *Country Fire Authority Act 1944*, and all other powers him thereunto enabling, doth by this Order consent to the borrowing by the Country Fire Authority of the sum of Fifty thousand pounds for a period of fifteen years, to be liquidated by half-yearly repayments on the principal sum, with interest at the rate of Four pounds two shillings and six pence per centum per annum.

And the Honorable Keith Dodgshun, His Majesty's Chief Secretary for the State of Victoria, shall give the necessary directions herein accordingly.

A. MAHLSTEDT,  
Clerk of the Executive Council.

## COUNTRY FIRE AUTHORITY ACTS.

*At the Executive Council Chamber, Melbourne, the  
sixteenth day of October, 1951.*

## PRESENT :

His Excellency the Governor of Victoria.  
Mr. Brose | Mr. Mitchell.  
Mr. Harvey |

## REGULATIONS RELATING TO THE ISSUE OF DEBENTURES.

WHEREAS by the Country Fire Authority Acts, it is amongst other things enacted that the Governor in Council may make Regulations for prescribing the form of debentures which the Country Fire Authority may issue for amounts borrowed and the term for which they may be issued and the manner in which they are to be redeemed and the amount or rate of the periodical or other payments to be made towards such redemption :

And whereas the Governor in Council by Order made on the sixteenth day of October, 1951, consented to the Country Fire Authority borrowing the sum of Fifty thousand pounds :

Now therefore His Excellency the Governor of the State of Victoria, in the Commonwealth of Australia, by and with the advice of the Executive Council of the said State, and in pursuance of the powers conferred by the said Country Fire Authority Acts and all other powers him thereunto enabling, doth hereby make the Regulations following (that is to say) :—

1. All debentures shall be in the form or to the effect of the form contained in the First Schedule hereto.
2. All debentures shall be dated the fifteenth day of November, 1951.
3. The debentures shall be numbered consecutively from 1 to 30.
4. The sum of Fifty thousand pounds shall be repaid and interest upon the balance of the principal outstanding from time to time shall be paid, on the dates and in the manner set out in the Second Schedule hereto.

## FIRST SCHEDULE.

*Loan £50,000.*

Debenture No. . . . .

*Country Fire Authority.*

Repayment of Principal	..	£
Interest	.. .. .	£
Payable		, 19

Issued by the Country Fire Authority under the provisions of the Country Fire Authority Acts.

Transferable by delivery.

This debenture is one of a series of thirty debentures for securing a loan of Fifty thousand pounds and interest thereon, at the rate of Four pounds two shillings and six pence per centum per annum, issued by the Country Fire Authority, in pursuance of the provisions of the Country Fire Authority Acts, and entitles the bearer thereof to the sum of \_\_\_\_\_ payable by the said Authority on the \_\_\_\_\_ day of \_\_\_\_\_, 19\_\_\_\_, at the Union Bank of Australia Limited, Smith-street, Collingwood.

This sum represents the proportion of the loan to be repaid and interest payable under the provisions of section 58 of Act No. 5040.

The amount of the loan and interest thereon shall be a charge upon all the property and revenue, whether accrued or to accrue, of the Authority.

Dated this fifteenth day of November, 1951.

The common seal of the Country Fire Authority was hereunto affixed by order of the Authority duly recorded in the presence of—

Chairman.

Secretary.

## SECOND SCHEDULE.

## Country Fire Authority.

Schedule showing the amounts and dates of the periodical payments for the redemption of a loan of £50,000 in fifteen years, with interest at the rate of £4 2s. 6d. per centum per annum, the said repayments and interest being included in thirty half-yearly instalments of £2,251 14s. 7d. each.

Number of Instalment.	Due Date of Instalment.	Principal Contained in Instalment.		Interest Contained in Instalment.		Balance of Principal Outstanding.	
		£	s. d.	£	s. d.	£	s. d.
1	15th May, 1952 ..	1,220	9 7	1,031	5 0	48,779	10 5
2	15th November, 1952 ..	1,245	13 0	1,006	1 7	47,533	17 5
3	15th May, 1953 ..	1,271	6 10	980	7 9	46,262	10 7
4	15th November, 1953 ..	1,297	11 3	954	3 4	44,964	19 4
5	15th May, 1954 ..	1,324	6 6	927	8 1	43,640	12 10
6	15th November, 1954 ..	1,351	12 9	900	1 10	42,289	0 1
7	15th May, 1955 ..	1,379	10 4	872	4 3	40,909	9 9
8	15th November, 1955 ..	1,407	19 5	843	15 2	39,501	10 4
9	15th May, 1956 ..	1,437	0 2	814	14 5	38,064	10 2
10	15th November, 1956 ..	1,466	12 11	785	1 8	36,597	17 3
11	15th May, 1957 ..	1,496	17 11	754	16 8	35,100	19 4
12	15th November, 1957 ..	1,527	15 5	723	19 2	33,573	3 11
13	15th May, 1958 ..	1,559	5 7	692	9 0	32,013	18 4
14	15th November, 1958 ..	1,591	8 10	660	5 9	30,422	9 6
15	15th May, 1959 ..	1,624	5 3	627	9 4	28,798	4 3
16	15th November, 1959 ..	1,657	15 3	593	19 4	27,140	9 0
17	15th May, 1960 ..	1,691	19 1	559	15 6	25,448	9 11
18	15th November, 1960 ..	1,726	17 1	524	17 6	23,721	12 10
19	15th May, 1961 ..	1,762	9 4	489	5 3	21,959	3 6
20	15th November, 1961 ..	1,798	16 5	452	18 2	20,160	7 1
21	15th May, 1962 ..	1,835	18 5	415	16 2	18,324	8 8
22	15th November, 1962 ..	1,873	15 9	377	18 10	16,450	12 11
23	15th May, 1963 ..	1,912	8 8	339	5 11	14,538	4 3
24	15th November, 1963 ..	1,951	17 6	299	17 1	12,586	6 9
25	15th May, 1964 ..	1,992	2 8	259	11 11	10,594	4 1
26	15th November, 1964 ..	2,033	4 5	218	10 2	8,560	19 8
27	15th May, 1965 ..	2,075	3 2	176	11 5	6,485	16 6
28	15th November, 1965 ..	2,117	19 2	133	15 5	4,367	17 4
29	15th May, 1966 ..	2,161	12 10	90	1 9	2,206	4 6
30	15th November, 1966 ..	2,206	4 6	45	10 1	..	..
	Total ..	50,000	0 0	17,551	17 6	..	..

And the Honorable Keith Dodgshun, His Majesty's Chief Secretary for the State of Victoria, shall give the necessary directions herein accordingly.

A. MAHLSTEDT,  
Clerk of the Executive Council.

## LANDLORD AND TENANT ACTS.

At the Executive Council Chamber, Melbourne, the  
sixteenth day of October, 1951.

## PRESENT:

His Excellency the Governor of Victoria.

Mr. Brose | Mr. Mitchell.  
Mr. Harvey |

## ORDER EXTENDING APPLICATION OF THE LANDLORD AND TENANT ACT 1948 TO CERTAIN PREMISES.

WHEREAS by Orders published in the *Government Gazette*, the several premises described in the Schedule hereto were excluded from the operation of certain parts of the *Landlord and Tenant Act 1948*: And whereas it is expedient that those parts should again extend to each of those premises: Now therefore, in pursuance of the powers conferred upon him by the *Landlord*

and *Tenant Act 1948*, as amended by the *Landlord and Tenant (Amendment) Act 1948*, His Excellency the Governor of Victoria, by and with the advice of the Executive Council thereof, doth hereby declare that the application of the whole of the *Landlord and Tenant Act 1849* shall extend to each of the premises described in such Schedule:—

## SCHEDULE.

1. Number 7 Tynan-street, West Preston.
2. The premises situated in Wicks-street, Yinnar, upon all that piece of land being lot 41 on plan of subdivision No. 1120, lodged in the Office of Titles, and being part of Crown allotment 11B, Parish of Yinnar, County of Buln Buln, and being the land more particularly described in certificate of title, volume 5864, folio 1172682.

And the Honorable Thomas Walter Mitchell, His Majesty's Attorney-General in and for the State of Victoria, shall give the necessary directions herein accordingly.

A. MAHLSTEDT,  
Clerk of the Executive Council.

## LANDLORD AND TENANT ACTS.

At the Executive Council Chamber, Melbourne, the sixteenth day of October, 1951.

## PRESENT:

His Excellency the Governor of Victoria.  
Mr. Brose | Mr. Mitchell.  
Mr. Harvey |

## ORDER EXCLUDING CERTAIN PREMISES FROM THE OPERATION OF THE PROVISIONS CONTAINED IN PARTS III. AND V. OF THE LANDLORD AND TENANT ACT 1948.

IN pursuance of the powers conferred upon him by the *Landlord and Tenant Act 1948*, as amended by the *Landlord and Tenant (Amendment) Act 1948*, His Excellency the Governor of Victoria, by and with the advice of the Executive Council thereof, doth hereby declare that the premises situated at No. 19 Leahy-street, Nhill, shall be excluded from the operation of the whole of the provisions contained in Parts III. and V. of the *Landlord and Tenant Act 1948*.

And the Honorable Thomas Walter Mitchell, His Majesty's Attorney-General in and for the State of Victoria, shall give the necessary directions herein accordingly.

A. MAHLSTEDT,  
Clerk of the Executive Council.

## APPROACHING LAND SALES.

SALES of Crown lands, in fee-simple, will be held at the under-mentioned places and dates, viz.:—

	No. of Gazette
Benalla.—Tuesday, 23rd October, 1951	945
Cann River.—Thursday, 1st November, 1951	1002
Colbinabbin.—Tuesday, 23rd October, 1951	970
Echuca.—Wednesday, 24th October, 1951	970
Manangatang.—Wednesday, 24th October, 1951	970
Swan Hill.—Wednesday, 24th October, 1951	995

## PROPOSED REVOCATION OF TEMPORARY RESERVATIONS OF LANDS BY ORDERS IN COUNCIL.

IN pursuance of the provisions of the *Land Act 1928*, notice is hereby given that it is the intention of the Governor in Council to revoke the temporary reservations of lands by the Orders in Council hereunder referred to, viz.:—

The following Notices were published 1° on the 3rd October, 1951, pursuant to Orders of the 25th September, 1951.

**CASTLEMAINE.**—The temporary reservation, by Order in Council of the 11th November, 1873 (see *Government Gazette* of the 14th November, 1873, page 2003) of 6 acres 3 roods 37 perches of land in the Borough of Castlemaine, as a site for Water Supply purposes, revoked as to part by Order of the 15th August, 1950, is about to be revoked so far as the balance thereof containing 5 acres 2 roods 27 perches, more or less, is concerned.—(C.99(4) (W.67165)).

**DRUMBORG.**—The temporary reservation, by Order in Council of the 6th February, 1903, of 2 roods of land in the Parish of Drumborg, being part of allotment 31c, as a site for a Public Hall, is about to be revoked.—(D.106(3) (Rs.1699)).

**DRUMBORG.**—The temporary reservation, by Order in Council of the 17th May, 1898, of 1 acre 3 roods 39 4/10 perches of land in the Parish of Drumborg, being part of allotment 31c, as a site for a State School, is about to be revoked.—(D.106(3) (C.29855)).

**DRUMBORG.**—The temporary reservation, by Orders in Council of the 6th February, 1903, and the 30th November, 1948, of 5 acres 0 roods 20 perches, more or less, of land in the Parish of Drumborg, as a site for Public Recreation, is about to be revoked.—(D.106(3) (Rs.1702)).

**LALLAT.**—The temporary reservation, by Order in Council of the 16th October, 1893, of 5 acres 0 roods 5 perches of land in the Parish of Lallat, as a site for a State

School, revoked as to part by Order of the 20th December, 1900, is about to be revoked so far as the balance thereof, containing 4 acres 3 roods 5 perches, is concerned.—(L.151(7) (C.93030)).

**SANDHURST (Grassy Flat).**—The temporary reservation, by Order in Council of the 29th July, 1867, of 10 acres 2 roods of land in the Parish of Sandhurst, as a site for Drainage purposes, is about to be revoked.—(S.371(20) (Rs.6172)).

A. E. LIND,  
Commissioner of Crown Lands and Survey.

## PROPOSED REVOCATION OF ORDER IN COUNCIL TEMPORARILY RESERVING AND WITHHOLDING CERTAIN LAND FROM SALE, LEASING, AND LICENSING.

IN pursuance of the provisions of the *Land Act 1928*, notice is hereby given that it is the intention of the Governor in Council to revoke the temporary reservation and the withholding from sale, leasing, and licensing of the land mentioned hereunder:—

The following Notice was published 1° on the 3rd October, 1951, pursuant to Order of the 25th September, 1951.

**SANDHURST (Grassy Flat).**—The temporary reservation as a site for Water Supply purposes and the withholding from sale, leasing, and licensing, by Order in Council of the 7th February, 1884, of 107 acres 0 roods 7 perches of land in the Parish of Sandhurst, revoked as to part by Order of the 2nd December, 1912, is about to be revoked so far only as the portion containing 69 acres 2 roods, more or less, indicated by hachure on plan hereunder, is concerned.—(S.371(20) (Rs.6170)).

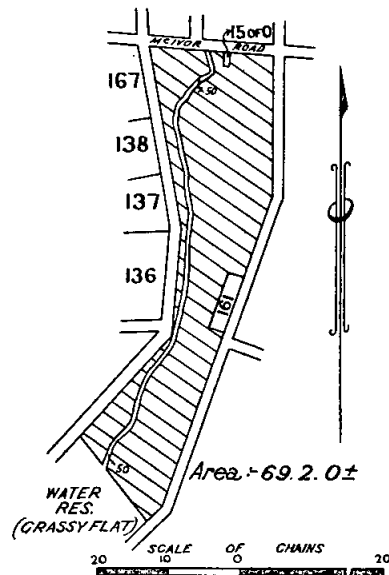

A. E. LIND,  
Commissioner of Crown Lands and Survey.

## PROPOSED REVOCATIONS OF TEMPORARY RESERVATIONS OF LANDS BY ORDERS IN COUNCIL.

IN pursuance of the provisions of the *Land Act 1928*, notice is hereby given that it is the intention of the Governor in Council to revoke the temporary reservations of lands by Orders in Council hereunder referred to, viz.:—

The following Notices were published 1° on the 26th September, 1951, pursuant to Orders of the 18th September, 1951.

**HAWKESDALE (Tp.).**—The temporary reservation, by Order in Council of the 30th January, 1865, of a certain area of land in the Parish of Kangertong, as a site for the Township of Hawkesdale, without prejudice to the sale or other disposal of the land contained therein, for the purposes of a Town (see *Government Gazette*, 1865, pages 391 and 609) is about to be revoked.—(H.54(3) (C.93277)).

**BOORONGIE.**—The temporary reservation, by Order in Council of the 16th November, 1914, of 2 acres 29 perches of land in the Parish of Boorongie, as a site for a State School, is about to be revoked.—(B.772(3) (Rs.336)).

A. E. LIND,  
Commissioner of Crown Lands and Survey.

**PROPOSED REVOCATIONS OF TEMPORARY RESERVATIONS OF LANDS BY ORDERS IN COUNCIL.**

IN pursuance of the provisions of the *Land Act 1928*, notice is hereby given that it is the intention of the Governor in Council to revoke the temporary reservations of lands by Orders in Council hereunder referred to, viz:—

The following Notices were published 1° on the 10th October, 1951, pursuant to Orders of the 2nd October, 1951.

**BYAWATHA.**—The temporary reservation, by Order in Council of the 26th June, 1893, of 45 acres of land in the Parish of Byawatha, as a site for Watering purposes, revoked as to part by Order of the 7th November, 1906, is about to be revoked so far only as the portion containing 2 acres 3 roods, more or less, indicated by hachure on plan hereunder, is concerned.—(B.615<sup>(3)</sup>) (Rs.6706).

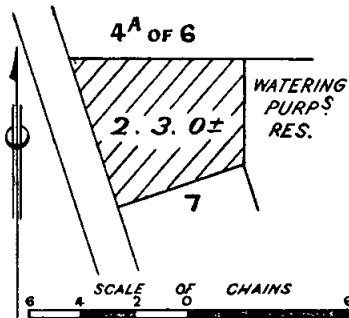

**HEATHCOTE.**—The temporary reservation, by Order in Council of the 26th March, 1935, of 7 acres 1 rood 5 perches of land in the town of Heathcote, as a site for Police purposes, is about to be revoked so far only as the portion containing 1 acre 1 rood 10 perches, more or less, indicated by hachure on plan hereunder, is concerned.—(H.74<sup>(3)</sup>) (Rs.6061).

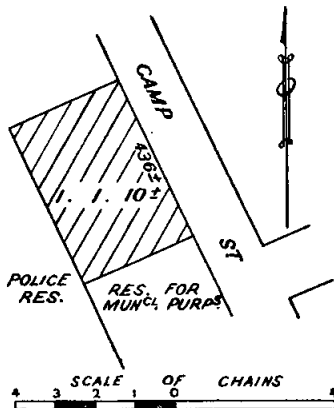

A. E. LIND,  
Commissioner of Crown Lands and Survey.

**PROPOSED REVOCATION OF ORDER IN COUNCIL TEMPORARILY RESERVING AND WITHHOLDING CERTAIN LAND FROM SALE, LEASING, AND LICENSING.**

IN pursuance of the provisions of the *Land Act 1928*, notice is hereby given that it is the intention of the Governor in Council to revoke the temporary reservation and the withholding from sale, leasing, and licensing of the land hereunder described:—

The following Notice was published 1° on the 17th October, 1951, pursuant to Order of the 9th October, 1951.

**DEREEL.**—The temporary reservation as a site for Public purposes (State School) and the withholding from sale, leasing, and licensing by Order in Council of the 14th February, 1876 (see *Government Gazette* of the 18th February, 1876, page 339), of 5 acres of land in the Parish of Dereel, is about to be revoked.—(D.172<sup>(4)</sup>) (O.60/121).

A. E. LIND,  
Commissioner of Crown Lands and Survey.

**REGULATIONS FOR THE CARE, PROTECTION, AND MANAGEMENT OF THE "LAKE WEEROONA RESERVE."**

WHEREAS by section 181 of the *Land Act 1928*, as re-enacted by section 9 of the *Land Act 1941*, power is given to the Board of Land and Works to make Regulations in respect of the care, protection, and management of any Crown land which has been reserved under the Land Acts for any public purpose whatsoever, and which has not been conveyed to or vested in trustees, and for the further purposes as enacted. Now therefore the Board of Land and Works, in pursuance of the powers conferred as aforesaid, doth hereby make the following Regulations in respect of the lands in the City of Bendigo reserved for Recreation purposes by Order in Council of 23rd March, 1874, known as the "Lake Weeroona Reserve," hereinafter referred to as the "Reserve."

**REGULATIONS.**

1. In these Regulations the expression "The Committee" shall mean the duly appointed Committee of Management of the Reserve.
2. The Reserve shall be open to the public from sunrise to sunset free of charge, except as hereinafter provided.
3. No person shall—
  - (a) Enter or remain in the Reserve who may offend against decency as regards, dress, language, or conduct, or who may behave in a disorderly, unseemly, or offensive manner, or create or take part in any disturbance.
  - (b) Enter or remain in the Reserve whilst in a state of intoxication.
  - (c) Use indecent or offensive language in the Reserve.
  - (d) Offer any article of food or drink or any other commodity whatsoever for sale, or bring any intoxicating liquor on to the Reserve without the consent of the Committee first obtained.
  - (e) Obstruct, hinder, or interfere with any person employed on the Reserve.
  - (f) Climb, jump on, or get over any of the gates, fences in or around the Reserve, or stick bills or advertisements or cut names thereon, or in any way damage or injure any of the buildings, furniture, or fittings, gates, stiles, fences, seats, or other structures in the Reserve.
  - (g) Interfere with, break, or damage in any way any of the trees, shrubs or plants, or pluck any of the flowers, or walk on the beds or borders in the Reserve.
  - (h) Leave or deposit any bottles, broken glass, paper, orange peel, banana skins, refuse, or rubbish whatever therein, nor roll or throw stones or missiles of any kind therein, or leave anything that might injure any person.
  - (i) Light a fire in the Reserve except at such places as are set apart for the purpose by the Committee.
  - (j) Carry or discharge any firearms or air guns in the Reserve, or shoot, snare, or destroy any game or birds therein.
  - (k) Bet publicly in the Reserve without the consent of the Committee.
  - (l) Spit or expectorate on the paths, or on any structure or erection in the Reserve.
  - (m) Erect any building, tent, or structure, or camp on any portion of the Reserve without permission, in writing, of the Committee first obtained, and then only under such conditions as may be determined by the said Committee.
  - (n) Bring into the Reserve any dog unless controlled by a chain or cord without the permission, in writing, of the Committee first obtained, but this clause shall not apply to greyhounds.
  - (o) Bring into the Reserve any greyhound for exercise or training or for any purpose.
  - (p) Do anything whatever in the Reserve for the purpose of making money without the consent, in writing, of the Committee first obtained.

Every person infringing this Regulation in any respect shall be liable to expulsion from the Reserve in addition to any other penalty to which such persons may be liable.

4. For the purpose of maintaining good order, any person authorized by the Committee may refuse admission to any person to the Reserve.

5. No person shall remain in the Reserve at any time when lawfully directed by an officer or employee of the Committee to leave the same.

6. The Committee shall have power to let any portion of the Reserve to any club, association, or person for the purpose of holding fêtes, carnivals, entertainments, musical performances, shows or sports, or for athletic

training, or other physical recreation, subject to payment of such fees, and on such terms and conditions as it may deem reasonable and consistent with these Regulations; and to authorize any club, association, or person to take a charge for admission thereto as hereinafter provided.

7. No club, association, or person shall hold or take part in any game of tennis, or any games of any description, entertainment, performance, show, or ceremony in any part of the Reserve without the written authority of the Committee first obtained.

8. No club or association of any kind having for its object physical recreation, or any member or members of any club or association, nor any other person shall play, practise, train, or engage in any game or sport or athletic exercise within the Reserve without the permission, in writing, of the Committee first obtained, unless any such person is at the time of playing a member of any club which is duly authorized to play in the Reserve at such time.

9. No person except the Committee or its officers and employees on duty shall enter any part of the Reserve when a charge is made for admission without first paying the fees chargeable for admission.

10. No person shall park a motor car within the Reserve except at such places, if any, as are set apart for the purpose.

11. No person shall take or put, or allow to be taken or put, in the Reserve any horses, cattle, sheep, goats, pigs, or other animals, or being the owner or having the possession, care, custody, control, or supervision thereof, shall suffer or allow such horses, cattle, sheep, goats, pigs, or other animals to be in or graze or wander upon the Reserve.

12. The owner of any horses, cattle, sheep, goats, pigs, or other animals that are found wandering upon any part of the reserve shall be guilty of an offence against these Regulations.

13. No person shall train or exercise any horse in the Reserve.

14. No person shall take or drive any carriage, cart, or any other vehicle drawn by a horse or other animal into the Reserve without the permission of the Committee; and no horse or other animal drawing any such carriage, cart, or other vehicle shall, whilst in the Reserve, be detached or unharnessed therefrom, or left without a person in charge thereof.

15. No person shall enter any building in the Reserve without the permission of the Committee and any person having entered such building shall leave the same on being requested so to do by any member of the Committee or by a police constable or Crown lands bailiff.

16. No person, except labourers and workmen employed on the Reserve, shall enter any plots therein which may be enclosed for plantations of young trees or shrubs or flowers.

17. The Committee may from time to time grant annual or temporary permission to any person or persons to place boats on the water of the lake in the said Reserve, and to use such boats in accordance with the conditions to be made by the said Committee and endorsed in such permit, and to erect suitable and convenient boat houses therein.

18. The Committee may, on a breach of the said conditions endorsed on such permit, in its discretion determine any such permit and remove the boat and any other property of the person or persons having obtained such a permit from the said Committee.

19. No person shall convey into the Reserve or place upon the lake therein any boat in respect of which a licence has not been obtained from the Committee.

20. No boat house shall be used for entertainment purposes or for any other purpose than that relating to the storage and use of boats without the permission, in writing, of the Committee first obtained.

21. The driver of a motor car entering the Reserve shall proceed at a speed not exceeding 5 miles per hour in one direction as indicated by a sign post near the entrance to the Reserve, and shall not on any pretence turn back from such direction.

22. No person shall ride a motor cycle in any part of the Reserve.

23. The Committee may set apart a portion or portions of the Reserve as and for the purpose of a camping area, and may fix and collect such fees or other charges for entering, and use of any such area as the Committee shall from time to time determine.

24. The maximum scale of fees which may be charged and taken for admission to the Reserve on such days, not exceeding ten in any one year, as the Reserve may be set apart for the purpose of sports, carnivals, or holiday amusements, shall be as follows:—For admission of every adult person, such sum as the Committee may determine not exceeding Two shillings and six pence: Provided that the net amount received by the Committee, after providing for any expenses and disbursements in connexion

therewith, shall be used and appropriated towards the maintenance and improvement of the Reserve, and an account thereof shall be made annually to the Board of Land and Works.

25. Every person to whom a ticket has been issued authorizing such person to enter upon the Reserve shall upon demand produce, and if required surrender, such ticket to any gatekeeper or other person duly authorized to demand such production or surrender of tickets.

26. Persons renting or hiring any stand, building, erection or enclosure on the occasion of fêtes, sports, carnivals, or holiday amusements, may be required to deposit with the Committee any sum, not exceeding Twenty pounds, which the Committee may at any time determine by way of guarantee that due care shall be taken of such stand, building, erection, or enclosure; and such Committee, in its absolute discretion, may repair or make good any damage or injury sustained by such stand, building, erection, or enclosure, or anything contained therein, during such occupancy or hiring, and deduct the cost of making good such loss or damage from the sum of money deposited by way of guarantee; and all persons so renting or hiring shall abide by these Regulations, and by any order given by the Committee.

27. Any person found in a state of intoxication or behaving in a disorderly manner, or creating or taking part in any disturbance, or committing any act of indecency in the Reserve, or otherwise offending against these Regulations, or refusing to obey those authorized by the Committee or by the club, association, or persons renting or having been granted the use of the Reserve for the time being, to keep order, shall be liable to be forthwith removed therefrom, notwithstanding that such person may have purchased a ticket for admission thereto, and shall also be liable to a prosecution for an offence against these Regulations.

Every person who contravenes or fails to comply with these Regulations shall, in accordance with the provisions of section 181 of the *Land Act* 1928, as re-enacted by section 9 of the *Land Act* 1941, for each offence be liable to a penalty of not more than Five pounds, and every person who contravenes or fails to comply with any such Regulation and who, after he has been warned by any bailiff of Crown lands or by any member of the Police Force, does not desist therefrom may be forthwith apprehended by such bailiff or member of the Police Force and taken before some justice to be dealt with according to law, and shall be liable to a penalty of not more than Ten pounds.

The common seal of the Board of Land and Works was hereunto affixed this 10th day of October, 1951, in the presence of—

(SEAL) A. E. LIND, President.  
W. M. CRAWFORD, Member.

The Reserve has been placed under the control of a Committee of Management with power and authority to enforce the foregoing Regulations.—(Rs.4314.)

#### COMMITTEES OF MANAGEMENT OF RESERVES.

##### APPOINTMENTS.

WHEREAS by section 184 of the *Land Act* 1928 it is provided that it shall be lawful for the Governor in Council or the Board of Land and Works to appoint and remove any number of persons, not less than three, or any municipal council, or the governing body of any corporation, to be a Committee of Management of any specified Crown land reserved either temporarily or permanently for any of the purposes set out in section 14 of the *Land Act* 1928, and not conveyed to or vested in trustees: Now therefore the Board of Land and Works doth hereby appoint the under-mentioned persons to be members of the Committee of Management of the Reserves named:—

##### "CASHMORE RECREATION RESERVE."

Leo David Breen, Frank Ronald Antony, Alexander Horne Logan, George Fredrick Kerr, and Herbert Wilnot as a Committee of Management for the period ending 10th April, 1954, of the land temporarily reserved by Order in Council dated 16th October, 1934, as a site for Public Recreation in the Parish of Trewalla, and known as the "Cashmore Recreation Reserve."—(Corres. Rs.4408.)

##### "CASHMORE PUBLIC HALL RESERVE."

Frank Ronald Antony, George Fredrick Kerr, and Stanley Keith Peters as a Committee of Management for the period ending 10th April, 1954, of the land temporarily reserved by Orders in Council dated 23rd March, 1914, and 16th October, 1934, as sites for a Public Hall in the Parish of Trewalla, and known as the "Cashmore Public Hall Reserve."—(Corres. Rs.734.)

"PETERBOROUGH FORESHORE RESERVE."

James Murray Irvine, John Robert Wiber, John Stuart Irvine, Kenneth Stuart Bryan Row, Thelma Mary Sturzaker, Leonard Sturzaker, Ruby Ellen Wiber, and James George Irvine as a Committee of Management for a period of three (3) years from 20th September, 1951, of such portion of the Reserve for Public purposes at Peterborough as is indicated by red colour on plan marked P.265.31, attached to Lands Department correspondence C.80017, and known as "Peterborough Foreshore Reserve."—(Corres. Rs.6093.)

"TOURISTS' CAMP RESERVE, PETERBOROUGH."

James Murray Irvine, John Robert Wiber, John Stuart Irvine, Kenneth Stuart Bryan Row, Thelma Mary Sturzaker, Leonard Sturzaker, Ruby Ellen Wiber, and James George Irvine as a Committee of Management for a period of three (3) years from 20th September, 1951, of the land temporarily reserved by Order in Council of the 25th March, 1947, as a site for Tourists' Camp purposes in the Parish of Narrawaturk, and known as the "Peterborough Tourist Camp Reserve."—(Corres. Rs.5937.)

"KILEY MEMORIAL RESERVE," AT SEA LAKE.

Robert Tully McKinna, Carl James Dettmann, Andrew John George-Arch McKenzie, Gerard George Payne, and Henry Kiley as a Committee of Management for a period of three (3) years of the land temporarily reserved by Order in Council dated 25th September, 1951, as a site for War Memorial and other Public purposes in the Township of Sea Lake, and known as the "Kiley Memorial Reserve."—(Corres. Rs.6675.)

In witness whereof the common seal of the Board of Land and Works was hereunto affixed this tenth day of October, One thousand nine hundred and fifty-one, in the presence of—

(SEAL) A. E. LIND, President.  
W. M. CRAWFORD, Member.

PUBLIC HEARING BY A PERSON APPOINTED UNDER THE 34TH SECTION OF THE LAND ACT 1928.

NOTICE is hereby given that at the time and place mentioned in the Schedule hereunder, applications for leases and licences under the Land Acts, objections

to such applications, objections to proposed proclamations, alterations, additions, diminutions, revocations, or unions of commons, and reasons against forfeiture of any leases or licences under the Land Acts deemed liable to forfeiture, will be publicly heard by the person whose name is set opposite such place respectively in such Schedule, being a person appointed by me, the responsible Minister of the Crown administering the Land Acts, to hear the same and report thereon in writing to me.

A. E. LIND,  
Commissioner of Crown Lands and Survey, and  
President of the Board of Land and Works.

Department of Crown Lands and Survey,  
Melbourne, 17th October, 1951.

SCHEDULE.

LAND OFFICE, BENDIGO, Thursday, 8th November, 1951, at 10 a.m., H. J. Henkel, Land Officer.

HEARING OF REASONS AGAINST THE FORFEITURE OF CERTAIN LICENCES AND LEASES BY A PERSON APPOINTED UNDER 34TH SECTION OF THE LAND ACT 1928.

NOTICE is hereby given that reasons against the forfeiture of the licences and leases in the Schedule hereto, which are deemed liable to forfeiture under the provisions of the Land Acts, will be publicly heard by the person appointed by me, the responsible Minister of the Crown administering the said Acts, to hear the same and report thereon in writing to me, when the person in the said Schedule mentioned as the holder of such licences and leases will be allowed to show cause against the same at the place and on the date mentioned in the Schedule hereto.

A. E. LIND,  
Commissioner of Crown Lands and Survey.

Department of Crown Lands and Survey,  
Melbourne, 17th October, 1951.

SCHEDULE.

LAND OFFICE, SALE, Friday, 16th November, 1951, at 11 a.m., J. F. Calcutt, Land Officer—  
72/44.81, Clair Andrew Stephenson, 538a. 2r. 7p., Booran.

THE CLOSER SETTLEMENT ACTS.

NOTICE is hereby given that the Board of Land and Works has accepted the surrender of the Lease mentioned in the Schedule hereunder for the reason specified.

LEASE UNDER THE CLOSER SETTLEMENT ACT 1938.

Corr.	District.	Lessee.	Allotment.	Section.	Parish.	Area.	Remarks.
778/12	Mallee	Kennedy, H. . .	5	..	Koorkab	A. B. P. 1,372 0 23	The lessee named has accepted compensation pursuant to the provisions of the <i>North-west Mallee Settlement Areas Act 1948</i>

10th October, 1951.

W. M. CRAWFORD,  
Acting Secretary for Lands.

Land Act 1928.

LICENCE UNDER THE LAND ACTS 1915 AND 1928 DECLARED VOID.

NOTICE is hereby given that the Licence in the Schedule hereunder has been declared void for the reason specified.

District.	Corr. No.	Name of Licensee.	Section of Land Act under which licensed.	Parish.	Allotment.	Section.	Area.	Annual Rental.	Reasons for Voiding.
Ballarat ..	0450/129	Estate of John Murphy (deceased)	129	City and Parish of Ballarat	10	170	A. B. P. 1 1 0 <sup>4</sup> / <sub>10</sub>	£ s. d. 0 15 0	Non-compliance with conditions

Department of Crown Lands and Survey,  
Melbourne, 17th October, 1951.

A. E. LIND,  
Commissioner of Crown Lands and Survey.



LIST OF CROWN LANDS AVAILABLE.

THE under-mentioned areas are available for application as provided by various sections of the *Land Act 1928*, and all applications received on or before Wednesday, 14th November, 1951, will be deemed to have been simultaneously made, but any application lodged after such date may be considered if received in time for inclusion in the advertisement of the cases to be heard at the Local Land Board. Applications on proper form, accompanied by 5s. duty stamp uncancelled (registration fee), may be delivered or forwarded by post to the Local Land Officer or to any Crown Lands Office in Victoria. Applicants may obtain from Local Land Officers, or the Crown Lands Department, Melbourne, a certificate authorizing the issue by the Railway Department of a return ticket at concession fares to enable them to inspect available areas or to attend Local Land Boards. When an applicant is granted an allotment he may, if travelling by rail, obtain reduced fares for his family and also freight concessions in regard to some of his effects.

Subject to the approval of the Secretary for Lands, when the survey fee exceeds £25 but does not exceed £50, a deposit of £25 may be paid, and when the fee exceeds £50 a deposit of 50 per cent. of the fee, the balance in either case being payable over six years in half-yearly instalments.

Marked plans of any particular area, application forms, and any further information may be obtained from the Crown Lands Department, Melbourne, and Land Officers, Ararat, Red Cliffs, and St. Arnaud.

Department of Crown Lands and Survey,  
Melbourne, 17th October, 1951.

A. E. LIND,  
Commissioner of Crown Lands and Survey.

\* Improvements may be subject to re-valuation after land has been granted to an applicant.

Local Land Office	County	Parish	Allotment	Section	Area	How Available.		Survey Fee.	Valuation of Improvements (if any).	Location of Land, &c.	Nearest Railway Station and distance in miles therefrom.	How Accessible.	Water Supply.	General Description of Land—Soil, Timber, Suitability (Grazing, &c.).	
						Classification.	Value per Acre.								
						£	s.	d.							
Red Cliffs.	Karkaroc	Mildura ..	179f and 178g 10b	B	110 0 0	1st	2 10 0	14 10 0	To be valued	In the south-east of the parish	Red Cliffs, 3½ miles	By road	To be conserved	Grey loam and good red sandy loam; suitable for vines and citrus. (M.35435)	
Melbourne (b)	Bulu Bulu	Waratah ..			486 0 20	3rd	1 0 0	46 10 0	Nil	In centre of parish, 3 miles from Waratah Bay	Fish Creek R.S., 17 miles	By road and track	Permanent Creek on allotment	Undulating; sandy loam; mesquite, peppermint, ti-tree; suitable for grazing. (1790/44.81)	
St. Arnaud (c)	Tatchera	Ninyeunook	49B	1	115 2 20	2nd	3 0 0	16 7 6	£102 10s.	In the north-east of the parish	Quambatook R.S., 6 miles	By road	To be conserved	Level country, consisting of reddish loam; is grassed and carries scattered buloke and box timber; part has been cultivated. (W.66741)	
St. Arnaud (a)	"	Townsinny	10D	2	50 0 0	2nd	3 0 0	10 5 0	Nil	In south-east of the parish	" "	" "	" "	Brown sandy loam, carrying scattered buloke and box timber; area mostly grassed. (W.66741)	
AVAILABLE UNDER SECTION 129, LAND ACT 1928.															
Ararat	Ripon	Parish and City of Ararat	6	88	0 0 38	Residence	Annual rental to be fixed	5 0 0	Nil	In south-east of the city fronting Moore-street	In the City of Ararat	By road	Town reclamation	Suitable as a site for a residence. (L.20635)	
Stawell	Borong	Borough and Parish of Stawell	7 6	88 49	0 0 38 0 1 0	" "	" "	5 0 0 5 5 0	" "	Fronting Patrick-street	Stawell R.S., ¾ mile	" "	To be conserved	" " Suitable as a site for a residence. (L.32769)	

(a) Subject to survey.—(b) Subject to mining condition.—(c) Subject to survey providing channel easements.

**PUBLIC SERVICE NOTICES.**

**PUBLIC SERVICE (PUBLIC SERVICE BOARD) REGULATION 39—RECLASSIFICATIONS.**

THE Public Service Board has raised the classification of the under-mentioned offices as shown, and the Permanent Heads of the Departments have recommended the officers named for appointment.

Office and Present Classification.	Revised Classification.	Duties.	Qualifications.	Officer Recommended for Appointment.		
				Name.	Classification.	Date of Classification.
<b>ADMINISTRATIVE DIVISION.</b>						
<b>DEPARTMENT OF CHIEF SECRETARY.</b>						
<i>Office of the Chief Commissioner of Police.—Motor Registration Branch.</i>						
Clerk, Class "C2"	Class "B"		To have a thorough knowledge of the Motor Car Acts, Motor Car (Third Party Insurance) Act, Omnibus Acts and the Regulations thereunder, and of the legal opinions, interpretations and rulings thereon; ability to direct and to control a large staff and experience in dealing with the public	Baglin, W. B.	Clerk, Class "C2"	14.8.50
<i>State Motor Car Insurance Office.</i>						
Clerk, Class "C"	Class "C1"	To act as assistant Claims Officer	A thorough knowledge of Comprehensive and Statutory Motor Vehicle Insurance with practical experience in connexion with the investigation and settlement of claims. A good knowledge of the Motor Car and Motor Car (Third Party Insurance) Act and Regulations. A knowledge of Insurance principles and practices and a knowledge of Insurance law	Carver, L. W.	Clerk, Class "C"	6.2.50

**PROFESSIONAL DIVISION.**

**DEPARTMENT OF WATER SUPPLY.**

District Engineer, Grade IV., Class "C2"	Grade III., Class "B"	To supervise staff and control all rural and urban water supplies, works and expenditure, within the Boort Centre	To possess a Technical School Diploma in Civil Engineering and to have had extensive experience in a responsible capacity of the administration of a District	Paul, A. C.	District Engineer, Grade IV., Class "C2"	9.1.50
--	-----------------------	---	---	-------------	--	--------

Appeals against such recommendations should be lodged with the Secretary to the Public Service Board not later than Saturday, the 27th October, 1951.

Office of the Public Service Board,  
Melbourne, 15th October, 1951.

By order,  
E. F. FITZGIBBON,  
Secretary.

**PUBLIC SERVICE (PUBLIC SERVICE BOARD) REGULATION 39.—VACANCY.**

THE Permanent Head of the Department shown has recommended the officer named hereunder for appointment to the under-mentioned vacancy.

Office and Classification.	Duties.	Qualifications.	Officer Recommended for Appointment.		
			Name.	Classification.	Date of Classification.
<b>ADMINISTRATIVE DIVISION.</b>					
<b>PREMIER'S DEPARTMENT.</b>					
Clerk, Class "C2"	To act as Secretary to the State Development Committee	Experience in secretarial work, in carrying out public investigations and in drafting official reports; a comprehensive knowledge of the State Development Acts and of the functions of Public Departments; ability to draw up regulations, analyse evidence, check estimates, and write shorthand	Howard, N. T.	Clerk, Class "C1"	2.11.49

Appeals against such recommendation should be lodged with the Secretary to the Public Service Board not later than Saturday, the 27th October, 1951.

Office of the Public Service Board,  
Melbourne, 15th October, 1951.

By order,  
E. F. FITZGIBBON,  
Secretary.

## PUBLIC SERVICE OF VICTORIA.—VACANCIES.

APPLICATIONS will be received by the Public Service Board up to Wednesday, 31st October, 1951, from persons employed in the Public Service of Victoria, who are eligible and qualified, for appointment to the under-mentioned positions:—

## PROFESSIONAL DIVISION.

**Chief Topographic Surveyor, Classes "A" and "A1," Aerial and Topographic Survey Branch, Department of Crown Lands and Survey.**

*Yearly Salary.*—£1,050, minimum; £1,200, maximum.

*Duties.*—Under the Assistant Surveyor-General, to have charge of the Aerial and Topographic Branch of the Survey Section; to prepare specifications for aerial photography; to carry out negotiations for aerial survey contracts and supervise flying operations; to make reports as required upon the utilization of Crown lands.

*Qualifications.*—To be a licensed surveyor experienced in the classification and subdivision of Crown lands; to have a thorough knowledge of the Land Acts, Survey Co-ordination Act, and the Regulations thereunder; to have a good knowledge of photogrammetry, and to be conversant with the use of stereoscopic equipment installed in the Department for the production of maps from air photos.

**Superintendent of Vermin and Noxious Weeds Destruction, Class "A," Inspection Branch, Department of Crown Lands and Survey.**

*Yearly Salary.*—£1,000, minimum; £1,150, maximum.

*Duties.*—To control the field staff and act as Chief Valuer of the Department; to take charge of all work associated with the Vermin and Noxious Weeds Acts.

*Qualifications.*—To be experienced in all aspects of field work required by the Department, including land valuations, and in controlling a large field staff; to have an intimate knowledge of vermin and weeds proclaimed under the Vermin and Noxious Weeds Acts and the methods for their control and eradication.

**Architect, Class "B," Public Works Department.**

*Yearly Salary.*—£761, minimum; £839, maximum.

*Duties.*—To assist the Building Regulations Committee and to conduct research, as considered necessary, into building construction, including costs, materials used, methods, and procedure.

*Qualifications.*—To have an appropriate University Degree, Technical School Diploma, or Associate Membership of the Institute of Engineers (Aust.); and to have wide experience in structural works of all kinds, and be capable of conducting tests as required.

**Dairy Research Officer (Bio-Chemist), Class "B," Department of Agriculture.**

*Yearly Salary.*—£761, minimum; £839, maximum.

*Duties.*—To conduct research into problems associated with dairying and give lectures and demonstrations at the School of Dairy Technology, Werribee.

*Qualifications.*—A Degree in Agricultural Science, or a Degree of Science with bio-chemistry as a major subject, together with experience in dairying and/or other industry.

*NOTE.*—House available at rental of approximately 10 per cent. of total emolument.

**Clerk of Courts, Grade II, Class "C2," Courts Branch, Law Department.**

*Yearly Salary.*—£683, minimum; £735, maximum.

*Qualifications.*—As prescribed by Regulation 47 of the Public Service (Public Service Board) Regulations.

**Assistant Engineer, Class "C2," Public Works Department. (Two vacancies.)**

*Yearly Salary.*—£683, minimum; £735, maximum.

*Duties.*—To make inspections and prepare reports, plans, and specifications, and to assist in field supervision of engineering works.

*Qualifications.*—To possess an approved Degree or Diploma in Civil Engineering, or to be the holder of a certificate issued by the Municipal Engineers' Board; to be well versed in modern engineering practice, particularly as applied to earthworks, grading, drainage, gravel, and asphalt surfacing.

**Assistant (Male), Class "E," National Museum Branch, Chief Secretary's Department.**

*Yearly Salary.*—Junior—Under 17 years of age, £156; at 17 years, £169; at 18 years, £195; at 19 years, £247; at 20 years, £273.

Adult—£325, minimum; £436, maximum.

*Duties.*—To assist and understudy senior scientific officers and, under their direction, to maintain collections, register specimens, and help in the general work of the Museum.

*Qualifications.*—To possess the School Leaving Certificate, including Biology, Geography, or Geology, and to have a general knowledge and aptitude for natural history.

## TECHNICAL AND GENERAL DIVISION.

**Warder, Penal and Gaols Branch, Chief Secretary's Department. (Forty vacancies.)**

*Yearly Salary.*—£339, minimum; £430, maximum.

*Duties.*—To control and to supervise male prisoners, and to perform other duties as required.

*Qualifications.*—As required by Regulation 31 of the Public Service (Public Service Board) Regulations.

**Assistant (Female), Grade IV, Stores Branch, Education Department.**

*Yearly Salary.*—£312, minimum; £325, maximum.

*Duties.*—Typing and preparing orders, quotations, requisitions, and correspondence; attending to accounts from firms for all goods ordered; recording amounts spent from various grants.

*Qualifications.*—To be a competent typist, and to possess mental alertness in respect of arithmetical calculations; general experience in commercial office work is desirable.

*NOTE.*—In addition to the salary rates quoted, a cost of living adjustment (£270 a year for adult males, £202 10s. a year for adult females, and £135 a year for minors), which varies in accordance with the rise or fall in the index number of the cost of living, is payable.

By order,

E. F. FITZGIBBON,  
Secretary.

Office of the Public Service Board,  
Melbourne, 15th October, 1951.

## PUBLIC SERVICE OF VICTORIA.—COMPETITIVE EXAMINATION FOR ADMISSION TO THE PUBLIC SERVICE.

## ADMINISTRATIVE DIVISION.

AN examination of male candidates for appointment to the Administrative Division of the Public Service of Victoria will be held on Saturday, 15th December, 1951.

The examination is open to persons who have, or will have, before 31st January, 1952, passed the School Intermediate Examination of the University of Melbourne, or an equivalent examination, and who, on 15th December, 1951—

- (a) not being members of the Public Service, are under 22 years of age; or
- (b) are temporary employees in the Public Service of Victoria, and under 46 years of age; or
- (c) are officers of the Technical and General Division of the Public Service of Victoria.

A candidate will be required to enter for competitive examination in English (an essay), General Intelligence, and Handwriting.

The maximum number of marks that may be awarded shall be—

English	150
General Intelligence	150
Handwriting	80

Candidates, in order to qualify for appointment, must obtain at least 50 per centum of the total number of marks in English and Handwriting, and at least 100 marks in General Intelligence.

Appointments proposed to be made 150  
Appointments reserved for officers of  
the Technical and General Division 30

Entries for the examination must be lodged at the Office of the Public Service Board, Public Offices, Treasury-place, Melbourne, C.2 (where the prescribed forms are obtainable), on or before Saturday, the 24th November, 1951.

Reasonable facilities will be provided for candidates residing in country districts to sit for the examination in local centres.

By order,  
E. F. FITZGIBBON,  
Secretary.

Office of the Public Service Board,  
Melbourne, 15th October, 1951.

**PUBLIC SERVICE OF VICTORIA.**

**A** COMPETITIVE examination of male candidates for appointment to the Professional Division of the Public Service of Victoria as Junior Draughtsman will be held on Saturday, the 15th December, 1951.

The examination is open to persons who, on the 15th December, 1951, are not less than fifteen years of age and are under 22 years of age and who have or will, before the 31st January, 1952, have passed one of the following:—

- (a) The School Leaving Examination, including English, Mathematics I. and Mathematics II.
- (b) The School Intermediate Examination, and, in addition, School Leaving English, Mathematics I. and Mathematics II.

Or

- (c) The equivalent Technical School Examination.

The subjects of examination will be Practical Mathematics and Penmanship. To secure a pass a candidate must obtain at least 50 per centum of the marks allotted in each subject.

Practical Mathematics will be within the scope of School Leaving Mathematics I. and Mathematics II., and will embrace simple problems in Engineering, Architecture, and Land Surveying, and Penmanship will comprise the formation of letters and figures and the use of drawing instruments such as scale, set square, parallel ruler, and protractor.

Entries for the examination must be lodged at the Office of the Public Service Board, Public Offices, Treasury-place, Melbourne, C.2, on or before Friday, the 23rd November, 1951.

By order,  
E. F. FITZGIBBON,  
Secretary.

Office of the Public Service Board,  
Melbourne, 16th October, 1951.

No. 184. ↗ *Public Service Act 1946, Section 39.*

**REGULATIONS.—PART III.—SALARIES, INCREMENTS, AND ALLOWANCES.**

**T**HE Public Service Board, in pursuance of the powers conferred by the *Public Service Act 1946*, hereby amends its Regulations as shown below:—

**FIRST SCHEDULE.**  
**PROFESSIONAL DIVISION.**  
*Offices and Rates of Salaries.*

Office.	Yearly Rate of Salary.	
	Minimum.	Maximum.
	£	£
<b>DEPARTMENT OF PUBLIC WORKS.</b>		
CLASS "C2."		
Add— Assistant Technical Stores Officer ..	683	735
CLASS "C1."		
Delete— Assistant Technical Stores Officer ..	605	657

D. D. PAINE, Chairman.  
E. F. FITZGIBBON, Secretary.

Office of the Public Service Board,  
Melbourne, 8th October, 1951.

No. 183. ↘

*Public Service Act 1946, Section 50.*

**REGULATIONS.—PART III.—SALARIES, INCREMENTS, AND ALLOWANCES.**

**T**HE Public Service Board, in pursuance of the powers conferred by the *Public Service Act 1946*, hereby amends its Regulations as shown below:—

**SECOND SCHEDULE.**  
**TECHNICAL AND GENERAL DIVISION.**  
*Offices and Rates of Salaries.*

Department and Office	Yearly Rate of Salary.	
	Minimum.	Maximum.
	£	£
<b>DEPARTMENT OF PUBLIC WORKS.</b>		
Add— Caretaker, Dental Clinic, St. Kilda-road, Melbourne .. .. .	299	325

D. D. PAINE, Chairman.  
E. F. FITZGIBBON, Secretary.

Office of the Public Service Board,  
Melbourne, 8th October, 1951.

No. 181. ↘

*Public Service Act 1946, Section 39.*

**REGULATIONS.—PART III.—SALARIES, INCREMENTS, AND ALLOWANCES.**

**T**HE Public Service Board, in pursuance of the powers conferred by the *Public Service Act 1946*, hereby amends its Regulations as shown below:—

**FIRST SCHEDULE.**  
**PROFESSIONAL DIVISION.**  
*Offices and Rates of Salaries.*

Office.	Yearly Rate of Salary.	
	Minimum.	Maximum.
	£	£
<b>DEPARTMENT OF WATER SUPPLY.</b>		
CLASS "C."		
Add— Cartographic Assistant .. .. .	475	579

*This Regulation shall have effect as on and from the 5th October, 1951.*

D. D. PAINE, Chairman.  
E. F. FITZGIBBON, Secretary.

Office of the Public Service Board,  
Melbourne, 1st October, 1951.

No. 180. ↘

*Public Service Act 1946, Section 39.*

**REGULATIONS.—PART III.—SALARIES, INCREMENTS, AND ALLOWANCES.**

**T**HE Public Service Board, in pursuance of the powers conferred by the *Public Service Act 1946*, hereby amends its Regulations as shown below:—

**FIRST SCHEDULE.**  
**PROFESSIONAL DIVISION.**  
*Offices and Rates of Salaries.*

Office.	Yearly Rate of Salary.	
	Minimum.	Maximum.
	£	£
<b>DEPARTMENT OF PREMIER.</b>		
CLASS "C."		
Add— Soil Physicist, Soil Conservation Authority	475	579

*This Regulation shall have effect as on and from the 7th September, 1951.*

D. D. PAINE, Chairman.  
E. F. FITZGIBBON, Secretary.

Office of the Public Service Board,  
Melbourne, 3rd October, 1951.

No. 182. 7

Public Service Act 1946, Section 39.

REGULATIONS.—PART III.—SALARIES, INCREMENTS, AND ALLOWANCES.

THE Public Service Board, in pursuance of the powers conferred by the Public Service Act 1946, hereby amends its Regulations as shown below:—

FIRST SCHEDULE.

PROFESSIONAL DIVISION.

Offices and Rates of Salaries.

Office.	Yearly Rate of Salary.	
	Minimum.	Maximum.
	£	£
DEPARTMENT OF CHIEF SECRETARY.		
CLASS "B1."		
Add— Supervising Librarian, Public Library ..	878	956
CLASS "B."		
Delete— Supervising Librarian, Public Library ..	761	839
Add— Supervising Inspector, Explosives ..	761	839
CLASS "C2."		
Delete— Supervising Inspector, Explosives ..	683	735

D. D. PAINE, Chairman.

E. F. FITZGIBBON, Secretary.

Office of the Public Service Board,  
Melbourne, 1st October, 1951.

No. 179. 1

Public Service Act 1946, Section 50.

REGULATIONS.—PART III.—SALARIES, INCREMENTS, AND ALLOWANCES.

THE Public Service Board, in pursuance of the powers conferred by the Public Service Act 1946, hereby amends its Regulations as shown below:—

SIXTH SCHEDULE.

TEMPORARY EMPLOYEES.

Designations of Positions and Rates of Salaries.

Department and Designation of Position.	Yearly Rate of Salary.		Increments (Annual).
	Minimum.	Maximum.	
	£	£	
DEPARTMENT OF PREMIER.			
SOIL CONSERVATION AUTHORITY.			
Delete— Conservation Officer, Assistant	436	501	2 of £26 and 1 of £13
Add— Conservation Officer, Assistant	371	501	1 of £39, 3 of £26 and 1 of £13

D. D. PAINE, Chairman.

E. F. FITZGIBBON, Secretary.

Office of the Public Service Board,  
Melbourne, 1st October, 1951.

TENDERS.

TENDERS will be received at this office until **TEN A.M.** on the days and for the purposes under mentioned.

Particulars may be learnt at this Office and also at places shown in parenthesis.

W.O. means Inspector of Works Office; P.S.—Police Station; T.S.—Technical School; H.E.S.—Higher Elementary School; S.S.—State School; H.S.—High School.

The Board of Land and Works will not necessarily accept the lowest or any tender.

NOTE.—No preliminary deposits are to be lodged with tenders, but a deposit, in accordance with the following Schedule, will be required from the successful tenderer:—

	£
For contract amounts not exceeding £200 ..	2
For contract amounts exceeding £200 and not exceeding £500 ..	5
For contract amounts exceeding £500 and not exceeding £1,000 ..	10
For contract amounts exceeding £1,000—1 per cent. of tender ..	500
	(maximum deposit)

23rd October, 1951.

Altona.—Supply of 50 tons of 45 lb. to the yard steel railway rails, together with the necessary fish plates, fish bolts, nuts, and spring washers. Explosives Reserve. Specification: To be in accordance with Australian Standard Association Specification or British Standard Specification. For foreign rails, specification to be submitted by tenderers.

Balwyn.—Electrical installation in police office and residence, P.S.

Bendigo.—Conversion of residence into four (4) flats, including hot-water services, sewerage, and electric light; also erection of new laundry and boiler house, Gaol. (W.O., Bendigo.)

Bendigo.—Repairs and renovations and attention to drains, &c., Gaol. (W.O., Bendigo; P.S., Castlemaine, Eaglehawk.)

Castlemaine.—Repairs and renovations, Court House. (W.O., Kyneton; P.S., Castlemaine.)

Cobram.—Electrical installation, P.S. and residence. (P.S., Cobram.)

Daylesford.—External and internal repairs and painting, Court House. (W.O., Kyneton; P.S., Daylesford.)

Dooen.—Erection of timber-framed hospital and residence, Longerenong Agricultural College. (W.O., Ballarat, Horsham; Longerenong Agricultural College, Dooen.) (Quantities available.)

Dookie.—Extension to domestic staff quarters, Agricultural College. (W.O., Shepparton; Agricultural College, Dookie.)

Fairfield.—Supply and installation of steam and hot-water service in Laboratory, Tuberculosis Section, Infectious Diseases Hospital.

Glenhuntly.—Electric light and power, P.S. (P.S., Glenhuntly.)

Grahamvale.—Repairs, painting, raising and re-blocking walls, new display boards, school and residence, S.S. No. 3696. (W.O., Shepparton; P.S., Kyabram, Murchison, Numurkah.)

Hawthorn West.—External and internal renovations and painting to school buildings and caretaker's residence, S.S. No. 293.

Heywood.—New teacher's residence in timber, Consolidated School. (W.O., Hamilton; P.S., Portland; Consolidated School, Heywood.)

Inverloch.—Electrical installation in Teacher's Residence, S.S. No. 2776. (P.S., Inverloch, Korumburra, Wonthaggi.)

Larundel.—Installation of power points in Nurses' Quarters; fire alarm system and street lighting throughout institution, Mental Hospital.

Manifold Heights.—Additional classrooms, boiler-room, office, and new toilets, S.S. No. 4224. (W.O., Geelong; S.S., Manifold Heights.)

Mont Park.—Erection of bus shelter and public toilets, Gresswell Sanatorium.

Neerim East.—Erection of a standard type residence with garage and out-buildings, S.S. No. 3158. (W.O., Traralgon; P.S., Warragul; S.S., Neerim East.)

North Balwyn.—Electrical installation in two (2) "Bristol" prefabricated buildings, S.S. No. 4638.

Orbost.—Electrical installation in Teacher's Residence, H.S. (W.O., Bairnsdale; P.S., Orbost.)

Rupanyup.—Erection of new timber out-office block and installation of septic tank system, S.S. No. 1595. (W.O., Warracknabeal; P.S., Murtoa; S.S., Rupanyup.)

Sandringham.—Erection of fencing, T.S. (T.S., Sandringham.)  
 Stawell.—Alterations to Inspector's Residence, Education Department. (W.O., Ararat; P.S., Stawell.)  
 Thornbury.—General repairs and painting, S.S. No. 3889. (S.S., Thornbury.)  
 Thornton.—Electrical installation in Teacher's Residence, S.S. No. 1371. (P.S., Alexandra, Thornton, Yea.)  
 Trafalgar.—Repairs and painting to residence, S.S. No. 3499. (W.O., Traralgon; S.S., Trafalgar.)  
 Walpeup.—Supply and delivery of two (2) Diesel alternator sets, Mallee Research Station.  
 Warburton.—Electrical installation in Teacher's Residence, S.S. No. 1485. (P.S., Warburton.)  
 Warracknabeal.—Additions to Court House. (W.O., Warracknabeal.)  
 Warracknabeal.—Conversion of Infectious Diseases Wards for Nurses and Domestic Staff, District Hospital. (W.O., Horsham, Warracknabeal; District Hospital, Warracknabeal.) (Amended specification.)  
 Wilson's Reef.—Repairs and painting, residence, S.S. No. 1437. (W.O., Bendigo, Maryborough; P.S., Dunolly, Inglewood; S.S., Wilson's Reef.)  
 Wonwondah North.—Erection of teacher's residence and removal and re-erection of shelter pavilion, S.S. No. 3451. (W.O., Horsham; S.S., Wonwondah North.)

30th October, 1951.

Apollo Bay.—Supply and delivery of 20,000 tons of rock spalls, Public Works Department, Breakwater. (Ports and Harbours, Treasury Buildings, Melbourne.)  
 Bairnsdale.—Erection of new teacher's residence, T.S. (W.O., Bairnsdale; T.S., Bairnsdale.)  
 Ballarat.—Underpinning foundation of Therapy Building, Mental Hospital. (W.O., Ballarat; Mental Hospital, Ballarat.)  
 Ballarat.—Repairs and renovations to out-buildings on Farm Block, Mental Hospital. (W.O., Ballarat; Mental Hospital, Ballarat.)  
 Ballarat.—Electrical installation, Girls' School. (W.O., Ballarat.)  
 Beveridge.—Alterations, additions, and repairs to Teacher's Residence, S.S. No. 1476. (P.S., Wallan; S.S., Beveridge.)  
 Broomfield.—Repairs and painting, &c., S.S. No. 1719. (W.O., Ballarat; P.S., Creswick; S.S., Broomfield.)  
 Caramut.—Supply, installation, and testing of an electric hot-water service, residence, Brown-street, S.S. No. 728. (W.O., Hamilton.)  
 Carlton.—Internal and external repairs and renovations to Resident Lecturers Quarters, Teachers' College.  
 Castlemaine.—General overhaul and repairs, internal renovations and external painting at all school buildings, also attention to art room windows, H.S. (W.O., Kyneton; H.S., Castlemaine.)  
 Cressy.—Internal and external repairs and painting, &c., P.S. (W.O., Camperdown; P.S., Colac, Cressy.)  
 Dookie.—Erection of Women's Hostel, Agricultural College. (W.O., Shepparton; P.S., Tatura; Agricultural College, Dookie.)  
 Dookie.—Erection of residence for house supervisor, Agricultural College. (W.O., Shepparton; P.S., Tallygaroopna, Tatura; Agricultural College, Dookie.)  
 Geelong.—Supply, installation, and testing of a gas hot-water service, Public Works Department Inspector's Residence. (W.O., Geelong.)  
 Geelong.—Supply, installation, and testing of a gas hot-water service, Mines Department Inspector's Residence, Denman-street. (W.O., Geelong.)  
 Gnarpurt.—Erection of new timber residence, S.S. No. 4616. (W.O., Camperdown; P.S., Colac, Lismore, S.S., Gnarpurt.)  
 Greta South.—Supply and installation of a kerosene hot-water service, teacher's residence, S.S. No. 2452. (W.O., Benalla.)  
 Hamilton.—Supply, installation, and testing of an electric hot-water service, residence, King-street, S.S. No. 295. (W.O., Hamilton.)  
 Kangaroo Ground.—Additions, renovations, and painting, S.S. No. 2105. (S.S., Kangaroo Ground.)  
 Kew.—Installation of chlorination plant and drainage, Mental Hospital.  
 Kongwak.—Repairs and painting to school and residence, S.S. No. 3323. (W.O., Korumburra; P.S., Wonthaggi; S.S., Kongwak.)  
 Macclesfield.—Erection of a new timber residence, S.S. No. 3620. (P.S., Emerald; S.S., Macclesfield.)  
 Mallacoota.—Internal painting and other minor works, Fisheries and Game Department Inspector's Residence. (W.O., Bairnsdale; Fisheries and Game Inspector's Residence, Mallacoota.)  
 Melbourne.—Supply and installation of ventilation system, Photographic Section, Technical College.  
 Melbourne.—Supply and installation of hot cathode fluorescent equipment, Newspaper Room, Public Library.

Mont Park.—Erection of brick residence including electrical installation, paths, fencing, site works, for Medical Officer, Mental Hospital.  
 Preston.—General renovations, cabinet partitions and drying equipment, Secondary School. (Secondary School, Preston.)  
 Queenscliff.—Erection of new timber residence, S.S. No. 1190. (W.O., Geelong; P.S., Queenscliff; S.S., Queenscliff.)  
 Royal Park.—Repairs and painting, Special School No. 3552.  
 Rutherglen.—Erection of wool shed, Research Station. (W.O., Wangaratta; Research Station, Rutherglen.)  
 Sale.—Re-building, renovations, and repairs to school buildings, S.S. No. 545. (W.O., Bairnsdale; S.S., Sale.)  
 Seymour.—New water service to out-offices, H.S. (W.O., Alexandra; H.S., Seymour.)  
 Stanley.—Purchase and removal of an old teacher's residence, S.S. No. 550. (W.O., Wangaratta; S.S., Stanley.)  
 Sunbury.—Additional lavatory accommodation, Administrative Block, Mental Hospital. (P.S., Sunbury, Woodend.)  
 Sunbury.—Electrical installation and reticulation, Male and Female Blocks 4, 5, and 6, Mental Hospital.  
 Swan Hill.—Erection of new station, P.S. (W.O., Bendigo, Swan Hill.)  
 Wahgunyah.—New floors and cupboards, S.S. No. 644. (W.O., Wangaratta; S.S., Wahgunyah.)  
 Tongala.—Electrical installation, Senior Wing, Consolidated School. (W.O., Shepparton; P.S., Echuca.)  
 Woomeiang.—Demolition and replacement of Boys' and Girls' out-offices and installation of septic tank system, S.S. No. 3373. (W.O., Warracknabeal; P.S., Hopetoun; S.S., Woomeiang.)

6th November, 1951.

Ararat.—Erection of timber residence, Soil Conservation Authority. (W.O., Ararat, Ballarat; P.S., Stawell.)  
 Ararat.—Additions to Male Staff Quarters, Mental Hospital. (W.O., Ararat, Ballarat; Mental Hospital, Ararat.)  
 Bairnsdale.—Conversion of office to residence, P.S. (W.O., Bairnsdale; P.S., Sale.)  
 Ballarat.—Erection of quarters in timber for students and staff, Teachers' Training College. (W.O., Ballarat.)  
 Ballarat.—Alterations and reconditioning of rooms adjoining main kitchen, Mental Hospital. (W.O., Ballarat; Mental Hospital, Ballarat.)  
 Barkstead.—Alterations and additions to residence, S.S. No. 985. (W.O., Ballarat; S.S., Barkstead.) (Amended specification.)  
 Beechworth.—Electrical installation in Nurses' Hostel Extensions, Mental Hospital. (W.O., Wangaratta; P.S., Beechworth.)  
 Beechworth.—Remodelling of kitchen, Reformatory Prison. (W.O., Wangaratta; P.S., Myrtleford; Reformatory Prison, Beechworth.)  
 Beechworth.—Roof repairs, Mental Hospital. (W.O., Wangaratta; P.S., Myrtleford; Mental Hospital, Beechworth.)  
 Beechworth.—Fencing to "Fletcher" Homestead, Mental Hospital. (W.O., Wangaratta; P.S., Myrtleford; Mental Hospital, Beechworth.)  
 Benalla.—Replacement in concrete of timber escape stairs, High School. (W.O., Benalla; P.S., Euroa.)  
 Bendigo.—Additional out-office accommodation, S.S. No. 877. (W.O., Bendigo; P.S., Castlemaine, Eaglehawk; S.S., Bendigo.)  
 Beveridge.—New floor, repairs, and painting internally and externally, S.S. No. 1476. (S.S., Beveridge.)  
 Birregurra.—Repairs, renovations, and reblocking, &c., to residence, S.S. No. 723. (W.O., Geelong; P.S., Colac; S.S., Birregurra.)  
 Bright.—Repairs, painting, &c., to school and residence, S.S. No. 776. (W.O., Benalla; P.S., Myrtleford; S.S., Bright.)  
 Echuca.—External and internal repairs and renewals and spouting, S.S. No. 208. (W.O., Shepparton; S.S., Echuca.)  
 Elingamite.—Erection of new timber residence, S.S. No. 1424. (W.O., Camperdown; P.S., Cobden; S.S., Elingamite.)  
 Elwood.—Electric light and power, P.S. and residence.  
 Golden Point.—Internal repairs and renovations, cupboards under blackboards, &c., S.S. No. 1493. (W.O., Ballarat; S.S., Golden Point.)  
 Janesfield.—Installation of power outlets in Wards F.2, F.3, and M.2, Mental Hospital.  
 Kew.—Supply and installation of a briquette hot-water service, Gardeners' Quarters, Mental Hospital.  
 Kew.—Supply and installation of a fuel hot-water service, Farm Manager's Quarters, Mental Hospital.  
 Lyndhurst South.—Repairs and painting, S.S. No. 1222. (W.O., Korumburra; S.S., Lyndhurst South.)  
 Malvern.—Extensions to girls' out-offices, Girls' Secondary School, Tooronga-road.

Melbourne.—Supply and installation of compressed air equipment and dust extraction fan, Weights and Measures Office, Observatory.

Melbourne.—Installation of telephone intercommunication six-line system, Parliament House.

Pakenham.—Supply and installation of a kerosene hot-water service, Lands Department Inspector's Residence. (W.O., Korumburra.)

Royal Park.—Renovations to Male Acute Ward, Female Workers' Quarters, and Female Infirmary Ward, Mental Hospital.

Stawell.—Enclosing of verandahs, Toddlers' and Junior Boys' Wards, Pleasant Creek Special School. (W.O., Ararat; P.S., Stawell; Pleasant Creek Special School, Stawell.)

Sunbury.—Erection of hostel for female artisans, Mental Hospital. (Mental Hospital, Sunbury.)

Tatura.—Erection of new station and cell block, P.S. (W.O., Bendigo, Shepparton; P.S., Echuca, Murchison, Tatura.)

Tawonga.—Repairs and painting, S.S. No. 2282. (W.O., Wangaratta; S.S., Tawonga.)

Traralgon.—New brick office, garage, and out-offices, Public Works Department Office Accommodation. (W.O., Traralgon; P.S., Moe, Sale.)

Warrnambool.—Erection of two (2) receiving wards, Mental Hospital. (W.O., Geelong, Warrnambool.) (Quantities available.)

Warrnambool.—Conversion and general renovation of two (2) residences, Mental Hospital. (W.O., Warrnambool; P.S., Port Fairy.)

13th November, 1951.

Heidelberg.—Supply and installation of mechanical services, H.S.

Tenders to be addressed to the Honorable the Commissioner of Public Works, and envelope containing tender marked "Tender for due . . ."

P. T. BYRNES,  
Commissioner of Public Works.

Melbourne, 16th October, 1951.

## PRIVATE ADVERTISEMENTS.

### CITY OF FOOTSCRAY.

#### BY-LAW No. 146.

A By-law of the City of Footscray, made under the Local Government Acts and numbered 146, for regulating traffic, appointing in streets and roads standing places for motor cars, and for other purposes.

THE Mayor, Councillors, and Citizens of the City of Footscray, in pursuance of the powers conferred by the Local Government Acts and by every other Act or power enabling it in that behalf, order as follows:—

1. From and after the coming into operation of this By-law, the following clause shall be included in By-law No. 83 of the City of Footscray, namely:—

28A. (1) No vehicle shall be driven and no animal shall be ridden or driven—

- (a) in a westerly direction along any part of Chambers-street, or
- (b) in a north-westerly direction along any part of Maldon-street, or
- (c) in a southerly direction along that part of Irving-street on the western side of plantation at the Hopkins-street end, or
- (d) in an easterly direction along any part of Dennis-street, or
- (e) in a southerly direction along right-of-way lying between Blackston and Barkly street, or
- (f) in a southerly direction along any part of Dalmahoy-street, or
- (g) in a northerly direction along any part of Greenham-place, or
- (h) in a northerly direction along any part of Barkly-place,

at any time, or

- (i) between the hours of One o'clock in the afternoon and Five o'clock in the afternoon—

(i) along Gordon-street lying between Barkly-street and Geelong-road,

(ii) along north-western side of Geelong-road lying between Gordon-street and Cross-street,

(iii) along Cross-street lying between Geelong-road and right-of-way east of Hocking-street,

on any afternoon on which the same are closed to traffic by barricades.

(2) Every driver who shall draw up his vehicle (except for the purpose of loading or unloading goods) in any part of the streets mentioned in sub-paragraphs (a) to (c) hereof inclusive shall do so only on the left or near side of the same respectively.

(3) No person shall leave a vehicle (whether unattended or not) in any of the following places:—

(a) along the north-western side of Irving-street from Nicholson-street to Leeds-street, or

(b) along the western side of Leeds-street from Irving-street to Paisley-street, or

(c) along the eastern side of Leeds-street from Irving-street to a point opposite the northern building line of Paisley-street, or

(d) along both sides of Dennis-street, or

(e) along right-of-way lying between Blackston and Barkly street, or

(f) along both sides of Dalmahoy-street, or

(g) along both sides of Greenham-place, or

(h) along both sides of Barkly-place, or

(i) along both sides of Barkly-street from Geelong-road to Victoria-street,

at any time on any day.

2. From and after the coming into operation of this By-law, the following shall be added after sub-clause (vi) of clause 28 of By-law No. 83:—

(vii) within 30 feet of a place on an omnibus route indicated by a bus sign of any description, and on the side thereof which is the nearer to the approaching vehicular traffic.

3. From and after the coming into operation of this By-law the words "and not otherwise" shall be deleted from clause 49 of By-law No. 83, and the words "if demanded" inserted in lieu thereof.

4. From and after the coming into operation of this By-law, the following additional standing places for motor cars within the City of Footscray, as provided in clause 48 of By-law No. 83, shall be included in the First Schedule of the said By-law:—

Raleigh-street—South side.

Short-street—North side.

Albert-street—Between the Railway and right-of-way south of Barkly-street.

Geelong-road—Side roadways adjacent and parallel to the plantations between the Railway and Droop-street.

Cowper-street—West side between Talbot-street and Hopkins-street.

Hyde-street—West side between Napier-street and Bunbury-street.

Approach-road to Footscray Station—East side between Napier-street and the Station.

Canterbury-street—North side between Willis-street and the Railway; south side between Willis-street and Ballarat-street.

Simpson-street—North side between Ballarat-street and the Railway.

Resolution for passing this By-law agreed to by the Council of the City of Footscray on the 2nd day of July, 1951, and confirmed on the 30th day of July, 1951.

The common seal of the Mayor, Councillors, and Citizens of the City of Footscray was hereunto affixed in our presence by order of the Council—

W. W. HATFIELD, Mayor.  
(SEAL) WALTER R. SMALLEY, Councillor.  
E. J. SMITH, Town Clerk.

Approved by the Governor in Council, 2nd October, 1951.  
—A. MAHLSTEDT, Clerk of the Executive Council, 8640

## CITY OF MELBOURNE.

## BY-LAW No. 312.

A By-law of the City of Melbourne, made under Part VII of the *Local Government Act 1946* and pursuant to clause 813 of the Uniform Building Regulations, Victoria, and numbered 312, prescribing areas in which buildings of Class II. Occupancy within the meaning of the Uniform Building Regulations, Victoria, shall not be constructed to contain more than three stories including the ground story, and amending By-law No. 248, and for other purposes.

**I**N pursuance of the powers conferred by the *Local Government Act 1946* and the Uniform Building Regulations, Victoria, and every other Act or power enabling it in that behalf, the Council of the City of Melbourne orders as follows:—

1. In this By-law, unless inconsistent with the context or subject matter—

"Builder" means the master builder or other person employed to construct any building and shall include the owner or occupier of the land upon which any such building is or is intended to be constructed or other the person for whom or by whose order or under whose direction and control such construction is done or is intended to be done as the case may be.

"Construct" and "construction" have the meanings ascribed thereto respectively by clause 102 of the Uniform Building Regulations, Victoria.

"Council" means the Council of the City of Melbourne.

"Story" and "ground story" have the respective meanings ascribed thereto by clause 102 of the Uniform Building Regulations, Victoria.

"Surveyor" means a building surveyor appointed by the Council and includes any deputy building surveyor appointed by the Council.

2. From and after the date of the coming into operation of this By-law those parts of the City of Melbourne comprised within the areas more particularly described in the Second Schedule to By-law No. 251 save and except therout those parts of the City of Melbourne more particularly described in the Schedule hereto are hereby prescribed as areas in which buildings of Class II. Occupancy within the meaning of the Uniform Building Regulations, Victoria, shall not be constructed to contain more than three stories including the ground story. Such areas are hereinafter referred to as prescribed areas.

3. No builder shall construct in any prescribed area any building of Class II. Occupancy within the meaning of the Uniform Building Regulations, Victoria, having more than three stories including the ground story.

4. Any builder who constructs a building contrary to the provisions of this By-law shall be guilty of an offence.

5. If any building is constructed contrary to the provisions of this By-law the surveyor may service notice in writing upon the owner or occupier of the land upon which such building is constructed requiring the person served with such notice forthwith to pull down any building constructed upon such land contrary to the provisions of this By-law.

6. If the pulling down of a building required by notice served under clause 5 is not commenced within seven days after the service of such notice or is not proceeded with and completed as speedily as the nature of the case will admit the Council may call upon the owner and the occupier of the land upon which the building has been constructed as aforesaid to show cause why an order should not be made for the pulling down or removal of such building and if such owner or occupier does not show cause as aforesaid the Council may order such owner or occupier to pull down and remove such building within the time to be fixed by the Council.

7. In the event of non-compliance with an order made by the Council under clause 6 the Council may pull down and remove such building or may authorize any person whom it thinks fit to do so and may sell the materials pulled down or removed in such manner as it may think fit and may apply the proceeds of such sale in or towards reimbursing itself for the expenses of such pulling down or removal and may also recover any balance of such expenses not satisfied as aforesaid from the owner or occupier in any Court of competent jurisdiction.

8. Any person who fails to comply with any order of the Council under clause 6 of this By-law shall be guilty of an offence.

9. Every person guilty of an offence against this By-law shall be liable to a penalty of not more than £10.

10. Any notice or order under this By-law may be served upon the owner or occupier of any building or land in the same manner as is prescribed by section 847 of the *Local Government Act 1946* with respect to notices which by that act are required to be given to the owner or occupier of any building or land.

11. Clause 3 of By-law No. 248 is hereby repealed.

## THE SCHEDULE.

All those pieces of land abutting on the sides respectively set out in the first column hereunder of the streets respectively set out in that column to a depth in each case of 100 feet where no depth is stated in that column from such street and to the greater depth stated in that column wherever a greater depth is so stated and lying between the streets set out in the second column hereunder.

<i>Street and Side Thereof.</i>	<i>Portion Thereof.</i>
Albert-street, north side, to a depth of 150 feet	between Lansdowne-street and Clarendon-street
Albert-street, north side, to a depth of 150 feet	between Nicholson-street and Gisborne-street
Albert-street, north side, to a depth of 150 feet	between Powlett-street and Simpson-street
Alexandra-avenue, south side	between Anderson-street and Punt-road
Anderson-street, east side to a depth of 150 feet	between Alexandra-avenue and Domain-road
Carlton-street, north side	between Rathdowne-street and Nicholson-street
Clarendon-street, east side	between Wellington-parade and Albert-street
Commercial-road, south side	From a point opposite the south-western corner of Fawkner Park to a point opposite the south-eastern corner of Fawkner Park
Domain-road, south side to a depth of 150 feet	between St. Kilda-road and Leopold-street
Flemington-road, south side	between Racecourse-road and Harker-street
Gatehouse-street, east side	between Flemington-road and Royal-parade
Grattan-street, south side	between Elizabeth-street and Swanston-street
Grey-street, south side	between Powlett-street and Simpson-street
Hoddle-street, west side	between Wellington-parade and Victoria-parade
Jolimont-street, north side	between Jolimont-road and Jolimont-terrace
Jolimont-terrace, west side to a depth of 150 feet	between Jolimont-street and Wellington-parade south
Lansdowne-street, west side	between Parliament-place and Albert-street
Powlett-street, west side	between Albert-street and Grey-street
Pasley-street, east side	between Pasley-street north and Pasley-street south
Rathdowne-street, west side to a depth of 150 feet	between Victoria-street and Grattan-street
Royal-parade, west side to a depth of 250 feet	between Cemetery-road and Park-street
St. Kilda-road, east side to a depth of 300 feet	between High-street and Toorak-road
Southgate-street, west side	between Flemington-road and Manningham-street
Simpson-street, east side	between Grey-street and Albert-street
The Avenue, east side to a depth of 250 feet	between Gatehouse-street and Park-street west
Toorak-road, north side to a depth of 200 feet	between Adams-street and a point opposite the north-eastern corner of Fawkner Park
Vale-street, east side	between Vale-street south and Wellington-parade
Vale-street south, north side	between Vale-street and Punt-road
Wellington-parade south, south side	between Jolimont-road and Jolimont-terrace

Resolution for passing this By-law agreed to by the Council of the City of Melbourne, the 18th day of June, 1951, and confirmed the 16th day of July, 1951.

(L.S.) JAMES S. DISNEY, Lord Mayor.  
G. J. DEAN, Acting Town Clerk.

Approved by the Governor in Council, the 2nd day of October, 1951.—A. MAHLSTEDT, Clerk of the Executive Council. 8661



## SHIRE OF BRIGHT.

## LOAN No. 19.

*Notice of Intention to Borrow the Sum of Three Thousand Three Hundred Pounds (£3,300) for Permanent Works and Undertakings in the Shire of Bright.*

**T**AKE notice that the Council of the Shire of Bright proposes to borrow, on the credit of the President, Councillors, and Ratepayers of the said shire, the sum of Three thousand three hundred pounds (£3,300), such sum to be raised by the issue of debentures, in accordance with the provisions of the Local Government Acts.

The rate of interest to be paid shall not exceed 4½ per centum per annum.

Such moneys shall be repayable by twenty equal half-yearly instalments, each including principal and interest, by providing such amounts out of the municipal fund on the 1st day of December and the 1st day of June in each respective year during the currency of the loan.

Such moneys shall be repayable, at Melbourne, at the Australia and New Zealand Bank Limited, or at the Council's bankers for the time being in Melbourne.

The purposes for which the loan is to be applied are:—

Shovel loader .. .. .	£1,750
Trailer grader .. .. .	385
Tip truck .. .. .	1,165
	<hr/>
	£3,300

The plans, specifications, and estimate of the cost of the works referred to above, and a statement showing the proposed expenditure of money to be borrowed, are open for inspection at the Shire Offices, Bright.

Dated this 15th day of October, 1951.

8686

H. G. HAYMES, Shire Secretary.

## SHIRE OF FERN TREE GULLY.

## ORDER CHANGING NAME OF ROAD.

**N**OTICE is hereby given that, at a meeting of the Council of the Shire of Fern Tree Gully on the 8th October, 1951, the said Council, in pursuance of the provisions of the *Local Government Act 1946*, did make an Order changing the name of the road set out hereunder:—

*Old name*—Ringwood-road.

*New name throughout*—Dorset-road.

*Location*—From the Main Fern Tree Gully-road, Lower Fern Tree Gully, for the full distance throughout to its junction with the Wantirna-Sassafras-road, Bayswater.

8642

C. C. DANCE, J.P., Shire Secretary.

## SHIRE OF KORUMBURRA.

## LOAN No. 17.

*Notice of Intention to Borrow the Sum of £9,000 for Permanent Works and Undertakings.*

**N**OTICE is hereby given that the Council of the Shire of Korumburra proposes to borrow the sum of Nine thousand pounds (£9,000), by the issue of debentures for such amount, on the credit of the President, Councillors, and Ratepayers of the Shire of Korumburra, in accordance with the provisions of the Local Government Act.

1. The rate of interest to be paid is £3 12s. 6d. per cent. per annum.

2. The purpose for which the loan is to be applied is construction of municipal sale yards at Poowong.

3. The period of the loan shall be ten years.

4. The loan is to be liquidated by 19 (nineteen) equal half-yearly instalments of £275 4s. 9d. each and a final instalment of £6,601 9s. 8d. at the end of ten years, which includes principal and interest, and the said instalments are to be made repayable on the 1st day of July and January each year during the currency of the loan at the Commonwealth Bank of Australia, Melbourne.

The plans and specifications and the estimate of the cost of the proposed works, and a statement showing the proposed expenditure of the moneys to be borrowed, are open for inspection at the Shire Hall, Korumburra.

N. M. SIMMONS, Shire Secretary.

9th October, 1951.

8631

## SHIRE OF MARONG.

## LOAN No. 4.

*Notice of Intention to Borrow the Sum of £5,000 for Permanent Works and Undertakings.*

**N**OTICE is hereby given that the Council of the Shire of Marong proposes to borrow the sum of Five thousand pounds on the credit of the Municipal Revenues of the President, Councillors, and Ratepayers of the said Shire, such sum to be raised by the issue of debentures, in accordance with the provisions of the Local Government Acts.

1. The maximum rate of interest that may be paid is 4 per cent. per annum.

2. The purpose for which the loan is to be applied is—  
Purchase of road-making plant, viz.:—  
Power Grader.

3. The period of the loan shall be ten years.

4. The moneys borrowed shall be repayable by providing out of the Municipal Fund twenty half-yearly instalments of approximately £305 15s. 6d. each, including principal and interest, on the 1st day of July and the 1st day of January during the currency of the loan. The first instalment shall be payable on the 1st day of July, 1952.

5. Such moneys shall be repayable at the Australia and New Zealand Bank Limited, Melbourne, or at the Council's bankers for the time being in Melbourne.

The estimate of the cost of the proposed works and a statement showing the proposed expenditure of the moneys to be borrowed are open for inspection at the Shire Office, Marong.

Dated this 17th day of October, 1951.

8663

A. GUTHRIE, Shire Secretary.

## SHIRE OF MULGRAVE.

## BY-LAW No. 56.

A By-law of the Shire of Mulgrave, made under the *Local Government Act 1946* and the Uniform Building Regulations Victoria, and numbered 56, for regulating, restricting, restraining, or prohibiting the erection, construction, conversion, and alteration of and any addition to buildings or erections, and for amending By-law No. 21 of the Shire of Mulgrave, and for other purposes.

**I**N pursuance of the powers conferred by the Local Government Acts, the President, Councillors, and Ratepayers of the Shire of Mulgrave order as follows:—

(1) By-law No. 21 of the Shire of Mulgrave shall be amended by substituting in Part 2, clause 14, the words "one thousand square feet" for the words "seven hundred and fifty square feet".

(2) This By-law shall apply to and have operation throughout the whole of the municipal district.

Resolution for passing this By-law agreed to by the Council the 24th day of May, 1951, and confirmed on the 21st day of June, 1951.

The common seal of the President, Councillors, and Ratepayers of the Shire of Mulgrave was hereto affixed the 2nd day of August, 1951, in the presence of—

(SEAL) L. ALLEN, President.  
A. J. BUNNY, Councillor.  
F. S. BALES, Shire Secretary.

Approved by the Governor in Council, the 25th day of September, 1951.—A. MAHLSTEDT, Clerk of the Executive Council. 8632

## SHIRE OF SEYMOUR.

**N**OTICE is hereby given that Sergeant Michael Francis Molloy has been appointed Prosecuting Officer for the Shire of Seymour.

8643

H. E. CLAREY, Shire Secretary.

## SHIRE OF TOWONG.

DEVIATION OF A PUBLIC HIGHWAY IN THE PARISH OF WAGRA.  
*Carmens-road.*

**I**N pursuance of the powers conferred by sections 521 and 525 of the *Local Government Act 1946*, the Council of the Shire of Towong doth hereby order that the lands hereinafter described shall be a public highway from and after the date of the publication of this Order in the *Government Gazette*, namely:—

All that piece of land, being part of Crown allotment 5, section IV., Parish of Wagra, County of Benambra, commencing at a point on the northern boundary of the said allotment 5 at a point distant 1,320.8 links westerly from

the north-east corner; thence south 64 deg. 21 min. west 212 links; thence north 85 deg. 48 min. west 373.2 links; thence east 552 links along the northern boundary of the said allotment 5 back to the point of commencement.

Dated the 3rd day of October, 1950.

The common seal of the President, Councillors, and Ratepayers of the Shire of Towong was hereunto affixed, in the presence of—

(SEAL) JAS. RONAN, Councillor.  
R. FRASER PATON, Councillor.  
W. J. GRAY, Secretary.

8641

## SHIRE OF WYCHEPROOF.

LOAN No. 12.

*Notice of Intention to Borrow the Sum of £26,000 for Permanent Works and Undertakings.*

NOTICE is hereby given that the Council of the Shire of Wycheproof proposes to borrow the sum of Twenty-six thousand pounds, on the credit of the municipal revenues of the President, Councillors, and Ratepayers of the said shire, such sum to be raised by the issue of debentures, in accordance with the provisions of the Local Government Acts.

1. The maximum rate of interest that may be paid is 4½ per cent. per annum.
2. The purposes for which the loan is to be applied are:—  
(a) Purchase of one heavy Diesel power grader, £6,000.  
(b) Purchase and installation of a crushing and quarrying plant at Wycheproof, £20,000.
3. The period of the loan shall be fifteen years.
4. The moneys borrowed shall be repayable by providing out of the municipal fund 30 half-yearly instalments of approximately £1,170 18s. each, including principal and interest, on the 1st day of January and the 1st day of July during the currency of the loan. The first instalment shall be payable on the 1st day of July, 1952.
5. Such moneys shall be repayable at the Australia and New Zealand Bank Limited, Melbourne, or at the Council's bankers for the time being in Melbourne.

The plans and specifications and the estimate of the cost of the proposed works, and a statement showing the proposed expenditure of the moneys to be borrowed, are open for inspection at the Shire Office, Shire Hall, Wycheproof.

Dated this 8th day of October, 1951.

8633

R. K. SOULSBY, Shire Secretary.

I PAUL WILLIAMS, of 228 Albert-street, East Brunswick, process worker, heretofore called and known by the name of Anastassiou Pavlos Metsidis, hereby give public notice that by a deed poll dated 3rd October, 1951, duly executed and attested and deposited with the Registrar-General of the State of Victoria, on the 9th day of October, 1951, I formally and absolutely renounced and abandoned the said names of Anastassiou Pavlos Metsidis and declared that I had assumed and adopted and intended thenceforth upon all occasions whatsoever to use and subscribe the names of Paul Williams, and so as to be at all times thereafter called, known, and subscribed by the said names of Paul Williams.

Dated 3rd October, 1951.

PAUL WILLIAMS (formerly Anastassiou Pavlos Metsidis). 8687

NOTICE OF INTENTION TO APPLY FOR A LICENCE TO DIVERT WATER AND CUT RACES FROM THE MURRAY RIVER, AT YELTA.

I HEREBY give notice that I intend to apply for a licence empowering me to divert water for a term of fifteen years to the extent of 90 acre-feet per annum at a maximum rate of 4 acre-feet per day of 24 hours for irrigation of 30 acres, being part of allotment 5, section H, Parish of Merbein, and to occupy certain Crown lands for works of storage and diversion, and to cut a race thereon.

Any objection to such application must be forwarded, in writing, to the State Rivers and Water Supply Commission, Melbourne, within 30 days of the date hereof.

GEORGE MORLAND ADAMS.

Box 58, Merbein, 27th September, 1951. 8634

NOTICE OF INTENTION TO APPLY FOR A LICENCE TO DIVERT WATER AND CUT RACES FROM THE MURRAY RIVER, AT HAYESDALE.

I HEREBY give notice that I intend to apply for a licence empowering me to divert water for a term of fifteen years to the extent of 200 acre-feet per annum at a maximum rate of 10 acre-feet per day of 24 hours for

irrigation of 100 acres, being part of allotment 37, Parish of Piambie, and to occupy certain Crown lands for works of storage and diversion, and to cut a race thereon.

Any objection to such application must be forwarded, in writing, to the State Rivers and Water Supply Commission, Melbourne, within 30 days of the date hereof.

IVAN JAMES O'BRIEN.

"Ivendale" Private Bag, Piangil, 9th October, 1951.  
Garden and Green, solicitors, Swan Hill. 8636

NOTICE OF INTENTION TO APPLY FOR A LICENCE TO DIVERT WATER AND CUT RACES FROM THE MURRAY RIVER, AT WEMEN.

I HEREBY give notice that I intend to apply for a licence empowering me to divert water for a term of fifteen years to the extent of 200 acre-feet per annum at a maximum rate of 4 acre-feet per day of 24 hours for irrigation of 100 acres, being part of allotments 7 and 8, Parish of Wemen, and to occupy certain Crown lands for works of storage and diversion, and to cut a race thereon.

Any objection to such application must be forwarded, in writing, to the State Rivers and Water Supply Commission, Melbourne, within 30 days of the date hereof.

BLANCHE E. MACFARLANE.

Private Bag, Wemen, 9th October, 1951.  
Garden and Green, solicitors, Swan Hill. 8637

NOTICE is hereby given that the partnership heretofore subsisting between the undersigned Chaim Teperman, David Lowe, Szlama Rozenewajc, and Fiszal Swider, carrying on business as footwear manufacturers at 735 Sydney-road, Brunswick, under the firm name of Diana Shoe Co., has been dissolved by mutual consent as from the 23rd day of June, 1951, by the retirement of Fiszal Swider therefrom. All debts due to and owing by the said late firm will be received and paid by the continuing partners, who will carry on the business at the same address and under the same firm name of Diana Shoe Co.

Dated at Melbourne, this 11th day of October, 1951.

FISZAL SWIDER.  
SZLAMA ROZENEWAJC.  
DAVID LOWE.  
CH. TEPERMAN.

Signed in the presence of J. OKNO, solicitor, Melbourne.  
J. Okno, LL.B., of 100-104 Queen-street, Melbourne, 8649  
solicitor.

The Companies Act 1938.

ELECTRO MOTORS PTY. LTD. (IN LIQ.).  
CONSTRUCTORS PTY. LTD. (IN LIQ.).

NOTICE is hereby given that a Meeting of members of these companies will be held, pursuant to section 245 (1) of the Companies Act 1938, on Monday, the 12th day of November, 1951, at 10.30 a.m. and 2.15 p.m. respectively, at the office of the liquidator.

J. K. HALL, Liquidator.

Hall and Rose, chartered accountants (Aust.), 390 Little Collins-street, Melbourne. 8645

Companies Act 1938.

NOTICE OF INTENTION TO APPLY TO ATTORNEY-GENERAL FOR LICENCE, PURSUANT TO SECTION 18 (1).

I MARIENNE VICTORIA TAYLOR, of 1 Hilda-crescent, Hawthorn, secretary, on behalf of Tintern Church of England Girls' Grammar School, an association about to be formed for the purposes of education and the conduct and management of educational establishments, and all things incidental thereto, hereby give notice of intention to apply to the Attorney-General for a licence directing that the said association be registered as a company with limited liability without the addition of the word "Limited" to its name.

Dated this 11th day of October, 1951.

8664 M. V. TAYLOR, Secretary.

COMPANIES ACT 1938, SECTION 245.

FINAL Meetings of contributories will be held on 8th December, 1951, at my office, for the purposes set out in section 245 of the Companies Act.

British and International Trading Co. Pty. Ltd.—9.30 a.m.  
Law Curry Pty. Ltd.—9.45 a.m.  
Broadway Frocks Pty. Ltd.—10 a.m.

LESLIE M. HICKMAN, liquidator, 40 Queen-street, Melbourne. 8683

## Companies Act 1938.

ASSOCIATED AUSTRALIAN OILFIELDS NO LIABILITY.  
INCREASE OF CAPITAL.

**I** THE undersigned manager, hereby give notice that an increase in the capital of the above-named company was, on the 10th day of October, 1951, resolved on. The mode adopted for the increase is by creating 2,497,500 new shares of 10s. each, in addition to the 2,500 shares now existing in the company.

Dated this 12th day of October, 1951.

L. B. TOMLINS, manager of the above-named company.  
8676

## Trustee Act 1928.

## NOTICE TO CLAIMANTS.

**P**URSUANT to the *Trustee Act 1928*, creditors, next of kin, and all other persons having claims in respect of the estate of any deceased person named below are required to send particulars to the legal personal representative or representatives, at the address stated, on or before the date stated, after which date the representative or representatives will distribute the assets, having regard only to the claims of which notice has been received:—

Clive Williamson Jones, late of 49 Paxton-street, East Malvern, salesman, deceased, died on the 10th June, 1951.—Claims to the executor, The Trustees, Executors, and Agency Company Limited, of 401 Collins-street, Melbourne, care of J. M. Shannon and Son, solicitors, 99 Queen-street, Melbourne, by the 17th December, 1951. 8660

George Percival Newton, late of 24 Tollington-avenue, East Malvern, in the State of Victoria, gentleman, deceased, who died on the 22nd July, 1951.—Claims to the executors, The Trustees, Executors, and Agency Company Limited, of 401 Collins-street, Melbourne, and Wilberforce Stephen Newton, of 375 Glenferrie-road, Malvern, doctor of medicine, by 21st December, 1951. Hedderwick, Fookes, and Alston, 103 William-street, Melbourne, solicitors for the executors. 8674

Agnes Waddell Grey, late of "Howick," Pakenham, spinster, deceased, died 2nd August, 1951.—Claims to the executor, The Equity Trustees, Executors, and Agency Company Limited, of 472 Bourke-street, Melbourne, by 20th December, 1951. Lucas and Mumme, solicitors, 383 Flinders-lane, Melbourne. 8684

Daniel Quirk, late of Killarney, farmer, deceased, died 8th August, 1951.—Claims to the executors, Peter Quirk, of Killarney, farmer, and John Quirk, of Port Fairy, labourer, care of Peter P. Conlan, solicitor, 36 Bank-street, Port Fairy, by 23rd December, 1951. 8658

79.

**P**URSUANT to the *Trustee Act 1928*, all persons having claims against the estate of Elizabeth Bradshaw Johnson, late of 51A Carlyon-street, Ormond, widow, deceased (who died on the 13th day of July, 1951, and probate of whose will was granted by the Supreme Court of Victoria, on the 5th day of October, 1951, to Leslie Stephens, of 17 Waverley-street, Essendon, formerly railway employee, but now clerk, and John William Johnson, of 43 Anthony-street, Ormond, formerly turner and fitter, but now engineering inspector, the executors named in and appointed by the said will), are hereby required to forward particulars of such claims to the executors, in care of their solicitor, Winnie L. Horsnell, 422 Collins-street, Melbourne, on or before the 28th day of December, 1951, after the expiration of which time the said executors will proceed to distribute the assets of the said deceased amongst the persons entitled thereto, having regard only to the claims of which they shall have had notice.

Dated the 12th day of October, 1951.

WINNIE L. HORSNELL, solicitor, 422 Collins-street, Melbourne. 8651

**C**REDITORS, next of kin, and others having claims in respect of the estate of Alberta Maud Simpson, late of 20 The Pantiles, Tunbridge Wells, Kent, England, widow, deceased (who died on the 1st day of December, 1950), are to send particulars of their claims to The Trustees, Executors, and Agency Company Limited, at its registered office, at 401 Collins-street, Melbourne, in the State of Victoria, Commonwealth of Australia, by the 11th day of January, 1952, after which date it will distribute the assets, having regard only to the claims of which it then has notice:

MALLESON, STEWART, & CO., solicitors, 46 Queen-street, Melbourne. 8685

## NOTICE TO CREDITORS AND OTHERS.—RE WALTER JAMES LOUIS GORMAN, DECEASED.

**P**URSUANT to the *Trustee Act 1928*, notice is hereby given that all persons having claims against the estate of Walter James Louis Gorman, late of 266 Glen Eira-road, Elsternwick, printer, deceased (who died on the 3rd day of May, 1951, and letters of administration of whose estate were granted by the Supreme Court of Victoria on the 25th day of September, 1951, to the administratrix, Gloria Mary Niemann), are hereby required to send particulars, in writing, of such claims to the said administratrix, care of the under-mentioned solicitors, on or before the 31st day of December, 1951, after which date the said administratrix will proceed to distribute the assets of the said deceased which shall have come to her hands amongst the persons entitled thereto, having regard only to the claims of which she shall then have had notice, and the said administratrix will not be liable for the assets so distributed or any part thereof to any person of whose claim she shall not have had notice as aforesaid.

ARTHUR ROBINSON & CO., 360 Collins-street, Melbourne, solicitors for the said administratrix. 8675

## WILLIAM ANDREW FISHER, DECEASED.

**P**URSUANT to the *Trustee Act 1928*, all persons having claims against the estate of William Andrew Fisher, late of Swan Hill, Victoria, grazier, deceased, intestate (who died on the 4th day of March, 1951), are required by the administrator of his estate, Sandhurst and Northern District Trustees, Executors, and Agency Company Limited, of View-street, Bendigo, Victoria, to which letters of administration have been granted, to send particulars of such claims to the said administrator company, at its address aforesaid, on or before the 18th day of December, 1951, after which date the said administrator company will proceed to distribute the assets of the said deceased amongst the persons entitled thereto, having regard only to the claims of which it then has had notice.

Dated the 10th day of October, 1951.

DAVIES & HAYES, of Campbell-street, Swan Hill, solicitors for the administrator. 8638

**P**URSUANT to the *Trustee Act 1928*, creditors, next of kin, and others having claims in respect of the estate of Beatrice Mary Quinn, late of 19 Cochrane-avenue, Camberwell, married woman, deceased, intestate (who died on the 15th day of August, 1951, and letters of administration of whose estate were granted by the Supreme Court of Victoria, on the 8th day of October, 1951, to Bert William Quinn, of 19 Cochrane-avenue, Camberwell aforesaid, foreman), are required to send particulars, in writing, of such claims to the said administrator, care of the under-mentioned solicitors, on or before the 21st day of December, 1951, after which date the said administrator will proceed to distribute the assets of the said deceased, having regard only to such claims of which he shall then have had notice.

Dated the 12th day of October, 1951.

HOME, WILKINSON, & LOWRY, solicitors, 401 Collins-street, Melbourne. 8681

**C**REDITORS, next of kin, and others having claims in respect of the estate of Harriet Arabella Hermon, late of 14 Berkeley-street, Hawthorn, widow, deceased, intestate (who died on 28th July, 1951), are to send the particulars of their claims to The Equity Trustees, Executors, and Agency Company Limited, of 472 Bourke-street, Melbourne, by the 21st day of December, 1951, after which date it will distribute the assets, having regard only to the claims of which it then has notice.

ARTHUR PHILLIPS & JUST, solicitors, 472 Bourke-street, Melbourne. 8656

JOHN ALEXANDER MITCHELL, late of Swan Hill, in the State of Victoria, grocer, DECEASED (who died on the 19th day of June, 1951).

**C**REDITORS, next of kin, and all other persons having claims against the estate of the deceased are required by the executors of the will, Kathleen Ellen Mitchell, of Swan Hill, in the said State, widow, and Reginald Keith Mitchell, of Anama-street, Greensborough, in the said State, instrument maker, to send particulars to them, care of the undersigned, on or before the 16th day of January, 1952, after which date they will distribute the assets, having regard only to the claims of which they then have notice.

Dated the 12th day of October, 1951.

GARDEN & GREEN, solicitors, McCallum-street, Swan Hill. 8657

**CREDITORS**, next of kin, and others having claims in respect of the estate of Henry Cairns, late of 98 Eglinton-street, Moonee Ponds, gentleman, deceased (who died on the 14th day of April, 1951, and probate of whose will was on the 12th day of July, 1951, granted to William Henry Stenning, of 11 Balmoral-street, Essendon, and Percy Wyton Briggs, of 15 Queen-street, Melbourne, the executors named therein), are required to send particulars of their claims to the said Percy Wyton Briggs, at his address as above, on or before the 17th day of December, 1951, after which date the assets will be distributed, having regard only to the claims of which notice has then been served.

KIDDLE, BRIGGS, & WILLOX, 15 Queen-street, Melbourne, solicitors for the executors. 8682

**CREDITORS**, next of kin, and all others having claims in respect of the estate of Dorothy Fisher, late of 150 Balwyn-road, Balwyn, in the State of Victoria, married woman, deceased, intestate (who died on the 29th day of May, 1951), are to send the particulars of their claims to her administrator, The Trustees, Executors, and Agency Company Limited, of 401 Collins-street, Melbourne, by the 19th day of December, 1951, after which date it will distribute the assets, having regard only to the claims of which it then has notice.

HADEN, SMITH, & FITCHETT, solicitors, 405 Collins-street, Melbourne. 8677

**CREDITORS**, next of kin, and others having claims in respect of the estate of Lilian Adele Bennett, late of 73 Park-street, St. Kilda, widow, deceased, intestate (who died on 24th July, 1951), are to send the particulars of their claims to The Equity Trustees, Executors, and Agency Company Limited, of 472 Bourke-street, Melbourne, by the 19th day of December, 1951, after which date it will distribute the assets, having regard only to the claims of which it then has notice.

ARTHUR PHILLIPS & JUST, solicitors, 472 Bourke-street, Melbourne. 8673

GRACE URQUHART, formerly of 14 St. Georges-road, Toorak, but late of 11 Kooyong-road, Armadale, married woman (who died on the 16th August, 1951).

**CREDITORS**, next of kin, and all others having claims in respect of the estate of the said deceased are required by the executor, The Trustees, Executors, and Agency Company Limited, of 401 Collins-street, Melbourne, to send particulars of such claims to the said company by the 27th December, 1951, after which date the said company will distribute the assets, having regard only to the claims of which it then has notice.

DAVIES, CAMPBELL, & PIESSE, 401 Collins-street, Melbourne, solicitors. 8672

MARGARET THOMPSON, formerly of 11 Moonga-road, Toorak, in Victoria, but late of 14 Montgomerie-terrace, Ayr, in Scotland, spinster, DECEASED (who died on the 23rd May, 1951).

**CREDITORS**, next of kin, and all others having claims in respect of the estate of the said deceased are required by the executor, The Trustees, Executors, and Agency Company Limited, of 401 Collins-street, Melbourne, to send particulars of such claims to the said company by the 27th December, 1951, after which date it will proceed to distribute the assets, having regard only to the claims of which it then has notice.

DAVIES, CAMPBELL, & PIESSE, 401 Collins-street, Melbourne, solicitors. 8671

**PURSUANT** to the *Trustee Act 1928*, creditors, next of kin, and all other persons having claims in respect of the estate of Catherine Angelina Cathcart Rothwell, of 23 Hoddle-street, Essendon, in the State of Victoria, married woman, deceased (who died on the 25th day of March, 1950, and letters of administration of whose estate with the will annexed was granted on the 4th day of October, 1950 to Florence Ava Pidd, of Ryot-street, Warrnambool, married woman), are hereby required to send particulars, in writing, of such claims to the said administratrix, care of the undersigned, at their office, at the address mentioned hereunder, on or before the 31st day of December, 1951, after which date the said administratrix will proceed to distribute the assets of the said deceased, having regard only to the claims of which she shall then have had notice, and she will not be liable to any person of whose claim she shall not have then received notice.

SLATER & GORDON, solicitors, 422 Collins-street, Melbourne. 8653

**PURSUANT** to the *Trustee Act 1928*, creditors, next of kin, and all other persons having claims in respect of the estate of Wade Charles Rothwell, late of 23 Hoddle-street, Essendon, in the State of Victoria, gentleman, deceased (who died on the 18th day of May, 1950, and letters of administration with the will annexed of whose estate were granted on the 1st day of December, 1950, to Florence Ava Pidd, of Ryot-street, Warrnambool, married woman), are hereby required to send particulars, in writing, of such claims to the said administratrix, care of the undersigned, at their office, at the address mentioned hereunder, on or before the 31st day of December, 1951, after which date the said administratrix will proceed to distribute the assets of the said deceased, having regard only to the claims of which she shall then have had notice, and she will not be liable to any person of whose claim she shall not have then received notice.

SLATER & GORDON, solicitors, 422 Collins-street, Melbourne. 8654

ADELINE ELIZA VAGG, DECEASED.

**PURSUANT** to the *Trustee Act 1928*, notice is hereby given that all persons having claims against the estate of Adeline Eliza Vagg, late of 25 Stewart-street, Williamstown, widow, deceased (who died on the 11th day of May, 1951), are hereby requested to send particulars, in writing, of such claims to Samuel Edwin Vagg, the executor appointed by the deceased's will, care of the under-mentioned solicitors, on or before the 14th day of December, 1951, after which date the said executor will proceed to distribute the assets of the said deceased amongst the persons entitled thereto, having regard only to the claims of which he shall have had notice.

Dated this 11th day of October, 1951.

MORGAN, FYFFE, & MULKEARNS, Vaughan House, 108 Queen-street, Melbourne, solicitors for the applicant. 8650

**CREDITORS**, next of kin, and others having claims in respect of the estate of Bridget O'Connell, late of 26 Canning-street, North Melbourne, widow, deceased, intestate (who died on the 20th July, 1951), are required by the administrator, National Trustees, Executors, and Agency Company of Australasia Limited, to send particulars of their claims to the said company, at 95 Queen-street, Melbourne, by the 22nd day of December, 1951, after which the said company will distribute the assets, having regard only to the claims of which it then has notice.

COOK & McCALLUM, solicitors, 422 Collins-street, Melbourne. 8679

**CREDITORS**, next of kin, and others having claims in respect of the estate of James Sproston Holland, late of Liebig-street, Avoca, retired farmer, deceased (who died on the 12th day of May, 1951), are to send the particulars of their claims to John Fetherstonhaugh Herring and Harry Lloyd Bathurst, both of Maryborough, solicitors, care of the undersigned solicitors, by the 23rd day of December, 1951, after which date they will distribute the assets, having regard only to the claims of which they then have notice.

HERRING & BATHURST, solicitors, Maryborough. 8635

**CREDITORS**, next of kin, and others having claims in respect of the estate of Mary Anne Shortell, also known as Mary Shortell and Mary Anne Theresa Shortell, formerly of Kirkstall, in the State of Victoria, but late of 22 Havelock-road, Hawthorn, in the said State, spinster, deceased (who died on the 21st day of July, 1951), are to send the particulars of their claims to the National Trustees, Executors, and Agency Company of Australasia Limited, whose registered office is at No. 95 Queen-street, Melbourne, by the 20th day of December, 1951, after which date it will distribute the assets, having regard only to the claims of which it then has notice. 8648

**CREDITORS**, next of kin, and others having claims against the estate of Albert Hossack, late of 43 Chapel-street, East St. Kilda, Victoria, paper merchant, deceased (who died on the 11th day of December, 1950), are required by the executor, Rex Oldham, care of The Union Bank of Australia Limited, 351 Collins-street, Melbourne, to send particulars, in writing, of such claims to the said executor, care of the under-mentioned solicitors, on or before the 20th day of December, 1951, after which date the said executor will distribute the assets, having regard only to the claims of which he then has notice.

NORVAL H. DOOLEY & BREEN, solicitors, 31 Queen-street, Melbourne. 8646

**P**URSUANT to the *Trustee Act* 1928, all persons having claims against the estate of William Temple, late of Selby, formerly farmer, but late carpenter, deceased, intestate (who died on the 4th day of June, 1951, and letters of administration of whose estate were granted by the Supreme Court of Victoria, on the 28th day of September, 1951, to Patrick Temple, of Narre Warren, farmer, a brother of the said deceased), are hereby required to forward particulars of such claims to the administrator, in care of his solicitor, Dudley A. Tregent, B.A., LL.M., 422 Collins-street, Melbourne, on or before the 28th day of December, 1951, after the expiration of which time the said administrator will proceed to distribute the assets of the said deceased amongst the persons entitled thereto, having regard only to the claims of which he shall have had notice.

Dated the 12th day of October, 1951.

DUDLEY A. TREGENT, B.A., LL.M., solicitor, 422  
Collins-street, Melbourne. 8652

**C**REDITORS, next of kin, and all others having claims in respect of the estate of Esther Charlotte Fitchett, late of 8 Ridgeway-avenue, Kew, in the State of Victoria, widow, deceased (who died on the 12th day of August, 1951), are to send the particulars of their claims to her executor, The Trustees, Executors, and Agency Company Limited, of 401 Collins-street, Melbourne, by the 19th day of December, 1951, after which date it will distribute the assets, having regard only to the claims of which it then has notice.

HADEN, SMITH, & FITCHETT, solicitors, 405 Collins-  
street, Melbourne. 8678

**NOTICE TO CLAIMANTS.—RE CATHERINE VICTORIA  
BRODIGAN, DECEASED.**

**N**OTICE is hereby given that all persons having claims against the property or estate of Catherine Victoria Brodigan, late of 245 Richardson-street, Middle Park, in Victoria, widow, deceased (who died on the 12th day of May, 1951, and probate of whose will and codicil thereto was granted to Walter Lancelot Duckett, of 967 Mount Alexander-road, Essendon, in Victoria, managing law clerk, and George Henry Turpin, of 111 Spray-street, Elwood, in Victoria, tailor), are hereby required to send, in writing, particulars of such claims to Septimus Jones, solicitor, 287 Collins-street, Melbourne, on or before the 20th day of January, 1952, after which date they will convey or distribute such property or estate to or among the persons entitled thereto, having regard only to the claims of which they shall then have had notice.

SEPTIMUS JONES, solicitor, 287 Collins-street, Mel-  
bourne. 8668

**P**URSUANT to the *Trustee Act* 1928, notice is hereby given that all persons having any claim against the estate of Phillip Duncan Touzel, formerly of 24 Milson-road, Cremorne, in the State of New South Wales, but late of 58 Wattle Valley-road, Canterbury, in the State of Victoria, retired actuary, deceased (who died on the 29th June, 1951, and probate of whose will was on the 4th October, 1951, granted by the Supreme Court to The Trustees, Executors, and Agency Company Limited, of 401 Collins-street, Melbourne, and Donald Louis Touzel, of 29 First-avenue, East Kew, accounting systems manager), are to send particulars, in writing, of their claims to the said executors, at the office of the said company, by the 18th December, 1951, after which date the said executors will distribute the assets of the said deceased which have come to their hands among the persons entitled thereto, having regard only to the claims of which they shall then have had notice.

McKEAN & PARK, solicitors, 84 William-street, Mel-  
bourne. 8670

**C**REDITORS, next of kin, and others having claims in respect of the estate of Harriet Annie Holmes McLennan, formerly of 172 Hotham-street, East Melbourne, in the State of Victoria, in Australia, but late of "Tasmania," Haven View-road, Seaton, in the County of Devon, England, widow, deceased (who died on the 9th day of February, 1951), are required by The Trustees, Executors, and Agency Company Limited, of 401-3 Collins-street, Melbourne, in the State of Victoria, Australia, as attorney under power by Harriet Jessie Constance Clark, of "Tasmania" aforesaid, formerly married woman, now widow, the sole executrix, to send particulars, in writing, of such claims to the said company by the 18th day of December, 1951, after which date it will distribute the assets to or among the persons entitled thereto, having regard only to the claims of which it then has notice.

V. S. HOLLOW, M.A., LL.B., solicitor, 140 Queen-street,  
Melbourne. 8647

THOMAS FRANCIS SHERIDAN, late of 114 Beveridge-  
street, Swan Hill, pensioner (who died on the 13th  
August, 1951).

**C**REDITORS, next of kin, and all other persons having claims against the estate of the above-named are required to send particulars of same to the executrix, Esther Lily Burns, care of the undersigned, on or before the 20th December, 1951, after which date she will distribute the assets, having regard only to the claims of which she then has notice.

GERALD E. DELANY, solicitor, 63 Campbell-street,  
Swan Hill. 8665

**C**REDITORS, next of kin, and others having claims in respect of the estate of Leslie Studley Bond, late of 92 Mount-street, Heidelberg, estate agent, deceased, intestate (who died on the 27th May, 1951), are required to send particulars of their claims to The Equity Trustees, Executors, and Agency Company Limited, whose registered office is situate at 472 Bourke-street, Melbourne, by the 1st January, 1952, after which date it will distribute the assets, having regard only to the claims of which it then has notice.

LEACH & THOMSON, solicitors, 472 Bourke-street,  
Melbourne, C.1. 8666

**C**REDITORS, next of kin, and others having claims in respect of the estate of Batzion Bryant, late of 35 Albenca-street, Mentone, married woman, deceased, intestate (who died on the 10th September, 1950), are required to send particulars of their claims to The Equity Trustees, Executors, and Agency Company Limited, whose registered office is situate at 472 Bourke-street, Melbourne, by the 1st January, 1952, after which date it will distribute the assets, having regard only to the claims of which it then has notice.

LEACH & THOMSON, solicitors, 472 Bourke-street,  
Melbourne, C.1. 8667

**C**REDITORS, next of kin, and others having claims in respect of the estate of Janet Lindsay Greig, formerly of Greydon-court, St. George's-road, Toorak, in the State of Victoria, but late of Bayswater, London, England, medical practitioner, deceased, intestate (who died on the 18th day of October, 1950), are to send in particulars of their claims to the Union Trustee Company of Australia Limited, of 333 Collins-street, Melbourne, by the 21st day of December, 1951, after which date it will distribute the assets, having regard only to the claims of which it then has notice.

CORNWALL, STODART & CO., 47 Queen-street, Mel-  
bourne, solicitors for the administrator. 8659

**C**REDITORS, next of kin, and others having claims in respect of the estate of Robert Wilson Macaulay, late of 20 Waterloo-street, Camberwell, minister of religion, deceased (who died on 1st August, 1951), are to send the particulars of their claims to The Trustees, Executors, and Agency Company Limited, the registered office of which is situate at Nos. 401-403 Collins-street, Melbourne, by the 19th day of December, 1951, after which date it will distribute the assets, having regard only to the claims of which it then has notice.

PROUDFOOT & HORTON, solicitors, 87 Queen-street,  
Melbourne. 8655

**P**URSUANT to the *Trustee Act* 1928, notice is hereby given that all persons having claims against the estate of Edith Myrtle Gilby, late of 620 Elgar-road, Box Hill, in the State of Victoria, married woman, deceased (who died on the 26th day of May, 1951, and probate of whose will dated the 20th day of July, 1945, was granted by the Supreme Court of the said State, in its probate jurisdiction, on the 30th day of July, 1951, to Alfred Aleston George Gilby, of 620 Elgar-road, Box Hill, gas worker, one of the executors named therein, leave being reserved to Charles Vivian Hore, of Longreach, in the State of Queensland, engineer, the other executor thereby appointed to come in and prove the same), are hereby required to send particulars, in writing, of such claims to the undersigned, at their office hereunder mentioned, on or before the 18th day of December, 1951, after which date the said Alfred Aleston George Gilby will proceed to distribute the assets of the said Edith Myrtle Gilby, deceased, which shall have come into his hands amongst the persons entitled thereto, having regard only to the claims of which he shall have had notice; and notice is hereby further given that the said Alfred Aleston George Gilby will not be liable for the assets so distributed, or any part thereof, to any person of whose claim he shall not have had notice as aforesaid.

MULLETT & LANGFORD, solicitors, 395 Collins-street,  
Melbourne. 8688

In the Supreme Court of the State of Victoria.—*Fi. Fa.*

**NOTICE** is hereby given that, under and by virtue of certain process issued out of the Supreme Court of the State of Victoria and directed to the Sheriff, requiring him to levy certain moneys of the real and personal estate of Susan Young, of 22 Kildare-street, Burwood, widow, the said Sheriff will, on Wednesday, the 21st day of November, 1951, at the hour of Eleven o'clock in the forenoon, cause to be sold, at the Police Station, Boundary-road, Burwood (unless the said process shall have been previously satisfied or the said Sheriff be otherwise stayed):—

All the right, title, estate, and interest (if any) of the said Susan Young, in and to all that piece of land being lot 93 on plan of subdivision, number 13066, lodged in the Office of Titles, and being part of Crown allotment B, portion 48, Parish of Nunawading, County of Bourke, and being the land more particularly described in certificate of title, volume 7149, folio 1429697.

N.B.—Terms: Cash. No cheques taken.

Dated at Melbourne this 8th day of October, 1951.

8669 JOSEPH H. BARLING, Sheriff's Officer.

**MINING NOTICE.**

LINDEN (W.A.) GOLD NO LIABILITY.

**NOTICE** is hereby given that all shares on which No. 13 (September) Call of Six pence per share remains unpaid, will be forfeited and sold by public auction in the vestibule of the Stock Exchange, 428 Chancery-lane, Melbourne, on Wednesday, 24th October, 1951, at Twelve o'clock noon, unless shares are redeemed on or before Tuesday, 23rd October, 1951, at Five p.m.

By order of the Board,

K. H. GRANT, Manager *pro tem.*

422 Collins-street, Melbourne, 5th October, 1951. 8680

**IMPOUNDINGS.**

**CHILTERN.**—Impounded at Chiltern, by W. J. White.

1 Hereford bullock, about 2 years old, no visible brand  
If not claimed and expenses paid, to be sold on 26th October, 1951.

8630—6/6 C. A. OATES, Poundkeeper.

**GISBORNE.**—Impounded at Gisborne, from Smith-street, Macedon, by Shire Ranger, on 7th October, 1951.

1 Jersey heifer, no visible brand  
1 Jersey bull, no visible brand  
If not claimed and expenses paid, to be sold on 31st October, 1951.

8644—8/8 J. M. MORTON, Poundkeeper.

**NUMURKAH.**—Impounded at Numurkah, on 15th October, 1951.

1 brown gelding, light delivery type, white hind fetlocks, blaze face, no visible brand

If not claimed and expenses paid, to be sold on 1st November, 1951.

8662—8/8 J. K. KILLMISTER, Poundkeeper.

**POOWONG.**—Impounded in Poowong Pound.

1 dark Jersey heifer, no visible brand  
1 yellow and white cow, no visible brand, calf at foot  
1 brown Jersey cow, no visible brand  
1 light-brown and white yearling heifer, no visible brand  
1 light Jersey yearling heifer, no visible brand

If not claimed and expenses paid, to be sold on 26th October, 1951.

8689—10/10 J. BALLANTYNE, Poundkeeper.

**RED CLIFFS.**—Impounded at Red Cliffs.

1 bay mare, hack type, blaze face, black points, no visible brand

If not claimed and expenses paid, to be sold on 25th October, 1951.

8629—7/7 J. HERAUD, Poundkeeper.

**TATURA.**—Impounded at Tatura.

3 dark Jersey heifers, no visible brand  
1 light Jersey heifer, slit out of off ear, no visible brand  
1 roan Jersey-cross heifer, no visible brand

If not claimed and expenses paid, to be sold on 8th November, 1951.

8639—8/8 E. SHEALES, Poundkeeper.

**STATE ACTS, 1949.**

COPIES of the following Acts of Parliament of Victoria may be obtained at the Government Printing Office, or from any bookseller, at the price set opposite to each:—

No.	Price.
	s. d.
5362. Miners' Phthisis (Treasury Allowances) Amendment	0 3
5363. Country Roads (Financial)	0 6
5364. Horsham Land	0 6
5365. Mental Institution Benefits	0 6
5366. Royal Commission (Communist Party)	0 6
5367. Melbourne and Metropolitan Tramways (Chairman)	0 6
5368. State Electricity Commission (Chairman)	0 6
5369. River Murray Waters	0 9
5370. Soldier Settlement	0 9
5371. Consolidated Revenue	0 6
5372. Agricultural Education	0 9
5373. Forestry Pulp and Paper Company's Afforestation Contracts	1 0
5374. Shearers Accommodation	1 3
5375. Water	0 9
5376. Consolidated Revenue	0 6
5377. Mildura Irrigation and Water Trusts (Financial)	0 8
5378. Collingwood (Unimproved Rating Poll)	0 6
5379. Crimes	1 3
5380. Governor's Salary	0 6
5381. Consolidated Revenue	0 5
5382. Wrongs (Tort-feasors)	0 6
5383. State Development	0 6
5384. Grain Elevators (Financial)	0 6
5385. Imported Materials Loan and Application	0 6
5386. Royal Commission (Communist Party) Amendment	0 6
5387. Minister of Education	0 6
5388. Municipal Endowment (Temporary Discontinuance)	0 6
5389. Land Tax	0 6
5390. Stamps (Increased Duty Continuance)	0 6
5391. Railways (Long Service)	0 6
5392. Williamstown Lands	0 6
5393. Creta Lands Exchange	0 6
5394. Consolidated Revenue	0 6
5395. Superannuation (Amendment)	1 0
5396. Mines (Amendment)	0 6
5397. Coal (Overseas Purchase) Amendment	0 6
5398. Country Roads Board Fund (Amendment)	0 6
5399. Lancefield and Kilmore Railway (Disposal of Land)	0 6
5400. Treasury Bonds	0 6
5401. North-West Mallee Settlement Areas (Amendment)	0 6
5402. Administration and Probate Duties	0 6
5403. Judges Pensions	0 9
5404. Town and Country Planning (Metropolitan Area)	0 9
5405. State Forests Loan and Application	0 6
5406. Legal Profession Practice	0 6
5407. Forests (Exchange of Lands) Extension	0 6
5408. Victorian Mining Accident Relief Fund (Winding-up)	0 6
5409. Consolidated Revenue	0 6
5410. Castlemaine Lands	0 6
5411. Soil Conservation and Land Utilization	0 9
5412. Public Account Advances (Amendment)	0 6
5413. Mothercraft Nurses	0 9
5414. Rural Finance Corporation	2 0
5415. Co-operative Housing Societies	0 6

STATE ACTS, 1949—continued.

No.	Price.
s. d.	s. d.
5416. Latrobe Valley Development Loan and Application	1 0
5417. Liquid Fuel	0 6
5418. Water Supply Loan and Application	1 3
5419. Fire Brigades (Appeal Tribunal)	0 6
5420. Railway Loan Application	1 0
5421. Local Authorities Superannuation (Amendment)	0 9
5422. Public Works Loan and Application	0 6
5423. Motor Car (Amendment)	0 6
5424. Barwon River Improvement (Amendment)	0 6
5425. Portland Harbor Trust	1 9
5426. Land (Grants and Leases)	0 6
5427. Geelong Waterworks and Sewerage	0 9
5428. Metropolitan Gas Company's	0 6
5429. Prices Regulation	0 6
5430. Masseurs (Registration)	0 6
5431. Vermin and Noxious Weeds	1 9
5432. Health (Tuberculosis Arrangement)	0 6
5433. Justices (Service of Process)	0 6
5434. Police Offences (Amendment)	0 6
5435. Revocation and Excision of Crown Reservations	0 9
5436. Coal Mine Workers Pensions (Amendment)	0 6
5437. Health (Cattle)	0 6
5438. Soldier Settlement (Amendment)	0 9
5439. Footwear Regulation (Amendment)	0 6
5440. Appropriation of Revenue, 1948-49	4 3
5441. Croydon Fruit Cool Stores	0 6
5442. Licensing (Amendment)	0 6
5443. Local Government	1 6
5444. Milk Pasteurization	0 9
5445. Building Operations and Building Materials Control (Amendment)	0 9
5446. Tourists' Resorts Development (Financial)	0 6
5447. Public Library National Gallery and Museums	0 6
5448. Police Regulation (Amendment)	0 9
5449. Business Investigations	0 9
5450. Motor Car (Amendment)	1 6

J. J. GOURLEY,  
Government Printer.

STATE ACTS, 1950—continued.

No.	Price.
s. d.	s. d.
5488. Melbourne and Metropolitan Board of Works (Borrowing Powers)	0 6
5489. Cattle Compensation	0 6
5490. Coal Mines Regulation (Accidents Relief)	0 6
5491. Public Contracts (Amendment)	0 6
5492. Water	0 9
5493. Administration and Probate Duties	0 6
5494. Country Roads Board	0 6
5495. Land Tax	0 6
5496. Motor Car (Drivers' Licences)	0 6
5497. Tallangatta Township (Removal)	0 9
5498. Medical	0 6
5499. State Forests Loan and Application	0 6
5500. Surplus Revenue (Unexpended Balances)	0 6
5501. Treasury Bonds	0 6
5502. Co-operative Housing Societies	1 0
5503. Police Offences (Idle and Disorderly Persons)	0 6
5504. Gelliondale Land (Mineral Lease)	0 6
5505. Local Government (Imported Houses)	0 6
5506. Police Offences (Animals)	0 6
5507. Gas and Fuel Corporation	2 6
5508. Jubilee and Centenary Sports	0 6
5509. Railways Dismantling	0 9
5510. Geelong (Kardinia Park) Land	0 6
5511. Coal Mine Workers Pensions (Amendment)	0 6
5512. Municipalities and Other Authorities Finances	0 9
5513. Public Officers Salaries	0 6
5514. State Electricity Commission	0 6
5515. Public Works Loan and Application (No. 2)	0 9
5516. Ministers of the Crown and Parliamentary Salaries	0 6
5517. Fire Brigades (Long-Service Leave)	0 9
5518. Fisheries (Inland Angling)	0 6
5519. Mental Hygiene Authority	1 6
5520. Railway Loan and Application	1 3
5521. Education (Religious Instruction)	0 6
5522. Workers' Compensation (Amendment)	1 0
5523. Public Trustee	0 6
5524. McPherson's Limited Pension Fund	0 6
5525. Landlord and Tenant (Servicemen)	0 6
5526. Local Government (Shire of Braybrook)	0 6
5527. Appropriation of Revenue	4 6

J. J. GOURLEY,  
Government Printer.

STATE ACTS, 1950.

COPIES of the following Acts of Parliament of Victoria may be obtained at the Government Printing Office, or from any bookseller, at the price set opposite to each:—

No.	Price.
s. d.	s. d.
5451. Consolidated Revenue	0 6
5452. Consolidated Revenue	0 6
5453. Superannuation	0 6
5454. Marine (Temporary Exemptions)	0 6
5455. Consolidated Revenue	0 6
5456. Melbourne Harbor Trust (Housing Advances)	0 6
5457. University (Veterinary Research)	0 6
5458. Pyalong Lands Exchange	0 9
5459. Goods (Textile Products)	0 9
5460. Police Regulation (Pensions)	0 6
5461. Melbourne (Bowen-street) Land	0 9
5462. Printers and Newspapers (Foreign Advertisements)	0 6
5463. Police Offences (Race-meetings)	0 6
5464. Non-Contributory State Pensions	0 6
5465. Legislative Council Reform	2 0
5466. State Electricity Commission (Contracts)	0 6
5467. Police Regulation (Pensions) Amendment	0 6
5468. Prices Regulation (Extension)	0 6
5469. Factories and Shops (Amendment)	0 6
5470. Nurses and Midwives	1 3
5471. Weights and Measures	1 6
5472. Supreme Court (Judges)	0 6
5473. Drainage Areas	1 3
5474. Consolidated Revenue	0 6
5475. Forests (Accounts and Funds)	0 6
5476. Coal Mining Industry (Long-Service Leave)	0 9
5477. Acts Interpretation (Amendment)	0 6
5478. Agricultural Colleges (Amendment)	0 6
5479. Building Operations and Building Materials, &c.	0 9
5480. Shrine of Remembrance Site	0 6
5481. Public Works Loan and Application	0 6
5482. Grain Elevators	0 6
5483. Teaching Service (Amendment)	0 9
5484. Imported Materials Loan and Application, &c.	0 6
5485. Water Supply Loan and Application	1 3
5486. Victorian Inland Meat Authority (Advances)	0 6
5487. Melbourne and Metropolitan Board of Works (Contracts)	0 6

J. J. GOURLEY,  
Government Printer.

STATE ACTS, 1951.

COPIES of the following Acts of Parliament of Victoria may be obtained at the Government Printing Office, or from any bookseller, at the price set opposite to each:—

No.	Price.
s. d.	s. d.
5528. Consolidated Revenue	0 6
5529. State Electricity Commission (Overdraft)	0 6
5530. Local Government (Enrolment)	0 6
5531. Crimes (Reformatory Prisons)	0 6
5532. The Geelong Gas Company's	0 6
5533. Railways (Amendment)	0 6
5534. Poisons	0 6
5535. Select Committee (Egg and Egg Pulp) Marketing	0 6
5536. Coal Mining Industry (Long-service Leave) Amendment	0 6
5537. Education (Amendment)	0 6
5538. Friendly Societies	0 6
5539. State Development	0 6
5540. Stamps (Cheques)	0 6
5541. Public Service	0 9
5542. Country Fire Authority (Financial)	0 6
5543. Consolidated Revenue	0 6
5544. Coal Mine Workers' Pensions (Contributions)	0 6
5545. Vermin and Noxious Weeds (Financial)	0 6
5546. Medical (Temporary Registration)	0 6

THE "VICTORIA GOVERNMENT GAZETTE."

SUBSCRIPTIONS.—The subscription, including postage, is £2 5s. per annum, £1 2s. 6d. half-yearly, or 11s. 3d. per quarter, payable in advance.

Subscriptions are required to commence and terminate with a month.

A lesser period than three months cannot be subscribed for.

Subscribers do not receive the Acts of Parliament with the GAZETTE.

ADVERTISEMENTS are charged at the rate of 1s. 1d. per line single column, and 2s. 2d. per line double column.

The title (£5 Reward, Dissolution of Partnerships, &c.) forms one or more lines as a heading.

On an average, ten words make a line.

Every signature must likewise be counted as a line.

The final words of a paragraph, though only portion of a line, must be counted as one line.

SIGNATURES (in particular) and proper names must be written very plainly in the text; ONE SIDE ONLY of each slip of paper should be WRITTEN UPON.

ALL COMMUNICATIONS should be addressed to "The Government Printer, Melbourne."

ALL DOCUMENTS illegibly written will be returned unpublished, and, where brands occur unprovided for by the ordinary letters of the alphabet, a worded explanatory description must be furnished.

THE VICTORIA GOVERNMENT GAZETTE is published on WEDNESDAY EVENING in each week, and Notices for insertion will be received by the Government Printer at or before Two p.m. at ordinary rates, and late advertisements between Two p.m. and FIVE p.m. at double rates on the day preceding the day of publication.

Single copies of the VICTORIA GOVERNMENT GAZETTE are Nine pence, posted One shilling, each.

No GAZETTES prior to January, 1942, in stock.

\*\*\*ALL PAYMENTS ARE REQUIRED IN ADVANCE.—Remittances should be made by postal note, money order, or draft in favour of the Government Printer. Advertisements unaccompanied by a remittance sufficient to cover the cost of insertion will be returned unpublished.

#### AGENTS FOR THE "VICTORIA GOVERNMENT GAZETTE."

THE following have been appointed agents to receive Advertisements and Subscriptions for the Victoria Government Gazette:—

ARMSTRONG'S AGENCY, 143 Queen-street, Melbourne.  
 ARMSTRONG BROS., Kyneton.  
 MESSRS. ARNALL & JACKSON, 115 Barkly-street, West Brunswick.  
 MR. M. R. BADE, Tobacconist, Sturt-street, Ballarat.  
 MR. WM. DAVIS, Mildura.  
 A. J. DIGBY (B. S. and N. W. CASH), Main-street, Bairnsdale.  
 EDGAR'S NEWS AGENCY, Hargreaves-street, Bendigo.  
 EDGAR'S NEWS AGENCY, 53 Murphy-street, Wangaratta.  
 H. E. EVERY & SON, 42 Fryers-street, Shepparton.  
 MESSRS. HENRY FRANKS & CO., Booksellers and Stationers, Market-square, Geelong.  
 MESSRS. GORDON & GOTCH, News Agents, 511 Little Collins-street, Melbourne; and corner Barrack and Clarence streets, Sydney.  
 W. GORDON HAMPTON, 243 Mitchell-street, Bendigo.  
 MESSRS. HARSTON, PARTRIDGE, & CO., 455 Little Collins-street, Melbourne.  
 MR. C. F. LATIMER, News Agent, Casterton.  
 MR. F. T. McCORMICK, Nurn-street, Benalla.  
 MESSRS. H. PAYNE & R. N. LOWE, 4 View Point, Bendigo.  
 MESSRS. R. H. & W. M. PETTY, News Agent, Wangaratta.  
 PIKE'S AUTHORIZED NEWS AGENCY, Sale.  
 J. PURDIE & CO., 138 Moorabool-street, Geelong.  
 MESSRS. A. S. RICHARDSON and T. C. GARDNER, trading as The Mercantile Exchange, 380 Collins-street, Melbourne.  
 ROBERTSON & MULLENS LTD., Elizabeth-street, Melbourne.

R. & A. SMALLMAN, News Agents, Toora.

MESSRS. SMITH & DUNNON, Hamilton.

TRAINOR'S NEWS AGENCY, 246 Wyndham-street, Shepparton.

E. W. B. WELSH, Hogan-street, Tatura.

A copy of the Gazette filed at each place for public reference.

#### PUBLICATION OF OFFICIAL MATTER.

ATTENTION is invited to the following procedure in relation to the publication of official matter in the Government Gazette:—

##### 1. Matter submitted to the Executive Council.

Matter submitted to the Executive Council which requires gazettal will normally be published in the issue of the following week.

Where urgent gazettal is required, special arrangements should be made with the Gazette Officer.

Publication will be facilitated by the submission of carbon copies for the use of the Gazette Officer.

##### 2. Other matter.

(a) All other matter duly certified by a responsible officer for publication should be lodged with the Gazette Officer not later than half-past Ten a.m. on Tuesday.

(b) Lengthy or involved notices should be forwarded several days before publication.

(c) Proofs, which will be supplied only when specifically requested, or at the direction of the Gazette Officer, should be returned promptly to avoid delay in publication.

(d) No additions or amendments to matter for publication will be accepted by telephone.

#### CONTENTS.

	Page.
Acts of Parliament .. .. .	6991
Acts of Parliament on sale at the Government Printing Office .. .. .	7036
Appointments .. .. .	6995
Auction Sales Act .. .. .	7001
Business Agents Act 1930 .. .. .	7008
Centenary Celebrations—Holiday .. .. .	6994
Contracts .. .. .	6996
Country Roads Board .. .. .	7001
Courts .. .. .	7001
Estates of Deceased Persons .. .. .	7000
Government Notices .. .. .	6996
Impoundings .. .. .	7036
Lands .. .. .	7020
Licences to Occupy Unused Roads .. .. .	7003
Licences to Occupy Water Frontages .. .. .	7007
Melbourne and Metropolitan Board of Works—Notice .. .. .	7009
Melbourne Cup Holiday .. .. .	6994
Mining .. .. .	7036
Ministers of Religion Registered to Celebrate Marriages in Victoria .. .. .	7008
Money Lenders Act 1938—Supplementary List .. .. .	7007
Orders in Council .. .. .	7001
Private Advertisements .. .. .	7029
Proclamations .. .. .	6991
Publication of Official Matter in Gazette .. .. .	6995
Public Holidays .. .. .	6994
Public Service Notices .. .. .	7024
Real Estate Agents Act .. .. .	7006
Resignations .. .. .	6996
Supplementary List of Fertilizers Registered .. .. .	7011
Tenders .. .. .	7027
Transport Regulation Board—Public Hearings .. .. .	6998