



# VICTORIA GOVERNMENT GAZETTE.

Published by Authority.

[Registered at the General Post Office, Melbourne, for transmission by post as a newspaper.]

No. 347]

FRIDAY, MARCH 30.

[1951

*Land Act 1928.*

AREAS OF LANDS COMPRISED IN CERTAIN CLASSES DIMINISHED OR INCREASED.

### PROCLAMATION

By His Excellency the Governor of the State of Victoria and its Dependencies in the Commonwealth of Australia,  
&c., &c., &c.

WHEREAS by the *Land Act 1928* it is amongst other things enacted that the Governor in Council may, by Proclamation to be published in the *Government Gazette*, at any time diminish or increase the area of land comprised in any of the classes mentioned in Part I., Division 1, section 5, of the said *Land Act 1928*, but that the area of lands which may be sold by auction (Class 6) shall not be increased except as in certain cases in the said Act provided; Now therefore I, the Governor of the State of Victoria, in the Commonwealth of Australia, by and with the advice of the Executive Council of the said State, and in accordance with the provisions of sections 94 and 117 of the *Land Act 1928* aforesaid, do hereby diminish or increase (as the case may be) the areas of Crown lands comprised in Classes 2, 3, 6, and 7 of the classes mentioned in section 5 of the *Land Act 1928* aforesaid to the extent set forth in the subjoined Schedule (that is to say) :—

Schedule referred to.

### CLASSES DIMINISHED OR INCREASED.

County.	Parish.	Allotment.	Section.	Area.	Diminished.	Increased.	Description.
					Class.	Class.	
				A. R. P.			
Moira ..	Yielima ..	100B	..	28 2 25	3	..	In east of parish. (H019783)
Moira ..	Yielima ..	100A	..	26 1 9	3	..	In east of parish. (H020084)
Kara Kara ..	St. Arnaud ..	6A	11B	0 2 6 <sup>9</sup> / <sub>10</sub>	7	6	Fronting Wolfe-street. (W66400)
Dalhousie ..	Clonbinane ..	1A	B	3 0 32	7	..	In north-east of parish. (H011711)
Moira ..	Yielima ..	102B	..	20 0 24	2	..	In north of parish. (H020067)
Talbot ..	Amherst ..	11	A <sup>2</sup>	1 0 0	..	6	Fronting Avoca-Maryborough-road. (C92442)
Bendigo ..	Marong ..	5M	10	10 0 0	7	6	In north of parish. (W66774)
Bendigo ..	Sandhurst ..	272	M	6 0 0	7	6	Fronting Nelson-street. (W68444)

Given under my Hand and the Seal of the State of Victoria aforesaid, at Melbourne, this nineteenth day of March, in the year of our Lord One thousand nine hundred and fifty-one, and in the fifteenth year of the reign of His Majesty King George VI.

(L.S.)

DALLAS BROOKS.

By His Excellency's Command,

A. E. LIND,  
Commissioner of Crown Lands and Survey.

GOD SAVE THE KING!

Country Fire Authority Acts.  
**VARIATION OF SUMMER PERIOD IN RESPECT OF  
 SPECIFIED PARTS OF THE COUNTRY AREA OF  
 VICTORIA.**

PROCLAMATION

By His Excellency the Governor of the State of Victoria and its Dependencies in the Commonwealth of Australia, &c., &c., &c.

WHEREAS by sub-section two of section four of the *Country Fire Authority Act 1944*, it is enacted that the Governor in Council, after consultation by the Chief Secretary of Victoria with the Minister of Forests may, from time to time, by Proclamation published in the *Government Gazette* proclaim any period as the summer period in respect of the country area of Victoria, or any specified part or parts thereof and, without affecting the generality of the foregoing, may proclaim different summer periods in respect of different parts of the said country area:

And whereas by the said sub-section it is further enacted that any Proclamation so published shall remain in force until revoked, amended, or varied by a subsequent Proclamation so published:

And whereas by Proclamations issued on the 5th, 12th, and 19th December, 1950, and published in the *Government Gazette* of the 6th, 13th, and 20th December, 1950, respectively, different summer periods expiring on the thirty-first day of March, 1951, were proclaimed in respect of the different parts of the country area of Victoria, including the parts of the said country area specified in the Schedule hereto:

And whereas it is deemed expedient that the aforesaid Proclamations should be varied in the manner hereinafter described:

And whereas the Chief Secretary and the Minister of Forests have consulted accordingly:

Now therefore I, the Governor of the State of Victoria, in the Commonwealth of Australia, by and with the advice of the Executive Council of the said State, and in pursuance of the powers conferred by the Country Fire Authority Acts, do by this my Proclamation vary the aforesaid Proclamations by proclaiming that the summer period in respect of the parts of the country area of Victoria, which are specified in the Schedule hereto, shall end on the fourteenth day of April, 1951.

SCHEDULE.

- The Fourth Fire Control Region, comprising the municipal districts of the Town of Portland, the Shires of Glenelg, Portland, and Wannon;
- the Fifth Fire Control Region, comprising the municipal districts of the Cities of Hamilton and Warrnambool, the Boroughs of Koroit and Port Fairy, the Shires of Belfast, Dundas, Minhamite, Mortlake, Mount Rouse, and Warrnambool;
- the Twelfth Fire Control Region, comprising the municipal districts of the Shires of Alexandra, Mansfield, and Yea;
- the Thirteenth Fire Control Region, comprising the municipal districts of the Shires of Fern Tree Gully, Healesville, and Upper Yarra, and those portions of the municipal districts of the Shires of Eltham and Lillydale outside the Metropolitan Fire District;
- and those portions of the Seventeenth Fire Control Region, comprised by the municipal districts of the Shires of Arapiles and Kowree.

Given under my Hand and the Seal of the State of Victoria aforesaid, at Melbourne, this twentieth day of March, in the year of our Lord One thousand nine hundred and fifty-one, and in the fifteenth year of the reign of His Majesty King George VI.

(L.S.)

DALLAS BROOKS.

By His Excellency's Command,

K. DODGSHUN,

Chief Secretary.

GOD SAVE THE KING!

*Forests Act 1928 (No. 3685).*  
**EXTENSION OF PROHIBITED PERIOD.**

PROCLAMATION

By His Excellency the Governor of the State of Victoria and its Dependencies in the Commonwealth of Australia, &c., &c., &c.

IN pursuance of the provisions of section 3 of the *Forests Act 1928*, I, the Governor of the State of Victoria, in the Commonwealth of Australia, by and with the advice of the Executive Council of the said State, do by this my Proclamation declare the fourteenth day of April, 1951, to be the end of the prohibited period in the year One thousand nine hundred and fifty-one with respect to any fire protected area other than a State forest or national park in such parts of Victoria as are specified in the Schedule hereto.

SCHEDULE.

Such parts of Victoria as are situated within the following Counties, viz:—

The County of Anglesey.  
 The County of Benambra.  
 The County of Bendigo.  
 The County of Bogong.  
 The County of Borung.  
 The County of Bourke.  
 The County of Buln Buln.  
 The County of Croajingolong.  
 The County of Dalhousie.  
 The County of Dargo.  
 The County of Delatite.  
 The County of Dundas.  
 The County of Evelyn.  
 The County of Follett.  
 The County of Gladstone.  
 The County of Grant.  
 The County of Grenville.  
 The County of Gunbower.  
 The County of Hampden.  
 The County of Heytesbury.  
 The County of Kara Kara.  
 The County of Lowan.  
 The County of Moira.  
 The County of Mornington.  
 The County of Normanby.  
 The County of Polwarth.  
 The County of Ripon.  
 The County of Rodney.  
 The County of Talbot.  
 The County of Tambo.  
 The County of Tanjil.  
 The County of Villiers.  
 The County of Wonnangatta.

Given under my Hand and the Seal of the State of Victoria aforesaid, at Melbourne, this twentieth day of March, in the year of our Lord One thousand nine hundred and fifty-one, and in the fifteenth year of the reign of His Majesty King George VI.

(L.S.)

DALLAS BROOKS.

By His Excellency's Command,

A. E. LIND,  
 Minister of Forests.

GOD SAVE THE KING!

PUBLIC HALF-HOLIDAYS.

PROCLAMATION

By His Excellency the Governor of the State of Victoria and its Dependencies in the Commonwealth of Australia, &c., &c., &c.

IN pursuance of the provisions contained in Part III. of the *Public Service Act 1946* (10 Geo. VI. No. 5124), I, the Governor of the State of Victoria, in the Commonwealth of Australia, by and with the advice of the Executive Council of the said State, do by this my Proclamation appoint the days and dates hereunder mentioned to be observed as Public Half-Holidays at the places respectively specified, viz:—

*Public Half-Holidays from the Hour of Twelve o'clock noon:—*

WEDNESDAY, THE 18TH DAY OF APRIL, 1951, throughout the Shire of Lowan.

THURSDAY, THE 17TH DAY OF MAY, 1951, throughout the Shire of Glenelg.

Given under my Hand and the Seal of the State of Victoria aforesaid, at Melbourne, this twenty-ninth day of March, in the year of our Lord One thousand nine hundred and fifty-one, and in the fifteenth year of the reign of His Majesty King George VI.

(L.S.) DALLAS BROOKS.

By His Excellency's Command,  
K. DODGSHUN,  
Chief Secretary.

GOD SAVE THE KING!

#### ANZAC DAY HOLIDAY.

IT is hereby notified that on—

WEDNESDAY, THE 25TH APRIL, 1951,

the Public Offices will be closed, such day having been appointed by the *Public Service Act 1946* to be observed as a holiday in the Public Offices throughout Victoria.

This Notice relates only to the closing of the State Public Offices. All inquiries regarding holidays in other offices and in shops and industry should be directed to the Department of Labour, Old Treasury Building, Spring-street, Melbourne, C.1 (Telephone F0234, Extension 266 or 882).

K. DODGSHUN,  
Chief Secretary.

Chief Secretary's Office,  
Melbourne, 23rd February, 1951.

#### COMMONWEALTH JUBILEE CELEBRATION DAY.

IT is hereby notified that on—

WEDNESDAY, THE 9TH MAY, 1951,

the Public Offices will be closed, such day having been appointed under the *Public Service Act 1946* to be observed as a holiday in the Public Offices throughout the State of Victoria.

This Notice relates only to the closing of the State Public Offices. All inquiries regarding holidays in other offices and in shops and industry should be directed to the Department of Labour, Old Treasury Building, Spring-street, Melbourne, C.1 (Telephone F0234, Extension 266 or 882).

K. DODGSHUN,  
Chief Secretary.

Chief Secretary's Office,  
Melbourne, 23rd February, 1951.

#### PUBLICATION OF THE "VICTORIA GOVERNMENT GAZETTE."

IT is hereby notified that, owing to Anzac Day and the Commonwealth Jubilee Celebration Day being Wednesdays, the *Victoria Government Gazette* will be published on—

FRIDAY, THE 27TH APRIL, 1951, and  
FRIDAY, THE 11TH MAY, 1951,

instead of the ordinary days of publication.

Official matter for publication in the *Gazette* of the 27th April should be lodged with the *Gazette* Officer, Chief Secretary's Department, Old Treasury Building, Spring-street, Melbourne, not later than 10.30 a.m. on Thursday, the 26th April, 1951, and in the case of the *Gazette* of the 11th May, not later than 10.30 a.m. on Thursday, the 10th May, 1951.

J. J. GOURLEY,  
Government Printer.

#### APPOINTMENTS.

HIS Excellency the Governor of the State of Victoria, by and with the advice of the Executive Council thereof, has, by Orders made on the 19th day of March, 1951, been pleased to make the under-mentioned appointments, viz.:—

##### CHIEF SECRETARY'S DEPARTMENT.

##### *Registrars of Births and Deaths.*

BERTHA ROSALIND DAKIN, J.P.,

pursuant to the provisions of section 4 of the *Registration of Births Deaths and Marriages Act 1928*, to be Registrar of Births and Deaths at Bacchus Marsh; with fees, *vice* Alfred Robert Willis, resigned; and

LESLIE VANCE BARKER,

pursuant to the provisions of section 4 of the *Registration of Births Deaths and Marriages Act 1928*, to be Registrar of Births and Deaths at Lorne, with fees, *vice* Etta Anderson, deceased.

##### DEPARTMENT OF HEALTH.

##### *Trustees of Cemeteries.*

TREVOR ERREY,  
MERLE CROCKER, and  
ARTHUR LINDSAY PEACOCK,  
to be Trustees of the Violet Town Public Cemetery, *vice* T. Giffin, resigned;  
PERCIVAL NORMAN WILKSCH  
to be Trustee of the Netherby Public Cemetery, *vice* V. H. Haustorfer, resigned;  
HAROLD VICTOR REDMOND,  
JOHN EDMUND MENADUE,  
VICTOR HUGO CANN,  
ARTHUR NORRIS HARDY, and  
ELVIE ELLEN WILLIAMS,  
to be Trustees of the Eganstown Public Cemetery;  
EDWARD WATERS, and  
ADA FRYBERG  
to be Trustees of the Ferntree Gully Public Cemetery;  
ALEXANDER MILLS,  
WALTER SPARROW,  
THOMAS SHIRREFF,  
ALLAN HOLDEN,  
GEORGE SIMPSON,  
JOSEPH PIANTA, and  
ERNEST ALTMAN,  
to be Trustees of the Concongella Public Cemetery;  
REUBEN OTTO BORGELT and  
ALFRED ALBERT SCHULTZ  
to be Trustees of the Woorak Public Cemetery, *vice* F. W. Borgelt, resigned, and P. Bone, resigned, respectively; and  
RAYMOND GEORGE STANYER  
to be a Trustee of the Blue Mountain Public Cemetery.

##### LAW DEPARTMENT.

##### *Bailiff of County Court.*

GEORGE FREDERICK HAMILTON, First Constable of Police, St. Arnaud,  
to be also a Bailiff of the County Court at Ballarat, during the absence on leave of A. E. Pearson.

##### *Commissioners for Taking Declarations, &c.*

JAMES LUCIS FRANCIS BRADLEY, 59 Devon-avenue, Coburg West,  
DAVID PURCELL, 62 King-street, Essendon,  
STANLEY DAVID COOPER, Gaffney's Creek,  
JACK GARDINER, Argile-street, Fawkner,  
JOSEPH ALFRED HAROLD COPPIN, 39 Fairmont-avenue, Hartwell, and  
ROBERT STANISLAUS MILLER, 192 Lygon-street, Carlton,  
to be Commissioners for taking Declarations and Affidavits, pursuant to the provisions of Division 8 of Part IV. of the *Evidence Act 1928*, to resign upon removing from the neighbourhood of the addresses stated;

GEORGE BRIGGS, Secretary, Collingwood Branch, Australian Natives Association, 172 Johnston-street, Collingwood, and

JOSEPH STANLEY McMANAMY, care of General Motors-Holden's Limited, Fisherman's Bend, Port Melbourne,  
to be Commissioners for taking Declarations and Affidavits, pursuant to the provisions of Division 8 of Part IV. of the *Evidence Act 1928*, to resign upon ceasing to occupy their present positions; and

JOHN ROBERT FITZGERALD, an officer of the Chief Office for Stamp Duties, 283 Queen-street, Melbourne,  
HENSON MONROE BARTON,  
HARRY EUSTACE BISHOP,  
FRANK CARMAN,

JOHN FRANCIS SHANAHAN, and  
CHARLES SAMUEL WEBB,

Officers of the Transport Regulation Board, Exhibition Building, Rathdown-street, Carlton, to be Commissioners for taking Declarations and Affidavits, pursuant to the provisions of Division 8 of Part IV, of the *Evidence Act 1928*, to refrain from charging fees, and to resign upon ceasing to occupy their present positions.

*Clerks of Children's Courts, &c.*

GREGORY DANIEL O'SULLIVAN  
to be also Clerk of the Children's Court at Ouyen, Murrayville, and Woomelang, during the absence on annual leave of J. E. Kean; and

JOHN JOSEPH CAVEN  
to be also Clerk of the Children's Court at Korumburra, Leongatha, and Meeniyah, during the absence on annual leave of A. L. Bock, and as Deputy Clerk of the Peace, Registrar of the County Court at Korumburra, to be appointed by virtue of section 92 of the *Juries Act 1928* to do and perform with respect to the Courts at that place, in the place and stead of the Sheriff, all such acts and things as the Sheriff is, by the said Act, authorized or required to do or perform, during the absence on annual leave of A. L. Bock.

*Deputy Prothonotary, &c.*

KEVIN ALOYSIUS McDONALD  
to be also a Deputy Prothonotary and Clerk of the Children's Court at Ballarat, during the absence on annual leave of C. E. Elvish, and as Deputy Clerk of the Peace and Registrar of the County Court at Ballarat, to be appointed by virtue of section 92 of the *Juries Act 1928* to do and perform with respect to the Courts at that place, in the place and stead of the Sheriff, all such acts and things as the Sheriff is, by the said Act, authorized or required to do or perform, during the absence on annual leave of C. E. Elvish.

*Acting Public Trustee.*

HAROLD CARTER CHIPMAN  
to be Acting Public Trustee, pursuant to the provisions of section 6 of the *Public Trustee Act 1939*, during the absence on annual leave of C. J. Gardner, from the 28th March, 1951, to the 10th April, 1951, both dates inclusive.

STATE ELECTRICITY COMMISSION (YALLOURN AREA) ACT.  
*Member and Chairman, Yallourn Town Advisory Council.*

THOMAS FORRISTAL  
to be a Member and Chairman of the Yallourn Town Advisory Council for a term of three years as from the 7th day of January, 1951.

DEPARTMENT OF WATER SUPPLY.

*Waterworks Trust Commissioner.*

ALEXANDER GORDON MCKENZIE  
to be a Commissioner of the Macedon Waterworks Trust, and to hold office as such during the present term of office of Ralph Nathaniel Ronalds, as a Councillor for the Macedon Riding of the Shire of Gisborne, subject to the provisions of the Water Acts.

A. MAHLSTEDT,  
Clerk of the Executive Council.

At the Executive Council Chamber,  
Melbourne, 19th March, 1951.

#### RESIGNATIONS.

HIS Excellency the Governor of the State of Victoria, by and with the advice of the Executive Council thereof, has, by Orders made on the 19th day of March, 1951, accepted the resignations of the persons named hereunder of the offices mentioned, viz.:—

CHIEF SECRETARY'S DEPARTMENT.

THOMAS MONTGOMERY, as a Licensing Inspector for each and every Licensing District in the State of Victoria, to date from and inclusive of the 8th March, 1951.

ALFRED ROBERT WILLIS, as Registrar of Births and Deaths at Bacchus Marsh, to date from and inclusive of the 22nd March, 1951.

LAW DEPARTMENT.

CLARENCE THOMAS ANDERSON, as a Commissioner for taking Declarations and Affidavits, pursuant to the provisions of the *Evidence Act 1928*.

A. MAHLSTEDT,  
Clerk of the Executive Council.

At the Executive Council Chamber,  
Melbourne, 19th March, 1951.

#### NOTICE TO MARINERS.

[No. 4 of 1951.]

#### AUSTRALIA.—VICTORIA.

THE following Notice to Mariners, which has been received from the Assistant Harbor Master, Geelong, is published for general information.

D. S. STEVENSON,  
Port Officer.

Ports and Harbors Branch,  
Department of Public Works,  
Melbourne, C.2, 22nd March, 1951.

#### PORT OF GEELONG.

WILSONS SPIT CHANNEL.—PROPOSED NEW LIGHT BEACON.

*Position.*—No. 5 Beacon—Wilson's Spit Channel. Lat. 38.07 deg. 5 min. S. Long. 144.28 deg. 3 min. E.

*Date.*—14th March, 1951.

*Details.*—On this date the construction of a light beacon was commenced in a position bearing 012 deg.—380 feet from the above position.

Following the completion of this structure—(position A)—similar beacons will be constructed in positions (B) and (C) as follows:—(B) 102 deg.—5,384 feet from (A). (C) 102 deg.—4,369 feet from (B).

These new structures will be situated on northern side of above channel and abreast of Nos. 5, 3, and 1 beacons respectively, and will be unlighted until further notice.

*Caution.*—All vessels must proceed at their minimum speed while passing any of the above positions when work is in progress.

#### MINES DEPARTMENT.

SUBJECT to any necessary excisions, &c., it is proposed to grant the following mining leases:—

- 9096, Ballarat; Herbert Clive Daniel; 305a. 1r. 23p., Parishes of Yarrowee and Buninyong.
- 8261, Beechworth; Morning Star (G.M.A.) Mines N. L., 43a. 3r. 29p., Parish of Lauraville.
- 9087, Castlemaine; Samuel George Lacy, Sidney Ellison Weeks, and Norma Scott; 40a. 2r. 20p., Parishes of Strangways and Muckleford.

#### APPLICATION FOR MINING LEASE DECLARED ABANDONED.

7051, Maryborough; Thomas William Allan; 1,100 acres, near Avoca.

#### APPLICATION FOR MINING LEASE REFUSED.

7234, Mineral; John Hartley Taylor and Ernest Montague George Swain; 2½ acres, Parish of Gembrook.

#### MINING LEASE AND TAILINGS LICENCES EXPIRED.

7782, Beechworth; James O'Brien, Harry Morgan, and William Boorman; 37a. 0r. 38p., Parish of Burrungabugge.

2149, Tailings Licence; Malcolm Valentine Pritchard; Parish of Boola Baloke.

1931, Tailings Licence; Edward Albert Rewell and Sydney George Rewell; 11a. 1r. 31p., at Maldon.

G. C. MOSS,  
Minister of Mines.

#### LAW DEPARTMENT.—ATTORNEY-GENERAL. CURATOR OF CONVICT'S PROPERTY.

HIS Excellency the Governor of the State of Victoria, by and with the advice of the Executive Council thereof, doth, by Order made on the 19th day of March, 1951, pursuant to the provisions of section 576 of the *Crimes Act 1928*, direct that the custody and management of the property of the convict Raymond James Cullen be committed to Freda Joyce Cullen, of 9 Jackson-parade, East Coburg, home duties, as a Curator hereby appointed in that behalf.

A. MAHLSTEDT,  
Clerk of the Executive Council.

At the Executive Council Chamber,  
Melbourne, the 19th March, 1951.

## Transport Regulation Acts.

## TRANSPORT REGULATION BOARD.

## NOTICES OF PUBLIC HEARINGS.

NOTICE is hereby given that the applications made by the persons named below for licences to operate the commercial goods vehicles on the route or routes, or in the manner set out opposite their names, will be heard at a time and place to be communicated to the parties concerned:—

*Name and Address; Nature of Application.*

- ASPLAND, H. H., Mt. Egerton; 1 commercial goods vehicle (100 cwt.) to operate—(a) in the course of trade as "sanitary contractor" within the limits of the Shire of Ballan, (b) from Mt. Egerton to Port Melbourne for the carriage of kaolin mined by the applicant.
- BERGMAN, ABRAHAM, 34 Hoddle-street, Essendon; 1 commercial goods vehicle (5 cwt.) to operate in the course of business as "hosiery and glove manufacturer" between Melbourne and decentralized factory at Terang.
- BERGMAN, S. L., 136 Puckle-street, Moonee Ponds; 1 commercial goods vehicle (5 cwt.) to operate in the course of business as "hosiery and glove manufacturer" between Melbourne and decentralized factory at Terang.
- CLARK, J. H., Hindmarsh-street, Dimboola; 1 commercial goods vehicle (80 cwt.) for the carriage of—(a) general goods within a radius of 20 miles from Dimboola, (b) road-making plant and materials within a radius of 50 miles from Dimboola.
- COLE, ARTHUR, & COMPANY, 34 Queens-road, Melbourne; 1 commercial goods vehicle (10 cwt.) for the carriage of—(a) own goods in the course of business as "electrical engineers and contractors" within a radius of 50 miles from Melbourne, (b) tools of trade, materials, and fittings to sites of contracts throughout the State of Victoria.
- COONEY, J. W., 17 Ballarat-road, Maidstone; 1 commercial goods vehicle (15 cwt.) for the carriage of marine stores in the course of business as "dealer" throughout the State of Victoria.
- HARCOURT, E. J., 58 Barkly-street, Benalla; 1 commercial goods vehicle (80 cwt.) for the carriage of—(a) general goods within a radius of 20 miles from Benalla, (b) road-making plant and materials within a radius of 50 miles from Benalla.
- HARRISON, W. F., & W. F. DENT, Chases-road, Yannathan; 1 commercial goods vehicle (157 cwt.) for the carriage of brewers' grain and fodder from Melbourne to places within a radius of 20 miles from Yannathan.
- KING, W. P., 64 Benjamin-street, Sunshine; 1 commercial goods vehicle (100 cwt.) for the carriage of road-making plant and materials throughout the State of Victoria.
- LOWE, H., 18 Jackson-street, St. Kilda; 1 commercial goods vehicle (200 cwt.) for the carriage of sawn timber from Tub Creek Sawmills at Nayook to the railway station at Nayook, or to any timber merchant or builder, if delivered *en route* to such railway station or to a timber yard or building site which is located within a radius of 20 miles from such railway station.
- MARSHALL, A. F., 490 Victoria-street, North Melbourne; 1 commercial goods vehicle (300 cwt.) for the carriage of—(a) general goods within a radius of 20 miles from Wodonga, (b) road-making plant and materials within a radius of 50 miles from Wodonga.
- PATERSON'S PTY. LTD., 152 Bourke-street, Melbourne; 1 commercial goods vehicle (12 cwt.) for the carriage of furniture and soft furnishings in the course of business as "home furnishers" within a radius of 50 miles from Ballarat.
- SCALLY, B. P., 46 Main-road, Ballarat; 1 commercial goods vehicle (60 cwt.) for the carriage of foodstuffs, liquor, crockery, and general equipment in the course of business as "caterer" throughout the State of Victoria.
- SPROULE, O., 55 Ferguson-street, Williamstown; 1 commercial goods vehicle (5 cwt.) for the carriage of—(a) own goods in the course of business as "caterer" within a radius of 25 miles from Melbourne, (b) drapery in the course of business as "hawker" throughout the State of Victoria.
- THORPE, W. A., Area 3, 37B Camp Pell; 1 commercial goods vehicle (60 cwt.) for the carriage of tires and batteries in the course of business as "second-hand dealer" throughout the State of Victoria.
- WAUGH, V. A., 174 Latrobe-terrace, West Geelong; 1 commercial goods vehicle (15 cwt.) for the carriage of tools of trade, scaffolding, and materials in the course of business as "bricklaying contractor" throughout the State of Victoria.
- WILLIAMSON, M. J., Moore-street, Kaniva; 1 commercial goods vehicle (10 cwt.) for the carriage of tools of trade, fittings, and materials in the course of business as "concrete and tiling contractor" throughout the State of Victoria.
- WILSON, M. A. E., Sherwood-street, Woomelang; 1 commercial goods vehicle (103 cwt.) for the carriage of—(a) general goods within a radius of 20 miles from Birchip, (b) road-making plant and materials within a radius of 50 miles from Birchip.

NOTICE is hereby given that the applications made by the persons named below for renewal of licences to operate the commercial goods vehicles on the route or routes, or in the manner set out opposite their names, will be heard at a time and place to be communicated to the parties concerned:—

*Name and Address; Present Franchise; Licence Number; Date of Expiry.*

- BETHUNE, F. N., PTY. LTD., 130 Mieler-street, West Melbourne, C3; tools of trade and spare parts in connexion with the servicing of pumping plants and water well drilling equipment throughout the State of Victoria; D.4094; 30th June, 1951.
- BOARD, M. S., Pakenham East; (a) general goods within a radius of 20 miles from Pakenham, (b) road-making plant and materials within a radius of 50 miles from Pakenham; D.4189; 30th June, 1951.
- BOYD, P. A., 12 Hethersett-grove, Murrumbeena; tools of trade, paints, and building materials in connexion with servicing and maintenance work to the premises of butter and cheese factories throughout the State of Victoria; D.4102; 30th June, 1951.
- BROWN, J. R., Dennington-road, Warrnambool; road-making plant and materials throughout the State of Victoria; D.4106; 30th June, 1951.
- COOPER, H. H., 61 Trevellyan-street, Elsternwick; books in the course of business as "bookbinder and servicing library" throughout the State of Victoria; D.4192; 30th June, 1951.
- CULLEN, J. F. (trading as F. C. Cullen), 162 Surrey-road, Blackburn; tools of trade and materials in connexion with the servicing of refrigerators throughout the State of Victoria; D.4109; 30th June, 1951.
- EMOLEUM (AUSTRALIA) LTD., Arden-street, North Melbourne; to operate throughout the State of Victoria for the purpose of towing a "bitumen emulsion sprayer" in connexion with Country Roads Board and shire contracts; D.4112; 30th June, 1951.
- FELLOWS, G. H., 439 Rae-street, North Fitzroy; scrap metals, tires, and batteries in the course of business as "dealer" throughout the State of Victoria; D.4193; 30th June, 1951.
- FOWLER, T., & SONS, Skipton; (a) general goods within a radius of 20 miles from Skipton, (b) sheep and lambs from and to places described in paragraph (a) above to and from markets at Ballarat and Geelong; D.4167, D.4168; 30th June, 1951.
- GOLDSWORTHY, J., & SONS, Dunlop-street, Mortlake; (a) own goods in the course of business as "builders and contractors" within a radius of 50 miles from Mortlake, (b) redgum from Cavendish to Mortlake, (c) sawn timber from the Beech Forest area to Mortlake; D.4169; 30th June, 1951.
- GREEN, W. W., Quinn-street, Numurkah; (a) general goods within a radius of 20 miles from Numurkah, (b) furniture within a radius of 50 miles from Numurkah, (c) live stock within a radius of 50 miles from Numurkah, but excluding towns on the main railway line between Seymour and Shepparton; D.4183; 30th June, 1951.
- INGRAM, J. R. & M. A., 16 Callister-street, Shepparton; (a) general goods within a radius of 20 miles from Shepparton, (b) furniture within a radius of 50 miles from Shepparton, (c) live stock within a radius of 50 miles from Shepparton and to and from Wangaratta, but excluding places situate on the main railway line between Seymour and Numurkah, which are beyond 20 miles from Shepparton; D.4184; 30th June, 1951.
- MACHAR, W. J., 4 Gertrude-street, Preston; bricks and tiles within a radius of 40 miles from Preston; D.4126; 30th June, 1951.
- MCCOMBE, W. A., McPherson-street, Casterton; (a) general goods within a radius of 25 miles from Casterton, (b) petroleum products and empty containers between Casterton and Portland; D.4129; 30th June, 1951.

NEIL, V. R., Amphitheatre; (a) general goods within a radius of 10 miles from Amphitheatre, (b) firewood, fencing posts, live stock, and fruit from places within paragraph (a) above to places within a radius of 10 miles from Windermere, (c) live stock and stock feed from places within a radius of 10 miles from Windermere to places described in paragraph (a) above; D.4132; 30th June, 1951.

PETERS ICE CREAM (VIC.) LTD., 171-183 Burnley-street, Richmond; refrigeration machines and tools of trade incidental to the service and repair of own refrigeration plants throughout the State of Victoria; D.4135; 30th June, 1951.

ROCHE BROS. PTY. LTD., 22 Dynon-road, South Kensington; earth-moving equipment in the course of own business and on behalf of the Forests Commission of Victoria and the Country Roads Board throughout the State of Victoria; D.4207; 30th June, 1951.

TALOCCHINO & SON, 47 Carrier-street, Benalla; (a) own goods in the course of business as "monumental masons" within a radius of 50 miles from Benalla, (b) masonry and materials incidental to the erection of same from Benalla to cemeteries throughout the State of Victoria, (c) finished masonry from Melbourne to own premises at Benalla and cemeteries throughout the State of Victoria; D.4177; 30th June, 1951.

WALKER, W. S. & M. L., 189 Lawrence-street, Wodonga; (a) sawn timber from holder's own mill at Shelley to Wodonga, (b) supplies, stores, petrol, oil, and general commodities in connexion with the operation of the mill aforesaid from Wodonga to Shelley; D.4213; 30th June, 1951.

NOTICE is hereby given that the applications made by the persons named below for licences to operate commercial passenger vehicles on the route or routes, or in the manner set out opposite their names, will be heard at a time and place to be communicated to the parties:—

*Name of Applicant; Nature of Application.*

BEAGLEY, R. L., Yarram; 1 commercial passenger vehicle with seating capacity for five persons, to operate as follows:—(a) at separate and distinct fares within a radius of five miles of Yarram Post Office, (b) under private hire conditions within a radius of 50 miles of Yarram Post Office.

BIRCHNELL, A. L., Mountain Highway, Bayswater; 1 commercial passenger vehicle with seating capacity for five persons, and one commercial passenger vehicle with seating capacity for five persons, to be purchased, to operate as follows:—(a) at separate and distinct fares within a radius of five miles of Bayswater Railway Station, (b) under private hire conditions within a radius of 50 miles of Bayswater Railway Station (subject to the cancellation of licences numbered A.2786 and A.2899 at present held by J. W. Stoddart, Bayswater).

DEMPSTER, J., Cobram; 1 commercial passenger vehicle with seating capacity for five persons, to operate as follows:—(a) at separate and distinct fares within a radius of five miles of Cobram Post Office, (b) under private hire conditions within a radius of 50 miles of Cobram Post Office.

DEVAR, J., Ramsay-street, Rochester; 1 commercial passenger vehicle with seating capacity for 33 persons, to be purchased, to operate as follows:—(a) as a stage omnibus between Rochester and Shepparton, via Kyabram, Lancaster, Merrigum, Byrneside, and Tatura.

*Time-table.*

<i>Read Down.</i>		<i>Read Up.</i>
Depart 11.30 a.m.	Rochester	Arrive 6.45 p.m.
Arrive 1.10 p.m.	Shepparton	Depart 5.00 p.m.

*Fares.*

	<i>s.</i>	<i>d.</i>
Rochester-Shepparton	8	6 single
Kyabram-Shepparton	5	0 single
Lancaster-Shepparton	4	6 single
Merrigum-Shepparton	4	0 single
Byrneside-Shepparton	3	6 single
Tatura-Shepparton	2	6 single
Mooroopna-Shepparton	1	0 single

(b) Interchangeable with all large seating capacity vehicles operated by the applicant.

EASTERN ROAD LINES PTY. LTD., 494 Olive-street, Albany; application for variation of licence No. A.2375 to include the ability to operate for the carriage only of school children between Wodonga West School and Wodonga, in accordance with the terms of a contract entered into with the Education Department.

FLOOD, T. R., Arnold-street, Bendigo; 1 commercial passenger vehicle, with seating capacity for 29 persons, to operate as follows:—(a) for the carriage only of school children between Dingee and Bendigo, in accordance with the terms of a contract entered into with the Education Department, (b) under charter conditions within a radius of 50 miles of Dingee Post Office, (c) under charter conditions within a radius of 50 miles of Bendigo Post Office.

GRAY, W., Glen-avenue, Croydon; 1 commercial passenger vehicle with seating capacity for five persons, to be purchased, to operate as follows:—(a) at separate and distinct fares within a radius of five miles of Mooroolbark Railway Station, (b) under private hire conditions within a radius of 50 miles of Mooroolbark Railway Station.

HARDING, W. C., 6 Gum-street, Nursery Ridge, Red Cliffs; 1 commercial passenger vehicle with seating capacity for five persons, to operate as follows:—(a) at separate and distinct fares within a radius of five miles from the Post Office at Red Cliffs, north of a line drawn east and west through Red Cliffs, (b) at separate and distinct fares within a radius of twenty miles from the Post Office at Red Cliffs, south of a line drawn east and west through Red Cliffs, (c) under private hire conditions within a radius of 100 miles of Red Cliffs Post Office.

HEALY, W. D. & S. A., Heal's Garage, Rowe-street, Ouyen; 1 commercial passenger vehicle with seating capacity for 27 persons, to operate as follows:—(a) for the carriage only of school children between Kiamal and Ouyen, in accordance with the terms of a contract entered into with the Education Department, (b) under charter conditions within a radius of 50 miles of Ouyen Post Office.

HODKINSON, R. J., Stevens-street, Hurstbridge; 1 commercial passenger vehicle with seating capacity for five persons, to operate as follows:—(a) at separate and distinct fares within a radius of five miles of Hurstbridge Railway Station, (b) under private hire conditions within a radius of 50 miles of Hurstbridge Railway Station.

MILNER, S. L., & S. W. LAWRENCE (trading as Traralgon Taxi Service), 8 Argyle-street, Traralgon; 5 commercial passenger vehicles, each with seating capacity for five persons, to operate as follows:—(a) at separate and distinct fares within a radius of five miles of Traralgon Post Office, (b) under private hire conditions within a radius of 50 miles of Traralgon Post Office (subject to the cancellation of licences Nos. A.1300, A.2353, A.3232, A.3233, and application for licence heard at Morwell on 21st February, 1951, granted subject to review, in the name of G. H. Ikin, trading as Ikin's Hire Car Service, Traralgon.)

PENINSULA BUS LINES LTD., Young-street, Frankston; application for variation of licences numbered A.3127 and collateral licences, to include the ability to operate the following school services in accordance with the terms of a contract entered into with the Education Department:—(a) vehicle licensed by licence No. A.3129, between Flinders, Main Ridge, and Red Hill Consolidated School, (b) vehicle licensed by licence No. A.3128, between Shoreham, Red Hill South, and Red Hill Consolidated School, (c) vehicle licensed by licence No. A.3137, between Merricks, Balnarring, Merricks North, and Red Hill Consolidated School, (d) vehicle licensed by licence No. A.3135, between Tulum, Balnarring, Merricks North, and Red Hill Consolidated School.

PROVINCIAL MOTORS PTY. LTD., 123 High-street, Bendigo; 1 commercial passenger vehicle with seating capacity for 33 persons, to operate as an additional vehicle under the same terms and conditions as contained in applicant company's existing stage omnibus licences.

RAINBOW, H. C., 6 Hillside, Yallourn; 1 commercial passenger vehicle with seating capacity for five persons, to operate as follows:—(a) at separate and distinct fares within a radius of five miles of Yallourn Post Office, (b) under private hire conditions within a radius of 50 miles of Yallourn Post Office.

READ & BRACK, 2 Nunn-street, Benalla; 1 commercial passenger vehicle, with seating capacity for 34 persons, to operate as follows:—(a) for the carriage only of school children between Tungamah and Benalla, in accordance with the terms of a contract entered into with the Education Department, (b) under charter conditions

within a radius of 50 miles of Benalla Post Office. (c) at separate and distinct fares, with the right to advertise, within a radius of 30 miles of Benalla, with the proviso that no trip shall commence before 6 p.m., (d) day tours from Benalla as follows:—

1. From Benalla to Mt. Buffalo and return, fare £1.
2. From Benalla to Hume Weir and return, fare 15s.
3. From Benalla to Mt. Buller and return, fare £1 10s.
4. From Benalla to Eildon Weir and return, fare £1.
5. From Benalla to Mt. Hotham and return, fare £1 10s.

READ & BRACK, 2 Nunn-street, Benalla; 1 commercial passenger vehicle, with seating capacity for 21 persons, to operate as follows:—(a) for the carriage only of school children between Lake Rowan and Tungamah via Yarrowonga-road, in accordance with the terms of a contract entered into with the Education Department, (b) under charter conditions within a radius of 50 miles of St. James Post Office and to Wangaratta, Shepparton, Yarrowonga, Rutherglen, Corowa, Cobram, Tocumwal, Numurkah, Kyabram, Myrtleford, Echuca, Beechworth, and Euroa, (c) under charter conditions within a radius of 25 miles of Benalla Post Office, as and when required, (d) at separate and distinct fares, with the right to advertise, within a radius of 30 miles of St. James, with the proviso that no journey shall commence before 6 p.m., (e) day tours from St. James as follows:—

1. From St. James to Mt. Buffalo and return, fare £1 5s.
2. From St. James to Eildon Weir and return, fare £1 5s.
3. From St. James to Hume Weir and return, fare £1.

READ & BRACK, 2 Nunn-street, Benalla; 1 commercial passenger vehicle, with seating capacity for 31 persons, to operate as follows:—(a) for the carriage only of school children between Lurg and Benalla, in accordance with the terms of a contract entered into with the Education Department, (b) under charter conditions within a radius of 50 miles of Benalla.

READ & BRACK, 2 Nunn-street, Benalla; 1 commercial passenger vehicle, with seating capacity for 33 persons, to operate as follows:—(a) for the carriage only of school children between Tungamah and Boosey via Katamatite East, in accordance with the terms of a contract entered into with the Education Department, (b) under charter conditions within a radius of 25 miles of Tungamah and to Wangaratta, Benalla, Shepparton, Yarrowonga, Rutherglen, Corowa, Cobram, Tocumwal, Numurkah, Kyabram, Myrtleford, Echuca, Beechworth, and Euroa, (c) under charter conditions within a radius of 25 miles of Benalla, as and when required, (d) at separate and distinct fares, with the right to advertise, within a radius of 30 miles of Tungamah, with the proviso that no trip shall commence before 6 p.m., (e) day tours from Tungamah, as follows:—

1. From Tungamah to Mt. Buffalo and return, fare £1 5s.
2. From Tungamah to Eildon Weir and return, fare £1 5s.
3. From Tungamah to Hume Weir and return, fare £1.

REISE, J. C., Post Office, Banyena; 1 commercial passenger vehicle, with seating capacity for five persons, to operate a stage omnibus service for the carriage of passengers, mails and newspapers between Banyena and Murtoa Railway Station via Banyena South, Rupanyup, and Murtoa Post Office, as follows:—

*Time-table.*

*Read Down.*

Mon. to Fri. inclusive.	Sat. only.	
Depart 10.30 a.m.	8.45 a.m.	Banyena
Depart 10.50 a.m.	9.05 a.m.	Banyena South
Depart 12 noon	10.15 a.m.	Rupanyup
Arrive 12.30 p.m.	10.40 a.m.	Murtoa

*Read Up.*

Mon. to Fri. inclusive.	Sat. only.	
Arrive 4.15 p.m.	12.30 p.m.	Banyena
Depart 3.55 p.m.	12.10 p.m.	Banyena South
Depart 3.15 p.m.	11.35 a.m.	Rupanyup
Depart 1.55 p.m.	10.45 a.m.	Murtoa

(Subject to the cancellation of licence numbered A.2676, at present held by H. Schaper, Banyena.)

SHERRY, F. P., 96 McCrae-street, Dandenong; 1 commercial passenger vehicle, with seating capacity for 30 persons, to be purchased, to operate a stage omnibus service between Dandenong and Hampton Beach via Lonsdale-street, Foster-street, Railway-parade, Chandler's-road, Heatherton-road, Noble Park, Lightwood Park, Springvale, thence via Railway-avenue, Osborne-avenue, Westall-avenue, Queen's-avenue, Wordsworth-avenue, Carnish-road to the Clayton Railway Station, thence via Carnish-road to Centre-road, Bignell-street, Smith-road to the Moorabbin Railway Station, thence via Henrietta-street, Exley-street, Spring-road, Deakin-street, Service-street to the Hampton Railway Station, thence via Hampton-street, Snell-street, Beach-road to the corner of Beach-road and Hampton-street, as follows:—

*Monday to Saturday.*

Depart Dandenong—	7.00 a.m.	9.00 a.m.	1.00 p.m.	2.50 p.m.	5.30 p.m.	7.30 p.m.
Depart Hampton—	3.00 a.m.	10.00 a.m.	1.55 p.m.	3.45 p.m.	6.35 p.m.	8.30 p.m.

*Sundays.*

Depart Dandenong—	10.00 a.m.	12 noon	2.00 p.m.	4.00 p.m.	7.00 p.m.
Depart Hampton—	11.00 a.m.	1.00 p.m.	3.00 p.m.	6.00 p.m.	10.30 p.m.

*Fares.*

- From Dandenong to Noble Park, 6d.
- From Dandenong to Springvale, 9d.
- From Dandenong to Clayton Station, 1s. 3d.
- From Dandenong to Clarianda Post Office, 1s. 6d.
- From Dandenong to corner of Centre and Warrigal roads, 1s. 9d.
- From Dandenong to Moorabbin Station, 2s. 3d.
- From Dandenong to corner of Wickham and Bluff roads, 2s. 6d.
- From Dandenong to Hampton, 3s.

(This replaces application gazetted on the 18th May, 1949.)

Application for variation of all "A" licences to include the ability to operate a service between Dandenong Railway Station and the new International Harvester Company's factory at Dandenong via Princes Highway, with the proviso that passengers may be taken up and set down along the route.

SHERRY, F. P., 96 McCrae-street, Dandenong; 1 commercial passenger vehicle, with seating capacity for 30 persons, to be purchased, to operate a stage omnibus service between Dandenong and Blackburn via Lonsdale-street, Foster-street, Railway-parade, Chandler's-road, Heatherton-road, Noble Park, Lightwood-road to Springvale, thence via Railway-avenue, Osborne-avenue, Westall-road, Queen's-avenue, Wordsworth-avenue, Carnish-road to Clayton Railway Station, thence via Carnish-road to Centre-road, Naughton-road, Princes Highway, May-road and Blackburn-road, as follows:—

*Monday to Saturday.*

Depart Dandenong—	7.00 a.m.	10.30 a.m.	2.00 p.m.	4.15 p.m.
Depart Blackburn—	8.05 a.m.	11.35 a.m.	3.05 p.m.	5.20 p.m.

*Fare—3s. single (through fare).*

(This replaces application gazetted 15th February, 1950.)

THOMAS, V. H., 27A Alma-street, Maryborough; application for variation of licences numbered T.A.3333, T.A.3334, and T.A.4363 to include the ability to operate the following day tours from Maryborough:—

1. From Maryborough to Daylesford via Newstead, Hepburn Springs, Jubilee Lake and Central Springs, returning via Creswick.

*Fare—7s. 6d. return.*

2. From Maryborough to Vaughan Springs, via Newstead and Guildford, returning via Castlemaine.

*Fare—6s. return.*

3. From Maryborough to Avoca via Learmonth Lake and Ballarat Gardens, returning via Clunes and Talbot.

*Fare—7s. 6d. return.*

TURNER, H. W., Neerim-street, Drouin; 1 commercial passenger vehicle, with seating capacity for five persons, to operate as follows:—(a) for the carriage of passengers, mails and parcels from the Drouin Railway Station on a round route via Drouin Post Office, Drouin West, Tarago, Jindivick West and Jindivick-road, thence return to Drouin Railway Station via Jindivick Post Office, Tarago, Glen Crombie, Drouin West, Robin Hood and the Princes Highway, (b) at separate and distinct fares within a radius of 6 miles of the Drouin Post Office, (c) at separate and distinct fares within a radius of 6 miles of the Jindivick Post Office, (d) under private hire conditions within a radius of 50 miles of the Drouin Post Office (subject to the cancellation of licence numbered A.3063, at present held by N. Turner, Drouin).

APPLICATIONS for licences to operate commercial passenger vehicles, with seating capacity for five persons, for the carriage of passengers throughout Victoria at otherwise than at separate and distinct fares for each passenger:—

- CAPP, A. H., 22 Goodwin-street, Preston.
- CAPP, F. G. & A. H., 27 Little Bourke-street, Melbourne.
- CLARKE, W. H. & F. J., 126 Stewart-street, East Brunswick.
- MILNER, S. L., & S. W. LAWRENCE (trading as Traralgon Taxi Service), 8 Argyle-street, Traralgon (subject to the cancellation of licence numbered P.H.105, in the name of G. H. Ikin, trading as Ikin's Hire Car Service, Traralgon).
- MORLEY, N. C. & C. C., Princes Highway, Moe (subject to the cancellation of licence numbered P.H.1070, at present held by N. C. Morley, Moe).
- SHARD, J. H., Verney-road, Shepparton. (This replaces application for Taxi Licence gazetted on the 24th January, 1951.)

SUTHERLAND, A. J., 19 Pickett-street, Dandenong.  
TRIM, A. W., 62 St. George's-road, Elsternwick.

Notice of any objection should be forwarded to reach the Secretary to the Board not later than Friday, 13th April, 1951.

E. V. FIELD,  
Secretary.

Exhibition Buildings, Rathdown-street, Carlton, N.3,  
30th March, 1951.

Cemeteries Act 1928.

SCALE OF FEES, LANDSBOROUGH PUBLIC CEMETERY.

IN pursuance of the powers conferred upon them by the Cemeteries Acts, the Trustees of the Landsborough Public Cemetery hereby make the following scale of fees, which shall come into operation upon publication in the *Government Gazette*, and from and after such publication every scale of fees heretofore made by the said Trustees shall be and is hereby rescinded to the extent to which it conflicts with this scale:—

Private Graves.

Sinking any grave 6 feet—£4.

- JOHN FFRENCH, Trustee.
- A. D. FRIEND, Trustee.
- CHAS. PEACOCK, Trustee.
- CHAS. CUNNINGHAM, Trustee.
- J. W. HODGETT'S, Trustee.
- JNO. FRIEND, Trustee.

Approved by the Governor in Council,  
19th March, 1951.

A. MAHLSTEDT,  
Clerk of the Executive Council.

AUCTION SALES ACT 1928.

LIST of Persons to whom Auctioneers' Licences have been issued during the month of February, 1951:—

Name.	Address.	Date of Issue.
Angus, W. W.	41 Malop-street, Geelong	20.2.51
Bourke, G. J.	12 Dell-road, Frankston	9.2.51
*Clements, R. B.	70 Brunswick-street, Fitzroy	6.2.51
†Fletcher, F.	439 Burnley-street, Burnley	19.2.51
Howden, G. B.	Point Lonsdale	26.2.51
Lean, B. B.	Nolan-street, Maryborough	22.2.51
Levey, G.	12 Villiers-street, Elsternwick	20.2.51
McInnes, J. F.	1121 Dandenong-road, East Malvern	6.2.51
Mackay, N. D.	25 Fifth-street, Black Rock	5.2.51
McPherson, O. W.	Numurkah	14.2.51
‡Monk, F. E.	Emerald-road, Belgrave	2.2.51
Mustow, W. L.	71 Park-street, Moonee Ponds	23.2.51
Nongrove, R. A.	27 St. Helen's-road, Hawthorn	20.2.51
Price, L. J. R.	Cr. Seventh-street, and Orange-avenue, Mildura	8.2.51
§Sampson, F. K.	9 Highton-grove, Balwyn	13.2.51
Semmler, C. V.	17 Garter-street, Werribee	26.2.51
Trevaskis, T. R.	Box 165, Shepparton	6.2.51
Wright, F. O.	Cobram	26.2.51

\* By transfer from H. C. Clements. † By transfer from L. E. Guy. ‡ By transfer from F. L. Byrne. § By transfer from G. J. Colquhoun.

The Treasury,  
Melbourne, 19th March, 1951.

A. T. SMITHERS,  
Director of Finance.

MONEY LENDERS ACT 1938.

IN accordance with the provisions of the above-mentioned Act, the following is published for general information:—

Supplementary List of Persons to whom Money Lenders' Licences have been issued for the year ending 30th June, 1951.

Name.	Authorized Name.	Authorized Address.	Date of Issue.
King, H. V.	H. V. King	108 Queen-street, Melbourne	8.2.51
Lygon Investments Pty. Ltd. (H. Kelly, appointee)	Lygon Investments Pty. Ltd.	300 Lygon-street, Carlton	26.1.51
Mack's Investments Ltd. (L. C. Pugsley, appointee)	Mack's Investments Ltd.	252 Flinders-lane, Melbourne	22.2.51

The Treasury,  
Melbourne, 20th March, 1951.

R. E. STAFFORD,  
Registrar.



## CONTRACTS ACCEPTED.—(Series 1950-51.)

## CEREALS.

Requirements under Sub-Schedule No. 5 of Schedule No. 1 for the month of April, 1951, are to be purchased under agreement from the under-mentioned firms, at the rates per cwt., respectively indicated, viz., Robert Harper & Co. Ltd., Oatmeal, plain, 55s. 10d.; Barley, pearl and unpolished, 26s.; Barley Kernels, 31s. 3d.; Rice, dressed and unpolished, 49s.; Rycena, 26s. 6d. H. S. K. Ward Pty. Ltd., Peas, split, 63s. All rates, less 3 per cent., 14 days, or 2½ per cent., 30 days. Rates are subject to variation in accordance with determination of the Prices Decontrol Commissioner.

W. H. RUTHERFORD, Secretary to the Tender Board.  
28.3.51.

## PUBLIC WORKS.

3700. (1) Ararat, Mental Hospital, supply and delivery of soup and tea cans, £249.—Milgar Stainless Pty. Ltd.  
3701. (2) Ararat, Mental Hospital, hot-water additions, £162 16s.—McLean and Boakes.  
3702. (1) Avalon, State School No. 3785, electrical installations, teacher's residence, £109 12s. 6d.—F. Purcell and Co.  
3703. (1) Broken Creek, State School No. 862, repairs and additions, &c., residence, £306.—H. C. Clarke.  
3704. (3) Brighton, Technical School, provision of new floor to carpenter's shop, £270.—J. W. Wood.  
3705. (2) Ballarat, School of Mines, Junior Technical School, erection of new sliding partition, moving partition wall, and disconnecting lead sink, £680.—L. and K. Webb.  
3706. (1) Ballarat East, State School No. 1998, Queen-street, new flooring to infants' room, £205 17s. 6d.—H. R. Dobbin.  
3707. (1) Ballarat, Inspector of Works residence, Ligar-street, new garage, flywire screens and door, rotary clothes hoist, £216 18s.—H. R. Dobbin.  
3708. (1) Ballarat, Mental Hospital, supply and delivery of stainless-steel food containers, £784.—Milgar Stainless Pty. Ltd.  
3709. (2) Buchan Caves, Lands Department, engineer mechanic's residence, supply and installation of a kerosene hot-water service, £149 16s. 9d.—R. McLaren.  
3710. (1) Cobden, State School No. 864, erection of teacher's residence (labour only), £920.—K. Dunn and F. Draffen.  
3711. (1) Cudgee, State School No. 105, erection of new shelter shed with concrete floor, £138 15s.—A. R. Greed.  
3712. (3) Eltham, Higher Elementary School, external and internal repairs and painting, £683.—C. D. Peck.  
3713. (1) Elphinstone, State School No. 220, erection of new garage, residence, £100 3s. 6d.—R. House.  
3714. (1) Fitzroy, State School No. 450, new cyclone fence, £207.—Cyclone Co. of Australia Ltd.  
3715. (2) Glenrowan, State School No. 1742, renovations to exterior of school, new floor in school and porch, renew all blackboards, and overhaul all windows, doors, &c., £245.—I. W. Ballinger.  
3716. (1) Geelong, High School, supply and installation of gas and hot-water service, teacher's residence, £155.—Geelong Gas Co.  
3717. (1) Harcourt North, State School No. 4043, general repairs, £105 2s.—R. House.  
3718. (1) King Valley, State School No. 2894, erection of residence (labour only), £930.—C. H. and G. J. Dale.  
3719. (2) Leonatha, State School No. 2981, erection of new E.4.L. type residence, £2,650.—A. G. Parsons.  
3720. (1) Marysville, Police Station, fibrous plaster work and internal painting, quarters, £295.—D. Tincknell.  
3721. (3) Melton, Court House, repairs and painting, £215.—W. J. Joy.  
3722. (2) Moe, State School No. 2142, teacher's residence, Fowler-street, supply and installation of a kerosene hot-water service, £115.—Quick and Tuck.  
3723. (1) Melbourne, Parliament House, supply and installation of servery ventilation, £567.—Triplett and Prentice.  
3724. (1) Melbourne, Public Works Department, supply of fifty (50) 800-gallon tanks (tall.), £375 (£7 10s. each).—H. W. Creek and Sons.  
3725. (1) Melbourne, Technical College, renewal of laboratory sink wastes, Metallurgy School, £680.—R. Crewther and Son.  
3726. (2) Newstead, Court House, repairs and renovations, £134 19s.—R. House.  
3727. (1) Nathalia, Higher Elementary School No. 2060, repairs to ant-damaged ceilings, &c., in infants' room, £134.—C. Brereton.  
3728. (4) Neerim South, Court House, painting and repairs, £265.—R. A. Holt.  
3729. (1) Preston, Girls' School, conversion of "Coke Store" into out-office for men, £151 12s.—A. Leffanue.

3730. (1) South Melbourne, Technical School, sewerage, water and gas plumbing, &c., to new laboratory bench, £196 7s.—Triplett and Prentice.

3731. (1) Speed, Police Station, supply and installation of a fuel hot-water service, £183 12s.—G. C. Kippe.

3732. (1) Seymour, State School No. 547, agriculture drains, new tank stand and tank, residence, £106.—R. H. Morris.

3733. (1) Sarsfield, State School No. 1228, installation of kerosene hot-water service, teacher's residence, £156 10s.—R. McLaren.

3734. (1) Shepparton North, State School No. 4657, supply and installation of heating system, "Bristol" prefabricated school rooms, £1,687 3s. 6d.—Shepparton Plumbing Services.

3735. (1) Shepparton South, State School No. 4666, supply and installation of heating system, "Bristol" prefabricated school rooms, £1,687 3s. 6d.—Shepparton Plumbing Services.

3736. (1) Shepparton, State School No. 1469, construction of woodshed and painting, £250.—Reid and Crabb.

3737. (1) Scotsburn, State School No. 2176, provision of septic tank system, school and residence, £411 2s. 6d.—W. S. Gudgeon.

3738. (1) South Yarra, Teachers Tribunal, Observatory House, painting and repairs, £549.—Avro Building Co.

3739. (1) Sea Lake, Court House, repairs and painting, £482.—R. House.

P. T. BYRNES, Commissioner of Public Works. 20.3.51.

## ORDERS IN COUNCIL.—(Series 1950-51.)

## STATE ELECTRICITY COMMISSION.

3740. The supply of 500 tons of imported cement for general construction works, to Quotation No. 5300, £6,102 1s. 8d.—Stark Trading Co. Pty. Ltd.

3741. The supply of one addressograph machine for printing of consumers' bills, &c., to Quotation No. 4780, £5,372.—Stott and Hoare Pty. Ltd.

Approved by the Governor in Council, 20th February, 1951.—A. MAHLSTEDT, Clerk of the Executive Council.

3742. The supply of one trench excavating machine, Morwell, to Quotation No. 4145, £7,653.—Armstrong-Holland (Melb.) Pty. Ltd.

3743. The supply of spare parts for synchronous condensers and frequency changers in metropolitan terminal stations and main sub-stations, to Quotation No. 3362, £7,873.—Australian General Electric Pty. Ltd.

3744. The supply of eight overhead loaders for attachment to crawler tractors, Kiewa Hydro-Electric Scheme, Yallourn and Morwell, to Quotation No. 5816, £10,240.—Construction Equipment Co. Pty. Ltd.

3745. The erection of post office, shop, and dwelling at Western Hostel, Yallourn, to Specification No. 50-51/219, £6,730.—Geo. Emmett.

3746. The supply of one horizontal boring and facing machine, Yallourn Workshops, to Specification No. 50-51/159, £13,019 10s.—McPhersons Ltd.

3747. The erection of goods shed and parcels office, Yallourn Rail Despatch Area, to Specification No. 50-51/173, £8,270.—J. J. Marr and Sons Pty. Ltd.

3748. The supply of 270 tons of mild steel flats for general maintenance and new works, to Quotation No. 5537, £12,435 10s.—Overseas Corporation (Australia) Ltd.

3749. The supply of 580 tons of galvanized corrugated iron, to Quotation No. 5870, £96,084 5s.—Overseas Corporation (Australia) Ltd.

3750. The supply of 1,000,000 super. feet of sawn hardwood, Yallourn, to Quotation No. 5277, £29,987 10s.—Farbury, Henty, and Co. Pty. Ltd.

3751. The supply of 700 relay units for centralized control of consumers' water-heating installations, to Quotation No. 5119, £5,670.—Standard Telephones and Cables Pty. Ltd.

3752. The supply of high-pressure steam and feed piping, Yallourn "D" Power Station, to Specification No. 50-51/130, £126,297 18s.—Stewarts and Lloyds (Aust.) Pty. Ltd.

3753. The erection and completion of sixteen English pre-cut houses, Morwell, to Specification No. 49-50/320, at schedule rates.—A. C. Thomson.

3754. The purchase of land, comprising 29 acres 3 roods 18 perches, situate at the north-west corner of Geelong and McDonald roads, Brooklyn, for store site, £26,000.—S. J. Willis Pty. Ltd.

3755. The supply of 30,000 sleeper plates for movable rail and dredger tracks, Morwell Project, to Specification No. 50-51/202, £32,312 10s.—Hytechnico Pty. Ltd.

3756. The supply of 24,000 sleeper plates for movable rail and dredger tracks, Morwell Project, to Specification No. 50-51/202, £22,000.—Sides and Skinner.

3757. The supply of 190 tons of copper conductors and trolley wire for transmission and distribution lines, to Specification No. 50-51/109, £66,594 7s. 6d.—Enfield Cables Pty. Ltd.

3758. The supply of 190 tons of copper conductors and trolley wire for transmission and distribution lines, to Specification No. 50-51/109, £66,591 7s. 6d.—Norman W. Hutchinson and Sons Pty. Ltd.

3759. The supply of 160 tons of copper conductors and trolley wire for transmission and distribution lines, to Specification No. 50-51/109, £56,013.—Liverpool Electric Cable Co. Ltd.

3760. The supply of 160 tons of copper conductors and trolley wire for transmission and distribution lines, to Specification No. 50-51/109, £56,016.—H. Rowe and Co. Pty. Ltd.

3761. The supply of 190 tons of copper conductors and trolley wire for transmission and distribution lines, to Specification No. 50-51/109, £66,519.—Steam and Mining Equipment Pty. Ltd.

Approved by the Governor in Council, 16th March, 1951.  
—A. MAHLSTEDT, Clerk of the Executive Council.

4 GEORGE VI. No. 4755, SECTION 6.

I HEREBY give notice that on the 6th March, 1951, I filed an election to administer the following deceased person's estate, in accordance with section 6 of the *Public Trustee Act 1940*:—

\*ROOFE, ROBERT MARCHBANKS, late of Wallup, Victoria, labourer, died 17th October, 1950.

\* According to the provisions of the will.

I HEREBY give notice that on the 13th March, 1951, I filed an election to administer the following deceased person's estate, in accordance with section 6 of the *Public Trustee Act 1940*:—

\*ROED, EVELYN CLIFFORD, formerly Evelyn Clifford Humphries, late of 698 Bush-street, San Francisco, in the United States of America, nurse, died 8th August, 1949.

\* According to the provisions of the will.

C. J. GARDNER,  
Public Trustee.

412 Collins-street, Melbourne, C.1, 21st March, 1951.

4 GEORGE VI. No. 4755, SECTION 6.

I HEREBY give notice that on the 22nd March, 1951, I filed elections to administer the following deceased persons' estates, in accordance with section 6 of the *Public Trustee Act 1940*:—

ANDERSEN, ERIK, late of Nepean Hotel, Portsea, useful, died 27th May, 1950, intestate.

\*BLACKSTOCK, LUCY MAY, also known as Lucie May Blackstock, late of 43 William-street, Newport, home duties, died 30th January, 1951.

BLAZIER, JOHN ALBERT, late of 78 Tennyson-street, Elwood, labourer, died 8th August, 1950, intestate.

BLYTH, CHARLES JOHN, late of Mount Royal, Royal Park, pensioner, died 30th March, 1947, intestate.

\*CONDON, ALICE, formerly of Hobart, Tasmania, but late of Castlemaine Benevolent Home, Castlemaine, widow, died 16th June, 1950.

DALY, KATE, also known as Catherine Daly, late of 187 Palmerston-street, Carlton, spinster, died 3rd July, 1949, intestate.

\*DEVLIN, MARY MARGARET, formerly of 30 Tuppin-street, Yarraville, but late of 42 Bay-road, Sandringham, married woman, died 25th November, 1950.

\*HEYMANSON, ELSIE ISABEL HUTCHISON, also known as Elsie Isabella Heymanson, Elsie Isabella Hutchinson Heymanson, Isobel Hutchison Heymanson, and Elsie Isobel Heymanson, late of 102 Grosvenor-street, East St. Kilda, pensioner, died 21st November, 1950.

\*HUBBARD, JAMES ROBERT, late of Yarra Glen, retired farmer, died 23rd January, 1951.

NORRIS, MARGARET ELIZABETH, late of 4 Duke-street, St. Kilda, pensioner, died 7th February, 1951, intestate.

PHILLIPS, DAVID, late of Rocklands Dam, Balmoral, labourer, died 9th January, 1951, intestate.

TORJAN, FRANC, late of Broadford, labourer, died 24th December, 1950, intestate.

WHEATLEY, MARY JANE, late Kooyong-road, Caulfield, widow, died 28th October, 1949, intestate.

\* According to the provisions of the will.

C. J. GARDNER,  
Public Trustee.

412 Collins-street, Melbourne, C.1, 28th March, 1951.

NOTICE.

ADMINISTRATION of the estate of each of the under-mentioned deceased persons has been granted to me, and creditors, next of kin, and all others having claims against the estate of any of the persons so mentioned are required to send particulars of their claims to the Public Trustee, No. 412 Collins-street, Melbourne, on or before the 30th May, 1951, or they will be excluded from the distribution of the estate when the assets are being distributed:—

\*BALLENNIE, GEORGE WILLIAM, late of 7 Moore-street, South Yarra, retired, died 23rd September, 1950.

BOULTON, JOHN, late of 325 Douglas-parade, Newport, storeman, died 9th October, 1950, intestate.

\*CROSS, ELLA LILIAN HANNAH, also known as Ella Lillian Cross, and Lillian Cross, and Ella Ross, late of 322 Walsh-street, South Yarra, spinster, died 5th January, 1951.

\*NATHAN, LILY LOUISE, also known as Lily Louisa Nathan, late of Bunyip, married woman, died 2nd September, 1950.

NEWLANDS, HENRY, late of 55 Alfred-street, Port Melbourne, coach builder, died 15th January, 1951, intestate.

\*NICHOLSON, EDWARD ARTHUR, late of 200 Hyde-street, Yarraville, labourer, died 31st December, 1950.

\*PADGETT, EMILY, formerly of 12 Railway-avenue, Malvern, but late of 68 Rennison-street, Mordialloc, widow, died 27th December, 1950.

ROGERS, LOBENA, late of 30 Leaburn-avenue, Caulfield, widow, died 14th October, 1950, intestate.

STRATTON, ROBERT DAVIDSON, late of 3 Hartington-street, Kew, attendant, died 12th January, 1951, intestate.

\* With the will annexed.

C. J. GARDNER,  
Public Trustee.

Melbourne, 21st March, 1951.

NOTICE.

ADMINISTRATION of the estate of each of the under-mentioned deceased persons has been granted to me, and creditors, next of kin, and all others having claims against the estate of any of the persons so mentioned are required to send particulars of their claims to the Public Trustee, No. 412 Collins-street, Melbourne, on or before the 6th June, 1951, or they will be excluded from the distribution of the estate when the assets are being distributed:—

ANDERSEN, ERIK, late of Nepean Hotel, Portsea, useful, died 27th May, 1950, intestate.

\*BLACKSTOCK, LUCY MAY, also known as Lucie May Blackstock, late of 43 William-street, Newport, home duties, died 30th January, 1951.

BLAZIER, JOHN ALBERT, late of 78 Tennyson-street, Elwood, labourer, died 8th August, 1950, intestate.

BLYTH, CHARLES JOHN, late of Mount Royal, Royal Park, pensioner, died 30th March, 1947, intestate.

\*CONDON, ALICE, formerly of Hobart, Tasmania, but late of Castlemaine Benevolent Home, Castlemaine, widow, died 16th June, 1950.

DALY, KATE, also known as Catherine Daly, late of 187 Palmerston-street, Carlton, spinster, died 3rd July, 1949, intestate.

\*DEVLIN, MARY MARGARET, formerly of 30 Tuppin-street, Yarraville, but late of 42 Bay-road, Sandringham, married woman, died 25th November, 1950.

\*HEYMANSON, ELSIE ISABEL HUTCHISON, also known as Elsie Isabella Heymanson, Elsie Isabella Hutchinson Heymanson, Elsie Isobel Hutchison Heymanson, and Elsie Isobel Heymanson, late of 102 Grosvenor-street, East St. Kilda, pensioner, died 21st November, 1950.

\*HUBBARD, JAMES ROBERT, late of Yarra Glen, retired farmer, died 23rd January, 1951.

NORRIS, MARGARET ELIZABETH, late of 4 Duke-street, St. Kilda, pensioner, died 7th February, 1951, intestate.

PHILLIPS, DAVID, late of Rocklands Dam, Balmoral, labourer, died 9th January, 1951, intestate.

TORJAN, FRANC, late of Broadford, labourer, died 24th December, 1950, intestate.

WHEATLEY, MARY JANE, late of Kooyong-road, Caulfield, widow, died 28th October, 1949, intestate.

\* According to the provisions of the will.

C. J. GARDNER,  
Public Trustee.

Melbourne, 28th March, 1951.

## SWAN HILL SEWERAGE AUTHORITY.

## RATING BY-LAW FOR 1951.

THE Swan Hill Sewerage Authority, in pursuance and exercise of the powers conferred by the Sewerage Districts Acts, doth hereby make a sewerage rate of One shilling and eight pence (1s. 8d) in the pound on the annual municipal valuation of seweraged properties liable to be rated within the Swan Hill Sewerage District:

Provided that in no case shall the amount of rate payable in respect of any rateable seweraged property be less than Twenty shillings.

Such rate is made and shall be levied upon the owners or occupiers of the said rateable seweraged properties for the year commencing on the 1st day of January, 1951, and shall be due and payable on the 5th day of April, 1951, at the office of the said Authority, Town Hall, Swan Hill.

The foregoing By-law was made and passed by the Swan Hill Sewerage Authority at a special meeting held on the 8th day of February, 1951, and confirmed at a subsequent special meeting of the Authority on the 8th day of March, 1951.

(SEAL) G. E. KURRLE, Chairman.  
A. R. CONN, Secretary.

Approved by the Governor in Council,  
19th March, 1951.

A. MAHLSTEDT,  
Clerk of the Executive Council.

## BENALLA WATERWORKS TRUST.

## RATING BY-LAW FOR THE YEAR 1951.

THE Benalla Waterworks Trust, in pursuance and exercise of the powers conferred by the Water Acts, doth hereby make a rate for the supply of water for domestic purposes of One shilling and nine pence in the pound on the annual municipal valuations of lands and tenements liable to be rated within the Benalla Urban District.

Provided that in no case shall the amount of rate payable per annum in respect of any tenement (other than land on which there is no building) be less than Thirty-five shillings, and in respect of land on which there is no building less than Twenty-five shillings.

Such rates are made and shall be levied upon the occupiers or owners of the said lands and tenements for the year commencing the 1st day of January, 1951, and shall be payable in one sum on the 31st day of March, 1951, at the office of the said Trust.

The maximum quantity of water to be supplied in any one year without further charge to any property rated by the Trust is hereby fixed at the quantity which, at a charge of One shilling per 1,000 gallons, would produce an amount equal to the amount of the rate levied on such property for the said year.

The charge for water supplied by measure to any property rated by the Trust in excess of such maximum quantity, computed as in the last preceding clause, is hereby fixed at One shilling per 1,000 gallons.

The charge for water supplied by measure to any property shall be payable, on demand, at the office of the said Trust.

Signed and sealed this 5th day of March, 1951.

(SEAL) W. McCALL SAY, Chairman.  
W. G. FERGUSON, Commissioner.  
D. C. LATCH, Secretary.

Approved by the Governor in Council,  
19th March, 1951.

A. MAHLSTEDT,  
Clerk of the Executive Council.

## HEATHCOTE WATERWORKS TRUST.

## RATING BY-LAW FOR YEAR 1951.

THE Heathcote Waterworks Trust, in pursuance and exercise of the powers conferred by the Water Acts, doth hereby make a rate for the supply of water for domestic purposes of Three shillings in the pound on the annual municipal valuation of the lands and tenements liable to be rated within the Heathcote Urban District:

Provided that in no case shall the amount of rate payable per annum in respect of any tenement (other than land upon which there is no building) be less than Sixty shillings, and in respect of any land on which there is no building less than Seventeen shillings and six pence.

Such rates are made and shall be levied upon the occupiers or owners of the said lands and tenements for the year commencing on the 1st day of January, 1951, and ending on the 31st day of December, 1951, and shall be payable on the 10th day of April, 1951, at the office of the Trust, High-street, Heathcote.

The maximum quantity of water to be supplied in any one year without further charge to any property rated by the Trust is hereby fixed at the quantity which, at a charge of Three shillings per 1,000 gallons, would produce an amount equal to the amount of the rate levied on such property for the said year.

The charge for water supplied by measure to any property rated by the Trust in excess of such maximum quantity, computed as in the last preceding clause, is hereby fixed at Two shillings per 1,000 gallons.

The charge for water supplied by measure shall be payable, on demand, at the office of the Trust.

Passed this 7th day of March, 1951.

(SEAL) P. J. McMAHON, Chairman.  
D. R. THOMAS, Commissioner.  
R. J. MURRAY, Secretary.

Approved by the Governor in Council,  
19th March, 1951.

A. MAHLSTEDT,  
Clerk of the Executive Council.

## BALLAN WATERWORKS TRUST.

## FIXING THE LIMIT OF A BANK OVERDRAFT.

HIS Excellency the Governor of the State of Victoria, by and with the advice of the Executive Council thereof, doth, by Order made on the 19th day of March, 1951, in pursuance of the provisions of section 273 of the *Water Act 1928* (No. 3801), fix the limit of the overdraft to be obtained by the Ballan Waterworks Trust from the Commercial Bank of Australia Limited, Ballan, at an amount not to exceed at any one time the sum of One thousand two hundred pounds (£1,200).

A. MAHLSTEDT,  
Clerk of the Executive Council.

At the Executive Council Chamber,  
Melbourne, the 19th March, 1951.

## BAIRNSDALE WATERWORKS TRUST.

## AUTHORITY TO OBTAIN A BANK OVERDRAFT.

HIS Excellency the Governor of the State of Victoria, by and with the advice of the Executive Council thereof, doth, by Order made on the 19th day of March, 1951, authorize the Bairnsdale Waterworks Trust to obtain, in pursuance of the provisions of section 271 of the *Water Act 1928* (No. 3801), an advance or advances during the year 1951 from the National Bank of Australasia Limited, Bairnsdale, by overdraft of the Trust's current account thereat, such overdraft not to exceed at any one time the sum of One thousand pounds (£1,000).

A. MAHLSTEDT,  
Clerk of the Executive Council.

At the Executive Council Chamber,  
Melbourne, the 19th March, 1951.

## COLAC WATERWORKS TRUST.

## FIXING THE LIMIT OF A BANK OVERDRAFT.

HIS Excellency the Governor of the State of Victoria, by and with the advice of the Executive Council thereof, doth, by Order made on the 19th day of March, 1951, in pursuance of the provisions of section 273 of the *Water Act 1928* (No. 3801), fix the limit of the overdraft to be obtained by the Colac Waterworks Trust from the Commercial Bank of Australia Limited, Colac, at an amount not to exceed at any one time the sum of Five thousand pounds (£5,000).

A. MAHLSTEDT,  
Clerk of the Executive Council.

At the Executive Council Chamber,  
Melbourne, the 19th March, 1951.

**COLAC WATERWORKS TRUST.**

**AUTHORITY TO OBTAIN A BANK OVERDRAFT.**

**HIS** Excellency the Governor of the State of Victoria, by and with the advice of the Executive Council thereof, doth, by Order made on the 19th day of March, 1951, authorize the Colac Waterworks Trust to obtain, in pursuance of the provisions of section 271 of the *Water Act* 1928 (No. 3801), an advance or advances during the year 1951 from the Commercial Bank of Australia Limited, Colac, by overdraft of the Trust's current account thereat, such overdraft not to exceed at any one time the sum of Three thousand pounds (£3,000).

A. MAHLSTEDT,  
Clerk of the Executive Council.

At the Executive Council Chamber,  
Melbourne, the 19th March, 1951.

**SWAN HILL WATERWORKS TRUST.**

**AUTHORITY TO OBTAIN A BANK OVERDRAFT.**

**HIS** Excellency the Governor of the State of Victoria, by and with the advice of the Executive Council thereof, doth, by Order made on the 19th day of March, 1951, authorize the Swan Hill Waterworks Trust to obtain, in pursuance of the provisions of section 271 of the *Water Act* 1928 (No. 3801), an advance or advances during the year 1951 from the English, Scottish, and Australian Bank Limited, Swan Hill, by overdraft of the Trust's current account thereat, such overdraft not to exceed at any one time the sum of One thousand pounds (£1,000).

A. MAHLSTEDT,  
Clerk of the Executive Council.

At the Executive Council Chamber,  
Melbourne, the 19th March, 1951.

**DEPARTMENT OF CROWN LANDS AND SURVEY.**

At the Executive Council Chamber, Melbourne, the sixteenth day of March, 1951.

**PRESENT:**

The Honorable Sir Charles Lowe, as Deputy for  
His Excellency the Governor of Victoria.  
Mr. Hyland | Mr. Byrnes.

**LANDS TEMPORARILY RESERVED FROM SALE.**

**THE** Honorable Sir Charles Lowe, as Deputy for His Excellency the Governor of the State of Victoria, by and with the advice of the Executive Council thereof, doth hereby, in pursuance of the provisions of the *Land Act* 1928, reserve, temporarily, and also except from occupation for mining purposes under any miner's right, the lands hereinafter described:—

**TANJIL (WILLOW GROVE).**—Site for Public Recreation, 3 acres, Parish of Tanjil, County of Buln Buln, as indicated on plan hereunder.—(T.189(9)) (Rs.4789).

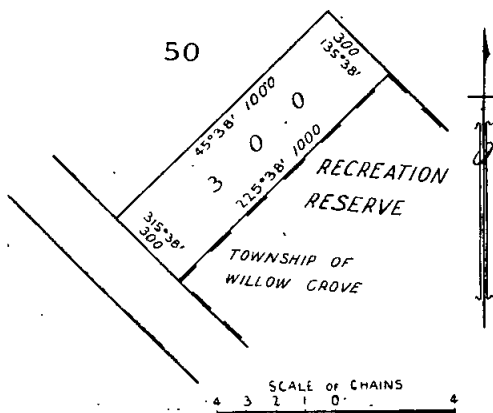

**WODONGA.**—Site for a Court House and Police Station, 3 roods 13/10 perches, Town of Wodonga, Parish of Wodonga, County of Bogong, as indicated by hachure on plan hereunder.—(W.308(s<sup>2</sup>)) (Rs.6632).

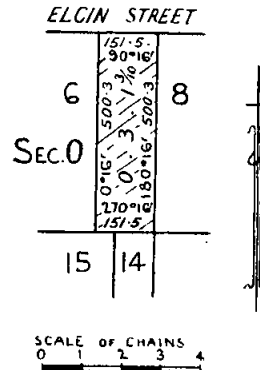

And the Honorable Albert Eli Lind, His Majesty's Commissioner of Crown Lands and Survey for the State of Victoria, shall give the necessary directions herein accordingly.

A. MAHLSTEDT,  
Clerk of the Executive Council.

**DEPARTMENT OF CROWN LANDS AND SURVEY.**

At the Executive Council Chamber, Melbourne, the nineteenth day of March, 1951.

**PRESENT:**

His Excellency the Governor of Victoria.  
Mr. McDonald | Mr. Dodgshun  
Mr. Lind | Mr. Hyland  
Mr. Byrnes | Mr. Inchbold  
Mr. Moss | Mr. Brose  
Mr. Fulton | Mr. Mitchell  
Mr. Swinburne | Mr. Harvey.

**LANDS TEMPORARILY RESERVED FROM SALE.**

**HIS** Excellency the Governor of the State of Victoria, by and with the advice of the Executive Council thereof, doth hereby, in pursuance of the provisions of the *Land Act* 1928, reserve, temporarily, and also except from occupation for mining purposes under any miner's right, the lands hereinafter described:—

**CASTLEMAINE.**—Site for a Public Library, 1 rood 14 perches, Township of Castlemaine, Parish of Castlemaine, County of Talbot, as indicated by hachure on plan hereunder.—(C.99(4)) (Rs.6113).

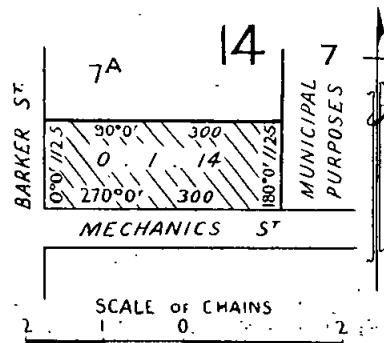

MALLACOOTA.—Site for Government Buildings, 2 acres 0 roods 8 perches, Parish of Mallacoota, County of Croajingolong, as indicated by hachure on plan hereunder.—(M.550<sup>(5)</sup>) (Rs.6546).

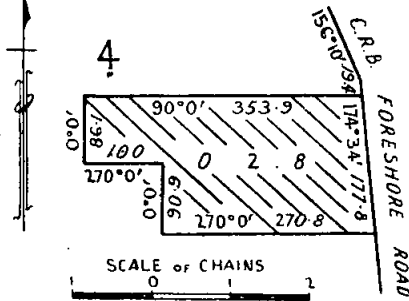

WOOMELANG.—Site for State School purposes, in addition to the site temporarily reserved therefor by Order in Council of the 18th February, 1908, 2 roods, Township of Woomelang, Parish of Cronomby, County of Karkaroc, as indicated by hachure on plan hereunder.—(W.390<sup>(2)</sup>) (Rs.6645).

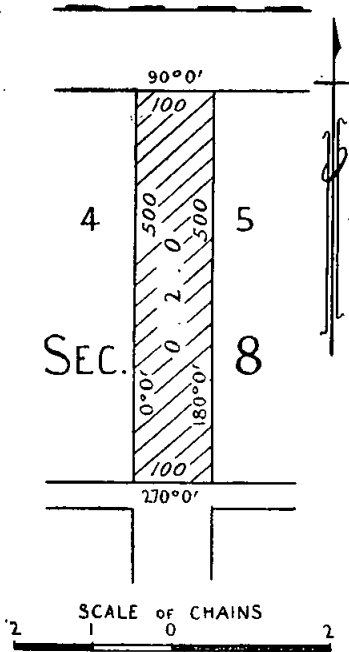

And the Honorable Albert Eli Lind, His Majesty's Commissioner of Crown Lands and Survey for the State of Victoria, shall give the necessary directions herein accordingly.

A. MAHLSTEDT,  
Clerk of the Executive Council.

DEPARTMENT OF CROWN LANDS AND SURVEY.

At the Executive Council Chamber, Melbourne, the nineteenth day of March, 1951.

PRESENT:

- |  |              |
|--|--------------|
| His Excellency the Governor of Victoria. |              |
| Mr. McDonald                             | Mr. Dodgshun |
| Mr. Lind                                 | Mr. Hyland   |
| Mr. Byrnes                               | Mr. Inchbold |
| Mr. Moss                                 | Mr. Brose    |
| Mr. Fulton                               | Mr. Mitchell |
| Mr. Swinburne                            | Mr. Harvey.  |

REVOCATION OF ORDER IN COUNCIL TEMPORARILY RESERVING AND WITHHOLDING FROM SALE, LEASING, OR LICENSING CERTAIN LAND IN THE TOWN OF COLAC.

HIS Excellency the Governor of the State of Victoria, by and with the advice of the Executive Council thereof, doth hereby, in pursuance of the provisions of the Land

Act 1928, revoke the Order in Council of the 19th July, 1880, temporarily reserving and withholding from sale, leasing, and licensing 2 acres of land in the Town of Colac, as a site for an Asylum for the Aged and Sick.

And the Honorable Albert Eli Lind, His Majesty's Commissioner of Crown Lands and Survey for the State of Victoria, shall give the necessary directions herein accordingly.

A. MAHLSTEDT,  
Clerk of the Executive Council.

DEPARTMENT OF CROWN LANDS AND SURVEY.

At the Executive Council Chamber, Melbourne, the nineteenth day of March, 1951.

PRESENT:

- |  |              |
|--|--------------|
| His Excellency the Governor of Victoria. |              |
| Mr. McDonald                             | Mr. Dodgshun |
| Mr. Lind                                 | Mr. Hyland   |
| Mr. Byrnes                               | Mr. Inchbold |
| Mr. Moss                                 | Mr. Brose    |
| Mr. Fulton                               | Mr. Mitchell |
| Mr. Swinburne                            | Mr. Harvey.  |

UNUSED AND UNMADE ROADS CLOSED.

HIS Excellency the Governor of the State of Victoria, by and with the advice of the Executive Council thereof, doth hereby direct that, in pursuance of the provisions of section 304 of the Land Act 1928 (No. 3709), the unused and unmade roads referred to hereunder be closed, viz.:-

Parish of Tawanga, County of Bogong, being:-

1. The road on the north boundary of allotment 7, section 15;
2. the road between allotment 8 and allotment 9, section 15.—(T.233<sup>(5, 6)</sup>) (H.020122).

Parish of Corinella, County of Mornington, being the road between allotment 152 and allotments 162 and 151.—(C.246<sup>(10)</sup>) (Misc. 2425).

And the Honorable Albert Eli Lind, His Majesty's Commissioner of Crown Lands and Survey, for the State of Victoria, shall give the necessary directions herein accordingly.

A. MAHLSTEDT,  
Clerk of the Executive Council.

DEPARTMENT OF CROWN LANDS AND SURVEY.

At the Executive Council Chamber, Melbourne, the nineteenth day of March, 1951.

PRESENT:

- |  |              |
|--|--------------|
| His Excellency the Governor of Victoria. |              |
| Mr. McDonald                             | Mr. Dodgshun |
| Mr. Lind                                 | Mr. Hyland   |
| Mr. Byrnes                               | Mr. Inchbold |
| Mr. Moss                                 | Mr. Brose    |
| Mr. Fulton                               | Mr. Mitchell |
| Mr. Swinburne                            | Mr. Harvey.  |

REVOCATION OF TEMPORARY RESERVATIONS OF LANDS BY ORDERS IN COUNCIL.

HIS Excellency the Governor of the State of Victoria, by and with the advice of the Executive Council thereof, doth hereby, in pursuance of the provisions of the Land Act 1928, revoke the temporary reservations of the lands by Orders in Council hereinafter referred to, viz.:-

EUROA.—Order in Council of 24th April, 1903, of 12 acres 0 roods 24 perches of land in the Town of Euroa as a site for Public Park and Recreation purposes, so far only as regards the portion thereof comprised within the boundaries published in the *Government Gazette* of 21st February, 1951, and containing 9 acres 2 roods 32 perches.—(Rs.4702.)

MERTON.—Order in Council of 20th November, 1865, of 2 acres of land at Merton as a site for Church of England.—(C.92537.)

MORTLAKE.—Order in Council of 23rd December, 1861, of 2 acres 0 roods 8 perches of land at Mortlake as a site for Police Station, so far only as regards the portion

thereof comprised within the boundaries published in the *Government Gazette* of 21st February, 1951, and containing 1 rood 16 perches.—(C.85832.)

TERRICK TERRICK WEST.—Order in Council of 10th March, 1913, of 3 acres of land in the Parish of Terrick Terrick West as a site for a State School.—(C.55926.)

And the Honorable Albert Eli Lind, His Majesty's Commissioner of Crown Lands and Survey, for the State of Victoria, shall give the necessary directions herein accordingly.

A. MAHLSTEDT,  
Clerk of the Executive Council.

#### SHIRE OF MOUNT ROUSE WATERWORKS TRUST.

*At the Executive Council Chamber, Melbourne, the nineteenth day of March, 1951.*

##### PRESENT:

His Excellency the Governor of Victoria.	
Mr. McDonald	Mr. Dodgshun
Mr. Lind	Mr. Hyland
Mr. Byrnes	Mr. Inchbold
Mr. Moss	Mr. Brose
Mr. Fulton	Mr. Mitchell
Mr. Swinburne	Mr. Harvey.

#### AMENDMENT OF ORDER.

UNDER the powers conferred by the Water Acts and all other powers enabling him in that behalf, His Excellency the Governor of the State of Victoria, by and with the advice of the Executive Council of the said State, doth hereby amend as follows the Order in Council made on the 16th day of January, 1951, and published in the *Government Gazette* dated 24th January, 1951, fixing the limit of the overdraft to be obtained by the Shire of Mount Rouse Waterworks Trust.

For the expression "at an amount not to exceed at any one time the sum of One thousand pounds (£1,000)" there shall be substituted the expression "at an amount not to exceed at any one time the sum of Five thousand pounds (£5,000)."

And the Honorable Richard Keats Brose, His Majesty's Minister of Water Supply for the State of Victoria, shall give the necessary directions herein accordingly.

A. MAHLSTEDT,  
Clerk of the Executive Council.

#### APPRENTICESHIP ACTS.

*At the Executive Council Chamber, Melbourne, the nineteenth day of March, 1951.*

##### PRESENT:

His Excellency the Governor of Victoria.	
Mr. McDonald	Mr. Dodgshun
Mr. Lind	Mr. Hyland
Mr. Byrnes	Mr. Inchbold
Mr. Moss	Mr. Brose
Mr. Fulton	Mr. Mitchell
Mr. Swinburne	Mr. Harvey.

#### APPOINTMENT OF DEPUTY CHAIRMAN OF TRADE COMMITTEES.

IN pursuance of the provisions of the Apprenticeship Acts, His Excellency the Governor of the State of Victoria, by and with the advice of the Executive Council thereof, doth by this Order appoint Valentine Gilbert Empey, an officer of the Public Service and a competent and impartial person of proved administrative ability and with a general knowledge of industrial matters, to be Deputy Chairman of Trade Committees, appointed under the said Acts for the term of one year from the 12th day of March, 1951, at a remuneration of £150 per annum, which sum shall be payable to him in addition to his salary as an officer of the Public Service.

And the Honorable Trevor Harvey, His Majesty's Minister of Labour for the State of Victoria, shall give the necessary directions herein accordingly.

A. MAHLSTEDT,  
Clerk of the Executive Council.

#### LANDLORD AND TENANT ACTS.

*At the Executive Council Chamber, Melbourne, the nineteenth day of March, 1951.*

##### PRESENT:

His Excellency the Governor of Victoria.	
Mr. McDonald	Mr. Dodgshun
Mr. Lind	Mr. Hyland
Mr. Byrnes	Mr. Inchbold
Mr. Moss	Mr. Brose
Mr. Fulton	Mr. Mitchell
Mr. Swinburne	Mr. Harvey.

#### ORDER EXCLUDING CERTAIN PREMISES FROM THE OPERATION OF PARTS III. AND V. OF THE LANDLORD AND TENANT ACT 1948.

IN pursuance of the powers conferred upon him by the *Landlord and Tenant Act 1948*, as amended by the *Landlord and Tenant (Amendment) Act 1948*, His Excellency the Governor of Victoria, by and with the advice of the Executive Council thereof, doth hereby declare that the premises known as No. 41 Mount-street, Prahran, shall be excluded from the operation of the whole of the provisions contained in Parts III. and V. of the *Landlord and Tenant Act 1948*.

And the Honorable Thomas Walter Mitchell, His Majesty's Attorney-General in and for the State of Victoria, shall give the necessary directions herein accordingly.

A. MAHLSTEDT,  
Clerk of the Executive Council.

#### LANDLORD AND TENANT ACTS.

*At the Executive Council Chamber, Melbourne, the nineteenth day of March, 1951.*

##### PRESENT:

His Excellency the Governor of Victoria.	
Mr. McDonald	Mr. Dodgshun
Mr. Lind	Mr. Hyland
Mr. Byrnes	Mr. Inchbold
Mr. Moss	Mr. Brose
Mr. Fulton	Mr. Mitchell
Mr. Swinburne	Mr. Harvey.

#### ORDER EXTENDING APPLICATION OF THE LANDLORD AND TENANT ACT 1948, TO CERTAIN PREMISES.

WHEREAS by Orders published in the *Government Gazette* the several premises described in the Schedule hereto, were excluded from the operation of certain parts of the *Landlord and Tenant Act 1948*: And whereas it is expedient that those parts should again extend to each of those premises: Now therefore, in pursuance of the powers conferred upon him by the *Landlord and Tenant Act 1948*, as amended by the *Landlord and Tenant (Amendment) Act 1948*, His Excellency the Governor of Victoria, by and with the advice of the Executive Council thereof, doth hereby declare that the application of the whole of the *Landlord and Tenant Act 1948* shall extend to each of the premises described in such Schedule.

##### SCHEDULE.

1. No. 57 Gordon-street, Deepdene.
2. No. 154 Gladstone-avenue, Northcote.
3. No. 21 Hall-street, Moonee Ponds.
4. The premises situated upon all that piece of land in Emily-street, Seymour, having a frontage of 2 chains to the northern side of Emily-street, by a depth of 5 chains, commencing at a point 2 chains north-easterly from Whitehead's Creek.

And the Honorable Thomas Walter Mitchell, His Majesty's Attorney-General in and for the State of Victoria, shall give the necessary directions herein accordingly.

A. MAHLSTEDT,  
Clerk of the Executive Council.

## Water Acts.

## STATE RIVERS AND WATER SUPPLY COMMISSION.

*At the Executive Council Chamber, Melbourne, the nineteenth day of March, 1951.*

## PRESENT:

His Excellency the Governor of Victoria.	
Mr. McDonald	Mr. Dodgshun
Mr. Lind	Mr. Hyland
Mr. Byrnes	Mr. Inchbold
Mr. Moss	Mr. Brose
Mr. Fulton	Mr. Mitchell
Mr. Swinburne	Mr. Harvey.

MORNINGTON PENINSULA WATERWORKS DISTRICT  
—CHELSEA-FRANKSTON URBAN DISTRICT—  
DISTRICT EXTENDED, PORTION EXCISED.

UNDER the powers conferred by the Water Acts and all other powers enabling him in that behalf, His Excellency the Governor of the State of Victoria, with the advice of the Executive Council of the said State, on the recommendation of the State Rivers and Water Supply Commission, doth hereby declare, order, and direct as follows:—

Firstly, that the Chelsea-Frankston Urban District of the Mornington Peninsula Waterworks District be extended by adding to the same the lands set out and described in the First Schedule hereto, and as on and from the date of this Order such urban district shall be deemed to be so extended.

Secondly, that there shall be excised from the Chelsea-Frankston Urban District of the Mornington Peninsula Waterworks District that portion of the same set out and described in the Second Schedule hereto, which portion, as from the date of this Order, shall be deemed to be excised accordingly.

## FIRST SCHEDULE.

1. Commencing at the most easterly angle of lot 55 on lodged plan of subdivision No. 17064, Parish of Lyndhurst; thence south-westerly by the south-eastern boundaries of lots 55 to 68 inclusive, and a line in continuation thereof to the north-eastern boundary of the Chelsea-Frankston Urban District; thence generally northerly by the last-mentioned boundary to the north-eastern boundary of Mill-street; thence south-easterly by that boundary and a line to the most northerly angle of lot 55 aforesaid; thence south-easterly by the north-eastern boundary of that lot to the point of commencement.

2. Commencing at the most westerly angle of lot 74 on lodged plan of subdivision No. 6679, Parish of Lyndhurst; thence north-easterly by the north-western boundaries of lots 74 to 82 inclusive, to the most northerly angle of the last-mentioned lot; thence south-easterly by the north-eastern boundaries of lots 82 and 91 and a line connecting those boundaries to the most easterly angle of said lot 91; thence south-westerly by the south-eastern boundaries of lots 91 to 99 inclusive, to the most southerly angle of the last-mentioned lot; thence north-westerly by the south-western boundaries of said lots 99 and 74 and a line connecting those boundaries to the point of commencement.

3. Commencing at the most easterly angle of lot 134 on lodged plan of subdivision No. 6832, Parish of Lyndhurst; thence south-westerly by the south-eastern boundaries of lots 134, 133, 132, 131, 130, 129, 106, 105, 104, 103, 102, and 101, and a line in continuation thereof, and a line connecting those boundaries to the south-western boundary of Ivan-avenue; thence north-westerly by the last-mentioned boundary and a line in continuation thereof to the north-western boundary of Edithvale-road; thence south-westerly by that road boundary to its intersection with the south-western boundary of Montrose-avenue; thence north-westerly by the last-mentioned boundary to a point in line with the south-eastern boundary of lot 133 on lodged plan of subdivision No. 6679; thence north-easterly by a line and the south-eastern boundaries of lots 133, 132, 131, 130, 129, 128, 127, 126, 125, 124, 123, 122, 121, 120, and 119 on said lodged plan of subdivision No. 6679 to the most easterly angle of the last-mentioned lot; thence north-westerly by the south-western boundary of Kinross-avenue to the most northerly angle of lot 116; thence north-easterly by a line in continuation of the north-western boundary of the last-mentioned lot to the north-eastern boundary of Kinross-avenue; thence south-easterly by that avenue boundary, the south-western boundary of Syme-street, and a line connecting those boundaries to the point of commencement.

4. Commencing at the most southerly angle of lot 35 on lodged plan of subdivision No. 12032, Parish of Lyndhurst; thence north-westerly by the north-eastern boundary of Fowler-street to its intersection with the south-eastern boundary of Troy-street; thence north-easterly by the last-mentioned boundary to the south-western boundary of Alleyne-avenue; thence north-westerly by that boundary to a point in line with the south-eastern boundary of lot 1 on lodged plan of subdivision No. 11989; thence north-easterly by a line, the south-eastern boundaries of lots 1 to 12 inclusive, and a line connecting those boundaries to the south-western boundary of Scotch-parade; thence north-westerly by the last-mentioned boundary to the most northerly angle of lot 51 on lodged plan of subdivision No. 9312; thence south-westerly by the north-western boundaries of lots 51 and 54 to 63 inclusive, and a line in continuation thereof to the south-western boundary of Alleyne-avenue aforesaid; thence north-westerly by that boundary and a line in continuation thereof to the south-eastern boundary of lodged plan of subdivision No. 5727; thence north-easterly by the south-eastern boundaries of lodged plans of subdivisions Nos. 5727 and 6371, to the north-eastern boundary of Scotch-parade; thence north-westerly by the last-mentioned boundary and a line in continuation thereof to the north-western boundary of Argyle-avenue; thence north-easterly by the last-mentioned boundary to a point in line with the north-eastern boundary of lot 1 on lodged plan of subdivision No. 10525; thence south-easterly by a line, the north-eastern boundaries of lots 1 to 10 inclusive, and a line in continuation thereof to the north-western boundary of lot 64 on lodged plan of subdivision No. 9312; thence north-easterly by the last-mentioned boundary and south-easterly by the north-eastern boundaries of lots 64 to 81 inclusive to the north-western boundary of Broadway-street; thence south-westerly by that street boundary and south-easterly by the north-eastern boundary of Scotch-parade aforesaid to a point in line with the southern boundary of lot 76 on lodged plan of subdivision No. 11742; thence south-westerly by a line and the south-eastern boundaries of lots 76, 75, 74, 73, 72, 71, 70, 69, 68, 67, 66, and 65 to the most southerly angle of the last-mentioned lot; thence north-westerly by the south-western boundaries of lots 65, 39, and 14 on said lodged plan of subdivision No. 11742, a line connecting those boundaries, and a line to the most easterly angle of lot 49 on lodged plan of subdivision No. 12032; thence south-westerly by the north-western boundary of Royal-road and a line in continuation thereof to the point of commencement.

5. Commencing at the most westerly angle of lot 37 on lodged plan of subdivision No. 12548, Parish of Frankston; thence easterly by the southern boundaries of lots 2 to 16 inclusive and a line connecting those boundaries to the south-eastern angle of said lot 16; thence southerly by a line, the eastern boundaries of lots 36, 35, 34, 32, 33, and 59, and a line connecting those boundaries to the south-eastern angle of said lot 59; thence westerly by the southern boundary of the last-mentioned lot and north-westerly by the north-eastern boundary of the Seaford to Frankston Railway Reserve to the point of commencement.

## SECOND SCHEDULE.

Commencing at the most easterly angle of lot 30 on lodged plan of subdivision No. 11532, Parish of Frankston; thence north-easterly by the south-eastern boundaries of lots 61 and 62 on said lodged plan of subdivision No. 11532, lot 62, on lodged plan of subdivision No. 2997, and lines connecting those boundaries to the south-western boundary of Frome-avenue; thence south-easterly by the last-mentioned boundary and a line in continuation thereof to the south-eastern boundary of Foot-street; thence north-easterly by that street boundary to the most westerly angle of lot 20 on lodged plan of subdivision No. 8140; thence south-easterly by the south-western boundaries of lots 20 to 30 inclusive and lot 1 and a line in continuation thereof to the eastern boundary of Hastings-road; thence north-westerly by that road boundary a distance of about 10½ chains to the south-western boundary of a lane adjoining the south-western boundary of lot 1 on lodged plan of subdivision No. 7091; thence south-easterly by that lane boundary to the eastern boundary of Samada-street; thence northerly by that street boundary to the most northerly angle of lot 20 on lodged plan of subdivision No. 7091; thence south-easterly by the north-eastern boundary of that lot to the most easterly angle thereof; thence north-easterly by the north-western boundaries of lots 9 to 22 inclusive on lodged plan of subdivision No. 7466, a line connecting those boundaries, and a line in continuation thereof to the south-western boundary of the Frankston to Baxter Railway Reserve; thence south-easterly by that reserve boundary to a point in line with the south-eastern boundary on lodged plan of subdivision No. 6833; thence south-westerly by the continuation of the

last-mentioned boundary to a point in line with the south-western boundary of Crown allotment 10, section 3; thence north-westerly by a line and the last-mentioned Crown allotment boundary to the most southerly angle of lot 29 on lodged plan of subdivision No. 11532 aforesaid; thence north-easterly by the south-eastern boundaries of lots 29 and 30 and a line connecting those boundaries to the point of commencement.

The lands described in the foregoing Schedules are shown on a plan approved by the Governor in Council, and deposited in the office of the State Rivers and Water Supply Commission, Melbourne.—(Corres. 50/5527, 50/23071, and 50/18590.)

And the Honorable Richard Keats Brose, His Majesty's Minister of Water Supply for the State of Victoria, shall give the necessary directions herein accordingly.

A. MAHLSTEDT,  
Clerk of the Executive Council.

#### CASTLEMAINE SEWERAGE AUTHORITY.

At the Executive Council Chamber, Melbourne, the nineteenth day of March, 1951.

##### PRESENT:

His Excellency the Governor of Victoria.	
Mr. McDonald	Mr. Dodgshun
Mr. Lind	Mr. Hyland
Mr. Byrnes	Mr. Inchbold
Mr. Moss	Mr. Brose
Mr. Fulton	Mr. Mitchell
Mr. Swinburne	Mr. Harvey.

#### EXTENT OF SEWERAGE DISTRICT INCREASED.

UNDER the powers conferred by the Sewerage Districts Acts and all other powers enabling him in that behalf, His Excellency the Governor of the State of Victoria, by and with the advice of the Executive Council of the said State, doth hereby declare, order, and direct as follows:—

That the extent of the Sewerage District of the Castlemaine Sewerage Authority be increased by adding to the same the land comprised within the boundaries described in the Schedule hereto, and as on and from the date hereof the extent of such District shall be deemed to be increased accordingly.

##### SCHEDULE.

Commencing at the north-western angle of Crown allotment 37, section D6, Borough of Castlemaine, Parish of Castlemaine, County of Talbot, such point being on the western boundary of the existing Castlemaine Sewerage District; thence southerly along the western boundary of the said Crown allotment 37 and by a line being a continuation thereof across Brown-street, to a point on the southern boundary of the said Brown-street; thence westerly along the said southern boundary of Brown-street to its intersection with the south-eastern boundary of Gaffney-street; thence south-westerly along the said south-eastern boundary of Gaffney-street to the most westerly angle of Crown allotment 23, section D6, Borough of Castlemaine; thence southerly by a line across a road to the north-western angle of Crown allotment 11, section D4; thence southerly along the western boundaries of the said Crown allotment 11 and Crown allotment 24, by a line being a continuation thereof across a road, along the western boundary of Crown allotment 18A, section D3, and by a line being a continuation thereof across portion of the said section D3, to a point in line with the northern boundary of Crown allotment 15B; thence easterly by a line across portion of section D3, along the said northern boundary of Crown allotment 15B, and by a line being a continuation thereof across a road to a point on the north-western boundary of Crown allotment 10A; thence north-easterly along the north-western boundaries of the said Crown allotment 10A and Crown allotment 11A to the most northerly angle of the said Crown allotment 11A; thence north-easterly by a line across a road to the south-western angle of Crown allotment 2; thence easterly along the southern boundary of the said Crown allotment 2, to its most easterly angle; thence generally southerly along the eastern boundaries of Crown allotments 3, 4, 5, and 6, and the eastern boundaries of a Public Purposes Reserve Extension (Sewerage) and a Public Purposes Reserve (Sewerage) to the most easterly angle of the said Public Purposes Reserve (Sewerage); thence south-easterly by a line bearing south 41 deg. 31 min. east across a road to a point on the southern boundary of the Borough

of Castlemaine; thence easterly along the said southern boundary of the Borough of Castlemaine, to the most easterly angle of Crown allotment 48, section B5, Borough of Castlemaine; thence north-westerly along the north-eastern boundaries of the said Crown allotment 48, Crown land, Crown allotments 49 and 49A, Crown allotments 8, 7, 6, 5, 4, 3, 2, and 1, section 127, Township of Castlemaine, to the north-eastern angle of the said Crown allotment 1; thence north-westerly by a line across a road to the south-eastern angle of Crown allotment 14, section 126; thence northerly along the western boundaries of the said Crown allotment 14 and Crown allotments 13, 12, and 11, and by a line across a road to the south-eastern angle of Crown allotment 14, section 125, being a point on the southern boundary of the existing Castlemaine Sewerage District; thence westerly, northerly, westerly, south-westerly, northerly, and westerly, along the southern, western, southern, south-eastern, western, and southern boundaries of the existing Castlemaine Sewerage District to the point of commencement.

All of which boundaries are shown on a plan approved by the Governor in Council and deposited in the office of the State Rivers and Water Supply Commission, Melbourne.

And the Honorable Richard Keats Brose, His Majesty's Minister of Water Supply for the State of Victoria, shall give the necessary directions herein accordingly.

A. MAHLSTEDT,  
Clerk of the Executive Council.

#### TARWIN RIVER IMPROVEMENT TRUST.

At the Executive Council Chamber, Melbourne, the nineteenth day of March, 1951.

##### PRESENT:

His Excellency the Governor of Victoria.	
Mr. McDonald	Mr. Dodgshun
Mr. Lind	Mr. Hyland
Mr. Byrnes	Mr. Inchbold
Mr. Moss	Mr. Brose
Mr. Fulton	Mr. Mitchell
Mr. Swinburne	Mr. Harvey.

#### LOAN OF £1,000.

IN pursuance of the powers conferred by section 43 of the *River Improvement Act 1948*, and all other powers him thereunto enabling, His Excellency the Governor of the State of Victoria, by and with the advice of the Executive Council of the said State, doth by this Order:—

1. Make advance by way of loan to the Tarwin River Improvement Trust of a sum of One thousand pounds (£1,000); and

2. Apply the following terms and conditions:—

- (a) That the said sum shall be used for the purpose of payment of preliminary expenses in connexion with the constitution of the Trust, the preparation of plans, specifications, and estimates of river improvement works in the district, and meeting liabilities taken over from the Middle and Lower Tarwin Drainage Area.
- (b) That the Tarwin River Improvement Trust shall in respect of such advance by way of loan be subject to the powers, rights, duties, and obligations conferred and imposed by—

- (i) the provisions of sections 267 to 270, 272 to 277, 279 and 280 of Part VII. of the *Water Act 1928*, so adapted that the word "Authority" therein shall mean the "Tarwin River Improvement Trust"; and
- (ii) the provisions of section 281 of the said Part VII. of the *Water Act 1928*, so adapted as if for the expressions "Any waterworks trust or local governing body" and "such waterworks trust or local governing body" there were substituted the expression "the Tarwin River Improvement Trust."

And the Honorable Richard Keats Brose, His Majesty's Minister of Water Supply for the State of Victoria, shall give the necessary directions herein accordingly.

A. MAHLSTEDT,  
Clerk of the Executive Council.



LICENSING ACTS.

At the Executive Council Chamber, Melbourne, the twenty-ninth day of March, 1951.

PRESENT:

His Excellency the Governor of Victoria.  
 Mr. Dodgshun                      Mr. Lind  
 Mr. Inchbold                      Mr. Moss  
 Mr. Brose                              Mr. Harvey.

REMOVAL OF LICENSING INSPECTOR FROM OFFICE.

HIS Excellency the Governor of the State of Victoria, in the Commonwealth of Australia, by and with the advice of the Executive Council of the said State, and in pursuance of the powers conferred by the Licensing Acts, doth by this Order remove—

SYDNEY NELSON

from the office of a Licensing Inspector for each and every Licensing District in the State of Victoria, as from the 20th day of February, 1951, owing to his retirement from the Police Force from and inclusive of that date.

And the Honorable Keith Dodgshun, His Majesty's Chief Secretary for the State of Victoria, shall give the necessary directions herein accordingly.

A. MAHLSTEDT,  
 Clerk of the Executive Council.

APPROACHING LAND SALES.

SALES of Crown lands, in fee-simple, will be held at the under-mentioned places and dates, viz.:—

	No. of Gazette.
Bendigo.—Thursday, 19th April, 1951 ..	326
Daylesford.—Wednesday, 11th April, 1951 ..	288
Geelong.—Tuesday, 3rd April, 1951 ..	221
Seymour.—Friday, 6th April, 1951 ..	221

PROPOSED REVOCATION OF TEMPORARY RESERVATION OF LAND BY ORDER IN COUNCIL.

IN pursuance of the provisions of the Land Act 1928, notice is hereby given that it is the intention of the Governor in Council to revoke the temporary reservation of land by Order in Council hereunder referred to, viz.:—

The following Notice was published 1° on the 14th March, 1951, pursuant to Order of the 6th March, 1951.

BENDIGO.—The temporary reservation, by Order in Council of the 21st January, 1931, of 2 acres 1 rood 17 perches of land in the City of Bendigo as a site for Recreation purposes, is about to be revoked so far only as regards the portion containing 20 perches, more or less, indicated by hachure on plan hereunder.—(S.372<sup>(a)</sup>) (Rs.4088).

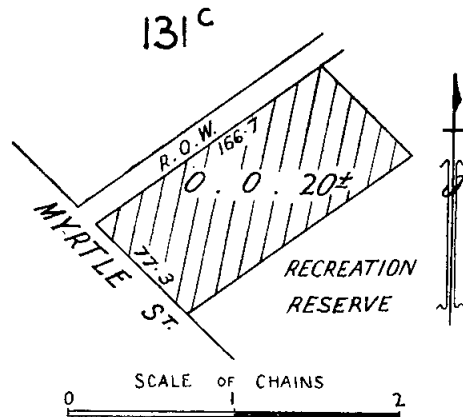

A. E. LIND,  
 Commissioner of Crown Lands and Survey.

PROPOSED REVOCATION OF TEMPORARY RESERVATION OF LAND BY ORDER IN COUNCIL.

IN pursuance of the provisions of the Land Act 1928, notice is hereby given that it is the intention of the Governor in Council to revoke the temporary reservation of land by Order in Council hereunder referred to, viz.:—

The following Notice was published 1° on the 7th March, 1951, pursuant to Order of the 27th February, 1951.

NARIOKA.—The temporary reservation by Order in Council of the 12th January, 1900, of 8 acres 2 roods 20 perches of land in the Parish of Narioka as a site for the Supply of Gravel is about to be revoked.—(N.130(A<sup>2</sup>)) (W.68454).

A. E. LIND,  
 Commissioner of Crown Lands and Survey.

PROPOSED REVOCATIONS OF TEMPORARY RESERVATIONS OF LANDS BY ORDERS IN COUNCIL.

IN pursuance of the provisions of the Land Act 1928, notice is hereby given that it is the intention of the Governor in Council to revoke the temporary reservations of lands by the Orders in Council hereunder referred to, viz.:—

The following Notices were published 1° on the 30th March, 1951, pursuant to Orders of the 16th March, 1951.

ARARAT.—The temporary reservation, by Order in Council of the 17th July, 1945, of 1 acre 2 roods 23 perches of land in the Town of Ararat as a site for Public purposes, revoked as to part by Order of the 18th January, 1949, is about to be revoked so far only as the portion containing 1 rood 25 perches, more or less, indicated by hachure on plan hereunder, is concerned.—(A.148<sup>(3)</sup>) (Rs.5675).

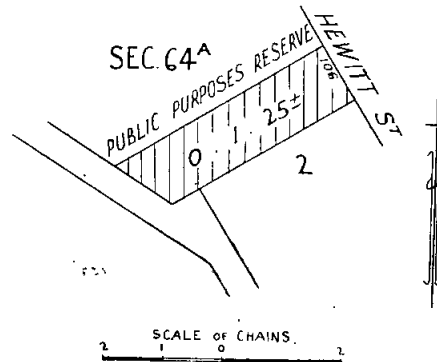

LANGWARRIN.—The temporary reservation, by Order in Council of the 27th August, 1907, of 38 acres 1 rood 7 perches of land in the Parish of Langwarrin as a site for a Public park and other purposes of Public recreation, is about to be revoked so far only as the portion containing 7 acres 0 roods 32 perches, more or less, indicated by hachure on plan hereunder, is concerned.—(L.16(F<sup>1</sup>)) (Rs.3660).

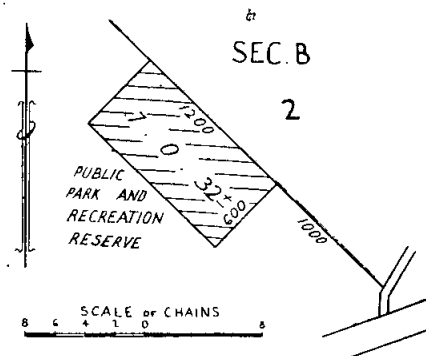

LILYDALE.—The temporary reservation, by Order in Council of the 3rd May, 1949, of 2 acres 0 roods 20 perches of land in the Town of Lilydale as a site for a Municipal Depot, revoked as to part by Order of the 31st October,

1950, is about to be revoked so far only as the portion containing 3 perches, more or less, indicated by hachure on plan hereunder, is concerned.—(L.66(2) (Rs.4885).

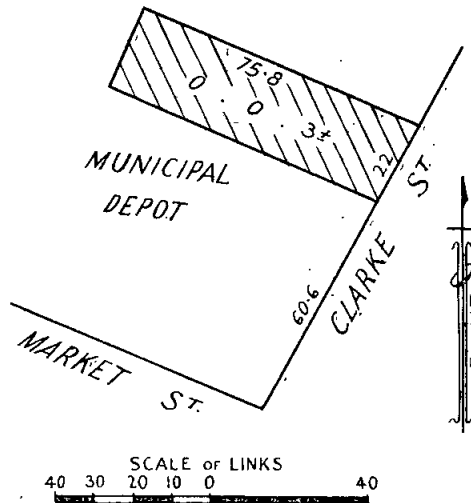

NARRACAN (HERNE'S OAK).—The temporary reservation, by Order in Council of the 4th July, 1939, of 2 roods 29 5/10 perches of land in the Parish of Narracan as a site for a Public Hall, is about to be revoked so far only as the portion containing 2 2/10 perches, indicated by hachure on plan hereunder, is concerned.—N.129(L1) (Rs.4957).

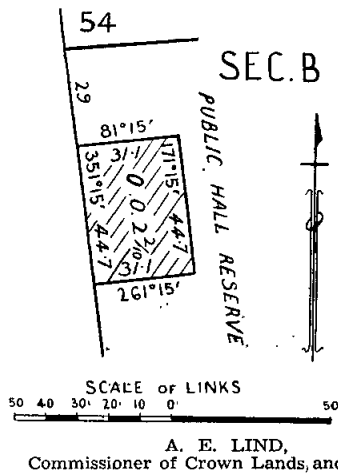

A. E. LIND,  
Commissioner of Crown Lands and Survey.

**PROPOSED REVOCATIONS OF TEMPORARY RESERVATIONS OF LANDS BY ORDERS IN COUNCIL.**

IN pursuance of the provisions of the *Land Act, 1928*, notice is hereby given that it is the intention of the Governor in Council to revoke the temporary reservations of lands by Orders in Council hereunder referred to, viz.:—

The following Notices were published 1° on the 30th March, 1951, pursuant to Orders of the 19th March, 1951.

AMHERST.—The temporary reservation, by Order in Council of the 25th January, 1864, of 1 acre of land at Adelaide Lead, as a site for Primitive Methodist Church purposes, is about to be revoked.—(A.28(12) (C.92442).

KURNWILL.—The temporary reservation, by Orders in Council of the 22nd May, 1928, and the 27th July, 1936, of 4 acres 2 roods of land in the Parish of Kurnwill, as a site for a State School, is about to be revoked.—(K.216(1) (Rs.3680).

MOE.—The temporary reservation, by Order in Council of the 16th December, 1907, of 10 acres of land in the Parish of Moe, as a site for a Night-soil Depot, is about to be revoked.—(M.498(7) (C.34111).

WOODEND.—The temporary reservation, by Order in Council of the 28th October, 1930, of 1 acre 2 roods 16 7/10 perches of land in the Town of Woodend, as a site for Police purposes, is about to be revoked.—(W.199(8) (Rs.4063).

CAMPERDOWN.—The temporary reservation, by Order in Council of the 27th June, 1870, of 1 acre 1 rood 5 perches of land in the Town of Camperdown, being part of section 18, as a site for Watering purposes, revoked as to part by Order of the 10th August, 1896, is about to be revoked so far as the balance thereof, containing 2 roods 22 perches, is concerned.—(C.165(2) (Rs.6642).

MARYVALE.—The temporary reservation, by Order in Council of the 6th March, 1939, of 22 acres, more or less, of land in the Parish of Maryvale, as a site for Public Recreation, is about to be revoked so far only as the portion containing 1 acre 1 rood 30 perches, more or less, indicated by hachure on plan hereunder, is concerned.—(M.481(6) (Rs.4862).

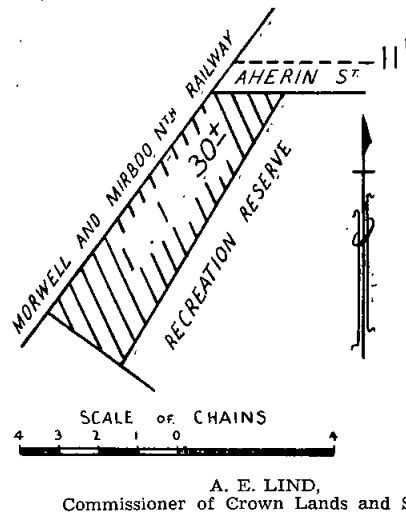

A. E. LIND,  
Commissioner of Crown Lands and Survey.

**APPOINTMENT OF COMMITTEE OF MANAGEMENT OF MOUNT MACEDON MEMORIAL CROSS RESERVE.**

WHEREAS by section 56 of the *Forests Act 1928*, it is provided that the Minister of Forests may, on the recommendation of the Forests Commission, appoint any number of persons, not less than three, to be a Committee of Management of any land forming part of any reserved forest, such land being a place of natural beauty or interest, or a health resort, and may remove any of such persons: Now therefore I, Albert Eli Lind, His Majesty's Minister of Forests for the State of Victoria, on the recommendation of the Forests Commission, do hereby appoint—

DAVID VICTOR DARWIN

as a member of the Committee of Management until the fifth day of July, 1951, of the land forming part of the reserved forest in the Parish of Macedon, County of Bourke, described in the accompanying Schedule, and known as "Mount Macedon Memorial Cross Reserve," such land being a place of natural beauty and interest.

**SCHEDULE ABOVE REFERRED TO:**

Parish of Macedon, County of Bourke, 15 acres, more or less, being the area shown by pink colour on plan marked A.44/933 over 23.5.44 in file of correspondence No. 44/933 of the Forests Department.

Dated at Melbourne the second day of March, 1951.

A. E. LIND,  
Minister of Forests.

## Land Act 1928.

## LEASES UNDER THE LAND ACTS 1915 AND 1928 DECLARED VOID.

NOTICE is hereby given that the Leases mentioned in the Schedule hereunder have been declared void by the Governor in Council for the reason specified in each case.

District.	Corr. No.	Name of Lessee.	Section of Land Act under which Leased.	Parish.	Allotment.	Area.	Class.	Annual Rental.		Reasons for Voiding.
								A. R. P.	£ s. d.	
Mallee ..	06285/198	Francis Otto Gebert	198	Tullillah ..	5	790 3 5	3rd	27	13 9	Lessee has received compensation pursuant to North-west Mallee Settlement Areas Act Non-compliance with conditions
Mallee ..	139/199	Francis Otto Gebert	199	Tullillah ..	12A	49 1 1	3rd	1	15 0	
Melbourne ..	1115/50	Mary Berkery Romey	50	Kinglake ..	6A	25 2 28	2nd	0	19 6	
Melbourne ..	1797/44	Charles Edward Cox	44	Neerim East	8 and 8A	116 3 28	2nd	4	7 9	

Department of Crown Lands and Survey,  
Melbourne, 21st March, 1951.

A. E. LIND,  
Commissioner of Crown Lands and Survey.

## THE CLOSER SETTLEMENT ACTS.

NOTICE is hereby given that the Lease mentioned in the Schedule hereunder has been forfeited by the Board of Land and Works for the reason specified.

## LEASE UNDER THE CLOSER SETTLEMENT ACT 1938.

Corr.	District.	Lessee.	Allotment.	Section.	Parish.	Area.	Remarks.
557/12	Mallee ..	Colman, C. J. ..	10	..	Tarrango ..	A. R. P. 690 3 37	Pursuant to sub-section 2 of section 5 of the North-west Mallee Settlement Areas Act 1948

22nd March, 1951.

W. M. CRAWFORD,  
Acting Secretary for Lands.

## THE CLOSER SETTLEMENT ACTS.

NOTICE is hereby given that the Board of Land and Works has accepted the surrender of the Leases mentioned in the Schedule hereunder for the reasons specified.

## LEASES UNDER THE CLOSER SETTLEMENT ACT 1938.

Corr.	District.	Lessee.	Allotment.	Section.	Parish.	Area.	Remarks.
1056	Mallee ..	Swann, A. P. ..	27 and 28	..	Koleya ..	A. R. P. 1,313 1 37	Has accepted compensation pursuant to the provisions of the North-west Mallee Settlement Areas Act 1948
616/12	Mallee ..	Eastmond, A. C.	13A, 17, and 18	..	Merrincee ..	1,409 2 0	Has accepted compensation pursuant to the provisions of the North-west Mallee Settlement Areas Act 1948
604/12	Mallee ..	Douglas, G. J. ..	24 and 25	..	Koleya ..	1,350 2 13	Has been granted perpetual lease as from 28th February, 1950, pursuant to the provisions of the North-west Mallee Settlement Areas Act 1948

22nd March, 1951.

W. M. CRAWFORD,  
Acting Secretary for Lands.

## COMMITTEES OF MANAGEMENT OF RESERVES.

## APPOINTMENTS.

WHEREAS by section 184 of the *Land Act* 1928 it is provided that it shall be lawful for the Governor in Council or the Board of Land and Works to appoint and remove any number of persons, not less than three, or any municipal council, or the governing body of any corporation, to be a Committee of Management of any specified Crown land reserved either temporarily or permanently for any of the purposes set out in section 14 of the *Land Act* 1928, and not conveyed to or vested in trustees: Now therefore the Board of Land and Works doth hereby appoint the under-mentioned persons to be members of the Committee of Management of the Reserves named:—

## "BEACONSFIELD PUBLIC HALL RESERVE."

James Norman Parkes, Patricia Joan Roberts, Charles Henry Grant, Dorothy Mary Barnes, Florence Rita Barby, William Eric Grant, Hector Norman Cole, Alan Albert Burgess, Ernest Gordon Ashton, and Robert Robson as a Committee of Management for a period of one (1) year from 13th February, 1951, of the land temporarily reserved by Order in Council dated 8th November, 1943, as a site for a Public Hall in the Parish of Pakenham, and known as the "Beaconsfield Public Hall Reserve."—(Corres. Rs.5406.)

## "BOORT RACECOURSE AND RECREATION RESERVE."

James Augustus Lackmann, Eric William Boyle, and Frederick Henry McClelland as the Committee of Management for a period of three (3) years from 16th January, 1951, of the land permanently reserved by Order in Council dated the 13th October, 1931, as a site for a Racecourse and other purposes of Public Recreation in the Parish of Boort, and known as the "Boort Racecourse and Recreation Reserve."—(Corres. Rs.650.)

## "BOWSER PUBLIC HALL RESERVE."

Denis T. Larkin, Thomas A. Norman, William Bryne, Allan Gard, John Patrick Bourke, Percy Cleary Plum, and Gordon Arthur Webster as a Committee of Management for a period of three (3) years from 19th March, 1951, of the land temporarily reserved by Order in Council dated the 30th September, 1912, as a site for a Public Hall in the Parish of Carraragarmungee, and known as the "Bowser Public Hall Reserve."—(Corres. Rs.5521.)

## "BUSHFIELD RECREATION RESERVE."

Adrian Patrick Harrington as a member of the Committee of Management for the period ending 15th June, 1953, of the land temporarily reserved by Order in Council dated the 12th February, 1877, as a site for Recreation in the Parish of Wangoom, and known as the "Bushfield Recreation Reserve," in the place of John Wilson, who has ceased to reside in the district.—(Corres. Rs.2164.)

## "CANNIBAL CREEK CAMPING AND WATER RESERVE."

Leonard Austin, John Kierce, John Phillips, John Payne, Fredrick Cox, William Parish, and Ernest Towt (for a period of three (3) years from 27th February, 1951), and John Cunningham Anderson and John Fallon (for so long as they continue to be councillors and the elect of the council of the Shire of Berwick), as a Committee of Management of the remaining portion of the land in the Parish of Bunyip temporarily reserved as a site for Camping and for affording Access to Water by Order in Council dated the 22nd October, 1883, and known as the "Cannibal Creek Camping and Water Reserve."—(Corres. C.69320.)

## "DARTMOOR RECREATION RESERVE."

John Alexander Ward Pratt, John Vernon Spencer, and Charlton Read Malseed as a Committee of Management for a period of three (3) years from 25th January, 1951, of the land temporarily reserved by Order in Council dated the 17th February, 1916, as a site for Public Recreation in the Town of Dartmoor, and known as the "Dartmoor Recreation Reserve."—(Corres. Rs.901.)

## "DRIK DRIK RECREATION RESERVE."

William Mullen Brown, William Clarke, Reginald Frederick Holmes, Leslie Gordon Bird, John Stanley Alexander McEachern, Ronald Keith Nicholson McLean, and Arthur Stanley John Holmes as a Committee of Management for a period of three (3) years from 20th March, 1951, of the land temporarily reserved by Order in Council dated 10th February, 1896, as a site for Public Recreation in the Township of Drik Drik, and known as the "Drik Drik Recreation Reserve."—(Corres. Rs.3200.)

## "DROMANA SOLDIERS' MEMORIAL HALL RESERVE."

James Clwydd Osborne, Clarence Aubrey Hickman, John Pritchard Wallace, James Crawford Molyneux, Gordon Lillingston, Edward William McDonald, and Arthur Herbert Matthews as a Committee of Management for a period of three (3) years from 1st March, 1951, of the land temporarily reserved by Order in Council dated the 25th October, 1921, as a site for a Public Hall in the Parish of Kangerong, at Dromana, and known as the "Dromana Soldiers' Memorial Hall Reserve."—(Corres. Rs.2405.)

## "GLENORCHY MECHANICS' INSTITUTE RESERVE."

Ebenezer William Giles, Joseph Jenkins, Norman Ernest Cooper, Robert Henry Hall, Frederick Percy Leslie, Robert James MacPherson, and William David McIntyre as the Committee of Management for a period of three (3) years from the 8th March, 1951, of the land temporarily reserved by Order in Council dated the 14th May, 1889, as a site for a Mechanics' Institute and Free Library at Glenorchy, and known as the "Glenorchy Mechanics' Institute Reserve."—(Corres. Rs.3469.)

## "GOROKE RECREATION RESERVE."

Robert Percy Walker, Allan Hamilton Major, and Reginald Packer as the Committee of Management for a period of three (3) years from 2nd March, 1951, of the lands temporarily reserved by Orders in Council dated 13th January, 1913, and 25th November, 1947, as sites for Public Recreation in the Parish of Goroke, and known as the "Goroke Recreation Reserve."—(Corres. Rs.1575.)

## "GREAT WESTERN PUBLIC PARK."

Colin Thomas Preece, Harold Stanley Carr, Walter Alexander Williamson, Donald John McKay, and Frederick Hamill Thomson as the Committee of Management for a period of three (3) years of the land temporarily reserved by Orders in Council dated 12th June, 1883, and 17th May, 1938, as sites for a Public Park and Garden in the Town of Great Western, and known as "Great Western Public Park."—(Corres. Rs.755.)

## "GRENVILLE RECREATION RESERVE."

William Gordon Turner, Edward Clifford Freeman, and Claude Robert Wylie as a Committee of Management for a period of three (3) years of the land temporarily reserved by Order in Council dated the 31st July, 1900, as a site for Public Recreation in the Township of Grenville, and known as the "Grenville Recreation Reserve."—(Corres. Rs.270.)

## "KOROIT RACECOURSE AND RECREATION RESERVE."

Martin Bourke, Thomas Carmody, James Lawrence Corbett, John Downey, Matthew Gleeson, John Fred O'Brien, and Walter Riddell as a Committee of Management for a period of three (3) years from 10th March, 1951, of the land permanently reserved by Order in Council dated the 16th April, 1883, as a site for Racecourse and other purposes of Public Recreation in the Parish of Yarpurk, and known as the "Koroit Racecourse and Recreation Reserve."—(Corres. Rs.1027.)

## "MURRABIT ORNAMENTAL PLANTATION RESERVE."

Charles Henry Humphry, Percy George Rupert Parkes, Henry William Purchase, Thomas Andrew Lornie, and Dudley Joseph Walters as the Committee of Management for a period ending the 30th July, 1953, of the land temporarily reserved by Order in Council dated the 25th March, 1947, as a site for Ornamental Plantation in the Parish of Murrabit West, and known as "Murrabit Ornamental Plantation Reserve."—(Corres. Rs.5927.)

## "MYRRHEE RECREATION RESERVE."

Joseph Reginald Jarrott, Ernest William Forge, Ivan Charles Frederick Wightman, Clive Owen Evans, David Allan Lindsay, William Henry Handcock, and Keith Gordon Handcock as a Committee of Management for a period of three (3) years of the land temporarily reserved by Order in Council dated the 2nd May, 1916, as a site for Public Recreation in the Parish of Whitfield, and known as the "Myrrhee Recreation Reserve."—(Corres. Rs.996.)

## "NATHALIA RACECOURSE RESERVE."

Bertram Charles Dohnt, Royce Albert Ernest Hutchins, James Robert Bourke, Henry Hutchins, Stephen Garonne, William George Baxter, and Alfred O'Malley as a Committee of Management for a period of three (3) years of the land temporarily reserved by Order in Council dated the 26th September, 1887, as a site for a Racecourse in the Parish of Barwo, and known as the "Nathalia Racecourse Reserve."—(Corres. Rs.4890.)

**"OAKLEIGH MEMORIAL HALL RESERVE."**

Francis James Orr, Vernon Carlisle Brown, and Herbert Spencer Gray as a Committee of Management for a period of three (3) years from 22nd February, 1951, of the land temporarily reserved by Order in Council dated 22nd November, 1921, as a site for a Public Hall in the Parish of Mulgrave, Town of Oakleigh, and known as the "Oakleigh Memorial Hall Reserve."—(Corres. Rs.2382.)

**"PORT CAMPBELL RECREATION RESERVE."**

William Harry Bellwood, Keith William McLaren, Norman Leslie McKenzie, Hugh Allan Cairns, George Joseph Cairns, John Duncan Morris, and Kenneth McKenzie as a Committee of Management for a period of three (3) years of the land temporarily reserved by Order in Council dated the 23rd August, 1937, as a site for Public Recreation in the Parish of Paaratte, Township of Port Campbell, and known as the "Port Campbell Recreation Reserve."—(Corres. Rs.4713.)

**"TARWIN LOWER RECREATION RESERVE."**

Allan Edmond Buckley, Colin Boag, Gottfried Jongbloed, Lynn William Ollington, Ewen Robertson Livingstone, Arthur McEwan, and Albert Keith Fisher as a Committee of Management for a period of three (3) years from 17th March, 1951, of the lands in the Township of Tarwin temporarily reserved by Orders in Council dated the 15th July, 1947, and the 9th January, 1951, as sites for Public Recreation, such lands being together known as the "Tarwin Lower Recreation Reserve."—(Corres. Rs.5992.)

**"UPPER BEACONSFIELD RECREATION RESERVE."**

Percy Mansfield Hamilton, George Preston, Edgar John Donaldson, Edwin Athol Fairless, Samuel James Begg, Donald James Sutherland, Trevor Basil Kilvington, and Henry George Gregory as a Committee of Management for the period ending 31st January, 1952, of the remaining portion of the land temporarily reserved by Order in Council dated 17th June, 1941, as a site for Public Recreation in the Parish of Gembrook at Beaconsfield Upper, and known as the "Upper Beaconsfield Recreation Reserve."—(Corres. Rs.5219.)

**"WODONGA RECREATION RESERVE."**

John Clarence Bernard McHarg, Jack Stanley Hore, Ernest Barrett Mann, Robert Richardson, Arthur Gordon Richardson, George Alfred William Boyes, Cecil Clifford Sheather, Oscar Gordon Hartsman, James Stewart Noel Harris, Percival John Newbound, Frank John Audas Grant, and Charles Felix Pollard as a Committee of Management for a period ending 12th November, 1953, of the land temporarily reserved for a Racecourse, Show Ground, and Public Recreation Ground in the Parish of Wodonga, and known as the "Wodonga Recreation Reserve."—(Corres. Rs.1734.)

**"JUBILEE PARK," AT WOODFORD.**

J. Mugavin, Andrew J. Jellie, Harry Lindsey, J. Bligh, Oliver Claude Wines, W. R. Jellie, and Arthur Wilkinson as a Committee of Management for a period of three (3) years from 24th February, 1951, of the land temporarily reserved by Order in Council dated the 8th January, 1889, as a site for Public Park and Garden, in the Parish of Wangoom, Town of Woodford, and known as "Jubilee Park."—(Corres. Rs.2486.)

**"WYUNA RECREATION RESERVE."**

Ronald James Stone, John Mervyn Lyle, George William Hearn, Anthony Thompson, John McGregor, John Lockhart de Soyres, Ernest Thomson, Angus Ernest Pell, James Albert Griffiths, and Raymond Lyle Pell as the Committee of Management for a period of three (3) years from 3rd March, 1951, of the land temporarily reserved by Order in Council dated the 4th August, 1908, as a site for Public purposes in the Parish of Wyuna, and known as the "Wyuna Recreation Reserve."—(Corres. Rs.2177.)

**"WY YUNG MECHANICS' INSTITUTE RESERVE."**

Herbert William Woodward, Robert Arnold Bruce Henderson, Horace Campbell, Albert John Overy, Albert Theodore Kleinitz, Bredan Sebastian Railton, and Alexander John Woodward as a Committee of Management for a period of three (3) years of the land temporarily

reserved by Order in Council dated the 22nd December, 1902, as a site for a Mechanics' Institute in the Parish of Wy Yung, and known as the "Wy Yung Mechanics' Institute Reserve."—(Corres. Rs.5463.)

**"YARRABY RECREATION RESERVE."**

Verner Lancelot Watson, Claude Henry Maple, Kenneth Stewart Brown, Austin Alexander Pearse, William Allen Wilkinson, John Frederick Metelmann, and Thomas Baden Pearse as the Committee of Management for a period of three (3) years from 13th March, 1951, of the land temporarily reserved by Order in Council dated the 14th December, 1922, as a site for a Park and Recreation purposes in the Parish of Towan, and known as the "Yarraby Recreation Reserve."—(Corres. Rs.2669.)

In witness whereof the common seal of the Board of Land and Works was hereunto affixed this twenty-second day of March, One thousand nine hundred and fifty-one, in the presence of—

(SEAL)

A. E. LIND, President.  
W. M. CRAWFORD, Member.

**LAND AVAILABLE UNDER THE SOLDIER SETTLEMENT ACTS.**

NOTIFICATION is hereby given, in accordance with section 16 of the *Soldier Settlement Act 1946*, that the under-mentioned lots are available or are about to become available for settlement.

Any discharged soldier who has applied to the Commission on or before the 28th March, 1951, for classification in the required class or classes of primary production for which the lots are made available and whose application has been accepted but not necessarily finalized, or any discharged soldier who has been classified as suitable in such class or classes of primary production, may apply on the prescribed form for settlement on any lot or lots, indicating where he applies in respect of more than one lot, his order of preference therefor.

The prescribed application forms, plans, and further particulars may be obtained from the Enquiry Branch, Soldier Settlement Commission, State Public Offices, Melbourne. The closing date for the receipt of completed applications for settlement on these holdings is the 23rd April, 1951, such applications to be in the hands of the Secretary, Soldier Settlement Commission, on or before that date.

E. SINGLETON,  
Secretary.

Soldier Settlement Commission,  
Melbourne, 21st March, 1951.

**SCHEDULE OF ALLOTMENTS.**

**SUBDIVISION OF "LAWTONS" ESTATE.  
PARISH OF MARDAN.—COUNTRY OF BULN BULN.  
*Suitable for Dairying.***

Lot Number on Plan of Subdivision.	Approximate Area in Acres (Subject to Survey).
1	123
2	110
3	121
4	124

**SUBDIVISION OF "HOPKINS HILL" ESTATE.  
PARISHES OF CHATSWORTH WEST AND NAREEB NAREEB.—  
COUNTY OF VILLIERS.  
*Suitable for Grazing (Sheep) and Mixed Farming.***

Lot Number on Plan of Subdivision.	Approximate Area in Acres (Subject to Survey).
1	580
2	595
3	593
4	605
5	831
6	807

**LIST OF CROWN LANDS AVAILABLE.**  
 THE under-mentioned areas are available for application as provided by various sections of the *Land Act 1928*, and all applications received on or before Friday, 27th April, 1951, will be deemed to have been simultaneously made, but any application lodged after such date may be considered if received in time for inclusion in the advertisement of the cases to be heard at the Local Land Board. Applications on proper form, accompanied by 5s. duty stamp uncancelled (registration fee), may be delivered or forwarded by post to the Local Land Officer or to any Crown Lands Office in Victoria. Applicants may obtain from Local Land Officers, or the Crown Lands Department, Melbourne, a certificate authorizing the issue by the Railway Department of a return ticket at concession fares to enable them to inspect available areas or to attend Local Land Boards. When an applicant is granted an allotment he may, if travelling by rail, obtain reduced fares for his family and also freight concessions in regard to some of his effects.

Subject to the approval of the Secretary for Lands, when the survey fee exceeds £25 but does not exceed £50, a deposit of £25 may be paid, and when the fee exceeds £50 a deposit of 50 per cent. of the fee, the balance in either case being payable over six years in half-yearly instalments.

Marked plans of any particular area, application forms, and any further information may be obtained from the Crown Lands Department, Melbourne, and Land Officers, Bairnsdale, and Geelong.

Department of Crown Lands and Survey, Melbourne, 30th March, 1951.  
 A. E. LIND,  
 Commissioner of Crown Lands and Survey.

\* Improvements may be subject to re-valuation after land has been granted to an applicant.

Local Land Office.	County.	Parish.	Allotment.	Section.	Area.	How Available.		Survey Fee.	Valuation of Improvements (if any).	Location of Land, &c.	Nearest Railway Station to Township and Distance in miles therefrom.	How Accessible.	Water Supply.	General Description of Land—Soil, Timber, Suitability (Grazing, &c.).	
						Classification.	Value per Acre.								
		A. B. P.		£ s. d.		£ s. d.									
Bairnsdale (a)	Croajingo-long	Noorinbee	2C	A	50 0 0	3rd	1 0 0	21 7 6	Nil	In east of parish	Cann River, 1-6 miles	By road	To be conserved	Hill country suitable for grazing. (H.021151)	
"	"	"	2D	A	100 0 0	3rd	1 0 0	26 12 6	"	"	"	"	"	"	
"	"	"	6C	A	10 0 0	3rd	1 0 0	9 12 6	"	"	"	"	"	"	
"	"	"	7D	A	4 0 0	3rd	1 0 0	9 12 6	"	"	"	"	"	"	
"	"	"	14B	A	50 0 0	3rd	1 0 0	21 7 6	"	"	"	"	"	"	
"	"	"	14C	A	50 0 0	3rd	1 0 0	21 7 6	"	"	"	"	"	"	
"	"	"	14D	A	40 0 0	3rd	1 0 0	21 7 6	"	"	"	"	"	"	
"	"	"	23H	A	50 0 0	3rd	1 0 0	21 7 6	"	"	"	"	"	"	
"	"	"	23J	A	38 0 0	3rd	1 0 0	16 2 6	"	"	"	"	"	"	
"	"	"	28C	A	100 0 0	3rd	1 0 0	26 12 6	"	"	"	"	"	"	
Bairnsdale (a, b, c)	Tambo	Waygara	9	A	150 0 0	3rd	1 0 0	31 17 6	"	In north of parish	Waygara R.S., ½ mile	"	"	Undulating, light grey loam; stringybark and gum; suitable for cultivation and grazing. (H.021472)	
"	"	"	10	A	150 0 0	3rd	1 0 0	31 17 6	"	"	"	"	"	"	
"	"	"	12	A	70 0 0	3rd	1 0 0	21 7 6	"	"	"	"	"	"	
"	"	"	13	A	150 0 0	3rd	1 0 0	31 17 6	"	"	"	"	"	"	
"	"	"	14	A	150 0 0	3rd	1 0 0	31 17 6	"	"	"	"	"	"	
"	"	"	15	A	150 0 0	3rd	1 0 0	31 17 6	"	"	"	"	"	"	
"	"	"	16	A	160 0 0	3rd	1 0 0	31 17 6	"	"	"	"	"	"	
"	"	"	17	A	70 0 0	3rd	1 0 0	21 7 6	"	"	"	"	"	"	
"	"	"	18	A	60 0 0	3rd	1 0 0	21 7 6	"	"	"	"	"	"	
AVAILABLE UNDER SECTION 129, LAND ACT 1928.															
Geelong	Polwarth	Yaughter	11	B	0 3 3 25/100	Residence	Annual rental to be fixed	5 5 0	Nil	In north of parish	Kawarren R.S., opposite	By road	By conservation	Suitable for a dwelling site. (0311/129)	

(a) Subject to survey. (b) Subject to timber condition. (c) Subject to mining condition.

## PUBLIC SERVICE NOTICES.

## PUBLIC SERVICE (PUBLIC SERVICE BOARD) REGULATION 39.—RECLASSIFICATIONS.

THE Public Service Board has raised the classification of the under-mentioned offices as shown, and the Permanent Heads of the Departments have recommended the officers named for appointment.

Office and Present Classification.	Revised Classification.	Duties.	Qualifications.	Officer Recommended for Appointment.		
				Name.	Classification.	Date of Classification.

## ADMINISTRATIVE DIVISION.

## DEPARTMENT OF CHIEF SECRETARY.

*Office of the Government Statist.*

Office and Present Classification.	Revised Classification.	Duties.	Qualifications.	Name.	Classification.	Date of Classification.
Clerk, Class "C2" (three offices)	Class "B" (three offices)	To supervise the collection, compilation and analysis of statistics relating to births, deaths, marriages and population; to prepare parts of the Victorian Year Book in respect of Vital Statistics and Population	To have experience in dissecting statistical statements and the ability to make accurate deductions therefrom; to be conversant with medical terms and to be thoroughly conversant with the Manual of the International List of Causes of Deaths and Joint Causes of Deaths	Kitson, G. E.	Clerk, Class "C2"	24.4.50
		To prepare Quarterly Abstracts of Statistics of Victoria, and to collect and to compile monthly statistics for incorporation therein; to act as liaison officer with the Commonwealth Bureau of Statistics on matters of special importance	To possess an extensive knowledge of all phases of statistics in order to co-ordinate the results obtained by the various sections of the branch; to have the capacity to carry out investigations into matters requiring special research	Dunbar, F. D.	Clerk, Class "C2"	24.4.50
		To have charge of the collection and compilation of agricultural, pastoral and dairying statistics of Victoria	To have experience of agricultural, dairying and pastoral statistics, the methods of marketing production and statistical valuation of primary production in Australia; to be familiar with the productive features of each statistical district of Victoria	Gates, G. A.	Clerk, Class "C2"	31.7.50

## DEPARTMENT OF TREASURER.

*Taxation (Land Tax) Branch.*

Office and Present Classification.	Revised Classification.	Duties.	Qualifications.	Name.	Classification.	Date of Classification.
Clerk, Class "C"	Class "C1"	To keep staff records; to be responsible for the preparation and payment of salaries, the preparation of estimates of expenditure, and the keeping of the Appropriation Ledger and Advance Account Cash Book	To have a good knowledge of the Public Service Act and Regulations, the regulations respecting Public Accounts and the Superannuation Act, and to be experienced in the preparation of salary sheets	Durrant, R. H.	Clerk, Class "C"	23.2.49

## DEPARTMENT OF EDUCATION.

Office and Present Classification.	Revised Classification.	Duties.	Qualifications.	Name.	Classification.	Date of Classification.
Clerk, Class "D"	Class "C"	To pass teachers' salaries for payment, including the computation of increments, cost of living adjustments, and allowances payable under the Teaching Service Regulations; to deal with correspondence and enquiries relating to salaries	A sound knowledge of the relevant portions of the Public Service and Teaching Service Acts and the regulations thereunder; a good knowledge of machine accounting	Collins, W. T.	Clerk, Classes "E" and "D"	24.7.44

Appeals against such recommendations should be lodged with the Secretary to the Public Service Board not later than Monday, the 9th April, 1951.

Office of the Public Service Board,  
Melbourne, 28th March, 1951.

By order,

E. F. FITZGIBBON,  
Secretary.

## PUBLIC SERVICE (PUBLIC SERVICE BOARD) REGULATION 39.—VACANCIES.

THE Permanent Heads of the Departments shown have recommended the officers named hereunder for appointment to the under-mentioned vacancies.

Office and Classification.	Duties.	Qualifications.	Officer Recommended for Appointment.		
			Name.	Classification.	Date of Classification.
<b>PROFESSIONAL DIVISION.</b>					
<b>DEPARTMENT OF STATE FORESTS.</b>					
Chief Forester, Class "B" (two offices)	To supervise and control all forest activities in a forest district	To be a graduate of the School of Forestry, Creswick, or the holder of a Science Degree (Forestry) or a Diploma of Forestry, and to have had approved experience in the administration of a Forest District and proved ability to control staff	Newey, J. P. . .	Chief Forester, Class "C2"	29.5.50
			Fitzpatrick, J. M.	Forest Assessor, Class "C2."	14.6.49

Appeals against such recommendations should be lodged with the Secretary to the Public Service Board not later than Monday the 9th April, 1951.

Office of the Public Service Board,  
Melbourne, 28th March, 1951.

By order,

E. F. FITZGIBBON,  
Secretary.

## PUBLIC SERVICE OF VICTORIA.—VACANCIES.

APPLICATIONS will be received by the Public Service Board up to Friday, the 13th April, 1951, from persons employed in the Public Service of Victoria, who are eligible and qualified for appointment to the under-mentioned positions.

## ADMINISTRATIVE DIVISION.

## Clerk, Class "C," Department of Agriculture.

*Yearly Salary.*—£475, minimum; £579, maximum.

*Duties.*—To verify, check, and charge accounts in respect of supplies purchased by the Department; to be in sub-charge of the Stores Branch, and to relieve the Officer in Charge.

*Qualifications.*—To have a thorough knowledge of the Public Service and Public Accounts Regulations and the procedure to be followed in securing supplies for Government departments.

## PROFESSIONAL DIVISION.

## Psychiatrist (Children's Court Clinic), Class "A1," Mental Hygiene Branch, Department of Health.

*Yearly Salary.*—£1,500, minimum; £1,600, maximum.

*Duties.*—To supervise the work of the Children's Court Clinic; to undertake the psychiatric examination and treatment of juvenile delinquents, and similar cases referred by the Children's Court, the Children's Welfare Department, and other agencies and institutions; to furnish psychiatric reports on the above cases when required.

*Qualifications.*—To be a legally qualified medical practitioner with experience in child psychiatry and in the diagnosis and treatment of juvenile delinquency.

## Assistant Clinical Tuberculosis Officer (Male), Prahran Bureau, Class "A1," Department of Health.

*Yearly Salary.*—£1,250, minimum; £1,400, maximum.

*Qualifications.*—To be a legally qualified medical practitioner with experience in the prevention, diagnosis, and treatment of tuberculosis.

## Professional Assistant, Class "C2," Office of the Public Trustee, Department of Law.

*Yearly Salary.*—£683, minimum; £735, maximum.

*Duties.*—To act as Assistant Solicitor to the Public Trustee and Assistant Legal Adviser to Trust officers.

*Qualifications.*—To be a barrister and solicitor of the Supreme Court of Victoria; to have a thorough knowledge of the law relating to and practical experience in the administration of estates and trusts; to be capable of drafting wills and legal documents.

## District Officer, Grade IV., Class "C2," Ouyen Centre, Department of Water Supply.

*Yearly Salary.*—£683, minimum; £735, maximum.

*Duties.*—To supervise staff and control all rural and urban water supplies, works, and expenditure within the Ouyen centre; to direct surveys and prepare plans, specifications, estimates, and reports in regard to new works within the district; to supervise construction and maintenance of works, and to control water distribution within the centre.

*Qualifications.*—To be competent to carry out surveys and supervise water distribution; to be well versed in modern engineering practice and in the design, construction, and maintenance of channels and structures and water supply works; to be conversant with the control of water and with land values and have a thorough knowledge of the provisions of the Water Acts. A knowledge of sand drift prevention and protection of channels is essential.

## Mechanical Engineer, Grade IV., Class "C2," Eildon Dam, Department of Water Supply.

*Yearly Salary.*—£683, minimum; £735, maximum.

*Duties.*—Under the direction of the Chief Engineer, Eildon Dam, to be responsible for the maintenance of construction plant, including tractor operated earth-moving equipment, power excavators, transport vehicles, stone crushing, screening and handling plant, air compression machinery and electric generating plant.

*Qualifications.*—To possess a University Degree or Diploma in Mechanical Engineering or other recognized professional mechanical engineering qualifications; to have had experience in the use and maintenance of heavy construction plant, and the management of workshops.

## Pharmaceutical Chemist, Class "C1," Royal Park Mental Hospital, Department of Health.

*Yearly Salary.*—£605, minimum; £657, maximum.

*Duties.*—To dispense medicines as required; to be in charge of the dispensary and stocks of drugs and surgical equipment; to prepare estimates and requisitions for supplies.

*Qualifications.*—To be a qualified and experienced pharmaceutical chemist.

## Draughtsman, Class "D," Eildon Project, Department of Water Supply.

*Yearly Salary.*—£338, minimum; £436, maximum.

*Duties.*—Under direction, to prepare survey plans and designs of civil and hydraulic engineering structures; to take out earthwork quantities and prepare longitudinal sections of channels and pipe lines for water supply and drainage.



**Qualifications.—**

1. To have passed—
  - (a) The School Leaving examination, including English, Mathematics I., and Mathematics II.; or
  - (b) the School Intermediate examination and, in addition, School Leaving English, Mathematics I., and Mathematics II.; or
  - (c) an equivalent Technical School examination; and
2. To be experienced in the type of work outlined in the duties.

**Draughtsman, Class "D," Department of Water Supply.**  
(One vacancy—Morrington Peninsula District (Frankston).  
(One vacancy—Loddon Division.)

*Yearly Salary.*—£338, minimum; £436, maximum.

*Duties.*—To prepare plans of reticulation works, main channels and pipe lines, fittings, and general draughting.

**Qualifications.—**

1. To have passed—
  - (a) The School Leaving examination, including English, Mathematics I., and Mathematics II.; or
  - (b) the School Intermediate examination and, in addition, School Leaving English, Mathematics I., and Mathematics II.; or
  - (c) an equivalent Technical School examination; and
2. To have had training or experience in the type of work outlined in the duties.

**TECHNICAL AND GENERAL DIVISION.**

**Inspector of Stock, Department of Agriculture.**

*Yearly Salary.*—£423, minimum; £501, maximum.

*Qualifications.*—To be the holder of a Dookie Diploma of Agriculture or its equivalent; to have a knowledge of (a) the relevant Acts administered by the Branch; (b) the contagious diseases of stock and the methods adopted for their control; (c) the vaccination of cattle with strain 19 vaccine; (d) sheep dips and sheep dipping; to be experienced in the artificial insemination of cattle, and the blood testing of poultry for pullorum disease; and to be competent to perform post-mortem examinations.

**Engineer, Leading Hand, Government Printing Office, Department of Treasurer.**

*Salary.*—£430 a year.

*Qualifications.*—To be a competent turner and fitter; to have an intimate knowledge of all classes of machinery used in the printing trade, and to be capable of installing new machinery when required.

**Reservoir Keeper (Wartook), Department of Water Supply.**

*Yearly Salary.*—£370, minimum; £409, maximum.

*Duties.*—To regulate the outflow from Wartook Reservoir; to carry out maintenance and repairs to all structures, buildings, embankments, and works appertaining to the reservoir; to be responsible for effective patrolling of the catchment areas in connexion with Wartook Reservoir; to keep records and record gaugings.

*Qualifications.*—To have had considerable experience in the regulation of water; a knowledge of the maintenance and operation of machinery; experience in charge of men engaged on construction and of quarrying, stone beaching, earthwork and concrete work; to be capable of keeping records of stores and costs of various operations, preparing pay sheets, and making records as required.

*NOTE.*—Accommodation is available to a successful married applicant at a rental of approximately 10 per cent. of salary. A remote allowance at the rate of £12 per annum will be paid. There is no school within travelling distance of the official residence.

**Painter, Mont Park Mental Hospital, Department of Health.**

*Salary.*—£364 a year.

*Duties.*—To assist the Senior Painter with general painting, paper-hanging and glazing and, if required, to assist in attention to roofs and spoutings.

*Qualifications.*—To be a competent painter (conversant with mixing and using of paints), paper-hanger and glazier.

**Storeman, Police Depot, Office of the Chief Commissioner of Police, Department of Chief Secretary.**

*Yearly Salary.*—£338, minimum; £364, maximum.

*Duties.*—To pack and despatch stores and equipment to police stations throughout the State and to assist generally in the store.

*Qualifications.*—To have experience of a storeman's duties and to be physically capable of handling heavy stores.

**Inspector (Female), Children's Welfare Branch, Department of Chief Secretary. (Two vacancies.)**

*Yearly Salary.*—£318, minimum; £357, maximum.

*Duties.*—To inspect and report on children and homes under the control and supervision of the Department.

*Qualifications.*—To be a certificated nurse; to possess the capacity to investigate and compile accurate and comprehensive reports on matters affecting the health, welfare, and environment of children under the care of the Department; to be competent to impart advice and guidance in the proper care and maintenance of children.

*NOTE.*—In addition to the salary rates quoted, a cost of living adjustment (£204 a year for adult males and £153 a year for adult females), which varies in accordance with the rise or fall in the index number of the cost of living, is payable.

By order,

E. F. FITZGIBBON,

Secretary.

Office of the Public Service Board,  
Melbourne, 28th March, 1951.

No. 38.

**PUBLIC SERVICE ACT 1946.**

THE Public Service Board, in pursuance of the powers conferred by the *Public Service Act 1946*, hereby amends the Public Service (Public Service Board) Regulations, as follows:—

**PART VI.—TRAVELLING EXPENSES.**

**DIVISION I.—REIMBURSEMENT OF PERSONAL EXPENSES.**

After paragraph (b) of Regulation 97 the following paragraph is inserted:—

"(c) Abroad—

Such allowance as the Board may determine having regard to the classification of the officer concerned and the country to be visited."

*This Regulation shall have effect as on and from the 8th April, 1951.*

E. F. FITZGIBBON, Secretary.

D. D. PAINE, Chairman.

Office of the Public Service Board,  
Melbourne, 20th March, 1951.

No. 35.

*Public Service Act 1946, Section 50.*

**REGULATIONS—PART III.—SALARIES, INCREMENTS, AND ALLOWANCES.**

THE Public Service Board, in pursuance of the powers conferred by the *Public Service Act 1946*, hereby amends its Regulations as shown below:—

**SIXTH SCHEDULE.**

**TEMPORARY EMPLOYEES.**

*Designations of Positions and Rates of Salaries.*

Department and Designation of Position.	Yearly Rate of Salary.		Increments (Annual).
	Minimum.	Maximum.	
DEPARTMENT OF HEALTH.	£	£	
GENERAL HEALTH.			
Add— Physiotherapist (Male)	390	416	1 of £26

*This Regulation shall have effect as on and from the 4th March, 1951.*

D. D. PAINE, Chairman.

E. F. FITZGIBBON, Secretary.

Office of the Public Service Board,  
Melbourne, 5th March, 1951.

No. 37.

*Public Service Act 1946, Section 50.*

REGULATIONS.—PART III.—SALARIES, INCREMENTS, AND ALLOWANCES.

THE Public Service Board, in pursuance of the powers conferred by the *Public Service Act 1946*, hereby amends its Regulations as shown below:—

SIXTH SCHEDULE.

TEMPORARY EMPLOYEES.

*Designations of Positions and Rates of Salaries.*

Department and Designation of Position.	Yearly Rate of Salary.		Increments (Annual).
	Minimum.	Maximum.	
DEPARTMENT OF PREMIER.	£	£	
SOIL CONSERVATION AUTHORITY.			
Add— Research Officer		850	

*This Regulation shall have effect as on and from the 1st April, 1951.*

D. D. PAINE, Chairman.  
E. F. FITZGIBBON, Secretary.

Office of the Public Service Board,  
Melbourne, 13th March, 1951.

No. 36.

*Public Service Act 1946, Section 39.*

REGULATIONS.—PART III.—SALARIES, INCREMENTS, AND ALLOWANCES.

THE Public Service Board, in pursuance of the powers conferred by the *Public Service Act 1946*, hereby amends its Regulations as shown below:—

FIRST SCHEDULE.

PROFESSIONAL DIVISION.

*Offices and Rates of Salaries.*

Office.	Yearly Rate of Salary.	
	Minimum.	Maximum.
DEPARTMENT OF PREMIER.	£	£
GLASS "A."		
Add— Principal Research Officer, Soil Conservation Authority	1,000	1,100

*This Regulation shall have effect as on and from the 1st April, 1951.*

D. D. PAINE, Chairman.  
E. F. FITZGIBBON, Secretary.

Office of the Public Service Board,  
Melbourne, 13th March, 1951.

TENDERS.

TENDERS will be received at this office until **TEN A.M.** on the days and for the purposes under mentioned. Particulars may be learnt at this Office and also at places shown in parenthesis.

W.O. means Inspector of Works Office; P.S.—Police Station; T.S.—Technical School; H.E.S.—Higher Elementary School; S.S.—State School; H.S.—High School; P.D.—Preliminary deposit; F.D.—Final deposit.

The Board of Land and Works will not necessarily accept the lowest or any tender.

3rd April, 1951.

Beechworth.—Painting and repairs, &c., Inspector's Residence, Education Department. (W.O., Wangaratta; P.S., Myrtleford; S.S. Beechworth.) P.D., £10. F.D., 2 per cent.

Burwood East.—Kerosene hot-water service, teacher's residence, S.S. No. 454. P.D., £3. F.D., 2 per cent.

Glenferrie.—Conversion of old chemistry laboratory to library classroom, Swinburne Technical School. P.D., £20. F.D., 2 per cent.

Leongatha.—Supply and installation of a kerosene hot-water service, teacher's residence, S.S. No. 2981. (W.O., Korumburra.) P.D., £3. F.D., 2 per cent.

Port Melbourne.—Supply and delivery to Public Works Department Depot, Salmon-street, of the following plant:—Two Leyland "Hippo" prime movers to be interchangeable with those held at Depot; four Leyland "Comet" semi-trailers, with drop sides and tail, to be interchangeable with prime movers held at Depot; two only 4-ton tip trucks; one only 5-ton flat-top truck, with drop sides and tail; one only 10 to 15-cwt. utility truck (for long distance country trips); one only 25-ton payload low loader (for use with one of the "Hippos" above) for transport of heavy plant. Full details, together with date of delivery, to be supplied by contractor.

Port Melbourne.—Electrical installation in twelve (12) prefabricated residences, Public Works Department Depot, Salmon-street. P.D., £15. F.D., 2 per cent.

Shelford.—Erection of new teacher's residence, State School No. 379. (W.O., Geelong; P.S., Colac; S.S. Shelford.) P.D., £15. F.D., 2 per cent.

Seymour.—Repairs and painting, H.S. (W.O., Alexandra; P.S., Seymour.) P.D., £15. F.D., 2 per cent.

South Melbourne.—Supply and installation of mechanical ventilation in kitchen, Police Depot, St. Kilda-road. P.D., £5. F.D., 2 per cent.

Tallangatta.—Electrical installation, S.S. No. 1365. (W.O., Wangaratta; P.S., Wodonga.) P.D., £4. F.D., 2 per cent.

Toora.—Erection of new out-offices and installation of septic tank, S.S. No. 2253. (W.O., Korumburra; P.S., Foster; S.S. Toora.) P.D., £10. F.D., 2 per cent.

Tottenham.—Fire protection of building, S.S. No. 3890. P.D., £10. F.D., 2 per cent.

Various.—Manufacture of one hundred (100) rain-water tanks, 800-gallon capacity, standard shape from iron supplied by Department, and delivery to nearest loading railway station to place of manufacture, Public Works Department.

Wangaratta.—Erection of new timber residence for Principal, T.S. (W.O., Wangaratta; T.S., Wangaratta.) P.D., £20. F.D., 2 per cent.

Wangaratta.—Erection of new timber residence, out-buildings and garage, Inspector's Residence, Fisheries and Game Department. (W.O., Wangaratta.) P.D., £15. F.D., 2 per cent.

Williamstown.—New Diesel type engine, tug *Goudie*, Public Works Department.

10th April, 1951.

Albert Park.—Repairs, re-blocking, and renovations, caretaker's residence, S.S. No. 1181. P.D., £5. F.D., 2 per cent.

Allansford.—Septic tank installation, S.S. No. 3. (W.O., Warrnambool; S.S., Allansford.) P.D., £10. F.D., 2 per cent.

Ararat.—Replacing of existing timber toilets with brick structures, Wards M.8, M.9, M.10, M.11, Mental Hospital. (W.O., Ararat, Ballarat; P.S., Stawell; Mental Hospital, Ararat.) P.D., £15. F.D., 2 per cent.

Axedale.—Erection of teacher's residence in timber, S.S. No. 1008. (W.O., Bendigo; S.S., Axedale.) P.D., £15. F.D., 2 per cent.

Badger Creek.—Additional class-room and alterations, S.S. No. 3309. (W.O., Alexandra; S.S., Badger Creek.) P.D., £15. F.D., 2 per cent.

Beechworth.—Provision of day room, kitchen extension, and glass screening to balcony, Mental Hospital. (W.O., Wangaratta; P.S., Myrtleford; Mental Hospital, Beechworth.) P.D., £20. F.D., 2 per cent.

Benalla.—Repairs and painting, H.S. (W.O., Benalla; H.S., Benalla.) P.D., £15. F.D., 2 per cent.

Bendigo.—Repairs, painting, paths, new garage, &c., Sergeant's Quarters, P.S. (W.O., Bendigo; P.S., Bendigo, Castlemaine.) P.D., £5. F.D., 2 per cent.

Bendigo.—Erection of new residence for Inspector of Boilers, Department of Mines, Finn-street. (W.O., Bendigo; P.S., Eaglehawk.) P.D., £15. F.D., 2 per cent.

Bendigo.—Supply and delivery of fluorescent lighting equipment, School of Mines. P.D., £15. F.D., 2 per cent.

Blackwood North.—Removal of State School No. 927, Glengower, and re-erection, S.S. No. 1636. (W.O., Ballarat, Kyneton, Maryborough; P.S., Daylesford; S.S., Blackwood North.) Deposit, £4.

Carrajung South.—Erection of new teacher's residence, S.S. No. 3304. (W.O., Traralgon; P.S., Yarram; S.S., Carrajung South.) P.D., £15. F.D., 2 per cent.

Cobram.—Erection of new station with single men's quarters, and including sewerage installations, P.S. (W.O., Benalla; P.S., Cobram.) P.D., £15. F.D., 2 per cent.

Colac West.—Erection of fire-escape staircase, S.S. No. 4064. (W.O., Camperdown, Geelong; S.S., Colac West.) Deposit, £4.

Coonooer Bridge.—Erection of new residence, S.S. No. 1736. (W.O., Bendigo; P.S., Charlton; S.S., Coonooer Bridge.) P.D., £15. F.D., 2 per cent.

Creswick.—Septic tank installation, S.S. No. 122. (W.O., Ballarat; S.S., Creswick.) P.D., £5. F.D., 2 per cent.

Daylesford.—External and internal repairs and painting, Court House. (W.O., Kyneton; P.S., Daylesford.) P.D., £5. F.D., 2 per cent.

Echuca.—Repairs and painting, T.S. (W.O., Shepparton; P.S., Numurkah; T.S., Echuca.) P.D., £10. F.D., 2 per cent.

Edithvale.—Erection of new fencing, S.S. No. 3790. (S.S., Edithvale.) Deposit, £4.

Euroa.—Provision of staff room, S.S. No. 1706. (W.O., Benalla; P.S., Seymour; S.S., Euroa.) P.D., £2. F.D., 2 per cent.

Eurobin.—Repairs to fencing, S.S. No. 1355. (W.O., Wangaratta; P.S., Bright; S.S., Eurobin.) P.D., £4. F.D., 2 per cent.

Geelong.—Erection of timber residence for Inspector, Fisheries and Game Department. (W.O., Geelong.) P.D., £15. F.D., 2 per cent.

Jung.—Installation of septic tank system and new out-offices with concrete floors, S.S. No. 1728. (W.O., Horsham, Warracknabeal; P.S., Murtoa; S.S., Jung.) Deposit, £4.

Kensington.—Alterations and repairs to cleaner's residence, S. S. No. 2374. P.D., £4. F.D., 2 per cent.

Kilmore.—Erection of office and residence, P.S. (W.O., Kyneton; P.S., Kilmore.) P.D., £20. F.D., 2 per cent.

Korumburra.—Erection of two offices, Court House. (W.O., Korumburra; P.S., Wonthaggi.) P.D., £20. F.D., 2 per cent.

Leongatha.—Renovations, repairs, and painting to Nurses' Quarters, District Hospital. (W.O., Korumburra; District Hospital, Leongatha.) P.D., £10. F.D., 2 per cent.

Manangatang.—Alterations and additions, District Hospital. (W.O., Bendigo, Swan Hill; P.S., Manangatang.) P.D., £20. F.D., 2 per cent.

Melbourne.—Construction of low-temperature skin storage room, National Museum. P.D., £5. F.D., 2 per cent.

Mia Mia.—External painting, school, and provision of sleepout, residence, S.S. No. 952. (W.O., Bendigo, Kyneton; S.S., Mia Mia.) P.D., £4. F.D., 2 per cent.

Mont Park.—Supply and delivery and bolting down of laundry equipment, Larundel Mental Hospital. P.D., £50. F.D., 2 per cent.

Mont Park.—Electrical installation, new Laundry Block, Larundel Mental Hospital. P.D., £15. F.D., 2 per cent.

Morwell.—Renovations to residence, Post Primary School No. 2, 34 Maryvale-road. (W.O., Traralgon; P.S., Morwell.) P.D., £10. F.D., 2 per cent.

Oxley.—Supply and installation of hard fuel hot-water service, teacher's residence, S.S. No. 1399. (W.O., Benalla; P.S., Oxley.) P.D., £3. F.D., 2 per cent.

Pannure.—Septic tank installation, S.S. No. 1079. (W.O., Warrnambool; P.S., Allansford; S.S., Pannure.) P.D., £5. F.D., 2 per cent.

Port Melbourne.—Provision of 5,000 lineal yards "C" marbled linoleum; 10,000 lineal yards "A" brown linoleum; 5,000 lineal yards of "A" marbled linoleum, Public Works Department Store, Salmon-street. P.D., £50. F.D., 2 per cent.

Rutherglen.—Alterations to infant's class-rooms, S.S. No. 522. (W.O., Wangaratta; S.S., Rutherglen.) P.D., £10. F.D., 2 per cent.

Stawell.—Timber residence for Engineer-Mechanic, Pleasant Creek Special School. (W.O., Ararat; P.S., Stawell; Pleasant Creek Special School, Stawell.) P.D., £15. F.D., 2 per cent.

Tungamah.—Repairs and painting, P.S. (W.O., Benalla; P.S., Tungamah, Yarrowonga.) P.D., £10. F.D., 2 per cent.

Waaia.—Erection of new teacher's residence, S.S. No. 2986. (W.O., Shepparton; P.S., Numurkah; S.S., Waaia.) P.D., £15. F.D., 2 per cent.

Wangaratta.—Repairs and painting, S.S. No. 643. (W.O., Wangaratta; S.S., Wangaratta.) P.D., £15. F.D., 2 per cent.

Williamstown.—External and internal repairs and renovations, Girls' School. P.D., £10. F.D., 2 per cent.

Winton.—Repairs to roof, new spouting and downpipes, S.S. No. 1870. (W.O., Benalla; S.S., Winton.) P.D., £5. F.D., 2 per cent.

Wonthaggi North.—Erection of new out-offices and provision of septic tank, S.S. No. 3716. (W.O., Korumburra; S.S., Wonthaggi North.) P.D., £10. F.D., 2 per cent.

17th April, 1951.

Culgoa.—General repairs and painting, S.S. No. 3246. (W.O., Swan Hill; S.S., Culgoa.) P.D., £5. F.D., 2 per cent.

Dimboola.—Erection of new out-office block, Memorial High School. (W.O., Horsham, Warracknabeal; Memorial High School, Dimboola.) P.D., £15. F.D., 2 per cent.

Dooen.—Provision of office for Housemaster, Longerenong Agricultural College. (W.O., Horsham.) Deposit, £4.

Dooen.—Erection of new residence, S.S. No. 1782. (W.O., Horsham; P.S., Murtoa; S.S., Dooen.) P.D., £15. F.D., 2 per cent.

Echuca East.—Provision of sleep-out to teacher's residence, S.S. No. 2667. (W.O., Shepparton; P.S., Echuca, Kyabram, Rochester; S.S., Echuca East.) Deposit, £3.

Edenhope.—Erection of two (2) new teacher's residences, S.S. No. 817. (W.O., Horsham; P.S., Goroke; H.E.S., Edenhope.) P.D., £20. F.D., 2 per cent (Amended specification.)

Geelong.—Supply, delivery, and installation of air-conditioning equipment, Gordon Institute of Technology. P.D., £15. F.D., 2 per cent.

Golden Square.—Repairs and painting, S.S. No. 1189. (W.O., Bendigo; P.S., Castlemaine; S.S., Golden Square.) P.D., £15. F.D., 2 per cent.

Greenvale.—Supply and installation of seven (7) briquette hot-water services, Sanatorium. P.D., £15. F.D., 2 per cent.

Horsham.—Erection of new timber residence, Country Roads Board, Baillie-street. (W.O., Ararat; Assistant District Architect's Office, Horsham; P.S., Stawell.) P.D., £20. F.D., 2 per cent.

King Valley.—Supply and installation of kerosene hot-water service, residence, S.S. No. 2894. (W.O., Wangaratta.) P.D., £3. F.D., 2 per cent.

Kotupna.—Repairs and renovations, S.S. No. 1999. (W.O., Shepparton; P.S., Numurkah; S.S., Kotupna.) P.D., £10. F.D., 2 per cent.

Kyneton.—Fitting room No. 7 as auxiliary Science Room, H.S. (W.O., Bendigo, Kyneton.) Deposit, £4.

Manangatang.—Electrical installation, Consolidated School. (P.S., Manangatang.) P.D., £10. F.D., 2 per cent.

Port Melbourne.—Internal and external repairs and painting, Court House. P.D., £5. F.D., 2 per cent.

Various.—Supply and installation of thirty-nine (39) hot-water services in various school residences from Melbourne to Camperdown, Public Works Department. (W.O., Ballarat, Geelong, Warrnambool.) P.D., £25. F.D., 2 per cent.

Willaura.—External and internal painting, general repairs and renovations and installation of electric light and power, &c., Court House. (W.O., Ararat; P.S., Stawell; Court House, Willaura.) P.D., £5. F.D., 2 per cent.

24th April, 1951.

Hampton.—External and internal repairs and painting, school buildings and fences, S.S. No. 3754. (S.S., Hampton.) P.D., £15. F.D., 2 per cent.

Manangatang.—Supply and installation of central heating system and hot-water service, Senior Wing, Consolidated School. P.D., £15. F.D., 2 per cent.

Mont Park.—Supply and installation of mechanical services in laundry, Larundel Mental Hospital. P.D., £25. F.D., 2 per cent.

Tenders to be addressed to the Honorable the Commissioner of Public Works, and envelope containing tender marked "Tender for  
due  
"

P. T. BYRNES,  
Commissioner of Public Works

Melbourne, 28th March, 1951.

## PRIVATE ADVERTISEMENTS.

## CITY OF MILDURA.

## LOAN No. 25.

*Notice of Intention to Borrow the Sum of £30,000 for Permanent Works in the City of Mildura.*

**T**AKE notice that the City of Mildura proposes to borrow on the credit of the Mayor, Councillors, and Citizens of the said city the sum of Thirty thousand pounds (£30,000), such sum to be raised by the issue of debentures in accordance with the respective provisions of the Local Government Act.

The maximum rate of interest that may be paid is Three pounds ten shillings (£3 10s.) per centum per annum.

Such moneys shall be repayable by 50 half-yearly instalments of principal and interest by providing out of the municipal fund the said amounts on the 1st day of December and the 1st day of June in each respective year during the currency of the loan.

Such moneys shall be repayable at Melbourne at the Commercial Banking Co. of Sydney Ltd., or at the Council's bankers for the time being in Melbourne.

The purpose for which the loan is to be applied is—

Construction of Roads, Footpaths, and Drainage—£30,000.

The plans, specifications, and estimate of the cost of the works referred to above, and a statement showing the proposed expenditure of money to be borrowed, are open for inspection at the Town Hall, Mildura.

Dated this 22nd day of March, 1951.

W. J. DOWNIE, Town Clerk.

Town Hall, Mildura, 24th March, 1951. 6377

## CITY OF MILDURA.

## LOAN No. 26.

*Notice of Intention to Borrow the Sum of £60,000 for Electricity Extensions, Including Purchase and Installation of Generating Plant.*

**T**AKE notice that the City of Mildura proposes to borrow on the credit of the Mayor, Councillors, and Citizens of the said city the sum of Sixty thousand pounds (£60,000) such sum to be raised by the issue of debentures in accordance with the respective provisions of the Local Government Act.

The maximum rate of interest that may be paid is Three pounds ten shillings (£3 10s.) per centum per annum.

Such moneys shall be repayable by 50 half-yearly instalments of principal and interest by providing out of the revenue of the electricity undertaking the said amounts on the 1st day of December and the 1st day of June in each respective year during the currency of the loan.

Such moneys shall be repayable at Melbourne at the Commercial Banking Co. of Sydney Ltd., or at the Council's bankers for the time being in Melbourne.

The purpose for which the loan is to be applied is—

Electricity Extensions, including purchase and installation of Generating Plant.

The plans, specifications, and estimate of the cost of the works referred to above, and a statement showing the proposed expenditure of money to be borrowed, are open for inspection at the Town Hall, Mildura.

Dated this 22nd day of March, 1951.

W. J. DOWNIE, Town Clerk.

Town Hall, Mildura, 24th March, 1951. 6387

## SHIRE OF GORDON.

## LOAN No. 9—£7,000.

*Notice of Intention to Borrow for Permanent Works and Undertakings.*

**T**AKE notice that the Council of the Shire of Gordon proposes to borrow on the credit of the President, Councillors, and Ratepayers of the said shire the sum of Seven thousand pounds, such sum to be raised by the issue of debentures in accordance with the provisions of the Local Government Acts.

It is further proposed that—

1. The rate of interest to be named in such debentures shall be £3 7s. 6d. per cent. per annum.

2. The moneys borrowed shall be repayable by providing out of the municipal fund 40 half-yearly instalments of approximately £242 1s. 6d. each, including principal and interest, on the 1st day of January and the 1st day of July during the currency of the loan. The first instalment shall be payable on the 1st day of January, 1952.

3. Such moneys shall be repayable at the National Bank of Australasia Limited, Melbourne, or at the Council's bankers for the time being in Melbourne.

4. The purposes for which the loan is to be applied are as follows:—

Purchase of additional plant and machinery, including all ancillary gear and extension to power house at the Council's Electric Light Undertaking at Pyramid Hill .. £7,000

The plans and specifications and estimate of the cost of the permanent works referred to above, with a statement of the proposed expenditure of the money to be borrowed, are open for inspection at the Shire Office, Boort.

Dated this 20th day of March, 1951.

6385 ROSS M. GRAHAM, Shire Secretary.

## SHIRE OF WODONGA.

*NOTICE OF INTENTION TO BORROW THE SUM OF FOUR THOUSAND SIX HUNDRED POUNDS (£4,600) FOR PERMANENT WORKS AND UNDERTAKINGS IN THE SHIRE OF WODONGA.*

**T**AKE notice that the Council of the Shire of Wodonga proposes to borrow on the credit of the President, Councillors, and Ratepayers of the said shire, the sum of Four thousand six hundred pounds (£4,600), such sum to be raised by the issue of debentures in accordance with the provisions of the Local Government Acts.

The maximum rate of interest that may be paid is £3 7s. 6d. per centum per annum.

Such moneys shall be repayable by 40 half-yearly instalments of approximately £159 1s. 6d. each, including principal and interest, by providing out of the municipal fund such amounts on the 1st day of June and the 1st day of December in each respective year during the currency of the loan. The first instalment shall be payable on the 1st day of December, 1951.

Such moneys shall be repayable at the Bank of New South Wales, Melbourne, or at the Council's bankers for the time being in Melbourne.

The purposes for which the loan is to be applied are:—

	£
Sealing of streets in township of Wodonga ..	1,000
Drainage works in township of Wodonga ..	2,000
Purchase of machinery for road-making purposes, viz.: One Power Front-end Loader ..	1,600
	£4,600

The plans, specifications and estimates of the cost of the works referred to above, and a statement showing the proposed expenditure of money to be borrowed, are open for inspection at the Shire Office, Wodonga.

Dated this 20th day of March, 1951.

6384 J. N. EDDY, Shire Secretary.

**N**OTICE is hereby given that Ballarat Associated Dairymen Limited, of 43 Lydiard-street south, Ballarat, has applied for a lease under section 125 of the *Land Act 1928*, for a term of 50 years over allotment 4A of section 3, in the Parish of Cardigan, as a site for a milk pasteurization factory. 6297

**N**OTICE is hereby given that Simmonds Aerocessories Pty. Ltd., of 357 Exhibition-street, Melbourne, has applied for a lease under section 125 of the *Land Act 1928*, for a term of 50 years over building No. 17 and an area of approximately 2½ acres of Crown land on the former explosives factory at Ballarat, as a site for the manufacture of aeronautical and industrial accessories. 6395

*River Improvement Act 1948.*

## PROPOSED RIVER IMPROVEMENT DISTRICT.

**N**OTICE is hereby given that the Council of the Shire of Avon has forwarded to the Minister of Water Supply an application for the constitution of a River Improvement District under the jurisdiction and control of a river improvement trust and comprising an area along the Avon River, under the provisions of the *River Improvement Act 1948*.

Copies of the application and general plan and description of the proposed works have been deposited for inspection at the offices of—

- The Minister of Water Supply, State Rivers and Water Supply Commission, 100-110 Exhibition-street, Melbourne;
- The Shire of Maffra at Maffra;
- The Shire of Avon at Stratford.

ERIC C. BOCK, Shire Secretary.

Stratford, 22nd March, 1951. 6372

**NOTICE OF INTENTION TO APPLY FOR A LICENCE TO DIVERT WATER AND CUT RACES FROM THE MURRAY RIVER AT PIANGIL.**

I HEREBY give notice that I intend to apply for a licence empowering me to divert water for a term of fifteen years to the extent of 140 acre-feet per annum at a maximum rate of 10 acre-feet per day of 24 hours for irrigation of 70 acres, being part of allotment 122, Parish of Piangil, and to occupy certain Crown lands for works of storage and diversion, and to cut a race thereon.

Any objection to such application must be forwarded, in writing, to the State Rivers and Water Supply Commission, Melbourne, within 30 days of the date hereof.

RALPH PHILBRICK.

Piangil, 27th March, 1951.

ALAN GARDEN & GREEN, solicitors, Nyahwest. 6406

**NOTICE OF INTENTION TO APPLY FOR A LICENCE TO DIVERT WATER AND CUT RACES FROM THE MURRAY RIVER AT PIANGIL.**

I HEREBY give notice that I intend to apply for a licence empowering me to divert water for a term of fifteen years to the extent of 40 acre-feet per annum at a maximum rate of 1 acre-feet per day of 24 hours for irrigation of 20 acres, being part of allotments 8 and 9, Parish of Piangil, and to occupy certain Crown lands for works of storage and diversion, and to cut a race thereon.

Any objection to such application must be forwarded, in writing, to the State Rivers and Water Supply Commission, Melbourne, within 30 days of the date hereof.

JOSEPH WILLIAM O'HARA.

Piangil, 27th March, 1951.

ALAN GARDEN & GREEN, solicitors, Nyahwest. 6405

**NOTICE OF INTENTION TO APPLY FOR A LICENCE TO DIVERT WATER AND CUT RACES FROM THE MURRAY RIVER AT PIANGIL.**

I HEREBY give notice that I intend to apply for a licence empowering me to divert water for a term of fifteen years to the extent of 180 acre-feet per annum at a maximum rate of 10 acre-feet per day of 24 hours for irrigation of 90 acres, being part of allotment 127, Parish of Piangil, and to occupy certain Crown lands for works of storage and diversion, and to cut a race thereon.

Any objection to such application must be forwarded, in writing, to the State Rivers and Water Supply Commission, Melbourne, within 30 days of the date hereof.

SHERIDAN DODGSHUN.  
IDA VICTORIA DODGSHUN.

Kooloonong, 27th March, 1951.

ALAN GARDEN & GREEN, solicitors, Nyahwest. 6404

**NOTICE OF INTENTION TO APPLY FOR A LICENCE TO DIVERT WATER AND CUT RACES FROM THE MURRAY RIVER AT PIANGIL.**

I HEREBY give notice that I intend to apply for a licence empowering me to divert water for a term of fifteen years to the extent of 100 acre-feet per annum at a maximum rate of 10 acre-feet per day of 24 hours for irrigation of 50 acres, being part of allotment 124A, Parish of Piangil, and to occupy certain Crown lands for works of storage and diversion, and to cut a race thereon.

Any objection to such application must be forwarded, in writing, to the State Rivers and Water Supply Commission, Melbourne, within 30 days of the date hereof.

FRANK REGINALD GRANT.

Chinkapook, 27th March, 1951.

ALAN GARDEN & GREEN, solicitors, Nyahwest. 6403

**NOTICE OF INTENTION TO APPLY FOR A LICENCE TO DIVERT WATER AND CUT RACES FROM THE MURRAY RIVER AT PIANGIL.**

I HEREBY give notice that I intend to apply for a licence empowering me to divert water for a term of fifteen years to the extent of 100 acre-feet per annum at a maximum rate of 10 acre-feet per day of 24 hours for irrigation of 50 acres, being part of allotments 118 and 119, Parish of Piangil, and to occupy certain Crown lands for works of storage and diversion, and to cut a race thereon.

Any objection to such application must be forwarded, in writing, to the State Rivers and Water Supply Commission, Melbourne, within 30 days of the date hereof.

LESLIE GEORGE WILLIAMS.

Piangil, 27th March, 1951.

ALAN GARDEN & GREEN, solicitors, Nyahwest. 6386

NOTICE is hereby given that the partnership heretofore subsisting between Frederick Henry Sforcina, of Cunningham-street, Northcote, Margaret Gene Welsh, of Windsor-avenue, North Essendon, and me, the undersigned, Keith James Kendall, of 43 Shelley-street, Elwood, carrying on business as caterers at 26 Bridge-road, Richmond, under the firm of Forham Catering Service, has been dissolved as from 22nd December, 1950, from which date the partnership ceased to carry on business.

Dated this 14th day of March, 1951.

K. J. KENDALL.

6394

NOTICE is hereby given that the partnership heretofore subsisting between the undersigned James Armstrong Bell, junior, and Lionel Edward Logan, carrying on business as merchants, garage proprietors, and contractors, at Camperdown, under the name of Bell and Logan, has been dissolved by mutual consent as from the 30th day of June, 1950. All debts due to and owing by the said late firm will be received and paid by the said Lionel Edward Logan, who has taken over and will continue to carry on the business of Garage Proprietor and Machinery Merchant at Pike-street, Camperdown, under the firm name of "L. E. Logan and Co." The said James Armstrong Bell, junior, has taken over and will continue to carry on the earth-moving and heavy contracting business at Camperdown under his own name.

Dated the 15th day of March, 1951.

J. A. BELL, JUNIOR.

L. E. LOGAN.

6398

NOTICE is hereby given that the partnership between Paul Winston and Alexander Dundas Reid, formerly carrying on the business of general engineering and machining, under the name of "Winston Engineering Co.," at 51 Grosvenor-street, South Yarra, has been dissolved as from the 28th day of February, 1951; and notice is further given that the said Alexander Dundas Reid will henceforth carry on the said business at the above-mentioned address under the same firm name. All debts due to and owing by the said firm will be received and paid by the said Alexander Dundas Reid at the said address.

Dated the 22nd of March, 1951.

P. WINSTON.

A. D. REID.

Davies, Campbell, and Piesse, 401 Collins-street, Melbourne, solicitors. 6402

NOTICE is hereby given that the partnership hitherto subsisting between Elsebe Wilhelmine Puls and Margery Greenberg, both of Horsham, carrying on business in Firebrace-street, Horsham, and also at Warracknabeal, under the style or name of "Suzette Modes," has been dissolved as from the 15th day of February, 1951, and that the said Margery Greenberg will carry on the Horsham branch of the said business solely on her own account, and the said Elsebe Wilhelmine Puls will likewise carry on the Warracknabeal branch thereof.

E. W. PULS.

M. GREENBERG.

6400

NOTICE is hereby given that the partnership heretofore subsisting between Harold Arthur Trew, Allan George Trew, and Clement Gerald Woodhouse, carrying on business as general storekeepers at Tinamba, under the name of "Tinamba General Store," has been dissolved by mutual consent as from the 20th day of November, 1950, so far as concerns the said Harold Arthur Trew and Clement Gerald Woodhouse, who retire from the said firm.

All debts due to and owing by the said late firm will be received and paid by the said Allan George Trew and the undersigned Unita Eileen Trew, who will continue to carry on the business under the said name of "Tinamba General Store," at the same place.

H. TREW.

A. G. TREW.

CLEM. G. WOODHOUSE.

UNITA TREW.

Arthur F. Rice and Co., solicitors, Maffra. 6379

NOTICE is hereby given that the partnership carried on by Alfred Gordon Cowland, formerly of 32 Thomas-street, Burwood, but now of corner of Middleborough-road and Ely-road, Box Hill South, and Alan Leslie Tough, of Burwood-road, Tally Ho, market gardeners, under the name of Cowland and Tough Nurseries, has been dissolved as from the 1st day of March, 1951, the said Alan Leslie Tough having retired from the partnership.

Dated this 22nd day of March, 1951.

JOHN H. KINNEAR & CO., 51 Riversdale-road, Camberwell Junction, solicitors for both parties herein. 6388

## Companies Act 1938.

D & L FOUNDRIES PROPRIETARY LIMITED  
(IN VOLUNTARY LIQUIDATION).

A GENERAL MEETING of the above company will be held at 11.30 a.m. on the 10th day of May, 1951, at 444 Collins-street, Melbourne, for the purpose of receiving the liquidators' final account of the winding up.

Dated the 29th day of March, 1951.

6399 C. V. TAYLOR, Liquidator.  
E. SCOTT, Liquidator.

Form No. 49 (section 226).

KIA ORA PRIVATE HOSPITAL PROPRIETARY  
LIMITED (IN LIQUIDATION).

AT an Extraordinary General Meeting of the above-named company duly convened and held at French-street, Hamilton, on Thursday, the 8th day of March, 1951, the following Resolution was duly passed as a Special Resolution:—

"That the company be wound up voluntarily."

And at such last-mentioned meeting Basil Lee Archer, and John Bertrand McLarty, of Hamilton, were appointed liquidators for the purposes of the winding up.

Dated the 9th day of March, 1951.

6382 SAMUEL C. FITZPATRICK, Chairman.

CREDITORS, next of kin, and others having claims in respect of the estate of Florence Edith Clarke, late of 129 Toorak-road, Camberwell, widow, deceased (who died on the 13th November, 1950), are to send the particulars of their claims to The Perpetual Executors and Trustees Association of Australia Limited, at its registered office, 100.104 Queen-street, Melbourne, by the 31st day of May, 1951, after which date it will distribute the assets, having regard only to the claims of which it then has notice.

TOLHURST, DRUCE, & EMMERSON, solicitors, 352 Collins-street, Melbourne. 6415

PURSUANT to the *Trustee Act 1928*, notice is hereby given that all persons having claims against the estate of Samuel Freeman, late of Yanac, in the State of Victoria, farmer, deceased (who died on the 16th day of September, 1950, and probate of whose will was granted by the Supreme Court of the said State, in its probate jurisdiction, on the 8th day of March, 1951; to The Fidelity Trustee Company Limited, of 101 Lydiard-street north, Ballarat, in the said State, and Reginald Blachley Turner, of Nhill, in the said State, solicitor), are hereby required to send particulars, in writing, of such claims to the said The Fidelity Trustee Company, at its above-mentioned address, or to the undersigned, at their office hereunder mentioned, on or before the 16th day of June, 1951, after which date the said The Fidelity Trustee Company Limited and the said Reginald Blachley Turner will proceed to distribute the assets of the said Samuel Freeman, deceased, which shall have come to their hands, amongst the persons entitled thereto, having regard only to the claims of which they shall then have had notice. And notice is hereby further given that the said The Fidelity Trustee Company Limited and the said Reginald Blachley Turner will not be liable for the assets so distributed, or any part thereof, to any person of whose claim he shall not have had notice as aforesaid.

Dated this 21st day of March, 1951.

TURNER & HOBDAY, 10 Victoria-street, Nhill, solicitors for the said The Fidelity Trustee Company Limited, and the said Reginald Blachley Turner. 6416

PURSUANT to the provisions of the *Trustee Act 1928*, notice is hereby given that all persons claiming against the estate of Sir George Cambourne Beauclerk Paynter, K.C.V.O., C.M.G., D.S.O., late of Eaton Grange, Grantham, Lincolnshire, England, brigadier-general in His Majesty's Army, deceased (who died on the 15th day of August, 1950, and probate of whose will was on the 20th day of February, 1951; re-sealed by The Supreme Court of Victoria upon being produced by Maxwell Rupert Ham, of 46 Queen-street, Melbourne, solicitor, the duly constituted attorney under power of the executors appointed thereby), are hereby required to send particulars, in writing, of such claims to the said Maxwell Rupert Ham, to care of Maleson, Stewart, and Co., at the address below, on or before the 31st day of May, 1951, after which date the said Maxwell Rupert Ham will proceed to survey or distribute the said estate to or among the persons entitled thereto, having regard only to the claims, whether formal or not, of which he shall then have had notice, and will not be liable for the assets so distributed to any person of whose claim he shall not then have had notice.

MALLESON, STEWART, & CO., solicitors, 46 Queen-street, Melbourne. 6412

## Trustee Act 1928.

## NOTICE TO CLAIMANTS.

PURSUANT to the *Trustee Act 1928*, creditors, next of kin, and all other persons having claims in respect of the estate of any deceased person named below are required to send particulars thereof to the legal personal representative or representatives, at the address stated below, on or before the date stated, after which date the representative or representatives will distribute the assets, having regard only to the claims of which notice has been received:—

Jessie Balmer Hay, formerly of Kamarooka, but late of "Lorna Doone," Sassafras, gentlewoman, who died on the 18th day of August, 1950.—Claims to the administrator, the Farmers and Citizens Trustees Company Bendigo Limited, of Charing Cross, Bendigo, not later than the 31st day of May, 1951. Tatchell, Dunlop, Smalley, and Balmer, solicitors, 290 Williamson-street, Bendigo. 6375

CREDITORS, next of kin, and others having claims in respect of the estate of Mary Jane Breen, late of Princes Highway, Dandenong, in the State of Victoria, married woman (who died on the 7th day of December, 1950), are to send the particulars of their claims to the Trustees, Executors, and Agency Company Limited, by the 28th day of May, 1951, after which date it will distribute the assets, having regard only to the claims of which it then has notice.

MORRISON & SAWERS, solicitors, Kyabram. 6380

NOTICE is hereby given that all persons interested, in particular, nephews and nieces of Patrick Gleeson, late of Barnard-street, Bendigo (at one time resident of Axedale district), in the State of Victoria, of no occupation at his death, he having died on the 9th day of March, 1949, and probate of whose will was on the 15th day of May, 1950, granted to Charles Xavier Taylor, formerly of 154 Barnard-street, Bendigo, aforesaid, law student, but now of 299 Hargreaves-street, Bendigo, in the said State, solicitor, are hereby required to send particulars, in writing, of relationship and such claims, to the executor, care of the under-mentioned solicitors, on or before the 9th day of June, 1951, after which latter date the executor will proceed to distribute the assets of the deceased amongst the persons entitled thereto, having regard only to claims of which he then shall have notice, and shall not be liable for the assets so distributed to any person of whose claim he shall not then have had notice. Nephews and nieces claiming as such are required to submit, in writing, identifying particulars, giving date and place of birth, full christian and surnames, and full name of each parent, and date and place of death of their respective parents.

Dated the 24th day of March, 1951.

MACOBOY, TAYLOR, & TAYLOR, solicitors, 299 Hargreaves-street, Bendigo. 6376

PURSUANT to the *Trustee Act 1928*, notice is hereby given that all creditors, next of kin, and others having claims against the property or estate of William Stanley McMullin, late of 23 Albert-street, East Melbourne, in the State of Victoria, secretary, deceased (who died on the 24th day of July, 1950, and probate of whose will and codicil thereto was granted by the Supreme Court of Victoria; in its probate jurisdiction, on the 15th day of March, 1951, to Robert Allison Eastwood, of Terang, in the said State, chartered accountant (Aust.)), are hereby required to send particulars, in writing, of such claims to the said executor, addressed to care of the under-mentioned solicitors, on or before the 30th day of May, 1951, after which date the said executor will proceed to distribute the assets of the said deceased amongst the persons entitled thereto, having regard only to the claims of which he shall then have had notice, and notice is hereby further given that the said executor will not be liable for the assets or any part thereof so distributed to any person of whose claim he shall not then have had notice.

WHITING & BYRNE, 101 William-street, Melbourne, solicitors for the executors. 6401

CREDITORS, next of kin, and others having claims in respect of the estate of Elsie May Weavell, late of 11 Halifax-street, Middle Brighton, in the State of Victoria, married woman, deceased (who died on the 28th day of February, 1950), are to send particulars of their claims to Henry Edward Weavell, care of his under-mentioned solicitors, by the 7th day of June, 1951, after which date he, the said Henry Edward Weavell, will distribute the assets, having regard only to the claims of which he shall then have notice.

UP'PON, ETTLESON, & OWEN, solicitors, 395 Collins-street, Melbourne. 6407

RICHARD PRYOR, late of Ultima, in the State of Victoria, farmer, DECEASED (who died on the 1st day of August, 1950).

CREDITORS, next of kin, and all other persons having claims against the estate of the deceased are required by the executors of the will, Richard Leslie Pryor, of Castlemaine, in the said State, driver, and Andrew Samuel Ferguson, of Dartmoor, in the said State, farmer, to send particulars to them, care of the undersigned, on or before the 21st day of June, 1951, after which date they will distribute the assets, having regard only to the claims of which they then have notice.

Dated the 21st day of March, 1951.

GARDEN & GREEN, solicitors, 29 McCallum-street, Swan Hill. 6396

CREDITORS, next of kin, and others having claims in respect of the estate of Mary O'Hagan, late of Lerderberg-street, Bacchus Marsh, in the State of Victoria, spinster, deceased (who died on the 2nd day of September, 1950, and probate of whose will has been granted to Kathleen Mary Vallenge and Una Mary Wittick, both of Bacchus Marsh aforesaid, and Marie Agnes George, of 17 Ashley-street, Reservoir, in the said State, all married women), are to send in particulars of their claims to the said executrices, care of the under-mentioned solicitors, by the 7th day of June, 1951, after which date they will distribute the assets, having regard only to the claims of which they then have notice.

VROLAND, PEARCE, & WEBSTER, solicitors, 430 Little Collins-street, Melbourne. 6410

CREDITORS, next of kin, and others having claims in respect of the estate of Horace Eldridge Clayton, late of 35 Jenkins-street, Northcote, railway employee (who died on the 29th January, 1951), are required to send particulars of their claims to Walter Edwin Carpenter, care of the undersigned solicitor, by the 7th day of July, 1951, after which date he will then distribute the assets, having regard only to the claims of which he then has notice.

Dated this 22nd March, 1951.

ROBERT C. ROY, solicitor, 472 Bourke-street, Melbourne. 6393

ROBERT FERGUSON PEDLEY, late of 3 Ballarat-street, Yarraville, dentist, DECEASED, intestate.

CREDITORS, next of kin, and others having claims in respect of the estate of the above-named deceased (who died on 22nd January, 1951), are to send particulars of their claims to National Trustees, Executors, and Agency Company of Australasia Limited, of 95 Queen-street, Melbourne, by the 6th day of June, 1951, after which date it will distribute the assets, having regard only to the claims of which it then has notice.

BROCKET & WOODS, solicitors, 108 Queen-street, Melbourne. 6392

PURSUANT to the *Trustee Act 1928*, all persons having claims against the estate of Rubina Rachel Jane Richards, late of 3 Viewbank-road, Glen Iris, in the State of Victoria, spinster (who died on the 30th day of August, 1950, and probate of whose will was granted by the Supreme Court of the said State, in its probate jurisdiction, on the 15th day of March, 1951, to Donald William McCutcheon and Paul Bothwell Osborn McCutcheon, both of 31 Queen-street, Melbourne, in the said State, solicitors), are hereby required to send particulars, in writing, of such claims to the said executors, care of the under-mentioned solicitors, on or before 31st May, 1951, after which date the executors will proceed to distribute the estate of the said deceased amongst the persons entitled thereto, having regard only to claims of which they shall then have had notice, and the said executors will not be liable for the assets so distributed, or any part thereof, to any person of whose claims they shall not then have had notice.

Dated the 22nd day of March, 1951.

W. B. & O. McCUTCHEON, solicitors, 31 Queen-street, Melbourne. 6390

CREDITORS, next of kin, and others having claims in respect of the estate of Everard Seth Ward, formerly of Kyabram, but late of Swan Hill, gentleman, deceased (who died on the 22nd day of June, 1950), are to send particulars of their claims to Andrew Warden, Herbert Smith, and Leo James Slattery, the executors, care of the undersigned, by the 28th of May, 1951, after which date they will distribute the assets, having regard only to the claims of which they then have notice.

MORRISON & SAWERS, solicitors, Kyabram. 6381

ALL persons having claims against the estate of George Frederick Alcock, late of No. 6 Flat, 35 Creswick-street, Hawthorn, in the State of Victoria, manufacturer, deceased (who died on the 4th day of November, 1950, and probate of whose will has been applied for by the National Trustees, Executors, and Agency Company of Australasia Limited, whose registered address is 95 Queen-street, Melbourne, in the said State), are hereby required to send particulars, in writing, of such claims to the said company, at its registered address aforesaid, on or before the 6th day of June, 1951, after which last-mentioned date the said company will proceed to distribute the assets of the said deceased amongst the persons entitled thereto, having regard only to the claims of which it shall then have had notice, and will not be liable for the assets, or any part thereof, so distributed to any person of whose claim it shall not have had notice as aforesaid.

BERNARD NOLAN, solicitor, 408 Collins-street, Melbourne. 6391

CREDITORS, next of kin, and others having claims against the estate of Lillias Mary Bergin, late of San Remo, in the State of Victoria, spinster, deceased (who died on the 14th day of December, 1950), are to send the particulars of their claims to National Trustees, Executors, and Agency Company of Australasia Limited; at its registered office, 95 Queen-street, Melbourne, by the 4th day of June, 1951, after which date it will distribute the assets, having regard only to the claims of which it then has notice.

GAVAN DUFFY & KING, solicitors, 95 Queen-street, Melbourne. 6389

CATHERINE MARY DERHAM, late of Pritchard-street west, Swan Hill, in the State of Victoria, married woman, DECEASED (who died on the 26th day of July, 1950).

CREDITORS, next of kin, and all other persons having claims against the estate of the deceased are required by the executors of the will, James Maurice Derham, of Beveridge-street, Swan Hill, in the said State, butcher, and Michael John Derham, of Pritchard-street west, Swan Hill aforesaid, labourer, to send particulars to them, care of the undersigned, on or before the 21st day of June, 1951, after which date they will distribute the assets, having regard only to the claims of which they then have notice.

Dated the 21st day of March, 1951.

ALAN GARDEN & GREEN, solicitors, McCallum-street, Swan Hill. 6397

PURSUANT to the provisions of the *Trustee Act 1928*, notice is hereby given that all persons claiming against the estate of William Oliver, late of "Grosvenor," 80 Walsh-street, South Yarra, in the State of Victoria, gentleman, deceased (who died on the 21st day of November, 1950, and probate of whose will was on the 20th day of March, 1951, granted by the Supreme Court of Victoria to Olive Margaret Oliver, of 80 Walsh-street, South Yarra aforesaid, spinster, and Roy James McArthur, of 46 Queen-street, Melbourne, in the said State, solicitor, the surviving executors appointed thereby), are hereby required to send particulars, in writing, of such claims to the said Olive Margaret Oliver and Roy James McArthur, to care of Malleison, Stewart, and Co., at the address below, on or before the 31st day of May, 1951, after which date the said executors will proceed to convey or distribute the said estate to or among the persons entitled thereto, having regard only to the claims, whether formal or not, of which they shall then have had notice, and will not be liable for the assets so distributed to any person of whose claim they shall not then have had notice.

MALLEISON, STEWART, & CO., solicitors, 46 Queen-street, Melbourne. 6411

CREDITORS, next of kin, and others having claims in respect of the estate of Lawrence McMahon, late of Darley, Bacchus Marsh, in the State of Victoria, labourer, deceased (who died on the 20th day of October, 1950, and probate of whose will has been granted to Blanche Vale McMahon, of Darley, Bacchus Marsh aforesaid, widow), are to send in particulars of their claims to the said executrix, care of the under-mentioned solicitors, by the 7th day of June, 1951, after which date she will distribute the assets, having regard only to the claims of which she then has notice.

VROLAND, PEARCE, & WEBSTER, solicitors, 430 Little Collins-street, Melbourne. 6408

**WILLIAM CAMPBELL**, son of the late Daniel and Ann Campbell (*née* Nicol) of Melbourne.

**WOULD** the above, or his child or children or any one knowing his or their address, communicate with Snowden, Neave, and Demaine, solicitors, 433 Little Collins-street, Melbourne, on or before 14th June, 1951. Otherwise William Campbell, or his child or children, may be excluded when the residuary estate of Annabelle Campbell, late of 48 Kooyong-road, Caulfield, Melbourne (who died on 27th May, 1950), is distributed among her next of kin.

6414

**CREDITORS**, next of kin, and others having claims in respect of the estate of Grace Williams, formerly of 100 Caroline-street, South Yarra, but late of 601 Toorak-road, Toorak, in the State of Victoria, widow, deceased (who died on the 18th day of December, 1950), are to send the particulars of their claims to The Perpetual Executors and Trustees Association of Australia Limited, of Nos. 100-104 Queen-street, Melbourne, by the 31st day of May, 1951, after which date it will distribute the assets, having regard only to the claims of which it then has notice.

**PARKINSON, WETTENHALL, & HART**, 357 Little Collins-street, Melbourne. 6413

**CREDITORS**, next of kin, and others having claims in respect of the estate of Annie Pigott, late of Werribee Vale, Bacchus Marsh, in the State of Victoria, widow, deceased (who died on the 13th day of May, 1950, and probate of whose will has been granted to William Joseph Pigott and Francis Joseph Pigott, both of Werribee Vale, Bacchus Marsh aforesaid, farmers), are to send in particulars of their claims to the said executors, care of the under-mentioned solicitors, by the 7th day of June, 1951, after which date they will distribute the assets, having regard only to the claims of which they then have notice.

**VROLAND, PEARCE, & WEBSTER**, solicitors, 430 Little Collins-street, Melbourne. 6409

**IMPOUNDINGS.**

**BOX HILL**.—Impounded at Box Hill, by L. C. Richards.

1 black gelding, hind fetlocks white, scars on inside flank, no visible brand

If not claimed and expenses paid, to be sold on 12th April, 1951.

**H. J. BARRETT**, Poundkeeper. 6383—7/

**ELMORE**.—Impounded at Elmore.

1 black and white steer, no visible brand  
1 red and white steer, no visible brand  
2 roan steers, no visible brands  
1 red heifer calf, no visible brand

If not claimed and expenses paid, to be sold on 6th April, 1951.

**G. HAZLETT**, Poundkeeper. 6417—9/

**LILYDALE**.—Impounded at Lilydale.

1 chestnut gelding, hind and near front feet white, white streak on face, no visible brand

1 light-bay draught horse, near hind and off front feet white, blaze face, no visible brand

1 bay draught horse, white feet, blaze face, no visible brand

1 bay medium draught mare, near hind foot white, blaze face, no visible brand

1 bay pony horse, white star on forehead, no visible brand

If not claimed and expenses paid, to be sold on 14th April, 1951.

**E. MASON**, Poundkeeper. 6373—14/

**MOORoopna**.—Impounded at Mooroopna, on 20th March, 1951.

1 black (sort of roan) draught mare, about 3 years, three white legs, blaze, no visible brand

1 bay medium draught gelding, 2 years, near eye blind, off hind fetlock white, no visible brand

1 bay pony gelding, thick-set, star, like JU3

If not claimed and expenses paid, to be sold on 12th April, 1951.

**T. J. CHALKER**, Poundkeeper. 6374—11/

**CONTENTS.**

	PAGE
Anzac Day Holiday .. .. .	2397
Appointments .. .. .	2397
Auction Sales Act .. .. .	2402
Cemetery—Scale of Fees .. .. .	2402
Commonwealth Jubilee Holiday .. .. .	2397
Contracts .. .. .	2403
Estates of Deceased Persons .. .. .	2404
Government Notices .. .. .	2398
Impoundings .. .. .	2426
Lands .. .. .	2411
Mining .. .. .	2398
Money Lenders Act 1938 .. .. .	2402
Notice to Mariners .. .. .	2398
Orders in Council .. .. .	2406
Private Advertisements .. .. .	2422
Proclamations .. .. .	2395
Publication of <i>Government Gazette</i> .. .. .	2397
Public Half-Holidays .. .. .	2396
Public Service Notices .. .. .	2417
Resignations .. .. .	2398
Tenders .. .. .	2420
Transport Regulation Board—Public Hearings .. .. .	2399
Waterworks Trusts .. .. .	2405