



# VICTORIA GOVERNMENT GAZETTE.

Published by Authority.

[Registered at the General Post Office, Melbourne, for transmission by post as a newspaper.]

No. 489]

FRIDAY, MAY 11.

[1951

## KING'S BIRTHDAY HOLIDAY.

It is hereby notified that on

MONDAY, THE 11TH JUNE, 1951,

the Public Offices will be closed, such day having been appointed under the *Public Service Act 1946*, to be observed as a holiday in the Public Offices throughout the State of Victoria.

This Notice relates only to the closing of the State Public Offices; all inquiries regarding holidays in other offices and in shops and industry should be directed to the Department of Labour, Old Treasury Building, Spring-street, Melbourne, C.1. (Telephone F0234, Extension 266 or 882.)

K. DODGSHUN,  
Chief Secretary.

Chief Secretary's Office,  
Melbourne, 24th April, 1951.

## BANK HALF-HOLIDAYS.

### PROCLAMATION

By His Excellency the Governor of the State of Victoria and its Dependencies in the Commonwealth of Australia, &c., &c., &c.

IN pursuance of the provisions of the Banks and Currency Acts, I, the Governor of the State of Victoria, in the Commonwealth of Australia, do by this my Proclamation appoint the days and dates named hereunder special days to be observed as Bank Half-Holidays at the places respectively mentioned, that is to say:—

*Bank Half-Holidays from the Hour of Twelve o'clock noon:—*

WEDNESDAY, THE 16TH DAY OF MAY, 1951, at Benalla.  
TUESDAY, THE 22ND DAY OF MAY, 1951, at Kyneton.  
FRIDAY, THE 25TH DAY OF MAY, 1951, at Coleraine.

Given under my Hand and the Seal of the State of Victoria aforesaid, at Melbourne, this eighth day of May, in the year of our Lord One thousand nine hundred and fifty-one, and in the fifteenth year of the reign of His Majesty King George VI.

(L.S.) DALLAS BROOKS.

By His Excellency's Command,  
K. DODGSHUN,  
Chief Secretary.

GOD SAVE THE KING!

## PUBLIC HOLIDAYS.

### PROCLAMATION

By His Excellency the Governor of the State of Victoria and its Dependencies in the Commonwealth of Australia, &c., &c., &c.

IN pursuance of the provisions contained in Part III. of the *Public Service Act 1946*, I, the Governor of the State of Victoria, in the Commonwealth of Australia, by and with the advice of the Executive Council of the said State, do by this my Proclamation appoint the days and dates hereunder mentioned to be observed as Public Holidays or Public Half-Holidays (as the case may be) at the places respectively specified, viz.:—

*Public Holidays:—*

MONDAY, THE 21ST DAY OF MAY, 1951, throughout the Parishes of Bitchigal, Chiprick, Cronomby, Dennyng, Gama, Gorya, Minapre, Tyenna, and Wathe, within the Shire of Karkaroc.

THURSDAY, THE 18TH DAY OF NOVEMBER, 1951, throughout the Shire of Mansfield.

*Public Half-Holiday from the Hour of Twelve o'clock noon:—*

TUESDAY, THE 15TH DAY OF MAY, 1951, throughout the Parish of Wedderburn, in the Shire of Korong.

Given under my Hand and the Seal of the State of Victoria aforesaid, at Melbourne, this eighth day of May, in the year of our Lord One thousand nine hundred and fifty-one, and in the fifteenth year of the reign of His Majesty King George VI.

(L.S.) DALLAS BROOKS.

By His Excellency's Command,  
K. DODGSHUN,  
Chief Secretary.

GOD SAVE THE KING!

*Banks and Currency Act 1928.*

ALTERATION OF DAY APPOINTED FOR BANK HOLIDAY (KING'S BIRTHDAY).

### PROCLAMATION

By His Excellency the Governor of the State of Victoria and its Dependencies in the Commonwealth of Australia, &c., &c., &c.

WHEREAS Monday, the seventeenth day of December, 1951, is by section 13 of the *Banks and Currency Act 1928* appointed for a Bank Holiday: And whereas it is made

to appear to the Governor in Council expedient that the said day should not be a Bank Holiday throughout Victoria: Now therefore I, the Governor of the said State, in pursuance of the provisions of section 16 of the said Act, do by this my Proclamation declare that the said day shall not be a Bank Holiday throughout Victoria, and appoint Monday, the eleventh day of June, 1951, to be a Bank Holiday throughout the said State.

Given under my Hand and the Seal of the State of Victoria aforesaid, at Melbourne, this eighth day of May, in the year of our Lord One thousand nine hundred and fifty-one, and in the fifteenth year of the reign of His Majesty King George VI.

(L.S.) DALLAS BROOKS.

By His Excellency's Command,  
K. DODGSHUN,  
Chief Secretary.

GOD SAVE THE KING!

Land Act 1928, Section 25, as amended by Land Act 1933, Section 2.

PROCLAMATION RESCINDED AND TOWNSHIP OF CAMPBELL'S CREEK PROCLAIMED.

PROCLAMATION

By His Excellency the Governor of the State of Victoria and its Dependencies in the Commonwealth of Australia, &c., &c., &c.

I, THE Governor of the State of Victoria, in the Commonwealth of Australia, by and with the advice of the Executive Council of the said State and in pursuance of the provisions contained in section 25 of the Land Act 1928, as amended by section 2 of the Land Act 1933, do by this notice revoke the Proclamation dated 17th October, 1892, defining a certain area of land as a Township in the Parish of Castlemaine (see Government Gazette 1892, page 4038), and in lieu thereof do proclaim as a Township under the designation of Campbell's Creek the area of land in the Parish of Castlemaine, County of Talbot, within the boundaries indicated by conventional township sign on the plan hereunder.—(C.100(42) (C.492(2) (C.92967).

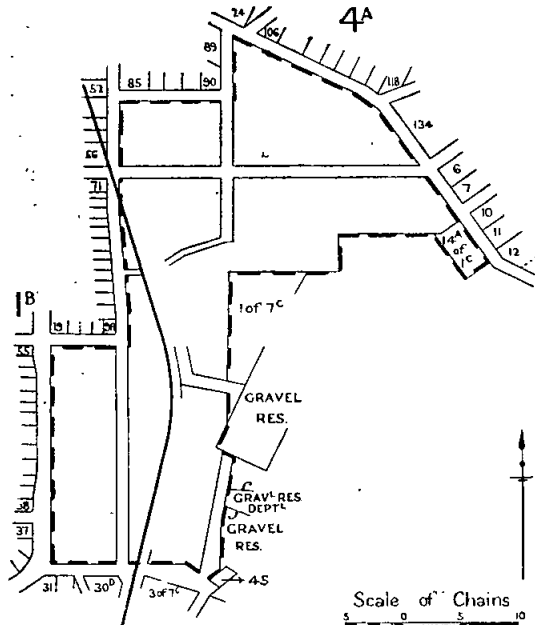

Given under my Hand and the Seal of the State of Victoria aforesaid, at Melbourne, this first day of May, in the year of our Lord One thousand nine hundred and fifty-one, and in the fifteenth year of the reign of His Majesty King George VI.

(L.S.) DALLAS BROOKS.

By His Excellency's Command,  
A. E. LIND,  
Commissioner of Crown Lands and Survey.  
GOD SAVE THE KING!

Land Act 1928, Section 25, as amended by Land Act 1933, Section 2.

PROCLAMATION RESCINDED AND TOWNSHIP OF DRIK DRIK PROCLAIMED.

PROCLAMATION

By His Excellency the Governor of the State of Victoria and its Dependencies in the Commonwealth of Australia, &c., &c., &c.

I, THE Governor of the State of Victoria, in the Commonwealth of Australia, by and with the advice of the Executive Council of the said State and in pursuance of the provisions contained in section 25 of the Land Act 1928, as amended by section 2 of the Land Act 1933, do by this notice rescind the Proclamation dated 9th April, 1895, defining a certain area of land in the Parish of Drik Drik as a Township (see Government Gazette 1895, page 1473), and in lieu thereof do proclaim as a Township under the designation of Drik Drik the area of land in the Parish of Drik Drik, County of Normanby, within the boundaries indicated by conventional township sign on the plan hereunder.—(D.152(2) (C.93044).

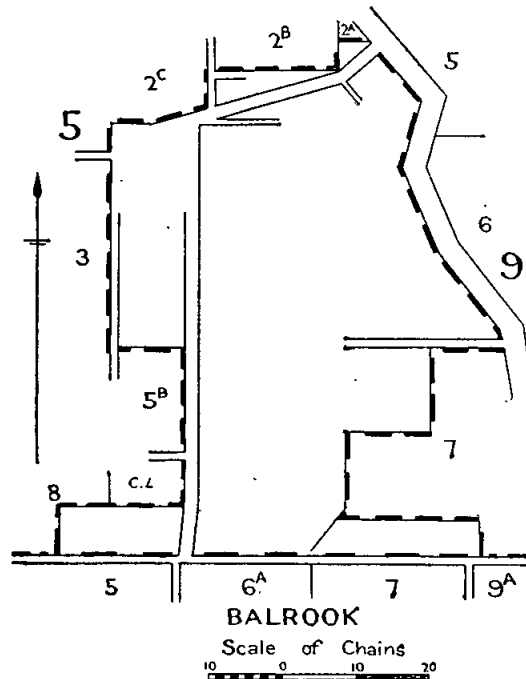

Given under my Hand and the Seal of the State of Victoria aforesaid, at Melbourne, this first day of May, in the year of our Lord One thousand nine hundred and fifty-one, and in the fifteenth year of the reign of His Majesty King George VI.

(L.S.) DALLAS BROOKS.

By His Excellency's Command,  
A. E. LIND,  
Commissioner of Crown Lands and Survey.  
GOD SAVE THE KING!

Land Act 1928, Section 25, as amended by Land Act 1933, Section 2.

PROCLAMATION RESCINDED AND TOWNSHIP OF FOSTERVILLE PROCLAIMED.

PROCLAMATION

By His Excellency the Governor of the State of Victoria and its Dependencies in the Commonwealth of Australia, &c., &c., &c.

I, THE Governor of the State of Victoria, in the Commonwealth of Australia, by and with the advice of the Executive Council of the said State and in pursuance of the provisions contained in section 25 of the Land Act 1928, as amended by section 2 of the Land Act 1933, do by this notice rescind the Proclamation dated 28th April,

1897, defining a certain area of land in the Parish of Ellesmere as a Township (see *Government Gazette* 1897, page 1769), and in lieu thereof do proclaim as a Township under the designation of Fosterville the area of land in the Parish of Ellesmere, County of Bendigo, within the boundaries indicated by conventional township sign on the plan hereunder.—(E.97<sup>(3)</sup>) (F.106<sup>(1)</sup>) (C.73512).

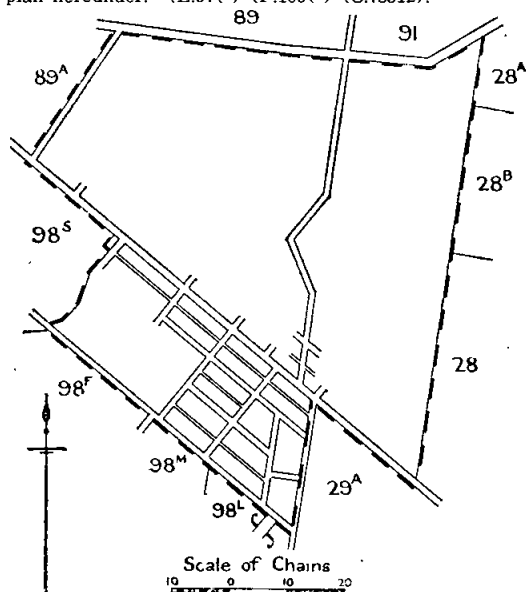

Given under my Hand and the Seal of the State of Victoria aforesaid, at Melbourne, this first day of May, in the year of our Lord One thousand nine hundred and fifty-one, and in the fifteenth year of the reign of His Majesty King George VI.

(L.S.) DALLAS BROOKS.

By His Excellency's Command,  
A. E. LIND,  
Commissioner of Crown Lands and Survey.  
GOD SAVE THE KING!

*Land Act* 1928, Section 25, as amended by *Land Act* 1933, Section 2.

VILLAGE AND TOWN OF ELSTERNWICK  
RESCINDED.

PROCLAMATION

By His Excellency the Governor of the State of Victoria and its Dependencies in the Commonwealth of Australia, &c., &c., &c.

I, THE Governor of the State of Victoria, in the Commonwealth of Australia, by and with the advice of the Executive Council of the said State and in pursuance of the provisions contained in section 25 of the *Land Act* 1928, as amended by section 2 of the *Land Act* 1933, do by this notice revoke the Order dated 9th September, 1851, fixing the site for a Village at Elsternwick in the Parish of Prahran, adjoining the northern boundary of the Brighton special survey (see *Government Gazette* 1851, page 557), and rescind the Proclamation dated 18th February, 1861, defining certain areas of land as Towns in so far as it relates to the Town of Elsternwick (see *Government Gazette* 1861, page 403).—(P.81<sup>(11, 13, 15)</sup>) (C.93042).

Given under my Hand and the Seal of the State of Victoria aforesaid, at Melbourne, this first day of May, in the year of our Lord One thousand nine hundred and fifty-one, and in the fifteenth year of the reign of His Majesty King George VI.

(L.S.) DALLAS BROOKS.

By His Excellency's Command,  
A. E. LIND,  
Commissioner of Crown Lands and Survey.  
GOD SAVE THE KING!

*Land Act* 1928, Section 25, as amended by *Land Act* 1933, Section 2.

TOWN OF EMERALD HILL RESCINDED.

PROCLAMATION

By His Excellency the Governor of the State of Victoria and its Dependencies in the Commonwealth of Australia, &c., &c., &c.

I, THE Governor of the State of Victoria, in the Commonwealth of Australia, by and with the advice of the Executive Council of the said State and in pursuance of the provisions contained in section 25 of the *Land Act* 1928, as amended by section 2 of the *Land Act* 1933, do by this notice rescind the Proclamation dated 30th May, 1861, defining a certain area of land as the Town of Emerald Hill (see *Government Gazette* 1861, page 1017).—(M.333<sup>(27)</sup>) (C.93041).

Given under my Hand and the Seal of the State of Victoria aforesaid, at Melbourne, this first day of May, in the year of our Lord One thousand nine hundred and fifty-one, and in the fifteenth year of the reign of His Majesty King George VI.

(L.S.) DALLAS BROOKS.

By His Excellency's Command,  
A. E. LIND,  
Commissioner of Crown Lands and Survey.  
GOD SAVE THE KING!

*Land Act* 1928, Section 25, as amended by *Land Act* 1933, Section 2.

ORDER REVOKED AND PROCLAMATION RESCINDED  
AS TO PART.—TOWN OF HAWTHORN.

PROCLAMATION

By His Excellency the Governor of the State of Victoria and its Dependencies in the Commonwealth of Australia, &c., &c., &c.

I, THE Governor of the State of Victoria, in the Commonwealth of Australia, by and with the advice of the Executive Council of the said State and in pursuance of the provisions contained in section 25 of the *Land Act* 1928, as amended by section 2 of the *Land Act* 1933, do by this notice revoke the Order dated 3rd February, 1852, fixing a site for a Village at Hawthorn in the Parish of Boroondara, near the Richmond Bridge (see *Government Gazette* 1852, page 138), and rescind the Proclamation dated 18th February, 1861, defining certain areas of land as Towns in so far as it relates to the Town of Hawthorn in the Parish of Boroondara, County of Bourke (see *Government Gazette* 1861, page 405).—(B.415<sup>(3)</sup>) (C.93037).

Given under my Hand and the Seal of the State of Victoria aforesaid, at Melbourne, this first day of May, in the year of our Lord One thousand nine hundred and fifty-one, and in the fifteenth year of the reign of His Majesty King George VI.

(L.S.) DALLAS BROOKS.

By His Excellency's Command,  
A. E. LIND,  
Commissioner of Crown Lands and Survey.  
GOD SAVE THE KING!

PUBLIC HIGHWAY.—BOROUGH OF RINGWOOD.

PROCLAMATION

By His Excellency the Governor of the State of Victoria and its Dependencies in the Commonwealth of Australia, &c., &c., &c.

WHEREAS by the *Local Government Act* 1946 (No. 5203), section 518, it is amongst other things enacted that it shall be lawful for the Governor in Council at any time, and from time to time, upon the request of the council of any municipality, by notice in the *Government Gazette*, to declare any land reserved, used, or by purchase or exchange acquired for a street, road, highway, thoroughfare, bridge, square, court, alley, or right-of-way to be a public highway, and that such land shall thereupon and thenceforth from the date of such Proclamation become and be absolutely dedicated to the public as a public highway within the meaning of any law then or thereafter in force: And whereas the Council of the Borough of Ringwood has requested that the land hereinafter mentioned, which has been reserved for a street within the said borough, be so declared to be a public

highway: Now therefore I, the Governor of the State of Victoria, in the Commonwealth of Australia, by and with the advice of the Executive Council of the said State, do by this Proclamation declare the land reserved for a street hereinafter described, and situated within the Borough of Ringwood aforesaid, to be a public highway within the meaning of the said Act, viz.:—

## PUBLIC HIGHWAY.—BOROUGH OF RINGWOOD.

*Thomas-street.*

Commencing at the north-west angle of Crown portion 16, Parish of Ringwood, County of Mornington; thence southerly on a bearing of 179 deg. 56 min. 30 sec. for 1,140 ft. 5 in.; thence southerly on a bearing of 179 deg. 58 min. for 612 ft. 2 in.; thence southerly on a bearing of 180 deg. 5 min. for 509 ft. 1½ in.; thence easterly on a bearing of 94 deg. 24 min. for 50 ft. 1½ in.; thence northerly on a bearing of 0 deg. 5 min. for 512 ft. 10 in.; thence northerly on a bearing of 359 deg. 58 min. for 612 ft. 2½ in.; thence northerly on a bearing of 359 deg. 56 min. 30 sec. for 1,137 ft. 2½ in. to the south building line of Bedford-road; thence westerly along the south building line of Bedford-road to the commencing point, and being the street shown as Thomas-street on the plan of subdivision lodged in the Office of Titles, and numbered 13641.

Given under my Hand and the Seal of the State of Victoria aforesaid, at Melbourne, this first day of May, in the year of our Lord One thousand nine hundred and fifty-one, and in the fifteenth year of the reign of His Majesty King George VI.

(L.S.) DALLAS BROOKS.

By His Excellency's Command,

P. T. BYRNES,  
Commissioner of Public Works.

GOD SAVE THE KING!

## PUBLIC HIGHWAY.—CITY OF BOX HILL.

## PROCLAMATION

By His Excellency the Governor of the State of Victoria and its Dependencies in the Commonwealth of Australia, &c., &c., &c.

WHEREAS by the *Local Government Act 1946* (No. 5203), section 518, it is amongst other things enacted that it shall be lawful for the Governor in Council at any time, and from time to time, upon the request of the council of any municipality, by notice in the *Government Gazette*, to declare any land reserved, used, or by purchase or exchange acquired for a street, road, highway, thoroughfare, bridge, square, court, alley, or right-of-way to be a public highway, and that such land shall thereupon and thenceforth from the date of such Proclamation become and be absolutely dedicated to the public as a public highway within the meaning of any law then or thereafter in force: And whereas the Council of the City of Box Hill has requested that the land hereinafter mentioned, which has been reserved for a street by the said Council within the said city, be so declared to be a public highway: Now therefore I, the Governor of the State of Victoria, in the Commonwealth of Australia, by and with the advice of the Executive Council of the said State, do by this Proclamation declare the land reserved for a street hereinafter described, and situated within the City of Box Hill aforesaid, to be a public highway within the meaning of the said Act, viz.:—

## PUBLIC HIGHWAY.—CITY OF BOX HILL.

Commencing at a point 960 feet south of the intersection of the southern boundary of Canterbury-road with the eastern boundary of Warrigal-road; thence north 89 deg. 37 min. 15 sec. east a distance of 346 feet; thence south a distance of 40 feet; thence south 89 deg. 37 min. 15 sec. west a distance of 346 feet; thence north a distance of 40 feet to the point of commencement, the whole of the land being part of a road and reserve as shown on lodged plan 1149, lodged at the Office of Titles.

Given under my Hand and the Seal of the State of Victoria aforesaid, at Melbourne, this first day of May, in the year of our Lord One thousand nine hundred and fifty-one, and in the fifteenth year of the reign of His Majesty King George VI.

(L.S.) DALLAS BROOKS.

By His Excellency's Command,

P. T. BYRNES,  
Commissioner of Public Works.

GOD SAVE THE KING!

*Milk and Dairy Supervision Act 1943* (No. 4997).  
SHIRE OF SOUTH BARWON INCLUDED IN THE METROPOLIS.

## PROCLAMATION

By His Excellency the Governor of the State of Victoria and its Dependencies in the Commonwealth of Australia, &c., &c., &c.

IN pursuance of the provisions contained in Part 1 of the *Milk and Dairy Supervision Act 1943* (No. 4997). I, the Governor of the State of Victoria, by and with the advice of the Executive Council of the said State, do hereby declare the Municipal District of the Shire of South Barwon to be included in the metropolis as from and including the first day of July, One thousand nine hundred and fifty-one.

Given under my Hand and the Seal of the State of Victoria aforesaid, at Melbourne, this first day of May, in the year of our Lord One thousand nine hundred and fifty-one, and in the fifteenth year of the reign of His Majesty King George VI.

(L.S.) DALLAS BROOKS.

By His Excellency's Command,

GEORGE C. MOSS,  
Minister of Agriculture.

GOD SAVE THE KING!

## APPOINTMENTS.

HIS Excellency the Governor of the State of Victoria, by and with the advice of the Executive Council thereof, has, by Orders made on the 1st day of May, 1951, been pleased to make the under-mentioned appointments, viz.:—

## CHIEF SECRETARY'S DEPARTMENT.

*Governor (Acting) of Pentridge.*

ERNEST RICHARD FOX,

pursuant to the provisions of the *Gaols Act 1928*, to be Governor (Acting) of His Majesty's Gaol, Pentridge, from the 30th April, 1951, to the 21st May, 1951, both dates inclusive, during the absence on leave of James Edwards.

*Superintendent (Acting) of Pentridge Reformatory Prison.*

ERNEST RICHARD FOX,

pursuant to the provisions of the *Crimes Act 1928*, to be Superintendent (Acting) of the Pentridge Reformatory Prison, from the 30th April, 1951, to the 21st May, 1951, both dates inclusive, during the absence on leave of James Edwards.

## DEPARTMENT OF CROWN LANDS AND SURVEY.

*Members of Surveyors Board.*GEORGE JAMES THORNTON-SMITH,  
HOWARD SPENCER MCCOMB,  
ALFRED ROBERT HENRY CHARLES URBAHNS, and  
CHARLES TREVOR COLEMAN,

in pursuance of section 4 of the *Land Surveyors Act 1942* as amended by section 2 of the *Land Surveyors (Amendment) Act 1945*, to be members of the Surveyors Board for a period from 1st May, 1951, to 30th April, 1953.

## LAW DEPARTMENT.

*Clerk of Children's Courts.*

JAMES EDMUND O'CONNOR

to be also Clerk of the Children's Courts at Numurkah, Cobram, and Nathalia during the absence on annual leave of J. L. Collins.

*Commissioners for Taking Declarations, &c.*

OTTO EDWARD RÖDER, an officer of the State Rivers and Water Supply Commission, Melbourne,

to be a Commissioner for taking Declarations and Affidavits, pursuant to the provisions of the *Evidence Act 1928*, to refrain from charging fees and to resign upon ceasing to occupy his present position; and

ARTHUR EWENS SPILLER, Manager, Robinvale Co-operative Packing Sheds, Robinvale, and  
ALAN BERESFORD PLUMRIDGE, Assistant Works Auditor, International Harvester Company of Australia Pty. Ltd., Geelong,

to be Commissioners for taking Declarations and Affidavits, pursuant to the provisions of the *Evidence Act 1928*, to resign upon ceasing to occupy their present positions.

*Magistrates.*

THOMAS POWELL BARHAM, Marnoo,  
to Keep the Peace in the Western Bailiwick of the State  
of Victoria;

HENRY WILLIAM BARRETT BOWERS, Herne's Oak,  
to Keep the Peace in the Eastern Bailiwick of the State  
of Victoria; and

WILLIAM CLIFTON STAINER, Undera,  
to Keep the Peace in the Midland and Northern Bailiwicks  
of the State of Victoria.

## PARLIAMENT OF VICTORIA.

*Clerk of Parliaments.*

HUGH KENNEDY MCLACHLAN  
to be Clerk of Parliaments, pursuant to the provisions of  
the *Constitution Act Amendment Act 1928* (No. 3660).

## PUBLIC WORKS DEPARTMENT.

*Acting Secretary of Marine Board.*

ALFRED ALLEN WELCH  
to be appointed Acting Secretary to the Marine Board of  
Victoria, from 30th April, 1951, *vice* R. S. Rohner, on  
leave.

*Member of Municipal Auditors Board.*

WILLIAM MABLE SCOTT  
to be a member of the Municipal Auditors Board, *vice*  
W. H. Cove, resigned, under the provisions of section 486  
of the *Local Government Act 1946* (No. 5203).

## DEPARTMENT OF THE TREASURER.

*Collectors of Imposts (Acting).*

ANDREW ERNEST JOHN SCOTLAND  
to act temporarily as Collector of Imposts, Office of the  
Government Statist, during the absence of R. H. Williams,  
on leave.

REGINALD CODE  
to act temporarily as Collector of Imposts, Motor Regis-  
tration Branch, Chief Secretary's Office, during the absence  
of A. H. J. O'Dee, on leave.

## DEPARTMENT OF WATER SUPPLY.

*Waterworks Trusts Commissioners.*

WILLIAM MALCOLM MCTAGGART  
to be a Commissioner of the Colbinabbin Waterworks  
Trust for a period of four years from the date hereof,  
subject to the provisions of the Water Acts.

ALEXANDER MURRAY MCKAY  
to be a Commissioner of the Tallangatta Waterworks  
Trust for a period of four years from the date hereof,  
subject to the provisions of the Water Acts.

A. MAHLSTEDT,  
Clerk of the Executive Council.

At the Executive Council Chamber,  
Melbourne, 1st May, 1951.

*Hospitals and Charities Act 1928* (No. 5300).—Section 46.  
PETITION TO INCORPORATE SEYMOUR MEMORIAL  
HOSPITAL.

IT is hereby notified, in accordance with the provisions  
of section 46 (2) of Act No. 5300, that the Hospitals  
and Charities Commission of Victoria has received a  
petition signed by not less than 25 contributors to  
Seymour Memorial Hospital, an institution capable of  
incorporation under the provisions of the said Act, praying  
that the said hospital be incorporated.

If a counter petition signed by an equal or greater  
number of contributors is not lodged with the aforesaid  
Commission within one month after the publication of  
this notice, the Governor in Council may, by Order made  
pursuant to Act No. 5300 and published in the *Government  
Gazette*, declare the contributors for the time being to  
the said institution to be a body corporate by the name  
set forth in such Order.

W O. FULTON,  
Minister of Health.

## INDUSTRIAL AND PROVIDENT SOCIETIES ACT 1928.

NOTICE is hereby given that a society called the  
"Balnarring and District Co-operative Society  
Limited" is registered under the provisions of the above  
Act.

Given under my hand this 1st day of May, 1951.

A. E. RASMUSSEN,  
Registrar of Friendly Societies.

## DEPARTMENT OF MINES.

## APPLICATION FOR MINING LEASE REFUSED.

7242, Mineral; Stanley Klaus; 347 acres, Parish of Toora.

CONSENTS GRANTED TO TRANSFER MINING  
LEASES.

9017, Castlemaine; Wilfred Albert Clayton to Francis  
William Birdsey and Keith Holmes Golding.

9051, Castlemaine; Wilfred Albert Clayton and David  
Lyle Dexter to Francis William Birdsey and  
Keith Holmes Golding.

## MINING LEASES GRANTED.

9119, Ballarat; Thomas Sutherland; 30 acres, Parish of  
Ascot (in lieu of Lease No. 8257, Ballarat,  
expired).

8261, Beechworth; Morning Star (G.M.A.) Mines N. L.;  
43a. 3r. 29p., Parish of Lauraville (in lieu of  
Lease No. 7700, Beechworth, expired).

9087, Castlemaine; Samuel George Lacy, Sydney Ellison  
Weeks, and Norma Scott; 40a. 2r. 20p., Parishes  
of Strangways and Muckleford.

6995, Mineral; Sulphates Limited; 36a. 3r. 12p., Parish of  
Mirboo.

7208, Mineral; Harold Archer and Reginald Greenham;  
69a. 3r., Parish of Faraday.

## TAILINGS LICENCE GRANTED.

2229, Tailings Licence; The Country Roads Board (in lieu  
of Tailings Licence No. 2152, expired).

G. C. MOSS,  
Minister of Mines.

## CONTRACTS ACCEPTED.—(Series 1950-51.)

## GENERAL STORES.

*Gazette* No. 541, 3rd July, 1950, Schedule No. 37, Electric  
Lamps, &c.—For the rates shown opposite the following  
items substitute the rates per coil as set out hereunder,  
as from 28th March, 1951:—Item No. 53, 19s. 5d.; Item  
No. 54, 11 9s. 6d.; Item No. 55, 11 5s. 3d.; Item No. 56,  
11 12s. 10d.; Item No. 57, 12 3s. 2d.; Item No. 58, 12 15s. 7d.;  
Item No. 59, 14 3s. 3d.; Item No. 60, 15 4s. 10d.; Item  
No. 61, 16 18s.; Item No. 62, 18 16s. 4d.; Item No. 63,  
15 19s. 1d.; Item No. 64, 11 16s. 10d.; Item No. 65,  
12 9s. 9d.; Item No. 66, 12 4s. 1d.; Item No. 67, 12 13s. 11d.;  
Item No. 68, 12 19s. 9d.; Item No. 69, 14 15s. 2d.; Item  
No. 70, 14 2s. 7d.; Item No. 71, 15 3s.; Item No. 72,  
16 8s. 6d.; Item No. 73, 18 2s. 11d.; Item No. 74, 12 10s. 11d.;  
Item No. 75, 13 1s. 5d.; Item No. 76, 13 16s. 11d.; Item  
No. 77, 14 12s. 7d.; Item No. 80, 16 17s. 2d.; Item No. 81,  
14 12s. 9d.; Item No. 82, 15 6s. 7d.; Item No. 83, 15 17s. 11d.;  
Item No. 84, 16 17s. 2d.

*Gazette* No. 541, 3rd July, 1950, Schedule No. 39, Furni-  
ture, &c.—For Items Nos. 27 and 28 substitute 19 0s. 8d.  
and 16 10s. each respectively, as from 11th April, 1951.

*Gazette* No. 541, 3rd July, 1950, Schedule No. 41, Gar-  
ments for Chauffeurs, &c.—For Item No. 4 substitute 12  
each, as from 9th April, 1951.

*Gazette* No. 541, 3rd July, 1950, Schedule No. 71, Tents  
and Flies.—For the rates shown opposite the following  
items substitute the rates as set out hereunder, as from  
24th April, 1951:—Item No. 1, 10 7s. 8d. each; Item  
No. 2, 14 5s. 11d. each; Item No. 3, 18 10s. each;  
Item No. 4, 12 4s. 5d. each; Item No. 5, 15 11s. 3d. each;  
Item No. 6, 17 12s. 7d. each; Item No. 7, 10 2s. 6d. each;  
Item No. 8, 11 9s. 1d. each.

*Gazette* No. 967, 29th November, 1950, Schedule No. 69,  
Stationery.—For the rates shown opposite the following  
items substitute the rates as set out hereunder, as from  
9th April, 1951:—Item No. 19, 3s. 5d. per gross; Item  
No. 20, 3s. 9d. per gross; Item No. 21, 4s. per gross;  
Item No. 22, 4s. 9d. per gross; Item No. 23, 5s. 5d. per  
gross; Item No. 60, 4s. per dozen; Item No. 61, 1s. 4d.  
per dozen; Item No. 78, 19s. 8d. per gross; Item No. 87,  
3s. 2d. per dozen; Item No. 88, 1s. 10d. per dozen.

*Gazette* No. 967, 29th November, 1950, Schedule No. 69,  
Stationery.—For Items Nos. 255, 256, and 257 substitute  
7s. 4d., 8s. 4d., and 9s. 4d. per dozen respectively, as from  
16th April, 1951.

*Gazette* No. 967, 29th November, 1950, Schedule No. 69,  
Stationery.—For the rates shown opposite the following  
items substitute the rates as set out hereunder, as from  
14th March, 1951:—Item No. 24, 11 12s. 6d. per gross;  
Item No. 26, 11 18s. 9d. per gross; Item No. 27, 12 per  
gross; Item No. 112, 4s. 10d. each.

*Gazette* No. 967, 29th November, 1950, Schedule No. 2,  
Education Requisites.—For Items Nos. 3 and 11 substitute  
19s. 6d. per dozen and 11 17s. 1d. per gross respectively,  
as from 9th April, 1951.

W. H. RUTHERFORD, Secretary to the Tender Board,  
8.5.51.

## PUBLIC WORKS.

4275. (4) Armadale, "Frank Tate" House, 373 Dandenong-road, electrical installation, £2,864 15s.—Lecol Electrical Co.
4276. (1) Ascot, State School No. 2507, installation of septic tank system and alterations to out-offices, £585 12s. 6d.—W. S. Gudgeon.
4277. (1) Bridgewater, Police Station, internal and external repairs and painting, £469 10s.—R. J. Butler.
4278. (1) Brankholme, State School No. 1978, repairs to school and renovations and alterations to residence, £399 12s. 6d.—H. L. Rundell.
4279. (2) Beechworth, Mental Hospital, supply, delivery, and bolting down of tumbler dryer, £1,249.—L. Horscroft Pty. Ltd.
4280. (2) East Burwood, State School No. 454, supply and installation of kerosene hot-water service, teacher's residence, £149 15s.—A. E. Smith.
4281. (2) Belgrave, Comfort Station, supply and installation of precast terrazzo slabs, £493 8s. 9d.—Adelaide Terrazzo Paving Co.
4282. (4) Beechworth, Education Department, Inspector's Residence, painting and repairs, &c., £966 15s.—T. E. McGeehan.
4283. (1) Castle Donnington, State School No. 3762, repairs and painting, £163.—Bond and Co.
4284. (1) Culfearn, State School No. 4204, painting and repairs, £231.—Bond and Co.
4285. (1) Charlton, State School No. 1480, repairs to desks, £296 16s. 4d.—A. F. J. Whitehead.
4286. (1) Dunolly, State School No. 1582, water service, bath heater, sink, stove, and repairs, £177 10s.—H. K. Christie.
4287. (2) Echuca, High School, internal and external repairs and painting, residence, £340 10s.—B. E. May.
4288. (2) Essendon North, State School No. 4015, painting and repairs, £1,481.—J. Lynch.
4289. (1) Glenrowan, State School No. 1742, erection of non-party fencing, £120.—K. Beard.
4290. (1) Leongatha, State School No. 2981, supply and installation of a kerosene hot-water service, teacher's residence, £148 15s.—Wittingslow Bros.
4291. (1) Lake Boga, Lands Department, Officer's Residence, electrical installation, £106.—R. J. Wilson.
4292. (1) Lake Boga, Police Station, new boundary fencing, £112.—J. M. Bond and H. S. Dunstan.
4293. (3) Langi Kal Kal, Penal and Gaols Reformatory, erection of seventeen (17) residences, £58,930.—A. W. Nicholson.
4294. (1) Mooroolbark, State School No. 4417, supplying and fixing to No. 2 Prefabricated Classrooms, hat and coat wardrobes and display panels, £233.—F. T. Pulling.
4295. (1) Myrtleford, State School No. 955, non-party fencing (netting to be supplied by Department) £108.—T. E. McGeehan.
4296. (1) Melbourne, Royal Mint, new stainless steel sink, cabinet, and basin, and renovate room, 1st floor, £194.—A. Crewther and Son.
4297. (1) Numurkah, State School No. 2134, provision and erection of combined garage and woodshed, residence, McCarthy-avenue, £183.—H. J. Faulkner.
4298. (2) Pakenham, Department of Lands, erection of new inspector's residence, £2,795.—S. L. Cockrane.
4299. (2) Royal Park, Mount Royal, Dunstan Tuberculosis Chalet, provision of hoods for windows, £137 10s.—Campbell and Ibbotson.
4300. (1) Red Hill, Consolidated School, provision of cupboards and benches, &c., £1,680 13s.—H. N. Oliver.
4301. (2) Rainbow, Higher Elementary School, painting and repairs, school removed from Pigick, £539.—R. Scott.
4302. (2) Sunbury, Mental Hospital, painting and repairs to laundry, £380.—J. Lynch.
4303. (1) Steiglitz, State School No. 1487, provision of blackboard, new porch, wash basin, and drainage, &c., £101.—J. C. Moreland.
4304. (1) Upwey, State School No. 4530, erection of a timber shelter shed, £697.—R. W. Sherwin.
4305. (1) Werribee, Research Farm, erection of three timber residences, £7,843 11s.—G. Medcroft.
4306. (4) White Hills, Police Station, painting and renovations, &c., £291 17s. 6d.—A. F. J. Whitehead.
4307. (1) Woolsthorpe, State School No. 688, erection of E4 residence, out-offices, septic tank, and drainage, £3,046 15s.—W. H. Bartlett.
4308. (2) Yarra Junction, State School No. 3216, painting and repairs, residence, £779.—J. Lynch.

P. T. BYRNES, Commissioner of Public Works. 35.51.

## ORDERS IN COUNCIL.—(Series 1950-51.)

## FORESTS COMMISSION.

Loan Act No. 5333, Item 8—

4274. To the purchase of parts of allotments 31A and 31B, Parish of Traawool, County of Anglesey, containing 3 acres 17 7/10 perches for forest purposes, £10 17s. 9d.—Messrs. McClelland and Stephens, both of "Glendaruel," Tallarook.

Approved by the Governor in Council, 27th February, 1951.—A. MAHLSTEDT, Clerk of the Executive Council.

## STATE ELECTRICITY COMMISSION.

4309. The supply of 200 tons of mild steel plate for construction works, to Quotation No. 6801, £18,472 10s.—Export and Import Development (Aust.) Pty. Ltd.

4310. The supply of 250 tons mild steel plates for lining of pressure tunnel, No. 4 Power Station site, Klewa Hydro-Electric Scheme, to Quotation No. 3679, £23,250 15s.—F. W. Green and Co. Pty. Ltd.

Approved by the Governor in Council, 17th April, 1951.—A. MAHLSTEDT, Clerk of the Executive Council.

4311. The supply of six "Matador" prime movers for fitment to semi-trailer units, to Quotation No. 4541, £19,860.—A.E.C. (Australia) Pty. Ltd.

4312. The supply of 80,000 porcelain service fuses for protection of consumers' services, to Specification No. 50-51/200, £48,916 13s. 4d.—Stanger and Co. Pty. Ltd.

4313. The supply and erection of two 10,000 kW. capacity packaged power plants and associated spare parts for power stations at Swan Hill and Mildura, to Specification No. 50-51/303, £1,716,493.—Westinghouse Rosebery Pty. Ltd.

4314. The supply of 1,000 22,000-volt air-break switch fuses, to Quotation No. 4151, £19,525.—E. R. Cornish.

4315. The supply of 200 22,000-volt air-break switch fuses, to Quotation No. 4151, £20,150.—Johnson and Phillips Ltd.

4316. The supply of 200 22,000-volt air-break switch fuses, to Quotation No. 4151, £17,243 15s.—D. E. Taplin Pty. Ltd.

Approved by the Governor in Council, 24th April, 1951.—A. MAHLSTEDT, Clerk of the Executive Council.

## State Electricity Commission Act 1934.

## STATE ELECTRICITY COMMISSION OF VICTORIA.—ELECTRICAL APPROVALS BOARD.

IN accordance with the requirements of the Electrical Approvals Regulations—Proceedings of Electrical Approvals Board, the State Electricity Commission of Victoria hereby gives notice that, pursuant to the provisions contained in section 7 of the *State Electricity Commission Act 1934*, and the said Regulations,

RONALD JAMES MARRIOTT

has been appointed, as representing the interests of the manufacturers in Victoria of electrical goods, to act as Acting Member in the place of Mr. L. J. Forbes, during the latter's leave of absence while overseas.

Dated the 11th day of May, 1951.

D. H. MUNRO,  
Secretary.

## NOTICE TO MARINERS.

[No. 5 of 1951.]

## AUSTRALIA.—VICTORIA.

## PORT PHILLIP—ALTERATION IN LIGHT.

Date.—On or about 23rd May, 1951.

Position.—Hovell Pile Light. Lat. 38 deg. 19 min. 44 sec. S.; Long. 144 deg. 53 min. 50 sec. E.

Abridged Description.—Gp. Fl. (2) every 8 sec.

Details.—The flashing white light in the above position will be altered to Group Flashing showing two flashes every 8 seconds as follows:—Flash 0.5 sec., eclipse 1.0 sec., flash 0.5 sec., eclipse 6 sec.

Remarks.—Other details remain unaltered.

Charts Affected.—2747, 1171, 1695B.

Publications.—General Notice to Mariners respecting Navigation in Victorian Waters, 1942, pages 106, 299. List of Lights, Vol. X., 1948, No. 2238.

D. S. STEVENSON,  
Port Officer.

Ports and Harbors Branch,  
Department of Public Works,  
Melbourne, C.2, 3rd May, 1951.

Transport Regulation Acts.  
TRANSPORT REGULATION BOARD.  
NOTICES OF PUBLIC HEARINGS.

NOTICE is hereby given that the applications made by the persons named below for licences to operate the commercial goods vehicles on the route or routes, or in the manner set out opposite their names, will be heard at a time and place to be communicated to the parties concerned:—

*Name and Address; Nature of Application.*

BANTICK BROS., Marysville; 1 commercial goods vehicle (160 cwt.) for the carriage of:—

1. Logs from any forest landing in the Niagara and Upper Yarra forestry districts—(a) to the railway station at Healesville and to any mill or dump which is located within a radius of 20 miles of such landing or of the railway station at Healesville, (b) to any mill or yard within a radius of 25 miles of the G.P.O., Melbourne.

2. Logs from such other areas or to such other destinations as may be authorized, in writing, by the Board from time to time.

3. Sawn timber from McNeil and Radcliffe, Marysville, Rowe, Webb, and Anderson, Thornton to Healesville and Melbourne.

BAULCH, D. K., Panmure; 1 commercial goods vehicle (100 cwt.) for the carriage of road contracting plant and materials throughout the State of Victoria.

BENNETT, W. J., 22 Meldan-street, Burwood; 1 commercial goods vehicle (96 cwt.) to operate within a radius of 45 miles of Narre Warren and to Morwell and Yallourn—screenings.

BURCHALL, A. G., Taggerty; 1 commercial goods vehicle (30 cwt.) for the carriage of mails, newspapers, milk, cream, and general goods between Marysville and Alexandra, via Buxton, Taggerty, and Acheron.

FALKENBERG, A. F., 6 Shaftesbury-parade, Thornbury; 1 commercial goods vehicle (100 cwt.) for the carriage of sand from pits in the Cranbourne and Frankston areas to places situate within a radius of 25 miles from Melbourne.

FORAN, H. W., Coleraine-road, North Hamilton; 1 commercial goods vehicle (190 cwt.) to operate within a 100 miles radius from Hamilton in the course of trade as "house removalist"—houses, sheds, &c., for removal from site to site.

THOMAS, R. H. (trading as Hamilton Aerated Water Co.), 118-122 Brown-street, Hamilton; application to vary the conditions of licence No. D.3603 by deletion of existing provisions and addition of the carriage of own aerated waters and cordials from Hamilton to places within the Western District of Victoria.

NOSKE, E. N., L. T., & L. W. (trading as Noske Bros. (Hamilton)), 18 Ballarat-road, Hamilton; 2 commercial goods vehicles (100 cwt. each)—(1) One vehicle for the carriage of:—(a) general goods within a radius of 20 miles of Hamilton, (b) road making plant and materials within a radius of 50 miles of Hamilton, (2) One vehicle for the carriage of road making plant and materials throughout the State of Victoria.

ROBERTSON & MULLENS LTD., 107-113 Elizabeth-street, Melbourne; 1 commercial goods vehicle (8 cwt.) for the carriage of own goods in the course of business as "stationers and booksellers"—(a) books, stationery, toys, and fancy goods from and to Melbourne and from Ballarat, (b) samples for display only throughout the State of Victoria.

SEALEY, W. D., Yackandandah-road, Myrtleford; 1 commercial goods vehicle (100 cwt.) for the carriage of:—(a) general goods within a radius of 20 miles of Myrtleford, (b) tools of trade, materials being the property of the State Electricity Commission, and used in connexion with applicant's construction and maintenance contracts within a radius of 50 miles of Myrtleford.

SUND, A. & J., care of P.O., Marysville; 1 commercial goods vehicle (160 cwt.) for the carriage of:—(a) logs from any forest landing in the Mt. Gordon area to holder's own mill at Marysville, (b) sawn timber from holder's own mill at Marysville to Millard's Timber Yard at Mt. Evelyn, and occasionally building blocks to the eastern suburbs.

WASHINGTON, S. M., Neerim Junction; 1 commercial goods vehicle (209 cwt.) for the carriage of:—(a) logs from any forest landing in the Whitelaw Basin area to consignees in the metropolitan area, (b) sawn timber from Kauri Mill at Nayook to Kauri Timber Yards at South Melbourne.

STAWELL TIMBER INDUSTRIES PTY. LTD., 141 Main-street, Stawell; 1 commercial goods vehicle (300 cwt.) for the carriage of:—(a) logs from any forest landing in the Mt. Cole area to holder's own mill at Stawell, (b) logs from any forest landing in the Mt. William area to holder's own mill at Stawell.

NOTICE is hereby given that the application made by the persons named below for licences to operate commercial passenger vehicles on the route or routes, or in the manner set out opposite their names, will be heard at a time and place to be communicated to the parties concerned:—

*Name of Applicant; Nature of Application.*

AISBETT, E. W., 2 Gardenia-street, Horsham; 1 commercial passenger vehicle, with seating capacity for 20 persons, to operate a service for the carriage only of school children between Brimpaen and Horsham High School, in accordance with the terms of a contract entered into with the Education Department.

BOLTON, L. N., 43 Thames Promenade, Chelsea; 1 commercial passenger vehicle, with seating capacity for five persons, to be purchased, to operate as follows:—(a) at separate and distinct fares from and to the Bonbeach Railway Station, and from places situate within a radius of 5 miles of Bonbeach Railway Station, (b) under private hire conditions within a radius of 50 miles of Bonbeach Railway Station.

CORDY, S. K., 4 Warby-street, Wangaratta; 1 commercial passenger vehicle, with seating capacity for five persons, to operate as follows:—(a) at separate and distinct fares within a radius of 5 miles of Wangaratta Railway Station, (b) under private hire conditions within a radius of 50 miles of Wangaratta Railway Station (subject to the cancellation of licence No. A.3085 at present held by J. E. O'Brien, of Wangaratta).

EASTICK, E. H., Streatham; 1 commercial passenger vehicle, with seating capacity for 23 persons, to operate as follows:—(a) for the carriage only of school children between Streatham and Yalla-y-poorra, in accordance with the terms of a contract entered into with the Education Department, (b) under charter conditions within a radius of 50 miles of Streatham Post Office.

FRASER, H. G., 91 Thomson-street, Hamilton, 1 commercial passenger vehicle, with seating capacity for five persons, to operate as follows:—(a) at separate and distinct fares within a radius of five miles of Hamilton Post Office, (b) under private hire conditions within a radius of 50 miles of Hamilton Post Office (subject to the cancellation of licence No. A.70, at present in the name of T. R. Povey, Hamilton).

GAINGER, A. R. & L. (trading as Gainger Brothers), Beac; application for permit to operate a service between Colac and Melbourne, via Geelong, on Sundays only of each week, as follows:—

TIME-TABLE.

<i>Read Down.</i>		<i>Read Up.</i>
Depart 3.30 p.m. Colac		Arrive 10.30 p.m.
Arrive 6.30 p.m. Melbourne		Depart 7.30 p.m.

in lieu of the present service between Beac and Geelong, via Colac.

HUTCHINSON, R. T., Skipton Hotel, Skipton; 1 commercial passenger vehicle, with seating capacity for four persons, to operate as follows:—(a) at separate and distinct fares within a radius of 5 miles of Skipton, (b) under private hire conditions within a radius of 50 miles of Skipton (subject to the cancellation of licence No. A.74, at present held in the name of A. H. L. Vaisey).

JENKIN, J. K., 1A Ritchie-street, Frankston; 1 commercial passenger vehicle, with seating capacity for five persons, and 1 commercial passenger vehicle with seating capacity for five persons, to be purchased, to operate as follows:—(a) at separate and distinct fares within a radius of 5 miles of Frankston Railway Station, (b) under private hire conditions within a radius of 50 miles of Frankston Railway Station.

LATROBE VALLEY BUS LINES, 66-68 Princes-street, Traralgon; application for variation of all "A" licences, to extend the present picking up points on the service operating between Derham's Hill and Warragul, via Morwell, so as to include Morwell Bridge, Yallourn South Migrant Camp, and Hernes Oak.

FARES.

Morwell Bridge-Warragul, 6s. return.  
Yallourn South Migrant Camp-Warragul, 6s. return.  
Hernes Oak-Warragul, 6s. return.

MOSS, J. H., Riverview Garage, Yarra-street, Warrandyte; 1 commercial passenger vehicle, with seating capacity for five persons, to operate as follows:—(a) at separate and distinct fares within a radius of 4 miles of Riverview Garage, Warrandyte, (b) under private hire conditions within a radius of 50 miles of Warrandyte.

PENINSULA BUS LINES LTD., Young-street, Frankston; 3 commercial passenger vehicles, each with seating capacity for approximately 30 persons, to be purchased, to operate as additional vehicles under the same terms and conditions as contained in the applicant's existing stage omnibus licences.

RYAN, J. W., Sallsbury-street, Orbost; 3 commercial passenger vehicles, each with seating capacity for 7, 10, and 26 persons respectively, to operate for the carriage of passengers, parcels, cream, beans, and other perishable goods, on the following routes:—(a) between Orbost and Noorinbee, via Cabbage Tree, Bell Bird, and Cann River, (b) between Cann River and Mallacoota, via Genoa, (c) between Cann River and the border of New South Wales *en route* to Bombala, via Rockton, (d) in respect to vehicle with seating capacity for seven persons, to operate under private hire conditions within a radius of 50 miles of Cann River (subject to the cancellation of licence Nos. A.2744, A.2742, and A.2768, at present held by J. F. and T. H. Stephenson and C. S. Shearer, trading as Gippsland Monaro Coaches, Cann River).

SOUTHERN COACH LINES PTY. LTD., 54-56 Nicholson-street, Healesville; 1 commercial passenger vehicle, with seating capacity for five persons, to operate as follows:—(a) at separate and distinct fares within a radius of 5 miles of the Healesville Post Office, (b) under private hire conditions within a radius of 50 miles of the Healesville Post Office.

SMITH, F. W., Fish Creek; 1 commercial passenger vehicle, with seating capacity for five persons, to operate as follows:—(a) a stage omnibus service between Fish Creek Railway Station and the Government Chalet, Wilson's Promontory, (b) at separate and distinct fares within a radius of 5 miles of Fish Creek Post Office, (c) under private hire conditions within a radius of 50 miles of Fish Creek Post Office (subject to the cancellation of licence No. A.2362, at present held by W. S. Grimshaw, Fish Creek).

STANGER, W., Box 82, Post Office, Morwell; 1 commercial passenger vehicle, with seating capacity for five persons, to operate as follows:—(a) at separate and distinct fares within a radius of 5 miles of Morwell Post Office, (b) under private hire conditions within a radius of 50 miles of Morwell Post Office.

THOMSON, A. H., 5 Alexander-avenue, Cullen Park, Kerang; 1 commercial passenger vehicle, with seating capacity for five persons, to operate as follows:—(a) at separate and distinct fares within a radius of 5 miles of Kerang Post Office, (b) under private hire conditions within a radius of 50 miles of Kerang Post Office.

TREMBATH, R. D., Mirboo North; 1 commercial passenger vehicle, with seating capacity for 29 persons, to operate as follows:—(a) for the carriage only of school children between Allembay and Mirboo North, via Childer, in accordance with the terms of a contract entered

into with the Education Department, (b) under charter conditions within a radius of 50 miles of Mirboo North.

U. S. MOTORS (BELGRAVE) PTY. LTD., Main-street, Belgrave; application in respect to vehicles at present licensed in the name of the company, to operate as follows:—(a) under all the existing terms and conditions at present authorized, (b) between Upper Ferntree Gully and Melbourne, via Burwood-road, Toorak-road, Camberwell-road, and Bridge-road (subject to the cancellation of "A" licences at present held by the applicant company).

WILKINSON, J. H., Marlo, via Orbost; 1 commercial passenger vehicle, with seating capacity for five persons, to be purchased to operate as follows:—(a) at separate and distinct fares within a radius of 5 miles of Club Terrace, East Gippsland, (b) under private hire conditions within a radius of 50 miles of Club Terrace, East Gippsland.

APPLICATIONS for licences to operate commercial passenger vehicles, with seating capacity for five persons, for the carriage of passengers throughout Victoria, at otherwise than at separate and distinct fares for each passenger:—

CHILD, D. O., 19 Cloyne-street, Highett (to operate from 11 Station-street, Sandringham).

FRASER, H. G., 91 Thomson-street, Hamilton (subject to the cancellation of private hire licence No. P.H.5, at present in the name of T. R. Povey, Hamilton).

HARRINGTON, M. L. (trading as Harrington's Bus Service), Forest-road, The Basin, via Bayswater.

HAY, A., Main-road, Lower Plenty (subject to the cancellation of licence No. P.H.1501, at present in the name of D. Budge, Lower Plenty).

JAMES, Mrs. E. H., Clunes (subject to the cancellation of private hire licence No. P.H.995, in the name of R. W. T. Oliver).

MARLAND, F. J., 22 Sherbourne-street, Essendon.

MOSS, J. H., Yarra-street, Warrandyte.

MCKENZIE, J. S., 63 Sydney-road, Coburg.

STEVENS, E. F. & M., Commercial Garage, Kilmore.

Notice of any objection should be forwarded to reach the Secretary to the Board not later than Friday, 25th May, 1951.

E. V. FIELD,

Secretary.

Exhibition Buildings, Rathdown-street, Carlton, N.3, 11th May, 1951.

#### RULES OF THE SUPREME COURT.

IN pursuance of the powers conferred by the Supreme Court Acts and all other powers hereunto enabling, the following rule is made and shall take effect from the date on which it is published in the *Government Gazette*:—

In Chapter I., the under-mentioned Rules are hereby amended as follows:—

(a) In Rule 5 of Order 52 the following words are hereby inserted immediately after the words "hearing the motion" namely:—

"and a copy of the notice shall, before the hearing of the motion, be filed in the Office of the Prothonotary by the party moving or his solicitor."

(b) In Rule 11 of Order 54 the following words are hereby substituted for the words "In all cases of applications originating in Chambers", namely:—

"In the case of every application in Chambers not made *ex parte* or upon originating summons."

(c) In Rule 14 of Order 54 the following words are hereby substituted for the words "at any time before the signing of the order so directs", namely:—

"does not before the signing of the order direct otherwise."

CHARLES J. LOWE, A.C.J.

RUSSELL MARTIN, J.

NORMAN O'BRYAN, J.

JOHN V. BARRY, J.

ARTHUR DEAN, J.

R. R. SHOLL, J.

T. W. SMITH, J.

E. G. COPPEL, A.J.

E. H. HUDSON, A.J.



List of Fungicides, Insecticides, Vermin Destroyers and Weed Destroyers Registered at the Office of the Director of Agriculture under the Fungicides Act 1935 (No. 4295) for the Year 1951.

Distinguishing Name of Fungicide and/or Insecticide.	Percentage of Declared Active Constituent(s).				Wholesale Dealer.
	Arsenic Pentoxide (As <sub>2</sub> O <sub>5</sub> ) Calculated on the Dry Basis.		Acidity Calculated as Nitric Dry Basis.	Content of Water.	
	Total.	Water Soluble.			
<i>Arsenate of Lead (Paste).</i>					
	Minimum.	Maximum.	Maximum.	Maximum.	
Hortico .. .. .	32.0	.50	.2	50.0	Horticultural Industries Pty. Ltd., 67 Burnley-street, Richmond
Berger's Mercury .. .. .	31.0	.50	.2	50.0	Neptune Oil Co. Pty. Ltd., 532 Bourke-street, Melbourne
Blue Bell .. .. .	31.0	.50	.2	50.0	Blyth Chemicals Ltd., 31 Queen-street, Melbourne
Elephant .. .. .	31.0	.50	.2	50.0	Jaques Pty. Ltd., 31 Queen-street, Melbourne
Lion .. .. .	31.0	.50	.2	50.0	Orchard Sprays Pty. Ltd., 549 Church-street, Richmond
Ramtre .. .. .	31.5	.25	.2	50.0	Ramsay and Treganowan Ltd., 475 Latrobe-street, Melbourne
Vallo .. .. .	32.0	.50	.2	50.0	Victor Leggo and Farmers Ltd., 282-290 Williamstown-road, Yarraville
Tip Top .. .. .	32.0	.50	.2	50.0	Law, Somner Pty. Ltd., 21 Elizabeth-street, Melbourne
Pannifex .. .. .	31.0	.50	.2	50.0	H. C. Pannifex and Co. Pty. Ltd., 53-57 Munster-terrace, North Melbourne, N.I.
Lane's .. .. .	31.0	.32	.2	50.0	Wm. Haughton and Co. Ltd., 545 Little Collins-street, Melbourne
<i>Arsenates of Lead (Powder).</i>					
Blue Bell .. .. .	31.0	.50	.2	..	Blyth Chemicals Ltd., 31 Queen-street, Melbourne
Arsinotic .. .. .	31.0	.50	.2	..	Ramsay and Treganowan Ltd., 475 Latrobe-street, Melbourne
Elephant .. .. .	31.0	.50	.2	..	Jaques Pty. Ltd., 31 Queen-street, Melbourne
Lion .. .. .	31.0	.50	.2	..	Orchard Sprays Pty. Ltd., 549 Church-street, Richmond
Ramtre .. .. .	31.5	.25	.2	..	Ramsay and Treganowan Ltd., 475 Latrobe-street, Melbourne
Flano .. .. .	31.0	.50	.2	..	N. N. McLean Pty. Ltd., 395 Queen-street, Melbourne
Vallo .. .. .	32.0	.50	.2	..	Victor Leggo and Farmers Ltd., 282-290 Williamstown-road, Yarraville
Berger's Mercury .. .. .	31.0	.50	.2	..	Neptune Oil Co. Pty. Ltd., 532 Bourke-street, Melbourne
Pannifex .. .. .	31.0	.50	.2	..	H. C. Pannifex and Co. Pty. Ltd., 53-57 Munster-terrace, North Melbourne
Lane's .. .. .	31.0	.50	.2	..	Wm. Haughton and Co. Ltd., 545 Little Collins-street, Melbourne
Tip Top .. .. .	32.0	.50	.2	..	Law, Somner Pty. Ltd., 21 Elizabeth-street, Melbourne
Hortico .. .. .	32.0	.50	.2	..	Horticultural Industries Pty. Ltd., 67 Burnley-street, Richmond
Sigma .. .. .	32.0	.50	.2	..	Sigma Co. Ltd., 562 Little Bourke-street, Melbourne
<i>Calcium Arsenate.</i>					
Lion .. .. .	40.0	..	..	..	Orchard Sprays Pty. Ltd., 549 Church-street, Richmond
Vallo .. .. .	40.0	..	..	..	Victor Leggo and Farmers Ltd., 282-290 Williamstown-road, Yarraville
<i>Sulphates of Copper (Bluestone).</i>					
	%				
Blyth's .. .. .	Copper (Cu)	25.0	..	..	Blyth Chemicals Ltd., 31 Queen-street, Melbourne
Jaques' Elephant .. .. .	"	25.0	..	..	Jaques Pty. Ltd., 31 Queen-street, Melbourne
Maclefield .. .. .	"	25.0	..	..	Neptune Oil Co. Pty. Ltd., 532 Bourke-street, Melbourne, C.1
Neptune .. .. .	"	25.0	..	..	" " " " " " " " " " " "
Neptune Snow .. .. .	"	25.0	..	..	" " " " " " " " " " " "
Hart's Sugar Bluestone .. .. .	"	25.0	..	..	Hart and Co. Pty. Ltd., 38 Clarendon-street, South Melbourne
Hortico .. .. .	"	25.0	..	..	Horticultural Industries Pty. Ltd., 67 Burnley-street, Richmond
Mellor's .. .. .	"	25.0	..	..	F. R. Mellor and Son, 452 Queen-street, Melbourne
	Percentage Copper (Cu).	Percentage Copper (Cu) Water Soluble.	Percentage through 200-mesh Sieve.		
<i>Basic Copper Salts.</i>					
I.O.L. A.N.Z. (Carbonate) .. .. .	%	%	%		Commonwealth Fertilizers and Chemicals Ltd., 65 William-street, Melbourne
Smatol (Oxychloride) .. .. .	52.0	Nil	99.0		
Vallo Anti-Bunt (Oxychloride) .. .. .	52.0	Nil	99.0		Victor "Leggo" and "Farmers" Ltd., 282-290 Williamstown-road, Yarraville
Cuprox (Oxychloride) .. .. .	50.0	..	..		Ramsay and Treganowan Ltd., 475 Latrobe-street, Melbourne
Elliot's Bunticide .. .. .	50.0	..	..		D. G. Officer Pty. Ltd., 90 William-street, Melbourne
Vallo Copper Spray (Oxychloride) .. .. .	50.0	..	..		Victor Leggo and Farmers Ltd., 282-290 Williamstown-road, Yarraville
Copper-50-Spray (Oxychloride) .. .. .	50.0	..	..		Wm. Haughton and Co. Ltd., 545 Little Collins-street, Melbourne
Kopi (Oxychloride) .. .. .	50.0	..	..		G. W. Allan, 323 Flinders-street, Melbourne
Soltosan (Oxychloride) .. .. .	50.0	..	..		" " " " " " " " " " " "
Elephant Coppo .. .. .	50.0	..	..		Jaques Pty. Ltd., 31 Queen-street, Melbourne
Blue Bell Coppo .. .. .	50.0	..	..		Blyth Chemicals Ltd., 31 Queen-street, Melbourne
Kilspor (Carbonate) .. .. .	50.0	.25	97.5		Alf. Hannaford and Co. Ltd., Port-road, Woodville, S.A., and Victoria-street, Dimboola
<i>Bordeaux Mixture.</i>					
	%				
Hortico (powder) .. .. .	Copper (Cu)	12.50	..	..	Horticultural Industries Pty. Ltd., 67 Burnley-street, Richmond
Lion (powder) .. .. .	"	12.50	..	..	Orchard Sprays Pty. Ltd., 549 Church-street, Richmond
Vallo (powder) .. .. .	"	12.50	..	..	Victor Leggo and Farmers Ltd., 282-290 Williamstown-road, Yarraville
Lane's Bordeaux (powder) .. .. .	"	12.50	..	..	Wm. Haughton and Co. Ltd., 545 Little Collins-street, Melbourne
Bord-O-Kwik (paste) .. .. .	"	17.5	..	..	Horticultural Industries Pty. Ltd., 67 Burnley-street, Richmond
Tip Top (powder) .. .. .	"	12.5	..	..	Law, Somner Pty. Ltd., 21 Elizabeth-street, Melbourne
<i>Burgundy or Copper-Soda.</i>					
Neptune Copper Spray .. .. .	Copper (Cu)	12.5	..	..	Neptune Oil Co. Pty. Ltd., 532 Bourke-street, Melbourne
Blue Bell .. .. .	"	12.0	..	..	Blyth Chemicals Ltd., 31 Queen-street, Melbourne
Elephant .. .. .	"	12.0	..	..	Jaques Pty. Ltd., 31 Queen-street, Melbourne
<i>Paris Green.</i>					
	%				
Felton, Grimwade, and Duerdin's .. .. .	Arsenious Oxide (As <sub>2</sub> O <sub>3</sub> )	50.0	..	..	Felton, Grimwade, and Duerdins Pty. Ltd., 342 Flinders-lane, Melbourne
Nosco .. .. .	"	"	50.0	..	Wm. Haughton and Co. Ltd., 545 Little Collins-street, Melbourne
<i>Miscellaneous Copper Compounds.</i>					
	%				
Hortico Cheshunt Compound .. .. .	Copper (Cu)	4.0 (on dry basis)	..	..	Horticultural Industries Pty. Ltd., 67 Burnley-street, Richmond
Bordnette .. .. .	"	12.7	..	..	Ramsay and Treganowan Ltd., 475 Latrobe-street, Melbourne
Bordesan Colloidal Copper .. .. .	"	15.0	..	..	Wm. Haughton and Co. Ltd., 545 Little Collins-street, Melbourne
<i>Lime.</i>					
	%				
Neptune .. .. .	Available Lime (CaO)	80	..	..	Neptune Oil Co. Pty. Ltd., 532 Bourke-street, Melbourne

LIST OF FUNGICIDES, ETC., ETC.—continued.

Distinguishing Name of Fungicide and/or Insecticide.	Percentage of Declared Active Constituent(s).			Wholesale Dealer.
	Thio-Sulphate Sulphur.	Poly-Sulphide Sulphur.	Total Soluble Sulphur.	
	Weight in Volume.			
<i>Concentrated Lime-Sulphur (Solution).</i>				
Hortico .. .. .	2.5	20.0	28.0	Horticultural Industries Pty. Ltd., 67 Burnley-street, Richmond
Blue Bell .. .. .	2.5	20.0	28.0	Blyth Chemicals Ltd., 31 Queen-street, Melbourne
Elephant .. .. .	2.5	20.0	28.0	Jaques Pty. Ltd., 31 Queen-street, Melbourne
Lion .. .. .	2.5	20.0	28.0	Orchard Sprays Pty. Ltd., 549 Church-street, Richmond
Neptune .. .. .	2.5	20.0	28.0	Neptune Oil Co. Pty. Ltd., 532 Bourke-street, Melbourne
Vallo .. .. .	2.5	20.0	28.0	Victor Leggo and Farmers Ltd., 282-290 Williamstown-road, Yarraville
X.L. .. .. .	2.5	20.0	28.0	Ramsay and Treganowan Ltd., 475 Latrobe-street, Melbourne
Harola .. .. .	1.5	20.0	28.0	Wm. Haughton and Co. Ltd., 545 Little Collins-street, Melbourne
Tip Top .. .. .	2.5	20.0	28.0	Law, Somner Pty. Ltd., 21 Elizabeth-street, Melbourne
Say .. .. .	2.5	20.0	28.0	Victor Say, Benalla
Wilmo .. .. .	2.5	20.0	28.0	Wilcox Mollin Ltd., 34 King-street, Melbourne
<i>Lime and Sulphur (Dry Mix).</i>				
Pannifex .. .. .	62.5		35.5	H. C. Pannifex and Co. Pty. Ltd., 53-57 Munster-terrace, North Melbourne
Vallo .. .. .	64.0		35.6	Victor Leggo and Farmers Ltd., 282-290 Williamstown-road, Yarraville
<i>Sulphur.</i>				
Commonwealth (Dusting) .. .. .	Sulphur 90.0			Commonwealth Fertilizers and Chemicals Ltd., 65 William-street, Melbourne
" (Powdered) .. .. .	" 99.5			" " " " " " " " " " " "
" (Atomic Dusting) .. .. .	" 90.0			" " " " " " " " " " " "
" (Atomic) .. .. .	" 99.5			" " " " " " " " " " " "
" (Wetomic) .. .. .	" 97.0			" " " " " " " " " " " "
Flotax .. .. .	" 95.0			H. C. Pannifex and Co. Pty. Ltd., 53-57 Munster-terrace, North Melbourne
Neptune (Powdered) .. .. .	" 99.0			Neptune Oil Co. Pty. Ltd., 532 Bourke-street, Melbourne
Vallo (Powdered) .. .. .	" 99.5			Victor Leggo and Farmers Ltd., 282-290 Williamstown-road, Yarraville
" (Dusting) .. .. .	" 90.0			" " " " " " " " " " " "
" (Wettable) .. .. .	" 98.0			" " " " " " " " " " " "
Wetsul .. .. .	" 97.0			Ramsay and Treganowan Ltd., 475 Latrobe-street, Melbourne
Plane (Dusting) .. .. .	" 90.0			N. N. McLean Pty. Ltd., 395 Queen-street, Melbourne
Blue Bell (Colloidal) .. .. .	" 50.0			Blyth Chemicals Ltd., 31 Queen-street, Melbourne
Elephant (Colloidal) .. .. .	" 50.0			Jaques Pty. Ltd., 31 Queen-street, Melbourne
Hortico (Dusting) .. .. .	" 90.0			Horticultural Industries Pty. Ltd., 67 Burnley-street, Richmond
Spregan (Colloidal) .. .. .	" 55.0			Spregan Colloidal Sulphur Pty. Ltd., 90 Queen-street, Melbourne
Oosan (Colloidal) .. .. .	" 50.0			Wm. Haughton and Co. Ltd., 545 Little Collins-street, Melbourne
Spersul .. .. .	" 78.0			Ramsay and Treganowan Ltd., 475 Latrobe-street, Melbourne
Lion (Wettable) .. .. .	" 97.0			Orchard Sprays Pty. Ltd., 549 Church-street, Richmond
Wilmo Sulfung (Wettable) .. .. .	" 75.0			Wilcox Mollin Ltd., 34 King-street, Melbourne
Sulfaloid .. .. .	" 75.0			Taubmans Ltd., 41 Rooney-street, Burnley
Tromax (Powder) .. .. .	" 100.0			Sigma Co. Ltd., 562 Little Bourke-street, Melbourne
Sulfadip .. .. .	" 75.0			Taubmans Ltd., 41 Rooney-street, Burnley
<i>Nicotine Sulphate.</i>				
Hortico .. .. .	Nicotine 40			Horticultural Industries Pty. Ltd., 67 Burnley-street, Richmond
Blue Bell .. .. .	" 40			Blyth Chemicals Ltd., 31 Queen-street, Melbourne
Elephant .. .. .	" 40			Jaques Pty. Ltd., 31 Queen-street, Melbourne
Plane .. .. .	" 40			N. N. McLean Pty. Ltd., 395 Queen-street, Melbourne
Vallo .. .. .	" 40			Victor Leggo and Farmers Ltd., 282-290 Williamstown-road, Yarraville
Black Leaf 40 (Neptune) .. .. .	" 40			Neptune Oil Co. Pty. Ltd., 532 Bourke-street, Melbourne
Neptune .. .. .	" 40			" " " " " " " " " " " "
Hart's .. .. .	" 40			Hart and Co. Pty. Ltd., 35 Clarendon-street, South Melbourne
Lane's Black Leaf 40 .. .. .	" 40			Wm. Haughton and Co. Ltd., 545 Little Collins-street, Melbourne
Elliott's .. .. .	" 40			D. G. Officer Pty. Ltd., 90 William-street, Melbourne
Taubman's .. .. .	" 40			Taubmans Ltd., 41 Rooney-street, Burnley
Kix .. .. .	" 40			Clark, King and Co. Pty. Ltd., 237 Queen-street, Melbourne
Grazcos .. .. .	" 40			Grazcos Co-op. Ltd., 90 William-street, Melbourne
Wilmo .. .. .	" 40			Wilcox Mollin Ltd., 34 King-street, Melbourne
Sigma .. .. .	" 40			Sigma Co. Ltd., 562 Little Bourke-street, Melbourne
Tip Top .. .. .	" 40			Law, Somner Pty. Ltd., 21 Elizabeth-street, Melbourne
<i>Tar Distillate.</i>				
Ovicide .. .. .	Tar Oil .. 48			Ramsay and Treganowan Ltd., 475 Latrobe-street, Melbourne
	Phenols .. 10			
	Mineral Oil .. 20			
Vallo Ovicide Wash .. .. .	Emulsifiable Oils .. 89			Victor Leggo and Farmers Ltd., 282-290 Williamstown-road, Yarraville
Blue Bell .. .. .	" .. 89			Blyth Chemicals Ltd., 31 Queen-street, Melbourne
Elephant .. .. .	" .. 89			Jaques Pty. Ltd., 31 Queen-street, Melbourne
Hortico Winterwash .. .. .	" .. 89			Horticultural Industries Pty. Ltd., 67 Burnley-street, Richmond
Winterwash A .. .. .	Tar Oil .. 70			Ramsay and Treganowan Ltd., 475 Latrobe-street, Melbourne
	Anthracene Oil .. 50			
	Phenols .. 8			
Wintrol (Tar Oil) .. .. .	Mineral Oil .. 12			Wm. Haughton and Co. Ltd., 545 Little Collins-street, Melbourne
Lion .. .. .	Tar Oil .. 70			Orchard Sprays Pty. Ltd., 549 Church-street, Richmond
	Tar Oil .. 45			
Say .. .. .	Phenols .. 9			Victor Say, Benalla
	Mineral Oil .. 25			
<i>White Spraying Oil or Emulsion.</i>				
Hortico .. .. .	White Mineral Oil 80.0			Horticultural Industries Pty. Ltd., 67 Burnley-street, Richmond
Blue Bell .. .. .	" .. 82.0			Blyth Chemicals Ltd., 31 Queen-street, Melbourne
Albolem .. .. .	" .. 80.0			Ramsay and Treganowan Ltd., 475 Latrobe-street, Melbourne
Elephant .. .. .	" .. 82.0			Jaques Pty. Ltd., 31 Queen-street, Melbourne
Gargoyle .. .. .	" .. 82.5			Vacuum Oil Co. Pty. Ltd., 29 Market-street, Melbourne
Kleentup .. .. .	" .. 83.0			H. C. Pannifex and Co. Pty. Ltd., 53-57 Munster-terrace, North Melbourne
Lion .. .. .	" .. 80.0			Orchard Sprays Pty. Ltd., 549 Church-street, Richmond
Neptune .. .. .	" .. 84.0			Neptune Oil Co. Pty. Ltd., 532 Bourke-street, Melbourne
Vallo Clarifol .. .. .	" .. 85.0			" " " " " " " " " " " "
	" .. 82.5			Victor Leggo and Farmers Ltd., 282-290 Williamstown-road, Yarraville
Volck .. .. .	" .. 83.0			H. C. Pannifex and Co. Pty. Ltd., 53-57 Munster-terrace, North Melbourne
Shell Whitespray .. .. .	" .. 84.0			Shell Co. of Australia Ltd., 163 William-street, Melbourne
X.L. .. .. .	" .. 80.0			Ramsay and Treganowan Ltd., 475 Latrobe-street, Melbourne
Atlantic Emulsified .. .. .	" .. 82.0			Atlantic Union Oil Co. Ltd., 396 Collins-street, Melbourne, C.1
Albarol .. .. .	" .. 80.0			Wm. Haughton and Co. Ltd., 545 Little Collins-street, Melbourne
Tip Top .. .. .	" .. 80.0			Law, Somner Pty. Ltd., 21 Elizabeth-street, Melbourne
Wilmo .. .. .	" .. 82.5			Wilcox Mollin Ltd., 34 King-street, Melbourne
Say .. .. .	" .. 82.5			Victor Say, Benalla

LIST OF FUNGICIDES, ETC., ETC.—continued.

Distinguishing Name of Fungicide and/or Insecticide.	Percentage of Declared Active Constituent(s).	Wholesale Dealer.
<i>Pale Spraying Oil.</i>		
	%	
Gargoyle .. .. .	Pale Mineral Oil 82.5 .. .. .	Vacuum Oil Co. Pty. Ltd., 29 Market-street, Melbourne
Neptune Palsol .. .. .	" " 85.0 .. .. .	Neptune Oil Co. Pty. Ltd., 532 Bourke-street, Melbourne
Shell Pale-Spray .. .. .	" " 85.0 .. .. .	Shell Co. of Australia Ltd., 163 William-street, Melbourne
Shellicide D. .. .. .	" " 85.0 .. .. .	
Vallo .. .. .	" " 83.0 .. .. .	Victor Leggo and Farmers Ltd., 282-290 Williamstown-road, Yarraville
Lane's .. .. .	" " 80.0 .. .. .	Wm. Haughton and Co. Ltd., 545 Little Collins-street, Melbourne
Blue Bell .. .. .	" " 82.5 .. .. .	Blyth Chemicals Ltd., 31 Queen-street, Melbourne
Elephant .. .. .	" " 82.5 .. .. .	Jaques Pty. Ltd., 31 Queen-street, Melbourne
<i>Red Spraying Oil.</i>		
	%	
Hortico .. .. .	Red Mineral Oil 85.0 .. .. .	Horticultural Industries Pty. Ltd., 67 Burnley-street, Richmond
Blue Bell .. .. .	" " 85.0 .. .. .	Blyth Chemicals Ltd., 31 Queen-street, Melbourne
Elephant .. .. .	" " 85.0 .. .. .	Jaques Pty. Ltd., 31 Queen-street, Melbourne
Gargoyle .. .. .	" " 85.0 .. .. .	Vacuum Oil Co. Pty. Ltd., 29 Market-street, Melbourne
Gargoyle M. .. .. .	" " 82.5 .. .. .	
Lion .. .. .	" " 85.0 .. .. .	Orchard Sprays Pty. Ltd., 549 Church-street, Richmond
Neptune "A" .. .. .	" " 85.0 .. .. .	Neptune Oil Co. Pty. Ltd., 532 Bourke-street, Melbourne
" " "C" .. .. .	" " 70.0 .. .. .	
Shell Red Spray .. .. .	" " 83.0 .. .. .	Shell Co. of Australia Ltd., 163 William-street, Melbourne
Vallo .. .. .	" " 85.0 .. .. .	Victor Leggo and Farmers Ltd., 282-290 Williamstown-road, Yarraville
X.L. .. .. .	" " 85.0 .. .. .	Ramsay and Treganowan Ltd., 475 Latrobe-street, Melbourne
X.L. (Emulsion) .. .. .	" " 82.0 .. .. .	
Atlantic .. .. .	" " 89.0 .. .. .	Atlantic Union Oil Co. Ltd., 398 Collins-street, Melbourne, C.I.
Harkas .. .. .	" " 75.0 .. .. .	Wm. Haughton and Co. Ltd., 545 Little Collins-street, Melbourne
Tip Top .. .. .	" " 80.0 .. .. .	Law, Somner Pty. Ltd., 21 Elizabeth-street, Melbourne
Wilno .. .. .	" " 85.0 .. .. .	Wilcox Moffin Ltd., 34 King-street, Melbourne
<i>Winter Spraying Oil.</i>		
	%	
Shell Universal Winter Spray .. .. .	Solution Nitrated Phenols in Oil 85.0 .. .. .	Shell Co. of Australia Ltd., 163 William-street, Melbourne
Winsol .. .. .	" " " " 85.0 .. .. .	Neptune Oil Co. Pty. Ltd., 532 Bourke-street, Melbourne
Vallo D.N.C. .. .. .	" " " " 85.0 .. .. .	Victor Leggo and Farmers Ltd., 282-290 Williamstown-road, Yarraville
Capsine D.N.O.C. Dormant Ovicideal Spray .. .. .	Mineral Oil .. 72.0 .. .. .	Ramsay and Treganowan Ltd., 475 Latrobe-street, Melbourne
	Dinitroorthocresol .. 2.0 .. .. .	
D.N.C. (Spraying Oil) .. .. .	Mineral Oil .. 80.0 .. .. .	Wm. Haughton and Co. Ltd., 545 Little Collins-street, Melbourne
	Dinitroorthocresol .. 2.5 .. .. .	
<i>Miscellaneous Spraying Oil.</i>		
Gargoyle Green Spraying Oil .. .. .	Pale mineral oil .. 79.0 .. .. .	Vacuum Oil Co. Pty. Ltd., 29 Market-street, Melbourne
	D.D.T. .. 3.0 .. .. .	
	Aliphatic Thiocyanate 1.0 .. .. .	
<i>Arsenic (Oxides).</i>		
	%	
Vallo (White) .. .. .	Arsenic (As <sub>2</sub> O <sub>3</sub> ) .. 98.0 .. .. .	Victor Leggo and Farmers Ltd., 282-290 Williamstown-road, Yarraville
(Pentoxide) Granulated .. .. .	Arsenic Pentoxide (As <sub>2</sub> O <sub>5</sub> ) .. 89.0 .. .. .	
Hart's (White) .. .. .	Arsenic (As <sub>2</sub> O <sub>3</sub> ) .. 89.5 .. .. .	Hart and Co. Pty. Ltd., 38 Clarendon-street, South Melbourne
Felton, Grimwade, and Duerdin's (White) .. .. .	" " .. 88.0 .. .. .	Felton, Grimwade, and Duerdin's Pty. Ltd., 342 Flinders-lane, Melbourne
<i>Snail and Slug Killers.</i>		
Bug-Geta .. .. .	Metaldehyde .. .. 1.5 .. .. .	Guano Plant Force and Pest Control Co., 53-57 Munster-terrace, North Melbourne
Sure Death .. .. .	" " .. 1.5 .. .. .	Sure Death Laboratories, 2A Lunan-avenue, Drumcondra, Geelong
Defender .. .. .	" " .. 1.25 .. .. .	Law, Somner Pty. Ltd., 21 Elizabeth-street, Melbourne
Slugtox .. .. .	" " .. 1.5 .. .. .	Horticultural Industries Pty. Ltd., 67 Burnley-street, Richmond
Brown Magic .. .. .	" " .. 1.0 .. .. .	E. H. Page, 1264 High-street, Malvern
Instant 265 .. .. .	" " .. 1.4 .. .. .	F. M. Grant, 6th Avenue, Rosebud
K.O.4 .. .. .	Metaldehyde .. 1.25 .. .. .	A. B. Gibson and Sons Pty. Ltd., Stubbs-street, Kensington
	Arsenic (As <sub>2</sub> O <sub>3</sub> ) .. 75 .. .. .	
	Sodium Fluosilicate .. 10.0 .. .. .	
Metaslug .. .. .	Metaldehyde .. 1.0 .. .. .	Ormond Plant Farm Pty. Ltd., Lillimur-road, Ormond
Kilsem (or Snail Slug) .. .. .	" " .. 1.25 .. .. .	Wm. Haughton and Co. Ltd., 545 Little Collins-street, Melbourne
Avery .. .. .	" " .. 1.5 .. .. .	R. Avery Fertilizer Co. Pty. Ltd., cr. Princess and Knox streets, East Preston
<i>Miscellaneous.</i>		
	%	
Felton's Formalin .. .. .	Formaldehyde .. .. 38.0 .. .. .	Felton, Grimwade, and Duerdin's Pty. Ltd., 342 Flinders-lane, Melbourne
I.C.I. A.N.Z. Carbon Bisulphide .. .. .	Carbon Bisulphide .. .. 90.0 .. .. .	Commonwealth Fertilizers and Chemicals Ltd., 65 William-street, Melbourne
Vallo Tree Bands .. .. .	D.D.T. .. .. 1.0 .. .. .	Victor Leggo and Farmers Ltd., 282-290 Williamstown-road, Yarraville
	Beta-naphthol .. .. 20.0 .. .. .	
Shirlan A. G. .. .. .	Salicylanilide .. .. 25.0 .. .. .	Ramsay and Treganowan Ltd., 475 Latrobe-street, Melbourne
	Sulphonated Organic Matter .. 25.0 .. .. .	
" W.S. .. .. .	Sodium Salicylanilide .. .. 98.0 .. .. .	
" 100% .. .. .	Salicylanilide .. .. 88.0 .. .. .	
Ceresan .. .. .	Mercury .. .. 1.5 .. .. .	Dalgety and Co. Ltd., 461-471 Bourke-street, Melbourne
	Sodium salt of .. 30.0 .. .. .	
Germisan .. .. .	Cyan-mercury cresol .. 60.0 .. .. .	N. N. McLean Pty. Ltd., 395 Queen-street, Melbourne
	Sodium chloride .. .. 1.54 .. .. .	Victor Leggo and Farmers Ltd., 282-290 Williamstown-road, Yarraville
Lunasan .. .. .	Organically combined mercury .. 1.5 .. .. .	Commonwealth Fertilizers and Chemicals Ltd., 65 William-street, Melbourne
Agrosan .. .. .	" " .. 4.0 .. .. .	F. R. Mellor and Son, 452 Queen-street, Melbourne
Phenyl Mercury Fixtan Spray .. .. .	" " .. 70.0 .. .. .	H. C. Panmiffex and Co. Pty. Ltd., 53-57 Munster-terrace, North Melbourne
Tubercul .. .. .	Stearoptenes and Oleoptenes .. 0.63 .. .. .	
	Nicotine .. .. 18.19 .. .. .	
Grenedeth .. .. .	Sulphur .. .. 2.27 .. .. .	E. H. Page, 1264 High-street, Malvern
	Paradichlorobenzene .. .. 4.22 .. .. .	
	Residual Oil .. .. 2.26 .. .. .	
	Naphthalene .. .. 2.0 .. .. .	
	Oil of Citronella .. .. 2.3 .. .. .	
Clensel .. .. .	Ammonia .. .. 60.0 .. .. .	Clensel Products Pty. Ltd., Youell and Cowper streets, Footscray
	Potash Soap .. .. 10.0 .. .. .	
	Naphthalene .. .. 1.0 .. .. .	
Killamite Manurial Insecticide .. .. .	Tar Acids .. .. 1.0 .. .. .	Horticultural Industries Pty. Ltd., 67 Burnley-street, Richmond
	Copper .. .. 2.0 .. .. .	
	Sulphur .. .. 90.0 .. .. .	Sulphates Ltd., 395 Collins-street, Melbourne
Fluor-o-cide .. .. .	Sodium Aluminium Fluoride .. 0.5 .. .. .	
	Ethyl mercury phosphate .. 3.0 .. .. .	
	Potassium permanganate .. 3.0 .. .. .	
Wilto Soil Treatment .. .. .	Paradichlorobenzene .. .. 12.0 .. .. .	Wm. Haughton and Co. Ltd., 545 Little Collins-street, Melbourne
	Copper .. .. 5.5 .. .. .	
	Phenols .. .. 12.5 .. .. .	
	Sodium fluosilicate .. .. 2.5 .. .. .	
Jen's Poultry Louse Powder .. .. .	Tar Salts .. .. 2.5 .. .. .	Jen's Vet. Products, 443 Little Collins-street, Melbourne
	Sulphur .. .. 2.5 .. .. .	
	Tobacco dust .. .. 4 .. .. .	
Sickie or I.C.I. Formalin .. .. .	Formaldehyde .. .. 38.0 .. .. .	Commonwealth Fertilizers and Chemicals Ltd., 65 William-street, Melbourne
Hortico Formalin .. .. .	" " .. 40.0 .. .. .	Horticultural Industries Pty. Ltd., 67 Burnley-street, Richmond
Lane's Tree Bands .. .. .	Beta-naphthol .. .. 10.0 .. .. .	Wm. Haughton and Co. Ltd., 545 Little Collins-street, Melbourne
	D.D.T. .. .. 2.0 .. .. .	

LIST OF FUNGICIDES, ETC., ETC.—continued.

Distinguishing Name of Fungicide and/or Insecticide.	Percentage of Declared Active Constituent(s).	Wholesale Dealer.																																								
<i>Miscellaneous—continued.</i>																																										
Vallo Manurial Insecticide	Naphthalene 50.0 Sulphur 5.0	Victor Leggo and Farmers Ltd., 282-290 Williamstown-road, Yarraville																																								
Shell D-D Soil Fumigant Tetroc	Chlorinated Hydrocarbons 100.0 Tetrachloroparabenzquinone 98.0	Shell Co. of Aust. Ltd., 163 William-street, Melbourne Wright, Stephenson and Co. (Aust.) Pty. Ltd., 34 Queen-street, Melbourne																																								
Tetroc Seed Protectant	Mercury 98.0	Wm. Haughton and Co. Ltd., 545 Little Collins-street, Melbourne																																								
Aretan	D.D.T. 3.0	G. W. Allan, 328 Flinders-lane, Melbourne																																								
Insecto	D.D.T. 25.0	Wm. Haughton and Co. Ltd., 545 Little Collins-street, Melbourne																																								
Lane's Destructol	Hexa-ethyl Tetraphosphate 15.6 D.D.T. 5.0	" " " " " " " " " " " "																																								
Kyipest Derris Wash	Isobornyl Thiocyno-acetate 25.0 Rotenone 1.1	" " " " " " " " " " " "																																								
" D " Death Poultry Spray	D.D.T. 5.0 Cresylic Acid 5.5	J. D. Harmsworth and Co. Pty. Ltd., 185 William-street, Melbourne																																								
Banexo Insecticide	Tar Oil 5.6	A. A. Walker, Lara.																																								
Anticarte S.D.	Hexachlorobenzene 11.0	F. V. Richards Pty. Ltd., 228 Stanley-street, West Melbourne																																								
Eusarc	Tetrachlorotribenzene 3.0	G. W. Allan, 328 Flinders-street, Melbourne																																								
<i>Nicotine Dusting Powders.</i>																																										
Plane Nicodust No. 3	Nicotine 3.00	N. N. McLean Pty. Ltd., 395 Queen-street, Melbourne																																								
" " No. 5	" 5.00	" " " " " " " " " " " "																																								
Ramtre No. 5	" 3.00	Ramsay and Treganowan Ltd., 475 Latrobe-street, Melbourne																																								
Vallo N.40	" 2.50	Victor Leggo and Farmers Ltd., 282-290 Williamstown-road, Yarraville																																								
Victory	" 3.00	R. H. Nankervis, 317 St. Kilda-street, Middle Brighton																																								
Pestend Tobacco Dust	" 0.50	W. D. and H. O. Wills (Aust.) Ltd., 411 Swanston-street, Melbourne																																								
Rudust No. 10	" 2.50	Taubmans Ltd., 41 Rooney-street, Burnley																																								
<i>Arsenical Dusting Powders.</i>																																										
Plane A.P. No. 50	Arsenic Pentoxide (As <sub>2</sub> O <sub>5</sub> ) 15.5	N. N. McLean Pty. Ltd., 395 Queen-street, Melbourne																																								
Vallo "A.L." 50	" " " " 18.0	Victor Leggo and Farmers Ltd., 282-290 Williamstown-road, Yarraville																																								
Lane's A.P. 50	" " " " 15.5	Wm. Haughton and Co. Ltd., 545 Little Collins-street, Melbourne																																								
<i>Copper Dusting Powders.</i>																																										
Plane Coppodust No. 7	Copper (Cu) 7.00	N. N. McLean Pty. Ltd., 395 Queen-street, Melbourne																																								
" " No. 11	" 11.00	" " " " " " " " " " " "																																								
<i>Rotenone Dusting Powders.</i>																																										
Pulvex (Cooper's)	Rotenone 1.00	New Zealand Loan and Mercantile Agency Co. Ltd., 538 Collins-street, Melbourne																																								
Drymac	" .25	Ramsay and Treganowan Ltd., 475 Latrobe-street, Melbourne																																								
Katakilla	" 1.00	" " " " " " " " " " " "																																								
Derris Dust	" 0.75	Wm. Haughton and Co. Ltd., 545 Little Collins-street, Melbourne																																								
Plane Rotodust No. 100	" 1.00	N. N. McLean Pty. Ltd., 395 Queen-street, Melbourne																																								
Derridust	" 0.75	Houghton and Byrne (Vic.) Pty. Ltd., Empire Arcade, Flinders-street, Melbourne																																								
<i>D.D.T. Dusting Powders.</i>																																										
Plane Noxide No. 100	D.D.T. 1.00	N. N. McLean Pty. Ltd., 395 Queen-street, Melbourne																																								
" " No. 200	" 2.00	" " " " " " " " " " " "																																								
" " No. 500	" 5.00	" " " " " " " " " " " "																																								
Hortico	" 2.00	Horticultural Industries Pty. Ltd., 67 Burnley-street, Richmond																																								
Pespruf No. 2	" 2.00	Ramsay and Treganowan Ltd., 475 Latrobe-street, Melbourne																																								
Deedust	" 2.00	" " " " " " " " " " " "																																								
No-Verm	" 2.00	Wm. Haughton and Co. Ltd., 545 Little Collins-street, Melbourne																																								
Taubman's Rudust No. 5	" 5.00	Taubmans Ltd., 41 Rooney-street, Burnley																																								
" 15 per cent.	" 15.00	" " " " " " " " " " " "																																								
" Rudust No. 4	" 2.00	" " " " " " " " " " " "																																								
Neptune Float-On No. 2	" 2.00	Neptune Oil Co. Pty. Ltd., 532 Bourke-street, Melbourne																																								
" Float-On No. 1	" 5.00	" " " " " " " " " " " "																																								
Say Garden Dust	" 2.00	Victor Say, Benalla " " " " " " " "																																								
Blue Bell Diaphid	" 4.00	Blyth Chemicals Ltd., 31 Queen-street, Melbourne																																								
Elephant Diaphid	" 4.00	Jaques Pty. Ltd., 31 Queen-street, Melbourne																																								
Pespruf No. 7	" 6.00	Ramsay and Treganowan Ltd., 475 Latrobe-street, Melbourne																																								
Caulleab	" 2.00	Houghton and Byrne (Vic.) Pty. Ltd., Empire Arcade, Flinders-street, Melbourne																																								
<i>Benzene Hexachloride Dusting Powders.</i>																																										
Gammexane No. 4	Benzene hexachloride .5	Ramsay and Treganowan Ltd., 475 Latrobe-street, Melbourne																																								
" No. 10	" 1.3	" " " " " " " " " " " "																																								
" No. 20	" 2.8	" " " " " " " " " " " "																																								
" Smoke Generator (Nos. 2 & 12)	" 3.2	" " " " " " " " " " " "																																								
" " No. 22	" 18.0	" " " " " " " " " " " "																																								
Plane Gammacide No. 2	" .26	N. N. McLean Pty. Ltd., 395 Queen-street, Melbourne																																								
" " No. 3	" .39	" " " " " " " " " " " "																																								
" " No. 5	" .52	" " " " " " " " " " " "																																								
B.H.C. 4	" 0.5	Wm. Haughton and Co. Ltd., 545 Little Collins-street, Melbourne																																								
" 10	" 1.3	" " " " " " " " " " " "																																								
" 20	" 2.6	" " " " " " " " " " " "																																								
Cooper's Louse Powder	" 0.6	New Zealand Loan and Mercantile Agency Co. Ltd., 538 Collins-street, Melbourne																																								
Lorexane	" 0.1	Imperial Chemical Industries of Aust. and N.Z. Ltd., 408 Latrobe-street, Melbourne																																								
<i>Mixed Dusting Powders.</i>																																										
Plane A.P. No. 50N	Nicotine 2.00	N. N. McLean Pty. Ltd., 395 Queen-street, Melbourne																																								
" " No. 50N <sub>1</sub>	Arsenic Pentoxide (As <sub>2</sub> O <sub>5</sub> ) 15.50	" " " " " " " " " " " "																																								
Vallo N.3 A.L.30	" 15.50	Victor Leggo and Farmers Ltd., 282-290 Williamstown-road, Yarraville																																								
Plane Aphidust No. 2	" 9.60	N. N. McLean Pty. Ltd., 395 Queen-street, Melbourne																																								
" Peanite No. 2	2.00	" " " " " " " " " " " "																																								
" " No. 2	2.50	" " " " " " " " " " " "																																								
Neptune Float-On No. 7	2.50	Neptune Oil Co. Pty. Ltd., 532 Bourke-street, Melbourne																																								
<table border="1"> <thead> <tr> <th>Nicotine.</th> <th>Arsenic Pentoxide (As<sub>2</sub>O<sub>5</sub>).</th> <th>Tar Oil.</th> <th>Sulphur.</th> </tr> </thead> <tbody> <tr> <td>%</td> <td>%</td> <td>%</td> <td>%</td> </tr> <tr> <td>Plane Tomato No. 50</td> <td>15.5</td> <td>4.0</td> <td>40.0</td> </tr> <tr> <td>" " Azurine No. 20</td> <td>6.2</td> <td>7.0</td> <td>40.0</td> </tr> <tr> <td>Vallo Tomato and Vegetable No. 1</td> <td>18.0</td> <td>5.0</td> <td>40.0</td> </tr> <tr> <td>" " " " " " No. 2</td> <td>8.0</td> <td>5.0</td> <td>40.0</td> </tr> <tr> <td>Tomato No. 2</td> <td>7.8</td> <td>4.0</td> <td>40.0</td> </tr> <tr> <td>Plane Azurine No. 2</td> <td>"</td> <td>7.0</td> <td>40.0</td> </tr> <tr> <td>" " No. 4</td> <td>"</td> <td>11.0</td> <td>35.0</td> </tr> <tr> <td>Neptune Float-On No. 6</td> <td>15.5</td> <td>5.0</td> <td>40.0</td> </tr> </tbody> </table>			Nicotine.	Arsenic Pentoxide (As <sub>2</sub> O <sub>5</sub> ).	Tar Oil.	Sulphur.	%	%	%	%	Plane Tomato No. 50	15.5	4.0	40.0	" " Azurine No. 20	6.2	7.0	40.0	Vallo Tomato and Vegetable No. 1	18.0	5.0	40.0	" " " " " " No. 2	8.0	5.0	40.0	Tomato No. 2	7.8	4.0	40.0	Plane Azurine No. 2	"	7.0	40.0	" " No. 4	"	11.0	35.0	Neptune Float-On No. 6	15.5	5.0	40.0
Nicotine.	Arsenic Pentoxide (As <sub>2</sub> O <sub>5</sub> ).	Tar Oil.	Sulphur.																																							
%	%	%	%																																							
Plane Tomato No. 50	15.5	4.0	40.0																																							
" " Azurine No. 20	6.2	7.0	40.0																																							
Vallo Tomato and Vegetable No. 1	18.0	5.0	40.0																																							
" " " " " " No. 2	8.0	5.0	40.0																																							
Tomato No. 2	7.8	4.0	40.0																																							
Plane Azurine No. 2	"	7.0	40.0																																							
" " No. 4	"	11.0	35.0																																							
Neptune Float-On No. 6	15.5	5.0	40.0																																							

LIST OF FUNGICIDES, ETC., ETC.—continued.

Distinguishing Name of Fungicide and/or Insecticide.	Percentage of Declared Active Constituent(s).				Wholesale Dealer.
	D.D.T.	Nicotine.	Copper (Cu).	Sulphur.	
<i>Mixed Dusting Powders—continued.</i>					
Plane Noxide No. 100N	1.00	1.00	..	..	N. N. McLean Pty. Ltd., 395 Queen-street, Melbourne
" " No. 100N <sub>2</sub>	1.00	2.00	..	..	" " " " " " " "
" " No. 200N	2.00	1.00	..	..	" " " " " " " "
" " No. 200N <sub>2</sub>	2.00	2.00	..	..	" " " " " " " "
Plane Azurine No. 100	1.00	..	7.00	40.00	" " " " " " " "
" " No. 200	2.00	..	7.00	40.00	" " " " " " " "
" " No. 400	1.00	..	11.00	35.00	" " " " " " " "
Tomato No. 1	2.00	..	4.00	42.00	Wm. Haughton and Co. Ltd., 545 Little Collins-street, Melbourne
Pespruf No. 5	2.00	..	7.50	40.00	Ramsay and Treganowan Ltd., 475 Latrobe-street, Melbourne
Plane Tomato No. 200	2.00	..	4.00	40.00	N. N. McLean Pty. Ltd., 395 Queen-street, Melbourne
Pespruf No. 3	2.00	..	7.00	..	Ramsay and Treganowan Ltd., 475 Latrobe-street, Melbourne
"D" Death	2.00	..	2.50	..	J. D. Harmsworth and Co. Pty. Ltd., 185 William-street, Melbourne
Neptune Float-On No. 5	2.00	..	5.00	40.00	Neptune Oil Co. Pty. Ltd., 532 Bourke-street, Melbourne
" " No. 3	2.00	2.50	..	..	" " " " " " " "
Rudust No. 1 (Tomato)	2.00	..	4.00	40.00	Taubmans Ltd., 41 Rooney-street, Burnley
" " No. 2 (Tomato)	2.00	..	..	50.00	" " " " " " " "
	D.D.T.	Benzene Hexachloride.			
	%	%			
Pespruf No. 2g	1.0	.13		Ramsay and Treganowan Ltd., 475 Latrobe-street, Melbourne	
Plane Noxide No. 1000 <sub>1</sub>	1.0	.13		N. N. McLean Pty. Ltd., 395 Queen-street, Melbourne	
" " No. 1000 <sub>2</sub>	1.0	.26		" " " " " " " "	
" " No. 2000 <sub>2</sub>	1.0	.40		" " " " " " " "	
" " Vegetus	1.0	.40		" " " " " " " "	
Neptune Float-On No. 8	2.0	.26		Neptune Oil Co. Pty. Ltd., 532 Bourke-street, Melbourne	
Cabbage No. 2	2.0	.26		Wm. Haughton and Co. Ltd., 545 Little Collins-street, Melbourne	
Rudust No. 8 Duplex	2.0	.26		Taubmans Ltd., 41 Rooney-street, Burnley	
Kix Garden	1.5	.13		Clark, King and Co. Pty. Ltd., 237 Queen-street, Melbourne	
Composite	D.D.T.	%		Wm. Haughton and Co. Ltd., 545 Little Collins-street, Melbourne	
	Pyrethrins	0.1			
	D.D.T.	2.0			
Plane G.P.	Copper	4.0		N. N. McLean Pty. Ltd., 395 Queen-street, Melbourne	
	Sulphur	40.0			
	Benzene Hexachloride	0.26			
	Copper	9.8			
	Sulphur	35.0			
Plane Azurine No. 3G2	Benzene Hexachloride	0.26		" " " " " " " "	
	D.D.T.	1.5			
Plane Tomato No. 157	Copper	7.0		" " " " " " " "	
	Sulphur	30.0			
	Benzene Hexachloride	0.1			
	Copper	7.0			
Plane Lettuce	Sulphur	40.0		" " " " " " " "	
	Benzene Hexachloride	0.4			
	D.D.T.	1.0			
Rudust No. 15	Sulphur	40.0		Taubmans Ltd., 41 Rooney-street, Burnley	
	Copper	4.0			
	Benzene Hexachloride	0.26			
Blue Bell D.D.T.—Lead	D.D.T.	14.0		Blyth Chemicals Ltd., 31 Queen-street, Melbourne	
Elephant D.D.T.—Lead	Arsenic Pentoxide	26.0			
	D.D.T.	14.0		Jaques Pty. Ltd., 31 Queen-street, Melbourne	
Neptune Float-On No. 4	Arsenic Pentoxide	26.0			
	D.D.T.	2.0		Neptune Oil Co. Pty. Ltd., 532 Bourke-street, Melbourne	
	Pyrethrins	0.13			
<i>D.D.T. Sprays.</i>					
	%				
Pespruf 20 Emulsion	D.D.T.	19.5		Ramsay and Treganowan Ltd., 475 Latrobe-street, Melbourne	
" " No. 50 Dispersible Powder	"	50.0		" " " " " " " "	
Vermipruf 1A	"	12.5		" " " " " " " "	
" " 30	"	15.0		" " " " " " " "	
Rudide	"	50.0		Taubmans Ltd., 41 Rooney-street, Burnley	
Taubmans' Rutene	"	25.0		" " " " " " " "	
" " Rutox	"	5.0		" " " " " " " "	
Wellspray Emulsion	"	25.0		Wm. Haughton and Co. Ltd., 545 Little Collins-street, Melbourne	
Emulsane 20	"	20.0		" " " " " " " "	
Lion	"	25.0		" " " " " " " "	
Neptune Emulsion	"	32.0		Orchard Sprays Pty. Ltd., 549 Church-street, Richmond	
Bovox	"	8.4		Neptune Oil Co. Pty. Ltd., 532 Bourke-street, Melbourne	
Kix	"	9.0		Wilcox, Mofflin Ltd., 34 King-street, Melbourne	
Agro-Kix No. 20	"	20.0		Clark, King and Co. Pty. Ltd., 237 Queen-street, Melbourne	
Wellspray 50	"	50.0		" " " " " " " "	
Neptune Aphidol	"	4.0		Wm. Haughton and Co. Ltd., 545 Little Collins-street, Melbourne	
Shell Aphid Spray	"	4.0		Neptune Oil Co. Pty. Ltd., 532 Bourke-street, Melbourne	
Blue Bell Non-Oil Emulsion	"	36.0		Shell Co. of Aust. Ltd., 163 William-street, Melbourne	
Elephant Non-Oil Emulsion	"	36.0		Blyth Chemicals Ltd., 31 Queen-street, Melbourne	
Guesarol G.H. 40 Suspending Powder	"	40.0		Jaques Pty. Ltd., 31 Queen-street, Melbourne	
" " F.S. 40 Suspending Powder	"	40.0		Wilcox, Mofflin Ltd., 34 King-street, Melbourne	
" " B.W. 40 Suspending Powder	"	40.0		" " " " " " " "	
Emulsane 50 Colloidal Paste	"	50.0		Wm. Haughton and Co. Ltd., 545 Little Collins-street, Melbourne	
" "D" Death Emulsion	"	20.0		J. D. Harmsworth and Co. Pty. Ltd., 185 William-street, Melbourne	
Shell 25 per cent. Emulsion	"	25.0		The Shell Co. of Aust. Ltd., 163 William-street, Melbourne	
Neptune 25 per cent. Emulsion	"	25.0		Neptune Oil Co. Pty. Ltd., 532 Bourke-street, Melbourne	
Osmotox	"	40.0		Osmond and Sons (Aust.) Pty. Ltd., 35 William-street, Melbourne	
Say 20 per cent. Emulsion	"	20.0		Victor Say, Benalla	
Grazcos Dispersible Powder	"	50.0		Grazcos Co-operative Ltd., 90 William-street, Melbourne	
<i>Benzene Hexachloride Sprays.</i>					
	%				
Gammexane No. 7 Miscible Oil	Benzene Hexachloride	7.0		Ramsay and Treganowan Ltd., 475 Latrobe-street, Melbourne	
" " Liquid L.G. 140	"	8.7		" " " " " " " "	
" " No. 50 Dispersible Powder	"	6.5		" " " " " " " "	
Gamaturf	"	6.0		" " " " " " " "	
Nik-kof	"	5.0		" " " " " " " "	
Grazcos Gammexane Dispersible Powder	"	6.5		Clark, King and Co. Pty. Ltd., 237 Queen-street, Melbourne	
<i>Organic Phosphates.</i>					
	%				
Hexone	Hexaethyl Tetraphosphate	95.0		Ramsay and Treganowan Ltd., 475 Latrobe-street, Melbourne	
Vallo H.E.T.P.	"	95.0		Victor Leggo and Farmers Ltd., 282-290 Williamstown-road, Yarraville	
Bluebell Demite	"	95.0		Blyth Chemicals Ltd., 31 Queen-street, Melbourne	
Elephant Demite	"	95.0		Jaques Pty. Ltd., 31 Queen-street, Melbourne	
Hetraphos	"	100.0		Wm. Haughton and Co. Ltd., 545 Little Collins-street, Melbourne	
Tephos	"	30.0		Taubmans Ltd., 41 Rooney-street, Burnley	
	Tetraethyl Pyrophosphate	20.0			

LIST OF FUNGICIDES, ETC., ETC.—continued.

Distinguishing Name of Fungicide and/or Insecticide.	Percentage of Declared Active Constituent(s).	Wholesale Dealer.
<i>Organic Phosphates—continued.</i>		
E 605 Folidol .. .. .	Diethyl-para-nitrophenyl-thiophosphate 22.4	Wm. Haughton and Co. Ltd., 545 Little Collins-street, Melbourne
Folidust E 605m .. .. .	Dimethyl " " " " 1.5	Taubmans Ltd., 41 Rooney-street, Burnley " "
Paraphos 40 .. .. .	Diethyl " " " " 40.0	Ramsay and Treaganowan Ltd., 475 Latrobe-street, Melbourne
Phosfene 20 .. .. .	" " " " 20.0	Blyth Chemicals Ltd., 31 Queen-street, Melbourne
Phosfene 15 Dispersible Powder .. .. .	" " " " 15.0	Jaques Pty. Ltd., 31 Queen-street, Melbourne
Blue Bell Parathion 25 per cent. .. .. .	" " " " 25.0	
Elephant Parathion 25 per cent. .. .. .	" " " " 25.0	
<i>Blowfly Preparations.</i>		
	%	
	D.D.T. .. .. . 5.0	
	Boric Acid .. .. . 5.5	
Alkon Blowfly Oil .. .. .	Phenol and Homologues 22.2	Alkon Pty. Ltd., 38 Clarendon-street, South Melbourne
	Orthodichlorbenzene .. .. . 5.0	
	Hydro-carbon Oils .. .. . 8.0	
	Naphthalene .. .. . 7.5	
Blo-Fli-DI .. .. .	Benzol .. .. . 13.7	The Nightingale Supply Co. (Vic.) Ltd., Ingles-street, Port Melbourne
	Sulphur .. .. . 8	
	Tar Oil .. .. . 8.4	
	Hydro-carbon Oils .. .. . 84.1	
Shell Defiance Blowfly Oil .. .. .	Coal Tar Derivatives .. .. . 12.0	The Shell Co. of Australia Ltd., 163 William-street, Melbourne
	Essential Oils .. .. . 3.0	
	D.D.T. .. .. . 5.0	
	Boric Acid .. .. . 5.5	
Immunol Blowfly Dressing .. .. .	Phenol and Homologues 22.2	Hart and Co. Pty. Ltd., 38 Clarendon-street, South Melbourne
	Orthodichlorbenzene .. .. . 5.0	
	Hydro-carbon-Oils .. .. . 8.0	
	Boric Acid .. .. . 21.5	Hart and Co. Pty. Ltd., 38 Clarendon-street, South Melbourne
Glycerine DI Boric .. .. .		
	D.D.T. .. .. . 20.0	
Osblo D.D.T. and B.H.C. Blowfly Dressing .. .. .	Benzene Hexachloride .. .. . 0.99	Osmond and Sons (Aust.) Pty. Ltd., 35 William-street, Melbourne
	Chlorbenzenes .. .. . 82.25	
	Cresylic Acid .. .. . 7.01	
	Boric Acid .. .. . 10.0	
Immunol C.B.E. .. .. .	Oil of Camphor .. .. . 13.5	Hart and Co. Pty. Ltd., 38 Clarendon-street, South Melbourne
	Boric Acid .. .. . 8.0	
	Zinc Sulphate .. .. . 1.0	
Vetamac .. .. .	Tar Oils .. .. . 2.0	A. H. McDonald, 627-631 Bridge-road, Richmond
	Essential Oils .. .. . 1.0	
	D.D.T. .. .. . 0.6	
Calarsente .. .. .	Arsenious Oxide .. .. . 43.0	D. G. Officer Pty. Ltd., 90 William-street, Melbourne
Mag-o-Tol .. .. .		Goldsbrough, Mort and Co. Ltd., 526 Bourke-street, Melbourne
	Cresylic Acid .. .. . 4.0	
Mag-o-Tol plus D.D.T. .. .. .	Cresylic Acid .. .. . 4.0	
	D.D.T. .. .. . 1.0	
	Hydrocarbon Oils .. .. . 84.0	
Squatter Blowfly Oil .. .. .	Coal Tar Derivatives .. .. . 13.0	Neptune Oil Co. Pty. Ltd., 532 Bourke-street, Melbourne
	Essential Oils .. .. . 3.0	
	Phenols .. .. . 10.0	B.H.P. By-Products Pty. Ltd., 422 Little Collins-street, Melbourne
B.H.P. Blowfly Oil .. .. .		
	D.D.T. .. .. . 0.0	
	Tar Acid .. .. . 7.5	Wilcox, Moffin Ltd., 34 King-street, Melbourne
	Orthodichlorbenzene .. .. . 15.0	
	Boric Acid .. .. . 15.0	
K.F.M. Concentrated D.D.T. Emulsion .. .. .	Lysol .. .. . 0.2	Imperial Chemical Industries of Aust. and N.Z. Ltd., 408 Latrobe-street, Melbourne
	Orthodichlorbenzene .. .. . 5.2	
	Boric Acid .. .. . 15.0	
I.C.I.—B.K.B. .. .. .	Lysol .. .. . 5.3	Wilcox, Moffin Ltd., 34 King-street, Melbourne
Wilmoff B.K.B. .. .. .	Orthodichlorbenzene .. .. . 5.4	
	Boric Acid .. .. . 40.0	Hart and Co. Pty. Ltd., 38 Clarendon-street, South Melbourne
Immunol B.K.B. .. .. .	Cresol .. .. . 0.7	
	Orthodichlorbenzene .. .. . 14.2	
	D.D.T. .. .. . 3.0	
Atlantic .. .. .	Eucalyptus Oil .. .. . 10.0	Atlantic Union Oil Co. Ltd., 396 Collins-street, Melbourne
	Cresylic Acid .. .. . 11.3	
	Eucalyptus Residual Oil .. .. . 50.0	
Blackers .. .. .	Naphthalene .. .. . 5.0	Pioneer Chemical Industries Pty. Ltd., 14-24 Lens-street, North Coburg
	Cresylic Acid .. .. . 2.5	
	Eucalyptus Oil .. .. . 4.0	
Kleenflox .. .. .	Phenol .. .. . 3.0	Taubmans Ltd., 41 Rooney-street, Burnley
	D.D.T. .. .. . 1.0	
	Mineral Oils .. .. . 61.0	
	Benzene Hexachloride .. .. . 0.72	
G.M.X. .. .. .	Tetrachlorethylene .. .. . 7.5	Wilcox, Moffin Ltd., 34 King-street, Melbourne
	Tar Acids .. .. . 7.5	
Younghusband .. .. .	Tar Oil .. .. . 55.0	Younghusband Ltd., 94 King-street, Melbourne
	Whale Oil .. .. . 45.0	
	D.D.T. .. .. . 15.0	
Kleep-Sheep .. .. .	Chlorinated Benzene .. .. . 44.0	Taubmans Ltd., 41 Rooney-street, Burnley
	Sulphanilamide .. .. . 1.5	
	Bactericide .. .. . 1.5	
	D.D.T. .. .. . 4.0	
Benex .. .. .	Benzene Hexachloride .. .. . 0.52	Goldsbrough, Mort and Co. Ltd., 526 Bourke-street, Melbourne
	Tar Acids .. .. . 8.0	
	Orthodichlorbenzene .. .. . 20.0	
Rujet .. .. .	D.D.T. .. .. . 25.0	Taubmans Ltd., 41 Rooney-street, Burnley
	Boric Acid .. .. . 2.5	
	Orthodichlorbenzene .. .. . 5.2	Grazcos Co-op. Ltd., 90 William-street, Melbourne
Grazcos B.K.B. .. .. .	Tar Acids .. .. . 3.1	
	Benzene Hexachloride .. .. . 3.5	
Flyxane .. .. .	" " " " 0.63	Imperial Chemical Industries of Aust. and N.Z. Ltd., 408 Latrobe-street, Melbourne
Gammexane .. .. .		
	D.D.T. .. .. . 2.0	D. G. Officer Pty. Ltd., 90 William-street, Melbourne
Elliott's Magfoil .. .. .	Benzene Hexachloride .. .. . 0.18	
	Orthodichlorbenzene .. .. . 32.0	
Elliott's Magspray .. .. .	Benzene Hexachloride .. .. . 7.5	" " " " " " " "
	D.D.T. .. .. . 4.0	
Fly-O-Leen Blowfly Dressing .. .. .	Benzene Hexachloride .. .. . 0.52	Welch, Perrin and Co. Pty. Ltd., 48-56 Queen's Bridge-street, South Melbourne
	Tar Acids .. .. . 8.0	
	O-dichlorbenzene .. .. . 20.0	
	D.D.T. .. .. . 7.0	
Di-Mag .. .. .	Benzene Hexachloride .. .. . 0.38	The Nightingale Supply Co. (Vic.) Ltd., Ingles-street, Port Melbourne
	Tar Acids .. .. . 3.7	
	Chlorinated benzenes .. .. . 23.8	
	D.D.T. .. .. . 10.0	
Flokguard .. .. .	O-dichlorbenzene .. .. . 25.0	J. S. Robertson (Aust.) Pty. Ltd., 131 Queen-street, Melbourne
	Tar Acids .. .. . 11.5	
	D.D.T. .. .. . 5.7	
Shell D.D.T. Blowfly Dressing .. .. .	Cresols .. .. . 7.0	The Shell Company of Australia Ltd., 163 William-street, Melbourne
	Dichlorbenzene .. .. . 14.0	
Sickle Gamady Blowfly Dressing .. .. .	Benzene Hexachloride .. .. . 3.5	Commonwealth Fertilizers and Chemicals Ltd., 65 William-street, Melbourne
Gama-Dee .. .. .	Benzene Hexachloride .. .. . 2.52	Wilcox, Moffin Ltd., 34 King-street, Melbourne
	D.D.T. .. .. . 20.0	
Flak D.D.T. Emulsion .. .. .	D.D.T. .. .. . 17.0	Flak Industries, 230 Collins-street, Melbourne
	Chlorinated benzenes .. .. . 20.0	







## MIRBOO NORTH WATERWORKS TRUST.

## RATING BY-LAW FOR THE YEAR 1951.

**T**HE Mirboo North Waterworks Trust, in pursuance and exercise of the powers conferred by the Water Acts, doth hereby make a rate for the supply of water for domestic purposes of Three shillings and four pence in the pound of the annual municipal valuation of lands and tenements liable to be rated within the Mirboo North Urban District.

Provided that in no case shall the amount of rate payable per annum in respect of any tenement (other than land on which there is no building) be less than Three pounds, and in respect of any land on which there is no building less than One pound.

Such rates are made and shall be levied on the occupiers or owners of the said lands and tenements for the year commencing 1st January, 1951, and ending the last day of December, 1951, and shall be payable on the 31st day of July, 1951, at the office of the said Trust.

The maximum quantity of water to be supplied in any one year without further charge to any property rated by the Trust is hereby fixed at the quantity which, at a charge of One shilling per 1,000 gallons, would produce an amount equal to the amount of the rate levied on such property for the said year.

The charge for water supplied by measure to any property rated by the Trust in excess of such maximum quantity, computed as in the last preceding clause, is hereby fixed at One shilling per 1,000 gallons.

The charge for water supplied by measure to any property not rated by the Trust is hereby fixed at One shilling per 1,000 gallons, and the minimum annual payment in cases where water is so supplied is hereby fixed at £3 per annum.

The charge for water supplied by measure shall be payable, on demand, at the office of the Trust, Mirboo North.

Passed this 23rd day of April, 1951.

(SEAL) WALTER J. TUCK, Chairman.  
W. J. BRYSON, Commissioner.  
J. C. SUMMERS, Secretary.

Approved by the Governor in Council,  
1st May, 1951.

A. MAHLSTEDT,  
Clerk of the Executive Council.

## LEONGATHA WATERWORKS TRUST.

## RATING BY-LAW FOR THE YEAR 1951 (No. 51).

**T**HE Leongatha Waterworks Trust, in pursuance and exercise of the powers conferred by the Water Acts, doth hereby make a rate for the supply of water for domestic purposes of One shilling in the pound on the net annual valuation of lands and tenements liable to be rated within the Leongatha Urban District.

Provided that in no case shall the amount of the rate payable per annum in respect of any tenement (other than land on which there is no building) be less than Fifteen shillings, and in respect of any land where there is no building less than Ten shillings.

Such rates are made and shall be levied upon the occupiers or owners of the said lands and tenements for the year commencing on the first day of January, 1951, and shall be due and payable on the twenty-first day of May, 1951, at the office of the Trust.

The maximum quantity of water to be supplied in any one year without further charge to any property rated by the Trust is hereby fixed at the quantity which, at a charge of Two shillings per 1,000 gallons, would produce an amount equal to the amount of the rate levied on such property for the said year.

The charge for water supplied by measure to any property rated by the Trust in excess of such maximum quantity, computed as in the last preceding clause, is hereby fixed at Two shillings per 1,000 gallons.

The charge for water supplied by measure shall be payable, on demand, at the office of the Trust.

Dated this 19th day of April, 1951.

(SEAL) C. A. S. BOND, Chairman.  
R. J. HAGAN, Commissioner.  
THOMAS G. MCGAW, Commissioner.  
E. R. HARDING, Secretary.

Approved by the Governor in Council,  
1st May, 1951.

A. MAHLSTEDT,  
Clerk of the Executive Council.

No. 489.—4115/51.—2

## KERANG SEWERAGE AUTHORITY.

## RATING BY-LAW FOR THE YEAR 1951.

**T**HE Kerang Sewerage Authority, in pursuance and exercise of the powers conferred by the Sewerage Districts Act, doth hereby make a sewerage rate of Two shillings and ten pence in the pound on the annual municipal valuation of all sewered properties liable to be rated within the Kerang Sewerage District.

Such rate is to be made and shall be levied upon the occupiers or owners of the said lands and tenements for the year commencing on the 1st day of January, 1951, and shall be payable on the 1st day of June, 1951, at the office of the said Authority.

The resolution for passing the foregoing By-law was agreed to by the Kerang Sewerage Authority on the 2nd day of February, 1951, and was confirmed by the said Authority on the 17th day of March, 1951.

(SEAL) G. S. GREENWOOD, Chairman.  
C. D. ATKINSON, Member.  
A. K. LYALL, Secretary.

Approved by the Governor in Council,  
1st May, 1951.

A. MAHLSTEDT,  
Clerk of the Executive Council.

## UNDERBOOL WATERWORKS TRUST.

## RATING BY-LAW FOR THE YEAR ENDING 31ST DECEMBER, 1951.

**T**HE Underbool Waterworks Trust, in pursuance and exercise of the powers conferred by the Water Acts, doth hereby make a rate for the supply of water for domestic purposes of Two shillings and eight pence in the pound of the annual municipal valuations of lands and tenements liable to be rated within the Underbool Urban District.

Provided that in no case shall the amount payable per annum in respect of any tenement (other than land on which there is no building) be less than Two pounds twelve shillings and six pence, and in respect of any land on which there is no building Twelve shillings and six pence.

Such rates are made and shall be levied upon the occupiers or owners of the said lands and tenements for the year commencing the 1st day of January, 1951, and shall be payable on the 1st day of June, 1951, at the office of the Trust, Underbool.

The maximum quantity of water to be supplied in any one year without further charge to any property rated by the Trust is hereby fixed at the quantity which, at a charge of One shilling and six pence per 1,000 gallons, would produce an amount equal to the amount of the rate levied on such property for the said year.

The charge for water supplied by measure to any property rated by the Trust in excess of such maximum quantity, computed as in the last preceding clause, is hereby fixed at One shilling and four pence per 1,000 gallons.

The charge for water supplied by measure shall be payable, on demand, at the office of the Trust, Underbool.

Passed this 24th day of April, 1951.

(SEAL) J. T. LEWIS, Chairman.  
E. J. GOULD, Secretary.

Approved by the Governor in Council,  
1st May, 1951.

A. MAHLSTEDT,  
Clerk of the Executive Council.

## BARNAWARTHA WATERWORKS TRUST.

## AUTHORITY TO OBTAIN A BANK OVERDRAFT.

**H**IS Excellency the Governor of the State of Victoria, by and with the advice of the Executive Council thereof, doth, by Order made on the 1st day of May, 1951, authorize the Barnawartha Waterworks Trust to obtain, in pursuance of the provisions of section 271 of the Water Act 1928 (No. 3801), an advance or advances during the year 1951 from the Bank of New South Wales, Chiltern, by overdraft of the Trust's current account thereat, such overdraft not to exceed at any one time the sum of Two hundred pounds (£200).

A. MAHLSTEDT,  
Clerk of the Executive Council.

At the Executive Council Chamber,  
Melbourne, the 1st May, 1951.

Victoria.

## ACT 391.—SECOND SCHEDULE.

A STATEMENT of trusts having been submitted by the head or authorized representative of the denomination of Church of England, under the provisions of the "Act to provide for the Abolition of State Aid to Religion," for allowance by the Governor, the same, was allowed by him on the first day of May, 1951, and the following is the form in which such statement of trusts has been allowed:—

Victoria.

## ACT No. 391.—FIRST SCHEDULE.

I, the Right Reverend William Herbert Johnson, of Cathedral Buildings, Dana-street, Ballarat, Bishop of Ballarat, head or authorized representative of the denomination known as the Church of England, in the Diocese of Ballarat, in Victoria, with the consent of the corporation styled The Ballarat Diocesan Trustees, of Cathedral Buildings, Dana-street, Ballarat, the trustee of the land described in the subjoined statement of trusts, and of the Reverend Arthur Joseph Gray, of Linton, being the person entitled to minister in or occupy a building or buildings upon the said land, hereby apply to the Governor of the State of Victoria for leave to dispose of the said land by the means and for the purposes mentioned in the said statement of trusts, and I hereby certify that the said land was reserved from sale by the Governor in Council as a site for a place of public worship and minister's dwelling in connexion with the Church of England denomination, at Carngham, by Order dated the 27th day of June, 1870: That the only trustee of the said land is the said corporation styled The Ballarat Diocesan Trustees: That there are no buildings upon the said land, and the only person entitled to minister in or occupy the same is the above-named Arthur Joseph Gray.

Dated the 1st day of February, 1951.

Signature of head or authorized representative—  
WILLIAM BALLARAT.

The corporation styled The Ballarat Diocesan Trustees hereby consents to this application.

The common seal of the corporation styled The Ballarat Diocesan Trustees was affixed hereto, in the presence of us, being three of the trustees authorized to attest the affixing of such seal—

(SEAL) WILLIAM BALLARAT, Trustee.  
RONALD S. RICHARDS, Trustee.  
R. ACHESON MUST, Trustee.

Signature of person entitled to minister in or occupy building or buildings—A. J. GRAY.

## STATEMENT OF TRUSTS.

*Description of Land.*—1 acre 2 roods, Parish of Carngham, County of Grenville, being Crown allotment 2B, section 14: Commencing at the southern angle of allotment 1A; bounded thence by that allotment bearing N. 66 deg. 0 min. E. 353 links, by the State School Reserve bearing S. 40 deg. 0 min. E. 305 links, by allotments 3 and 7 bearing S. 50 deg. 0 min. W. 505 links; and thence by a road bearing N. 14 deg. 40 min. W. 299 links and N. 23 deg. 59 min. W. 137 links to the point of commencement.

*Name of Trustee.*—The Ballarat Diocesan Trustees, of Cathedral Buildings, Dana-street, Ballarat.

*Powers of Disposition.*—To permit and suffer so much of the land as shall not be disposed of under the powers hereinafter specified to be used for the purposes for which it was promised or temporarily reserved from sale by the Crown. To let, lease, sell, mortgage, or exchange if concurred in by the said head or authorized representative for the time being, the said land, or any portion thereof, or any buildings thereon on such terms and conditions as shall be specified by such head or representative.

*Purposes to which Proceeds of Disposition are to be Applied.*—Moneys obtained from sale, leases, mortgages, or exchanges to be paid to the Bishop to be dealt with for Church of England purposes as shall be directed by the said trustee, but to be subject nevertheless to the payment or deduction therefrom of all costs, charges, and expenses incurred by the trustee, or for which it shall be liable in respect of the trust estate.

As witness the hand of the Governor of the State of Victoria, this first day of May, 1951.

DALLAS BROOKS,  
Governor of the State of Victoria.

## NOTICE.

ADMINISTRATION of the estate of each of the under-mentioned deceased persons has been granted to me, and creditors, next of kin, and all others having claims against the estate of any of the persons so mentioned are required to send particulars of their claims to the Public Trustee, No. 412 Collins-street, Melbourne, on or before the 11th July, 1951, or they will be excluded from the distribution of the estate when the assets are being distributed:—

BEATTIE, WILLIAM STANLEY, late of 50 Heller-street, West Brunswick, signwriter, died 1st October, 1950, intestate.

DYMOND, ELIZABETH MARY, also known as Elizabeth Dymond, formerly of 51 Albion-road, Elsternwick, but late of 24 O'Loughlin-street, Ormond, home duties, died 10th March, 1951, intestate.

† EDMUNDS, WILLIAM LEWIS, formerly of 17 Grattan-street, Carlton, but late of 20 Wright-street, Clifton Hill, examiner, died 2nd July, 1950.

EYRE, ALICE, late of 52 Moreland-road, Brunswick, music teacher, died 31st January, 1951, intestate.

FINN, JAMES HENRY, formerly of Mangalore, but late of Katunga, labourer, died 7th December, 1950, intestate.

GORMLY, KEITH ATHOL, late of 396 Station-street, Bon-beach, fibro-plasterer, died 10th July, 1950, intestate.

\* HARDY, BERTHA FLORENCE, late of 32 Combermere-street, Essendon, widow, died 30th December, 1950.

\* HORTON, ISOBEL MAUD, late of Greytown, New Zealand, married woman, died 6th October, 1950.

KELLY, ANN SARAH AMELIA, late of 14 Valerie-street, Pascoe Vale, spinster, died 1st February, 1950, intestate.

MORAN, THOMAS JOSEPH, late of 45 Grey-street, South Yarra, supervisor, died 13th February, 1951, intestate.

MULLAVEY, JOSEPH, late of 26 Salisbury-street, Werribee, ganger, died 19th February, 1951, intestate.

† MCEWAN, BRUCE AMBROSE DONALD, also known as Bruce McEwan, formerly of Australian Military Forces, but late of 19 Taylor-avenue, Regent, cement worker, died 17th January, 1951.

\* OTT, WILLIAM ALEXANDER, late of Invercargill, New Zealand, accountant, died 4th January, 1951.

PETRIE, HENRY JOHN, late of 63 Davis-avenue, South Yarra, retired public servant, died 23rd January, 1951, intestate.

† QUICK, SUSAN ELIZA, late of 68 Empress-avenue, Footscray, married woman, died 23rd February, 1951.

\* RAMSAY, MARY, late of 9 Murray-street, West Brunswick, widow, died 12th February, 1951.

ROWE, SOPHIA, late of Diamond Hill, Bendigo, retired nurse, died 8th October, 1950, intestate.

\* WARNE, ANNIE MAY, usually known as Annie Warne, late of 76 Nicholl-street, Broken Hill, New South Wales, widow, died 1st February, 1950.

\* With the will annexed.

† According to the provisions of the will.

C. J. GARDNER,  
Public Trustee.

Melbourne, 2nd May, 1951.

## NOTICE.

ADMINISTRATION of the estate of each of the under-mentioned deceased persons has been granted to me, and creditors, next of kin, and all others having claims against the estate of any of the persons so mentioned are required to send particulars of their claims to the Public Trustee, No. 412 Collins-street, Melbourne, on or before the 18th July, 1951, or they will be excluded from the distribution of the estate when the assets are being distributed:—

CAIRNS, MARY ROBINA, late of Home and Hospital for the Aged, Cheltenham, pensioner, died 18th September, 1950, intestate.

ELLIS, HERBERT, late of Beechworth, slater and tiler, died 20th January, 1951, intestate.

FLAHERTY, WILLIAM NICOL, also known as William Flaherty, as William Watson, and as William Waters, late of No. 1 "Curzon," Eildon-road, St. Kilda, publisher, died 20th February, 1950, intestate.

† FLYNN, JAMES WILLIAM, also known as James Flynn, formerly of 19 Napier-street, Footscray, Victoria, but late of 1 Alfonso-street, North Perth, West Australia, carpenter and lift engineer, died 14th May, 1950.

† FLYNN, NORAH MARY, also known as Norah Flynn and Nora Mary Flynn, formerly of 19 Napier-street, Footscray, Victoria, but late of 1 Alfonso-street, North Perth, West Australia, widow, died 15th June, 1950.

GALLOWAY, SHIRLEY, also known as John Galloway, late of Timboon, pensioner, died 30th December, 1950, intestate.

† GARLAND, JAMES ROBERT STATHER, late of 15 Edward-street, Essendon, retired postal employee, died 18th December, 1950.

\*GORMAN, MARGARET, formerly of 28 MacArthur-place, Carlton, but late of 26 McArthur-square, Carlton, spinster, died 22nd January, 1951.

GOW, DANIEL, formerly of Bundoora, but late of Plenty-road, South Morang, retired, died 12th July, 1950, intestate.

†HARRISON, JAMES, formerly of Gembrook, but late of 39 Weston-street, East Brunswick, retired farmer, died 5th December, 1950.

†HENKEL, DORIS MURIEL, late of 33 May-street, Preston, home duties, died 15th October, 1950.

JACOBS, MONTAGUE MELEOURNE, late of Yallourn North, labourer, died 27th December, 1950, intestate.

LINAKER, ALICE ANASTASIA, late of 12 Gladstone-avenue, Northcote, home duties, died 23rd October, 1950, intestate.

LITTLE, JOHN REGINALD, formerly of Mineral Spring, Donnybrook, and 66 Blair-street, Coburg, but late of 20 McGregor-street, Middle Park, plasterer, died 7th January, 1951, intestate.

LOWRIE, WILLIAM NICHOLAS, late of Castlemaine, pensioner, died 20th October, 1950, intestate.

MALONEY, JAMES FRANCIS, formerly of Grand Junction Hotel, Traralgon, but late of Cohuna, farm worker, died 27th January, 1951, intestate.

†MORRISON, NORMAN, late of 156 Cecil-street, Williamstown, retired master mariner, died 22nd January, 1951.

\*MORRISON, WILLIAM ERNEST, formerly of 2 Hope-street, West Footscray, but late of 41 Shackell-street, Coburg, retired foreman stevedore, died 14th March, 1951.

MCCARTHY, FLORENCE, sometimes known as Florrie McCarthy, late of 4 Selbourne-street, Ascot Vale, home duties, died 16th May, 1950, intestate.

†MCKEE, THOMAS JAMES, late of Auckland, New Zealand, mercer, died 5th October, 1950.

†O'CONNOR, JEREMIAH, late of 293 Clarendon-street, South Melbourne, storekeeper, formerly a member of the Australian Military Forces, died 5th May, 1949.

TAYLOR, ALBERT JUBILEE, late of Ripplebrook, labourer, died 15th December, 1950, intestate.

WALKER, SAMUEL JOHN, late of Weerangourt Station, Macarthur, labourer, died 1st February, 1951, intestate.

\* According to the provisions of the will.  
† With the will annexed.

C. J. GARDNER,  
Public Trustee.

Melbourne, 8th May, 1951.

#### 4 GEORGE VI. No. 4755, SECTION 6.

I HEREBY give notice that on the 26th April, 1951, I filed elections to administer the following deceased persons' estates, in accordance with section 6 of the *Public Trustee Act 1940*:—

DYMOND, ELIZABETH MARY, also known as Elizabeth Dymond, formerly of 51 Albion-road, Elsternwick, but late of 24 O'Loughlin-street, Ormond, home duties, died 10th March, 1951, intestate.

†EDMUNDS, WILLIAM LEWIS, formerly of 17 Grattan-street, Carlton, but late of 20 Wright-street, Clifton Hill, examiner, died 2nd July, 1950.

EYRE, ALICE, late of 52 Moreland-road, Brunswick, music teacher, died 31st January, 1951, intestate.

FINN, JAMES HENRY, formerly of Mangalore, but late of Katunga, labourer, died 7th December, 1950, intestate.

GORMLY, KEITH ATHOL, late of 396 Station-street, Bonbeach, fibro-plasterer, died 10th July, 1950, intestate.

KELLY, ANN SARAH AMELIA, late of 14 Valerie-street, Pascoe Vale, spinster, died 1st February, 1950, intestate.

MORAN, THOMAS JOSEPH, late of 45 Grey-street, South Yarra, supervisor, died 13th February, 1951, intestate.

MULLAVEY, JOSEPH, late of 26 Salisbury-street, Werribee, ganger, died 19th February, 1951, intestate.

†MCEWAN, BRUCE AMBROSE DONALD, also known as Bruce McEwan, formerly of Australian Military Forces, but late of 19 Taylor-avenue, Regent, cement worker, died 17th January, 1951.

†QUICK, SUSAN ELIZA, late of 68 Empress-avenue, Footscray, married woman, died 23rd February, 1951.

ROWE, SOPHIA, late of Diamond Hill, Bendigo, retired nurse, died 8th October, 1950, intestate.

† According to the provisions of the will.

C. J. GARDNER,  
Public Trustee.

412 Collins-street, Melbourne, C.1, 2nd May, 1951.

#### 4 GEORGE VI. No. 4755, SECTION 6.

I HEREBY give notice that on the 3rd May, 1951, I filed elections to administer the following deceased persons' estates, in accordance with section 6 of the *Public Trustee Act 1940*:—

CAIRNS, MARY ROBINA, late of Home and Hospital for the Aged, Cheltenham, pensioner, died 18th September, 1950, intestate.

ELLIS, HERBERT, late of Beechworth, slater and tiler, died 20th January, 1951, intestate.

GALLOWAY, SHIRLEY, also known as John Galloway, late of Timboon, pensioner, died 30th December, 1950, intestate.

\*GORMAN, MARGARET, formerly of 28 MacArthur-place, Carlton, but late of 26 McArthur-square, Carlton, spinster, died 22nd January, 1951.

GOW, DANIEL, formerly of Bundoora, but late of Plenty-road, South Morang, retired, died 12th July, 1950, intestate.

JACOBS, MONTAGUE MELBOURNE, late of Yallourn North, labourer, died 27th December, 1950, intestate.

LITTLE, JOHN REGINALD, formerly of Mineral Spring, Donnybrook, and 66 Blair-street, Coburg, but late of 20 McGregor-street, Middle Park, plasterer, died 7th January, 1951, intestate.

LOWRIE, WILLIAM NICHOLAS, late of Castlemaine, pensioner, died 20th October, 1950, intestate.

MALONEY, JAMES FRANCIS, formerly of Grand Junction Hotel, Traralgon, but late of Cohuna, farm worker, died 27th January, 1951, intestate.

\*MORRISON, WILLIAM ERNEST, formerly of 2 Hope-street, West Footscray, but late of 41 Shackell-street, Coburg, retired foreman stevedore, died 14th March, 1951.

MCCARTHY, FLORENCE, sometimes known as Florrie McCarthy, late of 4 Selbourne-street, Ascot Vale, home duties, died 16th May, 1950, intestate.

WALKER, SAMUEL JOHN, late of Weerangourt Station, Macarthur, labourer, died 1st February, 1951, intestate.

\* According to the provisions of the will.

C. J. GARDNER,  
Public Trustee.

412 Collins-street, Melbourne, C.1, 8th May, 1951.

#### Melbourne and Metropolitan Board of Works Acts.

#### MELBOURNE AND METROPOLITAN BOARD OF WORKS.

NOTICE DECLARING THAT THE COURSE OF PORTION OF A MAIN DRAIN WITHIN THE CITY OF HAWTHORN AND WITHIN THE METROPOLIS SHALL BE DEVIATED (AREA No. 32).

MELBOURNE AND METROPOLITAN BOARD OF WORKS, under the powers conferred upon it by the Melbourne and Metropolitan Board of Works Acts and otherwise, doth by this notice declare that the course of that portion of the main drain from the northern end of Symonds-street to the western end of Rose-street, described in the notice published in *Victoria Government Gazette*, No. 108, dated 18th September, 1929, page 3507, be deviated, and the said notice amended by addition of the words "thence easterly to Symonds-street; thence southerly along Symonds-street about 250 feet;" after the words "southerly along Munro-street 320 feet;" in the twenty-first line of paragraph (b).

The description of the course and a specification of the points of commencement and termination of the said main drain, including the deviated portion and the drains described in *Victoria Government Gazette*, No. 125, dated 29th October, 1930, page 2833, paragraph (c), are as follows:—

(a) Commencing at a point on the left bank of the River Yarra 160 feet north-west from the centre line of Wallen-road; thence northerly and westerly to and terminating at a point in Evandale-road 170 feet north from Austin-street at commencement of drain declared as a main drain in the *Victoria Government Gazette*, No. 23, dated 23rd February, 1927, paragraph (a).

(b) Commencing at a point 140 feet east of the east building line of Power-street at termination of the drain declared as a main drain in the aforesaid *Gazette* of 23rd February, 1927, paragraph (a); thence south-easterly to the north building line of Lynch-street; thence easterly in railway reserve about 1,000 feet to a junction point hereinafter known as junction point "a"; thence further easterly along one branch about 120 feet to where the drain bifurcates at Golding-street, one part continuing easterly about 350 feet; thence southerly about 260 feet; the other part going southerly along Golding-street and easterly along Burwood-road, both parts joining again in Burwood-road about 400 feet east of Golding-street; thence south-easterly about 3,100 feet to a point in Belgrave-street about 270 feet north of Riversdale-road; thence easterly about 800 feet to Auburn-road; thence north-easterly about 700 feet to a point in Bowler-street about 370 feet east of Auburn-road; thence easterly along Bowler-street to Munro-street; thence southerly along Munro-street 320 feet; thence easterly to Symonds-

street; thence southerly along Symonds-street about 250 feet; thence generally easterly to Camberwell-road at Council-street; thence south-easterly along Camberwell-road to the north building line of Riversdale-road; thence by three drains easterly to and terminating at the municipal boundary between the Cities of Hawthorn and Camberwell at the centre of Burke-road; and along the other branch going from the aforesaid junction point "a" north-easterly about 350 feet to a junction point hereinafter known as junction point "b"; thence continuing north-easterly about 380 feet to Linda-crescent; thence easterly along Linda-crescent across Glenferrie-road and along Park-street to a point about 490 feet west of William-street; thence generally northerly and easterly to and terminating at the north building line of Barker's-road at Edgevale-road and along another branch commencing at the aforesaid junction point "b" and going north-easterly to a point in Glenferrie-road about 110 feet south of Park-street; thence easterly to a point in William-street about 240 feet south of Park-street; thence generally easterly to Auburn-road; thence generally easterly to Victoria-grove at a point about 310 feet south of Rathmines-road; thence generally north-easterly to Rathmines-road at a point about 300 feet west of Cambridge-street; thence north-easterly to and terminating at a point on existing drain 300 feet north-easterly from Rathmines-road at commencement of drain declared as a main drain in the aforesaid *Gazette* of 23rd February, 1927.

- (c) Commencing at the terminating point of drain declared as a main drain in the aforesaid *Gazette* of 23rd February, 1927 (paragraph (b)); thence north-easterly to and terminating at the north building line of Harcourt-street and Westley-street.
- (d) Commencing at the south building line of Connell-street at the termination of second-mentioned branch of the drain declared as a main drain in the aforesaid *Gazette* of 23rd February, 1927 (paragraph (a)); thence generally in a north-westerly direction to a point in Church-street about 55 feet south of Melville-street; thence north-easterly along Church-street to and terminating at a point in line with the south building line of Barker's-road.

This notice is an amendment of the above-mentioned notice published on page 3507 of the *Victoria Government Gazette* of the 8th September, 1929.

Dated this 24th day of April, 1951.

The common seal of the Melbourne and Metropolitan Board of Works was affixed hereto, in the presence of—

(SEAL) J. C. JESSOP, Chairman.  
H. F. MOGG, Member.  
CHAS. J. W. BRIGGS, Secretary.

Town and Country Planning Acts.  
BOROUGH OF RINGWOOD.  
INTERIM DEVELOPMENT ORDER.

**WHEREAS** by virtue of the powers conferred by the Town and Country Planning Acts, and every other power enabling it in that behalf, the Council of the Borough of Ringwood (hereinafter referred to as the "Responsible Authority") having commenced the preparation of a planning scheme in accordance with the said Acts, hereby makes the following Interim Development Order:—

1. The development of all land referred to in the Schedule and the erection, construction, and carrying out of any buildings, roads, or other works on any of the said lands is hereby prohibited.
2. Any person may apply to the Responsible Authority for permission to develop, sub-divide, or otherwise use any land or erect or construct any buildings, roads or other works, during the operation of this Order.
3. Any applications for permission to develop, sub-divide or otherwise use any land or erect or construct any building, roads, or other works, may be granted by the Responsible Authority, subject to such conditions as are specified in the permit, or may be refused.
4. Any owner of any land who, after the publication of a copy of this Order, contravenes any of the provisions contained herein, shall, when directed by notice, in writing, remove, pull down, take up, or alter any building, roads, or other works and, if any owner fails to do so within the time specified by the notice, the Responsible Authority may carry out all or any of such works and recover all

expenses incurred, after due notice has been given to the owner, lessee, and/or occupier, in accordance with the provisions of section 12, sub-section 3, of the Acts.

5. None of the provisions of this Order shall prohibit the continuance of the use of any land or building for the purpose for which it was used immediately before the coming into operation of this Order.

6. This Order shall remain in operation until the approval of the planning scheme, in accordance with the Town and Country Planning Acts, or until this Interim Development Order is revoked by the Governor in Council.

7. *Schedule of land affected.*—Commencing at the junction of the north side of Maroondah Highway with the east side of Ringwood-street; thence southerly along the east building line of Ringwood-street for a distance of 300 feet; thence easterly and parallel with Maroondah Highway to the west side of Warrandyte-road; thence southerly along the western building line of Warrandyte-road to Maroondah Highway; thence westerly along the northern boundary of Maroondah Highway to the commencing point.

The corporate seal of the Mayor and Councillors and Burgesses of the Borough of Ringwood was hereunto affixed in the presence of—

(SEAL) H. E. PARKER, Mayor.  
J. F. CORR, Councillor.  
ALFRED KELLY, Town Clerk.

—on the 19th April, 1951.

Approved by the Governor in Council,  
8th May, 1951.

A. G. COULTHARD,  
Acting Clerk of the Executive Council.

LAW DEPARTMENT.—SOLICITOR-GENERAL.

**HIS** Excellency the Governor of the State of Victoria, by and with the advice of the Executive Council thereof, doth by Order made on the 1st day of May, 1951, remove Thomas Edward Sibson from the Commission of the Peace for the Eastern Balliwick of the State of Victoria.

A. MAHLSTEDT,  
Clerk of the Executive Council.

At the Executive Council Chamber,  
Melbourne, the 1st May, 1951.

LAW DEPARTMENT.—ATTORNEY-GENERAL.  
CURATOR OF CONVICT'S PROPERTY.

**HIS** Excellency the Governor of the State of Victoria, by and with the advice of the Executive Council thereof, doth, by Order made on the 1st day of May, 1951, pursuant to the provisions of section 576 of the *Crimes Act 1928*, direct that the custody and management of the property of the convict, Alexander Bazil John Peters, be committed to Mildred Ceriton Peters, of 2B Lorimer-street, Fishermen's Bend, home duties, as a curator hereby appointed in that behalf.

A. MAHLSTEDT,  
Clerk of the Executive Council.

At the Executive Council Chamber,  
Melbourne, the 1st May, 1951.

LAW DEPARTMENT.—ATTORNEY-GENERAL.

CURATOR OF CONVICT'S PROPERTY.

**HIS** Excellency the Governor of the State of Victoria, by and with the advice of the Executive Council thereof, doth, by Order made on the 1st day of May, 1951, pursuant to the provisions of section 576 of the *Crimes Act 1928*, direct that the custody and management of the property of the convict, George Edward Gallagher, be committed to his brother, Jack Gallagher, of Spencer-street, Melbourne, as a curator hereby appointed in that behalf.

A. MAHLSTEDT,  
Clerk of the Executive Council.

At the Executive Council Chamber,  
Melbourne, the 1st May, 1951.

THE POTATO MARKETING BOARD.

NOTICE TO POTATO GROWERS.  
1950-51 Pool.

**FOR** deliveries of No. 1 grade potatoes made on and after Thursday, 3rd May, 1951, until further notice, the first advance to producers will be £26 per ton net, Melbourne.

For deliveries of No. 2 or "Emergency" grade potatoes made on and after Thursday, 3rd May, 1951, until further notice, the first advance to producers will be £24 per ton net, Melbourne.

A. C. BOUSTEAD,  
Chairman.

## CITY OF HEIDELBERG.

## ORDER CONFIRMED SUBJECT TO A VARIATION.

PURSUANT to section 513 of the *Local Government Act* 1946, the Minister of the Crown administering the said Act on the 1st day of May, 1951, confirmed the Order of the Council of the City of Heidelberg, made on the 17th day of April, 1950, for the purpose of providing a place of public resort and recreation, subject to the variation that the land to be compulsorily acquired under such Order shall be all that piece of land being part of Crown allotment D., section 11, Parish of Nillumbik, County of Evelyn, and being lots 6 and 10, Block G., on plan of subdivision No. 6091, lodged in the Office of Titles.

P. T. BYRNES,  
Commissioner of Public Works.

## FIRST MILDURA IRRIGATION TRUST.—MILDURA URBAN WATER TRUST.

## PETITIONS UNDER THE MILDURA IRRIGATION AND WATER TRUSTS ACT 1928.

IN pursuance of the provisions of the *Mildura Irrigation and Water Trusts Act* 1928, the substance and prayer of petitions which have been presented to His Excellency the Governor in Council are published, viz.:—

Petitions purporting to be the majority of the rate-payers in the areas described in the petitions, such areas being described in the Schedule hereto.

Joint petitions from the First Mildura Irrigation Trust and the Mildura Urban Water Trust in respect of the above areas.

The petitioners pray that His Excellency the Governor in Council may be pleased to sever such areas from the District of the First Mildura Irrigation Trust and annex the said areas to the District of the Mildura Urban Water Trust, in accordance with the provisions of the said Act.

Copies of such petitions, together with plans showing the areas proposed to be severed and annexed may be seen at the office of the Mildura Urban Water Trust, Deakin-avenue, Mildura.

## SCHEDULE.

Lots 6 and 12, section 32, block D, on lodged plan of subdivision No. 2144, Parish of Mildura, County of Karkaroc.

Parts of lots 4, 5, and 11, and lot 10, section 32, block D, on lodged plan of subdivision No. 2144, Parish of Mildura, County of Karkaroc.

Lots 5, 6, and 11, section 33, block D, on lodged plan of subdivision No. 2144, Parish of Mildura, County of Karkaroc.

Part of lot 4, section 30, block F, on lodged plan of subdivision No. 2168, Parish of Mildura, County of Karkaroc.

Part of lot 8, section 30, block F, on lodged plan of subdivision No. 2168, Parish of Mildura, County of Karkaroc.

Lots 6 and 7, section 31, block F, on lodged plan of subdivision No. 2168, Parish of Mildura, County of Karkaroc.

R. K. BROSE,  
Minister of Water Supply.

19th April, 1951.

## COUNTRY ROADS BOARD.

At the Executive Council Chamber, Melbourne, the first day of May, 1951.

## PRESENT:

His Excellency the Governor of Victoria.  
Mr. Brose | Mr. Harvey.  
Mr. White

## DECLARATION OF THE NEW WESTERN HIGHWAY IN THE SHIRE OF DIMBOOLA.

WHEREAS by sections 21 and 74 of the *Country Roads Act* 1928 (No. 3662) it is amongst other things enacted that when the Country Roads Board under the provisions of the Country Roads Act has taken the land necessary for constructing a road or deviation it shall as soon as it thinks such road or deviation is fit to be used as a public highway by Resolution declare the road or deviation to be a State highway or part thereof and that upon publication in the *Government Gazette* of the Order of the Governor in Council confirming such Resolution such

road or deviation shall thereupon be a State highway or part thereof within the meaning of the said Act: And whereas the said Board has by Resolution declared the road on the land described in the Schedule to such Resolution to be part of a State Highway: Now therefore His Excellency the Governor of the State of Victoria by and with the advice of the Executive Council thereof doth hereby confirm the said Resolution.

## Resolution for Declaration of a New State Highway under the Country Roads Act.

Whereas the land the site of the road the course of which is below set out was taken by the Board under the provisions of the Country Roads Act for the purpose of constructing such new road which new road has now been laid out and formed on the same: And whereas the said Board (being the Country Roads Board incorporated under the said Act) thinks that the road aforesaid is fit to be used as a public highway such Board at a meeting now holden acting under the authority conferred upon it by sections 21 and 74 of the *Country Roads Act* 1928 doth hereby declare the said new road the course of which is described in the Schedule hereto with the commencing and terminating points thereof respectively specified to be part of a State Highway within the meaning and for the purposes of the Country Roads Act.

## SCHEDULE.

## Shire of Dimboola.

2. *Western Highway*.—All that piece of land in the Parish of Dimboola, the boundaries of which are as follow:—Commencing at a point on the eastern boundary of allotment 105 of the said parish distant 2,624 links from the south-eastern angle of the said allotment; thence by lines bearing respectively 336 deg. 43 min. 1,012 links, 133 deg. 39 min. 550 links, and 179 deg. 47 min. 550 links to the point of commencement—which said piece of land is particularly delineated and shown coloured red on survey plan numbered 4853, lodged in the office of the Country Roads Board.

The common seal of the Country Roads Board was hereto affixed at Melbourne, this twenty-third day of April, One thousand nine hundred and fifty-one, in the presence of—

(SEAL) D. V. DARWIN, Chairman.  
F. M. CORRIGAN, Member.  
W. H. NEVILLE, Secretary.

And the Honorable Percy Thomas Byrnes, His Majesty's Commissioner of Public Works for the State of Victoria, shall give the necessary directions herein accordingly.

A. MAHLSTEDT,  
Clerk of the Executive Council.

## COUNTRY ROADS BOARD.

At the Executive Council Chamber, Melbourne, the first day of May, 1951.

## PRESENT:

His Excellency the Governor of Victoria.  
Mr. Brose | Mr. Harvey.  
Mr. White

DECLARATION OF THE NEW BALLAN-MEREDITH ROAD IN THE SHIRE OF BANNOCKBURN; THE NEW BUFFALO RIVER ROAD IN THE SHIRE OF BRIGHT; THE NEW MT. DANDENONG ROAD IN THE SHIRE OF LILLYDALE; AND THE NEW MURCHISON-RUSHWORTH ROAD IN THE SHIRE OF WARANGA.

WHEREAS by section 21 of the *Country Roads Act* 1928 (No. 3662) it is amongst other things enacted that when the Country Roads Board under the provisions of the Country Roads Act has taken the land necessary for constructing a road or deviation it shall as soon as it thinks such road or deviation is fit to be used as a public highway by Resolution declare the road or deviation to be a main road or part thereof and that upon publication in the *Government Gazette* of the Order of the Governor in Council confirming such Resolution such road or deviation shall thereupon be a main road or part thereof within the meaning of the said Act: And whereas the said Board has by Resolution declared the roads on the land described in the Schedule to such Resolution to

be parts of the main roads: Now therefore His Excellency the Governor of the State of Victoria by and with the advice of the Executive Council thereof doth hereby confirm the said Resolution.

*Resolution for Declaration of New Main Roads under the Country Roads Act.*

Whereas the land the site the road the course of which is below set out was taken by the Board under the provisions of the Country Roads Act for the purpose of constructing such new roads which new roads have now been laid out and formed on the same: And whereas the said Board (being the Country Roads Board incorporated under the said Act) thinks that the roads aforesaid are fit to be used as parts of the public highways such Board at a meeting now holden doth by this Resolution hereby declare the said new roads the courses of which are described in the Schedule hereto with the commencing and terminating points thereof respectively specified to be part of the main roads within the meaning and for the purposes of the Country Roads Act.

SCHEDULE.

*Shire of Bannockburn.*

5. *Ballan-Meredith road* (1305).—All that piece of land in the Parish of Meredith, the boundaries of which are as follow:—Commencing at the south-western angle of Crown portion 71 of the said parish; thence by lines bearing respectively 25 deg. 6 min. 102 links, 190 deg. 0 min. 93.8 links, and 270 deg. 0 min. 27 links to the point of commencement—which said piece of land is particularly delineated and shown coloured red on survey plan numbered 4882, lodged in the office of the Country Roads Board.

*Shire of Bright.*

6. *Buffalo River-road* (2406).—All that piece of land in the Town of Myrtleford, Parish of Myrtleford, the boundaries of which are as follow:—Commencing at the southern angle of allotment 1, section L, of the said town; thence by lines bearing respectively 267 deg. 53 min. 106.5 links, 62 deg. 35 min. 167 links, and 209 deg. 47 min. 84 links to the point of commencement—which said piece of land is particularly delineated and shown coloured red on survey plan numbered 4937, lodged in the office of the Country Roads Board.

*Shire of Lillydale.*

4. *Mt. Dandenong-road* (9404).—All that piece of land in the Parish of Mooroolbark, the boundaries of which are as follow:—Commencing at the southern angle of allotment 35G of the said parish; thence by lines bearing respectively 289 deg. 45 min. 75 feet, 81 deg. 36 min. 136 ft. 9 in., and 235 deg. 0 min. 79 feet to the point of commencement—which said piece of land is particularly delineated and shown coloured red on survey plan numbered 4965, lodged in the office of the Country Roads Board.

*Shire of Waranga.*

1. *Murchison-Rushworth road* (17701).—All that piece of land in the Parish of Moora, the boundaries of which are as follow:—Commencing at the north-western angle of allotment 17, section A, of the said parish; thence by lines bearing respectively 51 deg. 33 min. 2,984.2 links, 59 deg. 2 min. 337.1 links, 66 deg. 32 min. 23 links, 231 deg. 33 min. 3,304.7 links, and 285 deg. 48 min. 61.6 links to the point of commencement—which said piece of land is particularly delineated and shown coloured red on survey plan numbered 4753, lodged in the office of the Country Roads Board.

The common seal of the Country Roads Board was hereto affixed at Melbourne, this twenty-third day of April, One thousand nine hundred and fifty-one, in the presence of—

(SEAL) D. V. DARWIN, Chairman.  
F. M. CORRIGAN, Member.  
W. H. NEVILLE, Secretary.

And the Honorable Percy Thomas Byrnes, His Majesty's Commissioner of Public Works for the State of Victoria, shall give the necessary directions herein accordingly.

A. MAHLSTEDT,  
Clerk of the Executive Council.

COUNTRY ROADS BOARD.

*At the Executive Council Chamber, Melbourne, the first day of May, 1951.*

PRESENT:

His Excellency the Governor of Victoria.  
Mr. Brose | Mr. Harvey.  
Mr. White |

ORDER APPROVING OF A NEW MAIN ROAD IN THE SHIRE OF NEWSTEAD.

WHEREAS the Country Roads Board constituted under the *Country Roads Act* 1928 (No. 3662) has represented to His Excellency the Governor in Council that it appears to it desirable that the new Creswick-road in the Shire of Newstead should be made by the said Board: And whereas the said Board in accordance with the requirements of section 19 of the said cited Act has caused to be prepared a map plan and estimate showing the points between which and on and through what land the said new road is proposed to be made and the cost of acquiring the land and constructing the said new road: And whereas on an inspection of the said map and plan and a consideration of the said estimate His Excellency the Governor in Council is satisfied that there are funds legally available for acquiring the land and constructing the said new road: Now therefore be it known by this present Order that His Excellency the Governor of the State of Victoria with the advice of the Executive Council thereof doth hereby approve of the said road being made, that is to say:—

All that piece of land in the Parish of Sandon, the boundaries of which are as follow:—Commencing at the north-eastern angle of allotment 16A, section 3, of the said parish; thence by lines bearing respectively 172 deg. 45 min. 418 links, 211 deg. 30 min. 418 links, 20 deg. 3 min. 415.3 links, and 3 deg. 29 min. 381.7 links to the point of commencement—which said piece of land is particularly delineated and shown coloured red on survey plan numbered 5309, lodged in the office of the Country Roads Board.

And the Honorable Percy Thomas Byrnes, His Majesty's Commissioner of Public Works for the State of Victoria, shall give the necessary directions herein accordingly.

A. MAHLSTEDT,  
Clerk of the Executive Council.

DEPARTMENT OF CROWN LANDS AND SURVEY.

*At the Executive Council Chamber, Melbourne, the first day of May, 1951.*

PRESENT:

His Excellency the Governor of Victoria.  
Mr. Brose | Mr. Harvey.  
Mr. White |

REVOCATION OF TEMPORARY RESERVATIONS OF LANDS BY ORDERS IN COUNCIL.

HIS Excellency the Governor of the State of Victoria, by and with the advice of the Executive Council thereof, doth hereby, in pursuance of the provisions of the *Land Act* 1928, revoke the temporary reservations of the lands by Orders in Council hereinafter referred to, viz.:—

MYRTLEFORD.—Order in Council of 11th March, 1941, of 1 road 10 4/10 perches of land in the Town of Myrtleford as a site for State School.—(Rs.5185).

COWES.—Order in Council of 13th June, 1870, of 1 acre 2 rods of land in the Township of Cowes as a site for Public purposes so far only as regards the portion thereof comprised within the boundaries published in the *Government Gazette* of 4th April, 1951, and containing 1 road.—(Rs.6646).

And the Honorable Albert Eli Lind, His Majesty's Commissioner of Crown Lands and Survey for the State of Victoria, shall give the necessary directions herein accordingly.

A. MAHLSTEDT,  
Clerk of the Executive Council.

DEPARTMENT OF CROWN LANDS AND SURVEY.

At the Executive Council Chamber, Melbourne, the first day of May, 1951.

PRESENT:  
His Excellency the Governor of Victoria.  
Mr. Brose | Mr. Harvey.  
Mr. White

UNUSED AND UNMADE ROAD CLOSED.

HIS Excellency the Governor of the State of Victoria, by and with the advice of the Executive Council thereof, doth hereby direct that, in pursuance of the provisions of section 304 of the Land Act 1928 (No. 3709), the unused and unmade road referred to hereunder be closed, viz.:—

Parishes of Jeetho and Jeetho West, County of Mornington, being the roads indicated by hachure on plan hereunder.—(J.41(7, 8) (Misc.2426).

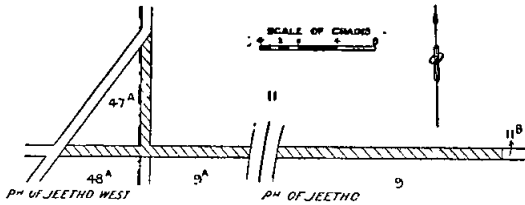

And the Honorable Albert Eli Lind, His Majesty's Commissioner of Crown Lands and Survey for the State of Victoria, shall give the necessary directions herein accordingly.

A. MAHLSTEDT,  
Clerk of the Executive Council.

DEPARTMENT OF CROWN LANDS AND SURVEY.

At the Executive Council Chamber, Melbourne, the first day of May, 1951.

PRESENT:  
His Excellency the Governor of Victoria.  
Mr. Brose | Mr. Harvey.  
Mr. White

LANDS TEMPORARILY RESERVED FROM SALE.

HIS Excellency the Governor of the State of Victoria, by and with the advice of the Executive Council thereof, doth hereby, in pursuance of the provisions of the Land Act 1928, reserve, temporarily, and also except from occupation for mining purposes under any miner's right, the lands hereinafter described:—

MILDURA (Cardross).—Site for Public recreation, 11 acres 3 roods 4 perches, Parish of Mildura, County of Karkarook, as indicated by hachure on plan hereunder.—(M.493(q<sup>2</sup>) (Rs.6657).

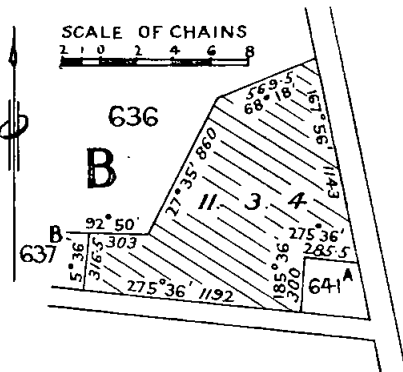

And the Honorable Albert Eli Lind, His Majesty's Commissioner of Crown Lands and Survey for the State of Victoria, shall give the necessary directions herein accordingly.

A. MAHLSTEDT,  
Clerk of the Executive Council.

MOE WATERWORKS TRUST.

At the Executive Council Chamber, Melbourne, the first day of May, 1951.

PRESENT:  
His Excellency the Governor of Victoria.  
Mr. Brose | Mr. Harvey.  
Mr. White

ALTERATION IN THE CONSTITUTION OF THE TRUST.

WHEREAS by an Order in Council bearing date the 20th day of June, 1933, the Moe Waterworks Trust was duly constituted; and whereas by clause 2 of the said Order in Council it was ordered and provided that four persons elected by the ratepayers of the Waterworks District and one other person should be Commissioners of the Waterworks Trust.

And whereas it is deemed expedient to repeal the aforesaid clause 2: Now therefore, His Excellency the Governor of the State of Victoria, by and with the advice of the Executive Council of the said State, and in pursuance of the powers conferred upon him by the provisions of the Water Acts, doth order:—

That the said clause 2 of the said Order in Council bearing date the 20th day of June, 1933, as aforesaid shall be, and the same is hereby repealed as on and from the fourth Thursday in the month of October, 1952, and in lieu thereof it is hereby ordered and provided that as on and from the fourth Thursday in the month of October, 1952, the following shall be and be deemed to be clause 2 of the said Order:—

"2. That six persons elected by the ratepayers of the Waterworks District and one other person shall be the Commissioners of the Waterworks Trust."

And the Honorable Richard Keats Brose, His Majesty's Minister of Water Supply for the State of Victoria, shall give the necessary directions herein accordingly.

A. MAHLSTEDT,  
Clerk of the Executive Council.

WARRACKNABEAL SEWERAGE AUTHORITY.

At the Executive Council Chamber, Melbourne, the first day of May, 1951.

PRESENT:  
His Excellency the Governor of Victoria.  
Mr. Brose | Mr. Harvey.  
Mr. White

EXTENT OF SEWERAGE DISTRICT INCREASED.

UNDER the powers conferred by the Sewerage Districts Acts and all other powers enabling him in that behalf, His Excellency the Governor of the State of Victoria, by and with the advice of the Executive Council of the said State, doth hereby declare, order, and direct as follows:—

That the extent of the Sewerage District of the Warracknabeal Sewerage Authority be increased by adding to the same the lands comprised within the boundaries described in the Schedule hereto, and as on and from the date hereof the extent of such District shall be deemed to be increased accordingly.

SCHEDULE.

Commencing at the intersection of the centreline of Yarriambiack Creek and a line being a continuation in a westerly direction of the northern boundary of lot 6 on lodged plan of subdivision No. 11348, Town of Warracknabeal, Parish of Werrigar, County of Borung, being a point on the northern boundary of the existing Warracknabeal Sewerage District; thence generally north-westerly along the said centreline of Yarriambiack Creek to a point in line with the northern boundary of Ross-street, as shown on lodged plan of subdivision No. 11348, Town of Warracknabeal, Parish of Werrigar; thence easterly by a line across the said Yarriambiack Creek, Crown land, Crown allotment 1, and along the said northern boundary of Ross-street to a point on the western boundary of a railway reserve; thence southerly along the said western boundary of a railway reserve to a point in line with the southern boundary of lot 43 on lodged plan of subdivision No. 11348, Town of Warracknabeal, Parish of Werrigar, being a point on the northern boundary of the

existing Warracknabeal Sewerage District; thence westerly, northerly, and westerly along the northern, eastern, and northern boundaries of the existing Warracknabeal Sewerage District to the point of commencement—all of which boundaries are shown on a plan approved by the Governor in Council and deposited in the office of the State Rivers and Water Supply Commission, Melbourne.

And the Honorable Richard Keats Brose, His Majesty's Minister of Water Supply for the State of Victoria, shall give the necessary directions herein accordingly.

A. MAHLSTEDT,  
Clerk of the Executive Council.

MOTOR OMNIBUS ACT 1928 (No. 3742).

At the Executive Council Chamber, Melbourne, the first day of May, 1951.

PRESENT:

His Excellency the Governor of Victoria.  
Mr. Brose | Mr. Harvey.  
Mr. White

AMENDMENT OF PRESCRIPTION OF METROPOLITAN MOTOR OMNIBUS ROUTE No. 93A (COBURG-NORTH ESSENDON).

HIS Excellency the Governor of the State of Victoria, by and with the advice of the Executive Council thereof, and in pursuance of the powers conferred by the *Motor Omnibus Act 1928* (No. 3742), doth by this Order amend, as set out hereunder, the prescription of a certain route, i.e., Route No. 93A, within the metropolitan area, along which route motor omnibuses for which "regular service" licences are granted may ply for hire, viz.:—

Under the heading "Description of Route, Including Commencing and Terminal Points" after Reynard-street where it first occurs delete "to the corner of Reynard-street and Melville-road, Coburg" and insert "Hillview-grove, Woodlands-avenue, Walhalla-street, and Ward-grove, to the corner of Ward-grove and Louisville-avenue."

Under the heading "Sections on Route" insert "(4) Melville-road, to the Track, or to the corner of Ward-grove and Louisville-avenue."

Under the heading "Fares to be Charged" delete "5d." and insert "6d."

*Licensing Authority.*—Pursuant to the provisions of section 15 (1) (c) of the said Act (No. 3742), the Governor in Council by this Order confers upon the Licensing Authority full power and authority for the carrying into effect by the said Licensing Authority of the foregoing provisions of this Order.

And the Honorable Percy Thomas Byrnes, His Majesty's Commissioner of Public Works for the State of Victoria, shall give the necessary directions herein accordingly.

A. MAHLSTEDT,  
Clerk of the Executive Council.

DEPARTMENT OF PUBLIC WORKS.

At the Executive Council Chamber, Melbourne, the first day of May, 1951.

PRESENT:

His Excellency the Governor of Victoria.  
Mr. Brose | Mr. Harvey.  
Mr. White

IN pursuance of the provisions of the *Local Government (Private Streets Construction) Act 1947*, as amended by the *Local Government Act 1949*, His Excellency the Governor of the State of Victoria, being satisfied that, owing to shortages in supplies of materials, the works provided for in the scheme adopted by the Council of the City of Footscray for the construction of New, Saltley, Truman, Aloha, Brunel, and Moresby streets, and parts of Paxton, Greene, Vernon, Kernot, Watt, and Stephenson streets, being private streets within the municipal district of the said city, cannot be satisfactorily executed in accordance with the specifications, maps, plans, sections, and elevations in the scheme, as previously varied, doth by this Order, by and with the advice of the Executive

Council of the said State, authorize the Council of the City of Footscray to execute the works with the following further variation of the said specifications, viz.:—

The following paragraph in clause 22, as previously varied, shall be deleted:—

4-in. *Agricultural Pipes:* The contractor shall supply and lay a line of 4-in. agricultural drain pipes underneath and to the same gradient as the channel. The top of the pipes shall just clear the underneath of the water service conduits, and the trench shall be filled with ashes. The pipes are to be connected to drains as instructed. For the purpose of tendering, the contractor shall include the cost of the agricultural pipes and the price for the concrete channels and buffer pitchers.

And the Honorable Percy Thomas Byrnes, His Majesty's Commissioner of Public Works for the State of Victoria shall give the necessary directions herein accordingly.

A. MAHLSTEDT,  
Clerk of the Executive Council.

LANDLORD AND TENANT ACTS.

At the Executive Council Chamber, Melbourne, the eighth day of May, 1951.

PRESENT:

His Excellency the Governor of Victoria.  
Mr. Dodgshun | Mr. Brose.

ORDER EXTENDING APPLICATION OF THE LANDLORD AND TENANT ACT 1948 TO CERTAIN PREMISES.

WHEREAS by Orders published in the *Government Gazette*, the several premises described in the Schedule hereto were excluded from the operation of Part V. of the *Landlord and Tenant Act 1948*: And whereas it is expedient that that part should again extend to each of those premises: Now therefore, in pursuance of the powers conferred upon him by the *Landlord and Tenant Act 1948*, as amended by the *Landlord and Tenant (Amendment) Act 1948*, His Excellency the Governor of Victoria, by and with the advice of the Executive Council thereof, doth hereby declare that the application of the whole of the *Landlord and Tenant Act 1948* shall extend to each of the premises described in such Schedule.

SCHEDULE.

1. Number 154 Bastings-street, Northcote.
2. Number 2 Tennyson-street, East Malvern.

And the Honorable Thomas Walter Mitchell, His Majesty's Attorney-General in and for the State of Victoria, shall give the necessary directions herein accordingly.

A. G. COULTHARD,  
Acting Clerk of the Executive Council.

LANDLORD AND TENANT ACTS.

At the Executive Council Chamber, Melbourne, the eighth day of May, 1951.

PRESENT:

His Excellency the Governor of Victoria.  
Mr. Dodgshun | Mr. Brose.

ORDER ABOLISHING A FAIR RENTS BOARD AND CONSTITUTING ANOTHER BOARD.

WHEREAS the Governor in Council for the purposes of the *Landlord and Tenant Act 1948*, as amended by the *Landlord and Tenant (Amendment) Act 1948*, may by Order published in the *Government Gazette* constitute Fair Rents Boards at such places and in respect of premises in such areas as he thinks fit and may by like Order abolish any Fair Rents Board and by the same or any subsequent Order make provision for the transfer of pending proceedings before such Board to some other Board: And whereas certain Fair Rents Boards have in pursuance of the powers aforesaid been constituted at certain places: And whereas it is expedient to abolish one of such Boards and to constitute another Board in its



place and to make the provision hereinafter appearing for the transfer of pending proceedings before the Board so abolished to such other Board: Now therefore His Excellency the Governor of the State of Victoria, by and with the advice of the Executive Council thereof, and in pursuance of the powers conferred upon him as aforesaid, doth hereby make the following Orders, that is to say:—

1. The Fair Rents Board, known as the Metropolitan Fair Rents Board, which was constituted by the Order in Council published in the *Government Gazette* on the 23rd day of March, 1949, is hereby abolished.

2. A Fair Rents Board, to be known as the Metropolitan Fair Rents Board, is hereby constituted at Melbourne, and such Board shall exercise the powers conferred by the above-mentioned Acts in respect of any premises situate within the Metropolitan Area as defined in the Schedule to this Order, and Roy Ellerslie Stapleton, Esquire, is hereby for the time being assigned to be the Stipendiary Magistrate constituting such Board.

3. All proceedings which at the date of the coming into operation of this Order were pending before the Board abolished by this Order in respect of premises situate within the said Metropolitan Area shall be transferred to the Metropolitan Fair Rents Board constituted under this Order.

4. This Order shall take effect on and from the 16th day of May, 1951.

SCHEDULE.

The Metropolitan Area shall consist of the following municipalities and portions of municipalities:—

Cities of Box Hill, Brighton, Brunswick, Camberwell, Caulfield, Chelsea, Coburg, Collingwood, Essendon, Fitzroy, Footscray, Hawthorn, Heidelberg, Kew, Malvern, Melbourne, Moorabbin, Mordialloc, Northcote, Nunawading, Oakleigh, Port Melbourne, Prahran, Preston, Richmond, Sandringham, South Melbourne, St. Kilda, and Williamstown; the River Ward, Central Ward, and Southern Ward of the City of Sunshine; that portion of the Shire of Broadmeadows which is south of the northern boundaries of the Parishes of Jika Jika and Doutta Galla; the Shire of Doncaster and Templestowe; the Southern Riding and Northern Riding of the Shire of Eltham; that portion of the Shire of Kellor which is south-east of the Albion-Broadmeadows railway line; the Shire of Mulgrave, except that portion which is east of Springvale-road and that portion which is south of North-road and Wellington-road; the Altona Riding of the Shire of Werribee; Borough of Ringwood.

And the Honorable Thomas Walter Mitchell, His Majesty's Attorney-General in and for the State of Victoria, shall give the necessary directions herein accordingly.

A. G. COULTHARD,  
Acting Clerk of the Executive Council.

LANDLORD AND TENANT ACTS.

At the Executive Council Chamber, Melbourne, the eighth day of May, 1951.

PRESENT:

His Excellency the Governor of Victoria.  
Mr. Dodgshun | Mr. Brose.

ORDER EXCLUDING CERTAIN PREMISES FROM THE OPERATION OF PARTS III. AND V. OF THE LANDLORD AND TENANT ACT 1948.

IN pursuance of the powers conferred upon him by the *Landlord and Tenant Act 1948*, as amended by the *Landlord and Tenant (Amendment) Act 1948*, His Excellency the Governor of Victoria, by and with the advice of the Executive Council thereof, doth hereby declare that the premises known as No. 68 Bayview-road, Yarraville, shall be excluded from the operation of the whole of the provisions contained in Parts III. and V. of the *Landlord and Tenant Act 1948*.

And the Honorable Thomas Walter Mitchell, His Majesty's Attorney-General in and for the State of Victoria, shall give the necessary directions herein accordingly.

A. G. COULTHARD,  
Acting Clerk of the Executive Council.

APPROACHING LAND SALES.

SALES of Crown lands, in fee-simple, will be held at the under-mentioned places and dates, viz.:—

	No. of Gazette.
Ballarat.—Wednesday, 16th May, 1951	.. 378
Bright.—Tuesday, 22nd May, 1951	.. 378
Horsham.—Friday, 8th June, 1951	.. 443
Kerang.—Tuesday, 22nd May, 1951	.. 391
Lakes Entrance.—Monday, 14th May, 1951	.. 378
Myrtleford.—Tuesday, 22nd May, 1951	.. 378
Swan Hill.—Tuesday, 22nd May, 1951	.. 391
Warracknabeal.—Thursday, 31st May, 1951	.. 443
Warragul.—Thursday, 17th May, 1951	.. 391

PROPOSED REVOCATION OF ORDER IN COUNCIL WITHHOLDING CERTAIN LAND FROM SALE, LEASING, AND LICENSING.

IN pursuance of the provisions of the *Land Act 1928*, notice is hereby given that it is the intention of the Governor in Council to revoke the withholding from sale, leasing, and licensing of the land described hereunder:—

The following Notice was published 1° on the 2nd May, 1951, pursuant to Order of the 24th April, 1951.

KANGERONG.—The temporary reservation as a site for Quarry and Road purposes, and the withholding from sale, leasing, and licensing, by Order in Council of the 7th May, 1878, of 18 acres 2 roods 10 perches of land in the Parish of Kangerong, being part of allotments 19 and 20A, is about to be revoked so far only as the portion containing 8 acres 3 roods, more or less, indicated by hachure on plan hereunder, is concerned.—(K.7(\*) (Rs.6655)).

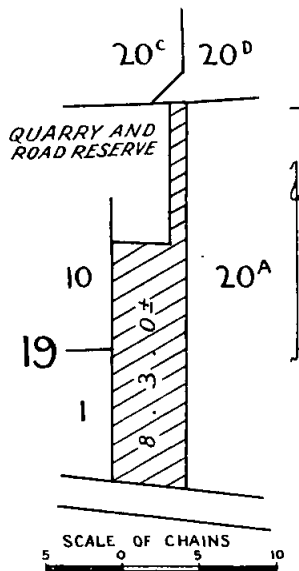

A. E. LIND,  
Commissioner of Crown Lands and Survey.

PROPOSED REVOCATION OF TEMPORARY RESERVATION OF LAND BY ORDER IN COUNCIL.

IN pursuance of the provisions of the *Land Act 1928*, notice is hereby given that it is the intention of the Governor in Council to revoke the temporary reservation of land by the Order in Council hereunder referred to, viz.:—

The following Notice was published 1° on the 18th April, 1951, pursuant to Order of the 10th April, 1951.

ELPHINSTONE.—The temporary reservation, by Order in Council of the 6th May, 1930, of 3 acres 1 rood 36 perches of land in the Parish of Elphinstone, as a site for a Quarry, is about to be revoked.—(E.34(2) (Rs.3992)).

A. E. LIND,  
Commissioner of Crown Lands and Survey.



## SOLDIER SETTLEMENT ACTS.

IN pursuance of section 88 (1) of the *Soldier Settlement Act 1946* (No. 5179), I, Albert Eli Lind, Commissioner of Crown Lands and Survey, hereby declare the farming land specified in the Schedule hereunder to be land suitable for soldier settlement.

## SCHEDULE.

All those pieces of land, being part of allotments 4A, 5A, and 5B, section 5; allotments 5A, 5B, 6A, 6B, 7A, and 7B, section 6; allotments 1A, 1B, 2A, 2B, 3A, 3B, 4A, and 4B, section 9; allotments 1AB, 2A, 2B, and part of 1AA, section 10; part of allotment 1AB, section 11, Parish of Nareeb Nareeb, comprising 1,441 acres 3 roods 16 perches.

Signed at Melbourne this 7th day of May, 1951.

A. E. LIND,  
Commissioner of Crown Lands and Survey.

## Soldier Settlement Acts.

## PRELIMINARY NOTICE OF COMPULSORY ACQUISITION.

TAKE notice that by virtue of the powers contained in the Soldier Settlement Acts the Governor in Council, by an Order made on the eighth day of May, 1951, a copy of which appears hereunder, directed that the land described in such Order be acquired compulsorily for the purposes of the said Acts.

Copy of Order of the Governor in Council made the eighth day of May, 1951.

## "DIRECTION FOR ACQUISITION OF LAND BY COMPULSORY PROCESS.

Whereas it is provided (*inter alia*) by the Soldier Settlement Acts that where it appears to the Governor in Council that any land proposed to be acquired for the purposes of such Acts cannot be acquired by agreement or cannot be so acquired at a reasonable price the Governor in Council may direct that such land be acquired compulsorily: And whereas by virtue of such Acts the Governor in Council has approved of the recommendation of the Soldier Settlement Commission that all those pieces of land comprising 208 acres 2 roods 35 perches, being part of lot 38 on plan of subdivision No. 4338, and being subdivision B and part of subdivision A of Crown allotment 5, section 6, Parish of Denison, the owner of which land is James Hutchison Murray, of Nambrok, should be acquired by the said Commission, pursuant to and in accordance with the Soldier Settlement Acts: And whereas by virtue of such Acts the Governor in Council directed the said Commission to negotiate for the acquisition of such land: And whereas it appears to the Governor in Council that the said land cannot be acquired by agreement: And whereas it is proposed that the said land be acquired for the purposes of the said Acts: Now therefore, His Excellency the Governor of the State of Victoria, by and with the advice of the Executive Council of the said State, doth by this Order direct that the land described above be acquired compulsorily for the purposes of the said Acts.

A. G. COULTHARD,  
Acting Clerk of the Executive Council."

Dated at Melbourne, this eighth day of May, One thousand nine hundred and fifty-one.

E. SINGLETON, Secretary,  
Soldier Settlement Commission.

## Soldier Settlement Acts.

## PRELIMINARY NOTICE OF COMPULSORY ACQUISITION.

TAKE notice that by virtue of the powers contained in the Soldier Settlement Acts the Governor in Council, by an Order made on the eighth day of May, 1951, a copy of which appears hereunder, directed that the land described in such Order be acquired compulsorily for the purposes of the said Acts.

Copy of Order of the Governor in Council made the eighth day of May, 1951.

## "DIRECTION FOR ACQUISITION OF LAND BY COMPULSORY PROCESS.

Whereas it is provided (*inter alia*) by the Soldier Settlement Acts that where it appears to the Governor in Council that any land proposed to be acquired for the purposes of such Acts cannot be acquired by agreement or cannot be so acquired at a reasonable price the Governor in Council may direct that such land be acquired compulsorily: And whereas by virtue of such Acts the Governor in Council has approved of the recommendation of the

Soldier Settlement Commission that all those pieces of land comprising 100 acres, being subdivisions A and B of Crown allotment 4A, section 12, Parish of Denison, the owner of which land is Albert Timms, of Nambrok, should be acquired by the said Commission, pursuant to and in accordance with the Soldier Settlement Acts: And whereas by virtue of such Acts the Governor in Council directed the said Commission to negotiate for the acquisition of such land: And whereas it appears to the Governor in Council that the said land cannot be acquired by agreement: And whereas it is proposed that the said land be acquired for the purposes of the said Acts: Now therefore, His Excellency the Governor of the State of Victoria, by and with the advice of the Executive Council of the said State, doth by this Order direct that the land described above be acquired compulsorily for the purposes of the said Acts.

A. G. COULTHARD,  
Acting Clerk of the Executive Council."

Dated at Melbourne, this eighth day of May, One thousand nine hundred and fifty-one.

E. SINGLETON, Secretary,  
Soldier Settlement Commission.

## Soldier Settlement Acts.

## PRELIMINARY NOTICE OF COMPULSORY ACQUISITION.

TAKE notice that by virtue of the powers contained in the Soldier Settlement Acts the Governor in Council, by an Order made on the eighth day of May, 1951, a copy of which appears hereunder, directed that the land described in such Order be acquired compulsorily for the purposes of the said Acts.

Copy of Order of the Governor in Council made the eighth day of May, 1951.

## "DIRECTION FOR ACQUISITION OF LAND BY COMPULSORY PROCESS.

Whereas it is provided (*inter alia*) by the Soldier Settlement Acts that where it appears to the Governor in Council that any land proposed to be acquired for the purposes of such Acts cannot be acquired by agreement or cannot be so acquired at a reasonable price the Governor in Council may direct that such land be acquired compulsorily: And whereas by virtue of such Acts the Governor in Council has approved of the recommendation of the Soldier Settlement Commission that all those pieces of land comprising 411 acres 1 rood 31 perches, being subdivisions A and B of Crown allotment 9, section 11; subdivisions A and B of Crown allotment 1, section 6; the whole being in the Parish of Denison, the owner of which land is William Herbert Brewer Lowe, of Nambrok, should be acquired by the said Commission, pursuant to and in accordance with the Soldier Settlement Acts: And whereas by virtue of such Acts the Governor in Council directed the said Commission to negotiate for the acquisition of such land: And whereas it appears to the Governor in Council that the said land cannot be acquired by agreement: And whereas it is proposed that the said land be acquired for the purposes of the said Acts: Now therefore, His Excellency the Governor of the State of Victoria, by and with the advice of the Executive Council of the said State, doth by this Order direct that the land described above be acquired compulsorily for the purposes of the said Acts.

A. G. COULTHARD,  
Acting Clerk of the Executive Council."

Dated at Melbourne, this eighth day of May, One thousand nine hundred and fifty-one.

E. SINGLETON, Secretary,  
Soldier Settlement Commission.

## Soldier Settlement Acts.

## PRELIMINARY NOTICE OF COMPULSORY ACQUISITION.

TAKE notice that by virtue of the powers contained in the Soldier Settlement Acts the Governor in Council, by an Order made on the eighth day of May, 1951, a copy of which appears hereunder, directed that the land described in such Order be acquired compulsorily for the purposes of the said Acts.

Copy of Order of the Governor in Council made the eighth day of May, 1951.

## "DIRECTION FOR ACQUISITION OF LAND BY COMPULSORY PROCESS.

Whereas it is provided (*inter alia*) by the Soldier Settlement Acts that where it appears to the Governor in Council that any land proposed to be acquired for the

purposes of such Acts cannot be acquired by agreement or cannot be so acquired at a reasonable price the Governor in Council may direct that such land be acquired compulsorily: And whereas by virtue of such Acts the Governor in Council has approved of the recommendation of the Soldier Settlement Commission that all those pieces of land comprising 591 acres 3 roods 26 perches, being lot 1 on plan of subdivision No. 5590, and being Crown allotments 4c, 4d, 4e and subdivisions A and B of Crown allotment 4a, section 12; lot 23 on plan of subdivision No. 4338, and being subdivision A and part of subdivision B of Crown allotment 5, section 3; lot 24 and part of lot 25 on plan of subdivision No. 4338, and being subdivision A and part of subdivision B of Crown allotment 6, and part of subdivision B of Crown allotment 5, section 3; the whole being in the Parish of Denison, the owner of which land is Benjamin Timms, of Nambrok, should be acquired by the said Commission, pursuant to and in accordance with the Soldier Settlement Acts: And whereas by virtue of such Acts the Governor in Council directed the said Commission to negotiate for the acquisition of such land: And whereas it appears to the Governor in Council that the said land cannot be acquired by agreement: And whereas it is proposed that the said land be acquired for the purposes of the said Acts: Now therefore, His Excellency the Governor of the State of Victoria, by and with the advice of the Executive Council of the said State, doth by this Order direct that the land described above be acquired compulsorily for the purposes of the said Acts.

A. G. COULTHARD,  
Acting Clerk of the Executive Council."

Dated at Melbourne, this eighth day of May, One thousand nine hundred and fifty-one.

E. SINGLETON, Secretary,  
Soldier Settlement Commission.

#### Soldier Settlement Acts

#### PRELIMINARY NOTICE OF COMPULSORY ACQUISITION.

TAKE notice that by virtue of the powers contained in the Soldier Settlement Acts the Governor in Council, by an Order made on the eighth day of May, 1951, a copy of which appears hereunder, directed that the land described in such Order be acquired compulsorily for the purposes of the said Acts.

Copy of Order of the Governor in Council made the eighth day of May, 1951.

#### "DIRECTION FOR ACQUISITION OF LAND BY COMPULSORY PROCESS.

Whereas it is provided (*inter alia*) by the Soldier Settlement Acts that where it appears to the Governor in Council that any land proposed to be acquired for the purposes of such Acts cannot be acquired by agreement or cannot be so acquired at a reasonable price the Governor in Council may direct that such land be acquired compulsorily: And whereas by virtue of such Acts the Governor in Council has approved of the recommendation of the Soldier Settlement Commission that all those pieces of land comprising 217 acres and 30 perches, being lot 40 on plan of subdivision No. 4338, and being subdivisions A and B of Crown allotment 4, section 7, Parish of Denison, the owner of which land is Charles George Newton, of Nambrok, should be acquired by the said Commission, pursuant to and in accordance with the Soldier Settlement Acts: And whereas by virtue of such Acts the Governor in Council directed the said Commission to negotiate for the acquisition of such land: And whereas it appears to the Governor in Council that the said land cannot be acquired by agreement: And whereas it is proposed that the said land be acquired for the purposes of the said Acts: Now therefore, His Excellency the Governor of the State of Victoria, by and with the advice of the Executive Council of the said State, doth by this Order direct that the land described above be acquired compulsorily for the purposes of the said Acts.

A. G. COULTHARD,  
Acting Clerk of the Executive Council."

Dated at Melbourne, this eighth day of May, One thousand nine hundred and fifty-one.

E. SINGLETON, Secretary,  
Soldier Settlement Commission.

#### Soldier Settlement Acts.

#### PRELIMINARY NOTICE OF COMPULSORY ACQUISITION.

TAKE notice that by virtue of the powers contained in the Soldier Settlement Acts the Governor in Council, by an Order made on the eighth day of May, 1951, a copy of which appears hereunder, directed that the land described in such Order be acquired compulsorily for the purposes of the said Acts.

Copy of Order of the Governor in Council made the eighth day of May, 1951.

#### "DIRECTION FOR ACQUISITION OF LAND BY COMPULSORY PROCESS.

Whereas it is provided (*inter alia*) by the Soldier Settlement Acts that where it appears to the Governor in Council that any land proposed to be acquired for the purposes of such Acts cannot be acquired by agreement or cannot be so acquired at a reasonable price the Governor in Council may direct that such land be acquired compulsorily: And whereas by virtue of such Acts the Governor in Council has approved of the recommendation of the Soldier Settlement Commission that all those pieces of land comprising 394 acres 3 roods 5 perches, being part of subdivisions A and B of Crown allotment 2, section 4; parts of lot 28 and whole of lot 29 on plan of subdivision No. 4338, being part of subdivisions A and B of Crown allotment 2, section 4, and subdivisions A and B of Crown allotment 1, section 4; the whole being in the Parish of Denison, the owner of which land is John Bermingham, of Nambrok, should be acquired by the said Commission, pursuant to and in accordance with the Soldier Settlement Acts: And whereas by virtue of such Acts the Governor in Council directed the said Commission to negotiate for the acquisition of such land: And whereas it appears to the Governor in Council that the said land cannot be acquired by agreement: And whereas it is proposed that the said land be acquired for the purposes of the said Acts: Now therefore, His Excellency the Governor of the State of Victoria, by and with the advice of the Executive Council of the said State, doth by this Order direct that the land described above be acquired compulsorily for the purposes of the said Acts.

A. G. COULTHARD,  
Acting Clerk of the Executive Council."

Dated at Melbourne, this eighth day of May, One thousand nine hundred and fifty-one.

E. SINGLETON, Secretary,  
Soldier Settlement Commission.

#### Soldier Settlement Acts.

#### PRELIMINARY NOTICE OF COMPULSORY ACQUISITION.

TAKE notice that by virtue of the powers contained in the Soldier Settlement Acts the Governor in Council, by an Order made on the eighth day of May, 1951, a copy of which appears hereunder, directed that the land described in such Order be acquired compulsorily for the purposes of the said Acts.

Copy of Order of the Governor in Council made the eighth day of May, 1951.

#### "DIRECTION FOR ACQUISITION OF LAND BY COMPULSORY PROCESS.

Whereas it is provided (*inter alia*) by the Soldier Settlement Acts that where it appears to the Governor in Council that any land proposed to be acquired for the purposes of such Acts cannot be acquired by agreement or cannot be so acquired at a reasonable price the Governor in Council may direct that such land be acquired compulsorily: And whereas by virtue of such Acts the Governor in Council has approved of the recommendation of the Soldier Settlement Commission that all those pieces of land comprising 203 acres 2 roods 11 perches, being lot 26 on plan of subdivision No. 4338, and being subdivisions A and B of allotment 7, section 5, Parish of Denison, the owner of which land is Vernon John Bermingham, of Nambrok, should be acquired by the said Commission, pursuant to and in accordance with the Soldier Settlement Acts: And whereas by virtue of such Acts the Governor in Council directed the said Commission to negotiate for the acquisition of such land: And whereas

it appears to the Governor in Council that the said land cannot be acquired by agreement: And whereas it is proposed that the said land be acquired for the purposes of the said Acts: Now therefore, His Excellency the Governor of the State of Victoria, by and with the advice of the Executive Council of the said State, doth by this Order direct that the land described above be acquired compulsorily for the purposes of the said Acts.

A. G. COULTHARD,  
Acting Clerk of the Executive Council."

Dated at Melbourne, this eighth day of May, One thousand nine hundred and fifty-one.

E. SINGLETON, Secretary,  
Soldier Settlement Commission.

Soldier Settlement Acts.

PRELIMINARY NOTICE OF COMPULSORY ACQUISITION.

TAKE notice that by virtue of the powers contained in the Soldier Settlement Acts the Governor in Council, by an Order made on the eighth day of May, 1951, a copy of which appears hereunder, directed that the land described in such Order be acquired compulsorily for the purposes of the said Acts.

Copy of Order of the Governor in Council made the eighth day of May, 1951.

"DIRECTION FOR ACQUISITION OF LAND BY COMPULSORY PROCESS.

Whereas it is provided (*inter alia*) by the Soldier Settlement Acts that where it appears to the Governor in Council that any land proposed to be acquired for the purposes of such Acts cannot be acquired by agreement or cannot be so acquired at a reasonable price the Governor in Council may direct that such land be acquired compulsorily: And whereas by virtue of such Acts the Governor in Council has approved of the recommendation of the Soldier Settlement Commission that all those pieces of land comprising 422 acres 2 roods 13 2/10 perches, being lots 33 and 34 on plan of subdivision No. 4338, and being part of subdivisions A and B of allotment 1, and being Crown allotment 2c, and part of subdivisions A and B of Crown allotment 2, section 3; lot 15 on plan of subdivision No. 5590, and being subdivision A of Crown allotment 2, section 5; the whole being in the Parish of Denison, the owners of which land are the executors of the will of Patrick Donoghue, late of Nambrok, deceased, should be acquired by the said Commission, pursuant to and in accordance with the Soldier Settlement Acts: And whereas by virtue of such Acts the Governor in Council directed the said Commission to negotiate for the acquisition of such land: And whereas it appears to the Governor in Council that the said land cannot be acquired by agreement: And whereas it is proposed that the said land be acquired for the purposes of the said Acts: Now therefore, His Excellency the Governor of the State of Victoria, by and with the advice of the Executive Council of the said State, doth by this Order direct that the land described above be acquired compulsorily for the purposes of the said Acts.

A. G. COULTHARD,  
Acting Clerk of the Executive Council."

Dated at Melbourne, this eighth day of May, One thousand nine hundred and fifty-one.

E. SINGLETON, Secretary,  
Soldier Settlement Commission.

Soldier Settlement Acts.

PRELIMINARY NOTICE OF COMPULSORY ACQUISITION.

TAKE notice that by virtue of the powers contained in the Soldier Settlement Acts the Governor in Council, by an Order made on the eighth day of May, 1951, a copy of which appears hereunder, directed that the land described in such Order be acquired compulsorily for the purposes of the said Acts.

Copy of Order of the Governor in Council made the eighth day of May, 1951.

"DIRECTION FOR ACQUISITION OF LAND BY COMPULSORY PROCESS.

Whereas it is provided (*inter alia*) by the Soldier Settlement Acts that where it appears to the Governor in Council that any land proposed to be acquired for the purposes of such Acts cannot be acquired by agreement

or cannot be so acquired at a reasonable price the Governor in Council may direct that such land be acquired compulsorily: And whereas by virtue of such Acts the Governor in Council has approved of the recommendation of the Soldier Settlement Commission that all those pieces of land comprising 5978 acres 3 roods 20 perches, being subdivisions A and B of allotment 3, section 1, of allotments 1, 2, and 3, section 2, of allotments 1 and 2, section 3, of allotments 4 and 5, section 4, of allotments 1, 2, 3, and 4, section 5, of allotments 1, 2, 4, and 5, section 6, of allotment 4, section 10, of allotments 2, 5, and 6, section 11, of allotments 1, 2, 4, and 5, section 13, allotments 3A and 3B, section 4, allotments 1A and 1B, section 11, and section A, Parish of Langulac, the owners of which land are The Trustees Executors and Agency Company Limited, as executors of the will of John Meagher, deceased, should be acquired by the said Commission, pursuant to and in accordance with the Soldier Settlement Acts: And whereas by virtue of such Acts the Governor in Council directed the said Commission to negotiate for the acquisition of such land: And whereas it appears to the Governor in Council that the said land cannot be acquired by agreement: And whereas it is proposed that the said land be acquired for the purposes of the said Acts: Now therefore, His Excellency the Governor of the State of Victoria, by and with the advice of the Executive Council of the said State, doth by this Order direct that the land described above be acquired compulsorily for the purposes of the said Acts.

A. G. COULTHARD,  
Acting Clerk of the Executive Council."

Dated at Melbourne, this eighth day of May, One thousand nine hundred and fifty-one.

E. SINGLETON, Secretary,  
Soldier Settlement Commission.

Soldier Settlement Acts.

PRELIMINARY NOTICE OF COMPULSORY ACQUISITION.

TAKE notice that by virtue of the powers contained in the Soldier Settlement Acts the Governor in Council, by an Order made on the eighth day of May, 1951, a copy of which appears hereunder, directed that the land described in such Order be acquired compulsorily for the purposes of the said Acts.

Copy of Order of the Governor in Council made the eighth day of May, 1951.

"DIRECTION FOR ACQUISITION OF LAND BY COMPULSORY PROCESS.

Whereas it is provided (*inter alia*) by the Soldier Settlement Acts that where it appears to the Governor in Council that any land proposed to be acquired for the purposes of such Acts cannot be acquired by agreement or cannot be so acquired at a reasonable price the Governor in Council may direct that such land be acquired compulsorily: And whereas by virtue of such Acts the Governor in Council has approved of the recommendation of the Soldier Settlement Commission that all those pieces of land comprising 2 acres, being part of lot 28 on plan of subdivision No. 4338, and being part of subdivision A of Crown allotment 2, section 4, Parish of Denison, the owners of which land are John Bermingham, of Nambrok, and Matthew Francis Bermingham, of Glengarry, as executors of the will of Patrick William Bermingham, deceased, should be acquired by the said Commission, pursuant to and in accordance with the Soldier Settlement Acts: And whereas by virtue of such Acts the Governor in Council directed the said Commission to negotiate for the acquisition of such land: And whereas it appears to the Governor in Council that the said land cannot be acquired by agreement: And whereas it is proposed that the said land be acquired for the purposes of the said Acts: Now therefore, His Excellency the Governor of the State of Victoria, by and with the advice of the Executive Council of the said State, doth by this Order direct that the land described above be acquired compulsorily for the purposes of the said Acts.

A. G. COULTHARD,  
Acting Clerk of the Executive Council."

Dated at Melbourne, this eighth day of May, One thousand nine hundred and fifty-one.

E. SINGLETON, Secretary,  
Soldier Settlement Commission.

LIST OF CROWN LANDS AVAILABLE.

THE under-mentioned areas are available for application as provided by various sections of the *Land Act 1928*, and all applications received on or before Wednesday, 6th June, 1951, will be deemed to have been simultaneously made, but any application lodged after such date may be considered if received in time for inclusion in the advertisement of the cases to be heard at the Local Land Board. Applications on proper form, accompanied by 5s. duty stamp uncancelled (registration fee), may be delivered or forwarded by post to the Local Land Officer or to any Crown Lands Office in Victoria. Applicants may obtain from Local Land Officers, or the Crown Lands Department, Melbourne, a certificate authorizing the issue by the Railway Department of a return ticket at concession fares to enable them to inspect available areas or to attend Local Land Boards. When an applicant is granted an allotment he may, if travelling by rail, obtain reduced fares for his family and also freight concessions in regard to some of his effects.

Subject to the approval of the Secretary for Lands, when the survey fee exceeds £25 but does not exceed £50, a deposit of £25 may be paid, and when the fee exceeds £50 a deposit of 50 per cent. of the fee, this balance in either case being payable over six years in half-yearly instalments.

Marked plans of any particular area, application forms, and any further information may be obtained from the Crown Lands Department, Melbourne, and Land Officers, Bairnsdale, Ballarat, Beechworth, Hamilton and Omeo.

Department of Crown Lands and Survey,  
Melbourne, 11th May, 1951.

A. E. LIND,  
Commissioner of Crown Lands and Survey.

\* Improvements may be subject to re-valuation after land has been granted to an applicant.

Local Land Office.	County.	Parish.	Allotment.	Holding No.	Area.	How Available.		Survey Fee.	Valuation of Improvements (if any).	Location of Land, &c.	Nearest Railway Station or Township and Distance in miles therefrom.	How Accessible.	Water Supply.	General Description of Land—Soil, Timber, Suitability (Grazing, &c.).	
						Classification.	Value per Acre.								
A. E. P.															
					£	s.	d.								
Bairnsdale (b)	Tambo	Buchan	10A	C	85 0 37	3rd	1 0 0	115 10 0	Nil	South-west of Buchan township	Nova Nowa R.S., 17 miles	By road	To be conserved	Hilly to undulating; sandy to light-red soil; stringybark and gum; grazing.	
"	"	Nova Nowa South	7, 7A	A	224 2 23	"	1 0 0	22 2 6	"	In centre of parish	Orbost R.S., 26 miles	"	"	Hilly; grey sandy loam; stringybark, honeysuckle, &c.; grazing and cultivation. (378/46)	
Ballarat	Grenville	Yarrowee	ASA	"	24 0 18	2nd	1 0 0	10 5 0	To be valued	In south-east of parish	Buninyong R.S., 6 miles	"	"	Undulating, gravelly; gum, messmate, and peppermint; grazing and cultivation when cleared. (J.28067)	
Beechworth	Bogong	Barwidgee	2	27	22 0 12	3rd	1 10 0	10 5 0	Nil	In south of parish	Eurobin, 4 miles	"	"	Undulating to hilly; grey and red loam; peppermint, apple box, &c.; grazing and cultivation. (3232/103)	
Hamilton	Lowan	Edenhope	8D	"	45 0 34	"	1 0 0	12 17 6	To be valued	In north-east of parish	Edenhope, 3 miles	Bitumen road	"	Undulating; light sandy; stringybark; fruit-growing. (Z.29401)	
Hamilton (a)	Follett	Langkoop	Parts of 50 and 51	"	480 0 0	"	1 0 0	39 15 0 (for 480 acres)	"	In south-west of parish	Edenhope, about 20 miles	By road	"	Undulating; sandy with a few swamps; stringybark; grazing. (Z34618)	
Omeo (a, c)	Bogong	Wollonahy	5A, 5B	1	100 0 0	"	0 10 0	26 12 6	Nil	"	Omeo, 40 miles	"	"	Undulating to hilly; light sandy loam; white gum and peppermint; grazing. (H.020791)	

AGRICULTURAL AND GRAZING LANDS—SELECTION PURCHASE ALLOTMENTS.

DIVISION 4, PART I, LAND ACT 1928.

(a) Subject to survey.—(b) Subject to timber condition.—(c) Subject to soil erosion prevention conditions.

LAND AVAILABLE UNDER THE SOLDIER SETTLEMENT ACT.

NOTIFICATION is hereby given, in accordance with Section 16 of the *Soldier Settlement Act 1946*, that the under-mentioned lots are available or are about to become available for settlement.

Any discharged soldier who has applied to the Commission on or before the 11th May, 1951, for classification in the required class or classes of primary production for which the lots are made available and whose application has been accepted but not necessarily finalized, or any discharged soldier who has been classified as suitable in such class or classes of primary production, may apply on the proscribed form for settlement on any lot or lots, indicating where he applies in respect of more than one lot his order of preference therefor.

The prescribed application forms, plans, and further particulars may be obtained from the Enquiry Branch, Soldier Settlement Commission, State Public Offices, Melbourne. The closing date for the receipt of completed applications for settlement on these holdings is the 4th June, 1951, such applications to be in the hands of the Secretary, Soldier Settlement Commission, on or before that date.

E. SINGLETON,  
Secretary.

Soldier Settlement Commission,  
Melbourne, 4th May, 1951.

SCHEDULE OF ALLOTMENTS.

PORTION OF MURRAY VALLEY IRRIGATION DISTRICT.

PARISHES OF YARROWEYAH, STRATHMERTON, BAULKAMAUGH, AND KATUNGA.—COUNTY OF MOIRA.

Allotment Number on Plan of Subdivision.	Section.	Parish.	Approximate Area in Acres (Subject to Survey).
<i>Suitable for Dairying under Irrigation.</i>			
5-6 .. ..	D	Baulkamaugh ..	107
5B .. ..	B	Katunga ..	97
60 .. ..	S	Yarroweyah ..	103
108 .. ..	S	Yarroweyah ..	107
219-221 ..	S	Strathmerton ..	145
<i>Suitable for the Growing of Soft Fruits under Irrigation..</i>			
8-8A .. ..	F	Katunga ..	50

PORTION OF "ARDGARTON" ESTATE.

PARISH OF GRASSDALE.—COUNTY OF NORMANBY.

*Suitable for Grazing (Sheep) and Mixed Farming.*

Lot Number on Plan of Subdivision.	Area.
3	497 acres 3 roods 28 perches

PORTION OF "HAREWOOD PARK" ESTATE.

PARISH OF GEMBROOK.—COUNTY OF EVELYN.

*Suitable for Mixed Farming, Mainly Potatoes, Other Root Crops, and Dairying.*

Lot Number on Plan of Subdivision.	Approximate Area in Acres (Subject to Survey).
7	101

SUBDIVISION OF PORTION OF "NIGRETTA" ESTATE.

PARISH OF TOOLKA.—COUNTY OF DUNDAS.

*Suitable for Grazing (Sheep) and Mixed Farming.*

Lot Number on Plan of Subdivision.	Approximate Area in Acres (Subject to Survey).
1	700
2	600
3	800
4	750

TENDERS.

TENDERS will be received at this office until **TEN A.M.** on the days and for the purposes under mentioned.

Particulars may be learnt at this Office and also at places shown in parenthesis.

W.O. means Inspector of Works Office; P.S.—Police Station; T.S.—Technical School; H.E.S.—Higher Elementary School; S.S.—State School; H.S.—High School; P.D.—Preliminary deposit; F.D.—Final deposit.

The Board of Land and Works will not necessarily accept the lowest or any tender.

15th May, 1951.

Albert Park.—Repairs to roofs, new spoutings, and downpipes to main building and infants' schools, S.S. No. 1181. P.D., £5. F.D., 2 per cent.

Ballarat.—Extension and alteration to vegetable preparation room, Mental Hospital. (W.O., Ballarat; Mental Hospital, Ballarat.) P.D., £5. F.D., 2 per cent.

Bell.—Internal painting and repairs, S.S. No. 4309. S.S., Bell.) P.D., £15. F.D., 2 per cent.

Boolarra South.—Supply and installation of kerosene hot-water service, teacher's residence, S.S. No. 3670. (W.O., Korumburra; P.S., Moe.) P.D., £3. F.D., 2 per cent.

Box Hill.—Supply, installation, and testing of central heating to Wood and Metal Trades Workshops, and alterations to boiler-room equipment, T.S. P.D., £15. F.D., 2 per cent.

Bright.—Supply and installation of kerosene hot-water service in new building, P.S. (W.O., Benalla, Wangaratta.) P.D., £3. F.D., 2 per cent.

Camberwell South.—Roof repairs and internal painting and renovations, S.S. No. 4170. P.D., £10. F.D., 2 per cent.

Camperdown.—Septic tank installation, S.S. No. 114. (W.O., Camperdown; P.S. Colac; S.S., Camperdown.) P.D., £5. F.D., 2 per cent.

Caulfield North.—General repairs and renovations to all buildings, S.S. No. 3820. P.D., £20. F.D., 2 per cent.

Chatham.—Alterations and repairs to shelter shed, S.S. No. 4314. P.D., £5. F.D., 2 per cent.

Cobram.—Supply and installation of mechanical services to Administrative Block and Senior Wing, Consolidated School. (W.O., Shepparton, Wangaratta.) P.D., £15. F.D., 2 per cent.

Coburg.—Sale of dross, skimmings, and flux, Wire Netting Factory, Pentridge. P.D., £10. F.D., full amount of purchase money.

Colac West.—Repairs and painting, S.S. No. 4064. (W.O., Camperdown; S.S., Colac West.) P.D., £15. F.D., 2 per cent.

Colac West.—Erection of fire-escape staircase, S.S. No. 4064. (W.O., Camperdown, Geelong; S.S., Colac West.) Deposit, £4.

Culgoa.—General repairs and painting, S.S. No. 3246. (W.O., Swan Hill; S.S., Culgoa.) P.D., £5. F.D., 2 per cent.

Diapur.—Alterations, painting, and repairs to residence, S.S. No. 2826. (W.O., Horsham, Warracknabeal; P.S., Nhill; S.S., Diapur.) P.D., £5. F.D., 2 per cent.

Dimboola.—Erection of two (2) timber residences for teachers, Memorial High School. (W.O., Warracknabeal; Assistant District Architect's Office, Horsham; Memorial High School, Dimboola.) P.D., £20. F.D., 2 per cent.

Dimboola.—Erection of new out-office block, Memorial High School. (W.O., Horsham, Warracknabeal; Memorial High School, Dimboola.) P.D., £15. F.D., 2 per cent.

Dooen.—Provision of office for housemaster, Longerenong Agricultural College. (W.O., Horsham.) Deposit, £4.

Dooen.—Erection of new residence, S.S. No. 1782. (W.O., Horsham; P.S., Murtoa; S.S., Dooen.) P.D., £15. F.D., 2 per cent.

Dromana.—Installation of septic tank and sewerage system and erection of lavatory, P.S. (P.S., Dromana.) P.D., £4. F.D., 2 per cent.

Edenhope.—Erection of two (2) new teachers' residences, S.S., No. 817. (W.O., Horsham; P.S., Goroke; H.E.S. Edenhope.) P.D., £20. F.D., 2 per cent.

Fawkner.—Provision of standard type cupboards in three classrooms, S.S. No. 3590. (S.S., Fawkner.) P.D., £4. F.D., 2 per cent.

Glenferrie.—Conversion of old chemistry laboratory to library classroom, Swinburne Technical School. P.D., £20. F.D., 2 per cent.

Glenhuntingly.—Painting and repairs to Junior School, S.S. No. 3703. P.D., £10. F.D., 2 per cent.

Heidelberg.—Erection of two (2) residences, Metropolitan Fire Brigade, Lower Plenty-road and Milford-grove. (Metropolitan Fire Station, Heidelberg.) P.D., £25. F.D., 2 per cent.

Janefield.—Re-lining of verandah roofs in "B" and "C" Wards with cement sheets, Mental Hospital. P.D., £4. F.D., 2 per cent.

Kew.—Construction of reinforced concrete and iron boiler house, Mental Hospital. P.D., £25. F.D., 2 per cent.

Kinglake.—Erection of new teacher's residence, S.S. No. 3315. (P.S., Whittlesea; S.S., Kinglake.) P.D., £15. F.D., 2 per cent.

Kotupna.—Repairs and renovations, S.S. No. 1999. (W.O., Shepparton; P.S., Numurkah; S.S., Kotupna.) P.D., £10. F.D., 2 per cent.

Lancaster.—New porch, folding partition, heating stove, &c. S.S. No. 1814. (W.O., Shepparton; P.S., Murchison, Numurkah, Kyabram; S.S., Lancaster.) Deposit, £4.

Leongatha.—Supply and installation of kerosene hot-water service, teacher's residence, H.S. (W.O., Korumburra.) P.D., £4. F.D., 2 per cent.

Melbourne.—Renovations to caretaker's quarters, State Offices, 61 Spring-street. P.D., £5. F.D., 2 per cent.

Mepunga East.—Septic tank installation to school and residence, S.S. No. 2762. (W.O., Warrnambool; P.S., Allansford; S.S., Mepunga East.) P.D., £5. F.D., 2 per cent.

Mirboo.—Supply and installation of kerosene hot-water service in teacher's residence, S.S. No. 3437. (W.O., Korumburra; P.S., Moe.) P.D., £3. F.D., 2 per cent.

Mont Park.—Supply and installation of electric hot-water services in residences for Medical Superintendent, Head Attendant, Medical Officer and Secretary, Larundel Mental Hospital. P.D., £10. F.D., 2 per cent.

Mont Park.—Coal handling plant, Mental Hospital. P.D., £20. F.D., 2 per cent.

Nayook.—Supply and installation of kerosene hot-water service, teacher's residence, S.S. No. 3227. (P.S., Warragul.) P.D., £3. F.D., 2 per cent.

Port Melbourne.—Internal and external repairs and painting, Court House. P.D., £5. F.D., 2 per cent.

Preston.—Internal renovations to school and out-buildings, Girls' School. (Girls' School, Preston.) P.D., £10. F.D., 2 per cent.

Richmond.—Electrical installation, Girls' School. P.D., £20. F.D., 2 per cent.

Royal Park.—Supply, delivery, and installation of laundry equipment, Children's Welfare Depot. P.D., £25. F.D., 2 per cent.

Royal Park.—External and internal repairs and renovations, Eleanor Shaw Chalet, Mount Royal. P.D., £10. F.D., 2 per cent.

Royal Park.—Erection of new laundry to Medical Officer's Quarters, Mental Hospital. P.D., £5. F.D., 2 per cent.

Royal Park.—Erection of two (2) residences for Medical Officers, Mental Hospital. P.D., £25. F.D., 2 per cent.

Sunbury.—External painting and repairs to Hospital Block, Mental Hospital. (P.S., Sunbury.) P.D., £5. F.D., 2 per cent.

Sunbury.—Supply and installation of household type refrigerator, Mental Hospital. P.D., £3. F.D., 2 per cent.

Terang.—Installation of septic tank system and new out-office block for girls, S.S. No. 617. (W.O., Camperdown, Warrnambool; S.S., Terang.) P.D., £5. F.D., 2 per cent.

Werribee.—Provision of plant breeding cage, Research Farm. (P.S., Werribee; Research Farm, Werribee.) P.D., £4. F.D., 2 per cent.

Willaura.—External and internal painting, general repairs and renovations and installation of electric light and power, &c., Court House. (W.O., Ararat; P.S., Stawell; Court House, Willaura.) P.D., £5. F.D., 2 per cent.

Wurruk.—Supply and installation of kerosene hot-water service, teacher's residence, S.S. No. 2518. (W.O., Bairnsdale.) P.D., £3. F.D., 2 per cent.

Yarra Junction.—Kerosene hot-water service, teacher's residence, S.S. No. 3216. P.D., £3. F.D., 2 per cent. S.S. No. 1501, Francis-street. Deposit, £10.

Yarraville.—Construction of two (2) shelter pavilions,

22nd May, 1951.

Belmont.—Additional out-office accommodation, S.S. No. 26. (W.O., Geelong; S.S., Belmont.) P.D., £5. F.D., 2 per cent.

Bendoc.—Additions, repairs, and painting, S.S. No. 1166. (W.O., Bairnsdale; S.S., Bendoc.) P.D., £10. F.D., 2 per cent.

Bennison.—Painting, repairs, and fencing to residence, S.S. No. 3025. (W.O., Korumburra; S.S., Bennison.) P.D., £10. F.D., 2 per cent.

Cannum East.—Purchase and removal of school building, out-offices, screen fences, gates, and other materials remaining on site, S.S. No. 2468. (W.O., Warracknabeal.) Deposit, £20.

Carpentait.—Erection of timber residence for teacher, S.S. No. 1500. (W.O., Camperdown; P.S., Colac; S.S., Carpentait.) P.D., £15. F.D., 2 per cent.

Cashmore.—Extension to classroom, repairs, and painting, S.S. No. 3838. (W.O., Hamilton; P.S., Portland; S.S., Cashmore.) P.D., £10. F.D., 2 per cent.

Cashmore.—Erection of new teacher's residence, &c., S.S. No. 3838. (W.O., Warrnambool; P.S., Portland; S.S., Cashmore.) P.D., £15. F.D., 2 per cent.

Casterton.—Internal and external repairs and painting, Infectious Diseases Hospital. (W.O., Hamilton; P.S., Cole-raine; Infectious Diseases Hospital, Casterton.) Deposit, £3.

Coburg.—Supply and delivery of electric mincer and other equipment for Female Division, Pentridge. P.D., £5. F.D., 2 per cent.

Coburg.—Supply and installation of heat storage cookers for Female Division, Pentridge. P.D., £15. F.D., 2 per cent.

Coburg.—Supply and delivery of hot press and other kitchen equipment for Female Division, Pentridge. P.D., £15. F.D., 2 per cent.

Creswick North.—Internal painting, blackboards, cupboards, and display boards, S.S. No. 2041. (W.O., Ballarat; S.S., Creswick North.) P.D., £4. F.D., 2 per cent.

Echuca.—Alterations and repairs, Patrol Residence, Country Roads Board. (W.O., Bendigo, Shepparton; P.S., Echuca.) P.D., £5. F.D., 2 per cent.

Erica.—Conversion of detached buildings for use as office, garage, and stable, P.S. (W.O., Traralgon; P.S., Moe, Erica.) P.D., £4. F.D., 2 per cent.

Fawkner.—Provision of new shelter shed and wood shed, S.S. No. 3590. P.D., £4. F.D., 2 per cent.

Footscray.—Erection of additional lavatory accommodation, removal and re-erection of bicycle shed and site works, T.S. P.D., £20. F.D., 2 per cent.

Gapsted.—Kerosene hot-water service, teacher's residence, S.S. No. 2240. (W.O., Wangaratta.) P.D., £3. F.D., 2 per cent.

Geelong.—Repairs and painting, residence (Normanby-street) H.S. (W.O., Geelong; H.S., Geelong.) Deposit, £3.

Geelong.—Supply and delivery of machine tools and precision measuring equipment, Gordon Institute of Technology. P.D., £25. F.D., 2 per cent.

Gippsland Lakes.—Cartage of stone from quarry at Lakes Entrance to various harbor works, Public Works Department. (W.O., Bairnsdale.) Deposit, £20.

Hawkesdale.—Installation of septic tank, school, and residence, S.S. No. 766. (W.O., Warrnambool; S.S., Hawkesdale.) P.D., £10. F.D., 2 per cent.

Hopetoun.—Repairs and renewals to party and non-party fencing, S.S. No. 3167. (W.O., Warracknabeal; P.S., Hopetoun.) Deposit, £4.

Huntly.—Raising floors, hyloplates, &c., and installation of heaters and provision of timber ramps, S.S. No. 306. (W.O., Bendigo; P.S., Castlemaine, Elmore, Raywood; S.S., Huntly.) P.D., £10. F.D., 2 per cent.

Jancourt East.—Supply and installation and testing of kerosene hot-water service, teacher's residence, S.S. No. 3783. (P.S., Camperdown.) P.D., £3. F.D., 2 per cent.

Kaniva.—Electrical installation, Consolidated School. (P.S., Kaniva; S.S., Kaniva.) P.D., £15. F.D., 2 per cent.

Kanya.—Repairs and painting, S.S. No. 2174. (W.O., Ararat; P.S., Marnoo, Stawell; S.S., Kanya.) P.D., £4. F.D., 2 per cent.

Katamatite.—Kerosene hot-water service, teacher's residence, S.S. No. 2069. (W.O., Shepparton.) P.D., £3. F.D., 2 per cent.

Lavers Hill.—Erection of timber residence for teacher, S.S. No. 3569. (W.O., Camperdown; P.S., Colac; Consolidated School, Lavers Hill.) P.D., £15. F.D., 2 per cent.

Malmsbury.—Erection of residence, office, and cell, excavations, paths, and fences, P.S. (W.O., Bendigo; Kyneton; P.S., Malmsbury.) P.D., £20. F.D., 2 per cent.

Manangatang.—Alterations and additions, District Hospital. (W.O., Bendigo, Swan Hill; P.S., Manangatang.) P.D., £20. F.D., 2 per cent.

Mont Park.—Renovations and alterations to Medical Officer's Quarters, Mental Hospital. P.D., £15. F.D., 2 per cent.

Mont Park.—Supply and delivery of electric potato peeler, Mental Hospital. P.D., £4. F.D., 2 per cent.

Morwell North.—Improvement to natural lighting, repairs and painting, S.S. No. 2621. (W.O., Traralgon; S.S., Morwell North.) P.D., £10. F.D., 2 per cent.

Munro.—Erection of teacher's residence, including out-buildings, garage, fencing, paths, drains, &c., S.S. No. 3814. (W.O., Bairnsdale; P.S., Sale; S.S., Munro.) P.D., £15. F.D., 2 per cent.

Prahran.—Additions to boys' dormitory and children's dining hall, Blind Institute, St. Kilda-road. P.D., £20. F.D., 2 per cent.

St. Arnaud.—Repairs and painting, Office, Department of Lands. (W.O., Maryborough; P.S., St. Arnaud.) P.D., £5. F.D., 2 per cent.

Stawell.—Alterations and additions to out-offices and washroom, Girls' and Toddlers' Ward, Pleasant Creek Special School. (W.O., Ararat; P.S., Stawell, Pleasant Creek.) P.D., £10. F.D., 2 per cent.



Stawell.—Erection of store and sewing room, Pleasant Creek Special School. (W.O., Ararat, Ballarat, Pleasant Creek Special School, Stawell.) P.D., £15. F.D., 2 per cent.

Stony Creek.—Erection of new residence, out-buildings paths, &c., S.S. No. 3665. (W.O., Korumburra; P.S., Leon-gatha; S.S., Stony Creek.) P.D., £15. F.D., 2 per cent.

Sunbury.—Supply and delivery of electric potato peeler, Mental Hospital. P.D., £4. F.D., 2 per cent.

Swan Hill.—Internal and external painting and repairs, Court House. (W.O., Swan Hill.) P.D., £15. F.D., 2 per cent.

Talbot.—Painting and repairs, S.S. No. 954. (W.O., Maryborough; S.S., Talbot.) Deposit, £10.

Wangaratta.—Supply and installation of a kerosene hot-water service in new building, T.S. (W.O., Wangaratta.) P.D., £3. F.D., 2 per cent.

Wangaratta West.—Erection of fencing, S.S. No. 4642. (W.O., Wangaratta; S.S., Wangaratta West.) P.D., £10. F.D., 2 per cent.

Warracknabeal.—Conversion of Infectious Diseases Wards for Nurses and Domestic Staff, District Hospital. (W.O., Ballarat, Warracknabeal; District Hospital, Warracknabeal.) P.D., £15. F.D., 2 per cent.  
S.S. No. 834. (W.O., Ararat; P.S., Stawell; S.S., Warrak.) Deposit, £4.

Warrnambool.—Erection of teacher's residence in timber, T.S. (W.O., Warrnambool; T.S., Warrnambool.) P.D., £15. F.D., 2 per cent.

Willowgrove.—Erection of new residence, S.S. No. 2529 (W.O., Traralgon; P.S., Moe.) P.D., £15. F.D., 2 per cent.

Wodonga.—Erection of office building, Transport Regulation Board. (W.O., Wangaratta; P.S., Wodonga.) P.D., £15. F.D., 2 per cent.

Woodleigh.—Erection of new teacher's residence, S.S. No. 2463. (W.O., Korumburra; S.S., Woodleigh.) P.D., £15. F.D., 2 per cent.

Wonthaggi.—Erection of three (3) new timber residences, S.S. No. 3650. (W.O., Korumburra; S.S., Wonthaggi.) P.D., £25. F.D., 2 per cent.

29th May, 1951.

Ascot Vale.—Electrical installation, station and residence, P.S. P.D., £4. F.O.D., 2 per cent.

Ballarat.—Extension of scullery to Ward F.11, Mental Hospital. (W.O., Ballarat; Mental Hospital, Ballarat.) P.D., £5. F.D., 2 per cent.

Ballarat.—Alterations and new kitchen, Mental Hospital. (W.O., Ballarat; Mental Hospital, Ballarat.) P.D., £25. F.D., 2 per cent.

Ballarat.—Alterations and additions to staff mess room, Mental Hospital. (W.O., Ballarat; Mental Hospital, Ballarat.) P.D., £15. F.D., 2 per cent.

Ballarat East.—Erection of new timber station and residence, brick cell and garage, P.S. (W.O., Ballarat; P.S., Ballarat East.) P.D., £25. F.D., 2 per cent.

Baliang East.—Erection of new residence, S.S. No. 3787. (W.O., Ballarat; P.S., Bacchus Marsh, Werribee; S.S., Baliang East.) P.D., £15. F.D., 2 per cent.

Beechworth.—Remodelling of kitchen, Reformatory Prison. (W.O., Wangaratta; P.S., Myrtleford; Reformatory Prison, Beechworth.) P.D., £15. F.D., 2 per cent.

Benalla.—New fittings, repairs, &c., to residence, 2 Egmont-street, P.S. (W.O., Benalla; P.S., Benalla.) P.D., £4. F.D., 2 per cent.

Bookar.—Erection of new residence, S.S. No. 3578. (W.O., Camperdown; P.S., Colac, Terang.) P.D., £15. F.D., 2 per cent.

Chewton.—Repairs and renovations, P.S. (W.O., Bendigo, Kyneton; P.S., Chewton.) P.D., £5. F.D., 2 per cent.

Dooen.—Erection of Demonstration Theatre at Butchery, Longerenong Agricultural College. (W.O., Horsham, Ballarat; P.S., Murtoa; Longerenong Agricultural College, Dooen.) P.D., £20. F.D., 2 per cent.

Euroa.—Provision of a store and equipment room, S.S. No. 1706. (W.O., Benalla; S.S., Euroa.) P.D., £3. F.D., 2 per cent.

Geelong.—Erection of timber residence for Inspector of Boilers, Department of Mines. (W.O., Geelong.) P.D., £15. F.D., 2 per cent.

Geelong.—Remodelling of existing out-office accommodation, S.S. No. 1094. (W.O., Geelong.) Deposit, £4.

Geelong East.—Septic tank installation, S.S. No. 541. (W.O., Geelong; S.S., Geelong East.) P.D., £5. F.D., 2 per cent.

Gnotuk.—Internal painting and repairs, &c., to residence, S.S. No. 3392. (W.O., Camperdown; P.S., Colac; S.S., Gnotuk.) Deposit, £4.

Greenvale.—Erection of sub-station buildings, Sanatorium. P.D., £15. F.D., 2 per cent.

Horsley's Estate.—Purchase and removal of old pavilion, out-offices, and fencing, S.S. No. 4395. (W.O., Korumburra; S.S., Outtrim.) P.D., £5. F.D., full amount of purchase money.

No. 489.—4115/51.—3

Jindivick.—Kerosene hot-water service, teacher's residence, S.S. No. 1951. P.D., £3. F.D., 2 per cent.

Kongwak.—Supply and installation of kerosene hot-water service, teacher's residence, S.S. No. 3323. (W.O., Korumburra.) P.D., £3. F.D., 2 per cent.

Lake Rowan.—Repairs and painting to residence, S.S. No. 1705. (W.O., Benalla; P.S., Yarrowonga; S.S., Lake Rowan.) P.D., £5. F.D., 2 per cent.

Melbourne.—Supply and installation of air-cooling equipment for skin storage room, National Museum of Victoria. P.D., £15. F.D., 2 per cent.

Melbourne.—Supply and installation of electric passenger lift in Commerce School, Technical College. P.D., £20. F.D., 2 per cent.

Merino.—Erection of timber residence for teacher, Consolidated School. (W.O., Hamilton; Consolidated School, Merino.) P.D., £15. F.D., 2 per cent.

Mt. Duneed.—Erection of timber teacher's residence, S.S. No. 2036. (W.O., Geelong; S.S., Mt. Duneed.) P.D., £15. F.D., 2 per cent. (Amended specification.)

Newmerella.—Erection of residence, including garage, out-building, hot-water service, fencing, paths, &c., S.S. No. 2930. (W.O., Bairnsdale; P.S., Orbost; S.S., Newmerella.) P.D., £15. F.D., 2 per cent.

Oxley.—Supply and installation of hard fuel hot-water service, teacher's residence, S.S. No. 1399. (W.O., Benalla; P.S., Oxley.) P.D., £3. F.D., 2 per cent.

Queenscliff.—Supply and delivery of approximately 1,000 tons of steel sheet piling, Harbor. P.D., £50. F.D., 2 per cent.

Red Cliffs.—Repairs and renovations, S.S. No. 4057. (W.O., Mildura; P.S., Ouyen, Merbein; S.S., Red Cliffs.) P.D., £15. F.D., 2 per cent.

Rutherglen.—Supply and installation of kerosene hot-water service, new building, Research Station. (W.O., Benalla, Wangaratta.) P.D., £3. F.D., 2 per cent.

Sale.—Erection of timber residence, S.S. No. 545. (W.O., Bairnsdale; S.S., Sale.) P.D., £15. F.D., 2 per cent.

Seymour.—Addition of a staff room, S.S. No. 547. (W.O., Alexandra; P.S., Euroa; S.S., Seymour.) P.D., £5. F.D., 2 per cent.

Seymour.—Repairs and painting, H.S. (W.O., Alexandra; P.S., Seymour.) P.D., £15. F.D., 2 per cent.

Shelford.—Erection of new teacher's residence, S.S. No. 379. (W.O., Geelong; P.S., Colac; S.S., Shelford.) P.D., £15. F.D., 2 per cent.

Stawell.—Repairs and painting, new fence, Married Constable's Quarters, P.S. (W.O., Ararat; P.S., Ararat, Stawell.) P.D., £5. F.D., 2 per cent.

Sunbury.—Erection of hostel for nurses, Mental Hospital. (P.S., Sunbury.) P.D., £50. F.D., 2 per cent.

Sunbury.—External and internal repairs and painting, Female Ward F.7, Mental Hospital. (W.O., Kyneton; P.S., Sunbury.) P.D., £15. F.D., 2 per cent.

Tatura.—Erection of timber residence and garage, Research Station. (W.O., Bendigo, Shepparton, Wangaratta.) P.D., £20. F.D., 2 per cent.

Trentham.—Alterations, repairs, and renovations, P.S. (W.O., Bendigo, Kyneton; P.S., Trentham.) P.D., £15. F.D., 2 per cent.

Wangaratta.—Supply and installation of kerosene hot-water service in new building, Inspector's Residence, Fisheries and Game Department. (W.O., Benalla, Wangaratta.) P.D., £3. F.D., 2 per cent.

Warracknabeal.—Repairs, painting, and new porch, &c., P.S. (W.O., Warracknabeal; P.S., Hopetoun, Rainbow, Warracknabeal.) P.D., £5. F.D., 2 per cent.

Woolsthorpe.—Provision of partition and heaters, S.S. No. 638. (W.O., Warrnambool; P.S., Koroit, Port Fairy; S.S., Woolsthorpe.) Deposit, £3.

Warracknabeal.—Erection of timber residence for teacher, H.S. (W.O., Warracknabeal; P.S., Nhill; H.S., Warracknabeal.) P.D., £15. F.D., 2 per cent.

Yarragon.—Internal and external painting and repairs, S.S. No. 2178. (W.O., Traralgon; S.S., Yarragon.) P.D., £10. F.D., 2 per cent.

5th June, 1951.

Berry's Creek.—Kerosene hot-water service, teacher's residence, S.S. No. 2925. P.D., £3. F.D., 2 per cent.

Mont Park.—Supply and installation of mechanical services in laundry, Larundel Mental Hospital. P.D., £25. F.D., 2 per cent.

Tenders to be addressed to the Honorable the Commissioner of Public Works, and envelope containing tender marked "Tender for

P. T. BYRNES,  
Commissioner of Public Works

Melbourne, 8th May, 1951.

## TENDERS FOR THE SERVICE, 1951-52.

## CARTAGE (COUNTRY).

TENDERS will be received until Eleven o'clock a.m. on Friday, 1st June, 1951, for the cartage and delivery at Ararat, Bairnsdale, Ballarat, Bendigo, Castlemaine, Hamilton, Horsham, Nowa Nowa, Stawell, Wangaratta, and Warrnambool, of such goods and furniture as may be forwarded to and from the railway station and various Government offices by the Stores and Transport Office for and on behalf of the Government of Victoria from 1st July, 1951, to 30th June, 1952.

Tenders for Nowa Nowa will be considered in conjunction with tenders for breadstuffs, Aboriginal Station, Lake Tyers.

Full particulars, forms of tender, and conditions of contract may be obtained at the office of the Secretary to the Tender Board, Gisborne-street, Melbourne, C.2, and at the police stations at the places named, and at Lakes Entrance.

A deposit of £10, preferably by non-negotiable cheque payable to the order of the Secretary to the Tender Board, must accompany each tender, and the deposit lodged by the successful tenderer will be retained as security for the due fulfilment of the contract. The deposit will be forfeited in the event of the tenderer withdrawing or attempting to withdraw his tender before notification of acceptance of same or in the event of the successful tenderer failing to sign and complete his contract within the period specified. Deposits will be returned to unsuccessful tenderers within thirty days of acceptance of tenders, on their application.

The contract must be signed within seven days of acceptance of the tender, failing which the service may be again advertised or another tender accepted.

Tenderers failing to take up their accepted tenders may be disqualified from tendering or holding any future contract or contracts for a period of twelve months from the date of such disqualification.

Tenders may be accepted for each place separately.

The lowest or any tender will not necessarily be accepted.

Tenders, enclosed in an envelope, and *having the words "Tender for Cartage" written thereon*, must be deposited in the Tender-box at the Tender Board Offices, Gisborne-street, Melbourne, or, if sent by post, postage must be prepaid, and the tenders addressed to the Chairman of the Tender Board, Tender Board Offices, Gisborne-street, Melbourne, C.2, which office they must reach not later than by first post on the date of closing of tenders.

## CONDITIONS OF CONTRACT.

1. The contract rates shall cover cartage and delivery of all descriptions of parcels and goods, including furniture, officers' furniture and effects, &c. (except for officers of Police Department), to and from the places named in the tender form.

2. The contract shall not be considered broken, infringed, or vitiated by the Government performing the service or arranging for the carrying out of the same otherwise than by the contractor in the event of urgency or emergency.

3. A separate charge is to be made for each consignment, such charge to be for the gross weight thereof, irrespective of the number of packages. Accounts in all cases to be made out by weight only, to be rendered monthly, supported by the vouchers properly received, and to be subject to any deductions for goods, parcels, furniture, &c., lost or damaged whilst in the custody of the contractor.

4. For removals of officers' furniture and effects, a separate charge must be made per van per hour, including loading and reloading as required, and a certificate from the officer concerned must accompany the voucher setting forth the number of hours employed, before payment can be made: Provided that, with the prior consent of the Tender Board, officers' furniture and effects may be removed in the manner and by the persons approved of by the Board. Transport sling vans are not to be requisitioned without the authority of the Secretary to the Tender Board.

5. The contractor shall in all cases, against each separate charge in his accounts, quote the number of the consignment note, which should be found on each consignment or

package forwarded by the contractors or departments, and the weight. Should the number not be on the package then the name of the consignor should be quoted and a description of the parcel given in lieu thereof. Any infringement of this condition will render the contractor liable, on report by the Tender Board, to such fine as the Treasurer may direct, and the amount may be deducted from any account due to the contractor or from the security money.

6. Contractors are not at liberty to transfer their contracts under cover of power of attorney, coupled with an interest or otherwise, and no such transfer will be recognised by the Government.

7. Under no circumstances will a contractor be permitted to abandon his contract. In the event of the contractor failing to carry on the contract, the security money will in that case be absolutely forfeited, and, in addition, the contractor will be held liable for any loss which the Government may sustain in consequence of such failure, and may be disqualified from tendering or holding any contract or contracts for a period of twelve months from the date of such disqualification.

8. In the event of any dispute arising as to matters or things contained in the contract or schedule the same shall be settled by the Tender Board, and the Board's decision shall be binding, final, and conclusive.

J. G. B. McDONALD,  
Treasurer.

The Treasury,  
Melbourne, 7th May, 1951.

## TENDERS FOR THE SERVICE, 1951-52.

## CARTAGE OF MIGRANTS' BAGGAGE.

TENDERS will be received until Eleven o'clock a.m. on Friday, 1st June, 1951, for superintending discharge, Customs clearance from Victoria Dock or Port Melbourne, and delivery or storage within the metropolitan area of migrants' baggage for and on behalf of the Government of Victoria, from 1st July, 1951, to 30th June, 1952, as per Schedule No. 1A.

In the event of the contractor carrying out the service to the satisfaction of the Tender Board the contract may, at the option of the Board and with the consent of the contractor, be extended for a further period of twelve months from 1st July, 1952.

A preliminary deposit of £10, preferably by non-negotiable cheque payable to the order of the Secretary to the Tender Board, must accompany each tender, such deposit to be forfeited in the event of the tenderer withdrawing or attempting to withdraw his tender before notification of acceptance of tender, or in the event of the successful tenderer failing to sign and complete his contract within the period specified. Deposits will be returned to unsuccessful tenderers within thirty days of acceptance of tender, on their application.

Security of £30 will be required either in Commonwealth Treasury Bonds, or approved bank guarantee, fixed deposit receipt, Savings Bank deposit book, or non-negotiable cheque in favour of the Secretary to the Tender Board, as the tenderer may elect.

The security must be completed and the contract signed within five days of acceptance of the tender, failing which the service may be again advertised, or another tender accepted.

Tenderers failing to take up their accepted tenders may be disqualified from tendering or holding any future contract or contracts for a period of twelve months from the date of such disqualification.

Full particulars, forms of tender, &c., may be obtained at the office of the Secretary to the Tender Board, Gisborne-street, Melbourne, C.2.

The lowest or any tender will not necessarily be accepted.

Tenders, enclosed in an envelope, and *having the words "Tender for Migrants' Baggage" written thereon*, must be deposited in the Tender-box at the Tender Board Offices, Gisborne-street, Melbourne, or, if sent by post, postage must be prepaid, and tenders addressed to the Chairman of the Tender Board, Tender Board Offices, Gisborne-street, Melbourne, C.2, which office they must reach not later than by first post on the date of closing of tenders.

## CONDITIONS OF CONTRACT.

1. No subletting shall be allowed; all work must be carried out by the contractor, and every person engaged in the cartage tendered for in this schedule shall be paid such wages and employed subject to such labour conditions as are or may be determined by any Federal Arbitration Court award or any State Wages Board determination, and a copy of such labour conditions shall be kept conspicuously and continually posted, in legible Roman characters, on the premises of the contractor. Any infringement of this condition, in the opinion of the Treasurer, will subject the contractor, upon report from the Tender Board, to such mulct, not exceeding Fifty pounds (£50), as the Treasurer may direct, and the amount will be deducted from the contractor's account or from the security money; and the Treasurer's decision shall be binding, final, and conclusive as to the fact of infringement and in all other respects.

2. Accounts shall be rendered monthly, and shall be subject to any deductions for baggage lost or damaged whilst in the custody of the contractor or for storage or demurrage charges which may accrue through delay or default by the contractor in taking delivery of the goods.

3. No claims for detention shall be entertained, but should the contractor be subjected to unreasonable delay the cause of delay, if reported, shall be investigated.

4. The contractor must have an office connected by telephone, and within a radius of 6 miles of the Melbourne (Elizabeth-street) Post Office. Thirty minutes will be deemed sufficient notice, and in the event of the contractor failing to supply the vehicles when ordered, and to the satisfaction of the officer requiring his services, such services will be performed at his risk and expense, and the extra expense incurred will be deducted as provided in clause 1.

5. No services performed under these contracts shall be deemed to be of a special nature, provided that the contractor be given 30 minutes' notice that his services shall be required, and no increase in the contract rates shall be permitted.

6. All vehicles in which the goods or parcels are carried must be fitted with good waterproof covers, be in thorough working order and, in general, suitable for requirements.

7. The contract shall not be considered broken, infringed, or vitiated by the Government performing the service or arranging for the carrying out of the same otherwise than by the contractor in the event of urgency or emergency.

8. The contractor is not at liberty to transfer his contract under cover of power of attorney, coupled with an interest or otherwise, and no such transfer will be recognized by the Government.

9. Under no circumstances will the contractor be permitted to abandon his contract. In the event of the contractor failing to carry on the contract, the security money will in that case be absolutely forfeited and, in addition, the contractor may be held liable for any loss which the Government may sustain in consequence of such failure.

10. A refusal to execute orders, irregularity, or delay in delivering the baggage as required, or failure to comply with the requirements of clause 2 or any breach of Railway or Harbor Trust Regulations, will subject the contractor, upon report from the Tender Board, to such mulct as the Treasurer may direct, and the amount may be deducted as provided in clause 1. It will also be in the power of the said Treasurer upon such refusal, irregularity, or delay to terminate the contract forthwith, and declare forfeit the whole or any portion of the security money, and, in addition, the contractor will be disqualified from tendering or holding any future contract or contracts for a period of twelve months from the date of such disqualification.

11. In the event of any dispute arising as to matters or things contained in the contract or schedule the same shall be settled by the Tender Board, and the Board's decision shall be binding, final, and conclusive.

J. G. B. McDONALD,  
Treasurer.

The Treasury,  
Melbourne, 7th May, 1951.

## TENDERS FOR THE SERVICE, 1951-52.

## CARTAGE OF HEAVY GOODS AND COAL (METROPOLITAN).

TENDERS will be received until Eleven o'clock a.m. on Friday, 1st June, 1951, for the cartage and delivery of heavy goods and coal within the metropolitan area, as may be required by the Government of Victoria, from 1st July, 1951, to 30th June, 1952, as per Schedule Nos. 2 and 3.

A preliminary deposit of £5, preferably by non-negotiable cheque payable to the order of the Secretary to the Tender Board, must accompany each tender, such deposit to be forfeited in the event of the tenderer withdrawing or attempting to withdraw his tender before notification of acceptance of tender or in the event of the successful tenderer failing to sign and complete his contract within the period specified. Deposits will be returned to unsuccessful tenderers within thirty days of acceptance of tenders, on their application.

Security of £10 for each Schedule will be required either in Commonwealth Treasury Bonds, or approved bank guarantee, fixed deposit receipt, Savings Bank deposit book, or non-negotiable cheque in favour of the Secretary to the Tender Board, as the tenderer may elect.

The security must be completed and the contract signed within five days of acceptance of the tender, failing which the service may be again advertised, or another tender accepted.

Tenders may be accepted for each schedule separately.

Tenderers failing to take up their accepted tenders may be disqualified from tendering or holding any future contract or contracts for a period of twelve months from the date of such disqualification.

Full particulars, forms of tender, conditions of contract, &c., may be obtained at the office of the Secretary to the Tender Board, Gisborne-street, Melbourne, C.2.

The lowest or any tender will not necessarily be accepted.

Tenders, enclosed in an envelope, and having the words "Tender for Cartage" written thereon, must be deposited in the Tender-box at the Tender Board Offices, Gisborne-street, Melbourne or, if sent by post, postage must be prepaid, and tenders addressed to the Chairman of the Tender Board, Tender Board Offices, Gisborne-street, Melbourne, C.2, which office they must reach not later than by first post on the date of closing of tenders.

## CONDITIONS OF CONTRACT.

1. The rates tendered cover all charges, including labour, bags, hire of cranes or other appliances, and weighbridge charges required in the performance of the service. Bags must be removed by the contractor when empty, and if not removed within a reasonable time or within the time named by the officer requiring the service, no claim will be entertained for cost of same.

2. No subletting shall be allowed; all work must be carried out by the contractor, and every person engaged in the cartage tendered for in this schedule shall be paid such wages and employed subject to such labour conditions as are or may be determined by any Federal Arbitration Court award or any State Wages Board determination, and a copy of such labour conditions shall be kept conspicuously and continually posted, in legible Roman characters, on the premises of the contractor. Any infringement of this condition, in the opinion of the Treasurer, will subject the contractor, upon report from the Tender Board, to such mulct, not exceeding Fifty pounds (£50), as the Treasurer may direct, and the amount will be deducted from the contractor's account or from the security money; and the Treasurer's decision shall be binding, final, and conclusive as to the fact of infringement and in all other respects.

3. Accounts in all cases shall be rendered *monthly* to the Department requiring the service, and must be supported by weighbridge tickets or railway consignment notes, and in the case of coal, the mine consignment notes. In the event of a weighbridge ticket or consignment notes not being available or obtainable, the weight vouched for by the Department requiring the delivery shall be accepted by the contractor as the weight of the particular consignment. Accounts shall be subject to any deductions for goods lost or damaged whilst in the custody of the contractor.

4. In the event of material forwarded by rail or steamer not being unloaded within reasonable time, and in accordance with the Railway Department or Harbor Trust Regulations relating to same, the contractor shall be held liable for such charges, including cost of demurrage, as may accrue, the amount thereof to be deducted as provided in clause 2.

5. The contractor shall take and make delivery within ordinary working hours. No claims for detention shall be entertained, but should the contractor be subjected to unreasonable delay, the cause of delay, if reported, shall be investigated.

6. The contractor must have an office connected by telephone and within a radius of 6 miles of the Melbourne (Elizabeth-street) Post Office.

7. Four hours will be deemed sufficient notice, and in the event of the contractor failing to perform the service when ordered, and to the satisfaction of the officer requiring same, such service will be performed at his risk and expense, and any extra expense incurred shall be deducted as provided in clause 2. No services performed under this contract shall be deemed to be of a special nature, provided that the contractor be given four hours' notice that his services shall be required, and no increase in the contract rates shall be allowed.

8. The vehicles in which the material is carried must be in thorough working order, and, if required, provided with good waterproof covers. Horses to be perfectly sound, and subject to the approval of the officer requiring the service.

9. The contract shall not be considered broken, infringed, or vitiated by the Government performing the service or arranging for the carrying out of the same otherwise than by the contractor in the event of urgency or emergency.

10. Contractors are not at liberty to transfer their contracts under cover of power of attorney, coupled with an interest or otherwise, and no such transfer will be recognized by the Government.

11. Under no circumstances will a contractor be permitted to abandon his contract. In the event of the contractor failing to carry on the contract, the security money will in that case be absolutely forfeited, and, in addition, the contractor may be held liable for any loss which the Government may sustain in consequence of such failure.

12. A refusal to execute orders, irregularity or delay in delivering the material when required, or failure to produce weighbridge tickets or consignment notes on delivery in accordance with clause 3, or any breach of Railway or Harbor Trust Regulations, will subject the contractor, upon report from the Tender Board, to such mulct as the Treasurer may direct, and the amount may be deducted as provided in clause 2. It will also be in the power of the said Treasurer upon such refusal, irregularity, or delay, to terminate the contract forthwith and declare forfeit the whole or any portion of the security money; and, in addition, the contractor will be disqualified from tendering or holding any future contract or contracts for a period of twelve months from the date of such disqualification.

13. In the event of any dispute arising as to matters or things contained in the contract or schedule the same shall be settled by the Tender Board, and the Board's decision shall be binding, final, and conclusive.

J. G. B. McDONALD,  
Treasurer.

The Treasury,  
Melbourne, 7th May, 1951.

#### TENDERS FOR THE SERVICE, 1951-52.

##### CARTAGE OF GOODS AND PARCELS (METROPOLITAN).

**TENDERS** will be received until Eleven o'clock a.m. on Friday, 1st June, 1951, for the cartage and delivery in the Metropolitan Area of such goods and parcels, with the exceptions set out in clause 1 of the Conditions of Contract, as may be forwarded to and from the various Government Offices and Institutions, Railways, &c., by the Stores and Transport Office, for and on behalf of the Government of Victoria, from 1st July, 1951, to 30th June, 1952, as per Schedule No. 1.

In the event of the contractor carrying out the service to the satisfaction of the Tender Board the contract may, at the option of the Board and with the consent of the contractor, be extended for a further period of twelve months from the 1st July, 1952.

A preliminary deposit of £10, preferably by non-negotiable cheque payable to the order of the Secretary to the Tender Board, must accompany each tender, such deposit to be forfeited in the event of the tenderer withdrawing or attempting to withdraw his tender before notification of acceptance of tender, or in the event of the successful tenderer failing to sign and complete his contract within the period specified. Deposits will be returned to unsuccessful tenderers within thirty days of acceptance of tender, on their application.

Security of £30 will be required either in Commonwealth Treasury Bonds, or approved bank guarantee, fixed deposit receipt, Savings Bank deposit book, or non-negotiable cheque in favour of the Secretary to the Tender Board, as the tenderer may elect.

The security must be completed and the contract signed within five days of acceptance of the tender, failing which the service may be again advertised, or another tender accepted.

Tenderers failing to take up their accepted tenders may be disqualified from tendering or holding any future contract or contracts for a period of twelve months from the date of such disqualification.

Full particulars, forms of tender, &c., may be obtained at the office of the Secretary to the Tender Board, Gisborne-street, Melbourne, C.2.

The lowest or any tender will not necessarily be accepted.

Tenders, enclosed in an envelope, and *having the words "Tender for Cartage"* written thereon, must be deposited in the Tender-box at the Tender Board Offices, Gisborne-street, Melbourne, or, if sent by post, postage must be prepaid, and tenders addressed to the Chairman of the Tender Board, Tender Board Offices, Gisborne-street, Melbourne, C.2, which office they must reach not later than by first post on the date of closing of tenders.

#### CONDITIONS OF CONTRACT.

1. The rates tendered shall be deemed to cover all descriptions of goods and parcels, with the exception of school books from Education Department to Victorian Railways, Melbourne, office and school furniture, officers' furniture and effects, exhibits for show purposes, and such are not included in the contract.

2. No subletting shall be allowed; all work must be carried out by the contractor, and every person engaged in the cartage tendered for in this schedule shall be paid such wages and employed subject to such labour conditions as are or may be determined by any Federal Arbitration Court award or any State Wages Board determination, and a copy of such labour conditions shall be kept conspicuously and continually posted, in legible Roman characters, on the premises of the contractor. Any infringement of this condition, in the opinion of the Treasurer, will subject the contractor, upon report from the Tender Board, to such mulct, not exceeding Fifty pounds (£50), as the Treasurer may direct, and the amount will be deducted from the contractor's account or from the security money; and the Treasurer's decision shall be binding, final, and conclusive as to the fact of infringement and in all other respects.

3. Accounts shall be rendered fortnightly, and shall be subject to any deductions for goods or parcels lost or damaged whilst in the custody of the contractor or for storage or demurrage charges which may accrue through delay or default by the contractor in taking delivery of the goods.

4. No claims for detention shall be entertained, but should the contractor be subjected to unreasonable delay, the cause of delay, if reported, shall be investigated.

5. The contractor must have an office connected by telephone, and within a radius of 6 miles of the Melbourne (Elizabeth-street) Post Office. Thirty minutes will be deemed sufficient notice, and in the event of the contractor failing to supply the vehicles when ordered, and to the satisfaction of the officer requiring his services, such services will be performed at his risk and expense, and the extra expense incurred will be deducted as provided in clause 2.

6. No services performed under these contracts shall be deemed to be of a special nature, provided that the contractor be given 30 minutes' notice that his services shall be required, and no increase in the contract rates shall be permitted.

7. All vehicles in which the goods or parcels are carried must be fitted with good waterproof covers, be in thorough working order and, in general, suitable for requirements.

8. Vehicles as required must call at the Railway Goods Sheds not later than 8.30 a.m. daily, and at the Stores and Transport Office not later than 11 a.m. and 3.30 p.m. on week-days and 10.30 a.m. on Saturdays, for the necessary instructions, and on such other occasions, when notified, without extra payment.

In the event of failure to provide vehicles as and when required, the service will be performed at the contractor's risk and expense and the amount deducted as provided in clause 2.

9. The contract shall not be considered broken, infringed, or vitiated by the Government performing the service or arranging for the carrying out of the same otherwise than by the contractor in the event of urgency or emergency.

10. The contractor is not at liberty to transfer his contract under cover of power of attorney, coupled with an interest or otherwise, and no such transfer will be recognized by the Government.

11. Under no circumstances will the contractor be permitted to abandon his contract. In the event of the contractor failing to carry on the contract, the security money will in that case be absolutely forfeited and, in addition, the contractor may be held liable for any loss which the Government may sustain in consequence of such failure.

12. A refusal to execute orders, irregularity, or delay in delivering the goods or parcels as required, or failure to comply with the requirements of clause 3, or any breach of Railway or Harbor Trust Regulations, will subject the contractor, upon report from the Tender Board, to such mulct as the Treasurer may direct, and the amount may be deducted as provided in clause 2. It will also be in the power of the said Treasurer upon such refusal, irregularity, or delay to terminate the contract forthwith, and declare forfeit the whole or any portion of the security money, and, in addition, the contractor will be disqualified from tendering or holding any future contract or contracts for a period of twelve months from the date of such disqualification.

13. In the event of any dispute arising as to matters or things contained in the contract or schedule the same shall be settled by the Tender Board, and the Board's decision shall be binding, final, and conclusive.

J. G. B. McDONALD,  
Treasurer.

The Treasury,  
Melbourne, 7th May, 1951.

#### TENDERS FOR THE SERVICE, 1951-52.

#### PURCHASE AND REMOVAL OF RAGS.

TENDERS will be received until Eleven o'clock a.m. on Friday, 1st June, 1951, from persons willing to purchase Rags in such quantities as the contractor may be required to remove from the various Mental Hospitals and from the Penal Establishment at Pentridge, from 1st July, 1951, to 30th June, 1952.

Full particulars, forms of tender, and conditions of contract may be obtained at the office of the Secretary to the Tender Board, Gisborne-street, Melbourne, C.2.

The rate tendered must be at per cwt., and for the whole quantity from all of the institutions enumerated in the conditions of contract.

It is necessary that tenderers should possess a Noxious Trade Licence.

A deposit of £10, preferably by non-negotiable cheque payable to the order of the Secretary to the Tender Board, must accompany each tender, and the deposit lodged by the successful tenderer will be retained as security for the due fulfilment of the contract. The

deposit will be forfeited in the event of the tenderer withdrawing or attempting to withdraw his tender before notification of acceptance of same or in the event of the successful tenderer failing to sign and complete his contract within the prescribed period. Deposits will be returned to unsuccessful tenderers within thirty days of acceptance of tenders, on their application.

The contract must be signed within five days of acceptance of the tender, failing which the service may be again advertised or another tender accepted.

Tenderers failing to take up their accepted tenders may be disqualified from tendering or holding any future contract or contracts for a period of two years from the date of such disqualification.

The highest or any tender will not necessarily be accepted.

Tenders, enclosed in an envelope, marked "Tender for Purchase of Rags," must be deposited in the Tender-box at the Tender Board Offices, Gisborne-street, Melbourne, or, if sent by post, postage must be prepaid and tenders addressed to the Chairman of the Tender Board, Tender Board Offices, Gisborne-street, Melbourne, C.2, which office they must reach not later than by first post on the date of closing of tenders.

#### CONDITIONS OF CONTRACT.

1. Delivery of the Rags from Ararat, Ballarat, Beechworth, and Sunbury must be taken at Spencer-street Railway Station, and from Mont Park, Royal Park, Kew, and Pentridge at the respective institutions.

2. Bags which must be returned by the contractor as soon as emptied, will be supplied by the institutions requiring the service.

3. The rags must be removed at such times as may be stated in the order issued to the contractor.

4. The contractor shall bear the cost of removing the rags, and of the return of the empty bags, from and to Spencer-street, Mont Park, Royal Park, Kew, and Pentridge; railway freight from the institutions will be covered by a Stores and Transport consignment note issued by the institution concerned when forwarding the rags.

5. The contractor shall be duly notified of each consignment, and shall bear any cost that may be incurred for demurrage, or for any delay in taking delivery of the rags consigned.

6. In the event of the contractor failing to remove the rags at the times directed, the officer of the Department ordering the removal is hereby empowered to send them to any store in Melbourne, there to be stored at the contractor's risk and expense, and, on report to the Tender Board, the amount will be deducted from the security money or added to any account that may be payable by the contractor.

7. Payment is to be made on the net weight of the rags. No allowance will be made for any foreign material that may be mixed with them. All practical care will, however, be exercised to keep them free from such impurity.

8. The contractor must make payment within one month of delivery to the officer of the Department ordering the removal of the rags. In the event of payment not being made within the prescribed period, the amount outstanding will be deducted from the security money.

9. Under no circumstances will a contractor be permitted to abandon his contract. In the event of the contractor failing to carry on the contract the security money will in that case be absolutely forfeited, and, in addition, the contractor will be held liable for any loss which the Government may sustain in consequence of such failure, and may be disqualified from tendering or holding any future contract or contracts for a period of two years from the date of such disqualification.

10. Contractors are not at liberty to transfer their contracts under cover of power of attorney, coupled with an interest or otherwise, and no such transfer will be recognized by the Government.

J. G. B. McDONALD,  
Treasurer.

The Treasury,  
Melbourne, 7th May, 1951.

## PUBLIC SERVICE NOTICES.

## PUBLIC SERVICE OF VICTORIA.—VACANCIES.

APPLICATIONS will be received by the Public Service Board up to Friday, the 25th May, 1951, from persons employed in the Public Service of Victoria, who are eligible and qualified for appointment to the under-mentioned positions:—

## ADMINISTRATIVE DIVISION.

## Clerk, Class "C," Office of Titles, Department of Law.

*Yearly Salary.*—£475, minimum; £579, maximum.

*Duties.*—To keep in correct order of lodgment all dealings awaiting answers to requisitions and produce same to the public when required; to answer inquiries on requisitions and advise thereon; to check statutory forms of documents lodged to satisfy requisitions; and to be responsible for correct disposal of documents on withdrawal of dealings.

*Qualifications.*—To have a good knowledge of the *Transfer of Land Act 1928* and cognate Acts, and of the practice of the Office of Titles.

## Clerk, Class "C," Chief Clerk's Branch, Department of Water Supply.

*Yearly Salary.*—£475, minimum; £579, maximum.

*Duties.*—To carry out special clerical and other administrative duties as required by the Chairman.

*Qualifications.*—To have a good general knowledge of the Commission's activities, in particular of the Water Acts and Head Office administration; to be capable of drafting correspondence and carrying out special administrative duties. Ability to write shorthand is desirable.

## PROFESSIONAL DIVISION.

## Field Geologist, Class "C1," Department of Mines.

*Yearly Salary.*—£605, minimum; £657, maximum.

*Duties.*—To conduct geological and topographical surveys and to prepare reports thereon.

*Qualifications.*—To hold a University Degree with geology as a major subject; to have had experience in geological survey work, in the preparation of plans and reports, and in the investigation of mineral deposits.

## Surveyor, Class "C," Survey Branch, Department of Water Supply. (Two vacancies.)

*Yearly Salary.*—£475, minimum; £579, maximum.

*Duties.*—To organize and supervise water supply surveys; to effect title surveys in accordance with Regulations under the *Transfer of Land Act*, and to carry out general engineering surveys in connexion with investigation of reservoir sites and foundations, and of channel systems and other water supply undertakings.

*Qualifications.*—To be a licensed surveyor.

## Draughtsman, Class "D," Survey Branch, Department of Water Supply.

*Yearly Salary.*—£338, minimum; £436, maximum.

*Duties.*—To prepare compilation of maps and plans for record and reproduction, including the preparing of mosaics of air photographs.

*Qualifications.*—

(1) to have passed—

(a) the School Leaving Examination, including English, Mathematics I., and Mathematics II.,

or

(b) the School Intermediate Examination, and in addition, School Leaving English, Mathematics I., and Mathematics II.,

or

(c) an equivalent Technical School examination; and

(2) To be experienced in the type of work outlined in the duties.

## TECHNICAL AND GENERAL DIVISION.

## Works Superintendent, Frankston Centre, Department of Water Supply.

*Yearly Salary.*—£514, minimum; £586, maximum.

*Duties.*—To set out and supervise the construction of all pipe lines within the urban districts, and supervise the maintenance of reticulation mains; to supervise the work of foremen, gangers, and workmen engaged on such works, and finalize extension plans for gazettal purposes.

*Qualifications.*—Ability to handle large numbers of men and supervise the construction and maintenance of reticulation mains, main pipe lines, reservoirs and service basins, and direct the work of foremen and gangers—to have a thorough knowledge of the various awards and conditions under which the men are employed; also of the Commission's cost accounting relating to stores and wages; to be capable of using a surveyor's level and theodolite for setting out work, and to have a thorough knowledge of construction of all types of pipe lines and be familiar with all pipe fittings.

## Photographer, Grade I., Department of Crown Lands and Survey.

*Yearly Salary.*—£475, minimum; £514, maximum.

*Duties.*—Under the direction of the Senior Photographer to supervise the work of the aerial photography section. To prepare rectified aerial photographs, enlargements, and diapositives for photogrammetric purposes. To photograph maps, plans, documents, and original subjects, and prepare bromide prints and enlargements. To carry out other photographic work and train juniors, as required.

*Qualifications.*—To be a competent photographer with a thorough knowledge of and experience in all branches of photography, and be especially skilled in the reproduction of aerial photographs, mosaics, and the rectification of aerial photographs by use of the Wild E2 rectifier and the Wild reduction printer. To have the ability to control staff.

## Health Inspector, General Health Branch, Department of Health.

*Yearly Salary.*—£423, minimum; £501, maximum.

*Duties.*—To carry out the duties imposed or conferred by the Health Acts, and any lawful direction of the Commission of Public Health, Chief Health Officer, and District Health Officer; to conduct legal proceedings when so authorized by the Commission of Public Health.

*Qualifications.*—To possess the Certificate of Competency, as a sanitary inspector issued by the Royal Sanitary Institute, London, or one equivalent thereto; to have a good knowledge of the *Health Act 1928*, amendments thereto, and the Regulations thereunder. A certificate of competency as a meat inspector under the Health Acts, Victoria, is desirable.

## Photographer, Grade II., Department of Crown Lands and Survey.

*Yearly Salary.*—£410, minimum; £462, maximum.

*Duties.*—To carry out all types of photographic work, particularly the accurate copying of maps, plans, and diagrams by the wet plate process. To print down on lithographic metal plates for offset or direct printing, and assist in the training of juniors.

*Qualifications.*—To be a competent photographer with a thorough knowledge of all branches of photography and be especially skilled in the wet plate process and printing down on lithographic metal plates. To be conversant with the use of lineal scales for the purposes of reduction or enlargement.

**Assistant (Male). Grade II., Children's Welfare Branch, Department of Chief Secretary.**

*Yearly Salary.*—Junior—According to age.  
Adult—£325, minimum; £390, maximum

*Duties.*—To have charge of records of payments due to assisted mothers, foster mothers, and to institutions in respect of State wards, to record transactions concerning the Suspense Account, to receive moneys paid to the office and issue receipts therefor, and to perform other clerical duties as directed.

*Qualifications.*—To have had experience in clerical work, to possess high capacity for accuracy, neatness, and expedition in the performance of the duties. A knowledge of the work of the branch is desirable.

**Crier, Sheriff's Office. Department of Law.**

*Yearly Salary.*—£299, minimum; £364, maximum.

*Duties and Qualifications.*—To attend in Court; to have a knowledge of the different oaths used in connexion with the business of the Court and to administer the same; to clean the Court and to carry out the instructions of the presiding Judge.

**Shorthand Writer and Typist (Female), Senior, Department of Water Supply.**

*Yearly Salary.*—£338, minimum; £351, maximum.

*Duties.*—To carry out the duties of typist and stenographer, and to supervise the work of other typists; to report deputations when required.

*Qualifications.*—To be a competent typist with a shorthand speed of 120 words a minute; to possess ability to set out reports, and to be capable of organizing and controlling the work of other typists.

**General Assistant, Mental Hospital, Mont Park, Mental Hygiene Branch, Department of Health.**

*Yearly Salary.*—£312, minimum; £338, maximum.

*Duties.*—To give general assistance in the various artisan activities associated with the hospital services and maintenance.

*Qualifications.*—To be a semi-skilled worker in good physical condition, and to possess average intelligence. Knowledge of some trade is desirable.

**Shorthand Writer and Typist (Female), Grade II., Office of the Chief Commissioner of Police, Department of Chief Secretary.**

*Yearly Salary.*—£299, minimum; £312, maximum.

*Duties.*—To act as shorthand writer and typist for the senior administrative officers of the Department.

*Qualifications.*—To be a competent shorthand writer and typist, and sufficiently experienced to be able to allocate and supervise the work of the typing staff.

**Typist (Female), Grade I., Motor Registration Branch, Office of the Chief Commissioner of Police, Department of Chief Secretary.**

*Yearly Salary.*—Junior—At 16 years of age, £143; at 17 years, £156; at 18 years, £169; at 19 years, £208; at 20 years, £234.

Adult—£260, minimum; £286, maximum.

*Duties.*—To type certificates for motor vehicle registrations, driving licences, and forms for balance payments, duplicate plates and labels.

*Qualifications.*—To be a competent typist; to possess a good knowledge of the procedure in the Mail and Assessment Sections, and to be conversant with the Motor Car and Motor Car (Third-Party Insurance) Acts.

**Labourer, Office of Titles, Department of Law.**

*Salary.*—£286 a year.

*NOTE.*—In addition to the salary rates quoted, a cost of living adjustment (£234 a year for adult males, £175 10s. a year for adult females, and £117 a year for minors), which varies in accordance with the rise or fall in the index number of the cost of living, is payable.

By order,

E. F. FITZGIBBON,  
Secretary.

Office of the Public Service Board,  
Melbourne, 10th May, 1951.

No. 71.

*Public Service Act 1946, Section 50.*

REGULATIONS—PART III.—SALARIES, INCREMENTS, AND ALLOWANCES.

THE Public Service Board, in pursuance of the powers conferred by the *Public Service Act 1946*, hereby amends its Regulations as shown below:—

SECOND SCHEDULE.

TECHNICAL AND GENERAL DIVISION.

*Offices and Rates of Salaries.*

Department and Office.	Yearly Rate of Salary.		Increments (Annual).
	Minimum.	Maximum.	
	£	£	
DEPARTMENT OF TREASURER.			
<i>Delete</i> — Customs Officer, Tender Board Office .. .. .	449	475	1 of £26
<i>Add</i> — Customs Officer, Tender Board Office .. .. .	475	553	3 of £26
STAMP DUTIES.			
<i>Delete</i> — Examiner, Embossing, Assistant	312	377	3 of £13 and 1 of £26
Machineman .. .. .	312	377	3 of £13 and 1 of £26
<i>Add</i> — Examiner, Embossing, Assistant	325	390	2 of £13, 1 of £26, and 1 of £13
Machineman .. .. .	325	390	2 of £13, 1 of £26, and 1 of £13
DEPARTMENT OF LAW.			
<i>Delete</i> — Searcher, Senior, Office of Titles	390	416	1 of £26
Searcher, Office of Titles .. .. .	312	377	3 of £13 and 1 of £26
<i>Add</i> — Searcher, Senior, Office of Titles	..	416	..
Searcher, Office of Titles .. .. .	325	390	2 of £13, 1 of £26, and 1 of £13

*This Regulation shall have effect as on and from the 29th April, 1951.*

D. D. PAINE, Chairman.  
E. F. FITZGIBBON, Secretary.

Office of the Public Service Board,  
Melbourne, 23rd April, 1951.

No. 72.

Public Service Act 1946, Section 50.

REGULATIONS—PART III.—SALARIES, INCREMENTS, AND ALLOWANCES.

THE Public Service Board, in pursuance of the powers conferred by the Public Service Act 1946, hereby amends its Regulations as shown below:—

SIXTH SCHEDULE.  
TEMPORARY EMPLOYEES.

Designations of Positions and Rates of Salaries.

Department and Designation of Position.	Yearly Rate of Salary.		Increments (Annual).
	Minimum.	Maximum.	
	£	£	
DEPARTMENT OF WATER SUPPLY.			
<i>Add—</i>			
Research Officer, Junior*—			
At 19 years of age .. .. .	..	364	..
At 20 years of age .. .. .	..	390	..
Adult .. .. .	436	462	1 of £26
<i>Delete—</i>			
Draughtsman, Assistant (Designing)†—			
At 19 years of age .. .. .	..	364	..
At 20 years of age .. .. .	..	390	..
Adult .. .. .	436	462	1 of £26
<i>Add—</i>			
Draughtsman, Assistant (Designing)‡—			
At 19 years of age .. .. .	..	364	..
At 20 years of age .. .. .	..	390	..
Adult .. .. .	436	462	1 of £26

\* To apply to employees qualified by examination to receive a Diploma in Applied Chemistry.  
† Rates are applicable only to graduates of Technical Schools with a Diploma in Civil Engineering.  
‡ To apply to employees qualified by examination to receive a Diploma in Civil Engineering.

This Regulation shall have effect as on and from the 19th March, 1951.

D. D. PAINE, Chairman.  
E. F. FITZGIBBON, Secretary.

Office of the Public Service Board,  
Melbourne, 23rd April, 1951.

No. 70.

Public Service Act 1946, Section 50.

REGULATIONS—PART III.—SALARIES, INCREMENTS, AND ALLOWANCES.

THE Public Service Board, in pursuance of the powers conferred by the Public Service Act 1946, hereby amends its Regulations as shown below:—

SECOND SCHEDULE.  
TECHNICAL AND GENERAL DIVISION.  
Offices and Rates of Salaries.

Department and Office.	Yearly Rate of Salary.		Increments (Annual).
	Minimum.	Maximum.	
	£	£	
DEPARTMENT OF WATER SUPPLY.			
<i>Delete—</i>			
Works Superintendent .. .. .	488	553	2 of £26 and 1 of £13
Works Supervisor .. .. .	429	481	2 of £26
<i>Add—</i>			
Works Superintendent .. .. .	514	586	2 of £26 and 1 of £20
Works Supervisor .. .. .	481	533	2 of £26

This Regulation shall have effect as on and from the 29th April, 1951.

D. D. PAINE, Chairman.  
E. F. FITZGIBBON, Secretary.

Office of the Public Service Board,  
Melbourne, 26th April, 1951.

No. 77.

Public Service Act 1946, Section 50.

REGULATIONS—PART III.—SALARIES, INCREMENTS, AND ALLOWANCES.

THE Public Service Board, in pursuance of the powers conferred by the Public Service Act 1946, hereby amends its Regulations as shown below:—

SEVENTH SCHEDULE.

TECHNICAL AND GENERAL DIVISION.

Department of Health—Mental Hygiene.

In the footnote commencing "Note.—When an officer is required" delete the amount "£62" and insert the amount "£74" in lieu thereof.

Delete the whole of the footnote headed—

"Salaries of Officers Residing in Separate Quarters in the Reserves of the Various Mental Institutions."

Add—

"Salaries of Officers Residing in Separate Quarters in the Reserves of the Various Mental Institutions."

Deductions will be made from the salaries of these officers in accordance with the Schedule hereunder:—

- Rent—As fixed.
- Fuel—£20 a year.
- Light—£9 a year.
- Water—£2 a year.
- Vegetables—£17 a year.
- Milk—£7 a year.
- Laundry—£12 a year.

The Chief Nurses and Housekeepers will be charged £74 a year for rations and allowances other than quarters.

Rent for quarters will be charged as under:—

- For quarters occupied by—
- Head Attendants—£20 a year.
- Farm Managers—£20 a year.
- Mechanics—£20 a year.
- Engineers—£20 a year.
- Curator of Gardens—£20 a year.
- Gardeners—£20 a year.
- Chief Nurses—£16 a year.
- Housekeepers—£16 a year.

Officers who are allowed quarters for themselves only and rations:—

Deductions will be made from the salaries of these officers as under—

- Rent and allowances—£20 a year.
- Rations—£54 a year.

Officers who are not supplied with quarters will be charged £39 a year for meals provided in an institution."

This Regulation shall have effect as on and from the 13th May, 1951.

D. D. PAINE, Chairman.  
E. F. FITZGIBBON, Secretary.

Office of the Public Service Board,  
Melbourne, 8th May, 1951.

No. 73.

Public Service Act 1946, Section 50.

REGULATIONS—PART III.—SALARIES, INCREMENTS, AND ALLOWANCES.

THE Public Service Board, in pursuance of the powers conferred by the Public Service Act 1946, hereby amends its Regulations as shown below:—

SECOND SCHEDULE.

TECHNICAL AND GENERAL DIVISION.

Offices and Rates of Salaries.

Department and Office.	Yearly Rate of Salary.		Increments (Annual).
	Minimum.	Maximum.	
	£	£	
DEPARTMENT OF AGRICULTURE.			
<i>Delete—</i>			
Technical Inspector, Grade I.	501	579	3 of £26
<i>Add—</i>			
Technical Inspector, Grade I.	501	605	4 of £26

D. D. PAINE, Chairman.  
E. F. FITZGIBBON, Secretary.

Office of the Public Service Board,  
Melbourne, 30th April, 1951.



No. 69.

*Public Service Act 1946, Section 39.*REGULATIONS—PART III.—SALARIES, INCREMENTS,  
AND ALLOWANCES.

THE Public Service Board, in pursuance of the powers conferred, by the *Public Service Act 1946*, hereby amends its Regulations as shown below :—

FIRST SCHEDULE.  
PROFESSIONAL DIVISION.  
*Offices and Rates of Salaries.*

Office.	Yearly Rate of Salary.	
	Minimum.	Maximum.
DEPARTMENT OF WATER SUPPLY. CLASS "C1."	£	£
<i>Add—</i> Supervising Instructor (Plant) .. ..	605	657

D. D. PAINE, Chairman.  
E. F. FITZGIBBON, Secretary.

Office of the Public Service Board,  
Melbourne, 23rd April, 1951.

No. 68.

*Public Service Act 1946, Section 50.*REGULATIONS—PART III.—SALARIES, INCREMENTS,  
AND ALLOWANCES.

THE Public Service Board, in pursuance of the powers conferred by the *Public Service Act 1946*, hereby amends its Regulations as shown below :—

SECOND SCHEDULE.  
TECHNICAL AND GENERAL DIVISION.  
*Offices and Rates of Salaries.*

Department and Office.	Yearly Rate of Salary.		Increments (Annual).
	Minimum.	Maximum.	
DEPARTMENT OF WATER SUPPLY.	£	£	
<i>Delete—</i> Supervising Instructor (Plant)	553	605	2 of £26

D. D. PAINE, Chairman.  
E. F. FITZGIBBON, Secretary.

Office of the Public Service Board,  
Melbourne, 23rd April, 1951.

## PUBLIC SERVICE (PUBLIC SERVICE BOARD) REGULATION 39.—VACANCY.

THE Permanent Head of the Department shown has recommended the officer named hereunder for appointment to the under-mentioned vacancy.

Office and Classification.	Duties.	Qualifications.	Officer Recommended for Appointment.		
			Name.	Classification.	Date of Classification.

## TECHNICAL AND GENERAL DIVISION.

## DEPARTMENT OF HEALTH.

*General Health Branch.*

District Health Inspector	To carry out, under the direction of the District Health Officer, any duty imposed or conferred by the Health Acts or other Acts administered by the Department. The successful applicant will be required to do duty in the country	To possess the Certificate of Competency as a Health Inspector granted by the Royal Sanitary Institute, London, and the Meat Inspector's Certificate of Competency granted by the Commission of Public Health; to have had approved experience as a Health Inspector under the Health Acts	Lyall, D. L.	Health Inspector	24.11.49
---------------------------	--	--	--------------	------------------	----------

Appeals against such recommendation should be lodged with the Secretary to the Public Service Board not later than Monday, the 21st May, 1951.

Office of the Public Service Board,  
Melbourne, 10th May, 1951.

By order,  
E. F. FITZGIBBON,  
Secretary.

## PUBLIC SERVICE (PUBLIC SERVICE BOARD) REGULATION 39.—VACANCY.

NOTIFICATION is hereby given that the Permanent Head, Department of Water Supply, has recommended to the Public Service Board that the under-mentioned vacancy, Professional Division, Department of Water Supply, be filled by the employee named hereunder.

Office and Classification.	Duties.	Qualifications.	Name.	Designation.	Date of Appointment.
Assistant Geologist, Class "C"	To carry out, under direction, the field work associated with the geological examination of sites for water supply dams, and to prepare plans showing geological features; to identify rock and other strata and carry out the necessary laboratory work associated with rock and clay mineral classification; to make comprehensive surveys of underground water resources and to investigate subsoil conditions affecting drainage problems in irrigation districts	To possess a University Degree in Science, specializing in Geology, or other approved geological qualification, and to have had experience in geological surveys preferably in connexion with engineering works	Threader, V. M.	Assistant Geologist	24.4.50

Appeals against such recommendation should be lodged with the Secretary to the Public Service Board not later than Monday, the 21st May, 1951.

Office of the Public Service Board,  
Melbourne, 10th May, 1951.

By order,  
E. F. FITZGIBBON,  
Secretary.

PUBLIC SERVICE (PUBLIC SERVICE BOARD) REGULATION 39—RECLASSIFICATIONS.

THE Public Service Board has raised the classification of the under-mentioned offices as shown, and the Permanent Heads of the Departments have recommended the officers named for appointment.

Office and Present Classification.	Revised Classification.	Duties.	Qualifications.	Officer Recommended for Appointment.		
				Name.	Classification.	Date of Classification.

ADMINISTRATIVE DIVISION.

DEPARTMENT OF CHIEF SECRETARY.

*Licences Reduction Board.*

Clerk, Class "C1"	Class "C2"	To act as Clerk of the Licensing Court; to prepare all business for hearing by the Licensing Court and Licences Reduction Board; to carry out the duties of the Registrar and Accountant during his absence	To have a thorough knowledge of the Licensing Act and rules and regulations thereunder, the Justices Act so far as it relates to proceedings in Licensing Courts, the practice and procedure of the Licensing Court and Licences Reduction Board, the practice and procedure in dealing with petitions and the taking of polls under the Licensing Act, and a practical knowledge of keeping books and the accounts of the Licences Reduction Board	McAllister, W. E.	Clerk, Class "C1"	26.4.49
-------------------	------------	---	---	-------------------	-------------------	---------

PROFESSIONAL DIVISION.

DEPARTMENT OF CROWN LANDS AND SURVEY.

Superintending Draughtsman, Class "B1" (two offices)	Class "A" (£1,000-£1,050) (two offices)	To supervise the compilation and examination of plans for reproduction, the preparation of reports concerning reservations, the mapping in connexion with the "Central Planning Authority", the preparation of technical descriptions and maps for "Electoral re-distributions" and the effecting of "Forest exchanges"	To be a competent survey draughtsman experienced in the compilation of plans and their preparation for reproduction, with a thorough knowledge of the computations involved therein and to have a good working knowledge of the Acts relating to land survey and tenure; to possess the personal qualities necessary for the supervision and control of staff	Dunn, R. S. . .	Superintending Draughtsman, Class "B1"	8.11.48
		To supervise the examination of Surveyors' plans and field notes, the preparation of certified plans, certificates of adjustment and survey information and to furnish reports to the Surveyor-General regarding cases submitted for his consent	To be a competent Survey Draughtsman with a thorough knowledge of field practice and the preparation of survey plans and field notes, and of all branches of mathematics applicable to surveys; to be conversant with survey regulations and the Acts relating to land survey and tenure; to possess the personal qualities necessary for the supervision and control of staff	Jones, J. B. . .	Superintending Draughtsman, Class "B1"	8.11.48
Officer in Charge, Central Plan Office, Class "B1"	Superintending Draughtsman, Class "A", (£1,000-£1,050)	To supervise the work of the Central Plan Office and Central Photographic Laboratory including lithographic process work; to advise surveyors as to the placement of permanent marks and the connexions of surveys, and to assist the Assistant Surveyor-General in the work of Survey Co-ordination	To be a competent Survey Draughtsman experienced in the compilation of all types of survey maps and plans and with a thorough knowledge of the various processes involved in map and plan reproduction; to have a good working knowledge of the Acts relating to land survey and tenure and in particular of the Survey Co-ordination Act; to possess the personal qualities necessary for the supervision and control of staff	Staveley, C. C.	Officer in Charge, Central Plan Office, Class "B1"	8.11.48

DEPARTMENT OF PUBLIC WORKS.

Senior Draughtswoman, Class "C"	Class "C1"	To prepare preliminary sketches, contract plans, details and specifications of modern buildings	To be a suitably qualified and experienced draughtswoman, competent to prepare working drawings, details and specifications for departmental structures	Ingpen, E. C.	Senior Draughtswoman, Class "C"	31.10.48
---------------------------------	------------	---	---	---------------	---------------------------------	----------

PUBLIC SERVICE (PUBLIC SERVICE BOARD) REGULATION 39.—RECLASSIFICATIONS—*continued.*

Office and Present Classification.	Revised Classification.	Duties.	Qualifications.	Officer Recommended for Appointment.		
				Name.	Classification.	Date of Classification.
PROFESSIONAL DIVISION— <i>continued.</i>						
DEPARTMENT OF AGRICULTURE.						
Poultry Instructor, Longerenong Agricultural College, Class "D"	Class "C"	Under the direction of the Principal to take charge of the Poultry Branch and be responsible for its management; to keep records and furnish reports relating to the Branch and to the work of the students; to deliver lectures and give demonstrations to students; to examine students, and to share house duties	Diploma, preferably with Honours, of a recognized agricultural college; proved ability and experience in the management of a poultry farm; experience in teaching and demonstrating in the principles and practice of poultry management	Harbison, H. S. J.	Poultry Instructor, Longerenong Agricultural College, Class "D"	21.4.47

Appeals against such recommendations should be lodged with the Secretary to the Public Service Board not later than Monday, the 21st May, 1951.

By order,

E. F. FITZGIBBON,  
Secretary.

Office of the Public Service Board,  
Melbourne, 10th May, 1951.

PRIVATE ADVERTISEMENTS.

I, FRANCIS ANTHONY LORIA (heretofore named Francis Anthony Tully), of care of Messrs. Douglas and Henry, builders, Rountree-street, Hamilton, in the State of Victoria, plasterer, hereby give public notice that, on the 1st day of February, 1940, I formally and absolutely renounced, relinquished, and abandoned the use of the said surname of Tully and determined thenceforth on all occasions whatsoever to use and subscribe the surname of Loria instead of the surname of Tully. And I give further notice that by a deed poll dated the 16th day of April, 1951, duly executed, attested, and filed in the office of the Registrar-General of the said State, I formally and absolutely renounced the said surname of Tully and declared that I had assumed and adopted and intended thenceforth on all occasions whatsoever to use and substitute the surname of Loria instead of the surname of Tully so as to be at all times thereafter called, known, and described by the name of Francis Anthony Loria absolutely.

Dated the 30th day of April, 1951.

F. A. LORIA.  
Palmer, Plummer, and Miller, solicitors, Hamilton. 6817

NOTICE is hereby given that the Ballarat Golf Club has applied for a lease under section 125, *Land Act 1928*, for a term of 20 years for allotments 8, 9, and 10, section 11, in the Parish of Cardigan, containing 112 acres 2 roods 34 perches, as a site for amusement and recreation. 6886

NOTICE OF INTENTION TO APPLY FOR A LICENCE TO DIVERT WATER AND CUT RACES FROM THE MURRAY RIVER AT TORRUMBARRY.

I HEREBY give notice that I intend to apply for a licence empowering me to divert water for a term of fifteen years to the extent of 240 acre-feet per annum at a maximum rate of 10 acre-feet per day of 24 hours for irrigation of 80 acres, being part of allotments 46 and 48, section D, and Parish of Patho, and to occupy certain Crown lands for works of storage and diversion, and to cut a race thereon.

Any objection to such application must be forwarded, in writing, to the State Rivers and Water Supply Commission, Melbourne, within 30 days of the date hereof.

WILLIAM O'HALLORAN.

Torrumbarry, 2nd May, 1951.  
Stewart, Sons, and Donohue, Echuca. 6848

NOTICE OF INTENTION TO APPLY FOR A LICENCE TO DIVERT WATER AND CUT RACES FROM THE MURRAY RIVER AT PIANGIL.

I HEREBY give notice that I intend to apply for a licence empowering me to divert water for a term of fifteen years to the extent of 120 acre-feet per annum at a maximum rate of 19 acre-feet per day of 24 hours for irrigation of 60 acres, being part of allotment 123 and Parish of Piangil, and to occupy certain Crown lands for works of storage and diversion, and to cut a race thereon.

Any objection to such application must be forwarded, in writing, to the State Rivers and Water Supply Commission, Melbourne, within 30 days of the date hereof.

ALAN WILFRED DUNSTONE.

Piangil, 8th May, 1951.  
Garden and Green, solicitors, Nyahwest. 6845

NOTICE OF INTENTION TO APPLY FOR A LICENCE TO DIVERT WATER AND CUT RACES FROM THE LODDON RIVER AT BRIDGEWATER.

I HEREBY give notice that I intend to apply for a licence empowering me to divert water for a term of fifteen years, to the extent of 40 acre-feet per annum at a maximum rate of 6 acre-feet per day of 24 hours, for irrigation of 20 acres, being part of allotment 128A, Parish of Derby, and to occupy certain Crown lands for works of storage and diversion, and to cut a race thereon.

Any objection to such application must be forwarded, in writing, to the State Rivers and Water Supply Commission, Melbourne, within 30 days of the date hereof.

EDWARD PATRICK BROWN.

Bridgewater, 12th April, 1951. 6819

NOTICE OF INTENTION TO APPLY FOR A LICENCE TO DIVERT WATER AND CUT RACES FROM THE MURRAY RIVER AT COLIGNAN.

I HEREBY give notice that I intend to apply for a licence empowering me to divert water for a term of fifteen years, to the extent of 100 acre-feet per annum at a maximum rate of 2 acre-feet per day of 24 hours, for irrigation of 50 acres, being part of allotment 7, Parish of Colignan, and to occupy certain Crown lands for works of storage and diversion, and to cut a race thereon.

Any objection to such application must be forwarded, in writing, to the State Rivers and Water Supply Commission, Melbourne, within 30 days of the date hereof.

JOHN ROWLAND POLLOCK.

Care of F. R. Pollock, Box 465, Red Cliffs, Victoria, 1st May, 1951. 6815

CITY OF BALLAARAT.

BY-LAW No. 130.

A By-law of the City of Ballaarat, made under the provisions of the Local Government Acts, and numbered 130, for the purpose of amending and altering By-law No. 107 of the said city, being a By-law for controlling, managing, and preserving the public reserve known as Lake Wendouree, and for other purposes as therein provided.

IN pursuance of the powers conferred by the Local Government Acts and every other power it thereto enabling, the Mayor, Councillors, and Citizens of the City of Ballaarat order as follows:—

1. This By-law shall be read and construed as one with By-law No. 107 of the City of Ballaarat and any By-law amending the same.

2. In clause 25 of By-law No. 107 after the words "and every such licence shall terminate on the 31st day of December next following the issue thereof" there shall be inserted the words "unless sooner terminated, suspended, or cancelled as hereinafter provided."

3. After clause 31 of By-law No. 107 the following clause shall be inserted:—

*Power of Council to Terminate, Cancel, or Suspend Private Motor Boat Licences.*

31. (a) The Council shall have the right to terminate, cancel, or suspend at any time on 24 hours' notice in writing any licence issued by it in respect of any motor boat for private use and on any such termination, cancellation, or suspension it shall refund to the owner any licence fee which he shall have paid in respect of such motor boat.

4. No person shall upon Lake Wendouree drive or use any motor boat licensed for private use or for hire or for carrying passengers for hire—

(a) recklessly or negligently or in a manner which is dangerous to any boats or persons using the lake;

(b) at a speed exceeding 15 miles per hour;

(c) in such a way to make or produce noise to an extent calculated to annoy, or to interfere with the comfort and enjoyment of the public using the lake area, or the Botanical and Public Gardens Reserve, or the occupiers of homes fronting on Wendouree-parade or situate in the vicinity of the lake area.

5. Nothing in this By-law contained shall be deemed to prevent the Council exercising a discretionary power to permit of the use of motor boats as regards speed and noise on occasions of regattas, aquatic carnivals, and speed boat racing on the lake approved of and consented to by the Council.

6. In Schedule 4, after the form of licence therein set out there shall be inserted the following form:—

CITY OF BALLAARAT.

Form "B."

Private Boat Licence.

No. \_\_\_\_\_ 19 \_\_\_\_\_  
 The Council of the City of Ballaarat hereby licences the private boat No. \_\_\_\_\_ in the name of Mr. \_\_\_\_\_ of \_\_\_\_\_ street, Ballaarat, for use as a private boat on Lake Wendouree for the year ending 31st day of December, 19 \_\_\_\_\_, subject to the provisions of By-law 107 and any By-law amending the same.  
 Description of boat:  
 Length: \_\_\_\_\_  
 Breadth: \_\_\_\_\_  
 Colour: \_\_\_\_\_  
 Type of motor (if any): \_\_\_\_\_  
 Fee: 5s. \_\_\_\_\_, Town Clerk.

Note.—The Council reserves the right to terminate, cancel, or suspend on 24 hours' notice at any time any licence issued by it in respect of any motor boat.

Resolution for passing this By-law agreed to by the Council of the City of Ballaarat on the 2nd day of April, 1951.

Confirmed by the Council of the City of Ballaarat, on the 30th day of April, 1951.

The common seal of the corporation, styled the Mayor, Councillors, and Citizens of the City of Ballaarat, was affixed hereto, in the presence of—

(SEAL) JOHN C. ROWE, Mayor.  
 E. G. SAVAGE, Councillor.  
 H. R. MADDERN, Town Clerk.

CITY OF BRIGHTON.

BY-LAW No. 119.

A By-law of the City of Brighton, made under the provisions of the Local Government Acts and every other power thereunto it enabling, and numbered 119, for altering and amending By-law No. 113 of the said City of Brighton.

IN pursuance of the powers conferred by the Local Government Acts and the Uniform Building Regulations, Victoria, and every other power in that behalf enabling it, the Mayor, Councillors, and Citizens of the City of Brighton, with the approval of the Governor in Council, order as follows:—

1. That on and after the coming into force of this By-law it shall form part of and be read as one with By-law No. 113.

2. Clause 503, section 5 of By-law No. 113 is hereby amended by adding after the words "The whole of the municipal district" the words "Save and except that part of the municipal district bounded as follows:—On the west by the eastern building line of The Esplanade, on the north by the southern building line of Canterbury-place, on the east by the western boundary of the railway land and on the south by the northern building line of South-road."

The Resolution for making and passing this By-law was agreed to by the Council at its meeting on the 5th day of February, 1951, and confirmed the 5th day of March, 1951.

The common seal of the Mayor, Councillors, and Citizens of the City of Brighton was hereto affixed in the presence of—

(SEAL) R. H. WALLMAN, Mayor.  
 D. GRANTER, Councillor.  
 H. C. FERGUSON, Town Clerk.

Approved by the Governor in Council, the 10th day of April, 1951.—A. MAHLSTEDT, Clerk of the Executive Council. 6854

CITY OF ESSENDON.

BY-LAW No. 112.

A By-law made under section 80 of the *Health Act* 1928, and numbered 112, for the purpose of regulating and prohibiting of the keeping in any place of any animals (including birds) or the storage of any things, in the opinion of the Council, offensive, injurious to health, or dangerous.

IN pursuance of the powers conferred by section 80 of the *Health Act* 1928 and of any other Act or power enabling it in that behalf, the Mayor, Councillors, and Citizens of the City of Essendon doth hereby order as follows:—

1. Throughout this By-law, unless inconsistent with the context or subject matter—

"City" shall mean the City of Essendon.

"Council" shall mean the Council of the City of Essendon.

"Inspector" shall mean the Inspector of Health of the City of Essendon, or person authorized by the Council to act under Health Acts.

"Animal" shall mean and include every animal other than an animal described as a domestic animal.

"Domestic Animal" shall mean and include the sheep, dog, cat, ferret, goat.

"Bird" shall mean and include every bird other than a bird described as a domestic bird.

"Domestic Bird" shall mean and include turkey, goose, duck, fowl, pigeon, and the young of each, and song birds.

"Property" shall include any tenement or land in separate occupation.

"Dwelling house, dwelling, or building" shall include a living room, sleepout, tent, or building used for business purposes.

Words importing the masculine gender shall include the feminine, and words in the singular shall include the plural, and words in the plural shall include the singular, and words relating to animal, domestic animals, birds, and domestic birds shall also include the young of each, and words relating to persons shall include corporations.

2. No person shall keep, or cause or permit to be kept any animal or bird, other than domestic animals or domestic birds, on any property without the written permission of the Council. Before granting such permission, the Council shall satisfy itself that the accommodation provided for the housing of same is adequate and not offensive or injurious to health.

3. No person shall keep, or cause, or permit to be kept on any property more than two of any one kind of domestic animal.

4. No person shall keep, or cause, or permit to be kept on any property any domestic animal, other than a dog or cat, so that the same will be within 40 feet of any dwelling.

5. (a) No person shall keep or permit to be kept on any property any ducks or geese without the written permission of the Council.

(b) No person shall keep or permit to be kept on any property more than twenty adult domestic birds without the written consent of the Council.

6. No person shall keep, or cause, or permit to be kept any domestic birds, other than song birds, except in yards or runs having an area of not less than 200 square feet, provided that if more than ten head of birds are kept at any one time, then for every five head in excess of such number there shall be an additional space of 100 square feet, but nothing in this clause contained shall be interpreted to mean that more than twenty adult birds may be kept on any property unless with the written permission of the Council.

Provided further that such yard or run shall be securely fenced with a fowl-proof fence, and shall be kept in a clean, wholesome, and sanitary state.

Every part of such yard or run shall be a clear 40 feet from any dwelling house, and the Council may, upon 21 days' notice to the occupier of any property on which is situated such yard or run, require such occupier to remove or alter such yard or run so that no part thereof shall be within 40 feet of any dwelling house as aforesaid, and such yard or run shall be at least 100 feet distant from the street on which the land upon which such yard or run is situated abuts as a frontage, and shall be at least 30 feet distant from any side street in which such land abuts, and is at least 10 feet distant from any other boundary of such land.

7. No domestic bird, other than song birds, shall be kept in any house, yard, or shelter unless such house, yard, or shelter complies with the following requirements:—

(a) It is at least 40 feet distant from any dwelling house erected on the land on which it is situated or any other land.

(b) It is at least 100 feet distant from the street on which the land on which it is situated abuts as a frontage, and is at least 30 feet distant from any side street on which such land abuts, and is at least 10 feet distant from any boundary of such land.

(c) Any such house or shelter is constructed of iron, and does not exceed 7 feet in height, and is of a standard approved by the City Engineer or Inspector of the City of Essendon.

(d) The total superficial area of such building is not to exceed 100 square feet.

(e) No person shall keep poultry on any land unless such land contains a dwelling house.

8. In clauses 6 and 7 of this By-law, where land is situated at the corner of two streets the word "frontage" therein used shall mean the shorter of the frontages to such streets, and where the land abuts at the front and rear thereof on streets at least 40 feet wide then such house, shelter, yard, or run, as mentioned therein, shall be at least 70 feet distant from the street to which such land fronts, and 40 feet distant from the rear street.

9. The occupier of any property on which any animal or bird or domestic animal or domestic bird is kept or housed shall cause the place of keeping to be thoroughly cleansed from time to time as often as may be necessary for the purpose of keeping such place in a clean and sanitary state and condition, with particular attention to drainage.

10. Any animal or bird or domestic animal or domestic bird, which shall develop diphtheria tubercle, or other contagious or infectious disease injurious to human beings, shall be forthwith destroyed, or caused to be destroyed, by the person keeping the same or causing or permitting the same to be kept.

11. The occupier of any property upon which any animal or bird or domestic animal or domestic bird is kept shall, at all reasonable times, afford free access to every part thereof, respectively, to the Health Officer or Inspector of the City or to any person appointed by the Council to act under this By-law.

12. No person shall obstruct, impede, resist, or oppose any officer of the Council in the performance of his duty, and no person shall refuse to give information or give false information in answer to any inquiry made by any officer of the Council in the performance of his duty under this By-law.

13. No person shall allow or permit any domestic birds to wander at large or under control in or upon any street, public place, or vacant land.

14. Any person doing any act forbidden to be done or failing to do any act directed to be done by this By-law, and any person guilty of an offence against this By-law shall be liable to a penalty of not more than Twenty pounds, and in the case of a continuing offence to a further

daily penalty of not more than Five pounds for each day upon which the offence shall continue after the giving of notice thereof by the Inspector to such person.

15. Division 4 of By-law No. 87 is hereby repealed. Clause 22. Part 3, of By-law No. 71 is hereby repealed. This By-law shall have force and apply throughout the City of Essendon and shall come into operation on its approval by the Governor in Council and immediately after its publication in the *Victoria Government Gazette*.

A Resolution adopting the foregoing By-law was passed by Special Order of the Council on the 2nd day of August, 1948, and confirmed by Special Order on the 13th day of September, 1948.

The common seal of the City of Essendon was hereunto affixed, in the presence of—

H. J. GIBBS, Mayor.  
(SEAL) E. PETHEBRIDGE, Councillor.  
K. LISTER, Acting Town Clerk.

Submitted to the Commission of Public Health on the 6th day of June, 1950.—J. WHITLOCK, Secretary.

Approved by the Governor in Council on the 4th day of July, 1950.—A. MAHLSTEDT, Clerk of the Executive Council.  
6862

#### CITY OF GEELONG.

##### BY-LAW No. 127.

A By-law of the City of Geelong, made under the provisions of section 6 of 6 Vic. No. 18, for imposing the rates, tolls, and dues to be levied in the Cattle Market of the city, and for repealing certain provisions of By-law No. 28 of the city.

IN pursuance of the powers conferred by the above-mentioned Act and of every other power enabling it in that behalf, it is hereby enacted by the Council of the City of Geelong as follows, that is to say:—

1. The provisions of By-law No. 28 of the city in so far as the same relate to the said Cattle Market and the schedule of charges for the same imposed thereby shall be and are hereby repealed.

2. The rates, tolls, and dues to be levied and paid in the Cattle Market of the city shall be as follows:—

	s. d.
(1) For every horse, mare, gelding, foal, ass, or mule sold or exposed for sale in the cattle market .. .. .	2 0
(2) For every head of neat cattle sold or exposed for sale in the cattle market .. .	1 0
(3) For every sheep, lamb, or goat sold or exposed for sale in the cattle market .. .	0 2
(4) For every pig sold or exposed for sale in the cattle market .. .	0 6
(5) For every horse, mare, gelding, foal, ass, mule, or pig yarded in the cattle market .. . per night	0 3
(6) For every head of neat cattle yarded in the cattle market .. . per night	0 3

Resolution for passing this By-law agreed to by the Council of the City of Geelong on the 20th day of March, 1951, and confirmed on the 24th day of April, 1951.

The common seal of the Mayor, Councillors, and citizens of the City of Geelong was affixed hereto, in the presence of—

(SEAL) B. E. PURNELL, Mayor.  
6809 L. L. WALTER, Town Clerk.

#### CITY OF HAMILTON.

##### LOAN No. 14.

*Notice of Intention to Borrow the Sum of £3,000 for Permanent Works and Undertakings.*

NOTICE is hereby given that the Council of the City of Hamilton proposes to borrow the sum of Three thousand pounds on the credit of the municipal revenues of the Mayor, Councillors, and Citizens of the said City of Hamilton, such sum to be raised by the issue of debentures, in accordance with the provisions of the Local Government Acts.

1. The rate of interest to be paid is Three pounds seven shillings and six pence per centum per annum.

2. The purpose for which the loan is to be applied is the purchase of machines for road-making purposes, viz.:—

Two motor tipping trucks with hoists.

3. The period of the loan shall be ten years.

4. The moneys borrowed shall be repayable by providing out of the municipal fund twenty half-yearly instalments of approximately £178 each, including principal and interest, on the 1st day of August and the 1st day of February during the currency of the loan. The first instalment shall be payable on the 1st day of February, 1952.

5. Such moneys shall be repayable at The Commercial Banking Company of Sydney Limited, Melbourne, or at the Council's bankers for the time being in Melbourne.

The plans and specifications and the estimate of the cost of the proposed works, and a statement showing the proposed expenditure of the moneys to be borrowed, are open for inspection at the office of the Council, Town Hall, Hamilton, during office hours.

Dated this 30th day of April, 1951.

By order of the Council,

6861 A. WALLS, A.I.C.A., Town Clerk.

CITY OF MELBOURNE.

AMENDED RULES AS TO TOLLS AND DUES FOR THE SALE AND OF CHARGES FOR THE YARDAGE OF STOCK AT THE CATTLE MARKETS OF THE CITY OF MELBOURNE.

1. These Rules shall be read and construed as one with Amended Rules made and passed by the Council of the City of Melbourne on the 5th day of May, 1919, intituled "Amended Rules as to the Tolls and Dues for the Sale and of Charges for the yardage of stock at the Cattle Markets of the City of Melbourne" and any Rules amending the same.

2. The said Amended Rules made and passed by the Council of the City of Melbourne on the 5th day of May, 1919, as so amended shall be further amended as follows:—

- (a) Clause 2 thereof shall be amended by substituting for the figures "0 0 1" the figures "0 0 1."
- (b) Clause 3 thereof is hereby repealed.

3. These Rules shall come into and be in force on and after the 12th day of May, 1951.

Resolution for passing these Rules agreed to by the Council of the City of Melbourne, the 9th day of April, 1951, and confirmed the 7th day of May, 1951.

(L.S.) JAMES S. DISNEY, Lord Mayor.  
6884 H. S. WOOTTON, Town Clerk.

CITY OF SOUTH MELBOURNE.

LOAN No. 21.

Notice of Intention to Borrow the Sum of £14,000 for Certain Permanent Works and Undertakings.

NOTICE is hereby given that the Council of the City of South Melbourne proposes to borrow on the credit of the Mayor, Councillors, and Citizens of the City of South Melbourne, the sum of Fourteen thousand pounds (£14,000) by the issue of debentures for such amount, in accordance with the provisions of the Local Government Act, under the following conditions:—

1. The maximum rate of interest to be paid is £3 7s. 6d. per centum per annum.

2. Such money shall be repayable by 30 half-yearly instalments of approximately £598 11s. 6d. each, covering principal and interest, on the 1st day of January and the 1st day of July in each year, at the English, Scottish, and Australian Bank Limited, or at the Melbourne office of the Council's bankers for the time being.

3. The permanent works and undertakings for which the loan is borrowed are—

- (a) Completion of ofal treatment plant at South Melbourne municipal abattoirs .. £10,800
  - (b) Purchase of new refrigeration plant at South Melbourne municipal abattoirs .. 3,200
- £14,000

4. The plans and specifications and estimates of cost of such works and undertakings, together with a full statement of proposed expenditure of the money to be borrowed, are open for inspection at the Town Hall, South Melbourne. 6807

CITY OF SOUTH MELBOURNE.

LOAN No. 22.

Notice of Intention to Borrow the Sum of £45,600 for Certain Permanent Works and Undertakings.

NOTICE is hereby given that the Council of the City of South Melbourne proposes to borrow on the credit of the Mayor, Councillors, and Citizens of the City of South Melbourne, the sum of Forty-five thousand six hundred pounds (£45,600) by the issue of debentures for such amount, in accordance with the provisions of the Local Government Act, under the following conditions:—

1. The maximum rate of interest to be paid is £3 7s. 6d. per centum per annum.

2. Such money shall be repayable by 40 half-yearly instalments of approximately £1,576 19s. each, covering principal and interest, on the 1st day of January and the 1st day of July in each year, at the English, Scottish, and Australian Bank Limited, or at the Melbourne office of the Council's bankers for the time being.

3. The permanent works and undertakings for which the loan is borrowed are—

Bridges.		
Reconstruction of road surfaces, iron mouldings, bearings, &c., of Queen's and Spencer-street Bridges .. .. .	£2,640	
Depots.		
Workshops and staff amenities at Depots at White-street and Coventry-street, South Melbourne .. .. .	3,650	
Drainage.		
Underground and surface drainage, Beaconsfield-parade .. .. .	1,550	
Health.		
Remodelling Health Centre, Albert Park .. .. .	£1,500	
Chest X-ray Centre reinstatement of residential flat occupied by T.B. examination centre at Town Hall, and adaptation of shop premises, 226-228 Bank-street, for new centre .. .. .	2,000	
Emergency Housekeeper service adaptation shop, &c., premises, 226-228 Bank-street, into two residential flats for Council's Emergency Housekeepers .. .. .	2,000	5,500
Market.		
Renewal of roofing and closing in open-backed stalls in "B" and "C" Sheds, South Melbourne municipal market .. .. .	3,200	
Property.		
Acquirement of properties 222-224-226-228 Bank-street, South Melbourne, adjoining Town Hall block, for adaptation for health, library, residential, and public purposes .. .. .	4,300	
Plant and Equipment.		
Purchase of .. .. .	12,760	
Streets (Footpath) Construction .. .. .	8,500	
Sewerage.		
Public Conveniences—		
St. Vincent Gardens .. .. .	£1,500	
Montague Reserve .. .. .	500	2,000
Town Hall.		
Reinstatement Town Hall block adapted during war years for A.R.P. and Emergency Services .. .. .	1,500	£45,600

4. The plans and specifications and estimates of cost of such works and undertakings, together with a full statement of proposed expenditure of the money to be borrowed, are open for inspection at the Town Hall, South Melbourne. 6808

BOROUGH OF BENALLA.

LOAN No. 3.

Notice of Intention to Borrow the Sum of £4,500 for Permanent Works and Undertakings.

NOTICE is hereby given that the Council of the Borough of Benalla proposes to borrow the sum of Four thousand five hundred pounds (£4,500) on the credit of the municipal revenues of the Mayor, Councillors, and Burgesses of the said borough, such sum to be raised by the issue of debentures, in accordance with the provisions of the Local Government Acts.

1. The maximum rate of interest that may be paid is £3 7s. 6d. per centum per annum.

2. The purpose for which the loan is to be applied is road construction, concrete kerbs and channels, and purchase of land.

3. The period of the loan shall be twenty years.

4. The moneys borrowed shall be repayable by providing out of the municipal fund half-yearly instalments of approximately £155 2s. 6d. each, including principal and interest, on the 1st day of August and the 1st day of March during the currency of the loan. The first instalment shall be paid on the 1st day of March, 1952.

5. Such money shall be repayable at the National Bank of Australasia Limited, Melbourne, or at the Council's bankers for the time being in Melbourne.

6. The plans and specifications and the estimate of the cost of the proposed works, and a statement showing the proposed expenditure of the moneys to be borrowed, are open for inspection at the office of the Council, 86 Bridge-street, Benalla, during office hours.

6841 D. C. LATCH, Town Clerk.

## SHIRE OF MORNINGTON.

## BY-LAW No. 59.

A By-law of the Shire of Mornington, made under the *Health Act 1928* and the *Local Government Act 1946*, and numbered 59, for and with respect to—

- (a) regulating or prohibiting the keeping of any place or any animals (including birds), or the storage of any things in the opinion of the Council offensive, injurious to health, or dangerous;
- (b) fixing the distance from any dwelling within which it shall be unlawful to keep any such place or animal or to store any such thing;
- (c) suppressing nuisances.

THE President, Councillors, and Ratepayers of the Shire of Mornington, in pursuance of the powers conferred by the Health Acts and the Local Government Acts and every other Act or power enabling them in that behalf, do hereby make the By-law, and order as follows:—

(1) This By-law shall come into full force and operation on its approval by the Governor in Council and immediately after its publication in the *Government Gazette*.

(2) This By-law shall apply to and have operation throughout those areas within the Shire of Mornington prescribed in the Schedule hereto, and shall be supplementary to the provisions of the Uniform Building Regulations Victoria.

(3) In this By-law, unless inconsistent with the context or subject matter—

- “Animals” shall mean horses, cattle, and dogs;
- “Birds” shall mean fowls, ducks, geese, turkeys, and all other classes of poultry and pigeons and doves;
- “Dwelling” shall include bathrooms, kitchens, sculleries, and all rooms used for sleeping, living, eating, cooking, or other like purposes.

(4) No person shall keep or cause or permit to be kept any animals and/or birds in any dwelling or in the yard of or attached to such dwelling or in any land whatsoever in such a manner as to be or be liable to be offensive, injurious to health, or dangerous.

(5) The occupier of the yard of or attached to any dwelling or of any other land in which any animals and/or birds are kept or housed shall cause the place of keeping of such animals and/or birds to be maintained in a good state of repair and thoroughly cleansed and effectually deodorized from time to time as may be necessary for the purpose of keeping such place in a clean, wholesome, and sanitary state and condition.

(6) The occupier of any land on which is erected any stable or shed or structure for the keeping or housing of animals shall—

- (a) cause all manure, refuse, and rubbish produced or accumulated therein to be placed in a receptacle properly constructed of durable material impervious to moisture and capable of being readily cleansed;
- (b) maintain such receptacle in a good state of repair as to prevent the escape or leakage of the contents;
- (c) keep such receptacle covered constantly, and from time to time effectually deodorize the same and the contents thereof;
- (d) cause the contents of such receptacle to be removed and satisfactorily disposed of at least once in every week;
- (e) cause the floor of such stable, shed, or structure to be properly drained and paved or flagged with brick, stone, concrete, or other impervious material;
- (f) keep such stable, shed, or structure in a good state of repair and cleanly and sanitary condition and free from rats;
- (g) such stable, shed, or structure shall not be erected within 30 feet of any dwelling.

(7) No person shall keep or cause or permit to be kept any fowls, ducks, geese, turkeys, or other class of poultry, within 40 feet from any dwelling, nor in any yard thereof or attached thereto, the area of which yard is less than 1,500 square feet, nor unless such fowls, ducks, geese, turkeys, and all other classes of poultry are housed or kept in a properly-constructed and securely-fastened shed, shelter, erection, structure, or other enclosure which shall be rat-proof.

(8) No person shall keep or cause or permit to be kept more than three animals and/or twenty birds in the yard of or attached to any dwelling without the permission of the Council.

(9) Any shed, shelter, erection, structure, or other enclosure for the housing or keeping of any animals and/or birds erected or placed in the yard of or attached

to any dwelling contrary to the provisions of this By-law shall be removed by the owner or occupier of such yard or dwelling within seven days after being required to do so by notice, in writing, under the hand of the Shire Secretary or Building Surveyor, failing which the Council may cause the same to be pulled down and removed and the expenses of such pulling down or removal shall be paid by such owner or occupier to the Council within seven days of demand therefor, otherwise the Council may recover the same from such owner or occupier.

(10) No occupier of any yard in which has been erected or placed any shed, shelter, erection, structure, or other enclosure for the housing or keeping of any animals and/or birds shall leave or suffer to remain therein for a longer period than is absolutely necessary, any food or other matter likely to become offensive or injurious to health, or attract or harbour rodents or other vermin. All food not immediately required for feeding such animals and/or birds shall be kept in metal bins or other approved receptacles, but in every case so as to prevent access of rats or mice to such feed.

(11) Any animals and/or birds which shall develop any infectious or contagious disease injurious to the health of the residents of the municipal district shall be forthwith destroyed, or caused to be destroyed, by the person keeping the same.

(12) The occupier of any premises upon which any animal or bird is kept shall at all reasonable times afford free access to every part thereof to each and every authorized officer of the shire.

## SCHEDULE.

A. The Mornington township area, as contained within the following boundaries: Commencing on the shores of Port Phillip Bay at a point opposite Beleura-road; thence southerly along Beleura-road to Nepean Highway; thence south-westerly along Nepean Highway to Tanti Creek; thence south-easterly along Tanti Creek to a point opposite the continuation of Yuille's-road and Yuille's-road to Hastings-road; thence easterly along Hastings-road to a point opposite the north-eastern corner of Crown allotment 12, section 24; thence along the eastern boundaries of Crown allotments 11 and 12, section 24, to the south-eastern corner of Crown allotment 11; thence westerly along the southern boundary of Crown allotment 11 to the Nepean Highway; thence north-westerly along Strachans-road to the shores of Port Phillip Bay; thence northerly along coastline to commencing point.

B. Mount Eliza area bounded by Gunyong Creek, Nepean Highway, Boundary-road, and the shore of Port Phillip Bay.

C. Such other areas as are designated as residential areas in any By-law of the Shire of Mornington.

(13) Any contravention of any of the foregoing sections by act or omission shall be an offence against this By-law.

(14) Every person who is guilty of an offence against this By-law shall be liable, on conviction, to a penalty of not more than Ten pounds, and in the case of a continuing offence to a further daily penalty of not more than One pound.

Resolution adopting this By-law agreed to by the Council of the Shire of Mornington on the 8th day of December, 1950, and confirmed at a meeting of the said Council on the 9th day of February, 1951.

(SEAL) S. L. BUTLER, President.  
D. R. MORELL, Councillor.  
L. T. McLAREN, Shire Secretary.

Submitted to the Commission of Public Health at its meeting on the 13th day of March, 1951.—A. BURKE, Acting Secretary.

Approved by the Governor in Council, 17th April, 1951.—A. MATHSTEDT, Clerk of the Executive Council. 6806

## NOTICE OF DISSOLUTION OF PARTNERSHIP.

NOTICE is hereby given that the partnership heretofore subsisting between the undersigned Leo Harty and Bryan Desmond McIntyre, late of Paynesville, in the State of Victoria, cafe and guest house proprietors, carrying on business at Paynesville under the name of “Harty and McIntyre,” has been dissolved by mutual consent as from the 18th day of April, 1951. The business will continue to be carried on by the said Leo Harty in his own name, and all debts due to and owing by the said late firm will be received and paid by Leo Harty, at Paynesville, aforesaid.

Dated at Bairnsdale, this 7th day of May, 1951.

LEO HARTY.  
B. MCINTYRE.  
Warren and Thomson, solicitors, Bairnsdale. 6860

## NOTICE OF DISSOLUTION OF PARTNERSHIP.

NOTICE is hereby given that the partnership heretofore subsisting between the undersigned, William James Allen, of 234 Barkly-avenue, Burnley, Leslie Frederick Brinsmead, of 14 Rowland-street, Mont Albert, Stephen Thomas Foot, of 40 Albion-road, Box Hill, Robert Grinyer, of 20 Moore-street, South Yarra, Anthony Francis Healy, of 80 Type-street, Burnley, Maurice Kohn, of Plumer-street, Croydon, and Richard Thomas, of Bushy Park-road, North Croydon, sewerage construction contractors, carrying on business of sewerage construction contractors at 80 Type-street, Burnley, under the name of Metropolitan Excavations, has been dissolved by mutual consent as from 19th April, 1951. All debts due to or owing by the said firm will be received and paid by the said William James Allen, Stephen Thomas Foot, Robert Grinyer, Anthony Francis Healy, Maurice Kohn, and Richard Thomas, who will carry on as partners the business at 80 Type-street, Burnley.

Dated at Melbourne the 19th day of April, 1951.

L. BRINSMEAD.  
A. F. HEALY.  
R. THOMAS.  
R. GRINYER.  
W. ALLEN.  
S. T. FOOT.  
M. KOHN.

Witness—W. HARRISON.

William Harrison, solicitor, Bank-place, Melbourne.

6829

## NOTICE OF DISSOLUTION OF PARTNERSHIP.

NOTICE is hereby given that the partnership heretofore subsisting between the undersigned Raymond Gerald Mason, Gordon Angus Kennedy, and Claude James Whittle, all of Ensay, in the State of Victoria, contractors, carrying on business at Ensay aforesaid, under the name of "Mason, Kennedy, and Whittle," has been dissolved by mutual consent as from the 30th day of April, 1951. All debts due to and owing by the said late firm will be received and paid by Gordon Angus Kennedy, at Ensay aforesaid.

Dated at Ensay, this 30th day of April, 1951.

R. G. MASON.  
G. A. KENNEDY.  
C. J. WHITTLE.

Warren and Thomson, solicitors, Bairnsdale.

6820

## PARTNERSHIP ACT 1928.

NOTICE is hereby given that the partnership heretofore carried on by Walter John Stoddart and Thomas Bruce Rodwell, under the name "The Orbest Furniture Centre," at Nicholson-street, Orbest, was dissolved by mutual agreement on the 30th day of April, 1951, when the said Thomas Bruce Rodwell retired from the said business on that date. The said Walter John Stoddart will continue conducting the said business and shall be responsible for the debts incurred in the said business. Thomas Bruce Rodwell will continue to trade in his own right as "Rodwell's Furniture Company," 610 High-street, Armadale.

W. J. STODDART.  
T. B. RODWELL.

Charles C. Palmer, solicitor, Orbest.

6818

NOTICE is hereby given that the partnership heretofore subsisting between us, the undersigned Lewis Henry Barnett and Henry Joseph Bowyer, carrying on business as garage proprietors, at the corner of Lygon and Albion streets, Brunswick, under the style or firm name of "Lyndhurst Service Station," has been dissolved by mutual consent, as from the 1st day of March, 1951. All debts due to and owing by the said late firm will be received and paid respectively by the said Lewis Henry Barnett, who will continue to carry on the said business under the said style or firm name of "Lyndhurst Service Station."

Dated this 3rd day of May, 1951.

L. H. BARNETT.  
H. BOWYER.

Phillips, Fox, and Masel, 450 Little Collins-street, Melbourne, solicitors for both parties.

6833

NOTICE is hereby given that the partnership as joinery manufacturers heretofore carried on at No. 12 Regent-street, Prahran, by Ronald James Turnbull Young, of Main-road, Sassafra, and Frank Williams, of 39 Bowen-street, Prahran, under the name of "United Joinery," was dissolved by mutual consent on the 19th day of January, 1951. Accounts may be paid or sent to either of the partners at their above addresses.

Dated the 30th day of March, 1951.

R. YOUNG.  
F. WILLIAMS.

Moule, Hamilton, and Derham, solicitors, 394 Collins-street, Melbourne.

6832

## Companies Act 1938.

## RENNY HILL PROPRIETARY LIMITED.

## PURSUANT TO SECTION 226.

AT an Extraordinary General Meeting of the above-named company duly convened and held at Camperdown on the 27th day of April, 1951, the following Resolution was duly passed as a Special Resolution:—

"That the company be wound up voluntarily."

And at such last-mentioned meeting Colin Wynne George, of Camperdown, was appointed liquidator for the purposes of the winding up.

Dated the 27th day of April, 1951.

6828 MARY J. COOPE, Chairman.

## EASY BEE HOME SUPPLIERS PTY. LTD. (IN LIQUIDATION).

NOTICE is hereby given that a meeting of creditors has been called in the above matter and will take place at the Board Room, Institute of Chartered Accountants in Australia, 18 Queen-street, Melbourne, on Wednesday, the 23rd day of May, 1951, at Two-thirty p.m.

J. KENNETH HALL, Trustee.

Hall and Rose, chartered accountants (Aust.), 390 Little Collins-street, Melbourne. 6868

## MORNA PROPRIETARY LIMITED.

## PURSUANT TO SECTION 226.

AT an Extraordinary General Meeting of the above-named company, duly convened and held at 95 Queen-street, Melbourne, on Wednesday, the 4th day of May, 1951, the following Resolution was duly passed as a Special Resolution:—

"That the company be wound up voluntarily."

And at such last-mentioned meeting Andrew William Hugh McEwan, of 95 Queen-street, Melbourne, was appointed liquidator for the purposes of winding up.

Dated the 4th day of May, 1951.

6847 I. MORNANE, Chairman.

## GEO. CUSSONS PROPRIETARY LIMITED (IN LIQUIDATION).

AT an Extraordinary General Meeting of the members of Geo. Cussons Proprietary Limited, duly convened and held at the registered office of the company, 47 Queen-street, Melbourne, on the 30th day of April, 1951, the following Special Resolution was duly passed:—

"It was unanimously resolved that the company be wound up voluntarily (and that Mr. James William Collins, of 47 Queen-street, Melbourne, Victoria, be and is hereby appointed liquidator for the purposes of such winding up)."

Dated this 7th day of May, 1951.

6855 J. W. COLLINS, Director.

## COMPANIES ACT 1938.

PURSUANT to section 226 of the Companies Act 1938, notice is hereby given that the following Special Resolution was duly passed on 2nd May, 1951, by Broadhurst Investments Pty. Ltd.:—

"That the company be wound up voluntarily, and that James Ogilvy, of 401 Collins-street, Melbourne, chartered accountant (Aust.) be appointed liquidator for the purposes of such winding up."

Dated 3rd May, 1951.

HEDDERWICK, FOOKES, & ALSTON, 103 William-street, Melbourne, solicitors to the company. 6834

PURSUANT to the Trustee Act 1928, notice is hereby given that all persons having claims against the estate of William Stephen Hardiman, late of 42 Bent-street, Altona, in the State of Victoria, labourer, deceased, intestate (who died on the 23rd day of November, 1950, and letters of administration of whose estate was, on the 9th day of April, 1951, granted by the Supreme Court of Victoria, to Margaret Louisa Bateson, of 381A Beach-road, Parkdale, in the State of Victoria, married woman, the eldest sister and one of the next of kin of the said deceased, the administratrix appointed thereby), are hereby required to send particulars, in writing, of such claims to Luke Murphy and Co., at the address below, on or before the 18th day of July, 1951, after which date the said administratrix will proceed to convey or distribute the said estate to or among the persons entitled thereto, having regard only to the claims, whether formal or not, of which she shall then have had notice, and will not be liable for the assets so distributed to any person of whose claims she shall not then have had notice.

Dated the 15th day of May, 1951.

LUKE MURPHY & CO., 422 Bourke-street, Melbourne, solicitors. 6867



*Trustee Act 1928.*  
NOTICE TO CLAIMANTS.

PURSUANT to the *Trustee Act 1928*, creditors, next of kin, and all other persons having claims in respect of the estate of any deceased person named below are required to send particulars thereof to the legal personal representative or representatives, at the address stated below, on or before the date stated, after which date the representative or representatives will distribute the assets, having regard only to the claims of which notice has been received:—

Elsie Florence Tomkins, formerly of No. 3 Darling-street, Warrnambool, in the State of Victoria, and Rockbrook-road, East St. Kilda, in the said State, but late of No. 15 The Avenue, Geelong West, in the said State, shop assistant, died on the 10th day of January, 1951.—Claims to Leonard William Tomkins and Archibald Robert Stokes, care of Doyle and Kerr, solicitors, Little Malop-street, Geelong, by the 16th day of July, 1951. 6816

Henry Hanson, late of Church-street, Eaglehawk, in the State of Victoria, retired engine driver, deceased, who died on the 22nd day of December, 1950.—Claims to the executors, William Henry Hanson, of 35 Hotham-street, Seddon, in the said State, engineer, and Sandhurst and Northern District Trustees, Executors, and Agency Company Limited, of 18 View-street, Bendigo, in the said State, in care of the undersigned solicitors, by the 16th day of July, 1951. Tatchell, Dunlop, Smalley, and Balmer, solicitors, Bendigo. 6814

Muriel Mabel Wilson, late of Brooke-street, Inglewood, Victoria, hotelkeeper, deceased, who died on the 7th day of December, 1950.—Claims to the executors, Arnold Hector Wilson, of Sullivan-street, Inglewood, clerk, and Adelaide Fitzpatrick, of Brooke-street, Inglewood, spinster, in care of the undersigned, not later than the 14th day of July, 1951. Tatchell, Dunlop, Smalley, and Balmer, solicitors, Verdon-street, Inglewood. 6853

Tom Lucas, formerly of Carlisle River, but late of Elliminyt, farmer, died 15th July, 1950.—Claims to the executors, The Fidelity Trustee Company Limited, of 101 Lydiard-street north, Ballarat, and William Henry Lucas, of Carlisle River, farmer, by 16th July, 1951. Sewell and Sewell, solicitors, Colac. 6879

Margaret Cock, late of 53 Chaucer-street, Moonee Ponds, widow, died 12th July, 1950.—Claims to the executor, Beatrice Adelaide Balharrie, of "Watch Hill," Beecac, married woman, by 16th July, 1951. Sewell and Sewell, solicitors, Colac. 6880

ELMA MARTIN, late of 78 Nimmo-street, Essendon, widow, DECEASED.

CREDITORS, next of kin, and others having claims in respect of the estate of the deceased (who died on the 29th day of November, 1949), are to send particulars of their claims to the executors of the will of the deceased, Ernest Walter Tutton and John Pringle Wilson, care of the undersigned solicitors, by the 16th July, 1951, after which date they will distribute the assets, having regard only to the claims of which they then have notice.

HARWOOD & PINCOTT, solicitors, 472 Bourke-street, Melbourne. 6836

CREDITORS, next of kin, and others having claims in respect of the estate of Caroline Tolhurst (generally known as Lena Tolhurst), late of "Warwillah," 572 St. Kilda-road, Melbourne, widow (who died on the 6th December, 1950), are to send the particulars of their claims to The Perpetual Executors and Trustees Association of Australia Limited, of Nos. 100-104 Queen-street, Melbourne, by the 26th day of July, 1951, after which date it will distribute the assets, having regard only to the claims of which it then has notice.

HENDERSON & BALL, of 430 Little Collins-street, Melbourne, solicitors. 6869

CREDITORS, next of kin, and all others having claims in respect of the estate of Elizabeth Abigail Turnbull, late of "Monda," 15 Orrong-road, Armadale, widow, deceased (who died on 1st January, 1951), are to send particulars of their claims to The Union Trustee Company of Australia Limited, of 333 Collins-street, Melbourne, by the 11th July, 1951, after which date the said company will distribute the assets, having regard only to the claims of which it then has notice.

PROUDFOOT & HORTON, solicitors, 87 Queen-street, Melbourne. 6830

CREDITORS, next of kin, and others having claims in respect of the estate of Margaret Isabella Hutton, late of 120 Kooyong-road, Armadale, Victoria, spinster, deceased (who died on the 1st day of November, 1950), are requested to forward particulars of their claims to William Frederick Weigall, the executor of the will of the deceased, at the address of the under-mentioned solicitors, on or before the 15th July, 1951, after which date the said executor will distribute the assets amongst the persons entitled thereto, having regard only to the claims of which he shall then have had notice.

WEIGALL & CROWTHER, 459 Chancery-lane, Melbourne, solicitors. 6837

ADA LOUISA WILLIAMS, formerly of 515 Skipton-street, Ballarat, but late of 102 Ascot-street, Ballarat, spinster, DECEASED (who died on the 6th day of December, 1950).

CREDITORS, next of kin, and all other persons having claims against the estate of the deceased are required by the executor, The Fidelity Trustee Company Limited (formerly The Ballarat Trustees, Executors, and Agency Company Limited), of 101 Lydiard-street north, Ballarat, to send particulars of their claims to it by the 12th day of July, 1951, after which date it will distribute the assets, having regard only to the claims of which it then has notice.

R. J. GRIBBLE, HOLLWAY, & HEINZ, solicitors, 22 Lydiard-street south, Ballarat. 6842

HARRY GEORGE MATHEWS, late of "Waitara," Valley-road, Highton, retired minister of religion, DECEASED.

CREDITORS, next of kin, and all other persons having claims against the estate of the deceased are required by the executors of the will, The Fidelity Trustee Company Limited, of 101 Lydiard-street north, Ballarat, to send particulars to the said company, care of the undersigned, on or before the 13th day of July, 1951, after which date it will distribute the assets, having regard only to the claims of which it then has notice.

J. L. PRICE, HIGGINS, & SPEED, solicitors, 47 Yarra-street, Geelong. 6844

NOTICE TO CLAIMANTS.—*RE* GRACE MARIE FINLAN, DECEASED.

WE, Reginald Patrick Finlan and Frederick Ormond Owen, both care of the under-mentioned solicitors, the executors of the will of Grace Marie Finlan, late of 178 Balwyn-road, Balwyn, married woman, deceased (who died on 5th January, 1951), require all creditors, next of kin, and others having claims against the property or estate of the deceased to send to the executors, on or before the 12th day of July, 1951, particulars, in writing, of such claims, after which date the executors intend to convey or distribute such property or estate to or among the persons entitled thereto, having regard only to the claims of which they will have had notice.

UPTON, ETTTELSON, & OWEN, solicitors, 395 Collins-street, Melbourne. 6877

NOTICE TO CLAIMANTS.—*RE* CHARLES CLARENCE CHETTLE, DECEASED.

I, Louisa Chettle, care of the under-mentioned solicitors, the administratrix of the estate of Charles Clarence Chettle, late of 88 Albert-street, East Brunswick, guillotine operator, deceased, intestate (who died on 15th March, 1951), require all creditors, next of kin, and others having claims against the property or estate of the said deceased to send to the administratrix, on or before 12th July, 1951, particulars, in writing, of such claims, after which date the administratrix intends to convey or distribute such property or estate to or among the persons entitled thereto, having regard only to the claims of which she will have had notice.

UPTON, ETTTELSON, & OWEN, solicitors, 395 Collins-street, Melbourne. 6876

THE TRUSTEE ACT 1928.

NOTICE is hereby given that all persons having claims against the property and estate of Margaret Eloise Taylor, late of Lansell-road, Toorak, in Victoria, spinster, deceased (who died on the 24th day of September, 1950, and probate of whose will was granted by the Supreme Court of Victoria, on the 3rd day of May, 1951, to The Equity Trustees, Executors, and Agency Company Limited, of 472 Bourke-street, Melbourne, and Francis Sargent Newell, of 360 Collins-street, Melbourne, solicitor), are hereby required to send particulars of such claims to the executors, at the address of the said company, as aforesaid, on or before the 12th day of July, 1951, after which day it is the intention of the executors to convey or to distribute such property and estate to or amongst the persons entitled of whose claims they have had notice.

Dated this 4th day of May, 1951.

F. S. NEWELL & MARSH, 360 Collins-street, Melbourne, proctors for the said executors. 6870

**CREDITORS**, next of kin, and others having claims in respect of the estate of Harry Edwin Lee, formerly of 2 Yeovil-road, Burwood, in the State of Victoria, but late of 8 Alfred-street, Auckland, New Zealand, gentleman, deceased (who died on the 8th day of December, 1950, and probate of whose will, dated the 21st day of November, 1945, was granted by the Supreme Court of Victoria, in its probate jurisdiction, to the Trustees, Executors, and Agency Company Limited, of 401 Collins-street, Melbourne), are to send particulars of their claims to the said company, at its above-mentioned address, by the 30th day of July, 1951, after which date it will distribute the assets, having regard only to the claims of which it then has notice.

Dated 2nd day of May, 1951.

H. W. HUNT, UTBER, & BATTEN, 285 Collins-street, Melbourne, solicitors for the said estate. 6825

**ALICE MARGUERITE KENT**, formerly of Main-road, Clematis, Victoria, but late of Fofest Hill-avenue, Albury, New South Wales, married woman, DECEASED.

**CREDITORS**, next of kin, and others having claims in respect of the estate of the deceased (who died on 18th February, 1950), are to send particulars of their claims to the executors of the will of the deceased, Robert Henry Vaughan Kent and Margaret Alison Vaughan Hopkins, care of the undersigned solicitors, by 16th July, 1951, after which date they will distribute the assets, having regard only to the claims of which they then have notice.

HARWOOD & PINCOTT, solicitors, 472 Bourke-street, Melbourne. 6835

**NOTICE** is hereby given that all persons having claims in respect of the property of William Paul Condon, late of 11 Carson-street, Kew, director, deceased (who died on the 21st day of May, 1950, probate of whose will was granted by the Supreme Court of Victoria, in its probate jurisdiction, on the 4th day of August, 1950, to Olive Condon, of 11 Carson-street, Kew aforesaid, widow, the executrix named in and appointed by the said will), are required to send particulars of such claims to the executrix, care of her solicitors, at their address below, on or before the 12th day of July, 1951, after which date it is the intention of the executrix to convey or distribute such property or estate to or amongst the persons entitled thereto, having regard only to the claims of which she shall then have had notice.

UPTON, ETTIELSON, & OWEN, solicitors, 395 Collins-street, Melbourne. 6873

**NOTICE TO CREDITORS AND OTHERS.—RE HERBERT NATHANIEL STRAUS, DECEASED.**

**PURSUANT** to the *Trustee Act 1928*, notice is hereby given that The Perpetual Executors and Trustees Association of Australia Limited, of 100-104 Queen-street, Melbourne, and Septimus Alway Ralph, of 430 Little Collins-street, Melbourne, solicitor, the executors of the will of Herbert Nathaniel Straus, formerly of 253 Burke-road, East Malvern, but late of 204 Burke-road, Glen Iris, gentleman, deceased (who died on 5th December, 1950), intend to convey or distribute the estate of the said deceased to or among the persons entitled thereto, and require all persons and creditors interested to send to the said executors, care of the said The Perpetual Executors and Trustees Association of Australia Limited, on or before the 14th day of July, 1951, particulars, in writing, of their claims against the said estate, after which date the said executors may convey or distribute the said estate to or among the persons entitled thereto, having regard only to the claims, whether formal or not, of which they shall then have had notice.

Dated the 27th day of April, 1951.

SEPTIMUS A. RALPH & SON, 430 Little Collins-street, Melbourne, solicitors to the estate. 6831

**NOTICE** is hereby given that all persons having claims in respect of the property of George Albert Carpenter, late of 43 Mason-street, Newport, fitter, deceased (who died on the 4th day of December, 1950, probate of whose will was granted by the Supreme Court of Victoria, in its probate jurisdiction, on the 13th day of March, 1951, to Irene Helen Carpenter, of 43 Mason-street, Newport aforesaid, widow, the executrix named in and appointed by the said will), are required to send particulars of such claims to the executrix, care of her solicitors, at their address below, on or before the 12th day of July, 1951, after which date it is the intention of the executrix to convey or distribute such property or estate to or amongst the persons entitled thereto, having regard only to the claims of which she shall then have had notice.

UPTON, ETTIELSON, & OWEN, solicitors, 395 Collins-street, Melbourne. 6874

**CREDITORS**, next of kin, and others having claims in respect of the estate of Jessie Gardner Knippler, late of Diamond Creek-road, Greensborough, in the State of Victoria, widow, deceased (who died on the 15th day of October, 1950, and letters of administration of whose estate, with the will of the said deceased, dated the 22nd day of December, 1949, annexed thereto, were granted by the Supreme Court of Victoria, in its probate jurisdiction, to the Union Trustee Company of Australia Limited, of 333 Collins-street, Melbourne), are to send particulars of their claims to the said company, at its above-mentioned address, by the 30th day of July, 1951, after which date it will distribute the assets, having regard only to the claims of which it then has notice.

Dated 2nd day of May, 1951.

H. W. HUNT, UTBER, & BATTEN, 285 Collins-street, Melbourne, solicitors for the said estate. 6824

**CREDITORS**, next of kin, and others having claims in respect of the estate of Thomas Charles Cooke, formerly of Lorne, but late of 119 Roslyn-road, Belmont, Geelong, retired newsagent, deceased (who died on the 17th day of November, 1950), are to send the particulars of their claims to The Fidelity Trustee Company Limited, at its branch office, situate at 8 Malop-street, Geelong, by the 12th day of July, 1951, after which date it will distribute the assets, having regard only to the claims of which it then has notice.

HARWOOD & PINCOTT, solicitors, 51 Yarra-street, Geelong. 6823

**CREDITORS**, next of kin, and others having claims in respect of the estate of Stanley William Hallett, late of 2 Miller-street, Richmond, monumental mason, deceased (who died on the 22nd day of January, 1951), are to send particulars of their claims to Sarah Mary Hallett, of Amphitheatre, Victoria, and the National Trustees, Executors, and Agency Company of Australasia Limited, of 95 Queen-street, Melbourne, by the 4th day of July, 1951, after which date they will distribute the assets, having regard only to the claims of which they then have notice.

E. P. PRENDERGAST & O'SULLIVAN, solicitors, 118 Queen-street, Melbourne. 6833

**CREDITORS**, next of kin, and others having claims in respect of the estate of Heinrich August Lange, late of Tarrington, farmer, deceased (who died on the 22nd day of December, 1949), are required to send particulars, in writing, of their claims to the executor, Walter Mibus, care of the under-mentioned solicitors, on or before the 13th day of July, 1951, otherwise they may be excluded when the assets are being distributed.

MELVILLE & WALTER, solicitors, 69-71 Thompson-street, Hamilton. 6827

**EDWARD JOSEPH HARRISON**, late of Hernes Oak, in the State of Victoria, retired storeman, DECEASED (who died on the 27th day of November, 1948).

**CREDITORS**, next of kin, and all other persons having claims against the estate of the deceased are required by the executor of the will, Sidney Joseph Oliver, of Hernes Oak, an employee of the State Electricity Commission, to send particulars to him, care of the undersigned, on or before the 20th day of July, 1951, after which date he will distribute the assets, having regard only to the claims of which he then has notice.

M. DAVINE, solicitor, Trafalgar. 6822

**CREDITORS**, next of kin, and others having claims in respect of the estate of Johan August Petterson (in his will called John August Petterson), formerly of Congupna, but late of Koo-wee-rup North, grazier, deceased (who died on the 14th day of January, 1951), are to send the particulars of their claims to The Fidelity Trustee Company Limited, whose registered office is at 101 Lydiard-street north, Ballarat, by the 20th day of July, 1951, after which date it will distribute the assets, having regard only to the claims of which it then has notice.

PAUL C. NUNAN, solicitor, 422 Little Collins-street, Melbourne. 6866

**EDWARD JOHN THOMSON**, late of Trafalgar, in the State of Victoria, farmer, DECEASED (who died on the 10th day of July, 1949).

**CREDITORS**, next of kin, and all other persons having claims against the estate of the deceased are required by the executrices of the will, Marjorie Evelyn Mackie, of Trafalgar, married woman, Estelle Nesbitt Cumming Tucker, of Maffra, married woman, and Jessie Ismay Gooding, of Trafalgar, widow, to send particulars to them, care of the undersigned, on or before the 5th day of July, 1951, after which date they will distribute the assets, having regard only to the claims of which they then have notice.

M. DAVINE, solicitor, Trafalgar. 6812

**CREDITORS**, next of kin, and others having claims in respect of the estate of Daniel McIntyre, formerly of Gre Gre Village, in the State of Victoria, farmer and grazier, but late of 60 Dundas-street, St. Arnaud, in the said State, retired farmer and grazier, deceased (who died on the 6th day of September, 1950), are to send particulars of their claims to the Fidelity Trustee Company Limited, whose registered office is situate at 101 Lydiard-street north, Ballarat, in the said State, by the 12th day of July, 1951, after which date it will distribute the assets, having regard only to the claims of which it then has notice.

H. L. DUNKLEY & KELLY, solicitors, 78 Napier-street, St. Arnaud. 6805

BELLA ARMSTRONG, late of 68 Wade-street, Golden Square, spinster, DECEASED.

**CREDITORS**, next of kin, and all other persons having claims against the estate of the deceased are required by John Edmund Mamouny, of 68 Wade-street, Golden Square, agent, the executor of the will, to send particulars to him, care of the under-mentioned solicitors, on or before the 9th day of July, 1951, after which date he will distribute the assets, having regard to the claims of which he shall then have notice.

Dated this 9th day of May, 1951.

T. M. WILLIAMS, WATSON, & JAMES, solicitors, 16 View-street, Bendigo. 6826

**CREDITORS**, next of kin, and others having claims in respect of the estate of Mabel Case Rice, late of 1261 High-street, Malvern, in the State of Victoria, spinster, deceased (who died on the 1st day of February, 1951), are to send the particulars of their claims to The Trustees, Executors, and Agency Company Limited, whose registered office is situate at 401 Collins-street, Melbourne, in the State of Victoria, by the 13th day of July, 1951, after which date it will distribute the assets, having regard only to the claims of which it then has notice.

HEDDERWICK, FOOKES, & ALSTON, 103 William-street, Melbourne, solicitors for the executors. 6846

**NOTICE** is hereby given that all persons having claims in respect of the property of Thomas James Harold Briggs, formerly of 222 Moray-street, South Melbourne, but late of 24 Webb-street, Glen Iris, grocer, deceased (who died on the 2nd day of November, 1949, probate of whose will was granted by the Supreme Court of Victoria, in its probate jurisdiction, on the 5th day of March, 1951, to Ellen Briggs, of 24 Webb-street, Glen Iris aforesaid, widow, the executrix named in and appointed by the said will), are required to send particulars of such claims to the executrix, care of her solicitors, at their address below, on or before the 12th day of July, 1951, after which date it is the intention of the executrix to convey or distribute such property or estate to or amongst the persons entitled thereto, having regard only to the claims of which she shall then have had notice.

UPTON, ETTTELSON, & OWEN, solicitors, 395 Collins-street, Melbourne. 6872

**NOTICE** is hereby given that all persons having claims in respect of the property of Isabella Maud Albert, formerly of 1 St. Ninian's-road, Middle Brighton, married woman, but late of Boronia, widow, deceased (who died on the 10th day of January, 1951, letters of administration of whose estate with the will annexed was granted by the Supreme Court of Victoria, in its probate jurisdiction, on the 26th day of April, 1951, to Isabella Connie Tatterson, of 112 Kirkham-road, Dandenong, married woman, a daughter of the said deceased and a legatee under the said will), are required to send particulars of such claims to the administratrix, care of her solicitors, at their address below, on or before the 12th day of July, 1951, after which date it is the intention of the administratrix to convey or distribute such property or estate to or amongst the persons entitled thereto, having regard only to the claims of which she shall then have had notice.

UPTON, ETTTELSON, & OWEN, solicitors, 395 Collins-street, Melbourne. 6875

CLIFFORD LAWLOR RAY, late of Swan Hill, in the State of Victoria, fruitgrower, DECEASED (who died on the 22nd day of January, 1951).

**CREDITORS**, next of kin, and all other persons having claims against the estate of the deceased are required by the executrix of the will, Vera Ray, of Beverford, in the State of Victoria, widow, to send particulars to her, care of the undersigned, on or before the 14th day of August, 1951, after which date she will distribute the assets, having regard only to the claims of which she then has notice.

Dated the 8th day of May, 1951.

GARDEN & GREEN, solicitors, 29 McCallum-street, Swan Hill. 6857

**CREDITORS**, next of kin, and others having claims in respect of the estate of Stephen Leslie Hunn, late of 71 Wellington-street, Flemington; architect, deceased (who died on the 26th day of September, 1950), are to send particulars to Trevor Charlton McCullough and James Henry Curnow, care of the undersigned, by the 29th day of June, 1951, after which date they will distribute the assets, having regard only to the claims of which they then have notice.

JAMES P. OGGE, LL.B., of 165 Greville-street, Prahran. 6883

**CREDITORS**, next of kin, and others having claims in respect of the estate of Anthony Patrick Dridan, late of Amphitheatre, grazier, deceased, intestate (who died on the 8th day of March, 1951), are to send the particulars of their claims to William Thomas Dridan, of Amphitheatre, grazier, care of the undersigned solicitors, by the 1st day of August, 1951, after which date he will distribute the assets, having regard only to the claims of which he then has notice.

HERRING & BATHURST, solicitors, Maryborough. 6885

**CREDITORS**, next of kin, and others having claims in respect of the estate of Adolph Strohaker, late of 29 Hardy-street, South Yarra, pastrycook, deceased (who died on the 21st day of October, 1947), are to send particulars of their claims to John Henry Paul Strohaker, care of the undersigned, by the 29th day of June, 1951, after which date he will distribute the assets, having regard only to the claims of which he then has notice.

JAMES P. OGGE, LL.B., of 165 Greville-street, Prahran. 6882

**CREDITORS**, next of kin, and others having claims in respect of the estate of Jane McIlrath, formerly of Taylor-street, Lilydale, but late of Mooroolbark, in the State of Victoria, spinster, deceased (who died on the 18th day of October, 1950), are to send particulars of their claims to The Union Trustee Company of Australia Limited, at 333 Collins-street, Melbourne, by the 15th day of July, 1951, after which date it will distribute the assets, having regard only to the claims of which it then has notice.

EALES & MILLER, solicitors, 443 Little Collins-street, Melbourne. 6881

**CREDITORS**, next of kin, and others having claims in respect of the estate of Cyril Henry Sawyer, of 16 Parkin-street, Glen Iris, Victoria, jeweller, deceased (who died on the 26th December, 1950), are to send particulars of their claims to Olive May Sawyer, care of her under-mentioned solicitors, by 12th July, 1951, after which date she will distribute the assets, having regard only to the claims of which she then has notice.

UPTON, ETTTELSON, & OWEN, solicitors, 395 Collins-street, Melbourne. 6878

**NOTICE TO CLAIMANTS.—RE ISABELLA JANE PATISON, DECEASED.**

**THE** Fidelity Trustee Company Limited, of 50 Market-street, Melbourne, the executor of the will of Isabella Jane Patison, late of Hexham, Victoria, married woman, deceased (who died on 5th January, 1951), requires all creditors, next of kin, and others having claims against the property or estate of the said deceased to send to the said company, on or before the 12th day of July, 1951, particulars, in writing, of such claims, after which date the company intends to convey or distribute such property or estate to or among the persons entitled thereto, having regard only to the claims of which it shall have had notice.

UPTON, ETTTELSON, & OWEN, solicitors, 395 Collins-street, Melbourne. 6871

**MINING NOTICE.**

**SOUTH COSTERFIELD ANTIMONY AND GOLD MINING COMPANY NO LIABILITY.**

**CALL NOTICE.**

**NOTICE** is hereby given that a Call (the 24th) of Three pence (3d.) per share on all the issued contributing shares in the capital of the company (making such shares paid to 6s. 9d. each); has been made, due and payable to the manager at the registered office of the company, 16 View-street, Bendigo, on Wednesday, 9th May, 1951.

By order of the Board,

N. McLAREN YOUNG, Manager.  
16 View-street, Bendigo, 1st May, 1951. 6813

**IMPOUNDINGS.**

**BEARS LAGOON.**—Impounded at Bears Lagoon.  
 1 bay pony mare, about 12 years old, J.H. on shoulder  
 1 black foal, off hind foot white, white star, snip on nose  
 If not claimed and expenses paid, to be sold on 21st May, 1951.  
 E. H. LAMB,  
 Poundkeeper.  
 6821—7/

**BENDIGO.**—Impounded at Bendigo, on 5th May, 1951.  
 1 grey gelding, no visible brand  
 1 black or dark-brown gelding, white spot on forehead, no visible brand  
 1 bay medium draught mare, no visible brand  
 If not claimed and expenses paid, to be sold on 24th May, 1951.  
 V. E. BOWER,  
 Poundkeeper.  
 6864—9/

**BERWICK.**—Impounded at Berwick, by Ranger.  
 1 black Jersey bull, no visible brand  
 If not claimed and expenses paid, to be sold on 18th May, 1951.  
 P. E. ALLISON,  
 Poundkeeper.  
 6810—6/

**COBURG.**—Impounded at Coburg.  
 1 chestnut delivery gelding, white blaze, hind stockings white, no visible brand, rope on neck  
 If not claimed and expenses paid, to be sold on 23rd May, 1951.  
 E. S. McNABB,  
 Poundkeeper.  
 6859—7/

**KEILOR.**—Impounded at Keilor.  
 3 old ewes, black spot on shoulder, black X on near rump  
 1 white or grey mare, roan mark on off side of face, no visible brand, roan foal at foot  
 If not claimed and expenses paid, to be sold on 24th May, 1951.  
 D. PASCOE,  
 Poundkeeper.  
 6851—8/

**LILYDALE.**—Impounded at Lilydale.  
 1 dark-brown light delivery mare, 3 white feet, blaze face, no visible brand  
 If not claimed and expenses paid, to be sold on 26th May, 1951.  
 E. MASON,  
 Poundkeeper.  
 6840—7/

**MANSFIELD.**—Impounded by C. H. McMillan, from Tolmie-road.  
 3 two-tooth wethers, nick out of point of near ear, branded black H  
 If not claimed and expenses paid, to be sold on 25th May, 1951.  
 R. WOMERSLEY,  
 Poundkeeper.  
 6839—8/

**MULGRAVE.**—Impounded at Mulgrave.  
 1 roan draught gelding, short tail, no visible brand  
 1 bay medium draught mare, white legs, crooked blaze face, shod, no visible brand  
 If not claimed and expenses paid, to be sold on 24th May, 1951.  
 R. LAMBERTON,  
 Poundkeeper.  
 6852—8/

**OXLEY.**—Impounded at Oxley, from Owens State Highway, by Keith L. Moss, C.R.B. Inspector.  
 1 black Jersey cow, notch out of ear, indistinct brand on rump  
 1 dark brindle heifer calf, progeny of above  
 If not claimed and expenses paid, to be sold on 24th May, 1951.  
 H. A. SIMPSON,  
 Acting Poundkeeper.  
 6849—9/

**RED CLIFFS.**—Impounded at Red Cliffs.  
 1 bay draught mare, blazed face, hind and off front feet white, cut tail, indistinct brand on shoulder  
 1 black draught gelding, blazed face, hind and off front feet white, indistinct brand near shoulder  
 1 bay mare, bald face, off side hind foot white, no visible brand, chain and lock around neck  
 If not claimed and expenses paid, to be sold on 24th May, 1951.  
 J. HERAUD,  
 Poundkeeper.  
 6863—11/

**TERANG.**—Impounded at Terang, off Noorat-road.  
 1 red shorthorn heifer, slightly roan face, no visible brand or ear mark  
 If not claimed and expenses paid, to be sold on 28th May, 1951.  
 DORIS M. KIDD,  
 Poundkeeper.  
 6850—7/

**TYLDEN.**—Impounded at Tylden, on 4th May, 1951.  
 1 aged black gelding, no visible brand  
 1 aged brown gelding, F near shoulder  
 1 aged bay mare, lame, no visible brand  
 If not claimed and expenses paid, to be sold on 18th May, 1951.  
 W. R. MACBEAN,  
 Poundkeeper.  
 6865—8/

**YARRA JUNCTION.**—Impounded at Yarra Junction.  
 1 bay draught mare, blaze face, hind legs white, white patches on front legs, A.S. near shoulder  
 If not claimed and expenses paid, to be sold on 19th May, 1951.  
 M. BERUDE,  
 Poundkeeper.  
 6811—7/

**YARRAWONGA.**—Impounded at Yarrowonga, 4th May, 1951.  
 1 light-brown draught gelding, no visible brand  
 If not claimed and expenses paid, to be sold on 23rd May, 1951.  
 F. N. E. JENKINS,  
 Poundkeeper.  
 6858—7/

**WANGARATTA.**—Borough of Wangaratta.  
 4 lambs, branded H  
 5 lambs, branded O  
 2 lambs, branded A  
 4 lambs, indistinct brand  
 2 4-year ewes, branded XB (smudged)  
 If not claimed and expenses paid, to be sold on 24th May, 1951.  
 1 brindle heifer calf, no visible brand  
 1 brindle steer calf, no visible brand  
 1 fawn Jersey cow, JW off rump  
 1 red heifer, piece out of top and bottom of one ear  
 1 white heifer, no visible brand  
 1 yellow and white Jersey steer  
 If not claimed and expenses paid, to be sold on 31st May, 1951.  
 J. McDONNELL,  
 Poundkeeper.  
 6856—18/

**CONTENTS.**

	PAGE
Appointments .. .. .	3364
Bank Holiday .. .. .	3361
Bank Half-Holidays .. .. .	3361
Contracts .. .. .	3365
Country Roads Board .. .. .	3381
Courts .. .. .	3368
Estates of Deceased Persons .. .. .	3378
Government Notices .. .. .	3365
Impoundings .. .. .	3412
King's Birthday Holiday .. .. .	3361
Lands .. .. .	3385
Melbourne and Metropolitan Board of Works— Notice .. .. .	3379
Mining .. .. .	3365, 3411
Notice to Mariners .. .. .	3366
Orders in Council .. .. .	3381
Private Advertisements .. .. .	3403
Proclamations .. .. .	3361
Public Holidays .. .. .	3361
Public Service Notices .. .. .	3398
Tenders .. .. .	3391
Transport Regulation Board—Public Hearings .. .. .	3367
Waterworks Trusts .. .. .	3377
List of Fungicides, &c., Registered under the Fungicides Act 1935 for the year 1951 .. .. .	3369