



VICTORIA  
GOVERNMENT GAZETTE.

Published by Authority.

[Registered at the General Post Office, Melbourne, for transmission by post as a newspaper.]

No. 751]

WEDNESDAY, AUGUST 8.

[1951

*Land Act 1928.*

AREAS OF LANDS COMPRISED IN CERTAIN CLASSES DIMINISHED OR INCREASED.

PROCLAMATION

By His Excellency the Governor of the State of Victoria and its Dependencies in the Commonwealth of Australia,  
&c., &c., &c.

WHEREAS by the *Land Act 1928* it is amongst other things enacted that the Governor in Council may, by Proclamation to be published in the *Government Gazette*, at any time diminish or increase the area of land comprised in any of the classes mentioned in Part I., Division 1, section 5, of the said *Land Act 1928*, but the area of lands which may be sold by auction (Class 6) shall not be increased except as in certain cases in the said Act provided: Now therefore I, the Governor of the State of Victoria, in the Commonwealth of Australia, by and with the advice of the Executive Council of the said State, and in accordance with the provisions of sections 94 and 117 of the *Land Act 1928* aforesaid, do hereby diminish or increase (as the case may be) the areas of Crown lands comprised in Classes 3, 6, and 7 of the classes mentioned in section 5 of the *Land Act 1928* aforesaid to the extent set forth in the subjoined Schedule (that is to say):—

Schedule referred to.

CLASSES DIMINISHED OR INCREASED.

County.	Parish.	Allotment.	Section.	Area.	Diminished.	Increased.	Description.
					Class.	Class.	
				A. R. P.			
Talbot ..	Guildford ..	16	5	8 3 19	7	6	In north-east of parish. (W.61701)
Buln Buln ..	Tanjil ..	48A	..	2 2 0	3	..	In north-west of parish. (H.019591)

Given under my Hand and the Seal of the State of Victoria aforesaid, at Melbourne, this Thirty-first day of July, in the year of our Lord One thousand nine hundred and fifty-one, and in the fifteenth year of the reign of His Majesty King George VI.

(L.S.)

DALLAS BROOKS.

By His Excellency's Command,

A. E. LEND,

Commissioner of Crown Lands and Survey.

GOD SAVE THE KING!

ACTS OF PARLIAMENT.

PROCLAMATION

By His Excellency the Governor of the State of Victoria and its Dependencies in the Commonwealth of Australia, &c., &c., &c.

I, THE Governor of the State of Victoria, in the Commonwealth of Australia, do hereby declare that I have this day assented, in His Majesty's name, to the Bills passed by the Parliament of the said State, the titles whereof are hereunder set forth, that is to say:—

- No. 5537. "An Act to amend the *Education Act 1928.*"
- No. 5538. "An Act to amend the *Friendly Societies Act 1928*, and for other purposes."

Given under my Hand and the Seal of the State of Victoria aforesaid, at Melbourne, this seventh day of August, in the year of our Lord One thousand nine hundred and fifty-one, and in the fifteenth year of the reign of His Majesty King George VI.

(L.S.) DALLAS BROOKS.

By His Excellency's Command,  
JOHN G. B. McDONALD,  
Premier.

GOD SAVE THE KING!

PUBLIC HIGHWAY.—CITY OF MILDURA.

PROCLAMATION

By His Excellency the Governor of the State of Victoria and its Dependencies in the Commonwealth of Australia, &c., &c., &c.

WHEREAS by the *Local Government Act 1946* (No. 5203), section 518, it is amongst other things enacted that it shall be lawful for the Governor in Council, at any time, and from time to time, upon the request of the council of any municipality, by notice in the *Government Gazette*, to declare any land reserved, used or by purchase or exchange acquired for a street, road, highway, thoroughfare, bridge, square, court, alley or right-of-way to be a public highway, and that such land shall thereupon and thenceforth from the date of such Proclamation become and be absolutely dedicated to the public as a public highway within the meaning of any law then or thereafter in force: And whereas the Council of the City of Mildura has requested that the land hereinafter mentioned, which has been used as a street within the said city, be so declared to be a public highway: Now, therefore, I, the Governor of the State of Victoria, in the Commonwealth of Australia, by and with the advice of the Executive Council of the said State, do by this Proclamation declare that all that piece of land, being part of Crown portion 1, Parish of Mildura, County of Karkaroc, indicated by hachure on plan hereunder, shall be a public highway within the meaning of the said Act, viz.:—

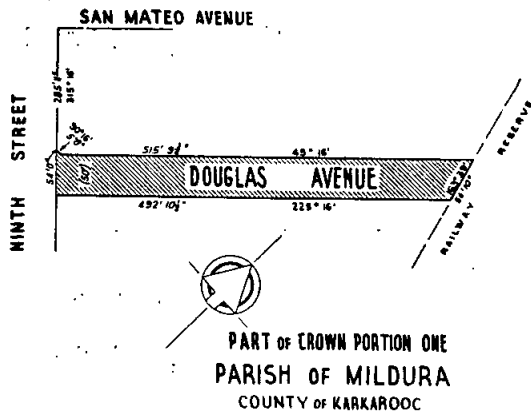

Given under my Hand and the Seal of the State of Victoria aforesaid, at Melbourne, this thirty-first day of July, in the year of our Lord One thousand nine hundred and fifty-one, and in the fifteenth year of the reign of His Majesty King George VI.

(L.S.) DALLAS BROOKS.

By His Excellency's Command,  
P. T. BYRNES,  
Commissioner of Public Works.

GOD SAVE THE KING!

PUBLIC HIGHWAYS.—CITY OF CAMBERWELL.

PROCLAMATION

By His Excellency the Governor of the State of Victoria and its Dependencies in the Commonwealth of Australia, &c., &c., &c.

WHEREAS by the *Local Government Act 1946* (No. 5203), section 518, it is amongst other things enacted that it shall be lawful for the Governor in Council, at any time, and from time to time, upon the request of the council of any municipality, by notice in the *Government Gazette*, to declare any land reserved, used or by purchase or exchange acquired for a street, road, highway, thoroughfare, bridge, square, court, alley or right-of-way to be a public highway, and that such land shall thereupon and thenceforth from the date of such Proclamation become and be absolutely dedicated to the public as a public highway within the meaning of any law then or thereafter in force: And whereas the Council of the City of Camberwell has requested that the lands hereinafter mentioned, which have been reserved as streets within the said city, be so declared to be public highways: Now, therefore, I, the Governor of the State of Victoria, in the Commonwealth of Australia, by and with the advice of the Executive Council of the said State, do by this Proclamation declare that all those pieces of land delineated and indicated by hachure on the plan hereunder, reserved as streets, and being part of Elgar's Crown Special Survey, Parish of Boroondara, County of Bourke, known as Clayton-road, Balwyn, shown on plan of subdivision No. 17028, and Caravan-street, Balwyn, shown on plan of subdivision No. 12815, the said plans of subdivision being lodged in the Office of Titles, shall be public highways within the meaning of the said Act, viz.:—

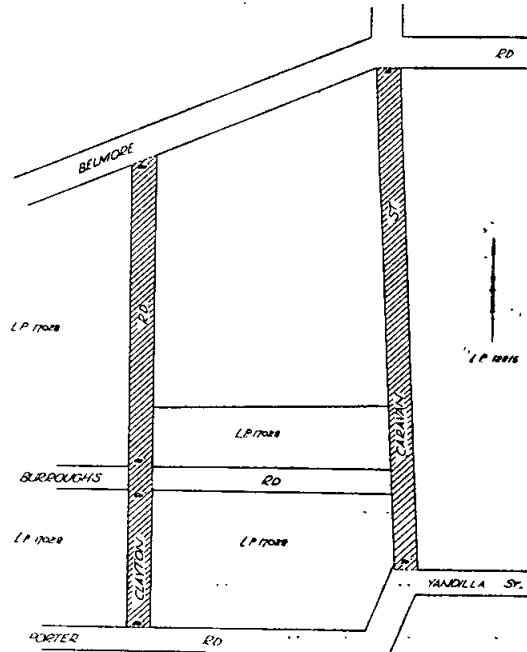

Given under my Hand and the Seal of the State of Victoria aforesaid, at Melbourne, this thirty-first day of July, in the year of our Lord One thousand nine hundred and fifty-one, and in the fifteenth year of the reign of His Majesty King George VI.

(L.S.) DALLAS BROOKS.

By His Excellency's Command,  
P. T. BYRNES,  
Commissioner of Public Works.

GOD SAVE THE KING!

PUBLIC HIGHWAY.—TOWN OF CASTLEMAINE.

PROCLAMATION

By His Excellency the Governor of the State of Victoria and its Dependencies in the Commonwealth of Australia, &c., &c., &c.

WHEREAS by the *Local Government Act 1946* (No. 5203), section 518, it is amongst other things enacted that it shall be lawful for the Governor in Council, at any time, and from time to time, upon the request of the council of any municipality, by notice in the *Government Gazette*, to declare any land reserved, used or by purchase or exchange acquired for a street, road, highway, thoroughfare, bridge, square, court, alley or right-of-way to be a public highway, and that such land shall thereupon and thenceforth from the date of such Proclamation become and be absolutely dedicated to the public as a public highway within the meaning of any law then or thereafter in force: And whereas the Council of the Town of Castlemaine has requested that the land herein-after mentioned, which has been reserved as a street within the said town, be so declared to be a public highway: Now, therefore, I, the Governor of the State of Victoria, in the Commonwealth of Australia, by and with the advice of the Executive Council of the said State, do by this Proclamation declare that all that piece of land reserved as a street, and being parts of Crown allotment 13, section 19, Town of Castlemaine, County of Talbot, and indicated by hachure on the plan hereunder, shall be a public highway within the meaning of the said Act, viz:—

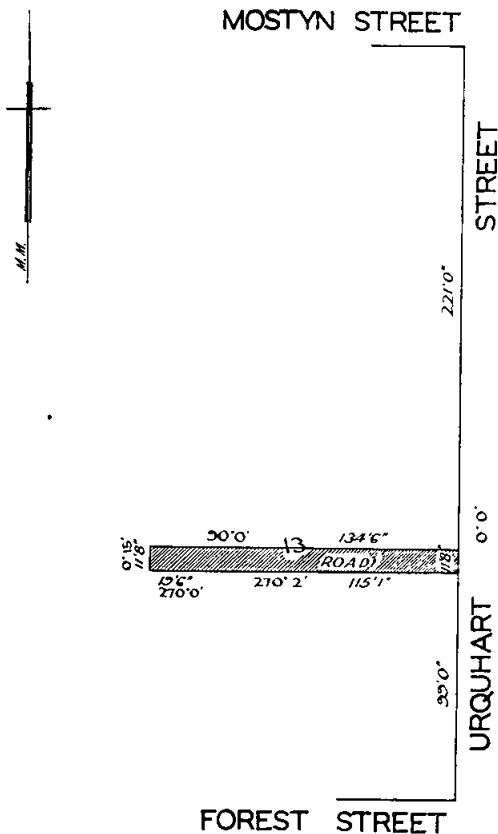

Given under my Hand and the Seal of the State of Victoria aforesaid, at Melbourne, this thirty-first day of July, in the year of our Lord One thousand nine hundred and fifty-one, and in the fifteenth year of the reign of His Majesty King George VI.

(L.S.) DALLAS BROOKS.

By His Excellency's Command,  
P. T. BYRNES,  
Commissioner of Public Works.

GOD SAVE THE KING!

PUBLIC HIGHWAYS.—SHIRE OF DANDENONG.

PROCLAMATION

By His Excellency the Governor of the State of Victoria and its Dependencies in the Commonwealth of Australia, &c., &c., &c.

WHEREAS by the *Local Government Act 1946* (No. 5203), section 518, it is amongst other things enacted that it shall be lawful for the Governor in Council, at any time, and from time to time, upon the request of the council of any municipality, by notice in the *Government Gazette*, to declare any land reserved, used or by purchase or exchange acquired for a street, road, highway, thoroughfare, bridge, square, court, alley or right-of-way to be a public highway, and that such land shall thereupon and thenceforth from the date of such Proclamation become and be absolutely dedicated to the public as a public highway within the meaning of any law then or thereafter in force: And whereas the Council of the Shire of Dandenong has requested that the land herein-after mentioned, which has been used as streets within the said shire, be so declared to be public highways: Now, therefore, I, the Governor of the State of Victoria, in the Commonwealth of Australia, by and with the advice of the Executive Council of the said State, do by this Proclamation declare that all those pieces of land used as streets, and being part of Crown portion 22, Parish of Dandenong, County of Bourke, known as Agnes-street, Noble Park, and Alfred-street, Noble Park, shown on plans of subdivision Nos. 5307, 8879, 9511, 11666, 12759, 13004, 18994, and 19607, lodged in the Office of Titles, and indicated by hachure on the plan hereunder, shall be public highways within the meaning of the said Act, viz:—

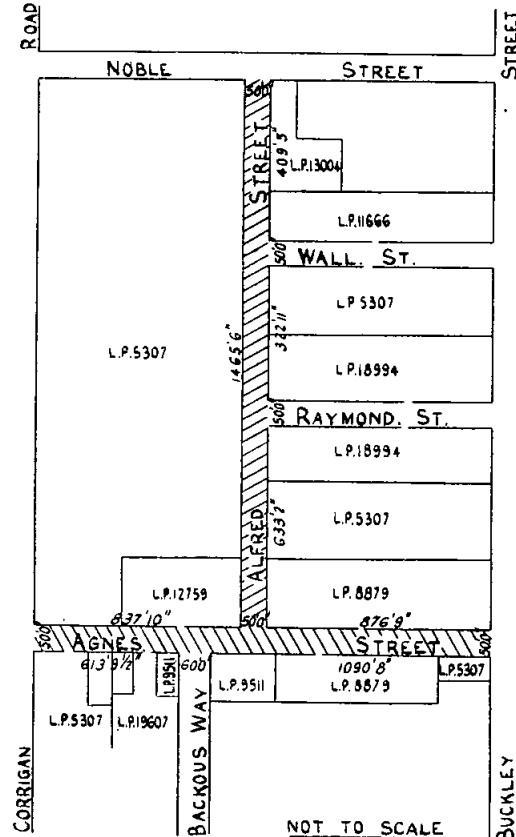

Given under my Hand and the Seal of the State of Victoria aforesaid, at Melbourne, this thirty-first day of July, in the year of our Lord One thousand nine hundred and fifty-one, and in the fifteenth year of the reign of His Majesty King George VI.

(L.S.) DALLAS BROOKS.

By His Excellency's Command,  
P. T. BYRNES,  
Commissioner of Public Works.

GOD SAVE THE KING!

*Weights and Measures Act 1928.*

## ALTERATION OF PROPORTION OF EXPENSES OF UNION.

## PROCLAMATION

By His Excellency the Governor of the State of Victoria and its Dependencies in the Commonwealth of Australia, &c., &c., &c.

I, THE Governor of the State of Victoria, in the Commonwealth of Australia, by and with the advice of the Executive Council of the said State, and in pursuance of the provisions of section 30 of the *Weights and Measures Act 1928*, at the request of the Councils of the municipalities constituting the Weights and Measures Union of the Shires of Dimboola, Dunmunkle, Kaniva, Karkaroc, Lowan, and Warracknabeal do by this my Proclamation alter the proportion in which the expenses devolving on such Union shall be borne by the several bodies corporate of the municipalities constituting the Union so as to be as follows:—

Shire of Dimboola	.. .. .	20 per centum.
Shire of Dunmunkle	.. .. .	16 per centum.
Shire of Kaniva	.. .. .	11 per centum.
Shire of Karkaroc	.. .. .	14 per centum.
Shire of Lowan	.. .. .	17 per centum.
Shire of Warracknabeal	.. .. .	22 per centum.

Given under my Hand and the Seal of the State of Victoria aforesaid, at Melbourne, this seventh day of August, in the year of our Lord One thousand nine hundred and fifty-one, and in the fifteenth year of the reign of His Majesty King George VI.

(L.S.) DALLAS BROOKS.

By His Excellency's Command,  
K. DODGSHUN,  
Chief Secretary.

GOD SAVE THE KING!

*Police Offences Act 1928.*

## EXTENSION OF THE PROVISIONS OF SECTION 5 TO THE SHIRE OF MORTLAKE.

## PROCLAMATION

By His Excellency the Governor of the State of Victoria and its Dependencies in the Commonwealth of Australia, &c., &c., &c.

I, IN pursuance of the provisions contained in section 4 of the *Police Offences Act 1928*, I, the Governor of the State of Victoria, in the Commonwealth of Australia, by and with the advice of the Executive Council of the said State, do by this my Proclamation extend the provisions of section 5 of the said Act to the Shire of Mortlake.

Given under my Hand and the Seal of the State of Victoria aforesaid, at Melbourne, this seventh day of August, in the year of our Lord One thousand nine hundred and fifty-one, and in the fifteenth year of the reign of His Majesty King George VI.

(L.S.) DALLAS BROOKS.

By His Excellency's Command,  
K. DODGSHUN,  
Chief Secretary.

GOD SAVE THE KING!

*Poisons Acts.*

## AMENDMENT OF THE SIXTH SCHEDULE TO POISONS ACT 1928 (No. 3748), AS AMENDED BY ACT No. 3918.

## PROCLAMATION

By His Excellency General Sir Reginald Alexander Dallas Brooks, K.C.B., C.M.G., D.S.O., Governor of the State of Victoria and its Dependencies in the Commonwealth of Australia, &c., &c., &c.

BY virtue of the powers conferred by section 38 of the *Poisons Act 1928*, as amended by section 5 of Act No. 3918, I, the Governor of the State of Victoria, by and with the advice of the Executive Council of the said State and on the recommendation of the Pharmacy Board of Victoria, do by this my Proclamation add the names

of the following substances and preparations to paragraph (2) of the Sixth Schedule to the *Poisons Act 1928*, as amended by Act No. 3918, namely:—

"Cortisone and other supra-renal cortical hormones either natural or synthetic, and adreno-cortico-trophic hormone (A.C.T.H.) and preparations containing these substances in free or combined form, or purporting to contain them in any pharmaceutically elaborated form."

And declare that the Division 2 of Part III. of the *Poisons Act 1928*, as amended by Act No. 3918, shall apply to the substances and preparations named in the same manner as it applies to the substances and preparations included in the said paragraph (2).

Given under my Hand and the Seal of the State of Victoria aforesaid, at Melbourne, this thirty-first day of July, in the year of our Lord One thousand nine hundred and fifty-one, and in the fifteenth year of the reign of His Majesty King George VI.

(L.S.) DALLAS BROOKS.

By His Excellency's Command,  
W. O. FULTON,  
Minister of Health.

GOD SAVE THE KING!

*Health Acts.*

## A DISEASE DECLARED TO BE AN INFECTIOUS DISEASE AND A NOTIFIABLE INFECTIOUS DISEASE.

## PROCLAMATION

By His Excellency the Governor of the State of Victoria and its Dependencies in the Commonwealth of Australia, &c., &c., &c.

I, THE Governor of the State of Victoria, in the Commonwealth of Australia, by and with the advice of the Executive Council of the said State, and by virtue of the powers conferred by the *Health Act 1928* (No. 3697), do by this Proclamation amend the Proclamation published in the *Victoria Government Gazette*, No. 36, of the 12th February, 1936, in which Psittacosis is declared to be a notifiable infectious disease, by substituting for the word "Psittacosis" the word—

"Ornithosis."

Given under my Hand and the Seal of the State of Victoria aforesaid, at Melbourne, this thirty-first day of July, in the year of our Lord One thousand nine hundred and fifty-one, and in the fifteenth year of the reign of His Majesty King George VI.

(L.S.) DALLAS BROOKS.

By His Excellency's Command,  
W. O. FULTON,  
Minister of Health.

GOD SAVE THE KING!

*Health Acts.*

## A DISEASE DECLARED TO BE AN INFECTIOUS DISEASE AND A NOTIFIABLE INFECTIOUS DISEASE.

## PROCLAMATION

By His Excellency the Governor of the State of Victoria and its Dependencies in the Commonwealth of Australia, &c., &c., &c.

I, THE Governor of the State of Victoria, in the Commonwealth of Australia, by and with the advice of the Executive Council of the said State, and by virtue of the powers conferred by the *Health Act 1928* (No. 3697), do by this Proclamation declare Rubella to be an infectious disease and a notifiable infectious disease within the meaning of the Health Acts.

Given under my Hand and the Seal of the State of Victoria aforesaid, at Melbourne, this seventh day of August, in the year of our Lord One thousand nine hundred and fifty-one, and in the fifteenth year of the reign of His Majesty King George VI.

(L.S.) DALLAS BROOKS.

By His Excellency's Command,  
W. O. FULTON,  
Minister of Health.

GOD SAVE THE KING!

*Public Service Act 1946.*

## ALTERATION OF DAY APPOINTED FOR PUBLIC HOLIDAY (KING'S BIRTHDAY).

## PROCLAMATION

By His Excellency the Governor of the State of Victoria and its Dependencies in the Commonwealth of Australia, &c., &c., &c.

WHEREAS Monday, the fifteenth day of December, 1952, is by sub-section (1) of section 67 of the *Public Service Act 1946* appointed for a Public Holiday; And whereas it is made to appear to me expedient that the said day should not be a Public Holiday throughout the State of Victoria: Now therefore I, the Governor of the said State, by and with the advice of the Executive Council thereof, and in pursuance of the provisions of sub-section (3) of section 67 of the aforesaid Act, do by this my Proclamation declare that the said day shall not be a Public Holiday throughout the said State and appoint—

MONDAY, THE 9TH DAY OF JUNE, 1952, to be a Public Holiday throughout the said State.

Given under my Hand and the Seal of the State of Victoria aforesaid, at Melbourne, this seventh day of August, in the year of our Lord One thousand nine hundred and fifty-one, and in the fifteenth year of the reign of His Majesty King George VI.

(L.S.) DALLAS BROOKS.

By His Excellency's Command,  
K. DODGSHUN,  
Chief Secretary.

GOD SAVE THE KING!

## BANK HOLIDAYS.

## PROCLAMATION

By His Excellency the Governor of the State of Victoria and its Dependencies in the Commonwealth of Australia, &c., &c., &c.

IN pursuance of the provisions of the Banks and Currency Acts, I, the Governor of the State of Victoria, in the Commonwealth of Australia, do by this my Proclamation appoint the days and dates named hereunder special days to be observed as Bank Holidays or Bank Half-Holidays (as the case may be) at the places respectively mentioned, that is to say:—

*Bank Holiday:—*

MONDAY, THE 20TH DAY OF AUGUST, 1951, at Ballarat.

*Bank Half-Holidays from the Hour of Twelve o'clock noon:—*

WEDNESDAY, THE 15TH DAY OF AUGUST, 1951, at Stawell.

THURSDAY, THE 30TH DAY OF AUGUST, 1951, at Goroke.

THURSDAY, THE 6TH DAY OF SEPTEMBER, 1951, at Hamilton.

Given under my Hand and the Seal of the State of Victoria aforesaid, at Melbourne, this seventh day of August, in the year of our Lord One thousand nine hundred and fifty-one, and in the fifteenth year of the reign of His Majesty King George VI.

(L.S.) DALLAS BROOKS.

By His Excellency's Command,  
K. DODGSHUN,  
Chief Secretary.

GOD SAVE THE KING!

## APPOINTMENTS.

HIS Excellency the Governor of the State of Victoria, by and with the advice of the Executive Council thereof, has, by Orders made on the 31st day of July, 1951, been pleased to make the under-mentioned appointments, viz.:—

## CHIEF SECRETARY'S DEPARTMENT.

*Electoral Registrar (Acting).*

RAYMOND GEORGE RENFREE

to be Electoral Registrar (Acting) for the Hampton Sub-division of the Electoral District of Brighton; for the Bentleigh and Cheltenham Subdivisions of the Electoral District of Dandenong; and for the Sandringham Sub-division of the Electoral District of Mentone—to take effect on and from the 13th July, 1951, during the absence on leave of Frederick Macaulay.

## DEPARTMENT OF HEALTH.

*Members of Masseurs Registration Board.*

CHARLES HUGH HEMBROW, M.B., B.S., F.R.C.S.,  
LEIGH THORNTON WEDLICK, M.B., B.S., M.R.C.P.,  
EDITH ANNIE MILDRED PRATT,  
MARJORIE FARNBACH,  
GEORGE BEATTIE, and  
FREDERICK JOHN LAIN,

to be Members of the Masseurs Registration Board of Victoria, pursuant to the provisions of section 4 of the *Masseurs Registration Act 1928* (No. 3728), for the period from the 1st July, 1951, to the 30th June, 1954.

*Trustees of Cemeteries.*

CHARLES ELDER CAMPBELL,  
ALBERT FINLAY,  
BERTIE WILLIAM MORRIS,  
JAMES KAY CANTWELL,  
NORMAN JAMES PATERSON,  
HERBERT ERNEST STARLING, and  
ERNEST JOHN LUCAS,

to be Trustees of the Woodside Public Cemetery; and  
FRANCIS CULVENOR  
to be a Trustee of the Glengower Public Cemetery, *vice* C. Culvenor, deceased.

*Public Vaccinators.*

BARRY JARVIS, M.B., B.S.,  
to be Public Vaccinator for the Shire of Kilmore;  
WILLIAM VIVIAN ROWE, M.B., B.S.,  
to be Public Vaccinator for the Shire of Kaniva;  
CECIL ALBERT THOMAS EDWARDS, M.B., B.S.,  
to be Public Vaccinator for the Shire of Numurkah;  
DONALD MCLEAN PEACE, M.B., B.S.,  
to be Public Vaccinator for the Shire of Hampden;  
RAY MORRAH GRANT SOBEY, M.B., B.S.,  
to be Public Vaccinator for the Shire of Broadford;  
JOHN FLETCHER CONNELL, M.B., B.S.,  
to be Public Vaccinator for the Shire of Kyneton; and  
MYLLES WYAMARUS CAVE, M.B., B.S.,  
to be Public Vaccinator for the Shire of Colac.

## LAW DEPARTMENT.

*Commissioners for Taking Declarations, &c.*

ARTHUR REUBEN MINTON, Staff Manager, and  
ALAN KEITH COOPER, Industrial Officer and Paymaster,  
Holeproof Limited, 204 Sydney-road, Brunswick,  
CYRIL HERBERT BROWN, Secretary, The Garrett Con-  
structions, 106 Melville-road, Brunswick, and  
NORMAN GEORGE MINNS, Shire Secretary, Werribee,  
to be Commissioners for taking Declarations and Affidavits,  
pursuant to the provisions of Division 8 of Part IV. of  
the *Evidence Act 1928*—to resign upon ceasing to occupy  
their present positions; and  
FREDERICK WILLIAM CHARTER, Boronia,  
ROY MERLO, 61 Hare-street, Echuca,  
FRANK HOLLOWAY, Macrae-street, East Bairnsdale,  
PATRICK MAJOR DANIELL, Montrose,  
JACK ARCHIE RINGHAM, Anglesea, and  
ALEXANDER MACRAE, 151 Eglinton-street, Kew,  
to be Commissioners for taking Declarations and Affidavits,  
pursuant to the provisions of Division 8 of Part IV. of  
the *Evidence Act 1928*—to resign upon removing from  
the neighbourhood of the addresses stated.

*Magistrates.*

WILLIAM PHILLIP HALES, 7 Wickham-grove, North  
Essendon,  
IAN MUNRO MCLENNAN, 160 Whitehorse-road, Balwyn,  
RAYMOND MEREFIELD EDWARDS, Auburn-road, Auburn,  
FREDERICK WILLIAM DODS, 54 Walpole-street, Kew, and  
BEATRICE ROLLO OLSEN, 10 Jackson-street, Toorak,  
to Keep the Peace in the Central Bailiwick of the State  
of Victoria; and  
HAROLD VERNON DOUGHTY, Mirimbah, and  
ROBERT NEWING, 10 Corio-avenue, Shepparton,  
to Keep the Peace in the Northern Bailiwick of the State  
of Victoria.

*Sworn Valuator.*

RONALD ERNEST PITMAN, 323 High-street, Ashburton,  
to be a Sworn Valuator, pursuant to the provisions of  
section 14 of the *Transfer of Land Act 1928* (No. 3791),  
for the Counties of Bourke, Mornington, and Evelyn.

## PUBLIC WORKS DEPARTMENT.

*Member of Municipal Building Surveyors Board.*

CYRIL EVELYN BELLORD WALDRON  
to be a Member of the Municipal Building Surveyors  
Board, *vice* Edward Andrew Hepburn, deceased, pursuant  
to the provisions of section 175 of the *Local Government  
Act 1946*.

## A. MAHLSTEDT,

Clerk of the Executive Council.

At the Executive Council Chamber,  
Melbourne, 31st July, 1951.

## RULES OF THE SUPREME COURT.

IN pursuance of the powers conferred by the Supreme Court Acts and all other powers hereunto enabling, the following Rule is made and shall take effect from the date on which it is published in the *Government Gazette*. In Appendix "N" to Chapter I., Items 1 to 98 inclusive of the Ordinary Scale of Costs, as amended, are repealed and the following items are substituted therefor:—

## ORDINARY SCALE OF COSTS.

## SUBJECT MATTER.

<i>Writs.</i>	£ s. d.
1. Writ of Summons for the commencement of an action or other writ not specially provided for .. ..	1 10 0
2. Indorsement of claim (if special) .. ..	0 12 0
3. If more than three folios, for every extra folio .. ..	0 3 0
4. Concurrent Writ of Summons .. ..	0 15 0
5. Citation in matrimonial causes .. ..	1 1 0
6. Writ of Mandamus .. ..	1 5 0
7. Writ of Subpoena <i>duces tecum</i> .. ..	0 15 0
8. Writ of Subpoena <i>ad testificandum</i> .. ..	0 12 0
9. If any of the above writs (except Writs of Summons) exceed four folios, for each extra folio .. ..	0 3 0
<i>These fees include all indorsements, and copies, or praecipis for the officers sealing them, and attendances to issue or seal, but not the Court fees.</i>	
<i>Summonses and Warrants.</i>	
10. Summons to attend at Judges' Chambers .. ..	0 15 0
11. Or, if special, at Taxing Officer's discretion, not exceeding .. ..	1 5 0
12. Warrant for proceeding in Master's Office .. ..	0 15 0
13. Originating summonses for proceedings in Chambers (including drawing, engrossing, and copy to file) ..	1 5 0
14. Or, at Taxing Officer's discretion, not exceeding ..	2 2 0
15. And attending to issue, including attendance to get date of return fixed .. ..	0 15 0
<i>No allowance is to be made for praecipis unless special and exceeding three folios.</i>	
<i>Notices and Memoranda.</i>	
16. In proceedings to wind up companies, for preparing or filling up each notice to creditor or to contributories	0 3 0
17. If special, at Taxing Officer's discretion, not exceeding per folio .. ..	0 3 0
18. Notice to produce or admit (including preparation and one copy to serve) .. ..	0 15 0
19. If more than seven folios, for each extra folio ..	0 3 0
20. Notice of originating motion .. ..	1 1 0
21. Notice of interlocutory motion .. ..	0 15 0
22. Or per folio .. ..	0 3 0
23. Any necessary or proper notice or memorandum not otherwise provided for, or any demand .. ..	0 10 0
<i>This provision shall not apply to short notices or memoranda indorsed on other documents, but the words or folios therein may be allowed as part of the document so indorsed.</i>	
24. If special, or necessarily exceeding three folios, for each folio .. ..	0 3 0
<i>The above allowances include preparation of notice and one copy for service. When notice of filing affidavits is required, only one notice is to be allowed for a set of affidavits filed, or which ought to be filed, together.</i>	
<i>Appearances.</i>	
25. Preparing and attending entering appearance .. ..	0 15 0
26. If entered at one time for more than one person, for every defendant beyond the first .. ..	0 3 0

SUBJECT MATTER—*continued.**Appearances—continued.*

	f	s.	d.
27. If a person appearing to a Writ of Summons to recover land limits his defence by his memorandum of appearance, in addition to the above .. .. .	0	10	0
28. Sealed copy appearance for service .. .. .	0	2	0

*Instructions.*

29. To sue, institute, or defend any action, cause, or matter, including appeals .. .. .	1	11	6
30. To make or oppose any motion or application to the Court or a Judge in the Lunacy, Probate, or Insolvency Jurisdictions, or in proceedings under the Companies Acts .. .. .	1	5	0
31. For documents to be brought into Judges' Chambers, or the Office of the Master, such as proposals, statements of facts, reports, accounts, and for special affidavits .. .. .	0	15	0
32. For interrogatories .. .. .	1	5	0
33. To institute or oppose an interlocutory proceeding not otherwise provided for .. .. .	0	15	0
34. For Statement of Claim, Special Case, or Petition .. .. .	3	0	0
35. For indorsement of writ (where no further Statement of Claim), Defence, Counterclaim, Reply, Answer in Matrimonial Cause, any other pleading not otherwise provided for, for particulars in lieu of pleading and for amendments of pleading (if not merely verbal) .. .. .	1	1	0

Instructions are not to be allowed in cases where the work intended to be included therein is charged for and allowed in detail.

36. For Counsel to advise on evidence, when the evidence in chief is to be taken orally .. .. .	1	10	0
37. For Counsel to make an application to the Court where no other brief .. .. .	0	15	0
38. For brief on hearing of originating motion, summons, or petition, special case or motion for special injunction (if the work done be not allowed for under any other heading in the bill of costs) .. .. .	1	10	0
39. For brief on hearing or trial of action or cause upon notice of trial, or notice of judgment given, whether such trial be before a Judge, with or without a jury, or before a special referee, or be the trial of an issue of fact before a Judge or referee, or on assessment of damages or on the hearing of an appeal when witnesses are to be examined or cross-examined .. .. .	3	0	0

Instead of the above fees for Instructions, such larger sum may be allowed as the Taxing Officer may think reasonable having regard to all the circumstances of the case, and to the other allowances made. The fees for instructions for brief are to apply to a hearing on further consideration in Court, when an order for accounts and inquiries has been made without such hearing or trial as above mentioned, but not otherwise.

*Drawing Pleadings and other Documents.*

40. Pleadings, including Petitions (but not including Particulars or Summonses), not exceeding eight folios .. .. .	1	4	0
41. If exceeding eight folios, for every extra folio .. .. .	0	3	0
42. Any other necessary document, per folio .. .. .	0	3	0

Allowance is not to be made to a Solicitor for drawing a document actually drawn by Counsel, but the Taxing Officer shall allow for drawing matter necessary in order to instruct Counsel.

In making allowances for drawing the Taxing Officer may disallow anything which, in his opinion, is a repetition or adaptation of matter for the drawing of which allowance has otherwise been made in the same action or matter.

SUBJECT MATTER—*continued.*

	£	s.	d.
<i>Copies.</i>			
43. Of documents, where no other provision is made, per folio .. .. .	0	1	0
44. Carbon or machine-made copies .. .. .	0	0	8
Where two or more copies could have been made with a typewriter by the same impression, the Taxing Officer may allow for each copy, however made, the same rate only as for carbon copies. This rule may be applied in cases where both or all copies are made by hand.			
Close copies are not to be allowed as of course, but the allowance is to depend on the propriety of making or sending the copies, which in each case is to be shown to and considered by the Taxing Officer.			
<i>Printing.</i>			
45. When, pursuant to Rules of Court, or for any sufficient reason, any document is printed, the Solicitor of the party printing shall be allowed for a copy for the printer (except where made by the Officer of the Court) at per folio .. .. .	0	1	0
46. And for examining the proof print, at per folio ..	0	0	6
47. And, for printing, the amount actually and properly paid to the printer.			
In addition, all necessary attendances on the printer.			
And, when any part shall properly be printed in a foreign language, or as a fac-simile, or in any unusual or special manner, or where any alteration in the document being printed becomes necessary after the first proof, such further allowance shall be made as the Taxing Officer shall think reasonable.			
<i>Attendances.</i>			
48. Personal service of any process or proceeding, where necessary .. .. .	1	5	0
49. If served at a distance of more than 2 miles from the nearest place of business or office of the Solicitor serving the same, according to the time occupied and expenses properly incurred.			
50. Where in consequence of the distance of the party to be served, it is proper to effect such service through an agent other than the Melbourne agent, instead of the allowance for service, for correspondence .. .. .	0	16	0
51. Correspondent's charges .. .. .	2	2	0
Or the amount actually and reasonably charged by and paid to the person serving.			
Where more than one attendance is necessary to effect service, or to ground an application for substituted service, such further allowance shall be made as the Taxing Officer shall think reasonable.			
For service out of the jurisdiction such allowance is to be made as the Taxing Officer shall think reasonable.			
52. Service on the Solicitor for a party who has issued process or entered an appearance, or at the address for service of a party .. .. .	0	10	0
53. Or, if authorized to be served by post .. .. .	0	4	0
When any two or more documents have to be, or may be, served together, one fee only for such service may be allowed.			
On Counsel with brief or other papers or to appoint consultation or conference.			
54. If Counsel's fee under £10 10s. .. .. .	0	10	6
55. If £10 10s. or over .. .. .	1	1	0
56. To mark refresher .. .. .	0	10	6
57. On consultation .. .. .	2	10	0



SUBJECT MATTER—*continued.*

<i>Attendances—continued.</i>		<i>£</i>	<i>s.</i>	<i>d.</i>
58. On conference if Counsel's fee does not exceed £2 2s. . . . .		1	1	0
59. If over £2 2s. . . . .		2	2	0
60. If conference or consultation occupies more than one hour, at the discretion of the Taxing Officer, not to exceed per hour, after the first hour . . . . .		1	1	0
61. Examining Appeal Books, per hour . . . . .		0	15	0
62. On a Summons or other application in Chambers . . . . .		0	15	0
63. Or according to circumstances, not to exceed . . . . .		5	5	0
64. On Motion, Special Case, Petition, Application adjourned from the Judges' Chambers, Appeal, or other application to the Court, when in list or likely to be heard . . . . .		1	1	0
65. When heard . . . . .		2	2	0
66. Or according to circumstances, not to exceed . . . . .		6	6	0
67. To present Petition . . . . .		1	1	0
68. On hearing or trial of any action, cause, or matter, or issue of fact, whether before a Judge with or without a jury, special referee, or on assessment of damages, when in the list . . . . .		1	1	0
69. When heard or tried . . . . .		2	2	0
70. Or according to circumstances, not to exceed . . . . .		8	8	0
71. For every hour, after the first two hours, including attendance to hear judgment . . . . .		1	11	6
As to attendances at Court or in Chambers, when the Solicitor has not given personal attendance, the maximum allowances shall be as follows:—				
		<i>£</i>	<i>s.</i>	<i>d.</i>
Applications in Chambers . . . . .		3	13	6
Motions or other applications to the Court . . . . .		5	5	0
Hearing or trial of actions, etc., per hour . . . . .		1	1	0
or per day . . . . .		5	5	0
72. When in the opinion of the Taxing Officer it is necessary for two principals, or for a Solicitor and managing clerk to attend the trial, an additional allowance may be made per day of . . . . .		3	3	0
73. Attending by appointment or on application at Judges' Chambers or before the Chief Clerk, the Prothonotary, or the Master . . . . .		0	18	0
74. Of if the Judge, Prothonotary, Chief Clerk, or Master shall certify that a further sum should be allowed, not exceeding . . . . .		5	5	0
75. On examination of witnesses before an Examiner, officer or other person, if attended by principal . . . . .		1	11	6
If attended by clerk . . . . .		1	4	0
76. Or, according to circumstances, not to exceed per day if Counsel employed and attended by principal . . . . .		5	5	0
If Counsel employed and attended by clerk . . . . .		4	14	6
Or, if without Counsel, at the discretion of the Taxing Master.				
77. To settle judgment or order, per hour . . . . .		1	1	0
78. On taxation of costs . . . . .		1	0	0
79. Or, according to circumstances, not to exceed per day of six hours (including luncheon adjournment) . . . . .		6	6	0
80. If for any purpose, such as attending a trial, conference with Counsel, taxation of costs, or collection of evidence, it is in the opinion of the Taxing Officer necessary for a Solicitor to leave the town where he resides or carries on business and journey to another place, for each day (except Sunday) that he is necessarily absent from such town . . . . .		6	6	0
81. And expenses (besides actual reasonable fares or payment for transport), each day (24 hours) of necessary absence . . . . .		2	0	0

SUBJECT MATTER—*continued.*

*Attendances—continued.*

f s. d.

In all such cases the Taxing Officer must be satisfied that the purpose of the journey could not have been satisfactorily accomplished by an agent.

If the journey be not undertaken solely for purposes of the cause or matter, such proportion of the above fees may be allowed as the Taxing Officer shall think reasonable.

- 82. To file, lodge, or deliver any document or other papers (including filing in lieu of service, but not other services), to obtain an appointment from any officer of the Court, to insert advertisement, or other attendance of a similar nature capable of performance by a junior clerk .. .. . 0 10 0
- 83. If the attendance is one requiring the personal attendance of the Solicitor or his managing clerk and involving the exercise of skill or legal knowledge, per hour .. 1 5 0
- 84. Or such larger amount as the Taxing Officer may think reasonable having regard to the importance or difficulty of the subject-matter of the attendance, not exceeding per hour .. .. . 2 2 0
- 85. Any attendance, for which no other provision is made .. 0 15 0

*Perusals.*

- 86. Of all Pleadings, including Petitions, Amendments of Pleadings (exceeding three folios), and Originating Summonses, Interrogatories, Answers thereto, Special Cases, Statements of Facts, Notices of Defendants' Claim under Order XVIIA Rule 1, Special Affidavits or Declarations, Draft Orders submitted for approval by the Solicitor for another party, Drafts of Documents to be settled by an Officer of the Court, Orders (unless an allowance has been made previously for perusal of the draft thereof), Notices of Motion, by the Solicitor for the party to whom the same are delivered, per folio .. .. . 0 1 6
- 87. Of Counsel's opinion or advice on evidence, per folio .. 0 1 6
- 88. Notices to produce or admit, deeds, correspondence and other documents, including exhibits which are necessary and proper to be perused, per folio .. .. . 0 1 0  

But if the Solicitor is already familiar with the contents of the document or if it is not necessary to carefully read the whole, such smaller sum (if any) as the Taxing Officer may think reasonable.

No allowance is to be made for perusal of letters received by the Solicitor, nor of notices or summonses except where specially provided.
- 89. For perusal of a bill of costs, with a view to taxing the same adversely, at the discretion of the Taxing Officer, not exceeding per folio .. .. . 0 0 8

OATHS, EXHIBITS, AND SPECIAL BAIL.

- 90. Commissioners to take oaths or affidavits, for every oath, declaration, or affirmation .. .. . 0 1 6
- 91. The Solicitor for preparing each exhibit .. .. . 0 1 0
- 92. The Commissioner for marking each exhibit .. .. . 0 0 6
- 93. The Commissioner on taking special bail .. .. . 1 1 0

*Correspondence, Agency, etc.*

- 94. Letters, if ordinary .. .. . 0 6 0
- 95. Letters, if special .. .. . 0 10 6
- 96. Circular letters, after the first .. .. . 0 1 6

Or at the discretion of the Taxing Officer. If the letter be in fact an opinion on a question of law, the Taxing Officer may allow a reasonable fee for work done in order to give such opinion.

## OATHS, EXHIBITS, AND SPECIAL BAIL—continued.

Correspondence, Agency, etc.—continued. £ s. d.

97. In cases where an agent is employed, for correspondence per quarter of the year .. .. .	1	1	0
		to	
	2	10	0

Or, if special or extensive, at the discretion of the Taxing Officer.

These provisions shall apply although the correspondence be not in a cause or matter.

An allowance may also be made, if the circumstances warrant it, for the necessary expense of postage, carriage, and transmission of documents.

98. Solicitor's Managing Clerk's fee, where there is a trial or hearing, at which witnesses are examined or cross-examined .. .. .	2	2	0
--	---	---	---

CHARLES J. LOWE, A.C.J.

RUSSELL MARTIN, J.

ARTHUR DEAN, J.

R. R. SHOLL, J.

E. G. COPPEL, A.J.

LAW DEPARTMENT.—SOLICITOR-GENERAL.  
COURTS OF PETTY SESSIONS.—ALTERATION OF  
DAYS AND HOURS.

HIS Excellency the Governor of the State of Victoria, by and with the advice of the Executive Council thereof, doth, by Order made on the 31st day of July, 1951, and pursuant to the provisions of section 61 of the *Justices Act 1928*, direct that the days and hours heretofore appointed for the holding of Courts of Petty Sessions at the places named in the first column of the Schedule below be altered to the days and hours set forth in the second column of such Schedule.

Place.	SCHEDULE. Days and Hours.
Minyip .. .. .	Every alternate Monday, at 2 p.m., as from and inclusive of the 13th August, 1951.
Hopetoun .. .. .	Every alternate Tuesday, at 2 p.m., as from and inclusive of the 14th August, 1951.
Beulah .. .. .	Every alternate Tuesday, at 9.30 a.m., as from and inclusive of the 14th August, 1951.
Warracknabeal .. .. .	Every Wednesday, at 10 a.m., as from and inclusive of the 15th August, 1951.

A. MAHLSTEDT,  
Clerk of the Executive Council.

At the Executive Council Chamber,  
Melbourne, the 31st July, 1951.

DEPARTMENT OF LAW.—SOLICITOR-GENERAL.  
REMOVAL FROM OFFICE OF MAGISTRATE.

HIS Excellency the Governor of the State of Victoria, by and with the advice of the Executive Council thereof, doth, by Order made on the 31st day of July, 1951, hereby remove JOSELYN DAVID LANGDON from the Commission of the Peace for the Central Bailiwick of Victoria.

A. MAHLSTEDT,  
Clerk of the Executive Council.

At the Executive Council Chamber,  
Melbourne, 31st July, 1951.

LAW DEPARTMENT.—ATTORNEY-GENERAL.  
CURATOR OF CONVICT'S PROPERTY.

HIS Excellency the Governor of the State of Victoria, by and with the advice of the Executive Council thereof, doth, by Order made on the 31st day of July, 1951, and pursuant to the provisions of section 576 of the *Crimes Act 1928*, direct that the custody and management of the

property of the convict Norman Francis Trevor Salon be committed to Thomas Alan Shields, of 125 Edgevale-road, Kew, storekeeper, as a curator hereby appointed in that behalf.

A. MAHLSTEDT,  
Clerk of the Executive Council.

At the Executive Council Chamber,  
Melbourne, the 31st July, 1951.

## SHIRE OF BET BET.

ROAD DEVIATION.

Order in Council.

IN pursuance of the powers conferred by sections 521 and 525 of the *Local Government Act 1928*, the Council of the Shire of Bet Bet doth hereby order that the lands next hereinafter described shall be a public highway from the date of the publication of this Order in the *Government Gazette*, that is to say:—

All that piece of land commencing at the north-east angle of allotment 97, Parish of Archdale, County of Gladstone; thence by a line bearing southerly 6 min. west of south for a distance of 3,596 links to south-east angle of said allotment; thence by a line bearing westerly north 89 deg. 54 min. west for a distance of 2,288 links; thence by a line bearing south a distance of 5,107.7 links to south-east angle of 82A; thence westerly by a line bearing north 74 deg. west for a distance of 104 links; thence due north 5,179.2 links; thence by a line bearing easterly south 89 deg. 54 min. east a distance of 2,288.2 links; thence northerly by a line bearing 6 min. east of north for a distance of 3,496 links; thence by a line bearing easterly 90 deg. 6 min. for 100 links to commencing point.

In lieu of land hereinafter described, commencing at south-west angle of allotment 85, Parish of Archdale, County of Gladstone; thence by a line bearing easterly south 89 deg. 54 min. east for a distance of 10,810 links; thence by a line bearing southerly 6 min. west of south for 100 links; thence westerly along northern boundaries of allotments 97 and 84 of said parish to north-west angle of allotment 84 a distance of 10,810 links; thence by a line northerly 6 min. east of north 100 links to commencing point.

Dated the 27th day of June, 1951.

The common seal of the President, Councillors, and Ratepayers of the Shire of Bet Bet was hereunto affixed, in the presence of—

(SEAL) ALLEN BROWNBILL, President.  
W. BELCHER, Councillor.  
K. A. G. LOWE, Secretary.

Approved by the Governor in Council,  
31st July, 1951.

A. MAHLSTEDT,  
Clerk of the Executive Council.

## MONEY LENDERS ACT 1938.

IN accordance with the provisions of the above-mentioned Act, the following is published for general information:—

*List of Persons to whom Money Lenders' Licences have been issued for the Year ending 30th June, 1952.*

Name.	Authorized Name.	Authorized Address.	Date of Issue.
Abraham, Isaac Pty. Ltd. (S. E. Abraham, appointee)	Isaac Abraham Pty. Ltd. . . . .	211 Mair-street, Ballarat . . . .	1.7.51
Abraham, M. D. . . . .	M. D. Abraham, carrying on business as D. L. Abraham	109 Swanston-street, Melbourne . . . .	1.7.51
Adams, Geo. Pty. Ltd. (C. J. Smith, appointee)	Geo. Adams Pty. Ltd. . . . .	89 North-street, Ascot Vale . . . .	1.7.51
Adams, Geo. Pty. Ltd. (G. M. Brooks, appointee)	Geo. Adams Pty. Ltd. . . . .	117 Pall Mall, Bendigo . . . .	2.7.51
Adams, Geo. Pty. Ltd. (J. N. Honey, appointee)	Geo. Adams Pty. Ltd. . . . .	304 Sydney-road, Brunswick . . . .	1.7.51
Adams, Geo. Pty. Ltd. (C. S. Jackson, appointee)	Geo. Adams Pty. Ltd. . . . .	351 Smith-street, Fitzroy . . . .	1.7.51
Adams, Geo. Pty. Ltd. (F. W. Brown, appointee)	Geo. Adams Pty. Ltd. . . . .	429 Chapel-street, South Yarra . . . .	1.7.51
Advance Footscray Pty. Ltd. (H. Davis, appointee)	Advance Footscray Pty. Ltd. . . . .	31 Leeds-street, Footscray . . . .	1.7.51
Advance Northcote Pty. Ltd. (J. Crogan appointee)	Advance Northcote Pty. Ltd. . . . .	318 High-street, Northcote . . . .	1.7.51
Advance Providers Pty. Ltd. (J. Goodenday, appointee)	Advance Providers Pty. Ltd. . . . .	306 Little Collins-street, Melbourne . . . .	1.7.51
Allwright, D. T. . . . .	D. T. Allwright . . . . .	432 Bay-street, East Brighton . . . .	1.7.51
Amalgamated Cash Orders Pty. Ltd. (F. O. Reinhart, appointee)	Amalgamated Cash Orders Pty. Ltd. . . . .	255 Smith-street, Fitzroy . . . .	1.7.51
Amalgamated Cash Orders Pty. Ltd. (F. O. Reinhart, appointee)	Amalgamated Cash Orders Pty. Ltd. . . . .	40 Leeds-street, Footscray . . . .	1.7.51
Amalgamated Cash Orders Pty. Ltd. (F. O. Reinhart, appointee)	Amalgamated Cash Orders Pty. Ltd. . . . .	Cr. Malop and Moorabool streets, Geelong . . . .	1.7.51
Amalgamated Cash Orders Pty. Ltd. (F. O. Reinhart, appointee)	Amalgamated Cash Orders Pty. Ltd. . . . .	130-132 Bourke-street, Melbourne . . . .	1.7.51
Amalgamated Cash Orders Pty. Ltd. (F. O. Reinhart, appointee)	Amalgamated Cash Orders Pty. Ltd. . . . .	327 Bourke-street, Melbourne . . . .	1.7.51
Assignment Mortgage and Finance Co. Pty. Ltd. (J. E. Dimelow, appointee)	Assignment Mortgage and Finance Co. Pty. Ltd. . . . .	422 Collins-street, Melbourne . . . .	1.7.51
Associated Finance Pty. Ltd. (J. T. Milward, appointee)	Associated Finance Pty. Ltd. . . . .	451 Elizabeth-street, Melbourne . . . .	1.7.51
Atlas Loan and Finance Co. Pty. Ltd. (T. Marshall, appointee)	Atlas Loan and Finance Co. Pty. Ltd. . . . .	303-9 Collins-street, Melbourne . . . .	1.7.51
Australian Guarantee Corporation Ltd. (G. V. Beattie, appointee)	Australian Guarantee Corporation Ltd. . . . .	44 Queen-street, Melbourne . . . .	1.7.51
Australian Mont de Piete Loan and Deposit Co. Ltd. (A. J. Thaw, appointee)	Australian Mont de Piete Loan and Deposit Co. Ltd. . . . .	330 Little Collins-street, Melbourne . . . .	1.7.51
Autotarms Pty. Ltd. (A. Lewis, appointee)	Autotarms Pty. Ltd. . . . .	16 Swan-street, Richmond . . . .	1.7.51
Barnes, W. G. . . . .	W. G. Barnes . . . . .	284 Plenty-road, Preston . . . .	1.7.51
Barnett, S. . . . .	S. Barnett, carrying on business as Henry Barrett	569 Swanston-street, Carlton . . . .	1.7.51
Booth, E. V. . . . .	E. V. Booth . . . . .	497 Brunswick-street, North Fitzroy . . . .	1.7.51
Browne, C. Dennys . . . . .	C. Dennys Browne . . . . .	84 Collins-street, Melbourne . . . .	1.7.51
C. A. Bowring, Estate of (C. B. O. Bowring, Agent)	C. A. Bowring . . . . .	100-4 Queen-street, Melbourne . . . .	1.7.51
Brooks, A. . . . .	A. Brooks, carrying on business as R.H.B. Cash Order Co.	99-109 Smith-street, Fitzroy . . . .	1.7.51
Building Guarantee and Discount Co. Ltd. (P. G. Proctor, appointee)	Building Guarantee and Discount Co. Ltd. . . . .	118 Queen-street, Melbourne . . . .	1.7.51
Burroughs, J. R. . . . .	J. R. Burroughs . . . . .	224 Camberwell-road, Hawthorn . . . .	1.7.51
Caplan, N. . . . .	N. Caplan, carrying on business as Brunswick Loan Co.	365b Lygon-street, East Brunswick . . . .	1.7.51
Carrick, A. . . . .	A. Carrick, carrying on business as C. Finance and Cash Order Co.	183 Elgin-street, Carlton . . . .	1.7.51
Case, H. E. . . . .	H. E. Case, carrying on business as H. and M. Case	38 Osborne-street, Williamstown . . . .	1.7.51
Case, M. A. . . . .	M. A. Case, carrying on business as H. and M. Case	38 Osborne-street, Williamstown . . . .	1.7.51
Casper, Edward Pty. Ltd. (G. S. Cox, appointee)	Edward Casper Pty. Ltd. . . . .	272 Bourke-street, Melbourne . . . .	1.7.51
Cheney, E. A. . . . .	E. A. Cheney, carrying on business as F. and E. Cheney	146 Hopkins-street, Footscray . . . .	1.7.51
Cheney, J. F. . . . .	J. F. Cheney, carrying on business as F. and E. Cheney	146 Hopkins-street, Footscray . . . .	1.7.51
City Insurance Finance Corporation Pty. Ltd. (R. G. Pinsent, appointee)	City Insurance Finance Corporation Pty. Ltd. . . . .	105 Swanston-street, Melbourne . . . .	1.7.51
Collins Trading Co. Pty. Ltd. (M. H. Joske, appointee)	Collins Trading Co. Pty. Ltd. . . . .	305 Collins-street, Melbourne . . . .	1.7.51
Commercial Discounters (Victoria) Pty. Ltd. (E. H. Shaw, appointee)	Commercial Discounters (Victoria) Pty. Ltd. . . . .	325 Collins-street, Melbourne . . . .	1.7.51
Corio Guarantee Corporation Ltd. (A. F. Madsen, appointee)	Corio Guarantee Corporation Ltd. . . . .	62 Ryrie-street, Geelong . . . .	1.7.51
Dennis, G. W. . . . .	G. W. Dennis . . . . .	73 Nicholson-street, Footscray . . . .	1.7.51
Deposit and Investment Co. Ltd. (H. W. Stephenson, appointee)	Deposit and Investment Co. Ltd. . . . .	351 Swanston-street, Melbourne . . . .	1.7.51
Deposit and Investment Co. Ltd. (A. T. Howe, appointee)	Deposit and Investment Co. Ltd. . . . .	309 Little Collins-street, Melbourne . . . .	1.7.51

## MONEY LENDERS ACT—continued.

Name.	Authorized Name.	Authorized Address.	Date of Issue.
Dickens, D. S.	D. S. Dickens, carrying on business as The Elsternwick Cash Order Co.	26 Riddell-parade, Elsternwick	1.7.51
Evans, J. W. H.	J. W. H. Evans	26 Holloway-road, Brunswick West	1.7.51
Everyone's Finance Co. Pty. Ltd. (H. L. Whykes, appointee)	Everyone's Finance Co. Pty. Ltd.	41 Lydiard-street south, Ballarat..	1.7.51
Extension Agency Pty. Ltd. (A. Mathier, appointee)	Extension Agency Pty. Ltd.	172A Flinders-street, Melbourne	1.7.51
Field, K. E.	K. E. Field, carrying on business as The Star Cash Order and Finance Co.	48 Leeds-street, Footscray	1.7.51
Field, K. E.	K. E. Field, carrying on business as The Star Cash Order and Finance Co.	441 Sydney-road, Brunswick	1.7.51
Fleet Investments Pty. Ltd. (E. Hogan, appointee)	Fleet Investments Pty. Ltd.	60 Collins-place, Melbourne	1.7.51
Fleming, M.	M. Fleming, carrying on business as Archie Wells Finance and Cash Order Co.	17 The Centreway, Chapel-street, Prahran	1.7.51
Gaffney, G. T.	R. K. McCleery and G. T. Gaffney	307 Sydney-road, Brunswick	1.7.51
Green, S.	S. Green	408 Collins-street, Melbourne	1.7.51
Hall, Harry Pty. Ltd. (H. C. Duffield, appointee)	Harry Hall Pty. Ltd.	131 Ryrie-street, Geelong	1.7.51
Hall, Harry Pty. Ltd. (H. A. Phillips, appointee)	Harry Hall Pty. Ltd.	57 Swanston-street, Melbourne	1.7.51
Hall, J.	J. Hall	58 North-road, Newport	1.7.51
Harris, E. H.	E. H. Harris	285 Barkly-street, Footscray	1.7.51
Hocking, J. B.	J. B. Hocking	69 Ryrie-street, Geelong	1.7.51
Hore, D. E. A.	D. E. A. Hore, carrying on business as Horton Cash Order Co.	64 Elizabeth-street, Melbourne	1.7.51
Horsington, W. F.	W. F. Horsington, carrying on business as Aussie Finance Co.	6 Paisley-street, Footscray	1.7.51
Ireland, T. M.	T. M. Ireland	229 Collins-street, Melbourne	1.7.51
Irons, J. F.	J. F. Irons	1 Woodlawn-street, Richmond	1.7.51
Izzard, H. W.	H. W. Izzard	135 Woodlands-street, Essendon	1.7.51
James, S. L.	S. L. James	26 James-street, Box Hill	1.7.51
Johnson, E. E.	E. E. Johnson, carrying on business as Vestor Finance Co.	149A Pakington-street, Geelong West	1.7.51
Jones, Marcus, Pty. Ltd. (M. Southwick, appointee)	Marcus Jones Pty. Ltd.	49 Elizabeth-street, Melbourne	1.7.51
Jubilee Investments Pty. Ltd. (M. S. Sheezel, appointee)	Jubilee Investments Pty. Ltd.	Cr. Bourke and Russell streets, Melbourne	1.7.51
K. and G. Business Finance Pty. Ltd. (G. A. Greenaway, appointee)	K. and G. Business Finance Pty. Ltd.	28 Elizabeth-street, Melbourne	1.7.51
Kendall, J. F.	J. F. Kendall	51 Leeds-street, Footscray	1.7.51
*Kiernan, E. L.	E. L. Kiernan, carrying on business as "K" Cash Order Co.	220-228 Smith-street, Collingwood	1.7.51
*Kiernan, E. L.	E. L. Kiernan, carrying on business as "K" Cash Order Co.	189 Bourke-street, Melbourne	1.7.51
Kiernan, F. A.	F. A. Kiernan, carrying on business as "K" Cash Order Co.	220-228 Smith-street, Collingwood	1.7.51
Kiernan, F. A.	F. A. Kiernan, carrying on business as "K" Cash Order Co.	189 Bourke-street, Melbourne	1.7.51
Kinder, M.	M. Kinder, carrying on business as H. S. Thompson and M. Kinder	282-4 Collins-street, Melbourne	1.7.51
King, H. V.	H. V. King	108 Queen-street, Melbourne	1.7.51
Knibb, J. E.	James Knibb	80 Swanston-street, Melbourne	1.7.51
Lawson Trading Co. Pty. Ltd. (A. G. Maver, appointee)	Lawson Trading Co. Pty. Ltd.	230 Collins-street, Melbourne	1.7.51
Leon Finance Co. Pty. Ltd. (L. M. Sheezel, appointee)	Leon Finance Co. Pty. Ltd.	Cr. Bourke and Russell streets, Melbourne	1.7.51
Livingston, L. A.	L. A. Livingston, carrying on business as General Cash Order Co.	270 Bridge-road, Richmond	1.7.51
Lygon Investments Pty. Ltd. (H. Kelly, appointee)	Lygon Investments Pty. Ltd.	300 Lygon-street, Carlton	1.7.51
McCleery, R. K.	R. K. McCleery and G. T. Gaffney	307 Sydney-road, Brunswick	1.7.51
McKay, W.	W. McKay	327 Collins-street, Melbourne	1.7.51
McKeown, W. J.	The W. J. McKeown Finance and Cash Order Co.	548 Sydney-road, Brunswick	1.7.51
Mack's Investments Ltd. (L. C. Pugsley, appointee)	Mack's Investments Ltd.	252 Flinders-lane, Melbourne	1.7.51
Madden, T. W.	T. W. Madden	495 Collins-street, Melbourne	1.7.51
Marshall, J. D.	J. D. Marshall	13 Miller-street, Thornbury	1.7.51
Matthews, V. R.	V. R. Matthews, carrying on business as The Grattan Finance and Cash Order Co.	209 Lygon-street, Carlton	1.7.51
Mayer, H. E.	H. E. Mayer	349 Collins-street, Melbourne	1.7.51
Melbourne Finance and Cash Order Co. Pty. Ltd. (M. Southwick, appointee)	Melbourne Finance and Cash Order Co. Pty. Ltd.	49 Elizabeth-street, Melbourne	1.7.51
Mitford Credit Finance Co. Pty. Ltd. (G. L. Anguey, appointee)	Mitford Credit Finance Co. Pty. Ltd.	109 Swanston-street, Melbourne	5.7.51
Mutual Finance Co. Pty. Ltd. (E. Jansen, appointee)	Mutual Finance Co. Pty. Ltd.	57 Swanston-street, Melbourne	1.7.51
Mutual Traders Credits Pty. Ltd. (B. Red-apple, appointee)	Mutual Traders Credits Pty. Ltd.	121-123 Johnston-street, Fitzroy	1.7.51
New Trading Agency Pty. Ltd. (G. R. Angus, appointee)	New Trading Agency Pty. Ltd.	163 Swanston-street, Melbourne	1.7.51
Norfolk Finance and Investment Co. Pty. Ltd. (G. Lindsay, appointee)	Norfolk Finance and Investment Co. Pty. Ltd.	296 Collins-street, Melbourne	1.7.51

\* Licence for which no fee is payable.

MONEY LENDERS ACT—continued.

Name.	Authorized Name.	Authorized Address.	Date of Issue.
Orr, F. H. . . . .	F. H. Orr . . . . .	46 Lydiard-street south, Ballarat . . .	1.7.51
Parry, R. G. . . . .	R. G. Parry . . . . .	64 Elizabeth-street, Melbourne . . .	1.7.51
Pembroke, F. . . . .	F. Pembroke . . . . .	57 Elizabeth-street, Melbourne . . .	1.7.51
Pitt, R. G. . . . .	R. G. Pitt . . . . .	148 Swan-street, Richmond . . .	1.7.51
Prahran Cash Order Pty. Ltd. (H. E. Goss, appointee)	The Prahran Cash Order Pty. Ltd. . . .	26 The Centreway, Prahran . . .	1.7.51
Rabinov, S. . . . .	S. Rabinov, carrying on business as Simplex Finance and Cash Order Co.	75 Crookford-street, Port Melbourne . . .	1.7.51
Raglan Investments Pty. Ltd. (G. W. Mansbridge, appointee)	Raglan Investments Pty. Ltd. . . .	236 Mitchell-street, Bendigo . . .	1.7.51
Redapple, J. . . . .	J. Redapple . . . . .	121-123 Johnston-street, Fitzroy . .	1.7.51
*Reddan, A. A. . . . .	A. A. Reddan, carrying on business as "K" Cash Order Co. . . . .	220-8 Smith-street, Collingwood . .	1.7.51
*Reddan, A. A. . . . .	A. A. Reddan, carrying on business as "K" Cash Order Co. . . . .	189 Bourke-street, Melbourne . . .	1.7.51
Rosen, L. . . . .	L. Rosen, carrying on business as Roseen Cash Order Co. . . . .	666 Sydney-road, Brunswick . . .	1.7.51
Rosen, L. . . . .	L. Rosen, carrying on business as Roseen Cash Order Co. . . . .	412 Brunswick-street, Fitzroy . . .	1.7.51
Scates, R. P. . . . .	R. P. Scates, carrying on business as Assurance Cash Order Co. . . . .	16 Koornang-road, Carnegie . . .	1.7.51
Searson, A. J., Estate of (W. T. Vickers, Trustee)	Estate of A. J. Searson, carrying on business as Harold Scott . . . . .	296 Collins-street, Melbourne . . .	1.7.51
Searson, A. J., Estate of (W. T. Vickers, Trustee)	Estate of A. J. Searson, carrying on business as Harold Scott . . . . .	2A Centreway, Chapel-street, Prahran . . .	1.7.51
Shepherd, J. C. . . . .	J. C. Shepherd . . . . .	79 Speight-street, Thornbury . . .	1.7.51
Smedley, L. J. . . . .	L. J. Smedley . . . . .	473 Bourke-street, Melbourne . . .	1.7.51
Adam Smith Pty. Ltd. (J. A. Ternes, appointee)	Adam Smith Pty. Ltd. . . . .	11 Elizabeth-street, Melbourne . . .	2.7.51
Adam Smith Pty. Ltd. (D. B. James, appointee)	Adam Smith Pty. Ltd. . . . .	519 High-street, Northcote . . .	1.7.51
Smith, C. D. J. . . . .	C. D. J. Smith, carrying on business as The Smith Cash Order Co. . . . .	194 Bank-street, South Melbourne . .	1.7.51
Smith, E. M. . . . .	E. M. Smith, carrying on business as H. Flanagan . . . . .	7 Bath-lane, Ballarat . . .	1.7.51
Smith, D. . . . .	D. Smith . . . . .	153 Chapel-street, St. Kilda . . .	1.7.51
Steele, S. C. . . . .	S. C. Steele . . . . .	57 Elizabeth-street, Melbourne . . .	1.7.51
Steele's Finance Pty. Ltd. (A. W. Steele, appointee)	Steele's Finance Pty. Ltd. . . . .	57 Elizabeth-street, Melbourne . . .	1.7.51
Swan Cash Order Pty. Ltd. (F. L. Pearce, appointee)	Swan Cash Order Pty. Ltd. . . . .	383 Brunswick-street, Fitzroy . . .	1.7.51
Swift's Pty. Ltd. (I. L. Schroeder, appointee)	Swift's Pty. Ltd. . . . .	257-9 Swanston-street, Melbourne . .	1.7.51
Tasman Investments Pty. Ltd. (A. F. Jones, appointee)	Tasman Investments Pty. Ltd. . . . .	239 Latrobe-street, Melbourne . . .	1.7.51
The Towns Supply Co. Pty. Ltd. (R. G. Pinsent, appointee)	The Towns Supply Co. Pty. Ltd. . . .	105 Swanston-street, Melbourne . . .	1.7.51
The Towns Supply Co. Pty. Ltd. (R. G. Pinsent, appointee)	The Towns Supply Co. Pty. Ltd. . . .	216 Glenferrie-road, Glenferrie . . .	1.7.51
Thompson, H. S. . . . .	H. S. Thompson, carrying on business as Murray Kinder and H. S. Thompson A. Tomasi . . . . .	282 Collins-street, Melbourne . . .	1.7.51
Tomasi, A. . . . .	A. Tomasi . . . . .	368-370 Lygon-street, Carlton . . .	1.7.51
Traders Finance Corporation Ltd. (G. V. Beattie, appointee)	Traders Finance Corporation Ltd. . . .	44-6 Queen-street, Melbourne . . .	1.7.51
Universal Providers Pty. Ltd. (E. Greenberg, appointee)	Universal Providers Pty. Ltd. . . . .	306 Little Collins-street, Melbourne . .	1.7.51
Universal Shopping and Finance Co. Pty. Ltd. (C. A. Fitman, appointee)	Universal Shopping and Finance Co. Pty. Ltd. . . . .	327 Bourke-street, Melbourne . . .	1.7.51
Watkins, W. E. . . . .	W. E. Watkins . . . . .	317 Collins-street, Melbourne . . .	1.7.51
Weir, J. L. . . . .	J. L. Weir . . . . .	330 Flinders-lane, Melbourne . . .	1.7.51
White, L. G. . . . .	L. G. White, carrying on business as Cleveland and Co. . . . .	94 Elizabeth-street, Melbourne . . .	1.7.51

\* Licence for which no fee is payable.

State Treasury,  
Melbourne, 20th July, 1951.

R. E. STAFFORD,  
Registrar.

Country Fire Authority Acts.  
PERMISSION TO HOLD FIRE BRIGADE  
DEMONSTRATIONS.

IN pursuance with the provisions of section 79 (1) and (2) of the *Country Fire Authority Act 1944*, the Country Fire Authority has granted permission for the holding of a fire brigade demonstration as under:—

Rural Fire Brigades.

At St. Arnaud, on Saturday, 29th March, 1952.

G. G. SINCLAIR,  
Secretary.

31st July, 1951.

COMMITTEE OF CLASSIFIERS UNDER THE  
TEACHING SERVICE ACT 1946.

IT is hereby notified that Alexander McDonell has been assigned the duties of Chief Inspector of Secondary Schools during the absence of Charles Thompson Scarff on sick leave, from and inclusive of the 1st of August, 1951, and that during the period of his assignment of such duties he will *ex officio* be a member of the Committee of Classifiers for the Secondary Schools Division.

A. H. RAMSAY,  
Director of Education.

Education Department,  
Melbourne, 1st August, 1951.

**CONTRACTS ACCEPTED.—(Series 1950-51.)****GENERAL STORES.**

*Gazette* No. 34, 17th January, 1951, Schedule No. 52, Tools (General).—For the rates shown opposite the following items, substitute the rates as set out hereunder, as from 1st July, 1951.—Item No. 19, 10 oz., 4s. 5d. each, 12 oz., 5s. 1d. each; Item No. 20, 7s. 8d. each; Item No. 54, 10s. 10d. each; Item No. 70, 16s. 1d. each; Item No. 71, 14s. 9d. each; Item No. 72, £1 0s. 5d. each; Item No. 73—Straight—12s. 10d. each, Bent—13s. 1d. each; Item No. 74, 17s. 5d. each; Item No. 75, £1 0s. 9d. each; Item No. 76, 15s. 4d. each; Item No. 77, 18s. 9d. each; Item No. 78, £2 7s. 5d. each; Item No. 79, 2s. 3d. each; Item No. 134, 6s. 8d. each; Item No. 135, 8s. 3d. each; Item No. 136, 13s. 1d. each; Item No. 138, 5s. each; Item No. 140, 10s. 10d. each; Item No. 141, 9s. each; Item No. 142, 9s. 1d. each; Item No. 143, 9s. 6d. each; Item No. 144, 8s. 7d. each; Item No. 145, 9s. 4d. each; Item No. 146, 10s. 7d. each; Item No. 147, 9s. 1d. each; Item No. 191, 2½d. per tooth; Item No. 192, 7d. per tooth; Item No. 193, 10d. per tooth; Item No. 228, 12s. 3d. each; Item No. 229, 12s. 3d. each; Item No. 230, 12s. 4d. each; Item No. 231, 12s. 6d. each; Item No. 232, 12s. 4d. each; Item No. 233, 12s. 6d. each; Item No. 234, 13s. 6d. each; Item No. 235, 12s. 7d. each; Item No. 236, 12s. 11d. each; Item No. 237, 17s. 6d. each; Item No. 238, 17s. 6d. each; Item No. 239, 17s. 6d. each; Item No. 240, 16s. 2d. each; Item No. 241, 16s. 2d. each; Item No. 242, 16s. 2d. each; Item No. 243, 11s. 11d. each; Item No. 246, 11s. 7d. each; Item No. 247, 11s. 8d. each; Item No. 248, 11s. 9d. each; Item No. 249, 13s. 1d. each.

*Gazette* No. 967, 29th November, 1950, Schedule No. 69, Stationery.—For Item No. 134 substitute 14s. 6d. per dozen, as from 25th July, 1951, and for Item No. 239 substitute £8 14s. 6d. per dozen, as from 24th July, 1951.

*Gazette* No. 967, 29th November, 1950, Schedule No. 2, Exercise Books, &c.—For Item No. 8 substitute £1 8s. 8d. per dozen, as from 30th July, 1951.

**CONTRACTS ACCEPTED.—(Series 1951-52.)****PROVISIONS.**

*Gazette* No. 671, 9th July, 1951, Provisions, Schedule No. 1, Sub-schedule No. 6.—For Item Nos. 1, 2, and 3 substitute 8½d. per lb., 1s. 6d. per tin, and 4s. 7½d. per tin respectively. Schedule No. 2, Sub-schedule No. 3.—For Item Nos. 1, 2, and 3 substitute 8½d. per lb., 4s. 7½d. per tin, and 4s. 7½d. per tin respectively. Schedule No. 4, Sub-schedule No. 2.—For Item No. 1 substitute 4s. 7½d. per tin; as from 9th July, 1951.

W. H. RUTHERFORD, Secretary to the Tender Board.  
6.8.51.

**PUBLIC WORKS.**

644. (1) Kew, Mental Hospital, supply and delivery of electric cloth-cutting machine, £115.—General Industries Corporation Pty. Ltd.

645. (1) Port Melbourne, Public Works Department Depot, supply of woodwork benches, £1,037 10s.—K. and S. Lyons.

646. (1) Williamstown, S.S. *Rip*, supply of fuel oil, £559 15s. 8d.—Atlantic Union Oil Co. Ltd.

647. (1) Langi Kal Kal, Penal Training Centre, supply 1,900 yards buckshot gravel, £1,116 5s.—A. Sist.

648. (1) San Remo, Jetty, supply messmate piles, £275 19s.—William Houghton and Co. Ltd.

649. (1) Carlton, Teachers' Training College, provision of 50 chairs, steel stackable, canvas backs and seats, £157 10s.—D. F. Cowan.

650. (1) Pascoe Vale, State School No. 3081, emergency repairs to roof structure, £145 5s.—L. H. Roberts.

651. (1) Moe, Multi-purpose School, professional fees, £2,500.—Robert Marsh.

652. (1) Nar-nar-noon, State School No. 4554, extensions to school, £141.—D. Tincknell.

653. (1) Melbourne, Parliament House, installation of steam hot water, &c., to two Bain Marias, £138 4s. 6d.—Charles E. Guy and Co.

654. (1) Melbourne, Parliament House, electrical installation, £126 4s.—R. G. Harris Pty. Ltd.

655. (1) Melbourne, Government House, supply shrubs and trees, £136 16s.—Warner's Nurseries.

656. (1) Portland, Mooring Springs, supply Coir Circ. springs, £632 15s. 6d.—Kinnear and Sons Pty. Ltd.

657. (4) South Melbourne, Technical School, nine tables, 6 ft. x 3 ft., £107.—Thear and Son.

658. (1) Stawell, High School, supplying and fixing fibro plaster walls and ceilings, new residence, £231.—J. R. Rathgeber.

659. (1) Sale, Technical School, supply and installation of two gas cookers and two gas coppers, £118 5s.—The Gas Supply Co.

660. (5) Melbourne, Printing Trades School, furniture and shelving, £145 5s.—McBaia and Young.

661. (4) Lakes Entrance, Harbor Works, cartage of stone, £50,000 (rates—various).—A. Curtis.

662. (5) Geelong, Gordon Institute of Technology, workshop equipment, £4,868 15s.—McPhersons Ltd.; £2,211 9s. 6d.—William Adams and Co. Ltd.; £420.—Alfred Herbert Pty. Ltd.; £5,005.—Gilbert Lodge and Co. Ltd.

663. (1) Coburg, Pentridge Gaol, supply of spare parts for ASA Lees Mule, £226 6s. 4d.—British Engineering Pty. Ltd.

664. (1) Parkville, Tuberculosis Chalet, Mount Royal, supply of pan sterilizer and pan rack, £149 9s. 1d.—The Victorian Hospitals Association.

665. (2) Ballarat, Mental Hospital, supply and delivery of sewerage pump and motor, £152.—Harland Engineering (Aust.) Pty. Ltd.

666. (1) South Melbourne, Public Works Department Storeyard, supply of glass blades, £175.—Oliver Davey Pty. Ltd.

667. (1) South Melbourne, Public Works Department Storeyard, supply of Tasmanian hardwood, £219 14s. 9d.—William Cook Pty. Ltd.

668. (1) Geelong, "Ariston" Teachers' Hostel, supply of hardwood, &c., £139 16s. 8d.—Fagg Bros. Pty. Ltd.

669. (3) Melbourne, Fisheries and Game Department, provision of wooden filing cabinets, £327 10s.—Norman Beard and Co.

670. (1) Mont Park, Mental Hospital, supply of 24 fire guards, £321.—B. Coster.

671. (1) Port Melbourne, Public Works Department Depot, supply of six only tip trucks, £7,755.—Melford Motors Pty. Ltd.

672. (1) Port Melbourne, Public Works Department Depot, supply of grit, £155 15s. 9d.—Willis Quarries.

P. T. BYRNES, Commissioner of Public Works. 31.7.51.

675. (4) Aspendale, State School No. 4193, internal and external painting and repairs, £1,214.—E. Beadle.

676. (2) Alexandra, State School No. 912, supply and installation of kerosene hot-water service, residence, £169.—Shepparton Plumbing Services.

677. (2) Burwood, Boys' Home No. 3841, erection of new out-offices, £1,473.—L. C. Wallis.

678. (1) Box Hill, Boys' High School, provision of toilet for female staff, £285.—L. C. Wallis.

679. (1) Broughton, State School No. 3094, repairs and painting, £266 10s.—Geo. Lange.

680. (1) Ballarat, Teachers' College, supply and installation of hot-water service, residence, £135.—L. Wilson.

681. (2) Caulfield North, State School No. 3820, repairs and painting, £3,888.—R. Bryant.

682. (8) Camberwell South, State School No. 4170, roof repairs and internal painting and renovations, £843.—Eakins and Brooking.

683. (5) Coburg, Pentridge Gaol, electrical installation, Female Division, £1,480.—G. Wilkie Electrical Co.

684. (2) Kew, Police Station, external and internal repairs and renovations, Sergeant's Quarters, £933 13s.—Netherton and Hughes.

685. (1) Mollonghip, State School No. 2715, electric hot-water service, residence, £146 5s. 6d.—L. Wilson.

686. (2) Poowong, State School No. 2111, supply and installation of a kerosene hot-water service, residence, £158 18s. 6d.—J. W. Short and Co.

687. (1) Port Welshpool, Fisheries and Game Department, septic tank and drainage, &c., Inspector's Residence, £181 7s. 3d.—A. J. Avage and Son.

688. (1) Preston, Technical School, internal and external repairs and painting, £3,767.—Netherton and Hughes.

689. (1) Royal Park, Mental Hospital, supply and installation of household type refrigerator for nurses, £156 5s.—Kelvinator Australia Ltd.

690. (2) Sassafras, State School No. 3222, installation of septic tank and additional water tanks, and new timber out-offices, £872 10s.—George Clarkson.

691. (1) Sunbury, Mental Hospital, provision of laundry drying equipment facilities (lint catcher not required), £2,566.—Roy Burton and Co. Pty. Ltd.

692. (2) Sunbury, Mental Hospital, supply and installation of household type refrigerator, £156 15s.—Kelvinator Australia Ltd.

693. (1) Sandringham East, State School No. 4449, erection of 2 type "A" shelter sheds with concrete floors, £333.—J. W. Wood.

694. (2) Thornton, State School No. 1371, supply and installation of kerosene hot-water service, residence, £173.—Shepparton Plumbing Services.

695. (4) Warrandyte, State School No. 12, additional out-office accommodation, £549.—Wood Bros.

696. (1) Yarra Glen, State School No. 956, essential repairs to school building, £315.—Wood Bros.

697. (1) Port Melbourne, Public Works Department Depot, supply of 2-in. metalling, £135 18s. 7d.—Willis Quarries.

698. (1) Melbourne, Government House, supply of joinery, &c., £309 7s.—W. S. Neelands Pty. Ltd.

699. (1) South Melbourne, Public Works Department Storeyard, supply of ant caps and pipes, £155 14s.—W. E. Cash.

700. (1) Walpeup, Mallee Research Farm, supply of wire fencing, £232 5s. 4d.—Cyclone Fence Co.

701. (1) South Melbourne, Public Works Department Storeyard, supply 24 only 3-gallon cisterns, £110 8s.—W. P. Thornton and Buchanan Pty. Ltd.

702. (1) Port Melbourne, Public Works Department Depot, manufacture of 100 800-gallon tanks, £712 10s.—Weickhardt and Co.

703. (1) Heatherton Sanatorium, provision of 6 metal overbed stands (hair-washing facilities, bed patients), £197 5s.—Denyers Pty. Ltd.

704. (1) Glenferrie, Swinburne Technical College, 110 theatre seats, £220.—Colonial Gas Association.

705. (1) Hamilton, High School, electrical installation, prefabricated residence, £111.—Strachans (Hamilton) Pty. Ltd.

706. (1) Benalla, Public Works Department, erection of residence for Inspector of Works, £2,953 10s.—John F. Strachan.

707. (1) French Island, Reformatory Prison, supply of 24 bedsteads, £127 10s.—Austral Home and Hospital Equipment Pty. Ltd.

708. (1) South Melbourne, Public Works Department Storeyard, supply of expanded metal and solder, £152 11s.—Carroll and Douglas.

709. (1) Melton, State School No. 430, supply of gravel, ploughing and grading, £125.—A. Minns.

710. (1) Creswick, State School No. 122, supplying and spreading 350 cubic yards of loam, £175.—H. T. Shaw.

711. (1) Mont Park, Mental Hospital, No. 2 Hostel, supply of rubber flooring on concrete stairway, £122.—Clark Matting and Rubber Ltd.

712. (1) Mont Park, Mental Hospital, supply and lay approximately 250 square yards of rubber flooring, £640.—Clark Matting and Rubber Ltd.

713. (3) Melbourne, Police Headquarters, Russell-street, supply and delivery of one 20-electric mixer, £197.—Brice Scale and Slicer Co.

714. (1) Melbourne, Mobile Painting Units, purchase of enamel supplies, £267 1s. 8d.—E. L. Yencken and Co. Pty. Ltd.

715. (1) Melbourne, Parliament House, services of firemen, £178 18s.—Metropolitan Fire Brigades Board.

716. (1) Merino, Consolidated School, sinking 300-ft. bore, £375.—J. C. Jehu.

717. (1) South Melbourne, Public Works Department Storeyard, supply of 40 sets of kitchen cupboards, £1,984.—F. H. Perry.

P. T. BYRNES, Commissioner of Public Works. 1.8.51.

#### ORDERS IN COUNCIL.—(Series 1950-51.)

##### STATE RIVERS AND WATER SUPPLY COMMISSION.

5262. Purchase of mild steel plate, £79,500.—M. J. Doble.

Approved by the Governor in Council, 19th December, 1950.—A. MAHLSTEDT, Clerk of the Executive Council.

5263. Supply of one model P.D.4 "Trackson" pipe layer with equipment as specified, mounted on a 60-in. gauge model D4 "Caterpillar" Diesel tractor, £5,400.—William Adams and Co. Ltd.

Approved by the Governor in Council, 31st January, 1951.—A. MAHLSTEDT, Clerk of the Executive Council.

5264. Purchase of 1,000 tons of Japanese cement, £12,400.—Gollin and Co. Pty. Ltd.

Approved by the Governor in Council, 6th February, 1951.—A. MAHLSTEDT, Clerk of the Executive Council.

5265. Supply of ten Fordson Major tractors, £11,700.—Malcolm Moore Pty. Ltd.

Approved by the Governor in Council, 27th February, 1951.—A. MAHLSTEDT, Clerk of the Executive Council.

5266. Purchase of four replacement engine assemblies, £6,100.—Victorian Industrial Sales and Service Pty. Ltd.

5267. Supply of attachments for Caterpillar tractors, £20,000.—William Adams and Co. Ltd.

Approved by the Governor in Council, 16th March, 1951.—A. MAHLSTEDT, Clerk of the Executive Council.

5268. Purchase of Wellpoint dewatering equipment, Heyfield, £A7,000.—Millar's Machinery Co. Ltd.

Approved by the Governor in Council, 29th March, 1951.—A. MAHLSTEDT, Clerk of the Executive Council.

5269. Operation of the sawmill at Eildon, in accordance with the Commission's specifications, schedule, and rates, £98,175.—L. G. Cupples and R. W. Pumpa.

Approved by the Governor in Council, 17th April, 1951.—A. MAHLSTEDT, Clerk of the Executive Council.

5270. Supply f.o.r. Fyansford of 12,500 tons of Portland cement, £69,400.—Australian Cement Ltd.

5271. Fabrication of mild steel pipes, £11,500.—Mephan Ferguson Pty. Ltd.

5272. Fabrication of mild steel pipes, £27,800.—Humes Limited.

Approved by the Governor in Council, 24th April, 1951.—A. MAHLSTEDT, Clerk of the Executive Council.

5273. Supply f.o.b. British port of steel sheet piling, £13,000.—Gollin and Co. Pty. Ltd.

Approved by the Governor in Council, 8th May, 1951.—A. G. COULTHARD, Acting Clerk of the Executive Council.

5274. Purchase of 30 caravans, £14,100.—Lincoln Engineering Industries Pty. Ltd.

5275. Purchase of tires and tubes, £7,600.—Dunlop Rubber Australia Ltd.

Approved by the Governor in Council, 26th June, 1951.—A. MAHLSTEDT, Clerk of the Executive Council.

#### FORESTS COMMISSION.

Loan Act No. 5333, Item 8—

5276. To purchase of allotment 14, section A, Parish of Tinamba, County of Tanjil, containing 398 acres 3 roods 5 perches, for forest purposes, £797 11s. 3d.—C. E. Ostberg, of Glenmaggie Weir.

Approved by the Governor in Council, 16th March, 1951.—A. MAHLSTEDT, Clerk of the Executive Council.

#### STATE ELECTRICITY COMMISSION.

5277. The supply of 20 tires and 32 tubes for Euclid rear dump trucks, Kiewa Hydro-Electric Scheme, to Quotation No. 7263, £9,334 14s. 4d.—The Goodyear Tyre and Rubber Co. (Aust.) Ltd.

Approved by the Governor in Council, 19th June, 1951.—A. MAHLSTEDT, Clerk of the Executive Council.

#### ORDERS IN COUNCIL.—(Series 1951-52.)

##### EDUCATION DEPARTMENT.

643. One only cathode ray oscilloscope 5-in. screen, for Caulfield Technical School, £175.—Austonic Engineering Laboratory Pty. Ltd.

Approved by the Governor in Council, 31st July, 1951.—A. MAHLSTEDT, Clerk of the Executive Council.

##### STATE RIVERS AND WATER SUPPLY COMMISSION.

673. Purchase of asbestos cement pipes, £18,500.—James Hardie and Co. Pty. Ltd.

674. Purchase of twelve standard mark 4A "Terrapin" mobile houses, £22,400.—Maresta Pty. Ltd.

Approved by the Governor in Council, 10th July, 1951.—A. MAHLSTEDT, Clerk of the Executive Council.

#### STATE ELECTRICITY COMMISSION.

718. The supply of two sets of triple effect evaporators with auxiliary plant and accessories, briquette factories 3 and 4, Morwell Project, to Specification No. 51-52/44, £29,802.—Aiton and Co. Ltd.

719. The supply of 100 tons of reinforcing steel for Richmond, Yallourn, Morwell, and Kiewa Hydro-Electric Scheme, to Quotation No. 545, £7,175.—Gollin and Co. Pty. Ltd.

720. The supply of pressure reducing and desuperheating equipment for briquette factories 3 and 4, Morwell Project, to Specification No. 51-52/46, £9,200.—Hopkinsons Ltd.

721. The supply of high pressure steam and feed water valves for briquette factories 3 and 4, Morwell Project, to Specification No. 51-52/45, £22,032.—Hopkinsons Ltd.

722. The supply of spare parts for Coles cranes at Morwell, Yallourn, and Kiewa Hydro-Electric Scheme, to Quotation No. 6661, £5,587 9s. 4d.—Horrocks Roxburgh Pty. Ltd.

723. The supply and erection of three mild-steel chimneys, Yallourn D. Power Station, to Specification No. 50-51/139, £70,520.—Johns and Waygood Ltd.



724. The fabrication of steelwork for machine room, Malvern Terminal Station, to Quotation No. 6153, £10,306 6s.—Johnson's Tyne Foundry Pty. Ltd.

725. The supply of 775 tons of reinforcing steel for construction works at Yallourn, Morwell, and Kiawa Hydro-Electric Scheme, to Quotation No. 764, £47,484 5s.—A. G. Kidson and Parker Ltd.

726. The erection of permanent amenities building, Newport Power Station, £143,000.—Lewis Construction Co. Pty. Ltd.

727. The supply of 3,600 feet of movable belt conveyor, Yallourn North Open Cut, to Quotation No. 7735, £26,244 19s. 6d.—Noyes Bros. (Melb.) Ltd.

728. The purchase of 4 acres of land, being part of Crown allotment 47, Parish of Maryvale, and being the whole of the land comprised in certificate of title, volume 7386, folio 1477030, together with all buildings thereon, sawmilling plant, and logging equipment, £25,000.—Christopher Charles Palmer and Albert Henry Palmer.

729. The supply of 120,000 ball and socket type disc insulators for transmission lines, to Specification No. 50-51/257, £105,696.—Pilkington Bros. Ltd.

730. The supply and delivery of 21,000 feet of 54-in. reinforced concrete piping and rubber rings for No. 4 race-line, Kiawa Hydro-Electric Scheme, to Specification No. 50-51/326, £153,900.—Rocia Pipes Ltd.

731. The excavation of approximately 14,250 feet of No. 1 headrace tunnel, Kiawa Hydro-Electric Scheme, to Specification No. 50-51/273, at Schedule rates.—Societe Etudes et Entreprises jointly with Societe Nationale de Travaux Publics.

732. The supply of 92 proofed duck tarpaulins for protection of materials and equipment, to Quotation No. 8261, £5,113 6s.—Thomas Evans Pty. Ltd.

733. The supply of 1,000 metric tons of reinforcing steel for Yallourn and Morwell Project, to Quotation No. 519, £75,250.—Tomasetti and Son Pty. Ltd.

734. The supply of 2,000 metric tons of reinforcing steel, Morwell and Yallourn, to Quotation No. 743, £147,800.—Tomasetti and Son Pty. Ltd.

735. The grading, draining, and surfacing of approximately 30 acres of storage area, Brooklyn, to Specification No. 50-51/335, at Schedule rates.—Victoria Roads Pty. Ltd.

736. The supply of four 4-ton Leyland chassis for preparation as mobile servicing units, Yallourn, Morwell, Kiawa Hydro-Electric Scheme, and metropolitan area, to Quotation No. 7063, £10,076.—Leyland Motors Ltd.

737. The supply of five 4-ton Thornycroft chassis for preparation as mobile servicing units, Yallourn, Morwell, Kiawa Hydro-Electric Scheme, and metropolitan area, to Quotation No. 7063, £13,402 10s.—Thornycroft (Australia) Pty. Ltd.

738. The supply of vulcanized rubber insulated copper cable, for a period of twelve months, to Specification No. 50-51/315, at Schedule rates.—Amalgamated Wireless Australasia Ltd.

739. The supply of vulcanized rubber insulated copper cable, for a period of twelve months, to Specification No. 50-51/315, at Schedule rates.—Gilbert Lodge and Co. Ltd.

740. The supply of vulcanized rubber insulated copper cable, for a period of twelve months, to Specification No. 50-51/315, at Schedule rates.—W. T. Henley's Telegraph Works Co. Ltd.

741. The supply of vulcanized rubber insulated copper cable, for a period of twelve months, to Specification No. 50-51/315, at Schedule rates.—Noyes Bros. (Melbourne) Ltd.

742. The supply of vulcanized rubber insulated copper cable, for a period of twelve months, to Specification No. 50-51/315, at Schedule rates.—Siemens (Australia) Pty. Ltd.

Approved by the Governor in Council, 24th July, 1951.  
—A. MAHLSTEDT, Clerk of the Executive Council.

#### Dried Fruits Act 1938.

##### NOTICE.

I, GEORGE COLIN MOSS, Minister of Agriculture, and acting upon the recommendation of the Victorian Dried Fruits Board, hereby give notice that I have determined that the maximum proportions of dried fruits produced in Victoria in the year One thousand nine hundred and fifty-one that may be marketed within Victoria are as follows:—

	Per cent.
Dried Currants .. .. .	39
Dried Sultanas .. .. .	47
Dried Lexias .. .. .	52

GEORGE C. MOSS,  
Minister of Agriculture.

Department of Agriculture,  
Melbourne, 8th August, 1951.

No. 751.—7626/51.—2

Town and Country Planning Acts.

#### TYERS PLANNING SCHEME.

##### INTERIM DEVELOPMENT ORDER.

WHEREAS by virtue of the powers conferred by the Town and Country Planning Acts and every other power enabling it in that behalf, the Town and Country Planning Board (hereinafter referred to as the "Responsible Authority") having commenced the preparation of a planning scheme in accordance with the said Acts, hereby makes the following Interim Development Order:—

1. The development of all land referred to in the schedule, and the erection, construction, and carrying out of any buildings, roads, or other works on any of the said land is hereby prohibited.

2. Any person may apply to the Responsible Authority for permission to develop, subdivide, or otherwise use any land or erect or construct any buildings, roads, or other works during the operation of this Order.

3. Any applications for permission to develop, subdivide, or otherwise use any land or erect or construct any buildings, roads, or other works, may be granted by the Responsible Authority, subject to such conditions as are specified in the permit, or may be refused.

4. Any owner of any land who, after the publication of a copy of this Order contravenes any of the provisions contained herein, shall, when directed by notice in writing, remove, pull down, take up, or alter any building, road, or other works, and if any owner fails to do so within the time specified by the notice, the Responsible Authority may carry out all, or any, of such works, and recover all expenses incurred, after due notice has been given to the owner, lessee, and/or occupier, in accordance with the provisions of section 12, sub-section (3) of the Acts.

5. None of the provisions of this Order shall prohibit the continuance of the use of any land or building for the purpose for which it was used immediately before the coming into operation of this Order.

6. This Order shall remain in operation until the approval of the planning scheme, in accordance with the Town and Country Planning Acts, or until this Interim Development Order is revoked by the Governor in Council.

##### 7. Schedule of land affected:—

Commencing at a point on the eastern boundary of allotment 14c, Parish of Boola Boola, County of Tanjil, distant 2,100 feet, more or less, from the south-eastern angle of that allotment; thence southerly along the eastern boundary of allotment 14c to the south-eastern angle thereof; thence easterly along the southern boundary of allotment 14b to the south-eastern angle thereof; thence southerly, crossing the Government road and continuing along the eastern boundary of allotment 6a to the south-eastern angle of that allotment; thence westerly and southerly along the northern and western boundaries of allotment 6b to the south-western angle thereof; thence westerly along the southern boundary of allotment 6, crossing the Government road, and continuing westerly in the same straight line through allotment 5 to a point on the eastern boundary of allotment 4; thence northerly along the eastern boundary of allotments 4 and 3, crossing the Government road, and continuing northerly in the same straight line through allotments 5a and 5b to a point within the allotment last named, distant 2,850 feet, more or less, from the northern boundary of allotment 5a; thence easterly by a straight line through allotment 5b, crossing the Government road, to the north-western angle of allotment 5e; thence easterly along the northern boundary of allotment 5e, crossing the Government road and continuing easterly in the same straight line through allotments 14b and 14c to the eastern boundary of allotment 14c and the point of commencement.

FRED. C. COOK, Chairman.

JOHN D. McNAMARA, Secretary.

Approved by the Governor in Council,

7th August, 1951.

A. MAHLSTEDT,

Clerk of the Executive Council.

## Transport Regulation Acts.

## TRANSPORT REGULATION BOARD.

## NOTICES OF PUBLIC HEARINGS.

NOTICE is hereby given that the applications made by the persons named below for licences to operate the commercial goods vehicles on the route or routes, or in the manner set out opposite their names, will be heard at a time and place to be communicated to the parties concerned:—

*Name and Address; Nature of Application.*

- BARCLAY, L. L., 45 Seymour-road, Elsternwick; 1 commercial goods vehicle (120 cwt.) for the carriage of concrete pipes, culverts, and material used in construction and maintenance of such, under contract to the Country Roads Board, throughout the State of Victoria.
- BOLWELL, W. E., Florence-street, Stawell; 1 commercial goods vehicle (117 cwt.) for the carriage of bricks and roofing tiles, on behalf of the Stawell Brick Co. Pty. Ltd., in the under-mentioned area:—(a) On the north by a direct line from the Township of St. Arnaud through the Townships of Donald and Hopetoun to the Victorian-South Australian border nearest to the Township of Serviceton, (b) on the west by the South Australian border, (c) on the south by the south coast from the Victorian-South Australian border to the City of Warrnambool, thence by a direct line through the Township of Terang to the Township of Camperdown, (d) on the east by a direct line from the Township of Camperdown through the Townships of Derrinallum and Avoca to the Township of St. Arnaud.
- BUGG, T., 13 Cassells-road, Brunswick North; 1 commercial goods vehicle (5 cwt.) to operate throughout the State of Victoria in the course of business as "rope, twine, and cordage merchant" for the purpose of arranging orders and incidental delivery of small lots to resellers.
- FEIGLIN, M., & SONS, Nunawading; 1 commercial goods vehicle (200 cwt.) for the carriage of sawn flitches from applicants' sawmill at Mansfield to mill at Nunawading.
- HANNAFORD, ALF., & CO. LTD., Port-road, Woodville, South Australia; 1 commercial goods vehicle (30 cwt.) for the carriage of seed grading and pickling machinery, seed dressings in connexion with applicants' business of "seed graders and picklers" throughout the State of Victoria.
- HOLLOWAY, C. J., Mirimbah, via Mansfield; 1 commercial goods vehicle (180 cwt.) for the carriage of—(a) logs from any forest landing in the Mt. Bulla area to mills at Mansfield, (b) sawn timber from H. V. Doughty's mill at Mirimbah to consignees at Benalla, Albury, Shepparton, Echuca, and Kyabram, in house lots only.
- LENNON, A. J., P.O. Box 270, Shepparton; 1 commercial goods vehicle (35 cwt.) for the carriage of own goods, bones, offal, sausage casings in connexion with business of "sausage casing manufacturer" throughout the State of Victoria.
- PERRETT, H. R., 24 Napoleon-street, West Footscray; 1 commercial goods vehicle (80 cwt.) for the carriage of fibrous plaster sheets, mouldings, scaffolding, paints, and tools of trade in connexion with business of "fibrous plaster supplier and fixer" throughout the State of Victoria.
- RYAN, T. W., 106 Firebrace-street, Horsham; 1 commercial goods vehicle (10 cwt.) for the carriage of spare parts and tools of trade incidental to installing and servicing electrical and refrigeration equipment throughout the State of Victoria.
- SCALLY, B. P., 46 Main-road, Ballarat; 1 commercial goods vehicle (30 cwt.) for the carriage of own goods in the course of business as "caterer" throughout the State of Victoria.
- WATKIN, E. A., 13 Broadway, Oakleigh; 1 commercial goods vehicle (60 cwt.) for the carriage of prefabricated houses, under contract to the Housing Commission of Victoria, throughout the State of Victoria.

NOTICE is hereby given that the applications made by the persons named below for renewal of licences to operate the commercial goods vehicles on the route or routes, or in the manner set out opposite their names, will be heard at a time and place to be communicated to the parties concerned:—

*Name and Address; Present Franchise; Licence No.; Date of Expiry.*

- JARVIS, H. T., Walwa; (a) general goods within a radius of 20 miles of Walwa, (b) general goods from and to the Townships of Tintalra and Walwa to and from the Township of Wodonga, via the Murray Valley Highway; D.3715; 19th August, 1951.
- LARKIN, W. F., Upper Gundowring; (a) general goods from Upper Gundowring to the New South Wales-Victorian border *en route* to and from Albury, New South Wales, via Huon and Wodonga, (b) general goods from Upper Gundowring to Huon Railway Station, (c) general goods within a radius of 10 miles of Upper Gundowring; D.3577; 12th August, 1951.
- POWELL, T. S., Chenery-street, Mansfield; (a) general goods within a radius of 30 miles of Mansfield, (b) live stock within a radius of 50 miles of Mansfield, (c) live stock to and from Borough of Shepparton from and to places within a radius of 30 miles of Mansfield, (d) household furniture, building materials, contractors' materials, and aerated waters from Benalla direct to Mansfield; D.129; 25th August, 1951.
- VAN LAWICK, M. R., 395 Station-street, Bonbeach; (a) general goods within a radius of 20 miles of Bonbeach, (b) bricks within a radius of 40 miles of Melbourne; D.2646; 28th August, 1951.

NOTICE is hereby given that the applications made by the persons named below for licences to operate commercial passenger vehicles on the route or routes, or in the manner set out opposite their names, will be heard at a time and place to be communicated to the parties:—

*Name of Applicant; Nature of Application.*

- CLEARY, W. T., 11 Norman-street, Traralgon; 1 commercial passenger vehicle, with seating capacity for five persons, to operate as follows:—(a) At separate and distinct fares within a radius of 5 miles of Traralgon Post Office, (b) under private hire conditions within a radius of 50 miles of Traralgon Post Office.
- GRENDA, G. F., 3B Warrigal-road, Oakleigh; 1 commercial passenger vehicle, with seating capacity for 33 persons, to operate as an additional vehicle, under the same terms and conditions as contained in the applicant's existing stage omnibus licences for large-seating capacity vehicles.
- MOORE, E., P.O. Box 95, Portland; application for variation of "A" licence, at present in the course of transfer from J. Stanford, Portland, to include the ability to operate the following round tour from Portland:—Commencing from the Portland Post Office, via Nelson-road, to Portland Cemetery, thence via Melton-road, Must-street, Wellington-road, Bancroft-street to the golf links, thence via Bancroft-street, Wellington-road, Clift-street to the Botanical Gardens, thence via Bentinck-street, Hanlon-parade, Dutton-way to Dutton's Beach, thence return via the Portland Freezing Works to Browning-street, thence via Browning-street, Otway-street, Hurd-street, and Gawler-street to the Portland Post Office.
- ORCHARD, J., & J. KERRIGAN, 145 San Mateo-avenue, Mildura; 1 commercial passenger vehicle, with seating capacity for five persons, to be purchased, to operate as follows:—(a) At separate and distinct fares within a radius of 5 miles of Mildura Post Office, (b) under private hire conditions to places throughout Victoria from Mildura.
- PAGE, Mrs. E. M., & H. HEWISON (trading as Mentone Taxis), 1A Swanston-street, Mentone; 2 commercial passenger vehicles, each with seating capacity for five persons, to operate as follows:—(a) At separate and distinct fares within a radius of 5 miles of Mentone Railway Station, (b) under private hire conditions within a radius of 50 miles of Mentone Railway Station (subject to the cancellation of licences Nos. A.3065 and A.2767, at present held by K. J. Wright, Mentone).

PORTER, A. E., Sassafras Creek-road, Sassafras; 1 commercial passenger vehicle, with seating capacity for five persons, to operate as follows:—(a) At separate and distinct fares within a radius of 5 miles of Sassafras Post Office, (b) under private hire conditions within a radius of 50 miles of Sassafras Post Office.

PORTSEA PASSENGER SERVICE LTD., Station-street, Frankston; application for variation of licences Nos. A.362, A.363, A.536, A.543, A.555, A.962, A.963, A.1168, A.1678, A.1677, A.1790, A.2548, A.2781, A.2831, A.2886, A.2939, A.2532, to include the ability to operate the following day tours from Portsea:—

1. From Portsea to Yallourn, via Sorrento, Rye, Rosebud, Dromana, Nepean Highway, to Mornington, thence via Tyabb, Somerville, Tooradin, Lang Lang, Drouin, Moe, and return via the same route.

Fare (including lunch)—

Portsea-Yallourn, 28s. 6d.  
 Sorrento-Yallourn, 28s.  
 Rye-Yallourn, 26s. 6d.  
 Rosebud-Yallourn, 25s. 6d.  
 Dromana-Yallourn, 24s. 6d.

2. From Portsea to Cowes, via Sorrento, Rye, Rosebud, Dromana, Nepean Highway, to Mornington, thence via Tyabb, Somerville, Tooradin, Lang Lang, Grantville, Bass, San Remo, a round trip of Phillip Island, and return via San Remo, Dandenong, Frankston, and Nepean Highway.

Fare (including lunch)—

Portsea-Cowes, 28s.  
 Sorrento-Cowes, 27s. 6d.  
 Rye-Cowes, 26s.  
 Rosebud-Cowes, 25s.  
 Dromana-Cowes, 24s.

SUTTON, J. N., & A. S. BANKS (trading as Premier Taxi Service), 106 McLeod-street, Bairnsdale; 1 commercial passenger vehicle, with seating capacity for five persons, to operate as follows:—(a) At separate and distinct fares within a radius of 5 miles of Bairnsdale Railway Station, (b) under private hire conditions within a radius of 50 miles of Bairnsdale Railway Station, (c) at separate and distinct fares from any point situate in the Borough of Bairnsdale to the showgrounds, the wharf, the football grounds, the picture theatres, and the oval (subject to the cancellation of licence No. A.162, at present held by W. T. Williams, Bairnsdale).

SUTTON, J. N., & A. S. BANKS (trading as Premier Taxi Service), 106 McLeod-street, Bairnsdale; 1 commercial passenger vehicle, with seating capacity for five persons, and one commercial passenger vehicle, with seating capacity for five persons, to be purchased, to operate as follows:—

(a) At separate and distinct fares within a radius of 5 miles of Bairnsdale Post Office.

(b) At separate and distinct fares from any point situate in the Borough of Bairnsdale to the showgrounds, the wharf, the football grounds, the picture theatres, and the oval.

(c) Under private hire conditions within a radius of 50 miles of Bairnsdale Post Office.

(d) As touring omnibuses on the following tours:—

*One-day Tours.*

1. From Bairnsdale to Bulga Park and Tarra Valley, via Stratford, Maffra, Tinamba, Heyfield, Toongabbie, and Traralgon, thence via Carrajung, Gormondale, Rosedale, Sale, and Stratford. Fare—£2 10s.

2. From Bairnsdale to Yallourn, via Stratford, Maffra, Tinamba, Heyfield, Traralgon, Morwell, Maffra Sugar Beet Factory, Paper Pulp Mills, Traralgon, and thence return via Prince's Highway East. Fare—£2 10s.

*Two-day Tour.*

From Bairnsdale to snowfields, via the Omeo Highway, to Omeo, thence to snow line on the Mt. Hotham-road, thence return via Cassilis, Swifts Creek, and Omeo Highway. Fare—£2 10s.

*Ten-day Tour.*

From Bairnsdale to Sydney, New South Wales, via the Prince's Highway and Canberra, thence return via Canberra, Bombala, Delegate, Bonang, Orbest, and the Prince's Highway East. Fare—£12 10s.

(Subject to the cancellation of two "A" licences, at present in the course of issue to J. N. Sutton, Bairnsdale.)

WANNENMACHER, V. G., Tocumwal-road, Numurkah; 1 commercial passenger vehicle, with seating capacity for five persons, to operate for the carriage of passengers, mails, and parcels between Numurkah and Picola, via Waaia and Nathalia, as follows:—

TIME-TABLE.

*Monday-Friday inclusive.*

Read Down.	Read Up.
Dep. 1.30 p.m. Numurkah	Arr. 3.40 p.m.
Dep. 1.45 p.m. Waaia	Dep. 3.25 p.m.
Dep. 2.00 p.m. Nathalia	Dep. 3.10 p.m.
Arr. 2.25 p.m. Picola	Dep. 2.35 p.m.

WHEAL, G. W., Marine-parade, Lorne; 1 commercial passenger vehicle, with seating capacity for five persons, to be purchased, to operate as follows:—(a) At separate and distinct fares within a radius of 5 miles of Lorne Post Office, (b) under private hire conditions within a radius of 50 miles of Lorne Post Office.

APPLICATIONS for licences to operate commercial passenger vehicles, with seating capacity for five persons, for the carriage of passengers throughout Victoria otherwise than at separate and distinct fares for each passenger:—

LUXON, F. B., 31 Heidelberg-road, Clifton Hill (to operate from Main-road, Diamond Creek).

PAGE, Mrs. E. M., & H. HEWISON (trading as Mentone Taxis), 1A Swanston-street, Mentone (subject to the cancellation of licences Nos. P.H.1556 and P.H.1874, at present held by K. J. Wright, Mentone).

WARD, P. J., Porepunkah.

Notice of any objection should be forwarded to reach the Secretary to the Board not later than Wednesday, 22nd August, 1951.

E. V. FIELD,

Secretary.

Exhibition Buildings, Rathdown-street, Carlton, N.3, 8th August, 1951.

*Cemeteries Act 1928.*

SCALE OF FEES, PAKENHAM PUBLIC CEMETERY.

IN pursuance of the powers conferred upon them by the Cemeteries Acts, the Trustees of the Pakenham Public Cemetery hereby make the following scale of fees, which shall come into operation upon publication in the *Government Gazette*, and from and after such publication every scale of fees heretofore made by the said Trustees shall be and is hereby rescinded to the extent to which it conflicts with this scale:—

	<i>Private Graves.</i>	£	s.	d.
Purchase of grave (adult)	.. ..	3	0	0
Purchase of grave (child)	.. ..	1	10	0
Sinking any grave (adult)	.. ..	3	0	0
Sinking any grave (child)	.. ..	1	10	0

R. RAMAGE, Trustee.  
 C. L. CONSTABLE, Trustee.  
 R. J. GREGORY, Trustee.

Approved by the Governor in Council,  
 31st July, 1951.

A. MAHLSTEDT,  
 Clerk of the Executive Council.

*Cemeteries Act 1928.*

SCALE OF FEES, ELTHAM PUBLIC CEMETERY.

IN pursuance of the powers conferred upon them by the Cemeteries Acts, the Trustees of the Eltham Public Cemetery hereby make the following scale of fees, which shall come into operation upon publication in the *Government Gazette*, and from and after such publication every scale of fees heretofore made by the said Trustees shall be and is hereby rescinded to the extent to which it conflicts with this scale:—

	<i>Private Graves.</i>	£	s.	d.
Interment fee	.. ..	1	0	0

ADRIAN E. DAGNALL, Trustee.  
 ANDREW M. LOWERSON, Trustee.  
 J. LYON, Trustee.  
 J. COLEMAN, Trustee.

Approved by the Governor in Council,  
 31st July, 1951.

A. MAHLSTEDT,  
 Clerk of the Executive Council.

## DEPARTMENT OF MINES.

**SUBJECT** to any necessary excisions, &c., it is proposed to grant the following mining leases:—

5531, Gippsland; Henry Heddle; 4a. 2r. 16p., Parish of Winyar.

7216, Mineral; Bendigo Pottery Pty. Ltd.; 3a. 1r. 6p., Parish of Weston.

## CONSENT GRANTED TO TRANSFER A MINING LEASE.

9001, Castlemaine; from John Stanistreet to J. and E. Syndicate Limited.

## MINING LEASES GRANTED.

11229, Bendigo; New Monument Gold Mining N. L.; 71a. Or. 2p., Parish of Sandhurst (in lieu of lease No. 11019, Bendigo, expired).

6987, Mineral; Sulphates Limited; 43a. 3r. 21p., Parish of Budgerec.

## TAILINGS LICENCES GRANTED.

2236, Tailings Licence; R. Coffield; Parish of Bungal.

2244, Tailings Licence; J. F. McKay; Parish of Smythesdale.

2262, Tailings Licence; A. C. Carey; 7a. 3r., Parish of Smythesdale.

G. C. MOSS,  
Minister of Mines.

## MINING LEASE DECLARED VOID.

11181, Bendigo; Charles George Martin; 62a. 2r., 39p., Parish of Sandhurst.

The applicant for forfeiture of the above-mentioned lease will be granted a new lease under section 91 of the *Mines Act 1928*.

REX R. NEAL,  
Secretary for Mines.

## 4 GEORGE VI. No. 4755, SECTION 6.

**I** HEREBY give notice that on the 12th July, 1951, I filed an election to administer the following deceased person's estate, in accordance with section 6 of the *Public Trustee Act 1940*:—

SINGH, HERMAN, late of Dookie, hawker, died 14th April, 1951, intestate.

**I** HEREBY give notice that on the 25th July, 1951, I filed elections to administer the following deceased persons' estates, in accordance with section 6 of the *Public Trustee Act 1940*:—

\*ALLAN, MAGGIE, also known as Margaret Allan, late of 10 Cotter-street, South Richmond, married woman, died 15th April, 1951.

BLACK, THOMAS JAMES, also known as Thomas James Gurry, late of Yallourn, labourer, died 19th August, 1950, intestate.

CLARK, ALFRED ERNEST, late of Bendigo Benevolent Home, Bendigo, war pensioner, died 13th October, 1950, intestate.

\*CONNOLLY, WILLIAM EDWARD, formerly of 382 Victoria-parade, East Melbourne, but late of 46 Hoddle-street, Abbotsford, pensioner, died 11th April, 1951.

CRUMP, PERCY SYDNEY, late of Doutta Galla Hotel, 339 Racecourse-road, Newmarket, storeman, died 24th April, 1951, intestate.

DIGBY, HENRY WILLIAM, late of Bendigo Benevolent Home, Bendigo, labourer, died 18th September, 1950, intestate.

DOW, ERNEST, late of Bendigo Benevolent Home, Bendigo, farm labourer, died 30th October, 1950, intestate.

HALE, ARTHUR JAMES, late of Castlemaine Benevolent Home, Castlemaine, retired orchardist, died 13th May, 1951, intestate.

KERR, EVELYN, late of 9 Higginbotham-street, Middle Brighton, music teacher, died 16th May, 1951, intestate.

LENNON, WILLIAM JOHN, formerly of 9 Hull-street, Richmond, but late of Mont Park, carpenter, died 26th December, 1950, intestate.

LYALL, JAMES ALEXANDER, formerly of 44 Station-street, Glenroy, but late of Ballarat, retired cab driver, died 16th April, 1951, intestate.

MARTIN, JOHN, late of 1A Drysdale-street, Malvern, truck driver, died 26th April, 1951, intestate.

MCINNES, DONALD, also known as Frank Greenwood, formerly of 65 Campbell-street, Ararat, Victoria, and Grey-street, South Brisbane, Queensland, but late of Gordon House, Melbourne, Victoria, military pensioner, died 23rd November, 1950, intestate.

MCKURLIE, JOHN WILLIAM, late of Bendigo Benevolent Home, Bendigo, pensioner, died 15th April, 1950, intestate.

\*NOLAN, HUGH THOMAS, late of 180 Park-street, West Brunswick, sheet metal worker, died 27th March, 1951.

RANKIN, LOUIE, late of 200 Victoria-parade, East Melbourne, domestic, died 2nd May, 1951, intestate.

RIBNIKOWA, ALEXANDRA, late of Bonegilla, domestic, died 14th April, 1951, intestate.

WENMOUTH, JOHN, late of Bendigo Benevolent Home, Bendigo, pensioner, died 14th March, 1951, intestate.

YOUNG, FRANCIS, late of 136 Victoria-avenue, Albert Park, labourer, died 29th March, 1951, intestate.

\* According to the provisions of the will.

C. J. GARDNER,  
Public Trustee.

412 Collins-street, Melbourne, C.1, 1st August, 1951.

## NOTICE.

**A**DMINISTRATION of the estate of each of the under-mentioned deceased persons has been granted to me, and creditors, next of kin, and all others having claims against the estate of any of the persons so mentioned are required to send particulars of their claims to the Public Trustee, No. 412 Collins-street, Melbourne, on or before the 10th October, 1951, or they will be excluded from the distribution of the estate when the assets are being distributed:—

\*ALLAN, MAGGIE, also known as Margaret Allan, late of 10 Cotter-street, South Richmond, married woman, died 15th April, 1951.

BLACK, THOMAS JAMES, also known as Thomas James Gurry, late of Yallourn, labourer, died 19th August, 1950, intestate.

CLARK, ALFRED ERNEST, late of Bendigo Benevolent Home, Bendigo, war pensioner, died 13th October, 1950, intestate.

\*CONNOLLY, WILLIAM EDWARD, formerly of 382 Victoria-parade, East Melbourne, but late of 46 Hoddle-street, Abbotsford, pensioner, died 11th April, 1951.

CRUMP, PERCY SYDNEY, late of Doutta Galla Hotel, 339 Racecourse-road, Newmarket, storeman, died 24th April, 1951, intestate.

DIGBY, HENRY WILLIAM, late of Bendigo Benevolent Home, Bendigo, labourer, died 18th September, 1950, intestate.

DOW, ERNEST, late of Bendigo Benevolent Home, Bendigo, farm labourer, died 30th October, 1950, intestate.

HALE, ARTHUR JAMES, late of Castlemaine Benevolent Home, Castlemaine, retired orchardist, died 13th May, 1951, intestate.

KERR, EVELYN, late of 9 Higginbotham-street, Middle Brighton, music teacher, died 16th May, 1951, intestate.

LENNON, WILLIAM JOHN, formerly of 9 Hull-street, Richmond, but late of Mont Park, carpenter, died 26th December, 1950, intestate.

LYALL, JAMES ALEXANDER, formerly of 44 Station-street, Glenroy, but late of Ballarat, retired cab driver, died 16th April, 1951, intestate.

MARTIN, JOHN, late of 1A Drysdale-street, Malvern, truck driver, died 26th April, 1951, intestate.

MCINNES, DONALD, also known as Frank Greenwood, formerly of 65 Campbell-street, Ararat, Victoria, and Grey-street, South Brisbane, Queensland, but late of Gordon House, Melbourne, Victoria, military pensioner, died 23rd November, 1950, intestate.

MCKURLIE, JOHN WILLIAM, late of Bendigo Benevolent Home, Bendigo, pensioner, died 15th April, 1950, intestate.

\*NOLAN, HUGH THOMAS, late of 180 Park-street, West Brunswick, sheet metal worker, died 27th March, 1951.

RANKIN, LOUIE, late of 200 Victoria-parade, East Melbourne, domestic, died 2nd May, 1951, intestate.

RIBNIKOWA, ALEXANDRA, late of Bonegilla, domestic, died 14th April, 1951, intestate.

SINGH, HERMAN, late of Dookie, hawker, died 14th April, 1951, intestate.

†THOMAS, ETHEL MAUDE, also known as Ethel Thomas, late of 18 Raleigh-street, Thornbury, married woman, died 20th April, 1940.

WENMOUTH, JOHN, late of Bendigo Benevolent Home, Bendigo, pensioner, died 14th March, 1951, intestate.

YOUNG, FRANCIS, late of 136 Victoria-avenue, Albert Park, labourer, died 29th March, 1951, intestate.

\* According to the provisions of the will.

† With the will annexed.

C. J. GARDNER,  
Public Trustee.

Melbourne, 1st August, 1951.

DEPARTMENT OF CROWN LANDS AND SURVEY.

At the Executive Council Chamber, Melbourne, the thirty-first day of July, 1951.

PRESENT:

His Excellency the Governor of Victoria.

Mr. Brose | Mr. Swinburne  
Mr. Harvey | Mr. White.

LANDS TEMPORARILY RESERVED FROM SALE.

HIS Excellency the Governor of the State of Victoria, by and with the advice of the Executive Council thereof, doth hereby, in pursuance of the provisions of the Land Act 1928, reserve, temporarily, and also except from occupation for mining purposes under any miner's right, the lands hereinafter described:—

PRAGRAN (at Elwood).—Site for State School purposes, 3 acres 3 roods 10 perches, at Elwood, Parish of Prahran, County of Bourke, as indicated by hachure on plan hereunder.—(S.226(u<sup>1</sup>)) (Rs.1633).

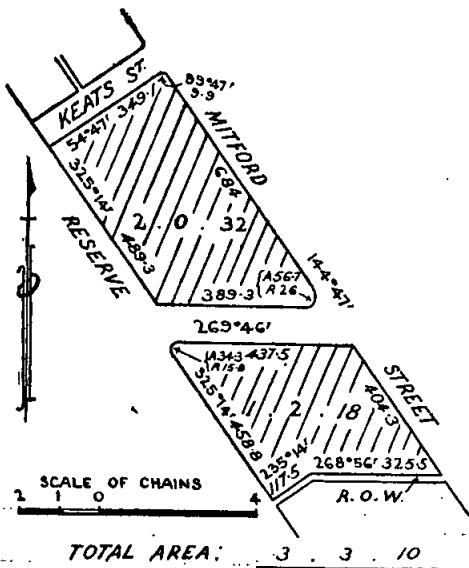

DOOEN.—Site for Public Recreation, 8 acres 1 rood 3 5/10 perches, Parish of Dooen, County of Borung, as indicated by hachure on plan hereunder.—(D.167<sup>(2)</sup>) (Rs.6688).

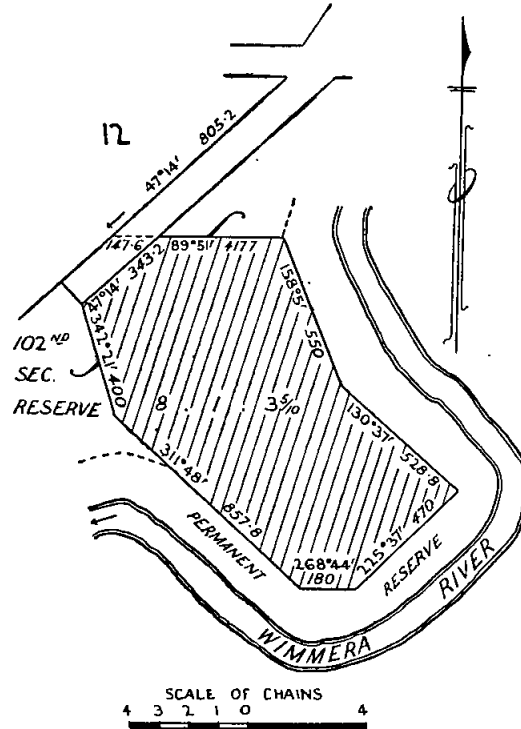

MURRAYVILLE.—Site for Public Recreation, 1 acre 0 roods 30 perches, Township of Murrayville, Parish of Danyo, County of Weeah, as indicated by hachure on plan hereunder.—(M.575<sup>(3)</sup>) (Rs.5882).

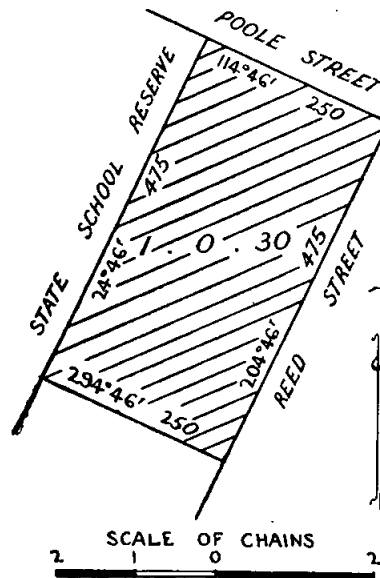

And the Honorable Sir Albert Eli Lind, His Majesty's Commissioner of Crown Lands and Survey for the State of Victoria, shall give the necessary directions herein accordingly.

A. MAHLSTEDT,  
Clerk of the Executive Council.

DEPARTMENT OF CROWN LANDS AND SURVEY.

DEPARTMENT OF CROWN LANDS AND SURVEY.

At the Executive Council Chamber, Melbourne, the thirty-first day of July, 1951.

At the Executive Council Chamber, Melbourne, the thirty-first day of July, 1951.

PRESENT:

His Excellency the Governor of Victoria.  
Mr. Brose | Mr. Swinburne  
Mr. Harvey | Mr. White.

PRESENT:

His Excellency the Governor of Victoria.  
Mr. Brose | Mr. Swinburne  
Mr. Harvey | Mr. White.

UNUSED AND UNMADE ROADS CLOSED.

HIS Excellency the Governor of the State of Victoria, by and with the advice of the Executive Council thereof, doth hereby direct that, in pursuance of the provisions of section 304 of the Land Act 1928 (No. 3709), the unused and unmade roads referred to hereunder be closed, viz.:-

Township of Bamawm, Parish of Bamawm, County of Bendigo, being the roads indicated by hachure on plan hereunder.—(B.94(e<sup>2</sup>)) (I.G.V.128).

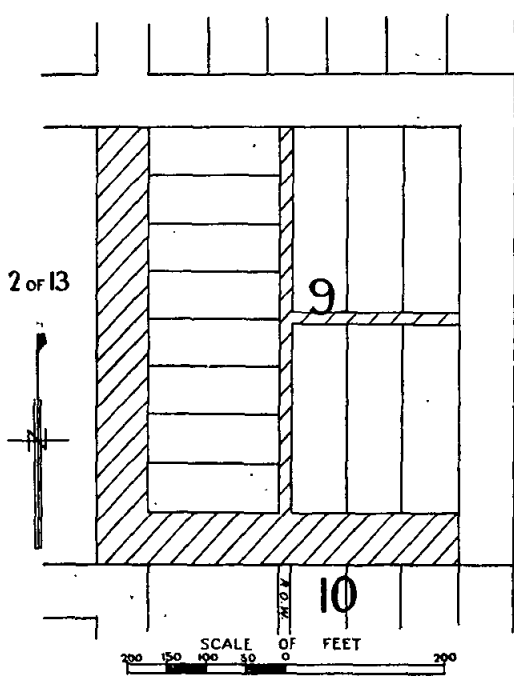

Parish of Heathcote, County of Dalhousie, being the road between allotments B18, B18P, and B18R, and allotment B18M.—(H.75(12)) (H.017678).

Parish of Moolerr, County of Kara Kara, being the road between allotment 15 and allotments 18A and 18, section 4.—(M.427(3)) (W.66616).

Parish of Salisbury West, County of Gladstone, being the road between allotments 46 and 9E, and allotments 45 and 9D, section C.—(S.441(6)) (W.60149).

Parish of Yarck, County of Anglesey, being the road between allotments 20A, 20, and 1, section A, and allotments 21, 22, and 24, section A.—(Y.84(4)) (H.020725).

And the Honorable Sir Albert Eli Lind, His Majesty's Commissioner of Crown Lands and Survey for the State of Victoria, shall give the necessary directions herein accordingly.

A. MAHLSTEDT,  
Clerk of the Executive Council.

REVOCATION OF TEMPORARY RESERVATIONS OF LANDS BY ORDERS IN COUNCIL.

HIS Excellency the Governor of the State of Victoria, by and with the advice of the Executive Council thereof, doth hereby, in pursuance of the provisions of the Land Act 1928, revoke the temporary reservations of the lands by Orders in Council hereinafter referred to, viz.:-

MARMAL.—Order in Council of 14th June, 1938, of 1 acre 1 rood 24 perches of land in the Parish of Marmal, as a site for a State School.—(Rs.4828.)

MOGLONEMBY.—Order in Council of 7th June, 1880, of 5 acres of land in the Parish of Moglonemby, as a site for Public purposes (State School).—(C.93024.)

MOYHU.—Order in Council of 18th March, 1941, of 5 acres of land in the Parish of Moyhu, as a site for a Sanitary Depot.—(Rs.5173.)

RUSHWORTH.—Order in Council of 11th March, 1872, of 4 acres 2 roods of land in the Town of Rushworth, as a site for Police purposes, so far only as regards the portion thereof comprised within the boundaries published in the Government Gazette of 4th July, 1951, and containing 1 acre 0 roods 20 perches.—(C.84793.)

And the Honorable Sir Albert Eli Lind, His Majesty's Commissioner of Crown Lands and Survey for the State of Victoria, shall give the necessary directions herein accordingly.

A. MAHLSTEDT,  
Clerk of the Executive Council.

DEPARTMENT OF CROWN LANDS AND SURVEY.

At the Executive Council Chamber, Melbourne, the thirty-first day of July, 1951.

PRESENT:

His Excellency the Governor of Victoria.  
Mr. Brose | Mr. Swinburne  
Mr. Harvey | Mr. White.

REVOCATION OF TEMPORARY RESERVATIONS, AND THE WITHHOLDING FROM SALE, LEASING, AND LICENSING, OF LANDS BY ORDERS IN COUNCIL.

HIS Excellency the Governor of the State of Victoria, by and with the advice of the Executive Council thereof, doth hereby, in pursuance of the provisions of the Land Act 1928, revoke the temporary reservations, and the withholding from sale, leasing, and licensing, of the lands by Orders in Council hereinafter referred to, viz.:-

WOMBAT.—Order in Council of 12th November, 1877, of 5 acres of land in the Parish of Wombat as a site for Abattoirs, so far only as regards the portion thereof comprised within the boundaries published in the Government Gazette of 26th June, 1951, and containing 1 rood 20 perches.—(Rs.4046.)

BALROOTAN.—Order in Council of 13th October, 1879, of 76 acres 0 roods 38 perches of land in the Parish of Balrootan (now in the Township of Nhill) as a site for Affording Access to Water, so far only as regards the portion thereof comprised within the boundaries published in the Government Gazette of 4th July, 1951, and containing 11 2/10 perches.—(Rs.379.)

And the Honorable Sir Albert Eli Lind, His Majesty's Commissioner of Crown Lands and Survey for the State of Victoria, shall give the necessary directions herein accordingly.

A. MAHLSTEDT,  
Clerk of the Executive Council.

## BARLEY MARKETING ACT 1948.

At the Executive Council Chamber, Melbourne, the  
thirty-first day of July, 1951.

## PRESENT:

His Excellency the Governor of Victoria.	
Mr. Brose	Mr. Swinburne
Mr. Harvey	Mr. White.

## REGULATIONS.

IN pursuance of the powers conferred by the *Barley Marketing Act 1948* (No. 5320), His Excellency the Governor of the State of Victoria in the Commonwealth of Australia, by and with the advice of the Executive Council of the said State, doth hereby make the following Regulations, that is to say:—

The Barley Marketing (Elections) Regulations 1948 are hereby amended as follows:

At the end of sub-clause (2) of clause eight of the said Regulations, there shall be inserted the following proviso—

Provided that for the purposes of the election to be held in the year One thousand nine hundred and fifty-one, any candidate may by written notice addressed to the Minister withdraw his consent to his nomination at any time not later than fourteen days prior to the day appointed for holding the election and such candidate shall be considered as not having been nominated.

And the Honorable George Colin Moss, His Majesty's Minister of Agriculture for the State of Victoria, shall give the necessary directions herein accordingly.

A. MAHLSTEDT,  
Clerk of the Executive Council.

## COUNTRY ROADS BOARD.

At the Executive Council Chamber, Melbourne, the  
thirty-first day of July, 1951.

## PRESENT:

His Excellency the Governor of Victoria.	
Mr. Brose	Mr. Swinburne
Mr. Harvey	Mr. White.

## ORDER APPROVING OF A NEW MAIN ROAD IN THE SHIRE OF COLAC.

WHEREAS the Country Roads Board constituted under the *Country Roads Act 1928* (No. 3662) has represented to His Excellency the Governor in Council that it appears to it desirable that the new Coragulac-Beeac road in the Shire of Colac should be made by the said Board: And whereas the said Board in accordance with the requirements of section 19 of the said cited Act has caused to be prepared a map plan and estimate showing the points between which and on and through what land the said new road is proposed to be made and the cost of acquiring the land and constructing the said new road: And whereas on an inspection of the said map and plan and a consideration of the said estimate His Excellency the Governor in Council is satisfied that there are funds legally available for acquiring the land and constructing the said new road: Now therefore be it known by this present Order that His Excellency the Governor of the State of Victoria with the advice of the Executive Council thereof doth hereby approve of the said road being made, that is to say:—

All those pieces of land in the Parish of Warrion, the boundaries of which are as follow:—

- (a) Commencing at the eastern angle of lot 3 on plan of subdivision numbered 9447, lodged in the Office of Titles, and being part of Crown portion 8B of the said parish: thence by lines bearing respectively 219 deg. 32 min. 258.2 links, 246 deg. 50 min. 183.5 links, and 50 deg. 49 min. 429.5 links to the point of commencement.

- (b) Commencing at a point on the western boundary of allotment 9c of the said parish, distant 26 deg. 50 min. 1,703 links and 10 deg. 7 min. 1,524 links from the south-western angle of the said Crown portion: thence by lines bearing respectively 10 deg. 7 min. 179 links, 30 deg. 44 min. 300 links, 59 deg. 57 min. 216 links, 221 deg. 50 min. 320 links, and 207 deg. 31 min. 343 links to the point of commencement—

which said pieces of land are particularly delineated and shown coloured red on survey plans numbered 5358 and 5359, lodged in the office of the Country Roads Board.

And the Honorable Percy Thomas Byrnes, His Majesty's Commissioner of Public Works for the State of Victoria, shall give the necessary directions herein accordingly.

A. MAHLSTEDT,  
Clerk of the Executive Council.

## COUNTRY ROADS BOARD.

At the Executive Council Chamber, Melbourne, the  
thirty-first day of July, 1951.

## PRESENT:

His Excellency the Governor of Victoria.	
Mr. Brose	Mr. Swinburne
Mr. Harvey	Mr. White.

## ORDER APPROVING OF A DEVIATION FROM A MAIN ROAD IN THE SHIRE OF BASS.

WHEREAS the Country Roads Board constituted under the *Country Roads Act 1928* (No. 3662) has represented to His Excellency the Governor in Council that it appears to it desirable that the deviation hereinafter referred to from the existing Almurta-Grantville road in the Shire of Bass (declared to be a main road under the said Act which declaration was confirmed by the Order in Council published in the *Government Gazette* of the

22nd May, 1929, on page 1553) should be made by the said Board: And whereas the said Board in accordance with the requirements of section 19 of the said cited Act has caused to be prepared a map plan and estimate showing the points between which and on and through what land the said deviation is proposed to be made and the cost of acquiring the land and constructing the said deviation: And whereas on an inspection of the said map and plan and a consideration of the said estimate His Excellency the Governor in Council is satisfied that there are funds legally available for acquiring the land and constructing the said deviation: Now therefore be it known by this present Order that His Excellency the Governor of the State of Victoria with the advice of the Executive Council thereof doth hereby approve of the said road being made, that is to say:—

All that piece of land in the Parish of Corinella, the boundaries of which are as follow:—Commencing at the south-western angle of allotment 157 of the said parish; thence by lines bearing respectively 347 deg. 6 min. 530 links, 134 deg. 27 min. 518 links, 139 deg. 0 min. 115.3 links, and 258 deg. 27 min. 333.9 links to the point of commencement—which said piece of land is particularly delineated and shown coloured red on survey plan numbered 5348, lodged in the office of the Country Roads Board.

And the Honorable Percy Thomas Byrnes, His Majesty's Commissioner of Public Works for the State of Victoria, shall give the necessary directions herein accordingly.

A. MAHLSTEDT,  
Clerk of the Executive Council.

#### COUNTRY ROADS BOARD.

At the Executive Council Chamber, Melbourne, the  
thirty-first day of July, 1951.

PRESENT:

His Excellency the Governor of Victoria.	
Mr. Brose	Mr. Swinburne
Mr. Harvey	Mr. White.

#### ORDER APPROVING OF A DEVIATION FROM A MAIN ROAD IN THE SHIRE OF YACKANDANDAH.

WHEREAS the Country Roads Board constituted under the *Country Roads Act 1928* (No. 3662) has represented to His Excellency the Governor in Council that it appears to it desirable that the deviation hereinafter referred to from the existing Kiewa East-road in the Shire of Yackandandah (declared to be a main road under the said Act which declaration was confirmed by the Order in Council published in the *Government Gazette* of the 14th October, 1931, on page 2854) should be made by the said Board: And whereas the said Board in accordance with the requirements of section 19 of the said cited Act has caused to be prepared a map plan and estimate showing the points between which and on and through what land the said deviation is proposed to be made and the cost of acquiring the land and constructing the said deviation: And whereas on an inspection of the said map and plan and a consideration of the said estimate His Excellency the Governor in Council is satisfied that there are funds legally available for acquiring the land and constructing the said deviation: Now therefore be it known by this present Order that His Excellency the Governor of the State of Victoria with the advice of the Executive Council thereof doth hereby approve of the said road being made, that is to say:—

All that piece of land in the Parish of Tangambalanga, the boundaries of which are as follow:—Commencing at the north-eastern angle of allotment 11, section 2, of the said parish; thence by lines bearing respectively 180 deg. 24 min. 126.4 links, 290 deg. 12 min. 572.5 links, 75 deg. 50 min. 297.7 links, and 120 deg. 2 min. 288 links to the point of commencement—which said piece of land is particularly delineated and shown coloured red on survey plan numbered 5356, lodged in the office of the Country Roads Board.

And the Honorable Percy Thomas Byrnes, His Majesty's Commissioner of Public Works for the State of Victoria, shall give the necessary directions herein accordingly.

A. MAHLSTEDT,  
Clerk of the Executive Council.

#### COUNTRY ROADS BOARD.

At the Executive Council Chamber, Melbourne, the  
thirty-first day of July, 1951.

PRESENT:

His Excellency the Governor of Victoria.	
Mr. Brose	Mr. Swinburne
Mr. Harvey	Mr. White.

#### ORDER APPROVING OF A NEW MAIN ROAD IN THE CITY OF BOX HILL.

WHEREAS the Country Roads Board constituted under the *Country Roads Act 1928* (No. 3662) has represented to His Excellency the Governor in Council that it appears to it desirable that the new Burwood-road in the City of Box Hill should be made by the said Board: And whereas the said Board in accordance with the requirements of section 19 of the said cited Act has caused to be prepared a map plan and estimate showing the points between which and on and through what land the said new road is proposed to be made and the cost of acquiring the land and constructing the said new road: And whereas on an inspection of the said map and plan and a consideration of the said estimate His Excellency the Governor in Council is satisfied that there are funds legally available for acquiring the land and constructing the said new road: Now therefore be it known by this present Order that His Excellency the Governor of the State of Victoria with the advice of the Executive Council thereof doth hereby approve of the said road being made, that is to say:—

All those pieces of land in the Parish of Nunawading, the boundaries of which are as follow:—

- Commencing at the north-western angle of allotment 1, section 10, Town of Burwood, in the said parish; thence by lines bearing respectively 68 deg. 49 min. 528 feet, 159 deg. 13 min. 57 ft. 6 in., 256 deg. 40 min. 266 ft. 3 in., 252 deg. 56 min. 264 ft. 6 in., and 339 deg. 13 min. 2 ft. 1½ in. to the point of commencement.
- Commencing at a point in Crown portion 11 of the said parish distant 180 deg. 0 min. 19 feet from the north-western angle of lot 1 on plan of subdivision numbered 7588, lodged in the Office of Titles; thence by a line bearing 266 deg. 7½ min. 376 ft. 3½ in. to the east bank of Gardiners Creek; thence northerly by the said bank a distance of 26 feet; thence by a line bearing 90 deg. 0 min. 370 feet to the point of commencement—

which said pieces of land are particularly delineated and shown coloured red on survey plan numbered 5314, lodged in the office of the Country Roads Board.

And the Honorable Percy Thomas Byrnes, His Majesty's Commissioner of Public Works for the State of Victoria, shall give the necessary directions herein accordingly.

A. MAHLSTEDT,  
Clerk of the Executive Council.

#### HOSPITALS AND CHARITIES ACT 1948 (No. 5300).—SECTION 52.

At the Executive Council Chamber, Melbourne, the  
thirty-first day of July, 1951.

PRESENT:

His Excellency the Governor of Victoria.	
Mr. Brose	Mr. Swinburne
Mr. Harvey	Mr. White.

#### ROYAL VICTORIAN INSTITUTE FOR THE BLIND EXTENSION OF OBJECTS.

WHEREAS the Royal Victorian Institute for the Blind is an institution incorporated pursuant to the provisions of the *Hospitals and Charities Act 1948* (No. 5300): And whereas the members of the Committee of Management of the said institute desire to extend the objects or purposes of such institute: And whereas the Hospitals and Charities Commission after inquiry recommends the extension desired by the members of the aforesaid committee: And whereas the Governor in Council may, under the powers conferred by section 52 of Act No. 5300 order such extension: Now therefore, His Excellency the



Governor of the State of Victoria, by and with the advice of the Executive Council of the said State, doth hereby extend the objects or purposes of the Royal Victorian Institute for the Blind by substituting the following paragraph for paragraph (b) of the Order extending the objects of the said institute approved by the Executive Council on the 3rd day of October, 1950, and published in the *Government Gazette* dated the 11th day of October, 1950:—

"(b) To provide a home at the institute and elsewhere for and to educate the youthful blind of the State of Victoria and give teaching in its school or schools, and afterwards to train them in trades and professions suitable for blind people and to afford them means of employment in such trades and professions, and for these purposes to carry on schools, classes, factories, trading, and mercantile operations."

And the Honorable William Oliver Fulton, His Majesty's Minister of Health in the State of Victoria, shall give the necessary directions herein accordingly.

A. MAHLSTEDT,  
Clerk of the Executive Council.

#### FORESTS ACT 1928.

*At the Executive Council Chamber, Melbourne, the thirty-first day of July, 1951.*

##### PRESENT:

His Excellency the Governor of Victoria.	
Mr. Brose	Mr. Swinburne
Mr. Harvey	Mr. White.

#### ALIENATED LAND ACQUIRED BY EXCHANGE, ETC., AND DEDICATED AS PERMANENT FOREST.

WHEREAS by Order in Council dated the 10th day of April, 1951, the Governor in Council approved of the dedication of certain land acquired from Kenneth Davey Pearce, of Mandurang, stated in Dedication Schedule No. 130 to be 9 acres 3 roods 29 perches, in the Parish of Mandurang, County of Bendigo:

Now, therefore, His Excellency the Governor of the State of Victoria, by and with the advice of the Executive Council of the said State, and in pursuance of the provisions of section 48, sub-section 9, of the *Forests Act* 1928, doth hereby amend the above Order to read:—

##### DEDICATION SCHEDULE No. 130.

Alienated land acquired from Kenneth Davey Pearce, of Mandurang, in exchange for an area of permanent forest, described in Schedule "B" and dedicated as permanent forest, 4 acres 0 roods 37 2/10 perches, Parish of Mandurang, County of Bendigo, being part of allotment 14, section 2.

And the Honorable Sir Albert Eli Lind, His Majesty's Minister of Forests for the State of Victoria, shall give the necessary directions herein accordingly.

A. MAHLSTEDT,  
Clerk of the Executive Council.

#### MOTOR OMNIBUS ACT 1928 (No. 3742).

*At the Executive Council Chamber, Melbourne, the thirty-first day of July, 1951.*

##### PRESENT:

His Excellency the Governor of Victoria.	
Mr. Brose	Mr. Swinburne
Mr. Harvey	Mr. White.

#### AMENDMENTS OF PRESCRIPTIONS OF CERTAIN METROPOLITAN MOTOR OMNIBUS ROUTES OPERATED BY THE MELBOURNE AND METROPOLITAN TRAMWAYS BOARD.

HIS Excellency the Governor of the State of Victoria, by and with the advice of the Executive Council thereof, and in pursuance of the powers conferred by the *Motor Omnibus Act* 1928 (No. 3742), doth by this Order amend, as set out hereunder, the prescriptions of certain routes within the metropolitan area, along which routes motor

omnibuses of the Melbourne and Metropolitan Tramways Board are used, with the consent of the Governor in Council, to ply for hire, viz.:—

*Footscray-Moonee Ponds (via Maidstone).*—Under the heading "Time-tables to be observed," delete the existing particulars, and in place thereof insert "as deemed by the Tramways Board to be required for factories."

*Footscray-Deer Park (via Ballarat-road).*—Under the heading "Description of route, including commencing and terminal points," after "State Electricity Commission's pole No. 12" insert "with extension from the corner of Ashley and Essex streets, via Ashley-street, South-road, and Darnley-street, to entrance to Munition Stores and Transport Department, Tottenham."

Under the heading "Sections on route," after "(3) junction of Ashley and Essex streets to Vine-street" insert "(3A) corner of Ashley and Essex streets to Munition Stores and Transport Department, Tottenham."

Under the heading "Time-tables to be observed," delete the existing particulars, and in place thereof insert "Minimum service, Footscray-Sunshine, 60 minutes—6.30 a.m. to 12 midnight, week days; 8.30 a.m. to 12.15 a.m., Sundays. On the extensions to S.E.C. pole No. 12 in Ballarat-road, and the Munition Stores and Transport Department, Tottenham—as deemed by the Tramways Board to be required."

And the Honorable Percy Thomas Byrnes, His Majesty's Commissioner of Public Works for the State of Victoria, shall give the necessary directions herein accordingly.

A. MAHLSTEDT,  
Clerk of the Executive Council.

#### Water Acts.

#### STATE RIVERS AND WATER SUPPLY COMMISSION.

*At the Executive Council Chamber, Melbourne, the seventh day of August, 1951.*

##### PRESENT:

His Excellency the Governor of Victoria.	
Mr. Brose	Mr. Harvey.

#### TRAGOWEL PLAINS IRRIGATION AND WATER SUPPLY DISTRICT.—PORTION EXCISED.

UNDER the powers conferred by the Water Acts and all other powers enabling him in that behalf, His Excellency the Governor of the State of Victoria, with the advice of the Executive Council of the said State, on the recommendation of the State Rivers and Water Supply Commission, doth hereby declare, order, and direct as follows:—

That there shall be excised from the Tragowel Plains Irrigation and Water Supply District that portion of the same set out and described in the Schedule hereto, which portion as from the date of this Order shall be deemed to be excised accordingly.

##### SCHEDULE.

Commencing at a point in the eastern boundary of allotment 39, section B, Parish of Mologa, County of Gunbower, distant 4 chains and 84 8/10 links southerly from the north-eastern angle of that allotment; thence westerly by a line parallel to the northern boundary of that allotment a distance of 2 chains and 27 3/10 links; thence northerly by a line parallel to the eastern boundary of aforesaid allotment 39 to the southern boundary of the Pyramid Hill Waterworks District; thence easterly by the last-mentioned boundary to the eastern boundary of Barber-street; thence southerly by that street boundary to a point due east of the point of commencement; thence by a line bearing west to the said point of commencement.

The portion described in the foregoing Schedule is shown on a plan approved by the Governor in Council and deposited in the Office of the State Rivers and Water Supply Commission, Melbourne.—(Corres. 51/6621.)

And the Honorable Richard Keats Brose, His Majesty's Minister of Water Supply for the State of Victoria, shall give the necessary directions herein accordingly.

A. MAHLSTEDT,  
Clerk of the Executive Council.

## Water Acts.

## STATE RIVERS AND WATER SUPPLY COMMISSION.

*At the Executive Council Chamber, Melbourne, the seventh day of August, 1951.*

## PRESENT:

His Excellency the Governor of Victoria.  
Mr. Brose | Mr. Harvey.

## PYRAMID HILL WATERWORKS DISTRICT—PYRAMID HILL URBAN DISTRICT.—DISTRICTS EXTENDED.

UNDER the powers conferred by the Water Acts and all other powers enabling him in that behalf, His Excellency the Governor of the State of Victoria, with the advice of the Executive Council of the said State, on the recommendation of the State Rivers and Water Supply Commission, doth hereby declare, order, and direct as follows:—

That the Pyramid Hill Waterworks District and the Pyramid Hill Urban District be extended by adding to the same the lands set out and described in the Schedule hereto, and as on and from the date of this Order, such district shall be deemed to be so extended.

## SCHEDULE.

Commencing at a point in the eastern boundary of allotment 39, section B, Parish of Mologa, County of Gunbower, distant 4 chains and 84 8/10 links southerly from the north-eastern angle of that allotment; thence westerly by a line parallel to the northern boundary of that allotment a distance of 2 chains and 27 3/10 links; thence northerly by a line parallel to the eastern boundary of aforesaid allotment 39 to the southern boundary of the Pyramid Hill Waterworks District; thence easterly by the last-mentioned boundary to the eastern boundary of Barber-street; thence southerly by that street boundary to a point due east of the point of commencement; thence by a line bearing west to the said point of commencement.

The lands described in the foregoing Schedule are shown on a plan approved by the Governor in Council and deposited in the Office of the State Rivers and Water Supply Commission, Melbourne.—(Corres. 51/6621.)

And the Honorable Richard Keats Brose, His Majesty's Minister of Water Supply for the State of Victoria, shall give the necessary directions herein accordingly.

A. MAHLSTEDT,  
Clerk of the Executive Council.

## Water Acts.

## STATE RIVERS AND WATER SUPPLY COMMISSION.

*At the Executive Council Chamber, Melbourne, the seventh day of August, 1951.*

## PRESENT:

His Excellency the Governor of Victoria.  
Mr. Brose | Mr. Harvey.

## RED CLIFFS—MERBEIN IRRIGATION AND WATER SUPPLY DISTRICT—RED CLIFFS URBAN DIVISION.—DIVISION EXTENDED.

UNDER the powers conferred by the Water Acts and all other powers enabling him in that behalf, His Excellency the Governor of the State of Victoria, with the advice of the Executive Council of the said State, on the recommendation of the State Rivers and Water Supply Commission, doth hereby declare, order, and direct as follows:—

That the Red Cliffs Urban Division of the Red Cliffs—Merbein Irrigation and Water Supply District be extended by adding to the same the lands set out and described in the Schedule hereto, and as on and from the date of this Order, such Division shall be deemed to be so extended.

## SCHEDULE.

All those pieces of land being the whole of allotment 232, section B, Parish of Mildura, County of Karkaroo, together with that portion of the No. 6 Channel Reserve adjoining the north-western and south-western boundaries of that allotment, and that portion of Indi-avenue adjoining the south-eastern boundary of said allotment 232 and extending south-westerly to the western boundary of the said Channel Reserve.

The lands described in the foregoing Schedule are shown on a plan approved by the Governor in Council and deposited in the Office of the State Rivers and Water Supply Commission, Melbourne.—(Corres. 50/22701.)

And the Honorable Richard Keats Brose, His Majesty's Minister of Water Supply for the State of Victoria, shall give the necessary directions herein accordingly.

A. MAHLSTEDT,  
Clerk of the Executive Council.

## ELECTRIC LIGHT AND POWER ACT 1928 AND STATE ELECTRICITY COMMISSION ACTS.

*At the Executive Council Chamber, Melbourne, the seventh day of August, 1951.*

## PRESENT:

His Excellency the Governor of Victoria.  
Mr. Brose | Mr. Harvey.

## THE OUYEN ELECTRIC LIGHTING ORDER No. 247—1941.—AMENDMENT TO TARIFF.

WHEREAS on the 26th August, 1941, the Council of the municipality of the President, Councillors, and Ratepayers of the Shire of Walpeup (hereinafter called "the undertakers") was granted an Order under the *Electric Light and Power Act 1928*, cited as The Ouyen Electric Lighting Order No. 247—1941 (hereinafter called "the said Order"), to supply electricity to the Township of Ouyen, within an area comprising a circle having its centre at the Power House at Ouyen and a radius of 1 mile, the Power House being situated on allotment 9, section No. 2, Township and Parish of Ouyen, County of Karkaroo, for a period of twenty years, commencing on 26th day of August, 1941: And whereas by Orders dated 29th day of March, 1949, and the 5th day of September, 1950, the Governor in Council did approve of amendments varying the maximum prices which may be charged for electricity supplied: And whereas the said undertakers have made application to vary the maximum rates which may be charged: Now therefore His Excellency the Governor of the State of Victoria, by and with the advice of the Executive Council thereof, acting pursuant to the provisions of section 13 of the *Electric Light and Power Act 1928*, doth hereby vary the maximum rates which may be charged for electricity supplied set forth in the Fourth Schedule of the said Order, and amendments dated 29th March, 1949, and 5th September, 1950, respectively, by substituting the following sections for those set forth, that is to say:—

## SECTION 1.

Where the undertakers charge any consumer by the electrical quantity supplied to him, they shall be entitled to charge him at the following rates:—

*For electricity supplied for lighting purposes—*

For any amount per month: 1s. 6d. per unit.

*For electricity supplied for purposes other than lighting—*

First 30 units per month: 8d. per unit.

All over 30 units per month: 6d. per unit.

## SECTION 3.

Notwithstanding anything contained in this Order the undertakers may charge any consumer a minimum charge of 7s. 6d. per month irrespective of whether the supply is used for lighting or other purposes. Such minimum charge shall be exclusive of meter rent.

And the foregoing amendments shall be effective as from the 5th day of September, 1951.

And the Honorable Keith Dodgshun, His Majesty's Minister in Charge of Electrical Undertakings for the State of Victoria, shall give the necessary directions herein accordingly.

A. MAHLSTEDT,  
Clerk of the Executive Council.

## EXPLOSIVES ACT 1928.

At the Executive Council Chamber, Melbourne, the seventh day of August, 1951.

PRESENT:

His Excellency the Governor of Victoria.  
Mr. Brose | Mr. Harvey.

## CLASSIFICATION OF EXPLOSIVES.

HIS Excellency the Governor of the State of Victoria, by and with the advice of the Executive Council thereof, and in pursuance of the provisions of section 53 of the Explosives Act 1928, doth, by this Order, classify the under-mentioned explosives as follows:—

## CLASS 3.—NITRO-COMPOUND.

## Division 1.

Geobel No. 3.  
Geophex.

And the Honorable Keith Dodgshun, His Majesty's Chief Secretary for the State of Victoria, shall give the necessary directions herein accordingly.

A. MAHLSTEDT,  
Clerk of the Executive Council.

## POLICE REGULATION ACTS.

At the Executive Council Chamber, Melbourne, the seventh day of August, 1951.

PRESENT:

His Excellency the Governor of Victoria.  
Mr. Brose | Mr. Harvey.

## APPOINTMENT OF AN ACTING MEMBER OF THE POLICE DISCIPLINE BOARD.

WHEREAS Harold Lepplastrier Jackson, a Stipendiary Magistrate, who is a member of the Police Discipline Board, is unable, by reason of absence from duty on account of illness, to carry out his duties as a member of the said Board:

Now therefore His Excellency the Governor of the State of Victoria, in the Commonwealth of Australia, by and with the advice of the Executive Council of the said State, and in pursuance of the powers conferred by the Police Regulation Acts and the Regulations made thereunder and all other powers him thereunto enabling, doth by this Order nominate and appoint—

REGINALD HARRY MOHR, Stipendiary Magistrate, to act as a member of the Police Discipline Board, during the absence on leave of the said Harold Lepplastrier Jackson.

And the Honorable Keith Dodgshun, His Majesty's Chief Secretary for the State of Victoria, shall give the necessary directions herein accordingly.

A. MAHLSTEDT,  
Clerk of the Executive Council.

## LANDLORD AND TENANT ACTS.

At the Executive Council Chamber, Melbourne, the seventh day of August, 1951.

PRESENT:

His Excellency the Governor of Victoria.  
Mr. Brose | Mr. Harvey.

## ORDER EXTENDING APPLICATION OF THE LANDLORD AND TENANT ACT 1948 TO CERTAIN PREMISES.

WHEREAS by Orders published in the Government Gazette the several premises, described in the Schedule hereto, were excluded from the operation of Part V. of the Landlord and Tenant Act 1948: And whereas it is expedient that that Part should again extend to each of those premises: Now therefore, in pursuance of the powers conferred upon him by the Landlord and Tenant Act 1948, as amended by the Landlord and Tenant (Amendment) Act 1948, His Excellency the Governor of Victoria, by and with the advice of the Executive Council thereof, doth hereby declare that the application of the whole of the Landlord and Tenant Act 1948 shall extend to each of the premises described in such Schedule.

## SCHEDULE.

1. No. 78 Stubbs-street, Kensington.
2. No. 45 Evans-street, East Brunswick.
3. The premises situated upon all that piece of land in Brisbane-parade, Warburton, being lots 20 and 21 on plan of subdivision No. 4908, lodged in the Office of Titles, and being part of Crown allotment 19, Parish of Yuonga, more particularly described in certificate of title, volume 6533, folio 1306437.

And the Honorable Thomas Walter Mitchell, His Majesty's Attorney-General in and for the State of Victoria, shall give the necessary directions herein accordingly.

A. MAHLSTEDT,  
Clerk of the Executive Council.

## LANDLORD AND TENANT ACTS.

At the Executive Council Chamber, Melbourne, the seventh day of August, 1951.

PRESENT:

His Excellency the Governor of Victoria.  
Mr. Brose | Mr. Harvey.

## ORDER EXCLUDING CERTAIN PREMISES FROM THE OPERATION OF CERTAIN PROVISIONS OF THE LANDLORD AND TENANT ACT 1948.

IN pursuance of the powers conferred upon him by the Landlord and Tenant Act 1948, as amended by the Landlord and Tenant (Amendment) Act 1948, His Excellency the Governor of Victoria, by and with the advice of the Executive Council thereof, doth hereby declare that the premises known as No. 1320 High-street, Malvern, shall be excluded from the operation of the whole of the provisions contained in sections 73 to 78 (both inclusive) of the Landlord and Tenant Act 1948.

And the Honorable Thomas Walter Mitchell, His Majesty's Attorney-General in and for the State of Victoria, shall give the necessary directions herein accordingly.

A. MAHLSTEDT,  
Clerk of the Executive Council.

## APPROACHING LAND SALES.

SALES of Crown lands, in fee-simple, will be held at the under-mentioned places and dates, viz.:—

	No. of Gazette.
Ararat.—Thursday, 30th August, 1951 ..	731
Ballarat.—Tuesday, 21st August, 1951 ..	685
Colac.—Tuesday, 28th August, 1951 ..	710
Lismore.—Tuesday, 4th September, 1951 ..	731
Koo-wee-rup.—Friday, 24th August, 1951 ..	710
Red Cliffs.—Thursday, 9th August, 1951 ..	673
Terang.—Tuesday, 4th September, 1951 ..	731
Timboon.—Wednesday, 5th September, 1951 ..	751
Warragul.—Thursday, 16th August, 1951 ..	685
Wedderburn.—Wednesday, 15th August, 1951 ..	685
Woomelang.—Wednesday, 22nd August, 1951 ..	710
Warrnambool.—Wednesday, 5th September, 1951 ..	751

## SALES OF CROWN LANDS BY AUCTION.

The lands will be sold in fee-simple, and subject to the covenants, conditions, exceptions, and reservations directed by the Governor in Council by an Order in Council dated the 5th August, 1930, and published in the Government Gazette of the 8th August, 1930, varied as herein.

Except where specifically stated, a deposit of at least twelve and a half per centum of the price at which each lot is sold must be paid by the purchaser at the time of sale, and all such payments shall be made in bank notes or cheques approved by the officer conducting the sale, and the residue of such price will be payable in equal instalments, in accordance with the scale hereunder, on the last day of each successive period of six months from the time of sale, or, if the purchaser choose, at any earlier time or times; such residue of the purchase money shall bear interest at the rate of Five pounds per centum per annum, to be computed with

respect to each instalment for the period which has elapsed between the time of sale and the time of the payment of such instalment. If the residue of the price be paid within thirty days after the time of the sale no interest will be payable thereon.

The Governor in Council may allow a transfer of the purchaser's interest to an approved person at any time before the final payment of the purchase money is made. The fee for transfer shall be One pound, and such transfer will be subject to payment of stamp duty.

#### SCALE OF PAYMENTS OF RESIDUE.

£20 and under, 6 instalments.  
Over £20, and not exceeding £50, 8 instalments.  
Over £50, and not exceeding £100, 10 instalments.  
Over £100, and not exceeding £200, 12 instalments.  
Over £200, and not exceeding £300, 14 instalments.  
Over £300, and not exceeding £400, 16 instalments.  
Over £400, and not exceeding £500, 18 instalments.  
Over £500, 20 instalments.

#### FEES, ETC.

The amount payable for Assurance Fund (one halfpenny for each £1 of purchase price) and Crown Grant fee must be paid with the balance of purchase money. The following is the scale of fees for Crown Grant:—

50 acres and under, £1 10s.

Over 50 acres, £2.

Where the purchase money does not exceed £5, the grant fee is £1.

Valuations of improvements (if not purchased by the owner thereof), and charges for survey, must also be paid at the time of sale.

A. E. LIND,

Commissioner of Crown Lands and Survey.

Office of Crown Lands and Survey.

Melbourne, 6th August, 1951.

**WARRNAMBOOL.**—Sale (No. 10884) of Crown lands, in fee-simple, by auction, will be held at the COURT HOUSE, WARRNAMBOOL, on WEDNESDAY, the 5th SEPTEMBER, 1951, at TEN o'clock a.m. To be conducted by A. L. REAH, Land Officer, Geelong. Auctioneer: N. K. MORRIS, 93 Kepler-street, Warrnambool.

CITY OF WARRNAMBOOL, PARISH OF WANGOOM, COUNTY OF VILLIERS.

Fronting Bostock-street.

Upset price £30 the lot. Charge for survey £5 5s.

Lot 1. Area 3r. 30p., allotment 2B. One month allowed to remove improvements.

Upset price £80 per lot. Charge for survey £5 per lot.  
Corner of Foster and Hotham Streets.

Lot 2. Area 26 4/10 perches, allotment 10 of section 49.

Fronting Hotham-street.

Lot 3. Area 26 5/10 perches, allotment 11 of section 49.

Lot 4. Area 26 8/10 perches, allotment 11A of section 49.

**TIMBOON.**—Sale (No. 10885) of Crown lands, in fee-simple, by auction, will be held at the LAND INSPECTOR'S OFFICE, TIMBOON, on WEDNESDAY, the 5th SEPTEMBER, 1951, at TWO o'clock p.m. To be conducted by A. L. REAH, Land Officer, Geelong.

COORIEJONG, PARISH OF COORIEJONG, COUNTY OF HEYTESBURY.

In the Centre of the Township.

Upset price £2 per acre. Charge for survey £8.

Lot 1. Area 6a. 2r. (subject to survey), allotment 3 of section 3.

PARISH OF PAARATTE, COUNTY OF HEYTESBURY.

Site of former State School at Timboon South.

Upset price £13 10s. the lot. Charge for survey £6 2s. 6d.

Lot 2. Area 3 acres, allotment 16B of section 2. Valuation of improvements, £29 (Crown).

Also,

Freehold land under the Transfer of Land Act for and on behalf of the Minister of Education.

PARISH OF TIMBOON, COUNTY OF HEYTESBURY.

Old Glenfyne School Site.

Upset price £20 15s. the lot.

Lot 3. Area 1 acre, part of allotment 9, and being the whole of the land comprised in certificate of title, volume 6229, folio 1245760.

Sale of lot 3 is subject to the following conditions:—

- (a) One month allowed for removal of any improvements;
- (b) the purchaser shall pay the purchase money in full at the sale;
- (c) the preparation and registration of the transfer under the Transfer of Land Act shall be attended to by the purchaser or his solicitor, and all costs relating thereto shall be borne by the purchaser.

#### SOLDIER SETTLEMENT ACTS.

IN pursuance of section 88 (1) of the *Soldier Settlement Act 1946* (No. 5179), I, Sir Albert Lind, Commissioner of Crown Lands and Survey, hereby declare the farming land specified in the Schedule hereunder to be land suitable for soldier settlement.

#### SCHEDULE.

All those pieces of land, comprising 19,701 acres 2 roods 35 perches, more or less, and being Crown portions 7, 8, 61 to 75 (both inclusive), 77A, 77C, 77E, and part Crown portions 12 and 76, Parish of Carrah; Crown portions 62 to 67 (both inclusive), 74 to 82 (both inclusive), 84, 86, 87, 88, 89, and part of Crown portions 71, 72 and 73 and 85, and Crown allotment 83, Parish of Burtwarrah; Crown portions 1, 2, 2A, 3, 4, 5, 6, 7, 8, 8A, 9, 9A, 10, 10A, 11, 12, 12A, 13, 13A, 14, 14A, 15, 16, 17, 18A, 19, 19A, 20A, 20, 21, 21A, 22, 23, 24, 25, 26, 27, 26A, 27A, 28 to 35 (both inclusive), and Crown portion B, section 5, Parish of Shelford.

Signed at Melbourne, this 6th Day of August, 1951.

A. E. LIND,

Commissioner of Crown Lands and Survey.

#### SOLDIER SETTLEMENT ACTS.

IN pursuance of section 88 (1) of the *Soldier Settlement Act 1946* (No. 5179), I, Sir Albert Lind, Commissioner of Crown Lands and Survey, hereby declare the farming land specified in the Schedule hereunder to be land suitable for soldier settlement.

#### SCHEDULE.

All those pieces of land comprising 5,393 acres 2 roods 11 perches, and being Crown allotment 151, Parish of Callawadda; Crown allotments 1A, 2, 3, 4A, 5A, 6, 7, 8, 9, 14, 15, 16, 17, 80A, 81, 83, 85, 90, 91, 107, and 110, Parish of Bolangum; Crown allotments 58A, 58B, Parish of Winjalok; Crown allotments 126, 127, 128, 129, 146, 148, 149, 150, 151, 147, and parts of Crown allotments 36 and 130, Parish of Wallaloo; lots 2 and 3 on P/S. No. 5212, being Crown allotment 1, section 17, part of Crown allotment 1, section 18, the whole of Crown allotment 1 and part of Crown allotment 2, section 27, the whole of Crown allotments 1, 4, 5, and 8, section 28, Parish of Toolerook.

Signed at Melbourne, this 31st day of July, 1951.

A. E. LIND,

Commissioner of Crown Lands and Survey.

#### NOTICE OF INTENTION TO DEDICATE AREAS OF CROWN LAND AS PERMANENT FOREST.

NOTICE is hereby given that after the expiration of one month following the first publication of this notice in the *Government Gazette*, it is intended, in pursuance of section 52 of the *Forests Act 1928*, to move His Excellency the Governor of the State of Victoria in Council to dedicate as permanent forest the areas of Crown land described in the accompanying Schedule No. 131.

A. E. LIND,

Minister of Forests and Minister of Lands.

Forests Commission of Victoria,

Melbourne, 18th July, 1951.

#### THE SCHEDULE ABOVE REFERRED TO.

##### DEDICATION SCHEDULE No. 131.

*Area Proposed to be Dedicated as Permanent Forest.*

163,000 acres, more or less, of unoccupied Crown lands in the Parishes of Bemm, Curlip, Goolingook, Jilwain, Jirrah, Murrungowar, Nungal, Purgagoolah, Tabbara, Tonghi, Winyar, and Yarrak, County of Croaingingolong, being the whole of the unoccupied Crown lands within the areas shown by diagonal hatched lines on diagram No. 647, on the accompanying plan A. 51/428 and 22.7.51 (correspondence Nos. 51/428, C.93152).

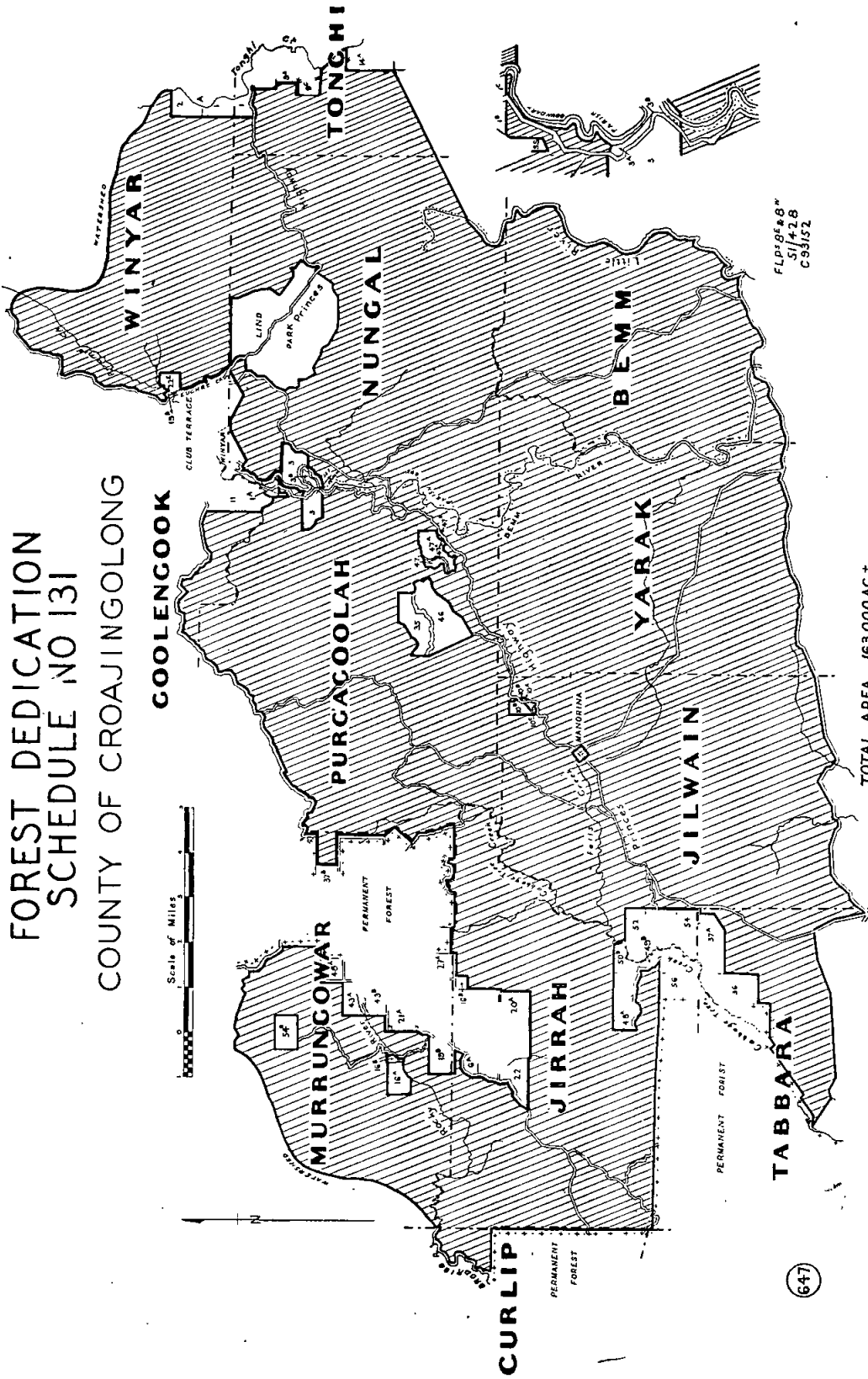

FLDS 95/87  
51/42 B  
C33152

TOTAL AREA 163,000 AC ±

647

LIST OF CROWN LANDS AVAILABLE.

THE under-mentioned areas are available for application as provided by various sections of the *Land Act 1928*, and all applications received on or before Wednesday, 5th September, 1951, will be deemed to have been simultaneously made, but any application lodged after such date may be considered if received in time for inclusion in the advertisement of the cases to be heard at the Local Land Board. Applications on proper form, accompanied by 5s. duty stamp uncanceled (registration fee), may be delivered or forwarded by post to the Local Land Officer or to any Crown Lands Office in Victoria. Applicants may obtain from Local Land Officers, or the Crown Lands Department, Melbourne, a certificate authorizing the issue by the Railway Department of a return ticket at concession fares to enable them to inspect available areas or to attend Local Land Boards. When an applicant is granted an allotment he may, if travelling by rail, obtain reduced fares for his family and also freight concessions in regard to some of his effects.

Subject to the approval of the Secretary for Lands, when the survey fee exceeds £25 but does not exceed £50, a deposit of £25 may be paid, and when the fee exceeds £50 a deposit of 50 per cent. of the fee, the balance in either case being payable over six years in half-yearly instalments.

Marked plans of any particular area, application forms, and any further information may be obtained from the Crown Lands Department, Melbourne, and Land Officers, Ballarat, Beechworth, Bendigo, Hamilton, Sale and Stawell.

Department of Crown Lands and Survey,  
Melbourne, 8th August, 1951.

A. E. LIND,  
Commissioner of Crown Lands and Survey.

\* Improvements may be subject to re-valuation after land has been granted to an applicant.

Local Land Office.	County.	Parish.	Allotment.	Area.	How Available.		Survey Fee.	Valuation of Improvements (if any).	Location of Land, &c.	Nearest Railway Station and Distance in miles therefrom.	How Accessible.	Water Supply.	General Description of Land—Soil, Timber, Suitability (Grazing, &c.).
					Classification.	Value per Acre.							
AGRICULTURAL AND GRAZING LANDS—SELECTION PURCHASE ALLOTMENTS.													
DIVISION 4, PART I, LAND ACT 1928.													
A. E. P.													
Ballarat (a, b, c)	Grenville..	Haddon ..	4	7 158 0 0	1st	4 0 0	18 2 6	Nil	In north of parish ..	Haddon R.S., 4 miles	By road	To be conserved	Undulating to hilly; gum and mesquite timber; suitable for grazing. (35/47-69)
Beechworth (a, b)	Bogong ..	Tallandoon	10, 11, and 12	6 140 0 0	3rd	0 15 0	35 0 0	To be valued	In west of parish ..	Eskdale, 6 miles	"	To be conserved	Creek flats and undulating country; peppermint, candlebox, &c.; suitable for grazing. (H017856)
Hamilton (a)	Follett ..	Nagwarry	74, Pt. 73	420 0 0	3rd	1 0 0	28 17 6	"	" ..	Casterton, 26 miles	"	To be conserved	Level country intersected with swamps; grey to black loam; large tussocks and sword grass; suitable for grazing. (Z.28769)
"	" ..	"	Pt. 73, 73B, 70B	409 0 0	3rd	1 0 0	28 17 6	"	" ..	"	"	"	"
"	" ..	"	26B, 26C, and 26D	125 0 0	3rd	1 0 0	18 2 6	"	" ..	"	"	"	"
Sale (c)	Tanjil ..	Marlooh ..	26C, 26D, and 26D	373 3 29	3rd	1 0 0	48 12 6	"	In south-east of parish ..	Fernbank R.S., 12 miles	"	"	Undulating, sandy soil; stringybark, gum, &c.; suitable for grazing. (114/121)
Bendigo ..	Tatchera	Township of Lake Boga, Parish of Kunat	4	1 0 1 5 <sup>10</sup> / <sub>100</sub>	Dwelling	AVAILABLE UNDER SECTION 129, LAND ACT 1928.	5 0 0	Nil	Fronting Lalbert-road	Lake Boga—adjoining	By road	To be conserved	Suitable for a dwelling site. (06049/121)
"	" ..	"	12	91 0 1 0	"	"	5 10 0	"	Corner of Mathers-street and Darling-ton-lane	Stawell, 2½ miles	By road	"	Suitable for a dwelling site. (Z.35018)
"	" ..	"	11	87 0 1 0	"	"	5 10 0	"	Fronting Navarre-road	Stawell, 1 mile	"	"	Suitable for a dwelling site. (Z.34102)

(a) Subject to survey. (b) Subject to mining condition. (c) Subject to timber condition.

**PROPOSED REVOCATION OF TEMPORARY RESERVATION AND ORDER IN COUNCIL WITHHOLDING CERTAIN LAND FROM SALE, LEASING, AND LICENSING.**

IN pursuance of the provisions of the *Land Act 1928*, notice is hereby given that it is the intention of the Governor in Council to revoke the temporary reservation and the withholding from sale, leasing, and licensing, by Order in Council of the land described hereunder:—

The following Notice was published 1° on the 18th July, 1951, pursuant to Order of the 10th July, 1951.

**JUNG JUNG.**—The temporary reservation, as a site for Watering purposes, and the withholding from sale, leasing, and licensing, by Order in Council of the 1st April, 1878 (see *Government Gazette* of the 5th April, 1878, page 771), of 742 acres, more or less, of land in the Parish of Jung Jung, revoked as to part by various Orders, is about to be revoked so far only as the portion containing 6 acres 2 roods 38 6/10 perches, indicated by hachure on plan hereunder.—(J.32(11)) (Rs.3749).

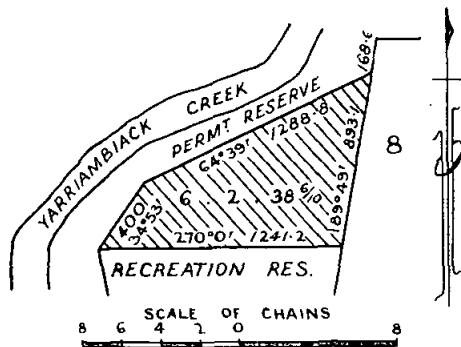

A. E. LIND,  
Commissioner of Crown Lands and Survey.

**PROPOSED REVOCATION OF TEMPORARY RESERVATIONS OF LANDS BY ORDERS IN COUNCIL.**

IN pursuance of the provisions of the *Land Act 1928*, notice is hereby given that it is the intention of the Governor in Council to revoke the temporary reservations of lands by the Orders in Council hereunder referred to, viz.:—

The following Notices were published 1° on the 1st August, 1951, pursuant to Orders of the 24th July, 1951.

**KERRIE (Riddell).**—The temporary reservation, by Order in Council of the 21st October, 1867, of 4 acres 1 rood 12 perches of land at Riddell, as a site for Public Gardens, is about to be revoked so far only as the portion containing 1 rood 7 perches, more or less, indicated by hachure on plan hereunder, is concerned.—(K.26(6)) (Rs.2455).

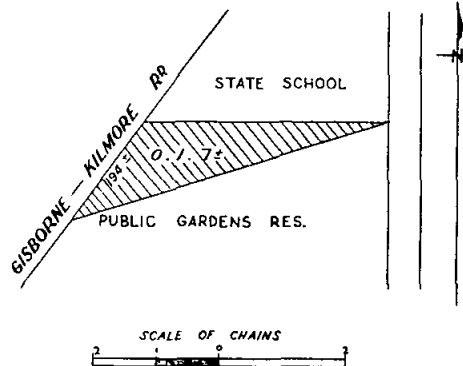

**ALLAMBEE.**—The temporary reservation, by Order in Council of the 17th June, 1889, of 1 acre 1 rood 2 perches of land in the Township of Allambree (now in the Parish of Warragul), as a site for a Mechanics' Institute and Free Library, is about to be revoked.—(A.177D) (Rs.6665).

A. E. LIND,  
Commissioner of Crown Lands and Survey.

**NOTICE OF INTENTION TO RESERVE PERMANENTLY CERTAIN LANDS AND TO REVOKE PORTION OF ORDER PERMANENTLY RESERVING CERTAIN LANDS IN THE PARISHES OF GLENMAGGIE AND TOONGABBIE NORTH, COUNTY OF TANJIL.**

IN pursuance of section 15 of the *Land Act 1928*, notice is hereby given that it is the intention of the Governor in Council to reserve permanently for Public purposes the Crown land forming the new bed of the Thomson River, in the Parishes of Glenmaggie and Toongabbie North, where the course of the said river has become altered since the 23rd May, 1881, together with the Crown land on the banks thereof indicated by hachure on plan hereunder, and to revoke the Order in Council of 23rd May, 1881, by which the beds of certain lakes, rivers, and creeks, specified therein, and Crown land on the margins and on the banks thereof respectively, were permanently reserved for Public purposes is so far as it relates to that portion of the Thomson River between the points marked A and B on plan hereunder to which it is no longer applicable in consequence of the course of the river having become altered after the date of the said Order.—(H.021133.)

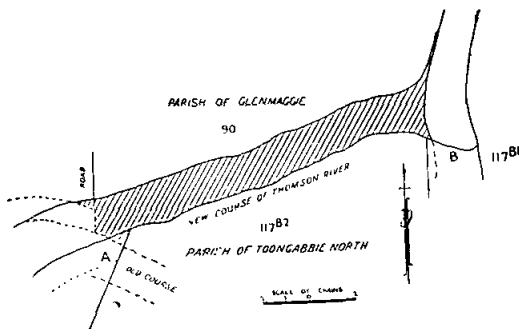

A. E. LIND,  
Commissioner of Crown Lands and Survey.

**PROPOSED REVOCATIONS OF TEMPORARY RESERVATIONS OF LANDS BY ORDERS IN COUNCIL.**

IN pursuance of the provisions of the *Land Act 1928*, notice is hereby given that it is the intention of the Governor in Council to revoke the temporary reservations of lands by Orders in Council hereunder referred to, viz.:—

The following Notices were published 1° on the 8th August, 1951, pursuant to Orders of the 31st July, 1951.

**KOONDRUCK.**—The temporary reservation, by Order in Council of the 7th November, 1906, of 4 perches of land in the Township of Koondrook as a site for a State School, is about to be revoked.—(K.163(2)) (Rs.1292).

**SANDHURST.**—The temporary reservation, by Order in Council of the 13th August, 1946, of 272 acres, more or less, of land in the Parish of Sandhurst as a site for the Growth of Timber for the purpose of the manufacture or production of eucalyptus oil, revoked as to part by various Orders, is about to be revoked so far only as the portion containing 2 roods 10 perches, more or less, indicated by hachure on plan hereunder, is concerned.—(S.371(17)) (Rs.5844).

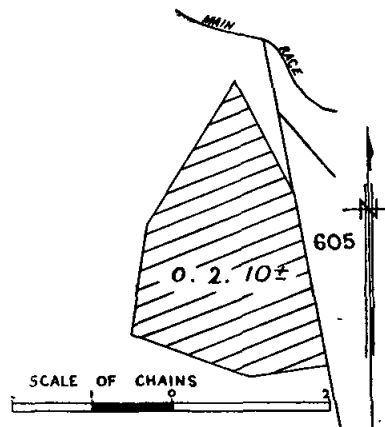

A. E. LIND,  
Commissioner of Crown Lands and Survey.

**LAND PROPOSED TO BE RESERVED PERMANENTLY.**

IN pursuance of the provisions of the *Land Act 1928*, notice is hereby given that it is the intention of the Governor in Council to reserve permanently the land set out hereunder:—

*The following Notice was published 1° on the 8th August, 1951, pursuant to Order of the 31st July, 1951.*

**YALLOCK.**—Land to be permanently reserved as a site for Public purposes, Parish of Yallock, County of Mornington: Crown land forming the portion of the foreshore of Western Port, indicated by hachure on plan hereunder. —(Y.22(4) (Rs.1071.)

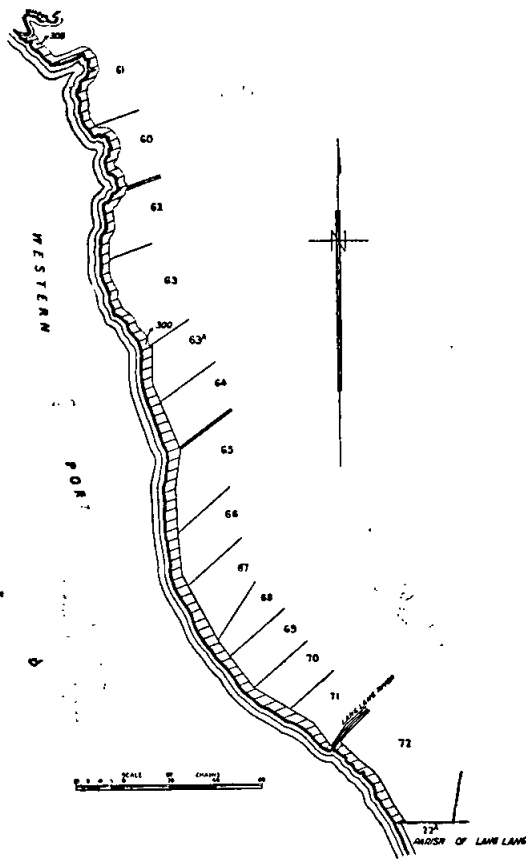

A. E. LIND,  
Commissioner of Crown Lands and Survey.

**PROPOSED REVOCATION OF TEMPORARY RESERVATION AND OF ORDER IN COUNCIL WITHHOLDING CERTAIN LAND FROM SALE, LEASING, AND LICENSING.**

IN pursuance of the provisions of the *Land Act 1928*, notice is hereby given that it is the intention of the Governor in Council to revoke the temporary reservation and the withholding from sale, leasing and licensing of the land hereunder described:—

*The following Notice was published 1° on the 8th August, 1951, pursuant to Order of the 31st July, 1951.*

**KOONDROOK.**—The temporary reservation as a site for Public purposes (State School) and the withholding from sale, leasing, and licensing, by Order in Council of the 6th October, 1879, of 5 acres of land in the Parish of Murrabit, at Koondrook, revoked as to part by previous Orders, is about to be revoked so far only as the portion

containing 1 acre 0 roods 14 2/10 perches, indicated by hachure on plan hereunder, is concerned.—(K.163(2) (Rs.1292).

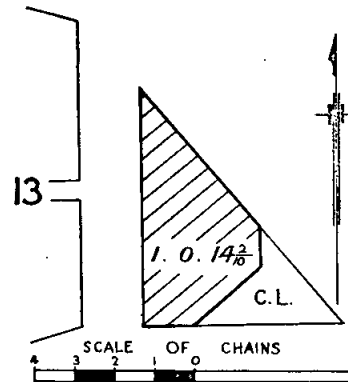

A. E. LIND,  
Commissioner of Crown Lands and Survey.

**REGULATIONS FOR THE CARE, PROTECTION, AND MANAGEMENT OF THE "ECHUCA OVAL RESERVE."**

WHEREAS by section 181 of the *Land Act 1928*, as enacted by section 9 of the *Land Act 1941*, power is given to the Board of Land and Works to make Regulations in respect of the care, protection, and management of any Crown land which has been reserved under the Land Acts for any purpose whatsoever, and which has not been conveyed to or vested in trustees, and for the further purposes as enacted: Now therefore the Board of Land and Works, in pursuance of the powers conferred as aforesaid, doth hereby make the following Regulations in respect of the land permanently reserved as a site for public recreation by Order in Council of the 27th June, 1898, in the Town of Echuca, and known as the "Echuca Oval Reserve," hereinafter referred to as the "Reserve," such reservation having been placed under the control of a Committee of Management hereinafter referred to as the "Committee."

**REGULATIONS.**

1. No person shall interfere with or damage the trees, shrubs, grass, flowers, statuary, fountains, fish, or any property in the Reserve, or throw stones or any missile, beat carpets, dry clothes, or commit any nuisance, or leave bottles, paper, orange peel, cast-off clothing, or any litter therein.
2. No person shall climb or jump over any buildings, seats, or fences in or around the Reserve, lie on any seats, steps, gangways, or landings, or sit in or on any gangways, steps, or landings, or stick bills on, cut letters or marks on, write or otherwise deface buildings, seats, fences, gates, posts, or trees therein.
3. No person, except those in the employ of or authorized by the Committee shall bring any horse or vehicle into plots of ground closed for plantation, garden, or other similar purposes.
4. No person shall bring into the Reserve any dog, unless controlled by a chain or cord. No dog shall be allowed in the Reserve, except as hereinbefore provided, and all dogs, goats, pigs, and poultry found in the Reserve shall be liable to be destroyed, and the owner shall make compensation, to be recovered before any justice, for any damage done.
5. No children under five (5) years of age shall be allowed in the Reserve unless in the charge of adult friends or nurses.
6. Any person found in a state of intoxication or behaving in a disorderly or objectionable manner, or creating or taking part in any disturbance, or committing in the Reserve any act of indecency shall be liable to be forthwith removed by the authorized officer or servant of the Committee, or by a member of the Police Force, and shall be guilty of an offence against these Regulations.
7. The Committee shall have the power to hold entertainments or performances in the Reserve, and to adopt and enforce a scale of charges for admission thereto, and also may make a charge for the admission of any motor car or other vehicle as provided hereinafter, but on not more than fifty-two (52) occasions in any one year.



8. The Committee shall have the power to let the whole, or any portion, of the Reserve to any club, association, or person for the purpose of cricket, football, and similar games, or for holding agricultural shows, entertainments, performances, or sports, and to authorize such club, association, or person to make a charge for admission thereto, and may demand the full rental in advance or on such terms as shall be specified in any authority issued by the Committee in accordance with this Regulation.

9. No charge or fee for admission to the Reserve shall exceed Four shillings for each person, nor shall the charge for the admission or parking of any car or vehicle exceed One shilling.

10. No person or persons, except the Committee and officers and employees of the Committee on duty, shall enter or drive or otherwise propel any motor car or vehicle into any portion of the Reserve, when a charge is made for admission without first paying the fee charged, unless otherwise authorized by the Committee.

11. No person shall carry firearms in or through the Reserve, or shoot, snare, or destroy any birds therein, unless by authority of the Committee.

12. No person shall engage in training or in cricket, football, tennis, hockey, lacrosse, or any like games in the Reserve, without the written authority of the Committee, and payment of any fees or charges that may be fixed from time to time by the Committee.

13. No person shall engage in training or in cricket, football, tennis, hockey, or lacrosse, or any like game in the Reserve on Sunday.

14. No person shall play any unlawful game or by unseemly conduct interfere with the comfort and enjoyment of others within the Reserve.

15. No person shall interfere with or in any way hinder or interrupt in their work any of the employees of the Committee engaged in the Reserve.

16. No person shall sell or offer for sale within the Reserve any article or food or drink, or any other commodity, or operate any money-making amusement without the written permission of the Committee and without the payment of such fee as the Committee may by Resolution determine.

17. No person shall remain in the Reserve at any time when lawfully directed by any officer or employee of the Committee to leave the same.

18. No person shall spit or expectorate on the paths at any time or on any structure or erection in the Reserve.

19. No persons shall assemble in the Reserve for fêtes, picnics, concerts, or for the purpose of public worship, preaching, or public speaking of any kind, or meeting of a like character, without the permission, in writing, of the Committee.

20. No person shall light any fires in the Reserve without the written consent of the Committee and then only where the coppers or fireplaces for supplies of hot water are provided.

21. No male over the age of six (6) years shall enter any building, part of building, or enclosures set aside for or being used by females, and no female over the age of six (6) years shall enter any building, part of a building, or enclosure set aside for or used by males.

22. Any person driving any horse, motor car, or other vehicle into the Reserve shall tether such horse and park such car in such place and in such manner as the authorized officer of the Committee shall direct.

23. No person shall enter or leave the arena riding or driving any horse or driving any car or other vehicle at a speed in any manner dangerous to the onlookers, nor shall a horse be ridden nor a vehicle or motor car be driven among any onlookers. Every such horse, motor car, or other vehicle shall travel by the route provided from arena exits to park exits or to the horse stalls site or the car parking site or vice versa.

24. No person, except with the consent of the Committee, shall ride any bicycle, motor cycle, tricycle, scooter, billy-cart, or other similar velocipede in the Reserve.

25. No person, without the consent of the Committee, shall graze any horse, cow, sheep, or other animal within the Reserve, and any wandering stock or stock tethered, without permission, may be impounded by the Committee or its duly authorized officer.

All costs recovered in proceedings for offences committed against the provisions of these Regulations shall be paid into the funds of the Committee of the said Reserve.

Every person who contravenes or fails to comply with these Regulations shall, in accordance with the provisions of section 181 of the *Land Act 1928*, as re-enacted by section 9 of the *Land Act 1941*, for each offence be liable to a penalty of not more than Five pounds, and every person who contravenes or fails to comply with any such Regulation and, who, after he has been warned by any bailiff of Crown lands or by any member of the Police Force, does not desist therefrom, may be forthwith apprehended by such bailiff or member of the Police Force and taken

No. 751.—7626/51.—3

before some justice to be dealt with according to law, and shall be liable to a penalty of not more than Ten pounds.—(Rs.1454.)

The common seal of the Board of Land and Works was hereunto affixed this 2nd day of August, 1951, in the presence of—

(SEAL) A. E. LIND, President.  
W. M. CRAWFORD, Member.

REGULATION FOR THE CARE, PROTECTION, AND MANAGEMENT OF THE RESERVE FOR PUBLIC PURPOSES AT FOOTSCRAY (KNOWN AS THE "FOOTSCRAY OVAL").

WHEREAS by section 181 of the *Land Act 1928*, as re-enacted by section 9 of the *Land Act 1941*, power is given to the Board of Land and Works to make Regulations in respect of the care, protection, and management of any Crown land which has been reserved under the *Land Acts*, for any public purpose whatsoever, and which has not been conveyed to or vested in trustees, and for the further purposes as enacted: Now therefore, the Board of Land and Works, in pursuance of the powers conferred as aforesaid, doth hereby rescind Regulation No. 1 of the Regulations made by it on the 27th October, 1932, for the care, protection, and management of the land in the City of Footscray, Parish of Cut-paw-paw, permanently reserved by Order in Council dated the 30th September, 1878, as a site for Public purposes, and known as the "Footscray Oval" (hereinafter referred to as the "Reserve"), and in lieu thereof doth hereby make the following Regulation:—

REGULATION.

1. The Reserve shall be open to the public from sunrise to sunset, except on such days, not exceeding 60 in any one year (the days set apart to include six days from sunrise to midnight for the purpose of holding night entertainments), as the Reserve may be set aside for cricket or football matches, fêtes, sports, entertainments, or holiday amusements, on any of which occasions a sum not exceeding 7s. 6d. may be charged and taken for the admission of every adult to the Reserve.

Every person who contravenes or fails to comply with this Regulation shall, in accordance with the provisions of section 181 of the *Land Act 1928*, as re-enacted by section 9 of the *Land Act 1941*, for each offence be liable to a penalty of not more than Five pounds (£5), and every person who contravenes or fails to comply with such Regulation and who, after he has been warned by any bailiff of Crown lands or by any member of the Police Force, does not desist therefrom may be forthwith apprehended by such bailiff or member of the Police Force and taken before some justice to be dealt with according to law, and shall be liable to a penalty of not more than Ten pounds (£10).—(Corres Rs.1714.)

The common seal of the Board of Land and Works was hereunto affixed this 2nd day of August, 1951, in the presence of—

(SEAL) A. E. LIND, President.  
W. M. CRAWFORD, Member.

AMENDMENT OF REGULATIONS FOR THE CARE, PROTECTION, AND MANAGEMENT OF CROWN RESERVES IN THE CITY OF MALVERN.

THE Board of Land and Works, in pursuance of the powers conferred on it, having amended, on the 1st March, 1949, the Regulations made by it on the 9th December, 1942, for the care, protection, and management of certain Reserves in the City of Malvern, doth hereby further amend such Regulations by substituting the following Schedule for that set out in the said amendment of the 1st March, 1949:—

SCHEDULE.

<i>Tennis Court Charges.</i>		£	s.	d.
1. Per game of one half-hour .. .. .			0	1 0
2. Children under fourteen years of age (if courts are vacant) .. .. .			Free	
<i>Golf Links Charges.</i>				
1. Daily tickets .. .. .		0	10	0
2. Per round of eighteen holes .. .. .		0	6	0
3. Annual tickets (tickets to be issued as from the 1st April in each year) .. .. .		10	10	0

As witness thereof the common seal of the Board of Land and Works was hereunto affixed this 2nd day of August, 1951, in the presence of—

(SEAL) A. E. LIND, President.  
W. M. CRAWFORD, Member.

(Rs.3637.)

REGULATIONS FOR THE CARE, PROTECTION, AND MANAGEMENT OF THE "GILSENAN RECREATION RESERVE" AT PAYNESVILLE.

WHEREAS by section 181 of the *Land Act* 1928, as re-enacted by section 9 of the *Land Act* 1941, power is given to the Board of Land and Works to make Regulations in respect of the care, protection, and management of any Crown land which has been reserved under the Land Acts for any purpose whatsoever, and which has not been conveyed to or vested in trustees, and for the further purposes as enacted: Now, therefore, the Board of Land and Works, in pursuance of the powers conferred as aforesaid, doth hereby make the following Regulations in respect of the land temporarily reserved by Order in Council of the 18th January, 1949, as a site for Public Recreation in the Parish of Bairnsdale, and known as the "Gilsenan Recreation Reserve" at Paynesville, hereinafter referred to as the "Reserve," such reservation having been placed under the control of a Committee of Management, hereinafter referred to as the "Committee."

REGULATIONS.

1. The Reserve shall be open to the public, free of charge, from sunrise to sunset, except on such days, not exceeding fifty-two (52) in any one year, as the Reserve may be set apart for cricket, football, or other matches, shows, sports, fêtes, musical performances, outdoor gatherings, or holiday amusements, on any of which occasions a sum, not exceeding Five shillings (5s.), may be charged and taken for the admission of each adult person to the Reserve, but no person shall be permitted to enter any of the buildings on the Reserve on days on which fees for admission are not being charged without the permission, in writing, of the Committee first obtained.

2. No person shall—

- (a) Enter or remain in the Reserve who may offend against decency as regards dress, language, or conduct, or who may behave in a disorderly, unseemly, or offensive manner, or create or take part in any disturbance.
- (b) Enter or remain in the Reserve whilst in a state of intoxication.
- (c) Use indecent or offensive language in the Reserve.
- (d) Bring any intoxicating liquor on to the Reserve without the consent of the Committee first obtained.
- (e) Obstruct, hinder, or interfere with any person under authority from the Committee or employed by it at the Reserve in the execution of his lawful duties.
- (f) Exercise or train any horse or pony on the Reserve, or any part thereof, without the consent of the Committee first obtained.

3. The Committee shall have power to hold entertainments, shows, or performances on the Reserve, and to make a charge for admission thereto as hereinbefore provided.

4. The Committee shall have power to let any portion of the Reserve to any club, association, person, or society for the purpose of holding entertainments, performances, shows, or sports, subject to the payment of such fees and on such terms as it may deem to be reasonable and consistent with these Regulations, and to authorize any club, association, society, or person to make a charge for admission thereto, as hereinbefore provided in these Regulations.

5. No club, association, society, or person shall hold any sport, entertainment, performance, show, or ceremony on any part of the Reserve without the authority of the Committee first obtained.

6. No person, except the Committee or its officers or employees on duty, shall enter any part of the Reserve on an occasion when a charge is made for admission thereto without first paying the fees chargeable for such admission.

7. No person shall park a motor car, vehicle, or motor cycle in the Reserve, except at such places as are set apart for the purpose by the Committee, who reserve the right to make a parking charge not exceeding 2s. for each vehicle.

8. No person shall take part in any games, sports, or entertainments of any kind in the Reserve at any time without the permission of the Committee first obtained.

9. No person, club, or other body using the Reserve shall damage any building thereon or the fittings of such building, and in the event of such damage occurring during their occupancy thereof such person, club, or other body shall be responsible for such damage, and pay to the Committee the cost of making good and repairing such building or fittings.

10. No person shall, in the Reserve, interfere with or break or damage any of the trees, plants, or shrubs, or pluck any flowers, or climb, jump, or get over or under any of the fences, gates, seats, or other structures therein, or

roll or throw stones or other missiles, or leave any bottles, broken glass, paper, orange peel, banana skins, or any refuse or rubbish whatever therein, or post bills or advertisements on any of the fences, gates, seats, or other structures therein.

11. No person shall remove any wood or timber from the Reserve unless with the consent of the Committee first obtained, and then only on such terms and conditions as shall be determined by the said Committee and approved of by the Board of Land and Works.

12. No person shall light a fire in the Reserve, except at such places as are set apart for that purpose by the Committee.

13. No person shall put in the Reserve any cattle, horses, pigs, goats, or other animals without the permission of the Committee first obtained.

14. No person shall camp on the Reserve or erect thereon any building or any other structure without the consent of the Committee first obtained.

15. No person shall sell or offer for sale any article in the Reserve without the permission of the Committee first had and obtained, and then only subject to such conditions as such Committee may determine.

16. No person, club, or other body shall, without the consent of the Committee first obtained, grade or scrape the ground off or cut or burn any grass growing on any part of the Reserve.

17. No person shall bring into the Reserve any dog unless controlled by a chain or cord, without the permission, in writing, of the Committee first obtained.

18. No person shall remove any sand, stone, rock, marl, or gravel from the Reserve.

19. No person shall play or engage in any organized sport within the Reserve on Sundays.

Every person who contravenes or fails to comply with these Regulations shall, in accordance with the provisions of section 181 of the *Land Act* 1928, as re-enacted by section 9 of the *Land Act* 1941, for each offence be liable to a penalty of not more than Five pounds, and every person who contravenes or fails to comply with any such Regulations, and who, after he has been warned by any bailiff of Crown lands or by any member of the Police Force, does not desist therefrom, may be forthwith apprehended by such bailiff or member of the Police Force, and taken before some justice to be dealt with according to law, and shall be liable to a penalty of not more than Ten pounds.—(Rs.6318.)

The common seal of the Board of Land and Works was hereunto affixed this 2nd day of August, 1951, in the presence of—

(SEAL) A. E. LIND, President.  
W. M. CRAWFORD, Member.

COMMITTEES OF MANAGEMENT OF RESERVES.

APPOINTMENTS.

WHEREAS by section 184 of the *Land Act* 1928 it is provided that it shall be lawful for the Governor in Council or the Board of Land and Works to appoint and remove any number of persons, not less than three, or any municipal council, or the governing body of any corporation, to be a Committee of Management of any specified Crown land reserved either temporarily or permanently for any of the purposes set out in section 14 of the *Land Act* 1928, and not conveyed to or vested in trustees: Now therefore the Board of Land and Works doth hereby appoint the under-mentioned persons to be members of the Committee of Management of the Reserves named:—

"ALBERT PARK RESERVE."

Alan Ernest Allen and D'Este Arthur McLeod Kibble for so long only as they remain councillors and the elect of the City of St. Kilda, as members of the Committee of Management as from the 1st July, 1951, of the land permanently reserved as a site for a Public Park in the Municipal Districts of the Cities of South Melbourne and St. Kilda, and known as "Albert Park."—(Corres. Rs.3321.)

"BENDIGO RACECOURSE RESERVE."

Walter Gordon Hyett and Frederick Oldfield, in the place of Frank Goynes and Walter George Jackson, both deceased, as members of the Committee of Management of the land in the City of Bendigo, Parish of Sandhurst permanently reserved by Order in Council dated 11th August, 1873, as a site for a Racecourse, and known as the "Bendigo Racecourse Reserve."—(Corres. Rs.5552.)

"CRESSY RECREATION RESERVE."

Stewart Reynolds, Joe Arthur Kebble Storrer, John Ross Mowat, Colin McLean, Albert Holmes, Roderick William McKenzie, and George Thomas Sykes as a Committee of Management for a period of three (3) years from 20th July, 1951, of the land temporarily reserved by Order in Council dated 22nd May, 1917, as a site for Recreation purposes in the Town of Cressy, and known as the "Cressy Recreation Reserve."—(Corres. Rs.1539.)

"DUNOLLY RACECOURSE AND RECREATION RESERVE."

Harry Raven, Ronald Greenwood, James William Jenkins, and John Pike as additional members of the Committee of Management for the period ending 17th November, 1953, of the land permanently reserved by Order in Council dated the 22nd May, 1917, as a site for a Racecourse and for the Recreation, Convenience or Amusement of the people in the Parish of Dunolly, and known as the "Dunolly Racecourse Reserve."—(Corres. Rs.1542.)

"ECHUCA OVAL RESERVE."

The Council of the Borough of Echuca as a Committee of Management of the land permanently reserved as a site for Public Recreation by Order in Council of the 27th June, 1898, in the Town of Echuca, and known as the "Echuca Oval Reserve."—(Corres. Rs.1454.)

"TURRIFF RECREATION RESERVE."

Ian Archibald Brown, Francis Welford Newell, Arthur Daniel Powell, James Robert Torpey, Thomas Torpey, and Alan John Collins as the Committee of Management for a period of three (3) years of the land temporarily reserved by Order in Council dated the 1st October, 1918, as a site for Recreation purposes in the Parish of Gorya at Turriff, and known as the "Turriff Recreation Reserve."—(Corres. Rs.1845.)

"INVERLOCH FORESHORE" AND "POINT SMYTHE" RESERVES.

William Edward Ramsey, George Henry Carter, Richard Stockdale, Philip Keith White, William Charles Robert Brown, John Alexander Flett, Leslie George Mills, James Duncan Grindlay, Richard E. Stockdale, John Batton, William Campbell Young, and Harold Percy St. Clair as a Committee of Management for a period of three (3) years from 1st August, 1951, of such portion of the Reserve for Public purposes in the Parish of Kirrak as is indicated by pink and red tints of the plans marked K/6.10.33 and B/28.1.1941 respectively, with Lands Department correspondence Rs.771, of the area temporarily reserved on the 16th July, 1946, and of the abutting permanent reserve for Public purposes in the Parish of Drumdemara as is indicated by pink tint on plan marked H/16.7.46 with Lands Department correspondence Rs.771, all of which lands are together known as the "Inverloch Foreshore Reserve"; also of the area in the Parish of Tarwin temporarily reserved by Order in Council of the 21st December, 1910, as a site for a Public Park, and of that area of foreshore reserve along Bass Strait and Anderson's Inlet between high-water mark and the aforesaid Public Park Reserve, both of which areas are together known as the "Point Smythe Reserve."—(Corres. Rs.771, Rs.2634.)

"EWING PARK RECREATION RESERVE."

The Council of the City of Bendigo as a Committee of Management of the land temporarily reserved by Order in Council of the 17th July, 1951, as a site for Public Recreation in the City of Bendigo, and known as "Ewing Park Recreation Reserve."—(Corres. Rs.5949.)

In witness whereof the common seal of the Board of Land and Works was hereunto affixed this second day of August, One thousand nine hundred and fifty-one, in the presence of—

(SEAL) A. E. LIND, President.  
W. M. CRAWFORD, Member.

Land Act 1928.

LEASE UNDER THE LAND ACTS 1915 AND 1928 DECLARED VOID.

NOTICE is hereby given that the Lease mentioned in the Schedule hereunder has been declared void by the Governor in Council for the reason specified.

District.	Corr. No.	Name of Lessee.	Section of Land Act under which Leased.	Parish.	Allotment.	Area.	Class.	Annual Rental.	Reasons for Voiding.
						A. R. P.		£ s. d.	
Geelong ..	262/44	John Alexander Knight	44	Coradgil ..	9, section A	150 0 1	3rd	3 15 6	Non-compliance with conditions

Department of Crown Lands and Survey,  
Melbourne, 1st August, 1951.

A. E. LIND,  
Commissioner of Crown Lands and Survey.

Land Act 1928.

LEASES SURRENDERED.

NOTICE is hereby given that the Governor in Council has accepted the surrender of the Leases mentioned in the Schedule hereunder for the reason specified in each case.

District.	Corr. No.	Name.	Section of Land Act under which Leased.	Parish.	Allotment.	Area.	Class.	Reason.
						A. R. P.		
Mallee ..	8/199	Patrick Alphonsus Callahan	199	Nurnurnemal	47	877 1 19	3rd	Lessee has received compensation pursuant to the North-west Mallee Settlement Areas Act
Omeo ..	28/54	Executors of the estate of Annie O'Connell (deceased)	54	Wollonaby ..	7 Sec. 1	239 3 30	3rd	Lessee's request

Department of Crown Lands and Survey,  
Melbourne, 1st August, 1951.

A. E. LIND,  
Commissioner of Crown Lands and Survey.

**PUBLIC SERVICE NOTICES.**

**PUBLIC SERVICE OF VICTORIA.—VACANCIES.**

APPLICATIONS will be received by the Public Service Board up to Wednesday, the 22nd August, 1951, from persons employed in the Public Service of Victoria, who are eligible and qualified, for appointment to the under-mentioned positions:—

**ADMINISTRATIVE DIVISION.**

**Clerk, Class "C1," Department of Agriculture.**

*Yearly Salary.*—£605, minimum; £657, maximum.

*Duties.*—To act as internal auditor to the Department; to audit the books and accounts of agricultural colleges, farms, &c.; audit all sources of revenue within the Department; investigate accounting methods for purposes of uniformity and efficiency; to instruct and advise district officers on accounting matters and to act as relieving officer where necessary.

*Qualifications.*—To be a qualified accountant; to possess a thorough knowledge of the Department's activities and organization, Treasury procedure, and the Regulations respecting public accounts; to be experienced in Departmental accounting methods and to have ability to conduct special inquiries and investigations.

**Clerk, Class "C," Correspondence Branch, Department of Treasurer.**

*Yearly Salary.*—£475, minimum; £579, maximum.

*Duties.*—To assist generally in the work (including staff matters) of the Correspondence Branch, and in particular to be responsible for correspondence, &c., in connexion with the granting of miners' phthisis allowances, with Treasury approvals for the raising of municipal loans and with indemnities issued in connexion with Co-operative Housing Society loans.

*Qualifications.*—Ability to conduct correspondence; a good knowledge of Treasury procedure and of the Regulations under the Public Service Act.

**PROFESSIONAL DIVISION.**

**Senior Draughtsman, Class "C1," Public Works Department.**

*Yearly Salary.*—£605, minimum; £657, maximum.

*Duties.*—To prepare, under direction, plans, specifications, and estimates of mechanical installations and services in all types of public buildings.

*Qualifications.*—To have had a sound technical training in mechanical engineering, together with several years' drawing office experience in plant design and lay-out, particularly in relation to heating, hot water supply, air conditioning, steam plant, and refrigeration.

**Science Master, Class "C1," Dookie Agricultural College, Department of Agriculture.**

*Yearly Salary.*—£605, minimum; £657, maximum.

*Duties.*—Under the direction of the Principal to teach one or more of the following subjects in the College curriculum:—Chemistry, Physics, Zoology, Entomology, Botany (applicants should indicate which of these subjects they are qualified to teach); to share house duties, and to engage in such other activities of the College as the Principal may require.

*Qualifications.*—To possess a University degree, preferably in Science or Agricultural Science, and experience in teaching.

**TECHNICAL AND GENERAL DIVISION.**

**Carpenter, Ballarat Mental Hospital, Mental Hygiene Branch, Department of Health.**

*Salary.*—£364 a year.

*Duties.*—To assist in carpentering work as directed by the Secretary.

*Qualifications.*—To be a competent and experienced carpenter.

**Machinist (Female), Grade III., Accounts Branch, Education Department.**

*Yearly Salary.*—£325, minimum; £338, maximum.

*Duties.*—To assist in the preparation of teachers' salary "pay rolls" and other statistical records as may be required.

*Qualifications.*—To be a competent "Remington" accounting machine operator.

**Shorthand Writer and Typist (Female), Grade II., Tuberculosis Branch, Department of Health.**

*Yearly Salary.*—£299, minimum; £312, maximum.

*Duties.*—To act as shorthand writer and typist to the Director of Tuberculosis and Senior Administrative Officers of the Branch.

*Qualifications.*—To be a competent shorthand writer and typist with ability to take notes at the rate of 100 words per minute, and set out and type correspondence, reports, and statements.

**Typist (Female), Grade II., Children's Welfare Branch, Chief Secretary's Department.**

*Yearly Salary.*—£286, minimum; £299, maximum.

*Duties.*—To type letters and prepared statistics and reports and to assist in clerical duties in connexion with the general procedure of the Maintenance Branch.

*Qualifications.*—To be a competent and experienced typist.

**Labourer, Law Courts, Department of Law.**

*Salary.*—£286 a year.

NOTE.—In addition to the salary rates quoted, a cost of living adjustment (£270 a year for adult males, £202 10s. a year for adult females, and £135 a year for minors), which varies in accordance with the rise or fall in the index number of cost of living, is payable.

By order,

E. F. FITZGIBBON,

Secretary.

Office of the Public Service Board,  
Melbourne, 6th August, 1951.

**PUBLIC SERVICE ACT 1946.**

**PUBLIC SERVICE (GOVERNOR IN COUNCIL) REGULATIONS.**

**PART IV.—LEAVE OF ABSENCE.**

*Leave for Defence Training Purposes.*

**CORRIGENDUM.**

In clause (c) of sub-regulation 8 of Regulation 52 appearing in the *Victoria Government Gazette* of 1st August, 1951, for the word "has" in the second line on page 5256 read "had."

No. 134.

*Public Service Act 1946, Section 39.*

**REGULATIONS—PART III.—SALARIES, INCREMENTS, AND ALLOWANCES.**

THE Public Service Board, in pursuance of the powers conferred by the *Public Service Act 1946*, hereby amends its Regulations as shown below:—

**FIRST SCHEDULE.**

**PROFESSIONAL DIVISION.**

*Offices and Rates of Salaries.*

Office.	Yearly Rate of Salary.	
	Minimum.	Maximum.
<b>DEPARTMENT OF AGRICULTURE.</b>		
<b>CLASS "B."</b>		
<i>Add—</i>		
Manager, Mallee Research Station ..	761	839
Manager, Rutherglen Research Station ..	761	839
<b>CLASS "C2."</b>		
<i>Delete—</i>		
Manager, Mallee Research Station ..	683	735
Manager, Rutherglen Research Station ..	683	735

D. D. PAYNE, Chairman.

E. F. FITZGIBBON, Secretary.

Office of the Public Service Board,  
Melbourne, 30th July, 1951.

No. 133.

*Public Service Act 1946, Section 50.*

REGULATIONS—PART III.—SALARIES, INCREMENTS, AND ALLOWANCES.

THE Public Service Board, in pursuance of the powers conferred by the *Public Service Act 1946*, hereby amends its Regulations as shown below :—

SIXTH SCHEDULE.

TEMPORARY EMPLOYEES.

*Designations of Positions and Rates of Salaries.*

Department and Designation of Position.	Yearly Rate of Salary.		Increments (Annual).
	Minimum.	Maximum.	
GENERAL.	£	£	
<i>Add—</i>			
Social Worker (Female), Grade I. . . . .	338	364	..
Social Worker (Female), Grade II. . . . .	390	442	2 of £26
Social Worker (Female), Assistant . . . . .	299	338	..
Social Worker (Male) . . . . .	436	462	1 of £26
DEPARTMENT OF CHIEF SECRETARY.			
CHILDREN'S WELFARE.			
<i>Delete—</i>			
Social Worker (Female), Grade I. . . . .	338	364	..
Social Worker (Female), Grade II. . . . .	390	442	2 of £26
DEPARTMENT OF HEALTH.			
GENERAL HEALTH.			
<i>Delete—</i>			
Social Worker (Female), Grade I. . . . .	338	364	..
Social Worker (Female), Grade II. . . . .	390	442	2 of £26
Social Worker (Female), Assistant . . . . .	299	338	..
TUBERCULOSIS.			
<i>Delete—</i>			
Social Worker (Female), Grade I. . . . .	338	364	..
Social Worker (Female), Grade II. . . . .	390	442	2 of £26
Social Worker (Female), Assistant . . . . .	299	338	..
MENTAL HYGIENE.			
<i>Delete—</i>			
Social Worker (Female), Grade I. . . . .	338	364	..
Social Worker (Female), Grade II. . . . .	390	442	2 of £26
Social Worker (Female), Assistant . . . . .	299	338	..
Social Worker (Male) . . . . .	436	462	1 of £26

*This Regulation shall have effect as on and from the 22nd July, 1951.*

D. D. PAINE, Chairman.  
E. F. FITZGIBBON, Secretary.

Office of the Public Service Board,  
Melbourne, 24th July, 1951.

No. 131.

*Public Service Act 1946, Section 39.*

REGULATIONS.—PART III.—SALARIES, INCREMENTS, AND ALLOWANCES.

THE Public Service Board, in pursuance of the powers conferred by the *Public Service Act 1946*, hereby amends its Regulations as shown below :—

FIRST SCHEDULE.

PROFESSIONAL DIVISION.

*Offices and Rates of Salaries.*

Office.	Yearly Rate of Salary.	
	Minimum.	Maximum.
DEPARTMENT OF HEALTH.	£	£
TUBERCULOSIS BRANCH.		
CLASS "A1."		
<i>Add—</i>		
Assistant Clinical Tuberculosis Officer, Prahran Bureau	1,250	1,400
D. D. PAINE, Chairman. E. F. FITZGIBBON, Secretary.		
Office of the Public Service Board, Melbourne, 25th July, 1951.		

No. 132.

*Public Service Act 1946, Section 50.*

REGULATIONS.—PART III.—SALARIES, INCREMENTS, AND ALLOWANCES.

THE Public Service Board, in pursuance of the powers conferred by the *Public Service Act 1946*, hereby amends its Regulations as shown below :—

SIXTH SCHEDULE.

TEMPORARY EMPLOYEES.

*Designations of Positions and Rates of Salaries.*

Department and Designation of Position.	Yearly Rate of Salary.		Increments (Annual).
	Minimum.	Maximum.	
DEPARTMENT OF HEALTH.	£	£	
GENERAL HEALTH.			
<i>Add—</i>			
Exotic Diseases—			
Domestic . . . . .	..	201	..
General Hand . . . . .	..	325	..
Sister . . . . .	344	370	..

*This Regulation shall have effect as on and from the 26th May, 1951.*

D. D. PAINE, Chairman.  
E. F. FITZGIBBON, Secretary.

Office of the Public Service Board,  
Melbourne, 16th July, 1951.

PUBLIC SERVICE (PUBLIC SERVICE BOARD) REGULATION 39.—VACANCIES.

THE Permanent Head of the Department shown has recommended the officers named hereunder for appointment to the under-mentioned vacancies.

Office and Classification.	Duties.	Qualifications.	Officer Recommended for Appointment.		
			Name.	Classification.	Date of Classification.

ADMINISTRATIVE DIVISION.

DEPARTMENT OF WATER SUPPLY.

Clerk, Class "C" (Bendigo Centre)	To record the attendance of workmen and to prepare time sheets for each fortnightly pay period, setting out details of work performed and the amount of wages earned by each workman; to record and charge all stores and material received and issued	To have a good knowledge of Industrial Awards and Workers' Compensation Acts; to have had experience in recording of attendance, the computation of wages and the receipt and issue of stores	Daniel, K. E. ..	Clerk, Classes "E" and "D"	26.6.48
-----------------------------------	--	---	------------------	----------------------------	---------

TECHNICAL AND GENERAL DIVISION.

DEPARTMENT OF WATER SUPPLY.

Inspector, Grade I, (Dromana Centre)	To inspect works carried out by licensed plumbers; to tap water mains and execute plumbing work as required, and to act as Turncock	To be a qualified plumber and to have had experience in the regulation of water; to be capable of driving a motor vehicle	Chambers, N. ..	Inspector, Grade II.	29.7.48
--------------------------------------	---	---	-----------------	----------------------	---------

Appeals against such recommendations should be lodged with the Secretary to the Public Service Board not later than Saturday, the 18th August, 1951.

Office of the Public Service Board,  
Melbourne, 6th August, 1951.

By order,  
E. F. FITZGIBBON,  
Secretary.

PUBLIC SERVICE (PUBLIC SERVICE BOARD) REGULATION 39.—RECLASSIFICATIONS.

THE Public Service Board has raised the classification of the under-mentioned offices as shown, and the Permanent Head of the Department has recommended the officers named for appointment.

Office and Present Classification.	Revised Classification.	Duties.	Qualifications.	Officer Recommended for Appointment.		
				Name.	Classification.	Date of Classification.

PROFESSIONAL DIVISION.

DEPARTMENT OF STATE FORESTS.

Assistant Forester, Class "D" (five offices)	Forester, Grade II., Class "C" (five offices)	To control district staff, stores and equipment, silvicultural operations, utilization of forest produce and measures for fire protection, and to make recommendations re forest estate alterations and forest offences	To be a graduate of the School of Forestry, Creswick; to have a thorough knowledge of the Forests Acts and Regulations, and experience of field and office methods and procedure in the Department	Gray, A. J. ..	Assistant Forester, Class "D"	1.7.28
				Lasich, B. T.		13.2.45
				Griffin, G. ..		13.2.45
				Crowther, G. H.		13.2.45
				Duncan, S. F.		13.2.45

Appeals against such recommendations should be lodged with the Secretary to the Public Service Board not later than Saturday, the 18th August, 1951.

Office of the Public Service Board,  
Melbourne, 6th August, 1951.

By order,  
E. F. FITZGIBBON,  
Secretary.

*Teaching Service Act 1946.*

## TEACHING SERVICE (TEACHERS TRIBUNAL) REGULATIONS.

THE Teachers Tribunal, in pursuance of the powers conferred by the *Teaching Service Act 1946*, hereby amends Regulation 1 of the Teaching Service (Teachers Tribunal) Regulations in the manner following, that is to say:—

## REGULATION 1.

1. In clause 17 delete the whole of the schedule of rates and substitute therefor the following:—

	For the first 5,000 miles in a financial year.	Mileage over 5,000 miles in a financial year.
Motor Cars—		
Over 20 h.p. . . . .	10½d. a mile	8½d. a mile
Over 12 h.p. and up to 20 h.p. . . . .	9½d. a mile	8½d. a mile
Over 9 h.p. and up to 12 h.p. . . . .	9½d. a mile	8d. a mile
9 h.p. and under . . . . .	8d. a mile	7d. a mile
Motor Cycles with side cars . . . . .	4d. a mile	3½d. a mile
Motor Cycles . . . . .	3½d. a mile	3d. a mile
Bicycles . . . . .	1½d. a mile	irrespective of mileage.

2. In sub-clause 18 (b) for "3½d. a mile" substitute "4½d. a mile."

3. In sub-clause 18 (c) for "1½d. a mile" substitute "2d. a mile."

4. In sub-clause 21 (d) for "Motor Car 3½d. a mile" substitute "Motor Car 4½d. a mile."

for "Motor cycle 1½d. a mile" substitute "Motor cycle 2d. a mile."

for "3s. 6d. a week" substitute "4s. 6d. a week."

and for "5s. a week" substitute "6s. 3d. a week."

5. In the proviso, sub-clause 21 (d), for "30s. a week" substitute "37s. 6d. a week," and for "12s. 6d. a week" substitute "15s. a week."

(To take effect from and including the first day of July, 1951.)

W. H. ELLWOOD, Chairman.

E. V. B. HIGGINS, Acting Secretary.

Office of the Teachers Tribunal,  
Melbourne, 30th July, 1951.

## TENDERS.

TENDERS will be received at this office until **TEN A.M.** on the days and for the purposes under mentioned.

Particulars may be learnt at this Office and also at places shown in parenthesis.

W.O. means Inspector of Works Office; P.S.—Police Station; T.S.—Technical School; H.E.S.—Higher Elementary School; S.S.—State School; H.S.—High School; P.D.—Preliminary deposit; F.D.—Final deposit.

The Board of Land and Works will not necessarily accept the lowest or any tender.

14th August, 1951.

Ballarat.—Supply and installation of two under-fired multi-tubular steam boilers and two automatic stokers, Mental Hospital. (W.O., Ballarat.) P.D., £50. F.D., 2 per cent.

Beaufort.—Additions and renovations to cookery room, State School No. 60. (W.O., Ararat, Ballarat; S.S., Beaufort.) P.D., £15. F.D., 2 per cent.

Charlton.—Erection of offices, State Rivers and Water Supply Commission. (W.O., Bendigo; P.S., Charlton, Wedderburn.) P.D., £20. F.D., 2 per cent.

Clunes.—Repairs and renovations, Town Hall and Court House. (W.O., Maryborough; P.S., Clunes.) P.D., £10. F.D., 2 per cent.

Cobram.—Repairs, &c., to head teacher's residence, S.S. No. 2881. (W.O., Benalla; S.S., Cobram.) P.D., £4. F.D., 2 per cent.

Coburg.—Re-arrangement of electrical services, covering reticulation in Metropolitan and Female Divisions, Pentridge. P.D., £10. F.D., 2 per cent.

Coburg.—Purchase and removal of six (6) Hattersleys 2 x 2 box looms, fitted with fast and loose pulleys, or, alternatively, the same looms fitted as at present with clutches and chain drives, but not including electric motors. Two looms are complete, but the remaining four

looms will require certain parts to put them into working order, Pentridge. (Inspection by arrangement with Pentridge authorities.)

Collingwood.—Internal renovations, Girls' School, Vere-street. P.D., £5. F.D., 2 per cent.

Collingwood.—Repairs and painting, Court House. P.D., £3. F.D., 2 per cent.

Creswick North.—Alterations to out-offices and installation of septic tank, S.S. No. 2041. (W.O., Ballarat; S.S., Creswick North.) P.D., £5. F.D., 2 per cent.

Echuca.—External and internal repairs and renewals and spouting, S.S. No. 208. (W.O., Shepparton. S.S., Echuca.) P.D., £15. F.D., 2 per cent.

Elingamite.—Erection of new timber residence, S.S. No. 1424. (W.O., Camperdown; P.S., Cobden; S.S., Elingamite.) P.D., £15. F.D., 2 per cent.

Footscray.—External and internal repairs and renovations, Technical School, Nicholson-street. P.D., £20. F.D., 2 per cent.

Gowerville.—Supply, delivery, installation, and testing of heating and ventilating system, S.S. No. 4674. P.D., £15. F.D., 2 per cent.

Greta South.—Erection of teacher's residence, garage, and out-buildings, S.S. No. 2452. (W.O., Benalla; S.S., Greta South.) P.D., £15. F.D., 2 per cent.

Kew.—General alterations and installation of fittings, &c., Ward F.4, Children's Cottages, Mental Hospital. Deposit, £15.

Lance Creek.—Erection of new residence for teacher, including garage, out-buildings, and site works, S.S. No. 3715. (W.O., Korumburra; S.S., Lance Creek.) P.D., £15. F.D., 2 per cent.

Langi Kal Kal.—Supply and installation of electric refrigerator for Boys' Quarters, Penal Camp. P.D., £5. F.D., 2 per cent.

Leopold.—Alterations, &c., to boys' and girls' out-offices and new septic tank, S.S. No. 1146. (W.O., Geelong; S.S., Leopold.) Deposit, £4.

Melbourne.—Sound-proofing of windows, William Angliss Food Trades School. P.D., £20. F.D., 2 per cent.

Mont Park.—Supply and installation of mechanical services in laundry, Larundel Mental Hospital. P.D., £25. F.D., 2 per cent.

Stawell.—Alterations and additions to out-offices and wash room, Girls' and Toddlers' Ward, Pleasant Creek Special School. (W.O., Ararat; P.S., Stawell; Pleasant Creek Special School, Stawell.) P.D., £10. F.D., 2 per cent.

Stawell.—Erection of store and sewing room, Pleasant Creek Special School. (W.O., Ararat, Ballarat; Pleasant Creek Special School, Stawell.) P.D., £15. F.D., 2 per cent.

Sunbury.—Supply, delivery, and installation of two steam boilers, Mental Hospital. P.D., £50. F.D., 2 per cent.

Tatura.—Erection of new station and cell block, P.S. (W.O., Bendigo, Shepparton; P.S., Echuca, Murchison, Tatura.) P.D., £15. F.D., 2 per cent.

Terang.—Installation of septic tank system and new out-office block for girls, S.S. No. 617. (W.O., Camperdown, Warrnambool; S.S., Terang.) P.D., £5. F.D., 2 per cent.

Various.—Manufacture of three hundred (300) rain water tanks, 800-gallon capacity, standard shape, from iron supplied by Department, and delivery to nearest railway station to place of manufacture, Public Works Department.

Wodonga.—Erection of a new timber residence, S.S. No. 37. (W.O., Wangaratta; S.S., Wodonga.) P.D., £15. F.D., 2 per cent.

Woolamai.—Kerosene hot-water service, teacher's residence, S.S. No. 3856. (W.O., Korumburra.) P.D., £3. F.D., 2 per cent.

## 21st August, 1951.

Ararat.—Erection of covered ways and porches, Mental Hospital. (W.O., Ararat, Ballarat; P.S., Stawell; Mental Hospital, Ararat.) P.D., £15. F.D., 2 per cent.

Ballarat.—Alterations and additions to staff mess room, Mental Hospital. (W.O., Ballarat; Mental Hospital, Ballarat.) P.D., £15. F.D., 2 per cent.

Beechworth.—Concreting, tiling and painting throughout Institution, Mental Hospital. (W.O., Wangaratta; Mental Hospital, Beechworth.) P.D., £25. F.D., 2 per cent.

Beechworth.—Supply and installation of stainless steel sinks and basins, Mental Hospital. (W.O., Wangaratta; Mental Hospital, Beechworth.) P.D., £20. F.D., 2 per cent.

Beechworth.—Extensions to Kitchen, Male Hospital, Mental Hospital. (W.O., Wangaratta; Mental Hospital, Beechworth.) P.D., £15. F.D., 2 per cent.

Benalla.—New fittings, repairs, &c., to residence (2 Egmont-street), P.S. (W.O., Benalla; P.S., Benalla.) P.D., £4. F.D., 2 per cent.

Benalla.—Repairs and painting, H.S. (W.O., Benalla; H.S., Benalla.) P.D., £15. F.D., 2 per cent.

Benalla East.—Repairs, renovations, and new out-offices, S.S. No. 2256. (W.O., Benalla; P.S., Euroa; S.S., Benalla East.) P.D., £15. F.D., 2 per cent.

Bendigo.—Renovations, Law Courts. (W.O., Bendigo.) P.D., £4. F.D., 2 per cent.

Bendoc.—Additions, repairs, and painting, S.S. No. 1166. (W.O., Bairnsdale; S.S., Bendoc.) P.D., £10. F.D., 2 per cent.

Birchip.—Supply and installation of a kerosene hot-water service, teacher's residence (Campbell-street), S.S. No. 2602. (P.S., Charlton.) P.D., £3. F.D., 2 per cent.

Camperdown.—Septic tank installation, S.S. No. 114. (W.O., Camperdown; P.S., Colac; S.S., Camperdown.) P.D., £5. F.D., 2 per cent.

Cavendish.—Supply, installation, and testing of a kerosene hot-water service, teacher's residence, S.S. No. 116. (W.O., Hamilton.) P.D., £3. F.D., 2 per cent.

Charlton.—Kerosene hot-water service in teacher's residence, S.S. No. 1480. (P.S., Charlton.) P.D., £2. F.D., 2 per cent.

Coburg.—Supply and delivery of combined electrically-heated Bain Marie and Hot Press, Female Division, Pentridge. P.D., £10. F.D., 2 per cent.

Coburg.—Supply and installation of boiler house auxiliaries and soot arresters in new Boiler House, Pentridge. P.D., £15. F.D., 2 per cent.

Dean's Marsh.—Raising residence and general renovations, S.S. No. 1642. (W.O., Geelong; S.S., Dean's Marsh.) P.D., £5. F.D., 2 per cent.

Dooen.—Erection of Demonstration Theatre at Butchery, Longerenong Agricultural College. (W.O., Ballarat, Horsham; P.S., Murtoa; Longerenong Agricultural College, Dooen.) P.D., £20. F.D., 2 per cent.

Drouin.—Erection of "A" type office and single out-office and fencing, P.S. (W.O., Traralgon; P.S., Drouin.) P.D., £10. F.D., 2 per cent.

Euroa.—Provision of a store and equipment room, S.S. No. 1706. (W.O., Benalla; S.S., Euroa.) P.D., £3. F.D., 2 per cent.

Flemington.—Enclosing of verandah, Special School No. 4465, Travancore Developmental Centre. P.D., £5. F.D., 2 per cent.

Frankston.—Provision of two new soakage shafts, S.S. No. 1464. (S.S., Frankston.) Deposit, £4.

Geelong.—Supply and delivery of stainless steel benches and other equipment for Kitchen, Gaol. P.D., £10. F.D., 2 per cent.

Geelong.—Supply and delivery of electric mincer and other equipment, Gaol. P.D., £5. F.D., 2 per cent.

Gowerville.—Electrical installation, S.S. No. 4674. P.D., £10. F.D., 2 per cent.

Hampton.—Removal of cleaner's residence and re-erection, &c., on adjoining site, S.S. No. 3754. (S.S., Hampton.) P.D., £10. F.D., 2 per cent.

Kilmore.—Erection of new combined out-offices and wood shed, and demolition of existing out-offices, S.S. No. 1568. (W.O., Bendigo, Kyneton; S.S., Kilmore.) P.D., £10. F.D., 2 per cent.

Marnoo.—Repairs and painting, school and residence, S.S. No. 1554. (W.O., Ararat; P.S., Murtoa, Stawell; S.S., Marnoo.) P.D., £10. F.D., 2 per cent.

Melbourne.—Additional sewerage facilities, Technical College. Deposit, £4.

Melbourne.—Extension of dark room, X-ray Branch, Tuberculosis Bureau, Mint-place. P.D., £5. F.D., 2 per cent.

Melbourne.—Supply and installation of central heating and hot-water services, Department of Health, 300 Queen-street. P.D., £15. F.D., 2 per cent.

Merbein.—External and internal painting and provision of fly-wire door and window screens, S.S. No. 3687. (W.O., Mildura; S.S., Merbein.) P.D., £15. F.D., 2 per cent.

Mont Park.—Conversion of existing pantry and bedroom into bathroom and kitchen, Mental Hospital. P.D., £5. F.D., 2 per cent.

Rosanna.—Additional out-offices and sewerage installation, S.S. No. 4568. (S.S., Rosanna.) P.D., £10. F.D., 2 per cent.

Rosedale.—Repairs and painting, school and residence, S.S. No. 770. (W.O., Traralgon; S.S., Rosedale.) P.D., £15. F.D., 2 per cent.

South Melbourne.—Supply and delivery of two hundred (200) crates of 12 ft. x 4 ft. x  $\frac{1}{2}$  in. hardboard, Public Works Department Storeyard, Wells-street. Deposit, £25. (Tenderers to state date of delivery.)

South Yarra.—Repairs to roof, Melbourne Boys' High School. P.D., £5. F.D., 2 per cent.

Stawell.—Additional out-office accommodation, H.S. (W.O., Ararat; P.S., Stawell.) P.D., £5. F.D., 2 per cent. (Amended specification.)

Various.—Supply and delivery of washer plates (alternative tenders for 20 tons or 25 tons), Harbor Works.

Various.—Manufacture of bolts and supply of nuts (total weight 100 tons), Harbor Works.

Warracknabeal.—Erection of new boiler house, District Hospital. (W.O., Ballarat, Horsham, Warracknabeal; District Hospital, Warracknabeal.) P.D., £15. F.D., 2 per cent.

Warrnambool.—Additional room and lavatory accommodation, Court House. (W.O., Warrnambool; P.S., Port Fairy.) P.D., £15. F.D., 2 per cent.

Wonthaggi.—Erection of new out-offices and installation of septic tank, S.S. No. 3650. (W.O., Korumburra; S.S., Wonthaggi.) P.D., £15. F.D., 2 per cent.

Wycheproof.—Kerosene hot-water service, teacher's residence, S.S. No. 1757. (P.S., Charlton.) P.D., £3. F.D., 2 per cent.

Yendon.—Installation of septic tank, &c., S.S. No. 719. (W.O., Ballarat; S.S., Yendon.) P.D., £5. F.D., 2 per cent.

## 28th August, 1951.

Ballarat.—External painting and minor repairs, S.S. No. 34 (Humffray-street). (W.O., Ballarat; S.S., Ballarat.) P.D., £5. F.D., 2 per cent.

Ballarat.—Extension to scullery to Ward F.11, Mental Hospital. (W.O., Ballarat; Mental Hospital, Ballarat.) P.D., £5. F.D., 2 per cent.

Beechworth.—Provision of day room, kitchen extension and glass screening to balcony, Mental Hospital. (W.O., Wangaratta; P.S., Myrtleford; Mental Hospital, Beechworth.) P.D., £20. F.D., 2 per cent.

Bendigo.—Repairs and renovations and attention to drains, &c., Gaol. (W.O., Bendigo; P.S., Castlemaine, Eaglehawk.) P.D., £10. F.D., 2 per cent.

Bylands.—Attention to marked school walls; repairs and painting to school and residence, S.S. No. 1105. (W.O., Kyneton; P.S., Castlemaine, Daylesford, Kilmore; S.S., Bylands.) P.D., £4. F.D., 2 per cent.

Castlemaine.—Repairs and renovations, Court House. (W.O., Kyneton; P.S., Castlemaine.) P.D., £5. F.D., 2 per cent.

Daylesford.—External and internal repairs and painting, Court House. (W.O., Kyneton; P.S., Daylesford.) P.D., £5. F.D., 2 per cent.

Dookie.—Erection and installation of vertical steam boiler, Agricultural College. (W.O., Benalla, Bendigo, Shepparton, Wangaratta.) Deposit, £4.



Dookie.—Extension to domestic staff quarters, Agricultural College. (W.O., Shepparton; Agricultural College, Dookie.) P.D., £15. F.D., 2 per cent.

Fairfield.—Electrical installation, new laboratory, Infectious Diseases Hospital. P.D., £5. F.D., 2 per cent.

Frankston.—External repairs and painting, S.S. No. 1464. (S.S., Frankston.) P.D., £10. F.D., 2 per cent.

Geelong.—Additional out-office accommodation, H.S. (W.O., Geelong; H.S., Geelong.) P.D., £10. F.D., 2 per cent.

Grahamvale.—Repairs, painting, raising, and re-blocking walls, new display boards, school and residence, S.S. No. 3696. (W.O., Shepparton; P.S., Kyabram, Murchison, Numurkah.) P.D., £10. F.D., 2 per cent.

Hillside.—Alterations, painting, &c., S.S. No. 4637. (W.O., Bairnsdale; P.S., Stratford; S.S., Hillside.) P.D., £5. F.D., 2 per cent.

Janefield.—Erection of three wash-houses, Mental Hospital. Deposit, £4.

Kew.—Electrical installation, new Assembly Hall, Mental Hospital. P.D., £4. F.D., 2 per cent.

Melbourne.—Supply and installation of oil-firing equipment to existing boiler at the Boiler Room, National Herbarium, Botanical Gardens. P.D., £5. F.D., 2 per cent.

Malmsbury.—Erection of residence, office, and cell, excavations, paths and fences, P.S. (W.O., Bendigo. Kyneton; P.S., Malmsbury.) Deposit, £20.

Malvern East.—Electrical installation, S.S. No. 4139. P.D., £2. F.D., 2 per cent.

Moe.—Supply and installation of mechanical services, Multi-Purpose School. (W.O., Traralgon.) P.D., £50. F.D., 2 per cent.

Mont Park.—Erection of new brick laundry block, Treatment Clinic, Mental Hospital. P.D., £20. F.D., 2 per cent.

Moreland.—Internal and external repairs and painting, also erection of new fuel shed and incineration area, S.S. No. 4635. (S.S. Moreland.) P.D., £15. F.D., 2 per cent.

Preston.—Electrical installation, three prefabricated classrooms, T.S. P.D., £5. F.D., 2 per cent.

Queenscliff.—Supply and delivery of 6-in. or 7-in. engine lathe, complete with motor and accessories, including a 6-in. self-centring chuck and a 10-in. independent chuck, Buoy Depot.

Rochester.—Repairs and renovations, Court House. (W.O., Bendigo; P.S., Echuca, Elmore, Rochester.) P.D., £5. F.D., 2 per cent.

Sandringham.—Erection of fencing, T.S. (T.S., Sandringham.) P.D., £10. F.D., 2 per cent.

Stawell.—Alterations to Inspector's residence, Education Department. (W.O., Ararat; P.S., Stawell.) P.D., £5. F.D., 2 per cent.

Trentham.—Alterations, repairs, and renovations, P.S. (W.O., Bendigo, Kyneton; P.S., Trentham.) P.D., £15. F.D., 2 per cent.

Wilson's Reef.—Repairs and painting, residence, S.S. No. 1437. (W.O., Bendigo, Maryborough; P.S., Dunolly, Inglewood; S.S., Wilson's Reef.) P.D., £5. F.D., 2 per cent.

Windsor.—Electrical installation, S.S. No. 1896. P.D., £2. F.D., 2 per cent.

4th September, 1951.

Chelsea.—Electrical installation, station, and residence, P.S. P.D., £4. F.D., 2 per cent.

Moe.—Electrical installation, Multi-Purpose School. P.D., £50. F.D., 2 per cent.

Melbourne.—Erection of new lavatory block, Parliament House. P.D., £25. F.D., 2 per cent.

Red Hill.—Supply and installation of warm air heating and ventilation, Assembly Hall, Consolidated School. P.D., £10. F.D., 2 per cent.

Various.—Supply and delivery of two-ton pile driving winches, jetties. (Full details to be submitted by tenderers together with delivery date.)

11th September, 1951.

Melbourne.—Fire alarm and watchman's clock installation, Geological Museum and Laboratory, Old Treasury Building. P.D., £10. F.D., 2 per cent.

Melbourne.—Fire alarm and watchman's clock installation, Government Printing Office. P.D., £2. F.D., 2 per cent.

Tenders to be addressed to the Honorable the Commissioner of Public Works, and envelope containing tender marked "Tender for

P. T. BYRNES,  
Commissioner of Public Works.

Melbourne, 7th August, 1951.

PRIVATE ADVERTISEMENTS.

CITY OF ESSENDON.

BY-LAW No. 124.

A By-law of the City of Essendon, and numbered 124, to amend that portion of By-law 87 relating to mechanical, vocal, or instrumental noises in any public highway.

IN pursuance of powers conferred by the Local Government Act 1946 and amending Acts, the Council of the City of Essendon doth hereby order as follows:—

1. Division 6, clauses 19 and 20, of By-law No. 87 are hereby repealed and the following clauses, to be numbered 19 and 20 respectively, substituted:—

(19) No person shall in any public highway cause or permit or suffer to be caused any noise—

(a) by shouting, calling out, haranguing, or singing, or

(b) by using, operating, controlling, sounding, or playing any instrument.

(20) No person shall in or upon any land, house, building, or place make or cause or permit or suffer to be made or cause such a volume or amount of sound or noise as to be an annoyance or nuisance to any other person being in or upon any other land, house, building, or place or in or upon any public highway—

(a) by shouting, calling out, haranguing, or singing, or

(b) by using, operating, controlling, sounding, or playing any instrument.

2. In this By-law, unless the context otherwise requires—

"Instrument" means any instrument, device, or thing whatsoever capable of making or being used for making sound or noise, and without affecting the generality of the foregoing includes any loud-speaker, amplifier, broadcasting set, wireless receiving set, gramophone, piano, player piano, or other instrument or device.

Resolution for passing this By-law was agreed to by the Council of the City of Essendon on the 18th day of June, 1951, and confirmed on the 16th day of July, 1951.

The common seal of the Mayor, Councillors, and Citizens of the City of Essendon was hereunto affixed this 25th day of July, 1951, in the presence of—

B. M. CROCKFORD, Mayor.

(SEAL) H. J. LYTTLE, Councillor.

7885

N. F. WELLINGTON, Town Clerk.

CITY OF GEELONG.

BY-LAW No. 128.

A By-law of the City of Geelong, No. 128, made under the provisions of the Carriages Acts, for the purpose of amending By-laws Nos. 124 and 126 respectively of the said city relating (inter alia) to hackney carriages.

IT is hereby enacted by the Council of the City of Geelong, as follows:—

By-law No. 124 shall be amended as follows:—

Clauses 1, 2, and 3 of the Tables of Rates and Fares appearing therein under the heading "Fourth Schedule" shall be omitted, and the following clauses substituted therefor:—

1. Taxi Cabs—

Fares by time—	s. d.
Detention for each five minutes or part thereof	0 7
per hour	7 0

Fares by distance—	
Service charge or flag fall	1 3
Distance—at the rate per mile of	1 6
with a minimum total charge of	2 6

Luggage—	
No charge shall be made for luggage carried inside the taxi-cab or boot.	
For each package carried outside the taxi-cab	0 3

2. Private Hire Cars—

Fares by time—	
Detention—for each five minutes or part thereof	0 7
per hour	7 0

Fares by distance—	
Service charge or flag fall	1 6
Distance—at the rate per mile of	1 6
with a minimum total charge of	2 6

Luggage—	
No charge shall be made for luggage carried inside the private hire car or boot. For each package carried outside the private hire car	0 3

3. Private Hire Cars and Taxi-cabs—

Weddings and Funerals—

Fares—to be by time only—

- (a) for the first hour or part thereof 30 0
- (b) for each subsequent half-hour or part thereof .. 10 0

By-law No. 126 shall be amended as follows:—

Sub-clause (b) of clause 2 of the said By-law shall be and the same is hereby amended by omission therefrom of the words "six pounds" for the words "three pounds" being the words appearing at the end of the said sub-clause and the words "three pounds" shall be and the same are hereby again inserted at the end of clause 9 of By-law No. 122.

Resolution for passing this By-law agreed to by the Council of the City of Geelong on the 26th day of June, 1951, and confirmed on the 31st day of July, 1951.

The common seal of the Mayor, Councillors, and Citizens of the City of Geelong was affixed hereto, in the presence of—

(SEAL) B. E. PURNELL, Mayor.  
L. L. WALTER, Town Clerk.

CITY OF SANDRINGHAM.

By-LAW No. 147.

A By-law of the City of Sandringham, made under section 228 of the Local Government Acts, with the approval of the Governor in Council, and numbered 147, for the purpose of altering By-law No. 110, as altered by By-law No. 140.

IN pursuance of the powers conferred by the Local Government Acts and of every power thereunto them enabling, the Mayor, Councillors, and Citizens of the City of Sandringham order as follows:—

By-law No. 110 of the City of Sandringham, as altered by By-law No. 140 of the City of Sandringham, is hereby altered to the following extent, viz.:—

The figures 1951 appearing in the said By-law No. 140 of the City of Sandringham are hereby deleted, and in lieu thereof there shall be substituted the figures 1953.

Resolution for passing this By-law agreed to by the Council on the 22nd day of May, 1951, and confirmed on the 19th day of June, 1951.

The common seal of the Mayor, Councillors, and Citizens of the City of Sandringham was hereto affixed the 3rd day of July, 1951, in the presence of—

(SEAL) JAMES R. CLEWORTH, Mayor.  
R. J. SILLITOE, Councillor.  
FRED. G. TRICKS, Town Clerk.

Approved by the Governor in Council, this 24th day of July, 1951.—A. MAHLSTEDT, Clerk of the Executive Council.

7894

SHIRE OF HEALESVILLE.

By-LAW No. 30.

A BY-LAW of the Shire of Healesville (hereinafter referred to as the "Municipality"), made pursuant to the Local Government Act 1946 and clause 813 of the Uniform Building Regulations Victoria as amended (hereinafter referred to as the "Regulations"), and any and all other Act or Acts in that behalf thereunto enabling, and numbered 30, for the purpose of exercising the powers conferred on the Council of the Municipality by the said clause 813.

Commencement.

1. This By-law shall come into operation on its confirmation by the Governor in Council and immediately after its publication in the Victoria Government Gazette, and By-laws Nos. 25 and 27 are hereby repealed.

No Person to Build Contrary to By-law.

2. No person shall erect, build, construct, repair, pull down, remove, alter, add to, or re-erect or cause or suffer to be erected, built, constructed, repaired, pulled down, removed, altered, added to, or re-erected, any building contrary to the provisions of this By-law.

Brick Areas.

3. No building shall be built, constructed, erected, added to, or extended on land fronting to or abutting upon any portions of both sides of any of the following streets or roads:—

- (i) The Maroondah Highway—
  - (a) from the junction of the northernmost side of the Maroondah Highway and St. Leonards-road to the junction of

the Maroondah Highway and McGrettons-road, and

- (b) from the junction of the southernmost side of the Maroondah Highway and Don-road to the junction of the Maroondah Highway and McGrettons-road;

- (ii) Green-street, from its intersection with the Maroondah Highway to its intersection with Symons-street;

- (iii) Harker-street, from its intersection with the Maroondah Highway to its junction with the Healesville-Kinglake road; and

- (iv) the Healesville-Kinglake road, from its junction with the Maroondah Highway to its junction with Harker-street

and including all land to a depth of 165 feet from the street alignments of the said land (hereinafter referred to as the "Brick Area" of the Municipality) unless the external walls of such buildings are of brick, stone, or concrete, provided that for the purpose of this clause buildings of brick veneer construction conforming to the requirements of Chapter 26 of the Regulations shall be deemed to have external walls of brick, and provided further that the foregoing restrictions shall extend and apply to the following outbuildings and outhouses, namely, garages, dairies, milking sheds, and such urinals as are attached to public buildings, hotels, and boarding houses.

Limit of Two Stories.

4. Excepting lands within the Brick Area of the Municipality, all the lands within the Townships of Healesville and Marysville, as defined on the respective township plans issued by the Department of Land and Survey of the State of Victoria (which areas are hereinafter referred to as the "Residential Areas" of the Municipality), are hereby prescribed as areas in which buildings of Classes II. and III. Occupancy, as classified in Chapter 6 of the Regulations, shall not be constructed to contain more than two stories, including the ground story, and no person shall in any such area construct or cause or suffer to be constructed any such building to contain more than two stories, including the ground story.

Limit of Three Stories.

5. All areas not being Residential Areas of the Municipality are hereby prescribed as areas in which buildings of Classes II. and III. Occupancy as described in Chapter 6 of the Regulations shall not be constructed to contain more than three stories including the ground story, and no person shall in any such area construct or cause or suffer to be constructed any such building to contain more than three stories including the ground story.

Minimum Area, Depth, and Width of Frontage.

6. (a) The minimum area, depth, and width of frontage specified in column 4 of Table 803 of the Regulations are hereby adopted as the minimum area, depth, and width of frontage of land on which a building of Classes I. and II. Occupancy, as described in Chapter 6 of the Regulations, shall be constructed throughout the Brick Area of the Municipality and throughout the aforesaid Township of Healesville in the Parish of Gracedale.

(b) The minimum area, depth, and width of frontage specified in column 5 of Table 803 of the Regulations are hereby adopted as the minimum area, depth, and width of frontage of land on which a building of Classes I. and II. Occupancy as described in Chapter 6 of the Regulations shall be constructed throughout all portions of the Municipality excepting the areas described in sub-clause (a) hereof.

Distance from Frontage.

7. The minimum distance of the outer wall of any building of Classes I. and II. Occupancy, as described in the Regulations, from the frontage of any land is hereby specified as 20 feet.

Sites Below Minimum Requirements.

8. Subject to the Regulations, made pursuant to section 17 of the Slum Reclamation and Housing Act, the Council of the Municipality may, upon written application being made, in its discretion permit any person to—

- (a) construct a building of Class I. Occupancy, as described in the Regulations, on land throughout all portions of the Brick Area of the Municipality having a lesser area, depth, or width of frontage than those specified in column 4 of Table 803 of the Regulations, or at a lesser distance from the boundaries than those specified in clauses 805 and 806 of the Regulations; or
- (b) construct a building of Class I. Occupancy, as described in the Regulations, on land throughout all portions of the Municipality excepting

the Brick Area having a lesser area, depth, or width of frontage than those specified in column 5 of Table 803 of the Regulations, or at a lesser distance from the boundaries than those specified in clauses 805 and 806 of the Regulations; or

- (c) construct a building of Class III., V., VI., VII., or VIII. Occupancy, as described in the Regulations, or a building to which a building of Class IV. Occupancy is attached on land having an area, depth, or width of front less than those specified in clause 808 of the Regulations:

Provided in all such cases that on the date of the commencement of the Regulations such land existed as a separate allotment and has not since been reduced in area or was shown on a plan of subdivision approved by the Council of the Municipality and lodged in the Office of Titles.

#### Rear Access.

9. In the case of a building on any land forming part of a subdivision approved by the Council of the Municipality and lodged in the Office of Titles prior to the date of commencement of the Regulations, the said Council may, upon written application being made to it, in its discretion dispense with the requirements of clause 811 of the Regulations.

#### Penalties.

10. Any person who shall be guilty of any wilful breach of any of the provisions of this By-law shall be liable for every offence to a penalty not exceeding Twenty pounds, and if such offence is continued, to a further penalty not exceeding Five pounds for each day such offence is continued.

Resolution for the passing of this By-law No. 30 agreed to by the Council of the Shire of Healesville on the 2nd day of April, 1951, and confirmed on the 30th day of April, 1951.

The common seal of the President, Councillors, and Ratepayers of the Shire of Healesville was hereto affixed, in the presence of—

(SEAL) R. G. POLLARD, President.  
RICHARD M. SWIFT, Councillor.  
JAS. HANSEN, Shire Secretary.

Approved by the Governor in Council, 3rd July, 1951.—  
A. MAHLSTEDT, Clerk of the Executive Council. 7851

Dog Act 1936 (No. 4447).

SHIRE OF MANSFIELD.

SHOPPING AREA.

NOTICE is hereby given that on the 1st day of August, 1951, the Council of the Shire of Mansfield passed an Order specifying that section of High-street, Mansfield, between Kitchen-street and Baldry-street, to be a shopping area under the above Act, which provides, *inter alia*—

1. The owner of any dog (other than a dog being used in the driving of stock)—

(a) which is found in any municipal district, in or on any shopping area specified for the purposes of this section by order of the Council of that municipality, published in the *Government Gazette*, and in some newspaper circulating in the municipal district, and

(b) which is not under the effective control of some person by means of a chain or cord or leash, shall be liable for a first offence to a penalty of not more than Two pounds, and for a second or any subsequent offence to a penalty of not more than Five pounds.

2. Any dogs so found may be seized by the police or by the officer of the municipality duly authorized in that behalf, and dealt with as if it had been seized under section 13 or section 14 (as the case requires) of the principal Act.  
7881

R. WOMERSLEY, Shire Secretary.

SHIRE OF NARRACAN.

NOTICE is hereby given that the Council of the Shire of Narracan has abolished the pound on Crown allotment 10, section D, Parish of Yarragon, and Miss Adelaide Eileen Osmond Mills has resigned as poundkeeper.

Further, in pursuance of section 4 of the *Pounds Act* 1928, the Council has appointed lot 11, part allotment 2a, section 3, Township of Trafalgar, Parish of Yarragon, to be a pound, and has appointed Alexander Robert Robertson, of Trafalgar, to be poundkeeper of such pound.

Dated this 2nd day of August, 1951.

7906

T. SHANAHAN, Shire Secretary.

Local Government Act 1946.

SHIRE OF SEYMOUR.

NOTICE TO ALL WHOM IT MAY CONCERN.

WHEREAS the Council of the municipality of the Shire of Seymour, in the State of Victoria, deems it expedient to execute a certain work or undertaking for the purpose of providing a place of public resort and recreation, for the purposes whereof it is, in the opinion of the said Council, necessary and desirable that the said Council exercise its power of taking land compulsorily within the municipal district of the said Council, as provided by the *Local Government Act* 1946, and the said Council has caused its surveyor to prepare specifications, maps, plans, sections, and elevations of the said work or undertaking as are necessary and in which are expressed the nature and extent of such work or undertaking and the exact site of admeasurements thereof, and on and through what land the said work or undertaking is proposed to be placed, and the names of the owners or reputed owners' lessees or reputed lessees, and the occupiers of such land so proposed to be taken so far as known, and the said specifications, maps, plans, sections, and elevations so prepared have been approved by the said Council.

In pursuance of the provisions of the *Local Government Act* 1946, the said council doth hereby publish and give notice that the description shortly of the purport of the said work or undertaking and of the said specifications, maps, plans, sections, and elevations is as follows:—

The providing of a place of public resort and recreation in Tallarook-street, Seymour.

And the said Council doth hereby give further notice that the said specifications, maps, plans, sections, and elevations are deposited at the office of the said Council, Town Hall, Seymour, and are there open for inspection and perusal on all the days and between the hours the municipal office is appointed to be open, for the space of 40 clear days from the date of the publication of this notice in the *Government Gazette*. And the said Council doth hereby call upon all persons interested in or affected by the said proposed work or undertaking to set forth, in writing, addressed to the said council or the Town Clerk thereof, at the Town Hall, Seymour, within 40 clear days from the date of the publication of this notice as aforesaid, all objections which they may have to the said work or undertaking.

Dated this 16th day of July, 1951.

The common seal of the President, Councillors, and Ratepayers of the Shire of Seymour was hereto affixed by me—

(SEAL) H. E. CLAREY, Shire Secretary.

in the presence of—

7856

W. R. McINTOSH, Councillor.  
M. E. COUGHLIN, Councillor.

I, JOHN FOSTER, of 122 Williams-road, Prahran, in the State of Victoria, company director, at one time known as Alfred John Foster, hereby give public notice that by a deed poll dated the 31st day of July, 1951, duly executed and attested and deposited with the Registrar General of the said State on the 31st day of July, 1951, I formally and absolutely renounced and abandoned the said Christian name of Alfred, and declared that I intended henceforth upon all occasions whatsoever to use and subscribe the name of John Foster, instead of the name of Alfred John Foster, and so to be at all times thereafter called, known, and described by the name of John Foster.

Dated this 31st day of July, 1951.

JOHN FOSTER.

Witness—JAMES H. BOSTON, J.P.

Oswald Burt and Co., solicitors, 394 Collins-street, Melbourne. 7924

I, TREVOR BASIL POWER, of 9 Pevensey-crescent, Geelong, in the State of Victoria, designing draughtsman, heretofore called and known by the name of Trevor Basil Powe, hereby give you notice that on the 11th day of July, 1951, I renounced and abandoned the use of my said surname of Powe, and assumed in lieu thereof the surname of Power, and further that such change of name is evidenced by a deed dated the 11th day of July, 1951, duly executed by me and attested and deposited in the office of the Registrar-General at Melbourne, on the 13th day of July, 1951.

TREVOR BASIL POWER (formerly known as Trevor Basil Powe). 7860

**I** IVY GLEN ASHTON, of Cranbourne-road, Dandenong, in the State of Victoria, married woman, heretofore called and known by the name of Ivy Glen Hawking, hereby give public notice that by deed poll dated the 2nd day of August, 1951, duly executed and attested and deposited with the Registrar-General of the said State, on the 3rd day of August, 1951, I formally and absolutely renounced and abandoned the said surname of Hawking, and declared that I had assumed and adopted and intended thenceforth upon all occasions whatsoever to use and subscribe the surname of Ashton instead of the said surname of Hawking, and so as to be at all times thereafter called, known, and described by the said surname of Ashton.

Dated the 3rd day of August, 1951.

Witness—JOAN V. CLARK. I. G. ASHTON. 7845

**NOTICE OF INTENTION TO APPLY FOR A LICENCE TO DIVERT WATER AND CUT RACES FROM THE MURRAY RIVER, at COWANNA, WENTWORTH-ROAD.**

**I** HEREBY give notice that I intend to apply for a licence empowering me to divert water for a term of fifteen years to the extent of 120 acre-feet per annum at a maximum rate of 2 acre-feet per day of 24 hours for irrigation of 40 acres, being part of allotment 1, section G, and allotment 7, section H, Parish of Merbein, and to occupy certain Crown lands for works of storage and diversion, and to cut a race thereon.

Any objection to such application must be forwarded, in writing, to the State Rivers and Water Supply Commission, Melbourne, within 30 days of the date hereof.

THOMAS JAMES ADAMS. 7852  
Box 58, Merbein Post Office, 23rd July, 1951.

**NOTICE OF INTENTION TO APPLY FOR A LICENCE TO DIVERT WATER AND CUT RACES FROM THE MURRAY RIVER, AT COWANNA, WENTWORTH-ROAD.**

**I** HEREBY give notice that I intend to apply for a licence empowering me to divert water for a term of fifteen years to the extent of 75 acre-feet per annum at a maximum rate of 2 acre-feet per day of 24 hours for irrigation of 25 acres, being part of allotment 5, section G, and allotment 9, section H, Parish of Merbein, and to occupy certain Crown lands for works of storage and diversion, and to cut a race thereon.

Any objection to such application must be forwarded, in writing, to the State Rivers and Water Supply Commission, Melbourne, within 30 days of the date hereof.

REGINALD PERCIVAL UNDERWOOD. 7855  
Box 221, Merbein Post Office, 23rd July, 1951.

**NOTICE OF INTENTION TO APPLY FOR A LICENCE TO DIVERT WATER AND CUT RACES FROM THE LODDON RIVER, AT LAANECOORIE.**

**I** HEREBY give notice that I intend to apply for a licence empowering me to divert water for a term of fifteen years to the extent of 60 acre-feet per annum at a maximum rate of 4 acre-feet per day of 24 hours for irrigation of 30 acres, being part of allotments 16 and 18, section A, Parish of Tarnagulla, and to occupy certain Crown lands for works of storage and diversion, and to cut a race thereon.

Any objection to such application must be forwarded, in writing, to the State Rivers and Water Supply Commission, Melbourne, within 30 days of the date hereof.

ISABELLA VICTORIA RUMBOLD. 7853  
Laanecoerie, 12th June, 1951.

**NOTICE OF INTENTION TO APPLY FOR A LICENCE TO DIVERT WATER AND CUT RACES FROM THE MURRAY RIVER, AT KARADOC.**

**I** HEREBY give notice that I intend to apply for a licence empowering me to divert water for a term of fifteen years to the extent of 120 acre-feet per annum at a maximum rate of 2 acre-feet per day of 24 hours for irrigation of 60 acres, being part of allotment Pt. A (Dewry P.R.), Parish of Karadoc, and to occupy certain Crown lands for works of storage and diversion, and to cut a race thereon.

Any objection to such application must be forwarded, in writing, to the State Rivers and Water Supply Commission, Melbourne, within 30 days of the date hereof.

PHILIP MAXWELL WEST. 7886  
Box 163, Red Cliffs, 3rd August, 1951.

**NOTICE OF INTENTION TO APPLY FOR A LICENCE TO DIVERT WATER AND CUT RACES FROM THE MURRAY RIVER, AT COWANA BEND, MERBEIN.**

**I** HEREBY give notice that I intend to apply for a licence empowering me to divert water for a term of fifteen years to the extent of 87 acre-feet per annum at a maximum rate of 4 acre-feet per day of 24 hours for irrigation of 29 acres, being part of allotment 8, section H, Parish of Merbein, and to occupy certain Crown lands for works of storage and diversion, and to cut a race thereon.

Any objection to such application must be forwarded, in writing, to the State Rivers and Water Supply Commission, Melbourne, within 30 days of the date hereof.

JAMES LYELL HOGG. 7863  
Box 185, Merbein, 23rd July, 1951.

**NOTICE OF INTENTION TO APPLY FOR A LICENCE TO DIVERT WATER AND CUT RACES FROM THE MURRAY RIVER, AT WEMEN.**

**WE** hereby give notice that we intend to apply for a licence empowering us to divert water for a term of fifteen years to the extent of 500 acre-feet per annum at a maximum rate of 2 acre-feet per day of 24 hours for irrigation of 250 acres, being part of allotment 2, Parish of Wemen, and to occupy certain Crown lands for works of storage and diversion, and to cut a race thereon.

Any objection to such application must be forwarded, in writing, to the State Rivers and Water Supply Commission, Melbourne, within 30 days of the date hereof.

HAROLD BOND.  
JOSEPH BOND.  
MARGARET BROPHY BOND. 7854  
Bannerton, 24th July, 1951.

**NOTICE OF INTENTION TO APPLY FOR A LICENCE TO DIVERT WATER AND CUT RACES FROM THE MURRAY RIVER, AT KARADOC.**

**WE** hereby give notice that we intend to apply for a licence empowering us to divert water for a term of fifteen years to the extent of 290 acre-feet per annum at a maximum rate of 2 acre-feet per day of 24 hours for irrigation of 145 acres, being part of allotment A, Dewry P.R., Parish of Karadoc, and to occupy certain Crown lands for works of storage and diversion, and to cut a race thereon.

Any objection to such application must be forwarded, in writing, to the State Rivers and Water Supply Commission, Melbourne, within 30 days of the date hereof.

THOMAS JAMES GIDDINGS.  
GERTRUDE EDITH GIDDINGS.  
THOMAS KEITH GIDDINGS.  
LESLIE DAVID GIDDINGS.  
STANLEY WILLIAM GIDDINGS. 7864  
Box 203, Red Cliffs, 30th July, 1951.

**GEELONG WATERWORKS AND SEWERAGE TRUST.**

**NOTICE** to owners of tenements in the under-mentioned streets, and the private streets, lanes, courts, and alleys opening thereto:—

CITY OF GEELONG WEST.  
Edinburgh-street, 214 ft. 5 in. north from Cooke-street.  
SHIRE OF SOUTH BARWON.  
Morris-street, 106 feet south from existing main.  
SHIRE OF CORIO.  
Stanley-street, 307 feet north from North Shore-road.  
Dudley-street, 704 ft. 6 in. westerly from Stanley-street.  
Stradbroke-street, 923 feet north from North Shore-road.  
Dudley-street, 316 feet west from Stradbroke-street.  
Lumeah-street, 647 feet north from Dudley-street.  
Bertram-street, 582 feet north from Cox's-lane.

SHIRE OF BELLARINE.  
Atkin-street, 321 feet north from Queenscliff-road.  
Gibb-street, 473 feet westerly from Atkin-street.  
Gibb-street, 119 ft. 6 in. east from Atkin-street.  
The main pipe in the said streets being laid down, the owners of all tenements situated as above are hereby required, on or before the 1st day of September, 1951, to cause a proper pipe and stop cocks to be laid so as to supply water within such tenements from the main pipe.

The common seal of the Geelong Waterworks and Sewerage Trust was hereunto affixed, this 27th day of July, 1951, in the presence of—

J. P. CARR, Chairman.  
F. H. WALLACE, Commissioner.  
B. C. HENSHAW, Secretary.  
(SEAL) 7907

NOTICE is hereby given that the partnership heretofore existing between Gordon Gilbert Griffiths, Jack Leslie Ellis, William Charles Briggs, and Joseph Henry Rundle, in the business of sawmakers at 18A Warburton-street, Brunswick, under the name of "Melbourne Saw Service," has been dissolved as at 8th May, 1951.

Dated this 31st day of July, 1951.

G. G. GRIFFITHS.  
W. BRIGGS.  
J. L. ELLIS.  
J. H. RUNDLE.

Herbert and Geer, solicitors, 20 Bank-place, Melbourne, C.I. 7911

NOTICE is hereby given that the partnership heretofore subsisting between Ronald William Bartlett, Ronald George Bartlett, and Leonard William Bartlett, carrying on business as farmers at Yambuk, under the name of "R. W. Bartlett and Sons," has been dissolved by mutual consent as from the 30th day of June, 1951. All debts due to and owing by the said late firm will be received and paid respectively by the said Ronald William Bartlett and the said Ronald George Bartlett, who will continue to carry on the said business at the same place, under the style or firm name of "R. W. Bartlett and Sons."

Dated the 30th day of July, 1951.

R. W. BARTLETT.  
R. G. BARTLETT.  
L. W. BARTLETT.

Peter P. Conlan, solicitor, 36 Bank-street, Port Fairy, 7877

NOTICE is hereby given that the partnership heretofore subsisting between Leonard Everard Ryder and Katie Pauline Beyer, under the style of Quiberon Milk Bar, has been dissolved by mutual consent as from this date. All debts due to and owing by the said late firm will be received and paid by the said Katie Pauline Beyer, who will continue to carry on the business under the same name.

Dated the 30th day of July, 1951.

L. E. RYDER.  
K. P. BEYER.

Middleton, McEacharn, and Shaw, solicitors, 60 Market-street, Melbourne. 7873

NOTICE is hereby given that the partnership hitherto subsisting between Thomas Edward Seferth and Edward William Wyatt, at 498-500 Flinders-street, Melbourne, under the style or firm of "A. A. Phoenix Co.," has been dissolved as from 30th June, 1951, and that the said Thomas Edward Seferth will henceforth carry on the said business at that address under the same trade name, and all debts owing by and all moneys payable to the said late firm will be paid and received by the said Thomas Edward Seferth at the said address.

Dated the 2nd day of August, 1951.

T. E. SEFERTH.  
E. W. WYATT.

G. A. Hilford, 19 Queen-street, Melbourne, solicitor for Thomas Edward Seferth.

A. B. Natoli, 24 Cotham-road, Kew, solicitor for Edward William Wyatt. 7893

NOTICE is hereby given that the partnership heretofore subsisting between the undersigned Herbert James Leversha and George Herbert Reynolds, carrying on business as landscape gardeners, at 12 Thanet-street, Malvern, in the State of Victoria, has been dissolved by mutual consent from the 30th day of June, 1951, and all debts due to and owing by the said late firm will be received and paid by the said Herbert James Leversha, who will continue to carry on the business at 35 Iris-road, Glen Iris, in the said State.

Dated at Malvern, the 24th day of July, 1951.

H. J. LEVERSHA.  
G. H. REYNOLDS.

Witness—Roy S. V. BOULTON. 7888

In the matter of the *Companies Act 1938*, and in the matter of *WARD SYMONS STUDIOS PTY. LTD.* (in Voluntary Liquidation).

AT an Extraordinary General Meeting of Ward Symons Studios Proprietary Limited, held at 252 Swanston-street, Melbourne, on 1st August, 1951, the following Resolution was passed as a Special Resolution:—

"That the company be wound up voluntarily."

And at such last-mentioned meeting Laurence Kimberley Cronin, of 252 Swanston-street, Melbourne, was appointed liquidator for the purpose of the winding up.

Dated, at Melbourne, this 2nd day of August, 1951.

7846 O. M. SYMONS, Chairman of Directors.

#### RADIO ELECTRIC PROPRIETARY LIMITED.

AT an Extraordinary General Meeting of the above-named company, duly convened and held at 133 Lava-street, Warrnambool, on Friday, the 3rd August, 1951, the following Resolution was duly passed as a Special Resolution:—

"That the company be wound up voluntarily."

And at such last-mentioned meeting, Winifred Helen Crutchfield, of Liebig-street, Warrnambool, accountant, was appointed liquidator for the purposes of the winding up.

Dated the 3rd day of August, 1951.

7892 J. K. HILL, Chairman.

In the matter of *MOODY'S SEYMOUR HOTEL PROPRIETARY LIMITED* and in the matter of the *Companies Act 1938*.

NOTICE is hereby given that the creditors of the above-named company, which is being voluntarily wound up, are required, on or before the 31st day of August, 1951, being the day for that purpose fixed by Donald Stanley Baker, of 459 Chancery-lane, Melbourne, the liquidator of the said company, to send their names and addresses and the particulars of their debts or claims, and the names and addresses of their solicitors, if any, to the undersigned, and if so required by notice in writing from the said liquidator, are by their solicitors to come and prove their said debts or claims at such time and place as shall be specified in such notice or in default thereof they will be excluded from the benefit of any distribution made before such debts are proved.

Dated this 2nd day of August, 1951.

WEIGALL & CROWTHER, of 459 Chancery-lane, Melbourne, solicitors to the above-named liquidator. 7875

NOTICE TO CREDITORS.—*RE MARY ELLIS, DECEASED.*

PURSUANT to the provisions of the *Trustee Act 1928*, notice is hereby given that all persons having any claims against the estate of Mary Ellis, formerly of 160 Hampton-street, Hampton, but late of Corio-street, Shepparton, in the State of Victoria, widow (who died on the 19th day of May, 1951, and probate of whose will was granted to Alfred Henry William Ellis, of Grant's-road, Tullamarine, farmer, and Eric Clive Ellis, of 23 Carrier-street, Benalla, dry cleaner), are hereby required to send in particulars of such claims, in writing, to the undersigned, before the 20th day of October, 1951, after which date the said executors will distribute the assets of the estate of the said Mary Ellis, deceased, which shall have come to the hands or possession of the said executors amongst the persons entitled thereto, having regard only to the claims of which the said executors shall have had notice. And the said executors will not be liable for the assets, or any part thereof, so distributed to any person of whose claim they shall not then have had notice.

Dated this 3rd day of August, 1951.

STRONGMAN & CROUCH, of 403 Bourke-street, Melbourne, solicitors for the above-named executors. 7923

FREDRICK JENNER, late of Cowes, Phillip Island, in the State of Victoria, farmer, DECEASED.

CREDITORS, next of kin, and all other persons having claims against the estate of the said deceased are required by the executor of the will, Leonard Norman Jenner, of "Lorraine," Ducklo, Tara Line, Queensland, grazier, to send particulars to him, care of the undersigned, on or before the 11th day of October, 1951, after which date he will distribute the assets, having regard only to the claims of which he shall then have notice.

P. J. RIDGEWAY & PEARCE, solicitors, 379 Collins-street, Melbourne. 7920

JOHN MAYHEW CORR, late of 25 Forster-avenue, East Malvern, in the State of Victoria, retired bank manager, DECEASED (who died on the 26th day of January, 1951).

CREDITORS, next of kin, and all others having claims against the estate of the deceased are required by the executrix of the estate, Mary Therese Corr, of 25 Forster-avenue, East Malvern, to send particulars to her, care of the undersigned, on or before the 15th day of October, 1951, after which date she will distribute the assets, having regard only to the claims of which she then has notice.

GORDON RENNICK, LL.B., 339 Collins-street, Melbourne. 7919

ALICE MAUD BATELIER (also known as Alice Maud Connell), late of 5 Hood-street, Elwood, married woman, DECEASED.

CREDITORS, next of kin, and all other persons having claims against the estate of the said deceased are required by the executors of the will, Jack Hubert Plunkett, of 102 Montpellier-road, Sandy Bay, Hobart, Tasmania, accountant, and Thomas Alfred Pearce, of 379 Collins-street, Melbourne, solicitor, to send particulars to them, care of the undersigned, on or before the 11th day of October, 1951, after which date they will distribute the assets, having regard only to the claims of which they shall then have notice.

P. J. RIDGEWAY & PEARCE, solicitors, 379 Collins-street, Melbourne. 7918

CREDITORS, next of kin, and others having claims in respect to the estate of Walter Montagu Corden, formerly of Naracoorte, in the State of South Australia, but late of 2 Gillman-street, Cheltenham, in the State of Victoria, clerk in holy orders, deceased (who died on the 15th day of April, 1951), are required by the executrix of the deceased's will, Ida Beatrice Corden, of 2 Gillman-street, Cheltenham, to send particulars of their claims to her, care of the under-mentioned solicitors, before the 17th day of October, 1951, after which date she will distribute the assets, having regard only to the claims she has then had notice.

Dated this 2nd day of August, 1951.

MCCRACKEN & MCCRACKEN, solicitors, 317 Collins-street, Melbourne, C.I. 7915

HAROLD GORDON THOMPSON, late of 17 Mountain-street, South Melbourne, cabinet-maker, DECEASED, intestate.

CREDITORS, next of kin, and others having claims in respect of the estate of the above-named deceased (who died on 13th March, 1951), are required to send the particulars of their claims to the administratrix, Kate Thompson, care of the under-named solicitors, by the 10th day of October, 1951, after which date she will distribute the assets, having regard only to the claims of which she then has notice.

NORRIS, COATES, & HEARLE, of 422 Collins-street, Melbourne, solicitors. 7916

CAROLINE FRANCES TODD, formerly of 73 Athol-street, Moonee Ponds, married woman, but late of 11 Storey-road, Reservoir, widow, DECEASED.

CREDITORS, next of kin, and others having claims in respect of the estate of the above-named deceased (who died on 12th March, 1951), are required to send the particulars of their claims to the executor, Roy William Tainsh, care of the under-named solicitors, by the 10th day of October, 1951, after which date he will distribute the assets, having regard only to the claims of which he then has notice.

NORRIS, COATES, & HEARLE, of 422 Collins-street, Melbourne, solicitors. 7917

WILLIAM CALDOW, DECEASED.

NOTICE is hereby given that all persons having claims against the property or estate of William Caldwell, formerly of 3 Laurel Bank-parade, Newtown, Geelong, but late of Cambrai Private Hospital, Pakington-street, Geelong West, retired farmer, deceased (who died on the 15th day of May, 1951, and probate of whose will was granted to Vera Rowe, of 182 Kilgour-street, Geelong, married woman, and Eustace Edmund Wilson, of 51 Yarra-street, Geelong, solicitor), are hereby required to send, in writing, particulars of such claims to the said Vera Rowe and Eustace Edmund Wilson, in the care of the under-mentioned solicitors, on or before the 11th day of October, 1951, after which date they will convey or distribute such property or estate to or among the persons entitled thereto, having regard only to the claims of which they shall then have had notice.

HARWOOD & PINCOTT, 51 Yarra-street, Geelong, solicitors for the said executors. 7904

CREDITORS, next of kin, and others having claims in respect of the estate of Mary Dunne, late of 4 Keats-street, Sandringham, spinster, deceased (who died on the 1st day of March, 1951), are to send the particulars of their claims to The Trustees, Executors, and Agency Company Limited, of 401 Collins-street, Melbourne, by the 11th day of October, 1951, after which date it will distribute the assets, having regard only to the claims of which it then has notice.

RUSSELL, KENNEDY, & COOK, solicitors, 401 Collins-street, Melbourne. 7895

JOHN NORTHAM, late of Glebe, in the State of New South Wales, A.I.D. inspector, DECEASED.

CREDITORS, next of kin, and others having claims against the estate of the said deceased (who died on the 10th day of May, 1951), are required to send particulars of their claims to the National Trustees, Executors, and Agency Company of Australasia Limited, whose registered office is situate at 95 Queen-street, Melbourne, in the State of Victoria, by the 15th day of October, 1951, after which date it will distribute the assets of the said estate, having regard only to the claims of which it then has notice.

RONALD STEWART, STOCK, & MCINTOSH, solicitors, of 422 Collins-street, Melbourne, solicitors for the applicant. 7897

ANNA ERNSTINE WERNER, late of Dimboola, in the State of Victoria, widow, DECEASED (who died on the 20th day of February, 1951).

CREDITORS, next of kin, and all others having claims against the estate of the above-named deceased are required by the executors, Carl Gustav Reinhold Werner, of Gerang Gerung, farmer, and August Bernhard Werner, of Arkona, storekeeper, to send particulars thereof to them, care of the under-mentioned solicitor, on or before the 2nd day of October, 1951, after which date they will distribute the assets of the said deceased, having regard only to the claims of which they shall then have had notice.

W. N. MUNTZ, solicitor, Dimboola. 7887

CREDITORS, next of kin, and others having claims in respect to the estate of Margaret Knox, late of 22 Warrigal-road, Surrey Hills, spinster (who died on the 11th day of May, 1951), are to send particulars of their claims to The Equity Trustees, Executors, and Agency Company Limited, whose registered office is situate at 472 Bourke-street, Melbourne, by the 25th day of October, 1951, after which date it will distribute the assets of the said estate, having regard only to the claims of which it then has notice.

LEACH & THOMSON, solicitors, 472 Bourke-street, Melbourne. 7898

KATHARINA RATAZZI, late of Ludwighofstrasse, 49 Frankfurt on Main, in Germany, widow, DECEASED (who died 24th March, 1945).

CREDITORS, next of kin, and others having claims against the estate of the above-named deceased are requested to send particulars of their claims to John Paterson Adam, the administrator (with will) in Victoria of the estate of the deceased, at the address of his solicitors hereunder named, on or before the 15th October, 1951, after which date the said administrator will proceed to distribute the assets of the said estate amongst the persons entitled thereto, having regard only to the claims of which he shall by such date have had notice.

WEIGALL & CROWTHER, 459 Chancery-lane, Melbourne, the solicitors to the said administrator. 7894

CREDITORS, next of kin, and others having claims in respect of the estate of William Henry Freer, late of 39 Balaclava-road, East St. Kilda, in the State of Victoria, gentleman, deceased (who died on the 14th day of April, 1950, and probate of whose will has been granted to Ellen Freer, widow, Mary Gertrude Freer, spinster, and John Anthony Freer, bank officer, all of 39 Balaclava-road, East St. Kilda, in the said State), are to send in particulars of their claims to the said executrices and executor, care of the under-mentioned solicitors, by the 20th day of October, 1951, after which date they will distribute the assets, having regard only to the claims of which they then have notice.

GILLOTT, MOIR, & AHERN, of 95 Queen-street, Melbourne, solicitors. 7912

MELBA HARRIET MULLIN, late of 6 Allison-avenue, Glen Iris, widow, DECEASED (who died on the 21st April, 1951).

CREDITORS and all others having claims against the estate of deceased are requested to forward full particulars thereof to Robert Alan Johnston and Thelma Elizabeth Coy, the executor and executrix respectively of deceased, at the address of their solicitors hereunder named, on or before the 15th October, 1951, after which date the said executor and executrix will proceed to distribute the assets of deceased amongst the persons entitled thereto, having regard only to the claims of which the executor and executrix shall by such date have had notice.

WEIGALL & CROWTHER, of 459 Chancery-lane, Melbourne, solicitors to the said executor and executrix. 7871

*Trustee Act 1928.*

## NOTICE TO CLAIMANTS.

**P**URSUANT to the *Trustee Act 1928*, creditors, next of kin, and all other persons having claims in respect of the estate of any deceased person named below are required to send particulars thereof to the legal personal representative or representatives, at the address stated below, on or before the date stated, after which date the representative or representatives will distribute the assets, having regard only to the claims of which notice has been received:—

William Thomas Harold Long, formerly of East Loddon, Serpentine, but late of 54 Lucan-street, Bendigo, Victoria, farmer and grazier, who died on the 4th day of December, 1950.—Claims to the executors, Alan Gillespie Long and William Harold Long, both of Serpentine, farmers, in care of the undersigned solicitors, not later than the 8th day of October, 1951. Tatchell, Dunlop, Smalley, and Balmer, solicitors, Williamson-street, Bendigo. 7865

Johannes Heinrich Jaede, late of 34 Redesdale-road, Ivanhoe, merchant, died 27th May, 1951.—Claims to Hans Wilhelm Jaede, of 6 Central-avenue, Ivanhoe, merchant, and Norman Robert Macaw, of 31 Queen-street, Melbourne, chartered accountant, the executors of the will of the said deceased, in the care of the under-mentioned solicitors, by the 10th day of October, 1951. James Hall and Sons, solicitors, 17 Queen-street, Melbourne. 7914

Dora Anna Jaede, late of 34 Redesdale-road, Ivanhoe, married woman, died 16th May, 1951.—Claims to Norman Robert Macaw, of 31 Queen-street, Melbourne, chartered accountant, and Hans Wilhelm Jaede, of 6 Central-avenue, Ivanhoe, merchant, two of the executors of the will of the said deceased, in the care of the under-mentioned solicitors, by the 10th day of October, 1951. James Hall and Sons, solicitors, 17 Queen-street, Melbourne. 7913

John George Burke, late of 1 Braemar-street, Essendon, retired railway employee, deceased, died the 12th day of June, 1951.—Claims to the executors, Christopher Burke and Arthur Alexander Brahe, care of the under-mentioned solicitors, by the 8th day of October, 1951. Gair and Brahe, 243 Collins-street, Melbourne, solicitors for the executors. 7908

**P**URSUANT to the *Trustee Act 1928*, notice is hereby given that all persons having claims against the estate of Reinhard Paul Menzel, formerly of Cowangie, but late of Murrayville, in the State of Victoria, farmer, deceased (who died on the 1st day of March, 1950, and probate of whose will was granted by the Supreme Court of the said State, in its probate jurisdiction, on the 3rd day of August, 1951, to The Union Trustee Company of Australia Limited, of 333 Collins-street, Melbourne), are hereby required to send particulars, in writing, of such claims to the said company, at 333 Collins-street, Melbourne, on or before the 10th day of October, 1951, after which date the said company will proceed to distribute the assets of the said Reinhard Paul Menzel which shall have come to their hands or possession amongst the persons entitled thereto, having regard only to the claims which it shall then have had notice. And the said company will not be responsible for the assets so distributed, or any part thereof, to any person of whose claim it shall not then have had notice.

Dated the 6th day of August, 1951.

LOUGHREY & LOUGHREY, of 108 Queen-street, Melbourne, proctors for the said company. 7896

*RE WILLIAM RICE, DECEASED.*

**N**OTICE is hereby given that all persons having claims against the property or estate of William Rice, late of Shelford, farmer and grazier, deceased (who died on the 8th day of February, 1951, and probate of whose will and two codicils thereto was granted to Lenard Alexander Rice, of Mount Mercer, in the State of Victoria, farmer, and William Alfred Rice, of Durham Lead, in the said State, farmer), are hereby required to send, in writing, particulars of such claims to the said Lenard Alexander Rice and William Alfred Rice, in the care of the under-mentioned solicitors, on or before the 11th day of October, 1951, after which date they will convey or distribute such property or estate to or among the persons entitled thereto, having regard only to the claims of which they shall then have had notice.

HARWOOD & PINCOTT, 51 Yarra-street, Geelong, solicitors for the said executors. 7905

**C**REDITORS, next of kin, and others having claims in respect of the estate of Evelyn Mabel Ogier, late of 73 (formerly 53) Carroll-crescent, Glen Iris, in the State of Victoria, spinster, deceased (who died on the 4th day of June, 1951), are to send the particulars of their claims to National Trustees, Executors, and Agency Company of Australasia Limited, whose registered office is at 95 Queen-street, Melbourne, by the 20th day of October, 1951, after which date it will distribute the assets, having regard only to the claims of which it then has notice.

A. C. SECOMB & TIBB, solicitors, 128 William-street, Melbourne. 7870

**C**REDITORS, next of kin, and others having claims in respect of the estate of Thomas Tucker, late of 40 Meek-street, Brighton, builder (who died on 23rd August, 1950), are to send particulars of their claims to The Equity Trustees, Executors, and Agency Company Limited, of 472 Bourke-street, Melbourne, by the 15th October, 1951, after which date it will distribute the assets, having regard only to the claims of which it shall then have had notice.

WEIGALL & CROWTHER, solicitors, of 459 Chancery-lane, Melbourne. 7872

FLORENCE GOOD, late of 6 Terry-street, Deepdene, spinster (who died on the 27th May, 1951).

**C**REDITORS, next of kin, and all others having claims in respect of the estate of the deceased are required by the executor, The Trustees, Executors, and Agency Company Limited, of 401 Collins-street, Melbourne, to send particulars of such claims to the said company by the 11th October, 1951, after which date the said company will distribute the assets, having regard only to the claims of which it then has notice.

DAVIES, CAMPBELL, & PIESSE, 401 Collins-street, Melbourne, solicitors. 7874

**C**REDITORS, next of kin, and all others having claims against the estate of Clara Blain, late of Kerang, widow, deceased (who died on the 17th day of May, 1951), are required to send particulars thereof to her executors, Horatio Smitheram and Adeline James, in care of the under-mentioned solicitor, on or before the 13th day of October, 1951, otherwise they may be excluded when the assets are being distributed.

H. E. EVERY, solicitor, 59 View-street, Bendigo. 7876

## NOTICE TO CLAIMANTS.

**C**REDITORS, next of kin, and others having claims in respect of the estate of Owen Patrick Daly, late of Milton-street, Hamilton, in the State of Victoria, gentleman, deceased (who died on the 27th day of April, 1951), are to send the particulars of their claims to The Fidelity Trustee Company Limited, of 52 Gray-street, Hamilton aforesaid, by the 15th day of October, 1951, after which date it will convey or distribute the assets, having regard only to the claims of which it then has notice.

PALMER, PLUMMER, & MILLER, solicitors, 56 Thompson-street, Hamilton. 7879

**C**REDITORS, next of kin, and all other persons having claims in respect of the estate of Thomas Girvan, late of Mosquito Creek, retired farmer and manager, deceased (who died on the 8th day of April, 1951), are required to send particulars of their claims to the sole executor, Sandhurst and Northern District Trustees, Executors, and Agency Company Limited, of View-street, Bendigo, by the 12th day of October, 1951, after which date it will distribute the assets, having regard only to the claims of which it then has notice.

Dated the 6th day of August, 1951.

HYETT, WILLIS, & HYETT, 51 Bull-street, Bendigo, solicitors for the executor. 7880

**C**REDITORS, next of kin, and others having claims in respect of the estate of Harold John Henry Young, late of 173 West Melbourne-road, Geelong West, carpenter, deceased (who died on the 25th day of March, 1951), are to send particulars of their claims to The Fidelity Trustee Company Limited, of 101 Lydiard-street north, Ballarat, care of the branch office of the said company, Trustees' Chambers, Malop-street, Geelong, by the 10th day of October, 1951, after which date it will distribute the assets, having regard only to the claims of which it then has notice.

F. RAYMOND APTED, of 63 Yarra-street, Geelong, solicitor for the executor. 7862



**P**URSUANT to the *Trustee Act* 1928, notice is hereby given that all creditors, next of kin, and other persons having claims against the estate of Michael Joseph Hogan, late of Northwood, in the State of Victoria, farmer, deceased (who died on the 13th day of March, 1951, and probate of whose will was granted by the Supreme Court of the State of Victoria, in its probate jurisdiction, on the 9th day of July, 1951, to William Francis Hogan, of Northwood, in the said State, farmer), are hereby required to send particulars, in writing, of such claims to the said executor, care of the undersigned, at his address hereunder set out, on or before the 2nd day of October, 1951, after which date the said executor will proceed to distribute the assets of the said deceased amongst the persons entitled thereto, having regard only to the claims of which he shall then have had notice.

W. J. OSBORNE, LL.B., solicitor, Seymour. 7869

**C**REDITORS, next of kin, and others having claims in respect of the estate of Samuel Adams, late of 44 Ebdon-street, Ballarat, retired (who died on the 19th June, 1951), are to send the particulars of their claims to The Fidelity Trustee Company Limited (formerly The Ballarat Trustees, Executors, and Agency Company Limited), of 101 Lydiard-street north, Ballarat, by the 10th day of October, 1951, after which date it will distribute the assets, having regard only to the claims of which it then has notice.

7882

**C**REDITORS, next of kin, and others having claims in respect of the estate of Christina Baker, late of 912 Gregory-street, Ballarat, widow, deceased, intestate (who died on 3rd May, 1951), are to send particulars of their claims to the administrator, The Fidelity Trustee Company Limited, at its address, 101 Lydiard-street north, Ballarat, by 12th October, 1951, after which date the administrator will distribute the assets, having regard only to the claims of which it then has notice.

BAIRD & BAIRD, solicitors, Ballarat. 7883

#### STATUTORY NOTICE TO CREDITORS.

**P**URSUANT to the *Trustee Act* 1928, notice is hereby given that all persons having claims against the estate of Edward Butterworth, formerly of Buchan South, in the State of Victoria, farmer, but late of Migrant Hostel, Cumberland-road, Pascoe Vale, in the said State, hostel assistant, deceased (who died on the 31st day of January, 1951, and probate of whose will was granted by the Supreme Court of the said State, in its probate jurisdiction, on the 18th day of July, 1951, to Edwin Walter Keat, of Buchan, in the said State, farmer), are hereby required to send particulars, in writing, of such claims to the said Edwin Walter Keat, in the care of the undersigned, at their office hereunder mentioned, on or before the 24th day of October, 1951, after which date the said Edwin Walter Keat will proceed to distribute the assets of the said Edward Butterworth, deceased, which shall have come to his hands amongst the persons entitled thereto, having regard only to the claims of which he shall then have had notice. And notice is hereby further given that the said Edwin Walter Keat will not be liable for the assets so distributed, or any part thereof, to any person of whose claim he shall not have had notice as aforesaid.

WARREN & THOMSON, solicitors, of Bailey-street, Bairnsdale. 7849

#### STATUTORY NOTICE TO CREDITORS.

**P**URSUANT to the *Trustee Act* 1928, notice is hereby given that all persons having claims against the estate of John Lachlan MacMillan, late of Metung, in the State of Victoria, gentleman, deceased (who died on the 24th day of October, 1950, and probate of whose will was granted by the Supreme Court of the said State, in its probate jurisdiction, on the 6th day of July, 1951, to Margaret Maude MacMillan, of Metung aforesaid, widow, and Robert Gasquoine Warren, of Bairnsdale, in the said State, solicitor), are hereby required to send particulars, in writing, of such claims to the said Margaret Maude MacMillan and Robert Gasquoine Warren, in the care of the undersigned, at their office hereunder mentioned, on or before the 24th day of October, 1951, after which date the said Margaret Maude MacMillan and Robert Gasquoine Warren will proceed to distribute the assets of the said John Lachlan MacMillan, deceased, which shall have come to their hands amongst the persons entitled thereto, having regard only to the claims of which they shall then have had notice. And notice is hereby further given that the said Margaret Maude MacMillan and Robert Gasquoine Warren will not be liable for the assets so distributed, or any part thereof, to any person of whose claim they shall not have had notice as aforesaid.

WARREN & THOMSON, solicitors, of Bailey-street, Bairnsdale. 7848

EMILY FRANCES BLACKBURN, formerly of Bayview-street, North Williamstown, in the State of Victoria, but late of 217 Osborne-street, Williamstown, in the said State, married woman, DECEASED (who died on the 12th day of December, 1950).

**A**LL persons having claims against the estate of the above-name deceased are required by National Trustees, Executors, and Agency Company of Australasia Limited, the registered office of which is at 95 Queen-street, Melbourne, in the said State (the executor to which probate of the will of the said deceased was granted by the Supreme Court of Victoria), to send particulars, in writing, of such claims to the said company, at its registered office aforesaid, on or before the 20th day of October, 1951, after which date the said company will distribute the assets of the said deceased among the persons entitled thereto, having regard only to the claims of which it has had notice as aforesaid.

H. HODGES HALL, LL.M., 11 Bank-place, Melbourne, solicitor for the said company. 7866

#### STATUTORY NOTICE TO CREDITORS.

**P**URSUANT to the *Trustee Act* 1928, notice is hereby given that all persons having claims against the estate of Herbert Arthur Huggins, late of McLeod-street, Bairnsdale, in the State of Victoria, retired grazier, deceased (who died on the 23rd day of April, 1951, and probate of whose will was granted by the Supreme Court of the said State, in its probate jurisdiction, on the 18th day of July, 1951, to Charles Frederick Huggins, of Hinnumunje, in the said State, grazier, and Ellie Ivy Olive Beverly, of Grant-street, Bairnsdale aforesaid, widow), are hereby required to send particulars, in writing, of such claims to the said Charles Frederick Huggins and Ellie Ivy Olive Beverly, in the care of the undersigned, at their office hereunder mentioned, on or before the 24th day of October, 1951, after which date the said Charles Frederick Huggins and Ellie Ivy Olive Beverly will proceed to distribute the assets of the said Herbert Arthur Huggins, deceased, which shall have come to their hands amongst the persons entitled thereto, having regard only to the claims of which they shall then have had notice. And notice is hereby further given that the said Charles Frederick Huggins and Ellie Ivy Olive Beverly will not be liable for the assets so distributed, or any part thereof, to any person of whose claim they shall not have had notice as aforesaid.

WARREN & THOMSON, solicitors, of Bailey-street, Bairnsdale. 7850

**C**REDITORS, next of kin, and others having claims in respect of the estate of Annie Eileen Mulcahy, late of 103 Charles-street, Ascot Vale, in the State of Victoria, typist, deceased (who died on the 29th day of June, 1951), are to send particulars of their claims to the executor, The Perpetual Executors and Trustees Association of Australia Limited, of Nos. 100-104 Queen-street, Melbourne, in the said State, by the 11th October, 1951, after which date the said company will distribute the assets, having regard only to the claims of which it shall then have had notice.

M. MORNANE, solicitor, 95 Queen-street, Melbourne. 7909

**C**REDITORS, next of kin, and others having claims in respect of the estate of William Harold Roberts, formerly of Hepburn Springs, but late of 115 The Right, Heidelberg, in the State of Victoria, mine manager, deceased (who died on the 26th day of January, 1951), are required to send particulars of their claims to The Fidelity Trustee Company Limited, whose registered office is situate at 101 Lydiard-street north, Ballarat, by the 29th day of September, 1951, after which date it will distribute the assets, having regard only to the claims of which it then has notice.

P. T. WALSH, solicitor, Vincent-street, Daylesford. 7867

**C**REDITORS, next of kin, and others having claims in respect of the estate of William Joseph Hay, late of Vincent-street, Daylesford, pensioner (who died on the 13th day of March, 1951), are required to send particulars of their claims to Patrick Trevers Walsh, of Vincent-street, Daylesford, solicitor, by the 29th day of September, 1951, after which date the executor will distribute the assets, having regard only to the claims of which he then has notice.

P. T. WALSH, solicitor, Vincent-street, Daylesford. 7868



In the Supreme Court of the State of Victoria.—*Fi. Fa.*

**NOTICE** is hereby given that under and by virtue of certain process issued out of the Supreme Court of the State of Victoria and directed to the Sheriff, requiring him to levy certain moneys of the real and personal estate of Cedric Swanton Waugh, of Glen Isla Drive, Mount Martha, consulting engineer, the said Sheriff will, on Wednesday, the 19th day of September, 1951, at the hour of Twelve o'clock noon, cause to be sold at the Post Office, Mount Martha (unless the said process shall have been previously satisfied or the said Sheriff be otherwise stayed):—

All the right, title, and interest (if any) of the said Cedric Swanton Waugh in and to all that piece of land, being lot 6 on plan of subdivision No. 17955, lodged in the Office of Titles, and being part of Crown section 36, Parish of Moorooduc, County of Mornington, and being the land more particularly described in certificate of title, volume 7375, folio 1474962.

N.B.—Terms: Cash. No cheques taken.

Dated at Melbourne, this 3rd day of August, 1951.

7890 FRANCIS H. TUCKER, Sheriff's Officer.

In the Supreme Court of the State of Victoria.—*Fi. Fa.*

**NOTICE** is hereby given that under and by virtue of certain process issued out of the Supreme Court of the State of Victoria and directed to the Sheriff, requiring him to levy certain moneys of the real and personal estate of H. L. Freeland, of Shaftesbury-avenue, Coburg, baker, the said Sheriff will, on Monday, the 17th day of September, 1951, at the hour of Eleven o'clock in the forenoon, cause to be sold at the Police Station, corner of Bell and Main streets, Coburg (unless the said process shall have been previously satisfied or the said Sheriff be otherwise stayed):—

All the right, title, estate, and interest (if any) of the said H. L. Freeland, as joint proprietor with his wife, Annie May Freeland, in and to all that piece of land, being part of Crown portion 133, Parish of Jilka Jilka, County of Bourke, and being the land comprised in certificate of title, volume 3617, folio 723246.

N.B.—Terms: Cash. No cheques taken.

Dated at Melbourne, this 1st day of August, 1951.

7891 FRANCIS H. TUCKER, Sheriff's Officer.

### MINING NOTICES.

#### WHIPPET CONSOLIDATED NO LIABILITY.

NOTICE OF EXTRAORDINARY GENERAL MEETING.

**NOTICE** is hereby given that an Extraordinary General Meeting of shareholders of Whippet Consolidated No Liability will be held in the Board Room of the Institute of Chartered Accountants in Australia, United Oil Building, 18 Queen-street, Melbourne, on Thursday, 23rd August, 1951, at Eleven a.m.

#### Business.

1. To receive and consider a report on the present position of the company.

2. To decide on the future of the company—

(a) to continue operations, or

(b) to liquidate the company,

and should the company continue, approve of any plans to provide for further finance.

By order of the Board,

7922 H. V. SAMPSON, Legal Manager.

#### KALGOORLIE SOUTHERN GOLD MINES NO LIABILITY.

**NOTICE** is hereby given that all shares in Kalgoorlie Southern Gold Mines No Liability forfeited for non-payment of the First Call of One shilling per share, which was due and payable on 11th July, 1951, will be sold by public auction in the vestibule of the Stock Exchange, Melbourne, on Thursday, 16th August, 1951, at Twelve o'clock noon, if not redeemed by payment of the above call, on or before the day previous to the day of sale.

By order of the Board,

L. EDWARDS, Manager.

360 Collins-street, Melbourne, 6th August, 1951. 7921

No. 751.—7626/51.—4

#### ARGUS HILL CHEWTON GOLD NO LIABILITY.

**NOTICE** is hereby given that all shares forfeited for non-payment of No. 90 (July) Call of Three pence per share will be sold by public auction in the vestibule of the Stock Exchange, 428 Chancery-lane, Melbourne, on Tuesday, 21st August, 1951, at a quarter to Twelve a.m., unless previously redeemed.

By order of the Board,

FRANK COOPER, Manager.

422 Collins-street, Melbourne, C.1. 7910

### IMPOUNDINGS.

**BENDIGO.**—Impounded at Bendigo, on 31st July, 1951.

1 chestnut gelding, blaze face, three white feet, no visible brand

1 bay pony gelding, black points, no visible brand

1 mousey pony, Shetland cross, black points, no visible brand

If not claimed and expenses paid, to be sold on 16th August, 1951.

V. E. BOWEN,

Poundkeeper.

7857—10/10

**BOX HILL.**—Impounded at Box Hill, by L. C. Richards.

1 bay pony gelding, star, near hind fetlock white, unshod, no visible brand

If not claimed and expenses paid, to be sold on 23rd August, 1951.

H. J. BARRETT,

Poundkeeper.

7926—7/7

**CARISBROOK.**—Impounded at Carisbrook.

1 black Jersey cow, P on rump

1 black, brown, and white cow, indistinct brand

1 black, brown, and white heifer, no visible brand

1 red and white steer, no visible brand

If not claimed and expenses paid, to be sold in fourteen days.

P. J. LANDRIGAN,

Poundkeeper.

7899—9/9

**DANDENONG.**—Impounded at Dandenong, off Prince's Highway, Harrisfield, by Shire Ranger, E. Osborne.

1 draught chestnut mare, white down face, white stockings, shod, no visible brand, filly foal at foot

If not claimed and expenses paid, to be sold on 24th August, 1951.

A. WALKER,

Poundkeeper.

7925—8/8

**EAGLEHAWK.**—Impounded at Eaglehawk, on 25th July, 1951.

1 dark-bay pony gelding, black points, no visible brand

1 dark-bay hack gelding, one hind fetlock white, white star on forehead, saddle marked, no visible brand

If not claimed and expenses paid, to be sold on 16th August, 1951.

A. J. PALLOT,

Poundkeeper.

7847—9/9

**FOXHOW.**—Impounded in Foxhow Pound, by Herdsman, V. Ayres, on 30th July, 1951.

1 brindle cow, top off near ear, two splits off ear, lame leg, no visible brand, black calf at foot

3 Jersey cows, top off near ear, two splits off ear, no visible brand

2 yearling Jersey heifers, no visible brand or ear mark

1 Jersey bull calf, no visible brand or ear mark

If not claimed and expenses paid, to be sold on 25th August, 1951.

MARGARET GIBSON,

Poundkeeper.

7878—13/

**KILMORE.**—Impounded in Kilmore Pound, by H. Supple.

1 grey gelding, aged, no visible brand

If not claimed and expenses paid, to be sold on 27th August, 1951.

M. L. DEAN,

Poundkeeper.

7900—6/6

**MERINO.**—Impounded at Merino, on 31st July, 1951.

1 yearling Jersey steer, no visible brand  
1 red and white shorthorn cow, notch back off ear, no visible brand, wire round neck

If not claimed and expenses paid, to be sold on 22nd August, 1951.

7901—8/8 J. C. ROGERS, Poundkeeper.

**MULGRAVE.**—Impounded at Mulgrave.

1 brown and white cow, dry, brush off tail, no visible brand  
If not claimed and expenses paid, to be sold on 23rd August, 1951.

7902—6/6 R. LAMBERTON, Poundkeeper.

**SALE.**—Impounded in Sale Pound.

1 Jersey bull calf, no visible brand  
1 Jersey heifer calf, like two pieces out of left ear, no visible brand  
1 Jersey heifer calf, like two pieces out of left ear, no visible brand

If not claimed and expenses paid, to be sold on 21st August, 1951.

7859—10/10 G. CLARK, Poundkeeper.

**TALLANGATTA.**—Impounded in Tallangatta Pound.

1 roan cow, indistinct brand off rump  
1 black baldy heifer calf, no visible brand, progeny of above  
1 aged Jersey cow, no visible brand  
1 Jersey bull calf, no visible brand, progeny of above  
1 Jersey heifer, no visible brand  
1 Jersey bull calf, no visible brand, progeny of above  
1 silver Jersey cow, quarter off ear, no visible brand  
1 Jersey heifer, no visible brand, calf at foot

If not claimed and expenses paid, to be sold on 22nd August, 1951.

7889—14/1 THOMAS J. KIRK, Poundkeeper.

**YACKANDANDAH.**—Impounded in Yackandandah Pound.

1 bay draught gelding, no visible brand  
If not claimed and expenses paid, to be sold on 16th August, 1951.

7903—6/6 T. HAIG, Poundkeeper.

**YARRA JUNCTION.**—Impounded at Yarra Junction.

1 bay delivery gelding, off hind foot white, star on forehead, no visible brand

If not claimed and expenses paid, to be sold on 18th August, 1951.

7858—7/7 M. BERUDE, Poundkeeper.

**STATE ACTS, 1949.**

COPIES of the following Acts of Parliament of Victoria may be obtained at the Government Printing Office, or from any bookseller, at the price set opposite to each:—

No.		Price.
		s. d.
5362.	Miners' Phthisis (Treasury Allowances) Amendment	0 5
5363.	Country Roads (Financial)	0 6
5364.	Horsham Land	0 6
5365.	Mental Institution Benefits	0 6
5366.	Royal Commission (Communist Party)	0 6
5367.	Melbourne and Metropolitan Tramways (Chairman)	0 6
5368.	State Electricity Commission (Chairman)	0 6
5369.	River Murray Waters	0 9
5370.	Soldier Settlement	0 9
5371.	Consolidated Revenue	0 6
5372.	Agricultural Education	0 9

**STATE ACTS, 1949—continued.**

No.		Price.
		s. d.
5373.	Forestry Pulp and Paper Company's Afforestation Contracts	1 6
5374.	Shearers Accommodation	1 3
5375.	Water	0 9
5376.	Consolidated Revenue	0 5
5377.	Mildura Irrigation and Water Trusts (Financial)	0 6
5378.	Collingwood (Unimproved Rating Poll)	0 6
5379.	Crimes	1 3
5380.	Governor's Salary	0 6
5381.	Consolidated Revenue	0 6
5382.	Wrongs (Tort-feasors)	0 6
5383.	State Development	0 6
5384.	Grain Elevators (Financial)	0 6
5385.	Imported Materials Loan and Application	0 6
5386.	Royal Commission (Communist Party) Amendment	0 6
5387.	Minister of Education	0 6
5388.	Municipal Endowment (Temporary Discontinuance)	0 6
5389.	Land Tax	0 6
5390.	Stamps (Increased Duty Continuance)	0 6
5391.	Railways (Long Service)	0 6
5392.	Williamstown Lands	0 6
5393.	Greta Lands Exchange	0 6
5394.	Consolidated Revenue	0 6
5395.	Superannuation (Amendment)	0 6
5396.	Mines (Amendment)	1 0
5397.	Coal (Overseas Purchase) Amendment	0 6
5398.	Country Roads Board Fund (Amendment)	0 6
5399.	Lancefield and Kilmore Railway (Disposal of Land)	0 6
5400.	Treasury Bonds	0 6
5401.	North-West Mallee Settlement Areas (Amendment)	0 6
5402.	Administration and Probate Duties	0 6
5403.	Judges Pensions	0 9
5404.	Town and Country Planning (Metropolitan Area)	0 9
5405.	State Forests Loan and Application	0 6
5406.	Legal Profession Practice	0 6
5407.	Forests (Exchange of Lands) Extension	0 6
5408.	Victorian Mining Accident Relief Fund (Winding-up)	0 6
5409.	Consolidated Revenue	0 6
5410.	Castlemaine Lands	0 6
5411.	Soil Conservation and Land Utilization	0 9
5412.	Public Account Advances (Amendment)	0 6
5413.	Mothercraft Nurses	0 9
5414.	Rural Finance Corporation	2 0
5415.	Co-operative Housing Societies	0 6
5416.	Latrobe Valley Development Loan and Application	1 0
5417.	Liquid Fuel	0 6
5418.	Water Supply Loan and Application	1 3
5419.	Fire Brigades (Appeal Tribunal)	0 6
5420.	Railway Loan Application	1 0
5421.	Local Authorities Superannuation (Amendment)	0 9
5422.	Public Works Loan and Application	0 6
5423.	Motor Car (Amendment)	0 6
5424.	Barwon River Improvement (Amendment)	0 6
5425.	Portland Harbor Trust	1 9
5426.	Land (Grants and Leases)	0 6
5427.	Geelong Waterworks and Sewerage	0 9
5428.	Metropolitan Gas Company's	0 6
5429.	Prices Regulation	0 6
5430.	Masseurs (Registration)	0 6
5431.	Vermin and Noxious Weeds	1 9
5432.	Health (Tuberculosis Arrangement)	0 3
5433.	Justices (Service of Process)	0 6
5434.	Police Offences (Amendment)	0 6
5435.	Revocation and Excision of Crown Reservations	0 9
5436.	Coal Mine Workers Pensions (Amendment)	0 6
5437.	Health (Cattle)	0 6
5438.	Soldier Settlement (Amendment)	0 9
5439.	Footwear Regulation (Amendment)	0 6
5440.	Appropriation of Revenue, 1948-49	4 3
5441.	Croydon Fruit Cool Stores	0 6
5442.	Licensing (Amendment)	0 6
5443.	Local Government	1 6
5444.	Milk Pasteurization	0 9
5445.	Building Operations and Building Materials Control (Amendment)	0 9
5446.	Tourists' Resorts Development (Financial)	0 5
5447.	Public Library National Gallery and Museums	0 6
5448.	Police Regulation (Amendment)	0 9
5449.	Business Investigations	0 9
5450.	Motor Car (Amendment)	1 6

J. J. GOURLEY,  
Government Printer.

## STATE ACTS, 1950.

COPIES of the following Acts of Parliament of Victoria may be obtained at the Government Printing Office, or from any bookseller, at the price set opposite to each:—

No.	Price.
	s. d.
5451. Consolidated Revenue	0 6
5452. Consolidated Revenue	0 6
5453. Superannuation	0 6
5454. Marine (Temporary Exemptions)	0 6
5455. Consolidated Revenue	0 6
5456. Melbourne Harbor Trust (Housing Advances)	0 6
5457. University (Veterinary Research)	0 6
5458. Pyalong Lands Exchange	0 9
5459. Goods (Textile Products)	0 9
5460. Police Regulation (Pensions)	0 6
5461. Melbourne (Bowen-street) Land	0 9
5462. Printers and Newspapers (Foreign Advertisements)	0 6
5463. Police Offences (Race-meetings)	0 6
5464. Non-Contributory State Pensions	0 6
5465. Legislative Council Reform	2 0
5466. State Electricity Commission (Contracts)	0 6
5467. Police Regulation (Pensions) Amendment	0 6
5468. Prices Regulation (Extension)	0 6
5469. Factories and Shops (Amendment)	0 6
5470. Nurses and Midwives	1 3
5471. Weights and Measures	1 6
5472. Supreme Court (Judges)	0 6
5473. Drainage Areas	1 3
5474. Consolidated Revenue	0 6
5475. Forests (Accounts and Funds)	0 6
5476. Coal Mining Industry (Long-Service Leave)	0 9
5477. Acts Interpretation (Amendment)	0 6
5478. Agricultural Colleges (Amendment)	0 6
5479. Building Operations and Building Materials, &c.	0 9
5480. Shrine of Remembrance Site	0 6
5481. Public Works Loan and Application	0 6
5482. Grain Elevators	0 6
5483. Teaching Service (Amendment)	0 9
5484. Imported Materials Loan and Application, &c.	0 6
5485. Water Supply Loan and Application	1 3
5486. Victorian Inland Meat Authority (Advances)	0 6
5487. Melbourne and Metropolitan Board of Works (Contracts)	0 6
5488. Melbourne and Metropolitan Board of Works (Borrowing Powers)	0 6
5489. Cattle Compensation	0 6
5490. Coal Mines Regulation (Accidents Relief)	0 6
5491. Public Contracts (Amendment)	0 6
5492. Water	0 9
5493. Administration and Probate Duties	0 6
5494. Country Roads Board	0 6
5495. Land Tax	0 6
5496. Motor Car (Drivers' Licences)	0 6
5497. Tallangatta Township (Removal)	0 9
5498. Medical	0 6
5499. State Forests Loan and Application	0 6
5500. Surplus Revenue (Unexpended Balances)	0 6
5501. Treasury Bonds	0 6
5502. Co-operative Housing Societies	1 0
5503. Police Offences (Idle and Disorderly Persons)	0 6
5504. Gelliondale Land (Mineral Lease)	0 6
5505. Local Government (Imported Houses)	0 6
5506. Police Offences (Animals)	0 6
5507. Gas and Fuel Corporation	2 6
5508. Jubilee and Centenary Sports	0 6
5509. Railways Dismantling	0 9
5510. Geelong (Kardinia Park) Land	0 6
5511. Coal Mine Workers Pensions (Amendment)	0 6
5512. Municipalities and Other Authorities Finances	0 9
5513. Public Officers Salaries	0 6
5514. State Electricity Commission	0 6
5515. Public Works Loan and Application (No. 2)	0 9
5516. Ministers of the Crown and Parliamentary Salaries	0 6
5517. Fire Brigades (Long-Service Leave)	0 9
5518. Fisheries (Inland Angling)	0 6
5519. Mental Hygiene Authority	1 6
5520. Railway Loan and Application	1 3
5521. Education (Religious Instruction)	0 6
5522. Workers' Compensation (Amendment)	1 0
5523. Public Trustee	0 6
5524. McPherson's Limited Pension Fund	0 6
5525. Landlord and Tenant (Servicemen)	0 6
5526. Local Government (Shire of Braybrook)	0 6
5527. Appropriation of Revenue	4 6

J. J. GOURLEY,  
Government Printer.

## PUBLICATION OF OFFICIAL MATTER.

ATTENTION is invited to the following procedure in relation to the publication of official matter in the *Government Gazette*:—

## 1. Matter submitted to the Executive Council.

Matter submitted to the Executive Council which requires gazettal will normally be published in the issue of the following week.

Where urgent gazettal is required, special arrangements should be made with the *Gazette Officer*.

Publication will be facilitated by the submission of carbon copies for the use of the *Gazette Officer*.

## 2. Other matter.

(a) All other matter duly certified by a responsible officer for publication should be lodged with the *Gazette Officer* not later than half-past Ten a.m. on Tuesday.

(b) Lengthy or involved notices should be forwarded several days before publication.

(c) Proofs, which will be supplied only when specifically requested or at the direction of the *Gazette Officer*, should be returned promptly to avoid delay in publication.

(d) No additions or amendments to matter for publication will be accepted by telephone.

## THE "VICTORIA GOVERNMENT GAZETTE."

SUBSCRIPTIONS.—The subscription, including postage, is £1 15s. per annum, 17s. 6d. half-yearly, or 8s. 9d. per quarter, payable in advance.

Subscriptions are required to commence and terminate with a month.

A lesser period than three months cannot be subscribed for.

Subscribers do not receive the Acts of Parliament with the GAZETTE.

ADVERTISEMENTS are charged at the rate of 1s. 1d. per line single column, and 2s. 2d. per line double column.

The title (£5 Reward, Dissolution of Partnerships, &c.) forms one or more lines as a heading.

On an average, ten words make a line.

Every signature must likewise be counted as a line.

The final words of a paragraph, though only portion of a line, must be counted as one line.

SIGNATURES (in particular) and proper names must be written very plainly in the text; ONE SIDE ONLY of each slip of paper should be WRITTEN UPON.

ALL COMMUNICATIONS should be addressed to "The Government Printer, Melbourne."

ALL DOCUMENTS illegibly written will be returned unpublished, and, where brands occur unprovided for by the ordinary letters of the alphabet, a worded explanatory description must be furnished.

THE VICTORIA GOVERNMENT GAZETTE is published on WEDNESDAY EVENING in each week, and Notices for insertion will be received by the Government Printer at or before Two p.m. at ordinary rates, and late advertisements between Two p.m. and Five p.m. at double rates on the day preceding the day of publication.

Single copies of the VICTORIA GOVERNMENT GAZETTE are Six pence, posted Eight pence, each.

No GAZETTES prior to January, 1942, in stock.

\*\*\*ALL PAYMENTS ARE REQUIRED IN ADVANCE.—Remittances should be made by postal note, money order, or draft in favour of the Government Printer. Advertisements unaccompanied by a remittance sufficient to cover the cost of insertion will be returned unpublished.

## AGENTS FOR THE "VICTORIA GOVERNMENT GAZETTE."

THE following have been appointed agents to receive Advertisements and Subscriptions for the *Victoria Government Gazette*:—

ARMSTRONG'S AGENCY, 143 Queen-street, Melbourne.

ARMSTRONG BROS., Kyneton.

MESSRS. ARNALL & JACKSON, 115 Barkly-street, West Brunswick.

MR. M. R. BADE, Tobacconist, Sturt-street, Ballarat.

MR. WM. DAVIS, Mildura.

A. J. DIGBY (B. S. and N. W. CASH), Main-street, Bairnsdale.

EDGAR'S NEWS AGENCY, Hargreaves-street, Bendigo.  
 EDGAR'S NEWS AGENCY, 53 Murphy-street, Wangan-  
 ratta.  
 H. E. EVERY & SON, 42 Fryers-street, Shepparton.  
 MESSRS. HENRY FRANKS & CO., Booksellers and  
 Stationers, Market-square, Geelong.  
 MESSRS. GORDON & GOTCH, News Agents, 511 Little  
 Collins-street, Melbourne; and corner Barrack and  
 Clarence streets, Sydney.  
 W. GORDON HAMPTON, 243 Mitchell-street, Bendigo.  
 MESSRS. HARSTON, PARTRIDGE, & CO., 455 Little  
 Collins-street, Melbourne.  
 MR. C. F. LATIMER, News Agent, Casterton.  
 MR. F. T. MCCORMICK, Nunn-street, Benalla.  
 MESSRS. H. PAYNE & R. N. LOWE, 4 View Point,  
 Bendigo.  
 MESSRS. R. H. & W. M. PETTY, News Agent, Wanga-  
 ratta.  
 PIKE'S AUTHORIZED NEWS AGENCY, Sale.  
 J. PURDIE & CO., 138 Moorabool-street, Geelong.  
 MESSRS. A. S. RICHARDSON and T. C. GARDNER,  
 trading as The Mercantile Exchange, 380 Collins-  
 street, Melbourne.  
 ROBERTSON & MULLENS LTD., Elizabeth-street, Mel-  
 bourne.  
 R. & A. SMALLMAN, News Agents, Toora.  
 MESSRS. SMITH & DUNNON, Hamilton.  
 TRAINOR & McBRIDE, 246 Wyndham-street, Shepparton.

A copy of the *Gazette* filed at each place for public  
 reference.

## CONTENTS.

	PAGE.
Acts of Parliament .. .. .	5498
Acts of Parliament on sale at the Government Printing Office .. .. .	5546
Appointments .. .. .	5501
Bank Holidays .. .. .	5501
Cemeteries—Scale of Fees .. .. .	5515
Contracts .. .. .	5511
Country Roads Board .. .. .	5519
Courts .. .. .	5502
Estates of Deceased Persons .. .. .	5516
Government Notices .. .. .	5507
Impoundings .. .. .	5545
King's Birthday Holiday .. .. .	5501
Lands .. .. .	5523
Mining .. .. .	5516, 5545
Money Lenders Act 1938 .. .. .	5508
Orders in Council .. .. .	5517
Private Advertisements .. .. .	5537
Proclamations .. .. .	5497
Public Service Notices .. .. .	5532
Tenders .. .. .	5535
Transport Regulation Board—Public Hearings .. .. .	5514