



VICTORIA
GOVERNMENT GAZETTE.

Published by Authority.

[Registered at the General Post Office, Melbourne, for transmission by post as a newspaper.]

No. 501]

WEDNESDAY, JUNE 18.

[1952

Land Act 1928.

AREAS OF LANDS COMPRISED IN CERTAIN CLASSES DIMINISHED OR INCREASED.

PROCLAMATION

By His Excellency the Governor of the State of Victoria and its Dependencies in the Commonwealth of Australia, &c., &c., &c.

WHEREAS by the *Land Act 1928* it is amongst other things enacted that the Governor in Council, may, by Proclamation to be published in the *Government Gazette*, at any time diminish or increase the area of land comprised in any of the classes mentioned in Part I., Division 1, section 5, of the said *Land Act 1928*, but that the area of lands which may be sold by auction (Class 6) shall not be increased except as in certain cases in the said Act provided: Now therefore I, the Governor of the State of Victoria, in the Commonwealth of Australia, by and with the advice of the Executive Council of the said State, and in accordance with the provisions of sections 94 and 117 of the *Land Act 1928* aforesaid, do hereby diminish or increase (as the case may be) the areas of Crown lands comprised in Classes 1, 5, 6, and 7 of the classes mentioned in section 5 of the *Land Act 1928* aforesaid to the extent set forth in the subjoined Schedule (that is to say):—

Schedule referred to.

CLASSES DIMINISHED OR INCREASED.

County.	Parish.	Allotment.	Section.	Area.	Diminished. Increased.		Description.
					Class.	Class.	
				A. R. P.			
Talbot ..	Guildford ..	50	6	0 2 13 ⁹ / ₁₀	..	6	In the south-east of the parish. (W.70267)
Normanby ..	Killara ..	5, 6, 7, 13, 14, 15, 16	..	323 0 0	5	1	In south of the parish. (01807/121)
Bendigo ..	Nerring ..	348E	A	1 2 0	7	6	Fronting Sailor's Gully-road. (W.69168)

Given under my Hand and the Seal of the State of Victoria aforesaid, at Melbourne, this eleventh day of June, in the year of our Lord One thousand nine hundred and fifty-two, and in the first year of the reign of Her Majesty Queen Elizabeth II.

(L.S.)

DALLAS BROOKS.

By His Excellency's Command,

A. E. LIND,
Commissioner of Crown Lands and Survey.

GOD SAVE THE QUEEN!

PROCLAMATIONS RESCINDED AS TO WHOLE AND AS TO PART AND TOWNSHIP OF AVENEL PROCLAIMED.

PROCLAMATION

By His Excellency the Governor of the State of Victoria and its Dependencies in the Commonwealth of Australia, &c., &c., &c.

THE Governor of the State of Victoria, in the Commonwealth of Australia, by and with the advice of the Executive Council of the said State, and in pursuance of the provisions contained in section 25 of the *Land Act 1928*, as amended by section 2 of the *Land Act 1933*, do by this notice rescind the Proclamation dated 18th February, 1861, defining the boundaries of certain areas of land as towns insofar as it refers to the Town of Avenel (see *Government Gazette 1861*, page 401), the Proclamation dated 3rd October, 1887, defining the boundaries of a Township in the Parish of Avenel (see *Government Gazette 1887*, page 2928), the Proclamation dated 18th June, 1888, defining the boundaries of an extension of the Township at Avenel Railway Station (see *Government Gazette 1888*, page 2046), the Proclamation dated 7th December, 1891, defining the boundaries of the Township adjoining the Town of Avenel (see *Government Gazette 1891*, page 4996), and the Proclamation dated 22nd July, 1908, defining the boundaries of the Township of Avenel (see *Government Gazette 1908*, page 3701), and in lieu thereof do hereby proclaim as a Township under the designation of Avenel the area of land in the Parish of Avenel, Counties of Anglesey, Delatite, and Moira, within the boundaries indicated by conventional township sign on the plan hereunder.—(A.74(2, 1) (C.92845).

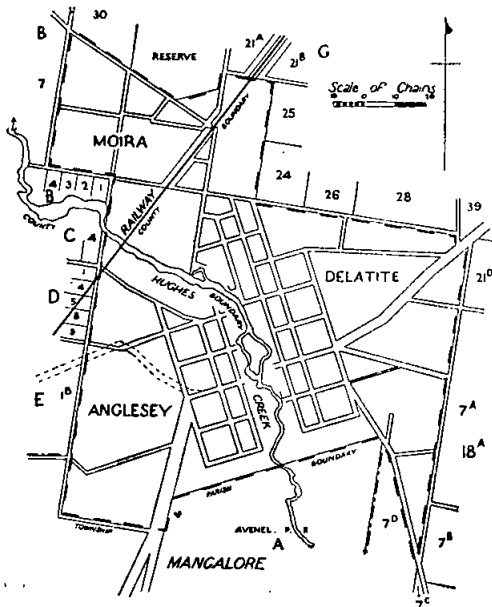

Given under my Hand and the Seal of the State of Victoria aforesaid, at Melbourne, this eleventh day of June, in the year of our Lord One thousand nine hundred and fifty-two, and in the first year of the reign of Her Majesty Queen Elizabeth II.

(L.S.) DALLAS BROOKS.

By His Excellency's Command,
A. E. LIND,
Commissioner of Crown Lands and Survey.

GOD SAVE THE QUEEN!

TOWNSHIP OF LISMORE PROCLAIMED.

PROCLAMATION

By His Excellency the Governor of the State of Victoria and its Dependencies in the Commonwealth of Australia, &c., &c., &c.

THE Governor of the State of Victoria, in the Commonwealth of Australia, by and with the advice of the Executive Council of the said State, and in pursuance of the provisions contained in section 25 of the *Land Act 1928*, do hereby proclaim as a Township under the designation of Lismore the area of land in the Parish of Lismore, County of Hampden, within the boundaries indicated by conventional township sign on the plan hereunder.—(L.71(2), (L.72(2), (C.93706).

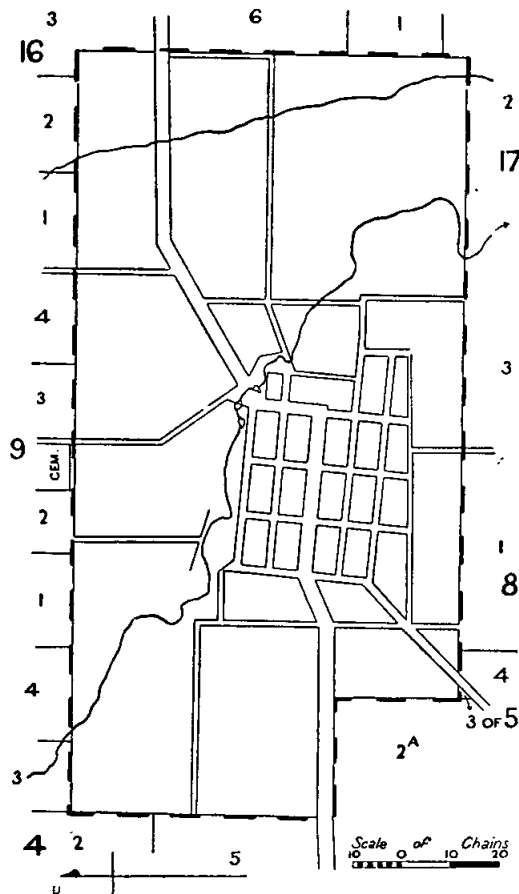

Given under my Hand and the Seal of the State of Victoria aforesaid, at Melbourne, this eleventh day of June, in the year of our Lord One thousand nine hundred and fifty-two, and in the first year of the reign of Her Majesty Queen Elizabeth II.

(L.S.) DALLAS BROOKS.

By His Excellency's Command,
A. E. LIND,
Commissioner of Crown Lands and Survey.

GOD SAVE THE QUEEN!

PROCLAMATION RESCINDED AS TO PART AND AS TO WHOLE AND TOWNSHIP OF GREEN'S CREEK PROCLAIMED.

PROCLAMATION

By His Excellency the Governor of the State of Victoria and its Dependencies in the Commonwealth of Australia, &c., &c., &c.

I, THE Governor of the State of Victoria, in the Commonwealth of Australia, by and with the advice of the Executive Council of the said State, and in pursuance of the provisions contained in section 25 of the *Land Act 1928*, as amended by section 2 of the *Land Act 1933*, do by this notice rescind the Proclamation dated 2nd December, 1870, revoking the Proclamation dated 26th September, 1870, defining a Town in the Parish of Malakoff and defining certain Crown lands in the Parish of Malakoff as a town insofar as it refers to the definition of the Town in the Parish of Malakoff (see *Government Gazette 1870*, page 1793), and the Proclamation dated 12th June, 1871, defining an addition to the town site in the Parish of Malakoff (see *Government Gazette 1871*, page 945) and in lieu thereof do hereby proclaim as a Township under the designation of Green's Creek the area of land in the Parishes of Glynwylln and Malakoff, County of Kara Kara, within the boundaries indicated by conventional township sign on the plan hereunder.—(G.171⁽²⁾), (M.454⁽²⁾), (C.93265).

GLYNWYLLN

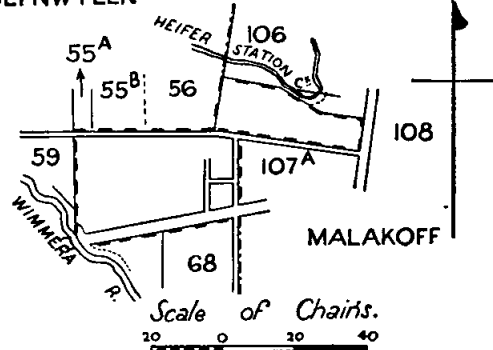

Given under my Hand and the Seal of the State of Victoria aforesaid, at Melbourne, this eleventh day of June, in the year of our Lord One thousand nine hundred and fifty-two, and in the first year of the reign of Her Majesty Queen Elizabeth II.

(L.S.) DALLAS BROOKS.

By His Excellency's Command,

A. E. LIND,
Commissioner of Crown Lands and Survey.
GOD SAVE THE QUEEN!

Milk and Dairy Supervision Act 1943 (No. 4997).

CITY OF BALLAARAT DEFINED AN URBAN DISTRICT.

PROCLAMATION

By His Excellency the Governor of the State of Victoria and its Dependencies in the Commonwealth of Australia, &c., &c., &c.

IN pursuance of the provisions contained in Part I. of the *Milk and Dairy Supervision Act 1943 (No. 4997)*, I, the Governor of the State of Victoria, by and with the advice of the Executive Council of the said State, do hereby define the Municipal District of the City of Ballaarat an urban district.

Given under my Hand and the Seal of the State of Victoria aforesaid, at Melbourne, this eleventh day of June, in the year of our Lord One thousand nine hundred and fifty-two, and in the first year of the reign of Her Majesty Queen Elizabeth II.

(L.S.) DALLAS BROOKS.

By His Excellency's Command,

G. C. MOSS,
Minister of Agriculture.

GOD SAVE THE QUEEN!

TRANSPORT ACT 1951.

DATE OF COMING INTO OPERATION OF PART II.

PROCLAMATION

By His Excellency the Governor of the State of Victoria and its Dependencies in the Commonwealth of Australia, &c., &c., &c.

WHEREAS by an Act of Parliament of the State of Victoria, passed in the first year of the reign of Her Majesty Queen Elizabeth II., intituled the *Transport Act 1951 (No. 5559)*, it is amongst other things enacted by sub-section (3) of section (1) of the Act that Part II. of the Act shall come into operation on a day to be fixed by Proclamation of the Governor in Council published in the *Government Gazette*: Now therefore I, the Governor of the State of Victoria, by and with the advice of the Executive Council thereof, do by this my Proclamation fix the first day of July, 1952, as the day upon which Part II. of the Act shall come into operation.

Given under my Hand and the Seal of the State of Victoria aforesaid, at Melbourne, this eleventh day of June, in the year of our Lord One thousand nine hundred and fifty-two, and in the first year of the reign of Her Majesty Queen Elizabeth II.

(L.S.) DALLAS BROOKS.

By His Excellency's Command,

H. J. HYLAND,
Minister of Transport.

GOD SAVE THE QUEEN!

The Game Acts.

SANCTUARY FOR NATIVE GAME AT RINGWOOD PARK, RINGWOOD, IN THE PARISH OF RINGWOOD, COUNTY OF MORNINGTON.

PROCLAMATION

By His Excellency the Governor of the State of Victoria and its Dependencies in the Commonwealth of Australia, &c., &c., &c.

I, THE Governor of the State of Victoria, in the Commonwealth of Australia, by and with the advice of the Executive Council of the said State, and in pursuance of the provisions of the Game Acts and all other powers me enabling in that behalf, do by this my Proclamation direct that the part of Victoria hereinafter described shall be a locality in which from the first day of January to the thirty-first day of December (both days inclusive) in each year it shall be unlawful for any person to kill or destroy any native game included in the Third Schedule to the *Game Act 1928*.

PART OF VICTORIA ABOVE REFERRED TO.

All that area of land comprising volume 5484, folio 1096628, containing 14 acres 1 rood 5 perches, or thereabouts, being part of Crown allotment 17d and part of former Government road, Parish of Ringwood, County of Mornington, and commencing at a point on the south-east building line of Maroondah Highway distant 627 ft. 1 in. from the intersection of the south-east building line of Maroondah Highway with the south building line of Mount Dandenong-road; thence along a line bearing S. 86 deg. 31 min. east for a distance of 120 ft. 6 in.; thence easterly along a line bearing S. 86 deg. 10 min. east for a distance of 1,164 ft. 6 in.; thence southerly along a line bearing S. 15 deg. 5 min. west for a distance of 505 ft. 6½ in.; thence westerly along an arc of radius 2,777 feet for a distance of 50 feet; thence westerly along a line bearing N. 84 deg. 28½ min. west for a distance of 1,049 ft. 2 in.; thence north-westerly along a line bearing S. 36 deg. 54 min. east for a distance of 415 ft. 9 in. to the south-east building line of Maroondah Highway; thence north-easterly along the south-east building line of Maroondah Highway on a line bearing N. 56 deg. 7 min. east for a distance of 199 ft. 9 in.; thence north-easterly along the south-east building line of Maroondah Highway on a line bearing N. 47 deg. 5 min. east for a distance of 37 ft. 7 in. to the commencing point.

Given under my Hand and the Seal of the State of Victoria aforesaid, at Melbourne, this seventeenth day of June, in the year of our Lord One thousand nine hundred and fifty-two, and in the first year of the reign of Her Majesty Queen Elizabeth II.

(L.S.) DALLAS BROOKS.

By His Excellency's Command,

K. DODGSHUN,
Chief Secretary.

GOD SAVE THE QUEEN!

PUBLIC HOLIDAY.

PROCLAMATION

By His Excellency the Governor of the State of Victoria and its Dependencies in the Commonwealth of Australia, &c., &c., &c.

IN pursuance of the provisions contained in Part III. of the *Public Service Act 1946*, I, the Governor of the State of Victoria, in the Commonwealth of Australia, by and with the advice of the Executive Council of the said State, do by this my Proclamation appoint the day and date hereunder mentioned to be observed as a Public Holiday at the place specified, viz.:—

Public Holiday:—

MONDAY, THE 11TH DAY OF AUGUST, 1952, throughout the Shire of Stawell.

Given under my Hand and the Seal of the State of Victoria aforesaid, at Melbourne, this eleventh day of June, in the year of our Lord One thousand nine hundred and fifty-two, and in the first year of the reign of Her Majesty Queen Elizabeth II.

(L.S.) DALLAS BROOKS.

By His Excellency's Command,
K. DODGSHUN,
Chief Secretary.

GOD SAVE THE QUEEN!

PUBLIC HOLIDAY.

PROCLAMATION

By His Excellency the Governor of the State of Victoria and its Dependencies in the Commonwealth of Australia, &c., &c., &c.

IN pursuance of the provisions contained in Part III. of the *Public Service Act 1946*, I, the Governor of the State of Victoria, in the Commonwealth of Australia, by and with the advice of the Executive Council of the said State, do by this my Proclamation appoint the day and date hereunder mentioned to be observed as a Public Holiday at the places specified, viz.:—

Public Holiday:—

WEDNESDAY, THE 20TH DAY OF AUGUST, 1952, throughout the Underbool and Murrayville Ridings of the Shire of Walpeup.

Given under my Hand and the Seal of the State of Victoria aforesaid, at Melbourne, this seventeenth day of June, in the year of our Lord One thousand nine hundred and fifty-two, and in the first year of the reign of Her Majesty Queen Elizabeth II.

(L.S.) DALLAS BROOKS.

By His Excellency's Command,
K. DODGSHUN,
Chief Secretary.

GOD SAVE THE QUEEN!

BANK HALF-HOLIDAY.

PROCLAMATION

By His Excellency the Governor of the State of Victoria and its Dependencies in the Commonwealth of Australia, &c., &c., &c.

IN pursuance of the provisions of the Banks and Currency Acts, I, the Governor of the State of Victoria, in the Commonwealth of Australia, do by this my Proclamation appoint the day and date named hereunder a special day to be observed as a Bank Half-Holiday at the place mentioned, that is to say:—

Bank Half-Holiday from the Hour of Twelve o'clock noon:—

WEDNESDAY, THE 9TH DAY OF JULY, 1952, at Benalla.

Given under my Hand and the Seal of the State of Victoria aforesaid, at Melbourne, this seventeenth day of June, in the year of our Lord One thousand nine hundred and fifty-two, and in the first year of the reign of Her Majesty Queen Elizabeth II.

(L.S.) DALLAS BROOKS.

By His Excellency's Command,
K. DODGSHUN,
Chief Secretary.

GOD SAVE THE QUEEN!

The Game Acts.

SANCTUARY FOR NATIVE GAME AT BOORCAN, IN THE PARISHES OF MARIDA YALLOCK AND TERANG, COUNTY OF HAMPDEN.

PROCLAMATION

By His Excellency the Governor of the State of Victoria and its Dependencies in the Commonwealth of Australia, &c., &c., &c.

I, THE Governor of the State of Victoria, in the Commonwealth of Australia, by and with the advice of the Executive Council of the said State, and in pursuance of the provisions of the Game Acts and all other powers me enabling in that behalf, do by this my Proclamation direct that the part of Victoria hereinafter described shall be a locality in which from the first day of January to the thirty-first day of December (both days inclusive) in each year, it shall be unlawful for any person to kill or destroy any native game included in the Third Schedule to the *Game Act 1928*.

PART OF VICTORIA ABOVE REFERRED TO.

1,500 acres more or less in the Parishes of Marida Yallock and Terang, County of Hampden, and more particularly described as follows:—Commencing at the north-east angle of the Marida Yallock Pre-emptive Right (section A, Parish of Marida Yallock); thence southerly by the eastern boundary thereof to the northern boundary of section 11A, Parish of Marida Yallock; thence by the northern, eastern, and southern boundaries of section 11A to the south-west angle thereof; thence by an imaginary line bearing westerly across the Mount Emu Creek and the permanent reserves on both banks thereof to the south-east angle of allotment 19 of section XII, Parish of Terang; thence by the southern boundary of such allotment to the south-west angle thereof; thence northerly by the western boundary of allotments 19, 18, 17, 16, and 15 to the north-west angle of the last-mentioned allotment; thence easterly by the northern boundary of such last-mentioned allotment to the south-west angle of allotment 14 of section XII, Parish of Terang; thence northerly and easterly by the western and northern boundaries of the last-mentioned allotment to the western boundary of the permanent reserve on the western bank of the Mount Emu Creek; thence northerly by the western boundary of such reserve to the main Geelong-Warrnambool road; thence by the southern boundary of such road in an easterly direction to the commencing point.

NOTE.—The above description includes sections A and 11A, Parish of Marida Yallock, allotments 14, 15, 16, 17, 18, and 19 of section XII, Parish of Terang, and the portion of Mount Emu Creek and the permanent reserves on either side of such Creek between the southern boundary of the main Geelong-Warrnambool road and a line between the southern boundaries of allotment 19 of section XII, Parish of Terang and section 11A, Parish of Marida Yallock.

Given under my Hand and the Seal of the State of Victoria aforesaid, at Melbourne, this eleventh day of June, in the year of our Lord One thousand nine hundred and fifty-two, and in the first year of the

(L.S.) DALLAS BROOKS.

By His Excellency's Command,
K. DODGSHUN,
Chief Secretary.

GOD SAVE THE QUEEN!

The Fisheries Acts.

NOTICE OF INTENTION TO DEFINE THE MOUTH OF THE TIDAL RIVER AT WILSON'S PROMONTORY AND PROHIBIT NETTING WITHIN A RADIUS OF A QUARTER OF A MILE THEREOF.

IT is hereby notified for general information that it is intended, after the expiration of one month from the date of publication of this notice in the *Government Gazette*, to move His Excellency the Governor in Council to make a Proclamation for the following purposes:—

1. Defining what shall be deemed to be the mouth of the Tidal River as an imaginary line running from the extreme seaward or outward point of either bank or side to the opposite extreme seaward or outward point where the waters of such river enter Norman Bay (near Wilson's Promontory).

2. Prohibiting during the whole of each year the use of trammels, trawls, or other nets or engines, whether fixed or unfixed, to be employed in fishing in the waters of Norman Bay, near Wilson's Promontory, within a quarter of a mile of the mouth of the Tidal River as herein defined.

K. DODGSHUN,
Chief Secretary.

A. DUNBAVIN BUTCHER,
Director of Fisheries and Game.

APPOINTMENTS.

HIS Excellency the Governor of the State of Victoria, by and with the advice of the Executive Council thereof, has, by Orders made on the 11th day of June, 1952, been pleased to make the under-mentioned appointments, viz.:

CHIEF SECRETARY'S DEPARTMENT.

Registrar of Births and Deaths.

JOHN DEAN VANSTON,
pursuant to the provisions of section 4 of the *Registration of Births Deaths and Marriages Act 1928*, to be Registrar of Births and Deaths at Drouin, to date from commencement of duty, with fees, *vice* Aubrey Benedict Leonard, resigned.

LAW DEPARTMENT.

Stipendiary Magistrate.

WILLIAM NORMAN THOMPSON
to be a Stipendiary Magistrate, pursuant to the provisions of the *Justices Act 1928*, a Coroner for the State of Victoria, pursuant to the provisions of the *Coroners Act 1928*, and a Warden of the Goldfields in and for the State of Victoria, pursuant to the provisions of the *Mines Act 1928*, to take effect from the date of commencement of duty.

Magistrates.

ALBERT EDWARD ROBERT HUDSON, 111 Elgin-street, Carlton,
WILLIAM EDWARD FYFE, 10 Flowers-street, Caulfield, and
JOSEPH LAURENCE CALLANAN, Werribee,
to Keep the Peace in the Central Bailiwick of the State of Victoria;
THOMAS BRUCE ELLIS, Ballarat-street, Talbot,
to Keep the Peace in the Midland Bailiwick of the State of Victoria; and
THOMAS GERARD GLEESON, Secretary, Victorian Prices Branch, 143-7 Collins-street, Melbourne,
to Keep the Peace in the Central, Northern, Southern, Eastern, Western, and Midland Bailiwicks of the State of Victoria.

Deputy Coroners.

CLARENCE HEDLEY COLLINS, J.P., Kerang,
to be a Deputy Coroner, pursuant to the provisions of the *Coroners Act 1928*, to act and have jurisdiction for and during the absence of the Coroner at and in the vicinity of Kerang; and
GEORGE ERIC LYLE, J.P., Warracknabeal,
to be a Deputy Coroner, pursuant to the provisions of the *Coroners Act 1928*, to act and have jurisdiction for and during the absence of the Coroner at and in the vicinity of Warracknabeal.

Commissioners for Taking Declarations, &c.

ERIC RICHARD HARVEY EBBS, Administrative Member of the Mental Hygiene Authority, and
HENRY JAMES MARTIN, Secretary to the Mental Hygiene Authority, 300 Queen-street, Melbourne,
to be Commissioners for Taking Declarations and Affidavits, pursuant to the provisions of Division 8 of Part IV. of the *Evidence Act 1928*, to refrain from charging fees and to resign upon ceasing to occupy their present positions;
COLIN FREDERICK MICHELL, 1 Thompson-street, Hamilton,
MARY FLORENCE CLARK, 31 Charles-street, Prahran,
WILLIAM JOHN HOLTON, Shire Offices, Cobden,
KEVIN JEROME LACY, care of The Mutual Life and Citizens Assurance Co. Ltd., cnr. Collins and Elizabeth streets, Melbourne,
FRANCIS JOSEPH BROWN, 9 Ripon-street south, Ballarat,
ALBERT GEORGE EDDY, 22 Peel-street north, Ballarat,
ALBERT JOHN O'TOOLE, 1 Gray-street, Ballarat East,
REGINALD WILLIAM WALSH, 12 Garnett-street, Preston,
ARTHUR WOOD, 30 O'Connor-street, Reservoir,
JOHN HENRY McNAUGHTON, 17 Glen Ebor-avenue, Blackburn,
GEORGE WILLIAM BRADEN, 16 Tyrrell-avenue, Blackburn,
DAVID ARTHUR OULD, 72 Williams-road, Blackburn,
JOHN WILLIAM WOOD, 13 Wolseley-crescent, Blackburn,
WALTER THOMAS BUTLER, 21 Main-street, Blackburn,
SARAH JOSEPHINE STEWART, corner Pakenham and Derby streets, Blackburn,
HENRY GEORGE BAKER, Springvale-road, Nunawading,
ROY HUGH SMITH, Springvale-road, Nunawading,
FRANCES GRACE DIXON, Whitehorse-road, Nunawading,
FREDERICK ALAN NETTLE, 59 Springvale-road, Nunawading,
ERNEST ALBERT CARNE, 13 Gill-street, Reservoir,
THOMAS HERBERT BOWEN, 86 Howard-street, Reservoir,
HECTOR FULFORD WALKER, 1 Albion-street, South Yarra,

JOHN PATRICK O'NEAL, 2 Barry-street, South Yarra,
PATRICK GEORGE THOMPSON, 3 River-street, South Yarra,
RONALD PATRICK LOUREY, 4 Arthur-street, South Yarra,
and

JOHN PATRICK HOOTON, 29 Hardy-street, South Yarra,
to be Commissioners for Taking Declarations and Affidavits, pursuant to the provisions of Division 8 of Part IV. of the *Evidence Act 1928*, to resign upon removing from the neighbourhood of the addresses stated.

Clerks of Children's Court.

GREGORY DANIEL O'SULLIVAN
to be Clerk of the Children's Court at Mildura, Red Cliffs, Robinvale, and Merbein, *vice* W. L. Bell, relieved; and
EWEN LESLIE ROSS
to be also Clerk of the Children's Court at Horsham and Natimuk, during the absence, on annual leave, of R. J. Brown, to take effect from the date of commencement of duty.

Deputy Clerks of the Peace and Registrars of the County Court.

GREGORY DANIEL O'SULLIVAN
to be a Deputy Clerk of the Peace and Registrar of the County Court at Mildura, to be appointed by virtue of section 92 of the *Juries Act 1928*, to do and perform with respect to the Courts at that place in the place and stead of the Sheriff, all such Acts and things as the Sheriff is by the said Act authorized or required to do or perform in the place of W. L. Bell, relieved; and
EWEN LESLIE ROSS
to be a Deputy Clerk of the Peace and Registrar of the County Court at Horsham, to be appointed by virtue of section 92 of the *Juries Act 1928*, to do and perform with respect to the Courts at that place in the place and stead of the Sheriff all such acts and things as the Sheriff is by the said Act authorized or required to do or perform during the annual leave of R. J. Brown, to take effect from the date of commencement of duty.

Bailiff of County Court.

REGINALD HAROLD BENSLEY, Senior Constable of Police, Alexandra,
to be a Bailiff of the County Court at Seymour, *vice* E. Freitag, resigned, with fees, to take effect from the date of commencement of duty.

Sworn Valuators.

WILLIAM EDWIN KIRWAN, care of Soldier Settlement Commission, Public Offices, Melbourne, and
ALAN STEWART MURRAY, 241 King-street, Melbourne,
to be Sworn Valuators, pursuant to the provisions of section 14 of the *Transfer of Land Act 1928*, No. 3791, for the State of Victoria.

Assistant Collector for Interstate Destitute Persons.

LEONARD THOMAS GRIFFIN
to be Assistant Collector for Interstate Destitute Persons, pursuant to section 69 of the *Maintenance Act 1928*, to take effect from the date of commencement of duty.

DEPARTMENT OF HEALTH.

Medical Superintendent (Senior).

JOHN FREDERICK JOSEPH CADE, M.B., B.S., M.D.,
to be Medical Superintendent (Senior), pursuant to the provisions of section 18 (2) of the *Mental Hygiene Authority Act 1950*, (No. 5519), as from the 1st July, 1952, *vice* Dr. J. K. Adey.

MINES DEPARTMENT.

Mining Registrar (Acting).

STEWART JAMES COISH, Senior Constable of Police, to act as Mining Registrar at Beaufort, for the Raglan Division of the Ararat Mining District, *vice* Senior Constable Arnold Brownlie McIntosh, transferred, fees received to be the only remuneration.

DEPARTMENT OF THE TREASURER.

Collector of Imposts.

HENRY FRANCIS O'NEILL
to be Collector of Imposts, Office of the Public Service Board, *vice* G. V. Stafford.

Receiver of Revenue (Acting).

GODFREY THOMAS BROMLEY
to act temporarily as Receiver of Revenue, Railways Department, during the absence of E. H. Bryan, on leave.

A. MAHLSTEDT,

Clerk of the Executive Council,
At the Executive Council Chamber,
Melbourne, 11th June, 1952.

REVOCATION OF APPOINTMENTS.

HIS Excellency the Governor of the State of Victoria, by and with the advice of the Executive Council thereof, has, by Order made on the 11th day of June, 1952, revoked the appointments of the persons named hereunder to the offices mentioned, viz.:—

LAW DEPARTMENT.

BURTON WAITE BOND and STANLEY BIRKETT, as Commissioners for taking Declarations and Affidavits, pursuant to the provisions of the *Evidence Act 1928*.

A. MAHLSTEDT,
Clerk of the Executive Council.

At the Executive Council Chamber,
Melbourne, the 11th June, 1952.

RESIGNATIONS.

HIS Excellency the Governor of the State of Victoria, by and with the advice of the Executive Council thereof, has, by Orders made on the 11th day of June, 1952, accepted the resignations of the persons named hereunder of the offices mentioned, viz.:—

CHIEF SECRETARY'S DEPARTMENT.

HUGH VALENTINE CLUGSTON, as a Licensing Inspector for each and every Licensing District in the State of Victoria, from and inclusive of the 29th May, 1952.

AUBREY BENEDICT LEONARD, as Registrar of Births and Deaths at Drouin.

LAW DEPARTMENT.

FRANCIS THOMAS SUTHERLAND, as a Deputy Coroner at and in the vicinity of Kerang.

ERNEST FREITAG, as a Bailiff of the County Court at Seymour.

A. MAHLSTEDT,
Clerk of the Executive Council,

At the Executive Council Chamber,
Melbourne, 11th June, 1952.

DEPARTMENT OF TRANSPORT.

Melbourne and Metropolitan Tramways Acts.

FIXING TERM OF OFFICE OF, AND APPOINTMENT OF, MEMBERS OF THE MELBOURNE AND METROPOLITAN TRAMWAYS BOARD.

HIS Excellency the Governor of the State of Victoria, by and with the advice of the Executive Council thereof, and in pursuance of the powers conferred by the Melbourne and Metropolitan Tramways Acts, doth, by Order made on the 11th day of June, 1952, fix the term of office of the persons to be appointed Members of the Melbourne and Metropolitan Tramways Board as two years from and inclusive of the first day of July, One thousand nine hundred and fifty-two, and appoint the following persons Members of such Board for the term fixed above:—

JAMES VINCENT O'CONNOR.

WILLIAM KENNEDY PARK.

BURNETT GRAY.

WILLIAM JOHN MCGRATH.

ROBERT HENRY SOLLY.

JOHN JOHNSON.

A. MAHLSTEDT,
Clerk of the Executive Council.

At the Executive Council Chamber,
Melbourne, 11th June, 1952.

Audit Act 1928.

CERTIFICATION OF ACCOUNTS.

HIS Excellency the Governor of the State of Victoria, by and with the advice of the Executive Council thereof, doth, by Order made on the 11th day of June, 1952, pursuant to the provisions of clause 31 of the General Regulations respecting Public Accounts, hereby authorize the Secretary for Mines or the Accountant, Mines Department, to certify accounts for expenditure in connexion with the Coal Mining Industry Long Service Leave Fund.

A. MAHLSTEDT,
Clerk of the Executive Council,

At the Executive Council Chamber,
Melbourne, the 11th June, 1952.

CONSUL.

HIS Excellency the Governor directs the recognition of Mr. Frank Lothar Berger as Honorary Consul of Austria, at Melbourne, with jurisdiction in the States of Victoria, Tasmania, South Australia, and Western Australia.

J. G. B. McDONALD,
Premier.

Premier's Department,
Melbourne, C.2,
13th June, 1952.

CONSUL.

HIS Excellency the Governor directs the recognition of Mr. James D. Crane as Vice-Consul of the United States of America, at Melbourne.

J. G. B. McDONALD,
Premier.

Premier's Department,
Melbourne,
17th June, 1952.

CONSUL.

HIS Excellency the Governor directs the recognition of Don Francisco Xipell as Honorary Vice-Consul of Spain, at Melbourne.

J. G. B. McDONALD,
Premier.

Premier's Department,
Melbourne,
17th June, 1952.

CONSUL.

HIS Excellency the Governor directs the provisional recognition of Mr. Joseph W. Thoman as Consul for the United States of America, at Melbourne.

J. G. B. McDONALD,
Premier.

Premier's Department,
Melbourne,
17th June, 1952.

CONSUL.

HIS Excellency the Governor directs the recognition of Mr. James T. Rush as Vice-Consul of the United States of America, at Melbourne.

J. G. B. McDONALD,
Premier.

Premier's Department,
Melbourne,
17th June, 1952.

CONSUL.

HIS Excellency the Governor directs the recognition of Mr. Russell C. Heater as Vice-Consul of the United States of America, at Melbourne.

J. G. B. McDONALD,
Premier.

Premier's Department,
Melbourne,
17th June, 1952.

DEPARTMENT OF MINES.

SUBJECT to any necessary excisions, &c., it is proposed to grant the following mining lease:—

7293, Mineral; Kenneth James Muirson; 35a. 3r. 9p., Parish of Eumana.

APPLICATION FOR LEASE DECLARED ABANDONED.

7286, Mineral; Arthur Henry Stephens; 160 acres, near Walwa.

TAILINGS LICENCES EXPIRED.

2014, Tailings Licence; Cecil Cooper; 44a. 3r. 18p., Parish of Wollonaby.

2254, Tailings Licence; Ernest Arthur Waller; 7a. 3r., Parish of Smythesdale.

2255, Tailings Licence; Ernest Arthur Waller; Parish of Bungal.

G. C. MOSS,
Minister of Mines,

Local Government Act 1946, Part 48, Section 826.

LICENCES TO OCCUPY UNUSED ROADS.

NOTICE is hereby given that Licences to occupy Unused Roads have been issued to the following approved applicants, and that the Licence Fee specified in each case has been received by the Accountant, Department of Crown Lands and Survey, Melbourne, C.2.

Number of Licence.	Name and Address of Licensee.	Municipality.	Parish.	Abutting— Allotments and Sections.	Area.	Fee for Licence.	Date of Issue of Licence.	Date of Expiry of Licence.
37331	Hocking, M. J., Tandarra ..	East Loddon	Yallock ..	North of 9A, 9B, 10A, 10B, section V	8 0 0	1 11 0	1.1.52	31.12.54
37332	Hocking, K. J., Tandarra ..	East Loddon	Yallock ..	North of 11A, 11B, 12A, 12B, section V	8 0 0	1 11 0	1.1.52	31.12.54
37333	Dean, V. P., Echuca ..	Echuca ..	Echuca ..	Part of Radcliffe-street, 1 of I	0 2 32	0 14 0	1.1.52	31.12.54
37334	Finnigan, P. A., Nagambie	McIvor ..	Cherrington	Between 18 and 23 ..	8 0 0	0 4 0	1.1.52	31.12.54
37335	Dougall, W. J., Daylesford	Glenlyon ..	Holcombe	Between 2E and 3A, section A	1 2 0	0 4 6	1.1.52	31.12.54
37336	Henderson, E., Amherst ..	Talbot ..	Lillicur ..	Between 4E and 4D and half road east of 4E and 4D	2 0 0	0 3 0	1.1.52	31.12.54
37337	Henderson, E., Amherst ..	Talbot ..	Amherst ..	West of 19, 23, 24, section 1	1 2 0	0 5 0	1.1.52	31.12.54
37338	Henderson, E., Amherst ..	Talbot ..	Amherst ..	West of 29 and 29A, section 1	1 0 0	0 2 6	1.1.52	31.12.54
37339	Grady, W. J., Metcalfe ..	Metcalfe ..	Metcalfe ..	East of 4, section 6 ..	4 0 0	1 4 0	1.1.52	31.12.54
37340	Pryse, J. V., Kyneton ..	Kyneton ..	Carlsruhe ..	Part of road north of 16	1 2 0	0 6 9	1.1.52	31.12.54
37341	Chase, A. H., Kyneton ..	Kyneton ..	Carlsruhe ..	Part of road north of 16	4 0 0	0 18 0	1.1.52	31.12.54
37342	McHugh, D. E., Wedderburn	Korong ..	Wedderburne	West of 6B, 6C, section 4A	5 1 0	0 8 9	1.1.52	31.12.54
37343	Medlyn, J. H., St. Arnaud ..	Kara Kara	Carapooee ..	Intersecting 10A of C ..	9 0 0	1 16 0	1.1.52	31.12.54
37344	Drechsler, W. F., Sedgwick	Strathfield-saye	Sedgwick ..	North of 1, section 19 ..	1 1 0	0 12 6	1.1.52	31.12.54
37345	Davies, F., Jarklin ..	East Loddon	Jarklan ..	Eastern half of road, south of 150E	4 1 0	0 10 6	1.1.52	31.12.54
37346	Maxted, J. H., Jarklin ..	East Loddon	Jarklan ..	Western half of road, south of 150E	4 1 0	0 10 9	1.1.52	31.12.54
37347	Wilson G., Sr., Metcalfe ..	Metcalfe ..	Metcalfe ..	North of 6, section 6, east and south-west of 20A, 20B, 27C, east of 23A	12 0 0	3 8 3	1.1.52	31.12.54
37348	Ead, D. J. and K., Amherst	Talbot ..	Amherst ..	West of 4A, 4, 3, and 6, section IV.	4 1 0	0 16 9	1.1.52	31.12.54
37349	Jones, D. C., Kyneton ..	Kyneton ..	Burke ..	East of 6, 7, and part of 10, section 5	6 0 16	0 18 0	1.1.52	31.12.54
37350	Walton, R. J., St. Arnaud	Donald ..	Rich Avon East	North of 1 and part of 2, section XIV.	9 2 0	1 8 6	1.1.52	31.12.54
36571	Jackson, Robert I., Dreeite	Colac ..	Dreeite ..	North of 22A, 22B ..	4 2 0	1 2 6	1.1.49	31.12.51
36572	Moffatt, John, estate ..	Mortlake	Chatsworth	East of 5, west of 3 and 4, north of 4, 5, and 6	14 2 26	..	1.1.49	31.12.51
			Towanway	South of 54A, 54B, 66A, 66B, 65A, 65B, 69B, 81A, 81B, 82 and 83; east of 67B, 82, 83, 84	52 3 3	..	1.1.49	31.12.51
			Chatsworth West	East of 3, section 18; east of 3 and 4, section 17; west of 3A, section 21; south-east of 2, 5, 6, and 7, section 19; south-west of 9, 10, 11, and 12, section 21; south of 1, 2, and 3A, section 21	34 1 13	17 16 0	1.1.49	31.12.51
36573	Vernon, Leslie J., 1525 Sturt-street, Ballarat	Ballaarat ..	Ascot ..	East of 151 and 153 ..	12 0 0	1 4 0	1.1.49	31.12.51
36574	Kirkham, Chas., 4 Barkly-street, Ararat	Ararat ..	Burrunbeep	East of 28A, section 8 ..	2 2 0	0 7 6	1.1.50	31.12.52
36575	Abbott, Eric T., Scarsdale ..	Grenville ..	Scarsdale (town and parish)	R. A. 8411 ..	1 2 0	0 11 6	1.1.49	31.12.51
36576	Collins, Saml. J., Amphitheatre	Avoca ..	Glenlogie ..	South of 9J ..	1 2 31	0 3 0	1.1.49	31.12.51
36577	Moncrieff, W. G., 35 Seymour-street, Terang	Heytesbury	Brucknell ..	Part of road south of 7	3 0 0	0 2 6	1.1.50	31.12.52
3657	Cole, Nicholas, "West Cloven Hills," Camperdown	Hampden ..	Kilnoorat ..	East of 2, section 16; north of part of 2, section 17	16 2 0	2 6 3	1.1.49	31.12.51
36579	Kurweeton Pty. Ltd., Woorndoo	Hampden ..	Pircarra ..	North of 81A, 81B, 82A, 82B, 78A, 78B, 92A, 93A; south of 44B, 45A, 45B, 80A, 80B; east of 80B, 81B	43 2 28	6 11 3	1.1.50	31.12.52
36580	Thompson, A. C., Sebastopol	Sebastopol	Sebastopol (borough)	North of 54, 55, 56, section 10	0 2 6	0 15 0	1.1.49	31.12.51
36581	Yelland, Howard, West Newlyn	Creswick ..	Spring Hill	North of A and 5, section E	1 3 0	0 12 3	1.1.49	31.12.51
36582	Spiers, C. W., estate of, Amphitheatre	Lexton ..	Glenlogie (town and parish)	South-east of 1A, 3A, 4A, 5A; north-east of 9 and 10, section 9	1 0 0	0 6 3	1.1.49	31.12.51
36583	Taylor, H., 901 Urquhart-street, Ballarat	Grenville ..	Smythesdale	Gravel reserve and 8H, section 27	3 0 0	0 4 6	1.1.49	31.12.51
36584	Glasgow, Robert and Ellen, Wangoom	Warrnambool	Garvoc ..	North-east of 69B ..	5 0 0	3 16 6	1.1.50	31.12.52

LICENCES TO OCCUPY UNUSED ROADS—continued.

Number of Licence.	Name and Address of Licensee.	Municipality.	Parish.	Abutting— Allotments and Sections.	Area.		Fee for Licence.	Date of Issue of Licence.	Date of Expiry of Licence.
					A. R. P.	£ s. d.			
36585	Harris, F. A., Sutherland-street, Clunes	Clunes ..	Clunes ..	South of 2 and 2A, section 29	1 1 0	0 10 0	1.1.49	31.12.51	
36586	Barclay, R. G., C. J., and C., Beecac	Colac ..	Turkeith ..	South of 53A, 53B ..	6 1 4	4 11 0	1.1.50	31.12.52	
36587	Walker, Nancy M., Tatyoon North	Ararat ..	Yalla-y-Poora	North of 7A, part of 5A, 7, 8A, 8B, 9A, 9B, 10A, 10B, part of 11A, 1, 2A, part of 3A; east of 2A, 2B, part of 6A, 7A, 7B, 8A, 8B, 3A, 3B, 4B, 2B, 7, 1, 6A, part of 6B; south-west of 7	79 1 9	11 18 0	1.1.50	31.12.52	
36588	Pilkington, F. D., Clarke-street, Cobden	Heytesbury	Jancourt ..	West of part of 112A ..	3 3 0	0 15 0	1.1.49	31.12.51	
36589	Boland, D. and M., Glenormiston North	Hampden ..	Glenormiston	East of 7 and 14, section 5A	2 0 0	1 2 0	1.1.49	31.12.51	
36590	O'Sullivan, Patrick, Glenormiston North	Hampden ..	Glenormiston	East of 4 and 17, section 5A	1 3 24	1 1 0	1.1.49	31.12.51	
36591	Ferrari, J. G., and C. H., Devondale	Otway ..	La Trobe ..	South of 81 and 93 ..	7 0 8	0 7 0	1.1.50	31.12.52	
36592	Hancock, R. E. J., Colac ..	Colac ..	Gerangamete	East of 49C, south and west of water reserve; south of 49C (part)	2 3 3	0 5 6	1.1.49	31.12.51	
36593	Neale, Geo. McK., Garvoc	Warrnambool	Garvoc (town and parish)	North of 6, section 14; north of 14A, 14A2, "L"; east of "F"; south-east of 2 to 6, section 2, 1 and 2, section 3; north-east of 2, section 3	5 3 11	4 0 0	1.1.50	31.12.52	
36594	Bailey, Geo. W., Elmhurst	Ararat ..	Glenpatrick	East of 5, section 13, town of Elmhurst	0 2 20	0 2 6	1.1.50	31.12.52	
36595	Country Roads Board ..	Sebastopol	Sebastopol	North of 9, section 2 ..	0 2 0	0 18 0	1.1.50	31.12.52	
36596	Weatherley, J. M. F., "Ennerdale," Nerrin	Mortlake ..	Eilyer ..	North of 25A, 25B, 47A, 29A, 29B, 20A, 20B; west of 19A, 19B, 20A, 21A, 21B, 22A, 22B, 23A, 23B, 24A, 24B	80 1 30	14 1 6	1.1.50	31.12.52	
			Terrinallum	North of part of 104A, 104B, 105A, 105B; west of 96A					
36597	Cole, Nicholas, Cole, Nicholas, Jr., and Rearing, L. C., "Warra Yadin," Camperdown	Hampden ..	Koort-Koort-Nong	South of "A", section 18; south of 1 to 4, section 19	19 1 1	3 7 6	1.1.50	31.12.52	
36598	Goodear, Albert, Anakie ..	Corio ..	Yowang ..	South of 130, 131, 134	7 3 0	1 14 0	1.1.49	31.12.51	
36599	Seppelt, B., and Sons, Great Western	Stawell ..	Concongella South	East of 6, section 2 ..	2 3 1	0 5 6	1.1.50	31.12.52	
36600	Rinaldi, W. L., Warrenheip	Buninyong	Warrenheip	South of 1 to 5, section 25	2 0 32	1 6 6	1.1.50	31.12.52	
36601	McDonald, M. M., Birregurra	Colac ..	Yeo ..	West of 115 ..	5 2 26	0 11 6	1.1.50	31.12.52	
36602	Little, Douglas F., Terang	Heytesbury	Ecklin ..	East of 1A, section 9 (north end)	9 0 0	2 14 0	1.1.50	31.12.52	
36603	Murch, Edgar J., Terang ..	Heytesbury	Ecklin ..	East of 1B and part of 1A, section 9	15 0 0	4 10 0	1.1.50	31.12.52	
36604	Ireland, Alfred E., Timboon	Heytesbury	Timboon ..	North-west of 80C ..	0 1 0	0 2 6	1.1.49	31.12.51	
36605	Western District Pastoral Co., 360 Collins-street, Melbourne	Ararat ..	Parrie Yallock	North of "A", section 3, 1A, 2A, 2B, section 4, 1A, section 5, "A," section 16, "A," section 16, "A," section 17, "A," section 18, "A," section 19, 1A, 1B, 2A, section 20; south of "B," section 28, "B," section 29, "B," section 30, 1A, 1B, section 27; west of 2B, section 14, "A" and "B", section 16, "A," section 31, "A" and "B", sections 13 to 17 and 30, "A," section 34, 1A, 1B, sections 4 and 11, "A" and "B", sections 19 to 28 and 36; east of 2A, 2B, sections 21, 26, 38	240 3 20	26 8 0	1.1.50	31.12.52	
			Watgania ..	North of 109, 116, 117, 118, 118A; west of 68, 108, 108A, 118, 119, 185; east of 184A, 184B					
36606	Ball, J. W., Little River ..	Corio ..	Wurdi Youang	South of 13, section 5 ..	6 1 0	1 17 6	1.1.50	31.12.52	
36607	Williams, Robt. G., Colac ..	Colac ..	Yeo ..	West of 54, 54Az, 55A, 50A, 57A	4 2 0	1 7 0	1.1.50	31.12.52	
36608	Crawford, N. D., Grenville	Leigh ..	Law-a-luk ..	South of 63 ..	9 0 0	2 0 0	1.1.50	31.12.52	

LICENCES TO OCCUPY UNUSED ROADS—continued.

Number of Licence.	Name and Address of Licensee.	Municipality.	Parish.	Abutting— Allotments and Sections.	Area.		Date of Issue of Licence.	Date of Expiry of Licence.
					A. R. P.	£ s. d.		
36609	Whyte, Wm. F. and K. F., Stawell	Ararat ..	Wickliffe South	North and south of B9; east and south of B7	11 3 0	1 3 6	1.1.50	31.12.52
36610	Paton, Ewan D., Ballangeich	Mortlake ..	Ballangeich	North of 96A ..	4 1 30	1 2 3	1.1.50	31.12.52
36611	Spruce, B. B., "Kia Ora," Yendon	Buninyong	Buninyong	South of 10 to 13, section 3	3 2 0	0 12 3	1.1.50	31.12.52
36612	Atkinson, Jr., W. H., Ballan- geich North	Mortlake ..	Ballangeich	North of part of 56 ..	4 1 0	1 7 0	1.1.50	31.12.52
36613	Daffy, M. T. and D. F., Beac	Colac ..	Cundare ..	North of 53A, 54B ..	11 0 0	3 17 0	1.1.50	31.12.52
36614	Shearer, Jas., Warrenheip ..	Buninyong	Warrenheip (town)	North-west of section 17; south-west of sections 17 and 18	2 2 20	1 19 6	1.1.50	31.12.52
36615	McCann, Ernest W., "Dryden," Fyansford, and Staughton, S. T., estate of, Melbourne	South Bar- won	Barrabool	South of 1, 2, 3, and 11; north of 3	4 2 15	1 11 0	1.1.50	31.12.52
36616	Stephens, R. (Mrs.), Avoca- road, Ararat	Ararat ..	Ararat ..	North of 456, 456D ..	1 0 0	0 2 6	1.1.50	31.12.52
36617	Whelan, W. J., Colac ..	Otway ..	Yaughar ..	South of 70, section A	1 2 33	0 2 6	1.1.50	31.12.52
36618	Ringin, Walter H., Linton ..	Grenville ..	Mannibadar	North of 119r and 119w	3 3 36	0 13 0	1.1.50	31.12.52
36619	Baker, L. G., Elmhurst ..	Ararat ..	Glenpatrick (town of Elmhurst)	East of 2, section 17; north of 1, 2, 6, 7, 9, section 17	2 2 0	0 11 0	1.1.50	31.12.52
36620	Carey, Wm., Italian Gully ..	Grenville ..	Clarksdale	North of 26A; east of 26x	1 0 0	0 4 0	1.1.50	31.12.52
36621	van Every, A. T., Mortlake	Mortlake ..	Ligar ..	South of 72, 73B, 74B, 75B	11 0 0	1 13 0	1.1.50	31.12.52
36622	Bronton, A. R. and P. M., Dereel	Loigh ..	Dereel	5 3 30	2 4 0	1.1.50	31.12.52
36623	Toulmin, J. A., Gnotuk ..	Hampden ..	Corangamite	North of 57 and 58 ..	7 3 24	1 0 0	1.1.50	31.12.52
36624	Curran, N. B., Mount Cole Creek	Ararat ..	Eversley ..	South of B7 ..	2 2 30	0 9 0	1.1.50	31.12.52
36625	United Felt Hats Pty. Ltd., Melbourne	Ballan ..	Ballan (town and parish)	South of part of 49D ..	0 2 27	0 2 6	1.1.50	31.12.52
36626	Coffey, M. (Miss), Illabarook	Grenville ..	Mindai ..	South of 15 and 15B ..	1 2 29	0 8 9	1.1.50	31.12.52
36627	Selwyn-Scott, F. C., Scots- burn	Buninyong	Clarendon	East of 35D, 35E, 35S ..	11 0 25	1 2 6	1.1.50	31.12.52
36628	Scarff, T. J., 31 Rodier- street, Ballarat	Buninyong	Warrenheip	West of 30 and 32, sec- tion 18	3 0 0	0 16 6	1.1.50	31.12.52
36629	Nolan, Daniel F., Berringa	Grenville ..	Dereel ..	East of 14c, 14E ..	0 2 10	0 3 0	1.1.50	31.12.52
36630	Harbour, R. C. and M. J., 1210 Howitt-street, Ballarat	Lexton ..	Lexton ..	North of part of 5B, section B	3 1 0	0 5 0	1.1.50	31.12.52
36631	Oman, N. T., Streatham ..	Ararat ..	Streatham (town and parish)	North of 65, section A	0 3 20	0 7 0	1.1.50	31.12.52
36632	Buchanan, Wm., Yendon	Buninyong	Buninyong	North of 1, 4, 6, 7A, section 18	4 0 17	1 11 0	1.1.50	31.12.52
36633	Cowley, D. D., Scott's Creek	Heytesbury	Timboon ..	South of 63H ..	0 1 25	0 2 6	1.1.50	31.12.52
36634	Adams, M. E. (Mrs.), 9 Grano-street, Ararat	Ararat ..	Ararat ..	10 and 11, section 38 ..	1 0 0	0 4 0	1.1.50	31.12.52
36635	Galvin, J. H., 342 Koornang- road, Carnegie	Worribee ..	Mambourin	West of 8, 9, 10, section 4	10 0 0	2 0 0	1.1.50	31.12.52
36636	Lowe, Robt. H., Dundonnell	Mortlake ..	Terrinallum	East of 100A, 107B ..	8 0 0	1 8 8	1.1.50	31.12.52
36637	Murnane, Ronald, Glenormis- ton North	Hampden ..	Glenormis- ton Wooriwyrite	East of 7 and 8, section 4	8 3 36	3 12 9	1.1.50	31.12.52
36638	O'Dell, J. E., 219 Eureka- street, Ballarat East	Ballaarat ..	Ballaarat (city)	West of 40A .. West of part of 17, sec- tion 205	0 1 2	0 5 0	1.1.50	31.12.52
36639	McCallum, Rokewood Junction	Loigh ..	Commerral- ghip	West of H30, J30 ..	2 2 6	0 11 6	1.1.50	31.12.52
36640	Jamieson, Robt. (Connabar Trust)	Mortlake ..	Eilyar ..	South of 101B, 82A, 82B, 59A, 49B; north of 78A, 78B, 79A, 112, 113, 114, 118, 119; east of 82B, 100B, 101A, 101B, 105A, 105B, 106A, 106BA, 106BB, 11, 112, 115	72 2 22	12 14 0	1.1.50	31.12.52
36641	Johnson, H. N., Balliang East	Worribee ..	Mouyong ..	North of 116, 117 ..	24 2 1	4 18 0	1.1.50	31.12.52
36642	Bell, J. A. Jnr., Camperdown	Heytesbury	Jancourt ..	North of part of 116A ..	3 0 20	0 2 6	1.1.50	31.12.52
36643	Bell, G. C., Camperdown ..	Heytesbury	Jancourt ..	North of part 116A, 118B	6 2 4	0 3 0	1.1.50	31.12.52
36644	Forster, P. E., Ararat ..	Ararat ..	Burrumbeep	East of 2A, 2B, 4B, sec- tion 14; east of 3D, section 17	11 1 30	3 9 0	1.1.50	31.12.52
36645	Apted, H., Lismore ..	Hampden ..	Lismore (town and parish)	East of 24, section 2 ..	1 0 0	0 10 0	1.1.50	31.12.52
36646	Moore, John E., 96 Spring- street, Regent	Otway ..	Wongarra	East of lot 1 in C.A.2 Wye River Sub- division	0 1 1	0 5 0	1.1.50	31.12.52
36647	Bryant, A. C., Sussex-street, Linton	Grenville ..	Argyle ..	North of 1, section 16 ..	0 1 20	0 3 0	1.1.50	31.12.52
36648	Dean, Wm., and Sons, Mere- dith	Bannock- burn	Bamganie	North of 28H, 28J, A12, A14; south of 28N, A22, 28c, 28H, 28J, 28° of 28P; east of 28B, 28J, 28P; west of 28, 28A, 28°, A12, A13	35 1 21	3 11 0	1.1.50	31.12.52

LICENCES TO OCCUPY UNUSED ROADS—continued.

Number of Licence.	Name and Address of Licensee.	Municipality.	Parish.	Abutting— Allotments and Sections.	Area.	Fee for Licence.	Date of Issue of Licence.	Date of Expiry of Licence.
					A. R. P.	£ s. d.		
36649	Convent of Mercy, Ballarat East	Ballaarat ..	Ballaarat (city)	West of 9, 10, 11, part of 17, section 205	1 3 30	1 18 9	1.1.50	31.12.52
36650	McCarthy, L. J., Maroona ..	Ararat ..	Tatyoan ..	West of 26 ..	2 0 0	0 6 0	1.1.50	31.12.52
36861	McKenzie, H. P., estate of, Trawalla	Ripon ..	Trawalla ..	East of 2 of A1, 3 section A1	12 1 8	3 14 0	1.1.50	31.12.52
36862	Troy, Patk. F., Gordon ..	Ballan ..	Moorarbool West	East, west and south of 3d, section 5	9 0 0	1 2 6	1.1.50	31.12.52
36863	Gleisner, F., and Sons, Amherst	Talbot ..	Lillicur ..	North-west of 8 and 9, section 1	9 0 30	1 7 6	1.1.50	31.12.52
36864	Gellert, C. F., Willaura ..	Ararat ..	Willaura ..	East of 51A ..	3 3 32	1 3 6	1.1.50	31.12.52
36865	Myers, Sidney, Langi Logan	Ararat ..	Langi Logan	North of 40A ..	3 3 34	0 12 0	1.1.50	31.12.52
36866	McDowall, Wm., "Endfield," Camperdown	Hampden ..	Corangamite	North of 59 and 60 ..	9 3 17	1 4 6	1.1.50	31.12.52
36867	Neven, Alex. T., "Rocky Hill," Werrona	Newstead, Mt. Alexander	Campbell-town	South of 48A ..	1 0 0	0 3 0	1.1.50	31.12.52
36868	Hutchings, Collin J., Raglan	Ripon ..	Raglan ..	South of 10B, section A	6 3 35	1 1 0	1.1.51	31.12.53
36869	Ballarat Girl Guides, 1610 Sturt-street, Ballarat	Creswick ..	Creswick (town and parish)	West of 1 to 6, section 86	1 0 0	0 5 0	1.1.50	31.12.52
36870	Vaughan, M., Swan Marsh ..	Colac ..	Pirron Yaloak	South-east and north end of 3	1 0 0	1 10 0	1.1.50	31.12.52
36871	Cowley, Donald D., Cowley's Creek	Heytesbury	Timboon ..	East of 66A; south of 65A	3 0 0	0 7 0	1.1.50	31.12.52
36872	le Couteur, Edgar J., Cowley's Creek	Heytesbury	Timboon ..	East of part of 66A, part of 65c	6 0 0	0 9 0	1.1.49	31.12.51
36873	Alsop, Cecil, Bambra ..	Winchelsea	Yan Yan Gurt	South of 31c ..	0 1 7	0 2 6	1.1.51	31.12.53
36874	Davey, Jas. M., Miner's Rest	Ballaarat ..	Miner's Rest (town), Dowling Forest	West of 55 and 56, section D	3 1 0	0 15 0	1.1.51	31.12.53
36875	Cotter, I. P., "Rockgrove," Darlington	Mortlake ..	Darlington West	South of 35A, 35B, 35C; east of 35C, and 36 South of 32A, 32B, 33A, 33B, 34A, 34B, 46A, 46B, 47A, 47B; east of 21B, 34B, 37B, 39B, 46B, 48B, 57A, 57B	81 1 12	12 3 0	1.1.50	31.12.52
36876	Borbidge, Jas. L., Mortlake	Mortlake ..	Darlington West	East of 23A, 23B, 24A, 24B, 32B	11 0 0	1 13 0	1.1.50	31.12.52
36877	Higgins, J. W., Stavely ..	Ararat ..	Wickliffe North	North-west of 1A and 6, section 11	14 2 25	4 15 0	1.1.50	31.12.52
36878	Bryant, Walter G., Mt. Fyans, Camperdown	Mortlake ..	Nerrin Nerrin	East of 106B, 107B, 108B; south of 106A, 106B	22 0 21	4 9 0	1.1.50	31.12.52
36879	Bryant, Richard G., Mt. Fyans, Camperdown	Mortlake ..	Nerrin Nerrin Kornong ..	East of 103B, 104B, 105B East of 115A, 116B, 117B, 118B, 119B, 120B; south of 114CB, 115A, 115B, 118A, 118B	47 2 32	9 11 0	1.1.50	31.12.52
36880	Durston, I. R. (Mrs.), Mt. Fyans, Camperdown	Mortlake ..	Nerrin Nerrin Kornong ..	East of 122B; south of 102B South of 122A, 122B; east of 121B, 122B	23 3 16	4 15 0	1.1.50	31.12.52
36881	Pickford, Chas. A., Clunes	Talbot ..	Clunes ..	South of part of 13B, section 5	1 2 0	0 7 6	1.1.50	31.12.52
36882	Loneragan, Lotitia, Cororooke	Colac ..	Eliminyt ..	East of 7 and 8, section "E"	0 3 8	1 12 0	1.1.50	31.12.52
36883	King, Richard W., "Bowmont," Tatyoan	Ararat ..	Helendoite	East of 19A, 19B ..	7 3 24	1 2 0	1.1.50	31.12.52
36884	Calvert, N. M. and J. Y., "Kornong," Nerrin Nerrin	Mortlake ..	Kornong ..	East of 111B, 114CA, 114CB; south of 111A, part of 111B; north-east of 113, 111B	22 0 5	4 8 0	1.1.50	31.12.52
36885	Rahles-Rahbula, H., "Yera," Camperdown	Hampden ..	Corangamite	North of 3, section 31	13 0 1	2 2 0	1.1.50	31.12.52
36886	Spittle, Wm. G., "Yamba," Rowsley	Ballan ..	Bungoeltap	North of 6A, section 4	2 3 0	0 7 6	1.1.50	31.12.52
36887	Brien, Albert G., Whoorel	Winchelsea	Murroon ..	East of part of 42B ..	2 0 0	0 5 0	1.1.50	31.12.52
36888	Non-issue							
36889	Millear, W. H., "Youranalee," Willaura	Ararat ..	Willaura Mellior ..	North of 61A North and south of 3A, 3B, 4A, 4B, section 24; west of 1A, 4A, section 23; west of 1A, 4A, section 26	24 1 10	8 0 0	1.1.50	31.12.52
36890	Keith, C. E., "Pretty Tower," Beaufort	Ripon ..	Wongan ..	East of 1A, 1B1, section 11	3 1 18	0 10 6	1.1.47	31.12.49
36891	Melbourne and Metropolitan Board of Works	Werribee ..	Cocoroc ..	South of 2 and 3, section 15	8 0 0	2 16 0	1.1.50	31.12.52
36892	McLeod, A. R., estate of, Miniera	Ararat ..	Mellier ..	North of 1B, section 19	1 1 34	0 9 0	1.1.51	31.12.53
36893	Fraser, C. W. and D. J., Streatham	Ripon ..	Wongan ..	South of 5A, 5B, 6B, 6C, section 14	9 0 24	1 10 6	1.1.49	31.12.51

LICENCES TO OCCUPY UNUSED ROADS—continued.

Number of Licence.	Name and Address of Licensee.	Municipality.	Parish.	Abutting— Allotments and Sections.	Area.	Fee for Licence.	Date of Issue of Licence.	Date of Expiry of Licence.
					A. R. P.	£ s. d.		
36894	Ramsay, Urquhart, Estate of, Birregurra	Colac ..	Turkeith ..	East of 4, 5, 6, 7, 15B to 22B	41 0 0	7 9 6	1.1.50	31.12.52
		Winchelsea	Warrac-barumah	East of 123A, 123B, 131				
36895	Fenton, Allan G., Ballangeich	Warrnambool	Cooramook	East of 62A, 62B, 65B	7 1 0	2 0 0	1.1.51	31.12.53
			Framlingham West	South of 4				
36896	Spittle, W. G., Bacchus Marsh	Ballan ..	Bungeeltap	West of 4, section 4 ..	4 2 0	0 18 0	1.1.51	31.12.53
36897	Tevelein, Stanley, Jas., Yeodene	Colac ..	Barongarook	South of 10, parish of Elliminyt	6 0 0	0 12 0	1.1.51	31.12.53
36898	Tudor, Leo M., Gordon ..	Ballan ..	Moorarbool West	East of 1A6, section 5	1 0 0	0 2 6	1.1.51	31.12.53
36899	Manifold and Richardson, Estate of	Hampden ..	Kariah ..	North of part of 1, section 16; 1 section 14	1 3 0	0 7 0	1.1.51	31.12.53
37561	Preston, Murray W., Glenpatrick	Lexton ..	Glenpatrick	South-west of 26, section 5; north and east of 24; east, south, and west of School Reserve	6 0 0	0 11 3	1.1.51	31.12.53
37562	Lindquist, Ida M., Scott's Creek	Heytesbury	Timboon ..	South of 79c; south and east of 79A	9 0 0	0 9 0	1.1.51	31.12.53
37563	McErvale, John, Chute ..	Lexton ..	Langi Kal	West of 25, section D	6 3 10	1 3 9	1.1.51	31.12.53
37564	Hannett, Ernest, Rocky Point, Ararat	Ararat ..	Ararat ..	South-west of 9, section 53; south of 8 to 15, section 78	2 0 0	1 12 6	1.1.51	31.12.53
37565	Trotter, A. W., Stoiglitz ..	Bannockburn	Durdidwarrah	North-east, south-east, and north-west of 68A	3 2 33	0 3 9	1.1.51	31.12.53
37566	Perpetual Executors and Trustees Association of Australia, 100 Queenstreet, Melbourne	Hampden ..	Kariah ..	South of 3, section 33, 2 and 3, section 34; south of 2, section 30, 2, section 29; east of 3, section 34; west of section 15	38 2 0	7 14 0	1.1.51	31.12.53
37567	Coad, I. G., Moyston ..	Ararat ..	Moyston ..	North-east of 30A; east of 31A	2 0 0	0 6 0	1.1.51	31.12.53
37568	Coxall, H. L. B., Cressy ..	Leigh ..	Kuruc-a-ruc	North of 1, 121; east of 121, 122, 123; through 120A	15 0 0	4 11 0	1.1.51	31.12.53
37569	Owen, David H., 22 Queenstreet, Ararat	Ararat ..	Ararat ..	East of 20, section 19	1 0 22	0 7 0	1.1.51	31.12.53
37570	Matthews, J., Mount Beckworth	Talbot ..	Clunes ..	West of A4 and A5, south of A1, A2, A3, A4; west end of road (Parish of Clunes); and north of 123 (Parish of Glendaruel)	8 2 16	1 6 6	1.1.51	31.12.53
37571	Fenton, Nancy, Ballangeich	Warrnambool	Cooramook	East of 60A, 60B, 61A, 61B	10 3 0	3 0 0	1.1.51	31.12.53
37572	O'Keefe, M. I., Elliminyt ..	Colac ..	Elliminyt ..	South part of 24 ..	2 0 23	2 4 0	1.1.51	31.12.53
37573	Stevenson, John G., Lethbridge	Bannockburn	Wabdallah	South-west of section B	1 2 0	0 7 6	1.1.51	31.12.53
37574	Crothers, M., "Armagh," Woodford	Warrnambool	Wangoom ..	South of 2, section K ..	4 0 0	1 11 6	1.1.51	31.12.53
37575	Heinz Bros. Pty. Ltd., Ballarat	Bungaree ..	Ballaarat ..	North of 3 and 5, section L	4 0 0	1 12 0	1.1.51	31.12.53
37576	Doery, C. and W., Streatham	Ripon ..	Carramalluc North	North of 1A, section 24; north of 1A, 4A, section 23; south of 3B, section 23; east of 1A, 1B, section 23; east of 1A, 1B, 2A, 2B, section 24	28 0 0	4 4 0	1.1.51	31.12.53
37577	Page, G. L., 108 Websterstreet, Ballarat	Bungaree ..	Ballaarat ..	West of 8A, 8B, 8C, section M	4 0 0	1 8 0	1.1.51	31.12.53
37578	Griffin, J., 6 Woodstreet, Ballarat North	Bungaree ..	Ballaarat ..	West of 13E, section M	2 0 0	0 6 0	1.1.51	31.12.53
37579	Eason, C. W., Buninyong	Buninyong	Buninyong	North of 8 and 10, section 4, Foreststreet	0 1 32	0 9 0	1.1.51	31.12.53
37580	Paatsch, J. B., Elliminyt ..	Colac ..	Elliminyt ..	South part of 24 ..	2 0 33	2 4 0	1.1.51	31.12.53
37581	Arnold, A. R., Dereel ..	Leigh ..	Dereel ..	West of A50A, Warrambine	1 1 0	0 2 6	1.1.51	31.12.53
37582	McGlone, Mary, 54 Maudstreet, North Balwyn	Mortlake ..	Ballangeich	East of "E" ..	5 1 30	1 7 0	1.1.51	31.12.53
37583	Thorburn, J. R., Hexham ..	Mortlake ..	Hexham East	East of 14 ..	1 2 25	0 8 6	1.1.51	31.12.53
37584	Hartwich, Alwin, Buangor ..	Ararat ..	Ballyrogan	West of 87A ² ..	4 0 0	0 12 0	1.1.51	31.12.53
37585	Austin, R. A., "Myuna," Mortlake	Mortlake ..	Eilyar ..	North of 87A, 87B, 91 ..	7 3 24	1 8 0	1.1.51	31.12.53
37586	Lawson, W. C., Gellibrand	Otway ..	Moorbanool	East of 35c; south of 35c	5 1 10	0 5 6	1.1.51	31.12.53
37587	McFarlane, E. R., 143 Cornishstreet, Castlemaine	Ballan ..	Moorarbool	South of 14 ..	3 2 0	0 2 6	1.1.51	31.12.53
37588	Permezel, P. Y., Tanybryn	Otway ..	Wongarra	South of 16H ..	2 2 10	0 5 0	1.1.51	31.12.53
37589	Amiet Bros, Murgheboluc ..	Bannockburn	Murgheboluc	East of part of "D", section 2	2 3 4	0 15 9	1.1.50	31.12.52
37590	Cumming, H. D., Jellalabad, Darlington	Mortlake ..	Darlington	East of 15 and 20, south of 15, section 12	11 1 17	2 5 0	1.1.51	31.12.53

LICENCES TO OCCUPY UNUSED ROADS—*continued.*

Number of Licence.	Name and Address of Licensee.	Municipality.	Parish.	Abutting— Allotments and Sections.	Area.		Date of Issue of Licence.	Date of Expiry of Licence.
					A. R. P.	£ s. d.		
37591	Gass, M. and J., Naroghid ..	Hampden ..	Marida	North of 49, section 16	1 3 24	0 7 6	1.1.51	31.12.53
37592	Brennan, P. J., Langi Logan	Ararat ..	Yallock	West of 7A, 7B ..	8 0 0	3 0 0	1.1.51	31.12.53
37593	Hill, G. P., Camperdown ..	Hampden ..	Marida	North of 44; west of 44, 45, section 17	6 3 14	1 14 0	1.1.51	31.12.53
37594	Hull, R. G., Dunach ..	Talbot ..	Yallock	West of 20B (3 chains wide)	6 0 7	3 0 0	1.1.51	31.12.53
37595	Corcoran, D., Ballan ..	Ballan ..	Moorarbool	North of 43 (west end)	1 0 0	0 2 6	1.1.51	31.12.53
37596	Commonwealth of Australia, Department of the Interior	Werribee ..	Mambourin	South of 1 and part of 2, section 22	4 0 0	2 5 0	1.1.51	31.12.53
			Bulban ..	East of part of 38, part 59, 39, 58; south of part of 57, 58	14 0 0			
37597	Membrey, A. W., Dundonnell	Mortlake ..	Terrinallum	West of part of 95 (Mount Violet Estate)	4 0 0	1 12 0	1.1.51	31.12.53
37598	Parks, J. J., Ballarat ..	Leigh ..	Dereel ..	South of A78 ² , B14 and A21	17 3 0	1 6 0	1.1.51	31.12.53
			Warrambine	South of A27, A28; west of A28, A29, A34				
37599	Whitten, J., Armstrongs ..	Stawell ..	Ararat ..	South-east of 34 and 5; south-west of 5, section 15A	3 0 0	0 3 0	1.1.51	31.12.53
37600	Bradley, R. M., Lexton ..	Lexton ..	Carahulup ..	South of 117 ..	5 3 18	0 17 6	1.1.51	31.12.53
37601	Allen, E. E., Drysdale ..	Bellarine ..	Bellarine ..	East of 3A, section 13 ..	1 0 6	0 5 0	1.1.51	31.12.53
37602	Whitworth, R., Swan Marsh	Colac ..	Irrewillipe ..	South of 86B ..	3 0 0	1 10 0	1.1.51	31.12.53
37603	Sharp, J. Page, Newtown, Geelong	Bannockburn	Yowang ..	East of 145; south of 147, 150, 151, 154, 155	17 0 32	3 16 0	1.1.50	31.12.52
37604	Bossence, A. W., Ryrrie-street, Geelong	Bannockburn	Lara ..	Through 34 ..	2 2 0	0 11 0	1.1.50	31.12.52
37605	Clarke, J., Geelong West ..	Corio ..	Lara ..	North of 38 ..	11 1 4	2 9 6	1.1.50	31.12.52
37606	Jolly, S. and W., Royce, Anakie	Corio ..	Yowang ..	West of 163, 164 ..	7 1 39	1 13 0	1.1.50	31.12.52
37607	Jolly, W. F., Anakie ..	Corio ..	Yowang ..	West of 155, 156 ..	7 1 39	1 13 0	1.1.50	31.12.52
37608	Walker, R., Geelong ..	Corio ..	Yowang ..	West of 80, 81; south of 101, 102	14 2 30	3 5 0	1.1.50	31.12.52
37609	Walters, E. N., Swan Marsh	Colac ..	Irrewillipe ..	South of 85 ..	5 0 0	2 10 0	1.1.51	31.12.53
37610	Erwin, J. O'H., Bannockburn	Bannockburn	Murghe- Boluc	North of 2, 3, section 20	3 0 0	0 15 0	1.1.51	31.12.53
37611	Gillett, R. A., "Jalna," Geelong	Corio ..	Yowang ..	West of 98, 99; east of 146, 90, 91; south of 93, 94, 97, 98, 99, 135, 138, 139, 142, 143, 146	52 2 32	11 12 0	1.1.50	31.12.52
37612	Whytcross, K. R., Anakie ..	Corio ..	Anakie ..	East of 2 ..	6 3 22	1 11 0	1.1.49	31.12.51
37613	Coomets, Pty. Ltd., 368 Collins-street, Melbourne	Mortlake ..	Caramut ..	North of 3, 4, section 6; east of 4, section 6	82 3 24	15 2 6	1.1.50	31.12.52
		Warnam- bool	Quamby ..	North of 3A, 3B, section 2; south of 3A, 3B, 4B, section 2; east of 2B, 3B, part of 4A, 6B, 8B, section 2				
			Quamby North	West of 5B, part of 5A, section 13				
			Yeth Youang	North of 4A, 5A, section 1; south of 7B, 8B, section 1, 9A, section 2; east of 3A, 6A, 6B, 7A, 7B, section 1				
37614	Drayton, G. P., Anakie ..	Corio ..	Durrid- warrah	East of F2, F3, F6, F10	8 3 39	1 18 6	1.1.50	31.12.52
37615	Vincent, W. L. R., Ararat	Ararat ..	Ararat ..	East of 7 of 23 ..	0 1 12	0 3 6	1.1.51	31.12.53
37616	Walton, W., Windermere ..	Ballaarat ..	Dowling Forest	South of 10, section 1 ..	3 2 0	2 2 0	1.1.51	31.12.53
37617	Wills, R. J., Scarsdale ..	Grenville ..	Scarsdale ..	Portion of Forbes and O'Connor streets, adjoining R.A. No. 8411	1 2 0	0 9 0	1.1.52	31.12.54
37618	Metherall, R. H., Belmont, Geelong	Corio ..	Anakie ..	South of 1 ..	5 0 18	1 2 0	1.1.50	31.12.52
37619	Jackson, J. R., Linton ..	Grenville ..	Argyle (township of Linton)	York-street, abutting 1 to 8 section 17 Morton-street, abutting 1 of 17	1 3 8	0 10 0	1.1.51	31.12.53
37620	Gardner, J. C., Beech Forest	Otway ..	Weeaprounah	North of 10A ..	7 0 15	0 10 0	1.1.51	31.12.53
37621	Marshall, N. S., "Mashobra," Camperdown	Hampden ..	Taaraak ..	South of 80, 81, 82 ..	11 3 16	3 0 0	1.1.52	31.12.54
37622	Manifold, J., and Sons, Cam- perdown	Hampden ..	Koort-Koort- Nong	East of 3, section 28 ..	4 0 0	1 0 0	1.1.51	31.12.53
37623	Knight, M. R. and E., Maude	Corio ..	Darriwil ..	South of B and D, section 16	10 1 5	2 5 0	1.1.50	31.12.52
37624	Bliss, L. J., Clunes ..	Talbot ..	Eglinton ..	South of 10A, 10B, section 7A	5 1 20	0 16 0	1.1.52	31.12.54
37625	Hardbattle, M. S. (Mrs.), Irewarra	Colac ..	Irewarra ..	East of 1 to 9, section 2	2 3 15	1 9 0	1.1.51	31.12.53
37626	Tucker, C., "Eldorado," Anakie	Corio ..	Yowang ..	South of 168 ..	7 0 32	1 12 0	1.1.50	31.12.52
37627	Hewitt, T. W., Moyston ..	Ararat ..	Kalymna ..	West of 6A, 6B; north of 6AA ²	7 3 24	0 16 0	1.1.52	31.12.54
37628	Maher, J. M., Inverleigh ..	Bannockburn	Doroq ..	West of 113, 116, 121, 124	3 3 8	3 0 0	1.1.52	31.12.54

LICENCES TO OCCUPY UNUSED ROADS—continued.

Number of Licence.	Name and Address of Licensee.	Municipality.	Parish.	Abutting— Allotments and Sections.	Area.		Fee for Licence.		Date of Issue of Licence.	Date of Expiry of Licence.
					A. R. P.	£ s. d.				
37629	Jackson, L. H., Moyston ..	Ararat ..	Moyston ..	West of 190k ..	3 2 30	0 8 0	1.1.52	31.12.54		
37630	Anderson, D. and J. G., Portarlington	Bellarine ..	Paywit ..	West of 39, section 1 ..	8 0 0	1 4 0	1.1.52	31.12.54		
37631	Hutchins, K., Colac ..	Colac ..	Barongarook	North of 6A ..	3 2 16	1 16 0	1.1.52	31.12.54		
37632	Hamilton, W. R., Ararat ..	Ararat ..	Moyston ..	North of 16A, 17A, 18A; west of 16A	8 2 33	0 4 6	1.1.52	31.12.54		
37633	Panther, E. J., Ararat ..	Ararat ..	Ararat ..	Triangular area opposite allotment 6, section 93 (town of Ararat)	0 1 0	0 5 0	1.1.52	31.12.54		
37634	Kuehne, A. W. and C. R., Horsham	Ararat ..	Concongella South	East of G6; north of G5, section 3	11 1 32	0 12 0	1.1.52	31.12.54		
37635	Kuehne, E. A., Horsham ..	Ararat ..	Concongella South	East of 13; south of 12, section 3	14 0 32	0 14 0	1.1.52	31.12.54		
37636	Fleming, J., "Marybank," Gronville	Buninyong	Enfield ..	East of 72 and 74 ..	3 3 4	0 10 0	1.1.52	31.12.54		
37637	de Crespigny, Dr. F. C., Ingor-street, Ararat	Ararat ..	Ararat ..	South-east of 21, section 14	1 2 28	0 9 0	1.1.52	31.12.54		
37638	Evans, R. H., Beacac ..	Colac ..	Ondit ..	East of 83A ..	1 0 0	0 12 0	1.1.52	31.12.54		
37639	Whitehead, W. R. (Mrs.), Framlingham	Mortlake ..	Framlingham East	South of 63, part 64 ..	2 2 0	0 7 6	1.1.52	31.12.54		
37640	Forrest, W. and C. L., Mortlake	Mortlake ..	Towanway	North of 92A, 92B, 93A, 93B; south of 102A, 102B, 103A, 103B; west of 92A, 103A	23 2 0	2 18 9	1.1.52	31.12.54		

A. E. LIND,
Commissioner of Crown Lands and Survey.

Department of Crown Lands and Survey,
Melbourne, 4th June, 1952.

AUCTION SALES ACT 1928.

LIST of Persons to whom Auctioneer's Licences have been issued during the month of May, 1952, and prior months.

Name.	Address.	Date of Issue.
Byrne, R. S.	196 Mitchell-street, Bendigo	1.1.52
Carroll, J.	Manangatang	8.5.52
Cohen, S.	67 Beimore-road, North Balwyn	1.5.52
*Cottle, R. M.	7 Buckland-avenue, Geelong	13.5.52
Currie, A. W.	282 Whitehorse-road, Balwyn	1.5.52
Ellison, W. S.	14 Chelsea-street, Middle Brighton	7.5.52
†Evans, E. F.	Euroa	2.5.52
Hanks, A. E.	515 Main-street, Mordialloc	2.5.52
Hastings, John	49 Elizabeth-street, Newtown, Geelong	9.5.52
Hewitt, W. F.	35 Sutherland-avenue, North Kew	13.5.52
Johnston, V. J.	6 Stott-street, Croxton	26.5.52
Mackinnon, E. D.	47 Lucas-street, Brighton	20.5.52
Mackinnon, N. I.	18 Marion-street, North Brighton	20.5.52
‡Norton, E. A.	High-street, Shepparton	26.5.52
Pascoe, G.	69 Denmark-street, Kew	26.5.52

* By transfer from E. M. Miles. † By transfer from D. C. B. Mitchell. ‡ By transfer from W. O. Shiels.

The Treasury,
Melbourne, 12th June, 1952.

A. T. SMITHERS,
Director of Finance.

MONEY LENDERS ACT 1938.

IN accordance with the provisions of the above-mentioned Act, the following is published for general information:—

Supplementary List of Persons to whom Money Lenders' Licences have been issued for the year ending 30th June, 1952.

Name.	Authorized Name.	Authorized Address.	Date of Issue.
Western Acceptance Proprietary Limited (A. M. Westhoven, appointee)	Western Acceptance Proprietary Limited	317 Toorak-road, South Yarra ..	23.5.52

The Treasury,
Melbourne, 12th June, 1952.

R. E. STAFFORD,
Registrar.

REAL ESTATE AGENTS' ACTS.

In accordance with the provisions of the above-mentioned Acts, the following is published for general information:—

(a) List of Real Estate Agents' Licences issued during the month of May, 1952, and prior months.

Name.	Principal Place of Business (Registered Office).	Name of Firm or Partnership.	Date from which Licence is Effective.
Brain, R. W.	Phillips-street, Boulah	22.5.52
Brownbill, H. L.	Paynesville	5.5.52
Carlin, A. E.	Flat 8, 650 Malvern-road, East Prahran	6.5.52
Cavanagh, C. S.	10 South-terrace, Clifton Hill	15.5.52
Clayton, L. P.	72 Bridport-street, Albert Park	Payne and Clayton	2.5.52
Colquhoun, L. J.	High-street, Wodonga	L. J. Colquhoun and Co.	22.5.52
Cowan, G. H.	340 Collins-street, Melbourne	J. W. Styles and Co.	6.5.52
Facey, K. F.	254 Lonsdale-street, Dandenong	Frank Facey	27.5.52
Fischer, R. K.	61 Main-street, Blackburn	Main Estate Agency	22.5.52
Geelong and Cressy Trading Co. Ltd., The (J. Baddeley, nominee)	Cr. Yarra and Malop streets, Geelong	29.5.52
Harvie, G. W.	85 Kollett-street, Northcote	23.5.52
Hay, A.	70 Kenmare-street, Box Hill	1.5.52
Hickson, J. P.	4 Nicholson-street, South Yarra	7.5.52
Jewell, C. F.	2 Clifton-street, Box Hill	Jewell's Estate Agency	6.5.52
Keen, A. S.	Pyramid Hill	27.5.52
Kim, H. C.	30 Lilley-street, Altona	13.5.52
McDougall, W. K.	15 Charlotte-place, St. Kilda	Astor Estate Agency	15.5.52
Marlan, R. F.	Alpine-street, Ferntree Gully	Whelan and Jones	12.5.52
*Moon, N. K.	Bairnsdale	29.4.52
Netto, A.	823 Nepean-highway, East Brighton	18.4.52
Pullen, W. H. T.	12 Smith-street, Collingwood	Denton and Co.	1.1.52
Sheean, G. T.	127 Glenroy-road, Glenroy	7.5.52
Sprague, G. M.	33 Huntley-road, Bentleigh	S. Sprague and Co.	27.5.52
Treweek, R. L.	92 Latrobe-street, Mentone	14.5.52
Warlimont, C. B.	Parer-street, Morningson	28.5.52
Westwood, C. J.	Yeodene	21.5.52
Winfield, Lewis, Estates Pty. Ltd. (J. L. Weir, nominee)	330 Flinders-lane, Melbourne	14.5.52
Younger, A. D.	8 Fairfield-grove, Caulfield	15.5.52

* By transfer from C. H. Perrett.

(b) List of Real Estate Sub-Agents' Licences issued during the month of May, 1952, and prior months.

Name.	Registered Address.	Date from which Licence is Effective.	Name.	Registered Address.	Date from which Licence is Effective.
Alexander, T. S.	105 Collins-street, Thornbury	13.5.52	McVicar, R. A.	Lot 40, Grant-crescent, Ringwood	6.5.52
Buckland, J. E.	51 Rose-street, McKinnon	8.5.52	Malcolm, R. B.	3 Julia-street, Portland	9.5.52
Burnett, M.	Beach-road, Torquay	6.5.52	Mason, P. F.	38 Gardenia-road, Gardenvale	22.4.52
Burnham, J. C.	218 Darebin-road, Northcote	2.5.52	Maxwell, W. A. H.	11 Stonington-place, Toorak	9.5.52
Chass, J.	220 Canterbury-road, St. Kilda	2.5.52	Meado, W. T.	Port Campbell	15.5.52
Clark, S. W.	22 Sussex-street, Brighton	18.4.52	Murphy, A. R.	Dumossa-avenue, Lower Templestowe	6.5.52
Daly, M. P.	108 Bruce-street, Preston	5.5.52	Nadenbousch, H. J.	24 Pinnock-street, Bairnsdale	29.4.52
Davies, G. T.	47 Linda-street, Coburg	29.5.52	O'Brien, M. T.	Mountain-road, Cockatoo	12.5.52
Donald, K. G.	62 Coorigal-road, Carnegie	2.5.52	Paizes, B. L.	48A Mathoura-road, Toorak	6.5.52
Emmett, H. V.	Central-road, Nunawading	27.5.52	Phelan, J.	113 Coulstook-street, Warrnambool	12.5.52
Ewart, G. M.	Flat 2, 97 Camberwell-road, Camberwell	8.5.52	Pitard, M.	23A Lynch-street, Footscray	26.5.52
Fiedler, H. A.	Lockington	9.5.52	Pitts, M. L.	Queen-street, Rochester	9.5.52
Flack, A. K.	Mackay-street, Rochester	9.5.52	Powell, J. W.	18 Beauchamp-street, Preston	21.5.52
Garner, N. M.	20 Cross-street, Elsternwick	16.5.52	Price, M. C.	221 Union-road, Surrey Hills	5.5.52
George, B. S.	Flat 3, Caversham Court, Esplanade, Morningson	21.5.52	Resch, G.	Boronia-road, Wantirna	27.5.52
Gillman, D. L.	Indigo, via Chiltern	19.5.52	Riley, V. V.	130 Elgin-street, Carlton	16.5.52
Graham, J. C.	Elmore	9.5.52	Ryan, M. C.	27 Banole-avenue, East Prahran	20.5.52
Hamilton, E. A.	608 Glenhuntly-road, Caulfield	16.5.52	Shaddock, N. R.	56 May-street, North Fitzroy	22.5.52
Harfield, G. M.	Natimuk	15.5.52	Shearwood, H. G.	7 Maypark-avenue, Ashburton	29.5.52
Haughton, E.	72 Mount-street, Heideiberg	6.5.52	Slevin, F. V.	High-street, Yea	1.5.52
Imbesi, N.	"San Souci," Melbourne-road, Lilydale	20.5.52	Smith, A. H.	225 Waterdale-road, Ivanhoe	13.5.52
Kearney, G. B.	High-street, Ngambie	8.5.52	Smith, R. D.	Michie-street, Elmore	9.5.52
Kennedy, A. J.	21 Box Hill-crescent, Box Hill	1.5.52	Sommerville, K. S.	18 Rose-street, Bentleigh	8.5.52
Long, A. H.	Lake Charm	27.5.52	Stainer, P. F. M.	6 Capon-street, Oakleigh	12.5.52
Lynch, A. A.	Mackay-street, Rochester	9.5.52	Stavelly, J. A.	Tarwin Lower	9.5.52
McCarthy, D. E.	Koroit-street, Warrnambool	5.5.52	Stewart, D. McC.	Dookie	3.4.52
Macfarlane, C. R.	22 Malsbury-street, Auburn	26.5.52	Sullivan, G. C.	Timboon	15.5.52
McGregor, D. M.	48 Lucknow-street, Ascot Vale	7.5.52	White, S. McL.	2 Overton-road, Frankston	16.5.52
McLauchlan, J. C.	Princes-street, Warrnambool	5.5.52	Williams, R. J.	Springvale-road, Tally Ho	16.5.52
McMeeken, H. N.	Rochester	9.5.52	Young, C. H.	206 North-road, East Oakleigh	12.5.52

BUSINESS AGENTS ACT 1930.

IN accordance with the provisions of the above-mentioned Act, the following is published for general information:—

(a) List of Business Agents' Licences issued during the month of May, 1952, and prior months.

Name.	Principal Place of Business (Registered Office).	Name of Firm or Partnership.	Date from which Licence is Effective.
Brownbill, H. L.	Paynesville		5.5.52
Carlin, A. E.	Flat 8, 650 Malvern-road, East Prahran		6.5.52
Cavanagh, C. S.	10 South-terrace, Clifton Hill		15.5.52
Clayton, L. P.	72 Bridport-street, Albert Park	Payne and Clayton	2.5.52
Cowan, G. H.	340 Collins-street, Melbourne	J. W. Styles and Co.	6.5.52
Ditchburn, A.	733 Rathdown-street, North Carlton	David Corbet and Sons	15.5.52
Facey, K. F.	254 Lonsdale-street, Dandenong	Frank Facey	27.5.52
Harvie, G. W.	85 Kellett-street, Northcote		23.5.52
Hay, A.	70 Kenmare-street, Box Hill		1.5.52
Hickson, J. P.	4 Nicholson-street, South Yarra		7.5.52
Jewell, C. F.	Whitehorse-road, Ringwood	Jewell's Estate Agency	6.5.52
Johnston, W.	358 Centre-road, Bentleigh	W. and L. T. Johnston	18.4.52
Lee, B. M.	595 Whitehorse-road, Surrey Hills	J. Harold Lee	1.5.52
Marlan, R. F.	Alpine-street, Lower Ferntree Gully	Whelan and Jones	12.5.52
Meallin, L. A.	4 Paisley-street, Footscray	Geo. R. Meallin and Son	26.5.52
Page, H. F.	Boronia-road, Boronia	Page's Estate Agency	26.5.52
Pullen, N. T.	971 Nepean-highway, Moorabbin	J. G. Wilson and N. T. Pullen	18.4.52
Sheean, G. T.	127 Glenroy-road, Glenroy		7.5.52
Sprague, G. M.	33 Huntley-road, Bentleigh	S. Sprague and Co.	27.5.52
Thistlethwaite, H. A.	228 Dorcas-street, South Melbourne	Thistlethwaite and Co.	13.5.52
Thistlethwaite, R. G.	228 Dorcas-street, South Melbourne	Thistlethwaite and Co.	13.5.52
Treweek, R. L.	92 Latrobe-street, Mentone		14.5.52
Warlinton, C. B.	Parer-street, Mornington		28.5.52
Winfield Lewis Estates Pty. Ltd. (J. L. Weir, nominee)	330 Flinders-lane, Melbourne		14.5.52

(b) List of Business Sub-Agents' Licences issued during the month of May, 1952, and prior months.

Name.	Registered Address.	Date from which Licence is Effective.	Name.	Registered Address.	Date from which Licence is Effective.
Chass, J.	229 Canterbury-road, St. Kilda	2.5.52	Nadenbousch, H. J.	296 Main-street, Bairnsdale	29.4.52
Donald, K. G.	62 Coorigal-road, Carnegie	2.5.52	Pitts, M. L.	Queen-street, Rochester	9.5.52
Harfield, G. M.	Natimuk	15.5.52	Somerville, K. S.	18 Rose-street, Bentleigh	8.5.52
Lynch, A. A.	Rochester	9.5.52	Turner, J. E.	2 Rushall-crescent, Clifton Hill	6.5.52
McMeeken, H. N.	P.B., Rochester	9.5.52	Williams, R. J.	Springvale-road, Tally Ho	16.5.52
Malcolm, R. B.	3 Julia-street, Portland	9.5.52			

The Treasury,
Melbourne, 12th June, 1952.

R. E. STAFFORD,
Registrar.

Hawkers and Pedlers Act 1928.

LAW DEPARTMENT—ATTORNEY-GENERAL.

HAWKERS' AND PEDLERS' LICENCES—DAY APPOINTED.

HIS Excellency the Governor of the State of Victoria, by and with the advice of the Executive Council thereof, has by Order made on the 11th day of June, 1952, pursuant to the provisions of section 6 of the *Hawkers and Pedlers Act 1928*, in lieu of the days heretofore appointed, appointed the day and hour set forth in the third column of the Schedule below for holding general meetings of Justices for the special purpose of taking into consideration applications for hawkers' and pedlers' licences at the Court named in the first column of such Schedule in the Police District indicated, to take effect as from and inclusive of the date shown.

SCHEDULE.

Court.	Police District.	Day Appointed.	Date of Commencement.
Warragul	Gippsland	Every Tuesday at 10.30 a.m.	1st July, 1952.

A. MAHLSTEDT,
Clerk of the Executive Council.

At the Executive Council Chamber,
Melbourne, the 11th June, 1952.

SUMMONING OFFICERS.

I HEREBY appoint the under-mentioned persons, under section 31 of the *Education Act 1928*, to summon parents within the State of Victoria:—

Senior Constable STEWART JAMES COISH, No. 9041.
WILLIAM KEVIN RITCHIE.

IVAN A. SWINBURNE,
Minister for the time being acting for or on behalf of the Minister of Education.

COMPANIES ACT 1938.

NOTICE is hereby given that in pursuance of section 350 (4) (d) of the *Companies Act 1938* the names of the companies referred to below have been struck off the Register, and on publication of this notice in the *Government Gazette* the said companies shall cease to be registered as companies to which Division 12 Part One of the said Act applies.

Dated the 13th day of June, 1952.

J. E. QUINLIVAN,
Deputy Registrar-General.

Registrar-General's Office,
Melbourne.

Name of Company.	Date of Registration.	Number of Registration.
Devonshire Sands (Bendigo) Limited	5.1.34	F1699
Nippon Menkwa Kabushiki Kaisha (Japan Cotton Trading Company Limited)	8.10.37	F1863
Willis Barrett and Duncan Limited	11.2.38	F1881
Gannon-Dunkerley (Australia) Pty. Limited	9.5.47	F2188

CONTRACTS ACCEPTED.—(Series 1951-52.)

VICTORIAN RAILWAYS.

154. Manufacture, supply, erection, and putting into service of one turbo-alternator and accessories, at rates (Contract 55443).—Australian General Electric Pty. Ltd. 155. Supply, delivery, and installation of fire alarm system at Tottenham, for £2,160 3s. 7d. (Contract 58968).—Thompson, Campbell Ltd. 156. Supply, delivery, and installation of fire alarm system at East Melbourne, for £527 14s. 6d. (Contract 59181).—Thompson, Campbell Ltd. 157. Trimming leather, at rates (Contract 59395).—Howe and Co. Pty. Ltd.

CORRIGENDA.

Serials 128, 129, and 130, *Gazette* 400, of 21st May, 1952, should be J. Morgan.

By order of the Victorian Railways Commissioners,

N. QUAIL, Secretary. 13.6.52.

PUBLIC WORKS.

4640. Melbourne, Public Works Department, (1) supply of "Fordigraph" machine, £109.—Fordigraph (Vic.) Pty. Ltd.
4641. South Melbourne, Storeyard, (1) supply of flooring, £479 19s. 6d.—Wm. Cook Pty. Ltd.
4642. Alexandra, Higher Elementary School No. 912, (1) supply and fix hat and coat hooks, wardrobes, and display boards, £240.—F. J. Pulling.
4543. Melbourne, Police Depot, (1) new wastes, drains, tiles, &c., £116 19s. 6d.—A. Crewther and Son.
4644. Gresswell, Sanatorium, (1) relaying of rubber flooring, £198.—Clark Matting and Rubber Ltd.
4645. Shepparton North, State School No. 4657, (1) supply of 400 cubic yards of filling, £130.—Maskell and Gribben.
4646. Port Melbourne, Public Works Department Depot, (1) supply of 98 cubic yards of metal, £155 19s. 8d.—Willis Quarries.
4647. Queenscliff, Public Works Department Depot, Queenscliff, (1) supply of hardwood, £183 13s. 5d.—N. Gordon.
4648. Melbourne, Olympic Park, (1) supply of aluminium sheet ridging and nails, £169 17s. 8d.—Gunnerson Allen Metals Pty. Ltd.
4649. Werribee, Research Farm, (1) supply of screenings, £121 14s. 6d.—Albion Quarrying Co. Pty. Ltd.
4650. Apollo Bay, Breakwater, (1) supply of gelnignite and monograin, £864 16s. 6d.—McMicking and Co.
4651. Stawell, High School (Teacher's Residence), (1) electrical installation, £112 15s.—A. J. Paulet.
4652. Port Melbourne, Public Works Department Depot, (1) supply of 223 "Oil King" heaters, £3,052 0s. 6d.—J. S. Nettleford and Sons Pty. Ltd.
4653. Ballarat, Girls' School, (1) supply and installation of four new gas cookers, £340 10s.—Ballarat Gas. Co.
4654. Ballarat, Mental Hospital, (6) supply of 24 tubular steel chairs, £106 4s.—O.H.C. Products Pty. Ltd.
4655. Sunbury, Mental Hospital, (1) supply of 190 yards of curtain material, £100 2s. 6d.—A. E. Hoad and Co.
4656. Warrnambool, Inspector of Works Residence, (1) supply and fixing roof tiles, £130.—Miller and Welsh.
4657. Sunbury, Mental Hospital, (1) supply of 60 bedspreads, £537.—C. Mott.
4658. Port Melbourne, Public Works Department Depot, (1) supply of hardwood, £445 14s.—Permewan Wright Ltd.
4659. Auburn South, State School No. 4183, (2) provision of external stairway, £725.—Haxton, Teffer and Co.
4660. Bayswater, State School No. 4152, (2) new tanks and stands, &c., to residence, £200.—F. G. Reid.
4661. Bruthen, Police Station, (2) renovations, repairs, and painting, £1,097.—A. Cadman.
4662. Beechworth, Mental Hospital, (1) supply and installation of exhaust ventilation system in Staff kitchen, £606.—Ross's Pty. Ltd.
4663. Carrum Downs, State School No. 3613, residence, (3) electrical installation, £125 17s. 6d.—G. L. Webster.
4664. Caulfield South, State School No. 4315, (2) painting and renovations, also new wash-hand basin, caretaker's residence, £180.—A. McKissock.
4665. Coburg East, State School No. 4260, Army Hut, (1) ventilation, £128.—L. W. Friezer.
4666. Coburg, State School No. 484, (1) repairs to plaster walls in various sections of the main school, £260.—L. W. Friezer.
4667. Castlemaine, Technical College, (4) supply and delivery and installation of hot cathode fluorescent fittings, £1,219.—Glamorlights Pty. Ltd.
4668. Clifton Creek, State School No. 3684, (1) internal and external repairs and painting, £346.—A. Cadman.
4669. Club Terrace, State School No. 3343, (1) repairs, painting, and fencing, £607.—A. Cadman.
4670. Coomboona, State School No. 3093, (1) provision and erection of shelter shed, £440.—C. C. Brereton.
4671. Footscray, State School No. 253, Geelong-road, (1) renew spouting to main school and repair downpipes, £229.—G. F. Smithwick.
4672. Grovedale, State School No. 283, (2) new partition and repairs, £737.—E. A. Rookes.
4673. Kew East, State School No. 3161, (5) provision of additional out-offices for girls, £650.—J. P. and F. Kelly.
4674. Mornington, Police Station residence, (4) electrical installation, £201 15s.—G. L. Webster.
4675. Mont Albert, State School No. 3943, (7) repairs and internal painting, £1,342.—J. and P. Oldman.
4676. Mitre, State School No. 2498, (1) erection of residence (labour only), £855.—J. H. McClure.
4677. Mont Park, Mental Hospital, (1) new brick residence and site works for Medical Officer, £6,154 10s.—H. W. Willis.
4678. Mont Park, Gresswell Sanatorium, (2) electrical installation in two identical residences (for Medical Officer and Secretary), £398 15s.—G. L. Webster.
4679. Melbourne, Parliament House, (3) re-decoration of corridor to Refreshment Rooms, £593.—L. W. Friezer.
4680. Melbourne, Technical College, (1) general renovations to pavilion class-room on roof, £468.—L. W. Friezer.
4681. Melbourne, Forests Commission of Victoria, 188 King-street, (2), £270 15s.—J. and K. Simpson.
4682. Royal Park, Mental Hospital, Female Convalescent Ward, (7) internal repairs and painting, £984.—A. H. Philip.
4683. Thornton, State School No. 1371, (3) repairs, new wood shed, new out-offices, internal and external painting, £1,009 5s.—W. E. Searle.
4684. Toorak, Teachers' College, (2) supply and fix five (5) new drinking troughs, £102 14s.—A. F. McDermott.
4685. Templestowe, State School No. 1395, (2) provision of new out-offices and woodshed, £925.—Wood Bros. Construction.
4686. Vermont, State School No. 1022, (1) internal repairs and painting, renewal of non-party fencing, £797.—A. Cadman.
4687. Wangaratta, Public Offices, (1) electrical installation, £1,256 6s. 9d.—A. Webster.
4688. Wangaratta, Supreme Court Room, Public Offices, (1) supply and installation of exhaust ventilation, £960 11s.—Ross's Pty. Ltd.
4689. Warragul, High School, (1) provision of new water service, £542 10s.—Handley and Sons.
4690. Watchem, State School No. 3224, (2) repairs, painting, new fencing, &c., residence, £386 11s.—W. Nolan.
4691. Yering, State School No. 1034, (2) provision of new out-offices and woodshed, £562.—Wood Bros. Construction.
4692. Northcote, State School No. 1401, (1) urgent attention to belfry, &c., £135 18s. 6d.—G. F. Smithwick.
4693. Nathalia, State School No. 2060, (1) new floor in Science Room, £187.—C. C. Brereton.
4694. Upwey, State School No. 4530, (1) supply of gravel, £460.—R. T. Sims.
4695. Royal Park, Camp Pell roads, (1) supply of crushed rock, £360 10s.—Albion Quarrying Co. Pty. Ltd.
4696. Port Albert, Harbor Works, (1) supply of timber, £157 10s. 11d.—Mount Alfred Timber Mills.
4697. Various Lakes Entrance and St. Kilda, (1) Harbor Works, £280 6s. 9d.—Mount Alfred Timber Mills.
4698. Melbourne, Parliament House, (1) electrical wiring, £398 18s. 6d.—R. G. Harris Pty. Ltd.
4699. Larundel, Mental Hospital, (3) removal of pine trees, £125.—A. A. Reed.
4700. Heidelberg, Metropolitan Fire Brigade, (1) supply and installation of gas stoves, gas coppers, and piping to two residences, £168 18s.—Gas and Fuel Corporation of Victoria.
4701. Melbourne, Public Library, (1) cleaning dome skylights, £218 15s.—Melbourne General Cleaning Co.
4702. Ballarat, Mental Hospital, (1) overhaul hot-water service, £190 13s. 6d.—McLean and Boakes.
4703. Mont Park, Mental Hospital, (1) overhaul of boiler feed pump, £100 7s. 2d.—H. Perks and Co. Pty. Ltd.
4704. Mont Park, Mental Hospital, (2) supply of two (2) invalid wheel chairs, £125.—Denyers Pty. Ltd.
4705. South Melbourne, Public Works Department Storeyard, (1) supply of plumbers' materials, £360 16s.—John McIlwraith Pty. Ltd.
4706. French Island, Reformatory Prison, (2) supply, cut, and drill 1/16-in. galvanized M.S. plate, £170 5s.—Johns Construction Co.
4707. Port Melbourne, Public Works Department Depot, (1) supply of five 30-cwt. rollers, £5,135.—Victorian Industrial Sales and Service Pty. Ltd.
4708. Sunbury, Mental Hospital, electrical installation to hydro-extractor and tumbler machines, &c., £146 16s.—J. P. Wallish.
4709. Port Melbourne, Public Works Department Depot, (1) supply of hardwood scantlings, £138 6s.—Permewan Wright Ltd.

4710. Port Melbourne, Public Works Department Depot, (1) supply of screenings, £160 3s. 8d.—Willis Quarries.
4711. Various, Altona, Stony Point, Public Works Department, (1) supply of sawn hardwood, £145 1s. 8d.—K. F. Gordon.
4712. Royal Park, Children's Welfare Department, (1) supply of 36 3-ft. mattresses (hair), £307 16s.—Penal and Gaols, Pentridge.
4713. Port Melbourne, Public Works Department, Store-yard, (1) provision of 200 garbage bins, £212 10s.—A. G. Way and Co. Pty. Ltd.
4714. Bendigo, Flora Hill School for Deaf Children, rubber flooring, £540 4s. 1d.—Dunlop Flooring Pty. Ltd.; sanding floors, supply and lay linoleum, £105 10s.—Flor-Lyfe; supply desks and chairs, £130 8s.—D. F. Cowan.
4715. Strathmerton, State School No. 2790, (1) removal and re-erection of State School Yielima to Strathmerton, £150.—G. L. Ross.
4716. Coburg, Wirenetting Factory, Pentridge Gaol, (1) supply of 150 bobbin spindles, £240.—S. A. Whitbourn.
4717. Ararat, Mental Hospital, (4) supply of boiler feed tank, £105 10s.—H. W. Creek and Sons.
4718. Kew, Mental Hospital, (1) completion of additional engineers' workshops, £198 10s.—F. H. Jarman.
4719. Highett, State School No. 4677, (1) clearing and levelling site, £344 17s. 6d.—Overseas Corp. (Aust.) Ltd.
4720. Williamstown, *Matthew Flinders*, (1) supply of bunker coal, £616 15s. 11d.—Melbourne Steamship Co. Ltd.
4721. Silvan South, State School No. 4259, (1) erection of new timber residence (labour only), £980.—A. E. Mitchell.
4722. Kew, Mental Hospital, (1) purchase of second-hand piano, £159.—C. C. Colson.
4723. South Melbourne, Public Works Department, Store-yard, (1) supply of timber, £138 6s. 9d.—R. W. Hall and Bloom Pty. Ltd.
4724. Altona, State School No. 3923, (3) new toilet block, £1,960.—G. Wood and Son.
4725. Bentleigh West, State School No. 4318, (4) enclosing verandah and balcony, &c., £345.—P. V. Bourke.
4726. Bylands, State School No. 1105, (3) repairs and painting, residence and out-office, £198 10s.—W. and D. Pitts and Son.
4727. Broadmeadows, State School No. 982, (3) erection of a new timber residence, £2,910.—P. T. Dawes.
4728. Corryong, State School No. 1309, (1) supplying and fixing of base battens, &c., £145 10s.—W. D. Pitts and Son.
4729. Cheltenham, State School No. 84, (1) erection of Bristol aluminium two-classroom school building, £2,102.—Overseas Corporation (Aust.) Ltd.
4730. Drouin, State School No. 1924, (1) erection and completion of a Bristol prefabricated class-room, section 3, £10,169.—Overseas Corporation (Aust.) Ltd.
4731. Eltham, State School No. 209, (1) erection and completion of Bristol aluminium school building on timber structure, &c., section 4, £2,142.—Overseas Corporation (Aust.) Ltd.
4732. Frankston, State School No. 1464, (3) provision of blackboards, display boards, and cupboards under, £237.—F. T. Pulling.
4733. Gardenvale, State School No. 3897, (5) provision of additional out-offices, £1,444.—J. P. and F. Kelly.
4734. Geelong, *Matthew Flinders Girls' School*, (1) erection of an additional class-room, £1,559.—Overseas Corporation (Aust.) Ltd.
4735. Heatherton, Sanatorium, (1) radio installation outlets, £390.—Telephone Construction and Maintenance Co.
4736. Kilmore, Police Station Buildings, (1) roof and sewerage plumbing, as per specification and quote, £352 15s.—W. J. Bugg.
4737. Kew, Mental Hospital, (2) supply and installation of boiler house auxiliaries in new boiler house, £6,332 18s. 6d.—C. H. Hohne.
4738. Koo-Wee-Rup, State School No. 2629, (1) supply and installation of mechanical services in new school and Army hut, £3,211 6s.—R. C. McKirdy.
4739. Kew, Mental Hospital, (1) installation of six (6) wash-hand basins, hot and cold water, £175 16s.—W. D. Swingler.
4740. Mont Park, Mental Hospital, (1) painting office of Medical Officer, £126 10s.—F. Free.
4741. Mont Park, Mental Hospital, (1) plaster repairs, South-east Block, £108.—J. Viney Construction Co.
4742. Mont Park, Mental Hospital, (2) extension to kitchen in Recreation Hall, £2,100.—Lockhart and Sons.
4743. Melbourne, Technical College, (2) supply and installation of fluorescent equipment, £218 8s.—Sun Electric Co. Pty. Ltd.
4744. Melbourne, Parliament House, (4) external office and portico, £578.—F. T. Pulling.
4745. Oakleigh, State School No. 1601, (2) repairs and painting, £2,220.—C. M. Wilson and Co.
4746. Preston, Technical School, (3) steel windows to corridors above lockers, £985.—W. M. Hosie.

No. 501.—5757/52.—2

4747. Preston West, State School No. 3885, (1) new switchboard and power points, £174.—F. G. Philbrick.
4748. Sunbury, Mental Hospital, (5) provision of flywire screens and enclosing verandahs, £1,221 10s.—W. L. Allan and G. Rainbow.
4749. Sandringham East, State School No. 4429, (4) provision of boys' new out-offices, £1,710.—J. L. Dare.
4750. South Melbourne, Technical School, (2) alterations to Engineering Shop, £1,220.—F. T. Pulling.
4751. South Melbourne, Dental Centre, City-road, (4) repairs and painting, £745.—R. B. Hallett.
4752. St. Albans, State School No. 2996, (1) supply and erection of combined out-offices and woodshed, £1,680.—H. L. Wood.
4753. Tallarook, State School No. 1488, (1) electrical installation, residence, £125 5s.—Wilkie Electrical Co.
4754. Woomelang, State School No. 3373, (2) provision of new out-offices and woodshed, £1,064.—J. Keleher.
4755. Werribee, Research Farm, (1) re-blocking, repairs, and painting to residence, £984.—J. W. Wood.
- A. E. LIND, for Commissioner of Public Works. 12.6.52.

ORDERS IN COUNCIL.—(Series 1951-52.)

EDUCATION DEPARTMENT.

4633. One only 3½-h.p. Diesel tank cooled engine, for Castlemaine Technical School, £172, less 20 per cent.—Ronaldson Bros. and Tippett Limited.
4634. One only vacuum tube voltmeter, £58 14s., and one only stroboscope, £68, for Maryborough Technical School, £126 14s.—Phillips Electrical Industries of Aust. Ltd.
4635. One only alternator set, 6 kVA 3-phase, 400 volts, 50 cycles, for Wangaratta Technical School, £193.—Bingle Machinery Company.
4636. One only 3½-h.p. Diesel engine, for Wangaratta Technical School, £138.—Ronaldson Brothers and Tippett Limited.
4637. One only 4-h.p. two-stroke Diesel engine, for Wangaratta Technical School, £132 10s.—Mordiesel Company Limited.
4638. One only Hercus Model C. lathe, with attachments, for Wangaratta Technical School.—£171 11s. 3d.—McPhersons Limited.
4639. One only E.M.F. Type TAD.1 portable pilot arc welder, complete with accessories, for Wangaratta Technical School, £155 10s. 6d., less 10 per cent.—E.M.F. Electric Company Pty. Ltd.

Approved by the Governor in Council, 11th June, 1952.—
A. MAHLSTEDT, Clerk of the Executive Council.

STATE ELECTRICITY COMMISSION.

4756. The excavation in Briquette Factory, Open Cut, and other areas, Morwell Project, to Specification No. 50-51/299, at Schedule rates.—J. S. Gilmore Pty. Ltd.
4757. The supply of 723 feet of rubber-covered coal conveyor belting, Yallourn Open Cut, to Quotation No. 4847, £5,271 17s. 6d.—Hopkins, Odlum Pty. Ltd.
4758. The removal and disposal of ashes from solid fuels, Newport Power Station, for a period of six months, to Quotation No. 4768, at Schedule rates.—J. B. Roberts.

Approved by the Governor in Council, 3rd June, 1952.—
A. MAHLSTEDT, Clerk of the Executive Council.

4 GEORGE VI. No. 4755, SECTION 6.

I HEREBY give notice that on the 4th June, 1952, I filed elections to administer the following deceased persons' estates, in accordance with section 6 of the *Public Trustee Act 1940*:—

- LEWICKE, WLADYSLAW, late of 12 Boyd-street, Burnley, munitions worker, died 28th September, 1951, intestate.
- MITCHELL, EDWARD JONES, late of Lambourn-road, Watsonia, brick maker, died 29th February, 1952, intestate.
- MCCLEAN, ROBERT JAMES, late of "Burrumbidgee" Estate, Maroona, labourer, died 21st February, 1951, intestate.
- WROTCHEFORD, SAMUEL BEARDMORE, commonly known as Samuel Beardmore, late of Western Camp, Yallourn, labourer, died 12th December, 1951, intestate.

I HEREBY give notice that on the 5th June, 1952, I filed elections to administer the following deceased persons' estates, in accordance with section 6 of the *Public Trustee Act 1940*:—

- *DONNELLY, FRANCIS JAMES, late of 16 Rowena-parade, Richmond, retired painter, died 28th April, 1952.
- FERRIS, FLORENCE MAY, late of Beechworth, of no occupation, died 18th May, 1949, intestate.
- *FINUCANE, MARIA, late of Mount Royal, Parkville, spinster, died 22nd April, 1951.

HARRISON, HARRY, late of 376 William-street, West Melbourne, pensioner, died 1st February, 1952, intestate.

*JOHNSTON, ELIZABETH SUSAN, also known as Elizabeth Johnston, formerly of 16 Salisbury-street, Moonee Ponds, but late of 182 Collins-street, Melbourne, married woman, died 24th October, 1950.

PURTON, MARGARET, late of Cheltenham, widow, died 16th December, 1951, intestate.

* According to the provisions of the will.

I HEREBY give notice that on the 6th June, 1952, I filed elections to administer the following deceased persons' estates, in accordance with section 6 of the *Public Trustee Act 1940*:—

GUILFOYLE, SAMUEL AUSTIN, also known as George Washington Guilfoyle, late of 85 Grey-street, East Melbourne, military pensioner, died 3rd December, 1951, intestate.

HAMMERBERG, ANNIE, formerly of 160 Moray-street, South Melbourne, but late of Mont Park, widow, died 31st March, 1952, intestate.

LECKIE, LILLAH ELLICE, late of 37 Ormond Esplanade, Elwood, married woman, died 4th May, 1950, intestate.

OSWALD, JAMES JEFFREYS, formerly of 69 Church-street, Richmond, but late of 7 Collins-street, Mentone, military pensioner, died 26th April, 1952, intestate.

VANCE, FLORENCE, formerly of 482 Drummond-street, Carlton, but late of Mount Royal, Parkville, pensioner, died 30th September, 1951, intestate.

I HEREBY give notice that on the 10th June, 1952, I filed elections to administer the following deceased persons' estates, in accordance with section 6 of the *Public Trustee Act 1940*:—

DONNELLY, MATTHEW PATRICK, late of 75 Gore-street, Fitzroy, railway employee, died 29th March, 1952, intestate.

LAWRENCE, JAMES ROBERT GEORGE, late of Middleborough-road, Box Hill, pensioner, died 15th July, 1951, intestate.

MORRIS, KATHERINE ESTHER, late of 18A Holroyd-avenue, East St. Kilda, married woman, died 21st April, 1952, intestate.

MURPHY, THOMAS JOSEPH, late of Sunbury, labourer, died 19th November, 1951, intestate.

C. J. GARDNER,
Public Trustee.

412 Collins-street, Melbourne, C.1, 11th June, 1952.

NOTICE.

ADMINISTRATION of the estate of each of the under-mentioned deceased persons has been granted to me, and creditors, next of kin, and all others having claims against the estate of any of the persons so mentioned are required to send particulars of their claims to the Public Trustee, No. 412 Collins-street, Melbourne, on or before the 20th August, 1952, or they will be excluded from the distribution of the estate when the assets are being distributed:—

*DONNELLY, FRANCIS JAMES, late of 16 Rowena-parade, Richmond, retired painter, died 28th April, 1952.

DONNELLY, MATTHEW PATRICK, late of 75 Gore-street, Fitzroy, railway employee, died 29th March, 1952, intestate.

FERRIS, FLORENCE MAY, late of Beechworth, of no occupation, died 18th May, 1949, intestate.

*FINUCANE, MARIA, late of Mount Royal, Parkville, spinster, died 22nd April, 1951.

GUILFOYLE, SAMUEL AUSTIN, also known as George Washington Guilfoyle, late of 85 Grey-street, East Melbourne, military pensioner, died 3rd December, 1951, intestate.

HAMMERBERG, ANNIE, formerly of 160 Moray-street, South Melbourne, but late of Mont Park, widow, died 31st March, 1952, intestate.

HARRISON, HARRY, late of 376 William-street, West Melbourne, pensioner, died 1st February, 1952, intestate.

HENLEY, JANET, late of 30 Kalkoura-avenue, Hawthorn East, married woman, died 9th January, 1943, intestate.

*JOHNSTON, ELIZABETH SUSAN, also known as Elizabeth Johnston, formerly of 16 Salisbury-street, Moonee Ponds, but late of 182 Collins-street, Melbourne, married woman, died 24th October, 1950.

LAWRENCE, JAMES ROBERT GEORGE, late of Middleborough-road, Box Hill, pensioner, died 15th July, 1951, intestate.

LECKIE, LILLAH ELLICE, late of 37 Ormond Esplanade, Elwood, married woman, died 4th May, 1950, intestate.

LEWICKE, WLADYSLAW, late of 12 Boyd-street, Burnley, munitions worker, died 28th September, 1951, intestate.

MARTIN, JOHN, late of 17 Ormond-place, Carlton, retired packer, died 2nd February, 1952, intestate.

MITCHELL, EDWARD JONES, late of Lambourn-road, Watsonia, brick maker, died 29th February, 1952, intestate.

MORRIS, KATHERINE ESTHER, late of 18A Holroyd-avenue, East St. Kilda, married woman, died 21st April, 1952, intestate.

MURPHY, THOMAS JOSEPH, late of Sunbury, labourer, died 19th November, 1951, intestate.

MCCLEAN, ROBERT JAMES, late of "Burrumbeep" Estate, Maroona, labourer, died 21st February, 1951, intestate.

OSWALD, JAMES JEFFREYS, formerly of 69 Church-street, Richmond, but late of 7 Collins-street, Mentone, military pensioner, died 26th April, 1952, intestate.

PURTON, MARGARET, late of Cheltenham, widow, died 16th December, 1951, intestate.

VANCE, FLORENCE, formerly of 482 Drummond-street, Carlton, but late of Mount Royal, Parkville, pensioner, died 30th September, 1951, intestate.

WROTCHFORD, SAMUEL BEARDMORE, commonly known as Samuel Beardmore, late of Western Camp, Yallourn, labourer, died 12th December, 1951, intestate.

* According to the provisions of the will.

C. J. GARDNER,
Public Trustee.

Melbourne, 11th June, 1952.

Town and Country Planning Acts.

SHIRE OF BROADMEADOWS.

INTERIM DEVELOPMENT ORDER.

THAT whereas by virtue of the powers conferred by the Town and Country Planning Acts and every other power enabling them in that behalf, the preparation of a planning scheme in accordance with the said Act has been commenced by the Council of the Shire of Broadmeadows (hereinafter referred to as the "Responsible Authority"), which hereby makes the following Interim Development Order:—

1. The development of all lands referred to in this Schedule, and the erection, construction, and carrying out of any buildings, roads, or other works on any of the said land, is hereby prohibited.

2. Any person may apply to the Responsible Authority for permission to develop, subdivide, or otherwise use any land, or erect or construct any buildings, roads, or other works, during the operation of this Order.

3. Any application for permission to develop, subdivide, or otherwise use land, or erect or construct any buildings, roads, or other works, may be granted by the Responsible Authority, subject to such conditions as are specified in the permit, or may be refused.

4. Any owner of any land who, after the publication of this Order, contravenes any of the provisions contained herein, shall, when directed by notice in writing, remove, pull down, take up, or alter any building, road, or other works, and if any owner fails to do so within the time specified by the notice, the Responsible Authority may carry out all or any of such works, and recover all expenses incurred, after due notice has been given to the owner, lessee, and/or occupier, in accordance with the provisions of section 12, sub-section 3, of the Act.

5. None of the provisions of this Order shall prohibit the continuance of the use of any land or buildings for the purposes for which it was used immediately before the coming into operation of this Order.

6. This Order shall remain in operation until the approval of the planning scheme, in accordance with the Town and Country Planning Acts, or until this Interim Development Order is revoked by the Governor in Council.

7. Schedule of land affected.—All that area of land comprising the Parish of Yuroke, and that portion of the Parish of Wollert situated within the Shire of Broadmeadows.

As witness, the common seal of the Council was hereto affixed this 3rd day of May, 1951, in the presence of—

(SEAL) S. G. SEWELL, President.
KEITH J. ROBINSON, Councillor.
E. F. SMILEY, Shire Secretary.

Approved by the Governor in Council,
17th June, 1952.

A. MAHLSTEDT,
Clerk of the Executive Council.

Transport Regulation Acts.

TRANSPORT REGULATION BOARD.

NOTICES OF PUBLIC HEARINGS.

NOTICE is hereby given that the applications made by the persons named below for licences to operate commercial passenger vehicles on the route or routes, or in the manner set out opposite their names, will be heard at a time and place to be communicated to the parties.

Name of Applicant; Nature of Application.

- DAVIS, E. & E. W., E. JOHNSTON, P. FREESTONE, & D. HOLT (trading as E. Davis Bus Service), Valley-street, East Oakleigh; 1 commercial passenger vehicle, with seating capacity for 26 persons, to operate as follows:—(a) as an additional vehicle on route 39A (Oakleigh-Glen Waverley), (b) as an additional vehicle to licence No. A.331, at present authorizing operations between Oakleigh Railway Station and Scoresby, (c) as a special service omnibus (charter conditions) within a radius of 50 miles with a three miles radius pick up, centred from the corner of Ferntree Gully-road and Springvale-road.
- DYSON, L. C., Plenty-road, Bundoora; 3 commercial passenger vehicles, with seating capacity for 24, 25, and 25 persons respectively, to operate under the same terms and conditions relating to Route 46A, as set out in *Government Gazette* No. 665, dated 27th June, 1951, and any subsequent amendment authorized. (Subject to the re-issue of Motor Omnibuses Licence Nos. M.O.270, M.O.271, and M.O.272, and Motor Car Owners' Licence Nos. 1168, 1167, and 1169 to the applicant, which are at present in the name of the estate of the late Edmond Gastin, per L. P. Le Grand, executor.)
- DYSON, L. C., Plenty-road, Bundoora; 1 commercial passenger vehicle, with seating capacity for 22 persons, to operate as a substitute vehicle under the same terms and conditions relating to Route 46A, as set out in *Government Gazette* No. 665, dated 27th June, 1951, and any subsequent amendment authorized. (Subject to the re-issue of Motor Omnibus Licence No. substitute M.O.45 and Motor Car Owners' Licence No. 1170 to the applicant, which are at present in the name of the estate of the late Edmond Gastin, per L. P. Le Grand, executor.)
- STEED, G. A., 17 Whitehorse-road, Ringwood; 1 commercial passenger vehicle, with seating capacity for five persons, to operate as follows:—(a) under the same terms and conditions as Hackney Carriage Licence No. 354, (b) otherwise than at separate and distinct fares from 50 Riversdale-road, Camberwell, to places throughout Victoria. (Subject to the re-issue of Hackney Carriage Licence No. 354 and Motor Car Owner's Licence No. 1210 to the applicant, and the cancellation of licence P.H.1123, at present held by A. P. Withers.)
- TANNER, V. N., 160 Wingrove-street, Fairfield; 1 commercial passenger vehicle, with seating capacity for 16 persons, to operate on Route 60A, as prescribed in *Government Gazette* No. 665, dated 27th June, 1951, and any subsequent amendment authorized thereto. (Subject to the cancellation of licence No. M.O.406, at present in the name of W. T. Howell, 281 Clarke-street, Northcote.)
- WILLIAMS, S. A., 2 East-street, Ascot Vale; 1 commercial passenger vehicle, with seating capacity for five persons, to operate as follows:—(a) under the same terms and conditions as Hackney Carriage Licence No. 540, (b) otherwise than at separate and distinct fares from Civic Motor Service, 57 City-road, South Melbourne, to places throughout Victoria. (Subject to the re-issue of Hackney Carriage Licence No. 540 and Motor Car Owner's Licence No. 1999 to the applicant, and the cancellation of licence P.H.27, at present held by L. Holden.)
- NOTICE is hereby given that the applications made by the persons named below for licences to operate commercial passenger vehicles on the route or routes, or in the manner set out opposite their names, will be heard at a time and place to be communicated to the parties.
- Name of Applicant; Nature of Application.*
- DYSON, A., Fernshaw-road, Healesville; 1 commercial passenger vehicle, with seating capacity for five persons, to operate as follows:—(a) at separate and distinct fares within a radius of six miles of Healesville Post Office, (b) under private hire conditions within a radius of 50 miles of Healesville Post Office. (Subject to the cancellation of licence No. A.3010, at present in the name of Southern Coachlines Pty. Ltd., Healesville.)
- MITCHELL, D. M., Nelson's-road, Trafalgar; 2 commercial passenger vehicles, each with seating capacity for five persons, to operate as follows:—(a) at separate and distinct fares within a radius of five miles of Trafalgar Post Office, (b) under private hire conditions within a radius of 50 miles of Trafalgar Post Office. (Subject to the cancellation of licence Nos. A.623 and A.3062, at present held by A. H. Hayes, Trafalgar.)
- PARKINSON, T., Ford-street, Beechworth; application for renewal of licence No. A.2055 (expiring 1st July, 1951), authorizing operations as follows:—(a) the holder of this licence is also the holder of a certain other "A" licence No. A.5. The vehicle hereby licensed may be operated in substitution for but not in addition to the vehicle licensed by the other said "A" licence numbered as aforesaid, and when so operated shall adhere and be subject to the same terms and conditions to which the other said "A" licence is subject, (b) specified day tours from Beechworth, as follows:—1. Beechworth to Mt. Buffalo, via Myrtleford and Porepunkah, and return via the same route, 2. Beechworth to Mt. Hotham, via Myrtleford, Bright, and Harrietville, and return via the same route, 3. Beechworth to Hume Weir, via Yackandandah, Kiewa, Tallangatta, and Granya, and return via Albury and Chiltern, 4. Beechworth to Pretty Valley, via Yackandandah, Dederang, and Mt. Beauty, and return via the same route, (c) under charter conditions within a 20 miles radius of the Beechworth Post Office and from Beechworth to Wangaratta, Mt. Buffalo, Mt. Hotham, Harrietville, Bright, Wandiligong, Porepunkah, Whitfield, Moyhu, and Greta.
- PROVINCIAL MOTORS PTY. LTD., 123 High-street, Bendigo; 1 commercial passenger vehicle, to operate as a substitute vehicle to licence Nos. A.520, A.521, A.522, A.1998, A.1999, A.1734, A.1735, A.1780, A.1738, and A.1623. (Subject to the cancellation of licence No. A.2873, at present held by the applicant.)
- WOODWARD, L., 17 Pickett-street, Dandenong; 1 commercial passenger vehicle, with seating capacity for five persons, to operate as follows:—(a) at separate and distinct fares within a radius of five miles of Dandenong, (b) under private hire conditions within a radius of 50 miles of Dandenong. (Subject to the cancellation of licence P.H.1433, at present held by the applicant.)
- SOUTER, J. V., 30 McIvor-road, Bendigo; application for variation of licence No. A.528 to include the ability to operate as follows:—
1. As a special service omnibus (charter conditions) within a radius of 50 miles of (a) Lancefield, Romsey, and Monegeeta, (b) Kyneton (High School trips only).
 2. Picture trips Wednesday nights only to Riddell, Monegeeta, Romsey, and return.
- WIGHT, A. R. (trading as Yarram-Traralgon Passenger Service), Bland-street, Yarram; application for renewal of licence Nos. A.2345 and A.2346 (expiring 5th April, 1952) authorizing operations as follows:—
- As stage omnibuses on the following routes:—(a) between Yarram and Traralgon via Wron Wron, Carajung, Willung, South Gormandale, and Flynn's Creek, (b) between Yarram and Traralgon, via Fover North, Mack's Creek, Balook, Callignee South, Callignee, North Le Roy Junction, and Traralgon South, (c) mails may be carried and parcels may also be carried to any place along the routes, total weight of parcels not to exceed five hundredweight (5 cwt.).
- APPLICATIONS for licences to operate commercial passenger vehicles, with seating capacity for five persons, for the carriage of passengers throughout Victoria, otherwise than at separate and distinct fares for each passenger:—
- LEYSHAN, F. C., & R. B. WALKER (trading as Central Taxi Service), George-street, Heyfield; seven passengers. (This replaces application gazetted 29th May, 1952.)
- RODGER, J. W., 23 O'Connor-street, East Brunswick (to operate from Edenhope). (This replaces application gazetted 29th May, 1952.)
- NOTICE is hereby given that the applications made by the persons named below for renewal of licences to operate commercial goods vehicles on the route or routes, or in the manner set out opposite their names, will be heard at a time and place to be communicated to the parties concerned:—
- Name and Address; Present Franchise; Licence No.; Date of Expiry.*
- JORGENSEN, E., Portarlinton; road contracting plant and materials throughout the State of Victoria; D.1605; 15th July, 1952.

MOYLE, A. J., 1 McBride-avenue, Wonthaggi; (a) within a radius of 20 miles from Wonthaggi—general goods, (b) from and to places situate within the area as defined in paragraph (a) above and from places situate within a radius of 75 miles from Wonthaggi—second-hand household furniture; D.2697; 24th June, 1952.

NUNN, N. L., 501A Raglan-street, Ballarat; throughout the State of Victoria in the course of business as "marine dealer"—bottles and scrap metals; D.4987; 25th July, 1952.

NOTICE is hereby given that the application made by the company named below for renewal of licence with variation to operate the commercial goods vehicle on the route or routes, or in the manner set out opposite their name, will be heard at a time and place to be communicated to the parties concerned:—

Name and Address; Present Franchise; Amended Conditions; Licence No.; Date of Expiry.

THE CHEETHAM SALT PTY. LTD., 71 Little Malop-street, Geelong; (a) from the works of the Cheetham Salt Pty. Ltd., situate at Geelong and Laverton respectively—manufactured salt products, (b) between the works at Geelong and the works at Laverton referred to in paragraph (a)—machinery, plant, and manufactured goods; (a) as per present conditions, (b) as per present conditions, (c) between Laverton and Melbourne with manufactured goods, supplies, machinery, and plant; D.3647; 24th June, 1952.

NOTICE is hereby given that the applications made by the persons named below for licences to operate the commercial goods vehicles on the route or routes, or in the manner set out opposite their names, will be heard at a time and place to be communicated to the parties concerned:—

Name and Address; Nature of Application.

BARRY, W. J., Narbethong; 1 commercial goods vehicle (100 cwt.) to operate between Narbethong and Melbourne for the carriage of firewood, sawn timber for fencing purposes, and petroleum products for own use.

BURNS, J., Monfeller-road, Burwood; 1 commercial goods vehicle (80 cwt.) for the carriage of—(a) general goods within a radius of 25 miles of Melbourne, (b) bricks within a radius of 40 miles of Melbourne.

MOFFAT, W. E., 86 Canterbury-street, Flemington; 1 commercial goods vehicle (10 cwt.) to operate throughout the State of Victoria in the course of business as "hawker"—drapery.

GRANDIN, N., & SON, P.O. Box 60, Myrtleford; 1 commercial goods vehicle (40-60 cwt.) for the carriage of—(a) mail, newspapers, and parcels from Wangaratta to Bright, via Whorouly, (b) parcels and vegetables from Bright to Wangaratta and places en route, (c) general goods within a radius of 20 miles of Myrtleford.

GARDINER GASKETS PTY. LTD., 19-23 Faraday-street, Carlton; 1 commercial goods vehicle (21 cwt.) to operate—(a) within a radius of 50 miles of Melbourne in the course of business as "gasket manufacturers and car accessory distributors"—own goods, (b) from the railway stations at Portland, Hamilton, Horsham, Ararat, Warrnambool, Camperdown, Colac, Ballarat, Daylesford, Maryborough, Castlemaine, Bendigo, Kerang, Swan Hill, Echuca, Numurkah, Shepparton, Nagambie, Seymour, Wangaratta, Benalla, Warragul, Korumburra, Traralgon, Sale, and Yarram to retailers tributary to such railway stations—bulk car accessories.

HOY, J. A., 141 McArthur-street, Sale; 1 commercial goods vehicle (80 cwt.) for the carriage of—(a) firewood from Lindenow to Sale, (b) briquettes from Yallourn to Sale, (c) pulp wood from Sale to Maryvale.

JACKSON, W. G., Sunnyside-road, Loch; 1 commercial goods vehicle (30 cwt.) for the carriage of—(a) general goods within a radius of 20 miles of Loch, (b) applicant's own farm produce and live stock from Loch to Dandenong and Melbourne.

LEE, A. R., Sherriff-street, Stawell; application to vary the conditions of licence No. D.5604 by the inclusion of carriage of petroleum products within a radius of 25 miles of Stawell.

PAYNE, G. A. & H. N. A., & T. H. WHITTINGTON (trading as Payne and Whittington), McKenzie-street, Alexandra; 1 commercial goods vehicle (76 cwt.) to operate—(a) within a radius of 50 miles of Alexandra in the course of trade as "joinery manufacturers"—own goods, (b) between Alexandra and Shepparton, Tatura, Kyabram, Koondrook, Kerang, Swan Hill, and Melbourne—manufactured joinery and raw materials used in the manufacture of same.

SHERRY, F. P., Foster-street, Dandenong; 2 commercial goods vehicles (60 and 70 cwt.) for the carriage of—(a) general goods within a radius of 20 miles of Dandenong, (b) household furniture within a radius of 50 miles of Dandenong.

TAHBILK PTY. LTD., Chateau Tahbilk, Tahbilk; 1 commercial goods vehicle (80-100 cwt.) to operate—(a) throughout the State of Victoria in the course of business as "primary producers," (b) between Tahbilk and Melbourne in the course of business as "vignerons"—own manufactured wine and raw materials used in the manufacture of same.

TASTY MAID BISCUITS PTY. LTD., 148 Liebig-street, Warrnambool; application to vary the conditions of licence No. D.6889 by the extension of paragraph (d) to include Maryborough, Avoca, and Beaufort, and adding as paragraph (f) a round route commencing and terminating at Warrnambool, via Warragul, Moe, Morwell, Trafalgar, Traralgon, Leongatha, Korumburra, and back to Warrnambool, via Dandenong, Geelong, and Colac—for the carriage only of licensee's own manufactured biscuits.

THORSON, W. A., 15 Little Page-street, Albert Park; 1 commercial goods vehicle (15 cwt.) to operate throughout the State of Victoria in the course of business as "second-hand bag collector."

Notice of any objections should be forwarded to reach the Secretary of the Board not later than Wednesday, 2nd July, 1952.

E. V. FIELD,
Secretary.

Exhibition Buildings, Rathdown-street, Carlton, N.3, 16th June, 1952.

BEALIBA WATERWORKS TRUST.

RATING BY-LAW 1952.

THE Commissioners of the Bealiba Waterworks Trust, in pursuance and exercise of the powers conferred by the Water Acts, doth hereby make a rate for the supply of water for domestic purposes of One shilling and four pence in the pound on the annual municipal valuation of the lands and tenements liable to be rated within the Bealiba Urban District.

Provided that in no case shall the amount of rate payable per annum in respect of any tenement (other than land on which there is no building) be less than Thirty-six shillings and eight pence, and in respect of any land on which there is no building less than Five shillings.

Such rates are made and shall be levied upon the occupiers or owners of the said lands and tenements for the year commencing 1st January, 1952, and ending on the 31st December, 1952, and shall be payable on the 20th day of June, 1952, at the offices of the Trust, Dunolly.

The maximum quantity of water to be supplied in any one year without further charge to any property rated by the Trust is hereby fixed at the quantity which, at a charge of One shilling and four pence per 1,000 gallons, would produce an amount equal to the amount of rate levied on such property for the said year.

The charge for water supplied by measure to any property rated by the Trust in excess of such maximum quantity, computed as in the last preceding clause, is hereby fixed at One shilling and four pence per 1,000 gallons.

The charge for water supplied by measure to any property not rated by the Trust is hereby fixed at One shilling and four pence per 1,000 gallons, and the minimum quantity of water to be charged for in cases where water is so supplied is hereby fixed at 33,000 gallons.

The charge for water supplied by measure shall be payable, on demand, at the offices of the Trust, Dunolly.

Passed this 21st day of May, 1952.

(SEAL) W. K. CAMERON, Chairman.
K. A. G. LOWE, Secretary.

Approved 6th June, 1952.—R. K. Brose, Minister of Water Supply.

Approved by the Governor in Council, 11th June, 1952.—A. MAHLSTEDT, Clerk of the Executive Council.

LORNE WATERWORKS TRUST.

RATING BY-LAW No. 62.

THE Lorne Waterworks Trust, in pursuance and exercise of the powers conferred by the Water Acts, doth hereby make a rate for the supply of water for domestic purposes of Two shillings and three pence in the pound on the net annual municipal valuation of lands and tenements liable to be rated within the Lorne Waterworks Urban District.

Provided that in no case shall the amount of rate payable per annum in respect of any tenement (other than land on which there is no building) be less than Two pounds ten shillings (£2 10s.), and in respect of any land on which there is no building less than Ten shillings.

The maximum quantity of water to be supplied in any one year without a further charge to any property rated by the Trust is hereby fixed at the quantity which, at a charge of Two shillings per 1,000 gallons, would produce an amount equal to the amount of the rate levied on such property for the said year.

The charge for water supplied by measure to any property rated by the Trust in excess of such maximum quantity, computed as in the last preceding clause, is hereby fixed at Two shillings per 1,000 gallons.

The charge for water supplied by measure shall be payable on demand.

Such rates are made and shall be levied upon the occupiers or owners of the said lands and tenements for the year commencing on the 1st day of January, 1952, and ending on the 31st day of December, 1952, and shall be payable on the 15th August, 1952, at the office of the said Trust, Shire Hall, Winchelsea.

Passed this 9th day of May, 1952.

(SEAL) JOHN F. ALSOP, Chairman.
W. W. WESTHORPE, Secretary.

Approved 6th June, 1952.—R. K. BROSE, Minister of Water Supply.

Approved by the Governor in Council, 11th June, 1952.—A. MAHLSTEDT, Clerk of the Executive Council.

TRAFALGAR WATERWORKS TRUST.

RATING BY-LAW FOR 1952.

THE Trafalgar Waterworks Trust, in pursuance and exercise of the powers conferred by the Water Acts, doth hereby make a rate for the supply of water for domestic purposes of One shilling and six pence in the pound of the annual municipal valuation of lands and tenements to be rated within the Trafalgar Urban District.

Provided that in no case shall the amount of rate payable in respect of any tenement (other than land on which there is no building) be less than Thirty-four shillings and six pence, and in respect of any land on which there is no building less than Twenty shillings.

Such rates are made and shall be levied upon the occupiers or owners of the said lands and tenements for the year commencing on the 1st day of January, 1952, and ending on the 31st day of December, 1952, and shall be payable on the 18th day of June, 1952, at the office of the said Trust.

The maximum quantity of water to be supplied in any one year without further charge to any property rated by the Trust is hereby fixed at the quantity which, at a charge of One shilling per 1,000 gallons, would produce an amount equal to the amount of rate levied on such property for the said year.

The charge for water supplied by measure to any property rated by the Trust in excess of such maximum quantity, computed as in the last preceding clause, is hereby fixed at One shilling per 1,000 gallons.

The charge for water supplied by measure shall be payable, on demand, at the office of the Trust.

Passed this 31st day of May, 1952.

(SEAL) R. L. DOWIE, Chairman.
JOHN R. BLACKER, Commissioner.
T. SHANAHAN, Secretary.

Approved 6th June, 1952.—R. K. BROSE, Minister of Water Supply.

Approved by the Governor in Council, 11th June, 1952.—A. MAHLSTEDT, Clerk of the Executive Council.

FARM PRODUCE AGENTS ACTS (Nos. 3678, 4208, 4662, AND 4736).

LIST of persons to whom Farm Produce Agents' Licences have been issued for the year ending December, 1952, and each of whom has lodged a fidelity bond, in accordance with the requirements of the Act:—

Name; Principal Place of Business.

Acme Seed Store, 95 O'Grady-street, Clifton Hill.
Aitken, D. S., Pty. Ltd., 24 Walsh-street, Coburg.
Alexander, G. N., 299 Plenty-road, Preston.
Allen, C. J., Station-street, Somerville.
Anderson, A., Raglan-street, Daylesford.
Anderson, David, and Co., Horsham.
Andrews Fruit and Vegetable Market, 7 Queen-street, Bendigo.
Angliss, W., and Co. (Aust.) Pty. Ltd., 42 Bourke-street, Melbourne.
Anguey, H., and Sons, 32 Peel-street, West Melbourne.
Ansell, Vernon, and Co. Pty. Ltd., 524 Collins-street, Melbourne.
Arena, Luigi, 282 Victoria-street, North Melbourne.
Ashworth, K. F., 49 McKillop-street, Geelong.
Ashworth, P. G., 10 Kardinia-street, Geelong.
Austral Fruit Agency, 147 Therry-street, Melbourne.
Austral Grain and Ambler Pty. Ltd., 46-52 King-street, Melbourne.
Australian Estates Coy. Ltd., 114 William-street, Melbourne.
Australian Ice and Cool Stores, 21 Grenville-street, Ballarat.
Australian Mercantile Land and Finance Co. Ltd., 122 William-street, Melbourne.
Baker, Harold, Wandin East.
Ballantyne, K. L., Pty. Ltd., 295 Grant-street, South Melbourne.
Bandias, A., Warrandyte South.
Banson, George, and Son Pty. Ltd., 20 Wholesale Fruit Market, Melbourne.
Barbaro, A., 4 Murray-street, Brunswick.
Barber, J. E., Birchip.
Barby, N. E., 24 Westbourne-street, Brunswick.
Barker, Green, and Parke Pty. Ltd., 209-211 King-street, Melbourne.
Barrow, Alfred, Pty. Ltd., 47 King-street, Melbourne.
Barrow Bros. Commission Agency Pty. Ltd., 460-466 Flinders-lane, Melbourne.
Beasley, Thomas, 18 Market-road, Werribee.
Bendigo Open Fruit Market, Hargreaves-street, Bendigo.
Bennett, J. F., and Co. Ltd., 1 Curtis-street, Ballarat.
Bentleigh Poultry Auctions and Moorabbin Poultry Auction Sales, corner Centre and Jasper roads, Bentleigh.
Bissett, A. F., and Sons, Whitehorse-road, Ringwood.
Black, D. C. and W. M., Pakenham Upper.
Black, H. R., 452 Queen-street, Melbourne.
Blackham, W. H., Pty. Ltd., 59-61 King-street, Melbourne.
Blain, R., and Sons Pty. Ltd., 122 King-street, Melbourne.
Blakely, Bob, and Co., 32 Main-street, Ballarat.
Blue Moon Fruit Co-op. Ltd., Blackburn.
Bodley, H. H., Riverside-avenue, South Melbourne.
Boldt, R. H., Silvan.
Bone, S. H., High-street, Belmont.
Bonsack, R. A., 7 Arlington-street, Ringwood.
Booth, F., and Son Pty. Ltd., 16 Wholesale Fruit Market, Melbourne.
Borgia Bros., 9-11 James-street, Geelong.
Borrett, J. R., Pty. Ltd., 5-7 Fish Market, Melbourne.
Borthwick, Thos., and Sons (Aust.) Ltd., 84 William-street, Melbourne.
Borwick, P. B. and R. W., Murray-street, Colac.
Bradbury, J. C., 122 King-street, Melbourne.
Bradley, P. A., 369 Sydney-road, Brunswick.
British United Dairies Pty. Ltd., 33-35 King-street, Melbourne.
Britt, J. L., and Sons, Main-road, Doncaster.
Brooks, R. B., and Co., Dandenong.
Brophy, Foley, and Co. (Ballarat), Market-square, Ballarat.
Brophy, Foley, and Co. (Melb.), 34 King-street, Melbourne.
Brown and Dureau Ltd., 422 Collins-street, Melbourne.
Brown, G. T., and Sons, Kaniva.
Bryant & Gourley, 6 Peel-street, Ballarat.
Bunge (Aust.) Pty. Ltd., 419 Collins-street, Melbourne.
Burrumbeet and Windermere Farmers Co-op. Society Ltd., 32 Doveton-street, Ballarat.
Butler, E., and Sons, Tallangatta.
Butler and Moss, 645 Elizabeth-street, Melbourne.
Butler, T. E., 486 Collins-street, Melbourne.
Callanders Pty. Ltd., Murphy-street, Wangaratta.
Cameron, F. W., Main-road, Doncaster.
Campbell's Mart, 49 Gray-street, Hamilton.
Captain Distributing Co., 481 Flinders-lane, Melbourne.
Carpinelli, Joseph, Parker-road, Silvan.

Name; Principal Place of Business.

Carter, H. R., and Co. Pty. Ltd., 524 Collins-street, Melbourne.
 Cave, F., and Co. Pty. Ltd., 209-211 King-street, Melbourne.
 Central Fruit Agency, 462 Queen-street, Melbourne.
 Chambers, G. E. and N. O., Red Hill.
 Charteris, George, Wandin.
 Chinese Fruit Merchants Association Pty. Ltd., 39 Wholesale Fruit Market, Melbourne.
 Chinn, F. A., and Co., 40 Wholesale Fruit Market, Melbourne.
 Christie, W. J., 30 Madden-avenue, Mildura.
 Ciancio, S., 17 Napier-street, Fitzroy.
 Cleary, Robert, 37 Flemington-road, North Melbourne.
 Clements, C. E., and Co. Pty. Ltd., 34 Queen-street, Melbourne.
 Conaughton, J. P., and Co., cnr. Doveton and Mair streets, Ballarat.
 Cook, G. P., Station-street, Somerville.
 Cooper, G. W., Main-road, Silvan.
 Co-operated Dried Fruit Sales Pty. Ltd., 16-24 Jeffcott-street, Melbourne.
 Corio Stores, Little Malop-street, Geelong.
 Cornish, R., and Sons Pty. Ltd., 406 Little Collins-street, Melbourne.
 Costa, F., and Sons, 200 Moorabool-street, Geelong.
 Costa, G., and Co., 9-11 James-street, Geelong.
 Cowin, W., 200 Brighton-street, Richmond.
 Cowling, W., Market Square, Bendigo.
 Cramer, E., and Sons Pty. Ltd., 54 Tuaggra-street, Maryborough.
 Crickard, F. B., and Co., 31 Queen-street, Melbourne.
 Cristafaro, Matteo, 53 Munro-street, Coburg.
 Croydon Market (Allan Brown), Croydon.
 Crystal Ice and Cool Stores Co., Garsed-street, Bendigo.
 Cummings and Saville, Hurstbridge.
 Curnow (Bendigo), Queen-street, Bendigo.
 Cutbush, G. C., and Co., Dean.
 Dalgety and Co. Ltd., 461-471 Bourke-street, Melbourne.
 Daniels, L., 86 Erskine-street, North Melbourne.
 Daut, S., Box 162, P.O., Shepparton.
 Davis, J., Pty. Ltd., 8 Wholesale Fruit Market, Melbourne.
 Davis, J., Curdie-street, Camperdown.
 Davy, F. S., Fish Market, Spencer-street, Melbourne.
 Dennys, Lascelles Ltd., Moorabool-street, Geelong.
 Dimatina, F., and Co., 50 Wholesale Fruit Market, Melbourne.
 Divola, D., and Sons, 122 Eighth-street, Mildura.
 Dixon Bros., L. C. S., and Co., c/o Angliss Gate, Lynch-street, Footscray.
 Dixon Bros. Pty. Ltd., 122 King-street, Melbourne.
 Dixon, D. N., 623 Collins-street, Melbourne.
 Doble Bros., 114 Creswick-road, Ballarat.
 Donoghue, J. E., 527 Collins-street, Melbourne.
 Downey, James, 34 King-street, Melbourne.
 Doyle and McCarthy, 22 King-street, Melbourne.
 Doyle, L. J., 473 Bourke-street, Melbourne.
 Dreyfus, Louis, and Co. Ltd., 465 Collins-street, Melbourne.
 Dykes, M. O., 8 Oakhill-avenue, Regent.
 Edwards, M. T., Red Hill South.
 Edgar, C. R., & Co. Pty. Ltd., 422 Collins-street, Melbourne.
 Elder Smith and Co. Ltd., 14 Malop-street, Geelong; 499 Bourke-street, Melbourne.
 Fabbris, G., 108 Peel-street, North Melbourne.
 Fairbairn, L. A., and Co., 137 William-street, Melbourne.
 Falla, R. J., and Son, Donald.
 Fallow Products Agency, 422 Collins-street, Melbourne.
 Ferlazzo, G., and Co., 53 Aberfeldie-street, Essendon.
 Ferris, H., Pty. Ltd., Mollison-street, Kyneton.
 Foley Bros. Pty. Ltd., 491 Flinders-lane, Melbourne.
 Footscray Produce Store, 71-73 Victoria-street, Footscray.
 Frankel, H. and S., 44 Wholesale Fruit Market, Melbourne.
 French, E. G., Victoria-street, Hastings.
 French, G., McLeod-road, Carrum.
 Friswell, Les, 338 Hargreaves-street, Bendigo.
 Gabriel Bros., 49 Errol-street, North Melbourne.
 Gandolfo, G., 31 Sheddon-street, Pascoe Vale.
 Gaudion, P. G., Wandin Yallock.
 Geelong and Cressy Trading Co. Ltd., 138 Malop-street, Geelong.
 Geer, A. S., McLeod-street, Orbost.
 Geraldton Fruit Co., 59 Wholesale Fruit Market, Melbourne.
 Giblin, T. J., Garfield.
 Gilchrist's Produce Store, Woodend.
 Gill, R. W., Yarra-road, Croydon.
 Gippsland and Northern Co-op. Co. Ltd., 492 Flinders-lane, Melbourne.
 Gleeson, Bridget, Tower Hill, Warrnambool.
 Godfrey, Dan, and Co. Pty. Ltd., Dandenong.

Name; Principal Place of Business.

Golden Valley Fruit Co. Pty. Ltd., 15 Wholesale Fruit Market, Melbourne.
 Goldsbrough, Mort, and Co. Ltd., 526 Bourke-street, Melbourne.
 Goodall, F. T., Croydon-road, Croydon.
 Goodwin, N. F., 3 Daley-street, Pascoe Vale.
 Goulding, J. F., 483 Collins-street, Melbourne.
 Goulding, J. W., 70 King-street, Melbourne.
 Gowling, A. W., Seville.
 Granter, D. F. F., 414 Pt. Nepean-road, Brighton.
 Great Southern Co-op. Co. Ltd., Beach-road, Foster.
 Green, Nathan, 155 Arnold-street, North Carlton.
 Greenfields Pty. Ltd., 34-36 Doveton-street, Ballarat.
 Greening, H. E., Lava-street, Warrnambool.
 Grindal, E. H., 23 Wales-street, West Brunswick.
 Guyett, N. F., corner Little Malop and James streets, Geelong.
 Guy's Fruit Service, 51 Wholesale Fruit Market, Melbourne.
 Haebich, Les., 249 Franklin-street, Melbourne.
 Hancock, A. W., and Co., 104 Armstrong-street north, Ballarat.
 Hanger, H., 91 Toorak-road, South Camberwell.
 Harris, H. R., cr. Flinders-lane and Knight's-place, Melbourne.
 Harrison, J. McP., 65 Pender-street, Thornbury.
 Harvey, Dann, and Co. Pty. Ltd., 57-59 Gheringhap-street, Geelong.
 Harvey, H., 216 Koroit-street, Warrnambool.
 Haughton, W., and Co. Pty. Ltd., 545 Little Collins-street, Melbourne.
 Hawke, C. H., 273 Williamson-street, Bendigo.
 Henderson, B. S., The Basin, Bayswater.
 Hermon, W. J., Menzies Creek.
 Hester Bros. Poultry Service, 214 Curnow-street, Bendigo.
 Hibbons, W. R., 40 Talbot-avenue, St. Kilda.
 Hill, Frank A., Pty. Ltd., Charing Cross, Bendigo.
 Holden, R. H., Wandin.
 Holden, W. M., Hogan-street, Tatura.
 Holland and Bourke, Station-street, Cobram.
 Hong On and Co., 42 Wholesale Fruit Market, Melbourne.
 Hoopell, J. S. (Mrs.), Mollison-street, Maimsbury.
 Howell, James, junr., Victoria-road, Wandin North.
 Hurst and Green, 92 Exhibition-street, Melbourne.
 Hutchinsons Finley Flour Milling and Agency Co. Pty. Ltd., Hartington-street, Glenroy.
 Hyland, David, and Sons Pty. Ltd., 456 Flinders-lane, Melbourne.
 Hyman, J., and Sons, 51 Wholesale Fruit Market, Melbourne.
 Ibrahim, Nuri, 745 High-street, Preston.
 International Fruit and Mercantile Co., 6 Wholesale Fruit Market, Melbourne.
 Interstate Fruit Co., 50 Wholesale Fruit Market, Melbourne.
 James, H. K., Fish Market, Melbourne.
 Johnston, T. W., Monbulk.
 Jonas, A., and Son, 89 Collins-street, Melbourne.
 Kealy, M. A., Coragulac.
 Kearney, Leo, Murchison.
 Kenny, W. R., Kalorama.
 Kilmore-Broadford Dairy Co., Kilmore.
 Kilpatrick, McLellan, and Co. Pty. Ltd., Melville-street, Numurkah.
 Kimpton, W. S., and Sons, 395 Collins-street, Melbourne.
 King and Heath, Main-street, Bairnsdale.
 King, E. G., Pty. Ltd., 2 Wholesale Fruit Market, Melbourne.
 King, J. L., 9 Queen-street, Bendigo.
 Kirks Bazaar, 1144 Mount Alexander-road, Essendon.
 Kirkwood, John, 51 William-street, Melbourne.
 Koroit and Tower Hill Farmers Co-op. Society Ltd., Koroit.
 Kotsiakos, G. J., Moyston-street, Castlemaine.
 Lambie, D. A., & Co., Merbein.
 Lanera, P. G., 66 Rose-street, Fitzroy.
 Lanteri, Santi, 20 Glen Eira-road, Ripponlea.
 Lauritz, W. G., 21 Viaduct Buildings, Melbourne.
 Lavery, Joe, Pty. Ltd., Colac.
 Leading Transport Co., 43 Mitchell-street, Bairnsdale.
 Ledger, Herbert, Wann and Co., Bridge-street, Benalla.
 Legg, F. J., and Son, Station-street, Burwood.
 Leong, Hoong Cheong and Co., 58 Wholesale Fruit Market, Melbourne.
 Lister, George, Pty. Ltd., 168 Franklin-street, Melbourne.
 Logan, T. G., 1105 Dandenong-road, East Malvern.
 Louey Pang, H., and Co. Pty. Ltd., 186 Franklin-street, Melbourne.
 Lovett, H. L. E., and Co., 23 Wholesale Fruit Market, Melbourne.

- Name; Principal Place of Business.*
- Lowan, H. W., 206 Edward-street, East Brunswick.
 Lucas, D. S., and Co., 9 Wholesale Fruit Market, Melbourne.
 Lyall and Sons Pty. Ltd., 39 Leveson-street, North Melbourne.
 Lyall, Sidney, Victoria-street, North Melbourne.
 Lyndon and Jones, 80 Princes-street, Traralgon.
 Mace, E. H., 122 King-street, Melbourne.
 Madafferri, F., 116 Peel-street, North Melbourne.
 Mahony, Charles, 33 Cobden-street, Kew.
 Man, Hop, 54 Wholesale Fruit Market, Melbourne.
 Martakis, G., 390 Clarendon-street, South Melbourne
 Maryborough Flour Mills Pty. Ltd., 38 Albert-street, Maryborough.
 Mason, G. F., Box 1580P, G.P.O., Melbourne.
 Meagher, T. G., Box 452, Red Cliffs.
 Melbourne Butter Supply Pty. Ltd., 184-188 Bank-street, South Melbourne.
 Melgaard, R. G., and Co. Pty. Ltd., Scott-street, Dandenong.
 Mellor, F. R., and Son, 452 Queen-street, Melbourne.
 Mentiplay, D., and Co. Pty. Ltd., 27 Wholesale Fruit Market, Melbourne.
 Mescall, Dan., Koo-wee-rup.
 Michell and Son, Newlyn.
 Miller, A. F., and Son, Main-road, Doncaster.
 Millis, Alfred, and Sons Pty. Ltd., 438 Queen-street, Melbourne.
 Mitchell, J. M., 12 McDonald-street, Glen Iris.
 Morris, G. N., and Co., Central Market, Colac.
 Morton, T. R. B., and Son, 34A Main-street, Box Hill.
 Moss, J., and Sons, 11 Wholesale Fruit Market, Melbourne.
 Moulden, E. T., and Sons Pty. Ltd., 294-8 Victoria-street, Melbourne.
 Mugavin, A. L., cnr. Dundas and Kerr streets, Preston.
 Mulholland, D. J., and Co. Pty. Ltd., 24 Arthurlton-road, Northcote.
 Mumford, J. G., 35 Wholesale Fruit Market, Melbourne.
 Murphy, W. T., Bros. Pty. Ltd., 594 Burwood-road, Auburn.
 Murray's Wholesale Fruit Supply, 4 Wallace Court, Wallace-avenue, Toorak.
 McBeth, J. P., 207 Neerim-road, Carnegie.
 McColl and Buzza Pty. Ltd., 865 Dandenong-road, Caulfield East.
 McCraith, John A., Fish Market, Melbourne.
 McCulloch Carrying Co. Pty. Ltd., 468 Collins-street, Melbourne.
 McDonnell, Thompson, and Williamson Pty. Ltd., 541 Flinders-street, Melbourne.
 McKeever and Co., "The Rialto," Collins-street, Melbourne.
 McLean, N. N., Pty. Ltd., 395 Queen-street, Melbourne.
 McLennan, K. N., 125 Hassett-street, Leongatha.
 McPhail, Anderson, and Co., 436 Bourke-street, Melbourne.
 McRae, John, and Son Pty. Ltd., Jung.
 Nash, S., and Sons, Drysdale.
 Natoli, Robert, 196 Bellarine-street, Geelong.
 Neim, Petrit., 166 a'Beckett-street, Melbourne and Shepparton.
 Newport Poultry Supply, 133 Johnstone-street, Newport.
 New Zealand Loan and Mercantile Agency Co. Ltd., 538-544 Collins-street, Melbourne.
 Nolan, C. H., 527 Collins-street, Melbourne.
 Nolan, T. J., Railway-street, Euroa.
 Noonan, J. F., Pty. Ltd., 623 Collins-street, Melbourne.
 Norris and Wilkinson, Tinning-street, Brunswick.
 North Eastern Co-op. Society Ltd., Reid-street, Wangaratta.
 North Western Fruit Growers Ltd., 33 Peel-street, Ballarat.
 Numurkah Wholesale Supply and Carrying Co., McGregor-street, Numurkah.
 Nuttall, Ellis, and Co., Williamson-street, Bendigo.
 O'berman, J., and Co. Pty. Ltd., 22 Wholesale Fruit Market, Melbourne.
 O'Kane, Maurice, Melville-street, Numurkah.
 Onians, R. and A., 100 King-street, Melbourne.
 Orlando, T., and Co., 57 Panoram-road, North Balwyn.
 O'Toole, H. J., Illowa.
 Pack, Kee, 55 Wholesale Fruit Market, Melbourne.
 Panton, M. J., 114 Chapel-street, Windsor.
 Parnham, C. J., 40 Balaclava-street, East St. Kilda.
 Patchett Produce Distributors Pty. Ltd., 103 Victoria-street, West Melbourne.
 Patkin, A., & Co. Pty. Ltd., 473 Bourke-street, Melbourne.
 Pays Victoria Stores, Victoria-street, Kerang.
 Peachey, R. A., and Son, 625 Collins-street, Melbourne.
 Pellegrino, A., 30 Greeves-street, Fitzroy.
 Pellegrino, C., 290 Victoria-street, North Melbourne.
 Permewan, Wright Ltd., 31 King-street, Melbourne.
 Perrett, C. H. and A. M., 84 Main-street, Bairnsdale.
 Perry, S. J., and Co., 364 Little Collins-street, Melbourne.
- Name; Principal Place of Business.*
- Pette, V., 139 Abbotsford-street, North Melbourne.
 Pilmore and Jackman, Dimboola.
 Pirrie Bros., 136 Exhibition-street, Melbourne.
 Pitt, A. E., 14 Wholesale Fruit Market, Melbourne.
 Plant, Seth, 121 Hotham-street, Traralgon.
 Potato Wholesale Merchants Pty Ltd., 3A Camp-street, Ballarat.
 Potter Bros. Pty. Ltd., Williamson-street, Bendigo.
 Poultryman and Farmers Trading Co., 280-86 Queensberry-street, North Melbourne.
 Pratt, David, and Sons, 215-221 Mair-street, Ballarat.
 Preston, W., 39 Murray-street, Elsternwick.
 Producers Co-op. Distributing Society Ltd., 7 Wholesale Fruit Market, Melbourne.
 Puller and Nephew, 59 Wholesale Fruit Market, Melbourne.
 Pyramid Co-op. Society Ltd., Kelly-street, Pyramid Hill.
 Quayle and Hutton, 23-25 Mair-street, Ballarat.
 Quick, P. R., and Sons, 458 Queen-street, Melbourne.
 Quong, Hi Shing, 113 Little Bourke-street, Melbourne.
 Quong, Hoong Wah, 41 Wholesale Fruit Market, Melbourne.
 Ramsay's Orange House, Red Cliffs.
 Regan and Kenny Pty. Ltd., 33 Wholesale Fruit Market, Melbourne.
 Reynolds, Bros., G. K. & M., 22 Courtney-street, North Melbourne.
 Richards, K. H., Nyora.
 Richardson, H. F., and Co., Little Malop-street, Geelong.
 Robertson, E. C., Pty. Ltd., 527 Collins-street, Melbourne.
 Rogerson, George, Railway Yards, Shepparton.
 Rohr, George, 9 Queen-street, Melbourne.
 Rose, Arthur Thomas, 30 Lambeth-avenue, Armadale.
 Rosenfield, B., 52 Wholesale Fruit Market, Melbourne.
 Ross, J. W., 15 Wholesale Fruit Market, Melbourne.
 Rossin, G., 75 Moreland-road, East Coburg.
 Royle, W., and Sons, 483 Flinders-lane, Melbourne.
 Rural Distributing Co. Pty. Ltd., 20 Wholesale Fruit Market, Melbourne.
 Rushan, Selim, Post Box 60, Shepparton.
 Sabatino and Nardella, 63 Rose-street, Fitzroy.
 Saltau and Son Pty. Ltd., 121 Kepler-street, Warrnambool.
 Salvaris, G., 161 Seventh-street, Mildura.
 Sang, Goon, and Co., 56 Wholesale Fruit Market, Melbourne.
 Santalucto, A., 125 Capel-street, North Melbourne.
 Sauer, Ernest E., 69 Langtree-avenue, Mildura.
 Sawyer and Devlin, Wilson-street, Horsham.
 Scanlon, J., 2 Bond-street, Sale.
 Schultz, A. J., 244 Barker's-road, Hawthorn.
 Schutt and Barrie Pty. Ltd., Geelong-road, West Footscray.
 Scott, Alex, and Co. Pty. Ltd., 297 Lonsdale-street, Dandenong.
 Scown, L. H., 15 Rutherford-street, Swan Hill.
 Sirro, L., 38 Curren-street, North Melbourne.
 Shea, Hood and Co. Pty. Ltd., 537 Flinders-lane, Melbourne.
 Silbert, Sharp and Davies Pty. Ltd., 17 Wholesale Fruit Market, Melbourne.
 Silk Bros. Pty. Ltd., 24 Wholesale Fruit Market, Melbourne.
 Simmons, S. F., 9 Blackwood-street, North Melbourne.
 Skews, Richard, and Son, 46 Queen-street, Warragul.
 Smith, D. and L., Warburton-road, Lilydale.
 Smith, David, Pty. Ltd., 3 Wholesale Fruit Market, Melbourne.
 Smith, L. A., 25 Doveton-street, Ballarat.
 Smith, Robert, 363 Flinders-street, Melbourne.
 Smith, W., 2 Olga-street, Coburg.
 Smith, W. D., Main-road, Seville.
 Smorgans Rabbit and Poultry Packing Co. Pty. Ltd., Somerville rd., Brooklyn.
 Stabb, A. E., 10 Payne-street, West Caulfield.
 Star Fruit Co., 464 Queen-street, Melbourne.
 Starr, R. K., 8 Orr-street, Yarrowonga.
 Stellarto, L. 741 Nepean Highway, East Brighton.
 Stott, T., and Sons Pty. Ltd., 26 Wholesale Fruit Market, Melbourne.
 Strachan and Co. Ltd., 25-43 Moorabool-street, Geelong.
 Stuart, Ralph A., and Co. Pty. Ltd., 357-367 King-street, Melbourne.
 Stuble, P., and Son Pty. Ltd., Main-road, Greensborough.
 Suburban Rabbit Centre, 37 Piper-street, Kyneton.
 Sun, Loong, 46 Wholesale Fruit Market, Melbourne.
 Symons and Sons, Heyfield.
 Sympag Pty. Ltd., Camp-street, Kangaroo Flat.
 Tainton, H. S., Canterbury-road, Forest Hill.
 Tassicker & Co. Pty. Ltd., Nelson-street, Nhill.
 Thomas, W. C., 693 Riversdale-road, Box Hill.
 Thompson Bros. Chaff and Produce Pty. Ltd., Cherry-street, Werribee.
 Thompson, Geoffrey, & Co., 40 Queen-street, Melbourne.

Name; Principal Place of Business.

Thompson, S. W., Wandin North.
 Thurstain, R. J., Red Hill.
 Till, Henry, & Son, 35 Peel-street, North Melbourne.
 Tinney Bros. & Hanrahan Pty. Ltd., Bungaree.
 Tinney, W. D., High-street, Lancefield.
 Tong, W. S., 31 Wholesale Fruit Market, Melbourne.
 Torney, R., Kingston.
 Torre, Charles, 348 Victoria-street, North Melbourne.
 Tricarico, Michael, Queens-road, Silvan.
 Tulloch, A., and Co., and Tulloch, Jenkins, and Co., 114 King-street, Melbourne.
 Tyner, J. and R., 465 Collins-street, Melbourne.
 Tyner, W., Pty. Ltd., 475 Collins-street, Melbourne.
 United Poultry Farmers' Co-op. Society Ltd., 124 Bell-street, Preston.
 Unthank, V. R., Watts-road, Hastings.
 Vawdrey, W., 66 Moorabool-street, Geelong.
 Vear, F. W., Pty. Ltd., 28 Wholesale Fruit Market, Melbourne.
 Victorian Butter Factorjes Co-op. Ltd., 54-60 King-street, Melbourne.
 Victorian Producers Co-op. Ltd., 578 Flinders-lane, Melbourne.
 Victorian Wheatgrowers Co-op. Ltd., 17 Queen-street, Melbourne.
 Villani, Antonio, 47 Rose-street, Fitzroy.
 Villani, Leonardo, 589 Station-street, Fairfield.
 Vincentiis, Dominio De, Queen's-road, Wandin.
 Virgona & Serra, 153 Ryrie-street, Geelong.
 Wade, H. M., and Co. Pty. Ltd., 21 Wholesale Fruit Market, Melbourne.
 Wadeson Bros., Diamond Creek.
 Wallis, C. N., Rainbow.
 Walter, W., & Sons Pty. Ltd., Main-street, Willaura.
 Ward, H. S. K., Pty. Ltd., 34-38 Spencer-street, Melbourne.
 Warne, R. E., and Sons, Birchip.
 Watkins Fruit Co. Pty. Ltd., 5 Wholesale Fruit Market, Melbourne.
 Watkins, F., Pty. Ltd., 184 Bourke-street, Melbourne.
 Watson, J., and Co., Retail Market, Little Malop-street, Geelong.
 Webber, E. F., and Co., 6 Bennett-parade, East Kew.
 Weddel & Co. (Aust.) Pty. Ltd., 43 King-street, Melbourne.
 Western District Co-op. Produce & Insurance Co. Ltd., 14-20 King-street, Melbourne.
 Western Fruit Produce Co. Pty. Ltd., Market-square, Ballarat.
 Western Murray Fruit Supply, 9 Chaffey-avenue, Mildura.
 Whaley, W. G., 9 Fitzgibbon-avenue, West Brunswick.
 Whitby, Ernest, Queens-road, Wandin East.
 White, A. G., Queen's-road, Silvan.
 Wilding, F., 643 Dandenong-road, Malvern.
 Williams, A. E., Queen's-road, Silvan.
 Williams, H. E., & Sons Pty. Ltd., 9 High-street, Maryborough.
 Willis Bros., Piper-street, Kyneton.
 Wilson, A., 407 Royal-parade, Parkville.
 Wilson & Frazer, 996-1000 Lygon-street, North Carlton.
 Wilson, H., Pty. Ltd., 10 Wholesale Fruit Market, Melbourne.
 Wing Hie & Co., 53 Wholesale Fruit Market, Melbourne.
 Wing, R. A., & Co., 37 Wholesale Fruit Market, Melbourne.
 Wing Young & Co. Pty. Ltd., 38 Wholesale Fruit Market, Melbourne.
 Wodonga Poultry Suppliers, Beechworth-road, Wodonga.
 Wood, C. W. and I. M., McKenzie-street, Rochester.
 Woods Bros., Devenish.
 Woods, C. R., Maude-street, Shepparton.
 Woolf, G., & Sons Pty. Ltd., 29-30 Wholesale Fruit Market, Melbourne.
 Wright, Stephenson (Australia) Pty. Ltd., 34 Queen-street, Melbourne.
 Yee Hop Loong & Co. Pty. Ltd., 32 Wholesale Fruit Market, Melbourne.
 Yee Tong & Co., 45 Wholesale Fruit Market, Melbourne.
 Yendall, O. L., 155 Ackland-street, St. Kilda.
 Yick Sam & Co., 39 Wholesale Fruit Market, Melbourne.
 Young & Co., 201 Main-street, Ballarat.
 Young, Sang, 45 Wholesale Fruit Market, Melbourne.
 Young, S. T., 65 Pynsent-street, Horsham.
 Young, Tim, & Co. Pty. Ltd., 18 Wholesale Fruit Market, Melbourne.
 Youngusband Ltd., 94 King-street, Melbourne.

LIST of persons to whom Farm Produce Agents' Licences have been issued for the year ending December, 1952, all of whom are exempt from the provisions of paragraphs (a) and (b) of sub-section (1) of section (5) of Act 4736 in regard to lodging a fidelity bond:—

Name; Principal Place of Business.

Alexander, J. M., 39 Liverpool-street, West Coburg.
 Anthony Bros., 34 Adelaide-street, Malvern.
 Argentino, Paulo, 29 Sheddon-street, Pascoe Vale.
 Australian Wholesale Grocery Pty. Ltd., 277 Brunswick-street, Fitzroy.
 Bartlett, R. D., and Co., 144 Ballarat-road, Maidstone.
 Bartlett, R. J., 33 Richelleu-street, Maidstone.
 Beckoff, Timothy, 19 Flemington-road, North Melbourne.
 Bretherton, Bruce & Son, 523 Glenhuntly-road, South Caulfield.
 Brown, A. J., and Son, 186 Nicholson-street, Footscray.
 Burke, John, 5 Autumn-street, West Coburg.
 Casamento, J., Market-arcade, Warrnambool.
 Chalker, Les., 91 Neptune-street, Burnley.
 Chamberlain, S. R., 117n Arthurton-road, Northcote.
 Chamberlain, T. (Mrs.), 26 Merribell-avenue, East Coburg.
 Cleary, H. J., 131 The Parade, Ascot Vale.
 Colacino, Guiseppi, 1 Chambers-street, East Brunswick.
 Coonan, Mark., 145-147 Victoria-street, West Melbourne.
 Copolov, Myer, Block 2, Flat 2, Ascot-street, Ascot Vale.
 Dalli, G., 30 Orvieto-street, Merlynston.
 Davis, Lancaster & Co., Queen's Wharf, King-street, Melbourne.
 Dennis, W. M., Wonthaggi.
 Dibble, Bennett Pty. Ltd., 67 Howard-street, North Melbourne.
 Diggers Stall, Little Malop-street, Geelong.
 Drouin Co-operative Butter Factory Co. Ltd., Drouin.
 Dyer, W. and A., 7 Princes-street, Fitzroy.
 Feehan, J. L., Area 5, 11B Camp Pell.
 Gandolfo, Salvatore, 35 Sheddon-street, Pascoe Vale.
 Gattuso, G., and Son, 33 Belgrave-street, Coburg.
 Ghiotti and Vitetta, The Ridge, Glenard-street, Heidelberg.
 Cledhill, A. J., 121 Fairy-street, Warrnambool.
 Greaves, Arthur, 81 Capel-street, North Melbourne.
 Grigg, James, & Son, 14-16 South-street, Ascot Vale.
 Hadwen, J. T., Pty. Ltd., 13 Fish Market, Spencer-street, Melbourne.
 Hamilton Fruit Supply, 279 Gray-street, Hamilton.
 Holden, J. H., 44 Gatehouse-street, Parkville.
 Jacobs, J. E., "Idamere," North-road, Murrumbena.
 Jochinke, O. W., Pty. Ltd., Upper Regeious-street, Dimboola.
 Klein, J., 67 Royal-parade, Parkville.
 Lawry, J. F., 23 Edward-street, Elsternwick.
 Layne, J. J., 30 River-street, North Richmond.
 Liston, R. N., 173 Wellington-street, Flemington.
 MacLeod, John, & Co. Pty. Ltd., 120-122 Lydiard-street, Ballarat.
 Marazita, George, junr., 132 Epsom-road, Ascot Vale.
 Marazita, G., 301 Batman-street, West Melbourne.
 Maver, Allan D., 62 Nicholson-street, East Coburg.
 Maver, G. B., 11 Albion-street, West Brunswick.
 Merrington, Wm. H., 18 Eveline-avenue, Parkdale.
 Mousley, C., 33 Hickford-street, East Brunswick.
 McCabe, J. A., 158 Ferrars-street, South Melbourne.
 McCarty, H., 50 Oakover-road, Preston.
 McKinnon, C., 3 Napier-street, St. Arnaud.
 McPherson, G. & R., 53 Hopkins-street, Footscray.
 Newell, E., 12 Foch-street, Preston.
 Ogden's Poultry Supply, 131 Carlisle-street, Balaclava.
 Oliver, R. & M., Erica.
 Paxinos, A. P., 9 Arnold-street, Carlton.
 Ponte, Frank, 580 Lygon-street, Carlton.
 Ponte, Luigi, 98 Davies-street, East Brunswick.
 Ponte, Vincent, 202 Capel-street, North Melbourne.
 Restuccia, Rosario, 277 Bay-street, Port Melbourne.
 Richardson, A., and Co., 2 King-street, Melbourne.
 Roberts, Leslie, 13 Devon-avenue, West Coburg.
 Robertson, H. A., 46 John-street, East Brunswick.
 Russo, Guiseppi, 362 Bell-street, Pascoe Vale.
 Santalucia, Nicola, 480 William-street, West Melbourne.
 Searles, J. L., 64 Madden-avenue, Mildura.
 Scott, John Arthur, 21 Wholesale Fruit Market, Melbourne.
 Shahin, Haxhi, Victoria Market and Shepparton.
 Singleton, C. W., 54 Brunswick-road, Brunswick West.
 Stephens, John, 64 Victoria-street, Sandringham.
 Stevens, R. A., 66 Teak-street, Caulfield.
 Taverna, D. & V., 109 Errol-street, North Melbourne.
 Thomas, E. W., 119 Victoria-street, Melbourne.
 Thomas, I. H., 942 Canterbury-road, Box Hill.

Name; Principal Place of Business.

- Turnbull, Peter, and Co. Pty. Ltd., 483 Collins-street, Melbourne.
 Wake, H. J., 101 Pearson-street, Brunswick.
 Walsh, E. J., Bros., 331 Latrobe-street, Melbourne.
 Webber, R. R., 16 Studley-avenue, Kew.
 White, G. S., 10 Sea-parade, Mentone.
 Williams Bros., 8 Buckingham-avenue, Bentleigh.
 Williams, G. R., 49 Welfare-parade, Burwood.
 Wilson, D. R., 91 Valentine-street, Ivanhoe.
 Wyatt, Leslie, 113 Edgevale-road, Kew.
 Young, David G., 21 Cadrington-street, Sandringham.
 Young's Wholesale Fruit Supply, 39 Railway-street, Seymour.

LIST of brokers to whom Farm Produce Agents' Licences have been issued for the year ending December, 1952, and each of whom is exempt from lodging a fidelity bond (in accordance with the provisions of section 5, sub-section (6) of Act 4208):—

Name; Principal Place of Business.

- Box, A. D., 528 Collins-street, Melbourne.
 Coutts, R. W., 422 Collins-street, Melbourne.
 Fox, E. J., 120 King-street, Melbourne.
 Fraser, A. H., 34 Queen-street, Melbourne.
 Gidley, John, 465 Collins-street, Melbourne.
 Jackett, Herbert, 317 Collins-street, Melbourne.
 Johnson, A. K., 528 Collins-street, Melbourne.
 Leaver, C. H., & Co. Pty. Ltd., 528 Collins-street, Melbourne.
 Moore, Robert S. M., 90-92 William-street, Melbourne.
 See, John, 465 Collins-street, Melbourne.
 Stephens, G. K., 538 Flinders-lane, Melbourne.
 Todd, J. A., 120 King-street, Melbourne.
 Wood, C. H., & Co., 422 Collins-street, Melbourne.

H. A. MULLETT,
 Director of Agriculture.

THE CONSTITUTION ACT AMENDMENT ACTS.

At the Executive Council Chamber, Melbourne, the twentieth day of May, 1952.

PRESENT :

His Excellency the Governor of Victoria.
 Mr. McDonald | Mr. Hyland
 Mr. Moss | Mr. Fulton
 Mr. Harvey | Mr. White.

LEGISLATIVE COUNCIL—REVOCATION OF APPOINTMENT OF POLLING PLACES.

PURSUANT to the provisions of The Constitution Act Amendment Acts, His Excellency the Governor of the State of Victoria, by and with the advice of the Executive Council thereof, doth hereby revoke the appointment of the polling places named in the first column of the Schedule hereto as polling places for the Subdivisions of the Provinces specified in conjunction therewith in the second and third columns of the said Schedule.

SCHEDULE.

1. Polling Place.	2. Subdivision.	3. Province.
Croxton	Thornbury	Melbourne North
Northcote East	Thornbury	Melbourne North
Hurstbridge	Diamond Creek	Southern

And the Honorable Keith Dodgshun, Her Majesty's Chief Secretary for the State of Victoria, shall give the necessary directions herein accordingly.

N. G. WISHART,
 Acting Clerk of the Executive Council.

THE CONSTITUTION ACT AMENDMENT ACTS.

At the Executive Council Chamber, Melbourne, the twentieth day of May, 1952.

PRESENT :

His Excellency the Governor of Victoria.
 Mr. McDonald | Mr. Hyland
 Mr. Moss | Mr. Fulton
 Mr. Harvey | Mr. White.

LEGISLATIVE COUNCIL—REVOCATION OF APPOINTMENT OF POLLING PLACES.

PURSUANT to the provisions of The Constitution Act Amendment Acts, His Excellency the Governor of the State of Victoria, by and with the advice of the Executive Council thereof, doth hereby revoke the appointment of the polling places named in the first column of the Schedule hereto as polling places within and for the Subdivisions of the Provinces specified in conjunction therewith in the second and third columns of the said Schedule.

SCHEDULE.

1. Polling Place.	2. Subdivision.	3. Province.
Ouyen North-west ..	Ouyen	North-Western
Boorongie	Ouyen	North-Western
Bambill South	Mildura	North-Western
Boonoonar	Mildura	North-Western
Cramenton	Mildura	North-Western
Tunart	Mildura	North-Western
Rocky Valley	Yackandandah	North-Eastern
Hawthorn South	Auburn	East Yarra
Upper Hawthorn	Auburn	East Yarra

And the Honorable Keith Dodgshun, Her Majesty's Chief Secretary for the State of Victoria, shall give the necessary directions herein accordingly.

N. G. WISHART,
 Acting Clerk of the Executive Council.

Published in lieu of the Order re Revocation of Appointment of Polling Places, appearing on Page 2744 of the *Government Gazette* dated the 28th May, 1952.

THE CONSTITUTION ACT AMENDMENT ACTS.

At the Executive Council Chamber, Melbourne, the twentieth day of May, 1952.

PRESENT :

His Excellency the Governor of Victoria.
 Mr. McDonald | Mr. Hyland
 Mr. Moss | Mr. Fulton
 Mr. Harvey | Mr. White.

LEGISLATIVE COUNCIL—REVOCATION AND APPOINTMENT OF A POLLING PLACE.

IN pursuance of the provisions of The Constitution Act Amendment Acts, His Excellency the Governor of the State of Victoria, by and with the advice of the Executive Council thereof, doth hereby revoke the appointment of—

McVEIGH'S

and in lieu thereof, appoint

UPPER YARRA DAM

as a Polling Place within and for the Warburton Subdivision of the Southern Province.

And the Honorable Keith Dodgshun, Her Majesty's Chief Secretary for the State of Victoria, shall give the necessary directions herein accordingly.

N. G. WISHART,
 Acting Clerk of the Executive Council.

DEPARTMENT OF CROWN LANDS AND SURVEY.

At the Executive Council Chamber, Melbourne, the eleventh day of June, 1952.

PRESENT:

His Excellency the Governor of Victoria.
Mr. Dodgshun | Sir Albert Lind.

UNUSED AND UNMADE ROADS CLOSED.

HIS Excellency the Governor of the State of Victoria, by and with the advice of the Executive Council thereof, doth hereby direct that, in pursuance of the provisions of section 304 of the *Land Act 1928*, the unused and unmade roads referred to hereunder be closed, viz:—

Parish of Gerang Gerung, County of Lowan, being the road between allotment 71 and allotment 74.—(G.212⁽²⁾) (M.30110).

Township of Gunbower, Parish of Patho, County of Gunbower, being the road between the State School Reserve and allotments 2 and 3, section 5.—(G.199⁽¹⁾) (Rs.6227).

Parish of Bungil East, County of Benambra, being the road indicated by hachure on plan hereunder.—(B.655⁽²⁾) (H.018096).

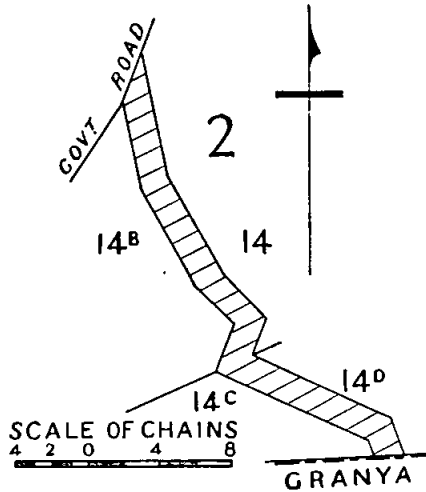

And the Honorable Sir Albert Eli Lind, Her Majesty's Commissioner of Crown Lands and Survey for the State of Victoria, shall give the necessary directions herein accordingly.

A. MAHLSTEDT,
Clerk of the Executive Council.

DEPARTMENT OF CROWN LANDS AND SURVEY.

At the Executive Council Chamber, Melbourne, the eleventh day of June, 1952.

PRESENT:

His Excellency the Governor of Victoria.
Mr. Dodgshun | Sir Albert Lind.

LAND TEMPORARILY RESERVED FOR ADDITIONAL PURPOSE.

HIS Excellency the Governor of the State of Victoria, by and with the advice of the Executive Council thereof, doth hereby, in pursuance of the provisions of the *Land Act 1928*, reserve, temporarily, the land hereinafter described for an additional purpose:—

Parish of Echuca North, County of Rodney, 27 acres 2 roods 33 perches, being the site temporarily reserved for a Public Park by Order in Council of the 13th January, 1930, is hereby temporarily reserved for the additional purpose of Public Recreation.—(E.96⁽²⁾) (Rs.3944).

And the Honorable Sir Albert Eli Lind, Her Majesty's Commissioner of Crown Lands and Survey for the State of Victoria, shall give the necessary directions herein accordingly.

A. MAHLSTEDT,
Clerk of the Executive Council.

DEPARTMENT OF CROWN LANDS AND SURVEY.

At the Executive Council Chamber, Melbourne, the eleventh day of June, 1952.

PRESENT:

His Excellency the Governor of Victoria.
Mr. Dodgshun | Sir Albert Lind.

LANDS TEMPORARILY RESERVED.

HIS Excellency the Governor of the State of Victoria, by and with the advice of the Executive Council thereof, doth hereby, in pursuance of the provisions of the *Land Act 1928*, reserve, temporarily, and also except from occupation for mining purposes under any miner's right, the lands hereinafter described:—

LINTON.—Site for a Children's Playground, 1 rood, more or less, Town of Linton, Parish of Argyle, County of Grenville, as indicated by hachure on plan hereunder.—(L.52⁽²⁾) (Rs.6949).

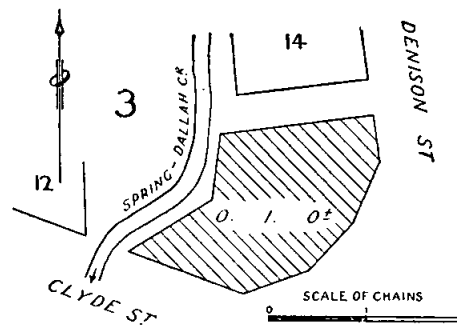

EURANDELONG (NUG NUG).—Site for Public Recreation, in addition to and adjoining the sites temporarily reserved therefor by Orders in Council of the 29th April, 1908, and the 8th October, 1940, 11 acres, more or less, Parish of Eurandelong, County of Delatite, as indicated by hachure on plan hereunder.—(E.107⁽³⁾) (Rs.5107).

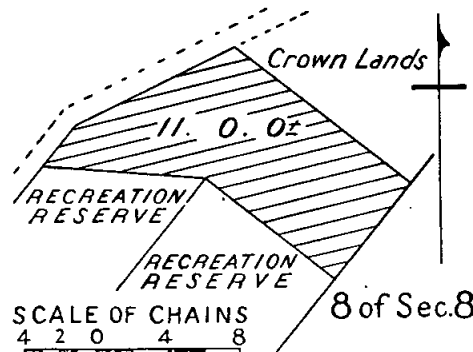

TYNTYNDER WEST (NYAH WEST).—Site for Police purposes, 1 rood 12 perches, Parish of Tyntynder West, County of Tatchera, as indicated by hachure on plan hereunder.—(T.244⁽²⁾) (Rs.6923).

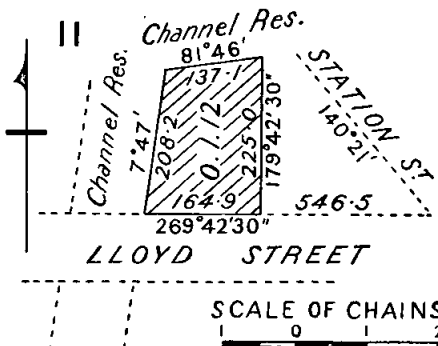

MILDURA.—Site for Police purposes, 24 perches, Parish of Mildura, County of Karkaroc, as indicated by hachure on plan hereunder.—(M.533⁽²⁾) (Rs.6922).

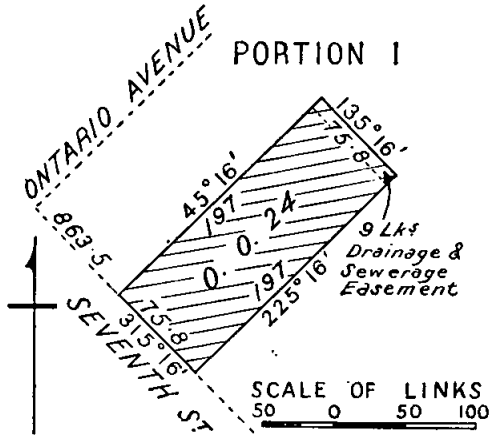

SAN REMO.—Site for Public purposes, 8 acres, more or less, Township of San Remo, Parish of Woolamai, County of Mornington, as indicated by hachure on plan hereunder.—(S.463⁽³⁾) (Rs.3972).

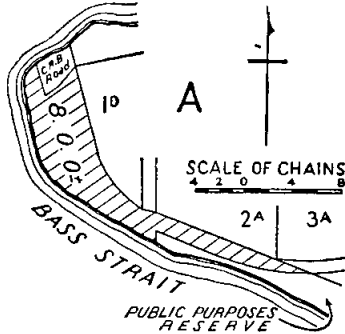

And the Honorable Sir Albert Eli Lind, Her Majesty's Commissioner of Crown Lands and Survey for the State of Victoria, shall give the necessary directions herein accordingly.

A. MAHLSTEDT,
Clerk of the Executive Council.

DEPARTMENT OF CROWN LANDS AND SURVEY.

At the Executive Council Chamber, Melbourne, the eleventh day of June, 1952.

PRESENT:

His Excellency the Governor of Victoria.
Mr. Dodgshun | Sir Albert Lind.

ROAD IN THE PARISH OF SCORESBY REDUCED IN WIDTH.

HIS Excellency the Governor of the State of Victoria, by and with the advice of the Executive Council thereof, in accordance with the provisions of, and in exercise of the powers conferred by the *Local Government Act 1946*, doth, by this Order, confirm the scheme for the reduction in width of the road in the Parish of Scoresby in the County of Mornington, in the State of Victoria, as set out in an agreement deposited in the Office of Crown Lands and Survey, Melbourne, the said scheme being under the seal of the corporation of the President, Councillors, and Rate-payers of the Shire of Ferntree Gully of the first part, the seal of the Board of Land and Works of the second part, and under the hands of the persons whose signatures are subscribed to the said scheme and who are called the parties of the third part.—(G.58680.)

And the Honorable Sir Albert Eli Lind, Her Majesty's Commissioner of Crown Lands and Survey for the State of Victoria, shall give the necessary directions herein accordingly.

A. MAHLSTEDT,
Clerk of the Executive Council.

FACTORIES AND SHOPS ACTS.

At the Executive Council Chamber, Melbourne, the eleventh day of June, 1952.

PRESENT:

His Excellency the Governor of Victoria.
Mr. Dodgshun | Sir Albert Lind.

A DEVICE KNOWN AS THE "PRESTO" PRESSURE COOKER (SIX QUARTS CAPACITY), EXEMPTED FROM CERTAIN PROVISIONS OF THE FACTORIES AND SHOPS ACTS.

BY virtue of the powers conferred by section 57 of the *Factories and Shops Act 1928*, His Excellency the Governor of the State of Victoria, by and with the advice of the Executive Council thereof, doth by this Order exempt from the operation of Division 16 of Part III. of the *Factories and Shops Act 1928*, the class of steam boiler known as the "Presto" Pressure Cooker (six quarts capacity), when manufactured in accordance with the specifications and sample lodged with the Chief Inspector of Factories by Gresham Industries Proprietary Limited, of 141 York-street, Sydney, New South Wales, until a further Order is made.

And the Honorable Trevor Harvey, Her Majesty's Minister of Labour for the State of Victoria, shall give the necessary directions herein accordingly.

A. MAHLSTEDT,
Clerk of the Executive Council.

INEBRIATES ACT 1928 (No. 3703).—SECTION 20.

At the Executive Council Chamber, Melbourne, the eleventh day of June, 1952.

PRESENT:

His Excellency the Governor of Victoria.
Mr. Dodgshun | Sir Albert Lind.

ESTABLISHMENT OF THE MALE INEBRIATES HOME, MENTAL HOSPITAL, SUNBURY.

PURSUANT to the provisions of section twenty of Act No. 3703, His Excellency the Governor of the State of Victoria, by and with the advice of the Executive Council of the said State, hereby establishes, as from the 1st day of July, One thousand nine hundred and fifty-two, the Male Division of the premises known under the provisions of the *Mental Hygiene Acts* as the Mental Hospital, Sunbury, as a place for the reception, control, and treatment of inebriates, to be styled the "Male Inebriates Home, Mental Hospital, Sunbury."

And the Honorable William Oliver Fulton, Her Majesty's Minister of Health for the State of Victoria, shall give the necessary directions herein accordingly.

A. MAHLSTEDT,
Clerk of the Executive Council.

INEBRIATES ACT 1928 (No. 3703).

At the Executive Council Chamber, Melbourne, the eleventh day of June, 1952.

PRESENT:

His Excellency the Governor of Victoria.
Mr. Dodgshun | Sir Albert Lind.

REVOCATION OF ORDER ESTABLISHING THE MALE INEBRIATES HOME, RECEIVING HOUSE, ROYAL PARK.

PURSUANT to the provisions of section twenty of Act No. 3703, His Excellency the Governor of the State of Victoria, by and with the advice of the Executive Council of the said State, hereby revokes, as from the 1st day of July, One thousand nine hundred and fifty-two, an Order made on the thirtieth day of September, One thousand nine hundred and forty-seven, establishing the Male Inebriates Home, Receiving House, Royal Park.

And the Honorable William Oliver Fulton, Her Majesty's Minister of Health for the State of Victoria, shall give the necessary directions herein accordingly.

A. MAHLSTEDT,
Clerk of the Executive Council.

MAFFRA SEWERAGE AUTHORITY.

At the Executive Council Chamber, Melbourne, the eleventh day of June, 1952.

PRESENT:

His Excellency the Governor of Victoria.
Mr. Dodgshun | Sir Albert Lind.

AMENDMENT OF ORDER.

UNDER the powers conferred by the Sewerage Districts Acts and all other powers enabling him in that behalf, His Excellency the Governor of the State of Victoria, by and with the advice of the Executive Council of the said State, doth hereby amend as follows the Order in Council proclaiming the sewerage district and constituting the Maffra Sewerage Authority made on the 6th day of September, 1933, and published in the *Victoria Government Gazette* of 14th September, 1933.

In clause (a) for the expression "Three thousand pounds (£3,000)", there shall be substituted the expression "Five thousand pounds (£5,000)."

And the Honorable Sir Herbert John Thornhill Hyland, for and on behalf of Her Majesty's Minister of Water Supply for the State of Victoria, shall give the necessary directions herein accordingly.

A. MAHLSTEDT,
Clerk of the Executive Council.

Water Acts.

STATE RIVERS AND WATER SUPPLY COMMISSION.

At the Executive Council Chamber, Melbourne, the eleventh day of June, 1952.

PRESENT:

His Excellency the Governor of Victoria.
Mr. Dodgshun | Sir Albert Lind.

RODNEY IRRIGATION AND WATER SUPPLY DISTRICT.—PORTION EXCISED.

UNDER the powers conferred by the Water Acts and all other powers enabling him in that behalf, His Excellency the Governor of the State of Victoria, by and with the advice of the Executive Council of the said State, on the recommendation of the State Rivers and Water Supply Commission, doth hereby declare, order, and direct as follows:—

That there shall be excised from the Rodney Irrigation and Water Supply District that portion of the same set out and described in the Schedule hereto, which portion as on and from the date of this Order shall be deemed to be excised accordingly.

SCHEDULE.

Commencing at the north-western angle of lot 1 on lodged plan of subdivision No. 21794, being part of Crown allotment 6, Parish of Kyabram East, County of Rodney; thence easterly by the northern boundaries of lots 1, 2, 3, 4, 5, 6, and 7 and a line connecting those boundaries to the north-eastern angle of the last-mentioned lot; thence northerly by a line in production of the eastern boundary of said lot 7, a distance of about 40 links, to the south-western boundary of the Kyabram Supply Channel; thence south-easterly by that channel boundary to the northern boundary of Allan-street; thence south by a line to the southern boundary of the last-mentioned street; thence westerly by that street boundary to a point in line with the western boundary of lot 1 aforesaid; thence northerly by a line and the last-mentioned boundary to the point of commencement.

The portion described in the foregoing Schedule is shown on a plan approved by the Governor in Council, and deposited in the office of the State Rivers and Water Supply Commission, Melbourne.—(Corres. 51/5437, 52/10407.)

And the Honorable Sir Herbert John Thornhill Hyland, for and on behalf of Her Majesty's Minister of Water Supply for the State of Victoria, shall give the necessary directions herein accordingly.

A. MAHLSTEDT,
Clerk of the Executive Council.

WATER ACTS.

At the Executive Council Chamber, Melbourne, the eleventh day of June, 1952.

PRESENT:

His Excellency the Governor of Victoria.
Mr. Dodgshun | Sir Albert Lind.

KYABRAM WATERWORKS TRUST.—EXTENT OF DISTRICT INCREASED.

UNDER the powers conferred by the Water Acts and all other powers enabling him in that behalf, His Excellency the Governor of the State of Victoria, by and with the advice of the Executive Council of the said State, doth hereby declare, order, and direct as follows:—

That the extent of the Waterworks District of the Kyabram Waterworks Trust be increased by adding to the same the lands set out and described in the Schedule hereto, and as on and from the date of this Order such district shall be deemed to be increased accordingly.

SCHEDULE.

Commencing at the north-western angle of lot 1 on lodged plan of subdivision No. 21794, being part of Crown allotment 6, Parish of Kyabram East, County of Rodney; thence easterly by the northern boundaries of lots 1, 2, 3, 4, 5, 6, and 7 and a line connecting those boundaries to the north-eastern angle of the last-mentioned lot; thence northerly by a line in production of the eastern boundary of said lot 7, a distance of about 40 links, to the south-western boundary of the Kyabram Supply Channel; thence south-easterly by that channel boundary to the northern boundary of Allan-street; thence south by a line to the southern boundary of the last-mentioned street; thence westerly by that street boundary to a point in line with the western boundary of lot 1 aforesaid; thence northerly by a line and the last-mentioned boundary to the point of commencement.

The lands set out and described in the foregoing Schedule are shown on a plan approved by the Governor in Council, and deposited in the office of the State Rivers and Water Supply Commission, Melbourne.—(Corres. 51/5437, 52/10407.)

And the Honorable Sir Herbert John Thornhill Hyland, for and on behalf of Her Majesty's Minister of Water Supply for the State of Victoria, shall give the necessary directions herein accordingly.

A. MAHLSTEDT,
Clerk of the Executive Council.

SEYMOUR WATERWORKS TRUST.

At the Executive Council Chamber, Melbourne, the eleventh day of June, 1952.

PRESENT:

His Excellency the Governor of Victoria.
Mr. Dodgshun | Sir Albert Lind.

ADDITIONAL LOAN OF £2,618.

UNDER the powers conferred by the Water Acts and all other powers enabling him in that behalf, His Excellency the Governor of the State of Victoria, by and with the advice of the Executive Council of the said State, doth hereby grant an additional loan of Two thousand six hundred and eighteen pounds (£2,618) to the Seymour Waterworks Trust for the construction of pipe mains and the purchase and installation of meters, as set forth in the detailed statement bearing date the 30th May, 1952, and verified under the seal of the State Rivers and Water Supply Commission.

The loan hereby granted shall be subject to the provisions of the Water Acts.

And the Honorable Sir Herbert John Thornhill Hyland, for and on behalf of Her Majesty's Minister of Water Supply for the State of Victoria, shall give the necessary directions herein accordingly.

A. MAHLSTEDT,
Clerk of the Executive Council.

MANSFIELD WATERWORKS TRUST.

At the Executive Council Chamber, Melbourne, the
eleventh day of June, 1952.

PRESENT:

His Excellency the Governor of Victoria.
Mr. Dodgshun | Sir Albert Lind.

ADDITIONAL LOAN OF £17,783.

UNDER the powers conferred by the Water Acts and all other powers enabling him in that behalf, His Excellency the Governor of the State of Victoria, by and with the advice of the Executive Council of the said State, doth hereby grant an additional loan of Seventeen thousand seven hundred and eighty-three pounds (£17,783) to the Mansfield Waterworks Trust for the construction of pipe mains and completion of service reservoir, as set forth in the detailed statement bearing date the 30th May, 1952, and verified under the seal of the State Rivers and Water Supply Commission.

The loan hereby granted shall be subject to the provisions of the Water Acts.

And the Honorable Sir Herbert John Thornhill Hyland, for and on behalf of Her Majesty's Minister of Water Supply for the State of Victoria, shall give the necessary directions herein accordingly.

A. MAHLSTEDT,
Clerk of the Executive Council.

LIFTS REGULATION ACT 1928.

At the Executive Council Chamber, Melbourne, the
eleventh day of June, 1952.

PRESENT:

His Excellency the Governor of Victoria.
Mr. Dodgshun | Sir Albert Lind.

AMENDMENT TO LIFTS REGULATIONS.

IN pursuance of the powers conferred by the *Lifts Regulation Act 1928*, His Excellency the Governor of the State of Victoria, by and with the advice of the Executive Council thereof, doth hereby amend Regulation 7 of the Lifts Regulations 1945, as follows:—

- (a) For the expression "21s." there shall be substituted the expression "£2."
- (b) For the expression "42s." there shall be substituted the expression "£4."
- (c) For the expression "12s. 6d." there shall be substituted the expression "£1."

And the Honorable Trevor Harvey, Her Majesty's Minister of Labour for the State of Victoria, shall give the necessary directions herein accordingly.

A. MAHLSTEDT,
Clerk of the Executive Council.

APPRENTICESHIP ACTS.

At the Executive Council Chamber, Melbourne, the
eleventh day of June, 1952.

PRESENT:

His Excellency the Governor of Victoria.
Mr. Dodgshun | Sir Albert Lind.

APPOINTMENT OF DEPUTY CHAIRMAN OF TRADE COMMITTEES.

IN pursuance of the provisions of the Apprenticeship Acts, His Excellency the Governor of the State of Victoria, by and with the advice of the Executive Council thereof, doth by this Order appoint Valentine Gilbert Empey, an officer of the Public Service and a competent and impartial person of proved administrative ability, and with a general knowledge of industrial matters, to be deputy chairman of trade committees, for the term of three years from the 26th day of May, 1952, at a remuneration of £50 per annum, which sum shall be payable to him in addition to his salary as an officer of the Public Service.

And the Honorable Trevor Harvey, Her Majesty's Minister of Labour for the State of Victoria, shall give the necessary directions herein accordingly.

A. MAHLSTEDT,
Clerk of the Executive Council.

LANDLORD AND TENANT ACTS.

At the Executive Council Chamber, Melbourne, the
seventeenth day of June, 1952.

PRESENT:

His Excellency the Governor of Victoria.
Mr. Moss | Mr. White.

ORDER EXCLUDING CERTAIN PREMISES FROM THE OPERATION OF CERTAIN PROVISIONS OF THE LANDLORD AND TENANT ACT 1948.

IN pursuance of the powers conferred upon him by the *Landlord and Tenant Act 1948*, as amended by the *Landlord and Tenant (Amendment) Act 1948*, His Excellency the Governor of the State of Victoria, by and with the advice of the Executive Council thereof, doth hereby declare that the several premises described hereunder shall be excluded from the operation of such of the provisions contained in the *Landlord and Tenant Act 1948* as are set out hereunder, that is to say:—

From the Provisions of Parts III. and V.

The front flat of the premises at Number 39 St. John's-avenue, Camberwell.

From the Provisions of Parts II., III., and V.

Number 1 Huntingfield-place, Heidelberg.
Number 3 Huntingfield-place, Heidelberg.
Number 2 Huntingfield-place, Heidelberg.
Number 4 Huntingfield-place, Heidelberg.
Number 6 Huntingfield-place, Heidelberg.
Number 5 Huntingfield-place, Heidelberg.
Number 48 Edwin-street, Heidelberg.
Number 50 Edwin-street, Heidelberg.
Number 52 Edwin-street, Heidelberg.
Number 54 Edwin-street, Heidelberg.
Number 56 Edwin-street, Heidelberg.

And the Honorable Thomas Walter Mitchell, Her Majesty's Attorney-General in and for the State of Victoria, shall give the necessary directions herein accordingly.

A. MAHLSTEDT,
Clerk of the Executive Council.

BENEFIT ASSOCIATIONS ACT 1951.

At the Executive Council Chamber, Melbourne, the
seventeenth day of June, 1952.

PRESENT:

His Excellency the Governor of Victoria.
Mr. Moss | Mr. White.

ASSOCIATION DECLARED TO BE EXEMPT FROM THE ACT.

HIS Excellency the Governor of the State of Victoria, in the Commonwealth of Australia, by and with the advice of the Executive Council of the said State, and in pursuance of the provisions of the *Benefit Associations Act 1951*, doth by this Order declare the association known as the Castlemaine District Community Hospital Contributory Fund to be exempt from the provisions of the said Act.

And the Honorable Keith Dodgshun, Her Majesty's Chief Secretary for the State of Victoria, shall give the necessary directions herein accordingly.

A. MAHLSTEDT,
Clerk of the Executive Council.

APPROACHING LAND SALES.

SALES of Crown lands, in fee-simple, will be held at the under-mentioned places and dates, viz.:-

	No. of Gazette.
Ararat.—Thursday, 24th July, 1952 ..	501
Castlemaine.—Thursday, 3rd July, 1952 ..	472
Daylesford.—Thursday, 3rd July, 1952 ..	484
Horsham.—Friday, 20th June, 1952 ..	328
Kaniva.—Wednesday, 2nd July, 1952 ..	400
Mansfield.—Friday, 27th June, 1952 ..	472
Nhill.—Thursday, 3rd July, 1952 ..	400
St. Arnaud.—Thursday, 24th July, 1952 ..	501
Warracknabeal.—Thursday, 26th June, 1952 ..	400

SALES OF CROWN LANDS BY AUCTION.

The lands will be sold in fee-simple, and subject to the covenants, conditions, exceptions, and reservations directed by the Governor in Council by an Order in Council dated the 5th August, 1930, and published in the *Government Gazette* of the 8th August, 1930, varied as herein.

A deposit of at least twelve and a half per centum of the price at which each lot is sold must be paid by the purchaser at the time of sale, such payments shall be made in coin, bank notes or cheques approved by the officer conducting the sale, and the residue of such price will be payable in equal instalments, in accordance with the scale hereunder, on the last day of each successive period of six months from the time of sale, or, if the purchaser choose, at any earlier time or times; and such residue of the purchase money shall bear interest at the rate of Five pounds per centum per annum, to be computed with respect to each instalment for the period which has elapsed between the time of sale and the time of the payment of such instalment. If the residue of the price be paid within thirty days after the time of the sale no interest will be payable thereon.

The Governor in Council may allow a transfer of the purchaser's interest to an approved person at any time before the final payment of the purchase money is made. The fee for transfer shall be One pound and such transfer will be subject to payment of stamp duty.

SCALE OF PAYMENTS OF RESIDUE.

£20 and under, 6 instalments.
Over £20, and not exceeding £50, 8 instalments.
Over £50, and not exceeding £100, 10 instalments.
Over £100, and not exceeding £200, 12 instalments.
Over £200, and not exceeding £300, 14 instalments.
Over £300, and not exceeding £400, 16 instalments.
Over £400, and not exceeding £500, 18 instalments.
Over £500, 20 instalments.

FEES, ETC.

The amount payable for assurance fund (One halfpenny for each £1 of purchase price) and Crown grant fee must be paid with the balance of purchase money. The following is the scale of fees for Crown grant:—

50 acres and under, £1 10s.
Over 50 acres, £2.

Where the purchase money does not exceed £5, the grant fee is £1.

Valuations of improvements (if not purchased by the owner thereof), and charges for survey, must also be paid at the time of sale.

A. E. LIND,

Commissioner of Crown Lands and Survey.

Office of Crown Lands and Survey,
Melbourne, 16th June, 1952.

ARARAT.—Sale (No. 10950) of Crown lands, in fee-simple, by auction, will be held at the COURT HOUSE, ARARAT, on THURSDAY, the 24th JULY, 1952, at half-past TWO o'clock p.m. To be conducted by H. H. DODD, Land Officer.

ARARAT, PARISH OF ARARAT, COUNTY OF RIPON.

In the South of the Township.

Upset price £25 the lot. Charge for survey £7 7s. 6d.

Lot 1. Area 2a. 2r. (subject to survey), allotment 15B of section O.

ELMHURST, PARISH OF GLENPATRICK, COUNTY OF KARA KARA.

Fronting Byerly-street.

Upset price £15 the lot. Charge for survey £5 5s.

Lot 2. Area 1 rood, allotment 20 of section 3. Valuation of improvements, £493 (Anthony Rogers).

PARISH OF ARARAT, COUNTY OF RIPON.

Near Centre of Parish.

Upset price £47 the lot. Charge for survey, £12 5s.

Lot 3. Area 9a. 2r. (subject to survey providing a one-chain road along the southern boundaries of allotments 22 and 23 of section 3A), allotment 1e of section 16. One month allowed for removal of improvements.

Fronting Stawell-Ararat Road, About Two Miles from City of Ararat.

Upset price £20 the lot. Charge for survey £5 17s. 6d.

Lot 4. Area 2 acres (subject to adjustment), allotment 27c of section 3A. Valuation of improvements, £22 (J. H. McGuire).

ST. ARNAUD.—Sale (No. 10951) of Crown lands, in fee-simple, by auction, will be held at the LAND OFFICE, ST. ARNAUD, on THURSDAY, the 24th JULY, 1952, at half-past TWO o'clock p.m. To be conducted by R. E. LAWES, Land Officer.

EMU, PARISH OF KOOROC, COUNTY OF KARA KARA.

Near Foley's Creek.

Upset price £7 the lot. Charge for survey £5 15s.

Lot 1. Area 3r. 18p., allotment 24 of section 2.

ST. ARNAUD, PARISH OF ST. ARNAUD, COUNTY OF KARA KARA.

Fronting Little Dundas-street.

Upset price £30 the lot. Charge for survey £5 10s.

Lot 2. Area 1r. 23p. (subject to survey), allotment 16 of section C1. Subject to drainage easement. One month allowed for removal of improvements.

REDBANK, PARISH OF REDBANK, COUNTY OF KARA KARA.

In the Centre of the Township.

Upset price £20 the lot. Charge for survey £5 5s.

Lot 3. Area 38 perches (subject to review), allotment 18 of section 7. One month allowed for removal of improvements.

PARISH OF ST. ARNAUD, COUNTY OF KARA KARA.

Fronting William-street.

Upset price £35 the lot. Charge for survey £5 10s.

Lot 4. Area 1r. 32 6/10p., allotment 25 of section 9b. One month allowed for removal of improvements.

ST. ARNAUD, PARISH OF ST. ARNAUD, COUNTY OF KARA KARA.

Upset price £25 per lot. Charge for survey £5 5s. per lot.

Corner Brudenall and Gray Streets.

Lot 5. Area 1 rood (subject to survey), allotment 1 of section 13F.

Fronting Brudenall-street.

Lot 6. Area 1 rood (subject to survey), allotment 2 of section 13F.

PUBLIC HEARINGS BY PERSONS APPOINTED UNDER THE 34TH SECTION OF THE LAND ACT 1928.

NOTICE is hereby given that at the times and places mentioned in the Schedule hereunder, applications for leases and licences under the Land Acts, objections to such applications, objections to proposed proclamations, alterations, additions, diminutions, revocations, or unions of commons, and reasons against forfeiture of any leases or licences under the Land Acts deemed liable to forfeiture, will be publicly heard by the persons whose names are set opposite such places respectively in such Schedule, being persons appointed by me, the responsible Minister of the Crown administering the Land Acts, to hear the same and report thereon in writing to me.

A. E. LIND,

Commissioner of Crown Lands and Survey, and
President of the Board of Land and Works.Department of Crown Lands and Survey,
Melbourne, 18th June, 1952.

SCHEDULE.

LAND INSPECTOR'S OFFICE, KOO-WEE-RUP, Tuesday,
1st July, 1952, at 10 a.m., C. E. Rice, Land Officer.COURT HOUSE, WARRAGUL, Monday, 7th July, 1952, at
11 a.m., C. E. Rice, Land Officer.COURT HOUSE, WARRAGUL, Monday, 14th July, 1952,
at 11 a.m., C. E. Rice, Land Officer.LANDS OFFICE, 80 HIGH-STREET, MARYBOROUGH,
Friday, 18th July, 1952, at 2 p.m., R. E. Lawes, Land
Officer, St. Arnaud.

PROPOSED REVOCATION OF TEMPORARY RESERVATION AND THE WITHHOLDING FROM SALE, LEASING, AND LICENSING OF CERTAIN LAND BY ORDER IN COUNCIL.

IN pursuance of the provisions of the *Land Act 1928*, notice is hereby given that it is the intention of the Governor in Council to revoke the temporary reservation and the withholding from sale, leasing, and licensing of certain land by the Order in Council hereunder referred to, viz.:—

The following Notice was published 1° on the 4th June, 1952, pursuant to Order of the 27th May, 1952.

BOIKERBERT.—The temporary reservation as a site for Watering purposes and the withholding from sale, leasing, and licensing, by Order in Council of the 8th April, 1878 (see *Government Gazette* of the 12th April, 1878, page 815), of 13 acres of land in the Parish of Boikerbert, being part of allotment 19, is about to be revoked.—(B.643(2) (Z.35022).

A. E. LIND,
Commissioner of Crown Lands and Survey.

COMMON ABOUT TO BE DIMINISHED.

IN pursuance of the provisions of the *Land Act 1928*, notice is hereby given that it is the intention of the Governor in Council to diminish the common hereinafter mentioned, viz.:—

The following Notice was published 1° on the 28th May, 1952, pursuant to Order of the 20th May, 1952.

The Ballaarat West Town Common, proclaimed as such by Proclamation bearing date the 28th January, 1861, is about to be diminished by the excision therefrom of the two separate portions, containing 213 acres 2 roods 8 perches, indicated by hachure on plan hereunder.—(C.91998.)

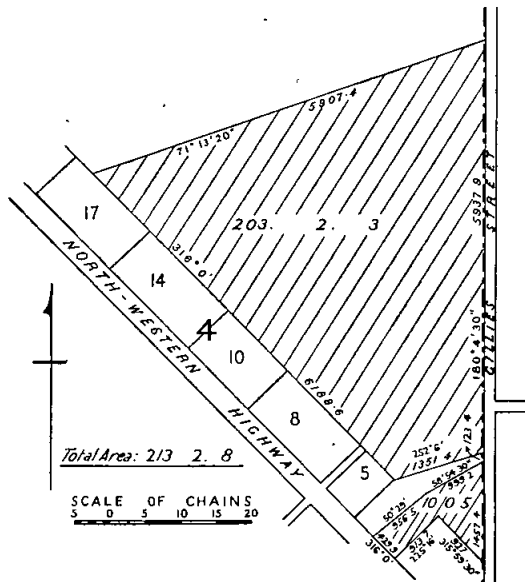

A. E. LIND,
Commissioner of Crown Lands and Survey.

COMMON ABOUT TO BE DIMINISHED.

IN pursuance of the provisions of the *Land Act 1928*, notice is hereby given that it is the intention of the Governor in Council to diminish the common hereinafter mentioned, viz.:—

The following Notice was published 1° on the 11th June, 1952, pursuant to Order of the 3rd June, 1952.

The Caramut Town Common, proclaimed as such by Proclamations bearing date the 20th November, 1865, and the 14th October, 1867, is about to be diminished by the excision therefrom of 5 acres, being the whole of the land within section 12, Town of Caramut.—(Rs.417.)

A. E. LIND,
Commissioner of Crown Lands and Survey.

PROPOSED REVOCATION OF ORDER DEFINING BOUNDARIES OF CERTAIN LAND.

IN pursuance of the provisions of the *Land Act 1928*, notice is hereby given that it is the intention of the Governor in Council to revoke the Order defining the boundaries of certain land hereunder referred to, viz.:—

The following Notice was published 1° on the 4th June, 1952, pursuant to Order of the 27th May, 1952.

The Order dated 25th July, 1860, defining the boundaries of certain land in the Parish of Neilborough situate about 13 miles north-westerly from Sandhurst (at Elysian Flat) set apart as a site for the Township of Neilborough (see *Government Gazette* 1860, page 1446), revoked as to part by the Order in Council dated 25th September, 1902 (see *Government Gazette* 1902, page 4719), is about to be revoked as regards the balance thereof.—(N.52(5,7) (C.20391).

A. E. LIND,
Commissioner of Crown Lands and Survey.

PROPOSED REVOCATIONS OF TEMPORARY RESERVATIONS OF LANDS BY ORDERS IN COUNCIL.

IN pursuance of the provisions of the *Land Act 1928*, notice is hereby given that it is the intention of the Governor in Council to revoke the temporary reservations of lands by Orders in Council hereunder referred to, viz.:—

The following Notices were published 1° on the 4th June, 1952, pursuant to Orders of the 27th May, 1952.

SHELFORD WEST.—The temporary reservation, by Order in Council of the 22nd May, 1871, of 1 acre 2 roods of land in the Parish of Shelford West as a site for a Presbyterian Place of Public Worship and Minister's Dwelling, is about to be revoked so far only as the portion containing 5 4/10 perches, indicated by hachure on plan hereunder, is concerned.—(S.281(2) (Rs.2010).

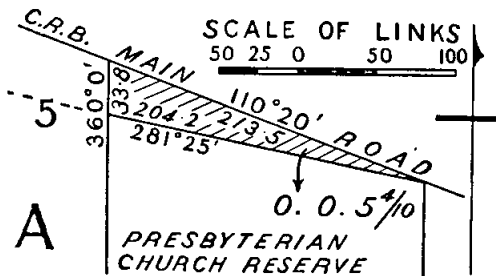

KILNOORAT.—The temporary reservation, by Order in Council of the 11th December, 1865 (see *Government Gazette* of the 19th December, 1865, page 2964), of 8 acres of land in the Parish of Kilnoorat as a site for a Cemetery, is about to be revoked so far only as the portion containing 3 acres 2 roods 20 perches, more or less, indicated by hachure on plan hereunder, is concerned.—(K.53(2) (C.92734).

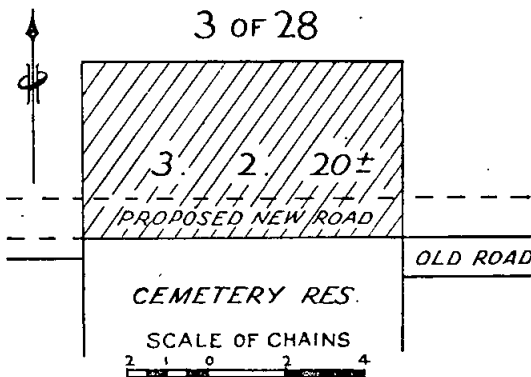

A. E. LIND,
Commissioner of Crown Lands and Survey.

PROPOSED REVOCATION OF TEMPORARY
RESERVATION OF LAND BY ORDER IN COUNCIL.

IN pursuance of the provisions of the *Land Act 1928*, notice is hereby given that it is the intention of the Governor in Council to revoke the temporary reservation of certain land by Order in Council hereunder referred to, viz.:—

The following Notice was published 1° on the 28th May, 1952, pursuant to Order of the 20th May, 1952.

SALE.—The temporary reservation, by Order in Council of the 23rd September, 1872, of 24 acres 3 roods of land in the Borough of Sale as a site for Friendly Societies' Recreation Ground, is about to be revoked.—(S.239^(a)) (Rs.820).

A. E. LIND,
Commissioner of Crown Lands and Survey.

PROPOSED REVOCATION OF TEMPORARY
RESERVATION OF LAND BY ORDER IN COUNCIL.

IN pursuance of the provisions of the *Land Act 1928*, notice is hereby given that it is the intention of the Governor in Council to revoke the temporary reservation of land by the Order in Council hereunder referred to, viz.:—

The following Notice was published 1° on the 11th June, 1952, pursuant to Order of the 3rd June, 1952.

CARLYLE (WAHGUNYAH).—The temporary reservation, by Order in Council of the 8th February, 1864, of 210 acres, more or less, of land in the parish of Carlyle, at Wahgunyah, as a site for Racing and other purposes of Recreation, is about to be revoked.—(C.187^(a)) (Rs.1040).

A. E. LIND,
Commissioner of Crown Lands and Survey.

PROPOSED REVOCATIONS OF TEMPORARY
RESERVATIONS OF LANDS BY ORDERS IN COUNCIL.

IN pursuance of the provisions of the *Land Act 1928*, notice is hereby given that it is the intention of the Governor in Council to revoke the temporary reservations of lands by the Orders in Council hereunder referred to, viz.:—

The following Notices were published 1° on the 18th June, 1952, pursuant to Orders of the 11th June, 1952.

OXLEY.—The temporary reservation, by Order in Council of the 27th April, 1868 (see *Government Gazette* of the 5th May, 1868, page 886), of 6 acres 1 rood 8 perches (now shown by re-survey as 5 acres) of land in the Parish of Oxley as a site from which Gravel can be procured, is about to be revoked.—(O.16^(r2)) (Rs.6942).

QUAMBATOOK.—The temporary reservation, by Order in Council of the 19th August, 1895, of 12 acres 0 roods 28 perches of land in the Parish of Quambatook as a site for Water Supply purposes, is about to be revoked.—(Q.37^(a)) (Rs.5593).

A. E. LIND,
Commissioner of Crown Lands and Survey.

HEARING OF REASONS AGAINST THE FORFEITURE
OF CERTAIN LICENCES AND LEASES BY A PERSON
APPOINTED UNDER 34TH SECTION OF THE LAND
ACT 1928.

NOTICE is hereby given that reasons against the forfeiture of the licences and leases in the Schedule hereto, which are deemed liable to forfeiture under the provisions of the *Land Acts*, will be publicly heard by the person appointed by me, the responsible Minister of the Crown administering the said *Acts*, to hear the same and report thereon in writing to me, when the persons in the said Schedule mentioned as holders of such licences and leases will be allowed to show cause against the same at the place and on the date mentioned in the Schedule hereto.

A. E. LIND,
Commissioner of Crown Lands and Survey,
Department of Crown Lands and Survey,
Melbourne, 18th June, 1952.

SCHEDULE.

COURT HOUSE, WEDDERBURN, Wednesday, 30th July, 1952, at 1.45 p.m., R. E. Lawes, Land Officer, St. Arnaud—
064/129, William Cashen, 3 acres, Wedderburn.
0204/129, Kenneth Robert Baker, 3 acres, Wedderburn.

REGULATIONS FOR THE CARE, PROTECTION, AND
MANAGEMENT OF "DAVIS PARK," AT NHILL.

WHEREAS by section 181 of the *Land Act 1928*, as re-enacted by section 9 of the *Land Act 1941*, power is given to the Board of Land and Works to make Regulations in respect of the care, protection, and management of any Crown land which has been reserved under the *Land Acts* for any public purpose whatsoever, and which has not been conveyed to or vested in trustees, and for the further purposes as enacted: Now therefore the Board of Land and Works, in pursuance of the powers conferred as aforesaid, doth hereby make the following Regulations in respect of the land in the Township of Nhill temporarily reserved by Order in Council dated the 24th March, 1890, as a site for Public Recreation, and known as "Davis Park" (hereinafter referred to as the "Reserve"), but excluding that portion of the Reserve as is fenced off and used for municipal swimming baths.

REGULATIONS.

1. The Reserve shall be open to the public, free of charge, from sunrise to sunset, except on such days, not exceeding fifty-two (52) in any one year, as the Reserve may be set apart for cricket, football, or other matches, shows, sports, fêtes, musical performances, outdoor gatherings, or holiday amusements, on any of which occasions a sum not exceeding Five shillings (5s.) may be charged and taken for the admission of each adult person to the Reserve, but no person shall be permitted to enter any of the buildings on the Reserve on days on which fees for admission are not being charged without the permission, in writing, of the Committee of Management first obtained.

2. No person shall—

(a) Enter or remain in the Reserve who shall or may offend against decency as regards dress, language, or conduct, or who shall or may behave in a disorderly, unseemly, or offensive manner, or create or take part in any disturbance.

(b) Enter or remain in the Reserve whilst in a state of intoxication.

(c) Bring any intoxicating liquor on to the Reserve for sale or disposal without the consent of the Committee of Management first had and obtained.

(d) Carry, fire, or discharge any gun, pistol, or firearm in or upon the Reserve, or throw or cause to be thrown any stones, sand, or other missiles, or commit any nuisance in the Reserve or in any buildings or other enclosures thereon.

(e) Obstruct or hinder any person under authority from the Committee of Management or employed by it at the Reserve in the execution of his lawful duties.

(f) Exercise or train any horse or pony on the Reserve, or any part thereof, without the consent of the Committee of Management first obtained.

3. The Committee of Management shall have power to hold entertainments, shows, or performances on the Reserve, and make a charge for admission thereto as hereinbefore provided.

4. The Committee of Management shall have power to let the whole or any portion of the Reserve to any club, association, person, or society for the purpose of holding entertainments, performances, shows, or sports, subject to the payment of such fees and on such terms as it may deem to be reasonable and consistent with these Regulations, and to authorize any club, association, society, or person to make a charge for admission thereto as hereinbefore provided in these Regulations.

5. No club, association, society, or person shall hold any entertainment, performance, show, or ceremony on any part of the Reserve without the authority of the Committee of Management first obtained.

6. No person other than members of the Committee of Management, or its officers or employees on duty, shall enter any part of the Reserve on an occasion when a charge is made for admission thereto without first paying the fees chargeable for such admission.

7. No person shall park a motor car, vehicle, or motor cycle in the Reserve, except at such places as are set apart for the purpose by the Committee of Management, who reserve the right to make a parking charge not exceeding Two shillings for each vehicle.

8. No person shall be entitled to play any game or practise, or take part in such practise, in any part or division of the Reserve, unless he be a member or authorized guest of one of the clubs that have been granted permission, in writing, to play or practise, as the case may be, by the Committee of Management, and unless he can produce, on demand, satisfactory evidence that he is a

member or authorized guest of the club concerned, provided, however, that the rights of the public to engage in recreation in the Reserve are not arbitrarily denied.

9. No person shall play, practise, or engage in any game or sport within the Reserve on Sundays or Good Fridays.

10. No person, club, or other body using the Reserve shall damage any building thereon or the fittings of such building, and in the event of such damage occurring during their occupancy thereof such person, club, or other body shall be responsible for such damage and pay to the Committee of Management the cost of making good and repairing such building or fittings.

11. No person shall, in the Reserve, interfere with or break or damage any of the trees, plants, or shrubs, or pluck any flowers, or climb, jump, or get over or under any of the fences, gates, seats, or other structures thereon, or leave any bottles, broken glass, paper, orange peel, banana skins, or any refuse or rubbish whatsoever thereon, except in receptacles provided for the purpose, or post bills or advertisements on any of the fences, gates, seats, or other structures thereon.

12. No person shall remove any wood or timber from the Reserve, unless with the consent of the Committee of Management first obtained, and then only on such terms and conditions as shall be determined by the said Committee and approved of by the Board of Land and Works.

13. No person shall light a fire in the Reserve, except at such places as are set apart for that purpose by the Committee of Management.

14. No person shall put in the Reserve any cattle or other animals without the permission of the Committee of Management first obtained.

15. No person shall bring into the Reserve any dog, unless controlled by a chain or cord, without consent of the Committee of Management first obtained.

16. No person shall camp on the Reserve or erect thereon any building or any other structure without the consent of the Committee of Management first obtained.

17. No person shall bet publicly in any part of the Reserve without permission of the Committee of Management first obtained, and every person infringing this Regulation shall be liable to expulsion from the Reserve.

18. No person shall sell or offer for sale any article in the Reserve without the permission of the Committee of Management first had and obtained, and then only subject to such conditions as such Committee may determine.

19. No person, club, or other body shall, without the consent of the Committee of Management first obtained, grade or scrape the ground off or cut or burn any grass growing on any part of the Reserve.

Every person who contravenes or fails to comply with these Regulations shall, in accordance with the provisions of section 181 of the *Land Act* 1928, as re-enacted by section 9 of the *Land Act* 1941, for each offence be liable to a penalty of not more than Five pounds, and every person who contravenes or fails to comply with any such Regulation, and who, after he has been warned by any bailiff of Crown lands or by any member of the Police Force, does not desist therefrom, may be forthwith apprehended by such bailiff or member of the Police Force and taken before some justice to be dealt with according to law, and shall be liable to a penalty of not more than Ten pounds.

The common seal of the Board of Land and Works was hereunto affixed this eleventh day of June, 1952, in the presence of—

(SEAL) . A. E. LIND, President.
W. M. CRAWFORD, Member.

The Reserve has been placed under the control of the Council of the Shire of Lowan as a Committee of Management thereof with power and authority to enforce the foregoing Regulations.—(Rs.6005.)

COMMITTEES OF MANAGEMENT OF RESERVES.

APPOINTMENTS.

WHEREAS by section 184 of the *Land Act* 1928 it is provided that it shall be lawful for the Governor in Council or the Board of Land and Works to appoint and remove any number of persons, not less than three, or any municipal council, or the governing body of any corporation, to be a Committee of Management of any specified Crown land reserved either temporarily or permanently for any of the purposes set out in section 14 of the *Land Act* 1928, and not conveyed to or vested in trustees: Now

No. 501.—5757/52.—3

therefore the Board of Land and Works doth hereby appoint the under-mentioned persons to be members of the Committee of Management of the Reserves named:—

"KOO-WEE-RUP NORTH (FIVE MILE) MECHANICS' HALL RESERVE."

Percy Bazil Fehner, Andrew Herbert Garbellini, Noel Wedgwood Piper, Gordon Henwood, Bernard Walsh, Thomas Francis Houlihan, and Alex Henry Watson as a Committee of Management for a period of three (3) years from 15th February, 1952, of the land temporarily reserved by Order in Council dated 4th April, 1911, as a site for a Mechanics' Institute in the Parish of Koo-Wee-Rup, and known as the "Koo-Wee-Rup North (Five Mile) Mechanics' Hall Reserve."—(Corres. Rs.3604.)

"KOONDRUCK RECREATION RESERVE."

Reginald Nicholas Penglase, Arthur Geoffrey Molin, Andrew James Fasham, Everett Henry Mooring, John George Hull, Gilbert Arthur Burnett, and Desmond Challis as the Committee of Management for a period of three (3) years from 7th June, 1952, of the lands in the Parish of Murrabit temporarily reserved by Orders in Council dated the 16th August, 1881, and 25th October, 1938, as sites for Cricket and other purposes of Public Recreation, and known as the "Koondrook Recreation Reserve."—(Corres. Rs.881.)

"WOOLSTHORPE RECREATION RESERVE."

Cecil Mitchem, Harold Richardson, Albert Templeton, Somerville Davidson, Charles Edgar Ponder, and Fitzgerald Kevin-McLaren as a Committee of Management for a period of three (3) years from 16th May, 1952, of the land in the Town of Woolsthorpe temporarily reserved by Order in Council dated 18th December, 1885, as a site for Public Recreation, and known as the "Woolsthorpe Recreation Reserve."—(Corres. Rs.652.)

"WATERLOO MECHANICS' INSTITUTE AND FREE LIBRARY RESERVE."

Charles Edward Jones, Christopher L. Herbert, Harold William Claude Lewis, John McErvale, and Norman Robert Gardiner as the Committee of Management for a period of three (3) years of the land temporarily reserved by Order in Council dated the 14th October, 1889, as a site for a Mechanics' Institute and Free Library at Waterloo, in the Parish of Raglan, and known as the "Waterloo Mechanics' Institute and Free Library."—(Corres. Rs.2244.)

"SALE MEMORIAL AUTO PARK."

George Neville Valentine, James Ernest Christie, Rex Castles, William David Walker, Len Fletcher, Andrew Guy Fogg, and William Andrew Thomson as a Committee of Management for a period of three (3) years of the land temporarily reserved by Order in Council of 11th January, 1949, as a site for Tourist Camping purposes in the Parish of Sale.—(Corres. Rs.6241.)

LAND RESERVED FOR AN INFANT WELFARE CENTRE AND CHILDREN'S PLAYGROUND IN THE CITY OF ESSENDON, AT MOONEE PONDS.

The Council of the City of Essendon as a Committee of Management of the land in the City of Essendon, at Moonee Ponds, temporarily reserved as a site for an Infant Welfare Centre and Children's Playground by Order in Council dated the 20th May, 1952.—(Corres. Rs.6918.)

"HEATHCOTE SHOW GROUNDS RESERVE."

Patrick John McMahon, Alwin Craig Thomas, James Louis Tranter, Martin O'Sullivan, and Edwin H. Kemp as a Committee of Management for a period of three (3) years of the land temporarily reserved as a site for Show Yards in the municipal district of Heathcote, and known as the "Heathcote Show Grounds Reserve."—(Corres. Rs.662.)

In witness whereof the common seal of the Board of Land and Works was hereunto affixed this eleventh day of June, One thousand nine hundred and fifty-two, in the presence of—

(SEAL) A. E. LIND, President.
W. M. CRAWFORD, Member.

Land Act 1928.

LICENCE UNDER THE LAND ACTS 1915 AND 1928 DECLARED VOID.

NOTICE is hereby given that the Licence in the Schedule hereunder has been declared void for the reason specified.

District.	Corr. No.	Name of Licensee.	Section of Land Act under which Licensed.	Parish.	Allotment.	Section.	Area	Annual Rental.	Reasons for Voiding.
Bairnsdale ..	12/129	Lola E. Kruse	129	Tildesley West	Jetty site opposite 1	1	A. R. P. ..	£ s. d. 0 10 0	Expired

Department of Crown Lands and Survey,
Melbourne, 18th June, 1952.

A. E. LIND,
Commissioner of Crown Lands and Survey.

THE CLOSER SETTLEMENT ACT 1938.

THE Farm Allotment mentioned in the Schedule hereunder is hereby proclaimed available for application, and may be taken up under Closer Settlement Lease.

Parish.	Allotment.	Section.	Area.	Monetary Liability.	Deposit, including Lease and Registration Fees.	Term of Lease.	Remarks.
Liparoo ..	3b	..	A. R. P. 25 0 0	£ s. d. 96 10 0	£ s. d. 22 15 0	36 years, £4 2s. 6d. yearly	Subject to survey fee, £7 7s. 6d. Valuation of improvements, £1,155, to be paid for in cash

Office of Crown Lands and Survey,
Melbourne, 18th June, 1952.

A. E. LIND,
Commissioner of Crown Lands and Survey.

APPOINTMENT OF COMMITTEE OF MANAGEMENT OF MOUNT BULLER RECREATIONAL RESERVE.

WHEREAS by section 56 of the *Forests Act 1928* it is provided that the Minister of Forests may, on the recommendation of the Forests Commission, appoint any number of persons, not less than three, to be a Committee of Management of any land forming part of any reserved forest, such land being a place of natural beauty or interest, or a health resort, and may remove any of such persons: Now therefore I, Albert Eli Lind, Her Majesty's Minister of Forests, in the State of Victoria, on the recommendation of the Forests Commission, do hereby appoint—

ARTHUR BLACKWOOD DAVY
as a member of the Committee of Management, in place of Cyril Nelson Davy, who has resigned, until the 25th day of November, 1954, of the land forming part of the reserved forest in the Parish of Changue, County of Wonnangatta, described in the accompanying Schedule, and known as "Mount Buller Recreational Reserve," such land being a place of natural beauty and interest.

SCHEDULE ABOVE REFERRED TO.

Parish of Changue, County of Wonnangatta, 34 acres, more or less, being the area shown by pink colour on plan marked 50/764 over 1.11.51 in file of correspondence No. 50/764 of the Forests Department.

Dated at Melbourne, the 2nd day of June, 1952.

A. E. LIND,
Minister of Forests.

TENDERS.

TENDERS will be received at this office until TEN A.M. on the days and for the purposes under mentioned.

Particulars may be learnt at this Office and also at places shown in parenthesis.

W.O. means Inspector of Works Office; P.S.—Police Station; T.S.—Technical School; H.E.S.—Higher Elementary School; S.S.—State School; H.S.—High School.

The Board of Land and Works will not necessarily accept the lowest or any tender.

NOTE.—No preliminary deposits are to be lodged with tenders, but a deposit, in accordance with the following Schedule, will be required from the successful tenderer:—

For contract amounts not exceeding £200 ..	£	2
For contract amounts exceeding £200 and not exceeding £500 ..	£	5
For contract amounts exceeding £500 and not exceeding £1,000 ..	£	10
For contract amounts exceeding £1,000—1 per cent. of tender ..	£	500
		(maximum deposit)

24th June, 1952.

Allansford.—Septic tank installation to school, S.S. No. 3. (W.O., Warrnambool; S.S., Allansford.)

Alphington.—General repairs and external painting and provision of new cupboards and display boards, S.S. No. 3599. (S.S., Alphington.)

Ardmona.—Repairs and renovations to residence, S.S. No. 1563. (W.O., Shepparton; P.S., Tatura; S.S., Ardmona.)

Arnold.—Provision of skylights to schoolroom, repairs and painting to the residence—fencing, S.S. No. 1664. (W.O., Maryborough; S.S., Arnold.)

Balwyn North.—Supply, installation, and testing of air heating of six-class prefabricated building, S.S. No. 4638.

Carlton.—Supply, installation, and testing of a fuel hot-water service, Students Hostel, 48 Drummond-street.

Eltham.—New out offices and septic tank installation, S.S. No. 209. (S.S., Eltham.)

Gama East.—General repairs and painting and fencing, S.S. No. 3985. (W.O., Warracknabeal; P.S., Woomelang; S.S., Gama East.)

Gresswell.—Alterations to Mortuary, Sanatorium.

Inglewood.—Additions, repairs and painting to residence previously removed from Kurting, S.S. No. 1052. (W.O., Bendigo, Maryborough; P.S., Wedderburn.)

Janefield.—Painting and repairs and laying of concrete floors, cow shed and dairy, Mental Hospital.

Janefield.—Installation of electric light and power in Entertainment Hall, Mental Hospital.

Maryborough East.—Removal of teacher's residence from Percydale and remodelling—renovation after re-erection, S.S. No. 2828. (W.O., Bendigo, Maryborough; S.S., Maryborough East.)

Melbourne.—Maintenance of hydraulic lifts for twelve (12) months, 1st July, 1952, to 30th June, 1953, Public Buildings.

Melbourne.—Glazing from 1st July, 1952, to 30th June, 1953, Public Buildings.

Orbost.—Supply and installation of a "Kerostat" hot-water service, Department of Lands, Inspectors residence. (W.O., Bairnsdale.)

Seymour.—General repairs and painting, P.S. (W.O., Alexandra; P.S., Seymour.)

Seymour.—Electrical installation in two (2) timber prefabricated units and typing room, H.S. (H.S., Seymour.)

Sunbury.—Mechanical services for Female Artisans Hostel, Mental Hospital.

Swan Hill.—Electrical installations, P.S. and residence. (W.O., Swan Hill.)

Tatura.—Erection of new station and cell block, P.S. (W.O., Bendigo, Shepparton; P.S., Echuca, Murchison, Tatura.)

Ultima.—Septic tank installation, P.S. (W.O., Swan Hill; P.S., Ultima.)

Wairewa.—Provision of new floor, general repairs, painting, S.S. No. 3739. (W.O., Bairnsdale; S.S., Wairewa.)

Wedderburn.—Repairs and remodelling to teacher's residence, S.S. No. 794. (W.O., Bendigo; S.S., Wedderburn.)

Woomelang.—Repairs and painting, new tanks, new out-offices, Court House. (W.O., Warracknabeal; P.S., Hope-toun, Woomelang.)

1st July, 1952.

Ballarat North.—Electrical installation in six (6) classroom "Bristol" prefabricated school, S.S. No. 4690. (W.O., Ballarat.)

Beechworth.—Installation of sewerage system to Government Offices. (W.O., Wangaratta; P.S., Beechworth.)

Burnley Gardens.—Renovations and painting, Stockman's residence, Department of Agriculture.

Caulfield.—New water service, S.S. No. 773.

Cheshunt.—Erection of a new timber residence, S.S. No. 2553. (W.O., Benalla; S.S., Cheshunt.)

Dromana.—Erection of timber-framed school, S.S. No. 184. (S.S., Dromana.)

Geelong.—Rewiring of Domestic Arts Block and electrical installations in "Bristol" prefabricated classroom units, H.S. (W.O., Geelong.)

Glenferrie.—Supply and installation of domestic refrigerator in Cookery Centre, S.S. No. 1508.

Greenvale.—New storage cupboards at the new brick ward building, Sanatorium.

Heywood.—Supply and installation of a kerosene hot-water service, Consolidated School. (W.O., Warrnambool; Consolidated School, Heywood.)

Hopetoun.—Hot-water service to three (3) school residences, S.S. No. 3167. (W.O., Warracknabeal; S.S., Hopetoun.)

Horsham.—Repairs and renovations, Court House. (W.O., Horsham; P.S., Horsham.)

Jancourt East.—Erection of a new timber classroom, S.S. No. 3783. (W.O., Camperdown, Warrnambool; P.S., Cobden; S.S., Jancourt East.)

Janefield.—Supply and installation of hot-water service to Wards "B" and "C," Mental Colony.

Janefield.—Plenum heating and hot-water service for Entertainments Hall, Mental Hospital.

Kangaroo Flat.—Plenum heating of six-room "Bristol" prefabricated school unit, S.S. No. 981. (W.O., Bendigo.)

Kaniva.—New fencing and repairs to fencing, Consolidated School. (W.O., Horsham; P.S., Dimboola, Nhill; Consolidated School, Kaniva.)

Kyneton.—Alterations to electrical installation, H.S. (W.O., Bendigo; H.S., Kyneton.)

Melbourne.—Supply and installation of meat rails, racks, &c., for refrigerated chambers, Parliament House.

Melbourne.—Maintenance of electric lifts for twelve (12) months, 1st July, 1952, to 30th June, 1953, Department of Public Works, Public Buildings.

Melbourne.—Purchase and removal of one under-fired multi-tubular boiler, Cancer Institute, 483 Little Lonsdale-street.

Mildura.—Heating and ventilating system, Court House. (W.O., Mildura.)

Orbost.—Erection of a new timber residence with garage, for Inspector, Department of Crown Lands and Survey. (W.O., Bairnsdale; P.S., Orbost.)

Richmond.—Erection of new external staircase and fixing of fire underwriters' doors, &c., S.S. No. 2084.

Sale.—Supply and installation of electric refrigerator, Department of Penal and Gaols, Prison.

Stawell.—Removal and re-erection of boiler-house and supply tank, Pleasant Creek Special School. (W.O., Ararat, Ballarat; Pleasant Creek Special School, Stawell.)

Strathmerton.—Electrical installation in a two (2) classroom "Hawkesley" prefabricated unit, S.S. No. 2790. (W.O., Shepparton; P.S., Numurkah.)

8th July, 1952.

Ascot Vale.—Painting Government Pavilion, Royal Agricultural Show Grounds.

Ballarat.—Installation of one motor-driven sewerage pump and pipe work, Mental Hospital. (W.O., Ballarat; Mental Hospital, Ballarat.)

Balwyn East.—Electrical installation in a four (4) classroom "Bristol" prefabricated unit, S.S. No. 4694.

Dimboola North.—Purchase and removal of school building, shelter shed, &c., S.S. No. 1875. (W.O., Horsham, Warracknabeal; P.S., Dimboola.)

Geelong West.—Repairs and painting to residence, S.S. No. 1492. (W.O., Geelong; S.S. Geelong West.)

Hamlyn.—Purchase and removal of school building, S.S. No. 4420. (W.O., Horsham; P.S., Nhill.)

Morwell.—Purchase and removal of cottage, shed, and out-offices, S.S. No. 4655. (W.O., Traralgon; S.S., Morwell.)

Nanneella Estate.—Erection of new shelter shed and out-offices, repairs and painting to residence, S.S. No. 3708. (W.O., Shepparton; S.S., Nanneella Estate.)

Natimuk.—New timber W.C. and septic tank, P.S. (W.O., Horsham; P.S., Natimuk.) (Amended specification.)

Piedmont.—Erection of shelter pavilion and two (2) out-offices, S.S. No. 4546. (W.O., Traralgon; S.S., Piedmont.)

Shirley.—New sleep-out, bathroom, laundry, and porch, S.S. No. 1760. (W.O., Ararat, Ballarat; P.S., Beaufort; S.S., Shirley.) (Amended specification.)

Streatham.—Alterations and additions, S.S. No. 844. (W.O., Ararat, Ballarat; P.S., Skipton; S.S., Streatham.)

Swan Hill.—Supply and installation of an air-gas plant in Science Room, H.S. (W.O., Swan Hill.)

Tatura.—Supply of S. and F.R.C. pipes (all pipes to be tested to take 30-lb. pressure per square inch, complete with rubber jointing rings), Research Station.

Tourello.—Purchase and removal of old residence, S.S. No. 740. (W.O., Ballarat; P.S., Clunes, Creswick; S.S., Tourello.)

Warracknabeal.—General renovations (internally), S.S. No. 1334. (W.O., Warracknabeal; S.S., Warracknabeal.)

Warrak.—Erection of sleep-out to residence, S.S. No. 834. (W.O., Ararat; P.S., Stawell; S.S., Warrak.) (Amended specification.)

West Melbourne.—Alterations and renovations to various buildings for painting and decorating classrooms, T.S., 553 Latrobe-street.

Woodleigh.—New residence, S.S. No. 2463. (W.O., Korumburra; S.S., Woodleigh.) (Amended specification.)

Yarrowonga.—Restoration of buildings, new shelter shed and out-offices, H.S. (W.O., Benalla, Wangaratta; P.S., Yarrowonga.)

15th July, 1952.

Portland.—Repairs and painting (Quarters No. 3), P.S. (W.O., Hamilton; P.S., Port Fairy, Portland.)

Tenders to be addressed to the Honorable the Commissioner of Public Works, and envelope containing tender marked "Tender for _____ due _____."

P. T. BYRNES,
Commissioner of Public Works.

Melbourne, 17th June, 1952.

PUBLIC SERVICE NOTICES.

PUBLIC SERVICE OF VICTORIA.—VACANCIES.

APPLICATIONS will be received by the Public Service Board up to Wednesday, the 2nd July, 1952, from persons employed in the Public Service of Victoria, who are eligible and qualified, for appointment to the under-mentioned positions:—

ADMINISTRATIVE DIVISION.

Clerk, Class "C," Motor Registration Branch, Office of the Chief Commissioner of Police, Department of Chief Secretary.

Yearly Salary.—£475, minimum; £579, maximum.

Duties.—To act as sub-officer in charge of Label Section, and to be responsible for the ordering and custody of labels. To act as a cash register operator when required.

Qualifications.—To have a thorough knowledge of the routine of the Department and of the regulations governing the issue of registration labels; to possess organizing ability, and to be capable of controlling staff and of operating a cash register.

PROFESSIONAL DIVISION.

Medical Officer (Female), Class "A," Maternal and Child Hygiene Branch, Department of Health.

Yearly Salary.—£1,000, minimum; £1,100, maximum.

Duties.—To supervise infant welfare and pre-school centres ensuring that departmental medical standards are maintained; to conduct medical examinations of pre-school children; to prepare educational talks and broadcasts on child care for guidance of parents, and to assist in the preparation of departmental literature dealing with child management and maternal hygiene.

Qualifications.—To be a legally qualified medical practitioner registered or eligible to be registered in Victoria. To possess specialized knowledge and

experience in the care of mother and child, and to be experienced in addressing meetings and giving lectures to trainees.

Building Surveyor, Class "C1," General Health Branch, Department of Health.

Yearly Salary.—£605, minimum; £657, maximum.

Duties.—To examine plans and specifications of public and other buildings, with special reference to hospitals and schools; to make and check structural calculations for steel, re-inforced concrete, and other buildings; to prepare plans and sketches, and to inspect and report upon buildings.

Qualifications.—To hold a diploma in building surveying or equivalent, and to be a competent draftsman; to have a good knowledge of building construction in relation to the Health Act and Regulations thereunder; to be able to make and check structural calculations, and to write concise and accurate reports.

TECHNICAL AND GENERAL DIVISION.

Gardener, Ballarat Mental Hospital, Department of Health.

Salary.—£364 a year.

Duties.—To assist the Senior Gardener and, in his absence, to take charge of the vegetable garden, and to direct operations of patients placed at his disposal.

Qualifications.—A good knowledge of gardening work and ability to handle staff.

NOTE.—In addition to the salary rates quoted, a cost of living adjustment (£324 a year for adult males and £243 a year for adult females), which varies in accordance with the rise or fall in the index number of the cost of living, is payable.

By order,

E. F. FITZGIBBON,
Secretary.

Office of the Public Service Board,
Melbourne, the 17th June, 1952.

PUBLIC SERVICE (PUBLIC SERVICE BOARD) REGULATION 39.—RECLASSIFICATIONS.

THE Public Service Board has raised the classification of the under-mentioned offices as shown, and the Permanent Heads of the Departments have recommended the officers named for appointment.

Office and Present Classification.	Revised Classification.	Duties.	Qualifications.	Officer Recommended for Appointment.		
				Name.	Classification.	Date of Classification.

ADMINISTRATIVE DIVISION.

DEPARTMENT OF EDUCATION.

Clerk, Class "B1"	Assistant Accountant, Class "A" (£1,000)		To be a qualified accountant. To possess ability to control and direct a staff; a good knowledge of the Public Service, Teaching Service, Education, and Superannuation Acts, of the Regulations thereunder, of the Regulations respecting public accounts, and of mechanized accounting systems. A knowledge of departmental practice and procedure is essential	Dynon, W. J.	Clerk, Class "B1"	8.2.49
-------------------	--	--	---	--------------	-------------------	--------

DEPARTMENT OF LAW.

Office of the Public Trustee.

Clerk, Class "B"	Class "B1"	To supervise the trust sections administering the estates of mental patients and to administer the estates of infirm persons	A thorough knowledge of the Public Trustee Acts and the regulations thereunder particularly in their relation to patients and infirm persons and of the Mental Hygiene Acts; experience in the management and conduct of estates and businesses and a knowledge of real estate values	Coman, O.	Clerk, Class "B"	1.5.50
Clerk, Class "C1"	Class "C2"	To act as property officer	A general knowledge of the Administration and Probate Acts, and Public Trustee Acts and the law relating to the administration of estates; to have satisfactory experience in the management and control of agricultural properties and to be a competent valuer	Leeming, D. B.	Clerk, Class "C1"	22.5.50

PUBLIC SERVICE (PUBLIC SERVICE BOARD) REGULATION 39—RECLASSIFICATIONS—*continued.*

Office and Present Classification.	Revised Classification.	Duties.	Qualifications.	Officer Recommended for Appointment.		
				Name.	Classification.	Date of Classification.

ADMINISTRATIVE DIVISION—*continued.*

DEPARTMENT OF AGRICULTURE.

Clerk, Class "B1"	Assistant Accountant, Class "A" (£1,000)		To be a qualified Accountant; to have had experience in the financial activities of the Department and in the administration of the financial provisions of the Acts controlled by it; to have ability to control and direct staff	Taylor, F. R.	Clerk, Class "B1"	10.11.49
-------------------	--	--	--	---------------	-------------------	----------

DEPARTMENT OF WATER SUPPLY.

Clerk, Class "C1"	Class "C2"	To prepare financial statements for inclusion in the annual report; to keep the depreciation and Redemption ledgers for all Commission districts; to supervise the checking of rates paid to casual employees; to relieve in country centres	To be a qualified accountant; to possess a sound knowledge of the Water Acts, of water supply works, of the various Awards and Wages Board Determinations applicable, and ability to conduct investigations and compile reports; to be familiar with the methods of ratings and handling and charging of stores and materials	Pullar, H. E.	Clerk, Class "C1"	23.10.50
Clerk, Class "C1"	Class "C2"	Under the general direction of the Resident Engineer, Central Gippsland Irrigation Project, to supervise all clerical officers engaged on these works, and, in accordance with the requirements of the Chief Accountant, to be responsible for all accounting work, including the preparation of wages sheets, adjustment sheets and apportionment sheets and the payment of wages; to control and record works costing data; to operate official bank accounts and mess accounts; the supervision of clerical work of stores officer and the reconciliation of stores control accounts	Ability to supervise and direct staff. To be familiar with Arbitration awards and conditions, and with the administration of a large construction camp. A sound knowledge of Government accounting procedure and costing principles is essential	Caffrey, H. W.	Clerk, Class "C1"	13.11.50

PROFESSIONAL DIVISION.

DEPARTMENT OF MINES.

Senior Chemist, Class "B"	Class "B1"	To act as Chemist in Charge of the Mines Section of the State Laboratories and to undertake special metallurgical analyses and investigations	To be an Associate of the Australian Chemical Institute and to have had wide experience in metallurgical investigations and analyses and in the control of a chemical staff	Field, F. F.	Senior Chemist, Class "B"	8.11.48
---------------------------	------------	---	---	--------------	---------------------------	---------

DEPARTMENT OF HEALTH.

Maternal and Child Hygiene Branch.

Medical Officer (Female), Grade II., Class "B1"	Medical Officer (Female), Class "A" (£1,000-£1,100)	Supervision of Infant Welfare and Pre-school Centres with regard to standards of infant feeding and hygiene, medical examination of children in pre-school centres. Preparation of educational talks and broadcasts for guidance of parents. Assisting in preparation of Departmental literature dealing with child management and maternal hygiene	To be a legally qualified medical practitioner with specialized knowledge in the care of mother and child. Ability to address meetings and to give lectures to trainees	Kolso, N.	Medical Officer (Female), Grade II., Class "B1"	21.11.47
---	---	---	---	-----------	---	----------

PUBLIC SERVICE (PUBLIC SERVICE BOARD) REGULATION 30—RECLASSIFICATIONS—*continued.*

Office and Present Classification.	Revised Classification.	Duties.	Qualifications.	Officer Recommended for Appointment.		
				Name.	Classification.	Date of Classification.

PROFESSIONAL DIVISION—*continued.*

DEPARTMENT OF AGRICULTURE.

Longerenong Agricultural College.

English, Mathematics, and House Master, Class "C2"	Class "B"	Under the direction of the Principal, to teach English, Mathematics, Book-keeping and Surveying to the standard required by the College Curriculum; to act as House Master	Proved ability and sound experience as a teacher, and as the House Master of a residential college	Jepson, C.	English, Mathematics, and House Master, Class "C2"	28.11.48
--	-----------	--	--	------------	--	----------

Appeals against such recommendations should be lodged with the Secretary to the Public Service Board not later than Saturday, the 28th June, 1952.

Office of the Public Service Board,
Melbourne, 17th June, 1952.

By order,

E. F. FITZGIBBON,
Secretary.

PUBLIC SERVICE (PUBLIC SERVICE BOARD) REGULATION 30.—VACANCIES.

THE Permanent Heads of the Departments shown have recommended the officers named hereunder for appointment to the under-mentioned vacancies.

Office and Classification.	Duties.	Qualifications.	Officer Recommended for Appointment.		
			Name.	Classification.	Date of Classification.

ADMINISTRATIVE DIVISION.

DEPARTMENT OF PREMIER.

Audit Office.

Clerk, "C2"	Class	To act as an Inspector of Audit, and to conduct such audits and inspections as the Auditor-General may direct	To be a qualified Accountant. To have a thorough knowledge of the Audit Act and of the General Regulations respecting Public Accounts, and a knowledge of the various activities which the Auditor-General is required by law to audit. Country work throughout Victoria is essential	Rorke, G. H. P.	Clerk, Class "C1"	20.3.50
-------------	-------	---	---	-----------------	-------------------	---------

Office of the Public Service Board.

Chief Clerk, Class "B"			An intimate knowledge of the Public Service Act, the Regulations thereunder, and of the procedure and practice of the Board's Office, and experience in conducting correspondence and in staff control	Scully, V. P.	Clerk, Class "C2"	6.11.50
------------------------	--	--	--	---------------	-------------------	---------

DEPARTMENT OF CROWN LANDS AND SURVEY.

Clerk, "C1"	Class	To keep the Crown Lands General Ledger and to assist in the preparation of accounts and Statements for the Annual Report of the Department	To have a good knowledge of the provisions of the Land Acts, the regulations thereunder and the regulations respecting public accounts; to have had experience of mechanized accounting and of departmental procedure, particularly as it affects the Treasury accounts	Robertson, E. J.	Clerk, Class "C"	28.7.47
-------------	-------	--	---	------------------	------------------	---------

PUBLIC SERVICE (PUBLIC SERVICE BOARD) REGULATION 39.—VACANCIES—continued.

Office and Classification.	Duties.	Qualifications.	Officer Recommended for Appointment.		
			Name.	Classification.	Date of Classification.
ADMINISTRATIVE DIVISION—continued.					
DEPARTMENT OF AGRICULTURE.					
Clerk, Class " B "	To have charge of the Licences, Dairy Farm Permit and Expenditure Sections of the Dairying Division ; to prepare divisional estimates of revenue and expenditure ; to be responsible for the payment of Herd Test Subsidies ; to control ledger in connexion with the Commonwealth Dairy Industry Grant ; to relieve the Senior Clerk of the Dairying Division when necessary	To possess an intimate knowledge of the activities of the Dairying Division and the Acts administered therein ; a sound knowledge of accountancy principles and the regulations governing public accounts ; ability to control and direct staff	Schmidt, W. C.	Clerk, Class " C2 "	13.2.50
Clerk, Class " C2 "	To keep Appropriation and Trust Fund Ledgers, prepare schedules and statements of Expenditure and reconcile with Treasury ; to keep Departmental Advance Account, prepare re-imbursements and adjustments ; to record expenditure in connexion with the Commonwealth Dairy Industry Improvement Account and prepare financial statements relating thereto ; to carry out special duties as instructed	Experience in Accounts Branch work, a good knowledge of Departmental and Treasury procedure and the Regulations respecting Public Accounts. Accountancy qualifications are desirable	Clark, E. J.	Clerk, Class " C1 "	7.10.49
PROFESSIONAL DIVISION.					
DEPARTMENT OF MINES.					
Senior Inspector of Boilers, Class " C2 "	To inspect and test steam boilers, pressure vessels, air and gas receivers, and to assist the Chief Inspector of Boilers to examine drawings, particulars of materials, and the design and construction of boilers, under the provisions of the Boilers Inspection Acts	To have not less than five years' experience as a Boiler Inspector under the Boilers Inspection Acts, and to be conversant with the latest construction of welded boilers, and to have had country experience in the inspection of boilers	Dewar, R. L.	Inspector of Boilers, Grade I, Class " C1 "	13.5.48
DEPARTMENT OF AGRICULTURE.					
Manager, Cool Stores, Class " A " (£1,000-£1,100)	Subject to the Director of Agriculture, to be responsible for the control and operation of the Government Cool Stores, Victoria Dock, West Melbourne	To possess a sound knowledge of refrigeration practices with a special knowledge of the problems of the storage of dairy products. Sound business experience and proved capacity to control and manage a large scale cool store of modern design	Steel, L. McD.	Assistant Works Manager, Cool Stores, Class " B "	11.7.51
TECHNICAL AND GENERAL DIVISION.					
DEPARTMENT OF HEALTH.					
<i>Mental Hygiene Branch.</i>					
Nurse, Grade II.	To be second in charge of a Ward and to relieve the Nurse in charge	To have had experience in a Mental Hospital and to possess the Mental Hygiene Nursing Certificate			
<i>Kew Mental Hospital (one office)</i>	Edwards, A. M.	Nurse, Grade III.	12.11.51
<i>Royal Park Mental Hospital (one office)</i>	Meyer, M.	Nurse, Grade III.	12.11.51
<i>Mont Park Mental Hospital (one office)</i>	O'Grady, K. M.	Nurse, Grade III.	30.4.46
<i>Trarancore Mental Hospital (one office)</i>	McDonald, M.	Nurse, Grade III.	2.2.51
<i>Janefield Mental Hospital (one office)</i>	Flannery, M. J. (Mrs.)	Nurse, Grade III.	20.2.52

Appeals against such recommendations should be lodged with the Secretary to the Public Service Board not later than Saturday, the 28th June, 1952.

Office of the Public Service Board,
Melbourne, 17th June, 1952.

By order,
E. F. FITZGIBBON,
Secretary.

No. 329. *Public Service Act 1946, Section 50.*

REGULATIONS—PART III.—SALARIES, INCREMENTS, AND ALLOWANCES.

THE Public Service Board, in pursuance of the powers conferred by the *Public Service Act 1946*, hereby amends its Regulations as shown below:—

SECOND SCHEDULE.
TECHNICAL AND GENERAL DIVISION.
Offices and Rates of Salaries.

Department and Office.	Yearly Rate of Salary.		Increments (Annual).
	Minimum.	Maximum.	
DEPARTMENT OF AGRICULTURE.	£	£	
<i>Add—</i> Stock Manager, Dookie Agricultural College	605	657	2 of £26

D. D. PAINE, Chairman.
E. F. FITZGIBBON, Secretary.

Office of the Public Service Board,
Melbourne, 5th June, 1952.

No. 328. PUBLIC SERVICE ACT 1946.

THE Public Service Board, in pursuance of the powers conferred by the *Public Service Act 1946*, hereby amends the Public Service (Public Service Board) Regulations as follows:—

PART VI.—TRAVELLING EXPENSES.
DIVISION IV.—GENERAL.
Regulation 108.

Sub-regulation (2) is deleted, and the following sub-regulation inserted in lieu thereof:—

(2) Where an unmarried officer whose total emolument payable by way of salary exclusive of cost of living adjustment does not exceed £436 a year is appointed, promoted, or transferred to a position and is thereby required to live away from home and to pay a weekly amount for board and lodging in excess of one-third of the weekly rate equivalent to his annual rate of total emolument payable by way of salary inclusive of cost of living adjustment, the Board may authorize payment of an allowance equal to one-half of the excess.

Provided that the allowance so calculated shall be taken to the nearest shilling, an amount of Six pence being taken to the next higher shilling, but no allowance shall be payable if the amount so determined is less than 2s.

Provided further that in no case shall the weekly allowance exceed 20s.

This Regulation shall have effect as on and from the 1st July, 1952.

D. D. PAINE, Chairman.
E. F. FITZGIBBON, Secretary.

Office of the Public Service Board,
Melbourne, C.2, 4th June, 1952.

No. 331. *Public Service Act 1946, Section 39.*

REGULATIONS—PART III.—SALARIES, INCREMENTS, AND ALLOWANCES.

THE Public Service Board, in pursuance of the powers conferred by the *Public Service Act 1946*, hereby amends its Regulations as shown below:—

FIRST SCHEDULE.
PROFESSIONAL DIVISION.
Offices and Rates of Salaries.

Office.	Yearly Rate of Salary.	
	Minimum.	Maximum.
DEPARTMENT OF CHIEF SECRETARY.	£	£
CLASS "C."		
<i>Add—</i> Assistant and Keeper of the Prints (Female), National Gallery	475	579
CLASS "D1" (FEMALE).		
<i>Delete—</i> Keeper of the Prints, National Gallery	390	468

D. D. PAINE, Chairman.
E. F. FITZGIBBON, Secretary.

Office of the Public Service Board,
Melbourne, 2nd June, 1952.

No. 330. *Public Service Act 1946, Section 39.*

REGULATIONS—PART III.—SALARIES, INCREMENTS, AND ALLOWANCES.

THE Public Service Board, in pursuance of the powers conferred by the *Public Service Act 1946*, hereby amends its Regulations as shown below:—

FIRST SCHEDULE.
PROFESSIONAL DIVISION.
Offices and Rates of Salaries.

Office.	Yearly Rate of Salary.	
	Minimum.	Maximum.
DEPARTMENT OF AGRICULTURE.	£	£
CLASS "C1."		
<i>Delete—</i> Stock Manager, Dookie Agricultural College	..	631

D. D. PAINE, Chairman.
E. F. FITZGIBBON, Secretary.

Office of the Public Service Board,
Melbourne, 5th June, 1952.

Teaching Service Act 1946.

AMENDMENT No. 10.

TEACHING SERVICE (TEACHERS TRIBUNAL) REGULATIONS.

THE Teachers Tribunal, in pursuance of the powers conferred by the *Teaching Service Act 1946*, hereby amends Regulation 1 of the Teaching Service (Teachers Tribunal) Regulations in the manner following, that is to say:—

REGULATION 1.

In sub-clause 11 (a) for the figure "90" shown for the Frankston district, substitute the figure "125".

(To take effect from and including the 27th May, 1952.)

W. H. ELLWOOD, Chairman.
G. FENNELL, Secretary.

Office of the Teachers Tribunal,
Melbourne, 16th June, 1952.

Teaching Service Act 1946.

TEACHING SERVICE (TEACHERS TRIBUNAL) REGULATIONS.

AMENDMENT No. 7.

THE Teachers Tribunal, in pursuance of the powers conferred by the *Teaching Service Act 1946*, hereby amends Regulation 1 of the Teaching Service (Teachers Tribunal) Regulations in the manner following, that is to say:—

REGULATION 1.

Rescind sub-clause 10 (a) and substitute therefor the following:—

“10. (a) Teachers who teach in their own schools for at least two hours in an evening and thereby find it necessary to have their evening meal away from their usual place of residence shall be reimbursed an amount of 5s. a meal: Provided that no payment shall be made unless the teacher is on full-time duty during the afternoon session of the evening concerned.”

W. H. ELLWOOD, Chairman.

G. FENNELL, Secretary.

Office of the Teachers Tribunal,
Melbourne, 12th June, 1952.

Teaching Service Act 1946.

TEACHING SERVICE (TEACHERS TRIBUNAL) REGULATIONS.

AMENDMENT No. 8.

THE Teachers Tribunal, in pursuance of the powers conferred by the *Teaching Service Act 1946*, hereby amends the Teaching Service (Teachers Tribunal) Regulations in the manner following, that is to say:—

PRELIMINARY.

In clause 2 delete the words “‘Standard Salary’ means salary excluding any cost of living adjustment” and insert the words “‘Standard Salary’ means salary as prescribed in Parts I., II., III., V., VII., VIII., IX., IXA. and X. of the Teaching Service (Classification, Salaries and Allowances) Regulations and does not include any cost of living adjustment or allowances.”

W. H. ELLWOOD, Chairman.

Office of the Teachers Tribunal, G. FENNELL, Secretary.
Melbourne, 12th June, 1952.

Teaching Service Act 1946.

TEACHING SERVICE (TEACHERS TRIBUNAL) REGULATIONS.

AMENDMENT No. 9.

THE Teachers Tribunal, in pursuance of the powers conferred by the *Teaching Service Act 1946*, hereby amends Regulation 1 of the Teaching Service (Teachers Tribunal) Regulations in the manner following, that is to say:—

REGULATION 1.

1. Rescind sub-clauses 21 (b) and (c), and substitute therefor the following:—

“21. (b) Where the standard salary of an unmarried member of the Teaching Service does not exceed £436 a year and he is appointed, promoted, or transferred to a position and is thereby required to live away from his home and to pay a weekly amount for board and lodging in excess of one-third of the weekly rate equivalent to his annual standard salary plus cost of living adjustment, the Tribunal may authorize payment of an allowance equal to one-half of the excess.

Provided that the allowance so calculated shall be taken to the nearest shilling, an amount of Six pence being taken to the next higher shilling, but no allowance shall be payable if the amount so determined is less than 2s.

Provided further that in no case shall the weekly allowance exceed 20s.”

2. Re-number the existing sub-clauses (d) and (e) to make them (c) and (d) respectively.

(To take effect from and including the 1st July, 1952.)

W. H. ELLWOOD, Chairman.

Office of the Teachers Tribunal, G. FENNELL, Secretary.
Melbourne, 12th June, 1952.

PRIVATE ADVERTISEMENTS.

CITY OF HEIDELBERG.

APPOINTMENT OF POUNDKEEPER.

NOTICE is hereby given that William Henry Pearce has been appointed Poundkeeper for the Macleod Pound.

F. PHILLIPS,

Town Clerk.

Town Hall, Ivanhoe, 13th June, 1952.

1363

CITY OF RICHMOND.

BY-LAW No. 155.

A By-law of the City of Richmond, made under the Local Government Acts, and numbered No. 155, for altering By-laws Nos. 95 and 97, prescribing residential areas, and for prescribing certain classes of trades, industries, manufactures, businesses, or public amusements which may be carried on therein, and for repealing By-law No. 101, amending By-law No. 97.

IN pursuance of the powers conferred by the Local Government Acts, the Mayor, Councillors and Citizens of the City of Richmond order as follows:—

(1) (a) Clause 3 of By-law No. 95 as amended by any By-law shall be amended by inserting after the words "No person shall" in line 1 the following words "(save as is hereinafter specified in clause 4 of this By-law)".

(b) Clause 1 of By-law No. 97 as amended by By-law No. 101 is hereby repealed and the following substituted therefor:—

"1. By-law No. 95 as amended by this or any By-law now or hereafter to be in force shall (subject to the provisions of clause 4 thereof) apply with respect to all classes of trades, industries, manufactures, businesses or public amusements."

(c) Clause 2 of By-law No. 97 as amended by By-law No. 101 is amended as follows:—

(i) In place of the words "any residential areas" shall be substituted the words "any Residential Area."

(ii) All the words after the words "any class of trade, industry," beginning with the words "or manufacture" down to and including the words "side shows, boxing, wrestling, gymnastics" shall be deleted and the following words substituted therefor "manufacture business or public amusement."

(d) By-law No. 101 is hereby repealed.

(2) (a) That clauses 3 and 4 of By-law No. 97 be and the same are hereby repealed.

(b) In clause 5 of By-law No. 97 the words "this By-law or" in line 2 are hereby deleted and the words "as altered by this By-law" in line 3 are hereby deleted and the words "as amended by this or any By-law" substituted therefor.

(c) In clause 7 of By-law No. 97 the words "this By-law or" in line 3 are hereby deleted, and the words "as altered by this By-law" in line 4 are hereby deleted, and the words "as amended by this or any By-law" substituted therefor.

(d) In clause 8 the words "as altered by this By-law" in lines 1 and 2 are hereby deleted, and the words "as amended by this or any By-law" substituted therefor, and after the words "prescribed by clause 2 of the said By-law No. 95" shall be added the words "or by any amendment thereof."

(3) That clause No. 4 of the said By-law No. 95 as amended by any By-law, be, and the same is, hereby repealed and the following clause is substituted therefor:—

(4) Nothing herein shall preclude:—

(a) the continuance of the use of any land or any building for any purpose for which the same was lawfully used immediately before and for which it has been continuously used since the coming into operation of this By-law, or,

(b) the enlargement, rebuilding or extension of any building and the continuance of the use of the building as so enlarged, rebuilt or extended for the purposes for which it was lawfully used immediately before the coming into operation of this By-law so long as the building as so enlarged, rebuilt or extended does not extend beyond:—

(i) The premises on which the building was situated immediately before the coming into operation of this By-law; and

(ii) Any adjoining land which immediately before the coming into operation of this By-law was in the same ownership and might lawfully have been used for the same purposes; or,

(c) the continuance of the use for the purposes of a motor service station and/or motor garage for public services of any land and/or building which was prior to and at the date of the coming into operation of this clause being used for such purpose, or,

(d) the use (subject to the proviso hereinafter contained) for any of the purposes specified in the Schedule hereto of any land or any building which immediately before the coming into operation of this By-law was lawfully used for the purposes of any class of trade, industry, manufacture, business or public amusement.

Provided always that no person shall use any land on building referred to in this sub-clause for any of the purposes specified in the Schedule hereto if the use of such land and/or building by the occupier for any of such purposes creates odours, fumes, smoke, dust, noise or vibration to such an extent as to cause discomfort or annoyance to the residents of premises in the vicinity of such land or building.

SCHEDULE.

(1) Professional chambers used by any barrister, solicitor, medical practitioner, dentist, teacher, or any person engaged in professional work.

(2) Bank or office.

(3) Funeral parlour (but not including the manufacture of coffins).

(4) Church, school, private hospital, boarding house or eating house.

(5) Shop in which goods are exposed, or offered, for sale by retail (including a workroom connected therewith in which such goods are manufactured or prepared for retail sale therein provided such workroom does not occupy more than 60 per cent. of the total floor area of the premises exclusive of so much of the premises (if any) as is used by any person as a dwelling, and provided that no single machine in such workroom shall be driven by motive power of a greater power than 2 h.p. and that no metal stamping machine is used in such workroom or shop).

(6) Hairdressing saloon, boot repair shop, watch and clock repair shop, library.

(7) Depot for collection and delivery for dyers and clothes cleaners (but not including the use of such premises for dyeing or clothes cleaning operations).

(8) Public amusements approved of by the Council.

Resolution for passing this By-law passed by the Council on the 11th day of February, 1952.

Confirmed this 11th day of March, 1952.

Sealed with the common seal of the Mayor, Councillors, and Citizens of the City of Richmond this 24th day of March, 1952, in the presence of—

MAURICE P. SHEEHY, Mayor.

W. WILLIAMS, Councillor.

F. L. HALLETT, Town Clerk.

(SEAL)

Approved by the Governor in Council, 3rd June, 1952.—
A. MAHLSTEDT, Clerk of the Executive Council. 1378

CITY OF RICHMOND.

BY-LAW No. 156.

A By-law made under sections 197 and 228 of the Local Government Act 1946, and numbered 156, for altering By-law No. 154, prescribing residential area No. 8, South Ward.

IN pursuance of the powers conferred by the Local Government Act 1946, the Mayor, Councillors and Citizens of the City of Richmond order as follows:—

That within that portion of the residential area No. 8 South Ward described in the first schedule hereto the use of any land or the erection (including adaption for use) or the use of any building or portion of a building for all classes of trades industries manufactures businesses or public amusements except those prescribed in the second schedule hereto is hereby prohibited.

THE FIRST SCHEDULE.

All that land commencing at a point distant north 89 deg. 46 min. east 101 ft. 4 in. from the north intersection of Brighton-street and Goodwin-street and bounded

by lines bearing respectively as follows:—North 0 deg. 22 min. east 54 ft. 7 in., north 1 deg. 48 min. west 20 ft. 6½ in., north 89 deg. 43 min. east 40 feet, north 0 deg. 23 min. west 32 ft. 11 in., south 89 deg. 56 min. east 61 ft. 5½ in., south 0 deg. 23 min. east 53 ft. 2 in., south 89 deg. 43 min. west 51 ft. 1½ in., south 0 deg. 6 min. east 54 ft. 7½ in., and south 89 deg. 46 min. west 50 ft. 9½ in. to the point of commencement. The area being that described in certificate of title, volume 6598, folio 1319533, and the eastern portion of land described in certificate of title, volume 3848, folio 769471.

THE SECOND SCHEDULE.

Bookbinding, boot and shoe manufacture, clothing manufacture, commercial offices, dress, frock, or mantle manufacture, hat manufacture, knitting mills (using no power other than electric), light engineering works including milling and assembly of gas fires, also repairs and maintenance of gas refrigerators and fires and testing of same but excluding use of heavy power presses or automatic riveting machines, shirt, pyjama, tie or scarf manufacture.

Resolution for passing this By-law agreed to by the Council of the City of Richmond this 21st day of April, 1952.

Confirmed the 19th day of May, 1952.

Sealed with the common seal of the Mayor, Councillors, and Citizens of the City of Richmond this 23rd day of May, 1952, in the presence of—

(SEAL) MAURICE P. SHEEHY, Mayor.
A. E. COLORETTE, Councillor.
F. HALLETT, Town Clerk.

Approved by the Governor in Council, 3rd June, 1952.—
A. MAHLSTEDT, Clerk of the Executive Council. 1379

CITY OF RICHMOND.

BY-LAW No. 157.

A By-law made under sections 197 and 228 of the *Local Government Act* 1946, and numbered 157, for altering By-law No. 133, prescribing residential area No. 3, West Ward.

IN pursuance of the powers conferred by the *Local Government Act* 1946, the Mayor, Councillors and Citizens of the City of Richmond order as follows:—

That within that portion of the residential area No. 3 West Ward described in the first schedule hereto the use of any land or the erection (including adaptation for use) or the use of any building or portion of a building for all classes of trades industries manufactures businesses or public amusements except those prescribed in the second schedule hereto is hereby prohibited.

THE FIRST SCHEDULE.

All that land commencing at the north-west intersection of Gipps-street and Waverley-street and bounded by lines bearing respectively as follows:—Westerly 114 ft. 9 in. to the east building line of Clifton-street, northerly 59 ft. 5 in. along the east building line of Clifton-street, easterly 57 ft. 10 in., northerly 42 ft. 4 in., easterly 56 ft. 11½ in. to the west building line of Waverley-street and southerly 101 ft. 9 in. to the point of commencement. The area is that described in certificate of title, volume 5678, folio 1135435.

THE SECOND SCHEDULE.

Bookbinding, boot and shoe manufacture, clothing manufacture, commercial offices, dress, frock or mantle manufacture, hat manufacture, knitting mills (using no power other than electric), shirt, pyjama, tie or scarf manufacture, tobacco, cigar or cigarette manufacture.

Resolution for passing this By-law agreed to by the Council of the City of Richmond this 21st day of April, 1952.

Confirmed the 19th day of May, 1952.

Sealed with the common seal of the Mayor, Councillors, and Citizens of the City of Richmond this 23rd day of May, 1952, in the presence of—

(SEAL) MAURICE P. SHEEHY, Mayor.
RAYMOND J. DONOVAN, Councillor.
F. HALLETT, Town Clerk.

Approved by the Governor in Council, 3rd June, 1952.—
A. MAHLSTEDT, Clerk of the Executive Council. 1380

CITY OF SOUTH MELBOURNE.

WHEREAS pursuant to the provisions of the Local Government Acts and in accordance with notices duly advertised in accordance with the provisions of such Acts, the Council of the City of South Melbourne by the sale of debentures borrowed moneys secured on the credit of the said municipality to be applied for the purposes set out in the notices aforesaid: And whereas parts of such moneys are expended and are not required for any of the said purposes but are required for other purposes for which money may legally be borrowed by the Council: And whereas the Council proposes to make a Special Order declaring that such parts of such unexpended moneys as are hereinafter set out shall be applied for other purposes for which money may legally be borrowed by the Council: Now notice is hereby given of the intention of the Council to apply such parts of the unexpended moneys of such loans, as are hereinafter set out, to the construction and purchase of such permanent works and undertakings as are hereinafter set out.

1. The plans, specifications, and estimate of the cost of the permanent works and undertakings in respect of which the unexpended moneys aforesaid are proposed to be applied, and a statement showing the proposed expenditure of the unexpended moneys aforesaid, have been prepared and will be open to the inspection of ratepayers at all reasonable times at the office of the Council, at the Town Hall, South Melbourne, for one month after the publication of this notice.

2. (a) The respective dates and amounts of the original loans are:—

Loan No. 17, 25th June, 1947, £11,800.
Loan No. 22, 12th September, 1951, £45,600.

(b) The several purposes for which the unexpended moneys aforesaid were to have been applied were:—

Loan No. 17. Construction of tar still at Council's depot	£933	7	3
Loan No. 22. Market—construction of closed sheds ("B" and "C") at South Melbourne Municipal Market	3,200	0	0
Total	£4,133	7	3

(c) The several purposes to which it is proposed that the unexpended moneys aforesaid shall be applied are:—

Loan No. 17. Purchase of plant and equipment for works and undertakings which the municipality is authorized to carry out	£933	7	3
Loan No. 22. Construction of market houses	3,200	0	0
Total	£4,133	7	3

(d) The amounts of the unexpended moneys which it is proposed to apply to the several purposes last mentioned are:—

Loan No. 17	£933	7	3
Loan No. 22	3,200	0	0
Total	£4,133	7	3

H. ALEXANDER, Town Clerk.

Town Hall, South Melbourne, 12th June, 1952. 1327

NOTICE is hereby given that D. R. Fullerton and Company Proprietary Limited, of 242 Pitt-street, Sydney, New South Wales, has applied for a lease under section 125 of the *Land Act* 1928, for a term of 50 years, over buildings No. 34 and 35 on the former Explosives Factory Area at Ballarat as a site for the manufacture of window frames and doors.
1236 D. R. FULLERTON, Managing Director.

LORNE FISHERMEN'S CO-OPERATIVE SOCIETY LIMITED.

NOTICE is hereby given that the Lorne Fishermen's Co-operative Society Limited, of Lorne, has applied for a lease, under section 125 of the *Land Act* 1928, for a term of twenty years over allotment 11, section 5, Town-Freezing Works.
1144 W. L. ROGERS, Secretary.

NOTICE is hereby given that the Apollo Bay Fishermen's Co-operative Society Limited of Apollo Bay has applied for a lease, under section 125 of the *Land Act* 1928, for a term of twenty years over allotment 11, section 2, Township of Krambruk, Parish of Krambruk, as a site for a fish freezing works.
1145 RONALD A. TELFORD, Secretary.

NOTICE is hereby given that A. W. Jackson Industries Proprietary Limited, has applied for a lease under section 125 of the Land Acts for a term of 30 years, from the 1st August, 1952, of allotment 12, section D, City of South Melbourne, containing 1 rood 32 perches, as a site for offices, stores, and manufacture of radio and electrical goods, hardware, and furniture. 1156

NOTICE is hereby given that the partnership heretofore subsisting between Edward Ernest Tovey and Ernest John Sutton, carrying on business as storekeepers at Foster under the firm name of "General Stores," has been dissolved by mutual consent as from the 31st day of May, 1952. All debts due to and owing by the said late firm will be paid by the aforementioned if particulars thereof are forwarded to R. Loftus, accountant, 173 Greville-street, Prahran.

E. E. TOVEY.
E. J. SUTTON.

Dated this 10th day of June, 1952.
Brew and McGuinness, solicitors, 357 Little Collins-street, Melbourne. 1344

NOTICE OF DISSOLUTION OF PARTNERSHIP.

NOTICE is hereby given that the partnership heretofore subsisting between the undersigned William James Allen, of 234 Barkly-avenue, Burnley, Stephen Thomas Foot, of 40 Albion-road, Box Hill, Robert Grinyer, of 20 Moore-street, South Yarra, Anthony Francis Healy, of 80 Type-street, Burnley, Maurice Kohn, of Plumer-street, Croydon, and Richard Thomas, of Brushy Park-road, North Croydon, sewerage construction contractors, carrying on business of sewerage construction contractors, at 80 Type-street, Burnley, under the name of Metropolitan Excavations, has been dissolved by mutual consent, as from 21st March, 1952. All debts due to or owing by the said firm will be received and paid by the said William James Allen, Stephen Thomas Foot, Robert Grinyer, Anthony Francis Healy, and Maurice Kohn, who will carry on as partners the business at 80 Type-street, Burnley.

Dated at Melbourne, the 12th day of June, 1952.

R. THOMAS.
W. J. ALLEN.
S. T. FOOT.
R. GRINYER.
A. F. HEALY.
M. KOHN.

Witness—W. HARRISON, solicitor, Melbourne. 1383

NOTICE is hereby given that the partnership heretofore subsisting between Albert Eaton, of 19 Young-street, Ivanhoe, and Annie Eliza Eaton, of 15 Longmore-street, St. Kilda, carrying on business of clothing and mercers at 95 Bourke-street, Melbourne, under the style or firm name of "London and American Supply Stores," has been dissolved as from the 1st day of May, 1952, and will, as from the said 1st day of May, 1952, be carried on by the said Albert Eaton as sole proprietor.

Dated the 11th day of June, 1952.

ALBERT EATON.
ANNIE EATON.

Witness to both signatures—D. R. DOOLEY, solicitor, Melbourne. 1348

NOTICE is hereby given that the partnership heretofore subsisting between Ernest Claude Hancock and Dorothy May Ledward Wallman, carrying on business as drapers at 106 Maling-road, Canterbury, under the style or firm name of Hancock Woollen and Silk Centre, has been dissolved as from the 31st May, 1952. The said Ernest Claude Hancock will continue to carry on the business at the above address, and will pay and discharge all debts of the said firm.

Dated the 31st day of May, 1952.

E. HANCOCK.

Witness—C. W. K. PEARSON.

D. M. L. WALLMAN.

Witness—R. H. WALLMAN.

1345

NOTICE is hereby given that the partnership heretofore subsisting between Allan Edgar Meaker and Douglas Maitland Forfar, carrying on business as builders at Winifred-street, Pascoe Vale, under the style or firm of Forfar and Meaker, has been dissolved by mutual consent as from the date hereof.

Dated the 10th day of June, 1952.

A. E. MEAKER.
D. FORFAR.

E. A. Atkins and Son, 422 Little Collins-street, Melbourne, solicitors for both partners. 1350

NOTICE is hereby given that the partnership heretofore subsisting between the undersigned Frank Pirronello, John Fronistas, and Constantine Carapalis, carrying on business as motor engineers at 6 Albert-street, East Brunswick, under the name of "Albert Engineers," has been dissolved by mutual consent as from the 29th day of February, 1952. Frank Pirronello has retired from the firm. All debts due to and owing by the late firm will be received and paid by the said John Fronistas and Constantine Carapalis, who will continue to carry on business at the same place.

Dated the 10th day of June, 1952.

F. PIRRONELLO.
J. FRONISTAS.
CON. CARAPALIS.

John F. Carroll, solicitor, 95 Queen-street, Melbourne. 1352

NOTICE OF DISSOLUTION OF PARTNERSHIP.

NOTICE is hereby given that the partnership heretofore subsisting between the undersigned William Thomas Brown and Norman William Neal, carrying on business as case manufacturers, at Main-road, Research, under the name of "Brown and Neal," has been dissolved by mutual consent, as from the 31st day of May, 1952. All debts due to and owing by the said late firm will be received and paid by William Thomas Brown, who will continue to carry on the business at the same place.

Dated at Melbourne, the 31st day of May, 1952.

W. BROWN.
N. NEAL.

Witness—F. LYNCH, solicitor, Melbourne. 1368

NORMAN ANZAC MITCHELL and Harold Jamieson Heath give notice that the partnership which was being carried on by them under the firm name of "Mitchell and Heath," at 189 McKinnon-road, McKinnon, was dissolved on 2nd June, 1952. All persons having claims against the partnership should forward their accounts without delay to the said Norman Anzac Mitchell, at 189 McKinnon-road, McKinnon, who is now carrying on the business under the said firm name at that address.

N. A. MITCHELL.
H. J. HEATH.

Ernest Allen, of 443 Little Collins-street, Melbourne, solicitor for both parties. 1406

BUKIT KUBU RUBBER ESTATES LIMITED. (IN VOLUNTARY LIQUIDATION.)

NOTICE is hereby given that at an Extraordinary General Meeting of the shareholders of the above-named company held at the registered office, 84 William-street, Melbourne, the following Resolution was carried as a Special Resolution, namely:—

"That the sale of the plantation of the Bukit Kubu Rubber Estates Limited, situated within the Federation of Malaya, which sale was made by the directors of the said company, be and is hereby confirmed and approved, and that the company be now wound up voluntarily, such being a members' voluntary winding up."

The secretary of the company, Sherrard Roy Warnock, was appointed liquidator. The preferential capital, with dividends accrued to the 30th June, 1952, will be repaid to such shareholders immediately after that date on surrender to the liquidator of the relevant scrip for cancellation. A distribution of One shilling and nine pence per share will be made to all ordinary shareholders on surrender of their scrip for marking.

Melbourne, 11th June, 1952.

1353

SHERRARD WARNOCK, Liquidator.

Companies Act 1938.

LE MIL PLASTICS PROPRIETARY LIMITED (IN VOLUNTARY LIQUIDATION.)

NOTICE OF MEETING, PURSUANT TO SECTION 236 (2).

NOTICE is hereby given that an Extraordinary General Meeting of the company will be held at the office of the liquidator, 361 Collins-street, Melbourne, on Monday, 21st July, 1952, at half-past Twelve p.m., for the purpose of having an account laid before it showing the manner in which the winding up has been conducted and the property of the company disposed of, and of hearing any explanation which may be given by the liquidator.

Dated this 17th day of June, 1952.

1397

C. L. JAMES, Liquidator.

*Companies Act 1938.***BOWDEN CYCLES PROPRIETARY LIMITED**
(IN VOLUNTARY LIQUIDATION).

NOTICE is hereby given that the Final Meeting of the above company will be held at the office of the liquidator, 141 Flinders-lane, Melbourne, at Ten a.m., on Wednesday, 23rd July, 1952, pursuant to section 236 of the *Companies Act 1938*.

Dated this 10th day of June, 1952.

1369

P. D. JARMAN, Liquidator.

A. J. REILLY PTY. LTD. (IN VOLUNTARY LIQUIDATION).
NOTICE OF GENERAL MEETING.

IN accordance with the provisions of section 236 of the *Companies Act 1938*, notice is hereby given that a General Meeting of the above-named company will be held on Thursday, 24th July, 1952, at 100-104 Queen-street, Melbourne, at Three p.m.

The purpose of the meeting is to receive a final account of the winding up of the company.

A. G. FORREST, 104 Queen-street, Melbourne, liquidator.
1404

In the matter of the *Companies Act 1938*, and in the matter of ROLFE AND COMPANY LIMITED (in Voluntary Liquidation).

TAKE notice that, pursuant to section 236, a meeting of contributories in the above matter will be held at the offices of Edwin V. Nixon and Partners, 401 Collins-street, Melbourne, on the 21st day of July, 1952, at Ten a.m., for the purpose of receiving the final account of the winding-up.

Dated this 12th day of June, 1952.

W. D. HIGGINS, F.C.A. (Aust.), liquidator, 401 Collins-street, Melbourne.
1403

*The Companies Act 1938.***SCOTT'S ESTATES PROPRIETARY LIMITED**
(IN VOLUNTARY LIQUIDATION).

NOTICE is hereby given that, in pursuance of section 245 (1) of the *Companies Act 1938*, a General Meeting of the above company will be held at 229 Collins-street, Melbourne, at Three o'clock p.m., on Friday, the 25th day of July, 1952, for the purpose of receiving the liquidator's final account of the winding-up of the company.

1402

HENRY SCOTT, Liquidator.

GAMBLE BRICK CO. PTY. LTD.

NOTICE is hereby given that a Meeting of Creditors of the above-named company will be held at 34 Queen-street, Melbourne, on Tuesday, the 24th day of June, 1952, at half-past Two o'clock in the afternoon, for the purposes mentioned in sections 238, 239, and 240 of the *Companies Act 1938*.

1387

SAMUEL J. WILSON, Secretary.

VOGUE FURNITURE PROPRIETARY LIMITED
(IN LIQUIDATION).

PURSUANT to sections 118, 224 (b), and 226 (1), *Companies Act 1938*, take notice that the following Special Resolution was duly passed at a General Meeting of the members of Vogue Furniture Proprietary Limited (in Liquidation), held at Inverloch, Victoria, on the 6th day of June, 1952:—

"That as all members of the company are present in person, formal requirements will be dispensed with, and that in view of the company having ceased operations that the company resolves by Special Resolution that the company be wound up voluntarily."

J. L. MATHEWS, Director.

Take further notice that a declaration of solvency undertaking that all debts of the company will be paid within twelve months from the 6th June, 1952, has been filed with the office of the Registrar-General, and that Geoffrey Lyon, of 243 Collins-street, Melbourne, Public Accountant, has been appointed liquidator of the company.
1399

METROPOLITAN HIRE AND DRIVE SERVICE LIMITED (IN LIQUIDATION).

NOTICE is hereby given that the Final Meeting of the shareholders of the above company will be held at 239 Latrobe-street, Melbourne, on Friday, 18th July, 1952, at Three p.m. Object is to lay before the meeting an account showing how the winding up has been conducted and how the property has been disposed of.

D. GLENISTER, 20 Terry-street, Deepdene, Liquidator.
1329

VICTORIA CAR INTERIORS PTY. LTD. (IN VOLUNTARY LIQUIDATION).

NOTICE is hereby given, in pursuance of section 236 (2) of the *Companies Act 1938*, that a General Meeting of the members of the above-named company will be held at 395 Elizabeth-street, Melbourne, on Saturday, the 12th day of July, 1952, at Two o'clock in the afternoon, for the purpose of receiving the liquidator's account showing how the winding up has been conducted and the company's property disposed of.

Dated this 4th day of June, 1952.

1328

ALFRED SHIFF, Liquidator.

CREDITORS, next of kin, and others having claims in respect of the estate of James McGrath, late of 1 Wattletree-road, Drumcondra, Geelong West, in the State of Victoria, retired stationmaster, deceased (who died on the 19th day of January, 1951), are required by Joseph Aloysius Phelan, of 17 Grandview-grove, Drumcondra, Geelong West, newsagent, and Lillian Mary Sheridan, of 15 Austin-street, Newtown, Geelong, manageress, the executor and executrix respectively to whom probate of deceased's will was granted, to send particulars, in writing, of their claims to the said Joseph Aloysius Phelan and Lillian Mary Sheridan, in the care of the undersigned, at his office hereunder mentioned, on or before the 25th day of August, 1952, after which date they will distribute the assets of the said deceased among the parties entitled thereto, having regard only to the claims of which they then have had notice.

ROGER O'HALLORAN, solicitor, of Corio Theatre Buildings, McCann-street, Geelong.
1334

CREDITORS, next of kin, and others having claims in respect of the estate of Una Mary Peake, formerly of White Hart Hotel, Moorabool-street, Geelong, in the State of Victoria, but late of 97 Aberdeen-street, Newtown, Geelong, in the said State, home duties, deceased (who died on the 22nd day of September, 1951), are required by Helen Lois Walker, of 15 Orrong-grove, North Caulfield, married woman, the executrix to whom probate of deceased's will was granted, to send particulars, in writing, of their claims to the said Helen Lois Walker, in the care of the undersigned, at his office hereunder mentioned, on or before the 25th day of August, 1952, after which date she will distribute the assets of the said deceased among the parties entitled thereto, having regard only to the claims of which she then has had notice.

ROGER O'HALLORAN, solicitor, of Corio Theatre Buildings, McCann-street, Geelong.
1333

CREDITORS, next of kin, and others having claims in respect of the estate of Percy Astill Gilbert, formerly of Yinnar, in the State of Victoria, farmer, but late of 56 Tarwin-street, Morwell, in the said State, retired farmer, deceased (who died at Morwell on the 9th day of December, 1951), are to send particulars of their claims to the executors of the deceased, namely, The Trustees, Executors, and Agency Company Limited, of 401 Collins-street, Melbourne, at its said address, by the 10th day of August, 1952, after which date the assets will be distributed, having regard only to the claims of which the said executors then have notice.

Dated this 3rd day of June, 1952.

BRUCE, LITTLETON, & WATT, solicitors, Morwell.
1342

PURSUANT to the *Trustee Act 1928*, all persons having claims against the estate of William Henry Winnett, late of 5 Malcolm-street, McKinnon, in the State of Victoria, retired departmental manager (who died on the 19th day of March, 1952, and probate of whose will was granted by the Supreme Court of the said State, in its probate jurisdiction, on the 6th day of June, 1952, to Colin Scott McCutcheon, of 31 Queen-street, Melbourne, in the said State, solicitor, and Kenneth Walter John Harrison, of 15 Sunnyside-grove, Bentleigh, in the said State, accountant), are hereby required to send particulars, in writing, of such claims to the said executors, care of the under-mentioned solicitors, on or before 21st August, 1952, after which date the executors will proceed to distribute the estate of the said deceased amongst the persons entitled thereto, having regard only to claims of which they shall then have had notice, and the said executors will not be liable for the assets so distributed, or any part thereof, to any person of whose claim they shall not then have had notice.

Dated the 18th day of June, 1952.

W. B. & O. MCCUTCHEON, solicitors, 31 Queen-street, Melbourne.
1343

Trustee Act 1928.

NOTICE TO CLAIMANTS.

PURSUANT to the *Trustee Act 1928*, creditors, next of kin, and all other persons having claims in respect of the estate of any deceased person named below are required to send particulars thereof to the legal personal representative or representatives at the address stated below, on or before the date stated, after which date the representative or representatives will distribute the assets, having regard only to the claims of which notice has been received:—

Kathleen Mary Simpson, late of 92 Asling-street, Gardenvale, in the State of Victoria, married woman, deceased, intestate, who died on the 27th day of July, 1951.—Claims to the administrator, National Trustees, Executors, and Agency Company of Australasia Limited, whose registered office is at 95 Queen-street, Melbourne, on or before 27th August, 1952. F. J. Corder, solicitor, 108 Queen-street, Melbourne. 1351

Elsie Eliza Brown, formerly of Pakington-street, Geelong West, but late of Ellis-road, Mount Duneed, near Geelong, widow, deceased, who died on 6th February, 1952.—Claims to the executor, The Equity Trustees, Executors, and Agency Company Limited, 472 Bourke-street, Melbourne, by 28th August, 1952. 1332

John Pigdon, the younger, late of "Kuranda," Tatura, in the State of Victoria, orchardist, who died on 4th April, 1952, intestate.—Claims to the administratrix, Patricia Pigdon, of "Kuranda," Tatura aforesaid, widow, in the care of the undersigned solicitors, by 29th August, 1952. Hedderwick, Fookes, and Alston, 103 William-street, Melbourne, solicitors for the administratrix. 1382

CREDITORS, next of kin, and others having claims in respect of the estate of Ellen Mary Ryan, late of 39 Bellerine-street, Geelong, in the State of Victoria, spinster, deceased (who died on the 10th day of November, 1951), are required by Francis Denis Kerley, of Ocean Grove, estate agent, and Leslie Joseph Dobbyn, of 40 Lonsdale-street, Geelong, secretary, the executors to whom probate of deceased's will was granted, to send particulars, in writing, of their claims to the said Francis Denis Kerley and Leslie Joseph Dobbyn, in the care of the undersigned, at his office hereunder mentioned, on or before the 25th day of August, 1952, after which date they will distribute the assets of the said deceased among the parties entitled thereto, having regard only to the claims of which they then have had notice.

ROGER O'HALLORAN, solicitor, of Corio Theatre Buildings, McCann-street, Geelong. 1335

CREDITORS, next of kin, and others having claims in respect of the estate of Joan Elizabeth Swords, late of Close-street, Dandenong, widow, deceased (who died on the 23rd day of January, 1948), are to send particulars of their claims to the administrator, The Equity Trustees, Executors, and Agency Company Limited, of 472 Bourke-street, Melbourne, by the 26th day of August, 1952, after which date the said administrator will distribute the assets, having regard only to the claims of which the said company shall then have notice.

JOHN P. RHODEN, solicitor, 376 Collins-street, Melbourne. 1405

CREDITORS, next of kin, and others having claims in respect of the estate of Frances Jane Dike, formerly of Back Beach-road, Sorrento, and 25 Church-street, Middle Brighton, but late of Rosyth Park, Glenhope, spinster, deceased (who died on the 6th day of March, 1952), are required by Frederick William Cox, of 87 Queen-street, Melbourne, solicitor, the executor to whom probate of deceased's will was granted, to send particulars in writing of their claims to the said Frederick William Cox, at his address above-mentioned, by the 19th day of August, 1952, after which date he will distribute the assets of the said deceased among the parties entitled thereto, having regard only to the claims of which he then has notice.

Dated this 16th day of June, 1952.

FREDERICK W. COX, solicitor, 87 Queen-street, Melbourne. 1392

CREDITORS, next of kin, and others having claims against the estate of William Hamilton Stirling Alston, late of A2 Albany, Piccadilly, London, England, retired, deceased (who died on the 20th day of September, 1950), are required to send particulars of their claims to The Union Trustee Company of Australia Limited, the registered office of which is situate at 333 Collins-street, Melbourne, in the State of Victoria, by the 20th day of August, 1952, after which date it will distribute the assets, having regard only to the claims of which it then has notice.

MADDEN, BUTLER, ELDER, & GRAHAM, 406 Collins-street, Melbourne. 1400

CREDITORS, next of kin, and others having claims in respect of the estate of Horace Alexander Wicks, late of 24 Beatty-street, Ivanhoe, clerk, deceased (who died on 26th January, 1952), are to send particulars of their claims to The Perpetual Executors and Trustees Association of Australia Limited, of 100-104 Queen-street, Melbourne, by the 30th August, 1952, after which date it will distribute the assets, having regard only to the claims of which it then has notice.

HENDERSON & BALL, solicitors, 430 Little Collins-street, Melbourne. 1398

CREDITORS, next of kin, and others having claims in respect of the estate of John James Hamilton, late of 24 Draper-street, South Melbourne, formerly council employee, but now labourer, deceased (who died on the 13th day of September, 1951), are to send particulars of their claims to The Equity Trustees, Executors, and Agency Company Limited, of 472 Bourke-street, Melbourne, by the 22nd day of August, 1952, after which date it will distribute the assets, having regard only to the claims of which it then has notice.

DARVALL & HAMBLETON, solicitors, 352 Collins-street, Melbourne. 1396

CREDITORS, next of kin, and others having claims in respect of the estate of Alan Geoffrey Collins, formerly of Wallaceville, railway employee, but late of Main-road, Kaitoke, Upper Hutt, in New Zealand, public works employee, deceased (who died on the 17th day of July, 1952, and reseat of exemplification of probate of whose will was granted by the Supreme Court of Victoria, on the 16th day of May, 1952, to Frederick William Cox, of 87 Queen-street, Melbourne, solicitor, the duly constituted attorney, under power of Rita Doreen Collins, of Main-road, Kaitoke, widow, the executrix named in the said will), are to send particulars of their claims to the said Frederick William Cox, at his address above-mentioned, by the 19th day of August, 1952, after which date he will distribute the assets of the said deceased, having regard only to the claims of which he then has notice.

Dated this 16th day of June, 1952.

FREDERICK W. COX, solicitor, 87 Queen-street, Melbourne. 1393

CREDITORS, next of kin, and others having claims in respect of the estate of William Crawford Merritt, late of Ultima, farmer, deceased (who died on the 7th day of January, 1952), are required to send particulars thereof, to the executrix, Sabina Ann Merritt, care of the undersigned, by the 25th day of August, 1952, after which date the executrix will distribute the assets, having regard only to the claims of which she then has notice.

R. A. SCHOOLING, LL.M., Ultima, proctor for the executrix. 1386

PURSUANT to the *Trustee Act 1928*, all persons having claims against the property or estate of Frederick Savory, late of 89 Donald-street, Brunswick, retired, deceased (who died on the 24th day of March, 1952, and probate of whose will was granted by the Supreme Court of Victoria, on the 26th day of May, 1952, to Minnie Henrietta McCarthy, of 206 Lygon-street, Carlton, widow, the executrix named therein), are hereby required to send particulars of such claims to the said executrix, addressed to the care of Messieurs Blake and Riggall, 120 William-street, Melbourne, solicitors, on or before the 19th day of August, 1952, after the expiration of which time the said executrix will proceed to distribute the assets of the said deceased amongst the persons entitled thereto, having regard only to the claims of which she shall have had notice.

Dated this 13th day of June, 1952.

BLAKE & RIGGALL, 120 William-street, Melbourne, solicitors for the executrix. 1388

PURSUANT to the *Trustee Act* 1928, notice is hereby given that all creditors, next of kin, and other persons having claims against the estate of Angus McLean, late of Seymour, in the State of Victoria, butcher, deceased (who died on the 22nd day of December, 1951, and probate of whose will was granted by the Supreme Court of the State of Victoria on the 7th day of May, 1952, to Douglas Scott McLean, butcher, and Mary Barbara McLean, spinster, both of Seymour aforesaid), are hereby required to send particulars of such claims to the executors, in care of the undersigned, at his address hereunder set out, on or before the 26th day of August, 1952, after which date the said executors will proceed to distribute the assets of the said deceased amongst the persons entitled thereto, having regard only to the claims of which they shall then have had notice.

W. J. OSBORNE, LL.B., solicitor, Station-street, Seymour. 1339

PURSUANT to the *Trustee Act* 1928, notice is hereby given that all creditors, next of kin, and other persons having claims against the estate of Hedley Osborne Williams, late of Strath Creek, in the State of Victoria, retired farmer, deceased (who died on the 3rd day of March, 1952, probate of whose will was granted by the Supreme Court of the State of Victoria on the 7th day of May, 1952, to Ernest Lamont Richards, of 192 Nicholson-street, Abbotsford, in the said State, hairdresser), are hereby required to send particulars of such claims to the executor, in care of the undersigned, at his address hereunder set out, on or before the 26th day of August, 1952, after which date the said executor will proceed to distribute the assets of the said deceased amongst the persons entitled thereto, having regard only to the claims of which he shall then have had notice.

W. J. OSBORNE, LL.B., solicitor, Station-street, Seymour. 1341

CREDITORS, next of kin, and others having claims in respect of the estate of Albert Edward Batten, late of 83 Wimble-street, Seymour, in the State of Victoria, retired farmer, deceased (who died on the 26th day of October, 1951), are to send particulars of their claims to the Equity Trustees, Executors, and Agency Company Limited, of 472 Bourke-street, Melbourne, by the 26th day of August, 1952, after which date it will distribute the assets, having regard only to the claims of which it then has notice.

W. J. OSBORNE, LL.B., solicitor, Station-street, Seymour. 1340

ADA JANE PEARSON, of Benalla, in the State of Victoria, widow, the sole executrix of the will and codicils of John William Pearson, late of Benalla, farmer (who died on the 9th day of April, 1952), requires all creditors, next of kin, and others having claims against the property or estate of the said deceased to send to the said executrix, care of Hamilton, Clarke, and Clarke, 63 Nunn-street, Benalla, on or before the 25th day of August, 1952, particulars, in writing, of such claims, after which date the said executrix intends to convey or distribute such property or estate to or among the persons entitled thereto, having regard only to the claims of which she shall have had notice.

Dated the 16th day of June, 1952.

HAMILTON, CLARKE, & CLARKE, 63 Nunn-street, Benalla, proctors for the said executrix. 1338

CREDITORS, next of kin, and all others having claims against the estate of Oliver Heywood, late of Trafalgar, farmer, deceased (who died on the 29th day of March, 1952), are to send the particulars of their claims to the executors, Henry John Heywood, of Torwood, farmer, and Ralph Norman Heywood, of Korumburra, milk retailer, care of the undersigned solicitors, by the 8th day of September, 1952, after which date the said executors will distribute the assets, having regard only to the claims of which they shall then have notice.

GRAY, FRIEND, & MOONIE, solicitors, Warragul. 1336

CREDITORS, next of kin, and others having claims in respect of the estate of Jane Dailey, late of 32 Park-street, West Brunswick, in the State of Victoria, widow, deceased (who died on the 17th day of January, 1951), are to send particulars of their claims to the executors, The Equity Trustees, Executors, and Agency Company Limited, of 472 Bourke-street, Melbourne, in the said State, and Marcia Provelson, of Railway-avenue, Malvern, in the said State, married woman, care of the said company, by the 20th day of August, 1952, after which date the said executor will distribute the estate, having regard only to the claims of which they then have notice.

WM. MURRAY & SON, solicitors, 469 Chancery-lane, Melbourne. 1356

CREDITORS, next of kin, and others having claims in respect of the estate of Elaine Patricia Chapman, late of "Baroni," 63 Murdoch-road, Wangaratta, in the State of Victoria, widow, deceased (who died on the 1st day of January, 1952), are required to send particulars of their claims to the executors, to whom probate of the will of the said deceased have been granted, viz., Trustees, Executors, and Agency Company Limited, of 401 Collins-street, Melbourne, in the said State, and Malcolm Hilliard McDougall, of Wangaratta, in the said State, grazier, in care of the said company, by the 21st day of August, 1952, after which date they will distribute the assets of the said deceased, having regard only to the claims of which they then have notice.

DANIEL J. CONNELL & MCKENNA, Reid-street, Wangaratta, solicitors. 1337

STATUTORY NOTICE TO CREDITORS.—JACK MACKIE, DECEASED.

PURSUANT to the *Trustee Act* 1928, notice is hereby given that all persons having claims against the estate of Jack Mackie, formerly of Shepparton, in the State of Victoria, but late of Gladstone-street, Bendigo, in the said State, grocer, deceased (who died on the 18th day of May, 1951, and letters of administration with the will annexed were on the 16th day of May, 1952, granted by the Supreme Court of the State of Victoria, in its probate jurisdiction, to Farmers and Citizens Trustees Company Bendigo Limited, of Charing Cross, in the City of Bendigo, in the said State), are hereby requested to send particulars, in writing, of such claims to the administrator, at the office, Charing Cross, Bendigo, on or before the 4th day of September, 1952, after which date the said administrator will proceed to distribute the assets of the said Jack Mackie, deceased, among the persons entitled thereto, having regard only to the claims of which the said administrator shall then have had notice, in writing, and the said administrator will not be liable for the assets so distributed, or any part thereof, to any person of whose claim the said administrator shall not then have had notice as aforesaid.

Dated this 4th day of June, 1952.

CAMERON & CAMERON, barristers and solicitors, Fraser-street, Shepparton, proctors for the applicant. 1366

PURSUANT to the *Trustee Act* 1928, all persons having claims against the property or estate of Jane Frances White, late of Chiltern, in the State of Victoria, spinster, deceased (who died on the 6th day of October, 1951, and probate of whose will was granted by the Supreme Court of Victoria, on the 12th day of February, 1952, to Margaret Louisa Leseberg, of 14 Lewis-street, Camp Hill, in the State of Queensland, married woman, the executrix named therein), are hereby required to send particulars of such claims to the said executrix, addressed to the care of Frank B. Lethbridge, solicitor, Conness-street, Chiltern, on or before the 21st day of August, 1952, after the expiration of which time the said executrix will proceed to distribute the assets of the said deceased amongst the persons entitled thereto, having regard only to the claims of which she shall then have had notice.

Dated the 13th day of June, 1952.

FRANK B. LETHBRIDGE, solicitor, Conness-street, Chiltern, solicitor for the executrix. 1367

CREDITORS, next of kin, and others having claims in respect of the estate of Keith Angus McMillan, formerly of 207 Darling-road, East Malvern, fruiterer and greengrocer, but late of 89 John-street, North Williamstown, in the State of Victoria, contractor, deceased (who died on the 14th day of December, 1951), are to send particulars of their claims to The Fidelity Trustee Company Limited, of 50 Market-street, Melbourne, in the said State, by the 14th day of August, 1952, after which date the said company will distribute the assets, having regard only to the claims of which it then has notice.

NORMAN MILLER & DONALDSON, 100 Queen-street, Melbourne, solicitors for the said company. 1401

CREDITORS, next of kin, and others having claims in respect of the estate of Margaret Gordon, late of "Glengairn," Waubra, spinster, deceased (who died on the 4th day of March, 1952), are to send the particulars of their claims to The Fidelity Trustee Company Limited, of 101 Lydiard-street north, Ballarat, by the 30th day of August, 1952, after which date it will distribute the assets, having regard only to the claims of which it then has notice.

HERRING & BATHURST, solicitors, Maryborough.

1365

PURSUANT to the provisions of the *Trustee Act 1928*, notice is hereby given that all persons having claims against the estate of Ernest Nonus Wood, late of 140 Kambrook-road, Caulfield, in the State of Victoria, veterinary surgeon, deceased (who died on the 17th day of December, 1951, and probate of whose will was granted by the Supreme Court of the State of Victoria, in its probate jurisdiction, on the 8th day of February, 1952, to Samuel Richard Creswick Wood, of 12 Henderson-avenue, Malvern, in the State of Victoria, share broker, and Kenneth Temple Towl, of 4 Epping-road, East Malvern, in the said State, accountant), are hereby required to send particulars of such claims to the said executors, care of Meares, Duigan, and Hall, 339 Collins-street, Melbourne, on or before the 22nd day of August, 1952, after which date the said executors will proceed to distribute the assets of the said Ernest Nonus Wood, deceased, which shall have come to their hands, amongst the persons entitled thereto, having regard only to the claims of which they shall then have had notice. And notice is hereby further given that the said executors will not be liable for the assets so distributed, or any part thereof, to any person of whose claim they shall not have then had notice.

MEARES, DUIGAN, & HALL, 339 Collins-street, Melbourne, solicitors for the said executors. 1385

GEORGE FLEMING, late of "St. Leonards," 33 McIndoe-parade, Parkdale, in the State of Victoria, gentleman, DECEASED.

THOMAS SMITH FLEMING, of Ultima, in the said State, farmer, and George Fleming, junior, of 15 Walsh-street, Deepdene, in the said State, manager, the executors of the will and codicil thereto of the said George Fleming (who died on the 17th day of February, 1952), require all creditors, next of kin, and others having claims against the property or estate of the said deceased, to send to the said executors, care of the under-mentioned proctors, on or before the 20th day of August, 1952, particulars, in writing, of such claims, after which date the said executors intend to convey or distribute such property or estate to or among the persons entitled thereto, having regard only to the claims of which they shall have had notice.

Dated the 16th day of June, 1952.

CORR & CORR, 104 Queen-street, Melbourne, proctors for the said executors. 1381

CREDITORS, next of kin, and others having claims in respect of the estate of Julius Zucker, late of Wellington, in New Zealand, agent, deceased (who died on the 22nd day of October, 1951, and reseal of exemplification of probate of whose will was granted by the Supreme Court of Victoria, on the 10th day of June, 1952, to The Union Trustee Company of Australia Limited, of 333 Collins-street, Melbourne, the duly constituted attorney under power of the Public Trustee of New Zealand, the executor named in the said will), are to send particulars of their claims to the said company, at its address above-mentioned, by the 19th day of August, 1952, after which date it will distribute the assets, having regard only to the claims of which it then has notice.

Dated this 13th day of June, 1952.

BLAKE & RIGGALL, 120 William-street, Melbourne, solicitors for the said company. 1391

NOTICE TO CREDITORS.

CREDITORS, next of kin, and others having claims in respect of the estate of Nellie Frith, late of 18 May-street, Coburg, married woman, deceased (who died on the 1st July, 1951), are to send their claims to The Perpetual Executors and Trustees Association of Australia Limited, of 100 Queen-street, Melbourne, in the State of Victoria, by the 26th day of August, 1952, after which date it will distribute the assets, having regard only to the claims of which it then has notice.

HOLT, GRAHAM, & NEWMAN, 178 Collins-street, Melbourne, solicitors for the applicants. 1384

CREDITORS, next of kin, and all others having claims in or against the estate of Ethellin Louisa McLennan, late of Dimboola, widow, deceased (who died on the 13th day of February, 1952), are required by the executor of her will, National Trustees, Executors, and Agency Company of Australasia Limited, of 95 Queen-street, Melbourne, to send particulars of such claims to the said company before the 16th day of August, 1952, after which date it will distribute the assets of the said deceased amongst the persons entitled thereto, having regard only to the claims of which it then has notice.

W. N. MUNTZ, of 48 Victoria-street, Dimboola, solicitor for the executor. 1377

PURSUANT to the *Trustee Act 1928*, all persons having claims against the property or estate of Marjorie Doris Fife Russell, late of 2 Turnbull-avenue, Toorak, spinster, deceased (who died on the 13th day of June, 1951, and reseal of probate of whose will was granted by the Supreme Court of Victoria, on the 17th day of April, 1952, to Elder's Trustee and Executor Company Limited, Ronald Lisle Johnson and Bernard Gore Brett, the executors named therein), are hereby required to send particulars of such claims to the said executors, addressed to the care of Messieurs Blake and Riggall, 120 William-street, Melbourne, solicitors, on or before the 19th day of August, 1952, after the expiration of which time the said executors will proceed to distribute the assets of the said deceased amongst the persons entitled thereto, having regard only to the claims of which they shall have had notice.

Dated this 13th day of June, 1952.

BLAKE & RIGGALL, 120 William-street, Melbourne, solicitors for the executors. 1390

PURSUANT to the *Trustee Act 1928*, all persons having claims against the property or estate of Marie Burrell Mangnall, late of 255 Nicholson-street, Carlton, widow, deceased (who died on the 1st day of January, 1952, and letters of administration of whose estate was granted by the Supreme Court of Victoria, on the 30th day of April, 1952, to Edna Dorothy Marie Butler, of 13 Gilbert-grove, Bentleigh, married woman), are hereby required to send particulars of such claims to the said administratrix, addressed to the care of Messieurs Blake and Riggall, 120 William-street, Melbourne, solicitors, on or before the 19th day of August, 1952, after the expiration of which time the said administratrix will proceed to distribute the assets of the said deceased amongst the persons entitled thereto, having regard only to the claims of which she shall have had notice.

Dated this 13th day of June, 1952.

BLAKE & RIGGALL, 120 William-street, Melbourne, solicitors for the administratrix. 1389

JAMES MAKEHAM, late of "South Atlas," Junortoun, farmer, DECEASED.

CREDITORS, next of kin, and all other persons having claims against the estate of the deceased are required by Farmers and Citizens Trustees Company Bendigo Limited, of Charing Cross, Bendigo, the executor of the will, to send particulars to it, care of the under-mentioned solicitors, on or before the 11th day of August, 1952, after which date the said company will distribute the assets, having regard only to the claims of which it shall then have notice.

Dated this 11th day of June, 1952.

T. M. WILLIAMS, WATSON, & JAMES, solicitors, 16 View-street, Bendigo. 1325

CREDITORS, next of kin, and others having claims in respect of the estate of Matthew Henry Reilly, late of 23 Christowell (otherwise Christowel) street, Camberwell, in the State of Victoria, gentleman, deceased (who died on the 4th day of May, 1952), are required to send particulars in writing of their claims against the estate of the said deceased to The Perpetual Executors and Trustees Association of Australia Limited, whose registered office is situate at 100-104 Queen-street, Melbourne, in the said State, by the 1st day of September, 1952, after which date it will distribute the assets, having regard only to the claims, whether formal or not, of which it then shall have had notice; and further, that it will not be liable to any person of whose claim it shall not then have had notice.

LEACH & THOMSON, solicitors, 472 Bourke-street, Melbourne. 1370

GWENDOLEN VIOLET HOOPER, late of Vinton-street, California Gully, in the State of Victoria, widow, DECEASED, intestate.

CREDITORS, next of kin, and all other persons having claims against the estate of the said deceased are requested by Edith Jane Tilson, of Maple-street, Golden Square, in the said State, married woman, the administratrix of the estate of the said deceased, to send particulars thereof, in writing, to her, care of the under-mentioned solicitors, on or before the 13th day of August, 1952, after which date she will proceed to distribute the assets of the said deceased, having regard only to the claims of which she shall then have notice.

Dated the 11th day of June, 1952.

T. M. WILLIAMS, WATSON, & JAMES, of Bull-street, Bendigo, solicitors for the administratrix. 1326

CREDITORS, next of kin, and others having claims in respect of the estate of Annie Fiscalini, formerly of Sturt-street, Ballarat, but late of 11 Eildon-road, St. Kilda, home duties, deceased (who died on 21st September, 1951), are to send particulars of their claims to Charles Fiscalini, of 11 Eildon-road, St. Kilda, care of J. W. Sackville, solicitor, 379 Collins-street, Melbourne, by the 12th day of August, 1952, after which date he will distribute the assets, having regard only to the claims of which he then has notice.

J. W. SACKVILLE, LL.B., solicitor, 379 Collins-street, Melbourne. 1357

CREDITORS, next of kin, and others having claims in respect of the estate of Charlotte Isabella Gall Payne, late of Coleraine, in the State of Victoria, spinster, deceased, intestate (who died on the 21st day of April, 1951), are required to send particulars of their claims to the administratrix, Charlotte Payne Kendall, of 29 Richardson-street, Essendon, widow, in care of the undersigned, by the 31st day of August, 1952, after which date the said administratrix will distribute the assets, having regard only to the claims of which she then has notice.

W. E. TAYLOR, solicitor, Coleraine. 1371

CREDITORS, next of kin, and others having claims in respect of the estate of Harold James Lawrence, late of 18 Comer-street, Brighton East, in the State of Victoria, leading linesman, deceased (who died on the 29th day of March, 1952), are to send particulars of their claims to Frank Ralph Murray, the executor of the will of the deceased, care of the undersigned solicitor, by the 30th day of August, 1952, after which date the said Frank Ralph Murray will distribute the assets, having regard only to the claims of which he then has notice.

JOHN F. CARROLL, solicitor, 95 Queen-street, Melbourne. 1355

CREDITORS, next of kin, and others having claims against the estate of Elizabeth Marjoribanks Andrews, late of 4 Mandeville-crescent, Toorak, widow, deceased (probate of whose will was on the 7th day of March, 1952, granted by the Supreme Court of Victoria, to Lillian Ellie Andrews, of 9 View-street, Hawthorn, home duties, the executrix named therein), are required to send particulars of such claims to the said executrix, care of her solicitors, Hoad and Bonella, 101 Queen-street, Melbourne, before the 20th day of August, 1952, after which date the executrix will proceed to distribute the assets of the said deceased, having regard only to the claims of which she shall then have had notice.

1354

CREDITORS, next of kin, and others having claims in respect of the estate of Walter John Rose, late of 8 Wolsley-grove, Brighton, in the State of Victoria, consulting engineer, deceased (who died on the 13th day of April, 1952), are to send particulars of their claims to the National Trustees, Executors, and Agency Company of Australasia Limited, at its registered office, No. 95 Queen-street, Melbourne, by the 20th day of August, 1952, after which date it will distribute the assets, having regard only to the claims of which it then has notice.

GODFREY & GODFREY, solicitors, 325 Collins-street, Melbourne. 1349

CREDITORS, next of kin, and others having claims in respect of the estate of Isabel Muriel Backous, late of 2 Wellington-street, Middle Brighton, married woman (who died on the 11th day of February, 1952), are to send particulars of their claims to The Trustees, Executors, and Agency Company Limited, of 401 Collins-street, Melbourne, the executor to which probate of the will of the said deceased has been granted, by the 20th day of August, 1952, after which date it will distribute the assets of the said deceased, having regard only to the claims of which it then has notice.

NORVAL H. DOOLEY & BREEN, solicitors, 31 Queen-street, Melbourne. 1346

CREDITORS, next of kin, and others having claims in respect of the estate of Robert Berthold Forsyth, formerly of No. 7 Havelock-road, Upper Hawthorn, but late of 8 Mundy-street, Mentone, both in the State of Victoria, deceased (who died on the 22nd day of December, 1951), are to send the particulars of their claims to The Equity Trustees, Executors, and Agency Company Limited, of 472 Bourke-street, Melbourne, in the said State, by the 21st day of August, 1952, after which date it will distribute the assets, having regard only to the claims of which it then has notice.

MOULE, HAMILTON, & DERHAM, solicitors, 394 Collins-street, Melbourne. 1347

No. 501.—5757/52.—4

WALTER ALLAN RAYNER, late of 96 Westbourne-grove, Northcote, gentleman (who died 15th April, 1952).

CREDITORS, next of kin, and all other persons having claims against the estate of the deceased are required by the executor of the will, Frederick George Rayner, of 56 Andrew-street, Northcote, furniture manufacturer, to send particulars to him, care of the undersigned, on or before the 30th day of August, 1952, after which date he will distribute the assets, having regard only to the claims of which he then has notice.

DESMOND FITZGERALD, CAREY, & MORAN, solicitors, 396 Little Flinders-street, Melbourne. 1358

CREDITORS, next of kin, and others having claims in respect of the estate of Walter Gardner, late of Majorca, returned soldier, deceased (who died on the 14th day of March, 1952), are to send the particulars of their claims to Harry Lloyd Bathurst, of Maryborough, solicitor, by the 30th day of August, 1952, after which date he will distribute the assets, having regard only to the claims of which he then has notice.

HERRING & BATHURST, solicitors, Maryborough.

1364

In the Supreme Court of the State of Victoria.—*Fi. Fa.*

NOTICE is hereby given that, under and by virtue of certain process issued out of the Supreme Court of the State of Victoria and directed to the Sheriff, requiring him to levy certain moneys of the real and personal estate of C. C. Wilson, of Flatrock-road, Hurstbridge, contractor, the said Sheriff will, on Monday, the 28th day of July, 1952, at the hour of Twelve o'clock noon, cause to be sold at the Police Station, Hurstbridge (unless the said process shall have been previously satisfied or the said Sheriff be otherwise stayed):—

All the right, title, estate, and interest (if any) of the said C. C. Wilson, in and to the surface and down to the depth of 50 feet below the surface of all that piece of land containing 36 acres 2 roods and 27 perches, or thereabouts, being Crown allotments 81 and 82, section E, Parish of Greensborough, County of Evelyn, and being the land more particularly described in certificate of title volume 6823, folio 1364591.

N.B.—Terms: Cash. No cheques taken.

Dated at Melbourne, this 12th day of June, 1952.

1372 FRANCIS H. TUCKER, Sheriff's Officer.

In the Supreme Court of the State of Victoria.—*Fi. Fa.*

NOTICE is hereby given that, under and by virtue of certain process issued out of the Supreme Court of the State of Victoria and directed to the Sheriff, requiring him to levy certain moneys of the real and personal estate of Alexander Chorstorphon Moody, of 14 Westgate-street, Oakleigh, builder, the said Sheriff will, on Tuesday, the 29th day of July, 1952, at the hour of Eleven o'clock in the forenoon, cause to be sold at the Police Station, Atkinson-street, Oakleigh (unless the said process shall have been previously satisfied or the said Sheriff be otherwise stayed):—

All the right, title, estate, and interest (if any) of the said Alexander Chorstorphon Moody, in and to all that piece of land, being part of Crown portion 1, Parish of Mulgrave, County of Bourke, and being the whole of the land described in certificate of title, volume 6345, folio 1268869.

N.B.—Terms: Cash. No cheques taken.

Dated at Melbourne, this 16th day of June, 1952.

1373 FRANCIS H. TUCKER, Sheriff's Officer.

In the Supreme Court of the State of Victoria.—*Fi. Fa.*

NOTICE is hereby given that, under and by virtue of certain process issued out of the Supreme Court of the State of Victoria and directed to the Sheriff, requiring him to levy certain moneys of the real and personal estate of Harold Benjamin Edwards, of Prince's Highway, Springvale North, carrier, the said Sheriff will, on Wednesday, the 30th day of July, 1952, at the hour of Eleven o'clock in the forenoon, cause to be sold at the Police Station, Springvale (unless the said process shall have been previously satisfied or the said Sheriff be otherwise stayed):—

All the right, title, estate, and interest (if any) of the Harold Benjamin Edwards in and to all that piece of land being lot 56 on plan of subdivision number 12519, lodged in the Office of Titles, and being part of Crown allotment 5, section 4, Parish of Mordialloc, County of Bourke, and being that land comprised in certificate of title, volume 7311, folio 1462173.

N.B.—Terms: Cash. No cheques taken.

Dated at Melbourne, this 16th day of June, 1952.

1374 FRANCIS H. TUCKER, Sheriff's Officer.

MINING NOTICES.**ARGUS HILL CHEWTON GOLD NO LIABILITY.**

NOTICE is hereby given that all shares forfeited for non-payment of No. 100 (May) Call of Three pence per share, will be sold by public auction in the vestibule of the Stock Exchange, 428 Chancery-lane, Melbourne, on Wednesday, 25th June, 1952, at a quarter to Twelve a.m., unless previously redeemed.

By order of the Board,

FRANK COOPER, Manager,
422 Collins-street, Melbourne. 1394

WHIPPET CONSOLIDATED NO LIABILITY.

NOTICE is hereby given that the sale of shares forfeited for non-payment of No. 2 (April) Call of Three pence per share, advertised for the 3rd June, 1952, was cancelled, and is re-advertised, and shares will now be sold by public auction in the vestibule of the Stock Exchange, 428 Chancery-lane, Melbourne, on Wednesday, 25th June, 1952, at ten minutes to Twelve a.m., unless previously redeemed. No postponement.

By order of the Board,

FRANK COOPER, Manager,
422 Collins-street, Melbourne. 1395

IMPOUNDINGS.**BRANXHOLME.—Impounded in Branxholme Pound, from "Sleat Bank."**

1 Merino ewe weaner, no visible brand or earmark
If not claimed and expenses paid, to be sold on 5th July, 1952.

J. ATKINSON,
Poundkeeper.
1362—7/7

COBURG.—Impounded in Coburg Pound.

1 bay pony gelding, white blaze, no visible brand
If not claimed and expenses paid, to be sold on 2nd July, 1952.

E. S. McNABB,
Poundkeeper.
1407—6/6

CRANBOURNE.—Impounded in Cranbourne Pound, by Ranger, from Cranbourne Township.

1 bay draught mare, aged, blaze face, hind feet white, no visible brand
1 chestnut draught mare, aged, white stripe on face, hind feet white, indistinct brand near shoulder

If not claimed and expenses paid, to be sold on 3rd July, 1952.

F. H. CLARK,
Poundkeeper.
1360—10/10

DANDENONG.—Impounded in Dandenong Pound, by Shire Ranger, E. Osborne, off David-street.

1 dark-bay draught gelding, near hind sock white, unshod, no visible brand

If not claimed and expenses paid, to be sold on 4th July, 1952.

A. WALKER,
Poundkeeper.
1361—8/8

ELTHAM.—Impounded in Eltham Pound, by Ranger.

1 black draught mare, blazed face, hind feet white, no visible brand

1 black medium draught horse, blazed face, two hind and near front feet white, no visible brand, rope on neck
1 bay gelding hack, no visible brand, rope on neck

If not claimed and expenses paid, to be sold on 2nd July, 1952.

W. J. WALSH,
Poundkeeper.
1408—10/10

HORSHAM.—Impounded in Horsham Pound.

3 full mouth ewes, F in circle on shoulder, dot on rump, lambs at foot

If not claimed and expenses paid, to be sold on 5th July, 1952.

A. G. FRASER,
Poundkeeper.
1375—7/7

KOO-WEE-RUP.—Impounded in Koo-wee-rup Pound, by Ranger.

3 brown Jersey heifers, no visible brand

If not claimed and expenses paid, to be sold on 3rd July, 1952.

W. JOHNSON,
Poundkeeper.
1359—7/7

MARYBOROUGH.—Impounded in Maryborough Pound.

1 light Jersey steer, piece out of left ear, tag No. 410 on head, no visible brand

If not claimed and expenses paid, to be sold on 1st July, 1952.

J. E. HOWDEN,
Poundkeeper.
1409—7/7

SALE.—Impounded in Sale Pound.

1 Hereford steer, scollop out top ear, no visible brand
1 Hereford steer (polled), scollop out top ear, no visible brand

1 Shorthorn heifer calf, square notch out side of right ear, no visible brand

1 brown pony mare, about 13 hands, small star, no visible brand, shoe on off hind foot

If not claimed and expenses paid, to be sold on 1st July, 1952.

G. CLARK,
Poundkeeper.
1330—13/

SOUTH BARWON.—Impounded in South Barwon Shire Pound, by Ranger Hooper.

1 bay draught gelding, white blaze, white legs, no visible brand

1 bay delivery gelding, hind feet white, blaze, shod, no visible brand

1 skewbald Shetland pony gelding, no visible brand

If not claimed and expenses paid, to be sold on 2nd July, 1952.

M. S. HOOPER,
Poundkeeper.
1331—11/11

WARRNAMBOOL.—Impounded in Warrnambool Pound.

1 bay gelding, blaze face, white on off front hoof, no visible brand

1 bay or brown gelding, both knees marked, white on off hind leg, no visible brand

If not claimed and expenses paid, to be sold on 25th June, 1952.

M. STONEHOUSE,
Poundkeeper.
1376—9/9

STATE ACTS, 1950.

COPIES of the following Acts of Parliament of Victoria may be obtained at the Government Printing Office, or from any bookseller, at the price set opposite to each:—

No.	Price.
	s. d.
5451. Consolidated Revenue	0 6
5452. Consolidated Revenue	0 6
5453. Superannuation	0 6
5454. Marine (Temporary Exemptions)	0 6
5455. Consolidated Revenue	0 6
5456. Melbourne Harbor Trust (Housing Advances)	0 6
5457. University (Veterinary Research)	0 6
5458. Pyalong Lands Exchange	0 9
5459. Goods (Textile Products)	0 9
5460. Police Regulation (Pensions)	0 6
5461. Melbourne (Bowen-street) Land	0 9
5462. Printers and Newspapers (Foreign Advertisements)	0 6
5463. Police Offences (Race-meetings)	0 6
5464. Non-Contributory State Pensions	0 6
5465. Legislative Council Reform	2 0
5466. State Electricity Commission (Contracts)	0 6
5467. Police Regulation (Pensions) Amendment	0 6
5468. Prices Regulation (Extension)	0 6
5469. Factories and Shops (Amendment)	0 6
5470. Nurses and Midwives	1 3
5471. Weights and Measures	1 6
5472. Supreme Court (Judges)	0 6
5473. Drainage Areas	1 3
5474. Consolidated Revenue	0 6
5475. Forests (Accounts and Funds)	0 6
5476. Coal Mining Industry (Long-Service Leave)	0 2
5477. Acts Interpretation (Amendment)	0 6

STATE ACTS, 1950—continued.

No.	Price.
	s. d.
5478. Agricultural Colleges (Amendment)	0 6
5479. Building Operations and Building Materials, &c.	0 9
5480. Shrine of Remembrance Site	0 6
5481. Public Works Loan and Application	0 6
5482. Grain Elevators	0 6
5483. Teaching Service (Amendment)	0 9
5484. Imported Materials Loan and Application, &c.	0 6
5485. Water Supply Loan and Application	1 3
5486. Victorian Inland Meat Authority (Advances)	0 6
5487. Melbourne and Metropolitan Board of Works (Contracts)	0 6
5488. Melbourne and Metropolitan Board of Works (Borrowing Powers)	0 6
5489. Cattle Compensation	0 6
5490. Coal Mines Regulation (Accidents Relief)	0 6
5491. Public Contracts (Amendment)	0 6
5492. Water	0 9
5493. Administration and Probate Duties	0 6
5494. Country Roads Board	0 6
5495. Land Tax	0 6
5496. Motor Car (Drivers' Licences)	0 6
5497. Tallangatta Township (Removal)	0 9
5498. Medical	0 6
5499. State Forests Loan and Application	0 6
5500. Surplus Revenue (Unexpended Balances)	0 6
5501. Treasury Bonds	0 6
5502. Co-operative Housing Societies	1 0
5503. Police Offences (Idle and Disorderly Persons)	0 6
5504. Gelliondale Land (Mineral Lease)	0 6
5505. Local Government (Imported Houses)	0 6
5506. Police Offences (Animals)	0 6
5507. Gas and Fuel Corporation	2 6
5508. Jubilee and Centenary Sports	0 6
5509. Railways Dismantling	0 9
5510. Geelong (Kardinia Park) Land	0 6
5511. Coal Mine Workers Pensions (Amendment)	0 6
5512. Municipalities and Other Authorities Finances	0 9
5513. Public Officers Salaries	0 6
5514. State Electricity Commission	0 6
5515. Public Works Loan and Application (No. 2)	0 9
5516. Ministers of the Crown and Parliamentary Salaries	0 6
5517. Fire Brigades (Long-Service Leave)	0 9
5518. Fisheries (Inland Angling)	0 6
5519. Mental Hygiene Authority	1 6
5520. Railway Loan and Application	1 3
5521. Education (Religious Instruction)	0 6
5522. Workers' Compensation (Amendment)	1 0
5523. Public Trustee	0 6
5524. McPherson's Limited Pension Fund	0 6
5525. Landlord and Tenant (Servicemen)	0 6
5526. Local Government (Shire of Braybrook)	0 6
5527. Appropriation of Revenue	4 6

J. J. GOURLEY,
Government Printer.

STATE ACTS, 1951.

COPIES of the following Acts of Parliament of Victoria may be obtained at the Government Printing Office, or from any bookseller, at the price set opposite to each:—

No.	Price.
	s. d.
5528. Consolidated Revenue	0 6
5529. State Electricity Commission (Overdraft)	0 6
5530. Local Government (Enrolment)	0 6
5531. Crimes (Reformatory Prisons)	0 6
5532. The Geelong Gas Company's	0 6
5533. Railways (Amendment)	0 6
5534. Poisons	0 6
5535. Select Committee (Egg and Egg Pulp) Marketing	0 6
5536. Coal Mining Industry (Long-service Leave) Amendment	0 6
5537. Education (Amendment)	0 6
5538. Friendly Societies	0 6
5539. State Development	0 6
5540. Stamps (Cheques)	0 6
5541. Public Service	0 9
5542. Country Fire Authority (Financial)	0 6
5543. Consolidated Revenue	0 6
5544. Coal Mine Workers' Pensions (Contributions)	0 6
5545. Vermin and Noxious Weeds (Financial)	0 6
5546. Medical (Temporary Registration)	0 6
5547. Consolidated Revenue	0 6
5548. Railways (Furlough)	0 6
5549. Police Regulation	0 6

STATE ACTS, 1951.—continued.

No.	Price.
	s. d.
5550. Milk Board	1 6
5551. Bendigo (Rosalind Park) Lands	1 0
5552. Railways Dismantling	0 9
5553. Transfer of Land (Forgeries)	0 6
5554. Newport "A" Power Station	0 6
5555. Local Government (Overdrafts)	0 6
5556. Marketing of Primary Products (Tomatoes)	0 6
5557. Winchelsea Coal Mine	1 0
5558. Special Funds (Amendment)	0 6
5559. Transport	1 3
5560. Marine (Amendment)	0 6
5561. Portland Harbor Trust (Amendment)	0 6
5562. Transport Regulation Board	0 6
5563. Imported Materials Loan and Application (Financial)	0 6
5564. Co-operative Housing Societies (Amendment)	0 6
5565. Egg and Egg Pulp Marketing Board	0 6
5566. Stamps (Betting Tax)	0 9
5567. Land Tax	0 6
5568. Consolidated Revenue	0 6
5569. Transport Regulation (Fees)	0 6
5570. Factories and Shops (Registration Fees)	0 6
5571. Soldier Settlement	0 9
5572. Marine (Pilotage Rates)	0 6
5573. Water (Amendment)	0 9
5574. Latrobe Valley Drainage	1 9
5575. Grace Joel Scholarship	0 6
5576. Building Operations and Building Materials Control (Extension)	0 6
5577. Benefit Associations	1 6
5578. Public Account	1 0
5579. University	0 6
5580. Prices Regulation (Amendment)	0 6
5581. Stamps (Duties)	0 6
5582. Gippsland Railway (Duplication and Re-grading) Extension	0 6
5583. Motor Car (Registration Fees)	0 6
5584. Licensing (Fees)	0 6
5585. Land (Development Leases)	0 9
5586. Parliamentary Salaries	0 6
5587. Parliamentary Contributory Retirement Fund	0 6
5588. State Forests Loan Application	0 6
5589. Water Supply Loan Application	1 0
5590. Administration and Probate (Estates)	1 6
5591. Kerang and Koondrook Tramway	0 6
5592. Ballaarat Gas Company's	0 6
5593. Revocation and Excision of Crown Reservations	1 3
5594. Wrongs (Contributory Negligence)	0 6
5595. Local Government (Imported Houses)	0 6
5596. Woorayl (Unimproved Rating Poll)	0 6
5597. Health (Radiological Examinations)	0 6
5598. Melbourne Harbor Trust	0 6
5599. Friendly Societies (Amendment)	0 6
5600. Railway Loan Application	1 0
5601. Workers Compensation	3 3
5602. Statute Law Revision	0 9
5603. Revenue Deficit Funding	0 6
5604. Solicitor-General	0 6
5605. Wheat Industry Stabilization (Amendment)	0 6
5606. Local Government (Warrnambool)	0 6
5607. Geelong Harbor Trust (Amendment)	0 9
5608. Justices (Service of Process)	0 6
5609. Melbourne and Metropolitan Board of Works (Borrowing Powers)	0 6
5610. Firearms	2 0
5611. Licensing (Mildura)	0 6
5612. Marketing of Primary Products (Egg and Egg Pulp)	0 9
5613. Lands (Charitable Trusts)	0 6
5614. Melbourne Cricket Ground	0 9
5615. Judges and Public Officers Salaries	0 6
5616. Motor Car	3 0
5617. Firearms Offences	0 6
5618. Public Works Loan Application	0 6
5619. Appropriation of Revenue	4 3

J. J. GOURLEY,
Government Printer.

AGENTS FOR THE "VICTORIA GOVERNMENT GAZETTE."

THE following have been appointed agents to receive Advertisements and Subscriptions for the *Victoria Government Gazette*:—
ARMSTRONG'S AGENCY, 143 Queen-street, Melbourne.
ARMSTRONG BROS., Kyneton.
MESSRS. ARNALL & JACKSON, 115 Barkly-street, West Brunswick.

MR. M. R. BADE, Tobacconist, Sturt-street, Ballarat.
 MR. WM. DAVIS, Mildura.
 A. J. DIGBY (B. S. and N. W. CASH), Main-street, Bairnsdale.
 EDGAR'S NEWS AGENCY, Hargreaves-street, Bendigo.
 EDGAR'S NEWS AGENCY, 53 Murphy-street, Wangaratta.
 H. E. EVERY & SON, 42 Fryers-street, Shepparton.
 MESSRS. HENRY FRANKS & CO., Booksellers and Stationers, Market-square, Geelong.
 MESSRS. GORDON & GOTCH, News Agents, 511 Little Collins-street, Melbourne; and corner Barrack and Clarence streets, Sydney.
 A. C. HAMPTON, 243 Mitchell-street, Bendigo.
 MESSRS. HARSTON, PARTRIDGE, & CO., 455 Little Collins-street, Melbourne.
 MR. C. F. LATIMER, News Agent, Casterton.
 MR. F. T. McCORMICK, Nunn-street, Benalla.
 MESSRS. H. PAYNE & R. N. LOWE, 4 View Point, Bendigo.
 MESSRS. R. H. & W. M. PETTY, News Agent, Wangaratta.
 J. PURDIE & CO., 138 Moorabool-street, Geelong.
 MESSRS. A. S. RICHARDSON and T. C. GARDNER, trading as The Mercantile Exchange, 380 Collins-street, Melbourne.
 ROBERTSON & MULLENS LTD., Elizabeth-street, Melbourne.
 SALE AUTHORIZED NEWSAGENCY, Sale.
 R. & A. SMALLMAN, News Agents, Toora.
 MESSRS. SMITH & DUNNON, Hamilton.
 F. D. & J. R. TRAINOR, 246 Wyndham-street, Shepparton.

A copy of the Gazette filed at each place for public reference.

Single copies of the VICTORIA GOVERNMENT GAZETTE are Nine pence, posted One shilling, each.

No GAZETTES prior to January, 1942, in stock.

***ALL PAYMENTS ARE REQUIRED IN ADVANCE.—Remittances should be made by postal note, money order, or draft in favour of the Government Printer. Advertisements unaccompanied by a remittance sufficient to cover the cost of insertion will be returned unpublished.

PUBLICATION OF OFFICIAL MATTER.

ATTENTION is invited to the following procedure in relation to the publication of official matter in the *Government Gazette*—

1. Matter submitted to the Executive Council.

Matter submitted to the Executive Council which requires gazettal will normally be published in the issue of the following week.

Where urgent gazettal is required, special arrangements should be made with the *Gazette* Officer.

Publication will be facilitated by the submission of carbon copies for the use of the *Gazette* Officer.

2. Other matter.

(a) All other matter duly certified by a responsible officer for publication should be lodged with the *Gazette* Officer not later than half-past Ten a.m. on Tuesday.

(b) Lengthy or involved notices should be forwarded several days before publication.

(c) Proofs, which will be supplied only when specifically requested, or at the direction of the *Gazette* Officer, should be returned promptly to avoid delay in publication.

(d) No additions or amendments to matter for publication will be accepted by telephone.

THE "VICTORIA GOVERNMENT GAZETTE."

SUBSCRIPTIONS.—The subscription, including postage, is £2 5s. per annum, £1.2s. 6d. half-yearly, or 11s. 3d. per quarter, payable in advance.

Subscriptions are required to commence and terminate with a month.

A lesser period than three months cannot be subscribed for.

Subscribers do not receive the Acts of Parliament with the GAZETTE.

ADVERTISEMENTS are charged at the rate of 1s. 1d. per line single column, and 2s. 2d. per line double column.

The title (£5 Reward, Dissolution of Partnerships, &c.) forms one or more lines as a heading.

On an average, ten words make a line.

Every signature must likewise be counted as a line.

The final words of a paragraph, though only portion of a line, must be counted as one line.

SIGNATURES (in particular) and proper names must be written very plainly in the text; ONE SIDE ONLY of each slip of paper should be WRITTEN UPON.

ALL COMMUNICATIONS should be addressed to "The Government Printer, Melbourne."

ALL DOCUMENTS illegibly written will be returned unpublished, and, where brands occur unprovided for by the ordinary letters of the alphabet, a worded explanatory description must be furnished.

THE VICTORIA GOVERNMENT GAZETTE is published on WEDNESDAY EVENING in each week, and Notices for insertion will be received by the Government Printer at or before Two p.m. at ordinary rates, and late advertisements between Two p.m. and Five p.m. at double rates on the day preceding the day of publication.

CONTENTS.

	PAGE
Acts of Parliament on sale at the Government Printing Office	3182
Appointments	3137
Auction Sales Act	3145
Bank Half-Holiday	3136
Business Agents Act 1930	3147
Contracts	3148
Estates of Deceased Persons	3149
Farm Produce Agents Acts	3153
Government Notices	3136
Impoundings	3182
Lands	3162
Licences to Occupy Unused Roads	3139
Mining	3138, 3182
Money Lenders Act 1938—Supplementary List	3145
Orders in Council	3157
Private Advertisements	3174
Proclamations	3133
Public Holiday	3136
Public Service Notices	3168
Real Estate Agents Act	3146
Resignations	3138
Tenders	3166
Transport Regulation Board—Public Hearings	3151
Waterworks Trusts	3152