



# VICTORIA GOVERNMENT GAZETTE

Published by Authority.

[Registered at the General Post Office, Melbourne, for transmission by post as a newspaper.]

No. 825]

FRIDAY, NOVEMBER 11.

[1955

Labour and Industry Act 1953.

## DETERMINATION OF A WAGES BOARD ADJUSTED PURSUANT TO SECTION 33 OF THE LABOUR AND INDUSTRY ACT 1953.

I, Henry Norman Jones, Acting Secretary for Labour and Industry, in pursuance of the powers conferred by the Labour and Industry Act, hereby make and issue the following adjusted Determination of the Wages Board referred to hereunder showing adjusted rates and prices to operate from the beginning of the first pay period to commence in August, 1955.

Dated at Melbourne, this  
8th day of August, 1955.

H. N. JONES,  
Secretary for Labour and Industry.

### MUSICAL INSTRUMENTS BOARD.

Clauses 2, 3, 4 and 5, of the Determination made on the 29th June, 1955, and in force as from the beginning of the first pay period to commence in June, 1955, shall be replaced by the following clauses:—

2.

#### WAGES.

Adults, Journeymen or Journeywomen.	Weekly Wages.	
	Within 20 Miles of G.P.O., Melbourne, 10 Miles of G.P.O., Geelong, at Warrnambool, and in the Mildura and Gippsland Districts.	Elsewhere in Victoria.
<b>PART I.—ADULT MALES.</b>		
<b>SECTION "A"—WOOD MACHINISTS AND GENERAL.</b>		
<i>Machinist—"A" Grade.</i>		
1. Boul's carver .. .. .	£ s. d. 15 15 0	£ s. d. 15 12 0
2. Shaper—who grinds cutters and/or sets up and operates or who works freehand .. .. .	15 15 0	15 12 0
3. Moulder—who grinds cutters sets up and operates .. .. .	15 15 0	15 12 0
4. Wood turner—who grinds cutters, sets up and operates, or who works freehand .. .. .	25 15 0	15 12 0
5. Router—who grinds cutters and/or sets up and operates, or who works freehand .. .. .	15 15 0	15 12 0
6. Lindenman or similar jointer .. .. .	15 15 0	15 12 0
<i>Machinist—"B" Grade.</i>		
7. Band and/or jig sawyer .. .. .	14 0 0	13 17 0
8. Circular sawyer—who sets up and operates .. .. .	14 0 0	13 17 0
9. Dovetailer—who sets up and operates .. .. .	14 0 0	13 17 0
10. Buzzer—who sets up and operates .. .. .	14 0 0	13 17 0
11. Planer—who sets up and operates .. .. .	14 0 0	13 17 0
12. Thicknesser—who sets up and operates .. .. .	14 0 0	13 17 0
13. Glue jointer—who sets up and operates .. .. .	14 0 0	13 17 0
14. Tenoner—who sets up and operates .. .. .	14 0 0	13 17 0
15. Turner—copying or automatic lathe—who sets up and operates .. .. .	14 0 0	13 17 0
16. Morticer—who sets up and operates .. .. .	14 0 0	13 17 0
17. Sander—tripledrum—who sets up and operates .. .. .	14 0 0	13 17 0
18. Belt sander on veneers .. .. .	14 0 0	13 17 0
19. Multiple borer—three or more bits—who sets up and operates .. .. .	14 0 0	13 17 0
20. Moulder—who sets up and operates .. .. .	14 5 0	14 2 0

Adults, Journeymen or Journeywomen.	Weekly Wages.	
	Within 20 Miles of G.P.O., Melbourne, 10 Miles of G.P.O., Geelong, at Warrnambool, and in the Mildura and Gippsland Districts.	Elsewhere in Victoria.
<b>PART I.—ADULT MALES—continued.</b>		
<i>Machinist—"C" Grade.</i>		
	£ s. d.	£ s. d.
21. Sander—others .. .. .	13 10 0	13 7 0
22. Borer—less than three bits .. .. .	13 10 0	13 7 0
23. All others—including employees of any of the above-named machines (except classes Nos. 1, 6 and 18) who are not required at any time to grind cutting tools or set up the machine and who are working from templates, dies or jigs, or fences .. .. .	13 10 0	13 7 0
<i>General.</i>		
24. Timber bender .. .. .	13 10 0	13 7 0
25. Timber stacker .. .. .	12 15 0	12 12 0
26. Yardman .. .. .	12 15 0	12 12 0
27. Tailor out .. .. .	12 15 0	12 12 0
28. Employees not elsewhere classified .. .. .	12 3 0	12 0 0
<b>SECTION "B"—POLISHING &amp;c.</b>		
29. Polisher .. .. .	15 15 0	15 12 0
30. Spray hand—		
(a) engaged on finishing coats of any type .. .. .	14 0 0	13 17 0
(b) engaged on priming and/or undercoating, and/or sealing .. .. .	13 10 0	13 7 0
31. Employee cutting or papering down and/or filling and/or staining .. .. .	13 10 0	13 7 0
<b>SECTION "C"—PIANOS.</b>		
32. Action regulator .. .. .	15 15 0	15 12 0
33. Tuner and/or action repairer .. .. .	15 15 0	15 12 0
34. Player mechanic .. .. .	15 15 0	15 12 0
35. Part maker .. .. .	15 15 0	15 12 0
36. Side gluer .. .. .	15 15 0	15 12 0
37. Sound board maker .. .. .	15 15 0	15 12 0
38. Fly finisher .. .. .	15 15 0	15 12 0
39. Maker and/or repairer of musical instruments .. .. .	15 15 0	15 12 0
40. Player action assembler .. .. .	14 2 6	13 19 6
41. Piano action assembler .. .. .	14 2 6	13 19 6
42. Iron frame driller .. .. .	13 10 0	13 7 0
43. Iron frame finisher by hand or spray .. .. .	13 10 0	13 7 0
44. Spring and brass wire spinner .. .. .	13 10 0	13 7 0
45. Veneer presser .. .. .	13 10 0	13 7 0
46. Veneer scraper .. .. .	13 10 0	13 7 0
47. Gluer up .. .. .	13 10 0	13 7 0
<b>PART II.—ADULT FEMALES.</b>		
Veneer matcher .. .. .	10 0 0	9 17 6
Upholstress .. .. .	10 0 0	9 17 6

Provided that all other adult females employed on work for which a male margin of 40s. or over is prescribed in clause 40 of the Determination published in *Government Gazette* No. 236, of the 12th April, 1954, shall receive a margin equal to 50 per centum of the male margin, but, if the male margin was less than 40s., they shall receive a margin equal to 25 per centum of the male margin. Where there is no male margin prescribed for their work they shall be paid a margin of 4s. per week.

**PART III.—SAVING.**

No employee shall have his or her rate reduced merely as a result of this Determination.

**SPECIAL RATES.**

3. (a) *Leading hands.*—In addition to the margins prescribed in clause 2 herein leading hands shall be paid the following allowances:—

- (1) Fifteen shillings per week if in charge of not less than three and not more than ten employees including apprentices;
- (2) Thirty shillings per week if in charge of not less than ten and not more than twenty employees including apprentices;
- (3) Forty-five shillings per week if in charge of more than twenty employees including apprentices.

(b) In addition to the rates set out in clause 2 herein the following additional rates shall be paid:—

- (i) Sixpence per hour to employees working in confined spaces;

Confined space means a compartment, space or place the dimensions of which necessitate an employee working in a stooped or otherwise cramped position or without proper ventilation.

- (ii) Fourpence per hour to employees working in any place where clothing or boots become saturated, whether by water, oil or otherwise. Provided that this extra rate shall not be payable to an employee who is provided by the employer with suitable and effective protective clothing and/or footwear. And provided further that any employee who becomes entitled to this extra rate shall be paid such extra rate for such part of the day or shift as he is required to work in wet clothing or boots.

- (iii) Sixpence per hour to employees handling loose slag wool, loose insul wool or other loose material of a like nature used for providing insulation against heat, cold or noise;
- (iv) Fourpence per hour where a foreman and workman shall agree that the work is of an unusually dirty or offensive nature.

In case of disagreement between the foreman and workman, the workman or a shop steward on his behalf shall be entitled within 24 hours, to ask for a decision on the workman's claim by the employer's Industrial Officer if there be one, or otherwise by the employer or the executive officer responsible for the management of superintendence of the plant concerned. In such case a decision shall be given on the workman's claim within 48 hours of its being asked for (unless that time expires on a non-working day, in which case it shall be given during the next working day) or else the said allowance shall be paid.

*Special Rates Not Cumulative.*

(c) Where more than one of the disabilities entitling a workman to extra rates exist on the same job the employer shall be bound to pay only one rate, namely, the highest rate for the disabilities so prevailing.

*Rates Not Subject To Penalty Additions.*

(d) The special rates herein prescribed shall be paid irrespective of the times at which the work is performed, and shall not be subject to any premium or penalty additions.

**MIXED FUNCTIONS.**

4. Where an employee is engaged in any one week for more than half of such week at work in a higher class than he or she is employed to perform, he or she shall be paid for the full week at the highest rate payable for any such work under this Determination; but if he or she is engaged for more than half of any one day he or she shall be so paid for the whole day. If the period on the higher class of work is half or less than half a week or half or less than half a day then he or she shall be paid at the rate fixed for the work he or she actually performs.

**APPRENTICES AND IMPROVERS—RATES OF PAY.**

5. The following shall be the rates of pay for apprentices and improvers:—

	Within 20 Miles of G.P.O., Melbourne, 10 Miles of G.P.O., Geelong, at Warrnambool, and in the Mildura and Gippsland Districts.	Elsewhere in Victoria.
<i>Male Apprentices.</i>		
<i>Five-year Term—</i>		
1st year's experience .. .. .	£ 3 17 0	£ 3 16 0
2nd year's experience .. .. .	5 3 0	5 2 0
3rd year's experience .. .. .	6 9 6	6 8 0
4th year's experience .. .. .	9 19 0	9 16 6
5th year's experience .. .. .	12 6 0	12 3 0
<i>Four-year Term—</i>		
1st year's experience .. .. .	4 1 6	4 0 6
2nd year's experience .. .. .	6 9 6	6 8 0
3rd year's experience .. .. .	9 19 0	9 16 6
4th year's experience .. .. .	12 6 0	12 3 0
<i>Male Improvers.</i>		
Under 16 years of age .. .. .	2 17 6	2 17 0
16 and under 17 .. .. .	3 10 6	3 9 6
17 and under 18 .. .. .	4 14 6	4 13 6
18 and under 19 .. .. .	6 6 6	6 4 6
19 and under 20 .. .. .	9 19 0	9 16 6
20 and under 21 .. .. .	12 5 0	12 2 0
<i>Female Apprentices.</i>		
1st year's experience .. .. .	4 3 0	4 1 6
2nd year's experience .. .. .	5 18 6	5 17 0
3rd year's experience .. .. .	7 18 6	7 16 6
4th year's experience .. .. .	9 1 0	8 18 6
<i>Female Improvers.</i>		
16 years and under .. .. .	2 19 6	2 18 6
17 years .. .. .	4 3 0	4 1 6
18 years .. .. .	5 18 6	5 17 0
19 years .. .. .	7 18 6	7 16 6
20 years .. .. .	9 1 0	8 18 6

Clauses, other than clauses 2, 3, 4 and 5, of the said Determination shall remain in force.





# VICTORIA GOVERNMENT GAZETTE.

Published by Authority.

[Registered at the General Post Office, Melbourne, for transmission by post as a newspaper.]

No. 826]

FRIDAY, NOVEMBER 11.

[1955

*Labour and Industry Act 1953.*

## DETERMINATION OF A WAGES BOARD ADJUSTED PURSUANT TO SECTION 33 OF THE LABOUR AND INDUSTRY ACT 1953.

I, Henry Norman Jones, Secretary for Labour and Industry, in pursuance of the powers conferred by the Labour and Industry Act, hereby make and issue the following adjusted Determination of the Wages Board referred to hereunder showing adjusted rates and prices to operate from the beginning of the first pay period to commence in August, 1955.

Dated at Melbourne, this  
8th day of August, 1955.

H. N. JONES,  
Secretary for Labour and Industry.

### SHOPS BOARD No. 22 (MOTOR REQUISITES).

Clause 2 of the Determination made on the 16th March, 1955, and in force as from the beginning of the first pay period to commence on or after the 31st March, 1955, shall be replaced by the following clause:—

2.

#### APPRENTICES OR IMPROVERS.

WAGES PER WEEK OF 40 HOURS.				PROPORTION (in any Shop).	
		Percentage of Basic Wage.	s. d.		
15 years of age or under	.. ..	28	67 0	<p><i>Apprentices.</i></p> <p>One apprentice to every three or fraction of three persons receiving not less than the minimum wage.</p> <p><i>Improvers.</i></p> <p>Two improvers to every worker receiving not less than the minimum wage.</p>	
16 years of age	.. ..	38	91 0		
17 years of age	.. ..	52	125 0		
18 years of age	.. ..	66	158 6		
19 years of age	.. ..	86	206 6		
20 years of age	.. ..	100 + 5s.	245 0		

#### ALL OTHER EMPLOYEES.

	Wages per Week of 40 Hours.
	s. d.
Manager, or Managers, of a shop, branch shop, or department (i.e., the principal employee in any shop, branch shop, or department, notwithstanding he may be under the orders of another person who does not devote his whole time to the supervision of such shop, branch shop, or department)	290 0
Employee solely engaged in the sale of lubricating oil, petrol, benzine, or other motor spirit	262 0
Other salesman or saleswoman	290 0

Clauses, other than clause 2, of the said Determination shall remain in force.

By Authority: W. M. HOUSTON, Government Printer, Melbourne.

...

...

...

...

...

...

...



# VICTORIA GOVERNMENT GAZETTE.

Published by Authority.

[Registered at the General Post Office, Melbourne, for transmission by post as a newspaper.]

No. 827]

FRIDAY, NOVEMBER 11.

[1955

*Labour and Industry Act 1953.*

## DETERMINATION OF A WAGES BOARD ADJUSTED PURSUANT TO SECTION 33 OF THE LABOUR AND INDUSTRY ACT 1953.

I, Henry Norman Jones, Secretary for Labour and Industry, in pursuance of the powers conferred by the Labour and Industry Act, hereby make and issue the following adjusted Determination of the Wages Board referred to hereunder showing adjusted rates and prices to operate from the beginning of the first pay period to commence in May, 1955, and August, 1955, respectively.

Dated at Melbourne, this  
14th day of October, 1955.

H. N. JONES,  
Secretary for Labour and Industry.

### FACTORY ENGINE DRIVERS BOARD.

(A) As from the beginning of the first pay period to commence in May, 1955, until the beginning of the first pay period to commence in August, 1955, clauses 2 and 4 of the Determination made on 21st February, 1955, and in force as from the beginning of the first pay period to commence on or after the 2nd January, 1955, shall be replaced by the following clauses:—

2.

*Wages.*

	Wages per Week.			
	Persons other than those Employed in Bush Saw-mills.			Persons Employed in— (a) Bush Saw-mills. (b) All parts of Victoria not elsewhere included.
	Within 20 miles of G.P.O., Melbourne; 10 miles of Chief P.O., Geelong; at Warrambool, and in the Gippsland District.	Within 15 miles of the Mildura Post Office.	At Yallourn.	
	£ s. d.	£ s. d.	£ s. d.	£ s. d.
<b>A. STATIONARY ENGINE DRIVERS</b>				
<i>Steam Engines—</i>				
First class .. .. .	14 9 6	14 15 6	14 16 0	14 6 6
First class with condenser .. .. .	15 0 0	15 6 0	15 6 6	14 17 0
Second class .. .. .	13 19 0	14 5 0	14 5 6	13 16 0
Second class with condenser .. .. .	14 9 6	14 15 6	14 16 0	14 6 6
<i>Suction Gas and Other Internal Combustion Engine—</i>				
50 brake horse power or over .. .. .	14 9 6	14 15 6	14 16 0	14 6 6
Under 50 brake horse power .. .. .	13 19 0	14 5 0	15 5 6	13 16 0
<i>Electric Motor Attendants—</i>				
On motors over 250 horse power .. .. .	14 9 6	14 15 6	14 16 0	14 6 6
On motors 100 horse power to 250 horse power inclusive .. .. .	13 12 6	13 18 6	13 19 0	13 9 6
On motors under 100 horse power .. .. .	13 0 0	13 6 0	13 6 6	12 17 0
Where the employee attends two or more motors he shall be paid a rate calculated on the aggregate horse power of such motors. <i>Note.</i> —Horse power shall be that shown on the makers' name plate.				

	Wages per Week.			
	Persons other than those Employed in Bush Saw-mills.			Persons Employed in— (a) Bush Saw-mills. (b) All parts of Victoria not elsewhere included.
	Within 20 miles of G.P.O., Melbourne; 10 miles of Chief P.O., Geelong; at Warrnambool, and in the Gippsland District.	Within 15 miles of the Mildura Post Office.	At Yallourn.	
£ s. d.	£ s. d.	£ s. d.	£ s. d.	
<b>B. LOCOMOTIVE ENGINE DRIVERS</b>				
If human beings other than train crew are sometimes or always carried .. .. .	15 18 0	16 4 0	16 4 6	15 15 0
Others .. .. .	15 6 0	15 12 0	15 12 6	15 3 0
If the gauge is less than three feet, 7s. 6d. per week less in each case.				
<b>C. WINCH DRIVERS</b>				
Log haulers on timber mills or on tramways on timber mill (exceeding 8 inch diameter cylinder) ..	14 9 6	14 15 6	14 16 0	14 6 6
Others .. .. .	14 0 6	14 6 6	14 7 0	13 17 6
<b>D. CRANE DRIVERS.</b>				
Lofty cranes—1st class .. .. .	15 12 0	15 18 0	15 18 6	15 9 0
Lofty cranes—2nd class .. .. .	15 5 6	15 11 6	15 12 0	15 2 6
Lofty cranes—3rd class .. .. .	14 19 6	15 5 6	15 6 0	14 16 6
Cantilever cranes .. .. .	15 5 6	15 11 6	15 12 0	15 2 6
Cranes transporting molten metal in foundries ..	14 7 0	14 13 0	14 13 6	14 4 0
Steam travelling cranes .. .. .	14 7 0	14 13 0	14 13 6	14 4 0
Other steam cranes .. .. .	14 0 6	14 6 6	14 7 0	13 17 6
Grab cranes .. .. .	14 7 0	14 13 0	14 13 6	14 4 0
Electric cranes not elsewhere included—				
Four motions and over .. .. .	13 14 6	14 0 6	14 1 0	13 11 6
Overhead traverser with auxiliary hoist .. .. .				
Traverser with jib hoist .. .. .				
Two or three motions .. .. .				
Overhead traverser .. .. .				
Stationary jib .. .. .				
Stationary jib hoist .. .. .				
Traverser jib .. .. .				
Hydraulic stationary jib cranes .. .. .	13 8 0	13 14 0	13 14 6	13 5 0
Mobile cranes lifting capacity up to and including 5 tons	14 17 0	15 3 0	15 3 6	14 14 0
Mobile cranes lifting capacity over 5 tons but not exceeding 10 tons .. .. .	15 4 6	15 10 6	15 11 0	15 1 6
Mobile cranes lifting capacity over 10 tons but not exceeding 20 tons .. .. .	15 14 0	16 0 0	16 0 6	15 11 0
Mobile cranes lifting capacity over 20 tons .. .. .	16 3 0	16 9 0	16 9 6	16 0 0
Fork lift driver .. .. .	14 7 0	14 13 0	14 13 6	14 4 0
Where two or more fork lifts are engaged on any one lift	14 13 0	14 19 0	14 19 6	14 10 0
Cranes and hoists not elsewhere included .. .. .	13 2 0	13 8 0	13 8 6	12 19 0
String cranes—5 tons or less .. .. .	13 0 0	13 6 0	13 6 6	12 17 0
<b>E. TRACTION ENGINE DRIVERS</b>				
<i>Road—</i>				
Traction engine (steam) .. .. .	14 15 6	15 1 6	15 2 0	14 12 6
Traction engine (oil—50 brake horse power or over)	14 13 0	14 19 0	14 19 6	14 10 0
Traction engine (oil—under 50 brake horse power)	14 7 0	14 13 0	14 13 6	14 4 0
When used as stationary engines, Division A. of this clause shall apply.				
<i>Rail—</i>				
Electric traction motor .. .. .	13 12 0	13 18 0	13 18 6	13 9 0
Internal combustion traction motor .. .. .	13 12 0	13 18 0	13 18 6	13 9 0
<i>Tow Motors—</i>				
Tow motor .. .. .	13 9 6	13 15 6	13 16 0	13 6 6
<b>F. MECHANICAL PLANT-DRIVERS AND/OR OPERATORS</b>				
Navvies and Dragline or Dredge type Excavators—				
(a) Driver .. .. .	16 3 0	16 9 0	16 9 6	16 0 0
(b) Second driver .. .. .	14 13 0	14 19 0	14 19 6	14 10 0
Traction Engines—				
Road roller (steam) .. .. .	14 15 6	15 1 6	15 2 0	14 12 6
Road roller (oil) .. .. .	14 13 0	14 19 0	14 19 6	14 10 0
Tractor Unit Plant—				
Tractors without power operated attachments or with power operated attachments not in use—				
(a) 50 brake horse power and under .. .. .	14 7 0	14 13 0	14 13 6	14 4 0
(b) over 50 brake horse power .. .. .	14 13 0	14 19 0	14 19 6	14 10 0



	Wages per Week.			
	Persons other than those Employed in Bush Saw-mills.			Persons Employed in— (a) Bush Saw-mills. (b) All parts of Victoria not elsewhere included.
	Within 20 miles of G.P.O., Melbourne; 10 miles of Chief P.O., Geelong; at Warrnambool, and in the Gippsland District.	Within 15 miles of the Mildura Post Office.	At Yallourn.	
	£ s. d.	£ s. d.	£ s. d.	£ s. d.
<b>F. MECHANICAL PLANT-DRIVERS AND/OR OPERATORS—continued.</b>				
Tractors while using power operated attachments—				
(a) 35 brake horse power and under .. .. .	14 13 0	14 19 0	14 19 6	14 10 0
(b) over 35 brake horse power to 70 brake horse power .. .. .	15 4 6	15 10 6	15 11 0	15 1 6
(c) over 70 brake horse power to 130 brake horse power .. .. .	15 12 0	15 18 0	15 18 6	15 9 0
(d) over 130 brake horse power .. .. .	16 2 0	16 8 0	16 8 6	15 19 0
Provided that the total margin payable to the operator of a tractor using a power operated attachment not normally operated while such tractor is in motion shall not exceed 67s. 6d.				
<i>Special Work.</i> —A driver operating a tractor of 70 brake horse power or over fitted with a blade and using such blade while engaged in breaking trail in heavy sidling country for any part of a day shall be paid an additional allowance of two and one half pence per hour for all work performed on that day.				
Loader, front end and overhead—Appropriate tractor wage .. .. .				
Loader, mechanical bucket type, truck or tractor mounted .. .. .	14 13 0	14 19 0	14 19 6	14 10 0
Grader, self-propelled over 40 b.h.p. .. .. .	15 11 0	15 17 0	15 17 6	15 8 0
Grader, self-propelled 40 b.h.p and under .. .. .	15 0 0	15 6 0	15 6 6	14 17 0
Drawn grader with power operated controls .. .. .	15 6 0	15 12 0	15 12 6	15 3 0
Concrete paver, single drum .. .. .	14 3 0	14 9 0	14 9 6	14 0 0
Mixer operator, Barber Greene plant (pugmill) .. .. .	15 5 0	15 11 0	15 11 6	15 2 0
Screed operator, Barber Greene tamper and/or finisher .. .. .	15 5 0	15 11 0	15 11 6	15 2 0
Mixer operator, bituminous pre-mix plant .. .. .	14 3 0	14 9 0	14 9 6	14 0 0
Mixer unit operator, pre-mix seal .. .. .	14 3 0	14 9 0	14 9 6	14 0 0
Operator, aggregate dryer (other than Barber Greene plant) .. .. .	14 3 0	14 9 0	14 9 6	14 0 0
Operator, aggregate dryer, Barber Greene plant .. .. .	14 12 0	14 18 0	14 18 6	14 9 0
Operator, pre-mix drag spreader .. .. .	14 12 0	14 18 0	14 18 6	14 9 0
Operator, rotating belt aggregate spreader .. .. .	14 3 0	14 9 0	14 9 6	14 0 0
<b>G. FIREMEN</b>				
Firemen .. .. .	13 4 0	13 10 0	13 10 6	13 1 0
Firemen—1st class .. .. .	13 18 0	14 4 0	14 4 6	13 15 0
Leading fireman—1st class .. .. .	14 14 0	15 0 0	15 0 6	14 11 0
Leading fireman—2nd class .. .. .	14 7 0	14 13 0	14 13 6	14 4 0
Locomotive fireman .. .. .	13 12 0	13 18 0	13 18 6	13 9 0
<b>H. GREASERS.</b>				
Greaser or oiler .. .. .	13 0 0	13 6 0	13 6 6	12 17 0
Greaser or oiler—1st class .. .. .	13 18 0	14 4 0	14 4 6	13 15 0
Trimmer .. .. .	12 16 0	13 2 0	13 2 6	12 13 0
Fuelman .. .. .	12 16 0	13 2 0	13 2 6	12 13 0
Engine cleaner .. .. .	12 16 0	13 2 0	13 2 6	12 13 0
Boiler cleaner .. .. .	12 16 0	13 2 0	13 2 6	12 13 0
<b>I. OTHERS</b>				
Pile-driving machine .. .. .	14 14 6	15 0 6	15 1 0	14 11 6

J. ADDITIONS TO WAGES AND LIMITATION OF MAXIMUM AND MINIMUM MARGINS.

	Per week s. d.
An engine driver or fireman engaged as hereinafter specified shall have his marginal rate increased as follows:—	
(a) Attending to refrigerating compressor or refrigerating compressors .. .. .	15 0
Attending to electric generator or dynamo exceeding 10 kilowatt capacity .. .. .	15 0
In charge of plant— .. .. .	15 0
Provided that except as to dragline excavators and tractors these rates shall not be cumulative to the extent of increasing the margin of an employee above 90s. and provided further that an engine driver attending a refrigerating compressor or compressors shall be paid a total margin of not less than—	
(i) where the capacity is 25 tons or less .. .. .	56 0
(ii) where the capacity is over 25 tons .. .. .	75 0
Extra rates payable under this sub-clause shall be regarded as part of an employee's ordinary wage for the purpose of this Determination.	
(b) In a bush sawmill required to do saw sharpening .. .. .	25 0
(c) Attending to switchboard where the generating capacity is 350 K.W. or over .. .. .	7 6

JUNIOR LABOR.

4. (a) The minimum rates of wage to be paid to juniors working as greasers or oilers other than on shafting, or as cleaners or as motor drivers or attendants where the motor does not exceed 50 horse power in all shall be the under-mentioned percentages of the basic wage prescribed for the area in which they are employed and in addition thereto the additional amounts specified.

	Percentage of Basic Wage.	Additional Amount per Week.	Total Wage Payable—			
			Persons other than those Employed in Bush Saw-mills.			Persons Employed in— (a) Bush Saw-mills; (b) All parts of Victoria not elsewhere included.
			Within 20 miles of G.P.O., Melbourne; 10 miles of Chief P.O., Geelong; at Warrnambool, and in the Gippsland District.	Within 15 miles of the Mildura Post Office.	At Yallourn.	
Per Week.	Per Week. s. d.	£ s. d.	£ s. d.	£ s. d.	£ s. d.	
If under 16 years of age ..	24	3 0	3 0 0	3 0 0	3 1 6	2 19 0
16 years of age ..	32	4 3	4 0 0	4 0 0	4 2 0	3 19 0
17 years of age ..	58	8 0	7 5 6	7 5 6	7 9 0	7 3 6
18 years of age ..	73	10 0	9 3 0	9 3 0	9 8 0	9 1 0
19 years of age but under 20 years of age ..	88	11 6	11 0 0	11 0 0	11 6 0	10 17 6

(b) If a cleaner, greaser or oiler sometimes under the supervision of an engine driver stops or starts an engine he shall be paid 15s. per week extra.

(c) The total wage shall be calculated to the nearest sixpence, any broken part of sixpence in the result not exceeding threepence to be disregarded.

(B) As from the beginning of the first pay period to commence in August, 1955, the wages specified in clause 2 shall be increased by 3s. per week and clause 4 shall be replaced by the following clause:—

JUNIOR LABOR.

4. (a) The minimum rates of wage to be paid to juniors working as greasers or oilers other than on shafting, or as cleaners or as motor drivers or attendants where the motor does not exceed 50 horse power in all shall be the under-mentioned percentages of the basic wage prescribed for the area in which they are employed and in addition thereto the additional amounts specified.

	Percentage of Basic Wage.	Additional Amount per Week.	Total Wage Payable—			
			Persons other than those Employed in Bush Saw-mills.			Persons Employed in— (a) Bush Saw-mills; (b) All parts of Victoria not elsewhere included.
			Within 20 miles of G.P.O., Melbourne; 10 miles of Chief P.O., Geelong; at Warrnambool, and in the Gippsland District.	Within 15 miles of the Mildura Post Office.	At Yallourn.	
Per Week.	Per Week. s. d.	£ s. d.	£ s. d.	£ s. d.	£ s. d.	
If under 16 years of age ..	24	3 0	3 0 6	3 0 6	3 2 0	3 0 0
16 years of age ..	32	4 3	4 1 0	4 1 0	4 3 0	4 0 0
17 years of age ..	58	8 0	7 7 0	7 7 0	7 11 0	7 5 6
18 years of age ..	73	10 0	9 5 0	9 5 0	9 10 0	9 3 0
19 years of age but under 20 years of age ..	88	11 6	11 2 6	11 2 6	11 8 6	11 0 0

(b) If a cleaner, greaser or oiler sometimes under the supervision of an engine driver stops or starts an engine he shall be paid 15s. per week extra.

(c) The total wage shall be calculated to the nearest sixpence, any broken part of sixpence in the result not exceeding threepence to be disregarded.

Clauses, other than clauses 2 and 4, of the said Determination shall remain in force.



**VICTORIA**  
**GOVERNMENT GAZETTE**

Published by Authority.

[Registered at the General Post Office, Melbourne, for transmission by post as a newspaper.]

No. 828]

FRIDAY, NOVEMBER 11.

[1955

*Labour and Industry Act 1953.*

**DETERMINATION OF A WAGES BOARD ADJUSTED PURSUANT TO  
SECTION 33 OF THE LABOUR AND INDUSTRY ACT 1953.**

I, Henry Norman Jones, Secretary for Labour and Industry, in pursuance of the powers conferred by the Labour and Industry Act, hereby make and issue the following adjusted Determination of the Wages Board referred to hereunder showing adjusted rates and prices to operate from the beginning of the first pay period to commence in August, 1955.

Dated at Melbourne, this  
8th day of August, 1955.

H. N. JONES,  
Secretary for Labour and Industry.

**CONFECTIONERS BOARD.**

Clauses 2 and 3 of the Determination made on the 6th June, 1955, and in force on 10th May, 1955, shall be replaced by the following clauses:—

2.

**APPRENTICES AND IMPROVERS.**

*Wages.*

Male.	s. d.	Female.	s. d.
<i>(Assisting the Storeman and Packer.)</i>			
18 years of age and under 19 years .. ..	163 0	15 years of age and under .. ..	72 0
19 years of age and under 20 years .. ..	204 0	16 years of age .. ..	84 0
20 years of age and under 21 years .. ..	243 0	17 years of age .. ..	108 0
<i>All Other Males.</i>			
15 years of age and under .. ..	108 0	18 years of age .. ..	132 0
16 years of age .. ..	132 0	19 years of age .. ..	156 0
17 years of age .. ..	156 0	20 years of age .. ..	180 0
18 years of age .. ..	180 0	<b>PROPORTION.</b>	
19 years of age .. ..	204 0	One female junior to every two female adults receiving not less than the adult minimum rate.	
20 years of age .. ..	228 0		
<b>PROPORTION.</b>			
<i>(Assisting the Storeman and Packer.)</i>			
One male apprentice to every three or fraction of three male workers receiving not less than 283s. 6d. per week			
One male improver to every four or fraction of four male workers receiving not less than 283s. 6d. per week.			
<i>Other Males.</i>			
One male junior to every two male adult workers receiving not less than the adult minimum rate.			





# VICTORIA GOVERNMENT GAZETTE.

Published by Authority.

[Registered at the General Post Office, Melbourne, for transmission by post as a newspaper.]

No. 829]

FRIDAY, NOVEMBER 11.

[1955

*Labour and Industry Act 1953.*

## DETERMINATION OF A WAGES BOARD ADJUSTED PURSUANT TO SECTION 33 OF THE LABOUR AND INDUSTRY ACT 1953.

I, Henry Norman Jones, Secretary for Labour and Industry, in pursuance of the powers conferred by the Labour and Industry Act, hereby make and issue the following adjusted Determination of the Wages Board referred to hereunder showing adjusted rates and prices to operate from the beginning of the first pay period to commence in August, 1955.

Dated at Melbourne, this  
8th day of August, 1955.

H. N. JONES,  
Secretary for Labour and Industry.

### HORSEHAIR BOARD.

Clause 2 of the Determination made on the 11th May, 1955, and in force as from the beginning of the first pay period to commence on or after the 26th May, 1955, shall be replaced by the following clause:—

2.

Apprentices.			Improvers and Juvenile Workers.			Other Employees.		
WAGES.			WAGES.			<i>Preparing Body Hair.</i>		
	Percentage of Basic Wage.	Per Week. s. d.		Percentage of Basic Wage.	Per Week. s. d.		WAGES.	Per Week. s. d.
1st year ..	36	86 6	1st year ..	36	86 6	Person in charge of hair-washing machine ..		281 0
2nd year ..	45	108 0	2nd year ..	54	129 6	Persons engaged on hair-washing machines ..		274 0
3rd year ..	54	129 6	3rd year ..	90	216 0	Persons engaged on hair-drying machines ..		274 0
4th year ..	65	156 0	4th year ..	100 + 6/-	246 0	Persons who press washed and dried hair into bales ..		274 0
5th year ..	90	216 0				All others ..		270 0
PROPORTION (by any employer).			PROPORTION (by any employer).			<i>Preparing any other kind of Hair.</i>		
One apprentice to every three or fraction of three workers receiving not less than 270s. per week.			One improver to every five workers receiving not less than 270s. per week.			WAGES.		
			<i>Juvenile Workers.</i>				Per Week. s. d.	
			One juvenile worker to every Hand Spinner.			Hand Spinners ..		287 0
						Machine Spinners—		
						1st year ..		277 0
						2nd year ..		283 0
						And thereafter ..		287 0
						Drafters ..		287 0
						Wet or dry hacklers ..		287 0
						Operators of teasing machine ..		274 0
						Tail pullers ..		274 0
						Dyers or Scalders ..		271 0
						All others ..		270 0

Clauses, other than clause 2, of the said Determination shall remain in force, provided that, to the weekly earnings of each piece-worker shall be added the sum of one hundred and twenty-seven shillings. Where less than forty hours is worked in any week by any piece-worker, a proportionate amount of such sum of one hundred and twenty-seven shillings shall be added in lieu thereof.

By Authority: W. M. HOUSTON, Government Printer, Melbourne.





# VICTORIA GOVERNMENT GAZETTE.

Published by Authority.

[Registered at the General Post Office, Melbourne, for transmission by post as a newspaper.]

No. 830]

FRIDAY, NOVEMBER 11.

[1955

*Labour and Industry Act 1953.*

## DETERMINATION OF A WAGES BOARD ADJUSTED PURSUANT TO SECTION 33 OF THE LABOUR AND INDUSTRY ACT 1953.

I, Henry Norman Jones, Secretary for Labour and Industry, in pursuance of the powers conferred by the Labour and Industry Act, hereby make and issue the following adjusted Determination of the Wages Board referred to hereunder showing adjusted rates and prices to operate from the beginning of the first pay period to commence in August, 1955.

Dated at Melbourne, this  
8th day of August, 1955.

H. N. JONES,  
Secretary for Labour and Industry.

### LAW CLERKS BOARD

Clause 2, of the Determination made on the 22nd June, 1955, and in force as from the beginning of the first pay period to commence in July, 1955, shall be replaced by the following clause:—

2. \*IMPROVERS.

MALES. Wages per Week.					FEMALES. Wages per Week.	
Experience.	Commencing Age.				Experience.	s. d.
	Under 16 Years.	16 Years.	17 Years.	18 Years or Over.		
	s. d.	s. d.	s. d.	s. d.		
1st year .. .. .	77 0	77 0	84 0	91 0	1st year .. .. .	79 0
2nd year .. .. .	103 0	103 0	120 0	148 6	2nd year .. .. .	92 0
3rd year .. .. .	120 0	132 0	173 0	197 0	3rd year .. .. .	119 0
4th year—					4th year .. .. .	147 6
1st six months .. .. .	161 0	180 0	201 6	251 6	5th year and until 21 years of age	182 6
2nd six months .. .. .	161 0	180 0	251 6	253 6		
5th year—						
1st six months .. .. .	216 0	225 6	274 0	280 6		
2nd six months .. .. .	216 0	270 6	274 0	280 6		
6th year and until 21 years of age	274 0	280 6	..	..		

## PROPORTION (in any place).

Where there is no person receiving the adult rate—three improvers. In all other places two improvers to each person receiving not less than the adult rate.

\* The Board has determined that no person shall be employed as an apprentice.

## OTHER EMPLOYEES.

	Wages per Week.	
	Within a radius of 25 miles of the G.P.O., Melbourne, and within a radius of 10 miles of the principal post offices at Geelong, Ballarat, Bendigo, and Warrnambool.	All other parts of Victoria where this Determination applies.
	£ s. d.	£ s. d.
<i>Males.</i>		
With less than three years' experience in a solicitor's office—		
1st year's experience .. .. .	14 11 6	14 8 6
2nd year's experience .. .. .	14 16 6	14 13 6
3rd year's experience .. .. .	15 1 6	14 18 6
All others .. .. .	15 4 0	15 1 0
<i>Females.</i>		
All adults .. .. .	11 7 6	11 4 6

Clauses, other than clause 2, of the said Determination shall remain in force.





VICTORIA  
GOVERNMENT GAZETTE.

Published by Authority.

[Registered at the General Post Office, Melbourne, for transmission by post as a newspaper.]

No. 831]

FRIDAY, NOVEMBER 11.

[1955

*Labour and Industry Act 1953.*

**DETERMINATION OF A WAGES BOARD ADJUSTED PURSUANT TO SECTION 33 OF THE  
LABOUR AND INDUSTRY ACT 1953.**

I, Henry Norman Jones, Secretary for Labour and Industry, in pursuance of the powers conferred by the Labour and Industry Act, hereby make and issue the following adjusted Determination of the Wages Board referred to hereunder showing adjusted rates and prices to operate from the beginning of the first pay period to commence in August, 1955.

Dated at Melbourne, this  
8th day of August, 1955.

H. N. JONES,  
Secretary for Labour and Industry.

**RADIO ANNOUNCERS BOARD.**

Clause 2 of the Determination made on the 8th June, 1955, and in force as from the beginning of the first pay period to commence on or after the 1st July, 1955, shall be replaced by the following clause:—

WAGES PER WEEK.

2.

		Males.		Females.	
		£ s. d.	£ s. d.	£ s. d.	£ s. d.
Announcers employed by Stations 3 SR, 3 BA, 3 BO, 3 GL, 3 HA .. .. .	{ Class I. ..	16 13 9	13 13 9		
	{ Class II. ..	15 12 0	12 12 0		
Announcers employed by Station 3 TR .. .. .	{ Class I. ..	16 6 6	13 6 6		
	{ Class II. ..	15 0 6	12 0 6		
Announcers employed by Stations 3 CV, 3 UL, 3 YB, 3 NE .. .. .	{ Class I. ..	15 12 0	12 12 0		
	{ Class II. ..	14 10 6	11 10 6		
Announcers employed by Stations 3 CS, 3 MA, 3 SH, and other Stations not hereinbefore specifically provided for .. .. .	{ Class I. ..	14 17 6	11 17 6		
	{ Class II. ..	13 16 0	10 16 0		

*Trainees.*

Age.	Percentage of Contemporaneous Basic Wage.	Weekly Wage.	
		Males.	Females.
		£ s. d.	£ s. d.
Under 17 years .. .. .	60	7 4 0	5 8 0
17 to 18 years .. .. .	70	8 8 0	6 6 0
18 to 19 years .. .. .	80	9 12 0	7 4 0
19 to 20 years .. .. .	90	10 16 0	8 2 0
20 to 21 years .. .. .	100	12 0 0	9 0 0

Clauses, other than clause 2 of the said Determination, shall remain in force.

By Authority: W. M. HOUSTON, Government Printer, Melbourne.













**VICTORIA**

# GOVERNMENT GAZETTE.

Published by Authority.

[Registered at the General Post Office, Melbourne, for transmission by post as a newspaper.]

No. 834]

FRIDAY, NOVEMBER 11.

[1955

*Labour and Industry Act 1953.*

## DETERMINATION OF A WAGES BOARD ADJUSTED PURSUANT TO SECTION 33 OF THE LABOUR AND INDUSTRY ACT 1953.

I, Henry Norman Jones, Secretary for Labour and Industry, in pursuance of the powers conferred by the Labour and Industry Act, hereby make and issue the following adjusted Determination of the Wages Board referred to hereunder showing adjusted rates and prices to operate from the beginning of the first pay period to commence in August, 1955.

Dated at Melbourne, this  
8th day of August, 1955.

H. N. JONES,  
Secretary for Labour and Industry.

### WHOLESALE GROCERS BOARD.

Clause 2 of the Determination made on the 17th March, 1955, and in force as from the beginning of the first pay period to commence on or after the 31st March, 1955, shall be replaced by the following clause:—

2.

APPRENTICES AND IMPROVERS.			ALL OTHER EMPLOYERS.			
—	Percentage of Basic Wage.	Wages per Week.	Wages per Week.			
			£ s. d.	£ s. d.	Within the cities of Ballarat and Bendigo, and the boroughs of Eaglehawk and Sebastopol.	All other Parts of Victoria where this Determination applies.
Under 16 years of age	31	3 14 6				
16 years of age ..	38	4 11 0				
17 years of age ..	49	5 17 6				
18 years of age ..	65	7 16 0				
19 years of age ..	83	9 19 0				
20 years of age ..	100 + 1s.	12 1 0				
PROPORTION (IN ANY PLACE).						
<i>Apprentices.</i>						
One apprentice to every three or fraction of three workers receiving not less than £13 18 0 per week.						
An indenture of apprenticeship prescribed by the Board was approved on 24th May, 1926.						
<i>Improvers.</i>						
One improver to every three or fraction of three workers receiving not less than £13 18 0 per week.						
			Head cellarman, i.e., the principal employee engaged in testing, blending, reducing, or fining wines or spirits .. .. .			
			Leading hand in charge of—			
			10 or more persons .. .. .			
			6, 7, 8, or 9 persons .. .. .			
			1, 2, 3, 4, or 5 persons .. .. .			
			Storeman employed singly .. .. .			
			All others .. .. .			
			£ s. d.	£ s. d.		
			15 1 6	15 5 0		
			15 1 6	15 5 0		
			14 13 0	14 16 6		
			14 2 6	14 6 6		
			14 2 6	14 6 6		
			13 18 0	14 3 0		

NOTE.—“Leading hand” means an adult employee who, notwithstanding that he may be under the orders of a superior, has by the instructions of his employer one or more adult employees usually under his direction.

Clauses, other than clause 2, of the said Determination shall remain in force.

By Authority: W. M. HOUSTON, Government Printer, Melbourne.







# VICTORIA GOVERNMENT GAZETTE.

Published by Authority.

[Registered at the General Post Office, Melbourne, for transmission by post as a newspaper.]

No. 835]

FRIDAY, NOVEMBER 11.

[1955

*Labour and Industry Act 1953.*

## DETERMINATION OF A WAGES BOARD ADJUSTED PURSUANT TO SECTION 33 OF THE LABOUR AND INDUSTRY ACT 1953.

I, Henry Norman Jones, Secretary for Labour and Industry, in pursuance of the powers conferred by the Labour and Industry Act, hereby make and issue the following adjusted Determination of the Wages Board referred to hereunder showing adjusted rates and prices to operate from the beginning of the first pay period to commence in August, 1955.

Dated at Melbourne, this

14th day of October, 1955.

H. N. JONES,

Secretary for Labour and Industry.

### IRON AND STEEL ROLLING BOARD.

Clauses 2 and 18 of the Determination made on the 11th February, 1955, and in force as from the beginning of the first pay period to commence on or after the 13th December, 1954, shall be replaced by the following clauses:—

2.

#### WAGES.

Improvers.	Percentage of Basic Wage.	Wages per Week of 40 Hours.		Other Employees.	Day Shift Wages per Week of 40 Hours.	
		£	s. d.		£	s. d.
17 to 19 years of age ..	85	10	4 0	Roller .. .. .	19	15 6
19 to 21 years of age ..	100 plus 1s. 6d.	12	1 6	Furnaceman .. .. .	18	16 0
				Rougher .. .. .	18	3 6
				Catcher (three high roughing Rolls) ..	18	3 6
				Catcher who is responsible for adjusting guards .. .. .	14	12 6
				Other catchers .. .. .	14	10 0
				Annealer or heat treatment hand ..	15	2 6
				Roller's assistant .. .. .	15	1 0
				Charger .. .. .	14	7 6
				Shearsman of scrap Crocodile Shears ..	14	7 6
				Yard shearsman .. .. .	14	7 6
				Billet shearsman .. .. .	14	7 6
				Scrap bar and/or scrap shearsman ..	14	0 0
				Shearsman (small mill Brooklyn) ..	14	0 0
				Other shearsmen .. .. .	13	13 6
				Setter up .. .. .	14	1 0
				Carrier up (large mill) .. .. .	13	6 0
				Carrier up (small mill) .. .. .	13	6 0
				Underhand, second, handling up to 300-lb. blooms .. .. .	14	0 0
				Underhand who also assists to feed furnace .. .. .	13	17 6
				Underhand .. .. .	13	13 6
				Hookman .. .. .	13	17 6
				Middleman .. .. .	14	5 0
				Straightener .. .. .	13	17 6
				Straightener's assistant .. .. .	13	13 6
				Chipper .. .. .	13	17 6
				Heater .. .. .	14	6 0
				Assistant furnaceman .. .. .	13	6 0
				Plate hand .. .. .	13	13 6
				Furnaceman at electric furnace ..	15	7 6
				Pitman at electric furnace .. .. .	14	12 6
				Ladleman at electric furnace ..	14	12 6
				Assistant at electric furnace ..	13	12 6
				Assistant to shearsman .. .. .	13	13 6
				Other employees with not less than three months' experience in this industry	12	12 0
				All others .. .. .	12	6 0

NOTE.—The Board has determined that the process, trade, business or occupation is so unskilled that no person shall be taken as an apprentice.

PIECEWORK.

18. The lowest piecework price payable to any person employed shall be the price mentioned in the following Schedule, which Schedule shall form part of this Determination:—

(i)

Column A.	Column B.	Column C.	Column D.
	<i>s. d.</i>	<i>* Four Roll—18-in. Mill.</i>	<i>s. d.</i>
Roller ...	8 0½	Per ton of finished bars of iron and steel	54 3
	7 7	Per ton of scrap iron bars	
Rougher	6 0½	Per ton of finished bars of iron and steel	41 6
	10 10½	Per ton of scrap iron bars	
Catcher ..	4 7	Per ton of finished bars of iron and steel	13 0
	6 9½	Per ton of scrap iron bars	
Middle man ..	4 5½	Per ton of finished bars of iron and steel	10 0
	4 4	Per ton of finished bars of iron and steel	
Large Hook	6 2½	Per ton of scrap iron bars	5 6
	4 4	Per ton of finished bars of iron and steel	
Small Hook	4 4	Per ton of finished bars of iron and steel	5 6
Platehand ..	4 5	Per ton of finished bars of iron and steel	
Leading Platehand	4 5½	Per ton of finished bars of iron and steel	5 6
	6 6½	Per ton of scrap iron bars	
Furnaceman	12 11	Per ton of finished bars of iron and steel	46 6
	18 9	Per ton of scrap iron bars	
Underhand	8 10½	Per ton of finished bars of iron and steel	4 0
	12 10	Per ton of scrap iron bars	
Carrier Up ..	4 6½	Per ton of finished bars of iron and steel	..
Carrier up (assistant)	4 5	Per ton of finished bars of iron and steel	..
		<i>* Ten Roll—10-in. Mill.</i>	
Roller ..	12 9½	Per ton of finished bars of iron and steel billets and iron piles up to 30 lb. each ..	54 3
	10 1½	Per ton of finished bars of iron and steel billets and iron piles over 30 and up to 40 lb. each ..	
	8 5½	Per ton of finished bars of iron and steel billets and iron piles over 40 lb. each ..	41 6
	11 2½	Per ton of finished bars of iron and steel billets and iron piles up to 30 lb. each ..	
Rougher	8 8½	Per ton of finished bars of iron and steel billets and iron piles over 30 and up to 40 lb. each ..	13 0
	7 8½	Per ton of finished bars of iron and steel billets and iron piles over 40 and up to 60 lb. each ..	
	7 5½	Per ton of finished bars of iron and steel billets and iron piles over 60 lb. each ..	10 0
	7 9½	Per ton of finished bars of iron and steel billets and iron piles up to 30 lb. each ..	
Catcher	6 2	Per ton of finished bars of iron and steel billets and iron piles over 30 and up to 40 lb. each ..	46 6
	5 8½	Per ton of finished bars of iron and steel billets and iron piles over 40 and up to 60 lb. each ..	
	5 4½	Per ton of finished bars of iron and steel billets and iron piles over 60 lb. each ..	4 0
	7 8½	Per ton of finished bars of iron and steel billets and iron piles up to 30 lb. each ..	
Middleman	6 1	Per ton of finished bars of iron and steel billets and iron piles over 30 and up to 40 lb. each ..	10 0
	5 7½	Per ton of finished bars of iron and steel billets and iron piles over 40 and up to 60 lb. each ..	
	5 3½	Per ton of finished bars of iron and steel billets and iron piles over 60 lb. each ..	46 6
	20 7½	Per ton of finished bars of iron and steel billets and iron piles up to 30 lb. each ..	
Furnaceman	17 11	Per ton of finished bars of iron and steel billets and iron piles over 30 and up to 40 lb. each ..	4 0
	16 1½	Per ton of finished bars of iron and steel billets and iron piles over 40 and up to 60 lb. each ..	
	12 11	Per ton of finished bars of iron and steel billets and iron piles over 60 lb. each ..	4 0
	14 1½	Per ton of finished bars of iron and steel billets and iron piles up to 30 lb. each ..	
Underhand	12 1	Per ton of finished bars of iron and steel billets and iron piles over 30 and up to 40 lb. each ..	4 0
	11 0½	Per ton of finished bars of iron and steel billets and iron piles over 40 and up to 60 lb. each ..	
	10 7	Per ton of finished bars of iron and steel billets and iron piles over 60 lb. each ..	4 0
	7 9	Per ton of finished bars of iron and steel billets and iron piles up to 30 lb. each ..	
	5 9½	Per ton of finished bars of iron and steel billets and iron piles over 30 and up to 40 lb. each ..	4 0
Plateman	5 5½	Per ton of finished bars of iron and steel billets and iron piles over 40 and up to 60 lb. each ..	
	5 0½	Per ton of finished bars of iron and steel billets and iron piles over 60 lb. each ..	4 0

NOTE.—The furnaceman and underhand are paid for the output of one furnace.

(ii) To the weekly earnings of pieceworkers as computed in accordance with Columns A, B, and C, shall be added the amounts set out in Column D. The said amounts are the increases in margins granted to time workers of appropriate classification by virtue of the Determination made on the 11th February, 1955, and operative as from the beginning of the first pay period to commence on or after the 13th December, 1954.

(iii) The piecework prices set out in Column B. are based on a Basic Wage of £11 14s. per week, and the earnings of a pieceworker as computed in accordance with Columns A, B, C, and D shall be increased or decreased from time to time, as the case may be, to accord with the amount of the increase or decrease in the said Basic Wage.

In accordance with this provision as from the beginning of the first pay period to commence in August, 1955, an amount of 6s. per week shall be added to the earnings of a pieceworker.

(iv) The Board has also determined that where any person employed on tonnage rates set out in such Schedule fails to earn during any day on which he is so employed an amount equal to one-fifth of the prescribed weekly rate he shall be paid for such day not less than one-fifth of the prescribed weekly rate. Provided that if such employee elects to work for a shorter period than the number of hours fixed for an ordinary day's work he shall be paid a sum proportionate to the time worked.

Clauses, other than clauses 2 and 18, of the said Determination shall remain in force.

[5949]  
[P.D.]



# VICTORIA GOVERNMENT GAZETTE

Published by Authority

[Registered at the General Post Office, Melbourne, for transmission by post as a newspaper.]

No. 836]

WEDNESDAY, NOVEMBER 16

[1955

*Land Act 1928.*

AREAS OF LANDS COMPRISED IN CERTAIN CLASSES DIMINISHED OR INCREASED.

### PROCLAMATION

By The Honorable Sir Charles Lowe as Deputy to His Excellency the Governor of the State of Victoria and its Dependencies in the Commonwealth of Australia, &c., &c., &c.

WHEREAS by the *Land Act 1928* it is amongst other things enacted that the Governor in Council may, by Proclamation to be published in the *Government Gazette*, at any time diminish or increase the area of land comprised in any of the classes mentioned in Part I, Division 1, section 5, of the said *Land Act 1928*; but that the areas of lands which may be sold by auction (Class 6) shall not be increased except as in certain cases in the said Act provided: Now therefore I, Sir Charles Lowe as Deputy to His Excellency the Governor of the State of Victoria, in the Commonwealth of Australia, by and with the advice of the Executive Council of the said State, and in accordance with the provisions of sections 94 and 117 of the *Land Act 1928* aforesaid, do hereby diminish or increase (as the case may be) the areas of Crown lands comprised in Classes 2, 3, 6, and 8 of the classes mentioned in section 5 of the *Land Act 1928* aforesaid to the extent set forth in the subjoined Schedule (that is to say) :—

Schedule referred to.

#### CLASSES DIMINISHED OR INCREASED.

County.	Parish.	Allotment.	Section.	Area.	Diminished.	Increased.	Description.
					Class.	Class.	
				A. R. P.			
Gunbower ..	Kerang ..	2B	C	183 3 13	8	2	In south of Parish. (177/44)
Lowan ..	Carchap ..	22	..	99 2 13	..	6	In centre of Parish. (22 A.C.)
Mornington ..	Poowong ..	60D	..	67 2 27	3	2	About 5 miles north of Poowong. (1728/44)

Given under my Hand and the Seal of the State of Victoria, aforesaid, at Melbourne, this eighth day of November, in the year of our Lord One thousand nine hundred and fifty-five, and in the fourth year of the reign of Her Majesty Queen Elizabeth II.

(L.S.)

CHARLES J. LOWE.

By His Excellency's Command.

KEITH TURNBULL,

Commissioner of Crown Lands and Survey.

GOD SAVE THE QUEEN!

## ACTS OF PARLIAMENT.

## PROCLAMATION

By the Honorable Sir Charles Lowe, as Deputy for His Excellency the Governor of the State of Victoria and its Dependencies in the Commonwealth of Australia, &c., &c., &c.

I, Sir Charles Lowe, as Deputy for His Excellency the Governor of the State of Victoria in the Commonwealth of Australia, do hereby declare that I have this day assented, in Her Majesty's name, to the Bills passed by the Parliament of the said State, the titles whereof are hereunder set forth, that is to say:—

No. 5879. "An Act to amend the Second Schedule to the *Health Act 1928*."

No. 5880. "An Act to amend Section Nine of the *Dietitians Registration Act 1942*."

No. 5881. "An Act to amend Section Eighty-five of the *Medical Act 1928*."

Given under my Hand and the Seal of the State of Victoria aforesaid, at Melbourne, this eighth day of November, in the year of our Lord One thousand nine hundred and fifty-five, and in the fourth year of the reign of Her Majesty Queen Elizabeth II.

(L.S.) CHARLES J. LOWE.

By His Excellency's Command,

HENRY E. BOLTE,  
Premier.

GOD SAVE THE QUEEN!

## Fisheries Acts

PROHIBITION OF ALL FISHING IN OR THE TAKING OF FISH FROM THE TEDDINGTON RESERVOIRS FROM THE 1ST DAY OF MAY TO THE LAST DAY PRECEDING THE FIRST SATURDAY IN SEPTEMBER IN EACH YEAR.

## PROCLAMATION

By the Honorable Sir Charles Lowe, as Deputy for His Excellency the Governor of the State of Victoria and its Dependencies in the Commonwealth of Australia, &c., &c., &c.

I, Sir Charles Lowe, as Deputy for His Excellency the Governor of the State of Victoria in the Commonwealth of Australia by and with the advice of the Executive Council of the said State, and in pursuance of the provisions of the Fisheries Acts and all other powers me enabling in that behalf, do by this my Proclamation prohibit all fishing in or the taking of fish from the Teddington Reservoirs during the period from the first day of May to the last day preceding the first Saturday in September in each year both days inclusive.

Given under my Hand and the Seal of the State of Victoria aforesaid, at Melbourne, this eighth day of November, in the year of our Lord One thousand nine hundred and fifty-five, and in the fourth year of the reign of Her Majesty Queen Elizabeth II.

(L.S.) CHARLES J. LOWE.

By His Excellency's Command,

A. G. RYLAH,  
Chief Secretary.

GOD SAVE THE QUEEN!

## Fisheries Acts.

PROHIBITION OF THE USE OF TENCH OR CARP AS BAIT IN FYANS LAKE.

## PROCLAMATION

By the Honorable Sir Charles Lowe, as Deputy for His Excellency the Governor of the State of Victoria and its Dependencies in the Commonwealth of Australia, &c., &c., &c.

I, Sir Charles Lowe, as Deputy for His Excellency the Governor of the State of Victoria in the Commonwealth of Australia by and with the advice of the Executive Council of the said State, and in pursuance of the provisions of the Fisheries Acts and all other powers

me enabling in that behalf, do by this my Proclamation prohibit the use of tench or carp as bait by any person fishing in Fyans Lake.

Given under my Hand and the Seal of the State of Victoria aforesaid, at Melbourne, this eighth day of November, in the year of our Lord One thousand nine hundred and fifty-five, and in the fourth year of the reign of Her Majesty Queen Elizabeth II.

(L.S.) CHARLES J. LOWE.

By His Excellency's Command,

A. G. RYLAH,  
Chief Secretary.

GOD SAVE THE QUEEN!

## Fisheries Acts.

PROHIBITION OF THE USE OF ENGLISH PERCH, TENCH, OR CARP AS BAIT IN THE TEDDINGTON RESERVOIRS.

## PROCLAMATION

By the Honorable Sir Charles Lowe, as Deputy for His Excellency the Governor of the State of Victoria and its Dependencies in the Commonwealth of Australia, &c., &c., &c.

I, Sir Charles Lowe, as Deputy for His Excellency the Governor of the State of Victoria in the Commonwealth of Australia by and with the advice of the Executive Council of the said State, and in pursuance of the provisions of the Fisheries Acts and all other powers me enabling in that behalf, do by this my Proclamation prohibit the use of English Perch, Carp or Tench as bait by any person fishing in the Teddington Reservoirs.

Given under my Hand and the Seal of the State of Victoria aforesaid, at Melbourne, this eighth day of November, in the year of our Lord One thousand nine hundred and fifty-five, and in the fourth year of the reign of Her Majesty Queen Elizabeth II.

(L.S.) CHARLES J. LOWE.

By His Excellency's Command,

A. G. RYLAH,  
Chief Secretary.

GOD SAVE THE QUEEN!

## Fisheries Acts.

BAG LIMIT FOR TROUT (NON-INDIGENOUS TO VICTORIA) TAKEN FROM LAKE MURDEDUKE AND LAKE MODEWARRE.

## PROCLAMATION

By the Honorable Sir Charles Lowe, as Deputy for His Excellency the Governor of the State of Victoria and its Dependencies in the Commonwealth of Australia, &c., &c., &c.

I, Sir Charles Lowe, as Deputy for His Excellency the Governor of the State of Victoria in the Commonwealth of Australia by and with the advice of the Executive Council of the said State, and in pursuance of the provisions of the Fisheries Acts and all other powers me enabling in that behalf, do by this my Proclamation provide that no person shall on any one day during the period in which the taking of trout is permitted from Lake Murdeduke or Lake Modewarre take from such waters more than five of such fish, being either brown or rainbow trout, or have in his possession more than such number of trout taken from such waters.

Given under my Hand and the Seal of the State of Victoria aforesaid, at Melbourne, this eighth day of November, in the year of our Lord One thousand nine hundred and fifty-five, and in the fourth year of the reign of Her Majesty Queen Elizabeth II.

(L.S.) CHARLES J. LOWE.

By His Excellency's Command,

A. G. RYLAH,  
Chief Secretary.

GOD SAVE THE QUEEN!

## Game Acts.

**REVOCATION OF PROCLAMATION PROTECTING  
NATIVE GAME OF ALL KINDS IN A CERTAIN  
AREA AT FISHERMAN'S BEND, PORT MELBOURNE.**

**PROCLAMATION**

By His Excellency the Governor of the State of Victoria and its Dependencies in the Commonwealth of Australia, &c., &c., &c.

I, THE Governor of the State of Victoria, in the Commonwealth of Australia, by and with the advice of the Executive Council of the said State, and in pursuance of the provisions of the Game Acts and all other powers me enabling in that behalf, do by this my Proclamation revoke the Proclamation made the twentieth day of April 1909 and published in the *Government Gazette* of the twenty-eighth day of April 1909 respecting protection of native game of all kinds in a certain area at Fisherman's Bend, Port Melbourne.

Given under my Hand and the Seal of the State of Victoria aforesaid, at Melbourne, this fifteenth day of November, in the year of Our Lord One thousand nine hundred and fifty-five, and in the fourth year of the reign of Her Majesty Queen Elizabeth II.

(L.S.)

DALLAS BROOKS.

By His Excellency's Command,

A. G. RYLAH,  
Chief Secretary.

GOD SAVE THE QUEEN!

## Country Fire Authority Acts.

**SUMMER PERIOD IN RESPECT OF SPECIFIED  
PARTS OF THE COUNTRY AREA OF VICTORIA.**

**PROCLAMATION**

By His Excellency the Governor of the State of Victoria and its Dependencies in the Commonwealth of Australia, &c., &c., &c.

WHEREAS by sub-section (2) of section 4 of the *Country Fire Authority Act 1944*, it is enacted that the Governor in Council, after consultation by the Chief Secretary of Victoria with the Minister of Forests, may from time to time by Proclamation published in the *Government Gazette* proclaim any period as the summer period in respect of the country area of Victoria or any specified part or parts thereof and, without affecting the generality of the foregoing, may proclaim different summer periods in respect of different parts of the said country area:

And whereas the Chief Secretary and the Minister of Forests have consulted accordingly:

Now therefore I, the Governor of the State of Victoria, in the Commonwealth of Australia, by and with the advice of the Executive Council of the said State and in pursuance of the powers conferred by the Country Fire Authority Acts, do by this my Proclamation proclaim the period commencing on the sixteenth day of November, 1955, and ending on the thirty-first day of March next following to be the summer period in respect of the parts hereinafter specified of the country area of Victoria, that is to say:

Those portions of the Eighteenth Fire Control Region comprised by the municipal districts of the City of Mildura, the Shire of Mildura excluding those portions of the aforesaid Shire which lie within the Parishes of Mildura and Merbein, and the Shires of Birchip, Karkaroc, Walpeup and Wycheproof;

and the Twentieth Fire Control Region comprising the municipal districts of the Borough of Swan Hill and the Shires of Cohuna, Kerang and Swan Hill.

Given under my Hand and the Seal of the State of Victoria aforesaid, at Melbourne, this fifteenth day of November, in the year of Our Lord One thousand nine hundred and fifty-five, and in the fourth year of the reign of Her Majesty Queen Elizabeth II.

(L.S.)

DALLAS BROOKS.

By His Excellency's Command,

A. G. RYLAH,  
Chief Secretary.

GOD SAVE THE QUEEN!

## Housing Acts.

**NOTICE OF RESOLUTION UNDER SECTION 40 (4)  
OF ACT No. 4568.**

NOTICE is hereby given that Housing Commission on the eleventh day of October, 1955, resolved as follows:—

Whereas Housing Commission in respect of the lands described in the Schedule hereto has given notice to the parties interested under section 9 of the *Lands Compensation Act 1928*, as incorporated with the *Slum Reclamation and Housing Act 1938*, Housing Commission hereby resolves that the lands described in the Schedule hereto are finally appropriated for the purposes of the Housing Acts.

**SCHEDULE.**

All that land situated within the municipality of the Borough of Swan Hill, being Crown allotment D of section 5A in the Township of Swan Hill, Parish of Castle Donnington, County of Tatchera.

R. J. THOMSON,  
Secretary.

**Housing Acts (Section 40 of Act 4996).**

**GENERAL NOTICE TO PARTIES EMPOWERED BY  
THE LANDS COMPENSATION ACT 1928 TO SELL  
AND CONVEY OR GRANT AND RELEASE, PUR-  
SUANT TO SECTION 40 OF ACT 4568, AS AMENDED  
BY PARAGRAPH (b) OF SECTION 40 OF ACT 4996.**

**GENERAL NOTICE TO TREAT FOR LAND IN A RECLAMATION  
AREA AT COLLINGWOOD.**

**No. 22.**

IN pursuance of the provisions contained in the *Slum Reclamation and Housing Act 1938* (No. 4568), as amended by the *Housing Act 1943* (No. 4996), and of the *Lands Compensation Act 1928* (No. 3711), the Housing Commission (hereinafter referred to as "the Commission") hereby doth give notice that the lands, tenements, and hereditaments described in the Schedule hereto are required for the purpose of the Housing Acts, and that the Commission is authorized by the provisions of section 20 of the said *Slum Reclamation and Housing Act 1938* (No. 4568) to purchase or take compulsorily the said lands.

And the Commission accordingly hereby gives notice to all the parties interested in such land and to all persons empowered by the *Lands Compensation Act 1928* to sell and convey or grant and release the land so required, that it requires to take and purchase the land referred to in the said Schedule hereto, and that it is willing to treat with such parties or persons for the purchase thereof and as to the compensation to be made and for the damage that may be sustained by reason of the execution of the works.

And further the Commission hereby requires such parties or persons on or before the expiration of 21 days from the 24th day of December, 1955, to deliver to the offices of the Commission, at 179 Queen-street, Melbourne, a statement in writing of the particulars of the estate and interest in the said lands, tenements, and hereditaments, and of the claims made in respect thereof.

Dated the twenty-seventh day of October, 1955.

By order of the Commission,

R. J. THOMSON,  
Secretary.

**SCHEDULE.**

All that land situated within the municipality of the City of Collingwood, being part of Crown portion 74, Parish of Jika Jika, County of Bourke, and being all of the land bounded by a line commencing at the intersection of the eastern boundary of Dight-street and the northern boundary of Vere-street; thence northerly by the eastern boundary of Dight-street to the southern boundary of Perry-street; thence easterly by the southern boundary of Perry-street to the western boundary of Harmsworth-street; thence southerly by the western boundary of Harmsworth-street to the northern boundary of Vere-street; thence westerly by the northern boundary of Vere-street to the point of commencement.

Plans are available for inspection at the Estates Branch of the Housing Commission, situated on the 4th Floor at 179 Queen-street, Melbourne, and forms for the making of claims will also be available on application to the Commission.

## Local Government Act 1946, Part 48, Section 876.

## LICENCES TO OCCUPY UNUSED ROADS.

NOTICE is hereby given that Licences to occupy Unused Roads have been issued to the following approved applicants, and that the Licence Fee specified in each case has been received by the Accountant, Department of Crown Lands and Survey, Melbourne, C.2.

Number of Licence.	Name and Address of Licensee.	Municipality.	Parish.	Abutting— Allotments and Sections.	Area.		Fee for Licence.	Date of Issue of Licence.	Date of Expiry of Licence.
					A. R. F.	£ s. d.			
38276	Telford, R. I. E., Richmond Hill, Kennedy-avenue, Mt. Gambier, South Australia	Glenelg	Werrikoo	East of 20A and 20B	6 0 0	0 9 0	1.1.54	31.12.56	
38277	The Mayor, Councillors, and Burgesses, Port Fairy	Belfast	Koroit	Through Crown 10	4 0 0	0 10 0	1.1.55	31.12.57	
38278	Hardy, H. G. (Mrs.), McLaren Vale, South Australia	Glenelg	Bogalara	North of 17 and east of 14	21 0 0	1 11 6	1.1.55	31.12.57	
38279	Jordan, V. (Mrs.), 43 King-street, Brighton, South Australia	Glenelg	Bogalara	West of 1A, south of 4, east of 2 and 3, and east of part 7	22 1 0	1 13 6	1.1.55	31.12.57	
38280	Jordan, T. L., 35 Grenfell-street, Adelaide	Glenelg	Bogalara	South of 16	5 0 0	0 7 6	1.1.55	31.12.57	
38281	Jordan, D. W., Caupaul, Dergholm	Glenelg	Bogalara and Dergholm	East of 21A, south of 21A, 30, north of 6 and 7, south and east of 25, north of 27, 27A, 28 and 29, west of 27A	51 2 0	3 17 3	1.1.55	31.12.57	
38282	Whittingham, J., Edenhope	Kowree	Durong	West of 45, section A	12 0 0	1 4 0	1.1.55	31.12.57	
38283	Mann, I. R., Brie Brie, Glenthompson	Mt. Rouse	Bilpah	North of 28A, 71A, and 72A	11 2 0	5 9 3	1.1.55	31.12.57	
38284	Roberts, C. W., Codrington, Victoria	Belfast	Tyrendarra	North-western half of road between 56 and 57	11 0 0	5 15 6	1.1.55	31.12.57	
38285	Wise, F. and M., Eversley	Ararat	Eversley	Between B7 and B5	3 3 0	1 2 6	1.1.54	31.12.56	
38286	Eales, Melva M. E. (Mrs.), Box 21, Peshurst	Mt. Rouse	Township of Peshurst	South-east of 9A, section 24	1 0 0	2 0 0	1.1.55	31.12.57	
38287	Tilly, A., Carngham, Victoria	Ararat	Eversley	Being south of B18	1 2 0	0 5 0	1.1.54	31.12.56	
38288	Buchanan, G. W. and D. P., Carráballuc	Mortlake	Kornong	North of 19 and 20	1 2 0	0 5 0	1.1.55	31.12.57	
38289	Martin, J. J. and J. F., Carrieton, South Australia	Kowree	Wombelano	South 5, 5A, 3A, and 2A, E 5A, 7, 12, 12B, south of 13E, 9, 9A, and 10	41 0 0	16 8 0	1.1.55	31.12.57	
38290	Condon, F., Tyrendarra East	Belfast	Tyrendarra	South-eastern half of road between 56 and 57	11 0 0	11 0 0	1.1.55	31.12.57	
38291	Trainor, S., Cape Clear	Gréville	Mannibadar	East of 151 and 151A	4 0 0	0 16 0	1.1.55	31.12.57	
38292	de Crespigny, F. Ch. (Dr.), Ingor-street, Ararat	Ararat	Ararat	Half width of road north of 1E, section 16	1 1 0	0 5 0	1.1.55	31.12.57	
38293	Curran, N. B., Eversley	Ararat	Eversley	Being road between B13 and B14	4 3 0	1 8 6	7.1.54	31.12.56	
38294	Robertson, R. L., Macarthur	Dundas	Macarthur	Being 12 chains of road in Parish of Macarthur, south-east of 3B1, section 22, Parish of Warraboak	1 2 0	0 15 0	1.1.55	31.12.57	
38295	Bishop, H. N. G., Macarthur	Dundas	Warrabkook	West of 1A and 3, and north of 1A, section 22	9 3 0	4 17 6	1.1.55	31.12.57	
38296	Barker, E. M. (Mrs.), "Roseleigh," Digby	Portland	Township of Digby	South of 5, 6, 7	3 1 0	0 16 3	1.1.55	31.12.57	
38297	Jackson, A., Box 112, Heywood	Portland	Myamyn	Between 5, section 11, and 2A, section 15, except 1A at the eastern end	6 3 0	0 13 6	1.1.55	31.12.57	
38298	Rentsch, L. E., Box 20, Peshurst	Mt. Rouse	Boram	West of J and Q, section 5, south of G, H, J, section XII.	8 0 0	5 0 0	1.1.55	31.12.57	
38299	Thomas, R. J., Heywood	Portland	Narrawong	Between 16 and 16c, section 16	0 3 0	0 5 0	1.1.55	31.12.57	
38300	Johnston, W. H. and V. M.	Minhamite	Macarthur	East of 1, section 14A	5 2 0	0 5 6	1.1.54	31.12.56	
39701	Kannenberg, A. E. (Miss), Box 106, Hamilton	Dundas	Napier	North of 2, 1A, and part 4 section A	6 0 0	0 6 0	1.1.55	31.12.57	
39702	Cranage, E. F., Box 12, Edenhope	Kowree	Edenhope	North of 78, 78A, 81, and southern half of road between 80 and 81	14 3 0	1 13 0	1.1.55	31.12.57	
39703	Bailey, C. W., Park Hill, Wannon	Wannon	Hilgay	South of 4B and part 3B, section 26	4 3 0	1 7 6	1.1.55	31.12.57	
39704	Cranage, P. E., Patyah, via Edenhope	Kowree	Edenhope	West of 2	6 0 0	0 9 0	1.1.55	31.12.57	
39705	Woods, A., 31 Miris-street, Newport	Ballan	Blackwood	South of 64A and 64B, section A	0 2 0	1 0 0	1.1.55	31.12.57	
39706	Dalton, J. R., Hall's Gap	Stawell	William	Being south of 15	2 3 0	0 10 0	1.1.55	31.12.57	
39707	King, J., Inglis-street, Ballan	Ballan	Township of Ballan	Between sections XIV. and XV.	1 0 0	0 15 0	1.1.55	31.12.57	
39708	Smith, J. W., Private Bag, Balmoral	Wannon	Balmoral	16, section 14 (Fulham Estate), Parish of Balmoral	0 3 0	0 10 0	1.1.55	31.12.57	
39709	Vincombe, R. G., Service-street, Clunes	Clunes	Clunes	Road known as Murray-street between 4, section B1, and 1 and 2, section C1	1 2 0	0 7 6	1.1.55	31.12.57	

## LICENCES TO OCCUPY UNUSED ROADS—continued.

Number of Licence.	Name and Address of Licensee.	Municipality.	Parish.	Abutting— Allotments and Sections.	Area.		Date of Issue of Licence.	Date of Expiry of Licence.
					A. R. P.	£ s. d.		
39710	Dickerson, A., Ballan	Ballan	Township of Ballan	Part of O'Cook-street, between 9, 10, and D, section 32	0 2 0	0 10 0	1.1.55	31.12.57
39711	Cranage, M., Box 12, Edenhope	Kowree	Edenhope	North of 11	6 3 0	0 10 6	1.1.55	31.12.57
39712	Moon, A. F., Coleraine-road, Hamilton	Portland	Audley and Branxholme	W22A, S3B, section 22A, Branxholme; W2, 3A, 5A, and 5B, section 24, Audley; 3-chain strip abutting 1A and 2A, section 22A, Branxholme	35 2 0	11 19 6	1.1.55	31.12.57
39713	Crouch Bros., Narroona	Ararat	Langi Logan	South of 42	4 0 0	1 16 0	1.1.55	31.12.57
39714	Hinchcliffe, A., Lexton	Lexton	Lexton	East of 16, 20, 22, and 23A, section C	5 1 0	1 13 0	1.1.55	31.12.57
39715	Rumler, J., Napoleons	Buninyong	Yarrowee	North of 1 to 6, section A	6 0 0	3 0 0	1.1.54	31.12.56
39716	Causar, D. A. (Miss), Macarthur	Dundas	Macarthur	South-west of 3 and 19 chains south-west of 3n1, section 22, Parish of Warrabkook	2 3 0	1 7 6	1.1.55	31.12.57
39717	Chirnside, R. A. G. and R. K. N., Skipton	Ripon and Hampden	Caramballuc North, Caramballuc South, and Baangal	East of 1A, 1B, 2A, 2B, section 5, east of 1B, 2B, section 6, north of 1A, 1B, 4A; section 6, south of 2A, 2B, 3B, section 6; east of 1A, 1B, section 39, east of 1A, section 32, west of 3A, 3B, section 30, west 2A, 12B, 3A, 3B, section 31, north of 1A, 2A, 2B, 3A, section 30, south of 1B, 12B, 3B, section 32, south of 1B, 2B, 3B, 5B, section 39; east of 99	93 0 0	15 2 6	1.1.55	31.12.57
39718	Dwyer, R. D., "Birkenlea," Merino	Glenelg	Merino	Between 3, section 8, and 3, section 37, Parish of Merino	2 2 0	1 0 0	1.1.55	31.12.57
39719	Walton, R. S. and W. R., "Wurrook," Rokewood	Leigh	Warrambine	East of 9 and 9A, and south of 9A and 16, section 12	14 2 0	5 8 9	1.1.55	31.12.57
39720	Farnsworth, L. A., Glenhurst, Tatyoon	Ararat	Walla Walla	South of 9A1, 9A2, 9B, and 8B, section 19	9 2 0	5 14 0	1.1.55	31.12.57
39721	Estate of A. M. Calvert, c/o Aiken, Walker, and Strachan	Ripon	Caramballuc North	East of 1A, 1B, 2A, 2B, section 7, east of 1B, 2A, 2B, section 8, north of 1A, 4A, section 7, south of 2B, 3B, section 7	32 3 0	5 2 0	1.1.55	31.12.57
39722	Wilson, G. T. and Mrs. T. J., Sturt-street, West Alfredton	Grenville	Haddon	Between 1, 2, and 3, section 19, Haddon and 1, section 14, Smythesdale	4 0 0	2 0 0	1.1.55	31.12.57
39723	Osman, E., Barkly-street, Ararat	Ararat	Colvinsby	North of 27a1	2 0 0	2 0 0	1.1.55	31.12.57
39724	Ross, N., Bell-street, Penschhurst	Mt. Rouse	Boram Boram	Between 1, 2, 3, and 4, and Z, Y, and part X, section 12	2 3 0	2 15 0	1.1.55	31.12.57
39725	Dunstan, W. L., Buninyong Estate, Buninyong	Buninyong	Buninyong	East of 25, south of 22 and 24, section 27	1 0 0	1 0 0	1.1.55	31.12.57
39726	O'Grady, J. J. (Dr.), Derg-holm, Victoria	Glenelg	Warrook	North of 12A and road east of 12A, 12B, 13A, 13B, section 2	18 2 0	2 3 9	1.1.54	31.12.56
39727	Harrison, W., Enfield	Buninyong	Enfield	South of 12, 11, and 13, section B	2 2 0	0 15 0	1.1.55	31.12.57
39728	Woodward, J. W., Melbourne-road, Ballarat	Bungaree	Bungaree	East of 24, section 8	1 2 0	0 10 6	1.1.54	31.12.56
39729	O'Shannessy, M. J., Dunkeld	Mt. Rouse	Jennawarra	West of 72d	30 0 0	14 5 0	1.1.55	31.12.57
39730	McKenzie, G. (Mrs.), Buangor	Ararat	Colvinsby	South of 83 and 84, east of 84, west of 45A1, 45A2, and 81	20 0 0	6 16 0	1.1.55	31.12.57
39731	McDougall, A., c/o Estate of J. T. McDougall, Edenhope	Kowree	Edenhope	Northern half of road east of 23	4 0 0	1 0 0	1.1.55	31.12.57
39732	McKenzie, A. J. and K. W., Buangor	Ararat	Colvinsby	East of 22, 22A, 35, and 42, east of 36B, south and east of 41	41 0 0	6 4 6	1.1.55	31.12.57
39733	Pope, W. H., Viewpoint-street, Ararat	Ararat	Colvinsby	West of 18B	3 0 0	0 18 0	1.1.55	31.12.57
39734	Brebner, J. G., "Willow Bank," Buangor	Ararat	Ballyrogan	South of 135, 136, 137, and 138, section J2	8 0 0	4 0 0	1.1.55	31.12.57
39735	Densley, F. W., Hawkesdale	Minhamite	Township of Hawkesdale	North of 21	0 2 0	0 5 0	1.1.55	31.12.57
39736	Wilson, D. G., Ozenkadook	Kowree	Edenhope	West of part 26	73 2 0	0 17 6	1.1.55	31.12.57

## LICENCES TO OCCUPY UNUSED ROADS—continued.

Number of Licence.	Name and Address of Licensee.	Municipality.	Parish.	Abutting— Allotments and Sections.	Area.	Fee for Licence.			Date of Issue of Licence.	Date of Expiry of Licence.
						A.	R.	F.		
						£	s.	d.		
39737	Bates, A. F. and G. F., Crowlands	Ararat ..	Colvinsby ..	East of 13A and 13c ..	3 2 0	0	10	6	1.1.55	31.12.57
39738	Finck, E. W., Heathmere, via Portland	Portland ..	Bolwarra ..	51 chains west of 3, section 11	5 0 0	0	12	6	1.1.55	31.12.57
39739	Kerr, S. W. A., Willaura ..	Ararat ..	Willaura ..	North of 49A ..	8 0 0	4	16	0	1.1.55	31.12.57
39740	Cookson, M. F., Ross Bridge	Ararat ..	Tatyoona and Town- ship of Ross- bridge	East of 16 and 18, roads north and east of school reserve	1 0 0	0	10	0	1.1.55	31.12.57
39741	Kelly, F. A., (Mrs.), 94 Jackson-street, Casterton	Glenelg ..	Tullich ..	North and east of 12A ..	4 2 0	0	17	0	1.1.55	31.12.57
39742	Pinniger, C. M. (Mrs.), 71 Landeox-street, Ararat	Ararat ..	Colvinsby ..	East of 91B ..	4 0 0	0	12	0	1.1.55	31.12.57
39743	Greenbank, L., Snake Valley	Ripon ..	Haddon ..	West of 36 and part of 39	2 2 0	0	7	6	1.1.55	31.12.57
39744	Slight, J. W., 17 Geo. Mitchell-square, Stawell	Stawell ..	Crowlands ..	East of part 2, 3, and part 9, section 9	10 2 0	0	10	6	1.1.55	31.12.57
39745	de Fegely, R. S., Dobie ..	Ararat ..	Colvinsby ..	North of 106 ..	4 0 0	1	12	0	1.1.55	31.12.57
39746	Christie, R. A., Byaduk ..	Dundas ..	Byaduk ..	North of 1c, and west of 1A and 1c, section 12	5 2 0	1	7	6	1.1.55	31.12.57
39747	Parker, C., Rokewood ..	Leigh ..	Corindhap ..	South of 58 and 63 ..	2 0 0	0	10	0	1.1.55	31.12.57
39748	McArthur, Mr. R. J. and Mrs. M. B., Miners' Rest Forest	Ballarat ..	Dowling ..	North of 62A and 63A ..	3 2 0	5	13	9	1.1.55	31.12.57
39749	Nicholson, R. A., Cathart, via Ararat	Ararat ..	Ararat ..	North and west of 20, section 12	4 2 0	0	15	9	1.1.55	31.12.57
39750	Kerr, W. J., "Belvoir," Linton	Grenville ..	Argyle ..	North of 2A, 2, and part 1, section A	2 2 0	0	10	0	1.1.55	31.12.57
39861	Gamble, M. H., Mortlake ..	Mortlake ..	Hexham East	South of 47 ..	3 2 0	1	8	0	1.1.54	31.12.56
39862	Stewart, J. K., 343 Little Collins-street, Melbourne	Phillip Island	Phillip Island	Between 152 and 153 ..	7 0 0	2	16	0	1.1.55	31.12.57
39863	Preece, G. K., Vite Vite ..	Hampden ..	Carrum- bulluc South	Between 33A and 32, south-west of 33A	2 2 0	2	10	0	1.1.55	31.12.57
39864	Meenan, L. P. and M. L., 42 White-street, Mor- dialloc	Werribee ..	Werribee ..	West of 55, 16, and north part of 5	10 0 0	2	0	0	1.1.55	31.12.57
39865	Kelly, C., and Co., Caramut	Warrnam- bool	Caramut ..	North-east of 1A, 2A, section 6, 1 and 2, section 7	210 0 0	73	10	0	1.1.55	31.12.57
39866	Estate of S. Ball (deceased), Manor	Werribee ..	Mambourin	North of 1, 2, 3, section 14, and west part of 1, section 15	9 0 0	1	16	0	1.1.55	31.12.57
39867	Presbyterian Church, Fram- lingham	Mortlake ..	Framling- ham	South of 58, township ..	1 0 0	0	12	0	1.1.54	31.12.56
39868	McDowell, W. K., Camper- down	Hampden ..	Corangamite	North of 42B, 44A, 44B	8 1 0	6	3	9	1.1.55	31.12.57
39869	Hand, R. A. J. and P. M., Strathmore	Werribee ..	Werribee ..	North of 19 and 20 ..	8 0 0	1	12	0	1.1.55	31.12.57
39870	Filice, G. A., Beac ..	Colac ..	Ondit ..	Between 25b and 25c ..	1 0 0	1	0	0	1.1.55	31.12.57
39871	Wilkinson, A. G. (junior), Rokeby	Buln Buln ..	Neerim ..	Between railway line and 15, section B	6 2 0	0	10	0	1.1.55	31.12.57
39872	Steele, H. C. C., Mortlake	Mortlake ..	Hexham East	South of 6, section 3, between 5, section 1	3 2 0	1	15	0	1.1.53	31.12.55
39873	Pomberton, T. (Mrs.), Vite Vite	Hampden ..	Caramballuc South	South of 75b and eastern part of 75a	4 0 0	4	0	0	1.1.55	31.12.57
39874	Depeler, A., Moderwarre ..	Barrabool ..	Modewarre	South of 27 and 28, section 5	5 1 0	2	12	6	1.1.55	31.12.57
39875	Chirnside, A. B., Skipton ..	Hampden ..	Caramballuc South	East and south of 103A	2 3 0	2	15	0	1.1.55	31.12.57
39876	Murphy, W. E. and P. A., Sunbury	Melton ..	Buttlejorrk	Between sections 10 and 11 (Township of the Gap)	3 0 0	1	10	0	1.1.55	31.12.57
39877	Estate of S. Kelly (deceased), Terang Presbytery	Hampden ..	Glenor- miston	East of 29, 32, section 3A, south of 3, section 5	9 3 0	10	14	6	1.1.55	31.12.57
39878	Bennett, U. L., Colin-avenue, Oakleigh	Eltham ..	Burgoyne ..	Between 28 and 33B ..	1 0 0	0	5	0	1.1.55	31.12.57
39879	Smith, A. R., Camperdown	Heytesbury	Purrumbete South	West of 16, B2 ..	2 0 0	0	5	0	1.1.55	31.12.57
39880	Richmond, T. C., Little River	Werribee ..	Bulban ..	East of 3A, section 5B, south of 10A	15 1 0	3	1	0	1.1.55	31.12.57
39881	McGinness, M. V. (Mrs.), Framlingham	Warrnam- bool	Garvoc ..	North of E1 ..	5 3 0	2	17	6	1.1.56	31.12.58
39882	Clark, G. J., Panmure ..	Warrnam- bool	Garvoc ..	North of E2 and E3 ..	4 0 0	2	0	0	1.1.56	31.12.58
39883	Gerlach, E. C., Tarwin East	Woorayl ..	Mirboo South	East of 52c and 52d ..	6 0 0	0	12	0	1.1.55	31.12.57
39884	Thom, K. D., Westmere ..	Mortlake ..	Neerim Neerim	West of I., section C ..	15 3 0	7	17	6	1.1.55	31.12.57
39885	Overend, B., 25 Rathdown- street, Carlton	Alberton ..	Binginwarri	Between 70D, 70G, 75B, and 70B, 70H, 75L, and northern half of 70H, and eastern part of 70B	8 0 0	0	16	0	1.1.55	31.12.57
39886	Hannah, J. W., Mortlake ..	Mortlake ..	Toorak ..	East of 4, section A ..	2 3 0	1	2	0	1.1.55	31.12.57



LICENCES TO OCCUPY UNUSED ROADS—continued.

Number of Licence.	Name and Address of Licensee.	Municipality.	Parish.	Abutting— Allotments and Sections.	Area.		Fee for Licence.	Date of Issue of Licence.	Date of Expiry of Licence.
					A. R. F.	£ s. d.			
39887	McPherson, A. G., Gisborne	Gisborne ..	Gisborne ..	North of 1 and 2, section 14 (Township of Gisborne)	0 3 0	0 11 3	1.1.55	31.12.57	
39888	Walker, A. K., Mortlake ..	Mortlake ..	Toorak ..	North of eastern part of 2	5 2 0	2 4 0	1.1.55	31.12.57	
39889	Badhan, T. B., Mortlake ..	Mortlake ..	Toorak ..	North and east of 3, section A	15 2 0	6 4 0	1.1.55	31.12.57	
39890	Woolamai Recreation Committee, o/o E. Yann, Loch Bell, A. D., Diamond Creek	Bass ..	Woolamai	South-west of 106A, 101A, and 101B	4 0 0	1 0 0	1.1.55	31.12.57	
39891	Bell, A. D., Diamond Creek	Heidelberg	Nillumbik	West of part 2, south-east part of 2A, section 21	0 2 0	0 10 0	1.1.55	31.12.57	
39892	Edge, J. H., Taroon ..	Heytesbury	Ecklin ..	North of western part of 1A, section 13	2 0 0	0 5 0	1.1.55	31.12.57	
39893	Swall, F. C., Mortlake ..	Mortlake ..	Toorak ..	East of northern part of 5, section A	3 1 0	1 6 0	1.1.53	31.12.56	
39894	Smith, C. G., Elaine ..	Hampden ..	Carambaluc South	East of 78B, 79B ..	6 1 0	6 5 0	1.1.55	31.12.57	
39895	McKenzie, W. P., Terang ..	Heytesbury	Ecklin ..	South of 8A, section A	2 2 0	1 5 0	1.1.55	31.12.57	
39896	Kerr, G. J., Cobrico ..	Heytesbury	Ecklin ..	North of 2B, section 10	5 0 0	0 10 0	1.1.55	31.12.57	
39897	Casey, A. G., Mortlake ..	Mortlake ..	Hexham	South of 5, section 3 ..	6 0 0	3 0 0	1.1.55	31.12.57	
39898	McGrath, T. J., South Ecklin	Heytesbury	Ecklin .. East	Southern part east of 2, section 17	2 0 0	0 5 0	1.1.55	31.12.57	
39899	Goldsmith, M. C., Dumbalk	Woorayl ..	Dumbalk	Between 9 and 12A ..	2 3 0	2 15 0	1.1.55	31.12.57	
39900	Wilson, T. J., Port Campbell	Heytesbury	Waarre ..	Between 19 and 20, section B	4 1 0	0 5 0	1.1.54	31.12.56	

Department of Crown Lands and Survey,  
Melbourne, 2nd November, 1955.

KEITH TURNBULL,  
Commissioner of Crown Lands and Survey.

MELBOURNE AND METROPOLITAN BOARD OF WORKS.

NOTICE TO THE OWNERS OF TENEMENTS IN THE UNDERMENTIONED STREETS AND THE PRIVATE STREETS, LANES, COURTS AND ALLEYS OPENING THERETO.

THE main pipe in the said streets being laid down, the owners of all tenements situated as under are hereby required on or before 19th December, 1955, to cause a proper pipe and stop cocks to be laid, so as to supply water within such tenements from the main pipe.

C. F. TRATHAN,  
Secretary.

8th November, 1955.

STREET AND POSITION.

*Box Hill.*

Erasmus-street, from Pembroke-street westwards 3½ chains.

*Coburg.*

Boundary-road, from Rodney-street eastwards 7 chains.  
Lincoln-street, from Boundary-road southwards 2½ chains.

*Eltham.*

Binns-street, from Were-street eastwards 4 chains.

*Heidelberg.*

Alamein-road, from Morobe-street to Dougharty-road.

*Keilor.*

Walter-street, from William-street northwards 17½ chains.  
Fox-street, from Walter-street eastwards 9 chains.  
Conrad-street, from Walter-street eastwards 8 chains.  
Henry-street, from Walter-street eastwards 7½ chains.  
Henry-street, from Walter-street westwards 17½ chains.  
Alfreida-street, from Henry-street northwards 10 chains.  
Conrad-street, from Alfreida-street eastwards 11½ chains.

*Moorabbin.*

Forrest-street, from Brooks-street northwards 3½ chains.  
Olympia-court, from Thomas-street eastwards 3½ chains.  
Biarritz-avenue, from Church-street to Marlo-grove.  
Cherbourg-avenue, from Biarritz-avenue northwards 2½ chains.  
Cannes-grove, from Church-street to Marlo-grove.  
Gordon-street, from Church-street to Spicer-street.  
Olympic-avenue, from Jack-street to Wembley-avenue.

*Preston.*

Clark-street, from Broadway southwards 5½ chains.  
Strathmerton-street, from Cuthbert-road north-westwards 11½ chains.

Dunolly-crescent, from Strathmerton-street to Boldrewood-parade.

*Richmond.*

R.O.W., 4½ chains east of Rotherwood-street, from Rowena-parade, northwards 2 chains.

*Sandringham.*

Hilton-street, from Keating-street eastwards 8½ chains.

*South Melbourne.*

College-place, from 3 chains west of Kerferd-road, northwards 1½ chains.

*Sunshine.*

Hassett-street, from McIntyre-road to Compton-parade, 9 chains.

Hammond-street, from McIntyre-road to Compton-parade, 10 chains.

Compton-parade, from Hammond-street southwards 15½ chains.

Bradman-street, from McIntyre-road to Compton-street, 9½ chains.

Suffolk-street, from McIntyre-road eastwards 6½ chains.  
Dunbar-street, from Wright-street southwards 12 chains.

Freeman-street, from Dunbar-street eastwards 1½ chains.  
Dunbar-avenue, from Freeman-street southwards 11½ chains.

Holehouse-street, from Suffolk-road to Rufford-street, 11½ chains.

McLeod-street, from Rufford-street to Warwick-road, 10 chains.

Collins-street, from Glengala-road to Keon-crescent.  
Keon-crescent, from Collins-street northwards 11½ chains.

Pellew-street, from Glengala-road to Douglas-street.  
Douglas-street, from Keon-crescent to McDonald-street.

McDonald-street, from Douglas-street northwards 6½ chains.

McDonald-street, from Douglas-street to Glengala-road.  
Carter-street, from Douglas-street southwards 12 chains.

Carter-street, from Douglas-street northwards 4½ chains.  
Neal-street, from McDonald-street to Bell-street.

Bell-street, from Neal-street to Glengala-road.  
Bell-street, from Neal-street north-eastwards 4½ chains.

Raymond-street, from Glengala-road south-westwards 13½ chains.

Walsh-street, from Suffolk-road to Downing-street.  
Downing-street, from Walsh-street to Mills-street.

Mills-street, from Downing-street northwards 6½ chains.  
Pennell-street, from Main-road west to Andrea-street.

Scott-street, from Main-road west to Andrea-street.  
Glendenning-street, from Main-road west to Andrea-street.

Lawton-street, from Duke-street eastwards 5½ chains.  
Palmer-street, from Duke-street eastwards 5½ chains.

## Transport Regulation Acts.

## TRANSPORT REGULATION BOARD.

## NOTICES OF PUBLIC HEARINGS.

NOTICE is hereby given that the applications made by the persons named below for licences to operate commercial passenger vehicles on the route or routes, or in the manner set out opposite their names, will be heard at a time and place to be communicated to the parties:—

*Name and Address; Nature of Application.*

LANGLOIS, F., 231 Nepean Highway, Edithvale; 1 commercial passenger vehicle, with seating capacity for five persons, to operate as follows:—(a) At separate and distinct fares within a radius of 5 miles of Edithvale Railway Station, (b) under private hire conditions, within a radius of 50 miles of Edithvale Railway Station (subject to the cancellation of licence No. C.H.336, held by the applicant).

JUDD, R. J., Ely-street, Yarrowonga; 1 commercial passenger vehicle, with seating capacity for 33 persons, to operate as a special service omnibus, subject to all regulations appertaining to such operations, and subject also to the condition that all journeys undertaken commence within a radius of 10 miles of Yarrowonga Post Office.

HILL, C. P. (trading as Clarinda Service Station), corner of Centre and Clarinda roads, Clarinda; 1 commercial passenger vehicle, with seating capacity for five persons, to be purchased, to operate for the carriage of passengers otherwise than at separate and distinct fares for each passenger throughout Victoria from corner of Centre and Clarinda roads, Clarinda.

TASKER, D. C., Marlino-avenue, Warburton; 1 commercial passenger vehicle, with seating capacity for five persons, to operate for the carriage of passengers otherwise than at separate and distinct fares for each passenger throughout Victoria from Marlino-avenue and Main-street, Warburton.

LANG, J., Ireland-street, Bright; application for renewal of licence No. C.T.67 (expiring 18th December, 1955) to operate as a country taxi and touring omnibus under the same terms and conditions at Bright.

HYNES, C., 91 Hume-street, Wodonga; application for renewal of licence No. C.T.136 (expiring 12th February, 1956) operating as a country taxi at Wodonga.

TRANS-OTWAY LIMITED, corner Ryrie and Fenwick streets, Geelong; application for renewal of licence No. C.T.697 (expiring 3rd December, 1955) operating as a country taxi at Lorne.

ROSS, G. L., PTY. LTD., 66 High-street, Maryborough; application for variation of licence Nos. C.O.28, C.O.562, C.O.563, C.O.871, C.O.869, C.O.875, C.O.860, to include the ability to operate the Wednesday, Maryborough-Ballarot stage service, picking up passengers on route at Talbot and carrying parcels of limited weight.

BEAGLEY, R. L., Yarram; application for renewal of licence No. C.T.332 (expiring 22nd January, 1956) operating as a country taxi with mail contract also at Yarram.

SLADE, P. G., R. K., & H. K. (trading as Slade's Hire Car Service), Mangan-street, Tongala; application for renewal of licence No. T.C.H.243 (expiring 7th February, 1956) operates as a country hire from Tongala.

HENDERSON, W. D., Victoria-street, Rochester; application for renewal of licence No. C.T.155 (expiring 25th February, 1956) operating as a country taxi at Rochester.

SCANLON, J., 74 Sturt-street, Echuca; application for renewal of licence No. C.T.157 (expiring 27th February, 1956) operating as a country taxi at Echuca.

LYON, J. (trading as Lyon Bros.), Main-road, Eltham; application for renewal of licence No. C.H.63 (expiring 18th December, 1955) to operate otherwise than at separate and distinct fares for each passenger (private hire) to places throughout Victoria from Eltham.

TRARALGON BUS LINES & MORWELL BUS LINES (trading as Latrobe Valley Bus Lines), 1 Seymour-street, Traralgon; application for renewal of licence No. C.O.161 (expired 21st January, 1955) operating under the same terms and conditions as "C.O." licences held in the name of the applicant company.

WAUGH, E. L., & J. H. RAWLINGS (trading as Trafalgar Passenger Service), Whitton-street, Trafalgar, Victoria; application for renewal of licence Nos. C.O.761, C.O.764 (expired 1st September, 1955) operating as stage omnibuses and country special service omnibuses under the same terms and conditions at Trafalgar.

NOTICE is hereby given that the applications made by the persons named below for licences to operate commercial passenger vehicles on the route or routes, or in the manner set out opposite their names, will be heard at a time and place to be communicated to the parties:—

## APPLICATIONS FOR RENEWAL OF METROPOLITAN HIRE LICENCES.

*Name and Address; Licence No.; Expiry Date; Operational Address.*

BISHOP, J., 29 Lucan-street, North Caulfield; M.H.211; 16th January, 1956; Embassy Private Hire Depots, 111 Bourke-street, Eastern Market, corner Acland-street and The Esplanade, St. Kilda.

CONNELL, T. F., 3 Errol-street, East Prahran; M.H.576; 21st January, 1956; Civic Motors, City-road, South Melbourne.

DONOVAN, M. E., 12 Roma-street, Bentleigh; M.H.746; 18th December, 1955; McKinnon Taxi Service, corner North and Jasper roads, Ormond.

GANGE, A. G., 214 Brunswick-street, Fitzroy; M.H.99; 18th December, 1955; Astoria Depots.

MUNRO, I. R., 22 Harding-street, Coburg; M.H.511, M.H.531, M.H.546; 10th September, 1955, 8th December, and 10th September, 1955, respectively; Embassy Private Hire Depots, 111 Bourke-street, Melbourne, Eastern Market, corner Acland-street and The Esplanade, St. Kilda.

GUEST, R. W., 33 Edgevale-road, Kew; M.H.586; 2nd December, 1955; Embassy Private Hire Depots, 111 Bourke-street, Melbourne, Eastern Market, corner Acland-street and The Esplanade, St. Kilda.

PAPPS, A. G., 222 Waverley-road, East Malvern; M.H.297; 18th December, 1955; 222 Waverley-road, East Malvern.

SAULTRY, W., Haughton-road, Oakleigh; M.H.718; 18th December, 1955; Haughton-road, Oakleigh, "Alma Taxis".

## APPLICATIONS FOR RENEWAL OF METROPOLITAN TAXI-CAB LICENCES.

*Name and Address; Licence No.; Expiry Date.*

BARKLEY, R. J., 36 Bent-street, Caulfield; M.T.1082; 21st January, 1956.

GANGE, A. J., 214 Brunswick-street, Fitzroy; M.T.403; 15th December, 1955.

MANNING, R. S., 36 Fowlett-street, Heidelberg; M.T.643; 17th January, 1956.

MOLLOY, J., 25 Sussex-street, East Preston; M.T.1027; 18th December, 1955.

MUIRHEAD, J., 21 Spring-road, South Caulfield; M.T.785; 15th December, 1955.

PILL, J. H., 14 Barton-street, Hawthorn; M.T.966; 21st January, 1956.

RUSSELL, A., 895 Nepean Highway, Moorabbin; M.T.1029; 21st January, 1956.

SCANLON, E. T., Flat 2, 42 Chapel Lodge, Chapel-street, East St. Kilda; M.T.6086; 21st January, 1956.

WALLIS, J. E., 26 Kent-grove, North Caulfield; M.T.568; 16th January, 1956.

APPLICATIONS for metropolitan private hire car licences have been made by the persons listed hereunder in respect of commercial passenger vehicles, with seating capacity for five persons, to be bespoken from the address shown with the application:—

*Name; Address; Proposed Operational Address.*

CHARTERIS, K. R., 42 Elstone-avenue, Essendon; Zone "J." NEWLAND, R. R. T., 2 Kelly-avenue, Moorabbin; Zone "A", Zone "B"—two applications.

PETERS, N. C., 8 Hillside-road, Rosanna; Zone "G." SZABO, C., Flat 6, 549 Toorak-road, Toorak; Zone "A", Zone "B", Zone "C", Zone "D"—four applications.

LITTLE, VICTORY CAB CO. PTY. LTD., 67, Crockford-street, Port Melbourne; application for renewal of metropolitan hire car licence No. M.H.417 (expiry date 18th December, 1955), authorizing operations from Astoria Private Hire Depots, 522 Swanston-street, Carlton, 59 Bridge-road, Richmond, and 78 Acland-street, St. Kilda.

NOTICE is hereby given that the applications made by the persons named below for licences to operate commercial goods vehicles on the route or routes, or in the manner set out opposite their names, will be heard at a time and place to be communicated to the parties concerned:—

*Name and Address; Nature of Application.*

BARTLEY, T. B., A. K. BOOL, & F. J. KERR (trading as Bartley, Bool, & Kerr), 26 Hughes-street, East Malvern; 1 commercial goods vehicle (12 cwt.) to operate throughout the State of Victoria in the

course of business as "refrigeration engineers" for the purpose of installing, servicing and maintaining refrigerators manufactured by R. Werner and Co. Pty. Ltd.—tools of trade, spare parts, and materials incidental to trade.

CAIN, E. (Mrs.), Bowser, via Wangaratta; 1 commercial goods vehicle (79 cwt.) to operate within a radius of 50 miles of Wangaratta—road-contracting plant and material on behalf of Oxley Shire Council.

CLARK, F. A., & W. H. ELLIS (trading as C. & E. Carrying Co.), 195 Stawell-street, Burnley; 1 commercial goods vehicle (79 cwt.) to operate—(a) within a radius of 25 miles of the G.P.O., Melbourne—general goods, (b) from pits at Langwarrin to consignees in the metropolitan area—sand.

HILL, I. P. (Mrs.), 31 Fletcher-street, Essendon; 1 commercial goods vehicle (12 cwt.) to operate within a radius of 50 miles of the G.P.O., Melbourne, and to and from Warragul in the course of business as "stallholder"—own millinery.

LONSDALE BUILDING SUPPLIES PTY. LTD., 34-42 Lonsdale-street, Dandenong; 1 commercial goods vehicle (12 cwt.) to operate throughout the State of Victoria for the purpose of servicing and maintaining New Holland Hay Balers—tools of trade, spare parts, and equipment incidental to such servicing and maintenance.

MCCALL, J. J., Monash-road, Newborough; 1 commercial goods vehicle (100 cwt.) to operate—(a) within a radius of 25 miles of Geelong in the course of business as "building contractor"—own goods, (b) from Housing Commission's store at Holmesglen to Housing Commission's construction sites at Norlane—building materials.

MCINERNEY, J. L., 18 Water-street, Ballarat; 1 commercial goods vehicle (10 cwt.) to operate throughout the State of Victoria in the course of business as "marine dealer"—marine stores and old metals.

QUEEN'S BRIDGE MOTOR & ENGINEERING CO. PTY. LTD., 31-43 Queen's Bridge-street, South Melbourne; 1 commercial goods vehicle (8 cwt.) to operate throughout the State of Victoria for the purpose of servicing and maintaining tractors and associated equipment—tools of trade, spare parts, and materials incidental to applicant's own contracts.

SAVILLE, R. W., Thurla-street, Swan Hill; application to vary the terms of existing licence No. D.A.15768 by the addition of the ability to operate within a radius of 50 miles of Swan Hill—fencing posts.

THOMAS, C. J., Tallangatta; 1 commercial goods vehicle (176 cwt.) to operate from A. Dunstan and Sons forest landing at Glen Wills to A. Dunstan and Sons sawmill at Eskdale—mill logs.

NOTICE is hereby given that the applications made by the persons named below for renewal of licences to operate the commercial goods vehicles on the route or routes, or in the manner set out opposite their names, will be heard at a time and place to be communicated to the parties concerned:—

*Name and Address; Present Franchise; Licence Number; Date of Expiry.*

CARRIER AIR CONDITIONING LTD., 1 Moore-street, Moonee Ponds; 1 commercial goods vehicle (10 cwt.) to operate throughout the State of Victoria for the purpose of installing and servicing air conditioning plants—air conditioning equipment, spare parts, and tools of trade incidental to such installation and servicing work; D.4621; 15th March, 1956.

JEHU, J. C., 68 Regent-street, Port Fairy; 1 commercial goods vehicle (40 cwt.) to operate throughout the State of Victoria in the course of business as "well boring contractor"—tools of trade, plant, and equipment incidental to such contracts; D.4587; 2nd December, 1956.

MERRETT, P. A., 24 Rockley-street, Nhill; 1 commercial goods vehicle (200 cwt.) to operate—(a) within a radius of 20 miles from the post office at Nhill—general goods, (b) within a radius of 50 miles from the post office at Nhill—petroleum products and empty containers; D.6971; 21st January, 1956.

RILEY DODDS AUSTRALIA LTD., 636 Swanston-street, Carlton; 1 commercial goods vehicle (7 cwt.) to operate throughout the State of Victoria for the purpose of servicing and maintaining steam generating plants—tools of trade, spare parts, and incidental materials for use at licensee's own contracts only; D.7083; 3rd March, 1956.

THOMPSON, H. L., 214 Creswick-road, Ballarat; 1 commercial goods vehicle (80 cwt.) to operate throughout the State of Victoria in the course of business as "marine dealer"—old junk, rags, bones, bottles, and marine stores of every description; D.4572; 21st December, 1955.

UEBERGANG, E. H., & SONS, 13 Kalkee-road, Horsham; 1 commercial goods vehicle (100 cwt.) to operate—(a) between Horsham and the licensee's properties at Dergholm, Coobool, and Robinvale—farm products in the course of licensee's business, as "primary producers," (b) within a radius of 50 miles from the licensee's place of business at Horsham—hay and chaff in the course of licensee's business as "chaff manufacturers," (c) from Horsham to places throughout Victoria west of Horsham—wool associated only with shearing contracts undertaken by the licensee; D.7011; 12th February, 1956.

NOTICE is hereby given that the applications made by the persons named below for renewal of licences with variation to operate the commercial goods vehicles on the route or routes, or in the manner set out opposite their names, will be heard at a time and place to be communicated to the parties concerned:—

*Name and Address; Present Franchise; Amended Conditions; Licence Number; Date of Expiry.*

ARNOLD, E. T., Gibson-street, Rupanyup; 1 commercial goods vehicle (70 cwt.) to operate—(a) within a radius of 20 miles of Rupanyup—general goods, (b) from Rupanyup to St. Arnaud—petroleum products in prescribed types of containers, on behalf of the Shell Co. of Aust. Ltd., returning with empty containers; 1 commercial goods vehicle (70 cwt.) to operate as per present franchise, deleting in paragraph (b) St. Arnaud, and adding in lieu Horsham; D.4411; 15th December, 1955.

RYAN, T. W., 106 Firebrace-street, Horsham; 1 commercial goods vehicle (10 cwt.) to operate throughout the State of Victoria for the purpose of installation and servicing of electrical and refrigeration equipment—tools of trade, spare parts, and materials for use at licensee's own contracts; 1 commercial goods vehicle (10 cwt.) to operate as per present franchise, adding the carriage of electrical appliances for demonstration purposes, with the ability to make an incidental urgent delivery; D.6809; 10th September, 1955.

NOTICE is hereby given that the applications made by the persons named below for renewal of temporary licences for a period of twelve months to operate the commercial goods vehicles on the route or routes, or in the manner set out opposite their names, will be heard at a time and place to be communicated to the parties concerned:—

*Name and Address; Present Franchise; Licence Number; Date of Expiry.*

BAKER, HENRY (trading as Baker & Morgan), Whitfield; 1 commercial goods vehicle (176 cwt.) to operate—(1) logs from private properties within a radius of 20 miles of the post office at Whitfield to Baker and Morgan's sawmill at Whitfield, (2) sawn timber from Baker and Morgan's sawmill at Whitfield to consignees within a radius of 50 miles of the post office at Whitfield, and to consignees at Shepparton, (3) sawmilling equipment for operations at Baker and Morgan's sawmill at Whitfield from suppliers within a radius of 50 miles of Whitfield, (4) logs from forest landings in the Whitfield area to sawmills within a radius of 50 miles of Whitfield; T.T.D.1631; 15th March, 1956.

THE BENDIGO TIMBER CO., Mollison-street, Bendigo; 1 commercial goods vehicle (150 cwt.) to operate—(1) red-gum sawn timber from Bonum's sawmill at Barham (N.S.W.) to Bendigo Timber Co.'s Timber Yards at Bendigo, (2) sawn timber from W. Ogdén's sawmills at Trentham and Daylesford, and McKay's sawmill at Gisborne (Bullengarook)—(a) to the Bendigo Timber Yards at Bendigo, or direct on to building sites within a radius of 20 miles of the G.P.O., Bendigo, (3) building materials delivered from the Bendigo Timber Yards at Bendigo to building sites and customers within a radius of 20 miles of Bendigo; T.T.D.1569; 2nd March, 1956.

BULACH, HEINZ A., Noojee; 1 commercial goods vehicle (190 cwt.) to operate—(1) logs from any forest landing in the Upper Yarra forestry district—(a) to the railway station at Nayook, and to any mill or dump which is located within a radius of 20 miles of such landing or of the railway station at Nayook, (2) sawn timber from the Noojee Sawmilling Co.'s sawmill at Noojee—(a) to the railway station at Nayook, (b) to any merchant or builder if delivered en route to such railway station, or to a timber yard, or building site located within a radius of 20 miles of such railway station; T.T.D.1636; 22nd March, 1956.

CAMBARVILLE TRANSPORT Co., Cambarville, via Marysville; 1 commercial goods vehicle (249 cwt.) to operate—(1) sawn timber from the Cambarville Timber Co.'s sawmill at Cambarville—(a) to the railway station at Healesville, (b) to any customer if delivered within a radius of 20 miles of the Healesville Railway Station, (c) south of the River Yarra within a radius of 25 miles but not within 8 miles of the G.P.O., Melbourne; T.T.D.1505; 3rd March, 1956.

CHASEMORE, K. R., 30 Cremorne-street, Balwyn; 1 commercial goods vehicle (114 cwt.) to operate—(1) logs from K. R. Chasemore's forest landing at Big River, via Warburton, to J. L. Smith's sawmill at Croydon; T.T.D.1700; 7th March, 1956.

CHIVERS, A., High-street, Mansfield; 1 commercial goods vehicle (180 cwt.) to operate—(1) sawn timber from the Delatite sawmills at Mirimbah to the Delatite Seasoning Factory at Seymour, the Mansfield Railway Station, and direct on to building sites at Yarrawonga, Benalla, Wangaratta, Seymour, Albury, Shepparton, and Numurkah; T.T.D.1275; 20th March, 1956.

COUTTS, A. C., Princes Highway, Noble Park; 1 commercial goods vehicle (190 cwt.) to operate—(1) logs from any forest landing in the Upper Yarra forestry districts—(a) to the railway station at Nayook, (b) to any mill or dump which is located within a radius of 20 miles of such landing or of the railway station at Nayook, (2) sawn timber from the Limberlost Sawmills at Nayook—(a) to the railway station at Nayook, (b) to any merchant or builder if delivered *en route* to such railway station, or to a timber yard, or building site within a radius of 20 miles of such railway station; T.T.D.1625; 2nd March, 1956.

DUNSTAN, A., & SONS, 1-7 Tallangatta-road, Wodonga; 2 commercial goods vehicles (239 and 240 cwt.) to operate—(1) logs from the Forest Commission's lease at Mt. Wills to A. Dunstan and Sons' sawmill at Eskdale, (2) sawn timber from A. Dunstan and Sons' sawmill at Eskdale to A. Dunstan and Sons' timber yards at Wodonga, and to the railway station at Wodonga and Albury, (3) to carry between Wodonga and Eskdale and Mt. Wills goods used for the maintenance and operation of own sawmill at Eskdale and logging camp at Mt. Wills; T.T.D.1570, 23rd March, 1956; T.T.D.1635, 15th March, 1956.

FARNSWORTH, C., Astbury-street, Avoca; 1 commercial goods vehicle (160 cwt.) to operate—(1) sawn timber from C. Farnsworth's sawmill at Avoca to building sites and timber yards at St. Arnaud and Donald; T.T.D.1509; 17th March, 1956.

FELGLIN, M., & SONS PRY. LTD., Station-street, Nunawading; 1 commercial goods vehicle (180 cwt.) to operate—(1) logs from any forest landing in the Niagaroon and Upper Yarra forestry districts and the North Big River areas—(a) to the railway station at Healesville and to any mill or dump which is located within a radius of 20 miles of such landing or of the railway station at Healesville, (b) to any mill or timber yard situated within a radius of 25 miles of the G.P.O., Melbourne, (2) sawn timber from M. Felglin and Sons' sawmill at Acheron—(a) to the railway station at Healesville, (b) to any customer if delivered within a radius of 20 miles of the railway station at Healesville, (c) to any merchant or builder if delivered to timber yard or direct on to building site which is located within a radius of 25 miles of the G.P.O., Melbourne; T.T.D.1696; 7th March, 1956.

GERRISH, E. J. (trading as Gerrish and Sons), Main-street, Warburton; 1 commercial goods vehicle (100 cwt.) to operate—(1) logs from any forest landing in the Niagaroon and Upper Yarra forestry districts and the North Big River areas—(a) to the railway station at Warburton and/or Yarra Junction, and to any mill or dump which is located within a radius of 20 miles of such landing or of the railway station at Warburton and/or Yarra Junction, (2) sawn timber from H. Tuchman's and the Alpine sawmills at Millgrove—(a) to the railway station at Warburton and/or Yarra Junction, (b) to any customer if delivered within a radius of 20 miles of the Warburton and/or Yarra Junction Railway Stations, (c) to any merchant or builder if delivered to timber yard or direct on to building site which is located within a radius of 25 miles of the G.P.O., Melbourne; T.T.D.1571; 30th March, 1956.

GLEESON, J. P., Neerim South; 1 commercial goods vehicle (100 cwt.) to operate—(1) logs from J. P. Gleeson's forest landing at Neerim South to J. P. Gleeson's sawmill at Neerim South, (2) sawn timber from J. P. Gleeson's sawmill at Neerim South—(a) to McGelson's timber yards at Warragul and I. D. Grubb's timber yards at Drouin, and to consignees within a radius of 20 miles of the afore-mentioned sawmills at Neerim South; T.T.D.1276; 20th March, 1956.

HERROD, S., Brown Hill P.O., Ballarat; 1 commercial goods vehicle (204 cwt.) to operate—(1) logs from Forest Commission's landings and private property in the Leonard Hill area to S. Herrod's sawmill at Ballarat; T.T.D.1698; 7th March, 1956.

MOLONEY, A., Camp-street, Trentham; 1 commercial goods vehicle (120 cwt.) to operate—(1) sawn timber from O'Hehir's sawmill at Trentham to consignees in metropolitan area (in house lots only), (2) sawn timber from P. and J. Frith's sawmill at Lyonsville direct on to building sites at Bendigo (in house lots only); T.T.D.1504; 3rd March, 1956.

SCHUBERT, F. A. & D. J. (trading as J. Schubert and Son), Baranduda, via Wodonga; 1 commercial goods vehicle (200 cwt.) to operate—(1) logs from any forest landing in the Eskdale area to J. Schubert and Sons' sawmill at Baranduda, (2) logs from forest landings in the Cravenville area to J. Schubert and Sons' sawmill at Baranduda, (3) sawn timber from J. Schubert and Sons' sawmill at Bucheen Creek to J. Schubert and Sons' timber yards at Baranduda; T.T.D.1279; 20th March, 1956.

SHEARMAN, A. J., & E. W. THOROUGHGOOD (trading as A. J. Shearman), 217 Nepean Highway, Mentone; 1 commercial goods vehicle (190 cwt.) to operate—(1) logs from A. J. Shearman's forest landing in the Darnum area to A. J. Shearman's sawmill at Mentone; T.T.D.1628; 15th March, 1956.

SPENCER, D. M., Maffra-road, Heyfield; 1 commercial goods vehicle (254 cwt.) to operate—(1) logs from any forest landing in the Licola area to sawmills at Heyfield; T.T.D.3; 7th March, 1956.

WILLIAMS, W. H. & A. V., 97 Bridge-street, West Benalla; 1 commercial goods vehicle (255 cwt.) to operate—(1) logs from the King Saddle, Mansfield, and Turnbullup areas to Terrett's sawmill at Benalla, (2) sawn timber from Terrett's sawmill at Benalla to consignees at Echuca, Swan Hill, Numurkah, and Kerang; T.T.D.1512; 17th March, 1956.

WILSON'S (BENALLA) TRANSPORT PTY. LTD., Bridge-street, Benalla; 3 commercial goods vehicles (170, 170, and 189 cwt.) to operate—(1) logs from any forest landing within a radius of 60 miles of the post office at Benalla—(a) to sawmills within a radius of 60 miles of the post office at Benalla, (2) sawn timber from sawmills at Benalla and Mirimbah—(a) to timber yards and on to housing sites within a radius of 60 miles of the Benalla Post Office; T.T.D.1513, T.T.D.1515, T.T.D.1516; 17th March, 1956.

BARKER, B. (trading as Yarra Valley Transport), Main-street, Lilydale; 1 commercial goods vehicle (200 cwt.) to operate—(1) sawn timber from Victoria Hardwood Co.'s sawmill at Powelltown, E. Lloyd's sawmill at Gladysville, and the Moreland Timber Co.'s sawmill at Yarra Junction—(a) to the railway station at Warburton and/or Yarra Junction, (b) to any customer if delivered within a radius of 20 miles of the railway station at Warburton and/or Yarra Junction, (c) to any merchant or builder if delivered to timber yard or direct on to building site which is situated within a radius of 25 miles of the G.P.O., Melbourne; T.T.D.1236; 20th March, 1956.

Notice of any objection should be forwarded to reach the Secretary of the Board not later than Wednesday, 30th November, 1955.

E. V. FIELD,  
Secretary.

Exhibition Buildings, Rathdown-street, Carlton, N.3.

Transport Regulation Acts.  
TRANSPORT REGULATION BOARD.  
NOTICE No. 14.

Stand for Taxi-cabs Within the Borough of Swan Hill.

NOTIFICATION of a stand approved by the Board for the use of commercial passenger vehicles licensed under the classification of "Country Taxi-cab" and authorized to operate within a specified radius from the post office at Swan Hill:—

Street; Location; Number of Taxi-cabs.

Campbell-street; hire stand, west side, extending south from a point 30 feet south from the southern building alignment of McCallum-street; five.

By order of the Transport Regulation Board,

E. V. FIELD,  
Secretary.

## CONTRACTS ACCEPTED.—(Series 1955-56.)

## VICTORIAN RAILWAYS.

85. Clearing, excavation, &c., Croydon to Mooroolbark Railway, for £5,720 (Contract 60497).—Melbourne Tractor Company. 86. Supply and erection of fencing at North and West Melbourne, for £1,420 2s. (Contract 60664).—A. Arnold's Fences Pty. Ltd. 87. Piles at 8s. per lineal foot (Contract 60681).—L. Simpson. 88. Supply and erection of fencing at Camberwell, for £1,456 8s. (Contract 60708).—A. Arnold's Fences Pty. Ltd.

By order of the Victorian Railways Commissioners.

N. QUAIL, Secretary. 11.11.55.

## PUBLIC WORKS.

2280. Richmond, Girls' School, (1) supply of pie heater, water urn, and milk urn, £112.—L. J. Morgan.
2281. Royal Park, Mental Hospital, (1) supply of Grindall machine, £155.—McPherson's Ltd.
2282. Dandenong, Technical School, (1) supply of "Goodrid" incinerator, £165.—J. D. MacDonald Engineering Co. Pty. Ltd.
2283. Sunbury, Mental Hospital, (1) supply of drying cabinets, £234 6s.—Meecelec Pty. Ltd.
2284. Queenscliff, South Pier, (1) supply of hardwood, £225 14s. 8d.—S. A. Armistead Pty. Ltd.
2285. South Melbourne, Public Works Department Storeyard, (1) supply of galvanized ridging, £132 7s. 5d.—A. E. Carlyle Pty. Ltd.
2286. Ballarat, Girls' Secondary School, (1) supply of refrigerators, £227 15.—Robert Taylor Pty. Ltd.
2287. Mildura, Technical School, (1) supply of saw bench and motor, £238 15s.—Charles Wolfenden and Co.
2288. Melbourne, Museum and National Gallery, (1) supply of hard copper, £1,018 11s. 7d.—Austral Bronze Co. Pty. Ltd.
2289. Sunbury, Mental Hospital, (2) supply of washing machines and concrete mixer, £660 12s. 3d.—Lightburn and Co. Ltd.
2290. Sunbury, Mental Hospital, (3) supply of vacuum cleaners, £360 17s. 6d.—H. Rowe and Co. Pty. Ltd.
2291. Cheltenham, Heatherton Sanatorium, (2) supply of refrigerator, £210.—A.X. Refrigeration Installation and Maintenance Pty. Ltd.
2292. Warracknabeal, High School, (2) supply of "Barker" bandsaw machine and 2 "Rapid" forges, £362 16s.—McPherson's Ltd.
2293. Melbourne, Law Courts, (1) supply of joinery, £139 6s. 4d.—W. S. Neelands Pty. Ltd.
2294. South Melbourne, Public Works Department Storeyard, (1) supply of redgum timber, £160.—Coldon Timbers Pty. Ltd.
2295. Sunbury, Mental Hospital, (1) supply of copper tubing, £840.—H. A. Barnard Pty. Ltd.
2296. South Melbourne, Public Works Department Storeyard, (1) supply of tarpaulins, £123 10s.—Gair's Pty. Ltd.
2297. Melbourne, Public Library, (1) supply of hot rolled copper sheet, £1,601 2s. 4d.—Austral Bronze Co. Pty. Ltd.
2298. Mont Park, Mental Hospital, (1) supply of timber, £858 8s. 5d.—Bowen and Pomeroy Pty. Ltd.
2299. Prahran, Girls' Technical School, (1) supply of Bain Marie, £465.—K. G. Luke (A'asia) Ltd.
2300. South Melbourne, Public Works Department Storeyard, (1) supply of rotary clothes hoists, £196 16s.—A. Arnold's Fences Pty. Ltd.
2301. Melbourne, Parliament House, (1) supply of coke, £160.—H. James.
2302. Dandenong, Technical School, (1) supply of bench grinder, drilling machines, £340 17s.—Waldown Distributors.
2303. Coburg, Penal Establishment, Pentridge, (1) supply of padlocks, £153.—J. Hubball Pty. Ltd.
2304. Ballarat, Mental Hospital, (1) supply of stainless-steel multipots for tea, £677 12s. 6d.—K. G. Luke (A'asia) Ltd.
2305. South Melbourne, Public Works Department Storeyard, (1) supply of caneite, £320 10s. 2d.—J. Murray More Pty. Ltd.
2306. Brighton, Technical School, (1) supply of dusty toppings, £288 8s. 7d.—Reid Bros. and Reid Pty. Ltd.
2307. South Melbourne, Public Works Department Storeyard, (1) supply of angle iron, £299 8s. 6d.—Melbourne Iron and Steel Mills Pty. Ltd.
2308. Northcote, State School No. 1401, (1) supply black-out blinds, £226 0s. 6d.—Carlisle Blind and Canvas Pty. Ltd.
2309. Cobram, Consolidated School, (2) supply tables and seats for cafeteria, £181 19s.—F. Fallshaw and Sons Pty. Ltd.
2310. Mentone, High School, (4) furniture for practice flat, £138 0s. 6d.—F. Fallshaw and Sons Pty. Ltd.
2311. Rosebud, High School, (4) furniture for practice flat, £138 0s. 6d.—F. Fallshaw and Sons Pty. Ltd.
2312. Bairnsdale, High School, (4) furniture for practice flat, £138 0s. 6d.—F. Fallshaw and Sons Pty. Ltd.
2313. Nhill, High School, (4) furniture for practice flat, £138 0s. 6d.—F. Fallshaw and Sons Pty. Ltd.
2314. Echuca, High School, (4) furniture for practice flat, £138 0s. 6d.—F. Fallshaw and Sons Pty. Ltd.
2315. Melbourne, High School, (2) supply of library shelving, £353 5s. 6d.—Lloyd Industries.
2316. Port Melbourne, P.W.D. Depot, (2) supply steel binning, £615 5s.—Steelbilt (Vic.) Pty. Ltd.
2317. Ballarat North, Technical School, (1) supply piano, £195.—Hamer and Woodward Pty. Ltd.
2318. Flemington, Girls' Secondary School, (2) supply science benches, £193 10s.—B. E. Purnell Pty. Ltd.
2319. Warracknabeal, High School, (2) supply furniture to Manual Arts Block, £633 6s. 3d.—Cherry and Sons Pty. Ltd.
2320. Collingwood, State School, Visual Education Centre, (1) supply four film-strip cabinets, £170.—E. T. Brown Ltd.
2321. Heidelberg, Technical School, (2) supply preparation and teachers' benches, £194.—W. R. Brooks Pty. Ltd.
2322. Melbourne, Lands Department, (2) supply and fix venetian blinds, £122 14s. 8d.—Delaney's.
2323. Richmond, Girls' Secondary School, (3) supply curtains as directed, £1,154.—Moonee Furnishings.
2324. Richmond, Girls' Secondary School, (1) painting cupboards, &c., £189 5s.—Pettigrews Pty. Ltd.
2325. Flemington, Travancore Developmental Centre, (1) supply of Sunray carpet, £171 9s.—W. P. Murison.
2326. Burwood, Teachers' College, (1) supply of 50 wardrobes, 4 ironing tables, £1,181 5s.—Kennett Bros. and Rayner Pty. Ltd.
2327. Tottenham North, State School No. 4703, (1) supply of 21 venetian blinds, £146.—Delaney's.
2328. Bellfield, State School No. 4656, (1) supply of 19 venetian blinds, £126.—C. H. Stirling.
2329. Royal Park, Mental Hospital, (1) supply eleven rubber mattresses, £223 6s.—Latex Products Pty. Ltd.
2330. Royal Park, Mental Hospital, (1) supply 11 canvas blinds, £124.—Evan Evans Pty. Ltd.
2331. Kiewa Valley, Consolidated School, (3) supply 6 tables and 12 forms, £181 19s.—F. Fallshaw and Sons Pty. Ltd.
2332. Royal Park, Mental Hospital, (3) supply rubber flooring, £206 8s.—Clark Matting and Rubber Ltd.
2333. Melbourne, Law Courts, (3) supply furniture and fittings for new courts, £3,238 8s.—Lloyd Industries.
2334. Traralgon, High School, (1) supply stackable steel chairs, £1,894 18s.—Aristoc Industries Pty. Ltd.
2335. Traralgon, High School, (4) supply 12 and 14 tubular steel dining tables, £221 9s. 6d.—G. A. Whiting Pty. Ltd.
2336. Sunshine West, State School No. 4744, (1) supply of venetian blinds, £109 13s. 4d.—C. H. Stirling.
2337. Reservoir East, State School No. 4686, (1) supply and install venetian blinds, £162.—C. H. Stirling.
2338. Flemington, Travancore Developmental Centre, (1) supply of 220 yards of Sunray carpeting, £349 5s.—W. P. Murison.
2339. Dookie, Agricultural College, (2) supply 8 dressing tables, £168.—B. E. Purnell Pty. Ltd.
2340. Colac, High School, (4) supply furniture for practice flat, £138 0s. 6d.—F. Fallshaw and Sons Pty. Ltd.
2341. Melbourne, Titles Office, (3) supply storage cabinets, £466 14s.—Cherry and Sons Pty. Ltd.
2342. Melbourne, Coroners Court, Flinders-street Extension (1) supply of Bendix chairs, £194 13s. 9d.—Bendix Co. Industries Ltd.
2343. Melbourne, P.W.D., 107 Russell-street, (1) supply of vertical plan filing cabinets, £910 13s. 6d.—Industrial Aids Pty. Ltd.
2344. Malvern, Health Department, (2) supply of two large and six easy chairs, £139 12s.—J. Quinsee.
2345. Prahran, Girls' Technical School, (1) supply and install 68 venetian blinds, £760 1s. 6d.—C. H. Stirling.
2346. Royal Park, Mental Hospital, Receiving House, (3) supply rubber flooring, £504.—Clark Matting and Rubber Ltd.
2347. Royal Park, Mental Hospital, Receiving House, (1) supply 23 bedside lockers, £181 2s. 6d.—C. H. Abbott.
2348. Royal Park, Mental Hospital, Receiving House, (1) supply reversible rubber mattresses, £466 18s.—Latex Products Pty. Ltd.
2349. Royal Park, Mental Hospital, Receiving House, (3) supply fifteen easy chairs, £163 2s. 6d.—L. Graham.
2350. Mont Park, Mental Hospital, (2) supply tubular steel furniture, £117 17s. 6d.—G. A. Whiting Pty. Ltd.
2351. Yarram, High School, (4) supply furniture for practice flat, £138 0s. 6d.—F. Fallshaw and Sons Pty. Ltd.
2352. Mildura, Court House, (3) supply bookcases, £385 10s.—W. R. Brooks Pty. Ltd.

2353. Mont Park, Mental Hospital, (1) supply special steel (tubular) furniture, £306 18s.—Medical Equipment Services Pty. Ltd.
2354. Beechworth, Mental Hospital, (3) supply and lay rubber flooring, £565 5s.—Clark Matting and Rubber Ltd.
2355. Clifton Hill, State Film Centre, (1) supply four film-strip cabinets, £170.—E. T. Brown Ltd.
2356. Heidelberg, Technical School, (1) supply of Brownbuilt cupboards, £131 1s. 11d.—E. T. Brown Ltd.
2357. Larundel, Mental Hospital, (1) laying, sealing, and polishing 400 square yards of "A" marble lino, £120.—W. Byrne.
2358. Fairfield, "Fairlea" Female Prison, (3) sanding of floors, £1,182 11s.—Flor Lyfe Pty. Ltd.
2359. Mirboo North, High School, (1) supply venetian blinds, £158.—Campbell and Heeps Pty. Ltd.
2360. Ararat, Mental Hospital, (2) supply venetian blinds, £114 7s. 6d.—Campbell and Johnston Pty. Ltd.
2361. Echuca, High School, (1) supply venetian blinds, £160.—Campbell and Heeps Pty. Ltd.
2362. Lilydale, High School, (1) laying, sealing, and polishing 740 square yards "A" brown lino, £222.—A. Easton.
2363. Royal Park, Mental Hospital, (1) supply and lay soft rubber covering, £681 7s.—Clark Matting and Rubber Ltd.
2364. Moe, High School, (1) laying, sealing, and polishing 480 square yards "A" brown lino, £144.—C. H. Borer.
2365. Mont Park, Mental Hospital, (3) supply curtains at Concert Hall, £198.—Moonee Furnishings.
2366. Port Melbourne, Education Department (storeyard), (3) supply 1,200 stackable steel chairs, £3,630.—G. A. Whiting Pty. Ltd.
2367. Royal Park, Mental Hospital, (1) supply piano for Nurses' Home, £195.—W. R. Beet.
2368. Footscray, High School, (1) lay, seal, and polish 570 square yards of lino, £171.—Flor Lyfe Pty. Ltd.
2369. Royal Park, Children's Welfare Depot, (4) supply of curtains, £298 15s. 9d.—A. E. Hoad and Co. Pty. Ltd.
2370. Flemington, Travancore Developmental Centre, (1) supply of steel cupboards, £109 17s. 6d.—Steelbilt (Vic.) Pty. Ltd.
2371. Kew, Mental Hospital, (3) supply of twelve bedssteads, £104 14s.—C. Mott.
2372. Kew, Mental Hospital, (1) supply of twelve rubber mattresses, £185 3s.—Latex Products Pty. Ltd.
2373. Swinburne, Technical College, (1) laying, sealing, and polishing lino, £445 16s.—A. Easton.
2374. Broadmeadows East, State School No. 4732, (1) supply and fix venetian blinds, £146.—C. H. Stirling.
2375. Armadale, Frank Tate House, (4) supply bathroom cabinets, £122 5s.—Waverley Cabinet Co.
2376. Horsham, High School, (4) supply benches and storage rack, £152.—Dandy Woodware Pty. Ltd.
2377. Port Melbourne, P.W.D. Storeyard, (1) supply 500 coir mats, £1,087 10s.—Royal Victorian Institute for the Blind.
2378. Kew, Mental Hospital, (3) supply six laundry trucks, £204.—Max Davis Pty. Ltd.
2379. Camberwell, Girls' Secondary School, (1) supply of 40 chairs, £155.—Aristoc Industries Pty. Ltd.
2380. Norlane, State School No. 4734, (1) lay, seal, and polish 388 square yards "A" brown lino, £116 8s.—H. W. Armitage.
2381. Port Melbourne, Storeyard, P.W.D., (1) supply 2,000 infant-room chairs, £4,400.—Berwin Manufacturing Pty. Ltd.
2382. Melbourne, Hospitals and Charities Commission, 61 Spring-street, (1) laying, sealing, and polishing 410 square yards "A" marble lino, £173.—C. H. Borer.
2383. Royal Park, Mental Hospital, (2) supply of tables and book shelves, £160 10s.—Kennett Bros. and Rayner Pty. Ltd.
2384. Melbourne, Royal Melbourne Technical College, (4) supply and fixing benches, &c., to Chemistry School, £7,943 5s.—Romney Woodcraft Pty. Ltd.
2385. Melbourne, Royal Melbourne Technical College, (4) supply and fixing benches to Chemistry School, £3,044.—B. E. Purnell Pty. Ltd.
2386. Melbourne, Coroner's Court, Flinders-street Extension, (2) supply of court room furniture, £1,146 17s. 4d.—Lloyd Industries.
2387. Melbourne, Coroner's Court, (1) supply of bedding, £143 10s.—Classic Bedding Co.
2388. Kyneton, High School, (1) supply 56 stackable steel chairs, £219 16s.—Aristoc Industries Pty. Ltd.
2389. Melbourne, Royal Melbourne Technical College, (3) supply additional curtains for stage, £147 10s.—A. E. Hoad and Co. Pty. Ltd.
- T. K. MALTBY, Commissioner of Public Works. 27.10.55.
2390. Sunshine, High School, (2) supply of Kelvinator household refrigerator, £113 17s. 6d.—Robert Taylor Pty. Ltd.
2391. South Melbourne, Public Works Department Storeyard, (1) supply of agricultural pipes, £286.—James Hicks Pty. Ltd.
2392. Port Campbell, Tourist Resort, (1) supply of 9,000-gallon water storage tank complete and hydroséal, £108 12s. 6d.—Welch, Perrin, & Co. Pty. Ltd.
2393. Ferntree Gully, Technical School, (1) supply of bandsaw, £268.—Wolfenden Machinery Pty. Ltd.
2394. Carlton, Teachers' College Hostel, (1) supply of electric rotary dishwasher, £265.—Brice Scale and Slicer Co. Pty. Ltd.
2395. Melbourne, Public Works Department (M.E. Branch), (1) supply of 600 rolls dyeline paper (Rapid), £675.—Max Wurcker (1930) Pty. Ltd.
2396. Larundel, Mental Hospital, (1) supply of six only covers and frames, £162 12s. 6d.—Gatic (Aust.) Pty. Ltd.
2397. Royal Park, Mental Hospital, (1) supply of Premix metal, £176 8s.—Albion Quarrying Co. Pty. Ltd.
2398. Queenscliff, South Pier, (1) supply of timber, £174 5s. 7d.—S. A. Armistead Pty. Ltd.
2399. Portland, High School, (1) supply of refrigerator, £259 4s. 7d.—Warburton Franki (Melbourne) Ltd.
2400. Werribee, Research Farm, (1) supply of refrigerator, £248 16s.—Robert Taylor Pty. Ltd.
2401. South Melbourne, Public Works Department Storeyard, (1) supply of head bolts with nuts, £100 19s. 7d.—West Footscray Engineering Works Pty. Ltd.
2402. Snobs Creek, Fish Hatchery, (1) supply of sand and gravel, £103 2s. 6d.—W. A. King.
2403. Box Hill, Technical School, (1) supply of Coldmix screenings, £102 10s.—Albion Quarrying Co. Pty. Ltd.
2404. Coburg North, State School No. 4543, (1) supply of Coldmix screenings, £105 12s.—Albion Quarrying Co. Pty. Ltd.
2405. Ararat, Mental Hospital, (1) electrical installation of new steam generator, £103 10s.—T. J. Coult's Pty. Ltd.
2406. Ararat, Mental Hospital, (1) extension of electric supply to 70 h.p. fire-protection motor, £392 11s.—Transmission Lines Pty. Ltd.
2407. Harcourt, State School No. 299, (3) repairs to fencing, £223 8s. 6d.—McClure and Taylor.
2408. Herne Hill, State School No. 4681, (2) installation of light and power in new classrooms, £132.—J. B. Electrics.
2409. Timboon, Consolidated School, (1) site works, £262 19s.—Country Roads Board.
2410. Coburg North, State School No. 4543, (3) electrical installation, £138 15s.—Coburg Electrical Service Pty. Ltd.
2411. Nullawil, State School No. 3301, (2) erection of tank stand and provision of two out-offices, £134.—Gledhill and McLennan.
2412. Royal Park, Mental Hospital, (1) repairs to washing machine, £168 6s. 10d.—Dornan Engineering Co. Pty. Ltd.
2413. Coburg, Pentridge Gaol, (1) repairs to three ovens, supply insulating bats, &c., £258 9s. 6d.—Small and Shattell Pty. Ltd.
2414. Melbourne, Crown Law Offices, Lonsdale-street, (1) electrical alterations and additions, £110 18s. 9d.—J. P. Eva and Town.
2415. Clifton Hill, Police Station, (1) connecting new sewer branch, £174 5s. 11d.—Melbourne and Metropolitan Board of Works.
2416. Traralgon, Police Station, (1) supply and installation of electric hot-water service, Sergeant's Residence, £178.—Ekon Heating Engineers Pty. Ltd.
2417. Bairnsdale, Public Works Department, (5) internal painting of residence, corner Murphy and Ligar streets, £200.—A. Cadman.
2418. Ballarat, Teachers' College, (4) erection of 40-ft. long, bicycle shelter, fencing, concrete paths, and gravel filling, £206 10s.—W. T. Bedson.
2419. Newtown, State School No. 1887, (2) alterations to bathroom, £158.—Nott and Drew Pty. Ltd.
2420. Richmond, State School No. 1561, (4) supply and installation of additional seating accommodation, £220.—F. T. Pulling and Sons Pty. Ltd.
2421. Ballarat East, State School No. 1071, (3) laying of sewer drain to residence (99 York-street), £165 10s.—R. W. Sherritt.
2422. Auburn South, State School No. 4183, (4) supply and installation of 2 Type No. 3 Warmray heaters to prefabricated classroom, £142.—D. Stewart.
2423. Footscray, Girls' School, (1) wiring of stoves, £181 10s.—G. Wilkie Electrical Co.
2424. Eastwood, State School No. 4702, (1) electrical installation, L.T.C. classrooms, £131 16s. 4d.—A. Raymond.
2425. Dumbalk East, State School No. 3172, (4) internal painting and installation of Warmray stove, £169.—G. Bellingham.

2426. Kinglake West, State School No. 3255, (2) renewal of approximately 900 linear feet of post and wire fence, £180.—Owen Bros.
2427. Mulgrave, State School No. 2172, (1) provision of new woodshed, £107 10s.—W. and D. Pitts and Son.
2428. Echuca, State School No. 208, (2) provision of additional drinking facilities, £239.—I. W. Huxtable.
2429. Bacchus Marsh, Court House, (2) renewal of spouting, &c., and provision of tank and stand, £146 10s.—H. C. Griffiths.
2430. Bayunga, State School No. 4302, (1) repairs to shelter sheds, £135.—H. A. Woodward.
2431. Mansfield, Higher Elementary School, (1) supply of domestic refrigerator, £108 17s. 7d.—Warburton, Frankl (Melbourne) Ltd.
2432. Various, Paynesville Boat Harbor, Slip and Bells Point Light, (1) supply of timber, £190 2s. 2d.—Mount Alfred Timber Mills.
2433. Royal Park, Mental Hospital, (1) supply of Premix metal, £167 4s. 3d.—Albion Quarrying Co. Pty. Ltd.
2434. Longwarry North, State School, (1) supply of loam, £508 16s.—R. T. Sims.
2435. Malvern East, State School, (1) supply of Coldmix screenings, £430 10s. 6d.—Albion Quarrying Co. Pty. Ltd.
2436. Clayton, State School, (1) supply of Coldmix screenings, £388 17s. 6d.—Albion Quarrying Co. Pty. Ltd.
2437. Oakleigh South, State School, (1) supply of Coldmix screenings, £384 7s. 6d.—Albion Quarrying Co. Pty. Ltd.
2438. Geelong, Junior Technical School, (1) supply of "Hercus" screw-cutting lathe, £911 8s. 9d.—McPherson's Ltd.
2439. Bendigo, Penal and Gaols, (1) supply of "Gilbro" buzzer and "Hycos" wood lathe, £137 5s. 4d.—James McEwan and Co. Pty. Ltd.
2440. Tatura, Research Station, (1) supply of Aga cooker, £343.—Levin and Co. Ltd.
2441. Box Hill, State School No. 2838, (1) supply of Coldmix screenings and topping, £765 0s. 6d.—Albion Quarrying Co. Pty. Ltd.
2442. Ringwood, State School No. 2997, (1) supply of fire extinguishers, £115 3s. 5d.—Wormald Bros. (Vic.) Pty. Ltd.
2443. Nunawading, "Winlaton" Children's Welfare Department, (1) supply of tiles, £199 7s.—The Australian Tesselated Tile Co. Pty. Ltd.
2444. Ararat, Mental Hospital, (1) supply of joinery, residences, £1,130 8s. 6d.—Ararat Joinery Works.
2445. Kew, Mental Hospital, (1) supply of Colortone bricks, £477 8s.—Colortone Brick Ltd.
2446. Royal Park, Mental Hospital, (1) supply of Premix metal, £169 1s.—Albion Quarrying Co. Pty. Ltd.
2447. Oakleigh South, State School No. 4712, (1) supply of crushed rock, £252 19s. 11d.—Reid Bros. and Reid Pty. Ltd.
2448. Port Melbourne, P.W.D. Depot, (1) supply of quick release turntable assembly and king pin, £252 17s. 3d.—Trailer Sales and Service Pty. Ltd.
2449. Ararat, Mental Hospital, (1) supply of timber, £296 12s. 8d.—Beaufort Timber Co. Pty. Ltd.
2450. Brighton, Foreshore, (1) supply of rough building stone, £101 0s. 4d.—R. Van Amstel.
2451. Kew, Mental Hospital, (1) supply of bricks, £277 4s.—Colortone Brick Ltd.
2452. Ararat, Mental Hospital, (1) supply of floor polishers, £495.—National Washing Equipment Pty. Ltd.
2453. West Melbourne, Government Cool Stores, (1) supply of timber, £529 4s. 9d.—Millars Timber and Trading Co. Ltd.
2454. Macleod, High School, (1) supply of refrigerator, £113 17s. 6d.—Robert Taylor Pty. Ltd.
2455. Mont Park, Mental Hospital, (1) supply of bedpan sterilizer, £201 15s.—K. G. Luke (Aust.) Ltd.
2456. Janefield, Mental Colony, (1) supply of "Lister" auto truck, £565.—Mitchell and Co. Pty. Ltd.
2457. Mont Park, Mental Hospital, (1) supply of opal glass balls, ceiling flanges and batten holders, £286.—H. Rowe and Co. Pty. Ltd.
2458. Port Melbourne, P.W.D. Depot, (1) supply of barrows, £406 0s. 3d.—Kelso Manufacturing Co. Pty. Ltd.
2459. Brighton, High School, (1) supply of crushed rock, £244 2s. 4d.—Albion Quarrying Co. Pty. Ltd.
2460. Traralgon, High School, (1) supply of reinforced concrete spun pipes, £210 2s. 8d.—Rocla Pipes Ltd.
2461. Mentone, Secondary Girls School, (1) supply of refrigerator, £113 17s. 6d.—Robert Taylor Pty. Ltd.
2462. Melbourne, School for Deaf Children, No. 3774, (1) supply of stainless-steel drainers with legs and brackets, £251 10s.—L. J. Morgan Pty. Ltd.
2463. Beechworth, Reformatory Prison, (1) supply of sanding machine, £288 10s.—E. J. Lacey Pty. Ltd.
2464. Beaumaris, Sea Wall, (1) supply of squared blue-stone and spalls, £249 4s.—J. Starbuck and Sons.
2465. St. Kilda, Breakwater, (1) supply of quarry stone, £703 4s. 1d.—James Starbuck and Sons.
2466. Williamstown, Technical School, (5) supply of workshop equipment, £967 11s.—Demco Machinery Co. Pty. Ltd.
2467. Beechworth, Mental Hospital, (1) supply of wire mesh mobile bread baskets, £319 10s.—Milgate, Jones, and Gawith Pty. Ltd.
2468. Sunbury, Mental Hospital, (1) supply of chain saw with motor, £166 3s. 2d.—D. and W. Chandler Ltd.
2469. Geelong, "Lunan House," Teachers' College, (4) supply of curtains, £391 10s.—Moonee Furnishings.
2470. Prahran, Girls' Technical School, (3) supply of 48 steel chairs, £201.—G. A. Whiting Pty. Ltd.
2471. Yarrowonga, High School, (1) laying, sealing, and polishing 500 square yards of lino, £150.—E. W. Lockhart.
2472. Reservoir West, State School No. 4711, (1) supply venetian blinds, £103 8s.—C. H. Stirling.
2473. Wonthaggi, Technical School, (2) supply ten science benches, £495.—K. and S. Lyons.
2474. Royal Park, Mental Hospital, (1) supply nine tables and 36 chairs, £323 2s.—D. F. Cowan Pty. Ltd.
2475. Heidelberg North, State School No. 4713, (1) supply of Coldmix screenings, £101 18s. 6d.—Albion Quarrying Co. Pty. Ltd.
2476. South Melbourne, Public Works Department Storeyard, (1) purchase of timber from Tasmania, £13,342 7s. 8d.—Gibbs, Bright, and Co.
2477. Melbourne, Technical School, (1) supply of parts, "Ideal" sectional boilers, £860.—Shanks and Co. Pty. Ltd.
2478. South Melbourne, Public Works Department Storeyard, (1) supply of 6-in. deck spikes, £364.—West Footscray Engineering Works Pty. Ltd.
2479. Paynesville, Boat Harbor, (1) supply of piles, £101 5s.—J. G. Baldwin.
2480. Heidelberg North, State School No. 4713, (1) supply of screenings and toppings, £101 18s. 6d.—Albion Quarrying Co. Pty. Ltd.
2481. Port Albert, Jetty, (1) supply of timber, £152 4s. 1d.—Mount Alfred Timber Mills.
2482. Paynesville, Boat Harbor, (1) supply of timber, £115 8s. 3d.—Mount Alfred Timber Mills.
2483. Various, Jetties, (1) Port Albert and Port Welshpool, supply of timber, £273 8s. 10d.—Mount Alfred Timber Mills.
2484. Kew, Mental Hospital, (1) supply of sand, £130.—Plover Albion Koo-Wee-Rup Washed Sand and Gravel Co. Pty. Ltd.
2485. South Melbourne, Public Works Department Storeyard, (1) supply of jacks and pumps, £147 16s. 6d.—McPherson's Ltd.
- T. K. MALTBY, Commissioner of Public Works.  
3.11.55.
2486. Ballarat, Teacher's College Hostel, 1415 Sturt-street, (1) installation of electric light and power, £478 7s.—T. J. Coutts Pty. Ltd.
2487. Ballarat, "Novar" Mental Hospital, Webster-street, (3) electrical installation, £847 17s. 6d.—T. J. Coutts Pty. Ltd.
2488. Ballarat, Mental Hospital, (6) supply and erection of main switchboard in new sub-station, £597 15s.—T. J. Coutts Pty. Ltd.
2489. Ballarat, Mental Hospital, (2) electrical installation in Female Recreation Hall, £330.—Able Electric.
2490. Beechworth, Training Prison, (1) improvements to hot-water service, £475 10s.—Carland Electrical Service.
2491. Beechworth, Education Department, School Inspector's Residence, Loch-street (4) renewal of battens and galvanized corrugated roof, £475 10s.—P. Bruce.
2492. Bendigo, High School, (2) repairs and renovations, £3,165 15s.—E. Foley.
2493. Blackburn South, State School No. 4035, (3) sewerage plumbing, drainage and water service, £2,435.—Egeberg Building and Plumbing Service.
2494. Broadmeadows East, State School No. 4732, (5) erection of No. 2 shelter pavilions, 32 ft. x 16 ft., £1,150.—W. M. Hosie.
2495. Brunswick North, State School No. 3585, (6) painting and repairs to shelter sheds, £298.—J. Lynch.
2496. Castlemaine North, State School No. 2051, (1) additional brick out-offices, £1,378 5s.—Marty and Johnson.
2497. Cheltenham East, State School No. 4754, (6) supply, delivery, installation and testing of a warm air-heating ventilation system, £1,545.—F. G. Ferguson (Air Conditioning) Pty. Ltd.
2498. Coburg North, Technical School and State School No. 4543, (7) chain wire mesh fencing, £3,230.—Cyclone Co. of Australia Ltd.
2499. Collingwood, Technical School, (3) installation of equipment in plating shops, £1,308.—W. E. Tuck.
2500. Creek View, State School No. 1248, (2) repairs, external and internal painting to school and out-buildings, £370 10s.—R. J. Carnie.

2501. Doncaster East, State School No. 2096, (12) erection of two shelter pavilions, 16 ft. x 20 ft., £730.—F. J. Free.

2502. Essendon, Technical School, (4) supply, delivery, installation and testing of heating to workshop block and prefabricated class-rooms, £3,048 16s.—W. E. Tuck.

2503. Goulburn Weir, State School No. 3358, (4) repairs and painting, £420.—R. P. Fuhrmann.

2504. Janefield, Mental Colony, (8) new steam generator in boiler house and oil firing of heating and hot-water boilers, Toddlers' Block, £4,800.—J. Van Loenen.

2505. Kew, Mental Hospital, (6) supply and installation and testing of fire service pump, £980.—Harland Engineering (Aust.) Pty. Ltd.

2506. Kew, Mental Hospital, (2) repairs to fire damage in Concert Hall, £445.—E. G. Wood.

2507. Kew, Mental Hospital, (3) fibro plaster lining to walls and ceilings to ten residences for medical staff, £3,870.—Glen Waverley Fibrous Plaster Works.

2508. Kew, Mental Hospital, (1) provision of two additional toilets and one hand basin, Ward 26, Children's Cottages, £357.—Egeberg Building and Plumbing Service.

2509. Kew, Mental Hospital, (2) supply and installation of telephone cables and instruments to serve twelve new staff residences, £2,550.—Telephone Construction and Maintenance Co.

2510. Kew, Mental Hospital, (7) sewerage to twelve residences and sanitary plumbing to ten residences, £3,600.—F. A. Quick.

2511. Kiewa Valley, Consolidated School, (1) additional drinking facilities, £259 14s.—Ross's Pty. Ltd.

2512. Kyabram, High School, (4) erection of two shelter pavilions, £1,315.—M. G. Gallagher.

2513. Mansfield, Police Station, (3) fencing, £328.—H. P. Jones.

2514. Maidstone, State School No. 4658, (5) new party and non-party fencing, £1,589 10s. 2d.—T. N. Chuck Wire Fence and Gate Co. Pty. Ltd.

2515. Malvern, "Stonington" Tuberculosis Convalescent Home, (3) installation of thermostatic fire alarm system, £2,600.—Electric Signals (Vic.) Pty. Ltd.

2516. Mardan South, State School No. 3166, (3) repairs and painting, £506.—R. Strykert.

2517. Melbourne, Lands Department, New Treasury Buildings, (2) cleaning, re-lamping and lowering, C.C. lighting, £358.—Neon Fluorescent Products.

2518. Melbourne, National Museum, (2) provision of additional storage racks and bolts to door, Low Temperature Skin Storage Room, £275 15s.—L. A. Stronach.

2519. Mildura, Technical School, (4) provision of two shelter pavilions, 32 ft. x 16 ft., £1,343.—S. Sandor.

2520. Mildura, State School No. 2915, (2) erection of two standard shelter pavilions, 32 ft. x 16 ft., £1,460.—Lewis and Hudswell.

2521. Moe, State School No. 4740, (5) supply, delivery, installation and testing of a warm air-heating ventilation system, £1,675.—F. G. Ferguson (Air Conditioning) Pty. Pty.

2522. Mont Park, Mental Hospital, (3) repairs and painting, Medical Officer's Residence, 3 Wattle-avenue, £575.—F. J. Free.

2523. Mooroolbark, State School No. 4417, (2) renewal of road boundary fencing, £299 10s.—W. and R. W. Lee.

2524. Noble Park, State School No. 3675, (6) minor repairs, new bath and shower, external and internal painting, residence 10 Jasper-street, £375.—E. C. Jones.

2525. Notting Hill, State School No. 4305, (3) erection of a new timber out-office block, £843.—Wood Brothers Construction.

2526. North Melbourne, New Printing Trades School, Queensberry-street, (4) supply and installation of cold cathode fluorescent lighting equipment, £8,653 3s.—Claude Neon Lights (Victoria) Ltd.

2527. Nunawading, High School, (8) erection of No. 2 shelter pavilions, 32 ft. x 16 ft.—£1,100.—H. I. and W. H. Johnson.

2528. Port Melbourne, Police Station, (4) internal renovations and repairs, &c., £525.—J. Lynch.

2529. Robinvale, Consolidated School, (4) erection of two shelter pavilions, 32 ft. x 16 ft., £1,230.—Hawkes Construction Pty. Ltd.

2530. Rye, State School No. 1667, (6) repairs and painting to all buildings, £276.—A. Kronbergs.

2531. Shepparton, High School, (1) electrical installation, Needlework Section, £459 12s.—W. G. Sanderson Pty. Ltd.

2532. South Melbourne, Technical School, (4) new partitions in class-rooms, £597.—Homer Constructions Pty. Ltd.

2533. Sunshine East, State School No. 4645, (2) sealing of floors, £392 18s. 9d.—Hardware Industries Pty. Ltd.

2534. Toorak, Marathon Spastic Centre, (4) standard single class-room and toilet block, £2,351.—W. R. McPherson.

2535. Warragul, High School, (5) supply and installation of work table, cupboards, shelving, &c., in Canteen, £289 14s.—C. H. Reimers.

2536. West Melbourne, State School No. 1639, (3) alterations to stairways and repairs, £465.—Silverman and Boyle.

2537. Wodonga, Police Station, (6) erection of double garage and fuel shed, £394 4s.—J. P. Robins and R. G. Hughes.

2538. Ararat, Mental Hospital, (4) construction of L.T.C. building, 56 ft. x 32 ft., £3,283.—T. W. Morris and Son Pty. Ltd.

2539. Baringhup, State School No. 1687, (8) external painting of school and residence, £291 10s.—A. Cox.

2540. Beechworth, Higher Elementary School No. 1560, (7) repairs and painting to Cookery Centre, £334 15s.—Robins and Hughes.

2541. Brunswick North, State School No. 3585, (3) replacement of chalkboards, £1,055.—F. T. Pulling and Sons Pty. Ltd.

2542. Caulfield, State School No. 773, (6) provision of cupboards under chalkboards, £260.—N. Harris and Son.

2543. Coburg, High School, (1) attention to damp walls, £344.—A. H. Phillip.

2544. Donald, Higher Elementary School, (1) repairs to fire damage and provision of ceiling in sheet metal room, £1,030.—J. E. Pearce.

2545. Donald, District Hospital, (2) installation of transpiration bed, £1,625.—H. J. and K. M. Onley.

2546. Ellinbank, Dairy Research Station, (4) erection of Farm Labourer's Residence, £3,575.—E. Vickery and F. J. Stevens.

2547. Eltham, High School, (6) supply, delivery, installation, and testing of mechanical services, £13,600.—J. Van Loenen.

2548. Eltham, High School, (2) electrical installations in extensions, £6,996 6s.—M. Rulevich.

2549. Foster, High School, (3) erection and completion of "Bristol" aluminium prefabricated Manual and Domestic Arts Block, £32,925.—R. E. Hilsberg Pty. Ltd.

2550. Geelong, "Lunan House" Teachers' Training College, (5) conversion of stable into store-room, £482 18s. 6d.—R. Doolan.

2551. Kew, Mental Hospital, (3) erection of single brick rooms to "O" Ward, £8,000.—J. P. and F. Kelly.

2552. Leongatha, High School, (6) repairs and external painting main school building, £597.—G. Bellingham.

2553. Leongatha, Court House, (6) general renovations, £717 15s.—J. L. Trotman.

2554. Little River, State School No. 1961, (4) external and internal painting and repairs to school; external painting and repairs to shelter shed; internal painting and minor repairs to residence, £744.—E. J. Lewis.

2555. Melbourne, Sailors' Home, Siddeley-street, (4) replacements and repairs to toilets, £830.—S. O. Cochran.

2556. Melbourne, Royal Melbourne Technical College, (2) alterations to Building No. 3, Engineering School, to permit installation of boiler and generator, £1,881.—G. E. Nicholls.

2557. Mont Park, Mental Hospital, (2) renovations to main kitchen, Central Block, £2,900.—C. K. Hardy.

2558. Mont Park, Mental Hospital, (3) alterations and additions of Wards "L" and "M", Central Block, £42,365.—R. Porter.

2559. Mysia, State School No. 1899, (5) external painting, school and residence, £261 2s.—F. Poole.

2560. Pascoe Vale, Melbourne Textile Trades School, (3) supply and fixing of fibrous plaster and perforated panels, £2,083.—Major Fibrous Plaster Works.

2561. Pascoe Vale, State School No. 3081, (5) electrical installation, £509 10s.—Coburg Electrical Service Pty. Ltd.

2562. Richmond, Girls' Secondary School, (5) new out-office block, £3,100.—W. S. Wood.

2563. Sandringham, Memorial Hospital, (4) construction of storm water drain, £4,200.—J. G. Hill.

2564. Undera, State School No. 1771, (3) repairs and painting to school and residence, £1,218 10s.—Bert G. Jarvis.

2565. Victoria Park, State School No. 2957, (4) replacement of chalkboards, &c., £438.—F. T. Pulling and Sons Pty. Ltd.

T. K. MALTBY, Commissioner of Public Works. 8.11.55.

#### ORDERS IN COUNCIL.—(Series 1955-56.)

##### EDUCATION DEPARTMENT.

2279. One only pneumatic power hammer for Royal Melbourne Technical College, £1,450.—Rockley Machinery Co., 28 Market-street, Sydney, New South Wales.

Approved by the Governor in Council, 8th November, 1955.—A. MAHLSTEDT, Clerk of the Executive Council.



## STATE ELECTRICITY COMMISSION.

2566. The re-winding of generator rotor from No. 7 turbo-generator, Yallourn Power Station, to Quotation No. 6157, £12,993.—Australian Electrical Industries Pty. Ltd.

2567. The drilling investigation work for No. 2 Development, Kiewa Hydro-Electric Scheme, to Specification No. 55-56/99, at Schedule Rates.—Goldfields Diamond Drilling Co. Pty. Ltd.

2568. The erection of control building and switch house, Morwell Project, to Specification No. 55-56/74, £65,935.—John Holland and Co. Pty. Ltd.

2569. The manufacture, supply and delivery of galvanized steel structures for Metropolitan Terminal Stations, to Specification No. 55-56/67, £5,819.—W. H. and S. Massey Pty. Ltd.

2570. The supply of 12,800 wooden meter boards for consumers' premises, to Specification No. 55-56/60, £6,196 9s. 2d.—Middendorp Electric Co. Pty. Ltd.

2571. The construction of storm water drains and pits, Workshops and Stores Area, Morwell Project, to Specification No. 55-56/62, at Schedule rates.—Schwartz and Cooper Pty. Ltd.

2572. The extensions to Red Cliffs Power Station, comprising the provision of buildings, foundations and site works, to Specification No. 55-56/76, £133,200.—John Holland and Co. Pty. Ltd.

2573. The extensions to Red Cliffs Power Station, including erection of generating sets and installation of electrical equipment, to Specification No. 55-56/76, £127,512.—Production Equipment Pty. Ltd.

2574. The supply of neutral screened cable for consumers' services, for a period of twelve months, to Specification No. 55-56/50, at Schedule Rates.—Enfield Cables (Aust.) Pty. Ltd.

2575. The supply of neutral screened cable for consumers' services, for a period of twelve months, to Specification No. 55-56/50, at Schedule Rates.—Gilbert Lodge and Co. Ltd.

2576. The supply of neutral screened cable for consumers' services, for a period of twelve months, to Specification No. 55-56/50, at Schedule Rates.—W. T. Henley's Telegraph Works Co. Ltd.

2577. The supply of neutral screened cable for consumers' services, for a period of twelve months, to Specification No. 55-56/50, at Schedule Rates.—Noyes Brothers (Melb.) Pty. Ltd.

2578. The supply of neutral screened cable for consumers' services, for a period of twelve months, to Specification No. 55-56/50, at Schedule Rates.—Sun Electric Co. Pty. Ltd.

2579. The supply of neutral screened cable for consumers' services, for a period of twelve months, to Specification No. 55-56/50, at Schedule Rates.—Warburton Franki (Melb.) Ltd.

Approved by the Governor in Council, 25th October, 1955.—A. MAHLSTEIT, Clerk of the Executive Council.

## Town and Country Planning Acts.

## FURTHER EXHIBITION OF EILDON SUB-REGIONAL PLANNING SCHEME.

AMENDMENT No. 1, 1955.

Notice that a Planning Scheme has been Prepared and is Available for Inspection.

NOTICE is hereby given that the Town and Country Planning Board, in pursuance of its powers under the Town and Country Planning Acts, has prepared a planning scheme generally for the Township of Eildon and adjacent lands for the purpose of amending the Eildon Sub-Regional Planning Scheme, 1951.

All maps, plans, descriptions, and other data fully setting out and explaining the planning scheme have been deposited at the office of the Council of the Shire of Alexandra, at Alexandra, and at the office of the Town and Country Planning Board, 107 Russell-street, Melbourne, and will be open for inspection without payment of any fee by all persons affected, between the hours of 9 a.m. and 5 p.m. on all days of the week except Saturdays, Sundays, and Public Holidays until and including the 17th day of February, 1956.

Any persons affected by the planning scheme are required to set forth, in writing, all objections they may have, addressed to the Secretary, Town and Country Planning Board, 107 Russell-street, Melbourne, on or before the 20th day of February, 1956.

NOEL L. LYNEHAM, Secretary,  
Town and Country Planning Board.

14th November, 1955.

## NOTICE TO MARINERS.

[No. 22 of 1955.]

## AUSTRALIA.—VICTORIA.

PORT PHILLIP.—WEST CHANNEL.

## Information About Shoal.

Position.—No. 6 B light beacon (Woodriff). Lat. 38 deg. 14 min. 50 sec. S., long. 144 deg. 43 min. 13 sec. E. (approx.).

Position of Shoal.—023 deg. distant 6.97 cables from the above position.

Caution.—Mariners are warned of an extension of William Sand to westward towards the West Channel leading line, between No. 6 B and No. 8 B.

Details.—The western extremity of the extension lies in the position as given, carries a depth of 15 feet L.W. (4m6), and clears the leads by 230 feet.

Remark.—Dredging operations will commence at an early date.

Charts Affected.—British Admiralty, Nos. 309, 1171, 2747.

Publications.—General Notice to Mariners Respecting Navigation in Victorian Waters, 1942, pages 120, 121, and 122; Australia Pilot, Vol. 11, 1944, page 74.

D. S. STEVENSON,  
Port Officer.

Ports and Harbors Branch,  
Department of Public Works,  
Melbourne, C.2, 31st October, 1955.

## EDUCATION DEPARTMENT.

## SUMMONING OFFICER.

I HEREBY appoint the under-mentioned person, under section 31 of the Education Act 1928, to summon parents within the State of Victoria:—

Senior Constable EDWARD JOHN DILLON, No. 9640.

W. WATT LEGGATT,  
Minister of Education.

## BOROUGH OF INGLEWOOD.

## BOROUGH OF INGLEWOOD WATER SUPPLY DISTRICT.

Rating By-law for the Year 1st October, 1955, to 30th September, 1956.

THE Inglewood Borough Council, in pursuance and exercise of the powers conferred by the Water Acts, doth hereby make and levy a rate for the supply of water for domestic purposes of Two shillings and six pence in the £1 on the annual municipal valuation of lands and tenements liable to be rated within the Borough of Inglewood Water Supply District.

Provided that in no case shall the amount of rate payable per annum in respect of any tenement (other than land on which there is no building) be less than One hundred and five shillings, and in respect of any land on which there is no building less than Twenty shillings.

Such rates are made and shall be levied upon the occupiers or owners of the said lands and tenements for the year commencing on the 1st day of October, 1955, and concluding on the 30th day of September, 1956, and shall be payable on the 17th day of November, 1955, at the office of the said Council, Town Hall, Inglewood.

The maximum quantity of water to be supplied in any one year, without further charge to any property rated by the Council, is hereby fixed at the quantity which, at a charge of One shilling per 1,000 gallons, would produce an amount equal to the amount of rate levied on such property for the said year.

The charge for water supplied by measure to any property rated by the Council in excess of such maximum quantity, computed as in the last preceding clause, is hereby fixed at One shilling per 1,000 gallons.

The charge for water delivered ex stand pipe shall be Two shillings per 1,000 gallons, provided that in no case shall a charge be less than Two shillings for any lesser quantity than 1,000 gallons taken at one delivery.

Passed this 14th day of September, 1955.

(SEAL)

H. SLOAN, Mayor.  
D. PUCKEY, Councillor.  
A. E. COOPER, Secretary.

Approved, 7th November, 1955.—W. J. MIBUS, Minister of Water Supply.

**CHILTERN WATERWORKS TRUST.**  
AUTHORITY TO OBTAIN BANK OVERDRAFT.

THE Honorable Sir Charles Lowe, as Deputy for His Excellency the Governor of the State of Victoria, by and with the advice of the Executive Council thereof, doth by Order made on the 8th day of November, 1955, authorize the Chiltern Waterworks Trust to obtain, in pursuance of the provisions of section 271 of the *Water Act 1928*, an advance or advances during the year 1955 from the Bank of New South Wales, Chiltern, by overdraft of the Trust's current account thereat, such overdraft not to exceed at any one time the sum of Five hundred pounds (£500).

A. MAHLSTEDT,  
Clerk of the Executive Council.

At the Executive Council Chamber,  
Melbourne, 8th November, 1955.

*Children's Welfare Act 1954.*

**DECLARATION OF INSTITUTIONS AS APPROVED CHILDREN'S HOMES.**

IN accordance with the provisions of clause 49 of Part VI. of the Children's Welfare Regulations 1955, notice is hereby given that on the third day of November, 1955, I, Arthur Gordon Rylah, Chief Secretary of the State of Victoria, acting in pursuance of the powers conferred by section fourteen of the *Children's Welfare Act 1954*, declared the under-mentioned institutions as approved Children's Homes for the purposes of the said Act:—

St. Anthony's Home  
St. Augustine's Orphanage  
Methodist Peace Memorial Homes  
The Menzies Home for Boys  
William Booth Memorial Home for Girls  
St. Catherine's Girls' Orphanage  
Victorian Children's Aid Society  
"Catherine Booth" Girls' Home  
Geelong and Western District Protestant Orphanage  
Ballarat Orphanage  
Burwood Boys' Home  
The Salvation Army Boys' Home.

A. G. RYLAH,  
Chief Secretary.

Chief Secretary's Office,  
Melbourne, 3rd November, 1955.

**SALE OF MOTOR TRUCK.**

AN owner is required for an unregistered Oldsmobile tray truck, engine No. TR-8261, which was previously registered in Victoria under No. ZV-420.

The truck came into the possession of the Police on the 10th June, 1954, and, if not claimed, will be sold by public auction at the Wangaratta Police Station at 3 p.m. on Thursday, the 1st December, 1955.

S. H. PORTER,  
Chief Commissioner of Police.

**COMPANIES ACT 1938.**

NOTICE is hereby given, in pursuance of section 350 (4) (c) of the *Companies Act 1938*, that at the expiration of three months from the date hereof the name of the company mentioned below will, unless cause is shown to the contrary, be struck off the Register.

Dated this 8th day of November, 1955.

T. S. WELSH,  
Deputy Registrar-General.  
Registrar-General's Office, Melbourne.

**COMPANY ABOVE REFERRED TO.**

Name of company: The North Pearl and Trading Company Limited.  
Number of registration: F2742.  
Date of registration: 19th August, 1953.

*Local Government Act 1946, Part 48.*

**RENEWAL OF UNUSED ROAD AND WATER FRONTAGE LICENCES.**

ALL unused road and water frontage licences expiring on 31st December, 1955 (excepting those cancelled or terminated) are hereby renewed for a further term of three years.

KEITH TURNBULL,  
Minister of Lands.

Department of Crown Lands and Survey,  
Melbourne.

*Stamps Act 1946.*  
**NOTICE.**

IN pursuance of the powers contained in the *Stamps Act 1946*, I hereby certify, until further notice, that the Great Boulder Proprietary Gold Mines Ltd. is a company engaged solely or principally in the search or mining for gold.

Dated 16th day of November, 1955.

W. E. CAMIER,  
Comptroller of Stamps.

**STAMPS ACT 1946.**

NOTICE is hereby given that the certificate appearing in *Government Gazette* No. 599, dated 5th August, 1953, that Hill 50 Extended No Liability was a company solely or principally engaged in the search or mining for gold, is withdrawn as from the 16th November, 1955.

Dated 16th day of November, 1955.

W. E. CAMIER,  
Comptroller of Stamps.

*Country Fire Authority Acts.*

**PERMISSION TO HOLD FIRE BRIGADE DEMONSTRATION.**

IN pursuance with the provisions of section 79 (1) and (2) of the *Country Fire Authority Act 1944*, the Country Fire Authority has granted permission for the holding of a fire brigade demonstration as under:—

**URBAN FIRE BRIGADES.**

At Kyneton, on Saturday, 4th February, 1956.

G. G. SINCLAIR,  
Secretary.

11th November, 1955.

*State Savings Bank Act 1928, Section 31.*

**THE STATE SAVINGS BANK OF VICTORIA.**

**ESTABLISHMENT OF BRANCH.**

THE Commissioners of the State Savings Bank of Victoria hereby give notice of their intention to establish a branch of the bank at Broadford, on Thursday, 1st December, 1955.

N. R. WILLIAMS,  
General Manager.

*Fisheries Acts.*

**NOTICE OF INTENTION REGARDING THE MARKING OF LONG LINE AND MESH NET BUOYS.**

IT is hereby notified for general information that it is intended, after the expiration of one month from the date of publication of this notice in the *Government Gazette*, to move His Excellency the Governor in Council to make a Proclamation revoking the Proclamation made the twenty-sixth day of August, 1940, and published in the *Government Gazette* of the twenty-eighth day of August, 1940, respecting the marking of long line buoys and prescribe that no person shall engage in long line or mesh net fishing or use any long line or mesh net or fleet of such nets unless there is clearly and distinctly marked on each buoy, stake, flag or other similar object attached to such long line or net or fleet of nets, the registered number of the boat used whilst setting such long line or net or nets.

A. G. RYLAH,  
Chief Secretary.

A. DUNBAVIN BUTCHER,  
Director of Fisheries and Game.

*Co-operation Act 1953.*

**EASTERN CO-OPERATIVE SOCIETY LIMITED.**

NOTICE is hereby given that Eastern Co-operative Society Limited, which was registered under the *Industrial and Provident Societies Act 1928*, was, on the twenty-fourth day of October, 1955, registered under the *Co-operation Act 1953* by virtue of which registration the society became incorporated thereunder.

Dated at Melbourne, this twenty-fourth day of October, 1955.

E. T. EBBELS,  
Registrar of Co-operative Societies.

## NOTICE.

**A**DMINISTRATION of the estate of each of the under-mentioned deceased persons has been granted to the Public Trustee and creditors, next of kin, and all others having claims against the estate of any of the persons so mentioned are required to send particulars of their claims to the Public Trustee, No. 412 Collins-street, Melbourne, on or before the 18th January, 1956, or they will be excluded from the distribution of the estate when the assets are being distributed:—

ALLSOP, FRANCES ANN, late of Cheltenham, pensioner, died 12th November, 1954, intestate.

BAKER, SYDNEY EDWIN, late of 224 Glenlyon-road, East Brunswick, labourer, died 19th June, 1955, intestate.

BROOKS, HARRIET, late of Pine-road, Mooroolbark, spinster, died 8th September, 1955, intestate.

\*BUSH, WALTER, formerly of 1st Australian Ordnance Depot, but late of 1 Belmont-avenue, Glen Iris, retired storeman, died 31st July, 1955.

CAMERON, MARION PATERSON, late of Mount Royal, Parkville, pensioner, died 30th April, 1955, intestate.

CHAMBERS, PATRICK, late of Queen Elizabeth Benevolent Home, Ballarat, pensioner, died 9th March, 1955, intestate.

\*CORNILLE, ZENOBIE MARIE, late of Veurne, Belgium, married woman, died 14th January, 1947.

\*DICKINSON, BENJAMIN SHAW, formerly of Timaru, but late of Eastbourne, New Zealand, retired wool spinner, died on or about 6th July, 1955.

†HALLORAN, JOHN, late of 41 Castlebar-road, Oakleigh, retired railway employee, died 7th September, 1955.

\*HUNTER, ROSE MAY, formerly of Birds Eye View-road, Ferny Creek, but late of Beach Reserve, Shenfield-avenue, Chelsea, widow, died 19th June, 1955.

JACHOWICZ, STANISLAW, late of Ocean-road, Apollo Bay, farm labourer, died 9th January, 1955, intestate.

\*JONES, EVAN HOSKINS, late of Paternoster-road, Emerald, retired engineer, died 1st April, 1955.

†MENGLER, BERTHA MATILDA, late of 67 Forest-street, Cottesloe, Western Australia, home duties, died 3rd February, 1955.

MIDDLETON, HAROLD ROY, late of 102 Eglinton-street, Moonee Ponds, crane driver, died 1st October, 1954, intestate.

McLEAN, ERNEST ALVIN, late of 26 Dickens-street, North Carlton, garage attendant, died 29th January, 1955, intestate.

McQUADE, JOHN, late of Cheltenham, pensioner, died 17th April, 1950, intestate.

O'CONNOR, MARY, also known as Sarah O'Connor, late of 35 Mitchell-street, East Brunswick, pensioner, died 20th July, 1955, intestate.

O'MALLEY, JAMES JOSEPH, also known as James Joseph Shanahan, late of 7 Chestnut-street, Richmond, pensioner, died 6th June, 1955, intestate.

†PRICE, JOHN VINCENT, formerly of 43 Elizabeth-street, Elsternwick, but late of 4 St. Georges-road, Armadale, retired printer, died 15th September, 1955.

RITT, HANS HENDRICK, late of 305 Clarke-street, Northcote, labourer, died 4th November, 1944, intestate.

RITT, JOSEPH, late of 305 Clarke-street, Northcote, brass finisher, died 2nd October, 1945, intestate.

†SHEAY, MAY, late of 21 Lillimur-road, Ormond, spinster, died 30th August, 1955.

STEWART, GEORGE ALEXANDER, late of 290 Mint-place, Melbourne, storeman, died 30th July, 1955, intestate.

TURTON, CYRIL FREDERICK, late of 50 Eva-street, Clayton, pensioner, died 20th August, 1955, intestate.

WILSON, FRANK ALBERT, late of 39 Derby-street, Kensington, gentleman, died 16th September, 1955, intestate.

ZAKAS, ANTARAS, late of 115 Royal-parade, Parkville, labourer, died 26th February, 1954, intestate.

\* With the will annexed.

† According to the provisions of the will.

C. J. GARDNER,  
Public Trustee.

Melbourne, 9th November, 1955.

No. 836.—11453/55.—2

## 4 GEORGE VI. No. 4755, SECTION 6.

**I** HEREBY give notice that on the 31st October, 1955, the Public Trustee filed elections to administer the following deceased persons' estates, in accordance with section 6 of the *Public Trustee Act 1940*:—

BAKER, SYDNEY EDWIN, late of 224 Glenlyon-road, East Brunswick, labourer, died 19th June, 1955, intestate.

CAMERON, MARION PATERSON, late of Mount Royal, Parkville, pensioner, died 30th April, 1955, intestate.

CHAMBERS, PATRICK, late of Queen Elizabeth Benevolent Home, Ballarat, pensioner, died 9th March, 1955, intestate.

\*HALLORAN, JOHN, late of 41 Castlebar-road, Oakleigh, retired railway employee, died 7th September, 1955.

JACHOWICZ STANISLAW, late of Ocean-road, Apollo Bay, farm labourer, died 9th January, 1955, intestate.

McLEAN, ERNEST ALVIN, late of 26 Dickens-street, North Carlton, garage attendant, died 29th January, 1955, intestate.

\* According to the provisions of the will.

**I** HEREBY give notice that on the 2nd November, 1955, the Public Trustee filed elections to administer the following deceased persons' estates, in accordance with section 6 of the *Public Trustee Act 1940*:—

ALLSOP, FRANCES ANN, late of Cheltenham, pensioner, died 12th November, 1954, intestate.

BROOKS, HARRIET, late of Pine-road, Mooroolbark, spinster, died 8th September, 1955, intestate.

McQUADE, JOHN, late of Cheltenham, pensioner, died 17th April, 1950, intestate.

O'CONNOR, MARY, also known as Sarah O'Connor, late of 35 Mitchell-street, East Brunswick, pensioner, died 20th July, 1955, intestate.

O'MALLEY, JAMES JOSEPH, also known as James Joseph Shanahan, late of 7 Chestnut-street, Richmond, pensioner, died 6th June, 1955, intestate.

\*SHEAY, MAY, late of 21 Lillimur-road, Ormond, spinster, died 30th August, 1955.

STEWART, GEORGE ALEXANDER, late of 290 Mint-place, Melbourne, storeman, died 30th July, 1955, intestate.

WILSON, FRANK ALBERT, late of 39 Derby-street, Kensington, gentleman, died 16th September, 1955, intestate.

\* According to the provisions of the will.

**I** HEREBY give notice that on the 3rd November, 1955, the Public Trustee filed elections to administer the following deceased persons' estates, in accordance with section 6 of the *Public Trustee Act 1940*:—

\*MENGLER, BERTHA MATILDA, late of 67 Forest-street, Cottesloe, Western Australia, home duties, died 3rd February, 1955.

MIDDLETON, HAROLD ROY, late of 102 Eglinton-street, Moonee Ponds, crane driver, died 1st October, 1954, intestate.

RITT, HANS HENDRICK, late of 305 Clarke-street, Northcote, labourer, died 4th November, 1944, intestate.

ZAKAS, ANTARAS, late of 115 Royal-parade, Parkville, labourer, died 26th February, 1954, intestate.

\* According to the provisions of the will.

**I** HEREBY give notice that on the 4th November, 1955, the Public Trustee filed an election to administer the following deceased person's estate, in accordance with section 6 of the *Public Trustee Act 1940*:—

RITT, JOSEPH, late of 305 Clarke-street, Northcote, brass finisher, died 2nd October, 1945, intestate.

**I** HEREBY give notice that on the 7th November, 1955, the Public Trustee filed an election to administer the following deceased person's estate, in accordance with section 6 of the *Public Trustee Act 1940*:—

\*PRICE, JOHN VINCENT, formerly of 43 Elizabeth-street, Elsternwick, but late of 4 St. Georges-road, Armadale, retired printer, died 15th September, 1955.

\* According to the provisions of the will.

C. J. GARDNER,  
Public Trustee.

412 Collins-street, Melbourne, C.1, 9th November, 1955.

*Local Government Act 1946.*

## SHIRE OF COLAC.

## ORDER FOR DEVIATION OF PUBLIC HIGHWAY.

IN pursuance of the powers conferred by sections 521 and 525 of the *Local Government Act 1946*, the Council of the Shire of Colac doth hereby order that the land next hereinafter described, which has been acquired by the Council, shall be a public highway from the date of the publication of this Order in the *Government Gazette*, that is to say—

All that piece of land being part of Crown allotment 176, Parish of Barongarook, County of Polwarth, commencing at a point distant 32 deg. 51 min. 1,418.5 links from the south-western angle of said Crown allotment 176; thence by lines bearing respectively 32 deg. 51 min. 166.5 links, 6 deg. 15 min. 105.3 links, 44 deg. 48 min. 547.4 links, 72 deg. 53 min. 212.4 links, 224 deg. 48 min. 980 links to the point of commencement.

And the said Council doth hereby declare that the land above described shall from the said date of publication in the *Government Gazette* be a public highway in lieu of the land next hereinafter described, that is to say—

All that piece of land in the Parish of Barongarook commencing at a point distant 32 deg. 51 min. 1,493.8 links from the south-east angle of Crown allotment 176 of the said parish; thence by lines bearing respectively 32 deg. 51 min. 133.2 links, 6 deg. 15 min. 430 links, 72 deg. 53 min. 628 links, 226 deg. 39 min. 25 links, 224 deg. 48 min. 189 links, 252 deg. 53 min. 371.6 links, 186 deg. 15 min. 280.7 links, 224 deg. 48 min. 255.7 links to the point of commencement.

Dated this 7th day of June, 1954.

The common seal of the President, Councillors and Ratepayers of the Shire of Colac was hereunto affixed by Order of the Council, in the presence of—

M. McGRATH, President.  
(SEAL) T. J. FINN, Councillor.  
J. W. TAYLOR, Shire Secretary.

Confirmed by the Governor in Council this 8th day of November, 1955.—A. MAHLSTEDT, Clerk of the Executive Council.

## ARARAT SEWERAGE AUTHORITY.

## BY-LAW No. 3.

THE Ararat Sewerage Authority, in pursuance and exercise of the powers conferred by the Sewerage Districts Acts, doth hereby make the by-law following:—

For Division 3 of By-law No. 1 there shall be substituted the following division:—

## DIVISION 3.—HOUSE DRAINAGE PLANS—ALTERATIONS.

Section 8. (1) Copies of the Authority's plans and/or designs of individual house drainage will be furnished by the Authority upon application and payment for the same and subject to such conditions as follows:—

- (a) (i) Where the Authority designs the work and has same carried out for the owner, a charge shall be made equal to Ten per centum (10 per cent.) on the capital cost of the work for designing, specifying, letting contract, and supervising all details in connexion with such work.
- (ii) Consent for additions to and/or amendments of approved plans or to works previously approved will be made only on the application of the owner or his authorized agent, and on payment of a minimum fee of Fifteen shillings (15s.).
- (b) When the Authority designs the work for the owner and the owner then carries out his own work—
  - (i) For plan of design Sixty shillings (60s.) plus Seven shillings and six pence (7s. 6d.) for each fitting.
  - (ii) For making and/or examining any alterations or additions to a plan previously issued or approved by the engineer, a minimum charge of Fifteen shillings (15s.) shall be made by the Authority for each fitting or drain altered or added.
  - (iii) For inspecting drains and testing by the Authority's inspector a minimum fee of Thirty shillings (30s.) plus Fifteen shillings (15s.) for each additional inspection necessary owing to faulty work.

- (iv) For inspecting plumbing by the Authority's inspector a minimum fee of Thirty shillings (30s.) for each ten (10) fittings or part of ten fittings in the installation, plus Fifteen shillings (15s.) for each additional inspection necessary owing to faulty work.
- (v) For the final inspection by the Authority's engineer and charting the work on the Authority's plans Thirty shillings (30s.) for each ten fittings or part of ten fittings in the installation, plus Fifteen shillings (15s.) for each additional inspection necessary owing to faulty work.

- (vi) The Engineer may during construction of the work order the owner to carry out such additions and/or amendments as may be necessary for the satisfactory completion of the work.

The house connexion will not be passed until the installation together with the amendments ordered have been completed to the engineer's satisfaction.

- (c) Where an owner designs and carries out his own work—
  - (i) For the supply of a block plan Seven shillings and six pence (7s. 6d.).
  - (ii) The owner shall submit for examination a properly drawn design and a type-written specification. The design and specification shall be supplied to the Authority in triplicate. The work shall not proceed until the owner's design and specification have been approved by the engineer and the third copy returned to him with the official endorsement.
  - (iii) For the examination of the owner's plan of design and specification a fee of Thirty shillings (30s.) for each plan of from one to five fittings, plus Seven shillings and six pence (7s. 6d.) for every fitting over five.
  - (iv) For examining any alterations or additions to a plan previously issued or approved by the engineer a minimum charge of Seven shillings and six pence (7s. 6d.) shall be made by the Authority for each fitting or drain altered or added.
  - (v) For inspecting drains and testing by the Authority's inspector a minimum fee of Thirty shillings (30s.) plus Fifteen shillings (15s.) for each additional inspection necessary owing to faulty work.
  - (vi) For inspecting plumbing by the Authority's inspector a minimum fee of Thirty shillings (30s.) for each ten (10) fittings or part of ten fittings in the installation, plus Fifteen shillings (15s.) for each additional inspection necessary owing to faulty work.
  - (vii) For the final inspection by the Authority's engineer and charting work on the Authority's plans Thirty shillings (30s.) for each ten fittings or part of ten fittings in the installation, plus fifteen shillings (15s.) for each additional inspection necessary owing to faulty work.
  - (viii) The engineer may during construction of the work order the owner to carry out such additions and/or amendments as may be necessary for the satisfactory completion of the work.

The house connexion will not be passed until the installation together with the amendments ordered have been completed to the engineer's satisfaction.

Resolution for the passing of this by-law was agreed to by the Ararat Sewerage Authority at a special meeting held on the 22nd August, 1955, and confirmed at a special meeting held on 19th September, 1955.

The common seal of the Ararat Sewerage Authority was hereunto affixed in the presence of—

F. P. CH. DE CRESPIGNY, Chairman.  
(SEAL) O. E. MARX, Member.  
C. C. MURRAY, Secretary.

Approved by the Governor in Council,  
8th November, 1955.

A. MAHLSTEDT,  
Clerk of the Executive Council.

## APPOINTMENTS.

THE Honorable Sir Charles Lowe, as Deputy for His Excellency the Governor of the State of Victoria, by and with the advice of the Executive Council thereof, has, by Orders made on the 8th day of November, 1955, been pleased to make the under-mentioned appointments, viz.:—

## CHIEF SECRETARY'S DEPARTMENT.

*Member of Racecourses Licences Board.*

HUGH BOURKE,

being a person nominated by racing clubs in the Gippsland Race-meetings District, to be a Member of the Racecourses Licences Board for the period ending the 1st June, 1957, *vice* S. J. Overend, deceased.

*Officer in Charge of Gaol.*

GEORGE ALLAN THOMAS PETRIE,

pursuant to the provisions of the *Gaols Act 1928*, to be Officer in Charge (Acting) of the Ballarat Gaol, from the 14th November, 1955, to the 27th November, 1955, both dates inclusive, during the absence, on leave, of Lionel Charles Wenn.

*Officer in Charge of Training Prison.*

IAN GORDON GRINDLAY,

pursuant to the provisions of the *Gaols Act 1928*, to be Officer in Charge (Acting) of the Bendigo Training Prison, from the 14th November, 1955, to the 28th November, 1955, both dates inclusive, during the absence, on leave, of Reginald John Souter.

*Probation Officer.*

NORMAN CHARLES HARRIS,

pursuant to the provisions of section 536 of the *Crimes Act 1928*, to be a Probation Officer for the purposes of the said Act in Melbourne and Suburbs.

*Registrar of Marriages.*

ALFRED THOMAS RYALL,

pursuant to the provisions of the *Marriage Act 1928*, to be a Registrar of Marriages at Bendigo, *vice* Bernard Isley Griffith, resigned.

## DEPARTMENT OF CROWN LANDS AND SURVEY.

*Inspector of Vermin and Noxious Weeds.*

NORMAN GROVE, an Inspector of Land Settlement,

to be also an Inspector under the provisions of section 4 of the *Vermin and Noxious Weeds Act 1949*, without additional salary, as from and inclusive of the 26th September, 1955.

## LAW DEPARTMENT.

*Magistrates.*

JOSEPH WILLIAM WILSON, Archie's Creek,  
LAURENCE REGINALD FITZMAURICE, care of Australia and New Zealand Bank Limited, 394 Collins-street, Melbourne,

EVELYN ANN HARROD, 368 Kooyong-road, Caulfield,  
FRANCIS THOMAS ROJO, 22 Cedric-street, Ivanhoe,  
WALTER THOMAS, 3 Yileen-court, Ashwood, and  
ARTHUR SMITH, 29 Gordon-crescent, Seymour,  
to Keep the Peace in the Central Bailiwick of the State of Victoria;

WALTER BUNNING GAYFER, Horticultural Research Station, Tatura,  
to Keep the Peace in the Midland Bailiwick of the State of Victoria;

KENNETH FREDERICK McPHERSON, Howlong-road, Rutherglen,

JOHN LEHANE MAHER, Camp-street, Beechworth, and  
HUGH ROBERT STEPHENS, Cowslip-street, Violet Town,  
to Keep the Peace in the Northern Bailiwick of the State of Victoria; and

FRANK MAXWELL KELLY, care of Shire Office, Kaniva,  
to Keep the Peace in the Western Bailiwick of the State of Victoria.

*Commissioners for Taking Declarations, &c.*

ALEXANDER JOSEPH NUTTALL, Mayoh-street, Sunshine,  
GEOFFREY GEORGE STOREY, 128 McMahon-road, Reservoir,

EDITH LILIAN ROBINS, Arundel-avenue, Keon Park,  
THOMAS HUGH WILLIAMS, 26 Cuthbert-road, Reservoir,  
ELEANOR KATHERINE GRAHAM, Braemar-street, Croydon,  
FRANCES MARY PICKETT, 244 Malop-street, Geelong,  
and

THOMAS HENRY CONNARD, 460 Como-parade, Mordialloc,  
to be Commissioners for taking Declarations and Affidavits, pursuant to the provisions of the *Evidence Act 1928*, to resign upon removing from the neighbourhood of the addresses stated; and

BERNARD BOARDSON, Inspector of Works, Department of Public Works, Warracknabeal,  
to be a Commissioner for taking Declarations and Affidavits, pursuant to the provisions of the *Evidence Act 1928*, to refrain from charging fees and to resign upon ceasing to be an officer of the Department of Public Works.

*Prothonotary of the Supreme Court.*

BERNARD ISLEY GRIFFITH

to be Prothonotary of the Supreme Court of Victoria, *vice* A. H. C. Pfeifer, promoted and transferred, to take effect from the date of commencement of duty.

*Registrar of the Supreme Court.*

BERNARD ISLEY GRIFFITH

to be Registrar of the Supreme Court of Victoria in its Admiralty Jurisdiction, to take effect from the date of commencement of duty.

## DEPARTMENT OF HEALTH.

*Deputy Superintendent of Receiving Houses.*

RICHARD RAMSAY WEBB, M.B., B.S.,

to be Deputy Superintendent of the Receiving Houses, Royal Park and Pleasant View, pursuant to the provisions of section 41 of the *Mental Hygiene Act 1928*, *vice* Dr. J. F. J. Cade for the period from the 24th to the 31st October, 1955.

*Acting Clerks of Mental Hospitals.*

FRANCIS STEPHEN CLAREBOROUGH

to be Acting Clerk of the Mental Hospital, Beechworth, pursuant to the provisions of section 35 of the *Mental Hygiene Act 1928*, *vice* F. J. Walsh, on annual leave, from the 21st October, 1955; and

JAMES JOSEPH DURMAN

to be Acting Clerk of the Mental Hospital, Kew, pursuant to the provisions of section 35 of the *Mental Hygiene Act 1928*, *vice* G. M. Muir, on extended sick leave, from the 15th October, 1955.

*Government Representatives on Hospital Committees.*

OCTAVIUS PAGET PALMER

to be Government Representative on the Committee of Management of the Mortlake District Hospital, pursuant to the provisions of section 48 of the *Hospitals and Charities Act 1948*, for a further term of three years as from the 2nd November, 1955; and

KEITH HAROLD LOVETT

to be Government Representative on the Committee of Management of the Wimmera Base Hospital, Horsham, pursuant to the provisions of section 48 of the *Hospitals and Charities Act 1948*, for a further term of three years as from the 15th November, 1955.

## DEPARTMENT OF THE TREASURER.

*Receiver of Revenue.*

JOHN WINDSOR EGAN

to act temporarily as Receiver of Revenue, Bendigo, *vice* B. I. Griffith, transferred.

*Collector of Imposts.*

BERNARD ISLEY GRIFFITH

to be Collector of Imposts, Office of the Prothonotary, Department of Law, *vice* A. H. C. Pfeifer.

## DEPARTMENT OF WATER SUPPLY.

*Waterworks Trust Commissioners.*

JOHN VIVIAN HAYES

to be a Commissioner of the Lorne Waterworks Trust, *vice* Leonard Vivian Lansell, resigned, to hold such office from the date hereof until the 19th July, 1958, subject to the provisions of the Water Acts;

SYDNEY HERBERT BRADSHAW

to be a Commissioner of the Healesville Waterworks Trust for a period of one year from the date hereof, subject to the provisions of the Water Acts; and

DAVID PATTERSON MARONEY

to be a Commissioner of the Warracknabeal Waterworks Trust, *vice* George Eric Lyle, resigned, to hold such office from the date hereof until the 21st September, 1953, subject to the provisions of the Water Acts.

*Member of Sewerage Authority.*

DAVID PATTERSON MARONEY  
to be a Member of the Warracknabeal Sewerage Authority, vice George Eric Lyle resigned, and to hold office as such from the date hereof until the 15th November, 1958, subject to the provisions of the Sewerage Districts Acts.

A. MAHLSTEDT,  
Clerk of the Executive Council.

At the Executive Council Chamber,  
Melbourne, 8th November, 1955.

RESIGNATIONS.

THE Honorable Sir Charles Lowe, as Deputy for His Excellency the Governor of the State of Victoria, by and with the advice of the Executive Council thereof, has, by Orders made on the 8th day of November, 1955, accepted the resignations of the persons named hereunder of the offices mentioned, viz.:

CHIEF SECRETARY'S DEPARTMENT.

HAMILTON GEORGE BOULTON, as a Licensing Inspector for Victoria, from and inclusive of the 24th October, 1955.

BERNARD ISLEY GRIFFITH, as a Registrar of Marriages at Bendigo.

A. MAHLSTEDT,  
Clerk of the Executive Council.

At the Executive Council Chamber,  
Melbourne, 8th November, 1955.

DEPARTMENT OF CROWN LANDS AND SURVEY.

At the Executive Council Chamber, Melbourne, the eighth day of November, 1955.

PRESENT:

The Honorable Sir Charles Lowe, as Deputy for His Excellency the Governor of Victoria.

Mr. Rylah	Mr. Whately
Mr. Bloomfield	Mr. Reid.
Mr. McArthur	

LANDS TEMPORARILY RESERVED AS SITES.

THE Honorable Sir Charles Lowe, as Deputy for His Excellency the Governor of the State of Victoria, by and with the advice of the Executive Council thereof, doth hereby, in pursuance of the provisions of the Land Act 1928, reserve, temporarily, and also except from occupation for mining purposes under any miner's right, the lands hereinafter described:—

CARPENDEIT.—Site for Public Recreation, 12 acres, more or less, Parish of Carpendeit, County of Heytesbury, as indicated by hachure on plan hereunder.—(C.386<sup>(\*)</sup>) (Rs.7389).

*Subject to Survey*

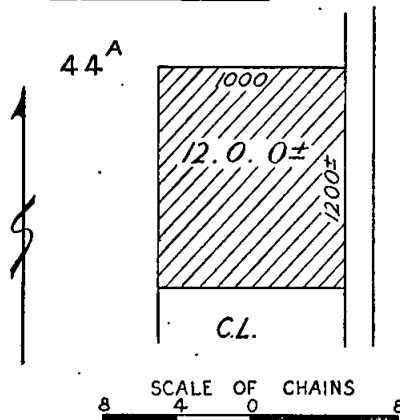

DARRIMAN.—Site for State School purposes, 4 acres, more or less, Parish of Darriman, County of Buln Buln, as indicated by hachure on plan hereunder.—(D.146<sup>(\*)</sup>) (Rs.7387).

*Subject to Survey*

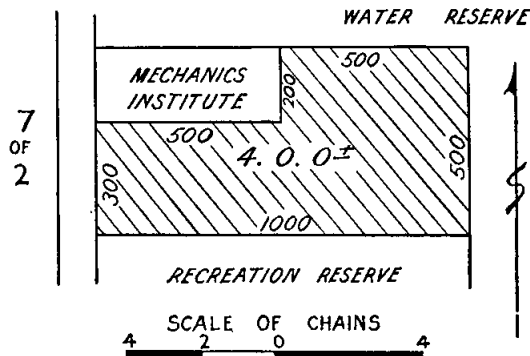

WORAIGWORM.—Site for the Protection of Native Fauna and Flora, 537 acres 2 roods 30 perches, Parish of Woraigworm, County of Lowan, as indicated by hachure on plan hereunder.—(W.325<sup>(\*)</sup>) (Rs.7401).

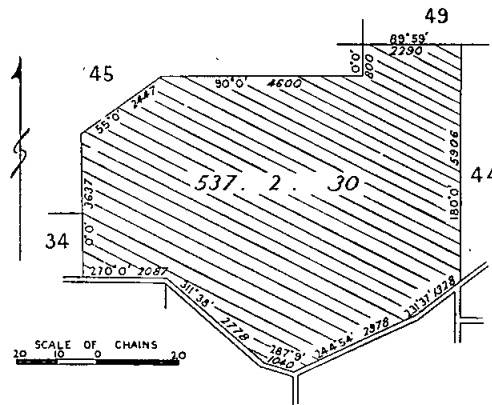

SANDHURST (BENDIGO).—Site for Public Recreation, 16 acres 1 rood, more or less, at Bendigo, Parish of Sandhurst, County of Bendigo, as indicated by hachure on plan hereunder.—(S.372<sup>(\*)</sup>) (Rs.7396).

*Subject to Survey*

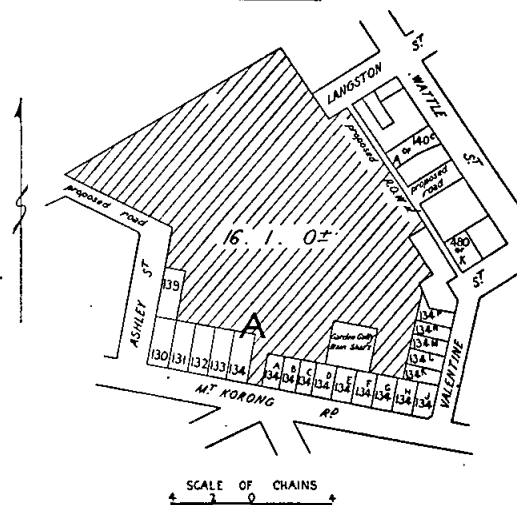

DUMBALK.—Site for Public purposes, 5 acres, more or less, Parish of Dumbalk, County of Buln Buln, as indicated by hachure on plan hereunder.—(D.200(4) (Rs.7388).

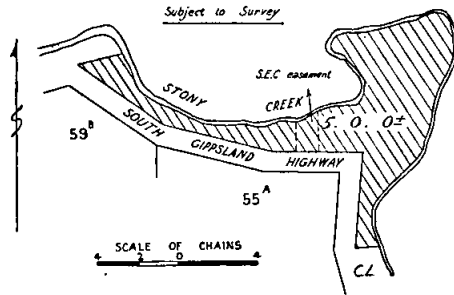

And the Honorable Keith Hector Turnbull, Her Majesty's Commissioner of Crown Lands and Survey for the State of Victoria, shall give the necessary directions herein accordingly.

A. MAHLSTEDT,  
Clerk of the Executive Council.

DEPARTMENT OF CROWN LANDS AND SURVEY.

At the Executive Council Chamber, Melbourne, the eighth day of November, 1955.

PRESENT:

The Honorable Sir Charles Lowe, as Deputy for His Excellency the Governor of Victoria.

Mr. Rylah	Mr. Whately
Mr. Bloomfield	Mr. Reid.
Mr. McArthur	

UNUSED AND UNMADE ROADS CLOSED.

THE Honorable Sir Charles Lowe, as Deputy for His Excellency the Governor of the State of Victoria, by and with the advice of the Executive Council thereof, doth hereby direct that, in pursuance of the provisions of section 304 of the *Land Act 1928*, the unused and unmade roads referred to hereunder be closed, viz.:

Parish of Gnarwarre, County of Grant, being the road between allotments D, C, B, A, section 16, Parish of Gnarwarre, and allotments 16, Parish of Gnarwarre and 19, Parish of Barrarbool.—(G.93(2) (B.34(3) (Misc. 2762).

Parish of Tanjil, County of Tanjil, being the road between allotment 13 and allotment 14, section D.—(T.189(9) (H.022992).

And the Honorable Keith Hector Turnbull, Her Majesty's Commissioner of Crown Lands and Survey for the State of Victoria, shall give the necessary directions herein accordingly.

A. MAHLSTEDT,  
Clerk of the Executive Council.

DEPARTMENT OF CROWN LANDS AND SURVEY.

At the Executive Council Chamber, Melbourne, the eighth day of November, 1955.

PRESENT:

The Honorable Sir Charles Lowe, as Deputy for His Excellency the Governor of Victoria.

Mr. Rylah	Mr. Whately
Mr. Bloomfield	Mr. Reid.
Mr. McArthur	

REVOCATIONS OF TEMPORARY RESERVATIONS OF LANDS (AS TO PORTIONS).

THE Honorable Sir Charles Lowe, as Deputy for His Excellency the Governor of the State of Victoria, by and with the advice of the Executive Council thereof, doth hereby, in pursuance of the provisions of the *Land Act 1928*, revoke portions of the temporary reservations of lands by Orders in Council hereinafter referred to, viz.:

MONBULK.—Order in Council of 24th December, 1935, of 3 acres 2 roods of land in the Parish of Monbulk, as a site for Camping and Picnic Ground, so far only as

regards the portion thereof comprised within the boundaries published in the *Government Gazette* of 12th October, 1955, and containing 1 rood 13 perches.—(Rs.4514.)

STAWELL.—Order in Council of 20th November, 1876, of 91 acres 0 roods 37 perches of land in the municipal district of Stawell, as a site for Racing and General Recreation, so far only as regards the portion thereof comprised within the the boundaries published in the *Government Gazette* of 12th October, 1955, and containing 1 acre 0 roods 12 perches.—(Rs.3938.)

And the Honorable Keith Hector Turnbull, Her Majesty's Commissioner of Crown Lands and Survey for the State of Victoria, shall give the necessary directions herein accordingly.

A. MAHLSTEDT,  
Clerk of the Executive Council.

COUNTRY ROADS BOARD.

At the Executive Council Chamber, Melbourne, the eighth day of November, 1955.

PRESENT:

The Honorable Sir Charles Lowe, as Deputy for His Excellency the Governor of Victoria.

Mr. Rylah	Mr. Whately
Mr. Bloomfield	Mr. Reid.
Mr. McArthur	

DECLARATION OF A DEVIATION FROM KORUMBURRA-WARRAGUL ROAD IN THE SHIRES OF KORUMBURRA AND WARRAGUL.

WHEREAS by sections 21 and 58 of the *Country Roads Act 1928* (No. 3662) it is amongst other things enacted that when the Country Roads Board under the provisions of the *Country Roads Act* has by Resolution declared a deviation to be a main road and the said Board may also declare that such deviation shall be in lieu of any existing road or part thereof named in such Resolution and that on publication in the *Government Gazette* of the Order confirming such Resolution the existing road or part thereof shall cease to be a main road or be discontinued as provided in the Resolution: And whereas the said Board has by Resolution declared the deviation on the land described in the First Schedule to such Resolution to be a main road and has also declared that such deviation shall be in lieu of the part of the existing road being the land described in the Second Schedule to the said Resolution: Now therefore the Honorable Sir Charles Lowe, as Deputy for His Excellency the Governor of the State of Victoria by and with the advice of the Executive Council thereof doth hereby confirm the said Resolution.

Resolution for Declaration of a Deviation Under the Country Roads Act.

Whereas the land the site of the road the course of which is below set out was taken by the Board under the provisions of the *Country Roads Act 1928* for the purpose of constructing such road deviation which road deviation has now been laid out and formed on the same: And whereas the said Board (being the Country Roads Board incorporated under the said Act) thinks that the road aforesaid is fit to be used as a public highway such Board at a meeting now holden acting under the authority conferred upon it by sections 21 and 58 of the said Act doth by this present Resolution hereby declare the said road deviation the course of which is described in the First Schedule hereto with the commencing and terminating points thereof respectively specified to be part of a main road within the meaning and for the purposes of the *Country Roads Act 1928*: And the said Board doth also declare that such deviation shall be in lieu of the existing road or part thereof described in the Second Schedule hereto and that such part of the said existing road shall be discontinued.

FIRST SCHEDULE.

Shires of Korumburra and Warragul.

2. Korumburra-Warragul road (9002).—All those pieces of land in the Parish of Allambie, the boundaries of which are as follow:—

(a) Commencing at a point on the southern boundary of allotment 10 of the said parish, distant 98 deg. 8 min. 97 links from the south-western

angle of the said allotment; thence by lines bearing respectively 5 deg. 15 min. 61.6 links, 167 deg. 36 min. 65.7 links, and 278 deg. 8 min. 20 links to the point of commencement.

- (b) Commencing at a point on the northern boundary of allotment 10A of the said parish, distant 98 deg. 16 min. 125.6 links from the north-western angle of the said allotment; thence by lines bearing respectively 98 deg. 16 min. 18.5 links, 193 deg. 4 min. 138 links, and 5 deg. 23 min. 137.7 links to the point of commencement—

which said pieces of land are particularly delineated and shown coloured red on survey plans numbered 5666 and 5667, lodged in the office of the Country Roads Board.

#### SECOND SCHEDULE.

##### Shires of Korumburra and Warragul.

2. *Korumburra-Warragul road.*—All that piece of land in the Parishes of Allambee and Poowong East, the boundaries of which are as follow:—Commencing at the north-eastern angle of allotment 46B, Parish of Poowong East; thence by lines bearing respectively 98 deg. 37 min. 69 links, 184 deg. 24 min. 648 links, 169 deg. 10 min. 724.6 links, 195 deg. 21 min. 427.3 links, 190 deg. 41 min. 450.7 links, 207 deg. 7 min. 103 links, 170 deg. 24 min. 144.9 links, 336 deg. 49 min. 636.9 links, 22 deg. 0 min. 684 links, 14 deg. 6 min. 60 links, 3 deg. 46 min. 267 links, 345 deg. 52 min. 274 links, and 8 deg. 15 min. 654 links to the point of commencement—which said piece of land is particularly delineated and shown coloured blue on survey plan numbered 5666, lodged in the office of the Country Roads Board.

The common seal of the Country Roads Board was hereto affixed, at Melbourne, this thirty-first day of October, One thousand nine hundred and fifty-five, in the presence of—

(SEAL) D. V. DARWIN, Chairman.  
F. M. CORRIGAN, Member.  
W. H. NEVILLE, Secretary.

And the Honorable Sir Thomas Karran Maltby, Her Majesty's Commissioner of Public Works for the State of Victoria, shall give the necessary directions herein accordingly.

A. MAHLSTEDT,  
Clerk of the Executive Council.

#### COUNTRY ROADS BOARD.

At the Executive Council Chamber, Melbourne, the eighth day of November, 1955.

##### PRESENT:

The Honorable Sir Charles Lowe, as Deputy for His Excellency the Governor of Victoria.

Mr. Rylah	Mr. Whately
Mr. Bloomfield	Mr. Reid.
Mr. McArthur	

#### ORDER APPROVING OF A DEVIATION FROM A MAIN ROAD IN THE SHIRE OF ELTHAM.

WHEREAS the Country Roads Board constituted under the *Country Roads Act 1928* (No. 3662) has represented to His Excellency the Governor in Council that it appears to it desirable that the deviation hereinafter referred to from the existing Hurstbridge-Kinglake road in the Shire of Eltham (declared to be a main road under the said Act which declaration was confirmed by the Order in Council published in the *Government Gazette* of the 1st April, 1914, on page 1544) should be made by the said Board: And whereas the said Board in accordance with the requirements of section 19 of the said cited Act has caused to be prepared a map plan and estimate showing the points between which and on and through what land the said deviation is proposed to be made and the cost of acquiring the land: And whereas on an inspection of the said map and plan and a consideration of the said estimate His Excellency the Governor in Council is satisfied that there are funds legally available for acquiring the land: Now therefore be it known by this present Order that the Honorable Sir Charles Lowe, as Deputy for His Excellency the Governor of the

State of Victoria, with the advice of the Executive Council thereof doth hereby approve of the said road being made, that is to say:—

All those pieces of land in the Parish of Greensborough, the boundaries of which are as follow:—

- (a) Commencing at a point on the eastern boundary of allotment 123, section E of the said parish, distant 179 deg. 36 min. 371.3 links from the north-eastern angle of the said allotment; thence by lines bearing respectively 179 deg. 36 min. 178.7 links, 219 deg. 6 min. 478.3 links, and 186 deg. 13½ min. 285.5 links, 2 deg. 15 min. 286.7 links, and 30 deg. 20 min. 634 links to the point of commencement.

- (b) Commencing at a point on the western boundary of allotment 124, section E, of the said parish, distant 219 deg. 24 min. 324 links from the north-western angle of the said allotment; thence by lines bearing respectively 208 deg. 0 min. 96.8 links, 196 deg. 51 min. 85.9 links, 182 deg. 15 min. 266.6 links, 144 deg. 30 min. 90.5 links, 284 deg. 47 min. 37.2 links, 333 deg. 15 min. 137.1 links, 6 deg. 44 min. 261.8 links, and 39 deg. 24 min. 150 links to the point of commencement.

- (c) Commencing at a point on the northern boundary of lot 8, on plan of subdivision numbered 4190, lodged in the Office of Titles, and being part of Crown portion 5, Parish of Nillumbik, the said point being distant 289 deg. 94 min. 342 links, and 270 deg. 54 min. 458.6 links from the north-eastern angle of the said lot; thence by lines bearing respectively 270 deg. 54 min. 200.1 links, 4 deg. 46 min. 172 links, 104 deg. 58½ min. 257.3 links, 233 deg. 36½ min. 74.9 links, and 182 deg. 15 min. 60.9 links to the point of commencement—

which said pieces of land are particularly delineated and shown coloured red and purple on survey plan numbered 6154, lodged in the office of the Country Roads Board.

And the Honorable Sir Thomas Karran Maltby, Her Majesty's Commissioner of Public Works for the State of Victoria, shall give the necessary directions herein accordingly.

A. MAHLSTEDT,  
Clerk of the Executive Council.

#### COUNTRY ROADS BOARD.

At the Executive Council Chamber, Melbourne, the eighth day of November, 1955.

##### PRESENT:

The Honorable Sir Charles Lowe, as Deputy for His Excellency the Governor of Victoria.

Mr. Rylah	Mr. Whately
Mr. Bloomfield	Mr. Reid.
Mr. McArthur	

#### ORDER APPROVING OF A DEVIATION FROM A MAIN ROAD IN THE SHIRE OF LILLYDALE.

WHEREAS the Country Roads Board constituted under the *Country Roads Act 1928* (No. 3662) has represented to His Excellency the Governor in Council that it appears to it desirable that the deviation hereinafter referred to from the existing Lillydale-Montrose road in the Shire of Lillydale (declared to be a main road under the said Act which declaration was confirmed by Order in Council published in the *Government Gazette* of the 12th March, 1941, on page 1248) should be made by the said Board: And whereas the said Board in accordance with the requirements of section 19 of the said cited Act has caused to be prepared a map plan and estimate showing the points between which and on and through what land the said deviation is proposed to be made and the cost of acquiring the land: And whereas on an inspection of the said map and plan and a consideration of the said estimate His Excellency the Governor in Council is satisfied that there are funds legally available for acquiring the land: Now therefore be it known by this present Order that the Honorable Sir Charles Lowe, as Deputy for His Excellency the Governor of the State of Victoria with the advice of the Executive Council thereof doth hereby approve of the said road being made, that is to say:—

All that piece of land in the Parish of Mooroolbark, the boundaries of which are as follow:—Commencing at a point in Crown portion 26 of the said parish, distant 179 deg. 44 min. 72 ft. 5 in., from the south-eastern angle of lot



1 on plan of subdivision numbered 10595, lodged in the Office of Titles, and being part of the said Crown portion; thence by lines bearing respectively 179 deg. 44 min. 320 ft., 326 deg. 34 min. 535 ft. 83 in., and 113 deg. 24 min. 320 feet to the point of commencement—which said piece of land is particularly delineated and shown coloured red on survey plan numbered 6052, lodged in the office of the Country Roads Board.

And the Honorable Sir Thomas Karran Maltby, Her Majesty's Commissioner of Public Works for the State of Victoria, shall give the necessary directions herein accordingly.

A. MAHLSTEDT,  
Clerk of the Executive Council.

#### LOUGH CALVERT DRAINAGE TRUST.

*At the Executive Council Chamber, Melbourne, the eighth day of November, 1955.*

##### PRESENT:

The Honorable Sir Charles Lowe, as Deputy for His Excellency the Governor of Victoria.

Mr. Rylah	Mr. Whately
Mr. Bloomfield	Mr. Reid.
Mr. McArthur	

##### LOAN OF £2,800.

IN pursuance of the powers conferred by section 43 of the *River Improvement Act 1948* and all other powers him thereunto enabling, the Honorable Sir Charles Lowe, as Deputy for His Excellency the Governor of the State of Victoria, by and with the advice of the Executive Council of the said State, doth by this Order—

(1) Make advance by way of loan to the Lough Calvert Drainage Trust of a sum of Two thousand eight hundred pounds (£2,800); and

(2) Apply the following terms and conditions:—

(a) That the said sum shall be used for the continuation of drainage and river improvement works within the boundaries of the Lough Calvert Drainage District as set forth in the detailed statement, description and report bearing date the 3rd day of November, 1955, and verified under the seal of the State Rivers and Water Supply Commission.

(b) That the Lough Calvert Drainage Trust shall in respect of such advance by way of loan be subject to the powers, rights, duties and obligations conferred and imposed by—

(i) the provisions of sections 268 to 270, 273 to 277, 279 and 280 of Part VII. of the *Water Act 1928*, as amended by any other Act, so adapted that the word "Authority" shall mean the "Lough Calvert Drainage Trust"; and

(ii) the provisions of section 281 of the said Part VII. of the *Water Act 1928*, so adapted as if for the expressions "any waterworks trust or local governing body" and "such waterworks trust or local governing body" there were substituted the expression "the Lough Calvert Drainage Trust".

And the Honorable Wilfred John Mibus, Her Majesty's Minister of Water Supply for the State of Victoria, shall give the necessary directions herein accordingly.

A. MAHLSTEDT,  
Clerk of the Executive Council.

#### TARWIN RIVER IMPROVEMENT TRUST.

*At the Executive Council Chamber, Melbourne, the eighth day of November, 1955.*

##### PRESENT:

The Honorable Sir Charles Lowe, as Deputy for His Excellency the Governor of Victoria.

Mr. Rylah	Mr. Whately
Mr. Bloomfield	Mr. Reid.
Mr. McArthur	

##### LOAN OF £3,300.

IN pursuance of the powers conferred by section 43 of the *River Improvement Act 1948* and all other powers him thereunto enabling, the Honorable Sir Charles Lowe, as Deputy for His Excellency the Governor of the State of Victoria, by and with the advice of the Executive Council of the said State, doth by this Order—

(1) Make advance by way of loan to the Tarwin River Improvement Trust of a sum of Three thousand three hundred pounds (£3,300); and

(2) Apply the following terms and conditions:—

(a) That the said sum shall be used for the carrying out of works of river improvement within the boundaries of the Tarwin River Improvement District, as set forth in the detailed statement, description and report bearing date the 3rd day of November, 1955, and verified under the seal of the State Rivers and Water Supply Commission.

(b) That the Tarwin River Improvement Trust shall in respect of such advance by way of loan be subject to the powers, rights, duties and obligations conferred and imposed by—

(i) the provisions of sections 269, 270, 273, to 277, and 279 and 280 of Part VII. of the *Water Act 1928*, as amended by any other Act, so adapted that the word "Authority" therein shall mean the "Tarwin River Improvement Trust"; and

(ii) the provisions of section 281 of the said Part VII. of the *Water Act 1928*, so adapted as if for the expressions "any waterworks trust or local governing body" and "such waterworks trust or local governing body" there were substituted the expression "the Tarwin River Improvement Trust".

And the Honorable Wilfred John Mibus, Her Majesty's Minister of Water Supply for the State of Victoria, shall give the necessary directions herein accordingly.

A. MAHLSTEDT,  
Clerk of the Executive Council.

#### LATROBE RIVER IMPROVEMENT TRUST.

*At the Executive Council Chamber, Melbourne, the eighth day of November, 1955.*

##### PRESENT:

The Honorable Sir Charles Lowe, as Deputy for His Excellency the Governor of Victoria.

Mr. Rylah	Mr. Whately
Mr. Bloomfield	Mr. Reid.
Mr. McArthur	

##### LOAN OF £15,000.

IN pursuance of the powers conferred by section 43 of the *River Improvement Act 1948* and all other powers him thereunto enabling, the Honorable Sir Charles Lowe, as Deputy for His Excellency the Governor of the State of Victoria, by and with the advice of the Executive Council of the said State, doth by this Order—

(1) Make advance by way of loan to the Latrobe River Improvement Trust of a sum of Fifteen thousand pounds (£15,000); and

(2) Apply the following terms and conditions:—

(a) That the said sum shall be used for the continuation of works of river improvement within the boundaries of the Latrobe River Improvement District, as set forth in the detailed statement description and report bearing date the 3rd day of November, 1955, and verified under the seal of the State Rivers and Water Supply Commission.

(b) That the Latrobe River Improvement Trust shall in respect of such advance by way of loan be subject to the powers, rights, duties, and obligations referred and imposed by—

(i) the provisions of sections 268 to 270, 273 to 277, 279 and 280 of Part VII. of the *Water Act 1928*, as amended by any other Act, so adapted that the word "Authority" therein shall mean the "Latrobe River Improvement Trust"; and

(ii) the provisions of section 281 of the said Part VII. of the *Water Act 1928*, so adapted as if for the expressions "any waterworks trust or local governing body" and "such waterworks trust or local governing body" there were substituted the words "the Latrobe River Improvement Trust".

And the Honorable Wilfred John Mibus, Her Majesty's Minister of Water Supply for the State of Victoria, shall give the necessary directions herein accordingly.

A. MAHLSTEDT,  
Clerk of the Executive Council.

#### OVENS RIVER IMPROVEMENT TRUST.

*At the Executive Council Chamber, Melbourne, the eighth day of November, 1955.*

##### PRESENT:

The Honorable Sir Charles Lowe, as Deputy for His Excellency the Governor of Victoria.

Mr. Rylah	Mr. Whately
Mr. Bloomfield	Mr. Reid.
Mr. McArthur	

##### LOAN OF £8,000.

IN pursuance of the powers conferred by section 43 of the *River Improvement Act 1948* and all other powers him thereunto enabling, the Honorable Sir Charles Lowe, as Deputy for His Excellency the Governor of the State of Victoria, by and with the advice of the Executive Council of the said State, doth by this Order—

(1) Make advance by way of loan to the Ovens River Improvement Trust of a sum of Eight thousand pounds (£8,000); and

(2) Apply the following terms and conditions:—

(a) That the said sum shall be used for the continuation of river improvement works, within the boundaries of the Ovens River Improvement District, as set forth in the detailed statement, description and report bearing date the 2nd day of November, 1955, and verified under the seal of the State Rivers and Water Supply Commission.

(b) That the Ovens River Improvement Trust shall, in respect of such advance by way of loan, be subject to the powers, rights, duties, and obligations conferred and imposed by—

(i) the provisions of sections 269, 270, 273 to 277, and 279 and 280 of Part VII. of the *Water Act 1928*, as amended by any other Act, so adapted that the word "Authority" shall mean the Ovens River Improvement Trust"; and

(ii) the provisions of section 281 of the said Part VII. of the *Water Act 1928*, so adapted as if for the expressions "any

waterworks trust or local governing body" and "such waterworks trust or local governing body" there were substituted the expression "the Ovens River Improvement Trust."

And the Honorable Wilfred John Mibus, Her Majesty's Minister of Water Supply for the State of Victoria, shall give the necessary directions herein accordingly.

A. MAHLSTEDT,  
Clerk of the Executive Council.

#### KIEWA RIVER IMPROVEMENT TRUST.

*At the Executive Council Chamber, Melbourne, the eighth day of November, 1955.*

##### PRESENT:

The Honorable Sir Charles Lowe, as Deputy for His Excellency the Governor of Victoria.

Mr. Rylah	Mr. Whately
Mr. Bloomfield	Mr. Reid.
Mr. McArthur	

##### LOAN OF £2,200.

IN pursuance of the powers conferred by section 43 of the *River Improvement Act 1948* and all other powers him thereunto enabling, the Honorable Sir Charles Lowe, as Deputy for His Excellency the Governor of the State of Victoria, by and with the advice of the Executive Council of the said State, doth by this Order—

(1) Make advance by way of loan to the Kiewa River Improvement Trust of a sum of Two thousand two hundred pounds (£2,200); and

(2) Apply the following terms and conditions:—

(a) That the said sum shall be used for the carrying out of works of river improvement within the boundaries of the Kiewa River Improvement District, as set forth in the detailed statement bearing date the 3rd day of November, 1955, and verified under the seal of the State Rivers and Water Supply Commission.

(b) That the Kiewa River Improvement Trust shall in respect of such advance by way of loan be subject to the powers, rights, duties, and obligations conferred and imposed by—

(i) the provisions of sections 269, 270, 273 to 277, and 279 and 280 of Part VII. of the *Water Act 1928*, as amended by any other Act, so adapted that the word "Authority" shall mean the "Kiewa River Improvement Trust"; and

(ii) the provisions of section 281 of the said Part VII. of the *Water Act 1928*, so adapted as if for the expression "any waterworks trust or local governing body" there were substituted the expression "the Kiewa River Improvement Trust".

And the Honorable Wilfred John Mibus, Her Majesty's Minister of Water Supply for the State of Victoria, shall give the necessary directions herein accordingly.

A. MAHLSTEDT,  
Clerk of the Executive Council.

*Audit Act 1928.*

## GENERAL REGULATIONS RESPECTING PUBLIC ACCOUNTS.

*At the Executive Council Chamber, Melbourne, the eighth day of November, 1955.*

## PRESENT:

The Honorable Sir Charles Lowe, as Deputy for His Excellency the Governor of Victoria.	
Mr. Rylah	Mr. Whately
Mr. Bloomfield	Mr. Reid.
Mr. McArthur	

## CLAUSE 30 OF THE GENERAL REGULATIONS RESPECTING PUBLIC ACCOUNTS AMENDED.

THE Honorable Sir Charles Lowe, as Deputy for His Excellency the Governor of the State of Victoria, by and with the advice of the Executive Council thereof, doth hereby amend clause 30 of the General Regulations respecting Public Accounts by the insertion, after paragraph (J) thereof, of the following paragraph:—

“(K) The Council of Adult Education in respect of its theatrical and concert activities”.

And the Honorable Henry Edward Bolte, Her Majesty's Treasurer for the State of Victoria, shall give the necessary directions herein accordingly.

A. MAHLSTEDT,  
Clerk of the Executive Council.

## POISONS ACTS.

*At the Executive Council Chamber, Melbourne, the eighth day of November, 1955.*

## PRESENT:

The Honorable Sir Charles Lowe, as Deputy for His Excellency the Governor of Victoria.	
Mr. Rylah	Mr. Whately
Mr. Bloomfield	Mr. Reid.
Mr. McArthur	

## DANGEROUS DRUGS REGULATIONS 1955 (No. 2).

UNDER the powers in that behalf conferred by the *Poisons Act* 1928 as amended by any Act, the Honorable Sir Charles Lowe, as Deputy for His Excellency the Governor of the State of Victoria, in the Commonwealth of Australia, by and with the advice of the Executive Council of the said State and on the recommendation of the Pharmacy Board of Victoria, doth make the Regulations following, that is to say:—

1. These Regulations may be cited as the Dangerous Drugs Regulations 1955 (No. 2) and shall be read and construed as one with the Dangerous Drugs Regulations 1930 and all Regulations amending the same.

2. Regulations 32 and 34 of the Dangerous Drugs Regulations 1930 as substituted by the Dangerous Drugs Regulations 1947 and amended by the Dangerous Drugs Regulations 1954 and the Dangerous Drugs Regulations 1955 are hereby amended as follows:—

(a) in sub-regulation (2) of Regulation 32 and in sub-regulation (2) of Regulation 34 after the words “or any preparation of penicillin” there shall be inserted the words “or for streptomycin and its salts and all other anti-biotic metabolites whether derived from natural sources or produced by synthetic means and preparations thereof”.

3. In paragraphs (5) and (6) of Part II. of the Second Schedule to the Dangerous Drugs Regulations 1930 as substituted by the Dangerous Drugs Regulations 1931, the expression “diacetylmorphine” is hereby repealed.

And the Honorable Ewen Paul Cameron, Her Majesty's Minister of Health for the State of Victoria, shall give the necessary directions herein accordingly.

A. MAHLSTEDT,  
Clerk of the Executive Council.

## SEEDS ACT 1935 (No. 4294).

*At the Executive Council Chamber, Melbourne, the  
fifteenth day of November, 1955.*

## PRESENT:

His Excellency the Governor of Victoria.

Sir Thomas Maltby		Mr. Whately
Mr. Petty		Mr. Turnbull
Mr. Reid		Mr. McArthur.

## REGULATIONS.

IN pursuance of the powers conferred by the *Seeds Act* 1935 (No. 4294) to make Regulations for or with respect to the carrying out of Victorian Seeds Certification Schemes, including the conditions under which certificates in accordance with such schemes may be granted, His Excellency the Governor of the State of Victoria, by and with the advice of the Executive Council thereof, doth hereby amend the Regulations made on the 26th August, 1947, by adding at the end of sub-paragraph (i) of paragraph (a) of Regulation 3 the following:—

“Notwithstanding the previous provisions of this clause a crop grown partly or wholly on land which carried a bean crop other than a certified or approved bean crop during the preceding season, will be eligible for certification if sown not earlier than 15th November and the preceding crop was grown from certified or other seed approved by the Department and was not known to be affected with Anthracnose (*Colletotrichum lindemuthianum*) or the bacterial blight disease caused by *Xanthomonas phaseoli*, and all bean stalks, pods, leaves and other trash from the preceding crop were burned and/or ploughed under not later than the preceding 30th June to the satisfaction of an officer.”

And the Honorable Gordon Stewart McArthur, for and on behalf of Her Majesty's Minister of Agriculture for the State of Victoria, shall give the necessary directions herein accordingly.

A. MAHLSTEDT,  
Clerk of the Executive Council.

## MARKETING OF PRIMARY PRODUCTS ACT 1935 (No. 4337).

*At the Executive Council Chamber, Melbourne, the  
fifteenth day of November, 1955.*

## PRESENT:

His Excellency the Governor of Victoria.

Sir Thomas Maltby		Mr. Whately
Mr. Petty		Mr. Turnbull
Mr. Reid		Mr. McArthur.

## REGULATIONS.

IN pursuance of the powers conferred by sections 23 (1) and 43 (1) of the *Marketing of Primary Products Act* 1935 (No. 4337), His Excellency the Governor of the State of Victoria, by and with the advice of the Executive Council thereof, and on the recommendation of the Onion Marketing Board, doth hereby make the following Regulation (that is to say):—

The forty-fourth period of time in respect of which the computation of or accounting for the net proceeds of the sale of onions may be made by the Onion Marketing Board shall be from the 16th November, 1954, to the 15th November, 1955 (both dates inclusive).

And the Honorable Gordon Stewart McArthur, for and on behalf of Her Majesty's Minister of Agriculture for the State of Victoria, shall give the necessary directions herein accordingly.

A. MAHLSTEDT,  
Clerk of the Executive Council.

## LOCAL GOVERNMENT ACT 1946.

At the Executive Council Chamber, Melbourne, the  
fifteenth day of November, 1955.

## PRESENT:

His Excellency the Governor of Victoria.	
Sir Thomas Maltby	Mr. Whately
Mr. Petty	Mr. Turnbull
Mr. Reid	Mr. McArthur.

ELECTION OF COUNCILLORS FOR THE GEORGE  
WARD.—CITY OF WARRNAMBOOL.

WHEREAS section 29 of the *Local Government Act* 1946 provides that when any portion of Victoria is, pursuant to the said Act, annexed as a new subdivision to any subdivided municipal district, the Governor in Council, if he thinks fit, may by Order provide for the election forthwith of councillors for such new subdivision and give all such directions therefor as are necessary or expedient:

And whereas by an Order published in the *Government Gazette* on the 26th October, 1955, portion of the municipal district of the Shire of Warrnambool was severed and annexed to the municipal district of the City of Warrnambool as a new subdivision under the name of the George Ward:

Now, therefore, His Excellency the Governor of the State of Victoria, by and with the advice of the Executive Council thereof, hereby orders that the first election of councillors for the said George Ward shall be held on the 3rd day of December, 1955.

And the Honorable Sir Thomas Karran Maltby, Her Majesty's Commissioner of Public Works for the State of Victoria, shall give the necessary directions herein accordingly.

A. MAHLSTEDT,  
Clerk of the Executive Council.

## MOUNT MACEDON WATERWORKS TRUST.

At the Executive Council Chamber, Melbourne, the  
fifteenth day of November, 1955.

## PRESENT:

His Excellency the Governor of Victoria.	
Sir Thomas Maltby	Mr. Whately
Mr. Petty	Mr. Turnbull
Mr. Reid	Mr. McArthur.

## EXTENT OF DISTRICT INCREASED.

UNDER the powers conferred by the Water Acts and all other powers enabling him in that behalf, His Excellency the Governor of the State of Victoria, by and with the advice of the Executive Council of the said State, doth hereby declare, order and direct as follows.—

That the extent of the Waterworks District of the Mount Macedon Waterworks Trust be increased by adding to the same the lands comprised within the boundaries described in the Schedule hereto, and as on and from the date hereof, the extent of such district shall be deemed to be increased accordingly.

## SCHEDULE.

## Portion I.

Commencing at the south-eastern angle of Crown allotment 21b, section II., Parish of Macedon, County of Bourke, being a point on the western boundary of the existing Waterworks District of the Mount Macedon Waterworks Trust; thence westerly along the southern boundary of the said Crown allotment 21b, by a line across a road, along the said southern boundary of Crown allotment 21b, by a line across a road, along the southern boundaries of Crown allotments 28 and 29, by a line across a road, along the said southern boundary of Crown allotment 29, by a line across a road and along the southern boundary of Crown allotment 30 to the south-western angle of the said Crown allotment 30; thence northerly along the western boundary of the said Crown allotment 30 to its north-western angle; thence easterly along the northern boundaries of the said Crown allotment 30 and of Crown allotments 31 and 32 and by a line across a road to the most south-westerly angle of

Crown allotment 22; thence northerly and north-easterly along the western and north-western boundaries of the said Crown allotment 22 to the most southerly angle of Crown allotment 23; thence generally northerly along the western boundaries of the said Crown allotment 23 and of Crown allotments 24, 25, 26, 27 and Crown allotments 6, 7 and 7b, section VII, and by a line being a continuation thereof across a road to a point on the southern boundary of a Forest Nursery; thence easterly along the said southern boundary of a Forest Nursery to its south-eastern angle; thence east by a line across a State Forest Reserve to a point on the western boundary of the existing Waterworks District of the Mount Macedon Waterworks Trust; thence generally south along the said western boundary of the existing Waterworks District of the Mount Macedon Waterworks Trust to the point of commencement.

## Portion II.

Commencing at the south-eastern angle of Crown allotment 1, section IV., Parish of Macedon, County of Bourke, being a point on the eastern boundary of the existing Waterworks District of the Mount Macedon Waterworks Trust; thence easterly along the northern boundary of Crown allotment 7, no section, and by a line being a continuation thereof across a road to a point on the western boundary of Crown allotment 238, no section, Parish of Kerrie; thence southerly along the said western boundary of Crown allotment 238, by a line across a road, and along the western boundaries of Crown allotments 6, 5, 5A, 5B, 3 and 2, section VIII., Parish of Macedon, and by a line being a continuation thereof across a road to a point on the northern boundary of Crown allotment 2a; thence westerly and southerly along the northern and western boundaries of the said Crown allotment 2a to the south-eastern angle of Crown allotment 1, no section; thence westerly along the southern boundary of the said Crown allotment 1 to its south-western angle; thence westerly by a line across a road to the south-eastern angle of Crown allotment 12; thence generally north-westerly along the north-eastern boundaries of the said Crown allotment 12 and of Crown allotment 11 to the north-eastern angle of the said Crown allotment 11, being a point on the eastern boundary of the existing Waterworks District of the Mount Macedon Waterworks Trust; thence northerly, easterly, and generally northerly along the eastern, southern and easterly boundaries of the existing Waterworks District of the Mount Macedon Waterworks Trust to the point of commencement—all of which boundaries are shown on a plan approved by the Governor in Council and deposited in the office of the State Rivers and Water Supply Commission, Melbourne. (Corres. 55/11165.)

And the Honorable Wilfred John Mibus, Her Majesty's Minister of Water Supply for the State of Victoria, shall give the necessary directions herein accordingly.

A. MAHLSTEDT,  
Clerk of the Executive Council.

## CASTLEMAINE SEWERAGE AUTHORITY.

At the Executive Council Chamber, Melbourne, the  
fifteenth day of November, 1955.

## PRESENT:

His Excellency the Governor of Victoria.	
Sir Thomas Maltby	Mr. Whately
Mr. Petty	Mr. Turnbull
Mr. Reid	Mr. McArthur.

## CONSENT TO BORROWING £7,500.

UNDER the powers conferred by the Sewerage Districts Acts and all other powers enabling him in that behalf, His Excellency the Governor of the State of Victoria, by and with the advice of the Executive Council of the said State, doth hereby consent to the Castlemaine Sewerage Authority borrowing by the issue of debentures the sum of Seven thousand five hundred pounds (£7,500) to meet the cost of sewer reticulation extensions, as set forth in the detailed statement bearing date the 7th November, 1955.

And the Honorable Wilfred John Mibus, Her Majesty's Minister of Water Supply for the State of Victoria, shall give the necessary directions herein accordingly.

A. MAHLSTEDT,  
Clerk of the Executive Council.

## ALEXANDRA WATERWORKS TRUST.

At the Executive Council Chamber, Melbourne, the  
fifteenth day of November, 1955.

## PRESENT:

His Excellency the Governor of Victoria.	
Sir Thomas Maltby	Mr. Whately
Mr. Petty	Mr. Turnbull
Mr. Reid	Mr. McArthur.

## ADDITIONAL LOAN OF £7,657.

UNDER the powers conferred by the Water Acts and all other powers enabling him in that behalf, His Excellency the Governor of the State of Victoria, by and with the advice of the Executive Council of the said State, doth hereby grant an additional loan of Seven thousand six hundred and fifty-seven pounds (£7,657) to the Alexandra Waterworks Trust for additions to service basin, the construction of pipe mains and the purchase and installation of meters, as set forth in the detailed statement bearing date the 11th November, 1955, and verified under the seal of the State Rivers and Water Supply Commission.

The loan hereby granted shall be subject to the provisions of the Water Acts.

And the Honorable Wilfred John Mibus, Her Majesty's Minister of Water Supply for the State of Victoria, shall give the necessary directions herein accordingly.

A. MAHLSTEDT,  
Clerk of the Executive Council.

## STAWELL BOROUGH COUNCIL.

At the Executive Council Chamber, Melbourne, the  
fifteenth day of November, 1955.

## PRESENT:

His Excellency the Governor of Victoria.	
Sir Thomas Maltby	Mr. Whately
Mr. Petty	Mr. Turnbull
Mr. Reid	Mr. McArthur.

## ADDITIONAL LOAN OF £14,169.

UNDER the powers conferred by the Water Acts and all other powers enabling him in that behalf, His Excellency the Governor of the State of Victoria, by and with the advice of the Executive Council of the said State, doth hereby grant an additional loan of Fourteen thousand one hundred and sixty-nine pounds (£14,169) to the Mayor, Councillors, and Burgesses of the Borough of Stawell for the construction of pipe mains and the purchase and installation of meters, as set forth in the detailed statement bearing date the 11th November, 1955, and verified under the seal of the State Rivers and Water Supply Commission.

The loan hereby granted shall be subject to the provisions of the Water Acts.

And the Honorable Wilfred John Mibus, Her Majesty's Minister of Water Supply for the State of Victoria, shall give the necessary directions herein accordingly.

A. MAHLSTEDT,  
Clerk of the Executive Council.

## SWAN HILL WATERWORKS TRUST.

At the Executive Council Chamber, Melbourne, the  
fifteenth day of November, 1955.

## PRESENT:

His Excellency the Governor of Victoria.	
Sir Thomas Maltby	Mr. Whately
Mr. Petty	Mr. Turnbull
Mr. Reid	Mr. McArthur.

## ADDITIONAL LOAN OF £6,852.

UNDER the powers conferred by the Water Acts and all other powers enabling him in that behalf, His Excellency the Governor of the State of Victoria, by and with the advice of the Executive Council of the said

State, doth hereby grant an additional loan of Six thousand eight hundred and fifty-two pounds (£6,852) to the Swan Hill Waterworks Trust for the construction of pipe mains and the purchase and installation of meters, as set forth in the detailed statement bearing date the 11th November, 1955, and verified under the seal of the State Rivers and Water Supply Commission.

The loan hereby granted shall be subject to the provisions of the Water Acts.

And the Honorable Wilfred John Mibus, Her Majesty's Minister of Water Supply for the State of Victoria, shall give the necessary directions herein accordingly.

A. MAHLSTEDT,  
Clerk of the Executive Council.

## APPROACHING LAND SALES.

SALES of Crown lands, in fee-simple, will be held at the under-mentioned places and dates, viz.:

	No. of Gazette.
Bairnsdale.—Thursday, 22nd December, 1955 ..	836
Bendigo.—Thursday, 15th December, 1955 ..	821
Horsham.—Thursday, 8th December, 1955 ..	788
Leongatha.—Tuesday, 13th December, 1955 ..	821
Melbourne.—Wednesday, 30th November, 1955 ..	784
Mirboo North.—Thursday, 24th November, 1955 ..	784
Nhill.—Wednesday, 14th December, 1955 ..	788
Rushworth.—Tuesday, 6th December, 1955 ..	788
Stawell.—Wednesday, 7th December, 1955 ..	788
Warragul.—Thursday, 17th November, 1955 ..	710

## SALE BY AUCTION OF RIGHT TO LEASE.

Melbourne.—Wednesday, 30th November, 1955 784

## SALE OF CROWN LANDS BY AUCTION.

The lands will be sold in fee-simple, and subject to the covenants, conditions, exceptions, and reservations directed by the Governor in Council by an Order in Council dated the 5th August, 1930, and published in the *Government Gazette* of the 8th August, 1930, varied as herein.

A deposit of at least twelve and a half per centum of the price at which each lot is sold must be paid by the purchaser at the time of sale, and all such payments shall be made in coin, bank notes or cheques approved by the officer conducting the sale, and the residue of such price will be payable in equal instalments, in accordance with the scale hereunder, on the last day of each successive period of six months from the time of sale, or, if the purchaser choose, at any earlier time or times; and such residue of the purchase money shall bear interest at the rate of Five pounds per centum per annum, to be computed with respect to each instalment for the period which has elapsed between the time of sale and the time of the payment of such instalment. If the residue of the price be paid within thirty days after the time of the sale no interest will be payable thereon.

The Governor in Council may allow a transfer of the purchaser's interest to an approved person at any time before the final payment of the purchase money is made. The fee for transfer shall be One pound and such transfer will be subject to payment of stamp duty.

## SCALE OF PAYMENTS OF RESIDUE.

£20 and under, 6 instalments.
Over £20, and not exceeding £50, 8 instalments.
Over £50, and not exceeding £100, 10 instalments.
Over £100, and not exceeding £200, 12 instalments.
Over £200, and not exceeding £300, 14 instalments.
Over £300, and not exceeding £400, 16 instalments.
Over £400, and not exceeding £500, 18 instalments.
Over £500, 20 instalments.

## FEES, ETC.

The amount payable for Assurance Fund (One halfpenny for each £1 of purchase price) and Crown grant fee must be paid with the balance of purchase money. The following is the scale of fees for Crown grants:—

50 acres and under, £1 10s.

Over 50 acres, £2.

Where the purchase money does not exceed £5, the grant fee is £1.

Valuations of improvements (if not purchased by the owner thereof), and charges for survey, must also be paid at the time of sale.

KEITH TURNBULL,  
Commissioner of Crown Lands and Survey.  
Office of Crown Lands and Survey,  
Melbourne, 14th November, 1955.

**BAIRNSDALE.**—Sale (No. 11188) of Crown lands, in fee-simple, by auction, will be held at the LAND OFFICE, BAIRNSDALE, on THURSDAY, the 22nd DECEMBER, 1955, at TWO o'clock p.m. To be conducted by R. A. WALKER, Land Officer.

RAYMOND ISLAND, PARISH OF BAIRNSDALE, COUNTY OF TANJIL.

*In South of Township.*

Upset price £15 the lot. Charge for survey £5 5s.  
Lot 1. Area 1 rood, allotment 2 of section 12.

Upset price £40 per lot. Charge for survey £5 5s. per lot.  
Lot 2. Area 32 perches, subject to survey and any necessary easements disclosed thereby, allotment 1 of section 9.

Lot 3. Area 32 perches, subject to survey and any necessary easements disclosed thereby, allotment 2 of section 9.

Upset price £50 per lot. Charge for survey £5 5s. per lot.

Lot 4. Area 1 rood, subject to survey and any necessary easements disclosed thereby, allotment 7 of section 9.

Lot 5. Area 1 rood, subject to survey and any necessary easements disclosed thereby, allotment 8 of section 9.

PROPOSED REVOCATIONS OF TEMPORARY RESERVATIONS OF LANDS BY ORDERS IN COUNCIL.

IN pursuance of the provisions of the *Land Act 1928*, notice is hereby given that it is the intention of the Governor in Council to revoke the temporary reservations of lands by Orders in Council hereunder referred to, viz.:—

The following Notices were published 1° on the 16th November, 1955, pursuant to Orders of the 8th November, 1955.

**BENALLA.**—The temporary reservation, by Order in Council of the 26th October, 1928, of 23 perches of land in the Town of Benalla as a site for Public purposes, is about to be revoked.—(B.390(3) (Rs.1362).

**HARCOURT.**—The temporary reservation by Order in Council of the 10th January, 1924, of 5 acres 2 roods 30 perches of land in the Parish of Harcourt as a site for Public Recreation, is about to be revoked so far only as the portion containing 1 rood 16 perches, indicated by hachure on plan hereunder, is concerned.—(H.16(5) (Rs.2877).

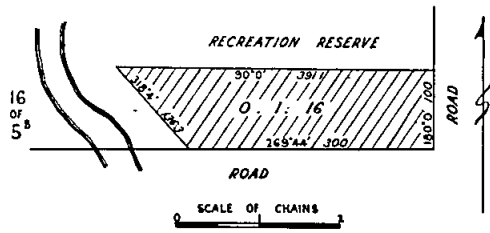

KEITH TURNBULL,  
Commissioner of Crown Lands and Survey.

PROPOSED REVOCATION OF TEMPORARY RESERVATION AND THE WITHHOLDING FROM SALE, LEASING, AND LICENSING OF CERTAIN LAND BY ORDER IN COUNCIL.

IN pursuance of the provisions of the *Land Act 1928*, notice is hereby given that it is the intention of the Governor in Council to revoke the temporary reservation and the withholding from sale, leasing, and licensing, of certain land by Order in Council hereinafter referred to:—

The following Notice was published 1° on the 16th November, 1955, pursuant to Order of the 8th November, 1955.

**KEILOR.**—The temporary reservation as a site for Public Recreation, and the withholding from sale, leasing and licensing, by Order in Council of the 6th August, 1877, of 13 acres of land in the Town of Keilor, is about to be revoked so far only as the portion containing 1 acre 1 rood 20 perches, more or less, indicated by hachure on plan hereunder, is concerned.—(K.24(2) (Rs.3755).

*Subject to Survey*

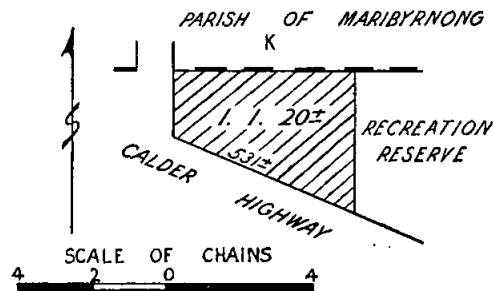

KEITH TURNBULL,  
Commissioner of Crown Lands and Survey.

PROPOSED REVOCATION OF TEMPORARY RESERVATION OF LAND BY ORDER IN COUNCIL—(AS TO PORTION).

IN pursuance of the provisions of the *Land Act 1928*, notice is hereby given that it is the intention of the Governor in Council to revoke portion of the temporary reservation of land by Order in Council hereunder referred to, viz.:—

The following Notice was published 1° on the 9th November, 1955, pursuant to Order of the 2nd November, 1955.

**WANALTA.**—The temporary reservation, by Order in Council of the 26th June, 1917, of 10 acres 3 roods of land in the Parish of Wanalta, as a site for Public Recreation, is about to be revoked, so far only as the portion containing 3 roods 22 perches, indicated by hachure on plan hereunder, is concerned.—(W.309(3) (Rs.1612).

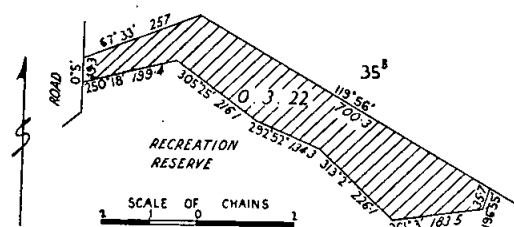

KEITH TURNBULL,  
Commissioner of Crown Lands and Survey.

**APPOINTMENT OF COMMITTEE OF MANAGEMENT OF CRESWICK KOALA PARK.**

WHEREAS by section 56 of the *Forests Act* 1928, it is provided that the Minister of Forests may, on the recommendation of the Forests Commission, appoint any number of persons not less than three to be a Committee of Management of any such land being a place of natural beauty or interest, or a health resort, and may remove any of such persons: Now therefore, I, Robert Kirkham Whately, Her Majesty's Minister of Forests for the State of Victoria, on the recommendation of the Forests Commission, do hereby appoint—

JOHN PHILIP NEWEY

as a Member of the Committee of Management until the 27th day of August, 1957, of the land forming part of the reserved forest in the Parish of Creswick, County of Talbot, described in the accompanying Schedule and known as "Creswick Koala Park," such land being a place of natural beauty and interest.

*Schedule Above Referred to.*

Parish of Creswick, County of Talbot, 50 acres, more or less, being the area shown by pink colour on plan marked A.41/746 over 15/7/42 on file of correspondence No. 41/746 of the Forests Department.

Dated at Melbourne the 4th day of November, 1955.

R. K. WHATELY,  
Minister of Forests.

**PUBLIC HEARING BY A PERSON APPOINTED UNDER THE 34TH SECTION OF THE LAND ACT 1928.**

NOTICE is hereby given that at the time and place mentioned in the Schedule hereunder, applications for leases and licences under the Land Acts, objections to such applications, objections to proposed proclamations, alterations, additions, diminutions, revocations, or unions of commons, and reasons against forfeiture of any leases or licences under the Land Acts deemed liable to forfeiture, will be publicly heard by the person whose name is set opposite such place in such Schedule, being a person appointed by me, the responsible Minister of the Crown administering the Land Acts, to hear the same and report thereon in writing to me.

KEITH TURNBULL,  
Commissioner of Crown Lands and Survey, and  
President of the Board of Land and Works.  
Department of Crown Lands and Survey,  
Melbourne, 13th November, 1955.

**SCHEDULE.**

COURT HOUSE, RUSHWORTH, Tuesday, 6th December, 1955, at 12 noon.—N. J. Cahill, Land Officer, Seymour.

**SOLDIER SETTLEMENT ACT 1946.**

IN pursuance of section 88 (1) of the *Soldier Settlement Act* 1946, I, Keith Hector Turnbull, Her Majesty's Commissioner of Crown Lands and Survey, hereby declare that the farming land specified in the Schedule hereunder to be land suitable for soldier settlement.

**SCHEDULE.**

All those pieces of land comprising 5,100 acres, more or less, being allotments 26 and 27, section 4; allotments 1, 2, 3, 4, 5, 6, 7, 8, 9, 10, 11, 12, 13, A, B, C, and D, section 11; allotments 1, 2, 3, 4, 5, 6, 7, 8, 9, and 10, section 12; part allotment 20, section 10; allotments 1, 1A, 2, 3, 4, 5, 6, 7, 8, 9, and 10, section 21; allotments 1, 2, 3, and 4, section 20; allotments 1, 2, 3, 4, 5, 6, 7, and 8, section 22; allotments 1, 2, 3, 4, 5, and 6, section 23; allotments 4, 5, 6, and 7, section 24, Parish of Gorong; allotments 1, 2, 3, 4, 5, 6, and 7, section 11; allotments 1, 2, 4, and 5, section 10; Parish of Yaloak; and being the property near Ballan known as "Ingliston."

Dated, at Melbourne, this ninth day of November, 1955.

KEITH TURNBULL,  
Commissioner of Crown Lands and Survey.

**LAND AVAILABLE UNDER THE SOLDIER SETTLEMENT ACTS.**

NOTIFICATION is hereby given in accordance with section 16 of the *Soldier Settlement Act* 1946, that the under-mentioned holdings are available or are about to become available for settlement.

Any discharged serviceman who has applied to the Commission on or before the 23rd November, 1955, for classification in the required class of primary production for which the holdings are made available and whose application has been accepted but not necessarily finalized, or any discharged serviceman who has been classified as suitable in such class of primary production, may apply on the prescribed form for settlement on any holding or holdings, indicating where he applies in respect of more than one holding, his order of preference therefor.

The prescribed application forms, plans and further particulars may be obtained from the Enquiry Branch, Soldier Settlement Commission, State Public Offices, Melbourne. The closing date for the receipt of completed applications for settlement on these holdings is the 19th December, 1955, such applications to be in the hands of the Secretary, Soldier Settlement Commission, on or before that date.

S. P. BROMFIELD,  
Secretary.

Soldier Settlement Commission,  
Melbourne, 14th November, 1955.

**SCHEDULE OF ALLOTMENTS.**

SUBDIVISION OF "O'ROURKES" ESTATE.  
PARISHES OF BRUTHEN AND WOODSIDE, COUNTY OF BULN BULN.  
*Suitable for Dairying.*

Lot Number on Plan of Subdivision.	Approximate Area in Acres (Subject to Survey).
1	205
2	200
3	282

*Land Act 1928.*

**LICENCES UNDER THE LAND ACTS 1915 AND 1928 DECLARED VOID.**

NOTICE is hereby given that the Licences mentioned in the Schedule hereunder have been declared void by the Governor in Council for the reason specified in each case.

District.	Corr. No.	Name of Lessee.	Section of Land Act under which Leased.	Parish.	Allotment.	Area.	Class.	Annual Rental.	Reasons for Voiding.
						A. R. P.		£ s. d.	
Bairnsdale ..	131/129	W. J. Collings ..	129	Tildesley West	31 Sec. C	2 0 21	..	1 0 0	Non-compliance with conditions
Bendigo ..	0693/129	S. L. Rechter ..	129	Sandhurst	196A Sec. M	0 2 29	..	2 10 0	Non-compliance with conditions

Department of Crown Lands and Survey,  
Melbourne, 3rd November, 1955.

KEITH TURNBULL,  
Commissioner of Crown Lands and Survey.



## PUBLIC SERVICE NOTICES

## PUBLIC SERVICE OF VICTORIA.—VACANCIES.

APPLICATIONS will be received by the Public Service Board up to Wednesday, the 30th November, 1955, from persons employed in the Public Service of Victoria, who are eligible and qualified, for appointment to the under-mentioned positions:—

## ADMINISTRATIVE DIVISION.

**Clerk, Class "B," Prothonotary's Office, Department of Law.**

*Yearly Salary.*—£1,022, minimum; £1,122, maximum.

*Duties.*—To issue all Supreme Court process and certificates and keep Court records; to receive and disburse moneys in Court, and to act as Prothonotary in that officer's absence.

*Qualifications.*—A sound knowledge of Supreme Court Act and Rules thereunder and of the provisions of all other Acts relating to the jurisdiction of the Supreme Court.

**Clerk, Class "C2," Office of the Public Trustee, Department of Law.**

*Yearly Salary.*—£892, minimum; £970, maximum.

*Duties.*—To inspect, report on and value real estate, stock, plant and machinery and to attend sales principally in country districts; to make recommendations as to the method of disposal of country properties or as to the most suitable method of carrying them on whether by way of share farming agreements, leases or other tenancies or otherwise.

*Qualifications.*—A general knowledge of the Administration and Probate Acts, the Public Trustee Acts and the law relating to the administration of estates; to have satisfactory experience in the management and control of agricultural properties and to be a competent valuer.

## PROFESSIONAL DIVISION.

**Court Reporter (Male), Classes "C1"—"B1," or (Female), Classes "C"—"C2," Court Reporting Branch, Department of Law.**

*Yearly Salary.*—Male—£844, minimum; £1,300, maximum. Female—£650, minimum; £970, maximum.

*Duties.*—To report cases in the Supreme and General Sessions &c., Courts, as required; to take notes for the Judges and of depositions, and to perform such other departmental reporting work as may be required.

*Qualifications.*—To be a licensed shorthand writer under the provisions of the *Evidence Act 1928* with sufficient experience in the duties of the kind mentioned.

**Assistant Architect, Classes "C"—"C2," Department of Public Works.**

*Yearly Salary.*—£766, minimum; £970, maximum—Graduates. £689, minimum; £970, maximum—Diplomates and Registered Architects (by examination) (commencing salary in accordance with experience).

*Duties.*—To prepare, under the direction of the Chief Architect, preliminary and contract plans, details, specifications, reports and estimates for modern buildings.

*Qualifications.*—To be a holder of a University Degree or Technical School Diploma in Architecture or to be qualified by examination for registration as an Architect, or to hold at least equivalent suitable qualifications; to have had considerable experience in the duties outlined.

**Assistant Engineer, Classes "C"—"C2," Department of State Forests.**

*Yearly Salary.*—£650, minimum; £970, maximum—Graduate. £598, minimum; £970, maximum—Diplomate (commencing salary in accordance with experience).

*Duties.*—To prepare working plans and designs for civil engineering structures, roads, and works; to control and supervise the Design Section and, when required, to carry out field work.

*Qualifications.*—To have a Degree or Diploma of Civil Engineering of a recognized University or Technical School; to have a knowledge of road design and be capable of supervising the work of personnel engaged in design.

**Draughtsman, Classes "C"—"C1," Survey Branch, Department of Water Supply.**

*Yearly Salary.*—£598, minimum; £844, maximum.

*Duties.*—Under the supervision of the Chief Surveyor, to take charge of a draughting section of the Survey Branch.

*Qualifications.*—A sound knowledge of engineering and land survey practice in the field and in the preparation of plans and field notes, and to be thoroughly conversant with the survey regulations and office procedure; to possess the prerequisite qualifications prescribed in paragraphs (a) and (b) of Public Service (Public Service Board) Regulation 23.

**Assistant Surveyor, Class "C," Department of Water Supply. (Two vacancies.)**

*Yearly Salary.*—£598, minimum; £728, maximum.

*Duties.*—To carry out general engineering surveys in connexion with the investigation of reservoir sites and foundations, and of channel systems and other water supply undertakings.

*Qualifications.*—To have completed at least three years of the terms of Articles of Indenture for the qualification of Licensed Surveyor, and to have passed or received credit for a pass in all written subjects, excepting Astronomy and Geodesy and Principles and Practice of Land Valuation, of the examination prescribed by the Surveyors' Board, and to have a sound knowledge of engineering and land survey or practice in the field.

**Social Worker (Male), Class "C" or Class "D1" (Female), Mental Hygiene Branch, Department of Health. (Four vacancies.)**

*Yearly Salary.*—Male—£598, minimum; £728, maximum. Female—£494, minimum; £572, maximum.

*Duties.*—To engage in social work in connexion with patients of mental hospitals under the direction of the Psychiatrist Superintendent.

*Qualifications.*—Diploma of Social Studies of the University of Melbourne or its equivalent.

**Occupational Therapist, Class "D1" (Female), Mental Hygiene Branch, Department of Health. (Nineteen vacancies.)**

*Yearly Salary.*—£494, minimum; £572, maximum.

*Qualifications.*—To possess a Diploma of a recognized School of Occupational Therapy or to be a Member of the Australian Association of Occupational Therapists.

## TECHNICAL AND GENERAL DIVISION.

**Dairy Supervisor, Department of Agriculture.**

*Yearly Salary.*—£553, minimum; £631, maximum.

*Duties.*—Subject to the Superintendent of Dairying, to undertake inspections of dairy farms and dairies as required; to advise and instruct on sanitation and dairy farm practice; to examine cows for notifiable disease and to assist generally in the administration of the Milk and Dairy Supervision Acts in the field.

*Qualifications.*—To possess a Dairy Supervisor's Certificate issued under the Milk and Dairy Supervision Acts.

**Radiographer, Tuberculosis Branch, Department of Health.**

*Yearly Salary.*—£547, minimum; £625, maximum.

*Duties.*—Subject to the Deputy Director of Tuberculosis to be responsible for the work of the X-ray staff of the Central Tuberculosis Bureau.

*Qualifications.*—To have had extensive experience in radiography; to hold a certificate recognized by the Australian Institute of Radiographers or an equivalent certificate; to be experienced in miniature chest and large scale radiography, and to have ability to control technical staff.

**Inspector of Land Settlement, Department of Crown Lands and Survey. (Two vacancies.)**

*Yearly Salary.*—£492, minimum; £622, maximum.

*Duties.*—To administer the *Vermin and Noxious Weeds Act 1949*; to inspect and furnish reports and valuations on land and improvements as required under the provisions of the following Acts administered by the Lands Department, i.e. Land, Closer Settlement, Wire Netting, Land (Residence Areas), Agricultural Colleges, and part of the Local Government Act (Unused roads and water frontages); to furnish reports and valuations on land improvements as required by the Soldier Settlement Commission and the Rural Finance Corporation.

**Qualifications.**—A knowledge of the relevant provisions of the above-mentioned Acts; ability to make land valuations and to advise on farming methods generally; including the correct utilization of land.

**Drill Sub-foreman, Department of Mines.**

**Yearly Salary.**—£490, minimum; £516, maximum.

**Duties.**—Under the direction of the Foreman, to take charge of the operation of the drill during a shift.

**Qualifications.**—To have a sound knowledge of drilling practice and in the operation of a percussion drilling plant; to be capable of controlling the work of a shift.

**Rental Officer (Male), Office of the Housing Commission, Department of Treasurer. (Five vacancies.)**

**Yearly Salary.**—£455, minimum; £507, maximum.

**Duties.**—To engage in the weekly collection of rents on the Commission's metropolitan estates; to interview tenants in regard to arrears; and to assist generally in regard to rental collections.

**Qualifications.**—To have had experience in dealing with the public; to be a good penman, capable of handling public moneys and keeping accurate records; to be active and between the ages of 25 and 45 years, and to hold a car driver's licence.

**Housing Officer (Female), Office of the Housing Commission, Department of Treasurer.**

**Yearly Salary.**—£377, minimum; £416, maximum.

**Duties.**—To supervise generally a housing estate and direct and advise tenants; to interview applicants for tenancy of Commission homes and make detailed investigations and recommendations in connexion therewith; and to make inspection of houses and report on various phases of management of new estates.

**Qualifications.**—To be educated to the Leaving Certificate standard; to have ability to make investigations and submit reports, and a knowledge of office routine and keeping of records. Diploma of Social Studies or an equivalent is desirable.

**Attendant (Male), Children's Welfare Branch, Department of Chief Secretary. (Three vacancies.)**

**Yearly Salary.**—£338, minimum; £403, maximum.

**Duties.**—To assist in the care and supervision of boys and to perform such duties as the Medical Superintendent may from time to time direct.

**Qualifications.**—To be of good physique and health; to be temperamentally and otherwise competent to supervise boys; to be prepared to undertake in-service training. First Aid Certificate and experience in organizing project and recreational activities are desirable.

**NOTE.**—Applicants, except in the case of discharged servicemen, must be between the ages of 22 and 41 years.

**Motor Truck Driver, Tuberculosis Branch, Department of Health. (Five vacancies.)**

**Yearly Salary.**—£382, minimum; £395, maximum.

**Duties.**—To drive X-ray vans and other vehicles as required and to ensure that regular maintenance is undertaken; to carry out other duties as directed.

**Qualifications.**—To be a licensed driver and to have had experience in driving trucks up to 5 tons capacity; to be capable of handling heavy X-ray equipment and have a good knowledge of roads throughout the State.

**Typist (Female), Grade II., Office of Titles, Department of Law.**

**Yearly Salary.**—£351, minimum; £377, maximum.

**Duties.**—To carry out secretarial duties and attend to the filing and recording of correspondence in the Survey Branch of the Office of Titles; to have charge of the stores of the Branch and perform such other duties as are required.

**Qualifications.**—To be an experienced typist with some knowledge of filing and recording; to have satisfied the Board by test of ability to type at rate of 42 words a minute.

**Labourer, Office of Titles, Department of Law.**

**Yearly Salary.**—£286, minimum; £299, maximum.

**Labourer, Sheriff's Office, Department of Law.**

**Yearly Salary.**—£286, minimum; £299, maximum.

**Labourer, Department of Public Works.**

**Yearly Salary.**—£286, minimum; £299, maximum.

**Hours of Duty.**—5 p.m. to 11 p.m.—Mondays to Fridays. 12 noon to 11 p.m.—Saturdays.

**NOTE.**—In addition to the salary rates quoted, a cost of living adjustment (£414 a year for adult males and £311 a year for adult females), which varies in accordance with the rise or fall in the index number of the cost of living, is payable.

By order,

V. P. SCULLY,  
Secretary.

Office of the Public Service Board,  
Melbourne, 15th November, 1955.

**PUBLIC SERVICE OF VICTORIA.—VACANCIES.**

**DEPARTMENT OF HEALTH.**

**MENTAL HYGIENE BRANCH.**

**TECHNICAL AND GENERAL DIVISION.**

**APPLICATIONS** will be received by the Public Service Board up to Wednesday, 7th December, 1955, from persons employed in the Public Service of Victoria, who are eligible and qualified, for appointment to the under-mentioned positions:—

**Nurse, Clinic, Observatory Clinic, The Domain, South Yarra.**

**Yearly Salary.**—£452, minimum; £491, maximum.

**Duties.**—To supervise medical equipment and assist the medical staff with the carrying out of physical examinations, and the administration of intravenous drugs, &c.; to supervise children waiting at the clinic; to provide clerical assistance as required.

**Qualifications.**—To be a registered nurse, preferably possessing the mental nursing certificate or its equivalent, and educated to at least Intermediate Certificate Standard. Experience with children and a knowledge of typing and record-keeping are desirable.

**Hostel Supervisor, Sunbury Mental Hospital.**

**Yearly Salary.**—£365, minimum; £391, maximum.

**Duties.**—To be responsible to the Housekeeper for the maintenance of discipline in the female hostels, and for the care and custody of the hostels and the stock therein; to relieve the Housekeeper in her duties as required.

**Qualifications.**—To be competent in the supervision of staff and in general housekeeping.

**Fireman.**

Janefield Colony—one vacancy.

Travancore Developmental Centre—one vacancy.

Kew Mental Hospital—one vacancy.

**Yearly Salary.**—£380, minimum; £393, maximum.

**Duties.**—To fire boilers and to assist Engineer

Mechanic.

**Qualifications.**—Boiler Attendant's Certificate or higher qualification.

**NOTE.**—In addition to the salary rates quoted, a cost of living adjustment (£414 a year for adult males and £311 a year for adult females), which varies in accordance with the rise or fall in the index number of the cost of living, is payable.

By order,

V. P. SCULLY,  
Secretary.

Office of the Public Service Board,  
Melbourne, 15th November, 1955.

**PUBLIC SERVICE OF VICTORIA.**

**SPEED TESTS FOR SHORTHAND WRITERS AND TYPISTS (FEMALE).**

**AT** the tests held on the 5th November, 1955, the under-mentioned candidates passed at the required standards, in the order of merit indicated:—

*Test at 120 Words a Minute.*

Gladman, Olive Jean Amelia

*Test at 100 Words a Minute.*

*Order of Merit.*

1. McCulkin, Mary Josephine
2. Milnes, Elaine Margaret
3. Thomas, Catherine May (Mrs.)

By order,

V. P. SCULLY,  
Secretary.

Office of the Public Service Board,  
Melbourne, 15th November, 1955.

## PUBLIC SERVICE (PUBLIC SERVICE BOARD) REGULATION 39.—RECLASSIFICATIONS.

THE Public Service Board has raised the classification of the under-mentioned offices as shown, and the Permanent Heads of the Departments have recommended the officers named for appointment.

Office and Present Classification.	Revised Classification.	Duties.	Qualifications.	Officer Recommended for Appointment.		
				Name.	Classification.	Date of Classification.

## PROFESSIONAL DIVISION.

## DEPARTMENT OF PUBLIC WORKS.

*Mechanical and Electrical Engineering Branch.*

Senior Draughtsman, Class "C1"	Class "C2"	To prepare, under direction, plans, specifications, and estimates of mechanical installations and services in all types of public buildings; to assist in the checking of plans and specifications of work prepared by a section of mechanical draughting staff	To have had a sound technical training in mechanical engineering together with several years' drawing office experience in plant design and layout, particularly in relation to heating, hot water supply, air conditioning, steam plant, and refrigeration	Broughton, N. L. R.	Senior Draughtsman, Class "C1"	6.8.51
--------------------------------	------------	---	---	---------------------	--------------------------------	--------

## DEPARTMENT OF HEALTH.

*General Health Branch.*

Building Inspector, Class "C" (two offices)	Class "C1" (two offices)	To inspect and report on public and other buildings on their completion and at other times, to inspect public buildings during occupation as to compliance with Regulations affecting public safety; to give evidence in Court as to breaches of Regulations; and to carry out such other duties as may be directed	To have a thorough knowledge of building materials and of the construction, lighting, and ventilation of buildings; to be capable of clear and concise reports and to be physically active	Dickason, I. C. Meldrum, E. A.	Building Inspector, Class "C"	29.10.50 29.10.50
---	--------------------------	---	--	-----------------------------------	-------------------------------	----------------------

## DEPARTMENT OF WATER SUPPLY.

*Geelong Centre.*

District Engineer, Grade II., Class "B1"	Grade I., Class "A" (£1,400-£1,500)	To supervise the construction and maintenance of all water supply works in the Bellarine and Otway Waterworks Districts	To possess a University Degree in Civil Engineering and qualification as an Engineer of Water Supply, together with extensive experience in construction and maintenance of town water supply systems; to have administrative ability	King, M. L.	District Engineer, Grade II., Class "B1"	25.8.52
--	-------------------------------------	---	---	-------------	--	---------

*Cohuna Centre.*

District Engineer, Grade III., Class "B"	Grade II., Class "B1"	To supervise staff and control all water supply works and expenditure within an irrigation district including urban divisions	To be qualified as an Engineer of Water Supply under Water Act or to hold other recognized civil engineering qualifications and to have had extensive experience in the administration of irrigation districts; to be competent to carry out surveys; to supervise water distribution and to organize and control the work of large numbers of men on water supply works	McCoy, C. G.	District Engineer, Grade III., Class "B"	28.7.52
--	-----------------------	---	--	--------------	--	---------

## TECHNICAL AND GENERAL DIVISION.

## DEPARTMENT OF TREASURY.

*Government Printing Office.*

Warehouseman, Assistant, Grade III.	Grade II.	To be responsible for the night shift activities of the Warehouse, and assist the Warehouseman, Assistant, Grade I., as required	To have a thorough knowledge of the Warehouse and methods of despatch; to possess the necessary ability to assist in the production of urgent work as directed by the Night Foreman	Dunn, D. T.	Warehouseman, Assistant, Grade III.	7.11.55 (Warehouseman, Second Assistant—18.10.43)
-------------------------------------	-----------	--	---	-------------	-------------------------------------	--

Appeals against such recommendations should be lodged with the Secretary to the Public Service Board not later than Saturday, the 26th November, 1955.

By order,

V. P. SCULLY,

Secretary.

Office of the Public Service Board,  
Melbourne, 15th November, 1955.

PUBLIC SERVICE (PUBLIC SERVICE BOARD) REGULATION 39.—VACANCIES.

THE Permanent Heads of the Departments shown have recommended the officers named hereunder for appointment to the under-mentioned vacancies.

Office and Classification.	Duties.	Qualifications.	Officer Recommended for Appointment.		
			Name.	Classification.	Date of Classification.
<b>ADMINISTRATIVE DIVISION.</b>					
<b>DEPARTMENT OF CHIEF SECRETARY.</b>					
<i>Office of the Chief Commissioner of Police.</i>					
Deputy Officer in Charge, Motor Registration Branch, Class "A" (£1,400)	To be Deputy Officer in Charge of the Branch; under the Officer in Charge, to organize and direct the activities of the Branch and relieve the Officer in Charge as required	To have had wide, practical experience in office administration; to possess initiative and organizing ability and to have had experience in the control of staff	O'Farrell, J. P.	Clerk, Class "B1"	9.12.54
<b>TECHNICAL AND GENERAL DIVISION.</b>					
<b>DEPARTMENT OF TREASURER.</b>					
<i>Taxation (Land Tax) Office.</i>					
Assistant (Female), Grade III.	To attend to the correct arrangement and distribution of change of ownership notices as received daily, and to assist with the Card Index relating thereto. Record dates of posting and due dates of assessments on the taxable files	To possess a practical knowledge of procedure in relation to receipt and recording methods of change of ownership notices and office routine generally, together with a capacity for accuracy and neatness	Peters, Carmen	Assistant (Female), Grade II.	2.8.48
<b>DEPARTMENT OF HEALTH.</b>					
<i>Mental Hygiene Branch.</i>					
Deputy Charge Nurse (Male)	To be second in charge of a ward and to relieve the Charge Nurse	To have had experience in a Mental Hospital, to be a registered Mental Nurse and possess the Mental Hygiene Nursing Certificate			
Mental Hospital—Repatriation, Bundoora (one office)	.. .. .	.. .. .	Sharman, C. ..	} Staff Nurse (Male)	31.5.55
Kew (one office)	.. .. .	.. .. .	Russ, E. ..		21.6.55

Appeals against such recommendations should be lodged with the Secretary to the Public Service Board not later than Saturday, the 26th November, 1955.

Office of the Public Service Board,  
Melbourne, 15th November, 1955.

By order,  
V. P. SCULLY,  
Secretary.

No. 312.

Public Service Act 1946, Section 50.

REGULATIONS—PART III.—SALARIES, INCREMENTS, AND ALLOWANCES.

THE Public Service Board, in pursuance of the powers conferred by the Public Service Act 1946, hereby amends its Regulations as shown below:—

SEVENTH SCHEDULE.

TECHNICAL AND GENERAL DIVISION.

DEPARTMENT OF HEALTH.

MENTAL HYGIENE.

Offices and Rates of Salaries.

Office.	Yearly Rate of Salary.		Increments (Annual).
	Minimum.	Maximum.	
GENERAL STAFF—MALES.	£	£	
Delete— Engineer Mechanic, Senior ..	..	588†	..
Add— Engineer Mechanic, Senior ..	..	653†	..

† Less deductions for quarters and allowances.

This Regulation shall have effect as on and from the 2nd October, 1955.

D. D. PAINE, Chairman.  
V. P. SCULLY, Secretary.

Office of the Public Service Board,  
Melbourne, 8th November, 1955.

No. 307.

Public Service Act 1946, Section 50.

REGULATIONS—PART III.—SALARIES, INCREMENTS, AND ALLOWANCES.

THE Public Service Board, in pursuance of the powers conferred by the Public Service Act 1946, hereby amends its Regulations as shown below:—

SECOND SCHEDULE.

TECHNICAL AND GENERAL DIVISION.

Offices and Rates of Salaries.

Department and Office.	Yearly Rate of Salary.		Increments (Annual).
	Minimum.	Maximum.	
	£	£	
DEPARTMENT OF CHIEF SECRETARY.			
Delete— Probation Officer, Indeterminate Sentences Board	599	625	1 of £26
Add— Probation Officer, Indeterminate Sentences Board	625	664	1 of £26 and 1 of £13

This Regulation shall have effect as on and from the 6th November, 1955.

D. D. PAINE, Chairman.  
V. P. SCULLY, Secretary.

Office of the Public Service Board,  
Melbourne, 3rd November, 1955.

No. 308.

*Public Service Act 1946, Section 50.*

REGULATIONS—PART III.—SALARIES, INCREMENTS, AND ALLOWANCES.

THE Public Service Board, in pursuance of the powers conferred by the *Public Service Act 1946*, hereby amends its Regulations as shown below :—

SECOND SCHEDULE.

TECHNICAL AND GENERAL DIVISION.

*Offices and Rates of Salaries.*

Department and Office.	Yearly Rate of Salary.		Increments (Annual).
	Minimum.	Maximum.	
DEPARTMENT OF STATE FORESTS.	£	£	
<i>Add—</i> Plant Inspector .. .. .	592	644	2 of £26

D. D. PAINE, Chairman.  
V. P. SCULLY, Secretary.

Office of the Public Service Board,  
Melbourne, 7th November, 1955.

No. 313.

*Public Service Act 1946, Section 50.*

REGULATIONS—PART III.—SALARIES, INCREMENTS, AND ALLOWANCES.

THE Public Service Board, in pursuance of the powers conferred by the *Public Service Act 1946*, hereby amends its Regulations as shown below :—

SECOND SCHEDULE.

TECHNICAL AND GENERAL DIVISION.

*Offices and Rates of Salaries.*

Department and Office.	Yearly Rate of Salary.		Increments (Annual).
	Minimum.	Maximum.	
DEPARTMENT OF STATE FORESTS.	£	£	
<i>Add—</i> Technical Assistant (Mechanical) .. .. .	468	520	2 of £26

D. D. PAINE, Chairman.  
V. P. SCULLY, Secretary.

Office of the Public Service Board,  
Melbourne, 11th November, 1955.

No. 309.

*Public Service Act 1946.*

REGULATIONS—PART III.—SALARIES, INCREMENTS, AND ALLOWANCES.

THE Public Service Board, in pursuance of the powers conferred by the *Public Service Act 1946*, hereby amends its Regulations as shown below :—

FOURTH SCHEDULE.

ADMINISTRATIVE DIVISION.

*Amount or Range of Salary Assigned to Offices in Class "A1", Classes "A" and "A1" and Class "A".*

Office.	Yearly Rate of Salary.		Increments (Annual).
	Minimum.	Maximum.	
DEPARTMENT OF CROWN LANDS AND SURVEY.	£	£	
CLASS "A".			
<i>Add—</i> Assistant Accountant .. .. .			1,400

D. D. PAINE, Chairman.  
V. P. SCULLY, Secretary.

Office of the Public Service Board,  
Melbourne, 3rd November, 1955.

No. 311.

*Public Service Act 1946, Section 50.*

REGULATIONS—PART III.—SALARIES, INCREMENTS, AND ALLOWANCES.

THE Public Service Board, in pursuance of the powers conferred by the *Public Service Act 1946*, hereby amends its Regulations as shown below :—

SECOND SCHEDULE.

TECHNICAL AND GENERAL DIVISION.

*Offices and Rates of Salaries.*

Department and Office.	Yearly Rate of Salary.	
	Minimum.	Maximum.
DEPARTMENT OF TREASURER.	£	£
GOVERNMENT PRINTING OFFICE.		
<i>Delete—</i> Warehouseman, Assistant .. .. .	487	539
Warehouseman, Second Assistant .. .. .	355	407
<i>Add—</i> Warehouseman, Assistant, Grade I. .. .. .	487	539
Warehouseman, Assistant, Grade II. .. .. .	381	433
Warehouseman, Assistant, Grade III. .. .. .	355	407

In the list of offices under the heading "(A) Acting Duty Allowance" in the footnotes to the schedule of rates

*Delete—*  
Machineman, Perfector Press.  
Warehouseman, Assistant.

*Add—*  
Warehouseman, Assistant, Grade I.

D. D. PAINE, Chairman.  
V. P. SCULLY, Secretary.

Office of the Public Service Board,  
Melbourne, 7th November, 1955.

No. 310.

*Public Service Act 1946.*

REGULATIONS—PART III.—SALARIES, INCREMENTS, AND ALLOWANCES.

THE Public Service Board, in pursuance of the powers conferred by the *Public Service Act 1946*, hereby amends its Regulations as shown below :—

FOURTH SCHEDULE.

ADMINISTRATIVE DIVISION.

*Amount or Range of Salary Assigned to Offices in Class "A1", Classes "A" and "A1" and Class "A".*

Office.	Yearly Rate of Salary.	
	Minimum.	Maximum.
DEPARTMENT OF TREASURER.	£	£
CLASS "A".		
<i>Add—</i> Accounting Officer (Loan and Capital Works), Treasury .. .. .		1,400

D. D. PAINE, Chairman.  
V. P. SCULLY, Secretary.

Office of the Public Service Board,  
Melbourne, 7th November, 1955.

**TENDERS—PUBLIC WORKS DEPARTMENT**

**TENDERS** will be received at this office until **TEN A.M.** on the days and for the purposes under mentioned.

Particulars may be learnt at this Office and also at places shown in parenthesis.

W.O. means Inspector of Works Office; P.S.—Police Station; T.S.—Technical School; H.E.S.—Higher Elementary School; S.S.—State School; H.S.—High School.

The Board of Land and Works will not necessarily accept the lowest or any tender.

**NOTE.**—No preliminary deposits are to be lodged with tenders, but a deposit, in accordance with the following Schedule, will be required from the successful tenderer:—

	£
For contract amounts not exceeding £200 .. .. .	2
For contract amounts exceeding £200 and not exceeding £500 .. .. .	5
For contract amounts exceeding £500 and not exceeding £1,000 .. .. .	10
For contract amounts exceeding £1,000—1 per cent. of tender .. .. .	500
	(maximum deposit)

All tenders should be on a "firm tender" basis.

In preparing tenders, regard should be had to the decision of the Commonwealth Court of Conciliation and Arbitration and the resultant effects in respect of wages and materials.

22nd November, 1955.

Bairnsdale.—Repairs and painting, Technical School. (W.O., Bairnsdale; T.S., Bairnsdale.)

Ballarat.—Supply and installation of central heating and hot-water service, "Novar" Mental Hospital. (W.O., Ballarat.) (Amended specification.)

Benalla.—Erection of No. 2 timber-framed combined boiler room and toilet blocks, High School. (W.O., Benalla.)

Briar Hill.—Additional out-office, drinking taps, stainless steel sink, and water to staff room, S.S. No. 4341. (S.S., Briar Hill.)

Burnley.—Electrical installation in new insectary, College of Horticulture.

Coburg North.—Conversion of existing coke-burning boiler to oil firing, S.S. No. 4543. (S.S., Coburg North.)

Dookie.—Repairs, renovations, &c., to the Registrar's Residence, Agricultural College. (W.O., Shepparton; Agricultural College, Dookie.) (Amended specification.)

Edithvale.—Additional out-offices, S.S. No. 3790.

Epping.—New partition and repairs, S.S. No. 1477. (S.S., Epping.)

Fairfield.—Installation of independent electrical service to Exotic Diseases Block, Infectious Diseases Hospital.

Foster.—Re-blocking, repairs, and painting, Police Station. (W.O., Korumburra; P.S., Foster.)

Heidelberg.—Purchase and removal of house property at 127 Buckland-street, S.S. No. 294.

Holmesgleng.—Erection of 1st section of new High School.

Holmesgleng.—Electrical installation in Stage 1, High School.

Holmesgleng.—Supply, delivery, installation, and testing of a warm air heating/ventilation system, Stage 1, High School.

Jack River.—Internal and external additions, remodelling, painting, S.S. No. 2765. (W.O., Traralgon; S.S., Jack River.)

Kew.—Supply and installation of Plenum heating and hot-water services, Ward M.6, Children's Cottages, Mental Hospital.

Kilmore.—Repairs and renewals of boundary fences, S.S. No. 1568. (W.O., Alexandra; S.S., Kilmore.)

Lower Ferntree Gully.—Repairs and painting, S.S. No. 1307. (S.S., Lower Ferntree Gully.)

Melbourne.—Alterations to provide for processing room, Milton House, Flinders-lane, Department of Health.

Melbourne.—Supply, delivery, installation, and testing of (2) two warm air ventilation systems, Law Courts.

Mont Park.—Conversion of two boilers to oil firing, Sanatorium, Gresswell.

Mont Park.—Supply, delivery, and installation of drying cabinet in Nursery Ward, Janefield Mental Hospital.

Mont Park.—Supply and delivery of four (4) 100 h.p. steam generators, Mental Hospital.

Nayook.—Additional out-offices and water facilities, S.S. No. 3227. (W.O., Traralgon; S.S., Nayook.)

North Balwyn.—Purchase and removal of 44 pine trees on south boundary of school site, at south-west corner of Greythorne and Doncaster roads, P.P.P. School, Greythorne.

Numurkah.—Supply, delivery, installation, and testing of mechanical services to Units 2, 5, and 6, High School. (W.O., Bendigo; P.S., Morwell.)

Parkdale.—Repairs and renewals to fencing, S.S. No. 4171. (S.S., Parkdale.) (Amended specification.)

Prahran.—Electrical installation, extension, and alteration, Court House.

Richmond.—Re-wire and extension of electrical installation, S.S. No. 1396 (Brighton-street), (S.S., Richmond).

Sunbury.—Roof renewal to dormitories at Ward F.7., Mental Hospital.

Warracknabeal.—Repairs and painting to residence, 258 Scott-street, High School. (W.O., Warracknabeal; W.O., Horsham; H.S., Warracknabeal.)

Waubra.—Renovations to school and residence, S.S. No. 859. (W.O., Maryborough; S.S., Waubra.)

Westgarth.—Renewal of water service, S.S. No. 4177. (S.S., Westgarth.)

29th November, 1955.

Abbotsford.—Electrical re-wiring and additions to existing installation, S.S. No. 1886.

Albert Park.—Replacement of blackboards and removal of platforms in Class-rooms, S.S. No. 1181. (Main School Building.)

Armadale.—Internal painting of new Wing, &c., Frank Tate House.

Beechworth.—Alterations to roofs, Training Prison. (W.O., Wangaratta.)

Burwood.—Sale and removal of old weatherboard residence, 215 Burwood-road, Teachers' College.

Carlton.—Repairs and renovations to cleaner's residence, S.S. No. 2365. (S.S., Carlton.)

Darlimurla.—Repairs and painting, S.S. No. 2782. (W.O., Korumburra; S.S., Darlimurla.)

Echuca.—Fencing to new boundaries, High School. (W.O., Shepparton; H.S., Echuca.)

Echuca.—Erection of a brick boiler house, High School. (W.O., Shepparton; H.S., Echuca.)

Flemington.—Repairs and painting, Court House.

Glenormiston.—Renovations of three cottages, Nos. 4, 6, and 10, Agricultural Estate. (W.O., Camperdown.)

Glenrowan.—Repairs and painting, installation of septic closet, Police Station. (W.O., Benalla; P.S., Glenrowan.)

Greenvale.—Painting new ward, Sanatorium. (Amended specification.)

Harcourt.—Alterations and renovations to school, residence, and out-buildings, S.S. No. 299. (W.O., Kyneton; S.S., Harcourt.)

Heathcote.—Repairs and painting, Court House. (W.O., Bendigo; P.S., Heathcote.) (Amended specification.)

Horsham.—Installation of sewerage to workshop and toilet block, High School. (W.O., Horsham; H.S., Horsham.) (Amended specification.)

Macorna.—Repairs and painting to school and residence, buildings, S.S. No. 2909. (W.O., Swan Hill; S.S., Macorna.)

Melbourne.—Electrical installation, alteration and addition, Barristers' Robing-room, Law Courts.

Melbourne.—Alterations to Barristers' Robing-room, Law Courts.

Melbourne.—Construction of new lift well, Parliament House.

Mildura.—Repairs and renovations to sergeant's quarters, Police Station. (W.O., Mildura, P.S., Mildura.)

Moe.—Erection of six unit teachers' flats, High School. (W.O., Traralgon; H.S., Moe.)

Moe.—Electrical installation in six (6) unit teachers' flats, High School. (W.O., Traralgon; H.S., Moe.)

Moe.—Supply and installation of hot-water service, six (6) unit teachers' flats. (W.O., Traralgon; H.S., Moe.)

Mont Park.—Supply and delivery of two (2) 2,000-gallon tanks to Boiler House, Mental Hospital.

Norwood.—Supply, delivery, installation, and testing of sump pump in septic tank, S.S. No. 4736. (S.S., Norwood.) (Amended specification.)

Rushworth.—Repairs and painting, Higher Elementary School No. 1057. (W.O., Shepparton, Bendigo; H.E.S., Rushworth.)

Sunbury.—Electrical installation, Wards F.1, 2, 3, and M.1, 2, 3, F.8, and M.8, Mental Hospital.

Sunbury.—Provision of sliding doors to laundry, Mental Hospital.

Sunbury.—Renewal of party fencing, S.S. No. 1002. (S.S., Sunbury.)

Tallangatta.—Electrical installation in (a) Police Station and residence, (b) Public Offices. (W.O., Wangaratta; P.S., Beechworth.)

Tatura.—Erection of brick laboratory and office building; Research Station. (W.O., Shepparton; Research Station, Tatura.)

Warragul.—New brick toilet addition, Court House. (W.O., Traralgon; P.S., Moe, Warragul.)

Wonthaggi North.—Minor repairs and external painting, residence, S.S. No. 3716. (W.O., Korumburra; S.S., Wonthaggi North.)

6th December, 1955.

Alvie.—Remodelling of Central Section, Consolidated School. (W.O., Camperdown; P.S., Colac; Consolidated School, Alvie.)

Ararat.—Erection of brick Boiler House, Mental Hospital. (W.O., Ararat, Ballarat.) (Amended specification.)

Ballarat.—Renovations to gardener's quarters, Mental Hospital. (W.O., Ballarat.)

Ballarat.—Lining roof of Modelling Room, &c., School of Mines and Industries, Junior Boys' Technical School. (W.O., Ballarat; T.S., Ballarat.)

Broadmeadows South.—Erection of concrete veneer timber-framed Primary School, S.S. No. 4782.

Broadmeadows South.—Supply, delivery, installation, and testing of a warm air heating/ventilation system, S.S. No. 4782.

Burnley.—Internal repairs and painting, Principals' residences, School of Horticulture.

Burwood.—Supply, delivery, installation, and testing of hot-water services, Teachers' College Hostel.

Ceres.—Renovations to school and residence, renewal of fencing, S.S. No. 1602. (W.O., Geelong; S.S., Ceres.)

Charlton.—Renewal of chalkboards, S.S. No. 1480. (W.O., Bendigo; S.S., Charlton.)

Devon Meadows.—Renewal of fencing, S.S. No. 3924. (W.O., Korumburra; S.S., Devon Meadows.)

Elsternwick.—Repairs and painting, S.S. No. 2870.

Fawkner.—Electrical services, High School.

Fawkner.—Erection of first section of new school, High School.

Ferntree Gully.—Out-offices and washing and drinking facilities, S.S. No. 1307.

Flora Hill.—Purchase and removal from site of residence, tanks and stands, School Site. (W.O., Bendigo.)

Geelong.—Additional class-rooms, Gordon Institute of Technology, Junior Technical School. (W.O., Geelong.)

Greensborough.—Additional out-office accommodation and water facilities, S.S. No. 2062. (S.S., Greensborough.)

Hamilton.—Internal and external painting of Cookery Centre, High School. (W.O., Hamilton; H.S., Hamilton.)

Hepburn.—Renewal of fencing, S.S. No. 767. (W.O., Kyneton; S.S., Hepburn.)

Horsham.—Repairs and painting, Police Station. (W.O., Horsham; P.S., Horsham.)

Ilbarook.—Provision of bathroom to residence, &c., S.S. No. 722. (W.O., Ballarat; S.S., Ilbarook.)

Jeparit.—Internal repairs and painting of office and residence, Police Station and residence. (W.O., Warracknabeal; P.S., Jeparit.)

Kew.—Re-wiring and improvements to electrical installations in Wards B and G, Mental Hospital.

Koonwarra.—Repairs and painting to school and out-buildings, S.S. No. 3177. (W.O., Korumburra; S.S., Koonwarra.)

Koo-Wee-Rup North.—Repairs and painting to school and residence, S.S. No. 3198. (W.O., Korumburra; S.S., Koo-Wee-Rup North.)

Lauriston.—Purchase and removal of buildings from site, S.S. No. 1083. (W.O., Kyneton.)

Marysville.—Repairs and painting, S.S. No. 1273. (W.O., Alexandra; S.S., Marysville.)

Modewarre.—Repairs and painting of school and residence, S.S. No. 396. (W.O., Geelong; S.S., Modewarre.)

Middle Indigo.—General repairs and painting, S.S. No. 1115. (W.O., Wangaratta; S.S., Middle Indigo.)

Norlane.—Erection of two (2) shelter-sheds, S.S. No. 4734. (W.O., Geelong.)

Northcote.—Re-blocking, repairs, and painting, cleaner's residence, S.S. No. 3139. (S.S., Northcote.)

Orrvale.—Repairs and painting, S.S. No. 3805. (W.O., Shepparton; S.S., Orrvale.)

Outtrim.—Repairs and painting to residence, S.S. No. 3229. (W.O., Korumburra; S.S., Outtrim.)

Powelltown.—Repairs and painting to school and residence buildings, S.S. No. 3957. (W.O., Alexandra; S.S., Powelltown.) (Amended specification.)

Rainbow.—Renewal of boundary fencing, S.S. No. 3313. (W.O., Warracknabeal; S.S., Rainbow.)

Speed.—Erection of verandah on north and west sides of premises, Police Station. (W.O., Warracknabeal; P.S., Speed.)

Stratford.—New out-office block, S.S. No. 596. (W.O., Bairnsdale; S.S., Stratford.)

Toora.—Repairs and painting to school and residence buildings, S.S. No. 2253. (W.O., Korumburra; S.S., Toora.)

Warrnambool.—Alterations, additions, and renovations to No. 2 Ward Block, Mental Hospital. (W.O., Warrnambool.)

Wendouree.—Connexion of sewerage, S.S. No. 1813. (W.O., Ballarat.)

13th December, 1955.

Melbourne.—Provision of additional toilet accommodation, 295 Queen-street, Department of Health.

Port Melbourne.—External painting, part internal painting, repairs, and replacement of chalkboards, S.S. No. 1427. (S.S., Port Melbourne.)

All tenders should be on a "firm tender" basis.

In preparing tenders, regard should be had to the decision of the Commonwealth Court of Conciliation and Arbitration and the resultant effects in respect of wages and materials.

Tenders to be addressed to the Honorable the Commissioner of Public Works, and envelope containing tender marked "Tender for \_\_\_\_\_ due"

T. K. MALTBY,  
Commissioner of Public Works.

Public Works Department,  
Melbourne, 15th November, 1955.

## PRIVATE ADVERTISEMENTS

### CITY OF BOX HILL.

#### By-LAW No. 102.

A By-law of the City of Box Hill made under the Health Acts and numbered 102, for repealing By-law 67, for fixing the fees to be paid in respect of the registration or renewal or transfer of registration of certain premises as set out hereunder:—

IN pursuance of the powers conferred by the Health Acts, the Mayor, Councillors, and Citizens of the municipality of the City of Box Hill order as follows:—

1. By-law 67 of the City of Box Hill is hereby repealed.

2. Upon the registration of the following premises, the renewal thereof, the fees set out hereunder shall be paid to the Council.

*Nature of Premises; Fee Payable.* £ s. d.

Offensive trade premises (being fat extracting or melting or rendering works which are conducted at premises occupied principally as a butcher's shop and at which fat is extracted melted or rendered only from materials derived from such shop .. .. . 1 0 0

Offensive trade premises (other than those referred to above) .. .. . 5 0 0

Boarding Houses .. .. . 1 0 0

Common Lodging Houses .. .. . 1 0 0

Eating Houses .. .. . 1 0 0

#### Apartment Houses—

containing not more than one apartment .. 0 10 0

containing more than one apartment .. .. 1 0 0

Camping areas .. .. . 1 0 0

#### Food Premises—

1. Where 5 or less than 5 persons are employed 0 10 0

2. Where from 6 to 20 persons are employed .. 1 0 0

3. Where from 21 to 50 persons are employed .. 2 0 0

4. Where more than 50 persons are employed .. 5 0 0

Premises at or in any part of which eggs for sale are received or stored for the purpose of being chilled .. .. . 1 0 0

3. Upon the transfer of registration of any such premises a fee of Two shillings and sixpence shall be paid to the Council.

4. This By-law shall apply to the whole of the municipal district of Box Hill.

The Resolution for passing this By-law was agreed to by the Council on the 29th day of August, 1955, and was confirmed on the 26th day of September, 1955.

The corporate seal of the Mayor, Councillors, and Citizens of the City of Box Hill was hereunto affixed, in the presence of—

(SEAL) R. H. L. SPARKS, Mayor.  
W. A. KEMP, Councillor.  
L. E. SCOTT, Town Clerk.

Submitted to the Commission of Public Health on the 18th day of October, 1955.—G. V. STAFFORD, Secretary, Commission of Public Health.

Confirmed by the Governor in Council on the 2nd day of November, 1955.—A. MAHLSTEDT, Clerk of the Executive Council.

CITY OF COBURG.

BY-LAW No. 80.

A By-law of the City of Coburg, made under the Health Acts, and numbered 80, for the purpose of prescribing the fees to be charged for the registration of premises, and for the renewal and transfer of registration of premises pursuant to such Acts and to repeal By-law No. 68.

IN pursuance of the powers conferred by the Health Acts and of any and every other power thereunto enabling, the Mayor, Councillors, and Citizens of the City of Coburg order as follows:—

1. The fees to be charged, received, and taken by the Council of the City of Coburg for the registration of premises or the renewal or transfer of the registration of premises, pursuant to the provisions of the Health Acts, shall be as follows:—

(a) Nature of premises—	Fees Payable.	
	£	s. d.
(i) Offensive trades premises (other than those referred to below)	5	0 0
(ii) Offensive trades premises (being fat extracting or melting or rendering works which are conducted at premises occupied principally as a butcher's shop, and at which fat is extracted, melted, or rendered only from materials derived from such shop)	1	0 0
(iii) Boarding-houses	1	0 0
(iv) Common lodging-houses	1	0 0
(v) Eating-houses	1	0 0
(vi) Apartment-houses—		
containing not more than one apartment	0	10 0
containing more than one apartment	1	0 0
(vii) Camping areas	1	0 0
(viii) Food premises—		
(i) where five or less than five persons are employed	0	10 0
(ii) where from 6 to 20 persons are employed	1	0 0
(iii) where from 21 to 50 persons are employed	2	0 0
(iv) where more than 50 persons are employed	5	0 0
(ix) Premises at or in any part of which eggs for sale are received or stored for the purpose of being chilled	1	0 0
(b) Any transfer of registration	0	2 6

2. This By-law shall apply to and have operation throughout the whole of the municipal district of the City of Coburg.

3. That By-law No. 68, made by the Council of the City of Coburg, be and it is hereby repealed, provided that such repeal shall not prejudice or affect any right accrued or liability incurred prior to the commencement of this By-law.

The Resolution for passing this By-law was agreed to by the Council on 22nd August, 1955, and confirmed on 26th September, 1955.

In witness whereof the common seal of the Mayor, Councillors, and Citizens of the City of Coburg was hereunto affixed this 27th day of September, 1955, in the presence of—

KENNETH H. WHEELER, Mayor.  
(SEAL) C. E. HOSKEN, Councillor.  
F. W. SHORE, Town Clerk.

Submitted to the Commission of Public Health on the 18th day of October, 1955.—G. V. STAFFORD, Secretary to the Commission.

Approved by the Governor-in-Council on the 2nd day of November, 1955.—A. MAHLSTEDT, Clerk of the Executive Council.

CITY OF HAWTHORN.

NOTICE is hereby given that, pursuant to provisions of the Local Government Act, the Council of the City of Hawthorn intends to make a special order for applying unexpended loan moneys, as set out in Schedule "A", which are now required for the purposes other than those for which they were borrowed, as set out in Schedule "B."

SCHEDULE "A."

	£	s. d.	£	s. d.
Loan No. 16.				
Construction of Sinclair-avenue, Elvins-avenue and Thomas-street (Council Proportion)	543	13 10		
Purchase of property No. 107 Kooyongkoot-road	850	0 0		
Purchase of property No. 105 Kooyongkoot-road	950	0 0		
Purchase of land, Burgess-street	360	0 0		
Construction of Toorak-road Bridge	1,570	0 0		
			4,273	13 10

Loan No. 17.				
Re-conditioning Wallen-road Bridge			382	0 8

Loan No. 19.				
Purchase of refuse vehicles			67	13 10
			4,723	8 4

SCHEDULE "B."

Portion of cost of machinery for treating refuse			£4,723	8 4
--	--	--	--------	-----

The plans, specifications and estimate of cost referred to above and a statement showing the proposed expenditure of the unexpended money, are open for inspection at the office of the Council, Town Hall, Hawthorn, on all days between the hours the said office is appointed to be open.

Dated this 10th day of November, 1955.

5273 J. T. GUNDRY, Town Clerk.

CITY OF HEIDELBERG.

BY-LAW No. 192.

Regulating the Supply and Distribution of Water at Diamond Creek.

A By-law of the City of Heidelberg, made under the provisions of the Local Government Act 1946, section 197 (1) (iv) and section 228, and numbered 192, for regulating the supply and distribution of water at Diamond Creek.

IN pursuance of the powers conferred by the Local Government Act 1946 and all other powers enabling, the Mayor, Councillors, and Citizens of the City of Heidelberg order as follows:—

1. That By-laws 56, 57, 131, and 183 be repealed as from the date of coming into operation of this By-law.

2. In this By-law unless inconsistent with the subject-matter or context—

- (a) "Council" means the Council of the City of Heidelberg.
- (b) "Town Clerk" means the Town Clerk of the City of Heidelberg for the time being or the Acting Town Clerk of the City of Heidelberg for the time being, and shall also mean and include any other officer or person appointed by the Council for the purpose of exercising the powers of the Town Clerk under this By-law.
- (c) "City Engineer" means the City Engineer of the City of Heidelberg for the time being or the Acting City Engineer of the City of Heidelberg for the time being, and shall also mean and include any other officer or person appointed by the Council for the purpose of exercising the powers of the City Engineer under this By-law.
- (d) "Daily Newspaper" means "The Age," "Argus," "Herald," "Sun," or other daily newspaper circulating in the water supply area of Diamond Creek.
- (e) "Period" means a succession of days whether broken or not commencing at a specified hour of a specified day and concluding at a specified hour of a specified day or at such hour of such day as shall subsequently be specified.



3. That the charge for water shall be at the rate of not less than One shilling and nine pence per 1,000 gallons, with a maximum of not more than Two shillings and six pence.

4. That the supply of water shall in all cases be by measure, and the Council may by notice, in writing, specify the size and type of meter or meters to be fixed to measure the quantity of water supplied to any premises.

5. Applications for water service must be made to the Council by the plumber laying such service, and three days' notice thereof, in writing, must be given. He shall also lodge with such application 10s. for ½-in. service, and 20s. for ¾-in. service, in addition to the usual deposit required for opening the road. The amount thus lodged shall entitle the consumer of 8,000 gallons of water for ½-in. connexion and 16,000 gallons of water for ¾-in. connexion.

6. All connexions shall be paid for by the consumer, and shall be made under the supervision and subject to the approval of the City Engineer.

7. No person shall, without notice in writing to Council, interfere with any pipe or connexion between the main and the meter.

8. Every consumer shall, at his own expense, provide a meter to Melbourne and Metropolitan Board of Works specifications, and maintain the same in good working order to the satisfaction of the City Engineer; such meter shall not be placed at a greater distance than 3 feet from the street or road frontage.

9. A high pressure screw-down stopcock, properly fitted, shall be placed on each service between the meter and the street or road frontage.

10. All connexions, meters, taps, &c., must be approved by the City Engineer, and any connexion, service pipe, meter taps, or other fittings that, in the opinion of the City Engineer, have become corroded or otherwise defective shall be renewed forthwith on receipt of notice, in writing, from him.

11. Any person desiring to remove or alter the position of a meter must give three days' notice, in writing, and the registration of the quantity of the water used shall be taken before such removal or alteration.

12. The Council may by notice, in writing, order any type and size of meter to be fixed in lieu of any other type or size of meter already fixed.

13. No person shall affix any service pipe to any of the Council's mains, or alter or repair, or in any manner interfere with, any pipe belonging to the Council or any service pipe, tap, or fitting except he shall be a licensed plumber.

14. Any alteration, removal, or work to be done under clauses 10 and 12 of this By-law shall be at the cost of the owner or occupier of the tenement supplied with water, each of whom shall be liable.

15. No person, whether licensed as aforesaid or not, shall uncover any pipe without giving three days' notice to the Council, or shall tamper with or alter any pipe without permission, in writing, or shall wilfully or negligently break, injure, or open any lock, cock, valve pipe, work, or injure the property of the Council.

16. All connexions with the Council's mains must be made in the same manner as required by the Melbourne and Metropolitan Board of Works.

17. The person appointed by the Council may at any time enter into any house or premises supplied from the Council's main, in order to examine if there be any misuse of water, or for the purpose of checking the meter, and if such person be refused admission or prevented from entering any such house or premises, the Council may refuse to continue the supply of water to such premises, and the occupier of the said premises shall, in addition, be liable to the penalties hereunder.

18. If, in the opinion of the Council, or the Town Clerk, it is necessary to reduce the consumption of water supplied by the Council within the whole of the water supply area of Diamond Creek, or within any area comprised therein, the Council or Town Clerk (as the case may be) may at any time, or from time to time, declare that in respect to the whole of the area, or in respect to such part, as are specified in the declaration—

(a) Any period to be a period of restricted use of water; or

(b) Any period to be a period of limited use of water.

19. If, in the opinion of the Council, or the Town Clerk, it is still necessary to reduce the consumption of water within the whole of the water supply area of Diamond Creek, or within any area comprised therein, specified in a declaration made pursuant to clause 18 hereof, the

Council, or the Town Clerk, may in respect to the whole of the water supply area of Diamond Creek, or in respect to any area comprised therein—

(a) during a period declared to be a period of limited use of water, terminate such period and declare the period commencing from the time of such termination to be a period of restricted use of water;

(b) during any period declared to be a period of restricted use of water or a period of limited use of water, declare any immediately ensuing period to be a period of restricted use of water or a period of limited use of water.

20. Any declaration made pursuant to clauses 18 or 19 hereof shall be in form or to the effect set forth in the Schedule hereto, and shall be signed by the Town Clerk, and shall be published in a daily newspaper.

21. Save as hereinafter provided, during any period declared to be a period of restricted use of water or a period of limited use of water, no person shall, in the whole of the water supply area of Diamond Creek, or where any declaration made pursuant to clauses 18 or 19 hereof specifies any portion of such water supply area, use or cause or permit to be used for the watering of any garden, lawn, or vegetation or of any ground used or adapted for use in connexion with any sport, game, or other form of recreation, water supplied directly, or indirectly, by the Council: Provided, however, that—

(a) During any period declared to be a period of restricted use of water, water supplied by the Council may be used for such watering if the watering be carried out by means of a watering can or other similar container held in the hand.

(b) During any period declared to be a period of limited use of water, water supplied by the Council may be used for watering if the watering be carried out by means of a watering can or hose held in the hand.

(c) During any period declared to be a period of restricted use of water, or a period of limited use of water, water supplied by the Council may be used for watering of any garden or any portion of any garden used wholly for the growing for sale of vegetables, fruit, seedlings, or flowers.

22. Any person committing any breach of this By-law shall be guilty of an offence and shall, upon conviction, be liable to a penalty not exceeding £20.

23. Before any period declared pursuant to clauses 18 and 19 hereof to be a period of restricted use of water or a period of limited use of water has expired, the Council or the Town Clerk, having regard to the water supply then available may, by declaration published in accordance with clause 20 hereof, terminate such period.

#### SCHEDULE REFERRED TO.

I,

Town Clerk of the City of Heidelberg,

in pursuance of the powers conferred by By-Law No. of the said Council:

Hereby declare that in respect of the period commencing at \_\_\_\_\_ o'clock in the noon of \_\_\_\_\_ the \_\_\_\_\_ day of \_\_\_\_\_ 19 \_\_\_\_\_ and concluding at \_\_\_\_\_ o'clock in the noon of the \_\_\_\_\_ day of \_\_\_\_\_ 19 \_\_\_\_\_ at such hour of such day as shall subsequently be specified (excepting between hours of \_\_\_\_\_ and \_\_\_\_\_ of each day comprised in such period) shall be a period of \_\_\_\_\_ use of water.

Signed by the said

in the presence of—

The Resolution for passing this By-law was agreed to by the Council on 10th October, 1955, and confirmed on 7th November, 1955.

(SEAL) D. SEDDON, Mayor.  
W. A. TUCKFIELD, Councillor.  
F. PHILLIPS, Town Clerk.

5240

CITY OF MELBOURNE.

By-Law No. 357.

A By-law of the City of Melbourne, made under Part VII., Division 1, of the Local Government Acts and numbered 357, requiring the destruction of Argentine ants and providing that in the event of failure of any owner or occupier of any property or premises to comply with the requirements of this By-law, the Council may cause measures to be taken to destroy such Argentine ants at the expense of the owner or occupier and recover the cost thereof as a civil debt recoverable summarily.

**I**N pursuance of the powers conferred by the Local Government Acts and every other Act or power enabling it in that behalf, the Council of the City of Melbourne doth hereby order as follows:—

1. In this By-law, unless inconsistent with the context or subject matter "Argentine ants" means the species of ants known by the entomological name of *Iridomyrmex humilis* Mayr.

"Council" means the Council of the City of Melbourne.  
"Inspector" means any person appointed by the Council to carry out the duties of an inspector.

"Premises" includes messuages buildings land and hereditaments of every tenure and also any machinery plant appliance or vehicle used in connexion with any trade carried on at any premises.

2. (a) It shall be lawful for an Inspector to enter from time to time at any reasonable hour without notice upon any premises in the City of Melbourne for the purpose of ascertaining whether there are Argentine ants in or about such premises.

(b) If the Inspector finds or believes that there are Argentine ants in or about any premises, he may give notice to the owner or occupier thereof, requiring him forthwith to destroy all Argentine ants in or upon such premises.

(c) Any owner or occupier so notified who, within seven days after service of the notice, does not destroy all Argentine ants in or about his premises shall be guilty of an offence against this By-law.

3. If after three days from the date of expiry of any notice served under clause 2 (b) hereof on any owner or occupier of any premises, such owner or occupier has not complied with the requirements thereof, the Council may—

(i) cause measures to be taken to destroy all Argentine ants in or about any such premises at the expense of the owner or occupier thereof; and

(ii) recover the cost thereof from such owner or occupier as a civil debt recoverable summarily.

4. Every person guilty of a breach of this By-law shall be liable to a penalty of not less than Five pounds or more than Twenty pounds, and in the case of continuing offence to a penalty of not more than Five pounds for each day on which an offence against this By-law is continued after a conviction or order by any court.

5. This By-law shall apply to and have operation throughout the whole of the municipal district of the City of Melbourne.

Resolution for passing this By-law agreed to by the Council of the City of Melbourne, the tenth day of October, 1955, and confirmed the seventh day of November, 1955.

(L.S.) F. P. SELLECK, Lord Mayor.  
5227 G. J. DEAN, Town Clerk.

**CITY OF MILDURA.**

**By-Law No. 39.**

**N**OTICE is hereby given that the Council of the City of Mildura has made a By-law under the provisions of the Health Acts and numbered 39 for the following purposes:—

(a) Repealing By-law No. 20.  
(b) Prescribing the fees to be charged and taken by the Council of the City of Mildura for the registration of certain premises under the Health Acts and for annual renewals thereof and for any transfers of such registrations.

(c) Fixing a day as being the last day for lodging applications for the renewal of the registration of such premises aforesaid.

A copy of this By-law is open for inspection, free of charge, during office hours at the offices of the Council, Town Hall, Mildura.

Resolution for making and passing this By-law was agreed to by the Council on the 11th day of August, 1955, and confirmed on the 8th day of September, 1955, and approved by the Commission of Public Health on the 4th day of October, and subsequently approved by the Governor in Council on the 25th day of October, 1955.

5213 W. J. DOWNIE, Town Clerk.

**CITY OF OAKLEIGH.**

**NOTICE OF CHANGE OF STREET NAME.**

**N**OTICE is hereby given that, in pursuance of the powers conferred by the Local Government Act, the Council of the City of Oakleigh, at a meeting held on the 7th day of November, 1955, did resolve to make the following alteration in a street name: Thompson-street (the section running east and west) to be changed to Haughton-road.

5272 J. A. PRICE, Town Clerk.

**CITY OF SANDRINGHAM.**

**By-Law No. 161.**

A By-law of the City of Sandringham, made under section 197 (1) (x) of the *Local Government Act* 1946, as amended by section 10 (b) of the *Local Government (Amendment) Act* 1954, and numbered 161, for the purposes of—

(a) Requiring the destruction of noxious weeds; and

(b) Providing that in the event of failure of any owner or occupier of any property or premises to comply with the requirements of this by-law, the Council may cause measures to be taken to destroy such weeds at the expense of the owner or occupier and recover the cost thereof as a civil debt recoverable summarily.

**I**N pursuance of the powers conferred by the Local Government Acts, and of any and every other power thereunto it enabling, the Mayor, Councillors and Citizens of the City of Sandringham order as follows:—

1. The Council of the City of Sandringham may at any time cause to be served on the owner or occupier of any property or premises a notice, in writing, requiring such owner or occupier within a time limited by such notice to destroy all such noxious weeds as may be specified in such notice and which are upon such property or premises. Any such notice may be signed by the Town Clerk or any other duly authorized officer of the municipality.

2. If any such owner or occupier shall within the time limited by such notice fail to comply with the requirements thereof the Council may take such measures as may be reasonably necessary to destroy such noxious weeds at the expense of such owner or occupier and may recover the cost thereof from such owner or occupier as a civil debt recoverable summarily.

3. In this By-law the words "noxious weeds" include the following weeds:—

*Botanical Name; Common Name.*

- Rubus fruticosus*, L.; Blackberry Bramble.
- Lycium ferocissimum*, Miers; Boxthorn.
- Ulex europaeus*, L.; Furze.
- Salpichroa rhomboidea*, M.; Pampas Lily of the Valley.
- Rosa rubiginosa*, L.; Sweet Briar.
- Foeniculum Vulgare*, Mill; Fennel.
- Homeria collina*, Vent; Cape Tulp.
- Watsonia meriana*, Mill; Merians Bugle Lily (Watsonia).

4. Notwithstanding any action taken under clause 2 of this By-law and apart from and in addition to any liability under that clause, any person who is guilty of any wilful act or default contrary to any of the provisions of this By-law shall be liable for every offence to a penalty not exceeding Twenty pounds.

5. This By-law shall apply and have operation throughout the whole of the municipal district of the City of Sandringham.

Resolution for passing this By-law agreed to by the Council on the 20th day of September, 1955, and confirmed on the 18th day of October, 1955.

The common seal of the Mayor, Councillors and Citizens of the City of Sandringham was hereto affixed the 31st day of October, 1955, in the presence of—

(SEAL) H. NANKERVIS, Mayor.  
5238 R. BARNETT, Councillor.  
FRED G. TRICKS, Town Clerk.

**CITY OF SANDRINGHAM.**

**By-Law No. 162.**

A By-law of the City of Sandringham, made under section 197 (1) (x) of the Local Government Acts, and numbered 162, for—

(a) requiring the destruction of Argentine ants; and

(b) providing that in the event of failure of any owner or occupier of any property or premises to comply with the requirements of this By-law the Council may cause measures to be taken to destroy such Argentine ants at the expense of the owner or occupier and recover the cost thereof as a civil debt recoverable summarily.

**I**N pursuance of the powers conferred by the Local Government Acts, the Mayor, Councillors and Citizens of the City of Sandringham order as follows:—

1. In this By-law, unless inconsistent with the context or subject-matter—

"Argentine ants" means the specie of ants known by the entomological name of "*Iridomyrmex humilis* Mayr."

"Council" means the Council of the City of Sandringham.

"Health Inspector" means any person appointed by the Council to carry out the duties of Health Inspector.

2. (a) Every owner or occupier of property or premises shall keep such property or premises free of Argentine ants.

(b) If the Health Inspector finds or believes that Argentine ants exist in or about any property or premises, he may give notice to the owner or occupier thereof to forthwith effectively destroy such Argentine ants. Such notice may be served in manner provided by section 847 of the Local Government Acts.

(c) Any owner or occupier so notified who within seven days after service of the notice has not effectively destroyed all Argentine ants in or about his property or premises shall be guilty of an offence against this By-law.

3. If after seven days from the date of the service of any notice under clause 2 (b) hereof on any owner or occupier of any property or premises such owner or occupier has not complied with the requirements thereof the Council may—

- (i) cause measures to be taken to effectively destroy any Argentine ants existing in or about any such property or premises at the expense of the owner or occupier thereof; and
- (ii) recover the cost thereof as a civil debt recoverable summarily.

4. Notwithstanding any action taken under the last preceding clause of this By-law and apart from and in addition to any liability under that clause, every person who is guilty of any wilful act or default contrary to any of the provisions of this By-law shall be liable for every offence to a penalty of not less than Five pounds or more than Twenty pounds.

5. This By-law shall apply and have operation throughout the whole of the municipal district of the City of Sandringham.

Resolution for passing this By-law agreed to by the Council on the 20th day of September, 1955, and confirmed on the 18th day of October, 1955.

The common seal of the Mayor, Councillors and Citizens of the City of Sandringham was hereto affixed the 31st day of October, 1955, in the presence of—

(SEAL) H. NANKERVIS, Mayor.  
R. BARNETT, Councillor.  
FRED G. TRICKS, Town Clerk.

5239

## BOROUGH OF RINGWOOD.

## BY-LAW No. 36.

*Residential Areas.*

A By-law of the Borough of Ringwood, made under the Local Government Acts, and numbered 36, for altering and adding to By-law No. 20 of the said Borough.

IN pursuance of the powers conferred by the Local Government Acts and of any and every other power it thereunto enabling, the Mayor, Councillors, and Burgesses of the Borough of Ringwood order as follows:—

1. There shall be added at the end of the Second Schedule to By-law No. 20 of the Borough of Ringwood the following paragraph:—

34. Commencing at the north-east corner of the right-of-way behind the shops facing Maroondah Highway between Adelaide-street and Melbourne-street; thence by a line running north for a distance of 87 ft. 3 in.; thence west for a distance of 203 ft. 10½ in.; thence south for a distance of 189 ft. 2 in.; thence by a line bearing 251 deg. 25 min. for a distance of 45 ft. 4 in.; thence by a line bearing 241 deg. 28 min. for a distance of 153 ft. 1½ in. to the commencing point.

2. There shall be added at the end of the Third Schedule to the said By-law No. 20 the following paragraph:—

8. Commencing at a point at the intersection of the east building line of Heatherdale-road with the north building line of Palmerston-road; thence northerly along the east building line of Heatherdale-road for a distance of 327 ft. 9 in.; thence easterly along a line bearing 90 deg. 0 min. for a distance of 1,991 ft. 1 in. to the west building line of New-street; thence southerly along the west building line of New-street for a distance of 328 ft. 8 in. to the north building line of Palmerston-road; thence westerly along the north building line of Palmerston-road for a distance of 1,991 feet to the commencing point.

Resolution for passing this By-law agreed to by the Council on 5th May, 1955, and confirmed on the 2nd June, 1955.

The corporate seal of the Mayor, Councillors, and Burgesses of the Borough of Ringwood was hereto affixed on the 2nd June, 1955, in the presence of—

(SEAL) R. C. HORMAN, Mayor.  
B. J. HUBBARD, Councillor.  
ALFRED KELLY, Town Clerk.

Approved by the Governor in Council, 2nd November, 1955.—A. MAHLSTEDT, Clerk of the Executive Council.

5274

## SHIRE OF AVON.

## LOAN No. 3.

*Notice of Intention to Borrow the Sum of £8,000 for Permanent Works and Undertakings.*

NOTICE is hereby given that the Council of the Shire of Avon proposes to borrow the sum of Eight thousand pounds, on the credit of the municipal revenues of the President, Councillors, and Ratepayers of the said Shire, such sum to be raised by the issue of debentures, in accordance with the provisions of the Local Government Acts.

1. The maximum rate of interest that may be paid is 4½ per cent. per annum.

2. The purposes for which the loan is to be applied are—

(a) Purchase of road-making plant and workshop equipment .. .. .	£3,090
(b) Township drainage .. .. .	£2,310
(c) Contribution to road construction works	£2,600

3. The period of the loan shall be ten years.

4. The moneys borrowed shall be repayable by providing out of the municipal fund twenty half-yearly instalments of approximately £510 3s. each, including principal and interest, on the 1st day of March and the 1st day of September during the currency of the loan. The first instalment shall be payable on the 1st day of September, 1956.

5. Such moneys shall be repayable at The National Bank of Australasia Limited, Melbourne, or at the Council's bankers for the time being in Melbourne.

The plans and specifications and the estimate of the cost of the proposed works, and a statement showing the proposed expenditure of the moneys to be borrowed, are open for inspection at the Shire Office, Stratford, Victoria.

Dated 10th November, 1955.

5229 ERIC C. BOCK, F.I.M.A., J.P., Shire Secretary.

## SHIRE OF AVON.

## BY-LAW No. 19.

*A By-law Relating to Granting or Annual Renewal of Registration of Premises.*

IN pursuance of the powers contained in the Health Act 1928, and amendments thereof, and of any other power thereunto enabling them in that behalf, the Council of the Shire of Avon, in the name and on behalf of the President, Councillors, Citizens, and Ratepayers of the said Shire, for the purpose of fixing fees payable for the granting or annual renewal of registration of premises, make the following By-law No. 19.

1. By-laws numbered 9 and 13 prescribing fees for registration of premises are hereby repealed.

2. This By-law shall come into force and operation on its approval by the Governor in Council, and immediately after its publication in the *Government Gazette*.

3. This By-law shall apply to and have operation throughout the Shire of Avon.

4. In this By-law, unless inconsistent with the context or subject-matter, "Proprietor" means the proprietor of any premises and includes the owner, occupier, or any person having the management or control thereof.

5. The Proprietor of any premises which is required by the Health Acts to be registered annually with the Council, shall make application for registration or renewal of in the prescribed manner, and such application shall be lodged with the Council not later than the 15th day of November next preceding the year for which registration or renewal of registration is being applied.

6. With each application for registration or renewal of registration there shall be lodged with the Council a fee as prescribed in the Schedule hereunder.

7. Where application for renewal of registration is not lodged with the Council until after the last day fixed by this By-law for the lodging thereof, an additional fee equal to one-half of the relevant prescribed fee otherwise payable for renewal of registration shall be paid.

SCHEDULE.

Fees payable for the granting or annual renewal of registration of premises:—

Nature of Premises.	Fee.		
	£	s.	d.
Offensive trade premises (other than those referred to below) .. .. .	3	0	0
Offensive trade premises (being fat extracting or melting or rendering works which are conducted at premises occupied principally as a butcher's shop and at which fat is extracted, melted, or rendered only from materials derived from such shop) .. .. .	1	0	0
Cattle sale yards .. .. .	1	0	0
Boarding-houses .. .. .	1	0	0
Common lodging-houses .. .. .	1	0	0
Eating-houses .. .. .	1	0	0
Apartment-houses—			
Containing not more than one apartment ..	0	10	0
Containing more than one apartment ..	1	0	0
Camping areas .. .. .	1	0	0
Food premises—			
(1) Where 5 or less than 5 persons are employed	0	10	0
(2) Where from 6 to 20 persons are employed	1	0	0
(3) Where from 21 to 50 persons are employed	2	0	0
(4) Where more than 50 persons are employed	5	0	0
(5) Premises at or in any part of which eggs for sale are received or stored for the purpose of being chilled .. .. .	1	0	0
Hairdressers, beauty parlours, and chiroprodists	1	0	0
For any transfer of registration .. .. .	0	2	6

Resolution for passing this By-law No. 19, agreed to by the Council on the 5th day of September, 1955, and confirmed on the 3rd day of October, 1955.

The common seal of the Shire of Avon was hereunto affixed, in pursuance of an Order of the Council, made this 3rd day of October, 1955, in the presence of—

THOMAS BLANDFORD, President.  
 (SEAL) KEITH DAVIDSON, Councillor.  
 ERIC LEE, Councillor.  
 ERIC C. BOCK, Shire Secretary.

Submitted to the Commission of Public Health, 18th day of October, 1955.—G. V. STAFFORD, Secretary to the Commission.

Approved by the Governor in Council, 2nd November, 1955.—A. MAHLSTEDT, Clerk of the Executive Council.  
 5230

SHIRE OF AVON.

BY-LAW No. 21.

Rubbish Tips, &c.

A By-law of the Shire of Avon, made under section 197 of the *Local Government Act 1946*, and every other power thereunto it enabling, and numbered 21, for suppressing nuisances, preventing fires, and generally for maintaining the good rule and government in the municipality.

IN pursuance of the powers conferred by the *Local Government Act 1946*, the President, Councillors, and Ratepayers of the Shire of Avon order as follows:—

1. No person shall do or permit to be done any of the following matters at any refuse tip or incinerator under the control of the Council of the Shire of Avon:—

- (a) Trespass on any part of such area.
- (b) Deposit or leave any refuse or rubbish except as directed by the Council's engineer or other officer in charge of any such areas.
- (c) Obstruct, disturb, interrupt, or annoy any person lawfully using such area.
- (d) Neglect or refuse to obey the lawful directions of the Council's Engineer or other officer or employee in charge of any such areas.
- (e) Deposit or leave any rubbish, refuse, factory waste, or any other material which, in the opinion of the Council's Engineer or other officer in charge of any such areas is inflammable or

subject to spontaneous combustion, or liable to ignite or if ignited to cause smoke or fumes. Provided that this prohibition shall apply for only such period of the year as the Council or its Engineer or other officer in charge of any such areas shall determine.

- (f) Bring, deposit, or leave any refuse or rubbish obtained from any place outside the municipal district of the Shire of Avon without the written authority of the Shire Secretary of the Shire of Avon.
- (g) Remove any sand or material.
- (h) Interfere with the surface of the tip or with any materials deposited or about to be deposited at the tip.
- (i) Behave in an unseemly, indecent, or improper manner, or use any profane or indecent language, or commit any nuisance at the tip.
- (j) Disfigure, damage, destroy, or interfere with any notice board, post, fence, building, appliance, tree, gate, or other equipment at the tip.

2. No person in or upon any road, street, footway, or public place within the municipal district of the Shire of Avon shall drive any vehicle laden with sand, dust, paper shavings, iron, steel or metal shavings, or waste or any other material which may drop or be blown about, unless such vehicle is provided with adequate sides and, where necessary, completely enclosed to the satisfaction of an officer of the Council.

3. This By-law shall apply to and have operation throughout the whole of the municipal district of the Shire of Avon.

4. Any person doing any act forbidden to be done or failing to do any act directed to be done by this By-law shall be liable to a penalty of not more than £20.

Resolution for passing this By-law agreed to by the Council of the Shire of Avon on the 5th day of September, 1955, and confirmed by the said Council on the 3rd day of October, 1955.

The common seal of the Shire President, Councillors, and Ratepayers of the Shire of Avon was hereunto affixed this 3rd day of October, 1955, in the presence of—

THOMAS BLANDFORD, President.  
 (SEAL) KEITH DAVIDSON, Councillor.  
 ERIC LEE, Councillor.  
 ERIC C. BOCK, Shire Secretary.

5231

SHIRE OF BULLA.

BY-LAW No. 14.

Health Act Registration Fees.

A By-law of the Shire of Bulla, made under the *Health Act 1928*, and any other Act amending the same, and numbered 14, for the purpose of prescribing the fees to be charged for the registration of certain premises required under the said Acts to be registered, and for the renewal of such registration, and for the transfer of registration thereof, pursuant to the said Acts.

IN pursuance of the powers conferred by the *Health Act 1928*, and any other Act amending the same, and by every other Act or power enabling it in that behalf, the President, Councillors and Ratepayers of the Shire of Bulla, order as follows:—

(1) Any by-laws previously made and dealing with the subject herein are hereby repealed.

(2) The fees to be charged, received and taken by the Council of the Shire of Bulla for the registration of the premises described in the Schedule hereto, and for the annual renewals thereof, and for any transfer of such registration respectively, pursuant to the provisions of the *Health Act*, shall be as set out in the Schedule hereto.

(3) Such fees shall be paid to the Shire Secretary by any person making application for such registration, renewal or transfer respectively.

(4) This By-law shall apply to and have operation throughout the whole of the municipal district of the Shire of Bulla.

SCHEDULE REFERRED TO IN THE BY-LAW.

	£	s.	d.
Offensive trade premises (other than those referred to below) .. .. .	5	0	0
Offensive trade premises—piggeries, where usual number exceeds ten .. .. .	5	0	0
Offensive trade premises—piggeries, where usual number does not exceed ten .. .. .	2	0	0
Offensive trade premises—poultry killing, or cleaning, or dressing .. .. .	2	0	0
Offensive trade premises—boiling-down works associated with another offensive trade .. .. .	2	0	0
Offensive trade premises—fat extraction, or melting, or rendering works conducted at rear of butchers business premises and at which fat is extracted, melted or rendered only from materials derived from such shop .. .. .	1	0	0
Food premises—where less than five employed .. .. .	0	10	0
—where from six to twenty employed .. .. .	1	0	0
—where from 21 to 50 employed .. .. .	2	0	0
—where more than 50 employed .. .. .	5	0	0
Boarding houses .. .. .	1	0	0
Common lodging houses .. .. .	1	0	0
Eating houses .. .. .	1	0	0
Cattle saleyards .. .. .	1	0	0
Camping areas .. .. .	1	0	0
Transfer of registration .. .. .	0	2	6

Resolution adopting this By-law agreed to by Council on the 9th August, 1955, and confirmed on the 13th September, 1955.

The common seal of the President, Councillors and Ratepayers of the Shire of Bulla was hereto affixed in the presence of—

W. ELLIS KELLY, President.  
J. T. STOCKFIELD, Councillor.  
THOS. F. MCCORMACK, Secretary.

Submitted to the Commission of Public Health on the 4th day of October, 1955.—G. V. STAFFORD, Secretary to the Commission.

Approved by the Governor in Council, 25th October, 1955.—A. MAHLSTEDT, Clerk of the Executive Council. 5209

SHIRE OF CRANBOURNE.

By-LAW No. 38.

A By-law of the Shire of Cranbourne, made under the Health Acts, and numbered 38, for prescribing fees to be charged for the registration of premises and for the renewal of such registration and for the transfer of registration thereof, pursuant to the said Acts.

IN pursuance of the powers conferred by the Health Acts and by every other Act or power enabling it in that behalf, the President, Councillors, and Ratepayers of the Shire of Cranbourne order as follows:—

1. By-law No. 24 of the Shire of Cranbourne is hereby repealed.

2. The fees to be charged, received and taken by the Council of the Shire of Cranbourne for the registration of premises and for annual renewals thereof, for any transfers of such registrations and additional fees for late application for renewals of the several classes of premises hereunder specified shall be as set out in the Schedule hereto.

3. Any party making application for such registration, renewal or transfer respectively shall pay to the Secretary of the Shire of Cranbourne such fees as are hereby made payable for registration of the premises, or annual renewal or transfer or registration thereof (as the case may be), which is the subject-matter of the application.

4. Save as to piggeries, this By-law shall have force and operation throughout the municipal district of the Shire of Cranbourne, and as to piggeries this By-law shall have force and operation in so much of the municipal district of the Shire of Cranbourne as is constituted by Crown allotments 4, 5, 6, 10, 11, 12, 13 and 13A, Parish of Lang Lang, County of Mornington, and the northern part of Crown allotment 14, said parish and county, such part being bounded on the south by a prolongation of the southern boundary of the said Crown allotment 12 bearing S. 80 deg. 5 min. W. to the eastern boundary of the aforesaid Crown allotment 14.

5. Any party who shall wilfully offend against any of the provisions of this By-law shall be liable to a penalty of not more than Twenty pounds, and in the case of a continuing offence to a further penalty of not more than Five pounds for each day on which an offence against this By-law is continued after a conviction or order by any Court in respect thereof against such party.

SCHEDULE ABOVE REFERRED TO.

(a) For every registration and for every annual renewal of registration and additional fee payable when application for renewal lodged after 15th November in any year:—

Nature of Premises.	Fees Payable.	Additional Fees Payable where Application for Renewal Lodged after 15th November, in any Year.
		£ s. d.
Offensive trades premises (other than those referred to below)	Five pounds ..	2 10 0
Offensive trade premises (being fat extracting or melting or rendering works which are conducted at premises occupied principally as a butcher's shop and at which fat is extracted melted or rendered only from materials derived from such shop)	One pound ..	0 10 0
Cattle Sale Yards .. .. .	One pound ..	0 10 0
Boarding Houses .. .. .	One pound ..	0 10 0
Common Lodging Houses .. .. .	One pound ..	0 10 0
Eating Houses .. .. .	One pound ..	0 10 0
Apartment Houses—		
Containing not more than one Apartment .. .. .	Ten shillings ..	0 5 0
Containing more than one Apartment .. .. .	One pound ..	0 10 0
Camping Areas .. .. .	One pound ..	0 10 0
Food Premises—		
(i) where five or less than five persons are employed;	Ten shillings ..	0 5 0
(ii) where from 6 to 20 persons are employed;	One pound ..	0 10 0
(iii) where from 21 to 50 persons are employed;	Two pounds ..	1 0 0
(iv) where more than 50 persons are employed	Five pounds ..	2 10 0
Premises at or in any part of which eggs for sale are received or stored for the purpose of being chilled	One pound ..	0 10 0

(b) For any transfer of registration—Two shillings and six pence.

Resolution for passing this By-law agreed to by the Council of the Shire of Cranbourne the 2nd day of September, 1955, and confirmed at a meeting of the said Council held the 7th of October, 1955.

The common seal of the President, Councillors and Ratepayers of the Shire of Cranbourne was hereto affixed by order of the Council this 7th day of October, 1955, in the presence of—

GEORGE F. KNOWLES, President.  
(SEAL) P. B. FECHNER, Councillor.  
W. B. CAMPBELL, Councillor.  
T. W. GRANT, Shire Secretary.

Submitted to the Commission of Public Health on the 18th day of October, 1955.—G. V. STAFFORD, Secretary to the Commission.

Approved by the Governor in Council, 2nd November, 1955.—A. MAHLSTEDT, Clerk of the Executive Council. 5270

SHIRE OF DONCASTER AND TEMPLESTOWE.

APPOINTMENT OF PROSECUTING OFFICER.

NOTICE is hereby given that First Constable HORACE EDWARD KNOWLES, 8756, of Doncaster, has been appointed Prosecuting Officer to the Shire of Doncaster and Templestowe, vice First Constable Frederick Harold Biggs.

J. W. THOMSON, Shire Secretary.  
11th November, 1955. 5269

SHIRE OF DIMBOOLA.

DECLARATION OF STREET AS PUBLIC HIGHWAY.

THE President, Councillors, and Ratepayers of the Shire of Dimboola, pursuant to the powers conferred by section 521 of the *Local Government Act 1946*, hereby declare the street in the Parish of Pullut, being Rigg-street, Rainbow, shown by hachure on plan hereunder, to be dedicated to the public as a public holiday.

**TOWNSHIP OF RAINBOW**  
**PARISH OF PULLUT**  
**COUNTY OF KARKAROOO**

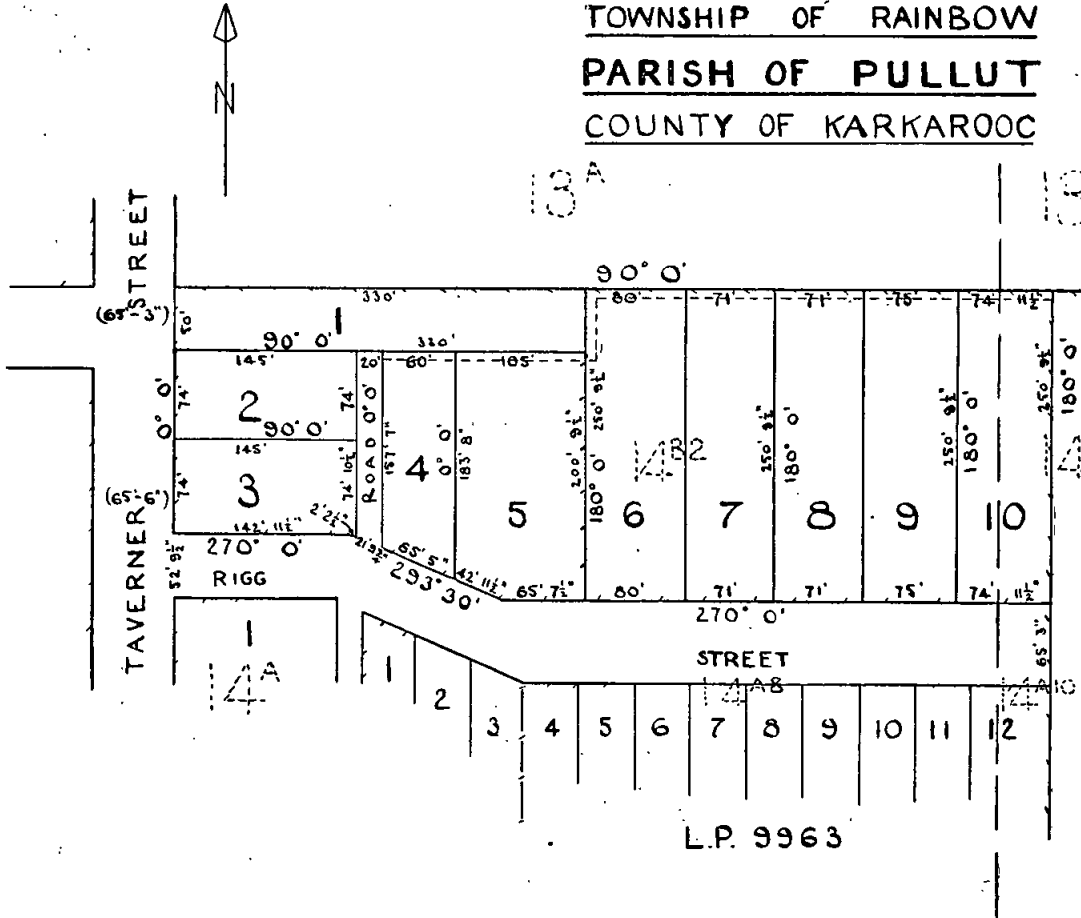

SCALE : 100 FEET TO AN INCH

The common seal of the President, Councillors, and Ratepayers of the Shire of Dimboola was hereunto affixed on the 13th day of September, 1955, in the presence of—

5215

(SEAL) A. H. ALLAN, President.  
 G. A. C. PERKINS, Councillor.  
 R. LIVINGSTON, Shire Secretary.

SHIRE OF FLINDERS.

BY-LAW No. 40.

Health Act—Registration Fees.

A By-law of the Shire of Flinders, made under the Health Acts, and numbered 40, for the purpose of prescribing the fees to be charged for the registration of premises and for the renewal and transfer of registration thereof, pursuant to the said Acts.

IN pursuance of the powers conferred by the Health Acts and of any other powers thereunto enabling them in that behalf, the President, Councillors, and Ratepayers of the Shire of Flinders hereby order as follows:—

1. By-law No. 20 of the Shire of Flinders published in the *Government Gazette* is hereby repealed.
2. The fees to be charged, received and taken by the Council for the registration or the renewal or transfer of registration of premises, pursuant to the Health Acts, shall be those specified in the Schedule hereto.
3. The said fees shall be paid to the Shire Secretary of the said Shire, or other authorized officer, by every person making application for such registration renewal or transfer.
4. This By-law shall apply to and have effect throughout the municipal district of the Shire of Flinders.

SCHEDULE.

(a) For the granting or annual renewal of registration of premises—

Nature of Premises.	Fees Payable for Registration or Renewal Thereof.
Offensive trades premises (other than those referred to below) .. .. .	Five pounds.
Offensive trade premises (being fat extracting or melting or rendering works which are conducted at premises occupied principally as a butcher's shop and at which fat is extracted, melted, or rendered only from materials derived from such shop) .. .. .	One pound.
Cattle sale-yards .. .. .	One pound.
Boarding-houses .. .. .	One pound.
Common lodging-houses .. .. .	One pound.
Eating-houses .. .. .	One pound.
Apartment-houses—	
containing not more than one apartment .. .. .	Ten shillings.
containing more than one apartment .. .. .	One pound.
Camping areas .. .. .	One pound.

## Food premises—

- (i) where five or less than five persons are employed .. Ten shillings.  
 (ii) where from six to twenty persons are employed .. One pound.  
 (iii) where from 21 to 50 persons are employed .. Two pounds.  
 (iv) where more than 50 persons are employed .. Five pounds.

Premises at or in any part of which eggs for sale are received or stored for the purpose of being chilled .. One pound.

(b) For any transfer of registration—Two shillings and six pence.

Resolution for passing this By-law was adopted by the Council of the Shire of Flinders on the 1st day of June, 1955, and confirmed on the 6th day of July, 1955.

In witness whereof the common seal of the President, Councillors, and Ratepayers of the Shire of Flinders was hereto affixed, in the presence of—

(SEAL) E. RUDDUCK, President.  
 H. BRADBURY, Councillor.  
 S. A. BAKER, Councillor.  
 H. H. STRICKLAND, Shire Secretary.

Submitted to the Commission of Public Health, on 18th October, 1955.—G. V. STAFFORD, Secretary to the Commission.

Approved by the Governor in Council, this 2nd day of November, 1955.—A. MAHLSTEDT, Clerk of the Executive Council. 5232

## SHIRE OF HAMPDEN.

NOTICE is hereby given that Constable R. J. Clarke, No. 8046, has been appointed Prosecuting Officer to this Shire, in place of the late Constable J. N. Brewis.

THOS. F. LITTLE, Shire Secretary.

4th November, 1955. 5218

## SHIRE OF KARKAROOC.

## LOAN No. 14.

*Notice of Intention to Borrow the Sum of £7,000 for Permanent Works and Undertakings.*

NOTICE is hereby given that the Council of the Shire of Karkaroc proposes to borrow the sum of Seven thousand pounds, on the credit of the municipal revenues of the President, Councillors, and Ratepayers of the said Shire, such sum to be raised by the issue of debentures, in accordance with the provisions of the Local Government Acts.

1. The maximum rate of interest that may be paid is 4½ (4 17s. 6d.) per cent. per annum.

2. The purpose for which the loan is to be applied is part purchase cost of heavy diesel motor power grader, complete as specified, and delivered to Hopetoun.

3. The period of the loan shall be ten (10) years.

4. The moneys borrowed shall be repayable by providing out of the municipal fund twenty half-yearly instalments of approximately £446 7s. 6d. each, including principal and interest, on the 1st day of March and the 1st day of September in each year during the currency of the loan. The first instalment shall be payable on the 1st day of September, 1956.

5. Such moneys shall be repayable at The Commercial Bank of Australia Limited, Melbourne, or at the Council's bankers for the time being in Melbourne.

The statement showing the proposed expenditure of the moneys to be borrowed is open for inspection at the Shire Offices, Lascelles-street, Hopetoun, during office hours, 9 a.m. to 5.30 p.m.

Dated this 8th day of November, 1955.

5237 JOHN T. COLLINS, Shire Secretary.

## SHIRE OF KORUMBURRA.

## LOAN No. 22.

*Notice of Intention to Borrow the Sum of £10,000 for Permanent Works and Undertakings.*

NOTICE is hereby given that the Council of the Shire of Korumburra proposes to borrow the sum of Ten thousand pounds on the credit of the municipal revenues of the President, Councillors, and Ratepayers of the said Shire, such sum to be raised by the issue of debentures, in accordance with the provisions of the Local Government Acts.

1. The maximum rate of interest that may be paid is 4½ per cent. per annum.

2. The purpose for which the loan is to be applied is for the construction of Municipal Offices at Korumburra.

3. The period of the loan shall be ten years.

4. The moneys borrowed shall be repayable by providing out of the municipal fund twenty half-yearly instalments of approximately £637 13s. 10d. each, including principal and interest, on the 1st day of October and the 1st day of April during the currency of the loan. The first instalment shall be payable on the 1st day of April, 1956.

5. Such moneys shall be repayable at the Australian and New Zealand Bank Ltd., Melbourne, or at the Council's bankers for the time being in Melbourne.

6. The plans and specifications and the estimate of the cost of the proposed works and a statement showing the proposed expenditure of the moneys to be borrowed, are open for inspection at the Shire Hall, Korumburra, during office hours.

5217 M. H. GARDNER, Shire Secretary.

## SHIRE OF KOWREE.

## BY-LAW No. 29.

NOTICE is hereby given that the Council of the Shire of Kowree has made a By-law under the provisions of the Local Government Acts and the Uniform Building Regulations, Victoria, and numbered 29, for the following purposes:—

Determining, applying, dispensing with, or regulating such matters or things as are left to be determined, applied, or dispensed with, or regulated by the Council of the Shire of Kowree under the Uniform Building Regulations, Victoria. Such matters relating to—

- (a) Brick areas;  
 (b) minimum area, depth, and width of frontage;  
 (c) distance from street alignment;  
 (d) sites below minimum requirements;  
 (e) rear access;  
 (f) flats.

A copy of this By-law is open for inspection, free of charge, during office hours, at the office of the Council, Edenhope.

5235 W. M. OLIVER, Shire Secretary.

## SHIRE OF KYNETON.

## LOAN No. 18.

*Notice of Intention to Borrow the Sum of £15,500 for Permanent Works and Undertakings.*

NOTICE is hereby given that the Council of the Shire of Kyneton proposes to borrow the sum of Fifteen thousand five hundred pounds, on the credit of the municipal revenues of the President, Councillors, and Ratepayers of the said Shire, such sum to be raised by the issue of debentures, in accordance with the provisions of the Local Government Acts.

1. The maximum rate of interest that may be paid is 4½ 17s. 6d. per cent. per annum.

2. The purpose for which the loan is to be applied is the provision of a dry-rendering plant at the Municipal Abattoirs.

3. The period of the loan shall be fifteen years.

4. The moneys borrowed shall be repayable by providing out of the municipal fund 30 half-yearly instalments of approximately £734 8s. each, including principal and interest, on the 1st day of March and the 1st day of September during the currency of the loan. The first instalment shall be payable on the 1st day of September, 1956.

5. Such moneys shall be repayable at The Commercial Banking Company of Sydney, Melbourne, or at the Council's bankers for the time being in Melbourne.

The plans and specifications and the estimate of the cost of the proposed works, and a statement showing the proposed expenditure of the moneys to be borrowed, are open for inspection at the Shire Hall, Kyneton.

5233 J. BORRELL, Shire Secretary.

## SHIRE OF KYNETON.

## LOAN No. 19.

*Notice of Intention to Borrow the Sum of £2,500 for Permanent Works and Undertakings.*

NOTICE is hereby given that the Council of the Shire of Kyneton proposes to borrow the sum of Two thousand five hundred pounds, on the credit of the municipal revenues of the President, Councillors, and Ratepayers of the said Shire, such sum to be raised by the issue of debentures, in accordance with the provisions of the Local Government Act.

1. The maximum rate of interest that may be paid is £4 16s. 3d. per cent. per annum.

2. The purpose for which the loan is to be applied is the purchase of a front-end loader.

3. The period of the loan shall be eight years.

4. The moneys borrowed shall be repayable by providing out of the municipal fund sixteen half-yearly instalments of approximately £190 2s. each, including principal and interest, on the 1st day of March and the 1st day of September during the currency of the loan. The first instalment shall be payable on the 1st day of September, 1956.

5. Such moneys shall be repayable at The Commercial Banking Company of Sydney, Melbourne, or at the Council's bankers for the time being in Melbourne.

The plans and specifications and the estimate of the cost of the proposed works, and a statement showing the proposed expenditure of the moneys to be borrowed, are open for inspection at the Shire Hall, Kyneton.

5234

J. BORRELL, Shire Secretary.

## SHIRE OF TAMBO.

## LOAN No. 7.

*Notice of Intention to Borrow the Sum of £3,500 for Permanent Works and Undertakings.*

NOTICE is hereby given that the Council of the Shire of Tambo proposes to borrow the sum of Three thousand five hundred pounds on the credit of the municipal revenues of the President, Councillors, and Ratepayers of the said Shire, such sum to be raised by the issue of debentures, in accordance with the provisions of the Local Government Acts.

1. The maximum rate of interest that may be paid is 4½ per cent. per annum.

2. The purpose for which the loan is to be applied is:—  
Part cost of provision of a reticulated water supply at Metung.

3. The period of the loan shall be fifteen years.

4. The moneys borrowed shall be repayable by providing out of the municipal fund 30 half-yearly instalments of approximately £165 16s. 6d. each, including principal and interest, on the 1st day of August and the 1st day of February during the currency of the loan. The first instalment shall be payable on the 1st day of August, 1956.

5. Such moneys shall be repayable at The Commercial Banking Company of Sydney Ltd., Melbourne, or at the Council's bankers for the time being in Melbourne.

The plans and specifications and the estimate of the cost of the proposed works and a statement showing the proposed expenditure of the moneys to be borrowed, are open for inspection at the Shire Office, Bruthen, during office hours.

Dated this 8th day of November, 1955.

5210

G. W. RIDSDALE, A.I.M.A., Shire Secretary.

## SHIRE OF TAMBO.

## LOAN No. 8.

*Notice of Intention to Borrow the Sum of £6,200 for Permanent Works and Undertakings.*

NOTICE is hereby given that the Council of the Shire of Tambo proposes to borrow the sum of Six thousand two hundred pounds on the credit of the municipal revenues of the President, Councillors and Ratepayers of the said Shire, such sum to be raised by the issue of debentures, in accordance with the provision of the Local Government Acts.

1. The maximum rate of interest that may be paid is £4 16s. 3d. per cent. per annum.

2. The purpose for which the loan is to be applied is purchase of road-making plant.

3. The period of the loan shall be seven years.

4. The moneys borrowed shall be repayable by providing out of the municipal fund fourteen half-yearly instalments of approximately £526 18s. each, including principal and interest on the first day of August and the first day of February during the currency of the loan. The first instalment shall be payable on the first day of August, 1956.

5. Such moneys shall be repayable at The Commercial Banking Company of Sydney Ltd., Melbourne, or at the Council's bankers for the time being in Melbourne.

The plans and specifications and the estimate of the cost of the proposed works and a statement showing the proposed expenditure of the moneys to be borrowed, are open for inspection at the Shire Office, Bruthen, during office hours.

Dated this 8th day of November, 1955.

5211

G. W. RIDSDALE, A.I.M.A., Shire Secretary.

## SHIRE OF TAMBO.

## LOAN No. 9.

*Notice of Intention to Borrow the Sum of £5,200 for Permanent Works and Undertakings.*

NOTICE is hereby given that the Council of the Shire of Tambo proposes to borrow the sum of Five thousand two hundred pounds on the credit of the municipal revenues of the President, Councillors and Ratepayers of the said Shire, such sum to be raised by the issue of debentures, in accordance with the provision of the Local Government Acts.

1. The maximum rate of interest that may be paid is 4½ per cent. per annum.

2. The purpose for which the loan is to be applied is purchase of road-making plant.

3. The period of the loan shall be five years.

4. The moneys borrowed shall be repayable by providing out of the municipal fund ten half-yearly instalments of approximately £590 6s. 6d. each, including principal and interest on the first day of August and the first day of February during the currency of the loan. The first instalment shall be payable on the first day of August, 1956.

5. Such moneys shall be repayable at The Commercial Banking Company of Sydney Ltd., Melbourne, or at the Council's bankers for the time being in Melbourne.

The plans and specifications and the estimate of the cost of the proposed works and a statement showing the proposed expenditure of the moneys to be borrowed, are open for inspection at the Shire Office, Bruthen, during office hours.

Dated this 8th day of November, 1955.

5212

G. W. RIDSDALE, A.I.M.A., Shire Secretary.

## SHIRE OF TRARALGON.—EIGHTH SCHEDULE.

NOTICE THAT A PLANNING SCHEME HAS BEEN PREPARED AND IS AVAILABLE FOR INSPECTION.

*Traralgon Town Plan.*

NOTICE is hereby given that the Council of the Shire of Traralgon, in pursuance of its powers under the Town and Country Planning Acts, has prepared a planning scheme for the area, comprising the Township of Traralgon and adjacent land for the purpose of regulating development within the planning area.

All maps, plans, descriptions, and other data fully setting out and explaining the planning scheme, have been deposited at the Shire Office, Hotham-street, Traralgon, and at the office of the Town and Country Planning Board, Melbourne, and will be open for inspection, without payment of any fee by all persons affected, between the hours of Ten o'clock in the forenoon and Four o'clock in the afternoon on all days of the week except Saturdays, Sundays, and public holidays until and including the 16th February, 1956.

Any persons affected by the planning scheme are required to set forth, in writing, all objections they may have, addressed to Shire Secretary, Shire of Traralgon, Shire Offices, Hotham-street, Traralgon, on or before the 16th day of February, 1956.

5206

E. F. TAYLOR, Shire Secretary.

## SHIRE OF UPPER YARRA.

## BY-LAW No. 38.

A By-law of the Shire of Upper Yarra, made under the Health Act 1928 and amendments thereto, and numbered 38, for prescribing the fees to be charged for the registration of premises and for the renewal of such registrations or for any transfer of registration thereof.

IN pursuance of the powers conferred by the Health Act 1928 and by every power or other Act enabling it in that behalf, the President, Councillors, and Ratepayers of the Shire of Upper Yarra order as follows:—

1. By-law No. 28 of the Shire of Upper Yarra is hereby repealed.

2. That the fees to be charged, received, and taken by the Council of the Shire of Upper Yarra for the registration of premises and for the annual renewal thereof, and



for any transfers of such registrations, pursuant to the provisions of the *Health Act 1928* and amendments thereto, shall be as set out in the Schedule hereto.

3. Such fees shall be paid to the Shire Secretary by any person making application for such registration, renewal, or transfer respectively.

4. This By-law shall apply to and have operation throughout the whole of the municipal district of the Shire of Upper Yarra.

5. This By-law shall come into operation and have effect immediately on its publication in the *Victoria Government Gazette*.

SCHEDULE ABOVE REFERRED TO.

(a) For the granting or annual renewal of registration of:—

- |  |                |
|--|----------------|
| (1) Offensive trade premises (other than those referred to below)  | Five pounds.   |
| (2) Offensive trade premises (being fat extracting or melting or rendering works which are conducted at premises occupied principally as a butcher's shop and at which fat is extracted, melted, or rendered only from materials derived from such shop) | One pound.     |
| (3) Cattle sale-yards  | One pound.     |
| (4) Boarding-houses  | One pound.     |
| (5) Common lodging-houses  | One pound.     |
| (6) Eating-houses  | One pound.     |
| (7) Apartment-houses—  |                |
| (a) containing not more than one apartment   | Ten shillings. |
| (b) containing more than one apartment   | One pound.     |
| (8) Camping areas  | One pound.     |
| (9) Food premises—   |                |
| (a) where five or less than five persons are employed  | Ten shillings. |
| (b) where from six to twenty persons are employed  | One pound.     |
| (c) where from 21 to 50 persons are employed   | Two pounds.    |
| (d) where more than 50 persons are employed  | Five pounds.   |
| (10) Premises at or in any part of which eggs for sale are received or stored for the purpose of being chilled   | One pound.     |

(b) For any transfer of registration—Two shillings and six pence.

Resolution for the passing of this By-law was agreed to by the Council of the Shire of Upper Yarra on the 5th September, 1955, and confirmed on the 3rd October, 1955.

The common seal of the President, Councillors, and Ratepayers of the Shire of Upper Yarra was hereunto affixed, in the presence of—

(SEAL) E. G. GODFREY, President.  
A. A. SCHULZ, Councillor.  
J. N. EDDY, Shire Secretary.

Submitted to the Commission of Public Health on the 18th day of October, 1955.—G. V. STAFFORD, Secretary to the Commission.

Approved by the Governor in Council, 2nd November, 1955.—A. MAHLSTEDT, Clerk of the Executive Council.

5236

SHIRE OF YACKANDANDAH

LOAN No. 1.

*Notice of Intention to Borrow.*

NOTICE is hereby given that the Council of the Shire of Yackandandah intends to borrow Ten thousand pounds on the credit of the President, Councillors, and Ratepayers of the said Shire by an issue of debentures, in accordance with the provisions of the *Local Government Act 1946*, and in connexion therewith the following information is stated:—

(a) The amount of the principal moneys which it is proposed to borrow is Ten thousand pounds.

(b) The maximum rate of interest that may be paid is 4½ per cent. per annum.

(c) The times which the moneys borrowed are to be repayable are on the 1st of June and 1st December during years 1956-65 inclusive, commencing on the 1st day of

June, 1956, and that the place such moneys shall be repayable is at the State Savings Bank of Victoria, Melbourne.

(d) The purpose for which the loan is to be applied is for the purchase of permanent works and undertakings, namely, plant for road-making purposes.

(e) The manner in which the loan is to be liquidated is by provision out of the Municipal Fund in each half-year during the currency of the loan of the sum of Six hundred and thirty-seven pounds and fourteen shillings, which includes principal and interest.

(f) The loan is to be expended in the purchase of plant for road making, viz:—

Heavy power grader	..	..	£9,000
Tip truck	..	..	£1,000

(g) An estimate of the cost thereof and a statement showing the proposed expenditure of the money proposed to be borrowed are open for inspection at the office of the Council, Yackandandah.

Dated this 14th day of November, 1955.

5208 L. KRUTLI, Shire Secretary.

*Landlord and Tenant Act 1948.*

To WILLIAM CUNNINGHAM.

APPLICATION FOR DETERMINATION OF THE FAIR RENT.

To the SOUTH-EASTERN FAIR RENTS BOARD, at Malvern.

FRANCES HILDA HOGAN, Lessor.  
WILLIAM CUNNINGHAM, Lessee.

I FRANCIS HILDA HOGAN, of 62 Walpole-street, Kew, in the State of Victoria, the lessor of prescribed premises, consisting of a dwelling house situate at 15 Kooyong-road, Armadale, do hereby apply to have the fair rent of such premises determined by the Board, having regard to the capital value of the premises at this date.

Dated the 23rd day of June, 1955.

FRANCIS HILDA HOGAN, Applicant.

I appoint Tuesday, the 29th day of November, 1955, at 11.30 in the forenoon or so soon thereafter as the parties can be heard as the day and hour for the hearing of this application. You should attend or be represented before the Board at the Court House, Malvern, at that time.

Dated the 3rd day of November, 1955.

D. ADDISON,

Stipendiary Magistrate constituting the said Fair Rents Board.

5220

GEELONG WATERWORKS AND SEWERAGE TRUST.

SEWER EXTENSIONS NOS. 207A, 231, 234 AND 235.

PURSUANT to section 55 (2) of the *Geelong Waterworks and Sewerage Act 1928* (No. 3692), notice is hereby given of the intention of the Trust to construct sewers to provide for properties situated in and adjacent to Nantes-street, Newtown; St. Georges and Distillery roads, Corio; Mitchell-street, Belmont; and Bacchus Marsh-road and Princes Highway, Norlane, and more particularly as shown on maps which are open for inspection at this office, between the hours of 9 a.m. and 4 p.m. from Monday to Friday inclusive.

Dated this 14th day of November, 1955.

5271

B. C. HENSHAW, Secretary.

TALLANGATTA SEWERAGE AUTHORITY.

THE Tallangatta Sewerage Authority hereby gives notice that the Governor in Council has consented to the compulsory purchase, for the purpose of constructing a sewage treatment plant and disposal area, the lands described hereunder:—

*Portion 1.*

Commencing at the south-eastern angle of Crown allotment 3, section XI, Parish of Beethang, County of Bogong; thence south-westerly along the south-eastern boundary of the said Crown allotment 3 a distance of 1,350 feet; thence generally northerly through the said Crown allotment 3 by lines bearing north 53 deg. 45 min. west a distance of 490 feet, north 26 deg. 24 min. west a distance of 459 feet, and north 15 deg. 15 min. west a distance of 356 feet to a point on the south-western boundary of the Wodonga-Cudgewa Railway Reserve; then south-easterly along the said south-western boundary of the Wodonga-Cudgewa Railway Reserve to a point on the south-eastern boundary of Crown allotment 7, section XI, Parish of Beethang; thence south-westerly along the said south-eastern boundary of Crown allotment 7 to the point of commencement.

## Portion II.

Commencing at a point on the north-western boundary of Crown allotment 1, section XA, Parish of Beethang, County of Bogong, such point being distant 233.64 feet north 72 deg. 55 min. east from the re-entrant angle on the north-western boundary of the said Crown allotment 1; thence through the said Crown allotment 1 by lines bearing south 43 deg. 15 min. east a distance of 800.00 feet, north 56 deg. 52 min. east a distance of 188.00 feet, south 35 deg. 47 min. east a distance of 362.96 feet, north 73 deg. 51 min. east a distance of 343.50 feet, north 24 deg. 15 min. east a distance of 226.27 feet, north a distance of 113.84 feet, north 12 deg. 11 min. west a distance of 100.88 feet, north 36 deg. 33 min. west a distance of 101.81 feet, north 39 deg. 50 min. west a distance of 76.97 feet, north 21 deg. 01 min. west a distance of 77.19 feet, north 4 deg. 11 min. west a distance of 77.19 feet, north 13 deg. 39 min. east a distance of 77.19 feet, north 12 deg. 42 min. east a distance of 96.22 feet, north 7 deg. 02 min. west a distance of 96.30 feet, north 16 deg. 53 min. west a distance of 266.10 feet, and north 4 deg. 24 min. west to a point on the north-western boundary of the said Crown allotment 1; thence south-westerly along the said north-western boundary of Crown allotment 1 a distance of 57.46 feet; thence through the said Crown allotment 1 by lines bearing south 4 deg. 24 min. east a distance of 77.66 feet, south 16 deg. 53 min. east a distance of 271.57 feet, south 7 deg. 02 min. east a distance of 79.10 feet, south 12 deg. 42 min. west a distance of 79.10 feet, south 13 deg. 39 min. east a distance of 92.69 feet, south 4 deg. 11 min. east a distance of 92.69 feet, south a distance of 136.00 feet, south 56 deg. 52 min. west a distance of 58.00 feet, and north 40 deg. 50 min. west to a point on the north-western boundary of the said Crown allotment 1; thence south-westerly along the said north-western boundary of Crown allotment 1 to the point of commencement—all of which lands are shown on a plan approved by the Governor in Council and deposited in the offices of the State Rivers and Water Supply Commission, Melbourne, and the Tallangatta Sewerage Authority, Tallangatta, and may be inspected between the hours of 9 a.m. and 5 p.m., Monday to Friday.

5244

ALAN SKILBECK, Secretary.

NOTICE is hereby given that the partnership heretofore subsisting between Herbert Edgar Prout and Richard Grant, carrying on business as plumbers and hardware merchants at Leongatha, under the style or firm of "Grant and Prout," has been dissolved by mutual consent, as from the 17th day of September, 1955. The said Richard Grant is carrying on the business of the said late firm under his own name. All moneys due to the said late firm should be paid to the said Richard Grant, at Leongatha.

Dated the 17th day of September, 1955.

RICHARD GRANT.  
H. E. PROUT.

Witness to signatures—K. R. A. MACKENZIE. 5228

NOTICE is hereby given that the partnership heretofore subsisting between Hugo Nigol, formerly of 73 Hodgson-street, Heidelberg, but now of 330 Auburn-road, Hawthorn, and Gunnar John Neeme, of 11 Green Gables-avenue, East Malvern, carrying on business as manufacturers of fancy leather goods under the style or firm name of "Nigol and Neeme," has been dissolved, as from the 31st day of August, 1955.

Dated the 31st day of October, 1955.

H. NIGOL.  
G. NEEME.

Gair and Brahe, solicitors, of 243 Collins-street, Melbourne. 5226

NOTICE is hereby given that the partnership heretofore subsisting between Jessie Mabel Campbell (now deceased), Archibald George Campbell (now deceased), Ronald Keith Campbell, and Ian Armytage Campbell, carrying on business as graziers and farmers at Whoorel and Bambra, under the firm name of "A. G. Campbell and Sons," has been dissolved by mutual consent as from the 30th day of June, 1955. All debts due to and owing by the said firm will be received and paid respectively by the said Ronald Keith Campbell and Ian Armytage Campbell.

Dated the 9th day of November, 1955.

HARWOOD &amp; PINCOTT, solicitors, Geelong. 5223

## NOTICE OF DISSOLUTION OF PARTNERSHIP.

NOTICE is hereby given that the partnership heretofore subsisting between Roman Hudes, of 117 Park-street, South Yarra, Allen Sydney Farrow, of 38 Mark-street, North Fitzroy, and John Kenneth Dougall, of 185 Kooyong-road, Caulfield, under the firm name of Miniature Camera House, was dissolved by mutual consent on the 30th day of June, 1955. All debts due by and moneys due to the late firm will be paid or received by the said Roman Hudes and Allen Sydney Farrow, at 366 Bourke-street, Melbourne, where they will continue to carry on the said business in partnership.

Dated this 11th day of November, 1955.

ROMAN HUDES.  
A. S. FARROW.  
J. K. DOUGALL.

Rodda, Ballard and Vroland, solicitors, of 430 Little Collins-street, Melbourne, solicitors for the above-named John Kenneth Dougall. 5299

WE, Francis George McIntosh and Arthur John Hicks, both of Yackandandah, garage proprietors, hereby give notice that the partnership carried on by us under the firm name of Yackandandah Motors, at High-street, Yackandandah, will cease from the 18th November, 1955, and the said business will henceforth be carried on at Yackandandah under the same name.

Dated the 4th day of November, 1955.

F. G. MCINTOSH.  
ARTHUR J. HICKS.

McKenzie-McHarg and Wray, solicitors, Yackandandah. 5262

In the Supreme Court of Victoria.—In the matter of Part I. of the Companies Act 1938, and in the matter of MALVERN TYRE SERVICE PTY. LIMITED.

NOTICE is hereby given that the Order of the Supreme Court of Victoria, dated the 7th day of October, 1955, confirming the reduction of capital of the above-named company from £12,000 to £3,000 and the minute approved by the court showing with respect to the capital of the company as altered the several particulars required by the above-named Act, was registered by the Deputy Registrar-General on the 9th day of November, 1955.

Dated this 14th day of November, 1955.

## MINUTE ABOVE REFERRED TO:

"That the issued capital of Malvern Tyre Service Pty. Limited is £3,000, divided into 3,000 shares of £1 each, instead of the original issued capital of £12,000, divided into 12,000 shares of £1 each. At the time of the registration of this minute the full sum of £1 per share has been and is to be deemed paid up on each of the said 3,000 shares of £1 each."

Dated this 14th day of November, 1955.

P. J. RIDGEWAY &amp; PEARCE, 379 Collins-street, Melbourne, C.I., solicitors for the company. 5298

## Companies Act 1938.

HUTCHINSON &amp; PAULIG PTY. LTD. (IN VOLUNTARY LIQUIDATION).

NOTICE is hereby given that by Extraordinary General Resolution dated 11th November, 1955, the above company resolved to wind up voluntarily, and that Alan Walter Burns, of 186 South-road, East Brighton, accountant, be appointed liquidator.

ALAN W. BURNS, Liquidator.

Melbourne, 11th November, 1955. 5207

In the matter of the Companies Act and in the matter of WASHMOBILE OF AUSTRALASIA PROPRIETARY LIMITED (in Voluntary Liquidation).—Notice to Creditors.

THE creditors of the above-named company are required on or before the 5th day of December, 1955, to send their names and addresses, and the particulars of their debts or claims, and the names and addresses of their solicitors, if any, to Thomas M. Kennedy, of 252 Swanston-street, Melbourne, the voluntary liquidator of the said company, and, if so required by notice in writing from the said liquidator, are by their solicitors or otherwise, to come in and prove their said debts or claims, at such time and place as shall be specified in such notice, or in default thereof they will be excluded from the benefit of any distribution made before such debts or claims are proved.

Dated this 7th day of November, 1955.

5249 T. M. KENNEDY, Liquidator.

In the matter of the Companies Act and in the matter of WASHMOBILE DISTRIBUTORS PROPRIETARY LIMITED (in Voluntary Liquidation).—Notice to Creditors.

THE creditors of the above-named company are required on or before the 5th day of December, 1955, to send their names and addresses, and the particulars of their debts or claims, and the names and addresses of their solicitors, if any, to Thomas M. Kennedy, of 252 Swanston-street, Melbourne, the voluntary liquidator of the said company, and, if so required by notice in writing from the said liquidator, are by their solicitors or otherwise, to come in and prove their said debts or claims, at such time and place as shall be specified in such notice, or in default thereof they will be excluded from the benefit of any distribution made before such debts or claims are proved.

Dated this 7th day of November, 1955.

5248 T. M. KENNEDY, Liquidator.

*Companies Act 1938.*

WAIPUNA INVESTMENTS PROPRIETARY LIMITED.  
COPY OF RESOLUTION, PURSUANT TO SECTION 118.

AT a General Meeting of the members of Waipuna Investments Proprietary Limited duly convened and held at 18 Victoria-rescent, Abbotsford, on the 26th day of October, 1955, the following Special Resolution was duly passed:—

"That the company be wound up voluntarily and that Archibald Norman Martin, of 340 Little Collins-street, Melbourne, Victoria, be and is hereby appointed liquidator for the purposes of such winding up, at a remuneration of 5 per centum of the amount realized from the sale of assets of the company, and no other commissions are to be paid."

Dated this 26th day of October, 1955.

5263 I. HATCHER, Chairman of Directors.

In the matter of the Companies Act 1938, and in the matter of WASHMOBILE DISTRIBUTORS PROPRIETARY LIMITED (in Voluntary Liquidation).—Notice pursuant to section 226.

AT an Extraordinary General Meeting of members of Washmobile Distributors Proprietary Limited duly convened and held at 252 Swanston-street, Melbourne, on the 7th day of November, 1955, at 10 o'clock in the forenoon, the following Resolution was passed:—

"That the company be wound up voluntarily and that Thomas Morris Kennedy, public accountant, of 252 Swanston-street, Melbourne, be and is hereby appointed liquidator of the company, and that his remuneration be fixed in accordance with the scale of fees laid down by the Institute of Chartered Accountants in Australia or a fixed amount of One hundred and fifty guineas, whichever is the greater."

Dated this 8th day of November, 1955.

5260 T. M. KENNEDY, Liquidator.

In the matter of the Companies Act 1938, and in the matter of WASHMOBILE OF AUSTRALASIA PROPRIETARY LIMITED (in Voluntary Liquidation).—Notice pursuant to section 226.

AT an Extraordinary General Meeting of members of Washmobile of Australasia Proprietary Limited duly convened and held at 252 Swanston-street, Melbourne, on the 7th day of November, 1955, at 10 o'clock in the forenoon, the following Resolution was passed:—

"That the company be wound up voluntarily and that Thomas Morris Kennedy, public accountant, of 252 Swanston-street, Melbourne, be and is hereby appointed liquidator of the company, and that his remuneration be fixed in accordance with the scale of fees laid down by the Institute of Chartered Accountants in Australia or a fixed amount of One hundred and fifty guineas, whichever is the greater."

Dated this 8th day of November, 1955.

5259 T. M. KENNEDY, Liquidator.

*Companies Act 1938, Section 226.*—In the matter of DEWAR PTY. LTD. (in Voluntary Liquidation).

NOTICE is hereby given that by Special Resolution dated the 8th day of November, 1955, the above company resolved to wind up voluntarily, and that Herbert James Raven, of 422 Collins-street, Melbourne, was appointed liquidator.

H. J. RAVEN, Liquidator.

Davis and Raven, chartered accountants (Aust.), Melbourne, 8th November, 1955. 5288

*Companies Act 1938, Section 226.*—In the matter of E. W. TORR PTY. LTD. (in Voluntary Liquidation).

NOTICE is hereby given that by Special Resolution dated the 8th day of November, 1955, the above company resolved to wind up voluntarily, and that Herbert James Raven, of 422 Collins-street, Melbourne, was appointed liquidator.

H. J. RAVEN, Liquidator.

Davis and Raven, chartered accountants (Aust.), Melbourne, 8th November, 1955. 5289

No. 836.—11453/55.—4

NORMA SHOE CO. PTY. LTD. (IN VOLUNTARY LIQUIDATION).

NOTICE is hereby given that a meeting of members of the above-named company will be held at 11 a.m. on the 16th day of December, 1955, at the office of N. L. Hocking, 472 Bourke-street, Melbourne, for the purpose of laying before the meeting the liquidator's account of the winding up and giving any explanations thereof.

Dated this 9th day of November, 1955.

N. L. HOCKING, 472 Bourke-street, Melbourne, Liquidator. 5258

*Victorian Companies Act 1938.*

A. W. WOODS & CO. PTY. LTD. (IN VOLUNTARY LIQUIDATION).

PURSUANT TO SECTION 236 (3).

NOTICE is hereby given that the Final Meeting of the shareholders of A. W. Woods and Co. Pty. Ltd. (in voluntary liquidation) will be held at the offices of C. W. Strling and Co., 11 Bank-place, Melbourne, C.1, on the 19th day of December, 1955, at 9.15 a.m., for the purpose of having an account laid before it, showing how the winding up of the company has been conducted and the property of the company has been disposed of.

5295 N. W. GLUCK, Liquidator.  
W. A. REID, Liquidator.

*Victorian Companies Act 1938.*

TOTTENHAM POWER COMPANY PTY. LTD. (IN VOLUNTARY LIQUIDATION).

PURSUANT TO SECTION 236 (3).

NOTICE is hereby given that the Final Meeting of the shareholders of Tottenham Power Co. Pty. Ltd. (in voluntary liquidation) will be held at the offices of C. W. Stirling and Co., 11 Bank-place, Melbourne, C.1, on the 19th day of December, 1955, at 9.30 a.m., for the purpose of having an account laid before it, showing how the winding up of the company has been conducted and the property of the company has been disposed of.

5294 N. W. GLUCK, Liquidator.  
W. A. REID, Liquidator.

No. of Company 29810

REGENCY STORES PROPRIETARY LIMITED.

COPY RESOLUTION, PURSUANT TO SECTION 118.

AT a General Meeting of the members of Regency Stores Proprietary Limited duly convened and held at 243 Collins-street, Melbourne, on the 14th day of November, 1955, the following Special Resolution was duly passed:—

"That the company be wound up voluntarily and that R. W. Ellis, of 243 Collins-street, Melbourne, Victoria, be and is hereby appointed liquidator for the purpose of such winding up."

Dated this 14th day of November, 1955.

5285 A. R. ISAACS, Chairman of Directors.

*Companies Act 1938, Section 226.*—In the matter of NEWPORT BUILDERS PTY. LTD. (in Voluntary Liquidation).

NOTICE is hereby given that by Special Resolution dated the 8th day of November, 1955, the above company resolved to wind up voluntarily, and that Herbert James Raven, of 422 Collins-street, Melbourne, was appointed liquidator.

H. J. RAVEN, Liquidator.

Davis and Raven, chartered accountants (Aust.), Melbourne, 8th November, 1955. 5290

In the Supreme Court.—In the matter of Part 1 of the Companies Act 1938 and in the matter of CRESCENT SALES PROPRIETARY LIMITED.

NOTICE is hereby given that a Petition for the winding up of the above-named company by the Supreme Court was on the 15th day of November, 1955, presented to the said court by Servex Electrical Company Proprietary Limited and that the said Petition is directed to be heard before the court sitting at Melbourne on the 6th day of December, 1955; and any creditor or contributory of the said company desirous to support or oppose the making of an Order on the said Petition, may appear at the time of hearing by himself or his counsel, for that purpose; and a copy of the Petition will be furnished to any creditor or contributory of the said company requiring the same by the undersigned on payment of the regulated charge for the same.

The Petitioner's address is 493 Albion-street, West Brunswick.

The Petitioner's solicitor is J. T. Brock, of 284 Lonsdale-street, Melbourne.

J. T. BROCK.

NOTE.—Any person who intends to appear on the hearing of the said Petition must serve on or send by post to the above-named solicitor, J. T. Brock, notice in writing of his intention so to do. The notice must state the name and address of the person, or, if a firm, the name and address of the firm, and must be signed by the person or firm or his or their solicitor (if any) and must be served

or if posted must be sent by post in sufficient time to reach the above-named not later than 4 o'clock in the afternoon of the 5th day of December, 1955. 5281

**BENEREMBAH PASTORAL COMPANY PROPRIETARY LIMITED.**

AT an Extraordinary General Meeting of Benerembah Pastoral Company Proprietary Limited duly convened and held at 9 Finch-street, East Malvern, on the 9th day of November, 1955, the following Resolution was passed as a Special Resolution:—

"That the company be wound up voluntarily and that John Thomas Morrow of Morundah Station, Morundah, New South Wales, pastoralist, be appointed liquidator for the purpose of winding up the affairs and distributing the assets of the company."

Dated this 9th day of November, 1955.

MARJORIE MORROW, Chairman.

Pavey, Wilson, Cohen and Carter, 360 Collins-street, Melbourne, solicitors for the company. 5257

JAMES GRANT STEWART, late of Tresco, in the State of Victoria, retired farmer, DECEASED, intestate (who died on the 8th day of August, 1955).

CREDITORS, next of kin, and all other persons having claims against the estate of the deceased, are required by the administrator, Robert Andrews Stewart, of Tresco, aforesaid orchardist, to send particulars to him, care of the undersigned, on or before the 11th day of February, 1956, after which date he will distribute the assets, having regard only to the claims of which he then has notice.

Dated the 11th day of November, 1955.

GARDEN & GREEN, solicitors, McCallum-street, Swan Hill. 5264

GEORGE ROBERT LACEY, late of Murrawee, in the State of Victoria, orchardist, DECEASED (who died on the 20th day of August, 1955).

CREDITORS, next of kin, and all other persons having claims against the estate of the deceased, are required by the executrix of the will, Emily Evelyn May Lacey (in the will called Emily May Lacey) of Murrawee, aforesaid, widow, to send particulars to her, care of the undersigned, on or before the 11th day of February, 1956, after which date she will distribute the assets, having regard only to the claims of which she then has notice.

Dated the 11th day of November, 1955.

GARDEN & GREEN, solicitors, McCallum-street, Swan Hill. 5265

CREDITORS, next of kin, and others having claims against the estate of Mary Ann Wall, late of 40 Alma-road, Camberwell, widow, deceased (who died on the 12th day of March, 1955, and probate of whose will has been granted by the Supreme Court of Victoria to Eileen Elizabeth Wall, of 40 Alma-road, Camberwell, spinster, and Lester Quintus Permezel, of 379 Collins-street, Melbourne, solicitor, the executors appointed by the said will), are required to send particulars of their claims to the said executors, in care of the undersigned solicitors, on or before the 20th January, 1956, after which date the said executors will distribute the deceased's estate amongst the persons entitled thereto, having regard only to those claims of which they then have had notice.

W. H. FLOOD & PERMEZEL, solicitors, 379 Collins-street, Melbourne. 5253

**NOTICE TO CLAIMANTS.**

RE ERNEST EDWARD VINES, late of 2 Dorrington-avenue, East Malvern, in Victoria, retired secretary (who died on the 9th May, 1955).

CREDITORS, next of kin, and all other persons having claims against the estate of the above-named deceased, are required by the executors, Elizabeth Muriel Vines and The Equity Trustees, Executors and Agency Company Limited, to send, on or before the 18th day of January, 1956, particulars thereof, in writing, to the said executors, in care of the said company, at its address at 472 Bourke-street, Melbourne, after which date the said executors may proceed to distribute the assets of the said deceased to or amongst the persons entitled thereto, having regard only to the claims, whether formal or not, of which notice shall then have been received.

MIDDLETON, McEACHARN & SHAW, solicitors, of 60 Market-street, Melbourne. 5245

CREDITORS, next of kin, and others having claims in respect of the estate of William Barratt Holdsworth, late of 14 Verdon-street, Williamstown, gentleman, deceased (who died on 22nd August, 1955), are to send particulars of their claims to The Perpetual Executors and Trustees Association of Australia Limited, of 100-104 Queen-street, Melbourne, by the 16th day of January, 1956, after which date it will distribute the assets, having regard only to the claims of which it then has notice.

JONES & KENNEDY, solicitors, 213 Nicholson-street, Footscray. 5292

**Trustee Act 1928.**

**NOTICE TO CLAIMANTS.**

PURSUANT to the Trustee Act 1928, creditors, next of kin, and all other persons having claims in respect of the estate of any deceased person named below are required to send particulars thereof to the legal personal representative or representatives at the address stated below, on or before the date stated, after which date the representative or representatives will distribute the assets, having regard only to the claims of which notice has been received:—

Thomas Quigley, late of Mount Moriac, in the State of Victoria, farmer, died on the 29th day of August, 1955.—Claims to Mary Veronica McCarthy, Thomas Leo Quigley, and John Joseph Quigley, care of Doyle and Kerr, solicitors, Little Malop-street, Geelong, by the 23rd day of January, 1956. 5214

John Joseph Baker, late of Rosedale, Bannockburn, in the State of Victoria, farmer, deceased, died on the 20th day of August, 1955.—Claims to John William Baker, care of Doyle and Kerr, solicitors, Little Malop-street, Geelong, by the 23rd day of January, 1956. 5261

Walter Kemp, late of 43 Cromwell-road, Hawksburn, in the State of Victoria, retired solicitor, died on the 26th July, 1955.—Claims to Matilda Kemp, care of Walter Kemp and Townsend, solicitors, 340 Collins-street, Melbourne, by 17th January, 1956. 5255

Michael James Fowler (commonly known as Michael Fowler), late of Tucker-street, Breakwater, in the State of Victoria, wool sorter, died on the 25th day of September, 1947.—Claims to Charles William Wyatt, in care of Freeman and Fallaw, solicitors, 41 Yarra-street, Geelong, by the first day of February, 1956. 5242

Bridget Anastasia Fowler, late of Tucker-street, Breakwater, in the State of Victoria, spinster, died on the 17th day of August, 1955.—Claims to Charles William Wyatt, in care of Freeman and Fallaw, solicitors, 41 Yarra-street, Geelong, by the 1st day of February, 1956. 5243

CREDITORS, next of kin, and others having claims against the estate of David Leahy, late of 63 Cardigan-street, Carlton, tinsmith, deceased (who died on the 29th July, 1955), are to send particulars of their claims to National Trustees, Executors and Agency Company of Australasia Limited, of 95 Queen-street, Melbourne, by the 17th January, 1956, after which date it will distribute the assets, having regard only to the claims of which it then has notice.

LANDER & ROBINSON, solicitors, 454 Collins-street, Melbourne. 5279

CREDITORS, next of kin, and others having claims in respect of the estate of Catherine Alice O'Dwyer, late of 90 Wright-street, Middle Park, in the State of Victoria, gentlewoman, deceased (who died on the 9th day of August, 1955), are required to send particulars of their claims to National Trustees, Executors and Agency Company of Australasia Limited, whose registered office is situate at 95 Queen-street, Melbourne, in the said State by the 23rd day of January, 1956, after which date it will distribute the assets, having regard only to the claims of which it then has notice.

RONALD, STEWART & MCINTOSH, solicitors, 422 Collins-street, Melbourne. 5276

CREDITORS, next of kin, and others having claims in respect of the estate of Harold Vernon Harcourt Newbigin, late of 12 Allenby-avenue, Glen Iris, gentleman (who died on 13th August, 1955), are to send particulars of their claims to The Trustees, Executors and Agency Company Limited, 401 Collins-street, Melbourne, by the 31st January, 1956, after which date it will distribute the assets, having regard only to the claims of which it then has notice.

MOULE, HAMILTON & DERHAM, solicitors, 394 Collins-street, Melbourne. 5256

CREDITORS, next of kin, and others having claims in respect of the estate of Anne Bridget Morton, late of 28 Roy-street, South Melbourne, in the State of Victoria, married woman, deceased, intestate (who died on the 6th day of July, 1955), are to send particulars of their claims to the administrator, who has applied for a grant of letters of administration of the estate of the said deceased, namely the National Trustees, Executors, and Agency Company of Australasia Limited, whose registered office is situate at 95 Queen-street, Melbourne, care of the said company, by the 20th day of January, 1956, after which date it will distribute the assets, having regard only to the claims of which the said company then has had notice.

GORDON, RENNICK & GAYNOR, 473 Bourke-street, Melbourne, solicitors for the said administrator. 5297

**CREDITORS**, next of kin, and others having claims in respect of the estate of Florence Maude Majury, late of 166 Normanby-avenue, Thornbury, widow, deceased (who died on the 23rd day of August, 1955), are to send particulars of their claims to The Perpetual Executors and Trustees Association of Australia Limited, of 100-104 Queen-street, Melbourne, the executors of the will of the said deceased, by the 19th day of January, 1956, after which date it will distribute the assets, having regard only to the claims of which it then has notice.

DUDLEY A. TREGENT, B.A., LL.M., of 422 Collins-street, Melbourne, solicitor for the company. 5252

FRANCIS ALBERT LOUIS MURPHY, late of 4 Cheffers-street, Moonee Ponds, brewery employee, formerly soldier, DECEASED.

**CREDITORS**, next of kin, and others having claims in respect of the estate of deceased (who died on the 20th day of November, 1954), are required by the trustee, Charles Murphy, of "Belmont," Filbert-street, Caulfield, railway employee, to send particulars to him by the 28th day of January, 1956, after which date the trustee may convey or distribute the assets, having regard only to the claims of which he then has notice.

JOHN GINNANE, solicitor, of 422 Collins-street, Melbourne. 5254

**CREDITORS**, next of kin, and others having claims in respect of the estate of Ada Grace Sharpe, late of 9 Elizabeth-street, Elsternwick, spinster, deceased (who died on the 4th day of September, 1955, and probate of whose will has been granted to The Perpetual Executors and Trustees Association of Australia Limited, of 100-104 Queen-street, Melbourne), are to send in particulars of their claims to the said executor, care of the under-mentioned solicitors, by the 19th day of January, 1956, after which date they will distribute the assets, having regard only to the claims of which they then have notice.

PEARCE & WEBSTER, solicitors, 430 Little Collins-street, Melbourne. 5251

**CREDITORS**, next of kin, and others having claims in respect of the estate of Alice Marian Ellen Bale, late of 83 Walpole-street, Kew, in the State of Victoria, artist, deceased (who died on the 14th day of February, 1955), are to send the particulars of their claims to The Perpetual Executors and Trustees Association of Australia Limited, whose registered office is situated at 100-104 Queen-street, Melbourne, by the 31st day of January, 1956, after which date it will distribute the assets, having regard only to the claims of which it then has notice.

H. S. W. LAWSON, HUGHES & CO., 314 Collins-street, Melbourne, solicitors. 5291

**CREDITORS**, next of kin, and others having claims in respect of the estate of Elijah Pert, late of Parker-avenue, Boronia, gentleman, deceased (who died on the 1st day of June, 1955, and probate of whose will has been granted to Walter John Roy Pert, of 44 Ferntree Gully-road, Oakleigh, sales manager, and Arthur Dean Pearce, of 430 Little Collins-street, Melbourne, solicitor), are to send in particulars of their claims to the said executors, care of the under-mentioned solicitors, by the 19th day of January, 1956, after which date they will distribute the assets, having regard only to the claims of which they then have notice.

PEARCE & WEBSTER, solicitors, 430 Little Collins-street, Melbourne. 5250

MARY MULLENS, late of Edgecliff, New South Wales, widow, DECEASED (who died on the 13th day of October, 1954).

**CREDITORS**, next of kin, and all other persons having claims against the estate of the deceased, are required by the executors of her will, Collin Wellesly Lindeman, of 3 Mortimer-street, Mudgee, New South Wales, and Permanent Trustee Company of New South Wales, of 23-25 O'Connell-street, Sydney, New South Wales, to send particulars thereof to them, care of the under-mentioned solicitors, on or before the 18th day of January, 1956, after which date they will distribute the assets of the deceased, having regard only to the claims of which they then have notice.

COLTMAN, WYATT & ANDERSON, solicitors, 456 Little Collins-street, Melbourne. 5246

HUBERT ARTHUR GOULD, late of 34 Harney-street, Bendigo, retired bank manager, DECEASED (who died on the 17th day of August, 1955).

**CREDITORS**, next of kin, and all others having claims against the estate of the said deceased are required by the executor, Kenneth Hubert Gould, of 313 Bell-street, Pascoe Vale South, bank official, to send particulars thereof to him, care of the under-mentioned solicitors, on or before the 18th day of January, 1956, after which date he will distribute the estate, having regard only to the claims of which he then has notice.

Dated the 9th day of November, 1955.

HYETT, WILLIS, & HYETT, of 51 Bull-street, Bendigo, solicitors for the executor. 5219

**CREDITORS**, next of kin, and others having claims in respect of the estate of Mary Ann Hardman (also known as Marion Hardman), late of 5 Church-street, Burwood, in the State of Victoria, married woman, deceased (who died on the 30th day of July, 1955), are to send particulars of their claims to the executors, who have applied for probate of the will of the said deceased, namely, the National Trustees, Executors, and Agency Company of Australasia Limited, whose registered office is situated at 95 Queen-street, Melbourne, and June Annette Morkham, of 1 Eden-court, Burwood, married woman, care of the said National Trustees, Executors, and Agency Company of Australasia Limited, by the 20th day of January, 1956, after which date they will distribute the assets, having regard only to the claims of which they then have had notice.

GORDON RENNICK & GAYNOR, 473 Bourke-street, Melbourne, solicitors for the said executors. 5296

**CREDITORS**, next of kin, and others having claims in respect of the estate of William John Baragwanath, late of 177 Orrong-road, Toorak, manufacturer's agent, deceased (who died on the 29th July, 1955), are to send particulars of their claims to The Equity Trustees, Executors, and Agency Company Limited, of 472 Bourke-street, Melbourne, by the 17th day of January, 1956, after which date it will distribute the assets, having regard only to the claims of which it then has notice.

MARTIN & MARTIN, solicitors, 37 Queen-street, Melbourne. 5293

**CREDITORS**, next of kin, and others having claims in respect of the estate of Florence Macrow, late of 31 Glenloch-road, Hampstead, London, in England, spinster, deceased (who died on 3rd April, 1955), are to send written particulars of their claims to The Trustees, Executors and Agency Company Limited, of 401 Collins-street, Melbourne, by the 19th day of January, 1956, after which date the said company will distribute the assets, having regard only to the claims of which it then has notice.

PROUDFOOT & HORTON, solicitors, 87 Queen-street, Melbourne. 5247

**CREDITORS**, next of kin, and others having claims in respect of the estate of Eric Emslie Priest, formerly of 29 Point Nepean-road, Elsternwick, but late of 24 Kendall-street, Elwood, in the State of Victoria, joiner, deceased (who died on or about the 5th day of September, 1955), are to send particulars of their claims to The Trustees, Executors, and Agency Company Limited, whose registered office is situated at 401 Collins-street, Melbourne, in the State of Victoria, by the 18th day of January, 1956, after which date it will distribute the assets of the deceased, having regard only to the claims of which it then has notice.

LOUIS E. BERNASCONI, solicitor, 395 Collins-street, Melbourne. 5287

WILLIAM RANDALL COMMINS, late of Rutherglen, in the State of Victoria, retired storekeeper, DECEASED.

**CREDITORS**, next of kin, and others having claims in respect of the estate of the deceased (who died on the 11th December, 1954) are required by the executor of his will, The Perpetual Executors and Trustees Association of Australia Limited, of 100-104 Queen-street, Melbourne, to send particulars to it, by the 20th day of January, 1956, after which date the said association may convey or distribute the assets, having regard only to the claims of which it then has notice.

Dated this 10th day of November, 1955.

W. M. STRONG & SON, Rutherglen, solicitors for the executor. 5278

**CREDITORS**, next of kin, and others having claims in respect of the estate of William Edward Lowe, late of 13 Princes-avenue, East Caulfield, in the State of Victoria, gentleman, deceased (who died on the 14th day of July, 1955), are required to send particulars of their claims to The Equity Trustees, Executors and Agency Company Limited, whose registered office is situated at 472 Bourke-street, Melbourne, in the said State, by the 23rd day of January, 1956, after which date it will distribute the assets, having regard only to the claims of which it then has notice.

RONALD STEWART & McINTOSH, solicitors, 422 Collins-street, Melbourne. 5277

STANLEY JAMES STANSMORE, late of Camperdown, grazier, DECEASED.

**CREDITORS**, next of kin, and others having claims in respect of the estate of the deceased (who died on 22nd September, 1955) are required by the executors, Ruby Smith, of 9 Olive-street, Reservoir, spinster, and James Ford Strachan and Robert Russell Altken, both of 123 William-street, Melbourne, solicitors, to send particulars to them, care of the under-mentioned solicitors, by 17th January, 1956, after which date the executors may convey or distribute the assets, having regard only to the claims of which they then have notice.

AITKEN, WALKER, & STRACHAN, of 123 William-street, Melbourne, solicitors. 5284

**CREDITORS**, next of kin, and others having claims in respect of the estate of Florence Mary Waters, late of 7 Lyall-street, Glenferrie, in the State of Victoria, spinster (who died on the 4th day of September, 1955, are to send the particulars of their claims to the Union Trustee Company of Australia Limited, of 333 Collins-street, Melbourne, by the 13th day of January, 1956, after which date it will distribute the assets, having regard only to the claims of which it then has notice.

**MORGAN, FYFFE, & MULKEARNS**, 108 Queen-street, Melbourne, solicitors for the applicants. 5280

**JOHN HENRY MOORE**, late of Lawson, in the State of New South Wales, retired storekeeper, DECEASED, intestate (who died on 25th December, 1954).

**CREDITORS**, next of kin, and all other persons having claims against the estate of the said deceased are required by the administrator of his estate, the Public Trustee in and for the State of New South Wales, of 19 O'Connell-street, Sydney, in the said State, to send particulars of such claims to him, in writing, on or before the 19th January, 1956, after which date the assets will be distributed, having regard only to the claims of which notice has then been received.

**PLANTE & HENTY**, 243 Collins-street, Melbourne, solicitors for the said administrator. 5282

**WILLIAM JAMES HALLIGAN**, late of Dry Creek, via Bonnie Doon, grazier, DECEASED.

**CREDITORS**, next of kin, and others having claims in respect of the deceased (who died on the 30th day of August, 1948), are required by his trustees, John Thomas Halligan and Leslie Christopher Halligan, both of Dry Creek, via Bonnie Doon, graziers, to send particulars to them, care of the under-mentioned firm of solicitors, by the 12th day of January, 1956, after which date the trustees may convey and distribute the assets, having regard only to the claims of which they then have notice.

Dated the 4th day of November, 1955.

**MAL RYAN & GLEN**, High-street, Mansfield, solicitors for the trustees. 5224

**DUNCAN McCOLL**, late of Mansfield, in the State of Victoria, farmer, DECEASED.

**CREDITORS**, next of kin, and others having claims in respect of the deceased (who died on the 25th day of April, 1941), are required by his trustee, National Trustees, Executors, and Agency Company of Australasia Limited, of 95 Queen-street, Melbourne, to send particulars to it, by the 12th day of January, 1956, after which date the trustee may convey and distribute the assets, having regard only to the claims of which it then has notice.

Dated the 4th day of November, 1955.

**MAL RYAN & GLEN**, High-street, Mansfield, solicitors for the trustee. 5225

In the Supreme Court of the State of Victoria.—*Fi. Fa.*

**NOTICE** is hereby given that, under and by virtue of certain process issued out of the Supreme Court of the State of Victoria and directed to the Sheriff, requiring him to levy certain moneys of the real and personal estate of M. Stark, of 485 Lygon-street, North Carlton, draper, the said Sheriff will, on Friday, the 6th day of January, 1956, at the hour of Eleven o'clock in the forenoon, cause to be sold at the Police Station, Fenwick-street, North Carlton (unless the said process shall have been previously satisfied or the said Sheriff be otherwise stayed):—

All the right, title, estate, and interest (if any) of the said M. Stark, in and to all that piece of land being part of Crown allotment 6, section 115, at Carlton, Parish of Jika Jika, County of Bourke, being the land comprised in certificate of title, volume 1887, folio 377379. Upon the land is erected a single-fronted brick villa, approximately 60 years old, with a party wall on the south side, being the end of a terrace of four, situate at and known as 485 Lygon-street, North Carlton. The roof of the said property is of slate and the outbuildings consist of a brick two-storied stable on to a rear right-of-way.

N.B.—Terms: Cash. No cheques taken.

Dated at Melbourne, this 9th day of November, 1955.

5283 **DAVID J. JOHNSTON**, Sheriff's Officer.

**IMPOUNDINGS**

**BRANXHOLME**.—Impounded in Branxholme Pound, by F. Healy.

2 Crossbred woolly ewes, one back and front notch near ear, one front notch on each ear, red blotched brand on back, green dot on head

If not claimed and expenses paid, to be sold on 3rd December, 1955.

5267—13/6 **J. ATKINSON**, Poundkeeper.

**CLUNES**.—Impounded in Clunes Pound.

1 red and white cow, with < piece out of left ear, no visible brand, calf at foot

1 red and white steer, notch bottom right ear, two notches bottom left ear, no visible brand

If not claimed and expenses paid, to be sold on 18th November, 1955.

5221—13/6 **GEORGE HIGGINS**, Poundkeeper.

**MORTLAKE**.—Impounded in Mortlake Pound, on 10th November, 1955.

2 black Jersey yearling heifers, no visible brand or earmarks

1 red and white yearling heifer, slit bottom near ear, no visible brand

1 red yearling heifer, white on legs, no visible brand or earmarks

If not claimed and expenses paid, to be sold on 1st December, 1955.

5268—18/ **GEO. ROBERTSON**, Poundkeeper.

**RINGWOOD**.—Impounded in Ringwood Pound.

1 medium draught bay gelding, white blaze, white socks, shod, bobtail, no visible brand

If not claimed and expenses paid, to be sold on 1st December, 1955.

5275—10/6 **E. KIKER**, Poundkeeper.

**TATURA**.—Impounded in Tatura Pound.

1 dark-bay pony mare, dark points, no visible brand

If not claimed and expenses paid, to be sold on 1st December, 1955.

5266—9/ **E. SHEALES**, Poundkeeper.

**MINING NOTICE**

**INTERSTATE OIL LIMITED.**

Registered office: 95 Collins-street, Melbourne.

SECOND CALL ON ISSUED SHARES.

**NOTICE** is hereby given that a Call (the Second) of One shilling per share on the issued capital of the company (making such shares called to 3s.) has been made, due and payable at the registered office of the company, 95 Collins-street, Melbourne, on Monday, 5th December, 1955.

By order of the Board,

5286 **H. C. WARREN**, Secretary.

**CONTENTS**

	<b>PAGE</b>
Acts of Parliament .. .. .	5950
Appointments .. .. .	5967
Companies Act 1938—Notice .. .. .	5964
Contracts .. .. .	5959
Country Roads Board .. .. .	5969
Estates of Deceased Persons .. .. .	5965
Government Notices .. .. .	5951
Impoundings .. .. .	6000
Lands .. .. .	5976
Licences to Occupy Unused Roads .. .. .	5952
Melbourne and Metropolitan Board of Works— Notice .. .. .	5955
Mining .. .. .	6000
Notice to Mariners .. .. .	5963
Orders in Council .. .. .	5968
Police Sale .. .. .	5964
Private Advertisements .. .. .	5985
Proclamations .. .. .	5949
Public Service Notices .. .. .	5979
Resignations .. .. .	5968
Tenders .. .. .	5984
Transport Regulation Board—Public Hearings .. .. .	5956
Waterworks Trusts .. .. .	5963



# VICTORIA GOVERNMENT GAZETTE.

Published by Authority.

[Registered at the General Post Office, Melbourne, for transmission by post as a newspaper.]

No. 837]

WEDNESDAY, NOVEMBER 16.

[1955

*Labour and Industry Act 1953.*

## DETERMINATION OF A WAGES BOARD ADJUSTED PURSUANT TO SECTION 33 OF THE LABOUR AND INDUSTRY ACT 1953.

I, Henry Norman Jones, Secretary for Labour and Industry, in pursuance of the powers conferred by the Labour and Industry Act, hereby make and issue the following adjusted Determination of the Wages Board referred to hereunder showing adjusted rates and prices to operate from the beginning of the first pay period to commence in August, 1955.

Dated at Melbourne, this  
8th day of August, 1955.

H. N. JONES,  
Secretary for Labour and Industry.

### HOSPITAL NURSES BOARD.

Clause 1 of Part 1, clause 1 of Sections I. and II. of Part 2, of the Determination published in *Government Gazette* No. 356 of the 23rd June, 1955, clause 1 of Part 3, of the Determination made on the 2nd August, 1955, and in force as from the 4th July, 1955, and clause 1 of Sections I. and II. of Part 4 of the Determination published in *Government Gazette* No. 356 of the 23rd June, 1955, shall be replaced by the following clauses:—

#### PART 1.

##### NOTE.—This part applies to—

- (a) Certified nurses in public, private, intermediate, or community hospitals, or in benevolent or convalescent homes;
- (b) Nurses in training in hospitals recognized as training schools by the Nurses Registration Board of Victoria.

#### WAGES.

1. An employee for whom the employer makes available board and lodging shall be provided with laundry, free of charge, but from the wages hereinafter prescribed, a sum of 56s. per week for male nurses and 50s. 9d. per week for female nurses and trainees may be deducted in respect of such board and lodging, notwithstanding that such employee may decide not to avail himself or herself of such accommodation.

An employee for whom the employer does not make available board and lodging shall receive in addition to the wages hereinafter prescribed, an allowance at the rate of 20s. per week, and shall be entitled also to one meal per day to be provided by the employer.

#### TRAINEES.

##### Females.

MIDWIFERY TRAINEES.		OTHER TRAINEES.	
Per Week.		Per Week.	
£ s. d.		£ s. d.	
1st year .. .. .	5 15 6	1st year .. .. .	5 15 6
and thereafter ..	6 9 0	2nd year .. .. .	6 3 0
		and thereafter ..	6 10 0

Provided that if a female person who has obtained a nurse's certificate elects to enter into further training for the purpose of obtaining a midwifery certificate, the wage to be paid for such further training shall be at the rate of £12 7s. 3d. per week.

*Males.*

	Per Week.
	£ s. d.
1st year .. .. .	7 2 6
2nd year .. .. .	8 6 0
and thereafter .. .. .	9 8 0

Provided that a trainee on reaching the age of 21 years shall be paid at the rate of £12 19s. per week.  
 Provided further that if a male person who has obtained a nurse's certificate elects to enter into further training for the purpose of obtaining another certificate the wages to be paid for such further training shall be at the rate of £9 8s. per week if under the age of 21 years and £14 12s. per week if 21 years of age or over.

*Proportion.*

The proportion of trainees in a training hospital approved by the Nurses' Registration Board of Victoria to certificated nurses shall be not more than six trainees to each certificated nurse exclusive of the matron.

**OTHER EMPLOYEES.**

*Matrons.*

(i) Subject to sub-clause (ii) hereof the wages payable to Matrons (other than these employed in benevolent homes) shall be based on the daily average occupied beds in a public hospital or the registered number of beds in any other institution as follows:—

	Per Week.
	£ s. d.
Under 10 beds .. .. .	16 14 9
From 10 to 19 beds .. .. .	16 19 9
" 20 " 39 " .. .. .	17 4 9
" 40 " 65 " .. .. .	17 12 3
" 66 " 100 " .. .. .	18 2 3
" 101 " 150 " .. .. .	18 12 3
" 151 " 200 " .. .. .	19 2 3
" 201 " 250 " .. .. .	19 12 3
" 251 " 300 " .. .. .	20 2 3
Over 300 beds .. .. .	20 12 3

Provided that the wages of any Matron in a Hospital Registered as a Training School or a part-time Training School shall not be less than £17 2s. 6d. per week.

(ii) Any Matron in a Hospital in which there is no Resident Medical Officer and which hospital is registered as a training school or a part time training school shall, in addition to the wages prescribed in sub-clause (i) hereof, receive an allowance at the rate of £52 per annum.

(iii) Wages payable to Matrons employed in benevolent homes shall be based on the daily average occupied number of beds as follows:—

	Per Week.
	£ s. d.
100 beds or under .. .. .	17 2 3
From 101 to 200 beds .. .. .	17 12 3
" 201 " 300 " .. .. .	18 2 3
" 301 " 450 " .. .. .	18 12 3
Over 450 beds .. .. .	19 2 3

*Deputy or Assistant Matrons.*

(i) Wages payable to deputy or assistant Matrons (other than those employed in benevolent homes) shall be based on the daily average occupied beds in a public hospital or the registered number of beds in any other institution as follows:—

	Per Week.
	£ s. d.
From 101 to 150 beds .. .. .	16 2 3
" 151 " 200 " .. .. .	16 12 3
" 201 " 250 " .. .. .	17 2 3
Over 250 beds .. .. .	17 12 3

(ii) Wages payable to deputy or assistant Matrons employed in benevolent homes shall be based on the daily occupied average number of beds as follows:—

	Per Week.
	£ s. d.
From 201 to 300 beds .. .. .	15 17 3
" 301 " 450 " .. .. .	16 2 3
Over 450 beds .. .. .	16 7 3

*Certificated Midwifery Nurses.*

	Per Week.
	£ s. d.
Certificated Midwifery Nurses .. .. .	12 4 3

*Employees not Elsewhere Provided for in Part 1.*

The wages of the following employees shall vary according to their length of service in the institution at which they are employed at the class of work mentioned, provided that a nurse with not less than an aggregate of three years' experience at such class, who then commences work in another institution, shall for the first twelve months' service in such institution, be paid not less than the rate herein provided in Column C, and thereafter not less than the rate herein in Column D.

	COLUMN A. During the First Year.	COLUMN B. During the Second Year.	COLUMN C During the Third Year.	COLUMN D. Thereafter.
	Per Week. £ s. d.	Per Week. £ s. d.	Per Week. £ s. d.	Per Week. £ s. d.
<i>Females.</i>				
Nurse Dietitian in Charge holding a certificate recognized by the Royal Victorian College of Nursing .. .. .	15 7 3	15 12 3	15 17 3	16 2 3
Assistant Dietitians holding certificates recognized by the Royal Victorian College of Nursing .. .. .	14 7 3	14 12 3	14 17 3	15 2 3
Senior Tutor Sister (which includes a Tutor Sister where only one is employed) .. .. .	15 7 3	15 12 3	15 17 3	16 2 3
Tutor Sisters other than senior tutor sister .. .. .	14 2 3	14 7 3	14 12 3	14 17 3
Night Sister in charge of 20 beds or more .. .. .	14 7 3	14 12 3	14 17 3	15 2 3
Other Night Sister in charge .. .. .	14 2 3	14 7 3	14 12 3	14 17 3
X-ray Sister who is a registered technician .. .. .	14 7 3	14 12 3	14 17 3	15 2 3
Sisters .. .. .	14 2 3	14 7 3	14 12 3	14 17 3
Staff Nurses .. .. .	12 7 3	12 17 3	13 2 3	13 7 3
<i>Males.</i>				
Male Nurses .. .. .	16 5 0	16 15 0	17 6 0	17 11 0



**PART 2**

NOTE.—Section I. of this part applies to—

Registered infant welfare nurses engaged in infant welfare work or in work requiring an infant welfare certificate, and who are employed—

- (i) by any municipality or industrial or commercial corporation; or
- (ii) in any pre-school centre (including any crèche, nursery school, kindergarten, or play group).

Section II. of this part applies to—

Registered infant welfare nurses engaged in infant welfare work or in work requiring an infant welfare certificate, and who are employed in any—

- infant welfare training school,
- mothercraft training school, or
- babies' home.

**SECTION I.**

**WAGES.**

1. Any employee required to live in shall be provided with laundry, free of charge, but a sum of 50s. 9d. per week may be deducted from the wages hereinafter provided, for board and lodging.

	Per Week.
	£ s. d.
Sister .. .. .	15 16 9

**SECTION II.**

**WAGES.**

1. All employees required to live in shall be provided with laundry, free of charge, but a sum of 50s. 9d. per week may be deducted from the wages hereinafter provided, for board and lodging.

Employees required to live out shall receive an allowance at the rate of 20s. per week, in addition to the wages hereinafter set out, and shall also be entitled to one meal per day to be provided by the employer.

(a) *Employees in Infant Welfare Training Schools only or in Infant Welfare and Mothercraft Training Schools combined.*

	Per Week.
	£ s. d.
Matron .. .. .	17 16 9
Sister—	
During the first year's service at the Institution .. .. .	14 7 3
During the second year's service at the Institution .. .. .	14 12 3
Thereafter at such Institution .. .. .	14 17 3

Should part of the duties of a sister be to relieve the matron at any time, she shall be entitled in each and every week to receive an additional sum of 5s.

(b) *Employees in Mothercraft Training Schools only.*

	Per Week.
	£ s. d.
Matron .. .. .	17 6 9
Sister—	
During the first year's service at the Institution .. .. .	14 7 3
During the second year's service at the Institution .. .. .	14 12 3
Thereafter at such Institution .. .. .	14 17 3

Should part of the duties of a sister be to relieve the matron at any time, she shall be entitled in each and every week to receive an additional sum of 5s.

(c) *Employees in Babies' Homes.*

	Per Week.
	£ s. d.
Matron .. .. .	16 12 9
Sister .. .. .	14 7 3

**PART 3.**

NOTE.—This part applies to—

Certificated nurses engaged in connexion with any industrial or commercial undertaking.

**WAGES.**

	Per Week.
	£ s. d.
During the first year's service .. .. .	13 7 3
During the second year's service .. .. .	13 12 3
Thereafter .. .. .	13 17 3

**PART 4.**

NOTE.—Section I. of this part applies to—

Certificated nurses employed in his practice by a qualified medical practitioner or dentist or employed by any medical or dental society, clinic or service.

Section II. of this part applies to—

Certificated nurses employed by any nursing society or association.

**SECTION I.**

**WAGES.**

	Per Week.
	£ s. d.
X-ray nurse, who is a registered technician :—	
During the first year's service .. .. .	14 7 3
During the second year's service .. .. .	14 12 3
Thereafter .. .. .	14 17 3
Other nurse :—	
During the first year's service .. .. .	14 2 3
During the second year's service .. .. .	14 7 3
Thereafter .. .. .	14 12 3

**SECTION II.**

**WAGES.**

1. An employee for whom the employer makes available board and lodging shall be provided with laundry, free of charge, but from the wages hereinafter prescribed, a sum of 50s. 9d. per week may be deducted in respect of such board and lodging notwithstanding that such employee may decide not to avail herself of such accommodation.

An employee for whom the employer does not make available board and lodging shall receive in addition to the wages hereinafter prescribed, an allowance at the rate of 20s. per week, and shall be entitled also to one meal per day to be provided by the employer.

										Per Week.			
										£	s.	d.	
During the first year	..	..	..	..	..	..	..	..	..	..	14	2	3
During the second year	..	..	..	..	..	..	..	..	..	..	14	7	3
Thereafter	..	..	..	..	..	..	..	..	..	..	14	12	3

Clauses, other than clause 1 of Part 1, clause 1 of Sections I. and II. of Part 2, clause 1 of Part 3, and clause 1 of Sections I. and II. of Part 4, of the said Determinations shall remain in force.



# VICTORIA GOVERNMENT GAZETTE.

Published by Authority.

[Registered at the General Post Office, Melbourne, for transmission by post as a newspaper.]

No. 838]

WEDNESDAY, NOVEMBER 16.

[1955

*Labour and Industry Act 1953.*

## DETERMINATION OF A WAGES BOARD ADJUSTED PURSUANT TO SECTION 33 OF THE LABOUR AND INDUSTRY ACT 1953.

I, Henry Norman Jones, Secretary for Labour and Industry, in pursuance of the powers conferred by the Labour and Industry Act, hereby make and issue the following adjusted Determination of the Wages Board referred to hereunder showing adjusted rates and prices to operate from the beginning of the first pay period to commence in August, 1955.

Dated at Melbourne, this  
8th day of August, 1955.

H. N. JONES,  
Secretary for Labour and Industry.

### ASBESTOS-CEMENT WORKERS BOARD.

Clause 2 of the Determination made on the 10th June, 1955, and in force as from the beginning of the first pay period to commence on or after the 25th June, 1955, shall be replaced by the following clause:—

2.

(a) WAGES.

Apprentices or Improvers.			Other Employees.	
	Per Week of 40 Hours.			Wages.
	Percentage of Basic Wage.	Wages.		Per Week of 40 Hours.
		<i>s. d.</i>		<i>s. d.</i>
16 and under 17 years of age	50	120 0	Wet sheet machine leading hand ..	273 0
17 and under 18 years of age	58	139 0	Wet sheet machine operator ..	269 0
18 and under 19 years of age	70	168 0	Mixer operator—in sole charge of Tide mill ..	269 0
19 and under 20 years of age	86	206 6	Mixer operator—other ..	266 0
20 and under 21 years of age	100+2s.	242 0	Asbestos treatment operator ..	268 0
			Cutter-off in charge ..	273 0
			Cutter-off ..	265 6
			Plateman or stacker ..	266 0
			Corrugating machine operator ..	266 0
			Hand corrugator ..	264 6
			Wet trimmer (Power guillotine only)	266 0
			Leading hand in charge of dry trimming ..	273 0
			Dry trimmer—operating power cutting machine ..	266 0
			Accessories hand moulder—welded or grafted mouldings ..	268 0
			Accessories hand moulder—plain mouldings ..	266 0

No apprentices or improvers under the age of sixteen years to be engaged.

WAGES—*continued.*

Apprentices or Improvers.	Other Employees.	
		Wages.
		Per Week of 40 Hours.
		<i>s. d.</i>
PROPORTION (IN ANY PLACE).	Operator cement bulk handling .. ..	268 0
<i>Apprentices and Improvers.</i>	Pipe machine leading hand .. ..	277 0
Two apprentices or improvers to every three or fraction of three workers receiving not less than the rate prescribed for the classification "All others".	Mazza machine control operator .. ..	268 0
	Pressure pipe curing tank hand .. ..	265 6
	Operator pressure pipe turning and socket boring machine .. ..	265 6
	Operator pressure pipe turning and socket boring machine (who sets up machine) ..	270 6
	Pressure pipe socket fitter .. ..	265 6
	All others .. ..	263 0

(b) An employee appointed as a leading hand or an employee temporarily in charge of three or more men shall be paid the rate herein prescribed for the class of work done, plus an allowance at the rate of 10s. per week, or the rate herein prescribed for his ordinary duties, whichever is the higher.

Clauses, other than clause 2, of the said Determination shall remain in force.



VICTORIA  
GOVERNMENT GAZETTE.

Published by Authority.

[Registered at the General Post Office, Melbourne, for transmission by post as a newspaper.]

No. 839]

WEDNESDAY, NOVEMBER 16.

[1955

*Labour and Industry Act 1953.*

**DETERMINATION OF A WAGES BOARD ADJUSTED PURSUANT TO SECTION 33 OF THE  
LABOUR AND INDUSTRY ACT 1953.**

I, Henry Norman Jones, Secretary for Labour and Industry, in pursuance of the powers conferred by the Labour and Industry Act, hereby make and issue the following adjusted Determination of the Wages Board referred to hereunder showing adjusted rates and prices to operate from the beginning of the first pay period to commence in August, 1955.

Dated at Melbourne, this

8th day of August, 1955.

H. N. JONES,

Secretary for Labour and Industry.

**BEDSTEAD MAKERS BOARD.**

Clauses 2, 3 and 4 of the Determination published in *Government Gazette* No. 149 of the 1st April, 1955, shall be replaced by the following clauses:—

2.

	Wages per Week of 40 Hours.	
	Within the Metropolitan District; the Cities of Geelong, Geelong West, Newtown and Chilwell, and Warrnambool.	Other Parts of Victoria where the Determination Applies.
	<i>s. d.</i>	<i>s. d.</i>
Bedstead smith .. .. .	267 6	264 6
Chill fitter called on to design and model .. .. .	297 6	294 6
Other chill fitter .. .. .	267 6	264 6
Machinist .. .. .	262 0	259 0
Plater in charge .. .. .	290 0	287 0
Plater's assistant .. .. .	263 0	260 0
Polisher and grinder .. .. .	265 0	262 0
Chipper and caster .. .. .	261 0	258 0
Bedstead fitter and mounter .. .. .	267 6	264 6
Employee engaged cutting, binding, straightening, drilling, or squaring up parts of bedsteads and frame setter .. .. .	265 0	262 0
Japanner and lacquerer .. .. .	262 0	259 0
Other employees with not less than three months' experience in the industry .. .. .	249 0	246 0
All others .. .. .	243 0	240 0

**SPECIAL RATES.**

3. In addition to the wages prescribed in clause 2 hereof the following special rates and allowances shall be paid :—
- (a) Leading hands in charge of not less than three and not more than ten employees, including apprentices, 15s. per week extra; more than ten and not more than twenty employees, including apprentices, 30s. per week extra; more than twenty employees, including apprentices, 45s. per week extra.
  - (b) Working in wet places, 1½d. per hour extra. Working in confined spaces, 3d. per hour extra.
  - (c) Working for more than one hour in the shade in places where the temperature is raised by artificial means to between 115 and 130 degrees Fahrenheit, 1½d. per hour extra; in places where the temperature exceeds 130 degrees Fahrenheit, 3d. per hour extra. Where work continues for more than two hours in temperatures exceeding 130 degrees Fahrenheit, employees shall also be entitled to twenty minutes' rest after every two hours' work without deduction of pay. The temperature shall be decided by the foreman of the work after consultation with the employees who claim the extra rate.
  - (d) Dirty work, i.e., work which a foreman and workman shall agree is of an unusually dirty or offensive nature, 1½d. per hour extra.
  - (e) Compensation to the extent of the damage sustained shall be made for work in which clothing or tools are damaged or destroyed by the use of acids.
  - (f) Where more than one of the disabilities entitling a workman to extra rates exist on the same job, the employer shall be bound to pay only one rate, viz., the highest for the disabilities so prevailing.

**JUNIOR MALE AND FEMALE LABOUR.**

*Wages Per Week of 40 Hours.*

	*Percentage of Basic Wage.	Additional Amount.	War Loading.	Total Wage Payable—	
				Within the Metropolitan District; the Cities of Geelong, Geelong West, Newtown and Chilwell, and Warrnambool.	Other Parts of Victoria where the Determination Applies.
	Per Week.	Per Week. s. d.	s. d.	s. d.	s. d.
<i>I.—Adult Females.</i>					
Under one month's experience .. .. .	75	.. .. .	.. .. .	180 0	177 6
All others .. .. .	75	16 0	.. .. .	196 0	193 6
<i>II.—Junior Females.</i>					
17 years of age and under .. .. .	52	3 6	.. .. .	97 0	96 0
18 years of age .. .. .	62	4 0	.. .. .	115 6	114 0
19 years of age .. .. .	72	4 6	.. .. .	134 0	132 6
20 years of age .. .. .	82	5 0	.. .. .	152 6	150 6
<i>III.—Junior Males.</i>					
Under 16 years of age .. .. .	24	2 0	.. .. .	59 6	59 0
16 years of age .. .. .	34	3 0	.. .. .	84 6	83 6
17 years of age .. .. .	40	4 0	.. .. .	114 6	113 0
18 years of age .. .. .	58	5 0	.. .. .	144 0	142 6
19 years of age .. .. .	73	6 0	.. .. .	181 0	179 0
20 years of age .. .. .	88	7 0	.. .. .	218 0	215 6
A junior employee of eighteen years or more shall be paid 3s. per week in addition to the rates prescribed herein while he is employed as a furnaceman or assistant to a furnaceman.					
<i>IV.—Junior Males (Foundries).</i>					
Under 16 years of age .. .. .	24	2 0	1 0	60 6	60 0
16 years of age .. .. .	32	2 6	1 9	81 0	80 0
17 years of age .. .. .	58	5 0	3 0	147 0	145 6
18 years of age .. .. .	73	6 0	4 0	185 0	183 0
19 years of age and over .. .. .	88	7 0	4 6	222 6	220 0

\* The percentages for junior females relate to the female basic wage, but in all other cases relate to the male basic wage.

Females and unapprenticed male juniors may be employed on piecework subject to clause 17 hereof.

The total wage shall be calculated to the nearest 6d., any broken part of 6d. in the result not exceeding 3d. to be disregarded.

Clauses, other than clauses 2, 3 and 4, of the said Determination shall remain in force.



PART 2.

1.

* Improvers.				Other Employees.	
				Wages per Week of 40 Hours.	
				<i>s. d.</i>	
Under 16 years of age	..	..	..	142	0
16 years of age	..	..	..	173	3
17 years of age	..	..	..	203	0
18 years of age	..	..	..	231	0
19 years of age	..	..	..	262	6
20 years of age	..	..	..	278	0
Stable Workers				285	6
All Others				302	6

PROPORTIONS—Wherever this Section applies.  
(In any place.)  
One improver to every four or fraction of four workers receiving not less than the minimum wage.

\* The Board has determined that no person shall be taken on as an apprentice.

PART 3.

1.

* Improvers.				Other Employees.	
				Wages per Week of 40 Hours.	
				<i>s. d.</i>	
Under 16 years of age	..	..	..	123	9
16 years of age	..	..	..	152	0
17 years of age	..	..	..	186	9
18 years of age	..	..	..	215	6
19 years of age	..	..	..	246	9
20 years of age	..	..	..	264	3
Stable workers				270	0
All others				285	0

Proportion.—Wherever this section applies :—  
One Improver to every four or fraction of four workers receiving not less than the minimum wage.

\* The Board has determined that no apprentice shall be taken to this Section.

PART 4.

1.

* Improvers.				Other Employees.	
				Wages per Week of 40 Hours.	
				<i>s. d.</i>	
Under 16 years of age	..	..	..	123	9
16 years of age	..	..	..	152	0
17 years of age	..	..	..	186	9
18 years of age	..	..	..	215	6
19 years of age	..	..	..	246	9
20 years of age	..	..	..	264	3
Stable workers				270	0
All others				285	0

Proportion.—Wherever this section applies :—  
One Improver to every four or fraction of four workers receiving not less than the minimum wage.

\* The Board has determined that no apprentice shall be taken to this Section.

Clauses, other than Clause 1 of Parts 1, 2, 3, and 4, of the said Determination shall remain in force.





# VICTORIA GOVERNMENT GAZETTE.

Published by Authority.

[Registered at the General Post Office, Melbourne, for transmission by post as a newspaper.]

**No. 841]**

**WEDNESDAY, NOVEMBER 16.**

**[1955**

*Labour and Industry Act 1953.*

## DETERMINATION OF A WAGES BOARD ADJUSTED PURSUANT TO SECTION 33 OF THE LABOUR AND INDUSTRY ACT 1953.

I, Henry Norman Jones, Secretary for Labour and Industry, in pursuance of the powers conferred by the Labour and Industry Act, hereby make and issue the following adjusted Determination of the Wages Board referred to hereunder showing adjusted rates and prices to operate from the beginning of the first pay period to commence in August, 1955.

Dated at Melbourne, this  
8th day of August, 1955.

H. N. JONES,  
Secretary for Labour and Industry.

### COAL AND COKE BOARD.

Clause 2 of Part 1 and clause 1 of Part 2 of the Determination made on the 14th June, 1955, and in force as from the beginning of the first pay period to commence on or after the 12th May, 1955, shall be replaced by the following clauses:—

**PART 1.**—Persons **OTHER THAN** those employed in the process, trade, business, or occupation of burning, preparing, grinding, grading, or distributing charcoal in a form suitable for use in power-producing or heat-producing units; in the manufacture of explosives or in the manufacture, repair, or maintenance of gas masks or respirators.

#### 2. (a) WAGES PER WEEK.

Improvers.			Other Employees.	
	Percentage of Basic Wage.			s. d.
		s. d.	Persons trimming or spreading coal that is heated or on fire .. .. .	359 0
			Persons employed driving and/or operating power-driven coal-loading or unloading machines, i.e., persons riding on, driving and/or operating mechanical or other levers of such coal-loading or unloading machines .. .. .	303 0
Under 17 years of age .. .. .	67	161 0	Persons employed trimming coal and/or feeding coal to and from coal loaders .. .. .	293 0
17 years of age .. .. .	79	189 6	Persons trimming coal from the "Grab" .. .. .	300 4
18 years of age .. .. .	91	218 6	Other coal trimmers .. .. .	293 0
19 years of age or over—the appropriate rate prescribed under the heading "other employees".			Coal baggers or loaders .. .. .	293 0
			Persons employed loading or unloading by shovel or fork loose coal from railway trucks to vehicles .. .. .	293 0
			Persons employed loading or unloading by shovel or fork loose coal from vehicles to railway trucks .. .. .	315 0
			Persons loading by shovel or fork loose coal from the ground into railway trucks .. .. .	326 0
			Coke stackers at wharf coal yards .. .. .	302 2
			Coke yard employees .. .. .	263 8
			Carters driving one horse .. .. .	263 6
			Carters driving two horses .. .. .	278 0
			Carters driving three horses .. .. .	283 0
			Carters driving four horses .. .. .	288 0
			Carters driving five horses .. .. .	291 0
			And 2s. extra per day for every additional horse.	
			Drivers of motor vehicle, including girlinger, having a maker's capacity of—	
			(a) 25 cwt. or less .. .. .	276 0
			(b) Over 25 cwt., but not over 3 tons .. .. .	285 6
			(c) Over 3 tons, but under 6 tons .. .. .	295 0
			Further tonnage—for each complete ton over 5 an extra 2s. 6d. per week.	
			All other coal yard employees .. .. .	286 0

NOTE.—The Board has determined that the trade is so unskilled that no apprentices shall be taken in the trade.

(b) *Gas Producer Units*.—The following provisions shall apply to drivers of gas producer units :—

- (i) Driver of a motor vehicle fitted and operated with a charcoal gas producer unit for each day or portion thereof upon which he is called upon to drive such vehicle, 1s. extra.
- (ii) Such driver for each day or portion thereof upon which he is called upon to clean the hopper and/or final filter of such unit, 1s. extra.
- (iii) Suitable overalls and gloves shall be provided by employers for the employees mentioned in sub-clauses (i) and (ii) hereof.
- (iv) Employers shall provide proper washing conveniences for such employees, and also hot water or some other efficient cleansing material.

**PART 2.**—Persons employed in the process, trade, business, or occupation of burning, preparing, grinding, grading, or distributing charcoal, in a form suitable for use in power-producing or heat-producing units ; in the manufacture of explosives or in the manufacture, repair, or maintenance of gas masks or respirators.

1. (a)			WAGES PER WEEK OF 40 HOURS.	
Improvers.			Other Employees.	
—	Percentage of Basic Wage.	—	<i>s. d.</i>	
		<i>s. d.</i>		
Under 17 years of age ..	65	156 0	Wood cutters, using axe, power crosscut circular saw, or other method	273 8
17 years of age ..	77	185 0	Carters driving one horse .. .. .	263 6
18 years of age ..	87	209 0	Carters driving two horses .. .. .	276 0
19 years of age or over—the appropriate rate prescribed under the heading "other employees".			Carters driving three horses .. .. .	283 0
			Carters driving four horses .. .. .	288 0
			Carters driving five horses .. .. .	291 0
			And 2s. extra per day for every additional horse.	
			Drivers of vehicle (including girlinger) having maker's capacity of—	
			(a) 25 cwt. or less .. .. .	276 0
			(b) Over 25 cwt., but not over 3 tons .. .. .	285 6
			(c) Over 3 tons, but under 6 tons .. .. .	295 0
			Further tonnage—for each complete ton over 5 an extra per 2s. 6d.	
			week. Charcoal burning by retorts, metal or brick kilns, or pits—	
			(a) Operator in charge of plant .. .. .	288 8
			(b) All other employees, including persons employed in emptying, bagging, sewing, stacking, or loading .. .. .	278 8
			Grinding or grading charcoal—	
			(a) Attendant in charge of plant—	
			(i) With four or more persons under his supervision .. .. .	298 8
			(ii) With three or fewer persons under his supervision .. .. .	294 8
			(b) All other persons, including those engaged in grinding, grading, or bagging charcoal or sewing bags .. .. .	288 8

**PROPORTION (BY ANY EMPLOYER).**

One improver to the first six workers, and thereafter one additional improver to every ten additional workers receiving not less than 263s. 6d. per week.

**NOTE.**—The Board determines that no person shall be employed as an apprentice.

Clauses, other than clause 2 of Part 1 and clause 1 of Part 2, of the said Determination shall remain in force.



VICTORIA  
GOVERNMENT GAZETTE.

Published by Authority.

[Registered at the General Post Office, Melbourne, for transmission by post as a newspaper.]

No. 842]

WEDNESDAY, NOVEMBER 16.

[1955

*Labour and Industry Act 1953.*

**DETERMINATION OF A WAGES BOARD ADJUSTED PURSUANT TO SECTION 33 OF THE  
LABOUR AND INDUSTRY ACT 1953.**

I, Henry Norman Jones, Secretary for Labour and Industry, in pursuance of the powers conferred by the Labour and Industry Act, hereby make and issue the following adjusted Determination of the Wages Board referred to hereunder showing adjusted rates and prices to operate from the beginning of the first pay period to commence in August, 1955.

Dated at Melbourne, this  
8th day of August, 1955.

H. N. JONES,  
Secretary for Labour and Industry.

**PHOTOGRAPHIC GOODS BOARD.**

Clause 2 of the Determination made on the 16th May, 1955, and in force as from the beginning of the first pay period to commence on or after the 1st June, 1955, shall be replaced by the following clause:—

2. WAGES PER WEEK OF 40 HOURS.

(a) Apprentices or Improvers.					(b) Other Employees.				
Age.	Per-centage of Basic Wage.	Males.	Per-centage of Female Basic Wage.	Females.					
		<i>s. d.</i>							
		<i>s. d.</i>							
16 years of age and under .. ..	45	108 0	60	108 0	<b>Adult Males—</b> <span style="float: right;"><i>s. d.</i></span> Emulsion mixers, emulsion washers, finishers, melters, preparers of emulsion for coating, costers, and employees in coating room .. .. . 272 6 All others .. .. . 259 6  Adult males employed on afternoon shift shall be paid 7½ per cent. in addition to existing rates of pay. Adult males employed on night shift shall be paid 10 per cent. in addition to existing rates of pay.  If an afternoon shift should overlap a night shift the rate for night shift shall be paid for the whole of such afternoon shift.				
17 years of age .. ..	54	129 6	66	119 0	<span style="float: right;"><i>s. d.</i></span> Adult females .. .. . 186 0  Females employed in the emulsion rooms or film coating rooms shall be paid 5s. per week in addition to the rate fixed for "adult females". Females employed examining portrait film, X-ray film, dry plates, and assisting in the plate coating room, shall be paid 3s. 6d. per week in addition to the rate fixed for "adult females". Females employed in any other dark rooms shall be paid 2s. 6d per week in addition to the rate fixed for "adult females".				
18 years of age .. ..	67	161 0	72	129 6					
19 years of age .. ..	81	194 6	78	140 6					
20 years of age .. ..	96	230 6	90	162 0					

Apprentices or improvers who are employed in a dark room shall be paid 2s. per week in addition to the rates fixed above.

Female apprentices or improvers who are employed in the emulsion rooms or film coating rooms shall be paid a further 2s. a week in addition to the rates fixed above.

**PROPORTION (in any place).**

*Apprentices or Improvers.*

Such number of apprentices and improvers as shall not in the aggregate exceed three to every two weekly workers receiving not less than the minimum wage.

An indenture of apprenticeship has been prescribed by the Board.

Clauses, other than clause 2, of the said Determination shall remain in force.





# VICTORIA GOVERNMENT GAZETTE.

Published by Authority.

[Registered at the General Post Office, Melbourne, for transmission by post as a newspaper.]

No. 843]

WEDNESDAY, NOVEMBER 16.

[1955

Labour and Industry Act 1953.

## DETERMINATION OF A WAGES BOARD ADJUSTED PURSUANT TO SECTION 33 OF THE LABOUR AND INDUSTRY ACT 1953.

I, Henry Norman Jones, Secretary for Labour and Industry, in pursuance of the powers conferred by the Labour and Industry Act, hereby make and issue the following adjusted Determination of the Wages Board referred to hereunder showing adjusted rates and prices to operate from the beginning of the first pay period to commence in August, 1955.

Dated at Melbourne, this  
8th day of August, 1955.

H. N. JONES,  
Secretary for Labour and Industry.

### SHOPS BOARD No. 13 (FUEL AND FODDER—COUNTRY).

Clauses 2 and 17 of the Determination made on the 21st June, 1955, and in force as from the beginning of the first pay to period commence in July, 1955, shall be replaced by the following clauses:—

Part 1.—Persons **OTHER THAN** those employed in the process, trade, business or occupation of burning, grinding, grading, or distributing charcoal.

2.			IMPROVERS.		OTHER EMPLOYEES.	
			Wages per Week of 40 Hours.		Wages per Week of 40 Hours.	
			—	Percent- age of Basic Wage.	Firewood Saw-mills, Mallee Roots, &c. s. d.	
					Benchmen at self-acting benches where not more than two persons are employed, viz., benchman and stacker .. .. . 293 0	
					Other benchmen .. .. . 286 0	
					Lumpers .. .. . 286 0	
					Trolley-men .. .. . 286 0	
					Skip loaders .. .. . 286 0	
					Truck loaders of wood 4 feet or over .. .. . 286 0	
					Wagon or dray loaders .. .. . 286 0	
					Block stackers .. .. . 277 6	
					Wood cutters using axe, power crosscut, circular saw, or other method .. 293 0	
					Carters driving one, two, or three horses .. .. . 281 0	
					And 2s. extra per day for every additional horse in excess of three.	
					Drivers of motor vehicles having a carrying capacity—	
					(a) not exceeding 25 cwt. .. .. . 276 0	
					(b) exceeding 25 cwt. but not exceeding 3 tons .. .. . 285 6	
					(c) exceeding 3 tons .. .. . 295 0	
					And if a trailer is attached to the vehicle—2s. 6d. per day extra.	
					Persons engaged in raising, digging out, cleaning, trimming, or loading mallee roots on to vehicles .. .. . 300 6	
					All others .. .. . 274 0	
					Foreman—If any person employed in any of the above capacities has under his control five or more other workers he shall be regarded as a foreman, and paid 5s. per day above the ordinary rate.	
					<i>Gas Producer Units.</i>	
					The following provisions shall apply to drivers of vehicles fitted with Gas Producer Units:—	
					(i) Driver of a motor vehicle fitted and operated with a charcoal gas producer unit for each day or portion thereof upon which he is called upon to drive such vehicle, 1s. extra.	
					(ii) Such driver for each day or portion thereof upon which he is called upon to clean the hopper and/or final filter of such unit, 1s. extra.	

PROPORTION (BY ANY EMPLOYER).  
One improver to the first three workers, receiving not less than 274s. per week of 40 hours, and thereafter one additional improver to every ten additional such workers.

NOTE.—The Board determines that no person shall be employed as an apprentice.

IMPROVERS.	OTHER EMPLOYEES—(continued).	
Wages per Week of 40 Hours.	Wages per Week of 40 Hours.	
	<i>Hay, Corn, or Chaff Stores.</i>	
		<i>s. d.</i>
	Storeman in charge .. .. .	291 0
	Carters driving one, two, or three horses .. .. .	281 0
	And 2s. extra per day for every additional horse.	
	Drivers of motor vehicles having a carrying capacity—	
	(a) not exceeding 25 cwt. .. .. .	276 0
	(b) exceeding 25 cwt., but not exceeding 3 tons .. .. .	285 6
	(c) exceeding 3 tons .. .. .	295 0
	And if a trailer is attached to a vehicle—2s. 6d. per day extra.	
	All others .. .. .	282 0
	<i>Wood, Coal, or Cots Yards.</i>	
	Carters driving one, two, or three horses .. .. .	281 0
	And 2s. extra per day for every additional horse.	
	Drivers of motor vehicles having a carrying capacity—	
	(a) not exceeding 25 cwt. .. .. .	276 0
	(b) exceeding 25 cwt., but not exceeding 3 tons .. .. .	285 6
	(c) exceeding 3 tons .. .. .	295 0
	And if a trailer is attached to a vehicle—2s. 6d. per day extra.	
	All others .. .. .	280 0
	<i>Gas Producer Units.</i>	
	The following provisions shall apply to drivers of vehicles fitted with gas producer units:—	
	(i) Driver of a motor vehicle fitted and operated with a charcoal gas producer unit for each day or portion thereof upon which he is called upon to drive such vehicle, 1s. extra.	
	(ii) Such driver for each day or portion thereof upon which he is called upon to clean the hopper and/or final filter of such unit, 1s. extra.	

**Part 2.—Persons employed in the process, trade, business or occupation of burning, grinding, grading, or distributing charcoal.**

17. IMPROVERS.			OTHER EMPLOYEES.	
Wages per Week of 40 Hours.			Wages per Week of 40 Hours.	
	Percent- age of Basic Wage.	<i>s. d.</i>		<i>s. d.</i>
Under 17 years of age	73	175 0	Wood cutters, using axe, power crosscut, circular saw, or other method .. .. .	203 0
17 years of age ..	84	201 6	Carters driving one, two, or three horses .. .. .	281 0
18 years of age ..	100+2s.	242 0	And 2s. extra per day for every additional horse in excess of three.	
19 years of age or over—the appropriate rate prescribed under the heading "other employees."			Drivers of motor vehicles having a carrying capacity—	
			(a) not exceeding 25 cwt. .. .. .	276 0
			(b) exceeding 25 cwt. but not exceeding 3 tons .. .. .	285 6
			(c) exceeding 3 tons but not exceeding 6 tons .. .. .	295 0
			(d) Further tonnage—for each complete ton over 5, an extra 1s. per week.	
			And if a trailer is attached to the vehicle—2s. 6d. per day extra.	
			<i>Gas Producer Units.</i>	
			The following provision shall apply to drivers of vehicles fitted with gas producer units:—	
			(i) Driver of a motor vehicle fitted and operated with a charcoal gas producer unit for each day or portion thereof upon which he is called upon to drive such vehicle, 1s. extra.	
			(ii) Such driver for each day or portion thereof upon which he is called upon to clean the hopper and/or final filter of such unit, 1s. extra.	
			Charcoal burning by retorts, metal or brick kilns, or pits—	
			(a) Operator in charge of plant .. .. .	315 0
			(b) All other employees, including persons employed in emptying, bagging, sewing, stacking, or loading .. .. .	300 6
			Grinding or grading charcoal—	
			(a) Attendant in charge of plant—	
			(i) With four or more persons under his supervision .. .. .	329 0
			(ii) With three or fewer persons under his supervision .. .. .	323 6
			(b) All other persons, including those engaged in grinding, grading, or bagging charcoal or sewing bags .. .. .	315 0

Clauses, other than clauses 2 and 17 of the said Determination, shall remain in force, provided that, to the weekly earnings of each pieceworker shall be added the sum of three shillings. Where less than 40 hours is worked in any week by any pieceworker, a proportionate amount of such sum of three shillings shall be added in lieu thereof.