



VICTORIA GOVERNMENT GAZETTE

Published by Authority

[Registered at the General Post Office, Melbourne, for transmission by post as a newspaper.]

No. 257]

WEDNESDAY, NOVEMBER 20

[1957

ACT OF PARLIAMENT.

PROCLAMATION

By His Excellency the Governor of the State of Victoria and its Dependencies in the Commonwealth of Australia, &c., &c., &c.

I, THE Governor of the State of Victoria, in the Commonwealth of Australia, do hereby declare that I have this day assented, in Her Majesty's name, to the Bill passed by the Parliament of the said State, the title whereof is hereunder set forth, that is to say:—

No. 6112. "An Act to revise the Statute Law and for other purposes."

Given under my Hand and the Seal of the State of Victoria aforesaid, at Melbourne, this twelfth day of November, in the year of our Lord One thousand nine hundred and fifty-seven, and in the sixth year of the reign of Her Majesty Queen Elizabeth II.

(L.S.) DALLAS BROOKS.

By His Excellency's Command,
HENRY E. BOLTE,
Premier.

GOD SAVE THE QUEEN!

PUBLIC HIGHWAY.—BOROUGH OF RINGWOOD.

PROCLAMATION

By His Excellency the Governor of the State of Victoria and its Dependencies in the Commonwealth of Australia, &c., &c., &c.

WHEREAS by the *Local Government Act 1946*, section 518, it is amongst other things enacted that it shall be lawful for the Governor in Council at any time, and from time to time, upon the request of the council of any municipality, by notice in the *Government Gazette*, to declare any land reserved, used or by purchase or exchange acquired for a street, road, highway, thoroughfare, bridge, square, court, alley or right-of-way to be a public highway, and that such land shall thereupon and thenceforth from the date of such Proclamation become and be absolutely dedicated to the public as a public highway within the meaning of any law then or thereafter in force:

And whereas the Council of the Borough of Ringwood has requested that the land hereinafter mentioned, which has been used for a road within the said Borough, be so declared to be a public highway:

Now, therefore, I, the Governor of the State of Victoria in the Commonwealth of Australia, by and with the advice of the Executive Council of the said State, do, by this Proclamation declare that all that piece of land, used for a road, being part of Crown portions 16 and 18, Parish of Ringwood, and being the land described hereunder, shall be a public highway within the meaning of the said Act, namely:—

Commencing at the north-western angle of lot 3 shown on L.P. No. 10917, bounded thence by a line bearing 155 deg. 13½ min. 1,885 ft. 10 in. to the south-eastern angle of lot 32, thence by a line bearing 154 deg. 23 min. 692 ft. 5 in. to the northern boundary of the road on the northern boundary of lot 19 shown on L.P. No. 11701, thence by lines bearing respectively 156 deg. 44 min. 700 feet, 150 deg. 37 min. 230 ft. 1½ in., 156 deg. 44 min. 529 ft. 3¼ in., and 156 deg. 44 min. 369 ft. 9 in. to a point where the northern boundary of Station-street produced meets the eastern boundary of Heathmont-road as shown on L.P. No. 11248, thence by a line bearing 156 deg. 44 min. 566 ft. 5 in. to Canterbury-road as shown on L.P. No. 11009, thence by a line bearing 214 deg. 47 min. 70 ft. 8 in. to the south-western angle of lot 16 shown on L.P. No. 11009, thence by a line bearing 336 deg. 44 min. 588 ft. 5 in. to the north-eastern angle of lot 116 shown on L.P. No. 11009, thence by a line bearing 342 deg. 0 min. 103 ft. 1 in. to the southernmost angle of lot 1 shown on L.P. No. 11248, thence by a line bearing 336 deg. 44 min. 314 ft. 1 in. to the north-eastern angle of lot 10 shown on L.P. No. 11248, thence by lines bearing respectively 336 deg. 44 min. 491 ft. 1 in., 330 deg. 37 min. 230 ft. 1½ in. and 336 deg. 44 min. 702 ft. 8 in. to the north-eastern angle of lot 53 shown on L.P. No. 11701, thence by lines bearing respectively 334 deg. 23 min. 691 ft. 0½ in. and 335 deg. 13 min. 23 ft. 4 in. to the south-eastern angle of lot 71 shown on L.P. No. 10917, thence by lines bearing respectively 335 deg. 13½ min. 1,753 ft. 4 in. to the eastern boundary of Great Ryrie-street, as shown on L.P. No. 10917, and 360 deg. 0 min. 120 ft. 5 in. to the point of commencement.

Given under my Hand and the Seal of the State of Victoria aforesaid, at Melbourne, this twelfth day of November, in the year of our Lord One thousand nine hundred and fifty-seven, and in the sixth year of the reign of Her Majesty Queen Elizabeth II.

(L.S.) DALLAS BROOKS.

By His Excellency's Command,
T. K. MALTBY,
Commissioner of Public Works.

GOD SAVE THE QUEEN!

Forests Act 1957 (No. 6073).

PROCLAMATION OF PROHIBITED PERIOD.

PROCLAMATION

By His Excellency the Governor of the State of Victoria and its Dependencies in the Commonwealth of Australia, &c., &c., &c.

IN pursuance of the powers conferred by section 3 of the *Forests Act 1957*, I, the Governor of the State of Victoria in the Commonwealth of Australia, by and with the advice of the Executive Council of the said State, do by this my Proclamation proclaim the period commencing at midnight between the twentieth and twenty-first days of November, One thousand nine hundred and fifty-seven and ending at midnight between the fifteenth and sixteenth days of April, One thousand nine hundred and fifty-eight, to be the prohibited period in respect to any fire protected area other than a State forest or national park in the State of Victoria situated in such Municipalities as are specified in the Schedule hereto.

SCHEDULE.

The Shires of Bairnsdale.
Belfast.
Dundas.
Glenelg.
Minhamite.
Mount Rouse.
Omeo.
Orbost.
Portland.
Tambo.

Given under my Hand and the Seal of the State of Victoria aforesaid, at Melbourne, this twentieth day of November, in the year of our Lord One thousand nine hundred and fifty-seven, and in the sixth year of the reign of Her Majesty Queen Elizabeth II.

(L.S.) DALLAS BROOKS.

By His Excellency's Command,
G. S. McARTHUR,
Minister of Forests.

GOD SAVE THE QUEEN!

Local Government Act 1946.

ALTERATION OF HOUR FOR CLOSING POLL AT MUNICIPAL ELECTIONS, CITY OF BROADMEADOWS.

HIS Excellency the Governor of the State of Victoria, by and with the advice of the Executive Council thereof, doth by Order made on the 12th day of November, 1957, pursuant to the provisions of section 134 of the *Local Government Act 1946* and acting on a petition presented by the Council of the City of Broadmeadows, direct that the hour for closing the poll at the municipal elections for the said City shall be Eight (8) o'clock in the afternoon.

A. MAHLSTEDT,
Clerk of the Executive Council.

At the Executive Council Chamber,
Melbourne, 12th November, 1957.

Local Government Acts.

PROPOSED TOWN OF OCEAN GROVE.

PURSUANT to the provisions of section 43 of the *Local Government Act 1946*, the substance and prayer of a petition presented to the Governor in Council in accordance with section 17 of the said Act are published, viz.:—

The petitioners are 25 ratepayers of the Shire of Bellarine resident in portion of the shire not exceeding 3 square miles in extent and distant more than 10 miles from the boundaries of the City of Melbourne.

The petitioners pray that the Governor in Council may be pleased to proclaim certain land in the Parish of Bellarine a township under the name of the Township of Ocean Grove.

T. K. MALTBY,
Commissioner of Public Works.

Local Government Act 1946, Part 48.

RENEWAL OF UNUSED ROAD AND WATER FRONTAGE LICENCES.

ALL Unused Road and Water Frontage Licences expiring on 31st December, 1957 (excepting those cancelled or terminated), are hereby renewed for a further term of three years.

KEITH TURNBULL,
Minister of Lands.

Department of Crown Lands and Survey,
Melbourne.

Local Government Acts.
BOROUGH OF BENALLA.

ORDER CONFIRMED.

THE Minister of the Crown administering the *Local Government Act 1946*, on the eleventh day of November, 1957, confirmed the Order hereinafter referred to, in pursuance of section 513 of the said Act, viz.:—

An Order of the Council of the Borough of Benalla, made on the 23rd September, 1957, for the purpose of providing recreation area, and for acquiring for such purpose certain land being Crown allotment 10, section Y, Township and Parish of Benalla, County of Delatite.

T. K. MALTBY,
Commissioner of Public Works.

ORDERS IN COUNCIL.—(Series 1957-58.)

STATE ELECTRICITY COMMISSION.

1619. The supply of automotive and general replacement parts for Caterpillar tractors, graders, and associated equipment, for a period of twelve months, to Specification No. 57-58/31, at Schedule rates.—William Adams Tractors Pty. Ltd.

1620. The supply and installation of control cables, Morwell Power Station, to Specification No. 57-58/61, £88,962.—W. T. Henleys Telegraph Works Co. Ltd.

1621. The erection of amenities block between "A" and "D" boilerhouses, Yallourn Power Station, to Specification No. 57-58/34, £48,606.—John Holland and Co. Pty. Ltd.

1622. The reconditioning of stator casing of No. 1 turbo-generator, Newport "B" Power Station, to Quotation No. 3454, £6,000.—Ordnance Factory, Maribyrnong.

1623. The supply of nine single-phase 220 kV transformers and spares for Ringwood Terminal Station and Dederang Switching Station, to Specification No. 56-57/131, £9,862.—Perkins Pty. Ltd.

1624. The construction of concrete and macadam roads in Coal Storage Area, Geelong "B" Power Station, to Specification No. 57-58/75, £5,500.—Western District Terrazzo and Granolithic Co.

1625. The supply of automotive replacement parts for G.M.H. vehicles within the metropolitan area, for a period of twelve months, to Specification No. 57-58/38, at Schedule rates.—S. A. Cheney Pty. Ltd.

1626. The supply of automotive replacement parts for G.M.H. vehicles within the metropolitan area, for a period of twelve months, to Specification No. 57-58/38, at Schedule rates.—Southern Motors Pty. Ltd.

Approved by the Governor in Council, 6th November, 1957.—A. MAHLSTEDT, Clerk of the Executive Council.

FORESTS COMMISSION.

Loan Fund Act No. 6040, Item 1—

1627. To the purchase of allotment 13, section L, Township of Bolga, Parish of Beethang, County of Bogong, and improvements thereon, for forest purposes (see the following amending Order), £3,100.—The State Rivers and Water Supply Commission.

Approved by the Governor in Council, 27th September, 1955.—A. MAHLSTEDT, Clerk of the Executive Council.

AMENDING ORDER.

That the above Order be amended by inserting "allotment 12" in lieu of "allotment 13".

Approved by the Governor in Council, 25th June, 1957.—A. MAHLSTEDT, Clerk of the Executive Council.

EDUCATION DEPARTMENT.

1618. Science equipment, for Sale Technical School, £222 10s.—H. B. Selby and Co. Pty. Ltd.

Approved by the Governor in Council, 12th November, 1957.—A. MAHLSTEDT, Clerk of the Executive Council.

MELBOURNE AND METROPOLITAN BOARD OF WORKS.

NOTICE is hereby given that, after the publication of this advertisement in four consecutive ordinary numbers of the *Government Gazette* and four numbers of one of the daily newspapers published in the metropolis, the Melbourne and Metropolitan Board of Works will proceed to compulsorily take (unless the same is in the meantime acquired by the Board from the owner or owners or other persons interested by mutual agreement)—

- (a) the land mentioned and described in the First Schedule hereto, and
- (b) an easement 50-ft. wide over the land mentioned and described in the Second Schedule hereto.

The nature of the works in respect of which the land and the easement are proposed to be taken is for purposes in connexion with water supply to the metropolis as more fully appears on the plan of the proposed works hereafter mentioned.

A plan of the proposed works will be open for inspection at the offices of the Board, 110 Spencer-street, Melbourne, from the date hereof until the Fourth day of December One thousand nine hundred and fifty-seven, during office hours.

The quantity of land which the Board requires for the purpose of such works and other particulars are set forth below.

The consent of the Governor in Council was duly obtained in terms of the Board's principal Act (No. 3731) on the twenty-fourth day of September, One thousand nine hundred and fifty-seven.

County.	Parish.	Crown Description.	Quantity of Land Required.
FIRST SCHEDULE.			
1. Bourke	Mulgrave	Part of C.P. 79	A. R. P. 3 0 7 ¹ / ₁₀
2. Bourke	Mulgrave	Part of C.P. 82	0 2 18 ⁹ / ₁₀
3. Bourke	Dandenong	Part of C.P. 5	0 3 29 ⁷ / ₁₀
SECOND SCHEDULE.			
1. Bourke	Mulgrave	Part of C.P. 82	An easement 50-ft. wide as more particularly described in the plan hereinbefore mentioned
2. Bourke	Mulgrave	Part of C.P. 83	
3. Bourke	Dandenong	Part of C.A. 'J', Section 1	
4. Bourke	Dandenong	Part of C.A. 'A', Section 2	
5. Bourke	Dandenong	Part of C.A. 'C', Section 2	
6. Bourke	Dandenong	Part of C.A. 'D', Section 2	
7. Bourke	Dandenong	Part of C.A. 'F', Section 2	
8. Bourke	Dandenong	Part of C.A. 1, Section 2	
9. Bourke	Dandenong	Part of C.A. 2, Section 2	
10. Bourke	Dandenong	Part of C.A. 4	
11. Bourke	Dandenong	Part of C.P. 5	

Dated this first day of November 1957.

Offices of the Melbourne and Metropolitan Board of Works,
110 Spencer-street, Melbourne.

C. TRATHAN,
Secretary.

Local Government Act 1946, Part 48, Section 876.

LICENCES TO OCCUPY UNUSED ROADS.

NOTICE is hereby given that Licences to occupy Unused Roads have been issued to the following approved applicants, and that the Licence Fee specified in each case has been received by the Accountant, Department of Crown Lands and Survey, Melbourne, C.2.

Number of Licence.	Name and Address of Licensee.	Municipality.	Parish.	Abutting— Allotments and Sections.	Area.	Fee for Licence.	Date of Issue of Licence.	Date of Expiry of Licence.
					A. R. P.	£ s. d.		
40881	McGregor, J., Ritchies-road, Jumbuk, via Yinnar	Morwell	Jumbuk	Between 17 and 17D, section A	3 0 0	0 12 0	1.1.57	31.12.59
40882	Onley, F. B., Newry	Maffra	Maffra	North of 7E	1 1 0	1 5 0	1.1.57	31.12.59
40883	Hagger, A. M. and H. B., 26 Guthridge Parade, Sale.	Avon	Nuntin	Between 18H and 18L, section 2	5 0 0	1 0 0	1.1.57	31.12.59
40884	Hagan, A. E. and T. H., Box 7, P.O. Sale	Avon	Yeerung	Between 16A2 and 17B, section 4	4 0 0	1 0 0	1.1.57	31.12.59
40885	Williamson, L. H., Heyfield	Maffra	Tinamba	Between 94c and 109c	4 0 0	2 16 0	1.1.57	31.12.59
40886	Zacher, F. M., Heyfield	Maffra	Tinamba	Between 94 and 109	3 0 0	2 2 0	1.1.57	31.12.59
40887	James, R. J., 28 Wallace-street, Morwell	Avon	Meerlieu	Between 5 and 24; between 4 and 7, section 3	8 0 0	1 0 0	1.1.57	31.12.59
40888	French, S. P. R., Briagolong	Avon	Bow Wor-rung	North and east boundary Cemetery Reserve to south-west of 25, section B	2 0 0	1 0 0	1.1.57	31.12.59
40889	Hughes, G. F., Sale P.O.	Avon	Nuntin	Between 57A and 58	2 0 0	2 0 0	1.1.57	31.12.59
40890	Bryant, Mrs. L. E., P.O. Box 113, Lakes Entrance	Tambo	Township of Cuning-ham, Parish of Colquhoun	Between 2 and 3 and 9A, section 5	1 2 0	1 10 0	1.1.58	31.12.60

Department of Crown Lands and Survey,
Melbourne, 20th November, 1957.

KEITH TURNBULL,
Commissioner of Crown Lands and Survey.

Transport Regulation Acts.
TRANSPORT REGULATION BOARD.

NOTICES OF PUBLIC HEARINGS.

NOTICE is hereby given that the applications made by the persons named below for licences to operate commercial passenger vehicles, on the route or routes or in the manner set out opposite their names, will be heard at a time and place to be communicated to the parties:—

Name and Address; Nature of Application.

- GAFFNEY, R. E., Koonya-avenue, Koonya, via Sorrento; 1 commercial passenger vehicle, to be purchased, with seating capacity for five persons, to operate under private hire conditions from the corner of Hughes and Melbourne roads, Koonya, from 1st December, 1957, to 31st March, 1958.
- SOUTER, J. V., 54 High-street, Bendigo; application for renewal of licences Nos. C.O.66 and C.O.95 (expired 10th November, 1957) authorizing operations as stage omnibuses under the same terms and conditions.
- PLOWMAN, G. E. & E. N., 24 Market-street, Kyneton; application for renewal of licences Nos. C.T.757 (expiring 25th November, 1957) authorizing operations as a country taxi from Kyneton and C.H.505 (expiring 25th November, 1957) to operate as a country private hire from Kyneton.

APPLICATIONS by the persons listed hereunder for metropolitan taxi-cab licences, subject to the cancellation of metropolitan private hire car licence held by each applicant, as shown:—

Name and Address; "M.H." Licence Held.

- BRADSHAW, L., 146 Thomas-street, East Brighton; M.H.1501.
- BODONYI, E. K., 186 Leicester-street, Carlton; M.H.1565.
- COLLYER, E. H., 12 Roberts-street, Elwood; M.H.1563.
- PATRIKIOS, M. J. (Mrs.), 31 Toorak-road, Hawthorn East; M.H.1201.

STEEN, J., 20 Hudson-street, Coburg; 1 commercial passenger vehicle, with seating capacity for five persons, to operate as a metropolitan taxi-cab.

UBL, V., 2 Percy-street, St. Albans; 1 commercial passenger vehicle, with seating capacity for five persons, to operate as a metropolitan private hire car, to be bespoken from 2 Percy-street, St. Albans.

PICKETT, L. J., Taylor's-road, St. Albans; 1 commercial passenger vehicle, with seating capacity for five persons, to operate as a metropolitan private hire car, to be bespoken from Taylor's-road, St. Albans.

ARBUTHNOT'S BUS SERVICE (per C. A. Wright, nominee), 63 Nicholson-street, East Coburg; application for variation of Route 8A (Moreland-Essendon-North Essendon) to extend extension (d) of service from the corner of High-street and Normanby-avenue, via Clarendon-street, Wales-street, Clyde-street, Victoria-road, to the corner of Clarendon-street, Thornbury. (Returning to normal route via Clarendon-street.) Sections, fares, and time-table to be determined.

BRIDGES, O. J., 29 Florence-street, Mentone; application for renewal of licence No. C.O.1018 (expiring 15th December, 1957) authorizing operations on Route 211A (Mentone-Keysborough-Springvale), Route 212A (Springvale-Noble Park), Route 213A (Dandenong-Glen Waverley), Route 214A (Mentone-Mordialloc), as prescribed.

RICARDO, F., 26 Beauvlew-parade, Ivanhoe; application for renewal of licence No. M.O.493 (expiring 25th November, 1957) authorizing operations on Route 10A (Fairfield-Moonee Ponds) as prescribed.

NOTICE is hereby given that the applications made by the persons named below for licences to operate the commercial goods vehicles, on the route or routes or in the manner set out opposite their names, will be heard at a time and place to be communicated to the persons concerned:—

Name and Address; Nature of Application.

- ANSETT, G. H., 159 McCrae-street, Bendigo; 1 commercial goods vehicle (109 cwt.) to operate within the Bendigo Division of the C.R.B.—road-contracting plant and materials.
- BALLARAT METALS PTY. LTD., P.O. Box 46, Coburg; 1 commercial goods vehicle (108 cwt.) to operate throughout the State of Victoria in the course of business as "marine dealers"—marine stores and old metals.
- BROWN, L. A., 9 Tasman-avenue, Belmont, Geelong; 1 commercial goods vehicle (70 cwt.) to operate within a radius of 50 miles of Geelong—road-contracting plant and materials.

CHILTON, S. H. & K. M., Jeparit; 1 commercial goods vehicle (85 cwt.) to operate—(a) within a radius of 20 miles of Jeparit—general goods, (b) from Horsham and Warracknabeal to places within a radius of 20 miles of Jeparit—petroleum products in prescribed types of containers and empty returns.

COLAC AERATED WATERS, 286 Murray-street, Colac; 1 commercial goods vehicle (60 cwt.) to operate within a radius of 60 miles of the post office at Colac in the course of business as "aerated waters and cordial manufacturers"—own aerated waters, cordials, vinegar, hayzone, and jelly crystals.

FISHER, J. M., & SONS, Apollo Bay; 1 commercial goods vehicle (60 cwt.) to operate throughout the State of Victoria as a tow truck for the purpose of repairing or towing disabled or wrecked vehicles.

GLENN, D. R. S., 117 York-street, Sale; 1 commercial goods vehicle (120 cwt.) to operate within the Traralgon and Bairnsdale Divisions of the C.R.B.—road-contracting plant and materials.

GULBIN, H. P., 23 Kenna-avenue, Hamilton; 1 commercial goods vehicle (8 cwt.) to operate within a radius of 50 miles of Hamilton solely on behalf of Payne's Bon Marche—manchester and hardware, the property of the said company.

HEATH'S SERVICE STATION PTY. LTD., 150 Little Malop-street, Geelong; 3 commercial goods vehicles (15, 20, and 18 cwt.) to operate throughout the State of Victoria as tow trucks for the purpose of repairing or towing disabled or wrecked vehicles.

JONES, F. W. & L. A., Oman-street, Lismore; 1 commercial goods vehicle (109 cwt.) to operate—(a) within a radius of 20 miles from the post office at Lismore—general goods, (b) from places situate within the radius as defined in paragraph (a) to Camperdown—general farm produce, grain, and firewood, (c) from the City of Geelong to places situate within a radius of 10 miles of the post office at Lismore—superphosphate, bulk coke, and second-hand household furniture, (d) from and to Terang and Beaufort to and from Lismore—sawn timber and firewood, (e) from the City of Ballarat—bricks ex the Eureka Brick and Tile Co. to consignees at Lismore.

LIND, A. D., 64 Moore-street, Traralgon; application to vary conditions of licence No. T.T.D.1730 by the addition of the ability to operate for the carriage of logs from A.P.M. forest landings to Stoll Bros. sawmill at Rokeby, via Warragul.

LUMMIS, L. H., 266 McKenzie-street, Golden Square; 1 commercial goods vehicle (87 cwt.) to operate within the Shires of Rushworth and Nagambie and the City of Bendigo—road-contracting plant and materials.

MAMOUNEY, J. FRANK, PTY. LTD., 257 Williamson-street, Bendigo; 1 commercial goods vehicle (8 cwt.) to operate within a radius of 75 miles of Bendigo and to and from Birchip, Nullawil, Quambatook, Wyche-proof, and Donald in the course of business as "home furnishers"—carpets, linoleums, and curtains for laying or fixing, also tools of trade and materials incidental to such work.

MILNER, J. R., Roger-street, Pakenham East; 1 commercial goods vehicle (100 cwt.) to operate from and to places within a radius of 7 miles from the post office at Pakenham East to and from the City of Melbourne, via the Princes Highway—general goods.

MONAHAN, J. E., & T. W. WESTON, 58 Learmonth-street, Queenscliff; 2 commercial goods vehicles (110 and 79 cwt.) to operate—(a) within a radius of 25 miles of Geelong—general goods, (b) from Queenscliff Fishermen's Co-op. Socy. to fish markets at Melbourne—fish.

MCKAY MASSEY HARRIS, H. V., PTY. LTD., 2 Devonshire-road, Sunshine; 1 commercial goods vehicle (12 cwt.) to operate throughout the State of Victoria for the purpose of servicing and maintaining agricultural machinery—spare parts, tools of trade, and materials incidental to own contracts.

MCLENNAN, J. G., "Derrinal," Corowa, N.S.W.; 1 commercial goods vehicle (100 cwt.) to operate within the Benalla Division of the C.R.B.—road-contracting plant and materials.

NEWLANDS LUMBER CO. PTY. LTD., Yarra Junction; application to vary the terms of existing licence No. T.T.D.59 by the addition of the ability to operate for the carriage of logs from forest landings in the Niagaroon and Upper Yarra forestry districts and the Big River areas—(a) to the railway stations at Warburton and/or Yarra Junction and to any mill or dump which is located within a radius of 20 miles of such landings or of the railway stations at Warburton and/or Yarra Junction, (b) to any mill or timber yard situated within a radius of 25 miles of the G.P.O., Melbourne.

PATERSON'S PTY. LTD., 152 Bourke-street, Melbourne; 1 commercial goods vehicle (8 cwt.) to operate within a radius of 50 miles of own branch store at Swan Hill in the course of business as "home furnishers"—own furniture and furnishings.

POPE PRODUCTS LTD., 304 Spencer-street, Melbourne; 1 commercial goods vehicle (13 cwt.) to operate throughout the State of Victoria for the purpose of servicing and maintaining refrigerators, washing machines, and electrical appliances previously manufactured by the licensees—tools of trade, spare parts, and materials incidental to such work.

TAYLOR, E. M. & M. R., 242 Charman-road, Cheltenham; 1 commercial goods vehicle (125 cwt.) to operate—(a) within a radius of 20 miles of Cheltenham—general goods, (b) within a radius of 50 miles of Cheltenham—road-contracting plant and materials.

TUCKFIELD, F. S. & H. J. (trading as Tuckfield Teas), 3 Market-street, South Yarra; 1 commercial goods vehicle (40 cwt.) to operate—(a) within a radius of 50 miles of own premises at South Yarra in the course of business as "blenders and distributors of Ty-nee Tips, Tango, and Orange Pekoe teas," (b) from the railway station at Ballarat in the course of business as "distributors of teas" to retailers within a radius of 50 miles of such railway station—own teas, (c) from the railway station at Bendigo in the course of business as "distributors of teas" to retailers within a radius of 50 miles of such railway station—own teas, (d) to operate within a radius of 50 miles of own premises at South Yarra to places *en route*, to and including Lorne, in the course of business as "distributors of teas" to retailers—own teas.

WILLOX, L. H., 37 Cunningham-street, Sale; 1 commercial goods vehicle (100 cwt.) to operate throughout the Shires of Alberton, Tambo, Orbost, Bairnsdale, Avon, Traralgon, and Morwell—road-contracting plant and materials.

CHASEMORE, K. R., 30 Cremorne-street, Balwyn; 1 commercial goods vehicle (259 cwt.) to operate from private property in the Avoca area to consignees in the metropolitan area and Dandenong and Montrose—redgum logs.

NOTICE is hereby given that the applications made by the persons named below for renewal of licences to operate the commercial goods vehicles, on the route or routes or in the manner set out opposite their names, will be heard at a time and place to be communicated to the persons concerned:—

Name and Address; Present Franchise; Licence No.; Date of Expiry.

CUNNINGHAM, R. H., PTY. LTD., 2-8 Bromham-place, Richmond; 1 commercial goods vehicle (10 cwt.) to operate—(a) within a radius of 50 miles from the G.P.O., Melbourne, in the course of business as "distributor of electrical equipment"—own goods, (b) throughout the State of Victoria in the course of business as "electrical equipment distributors and

installation and servicing agents"—tools of trade, spare parts, test equipment, materials for use on own contracts, and samples of equipment permanently fitted in vehicles; D.8111; 14th December, 1957.

FAR WESTERN TYRE SERVICE PTY. LTD., corner of French and Cox streets, Hamilton; 1 commercial goods vehicle (9 cwt.) to operate within a radius of 80 miles from the place of business of licensee situate at Hamilton in the course of business as "tire dealers and re-treaders"—new tires for delivery to clients and second-hand tires for retread and recapping; D.5878; 30th January, 1958.

MORSE, F., PTY. LTD., Lava-street, Warrnambool; 1 commercial goods vehicle (142 cwt.) to operate within a radius of 75 miles from the post office at Warrnambool for the purpose of repairing or towing disabled or wrecked vehicles—tools, spare parts, and materials incidental to trade; D.8167; 25th January, 1958.

RONALDSON BROS. & TIPPETT LTD., Creswick-road, Ballarat; 1 commercial goods vehicle (8 cwt.) to operate throughout the State of Victoria for the purpose of servicing and maintaining agricultural machinery and lighting plants—tools of trade and spare parts incidental to such servicing; D.5812; 5th December, 1957.

ANDERSON, E. A. & S. F. (trading as Werribee Carrying Co.), 42 Synott-street, Werribee; 1 commercial goods vehicle (70 cwt.) to operate—(a) within a radius of 25 miles from the G.P.O., Melbourne—general goods, (b) from and to places situate within the area as defined in paragraph (a) above to and from places situate within a radius of 50 miles from aforementioned G.P.O.—second-hand household furniture; D.5933; 30th January, 1958.

NOTICE is hereby given that the application made by the persons named below for renewal of the licence with variation to operate the commercial goods vehicle, on the route or routes or in the manner set out opposite their names, will be heard at a time and place to be communicated to the parties concerned:—

Name and Address; Present Conditions; Amended Conditions; Licence No.; Date of Expiry.

LEURY, T. J. & A. C. (trading as Leury Bros.), 12 Burnell-street, West Brunswick; 1 commercial goods vehicle (122 cwt.) to operate—(a) within a radius of 25 miles from the G.P.O., Melbourne—general goods, (b) within a radius of 40 miles from the G.P.O., Melbourne—bricks, roofing tiles, and sewerage pipes; 1 commercial goods vehicle (122 cwt.) to operate—(a) as per present conditions, (b) within a radius of 70 miles from the G.P.O., Melbourne—bricks, roofing tiles, and sewerage pipes; D.A.1491; 14th December, 1957.

Notice of any objection should be forwarded to reach the Secretary of the Board not later than Wednesday, 4th December, 1957.

E. V. FIELD,
Secretary.

Exhibition Buildings, Rathdown-street, Carlton, N.3,
18th November, 1957.

STATE RIVERS AND WATER SUPPLY COMMISSION.

LICENCES TO DIVERT WATER AND CUT RACES, PURSUANT TO THE PROVISIONS OF THE WATER ACTS.

TRANSFERS of Licences detailed have been approved by the Governor in Council, and effected as on and from the 12th November, 1957.

Licence Number.	Source of Supply.	Name of Transferor.	Name and Address of Transferee.
892/	River Murray	John Henry Evans	Leila Iris Muller of Merbein
339/	Gum Lagoon, (Gunbower Creek)	N. McGillivray	Bartolo Francesco Scarfo, and Raffaele Scarfo, of Gunbower
1133/352	River Murray	Gordon Keith Mills	William James Brett Goddard, of Boundary Bend
1134/352	River Murray	Arthur Kinerl Mills	Rupert Allan Hammet, and Norman Francis Hammet, of Boundary Bend

Office of the State Rivers and Water Supply Commission,
Melbourne, 12th November, 1957.

J. R. MOORE, Acting Secretary,
State Rivers and Water Supply Commission.

4 GEORGE VI. No. 4755, SECTION 6.

I HEREBY give notice that on the 1st November, 1957, the Public Trustee filed elections to administer the following deceased persons' estates, in accordance with section 6 of the *Public Trustee Act 1940*:—

FITZCLARENCE, ROY, also known as John Henry Taylor, late of Pheasant Creek, via Whittlesea, labourer, died 18th December, 1956, intestate.

TAYLOR, MAY, late of 782 Drummond-street, North Carlton, housekeeper, died 4th August, 1957, intestate.

*WARDMAN, CECIL WOOD, formerly of Manchester, England, but late of 250 Swan-street, Richmond, pensioner, died 6th May, 1957.

* According to the provisions of the will.

I HEREBY give notice that on the 6th November, 1957, the Public Trustee filed elections to administer the following deceased persons' estates, in accordance with section 6 of the *Public Trustee Act 1940*:—

BRENNAN, JOHN JOSEPH, formerly of Eastern Hill Hotel, 77 Victoria-parade, Fitzroy, but late of 127 Victoria-parade, Fitzroy, retired public servant, died 18th August, 1957, intestate.

*HILL, AUGUSTA CHRISTINE, late of 17 Henry-street, Fitzroy, widow, died 3rd June, 1957.

*MILLIS, SARAH, late of 28 Raglan-street, Port Melbourne, widow, died 31st August, 1957.

MURPHY, JOHN EDWARD, formerly of Orbost, but late of Kew, gentleman, died 3rd August, 1957, intestate.

NOLAN, CHARLES KELTON, late of 24 Edwin-street, Preston, pensioner, died 28th July, 1956, intestate.

* According to the provisions of the will.

I HEREBY give notice that on the 7th November, 1957, the Public Trustee filed elections to administer the following deceased persons' estates, in accordance with section 6 of the *Public Trustee Act 1940*:—

BENNETT, WILLIAM ALEXANDER, late of 25 Morey-street, Burwood, painter, died 21st April, 1951, intestate.

GARGARO, SALVATORE, late of 22 Tait-street, North Fitzroy, railway employee, died 30th August, 1956, intestate.

I HEREBY give notice that on the 8th November, 1957, the Public Trustee filed elections to administer the following deceased persons' estates, in accordance with section 6 of the *Public Trustee Act 1940*:—

BROWN, THOMAS, late of 96A Stewart-street, Brunswick, pensioner, died 14th August, 1957, intestate.

*TOMAMICHEL, EVERARD NORMAN, late of 26 Walton-street, Richmond, retired railway employee, died 4th August, 1955.

* According to the provisions of the will.

I HEREBY give notice that on the 11th November, 1957, the Public Trustee filed an election to administer the following deceased person's estate, in accordance with section 6 of the *Public Trustee Act 1940*:—

CHERRILL, VICTOR FREDERICK, formerly of "Southview," New-road, Porchfield, Isle of Wight, but late of Australian Military Forces, sergeant, died 28th July, 1957, intestate.

H. C. CHIPMAN,
Public Trustee.

412 Collins-street, Melbourne, 13th November, 1957.

NOTICE.

ADMINISTRATION of the estate of each of the under-mentioned deceased persons has been granted to the Public Trustee, and creditors, next of kin, and all others having claims against the estate of any of the persons so mentioned are required to send particulars of their claims to the Public Trustee, No. 412 Collins-street, Melbourne, on or before the 23rd January, 1958, or they will be excluded from the distribution of the estate when the assets are being distributed:—

*BELL, ROBERT, late of 6 Ruabon-road, Toorak, retired insurance officer, died 8th August, 1957.

BENNETT, WILLIAM ALEXANDER, late of 25 Morey-street, Burwood, painter, died 21st April, 1951, intestate.

*BRADFORD, ALAN LESLIE, formerly of 8 Lovelock-street, St. Kilda, storeman, died 20th January, 1957.

BRENNAN, JOHN JOSEPH, formerly of Eastern Hill Hotel, 77 Victoria-parade, Fitzroy, but late of 127 Victoria-parade, Fitzroy, retired public servant, died 18th August, 1957, intestate.

*BROWN, SUSAN, late of 26 Nicholson-street, Moreland, married woman, died 12th April, 1957.

BROWN, THOMAS, late of 96A Stewart-street, Brunswick, pensioner, died 14th August, 1957, intestate.

CHERRILL, VICTOR FREDERICK, formerly of "Southview," New-road, Porchfield, Isle of Wight, but late of Australian Military Forces, sergeant, died 28th July, 1957, intestate.

*CHRISTIE, ERNEST MACGREGOR, sometimes known as Ernest Francis MacGregor Christie, but late of "Thirlmere," 600 St. Kilda-road, Melbourne, gentleman, died 22nd August, 1957.

*CLEAK, ALFRED, late of 41 Bonanza-road, Beaumaris, gentleman, died 23rd July, 1957.

FITZCLARENCE, ROY, also known as John Henry Taylor, late of Pheasant Creek, via Whittlesea, labourer, died 18th December, 1956, intestate.

GARGARO, SALVATORE, late of 22 Tait-street, North Fitzroy, railway employee, died 30th August, 1956, intestate.

GREENSLADE, WILLIAM JAMES, formerly of 37 King-street, Prahran, but late of 26 Fernhill-road, Sandringham, retired watchmaker, died 12th August, 1957, intestate.

†HILL, AUGUSTA CHRISTINE, late of 17 Henry-street, Fitzroy, widow, died 3rd June, 1957.

*JOHNSTONE, SUSAN, formerly of 19 Stephenson-street, Richmond, but late of 21 Hammond-street, Thornbury, spinster, died 19th July, 1957.

LENTHALL, ROSE MARIE, also known as Rose Marie Scott, late of 2 Elgin-avenue, Armadale, housekeeper, died 3rd August, 1957, intestate.

MEE, LAWRENCE NOEL, formerly of Elliminyt, but late of 24 Morrison-street, Colac, bread carter, died 29th March, 1957, intestate.

†MILLIS, SARAH, late of 28 Raglan-street, Port Melbourne, widow, died 31st August, 1957.

*MILNE, ALBERT WILLIAM, late of 601 Canning-street, North Carlton, retired railway employee, died 27th September, 1956.

MURPHY, JOHN EDWARD, formerly of Orbost, but late of Kew, gentleman, died 3rd August, 1957, intestate.

MCDIARMID, JOHN STANLEY, formerly of Bundoora, but late of Repatriation General Hospital, Heidelberg, war pensioner, died 29th September, 1956, intestate.

*MCINERNEY, FRANCIS BERNARD, late of 7 Plant-street, Malvern, printer's assistant, died 30th July, 1957.

NEWMAN, THELMA FANNY, late of 13 Gibdon-street, Burnley, tailor, died 1st June, 1957, intestate.

*NICHOLLS, THOMAS, late of 52A Alexandra-street, East St. Kilda, tramway employee, died 17th July, 1957.

NOLAN, CHARLES KELTON, late of 24 Edwin-street, Preston, pensioner, died 28th July, 1956, intestate.

*PERRY, ISABEL, formerly of 631 Plenty-road, Preston, but late of "Kalimna," Benson-street, Belgrave, widow, died 1st September, 1957.

*PRESSER, RUDOLPH ADRIAN, late of 38 Adelaide-street, Footscray, sheet metal worker, died 18th June, 1957.

REYNOLDS, HUGH, late of Warrion, via Colac, gentleman, died 1st July, 1957, intestate.

*RUST, ALBERTA, formerly of 282 Cardigan-street, Carlton, but late of 85 Brunswick-road, Brunswick, widow, died 19th September, 1956.

SEDDON, DAVID, late of 206 Alexander-parade, Clifton Hill, pattern cutter, died 2nd September, 1957, intestate.

TAYLOR, MAY, late of 782 Drummond-street, North Carlton, housekeeper, died 4th August, 1957, intestate.

*THOMAS, WILLIAM PENROSE, late of 28 Collins-street, Box Hill, retired teacher, died 7th August, 1957.

†TOMAMICHEL, EVERARD NORMAN, late of 26 Walton-street, Richmond, retired railway employee, died 4th August, 1955.

*WALKER, ELIZABETH, late of Yackandandah, spinster, died 18th November, 1956.

*WALKER, MARY JANE, late of Yackandandah, spinster, died 26th July, 1956.

†WARDMAN, CECIL WOOD, formerly of Manchester, England, but late of 250 Swan-street, Richmond, pensioner, died 6th May, 1957.

*WHITE, WILLIAM ROBERT, late of 214 Biggs-street, St. Albans, fitter, died 15th July, 1957.

* With the will annexed.

† According to the provisions of the will.

H. C. CHIPMAN,
Public Trustee.

Melbourne, 13th November, 1957.

COMPANIES ACT 1938.

NOTICE is hereby given in pursuance of section 295 (3 and 4) of the Companies Act 1938, that at the expiration of three months from the date hereof the names of the following companies will, unless cause is shown to the contrary, be struck off the Register, and the said companies will be dissolved.

Dated this 18th day of November, 1957.

T. S. WELSH,
Deputy Registrar-General.
Registrar-General's Office, Melbourne.

Companies Above Referred to.

Name of Company.	No. of Registration.
J. Macartney and Co. Proprietary Limited	5429
The Blue Bird Preserving Company Proprietary Limited	7068
Spice & Condiment Grinders Proprietary Limited	10095
Preston Estates Proprietary Limited	11914
Franklin Bros. Men's Stores Proprietary Limited	12749
Pyramid Quarries and Concrete Limited	13322
Town Hall Hotel (St. Arnaud) Proprietary Limited	13360
J. J. Winters Proprietary Limited	13522
F. B. Brady Proprietary Limited	13611
Morna Proprietary Limited	14713
Bonds Millinery Proprietary Limited	16257
Jim's Service Station Proprietary Limited	17456
M. O. Williams Proprietary Limited	17758
Pembroke Investments Proprietary Limited	17979
Italrayon & Cotton Textile Co. Proprietary Limited	18435
Meteor Mills Proprietary Limited	18548
Edenhope Electric Supply Company Proprietary Limited	19238
Jubilee Publications Proprietary Limited	19500
E. A. Miller Proprietary Limited	19745
Rolco Office Systems Proprietary Limited	20032
Remo Manufacturing Company Proprietary Limited	20148
S. P. Furs Proprietary Limited	20376
Archer Byrne and Upward Proprietary Limited	20382
Trading Terms Limited	20536
Derbins Proprietary Limited	20767
Service Radio Electrical Company Proprietary Limited	21301
Yallourn Passenger Services Proprietary Limited	21405
McMahon's Hotel Proprietary Limited	21929
Fitz's Free Credit Stores Proprietary Limited	22396
Roller Regulators (Aust.) Proprietary Limited	22845
Engineering and Combustion Company (Victoria and South Australia) Proprietary Limited	23017
Martyr & Mitchell Proprietary Limited	23465
Air Separation Leases Limited	23665
Grosvenor Private Club Limited	23757
E. G. Morgan & Co. Proprietary Limited	23890
Downs Travel Goods Pty. Limited	23989
Australian-Oriental Agency Co. Proprietary Limited	24010
Roger Berry (Vic.) Pty. Limited	24063
Gregory Lloyd Proprietary Limited	24351
Murray Black Coal Development Limited	24526
Burnbrae Farms Proprietary Limited	24694
Speak-Easy Telephones (Vic. Sales) Proprietary Limited	24970
Paltex Proprietary Limited	24999
Macs Catering Services Proprietary Limited	25104
Fractional H.P. Motors Pty. Limited	25300
Corinthian Tile Manufacturers Proprietary Limited	25469
Australian Action Pictures Proprietary Limited	25498
Kangaroo Coach Lines Proprietary Limited	25544
Star Traps Proprietary Limited	25751
Scientific Instrument Service Pty. Limited	25776
Dominion Linen Manufacturing Company Proprietary Limited	26041
Merton Publishing Company Proprietary Limited	26052
Greyhound Lines of Australia Proprietary Limited	26257
Allan Smith (Victoria) Proprietary Limited	26559
Preston Meatworks Pty. Limited	26630
Bass Islands Airways Proprietary Limited	26942
Rye-Terre Proprietary Limited	27105
Sugar Loaf Creek Hotel Proprietary Limited	27107
Grabearth Proprietary Limited	27208
Bell Carton and Printing Company Proprietary Limited	27535
C. T. Davey & Company Proprietary Limited	27566
Ever-Dry Containers Proprietary Limited	27630
James Oswald's Art Potteries Proprietary Limited	27754
Property in Pictures Proprietary Limited	27809
Ballarat Bus Lines Pty. Limited	27963
H. & J. Daff Proprietary Limited	28295
John H. Green & Co. (Victoria) Proprietary Limited	28481
Preston Ice & Cool Stores Pty. Limited	28648
Quality Heels Proprietary Limited	28811
Robert Salkind Proprietary Limited	28818
Tolhurst Constructions Proprietary Limited	28868
Indents (A'asia.) Proprietary Limited	29051
Acme Motor Rentals Proprietary Limited	29224
The Wholesale Fish Salesmens Association of Victoria Limited	29404
Intercoastal Airlines Proprietary Limited	29963
Imco (Australia) Proprietary Limited	30057
Laird & Graham Pty. Limited	30182
J. Godwin Proprietary Limited	30733
Sportsman Industries Proprietary Limited	31017
Electric-Forge Proprietary Limited	31312
Proctor's Patent Wreath Base Proprietary Limited	31369
Dundee Textiles & Co. Pty. Limited	31439
D. & N. Trading and Construction Company Proprietary Limited	31456
Fifteen Collins Street Proprietary Limited	31483
K. B. Harris Proprietary Limited	31571
Emtif Proprietary Limited	32020
Beves Investments Proprietary Limited	32111
William G. Allen (Constructions) Proprietary Limited	32263
Seymour Constructions Proprietary Limited	32287
Noll & Bourke Pty. Limited	32314
Village Belle Market Proprietary Limited	32638
Aerosol Packers (Aust.) Proprietary Limited	32664
Warming's Used Cars Proprietary Limited	33055
House of Fashion Harmony (Distributors) Proprietary Limited	33064
20th Century Autos Proprietary Limited	33116
Champion Hotel Proprietary Limited	33196
Woongarra Motel Proprietary Limited	33262
South Pacific Motels Proprietary Limited	33263
D. G. Lydiard Proprietary Limited	33272
Tally Ho Products & Installations Proprietary Limited	33380
Vimco Proprietary Limited	33770
Heyday Printing & Publishing Company Proprietary Limited	33780
H. E. Sizer Proprietary Limited	33990
Abbey Plumbing Service Proprietary Limited	34168
Connaught Chemicals Proprietary Limited	34172
Rochelle Flats Proprietary Limited	34201
Niagara Electrics (Australia) Proprietary Limited	34250
Melody Electrical Services Proprietary Limited	34421
Kelson Auto Sales Proprietary Limited	34702
Coast Hotels Queenscliff Proprietary Limited	34937
Malay Queen Rubber Proprietary Limited	35225
York Street Sack Company Pty. Limited	37044
The Victorian Coal Mining Company Limited	M9838
Cocks Pioneer Gold & Tin Mines (1934) No Liability	M9897
Central Napoleon Gold Mining Company No Liability	M9947
Austral Oil Drilling Syndicate No Liability	M10195
Majorca Gold Development Syndicate No Liability	M10323
South Costerfield Antimony and Gold Mining Company No Liability	M10442
Hillsborough Gold Mining Company No Liability	M10437
Bendigo Exploration & Gold Development Company No Liability	M10474

COMPANIES ACT 1938.

NOTICE is hereby given in pursuance of section 350 (4) (c) of the Companies Act 1938, that at the expiration of three months from the date hereof the names of the following companies will, unless cause is shown to the contrary, be struck off the Register.

Dated this 18th day of November, 1957.

T. S. WELSH,
Deputy Registrar-General.
Registrar-General's Office, Melbourne.

Companies Above Referred to.

Name of Company.	No. of Registration.
Adelaide Tailoring Company Limited ..	F1091
International Wholesalers Pty. Limited ..	F2446
Kleen Cloth Co. Limited ..	F2910

Pounds Act 1928.

SHIRE OF OMEO.

TABLE of Rates to be charged for the trespass of cattle and their sustenance while impounded, fixed by the Council of the Shire of Omeo.

Description of Cattle Trespassing.	Trespass Rates.		Sustenance Fees.
	Upon Land other than Tillage Land Enclosed by a Substantial Fence.	Upon Tillage Land Enclosed by a Substantial Fence.	Amount to be Charged Daily for Sustenance while Impounded.
For every sheep ..	£ s. d. 0 0 3	£ s. d. 0 1 0	£ s. d. 0 0 3
For every goat ..	0 5 0	0 5 0	0 2 6
For every pig ..	0 10 0	0 10 0	0 5 0
For every head of other cattle ..	0 10 0	0 10 0	0 3 0

By order of the Council,

H. L. TEAGUE,
Shire Secretary.

Approved by the Governor in Council,
12th November, 1957.

A. MAHLSTEDT,
Clerk of the Executive Council.

Pounds Act 1928.

SHIRE OF MAFFRA.

TABLE of rates to be charged for the trespass of cattle and their sustenance while impounded, fixed by the Council of the Shire of Maffra.

Description of Cattle Trespassing.	Trespass Rates.		Sustenance Fees.
	Upon Land other than Tillage Land Enclosed by a Substantial Fence.	Upon Tillage Land Enclosed by a Substantial Fence.	Amount to be Charged Daily for Sustenance while Impounded.
For every sheep ..	£ s. d. 0 0 3	£ s. d. 0 3 0	£ s. d. 0 0 6
For every head of other cattle ..	0 10 0	0 10 0	0 2 0

By order of the Council,

M. H. McMAHON,
Shire Secretary.

Approved by the Governor in Council,
12th November, 1957.

A. MAHLSTEDT,
Clerk of the Executive Council.

Pounds Act 1928.

BOROUGH OF MOE.

TABLE of Rates to be charged for the trespass of cattle and their sustenance while impounded in the Moe Pound, fixed by the Council of the Borough of Moe.

Description of Cattle Trespassing.	Trespass Rates.		Sustenance Fees.
	Upon Land other than Tillage Land Enclosed by a Substantial Fence.	Upon Tillage Land Enclosed by a Substantial Fence.	Amount to be Charged Daily for Sustenance while Impounded.
For every sheep ..	£ s. d. 0 0 3	£ s. d. 0 0 3	£ s. d. 0 0 6
For every goat ..	0 10 0	0 10 0	0 2 0
For every pig ..	0 10 0	0 10 0	0 2 0
For every head of other cattle ..	0 10 0	0 10 0	0 7 6

By order of the Council,

F. E. BARTLETT,
Town Clerk.

Approved by the Governor in Council,
12th November, 1957.

A. MAHLSTEDT,
Clerk of the Executive Council.

BUILDING SOCIETIES ACT 1928.

NOTICE is hereby given that a Building Society called "Family Trust Permanent Building and Investment Society" is duly registered under the provisions of the above Act.

Dated this 14th day of November, 1957.

A. DOUGLAS,
Registrar of Building Societies.

Dried Fruits Act 1938.

DRIED FRUITS REGULATIONS.

GENERAL ELECTION OF MEMBERS OF THE VICTORIAN DRIED FRUITS BOARD.

IN accordance with clause 59 of the Dried Fruits Regulations, I hereby announce that the under-mentioned persons have been duly nominated for election as representatives of the growers on the Victorian Dried Fruits Board for the respective areas, viz.:-

Area No. 1.

ALLISON, JAMES STUART, "Greenacres," West Merbein—Horticulturist.

CUTLER, JOHN STANLEY, Box 51, Mildura—Horticulturist.

DAVEY, HENRY VICTOR, Block 554, Redcliffs—Horticulturist.

Area No. 2.

COCKROFT, DAVID WALLACE, Woorinen South—Orchardist.

Area No. 3.

WOOD, DONALD EDWARD BARRY, "Hawthorne," Tongala East—Orchardist.

As only the required number of candidates has been nominated for each area, Nos. 1, 2, and 3, respectively, I hereby declare, pursuant to clause 61 of the aforesaid Regulations—

JAMES STUART ALLISON, JOHN STANLEY CUTLER, HENRY VICTOR DAVEY, DAVID WALLACE COCKROFT, and DONALD EDWARD BARRY WOOD,

duly elected as representatives of growers on the Victorian Dried Fruits Board for the respective areas for which they have been so nominated.

S. R. MCCOLL, Returning Officer,
Victorian Dried Fruits Board Elections.

Department of Agriculture, Treasury Gardens, Melbourne, C.2, 13th November, 1957.

FARM PRODUCE AGENTS ACTS (Nos. 3678, 4208, 4662, AND 4736).

A FURTHER list of persons to whom Farm Produce Agents' Licences have been issued for the year ending December, 1957, and each of whom has lodged a fidelity bond in accordance with the requirements of the Act:—

Name; Principal Place of Business.

Amalfi, John; 201 Camberwell-road, Camberwell.
Bryant and Gourley; 18 Peel-street north, Ballarat.
Cameron, Chas. A.; 56 Eglinton-street, Moonee Ponds.
Corlass, Ian; Katunga.
Garden, Frank; 151 Union-street, West Brunswick.
Geron, P. and Son; 132 Rennie-street, East Coburg.
Gugger, N. A.; Hyland-street, Fyansford.
Gunn, D. McA.; Bank-street, Kangaroo Flat.
Iuele, Pasquale; Box 44, Mirboo North.
Keating, Allan John; Ondit.
Lavery, Joe, Pty. Ltd.; Colac.
Meadows, Norman Henry; Moore-street, Moc.
Nash, Bernard G.; The Terrace, Ocean Grove.
Natalizio, Emanuele; 201 Raleigh-street, Thornbury.
Raymond, B. K. (trading as Raymond and Oliveri); 15 Oakhill-avenue, Reservoir.
Rullo, Pasquale; 9 Byron-street, Moonee Ponds.
Rural Distributing Co. Pty. Ltd.; 20 Wholesale Fruit Market, Melbourne.
S.A. Fruit Supply Pty. Ltd.; 462 Queen-street, Melbourne.
Spence, J. G.; Stanley-road, Red Hill South.
Street, Ronald J.; Main-road, Hastings.
Taranto, Bartolomeo; Settlement-road, Bundoora.
Trickey, K. H.; 35 Chaffey-avenue, Mildura.
Valpied, W. R.; 13 Sturt-street, Ballarat.

P. RYAN,
Director of Agriculture.

APPOINTMENTS.

HIS Excellency the Governor of the State of Victoria, by and with the advice of the Executive Council thereof, has, by Orders made on the 12th day of November, 1957, been pleased to make the under-mentioned appointments, viz.:—

CHIEF SECRETARY'S DEPARTMENT.

Electoral Registrars (Acting).

WILLIAM DAVID MILLAR
to be Electoral Registrar (Acting) for the Caulfield West, Elsternwick North, Ripponlea, and St. Kilda North Subdivisions of the Electoral District of Ripponlea; and for the St. Kilda, St. Kilda Park, and St. Kilda West Subdivisions of the Electoral District of St. Kilda, to take effect on and from the 28th October, 1957, during the absence on leave of James Edwin Moses; and

WILLIAM CHARLES JAMESON
to be Electoral Registrar (Acting) for the Essendon, Essendon North, and Pascoe Vale Subdivisions of the Electoral District of Essendon; and for the Essendon West and Moonee Ponds Subdivisions of the Electoral District of Moonee Ponds, to take effect on and from the 4th November, 1957, during the absence on leave of Francis Peter Mills.

LAW DEPARTMENT.

Magistrates.

VIOLET MARY WAUGH, St. Joseph's Foundling Hospital, Broadmeadows.
MARGARET NOEL ROBERTSON, St. Joseph's Foundling Hospital, Broadmeadows.
ROBERT AUBREY BISHOP, 74 Hudson-road, Spotswood.
CYRIL HOPETOUN DICKSON, 426 Albert-street, East Melbourne.
JOSEPH REGINALD LANNAN, 28 Elphin-street, Ivanhoe.
EDWARD CHARLES DEUTSCHER, 63 Hoffmans-road, Niddrie.
ALFRED JAMES PARRY, High-street, Broadford.
WALTON DUDLEY SHERRIFF, 92 Paget-avenue, Glenroy.
MYER BROTT, 6 Boandyn-court, Toorak.
DORIS CATHERINE CONDON, 272 Albert-road, South Melbourne.
WILLIAM MURRAY OLIVIER, Shire Secretary, Healesville, and
JOHN LAURENCE BUNTEN, 3 Murray-street, Yarraville, to Keep the Peace in the Central Bailiwick of the State of Victoria;
NELLIE PEARL LIBBIS, 15 Scott-street, Colac, and
JOHN HENRY JONES, Curdie-street, Cobden, to Keep the Peace in the Southern Bailiwick of the State of Victoria;

JAMES HAY MOUNTAIN, Macarthur, to Keep the Peace in the Western Bailiwick of the State of Victoria; and

JOHN WALTER BRASHER, 58 Armstrong-street, Tongala, to Keep the Peace in the Midland Bailiwick of the State of Victoria.

Commissioners for Taking Declarations, &c.

HENRY JOHN JAMES, 66 Hamilton-street, Yarraville,
LEO JOSEPH BIRMINGHAM, 39 Evelyn-street, Clayton,
REVELL CUTHBERT RADCLYFFE POWELL, Cass-avenue, Croydon,
ALFRED KEITH BRIERLEY, 9 Myring-street, Castlemaine, and
JOHN LEO BRENNAN, 17 Wattletree-road, Ferntree Gully,
to be Commissioners for taking Declarations and Affidavits, pursuant to the provisions of the *Evidence Act 1928*, to resign upon removing from the neighbourhood of the addresses stated; and

PERCY HALPIN, officer of Young's Transport Agency, 33-35 King-street, Melbourne, to be a Commissioner for taking Declarations and Affidavits, pursuant to the provisions of the *Evidence Act 1928*, to resign upon ceasing to occupy his present position.

Probation Officers for Children's Courts.

LESLIE GEORGE BOOTLE ROSE, Nathalia, and
VINCENT ERNEST COCHRANE, Nathalia, to be Probation Officers, pursuant to the provisions of the *Children's Court Act 1956*, for the Children's Court at Nathalia.

DEPARTMENT OF THE TREASURER.

Receiver of Revenue.

WILLIAM GEORGE BAGLIN
to be Receiver of Revenue, Commonwealth Taxation Office, 436 Lonsdale-street, Melbourne, *vice* P. W. Bennett, from and inclusive of 4th November, 1957.

Collectors of Revenue.

ERIC CHARLES WESTMORE
to act temporarily as Collector of Imposts, Government Printing Office, Melbourne, during the absence of A. J. C. Teague, on leave from and inclusive of 18th November, 1957; and

LAWRENCE GEORGE COMER
to act temporarily as Collector of Imposts, Department of Mental Hygiene, Melbourne, during the absence of D. Gallivan, on leave from and inclusive of 1st November, 1957.

A. MAHLSTEDT,
Clerk of the Executive Council.

At the Executive Council Chamber,
Melbourne, 12th November, 1957.

RESIGNATIONS.

HIS Excellency the Governor of the State of Victoria, by and with the advice of the Executive Council thereof, has, by Orders made on the 12th day of November, 1957, accepted the resignations of the persons named hereunder of the offices mentioned, viz.:—

CHIEF SECRETARY'S DEPARTMENT.

CLIFFORD HENRY WEBB, as Registrar of Births and Deaths at Beechworth.

LAW DEPARTMENT.

PAUL MILLER MAURICE, as a Commissioner for taking Declarations and Affidavits, pursuant to the provisions of the *Evidence Act 1928*.

KEVIN CAMPBELL FINDLAY, as a Probation Officer, pursuant to the provisions of the *Children's Court Act 1956*, for the Children's Court at Prahran.

SUSANNAH HELENE HARRISON, as a Probation Officer, pursuant to the provisions of the *Children's Court Act 1956*, for the Children's Court at Williamstown.

DANIEL KEARNS, as a Probation Officer, pursuant to the provisions of the *Children's Court Act 1956*, for the Children's Court at Flemington.

WILLIAM CHARLES FRANK NELLOR, as a Probation Officer, pursuant to the provisions of the *Children's Court Act 1956*, for the Children's Court at Tatura.

A. MAHLSTEDT,
Clerk of the Executive Council.

At the Executive Council Chamber,
Melbourne, 12th November, 1957.

AGRICULTURAL COLLEGES ACT 1944 (No. 5044).

*At the Executive Council Chamber, Melbourne, the
twelfth day of November, 1957.*

PRESENT:

His Excellency the Governor of Victoria.	
Mr. Rylah	Mr. Chandler
Mr. Cameron	Mr. McArthur.

REGULATIONS AMENDED.

IN pursuance of the powers in that behalf conferred by the *Agricultural Colleges Act 1944* (No. 5044), His Excellency the Governor of the State of Victoria, by and with the advice of the Executive Council thereof, doth hereby amend the Regulations made under the provisions of the said Act on the 12th June, 1956, as follows (that is to say):—

In paragraph 2 of Regulation 24, for the expression "£728" there shall be substituted the expression "£1,750" and the words "as in force at the commencement of these Regulations," wherever appearing, shall be deleted.

And the Honorable Gilbert Lawrence Chandler, Her Majesty's Minister of Agriculture for the State of Victoria, shall give the necessary directions herein accordingly.

A. MAHLSTEDT,
Clerk of the Executive Council.

MILK PASTEURIZATION ACT 1949.

*At the Executive Council Chamber, Melbourne, the
twelfth day of November, 1957.*

PRESENT:

His Excellency the Governor of Victoria.	
Mr. Rylah	Mr. Chandler
Mr. Cameron	Mr. McArthur.

REGULATIONS AMENDED.

IN pursuance of the powers in that behalf conferred by the *Milk Pasteurization Act 1949*, His Excellency the Governor of the State of Victoria, by and with the advice of the Executive Council thereof, doth hereby amend the Regulations made under the said Act on the 5th July, 1955, prescribing the remuneration and travelling expenses which certain members of the Milk Pasteurization Committee shall be entitled to be paid, as follows (that is to say):—

Regulation 2 shall be deleted and the following Regulation shall be substituted in lieu thereof:—

"2. Personal expenses when outside a radius of 15 miles from his usual residence at the rates and in accordance with the conditions prescribed in the Regulations under the *Public Service Act 1946*, for personal expenses for officers other than Permanent Heads whose standard salaries are more than £1,750 a year, provided that where a member leaves his house and returns the same day he shall be entitled to receive—

- (a) 5s. 6d. for breakfast, where he is required to leave before 7 a.m. and is unable to return until after 9.30 a.m.
- (b) 5s. 6d. for lunch, where he is required to leave before 12 noon, is unable to return until after 3 p.m., and is absent for a period of at least seven hours.
- (c) 8s. for tea, where he is required to leave before 5 p.m. and is unable to return until after 7 p.m."

And the Honorable Gilbert Lawrence Chandler, Her Majesty's Minister of Agriculture for the State of Victoria, shall give the necessary directions herein accordingly.

A. MAHLSTEDT,
Clerk of the Executive Council.

SOIL CONSERVATION AND LAND UTILIZATION ACT 1947.

*At the Executive Council Chamber, Melbourne, the
twelfth day of November, 1957.*

PRESENT:

His Excellency the Governor of Victoria.
Mr. Rylah | Mr. Chandler
Mr. Cameron | Mr. McArthur.

SOIL CONSERVATION AUTHORITY DISTRICT ADVISORY
COMMITTEE ELECTION REGULATIONS.

IN pursuance of the powers conferred by the *Soil Conservation and Land Utilization Act 1947* His Excellency the Governor of the State of Victoria by and with the advice of the Executive Council thereof doth hereby amend the Soil Conservation Authority District Advisory Committee Election Regulations as follows:—

In Regulation 2 sub-regulation (2) (e) the words "in the said district" shall be deleted and the following words shall be added in lieu thereof:—

"within the prescribed subdivision of the said district".

And the Honorable Henry Edward Bolte, Her Majesty's Minister for Conservation in the State of Victoria, shall give the necessary directions herein accordingly.

A. MAHLSTEDT,
Clerk of the Executive Council.

VICTORIAN INLAND MEAT AUTHORITY ACT 1942.

*At the Executive Council Chamber, Melbourne, the
twelfth day of November, 1957.*

PRESENT:

His Excellency the Governor of Victoria.
Mr. Rylah | Mr. Chandler
Mr. Cameron | Mr. McArthur.

REGULATIONS AMENDED.

IN pursuance of the powers conferred by the *Victorian Inland Meat Authority Act 1942* (No. 4927), His Excellency the Governor of the State of Victoria, by and with the advice of the Executive Council thereof, doth hereby amend the Regulations made under the said Act on the 5th July, 1943, as amended on the 25th October, 1949 and the 19th December, 1949, as follows (that is to say):—

Regulation 3 shall be deleted and the following Regulation shall be substituted in lieu thereof:—

"3. The members of the Authority shall each be entitled to be paid out of the funds of the Authority travelling expenses at the rates and in accordance with the conditions prescribed in the Regulations under the *Public Service Act 1946* for personal expenses for officers other than Permanent Heads whose standard salaries are more than £1,750 a year, during the period of absence from the City or Town in which members reside whilst so absent on the business of the Authority, and also the reimbursement of any reasonable amount expended on rail transport.

Provided that where a member of the Authority leaves his home on the business of the Authority and returns the same day he shall be entitled to receive—

- (a) 5s. 6d. for breakfast, where he is required to leave before 7 a.m. and is unable to return until after 9.30 a.m.
- (b) 5s. 6d. for lunch, where he is required to leave before 12 noon, is unable to return until after 3 p.m., and is absent for a period of at least seven hours.
- (c) 8s. for tea, where he is required to leave before 5 p.m. and is unable to return until after 7 p.m.

"Should it be necessary for a member to use his own private motor car on the business of the Authority he shall be entitled to be paid a mileage allowance in accordance with the scale prescribed by Regulation under the Public Service Acts."

And the Honorable Gilbert Lawrence Chandler, Her Majesty's Minister of Agriculture for the State of Victoria, shall give the necessary directions herein accordingly.

A. MAHLSTEDT,
Clerk of the Executive Council.

MARKETING OF PRIMARY PRODUCTS ACT 1935.

*At the Executive Council Chamber, Melbourne, the
twelfth day of November, 1957.*

PRESENT:

His Excellency the Governor of Victoria.

Mr. Rylah		Mr. Chandler
Mr. Cameron		Mr. McArthur.

REGULATIONS.

IN pursuance of the powers conferred by the *Marketing of Primary Products Act 1935* (No. 4337) His Excellency the Governor of the State of Victoria, by and with the advice of the Executive Council thereof doth hereby rescind the Regulations made under the said Act on the 25th October, 1949, as amended on the 19th December, 1949, the 25th November, 1953 and the 16th June, 1954, prescribing the travelling expenses which may be paid to members of the Chicory Marketing Board, and doth hereby make the following Regulations (that is to say):—

Members of the Chicory Marketing Board, constituted under the above-mentioned Act, shall each be entitled to receive travelling expenses at the rates and in accordance with the conditions prescribed in the Regulations under the *Public Service Act 1946* for personal expenses for officers other than Permanent Heads whose standard salaries are more than £1,750 a year.

Provided that where a Board member leaves his home on Board business and returns the same day he shall be entitled to receive—

- (a) 5s. 6d. for breakfast, where he is required to leave before 7 a.m. and is unable to return until after 9.30 a.m.
- (b) 5s. 6d. for lunch, where he is required to leave before 12 noon, is unable to return until after 3 p.m., and is absent for a period of at least seven hours.
- (c) 8s. for tea, where he is required to leave before 5 p.m. and is unable to return until after 7 p.m.

Should it be necessary for a member to use his own private motor car on the business of the Board he shall be entitled to be paid a mileage allowance in accordance with the scale prescribed in the Regulations under the *Public Service Act 1946*.

The total expenses incurred for the purpose of visiting chicory growers shall not exceed Fifty pounds (£50) a year in the case of the Chairman and Twenty-five pounds (£25) a year in the case of the other elected member.

And the Honorable Gilbert Lawrence Chandler, Her Majesty's Minister of Agriculture for the State of Victoria, shall give the necessary directions herein accordingly.

A. MAHLSTEDT,
Clerk of the Executive Council.

MARKETING OF PRIMARY PRODUCTS ACT 1935.

*At the Executive Council Chamber, Melbourne, the
twelfth day of November, 1957.*

PRESENT:

His Excellency the Governor of Victoria.	
Mr. Rylah	Mr. Chandler
Mr. Cameron	Mr. McArthur.

REGULATIONS.

IN pursuance of the powers conferred by the *Marketing of Primary Products Act 1935* (No. 4337) His Excellency the Governor of the State of Victoria, by and with the advice of the Executive Council thereof, doth hereby rescind the Regulation made under the said Act on the 26th January, 1954, as amended on the 22nd June, 1954, prescribing the travelling expenses which may be paid to members of the Seed Beans Marketing Board and doth hereby make the following Regulations (that is to say):—

Members of the Seed Beans Marketing Board constituted under the above-mentioned Act shall each be entitled to receive—

1. Travelling expenses at the rates and in accordance with the conditions prescribed in the Regulations under the *Public Service Act 1946* for personal expenses for officers other than Permanent Heads whose standard salaries are more than £1,750 a year:

Provided that where a Board member leaves his home on Board business and returns the same day he shall be entitled to receive—

- (a) 5s. 6d. for breakfast, where he is required to leave before 7 a.m. and is unable to return until after 9.30 a.m.
- (b) 5s. 6d. for lunch, where he is required to leave before 12 noon, is unable to return until after 3 p.m., and is absent for a period of at least seven hours.
- (c) 8s. for tea, where he is required to leave before 5 p.m. and is unable to return until after 7 p.m.

2. Reimbursement of actual railway fares paid by him, or, where a member, with the approval of the Board, uses his own car on Board business, mileage rates as prescribed in the Regulations under the *Public Service Act*.

And the Honorable Gilbert Lawrence Chandler, Her Majesty's Minister of Agriculture for the State of Victoria, shall give the necessary directions herein accordingly.

A. MAHLSTEDT,
Clerk of the Executive Council.

MARKETING OF PRIMARY PRODUCTS ACT 1935.

*At the Executive Council Chamber, Melbourne, the
twelfth day of November, 1957.*

PRESENT:

His Excellency the Governor of Victoria.	
Mr. Rylah	Mr. Chandler
Mr. Cameron	Mr. McArthur.

REGULATIONS.

IN pursuance of the powers conferred by the *Marketing of Primary Products Act 1935* (No. 4337) His Excellency the Governor of the State of Victoria, by and with the advice of the Executive Council thereof doth hereby rescind the Regulations made under the said Act on the 25th October, 1949, as amended on the 19th December, 1949, the 25th November, 1953 and the 16th June, 1954, prescribing the travelling expenses which may be paid to members of the

Onion Marketing Board, the Maize Marketing Board, the Egg and Egg Pulp Marketing Board and the Potato Marketing Board and doth hereby make the following Regulations (that is to say):—

Members of the Onion Marketing Board, the Maize Marketing Board, the Egg and Egg Pulp Marketing Board and the Potato Marketing Board constituted under the above-mentioned Act shall each be entitled to receive travelling expenses at the rates and in accordance with the conditions prescribed in the Regulations under the *Public Service Act* 1946 for personal expenses for officers other than Permanent Heads whose standard salaries are more than £1,750 a year.

Provided that where a Board member leaves his home on Board business and returns the same day he shall be entitled to receive—

- (a) 5s. 6d. for breakfast, where he is required to leave before 7 a.m. and is unable to return until after 9.30 a.m.
- (b) 5s. 6d. for lunch, where he is required to leave before 12 noon, is unable to return until after 3 p.m., and is absent for a period of at least seven hours.
- (c) 8s. for tea, where he is required to leave before 5 p.m. and is unable to return until after 7 p.m.

And the Honorable Gilbert Lawrence Chandler, Her Majesty's Minister of Agriculture for the State of Victoria, shall give the necessary directions herein accordingly.

A. MAHLSTEDT,
Clerk of the Executive Council.

LOCAL GOVERNMENT ACTS.

At the Executive Council Chamber, Melbourne, the twelfth day of November, 1957.

PRESENT:

His Excellency the Governor of Victoria.	
Mr. Rylah	Mr. Chandler
Mr. Cameron	Mr. McArthur.

ROAD DISCONTINUED.—SHIRE OF BANNOCKBURN.

WHEREAS it is provided in section 527 (2) of the *Local Government Act* 1946 that where a road (whether or not a public highway but not being a road set out on land of the Crown) or any part thereof is not required for public use, the Governor in Council, on the request of the council of the municipality in which such road is situated, made not less than one month after publishing in a newspaper generally circulating in the district and posting to the registered proprietor (if any) of the land and any person known to have an interest in the land, notice of intention to make such a request, may, by Order published in the *Government Gazette*, direct that such road or part shall be discontinued and thereupon such road or part shall be discontinued accordingly:

And whereas the Council of the Shire of Bannockburn has requested that the Governor in Council direct that the road described hereunder be discontinued, and, not less than one month previously, has published in a newspaper generally circulating in the district and posted to all persons known to have an interest in the land notice of intention to make such request:

And whereas the Council of the Shire of Bannockburn is the registered proprietor of the land in the said road:

Now, therefore, His Excellency the Governor of the State of Victoria, by and with the advice of the Executive Council thereof, hereby directs that the road described hereunder shall be discontinued and shall be sold by the Council of the Shire of Bannockburn to the owner of the land abutting on the southern side of such road, namely:—

All that piece of land, being part of Crown portion E, section 12, and part of section 13, Parish of Murgheboluc, commencing at a point on the south-west boundary of the said Crown portion E, bearing north 44 deg. 55½ min. west 14,873¼ links from the south-east corner of Crown portion F, section 10, of the said parish, bounded thence by lines bearing respectively north 44 deg. 55½ min. west 141 4/10 links, south 89 deg. 56 min. east 6,761 4/10 links, south 0 deg. 8½ min. east 100 links, and north 89 deg. 56 min. west 6,661 8/10 links to the point of commencement.

And the Honorable Thomas Karran Maltby, Her Majesty's Commissioner of Public Works for the State of Victoria, shall give the necessary directions herein accordingly.

A. MAHLSTEDT,
Clerk of the Executive Council.

DEPARTMENT OF CROWN LANDS AND SURVEY.

At the Executive Council Chamber, Melbourne, the twelfth day of November, 1957.

PRESENT:

His Excellency the Governor of Victoria.	
Mr. Rylah	Mr. Chandler
Mr. Cameron	Mr. McArthur.

UNUSED ROADS CLOSED.

HIS Excellency the Governor of the State of Victoria, by and with the advice of the Executive Council thereof, doth hereby direct that, in pursuance of the provisions of section 304 of the *Land Act* 1928, the unused roads referred to hereunder be closed, viz.:—

Parishes of Mirboo and Mirboo South, being the roads indicated by hachure on plan hereunder.—(M.517(14) (M.517(10) (Misc. 2257).

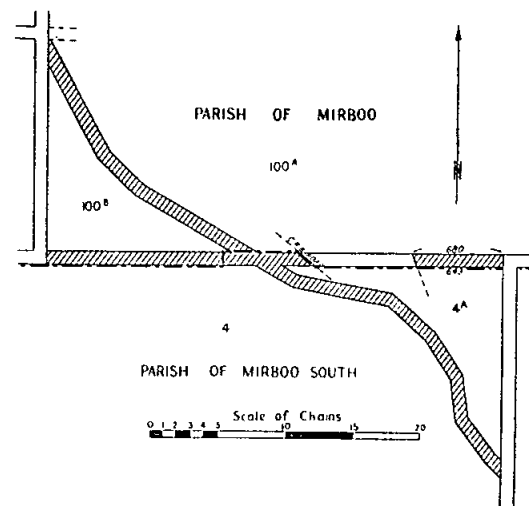

And the Honorable Keith Hector Turnbull, Her Majesty's Commissioner of Crown Lands and Survey for the State of Victoria, shall give the necessary directions herein accordingly.

A. MAHLSTEDT,
Clerk of the Executive Council.

DEPARTMENT OF CROWN LANDS AND SURVEY.

At the Executive Council Chamber, Melbourne, the twelfth day of November, 1957.

PRESENT:

His Excellency the Governor of Victoria.
 Mr. Rylah | Mr. Chandler
 Mr. Cameron | Mr. McArthur.

LANDS TEMPORARILY RESERVED AS SITES.

HIS Excellency the Governor of the State of Victoria, by and with the advice of the Executive Council thereof, doth hereby, in pursuance of the provisions of the Land Act 1928, reserve, temporarily, and also except from occupation for mining purposes under any miner's right, the lands hereinafter described:—

BARWIDGEE.—Site for Supply of Gravel, 11 acres 0 roods 39 perches, Parish of Barwidgee, County of Bogong, as indicated by hachure on plan hereunder.—(B.637^(s)) (Rs.7678).

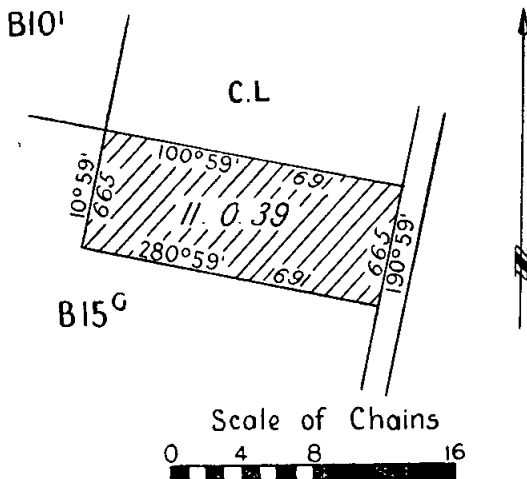

ROWSLEY.—Site for a Public Hall and for Public Recreation, 1 acre 0 roods 38 perches, Township of Rowsley, Parish of Gorrockburkghap, County of Grant, as indicated by hachure on plan hereunder.—(R.23⁽¹⁾) (Rs.1826).

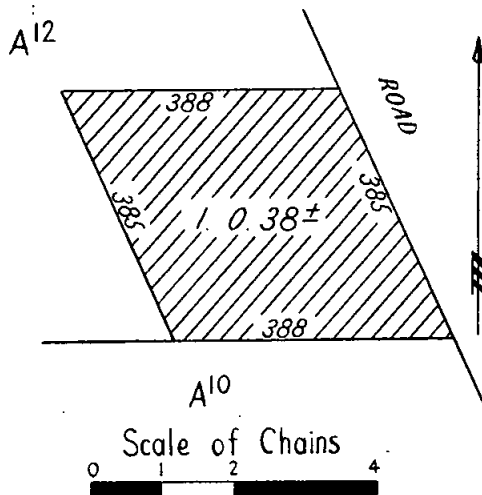

TRENTHAM.—Site for the purposes of the Forests Acts, 3 roods 24 perches, more or less, Township of Trentham, Parish of Trentham, County of Dalhousie, as indicated by hachure on plan hereunder.—(T.168⁽²⁾) (Rs.7627).

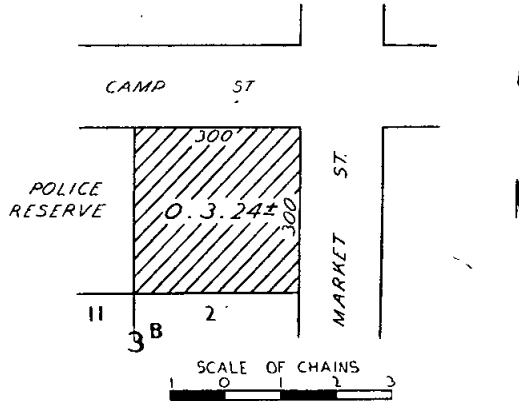

LIMA (SWANPOOL).—Site for Public Recreation, in addition to and adjoining the site temporarily reserved therefor by Order in Council of the 16th March, 1955, 1 acre 3 roods 3 perches, Parish of Lima, County of Delatite, as indicated by hachure on plan hereunder.—(L.153^(s)) (Rs.7338).

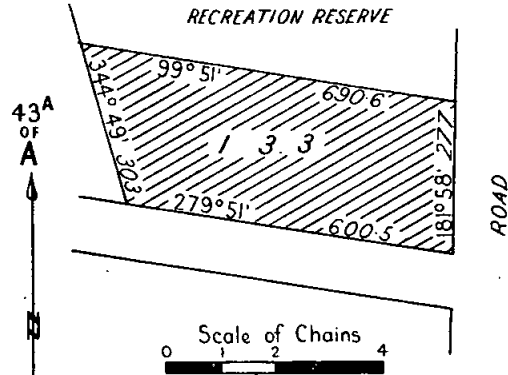

And the Honorable Keith Hector Turnbull, Her Majesty's Commissioner of Crown Lands and Survey for the State of Victoria, shall give the necessary directions herein accordingly.

A. MAHLSTEDT,
 Clerk of the Executive Council.

BENDIGO CREEK IMPROVEMENT TRUST.

At the Executive Council Chamber, Melbourne, the twelfth day of November, 1957.

PRESENT:

His Excellency the Governor of Victoria.
 Mr. Rylah | Mr. Chandler
 Mr. Cameron | Mr. McArthur.

CONSENT TO BORROWING £1,000.

UNDER the powers conferred by the Water Acts and all other powers thereunto him enabling, His Excellency the Governor of the State of Victoria, by and with the advice of the Executive Council of the said State, doth hereby consent to the borrowing at interest, at the rate of Five pounds ten shillings per centum per annum (£5 10s.), by the Bendigo Creek Improvement Trust of a sum of One thousand pounds (£1,000), subject to the Water Acts, for the purpose of continuation of works of river improvement within the Bendigo Creek Improvement District.

And the Honorable Wilfred John Mibus, Her Majesty's Minister of Water Supply for the State of Victoria, shall give the necessary directions herein accordingly.

A. MAHLSTEDT,
 Clerk of the Executive Council.

COUNTRY ROADS BOARD.

At the Executive Council Chamber, Melbourne, the
twelfth day of November, 1957.

PRESENT:

His Excellency the Governor of Victoria.

Mr. Rylah	Mr. Chandler
Mr. Cameron	Mr. McArthur.

ORDER APPROVING OF WIDENING AN EXISTING
MAIN ROAD IN THE CITY OF BOX HILL.

WHEREAS the Country Roads Board constituted under the *Country Roads Act 1928* (hereinafter called "the principal Act") has, in exercise of its powers under the *Country Roads Act 1948* for the purpose of widening Burwood-road in the City of Box Hill (declared to be a main road under the principal Act which declaration was confirmed by an Order in Council published in the *Government Gazette* of the 27th day of June, 1934, on page 1506) by Resolution dated the first day of September, 1952, fixed a new alignment for the north side of the said road: And whereas by sub-section (3) of section 2 of the *Country Roads Act 1948* it is provided (*inter alia*) that the widening of any main road pursuant to such Act shall for all purposes be deemed to be the making of such main road pursuant to the principal Act: And whereas by sub-section (2) of section 2 of the *Country Roads Act 1948* it is provided (*inter alia*) that no main road shall be widened pursuant to that Act unless the Governor in Council has by Order published in the *Government Gazette* approved such widening: And whereas the said Board in accordance with the requirements of section 19 of the principal Act has caused to be prepared a map plan and estimate showing the points between which and on and through what land the said road is proposed to be made and the cost of acquiring the land: And whereas on an inspection of the said map and plan and a consideration of the said estimate His Excellency the Governor in Council is satisfied that there are funds legally available for acquiring the land which it is necessary to acquire for the purpose: Now therefore be it known by this present Order that His Excellency the Governor of the State of Victoria with the advice of the Executive Council thereof doth hereby, for the purposes of the *Country Roads Act 1948*, approve of the said road being widened so as to include therein the land described in the Schedule hereto and doth hereby for the purposes of the principal Act approve of the said road being made over the land described in the said Schedule.

SCHEDULE.

All those pieces of land in the Parish of Nunawading, the boundaries of which are as follow:—

- (a) Commencing at the south-western angle of allotment B, portion 46, of the said parish; thence by lines bearing respectively 0 deg. 17½ min. 61 feet, 135 deg. 16 min. 56 ft. 6½ in., 90 deg. 14½ min. 45 ft. 11½ in., 180 deg. 14½ min. 21 feet, and 270 deg. 14½ min. 86 feet to the point of commencement.
- (b) Commencing at the south-western angle of lot 14 on plan of subdivision numbered 7314, lodged in the Office of Titles, and being part of allotment B, portion 46, of the said parish; thence by lines bearing respectively 0 deg. 14½ min. 21 feet, 90 deg. 14½ min. 20 feet, 180 deg. 14½ min. 21 feet, and 270 deg. 14½ min. 20 feet to the point of commencement.
- (c) Commencing at the south-western angle of lot 17 on plan of subdivision numbered 7314, lodged in the Office of Titles, and being part of allotment B, portion 46, of the said parish; thence by lines bearing respectively 0 deg. 14½ min. 21 feet, 90 deg. 14½ min. 20 feet, 180 deg. 14½ min. 21 feet, and 270 deg. 14½ min. 20 feet to the point of commencement.
- (d) Commencing at the south-western angle of lot 1 on plan of subdivision numbered 7876, lodged in the Office of Titles, and being part of allotment B, portion 46, of the said parish; thence by lines bearing respectively 0 deg. 48½ min. 21 feet, 90 deg. 14½ min. 115 feet, 180 deg. 48½ min. 21 feet, and 270 deg. 14½ min. 115 feet to the point of commencement.

- (e) Commencing at the south-western angle of lot 31 on plan of subdivision numbered 7876, lodged in the Office of Titles, and being part of allotment B, portion 46, of the said parish; thence by lines bearing respectively 0 deg. 48½ min. 24 ft. 6½ in., 85 deg. 26 min. 100 ft. 5 in., 180 deg. 48½ min. 32 ft. 11½ in., and 270 deg. 14½ min. 100 feet to the point of commencement.
- (f) Commencing at the south-western angle of lot 1 on plan of subdivision numbered 16183, lodged in the Office of Titles, and being part of allotment A, portion 47, of the said parish; thence by lines bearing respectively 0 deg. 26 min. 57 ft. 8 in., 130 deg. 47 min. 12 ft. 11½ in., 81 deg. 8 min. 124 feet, 77 deg. 2 min. 203 ft. 8½ in., 180 deg. 25 min. 24 ft. 1½ in., and 254 deg. 48 min. 343 ft. 1½ in. to the point of commencement.
- (g) Commencing at the south-western angle of lot 5 on plan of subdivision numbered 7040, lodged in the Office of Titles, and being part of allotment B, portion 47, of the said parish; thence by lines bearing respectively 0 deg. 25 min. 21 ft. 10½ in., 75 deg. 8 min. 51 ft. 10 in., 180 deg. 25 min. 21 ft. 10 in., and 255 deg. 7 min. 51 ft. 10 in. to the point of commencement.
- (h) Commencing at the south-western angle of lot 8 on plan of subdivision numbered 7040, lodged in the Office of Titles, and being part of allotment B, portion 47, of the said parish; thence by lines bearing respectively 0 deg. 25 min. 21 ft. 9½ in., 75 deg. 8 min. 51 ft. 10 in., 180 deg. 25 min. 21 ft. 9½ in., and 255 deg. 7 min. 51 ft. 10 in. to the point of commencement.
- (i) Commencing at the south-western angle of lot 10 on plan of subdivision numbered 7040, lodged in the Office of Titles, and being part of allotment B, portion 47, of the said parish; thence by lines bearing respectively 0 deg. 25 min. 31 ft. 9 in., 126 deg. 16 min. 11 ft. 8½ in., 72 deg. 7 min. 142 ft. 5 in., 180 deg. 19 min. 30 feet, and 255 deg. 7 min. 150 ft. 1 in. to the point of commencement.
- (j) Commencing at the south-eastern angle of allotment C, portion 49, of the said parish; thence by lines bearing respectively 270 deg. 22 min. 264 ft. 4 in., 0 deg. 37 min. 67 ft. 2½ in., 90 deg. 42 min. 264 ft. 4 in., and 180 deg. 37 min. 65 ft. 8 in. to the point of commencement.
- (k) Commencing at the south-western angle of lot 116 on plan of subdivision numbered 8828, lodged in the Office of Titles, and being part of allotment B, section 52, of the said parish; thence by lines bearing respectively 0 deg. 2 min. 76 ft. 3 in., 135 deg. 13 min. 14 ft. 2½ in., 90 deg. 24 min. 233 ft. 6 in., 180 deg. 2 min. 65 ft. 6½ in., and 270 deg. 14 min. 243 ft. 6 in. to the point of commencement.
- (l) Commencing at the south-western angle of lot 121 on plan of subdivision numbered 8828, lodged in the Office of Titles, and being part of allotment B, section 52, in the said parish; thence by lines bearing respectively 0 deg. 2 min. 65 ft. 4½ in., 90 deg. 24 min. 60 feet, 180 deg. 2 min. 65 ft. 2½ in., and 270 deg. 14 min. 60 feet to the point of commencement.
- (m) Commencing at the south-western angle of lot 125 on plan of subdivision numbered 8828, lodged in the Office of Titles, and being part of allotment B, section 52, in the said parish; thence by lines bearing respectively 0 deg. 2 min. 64 ft. 8 in., 82 deg. 48 min. 60 ft. 5½ in., 180 deg. 2 min. 72 ft. 6 in., and 270 deg. 14 min. 60 feet to the point of commencement—

which said pieces of land are particularly delineated and shown coloured red on survey plans numbered 5437, 5438, 5439, and 5440, lodged in the office of the Country Roads Board.

And the Honorable Sir Thomas Karran Maltby, Her Majesty's Commissioner of Public Works for the State of Victoria, shall give the necessary directions herein accordingly.

A. MAHLSTEDT,
Clerk of the Executive Council.

COUNTRY ROADS BOARD.

At the Executive Council Chamber, Melbourne, the
twelfth day of November, 1957.

PRESENT:

His Excellency the Governor of Victoria.	
Mr. Rylah	Mr. Chandler
Mr. Cameron	Mr. McArthur.

ORDER APPROVING OF WIDENING AN EXISTING
MAIN ROAD IN THE SHIRE OF MORNINGTON.

WHEREAS the Country Roads Board constituted under the *Country Roads Act 1928* (No. 3662) has represented to His Excellency the Governor in Council that it appears to be desirable that the existing Mornington-Dromana road in the Shire of Mornington (declared to be a main road under the said Act which declaration was confirmed by the Order in Council published in the *Government Gazette* of the 5th October, 1932, on page 2256) should be widened by the said Board: And whereas the said Board in accordance with the requirements of section 19 of the said cited Act as amended by the *Country Roads Act 1956* (No. 5978) has caused to be prepared a map plan and estimate showing the points between which and on and through what land the said widening is proposed to be made and the cost of acquiring the land: And whereas on an inspection of the said map and plan and a consideration of the said estimate His Excellency the Governor in Council is satisfied that there are funds legally available for acquiring the land: Now therefore be it known by this present Order that His Excellency the Governor of the State of Victoria with the advice of the Executive Council thereof doth hereby approve of the said road being widened, that is to say:—

All those pieces of land in the Parish of Moorooduc, the boundaries of which are as follow:—

- (a) Commencing at a point on the western boundary of section 36 of the said parish, the said point being the intersection of the northern boundary of Dominion-road and the western boundary of Mount Martha Esplanade, and being the western angle of the land comprised in certificate of title, volume 5855, folio 886; thence by lines bearing respectively 49 deg. 30 min. 30 feet, 184 deg. 30 min. 42 ft. 5 in., and 319 deg. 30 min. 30 feet to the point of commencement.
- (b) Commencing at a point on the western boundary of section 36 of the said parish, the said point being the intersection of the southern boundary of Dominion-road and the eastern boundary of Mount Martha Esplanade, and being the northern angle of the land comprised in certificate of title, volume 7510, folio 008; thence by lines bearing respectively 139 deg. 30 min. 30 feet, 274 deg. 30 min. 42 ft. 5 in., and 49 deg. 30 min. 30 feet to the point of commencement—

which said pieces of land are particularly delineated and shown coloured red on survey plan numbered 6654, lodged in the office of the Country Roads Board.

And the Honorable Sir Thomas Karran Maltby, Her Majesty's Commissioner of Public Works for the State of Victoria, shall give the necessary directions herein accordingly.

A. MAHLSTEDT,
Clerk of the Executive Council.

COUNTRY ROADS BOARD.

At the Executive Council Chamber, Melbourne, the
twelfth day of November, 1957.

PRESENT:

His Excellency the Governor of Victoria.	
Mr. Rylah	Mr. Chandler
Mr. Cameron	Mr. McArthur.

ORDER APPROVING OF WIDENING AN EXISTING
MAIN ROAD IN THE SHIRE OF OXLEY.

WHEREAS the Country Roads Board constituted under the *Country Roads Act 1928* (No. 3662) has represented to His Excellency the Governor in Council that it appears to be desirable that the existing King Valley-road in the Shire of Oxley (declared to be a

main road under the said Act which declaration was confirmed by the Order in Council published in the *Government Gazette* of the 27th November, 1935, on page 205) should be widened by the said Board: And whereas the said Board in accordance with the requirements of section 19 of the said cited Act as amended by the *Country Roads Act 1956* (No. 5978) has caused to be prepared a map plan and estimate showing the points between which and on and through what land the said widening is proposed to be made and the cost of acquiring the land: And whereas on an inspection of the said map and plan and a consideration of the said estimate His Excellency the Governor in Council is satisfied that there are funds legally available for acquiring the land: Now therefore be it known by this present Order that His Excellency the Governor of the State of Victoria with the advice of the Executive Council thereof doth hereby approve of the said road being widened, that is to say:—

All that piece of land in the Parish of Whitfield, the boundaries of which are as follow:—Commencing at the south-western angle of allotment 11, section 1, of the said parish; thence by lines bearing respectively 336 deg. 36 min. 482 links, 133 deg. 46 min. 420 links, 120 deg. 11 min. 416 links, 99 deg. 56 min. 249 links, 188 deg. 9 min. 2.3 links, and 278 deg. 9 min. 723.8 links to the point of commencement—which said piece of land is particularly delineated and shown coloured red on survey plan numbered 6699, lodged in the office of the Country Roads Board.

And the Honorable Sir Thomas Karran Maltby, Her Majesty's Commissioner of Public Works for the State of Victoria, shall give the necessary directions herein accordingly.

A. MAHLSTEDT,
Clerk of the Executive Council.

COUNTRY ROADS BOARD.

At the Executive Council Chamber, Melbourne, the
twelfth day of November, 1957.

PRESENT:

His Excellency the Governor of Victoria.	
Mr. Rylah	Mr. Chandler
Mr. Cameron	Mr. McArthur.

ORDER APPROVING OF WIDENING AN EXISTING
STATE HIGHWAY IN THE CITY OF GEELONG.

WHEREAS the Country Roads Board constituted under the *Country Roads Act 1928* (hereinafter called "the principal Act") has, in exercise of its powers under the *Country Roads Act 1948* for the purpose of widening Midland Highway in the City of Geelong (declared to be a State highway under the principal Act which declaration was confirmed by an Order in Council published in the *Government Gazette* of the 30th day of December, 1947, on pages 6281-2) by Resolution dated the ninth day of November, 1953, fixed new alignments for the north and east sides of the said highway: And whereas by sub-section (3) of section 2 of the *Country Roads Act 1948* it is provided (*inter alia*) that the widening of any State highway pursuant to such Act shall for all purposes be deemed to be the making of such State highway pursuant to the principal Act: And whereas by sub-section (2) of section 2 of the *Country Roads Act 1948* it is provided (*inter alia*) that no State highway shall be widened pursuant to that Act unless the Governor in Council has by Order published in the *Government Gazette* approved such widening: And whereas the said Board in accordance with the requirements of section 19 of the principal Act has caused to be prepared a map plan and estimate showing the points between which and on and through what land the said highway is proposed to be made and the cost of acquiring the land: And whereas on an inspection of the said map and plan and a consideration of the said estimate His Excellency the Governor in Council is satisfied that there are funds legally available for acquiring the land which it is necessary to acquire for the purpose: Now therefore be it known by this present Order that His Excellency the Governor of the State of Victoria with the advice of the Executive Council thereof doth hereby, for the purposes of the *Country Roads Act 1948*, approve of the said highway being widened so as to include therein the land described in the Schedule hereto and doth hereby for the purposes of the principal Act approve of the said highway being made over the land described in the said Schedule.

SCHEDULE.

All that piece of land in the Parish of Moorpanyal, the boundaries of which are as follow:—Commencing at the south-eastern angle of allotment 81 of the said parish; thence by lines bearing respectively 2.69 deg. 47 min. 15 ft. 53 in., 318 deg. 10 min. 10 sec. 334 ft. 8 in., 93 deg. 10 min. 48 ft. 11 in., 138 deg. 10 min. 20 sec. 123 ft. 7½ in., 127 deg. 16½ min. 135 ft. 11 in., and 180 deg. 0 min. 72 ft. 2½ in. to the point of commencement—which said piece of land is particularly delineated and shown coloured red on survey plan numbered 5799A, lodged in the office of the Country Roads Board.

And the Honorable Sir Thomas Karran Maltby, Her Majesty's Commissioner of Public Works for the State of Victoria, shall give the necessary directions herein accordingly.

A. MAHLSTEDT,
Clerk of the Executive Council.

NATIONAL PARKS ACT 1956.

At the Executive Council Chamber, Melbourne, the twelfth day of November, 1957.

PRESENT:

His Excellency the Governor of Victoria.
Mr. Rylah | Mr. Chandler
Mr. Cameron | Mr. McArthur.

WHEREAS by an Order made on the seventh day of May, 1957, John Charles Dickson was appointed as the member of the National Parks Authority representing the Victorian Tourist Bureau:

And whereas the said John Charles Dickson has resigned from the National Parks Authority:

Now, in pursuance of the powers conferred by subsection (5) of section 5 of the *National Parks Act 1956*, His Excellency the Governor of the State of Victoria, by and with the advice of the Executive Council thereof, doth hereby appoint in his stead—

MAURICE JAMES HARKINS
(as representing the Victorian Tourist Bureau) for the period the ninth day of November, 1957, to the sixth day of May, 1960, both dates inclusive.

And the Honorable Henry Edward Bolte, Her Majesty's Premier for the State of Victoria, shall give the necessary directions herein accordingly.

A. MAHLSTEDT,
Clerk of the Executive Council.

SOIL CONSERVATION AND LAND UTILIZATION ACT 1947.

At the Executive Council Chamber, Melbourne, the twelfth day of November, 1957.

PRESENT:

His Excellency the Governor of Victoria.
Mr. Rylah | Mr. Chandler
Mr. Cameron | Mr. McArthur.

SOIL CONSERVATION DISTRICTS.

WHEREAS in pursuance of the powers conferred by section 15 of the *Soil Conservation and Land Utilization Act 1947* an Order constituting the Avoca River Soil Conservation District was approved by His Excellency the Governor in Council on 13th day of February, 1951:

Now therefore His Excellency the Governor of the State of Victoria, upon the recommendation of the Soil Conservation Authority, by and with the advice of the Executive Council thereof, doth hereby subdivide the aforesaid district thus:—

- Subdivision No. 1, comprising the Shires of Donald and Charlton.
- Subdivision No. 2, comprising the Shire of Kara Kara.
- Subdivision No. 3, comprising the Shire of Bet Bet.
- Subdivision No. 4, comprising the Shire of Korong.
- Subdivision No. 5, comprising the Shire of Gordon.

And the Honorable Henry Edward Bolte, Her Majesty's Minister for Conservation in the State of Victoria, shall give the necessary directions herein accordingly.

A. MAHLSTEDT,
Clerk of the Executive Council.

APPROACHING LAND SALES.

SALES of Crown lands, in fee-simple, will be held at the under-mentioned places and dates, viz.:—

	No. of Gazette
Bairnsdale.—Friday, 6th December, 1957	255
Bendigo.—Thursday, 19th December, 1957	256
Castlemaine.—Tuesday, 17th December, 1957	256
Daylesford.—Tuesday, 17th December, 1957	256
Girgarre.—Thursday, 12th December, 1957	256
Kyneton.—Tuesday, 17th December, 1957	256
Mansfield.—Thursday, 19th December, 1957	257
Murrayville.—Thursday, 21st November, 1957	249
Ouyen.—Friday, 22nd November, 1957	249
Underbool.—Thursday, 21st November, 1957	249
Yarram.—Tuesday, 26th November, 1957	249

CLOSER SETTLEMENT ACT.

Girgarre.—Thursday, 12th December, 1957 .. 256

SALE BY AUCTION.

MANSFIELD.—A Sale, by auction, of the under-mentioned land for and on behalf of the Minister of Education will be held at the LAND INSPECTOR'S OFFICE, MANSFIELD, on THURSDAY, the 19th DECEMBER, 1957, at ELEVEN o'clock a.m. To be conducted by N. J. CAHILL, Land Officer, Seymour.

PARISH OF BARWITE, COUNTY OF DELAWARE.

On Mansfield-Tolmie Road.

Upset price £200 the lot, including improvements.
Lot 1. Area 1 acre, part allotment 20A, and being the land described in freehold certificate of title, Vol. 3947/258.

Sale of Lot 1 is subject to the following conditions:—

- (a) The purchaser shall pay the purchase money in full at the sale;
- (b) the preparation and registration of the transfer under the Transfer of Land Act shall be attended to by the purchaser or his solicitor, and all costs relating thereto shall be borne by the purchaser.

KEITH TURNBULL,
Commissioner of Crown Lands and Survey.

Office of Crown Lands and Survey,
Melbourne, 15th November, 1957.

PROPOSED REVOCATION OF TEMPORARY RESERVATION OF LAND BY ORDER IN COUNCIL.

IN pursuance of the provisions of the *Land Act 1928*, notice is hereby given that it is the intention of the Governor in Council to revoke the temporary reservations of lands by Orders in Council hereunder referred to, viz.:—

The following Notice was published 1* on the 13th November, 1957, pursuant to Order of the 6th November, 1957.

OME0.—The temporary reservation, by Order in Council of the 1st February, 1864, of 6 acres 2 roods 16 perches of land in the Township of Omeo as a site for Public Buildings, revoked as to part by Order of the 25th June, 1919, so far as the balance thereof containing 6 acres 0 roods 12 perches is concerned.—(O.19(*) (Rs.7367).

KEITH TURNBULL,
Commissioner of Crown Lands and Survey.

PROPOSED REVOCATION OF TEMPORARY RESERVATION OF LAND BY ORDER IN COUNCIL.

IN pursuance of the provisions of the *Land Act 1928*, notice is hereby given that it is the intention of the Governor in Council to revoke the temporary reservation of land by Order in Council hereunder referred to, viz.:—

The following Notice was published 1* on the 30th October, 1957, pursuant to Order of the 22nd October, 1957.

GRE GRE.—The temporary reservation, by Order in Council of the 8th February, 1887, of 5 acres of land in the Parish of Gre Gre as a site for a State School.—(G.177(*) (C.14619).

KEITH TURNBULL,
Commissioner of Crown Lands and Survey.

LAND-AVAILABLE UNDER THE SOLDIER SETTLEMENT ACTS.

NOTIFICATION is hereby given in accordance with Section 16 of the *Soldier Settlement Act 1946*, that the undermentioned holdings are available or are about to become available for settlement.

Any discharged serviceman who has applied to the Commission on or before the 20th November, 1957, for classification in the required class or classes of primary production for which the holdings are made available and whose application has been accepted but not necessarily finalized, or any discharged serviceman who has been classified as suitable in such class or classes of primary production, may apply on the prescribed form for settlement on any holding or holdings, indicating where he applies in respect of more than one holding, his order of preference therefor.

The prescribed application forms, plans and further particulars may be obtained from the Enquiry Branch, Soldier Settlement Commission, State Public Offices, Melbourne. The closing date for the receipt of completed applications for settlement on these holdings is the 16th December, 1957, such applications to be in the hands of the Secretary, Soldier Settlement Commission, on or before that date.

I. K. MORTON,
Secretary.

Soldier Settlement Commission,
Melbourne, 16th November, 1957.

SCHEDULE OF ALLOTMENTS.

SUBDIVISION OF "JELLALABAD" ESTATE.
PARISHES OF JELLALABAD, GRENGLA AND DARLINGTON—
COUNTY OF HAMPTON.
Suitable for Grazing (Sheep) and Mixed Farming.

Lot Number on Plan of Subdivision.	Approximate Area in Acres (Subject to Survey).
1	535
2	445
3	430
4	530
5	550
6	585
7	600
8	515
9	515
10	490

COMMITTEES OF MANAGEMENT OF RESERVES.

APPOINTMENTS.

WHEREAS by section 184 of the *Land Act 1928* it is provided that it shall be lawful for the Governor in Council or the Board of Land and Works to appoint and remove any number of persons, not less than three, or any municipal council, or the governing body of any corporation, to be a Committee of Management of any specified Crown land reserved either temporarily or permanently for any of the purposes set out in section 14 of the *Land Act 1928*, and not conveyed to or vested in trustees: Now therefore the Board of Land and Works doth hereby appoint the under-mentioned persons to be members of the Committee of Management of the Reserves named:—

"LIMA SOUTH PUBLIC HALL SITE."

Angus Lachlan Gordon, John Arthur Warnock, Leo Thomas Brennan, Frederick James Richard Kellam, Thomas Hugh Warnock, James Matthew Cason, Ross William Bowman Macgibbon, Sydney Gordon Warnock, Harold Frippet, and Henry John Lowther as a Committee of Management for a period of three (3) years of the land in the Parish of Toorour temporarily reserved by Order in Council of the 27th August, 1957, as a site for a Public Hall, and known as the "Lima South Public Hall Site."—(Corres. Rs.7658.)

"WANNON AND NIGRETTE PARK RESERVES."

Martin Joseph Blake, Charles William Bailey, Leslie Thomas Clayton, John Harrison Falkenberg, J. L. C. Young, Frederick George Larmour, William Norman Chute Ellis, Henry Reginald A. Bull, Robert Henry Blake, James Robbie McDonald, J. W. Kelly, A. B. Gurry, E. V. Baulch, M. Karovic, A. H. Baulch, Stanley William Falkenberg, Donald Thomas McDonald, and W. Elijah as

a Committee of Management for a period of three (3) years of the lands temporarily reserved by Orders in Council of 24th February, 1915, 20th March, 1917, 12th February, 1924, and 27th July, 1925, as sites for Public Recreation in the Township of Redruth, Parish of Bochara, and of the land temporarily reserved by Orders in Council of 1st December, 1909, and 30th October, 1933, as sites for Public purposes in the Township of Redruth, Parish of Bochara, and of the land permanently reserved by Order in Council of 23rd January, 1912, as a site for the Recreation, Convenience, and Amusement of the People in the Parish of Bochara, such lands being known as the "Wannon and Nigretta Park Reserves."—(Corres. Rs.576, Rs.1911.)

"CROWLANDS PUBLIC HALL."

Charles Allan Bates, Ernest Boatman, Arthur Noel Boatman, George Herbert Hart, Elizabeth Margaret Hart, Alma Lillian Matthews, George Ronald Matthews, William Thomas Lewis, Eileen Margaret O'Halloran, James Russell Price, Edward Victor Start, George Wollard Start, Robert Shields, Alexander Tucker, and Rupert Hendy Williams as a Committee of Management for a period of three (3) years of the land in the Township of Crowlands temporarily reserved by Order in Council of 17th September, 1957, as a site for a Public Hall, and known as the "Crowlands Public Hall."—(Corres. Rs.7659.)

"BOX SWAMP," PARISH OF WINNAMBOOL.

John Henry Mowat, Edwin Edward Huggett, William Mowat, John Mowat, Trevor Presley, Walter Frost, Leonard Plant, Roy Jones, Vincent Morris, and Ronald Baker as the Committee of Management for a period of three (3) years of the land in the Parish of Winnambool reserved by Order in Council of 3rd May, 1949, as a site for Public Recreation and Water Supply purposes, and known as the "Box Swamp."—(Corres. Rs.6348.)

"KYABRAM LAKE RESERVE."

The Council of the Borough of Kyabram as a Committee of Management of the lands temporarily reserved by Orders in Council dated 7th November, 1898, 12th November, 1903, and 16th March, 1910, as sites for Public Recreation in the Parish of Kyabram East, and known as the "Kyabram Lake Reserve."—(Corres. Rs.1918.)

"BERRINGA MECHANICS' INSTITUTE RESERVE."

Charles Michell, Harold Charles Burridge, Charles Harold Burridge, Edward Hugh McLean, and Robert McLean as a Committee of Management for a period of three (3) years of the land temporarily reserved by Order in Council dated 26th October, 1915, as a site for a Mechanics' Institute in the Township of Berringa, and known as the "Berringa Mechanics' Institute Reserve."—(Corres. Rs.876.)

"NEERIM RECREATION RESERVE."

Harold Ronald English, Harold Herbert Hyne, Lloyd Aldersea, Thomas Hamono, Clive Stammers, John Halvy, Donald Stephen Lawry, Charles Litaize, and Francis James Barr as a Committee of Management for a period of three (3) years of the land temporarily reserved for Cricket and other purposes of Public Recreation in the Village of Neerim, and known as "Neerim Recreation Reserve."—(Corres. Rs.2270.)

"GROVEDALE PARK, RECREATION AND PUBLIC HALL RESERVE."

Robert William Schneider, John Frederick Rossack, Eric George Fry, Maxwell George Dodd, Arthur William Cook, Albert Woodrow Wilson, and George Frederick Rossack as a Committee of Management for a period of three (3) years from 7th December, 1957, of the land temporarily reserved as a site for Park and Recreation purposes and a Public Hall in the Parish of Conewarre, and known as the "Grovedale Park, Recreation and Public Hall Reserve."—(Corres. Rs.1367.)

"LANDSBOROUGH WEST PUBLIC HALL SITE."

Keith Slorack, G. Vance, John Matheson, Don Slorack, G. T. Peacock, Edward Dean, and Ronald Leslie as a Committee of Management for a period of three (3) years from 11th November, 1957, of the land in the Parish of Landsborough temporarily reserved as a site for a Public Hall by Order in Council dated 3rd November, 1954, and known as the "Landsborough West Public Hall Site."—(Corres. Rs.7313.)

"CLAYTON (SPRINGS ROAD) RECREATION RESERVE."

Clarence Leonard Barnett, Arthur Frank Webb, and Francis Russell Archer for a period of three (3) years from 5th November, 1957, together with Everest Albert Le Page, Albert John Smith, Gerald Laurence Basterfield, and Donald Stevens for so long as they continue to be Councillors and the elect of the Council of the City of Moorabbin as a Committee of Management of the land temporarily reserved by Order in Council dated 30th January, 1923, as a site for Recreation purposes in the Parish of Mordialloc at Clarinda, and known as the "Clayton (Springs Road) Recreation Reserve."—(Corres. Rs.2690.)

"MANSFIELD RACECOURSE RESERVE."

Maurice Anthony Clancy, Edward Nolan, Lloyd Arnold Parks, Alfred Edward John Wigley, and Donald Wilson Tolmie as a Committee of Management for a period of three (3) years of the land permanently reserved by Order in Council dated 19th January, 1932, as a site for Racecourse and other purposes of Public Recreation in the Parish of Mansfield, and known as the "Mansfield Racecourse Reserve."—(Corres. Rs.4164.)

"PORTSEA FORESHORE RESERVE."

Thomas Frederick Stock, Thomas Henry Houghton, John James Farnsworth, Archibald Stirling Knight, James Michael Wishart, Frank Watson, George Keith Burgess for the period ending 30th September, 1960, and W. S. W. Croad (as Chairman) for so long as he shall continue to be a Councillor and the elect of the Shire of Flinders, as a Committee of Management of such portion of the Foreshore Reserve of Port Phillip Bay in the Parish of Nepean, as is indicated by red colour on plan marked P. 12/2/23 with Lands Department correspondence Rs.3289, and known as "Portsea Foreshore Reserve."—(Corres. Rs.3289.)

"ST. LEONARDS FORESHORE RESERVE."

Dominic Sylvester Rigby, George Francis Rigby, Joseph McKelson, Eric James Hanslow, Bernard Thomas Rigby, John Harold Baxter, and Francis Bernard Rigby as a Committee of Management for a period of three (3) years from 12th December, 1957, of those portions of the land permanently reserved for Public purposes along the shores of Port Phillip Bay and Swan Bay in the Parish of Paywit as are indicated by red colour on plan marked "P" over 20.149, attached to Lands Department correspondence Rs.5116, such portions of land being known as the "St. Leonards Foreshore"—(Corres. Rs.5116.)

In witness whereof the common seal of the Board of Land and Works was hereunto affixed this fourteenth day of November, One thousand nine hundred and fifty-seven, in the presence of—

(SEAL) KEITH TURNBULL, President.
W. T. LONG, Member.

PUBLIC HEARING BY A PERSON APPOINTED UNDER THE 34TH SECTION OF THE LAND ACT 1928.

NOTICE is hereby given that at the time and place mentioned in the Schedule hereunder, applications for leases and licences under the Land Acts, objections to such applications, objections to proposed proclamations, alterations, additions, diminutions, revocations, or unions of commons, and reasons against forfeiture of any leases or licences under the Land Acts deemed liable to forfeiture, will be publicly heard by the person whose name is set opposite such place in such Schedule, being a person appointed by me, the responsible Minister of the Crown administering the Land Acts, to hear the same and report thereon in writing to me.

KEITH TURNBULL,
Commissioner of Crown Lands and Survey,
and President of the Board of Land and Works.

Department of Crown Lands and Survey,
Melbourne, 15th November, 1957.

SCHEDULE.

LAND OFFICE, HORSHAM, Thursday, 5th December, 1957, at 9 a.m., S. C. Lepp, Land Officer, Horsham.

AMENDMENT OF REGULATIONS FOR THE CARE, PROTECTION, AND MANAGEMENT OF THE "ROSEBUD FORESHORE AND RECREATION RESERVE."

THE Board of Land and Works, in pursuance of the powers conferred on it, doth hereby amend the Regulations made on the 16th January, 1947, for the care, protection, and management of such portion of the Reserve for Public purposes in the Parish of Wannaeue as is indicated by red colour on plan marked A.11/2/1937 with Lands Department correspondence Rs.3351, and known as the "Rosebud Foreshore and Recreation Reserve," by the deletion of Regulation 15 therefrom.—(Corres. Rs.3351.)

The common seal of the Board of Land and Works was hereunto affixed this fourteenth day of November, 1957, in the presence of—

(SEAL) KEITH TURNBULL, President.
W. T. LONG, Member.

PUBLIC SERVICE NOTICES

No. 753.

Public Service Act 1946, Section 50.

REGULATIONS—PART III.—SALARIES, INCREMENTS, AND ALLOWANCES.

THE Public Service Board, in pursuance of the powers conferred by the *Public Service Act 1946*, hereby amends its Regulations as shown below:—

SECOND SCHEDULE.

TECHNICAL AND GENERAL DIVISION.

Offices and Rates of Salaries.

Department and Office.	Yearly Rate of Salary.		Increments (Annual).
	Minimum.	Maximum.	
DEPARTMENT OF TREASURER.	£	£	
HOUSING COMMISSION.			
Add— District Works Officer, Assistant	728	754	1 of £26

R. E. HARDING, Member.
F. McARDLE, Member.
V. P. SCULLY, Secretary.

Office of the Public Service Board,
Melbourne, 12th November, 1957.

No. 754.

Public Service Act 1946.

REGULATIONS—PART III.—SALARIES, INCREMENTS, AND ALLOWANCES.

THE Public Service Board, in pursuance of the powers conferred by the *Public Service Act 1946*, hereby amends its Regulations as shown below:—

FOURTH SCHEDULE.

ADMINISTRATIVE DIVISION.

Amount or Range of Salary Assigned to Offices in Class "A1", Classes "A" and "A1" and Class "A".

Office.	Yearly Rate of Salary.	
	Minimum.	Maximum.
DEPARTMENT OF WATER SUPPLY.	£	£
CLASS "A".		
Delete— Assistant Chief Accountant	1,550	1,600
Add— Assistant Chief Accountant	1,550	1,650

R. E. HARDING, Member.
F. McARDLE, Member.
V. P. SCULLY, Secretary.

Office of the Public Service Board,
Melbourne, 13th November, 1957.

No. 755.

Public Service Act 1946, Section 39.

REGULATIONS—PART III.—SALARIES, INCREMENTS, AND ALLOWANCES.

THE Public Service Board, in pursuance of the powers conferred by the *Public Service Act 1946*, hereby amends its Regulations as shown below:—

FIRST SCHEDULE.
PROFESSIONAL DIVISION.
Offices and Rates of Salaries.

Office.	Yearly Rate of Salary.	
	Minimum.	Maximum.
DEPARTMENT OF PUBLIC WORKS.	£	£
CLASS "A".		
<i>Add—</i> Assistant Chief Structural Engineer ..	1,550	1,650
CLASS "B1".		
<i>Delete—</i> Structural Engineer	1,300	1,400
R. E. HARDING, Member. F. McARDLE, Member. V. P. SCULLY, Secretary.		
Office of the Public Service Board, Melbourne, 18th November, 1957.		

No. 750.

Public Service Act 1946, Section 39.

REGULATIONS.—PART III.—SALARIES, INCREMENTS, AND ALLOWANCES.

THE Public Service Board, in pursuance of the powers conferred by the *Public Service Act 1946*, hereby amends its Regulations as shown below:—

FIRST SCHEDULE.
PROFESSIONAL DIVISION.
Offices and Rates of Salaries.

Office.	Yearly Rate of Salary.	
	Minimum.	Maximum.
DEPARTMENT OF PREMIER.	£	£
CLASS "C1".		
<i>Add—</i> Assistant Publications and Information Officer, Soil Conservation Authority ..	785	875
CLASS "C".		
<i>Delete—</i> Assistant Publications and Information Officer, Soil Conservation Authority ..	598	728
DEPARTMENT OF PUBLIC WORKS.		
CLASS "B".		
<i>Add—</i> Supervising Draughtsman	1,100	1,200
DEPARTMENT OF HEALTH.		
MATERNAL AND CHILD HYGIENE BRANCH.		
CLASS "A1".		
<i>Delete—</i> Deputy Director of Child Health (Dental)	2,300	2,500
<i>Add—</i> Director of Child Health (Dental) ..	2,300	2,500
Superintending Medical Inspector (Audiometry)	2,000	2,150
A. GARRAN, Chairman. V. P. SCULLY, Secretary.		
Office of the Public Service Board, Melbourne, 11th November, 1957.		

No. 751.

Public Service Act 1946.

REGULATIONS—PART III.—SALARIES, INCREMENTS, AND ALLOWANCES.

THE Public Service Board, in pursuance of the powers conferred by the *Public Service Act 1946*, hereby amends its Regulations as shown below:—

FOURTH SCHEDULE.
ADMINISTRATIVE DIVISION.

Amount or Range of Salary Assigned to Offices in Class "A1", Classes "A" and "A1" and Class "A".

Office.	Yearly Rate of Salary.	
	Minimum.	Maximum.
DEPARTMENT OF WATER SUPPLY.	£	£
CLASSES "A" AND "A1".		
<i>Delete—</i> Officer in Charge, Stores Branch ..	1,550	1,850
CLASS "A".		
<i>Add—</i> Officer in Charge, Stores Branch ..	1,550	1,850

A. GARRAN, Chairman.
V. P. SCULLY, Secretary.

Office of the Public Service Board,
Melbourne, 13th November, 1957.

No. 752.

Public Service Act 1946, Section 39.

REGULATIONS—PART III.—SALARIES, INCREMENTS, AND ALLOWANCES.

THE Public Service Board, in pursuance of the powers conferred by the *Public Service Act 1946*, hereby amends its Regulations as shown below:—

FIRST SCHEDULE.
PROFESSIONAL DIVISION.
Offices and Rates of Salaries.

Office.	Yearly Rate of Salary.	
	Minimum.	Maximum.
DEPARTMENT OF STATE FORESTS.	£	£
CLASS "A".		
<i>Delete—</i> Sales and Marketing Officer	1,550	1,750
CLASS "B1".		
<i>Add—</i> Sales and Marketing Officer	1,300	1,400

R. E. HARDING, Member.
F. McARDLE, Member.
V. P. SCULLY, Secretary.

Office of the Public Service Board,
Melbourne, 11th November, 1957.

PUBLIC SERVICE (PUBLIC SERVICE BOARD) REGULATION 39.—VACANCIES.

THE Permanent Heads of the Departments shown have recommended the officers named hereunder for appointment to the under-mentioned vacancies.

Office and Classification.	Duties.	Qualifications.	Officer Recommended for Appointment.		
			Name.	Classification.	Date of Classification.

ADMINISTRATIVE DIVISION.

DEPARTMENT OF HEALTH.

MENTAL HYGIENE BRANCH.

Kew Cottages.

Class "C2"	To be secretary of the Hospital	Experience in organization of a Mental Hospital, including control of stores, clothing, provisions, &c., and artisan activities. A good knowledge of the Mental Hygiene Acts and Regulations thereunder; ability to control staff	Nugent, D.	Class "C1"	1.3.54
------------	---------------------------------	---	------------	------------	--------

Sunbury Mental Hospital.

Class "C2"	To supervise office staff; to assist Secretary.	Experience in organization of a Mental Hospital, including control of stores, provisions, clothing, &c., and artisan activities. A good knowledge of the Mental Hygiene Acts and Public Service Acts and the Regulations thereunder; ability to control staff	Clarebrough, F. S.	Class "C1"	3.12.53
------------	---	---	--------------------	------------	---------

TECHNICAL AND GENERAL DIVISION.

DEPARTMENT OF HEALTH.

MENTAL HYGIENE BRANCH.

Larundel Mental Hospital.

Principal Nurse (Female) (£638-£664)	Under direction of the Psychiatrist Superintendent, to have charge of Female Division, staff and patients	To possess Mental Hygiene Certificate and to be a registered Mental Nurse; experience in a senior position in a Mental Hospital, tact and ability to control patients and staff, compile reports and records relating to these duties and to be prepared to give lectures to Student Nurses	McNabb, Eliza-both J.	Head Nurse (Female)	23.9.52
--------------------------------------	---	---	-----------------------	---------------------	---------

DEPARTMENT OF WATER SUPPLY.

Hopetoun Centre.

Works Inspector (£565-£617)	Under the direction of the District Engineer to supervise the construction of new, and the reconstruction and maintenance of existing channels and works in Waterworks Districts administered from Hopetoun; to supervise workmen employed in the Districts; to keep records of works; to be capable of carrying out surveys in connection with the construction of earthen channels and pipe line systems	To be capable of setting out works from plans, and to have had experience in repairs and maintenance of channels and channel structures, carrying out surveys, and in preparing reports and estimates of works, to have ability to handle men	Clancy, H.	Survey Assistant	22.9.54
-----------------------------	--	---	------------	------------------	---------

Appeals against such recommendations should be lodged with the Secretary to the Public Service Board not later than Saturday, the 30th November, 1957.

By order,

V. P. SCULLY,
Secretary.

Office of the Public Service Board,
Melbourne, 19th November, 1957.

PUBLIC SERVICE (PUBLIC SERVICE BOARD) REGULATION 39.—RECLASSIFICATIONS.

THE Public Service Board has raised the classification of the under-mentioned offices as shown, and the Permanent Heads of the Departments have recommended the officers named for appointment.

Office and Present Classification.	Revised Classification.	Duties.	Qualifications.	Officer Recommended for Appointment.		
				Name.	Classification.	Date of Classification.

ADMINISTRATIVE DIVISION.

DEPARTMENT OF CHIEF SECRETARY.

State Accident Insurance Office.

Class "C2"	Class "B"	To be Assistant Accountant of State Accident and State Motor Car Insurance Offices and to be responsible for Punched Card Accounting System	To be a qualified Accountant with a specialized knowledge and practical experience of Insurance, Re-insurance, and Agency Accounts; and a thorough knowledge of Workers' Compensation and Motor Car Insurance and the Regulations respecting Public Accounts	Hammond, M. V.	Class "C2"	13.8.56
------------	-----------	---	--	----------------	------------	---------

PROFESSIONAL DIVISION.

DEPARTMENT OF CROWN LANDS AND SURVEY.

Cartographic Assistant, Class "C1" (two offices)	Class "C2" (two offices)	To examine final drawings of standard topographic maps; to have charge of the preparation and examination of photo-mosaics	To be a first class penman with a thorough knowledge of and experience in the final drawing of topographic maps and in the preparation of photo-mosaics; to have a knowledge of the methods of reproduction in colours; to be able to control staff	Sticklan, J. N.	Cartographic Assistant, Class "C1"	9.1.52
		To have charge of the preparation and examination of special large-scale projects, maps and mosaics; to annotate compilation sheets from photographic and field information	To have a thorough knowledge of and experience in the compilation of maps from aerial and terrestrial survey data, and a knowledge of their reproduction	Bond, W. J.	Cartographic Assistant, Class "C1"	9.1.52

DEPARTMENT OF WATER SUPPLY.

Research Officer, Class "B1"	Superintendent of Testing, Class "A" (£1,550-£1,650)	Under the direction of the Chief Designing Engineer, to control the work of the Engineering Research Laboratory which conducts research into, and testing and inspection of materials used on large construction works, as well as the examination of water supplies and the determination of methods for protection and purification of water supplies	To possess a Degree in Engineering or Science or other recognized scientific qualifications; to have had extensive experience in the direction of testing cement, concrete, aggregates, soils and other materials used on water supply construction works; to have a thorough knowledge of the sanitary and mineral examination of water supplies and the purification of water	Lovely, M.	Research Officer, Class "B1"	1.1.56
Mechanical Engineer, Grade III, Class "B"	Grade II, Class "B1"	To assist the Plant Engineer in the management, employment and maintenance of the Commission's construction plant and equipment; to assist with the acquisition of new items, to investigate new developments in plant maintenance use and repair; to carry out performance studies and to make recommendations for disposal or replacement of major plant items and to act as Deputy Plant Engineer	To possess a Degree or Diploma in Mechanical Engineering and to have had experience in the operation, maintenance and repair of construction plant; to have a wide knowledge of modern construction methods; to be experienced in recording plant performances and in the administration of a central plant control organization	MacGilp, R. B.	Mechanical Engineer, Grade III, Class "B"	26.9.55
Surveyor, Class "C2"	Senior Surveyor, Class "B"	To effect title surveys in accordance with regulations under the Transfer of Land Act, and to carry out general engineering surveys in connexion with investigations of reservoir sites and foundations of channel systems and other water supply undertakings	To be a Licensed Surveyor with experience of water supply engineering surveys	Campbell, B. A.	Surveyor, Class "C2"	20.6.55

PUBLIC SERVICE (PUBLIC SERVICE BOARD) REGULATION 39.—RECLASSIFICATIONS—continued.

Office and Present Classification.	Revised Classification.	Duties.	Qualifications.	Officer Recommended for Appointment.		
				Name.	Classification.	Date of Classification.
TECHNICAL AND GENERAL DIVISION.						
DEPARTMENT OF PREMIER.						
<i>Office of the Public Service Board.</i>						
Assistant (Male), Grade I.	Senior, Grade II. (£520-£546)	To answer inquiries at the public counter; to be responsible for the despatch of all outward correspondence, certificates, &c., and to attend on the Board as required	To be familiar with the provisions of the Public Service Act and Regulations and to be experienced in the performance of clerical duties	Bourke, W. F.	Assistant (Male), Grade I.	3.11.55
<i>Audit Office.</i>						
Machinist (Female), Grade II.	Grade III. (£429-£455)	The checking of calculations connected with the audit of authorities throughout Victoria and to assist generally in the work of the office	To be a competent calculating machine operator, and to have a sound knowledge of the systems in operation in the various activities	O'Dowd, Monica K.	Machinist (Female), Grade II.	31.8.53

Appeals against such recommendations should be lodged with the Secretary to the Public Service Board not later than Saturday, the 30th November, 1957.

Office of the Public Service Board,
Melbourne, 19th November, 1957.

By order,
V. P. SCULLY,
Secretary.

PUBLIC SERVICE OF VICTORIA.—VACANCIES.

APPLICATIONS will be received by the Public Service Board up to Wednesday, the 4th December, 1957, from persons employed in the Public Service of Victoria who are eligible and qualified for appointment to the under-mentioned positions:—

ADMINISTRATIVE DIVISION.

Class "B" (Deputy Sheriff), Sheriff's Office, Department of Law.

Yearly Salary.—£1,100, minimum; £1,200, maximum.

Duties.—To be Deputy Sheriff and perform the statutory duties thereof.

Qualifications.—To have a thorough knowledge of Sheriff Law particularly as regards execution of process; to be thoroughly conversant with the Juries Acts and Supreme Court Acts and the Practice and Rules of the Supreme Court.

Assistant Public Service Inspector, Class "C2," Office of the Public Service Board, Department of Premier.

Yearly Salary.—£940, minimum; £1,030, maximum.

Duties.—To assist the Public Service Inspectors in the performance of duties as prescribed by section 44 (2) of the *Public Service Act 1946*.

Qualifications.—To possess a Diploma of Public Administration or other appropriate qualification; to have a good knowledge of the Public Service Act and the Regulations thereunder; to have had experience in investigation work and in the compilation of reports.

Class "C2," Office of the Public Service Board, Department of Premier.

Yearly Salary.—£940, minimum; £1,030, maximum.

Duties.—To keep the authorized establishment records of departmental staffing and continuous records of staff changes; to prepare the annual classified list of officers and employees for publication; to compile statistical information as required and to prepare the statistical section of the Board's annual report.

Qualifications.—To possess a good knowledge of the Public Service Act and Regulations; to be experienced in the keeping of detailed records and in the preparation of matter for publication. A knowledge of statistical method is desirable.

Class "C2," Department of Public Works.

Yearly Salary.—£940, minimum; £1,030, maximum.

Duties.—Under the direction of the Officer in Charge, Stores Branch, to assist in the supervision and general control of stores and materials received by the Department including the custody, issue, delivery, stocktaking and disposal of materials, the maintaining of adequate stocks in Storeyards and Depots and the checking and passing of claims.

Qualifications.—To be a qualified Accountant; to have a sound knowledge of Stores Branch organization and the operation of storeyards; to be familiar with the various types of stores and materials used in building and engineering construction works and with furniture and fittings used in Government buildings and offices; to have a sound knowledge of the Public Service Acts and Regulations and the General Regulations respecting Public Accounts.

Class "C1," Office of the Housing Commission, Department of Treasurer.

Yearly Salary.—£785, minimum; £875, maximum.

Duties.—To be Officer in Charge of the Maintenance Administration Section of the Chief Architect's Branch; to be responsible under direction for the administration of the section and of the Commission's Metropolitan and Provincial Maintenance and Repainting Programme.

Qualifications.—To be capable of controlling and directing staff and of conducting correspondence and interviews with the public; to possess ability to organize the general details of Maintenance and Recording work; to have a good general knowledge of commercial aspects of the building trade and of contract arrangement.

Class "C1," Department of Public Works.

Yearly Salary.—£785, minimum; £875, maximum.

Duties.—Under the direction of the Officer in Charge, Stores Branch, to be responsible for the receipt, custody, stowage, issue and transport to works sites, of stores and materials at the Port Melbourne Storeyard and the keeping of relevant records, the supervision of staff and all clerical work; to assist in the supervision of other Departmental storeyards controlled and operated by the Stores Branch.

Qualifications.—To be familiar with the various types of stores and materials used in buildings and general engineering construction works, mechanical and woodworking workshops and with office furniture and fittings; to have a sound knowledge of stores organization and systems and of the Public Service Acts and Regulations and Regulations respecting Public Accounts. Accountancy qualifications are desirable.

Class "C1," Mental Hygiene Branch, Department of Health. (Three vacancies.)

Yearly Salary.—£785, minimum; £875, maximum.

POSITION No. 1.
Head Office.

Duties.—To assist in the Staff Section; keep records, conduct correspondence and prepare all necessary returns relating thereto.

Qualifications.—A sound knowledge of the Audit, Public Service, and Superannuation Acts and Regulations, experience in preparation of all necessary returns relating to staff matters.

POSITION No. 2.
Bendigo Training Centre.

Duties.—To be Secretary of the Centre.

Qualifications.—Experience in organization of a Mental Hospital, including control of stores, clothing, provisions, &c., and artisan activities, a good knowledge of the Mental Hygiene Acts and the Regulations thereunder; ability to control staff.

POSITION No. 3.
Beechworth Mental Hospital.

Duties.—To supervise office staff and assist the Secretary.

Qualifications.—Experience in the organization of a Mental Hospital, including control of stores, provisions, clothing, &c., and artisan activities; a good knowledge of the Mental Hygiene Acts and Public Service Acts and the Regulations thereunder; ability to control staff.

Class "C," Office of the Housing Commission, Department of Treasurer.

Yearly Salary.—£598, minimum; £728, maximum.

Duties.—To conduct interviews with tenants in arrears of rent, and to make arrangements for liquidation of such arrears; to prepare cases for eviction or prosecution; to appear in Court when necessary; and generally to assist in supervision of rental arrears.

Qualifications.—To possess administrative ability and to have a knowledge of mechanized accounting.

Class "C," Department of Crown Lands and Survey.

Yearly Salary.—£598, minimum; £728, maximum.

Duties.—To deal with correspondence regarding the reservation, control and management by regulations framed in accordance with the provisions of the Land Acts of Crown reserves and commons and also correspondence concerning reserves throughout the State involving special investigations.

Qualifications.—To have a good knowledge of the various Land Acts, with particular regard to reserves and commons and a working knowledge of the Local Government Acts.

Class "C," Department of Public Works.

Yearly Salary.—£598, minimum; £728, maximum.

Duties.—To carry out periodical and continuous stocktakes of a wide range of stores and materials and to report thereon; to carry out investigations as may become necessary; to be responsible for records relating to non-expendable tools and equipment and to furniture on issue to works and centres; to assist in the disposal of obsolete and unserviceable materials and to assist generally in the work of the Stores Branch.

Qualifications.—To have a good knowledge of the organization and operation of a Stores Branch, particularly with regard to stocktaking procedure; to be familiar with stores and materials used in building and engineering construction works and with the Public Service Acts and Regulations and the General Regulations respecting Public Accounts.

PROFESSIONAL DIVISION.

Assistant District Engineer (Mechanical), Classes "C2"—"B," Department of Public Works.

Yearly Salary.—£940, minimum; £1,200, maximum.

(Commencing salary will be determined within this initial career range according to experience.)

Position No. 1.

Duties.—To assist a District Engineer (Mechanical) in the supervision of contracts for mechanical plant and installations in all types of Government buildings, also associated maintenance works; to assist in the supervision and checking of plans and specifications for the above works and to prepare reports as directed.

Qualifications.—To have a Diploma in Mechanical Engineering from a recognized Technical College or its equivalent; to have had extensive practical experience in the design, operation and testing of modern mechanical equipment in large buildings and hospitals.

Position No. 2.

Duties.—To assist a District Engineer (Mechanical) in the supervision of contracts for mechanical plant and installations for Government Buildings, also associated maintenance works; to prepare reports on maintenance works and carry out tests on completed mechanical installations as directed.

Qualifications.—To possess a Technical School Diploma in Mechanical Engineering or equivalent qualifications; to have had a good practical experience in the design, installation, maintenance, and testing of modern mechanical equipment in buildings.

Chemist (Male), Classes "O"—"C2," Office of the Chief Inspector of Explosives and Gas Examiner, Department of Chief Secretary. (Two vacancies.)

Yearly Salary.—£728, minimum; £1,030, maximum.
(Commencing salary will be determined within this initial career range, according to experience.)

Duties.—To test gas in accordance with the provisions of the Gas Regulation Act. As required, to analyse and test explosives and materials connected with their manufacture; to give evidence in Court and to perform inspectional and other duties as directed.

Qualifications.—To hold a University Degree in Science or Chemical Engineering or an approved diploma with Chemistry as a major subject. Applicants should preferably be between the ages of 21 and 40 years.

Chemist (Male), Classes "C"—"C2," Department of Agriculture.

Yearly Salary.—£728, minimum; £1,030, maximum.
(Commencing salary will be determined within this initial career range according to experience.)

Duties.—Under the Chief Chemist, to undertake chemical analyses and investigations associated with barley improvement, and such other chemical work as may be directed.

Qualifications.—To hold a Science Degree or approved Diploma with Chemistry as the major subject with, preferably, some experience in Analytical Chemistry.

Assistant Mechanical Engineer, Classes "C"—"C2," Department of Water Supply.

Yearly Salary.—£785, minimum; £1,030, maximum—
Graduate.
£683, minimum; £1,030, maximum—
Diplomate.

(Commencing salary will be determined within this initial career range according to experience.)

Duties.—To assist the Engineer in Charge of the Central Plant Workshops, Bendigo, in the organization and control of operations carried out in this workshop in the overhaul and repair of construction plant and equipment.

Qualifications.—To possess a degree or diploma or equivalent qualifications in Mechanical Engineering. Experience in the usage of mechanical workshop equipment and machine tools is required and a knowledge of the mechanical operation of earthmoving and construction plant will be an advantage.

NOTE.—A residence is available for the successful applicant, if married, for which rental of 10 per cent. of standard salary, plus £16 per annum, will be charged.

Assistant Librarian, Class "D" (Female), Department of Agriculture.

Yearly Salary.—£364, minimum; £468, maximum.

Duties.—To catalogue and classify books and pamphlets in the Technical Library of the Department; to handle book and pamphlet loans and to perform reference work as required.

Qualifications.—To be under 30 years of age; to possess the Preliminary Certificate of the Library Association of Australia and to have had experience in library work.

TECHNICAL AND GENERAL DIVISION.

Field Officer, Senior, Department of Agriculture.

Yearly Salary.—£683, minimum; £761, maximum.

Duties.—Under the Senior Agronomist, to conduct demonstrations and investigations concerning barley growing in Victoria; to make farm visits and reports, and to judge competitions; to carry out such other duties as may be required.

Qualifications.—A Diploma or Certificate of an approved Agricultural College. Experience in the conduct of cereal experimental work and the operation of farm machinery.

Inspector of Stock, Department of Agriculture.

Yearly Salary.—£605, minimum; £709, maximum.

Duties.—To inspect stock under the Stock Diseases Act, the Cattle Compensation Acts, and the Swine Acts; sheep under the Sheep Dipping Acts; bulls under the Cattle Breeding Acts; and accommodation under the Shearers Accommodation Act; to conduct post-mortem examinations and such investigations under the Sheep Owners Protection Act and the Stock Medicines Act as are necessary or required by the Superintendent of Live Stock.

Qualifications.—To be the holder of a Diploma of an Agricultural College or its equivalent and to have had experience and training within the Department as a Field Officer, Live Stock, or to have had suitable experience in stock management and to have passed the prescribed examination.

Works Inspector, Tongala Centre, Department of Water Supply.

Yearly Salary.—£565, minimum; £617, maximum.

Duties.—Under the direction of the District Officer to supervise the construction of new, and the reconstruction and maintenance of existing channels and works in the irrigation districts administered from Tongala; and of pipe reticulation systems and works in urban districts; to supervise all gangs and workmen employed in the districts; to keep records of works and stores.

Qualifications.—To be capable of setting out works from plans, and to have had experience in repairs and maintenance of channels and channel structures, and in preparing reports and estimates of works; to have ability to handle gangs of men.

Cash Register Operator, Motor Registration Branch, Office of the Chief Commissioner of Police, Department of Chief Secretary.

Yearly Salary.—£520, minimum; £598, maximum.

Duties.—To operate a cash register.

Qualifications.—Ability to operate a multiple cash register and to handle and account for public moneys.

Assistant (Male), Grade I., Taxation Office, Department of Treasurer.

Yearly Salary.—£481, minimum; £494, maximum.

Duties.—To take charge of office stores and to keep the appropriate records; to assist generally in the Accounts Branch.

Qualifications.—To possess a practical knowledge of the handling of office stores and the keeping of stores records, and ability to perform clerical work involved.

NOTE.—To be eligible to apply for this position temporary employees or officers of the Technical and General Division other than Assistants (Male), must have passed the Board's examination for registration for appointment as Assistant (Male), Grade II., Technical and General Division.

Fisheries and Wild Life Officer, Grade II., Fisheries and Game Branch, Department of Chief Secretary. (Two vacancies.)

Yearly Salary.—£364, minimum; £455, maximum.

Duties.—Under the direction of the Director to enforce the provisions of the Fisheries and Game Acts and the Regulations thereunder and generally to assist in the outside work of the Branch.

Qualifications.—An applicant must be strong, healthy and active, able to drive a motor vehicle and to manage a motor boat. He should have a good knowledge of and be able to effect running repairs to motor vehicles and marine engines. A knowledge of all classes of fish and native game and the methods of fishermen and shooters would be an advantage. An education to Intermediate standard is desirable. Applicants should be under forty (40) years of age.

NOTE.—The salary rates quoted above do not include the additional amounts which are payable under Regulation 77A of the Board's Regulations.

By order,

V. P. SCULLY,
Secretary.

Office of the Public Service Board,
Melbourne, 19th November, 1957.

DEPARTMENT OF HEALTH.

MENTAL HYGIENE BRANCH.

TECHNICAL AND GENERAL DIVISION.

A PPLICATIONS will be received by the Public Service Board up to Wednesday, the 11th December, 1957, from persons employed in the Public Service of Victoria, who are eligible and qualified, for appointment to the under-mentioned positions:—

Head Nurse (Male), Larundel Mental Hospital.

Yearly Salary.—£637, minimum; £663, maximum.

Duties.—To assist Principal Nurse in management of Male Division and to prepare leave sheets and other records as directed by the Principal Nurse; to be prepared to give lectures to Student Nurses; to act as Principal Nurse in his absence.

Qualifications.—To possess the Mental Hygiene Nursing Certificate and to be a registered trained Mental Nurse. Ability to direct and control staff and patients and to keep records relating thereto.

Assistant Head Nurse (Male), Larundel Mental Hospital.

Yearly Salary.—£572, minimum; £598, maximum.

Duties.—To assist Head Male Nurse in management of male division, and to prepare leave sheets and other records as directed; to relieve senior officers as required, and be prepared to give lectures to Student Nurses.

Qualifications.—To possess Mental Hygiene Nursing Certificate, ability to direct and control staff and patients, and to keep records relating thereto; to be a registered Mental Nurse.

Assistant Head Nurse (Male), Beechworth Mental Hospital.

Yearly Salary.—£572, minimum; £598, maximum.

Duties.—To assist Principal Male Nurse or Head Male Nurse in management of Male Division, and to prepare leave sheets and other records as directed; to relieve senior officers as requested, and to be prepared to give lectures to Student Nurses.

Qualifications.—To possess Mental Hygiene Nursing Certificate. Ability to direct and control staff and patients, and to keep records relating thereto; to be a registered Mental Trained Nurse.

Charge Nurse (Male).

Children's Cottages, Kew—one vacancy.

Royal Park Receiving House—one vacancy.

Yearly Salary.—£520, minimum; £546, maximum.

Duties.—To take charge or sub-charge of a ward in a Mental Hospital.

Qualifications.—To possess the Mental Hygiene Nursing Certificate, and to have had experience as a Deputy Charge Nurse (Male) in a Mental Hospital; to be a registered Mental Nurse.

Assistant Head Nurse (Female), Larundel Mental Hospital.

Yearly Salary.—£495, minimum; £521, maximum.

Duties.—To assist Head Female Nurse in management of female division, and to prepare leave sheets and other records as directed; to relieve senior officers as required, and be prepared to give lectures to Student Nurses.

Qualifications.—To possess Mental Hygiene Nursing Certificate; ability to direct and control staff and patients, and to keep records relating thereto; to be a registered Mental Nurse.

Deputy Charge Nurse (Male), Larundel Mental Hospital.
(Twelve vacancies.)

Yearly Salary.—£468, minimum; £494, maximum.
Duties.—To be second in charge of a Ward, and to relieve the Charge Nurse.
Qualifications.—To have had experience in a Mental Hospital; to be a registered Mental Nurse and possess the Mental Hygiene Nursing Certificate.

Fireman, Larundel Mental Hospital.

Yearly Salary.—£393, minimum; £406, maximum.
Duties.—To fire boilers and to assist Engineer Mechanic.
Qualifications.—Boiler Attendant's Certificate or higher qualification.

Gardener, Grade II, Royal Park Receiving House.

Salary.—£396 a year.
Duties.—To be in charge of ornamental and vegetable gardens.
Qualifications.—Sound knowledge of ornamental and vegetable gardening, with ability to design and plant out new ground. Ability to control Mental Patients, and experience in the use of mechanical equipment.

Kitchenman, Sunbury Mental Hospital.

Yearly Salary.—£338.
Duties.—To assist Cooks generally, preparation of vegetable and other foodstuffs. Attending to cleanliness of kitchen.
Qualifications.—Ability to carry out above-mentioned duties. Some knowledge of cooking is desirable.

NOTE.—The salary rates quoted above do not include the additional amounts which are payable under Regulation 77A of the Board's Regulations.

By order,
V. P. SCULLY,
Secretary.

Office of the Public Service Board,
Melbourne, 19th November, 1957.

PUBLIC SERVICE OF VICTORIA.
SPEED TESTS FOR SHORTHAND WRITERS AND TYPISTS
(FEMALE).

AT the tests held on Saturday, the 2nd November, 1957, the under-mentioned candidates passed at the required standards, in order of merit indicated:—

TEST AT 100 WORDS A MINUTE.

Order of Merit.	Name
1	Jenkins, Ada Doris Mary
2	Thatcher, Lorraine
3	Hay, Elaine Janette
4	Robertson, Eileen (Mrs.)
5	Plain, Joan
6	Closter, Lois Marjorie

TEST AT 120 WORDS A MINUTE.

1	Gibbs, Helen Jean
2	Burke, Gwendoline Agnes

By order,
V. P. SCULLY,
Secretary.

Office of the Public Service Board,
Melbourne, 19th November, 1957.

**PUBLIC SERVICE EXAMINATION—ENGLISH
EXPRESSION.**

AT the examination held on the 26th October, 1957, the under-mentioned candidates passed the required standard in the order of merit indicated:—

Order of Merit.	Name
1	Vaudrey, Alfred
2	Mennie, Ronald Edward
3	Martin, Joseph
4	Eastley, Charles Arthur William
5	Banner, George Robert Walter
6	Dale, Charles Eatock
7	Leslie-Miller, Humphrey Ernst
8	Scheromsky, Gennadi

By order,
V. P. SCULLY,
Secretary.

Office of the Public Service Board,
Melbourne, 19th November, 1957.

TENDERS—PUBLIC WORKS DEPARTMENT

TENDERS will be received at this office until **TEN a.m.** on the days and for the purposes under-mentioned.

Particulars may be learnt at this Office and also at places shown in parenthesis.

W.O. means Inspector of Works Office; P.S.—Police Station; T.S.—Technical School; H.E.S.—Higher Elementary School; S.S.—State School; H.S.—High School.

The Board of Land and Works will not necessarily accept the lowest or any tender.

NOTE.—No preliminary deposits are to be lodged with tenders, but a deposit, in accordance with the following Schedule, will be required from the successful tenderer:—

For contract amounts exceeding £200 and not exceeding £500	£ 5
For contract amounts exceeding £500 and not exceeding £1,000	10
For contract amounts exceeding £1,000—1 per cent. of tender	500 (maximum deposit)

All tenders should be on a "firm tender" basis.

26th November, 1957.

Blackburn.—Repairs, painting, and provision of cupboards and display boards, S.S. No. 2923. (S.S., Blackburn.)

Burnley.—Purchase and removal of old weatherboard house, poultry pens and fencing, Horticultural Gardens.

Burnley.—Internal and external painting and repairs to curator's residence, School of Horticulture.

Carlton.—Re-slating of roof, S.S. No. 2605. (S.S., Carlton.)

Chewton.—External painting, S.S. No. 1054. (W.O., Kyneton; P.S., Castlemaine; S.S., Chewton.)

Coleraine.—New room and renovations to all buildings, Lands Department residence, McLeod-street. (W.O., Hamilton; P.S., Coleraine.)

Coomboona.—Painting and repairs, S.S. No. 3093. (W.O., Shepparton; S.S., Coomboona.)

Daylesford.—Rewiring and improved lighting, S.S. No. 1609. (W.O., Ballarat; S.S., Daylesford.)

Golden Square (Bendigo).—Complete rewiring and additions to electrical installation, S.S. No. 1189. (W.O., Bendigo; S.S., Golden Square.)

Goorambat.—Installation of septic closets to school and residence, S.S. No. 3123. (W.O., Benalla; S.S., Gooram-bat.)

Heather Hill.—Erection of an eight (8) classroom L.T.C. primary school, S.S. No. 4802.

Heather Hill.—Electrical installation in new L.T.C. eight (8) classroom, &c., primary school, S.S. No. 4802.

Heather Hill.—Warm air heating/ventilation system in S.S. No. 4802.

Inglewood.—Fencing, S.S. No. 1052. (W.O., Bendigo; S.S., Inglewood.)

Linton.—New flooring, various repairs, &c., S.S. No. 880. (W.O., Ballarat; S.S., Linton.)

Malmsbury.—Installation of septic tanks, S.S. No. 1408. (W.O., Bendigo, Kyneton.)

Maribyrnong.—Supply and erection of pipe rail and chain mesh fencing (including gates), S.S. No. 3736. (S.S., Maribyrnong.)

Maribyrnong.—Laying of sewer drains, water and gas supply, &c., first and second sections, High School.

Melbourne.—Alterations, renovations, and fireproofing of boiler and fuel rooms, State Offices, New Treasury Building.

McKinnon.—Erection of three additional L.T.C. classrooms, High School. (H.S., McKinnon.)

McKinnon.—Electrical installation in three additional classrooms, High School. (H.S., McKinnon.)

McKinnon.—Mechanical services for additions to class-room wing, High School. (H.S., McKinnon.)

Newtown.—Repairs and painting, S.S. No. 1887. (W.O., Geelong; S.S., Newtown.)

Nullawarre.—Internal and external renovations, residence, S.S. No. 1652. (W.O., Warrnambool; S.S., Nullawarre.)

Pomborneit.—External painting and repairs, S.S. No. 1031. (W.O., Warrnambool; S.S., Pomborneit.)

Port Melbourne.—Supply and delivery to Salmon-street Depot of one (1) No. 30 cwt. (approximately) three-wheel type footpath rollers, Plant Depot, Public Works Department. (Specifications to be submitted with tender.)

Shepparton.—Extension to central heating to woodwork room, High School. (H.S., Shepparton; W.O., Shepparton.)

Sydenham.—Construction of new out-office block, installation of septic closets, S.S. No. 3559. (S.S., Sydenham.)
Yarraman.—Erection of a six (6) room concrete veneer timber-framed primary school, S.S. No. 4807.
Yarraman.—Electrical installation in new six (6) class-room, &c., L.T.C. primary school, S.S. No. 4807.
Yarraman.—Warm air heating/ventilation system in S.S. No. 4807.
Yellingbo.—New porch, renewal of tank stands, S.S. No. 4705. (P.S., Warburton; S.S., Yellingbo.)

3rd December, 1957.

Ararat.—Removal of old fencing and renewal with pipe rail and wire mesh fence to Male Cottage Wards, Mental Hospital. (W.O., Ararat; Mental Hospital, Ararat.)
Ararat.—Renovations to medical officers' residence, Mental Hospital. (W.O., Ararat; Mental Hospital, Ararat.)
Bairnsdale.—Supply and delivery of fitting and turning trades school equipment, Technical School. (W.O., Bairnsdale; T.S., Bairnsdale.)
Blackburn.—Internal and external painting, Open Air S.S. No. 3850. (S.S., Blackburn.)
Bruthen.—Septic tank installation, new out-office block, woodshed and extension of water service, S.S. No. 1141. (W.O., Bairnsdale; S.S., Bruthen.)
Castlemaine.—Part rewiring and additions to the electrical installation in main brick building, High School. (W.O., Bendigo, Kyneton; H.S., Castlemaine.)
Caulfield.—Supply, delivery, installation, and testing of ventilation in Chemistry Laboratory, Technical School. (T.S., Caulfield.)
Chesney Vale.—Restoration of school building, S.S. No. 4403. (W.O., Benalla; S.S., Chesney Vale.)
Clayton North.—Additional lavatory accommodation, S.S. No. 734. (S.S., Clayton North.)
Darriman.—Provision of a 20-ft. x 10-ft. new shelter pavilion and 8-ft. x 6-ft. woodshed, S.S. No. 3013. (W.O., Traralgon; S.S., Darriman.)
Deepdene.—External painting, renewal of chalkboards, S.S. No. 3680. (S.S., Deepdene.)
Franklinford.—Purchase and removal of residence, fittings, tanks, out-office, &c., S.S. No. 257. (W.O., Kyneton.)
Glenluce.—Purchase and removal of all buildings on site, S.S. No. 771. (W.O., Kyneton.)
Gunbower Island.—Alterations, renovations, and painting, S.S. No. 3503. (W.O., Bendigo; S.S., Gunbower Island.)
Hampton.—Extension of tuck shop verandah, High School. (H.S., Hampton.)
Hughesdale.—Extension of heating to four new classrooms and conversion of boiler to oil firing, S.S. No. 4176. (S.S., Hughesdale.)
Inverloch.—Additional out-offices for boys and girls, S.S. No. 2776. (W.O., Korumburra; S.S., Inverloch.)
Koo-wee-rup.—Repairs and painting to residence No. 1 Rossiter-road, S.S. No. 2629. (S.S., Koo-wee-rup.)
Marnoo.—New out-office block and septic tank installation, S.S. No. 1554. (W.O., Ararat, Horsham; S.S., Marnoo.)
Melbourne.—Installation of two (2) sinks, and timber partition, Fisheries and Game Department, 605 Flinders-street Extension.
Melbourne.—Repairs to bluestone entrance steps to building No. 1, Royal Melbourne Technical College. (Royal Melbourne Technical College, Melbourne.)
Melbourne.—Supply and installation of cables for air-conditioning plants, Stereo and Manual Plotting, &c., New Treasury Building, Lands and Survey Department.
Mont Park.—Sewerage and sanitary plumbing, fire service, and water supply, Mental Hospital. (W.O., Mont Park.)
Mont Park.—Conversion of the existing steam boilers from hard fuel firing to heavy oil firing, Larundel Mental Hospital. (Mental Hospital, Mont Park.)
Mont Park.—Connexion of water and sewerage to L.T.C. buildings, Larundel Mental Hospital. (W.O., Mont Park.)
Murchison.—Painting repairs, construction of new out-offices, S.S. No. 1126. (W.O., Shepparton; S.S., Murchison.) (Re-amended specification.)
Murtoa.—Under-pinning foundations of Court House. (W.O., Warracknabeal, Horsham; P.S., Murtoa.)
Nunawading South.—Erection of six class-room primary school, S.S. No. 4808.
Nunawading South.—Electrical installation in new L.T.C. six (6) class-room, &c., primary school, S.S. No. 4808.
Nunawading South.—Warm air heating/ventilation system in S.S. No. 4808.
Oakleigh.—Supply and delivery of equipment for metal work-room, High School. (H.S., Oakleigh.)
Redan.—New out-office block and woodshed, new water service, and connexion to sewer at Redan, S.S. No. 1289. (W.O., Ballarat; S.S., Redan.)

Stony Creek.—General repairs, renovations, and painting to all buildings, S.S. No. 3665. (W.O., Korumburra; S.S., Stony Creek.)
Sunshine.—Internal and external repairs and painting, Technical School. (T.S., Sunshine.)
Upwey.—Erection of a new shelter pavilion, 32 ft. x 16 ft., and repairs, S.S. No. 4530. (S.S., Upwey.)
Warrnambool.—Erection of Welco garage, 36 ft. x 15 ft., Mental Hospital. (W.O., Warrnambool.)

10th December, 1957.

Ararat.—Renewal of spouting, repairs to flashings, roof gutters, &c., S.S. No. 800. (W.O., Ararat; S.S., Ararat.)
Bairnsdale.—Supply and delivery of the motor mechanics' equipment, Technical School. (W.O., Bairnsdale; T.S., Bairnsdale.)
Balmoral.—Erection of "A" type office, Police Station. (W.O., Hamilton; P.S., Balmoral.)
Bendigo.—Internal renovations, external repairs and painting, provision of window guards, Teachers' College Hostel, "Comersdale." (W.O., Bendigo.)
Briargolong.—Septic tank installation, construction of new out-office block, &c., S.S. No. 1117. (W.O., Bairnsdale; S.S., Briargolong.)
Carlton.—Renewal of water service, University High School. (University High School, Carlton.)
Caulfield.—Provision of concrete floor to welding shop, Technical School. (T.S., Caulfield.)
Charlton.—Erection of new Police Station office, type "A." (W.O., Bendigo; P.S., Charlton.)
Elmhurst.—General repairs and renovations, Police Station. (W.O., Ararat; P.S., Elmhurst.)
Fairfield.—Provision of internal toilets for female teachers, S.S. No. 2711. (S.S., Fairfield.)
Ferntree Gully.—Supply and delivery of two 12-in. swing lathes and two metal pots, Technical School. (T.S., Ferntree Gully.)
Footscray.—Erection of chain mesh fencing to school boundaries, High School. (H.S., Footscray.)
Frankston.—Repairs and painting, S.S. No. 1464. (S.S., Frankston.)
Geelong North.—Repairs and painting, Police Station. (W.O., Geelong.)
Gisborne.—Installation of septic tank, including new toilet block, &c., S.S. No. 262. (W.O., Kyneton; S.S., Gisborne.)
Glenthompson.—Installation of septic tank system at school and residence, S.S. No. 947. (W.O., Hamilton; S.S., Glenthompson.)
Heatherton.—Supply and delivery of one 12-in. swing engineer's lathe, Sanatorium. (Sanatorium, Heatherton.)
Heywood.—Removal of Condah S.S. No. 1019 residence to Heywood Consolidated School site. (W.O., Warrnambool; Consolidated School, Heywood.)
Horsham.—Erection of brick veneer headquarters building and new brick female toilet block, Police Station. (W.O., Horsham; P.S., Horsham.)
Kew.—Supply and delivery of 150-h.p. package boiler unit, Mental Hospital. (W.O., Kew Mental Hospital.)
Kew.—Erection of two brick cottage wards and connecting covered ways, Mental Hospital. (Amended specification.)
Linton.—General repairs and painting, Police Station. (W.O., Ballarat; P.S., Linton.)
Maribyrnong.—Repairs, external painting, and renewal of fencing, Police Station. (P.S., Maribyrnong.)
Maryborough.—Connexion of sewerage, Clerk of Court's residence, Crown Law Department. (W.O., Maryborough.)
Melbourne.—Repairs to roof, Emily McPherson College of Domestic Economy.
Mont Park.—The supply and delivery of two (2) package boiler units to the Mont Park boiler-house, South-East Area, Mental Hospital.
Ouyen.—Erection of boundary fencing, S.S. No. 3615. (W.O., Mildura; S.S., Ouyen.)
Port Fairy.—Repairs, painting, and replacements, Consolidated School. (W.O., Warrnambool; Consolidated School, Port Fairy.)
Prahran.—Internal renovations, Chest Clinic. Health Department, Clarence-street.
Rosanna West.—Laying of sewer drains, &c., S.S. No. 4774.
Tawonga.—Drinking facilities to school, and internal and external repairs and painting to residence, S.S. No. 2282. (W.O., Benalla; P.S., Myrtleford, Bright; S.S., Tawonga.)
Tooradin.—Repairs and painting to old school, shelter pavilion, and out-offices, S.S. No. 1503. (S.S., Tooradin.)
Tottenham.—Installation of sawdust extraction system, Technical School. (T.S., Tottenham.)
Traralgon.—Conversion of heating system boiler to oil firing, S.S. No. 4652. (S.S., Traralgon.)
Wallington.—Septic tank installation and construction of out-office block, S.S. No. 3345. (W.O., Geelong; S.S., Wallington.)

Watchem.—Installation of septic tank system at school and residence, S.S. No. 3224. (W.O., Maryborough.)

Wattle Park.—Additional out-office accommodation, drinking and washing facilities, S.S. No. 3841. (S.S., Wattle Park.)

Werribee.—External and internal painting and repairs, residence, Police Station. (P.S., Werribee.)

Wurruk.—Septic tank installation at school and residence, construction of new out-offices, S.S. No. 2518. (W.O., Traralgon; S.S., Wurruk.)

Yallourn.—Erection of rail-less type chain mesh fence to Newborough School site, Technical School. (W.O., Traralgon; T.S., Yallourn.)

All tenders should be on a "firm tender" basis.

Tenders to be addressed to the Honorable the Commissioner of Public Works, and envelope containing tender marked "Tender for _____ due _____"

T. K. MALTBY,
Commissioner of Public Works.

Public Works Department,
Melbourne, 19th November, 1957.

PRIVATE ADVERTISEMENTS

CITY OF BRIGHTON.

LOAN No. 36.

Notice of Intention to Borrow the Sum of £25,000 for Permanent Works and Undertakings.

NOTICE is hereby given that the Council of the City of Brighton proposes to borrow the sum of Twenty-five thousand pounds, on the credit of the municipal revenues of the Mayor, Councillors, and Citizens of the said City, such sum to be raised by the issue of debentures, in accordance with the provisions of the Local Government Acts.

1. The maximum rate of interest that may be paid is 5½ per cent. per annum.

2. The purpose for which the loan is to be applied is the reconstruction of St. Kilda-street (second stage).

3. The period of the loan shall be fifteen years.

4. The moneys borrowed shall be repayable by providing out of the municipal fund 30 half-yearly instalments of approximately £1,234 12s. each, including principal and interest, on the 1st day of September and the 1st day of March during the currency of the loan. The first instalment shall be payable on the 1st day of September, 1958.

5. Such moneys shall be repayable at the Commonwealth Bank, Melbourne, or the Council's bankers for the time being in Melbourne.

The plans and specifications and the estimate of cost of the proposed works, and a statement showing the proposed expenditure of the moneys to be borrowed, are open for inspection at the Town Hall, Wilson-street, Brighton.

H. C. FERGUSON, Town Clerk.
Town Hall, Brighton, 18th November, 1957. 3088

CITY OF COBURG.

LOAN No. 62.

Notice of Intention to Borrow the Sum of £20,000 for Permanent Works and Undertakings.

NOTICE is hereby given that the Council of the City of Coburg proposes to borrow the sum of Twenty thousand pounds on the credit of the municipal revenues of the Mayor, Councillors, and Citizens of the said City, such sum to be raised by the issue of debentures, in accordance with the provisions of the Local Government Acts.

1. The maximum rate of interest that may be paid is 5½ per cent. per annum.

2. The purpose for which the loan is to be applied is Electric Supply Capital Expenditure (for supply of electricity to the factory premises of Kodak (Australasia) Pty. Ltd., at North-east Coburg).

3. The period of the loan shall be fifteen years.

4. The moneys borrowed shall be repayable by providing out of the municipal fund 30 equal half-yearly instalments of £987 13s. 10d., including principal and interest, on the 1st day of April and the 1st day of October during the currency of the loan. The first instalment shall be payable on the 1st day of October, 1958.

5. Such moneys shall be repayable at the Commonwealth Trading Bank of Australia, Melbourne, or at the Council's bankers for the time being in Melbourne.

The plans and specifications and the estimate of the cost of the proposed works, and a statement showing the proposed expenditure of the moneys to be borrowed, are open for inspection at the Town Hall, Coburg, during office hours.

3029

G. A. BRIDGES, Acting Town Clerk.

CITY OF COBURG.

LOAN No. 61.

Notice of Intention to Borrow the Sum of £20,000 for Permanent Works and Undertakings.

NOTICE is hereby given that the Council of the City of Coburg proposes to borrow the sum of Twenty thousand pounds on the credit of the municipal revenues of the Mayor, Councillors, and Citizens of the said City, such sum to be raised by the issue of debentures, in accordance with the provisions of the Local Government Acts.

1. The maximum rate of interest that may be paid is 5½ per cent. per annum.

2. The purposes for which the loan is to be applied are—

Purchase of Land, Louisa-street ..	£2,150
Road and Drainage Works ..	7,850
Electric Supply Capital Expenditure ..	10,000

3. The period of the loan shall be fifteen years.

4. The moneys borrowed shall be repayable by providing out of the municipal fund 30 equal half-yearly instalments of £987 13s. 10d., including principal and interest, on the 1st day of April and the 1st day of October during the currency of the loan. The first instalment shall be payable on the 1st day of October, 1958.

5. Such moneys shall be repayable at the Commonwealth Trading Bank of Australia, Melbourne, or at the Council's bankers for the time being in Melbourne.

The plans and specifications and the estimate of the cost of the proposed works, and a statement showing the proposed expenditure of the moneys to be borrowed, are open for inspection at the Town Hall, Coburg, during office hours.

3030

G. A. BRIDGES, Acting Town Clerk.

CITY OF HAMILTON.

NOTICE is hereby given that Sergeant Vincent James Alfred Condon, No. 8261, has been appointed Prosecuting Officer to the City of Hamilton, *vice* Sergeant J. Thompson, No. 7752, resigned.

3024

H. F. DONALD, Town Clerk.

CITY OF NUNAWADING.

LOAN No. 27.

Notice of Intention to Borrow the Sum of £25,000 for Permanent Works and Undertakings.

NOTICE is hereby given that the Council of the City of Nunawading proposes to borrow the sum of Twenty-five thousand pounds, on the credit of the municipal revenues of the Mayor, Councillors, and Citizens of the City of Nunawading, such sum to be raised by the issue of debentures, in accordance with the provisions of the Local Government Acts.

1. The maximum rate of interest that may be paid is Five pounds ten shillings per cent. per annum.

2. The purposes for which the loan is to be applied are for drain, road, channel, and footpath construction and purchase of land for street extension.

3. The period of the loan shall be ten years.

4. The moneys borrowed shall be repayable by providing out of the municipal fund twenty half-yearly instalments of approximately £1,641 15s. 6d. each, including principal and interest, on the 1st day of March and the 1st day of September during the currency of the loan. The first instalment shall be payable on the 1st day of September, 1958.

5. Such moneys shall be repayable at the Commonwealth Trading Bank of Australia, Melbourne, or at the Council's bankers for the time being in Melbourne.

The plans, specifications, and estimate of cost of the proposed work, and a statement showing the proposed expenditure of the moneys to be borrowed, are open for inspection at the Municipal Offices, Nunawading.

3023

A. ROY CHARLESWORTH, Town Clerk.

CITY OF NUNAWADING.

LOAN No. 23.

Notice of Intention to Borrow the Sum of £50,000 for Permanent Works and Undertakings.

NOTICE is hereby given that the Council of the City of Nunawading proposes to borrow the sum of Fifty thousand pounds on the credit of the municipal revenues of the Mayor, Councillors, and Citizens of the City of Nunawading, such sum to be raised by the issue of debentures, in accordance with the provisions of the Local Government Acts.

1. The maximum rate of interest that may be paid is Five pounds ten shillings per cent. per annum.

2. The purposes for which the loan is to be applied are construction of drains and footpaths, widening of streets, part purchase of public hall, erection of sports pavilion, and purchase of a reserve.

3. The period of the loan shall be ten years.

4. The moneys borrowed shall be repayable by providing out of the municipal fund twenty half-yearly instalments of approximately £3,283 12s. each, including principal and interest, on the 1st day of March and the 1st day of September during the currency of the loan. The first instalment shall be payable on the 1st day of September, 1958.

5. Such moneys shall be repayable at the Commonwealth Trading Bank of Australia, Melbourne, or at the Council's bankers for the time being in Melbourne.

The plans, specifications, and estimate of cost of the proposed work, and a statement showing the proposed expenditure of the moneys to be borrowed, are open for inspection at the Municipal Offices, Nunawading.

3020 A. ROY CHARLESWORTH, Town Clerk.

CITY OF NUNAWADING.

LOAN No. 24.

Notice of Intention to Borrow the Sum of £3,500 for Permanent Works and Undertakings.

NOTICE is hereby given that the Council of the City of Nunawading proposes to borrow the sum of Three thousand five hundred pounds on the credit of the municipal revenues of the Mayor, Councillors, and Citizens of the City of Nunawading, such sum to be raised by the issue of debentures, in accordance with the provisions of the Local Government Acts.

1. The maximum rate of interest that may be paid is Five pounds ten shillings per cent. per annum.

2. The purposes for which the loan is to be applied are for the construction of a drain and footpath.

3. The period of the loan shall be ten years.

4. The moneys borrowed shall be repayable by providing out of the municipal fund twenty half-yearly instalments of approximately £229 17s. each, including principal and interest, on the 1st day of March and the 1st day of September during the currency of the loan. The first instalment shall be payable on the 1st day of September, 1958.

5. Such moneys shall be repayable at the Commonwealth Trading Bank of Australia, Melbourne, or at the Council's bankers for the time being in Melbourne.

The plans, specifications, and estimate of cost of the proposed work, and a statement showing the proposed expenditure of the moneys to be borrowed, are open for inspection at the Municipal Offices, Nunawading.

3021 A. ROY CHARLESWORTH, Town Clerk.

CITY OF NUNAWADING.

LOAN No. 26.

Notice of Intention to Borrow the Sum of £10,000 for Permanent Works and Undertakings.

NOTICE is hereby given that the Council of the City of Nunawading proposes to borrow the sum of Ten thousand pounds on the credit of the municipal revenues of the Mayor, Councillors, and Citizens of the City of Nunawading, such sum to be raised by the issue of debentures, in accordance with the provisions of the Local Government Acts.

1. The maximum rate of interest that may be paid is Five pounds ten shillings per cent. per annum.

2. The purposes for which the loan is to be applied are for drain, road, and footpath construction and extensions to hall.

3. The period of the loan shall be fifteen years.

4. The moneys borrowed shall be repayable by providing out of the municipal fund 30 half-yearly instalments of approximately £493 16s. 11d. each, including principal and interest, on the 1st day of March and the 1st day of September during the currency of the loan. The first instalment shall be payable on the 1st day of September, 1958.

5. Such moneys shall be repayable at the Commonwealth Trading Bank of Australia, Melbourne, or at the Council's bankers for the time being in Melbourne.

The plans, specifications, and estimate of cost of the proposed work, and a statement showing the proposed expenditure of the moneys to be borrowed, are open for inspection at the Municipal Offices, Nunawading.

3022 A. ROY CHARLESWORTH, Town Clerk.

CITY OF OAKLEIGH.

By-LAW No. 145.

A By-law of the City of Oakleigh, made under the provisions of the Health Act, and numbered 145, for the purpose of preventing or regulating the deposit of refuse and rubbish upon streets, lands, and other places under the control of the Council.

IN pursuance of the powers conferred by the Health Act and all other powers thereunto enabling, the Mayor, Councillors, and Citizens of the City of Oakleigh order as follows:—

1. In this By-law—

“Street” includes any highway and any public bridge and any road, lane, footway, square, court, alley, or passage whether a thoroughfare or not.

2. By-laws numbered 33 and 91 are hereby repealed.

3. No person shall deposit or cause to be deposited any refuse or rubbish upon any street, land, or other place under the control of the Council, unless before so doing written permission to deposit such refuse or rubbish has been obtained from the Council or its authorized officer.

The Resolution for making and passing this By-law was agreed to by the Council at a meeting held on the 19th day of August, 1957, and confirmed at a meeting held on the 16th day of September, 1957.

In witness whereof the common seal of the Mayor, Councillors, and Citizens of the City of Oakleigh was hereunto affixed this 17th day of September, 1957—

(SEAL) F. B. LINTON, Mayor.
A. P. DONNELLY, Councillor.
J. A. PRICE, Town Clerk.

Submitted to the Commission of Public Health, on the 1st day of October, 1957.—G. V. STAFFORD, Secretary to the Commission.

Approved by the Governor in Council, on the 6th November, 1957.—A. MAHLSTEDT, Clerk of the Executive Council. 3067

SHIRE OF BENALLA.

LOAN No. 25.

NOTICE is given that the Shire Council of the Shire of Benalla proposes to borrow the sum of £12,000 upon the credit of the municipality and in accordance with the provisions of the Local Government Acts for the purpose of purchasing two tandem-drive power graders.

Such loan will be liquidated over a period of five (5) years by periodical half-yearly payments of £1,384 8s. 5d., being principal together with interest at a rate not to exceed 5½ per centum per annum on so much of the total amount of the said loan as is unpaid; repayments to be made at the National Bank of Australasia Limited, Melbourne, or at the Council's bankers for the time being.

By order,

3050 E. C. BATES, Shire Secretary.

SHIRE OF BUNGAREE.

LOAN No. 6.

Notice of Intention to Borrow the Sum of £5,000 for Permanent Works and Undertakings.

NOTICE is hereby given that the Council of the Shire of Bungaree proposes to borrow the sum of Five thousand pounds, on the credit of the municipal revenues of the President, Councillors, and Ratepayers of the said Shire, such sum to be raised by the issue of debentures, in accordance with the provisions of the Local Government Acts.

1. The maximum rate of interest that may be paid is 5½ per cent. per annum.

2. The purposes for which the loan is to be applied are:—

Erection of municipal chambers and offices and the purchase of road-making plant.

3. The period of the loan shall be ten years.

4. The moneys borrowed shall be repayable by providing out of the municipal fund twenty half-yearly instalments of approximately £328 7s. each, including principal and interest, on the 1st day of September and the 1st day of March during the currency of the loan. The first instalment shall be payable on the 1st day of September, 1958.

5. Such moneys shall be repayable at The English, Scottish, and Australian Bank Ltd., Melbourne, or at the Council's bankers for the time being in Melbourne.

The plans and specifications and the estimate of the cost of the proposed works, and a statement showing the proposed expenditure of the moneys to be borrowed, are open for inspection at the Shire Office, Leigh Creek.

V. C. NIELSEN, Shire Secretary.

13th November, 1957. 3053

SHIRE OF KARKAROOC.

LOAN No. 16.

Notice of Intention to Borrow the Sum of £5,000 for Permanent Works and Undertakings.

NOTICE is hereby given that the Council of the Shire of Karkaroc proposes to borrow the sum of Five thousand pounds (£5,000), on the credit of the municipal revenues of the President, Councillors, and Ratepayers of the said Shire, such sum to be raised by the issue of debentures, in accordance with the provisions of the Local Government Acts.

1. The maximum rate of interest that may be paid is 5½ per cent. per annum.

2. The purpose for which the loan is to be applied is towards the cost of purchase of heavy diesel motor power grader.

3. The period of the loan shall be ten years.

4. The moneys borrowed shall be repayable by providing out of the municipal fund twenty half-yearly instalments of approximately £328 7s. 2d each, including principal and interest, on the 1st day of February and the 1st day of August during the currency of the loan. The first instalment shall be payable on 1st August, 1958.

5. Such moneys shall be repayable at The Commercial Bank of Australia Ltd., Melbourne, or at the Council's bankers for the time being in Melbourne.

The plans and specifications and the estimate of the cost of the proposed works, and a statement showing the proposed expenditure of the moneys to be borrowed, are open for inspection at the Shire Offices, Lascelles-street, Hopetoun, during office hours.

Dated this 12th day of November, 1957.

3052 JOHN T. COLLINS, Shire Secretary.

SHIRE OF KOWREE.

BY-LAW No. 31.

A By-law of the Shire of Kowree, made under the Local Government Acts and the Uniform Building Regulations, Victoria, and numbered 31, for determining, applying, dispensing with, or regulating such matters or things as are left to be determined, applied, dispensed with, or regulated by the Council of the said Shire under the Uniform Building Regulations, Victoria.

IN pursuance of the powers conferred by the Local Government Acts and the Uniform Building Regulations, Victoria, and of any and every other power it thereunto enabling, the President, Councillors, and Ratepayers of the Shire of Kowree order as follows:—

1. By-law No. 29 is hereby repealed.

Brick Areas.

2. The areas set out and described in the First Schedule hereto are hereby prescribed as brick areas, and no person shall in any such area construct or cause to be constructed any building the external walls of which are of materials other than masonry or concrete, provided that buildings of reinforced concrete or masonry veneer construction conforming to the requirements of Chapter 26 of the Uniform Building Regulations, Victoria (hereinafter called the Regulations) shall be deemed to have external walls of masonry or concrete, and also provided that this clause shall apply to out-buildings of laundries and garages, and provided further that this clause shall apply to any addition to or extension of an existing building not having external walls of masonry or concrete, with the exception of a building of Class I. or Class IV. occupancy.

Minimum Area, Depth, and Width of Frontage.

3. The minimum area, depth, and width of frontage specified in column 3 of Table 803 of the Regulations as amended are hereby adopted as the minimum area, depth, and width of frontage of land on which a building of Class I. or Class II. occupancy shall be constructed throughout those portions of the municipal district to which the operation of the Regulations has been or shall hereafter be extended by proclamation.

Distance from Frontage.

4. (a) The minimum distance from the frontage of any land of the outer walls of any building of Class I. or Class II. occupancy is hereby specified as 20 feet.

(b) No person shall construct any building of Class I. or Class II. occupancy closer to the frontage of any land than 20 feet.

Rear Access.

5. In the case of a building on any land forming part of a subdivision approved by the Council and lodged with the Office of Titles prior to the date of commencement of the Regulations, the requirements of clause 811 of the Regulations are hereby dispensed with.

Penalties.

6. Every person guilty of any wilful breach of any of the provisions of this By-law shall be liable for every offence to a penalty not exceeding Twenty pounds, and to a further penalty not exceeding Five pounds for each day on which such offence is continued or repeated after a conviction or order by any court in relation to the offence.

THE SCHEDULE ABOVE REFERRED TO.

Those areas being areas which abut respectively on the several portions of the streets described hereunder and which have a depth of 250 links therefrom:—

1. Town of Edenhope—

both sides of Elizabeth-street, between Orme-street and Dundas-street.

2. (a) Township of Goroke—

the southern side of Main-street, between Mill-street and Compston-street.

(b) Parish of Goroke—

the northern side of Main-street, Goroke, between Kiely-street and the eastern boundary of lot 14 on plan of subdivision lodged in the Office of Titles, and numbered L.P. 1648.

Resolution for passing this By-law agreed to by the Council on the 1st day of July, 1957, and confirmed on the 2nd day of September, 1957.

The common seal of the President, Councillors, and Ratepayers of the Shire of Kowree was hereto affixed this 2nd day of September, 1957, in the presence of—

(SEAL) J. B. FORSTER, President.
L. G. DIXON, Councillor.
M. B. WATSON, Secretary.

Approved by the Governor in Council, on the 29th day of October, 1957.—A. MAHLSTEDT, Clerk of the Executive Council. 3025

SHIRE OF McIVOR.

LOAN No. 19.

NOTICE is hereby given that the Council of the Shire of McIvor proposes to borrow the sum of Four thousand pounds, on the credit of the municipal revenues of the President, Councillors, and Ratepayers of the said Shire, such sum to be raised by the issue of debentures, in accordance with the provisions of the Local Government Acts.

1. The maximum rate of interest that may be paid is £5 10s. per cent. per annum.

2. The purpose for which the loan is to be applied is the installation of a filtration plant at the swimming pool.

3. The period of the loan shall be 25 years.

4. The moneys borrowed shall be repayable by providing out of the municipal fund 50 half-yearly instalments of approximately £148 3s. 3d. each, including principal and interest, on the 1st day of June, and the 1st day of December during the currency of the loan. The first instalment shall be payable on the 1st day of June, 1958.

5. Such moneys shall be repayable at the Commercial Bank of Australia Limited, Melbourne, or at the Council's bankers for the time being in Melbourne.

The plans and specifications and the estimate of the cost of the proposed works, and a statement showing the proposed expenditure of the moneys to be borrowed, are open for inspection at the Council's Office, Heathcote.

Dated 15th November, 1957.

3051 R. J. MURRAY, Shire Secretary.

SHIRE OF MORTLAKE.

NOTICE is hereby given that the Council of the Shire of Mortlake has appointed Friday as the day on which unclaimed impounded cattle are to be sold at the Mortlake Pound.

3092 W. J. GRAY, Shire Secretary.

SHIRE OF PORTLAND.

LOAN No. 14.

Notice of Intention to Borrow the Sum of Eight Thousand Four Hundred Pounds (£8,400) for Permanent Works and Undertakings in the Shire of Portland.

TAKE notice that the Council of the Shire of Portland proposes to borrow, on the credit of the President, Councillors, and Ratepayers of the said Shire, the sum of Eight thousand four hundred pounds (£8,400), such sum to be raised by the issue of debentures, in accordance with the provisions of the Local Government Acts.

The maximum rate of interest that may be paid is £5 10s. per centum per annum.

Such moneys shall be repayable by 20 half-yearly instalments of approximately £51 12s. 10d. each, including principal and interest, by providing out of Municipal Fund such amounts on the 1st day of May and the 1st day of November in each respective year during the currency of the loan. The first instalment shall be payable on the 1st day of November, 1958.

Such moneys shall be repayable at Melbourne, at the Commercial Bank of Australia Ltd., or at the Council's bankers for the time being in Melbourne.

The purpose for which the loan is to be applied is:—

Bridge Construction	£2,000
Drain Construction and alteration .. .	4,000
Kerb Construction	2,000
Comfort Station construction	400
	<hr/>
	£8,400

The necessary plans and specifications and estimates of cost, and a statement showing the proposed expenditure of the money to be borrowed, are open for inspection at the Shire Hall, Heywood.

Dated this 11th day of November, 1957.

3031 M. D. ALLARDICE, Shire Secretary.

SHIRE OF ROMSEY.

LOAN No. 17.

Notice of Intention to Borrow the Sum of Five Thousand Six Hundred Pounds (£5,600) for Permanent Works and Undertakings in the Shire of Romsey.

TAKE notice that the Council of the Shire of Romsey proposes to borrow, on the credit of the President, Councillors, and Ratepayers of the said Shire, the sum of Five thousand six hundred pounds (£5,600), such sum to be raised by the issue of debentures, in accordance with the provisions of the Local Government Act.

The rate of interest to be paid shall not exceed £5 10s. per centum per annum.

Such moneys shall be repayable by 40 half-yearly instalments, each including principal and interest, by providing out of the Municipal Fund, such amounts on the 1st day of February and the 1st day of August in each respective year during the currency of the loan. The first instalment shall be repayable on the 1st day of August, 1958.

Such moneys shall be repayable at Melbourne at the National Bank of Australasia, or at the Council's bankers for the time being in Melbourne.

The purpose of which the loan is to be applied is:—

Road construction within the Shire .. .	£5,600
---	--------

The plans, specifications and estimate of cost of the works referred to above and a statement showing the proposed expenditure of money to be borrowed are open for inspection at the Shire Offices.

Dated this 6th day of November, 1957.

3027 J. PATTERSON, Shire Secretary.

SHIRE OF SHEPPARTON.

LOAN No. 39.

Notice of Intention to Borrow the Sum of £10,000 for Permanent Works and Undertakings.

NOTICE is hereby given that the Council of the Shire of Shepparton proposes to borrow the sum of Ten thousand pounds, on the credit of the municipal revenues of the President, Councillors, and Ratepayers of the said Shire, such sum to be raised by the issue of debentures, in accordance with the provisions of the Local Government Acts.

1. The maximum rate of interest that may be paid is £5 8s. 9d. per cent. per annum.

2. The purpose for which the loan is to be applied is the purchase of motor vehicles.

3. The period of the loan shall be seven years.

4. The moneys borrowed shall be repayable by providing out of the Municipal Fund fourteen half-yearly instalments of approximately £868 7s. 7d. each, including principal and interest, on the 1st day of February and the 1st day of August during the currency of the loan. The first instalment shall be payable on the 1st day of August, 1958.

5. Such moneys shall be repayable at the Commonwealth Trading Bank of Australia, Melbourne, or at the Council's bankers for the time being in Melbourne.

The specifications and the estimate of the cost of the proposed plant and a statement showing the proposed expenditure of the moneys to be borrowed are open for inspection at the Shire Office, Shepparton.

Dated this 18th day of October, 1957.

3028 K. LITTLE, Shire Secretary.

SHIRE OF SWAN HILL.

LOAN No. 18.

Notice of Intention to Borrow the Sum of Five Thousand Pounds (£5,000) for Permanent Works and Undertakings in the Shire of Swan Hill.

TAKE notice that the Council of the Shire of Swan Hill proposes to borrow on the credit of the President, Councillors and Ratepayers of the said shire, the sum of Five thousand pounds (£5,000), such sum to be raised by the issue of debentures, in accordance with the provisions of the Local Government Act.

The rate of interest to be paid shall not exceed £5 10s. per centum per annum.

Such money shall be repayable by 50 equal half-yearly instalments, each including principal and interest, by providing such amounts out of the Municipal Fund on the 1st day of March and the 1st day of September in each respective year during the currency of the loan.

Such moneys shall be repayable at Melbourne at the Commonwealth Trading Bank of Australia, or at the Council's bankers for the time being in Melbourne.

The purpose for which the loan is to be applied is for the erection of Shire Offices at Swan Hill.

The plans, specifications and estimate of the cost of the works referred to above, and a statement showing the proposed expenditure of moneys to be borrowed, are open for inspection at the Shire Offices, Swan Hill.

Dated this 12th day of November, 1957.

3044 F. B. WOMERSLEY, Shire Secretary.

SHIRE OF TALBOT.

NOTICE OF SPECIAL ORDER TO BORROW THE SUM OF £3,500.

PURSUANT to the provisions of section 583 of the Local Government Act the Council of the Shire of Talbot, by special order made on 7th October, 1957, and confirmed on 4th November, 1957, did resolve to borrow, by an issue of debentures, the sum of £3,500 for the installation of septic sewerage at Talbot.

1. The maximum rate of interest to be paid is 5½ per cent. per annum.

2. The period of the loan shall be ten years.

3. The money borrowed shall be repayable by half-yearly instalments, including the principal and interest on the 1st day of June and the 1st day of December in each year.

3019 F. W. GLARE, Shire Secretary.

I HENRY TONKIN, of 6 Barkers-road, Hawthorn, in the State of Victoria, company director, heretofore called and known by the names of Leib Tankowski, hereby give public notice that by deed poll dated the 23rd October, 1957, duly executed and attested and deposited with the Registrar-General of the said State on the 29th October, 1957, I formally and absolutely renounce and abandon the said names of Leib Tankowski and declare that I have assumed and adopted and intend thenceforth upon all occasions whatsoever to use and subscribe the names of Henry Tonkin instead of the said names of Leib Tankowski, and so as to be at all times thereafter called, known, and described by the said names of Henry Tonkin.

Dated this 6th day of November, 1957.

HENRY TONKIN.

Witness—J. POCHOJKA.

ALAN WAINWRIGHT & CO., solicitors, 390 Little Collins-street, Melbourne, MU 5626. 3082

I EDITH TONKIN, of 6 Barkers-road, Hawthorn, in the State of Victoria, married woman, heretofore called and known by the names of Edith Tankowski, hereby give public notice that by deed poll dated the 23rd October, 1957, duly executed and attested and deposited with the Registrar-General of the said State on the 29th October, 1957, I formally and absolutely renounce and abandon the said surname of Tankowski and declare that I have assumed and adopted and intend thenceforth upon all occasions whatsoever to use and subscribe the surname of Tonkin instead of the said surname of Tankowski, and so as to be at all times thereafter called, known, and described by the said surname of Tonkin.

Dated this 6th day of November, 1957.

EDITH TONKIN.

Witness—J. POCHOJKA.

ALAN WAINWRIGHT & CO., solicitors, 390 Little Collins-street, Melbourne, MU 5626. 3081

NOTICE OF INTENTION TO APPLY FOR A LICENCE TO DIVERT WATER AND CUT RACE FROM THE VALENCIA CREEK, AT VALENCIA CREEK.

I HEREBY give notice that I intend to apply for a licence empowering me to divert water for a term of fifteen years to the extent of 80 acre-feet per annum at a maximum rate of 6 acre-feet per day of 24 hours for the irrigation of 80 acres, being part of allotments 88, 89, and 90, Parish of Briagolong, and to occupy certain Crown lands for works of diversion, and to cut a race thereon.

Any objection to such application must be forwarded, in writing, to the State Rivers and Water Supply Commission, Melbourne, within 30 days of the date hereof.

WILFRED BURGERMEISTER. 3039

Valencia Creek.

NOTICE OF INTENTION TO APPLY FOR A LICENCE TO DIVERT WATER AND CUT RACE FROM THE RIVER MURRAY, AT COWANIE BEND.

I HEREBY give notice that I intend to apply for a licence empowering me to divert water for a term of fifteen years to the extent of 120 acre-feet per annum at a maximum rate of 2 acre-feet per day of 24 hours for irrigation of 25 acres, being part of allotment 11, section H, Parish of Merbein, and to occupy certain Crown lands for works of storage and diversion, and to cut a race thereon.

Any objection to such application must be forwarded, in writing, to the State Rivers and Water Supply Commission, Melbourne, within 30 days of the date hereof.

EDMUND HENDERSON ADAMS. 3032

Box 58, Merbein, 11th November, 1957.

NOTICE OF INTENTION TO APPLY FOR A LICENCE TO DIVERT WATER AND CUT RACE FROM THE EILDON RESERVOIR, AT WAPPAN, MAINDAMPLE.

WE hereby give notice that we intend to apply for a licence empowering us to divert water for a term of fifteen years to the extent of 100 acre-feet per annum at a maximum rate of 4 acre-feet per day of 24 hours for the irrigation of 100 acres, being part of Mulla Mullane P.R., allotments 39C, 25A, and 38, Parish of Wappan, and to occupy certain Crown lands for works of diversion, and to cut a race thereon.

Any objection to such application must be forwarded, in writing, to the State Rivers and Water Supply Commission, Melbourne, within 30 days of the date hereof.

TEHAN BROS. 3036

Wappan, Maindample.

No. 257.—10783/57.—3

Water Acts.

PROPOSED SHIRE OF NUMURKAH WATERWORKS TRUST.

NOTICE is hereby given that the Numurkah Shire Council has made application to the Honorable the Minister of Water Supply for the constitution of a Waterworks Trust, and for the proclamation of Waterworks Districts at Numurkah, Strathmerton, Wunghnu, and Katunga and a Rural District in the Parishes of Muntoona, Drumanure, and Katunga, and the construction, maintenance, and continuance of water supply works within that district under the provisions of the Water Acts.

General plans and descriptions of the proposed works have been submitted with the application, and copies of same may be seen at Shire Office, Numurkah.

Dated at Numurkah the 4th day of November, 1957.

J. W. REED, Secretary, Shire of Numurkah. 2933

NOTICE is hereby given that Australian National Industries Limited has applied for a lease under section 125 of the Land Acts, for a term of 35 years from 1st January, 1958, of allotments 14, 15, 16 and 17, section A, City of South Melbourne, Parish of Melbourne South, containing 1 acre 3 roods 28 7/10 perches, as a site for Offices, Showrooms, and Stores. 2861

NOTICE is hereby given that the partnership heretofore subsisting between John William Robinson, Archie Hinchliffe and John Arthur Hinchliffe, carrying on business as orchardists and poultry farmers at Tongala, in the State of Victoria, under the style or firm name of "Robinson and Hinchliffe" has been dissolved as at the 2nd day of September, 1957, and a new partnership has been entered into therefrom between Archie Hinchliffe and John Arthur Hinchliffe, who have carried on from the date aforesaid and will continue to carry on the business of orchardists and poultry farmers in partnership at Tongala, aforesaid, under the style or firm name of "A. and J. A. Hinchliffe," and notice is also given that all debts due to and owing by the said late firm will be received and paid respectively by the said Archie Hinchliffe and John Arthur Hinchliffe.

Dated the 1st day of November, 1957.

A. HINCHLIFFE.
J. A. HINCHLIFFE.

(J. A. Hinchliffe sole surviving executor of the will of John William Robinson, deceased.)

James F. Brady, solicitor, 171 Hare-street, Echuca. 3040

NOTICE OF DISSOLUTION OF PARTNERSHIP.

NOTICE is hereby given that the partnership heretofore subsisting between the undersigned Alexander Crombie Matthew Craig and Patrick Aubrey Moloney, carrying on the business of wool and skin buyers at King-street, Koroit, under the firm name of "A. C. Craig and Co.," has been dissolved by mutual consent as from the 11th day of October, 1957. All debts due to or owing by the said late firm will be received and paid by the said Alexander Crombie Matthew Craig, who will continue to carry on the said business under the same name, at the same place.

Dated at Koroit, the 31st day of October, 1957.

A. C. M. CRAIG.
P. A. MOLONEY.

Witness—C. A. LEISHMAN.

Conlan and Leishman, solicitors, 38 Bank-street, Port Fairy. 3038

NOTICE OF DISSOLUTION OF PARTNERSHIP.

NOTICE is hereby given that the partnership heretofore subsisting between the undersigned Albert George Hanson and Ivor Anglessey Jones, carrying on business as hotel brokers, licensed real estate and business agents, business managers and insurance agents at The Block, Collins-street, Melbourne, under the name of Hanson, Jones & Co., has been dissolved by mutual consent, as from the 16th day of November, 1957.

Dated at Melbourne the 16th day of November, 1957.

A. G. HANSON.
IVOR JONES.

Witness—AMBROSE V. MCCARTHY. 3060

NOTICE is hereby given that the partnership heretofore subsisting between the undersigned John William Hugh Merry and Arnold Revell Silcock, carrying on business as surgeons and general medical practitioners, at 258 Dorset-road, Boronia, has been dissolved by mutual consent, as from the 28th day of October, 1957, when the said John William Hugh Merry retired from the said partnership. All debts due to and owing by the said late firm will be received and paid by the said Arnold Revell Silcock, who will continue to carry on the said business in partnership with Sydney James Rumbold at the same place.

J. MERRY.
A. R. SILCOCK.

Russell, Kennedy and Cook, 401 Collins-street, Melbourne, solicitors for the said John William Hugh Merry.
Abbott, Stillman and Wilson, 422 Little Collins-street, Melbourne, solicitors for the said Arnold Revell Silcock.

3034

NOTICE OF DISSOLUTION.

NOTICE is hereby given that the partnership heretofore subsisting between Lionel Jesse Kinsella, David Klein, and Maurice Klein, carrying on at 11 Lonsdale-street, Melbourne, the business of plumbers, under the firm name of "Penry & Co.," has been dissolved by mutual consent as from the 31st day of October, 1957. The said business will be carried on by the said Lionel Jesse Kinsella at the same address, and all debts due and owing by the said partnership will be received and paid by him.

Dated the 13th day of November, 1957.

L. J. KINSELLA.
DAVID KLEIN.
MAURICE KLEIN
(by his attorney, D. Klein).

3080

NOTICE OF DISSOLUTION.

NOTICE is hereby given that the partnership heretofore subsisting between William Ashcroft, of Moama Motel, Nepean Highway, Frankston, manufacturer, and Brian Ernest Kay, of 59 Napier-street, Footscray, manufacturer, carrying on business as battery manufacturers and repairs at 26 Kelso-street, Frankston, under the firm name of "Peninsula Battery Service," has been dissolved by mutual consent as from the 1st day of July, 1957. All debts due and owing by the said firm will be received and paid by the said William Ashcroft, who will continue to carry on the said business under the said firm name and at the same address.

Dated this 8th day of November, 1957.

BRIAN ERNEST KAY.
W. ASHCROFT.

Maxwell A. White, solicitor, 94 Young-street, Frankston.

3074

Companies Act 1938.—In the matter of L. & M. NEWMAN PTY. LTD.—Notice of Appointment of Provisional Liquidator.

TAKE notice that on the 15th day of November, 1957, His Honour Mr. Justice Pape appointed John Kenneth Hall an official liquidator of the Supreme Court of Victoria as provisional liquidator of the above-named company, and that in such Order it was directed that notice of the Order be published within five days thereof.

Dated at Melbourne this 19th day of November, 1957.

JOHN KENNETH HALL, Provisional Liquidator.

Hall and Rose, chartered accountants (Aust.), 390 Little Collins-street, Melbourne.

3087

No. of company—34284. Form No. 40.

Companies Act 1938.

RE-CON CAR SALES PROPRIETARY LIMITED.

COPY RESOLUTION, PURSUANT TO SECTION 118.

AT a General Meeting of members of Re-Con Car Sales Proprietary Limited, duly convened and held at 578 Bourke-street, Melbourne, on the 15th day of November, 1957, the following Extraordinary Resolution was duly passed:—

"That the company be wound up voluntarily, and that Keith Walter Ferguson, of 37 Berrima-avenue, East Malvern, accountant, be appointed liquidator for the purposes of such winding up."

Dated this 15th day of November, 1957.

3086

F. STOREY, Director.

Companies Act 1938.

KEAM CREATIONS PTY. LTD. (IN VOLUNTARY LIQUIDATION).—Formerly of 52 Flinders-lane, Melbourne.

NOTICE OF CREDITORS OF INTENTION TO DECLARE DIVIDEND.

A FIFTH and Final Dividend is intended to be declared in the above matter. Creditors who have not proved their debt by 29th day of November, 1957, will be excluded. The date of liquidation was the 24th day of November, 1954.

Dated this 14th day of November, 1957.

LEWIS LUCKINS, Liquidator.

Lewis Luckins and Co., chartered accountants (Aust.), 41 Grandview-grove, Prahran, S.1.

3078

The *Companies Act 1938.*—In the matter of C. WARNS PROPRIETARY LIMITED (in Voluntary Liquidation).

NOTICE is hereby given that, pursuant to section 245 of the Companies Act, a Final Meeting of the creditors of the above company will be held at the offices of Kennedy, Small, and Middlemiss, 31 Queen-street, Melbourne, on Wednesday, the 11th day of December, 1957, at Ten a.m.

Business: To receive the liquidator's accounts.

Dated this 20th day of November, 1957.

E. R. SMALL, Liquidator.

Kennedy, Small, and Middlemiss, solicitors, 31 Queen-street, Melbourne.

3079

Companies Act 1938.

WOODSIDE (LAKES ENTRANCE) OIL CO.
NO LIABILITY.

NOTICE OF CHANGE IN SITUATION OF REGISTERED OFFICE OF A MINING COMPANY, PURSUANT TO SECTION 410 (3).

WOODSIDE (LAKES ENTRANCE) OIL COMPANY NO LIABILITY hereby gives notice that on the 11th day of November, 1957, the situation of the registered office of the company was changed to, and is now at 792 Elizabeth-street, Melbourne.

Dated this 14th day of November, 1957.

By order of the Board,

3042

REES B. WITHERS, Legal Manager.

NOTICE is hereby given that the Final General Meeting of Geelong Machinery Company Proprietary Limited (in Liquidation) will be held at 11 a.m. on the 20th December, 1957, at 50 Glenferrie-road, Malvern, to receive the final accounts of the liquidator.

3041

D. MCK. STEVENSON, Liquidator.

In the matter of KEITH J. ROBINSON PROPRIETARY LIMITED (In Liquidation).

NOTICE is hereby given, pursuant to section 236 of the *Companies Act 1938*, that a General Meeting of the members of the above-named company will be held at the offices of Best, Hooper, Rintoul, and Shallard, 100 Queen-street, Melbourne, on the 23rd day of December, 1957, at Twelve o'clock noon, for the purpose of having an account laid before the company showing the manner in which the winding up has been conducted and the property of the company disposed of, and of hearing any explanation thereof that may be given by the liquidator.

Dated the 19th day of November, 1957.

3066

KEITH J. ROBINSON, Liquidator.

Companies Act 1938.

THE LITHUANIAN CLUB IN MELBOURNE.

NOTICE OF INTENTION TO APPLY TO ATTORNEY-GENERAL FOR LICENCE, PURSUANT TO SECTION 18 (1).

THE LITHUANIAN CLUB IN MELBOURNE, being an association about to be formed for the purposes of charity and amusement and the promoting and fostering of a spirit of loyalty to Australia and to cultivate good relations between the Lithuanian migrants and the general public and the preservation and promotion of the customs and heritage of the Lithuanian nation, hereby gives notice of intention to apply to the Attorney-General for a licence directing that the said association be registered as a company with limited liability without the addition of the word "Limited" to its name.

Dated this 14th day of November, 1957.

3059

ALGIS KABAILA, Director.

Companies Act 1938.

RE SAYNOR & BAYLEY PTY. LTD. (IN VOLUNTARY LIQUIDATION).

MEMBERS' VOLUNTARY WINDING UP.

Final Meeting.

A GENERAL Meeting of the company will be held at 418 Centre-road, Bentleigh, at 8 p.m. on Friday, 20th December, 1957.

Object: Laying before the meeting the account of the liquidator and giving any explanation thereof.

Dated this 19th day of November, 1957.

THOMAS L. PHELAN, Liquidator.

418 Centre-road, Bentleigh. 3055

LATROBE VALLEY HOTEL PTY. LTD. (IN VOLUNTARY LIQUIDATION).

NOTICE is hereby given under section 236 of the Companies Act, that a General Meeting of the above company will be held at its registered office, 403 Bourke-street, Melbourne, at 10.30 a.m. on Monday, 23rd December, 1957.

3054 BRYAN HOY, Liquidator.

ERNEST ALBERT HILL, late of Cobains, via Sale, farmer (who died 7th May, 1957).

CREDITORS, next of kin, and all other persons having claims against the estate of the deceased, are required by the executor of the will, George Charles Hill, of Cobains, via Sale, farmer, to send particulars to him, care of the undersigned, on or before 31st January, 1958, after which date he will distribute the assets, having regard only to the claims of which he then has notice.

R. M. ROLLAND, solicitor, 57c Raymond-street, Sale. 3048

ROBERT LAMB, late of York-street, Sale, grazier (who died 24th June, 1957).

CREDITORS, next of kin, and all other persons having claims against the estate of the deceased, are required by the executors of the will, Robert Norman Lamb, of Barkly-street, Sale, grazier, and Barbara Muriel Aveline Traill, of Fulham, married woman, to send particulars to them, care of the undersigned, on or before 31st January, 1958, after which date they will distribute the assets, having regard only to the claims of which they then have notice.

R. M. ROLLAND, solicitor, 57c Raymond-street, Sale. 3049

HUBERT ALFRED ROBINSON, late of Dutton, grazier (who died on 8th April, 1957).

CREDITORS, next of kin, and all other persons having claims against the estate of the deceased, are required by the executrices of the will, Mary Isobel Kelly, of 1182 Nepean Highway, Cheltenham, married woman, and Roma May Mathieson, of 55 Comer-street, East Brighton, stenographer, to send particulars to them, care of the undersigned, on or before 31st January, 1958, after which date they will distribute the assets, having regard only to the claims of which they then have notice.

R. M. ROLLAND, solicitor, 57c Raymond-street, Sale. 3047

JOHN ROBERT HUSTON, late of 50 Cook-road, Centennial Park, Sydney, in the State of New South Wales, foreman, DECEASED, intestate.

CREDITORS, next of kin, and others having claims in respect of the estate of the deceased (who died on the 25th day of December, 1956), are required by the Fidelity Trustee Company Limited, of 101 Lydiard-street north, Ballarat, to send particulars to the company by the 18th day of February, 1958, after which date the company may convey or distribute the assets, having regard only to the claims of which the company then has notice.

Dated the 18th day of November, 1957.

EUGENE M. ALLMAN, solicitor, 49 Raymond-street, Sale. 3046

DAVID RINDER, late of Swan Hill, in the State of Victoria, retired pensioner, DECEASED.

CREDITORS, next of kin, and other persons having claims against the estate of the deceased are required to send particulars of same to the executor, Edward Francis Day, in care of the undersigned, on or before the 30th January, 1958, after which date he will distribute the assets, having regard only to the claims of which he then has notice.

GERALD E. DELANY & CO., solicitors, 63 Campbell-street, Swan Hill. 3065

ROBERT SMITH, late of Newham, retired farmer, DECEASED.

CREDITORS, next of kin, and others having claims in respect of the estate of the deceased (who died on the 26th day of February, 1957), are required by the personal representative, Julia Florence Muir, of S.S. 1004, Hasket, married woman, to send particulars to her, at the office of H. Hurry and Son, at Kyneton, by the 31st day of January, 1958, after which date the personal representative may convey or distribute the assets, having regard only to the claims of which she then has notice.

H. HURRY & SON, solicitors, Kyneton, and at Wood-end and Gisborne. 3045

JOHN ADRIAN MANSON, late of Woorinen, in the State of Victoria, orchardist, DECEASED (who died on the 26th day of April, 1957).

CREDITORS, next of kin, and all other persons having claims against the estate of the deceased are required by the executrix of the will, Ada Margaret Manson, of Woorinen aforesaid, widow, to send particulars to her, care of the undersigned, on or before the 11th day of February, 1958, after which date she will distribute the assets, having regard only to the claims of which she then has notice.

Dated the 11th day of November, 1957.

GARDEN & GREEN, solicitors, McCallum-street, Swan Hill. 3037

JOHN HENRY RUDGE, late of 10 Ashted-road, Box Hill, gentleman, DECEASED.

CREDITORS, next of kin, and others having claims in respect of the estate of the deceased (who died on 22nd August, 1957), are required by the personal representative, The Equity Trustees, Executors, and Agency Company Limited, whose registered office is situate at 472 Bourke-street, Melbourne, to send particulars to it by the 31st January, 1958, after which date the personal representative may convey or distribute the assets, having regard only to the claims of which it then has notice.

Dated 12th November, 1957.

LEACH & THOMSON, solicitors, 472 Bourke-street, Melbourne. 3061

JOSEPH GORDON KEENAN, late of 40 Albert-street, Warragul, postal employee, DECEASED.

CREDITORS, next of kin, and others having claims in respect of the estate of the deceased (who died on the 7th day of April, 1957), are required by the executor, Gordon Victor Keenan, of 40 Albert-street, Warragul, retired farmer, to send particulars to him, care of the undersigned solicitors, by the 20th day of January, 1958, after which date the executor may convey or distribute the assets, having regard only to the claims of which he then has notice.

GRAY, FRIEND, & LONG, solicitors, Warragul. 3026

ALBERT EDWARD KING, late of Sea Lake, in the State of Victoria, farmer, DECEASED.

CREDITORS, next of kin, and other persons having claims against the estate of the deceased are required to send particulars of same to the executor, Albert King, in care of the undersigned, on or before the 30th January, 1958, after which date he will distribute the assets, having regard only to the claims of which he then has notice.

GERALD E. DELANY & CO., solicitors, 63 Campbell-street, Swan Hill. 3064

EDWIN JOHN VIVIAN, late of Hopetoun, in the State of Victoria, retired farmer, DECEASED.

CREDITORS, next of kin, and others having claims in respect of the estate of the deceased (who died on the 30th day of December, 1956), are required by the executors, John Findlay Edelman, of Hopetoun aforesaid, and Leslie William Brown, of Cambacanya, via Hopetoun, both farmers, to send particulars to them, in care of the under-mentioned solicitors, by the 15th day of February, 1958, after which date the said executors may convey or distribute the assets, having regard only to the claims of which they then have notice.

Dated the 12th day of November, 1957.

COMMONS & ENTWISLE, solicitors, of Toole-street, Hopetoun, Victoria. 3063

MATHILDE RUTH KENNEDY, formerly of Benalla, but now of 8 Mirams-street, Ascot Vale, widow, and Antony William Kennedy, formerly of Benalla, but now of 1 Sylvester-street, Redcliffe, Queensland, clerk, the executors of the will of Leo Vincent Kennedy, formerly of 221 Bridge-street, Benalla, but late of Kathryn-street, Benalla, in the State of Victoria, public accountant, deceased (who died on the 29th day of April, 1955), require all creditors, next of kin, and others having claims against the property or estate of the said deceased to send particulars, in writing, of such claims to Hamilton, Clarke, and Clarke, 55 Nunn-street, Benalla, on or before the 9th day of February, 1958, after which date the said executors intend to convey or distribute such property or estate to or among the persons entitled thereto, having regard only to the claims of which they shall then have had notice.

Dated this 10th day of November, 1957.

HAMILTON, CLARKE, & CLARKE, 55 Nunn-street, Benalla, proctors for the said executors. 3033

CREDITORS, next of kin, and others having claims in respect of the estate of Walter Cotton, late of 432 Flinders-street, Melbourne, in the State of Victoria, boot salesman, deceased (who died on the 23rd day of August, 1957, and probate of whose will (dated 16th day of January, 1953) was granted to The Equity Trustees, Executors, and Agency Company Limited, of 472 Bourke-street, Melbourne aforesaid, on the 29th day of October, 1957), are hereby requested to send particulars of such claims to the said company, at its address, on or before the 1st day of February, 1958, after which date the said company will proceed to distribute the assets of the said deceased amongst the persons entitled thereto, having regard only to the claims of which it shall then have had notice.

Dated this 14th day of November, 1957.

D. BRUCE TUNNOCK & CLARKE, 452 Lonsdale-street, Melbourne, solicitors for the executor. 3058

CREDITORS, next of kin, and others having claims in respect of the estate of Harold Lascelles Carless, formerly of 121 Victoria-street, Flemington, in the State of Victoria, but late of 20 Shaftesbury-street, Essendon, in the said State, furniture manufacturer, deceased (who died on the 13th day of May, 1957), and probate of whose will was granted by the Supreme Court of Victoria, on the 5th day of August, 1957, to the Fidelity Trustee Company Limited (formerly The Ballarat Trustees, Executors, and Agency Company Limited), whose registered office is situate at 101 Lydiard-street north, Ballarat, in the said State, are to send particulars of their claims to Allan Moore, LL.B., of 272 Bourke-street, Melbourne, in the said State, solicitor for the executor, by the 6th day of February, 1958, after which date the executor will distribute the assets, having regard only to the claims of which he then has notice.

ALLAN MOORE, LL.B., solicitor, 272 Bourke-street, Melbourne. 3057

HILDA JESSIE BURNSIDE, late of 15 Withers-street, Sunshine, married woman, DECEASED.

CREDITORS, next of kin, and others having claims in respect of the estate of the above-named deceased (who died on the 3rd May, 1957), are required by the executrix, Dorothy Florence Batties, of 6 Taunton-street, Sunshine, married woman, to send particulars to her by the 15th day of February, 1958, after which date she may convey or distribute the assets, having regard only to the claims of which she then has notice.

JOHN GINNANE, solicitor, 153a Barkly-street, Footscray. 3056

CREDITORS, next of kin, and others having claims in respect of the estate of Robert Webb, late of Narre Warren, in the State of Victoria, retired orchardist, deceased (who died on the 30th day of August, 1957), are required by the executors, Percy John Webb, of Woorinyan Culcairn, in the State of New South Wales, grazier, and Ralph Hart Moran, of Pound-road, Narre Warren, in the State of Victoria, farmer, to send particulars of their claims to them, care of Rogers and Gaylard, solicitors, of 281 Collins-street, Melbourne, by the 29th day of January, 1958, after which date the said executors will distribute the assets of the deceased, having regard only to the claims of which they then shall have had notice.

ROGERS & GAYLARD, solicitors, 281 Collins-street, Melbourne. 3070

CREDITORS, next of kin, and others having claims in respect of the estate of Florence Meta White, late of 9 Tennyson-street, St. Kilda, widow, deceased (who died on 9th day of September, 1957), are to send particulars of their claims to the Trustees, Executors, and Agency Company Limited, of 401 Collins-street, Melbourne, by the 25th day of January, 1958, after which date it will distribute the assets, having regard only to the claims of which it then has notice.

JOHN D. MUSTOW, solicitor, 89 Queen-street, Melbourne. 3071

CREDITORS, next of kin, and others having claims in respect of the estate of the late Elizabeth Catherine Calder, late of 12 Kerford-road, Albert Park, in the State of Victoria, spinster, deceased (who died on the 7th day of September, 1957), are to send particulars of their claims to the executor, The Equity Trustees, Executors, and Agency Company Limited, of 472 Bourke-street, Melbourne, by the 31st day of January, 1958, after which date it will distribute the assets having regard only to the claims of which it then has notice.

K. P. REES, B.A., LL.B., solicitor, 314 Collins-street, Melbourne, C.I. 3072

CREDITORS, next of kin, and others having claims against the estate of Max Bernard Beddard, late of 99 Evans-street, Port Melbourne, meat worker, deceased (who died on the 2nd day of March, 1957), are to send particulars of their claims to Frank Beddard, care of J. P. Brent & Stephens, solicitors, 375 Collins-street, Melbourne, in the State of Victoria, by the 31st January, 1958, after which date he will distribute the assets, having regard only to the claims of which he then has notice.

J. P. BRENT & STEPHENS, solicitors, 375 Collins-street, Melbourne. 3073

CREDITORS, next of kin, and others having claims in respect of the estate of Julian Scott Jeffries, late of 7 Warwick-avenue, Surrey Hills, in the State of Victoria, analyst, deceased (who died on the 2nd day of January, 1957), and probate of whose will was granted by the Supreme Court of Victoria, on the 26th July, 1957, to The Perpetual Executors and Trustees Association of Australia Limited, of 100-104 Queen-street, Melbourne, the executor named in the said will, are to send the particulars of their claims to The Perpetual Executors and Trustees Association of Australia Limited, of 100-104 Queen-street, Melbourne, by the 31st day of January, 1958, after which date it will distribute the assets, having regard only to the claims of which it then has notice.

Dated the 18th day of November, 1957.

HODGSON & FINLAYSON, 360 Collins-street, Melbourne, solicitors for the executor. 3075

CREDITORS, next of kin, and others having claims against the estate of Ernest Alfred Cecil North, late of 29 Sunnyside-avenue, Camberwell, gentleman, deceased (who died on the 9th September, 1957), are to send particulars of their claims to The Equity Trustees, Executors, and Agency Company Limited, the registered office of which is situate at 472 Bourke-street, Melbourne, in the State of Victoria, by the 22nd January, 1958, after which date it will distribute the assets, having regard only to the claims of which it then has notice.

BLAKE & RIGGALL, solicitors, 120 William-street, Melbourne. 3076

CREDITORS, next of kin, and others having claims against the estate of Alexander Carl Welsh, late of "Innisfail" 7 Leonard-street, Hay, in New South Wales, librarian, deceased (who died on 25th February, 1957), are to send particulars of their claims to The Union Trustee Company of Australia Limited, the registered office of which is situate at 333 Collins-street, Melbourne, in the State of Victoria, by the 22nd January, 1958, after which date it will distribute the assets having regard only to the claims of which it then has notice.

BLAKE & RIGGALL, solicitors, 120 William-street, Melbourne. 3077

CREDITORS, next of kin, and others having claims in respect of the estate of James Arthur Berwick, late of 133 Westbury-street, East St. Kilda, gentleman, deceased (who died on 3rd August, 1957), are to send the particulars of their claims to The Trustees Executors and Agency Company Limited, of 401 Collins-street, Melbourne, by the 25th January, 1958, after which date it will distribute the assets, having regard only to the claims of which it then has notice.

SNOWDEN, NEAVE, & DEMAINE, solicitors. 3083

CREDITORS, next of kin, and all others having claims in respect of the estate of Joseph Carl Fackler, formerly of 103 Drummond-street, Carlton, but late of 20 Dominic-street, Camberwell, in the State of Victoria, gentleman, deceased (who died on the 14th day of August, 1957), are required to send particulars of their claims to Carl Joseph Fackler, of 20 Dominic-street, Camberwell, gentleman, and Mary Frances Tiernan, solicitor, of 480 Bourke-street, Melbourne, the executors appointed by the said deceased's will, care of the undersigned, by the 27th day of January, 1958 (not the 16th day of November, 1958, as previously advertised), after which date they will distribute the assets, having regard only to the claims of which they shall then have had notice.

J. M. SMITH & EMMERTON, solicitors, 480 Bourke-street, Melbourne. 3084

CREDITORS, next of kin, and others having claims in respect of the estate of Grace Genevieve Callanan, late of 400 Dryburgh-street, North Melbourne, spinster, deceased (who died on the 30th day of August, 1957), are to send particulars of their claims to the executor, National Trustees, Executors, and Agency Company of Australasia Limited, of 95 Queen-street, Melbourne, and Lillie Gellie, care of the said company, by the 23rd day of January, 1958, after which date the said company will distribute the assets, having regard only to the claims of which it shall then have had notice.

M. MORNANE, solicitor, 95 Queen-street, Melbourne. 3085

Trustee Act 1928.

NOTICE TO CLAIMANTS.

PURSUANT to the *Trustee Act 1928*, creditors, next of kin, and all other persons having claims in respect of the deceased person named below are required to send particulars of such claims to the legal personal representatives at the address stated, on or before the date stated, after which date the representatives will distribute the assets, having regard only to the claims of which notice has been received:—

Joseph Finch, late of 69 Dover-road, Williamstown, retired painter, deceased, died 25th August, 1957.—Claims to the executor, Andrew James Finch, of 152 Cecil-street, Williamstown, painter, care of John F. Carroll, solicitor, 4 Paisley-street, Footscray, by the 23rd January, 1958. John F. Carroll, LL.B., solicitor, 4 Paisley-street, Footscray. 3062

Sydney Benjamin Sharrock, late of Port Fairy, retired grazier, deceased.—Claims to the trustees, Annie Myrtle Sharrock and Gordon Thomas Watt, care of J. W. Powling, solicitor, Port Fairy, by the 30th day of January, 1958. 3035

John Rea, late of Yarpturk, farmer, deceased, intestate, died 15th July, 1957.—Claims to the administrator, Patrick Rea, of High-street, Koroit, factory employee, care of Conlan and Leishman, solicitors, 38 Bank-street, Port Fairy, by the 25th January, 1958. Conlan and Leishman, solicitors, 38 Bank-street, Port Fairy. 3069

IMPOUNDINGS

DANDENONG.—Impounded in Dandenong Pound, by T. Carroll, from Kidds-road, Dandenong.

1 black bull, no visible brand

Impounded off Brighton-road.

1 black heifer, no visible brand

If not claimed and expenses paid, to be sold on 3rd December, 1957.

3089—13/6 A. WALKER, Poundkeeper.

KEILOR.—Impounded in Keilor Pound.

1 cream pony gelding, no visible brand

If not claimed and expenses paid, to be sold on 5th December, 1957.

3090—9/ D. PASCOE, Poundkeeper.

MELBOURNE.—Impounded in Arden-street Pound, by Senior Constable A. E. Thompson.

1 sheep (ewe), marked with a circle enclosing the letter K
If not claimed and expenses paid, to be sold on 5th December, 1957.

3088—10/6 R. HAMILTON, Poundkeeper.

TONGALA.—Impounded in Tongala Pound.

1 roan bull, no visible brand
1 yellow Jersey steer, no visible brand

If not claimed and expenses paid, to be sold on 9th December, 1957.

3091—10/6 B. PEARL, Poundkeeper.

STATE ACTS, 1954

COPIES of the following Acts of Parliament of Victoria may be obtained at the Government Printing Office, or from any bookseller, at the price set opposite to each:—

No.	Price.
	s. d.
5773. Coal Mine Workers Pensions (Amendment) ..	0 6
5774. Police Offences (Unlawful Games) ..	0 6
5775. Local Government (City of Sunshine) ..	0 6
5776. State Savings Bank (Deposits) ..	0 6
5777. Chandler Highway and Bridge ..	0 6
5778. Town and Country Planning ..	1 0
5779. Police Offences (Obscene Publications) ..	0 9
5780. Health (Infectious Diseases) ..	0 6
5781. Melbourne Cricket Ground (Guarantee) ..	0 6
5782. Superannuation (Female Officers) ..	0 6
5783. Crimes ..	0 6
5784. Melbourne and Metropolitan Tramways (Board) ..	0 9
5785. Consolidated Revenue ..	0 6
5786. Consolidated Revenue ..	0 6
5787. Consolidated Revenue ..	0 6
5788. Auditor-General's Salary ..	0 6
5789. Corneal Grafting ..	0 6
5790. Totalizator (Amendment) ..	0 6
5791. Country Roads and Level Crossings Funds ..	0 6
5792. Entertainments Tax (Amendment) ..	0 6
5793. Finance (Racing) ..	1 0
5794. Bellarine Water Supply ..	0 6
5795. Melbourne and Metropolitan Board of Works (Amendment) ..	0 6
5796. Apprenticeship (Amendment) ..	0 6
5797. Judges (Powers) ..	0 6
5798. Goods (Amendment) ..	0 6
5799. Police Offences (Female Offenders) ..	0 6
5800. Friendly Societies (Amendment) ..	0 6
5801. Portland Harbor Trust (Amendment) ..	0 6
5802. Public Service (Amendment) ..	0 6
5803. Geelong and District Cultural Institute ..	0 9
5804. Vermin and Noxious Weeds (Amendment) ..	0 9
5805. Surplus Revenue ..	0 6
5806. Gas Regulation (Amendment) ..	0 9
5807. Parking of Vehicles (Amendment) ..	0 6
5808. Parliamentary Salaries and Allowances ..	0 9
5809. County Court (Judges) ..	0 6
5810. Swan Hill Lands Exchange ..	0 6
5811. Miners' Phthisis (Treasury Allowances) Amendment ..	0 6
5812. Gas and Fuel Corporation (Kyneton Undertaking) ..	0 9
5813. Dog Races ..	1 3
5814. Infectious Diseases Hospitals ..	1 0
5815. Public Officers Salaries ..	0 6
5816. Wheat Industry Stabilization ..	1 3
5817. Children's Welfare ..	2 0
5818. Consolidated Revenue ..	0 6
5819. Mental Hygiene (Maintenance) ..	0 6
5820. Parliamentary Contributory Retirement Fund ..	0 6
5821. Water Supply Loan Application ..	1 0
5822. Napier-street Bridge ..	0 9
5823. Health (Amendment) ..	1 6
5824. Forests (Amendment) ..	0 9
5825. Co-operative Housing Societies (Guarantees) ..	0 6
5826. Midwives (Amendment) ..	0 6
5827. State Electricity Commission (Borrowing) ..	0 6
5828. Justices (Amendment) ..	0 6
5829. Fire Brigades (Amendment) ..	0 9
5830. Mildura College Lands (Amendment) ..	0 6
5831. Country Roads (Amendment) ..	0 6
5832. Soldier Settlement (Financial) ..	0 6
5833. River Murray Waters ..	0 9
5834. Town and Country Planning (Metropolitan Area) ..	1 0
5835. Housing ..	0 9
5836. Gas and Fuel Corporation (Mornington Undertaking) ..	0 9

STATE ACTS, 1954—continued.

No.	Price. s. d.
5837. Railways (Commissioners' Salaries) ..	0 6
5838. Water ..	0 9
5839. State Forests Loan Application ..	0 6
5840. Railway Loan Application ..	1 3
5841. Police Offences (Sports Grounds) ..	0 6
5842. Transfer of Land ..	3 9
5843. Local Government (Amendment) ..	1 9
5844. Land Tax ..	0 6
5845. Water (Connexions to Mains) ..	0 6
5846. Statutes Amendment ..	0 9
5847. Landlord and Tenant ..	1 0
5848. Transport Regulation (Amendment) ..	0 6
5849. Judges Salaries ..	0 6
5850. Public Works Loan Application ..	0 6
5851. Adoption of Children (Amendment) ..	0 6
5852. Hide and Leather Industries (Suspension) ..	0 6
5853. Appropriation of Revenue ..	4 0

W. M. HOUSTON,
Government Printer.

STATE ACTS, 1955

COPIES of the following Acts of Parliament of Victoria may be obtained at the Government Printing Office, or from any bookseller, at the price set opposite to each:—

No.	Price. s. d.
5854. Consolidated Revenue ..	0 6
5855. Statute Law Revision Committee (Amendment) ..	0 6
5856. Consolidated Revenue ..	0 6
5857. Auditor-General's Salary ..	0 6
5858. Consolidated Revenue ..	0 6
5859. Hide and Leather Industries (Repeal) ..	0 6
5860. Teaching Service (Amendment) ..	0 6
5861. Maintenance (Enforcement of Orders) ..	0 6
5862. Companies (Names) ..	0 6
5863. Legal Profession Practice (Amendment) ..	0 9
5864. Newport "A" Power Station ..	0 6
5865. Adoption of Children ..	0 6
5866. Geelong Waterworks and Sewerage (Amendment) ..	0 6
5867. Parliamentary Elections (State Servants) Amendment ..	0 6
5868. Firearms (Olympic Games) ..	0 6
5869. Justices (Amendment) ..	0 9
5870. Country Fire Authority (Financial) ..	0 6
5871. Supreme Court and County Court (Judges) ..	0 6
5872. Railway Deviations ..	0 9
5873. State Savings Bank (Amendment) ..	0 6
5874. Crown Proceedings ..	0 6
5875. Gas and Fuel Corporation (Financial) ..	0 6
5876. Children's Welfare (Amendment) ..	0 6
5877. Evidence (Amendment) ..	0 9
5878. Land Tax (Exemptions and Rates) ..	0 6
5879. Health (Offensive Trades) ..	0 6
5880. Dietitians Registration (Amendment) ..	0 6
5881. Medical (Pharmacy Board Fees) ..	0 6
5882. Benefit Associations (Amendment) ..	0 6
5883. Surplus Revenue ..	0 6
5884. Landlord and Tenant (Amendment) ..	1 3
5885. Police Offences (Valueless Cheques) ..	0 6
5886. Dairy Produce (Cheese) ..	0 6
5887. Coal Mine Workers Pensions (Amendment) ..	0 6
5888. Parking of Vehicles (Amendment) ..	0 6
5889. Public Service (Amendment) ..	0 6
5890. Police Regulation (Junior Trainees) ..	0 6
5891. Wonthaggi Railway Land ..	0 6
5892. Licensing ..	0 9
5893. Stock Medicines (Amendment) ..	0 6
5894. Marine (Temporary Exemptions) ..	0 6
5895. Administration and Probate (Estates) ..	0 9
5896. Statute Law Revision ..	0 9
5897. Police Regulation (Pensions) ..	0 6
5898. Bailiffs ..	0 6
5899. Housing ..	1 0
5900. Soldier Settlement (Amendment) ..	0 9
5901. Old Colonists' Association ..	0 6
5902. Supreme Court (Officers) ..	0 6
5903. Co-operative Housing Societies (Amendment) ..	0 6
5904. Dog Races ..	0 6
5905. Olympic Games ..	0 6
5906. Water Supply Loan Application ..	1 0
5907. Friendly Societies (Amendment) ..	0 6
5908. Licensing (Amendment) ..	1 0
5909. Revocation and Excision of Crown Reservations ..	1 3
5910. Forests (Amendment) ..	0 6
5911. Superannuation ..	1 3
5912. Fisheries (Proclamation) ..	0 6

STATE ACTS, 1955—continued.

No.	Price. s. d.
5913. Melbourne Market and Park Lands ..	0 6
5914. Limitation of Actions ..	1 9
5915. Motor Car (Amendment) ..	0 9
5916. Milk Board (Amendment) ..	0 6
5917. Crimes (Amendment) ..	0 9
5918. Railways (Amendment) ..	0 9
5919. Labour and Industry (Long Service Leave) ..	0 6
5920. Home Finance ..	0 6
5921. Public Works Loan Application ..	0 6
5922. State Forests Loan Application ..	0 6
5923. Mental Hygiene (Amendment) ..	0 9
5924. Local Government (Amendment) ..	0 9
5925. Mines (Petroleum) ..	1 0
5926. Geelong Market Site ..	0 6
5927. Railway Loan Application ..	1 3
5928. Lang Lang Land ..	0 6
5929. Geelong Harbor Trust (Amendment) ..	0 6
5930. Transport Regulation ..	1 9
5931. Commercial Goods Vehicles ..	1 6
5932. Motor Car (Road Safety) ..	0 6
5933. Public Officers Salaries ..	0 6
5934. Property Law and Transfer of Land ..	0 9
5935. Companies ..	1 6
5936. Crimes (Driving Offences) ..	0 9
5937. Labour and Industry (Shops) ..	0 9
5938. Mines (Uranium and Thorium) ..	0 9
5939. Railways Dismantling ..	0 9
5940. Appropriation of Revenue ..	4 3

W. M. HOUSTON,
Government Printer.

STATE ACTS, 1956

COPIES of the following Acts of Parliament of Victoria may be obtained at the Government Printing Office, or from any bookseller, at the price set opposite to each:—

No.	Price. s. d.
5941. Limitation of Actions (Extension) ..	0 6
5942. Serviceton Public Hall ..	0 6
5943. Keilor (Unimproved Rating Poll) ..	0 6
5944. Portland Harbor Trust (Land) ..	0 6
5945. Motor Car (Third-Party Insurance) ..	0 6
5946. Local Government (Broadmeadows) ..	0 6
5947. Melbourne Harbor Trust (Amendment) ..	0 6
5948. Returned Servicemen's Badges ..	0 6
5949. Grain Elevators (Financial) ..	0 6
5950. Workers' Compensation (Police) ..	0 6
5951. North Carlton Land ..	0 6
5952. Superannuation (Amendment) ..	0 6
5953. Country Fire Authority (Borrowing) ..	0 6
5954. Operation Gratitude Race Meeting ..	0 6
5955. Rural Finance Corporation (Amendment) ..	0 6
5956. Melbourne College of Divinity (Amendment) ..	0 6
5957. Supreme Court (Wards of Court) ..	0 6
5958. Stamps (Amendment) ..	0 6
5959. Cancer Institute (Loan Movies) ..	0 6
5960. The Victoria Racing Club ..	0 6
5961. Penal Reform ..	1 9
5962. Police Offences (Control of Raffles) ..	0 6
5963. Process Servers and Inquiry Agents ..	1 3
5964. Consolidated Revenue ..	0 6
5965. Medical (Registration) ..	0 6
5966. Gas and Fuel Corporation (Castlemaine Undertaking) ..	0 9
5967. Home Finance ..	0 9
5968. Police Offences (Amendment) ..	0 6
5969. Judges Salaries and Allowances ..	0 6
5970. Public Officers Salaries and Allowances ..	0 9
5971. Motor Car (Registration Fees) ..	0 6
5972. Melbourne Subways (Borrowing) ..	0 6
5973. Railways (Commissioners) ..	0 6
5974. Game (Destruction) ..	0 6
5975. Boilers Inspection (Amendment) ..	0 6
5976. The Geelong Gas Company's ..	0 6
5977. St. Kilda and Brighton Electric Street Railway (Partial Dismantling) ..	0 9
5978. Country Roads ..	1 0
5979. Health (Narcotics) ..	0 6
5980. Water (Compensation) ..	0 9
5981. Land (Improvement Purchase Lease) ..	0 9
5982. Melbourne and Metropolitan Board of Works ..	1 3
5983. Road Traffic ..	1 0
5984. Housing (Slum Research Officer) ..	0 6
5985. Firearms (Industrial Tools) ..	0 6
5986. Hospitals and Charities (Liability of Patients) ..	0 6
5987. The Constitution Act Amendment (Committee of Public Accounts) ..	0 6
5988. Local Government (Building Regulations) ..	0 9

STATE ACTS, 1956.—continued.

No.	Price s. d.
5989. Estate Agents	2 3
5990. Freedom of the City of Melbourne	0 6
5991. Subordinate Legislation Committee	0 6
5992. Local Authorities Superannuation	0 6
5993. West Melbourne Market Land	0 6
5994. Consolidated Revenue	0 6
5995. Juries	1 9
5996. Administration and Probate	0 6
5997. Consolidated Revenue	0 6
5998. Amendments Incorporation	0 6
5999. Labour and Industry (Long Service Leave)	0 6
6000. Melbourne Racing Club	1 3
6001. State Electricity Commission	0 6
6002. Gas and Fuel Corporation (Acquisition)	0 6
6003. Land (Unused Roads)	0 6
6004. Police Regulation (Retirement)	0 6
6005. Labour and Industry (Wages Boards)	0 6
6006. The Constitution Act Amendment	8 6
6007. Sheep (Foot Rot)	0 9
6008. The Ballarat Gas Company's	0 6
6009. Veterinary Surgeons (Amendment)	0 6
6010. Gas Regulation (Amendment)	0 9
6011. Land Tax (Rates)	0 6
6012. Registrar-General's Fees	1 0
6013. Instruments (Amendment)	0 9
6014. Entertainments Tax (Rates)	0 6
6015. Soldier Settlement (Amendment)	0 6
6016. Electoral	1 6
6017. Police Regulation (Reservists)	0 9
6018. Police Pensions Fund (Investment)	0 6
6019. Revenue Deficit Funding	0 6
6020. Portland Harbor Trust (Borrowing Powers)	0 6
6021. Stamps (Cheques and Receipts)	0 6
6022. Motor Car (Driving Licences)	0 6
6023. National Parks	1 0
6024. Health	7 9
6025. National Art Gallery and Cultural Centre	0 9
6026. Youth Organizations Assistance	0 6
6027. Appleton Dock Railway Construction	0 6
6028. Co-operative Housing Societies (Guarantees and Indemnities)	0 6
6029. Education (Kindergarten Teachers)	0 6
6030. Teaching Service (Married Women)	1 0
6031. Workers Compensation (Supplementary Board)	0 6
6032. Hospital Benefits (Amendment)	0 6
6033. Railways (Malvern Subways)	0 6
6034. Water Supply Loan Application	1 3
6035. Nurses	1 9
6036. Housing (Land)	1 0
6037. Police Offences (Trespass to Farms)	0 6
6038. Motor Car (Fees)	0 6
6039. Police Offences (Cruelty to Animals)	0 6
6040. State Forests Loan Application	0 6
6041. Melbourne and Metropolitan Board of Works (Borrowing Powers)	0 6
6042. Racing (Finance)	0 6
6043. Railway Loan Application	1 3
6044. Gas and Fuel Corporation (Frankston and Dandenong Undertakings)	1 9
6045. Stamps (Hire-Purchase Agreements)	0 6
6046. Forests (Masonite Agreement)	1 3
6047. Companies (Unit Trusts)	0 9
6048. Local Government (Amendment)	0 6
6049. Public Works Loan Application	0 9
6050. Marriage (Property)	0 9
6051. Parliamentary Contributory Retirement Fund (Amendment)	0 6
6052. Housing (Broadmeadows Land)	0 6
6053. Children's Court	2 0
6054. Housing (Staff)	0 6
6055. Appropriation of Revenue	4 3
6056. Governor's Salary	0 6

W. M. HOUSTON,
Government Printer.

STATE ACTS, 1957

COPIES of the following Acts of Parliament of Victoria may be obtained at the Government Printing Office, or from any bookseller, at the price set opposite to each:—

No.	Price s. d.
6057. Trinity College	0 6
6058. Vermin and Noxious Weeds (Financial)	0 6
6059. Victorian Inland Meat Authority (Financial)	0 6
6060. Melbourne and Metropolitan Board of Works (Contributions)	0 6
6061. Moorabbin Land	0 6
6062. Pounds (Fees)	0 6
6063. Dried Fruits (Amendment)	0 6

STATE ACTS, 1957—continued.

No.	Price s. d.
6064. Public Account (Amendment)	0 6
6065. Rabbit (Biological Destruction)	0 6
6066. Public Works Loan Application	0 6
6067. Game (Destruction)	0 6
6068. Coal Mine Workers Pensions (Amendment)	0 6
6069. Police Offences	5 6
6070. Racing	3 3
6071. Yinnar Lands	0 6
6072. Sandringham to Black Rock Electric Street Railway (Dismantling)	0 9
6073. Forests	3 0
6074. Wodonga (Unimproved Rating Poll)	0 6
6075. Housing (Commonwealth and State Agreement)	1 3
6076. Cemeteries (Financial)	0 6
6077. Consolidated Revenue	0 6
6078. Masseurs (Registration)	0 6
6079. Country Roads (Amendment)	0 6
6080. Maintenance	1 0
6081. Stamps (Hire-Purchase Agreements) Amendment	0 6
6082. Justices	8 0
6083. Mornington Land	0 6
6084. Medical (Registration)	0 9
6085. Soil Conservation and Land Utilization (River Flats)	0 6
6086. Aborigines	0 9
6087. Grain Elevators (Border Railways)	0 6
6088. Barley Marketing (Amendment)	0 6
6089. Administration and Probate (Amendment)	0 6
6090. Housing	0 9
6091. Police Regulation (Amendment)	0 6
6092. Trotting Races	1 0
6093. Weights and Measures (Amendment)	0 6
6094. Benefit Associations (Amendment)	0 6
6095. Transport (Westernport Bay)	0 6
6096. Labour and Industry (Amendment)	0 6
6097. Game (Amendment)	0 6
6098. Landlord and Tenant (Control)	3 3
6099. Consolidated Revenue	0 6
6100. Wangaratta (Rating on Unimproved Values)	0 6

W. M. HOUSTON,
Government Printer.

THE VICTORIA GOVERNMENT GAZETTE is published on WEDNESDAY EVENING in each week, and Notices for insertion will be received by the Government Printer at or before Two p.m. at ordinary rates, and late advertisements between Two p.m. and Five p.m. at double rates on the day preceding the day of publication.

Single copies of the VICTORIA GOVERNMENT GAZETTE are One shilling, posted One shilling and three pence.

No GAZETTES prior to January, 1950, in stock.

***ALL PAYMENTS ARE REQUIRED IN ADVANCE.—Remittances should be made by postal note, money order, or draft in favour of the Government Printer. Advertisements unaccompanied by a remittance sufficient to cover the cost of insertion will be returned unpublished.

SUBSCRIPTIONS.—The subscription, including postage, is £2 15s. per annum, £1 7s. 6d. half-yearly, or 13s. 9d. per quarter, payable in advance.

Subscriptions are required to commence and terminate with a month.

A lesser period than three months cannot be subscribed for.

Subscribers do not receive the Acts of Parliament with the GAZETTE.

ADVERTISEMENTS are charged at the rate of 1s. 6d. per line single column, and 3s. per line double column.

The title (£5 Reward, Dissolution of Partnerships, &c.) forms one or more lines as a heading.

On an average, ten words make a line.

Every signature must likewise be counted as a line.

The final words of a paragraph, though only portion of a line, must be counted as one line.

SIGNATURES (in particular) and proper names must be written very plainly in the text; ONE SIDE ONLY of each slip of paper should be WRITTEN UPON.

ALL COMMUNICATIONS should be addressed to "The Government Printer, Melbourne."

ALL DOCUMENTS illegibly written will be returned unpublished, and, where brands occur unprovided for by the ordinary letters of the alphabet, a worded explanatory description must be furnished.

THE "VICTORIA GOVERNMENT GAZETTE."

ATTENTION is invited to the following procedure in relation to the publication of official matter in the *Government Gazette*.—

1. *Matter submitted to the Executive Council.*

Matter submitted to the Executive Council which requires gazettal will normally be published in the issue of the following week.

Where urgent gazettal is required, special arrangements should be made with the *Gazette Officer*.

Publication will be facilitated by the submission of carbon copies for the use of the *Gazette Officer*.

2. *Other matter.*

(a) All other matter duly certified by a responsible officer for publication should be lodged with the *Gazette Officer* not later than half-past Ten a.m. on Tuesday.

(b) Lengthy or involved notices should be forwarded several days before publication.

(c) Proofs, which will be supplied only when specifically requested, or at the direction of the *Gazette Officer*, should be returned promptly to avoid delay in publication.

(d) No additions or amendments to matter for publication will be accepted by telephone.

MESSRS. R. H. & W. M. PETTY, News Agent, Wangaratta.

MESSRS. POWELL & DIXON, 89 Firebrace-street, Horsham.

J. PURDIE & CO., 138 Moorabool-street, Geelong.

F. W. RASHLEIGH & SON, Nunn-street, Benalla.

ROBERTSON & MULLENS LTD., Elizabeth-street, Melbourne.

SALE AUTHORIZED NEWS AGENTS, Sale.

SKINNER'S AUTHORIZED NEWSAGENCY, 49-51 Franklin-street, Traralgon.

MESSRS. SMITH & DUNNON, Hamilton.

THE MERCANTILE EXCHANGE, 380 Collins-street, Melbourne.

F. D. & J. R. TRAINOR, 246 Wyndham-street, Shepparton.

C. F. & H. J. VERNON, 162 Bridge-road, Richmond.

VIEW POINT AUTHORIZED NEWSAGENCY, 4 View Point, Bendigo.

E. W. B. WELSH, Hogan-street, Tatura.

A copy of the *Gazette* filed at each place for public reference.

CONTENTS

AGENTS FOR THE "VICTORIA GOVERNMENT GAZETTE."

THE following have been appointed agents to receive Advertisements and Subscriptions for the *Victoria Government Gazette*.—

ARMSTRONG'S AGENCY, 143 Queen-street, Melbourne.

ARMSTRONG BROS., Kyneton.

MESSRS. ARNALL & JACKSON, 115 Barkly-street, West Brunswick.

BERRY, ANDERSON, & CO., 207 Sturt-street, Ballarat.

MR. WM. DAVIS, Mildura.

A. J. DIGBY (B. S. and N. W. Cash), Main-street, Bairnsdale.

EDGAR'S NEWS AGENCY, Hargreaves-street, Bendigo.

MESSRS. HENRY FRANKS & CO., Booksellers and Stationers, Market-square, Geelong.

MESSRS. GORDON & GOTCH, News Agents, 511 Little Collins-street, Melbourne; and corner Barrack and Clarence streets, Sydney.

A. C. HAMPTON, 243 Mitchell-street, Bendigo.

MESSRS. HARSTON, PARTRIDGE, & CO., 455 Little Collins-street, Melbourne.

MR. C. F. LATIMER, News Agent, Casterton.

McARTHUR'S AUTHORIZED NEWSAGENCY, 345 Wyndham-street, Shepparton.

	PAGE
Act of Parliament	3643
Acts of Parliament on sale at the Government Printing Office	3679
Appointments	3651
Companies Act 1938—Notice	3649
Contracts	3644
Country Roads Board	3658
Estates of Deceased Persons	3648
Government Notices	3644
Impoundings	3679
Lands	3660
Licences to Occupy Unused Roads	3645
Melbourne and Metropolitan Board of Works—Notices	3645
Orders in Council	3652
Private Advertisements	3671
Proclamations	3643
Public Service Notices	3662
Resignations	3651
State Rivers and Water Supply Commission	3647
Tenders	3669
Transport Regulation Board—Public Hearings	3646