



VICTORIA GOVERNMENT GAZETTE

Published by Authority

[Registered at the General Post Office, Melbourne, for transmission by post as a newspaper.]

No. 112]

WEDNESDAY, DECEMBER 23

[1959

ACTS OF PARLIAMENT.

PROCLAMATION

By His Excellency the Governor of the State of Victoria and its Dependencies in the Commonwealth of Australia, &c., &c., &c.

I, THE Governor of the State of Victoria, in the Commonwealth of Australia, do hereby declare that I have this day assented, in Her Majesty's name, to the Bills passed by the Parliament of the said State, the titles whereof are hereunder set forth, that is to say:—

- No. 6599: "An Act relating to Fair Rents of Dwelling-houses."
- No. 6600. "An Act to amend the *Labour and Industry Act 1958*."
- No. 6601. "An Act to amend the *Local Government Act 1958* and for other purposes."
- No. 6602. "An Act to sanction the Issue and Application of Loan Money for Public Works and other purposes."
- No. 6603. "An Act to amend the *Soldier Settlement Act 1958*."
- No. 6604. "An Act to authorize the State Rivers and Water Supply Commission to purchase and reclaim land affected by salt and to dispose of any land so purchased and reclaimed, and for other purposes."
- No. 6605. "An Act to consolidate and amend the Law relating to Mental Health and for other purposes."

Given under my Hand and the Seal of the State of Victoria aforesaid, at Melbourne, this fifteenth day of December, in the year of our Lord One thousand nine hundred and fifty-nine, and in the eighth year of the reign of Her Majesty Queen Elizabeth II.

(L.S.)

DALLAS BROOKS.

By His Excellency's Command,

HENRY E. BOLTE,
Premier.

GOD SAVE THE QUEEN!

Marine Act 1958.

PORTS IN VICTORIA.—AMENDMENT TO PORT RULES.

PROCLAMATION

By His Excellency the Governor of the State of Victoria and its Dependencies in the Commonwealth of Australia, &c., &c., &c.

WHEREAS by Part II. of the *Marine Act 1958*, it is amongst other things enacted that the Governor in Council, by Proclamation published in the *Government Gazette* may from time to time define the limits and boundaries of ports in Victoria, and frame rules and regulations for the governance and preservation of the said ports respectively, and for the regulation of shipping in the same, and also for the due protection and preservation and the good government and management of all public wharfs: And that any such regulation may from time to time be in like manner altered, amended, or repealed and others substituted in their stead: Now, therefore I, the Governor of the State of Victoria, in the Commonwealth of Australia, by and with the advice of the Executive Council thereof, and in exercise of the powers conferred by the said Act by this Proclamation do hereby make the following amendment to Rule 61 of the Rules and Regulations for the Ports in Victoria concerning signals to be used when requisite within the Ports of Victoria:—

Add thereto the following signal:—

Diver below—Red flag with white diagonal cross shown prominently from attendant vessel.

Given under my Hand and the Seal of the State of Victoria aforesaid, at Melbourne, this fifteenth day of December, in the year of our Lord One thousand nine hundred and fifty-nine, and in the eighth year of the reign of Her Majesty Queen Elizabeth II.

(L.S.)

DALLAS BROOKS.

By His Excellency's Command,

T. K. MALTY,
Commissioner of Public Works.

GOD SAVE THE QUEEN!

Vermin and Noxious Weeds Act 1958.

PIGS RUN WILD DECLARED TO BE A VERMIN WITHIN CERTAIN PARISHES.

PROCLAMATION

By His Excellency the Governor of the State of Victoria and its Dependencies in the Commonwealth of Australia, &c., &c., &c.

IN pursuance of the provisions of section 3, sub-section (2) of the *Vermin and Noxious Weeds Act 1958* (No. 6409), I, the Governor of the State of Victoria, by and with the advice of the Executive Council of the said State, do, by this my Proclamation, declare that Pigs run wild be declared vermin for the purpose of the above Act within the Parishes named in the Schedule hereto.

SCHEDULE.

WITHIN CERTAIN PARISHES.

Parish.	Municipality.
Bet Bet	Bet Bet and Tullaroop (Shires)
Maryborough	Tullaroop (Shire)
Wareek	Avoca, Bet Bet, Tullaroop (Shires)

Given under my Hand and the Seal of the State of Victoria aforesaid, at Melbourne, this fifteenth day of December, in the year of our Lord One thousand nine hundred and fifty-nine, and in the eighth year of the reign of Her Majesty Queen Elizabeth II.

(L.S.) DALLAS BROOKS.

By His Excellency's Command,
KEITH TURNBULL,
 Commissioner of Crown Lands and Survey.
 GOD SAVE THE QUEEN!

Poisons Act 1958.

AMENDMENT OF THE SECOND SCHEDULE TO THE POISONS ACT 1958 (No. 6336).

PROCLAMATION

By His Excellency the Governor of the State of Victoria and its Dependencies in the Commonwealth of Australia, &c., &c., &c.

BY virtue of the powers conferred by section four of the *Poisons Act 1958* and all other powers enabling me in that behalf, I, the Governor of the State of Victoria in the Commonwealth of Australia, by and with the advice of the Executive Council of the said State and on the recommendation of the Pharmacy Board of Victoria do by this my Proclamation amend the Second Schedule to the *Poisons Act 1958* by the addition to the 1st Part of the said Schedule of the following item:—

Phosphides which liberate phosphine on exposure to moist air and which are used as fumigants for grain or the destruction of vermin.

Given under my Hand and the Seal of the State of Victoria aforesaid, at Melbourne, this fifteenth day of December, in the year of our Lord One thousand nine hundred and fifty-nine, and in the eighth year of the reign of Her Majesty Queen Elizabeth II.

(L.S.) DALLAS BROOKS.

By His Excellency's Command,
E. P. CAMERON,
 Minister of Health.
 GOD SAVE THE QUEEN!

Poisons Act 1958.

AMENDMENT OF THE SIXTH SCHEDULE TO THE POISONS ACT 1958 (No. 6336).

PROCLAMATION

By His Excellency the Governor of the State of Victoria and its Dependencies in the Commonwealth of Australia, &c., &c., &c.

BY virtue of the powers conferred by section thirty-nine of the *Poisons Act 1958* and all other powers enabling me in that behalf, I, the Governor of the State of Victoria, in the Commonwealth of Australia, by and with the advice of the Executive Council of the said State and on the recommendation of the Pharmacy Board of Victoria do by this my Proclamation amend paragraph (2) of the Sixth Schedule to the said Act by the addition of the following items:—

- (i) Melanin stimulators such as Methoxsalen, 8-methoxypsoralen, Xanthotoxin, 8-MOP, Ammoidin, Meladnine, Meloxine.
- (ii) Monoamine Oxidase Inhibitors such as Iproniazid, Phenelzine, Catron, Ditrán, Niamid, Nardil, RO 5-0831, B-phenylethyldiazine.
- (iii) Imipramine.

And declare that Division 2 of Part III. of the *Poisons Act 1958* shall apply to the substances or preparations so added in the same manner as it applies to the substances or preparations already included in the said paragraph (2).

Given under my Hand and the Seal of the State of Victoria aforesaid, at Melbourne, this fifteenth day of December, in the year of our Lord One thousand nine hundred and fifty-nine, and in the eighth year of the reign of Her Majesty Queen Elizabeth II.

(L.S.) DALLAS BROOKS.

By His Excellency's Command,
E. P. CAMERON,
 Minister of Health.
 GOD SAVE THE QUEEN!

Forests Act 1958 (No. 6254).

PROCLAMATION OF PROHIBITED PERIOD.

PROCLAMATION

By His Excellency the Governor of the State of Victoria and its Dependencies in the Commonwealth of Australia, &c., &c., &c.

IN pursuance of the powers conferred by section 3 of the *Forests Act 1958*, I, the Governor of the State of Victoria in the Commonwealth of Australia, by and with the advice of the Executive Council of the said State, do by this my Proclamation proclaim the period commencing at midnight between the twenty-third and twenty-fourth days of December, One thousand nine hundred and fifty-nine, and ending at midnight between the fifteenth and sixteenth days of April, One thousand nine hundred and sixty, to be the prohibited period in respect to any fire protected area other than a State forest or national park in the State of Victoria situated in such municipalities as are specified in the Schedule hereto.

SCHEDULE.

The Shires of Bairnsdale, Cranbourne, Flinders, Frankston and Hastings, Mornington, Mulgrave, Omeo, Orbost, Phillip Island, Tambo.

The City of Dandenong and French Island.

Given under my Hand and the Seal of the State of Victoria aforesaid, at Melbourne, this twenty-second day of December, in the year of our Lord One thousand nine hundred and fifty-nine, and in the eighth year of the reign of Her Majesty Queen Elizabeth II.

(L.S.) DALLAS BROOKS.

By His Excellency's Command,
A. J. FRASER,
 Minister of Forests.
 GOD SAVE THE QUEEN!

Water Acts.

BELLARINE PENINSULA WATERWORKS DISTRICT.—
PORTION OF DISTRICT PROCLAIMED AN "URBAN
DISTRICT".

PROCLAMATION

By His Excellency the Governor of the State of Victoria and its Dependencies in the Commonwealth of Australia, &c., &c., &c.

UNDER the powers conferred by the Water Acts and all other powers enabling me in that behalf, I, the Governor of the State of Victoria, with the advice of the Executive Council thereof, do hereby proclaim that as on and from the date hereof that portion of the Bellarine Peninsula Waterworks District included within the boundaries set out and described in the Schedule hereto, shall be, and become an "Urban District" for the purpose of the said Acts and shall be known as Leopold Urban District.

SCHEDULE.

Boundaries of Leopold Urban District.

Commencing at the south-eastern angle of lot 33 on lodged plan of subdivision No. 41810, being part of Crown portion 16, Parish of Moolap; thence westerly by the southern boundaries of said lot 33, lot 22 on lodged plan of subdivision No. 41040, a line connecting those boundaries, the southern boundaries of lots 23 to 31 inclusive on lodged plan of subdivision No. 43235, and a line in continuation thereof to the eastern boundary of Crown portion 15; thence northerly by the last-mentioned boundary to the southern boundary of the Geelong to Queenscliff road; thence westerly by that road boundary to a point in line with the western boundary of Kensington-road; thence northerly by a line and the last-mentioned road boundary to a point in line with the northern boundary of Dorothy-street on lodged plan of subdivision No. 33343; thence easterly by a line and the last-mentioned street boundary to a point in line with the eastern boundary of lot 69 on the last-mentioned plan of subdivision; then southerly by a line, the eastern boundaries of lots 69 to 85 inclusive and a line in continuation thereof to the southern boundary of the Geelong to Queenscliff road aforesaid; thence westerly by that road boundary to a point in line with the eastern boundary of lot 58 on lodged plan of subdivision No. 41810 aforesaid; thence southerly by a line and the eastern boundary of the lands in said lodged plan of subdivision No. 41810 to the point of commencement.

The boundaries set out and described in the foregoing Schedule are shown on a plan approved by the Governor in Council, and deposited in the office of the State Rivers and Water Supply Commission, 100-110 Exhibition-street, Melbourne, C.I.—(Corres. 53/20164.)

Given under my Hand and the Seal of the State of Victoria aforesaid, at Melbourne, this twenty-second day of December, in the year of our Lord One thousand nine hundred and fifty-nine, and in the eighth year of the reign of Her Majesty Queen Elizabeth II.

(L.S.)

DALLAS BROOKS.

By His Excellency's Command,

W. J. MIBUS,
Minister of Water Supply.

GOD SAVE THE QUEEN!

*Weights and Measures Act 1958.*DECLARATION OF MUNICIPALITIES AND PORTIONS
THEREOF TO WHICH THE PROVISIONS OF
DIVISION 3 OF PART V. OF THE WEIGHTS AND
MEASURES ACT 1939, OR CORRESPONDING
PREVIOUS ENACTMENTS HAVE BEEN EXTENDED.

PROCLAMATION

By His Excellency the Governor of the State of Victoria and its Dependencies in the Commonwealth of Australia, &c., &c., &c.

WHEREAS by the *Weights and Measures Act 1958*, it is amongst other things enacted that the Governor in Council may by Proclamation declare the municipalities

and portions thereof to which the provisions of Division 3 of Part V. of the *Weights and Measures Act 1939* or any corresponding previous enactment have been extended:

Now therefore I, the Governor of the State of Victoria, in the Commonwealth of Australia, by and with the advice of the Executive Council of the said State, and in pursuance of the powers conferred by the *Weights and Measures Act 1958*, do by this my Proclamation declare that the provisions of Division 3 of Part V. of the *Weights and Measures Act 1939* or any corresponding previous enactment have been extended to the following municipalities, namely:—

- (i) The Boroughs of Benalla, Echuca, Maryborough, Moe and the Yallourn Works Area;
- (ii) the Shires of Alberton, Altona, Buln Buln, Bass, Benalla, Birchip, Charlton, Chiltern, Cobram, Colac, Cranbourne, Dimboola, Donald, Dunmunkle, Eltham, Fern Tree Gully, Flinders, Frankston and Hastings, Hampden, Kaniva, Karkaroc, Keilor, Korumburra, Mirboo, Mortlake, Morwell, Mornington, Newham and Woodend, Narracan, Otway, Shepparton, South Gippsland, Springvale and Noble Park, Stawell, Towong, Traralgon, Upper Murray, Violet Town, Warracknabeal, Warragul, Werribee, Wodonga, Woorayl and Yackandandah;
- (iii) that part of the Shire of Mulgrave which lies west of the west side of Springvale-road.

Given under my Hand and the Seal of the State of Victoria aforesaid, at Melbourne, this twenty-second day of December, in the year of our Lord One thousand nine hundred and fifty-nine, and in the eighth year of the reign of Her Majesty Queen Elizabeth II.

(L.S.)

DALLAS BROOKS.

By His Excellency's Command,

A. G. RYLAH,
Chief Secretary.

GOD SAVE THE QUEEN!

POLICE OFFENCES (BETTING) ACT 1959 (No. 6586).

DATE OF COMING INTO OPERATION.

PROCLAMATION

By His Excellency the Governor of the State of Victoria and its Dependencies in the Commonwealth of Australia, &c., &c., &c.

WHEREAS by an Act of Parliament of the State of Victoria passed in the eighth year of the reign of Her Majesty Queen Elizabeth II., intitled the *Police Offences (Betting) Act 1959* (No. 6586), it is amongst other things enacted that the said Act shall come into operation on a day to be fixed by Proclamation of the Governor in Council published in the *Government Gazette*:

Now therefore I, the Governor of the State of Victoria, in the Commonwealth of Australia, by and with the advice of the Executive Council of the said State, do by this my Proclamation fix Monday, the eighteenth day of January, One thousand nine hundred and sixty, as the day on which the said *Police Offences (Betting) Act 1959* (No. 6586) shall come into operation.

Given under my Hand and the Seal of the State of Victoria aforesaid, at Melbourne, this twenty-second day of December, in the year of our Lord. One thousand nine hundred and fifty-nine, and in the eighth year of the reign of Her Majesty Queen Elizabeth II.

(L.S.)

DALLAS BROOKS.

By His Excellency's Command,

A. G. RYLAH,
Chief Secretary.

GOD SAVE THE QUEEN!

Land Act 1958.

UNALIENATED CROWN LAND AVAILABLE FOR SETTLEMENT UNDER IMPROVEMENT PURCHASE LEASES.

PROCLAMATION

By His Excellency the Governor of the State of Victoria and its Dependencies in the Commonwealth of Australia, &c., &c., &c.

IN pursuance of the provisions of Section 153 of the *Land Act 1958*, I, the Governor of the State of Victoria, in the Commonwealth of Australia, by and with the advice of the Executive Council of the said State, do by this Proclamation declare the unalienated Crown lands mentioned in the subjoined Schedule, to be available for settlement under improvement purchase leases.

SCHEDULE.

Country.	Parish.	Allotment.	Section.	Area.	Land Valuation.
				A. R. P.	£ s. d.
Delatite	Whitfield	9	3	135 2 21	2 10 0 per acre
Buln Buln	Fumina	59A	..	120 2 32	5 0 0 per acre
Dargo	Sarsfield	20A	1	344 3 15	1 0 0 per acre

Given under my Hand and the Seal of the State of Victoria aforesaid, at Melbourne, this fifteenth day of December, in the year of our Lord One thousand nine hundred and fifty-nine, and in the eighth year of the reign of Her Majesty Queen Elizabeth II.

DALLAS BROOKS.

(L.S.)

By His Excellency's Command,

KEITH TURNBULL,
Commissioner of Crown Lands and Survey.

GOD SAVE THE QUEEN!

CHRISTMAS AND NEW YEAR HOLIDAYS.

IT is hereby notified that on—

FRIDAY, THE 25TH DECEMBER, 1959,
MONDAY, THE 28TH DECEMBER, 1959, and
FRIDAY, THE 1ST JANUARY, 1960,

the Public Offices will be closed, such days having been appointed by the *Public Service Act 1958* to be observed as holidays in the Public Offices throughout the State of Victoria.

This notice relates only to the closing of the State Public Offices. All inquiries regarding holidays in other offices and in shops and industry should be directed to the Department of Labour and Industry, Old Treasury Building, Spring-street, Melbourne, C.1. (Telephone MF 0321, Extension 266 or 6382.)

A. G. RYLAH,
Chief Secretary.

Chief Secretary's Office,
Melbourne, C.1. 2nd December, 1959.

PUBLICATION OF THE "VICTORIA GOVERNMENT GAZETTE".

IT is hereby notified that, owing to the Christmas and New Year Holidays, the last issue of the *Victoria Government Gazette* for the year 1959 will be published on Wednesday, the 23rd December, except if special circumstances shall require otherwise.

The next *Gazette* after the 23rd December, 1959, will be published on Friday, the 8th January, 1960, and thereafter on each Wednesday, as usual.

A. C. BROOKS,
Government Printer.

State Savings Bank Act 1958, Section 30.
THE STATE SAVINGS BANK OF VICTORIA.
ESTABLISHMENT OF BRANCH.

THE Commissioners of the State Savings Bank of Victoria hereby give notice of their intention to establish a Branch of the Bank at Cowes, on 4th January, 1960.

O. R. CARLSON,
General Manager.

Licensing Act 1958.

ANNUAL SITTINGS OF THE VICTORIAN LICENSING COURT—TIME EXTENDED.

HIS Excellency the Governor of the State of Victoria, by and with the advice of the Executive Council thereof, doth by Order made on the 22nd December, 1959, pursuant to the provisions of the *Licensing Act 1958*, extend the time for holding the Annual Sittings of the Victorian Licensing Court for the Licensing Areas set out in the first column of the Schedule hereunder for a period not exceeding two months from the last day of the period appointed as indicated in the second column of such Schedule.

SCHEDULE.

Licensing Area.	Date of Sitting.
Bairnsdale	31st December, 1959.
Central Metropolitan	31st December, 1959.
Eastern Metropolitan	31st December, 1959.
Southern Metropolitan	31st December, 1959.
Geelong	31st December, 1959.
Warragul	31st December, 1959.
Warrnambool	31st December, 1959.

A. MAHLSTEDT,
Clerk of the Executive Council.

At the Executive Council Chamber,
Melbourne, 22nd December, 1959.

Co-operation Act 1958.

FAWKNER CO-OPERATIVE COMMUNITY
ADVANCEMENT SOCIETY LIMITED.

NOTICE OF DISSOLUTION OF SOCIETY.

NOTICE is hereby given that I have this day registered the dissolution of the above-named society and cancelled its registration under the above-named Act.

Dated at Melbourne, this 14th day of December, 1959.

E. T. EBBELS,
Registrar of Co-operative Societies.

BUILDING SOCIETIES ACT 1958.

NOTICE is hereby given that a building society called "Victorian Deposit and Loan Association" is duly registered under the provisions of the above Act.

Given under my Hand this 15th day of December, 1959.

A. DOUGLAS,
Registrar of Building Societies.

ENGINEERS OF WATER SUPPLY—EXAMINATIONS
1959.

THE under-mentioned candidates have passed examinations conducted by the Board of Examiners of Engineers of Water Supply, and on payment of the prescribed fees may obtain certificates of qualification:—

DARBY, H. P.
FRASER, E.
KEMPTON, K.
MACKLIN, R. J.
SHARP, D. R.
WILLIAMSON, W. H.

K. E. FINDLAY,
Secretary, Board of Examiners.
State Rivers and Water Supply Commission,
Melbourne, 14th December, 1959.

Country Fire Authority Acts.

PERMISSION TO HOLD FIRE BRIGADE
DEMONSTRATION.

THIS is to certify that, in pursuance with section 103 of the *Country Fire Authority Act 1958*, the Authority has granted permission for a rural fire brigades demonstration to be held at Geelong, on Friday, 1st April, 1960.

G. G. SINCLAIR,
Secretary.

17th December, 1959.

RACING ACT 1958.

CORRIGENDUM.—Trotting Control Board Regulations, p. 3664, *Government Gazette*, 16th December, 1959. In clause 3 (2) (a), the phrase "of any part" should read "or any part".

Health Acts.

MEAT SUPERVISION REGULATIONS 1956.

ALLOCATION OF MEAT BRANDS.

NOTICE is hereby given that the Commission of Public Health has allotted the letters "BAC" as the letters to be used in meat brands as indicating the Shire of Benalla.

G. W. ROGAN, Secretary,
Commission of Public Health.
Department of Health,
Melbourne, 18th December, 1959.

CITY OF BROADMEADOWS.

ORDER CONFIRMED.

THE Minister of the Crown administering the *Local Government Act 1958*, on the 17th day of December, 1959, confirmed the Order hereinafter referred to in pursuance of section 514 of the said Act, viz.:—

An Order of the Council of the City of Broadmeadows made on the 23rd day of November, 1959, for the purpose of providing a place of public resort and recreation and for acquiring for such purpose all that piece of land being Crown allotment 1, section 2A, in the Township of Broadmeadows, Parish of Will Will Rook, and being the land more particularly described in Crown grant, volume 2177, folio 205.

MURRAY PORTER,
Minister for Local Government.

Police Regulation Act 1958.

POLICE FORCE OF VICTORIA.

DETERMINATION NO. 78 OF THE POLICE CLASSIFICATION BOARD.

THE Police Classification Board, in pursuance of the powers in that behalf conferred by the *Police Regulation Act 1958*, hereby makes the following Determination, that is to say:—

1. The Determination No. 59 of the Police Classification Board of the 23rd July, 1956, and published in the *Government Gazette* of the 21st August, 1956, as amended, is hereby further amended as follows:—

(a) By deleting in Division III., Sub-Division I., the words "Members of the Scientific Section of the Information Bureau" and paragraph 16, and substituting therefor the following:—

"MEMBERS OF THE FORENSIC SCIENCE LABORATORY OF
THE CRIMINAL INVESTIGATION BRANCH.

16. There shall be paid to a member while performing duties as a member of the Forensic Science Laboratory of the Criminal Investigation Branch, an allowance at the following rate:—

Rank or Position.	Allowance Per Day.
	s. d.
Officer in Charge	5 6
Sub-officers, First Constables and Constables	2 0."

2. This Determination shall come into operation on the 18th day of December, 1959.

Dated at Melbourne, this 18th day of December, 1959.

J. F. MULVANY,
A Judge of the County Court of Victoria,
Chairman and Member of the Police
Classification Board.

D. S. RAMAGE,
Member of the Police Classification Board.

F. G. HOLLAND,
Member of the Police Classification Board.

CLAIMS AGAINST THE SOLICITORS' GUARANTEE FUND RULES.

PURSUANT to section 88 of the *Legal Profession Practice Act 1958* and all other provisions in that behalf enabling, the Council of the Law Institute of Victoria doth hereby make the following rules of the Institute (that is to say):—

1. These rules may be cited as the Claims Against the Solicitors' Guarantee Fund Rules 1959 and shall be read and construed as one with the Claims Against the Solicitors' Guarantee Fund Rules 1949, which rules and these rules may be cited as the Claims Against the Solicitors' Guarantee Fund Rules.

2. These rules shall come into operation on the publication thereof in the *Victoria Government Gazette*.

3. Rule 2 is amended by substituting the words and figures "section 65 of the *Legal Profession Practice Act 1958*" for the words and figures "section 17 of the *Legal Profession Practice Act 1946*".

4. Rule 3 is amended by substituting the words and figures "Division 2 of Part V. of the *Legal Profession Practice Act 1958*" for the words and figures "Part II. of the *Legal Profession Practice Act 1946*".

5. Form 1 in the Schedule is amended—

(a) by substituting in the heading thereof the words and figures "*Legal Profession Practice Act 1958*" for the words and figures "*Legal Profession Practice Act 1946*";

(b) by substituting the words and figures "section 64 of the *Legal Profession Practice Act 1958*" for the words and figures "section 16 of the *Legal Profession Practice Act 1946*".

6. Form 2 in the Schedule is amended—

(a) by substituting in the heading thereof the words and figures "*Legal Profession Practice Act 1958*" for the words and figures "*Legal Profession Practice Act 1946*";

(b) by inserting after paragraph 4 the following paragraph:—

"5. I claim to be compensated out of the Solicitors' Guarantee Fund for the said pecuniary loss and in support of such claim I submit the following evidence:—

(Set out in detail together with documentary evidence and (if necessary) statutory declarations by other witnesses, sufficient to establish a prima facie case.)"

Signed for and on behalf of the Council of the Law Institute of Victoria this twelfth day of November, 1959.

J. R. BURT, President.

ARTHUR HEYMANSON, Secretary.

I approve the above Rules.

Dated this twenty-fourth day of November, 1959.

E. F. HERRING, Chief Justice.

SOLICITORS (PROFESSIONAL CONDUCT AND PRACTICE) RULES.

PURSUANT to section 88 of the *Legal Profession Practice Act 1958* and all other provisions in that behalf enabling, the Council of the Law Institute of Victoria doth hereby make the following rules of the Institute (that is to say):—

1. These rules may be cited as the Solicitors (Professional Conduct and Practice) Rules 1959 and shall be read and construed as one with the Solicitors (Professional Conduct and Practice) Rules 1948 and any rules amending those rules, all of which rules and these rules may be cited as the Solicitors (Professional Conduct and Practice) Rules.

2. These rules shall come into operation on the publication thereof in the *Victoria Government Gazette*.

3. Sub-rule (4) of Rule 2 is amended by substituting in the proviso thereto the words and figures "*Building Societies Act 1958*" for the words and figures "*Building Societies Act 1928*".

4. Sub-rule (2) of Rule 4 is amended by substituting the words and figures "*Business Names Act 1958*" for the words and figures "*Business Names Act 1928*".

Signed for and on behalf of the Council of the Law Institute of Victoria this twelfth day of November, 1959.

J. R. BURT, President.

ARTHUR HEYMANSON, Secretary.

I approve the above Rules.

Dated this twenty-fourth day of November, 1959.

E. F. HERRING, Chief Justice.

AUDITORS (DISCLOSURE OF INFORMATION) RULES.

PURSUANT to section 88 of the *Legal Profession Practice Act 1958* and all other provisions in that behalf enabling, the Council of the Law Institute of Victoria doth hereby make the following rules of the Institute (that is to say):—

1. These rules may be cited as the Auditors (Disclosure of Information) Rules 1959 and shall be read and construed as one with the Auditors (Disclosure of Information) Rules 1949 and any rules amending those rules; all of which rules and these rules may be cited as the Auditors (Disclosure of Information) Rules.

2. These rules shall come into operation on the publication thereof in the *Victoria Government Gazette*.

3. Rule 2 is amended—

- (a) by substituting the words and figures "*Legal Profession Practice Act 1958*" for the words and figures "*Legal Profession Practice Act 1946*";
- (b) by substituting the words and figures "*Evidence Act 1958*" in paragraph (a) thereof for the words and figures "*Evidence Act 1928*";
- (c) by substituting the words and figures "*Legal Profession Practice Act 1958*" in paragraph (b) thereof for the words and figures "*Law Institute Act 1958*";
- (d) by substituting the words and figures "section 84 or 86 of the *Legal Profession Practice Act 1958*" in paragraph (c) thereof for the words and figures "section 39 or 41 of the *Legal Profession Practice Act 1946*".

Signed for and on behalf of the Council of the Law Institute of Victoria this twelfth day of November, 1959.

J. R. BURT, President.

ARTHUR HEYMANSON, Secretary.

I approve the above Rules.

Dated this twenty-fourth day of November, 1959.

E. F. HERRING, Chief Justice.

Local Government Act.

MUNICIPAL CLERKS BOARD.

REGULATIONS FOR EXAMINATION FOR CERTIFICATE OF COMPETENCY AS MUNICIPAL CLERK.

WHEREAS section 169 (1) of the Local Government Act prescribes that the Municipal Clerks Board may from time to time make alter or rescind regulations to be approved by the Governor in Council and published in the *Government Gazette* prescribing the time place and manner of holding examinations of such persons as desire to qualify themselves to hold the office of municipal clerk, the subjects of such examinations, the fees payable by candidates thereat, the qualifications necessary and the conditions of entry for those examinations, the recognition of other qualifications in lieu of any examination, and the conditions (including conditions as to age training and experience) necessary for the issue of appropriate certificates, the Municipal Clerks Board hereby rescinds the Regulations published in the *Government Gazette* of 26th March, 1952, and in lieu thereof makes the following Regulations:—

1. An examination shall be held at least once in every year, at such place or places and at such times as the Board may from time to time determine.

2. The subjects of such examination shall be:—

- (i) Accounting.
- (ii) Local Government Law, Part I.
- (iii) Local Government Law, Part II.
- (iv) Commercial Law.
- (v) Secretarial Practice.
- (vi) Public Administration.

3. An exemption from examination in any subject will be granted to a candidate who proves to the satisfaction of the Board that, at an examination conducted by a University or a secretarial or accountancy institute or other examining body recognized by the Board for the purpose, he has passed in a subject based on a like syllabus and of a like standard to the appropriate subject of the Board's examination.

4. Every person desiring to sit for the examination shall, not less than twenty-eight (28) days before the examination, submit an application in a form approved by the Board, for permission to enter, accompanied by:—

- (a) A statement giving his full name and address and date and place of his birth.

(b) Documentary evidence of his having passed—

- (i) In English and three other subjects, including one subject from Group B and one from Group C of the subjects prescribed for the School Leaving Examination of the University of Melbourne;
 - (ii) such other examination as is, in the opinion of the Board, equivalent to that mentioned in paragraph (i).
- (c) Two recent testimonials relating to his conduct and character.
- (d) A detailed statement of his experience, showing the times engaged and the nature of the work, to be certified as correct by a municipal clerk where practicable.

5. The Board will grant to any applicant who complies to its satisfaction with the requirements of clause 4 of these Regulations permission to enter for the Board's examination.

6. Where after commencement of these Regulations a candidate has received permission to enter for the Board's examination, he may be admitted to a subsequent examination on application and payment of the prescribed fee.

7. Every examination shall be in writing, but the Board may conduct oral tests in any case where, after examination in writing, the Board considers such a course necessary to assure itself of a candidate's competency.

8. A candidate shall, at not more than three of the examinations for which he sits, pass in all subjects in which he is required to pass to qualify for a certificate of competency.

9. A satisfactory standard of English shall be demonstrated in each subject of examination and marks shall be deducted from candidates failing to meet the requirement of this regulation.

10. A certificate of competency shall not be issued to any person until he has attained the age of 23 years and until he has had at least two years' administrative experience approved by the Board.

11. The Board may require any applicant for a certificate to produce further evidence of good conduct and character and may refuse to grant a certificate of competency to any person, if, in its opinion, his general conduct and character do not entitle him to receive such certificate.

12. No person shall be eligible to receive a certificate of competency unless he is a natural born or naturalized subject of Her Majesty.

13. Subject to the provisions of these Regulations, the Board will grant a certificate of competency to any person who has passed the Board's examination.

14. The fees payable by candidates under these Regulations shall be £1 1s. for each examination subject.

15. Applications under these Regulations shall be addressed to the Secretary, Municipal Clerks Board, Local Government Department, 61 Spring-street, Melbourne, C.I.

P. P. MITHEN, Chairman.
D. M. PURDIE, Member.
F. PHILLIPS, Member.
J. O'DONNELL, Secretary.

Approved by the Governor in Council,
15th December, 1959.
A. MAHLSTEDT,
Clerk of the Executive Council.

UNIFORM BUILDING REGULATIONS.

NOTICE is hereby given that, pursuant to the provisions of sub-clause (a) of clause 703 of the Uniform Building Regulations, Victoria, 1959, made under Part XLIX. of the *Local Government Act 1958*, the Building Regulations Committee has approved of the erection of single-storey houses in laminated timber construction, subject to the requirements set out hereunder.

1. All timber other than sub-floor timbers shall be kiln-dried to a moisture content not exceeding 15 per cent at the time of erection.
2. External wall sections shall be—
 - (a) of Radiata Pine not less than 2½ inches in thickness;
 - (b) either solid or laminated from two planks, double-tongued and grooved and weathered.
3. Internal wall sections shall be—
 - (a) of Radiata Pine not less than 1½ inch in thickness;
 - (b) either solid or laminated from two planks, and double-tongued and grooved;
 - (c) securely fixed into external walls at junctions by dove-tailing or other similar method.

4. External corners of external walls shall be clamped for their full height by angle posts of corrosion-resisting metal not less than 3 in. x 3 in. x $\frac{1}{4}$ in., let into vertical grooves in the external lamination.
5. Door and window frames shall be of not less than 4-in. x 4-in. timber, solid or laminated, and deeply grooved to act as stiffeners to the wall sections which shall fit into the frames at top, bottom and sides.
6. Roofs shall be—
 - (a) constructed in accordance with the recommendations set out for Class I. Construction in Building Frames (Timbers and Sizes) being Pamphlet No. 112 Second Edition, issued by the Commonwealth Scientific and Industrial Research Organization; or
 - (b) double-tongued and grooved solid or laminated boarding not less than $1\frac{1}{4}$ inch in thickness with battens provided at normal spacings for the type of roof covering to be used.
7. All Radiata Pine sapwood shall be treated against decay and insect attack with a preservative approved by the Committee and to a retention and penetration approved by the Committee.
8. The lamination of planks shall be carried out in such a manner that any given sample shall pass the following test:—

The timber on one side of the glue line shall be removed, leaving $1\frac{1}{16}$ inch— $\frac{1}{4}$ inch of material. The test sample shall then be boiled for a period of three hours, after which a knife test shall be carried out as laid down in Appendix B of Australian Standard No. O.59 (1952) "Waterproof Plywood, Marine and Standard Grades".
9. End-jointing of timbers where necessary after glueing shall be done with multiple saw-cut glued finger joints.
10. Unsupported lengths of walls and solid board roofs shall not exceed 12 feet and 10 feet respectively without satisfactory stiffening.
11. All plumbing and electrical work built into external walls shall in no way prejudice the weathering thereof.
12. All jointing shall be accurate and tight.
13. Compliance with the provisions of the Uniform Building Regulations, Victoria, with the exception of clauses 2501, 2505 and 2507 thereof.

L. T. DUDLEY,

Secretary, Building Regulations Committee.

Local Government Department,
Melbourne, 18th December, 1959.

MELBOURNE AND METROPOLITAN BOARD OF
WORKS.

NOTICE TO THE OWNERS OF TENEMENTS IN THE UNDER-
MENTIONED STREETS, AND THE PRIVATE STREETS, LANES,
COURTS AND ALLEYS OPENING THERETO.

THE main pipe in the said streets being laid down, the owners of all tenements situated as under are hereby required, on or before 25th January, 1960, to cause a proper pipe and stop cocks to be laid, so as to supply water within such tenements from the main pipe.

V. C. TREYVAUD,
Secretary.

15th December, 1959.

STREET AND POSITION.
Box Hill.

Warrigal-road, from Canterbury-road southwards 5 chains.
Newton-street, from Erasmus-street southwards to existing main $5\frac{1}{2}$ chains.

Broadmeadows.

Bay View-road, from $8\frac{1}{2}$ chains south-east of Plumpton-avenue to Cardinal-road.
Gold Links-road, from 11 chains south-east of Plumpton-avenue south-eastwards 10 chains.
Hillcrest-road, from Plumpton-avenue eastwards 7 chains.
Chester-court, at western end of court $\frac{1}{2}$ chain.
Lee-street, from Wembley-road westwards $8\frac{1}{2}$ chains.
Wembley-road, from Argyle-street northwards $5\frac{1}{2}$ chains.
Esther-street, from Lorne-street southwards 7 $\frac{1}{2}$ chains.
Vincent-street, from 12 $\frac{1}{2}$ chains north-west of Xavier-street north-westwards 48 chains.
Winifred-street, from Gregory-street to Vincent-street.
Gregory-street, from 9 $\frac{1}{2}$ chains south-west of Winifred-street south-westwards 5 $\frac{1}{2}$ chains.
John-street, from Winifred-street south-westwards 10 chains.

Sylvester-street, from Winifred-street south-westwards $8\frac{1}{2}$ chains.

Francis-street, from Winifred-street to Vincent-street.
Ash-grove, from Vincent-street to Summit-avenue.
Summit-avenue, from Ash-grove to Murphy-street.
Josephine-street, from Summit-avenue south-eastwards 4 chains.
Kerr-avenue, from Vincent-street northwards 5 $\frac{1}{2}$ chains.
Percival-street, from Kerr-avenue westwards 11 chains.
Devereaux-street, from Summit-avenue westwards 20 $\frac{1}{2}$ chains.
Short-avenue, from Devereaux-street southwards 5 $\frac{1}{2}$ chains.
Marie-street, from Josephine-street north-westwards 3 $\frac{1}{2}$ chains.
Middle-street, from West-street eastwards 45 $\frac{1}{2}$ chains.
Tassell-street, from Middle-street to South-street.
Neil-street, from Middle-street to Walter-street.
Halsbury-street, from Middle-street to South-street.
Barbara-street, from Middle-street to Walter-street.
Lawrence-street, from Middle-street to Walter-street.
Volga-street, from Middle-street to Patience-street.
Eileen-street, from Volga-street to West-street.
Geum-street, from Volga-street to West-street.
Patience-street, from Volga-street to West-street.
Mikado-street, from Volga-street to West-street.
Sutherland-street, from Middle-street northwards 6 chains.
Graham-street, from Sutherland-street westwards 10 chains.

Camberwell.

Balwyn-road, from Doncaster-road to Willis-avenue.
Warrigal-road, from Canterbury-road southwards to existing main 5 chains.
Robinson-road, from Kingston-road to Sunbury-crescent.

Coburg.

McLoughlin-court, from Dorothy-street eastwards 3 $\frac{1}{2}$ chains.

Dandenong.

Brady-road, from Gladstone-road to Stud-road.

Heidelberg.

Kenmare-street, from French-street to Curtis-avenue.
 Curtis-avenue, from Kenmare-street westwards and southwards to Lynette-court.
 Lynette-court, from Curtis-avenue westwards 1 chain.
 Lynette-court, from Curtis-avenue eastwards 1 chain.
 Leafield-street, from Kenmare-street westwards 7½ chains.
 Linacre-street, from 8½ chains west of Kenmare-street westwards 2 chains.
 Boger-road, from Lambourne-road southwards and westwards 9 chains.

Moorabbin.

Station-street, from 10 chains south of Highett-road southwards 3 chains.
 Highview-road, from Brady-road westwards 11 chains.

Mulgrave.

Swayfield-street, from Highbury-road southwards 9½ chains.
 Campbell-street, from Springvale-road eastwards 33½ chains.
 Coomleigh-street, from Springvale-road eastwards 11½ chains.

Oakleigh.

Elizabeth-street, from Huntingdale-road to Dublin-road.

Richmond.

Brady-street, from Lord-street westwards 3½ chains.

Werribee.

A Government road, from Bladen-street westwards 15½ chains.
 Heffernan-street, from Government-road northwards 13 chains.
 Goble-street, from Government-road northwards 9 chains.
 Studley-court, from Goble-street westwards 6 chains.
 Burke-court, from Goble-street westwards 5½ chains.

Dairy Products Acts.

QUOTAS FOR BUTTER AND CHEESE.

BUTTER QUOTA.

I GILBERT LAWRENCE CHANDLER, Minister of Agriculture in the State of Victoria, after consultation with the Victorian Dairy Products Board, and after ascertaining that the supply and distribution of butter at reasonable prices to consumers thereof in Victoria will be ensured, hereby determine a quota for butter as follows:—

The proportion shall be Forty-four point seven one per cent.

The period for which this quota is to operate shall be the month of January, 1960.

CHEESE QUOTA.

I GILBERT LAWRENCE CHANDLER, Minister of Agriculture in the State of Victoria, after consultation with the Victorian Dairy Products Board, and after ascertaining that the supply and distribution of cheese at reasonable prices to consumers thereof in Victoria will be ensured, hereby determine a quota for cheese as follows:—

The proportion shall be Forty-one point eight six per cent.

The period for which this quota is to operate shall be the month of January, 1960.

G. L. CHANDLER,

Minister of Agriculture.

21st December, 1959.

DEPARTMENT OF MINES.

SUBJECT to any necessary excisions, &c., it is proposed to grant the following mining lease:—

7677, Mineral; Leon Jerome Le Grand; 9a. Or. 35p., Parish of Allambce East.

APPLICATIONS FOR LEASES DECLARED ABANDONED.

7605, Mineral; McKenzie Creek Quarrying Co. Pty. Ltd.; 25a. Or. 20p., Parish of Ledcourt.

7787, Mineral; David Christopher Debenham, William John Davies, John Davies and Charles Alexander Nicoll; 3 acres, Parish of Yanakie South.

TAILINGS LICENCE GRANTED.

2998, Tailings Licence; Leslie David Deas; Parish of Chiltern West (in lieu of Tailings Licence No. 2904, expired).

PETROLEUM EXPLORATION PERMIT GRANTED.

25, Petroleum Exploration Permit; Woodside (Lakes Entrance) Oil Company N. L.; 1,000 square miles, seaward a distance of 8 miles from the coast, between Woodside and Bemm.

TAILINGS LICENCE EXPIRED.

2745, Tailings Licence; The Mayor, Councillors and Citizens of the City of Ballarat; Parish of Smythesdale.

W. J. MIBUS,

Minister of Mines.

THE BENDIGO SEWERAGE AUTHORITY.

RATING BY-LAW No. 6.

The Bendigo Sewerage District.

THE Bendigo Sewerage Authority, in pursuance and exercise of the powers conferred by the Sewerage Districts Acts, doth hereby make the following By-law:—

The following sewerage rate is hereby made, under the provisions of the Sewerage Districts Act, and shall be levied upon the nett annual value of the rateable sewerer properties within the Bendigo Sewerage District.

1. Of any land or tenements situate within the Bendigo Sewerage District, a sewerage rate of One shilling and one penny in the £1 of the nett annual value of all rateable "sewerer property" within the said district.

2. In no case shall the amount of sewerage rate payable annually be less than £4 5s. in respect of any rateable sewerer property on which there is a building, and £2 in respect of any rateable sewerer property on which there is no building.

3. Such rate is made and shall be levied for the year beginning with the first day of October, 1959, and ending with the 30th day of September, 1960, and shall be payable on the first day of February, 1960, at the office of the Authority, situate at the Civic Buildings, Bendigo.

4. If any rateable property which is unsewered at the time of the making of the aforesaid rate becomes during the said year a "sewerer property", there shall be levied upon such property a proportionate part of the sewerage rate for the portion of the year after it has become a sewerer property, and such property shall be deemed to have been lawfully rated accordingly.

5. For making and levying such rate the valuation for the time being of such lands and tenements for the municipal rate of the municipality in the municipal district of which such lands and tenements are situate shall be deemed and taken to be the valuation of such lands and tenements respectively; but if any such lands and tenements are not included in a valuation in force for the municipality in whose district they are situate, or if there is no such valuation, the nett annual value thereof may for all purposes of such rate be determined in the manner provided in the Sewerage Districts Act.

6. Such person or persons as the Bendigo Sewerage Authority may from time to time appoint for that purpose shall be and is or are hereby authorized to demand, receive, collect and recover the said rates and charges.

The resolution for passing the foregoing By-law was agreed to by the Bendigo Sewerage Authority on the twenty-sixth day of October, 1959, and was confirmed by the said Authority on the twenty-third day of November, 1959.

(SEAL)

H. W. SNELL, Chairman.

ALEX. S. CRAIG, Member.

H. A. MOORS, Secretary.

Approved by the Governor in Council, 15th December, 1959.—A. MAHLSTEDT, Clerk of the Executive Council.

KILMORE WATERWORKS TRUST.

RATING BY-LAW FOR THE YEAR 1960 WITHIN THE KILMORE URBAN DISTRICT, AND THE WANDONG URBAN DISTRICT.

THE Kilmore Waterworks Trust, in pursuance and exercise of the powers conferred by the Water Acts, doth hereby make a rate for the supply of water for domestic purposes of Two shillings and three pence (2s. 3d.) in the £1 on the municipal valuation of lands and tenements liable to be rated within the Kilmore Urban District, and Wandong Urban District.

Provided that in no case shall the amount of rate payable in respect of any tenement (other than land on which there is no building) be less than Two pounds fifteen shillings (£2 15s.), and in respect of land on which there is no building less than One pound five shillings (£1 5s.).

Such rates are made and shall be levied upon the occupiers or owners of the said lands and tenements for the year commencing on the 1st day of January, 1960, and shall be payable on the 8th day of April, 1960, at the office of the said Trust.

The maximum quantity of water to be supplied in any one year without further charge to any property rated by the Trust is hereby fixed at the quantity which, at a charge of One shilling per 1,000 gallons, would produce an amount equal to the amount of the rate levied on such property for the said year.

The charge for water supplied by measure to any property rated by the Trust in excess of such maximum quantity, computed as in the last preceding clause, is hereby fixed at 1s. per 1,000 gallons.

The charge for water supplied by measure shall be payable, on demand, at the office of the Trust.

The owners of every piece of vacant or unoccupied land supplied with water by trough must provide an approved self-acting ball tap to prevent overflow.

Passed this 21st day of October, 1959.

(SEAL)

G. L. HUDSON, Chairman.
A. McDONALD, Secretary.

Approved 14th December, 1959.—W. J. MIBUS, Minister of Water Supply.

DROUIN WATERWORKS TRUST.

RATING BY-LAW 1960.

THE Drouin Waterworks Trust, in pursuance and exercise of the powers conferred by the Water Acts, doth hereby make a rate for the supply of water for domestic purposes of Twelve pence in the £1 on the annual municipal valuation of lands and tenements to be rated within the Drouin Urban District.

Provided that in no case shall the amount of rate in respect of any tenement (other than land on which there is no building) be less than Twenty shillings, and in respect of any land on which there is no building less than Ten shillings.

Such rates are made and shall be levied upon the occupiers or owners of the said lands and tenements for the year commencing the 1st day of January, 1960, and ending the last day of December, 1960, and shall be payable on the 1st day of March, 1960, at the office of the said Trust.

The maximum quantity of water to be supplied in any one year without further charge to any property rated by the Trust is hereby fixed at the quantity which, at a charge of Eighteen pence per 1,000 gallons, would produce an amount equal to the amount of the rate levied on such property for the said year.

The charge for water supplied by measure to any property rated by the Trust in excess of such maximum quantity, computed as in the last preceding clause, is hereby fixed at Eighteen pence per 1,000 gallons.

The charge for water supplied by measure shall be payable, on demand, at the office of the Trust.

(SEAL) E. G. PORTER, Chairman.
W. G. WHELLER, Commissioner.
E. J. AUSTIN, Secretary.

Approved 14th December, 1959.—W. J. MIBUS, Minister of Water Supply.

HAMILTON WATERWORKS TRUST.

BY-LAW No. 74.

THE Hamilton Waterworks Trust (hereinafter referred to as "the Trust"), the Waterworks District of which Trust has been proclaimed an urban district for the purposes of the Water Acts doth hereby make the following By-law for such urban district:—

1. This By-law shall come into operation at such time as the Trust may from time to time direct by notice published in the *Hamilton Spectator*, and cease to have operation at such time as the Trust may from time to time direct by notice published in the said newspaper.

2. During any period in which this By-law shall be in operation as hereinbefore provided, the provisions contained in the following clauses shall apply, that is to say:—

(a) Subject as hereinafter provided no person shall apply or permit or suffer to be applied water supplied by the Trust to any garden plantation or any vegetation.

(b) The prohibition contained in the last preceding clause shall not apply—

(1) To persons carrying on business as commercial nurseries or commercial market gardens nor to water used from the Trust's old storage reservoir.

(2) Between the hours of Seven and Nine in the evenings of every day during the period aforesaid, provided that the water used for any of the purposes mentioned in the last preceding clause (a) is supplied by the Trust by measure and is so used either through or by means of one portable sprinkler per tenement only or through or by means of a hose held during such use by the person so using the water.

(c) No person supplied with water by the Trust shall waste the same or permit or suffer the same to run to waste.

(d) Except for fire-fighting purposes no person shall take or carry away from any premises water supplied by the Trust.

(e) No person shall sell water supplied by the Trust.

3. This By-law shall have effect throughout the whole of the Waterworks District of the Trust.

The foregoing By-law was made on the 29th day of January One thousand nine hundred and fifty-nine, and the seal of the Trust affixed hereto, in the presence of—

(SEAL) M. C. JAMES, Chairman.
E. C. DEMPSTER, Commissioner.
H. F. DONALD, Secretary.

Approved by the Governor in Council, 15th December, 1959.—A. MAHLSTEDT, Clerk of the Executive Council.

HAMILTON WATERWORKS TRUST.

BY-LAW No. 75.

THE Hamilton Waterworks Trust (hereinafter referred to as "the Trust"), the Waterworks District of which Trust has been proclaimed an urban district for the purposes of the Water Acts doth hereby make the following By-law for such urban district:—

1. This By-law shall come into operation at such time as the Trust may from time to time direct by notice published in the *Hamilton Spectator*, and cease to have operation at such time as the Trust may from time to time direct by notice published in the said newspaper.

2. During any period in which this By-law shall be in operation as hereinbefore provided, the provisions contained in the following clauses shall apply, that is to say:—

(a) Subject as hereinafter provided no person shall apply or permit or suffer to be applied water supplied by the Trust to any garden plantation or any vegetation.

(b) The prohibition contained in the last preceding clause shall not apply—

(1) To persons carrying on business as commercial nurseries or commercial market gardens nor to water used from the Trust's old storage reservoir.

(2) Between the hours of Seven and Eight in the morning and between the hours of Seven and Eight in the evening of every day during the period aforesaid, provided that the water used for any of the purposes mentioned in the last preceding clause (a) is supplied by the Trust by measure and is so used either through or by means of one portable sprinkler per tenement, only.

(c) No person supplied with water by the Trust shall waste the same or permit or suffer the same to run to waste.

(d) Except for fire-fighting purposes no person shall take or carry away from any premises water supplied by the Trust.

(e) No person shall sell water supplied by the Trust.

3. This By-law shall have effect throughout the whole of the Waterworks District of the Trust.

The foregoing By-law was made on the nineteenth day of March, 1959, and the seal of the Trust was hereunto affixed in the presence of—

(SEAL) M. C. JAMES, Chairman.
E. C. DEMPSTER, Commissioner.
H. F. DONALD, Secretary.

Approved by the Governor in Council, 15th day of December, 1959.—A. MAHLSTEDT, Clerk of the Executive Council.

VIOLET TOWN WATERWORKS TRUST.

RATING BY-LAW 1960.

THE Violet Town Waterworks Trust, in pursuance of the powers conferred by the Water Acts, doth hereby make a rate for the supply of water for domestic purposes of Three shillings in the £1 on the nett annual municipal valuation of lands and tenements liable to be rated within the district of the Violet Town Waterworks Trust.

Provided that in no case shall the amount of rate payable in respect of any tenement (other than on land where there is no building) be less than Two pounds ten shillings.

Such rates are made and shall be levied upon the occupiers or owners of the said lands and tenements for the year commencing on the 1st day of January, 1960, and shall be payable on the 1st February, 1960, at the office of the said Trust.

The maximum quantity of water to be supplied in any one year without any further charge to any property rated by the Trust is hereby fixed at the quantity which, at a charge of Two shillings per 1,000 gallons, would produce an amount equal to the amount of rate levied on such property for the said year.

The charge for water supplied by measure to any property rated by the Trust in excess of such maximum quantity, computed as in the last preceding clause, is hereby fixed at One shilling per 1,000 gallons.

A charge of Three pounds for the supply of water to any troughs within the district (for sheep, cattle or horses).

All charges for the supply of water shall be payable on demand at the office of the Trust at Violet Town.

Passed this 9th day of November, 1959.

(SEAL) OSBERT J. RAMAGE, Chairman.
R. J. HAMMETT, Secretary.

Approved 14th December, 1959.—W. J. MIBUS, Minister of Water Supply.

WARBURTON WATERWORKS TRUST.

FIXING THE LIMIT OF A BANK OVERDRAFT.

HIS Excellency the Governor of the State of Victoria, by and with the advice of the Executive Council thereof, doth by Order made on the 22nd December, 1959, in pursuance of the provisions of section 288 of the Water Act 1958, fix the limit of the overdraft to be obtained by the Warburton Waterworks Trust from the National Bank of Australasia Limited, Warburton, at an amount not to exceed at any one time, the sum of One thousand pounds (£1,000).

A. MAHLSTEDT,
Clerk of the Executive Council.

At the Executive Council Chamber,
Melbourne, 22nd December, 1959.

WARRAGUL WATERWORKS TRUST.

RATING BY-LAW FOR THE YEAR 1960—No. 52.

THE Warragul Waterworks Trust, in pursuance of the powers conferred by the Water Acts, doth hereby make a rate for the supply of water for domestic purposes of Eighteen pence (1s. 6d.) in the pound of the annual municipal valuation of lands and tenements liable to be rated within the Warragul Urban District.

1. Provided that in no case shall the amount of rate payable per annum in respect of any tenement (other than land on which there is no building) be less than Twenty-six shillings (26s.), and in respect of any land on which there is no building be less than Twelve shillings and six pence (12s. 6d.).

2. Such rates are made and shall be levied upon the occupiers or owners of the said lands and tenements for the year commencing on the 1st day of January, 1960, and shall be due and payable on the 2nd day of March, 1960, at the office of the Trust, Queen-street, Warragul.

3. The maximum quantity of water to be supplied in any one year without further charge to any property rated by the Trust is hereby fixed at the quantity which, at a charge of Eighteen pence (1s. 6d.) per 1,000 gallons, would produce an amount equal to the amount of rates levied on such property for the said year.

4. The charge for water supplied by measure to any property rated by the Trust in excess of such maximum quantity, computed as in the last preceding clause, is hereby fixed at Eighteen pence (1s. 6d.) per 1,000 gallons.

5. The minimum charge per annum for the supply of water to Government premises shall be Ninety shillings (90s.), and for excess water over 60,000 gallons the charge shall be Eighteen pence (1s. 6d.) per 1,000 gallons.

6. The charge for water supplied by measure shall be payable, on demand, at the office of the Trust.

Passed this 17th day of November, 1959.

(SEAL) C. W. PEDERSEN, Chairman.
R. W. LEASK, Secretary.

Approved, 14th December, 1959.—W. J. MIBUS, Minister of Water Supply.

LINTON WATERWORKS TRUST.

BY-LAW No. 4.—LINTON URBAN DISTRICT.

THE Linton Waterworks Trust, hereinafter referred to as "the Trust", in pursuance and exercise of the powers conferred by the Water Acts, doth hereby make the By-law following, restricting the use for other than domestic purposes of water supplied by the said Trust within the Linton Urban District:—

1. This By-law shall apply to and have force in the Linton Urban District.

2. This By-law shall come into operation at such time or times as the Trust directs by notice published in a newspaper circulating generally within the above-mentioned urban district, and shall cease to operate at such time or times as the Trust may direct by notice so published.

3. No person shall with water supplied by the Trust, water any garden, lawn or other land at any time within the above-mentioned urban district.

4. Every person who uses or permits or suffers water supplied by the Trust to be used contrary to the provisions of this By-law shall be guilty of an offence, and shall be liable to a penalty not exceeding Five pounds, recoverable summarily before any court of competent jurisdiction.

5. If any person supplied with water by the Trust wrongfully does or causes or permits to be done anything in contravention of this By-law, the Trust may (without prejudice to any remedy in respect thereof) close or cut off any of the pipes by or through which water is supplied by the Trust to him or for his use, and may cease to supply him with water as provided by the Water Acts.

The foregoing By-law was made by the Linton Waterworks Trust on the 30th day of November, 1959, and the common seal of the said Trust was hereunto affixed the 30th day of November, 1959, in the presence of—

(SEAL) H. O'C. KENNEDY, Chairman.
J. STODDART, Commissioner.
W. S. GRIGG, Commissioner.
L. OLDHAM, Secretary.

Approved by the Governor in Council, 15th December, 1959.—A. MAHLSTEDT, Clerk of the Executive Council.

LINTON WATERWORKS TRUST.

BY-LAW No. 2.—LINTON URBAN DISTRICT.

THE Linton Waterworks Trust, hereinafter referred to as "the Trust", in pursuance and exercise of the powers conferred by the Water Acts, doth hereby make the By-law following, restricting the use for other than domestic purposes of water supplied by the said Trust within the Linton Urban District:—

1. This By-law shall apply to and have force in the Linton Urban District.

2. This By-law shall come into operation at such time or times as the Trust directs by notice published in a newspaper circulating generally within the above-mentioned urban district, and shall cease to operate at such time or times as the Trust may direct by notice so published.

3. No person shall with water supplied by the Trust, water any garden, lawn, or other land within the above-mentioned urban district unless by means of a hose held in the hand, or by means of a can or other vessel held in the hand.

4. Every person who uses or permits or suffers water supplied by the Trust to be used contrary to the provisions of this By-law shall be guilty of an offence, and shall be liable to a penalty not exceeding Five pounds, recoverable summarily before any court of competent jurisdiction.

5. If any person supplied with water by the Trust wrongfully does or causes or permits to be done anything in contravention of this By-law, the Trust may (without prejudice to any remedy in respect thereof) close or cut off any of the pipes by or through which water is supplied by the Trust to him or for his use, and may cease to supply him with water as provided by the Water Acts.

The foregoing By-law was made by the Linton Waterworks Trust on the 30th day of November, 1959, and the common seal of the said Trust was hereunto affixed the 30th day of November, 1959, in the presence of—

(SEAL) H. O'C. KENNEDY, Chairman.
J. STODDART, Commissioner.
W. S. GRIGG, Commissioner.
L. OLDHAM, Secretary.

Approved by the Governor in Council, 15th December, 1959.—A. MAHLSTEDT, Clerk of the Executive Council.

LINTON WATERWORKS TRUST.

BY-LAW No. 3.—LINTON URBAN DISTRICT.

THE Linton Waterworks Trust, hereinafter referred to as "the Trust", in pursuance and exercise of the powers conferred by the Water Acts, doth hereby make the By-law following, restricting the use for other than domestic purposes of water supplied by the said Trust within the Linton Urban District:—

1. This By-law shall apply to and have force in the Linton Urban District.

2. This By-law shall come into operation at such time or times as the Trust directs by notice published in a newspaper circulating generally within the above-mentioned urban district, and shall cease to operate at such time or times as the Trust may direct by notice so published.

3. No person shall with water supplied by the Trust, water any garden, lawn, or other land within the above-mentioned urban district unless by means of a hose held in the hand, or by means of a can or other vessel held in the hand and then only between the hours of 5.30 p.m. and 8 p.m. of the same day.

4. Every person who uses or permits or suffers water supplied by the Trust to be used contrary to the provisions of this By-law shall be guilty of an offence, and shall be liable to a penalty not exceeding Five pounds, recoverable summarily before any court of competent jurisdiction.

5. If any person supplied with water by the Trust wrongfully does or causes or permits to be done anything in contravention of this By-law, the Trust may (without prejudice to any remedy in respect thereof) close or cut

off any of the pipes by or through which water is supplied by the Trust to him or for his use, and may cease to supply him with water as provided by the Water Acts.

The foregoing By-law was made by the Linton Waterworks Trust on the 30th day of November, 1959, and the common seal of the said Trust was hereunto affixed the 30th day of November, 1959, in the presence of—

(SEAL) H. O'C. KENNEDY, Chairman.
J. STODDART, Commissioner.
W. S. GRIGG, Commissioner.
L. OLDHAM, Secretary.

Approved by the Governor in Council, 15th December, 1959.—A. MAHLSTEDT, Clerk of the Executive Council.

LISMORE WATERWORKS TRUST.

RATING BY-LAW FOR THE YEAR 1960.

THE Lismore Waterworks Trust, in pursuance and exercise of the powers conferred by the Water Acts, doth hereby make a rate for the supply of water for domestic purposes of Two shillings in the £1 of the annual municipal valuation of lands and tenements liable to be rated within the Lismore Urban District.

Provided that in no case shall the amount of rate payable per annum in respect of any tenement (other than land on which there is no building) be less than Four pounds (£4) and in respect of any land on which there is no building less than One pound (£1).

Such rates are made and shall be levied upon the occupiers or owners of the said lands and tenements for the year commencing 1st January, 1960, and shall be payable on the 1st March, 1960, at the office of the said Trust.

The maximum quantity of water to be supplied in any one year without further charge to any property rated by the Trust is hereby fixed at the quantity which, at a charge of Two shillings per 1,000 gallons, would produce an amount equal to the amount of rate levied on such property for the said year.

The charge for water supplied by measure to any property rated by the Trust in excess of the maximum quantity, computed as in the last preceding clause, is hereby fixed at Three shillings per 1,000 gallons.

The charge for water supplied by measure shall be payable on demand, at the office of the Trust.

Passed this 19th day of November, 1959.

(SEAL) J. W. BAIRD, Chairman.
M. M. BRUMBY, Secretary.

Approved 14th December, 1959.—W. J. MIBUS, Minister of Water Supply.

APOLLO BAY WATERWORKS TRUST.

RATING BY-LAW FOR THE YEAR 1960.

THE Apollo Bay Waterworks Trust, in pursuance and exercise of the powers conferred by the Water Acts, doth hereby make a rate for the supply of water for domestic purposes of One shilling and eight pence (1s. 8d.) in the pound of the annual municipal valuation of lands and tenements liable to be rated within the Apollo Bay Urban District.

Provided that in no case shall the amount of rate payable per annum in respect of any tenement (other than land on which there is no building) be less than Fifty shillings (50s.), and in respect of any land on which there is no building less than Twenty shillings (20s.).

Such rates are made and shall be levied upon the occupiers or owners of the said lands and tenements for the year commencing on the 1st day of January, 1960, and shall be payable on the 1st day of April, 1960, at the office of the said Trust.

The maximum quantity of water to be supplied in any one year without further charge to any property rated by the said Trust is hereby fixed at the quantity which, at a charge of One shilling and six pence (1s. 6d.) per 1,000 gallons, would produce an amount equal to the amount of the rate levied on such property for the said year.

The charge for water supplied by measure to any property rated by the Trust in excess of such maximum quantity, computed as in the last preceding clause, is hereby fixed at One shilling and six pence (1s. 6d.) per 1,000 gallons.

Water supplied to cricket, tennis, or bowling clubs, and to Government departments, showgrounds, and similar properties shall be charged for at the rate of One shilling and six pence (1s. 6d.) per 1,000 gallons, provided that the minimum quantity to be charged for shall not be less than 15,000 gallons.

The charge for water supplied by measure shall be payable, on demand, at the office of the Trust.

Passed this 20th day of November, 1959.

C. ALLEN, Chairman.
J. TRESEDER, Secretary.

Approved, 14th December, 1959.—W. J. MIBUS, Minister of Water Supply.

MIRBOO NORTH WATERWORKS TRUST.

RATING BY-LAW FOR THE YEAR 1960.

THE Mirboo North Waterworks Trust, in pursuance and exercise of the powers conferred by the Water Acts, doth hereby make a rate for the supply of water for domestic purposes of Two shillings and six pence in the £1 of the annual municipal valuation of land and tenements liable to be rated within the Mirboo North Urban District.

Provided that in no case shall the amount of rate payable per annum in respect of any tenement (other than land on which there is no building) be less than Three pounds, and in respect of any land on which there is no building less than One pound.

Such rates are made and shall be levied upon the occupiers or owners of the said lands and tenements for the year commencing 1st January, 1960, and ending on the last day of December, 1960, and shall be payable on the 2nd day of February, 1960, at the office of the said Trust.

The maximum quantity of water to be supplied in any one year without further charge to any property rated by the Trust is hereby fixed at the quantity which, at a charge of One shilling per 1,000 gallons, would produce an amount equal to the amount of rate levied on such property for the said year.

The charge for water supplied by measure to any property rated by the Trust in excess of such maximum quantity, computed as in the last preceding clause, is hereby fixed at One shilling per 1,000 gallons.

The charge for water supplied by measure to any property not rated by the Trust is hereby fixed at One shilling per 1,000 gallons, and the minimum charge in cases where water is so supplied, is hereby fixed at Three pounds per annum.

The charge for water supplied by measure shall be payable, on demand, at the office of the Trust, Mirboo North.

Passed this 19th day of November, 1959.

(SEAL) WALTER J. TUCK, Chairman.
FRANK OTTO FISHMAN, Commissioner.
C. J. BREN, Secretary.

Approved, 14th December, 1959.—W. J. MIBUS, Minister of Water Supply.

RIDDELL'S CREEK WATERWORKS TRUST.

RATING BY-LAW FOR THE YEAR 1960.

THE Riddell's Creek Waterworks Trust, in pursuance and exercise of the powers conferred by the Water Acts, doth hereby make a rate for the supply of water for domestic purposes of Two shillings and six pence (2s. 6d.) in the £1 of the annual municipal valuation of lands and tenements liable to be rated within the Riddell's Creek Urban District.

Provided that in no case shall the amount of rate payable per annum in respect of any tenement (other than land on which there is no building) be less than Two pounds ten shillings (£2 10s.), and in respect of land on which there is no building less than One pound (£1).

Such rates are made and shall be levied upon the occupiers or owners of the said lands and tenements for the year commencing on the 1st day of January, 1960, and shall be made payable on the 26th day of February, 1960, at the office of the said Trust.

The maximum quantity of water to be supplied in any one year without further charge to any property rated by the Trust is hereby fixed at the quantity which, at a charge of One shilling (1s.) per 1,000 gallons, would produce an amount equal to the amount of rate levied on the property for the said year.

The charge for water supplied by measure to any property rated by the Trust in excess of such maximum quantity, computed as in the last preceding clause, is hereby fixed at One shilling (1s.) per 1,000 gallons.

The charge for water supplied by measure shall be payable, on demand, at the office of the Trust.

Passed this 3rd day of November, 1959.

(SEAL) A. WATKIN WYNNE, Chairman.
UNA I. WRIGHT, Trust Secretary.

Approved, 14th December, 1959.—W. J. MIBUS, Minister of Water Supply.

TONGALA WATERWORKS TRUST.

RATING BY-LAW FOR THE YEAR 1960.

THE Tongala Waterworks Trust, in pursuance and exercise of the powers conferred by the Water Acts, doth hereby make a rate for the supply of water for domestic purposes of One shilling and three pence in the £1 of the annual municipal valuation of lands and tenements liable to be rated within the Tongala Urban District.

Provided that in no case shall the amount of rate payable per annum in respect of any tenement (other than on land on which there is no building) be less than Two pounds (£2) and in respect of any land on which there is no building less than Fifteen shillings.

Such rates are made and shall be levied upon the occupiers or owners of the said lands and tenements for the year commencing on the 1st day of January, 1960, and shall be payable on the 1st day of February, 1960, at the office of the said Trust.

The maximum quantity of water to be supplied in any one year without further charge to any property rated by the Trust is hereby fixed at the quantity which, at a charge of Two shillings and six pence per 1,000 gallons would produce an amount equal to the amount of the rate levied on such property for the said year.

The charge for water supplied by measure to any property rated by the Trust in excess of such maximum quantity, computed as in the last preceding clause, is hereby fixed at One shilling and six pence per 1,000 gallons.

The charge for water supplied by measure shall be payable, on demand, at the office of the Trust.

For water supplied from stand-pipe or hydrant, the charge for every 1,000 gallons or portion of same, to be at the rate of Two shillings and six pence per 1,000 gallons, with a minimum of One shilling for any tank or load.

Such person or persons as the Commissioners of the said Trust may from time to time appoint for the purposes, are hereby authorized to collect and recover the said rates and charges.

The foregoing By-law was made by the Tongala Waterworks Trust, and passed this 25th day of November, 1959.

(SEAL) C. R. BUCHANAN, Chairman.
K. C. GRAHAM, Secretary.

Approved, 14th December, 1959.—W. J. MIBUS, Minister of Water Supply.

BAIRNSDALE WATERWORKS TRUST.

AUTHORITY TO OBTAIN BANK OVERDRAFT.

HIS Excellency the Governor of the State of Victoria, by and with the advice of the Executive Council thereof, doth by Order made on the 22nd December, 1959, authorize the Bairnsdale Waterworks Trust to obtain, in pursuance of the provisions of section 286 of the Water Act 1958 (No. 6413), an advance or advances during the year 1960 from the Bank of New South Wales, Bairnsdale, by overdraft of the Trust's current account thereat, such overdraft not to exceed at any one time the sum of Eight thousand pounds (£8,000).

A. MAHLSTEDT,
Clerk of the Executive Council.

At the Executive Council Chamber,
Melbourne, 22nd December, 1959.

BOOLARRA WATERWORKS TRUST.**AUTHORITY TO OBTAIN BANK OVERDRAFT.**

HIS Excellency the Governor of the State of Victoria, by and with the advice of the Executive Council thereof, doth by Order made on the 22nd December, 1959, authorize the Boolarra Waterworks Trust to obtain, in pursuance of the provisions of section 286 of the *Water Act 1958* (No. 6413), an advance or advances during the year 1960 from the National Bank of Australasia Limited, Morwell, by overdraft of the Trust's current account thereat, such overdraft not to exceed at any one time the sum of Six hundred pounds (£600).

A. MAHLSTEDT,
Clerk of the Executive Council.

At the Executive Council Chamber,
Melbourne, 22nd December, 1959.

YACKANDANDAH WATERWORKS TRUST.**RATING BY-LAW FOR THE YEAR 1960.**

THE Yackandandah Waterworks Trust, in pursuance and exercise of the powers conferred by the *Water Acts*, doth hereby make a rate for the supply of water for domestic purposes, of One shilling and eight pence in the £1 of the annual municipal valuation of lands and tenements liable to be rated within the Yackandandah Urban District.

Provided that in no case shall the amount of rate payable per annum in respect of any tenement (other than land on which there is no building) be less than Sixty-two shillings and four pence, and in respect of any land on which there is no building, less than Forty-three shillings and eight pence.

Such rates are made and shall be levied upon the occupiers or owners of the said lands and tenements for the year commencing the 1st day of January, 1960, and shall be payable on the 1st day of April, 1960, at the office of the Trust.

Passed this 12th day of November, 1959.

(SEAL) A. R. McKIBBIN, Acting Chairman.
R. McDERMOTT, Commissioner.
Y. A. PERMEZEL, Secretary.

Approved, 14th December, 1959.—W. J. MIBUS, Minister of Water Supply.

SEYMOUR WATERWORKS TRUST.**RATING BY-LAW FOR THE YEAR 1960.**

THE Seymour Waterworks Trust, in pursuance and exercise of the powers conferred by the *Water Acts*, doth hereby make a rate for the supply of water for domestic purposes of One shilling in the pound of the annual municipal valuation of lands and tenements liable to be rated within the Seymour Urban District.

Provided that in no case shall the amount of rate payable per annum in respect of any tenement (other than land on which there is no building) be less than Twenty-five shillings, and in respect of any land on which there is no building, less than Ten shillings.

Such rates are made and shall be levied upon the occupiers or owners of the said lands and tenements for the year commencing the 1st day of January, 1960, and shall be payable on the 1st day of March, 1960, at the office of the said Trust.

The maximum quantity of water to be supplied in any one year without further charge to any property rated by the Trust is hereby fixed at the quantity which, at a charge of One shilling per 1,000 gallons, would produce an amount equal to the amount of the rate levied on such property for the said year.

The charge for water supplied by measure to any property rated by the Trust in excess of such maximum quantity, computed as in the last preceding clause, is hereby fixed at One shilling and six pence per 1,000 gallons.

The charge for water supplied by measure shall be payable, on demand, at the office of the said Trust.

Dated this 16th day of November, 1959.

(SEAL) T. G. WILKINSON, Chairman.
J. W. ELLIOTT, Commissioner.
ARTHUR SMITH, Commissioner.
M. E. COUGHLIN, Commissioner.
W. E. HEYWOOD, Commissioner.
H. CLYDESDALE, Secretary.

Approved, 14th December, 1959.—W. J. MIBUS, Minister of Water Supply.

LAKES ENTRANCE WATERWORKS TRUST.**AUTHORITY TO OBTAIN BANK OVERDRAFT.**

HIS Excellency the Governor of the State of Victoria, by and with the advice of the Executive Council thereof, doth by Order made on the 22nd December, 1959, authorize the Lakes Entrance Waterworks Trust to obtain, in pursuance of the provisions of section 286 of the *Water Act 1958* (No. 6413), an advance or advances during the year 1960 from the National Bank of Australasia Limited, Lakes Entrance, by overdraft of the Trust's current account thereat, such overdraft not to exceed at any one time the sum of Three thousand pounds (£3,000).

A. MAHLSTEDT,
Clerk of the Executive Council.

At the Executive Council Chamber,
Melbourne, 22nd December, 1959.

KOROIT WATERWORKS TRUST.**RATING BY-LAW 60.**

THE Koroit Waterworks Trust, in pursuance and exercise of the powers conferred by the *Water Acts*, doth hereby make a rate for the supply of water for domestic purposes of Twenty-two pence in the £1 of the annual municipal valuation of lands and tenements liable to be rated within the Koroit Urban District.

Provided that in no case shall the amount of rate payable per annum in respect of any tenement (other than land on which there is no building) be less than Fifteen shillings, and in respect of any land on which there is no building, be less than Thirteen shillings and four pence.

Such rate shall be levied upon the occupiers or owners of the said lands and tenements for the year commencing 1st January, 1960, and shall be payable on 8th April, 1960.

Passed this 4th day of November, 1959.

(SEAL) JOHN MURRAY, Chairman.
R. PRICE, Secretary.

Approved, 14th December, 1959.—W. J. MIBUS, Minister of Water Supply.

SHIRE OF MOUNT ROUSE WATERWORKS TRUST.**AUTHORITY TO OBTAIN BANK OVERDRAFT.**

HIS Excellency the Governor of the State of Victoria, by and with the advice of the Executive Council thereof, doth by Order made on the 22nd December, 1959, authorize the Shire of Mount Rouse Waterworks Trust to obtain, in pursuance of the provisions of section 286 of the *Water Act 1958* (No. 6413), an advance or advances during the year 1960 from the National Bank of Australasia Limited, Peshurst, by overdraft of the Trust's current account thereat, such overdraft not to exceed at any one time the sum of One thousand three hundred pounds (£1,300).

A. MAHLSTEDT,
Clerk of the Executive Council.

At the Executive Council Chamber,
Melbourne, 22nd December, 1959.

STATE RIVERS AND WATER SUPPLY COMMISSION.

LICENCES TO DIVERT WATER AND CUT RACES, PURSUANT TO THE PROVISIONS OF THE WATER ACTS.

LICENCES as detailed hereunder for the term of years from the date specified in each case have been granted by the Governor in Council to the persons named in the following Schedule:—

SCHEDULE.

Licence No.	Term of Licence and Commencing Date.	Name and Address of Person to Whom Licence is to be Granted.	Source of Supply.	Area Authorized to be Irrigated Per Annum.	Volume of Water Authorized to be Diverted Per Annum.
				acres.	ac. ft.
S24/316	Five years from 1.7.59 ..	Gouge Country Services Proprietary Limited	Kow Swamp ..	155	310
1334	Eleven and a half years from 1.1.60	Samuel James Dudley, Baringhup ..	Loddon River ..	10	20
1335	Eleven and a half years from 1.1.60	Ernest William Graham, Arnold ..	Loddon River ..	10	20
1336	Eleven and a half years from 1.1.60	Elizabeth Lamb Stephenson, Malmesbury	Loddon River ..	20	40
1337	Twelve and a half years from 1.1.60	The Executors of the Estate of Thomas Mossop, Piangil	Serpentine Creek ..	20	40
1338	Twelve and a half years from 1.1.60	Thomas Mossop, Bears Lagoon ..	Serpentine Creek ..	10	20
1339	Fifteen years from 1.7.59 ..	Geoffrey Edgar Davies, and John William Davies, Eddington	Bet Bet Creek (Laanecoorie Reservoir)	20	40
1340	Thirteen and a half years from 1.1.60	Edgar Percival Davies, Eddington ..	Bet Bet Creek (Laanecoorie Reservoir)	10	20
1341	Eleven and a half years from 1.1.60	Arthur Louis Dehnert, Bridgewater ..	Loddon River ..	20	40
1342	Fourteen and a half years from 1.1.60	Stephen Foley, Inglewood ..	Loddon River ..	25	50
938	Five years from 1.7.59 ..	Herbert James Davey, Fish Point ..	Tutchewop Outfall	13	26
1343	Eleven and a half years from 1.1.60	Mary Isabel Maude Ellis, Bridgewater ..	Loddon River ..	4	8

Office of the State Rivers and Water Supply Commission,
Melbourne, 22nd December, 1959.

E. BROWN, Secretary,
State Rivers and Water Supply Commission.

NOTICE.

ADMINISTRATION of the estate of each of the under-mentioned deceased persons has been granted to the Public Trustee, and creditors, next of kin, and all others having claims against the estate of any of the persons so mentioned are required to send particulars of their claims to the Public Trustee, 7th Floor, 601 Little Collins-street, Melbourne, on or before the 26th February, 1960, or they will be excluded from the distribution of the estate when the assets are being distributed:—

AITA, ROBERTO, formerly of 3 Grey-street, Mount Gambier, but late of Flax Mill, Lake Bolac, mill hand, died between 1st and 7th April, 1959, intestate.

*ANDERSON, HARRIETT EMILY, also known as Harriet Emily Anderson, formerly of 61 Embankment-grove, Chelsea, but late of 15 Eastfield-road, Croydon, widow, died 6th October, 1959.

*BEEDEN, MARY BRIDGET, also known as Mary Bridget Beeden, late of 9 Sycamore-grove, East St. Kilda, retired school teacher, died 19th October, 1959.

BROWN, THOMAS ROBERT NEIL, late of Grandview-crescent, Tecoma, postal officer, died 9th April, 1959, intestate.

†DEARING, RICHARD FRANCIS WILLIAM, late of 19 Nicholson-street, East Coburg, stove fitter, died 13th October, 1959.

DEXTER-CLARKE, HENRY EDWIN, also known as Edwin Henry Dexter-Clarke, late of 27A Heidelberg-road, Clifton Hill, watchman, died 9th September, 1959, intestate.

GILLIES, ANNIE JOSEPHINE, formerly of 14 Avoca-street, South Yarra, but late of 19 Grattan-street, Carlton, pensioner, died 25th August, 1959, intestate.

*GOLDIE, KENNETH MACLEAY ALLAN, formerly of 105 Stevedore-street, North Williamstown, but late of Mont Park, fitter and turner, died 2nd June, 1959.

HANSON, SUSANNA RUBY, late of 11 West-street, Brunswick, widow, died 9th June, 1959, intestate.

*HOULIHAN, RICHARD EDWARD, late of "Eventide", Sandgate, Queensland, retired toolmaker, died 3rd September, 1956.

†KANE, ADELAIDE, late of Barraport, widow, died 20th December, 1950.

LANGLEY, ALEXANDER, formerly of 183 Canning-street, Carlton, but late of 135 Neill-street, Carlton, labourer, died 26th August, 1959, intestate.

*MILLER, MARIA LOUISA, in the will called Maria Miller, late of Trafalgar, widow, died 19th January, 1959.

MCQUALTER, VERNON, late of 148 Victoria-parade, East Melbourne, driver, died 15th March, 1958, intestate.

* With the will annexed.

† According to the provisions of the will.

A. D. DUNCAN,

Public Trustee.

Melbourne, 16th December, 1959.

PUBLIC TRUSTEE ACT 1958 (No. 6350).—SECTION 17.

I HEREBY give notice that on the 20th November, 1959, the Public Trustee filed an election to administer the following deceased person's estate, in accordance with section 17 of the *Public Trustee Act 1958*:—

GILLIES, ANNIE JOSEPHINE, formerly of 14 Avoca-street, South Yarra, but late of 19 Grattan-street, Carlton, pensioner, died 25th August, 1959, intestate.

I HEREBY give notice that on the 4th December, 1959, the Public Trustee filed an election to administer the following deceased person's estate, in accordance with section 17 of the *Public Trustee Act 1958*:—

MCQUALTER, VERNON, late of 148 Victoria-parade, East Melbourne, driver, died 15th March, 1958, intestate.

I HEREBY give notice that on the 8th December, 1959, the Public Trustee filed elections to administer the following deceased persons' estates, in accordance with section 17 of the *Public Trustee Act 1958*:—

*DEARING, RICHARD FRANCIS WILLIAM, late of 19 Nicholson-street, East Coburg, stove fitter, died 13th October, 1959.

*KANE, ADELAIDE, late of Barraport, widow, died 20th December, 1950.

* According to the provisions of the will.

A. D. DUNCAN,

Public Trustee.

601 Little Collins-street, Melbourne, 16th December, 1959.

CONTRACTS ACCEPTED.—(Series 1959-60.)

Contract No.	Particulars.	Amount.	Name of Contractor.	Charge against Vote or Fund
1651	GENERAL STORES— Supply of Tyres and Tubes, Pneumatic, in such quantities as may be ordered from 1st January, 1960, to 30th June, 1960	Rates as per annex	Dunlop Rubber Australia Ltd.	} Contingencies, 1959-60.
1652	" " " " " " " "	" "	The Goodyear Tyre and Rubber Co. (Aust.) Ltd.	
1653	" " " " " " " "	" "	The Olympic Tyre and Rubber Co. Pty. Ltd.	
1654	" " " " " " " "	" "	Hardie Rubber Co. Ltd.	

Approved—H. E. BOLTE, Treasurer, 22.12.59.

ANNEX TO CONTRACTS.

Item No.	Description of Articles.	Rate.	Name of Contractor.
ANNEX TO CONTRACTS Nos. 1959/1651 to 1959/1654. Schedule No. 75. TYRES AND TUBES, PNEUMATIC. Contract from 1st January, 1960, to 30th June, 1960. 1959/1651.—Dunlop Rubber Australia Ltd. Security, £100. 1959/1652.—The Goodyear Tyre and Rubber Co. (Aust.) Ltd. Security, £100. 1959/1653.—Olympic Tyre and Rubber Co. Pty. Ltd. Security, £100. 1959/1654.—Hardie Rubber Co. Ltd. Security, £100.		£ s. d.	
1	Tyres and Tubes, Pneumatic, and Tubeless Tyres, as ordered— For Motor Cars, Trucks, Buses, Tractors, Earth Movers, Graders, Farm Implements and Industrial	} *List Price	} Dunlop Rubber Australia Ltd. The Goodyear Tyre and Rubber Co. (Aust.) Ltd. The Olympic Tyre and Rubber Co. Pty. Ltd. Hardie Rubber Co. Ltd.
2	For Motor Cycles and Side Cars		
3	For Bicycles— Tyres, "Grand Prix" each Tubes " " "		

*Discounts.—All contracts are subject to a settlement discount of 2½% for payment by end of month following month of delivery.

Contractors must supply copies of current Price Lists to Departments requiring same.

Warranty.—No specific warranty is given, but complaints as to faults or unsatisfactory service will receive consideration.

Special Conditions.—All contracts are subject to adjustment of rates, availability of stocks, and ability to supply in conformity with Government regulations.

On receipt of notification by a contractor that tyres and tubes of the sizes ordered are out of stock, Departments are authorized to place the whole or portion of their unsatisfied orders with another contractor who is able to supply the sizes required.

Distribution of Orders for Motor Tyres and Tubes.—Orders by Departments are to be issued on the respective contractors in accordance with the following allocation :—

Dunlop Rubber Australia Ltd.	The Goodyear Tyre and Rubber Co. (Aust.) Ltd.	The Olympic Tyre and Rubber Co. Ltd.	Hardie Rubber Co. Ltd.
Department— Forests Commission (as to one-quarter of requirements), Lands and Survey, Labour, Law, Police (as to one-quarter of requirements), Premier, Public Works (as to one-half of requirements), Transport Regulation Board.	Department— Police (as to one-quarter of requirements), Public Works (as to one-half of requirements).	Department— Forests Commission, (as to three-quarters of requirements), Police (as to one-half of requirements), Mines.	Department— Agriculture, Chief Secretary, Education, Health, Treasury.

CONTRACTS ACCEPTED.—(Series 1958-59.)**GENERAL STORES.**

Gazette No. 26, 18th March, 1959, Schedule No. 56, Motor Spirit, Kerosene, &c.—For Item Nos. 11 and 12, substitute 3s. 1d. and 3s. 1d. per gallon respectively, as from 15th December, 1959.

W. H. RUTHERFORD, Secretary to the Tender Board. 22.12.59.

CONTRACTS ACCEPTED.—(Series 1959-60.)**VICTORIAN RAILWAYS.**

114. Piles, at rates (Contract 61546).—G. McDiarmid. 115. Girders, &c., for bridge at Patterson-road, for £4,633 (Contract 61564).—Kelly and Lewis Ltd. 116. Piles, at rates (Contract 61580).—Alex. Sturrock and Sons Pty. Ltd. 117. Girders, &c., for bridge at Mortlake-road, at rates (Contract 61584).—Kelly and Lewis Ltd.

By order of the Victorian Railways Commissioners,
A. GILMORE, Secretary. 18.12.59.

CEREALS.

Requirements under Sub-Schedule No. 7 of Schedule No. 1 for the month of January, 1960, are to be purchased from the under-mentioned firms at the rate per cwt. respectively indicated, viz.:—Robert Harper and Co. Ltd., Peas, split, yellow, 80s.; Rice, dressed, 82s.; Rice, unpolished, 82s.; Tapioca, seed, 83d. per lb., less 3 per cent. 14 days or 2½ per cent. 30 days. H. S. K. Ward Pty. Ltd., Barley, pearl, 41s. 6d.; Oatmeal, plain, 48s.; Oatmeal, flaked, 48s.

W. H. RUTHERFORD, Secretary to the Tender Board. 22.12.59.

ORDERS IN COUNCIL.—(Series 1959-60.)**STATE ELECTRICITY COMMISSION.**

1642. The supply of 4,500 spacers and 290 galvanized malleable cast-iron suspension clamps for 220-kV line, Bendigo to Kerang, to Specification No. 67/59-60, £8005 5s.—Alconac Pty. Ltd.

1643. The supply of 120 strain assemblies, 840 suspension assemblies, 60 compression type dead-end assemblies and 100 compression type midspan joints for the 220-kV line, Bendigo to Kerang, to Specification No. 67/59-60, £11,549 15s.—Dulmison (Aust.) Pty. Ltd.

1644. The supply of lead acid batteries, automobile type, for maintenance of Commission fleet and plant for a period of 27 months, to Specification No. 79/59-60, at Schedule rates.—Dunlop Rubber Aust. Ltd.

1645. The construction of Langfords West Aqueduct, No. 1 Development, Kiewa Hydro-Electric Scheme, to Specification No. 107/59-60, £273,000.—Leighton Pty. Ltd.

1646. The supply of 7,000 tons of crushed raw brown coal for Geelong "B" Power Station, £14,787 10s.—Roche Bros. Pty. Ltd.

1647. The supply of 300,000 sheets of printed briquette packaging paper for Yallourn briquette packaging plant, £7,500.—Sisalkraft Distributors Pty. Ltd.

1648. The construction of a rail siding at Paisley Fuel Storage Depot, £5,300 (estimate).—Victorian Railways.

1649. The supply and erection of two 200 MW turbo-generators and associated plant, Hazelwood Power Station, to Specification No. 73/58-59, £4,751,916.—Australian Electrical Industries Pty. Ltd.

1650. The supply and erection of two 1,650,000-lb.-per-hour boilers and associated plant, Hazelwood Power Station, to Specification No. 73/58-59, £9,975,093.—Babcock and Wilcox of Aust. Pty. Ltd.

Approved by the Governor in Council, 8th December, 1959.—A. MAHLSTEDT, Clerk of the Executive Council.

EDUCATION DEPARTMENT.

1628. One only dictation machine, complete with accessories and case, for Swinburne Technical College, £113.—Philips Electrical Industries Pty. Limited.

1629. One only cathode ray oscilloscope for Swinburne Technical College, £118.—Philips Electrical Industries Pty. Limited.

1630. One only valve tester for Swinburne Technical College, £130.—A.E. Supplies Pty. Ltd.

1631. One only dumpy level for Warrnambool Technical College, £116.—A. E. Parsons.

1632. One only Venturi meter and manometer, for Warrnambool Technical College, £146 15s.—George Kent Pty. Ltd.

1633. Two electric sewing machines, at £54 each, £108; one only automatic sewing machine, £64 10s., for Warrnambool Technical College.—Singer Sewing Machine Co.

Approved by the Governor in Council, 15th December, 1959.—A. MAHLSTEDT, Clerk of the Executive Council.

PUBLIC WORKS.

1634. Ararat Mental Hospital, supply of galvanized piping and fittings, £430 12s. 2d.—Keith Clover and Co. Pty. Ltd. (W.127638.)

1635. Dredges *Matthew Flinders* and *Pioneer*, supply of coal by Melbourne Steamship Co. Ltd. for period 1st July, 1959, to 30th June, 1960. (M.227862.)

1636. Larundel Mental Hospital, supply and erection of one (1) only aluminium kitchen canopy, £439.—The Bronze Window Frame Co. Pty. Ltd. (N.E.97220 "A".)

1637. Parliament House, Melbourne, maintenance of dining-room passenger lift from 1st July, 1959, to 30th June, 1960, £260 18s.—Otis Elevator Co. Pty. Ltd. (M.102805.)

1638. Secondary Teachers' College, Carlton, supply of 34 C.6 chairs and 279 C.3 chairs, £887 1s. 6d.—Reed Engineering Pty. Ltd. (M.212032.)

1639. S.S. *Rip*, the under-mentioned works:—

Firm; Works; Price.

(1) Hobson's Bay Dock and Engineering Co. Pty. Ltd.; general repairs; £1,237 19s. 10d.

(2) F. Pullinger; repair and refix galley stove; £385. (M.205598.)

1640. Secondary Teachers' College, Carlton, supply and installation of underground cable to supply electricity, £385.—The Corporation of the City of Melbourne. (M.106582 "C".)

1641. Warrnambool Mental Hospital, supply of 76 standard beds, £589.—Arnbro Products. (S.W.217932.)

Approved by the Governor in Council, 15th December, 1959.—A. MAHLSTEDT, Clerk of the Executive Council.

APPOINTMENTS.

HIS Excellency the Governor of the State of Victoria, by and with the advice of the Executive Council thereof, has, by Orders made on the fifteenth day of December, 1959, been pleased to make the under-mentioned appointments, viz.:—

CHIEF SECRETARY'S DEPARTMENT.*Electoral Registrars (Acting).***EDWARD JOSEPH GOODWIN**

to be Electoral Registrar (Acting) for the Oakleigh and Oakleigh East Subdivisions of the Electoral District of Oakleigh; and for the Bentleigh North, Carnegie and Glenhantly Subdivisions of the Electoral District of Ormond, to take effect on and from the 7th December, 1959, during the absence on leave of Arthur Ross Croucher;

GEORGE MORRIS BOURKE

to be Electoral Registrar (Acting) for the Ararat, Beaufort, Beeac, Camperdown, Cobden, Linton, Rokewood, Smythesdale, Terang and Willaura Subdivisions of the Electoral District of Hampden; and for the Beech Forest, Birregurra, Colac, Jancourt, Krambruk, Port Campbell and South Barwon Subdivisions of the Electoral District of Polwarth, to take effect on and from the 9th December, 1959, during the absence on leave of Norman Clifford Erwin; and

JOHN RONALD GEOFFREY HAYES

to be Electoral Registrar (Acting) for the Drouin, Koo-wee-Rup, Korumburra, Loch, Pakenham, Warragul and Wonthaggi Subdivisions of the Electoral District of Gippsland West; and for the Morwell, Neerim South, Trafalgar, Warragul North and Yallourn Subdivisions of the Electoral District of Morwell, to take effect on and from the 16th December, 1959, during the absence on leave of Owen Patrick Griffin.

*Governor (Acting) of Gaol.***REGINALD GEORGE MATHIESON,**

pursuant to the provisions of the *Gaols Act* 1958, to be Governor (Acting) of the Sale Gaol, from the 10th January, 1960, to the 30th January, 1960, both dates inclusive, during the absence on leave of Donald Stewart Ross.

*Registrar of Births and Deaths.***FREDERICK HENRY ROSENBRICK,**

pursuant to the provisions of section 4 of the *Registration of Births Deaths and Marriages Act* 1958, to be Registrar of Births and Deaths at Fern Tree Gully, to date from commencement of duty, with fees, *vice* Ada Mary Catherine Friberg, resigned.

DEPARTMENT OF CROWN LANDS AND SURVEY.

Members of North-West Mallee Committee.

DONALD RICHARD VARCOE, a Field Officer of the Department of Crown Lands and Survey,

EVERARD BROWN, J.P., an officer of the State Rivers and Water Supply Commission, and

GERALD JAMES DOUGLAS,

pursuant to the provisions of section 251 of the *Land Act 1958*, to be Members of the North-West Mallee Committee for a term of two (2) years from 10th December, 1959.

DEPARTMENT OF HEALTH.

Official Visitor to Mental Hospital.

MARION TRIGG (Mrs.)

to be Official Visitor to the Mental Hospital, Ararat, pursuant to the provisions of section 78 of the *Mental Hygiene Act 1958*, vice Miss Elsie Scholes, resigned.

LAW DEPARTMENT.

Justices of the Peace.

JOHN LAWRENCE HUNTINGTON, Ebdon, via Wodonga, to Keep the Peace in the Northern Bailiwick of the State of Victoria;

CHARLES ROBERT JAMES CLARK, 126 Barkly-street, Ararat,

to Keep the Peace in the Western Bailiwick of the State of Victoria; and

JOHN GEORGE SCOTT, 2 Keats-avenue, Kingsbury,

to Keep the Peace in the Central Bailiwick of the State of Victoria.

Commissioners for Taking Declarations, &c.

JOHN WEBB O'NEIL, and

HENRY WALKER THOMPSON,

Officers of the Department of Law, 459 Lonsdale-street, Melbourne,

to be Commissioners for taking Declarations and Affidavits, pursuant to the provisions of the *Evidence Act 1958*, to refrain from charging fees and to resign upon ceasing to be officers of the Department of Law;

FRANCIS JOHN SLEVISION, Officer of the Victorian Government Tourist Bureau, 272 Collins-street, Melbourne,

to be a Commissioner for taking Declarations and Affidavits, pursuant to the provisions of the *Evidence Act 1958*, to refrain from charging fees and to resign upon ceasing to be an officer of the Victorian Government Tourist Bureau;

JOHN EDWIN ELSWORTHY, 6 Wedge-street, Hamilton,

to be a Commissioner for taking Declarations and Affidavits, pursuant to the provisions of the *Evidence Act 1958*, to resign upon removing from the neighbourhood of the address stated; and

PETER ALAN EDMANSON, Officer of the Commonwealth Bank of Australia, 367 Collins-street, Melbourne,

to be a Commissioner for taking Declarations and Affidavits, pursuant to the provisions of the *Evidence Act 1958*, to resign upon ceasing to be an officer of the Commonwealth Bank of Australia.

Probation Officers of Children's Court.

BURNIE WHITTAKER, St. Mary's Vicarage, Warburton, and

CHARLES CERINI, Catholic Presbytery, Warburton,

to be Probation Officers, pursuant to the provisions of the *Children's Court Act 1958*, for the Children's Court at Warburton.

Sworn Valuator.

DAVID JOHN TILSON, 57 Ryley-street, Wangaratta,

to be a Sworn Valuator, pursuant to the provisions of the *Transfer of Land Act 1958*, for the Counties of Bogong, Delatite and Moira.

DEPARTMENT OF PUBLIC WORKS.

Commissioner and Deputy Chairman of Geelong Harbor Trust.

HAROLD ROY FIDGE,

pursuant to the provisions of section 4 of the *Geelong Harbor Trust Act 1958*, to be a Commissioner and Deputy Chairman of the Geelong Harbor Trust Commissioners for a period of four (4) years on and from the 1st January, 1960.

RAILWAYS DEPARTMENT.

Chairman of the Board of Discipline.

THOMAS ROBINSON COLLIER, pursuant to the provisions of section 169 of the *Railways Act 1958*, to be Chairman of the Board of Discipline for a period of five (5) years as from the 1st January, 1960.

STATE ELECTRICITY COMMISSION.

Chairman and Members of the Yallourn Town Advisory Council.

THOMAS FORRISTAL,

pursuant to the provisions of the *State Electricity Commission Act 1958*, to be a member and chairman of the Yallourn Town Advisory Council for a term of three (3) years as from the 7th January, 1960;

THOMAS BROUGHTON JENSEN,

JOSEPH PHIL ASHMEAD, and

AUSTIN LYNCH,

pursuant to the provisions of the *State Electricity Commission Act 1958*, to be members of the Yallourn Town Advisory Council for a term of three (3) years as from the 7th January, 1960.

A. MAHLSTEDT,

Clerk of the Executive Council.

At the Executive Council Chamber,
Melbourne, 15th December, 1959.

APPOINTMENTS.

HIS Excellency the Governor of the State of Victoria, by and with the advice of the Executive Council thereof, has, by Orders made on the 22nd day of December, 1959, been pleased to make the under-mentioned appointments, viz.:—

DEPARTMENT OF THE TREASURER.

Chairman of Commissioners of State Savings Bank of Victoria.

REGINALD GERARD HOBAN, LL.B.,

pursuant to the provisions of the *State Savings Bank Act 1958*, to be Chairman of the Commissioners of the State Savings Bank of Victoria, for the year commencing on the 1st January, 1960.

DEPARTMENT OF WATER SUPPLY.

Member of Sewerage Authority.

VINCENT JAMES RYAN

to be a Member of the Charlton Sewerage Authority and to hold office as such from the date hereof until the 7th October, 1961, subject to the provisions of the *Sewerage Districts Act 1958*.

Waterworks Trust Commissioner.

MATHEW MOYLAN

to be a Commissioner of the Shire of Shepparton Waterworks Trust for a period of two years from the date hereof, subject to the provisions of the Water Acts.

A. MAHLSTEDT,

Clerk of the Executive Council.

At the Executive Council Chamber,
Melbourne, 22nd December, 1959.

RESIGNATIONS.

HIS Excellency the Governor of the State of Victoria, by and with the advice of the Executive Council thereof, has, by Orders made on the fifteenth day of December, 1959, accepted the resignations of the persons named hereunder, of the offices mentioned, viz.:—

CHIEF SECRETARY'S DEPARTMENT.

ADA MARY CATHERINE FRIBERG, as registrar of Births and Deaths at Fern Tree Gully.

LAW DEPARTMENT.

JAMES HENRY FORGE PROSSER, from the Commission of the Peace for the Western Bailiwick of the State of Victoria.

LEONARD BROWN, as a Commissioner for taking Declarations and Affidavits, pursuant to the provisions of the *Evidence Act 1958*.

A. MAHLSTEDT,

Clerk of the Executive Council.

At the Executive Council Chamber,
Melbourne, 15th December, 1959.

LABOUR AND INDUSTRY ACTS.

*At the Executive Council Chamber, Melbourne, the
fifteenth day of December, 1959.*

PRESENT:

His Excellency the Governor of Victoria.
Sir Thomas Maltby | Mr. Reid.
Mr. Porter |

ADJUSTMENT OF THE POWERS OF THE COMMERCIAL CLERKS BOARD AND OF THE LAW CLERKS BOARD.

UNDER the powers in that behalf conferred by the Labour and Industry Acts, His Excellency the Governor of the State of Victoria, by and with the advice of the Executive Council thereof, doth, by this Order, adjust the powers of the Commercial Clerks Board and of the Law Clerks Board by depriving the said Commercial Clerks Board of the power to determine the lowest prices or rates which may be paid to any person employed in his practice by a barrister or solicitor as a typewriter or stenographer, and conferring such power exclusively on the Law Clerks Board.

And the Honorable George Oswald Reid, Her Majesty's Minister of Labour and Industry for the State of Victoria, shall give the necessary directions herein accordingly.

A. MAHLSTEDT,
Clerk of the Executive Council.

LABOUR AND INDUSTRY ACT 1958 (No. 6283).

*At the Executive Council Chamber, Melbourne, the
fifteenth day of December, 1959.*

PRESENT:

His Excellency the Governor of Victoria.
Sir Thomas Maltby | Mr. Reid.
Mr. Porter |

HOLIDAYS IN CERTAIN TRADES.

UNDER the powers in that behalf conferred by the Labour and Industry Act 1958, His Excellency the Governor of the State of Victoria, by and with the advice of the Executive Council thereof, and—

1. On the recommendation of a Wages Board, described as the Animal Manure Board, doth hereby make the following Regulation, that is to say:—

The twentieth day of January, 1960, shall, within the whole of the State of Victoria, be fixed as a holiday for persons employed subject to the Determination of the Animal Manure Board.

2. On the recommendation of a Wages Board, described as the Bagmakers Board, doth hereby make the following Regulation, that is to say:—

The twenty-ninth day of February, 1960, shall, in the Metropolitan District as defined in the Labour and Industry Act 1958, be fixed as a holiday for persons employed subject to the Determination of the Bagmakers Board.

3. On the recommendation of a Wages Board, described as the Biscuit Board, doth hereby make the following Regulation, that is to say:—

The eighth day of February, 1960, shall, within the whole of the State of Victoria, be fixed as a holiday for persons employed subject to the Determination of the Biscuit Board.

4. On the recommendation of a Wages Board, described as the Bottle Covers Board, doth hereby make the following Regulation, that is to say:—

The twenty-ninth day of February, 1960, shall, in the Metropolitan District as defined in the Labour and Industry Act 1958, and within the Shire of Keilor, be fixed as a holiday for persons employed subject to the Determination of the Bottle Covers Board.

5. On the recommendation of a Wages Board, described as the Chaffcutters Board, doth hereby make the following Regulation, that is to say:—

The twenty-ninth day of February, 1960, shall, in the Metropolitan District as defined in the Labour and Industry Act 1958, and in the Shires of Keilor,

Kyneton and Melton, be fixed as a holiday for persons employed subject to the Determination of the Chaffcutters Board.

6. On the recommendation of a Wages Board, described as the Confectioners Board, doth hereby make the following Regulation, that is to say:—

The fifteenth day of February, 1960, shall, within the whole of the State of Victoria, be fixed as a holiday for persons employed subject to the Determination of the Confectioners Board.

7. On the recommendation of a Wages Board, described as the Cork Trade Board, doth hereby make the following Regulation, that is to say:—

The eighteenth day of January, 1960, shall, within the whole of the State of Victoria, be fixed as a holiday for persons employed subject to the Determination of the Cork Trade Board.

8. On the recommendation of a Wages Board, described as the Frozen Goods Board, doth hereby make the following Regulation, that is to say:—

The twentieth day of January, 1960, shall, in the Metropolitan District as defined in the Labour and Industry Act 1958, be fixed as a holiday for persons employed subject to the Determination of the Frozen Goods Board.

9. On the recommendation of a Wages Board, described as the Gas Meter Board, doth hereby make the following Regulation, that is to say:—

The fifth day of March, 1960, shall, in the Metropolitan District as defined in the Labour and Industry Act 1958, be fixed as a holiday for every person employed in the process, trade, business, or occupation of making or repairing gas meters.

10. On the recommendation of a Wages Board, described as the Hairdressers Board, doth hereby make the following Regulation, that is to say:—

The fifteenth day of February, 1960, shall, in the Metropolitan District and Geelong District as defined in the Labour and Industry Act 1958, be fixed as a holiday for persons employed in the business of a hairdresser or barber, or other workers of hair, or employed at—

- (a) hair or scalp treatment;
- (b) toilet work.

11. On the recommendation of a Wages Board, described as the Ham and Bacon Curers Board, doth hereby make the following Regulation, that is to say:—

The twentieth day of January, 1960, shall, in the Metropolitan District as defined in the Labour and Industry Act 1958, be fixed as a holiday for persons employed subject to the Determination of the Ham and Bacon Curers Board.

12. On the recommendation of a Wages Board, described as the Horsehair Board, doth hereby make the following Regulation, that is to say:—

The eighteenth day of January, 1960, shall, within the whole of the State of Victoria, be fixed as a holiday for persons employed subject to the Determination of the Horsehair Board.

13. On the recommendation of a Wages Board, described as the Ice Board, doth hereby make the following Regulation, that is to say:—

The twentieth day of January, 1960, shall, in the Metropolitan District as defined in the Labour and Industry Act 1958, be fixed as a holiday for persons employed in the business of a maker of ice for trade or sale (other than persons employed solely in issuing ice for distribution).

14. On the recommendation of a Wages Board, described as the Manufacturing Chemists Board, doth hereby make the following Regulation, that is to say:—

The eighteenth day of January, 1960, shall, within the whole of the State of Victoria, be fixed as a holiday for persons employed subject to the Determination of the Manufacturing Chemists Board.

15. On the recommendation of a Wages Board, described as the Meat Preservers Board, doth hereby make the following Regulation, that is to say:—

The twentieth day of January, 1960, shall, in the Metropolitan District as defined in the Labour and Industry Act 1958, be fixed as a holiday for persons employed subject to the Determination of the Meat Preservers Board.

16. On the recommendation of a Wages Board, described as the Pastrycooks Board, doth hereby make the following Regulation, that is to say:—

The eighth day of February, 1960, shall, within a radius of 40 miles from the G.P.O., Melbourne, the Cities of Geelong, Geelong West, Newtown and Chilwell, Ballarat and Bendigo; and the Boroughs of Sebastopol and Eaglehawk, be fixed as a holiday for persons employed subject to the Determination of the Pastrycooks Board.

17. On the recommendation of a Wages Board, described as the Rabbit Processing Board, doth hereby make the following Regulation, that is to say:—

The twentieth day of January, 1960, shall, within the whole of the State of Victoria, be fixed as a holiday for persons employed subject to the Determination of the Rabbit Processing Board.

18. On the recommendation of a Wages Board, described as the Sausage Casings Board, doth hereby make the following Regulation, that is to say:—

The twentieth day of January, 1960, shall, within the whole of the State of Victoria, be fixed as a holiday for persons employed in the process, trade, or business of preparing or cleaning casings for sausages or similar products.

19. On the recommendation of a Wages Board, described as the Shops Board No. 2 (Boot Repairers), doth hereby make the following Regulation, that is to say:—

The twenty-second day of February, 1960, shall, within the whole of the State of Victoria, be fixed as a holiday for persons employed in boot repairers' shops.

20. On the recommendation of a Wages Board, described as the Shops Board No. 3 (Butchers), doth hereby make the following Regulation, that is to say:—

The twentieth day of January, 1960, shall, within the whole of the State of Victoria, be fixed as a holiday for persons employed subject to the Determination of the Shops Board No. 3 (Butchers).

21. On the recommendation of a Wages Board, described as the Shops Board No. 8 (Delicatessen), doth hereby make the following Regulation, that is to say:—

The fifteenth day of February, 1960, shall, within the Metropolitan District as defined in the Labour and Industry Acts, the Cities of Ballarat, Geelong, Geelong West, and Newtown and Chilwell, and the Borough of Sebastopol be fixed as a holiday for persons employed in the trade of a seller of dairy produce, cooked meat, pickles, sauces, salad dressings, and sandwich spreads.

22. On the recommendation of a Wages Board, described as the Shops Board No. 10 (Fish and Poultry), doth hereby make the following Regulation, that is to say:—

The twenty-second day of February, 1960, shall, within the whole of the State of Victoria, be fixed as a holiday for persons wheresoever employed in the business of—

- (a) killing, plucking, dressing poultry or game;
- (b) preparing fish for sale, uncooked or for canning, drying, or smoking;
- (c) selling by wholesale or retail (except for consumption on the premises), poultry, game, fish, or oysters;
- (d) marketing (in fish and poultry markets), poultry, game, or fish—

(but not including any person or persons, or classes of persons, employed in or in connexion with the trade, business, or occupation of preparing or processing uncooked rabbits or hares for the retail, wholesale, or export trade).

23. On the recommendation of a Wages Board, described as the Shops Board No. 12 (Fuel and Fodder), doth hereby make the following Regulation, that is to say:—

The twenty-ninth day of February, 1960, shall, in the Metropolitan District as defined in the Labour and Industry Act 1958, the Cities of Ballarat, Bendigo, Geelong, Geelong West, Warrnambool, and Newtown and Chilwell, and the Boroughs of Eaglehawk and Sebastopol, be fixed as a holiday for persons employed subject to the Determination of the Shops Board No. 12 (Fuel and Fodder).

24. On the recommendation of a Wages Board, described as the Shops Board No. 15 (Grocers), doth hereby make the following Regulation, that is to say:—

The fifteenth day of February, 1960, shall, within the Metropolitan District as defined in the Labour and Industry Act 1958, the Cities of Ballarat, Geelong, Geelong West, and Newtown and Chilwell, and the

Borough of Sebastopol be fixed as a holiday for persons employed in the business of a grocer, including a seller of tea.

25. On the recommendation of a Wages Board, described as the Shops Board No. 19 (Confectionery, Pastry, Fruit and Vegetable), doth hereby make the following Regulation, that is to say:—

The twenty-third day of May, 1960, shall, within the Metropolitan District as defined in the Labour and Industry Act 1958, be fixed as a holiday for persons employed in fruit and vegetable shops.

26. On the recommendation of a Wages Board, described as the Slaughtering for Export Board, doth hereby make the following Regulation, that is to say:—

The twentieth day of January, 1960, shall, within the whole of the State of Victoria, be fixed as a holiday for persons employed subject to the Determination of the Slaughtering for Export Board.

27. On the recommendation of a Wages Board, described as the Tar and Bitumen Board, doth hereby make the following Regulation, that is to say:—

The twenty-ninth day of February, 1960, shall, within the whole of the State of Victoria, be fixed as a holiday for persons employed subject to the Determination of the Tar and Bitumen Board.

28. On the recommendation of a Wages Board, described as the Tea Packing Board, doth hereby make the following Regulation, that is to say:—

The fifteenth day of February, 1960, shall, within the whole of the State of Victoria, be fixed as a holiday for persons employed subject to the Determination of the Tea Packing Board.

29. On the recommendation of a Wages Board, described as the Tennis Strings Board, doth hereby make the following Regulation, that is to say:—

The twentieth day of January, 1960, shall, within the whole of the State of Victoria, be fixed as a holiday for persons employed subject to the Determination of the Tennis Strings Board.

30. On the recommendation of a Wages Board, described as the Vegetable Growers Board, doth hereby make the following Regulation, that is to say:—

The twenty-third day of February, 1960, shall, within the whole of the State of Victoria, be fixed as a holiday for persons employed subject to the Determination of the Vegetable Growers Board.

31. On the recommendation of a Wages Board, described as the Vehicle Building Industry Board, doth hereby make the following Regulation, that is to say:—

The twenty-seventh day of February, 1960, shall, in the Metropolitan District as defined in the Labour and Industry Act 1958, be fixed as a holiday for persons employed in the process, trade, or business connected with or incidental to the manufacturing, making or repairing of—

- (a) carriages, carts, and other vehicles (other than perambulators), or any part or parts thereof, such as the ironwork or bodies, hoods, cushions, springs, axles, wheels, tires, rims, hubs, or spokes;
- (b) motor car bodies, or any part or parts thereof, such as the hoods or cushions;
- (c) tramcars, or any part or parts thereof, such as the ironwork or bodies, cushions, springs, axles, wheels, tires, rims, hubs, or spokes;
- (d) motor cycle sidecar bodies, or any part or parts thereof, such as the hoods or cushions;
- (e) aircraft.

32. On the recommendation of a Wages Board, described as the Wholesale Grocers Board, doth hereby make the following Regulation, that is to say:—

(a) The eighteenth day of January, 1960, shall, within the whole of the State of Victoria, be fixed as a holiday for persons employed subject to the Determination of the Wholesale Grocers Board in wholesale wine and spirit stores.

(b) The fifteenth day of February, 1960, shall, in the Metropolitan District as defined in the Labour and Industry Act 1958, be fixed as a holiday for persons employed subject to the Determination of the Wholesale Grocers Board other than persons employed in wholesale wine and spirit stores.

And the Honorable George Oswald Reid, Her Majesty's Minister of Labour and Industry for the State of Victoria, shall give the necessary directions herein accordingly.

A. MAHLSTEDT,
Clerk of the Executive Council.

DEPARTMENT OF CROWN LANDS AND SURVEY.

At the Executive Council Chamber, Melbourne, the
fifteenth day of December, 1959.

PRESENT:

His Excellency the Governor of Victoria.
Sir Thomas Maltby | Mr. Reid.
Mr. Porter |

ROAD IN THE PARISH OF WONGA WONGA SOUTH
—REDUCED IN WIDTH.

HIS Excellency the Governor of the State of Victoria, by and with the advice of the Executive Council thereof, in accordance with the provisions of and in exercise of the powers conferred by the *Local Government Act 1958*, doth, by this Order, confirm the scheme for the reduction in width of the road in the Parish of Wonga Wonga South, County of Buln Buln, in the State of Victoria, as set out in an agreement deposited in the Office of Crown Lands and Survey, Melbourne, the said scheme being under the seal of the corporation of the President, Councillors and Ratepayers of the Shire of South Gippsland of the first part, the seal of the Board of Land, and whose signatures are subscribed to the said scheme and who are called the parties of the third part.—(Misc. 3152.)

And the Honorable Keith Turnbull, Her Majesty's Commissioner of Crown Lands and Survey for the State of Victoria, shall give the necessary directions herein accordingly.

A. MAHLSTEDT,
Clerk of the Executive Council.

DEPARTMENT OF CROWN LANDS AND SURVEY.

At the Executive Council Chamber, Melbourne, the
fifteenth day of December, 1959.

PRESENT:

His Excellency the Governor of Victoria.
Sir Thomas Maltby | Mr. Reid.
Mr. Turnbull |

LANDS TEMPORARILY RESERVED AS SITES.

HIS Excellency the Governor of the State of Victoria, by and with the advice of the Executive Council thereof, doth hereby, in pursuance of the provisions of the *Land Act 1958*, reserve, temporarily, and also except from occupation for mining purposes, under any miner's right, the lands hereinafter described:—

YEO.—Site for a Public Hall, 2 roods, Parish of Yeo, County of Polwarth, as indicated by hachure on plan hereunder.—(Y.75(2)) (Rs.7882.)

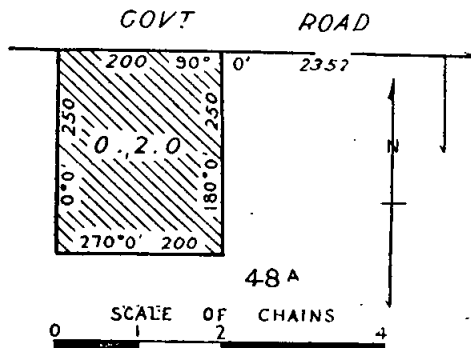

DUNBULBALANE.—Site for a Rubbish Depot, 3 acres 2 roods, 13 perches, Parish of Dunbulbalane, County of Moira, as indicated by hachure on plan hereunder.—(D.193(2)) (Rs.7897.)

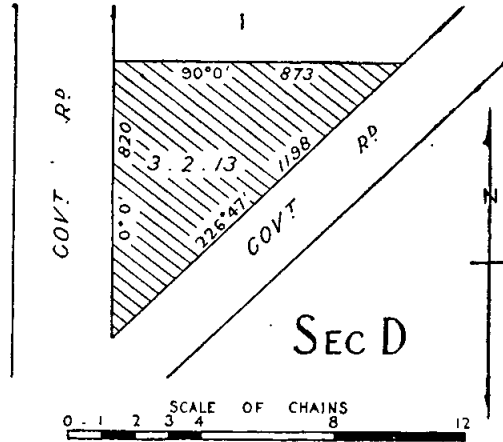

NARRACAN (NEWBOROUGH).—Site for Public Recreation, 45 acres, 3 roods, 35 perches, Parish of Narracan, County of Buln Buln, as indicated by hachure on plan hereunder.—(N.129M) (Rs.7895.)

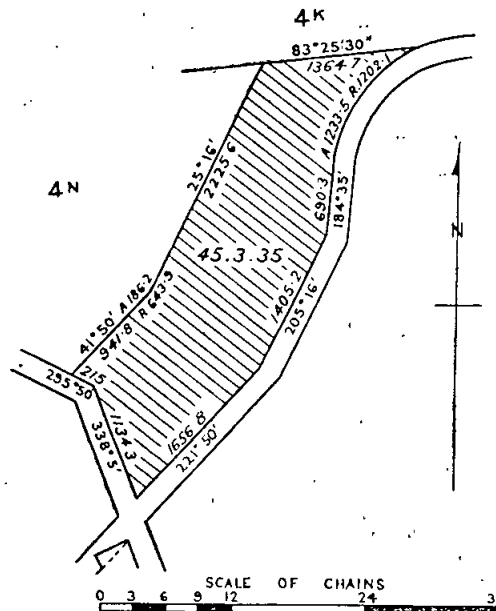

And the Honorable Keith Hector Turnbull, Her Majesty's Commissioner of Crown Lands and Survey for the State of Victoria, shall give the necessary directions herein accordingly.

A. MAHLSTEDT,
Clerk of the Executive Council.

DEPARTMENT OF CROWN LANDS AND SURVEY.

At the Executive Council Chamber, Melbourne, the
fifteenth day of December, 1959.

PRESENT:

His Excellency the Governor of Victoria.
Sir Thomas Maltby | Mr. Reid.
Mr. Porter |

UNUSED ROADS CLOSED.

HIS Excellency the Governor of the State of Victoria, by and with the advice of the Executive Council thereof, doth hereby direct that, in pursuance of the provisions of section 349 of the *Land Act 1958*, the unused roads referred to hereunder be closed, viz:—

Parish of Watchem, County of Borung, being the portion of the width of road indicated by hachure on plan hereunder.—(W.304⁽⁶⁾) (W.82312).

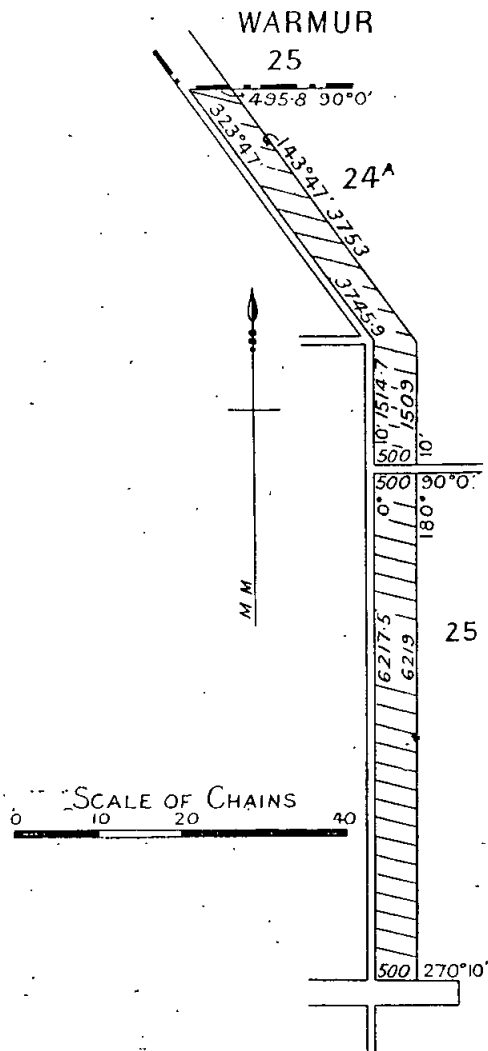

Township of Lockwood, Parish of Lockwood, County of Bendigo, being the road indicated by hachure on plan hereunder.—(L.87⁽³⁾) (L.87⁽³⁾) (W.84638).

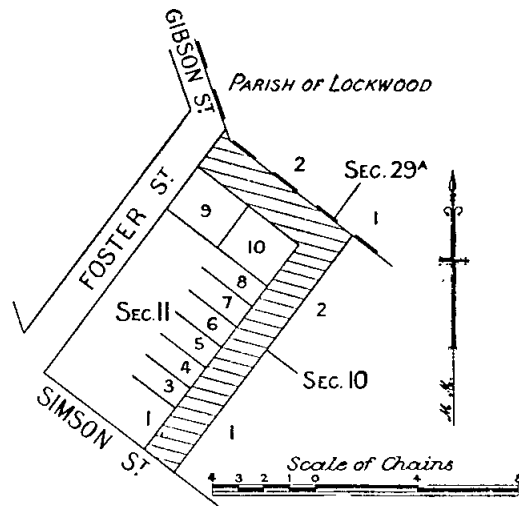

And the Honorable Keith Hector Turnbull, Her Majesty's Commissioner of Crown Lands and Survey for the State of Victoria, shall give the necessary directions herein accordingly.

A. MAHLSTEDT,
Clerk of the Executive Council.

DEPARTMENT OF CROWN LANDS AND SURVEY.

At the Executive Council Chamber, Melbourne, the
fifteenth day of December, 1959.

PRESENT:

His Excellency the Governor of Victoria.
Sir Thomas Maltby | Mr. Reid.
Mr. Porter |

ROAD (PARISH OF WONGA WONGA SOUTH)
REDUCED IN WIDTH.

HIS Excellency the Governor of the State of Victoria, by and with the advice of the Executive Council thereof, in accordance with the provisions of and in exercise of the powers conferred by the *Local Government Act 1958*, doth, by this Order, confirm the Scheme for the reduction in width of the road in the Parish of Wonga Wonga South, County of Buln Buln, in the State of Victoria, as set out in an agreement deposited in the Office of Crown Lands and Survey, Melbourne, the said Scheme being under the seal of the corporation of the President, Councillors, and Ratepayers of the Shire of South Gippsland of the first part, the seal of the Board of Land and Works of the second part, and under the hands of the persons whose signatures are subscribed to the said Scheme and who are called the parties of the third part.—(G.60098.)

And the Honorable Keith Hector Turnbull, Her Majesty's Commissioner of Crown Lands and Survey for the State of Victoria, shall give the necessary directions herein accordingly.

A. MAHLSTEDT,
Clerk of the Executive Council.

HOSPITALS AND CHARITIES ACT 1958 (No. 6274).
Section 46.

*At the Executive Council Chamber, Melbourne, the
fifteenth day of December, 1959.*

PRESENT:

His Excellency the Governor of Victoria.
Sir Thomas Maltby | Mr. Reid.
Mr. Porter |

INCORPORATION OF MACARTHUR AND DISTRICT
MEDICAL CENTRE.

WHEREAS a Petition signed by not less than twenty-five contributors to Macarthur and District Medical Centre, an institution capable of incorporation under the *Hospitals and Charities Act 1958*, praying that that institution be incorporated has been received by the Hospitals and Charities Commission:

And whereas the substance or prayer of the said Petition has been published in the *Government Gazette*:

And whereas no counter petition signed by an equal or greater number of contributors has been lodged with the Hospitals and Charities Commission within one month after the date of such publication:

Now, therefore, the Governor of the State of Victoria, by and with the advice of the Executive Council of the said State, doth hereby declare that the contributors for the time being to Macarthur and District Medical Centre shall be a body corporate by the name of MACARTHUR AND DISTRICT MEDICAL CENTRE.

And the Honorable Ewen Paul Cameron, Her Majesty's Minister of Health for the State of Victoria, shall give the necessary directions herein accordingly.

A. MAHLSTEDT,
Clerk of the Executive Council.

HOSPITALS AND CHARITIES ACT 1958 (No. 6274).
Section 65.

*At the Executive Council Chamber, Melbourne, the
fifteenth day of December, 1959.*

PRESENT:

His Excellency the Governor of Victoria.
Sir Thomas Maltby | Mr. Reid.
Mr. Porter |

AUTHORITY FOR SALE OF LAND BY WOORAYL
DISTRICT MEMORIAL HOSPITAL, LEONGATHA.

WHEREAS Woorayl District Memorial Hospital, Leongatha, an incorporated institution within the meaning of the *Hospitals and Charities Act 1958*, is the owner of all that piece of land being allotment 6, section 4, Township and Parish of Leongatha, County of Buln Buln, and more particularly described in certificate of title, volume 7176, folio 147:

And whereas no part of such land is granted, reserved, or set apart by the Crown for the purposes of Woorayl District Memorial Hospital, Leongatha:

And whereas the majority of the members of the Committee of Management of Woorayl District Memorial Hospital, Leongatha, desire that the said land be sold:

And whereas the Hospitals and Charities Commission after inquiry has reported that it would be advantageous to Woorayl District Memorial Hospital, Leongatha, if the Hospital sold the said land:

Now therefore the Governor of the State of Victoria, by and with the advice of the Executive Council of the said State, being satisfied in the hereinbefore recited special circumstances that the sale of the said land would be advantageous to Woorayl District Memorial Hospital, Leongatha, doth authorize the sale of such land freed and discharged from any trusts affecting the same and doth hereby direct that such land be sold to the Rotary Club of Leongatha, in accordance with the following conditions, that is to say:—

1. The sale price shall be an amount of not less than Three thousand four hundred pounds (£3,400), such amount to be paid by the purchaser immediately upon signature of the contract of sale.

2. The contract of sale shall be in the form of the contract of sale approved for use by its members as at the date hereof by the Real Estate and Stock Institute of Victoria.

And His Excellency, by and with the advice aforesaid, doth hereby further direct that from the proceeds of the sale a sum of Two thousand eight hundred and twenty pounds (£2,820) be applied to the Government Building Trust Funds held by the Hospital.

And the Honorable Ewen Paul Cameron, Her Majesty's Minister of Health for the State of Victoria, shall give the necessary directions herein accordingly.

A. MAHLSTEDT,
Clerk of the Executive Council.

UNIVERSITY ACT 1958.

*At the Executive Council Chamber, Melbourne, the
fifteenth day of December, 1959.*

PRESENT:

His Excellency the Governor of Victoria.
Sir Thomas Maltby | Mr. Reid.
Mr. Porter |

APPOINTMENT OF MEMBERS OF THE COUNCIL OF
THE UNIVERSITY OF MELBOURNE.

HIS Excellency the Governor of the State of Victoria, by and with the advice of the Executive Council thereof, and in pursuance of the powers conferred by the *University Act 1958*, doth by this Order hereby appoint the under-named persons to be members of the Council of the University of Melbourne for the period of four years from and including the 17th December, 1959:—

- (i) The Honorable RUPERT JAMES HAMER, M.L.C. (as being a member of the Legislative Council);
- (ii) The Honorable JOHN STOUGHTON BLOOMFIELD, M.L.A., and CAMPBELL TURNBULL, M.L.A. (as being members of the Legislative Assembly);
- (iii) Sir WILLIAM JOHN ALLISON, K.B.E. (as representing manufacturing and commercial interests);
- (iv) PATRICK RYAN, B.Agr.Sc. (as representing agricultural interests);
- (v) ALEXANDER LESLIE CAHILL, and NORMAN EDWARD THOMAS JONES (as representing industrial interests);
- (vi) ROBERT RUTHERFORD BLACKWOOD, M.C.E., B.E.E., A.M.I.E. (Aust.) (as representing technical education).

And the Honorable John Stoughton Bloomfield, Her Majesty's Minister of Education for the State of Victoria, shall give the necessary directions herein accordingly.

A. MAHLSTEDT,
Clerk of the Executive Council.

COUNTRY ROADS BOARD.

*At the Executive Council Chamber, Melbourne, the
fifteenth day of December, 1959.*

PRESENT:

His Excellency the Governor of Victoria.
Sir Thomas Maltby | Mr. Reid.
Mr. Porter |

DECLARATION OF THE WIDENING OF GOORAMBAT-
THOONA ROAD, LILYDALE-MONBULK ROAD AND
GEELONG-HAMILTON ROAD IN THE SHIRES
OF BENALLA, LILLYDALE AND MORTLAKE
RESPECTIVELY.

WHEREAS by section 21 of the *Country Roads Act 1958* (No. 6229) it is amongst other things enacted that when the Country Roads Board under the provisions of the Country Roads Act has taken the land necessary for constructing the road or deviation or widening it shall as soon as it thinks such road or deviation or widening is fit to be used as a public highway by Resolution declare the road or deviation or widening to be a main road or part thereof and that upon publication in the *Government Gazette* of the Order of the Governor in Council confirming such Resolution, such road or deviation or widening shall thereupon be a main road or a part thereof within the meaning of the said Act: And whereas the said Board has by Resolution declared the roads on the land described in the Schedules to such Resolution to be parts of main roads: Now therefore His Excellency the

Governor of the State of Victoria, by and with the advice of the Executive Council thereof, doth hereby confirm the said Resolution.

Resolution for Declaration of the Widening of Main Roads under the Country Roads Act.

Whereas the land the sites of the roads the courses of which are below set out was taken by the Board under the provisions of the Country Roads Act for the purpose of widening the main roads aforesaid which widenings have now been laid out and formed on the same: And whereas the said Board (being the Country Roads Board incorporated under the said Act) thinks that the widenings aforesaid are fit to be used as parts of public highways, such Board at a meeting now holden doth by this Resolution hereby declare the same as described in the Schedules hereto with the commencing and terminating points thereof respectively specified to be parts of the main roads within the meaning and for the purposes of the Country Roads Act.

SCHEDULE.

Shire of Benalla.

4. *Goorambat-Thoona road (1804).*—All that piece of land in the Parish of Bungeet, the boundaries of which are as follow:—Commencing at the north-western angle of allotment 56A of the said parish; thence by lines bearing respectively 89 deg. 54 min. 320 links, 243 deg. 31 min. 497.8 links, and 29 deg. 33 min. 254.5 links to the point of commencement—which said piece of land is particularly delineated and shown coloured red on survey plan numbered 6270, lodged in the office of the Country Roads Board.

SCHEDULE.

Shire of Lillydale.

3. *Lilydale-Monbulk road (9403).*—All that piece of land in the Parish of Wandin Yallock, the boundaries of which are as follow:—Commencing at the south-western angle of allotment 80C of the said parish; thence by lines bearing respectively 339 deg. 1 min. 199.5 links, 124 deg. 19 min. 149.8 links, 114 deg. 51 min. 331.5 links, and 276 deg. 6 min. 355.1 links to the point of commencement—which said piece of land is particularly delineated and shown coloured red on survey plan numbered 7115, lodged in the office of the Country Roads Board.

SCHEDULE.

Shire of Mortlake.

5. *Geelong-Hamilton road (11105).*—All those pieces of land in the Parish of Darlington, the boundaries of which are as follow:—

- (a) Commencing at the northern angle of allotment 2, section 6 of the said parish; thence by lines bearing respectively 193 deg. 4 min. 615 links, 259 deg. 19½ min. 935.3 links, and 53 deg. 53 min. 1,310.3 links to the point of commencement.
- (b) Commencing at a point on the southern boundary of allotment 1, section 6 of the said parish, distant 53 deg. 53 min. 3,661.9 links from the south-western angle of the said allotment; thence by lines bearing respectively 345 deg. 41 min. 880.3 links, 110 deg. 40 min. 977 links, and 233 deg. 53 min. 862.1 links to the point of commencement.
- (c) Commencing at the north-western angle of allotment 3, section 6 of the said parish; thence by lines bearing respectively 53 deg. 53 min. 500 links, 103 deg. 0 min. 1,000 links, 251 deg. 7 min. 1,563.9 links, and 13 deg. 4 min. 447.9 links to the point of commencement—

which said pieces of land are particularly delineated and shown coloured red on survey plan numbered 6268, lodged in the office of the Country Roads Board.

The Common seal of the Country Roads Board was hereto affixed, at Carlton, this seventh day of December, One thousand nine hundred and fifty-nine, in the presence of—

(SEAL) D. V. DARWIN, Chairman.
W. H. NEVILLE, Member.
R. E. V. DONALDSON, Secretary.

And the Honorable Sir Thomas Karran Maltby, Her Majesty's Commissioner of Public Works for the State of Victoria, shall give the necessary directions herein accordingly.

A. MAHLSTEDT,
Clerk of the Executive Council.

PATRIOTIC FUNDS ACTS.

At the Executive Council Chamber, Melbourne, the twenty-second day of December, 1959.

PRESENT:

His Excellency the Governor of Victoria.
Mr. Rylah | Mr. Cameron
Mr. Mibus | Mr. Fraser.

APPOINTMENT OF MEMBERS FOR THE PATRIOTIC FUNDS COUNCIL OF VICTORIA.

IN pursuance of the provisions of the *Patriotic Funds Act 1958* (No. 6331), His Excellency the Governor of the State of Victoria, by and with the advice of the Executive Council thereof, doth by this Order—

(1) Appoint the under-mentioned persons to be members of the Patriotic Funds Council of Victoria for a period of one year as from and including the 22nd day of December, 1959:—

The Right Honorable the LORD MAYOR OF MELBOURNE for the time being.

The Honorable LESLIE GEORGE NORMAN, being a representative nominated by the Chairman of the Australian Red Cross Society (Victorian Division) for the time being.

The Honorable Sir ARCHIE MICHAELIS.
Sir GEORGE WILLIAM FREDERICK HOLLAND, C.B.E., M.M.,
Sir WILLIAM JOHN JUNGWIRTH, C.M.G.,
OSWALD GAWLER, F.I.A.,
Dr. JOHN HENRY LINDELL, M.D., M.S.,
ROY WARWICK NEVILLE, C.B.E.,
WILLIAM ANDREWS PERRIN, O.B.E.,
ROBERT FITZROY SANDERSON, C.B.E.,
LEWIS GRANT WILSON,
FRANCIS JAMES ERIC GYNGELL,
MATTHEW HARRISON, M.B.E., J.P.,
FREDERICK GEORGE ROBOTHAM CLAYTON.

(2) Appoint Sir GEORGE WILLIAM FREDERICK HOLLAND, C.B.E., M.M., to be Chairman of the said Council, and ROBERT FITZROY SANDERSON, C.B.E., to be Vice-Chairman of the said Council.

And the Honorable Arthur Gordon Rylah, Her Majesty's Attorney-General for the State of Victoria, shall give the necessary directions herein accordingly.

A. MAHLSTEDT,
Clerk of the Executive Council.

MINES ACT 1958.

At the Executive Council Chamber, Melbourne, the twenty-second day of December, 1959.

PRESENT:

His Excellency the Governor of Victoria.
Mr. Rylah | Mr. Cameron
Mr. Mibus | Mr. Fraser.

PORTION OF THE PERMANENT FOREST RESERVE IN THE PARISH OF HARCOURT EXCEPTED FROM OCCUPATION FOR MINING PURPOSES.

HIS Excellency the Governor of the State of Victoria, by and with the advice of the Executive Council thereof, doth hereby, in pursuance of the provisions of section 7 of the *Mines Act 1958* (No. 6320), except from occupation for mining purposes under any miner's right or from being leased under a mining lease the under-mentioned land, being portion of the Permanent Forest Reserve in the Parish of Harcourt, County of Talbot, and known as "Dog Rocks" Scenic Reserve, viz:—

Commencing at a point bearing north 77 degrees east 2,000 links from the north-east corner of allotment 6A, section 6A; bounded thence by lines bearing south 6 degrees west 660 links, south 42 deg. 30 min. west 375 links, north 77 degrees west 325 links, north 14 degrees west 375 links, north 9 degrees east 570 links, and south 84 degrees east 640 links to the point of commencement, comprising an area of 5 acres, more or less.

And the Honorable Wilfred John Mibus, Her Majesty's Minister of Mines for the State of Victoria, shall give the necessary directions herein accordingly.

A. MAHLSTEDT,
Clerk of the Executive Council.

WORKERS COMPENSATION ACT 1958.

At the Executive Council Chamber, Melbourne, the
twenty-second day of December, 1959.

PRESENT:

His Excellency the Governor of Victoria.

Mr. Rylah
Mr. Mibus

Mr. Cameron
Mr. Fraser.

REGULATIONS.

IN pursuance of the powers conferred by the *Workers Compensation Act 1958* and all other powers him thereunto enabling, His Excellency the Governor of the State of Victoria, in the Commonwealth of Australia, by and with the advice of the Executive Council of the said State, doth hereby further amend the "Workers Compensation Regulations 1954" as follows (that is to say):—

Clause 33A is hereby revoked and the following clause substituted therefor—

"33A. The fees for hospital service for the purpose of section 26 of the Act shall be—

- (a) for in-patient maintenance and attendance—Three pounds a day;
- (b) for out-patients attendance—
 - (i) for each attendance at a special accident clinic approved by the Hospitals and Charities Commission—Twenty shillings;
 - (ii) for each attendance other than at such a special accident clinic—Thirty shillings.

And the Honorable Arthur Gordon Rylah, Her Majesty's Chief Secretary, for the State of Victoria, shall give the necessary directions herein accordingly.

A. MAHLSTEDT,
Clerk of the Executive Council.

TRARALGON SEWERAGE AUTHORITY.

At the Executive Council Chamber, Melbourne, the
twenty-second day of December, 1959.

PRESENT:

His Excellency the Governor of Victoria.

Mr. Rylah
Mr. Mibus

Mr. Cameron
Mr. Fraser.

EXTENT OF SEWERAGE DISTRICT INCREASED.

UNDER the powers conferred by the *Sewerage Districts Act 1958*, and all other powers enabling him in that behalf, His Excellency the Governor of the State of Victoria, by and with the advice of the Executive Council of the said State, doth hereby declare, order and direct as follows:—

That the extent of the Sewerage District of the Traralgon Sewerage Authority be increased by adding to the same the lands comprised within the boundaries described in the Schedule hereto and as on and from the date hereof the extent of such District shall be deemed to be increased accordingly.

SCHEDULE.

Portion 1.

Commencing at a point on the northern boundary of section 13, Township of Traralgon, Parish of Traralgon, County of Buln Buln in line with the eastern boundary of Crown allotment 5A, no section, Parish of Traralgon, being a point on the northern boundary of the existing Traralgon Sewerage District; thence northerly by a line across a road to the south-eastern angle of the said Crown allotment 5A, and along the eastern boundaries of the said Crown allotment 5A and Crown allotment 14B to the north-eastern angle of the said Crown allotment 14B; thence generally easterly a line along the southern boundary of Crown allotment 14A, across a road and along the northern boundary of lot 19 on lodged plan No. 4027 to its north-eastern angle; thence easterly by a line

parallel to the southern boundary of lot 18 across the said lot 18 and lot 17, a road and the Traralgon-Strathford Railway Reserve to a point on the western boundary of Crown allotment A10; thence southerly and easterly along the western and southern boundaries of the said Crown allotment A10 to a point in line with the western boundary of Crown allotment 5A, Parish of Loy Yang, County of Buln Buln; thence generally southerly by a line across a road and along the western boundary of the said Crown allotment 5A, across the Eastern Railway Reserve and along the eastern boundaries of the said Crown allotment 5A and Crown allotment 8 to a point in line with the northern boundary of Crown allotment 74c, Parish of Traralgon; thence westerly by a line across a road, across Crown allotment 4A, Parish of Loy Yang and across a road to the north-eastern angle of the aforesaid Crown allotment 74c, Parish of Traralgon; thence southerly along the eastern boundary of the said Crown allotment 74c, a distance of 150 feet; thence westerly by a line parallel to the northern boundary of the said Crown allotment 74c across portion of the said Crown allotment 74c, a Country Roads Board road and through the said Crown allotment 74c to a point distant 200 feet westerly from the western boundary of the said Country Roads Board road; thence generally northerly by a line parallel to the western boundary of the said Country Roads Board road through the said Crown allotment 74c and by a line across a road to a point on the southern boundary of Crown allotment 87, Township of Traralgon, Parish of Traralgon, distant 200 feet westerly from its south-eastern angle; thence northerly by a line parallel to the eastern boundary of the said Crown allotment 87 across the said Crown allotment 87 and Crown allotments 86, 85, 84 and 83 to a point on the northern boundary of the said Crown allotment 83, being a point on the southern boundary of the existing Traralgon Sewerage District; thence easterly, northerly and westerly along the boundary of the existing Traralgon Sewerage District to the point of commencement.

Portion 2.

Commencing at the south-eastern angle of Crown allotment 77, Township of Traralgon, Parish of Traralgon, County of Buln Buln, being a point on the southern boundary of the existing Traralgon Sewerage District;

thence generally southerly along the left bank of the Traralgon Creek to a point on a line parallel to and distant 200 feet southerly from the northern boundary of Crown allotment 73, no section, Parish of Traralgon; thence westerly by the said line parallel to and distant 200 feet southerly from the northern boundary of Crown allotment 73 across the said Crown allotment 73, a road, Crown allotments 72 and 69 and a road to a point on the eastern boundary of Crown allotment 10A²; thence southerly along the said eastern boundary of Crown allotment 10A² to its south-eastern angle; thence southerly and westerly along the eastern and southern boundaries of a Railway Reserve to its south-western angle; thence westerly by a line across a road to the south-eastern angle of lot 3 on lodged plan No. 7043; thence generally westerly and northerly along the southern, and western boundaries of the said lot 3 to its north-western angle; thence westerly by a line being the continuation of the northern boundary of the said lot 3 across a road, across lot 4 and through lot 5 to a point distant 600 links from its eastern boundary; thence northerly by a line through lot 5, across a road and the Eastern Railway Reserve to a point on the northern boundary of the said Eastern Railway Reserve in line with the eastern boundary of lot 6, section I. on lodged plan No. 8314, being an angle on the western boundary of the existing Traralgon Sewerage District; thence generally easterly along the southern boundary of the existing Traralgon Sewerage District to the point of commencement.

Portion 3.

Commencing at a point on the southern boundary of Crown allotment 32, no section, Parish of Traralgon, County of Buln Buln in line with the western boundary of lot 78 on lodged plan No. 22117 being an angle on the western boundary of the existing Traralgon Sewerage District; thence northerly by a line parallel to the eastern boundary of the said Crown allotment 32 across the said Crown allotment 32, Crown allotment 31, part of Crown allotment 30 and a road gazetted 07-4208 to a point on the northern boundary of the said road; thence generally easterly along the northern boundary of the said road and by a line across a road to the south-western angle of lot 3 on lodged plan No. 4847; thence easterly along the southern boundary of the said lot 3 to its south-eastern angle being an angle on the western boundary of the existing Traralgon Sewerage District; thence southerly and westerly along the boundary of the existing Traralgon Sewerage District to the point of commencement.

Portion 4.

Commencing at the south-eastern angle of lot 5, section I. on lodged plan No. 8314, Parish of Traralgon, County of Buln Buln, being a point on the western boundary of the existing Traralgon Sewerage District; thence westerly along the southern boundary of the said lot 5 a distance of 687.5 links; thence generally northerly by a line across lots 5, 4 and 3 to the south-western angle of lot 2, and along the western boundary of the said lot 2 to its north-western angle being a point on the western boundary of the existing Traralgon Sewerage District; thence easterly and southerly along the boundary of the existing Traralgon Sewerage District to the point of commencement.

All of which boundaries are shown on a plan approved by the Governor in Council and deposited in the office of the State Rivers and Water Supply Commission, Melbourne.—(Corres. 59/1311.)

And the Honorable Wilfred John Mibus, Her Majesty's Minister of Water Supply for the State of Victoria, shall give the necessary directions herein accordingly.

A. MAHLSTEDT,
Clerk of the Executive Council.

ROCHESTER WATERWORKS TRUST.

At the Executive Council Chamber, Melbourne, the twenty-second day of December, 1959.

PRESENT:

His Excellency the Governor of Victoria.	
Mr. Rylah	Mr. Cameron
Mr. Mibus	Mr. Fraser.

ADDITIONAL LOAN OF £1,500.

UNDER the powers conferred by the Water Acts and all other powers enabling him in that behalf, His Excellency the Governor of the State of Victoria, by and with the advice of the Executive Council of the said State, doth hereby grant an additional loan of One thousand five

hundred pounds (£1,500) to the Rochester Waterworks Trust for the construction of pipe mains and the purchase and installation of meters as set forth in the detailed statement bearing date the 18th December, 1959, and verified under the seal of the State Rivers and Water Supply Commission.

The loan hereby granted shall be subject to the provisions of the Water Acts.

And the Honorable Wilfred John Mibus, Her Majesty's Minister of Water Supply for the State of Victoria, shall give the necessary directions herein accordingly.

A. MAHLSTEDT,
Clerk of the Executive Council.

SHIRE OF WERRIBEE.—WATER SUPPLY DISTRICT.

At the Executive Council Chamber, Melbourne, the twenty-second day of December, 1959.

PRESENT:

His Excellency the Governor of Victoria.	
Mr. Rylah	Mr. Cameron
Mr. Mibus	Mr. Fraser.

ADDITIONAL LOAN OF £7,000.

UNDER the powers conferred by the Water Acts and all other powers enabling him in that behalf, His Excellency the Governor of the State of Victoria, by and with the advice of the Executive Council of the said State, doth hereby grant an additional loan of Seven thousand pounds (£7,000) to the Council of the Shire of Werribee for the construction of pipe mains and the purchase and installation of meters as set forth in the detailed statement bearing date the 18th December, 1959, and verified under the seal of the State Rivers and Water Supply Commission.

The loan hereby granted shall be subject to the provisions of the Water Acts.

And the Honorable Wilfred John Mibus, Her Majesty's Minister of Water Supply for the State of Victoria, shall give the necessary directions herein accordingly.

A. MAHLSTEDT,
Clerk of the Executive Council.

WARBURTON WATERWORKS TRUST.

At the Executive Council Chamber, Melbourne, the twenty-second day of December, 1959.

PRESENT:

His Excellency the Governor of Victoria.	
Mr. Rylah	Mr. Cameron
Mr. Mibus	Mr. Fraser.

ADDITIONAL LOAN OF £15,000.

UNDER the powers conferred by the Water Acts and all other powers enabling him in that behalf, His Excellency the Governor of the State of Victoria, by and with the advice of the Executive Council of the said State, doth hereby grant an additional loan of Fifteen thousand pounds (£15,000) to the Warburton Waterworks Trust for the construction of pipe mains and the purchase and installation of meters as set forth in the detailed statement bearing date the 18th December, 1959, and verified under the seal of the State Rivers and Water Supply Commission.

The loan hereby granted shall be subject to the provisions of the Water Acts.

And the Honorable Wilfred John Mibus, Her Majesty's Minister of Water Supply for the State of Victoria, shall give the necessary directions herein accordingly.

A. MAHLSTEDT,
Clerk of the Executive Council.

STATE RIVERS AND WATER SUPPLY COMMISSION.

At the Executive Council Chamber, Melbourne, the twenty-second day of December, 1959.

PRESENT:

His Excellency the Governor of Victoria.	
Mr. Rylah	Mr. Cameron
Mr. Mibus	Mr. Fraser.

OTWAY WATERWORKS DISTRICT—PORTION EXCISED.

UNDER the powers conferred by the Water Acts and all other powers enabling him in that behalf, His Excellency, the Governor of the State of Victoria, with the advice of the Executive Council of the said State, on the recommendation of the State Rivers and Water Supply Commission, doth hereby declare, order and direct as follows:—

That there shall be excised from the Otway Waterworks District, that portion of the same set out and described in the Schedule hereto, which portion as from the date of this Order shall be deemed to be excised accordingly.

SCHEDULE.

Commencing at the south-western angle of allotment 11, section A, Parish of Wangoom; thence northerly by the western boundary of that allotment and a line in continuation thereof to the northern boundary of allotment 14; thence easterly by the last-mentioned boundary and a line in continuation thereof to the western boundary of allotment 8, section E; thence southerly by the eastern boundary of a road to the south-western angle of allotment 1; thence easterly by the northern boundary of a road to the south-western angle of allotment 3, section H; thence southerly by the eastern boundary of a road to the right bank of the Hopkins river; thence generally westerly by that river bank to the most southerly angle of allotment 24A, section 1; thence northerly and westerly by the eastern and northern boundaries of the township of Warrnambool to the point of commencement.—(Corres. 58/12839.)

And the Honorable Wilfred John Mibus, Her Majesty's Minister of Water Supply for the State of Victoria, shall give the necessary directions herein accordingly.

A. MAHLSTEDT,
Clerk of the Executive Council.

WARRAGUL WATERWORKS TRUST.

At the Executive Council Chamber, Melbourne, the twenty-second day of December, 1959.

PRESENT:

His Excellency the Governor of Victoria.	
Mr. Rylah	Mr. Cameron
Mr. Mibus	Mr. Fraser.

ADDITIONAL LOAN OF £48,760.

UNDER the powers conferred by the Water Acts and all other powers enabling him in that behalf, His Excellency the Governor of the State of Victoria, by and with the advice of the Executive Council of the said State, doth hereby grant an additional loan of Forty-eight thousand seven hundred and sixty pounds (£48,760) to the Warragul Waterworks Trust for the construction of service basin, pipe mains and the purchase and installation of meters as set forth in the detailed statement bearing date the 18th December, 1959, and verified under the seal of the State Rivers and Water Supply Commission.

The loan hereby granted shall be subject to the provisions of the Water Acts.

And the Honorable Wilfred John Mibus, Her Majesty's Minister of Water Supply for the State of Victoria, shall give the necessary directions herein accordingly.

A. MAHLSTEDT,
Clerk of the Executive Council.

CHILTERN WATERWORKS TRUST.

At the Executive Council Chamber, Melbourne, the twenty-second day of December, 1959.

PRESENT:

His Excellency the Governor of Victoria.	
Mr. Rylah	Mr. Cameron
Mr. Mibus	Mr. Fraser.

ADDITIONAL LOAN OF £6,000.

UNDER the powers conferred by the Water Acts and all other powers enabling him in that behalf, His Excellency the Governor of the State of Victoria, by and with the advice of the Executive Council of the said State, doth hereby grant an additional loan of Six thousand pounds (£6,000) to the Chiltern Waterworks Trust for the construction of pipe mains and purchase and installation of meters as set forth in the detailed statement bearing date the 18th December, 1959, and verified under the seal of the State Rivers and Water Supply Commission.

The loan hereby granted shall be subject to the provisions of the Water Acts.

And the Honorable Wilfred John Mibus, Her Majesty's Minister of Water Supply for the State of Victoria, shall give the necessary directions herein accordingly.

A. MAHLSTEDT,
Clerk of the Executive Council.

FIRST MILDURA IRRIGATION TRUST.

At the Executive Council Chamber, Melbourne, the twenty-second day of December, 1959.

PRESENT:

His Excellency the Governor of Victoria.	
Mr. Rylah	Mr. Cameron
Mr. Mibus	Mr. Fraser.

ADDITIONAL LOAN OF £50,000.

UNDER the powers conferred by the *Mildura Irrigation and Water Trusts Act 1958*, and all other powers enabling him in that behalf, His Excellency the Governor of the State of Victoria, by and with the advice of the Executive Council of the said State, doth hereby grant an additional loan of Fifty thousand pounds (£50,000) to the First Mildura Irrigation Trust for the construction of pumping plant, channel improvements and pipe-lines as set forth in the detailed statement bearing date the 18th December, 1959, and verified under the seal of the State Rivers and Water Supply Commission.

The loan hereby granted shall be subject to the provisions of the *Mildura Irrigation and Water Trusts Act 1958*.

And the Honorable Wilfred John Mibus, Her Majesty's Minister of Water Supply for the State of Victoria, shall give the necessary directions herein accordingly.

A. MAHLSTEDT,
Clerk of the Executive Council.

MOOROOPNA WATERWORKS TRUST.

At the Executive Council Chamber, Melbourne, the twenty-second day of December, 1959.

PRESENT:

His Excellency the Governor of Victoria.	
Mr. Rylah	Mr. Cameron
Mr. Mibus	Mr. Fraser.

ADDITIONAL LOAN OF £35,000.

UNDER the powers conferred by the Water Acts and all other powers enabling him in that behalf, His Excellency the Governor of the State of Victoria, by and with the advice of the Executive Council of the said State, doth hereby grant an additional loan of Thirty-five thousand pounds (£35,000) to the Mooropna Waterworks Trust for the construction of treatment plant, pipe mains and the purchase and installation of meters as set forth

in the detailed statement bearing date the 18th December, 1959, and verified under the seal of the State Rivers and Water Supply Commission.

The loan hereby granted shall be subject to the provisions of the Water Acts.

And the Honorable Wilfred John Mibus, Her Majesty's Minister of Water Supply for the State of Victoria, shall give the necessary directions herein accordingly.

A. MAHLSTEDT,
Clerk of the Executive Council.

LATROBE VALLEY WATER AND SEWERAGE BOARD.

At the Executive Council Chamber, Melbourne, the twenty-second day of December, 1959.

PRESENT:

His Excellency the Governor of Victoria.
Mr. Rylah | Mr. Cameron
Mr. Mibus | Mr. Fraser.

ADDITIONAL LOAN OF £80,000.

UNDER the powers conferred by the *Latrobe Valley Act 1958* and all other powers enabling him in that behalf, His Excellency the Governor of the State of Victoria, by and with the advice of the Executive Council of the said State, doth hereby grant an additional loan of Eighty thousand pounds (£80,000) to the Latrobe Valley Water and Sewerage Board for the purpose of constructing sewers, pipe-lines, channels, storages, and purchase of land and construction or purchase of works or buildings, and development of land-disposal scheme, as set forth in the detailed statement bearing date the 18th December, 1959, and verified under the seal of the State Rivers and Water Supply Commission.

The loan hereby granted shall be subject to the provisions of the *Latrobe Valley Act 1958*.

And the Honorable Wilfred John Mibus, Her Majesty's Minister of Water Supply for the State of Victoria, shall give the necessary directions herein accordingly.

A. MAHLSTEDT,
Clerk of the Executive Council.

LIBRARIES ACT 1958.

At the Executive Council Chamber, Melbourne, the twenty-second day of December, 1959.

PRESENT:

His Excellency the Governor of Victoria.
Mr. Rylah | Mr. Cameron
Mr. Mibus | Mr. Fraser.

ORDER APPROVING TRANSFER OF LAND TO THE MUNICIPALITY OF THE CITY OF HAMILTON.

WHEREAS:

- I. The land described in the Schedule hereto is vested in trustees in trust that it may be used as a site for a Mechanics' Institute and free library at Hamilton in the State of Victoria.
- II. The said land is no longer required for that purpose.
- III. The trustees for the time being of the said land and the Council of the municipality of the City of Hamilton within the municipal district of which the said land is situate have petitioned the Governor in Council in writing pursuant to section 23 of the *Libraries Act 1958* to grant authority for the said trustees to transfer the said land to the said municipality.
- IV. Apart from two tenants of premises on the said land no lessee mortgagee or other person holds any interest in or right over the said land.
- V. The two tenants aforesaid have consented in writing to such authority being granted.

Now therefore in pursuance of the powers conferred by the said Act His Excellency the Governor of the State of Victoria, by and with the advice of the Executive Council thereof, doth hereby authorize the said trustees for the time being of the said land notwithstanding any trusts

conditions restrictions or limitations contained in any document of title concerning the said land to transfer the said land to the municipality aforesaid.

SCHEDULE.

All that piece of land being lot 1 on plan of subdivision No. 50490, lodged in the Office of Titles, Parish of North Hamilton, County of Dundas, and being part of the land described in certificate of title, volume 5287, folio 209.

And the Honorable Arthur Gordon Rylah, Her Majesty's Chief Secretary for the State of Victoria, shall give the necessary directions herein accordingly.

A. MAHLSTEDT,
Clerk of the Executive Council.

SUPERANNUATION ACT 1958.

At the Executive Council Chamber, Melbourne, the twenty-second day of December, 1959.

PRESENT:

His Excellency the Governor of Victoria.
Mr. Rylah | Mr. Cameron
Mr. Mibus | Mr. Fraser.

PURSUANT to the powers conferred under the provisions of section 3 (1) of the *Superannuation Act 1958*, His Excellency the Governor of the State of Victoria, by and with the advice of the Executive Council thereof, doth by this Order declare that the provisions of the Superannuation Act shall apply to the office of Member of the Rural Finance Corporation constituted pursuant to the provisions of section 6 of the *Rural Finance Corporation Act 1958*.

And the Honorable Henry Edward Bolte, Her Majesty's Treasurer for the State of Victoria, shall give the necessary directions herein accordingly.

A. MAHLSTEDT,
Clerk of the Executive Council.

APPROACHING LAND SALES.

SALES of Crown lands, in fee-simple, will be held at the under-mentioned places and dates, viz.:

	No. of Gazette.
Ararat.—Thursday, 18th February, 1960 ..	112
Avoca.—Friday, 12th February, 1960 ..	112
Bairnsdale.—Wednesday, 3rd February, 1960 ..	109
Dunolly.—Friday, 19th February, 1960 ..	112
Geelong.—Wednesday, 6th January, 1960 ..	106
Mallacoota.—Friday, 29th January, 1960 ..	109
Port Campbell.—Friday, 29th January, 1960 ..	112
Wedderburn.—Monday, 15th February, 1960 ..	112

SALES OF CROWN LANDS BY AUCTION.

The land will be offered for sale in fee-simple, and subject to the provisions of the Land Act and Regulations thereunder.

The **upset price** is the sum at which bidding will start, and no bid below that sum can be accepted. The highest bidder at or above that sum shall be the purchaser, subject to signature of contract and any necessary payment.

TERMS:

A **deposit of at least 12½%** of the purchase price must be paid at the sale, either in cash or by cheque.

The **residue** is payable in half-yearly instalments, in accordance with the following scale, or may be paid off at any earlier time.

£20 and under, 6 instalments.

Over £20, and not exceeding £50, 8 instalments.

Over £50, and not exceeding £100, 10 instalments.

Over £100, and not exceeding £200, 12 instalments.

Over £200, and not exceeding £300, 14 instalments.

Over £300, and not exceeding £400, 16 instalments.

Over £400, and not exceeding £500, 18 instalments.

Over £500, 20 instalments.

Interest at the rate of 5% per annum is payable with all payments of residue, and is computed for each instalment from the date of sale to the date of such payment. Additional interest is charged if any instalment is not paid on or before the due date.

If paid off within 30 days of sale, no interest is payable.

FEES, ETC.:

Also payable at the sale, in addition to the deposit, are the survey fee and the valuation of improvements (if purchaser be not the owner thereof).

Payable with balance of purchase money—

Crown Grant fee—50 acres and under	£1 10s.
Over 50 acres	£2
Purchase money £5 or under	£1

Assurance Fund contribution—One halfpenny for each £1. of purchase price. (This is a fund established to guarantee the validity of freehold titles.)

Transfer of interest prior to completion of payment may be allowed on payment of £1 fee and subject to stamp duty.

If unable to attend personally, a prospective purchaser may arrange for another person to bid as his agent.

KEITH TURNBULL,
Commissioner of Crown Lands and Survey.

Office of Crown Lands and Survey,
Melbourne, 23rd December, 1959.

PORT CAMPBELL.—Sale (No. 11466) of Crown lands, in fee-simple, by auction, will be held at the MECHANICS HALL, PORT CAMPBELL, on FRIDAY, the 29th JANUARY, 1960, at TWO o'clock p.m. To be conducted by W. M. WALSH, Land Officer, Geelong.

TOWNSHIP OF PORT CAMPBELL, PARISH OF PAARATTE,
COUNTY OF HEYTESBURY.

In the East of the Township.

Upset price	£75 per lot. Survey fee £5 10s. per lot.
Lot 1.	Area 32 perches, allotment 1 of section 11.
Lot 2.	Area 32 perches, allotment 2 of section 11.
Lot 3.	Area 32 perches, allotment 3 of section 11.
Lot 4.	Area 32 perches, allotment 4 of section 11.
Lot 5.	Area 32 perches, allotment 5 of section 11.
Lot 6.	Area 32 perches, allotment 6 of section 11.

(G.65096.)

NOTE.—All the above allotments are sold subject to survey and any necessary easements disclosed thereby.

AVOCA.—Sale (No. 11467) of Crown lands, in fee-simple, by auction, will be held at the LAND INSPECTOR'S OFFICE, AVOCA, on FRIDAY, the 12th FEBRUARY, 1960, at half-past NINE o'clock a.m. To be conducted by R. E. LAWES, Land Officer, St. Arnaud.

TOWNSHIP OF AVOCA, PARISH OF AVOCA, COUNTY OF GLADSTONE.

Lot 1.

In the East of the Township. Fronting East side of a Government road and about 3 chains North of Russell-street.

Upset price £15 the lot. Survey fee £6.

Area 1r. 8p., subject to survey and any necessary easements disclosed thereby, allotment 4 of section 26b. Valuation of improvements £370 (house, shed, garage) (W. J. Simmons).—(W.71180.)

Lot 2.

Fronting Boyce-street about 2 chains South of Duke-street.

Upset price £50 the lot. Survey fee £6.

Area 1 rood, subject to survey and any necessary easements disclosed thereby, allotment 3 of section 26b. Valuation of improvements £115 (septic closet, fencing and gate) (Mrs. M. F. Kaye).—(W.62493.)

PARISH OF WARRENMANG, COUNTY OF KARA KARA.

Lot 3.

In the South-east of the Parish.

Upset price £50 the lot. Survey fee £7 12s. 6d.

Area 5 acres, subject to survey and any necessary easements disclosed thereby, allotment 21A of section 2. Valuation of improvements £10 (fencing) (P. Turpin).—(W.85367.)

WEDDERBURN.—Sale (No. 11468) of Crown lands, in fee-simple, by auction, will be held at the COURT HOUSE, WEDDERBURN, on MONDAY, the 15th FEBRUARY, 1960, at half-past ONE o'clock p.m. To be conducted by R. E. LAWES, Land Officer, St. Arnaud.

Lot 1.

PARISH OF BARRAKEE, COUNTY OF GLADSTONE.

In the South-west of the Parish.

Upset price £380 the lot. Survey fee £17 5s.

Area 137a. 3r. 17p., allotment 123A.—(W.84391.)

Also, the following freehold land will be offered for and on behalf of the Minister of Education:—

Lot 2.

PARISH OF BARRAKEE, COUNTY OF GLADSTONE.

In the North-west of the Parish, being the site and buildings of former Barrakee South State School.

Upset price £142 the lot.

Area 1 acre, being part of allotment 26 and being the land more particularly described in freehold certificate of title, volume 2707, folio 209.

Sale of lot 2 is subject to the following conditions:—

- A deposit of at least 12½ per cent. shall be paid at the sale, and the balance of the purchase money shall be paid within 60 days.
- The purchaser shall, at his own expense, arrange for all necessary action to prepare and register the transfer.—(C.97878.)

ARARAT.—Sale (No. 11469) of Crown lands, in fee-simple, by auction, will be held at the LAND OFFICE, ARARAT, on THURSDAY, the 18th FEBRUARY, 1960, at half-past TWO o'clock p.m. To be conducted by H. H. DODD, Land Officer, Ballarat.

Lot 1.

PARISH OF BURRUMBEEF, COUNTY OF RIPON.

About 10 chains West of main Country Roads Board road, fronting North side of a Government road, and being the Site and Buildings of former Cathcart State School.

Upset price £25 the lot. Survey fee £7.

Area 2 acres, allotment 19 of section 1. Valuation of improvements £34 (school buildings, tanks, fencing) (Education Department).—(J.30183.)

DUNOLLY.—Sale (No. 11470) of Crown lands, in fee-simple, by auction, will be held at the LAND INSPECTOR'S OFFICE, DUNOLLY, on FRIDAY, the 19th FEBRUARY, 1960, at half-past ONE o'clock p.m. To be conducted by R. E. LAWES, Land Officer, St. Arnaud.

TOWNSHIP OF DUNOLLY, PARISH OF DUNOLLY, COUNTY OF GLADSTONE.

Lot 1.

Fronting gravelled road about 3 chains West of Dunolly Railway Yards.

Upset price £25 the lot. Survey fee £5 17s. 6d.

Area 1a. 1r. 32p., allotment 6 of section 34b. One month allowed for removal of improvements.—(W.81108.)

TOWNSHIP OF GOLDSBOROUGH, PARISH OF PAINSWICK,
COUNTY OF GLADSTONE.

Lot 2.

East of Dam in the centre of the Township.

Upset price £17 10s. the lot. Survey fee £6 2s. 6d.

Area 2a. 2r., allotment 8 of section A. Valuation of improvements £1,050 (eucalyptus plant, shed and fencing) (W. H. Britten).—(W.67476.)

Lot 3.

In the West of the Township.

Upset price £14 the lot. Survey fee £5 10s.

Area 1r. 17p., allotment 14 of section B.

NOTE.—Allotment 14 as now offered embraces the land hitherto shown on plans as allotments 14 and 15.

PARISH OF BEALIBA, COUNTY OF GLADSTONE.

About 1 mile North-east of Township of Bealiba.

Lot 4.

Upset price £15 the lot. Survey fee £7 12s. 6d.

Area 3a. 3r. 10p., subject to examination of survey and any necessary easements disclosed thereby, allotment 6B or section G. Subject to special mining condition referred to in section 81, Land Act 1958.

Lot 5.

Upset price £170 the lot. Survey fee £13 2s. 6d.

Area 41a. 3r. 6p., subject to examination of survey and any necessary easements disclosed thereby, allotment 6C of section G. Subject to special mining condition referred to in section 81, Land Act 1958.—(W.70747.)

LIST OF CROWN LANDS AVAILABLE.

THE under-mentioned areas are available for application as provided by various sections of the Land Act 1958, and all applications received on or before Wednesday, 27th January, 1960, will be deemed to have been made simultaneously, but any application lodged after such date may be considered if received in time for inclusion in the advertisement of the cases to be heard at the Local Land Board. Applications on proper form, accompanied by 5s. duty stamp uncanceled (registration fee), may be delivered or forwarded by post to the Local Land Officer or to any Crown Lands Office in Victoria. Subject to the approval of the Secretary for Lands, when the survey fee exceeds £25 but does not exceed £50, a deposit of £25 may be paid, and when the fee exceeds £50, a deposit of 50 per cent. of the fee, the balance in either case being payable over six years in half-yearly instalments.

Marked plans of any particular area, application forms, and any further information may be obtained from the Crown Lands Department, Melbourne, and Land Officers.

Department of Crown Lands and Survey,
Melbourne, 21st December, 1959.

KEITH TURNBULL,
Commissioner of Crown Lands and Survey.

* Improvements may be subject to re-valuation after land has been granted to an applicant.

Local Land Office.	County.	Parish.	Allotment.	Section.	Area.	How Available.		Valuation of Improvements (if any).*	Location of Land, &c.	Nearest Railway Station or Township and Distance in miles therefrom.	How Accessible.	Water Supply.	General Description of Land—Soil, Timber, Suitability (grazing, &c.).
						Classification.	Value per Acre.						
						A.	R.	P.					
						£	s.	d.					
DIVISION 4, PART I., LAND ACT 1958.													
AGRICULTURAL AND GRAZING LANDS—SELECTION PURCHASE ALLOTMENTS.													
Geelong ..	Totworth ..	Barwong-emoong	6c	..	105 0 0	2nd	25 0 28 7 6	..	South East of former Lavers Hill Railway Station 2 miles N-W of Myrtleford	Colac R.S., 39 miles	By Ocean-road	By con-servation	Hilly country, heavy red loam, saplings and scrub. Suitable for grazing. (438/44)
Beechworth	Bogong ..	Myrtleford	27	A one	19 0 0±	3rd	2 0 0 10 2 6	Myrtleford R.S., 2 miles	Formed track	To be con-served	Stony loam and thin stony soil. Some red box, long leaf box, red stringy bark, medium density sapling, wattle and native grasses. Suitable only as an additional area (H.0208341)
Bendigo (a)	Talbot ..	Maldon ..	6a and 6c	7	27 2 0±	3rd	2 0 0 18 2 6	£395.	In north of Parish	Maldon Town-ship, 3½ miles	Maldon—Baringhup road, thence by formed and gravelled road and un-made track	To be con-served	Portion fair quality brown sandy loam, balance poor stony ground. Cleared and grassed. Scattered box timber in South West corner. Suitable only for grazing. (W. 67365)
AVAILABLE UNDER SECTION 138, LAND ACT 1958.													
Ballarat ..	Talbot ..	and Town-ship of Creswick	33	48A	0 1 30± (Subject to survey)	..	Rental to be fixed	0 0 0	Pronting Lutlet St.	In the Township of Creswick	By road	To be con-served	Suitable for dwelling and garden. (J.21976)

(a) Subject to special mining condition.

Land Act 1958.

LEASES SURRENDERED.

NOTICE is hereby given that the Governor in Council has accepted the surrender of the Leases mentioned in the Schedule hereunder for the reason specified in each case.

District.	Corr. No.	Name.	Section of Land Act under which Leased.	Parish.	Allotment.	Area.	Class.	Reason.
Mallee ..	023/217	H. L. Yard	Carina ..	Part of 36	A. R. P. 1 3 8	..	Area acquired for road purposes
Melbourne	0534/125	Food Machinery (Australia) Limited	..	Melbourne South	1	1 2 28	..	Lease surrendered as from 1.1.1960. (New lease to issue)

Department of Crown Lands and Survey,
Melbourne, 10th December, 1959.

KEITH TURNBULL,
Commissioner of Crown Lands and Survey.

Land Act 1958.

LAND PROPOSED TO BE PERMANENTLY RESERVED.

IN pursuance of the provisions of the Land Act 1958, notice is hereby given that it is the intention of the Governor in Council to permanently reserve land by Order in Council hereunder referred to, viz.:—

The following Notice was published 1° on the 9th December 1959, pursuant to Order of the 1st December, 1959.

OAKLEIGH.—Land to be permanently reserved as a site for a Cemetery, 4 acres 3 roods 1 perch, Township of Oakleigh, Parish of Mulgrave, County of Bourke, as indicated by hachure on plan hereunder.—(O.1(2) (Rs.3802).

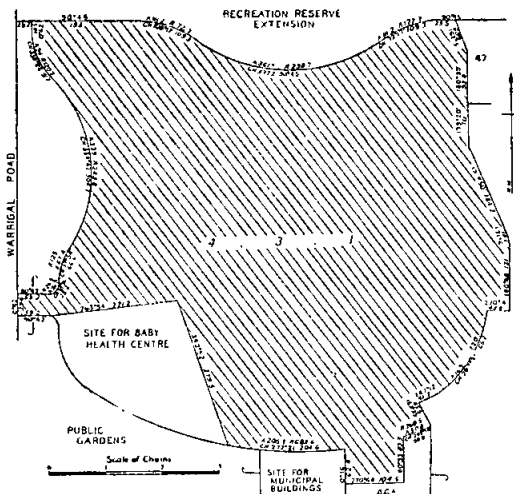

KEITH TURNBULL,
Commissioner of Crown Lands and Survey.

PROPOSED REVOCATION OF TEMPORARY RESERVATION OF LAND BY ORDER IN COUNCIL.

IN pursuance of the provisions of the Land Act 1958, notice is hereby given that it is the intention of the Governor in Council to revoke the temporary reservation of land by Order in Council hereunder referred to, viz.:—

The following Notice was published 1° on the 9th December, 1959, pursuant to Order of the 8th December, 1959.

BENDIGO.—The temporary reservation by Order in Council of the 12th April, 1943, of 3 acres 1 rood 37 perches of land in the City of Bendigo as a site for Plantation purposes.—(S.372(34) (Rs.5408).

KEITH TURNBULL,
Commissioner of Crown Lands and Survey.

PROPOSED REVOCATION OF TEMPORARY RESERVATION AND THE WITHHOLDING FROM SALE, LEASING, AND LICENSING OF LAND BY ORDER IN COUNCIL.

IN pursuance of the provisions of the Land Act 1958, notice is hereby given that it is the intention of the Governor in Council to revoke the temporary reservation and the withholding from sale, leasing, and licensing of land by Order in Council hereunder referred to, viz.:—

The following Notice was published 1° on the 23rd December, 1959, pursuant to Order of the 15th December, 1959.

GARIBALDI.—The temporary reservations as sites for Public purposes (State School) and the withholding from sale, leasing and licensing, by Orders in Council of the 8th July, 1878, and the 20th September, 1878, of 4 acres and 1 rood 19 perches, respectively, of land in the Township of Garibaldi (formerly in the Parish of Enfield).—(E.52(1) (Rs.7848).

KEITH TURNBULL,
Commissioner of Crown Lands and Survey.

PROPOSED REVOCATION OF PORTION OF TEMPORARY RESERVATION OF LAND BY ORDER IN COUNCIL.

IN pursuance of the provisions of the Land Act 1958, notice is hereby given that it is the intention of the Governor in Council to revoke portion of the temporary reservation of land by Order in Council hereunder referred to, viz.:—

The following Notice was published 1° on the 23rd December, 1959, pursuant to Order of the 15th December, 1959.

MARIBYRNONG.—The temporary reservation, by Order in Council of the 21st November, 1950, of 32 acres, more or less, of land in the Parish of Maribyrnong as a site for Public Recreation, so far only as the portion containing 4 acres 1 rood, more or less, indicated by hachure on plan hereunder, is concerned.—(M.46(9) (Rs.6601).

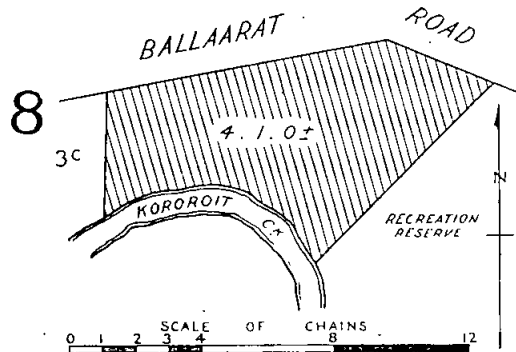

KEITH TURNBULL,
Commissioner of Crown Lands and Survey.

PROPOSED REVOCATION OF TEMPORARY RESERVATION OF LAND BY ORDER IN COUNCIL.

IN pursuance of the provisions of the *Land Act* 1958, notice is hereby given that it is the intention of the Governor in Council to revoke the temporary reservation of land by Order in Council hereunder referred to, viz.:—
The following Notice was published 1° on the 9th December, 1959, pursuant to Order of the 1st December, 1959.

Moe.—The temporary reservation, by Order in Council of the 21st November, 1887, revoked as to part by Order of the 26th March, 1935, and the temporary reservation by Order of the 12th February, 1935, of 82 acres 0 roods 36 perches and 1 acre 0 roods 20 1/10 perches, respectively, of land in the Parish of Moe, as sites for Railway purposes, so far only as the balance thereof containing 81 acres 3 roods 31 6/10 perches is concerned.—(M.498(?) (C.81835).

KEITH TURNBULL,
 Commissioner of Crown Lands and Survey.

Teaching Service Act 1958.

TEACHING SERVICE (TEACHERS TRIBUNAL) REGULATIONS. AMENDMENT No. 260.

THE Teachers Tribunal, in pursuance of the powers conferred by the *Teaching Service Act* 1958, hereby amends Regulation 1 of the Teaching Service (Teachers Tribunal) Regulations in the manner following, that is to say:—

REGULATION 1.

1. Clause 20 to be renumbered 20 (a).
2. After sub-clause 20 (a), insert the following sub-clause:—
 “(b) Where a member has not served the requisite time in his present position but has served in his present school for more than five years, the Tribunal may allow reimbursement of removal expenses in whole or in part.”
3. In clause 24, delete the proviso and substitute therefor the following proviso:—
 “Provided that, except in any instance where the Tribunal is satisfied that an increased rate of reimbursement should be allowed, the reimbursement to members travelling by motor car or motor cycle shall not exceed 40s. a week or 15s. a week respectively.”

LOUIS F. C. GARLICK, Chairman.
 G. FENNELL, Secretary.

Office of the Teachers Tribunal,
 Melbourne, 17th December, 1959.

PUBLIC SERVICE NOTICES

No. 988.

Public Service Act 1958, Section 39.

REGULATIONS.—PART III.—SALARIES, INCREMENTS, AND ALLOWANCES.

THE Public Service Board, in pursuance of the powers conferred by the *Public Service Act* 1958, hereby amends its Regulations as shown below:—

FIRST SCHEDULE.

PROFESSIONAL DIVISION.

Amount of Salary Assigned to Offices in Class "A1".

Office.	Yearly Rate of Salary.
DEPARTMENT OF HEALTH. TUBERCULOSIS BRANCH. Senior Medical Officer, Thoracic Unit	£ 2,400

A. GARRAN, Chairman.
 V. P. SCULLY, Secretary.

Office of the Public Service Board,
 Melbourne, 14th December, 1959.

No. 112.—11676/59.—3

No. 986.

Public Service Act 1958, Section 39.

REGULATIONS.—PART III.—SALARIES, INCREMENTS, AND ALLOWANCES.

THE Public Service Board, in pursuance of the powers conferred by the *Public Service Act* 1958, hereby amends its Regulations as shown below:—

FIRST SCHEDULE.

PROFESSIONAL DIVISION.

Amount of Salary Assigned to Offices in Class "A1".

Office.	Yearly Rate of Salary.
DEPARTMENT OF TREASURER. <i>Delete—</i> Economics Research Officer	£ 2,600

A. GARRAN, Chairman.
 V. P. SCULLY, Secretary.

Office of the Public Service Board,
 Melbourne, 10th December, 1959.

No. 989.

Public Service Act 1958, Section 39.

REGULATIONS.—PART III.—SALARIES, INCREMENTS, AND ALLOWANCES.

THE Public Service Board, in pursuance of the powers conferred by the *Public Service Act 1958*, hereby amends its Regulations as shown below:—

**FIRST SCHEDULE.
PROFESSIONAL DIVISION.**

Amount of Salary Assigned to Offices in Class "A1".

Office.	Yearly Rate of Salary.
DEPARTMENT OF HEALTH.	
MATERNAL AND CHILD HYGIENE BRANCH.	
Add— Senior Superintending Dental Officer	2,600

A. GARRAN, Chairman.
V. P. SCULLY, Secretary.

Office of the Public Service Board,
Melbourne, 10th December, 1959.

No. 987.

Public Service Act 1958.

REGULATIONS.—PART III.—SALARIES, INCREMENTS, AND ALLOWANCES.

THE Public Service Board, in pursuance of the powers conferred by the *Public Service Act 1958*, hereby amends its Regulations as shown below:—

**FOURTH SCHEDULE.
ADMINISTRATIVE DIVISION.**

Amount of Salary Assigned to Offices in Class "A1".

Office.	Yearly Rate of Salary.
DEPARTMENT OF TREASURER.	
Add— Economist	2,200

A. GARRAN, Chairman.
V. P. SCULLY, Secretary.

Office of the Public Service Board,
Melbourne, 10th December, 1959.

No. 991.

PUBLIC SERVICE ACT 1958.

THE Public Service Board, in pursuance of the powers conferred by the *Public Service Act 1958*, hereby amends the Public Service (Public Service Board) Regulations as follows:—

**PART III.—SALARIES, INCREMENTS, AND ALLOWANCES.
REGULATION 61.**

(a) SECOND SCHEDULE.

DEPARTMENT OF PUBLIC WORKS.

Ports and Harbours.

Immediately after clause (xiii) the following clause is inserted:—

"(xiv) Each officer, who is a crew member of the mining boat which operates from the S.S. *Rip* in connexion with mining operations for the deepening of the Rip bank, shall receive an allowance for the performance of such duties at the rate of 5s. a shot."

This Regulation shall have effect as on and from the 10th December, 1959.

(b) SEVENTH SCHEDULE.

DEPARTMENT OF HEALTH.

Mental Hygiene.

The final paragraph in clause (vi) is deleted and the following is substituted therefor:—

"Officers who are not supplied with quarters shall be charged £77 a year for meals provided in an institution, provided that for officers other than nursing staff or non-resident officers being nursing staff employed on an eight (8) hours shift the charge shall be 2s. 9d. for any meal supplied."

This Regulation shall have effect as on and from the 15th December, 1959.

A. GARRAN, Chairman.
V. P. SCULLY, Secretary.

Office of the Public Service Board,
Melbourne, 15th December, 1959.

No. 990.

Public Service Act 1958, Section 50.

REGULATIONS.—PART III.—SALARIES, INCREMENTS AND ALLOWANCES.

THE Public Service Board, in pursuance of the powers conferred by the *Public Service Act 1958*, hereby amends its Regulations as shown below:—

**SIXTH SCHEDULE.
TEMPORARY EMPLOYEES.**

Designations of Positions and Rates of Salaries.

Department and Designation of Position.	Yearly Rate of Salary.		Increments (Annual).
	Minimum.	Maximum.	
DEPARTMENT OF PUBLIC WORKS.	£	£	
Delete— PORTS AND HARBOURS.			
Add— PORTS AND HARBOURS††			

†† Each employee, who is a crew member of the mining boat which operates from the S.S. *Rip* in connexion with mining operations for the deepening of the Rip bank, shall receive an allowance for the performance of such duties at the rate of 5s. a shot.

A. GARRAN, Chairman.
V. P. SCULLY, Secretary.

Office of Public Service Board,
Melbourne, 10th December, 1959.

PRIVATE ADVERTISEMENTS

NOTICE is hereby given that the Merino Golf Club has applied for a lease under section 134 of *Land Act 1958*, for a term of 21 years, for allotment 1, section 46, Parish of Merino, containing 21 acres 2 roods 28 perches, as a site for amusement and recreation. 8272

NOTICE is hereby given that the Myrtleford Golf Club has applied for a lease for a term of 21 years, under section 134, *Land Act 1958*, of about 32 perches, more or less, of Crown land in section 9A, Parish of Myrtleford, for purposes of Amusement and Recreation (Club House). 8002

Victoria.

ACT 391.—FIRST SCHEDULE.

I, THE Most Reverend Frank Woods, of Cathedral Buildings, head or authorized representative of the denomination known as the Church of England in the Diocese of Melbourne, with the consent of the Church of England Trusts Corporation for the Diocese of Melbourne, trustees of the land described in the subjoined statement of trusts, being the person entitled to minister in or occupy a building or buildings upon the said land, hereby apply to the Governor of the State of Victoria for leave to dispose of the said land by the means and for the purposes mentioned in the said statement of trusts, and I hereby certify that the said land was reserved by the Crown on the 23rd day of August, 1869, as a site for

Church of England purposes: That the only trustees of the said land resident in the State of Victoria are the Church of England Trusts Corporation: That the only buildings upon the said land are nil: And that the only persons entitled to minister in or occupy the same are the Church of England Trusts Corporation.

Signature of head or authorized representative—FRANK MELBOURNE.

We consent to this application.

The common seal of the Church of England Trusts Corporation for the Diocese of Melbourne was hereto affixed, in the presence of—

(SEAL) H. W. BUCKLEY, Trustee.
JOHN MCKIE, Trustee.
R. C. WARDLE, Trustee.

STATEMENT OF TRUSTS.

Description of Land.—Two acres, Township of Kalkallo, Parish of Kalkallo, County of Bourke, being allotment 1, section 12: Commencing at the junction of the eastern boundary of Hawkey-street and the northern boundary of Arrow Smith-street; bounded thence by Hawkey-street bearing north 500 links; by Power-street bearing east 400 links; by allotment 5 bearing south 500 links; and thence by Arrow Smith-street bearing west 400 links to the commencing point.

Name of Trustees.—Church of England Trusts Corporation.

Powers of Disposition.—To sell, lease, mortgage, or exchange all or any part of such land subject to the approval of the Archbishop of Melbourne for the time being, or during the absence of the Archbishop from the Diocese or the vacancy of the See, to the approval of the person for the time being administering the affairs thereof. The land, until otherwise disposed of, to be held for the purposes for which it was granted or reserved by the Crown.

Purposes to which Proceeds of Disposition are to be Applied.—To be paid to the Archbishop or Administrator aforesaid to be applied to such purposes of the Church of England in the Diocese of Melbourne as may by such Archbishop or Administrator acting under the advice of the Council of the Diocese, be from time to time deemed desirable. 8336

NOTICE OF INTENTION TO APPLY FOR A LICENCE TO DIVERT WATER AND CUT RACE (RE-ISSUE) FROM THE THOMSON RIVER, AT DAWSON.

I HEREBY give notice that I intend to apply for a licence empowering me to divert water for a term of fifteen years to the extent of 30 acre-feet per annum at a maximum rate of 2 acre-feet per day of 24 hours for the irrigation of 15 acres of pasture, being part of allotment 82b, Parish of Glenmaggie, and to occupy certain Crown Lands for works of diversion, and to cut a race thereon.

Any objection to such application must be forwarded, in writing, to reach the State Rivers and Water Supply Commission, Melbourne, before 9th January, 1960, being 30 days from the first publication of this notice.

FREDERICK WILLIAM WILSON.

Dawson, via Heyfield. 8370

CITY OF BOX HILL.

By-Law No. 109.

Baths.

A By-law of the City of Box Hill made under sections 228 and 800 of the *Local Government Act 1958*, and numbered 109, for altering By-law No. 72 of the said City.

IN pursuance of the powers conferred by the *Local Government Act 1958*, and of any and every other power it thereunto enabling the Mayor, Councillors and Citizens of the City of Box Hill order as follows:—

1. By-law No. 72 of the City of Box Hill as amended by By-law Nos. 75 and 88 of the said City is hereby amended by substituting for the Schedule of the said By-law No. 72, the following Schedule, namely:—

SCHEDULE HEREBEFORE REFERRED TO.	£	s.	d.
Persons over the age of sixteen years	0	1	0
Persons under the age of sixteen years	0	0	6
School children under the control of a recognized teacher and attending during the hours allocated to the School from which they have come and which is situated within the Municipal District	No charge		
School parties otherwise	per person	0	0

	£	s.	d.
Hire of Locker by persons other than the holder of a season's ticket	0	0	6
Deposit on Locker key	0	2	6
Ticket for the Season 1959-1960 and every season thereafter for persons over the age of sixteen years	1	10	0
Ticket for the Season 1959-60 and every season thereafter for persons under the age of sixteen years	0	15	0
Ticket for the Season 1959-1960 and every season thereafter for the Members of the Surrey Park Swimming Club being over the age of sixteen years	1	5	0
Ticket for the Season 1959-1960 and every season thereafter for Members of the Surrey Park Swimming Club being under the age of sixteen years	0	10	0
Book of twelve admission tickets for use by persons under sixteen years of age	0	4	0

Resolution for passing this By-law was agreed to by the Council of the City of Box Hill on the 19th day of October, 1959, and confirmed on the 16th day of November, 1959.

The corporate seal of the Mayor, Councillors and Citizens of the City of Box Hill was hereto affixed in the presence of—

(SEAL) GEO. PADGHAM, Mayor.
E. O. LUNDRGREN, Councillor.
A. N. WALLS, Town Clerk.

Consented to by the Governor in Council on the 22nd day of December, 1959.—A. MAHLSTEDT, Clerk of the Executive Council. 8351

CITY OF BOX HILL.

LOAN No. 117.

Notice of Intention to Borrow the Sum of £30,000 for Permanent Works and Undertakings.

NOTICE is hereby given that the Council of the City of Box Hill proposes to borrow the sum of Thirty thousand pounds on the credit of the municipal revenues of the Mayor, Councillors and Citizens of the said City, such sum to be raised by the grant of a mortgage, in accordance with the provisions of the *Local Government Act 1958*.

1. The maximum rate of interest that may be paid is 5½ per cent. per annum.

2. The purpose for which the loan is to be applied is capital works in the Council's electricity supply undertaking.

3. The period of the loan shall be 40 years.

4. The loan is to be liquidated by the creation of a sinking fund, pursuant to the provisions of section 428A of the *Local Government Act 1958*.

5. Such moneys shall be repayable at the English, Scottish and Australian Bank Limited, Canberra, or at the Council's bankers for the time being in Canberra, and shall be free of exchange.

The plans and specifications and the estimate of the cost of the proposed works, and a statement showing the proposed expenditure of the moneys to be borrowed, are open for inspection at the Town Hall, Box Hill. 8354

A. N. WALLS, Town Clerk.

CITY OF BRIGHTON.

LOAN No. 41.

Notice of Intention to Borrow the Sum of £40,000 for Permanent Works and Undertakings.

NOTICE is hereby given that the Council of the City of Brighton proposes to borrow the sum of Forty thousand pounds (£40,000), on the credit of the municipal revenues of the Mayor, Councillors and Citizens of the said City, such sum to be raised by the grant of a mortgage, in accordance with the provisions of the *Local Government Act 1958*.

1. The amount of the principal moneys which it is proposed to borrow is £40,000.

2. The maximum rate of interest that may be paid is 5½ per centum per annum.

3. The purpose for which the loan is to be applied is for part payment of the cost of the erection of Council Chamber and Municipal Offices.

4. The period of the loan shall be thirty (30) years.

5. The moneys borrowed shall be repayable by providing out of the municipal fund sixty (60) equal and consecutive half-yearly instalments of £1,368 16s. 1d., including principal and interest, on the 1st day of November and the 1st day of May each year during the currency of the loan. The first instalment shall be payable on the 1st day of November, 1960. 8354

6. Such moneys shall be repayable at the Commonwealth Bank of Australia, Melbourne, or at the Council's bankers for the time being in Melbourne.

The plans and specifications and the estimate of the cost of the proposed works, and a statement showing the proposed expenditure of the moneys to be borrowed, are open for inspection at the Town Hall, Brighton, during office hours.

H. C. FERGUSON, Town Clerk.

15th December, 1959.

8294

CITY OF BROADMEADOWS.

PRIVATE STREET LOAN NO. 13.

Notice of a Special Order to Borrow the sum of Ten Thousand Pounds (£10,000) for the Construction of Private Streets.

THAT the Council of the City of Broadmeadows hereby proceeds to make an Order to borrow the sum of Ten thousand pounds (£10,000), on the credit of the municipal revenue of the Mayor, Councillors and Citizens of the said City, such sum to be raised by the issue of debentures, in accordance with the provisions of section 585 of the Local Government Act.

1. The maximum rate of interest that may be paid is 5½ per cent. per annum.

2. The purpose for which the loan is to be applied is for the construction of private streets.

3. The period of the loan shall be ten years.

4. The loan is to be liquidated by the creation of a sinking fund, and the sum of £802 6s. will be set aside annually for such purpose, and such moneys borrowed shall be repayable at the Commonwealth Bank of Australia, Glenroy, or Council's bankers for the time being in Melbourne, on the 1st day of January, 1970.

Dated this 15th day of December, 1959.

8292 E. F. SMILEY, Town Clerk.

CITY OF BROADMEADOWS.

PRIVATE STREET LOAN NO. 10.

Notice of Special Order to Borrow the Sum of £10,000 for the Construction of Private Streets.

THAT the Council of the City of Broadmeadows hereby proceeds to make an Order to borrow the sum of Ten thousand pounds (£10,000) on the credit of the municipal revenues of the Mayor, Councillors and Citizens of the said City, such sum to be raised by the grant of a mortgage, in accordance with the provisions of section 585, Division 10, Part XIX. of the Local Government Act 1958.

1. The maximum rate of interest that may be paid is 5½ per cent. per annum.

2. The purpose for which the loan is to be applied is the construction of Esmale-street and construction of Lebanon-street from Dagonet-street to Carnarvon-road.

3. The period of the loan shall be ten years.

4. The moneys borrowed shall be repayable by twenty half-yearly instalments of approximately £656 14s. 4d. each, including principal and interest on the 1st day of February and the 1st day of August during the currency of the loan. The first instalment shall be on the 1st day of August, 1960.

5. Such moneys shall be repayable at the Commonwealth Trading Bank, Melbourne.

The above-mentioned Special Order was confirmed at a meeting of Council held on 14th December, 1959.

E. F. SMILEY, Town Clerk.

Town Hall, Broadmeadows, 17th December, 1959. 8298

CITY OF BROADMEADOWS.

PRIVATE STREET LOAN NO. 11.

Notice of Special Order to Borrow the Sum of £20,000 for the Construction of Private Streets.

THAT the Council of the City of Broadmeadows hereby proceeds to make an Order to borrow the sum of Twenty thousand pounds (£20,000) on the credit of the municipal revenues of the Mayor, Councillors and Citizens of the said City, such sum to be raised by the grant of a mortgage, in accordance with the provisions of section 585, Division 10, Part XIX. of the Local Government Act 1958.

1. The maximum rate of interest that may be paid is 5½ per cent. per annum.

2. The purpose for which the loan is to be applied is the construction of Bonwick-street.

3. The period of the loan shall be ten years.

4. The moneys borrowed shall be repayable by twenty half-yearly instalments of approximately £1,313 8s. 8d. each, including principal and interest on the 1st day of August and the 1st day of February during the currency of the loan. The first instalment shall be on the 1st day of August, 1960.

5. Such moneys shall be repayable at the Commonwealth Trading Bank, Melbourne.

The above-mentioned Special Order was confirmed at a meeting of Council held on 14th December, 1959.

E. F. SMILEY, Town Clerk.

Town Hall, Broadmeadows, 17th December, 1959. 8299

CITY OF BROADMEADOWS.

PRIVATE STREET LOAN NO. 12.

Notice of Special Order to Borrow the Sum of £25,000 for the Construction of Private Streets.

THAT the Council of the City of Broadmeadows hereby proceeds to make an Order to borrow the sum of Twenty-five thousand pounds (£25,000) on the credit of the municipal revenues of the Mayor, Councillors and Citizens of the said City, such sum to be raised by the grant of a mortgage, in accordance with the provisions of section 585, Division 10, Part XIX. of the Local Government Act 1958.

1. The maximum rate of interest that may be paid is 5½ per cent. per annum.

2. The purpose for which the loan is to be applied is the construction of Kennedy-street, Stanley-street, Curie-avenue and partial construction of Clovelly-avenue.

3. The period of the loan shall be ten years.

4. The moneys borrowed shall be repayable by twenty half-yearly instalments of approximately £1,641 15s. 6d. each, including principal and interest on the 1st day of June and the 1st day of December during the currency of the loan. The first instalment shall be payable on the 1st day of June, 1960.

5. Such moneys shall be repayable at the State Savings Bank of Victoria, Melbourne.

The above-mentioned Special Order was confirmed at a meeting of Council held on 14th December, 1959.

E. F. SMILEY, Town Clerk.

Town Hall, Broadmeadows, 17th December, 1959. 8300

Town and Country Planning Acts.

CITY OF CAMBERWELL.

Amendment No. 4, 1959.

Notice that a Planning Scheme to amend the City of Camberwell Planning Scheme has been prepared and is available for inspection.

NOTICE is hereby given that the Council of the City of Camberwell in pursuance of its powers under the Town and Country Planning Acts, has prepared a Planning Scheme for those portions of the City of Camberwell as defined on the maps comprising the First Schedule to the City of Camberwell Planning Scheme for the purpose of zoning and regulating building and other works: all maps, plans, descriptions, and other data fully set out and explaining the Planning Scheme have been deposited at the Municipal Offices, Camberwell-road, Camberwell, and at the offices of the Town and Country Planning Board, Melbourne, and will be open for inspection, without payment of any fee, by all persons affected, between the hours of 9 a.m. and 4 p.m. on all days of the week except Saturdays, Sundays and Public Holidays until and including the 23rd day of March, 1960.

Any persons affected by the Planning Scheme are required to set forth, in writing, all objections they may have, addressed to the Chief Administrator, Camberwell City Council, Town Hall, Camberwell-road, Camberwell, E.6, on or before the 23rd day of March, 1960.

L. F. CHEFFERS, Chief Administrator.

Dated this 21st day of December, 1959. 8237

Local Government Act 1958.

CITY OF DANDENONG.

NOTICE OF INTENTION TO TAKE LAND COMPULSORILY.

NOTICE is hereby given that it is the intention of the Council of the City of Dandenong, in exercising the powers conferred on it by the Local Government Act 1958, to take compulsorily the following land:

All that piece of land being lot 2 on plan of subdivision No. 45675, lodged in the Office of Titles, and being part of Crown allotment 5, section 5, Township and Parish of Dandenong, and being part of the land described in certificate of title, volume 3725, folio 302.

The said land is required for and being taken for the purpose of executing the following work or undertaking by the said Council:—The provision of parking facilities within its municipal district.

The Council has caused to be prepared a specification, map and plan showing the nature and extent of such work or undertaking and more particularly describing the said land and the exact site and admeasurements thereof and stating that the name of the owner of the said land is Coles Country Stores Limited.

The said specification, map and plan have been approved by the Council and are now deposited for inspection by all persons interested at the offices of the City of Dandenong, situate at the Town Hall, Lonsdale-street, Dandenong, and may be inspected there during office hours.

All persons affected by the proposed work and undertaking are hereby required to set forth in writing, addressed to the said Council or to the Municipal Clerk thereof, within 40 clear days from the publication of this notice in the *Government Gazette*, all objections which they may have to such work or undertaking.

Dated the 15th day of December, 1959.

By order of the Council,

8288 R. BOOTH, Town Clerk and Municipal Clerk

CITY OF PRESTON.

DEDICATION OF PUBLIC HIGHWAYS.

WHEREAS certain private streets being more than 15 feet in width having been constructed to the satisfaction of the Council, but were not constructed pursuant to Division 10 of Part XIX. or Part XLII. of the *Local Government Act 1958* or any corresponding previous enactment:

And whereas the Housing Commission of Victoria being the owners of so many of the premises fronting on such streets as in rateable value are the greater parts of all the premises so fronting each street respectively has made application to the Council to have such streets declared to be dedicated to the public as public highways:

Now therefore the Council of the City of Preston, in pursuance of the provisions of section 587 (3) of the *Local Government Act 1958*, hereby declares that the said streets as listed hereinafter shall be dedicated to the public as public highways, viz:—

East Preston Estate.—Summerhill-road, from Angliss-street to Seston-street; Nisbett-street, from Oulton-crescent to Seston-street; Chaleyer-street, from Angliss-street to Crevelli-street; Clingin-street, from Seston-street westwards; Andrews-avenue, from Seston-street westwards; Kirby-street, from Seston-street westwards; Blake-street, from Seston-street westwards; Bird-avenue, from Crevelli-street to proposed railway; Seston-street, from Blake-street northwards; Newton-street, from 120 feet west of Angliss-street to Eisenhower-street; Steane-street, from 120 feet west of Angliss-street to Eisenhower-street; McComas-street, from 120 feet west of Angliss-street to Eisenhower-street; Drysdale-street, from 120 feet west of Angliss-street to Eisenhower-street; Dorrington-avenue, from Angliss-street to Faye-street; Angliss-street, from Tyler-street to Plenty-road; Crevelli-street; Mathews-court; Caddy-court; Crabtree-court; Oulton-crescent; Eisenhower-street; Faye-street.

East Reservoir Estate.—Royal-parade, from Strathmerton-street to McMahon-road; Marchant-avenue, from Strathmerton-street to McMahon-road; Whitelaw-street, from Strathmerton-street to Boldrewood-parade; Lanc-crescent, from Strathmerton-street to Boldrewood-parade; Fordham-road, from Strathmerton-street to Boldrewood-parade; Boldrewood-parade, from Broadway to McMahon-road; Black-street, from Fordham-road to McMahon-road; North-road, from Nicholson-avenue to Boldrewood-parade; Evans-crescent; Dunolly-crescent; Clements-grove; Loddon-avenue; Nicholson-avenue; Charlton-crescent; Mulgrave-street; Arcadia-avenue; Kyneton-avenue; Kilmore-avenue; Kellor-avenue; Gisborne-crescent; Winter-crescent; Kerang-avenue.

The common seal of the Mayor, Councillors and Citizens of the City of Preston was affixed hereto this 17th day of December, 1959, in the presence of—

(SEAL) W. S. TUNALEY, Mayor.
G. L. KELLETT, Councillor.
8304 J. C. DONATH, Town Clerk:

Local Government Act 1958.

CITY OF PRESTON.

SPECIAL ORDER MADE BY THE COUNCIL FOR THE PURPOSE OF PRIVATE STREET CONSTRUCTION.

(i) That this Council borrow the sum of Ten thousand pounds (£10,000) by the grant of a mortgage for such amount secured upon the credit of the Mayor, Councillors and Citizens of the municipality in accordance with the provisions of section 585 (1) (b) of the *Local Government Act 1958*.

(ii) That the rate of interest to be paid be 5 10s. per centum per annum.

(iii) That the period of the loan be twenty (20) years and that the moneys borrowed be repayable by equal half-yearly instalments of £415 6s. 4d., including interest on the 15th day of August and the 15th day of February during the currency of the loan, the first instalment being repayable on the 15th day of August, 1960.

(iv) That such moneys be repayable at the Commercial Bank of Australia Limited, 337 Collins-street, Melbourne, or at the bankers of the lender, for the time being in the City of Melbourne.

(v) That the loan be applied for the purpose of liquidating part of the amount of bank overdraft obtained under the provisions of section 583 of the *Local Government Act 1958*, for the purpose of defraying the cost of the execution of private street construction schemes.

The common seal of the Mayor, Councillors and Citizens of the City of Preston was affixed hereto this 14th day of December, 1959, in the presence of—

(SEAL) W. S. TUNALEY, Mayor.
G. L. KELLETT, Councillor.
8303 J. C. DONATH, Town Clerk:

BOROUGH OF RINGWOOD.

ORDER CHANGING NAME OF STREET.

NOTICE is hereby given that at a Meeting of the Council of the Borough of Ringwood, held on 10th December, 1959, the said Council, in pursuance of the provisions of the *Local Government Act 1958*, did make an Order changing the name of the street set out hereunder:—

Old Name.—George-street, extending from the east side of Campbell-street in an easterly direction to the western extremity of the street forming a cul-de-sac.

New Name.—Tudor-court.

F. P. DWERRYHOUSE, Town Clerk.

Town Hall, Ringwood, 16th December, 1959. 8290

SHIRE OF ALTONA.

LOAN No. 10.

Notice of Intention to Borrow the Sum of £30,000 for Permanent Works and Undertakings.

NOTICE is hereby given—

(a) That the Council of the Shire of Altona proposes to borrow the sum of Thirty thousand pounds on the credit of the municipal revenues of the President, Councillors and Ratepayers of the said Shire by the grant of a mortgage under the provisions of the *Local Government Act*.

(b) The maximum rate of interest to be paid is Five pounds ten shillings per centum per annum.

(c) The period of the loan shall be 30 years, and such moneys shall be repayable at the Commonwealth Trading Bank of Australia, Williamstown, or at the Council's bankers for the time being in Melbourne.

(d) The purposes for which the loan is to be applied are—

(a) Underground drainage in Altona North area,

(b) Part cost of a Hall on Langshaw Reserve,

(c) Part of Council contribution towards C.R.B. works on Blackshaws-road.

(e) The moneys borrowed shall be repayable by providing out of the Municipal Fund approximately £491 14s. 11d. annually for 30 years, to be invested in accordance with the said Act to form a sinking fund, and interest to be paid half-yearly during the currency of the loan. The first payments shall be on the 1st day of October, 1960.

The plans and specifications and the estimate of the cost of the proposed work, and a statement showing the proposed expenditure of the moneys to be borrowed, are open for inspection at the Municipal Offices, Queen-street, Altona, during office hours.

Dated this 23rd day of December, 1959.

8352 JAMES W. WATERS, Shire Secretary.

Town and Country Planning Acts.

SHIRE OF BALLARAT.

NOTICE THAT A PLANNING SCHEME HAS BEEN PREPARED AND IS AVAILABLE FOR INSPECTION.

Shire of Ballarat Planning Scheme—Amendment No. 2, 1959.

NOTICE is hereby given that the Shire of Ballarat in pursuance of its powers under the Town and Country Planning Acts has prepared a planning scheme for the purpose of amending the Shire of Ballarat Planning Scheme 1956.

All maps, plans, descriptions and other data fully setting out and explaining the Planning Scheme have been deposited at the Shire Hall, Learmonth, Shire Offices, Gillies-street, Wendouree, and at the office of the Town and Country Planning Board, Melbourne, and will be open for inspection without payment of any fee by all persons affected between the hours of 10 a.m. and 4 p.m. on all days of the week except Saturdays, Sundays and Public Holidays, until and including the 25th day of January, 1960.

Any persons affected by the planning scheme are required to set forth, in writing, all objections they may have, addressed to the Shire Secretary, Shire Offices, Wendouree, on or before the 25th day of January, 1960.

K. S. LANE, Shire Secretary.

SHIRE OF BULN BULN.

BY-LAW No. 40.

A By-law of the Shire of Buln Buln made under the Dog Acts and numbered 40 for fixing registration and other fees thereunder.

IN pursuance of the powers conferred by the Dog Acts and of any and every other power it thereunto enabling the President, Councillors and Ratepayers of the Shire of Buln Buln, order as follows:—

1. By-law No. 34 of the Shire of Buln Buln is hereby repealed.

2. The following fees and sums are hereby fixed pursuant to the Dog Acts—

	<i>s. d.</i>
(a) For registration pursuant to section 6 of the <i>Dog Act 1958</i>	7 6
(b) For particulars of any dog or for the name of the registered owner thereof or for a certified copy of the receipt mentioned in section 12 of the <i>Dog Act 1958</i>	2 6
(c) Sum payable to the Registration Officer pursuant to section 15 of the <i>Dog Act 1958</i>	10 0
(d) Sum payable to the Registration Officer pursuant to section 16 of the <i>Dog Act 1958</i>	10 0

3. This By-law shall apply to and have operation throughout the whole of the municipal district.

Resolution for passing this By-law agreed to by the Council of the Shire of Buln Buln on the 16th day of November, 1959, and confirmed on the 14th day of December, 1959.

The corporate seal of the President, Councillors and Ratepayers of the Shire of Buln Buln was hereunto affixed in pursuance of an Order of the Council made on the 14th day of December, 1959.

(SEAL) W. REA, President.
W. J. MOYES, Councillor.
K. A. PRETTY, Shire Secretary.

8320

SHIRE OF COBRAM.

LOAN No. 11.

Notice of Intention to Borrow the Sum of £8,000 for Permanent Works and Undertakings.

NOTICE is hereby given that the Council of the Shire of Cobram proposes to borrow the sum of Eight thousand pounds on the credit of the municipal revenues of the President, Councillors and Ratepayers of the said Shire, such sum to be raised by the grant of a mortgage in accordance with the provisions of the *Local Government Act 1958*.

1. The maximum rate of interest that may be paid is 5½ per centum per annum.

2. The purpose for which the loan is to be applied is for street construction in Cobram.

3. The period of the loan shall be ten years.

4. The moneys borrowed shall be repayable by providing out of the municipal fund twenty half-yearly instalments of approximately £525 7s. 6d. each, including principal and interest, on the 1st day of April and the 1st day of October during the currency of the loan. The first instalment shall be payable on the 1st day of October, 1960.

5. Such moneys shall be repayable at the State Savings Bank of Victoria, Melbourne.

The plans and specifications and the estimate of the cost of the proposed works and a statement showing the proposed expenditure of the moneys to be borrowed, are open for inspection at the Shire Office, Cobram.

R. T. CUTTS, Shire Secretary.

Date 17th December, 1959.

8319

SHIRE OF CRANBOURNE.

NOTICE is hereby given that Joseph George Mynard, of Lang Lang, has been appointed Poundkeeper of the Lang Lang Pound *vice* I. Densley, resigned.

8309

T. W. GRANT, Shire Secretary.

Dog Act 1958 (No. 6236).

SHIRE OF DIMBOOLA.

SHOPPING AREA AND BATHING BEACH.

TAKE notice that on the 15th day of December, 1959, the Council of the Shire of Dimboola passed an Order specifying streets and bathing beach set out in the Schedule hereunder to be shopping areas and bathing beach under the above Act, which provides, *inter alia*:—

1. The owner—

(a) of any dog which is found in any shop (other than a shop where dogs are sold or treated for illness), or

(b) of any dog (other than a dog being used in the droving of stock)—

(i) which is found in any municipal district in or on any shopping area or bathing beach specified for the purposes of this section by Order of the Council of that municipality published in the *Government Gazette* and in some newspaper circulating in the municipal district; and

(ii) which is not under the effective control of some person by means of a chain or cord or leash—

shall be liable for a first offence to a penalty of not more than Four pounds, and for a second or any subsequent offence to a penalty of not more than Ten pounds.

2. Any dogs so found may be seized by the police or by officers of the municipality duly authorized in that behalf and dealt with as if it had been seized under section 15 or section 16 (as the case requires) of the *Dog Act 1958*.

SCHEDULE.

Dimboola.—Lloyd-street, between Lochiel and Wimmera streets, Victoria-street, between Wimmera and Lochiel streets, Lochiel-street, between Lloyd and Victoria streets, Wimmera-street, between Lloyd and Victoria streets.

Jeparit.—Roy-street, between Scott and Riverside streets.

Rainbow.—Federal-street.

Bathing Beach.—Bathing beach at spot known as Picnic Point on east side of Lake Hindmarsh, between area defined by notices.

R. T. LIVINGSTON, Shire Secretary.

Shire Offices, Jeparit, 16th December, 1959.

8302

SHIRE OF DONCASTER AND TEMPLESTOWE.

NOTICE OF INTENTION TO BORROW £4,000.

NOTICE is hereby given that the Council of the Shire of Doncaster and Templestowe proposes to borrow the sum of Four thousand pounds (£4,000) on the credit of the municipal revenues of the President, Councillors and Ratepayers of the said Shire, such sum to be raised by the issue of a debenture, in accordance with the provision of the *Local Government Acts*.

1. The maximum rate of interest that may be paid is 5½ per centum per annum.

2. The purpose for which the Loan is to be applied is the purchase of Lots 93 and 94, Lots 87, 88, 89, 101, 102 and 103 on plan of subdivision No. 13585.

3. The period of the Loan shall be five years.

4. The Loan is to be liquidated by providing out of the Municipal Fund five annual instalments of approximately

£933 10s. each, including principal and interest, on the 1st day of March during the currency of the Loan. The first instalment shall be payable on the 1st day of March, 1961.

5. Such moneys shall be repayable at the English, Scottish and Australian Bank Limited, Melbourne, or at the Council's bankers for the time being in Melbourne.

The plans, specifications and estimate of cost of the proposed works and a statement showing the proposed expenditure of moneys to be borrowed, are open for inspection at the Municipal Offices, Doncaster-road, Doncaster.

8369

J. W. THOMSON, Shire Secretary.

SHIRE OF KERANG.

LOAN No. 47.

NOTICE is hereby given that the Council of the Shire of Kerang proposes to borrow the sum of Fifty thousand pounds (£50,000) on the credit of the municipal revenues of the President, Councillors and Ratepayers of the Shire of Kerang, such sum to be raised by the issue of debentures in accordance with the provisions of the Local Government Acts.

1. The maximum rate of interest that may be paid is 5½ per cent. per annum.

2. The purpose for which the loan is to be applied is to pay part of the cost of the extension of the State Electricity Commission's transmitted supply to Kerang and Koondrook and the reconstruction of the existing electricity distribution system in the Kerang and Koondrook areas—£50,000.

3. The period of the loan shall be fifteen years.

4. The moneys borrowed shall be repayable by providing out of the municipal fund 30 half-yearly instalments of approximately £2,469 4s. 5d. each, including principal and interest, on the 1st day of April and the 1st day of October during the currency of the loan. The first instalment shall be payable on the 1st day of October, 1960.

5. Such moneys shall be repayable at the Commercial Banking Company of Sydney Limited, Melbourne, or at the Council's bankers for the time being in Melbourne.

The plans and specifications and the estimate of the cost of the proposed works, and a statement showing the proposed expenditure of the moneys to be borrowed, are open for inspection at the Memorial Municipal Chambers, Kerang.

Dated at Kerang this 16th day of December, 1959.

8316

A. K. LYALL, Shire Secretary.

SHIRE OF KEILOR.

LOAN No. 26.

Notice of Intention to Borrow the Sum of Fifty Thousand Pounds (£50,000) for Permanent Works and Undertakings.

NOTICE is hereby given that the Council of the Shire of Keilor proposes to borrow the sum of Fifty thousand pounds (£50,000) on the credit of the municipal revenues of the President, Councillors and Ratepayers of the Shire of Keilor, such sum to be raised by the grant of a mortgage in accordance with the provisions of the *Local Government Act 1958*.

1. The amount of principal moneys which it is proposed to borrow is £50,000.

2. The maximum rate of interest that may be paid is £5 10s. per centum per annum.

3. The times at which the moneys borrowed are to be repayable are the 1st days of September and March in each year, commencing on the 1st day of September, 1960, and ending on the 1st day of March, 1995.

4. The purposes for which the loan is to be applied are:—

(a) Purchase of plant and equipment ..	£18,500
(b) Reconstruction of Walmer-avenue between Oberon-avenue and Main-road, East St. Albans ..	11,000
(c) Completion—St. Albans hall ..	10,000
(d) Council's share of cost of providing Infant Welfare Centre building at Tullamarine, West Essendon and Avondale Heights ..	4,500
(e) Contribution towards public hall at Tullamarine ..	1,000
(f) Contribution towards public hall at Avondale Heights ..	1,000
(g) Contribution towards Niddrie and Airport West Citizens' and Police Boys' Club Building ..	1,000
(h) Footpath construction work in various parts of the Shire ..	3,000
	£50,000

5. The manner in which the loan is to be liquidated is by the provision out of the municipal fund in each half-year, during the currency of the loan of the sum of £1,617 2s. 2d., including principal and interest.

6. Such moneys shall be repayable at the Superannuation Board, Canberra.

The plans, specifications and the estimate of the cost of the proposed works and a statement showing the proposed expenditure of the money to be borrowed, are open for inspection at the Municipal Offices, Kellor, during office hours.

Dated this 18th day of December, 1959.

8317

N. A. WOODS, Shire Secretary.

SHIRE OF KOWREE.

BY-LAW No. 33.

A By-law of the Shire of Kowree, made under Part VII, Division 1, of the *Local Government Act 1958*, and numbered 33, for the carrying out of the purposes provided for in subdivision (2) of Part 1 of the Fifteenth Schedule to the *Local Government Act 1958*, relating to the naming of streets and numbering of houses.

THE Council of the Shire of Kowree doth hereby, in pursuance of the powers conferred by Part VII, of Division 1 of the *Local Government Act 1958* and every other Act or power enabling it in that behalf, order as follows:—

1. This By-law may be cited as "The Shire of Kowree Naming of Streets and Numbering of Houses By-law".

2. Any By-law previously made for "the naming of streets and numbering of houses" is hereby repealed.

3. It shall be lawful for the Council from time to time to cause to be painted or affixed on a conspicuous part of some house or building or on a pole erected for the purpose or on any other pole subject to the approval of the authority erecting such other pole at or near each end, corner or entrance of every street, and in the direction of the line of such street, the name of such street in legible characters, and the Council may alter the name of any street or road in the municipal district (to be described in the order altering the same) to any other name which to the Council may seem fit, and before any name is given to any new street or road notice of the intended name shall be given to the Council, and the Council may, by notice given to the person to whom notice of such intended name was given to them, at any time within fourteen days of the receipt of such last-mentioned notice, object to such intended name, and it shall not be lawful to give any name to any street or road or to set up any such name thereto until the expiration of fourteen days after notice thereof has been given as aforesaid to the Council, or to give or set up any name objected to as aforesaid. Where the Council changes the name of any street it shall forthwith cause a notice thereof, stating the old name and the new name, to be published in the *Government Gazette*.

4. The owners or occupiers of houses or buildings shall, on the gate or gatepost or in such other conspicuous position as the Council determines, mark such houses or buildings with such numbers and names, for the purpose of distinguishing the same, as the Council may from time to time direct or approve, and shall renew the numbers or names of such houses or buildings as often as they are obliterated or defaced; and if any owner or occupier of any such house or building neglects for one week after notice to him from the Council to mark such house or building with such number or name as the Council may direct or approve, or to renew the number of name thereof as aforesaid, he shall forfeit a sum not exceeding Forty shillings and the Council may cause such number or name to be so marked or renewed, and recover the expense thereof from the owner or occupier of such house or building before any justice; and where such expense is paid by or recovered from the occupier he may deduct the same from any rent payable by him to the owner.

5. It shall be lawful for the Council from time to time to cause to be painted or affixed immediately beneath the name of any street painted or affixed pursuant to clause 3 of this By-law the distinguishing numbers of the houses or buildings marked or liable to be marked pursuant to clause 4 of this By-law and the distinguishing number or numbers allocated by the Council as aforesaid to any property on which for the time being there is no house or building in that street or in any indicated part thereof.

6. If any person wilfully and maliciously destroys, pulls down, obliterates or defaces the name of any street or

road, or the name or number of any houses or buildings, or paints, affixes or sets up any name to any street or road, or any name or number to any house or building, contrary to the provisions of this By-law, he shall for every such offence forfeit a sum not exceeding Five pounds; and it shall be lawful for the Council to cause such name or number so unlawfully painted, affixed or set up to be obliterated or destroyed.

7. This By-law shall apply to and have operation throughout the whole of the municipal district.

Resolution for passing this By-law agreed to at the meeting of the Kowree Shire Council held on the 10th day of August, 1959, and confirmed at the meeting thereof held on the 7th day of December, 1959.

The common seal of the Shire President, Councillors and Ratepayers of the Shire of Kowree was hereto affixed this 7th day of December, 1959, in the presence of—

(SEAL) R. S. HARKNESS, Shire President.
S. C. HOBBS, Councillor.
8297 H. ERNEST WALKEAR, Secretary.

SHIRE OF KYNETON.

NOTICE OF INTENTION TO BORROW THE SUM OF £10,000 FOR PERMANENT WORKS AND UNDERTAKINGS.

NOTICE is hereby given that the Council of the Shire of Kyneton proposes to borrow the sum of Ten thousand pounds on the credit of the municipal revenues of the President, Councillors and Ratepayers of the said Shire, such sum to be raised by the issue of debentures, in accordance with the provisions of the Local Government Acts.

1. The maximum rate of interest that may be paid is 5 7/16 per cent. per annum.

2. The purpose for which the loan is to be applied is:—

- (a) Purchase of plant and office equipment,
- (b) Roadworks in various Ridings of the Shire,

3. The period of the loan shall be eight years.

4. The moneys borrowed shall be repayable by providing out of the municipal fund sixteen half-yearly instalments of approximately £779 1s. 10d. each, including principal and interest, on the 1st day of April and the 1st day of October during the currency of the loan. The first instalment shall be payable on the 1st day of October, 1960.

5. Such moneys shall be repayable at the Commercial Banking Company of Sydney Limited, Melbourne, or at the Council's bankers, for the time being in Melbourne.

The plans and specifications and the estimate of the cost of the proposed works and a statement showing the proposed expenditure of the moneys to be borrowed, are open for inspection at the Shire Hall, Kyneton.

9th December, 1959.

8355 S. G. PORTER, Shire Secretary.

SHIRE OF MORTLAKE.

LOAN No. 4.

NOTICE is hereby given that the Council of the Shire of Mortlake proposes to borrow the sum of Three thousand eight hundred pounds on the credit of the municipal revenues of the President, Councillors and Ratepayers of the said Shire, such sum to be raised by the grant of a mortgage, in accordance with the provisions of the Local Government Act 1958.

1. The maximum rate of interest that may be paid is 5½ per cent. per annum.

2. The purpose for which the loan is to be applied is—
Purchase of road-making plant—£3,800.

3. The period of the loan shall be ten years.

4. The moneys borrowed shall be repayable by providing out of the municipal fund twenty half-yearly instalments of approximately £249 11s. each, including principal and interest, on the 1st day of September and the 1st day of March during the currency of the loan. The first instalment shall be payable on the 1st day of September, 1960.

5. Such moneys shall be repayable at The State Savings Bank of Victoria, Melbourne.

The plans and specifications and the estimate of the cost of the proposed works, and a statement showing the proposed expenditure of the moneys to be borrowed, are open for inspection at the Shire Office, Mortlake, during office hours.

W. J. GRAY, Shire Secretary.

Shire Offices, Mortlake, 15th December, 1959. 8296

SHIRE OF MORWELL.

LOAN No. 19.

Notice of Intention to Borrow the Sum of £9,000 for Permanent Works and Undertakings.

NOTICE is hereby given that the Council of the Shire of Morwell proposes to borrow the sum of Nine thousand pounds, on the credit of the municipal revenues of the President, Councillors and Ratepayers of the said Shire, such sum to be raised by the issue of debentures, in accordance with the provisions of the Local Government Acts.

1. The maximum rate of interest that may be paid is 5½ per cent. per annum.

2. The purposes for which the loan is to be applied are:—

- Purchase and acquisition of land for recreation reserves, parks and gardens—extension of Norman Brookes Park £5,200
- Widening and construction of Helen and Grant streets, Morwell 2,600
- Installation of bitumen plant at Council depot 1,200

£9,000

3. The period of the loan shall be twenty years.

4. The moneys borrowed shall be repayable by providing out of the municipal fund 40 equal half-yearly instalments, each including principal and interest, on the 30th day of September and the 30th day of March during the currency of the loan. The first instalment shall be payable on the 30th September, 1960.

5. Such moneys shall be repayable at the National Bank of Australasia Ltd., Melbourne, or at the Council's bankers for the time being in Melbourne.

The plans and specifications and the estimate of the cost of the proposed works, and a statement showing the proposed expenditure of the money to be borrowed, are open for inspection at the Shire Office, Town Hall, Morwell.

Dated this 17th day of December, 1959.

8295 W. K. MATHISON, Shire Secretary.

SHIRE OF OTWAY.

BY-LAW No. 33.

NOTICE is hereby given that the Council has passed By-law No. 33 on the 16th day of September, 1959, and confirmed on 21st day of October, 1959, and has been approved by the Governor in Council on 24th November, 1959:—

Such By-law relates to the following:—

- (a) Repeal of By-law No. 19.
- (b) The placing, fixing, and maintaining of petrol pumps in or on footways, and of any apparatus, pipes, and appliances in, on, or under footways for the supply of motor spirit to such pumps, apparatus, and appliances.
- (c) The granting, renewal, and transfer of licences and applications therefor.
- (d) Licences and conditions contained therein.
- (e) Prescribing fees.
- (f) Providing for proportionate reduction of fees payable in respect to licences granted for any number of months less than twelve.
- (g) Insurance by licensees against liabilities which may be incurred by them in respect of petrol pumps.

A full copy of the said By-law may be seen, free of charge, during office hours, at the Shire Office, Beech Forest.

8289 T. J. FRY, Shire Secretary.

SHIRE OF RODNEY.

LOAN No. 41.

Notice of Intention to Borrow the Sum of £6,000 for Permanent Works and Undertakings.

NOTICE is hereby given that the Council of the Shire of Rodney proposes to borrow the sum of Six thousand pounds, on the credit of the municipal revenues of the President, Councillors and Ratepayers of the said Shire, such sum to be raised by the grant of a mortgage, in accordance with the provisions of the Local Government Act 1958.

1. The maximum rate of interest that may be paid is 5½ per centum per annum.

2. The purposes for which the loan is to be applied are:—

- (a) Street construction in Township of Mooropna £5,000
- (b) Street construction in Township of Tatura 1,000

£6,000

3. The period of the loan shall be fifteen years.
 4. The moneys borrowed shall be repayable by providing out of the municipal fund 30 half-yearly instalments of approximately £296 6s. 4d. each, including principal and interest, on the 1st day of March and the 1st day of September during the currency of the loan. The first instalment shall be payable on the 1st day of September, 1960.

5. Such moneys shall be repayable at the Commercial Bank of Australia Limited, Melbourne.

The plans and specifications and the estimate of the cost of the proposed works are open for inspection at the Shire Office, Tatura.
 8286

R. PERRY, Shire Secretary.

Local Government Act 1958.

SHIRE OF SPRINGVALE AND NOBLE PARK.

NOTICE OF INTENTION TO TAKE LAND COMPULSORILY.

NOTICE is given that it is the intention of the Council of the Shire of Springvale and Noble Park, in exercise of the powers conferred on it by the *Local Government Act 1958*, to take compulsorily the following land—All that piece of land being part of Crown portion 22, Parish of Dandenong, County of Bourke, the boundaries of which are as follows:—

Commencing at a point on the southern boundary of Rutherglen-street 140 feet west of the western boundary of Buckley-street; thence by lines bearing respectively 225 deg. 14 ft. 2 in., 180 deg. 222 feet, 270 deg. 94 ft. 1 in., 45 deg. 14 ft. 2 in., 0 deg. 212 feet, 315 deg. 14 ft. 2 in., to the southern boundary of Rutherglen-street, 90 deg. 104 ft. 1 in., along the southern boundary of Rutherglen-street to the point of commencement.

The said land is required for and being taken for the following work or undertaking by the said Council—the provision of playgrounds for children and places of public resort and recreation within its municipal district.

The Council has caused to be prepared specification map and plan showing the nature and extent of such work or undertaking and more particularly describing the said land and the exact site and measurements thereof, and stating that the name of the owner or reputed owner of the said land is—Estate of Allan Frank Buckley, administered by the Public Trustee, 601 Little Collins-street, Melbourne, and the name of the occupier thereof is—Nil unoccupied.

The said specification map and plan have been approved by the Council and are now deposited for inspection by all persons interested, at the offices of the Shire of Springvale and Noble Park situate at Springvale-road, Springvale, and may be inspected there during office hours.

All persons affected by the proposed work or undertaking are hereby required to set forth, in writing, addressed to the said Council or to the Municipal Clerk within 40 clear days from the publication of this notice in the *Government Gazette*, all objections which they may have to such work or undertaking.

Dated the 21st day of December, 1959.

By order of the Council,

H. L. WILLIAMS,

8353 Shire Secretary and Municipal Clerk.

SHIRE OF SOUTH BARWON.

ORDER CHANGING NAME OF STREET.

NOTICE is hereby given that at a meeting of the Council of the Shire of South Barwon held on the 1st day of December, 1959, the said Council, in pursuance of the powers conferred by the *Local Government Act 1958*, did make an order changing the names of the following streets:—

Old Name; New Name.

Belmont-avenue (Belmont); Apex-avenue.
 Belmont-crescent (Belmont); Nagle-drive.
 Fisher-street (Belmont); Regent-street.
 Kardinia-place (Highton); Larcombe-street.

8315 E. T. CORNISH, Shire Secretary.

SHIRE OF TRARALGON.

SPECIAL ORDER LOAN No. 48.

NOTICE is hereby given that at a Meeting of the Council of the Shire of Traralgon, held in the Council Chambers, Traralgon, on the 5th day of November, 1959, the said Council did agree to the following Resolution, viz.:—That the Council of the Shire of Traralgon do by Special Order and it hereby does resolve to borrow the sum of Twenty thousand pounds in accordance with the provisions of the *Local Government Acts*; that the rate of interest shall be Five pounds ten shillings per centum per

annum; that the loan shall be repayable by twenty half-yearly instalments of approximately £1,313 8s. 8d. each, including principal and interest, at the Australia and New Zealand Bank Limited, Melbourne, or the Council's bankers for the time being in Melbourne, the first of such instalments to be due and payable on the 1st day of June, 1960; that such loan shall be applied towards the cost of construction, under the provisions of Division 10 of Part XIX. of the *Local Government Act*, of Byron-street, Burns-street, Moore-street west of Breed-street, and Breed-street north of Grey-street; and that the loan shall be liquidated from the receipt of moneys payable by property owners, pursuant to the said Division 10 of Part XIX. of the *Local Government Act*.

Notice is hereby further given that at a meeting of the said Council, held in the Council Chambers, Traralgon, on the 3rd day of December, 1959, the said Resolution was confirmed.

8293 E. F. TAYLOR, Shire Secretary.

SHIRE OF WINCHELSEA.

NOTICE OF INTENTION TO ACQUIRE LAND COMPULSORILY.

TO all whom it may concern:

Whereas pursuant to the powers conferred on the Council of the Shire of Winchelsea by section 511 of the *Local Government Act 1958*, the Council deems it expedient in order to provide a place of public resort or recreation to acquire certain land in the Parish of Barwon Downs and for such purpose in the Council's opinion the exercise of its powers of taking land compulsorily will be necessary. Notice is hereby given as follows:—

1. The Council intends to acquire the whole of the land described in certificate of title volume 2993, folio 567, to be used for the purpose of providing a place of public resort or recreation.

2. A copy of the plan shown on the said certificate of title and a schedule of the registered proprietors of the said land are deposited at the office of the Shire, Shire Hall, Winchelsea, and are there available for inspection by all interested persons during office hours free of charge for the space or period of 40 clear days from the date of publication of this notice in the *Government Gazette*.

3. The Council hereby requires all persons affected by the said proposal to set forth, in writing, addressed to the Shire Secretary, Shire Hall, Winchelsea, within 40 clear days from the date of publication aforesaid all objections which they may have to the said proposal.

4. At the ordinary meeting of the Council next after the expiration of the said 40 clear days the Council will consider any objections to the said proposal and any person so objecting as aforesaid may appear before the Council in support of such objection.

Dated the 15th day of December, 1959.

By order of the Council,

W. W. WESTHORPE, Shire Secretary.

Harwood and Pincott, Geelong, solicitors for the Council. 8318

SHIRE OF WYCHEPROOF.

LOAN No. 28.

Notice of Intention to Borrow the Sum of £4,000 for Permanent Works and Undertakings.

NOTICE is hereby given that the Council of the Shire of Wycheproof proposes to borrow the sum of Four thousand pounds on the credit of the municipal revenues of the President, Councillors and Ratepayers of the said Shire, such sum to be raised by the grant of a mortgage in accordance with the provisions of the *Local Government Act 1958*.

1. The maximum rate of interest that may be paid is £5 10s. per cent. per annum.

2. The purposes for which the loan is to be applied are purchase of land for, and establishment of, municipal storeyards—£4,000.

3. The period of the loan shall be ten years.

4. The moneys borrowed shall be repayable by providing out of the municipal fund twenty half-yearly instalments of approximately £262 13s. 6d. each, including principal and interest, on the 1st day of April and the 1st day of October during the currency of the loan. The first instalment shall be payable on the 1st day of October, 1960.

5. Such moneys shall be repayable at the State Savings Bank of Victoria, Melbourne.

The plans and specifications and the estimate of the cost of the proposed works, and a statement showing the proposed expenditure of the moneys to be borrowed, are open for inspection at the Shire Office, Wycheproof.

8314 ADRIAN SAYERS, Shire Secretary.

NOTICE.

CLIFFORD ARLEIGHT FERNANDES and Marjorie Phyllis Fernandes, carrying on business at 76 Scott-street, Warracknabeal, under the firm name of C. Fernandes, will dissolve partnership on the 17th day of December, 1959, and the business will then be carried on by C. A. Fernandes. 8339

In the Supreme Court of Victoria.—No. 6344 of 1959.—In the matter of Part VI. of the *Companies Act 1958* and in the matter of **SPEED NUTS PROPRIETARY LIMITED**.

NOTICE is hereby given that a petition for the winding up of the above-named company by the Supreme Court was, on the 9th day of December, 1959, presented to the said Court by Daniel Leo Canavan, Deputy Commissioner of Taxation of the Commonwealth of Australia, and that the said petition is directed to be heard before the Court sitting at the Law Courts, William-street, Melbourne, on Monday, the 8th day of February, 1960; and any creditor or contributory of the said company desirous to support or oppose the making of an order on the said petition may appear at the time of hearing by himself or his counsel for that purpose; and a copy of the petition will be furnished to any creditor or contributory of the said company requiring the same by the undersigned on payment of the regulation charge for the same.

Petitioner's address is 436 Lonsdale-street, Melbourne.

The petitioner's solicitor is Harold Edward Renfree, of 440 Little Collins-street, Melbourne.

H. E. RENFREE.

NOTE.—Any person who intends to appear on the hearing of the said petition must serve on or send by post to the above-named H. E. Renfree notice in writing of his intention so to do. The notice must state the name and address of the person or, if a firm, the name and address of the firm, and must be signed by the person or firm, or his or their solicitor (if any), and must be served or if posted must be sent by post in sufficient time to reach the above named not later than 12 o'clock midday on Saturday, the 6th day of February, 1960. 8342

In the Supreme Court of Victoria.—No. 6345 of 1959.—In the matter of Part VI. of the *Companies Act 1958* and in the matter of **FOOTSCRAY CATERING SERVICE PROPRIETARY LIMITED**.

NOTICE is hereby given that a petition for the winding up of the above-named company by the Supreme Court was, on the 9th day of December, 1959, presented to the said Court by Daniel Leo Canavan, Deputy Commissioner of Taxation of the Commonwealth of Australia, and that the said petition is directed to be heard before the Court sitting at the Law Courts, William-street, Melbourne, on Monday, the 8th day of February, 1960; and any creditor or contributory of the said company desirous to support or oppose the making of an order on the said petition may appear at the time of hearing by himself or his counsel for that purpose; and a copy of the petition will be furnished to any creditor or contributory of the said company requiring the same by the undersigned on payment of the regulated charge for the same.

Petitioner's address is 436 Lonsdale-street, Melbourne.

The petitioner's solicitor is Harold Edward Renfree, of 440 Little Collins-street, Melbourne.

H. E. RENFREE.

NOTE.—Any person who intends to appear on the hearing of the said petition must serve on or send by post to the above-named H. E. Renfree notice in writing of his intention so to do. The notice must state the name and address of the person or, if a firm, the name and address of the firm, and must be signed by the person or firm, or his or their solicitor (if any), and must be served or if posted must be sent by post in sufficient time to reach the above named not later than 12 o'clock midday on Saturday, the 6th day of February, 1960. 8343

NOTICE is hereby given that, in pursuance of section 195 (3) of the *Companies Act 1958*, the members of Atomic Age Enterprises Proprietary Limited, whose registered office is situate at 18 Warren-road, Mordialloc, Victoria, resolved by a Special Resolution passed at a General Meeting of the company, held on the 18th day of December, 1959, that the company be wound up voluntarily.

Dated this 18th day of December, 1959.

8307

D. A. PALMER, Liquidator.

The *Companies Act 1958*.

UNITED DAIRIES AND COOL STORES OF TASMANIA LIMITED (IN LIQUIDATION).

NOTICE is hereby given that a First and Final Dividend is intended to be declared in the above matter, and that creditors who have not proved their debts by the 7th day of January, 1960, may be excluded from this distribution.

Dated this 17th day of December, 1959.

J. KENNETH HALL, Official Liquidator.

Hall and Rose, chartered accountants (Aust.), 390 Little Collins-street, Melbourne, C.I. 8346

The *Companies Act 1958*.—In the matter of **FLASH TAXI & AUTO SERVICE PTY. LTD. (in Voluntary Liquidation)**.

NOTICE is hereby given that at an Extraordinary Meeting of the members of the above-named company held on Monday the 14th day of December, 1959, it was resolved that the company be wound up voluntarily and at a meeting of creditors held on the same day pursuant to section 201, it was resolved that for such purpose Edward Ronald Smail, of 31 Queen-street, Melbourne, chartered accountant, be appointed liquidator. Notice is also given that after 21 days from this day I shall proceed to distribute the assets. All creditors having any claims against the company should furnish particulars of same by that date, otherwise I shall proceed to distribute the assets without regard to their claim.

Dated this 18th day of December, 1959.

E. R. SMALL, Liquidator.

Kennedy, Small and Middlemiss, 31 Queen-street, Melbourne, C.I. 8331

No. of Company 27181.

The *Companies Act 1958*.

THURVAL PTY. LTD. (IN LIQUIDATION).

NOTICE CONVENING FINAL MEETING OF MEMBERS, PURSUANT TO SECTION 210.

NOTICE is hereby given in pursuance of section 210 of the *Companies Act 1958*, that a General Meeting of the members of the above-named company will be held at 390 Little Collins-street, Melbourne, on Wednesday, the 13th day of January, 1960, at 10.30 a.m., for the purpose of having an account laid before them, showing the manner in which the winding up has been conducted and the property of the company disposed of, and of hearing any explanation that may be given by the liquidator.

Dated this 15th day of December, 1959.

J. KENNETH HALL, Liquidator.

Hall and Rose, chartered accountants, 390 Little Collins-street, Melbourne, C.I. 8345

The *Companies Act 1958*.

STROBEL CONSTRUCTIONS PTY. LIMITED (IN LIQUIDATION).

NOTICE is hereby given that a First and Final Dividend is intended to be declared in the above matter and creditors who have not proved their debts by the 7th day of January, 1960, may be excluded from this distribution.

J. KENNETH HALL, Liquidator.

Dated this 21st day of December, 1959.

Hall and Rose, chartered accountants, 390 Little Collins-street, Melbourne, C.I. 8344

The *Companies Act 1958*.—In the matter of **SPICER SHOE COMPANY PROPRIETARY LIMITED**.—Notice of Meeting of Creditors, Pursuant to Section 201 (1) and (2).

NOTICE is hereby given that a Meeting of Creditors of the above-named company will be held in the Board Room of The Institute of Chartered Accountants, 4th floor, McKillop House, 23 McKillop-street, Melbourne, on Thursday, 24th December, 1959, at Eleven a.m., the company having convened a meeting of its members for the same day, for the purpose of considering and if thought fit approaching a proposed Resolution that the company be wound up voluntarily.

Dated this 16th day of December, 1959.

COLIN A. J. SPICER, Director.

Fuller, King and Co., chartered accountants, 83 William-street, Melbourne, C.I. 8326

The Companies Act 1958.—In the matter of GODDARD PROPRIETARY LIMITED (IN LIQUIDATION).

NOTICE is hereby given that a First and Final Dividend is intended to be declared in this matter. Creditors who have not proved their debts by the 8th day of January, 1960, will be excluded from the dividend.

Dated this 18th day of December, 1959.

E. R. SMAIL, Liquidator.

Kennedy, Small and Middlemiss, 31 Queen-street, Melbourne. 8332

Companies Act 1958.

CAPEL COURT LIMITED.

NOTICE PURSUANT TO SECTION 195 (3).

NOTICE is hereby given that an Extraordinary General Meeting of members of this company, duly convened and held at the registered office, "Capel Court", 375-377 Collins-street, Melbourne, on Wednesday, 16th December, 1959, the following Resolutions were passed as Special Resolutions:—

(1) That the company be wound up voluntarily.

(2) That Frederick Benjamin Gascoigne be appointed liquidator of the company.

Dated this 16th day of December, 1959.

8328 F. B. GASCOIGNE, Liquidator.

CREDITORS, next of kin, and others having claims in respect of the estate of Herbert Vaughan Miller, late of 9 Chastleton-avenue, Toorak, gentleman, deceased (who died on the 3rd day of September, 1959), are to send particulars of their claims to the Fidelity Trustee Company Limited, of 50 Market-street, Melbourne, by 22nd February, 1960, after which date it will distribute the assets, having regard only to the claims of which it then has notice.

CORR & CORR, solicitors, 104 Queen-street, Melbourne. 8363

CREDITORS, next of kin, and others having claims in respect of the estate of Beni Sender, formerly of 10 Valentine-grove, Armadale, but late of 28 Coppin-street, East Malvern, in the State of Victoria, retired dental surgeon, deceased (who died on the 31st day of May, 1958), are to send particulars of their claims to the executors, Kurt Fraenkel and Kurt Edward Lippmann, care of the undersigned solicitor, by the 28th day of February, 1960, after which date they will distribute the assets, having regard only to the claims of which they then have notice.

K. FRAENKEL, LL.B., solicitor, 422 Collins-street, Melbourne. 8362

CREDITORS, next of kin, and others having claims in respect of the estate of William Meikle, late of "Bonnie View", Welshpool-road, Toora, retired farmer, deceased (who died on 21st September, 1959), are to send particulars of their claims to National Trustees, Executors, and Agency Company of Australasia Limited, whose registered office is at 95 Queen-street, Melbourne, by 8th March, 1960, after which date it will distribute the assets, having regard only to the claims of which it then has notice.

SKINNER & HART, solicitors, Commercial-road, Yarram. 8361

CREDITORS, next of kin and others having claims in respect of the estate of William Albert Nash, late of 9 Perry-street, Seddon, member of the Royal Australian Air Force, deceased (who died on the 19th day of June, 1959), are required to send particulars of their claims to the executors, the National Trustees, Executors, and Agency Company of Australasia Limited, of 95 Queen-street, Melbourne, by the 1st day of March, 1960, after which date the said company will distribute the assets, having regard only to the claims of which it then has notice.

LOUIS P. LE GRAND, solicitor, 660 Sydney-road, Brunswick. 8359

CREDITORS, next of kin and others having claims in respect of the estate of Thelma Mary Toole, late of 38 McGregor-street, Middle Park, dressmaker, deceased, intestate (who died on the 24th day of October, 1959), are to send particulars of their claims to the administratrix of the estate, Lily May Woodhead, care of the under-mentioned solicitors, by the 29th day of February, 1960, after which date she will distribute the assets, having regard only to the claims of which she then has notice.

MOLOMBY & MOLOMBY, 99 Queen-street, Melbourne, solicitors. 8347

EUSTACE LEONARD CLARK, late of Nilma, gentleman, DECEASED.

CREDITORS, next of kin and others having claims in respect of the estate of the deceased (who died on 8th October, 1959), are required by the executrix, Charlott Matilda Clark, of Nilma, widow, to send particulars to her, care of the undersigned solicitors, by the 25th day of February, 1960, after which date the executrix may convey or distribute the assets, having regard only to the claims of which she then has notice.

GRAY, FRIEND & LONG, solicitors, Warragul. 8310

CREDITORS, next of kin and all other persons having claims against the estate of Reginald French, formerly of 72 Riddell-parade, Elsternwick, but late of 36 Riddell-parade, Elsternwick, civil servant, deceased (who died on the 31st day of August, 1959, letters of administration of whose estate were approved on the 6th day of November, 1959, to Albert Ernest French, of 36 Riddell-parade, Elsternwick, retired tailor), are requested to send particulars of their claim, in writing, addressed to the said Albert Ernest French, of 36 Riddell-parade, Elsternwick, by the 25th day of February, 1960, after which date the said Albert Ernest French will distribute the assets, having regard only to the claims of which he then will have had notice.

ROY L. YELLAND, solicitor, of 37 Swanston-street, Melbourne. 8341

Trustee Act 1958.

NOTICE TO CLAIMANTS.

PURSUANT to the Trustee Act 1958, creditors, next of kin and all other persons having claims in respect of the deceased person named below are required to send particulars of such claims to the legal personal representatives, at the address stated, on or before the date stated, after which date the representatives will distribute the assets, having regard only to the claims of which notice has been received:—

Doris Finnigan, late of Toolong, married woman, deceased.—Claims to the trustees, John Joseph Finnigan and John Finnigan, care of J. W. Powling, solicitor, Port Fairy, by 14th March, 1960. 8301

Margaret Agnes Nield, late of Macarthur, widow, deceased (died 29th August, 1959).—Claims to the executor, John Stanley Nield, of Macarthur, hotel manager, care of Conlan and Leishman, solicitors, 38 Bank-street, Port Fairy, by 24th February, 1960. 8306

ARTHUR TALBOT, late of Buln Buln-road, Drouin, farmer, DECEASED.

CREDITORS, next of kin and others having claims in respect of the estate of the deceased (who died on 10th October, 1959), are required by the executrix, Elsie Waverley Talbot, of Buln Buln-road, Drouin, widow, to send particulars to her care of the undersigned solicitors by the 25th day of February, 1960, after which date the executrix may convey or distribute the assets, having regard only to the claims of which she then has notice.

GRAY, FRIEND & LONG, solicitors, Warragul. 8311

CREDITORS, next of kin and others having claims in respect of the estate of Ingri Mabel McKenzie, late of 11 Higinbotham-street, Brighton, married woman, deceased (who died on 11th June, 1959), are required to send the particulars of their claims to The Union Trustee Company of Australia Limited, of 333 Collins-street, Melbourne, by the 24th February, 1960, after which date the said company will distribute the assets, having regard only to the claims of which it then has notice.

PROUDFOOT & HORTON, solicitors, 452 Lonsdale-street, Melbourne. 8348

CREDITORS, next of kin and all other persons having claims against the estate of Rosie Campbell Stillman, late of 26 Queen-street, Mornington, married woman, deceased (who died on the 28th day of January, 1958, letters of administration of whose estate were approved on the 7th day of May, 1959, to Alexander Stillman, of 26 Queen-street, Mornington, gentleman), are requested to send particulars of their claim, in writing, addressed to the said Alexander Stillman, of 26 Queen-street, Mornington, by the 25th day of February, 1960, after which date the said Alexander Stillman will distribute the assets, having regard only to the claims of which he then will have had notice.

ROY L. YELLAND, solicitor, of 37 Swanston-street, Melbourne. 8340

CREDITORS, next of kin and others having claims in respect of the estate of Reginald Ernest Goldfinch, late of 154 Ferguson-street, Williamstown, gentleman, deceased (who died on 20th October, 1959), are to send particulars of their claims to the Union Trustee Company of Australia Limited, of 333 Collins-street, Melbourne, by the 24th day of February, 1960, after which date it will distribute the assets, having regard only to the claims of which it then has notice.

RYLAH & RYLAH, solicitors, 349 Collins-street, Melbourne. 8333

CREDITORS, next of kin and others having claims in respect of the estate of Adeliza Constance Holland, late of 18 Luxton-road, Hawksburn, widow, deceased (who died on the 18th day of September, 1959), are to send particulars of their claims to the Trustees, Executors, and Agency Company Limited, of 401 Collins-street, Melbourne, by the 1st day of March, 1960, after which date it will distribute the assets, having regard only to the claims of which it then has notice.

WILLAN, MILLER & CO., 100 Queen-street, Melbourne, solicitors. 8325

NOTICE TO CREDITORS.

CREDITORS, next of kin and others having claims in respect of the estate of Margaret Honora Carr, formerly of Talbot-avenue, East St. Kilda, and of 24 Newland-street, Caulfield, but late of 12 Airdrie-street, Caulfield, in the State of Victoria, widow, deceased (who died on the 23rd day of February, 1959), are to send the particulars of their claims to The Manager, The Equity Trustees, Executors and Agency Company Limited, of 472 Bourke-street, Melbourne, by the 28th day of March, 1960, after which date it will distribute the assets, having regard only to the claims of which it then has notice.

R. J. CROWE & CO., solicitors, Charlton. 8335

CREDITORS, next of kin and others having claims in respect of the estate of Rose Helene Gardiner, formerly of 9 Huntingfield-road, Middle Brighton, but late of 18 Stanley-street, Black Rock, widow, deceased (who died on the 18th August, 1959), are to send particulars of their claims to The Union Trustee Company of Australia Limited, of 303 Collins-street, Melbourne, by the 1st day of March, 1960, after which date it will distribute the assets, having regard only to the claims of which it then has notice.

NORVAL H. DOOLEY & BREEN, solicitors, 31 Queen-street, Melbourne. 8350

DORCAS JESSIE SLEEMAN, late of 3A Wattle Valley-road, Canterbury, widow, DECEASED.

CREDITORS, next of kin and others having claims in respect of the estate of the deceased (who died on the 9th October, 1959), are required by the executor, William Frank McLaren Dimmick, of 486 Bourke-street, Melbourne, solicitor, to send particulars of their claims to him by the 2nd day of March, 1960, after which date the said executor may convey or distribute the assets, having regard only to the claims of which he shall then have had notice.

DUGDALE, SIMMONS & STEVENS, "Peacock House," 486 Bourke-street, Melbourne, solicitors. 8349

MARGARET ANN REYNOLDS (usually known as MARGARET TERESA REYNOLDS), late of 2A Holroyd-court, East St. Kilda, widow, DECEASED.

CREDITORS, next of kin, and others having claims in respect of the estate of the deceased (who died on the 12th day of October, 1959), are required to send particulars of such claims to the executor, Ronald Stewart, addressed to him, care of Ronald Stewart and McIntosh, of 422 Collins-street, Melbourne, on or before the 8th day of March, 1960, after which date the assets will be distributed, having regard only to the claims of which the executor then has notice.

RONALD STEWART & MCINTOSH, solicitors, 422 Collins-street, Melbourne. 8360

CREDITORS, next of kin and others having claims against the estate of Agnes Mary Challinor, late of "Chevron", St. Kilda-road, Melbourne, widow, deceased (who died on 10th December, 1958), are to send particulars of their claims to Elder's Trustee and Executor Company Limited, the registered office of which is situate at 37-39 Currie-street, Adelaide, in the State of South Australia, by the 25th February, 1960, after which date it will distribute the assets, having regard only to the claims of which it then has notice.

BLAKE & RIGGALL, 120 William-street, Melbourne, solicitors. 8322

RONALD DOUGLAS SCOTT, formerly of 9 Scenic-road west, Warragul, but late of 44 Latrobe-street, Warragul, municipal employee, DECEASED.

CREDITORS, next of kin and others having claims in respect of the estate of the deceased (who died on the 16th day of August, 1959), are required by the trustee, Patricia Scott, to send particulars to her, care of the undersigned solicitors, by the 22nd day of February, 1960, after which date the trustee may convey or distribute the assets, having regard only to the claims of which she then has notice.

GRAY, FRIEND & LONG, solicitors, Warragul. 8312

LESLIE THOMAS SAUNDERS, late of Allambee Reserve, via Mirboo North, farmer, DECEASED.

CREDITORS, next of kin and others having claims in respect of the estate of the deceased (who died on 24th June, 1959), are required by the executrix, Marion Finetta Saunders, widow, and executors, Allan Leslie Saunders and Francis Neil Saunders, farmers, all of Allambee Reserve, via Mirboo North, to send particulars to them, care of the undersigned solicitors, by the 18th day of February, 1960, after which date they may convey or distribute the assets, having regard only to the claims of which they then have notice.

GRAY, FRIEND & LONG, solicitors, Warragul. 8287

CREDITORS, next of kin and others having claims in respect of the estate of Alexander Frederick Gillies, late of 16 Moruben-road, Mosman, in the State of New South Wales, engineer, deceased (who died on the 11th September, 1959), are required by the trustee, National Trustees, Executors and Agency Co. of Australasia Ltd., of 95 Queen-street, Melbourne, to send particulars to it at its said address by the 24th day of March, 1960, after which date the trustee may distribute the assets, having regard only to the claims of which it then shall have had notice.

A. NEWTON SUPER, M.A., LL.B., barrister and solicitor, 366 Bourke-street, Melbourne. 8338

MARION ROACH, late of Alexandra-avenue, Surrey Hills, widow, DECEASED.

CREDITORS, next of kin and others having claims in respect of the estate of the said deceased (who died on the 17th day of March, 1957) are required by the executors, Godfrey David Hollidge and Alan Justin MacKay, both of St. Vincent-street, Port Adelaide, South Australia, solicitors, to send particulars of such claims to them, in care of the under-mentioned office, by the 10th day of March, 1960, after which date they may convey or distribute the assets of the said estate, having regard only to the claims of which they then have notice.

UPTON & ETTTELSON, solicitors, 395 Collins-street, Melbourne. 8321

CREDITORS, next of kin and others having claims in respect of the estate of Frederick George Wood, late of 62 McGregor-street, Middle Park, in the State of Victoria, accountant, deceased (who died on the 21st July, 1959), are required to send particulars of their claims to the executor, the Equity Trustees, Executors and Agency Company Limited, of 472 Bourke-street, Melbourne, by the 28th day of February, 1960, after which date they will distribute the assets, having regard only to the claims of which they then have notice.

TOLHURST, DRUCE & EMMERSON, 352 Collins-street, Melbourne, solicitors. 8327

CREDITORS, next of kin and others having claims in respect of the estate of James Alfred Frecker, formerly of 9 Hunter-street, Auburn, but late of 33 Sir Garnet-road, Surrey Hills, tobacco worker, deceased (who died on the 10th day of October, 1959), are to send particulars of their claims to the Equity Trustees, Executors and Agency Company Limited, of 472 Bourke-street, Melbourne, by the 26th day of February, 1960, after which date it will distribute the assets, having regard only to the claims of which it then has notice.

GILBERT, FIELD & WARNE, solicitors, 406 Collins-street, Melbourne. 8329

CREDITORS, next of kin, and others having claims in respect of the estate of Nellie Nigan, late of 137 High-street, Prahran, spinster, deceased (who died on 25th June, 1959), are to send particulars to the executor, the National Trustees, Executors, and Agency Company of Australasia Limited, of 95 Queen-street, Melbourne, by the 26th February, 1960, after which date it will distribute the assets, having regard only to the claims of which it then has notice.

LINDLEY H. HENNESSY, solicitor, 175 Greville-street, Prahran. 8357

FLORENCE PEACOCK (also known as Evangeline Love), late of 699 North Broad-street, Philadelphia, Pennsylvania, in the United States of America, widow, DECEASED, intestate.

CREDITORS, next of kin and others having claims in respect of the estate of the deceased (who died on the 29th May, 1958) are required by Arthur Walker Martin, of 6 Francis-street, Highett, in the State of Victoria, machinery merchant (the administrator to whom letters of administration were granted on the 8th day of December, 1959), to send particulars to him, in care of the undersigned solicitor, by the 26th day of February, 1960, after which date the administrator may convey or distribute the assets, having regard only to the claims of which he then has notice.

DUDLEY A. TREGENT, B.A., LL.M., solicitor, of 422 Collins-street, Melbourne. 8330

CHARLES VILLIGER, late of 40 The Boulevard, North Balwyn, hairdresser, DECEASED (who died on the 10th day of November, 1959).

CREDITORS, next of kin, and all other persons having claims against the estate of the said deceased are required by the executors of his will and codicil, Roberta Alma Villiger, of 40 The Boulevard, North Balwyn, widow; Marie Louise Farkas, of 59 Devonshire-road, Watsonia, married woman; and John Stuart Doyle, of 578 Bourke-street, Melbourne, solicitor, to send particulars thereof to them, care of the under-mentioned solicitors, on or before the 28th day of February, 1960, after which date they may proceed to distribute the assets of the deceased, having regard only to the claims of which they then have notice.

COLTMAN WYATT, & ANDERSON, solicitors, 578 Bourke-street, Melbourne. 8364

RICHARD WILLIAM BARTLETT, late of 103 Primrose-street, Essendon, in the State of Victoria, retired military instructor, DECEASED.

CREDITORS, next of kin and others having claims in respect of the estate of the deceased (who died on the 2nd day of April, 1959) are required by the personal representative, Ruby Burn Bartlett, of 103 Primrose-street, Essendon, aforesaid, widow, to send particulars to her by the 28th day of February, 1960, after which date the said personal representative may convey or distribute the assets, having regard only to the claims of which she then has notice.

Dated the 22nd day of December, 1959.

RIGBY & FIELDING, solicitors, 90 William-street, Melbourne. 8334

ETHEL MANN, late of 8 Howard-street, South Yarra, widow, DECEASED, intestate.

CREDITORS, next of kin, and others having claims against the estate of deceased (who died on the 10th October, 1958), are required to send particulars thereof to Elizabeth Agnes McKenzie, of 11 Wellington-avenue, Beaumaris, care of the undersigned solicitor, by the 15th day of February, 1960, after which date he will distribute the assets of the deceased, having regard only to the claims of which he then has notice.

E. K. O'DONNELL, solicitor, 173 Greville-street, Prahran. 8367

ETHEL MARY DRUMMOND, late of 9 St. Georges-court, Toorak, in the State of Victoria, spinster, DECEASED.

CREDITORS, next of kin, and others having claims in respect of the estate of the above-named deceased (who died on the 25th day of August, 1959), are required by the Trustees, Executors and Agency Company Limited, of 401 Collins-street, Melbourne, in the said State, and Septimus Colman Jones, of 287 Collins-street, Melbourne, aforesaid solicitor, the executors of the will of the deceased to send particulars to them, care of the Trustees, Executors and Agency Company Limited, 401 Collins-street, Melbourne, aforesaid, by the 26th day of February, 1960, after which date the executors may convey or distribute the assets, having regard only to the claims of which they then have notice.

SEPTIMUS JONES & LEE, solicitors, 287 Collins-street, Melbourne. 8368

CREDITORS, next of kin, and others having claims in respect of the estate of Rose Nigan, late of 137 High-street, Prahran, spinster, deceased (who died on the 8th day of May, 1946), are to send particulars to the National Trustees, Executors and Agency Company of Australasia Limited, the administrator, with the will annexed of the estate of the said deceased by the 26th February, 1960, after which date it will distribute the assets, having regard only to the claims of which it then has notice.

LINDLEY H. HENNESSY, solicitor, 175 Greville-street, Prahran. 8356

CREDITORS, next of kin, and others having claims in respect of the estate of Alfred John Gray, late of 22 Victoria-grove, Brunswick, retired gateman, deceased (who died on the 17th day of July, 1959), are required to send particulars of their claims to the executor, the National Trustees, Executors and Agency Company of Australasia Limited, of 95 Queen-street, Melbourne, by the 1st day of March, 1960, after which date the said company will distribute the assets, having regard only to the claims of which it then has notice.

LOUIS P. LE GRAND, solicitor, 660 Sydney-road, Brunswick. 8358

In the Supreme Court of the State of Victoria.
SALE BY THE SHERIFF.

ON Thursday, the Fourth day of February, 1960, at Eleven a.m., at Police Station, Mentone-parade, Mentone (unless process be stayed or satisfied):—

All the estate and interest (if any) of David Forsyth Shanks Melville and Pearl Ann Melville, private hospital proprietors, both of 42 Mentone-parade, Mentone, as joint proprietors of an estate in fee-simple in the land described in certificate of title, volume 8158, folio 957, upon which is erected a single-story slate-roofed solid brick home, of approximately twelve rooms and 35 squares, together with a laundry and large storage shed and known as "Devon Private Hospital," 42 Mentone-parade, Mentone. The land has a frontage of 175 ft. 10 in. to Mentone-parade, narrowing down to 113 ft. 8 in. at rear by a depth of 177 ft. 6 in. along Naples-road on the northern boundary, with a depth of 168 ft. 9 in. on the southern boundary.

Registered mortgages Nos. A390258 for approximately £10,000 and A596178 for an undisclosed amount affects the said estate and interest.

Terms: Cash only.

DAVID J. JOHNSTON, Sheriff's Officer.

21st December, 1959. 8366

In the Supreme Court of the State of Victoria.
SALE BY THE SHERIFF.

ON Wednesday, the Third day of February, 1960, at Eleven a.m., at Police Station, 175 Whitehorse-road, Blackburn (unless process be stayed or satisfied):—

All the estate and interest (if any) of Nicola Mirabella and Micheline Mirabella, tile maker and married woman respectively, both of 18 Donald-street, Blackburn, as joint proprietors of an estate in fee-simple in the land described in certificate of title, volume 8177, folio 611, upon which is erected a six-roomed brick veneer dwelling-house and a two-roomed weatherboard fibro-cement bungalow known as No. 18 Donald-street, Blackburn.

Registered mortgages Nos. A647970 for approximately £2,750 and A653018 for approximately £850, affect the said estate and interest.

Terms: Cash only.

DAVID J. JOHNSTON, Sheriff's Officer.

17th December, 1959. 8365

MINING NOTICES

NORTHERN HERCULES NO LIABILITY.

NOTICE is hereby given that an Extraordinary General Meeting of Northern Hercules No Liability will be held in the Board Room of the Honorary Justices Association, 34 Queen-street, Melbourne, on Thursday, the 21st day of January, 1960, at Two-thirty p.m. when the following Resolution will be proposed as a Special Resolution:—

That the directors be and are hereby authorized to proceed as soon as practical with the discharge of the liabilities of the company and the distribution of the

surplus then remaining amongst the shareholders in proportion to the shares held by them respectively; that all or any investments forming part of the surplus assets be distributed either in their then state of investment or after conversion into money as the directors think fit; and that the directors be and are hereby authorized to settle any difficulties arising on such distribution in such manner as they think fit, and in particular in carrying out the distinction in specie of any investments may sell shares representing unmarketable parcels or fractions of shares to which any shareholders may be entitled, and distribute the proceeds to those shareholders in proportion to their entitlements.

Dated this 4th day of December, 1959.

By order of the Board,

8323 FRANK COOPER, Manager.

NORTHERN MINES DEVELOPMENT NO LIABILITY.

NOTICE is hereby given that an Extraordinary General Meeting of Northern Mines Development No Liability will be held in the Board Room of the Honorary Justices Association, 34 Queen-street, Melbourne, on Thursday, the 21st day of January, 1960, at Two-fifteen p.m. when the following Resolution will be proposed as a Special Resolution:—

That the directors be and are hereby authorized to proceed as soon as practical with the discharge of the liabilities of the company and the distribution of the surplus then remaining amongst the shareholders in proportion to the shares held by them respectively; and that in carrying out such distribution the shareholders other than Northern Hercules No Liability be paid their respective entitlements in cash.

Dated this 4th day of December, 1959.

By order of the Board,

8324 FRANK COOPER, Manager.

Local Government Act 1958.

CITY OF HEIDELBERG.

NOTICE TO ALL WHOM IT MAY CONCERN.

THE Council of the City of Heidelberg has passed a resolution that it is desirable to divert portion of Somers-avenue and close Brighton-court within the municipal district and that in addition to purchasing or compulsorily taking land required for the above purposes, it is also desirable that other land situate in the neighbourhood, though not actually required for those purposes, should also be purchased or compulsorily taken.

Particulars of the land which forms part of Crown portion 9, Parish of Keelbundora, proposed to be purchased or compulsorily taken are as follows:—

Street.	Lot No.	Size.	Owner.
Somers-avenue..	60	52' x V	Harold W. Gray
" " "	61	52' x V	Lindsay Jackson
" " "	Pt. 62	Varying	James Moran and Eileen Moran
" " "	Pt. 63	Varying	Harold W. Gray
" " "	68	114' 2" x V	Leader Construction Pty. Ltd.
" " "	1	62' 10" x V	Lars E. Hansson and June N. Hansson
" " "	2	51' x 125'	James F. Lashford
" " "	3	51' x 125'	James F. Lashford and Doris E. Lashford
" " "	4	51' x 125'	Ronald Edmonds
" " "	5	51' x 125'	Ronald Edmonds
" " "	71	149' 3" x V	Raymond V. Chong
" " "	72	203' 3" x V	Raymond V. Chong
" " "	Pt. 73	Varying	Minister of Education
" " "	Pt. 74	Varying	Minister of Education
Brighton-court..	6	Varying	James F. Lashford
" " "	7	40' x V	James F. Lashford
" " "	8	45' x V	James F. Lashford
" " "	9	40' x V	James F. Lashford
" " "	10	49' 7½" x V	James F. Lashford

After the aforesaid purchase or compulsorily taking of the said land has been completed it is proposed to divert Somers-avenue and subdivide the surplus land into allotments and to submit it for sale pursuant to the provisions of Division 13 of Part XIX. of the *Local Government Act 1958.*

A copy of the said scheme is deposited at the office of the said Council and is open for inspection during office hours by any person.

And the said Council doth hereby call upon all persons affected by the scheme to set forth in writing addressed to the Municipal Clerk within forty clear days from the date of publication of this notice in the *Government Gazette* all objections which they may have to the scheme.

Any objections to the scheme will be considered at the next ordinary meeting of the said Council after the expiration of the said forty clear days and any person affected by the scheme or any person acting on his behalf may appear before the said Council in support of any written objections or may submit any other objections to the scheme.

Dated this 21st day of December, 1959.

The Common Seal of the Mayor, Councillors, and Citizens of the City of Heidelberg was hereto affixed by me—

F. PHILLIPS, Town Clerk,

in the presence of—

(SEAL)

F. C. SWEENEY, Mayor.

8337

A. K. LINES, Councillor.

IMPOUNDINGS

BETHANGA.—Impounded in Bethanga Pound.

1 baldy cow, V in right ear, V under left ear, no visible brand, calf at foot

If not claimed and expenses paid, to be sold on 4th January, 1960.

8305—10/6

M. HARRIS,

Poundkeeper.

ECHUCA.—Impounded in the Echuca Pound.

8 mixed lambs

If not claimed and expenses paid, to be sold on 8th January, 1960.

8308—9/

B. CLEE,

Poundkeeper.

CONTENTS

	PAGE
Acts of Parliament	3697
Appointments	3714
Christmas and New Year Holidays	3700
Contracts	3713
Country Roads Board	3720
Courts	3700
Estates of Deceased Persons	3712
Government Notices	3700
Impoundings	3742
Lands	3725
Melbourne and Metropolitan Board of Works— Notices	3705
Mining	3706, 3741
Orders in Council	3716
Private Advertisements	3730
Proclamations	3697
Publication of the <i>Victoria Government Gazette</i>	3700
Resignations	3715
State Rivers and Water Supply Commission	3712
Waterworks Trusts	3707