



VICTORIA GOVERNMENT GAZETTE

Published by Authority

[Registered at the General Post Office, Melbourne, for transmission by post as a newspaper.]

No. 55]

WEDNESDAY, JUNE 24

[1959

Land Act 1958.

AREA OF LAND COMPRISED IN CERTAIN CLASSES DIMINISHED OR INCREASED.

PROCLAMATION

By His Excellency the Governor of the State of Victoria and its Dependencies in the Commonwealth of Australia,
&c., &c., &c.

WHEREAS by the *Land Act 1958* it is amongst other things enacted that the Governor in Council may, by Proclamation to be published in the *Government Gazette*, at any time diminish or increase the area of land comprised in any of the classes mentioned in Part I., Division 1, section 5, of the said *Land Act 1958*, but that the area of lands which may be sold by auction (Class 6), shall not be increased except as in certain cases in the said Act provided: Now therefore I, the Governor of the State of Victoria, in the Commonwealth of Australia, by and with the advice of the Executive Council of the said State, and in accordance with the provisions of sections 94 and 117 of the *Land Act 1958* aforesaid, do hereby diminish or increase (as the case may be) the areas of Crown lands comprised in Classes 2, 6 and 7 of the classes mentioned in section 5. of the *Land Act 1958* aforesaid, to the extent set forth in the subjoined Schedule (that is to say):—

Schedule referred to.

CLASSES DIMINISHED OR INCREASED.

County.	Parish.	Allotment.	Section.	Area.	Diminished.	Increased.	Description.
					Class.	Class.	
				A. B. P.			
Bendigo ..	Sandhurst, at Eaglehawk ..	9	47	0 1 5	7	6	In the north of Parish, fronting road about 4 chains east of Hicks-street At Kinglake West about 1 mile south of main Whittlesea-Kinglake Road
Evelyn ..	Kinglake ..	13D	..	47 0 30	2	6	

Given under my Hand and the Seal of the State of Victoria, aforesaid, at Melbourne, this seventeenth day of June, in the year of our Lord One thousand nine hundred and fifty-nine, and in the eighth year of the reign of Her Majesty Queen Elizabeth II.

(L.S.)

DALLAS BROOKS.

By His Excellency's Command,

KEITH TURNBULL,

Commissioner of Crown Lands and Survey.

GOD SAVE THE QUEEN!

Land Act 1958.

UNALIENATED CROWN LAND AVAILABLE FOR SETTLEMENT UNDER IMPROVEMENT PURCHASE LEASES.

PROCLAMATION

By His Excellency the Governor of the State of Victoria and its Dependencies in the Commonwealth of Australia, &c., &c., &c.

IN pursuance of the provisions of section 153 of the *Land Act 1958*, I, the Governor of the State of Victoria, in the Commonwealth of Australia, by and with the advice of the Executive Council of the said State, do by this Proclamation declare the unalienated Crown lands mentioned in the subjoined Schedule, to be available for settlement under improvement purchase leases.

SCHEDULE.

County.	Parish.	Allotment.	Section.	Area.	Land Valuation.
				A. B. P.	
Lowan	Awonga	92	..	795 0 0	£1 7s. 6d. per acro
Lowan	Charam	10 and 13

Given under my Hand and the Seal of the State of Victoria aforesaid, at Melbourne, this seventeenth day of June, in the year of our Lord One thousand nine hundred and fifty-nine and in the eighth year of the reign of Her Majesty Queen Elizabeth II.

(L.S.)

DALLAS BROOKS.

By His Excellency's Command,

KEITH TURNBULL,
Commissioner of Crown Lands and Survey.

GOD SAVE THE QUEEN!

Game Act 1958.

REVOCATION OF SANCTUARY FOR NATIVE GAME AT "RURAMIHI", BUNYIP.

PROCLAMATION

By His Excellency the Governor of the State of Victoria and its Dependencies in the Commonwealth of Australia, &c., &c., &c.

I THE Governor of the State of Victoria, in the Commonwealth of Australia, by and with the advice of the Executive Council of the said State, and in pursuance of the provisions of the *Game Act 1958* and all other powers me enabling in that behalf do by this Proclamation revoke the Proclamation made the first day of May, 1940, and published in the *Government Gazette* of the eighth day of May, 1940, respecting a sanctuary for native game at "Ruramihi", Bunyip.

Given under my Hand and the Seal of the State of Victoria aforesaid, at Melbourne, this seventeenth day of June, in the year of our Lord One thousand nine hundred and fifty-nine, and in the eighth year of the reign of Her Majesty Queen Elizabeth II.

(L.S.)

DALLAS BROOKS.

By His Excellency's Command,

L. H. S. THOMPSON,
Acting Chief Secretary.

GOD SAVE THE QUEEN!

Game Acts.

REVOCATION OF PROCLAMATION OF SANCTUARY FOR NATIVE GAME AT WALLINDUC IN THE PARISH OF NARINGHIL NORTH.

PROCLAMATION

By His Excellency the Governor of the State of Victoria and its Dependencies in the Commonwealth of Australia, &c., &c., &c.

I THE Governor of the State of Victoria, in the Commonwealth of Australia, by and with the advice of the Executive Council of the said State, and in pursuance of the provisions of the *Game Acts* and all other powers me enabling in that behalf, do by this Proclamation revoke paragraph (2) of the Proclamation

made the twenty-eighth day of June, 1928, and published in the *Government Gazette* of the fourth day of July, 1928 respecting sanctuaries for native game.

Given under my Hand and the Seal of the State of Victoria aforesaid, at Melbourne, this seventeenth day of June, in the year of our Lord One thousand nine hundred and fifty-nine, and in the eighth year of the reign of Her Majesty Queen Elizabeth II.

(L.S.)

DALLAS BROOKS.

By His Excellency's Command,

L. H. S. THOMPSON,
Acting Chief Secretary.

GOD SAVE THE QUEEN!

LAND SETTLEMENT ACT 1959.

PROCLAMATION

By His Excellency the Governor of the State of Victoria and its Dependencies in the Commonwealth of Australia, &c., &c., &c.

WHEREAS by an Act of Parliament of the State of Victoria, passed in the eighth year of the reign of Her Majesty Queen Elizabeth II, intituled the *Land Settlement Act 1959*, it is amongst other things enacted that the said Act shall come into operation on a date to be fixed by Proclamation of the Governor in Council published in the *Government Gazette*: Now therefore I, the Governor of the State of Victoria, acting by and with the advice of the Executive Council thereto, do by this my Proclamation fix Wednesday, the first day of July, One thousand nine hundred and fifty-nine, as the day upon which the *Land Settlement Act 1959* shall come into operation.

Given under my Hand and Seal of the State of Victoria aforesaid, at Melbourne, this twenty-third day of June, in the year of our Lord One thousand nine hundred and fifty-nine, and in the eighth year of the reign of Her Majesty Queen Elizabeth II.

(L.S.)

DALLAS BROOKS.

By His Excellency's Command,

KEITH TURNBULL,
Commissioner of Crown Lands and Survey.

GOD SAVE THE QUEEN!

PUBLIC HALF-HOLIDAY.

PROCLAMATION

By His Excellency the Governor of the State of Victoria and its Dependencies in the Commonwealth of Australia, &c., &c., &c.

IN pursuance of the provisions contained in Part III. of the *Public Service Act 1958*, I, the Governor of the State of Victoria, in the Commonwealth of Australia, by and with the advice of the Executive Council of the said State, do by this my Proclamation appoint the day and date hereunder mentioned to be observed as a Public Half-Holiday at the place specified, viz.:—

Public Half-Holiday from the Hour of Twelve o'clock noon:—

THURSDAY, THE 1ST OCTOBER, 1959, within the municipality of the City of Horsham.

Given under my Hand and the Seal of the State of Victoria aforesaid, at Melbourne, this seventeenth day of June, in the year of our Lord One thousand nine hundred and fifty-nine, and in the eighth year of the reign of Her Majesty Queen Elizabeth II.

(L.S.) DALLAS BROOKS.

By His Excellency's Command,
L. H. S. THOMPSON,
Acting Chief Secretary.

GOD SAVE THE QUEEN!

MELBOURNE AND METROPOLITAN BOARD OF WORKS.

NOTICE TO THE OWNERS OF TENEMENTS IN THE UNDERMENTIONED STREETS, AND THE PRIVATE STREETS, LANES, COURTS, AND ALLEYS OPENING THERETO.

THE main pipe in the said streets being laid down, the owners of all tenements situated as under are hereby required, on or before 27th July, 1959, to cause a proper pipe and stop cocks to be laid so as to supply water within such tenements from the main pipe.

V. C. TREYVAUD,
Secretary.

16th June, 1959.

STREET AND POSITION.

Broadmeadows.

Electric-street, from Waverley-street southwards 7½ chains
Bicknell-court, from Electric-street eastwards 17½ chains.

Essendon.

Clifton-street, from 6½ chains north-west of Fawcner-street north-westwards 3 chains.

Heidelberg.

Grove-road, from Douglas-street southwards 6½ chains.
Douglas-street, from Greenhilda-street to Rosanna-road.
Rosanna-road, from Douglas-street northwards 3 chains.
Strasbourg-road, from 3 chains west of Grove-road westwards 4½ chains.
Ellesmere-parade, from 17½ chains north of Invermay-grove northwards 8 chains.

Moorabbin.

Elder-road, from Old Dandenong-road eastwards and northwards 36 chains.
Oak-grove, from Warrigal-road westwards 16 chains.

Mordialloc.

Victoria-street, from 12½ chains east of Chandler-street eastwards 3 chains.

Mulgrave.

Kingsway, from Coleman-parade to Bogong-avenue.
Bogong-avenue, from Kingsway to Myrtle-street.
Montclair-avenue, from Kingsway westwards 10½ chains.
Home-street, from Myrtle-street to Waverley-road.
Florence-street, from Home-street southwards 15½ chains.
Short-street, from Florence-street to Myrtle-street.
Southdown-avenue, from Myrtle-street eastwards 5 chains.
Marriot-parade, from Myrtle-street eastwards 5½ chains.
Carmichael-street, from Aristoc-road eastwards 4½ chains.
Carmichael-street, from Home-street westwards 2 chains.
Myrtle-street, from Waverley-road northwards 17½ chains.
Ada-street, from Myrtle-street eastwards 4½ chains.
Myrtle-street, from Carmichael-street to Marriot-parade.
Gnarwin-street, from Smyth-street westwards 4 chains.

Nunawading.

Barker-street, from Dundee-street southwards 4½ chains.
Mansfield-street, from Aberdeen-road to Hone-avenue.
Hone-avenue, from Mansfield-street to Canterbury-road.
Branksome-grove, from Canterbury-road to Highfield-road.
Barrina-street, from Aberdeen-road eastwards 11½ chains.
Highfield-road, from Branksome-grove westwards 1½ chains.
Glen-road, from Doncaster East-road eastwards 10 chains.
Tourello-street, from Casella-street to Collina-street.
Collina-street, from Tourello-street southwards ¾ chain.
Luckie-street, from Springvale-road westwards 36½ chains.
Creek-street, from Springvale-road westwards 16½ chains.
Russell-street, from Luckie-street southwards 6 chains.
Jubilee-street, from Russell-street westwards 5½ chains.

Oakleigh.

Harlington-street, from Robinson-street southwards 16 chains.
Valley-street, from Olinda-street to Haughton-road.
Haughton-road, from Valley-street south-eastwards ¼ chain.
Stamford-road, from Estelle-street eastwards 11½ chains.
Raymond-street, from Stamford-road northwards 5 chains.

Werribee.

Woods-street, from 2 chains west of Burton-street to Hickey-street.
Hickey-street, from Woods-street southwards 4½ chains.
A. Government road (on the north side of Geelong railway), from Thomas-street eastwards 15 chains.

Victoria.

ACT 391.—SECOND SCHEDULE.

A STATEMENT of trusts having been submitted by the head or authorized representative of the denomination of the Church of England, under the provisions of the "Act to provide for the Abolition of State Aid to Religion", for allowance by the Governor, the same was allowed by him on the twenty-second day of May, 1871, and the following is the form in which such statement of trusts has been allowed:—

STATEMENT OF TRUSTS.

Description of Land.—2 acres, Township of Avoca, Parish of Avoca, County of Gladstone, being allotment 5, section 26A: Commencing at the intersection of the northern side of Russell-street and the eastern side of Barnett-street; bounded thence by the latter street bearing north 20 deg. 37 min. west 400 links; by allotment 4 bearing north 69 deg. 23 min. east 500 links; by Boyce-street bearing south 20 deg. 37 min. east 400 links; and thence by Russell-street bearing south 69 deg. 23 min. west 500 links to the commencing point.

Name of Trustees.—The St. Arnaud Diocesan Trustees, of McMahon-street, St. Arnaud.

Powers of Disposition.—Power to leases (whether on building lease or otherwise), sell, create easements over, make, reserve, and close roads upon or over, mortgage, or exchange the said lands or any part thereof, and to erect buildings thereon, such powers to be exercised with the consent of the Bishop or Administrator of the Diocese of St. Arnaud for the time being acting under the advice of the Council of the Diocese; and subject to such powers and the exercise thereof to hold the said lands or so much thereof as may from time to time remain vested in the said corporation for such purposes of the Church of England within the Diocese of St. Arnaud as the said Bishop or Administrator for the time being, acting under the advice of the said Council of the Diocese, may direct.

Purposes to which Proceeds of Disposition are to be Applied.—To such purposes of the Church of England within the Diocese of St. Arnaud as the said Bishop or Administrator for the time being, acting under the advice of the said Council, may direct.

As witness the hand of the Governor of the State of Victoria, this seventeenth day of June, 1959.

DALLAS BROOKS,
Governor of the State of Victoria.

BUILDING SOCIETIES ACT 1958.

NOTICE is hereby given that a Building Society called "Parkmore Permanent Building Society" is duly registered under the provisions of the above Act.

Dated this 17th day of June, 1959.

A. DOUGLAS,
Registrar of Building Societies.

Marriage Act 1958.

MINISTERS OF RELIGION REGISTERED TO CELEBRATE MARRIAGES IN VICTORIA.

It is hereby notified that in pursuance of the provisions of the *Marriage Act* 1958, 7 Eliz. II. No. 6306, Sec. 11, the undermentioned Officiating Ministers of Religion have been registered at this Office for the celebration of marriages in Victoria:—

Number in Register.	Name.	Designation.	Denomination.	Residence.	Date of Registration.
12053	Melnick, Michael	Priest ..	Roman Catholic ..	35 Canning-street, North Melbourne	27.5.59
12054	Smith, Henry Austin .. .	Priest ..	Roman Catholic ..	73 Glengala-road, Sunshine Heights	27.5.59
12055	Hull, Robert Edward Davison ..	Priest ..	Church of England ..	Ford-street, Beechworth .. .	27.5.59
12056	Andrews, Gordon Joseph Stanbury	Preacher	Churches of Christ ..	6 Burr-street, Bendigo .. .	9.6.59
12057	Sanders, Edward Spencer .. .	Preacher	Churches of Christ ..	14 St. Georges-arcuate, Ashburton ..	18.6.59
12058	Phillips, Elzear Basil .. .	Priest ..	Roman Catholic ..	The Priory, 75 Wright-street, Middle Park	18.6.59
12059	Pitman, Brian Hilarion .. .	Priest ..	Roman Catholic ..	The Priory, 75 Wright-street, Middle Park	18.6.59

Office of the Government Statist,
Melbourne, 22nd June, 1959.

G. W. CORRIE,
Assistant Government Statist.

STATE RIVERS AND WATER SUPPLY COMMISSION.

LICENCES TO DIVERT WATER AND CUT RACES, PURSUANT TO THE PROVISIONS OF THE WATER ACTS.

LICENCES as detailed hereunder for the term of years from the date specified in each case have been granted by the Governor in Council to the persons named in the following Schedule:—

Licence No.	Term of Licence and Commencing Date.	Name and Address of Person to Whom Licence is to be Granted.	Source of Supply.	Area Authorized to be Irrigated Per Annum.	Volume of Water Authorized to be Diverted Per Annum.
				acres.	ac.-ft.
342	Fifteen years from 1.7.59..	J. D. Parry and the Executors of the Estate of T. W. Parry, Serpentine	Gunbower Creek ..	45	90
1260	Fifteen years from 1.7.58..	Ernest Edward Clarke, Kotupna ..	Wakiti Lagoon ..	60	120
1261	Fifteen years from 1.7.58..	Reginald John Malcolm Eastman, Kotupna	Wakiti Lagoon ..	60	120

Office of the State Rivers and Water Supply Commission,
Melbourne, 17th June, 1959.

E. BROWN, Secretary,
State Rivers and Water Supply Commission.

STATE RIVERS AND WATER SUPPLY COMMISSION.

LICENCES TO DIVERT WATER AND CUT RACES, PURSUANT TO THE PROVISIONS OF THE WATER ACTS.

LICENCES as detailed hereunder for the term of years from the date specified in each case have been granted by the Governor in Council to the persons named in the following Schedule:—

Licence No.	Term of Licence and Commencing Date.	Name and Address of Person to Whom Licence is to be Granted.	Source of Supply.	Area Authorized to be Irrigated Per Annum.	Volume of Water Authorized to be Diverted Per Annum.
				acres.	ac. ft.
1262	Fifteen years from 1.7.59	Arthur James Galvin, Werribee ..	Werribee River ..	10	10
1263	Fifteen years from 1.7.59	Colin Matthew Thompson, Murchison North	Goulburn River ..	10	20
1264	Fifteen years from 1.7.59	R. F. Millard Pty. Ltd., Carnegie ..	Goulburn River ..	100	200

Office of the State Rivers and Water Supply Commission,
Melbourne, 23rd June, 1959.

E. BROWN, Secretary,
State Rivers and Water Supply Commission.

STATE RIVERS AND WATER SUPPLY COMMISSION.

LICENCE as detailed hereunder to divert water and cut race pursuant to the provisions of the Water Act has been revoked by the Governor in Council, as from the date indicated.

Licence No.	Name and Address of Person to whom Licence has been Granted.	Source of Supply.	Date of Revocation.
172	James Geoffrey Russell .. .	Gunbower Creek .. .	1.7.59

Office of the State Rivers and Water Supply Commission,
Melbourne, 23rd June, 1959.

E. BROWN, Secretary,
State Rivers and Water Supply Commission.

Local Government Act 1946, Part 48, Section 876.

LICENCES TO OCCUPY WATER FRONTAGES.

NOTICE is hereby given that Licences to occupy Water Frontages have been issued to the following approved applicants, and that the Licence Fee specified in each case has been received by the Accountant, Department of Crown Lands and Survey, Melbourne, C.2.

Number of Licence.	Name and Address of Licensee.	Municipality.	Parish.	Abutting— Allotments and Sections.	Fee for Licence.	Date of Issue of Licence.	Date of Expiry of Licence.
24201	Davis, A. V., Yarram ..	Alberton ..	Devon ..	74	2 10 0	1.1.57	31.12.59
24202	Pask, S., Neerim North ..	Buln Buln ..	Neerim ..	181	5 0	1.1.57	31.12.59
24203	Taylor, B. H., 66 Nicholas-street, Ashburton ..	Berwick ..	Gembrook ..	67 of D	5 0	1.1.57	31.12.59
24204	House, F. J., Foster ..	South Gipps- land ..	Foster (Township)	11A and 1B of 13 ..	5 0	1.1.57	31.12.59
24205	McCormack, W. G., Trafalgar East ..	Narracan ..	Darnum ..	89c and part 90 ..	1 0 0	1.1.57	31.12.59
24206	O'Neill, A. C., Tarra Valley ..	Alberton ..	Devon ..	116	1 10 0	1.1.57	31.12.59
24207	Wight, C. E., Yarram ..	Alberton ..	Boodyarn ..	4 of B	1 8 0	1.1.57	31.12.59
24209	Leigh, J., 118 Flinders-lane, Melbourne ..	Upper Yarra ..	Yuonga ..	Yarra River, 25A (part) ..	5 0	7.7.58	31.12.60
24210	Boy Scouts' Association, 6 Lowther-street, Alphington ..	Eltham ..	Sutton ..	Yarra River, 16 and 17 ..	5 0	22.8.58	31.12.60
24211	Lee, G. E., Hill End, via Moe ..	Narracan ..	Neerim East ..	16A, section C	2 5 0	15.8.58	31.12.60
24212	Pike, W. B., Wandin ..	Upper Yarra ..	Yuonga ..	Yarra, 25A (part) ..	5 0	29.10.58	31.12.60
24213	Vardy, K. McG., Stacey's Bridge ..	Alberton ..	Binginwarri ..	Billy Creek, 6, section B ..	1 0 0	14.10.58	31.12.61
24214	Faulkner, L. A., Inverleigh ..	Bannockburn ..	Carrah ..	Leigh River, 81	1 0 0	29.10.58	31.12.60
24215	Peel, T. G., Inverleigh ..	Bannockburn ..	Carrah ..	Leigh River, 32A	1 0 0	30.10.58	31.12.60
24216	Marslan, L. J., Hill End ..	Narracan ..	Neerim East ..	Russell's Creek, 1A, section C	3 15 0	6.11.58	31.12.60
24217	Frans, L., 245 Moreland-road, Coburg ..	Upper Yarra ..	Brimbonga ..	McMahon's Creek 6, Pheasant Creek 15	8 0 0	10.11.58	31.12.60
24218	Cousins, H. E., Poowong ..	Buln Buln ..	Lang Lang ..	of Nyora Estate	1 5 0	10.11.58	31.12.60
24219	Goldsmith, R., 258 Glenhuntly- road, Elwood ..	Berwick ..	Gembrook ..	96A	5 0	18.2.58	31.12.60
24220	Taylor, E., Mornda ..	Whittlesea ..	Yan Yean ..	Plenty River, 10, section 3 ..	17 6	18.6.58	31.12.60
24221	Daro, J. K., 104 Haig-street, Heidelberg West ..	Eltham ..	Sutton ..	Yarra, 46A (part)	5 0	18.6.58	31.12.60
24222	Clark, J. L. and C. E., Kangaroo Ground ..	Eltham ..	Sutton ..	Yarra, 46A (part)	12 6	18.6.58	31.12.60
24223	Williams, N. F., 25 Newman- street, Niddrie ..	Eltham ..	Sutton ..	Yarra, 35 (part)	5 0	18.6.58	31.12.60
24224	Brodie, W. A. and L. G., 12 Carmichael-street, Ivanhoe ..	Eltham ..	Sutton ..	Yarra, 35 (part)	5 0	18.6.58	31.12.60
24225	Hamono, D. T. and E. M. ..	Buln Buln ..	Neerim (Town- ship) ..	Shady Creek 37, 37A, 38 and 39	1 15 0	9.7.58	31.12.60
24226	Heyman, W. A., 12 Matthew- street, Glenhuntly ..	Eltham ..	Sutton ..	Yarra, 7 (L.P. 12866)	5 0	18.6.58	31.12.60
24227	Gurney, R. W. and P. A., 1 Anderson's-road, Hawthorn ..	Eltham ..	Sutton ..	Yarra, 9 (L.P. 12866)	5 0	19.6.58	31.12.60
24228	Senior, K. S., Warrandyte ..	Eltham ..	Sutton ..	Yarra, 46A (part)	5 0	19.6.58	31.12.60
24229	Elliott, F. W., 77 The Eyrie, Eaglemont ..	Eltham ..	Sutton ..	Yarra, 46A (part)	6 0	19.6.58	31.12.60
24230	Ayro, S. G., 81 Banksia-street, Heidelberg ..	Eltham ..	Sutton ..	Yarra, 46A (part)	5 0	19.6.58	31.12.60
24231	Pearce, J., 81 Banksia-street, Heidelberg ..	Eltham ..	Sutton ..	Yarra, 46A (part)	5 0	19.6.58	31.12.60
24232	Hatherley, K., 6 Baringa-street, Mt. Waverley ..	Eltham ..	Sutton ..	Yarra, 3 (L.P. 12866)	5 0	19.6.58	31.12.60
24233	Kalwig, S. J., 60 Fehon-street, Yarraville ..	Eltham ..	Sutton ..	Yarra, 46A (part)	5 0	19.6.58	31.12.60
24234	Maynard, A. L., 18 Molesworth- street, North Melbourne ..	Eltham ..	Sutton ..	Yarra, 34 (L.P. 12866)	5 0	19.6.58	31.12.60
24235	Berry, C. L., Apollo Bay ..	Otway ..	Krambruk ..	Barham, 16 and 17, section 2	5 0	19.6.58	31.12.60
24236	Houghton, J., Benalla ..	Eltham ..	Sutton ..	Yarra, 22 (L.P. 12866)	15 0	19.6.58	31.12.60
24237	Reid, A. L., 137 Thomas-street, Hampton ..	Eltham ..	Sutton ..	Yarra, 46A (part)	16 0	24.6.58	31.12.60
24238	Cannard, R. A., W. J. and C. M., Elingamite North ..	Heytesbury ..	Elingamite ..	Lake Elingamite 3B and 4B, section XV	3 0 0	9.7.58	31.12.60
24239	Le Rossignol, R., Strasboutg- street, Rosanna ..	Eltham ..	Sutton ..	Yarra, 32 and 33 (L.P. 12866)	6 0	24.6.58	31.12.60
24240	Holt, G. R., Leongatha ..	Woorayl ..	Nerrena ..	Tarwin, 33E	4 5 0	26.6.58	31.12.60
24241	Trotman, K. A., Koonwarra ..	Woorayl ..	Leongatha ..	Tarwin, 2 and 3, section 6, 1, 2, 3, 4, section 7 (Town- ship of Koonwarra)	8 10 0	26.6.58	31.12.60
24242	Hiekinbotham, A., 17 Fair- mount-road, East Hawthorn ..	Eltham ..	Sutton ..	Yarra, 41B (part)	1 0 0	8.7.58	31.12.60
24243	Fretwell, K. R. and E. D., 4 Mary-street, Hawthorn ..	Eltham ..	Sutton ..	Yarra, 41B (part)	1 0 0	8.7.58	31.12.60
24244	Befrends, B. and M., Kangaroo Ground ..	Eltham ..	Sutton ..	Yarra, 41B (part)	1 0 0	8.7.58	31.12.60
24245	Penn, R. S., 20 St. Elms-road, Ivanhoe ..	Eltham ..	Sutton ..	Yarra, 41B (part)	1 0 0	8.7.58	31.12.60
24246	Worcester, A., Warragul ..	Buln Buln ..	Noojee East ..	Loch, 25A	1 0 0	9.12.58	31.12.61
24247	Wearne, I., 15 Alma-street, Chadstone ..	Berwick ..	Gembrook ..	Craig's Creek, 67A, section D	1 0 0	21.1.59	31.12.59
24248	Cahn, A. J., Warrandyte ..	Eltham ..	Nillumbik ..	Yarra, 25F (part) and 25D ..	1 0 0	21.1.59	31.12.61
24249	Pelling, C. M., Kangaroo Ground ..	Eltham ..	Nillumbik ..	Yarra, 25E (part), section 4A ..	1 0 0	29.1.59	31.12.61
24250	Scott, W., Warrandyte ..	Eltham ..	Nillumbik ..	Yarra, 25F (part)	1 0 0	30.1.59	31.12.61

LICENCES TO OCCUPY WATER FRONTAGES—*continued.*

Number of Licence.	Name and Address of Licensee.	Municipality.	Parish.	Abutting— Allotments and Sections.	Fee for Licence.	Date of Issue of Licence.	Date of Expiry of Licence.
					£ s. d.		
24251	Brown, W. C., Estate of, c/o 401 Collins-street, Melbourne	Buln Buln ..	Neerim ..	Latrobe, 185 and 185A ..	1 0 0	4.2.59	31.12.61
24252	Fitts, Y. E., 21 Kooyong Koot-road, Hawthorn	Eltham ..	Nillumbik ..	Yarra, 25E (part), section 4A	1 2 6	3.2.59	31.12.61
24253	Barry, J. A., James-street, Pakenham East	Berwick ..	Tonimbuk ..	Cannibal Creek, 38 ..	3 5 0	24.2.59	31.12.61
24254	McMeel, E. M. and M. M., Scotts Creek	Heytesbury ..	Cooriejong ..	Cooriemungel Creek, 27 (part)	7 10 0	26.2.59	31.12.61
24256	Parsons, W. H., Mortlake ..	Mortlake ..	Mortlake ..	Salt Lake, 3A, 4A, 4B, 4C, section 25	2 15 0	12.3.59	31.12.61

Department of Crown Lands and Survey,
Melbourne, 11th June, 1959.

KEITH TURNBULL,
Commissioner of Crown Lands and Survey.

MONEY LENDERS ACT 1958.

IN accordance with the provisions of the above-mentioned Act, the following is published for general information:—
List of persons to whom Money Lenders Licences have been issued for the year ending 30th June, 1959.

Name.	Authorized Name.	Authorized Address.	Date of Issue.
Promotions Pty. Ltd., C. K. Cutting (appointee)	Promotions Pty. Ltd. ..	300 Little Collins-street, Melbourne	21.5.59
Associated Securities Ltd., E. J. Upton, (appointee)	Associated Securities Ltd. ..	410 Collins-street, Melbourne ..	15.5.59

State Treasury,
Melbourne, C.2, 18th June, 1959.

M. A. R. SYNNOT,
Registrar.

RAILWAYS DEPARTMENT.

REGULATION No. 96.

THE Victorian Railways Commissioners, in pursuance of the powers conferred in that behalf by the Railways Acts, do hereby repeal Regulations Nos. 90 and 91, and make the following Regulation in regard to the qualifications for appointment to a permanent office in the Railways Service of any person who immediately before such appointment is in the temporary employment of the Commissioners.

No person in the temporary employment of the Commissioners shall be eligible for permanent appointment unless—

- (a) He is certified by the Railways Medical Officer as being up to the required medical standard;
- (b) The Commissioners are of opinion that such person has a satisfactory record of service, is of good character and is qualified and efficient; and
- (c) He is under the age of 53 years provided that this requirement shall not apply in the case of any officer or employee who is in the temporary employment of the Commissioners at the date of the coming into operation of this Regulation, but no such officer or employee shall be eligible for appointment on attaining the age of 60 years.

Any person who has been dismissed from the Railways Department or the Public Service for misconduct or who has been convicted of a felony or infamous offence shall not be eligible for permanent appointment in the service of the Commissioners unless, after consideration of the circumstances, the Commissioners are satisfied that he would be a suitable appointee to the permanent staff.

The common seal of the Victorian Railways Commissioners was hereto affixed this thirtieth day of April, One thousand nine hundred and fifty-nine, in the presence of—

E. H. BROWNBILL, } Victorian Railways
N. QUAIL, } Commissioners.

Approved by the Governor in Council,
17th June, 1959.

A. MAHLSTEDT,
Clerk of the Executive Council.

Local Government Act 1946, Part 48, Section 876.

LICENCES TO OCCUPY UNUSED ROADS.

NOTICE is hereby given that Licences to occupy Unused Roads have been issued to the following approved applicants, and that the Licence Fee specified in each case has been received by the Accountant, Department of Crown Lands and Survey, Melbourne, C.2.

Number of Licence.	Name and Address of Licensee.	Municipality.	Parish.	Abutting— Allotments and Sections.	Area.	Fee for Licence.		Date of Issue of Licence.	Date of Expiry of Licence.
						£	s. d.		
40631	Gray, F. W., Leongatha	Woorayl ..	Norrena ..	16A (North half between 15A)	2 2 0	1	5 0	19.11.57	31.12.60
40632	Tonks, P. J. W., Carnegie	Buln Buln	Longwarry	Between 69 and 122 ..	3 2 0	0	17 6	4.12.57	31.12.60
40633	McDonald, J., Pakenham Upper	Berwick ..	Nar-Nar-Goon	North of 81 ..	2 1 24	1	4 0	10.12.57	31.12.60
40634	Teal, W. H., Camperdown	Camperdown	Colongulac	South of 4, section 13A, east of 1, 2, 3, 4, section 13A	1 1 0	3	15 0	19.12.57	31.12.60
40635	Evans, L. K., Catani ..	Berwick ..	Koo-Wee-Rup	East of 21, section M (northern part)	0 3 0	0	11 9	12.12.58	31.12.60
40636	Cumming, H. G., Moreland	Lillydale ..	Wandin Yallock	North of 148 and part 110	14 0 0	8	15 0	20.1.58	31.12.60
40637	Gilliland, F. G., Woorndoo	Mortlake ..	Towanway	West of Lot 3, Cattle Runs Estate	9 0 0	4	10 0	7.2.58	31.12.59
40638	Goldsmith, R., Elwood ..	Berwick ..	Gembrook ..	North of 96A (western part)	2 0 0	0	5 0	18.2.58	31.12.60
40639	Giblin, E. N., Iona ..	Berwick ..	Koo-Wee-Rup East	West of 137, section O	0 0 10	0	5 0	11.3.58	31.12.60
40640	Bowden, K., Buln Buln	Warragul ..	Drouin East	South-east of 113 ..	1 2 0	0	7 6	11.3.58	31.12.60
40641	Williams, M. P., Hill End	Narracan ..	Neerim East	North of 37B, section A1	3 0 0	0	12 0	29.4.58	31.12.60
40642	Loone, A. J., Modewarre	Barrabool ..	Modewarre (Township)	Between sections 3 and 6	1 2 0	0	9 0	17.6.58	31.12.60
40643	Abraham, A. R., Ecklin South	Heytesbury	Ecklin ..	West of 4B (northern part)	0 3 0	0	5 0	29.4.58	31.12.60
40644	Bodewitz, J., Fish Creek	South Gippsland	Doomburrim	Between 91A, 54 and 55	7 2 0	1	2 6	29.4.58	31.12.60
40645	Carpenter, J. L., Shelford	Leigh ..	Doroq ..	West of sections 8 and 9 (Township of Shelford)	3 2 0	3	10 0	29.4.58	31.12.60
40646	Roddie, C., Shelford ..	Leigh ..	Doroq ..	North and west of section 7 (Township of Shelford)	2 0 0	2	0 0	9.7.58	31.12.60
40647	Broderick, T., G. F., and Barnett, C. L., Neerim South	Buln Buln	Neerim ..	South of A3 (western part)	5 0 0	3	0 0	9.7.58	31.12.59
40648	Austin, L. A., Darra	Bannockburn	Moreep ..	North of 12 ..	5 0 0	1	5 0	9.7.58	31.12.60
40649	Bound, J. R., Modewarre	Barrabool ..	Modewarre (Township)	Between sections 4 and 5	1 2 0	0	9 0	15.5.58	31.12.60
40650	Hamono, D. T., and E. M., Neerim	Buln Buln	Neerim ..	South of 37 (Township of Neerim)	2 0 0	0	10 0	9.7.58	31.12.60
40651	Berryman, F. J., Thorpdale	Mirboo ..	Allambee East	West of 28 (south part)	2 2 0	0	12 6	12.6.58	31.12.60
40652	Findlay, W., Mirboo North	Narracan ..	Allambee East	North and east of 96 ..	7 0 0	0	15 0	12.6.58	31.12.60
40653	Izrael, I. and C., 329 Bourke-street, Melbourne	Eltham ..	Nilumbik ..	West of 11, section 18	1 0 0	0	7 6	29.9.58	31.12.60
40654	Trembath, R., Mirboo North	Mirboo ..	Narracan South	West of 30 ..	2 2 0	0	12 6	12.6.58	31.12.60
40655	Berryman, F. J., Thorpdale	Mirboo ..	Narracan South	North of 28 ..	3 2 0	0	17 6	12.6.58	31.12.60
40656	Bounds, R., Yarragon ..	Narracan ..	Warragul ..	North of 6, section 15A (Township of Yarragon)	1 0 0	1	0 0	8.7.58	31.12.60
40657	Forte, S., Hill End ..	Narracan ..	Neerim East	North of 37A, section A1	4 2 0	0	18 0	30.7.58	31.12.60
40658	Harrison, C., Woodside ..	Alberton ..	Woodside (Township)	North of section 1 ..	3 0 0	0	15 0	30.9.58	31.12.60
40659	Henderson, D. G., Healesville	Healesville	Tarrawarra	East of 47E (southern part)	0 2 0	1	0 0	19.9.58	31.12.61
40660	Humphries, N. I., Birregurra	Colac ..	Birregurra ..	West of 1, 2, section T	0 2 0	1	0 0	19.9.58	31.12.61
40661	Ferres, H., Emerald ..	Fern Tree Gully	Narree Worrان	North of 25, section A (east part)	1 3 0	1	15 0	10.9.58	31.12.61
40662	Teal, W. H., Camperdown	Camperdown	Colongulac	South of 8, section 13B	0 1 25	2	0 0	16.10.58	31.12.61
40663	Deamond, J. D., Camperdown	Camperdown	Colongulac	East of 5, 6, 7, 8, 9, 10, section 13A	1 1 0	2	10 0	27.10.58	31.12.60
40666	Downton, E., Yarragon ..	Narracan ..	Warragul ..	North of 5 and north-west of 6, section 15A	1 0 0	1	0 0	24.10.58	31.12.60
40667	Gardiner, W. A., Modella	Cranbourne	Yannathan	West of 59, south of 59 (part)	6 2 0	3	12 3	31.10.58	31.12.60
40668	Lawless, W. M. and R. E., Drouin East	Buln Buln	Drouin West	Between 33 and 36 (western half)	1 0 0	1	0 0	5.11.58	31.12.60
40669	Bloye, W. J., Drouin ..	Buln Buln	Drouin West	Between 33 and 36 (eastern half)	1 0 0	1	0 0	6.11.58	31.12.60
40670	Frana, L., 245 Moreland-road, Coburg	Upper Yarra	Brimbonga	North of 6 ..	7 2 0	1	0 0	15.11.58	31.12.60
40671	Meyer, J. W., Fish Creek	South Gippsland	Doomburrim	Between 35A and 90B	3 3 0	1	17 6	25.11.58	31.12.61
40672	Hoban, M., Wonthaggi ..	Wonthaggi	Kirrak ..	North and west of 61A, north of 61 (part), and east of 61 (part)	21 0 0	1	1 0	26.11.58	31.12.61
40673	Lyons, L. R., 18 Peter-street, Cobden	Heytesbury	Jancourt ..	South of 44A and north of 44B	3 0 0	1	0 0	3.12.58	31.12.61

LICENCES TO OCCUPY UNUSED ROADS—continued.

Number of Licence.	Name and Address of Licensee.	Municipality.	Parish.	Abutting— Allotments and Sections.	Area.	Fee for Licence.	Date of Issue of Licence.	Date of Expiry of Licence.
					A. R. P.	£ s. d.		
40674	Yarragon Dairy Co. Pty. Ltd., Yarragon	Warragul ..	Darnum ..	North of 49 ..	7 0 0	1 15 0	3.12.58	31.12.60
40675	Morris, E. J., Cobden ..	Heytesbury	Tandaroo	West of 62A and 62B ..	4 0 0	4 0 0	3.12.58	31.12.61
40676	Atherton, W. G., Kilcunda	Bass ..	Woolamai	Between 14 and 8 and part 7	12 0 0	6 0 0	16.12.58	31.12.61
40677	Maslen, C. F., Neerim (South)	Buln Buln	Neerim ..	Between 40 and 52 ..	0 3 0	0 0 0	18.12.58	31.12.61
40678	Falkon, D. E., Iona, via Bunyip	Berwick ..	Koo-Wee-Rup E.	South of 112 and 113, section O	1 0 0	1 0 0	23.12.58	31.12.60
40679	Thatcher, R. H., Athlone	Buln Buln	Longwarry	North of 122 ..	4 1 0	1 1 3	23.12.58	31.12.61
40680	Wormald, E. J., Garvoc	Hampden	Garvoc (Township)	East of 44, 45, 46, 47, 48, 49 and 50	1 3 0	1 6 3	6.1.59	31.12.61
40681	Daniel, J. C., Dumbalk	Woorayl ..	Neerena ..	Between 1c and 1b ..	2 1 0	1 16 0	6.1.59	31.12.61
40682	Reilly, D. T., Jancourt (East)	Heytesbury	Jancourt ..	Between 44B and 47B	4 0 0	3 0 0	22.1.59	31.12.61
40683	Gregg, D. N., South Gippsland	Korumburra	Poowong ..	West of 10 (southern portion)	3 1 0	1 19 0	29.1.59	31.12.61
40684	Slater, R. M., Cora Lynn	Berwick ..	Koo-Wee-Rup T	Between 5 and 6, section T	2 1 0	1 2 6	30.1.59	31.12.61
40685	MacDonald, G., Pakenham (East)	Berwick ..	Nar-Nar-Goon	West of 13 ..	2 1 0	1 0 0	30.1.59	31.12.61
40686	Alkemade, I. W. and R. P., Coimadai	Bacchus Marsh	Merrimu ..	North of 18 and east of 17A, section 22	4 3 0	1 5 0	30.1.59	31.12.61
40687	Slater, D. C., Elaine ..	Runinyong	Cargerie (Township)	South-east of 1 and 7, west of 6 and 7, section 2	0 3 0	1 0 0	30.1.59	31.12.61
40688	Avery, J. S., Port Albert	Alberton ..	Port Albert (Township)	East of 1 and 2, section 8	0 3 0	1 0 0	10.2.59	31.12.61
40689	Osbome, H. G. A., War-randyte	Eltham ..	Nillumbik	South-east of 25r, between 25D and 25c	1 3 0	2 12 6	27.2.59	31.12.61
40690	Hole, E. M., Winchelsea	Winchelsea	Mirnee ..	North of 52 and 53 ..	4 2 0	1 16 0	27.2.59	31.12.60
40691	Falk, A., 63 Holmes-road, Morwell	Morwell ..	Narracan S.	North of 87B ..	1 2 0	1 0 0	26.3.59	31.12.61
40692	Williamson, R. S., Won-thaggi	Bass ..	Wonthaggi	West of 23A ..	7 0 0	1 0 0	24.3.59	31.12.61
40693	Pascoe, F. G., South Morang	Whittlesea	Morang ..	North of A, B, C of 1A, section 11	2 1 0	1 0 0	14.4.59	31.12.61
40694	Munro, A. H., 35 Mont Albert-road, Canterbury	Berwick ..	Tonimbuk E.	North of 1, section B (western part)	2 3 0	1 7 6	8.4.59	31.12.61
40695	Gartner, P. E., 51 Fifth-street, Mentone	Bass ..	Corinella ..	Between 8 and 4, section C (Township of Grantville)	1 0 20	1 10 0	14.4.59	31.12.61
40696	Nash, A. A., Mortlake ..	Mortlake ..	Hoxham West	Between 1B, section 8 and 1A, 1B, 2A, 2B, section 12	8 0 0	2 8 0	5.5.59	31.12.61
40697	Down, E. G., Mortlake ..	Mortlake ..	Connawarren	Between 45 and 46 ..	2 0 0	1 0 0	6.5.59	31.12.61
40698	Cooke, G., Belgrave South	Fern Tree	Narree	Between 101 and 102	4 0 0	5 0 0	5.5.59	31.12.61
41351	Estate of o/o Messrs. Coulston, B., and M. Coulston, Tangambalanga	Yackandandah	Yackandandah	West of 19, section 7, west of part 16A, section 7	4 0 0	1 15 0	1.1.59	31.12.61
41352	Brennan, K., Winton (North)	Benalla ..	Mokoan ..	East of 56A ..	3 3 0	1 0 0	1.1.59	31.12.61
41353	Cavicchiolo, G. G. and G. Myrree	Oxley ..	Whitfield ..	Between 5 and 8 ..	2 0 0	1 0 0	1.1.59	31.12.61
41354	Clancy, John V., Kilmore	Kilmore ..	Bylands ..	East of 146 ..	3 0 0	4 10 0	1.1.59	31.12.61
41355	McFarlane, N., Clarke-street, Benalla West	Benalla ..	Benalla ..	West of 11 and 12, section U	2 2 0	2 2 6	1.1.58	31.12.60
41356	Nichol, N. K., Bethanga	Towong ..	Tatonga ..	Between 9A and 7, north of 2 and 3, section 16 west of 5, section 12	10 0 0	2 10 0	1.1.59	31.12.61
41357	Cooke, A. J., Morell's Hill, via Boolarra	Morwell ..	Budgerce ..	East of 21, section A, parish of Budgerce	5 0 0	2 0 0	1.1.59	31.12.61
41358	Baker, F. W., Marda Vale, Munro	Avon ..	Yeerung ..	South of 22A and east of southern part of 22, section 2	1 2 0	1 0 0	1.1.59	31.12.61
41359	Ekersley, J. T., Millbrook	Yea ..	Billian and Yea	Between 11 and 12, section C, parish of Billian, west of 215K, 215K2, 215N2, 215N, between 215N and 215N2, parish of Yea	36 0 0	6 14 0	1.1.58	31.12.60
41360	Worland, E., Euron ..	Euron ..	Brangjoe ..	Between 22 and eastern part of 20B, and Rail-way line	4 1 0	1 9 9	1.1.59	31.12.61
41361	Say, W., Box 2, Benalla ..	Benalla ..	Benalla ..	North of 27 and 29, section U	3 2 0	2 19 6	1.1.50	31.12.60
41362	Corker, J. R., Moyhu ..	Oxley ..	Moyhu ..	East of 1c and 2E and south of 2E, section 49	16 0 0	1 0 0	1.1.59	31.12.61
41363	Martin, W. A., "Illabonga", P. B., Benalla	Benalla ..	Rothesay ..	North of 12A, 13, 30A, 30B	10 0 0	3 3 0	1.1.59	31.12.61
41364	Romero, A. B., Chiltern	Chiltern ..	Township of Chiltern	North-east of 1 and 2, south-east of 2, 3, 4, 5, 6 and part 7, section P	2 0 0	3 10 0	1.1.59	31.12.61
41365	Beale, A. E., Motung ..	Tambo ..	Bumburrah	West of 15, 14, 13, section F, Township of Motung	0 3 0	1 0 0	1.1.59	31.12.61

LICENCES TO OCCUPY UNUSED ROADS—continued.

Number of Licence.	Name and address of Licensee.	Municipality.	Parish.	Abutting— Allotments and Sections.	Area.		Fee for Licence.		Date of Issue of Licence.	Date of Expiry of Licence.
					A. R. P.	£ s. d.	£	s. d.		
41366	Nielson, J. E., Munro ..	Avon ..	Yeerung and Merlieu	South of 22, between 21c and 21b, section 2, parish of Yeerung; N of 1, section 24, between 39, 39A, section 3, parish of Meerlieu	16 2 0	4 2 6	1.1.59	31.12.61		
41367	Redfern, J. W., "Merton Park", Merton	Mansfield ..	Merton ..	South of 10, 11 ..	8 2 0	2 3 0	1.1.59	31.12.61		
41368	Hearn, F., Mansfield ..	Mansfield ..	Dolatite ..	South of 71A, also north of 80A for a distance of 5 chains east from the north and south road through 80A	2 3 0	1 7 6	1.1.59	31.12.61		
41369	Elliott, W. B., P.O. Walwa	Towong ..	Walwa ..	East of 3A, south of 3 ..	7 3 0	1 0 0	1.1.59	31.12.61		
41370	Cummins, J. M., Boorolite, via Mansfield	Mansfield ..	Boorolite ..	South and west of 1B ..	6 0 0	3 2 6	1.1.59	31.12.61		

Department of Crown Lands and Survey,
Melbourne, 11th June, 1959.

KEITH TURNBULL,
Commissioner of Crown Lands and Survey.

DEPARTMENT OF MINES.

SUBJECT to any necessary excisions, &c., it is proposed to grant the following mining leases:—

- 7597, Mineral; Robert William McMaster, and Doreen McMaster; 5a. 2r. 33 p., Parish of Toora.
7603, Mineral; Thomas Edward Lightfoot; 18a. 2r. 17p., Parish of Kunat Kunat.
7754, Mineral; Estate of Joseph Blight, deceased; 5a. 1r. 10p., Parish of Harcourt.

APPLICATION FOR LEASE DECLARED ABANDONED.

- 7681, Mineral; Harold Hanrahan, and Frank Robert Yates; 75 acres, Parish of Piangil West.

MINING LEASE GRANTED.

- 9183, Castlemaine; Frank Edgar John Blake; 7a. 3r. 34p., Parish of Wombat.

CONSENTS GRANTED TO TRANSFER MINING LEASES.

- 7229, Mineral; from State Electricity Commission of Victoria to Mobile Quarries (Vic.) Pty. Ltd.
7240, Mineral; from State Electricity Commission of Victoria to Mobile Quarries (Vic.) Pty. Ltd.
7294, Mineral; from State Electricity Commission of Victoria to Mobile Quarries (Vic.) Pty. Ltd.

TAILINGS LICENCES GRANTED.

- 2928, Tailings Licence; James McDonald Richardson, Parishes of Moondarra and Numbruk.
2931, Tailings Licence; Alexander Clarence Smith, Parish of Moolpah.

MINERAL SEARCH LICENCE GRANTED.

- 195, Mineral Search Licence; Godfrey Jack Evans; 50 acres, Parish of Ellinging.

W. J. MIBUS,
Minister of Mines.

MINING LEASES DECLARED VOID.

- 9096, Ballarat; Ballarat South Goldfields N.L.; 305a. 1r. 0p., Parishes of Yarrowee and Buninyong.
9103, Ballarat; Ballarat South Goldfields N.L.; 861a. 2r. 22p., Parishes of Yarrowee and Buninyong.
7332, Mineral; Sunbeam Collieries Pty. Ltd.; 14a. 2r. 0p., Parish of Korumburra.
7380, Mineral; Cardiff Collieries Pty. Ltd.; 383a. 1r. 21p., Parish of Korumburra.

J. B. TILLEY,
Secretary for Mines.

Dairy Products Acts.

QUOTAS FOR BUTTER AND CHEESE.

BUTTER QUOTA.

I GILBERT LAWRENCE CHANDLER, Minister of Agriculture in the State of Victoria, after consultation with the Victorian Dairy Products Board, and after ascertaining that the supply and distribution of butter at reasonable prices to consumers thereof in Victoria will be ensured, hereby determine a quota for butter as follows:—

The proportion shall be Seventy-nine point one seven per cent.

The period for which this quota is to operate shall be the month of July, 1959.

CHEESE QUOTA.

I GILBERT LAWRENCE CHANDLER, Minister of Agriculture in the State of Victoria, after consultation with the Victorian Dairy Products Board, and after ascertaining that the supply and distribution of cheese at reasonable prices to consumers thereof in Victoria will be ensured, hereby determine a quota for cheese as follows:—

The proportion shall be Seventy-five per cent.

The period for which this quota is to operate shall be the month of July, 1959.

G. L. CHANDLER,
Minister of Agriculture.

22nd June, 1959.

WAHGUNYAH WATERWORKS TRUST.

RATING BY-LAW FOR THE YEAR 1959.

THE Wahgunyah Waterworks Trust, in pursuance and exercise of the powers conferred by the Water Acts, doth hereby make a rate for the supply of water for domestic purposes of Two shillings in the pound on the annual municipal valuation of lands and tenements liable to be rated within the Wahgunyah Urban District.

Provided that in no case shall the amount of rate payable per annum in respect of any tenement (other than land on which there is no building) be less than Eighty shillings, and in respect of any land on which there is no building less than Forty shillings.

Such rates are made and shall be levied upon the occupiers or owners of the said lands and tenements for the year commencing the 1st day of January, 1959, and shall be payable on the 25th day of June, 1959, at the office of the said Trust, Shire Hall, Rutherglen.

The maximum quantity of water to be supplied in any one year without further charge to any property rated by the Trust, is hereby fixed at the quantity which, at a charge of One shilling and six pence per 1,000 gallons, would produce an amount equal to the amount of the rate levied on such property for the said year.

The charge for water supplied by measure to any property rated by the Trust in excess of such maximum quantity, computed as in the last preceding clause, is hereby fixed at One shilling per 1,000 gallons.

The charge for water supplied by measure to any property not rated by the Trust, is hereby fixed at One shilling and six pence per 1,000 gallons, and the minimum quantity of water to be charged for in cases where water is so supplied is hereby fixed at 73,000 gallons.

The charge for water supplied by measure shall be payable, on demand, at the office of the Trust, Shire Hall, Rutherglen.

Passed this 13th day of May, 1959.

(SEAL) J. B. ELLIOTT, Chairman.
A. FORBES, Commissioner.
C. A. RICKETTS, Secretary.

Approved, 23rd June, 1959.—W. J. MIBUS, Minister of Water Supply.

FOSTER WATERWORKS TRUST. RATING BY-LAW 1959.

THE Foster Waterworks Trust, in pursuance and exercise of the powers conferred by the Water Acts, doth hereby make a rate for the supply of water for domestic purposes of One shilling and six pence in the pound on the annual municipal valuation of lands and tenements within the Foster Urban District.

Provided that in no case shall the amount payable per annum in respect of any tenement (other than land where there is no building) be less than Forty-two shillings and in respect of any land on which there is no building less than Fifteen shillings per annum.

Such rate is made for the year commencing the 1st day of January, 1959, and shall be payable on the 30th day of June, 1959, at the office of the said Trust.

The maximum quantity of water to be supplied in any one year without further charge to any property rated by the Trust, is hereby fixed at the quantity which, at the charge of One shilling and six pence per 1,000 gallons, would produce an amount equal to the amount of rate levied on such property for the said year.

The charge for water supplied by measure to any property rated by the Trust in excess of such maximum quantity, computed as in the last preceding clause, is hereby fixed at One shilling and six pence per 1,000 gallons.

The charge for water supplied by measure to any property not rated by the Trust, is hereby fixed at One shilling and six pence per 1,000 gallons, and the minimum quantity of water to be charged for in cases where water is so supplied is hereby fixed at 42,000 gallons.

The charge for water supplied by measure shall be payable, on demand, at the office of the Trust.

Passed at a meeting of the Trust held on the 12th day of June, 1959.

(SEAL) J. DAVIES, Commissioner.
H. L. PHILLIPS, Commissioner.
D. J. VAN DER BURGH, Secretary.

Approved, 23rd June, 1959.—W. J. MIBUS, Minister of Water Supply.

LANG LANG WATERWORKS TRUST.

RATING BY-LAW FOR THE YEAR 1ST JANUARY TO 31ST DECEMBER, 1959.

THE Lang Lang Waterworks Trust, in pursuance and exercise of the powers conferred by the Water Acts, doth hereby make a rate for the supply of water for domestic purposes of Three shillings and six pence in the pound of the annual municipal valuation of lands and tenements liable to be rated within the Lang Lang Urban District.

Provided that in no case shall the amount of rate payable per annum in respect of any tenement (other than land on which there is no building) be less than Seven pounds and in respect of any land on which there is no building less than Two pounds.

Such rates are made and shall be levied upon the occupiers or owners of the said lands and tenements for the year commencing the 1st day of January, 1959, and ending the 31st day of December, 1959, and shall be payable on the 6th day of July, 1959, at the office of the said Trust.

The maximum quantity of water to be supplied in any one year without further charge to any property rated by the Trust, is hereby fixed at the quantity which, at a charge of One shilling and six pence per 1,000 gallons, would produce an amount equal to the amount of the rate levied on such property for the said period.

The charge for water supplied by measure to any property rated by the Trust in excess of such maximum quantity, computed as in the last preceding clause, is hereby fixed at One shilling and six pence per 1,000 gallons.

The charge for water supplied by measure to any property not rated by the Trust, is hereby fixed at One shilling and six pence per 1,000 gallons, and the minimum quantity of water to be charged for in cases where water is so supplied is hereby fixed at 94,000 gallons.

The charge for water supplied by measure shall be payable on demand at the office of the Trust.

Passed this 27th day of May, 1959.

(SEAL) MAURICE SUPER, Chairman.
H. T. ROBOTHAM, Secretary.

Approved, 23rd June, 1959.—W. J. MIBUS, Minister of Water Supply.

NAGAMBIE WATERWORKS TRUST. AUTHORITY TO OBTAIN BANK OVERDRAFT.

HIS Excellency the Governor of the State of Victoria, by and with the advice of the Executive Council thereof, doth by Order made on the 17th day of June, 1959, authorize the Nagambie Waterworks Trust to obtain, in pursuance of the provisions of section 286 of the *Water Act 1958*, an advance or advances during the year 1959 from the Commercial Bank of Australia Limited, Nagambie, by overdraft of the Trust's current account thereat, such overdraft not to exceed at any one time the sum of Five hundred pounds (£500).

A. MAHLSTEDT,
Clerk of the Executive Council.

At the Executive Council Chamber,
Melbourne, 17th June, 1959.

KERANG SEWERAGE AUTHORITY. RATING BY-LAW FOR THE YEAR 1959.

THE Kerang Sewerage Authority, in pursuance and exercise of the powers conferred by the Sewerage Districts Acts, doth hereby make a sewerage rate of Two shillings and four pence in the pound on the annual municipal valuation of all sewered properties liable to be rated within the Kerang Sewerage District.

Provided that in no case shall the amount of rate payable per annum in respect of any tenement (other than land on which there is no building) be less than Five pounds, and in respect of land on which there is no building Two pounds.

Such rate is to be made and shall be levied upon the occupiers or owners of the said land and tenements for the year commencing on 1st day of January, 1959, and shall be payable on the 25th day of June, 1959, at the office of the said Authority.

The resolution for passing the foregoing By-law was agreed to by the Kerang Sewerage Authority on the 18th April, 1959, and was confirmed by the said Authority on the 4th May, 1959.

(SEAL) NEVILLE H. BISHOP, Member.
DAVID HAWTHORN, Member.
A. K. LYALL, Secretary.

Approved by the Governor in Council, 17th June, 1959.—
A. MAHLSTEDT, Clerk of the Executive Council.

DEPARTMENT OF CROWN LANDS AND SURVEY. MALLEE CLASSIFICATION BOARDS.—APPOINTMENTS AMENDED.

HIS Excellency the Governor of the State of Victoria, by and with the advice of the Executive Council thereof, doth by Order made on the 2nd June, 1959, amend the Order made on the 5th May, 1959, and published in the *Government Gazette* dated the 13th May, 1959, appointing Mallee Classification Boards, by the substitution of the name Allan Clarence Brown for that of Alan Charles Brown, wherever appearing in the said Order.

A. MAHLSTEDT,
Clerk of the Executive Council.

At the Executive Council Chamber,
Melbourne, 2nd June, 1959.

Transport Regulation Acts.
TRANSPORT REGULATION BOARD.

NOTICES OF PUBLIC HEARINGS.

NOTICE is hereby given that the applications made by the persons named below for licences to operate commercial passenger vehicles, on the route or routes or in the manner set out opposite their names, will be heard at a time and place to be communicated to the parties:—

Name and Address; Nature of Application.

- WALSII, M. F., 525 Burke-road, South Camberwell; 1 commercial passenger vehicle, with seating capacity for five persons, to operate as a country taxi-cab at Laverton.
- JENNINGS, I. F. & W. M., 22 Queens-avenue, St. Arnaud; 1 commercial passenger vehicle, to be purchased, with seating capacity for 33 persons, to operate as follows:—(a) As an additional stage omnibus, under the same terms and conditions as licence No. T.S.544, (b) as a special service omnibus, subject to all regulations appertaining to such operations and subject also to the condition that all journeys undertaken commence within a radius of ten (10) miles of St. Arnaud Post Office.
- THE QUEEN ELIZABETH HOME, 102 Ascot-street, Ballarat; application for renewal of licence No. T.P.60, expiring 21st July, 1959, to operate as required for the carriage of patients of the Queen Elizabeth Home free of charge and without reward throughout the State of Victoria.
- SAULTRY, W., 34 Dandenong-road, Oakleigh; application for renewal of licence No. T.P.89, expiring 31st July, 1959, to operate under contract to the Oakleigh Retarded Children's Centre for the carriage only of children attending the said centre, under the same terms and conditions.
- NORTH ESSENDON CHURCH OF CHRIST, 17 William-street, Essendon; application for renewal of licence No. T.P.15, expiring 9th July, 1959, to operate for the carriage of parishioners of the Church of Christ, under the same terms and conditions.

APPLICATIONS for renewal of licences by persons listed hereunder to operate under the same terms and conditions from the date of expiry:—

Name and Address; Licence No.; Classification; Expiry Date.

- CARGILL, M. W., 10 Dixon-street, Wonthaggi; C.O.626; country omnibus; 18th July, 1959.
- JOLLY, R. E., & J. W. DYKE, Traralgon; C.O.761; country omnibus; 1st September, 1959.
- LATROBE VALLEY BUS LINES, 1 Seymour-street, Traralgon; C.O.464, C.O.485, C.O.492, C.O.494, C.O.503, C.O.509; country omnibus; 8th February, 1959; C.O.29; country omnibus; 23rd August, 1959.
- PLYLE, T. J., Tawonga South; C.O.243; country omnibus; 20th September, 1959.
- WARRAGUL BUS LINES PTY. LTD., Queen-street, Warragul; C.O.866; country omnibus; 26th October, 1959.
- WATERTON, H. W., Jamieson-street, Daylesford; C.O.817; country omnibus; 14th September, 1959.
- BLACK, W. A., 35 Main-road, Korumburra; C.T.48; country taxi, Korumburra; 2nd November, 1959.
- BROOK, R. A., & K. R. MCBRIDE, 86 Graham-street, Wonthaggi; C.T.546; country taxi, Wonthaggi; 10th September, 1959.
- HOBBS, G. L., K. L., & M. D., 43 O'Callaghan-parade, Horsham; C.T.403, C.T.415; country taxi, Horsham; 1st October, 1959.
- LONGERAN, K. P., 2 Punt-road, Cobram; C.T.595; country taxi, Cobram; 6th October, 1959.
- MCBRIDE, K. R., 86 Graham-street, Wonthaggi; C.T.596; country taxi, Wonthaggi; 6th October, 1959.
- MCPHERSON, W. A., 43 Royal-avenue, Springvale; C.T.521; country taxi, Springvale; 3rd September, 1959.
- WATERTON, H. W., Jamieson-street, Daylesford; C.T.560; country taxi, Daylesford; 14th September, 1959.
- YOUNG, C. F. W., 24 Casella-street, Mitcham; C.T.524; country taxi, Mitcham; 3rd September, 1959.
- READ & BRACK PTY. LTD., 6 Nunn-street, Benalla; C.H.424; country hire, Benalla; 23rd October, 1959.
- STONE, C. T., Chute-street, Diamond Creek; C.H.384; country hire, Diamond Creek; 16th September, 1959.
- LEYSHAN, F. C. (trading as Heyfield Bus Service), Heyfield; T.S.51; school service; 2nd August, 1959.
- HALL, E. J., 5 Banool-street, East Preston; M.H.1424; metropolitan private hire; 8th August, 1959.
- HAINES, A. G., Lot 60, Florence-avenue, Clayton North; M.H.1620; metropolitan private hire; 2nd August, 1959.
- JONES, R. W., 22 Hall-street, McKinnon; M.H.1680; metropolitan private hire; 2nd August, 1959.

- WAKEFIELD, H. S., 2 Sallsbury-street, Elsternwick; M.H.2183; metropolitan private hire; 12th August, 1959.
- WOODS, R. S., 27 Avondale-street, Hampton; M.H.2182; metropolitan private hire; 12th August, 1959.
- BEAMISH, C. I. (Mrs.), 1 Acre-place, Malvern; M.T.518; metropolitan taxi-cab; 10th August, 1959.
- CUMMINS, M. R., 369 Kunyung-road, Mt. Eliza; M.T.1318; metropolitan taxi-cab; 2nd August, 1959.
- FRANKS, H. F., 11 Hoban-avenue, Montmorency; M.T.868; metropolitan taxi-cab; 28th August, 1959.
- NICHOLSON, E. B., 3 Greta-court, Lower Templestowe; M.T.1321; metropolitan taxi-cab; 8th August, 1959.
- ROSENFELD, R. J., 2A Garrell-street, Caulfield; M.T.876; metropolitan taxi-cab; 27th August, 1959.
- VENTURA MOTORS PTY. LTD., 17 Centre-road, South Oakleigh; C.O.560; country omnibus on Route 208A; 16th August, 1959.
- REAFER, R. R., 589 South-road, Moorabbin; 1 commercial passenger vehicle, with seating capacity for five persons, to operate for the carriage of trainers and owners attending country greyhound racing meetings and Melbourne and return. In addition, the vehicle will be required to haul a float containing dogs to the various country greyhound racing meetings and Melbourne and return.
- CURRER, C. (trading as Sandringham-Mentone Bus Lines), 379 Beach-road, Mentone; application for one commercial passenger vehicle, with seating capacity for 22 persons, to operate under the same terms and conditions as "C.O." licences already held in the name of the applicant.
- CURRER, C. (trading as Sandringham-Mentone Bus Lines), 379 Beach-road, Mentone; application for one commercial passenger vehicle, with seating capacity for 23 persons, to operate under the same terms and conditions as "C.O." licences already held in the name of the applicant.
- BRIDGES, J. A., & C. H. DUNN, 95 Shannon-street, Box Hill; application for one commercial passenger vehicle, with seating capacity for 29 persons, to operate as an additional metropolitan stage omnibus on Route 136A (Box Hill-Camberwell), under the same terms and conditions as licences already held in the name of the applicants.

- BELL STREET BUS CO. PTY. LTD., 324-326 Bell-street, Preston; application for one commercial passenger vehicle, to be purchased, to operate as an additional metropolitan stage omnibus on Route 6A (Westbreen-Pascoe Vale-Coburg-Heidelberg), under the same terms and conditions as licences already held in the name of the applicant company.
- VENTURA MOTORS PTY. LTD., 17 Centre-road, South Oakleigh; application for one commercial passenger vehicle, with seating capacity for 35 persons, to operate as an additional country stage omnibus on Route 208A (Box Hill-Mordialloc), under the same terms and conditions as licences already held in the name of the applicant company.
- MEMERY, H. V. & M., 962 Mount Alexander-road, Essendon; application for variation of Route 17A (Essendon) to extend service from the present terminus at the corner of Hoffmans-road and Buckley-street, via Buckley-street, to the corner of Colin-street. (Sections, fares, and time-tables to be determined.)
- MCCONNELL, A. R. & J. L. (trading as Yarraville-Kingsville Bus Service), 299 Somerville-road, Yarraville; application for permit authority to operate any one of "M.O." licensed vehicles for the carriage of pupils of the Corpus Christi School, situated Ormond-road, West Footscray (under contract to said school), from the corner of Drew and Roberts streets, Yarraville, thence via Adney, Stanger, Sanderson, and Roberts streets to school.

TIME-TABLE TO BE FOLLOWED.

School Days only.

Depart corner Drew and Roberts streets, Yarraville—8.30 a.m.

Depart school—3.40 p.m.

APPLICATIONS for metropolitan private hire car licences by the persons listed hereunder in respect of commercial passenger vehicles with seating capacity for five persons, to operate under composite conditions from an approved depot in zone set out opposite their names:—

Name and Address; Zone.

- DANIELS, R. T., 287 Rossmoyne-street, Thornbury; "G".
- PINKNEY, R. J., 40 Griffith-street, West Heidelberg; "G".
- MCDONALD, A. D., 73 Essex-road, Surrey Hills; "B".
- MCDONALD, A. D., 73 Essex-road, Surrey Hills; "H".

NOTICE is hereby given that the applications made by the persons named below for licences to operate the commercial goods vehicles, on the route or routes or in the manner set out opposite their names, will be heard at a time and place to be communicated to the persons concerned:—

Name and Address; Nature of Application.

- ALBION QUARRYING CO. PTY. LTD., corner of Arden and Laurens streets, North Melbourne; 1 commercial goods vehicle (7 cwt.) to operate throughout the State of Victoria in the course of business as "road contractors"—tools of trade and equipment incidental to own contracts.
- BAIRNSDALE BATTERY & ELECTROPLATING PTY. LTD., 32 McMillian-street, Bairnsdale; 1 commercial goods vehicle (6 cwt.) to operate within the Shires of Rosedale, Maffra, Avon, Bairnsdale, Omeo, Tambo, Orbost, and Traralgon in the course of business as "battery distributor"—batteries and auto electrical parts.
- BEAUFREPAIRE TYRE SERVICE PTY. LTD., 83-95 Franklin-street, Melbourne; 1 commercial goods vehicle (13 cwt.) to operate between the City of Melbourne and the Townships of Noojee, Foster, Morwell, and Wonthaggi in the course of licensee's business as "tire retreaders and distributors"—tires and tubes for sale and delivery, used tires for repair or retread or having been repaired or retreaded, batteries, oil, and car accessories.
- BELL, C. H., Rohs-road, Bendigo East; 1 commercial goods vehicle (120 cwt.) to operate—(a) within a radius of 25 miles of own works at Bendigo in course of business as "fertilizer manufacturers"—own goods, (b) within a radius of 100 miles of Bendigo for the collection of bones, offal, &c., from country abattoirs, slaughter-houses, &c.
- CARTER, F. A., 61 Market-street, Essendon; 1 commercial goods vehicle (6 cwt.) to operate throughout the State of Victoria in the course of business as "painter" under contract to the National Bank for the purpose of painting bank premises—tools of trade, ladders, and materials incidental to own contracts.
- C.I.G. (VICTORIA) PTY. LTD., 90 Bell-street, Preston; 1 commercial goods vehicle (99 cwt.) to operate—(a) within a radius of 25 miles of the G.P.O., Melbourne, for the carriage of liquid oxygen in bulk tankers, (b) between own plant at Preston and Geelong—liquid oxygen in bulk tankers.
- COLLINS, M. W., 481 Kottlott-street, Lavington, New South Wales; variation of licence No. D.A.34490 by the addition of the ability to operate from Rocla Pipes Limited at Bandiana to Mt. Beauty and points on Mount Bogong—reinforced concrete pipes.
- DAILY, J. E., Clyde-street, Myrtleford; variation of licence No. D.A.33037 by deleting paragraph (b) and adding in lieu the ability to operate within the Benalla Division of the Country Roads Board—road-contracting plant and equipment on behalf of the Country Roads Board.
- DIMOND, S. G., 21 Victoria-street, Boort; 1 commercial goods vehicle (117 cwt.) to operate—(a) within a radius of 20 miles of the post office at Boort—general goods, (b) within the Bendigo Division of the Country Roads Board—road-contracting plant and materials.
- DINSDALE, F. H., Station-street, Fern Tree Gully; 1 commercial goods vehicle (80 cwt. approximately) to operate—(a) within a radius of 20 miles of the post office at Fern Tree Gully—general goods, (b) within a radius of 70 miles of the City Brick Works Pty. Ltd. at East Hawthorn—bricks.
- FERGUSON, L., Government-road, Robinvale; 1 commercial goods vehicle (89 cwt.) to operate—(a) within a radius of 20 miles of the post office at Robinvale—general goods, (b) from Mildura to Robinvale—petroleum products and empty returns.
- HALL, G., 108 Separation-street, Northcote; 1 commercial goods vehicle (12 cwt.) to operate throughout the State of Victoria in course of trade as "petrol pump engineer" on behalf of Gilbert and Barker (Aust.) Pty. Ltd. for the purpose of servicing and installation of petrol pumps—tools of trade, and spare parts incidental to repair only.
- HESSE, H. M., 239-243 Lyttleton-terrace, Bendigo; 1 commercial goods vehicle (7 cwt.) to operate within a radius of 100 miles of the Bendigo Post Office, but excluding operations between Bendigo and Melbourne, in the course of business as "electrical contractor"—tools of trade, materials, and equipment incidental to own contracts.
- JENKIN, K. R., 16 Riley-street, South Oakleigh; 1 commercial goods vehicle (10 cwt.) to operate throughout the State of Victoria in the course of business as "electrical contractor"—tools of trade, electrical fittings, and materials incidental to own contracts.
- JESSUP, V. (M/s); 244 Ballarat-road, Footscray; 1 commercial goods vehicle (30 cwt.) to operate throughout the State of Victoria as a tow truck for the purpose of repairing or towing disabled or wrecked vehicles.
- KEYSTONE GENERAL ELECTRIC PTY. LTD., 2 Sussex-street, Coburg; 5 commercial goods vehicles (8, 10, 10, 12, and 10 cwt.) to operate throughout the State of Victoria for the installation and maintenance of petrol pumps, tanks and bowsers, garage equipment—tools of trade, equipment, and materials incidental to such installations and maintenance.
- LOUREY, J. F., 16 Shadforth-street, Terang; 1 commercial goods vehicle (8 cwt.) to operate throughout the State of Victoria in the course of business as "funeral directors".
- LUDEMAN, V. MCN., "Ravena", Nirranda; 1 commercial goods vehicle (111 cwt.) to operate—(a) within a radius of 20 miles of the post office at Nirranda—general goods, (b) from and to places in paragraph (a) above to and from places within a radius of 50 miles of Nirranda Post Office—livestock.
- LYNN, J. H., 39 Gladston-street, Orbost; variation of licence No. T.T.D.1854 by the addition of the ability to operate from the railway station at Dandenong to consignees within a radius of 25 miles of the G.P.O., Melbourne—sawn timber.
- MASSEY-FERGUSON (AUST.) LTD., 2 Devonshire-road, Sunshine; 3 commercial goods vehicles (8, 8, and 12 cwt.) to operate throughout the State of Victoria for the display, demonstration, and servicing of agricultural equipment—items for demonstration and display and tools of trade and spare parts incidental to servicing.
- McKENZIE, J. & D., PTY. LTD., 159 Sparks-road, Norlane; 1 commercial goods vehicle (149 cwt.) to operate within a radius of 50 miles of the Geelong Post Office in the course of business as "excavation-contractors"—tools of trade, equipment, and materials incidental to own contracts.
- McTIGHE, E. M., Princes Highway, Darnum; 1 commercial goods vehicle (79 cwt.) to operate throughout the State of Victoria as a tow truck for the purpose of repairing or towing disabled or wrecked vehicles.
- PRIMMER, T. L., 71 Koroit-street, Warrnambool; 1 commercial goods vehicle (90 cwt.) to operate throughout the State of Victoria in the course of business as "marine dealer"—marine stores and old metals.
- SERVICE MASTER PTY. LTD., 14 Bangs-street, Prahran; 5 commercial goods vehicles (11, 14, 10, 12, and 10 cwt.) to operate throughout the State of Victoria for the installation and maintenance of petrol pumps, tanks and bowsers, garage equipment—tools of trade, equipment, and materials incidental to such installations and maintenance.
- SHELL CO. OF AUST. LTD., 163 William-street, Melbourne; 1 commercial goods vehicle (13 cwt.) to operate throughout the State of Victoria for the installation and maintenance of licensee's own petrol pumps, tanks, and bowsers—petrol pumps, tanks, bowsers, fittings, tools of trade, equipment, and materials incidental to such installations and maintenance.
- SMITH, H. H., 100 Duke-street, Castlemaine; 1 commercial goods vehicle (8 cwt.) to operate throughout the State of Victoria in the course of business as "pest exterminator"—tools of trade, chemicals, and equipment incidental to own contracts.
- SMITH'S, R. W. J., AUTO SERVICE, 221 Nepean Highway, Edithvale; 2 commercial goods vehicles (68 and 40 cwt.) to operate throughout the State of Victoria as a tow truck for the purpose of towing disabled or wrecked vehicles.
- SPICER, C. E., 2 Cross-street, West Geelong; 1 commercial goods vehicle (80 cwt.) to operate—(a) within a radius of 25 miles of the Geelong Post Office—general goods, (b) within the Geelong Division of the Country Roads Board—road-contracting plant and materials.
- STAFFORD, C., McCrae-street, Bacchus Marsh; 1 commercial goods vehicle (105 cwt.) to operate within a radius of 35 miles of the G.P.O., Melbourne—sand, screenings, earth, and filling.
- SUNRAYSLIA CARRIERS, Mildura; variation of licence No. D.A.34507 by the addition of the ability to operate throughout the State of Victoria as a specially-constructed house frame jinker—partly dismantled house and shed sections.
- SWALLOW'S BISCUITS PTY. LTD., 60 Stokes-street, Port Melbourne; 1 commercial goods vehicle (58 cwt.) to operate within a radius of 50 miles of own depot at Heyfield in the course of business as "biscuit manufacturers"—own biscuits and empty containers.

THERMAL TRADERS (VIC.) PTY. LTD., 55 Flemington-road, North Melbourne; 3 commercial goods vehicles (8 cwt. each) to operate throughout the State of Victoria in the course of business as "liquid gas suppliers" for the purpose of servicing and maintaining liquid gas cylinders—tools of trade and materials incidental to such work.

VINNICOMBE, J., Skipton; variation of licence No. D.A.2210/1 by the addition of the ability to operate from the City of Geelong direct to farms within a radius of 70 miles from the post office at Skipton—agricultural lime in bulk for spreading.

NOTICE is hereby given that the applications made by the persons named below for renewal of licences to operate the commercial goods vehicles, on the route or routes or in the manner set out opposite their names, will be heard at a time and place to be communicated to the persons concerned:—

Name and Address; Present Franchise; Licence No.; Date of Expiry.

BISHOP, E., 163 Swanston-street, Melbourne; 1 commercial goods vehicle (14 cwt.) to operate throughout the State of Victoria in the course of business as "herbalist"—medicines and herbs; D.A.11139/2; 17th September, 1959.

BULLER, A. E., 18 Queen-street, Mornington; 1 commercial goods vehicle (94 cwt.) to operate from and to places situate within the corporate limits of the City of Melbourne and within a distance of 8 miles beyond the limits thereof direct only via the route set out below and from places situate within the limits of the Townships of Mt. Eliza, Mornington, and Mt. Martha and to and from places situate on or most conveniently reached from the roads between Mt. Eliza and Mornington and Mornington and Mt. Martha—general goods. Route referred to: The Point Nepean Road between the City of Melbourne and the Township of Mornington, and thence via the coast road as far as Mt. Martha; D.A.35134/1; 1st September, 1959.

CALLANAN'S DRY CLEANERS, Colac; 1 commercial goods vehicle (10 cwt.) to operate—(a) in the course of business as "dry cleaners" for the carriage of garments to be dry cleaned or having been dry cleaned in the following areas:—(i) Within a radius of 20 miles from the post office at Colac, (ii) from and to the Township of Colac to and from depots at the Townships of Anglesea, Kennett River, Wye River, Apollo Bay, Deans Marsh, Birregurra, and Lorne, (iii) from and to the Township of Colac to and from the City of Melbourne for the carriage of own dry-cleaning machinery for repair and new machinery for installation on own premises; D.A.20999; 20th August, 1959.

COLAC AERATED WATER CO., 286-288 Murray-street, Colac; 1 commercial goods vehicle (85 cwt.) to operate within a radius of 60 miles from the post office at Colac in the course of business as "aerated water and cordial manufacturers"—licensee's aerated water, cordials, drinking straws, vinegar, and jelly crystals; D.A.864; 20th August, 1959.

HACKETT, T., 191 Raymond-street, Sale; 1 commercial goods vehicle (9 cwt.) to operate for the carriage of laundry, clothing, and garments for cleaning or having been cleaned in the course of business as "dry cleaner" only as set out hereunder:—(a) Within a radius of 20 miles from the place of business of the licence holder situate at Sale, (b) from and to the place of business of the aforesaid to and from the Townships of Bairnsdale and Lakes Entrance; D.A.1212/1; 29th August, 1959.

HAMMILL, J. F. & J. F., 46 Fitzroy-street, Sale; 1 commercial goods vehicle (160-cwt. low loader) to operate within a radius of 50 miles from the post office at Sale in the course of business as "clearers and dam sinkers"—own bulldozer and equipment; D.A.22121; 1st August, 1959.

HARDINGE BROS. PTY. LTD., 45-47 Dimboola-road, Horsham; 1 commercial goods vehicle (16 cwt.) to operate throughout the State of Victoria for the carriage of own goods in the course of business as "manufacturers of electric fences, communications radio and electronic appliances"—electric fences, tools and equipment incidental to the installation of such fences; D.A.1242; 1st September, 1959.

KOHLER, A. S., 61 Weybridge-street, Surrey Hills; 1 commercial goods vehicle (12 cwt.) to operate—(a) within a radius of 25 miles from the G.P.O., Melbourne, in the course of business as "refrigerator engineer"

for the purpose of installing and servicing refrigerators—refrigerators for installation, for repair or having been repaired, tools of trade, spare parts, and materials for use on own contracts, (b) throughout the State of Victoria in the course of business as "refrigeration engineer" for the purpose of servicing and repairing refrigerators—tools of trade, spare parts, and materials incidental for use on own contracts; D.A.22678; 27th June, 1959.

LARKIN, W. F., Upper Gundowring, via Wodonga; 1 commercial goods vehicle (40 cwt.) to operate—(a) between the Township of Upper Gundowring and the Township of Wodonga, via the Township of Huon—general goods, (b) between the Township of Upper Gundowring, and the Huon Railway Station—general goods; (c) within a radius of 10 miles from the post office at Upper Gundowring—general goods; D.A.1471; 12th August, 1959.

MELLINGTON, J. S., Box 206, Rainbow; 1 commercial goods vehicle (84 cwt.) to operate—(a) within a radius of 20 miles from the post office at Rainbow—general goods, (b) within a radius of 50 miles from the post office at Rainbow—road-contracting plant and materials; D.A.22480; 12th September, 1959.

MCLAREN, F. K., Woolsthorpe; 1 commercial goods vehicle (60 cwt.) to operate—(a) within a radius of 20 miles from the post office at Woolsthorpe—general goods; (b) from and to places situate within the radius as defined in paragraph (a) above to and from places situate within a radius of 50 miles of the aforesaid post office—livestock; D.A.1691; 6th August, 1959.

WHEAT, W. J., 153 Cumberland-road, Pascoe Vale; 1 commercial goods vehicle (66 cwt.) to operate throughout the State of Victoria in the course of business as "building renovator" for the carriage of building materials and tools of trade used in connexion with licensee's renovation and constructional projects under contract to the Public Works Department; D.A.2273; 17th September, 1959.

Notice of any objection should be forwarded to reach the Secretary of the Board not later than Wednesday, 8th July, 1959.

E. V. FIELD,
Secretary.

Exhibition Buildings, Rathdown-street, Carlton, N.3,
22nd June, 1959.

APPOINTMENT OF COMMITTEE OF MANAGEMENT OF MYERS CREEK SCENIC RESERVE.

WHEREAS by section 50 of the *Forests Act* 1958, it is provided that the Minister of Forests may, on the recommendation of the Forests Commission, appoint any number of persons not less than three to be a Committee of Management of any land forming part of any reserved forest, such land being a place of natural beauty or interest or a health resort, and may remove any such persons; Now therefore, I, Alexander John Fraser, Her Majesty's Minister of Forests for the State of Victoria, on the recommendation of the Forests Commission, do hereby appoint—

Cr. R. J. RICHARDS,
Cr. L. T. HARMSWORTH,
Cr. J. G. McVEA,
Cr. A. KAY,
Cr. R. COX,
Cr. R. J. GORMAN,

as members of the Committee of Management for a period of three years from the 1st July, 1959, of the land forming part of the reserved forest in the Parish of Tarrawarra North, County of Evelyn, described in the accompanying Schedule, and known as Myers Creek Scenic Reserve, such land being a place of natural beauty and interest.

SCHEDULE ABOVE REFERRED TO.

Parish of Tarrawarra North, County of Evelyn, 170 acres more or less, being the area shown by pink colour on plan marked A.56/1304 over 1.7.59 on file of correspondence No. 56/1304 of the Forests Department.

Dated at Melbourne, the 22nd day of June, 1959.

A. J. FRASER,
Minister of Forests.

CONTRACTS ACCEPTED.—(Series 1959-60.)**CEREALS.**

Requirements under Sub-Schedule No. 7 of Schedule No. 1 for the month of July, 1959, are to be purchased under agreement from the under-mentioned firms, at the rate per cwt. respectively indicated, viz., Robert Harper & Co., Ltd., Oatmeal—plain, 32s.; Peas—split—yellow, 66s.; Rice—dressed, 82s.; Rice—unpolished, 82s.; Tapioca—seed, 8d. per lb.; less 3 per cent., fourteen days, or 2½ per cent., 30 days. Parsons Pty. Ltd.; Oatmeal—flaked, 38s.; H. S. K. Ward Pty. Ltd., Barley—pearl, 35s. 3d.

W. H. RUTHERFORD, Secretary to the Tender Board.
22.6.59.

ORDERS IN COUNCIL.—(Series 1958-59.)**EDUCATION DEPARTMENT.**

4039. One only liquid limit apparatus, for Bendigo Technical College, £45 4s.; one only Proctor compaction apparatus, for Bendigo Technical College, £68 18s.—Watson Victor Ltd.

4040. One only 0-30 lb. indicating scales, for Bendigo Technical College, £119 3s. 6d.—Toledo-Berkel Pty. Ltd.

4041. One only John Heine bench folding machine, for Brighton Technical School, £138.—McPherson's Ltd.

4042. Sheetmetal tools, for Watsonia Technical School, £114 16s.—Precision Engineering Co. Pty. Ltd.

4043. Miscellaneous small tools, for Dandenong Technical School, £103 12s.—James Walker Pty. Ltd.

4044. Three multimeters, at £40 each, for Footscray Technical College, £120.—Siemens Edison Swan (Aust.) Pty. Ltd.

4045. One only cathode ray oscilloscope, for Footscray Technical College, £443 14s.; one only regulated power supply, for Footscray Technical College, £183 12s.—R. J. T. Payne Pty. Ltd.

4046. One only electric counter, for Footscray Technical College, £189.—Noyes Bros. Pty. Ltd.

4047. Twelve lead acid accumulators, at £17 10s. each, for Footscray Technical College, £210.—Clyde Batteries Pty. Ltd.

4048. One only docking saw, for Footscray Technical College, £180; one only portable router, for Footscray Technical College, £26 11s.—McPherson's Ltd.

4049. One only bench lathe (4½-in. Sheraton), for Stawell Technical School, £223.—Bennie Teare Ltd.

4050. One only wood-turning lathe, for Stawell Technical School, £107.—McPherson's Ltd.

4051. One only spot welder, for Stawell Technical School, £115.—E.M.F. Electric Co. Pty. Ltd.

Approved by the Governor in Council, 17th June, 1959.
—A. MAHLSTEDT, Clerk of the Executive Council.

PUBLIC WORKS.

4052. Ararat Mental Hospital, extension of telephone facilities, £2,585.—Standard Telephones and Cables Pty. Ltd. (W.116721).

4053. Dredge *Matthew Flinders*, work authorized, £589 3s. 5d.—Miller and Co. (Machinery) Pty. Ltd. (M.206374).

4054. Greythorn State School Committee, special grant authorized by Education Department as contribution towards the cost of erection of a canteen (M.208108).

4055. Geelong West Technical School, supply and delivery of two portable electric machines and four treadle machines, £291 16s.—Singer Sewing Machine Coy. (S.W.208948).

4056. Hamilton Research Station, supply of farm machinery, £251 4s.—British Farm Equipment Pty. Ltd. (S.W.214115).

4057. Hamilton Research Station, supply of farm machinery, £607 18s.—Connor, Shea and Co. Pty. Ltd. (S.W.214116).

4058. T.B. Wards, Mont Park Mental Hospital, supply of two (2) electric gravity-feed slicers, Model B.L.N., £326.—Brice Scale and Slicer Co. Pty. Ltd. (N.E.212730).

4059. Royal Park Mental Hospital, doctor's residence, supply and making and laying of Australian A1 Axminster body carpet, £256 3s. 2d.—W. P. Murison (M.206492).

4060. Royal Melbourne Technical College, supply of 90 single stackable chairs, £288.—Tierstack Seating Pty. Ltd. (M.214721).

4061. Royal Melbourne Technical College, supply of 108 "Tierstack" units, £2,399 10s.—Tierstack Seating Pty. Ltd. (M.214646).

4062. State School No. 849, Healesville, supply and installation of four (4) slow-combustion heaters, £360.—W. and D. Pitts and Son Pty. Ltd. (N.E.196055).

4063. "Turana", Children's Welfare Department, Royal Park, supply of 48 tubular steel beds, £372.—Arnbro Products.—(M.210117).

Approved by the Governor in Council, 11th June, 1959.
—A. MAHLSTEDT, Clerk of the Executive Council.

4064. Lighter *Derrimut*, docking and painting £324.—Hobson's Bay Dock and Engineering Co. Pty. Ltd. (M.205990).

4065. Geelong Gaol, supply and delivery of refrigeration equipment, £335.—B. & M. Refrigeration Pty. Ltd. (S.W.213191).

4066. "Hillside", Hostel, Children's Welfare Department, Wheeler's Hill, Glen Waverley, installation of new water service, £318.—S. O. Cochran. (S.E.214842.)

4067. Kew Mental Hospital (New Butcher's Cold Room), supply and installation of corkboard insulation, £379.—W. H. Brewer Pty. Ltd. (M.146959).

4068. Mont Park Mental Hospital, supply of two (2) electric food-slicing machines, £326.—Brice Scale and Slicer Co. Pty. Ltd. (N.E.211617).

4069. Pentridge Gaol, supply of one (1) brush and broom trimming machine, £300.—John Zevenboom & Co. Pty. Ltd. (N.214512).

4070. Public Works Department (Accounts Branch), supply of two (2) accounting machines, £2,493 2s. 6d.—Chartres (Victoria) Pty. Ltd. (M.10109).

4071. Sunshine Boys' Home, supply of one (1) electric stove and two (2) electric toasters, £279 4s. 6d.—E.G.A. (S. Cunningham) Pty. Ltd. (W.210902 "C").

4072. State School No. 1978, Branzholme, supply and erection of one (1) Plymouth P.8-3 type residence, £4,428 4s. 9d.—W. Phelan & Sons Pty. Ltd. (S.W.191279.)

4073. Explosives Lighter *Truganina*, certain work authorized by the Public Works Department, £811 14s. 7d.—Hobson's Bay Dock and Engineering Co. Pty. Ltd. (M.206478.)

Approved by the Governor in Council, 17th June, 1959.—
A. MAHLSTEDT, Clerk of the Executive Council.

STATE ELECTRICITY COMMISSION.

4074. The supply of 275 miles of aluminium conductor, to Specification No. 255/57-58, £41,818 15s.—British Insulated Callender's Cables (Aust.) Pty. Ltd.

4075. The supply and erection of two (2) self-propelling rail mounted hoppers, Morwell Open Cut, to Specification No. 181/58-59, £10,100 3s.—Gibson Battle (Melb.) Pty. Ltd.

4076. The hire and operation of tipper type motor trucks for construction work in Melbourne and metropolitan area for a period of two years, to Specification No. 258/58-59, at Schedule rates.—H. J. Neil.

4077. The supply of ready-mixed concrete to construction sites at Yallourn and Morwell for a period of twelve months, to Specification No. 246/58-59, at Schedule rates.—Ready Mixed Concrete (Vic.) Pty. Ltd.

4078. The supply of 22 kV. metal-clad switchgear for Brunswick and Malvern Terminal Stations, to Quotation No. 3810, £41,915.—A. Reyrolle & Co. Ltd. (care of Wm. Begg & Sons Pty. Ltd.).

4079. The supply and installation of electrical plant for modernization of electrostatic precipitators for boilers at Newport Power Station, to Quotation Nos 532 and 1,003, £24,979.—Sturtevant Engineering (A'asia.) Ltd. (care of Geo. W. T. Hall Pty. Ltd.).

4080. The supply of two diesel crawler tractors and two hydraulically operated angle dozers, to Specification No. 273/58-59, £31,002.—William Adams Tractors Pty. Ltd.

4081. The supply of sensitized papers for printing of maps and plans for a period of two years, to Specification No. 230 (A)/58-59, at Schedule rates.—Austral Sensitizing Co. Pty. Ltd.

4082. The supply of sensitized papers for printing of maps and plans, for a period of two years, to Specification No. 230 (A)/58-59, at Schedule rates.—Harding & Halden Pty. Ltd.

4083. The supply of sensitized papers for printing of maps and plans, for a period of two years, to Specification No. 230 (A)/58-59, at Schedule rates.—Harston Sensitizing Co. Pty. Ltd.

4084. The supply of sensitized papers for printing of maps and plans, for a period of two years, to Specification No. 230 (A)/58-59, at Schedule rates.—Max Wurcker (1930) Pty. Ltd.

4085. The supply of sensitized papers for printing of maps and plans, for a period of two years, to Specification No. 230 (A)/58-59, at Schedule rates.—Ozapaper Ltd.

4086. The supply of sensitized papers for printing of maps and plans, for a period of two years, to Specification No. 230 (A)/58-59, at Schedule rates.—Sensitizers Pty. Ltd.

4087. The supply of creosote oil for the protection of wooden poles, for a period of two years, to Specification No. 253/58-59, at Schedule rates.—Duratar Pty. Ltd.

4088. The supply of creosote oil for the protection of wooden poles, for a period of two years, to Specification No. 253/58-59, at Schedule rates.—James Forbes (Tar Distillers) Pty. Ltd.

4089. The supply of ready-mixed concrete for construction sites in Melbourne, metropolitan and Geelong areas, for a period of two years, to Specification No. 260/58-59, at Schedule rates.—Ready Mixed Concrete (Vic.) Pty. Ltd.

4090. The supply of ready-mixed concrete for construction sites in Melbourne and metropolitan areas, for a period of two years, to Specification No. 260/58-59, at Schedule rates.—Specified Concrete (Vic.) Pty. Ltd.

Approved by the Governor in Council, 2nd June, 1959.—
A. MAHLSTEDT, Clerk of the Executive Council.

Cemeteries Act 1958 (No. 6217).

SCALE OF FEES OF THE PRESTON GENERAL CEMETERY.

IN pursuance of the powers conferred upon them by the Cemeteries Acts, the Trustees of the Preston General Cemetery hereby make the following scale of fees, which shall come into operation upon publication in the *Government Gazette*, and from and after such publication every scale of fees heretofore made by the said Trustees shall be and is hereby rescinded:—

Land for Private Graves.

	£	s.	d.
8 ft. x 4 ft., selected by Trustees	12	12	0
8 ft. x 4 ft., facing footpath or specially selected by Trustees	15	0	0
8 ft. x 4 ft., specially selected by Trustees on carriage-way	21	0	0
8 ft. x 8 ft., specially selected corner blocks	35	0	0

Public Graves.

Interment in grave without exclusive right	3	3	0
Interment in grave without exclusive right, child under seven years	1	0	0
Interment in grave without exclusive right, stillborn	15	0	0

Sinking Private Graves.

7 feet deep	10	0	0
8 feet deep	11	10	0
9 feet deep	13	0	0
10 feet deep	15	0	0
Re-opening grave (no cover)	8	10	0
Re-opening (with cover)	10	0	0
Grave 2 ft. 3 in. at the shoulder, extra	1	0	0
Grave 2 ft. 3 in. at the shoulder, and 7 feet long, extra	1	10	0
Cancellation of order to sink (if commenced)	1	1	0

Miscellaneous Charges.

Inspecting plan or register	5	0	0
Insufficient notice for sinking grave 7 feet deep, extra	2	2	0
Insufficient notice for sinking grave over 7 feet deep, extra	3	3	0
Interment on Saturday morning, extra	4	10	0
Interment on Saturday afternoon, extra	6	10	0
Interment on Sunday (when permitted), extra	6	10	0
Interment on a public holiday and Cemetery Employees' picnic day, extra	6	10	0
Interment of ashes	2	0	0
Permission to construct a brick grave	2	0	0
Search of records	10	6	0
Certificate of right of burial	5	0	0
Number plate or brick	7	6	0
Annual maintenance (single grave)	2	2	0
Annual maintenance (double grave)	3	3	0
Maintenance in perpetuity—per grave	75	0	0
Late fee (per half hour or part thereof in excess of first fifteen minutes)	1	1	0
Fees for exhumation, when authorized	12	0	0
Fees for erection of monument, headstones, kerbings (plus 2½ per cent. on cost over £25)	2	2	0
Any work carried out after original job completed—5 per cent. of value.			
Construction of concrete footpath in front of grave site, extra	2	2	0

A. H. CAPP, Chairman.
B. T. CONNOR, Trustee.
W. McDONALD, Trustee.
K. RIDDLE, Secretary.

Approved by the Governor in Council,
17th June, 1959.

A. MAHLSTEDT,
Clerk of the Executive Council.

TAMBO RIVER IMPROVEMENT TRUST.

BY-LAW No. 5.

THE Tambo River Improvement Trust, in pursuance and exercise of the powers conferred by the *River Improvement Act 1958* doth hereby make the By-law following:—

1. The following rate to be called the "Tambo River Improvement District River Improvement Rate" is hereby made and shall be levied upon the occupiers or owners of all properties within the Tambo River Improvement District which are rateable to any municipality.

A rate of Three pence in the pound on the net annual value of all those properties within the First Division, as determined by the Order in Council made on the 12th day of August, 1958, and published in the *Government Gazette* on the 13th day of August, 1958.

A rate of Nine pence in the pound on the net annual value of all those properties within the Second Division, as determined by the said Order in Council.

A rate of Eighteen pence in the pound on the net annual value of all those properties within the Third Division, as determined by the said Order in Council.

A rate of Twenty-eight pence in the pound on the net annual value of all those properties within the Fourth Division, as determined by the said Order in Council.

A rate of Thirty-eight pence in the pound on the net annual value of all those properties within the Fifth Division, as determined by the said Order in Council.

A rate of Fifty-three pence in the pound on the net annual value of all those properties within the Sixth Division, as determined by the said Order in Council.

A rate of Sixty-six pence in the pound on the net annual value of all those properties within the Seventh Division, as determined by the said Order in Council.

A rate of One hundred and twenty-five pence in the pound on the net annual value of all those properties within the Eighth Division, as determined by the said Order in Council.

A rate of Three hundred and eleven pence in the pound on the net annual value of all those properties within the Ninth Division, as determined by the said Order in Council.

2. Such rates are made and shall be levied for the period beginning with the 1st day of January, 1959, and ending with the 31st day of December, 1959, and shall be payable on the 26th day of June, 1959, at the office of the Tambo River Improvement Trust, Bruthen.

3. Such person or persons as the Tambo River Improvement Trust may from time to time appoint for that purpose shall be and is or are hereby authorized to demand, receive, collect, and recover the said rate.

The foregoing By-law was made by the Tambo River Improvement Trust on the 25th day of May, 1959, and the common seal of the Trust was hereunto affixed on the 25th day of May, 1959, in the presence of—

(SEAL) J. A. NEAL, Chairman.
R. T. REDENBACH, Commissioner.
G. W. RIDSDALE, Secretary.

Approved by the Governor in Council, 17th June, 1959.—
A. MAHLSTEDT, Clerk of the Executive Council.

NOTICE.

ADMINISTRATION of the estate of each of the under-mentioned deceased persons has been granted to the Public Trustee, and creditors, next of kin, and all others having claims against the estate of any of the persons so mentioned are required to send particulars of their claims to the Public Trustee, 7th Floor, 601 Little Collins-street, Melbourne, on or before the 27th August, 1959, or they will be excluded from the distribution of the estate when the assets are being distributed:—

*ARCHER, ARTHUR, formerly of 8 Gladstone-avenue, Spendale, but late of Middleborough-road, Blackburn, retired railway employee, died 22nd February, 1959.

*COLLIS, CHARLES, late of "Alexander", Castlemaine, pensioner, died 20th January, 1959, intestate.

*COMFORT, CLAIR VIOLET, formerly of 37 Godfrey-avenue, St. Kilda, but late of 2 Hopetoun-street, Elsternwick, widow, died 20th October, 1958.

*CROWE, HARRIET ANN, late of 34 Lysbeth-street, McKinnon, widow, died 5th February, 1959.

*DAY, JAMES HENRY, late of 4 Shepherd-street, Footscray, retired fitter, died 1st March, 1959.

DERDAU, GERHARD, late of State Electricity Commission Camp, Rocky Valley, via Bogong, labourer, died 13th January, 1959, intestate.

*EWERT, MAUDE ELIZABETH, late of 88 Were-street, Brighton Beach, widow, died 24th March, 1959.

*FLOWER, BERYL HASLEM, late of 567 Canterbury-road, Surrey Hills, widow, died 10th November, 1958.

*GILLARD, MAY PEARL ELLEN FRANCES, late of 1 Napier-street, Mentone, married woman, died 15th September, 1958.

*GROVES, GEORGE WILLIAM LESLIE, also known as George William Groves, late of 16 Millers-road, Altona, railway foreman, died 12th January, 1959.

*HENRY, ELSIE ELIZABETH, late of 19 Junction-street, Newport, retired librarian, died 31st January, 1959.

JONES, CHARLES HENRY, late of 216 Hotham-street, Elsternwick, pensioner, died 25th February, 1959, intestate.

NORSTER, EVA EMMA, late of Mont Park, pensioner, died 5th February, 1959, intestate.

† REED, GEORGE ROBERT, late of 69 Roseneath-street, Clifton Hill, retired engine driver, died 11th April, 1959.

*ROSENBROCK, JAMES HENRY, late of 23 Rathmines-street, Fairfield, retired miner, died 20th January, 1959.

*TELFER, KEITH, late of 5 Ward-grove, Pascoe Vale South, senior clerk, died 24th December, 1958.

TONIATO, BRUNO, late of 56 Miller-street, North Fitzroy, labourer, died 2nd December, 1958, intestate.

WORLAND, EDGAR JOHN, late of Baxter, retired farmer, died 18th September, 1958, intestate.

* With the Will annexed.

† According to the provisions of the Will

A. D. DUNCAN,
Public Trustee.

Melbourne, 17th June, 1959.

4 GEORGE VI. No. 4755, SECTION 6.

I HEREBY give notice that on the 4th June, 1959, the Public Trustee filed an election to administer the following deceased person's estate, in accordance with section 6 of the *Public Trustee Act 1940*:—

DERDAU, GERHARD, late of State Electricity Commission Camp, Rocky Valley, via Bogong, labourer, died 13th January, 1959, intestate.

I HEREBY give notice that on the 8th June, 1959, the Public Trustee filed elections to administer the following deceased persons' estates, in accordance with section 6 of the *Public Trustee Act 1940*:—

JONES, CHARLES HENRY, late of 216 Hotham-street, Elsternwick, pensioner, died 25th February, 1959, intestate.

NORSTER, EVA EMMA, late of Mont Park, pensioner, died 5th February, 1959, intestate.

* REED, GEORGE ROBERT, late of 69 Roseneath-street, Clifton Hill, retired engine driver, died 11th April, 1959.

TONIATO, BRUNO, late of 56 Miller-street, North Fitzroy, labourer, died 2nd December, 1958, intestate.

WORLAND, EDGAR JOHN, late of Baxter, retired farmer, died 18th September, 1958, intestate.

* According to the provisions of the Will.

I HEREBY give notice that on the 9th June, 1959, the Public Trustee filed an election to administer the following deceased person's estate, in accordance with section 6 of the *Public Trustee Act 1940*:—

COLLIS, CHARLES, late of "Alexander", Castlemaine, pensioner, died 20th January, 1959, intestate.

A. D. DUNCAN,
Public Trustee.

601 Little Collins-street, Melbourne, C.1, 17th June, 1959.

LAW DEPARTMENT.

SUPREME COURT, BENDIGO.—ALTERATION OF DAY.

HIS Excellency the Governor of the State of Victoria, by and with the advice of the Executive Council thereof, doth by Order made on the 17th day of June, 1959, appoint Monday, the 20th day of July, 1959, a day for the sittings of the Supreme Court at Bendigo in lieu of Monday, the 27th day of July, 1959, heretofore appointed.

A. MAHLSTEDT,
Clerk of the Executive Council.

At the Executive Council Chamber,
Melbourne, 17th June, 1959.

LAW DEPARTMENT.

SUPREME COURT, MELBOURNE.—ALTERATION OF DAY.

HIS Excellency the Governor of the State of Victoria, by and with the advice of the Executive Council thereof, doth by Order made on the 17th day of June, 1959, appoint Monday, the 20th day of July, 1959, a day for the sittings of the Supreme Court in its Criminal jurisdiction at Melbourne, in lieu of Monday, the 27th day of July, 1959, heretofore appointed.

A. MAHLSTEDT,
Clerk of the Executive Council.

At the Executive Council Chamber,
Melbourne, 17th June, 1959.

Police Regulation Act 1958.

POLICE FORCE, VICTORIA.

DETERMINATION No. 75 OF THE POLICE CLASSIFICATION BOARD.

THE Police Classification Board, in pursuance of the powers in that behalf conferred by the *Police Regulation Act 1958*, hereby makes the following Determination, that is to say:—

1. The Determination No. 59 of the Police Classification Board of the 23rd July, 1956, and published in the *Government Gazette* of the 21st August, 1956, as amended, is hereby further amended as follows:—

(a) By deleting sub-paragraphs (a), (b) and (c) of paragraph 7 and substituting therefor the following:—

“(a) OFFICERS.

Rank.	Salary per Annum.
	£
Inspecting Superintendent	2,729
Superintendent, Grade I.	2,251
Superintendent, Grade II.	2,001
Chief Inspector	1,781
Inspector	1,666
Station Officer	1,504

(b) SUB-OFFICERS.

Rank.	Salary per Annum.
	£
Sergeant	1,342
Senior Constable	1,214

(c) FIRST CONSTABLES AND CONSTABLES.

<i>Rank.</i>	<i>Salary per Annum.</i>
	£
First Constable—	
During twelfth year of service and after	1,155
During eleventh, tenth, ninth, eighth, and seventh years of service	1,134
During sixth and fifth years of service	1,129
During fourth and third years of service	1,123
During second and first years of service	1,112
Constable—	
During seventh year of service and after	1,038
During sixth year of service	1,028
During fifth year of service	1,018
During fourth year of service	1,008
During third year of service	998
During second year of service	973
During first year of service	963."

(b) By deleting paragraph 8 and substituting therefor the following:—

"8. The salaries to be paid to members designated in this paragraph shall be in accordance with the following scale:—

SCALE OF ANNUAL SALARIES.

Junior Police Trainees.

<i>Age.</i>	<i>Salary per Annum.</i>	
	<i>(If Single)</i>	<i>(If Married)</i>
	£	£
At sixteen years	428	673
At seventeen years	503	699
At eighteen years	591	738."

(c) By deleting paragraph 76A and substituting therefor the following:—

"76A (1). A member, whilst attending a Training Course at the Police College, shall be entitled—

- (a) whilst residing at the College, to an allowance of 18s. per day by way of reimbursement of the cost of his maintenance;
- (b) whilst not in residence at the College but partaking of one or more meals there, to an allowance by way of reimbursement for

	<i>s.</i>	<i>d.</i>
(i) breakfast	4	0;
(ii) lunch	6	6;
(iii) dinner	7	6;

- (c) to an allowance of 4s. per day for incidental expenses for each day he is actually in attendance at the College.

(2) Any allowance hereunder shall be reviewed from time to time and varied by the Board as it thinks fit."

2. This Determination shall come into operation on the 14th day of June, 1959.

Dated at Melbourne this 16th day of June, 1959.

J. F. MULVANY,
A Judge of the County Court of Victoria,
Chairman and Member of the Police
Classification Board.

D. S. RAMAGE,
Member of the Police Classification Board.

F. G. HOLLAND,
Member of the Police Classification Board.

APPOINTMENTS.

HIS Excellency the Governor of the State of Victoria, by and with the advice of the Executive Council thereof, has, by Orders made on the 17th day of June, 1959, been pleased to make the under-mentioned appointments, viz.:—

DEPARTMENT OF CROWN LANDS AND SURVEY.

Bailiffs of Crown Land.

MAXWELL CRICHTON DOWNES, of 605 Flinders-street Extension, Melbourne, and
ROBERT HENRY AUSTIN, of Port Welshpool, to be Bailiffs of Crown land, without additional salary.

Trustee of Site.

WALTER OSWALD BURT to be a Trustee of the Site in the City of Melbourne, Parish of North Melbourne, for a Picture Gallery for holding the Art Exhibitions of the Victorian Artists' Society and for the study of Fine Arts, in the place of Ralph Malcolm Warner, resigned.

DEPARTMENT OF HEALTH.

Deputy Superintendent of Receiving House.

GEORGE CAMPBELL YOUNG, M.R.C.S., L.R.C.P., D.P.M., to be Deputy Superintendent of the Receiving House, Royal Park, pursuant to the provisions of section 45 of the *Mental Hygiene Act 1958*, as from the 18th May, 1959, *vice* Dr. R. R. Webb, transferred.

Government Representative on Hospital Committee.

JOHN CHARLES WHITELAW to be Government Representative on the Committee of Management of Portland District Hospital, pursuant to the provisions of section 48 of the *Hospitals and Charities Act 1958*, for a term of three years, *vice* D. Parker, resigned.

Member of Masseurs' Registration Board.

PATRICIA COSH to be a Member of the Masseurs' Registration Board of Victoria, pursuant to the provisions of section 4 (3) (b) of the *Masseurs Act 1958*, for the period ending on the 30th June, 1960.

Trustees of Cemeteries.

JOHN KENNETH EADES to be a Trustee of the Pyalong Public Cemetery;
MOSS JOHN DAVIS to be a Trustee of the Melbourne General Cemetery, *vice* C. J. Perlstein, deceased;
WILLIAM JOHN CLAGUE and ROBERT JAMES MCKENZIE to be Trustees of the Mortlake Public Cemetery;
JAMES FINN KIRBY to be a Trustee of the Harrow Public Cemetery, *vice* E. P. Kirby, deceased;
JOHN FEARNLEY MUIR to be a Trustee of the Ballangeich Public Cemetery, *vice* A. C. Patison, deceased;
GERALD STANISLAUS BYRNE to be a Trustee of the Terrapsee Public Cemetery, *vice* G. Byrne, deceased;
LEWIS THOMAS to be a Trustee of the Terrapsee Public Cemetery, *vice* Lewis Thom;
NEIL STANLEY NIXON and KEITH HOLMES to be Trustees of the Boort Public Cemetery;
JOHN RUSSELL MALONE to be a Trustee of the Boort Public Cemetery, *vice* S. J. Dunstan, retired;
JOHN STRAHAN to be a Trustee of the Boort Public Cemetery;
ROBERT HENRY WEBB to be a Trustee of the Boort Public Cemetery, *vice* J. Embry, retired;
ALAN STREADER and IVAN STREADER to be Trustees of the Boort Public Cemetery;
STANLEY JAMES DIFFEY to be a Trustee of the Tarrawingee Public Cemetery, *vice* D. A. Diffey, deceased;
KEITH ALEXANDER HOWES to be a Trustee of the Mount Egerton Public Cemetery, *vice* W. Hopwood, retired;

EDWIN CLIFFORD WATKINS and HERBERT GEORGE WOLTER to be Trustees of the Leopold Public Cemetery.

Public Vaccinators.

MARGARET WILKINSON AIKIN, M.B., B.S., to be a Public Vaccinator, City of Prahran;
VICTOR DONALD PIPPETT, M.B., B.Ch., D.R.C.O.G., to be a Public Vaccinator, Myrtleford Riding of Shire of Bright; and
PRISCILLA SHEATH KINCAID-SMITH, M.B., B.Ch., D.C.P., M.R.C.P., to be a Public Vaccinator, City of Essendon.

LAW DEPARTMENT.

Acting Master of the Supreme Court.

ERIC SMITH VANCE, Barrister at Law of Victoria, to be Acting Master of the Supreme Court of Victoria, under the provisions of the Supreme Court Act, during the absence of E. H. Coghill on special leave, to take effect from the 13th July, 1959, to the 23rd July, 1959, both dates inclusive.

Justices of the Peace.

LENNERT MAX WEGENER, Western Highway, Bungaree, to Keep the Peace in the Southern Bailiwick of the State of Victoria;
GUSTAV EDWIN DALITZ, Dimboola-road, Nhill, and LESLIE ROBERT ERWIN, 43 Seaby-street, Stawell, to Keep the Peace in the Western Bailiwick of the State of Victoria;
CHARLES HENRY MENZ, 16th-street, Hepburn, ARNOLD FRASER CADDY, Kotta, and FREDERICK HARRIS OLDFIELD, Myers-street, Bendigo, to Keep the Peace in the Midland Bailiwick of the State of Victoria; and
WILLIAM DOWNIE, "Turana" Boys' Home, Park-street, West Brunswick, and RAFFAËLE NARDELLA, 202 Hope-street, West Brunswick, to Keep the Peace in the Central Bailiwick of the State of Victoria.

Commissioners for Taking Declarations, &c.

FRANCIS GERARD KEATING, c/o Glen Waverley Co-operative Housing Society Limited, 379 Collins-street, Melbourne,
MAXWELL DAVID JAMES ELLIS, 7 McDonald-avenue, Ivanhoe,
ARTHUR THOMAS JAMES ROBERTS, c/o R. E. Mustow, Lane Centre, 325 Flinders-lane, Melbourne,
LESLIE ARGYLE MCINTYRE, Main-street, Romsey,
FRANCIS JOSEPH HIGGINS, 198 Queensberry-street, North Melbourne,
FRANK JOSEPH CASSAR, Flat 9, Block 1, Solly-avenue, North Carlton,
JOHN MACCRAMMOND RICHARDSON-ELLIS, 8 Lucas-street, Brighton, and
RONALD MAURICE ELLIOTT, 12 Barilla-road, Moorabbin, to be Commissioners for taking Declarations and Affidavits, pursuant to the provisions of the *Evidence Act 1958*, to resign upon removing from the neighbourhood of the addresses stated;
LESLIE CHARLES ERREY and LEO BERNARD HOARE, Officers of the Motor Registration Branch, Exhibition Buildings, Rathdown-street, Carlton, to be Commissioners for taking Declarations and Affidavits, pursuant to the provisions of the *Evidence Act 1958*, to refrain from charging fees and to resign upon ceasing to be Officers of the Motor Registration Branch; and
ROBERT RONALD FARNES, Officer of Stewarts and Lloyds Pty. Ltd., 157-165 City-road, South Melbourne, to be a Commissioner for taking Declarations and Affidavits, pursuant to the provisions of the *Evidence Act 1958*, to resign upon ceasing to occupy his present position.

Sworn Valuator.

HERBERT THOMAS BOWDEN, 53 Rose-street, Essendon, to be a Sworn Valuator, pursuant to the provisions of the *Transfer of Land Act 1958*, for the Counties of Bourke, Evelyn, and Mornington.

A Properly Qualified Analyst.

GEOFFREY WILLIAM BARRELL, Consulting Chemist and Public Analyst, 3 Exchange-street, Ballarat, to be approved as a Properly Qualified Analyst for the purposes of section 408 of the *Crimes Act 1958*, to take effect from the date of commencement of duty.

PUBLIC WORKS DEPARTMENT.
Wharf Managers.

SENIOR CONSTABLE FRANK JAMES McCLINTOCK, No. 9276,
to be Wharf Manager at Rosebud, Rye, and Flinders, to carry out that portion of Part II. of the *Marine Act* 1958 which relates to the management of public wharfs, and to be an Officer under section 19 of such Act to levy and collect wharfage rates thereat, at a remuneration of £25 per annum, and that as on and from the 1st day of July, 1959, Order in Council of 30th September, 1958, as to locations and remunerations shall be deemed to be amended accordingly; and

SENIOR CONSTABLE DESMOND JOHN SUTTIE, No. 9566,
to be Wharf Manager at Dromana to carry out that portion of Part II. of the *Marine Act* 1958 which relates to the management of public wharfs, and to be an Officer under section 19 of such Act to levy and collect wharfage rates thereat, at a remuneration of £12 10s. per annum, and that as on and from the 1st day of July, 1959, Orders in Council of 30th September, 1958, as to locations and remuneration shall be deemed to be amended accordingly.

A. MAHLSTEDT,
Clerk of the Executive Council.

At the Executive Council Chamber,
Melbourne, 17th June, 1959.

RESIGNATIONS.

HIS Excellency the Governor of the State of Victoria, by and with the advice of the Executive Council thereof, has, by Orders made on the 17th day of June, 1959, accepted the resignations of the persons named hereunder of the offices mentioned, viz.:—

CHIEF SECRETARY'S DEPARTMENT.

ANNIE MAY BYRNE, as a Probation Officer, pursuant to the provisions of the *Children's Court Act* 1958, for the Children's Court at Bendigo.

LAW DEPARTMENT.

CHARLES MASON from the Commission of the Peace for the Western Bailiwick of the State of Victoria.
ALEC. HORACE ABBEY, as a Commissioner for taking Declarations and Affidavits, pursuant to the provisions of the *Evidence Act* 1958.
ARTHUR LUDWIG VANSELOW, as a Commissioner for taking Declarations and Affidavits, pursuant to the provisions of the *Evidence Act* 1958.

A. MAHLSTEDT,
Clerk of the Executive Council.

At the Executive Council Chamber,
Melbourne, 17th June, 1959.

DEPARTMENT OF CROWN LANDS AND SURVEY.

At the Executive Council Chamber, Melbourne, the seventeenth day of June, 1959.

PRESENT:

His Excellency the Governor of Victoria.
Sir Arthur Warner | Sir Thomas Maltby.

UNUSED ROADS CLOSED.

HIS Excellency the Governor of the State of Victoria, by and with the advice of the Executive Council thereof, doth hereby direct that, in pursuance of the provisions of section 349 of the *Land Act* 1958, the unused roads referred to hereunder be closed, viz.:—

Township of Talbot, Parish of Amherst, County of Talbot, being the road between allotments 7, 8, 2, section K², and allotments 18, 17, 16, 15, section O.—(T.136(7) (W.80656).

Parish of Korumburra, County of Buln Buln, being the road between allotments 16H, 16J, 15, 15B, and allotments 18A, 18D, 19H, 19N.—(K.172(10) (Misc. 3094).

Parish of Maldon, County of Talbot, being the road on the northern boundary of allotment 41, section 10.—(M.449(9) (455/44-81).

Township of Rutherglen, Parish of Carlyle, County of Bogong, being the road forming the western boundary of allotment 1, section C.—(R.50(8) (H.023569).

Parish of Stawell, County of Borung, being the portions of High-street and Hill-street north-easterly from Napier-street.—(S.329(18) (05/125).

Township of Newbridge, Parish of Tarnagulla, County of Bendigo, being the road between allotment 10, section 8A, and allotment 1, section 9.—(N.56(1) (W.67755).

Parish of Glenhope, County of Dalhousie, being the road indicated by hachure on plan hereunder.—(G.64(9) (W.80438).

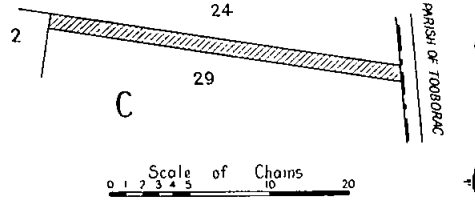

Parish of Narrang, County of Tanjil, being the roads indicated by hachure on plan hereunder.—(N.139(8) (H.025031).

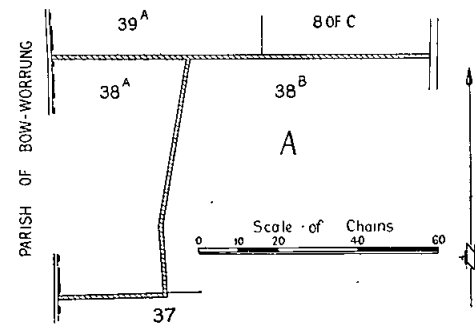

At Eaglehawk, Parish of Sandhurst, County of Bendigo, being the roads indicated by hachure on plan hereunder.—(S.371(20) (Rs.2005).

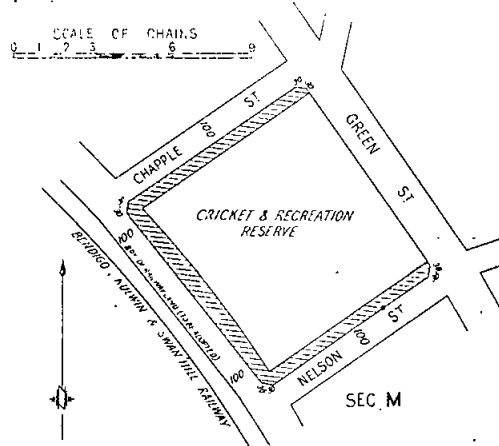

Parish of Wilkin, County of Follett, being the road indicated by hachure on plan hereunder.—(W.315(1) (C.97114).

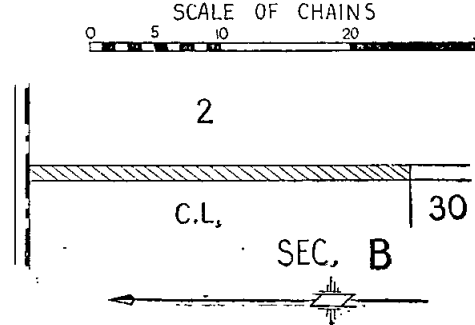

Parish of Traralgon, County of Buln Buln, being the road indicated by hachure on plan hereunder.—(T.115(12) (H.025054).

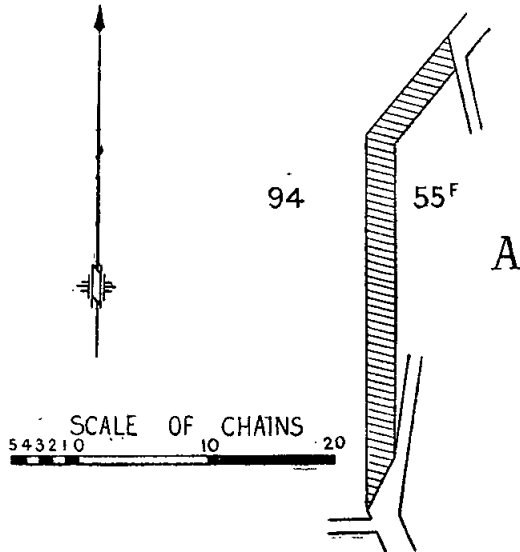

And the Honorable Keith Hector Turnbull, Her Majesty's Commissioner of Crown Lands and Survey for the State of Victoria, shall give the necessary directions herein accordingly.

A. MAHLSTEDT,
Clerk of the Executive Council.

DEPARTMENT OF CROWN LANDS AND SURVEY.

At the Executive Council Chamber, Melbourne, the seventeenth day of June, 1959.

PRESENT:

His Excellency the Governor of Victoria.
Sir Arthur Warner | Sir Thomas Maltby.

LANDS TEMPORARILY RESERVED AS SITES.

HIS Excellency the Governor of the State of Victoria, by and with the advice of the Executive Council thereof, doth hereby, in pursuance of the provisions of the Land Act 1958, reserve, temporarily, and also except from occupation for mining purposes under any miner's right, the lands hereinafter described:—

EAGLEHAWK.—Site for Railway purposes, 8 perches, more or less, at Eaglehawk, Parish of Nerring, County of Bendigo, as indicated by hachure on plan hereunder.—(N.116(12) (Rs.7818).

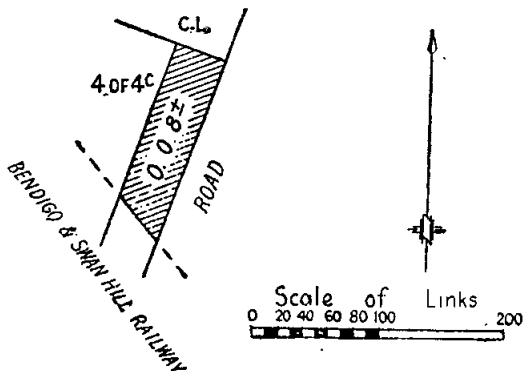

COBURG.—Site for Penal purposes, 69 acres 3 roods 9 perches, Township of Coburg, Parish of Jilka Jilka, County of Bourke, as indicated by hachure on plan hereunder.—(J.16(*) (Rs.3055).

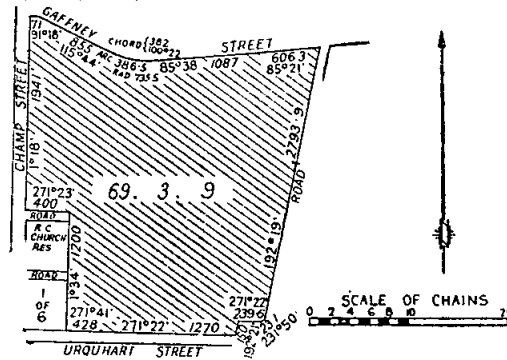

CHILTERN WEST.—Site for Public Hall and Public Recreation, 1 acre 2 roods 28 perches, Parish of Chiltern West, County of Bogong, as indicated by hachure on plan hereunder.—(C.381(*) (Rs.6981).

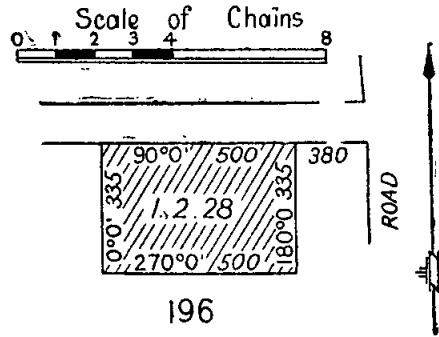

And the Honorable Keith Hector Turnbull, Her Majesty's Commissioner of Crown Lands and Survey for the State of Victoria, shall give the necessary directions herein accordingly.

A. MAHLSTEDT,
Clerk of the Executive Council.

DEPARTMENT OF CROWN LANDS AND SURVEY.

At the Executive Council Chamber, Melbourne, the seventeenth day of June, 1959.

PRESENT:

His Excellency the Governor of Victoria.
Sir Arthur Warner | Sir Thomas Maltby.

REVOCATIONS OF PORTIONS OF TEMPORARY RESERVATIONS OF LANDS BY ORDERS IN COUNCIL.

HIS Excellency the Governor of the State of Victoria, by and with the advice of the Executive Council thereof, doth hereby, in pursuance of the provisions of the Land Act 1958, revoke portions of the temporary reservations of lands by Orders in Council hereinafter referred to, viz.:—

COLLINGWOOD.—Order in Council of 13th November, 1933, of 3 roods 19 perches of land in the City of Collingwood as a site for Plantation purposes, so far only as regards the portion thereof comprised within the boundaries published in the Government Gazette of 27th May, 1959, and containing 16 perches.—(Rs.3588.)

YUONGA.—Order in Council of 22nd August, 1887, of 5 acres of land in the Parish of Yuonga as a site for a State School, so far only as regards the portion thereof comprised within the boundaries published in the Government Gazette of 27th May, 1959, and containing 35 perches, more or less.—(C.95145.)

And the Honorable Keith Hector Turnbull, Her Majesty's Commissioner of Crown Lands and Survey for the State of Victoria, shall give the necessary directions herein accordingly.

A. MAHLSTEDT,
Clerk of the Executive Council.

EXPLOSIVES ACT 1958.

At the Executive Council Chamber, Melbourne, the
seventeenth day of June, 1959.

PRESENT:

His Excellency the Governor of Victoria.
Sir Arthur Warner | Sir Thomas Maltby.

AMENDMENT OF REGULATIONS.

IN pursuance of the powers conferred by the *Explosives Act 1958* and all other powers him thereunto enabling, His Excellency the Governor of the State of Victoria, in the Commonwealth of Australia, by and with the advice of the Executive Council of the said State, doth hereby amend the Explosives (Carriage) Regulations 1957 as follows (that is to say):—

In sub-clause (d) of clause 20, for the expressions "12,000 lb." and "60,000 lb.", there shall be substituted respectively the expressions "15,000 lb." and "75,000 lb."

And the Honorable Lindsay Hamilton Simpson Thompson, for and on behalf of Her Majesty's Chief Secretary for the State of Victoria, shall give the necessary directions herein accordingly.

A. MAHLSTEDT,
Clerk of the Executive Council.

MORNINGTON SEWERAGE AUTHORITY.

At the Executive Council Chamber, Melbourne, the
seventeenth day of June, 1959.

PRESENT:

His Excellency the Governor of Victoria.
Sir Arthur Warner | Sir Thomas Maltby.

EXTENT OF SEWERAGE DISTRICT INCREASED.

UNDER the powers conferred by the *Sewerage Districts Act 1958* and all other powers enabling him in that behalf, His Excellency the Governor of the State of Victoria, by and with the advice of the Executive Council of the said State doth hereby declare, order and direct as follows:—

That the extent of the Sewerage District of the Mornington Sewerage Authority be increased by adding to the same the lands comprised within the boundaries described in the Schedule hereto and as on and from the date hereof the extent of such District shall be deemed to be increased accordingly.

SCHEDULE.

Portion I.

Commencing at the most southerly angle of lot 10 on lodged plan of subdivision No. 17357, Parish of Moorooduc, County of Mornington, being a point on the south-eastern boundary of the existing Sewerage District; thence south-easterly by a line across Yuilles-road to the intersection of its south-eastern boundary with the north-eastern boundary of Tyabb-road; thence south-easterly along the said north-eastern boundary of Tyabb-road to a point in line with the north-eastern boundary of Diane-street; thence south-easterly along the said north-eastern boundary of Diane-street, being the south-western boundaries of lots 22, 21, 20, 19, 18, 17, 16, 15, 14, 13 and 12 on lodged plan of subdivision No. 25123 and of lots 6, 5 and 4 on lodged plan of subdivision No. 41750 to the most southerly angle of the said lot 4; thence south-westerly by a line across a road to the most easterly angle of lot 10 and along the south-eastern boundary of the said lot 10 to a point on a line parallel to and distant 200 links north-easterly from the south-western boundary of Crown allotment 12; thence south-easterly by the said line parallel to and distant 200 links north-easterly from the south-western boundary of Crown allotment 12, through the said Crown allotment 12 to a point on a line parallel to and distant 200 links south-easterly from the said south-eastern boundary of lot 10; thence north-easterly by the said line parallel to and distant 200 links south-easterly from the said south-eastern boundary of lot 10 to a point in line with the aforesaid

south-western boundary of lot 4 on lodged plan of subdivision No. 41750; thence by a line bearing south 68 deg. 21 min. east to a point on a line parallel to and distant 500 links south-easterly from the south-eastern boundary of lot 10; thence south-westerly by the said line parallel to and distant 500 links south-easterly from the south-eastern boundary of lot 10, through the aforementioned Crown allotment 12 and across Tyabb-road to a point on its southern boundary; thence generally north-westerly along the southern boundary of Tyabb-road to its intersection with the south-eastern boundary of Yuilles-road; thence south-westerly along the said south-eastern boundary of Yuilles-road to a point in line with the south-western boundary of lot 27 on lodged plan of subdivision No. 25681; thence north-westerly by a line across Yuilles-road to the most southerly angle of the said lot 27 and along the south-western boundaries of the said lot 27 and of lot 26 to the most westerly angle of the said lot 26; thence north-westerly by a line across a road to the most southerly angle of lot 25 and along the south-western boundaries of the said lot 25 and of lot 24 and by a line being a continuation thereof across lots 2 and 1 on lodged plan of subdivision No. 17520 and the Nepean Highway to a point in line with its north-western boundary being a point on the south-eastern boundary of the existing Sewerage District; thence north-easterly, south-easterly and north-easterly along the south-eastern boundary of the existing Sewerage District to the point of commencement.

Portion II.

Commencing at the north-western angle of lot 1 on lodged plan of subdivision No. 16406, Section 25, Parish of Moorooduc, County of Mornington; thence easterly along the northern boundaries of the said lot 1 and of lots 2, 3 and of lots 34, 33 and 32 on lodged plan of subdivision No. 7859 to the most easterly angle of the said lot 32; thence south-westerly along the south-eastern boundaries of the said lot 32 and of lot 25 to its most southerly angle; thence south-westerly by a line across a road to the most northerly angle of lot 19 and along its north-western boundary to its most westerly angle; thence easterly along the southern boundaries of the said lot 19 and of lots 18 and 17 to a point on the north-western boundary of Albert-street; thence south-westerly along the said north-western boundary of Albert-street to a point on the northern boundary of Craigie-road; thence south-easterly by a line across the said Craigie-road to the north-western angle of a Cemetery Reserve, Section A; thence southerly and easterly along the western and southern boundaries of the said Cemetery Reserve to a point in line with the eastern boundary of lot 20 on lodged plan of subdivision No. 7087; thence southerly by a line across a road to the north-eastern angle of the said lot 20 and along the eastern boundaries of lot 20 and of lots 19, 18, 17, 16, 15, 14, 13, 12, 11, 10, 9 and 8 to the south-eastern angle of the said lot 8; thence south-westerly by a line across a road to the north-eastern angle of Crown

allotment 33; thence westerly and southerly along the northern and western boundaries of the said Crown allotment 33 to a point in line with the northern boundary of lot 13 on lodged plan of subdivision No. 85/246; thence westerly by a line parallel to the said boundary of lot 13 through Crown allotment 36 to a point on a line parallel to and distant 10 links easterly from the eastern boundary of the said lot 13; thence southerly by the said line parallel to and distant 10 links easterly from the eastern boundary of the said lot 13 through Crown allotments 36 and 35 to a point in line with the southern boundary of lot 9; thence westerly through the said Crown allotment 35 to the south-eastern angle of the said lot 9 and along its southern boundary to its south-western angle; thence north-westerly by a line across a road to the south-eastern angle of lot 44; thence westerly along the southern boundary of the said lot 44 to its south-western angle; thence north-westerly along the south-western boundary of lot 32 to its south-western angle; thence westerly by a line across a road to the north-eastern angle of lot 26; thence westerly along the northern boundary of the said lot 26 to its north-western angle; thence south-westerly along the north-western boundaries of the said lot 26 and lot 30 to the most westerly angle of the said lot 30; thence south-westerly by a line across a road and through Crown allotment 43 to the most southerly angle of lot 21 on lodged plan of subdivision No. 18906; thence south-westerly by a line across Crown allotment 43 and Crown land to the most southerly angle of lot 11 and by a line being a continuation thereof across Alice-street to a point on its south-western boundary; thence north-westerly along the said south-western boundary of Alice-street to the most easterly angle of Crown allotment 11, Section 4, Town of Osborne; thence south-westerly along the south-eastern boundaries of the said lot 11 and of lots 12, 13, 14, 15, 16, 17, 18, 19, 20, 21, 22 and 23 to the most southerly angle of the said lot 23; thence south-westerly by a line across a road to the most easterly angle of Crown allotment 20, Section 2; thence south-westerly by a line across a road, Crown land, the Balcombe Creek and Crown land to the most easterly angle of lot 33 on lodged plan of subdivision No. 13475, Section B, Parish of Moorooduc; thence southerly along the eastern boundaries of the said lot 33 and of lots 32 and 31 to the most southerly angle of the said lot 31; thence easterly a distance of 500 links by a line being a continuation of the southern boundary of the said lot 31 across a road and Crown allotment 42 to a point in Crown allotment 43; thence southerly by a line parallel to the eastern boundaries of lots 30 and 29 on lodged plan of subdivision No. 13475 through Crown allotment 43 to a point on the northern boundary of Watsons-road; thence easterly along the said northern boundary on Watsons-road to a point in line with the western boundary of lot 9 on lodged plan of subdivision No. 26846; thence southerly by a line across the said Watsons-road to the north-western angle of the said lot 9 and along its western boundary to its south-western angle; thence westerly by a line across lot 8 to the south-eastern angle of lot 7 and along its southern boundary to the north-eastern angle of lot 26; thence southerly along the eastern boundaries of the said lot 26 and of lots 27, 28, 29, 16, and by a line being a continuation thereof across Bay-road to a point on its southern boundary; thence westerly along the said southern boundary of Bay-road to the most easterly angle of lot 1 on lodged plan of subdivision No. 3015; thence generally south-westerly along the south-eastern boundaries of the said lot 1 and of lots 9 and 8, to the most southerly angle of the said lot 8; thence south-easterly along the north-eastern boundary of Dominion-road to a point in line with the north-western boundary of Normanby-terrace; thence south-westerly along the said north-western boundary of Normanby-terrace to a point on the south-western boundary of Glenisla-drive; thence generally south-easterly along the said south-western boundary of Glenisla-drive to a point on the south-eastern boundary of Ferrero-grove; thence south-westerly along the said south-eastern boundary of Ferrero-grove and by a line being a continuation thereof across a road to a point on the eastern boundary of lot 6 on lodged plan of subdivision No. 23815; thence southerly along the said eastern boundary of lot 6 and of lot 7 to its south-eastern angle; thence westerly along the southern boundary of the said lot 7 to a point on the eastern boundary of lot 41 on lodged plan of subdivision No. 19992; thence southerly along the said eastern boundary of lot 41 to its south-easterly angle; thence westerly along the southern boundary of the said lot 41 and by a line being a continuation thereof across a road to a point on the eastern boundary of lot 5; thence generally northerly along the said eastern boundary of lot 5 and of lots 4, 3, 2 and 1 to the most northerly angle of the said lot 1; thence generally south-westerly along the north-western boundary of the said lot 1 and of lot 16 to its north-western angle; thence south-westerly by a line across a

road to the most easterly angle of lot 17 and along its northern and north-western boundaries to its most westerly angle; thence north-westerly along the south-western boundary of lot 18 to its most westerly angle; thence south-westerly along the south-eastern boundary of lot 20 to its most southerly angle; thence north-westerly along the south-western boundary of the said lot 20 and by a line being a continuation thereof across Lempriere-avenue to a point on its western boundary; thence westerly by a line, parallel to the southern boundaries of lots 1, 2 and 3 on lodged plan of subdivision No. 13692 a distance of 880 links; thence generally northerly by a line parallel to the said western boundary of Lempriere-avenue to the south-western angle of the said lot 3; thence northerly along its western boundary and by a line being a continuation thereof across the Mornington to Dromana road to a point on the northern boundary of the said Mornington to Dromana road; thence generally easterly and northerly along the western boundary of the said Mornington-Dromana-road to a point in line with the aforesaid northern boundary of lot 1 on lodged plan of subdivision No. 16406; thence easterly by a line across the said Mornington to Dromana road to the north-westerly angle of the said lot 1 being the point of commencement.

All of which boundaries are shown on a plan approved by the Governor in Council and deposited in the office of the State Rivers and Water Supply Commission, Melbourne.—(Corres. No. 59/1323/9.)

And the Honorable Wilfred John Mibus, Her Majesty's Minister of Water Supply for the State of Victoria, shall give the necessary directions herein accordingly.

A. MAHLSTEDT,
Clerk of the Executive Council.

MORNINGTON SEWERAGE AUTHORITY.

At the Executive Council Chamber, Melbourne, the seventeenth day of June, 1959.

PRESENT:

His Excellency the Governor of Victoria.
Sir Arthur Warner | Sir Thomas Maltby.

CONSENT TO BORROWING £25,000.

UNDER the powers conferred by the *Sewerage Districts Act 1958* and all other powers enabling him in that behalf, His Excellency the Governor of the State of Victoria, by and with the advice of the Executive Council of the said State, doth hereby consent to the Mornington Sewerage Authority borrowing by the issue of debentures the sum of Twenty-five thousand pounds (£25,000) to meet the cost of sewerage works at Mornington, as set forth in the detailed statement bearing date the 12th June, 1959.

And the Honorable Wilfred John Mibus, Her Majesty's Minister of Water Supply for the State of Victoria, shall give the necessary directions herein accordingly.

A. MAHLSTEDT,
Clerk of the Executive Council.

COUNTRY ROADS BOARD.

At the Executive Council Chamber, Melbourne, the seventeenth day of June, 1959.

PRESENT:

His Excellency the Governor of Victoria.
Sir Arthur Warner | Sir Thomas Maltby.

ORDER APPROVING OF A DEVIATION FROM A MAIN ROAD IN THE SHIRE OF LEXTON.

WHEREAS the Country Roads Board constituted under the *Country Roads Act 1958* (No. 6229) has represented to His Excellency the Governor in Council that it appears to it desirable that the deviation hereinafter referred to from the existing Lexton-Talbot road in the Shire of Lexton (declared to be a main road under the said Act which declaration was confirmed by the Order in Council published in the *Government Gazette* of the 16th July, 1947, on pages 2851-5) should be made by the said Board; And whereas the said Board in accordance

with the requirements of section 19 of the said cited Act has caused to be prepared a map plan and estimate showing the points between which and on and through what land the said deviation is proposed to be made and the cost of acquiring the land: And whereas on an inspection of the said map and plan and a consideration of the said estimate His Excellency the Governor in Council is satisfied that there are funds legally available for acquiring the land: Now therefore be it known by this present Order that His Excellency the Governor of the State of Victoria with the advice of the Executive Council thereof doth hereby approve of the said road being made, that is to say:—

All those pieces of land in the Parish of Caralulup the boundaries of which are as follow:—

- (a) Commencing at the south-eastern angle of allotment 1 of the said Parish; thence by lines bearing respectively 272 deg. 15 min. 1,670.1 links, 71 deg. 54 min. 838.1 links, 45 deg. 28 min. 864.5 links, 19 deg. 3 min. 783.8 links, and 180 deg. 0 min. 1,673.1 links to the point of commencement.
- (b) Commencing at the north-western angle of subdivision A of allotment 4 of the said Parish; thence by lines bearing respectively 90 deg. 0 min. 8,000 links, 214 deg. 0 min. 60.3 links, 270 deg. 0 min. 6,371.3 links, 251 deg. 42 min. 716.7 links, 225 deg. 40 min. 866.5 links, 198 deg. 53 min. 888.2 links, and 359 deg. 45 min. 1,720.9 links to the point of commencement—

which said pieces of land are particularly delineated and shown coloured red and yellow on survey plan numbered 7139, lodged in the office of the Country Roads Board.

And the Honorable Sir Thomas Karran Maltby, Her Majesty's Commissioner of Public Works for the State of Victoria, shall give the necessary directions herein accordingly.

A. MAHLSTEDT,
Clerk of the Executive Council.

COUNTRY ROADS BOARD.

At the Executive Council Chamber, Melbourne, the
seventeenth day of June, 1959.

PRESENT:

His Excellency the Governor of Victoria.
Sir Arthur Warner | Sir Thomas Maltby.

DECLARATION OF THE WIDENING OF BUXTON-MARYSVILLE ROAD AND YARRAM-TRARALGON ROAD IN THE SHIRES OF HEALESVILLE AND TRARALGON RESPECTIVELY.

WHEREAS by section 21 of the *Country Roads Act* 1958 (No. 6229) it is amongst other things enacted that when the Country Roads Board under the provisions of the Country Roads Act has taken the land necessary for constructing the road or deviation or widening it shall as soon as it thinks such road or deviation or widening is fit to be used as a public highway by Resolution declare the road or deviation or widening to be a main road or part thereof and that upon publication in the *Government Gazette* of the Order of the Governor in Council confirming such Resolution such road or deviation or widening shall thereupon be a main road or a part thereof within the meaning of the said Act: And whereas the said Board has by Resolution declared the roads on the land described in the Schedules to such Resolution to be parts of main roads: Now therefore His Excellency the Governor of the State of Victoria by and with the advice of the Executive Council thereof doth hereby confirm the said Resolution.

Resolution for Declaration of the Widening of Main Roads under the Country Roads Act.

Whereas the land the sites of the roads the courses of which are below set out was taken by the Board under the provisions of the Country Roads Act for the purpose of widening the main roads aforesaid which widenings have now been laid out and formed on the same: And whereas the said Board (being the Country Roads Board incorporated under the said Act) thinks that the widenings aforesaid are fit to be used as parts of public highways such Board at a meeting now holden doth by this Resolution hereby declare the same as described in

the Schedules hereto with the commencing and terminating points thereof respectively specified to be parts of the main roads within the meaning and for the purposes of the Country Roads Act.

SCHEDULE.

Shire of Healesville.

9. Buxton-Marysville road (7309).—All those pieces of land in the Parish of Buxton, the boundaries of which are as follow:—

- (a) Commencing at the eastern angle of allotment 12a of the said parish; thence by lines bearing respectively 139 deg. 18 min. 4 links, 178 deg. 45 min. 197.7 links, 340 deg. 20 min. 350.2 links, and 139 deg. 18 min. 170.2 links to the point of commencement.
- (b) Commencing at a point on the south-western boundary of allotment 21 of the said parish distant 305 deg. 20 min. 393 links and 282 deg. 32 min. 544.9 links from the southern angle of the said allotment; thence by lines bearing respectively 282 deg. 32 min. 156.1 links, 323 deg. 36 min. 170 links, and 123 deg. 59 min. 305.4 links to the point of commencement—

which said pieces of land are particularly delineated and shown coloured red on survey plans numbered 6261 and 6262, lodged in the office of the Country Roads Board.

SCHEDULE.

Shire of Traralgon.

2. Yarram-Traralgon road (16402).—All that piece of land in the Parish of Traralgon, the boundaries of which are as follow:—Commencing at the north-western angle of suburban allotment 91, Township of Traralgon, in the said parish; thence by lines bearing respectively 86 deg. 51 min. 1,216 ft. 4½ in., 176 deg. 22 min. 131 ft. 7½ in., 311 deg. 36½ min. 93 ft. 21 in., 266 deg. 51 min. 1,050 ft. 5 in., 227 deg. 19 min. 130 ft. 10 in., and 356 deg. 51 min. 149 ft. 3½ in. to the point of commencement—which said piece of land is particularly delineated and shown coloured red on survey plan numbered 6089, lodged in the office of the Country Roads Board.

The common seal of the Country Roads Board was hereto affixed at Carlton, this eighth day of June, One thousand nine hundred and fifty-nine, in the presence of—

(SEAL) D. V. DARWIN, Chairman.
W. H. NEVILLE, Member.
R. E. V. DONALDSON, Secretary.

And the Honorable Sir Thomas Karran Maltby, Her Majesty's Commissioner of Public Works for the State of Victoria, shall give the necessary directions herein accordingly.

A. MAHLSTEDT,
Clerk of the Executive Council.

COUNTRY ROADS BOARD.

At the Executive Council Chamber, Melbourne, the
seventeenth day of June, 1959.

PRESENT:

His Excellency the Governor of Victoria.
Sir Arthur Warner | Sir Thomas Maltby.

ORDER APPROVING OF A DEVIATION FROM A MAIN ROAD IN THE SHIRE OF MORWELL.

WHEREAS the Country Roads Board constituted under the *Country Roads Act* 1958 (No. 6229) has represented to His Excellency the Governor in Council that it appears to it desirable that the deviation hereinafter referred to from the existing Tyers-road in the Shire of Morwell (declared to be a main road under the said Act which declaration was confirmed by the Order in Council published in the *Government Gazette* of the 28th May, 1947, on pages 2732-3) should be made by the said Board: And whereas the said Board in accordance with the requirements of section 19 of the said cited Act has caused to be prepared a map plan and estimate showing the points between which and on and through what land the said deviation is proposed to be made and the cost of acquiring the land: And whereas on an inspection of the said map and plan and a consideration of the said estimate His Excellency the Governor in Council is satisfied that

there are funds legally available for acquiring the land: Now therefore be it known by this present Order that His Excellency the Governor of the State of Victoria with the advice of the Executive Council thereof doth hereby approve of the said road being made, that is to say:—

All that piece of land in the Parish of Tanjil East, the boundaries of which are as follow:—Commencing at a point on the eastern boundary of allotment 7, section A of the said parish distant 0 deg. 1 min. 172 links from the south-eastern angle of the said allotment; thence by lines bearing respectively 293 deg. 1 min. 96.5 links, 317 deg. 1½ min. 362.4 links, 304 deg. 4½ min. 369.8 links, 295 deg. 32½ min. 513.5 links, 302 deg. 0 min. 318.2 links, 316 deg. 4 min. 342.9 links, 330 deg. 20 min. 263 links, 0 deg. 1 min. 595.2 links, 167 deg. 57½ min. 473.2 links, 150 deg. 20 min. 310.1 links, 136 deg. 4 min. 305.2 links, 122 deg. 0 min. 291 links, 115 deg. 32½ min. 516.3 links, 124 deg. 4½ min. 398.3 links, 137 deg. 1½ min. 347.4 links, and 180 deg. 1 min. 164.6 links to the point of commencement— which said piece of land is particularly delineated and shown coloured red on survey plan numbered 7128, lodged in the office of the Country Roads Board.

And the Honorable Sir Thomas Karran Maltby, Her Majesty's Commissioner of Public Works for the State of Victoria, shall give the necessary directions herein accordingly.

A. MAHLSTEDT,
Clerk of the Executive Council.

COUNTRY ROADS BOARD.

*At the Executive Council Chamber, Melbourne, the
seventeenth day of June, 1959.*

PRESENT:

His Excellency the Governor of Victoria.

Sir Arthur Warner | Sir Thomas Maltby.

DECLARATION OF A DEVIATION FROM THE WOORI YALLOCK-PAKENHAM-KOO-WEE-RUP ROAD IN THE SHIRE OF BERWICK.

WHEREAS by sections 21 and 58 of the *Country Roads Act 1958* (No. 6229) it is amongst other things enacted that when the Country Roads Board under the provisions of the *Country Roads Act* has by Resolution declared a deviation to be a main road the said Board may also declare that such deviation shall be in lieu of any existing road or part thereof named in such Resolution and that on publication in the *Government Gazette* of the Order confirming such Resolution the existing road or part thereof shall cease to be a main road or be discontinued as provided in the Resolution: And whereas the said Board has by Resolution declared the deviation on the land described in the First Schedule to such Resolution to be a main road and has also declared that such deviation shall be in lieu of the part of the existing road being the land described in the Second Schedule to the said Resolution: Now therefore His Excellency the Governor of the State of Victoria by and with the advice of the Executive Council thereof doth hereby confirm the said Resolution.

Resolution for Declaration of a Deviation under the Country Roads Act.

Whereas the land the site of the road the course of which is below set out was taken by the Board under the provisions of the *Country Roads Act 1958* for the purpose of constructing such road deviation which road deviation has now been laid out and formed on the same: And whereas the said Board (being the Country Roads Board incorporated under the said Act) thinks that the road aforesaid is fit to be used as a public highway such Board at a meeting now holden acting under the authority conferred upon it by sections 21 and 58 of the said Act doth by this present Resolution hereby declare the said road deviation the course of which is described in the First Schedule hereto with the commencing and terminating points thereof respectively specified to be part of a main road within the meaning and for the purposes of the *Country Roads Act 1958*: And the said Board doth also declare that such deviation shall be in lieu of the existing road or part thereof described in the Second Schedule hereto.

FIRST SCHEDULE.

Shire of Berwick.

2. *Woori Yallock-Pakenham-Koo-Wee-Rup road (1902).*
—All that piece of land in the Parish of Nar-Nar-Goon, the boundaries of which are as follow:—Commencing at a point on the western boundary of allotment 60A of the said parish distant 189 deg. 44 min. 414 links from the north-western angle of the said allotment; thence by lines bearing respectively 173 deg. 6 min. 906.5 links, 150 deg. 19 min. 913 links, 135 deg. 21 min. 1,232 links, 279 deg. 48 min. 247.6 links, 325 deg. 49 min. 242.5 links, 315 deg. 21 min. 912 links, 322 deg. 42 min. 934.5 links, and 9 deg. 44 min. 948.3 links to the point of commencement— which said piece of land is particularly delineated and shown coloured red on survey plan numbered 5105, lodged in the office of the Country Roads Board.

SECOND SCHEDULE.

Shire of Berwick.

2. *Woori Yallock-Pakenham-Koo-Wee-Rup road (1902).*
—All that piece of land in the Parish of Nar-Nar-Goon, being a roadway generally 1 chain wide and commencing at a point on the southern boundary of allotment 69 of the said parish distant 99 deg. 48 min. 1,694.7 links from the south-eastern angle of allotment 59 of that parish; thence westerly and northerly to a point on the eastern boundary of the said allotment 59 distant 9 deg. 44 min. 1,450 links from the south-eastern angle thereof— which said piece of land is more particularly delineated and shown coloured blue on survey plan numbered 5105, lodged in the office of the Country Roads Board.

The common seal of the Country Roads Board was hereto affixed at Carlton, this eighth day of June, One thousand nine hundred and fifty-nine, in the presence of—

(SEAL) D. V. DARWIN, Chairman.
W. H. NEVILLE, Member.
R. E. V. DONALDSON, Secretary.

And the Honorable Sir Thomas Karran Maltby, Her Majesty's Commissioner of Public Works for the State of Victoria, shall give the necessary directions herein accordingly.

A. MAHLSTEDT,
Clerk of the Executive Council.

COUNTRY ROADS BOARD.

*At the Executive Council Chamber, Melbourne, the
seventeenth day of June, 1959.*

PRESENT:

His Excellency the Governor of Victoria.

Sir Arthur Warner | Sir Thomas Maltby.

DECLARATION OF A DEVIATION FROM THE PRINCES HIGHWAY IN THE SHIRE OF ORBOST.

WHEREAS by sections 74 and 58 of the *Country Roads Act 1958* (No. 6229) it is amongst other things enacted that when the Country Roads Board under the provisions of the *Country Roads Act* has by Resolution declared a deviation to be a State highway the said Board may also declare that such deviation shall be in lieu of any existing highway or part thereof named in such Resolution and that on publication in the *Government Gazette* of the Order confirming such Resolution the existing highway or part thereof shall cease to be a State highway or be discontinued as provided in the Resolution: And whereas the said Board has by Resolution declared the deviation on the land described in the First Schedule to such Resolution to be a State highway and has also declared that such deviation shall be in lieu of the part of the existing highway being the land described in the Second Schedule to the said Resolution and that such part of the said existing highway shall be discontinued: Now therefore His Excellency the Governor of the State of Victoria by and with the advice of the Executive Council thereof doth hereby confirm the said Resolution.

Resolution for Declaration of a Deviation under the Country Roads Act.

Whereas the land the site of the highway the course of which is below set out was taken by the Board under the provisions of the *Country Roads Act 1958* for the purpose of constructing such highway deviation which highway deviation has now been laid out and formed on the same:

And whereas the said Board (being the Country Roads Board incorporated under the said Act) thinks that the highway aforesaid is fit to be used as a public highway such Board at a meeting now holden acting under the authority conferred upon it by sections 74 and 58 of the said Act doth by this present Resolution hereby declare the said highway deviation the course of which is described in the First Schedule hereto with the commencing and terminating points thereof respectively specified to be part of a State highway within the meaning and for the purposes of the *Country Roads Act 1958*: And the said Board doth also declare that such deviation shall be in lieu of the existing highway or part thereof described in the Second Schedule hereto and that such part of the said existing highway shall be discontinued.

FIRST SCHEDULE.

Shire of Orbst.

1. *Princes Highway*.—All that piece of land in the Parish of Jilwain, the boundaries of which are as follow:—Commencing at an angle in the northern boundary of allotment 53b of the said parish, the said angle being formed by the intersection of lines bearing 90 deg. 55 min. and 42 deg. 5 min.; thence by lines bearing respectively 227 deg. 27 min. 323.5 links, 349 deg. 39 min. 227 links, and 90 deg. 55 min. 279 links to the point of commencement—which said piece of land is particularly delineated and shown coloured red on survey plan numbered 6500, lodged in the office of the Country Roads Board.

SECOND SCHEDULE.

Shire of Orbst.

1. *Princes Highway*.—All that piece of land in the Parish of Jilwain, the boundaries of which are as follow:—Commencing at a point on the eastern boundary of allotment 53c of the said parish, distant 24 deg. 51 min. 257.5 links from the southern angle of the said allotment; thence by lines bearing respectively 349 deg. 39 min. 249.5 links, 90 deg. 55 min. 333 links, and 230 deg. 12 min. 375 links to the point of commencement—which said piece of land is particularly delineated and shown coloured blue on survey plan numbered 6500, lodged in the office of the Country Roads Board.

The common seal of the Country Roads Board was hereto affixed at Carlton, this eighth day of June, One thousand nine hundred and fifty-nine, in the presence of—

(SEAL) D. V. DARWIN, Chairman.
W. H. NEVILLE, Member.
R. E. V. DONALDSON, Secretary.

And the Honorable Sir Thomas Karran Maltby, Her Majesty's Commissioner of Public Works for the State of Victoria, shall give the necessary directions herein accordingly.

A. MAHLSTEDT,
Clerk of the Executive Council.

COUNTRY ROADS BOARD.

At the Executive Council Chamber, Melbourne, the seventeenth day of June, 1959.

PRESENT:

His Excellency the Governor of Victoria.
Sir Arthur Warner | Sir Thomas Maltby.

DECLARATION OF THE WIDENING OF THE PRINCES HIGHWAY, MURRAY VALLEY HIGHWAY AND SOUTH GIPPSLAND HIGHWAY IN THE CITY OF OAKLEIGH AND SHIRES OF SWAN HILL AND WOORAYL RESPECTIVELY.

WHEREAS by sections 21 and 74 of the *Country Roads Act 1958* (No. 6229) it is amongst other things enacted that when the Country Roads Board under the provisions of the *Country Roads Act* has taken the land necessary for constructing the highway or deviation or widening it shall as soon as it thinks such highway or deviation or widening is fit to be used as a public highway by Resolution declare the highway or deviation or widening to be a State highway or part thereof and that upon publication in the *Government Gazette* of the Order of the Governor in Council confirming such Resolution such highway or deviation or widening shall thereupon be a State highway or a part thereof within the meaning of the said Act: And whereas the said Board has by Resolution

declared the highways on the land described in the Schedules to such Resolution to be parts of State highways: Now therefore His Excellency the Governor of the State of Victoria by and with the advice of the Executive Council thereof doth hereby confirm the said Resolution.

Resolution for Declaration of the Widening of State Highways under the Country Roads Act.

Whereas the land the sites of the highways the courses of which are below set out was taken by the Board under the provisions of the *Country Roads Act* for the purpose of widening the State highways aforesaid which widenings have now been laid out and formed on the same: And whereas the said Board (being the Country Roads Board incorporated under the said Act) thinks that the widenings aforesaid are fit to be used as parts of public highways such Board at a meeting now holden doth by this Resolution hereby declare the same as described in the Schedules hereto with the commencing and terminating points thereof respectively specified to be parts of the State highways within the meaning and for the purposes of the *Country Roads Act*.

SCHEDULE.

City of Oakleigh.

1. *Princes Highway*.—All those pieces of land in the Parish of Mulgrave, the boundaries of which are as follow:—

- Commencing at the south-eastern angle of allotment 15 of the said parish; thence by lines bearing respectively 300 deg. 13 min. 60 feet, 79 deg. 23 min. 53 ft. 2½ in., and 180 deg. 37 min. 40 feet to the point of commencement.
- Commencing at the south-western angle of Crown portion 10 of the said parish; thence by lines bearing respectively 0 deg. 47 min. 40 feet, 150 deg. 20½ min. 68 ft. 11½ in., and 299 deg. 54 min. 40 feet to the point of commencement.
- Commencing at the north-western angle of Crown portion 9 of the said parish; thence by lines bearing respectively 119 deg. 53 min. 60 feet, 259 deg. 5 min. 53 ft. 5 in., and 0 deg. 37 min. 40 feet to the point of commencement—

which said pieces of land are particularly delineated and shown coloured red on survey plan numbered 5431, lodged in the office of the Country Roads Board.

SCHEDULE.

Shire of Swan Hill.

7. *Murray Valley Highway*.—All that piece of land in the Parish of Yungera, the boundaries of which are as follow:—Commencing at the northern angle of allotment 2, section A, of the said parish; thence by lines bearing respectively 114 deg. 48 min. 70.2 links, 275 deg. 32 min. 204.3 links, and 86 deg. 1 min. 140 links to the point of commencement—which said piece of land is particularly delineated and shown coloured red on survey plan numbered 6094, lodged in the office of the Country Roads Board.

SCHEDULE.

Shire of Woorayl.

8. *South Gippsland Highway*.—All those pieces of land in the Parish of Leongatha, the boundaries of which are as follow:—

- Commencing at the north-western angle of allotment 84F of the said parish; thence by lines bearing respectively 90 deg. 8 min. 213.7 links, 0 deg. 53 min. 374 links, 80 deg. 23 min. 299.5 links, 72 deg. 41 min. 476.4 links, 233 deg. 11 min. 944.2 links, 208 deg. 58 min. 453.9 links, and 0 deg. 53 min. 397.6 links to the point of commencement.
- Commencing at an angle in the western boundary of the existing South Gippsland Highway through allotment 84A of the said parish, the said angle being formed by the intersection of lines bearing 63 deg. 57 min. and 5 deg. 45 min.; thence by lines bearing respectively 243 deg. 57 min. 303 links, 27 deg. 15 min. 702.8 links, and 185 deg. 45 min. 494.2 links to the point of commencement.
- Commencing at an angle in the western boundary of the existing South Gippsland Highway through allotment 84A of the said parish, the said angle being formed by the intersection of lines bearing 5 deg. 45 min. and 45 deg. 40 min.; thence by lines bearing respectively 20 deg.

25 min. 309.9 links, 186 deg. 10 min. 207.8 links, and 225 deg. 40 min. 120 links to the point of commencement—

which said pieces of land are particularly delineated and shown coloured red on survey plan numbered 6570, lodged in the office of the Country Roads Board.

The common seal of the Country Roads Board was hereto affixed at Carlton, this eighth day of June, One thousand nine hundred and fifty-nine, in the presence of—

(SEAL) D. V. DARWIN, Chairman.
W. H. NEVILLE, Member.
R. E. V. DONALDSON, Secretary.

And the Honorable Sir Thomas Karran Maltby, Her Majesty's Commissioner of Public Works for the State of Victoria, shall give the necessary directions herein accordingly.

A. MAHLSTEDT,
Clerk of the Executive Council.

COUNTRY ROADS BOARD.

At the Executive Council Chamber, Melbourne, the seventeenth day of June, 1959.

PRESENT:

His Excellency the Governor of Victoria.
Sir Arthur Warner | Sir Thomas Maltby.

ORDER APPROVING OF WIDENING AN EXISTING STATE HIGHWAY IN THE SHIRE OF BERWICK.

WHEREAS the Country Roads Board constituted under the *Country Roads Act 1958* (No. 6229) has represented to His Excellency the Governor in Council that it appears to it desirable that the existing Princes Highway in the Shire of Berwick (declared to be a State highway under the said Act which declaration was confirmed by the Order in Council published in the *Government Gazette* of the 8th July, 1925, on pages 2371-3) should be widened by the said Board: And whereas the said Board in accordance with the requirements of section 19 of the said cited Act has caused to be prepared a map plan and estimate showing the points between which and on and through what land the said widening is proposed to be made and the cost of acquiring the land: And whereas on an inspection of the said map and plan and a consideration of the said estimate His Excellency the Governor in Council is satisfied that there are funds legally available for acquiring the land: Now therefore be it known by this present Order that His Excellency the Governor of the State of Victoria with the advice of the Executive Council thereof doth hereby approve of the said highway being widened, that is to say:—

All those pieces of land in the Parish of Nar-Nar-Goon, the boundaries of which are as follow:—

- (a) Commencing at a point on the southern boundary of allotment 84 of the said parish, distant 99 deg. 25 min. 4,390.4 links from the south-western angle of the said allotment; thence by lines bearing 73 deg. 5½ min. 893.4 links and 229 deg. 42 min. 385 links; thence by the arc of a circle of radius of 290 links, a distance of 251 links, the chord of which arc bears 254 deg. 33½ min.; thence by a line bearing 279 deg. 25 min. 330.6 links to the point of commencement.
- (b) Commencing at the north-eastern angle of allotment 85A of the said Parish; thence by lines bearing respectively 63 deg. 6 min. 415.6 links, 76 deg. 43 min. 520.9 links, 242 deg. 9 min. 1,582.5 links, and 50 deg. 24 min. 677 links to the point of commencement—

which said pieces of land are particularly delineated and shown coloured red on survey plan numbered 7209, lodged in the office of the Country Roads Board.

And the Honorable Sir Thomas Karran Maltby, Her Majesty's Commissioner of Public Works for the State of Victoria, shall give the necessary directions herein accordingly.

A. MAHLSTEDT,
Clerk of the Executive Council.

COUNTRY ROADS BOARD.

At the Executive Council Chamber, Melbourne, the seventeenth day of June, 1959.

PRESENT:

His Excellency the Governor of Victoria.
Sir Arthur Warner | Sir Thomas Maltby.

ORDER APPROVING OF WIDENING AN EXISTING MAIN ROAD IN THE SHIRE OF MANSFIELD.

WHEREAS the Country Roads Board constituted under the *Country Roads Act 1958* (No. 6229) has represented to His Excellency the Governor in Council that it appears to it desirable that the existing Mansfield-Woods Point road in the Shire of Mansfield (declared to be a main road under the said Act which declaration was confirmed by the Order in Council published in the *Government Gazette* of the 9th December, 1914, on page 5527) should be widened by the said Board: And whereas the said Board in accordance with the requirements of section 19 of the said cited Act has caused to be prepared a map plan and estimate showing the points between which and on and through what land the said widening is proposed to be made and the cost of acquiring the land: And whereas on an inspection of the said map and plan and a consideration of the said estimate His Excellency the Governor in Council is satisfied that there are funds legally available for acquiring the land: Now therefore be it known by this present Order that His Excellency the Governor of the State of Victoria with the advice of the Executive Council thereof doth hereby approve of the said road being widened, that is to say:—

All that piece of land in the Parish of Jamieson, the boundaries of which are as follow:—Commencing at the northern angle of allotment 1A, section 10, Township of Jamieson in the said parish; thence by lines bearing respectively 119 deg. 45 min. 100 links, 222 deg. 52 min. 118 links, and 357 deg. 15 min. 136.3 links to the point of commencement—which said piece of land is particularly delineated and shown coloured red on survey plan numbered 7180, lodged in the office of the Country Roads Board.

And the Honorable Sir Thomas Karran Maltby, Her Majesty's Commissioner of Public Works for the State of Victoria, shall give the necessary directions herein accordingly.

A. MAHLSTEDT,
Clerk of the Executive Council.

EXPLOSIVES ACT 1958.

At the Executive Council Chamber, Melbourne, the seventeenth day of June, 1959.

PRESENT:

His Excellency the Governor of Victoria.
Sir Arthur Warner | Sir Thomas Maltby.

CLASSIFICATION OF EXPLOSIVES.

HIS Excellency the Governor of the State of Victoria, by and with the advice of the Executive Council thereof, and in pursuance of the provisions of section 53 of the *Explosives Act 1958*, doth by this Order classify the under-mentioned explosives as follows:—

CLASS 3.—NITRO-COMPOUND.

Division 1.

Norma Smokeless Powder (ZZ).

Division 2.

Plastic Explosive PE3 (ZZ).

CLASS 6.—AMMUNITION.

Division 1.

Electric Multiple Fuse Igniters (X).

And the Honorable Lindsay Hamilton Simpson Thompson, for and on behalf of Her Majesty's Chief Secretary for the State of Victoria, shall give the necessary directions herein accordingly.

A. MAHLSTEDT,
Clerk of the Executive Council.

INVERLOCH WATERWORKS TRUST.

*At the Executive Council Chamber, Melbourne, the
seventeenth day of June, 1959.*

PRESENT:

His Excellency the Governor of Victoria.
Sir Arthur Warner | Sir Thomas Maltby.

ADDITIONAL LOAN OF £15,717.

UNDER the powers conferred by the Water Acts and all other powers enabling him in that behalf, His Excellency the Governor of the State of Victoria, by and with the advice of the Executive Council of the said State, doth hereby grant an additional loan of Fifteen thousand seven hundred and seventeen pounds (£15,717) to the Inverloch Waterworks Trust for the completion of construction of a new town water supply scheme at Inverloch, as set forth in the detailed statement bearing date the 11th June, 1959, and verified under the seal of the State Rivers and Water Supply Commission.

The loan hereby granted shall be subject to the provisions of the Water Acts.

And the Honorable Wilfred John Mibus, Her Majesty's Minister of Water Supply for the State of Victoria, shall give the necessary directions herein accordingly.

A. MAHLSTEDT,
Clerk of the Executive Council.

MORWELL WATERWORKS TRUST.

*At the Executive Council Chamber, Melbourne, the
seventeenth day of June, 1959.*

PRESENT:

His Excellency the Governor of Victoria.
Sir Arthur Warner | Sir Thomas Maltby.

ADDITIONAL LOAN OF £15,000.

UNDER the powers conferred by the Water Acts and all other powers enabling him in that behalf, His Excellency the Governor of the State of Victoria, by and with the advice of the Executive Council of the said State, doth hereby grant an additional loan of Fifteen thousand pounds (£15,000) to the Morwell Waterworks Trust for the construction of pipe mains and the purchase and installation of meters at Morwell and the construction of a town water supply scheme at Yinnar, as set forth in the detailed statement bearing date the 11th June, 1959, and verified under the seal of the State Rivers and Water Supply Commission.

The loan hereby granted shall be subject to the provisions of the Water Acts.

And the Honorable Wilfred John Mibus, Her Majesty's Minister of Water Supply for the State of Victoria, shall give the necessary directions herein accordingly.

A. MAHLSTEDT,
Clerk of the Executive Council.

COBRAM WATERWORKS TRUST.

*At the Executive Council Chamber, Melbourne, the
seventeenth day of June, 1959.*

PRESENT:

His Excellency the Governor of Victoria.
Sir Arthur Warner | Sir Thomas Maltby.

ADDITIONAL LOAN OF £1,382.

UNDER the powers conferred by the Water Acts and all other powers enabling him in that behalf, His Excellency the Governor of the State of Victoria, by and with the advice of the Executive Council of the said State, doth hereby grant an additional loan of One thousand three hundred and eighty-two pounds (£1,382) to the Cobram Waterworks Trust for the construction of pipe mains and the purchase and installation of meters, as set forth in the detailed statement bearing date the 11th June, 1959, and verified under the seal of the State Rivers and Water Supply Commission.

The loan hereby granted shall be subject to the provisions of the Water Acts.

And the Honorable Wilfred John Mibus, Her Majesty's Minister of Water Supply for the State of Victoria, shall give the necessary directions herein accordingly.

A. MAHLSTEDT,
Clerk of the Executive Council.

CORRYONG WATERWORKS TRUST.

*At the Executive Council Chamber, Melbourne, the
seventeenth day of June, 1959.*

PRESENT:

His Excellency the Governor of Victoria.
Sir Arthur Warner | Sir Thomas Maltby.

ADDITIONAL LOAN OF £3,000.

UNDER the powers conferred by the Water Acts and all other powers enabling him in that behalf, His Excellency the Governor of the State of Victoria, by and with the advice of the Executive Council of the said State, doth hereby grant an additional loan of Three thousand pounds (£3,000) to the Corryong Waterworks Trust for the construction of pipe mains and the purchase and installation of meters, as set forth in the detailed statement bearing date the 11th June, 1959, and verified under the seal of the State Rivers and Water Supply Commission.

The loan hereby granted shall be subject to the provisions of the Water Acts.

And the Honorable Wilfred John Mibus, Her Majesty's Minister of Water Supply for the State of Victoria, shall give the necessary directions herein accordingly.

A. MAHLSTEDT,
Clerk of the Executive Council.

HAMILTON WATERWORKS TRUST.

*At the Executive Council Chamber, Melbourne, the
seventeenth day of June, 1959.*

PRESENT:

His Excellency the Governor of Victoria.
Sir Arthur Warner | Sir Thomas Maltby.

ADDITIONAL LOAN OF £50,000.

UNDER the powers conferred by the Water Acts and all other powers enabling him in that behalf, His Excellency the Governor of the State of Victoria, by and with the advice of the Executive Council of the said State, doth hereby grant an additional loan of Fifty thousand pounds (£50,000) to the Hamilton Waterworks Trust for the construction of main pipe-line and pipe mains and the purchase and installation of meters, as set forth in the detailed statement bearing date the 11th June, 1959, and verified under the seal of the State Rivers and Water Supply Commission.

The loan hereby granted shall be subject to the provisions of the Water Acts.

And the Honorable Wilfred John Mibus, Her Majesty's Minister of Water Supply for the State of Victoria, shall give the necessary directions herein accordingly.

A. MAHLSTEDT,
Clerk of the Executive Council.

WARRNAMBOOL SEWERAGE AUTHORITY.

*At the Executive Council Chamber, Melbourne, the
seventeenth day of June, 1959.*

PRESENT:

His Excellency the Governor of Victoria.
Sir Arthur Warner | Sir Thomas Maltby.

CONSENT TO BORROWING £50,000.

UNDER the powers conferred by the *Sewerage Districts Act 1958* and all other powers enabling him in that behalf, His Excellency the Governor of the State of

Victoria, by and with the advice of the Executive Council of the said State, doth hereby consent to the Warrnambool Sewerage Authority borrowing by the issue of debentures the sum of Fifty thousand pounds (£50,000) in two amounts of Thirty thousand pounds (£30,000) and Twenty thousand pounds (£20,000) respectively to meet the cost of sewerage extensions, as set forth in the detailed statement bearing date the 12th June, 1959.

And the Honorable Wilfred John Mibus, Her Majesty's Minister of Water Supply for the State of Victoria, shall give the necessary directions herein accordingly.

A. MAHLSTEDT,
Clerk of the Executive Council.

BALLARAT WATER COMMISSIONERS.

At the Executive Council Chamber, Melbourne, the seventeenth day of June, 1959.

PRESENT:

His Excellency the Governor of Victoria.
Sir Arthur Warner | Sir Thomas Maltby.

ADDITIONAL LOAN OF £30,000.

UNDER the powers conferred by the Water Acts and all other powers enabling him in that behalf, His Excellency the Governor of the State of Victoria, by and with the advice of the Executive Council of the said State, doth hereby grant an additional loan of Thirty thousand pounds (£30,000) to the Ballarat Water Commissioners for the construction of pipe mains and the purchase and installation of meters, as set forth in the detailed statement bearing date the 11th June, 1959, and verified under the seal of the State Rivers and Water Supply Commission.

The loan hereby granted shall be subject to the provisions of the Water Acts.

And the Honorable Wilfred John Mibus, Her Majesty's Minister of Water Supply for the State of Victoria, shall give the necessary directions herein accordingly.

A. MAHLSTEDT,
Clerk of the Executive Council.

TRARALGON SEWERAGE AUTHORITY.

At the Executive Council Chamber, Melbourne, the seventeenth day of June, 1959.

PRESENT:

His Excellency the Governor of Victoria.
Sir Arthur Warner | Sir Thomas Maltby.

POWER TO BORROW £30,000.

UNDER the powers conferred by the *Sewerage Districts Act 1958* and all other powers enabling him in that behalf, His Excellency the Governor of the State of Victoria, by and with the advice of the Executive Council of the said State, doth hereby consent to the Traralgon Sewerage Authority borrowing at interest an additional sum of Thirty thousand pounds (£30,000) for the carrying out of works in accordance with the provisions of sections 95, 130, and 137 of the *Sewerage Districts Act 1958*, the said sum to be borrowed by way of overdraft from the Commonwealth Trading Bank of Australia. All moneys received by the said Authority in repayment of costs and expenses of the said works, or any of them, shall be set aside for the purposes of and applied in repayment of the said sum so borrowed.

And the Honorable Wilfred John Mibus, Her Majesty's Minister of Water Supply for the State of Victoria, shall give the necessary directions herein accordingly.

A. MAHLSTEDT,
Clerk of the Executive Council.

TALLANGATTA SEWERAGE AUTHORITY.

At the Executive Council Chamber, Melbourne, the seventeenth day of June, 1959.

PRESENT:

His Excellency the Governor of Victoria.
Sir Arthur Warner | Sir Thomas Maltby.

ADDITIONAL LOAN OF £7,262.

UNDER the powers conferred by the *Sewerage Districts Act 1958* and all other powers enabling him in that behalf, His Excellency the Governor of the State of Victoria, by and with the advice of the Executive Council of the said State, doth hereby grant an additional loan of Seven thousand two hundred and sixty-two pounds (£7,262) to the Tallangatta Sewerage Authority to meet the cost of sewerage works at Tallangatta, as set forth in the detailed statement bearing date the 12th June, 1959.

The loan hereby granted shall be subject to the provisions of the *Sewerage Districts Act 1958*.

And the Honorable Wilfred John Mibus, Her Majesty's Minister of Water Supply for the State of Victoria, shall give the necessary directions herein accordingly.

A. MAHLSTEDT,
Clerk of the Executive Council.

MOE SEWERAGE AUTHORITY.

At the Executive Council Chamber, Melbourne, the seventeenth day of June, 1959.

PRESENT:

His Excellency the Governor of Victoria.
Sir Arthur Warner | Sir Thomas Maltby.

CONSENT TO BORROWING £15,000.

UNDER the powers conferred by the *Sewerage Districts Act 1958* and all other powers enabling him in that behalf, His Excellency the Governor of the State of Victoria, by and with the advice of the Executive Council of the said State, doth hereby consent to the Moe Sewerage Authority borrowing by the issue of debentures the sum of Fifteen thousand pounds (£15,000) to meet the cost of sewerage works at Moe, as set forth in the detailed statement bearing date the 12th June, 1959.

And the Honorable Wilfred John Mibus, Her Majesty's Minister of Water Supply for the State of Victoria, shall give the necessary directions herein accordingly.

A. MAHLSTEDT,
Clerk of the Executive Council.

LORNE SEWERAGE AUTHORITY.

At the Executive Council Chamber, Melbourne, the seventeenth day of June, 1959.

PRESENT:

His Excellency the Governor of Victoria.
Sir Arthur Warner | Sir Thomas Maltby.

CONSENT TO BORROWING £85,000.

UNDER the powers conferred by the *Sewerage Districts Act 1958* and all other powers enabling him in that behalf, His Excellency the Governor of the State of Victoria, by and with the advice of the Executive Council of the said State, doth hereby consent to the Lorne Sewerage Authority borrowing by the issue of debentures the sum of Eighty-five thousand pounds (£85,000) to meet the cost of sewerage works at Lorne, as set forth in the detailed statement bearing date the 12th June, 1959.

And the Honorable Wilfred John Mibus, Her Majesty's Minister of Water Supply for the State of Victoria, shall give the necessary directions herein accordingly.

A. MAHLSTEDT,
Clerk of the Executive Council.

HORSHAM SEWERAGE AUTHORITY.

At the Executive Council Chamber, Melbourne, the
seventeenth day of June, 1959.

PRESENT:

His Excellency the Governor of Victoria.
Sir Arthur Warner | Sir Thomas Maltby.

CONSENT TO BORROWING £40,000.

UNDER the powers conferred by the *Sewerage Districts Act 1958* and all other powers enabling him in that behalf, His Excellency the Governor of the State of Victoria, by and with the advice of the Executive Council of the said State, doth hereby consent to the Horsham Sewerage Authority borrowing by the issue of debentures the sum of Forty thousand pounds (£40,000) in two amounts of Thirty thousand pounds (£30,000) and Ten thousand pounds (£10,000) respectively to meet the cost of sewerage works, as set forth in the detailed statement bearing date the 12th June, 1959.

And the Honorable Wilfred John Mibus, Her Majesty's Minister of Water Supply for the State of Victoria, shall give the necessary directions herein accordingly.

A. MAHLSTEDT,
Clerk of the Executive Council.

LATROBE VALLEY WATER AND SEWERAGE BOARD.

At the Executive Council Chamber, Melbourne, the
seventeenth day of June, 1959.

PRESENT:

His Excellency the Governor of Victoria.
Sir Arthur Warner | Sir Thomas Maltby.

ADDITIONAL LOAN OF £82,977.

UNDER the powers conferred by the *Latrobe Valley Act 1958* and all other powers enabling him in that behalf, His Excellency the Governor of the State of Victoria, by and with the advice of the Executive Council of the said State, doth hereby grant an additional loan of Eighty-two thousand nine hundred and seventy-seven pounds (£82,977) to the Latrobe Valley Water and Sewerage Board for the purpose of constructing sewers, channels, storages, and purchase of land and construction or purchase of works or buildings, and development of land disposal scheme, as set forth in the detailed statement bearing date the 11th June, 1959, and verified under the seal of the State Rivers and Water Supply Commission.

The loan hereby granted shall be subject to the provisions of the *Latrobe Valley Act 1958*.

And the Honorable Wilfred John Mibus, Her Majesty's Minister of Water Supply for the State of Victoria, shall give the necessary directions herein accordingly.

A. MAHLSTEDT,
Clerk of the Executive Council.

HOSPITALS AND CHARITIES ACT 1958 (No. 6274).—
SECTION 65.

At the Executive Council Chamber, Melbourne, the
seventeenth day of June, 1959.

PRESENT:

His Excellency the Governor of Victoria.
Sir Arthur Warner | Sir Thomas Maltby.

AUTHORITY FOR THE SALE OF LAND BY THE
ROYAL WOMEN'S HOSPITAL.

WHEREAS the Royal Women's Hospital, an incorporated institution within the meaning of the *Hospitals and Charities Act 1958* (No. 6274), is the owner of certain land no part of which is land granted, reserved or set apart by the Crown for the purposes of the institution and is situated at 6 Ulupna-road, Ormond, and described in the Schedule hereunder:

And whereas the majority of the members of the Committee of Management of the Royal Women's Hospital desire that the said land be sold:

And whereas the Hospitals and Charities Commission after inquiry has reported that it would be advantageous to the Royal Women's Hospital if the hospital sold the said land:

Now therefore, the Governor of the State of Victoria, by and with the advice of the Executive Council thereof, being satisfied that in the hereinbefore recited special circumstances the sale of the said land would be advantageous to the Royal Women's Hospital, doth hereby authorize the sale of such land freed and discharged from any trusts affecting the same and doth hereby direct that such land be sold in accordance with the following terms and on the following conditions, that is to say:—

1. The sale price shall be an amount of not less than £8,600, subject to the immediate payment of a deposit of £1,000 and to a further payment of £2,000 within a period of not more than six months from the date on which the contract of sale is signed;
2. The balance of the purchase price shall be paid by the purchaser within a period of not more than two years from the date on which the contract of sale is signed together with interest on the unpaid balance calculated quarterly at the rate of Six and a half per centum per annum.

SCHEDULE.

All that piece of land being part of Crown portion 67, Parish of Prahran East of Elsternwick, County of Bourke, being the whole of the land described in certificate of title, volume 6501, folio 003.

And the Honorable Ewen Paul Cameron, Her Majesty's Minister of Health for the State of Victoria, shall give the necessary directions herein accordingly.

A. MAHLSTEDT,
Clerk of the Executive Council.

LATROBE RIVER IMPROVEMENT TRUST.

At the Executive Council Chamber, Melbourne, the
twenty-third day of June, 1959.

PRESENT:

His Excellency the Governor of Victoria.
Mr. Cameron | Mr. Mibus
Mr. Reid | Mr. Fraser.

LOAN OF £1,500.

IN pursuance of the powers conferred by section 43 of the *River Improvement Act 1958* and all other powers enabling him in that behalf, His Excellency the Governor of the State of Victoria, by and with the advice of the Executive Council of the said State, doth by this Order—

1. Make advance by way of loan to the Latrobe River Improvement Trust of a sum of One thousand five hundred pounds (£1,500); and
2. Apply the following terms and conditions:—
 - (a) That the said sum shall be used for the continuation of river improvement works within the boundaries of the Latrobe River Improvement District;
 - (b) That the Latrobe River Improvement Trust shall, in respect of such advance by way of loan, be subject to the powers, rights, duties, and obligations conferred and imposed by—
 - (i) the provisions of sections 284, 285, and 287 to 294 of Part VII. of the *Water Act 1958*, so adapted that the word "Authority" therein shall mean "the Latrobe River Improvement Trust"; and
 - (ii) the provisions of section 295 of the said Part VII. of the *Water Act 1958*, so adapted as if for the expressions "any waterworks trust or local governing body" and "such waterworks trust or local governing body" there were substituted the expression "the Latrobe River Improvement Trust".

And the Honorable Wilfred John Mibus, Her Majesty's Minister of Water Supply for the State of Victoria, shall give the necessary directions herein accordingly.

A. MAHLSTEDT,
Clerk of the Executive Council.

MITCHELL RIVER IMPROVEMENT TRUST.

At the Executive Council Chamber, Melbourne, the twenty-third day of June, 1959.

PRESENT:

His Excellency the Governor of Victoria.	
Mr. Cameron	Mr. Mibus
Mr. Reid	Mr. Fraser.

LOAN OF £2,000.

IN pursuance of the powers conferred by section 43 of the *River Improvement Act 1958* and all other powers enabling him in that behalf, His Excellency the Governor of the State of Victoria, by and with the advice of the Executive Council of the said State, doth by this Order—

1. Make advance by way of loan to the Mitchell River Improvement Trust of a sum of Two thousand pounds (£2,000); and
2. Apply the following terms and conditions:—
 - (a) That the said sum shall be used for the continuation of river improvement works within the boundaries of the Mitchell River Improvement District.
 - (b) That the Mitchell River Improvement Trust shall, in respect of such advance by way of loan, be subject to the powers, rights, duties, and obligations conferred and imposed by—
 - (i) the provisions of sections 284, 285, and 287 to 294 of Part VII. of the *Water Act 1958*, so adapted that the word "Authority" therein shall mean "the Mitchell River Improvement Trust"; and
 - (ii) the provisions of section 295 of the said Part VII. of the *Water Act 1958*, so adapted as if for the expressions "any waterworks trust or local governing body" and "such waterworks trust or local governing body" there were substituted the expression "the Mitchell River Improvement Trust".

And the Honorable Wilfred John Mibus, Her Majesty's Minister of Water Supply for the State of Victoria, shall give the necessary directions herein accordingly.

A. MAHLSTEDT,
Clerk of the Executive Council.

YARRA RIVER IMPROVEMENT TRUST.

At the Executive Council Chamber, Melbourne, the twenty-third day of June, 1959.

PRESENT:

His Excellency the Governor of Victoria.	
Mr. Cameron	Mr. Mibus
Mr. Reid	Mr. Fraser.

LOAN OF £5,000.

IN pursuance of the powers conferred by section 43 of the *River Improvement Act 1958* and all other powers enabling him in that behalf, His Excellency the Governor of the State of Victoria, by and with the advice of the Executive Council of the said State, doth by this Order—

1. Make advance by way of loan to the Yarra River Improvement Trust of a sum of Five thousand pounds (£5,000); and
2. Apply the following terms and conditions:—
 - (a) That the said sum shall be used for the carrying out of works of river improvement within the boundaries of the Yarra River Improvement District.
 - (b) That the Yarra River Improvement Trust shall, in respect of such advance by way of loan, be subject to the powers, rights, duties, and obligations conferred and imposed by—
 - (i) the provisions of sections 284, 285, and 287 to 294 of Part VII. of the *Water Act 1958*, so adapted that the word "Authority" therein shall mean "the Yarra River Improvement Trust"; and

- (ii) the provisions of section 295 of the said Part VII. of the *Water Act 1958*, so adapted as if for the expressions "any waterworks trust or local governing body" and "such waterworks trust or local governing body" there were substituted the expression "the Yarra River Improvement Trust".

And the Honorable Wilfred John Mibus, Her Majesty's Minister of Water Supply for the State of Victoria, shall give the necessary directions herein accordingly.

A. MAHLSTEDT,
Clerk of the Executive Council.

Water Acts.

STATE RIVERS AND WATER SUPPLY COMMISSION.

At the Executive Council Chamber, Melbourne, the twenty-third day of June, 1959.

PRESENT:

His Excellency the Governor of Victoria.	
Mr. Cameron	Mr. Mibus
Mr. Reid	Mr. Fraser.

DIRECTION AS TO MAINTENANCE AND MANAGEMENT OF WORKS IN CERTAIN DISTRICTS.

WHEREAS by section 47 of the *Water Act 1958* (No. 6413), it is provided that where Parliament or the Governor in Council directs the Commission to maintain any works in respect of which the Commission has submitted, to the Minister, a report, in writing, that such works will not produce sufficient revenue to cover the expense of the maintenance and management (including depreciation) thereof, the amount of the loss resulting from the maintenance and management of such works shall be transferred to an account in the books of the Commission called the "Revenue Expenditure Chargeable to the State Account", and whereas the Commission has submitted, to the Minister, a report, in writing, that the works of the Districts set out hereunder will not produce sufficient revenue to cover the expense of the maintenance and management thereof: Now therefore His Excellency the Governor of the State of Victoria, acting by and with the advice of the Executive Council thereof, and in pursuance of the provisions of the said section, doth hereby direct the State Rivers and Water Supply Commission as on and from the first day of July, 1958, to continue to maintain the works of each of the said Districts, and doth hereby direct that the amount of loss resulting from the maintenance and management of the works of each of the said Districts during the period 1st July, 1958 to 30th June, 1959, shall be transferred to an account in the books of the said Commission called "Revenue Expenditure Chargeable to the State Account".

DISTRICTS REFERRED TO ABOVE.

Irrigation and Water Supply Districts.

Boort, Cohuna, Deakin, Fish Point, Kerang, Koondrook, Mystic Park, Nyah, Red Cliffs, Robinvale, Rodney, Shepparton, Swan Hill, Third Lake, Tragowel Plains, and Trésco.

Waterworks Districts.

Axe Creek, Birchip, Harcourt, Karkarook, Loddon, Long Lake, Millewa, Normanville, Ouyen, Otway, Sea Lake, Tyntynder, Tyntynder North, Tyrrell, Tyrrell West, Upper Western Wimmera, Werribee, Wycheproof, and Wychitella.

Urban Districts.

Allansford, Berwick, Brim, Chinkapook, Coliban, Dingee, Dooen, Elphinstone, Hopetoun, Jung Jung, Lake Boga, Lalbert, Macorna, Marong, Meringur, Mitiamo, Murrabit, Nandaly, Natimuk, Newstead, Nullawil, Pimpimio, Quambatook, Speed, Tempy, Waitchie, Walpeup, Watchem, Werrimul, and Yaapeet.

Flood Protection District.

Cardinia.

And the Honorable Wilfred John Mibus, Her Majesty's Minister of Water Supply for the State of Victoria, shall give the necessary directions herein accordingly.

A. MAHLSTEDT,
Clerk of the Executive Council.

Water Acts.

STATE RIVERS AND WATER SUPPLY COMMISSION.
—SWAN HILL IRRIGATION AND WATER SUPPLY DISTRICT.

At the Executive Council Chamber, Melbourne, the
twenty-third day of June, 1959.

PRESENT:

His Excellency the Governor of Victoria.
Mr. Cameron | Mr. Mibus
Mr. Reid | Mr. Fraser.

PORTION EXCISED.

UNDER the powers conferred by the Water Acts and all other powers enabling him in that behalf, His Excellency the Governor of the State of Victoria, with the advice of the Executive Council of the said State, on the recommendation of the State Rivers and Water Supply Commission, doth hereby declare, order and direct as follows:—

That there shall be excised from the Swan Hill Irrigation and Water Supply District that portion of the same set out and described in the Schedule hereto, which portion as from the 30th June, 1959, shall be deemed to be excised accordingly.

SCHEDULE.

Commencing at the south-western angle of allotment F, section 7A, Parish of Castle Donnington, County of Tatchera; thence northerly, easterly and southerly by the western, northern and eastern boundaries of said allotment F to its south-eastern angle; thence south-easterly by a line across a road to the north-eastern angle of allotment D, section 8; thence westerly by the northern boundaries of allotments D and C to the north-western angle of the last-mentioned allotment; thence northerly by a line across a road to the point of commencement.

The portion described in the foregoing Schedule is shown on a plan approved by the Governor in Council, and deposited in the office of the State Rivers and Water Supply Commission, Melbourne.—(Corres. 58/14379.)

And the Honorable Wilfred John Mibus, Her Majesty's Minister of Water Supply for the State of Victoria, shall give the necessary directions herein accordingly.

A. MAHLSTEDT,
Clerk of the Executive Council.

Water Acts.

SWAN HILL WATERWORKS TRUST.

At the Executive Council Chamber, Melbourne, the
twenty-third day of June, 1959.

PRESENT:

His Excellency the Governor of Victoria.
Mr. Cameron | Mr. Mibus
Mr. Reid | Mr. Fraser.

EXTENT OF DISTRICT INCREASED.

UNDER the powers conferred by the Water Acts and all other powers enabling him in that behalf, His Excellency the Governor of the State of Victoria, with the advice of the Executive Council of the said State, doth hereby declare, order and direct as follows:—

That the extent of the Waterworks District of the Swan Hill Waterworks Trust be increased by adding to the same the lands set out and described in the Schedule hereto, and as on and from the 1st day of July, 1959, the extent of such district shall be deemed to be increased accordingly.

SCHEDULE.

Commencing at the south-western angle of allotment F, section 7A, Parish of Castle Donnington, County of Tatchera; thence northerly, easterly and southerly by the western, northern and eastern boundaries of said allotment F to its south-eastern angle; thence south-easterly by a line across a road to the north-eastern angle of allotment D, section 8; thence westerly by the northern boundaries of allotments D and C to the north-western angle of the last-mentioned allotment; thence northerly by a line across a road to the point of commencement.

The lands described in the foregoing Schedule are shown on a plan approved by the Governor in Council, and deposited in the office of the State Rivers and Water Supply Commission, Melbourne.—(Corres. 58/14379.)

And the Honorable Wilfred John Mibus, Her Majesty's Minister of Water Supply for the State of Victoria, shall give the necessary directions herein accordingly.

A. MAHLSTEDT,
Clerk of the Executive Council.

WURRUK WATERWORKS TRUST CONSTITUTED.

At the Executive Council Chamber, Melbourne, the
twenty-third day of June, 1959.

PRESENT:

His Excellency the Governor of Victoria.
Mr. Cameron | Mr. Mibus
Mr. Reid | Mr. Fraser.

UNDER the powers conferred by the Water Acts and all other powers enabling him in that behalf, His Excellency the Governor of the State of Victoria, by and with the advice of the Executive Council of the said State, doth hereby approve of the constitution of a Waterworks Trust, subject to the provisions of the said Acts, to take over, manage and maintain the works for the supply of water to the Township of Wurruk and doth hereby order and appoint as follows:—

1. That the principal works to be taken over by the said Waterworks Trust shall consist of the pipe reticulation of the Township of Wurruk.

2. That the limits of the land within which the said Waterworks Trust shall have authority shall be those comprised within the boundaries described in the Schedule hereto.

SCHEDULE.

Commencing at the south-eastern angle of Crown allotment 14, Parish of Wurruk Wurruk, County of Tanjil; thence northerly along the eastern boundaries of the said Crown allotment 14 and of Crown allotment 14A and by a line being a continuation thereof across Crown land to a point on the right bank of the Thomson River; thence generally south-easterly along the said right bank of the Thomson River to the most northerly angle on the boundary of the Township of Wurruk; thence generally south-easterly along the north-eastern boundary of the Township of Wurruk to the north-eastern angle of allotment 1A, section A, Township of Wurruk; thence south-easterly by a line parallel to the north-eastern boundaries of allotments 1 and 2, section 1 through Crown allotment 3, section A, Parish of Wurruk Wurruk to a point on the southern boundary of the said Crown allotment 3 being a point on the northern boundary of the Princes Highway; thence due south by a line across the said Princes Highway to a point on its southern boundary; thence westerly, north-westerly and westerly along the said boundary to a point in line with the eastern boundary of Crown allotment 14; thence northerly by a line across the aforesaid Princes Highway to the south-eastern angle of the said Crown allotment 14 being the point of commencement.

All of which boundaries are shown on a plan approved by the Governor in Council and deposited in the office of the State Rivers and Water Supply Commission, Melbourne.—(Corres. 59/1643.)

3. That three Councillors elected by the Shire of Rosedale and two other persons appointed by the Governor in Council shall be Commissioners of the Waterworks Trust.

4. That the name of the Trust shall be "Wurruk Waterworks Trust".

5. That on and from the first day of July, 1959, all works, liabilities, assets, receipts, disbursements, funds, properties, duties and powers of the Shire of Rosedale appertaining to the Wurruk Water Supply shall be taken over by the Wurruk Waterworks Trust.

6. That the Trust may borrow subject to the provisions of the said Acts an amount of money which shall not exceed in the whole the sum of One thousand six hundred pounds (£1,600) for the purpose of defraying the capital liability incurred by the Rosedale Shire Council in respect of the said waterworks.

And the Honorable Wilfred John Mibus, Her Majesty's Minister of Water Supply for the State of Victoria, shall give the necessary directions herein accordingly.

A. MAHLSTEDT,
Clerk of the Executive Council.

TATURA WATERWORKS TRUST.

At the Executive Council Chamber, Melbourne, the twenty-third day of June, 1959.

PRESENT:

His Excellency the Governor of Victoria.

Mr. Cameron		Mr. Mibus
Mr. Reid		Mr. Fraser.

ADDITIONAL LOAN OF £2,000.

UNDER the powers conferred by the Water Acts and all other powers enabling him in that behalf, His Excellency the Governor of the State of Victoria, by and with the advice of the Executive Council of the said State, doth hereby grant an additional loan of Two thousand pounds (£2,000) to the Tatura Waterworks Trust for the construction of emergency pumping plant, pipe mains, and the purchase and installation of meters, as set forth in the detailed statement bearing date the 19th June, 1959, and verified under the seal of the State Rivers and Water Supply Commission.

The loan hereby granted shall be subject to the provisions of the Water Acts.

And the Honorable Wilfred John Mibus, Her Majesty's Minister of Water Supply for the State of Victoria, shall give the necessary directions herein accordingly.

A. MAHLSTEDT,
Clerk of the Executive Council.

rate of Five pounds per centum per annum, to be computed with respect to each instalment for the period which has elapsed between the time of sale and the time of the payment of such instalment. If the residue of the price be paid within thirty days after the time of the sale no interest will be payable thereon.

The Governor in Council may allow a transfer of the purchaser's interest to an approved person at any time before the final payment of the purchase money is made. The fee for transfer shall be One pound and such transfer will be subject to payment of stamp duty.

SCALE OF PAYMENTS OF RESIDUE.

£20 and under, 6 instalments.
Over £20, and not exceeding £50, 8 instalments.
Over £50, and not exceeding £100, 10 instalments.
Over £100, and not exceeding £200, 12 instalments.
Over £200, and not exceeding £300, 14 instalments.
Over £300, and not exceeding £400, 16 instalments.
Over £400, and not exceeding £500, 18 instalments.
Over £500, 20 instalments.

FEES, ETC.

The amount payable for Assurance Fund (One half-penny for each £1 of purchase price) and Crown grant fee must be paid with the balance of purchase money. The following is the scale of fees for Crown grants:—

50 acres and under, £1 10s.
Over 50 acres, £2.
Where the purchase money does not exceed £5, the grant fee is £1.

Valuations of improvements (if not purchased by the owner thereof), and charges for survey, must also be paid at the time of sale.

KEITH TURNBULL,
Commissioner of Crown Lands and Survey.

Office of Crown Lands and Survey,
Melbourne, 23rd June, 1959.

APPROACHING LAND SALES.

SALES of Crown lands, in fee-simple, will be held at the under-mentioned places and dates, viz.:—

	No. of Gazette
Ballarat.—Tuesday, 28th July, 1959 ..	55
Casterton.—Thursday, 30th July, 1959 ..	53
Castlemaine.—Thursday, 16th July, 1959 ..	49
Daylesford.—Thursday, 16th July, 1959 ..	49
Hamilton.—Wednesday, 29th July, 1959 ..	55
Kerang.—Tuesday, 30th June, 1959 ..	43
Kyneton.—Thursday, 16th July, 1959 ..	49
Maldon.—Thursday, 16th July, 1959 ..	49
Melbourne.—Wednesday, 15th July, 1959 ..	49
Murrayville.—Wednesday, 5th August, 1959 ..	55
Portland.—Friday, 31st July, 1959 ..	53
Sea Lake.—Monday, 29th June, 1959 ..	43
Stawell.—Wednesday, 15th July, 1959 ..	49

CLOSER SETTLEMENT ACT 1938.

Piangil.—Tuesday, 30th June, 1959 .. 43

SALE BY AUCTION OF RIGHT TO LEASE CROWN ALLOTMENTS.

Melbourne.—Wednesday, 1st July, 1959 .. 43

SALES OF CROWN LANDS BY AUCTION.

The lands will be sold in fee-simple, and subject to the covenants, conditions, exceptions, and reservations directed by the Governor in Council by an Order in Council dated the 5th August, 1930, and published in the *Government Gazette* of the 8th August, 1930, varied as herein.

A deposit of at least twelve and a half per centum of the price at which each lot is sold must be paid by the purchaser at the time of sale, and all such payments shall be made in coin, bank notes or cheques approved by the officer conducting the sale, and the residue of such price will be payable in equal instalments, in accordance with the scale hereunder, on the last day of each successive period of six months from the time of sale, or, if the purchaser choose, at any earlier time or times; and such residue of the purchase money shall bear interest at the

HAMILTON.—Sale (No. 11427) of Crown lands in fee-simple, by auction, will be held at the LAND OFFICE, HAMILTON, on WEDNESDAY, the 29th JULY, 1959, at TWO o'clock p.m. To be conducted by H. E. MICHELL, Land Officer.

Lot 1.

TOWNSHIP OF BALMORAL, PARISH OF BALMORAL, COUNTY OF DUNDAS.

Fronting South-west side of Glendinning-street, about 10 chains North-west of Fairburn-street.

Upset price £40 the lot. Charge for survey £6.

Area 2 roods, subject to survey and any necessary easements disclosed thereby, allotment 6 of section 20.—(J.30028.)

Lot 2.

TOWNSHIP OF HARROW, PARISH OF HARROW, COUNTY OF LOWAN.

In the South of the Township.

Upset price £5 the lot. Charge for survey £7.

Area 3r. 24p., subject to survey and any necessary easements disclosed thereby, allotment 1B of section 1B.—(Z.34123.)

TOWNSHIP OF CAVENDISH, PARISH OF CAVENDISH, COUNTY OF DUNDAS.

In the North-west of the Township, fronting North-east side of road to Coleraine.

Upset price £25 per lot. Charge for survey £5 15s. per lot.

Lot 3.

Area 2r. 3p., subject to survey and any necessary easements disclosed thereby, allotment 1 of section D.

Lot 4.

Area 2 roods, subject to survey and any necessary easements disclosed thereby, allotment 2 of section D.

Lot 5.

Area 2 roods, subject to survey and any necessary easements disclosed thereby, allotment 3 of section D.

Lot 6.

Area 1r. 21p., subject to survey and any necessary easements disclosed thereby, allotment 4 of section D.—(J.29970.)

NOTE.—The foregoing notification is in lieu of that relating to a sale at Hamilton published in the *Gazette* of 17th June, 1959. (additional lots have been included).

BALLARAT.—Sale (No. 11430) of Crown lands, in fee-simple, by auction, will be held at the LAND OFFICE, BALLARAT, on TUESDAY, the 28th JULY, 1959, at a quarter-past TWO o'clock p.m. To be conducted by H. H. DODD, Land Officer.

TOWNSHIP OF BALLARAT EAST, PARISH OF BALLARAT, COUNTY OF GRANT.

Fronting West side of Lane-street, South of Canterbury-street.

Upset price £100 per lot. Charge for survey £5 5s. per lot.
Lot 1.

Area 25 perches, allotment 5 of section 64. One month allowed for removal of street fencing.

Lot 2.

Area 25 perches, allotment 6 of section 64. One month allowed for removal of street fencing.

Lot 3.

Area 27 perches, allotment 7 of section 64. One month allowed for removal of street fencing.—(J.20856.)

Lot 4.

Fronting a formed road, off Bennett-street.

Upset price £20 the lot. Charge for survey £7 7s. 6d.

Area 2a. 0r. 13p., allotment 7 of section 123. One month allowed for removal of improvements.—(J.27100.)

TOWNSHIP OF CRESWICK, PARISH OF CRESWICK, COUNTY OF TALBOT.

Lot 5.

Fronting East side of Hutchinson-street, about 3 chains North of Lees-street.

Upset price £20 the lot. Charge for survey £6.

Area 1r. 23p., allotment 2 of section 23.

Lot 6.

Fronting East side of Hutchinson-street, about 1 chain North of Lees-street.

Upset price £20 the lot. Charge for survey £6.

Area 1r. 24p., allotment 3 of section 23.—(J.28578.)

Lot 7.

Fronting South-west side of Melbourne-road, about 25 chains South-east of Slaty Creek.

Upset price £10 the lot. Charge for survey £6.

Area 1r. 28p., allotment 18c of section 51.—(J.30134.)

MURRAYVILLE.—Sale (No. 11431) of Crown lands, in fee-simple, by auction, will be held at the LAND INSPECTOR'S OFFICE, MURRAYVILLE, on WEDNESDAY, the 5th AUGUST, 1959, at ELEVEN o'clock a.m. To be conducted by H. H. DODD, Land Officer, Ballarat.

TOWNSHIP OF MURRAYVILLE, PARISH OF DANYO, COUNTY OF WEEAH.

Fronting South side of Poolc-street, West of the State School.

Upset price £20 per lot. Charge for survey £5 10s. per lot.

Lot 1.

Area 1r. 8p., allotment 4 of section 8.

Lot 2.

Area 1r. 8p., allotment 5 of section 8.—(M.56544.)

Lot 3.

Area 1r. 8p., allotment 6 of section 8.

Lot 4.

Area 1r. 8p., allotment 7 of section 8.—(M.40008.)

Lot 5.

Area 1r. 29p., allotment 8 of section 8.

Lot 6.

Area 1r. 30p., allotment 9 of section 8.—(M.47736.)

OUYEN.—Sale (No. 11432) of Crown lands, in fee-simple, by auction, will be held at the LAND INSPECTOR'S OFFICE, OUYEN, on THURSDAY, the 6th AUGUST, 1959, at TWO o'clock p.m. To be conducted by H. H. DODD, Land Officer, Ballarat.

Lot 1.

PARISH OF OUYEN, COUNTY OF KARKAROOO.
South of the Township of Ouyen.

Upset price £110 the lot. Charge for survey £5 10s.

Area 35 perches, allotment 2 of section 1. Subject to drainage easement 10 links wide.—(M.41543.)

No. 55.—5297/59.—3

PROPOSED REVOCATION OF TEMPORARY RESERVATION OF LAND BY ORDER IN COUNCIL.

IN pursuance of the provisions of the Land Act 1958, notice is hereby given that it is the intention of the Governor in Council to revoke the temporary reservation of land by Order in Council hereunder referred to, viz.:—

The following Notice was published 1° on the 3rd June, 1959, pursuant to Order of the 26th May, 1959.

SALE.—The temporary reservation, by Order in Council of the 6th June, 1956, of 92 acres, more or less, of land in the Township of Sale as a site for Public Park and Public Recreation, so far only as the portion containing 1 acre 1 rood 19 perches, indicated by hachure on plan hereunder, is concerned.—(S.239(*) (Rs.1321).

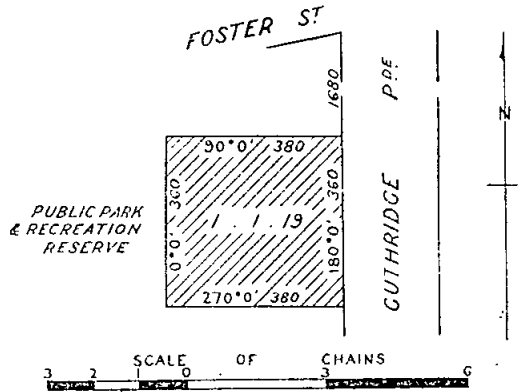

KEITH TURNBULL,
Commissioner of Crown Lands and Survey.

PROPOSED REVOCATIONS OF TEMPORARY RESERVATIONS OF LANDS BY ORDERS IN COUNCIL.

IN pursuance of the provisions of the Land Act 1928, notice is hereby given that it is the intention of the Governor in Council to revoke the temporary reservations of lands by Orders in Council hereunder referred to, viz.:—

The following Notices were published 1° on the 10th June, 1959, pursuant to Orders of the 2nd June, 1959.

COMOORA.—The temporary reservation, by Order in Council of the 9th February, 1874, of 3 roods 34 perches of land in the Township of Comoora as a site for State School purposes.—(C.434(*) (Rs.6935).

VECTIS EAST.—The temporary reservation, by Order in Council of the 31st October, 1887, of 5 acres of land in the Parish of Vectis East as a site for a State School.—(V.12(*) (C.97660).

WARBURTON (WESBURN).—The temporary reservation, by Orders in Council of the 30th August, 1886, and the 29th July, 1889, of 79 acres 3 roods 33 perches of land in the Parish of Warburton as a site for Public Recreation and Public Park respectively, revoked as to part by various Orders, so far only as the portion containing 2 roods 13 perches, indicated by hachure on plan hereunder, is concerned.—(W.348(*) (Rs.2136).

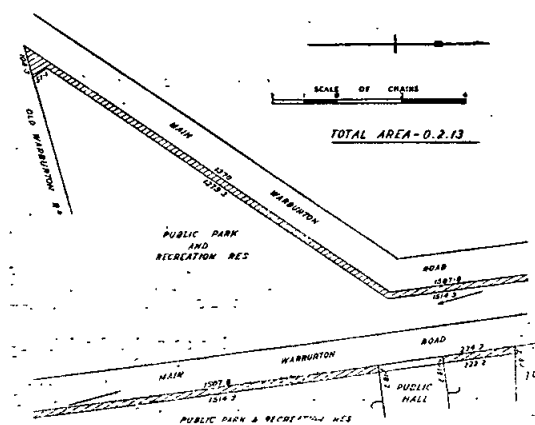

WINCHELSEA.—The temporary reservation, by Order in Council of the 10th January, 1924, of 6 acres 39 perches of land in the Township of Winchelsea, as a site for Drainage purposes, revoked as to part by Order of the 27th July, 1942, so far only as the portion containing 8 perches, indicated by hachure on plan hereunder, is concerned.—(W.168(2) (Rs.2876).

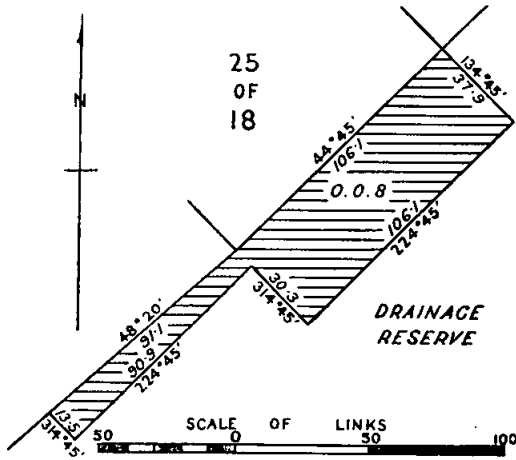

KEITH TURNBULL,
Commissioner of Crown Lands and Survey.

PROPOSED REVOCATIONS OF TEMPORARY RESERVATIONS OF LANDS BY ORDERS IN COUNCIL.

IN pursuance of the provisions of the *Land Act 1958*, notice is hereby given that it is the intention of the Governor in Council to revoke the temporary reservations of lands by Orders in Council hereunder referred to, viz.:—

The following Notices were published 1° on the 19th June, 1959, pursuant to Orders of the 11th June, 1959.

BAILLESTON.—The temporary reservation, by Order in Council of the 22nd November, 1869, of 2 acres of land in the Parish of Bailleston, as a site for Common School purposes.—(B.676(4) (C.42457).

REDCASTLE.—The temporary reservation, by Order in Council of the 31st December, 1873 (see *Government Gazette* of the 9th January, 1874, page 61), of 3 roods 21 perches of land in the Township of Redcastle, as a site for State School purposes.—(R.16(4) (C.89856).

WUNGHNU.—The temporary reservation, as a site for the use of the Police Department, and the withholding from sale, leasing and licensing, by Order in Council of the 17th June, 1873, of 2 acres of land in the Parish of Wunghnu.—(W.305(2) (C.96999).

KEITH TURNBULL,
Commissioner of Crown Lands and Survey.

PROPOSED REVOCATIONS OF TEMPORARY RESERVATIONS, AND THE WITHHOLDING FROM SALE, LEASING, AND LICENSING, OF LANDS BY ORDERS IN COUNCIL.

IN pursuance of the provisions of the *Land Act 1958*, notice is hereby given that it is the intention of the Governor in Council to revoke the temporary reservations, and the withholding from sale, leasing, and licensing, of lands by Orders in Council hereunder referred to, viz.:—

The following Notices were published 1° on the 24th June, 1959, pursuant to Orders of the 17th June, 1959.

EAGLEHAWK.—The temporary reservation as a site for Cricket and other purposes of Public Recreation, and the withholding from sale, leasing, and licensing, by Order in Council of the 4th August, 1884, of 5 acres 2 roods 33 perches of land at Eaglehawk, Parish of Sandhurst.—(Rs.2005) (S.371(2a)).

NHILL.—The temporary reservation as a site for Watering purposes, and the withholding from sale, leasing, and licensing, by Order in Council of the 13th October, 1879, of 76 acres 0 roods 38 perches of land in the Township of Nhill, revoked as to part by various Orders, so far

only as the portion containing 1 rood 21 perches, indicated by hachure on plan hereunder, is concerned.—(N.102(8) (M.37071) (Rs.379).

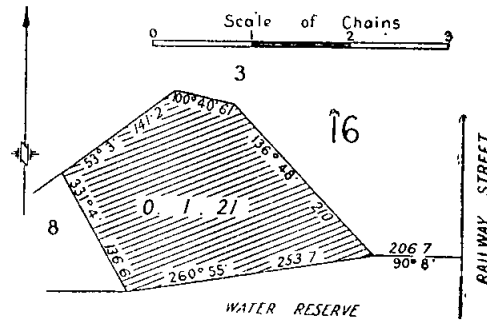

KEITH TURNBULL,
Commissioner of Crown Lands and Survey.

PROPOSED REVOCATIONS OF TEMPORARY RESERVATIONS OF LANDS BY ORDERS IN COUNCIL.

IN pursuance of the provisions of the *Land Act 1958*, notice is hereby given that it is the intention of the Governor in Council to revoke the temporary reservations of lands by Orders in Council hereunder referred to, viz.:—

The following Notices were published 1° on the 24th June, 1959, pursuant to Orders of the 17th June, 1959.

LONGFORD.—The temporary reservation, by Order in Council of the 16th March, 1897, of 3 acres 3 roods 4 perches of land in the Township of Longford as a site for Watering purposes.—(L.91(2) (C.40091).

BEAUFORT.—The temporary reservation, by Order in Council of the 30th June, 1873, of 145 acres 3 roods 12 perches of land in the Parish of Beaufort as a site for Racecourse and Recreation purposes, revoked as to part by Order of the 18th February, 1887, so far only as the balance thereof, containing 142 acres 1 rood 32 perches, is concerned.—(B.305(8) (Rs.4520).

KEITH TURNBULL,
Commissioner of Crown Lands and Survey.

COMMITTEES OF MANAGEMENT OF RESERVES. APPOINTMENTS.

WHEREAS by section 221 of the *Land Act 1958* it is provided that it shall be lawful for the Governor in Council or the Board of Land and Works to appoint and remove any number of persons, not less than three, or any municipal council, or the governing body of any corporation, to be a Committee of Management of any specified Crown land reserved either temporarily or permanently for any of the purposes set out in section 14 of the *Land Act 1958*, and not conveyed to or vested in trustees: Now therefore the Board of Land and Works doth hereby appoint the under-mentioned persons to be members of the Committee of Management of the Reserves named:—

"KAMAROOKA RECREATION RESERVE."

Geoffrey Pedersen, Bruce Albert Cail, John Home Hay, Herbert Hunter Hay, John Frederick Cail, William George Cail, Thomas Keith Watson, Richard Matchett Ayres, George Geoffrey Cail, Claus Henry Ludeman, Arthur Clement Evans, John James Demeo, Desmond O'Donoghue, Claude Watts, Raymond Alexander Wilson, Donald Stillman and Neville John McKenzie as a Committee of Management for a period of three (3) years of the land temporarily reserved by Order in Council of 18th April, 1950, as a site for Public Recreation in the Parish of Kamarooka, and known as the "Kamarooka Recreation Reserve".—(Corres. Rs.6529.)

"WARRNAMBOOL CRICKET GROUND RESERVE."

Walter Shaw Crowe, Jack Hazeldine and William John Taggart Walter (as representatives of the Warrnambool Technical School) and Frederick William Reid (as the representative of the public), all for a period of three (3) years, and Alan Leslie Lane (for so long as he continues to be a Councillor and the elect of the Council of the City of Warrnambool) as a Committee of Management of the land permanently reserved by Order in Council dated the 27th May, 1903, as a site for Cricket and other purposes of Public Recreation in the Town of Warrnambool, and known as the "Warrnambool Cricket Ground Reserve".—(Corres. Rs.1825.)

"BORUNG PUBLIC HALL RESERVE."

Fred Luke Perryman, Lindsay Alexander Bell, Edward Marshall Perryman, Howard Perryman, William Perryman, Lawrence Verley, George W. Bremner and James Leslie Bell as a Committee of Management for a period of three (3) years of the land permanently reserved by Order in Council dated the 25th February, 1941, as a site for a Public Hall in the Parish of Kinypanial, and known as the "Borong Public Hall Reserve".—(Corres. Rs.5162.)

"CAMPERDOWN CRICKET AND RECREATION RESERVE."

The Council of the Town of Camperdown as a Committee of Management of the land permanently reserved by Order in Council dated the 12th March, 1889, as a site for a Cricket Ground and other purposes of Public Recreation in the Town of Camperdown, and known as the "Camperdown Cricket Ground Reserve".—(Corres. Rs.2223.)

"BOBINAWARRAH MEMORIAL HALL RESERVE."

Lindsay McDonald Simpson, John Kenneth Gibb, Clarence McAlicce, Norman French Gibb, Roy Humphrey, Charles Joseph Lloyd, Thomas William Wadley, David Lewis Honybun and Charles Augustus Charlton as a Committee of Management for a period of three (3) years of the land temporarily reserved by Order in Council dated the 7th April, 1925, as a site for a Public Hall in the Parish of Moyhu, and known as the "Bobinawarrah Memorial Hall".—(Corres. Rs.3097.)

"BOINKA RACECOURSE AND RECREATION RESERVES."

John Archibald Kinnersley, Glen Roy Chaplin, James John Cummings, Oliver Clarence Jones, William John Megaw, Lawrence Raymond Jones and Donald Joseph Morrison as a Committee of Management for a period of three (3) years of the land temporarily reserved by Orders in Council dated 29th August, 1922, and 30th November, 1915, as sites for Racecourse and Public Recreation respectively in the Parish of Boinka, and known as the "Boinka Racecourse and Recreation Reserves".—(Corres. Rs.2574, Rs.877.)

"EMERALD RECREATION RESERVE."

Andrew Scott, Gustaf F. Ryberg, Joseph Grady, Frank Thomas Eaton, C. G. Little, Angus Douglas, and Thomas William Dalziell as a Committee of Management for a period of three (3) years of the land temporarily reserved as a site for Public Recreation in the Parish of Gembrook, Township of Emerald, and known as the "Emerald Recreation Reserve".—(Corres. Rs.192.)

"MIRBOO RECREATION RESERVE."

Christopher Stoney, Maurice William Pyle, Robert McRae, George W. Smith and Ronald Gregory Peart as a Committee of Management for a period of three (3) years of the land temporarily reserved by Order in Council dated the 21st March, 1934, as a site for Recreation and

Amusement of the people in the Parish of Mirboo South, Township of Mirboo, and known as the "Mirboo Recreation Reserve".—(Corres. Rs.4196.)

"BLACKBURN PARK RESERVE," OUYEN.

J. H. C. Black, Mervyn Kenny, John William Greig, Alfred Joseph Vincent, L. Zilm, J. T. Knight, Francis Murray James Nulty, John Kevin Monaghan, Francis Joseph Healy, Mervyn L. Clarke, J. R. Gibbs, Francis Thomas Clark, Peter Francis Williams, Ian Wallace Johnstone, Keith S. Vallance, Thomas C. Giles, John Gordon Cameron, William Tyrell Golding, Michael Francis O'Callaghan, M. J. Williams, Soward Lavery and J. J. Williams as a Committee of Management for a period of three (3) years of the lands temporarily reserved by Orders in Council dated the 1st December, 1908, and 6th December, 1949, for Public Recreation in the Township of Ouyen, and known as "Blackburn Park".—(Corres. Rs.2247.)

"WILLUNG RECREATION RESERVE."

William Eric Mowat, John Edward Attenborough, Percy Edward Macreadie, Alfred Ernest Macreadie, Henry T. Attenborough, Keith Laurence Andrew, Walter Edward Mowat and Ernest Douglas Mowat as a Committee of Management for a period of three (3) years of the land temporarily reserved by Order in Council dated the 7th February, 1950, as a site for Public Recreation in the Township of Willung.—(Corres. Rs.6512.)

"HORDERN VALE-GLEN AIRE RECREATION RESERVE."

Henry Hamilton, Cyril Robert Marriner, Ian Trevor Denney, Winifred Lily Denney, Stewart Earl Marriner, Edith Hamilton and John William Soares as a Committee of Management for a period of three (3) years of the land in the Parish of Otway temporarily reserved by Order in Council of the 15th May, 1956, as a site for a Public Hall and for Public Recreation, and known as "The Hordern Vale-Glen Aire Recreation Reserve".—(Corres. Rs.1705.)

"TOORADIN FORESHORE RESERVE."

S. W. Staples, J. Hartrup, J. Kernot, K. E. Anderson, H. M. Johnstone, R. Bisgrove, F. Hamilton, M. Brown, K. J. Mundy and E. Scott as a Committee of Management for a period of three (3) years of the land temporarily reserved by Order in Council dated the 23rd April, 1929, as a site for Public Purposes in the Parish of Koo-Wee-Rup (Tooradin Foreshore), and known as the "Tooradin Foreshore Reserve".—(Corres. Rs.3850, Rs.3697.)

In witness whereof the common seal of the Board of Land and Works was hereunto affixed this eleventh day of June, One thousand nine hundred and fifty-nine, in the presence of—

(SEAL) KEITH TURNBULL, President.
J. WALSHE, Member.

Soldier Settlement Act.

LEASE SURRENDERED.

NOTICE is hereby given that the Soldier Settlement Commission, pursuant to the powers conferred upon it by the Soldier Settlement Act, has accepted the surrender of the lease mentioned in the Schedule hereunder for the reason specified.

SCHEDULE.

Corr. No.	Name.	Section of Act No. 5179 under which Leased.	Parish.	Allotment.	Area.	Reason.
1531/27	A. E. Aldridge	27	Baulkamaugh	10 Section E.	A. R. P. 130 2 0	New lease to issue

Soldier Settlement Commission,
Melbourne, 18th June, 1959.

I. K. MORTON,
Secretary.

Land Act 1958.

LICENCES UNDER THE LAND ACTS 1915 AND 1928 DECLARED VOID.

NOTICE is hereby given that the Licence in the Schedule hereunder has been Declared Void for the reason specified.

District.	Corr. No.	Name of Licensee.	Section of Land Act under which Licensed.	Parish.	Allotment.	Section.	Area.	Annual Rental.	Reasons for Voiding.
Bendigo	1357/129	B. T. Devanny	129	Sandhurst	..	C	A. R. P. 0 0 37	..	Non-compliance with conditions

Department of Crown Lands and Survey,
Melbourne, 22nd June, 1959.

KEITH TURNBULL,
Commissioner of Crown Lands and Survey.

LAND AVAILABLE UNDER THE SOLDIER SETTLEMENT ACTS.

NOTIFICATION is hereby given in accordance with section 50 of the *Soldier Settlement Act 1959*, that the under-mentioned holdings are available or are about to become available for settlement.

Any discharged serviceman who has applied to the Commission on or before the 24th June, 1959, for classification in the required class or classes of primary production for which the holdings are made available and whose application has been accepted but not necessarily finalized, or any discharged serviceman who has been classified as suitable in such class or classes of primary production may apply on the prescribed form for settlement on any holding or holdings, indicating where he applies in respect of more than one holding his order of preference therefor.

The prescribed application forms, plans and further particulars may be obtained from the Enquiry Branch, Soldier Settlement Commission, State Public Offices, Melbourne. The closing date for the receipt of completed applications for settlement on these holdings is the 20th July, 1959, such applications to be in the hands of the Secretary, Soldier Settlement Commission, on or before that date.

I. K. MORTON,
Secretary.

Soldier Settlement Commission,
Melbourne, 16th June, 1959.

SCHEDULE OF ALLOTMENTS.

SUBDIVISION OF "TARRAYOUKYAN" ESTATE.

PARISHES OF MOORWINSTONE AND TARRAYOUKYAN,
COUNTY OF DUNDAS.

Suitable for Grazing (Sheep) and Mixed Farming.

Lot Number on Plan of Subdivision.	Approximate Area in Acres (Subject to Survey).
1	500
2	500
3	507
4	507

SUBDIVISION OF THIRD PORTION OF "YANAKIE" ESTATE.

PARISH OF YANAKIE SOUTH, COUNTY OF BULN BULN.

Suitable for Mixed Farming (Grazing and Dairying).

Lot Number on Plan of Subdivision.	Approximate Area in Acres (Subject to Survey).
14	480
15	480
16	570

SUBDIVISION OF "RENDELL'S" ESTATE.

PARISH OF NEBBIM, COUNTY OF BULN BULN.

Suitable for Potato Growing and Dairying.

Lot Number on Plan of Subdivision.	Approximate Area in Acres (Subject to Survey).
1	110

TENDERS—PUBLIC WORKS DEPARTMENT

TENDERS will be received at this Department until TEN a.m. on the Tuesdays, and for the purposes, under mentioned.

Particulars may be learnt at the Department and also at places shown in parenthesis.

W.O. means Inspector of Works Office; P.S.—Police Station; T.S.—Technical School; H.E.S.—Higher Elementary School; S.S.—State School; H.S.—High School; C.S.—Consolidated School.

Tenders should be submitted on the Department's printed Tender Form. All tenders must be on a "Firm Tender" basis. The Board of Land and Works will not necessarily accept the lowest or any tender.

NOTE.—No preliminary deposit is to be lodged with any tender, but a deposit in accordance with the following Schedule, will be required from each successful tenderer:—

For contract amounts exceeding £200 and not exceeding £500	£ 5
For contract amounts exceeding £500 and not exceeding £1,000	10
For contract amounts exceeding £1,000—1 per cent. of tender	500 (maximum deposit)

30th June, 1959.

Ashwood.—Installation of larger boiler, S.S. No. 4698. (S.S., Ashwood.)

Ballarat.—Fencing of single tennis-court, Girls' Secondary School, Barkly-street. (W.O., Ballarat; Girls' Secondary School, Ballarat.)

Blackburn South.—First and second sections of new building, High School.

Blackburn South.—Electrical installation in stages 1 and 2, High School.

Blackburn South.—Mechanical services for stages 1 and 2, High School.

Broadmeadows.—Electricity supply—anti-skid pan, "Attwood", Stud Farm Depot, Police Department.

Cannum.—Erection of new out-office block, installation of septic closets, &c., S.S. No. 1867. (W.O., Warracknabeal, Horsham; S.S., Cannum.)

Carlton.—Internal renovations, Teachers' College Hostel, 93-97 Drummond-street.

Coromby.—Construction of out-offices, woodshed, installation of septic closets, S.S. No. 2082. (W.O., Warracknabeal, Horsham, S.S., Coromby.)

Dartmoor.—Repairs and painting, Police Station. (W.O., Warrnambool; P.S., Dartmoor.)

Daylesford.—Erection of new block for Boys and extension of existing out-office for Girls, S.S. No. 1609. (W.O., Kyneton; S.S., Daylesford.)

Echuca.—Supply of two demonstration benches, sixteen drawing benches and one teachers' preparation bench, timber construction, Technical School.

Healesville.—Renewal of fencing, Police Station. (P.S., Healesville.)

Hughesdale.—Erection of non-party fencing in chain mesh, S.S. No. 4176. (S.S., Hughesdale.)

Jacana.—Erection of two (2) 32-ft. x 16-ft. shelter pavilions, S.S. No. 4839.

Kilmore.—Roof and general repairs, Court House. (P.S., Kilmore.)

Melbourne.—Completion of North Wing, Public Library. Melbourne.—Installation of fire-alarm system, Government Statist's Offices, 295 Queen-street. (Amended specification.)

Melbourne.—Re-upholstering ninety (90) chairs, Government House.

Melbourne.—Supply eighteen (18) pigeonhole units, Information Bureau, Police Headquarters, Russell-street.

Montague.—Demolition and erection of new shelter shed, repairs to fences, &c., Special School No. 2784.

Mont Park.—Replacement of main switchboards in Chronic Block Wards, Mental Hospital. (W.O., Mont Park.)

Mont Park.—Supply, make and fix curtains, Ward F.5, Mental Hospital.

Morwell.—Repairs and renovations, residence, 9 Madden-street, Police Station. (W.O., Traralgon.)

Newstead.—Internal and external repairs and painting, renewals of fencing, Police Station. (W.O., Kyneton; P.S., Newstead.)

North Park.—Erection of school fencing, S.S. No. 4787. (S.S., North Park.)

Nunawading.—Supply and erection of a chain wire iron-sheeted security fence, "Winlaton", Children's Welfare Department.

Port Melbourne.—Supply and delivery to Salmon-street of one (1) rotary hoe attachment for Ferguson Tractor, three-point linkage type, 50-in. cut, centrally mounted, Storeyard, Public Works Department. (Specifications to be submitted with tender.)

Traralgon.—Electrical installation in four (4) Industrial Units, New Mental Hospital. (W.O., Traralgon.)

Traralgon.—Supply and installation of the mechanical services in the four (4) new Industrial Workers' Dormitories, Mental Hospital. (W.O., Traralgon.)

Warrnambool.—Electrical installation in Administration Building, Mental Hospital. (W.O., Warrnambool.)

Warrnambool.—Hot-water service and plenum-heating system installations to Administration Building, Mental Hospital. (W.O., Warrnambool.)

Warrnambool East.—Supply, delivery, installation and testing of an extension of heating system to five (5) additional class-rooms, S.S. No. 4773. (W.O., Warrnambool; S.S., Warrnambool East.)

Warrnambool East.—Electrical installation in five (5) additional L.T.C. classrooms, S.S. No. 4773. (W.O., Warrnambool; S.S., Warrnambool East.)

Yinnar.—New water service to school and residence, S.S. No. 2419. (W.O., Traralgon; S.S., Yinnar.)

7th July, 1959.

Altona North.—Erection of first section, Technical School.

Altona North.—Electrical installation in Stage 1, Technical School.

Altona North.—Supply, delivery, installation, and testing of the mechanical services for Stage 1, Technical School.

Ararat.—Provision of porches to residences, Mental Hospital. (W.O., Ararat; Mental Hospital, Ararat.)

Bendigo.—Electrical installation in new Engineering Workshop, Training Centre, Mental Hygiene Authority. (W.O., Bendigo.)

Boronia.—Internal and external renovations to residence, Police Station. (P.S., Boronia.)

Brighton Beach.—Demolition of, removal of, and purchase of materials from Pier, Public Works Department.

Creswick.—Supply, delivery, installation, and testing of heating and hot-water services, and electrically-heated lockers, School of Forestry. (W.O., Ballarat.)

Fitzroy.—Additions to electrical installation, Health Clinic, Mental Hygiene Authority.

Flemington.—Curtain treatment to windows of Concert Hall, Travancore Developmental Centre.

Geelong.—Provision of roof over motor cycle area, Police Station. (W.O., Geelong.)

Guildford.—Renovations to residence, new out-office, &c., S.S. No. 264. (W.O., Kyneton; S.S., Guildford.)

Haven.—New out-office block, installation of septic closets, S.S. No. 3765. (W.O., Horsham; S.S., Haven.)

Kew.—Alteration and conversion of hot-water service from 180°F. to 105°F. in Wards 14 "A" and 16 "A", Children's Cottages, Mental Hospital. (W.O., Kew Mental Hospital.)

Kew.—Conversion of existing hot-water service from 180°F. to 105°F. and extension of plenum heating to three (3) additional rooms, Mental Hospital. (W.O., Kew Mental Hospital.)

Lake Bolac.—Erection of No. 2 shelter pavilions, 32 ft. x 16 ft., Higher Elementary School. (W.O., Ararat, Ballarat; H.E.S., Lake Bolac.)

Laver's Hill.—Erection of new shelter pavilion, 20 ft. x 16 ft., Consolidated School. (W.O., Camperdown; C.S., Laver's Hill.)

Malvern.—Alterations to the electrical installation, Mental Hygiene Clinic, Glenferrie-road.

Melbourne.—Six (6) special steel filing cabinets for Finger Print Records, Police Headquarters, Russell-street. (Amended specification.)

Melbourne.—Supply and installation of electric lift, Parliament House.

Melbourne.—Supply and installation of an electric lift, City Courts, Law Department.

Mentone.—Demolition of, removal of, and purchase of materials from Pier, Public Works Department.

Mont Park.—Electrical reticulation to Secretary's Residence, Plenty Mental Hospital.

Newlands.—First and second sections in concrete veneer L.T.C., High School.

Newlands.—Supply, delivery, installation, and testing of the mechanical services for Stages 1 and 2, High School.

Royal Park.—Supply and installation of refrigeration plant for cool room in the new extension to store, Mental Hospital.

Rutherglen.—Repairs, replacements, and painting, Police Station. (W.O., Wangaratta; P.S., Rutherglen, Wodonga.)

Rutherglen.—Alterations and additions to electrical installation, Research Station. (W.O., Wangaratta; P.S., Rutherglen.)

St. Arnaud.—Erection of residence, office, and garage, Fisheries and Game Department. (W.O., Maryborough, Ballarat.)

Sebastopol.—Division of class-room to provide new office, staff-rooms, &c., S.S. No. 1167. (W.O., Ballarat; S.S., Sebastopol.)

Sebastopol.—Gas heating, S.S. No. 1167. (W.O., Ballarat; S.S., Sebastopol.)

Shepparton.—Improved heating system and heating of additional class-rooms, S.S. No. 4657. (W.O., Shepparton; S.S., Shepparton.)

Sunbury.—Erection of brick veneer residence and garage for Dentist, Mental Hospital.

Sunbury.—Electrical installation in Dentist's Residence, Mental Hospital.

Sunbury.—Supply sixty (60) plastic mattress covers, Mental Hospital.

Tanjil South.—Construction of out-offices and installation of septic closets, S.S. No. 2840. (W.O., Warragul; S.S., Tanjil South.)

Werribee.—Repairs to various farm buildings, Research Farm. (Research Farm, Werribee.)

14th July, 1959.

Bayswater.—Erection of a new brick veneer Police Station, Residence, &c., Police Station.

Bayswater.—Electrical installation, Police Station.

Bendigo.—Erection of three (3) additional rooms, Police Station. (W.O., Bendigo.)

Bendigo.—Alterations to Cell Block, Police Station. (W.O., Bendigo.)

Campmeadows.—Erection of shelter pavilions, S.S. No. 4833.

Carlton.—Supply and deliver aluminium windows, doors, and curtain walling, New Hydraulic Laboratory and Engineering School, University of Melbourne.

Charlton.—External painting, repairs, renovations, and fencing, Police Station. (W.O., Bendigo; P.S., Charlton.)

PUBLIC SERVICE NOTICES

PUBLIC SERVICE OF VICTORIA.—VACANCIES.

APPLICATIONS will be received by the Public Service Board up to Wednesday, the 8th July, 1959, from persons employed in the Public Service of Victoria, who are eligible and qualified, for appointment to the under-mentioned positions:—

ADMINISTRATIVE DIVISION.

Deputy Registrar-General and Assistant Registrar of Titles, Class "A1", Office of Titles, Department of Law.

Yearly Salary.—£2,050.

Duties.—To be Deputy Registrar-General and Registrar of Titles; to supervise the staff and work of the Office of the Registrar-General and the Office of Titles and to advise the staff, solicitors and the public on the practice of the Office relating to dealings lodged under the various Acts administered in the Office.

Qualifications.—A complete knowledge of the Transfer of Land Act and all other Acts dealing with real property and of the practice of the Office of Titles and a knowledge of the several Acts administered by the Registrar-General.

Class "B1", Department of Labour and Industry.

Yearly Salary.—£1,390, minimum; £1,500, maximum.

Duties.—As Chief Clerk to be responsible to the Permanent Head for the management of the central administrative services of the department, including correspondence, records, typing, accounts, stores, accommodation, staffing, training, methods review and statistics.

Qualifications.—To be familiar with the department's functions and activities; to have had a broad administrative experience and the ability to direct and control a range of administrative services as outlined in the duties.

Class "C2", Audit Office, Department of Premier.

Yearly Salary.—£1,000, minimum; £1,100, maximum.

Duties.—To perform the duties of Audit Inspector under the Audit Act.

Qualifications.—To be a qualified Accountant and to have had experience in the practice of governmental and public auditing.

Class "C2", Department of Crown Lands and Survey.

Yearly Salary.—£1,000, minimum; £1,100, maximum.

Duties.—To assist and relieve the Chief Cashier. To supervise the receipt and banking of public moneys received by the Department and the Soldier Settlement Commission, and to deal with correspondence. To act as internal auditor of stores.

Qualifications.—To have a good knowledge of the Public Accounts and Stores Regulations 1953, the Acts administered by the Department and the Soldier Settlement Commission and the Regulations thereunder. To be familiar with the provisions made for financing the various activities of the Department and the Commission, together with the arrangements entered into with the Commonwealth and other departments.

Class "C1", Office of the Public Service Board, Department of Premier.

Yearly Salary.—£830, minimum; £920, maximum.

Duties.—To have charge of the registration, attachment and filing of correspondence and the recording and indexing of applications for employment.

Qualifications.—To be conversant with the principles of recording correspondence and to have had experience in this type of work; to be capable of controlling staff and preferably to have a knowledge of the Public Service Act and Regulations thereunder.

Class "C1", Audit Office, Department of Premier.

Yearly Salary.—£830, minimum; £920, maximum.

Duties.—To conduct audits throughout Victoria as directed by the Auditor-General.

Qualifications.—To be a qualified Accountant or to have made substantial progress towards such qualification and to have had experience in the practice of governmental and public auditing.

Daylesford.—Erection of 1st stage of combined Technical School. (W.O., Kyneton.)

Dooen.—Repairs and painting to Field Experiment Officer's Residence, Longerenong Agricultural College. (W.O., Horsham; Longerenong Agricultural College, Dooen.)

Frankston.—Renewal of roofing, S.S. No. 1464. (S.S., Frankston.)

Hill End.—New out-office Block and installation of septic closet, S.S. No. 3054. (W.O., Warragul; S.S., Hill End.)

Laang.—Supply and installation of slow-combustion stove and hot-water service, Residence, S.S., No. 1411. (W.O., Warrnambool; P.S., Terang.)

Melbourne.—Internal repairs and painting to main brick building, internal and external repairs and painting, Canteen Building, Police Depot, St. Kilda-road. (Amended specification.)

Melbourne.—Mechanical services to 5th Floor, Allans Building, Tourist Development Authority and National Parks Authority.

Melbourne.—Provision of stainless steel sink, &c., Painting School, Royal Melbourne Technical College, 550 Little Lonsdale-street.

Merbein.—New sleep-out, porch, alterations, painting, &c., Residence, River-avenue, Higher Elementary School No. 3687. (W.O., Mildura; H.E.S., Merbein.)

Moyhu.—Installation of septic tank system to School and Residence, erection of new out-office block, S.S. No. 1335. (W.O., Benalla, Wangaratta; S.S., Moyhu.)

Neerim South.—Repairs and painting, Police Station. (W.O., Warragul; P.S., Neerim South.)

Newlands.—Electrical installations in Sections 1 and 2, High School.

Norlane.—Supply, delivery, installation, and testing of new furnace room equipment in a Class-room Block, S.S. No. 4734. (W.O., Geelong; S.S., Norlane.)

Northcote.—Provision of new Cell Block, Police Station.

Outtrim.—Erection of a new 20 ft. x 10 ft. timber shelter pavilion, S.S. No. 3229. (W.O., Korumburra; S.S., Outtrim.)

St. Arnaud.—Provision of new fittings to laundry and kitchen in Cooking Centre, High School. (W.O., Maryborough; H.S., St. Arnaud.)

Shepparton.—Purchase and removal of disused out-offices, &c., S.S. No. 4657. (W.O., Shepparton.)

South Melbourne.—Provision of Male and Female toilets, Technical School.

Tottenham.—Erection of Caretaker's Residence, Technical School. (T.S., Tottenham.)

Warragul.—Erection of a main store, Ellinbank Dairy Research Farm. (W.O., Warragul.)

Warragul.—Internal and external painting, Police Station. (W.O., Warragul.)

21st July, 1959.

Belle Vue.—Erection of additional five (5) Class-room Wing in concrete veneer timber-framed construction, S.S. No. 4733.

Belle Vue.—Supply, delivery, installation, and testing of a warm air heating/ventilation system in new Class-room Wing, S.S. No. 4733.

Hawthorn.—Erection of new Workshop Block, Swinburne Boys' Technical School.

Hawthorn.—Electrical installation to new Junior Boys' Manual Arts Wing, Swinburne Technical School. (Swinburne Technical School, Hawthorn.)

Hawthorn.—Supply, delivery, installation, and testing of heating equipment and hot-water service to new Workshop Block of new Junior School for Boys, Swinburne Technical School. (Swinburne Technical School, Hawthorn.)

Melbourne.—Roof repairs and internal and external renovations, Police Station, Bourke-street West.

Tenders to be addressed to the Commissioner of Public Works, and envelope containing tender to be marked "Tender for _____, closing Tuesday, _____".

T. K. MALTEY,

Commissioner of Public Works.

Public Works Department,
Melbourne, 23rd June, 1959.

Class "C1", Motor Registration Branch, Office of the Chief Commissioner of Police, Department of Chief Secretary.

Yearly Salary.—£830, minimum; £920, maximum.

Duties.—To assist in the administration of the Car Section, and to be responsible for the issue of certified extracts for offences under the *Motor Car Act 1958* and the *Road Traffic Act 1958*.

Qualifications.—A knowledge of the *Motor Car Act 1958* and the *Road Traffic Act 1958* and ability to control staff. A knowledge of the routine and procedure in the Car Section would be an advantage.

Class "C1", Department of Crown Lands and Survey.

Yearly Salary.—£830, minimum; £920, maximum.

Duties.—To relieve Country Land Officers as required.

Qualifications.—A sound knowledge of the various Acts and Regulations administered by the Department; to be a competent Clerk and Draughtsman as required by Public Service (Public Service Board) Regulation 42. Experience in a Land Office is desirable.

Class "C1", Department of Water Supply.

Yearly Salary.—£830, minimum; £920, maximum.

Duties.—To assist in the supervision and operation of the Commission's advance accounts and the reimbursement of vouchers covering expenditure incurred by Districts and Works; to examine expenditure vouchers in regard to charging to appropriate Funds.

Qualifications.—To possess a knowledge of the Public Accounts and Stores Regulations, 1958, and the Commission's system of expenditure control.

Class "C1", Department of Local Government.

Yearly Salary.—£830, minimum; £920, maximum.

Duties.—To examine the by-laws submitted by municipalities for approval; to deal with applications for road deviations and the proclamation of public highways; to draft correspondence and prepare Orders-in-Council arising out of the administration of the various Acts administered in the Department; to supervise the checking of accounts submitted by municipalities.

Qualifications.—Ability to draft correspondence; to have a knowledge of departmental practice and procedure, and of the Local Government Acts and other relevant Acts.

Class "C", Department of Treasurer.

Yearly Salary.—£624, minimum; £759, maximum.

Duties.—To assist generally in the work (including staff matters) of the Correspondence Branch, and in particular to be responsible for correspondence, &c., in connexion with the granting of miners' phthisis allowances, and with indemnities issued in connexion with Co-operative Housing Society loans.

Qualifications.—Ability to conduct correspondence; a good knowledge of Treasury procedure and of the Regulations under the Public Service Act.

Class "C", Office of Titles, Department of Law.

Yearly Salary.—£624, minimum; £759, maximum.

Duties.—To check the endorsements on all dealings registrable without new titles issuing thereon and determine the correctness of same; to certify that all requisitions and submissions have been dealt with and documents are in order for affixing the office seal.

Qualifications.—To have a good knowledge of the Transfer of Land Act and cognate Acts and of the practice of the Office of Titles and a knowledge of essential endorsements.

Class "C", Department of Crown Lands and Survey.

Yearly Salary.—£624, minimum; £759, maximum.

Duties.—To assist and relieve the officer in charge of the departmental advances cash book and journal of expenditure. To supervise the registration, charging, checking and passing of accounts for payment and the preparation of schedules of accounts for payment by the Treasury. To keep the ledger recording commitments against the departmental votes.

Qualifications.—To have a knowledge of those sections of the Acts administered by the Department which authorise expenditure of public moneys and of the Public Accounts and Stores Regulations. To have had experience in the keeping of departmental advances cash books.

PROFESSIONAL DIVISION.

Executive Engineer, Classes "B"—"B1", Department of Water Supply.

Yearly Salary.—£1,180, minimum; £1,500, maximum.

Duties.—Under the direction of the Chief Constructional Engineer or Resident Engineer of major construction project, to be in responsible charge of the supervision and organization of such construction project or section of project as the Commission may direct.

Qualifications.—To possess a University Degree or Technical School Diploma or other recognized engineering qualification and to possess the qualification as an Engineer of Water Supply under the Water Acts; to have had extensive experience in the construction of works and in the organization and control of the work of officers and employees engaged upon civil engineering construction operations.

Engineer, Class "B", Department of State Forests.

Yearly Salary.—£1,180, minimum; £1,280, maximum.

Duties.—To assist Chief Engineer and take charge of Civil Engineering Section.

Qualifications.—To hold a University Degree or Diploma in Civil Engineering or equivalent qualifications and to have had comprehensive experience in civil engineering, particularly in road design and construction.

Assistant Engineer, Classes "C"—"C2", Office of the Housing Commission, Department of Treasurer.

Yearly Salary.—£830, minimum; £1,100, maximum—Graduates.

£714, minimum; £1,100, maximum—Diplomates.

(Commencing salary will be determined within this initial career range according to experience, but advancement is not limited to the maximum quoted.)

Duties.—To be responsible to the Engineer (Design and Supervision) for preparation of designs for and/or setting out and supervision of road and drainage construction and site grading on housing estates.

Qualifications.—Diploma of Civil Engineering or a recognized Technical School or equivalent qualification. Experience of at least three years in design and construction of road and drainage works. Not less than one year shall have been spent on design and not less than one year on supervision (including setting out).

Clerk of Courts, Grade III., Class "C", Department of Law.

Ballarat one vacancy.

Relieving one vacancy.

Yearly Salary.—£624, minimum; £759, maximum.

Qualifications.—As prescribed by Public Service (Public Service Board) Regulation 46.

TECHNICAL AND GENERAL DIVISION.

Forest Overseer, Grade I, Department of State Forests. (Two vacancies.)

Yearly Salary.—£650, minimum; £728, maximum.

Duties.—To supervise operations of forest employees and licensees, and to carry out general and fire patrol duties.

Qualifications.—To possess a good knowledge of the Victorian Forests Act and Regulations and of office procedure and to have extensive practical experience of field methods and operations in the State Forests Department.

Shorthand Writer and Typist (Female), Senior, Department of Water Supply.

Yearly Salary.—£494, minimum; £520, maximum.

Duties.—To act as confidential stenographer to the Chairman of the Commission.

Qualifications.—To be a competent Shorthand Writer and Typist; to have passed the Board's shorthand test of 120 words a minute; to have a knowledge of the organization of the Commission and ability to deal with the public.

Printer, Lithographic, Visual Education Centre, Department of Education.

Yearly Salary.—£494 a year.

Duties.—To prepare lithographic plates for printing; to operate a Solna Chief 24 (single colour) offset press; to be responsible for the maintenance of printing machinery; to perform any other associated printing duties required by the Visual Education Officer.

Qualifications.—To be a qualified tradesman, having served the necessary technical course.

Butcher, Grade I., Longerenong Agricultural College, Department of Agriculture.

Yearly Salary.—£455, minimum; £494, maximum.

Duties.—Under the direction of the Principal to be in charge of the College butchery; to slaughter ration stock and prepare meat for delivery to the College kitchen and residences; to maintain accurate records of animals slaughtered and deliveries of meat; to instruct students in the killing and dressing of ration stock; to perform other duties as the Principal may require.

Qualifications.—To be a qualified and experienced butcher and have ability to instruct students.

NOTE.—A residence is available for the successful applicant, if married, for which rental of 10 per cent. of standard salary, plus £16 a year, will be charged. Particulars are available from the Department of Agriculture.

Machinist (Female), Grade III., Department of State Forests.

Yearly Salary.—£429, minimum; £455, maximum.

Duties.—To post expenditure to Loan and Vote Appropriations and to balance with Funds Ledger control.

Qualifications.—To be a competent Mercedes or Remington Accounting Machine Operator, and to have a thorough knowledge of the Commission's mechanized accounting system.

Water Bailiff, Kerang Centre, Department of Water Supply.

Yearly Salary.—£390, minimum; £442, maximum.

Qualifications.—Ability to control and regulate the supply of water to irrigators and to keep the necessary records and make arithmetical computations in connexion therewith; a knowledge of water requirements for crops and grasses grown under irrigation, the methods of preparation of land for same and methods of channel and drain construction and maintenance.

NOTE.—A house is available for the successful applicant, if married, for which rental of 10 per cent. of standard salary, plus £16 per annum, will be charged. Particulars available from the Department of Water Supply.

Departmental Chauffeur, Children's Welfare Branch, Department of Chief Secretary.

Yearly Salary.—£390, minimum; £403, maximum.

Duties.—To act as chauffeur in the transport of officers and children, and to perform other duties as directed.

Qualifications.—To be a competent, careful, and experienced car driver; to possess a good knowledge of traffic rules and regulations, and a sound working knowledge of car mechanism.

Watchman, Ports and Harbors Branch, Department of Public Works.

Yearly Salary.—£325, minimum; £338, maximum.

Duties.—To act as a watchman at the Departmental Dredging Depot, Williamstown, and to be prepared to work rostered hours of duty including Saturday and Sunday as required; to attend to mooring lines of floating plant.

Qualifications.—To have had sea-faring experience and to be capable of receiving and relaying telephone messages; to be physically active.

NOTE.—The salary rates quoted above do not include the additional amounts which are payable under Regulation 77A of the Board's Regulations.

By order,

V. P. SCULLY,
Secretary.

Office of the Public Service Board,
Melbourne, 23rd July, 1959.

PUBLIC SERVICE OF VICTORIA.—VACANCIES.

DEPARTMENT OF HEALTH.

MENTAL HYGIENE BRANCH.

TECHNICAL AND GENERAL DIVISION.

APPLICATIONS will be received by the Public Service Board up to Wednesday, the 15th July, 1959, from persons employed in the Public Service of Victoria, who are eligible and qualified, for appointment to the under-mentioned positions:—

Head Nurse (Female), Beechworth Mental Hospital.

Yearly Salary.—£624, minimum; £650, maximum.

Duties.—To assist Principal Nurse in management of female division, and to prepare leave sheets and other records as directed by the Principal Nurse; to be prepared to give lectures to Student Nurses; to act as Principal Nurse in her absence.

Qualifications.—To possess the Mental Hygiene Nursing Certificate and to be a registered Trained Mental Nurse and possess a current practising certificate. Ability to direct and control staff and patients, and to keep records relating thereto.

Farm Assistant, Sunbury Mental Hospital.

Yearly Salary.—£338, minimum; £390, maximum.

Duties.—To assist in all farm work.

Qualifications.—Ability to carry out all ordinary farm work and possession of a motor driver's licence.

Laundress, Grade II., Kew Mental Hospital.

Yearly Salary.—Junior—Under 16 years of age, £117; at 16 years of age, £143; at 17 years of age, £156; at 18 years of age, £182; at 19 years of age, £221; at 20 years of age, £260. Adult—£325, minimum; £351, maximum.

Duties.—To assist in laundry.

Qualifications.—Ability to operate laundry machinery.

NOTE.—The salary rates quoted above do not include the additional amounts which are payable under Regulation 77A of the Board's Regulations.

By order,

V. P. SCULLY,
Secretary.

Office of the Public Service Board,
Melbourne, 23rd June, 1959.

PUBLIC SERVICE OF VICTORIA.

QUALIFYING EXAMINATION—ASSISTANTS (MALE), GRADE II., TECHNICAL AND GENERAL DIVISION.

Preliminary Notice.

NOTICE is hereby given that it is proposed to hold an examination of persons in the Public Service desirous of being registered as candidates qualified for appointment as Assistant (Male), Grade II., Technical and General Division.

The examination, which will consist of papers in English (an essay and précis writing) and Arithmetic (Proficiency Standard), will be held towards the end of September, 1959. Applications will be invited in the *Government Gazette* in due course.

By order,

V. P. SCULLY,
Secretary.

Office of the Public Service Board,
Melbourne, 23rd June, 1959.

No. 945.

Public Service Act 1958, Section 50.

REGULATIONS.—PART III.—SALARIES, INCREMENTS AND ALLOWANCES.

THE Public Service Board, in pursuance of the powers conferred by the *Public Service Act 1958*, hereby amends its Regulations as shown below :—

SIXTH SCHEDULE.
TEMPORARY EMPLOYEES.

Designations of Positions and Rates of Salaries.

Department and Designation of Position.	Yearly Rate of Salary.		Increments (Annual).
	Minimum.	Maximum.	
	£	£	
DEPARTMENT OF PUBLIC WORKS.			
<i>Delete—</i> Inspector of Works ..	508	728	2 of £26 and 2 of £39
<i>Add—</i> Inspector of Works ..	728	806	2 of £39

This Regulation shall have effect as on and from the 2nd June, 1959.

A. GARRAN, Chairman.
V. P. SCULLY, Secretary.

Office of the Public Service Board,
Melbourne, 1st June, 1959.

No. 944.

Public Service Act 1958, Section 50.

REGULATIONS.—PART III.—SALARIES, INCREMENTS AND ALLOWANCES.

THE Public Service Board, in pursuance of the powers conferred by the *Public Service Act 1958*, hereby amends its Regulations as shown below :—

SIXTH SCHEDULE.
TEMPORARY EMPLOYEES.

Designations of Positions and Rates of Salaries.

Department and Designation of Position.	Yearly Rate of Salary.		Increments (Annual).
	Minimum.	Maximum.	
	£	£	
DEPARTMENT OF MINES.			
<i>Delete—</i> Bulldozer Operator ..	455	494	1 of £26 and 1 of £13
<i>Add—</i> Bulldozer Operator (70-130 brake horse power)	455	494	1 of £26 and 1 of £13
DEPARTMENT OF AGRICULTURE.			
<i>Delete—</i> Seeds Inspector ..	572	650	3 of £26

A. GARRAN, Chairman.
V. P. SCULLY, Secretary.

Office of the Public Service Board,
Melbourne, 1st June, 1959.

No. 947.

Public Service Act 1958.

REGULATIONS.—PART III.—SALARIES, INCREMENTS AND ALLOWANCES.

THE Public Service Board, in pursuance of the powers conferred by the *Public Service Act 1958*, hereby amends its Regulations as shown below :—

FOURTH SCHEDULE.
ADMINISTRATIVE DIVISION.

Amount of Salary Assigned to Offices in Class "A1".

Office.	Yearly Rate of Salary.
	£
DEPARTMENT OF WATER SUPPLY.	
<i>Add—</i> Chief Finance Officer ..	2,200

This Regulation shall have effect as on and from the 9th April, 1959.

A. GARRAN, Chairman.
V. P. SCULLY, Secretary.

Office of the Public Service Board,
Melbourne, 11th June, 1959.

No. 946.

Public Service Act 1958, Section 39.

REGULATIONS.—PART III.—SALARIES, INCREMENTS AND ALLOWANCES.

THE Public Service Board, in pursuance of the powers conferred by the *Public Service Act 1958*, hereby amends its Regulations as shown below :—

FIRST SCHEDULE.
PROFESSIONAL DIVISION.

Amount of Salary Assigned to Offices in Class "A1".

Office.	Yearly Rate of Salary.
	£
DEPARTMENT OF AGRICULTURE.	
<i>Delete—</i> Senior Inspector of Agricultural Education ..	1,950
<i>Add—</i> Senior Inspector of Agricultural Education ..	2,050

A. GARRAN, Chairman.
V. P. SCULLY, Secretary.

Office of the Public Service Board,
Melbourne, 8th June, 1959.

PUBLIC SERVICE (PUBLIC SERVICE BOARD) REGULATION 39.—RECLASSIFICATIONS.

THE Public Service Board has raised the classification of the under-mentioned offices as shown, and the Permanent Heads of the Departments have recommended the officers named for appointment.

Office and Present Classification.	Revised Classification.	Duties.	Qualifications.	Officer Recommended for Appointment.		
				Name.	Classification.	Date of Classification.
PROFESSIONAL DIVISION.						
DEPARTMENT OF TREASURER.						
<i>Taxation (Land Tax) Office.</i>						
Valuer, Class "C2"	Class "B"	To carry out inspections and make valuations for Land Tax, Probate Duty and Stamp Duty purposes of all classes of real estate, including hotels, shops, factories, residential properties and broad acres	To have a sound knowledge of the principles governing valuation of land and improvements, and ability to discuss valuations with taxpayers or their representatives; and to be an Associate of the Commonwealth Institute of Valuers, or to be qualified for admission to the Institute	Southee, C. . .	Valuer, Class "C2"	27.9.57
DEPARTMENT OF WATER SUPPLY.						
Draughtsman, Class "E"	Assistant Engineer, Class "C"	To carry out, under the direction of the Senior Executive Engineer, drainage investigations in irrigation districts, including the design of earthworks and structures for drainage channels	To possess a Degree or Diploma in Civil Engineering or other recognized engineering qualification, preferably with some experience in design and construction of water supply works	Gowan, J. R.	Draughtsman, Class "E"	5.5.58
TECHNICAL AND GENERAL DIVISION.						
DEPARTMENT OF PUBLIC WORKS.						
Typist (Female), Grade II.	Typist (Female), Supervising (£416-£429)	To supervise the allocation of work to the typing pool and, under the direction of the Officer-in-Charge, General Correspondence Branch, to assist in the general supervision of female staff, as required	To be an experienced typist, and fully conversant with all phases of typing work required by the Department	Clark, Hilda H.	Typist (Female), Grade II.	5.10.56
DEPARTMENT OF AGRICULTURE.						
Photographer, Grade II.	Grade I. (£624-£689)	To undertake all phases of still photographic work and assist in photographing for motion pictures	Experience in outdoor and indoor photography, in dark room work and in cine photography. A knowledge of colour photography is essential	White, J. H. F.	Photographer, Grade II.	20.2.58

Appeals against such recommendations should be lodged with the Secretary to the Public Service Board not later than Saturday, the 4th July, 1959.

Office of the Public Service Board,
Melbourne, 23rd, June, 1959.

By order,
V. P. SCULLY,
Secretary.

PRIVATE ADVERTISEMENTS

CITY OF BOX HILL.

LOAN No. 105.

Notice of Intention to Borrow the Sum of £20,000 for Permanent Works and Undertakings.

NOTICE is hereby given that the Council of the City of Box Hill proposes to borrow the sum of £20,000 on the credit of the municipal revenues of the Mayor, Councillors and Citizens of the said city, such sum to be raised by the issue of debentures, in accordance with the provisions of the *Local Government Act 1958*.

1. The maximum rate of interest that may be paid is 5½ per cent. per annum.
2. The purpose for which the loan is to be applied is—
Capital Works in the Council's Electric Supply Undertaking.
3. The period of the loan shall be twenty years.
4. The moneys borrowed shall be repayable by providing out of the municipal fund 40 half-yearly instalments of approximately £330 12s. 7d. each, including principal and interest, on the 31st day of March and the 30th day of

September during the currency of the loan. The first instalment shall be payable on the 31st day of March, 1960.

5. Such moneys shall be repayable at The English, Scottish and Australian Bank Limited, Melbourne, or at the Council's bankers for the time being in Melbourne.

The plans and specifications and the estimate of the cost of the proposed works, and a statement showing the proposed expenditure of the moneys to be borrowed, are open for inspection at the Town Hall, Box Hill.

6101

A. N. WALLS, Town Clerk.

CITY OF BOX HILL.

LOAN No. 108.

Notice of Intention to Borrow the Sum of £10,000 for Permanent Works and Undertakings.

NOTICE is hereby given that the Council of the City of Box Hill proposes to borrow the sum of £10,000 on the credit of the municipal revenues of the Mayor, Councillors and Citizens of the said City, such sum to be raised by the issue of debentures in accordance with the provisions of the *Local Government Act 1958*.

1. The maximum rate of interest that may be paid is 5½ per cent. per annum.

2. The purpose for which the loan is to be applied is—

Purchase of Road Roller	£5,500
Construction of part of Bedford-street	3,900
Concrete paving of footpaths—Council's portion	600
	£10,000

3. The period of the loan shall be fifteen years.

4. The moneys borrowed shall be repayable by providing out of the municipal fund 30 half-yearly instalments of £493 16s. 11d. each, including principal and interest, on the 31st day of March and the 30th day of September during the currency of the loan. The first instalment shall be payable on the 31st day of March, 1960.

5. Such money shall be repayable at The Commonwealth Savings Bank of Australia, Melbourne.

The plans and specifications and the estimate of the cost of the proposed works, and a statement showing the proposed expenditure of the moneys to be borrowed, are open for inspection at the Town Hall, Box Hill.

6100 A. N. WALLS, Town Clerk.

CITY OF BOX HILL.

LOAN No. 109.

Notice of Intention to Borrow the Sum of £50,000 for Permanent Works and Undertakings.

NOTICE is hereby given that the Council of Box Hill proposes to borrow the sum of Fifty thousand pounds on the credit of the municipal revenues of the Mayor, Councillors, and Citizens of the said City, such sum to be raised by the issue of debentures in accordance with the provisions of the *Local Government Act 1958*.

1. The maximum rate of interest that may be paid is 5½ per cent. per annum, payable half-yearly, the first of such payments to be made on 1st April, 1960.

2. The purpose for which the loan is to be applied is:—

Capital Works in the Council's Electric Supply Undertaking.

3. The period of the loan shall be 30 years.

4. The loan is to be liquidated by the creation of a Sinking Fund pursuant to the provisions of section 420 of the *Local Government Act 1958*.

5. Such moneys shall be repayable at The English, Scottish, and Australian Bank Limited, Melbourne, or at the Council's bankers for the time being in Melbourne.

The plans and specifications and the estimate of the cost of the proposed works and a statement showing the proposed expenditure of the moneys to be borrowed, are open for inspection at the Town Hall, Box Hill.

6069 A. N. WALLS, Town Clerk.

CITY OF BROADMEADOWS.

BY-LAW No. 15.

A By-law of the City of Broadmeadows, made under the provisions of section 93 (j) and (k) of the *Health Act 1958*, sections 197 (1) (x) (a) and (c), 197 (1) (xxxi.) (f), 212, 213 and 222 of the *Local Government Act 1958*, and all other powers it enabling thereto, and numbered 15, for and with respect to—

(a) the regulating of the keeping of any animals and the regulating or prohibiting of the keeping of any place or the storage of any things which in the opinion of the Council may be offensive injurious to health or dangerous;

(b) fixing the distance from any boundary or from any dwelling within which it shall be unlawful to keep any such animal or place or to store any such thing;

(c) suppression of nuisances;

(d) imposing penalties for breaches of this By-law.

IN pursuance of the powers conferred upon it by the *Health Act*, the *Local Government Act*, and in pursuance of all other powers it thereunto enabling, the Mayor, Councillors, and Citizens of the City of Broadmeadows hereby Orders as follows:—

1. This By-law shall come into operation on its publication in the *Government Gazette*.

2. This By-law shall apply to and have operation throughout the whole of the Municipal District.

3. In this By-law unless inconsistent with the context or subject-matter—

(a) "Council" means the Council of the City of Broadmeadows.

(b) "Inspector" means a person appointed by the Council, pursuant to the provisions of section 31 of the *Health Act 1958*, to be an Inspector within the meaning of the said Act.

(c) "Animal" means and includes horse, mare, gelding, donkey, mule, bull, bullock, cow, steer, heifer, goat, sheep, boar, sow, barrow or sucker.

(d) "Enclosure" means any area of land within which any animal is confined or kept.

(e) "Structure" means and includes any pen, shed, building or erection within or comprising an enclosure used or intended to be used for the purpose of confining, protecting or sheltering any animal.

4. No occupier of any land shall cause, permit or suffer any enclosure or structure to be otherwise than in a clean, wholesome and sanitary state and condition.

5. No occupier of any land shall permit or suffer any animal to remain or wander in any enclosure or structure such enclosure or structure (as the case may be) not being in conformity with the provisions of this By-law.

6. No occupier of any land shall keep or permit to be kept any animal in any enclosure less than 1 acre in extent without the consent, in writing, of the Inspector first had and obtained.

7. An occupier of any land upon which any animal is kept shall—

(a) not permit or suffer any manure, rubbish or refuse to lie or to be accumulated otherwise than in a properly constructed fly and vermin-proof receptacle of impervious walls together with an impervious floor.

(b) at all times cause such receptacle to be effectively covered.

(c) cause the contents of such receptacle to be emptied within such time as may be directed, in writing, by the Inspector.

(d) not erect, keep or allow to be erected or kept any structure—

(i) within 50 feet of any street or road having a greater width than 25 feet.

(ii) within 10 feet of any street or road having a width of 25 feet or less than 25 feet.

(iii) within 10 feet from the boundary of the enclosure within such structure subsists or if erected would subsist.

(iv) so as to be a nuisance or dangerous to health or offensive.

(v) without the consent, in writing, of the Inspector first had and obtained.

(vi) not store any fodder within an enclosure otherwise than in a rat-proof container.

8. If any person is erecting or has erected any structure contrary to the provisions of this By-law the Council may by notice, in writing, which notice shall specify the manner in which it is alleged such structure is being or has been erected contrary to the provisions of this By-law require such person to rectify the matters in respect of which such person is in default or to remove such structure within a period to be specified in such notice and if any person having been served with such notice as aforesaid shall fail to comply therewith he shall be guilty of an offence and the Council may cause any such structure as aforesaid to be demolished and may recover the cost of so doing from the person in default.

9. Any person who does not do anything directed to be done or does anything forbidden to be done by this By-law shall be guilty of an offence against this By-law.

10. Any person who is guilty of an offence against this By-law shall be liable, on conviction, to a penalty of not more than Twenty pounds and in the case of a continuing offence a further daily penalty of not more than Five pounds.

Resolution for passing this By-law agreed to by the Council of the City of Broadmeadows on the 23rd day of February, 1959, and confirmed on the 23rd day of March, 1959.

The common seal of the Mayor, Councillors, and Citizens of the City of Broadmeadows was hereunto affixed, in our presence, by order of the Council.

(SEAL) S. G. SEWELL, Mayor.
ERNEST G. SELL, Councillor.
E. F. SMILEY, Town Clerk.

Approved by the Governor in Council, 11th June, 1959.—
A. MAHLSTEDT, Clerk of the Executive Council. 6102

CITY OF ESSENDON.

WHEREAS the Council of the City of Essendon deems it expedient to provide the land described in the Schedule hereto for the widening of portion of an unnamed street at the rear of Young-street, Moonee Ponds: And whereas the said Council has caused to be prepared maps and plans showing such land and the names of the owners or reputed owners, lessees or reputed lessees and the occupiers thereof as far as such names can be ascertained by the said Council: And whereas such maps and plans are deposited at the office of the said Council of the City of Essendon and are and shall be open for inspection by all persons interested at all reasonable hours for the space of 40 clear days after publication of this Notice in the *Government Gazette*: Now notice is hereby given to all persons affected by the proposed work and undertaking and they are hereby called upon to set forth, in writing, addressed to the said Council or the Town Clerk of the City of Essendon within 40 clear days from the publication of this Notice in the *Government Gazette* all objections which they may have to the said work or undertaking.

THE SCHEDULE HEREINBEFORE REFERRED TO.

1. The said right-of-way is delineated and hatched on the plan hereunder.
2. The land proposed to be so compulsorily acquired is all that piece of land being the land delineated and cross hatched on the plan hereunder, being part of land more particularly described in certificate of title, volume 3910, folio 781952.

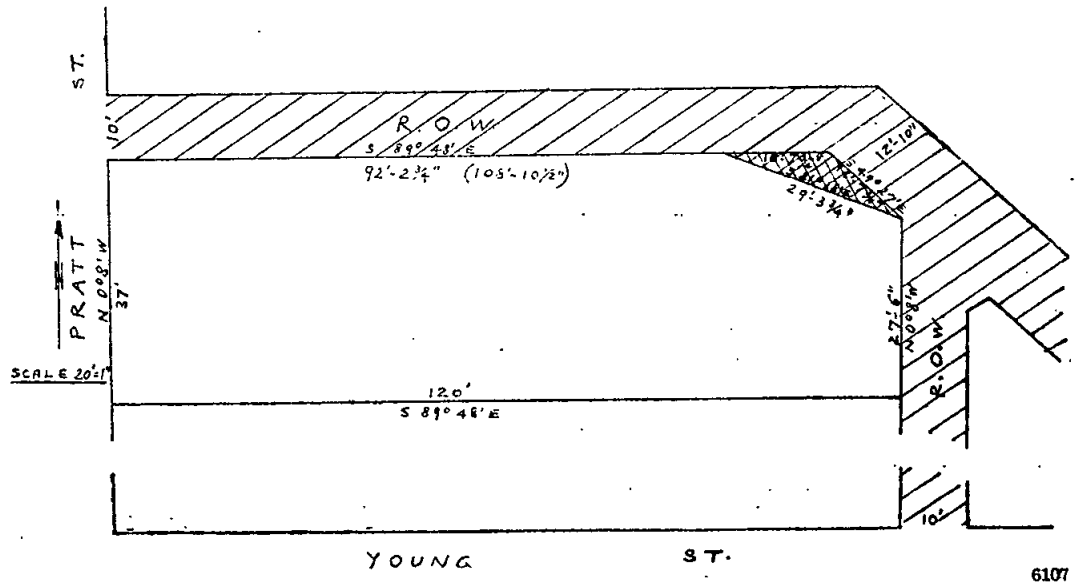

CITY OF COBURG.

LOAN No. 69.

Notice of Intention to Borrow the Sum of £10,000 for Permanent Works and Undertakings.

NOTICE is hereby given that the Council of the City of Coburg proposes to borrow the sum of Ten thousand pounds (£10,000) on the credit of the municipal revenues of the Mayor, Councillors, and Citizens of the said City, such sum to be raised by the issue of debentures, in accordance with the provisions of the Local Government Acts.

1. The maximum rate of interest that may be paid is 5½ per cent. per annum.
2. The purpose for which the loan is to be applied is purchase of plant.
3. The period of the loan shall be ten years.
4. The moneys borrowed shall be repayable by providing out of the municipal fund twenty (20) equal half-yearly instalments of £656 14s. 4d. including principal and interest, on the 1st day of March and the 1st day of September during the currency of the loan. The first instalment shall be payable on the 1st day of March, 1960.
5. Such moneys shall be repayable at the Commonwealth Trading Bank of Australia, Melbourne, or at the Council's bankers for the time being in Melbourne.

The plans and specifications and the estimate of the cost of the proposed works and a statement showing the proposed expenditure of the moneys to be borrowed, are open for inspection at the Town Hall, Coburg, during office hours.

6075

G. A. BRIDGES, Town Clerk.

CITY OF NORTHCOTE.

NAMING OF UNNAMED STREET.

NOTICE is hereby given that at a Meeting held on the 11th day of May, 1959, the Council of the City of Northcote resolved that the street at the rear of Flinders-street and Collins-street, Thornbury, between Victoria-road and Harry-street, be named Boyd-street.

6078 E. MASON, Town Clerk and City Manager.

CITY OF SUNSHINE.

LOAN No. 33.

Notice of Intention to Borrow the Sum of Ten Thousand Pounds (£10,000) for Permanent Works and Undertakings.

TAKE notice that the Council of the City of Sunshine proposes to borrow on the credit of the Mayor, Councillors, and Citizens of the said City, the sum of Ten thousand pounds (£10,000) such sum to be raised by the issue of debentures in accordance with the provisions of the Local Government Acts; the maximum rate of interest to be paid shall be Five pounds ten shillings (£5 10s.) per centum per annum; the period of the loan shall be ten years; the loan shall be liquidated by twenty equal half-yearly instalments of £656 13s. 4d. which shall cover principal and interest payable on the 1st day of August and the 1st day of February each year during the currency of the loan at the National Bank of Australasia Ltd., Melbourne, or at the Council's bankers for the time being in Melbourne.

The permanent works and undertakings upon which such loan is to be expended are completion of Durham-road bridge, £10,000.

The plans and specifications and estimate of cost of the works referred to above, and a statement showing the proposed expenditure of the money to be borrowed are open for inspection at the municipal offices, Hampshire-road, Sunshine.

6067

T. W. DEUTSCHMANN, Town Clerk.

CITY OF WANGARATTA.

SPECIAL ORDER.

Loan No. 41.

NOTICE is hereby given that at a meeting of the Council held on Monday, 1st June, 1959, the Council agreed to the following Resolution:—

“Loan No. 41.—That the Council do now by Special Order borrow under the provisions of the Local Government Acts the sum of £10,000 for—

Council's Contribution—	
Country Roads Board Works ..	£5,220
Construction of Concrete Kerbs, Channels and Footpaths ..	1,500
Fire Plugs ..	900
Private Streets Construction ..	2,380
	<u>£10,000</u>

by the issue of debentures on the credit of the Mayor, Councillors and Citizens of the City of Wangaratta, repayable by twenty half-yearly instalments of principal and interest at £5 10s. per centum per annum, such debentures to be repayable at the Bank of New South Wales, Melbourne, or the Council's bankers for the time being in Melbourne, and that the relevant debentures be signed and sealed, and further that this Resolution be submitted for confirmation at the Ordinary Meeting to be held on Monday, 29th June, 1959”.

6096

B. MORAN, Town Clerk.

TOWN OF STAWELL.

NOTICE is given that Mrs. Lillian Joyce Henderson has been appointed Poundkeeper for the Stawell Pound, Navarre-road.

6094

L. L. SMITH, Town Clerk.

SHIRE OF BALLARAT.

LOAN No. 17.

Notice of Intention of Borrow.

NOTICE is hereby given that the Council of the Shire of Ballarat proposes to borrow the sum of £20,000 on the credit of the President, Councillors and Ratepayers of the said Shire by an issue of debentures, in accordance with the provisions of the Local Government Acts. In connexion therewith the following information is stated:—

- The amount of the principal moneys which it is proposed to borrow is £20,000.
- The maximum rate of interest that may be paid is 5½ per cent. per annum.
- The times which the moneys borrowed are to be repayable are on the first days of March and September during the years 1960–1985 inclusive, commencing on the first day of March, 1960, and that the place such moneys shall be repayable is at The National Bank of Australasia Limited, Melbourne, or at the Council's bankers for the time being in Melbourne.
- The purpose for which the loan is to be applied is for erection of a new Municipal Hall.
- The manner in which the Loan is to be liquidated is by provision out of the Municipal Fund in each half-year during the currency of the Loan of the sum of £987 13s. 9d., which includes principal and interest.

The plans and specifications and estimate of the cost of the works, and a statement showing the proposed expenditure of the moneys to be borrowed, are open for inspection at the Shire Offices.

Dated the 19th day of June, 1959.

K. S. LANE, Shire Secretary.

Shire Offices, Gillies-street, Wendouree. 6105

SHIRE OF BALLARAT.

ALTERATION OF STREET NAME.

NOTICE is hereby given that the Council of the Shire of Ballarat has by Order renamed the following street:—

Old Name.—Pickford-street, between Head-street and Brown's-parade.

New Name.—Lambert-street.

K. S. LANE, Shire Secretary.

12th June, 1959. 6066

SHIRE OF CRANBOURNE.

BY-LAW No. 46.

A By-law of the Shire of Cranbourne made under section 326 of the Health Act 1958, and numbered 46, for the regulation and management of the meat area within the municipal district of the said Shire, and for—

- prescribing the conditions on which animals may be received into or supplied or removed from the abattoirs therein situate;
- fixing the rates of fees or dues payable to the Council of the said Shire under Part XV. of the Health Act 1958;
- prescribing the times for selling and for slaughtering animals, and for selling carcasses or meat, at the said abattoirs;
- the feeding, watering and tending, and the preventing of cruelty to and overcrowding of, animals in the said abattoirs;
- stopping temporarily the manufacture of and the sale of small goods in circumstances in which danger to the consumer is apprehended owing to uncleanness or to the presence of infection on or about the premises where such manufacture of and the sale is carried on; and
- By-law No. 42 of the Shire of Cranbourne is hereby repealed.

IN exercise of the powers conferred by the Health Act 1958, and of every and any other power it thereunto enabling the President, Councillors, and Ratepayers of the Shire of Cranbourne hereby order as follows:—

1. In this By-law—

“The Council” means the Council of the Shire of Cranbourne.

“The Meat Inspector” means the meat inspector appointed and/or provided by the Council for the inspection and supervision of any abattoir in the meat area.

“The Meat Area” means the whole of the municipal district of the Shire of Cranbourne proclaimed as a meat area in the Victoria Gazette No. 114, 1958, at the page 3987.

2. This By-law shall apply to the meat area as defined in clause 1 hereof and such area shall, as to the enforcement of the Meat Supervision Regulations therein, be under the direction of the meat inspector.

3. This By-law shall come into full force and operation on its approval by the Governor in Council, and immediately after its publication in the Government Gazette.

4. The times for slaughtering animals in the meat area shall be between the hours of Seven o'clock a.m. and Four o'clock p.m. on Mondays, Tuesdays, Wednesdays, Thursdays, and Fridays in each week.

No animals shall be slaughtered in the meat area on Saturdays, Sundays or gazetted holidays, unless with the consent, in writing, of the meat inspector, to whom at least 24 hours' notice of intention to slaughter on these days must be given. All expenses incurred by reason of such slaughtering on Saturdays, Sundays or gazetted public holidays shall be paid by the person obtaining such consent.

5. No animal shall be slaughtered before it has been examined on the hoof in the meat area by the meat inspector on the days and within the times set out in clause 4 hereof.

6. No animal visibly or known to be affected by any contagious or infectious disease shall be received into any abattoir in the meat area, except with the express permission of the meat inspector.

7. No person shall remove or permit to be removed from any abattoir in the meat area any carcass, or part of the carcass, of any animal slaughtered thereat until the same has been examined by the meat inspector and passed by him as fit for human food and branded by him with the regulation brand, or rendered unfit for human consumption in the manner prescribed by the Meat Supervision Regulations.

8. No sheep shall be removed from any abattoir in the meat area with the head attached.

9. The fees payable to the Council for examining and branding carcasses, parts of carcasses, or meat by or under the direction of the meat inspector, shall be as follows:—

	£	s.	d.
(a) For examining any—			
(i) bull, cow, calf (other than a bobby-calf), helper, ox or steer	0	2	6
(ii) bobby-calf, goat, kid, lamb or sheep	0	1	0
(iii) head of swine	0	2	0

- (b) For examining and branding any carcass *£ s. d.*
of or meat derived from any—
- | | | | |
|--|---|---|---|
| (i) bull, cow, calf (other than a bobby-calf), heifer, ox or steer | 0 | 4 | 0 |
| (ii) bobby-calf, goat, kid, lamb or sheep | 0 | 1 | 6 |
| (iii) swine | 0 | 2 | 0 |
- (c) For any certificate as to an examination made by a meat inspector
- | | | | |
|---------|---|---|---|
| | 0 | 4 | 0 |
|---------|---|---|---|
- In this By-law "Bobby-calf" means a calf not more than six weeks old.

In addition to these fees and the expenses referred to in clause 4 hereof, a fee of ten shillings shall be paid by any person slaughtering animals on any Saturday, Sunday or gazetted public holiday.

The said fees shall be paid by the proprietor of any abattoir carried on in the meat area to the Council, and shall be so paid by the proprietor thereof to the Shire Secretary of the Council at the office of the Council at Cranbourne once at least in every week, and the amount of each such payment shall correspond with and be accompanied by a voucher from the meat inspector.

10. The proprietor of any abattoir in the meat area shall not, nor shall any person having the management or control of any animal or animals in the abattoir—

- (a) Suffer any cruelty to take place towards any animal at any time in the abattoir;
- (b) Suffer animals to be overcrowded in the abattoir.

11. If the meat inspector, the health inspector of the Council, or the Council's medical officer of health shall at any time find a condition of uncleanness or the presence of infection on or about the premises within the meat area where the manufacture or sale of small goods is carried on in circumstances in which danger to the consumer of such small goods is apprehended by such inspector or officer, such inspector or officer may by notice, in writing under his hand, directed to the proprietor of such premises prohibit the manufacture thereof and/or the sale therefrom of small goods until such condition of uncleanness is rectified or such infection is removed, and any such notice may be served in the manner provided by section 425 of the *Health Act 1958*.

12. Any person who shall, by wilful act or default, contravene any of the provisions of this By-law shall be guilty of an offence, and shall, on conviction, be liable to a penalty not exceeding Twenty pounds.

Resolution for passing this By-law was adopted by the Council of the Shire of Cranbourne on the 16th day of January, 1959, and confirmed on the 13th day of February, 1959.

In witness whereof the common seal of the President, Councillors, and Ratepayers of the Shire of Cranbourne was hereto affixed, in the presence of—

(SEAL) W. THWAITES, Shire President.
W. B. CAMPBELL, Councillor.
NORMAN L. BRUNT, Councillor.
T. W. GRANT, Shire Secretary.

Submitted to the Commission of Public Health on the 12th day of May, 1959.—G. W. ROGAN, Secretary to the Commission.

Approved by the Governor in Council, 2nd June, 1959.—A. MAHLSTEDT, Clerk of the Executive Council. 6119

SHIRE OF CRESWICK.

By-Law No. 19.

A By-law of the Shire of Creswick made under the Local Government Acts and numbered 19 for prohibiting the leaving standing of derelict or unregistered motor cars on streets or roads.

IN pursuance of the powers conferred by the Local Government Acts and of any and every other power it thereunto enabling the Council of the Shire of Creswick Orders as follows:—

1. In this By-law the words "derelict motor car" shall mean any derelict motor car which has remained in any street for a period exceeding 28 days.

2. No person shall leave any derelict or unregistered motor car standing on any street or road.

3. Any officer of the Council authorized by it in that behalf may cause any derelict or unregistered motor car left standing in any street or road to be removed by such reasonable means as he may think fit to some place set aside by the Council for that purpose.

4. As soon as reasonably may be after any such car has been removed as aforesaid, the Council shall cause to be published in a newspaper generally circulating in the Municipal District, a notice in the form in the Schedule hereto.

5. If within fourteen days after such publication such motor car shall be claimed by any person producing to the Council proof to its satisfaction that he is the owner thereof and the appropriate charge prescribed by this By-law shall be paid in respect thereof, such motor car shall be released to the person so claiming it.

6. (a) Where any such motor car shall not be so released within fourteen days after the publication of such notice as aforesaid, the Council may after the expiration of 21 days after the expiration of such notice, cause the same to be sold either by public auction or private contract.

(b) The proceeds of such sale shall be applied firstly in payment of the appropriate charge for the removal thereof and the residue (if any) shall be payable to any person producing to the Council proof to its satisfaction that he is the owner of such motor car.

(c) If within three months after the date of such sale, no person shall have claimed such residue and produced such proof as aforesaid to the Council, such residue shall be paid into the Municipal Fund.

7. If the Council shall be unable to sell such motor car within fourteen days from the expiration of such period of 21 days, the same may be disposed of by the Council in such manner as it may think fit.

8. The charge for the removal of any derelict or unregistered motor car pursuant to this By-law is hereby prescribed as a sum equivalent to 10s. For each mile or part thereof of the distance between the place where such motor car was left standing to the place set aside by the Council pursuant to clause 2 hereof.

9. This By-law shall apply to and have operation throughout the whole of the Municipal District.

THE SCHEDULE HEREINBEFORE REFERRED TO.

Notice is hereby given that the under-mentioned derelict or unregistered motor car was pursuant to the provisions of By-law No. 19 of the Shire of Creswick removed from -street/road on the day of 19 to the Council's yard in

Unless the charges for the removal thereof are paid within fourteen days (14) and the said motor car released the same will be sold by the Council.

Description of the Motor Car Referred To.

Make
Colour
Approximate year of manufacture
Number plate (if any)

Resolution for passing this By-law was agreed to by the Council of the Shire of Creswick on the 13th day of April, 1959, and confirmed on the 11th day of May, 1959.

The corporate seal of the President, Councillors, and Ratepayers of the Shire of Creswick was hereto affixed in the presence of—

(SEAL) W. A. COSGRAVE, President.
E. J. SEMMENS, Councillor.
J. B. WILKIE, Shire Secretary.

Approved by the Governor in Council on the 26th day of May, 1959.—A. MAHLSTEDT, Clerk of the Executive Council. 6071

SHIRE OF GORDON.

Dog Act 1958 (No. 6236).

THE owner of any dog (other than a dog used in the driving of stock) which is not under the effective control of some person by means of a chain or cord or leash found on any of the following shopping areas of Boort Township, namely—

- (a) Godfrey-street from Lake View-street to Gordon-street,
(b) Station-street from Godfrey-street to Bertoli-street,
(c) Bertoli-street from Lake View-street to Railway-crescent,

shall be liable for a first offence to a penalty of not more than Four pounds, and for a second or any subsequent offence to a penalty of not more than Ten pounds.

J. P. SCOTT, Shire Secretary.

Shire Office, Boort, 18th June, 1959.

6104

SHIRE OF HAMPDEN.

NOTICE is hereby given that James Hynes has been appointed by the Council of the Shire of Hampden as Ranger, Impounding Officer and officer to administer the provisions of the Dog Acts, with authority to collect dog registration fees throughout the Shire of Hampden area, and impound any stock trespassing on any road or land under the control of the Council within the boundaries of the Shire of Hampden.

THOS. F. LITTLE, Shire Secretary.
Shire Office, Camperdown, 18th June, 1959. 6073

SHIRE OF HAMPDEN.

LOAN No. 5.

Notice of Intention to Borrow the Sum of £7,000 for Permanent Works and Undertakings.

NOTICE is hereby given that the Council of the Shire of Hampden proposes to borrow the sum of £7,000 on the credit of the municipal revenues of the President, Councillors and Ratepayers of the said Shire, such sum to be raised by the issue of debentures, in accordance with the provisions of the Local Government Act.

1. The maximum rate of interest that may be paid is 5½ per cent. per annum.
2. The purpose for which the loan is to be applied is the purchase of Road-making Machinery and Equipment.
3. The period of the loan shall be ten years.
4. The moneys borrowed shall be repayable by providing out of the municipal fund twenty half-yearly instalments of approximately £459 14s. each, including principal and interest on the first day of April and the first day of October during the currency of the loan. The first instalment shall be payable on the first day of April, 1960.
5. Such moneys shall be repayable at The National Bank of Australasia Limited, Melbourne, or at the Council's bankers for the time being in Melbourne.

The plans and specifications and the estimate of the cost of the proposed works, and a statement showing the proposed expenditure of the moneys to be borrowed, are open for inspection at the Shire Office, Camperdown.

THOS. F. LITTLE, Shire Secretary.
22nd day of June, 1959. 6117

NOTICE OF INTENTION TO APPLY FOR A LICENCE TO DIVERT WATER AND CUT RACE (RE-ISSUE) FROM THE GUNBOWER CREEK, AT WEE WEE RUP.

I HEREBY give notice that I intend to apply for a licence empowering me to divert water for a term of fifteen years to the extent of 60 acre-feet per annum, at a maximum rate of 6 acre-feet per day of 24 hours for the purpose of irrigating 53 acres by pumping, being allotment 11, section 8, Parish of Gunbower, and to occupy certain Crown lands for works of diversion, and to cut a race thereon.

Any objection to such application must be forwarded, in writing, to reach the State Rivers and Water Supply Commission, Melbourne, before 24th July, 1959, being 30 days from the first publication of this notice.

CYRIL GORDON MOFFATT.
Burke's Bridge, via Cohuna. 6064

NOTICE OF INTENTION TO APPLY FOR A LICENCE TO DIVERT WATER AND CUT RACE (RE-ISSUE) FROM THE TUTCHEWOP OUTFALL CHANNEL, AT FISH POINT.

WE hereby give notice that we intend to apply for a licence empowering us to divert water for a term of fifteen years to the extent of 80 acre-feet per annum at a maximum rate of 10 acre-feet per day of 24 hours for the irrigation of 320 acres, being part of allotment 32, section 1, Parish of Benjeroop, and to occupy certain Crown lands for works of diversion, and to cut a race thereon.

Any objection to such application must be forwarded, in writing, to reach the State Rivers and Water Supply Commission, Melbourne, before 24th July, 1959, being 30 days from the first publication of this notice.

REUBEN LESLIE BRASSER.
CHARLES ALFRED BRASSER.
JAMES HENRY BRASSER.
Fish Point, Victoria. 6062

NOTICE OF INTENTION TO APPLY FOR A LICENCE TO DIVERT WATER AND CUT RACE (RE-ISSUE) FROM THE GUNBOWER CREEK, AT PATHO.

I HEREBY give notice that I intend to apply for a licence empowering me to divert water for a term of fifteen years to the extent of 50 acre-feet per annum at a maximum rate of 10 acre-feet per day of 24 hours for the purpose of irrigating 35 acres by pumping, being allotment 36, section D, Parish of Patho, and to occupy certain Crown lands for works of diversion, and to cut a race thereon.

Any objection to such application must be forwarded, in writing, to reach the State Rivers and Water Supply Commission, Melbourne, before 24th July, 1959, being 30 days from the first publication of this notice.

CYRIL GORDON MOFFATT.
Burke's Bridge, via Cohuna. 6065

NOTICE OF INTENTION TO APPLY FOR A LICENCE TO DIVERT WATER AND CUT RACE (RE-ISSUE) FROM THE TUTCHEWOP OUTFALL CHANNEL, AT FISH POINT.

I HEREBY give notice that I intend to apply for a licence empowering me to divert water for a term of fifteen years to the extent of 80 acre-feet per annum at a maximum rate of 10 acre-feet per day of 24 hours for the watering of pastures, being part of allotment 15A, and 18, section 2, Parish of Boga, and to occupy certain Crown lands for works of diversion, and to cut a race thereon.

Any objection to such application must be forwarded, in writing, to reach the State Rivers and Water Supply Commission, Melbourne, before 24th July, 1959, being 30 days from the first publication of this notice.

JOHN WILLIAMS TRIPCONY.
Box 94, Lake Boga, Victoria. 6070

NOTICE OF INTENTION TO APPLY FOR A LICENCE TO DIVERT WATER AND CUT RACE (RE-ISSUE) FROM THE TUTCHEWOP OUTFALL AT LITTLE MURRAY RIVER (FISH POINT).

I HEREBY give notice that I intend to apply for a licence empowering me to divert water for a term of fifteen years to the extent of 32 acre-feet per annum at a maximum rate of 10 acre-feet per day of 24 hours for the purpose of irrigating 16 acres of pasture, being part of allotment 3, section 2, Parish of Boga, and to occupy certain Crown lands for works of diversion, and to cut a race thereon.

Any objection to such application must be forwarded, in writing, to reach the State Rivers and Water Supply Commission, Melbourne, before 24th July, 1959, being 30 days from the first publication of this notice.

THOMAS LESLIE RITCHIE.
Fish Point, via Lake Boga. 6063

NOTICE OF INTENTION TO APPLY FOR A LICENCE TO DIVERT WATER AND CUT RACE FROM THE RIVER MURRAY, AT NANGILOC.

I HEREBY give notice that I intend to apply for a licence empowering me to divert water for a term of fifteen years to the extent of 45 acre-feet per annum, at a maximum rate of 2 acre-feet per day of 24 hours for the irrigation of 15 acres of vegetables and citrus, being part of allotment 6, Parish of Colignan, and to occupy certain Crown lands for works of diversion, and to cut a race thereon.

Any objection to such application must be forwarded, in writing, to reach the State Rivers and Water Supply Commission, Melbourne, before 24th July, 1959, being 30 days from the first publication of this notice.

NEIL J. HARRISON.
16 Highbury-road, Burwood. 6061

NOTICE OF INTENTION TO APPLY FOR A LICENCE TO DIVERT WATER AND CUT RACE FROM THE RIVER MURRAY, AT ROBINVALE.

I HEREBY give notice that I intend to apply for a licence empowering me to divert water for a term of fifteen years to the extent of 45 acre-feet per annum, at a maximum rate of 10 acre-feet per day of 24 hours for the irrigation of 15 acres, being part of allotments 7, and 10, 17, 21, 22, Parish of Bumbang, and to occupy certain Crown lands for works of diversion, and to cut a race thereon.

Any objection to such application must be forwarded, in writing, to reach the State Rivers and Water Supply Commission, Melbourne, within 30 days of the date hereof.

V. NATALE.
Box 30, Robinvale, 9th June, 1959. 6060

NOTICE OF INTENTION TO APPLY FOR A LICENCE TO DIVERT WATER FROM THE TUTCHEWOP OUTFALL CHANNEL AT BENJEROOP.

I HEREBY give notice that I intend to apply for a licence empowering me to divert water for a term of fifteen years to the extent of 80 acre-feet per annum at a maximum rate of 10 acre-feet per day of 24 hours for the irrigation of 140 acres of pasture and lucerne, being part of allotments 31 and 35, section 1, Parish of Benjeroop, and to occupy certain Crown lands for works of diversion, and to cut a race thereon.

Any objection to such application must be forwarded, in writing, to reach the State Rivers and Water Supply Commission, Melbourne, before 24th July, 1959, being 30 days from the first publication of this notice.

ARTHUR D. NIXON.

Box 57, Lake Boga, Victoria. 6108

NOTICE OF INTENTION TO APPLY FOR A LICENCE TO DIVERT WATER AND CUT RACE (RE-ISSUE) FROM THE GUNBOWER CREEK AT GUNBOWER ISLAND.

I HEREBY give notice that I intend to apply for a licence empowering me to divert water for a term of fifteen years to the extent of 150 acre-feet per annum at a maximum rate of 6 acre-feet per day of 24 hours for the purpose of irrigating 75 acres by pumping, being part of allotments 45, 48c, 49, 50, 50A, section 7, Parish of Gunbower, and to occupy certain Crown lands for works of diversion, and to cut a race thereon.

Any objection to such application must be forwarded, in writing, to reach the State Rivers and Water Supply Commission, Melbourne, before 24th July, 1959, being 30 days from the first publication of this notice.

CHARLES CAMERON MCINNES.

"Inverness", Gunbower. 6109

NOTICE OF INTENTION TO APPLY FOR A LICENCE TO DIVERT WATER AND CUT RACE (RE-ISSUE) FROM THE COCKATOO LAGOON AT GUNBOWER ISLAND.

I HEREBY give notice that I intend to apply for a licence empowering me to divert water for a term of fifteen years to the extent of 100 acre-feet per annum at a maximum rate of 5 acre-feet per day of 24 hours for the purpose of irrigating 50 acres by pumping, being part of allotments 35-37, section 7, Parish of Gunbower, and to occupy certain Crown lands for works of diversion, and to cut a race thereon.

Any objection to such application must be forwarded, in writing, to reach the State Rivers and Water Supply Commission, Melbourne, before 24th July, 1959, being 30 days from the first publication of this notice.

CHARLES CAMERON MCINNES.

"Inverness", Gunbower. 6110

Form 1.—Reg. 9.

Industrial and Provident Societies Act 1958.

ADVERTISEMENT OF CANCELLING OR SUSPENSION.

NOTICE is hereby given that the Registrar of Friendly Societies has, pursuant to the *Industrial and Provident Societies Act 1958*, this day cancelled the registration of the Co-operative Society of Hungarian Veterans Ltd. (Register No. 1500PP), the registered office of which is at 361 Williamstown-road, Yarraville, on the grounds that the Society is not trading and is defunct within the meaning of the Act.

The Society ceases to enjoy the privileges of a registered society, but without prejudice to any liability incurred by the Society, which may be enforced against it as if such cancelling had not taken place.

A. DOUGLAS, Registrar of Friendly Societies.

Dated the 3rd day of June, 1959. 6097

NOTICE is hereby given that the partnership heretofore existing between Arthur Frederick Walker and James Percival Walker, under the firm or business name of Walker's Lawnmower Repair Service carried on at 441 Nepean Highway, East Brighton, will be dissolved as at the 30th day of June, 1959, and from and after that date the said James Percival Walker will carry on the said business under the same name for his own use and benefit as sole owner thereof, and will pay and discharge all debts and liabilities incurred by the firm up to and including the 30th day of June, 1959.

KIDDLE, BRIGGS & WILLOX, 15 Queen-street, Melbourne, solicitors for the above parties. 6131

NOTICE is hereby given that the partnership heretofore subsisting between Henry Philipp and Bina Philipp and Francis Paul Podosky and Doreen Mavis Podosky, carrying on business as garage proprietors at 254 Inkerman-street, East St. Kilda, under the name of "T.V. Motors", has been dissolved by mutual consent as from the 22nd day of May, 1959. All debts due to and owing by the said late firm will be received and paid by Francis Paul Podosky and Mavis Doreen Podosky, who will continue to carry on the business at the same place and under the same business name.

Dated the 22nd day of May, 1959.

JULIAN MERCER, 224 Queen-street, Melbourne, solicitor and agent for the said Henry Philipp and Bina Philipp. 6120

NOTICE is hereby given that the partnership heretofore subsisting between the undersigned Ernest Henry Roughley and Albert Roy Charlesworth, carrying on business as engineers at 187 Buckley-street, Essendon, under the name "Regal Engineering Co.," has been dissolved by mutual consent, as from the 5th day of June, 1959. All debts due to and owing by the said late firm will be received and paid by Ernest Henry Roughley, who will continue to carry on the business at the same place and under the same business name.

Dated this 5th day of June, 1959.

E. H. ROUGHLEY.

Witness—A. L. PARK.

A. R. CHARLESWORTH.

Witness—E. WAITES.

McKean and Park, solicitors, 84 William-street, Melbourne. 6154

Partnership Act 1928.

FORM OF NOTICE OF DISSOLUTION.

NOTICE is hereby given that the partnership heretofore subsisting between John Finch Akeroyd, Thomas Bowen Ready, Geoffrey James Cornish, George Murray Hayward and Philip John Crawford Stretton, all of Melbourne-road, Frankston, medical practitioners, carrying on business as medical practitioners at "Maxwellton," Nepean Highway, Frankston, under the firm name of "Dr. J. F. Akeroyd, Dr. T. B. Ready, Dr. G. J. Cornish, Dr. G. M. Hayward and Dr. P. J. C. Stretton," has been dissolved by mutual consent as from the 31st day of August, 1959. All debts due to and owing by the said firm will be received and paid by the said John Finch Akeroyd, Thomas Bowen Ready, Geoffrey James Cornish and George Murray Hayward, who will continue to carry on the said business under the firm name of "Dr. J. F. Akeroyd, Dr. T. B. Ready, Dr. G. J. Cornish and Dr. G. M. Hayward," at the same address.

Dated the 24th day of June, 1959.

J. F. AKEROYD.

T. B. READY.

G. J. CORNISH.

G. M. HAYWARD.

J. C. STRETTON.

Barnet Rockman and Co., solicitors, 62A Young-street, Frankston. 6088

BENDIGO PRESERVING COMPANY LIMITED.

UNCLAIMED Dividends at the 31st May, 1959, on Dividend of 6½ per cent. declared on the 31st December, 1957.

Name and Address of Owner on Books.	Total Amount Due to Owner.	Description of Unclaimed Money.
	£ s. d.	
K. Chambers, Caulfield ..	0 3 9	Cheque unrepresented
Exec. H. Child, Kalorama ..	0 6 3	" "
Miss A. W. Hunt, Sunshine ..	1 7 6	" "
W. Loveland, California Gully	0 5 0	" "
Louey H. Yick, Bendigo ..	1 3 9	" "
C. E. G. Rawsthorne, Moreland	0 10 0	" "
Exec. M. Roberts, Bendigo ..	0 2 6	" "
Mrs. M. Strotton, Essendon ..	3 5 0	" "
	7 3 9	

6068

Companies Act 1958.—In the matter of TAWONGA GOLD MINING COMPANY NO LIABILITY (In Voluntary Liquidation).—A Return of Capital (being the first and final distribution) to Shareholders is about to be made in this matter.

CREDITORS are required to prove their claims by affidavit on or before 5th day of August, 1959, or otherwise the return of capital to shareholders will be made without regard to such claims.

Dated this 19th day of June, 1959.

GILBERT JEFFERY, Liquidator.

247 Collins-street, Melbourne. 6098

Companies Act 1958.—Section 195.

ASHBURTON CIVIC THEATRE PROPRIETARY LIMITED (IN VOLUNTARY LIQUIDATION).

NOTICE is hereby given that at a Special Meeting of shareholders of Ashburton Civic Theatre Proprietary Limited, held 18th June, 1959, the following Special Resolution was passed:—

"That the company be wound up voluntarily."

K. G. COLHOUN, Liquidator.

375 Collins-street, Melbourne. 6095

In the matter of the *Companies Act 1958*, and in the matter of PORT PHILLIP CLUB HOTEL PROPRIETARY LIMITED.

AT a General Meeting of Port Phillip Club Hotel Proprietary Limited, held at 470 Bourke-street, Melbourne, on the 16th day of June, 1959, the following Special Resolution was duly passed:—

Resolution—

"That the company be wound up voluntarily, and that Forbes Yorke Rattray, chartered accountant (Aust.), of 24 Jeffcott-street, Melbourne, be and is hereby appointed liquidator for the purpose of such winding up."

I hereby certify that the above is a true copy of the Resolution passed at the aforesaid General Meeting of the company.

Dated at Melbourne, this 16th day of June, 1959.

6090 P. L. COLEMAN, Chairman of Meeting.

In the matter of the *Companies Act 1958*, and in the matter of W. TYNER INVESTMENTS PROPRIETARY LIMITED.

AT a General Meeting of W. Tyner Investments Proprietary Limited, held at 18 Warida-avenue, East Malvern, on the 16th day of June, 1959, the following Special Resolution was duly passed:—

Resolution—

"That the company be wound up voluntarily and that Forbes Yorke Rattray, chartered accountant (Aust.), of 24 Jeffcott-street, Melbourne, be and is hereby appointed liquidator for the purpose of such winding up."

I hereby certify that the above is a true copy of the Resolution passed at the aforesaid General Meeting of the company.

Dated at Melbourne, this 16th day of June, 1959.

6089 F. M. EVANS, Chairman of Meeting.

FORBCO INDUSTRIES PTY. LTD. (IN LIQUIDATION).

NOTICE TO CREDITORS OF INTENTION TO DECLARE DIVIDEND.

A SECOND and Final Dividend is intended to be declared in the above matter. Creditors who have not lodged their proofs of debt with me, on or before the 1st day of July, 1959, will be excluded from this dividend.

Dated this 18th day of June, 1959.

6080 JOHN J. COURTNEY, Liquidator.

DYCHEM TRADING CO. PTY. LTD.

NOTICE OF SPECIAL RESOLUTION TO WIND UP.

AT an Extraordinary General Meeting of the above-named company duly convened and held at 62 Clarence-street, Sydney, on Tuesday, the 16th day of June, 1959, the following Resolution was duly passed as a Special Resolution:—

"That the company be wound up voluntarily."

And at such last-mentioned meeting Kathleen Mildred Ryan, of 5 Moore-street, Roseville, was appointed liquidator for the purposes of the winding up.

Dated the 16th day of June, 1959.

6146 HENRY H. YORK, Chairman.

Companies Act 1958.

LYONS CONTINENTAL SMALLGOODS PTY. LTD (IN VOLUNTARY LIQUIDATION).

NOTICE CONVENING FINAL MEETING, PURSUANT TO SECTION 236.

NOTICE is hereby given, in pursuance of section 236 of the *Companies Act 1958*, that a General Meeting of the company and a Meeting of creditors, will be held at the office of the liquidator, 3 Queens-road, Melbourne, on Monday, 27th July, 1959, at 4 p.m. for the purpose of having an account laid before them showing the manner in which the winding up of the company has been conducted and the property of the company disposed of, and of hearing any explanation that may be given by the liquidator.

Dated this 17th day of June, 1959.

6148 JOHN REZAK, Liquidator.

NOTICE.—Final Meeting for the voluntary liquidation of South East Manufacturing Co. Pty. Ltd., will be held on Thursday, 30th July, 1959, at the registered office, at 2 o'clock in the afternoon, in order to approve statement of liquidation dated 22nd June, 1959.

6142 GERALD ISRAEL, Liquidator.

The *Companies Act 1958.*—In the matter of MATTHEWS BROS. PROPRIETARY LIMITED.

NOTICE is hereby given that at an Extraordinary Meeting of the members of the above-named company held on Tuesday, the 16th day of June, 1959, it was resolved that the company be wound up voluntarily, and at a Meeting of creditors held on the same day, pursuant to section 201, it was resolved that for such purpose Edward Ronald Small, of 31 Queen-street, Melbourne, chartered accountant (Aust.), be appointed liquidator.

Notice is also given that after 21 days from this date, I shall proceed to distribute the assets. All creditors having any claims against the company should furnish particulars of same by that date, otherwise I shall proceed to distribute the assets, without regard to their claim.

Dated this 23rd day of June, 1959.

E. R. SMAIL, Liquidator.

Kennedy, Smail, and Middlemiss, 31 Queen-street, Melbourne. 6139

The *Companies Act 1958.*—In the matter of HAMPTON ELECTRICS PTY. LTD.—Notice re Meeting of Creditors, pursuant to section 201 (2).

NOTICE is hereby given that a Meeting of Creditors of the above-named company will be held in the office of Kennedy, Smail and Middlemiss, 31 Queen-street, Melbourne, on Thursday, the 25th day of June, 1959, at Three o'clock p.m., the company having convened a meeting of its members for the same day for the purpose of considering a Resolution that the company be wound up voluntarily.

Dated this 12th day of June, 1959.

A. J. ANDERSON, Director.

Kennedy, Smail and Middlemiss, 31 Queen-street, Melbourne. 6132

The *Companies Act 1958.*—In the matter of W. O. WILSON STEEL PRODUCTS PTY. LTD.—Notice re Meeting of Creditors, pursuant to section 201 (2).

NOTICE is hereby given that a Meeting of Creditors of the above-named company will be held in the office of M. V. Anderson and Co., 377 Little Collins-street, Melbourne, on Monday, 29th June, 1959, at Three-thirty p.m., the company having convened a meeting of its members for the same day for the purpose of considering a Resolution that the company be wound up voluntarily.

Dated this 19th day of June, 1959.

W. O. WILSON, Director.

M. V. Anderson and Co., 377 Little Collins-street, Melbourne. 6129

WESTERN DISTRICT CEMENT LIMITED (IN LIQUIDATION).

CREDITORS MEETING.

NOTICE is hereby given that a General Meeting of Creditors will be held on Wednesday, 26th August, 1959, at Three o'clock in the afternoon, at 164 Koroff-street, Warrnambool. The business at the meeting will be to receive the liquidators account of the winding up, showing how the winding up has been disposed of.

Dated at Warrnambool, this 10th day of June, 1959.

6126 I. E. LOHREY, Liquidator.

No. of Company 23636.

NORTHCOTE INVESTMENTS PROPRIETARY LIMITED.

SPECIAL RESOLUTION.

Notice of Members Voluntary Winding Up of a Company Registered Under the Companies Act 1958.

AT an Extraordinary General Meeting of members of Northcote Investments Proprietary Limited, duly convened and held at 422 Little Collins-street, Melbourne, on the 22nd day of June, 1959, the following Special Resolution was duly passed:—

"That the company be wound up voluntarily under the provisions of the *Companies Act 1958*."

Walter Summerton, care of E. B. Edwards and Associates, 422 Little Collins-street, Melbourne, was duly appointed liquidator.

M. BALL, Chairman of Directors, Northcote Investments Proprietary Limited. 6125

Companies Act 1958.

THE WANGARATTA AGRICULTURAL CO-OPERATIVE SOCIETY LTD.

SPECIAL RESOLUTION TO WIND UP, PURSUANT TO SECTION 195.

AT an Extraordinary General Meeting of the above-named company duly convened and held at 59 Reid-street, Wangaratta, on Thursday, the 11th day of June, 1959, the following Resolution was duly passed as a Special Resolution:—

"That the company be wound up voluntarily."

And at such last-mentioned meeting Alexander Luxmoore Macgeorge, of 8 Ely-street, Wangaratta, was appointed liquidator for the purposes of the winding up.

Dated the 17th day of June, 1959.

6118 W. B. RICHARDSON, Chairman.

DYCHEM TRADING CO. PTY. LTD.

NOTICE is hereby given that the creditors of the above-named company which is being voluntarily wound up are required on or before the 29th day of June, 1959, being the day for that purpose fixed by me, the undersigned, the liquidator of the company, to send their names and addresses and the particulars of their debts or claims and the names and addresses of their solicitors, if any, to the undersigned, and if so required by notice in writing from me are by their solicitors to come in and prove their said debts and claims at such time and place as shall be specified in such notice or in default thereof they will be excluded from the benefit of any distribution made before such debts are proved.

Dated this 16th day of June, 1959.

6127 K. M. RYAN, Liquidator.

NOTICE is hereby given that at a General Meeting of County of Bourke Permanent Building and Investment Society, the following Special Resolution was duly passed:—

"That the Society be wound up voluntarily and that Neil Ferguson Gerrand, of 360 Collins-street, Melbourne, chartered accountant (Aust.), be appointed liquidator for the purposes of such winding up."

Dated this 22nd day of June, 1959.

6112 N. F. GERRAND, Liquidator.

NOTICE is hereby given that at a General Meeting of The Federal Building Society, the following Special Resolution was duly passed:—

"That the Society be wound up voluntarily and that Neil Ferguson Gerrand, of 360 Collins-street, Melbourne, chartered accountant (Aust.), be appointed liquidator for the purposes of such winding up."

Dated this 22nd day of June, 1959.

6111 N. F. GERRAND, Liquidator.

A MEETING of creditors of Television Wholesalers Pty. Ltd. will be held at the Board Room of the Honorary Justices Association, 6th floor, 34 Queen-street, Melbourne, at 10 a.m., on Friday, 3rd July, 1959.

6114 P. J. GILL, Director.

THE PERPETUAL EXECUTORS AND TRUSTEES ASSOCIATION OF AUSTRALIA LIMITED, whose registered office is situate at Nos. 100-104 Queen-street, Melbourne, in the State of Victoria, and Elmira Needham, of Willow Grove, via Moe, in the said State, the executors of the will of John Wetmore, late of 132 Vere-street, Abbotsford (who died on the 20th day of November, 1958), require all creditors, next of kin, and others having claims against the property or estate of the said deceased to send to the said executors, in the care of the said association, on or before the 23rd day of August, 1959, particulars, in writing, of such claims, after which date the said executors intend to convey or distribute such property or estate to or among the persons entitled thereto, having regard only to the claims of which they shall have had notice.

Dated the 18th day of June, 1959.

T. A. I. A. FORBES & CO., solicitors, of 303 Bridge-road, Richmond, solicitors for the executors. 6072

CREDITORS, next of kin, and others having claims against the estate of Walter William Matthews formerly of Cora Lynn, but late of Tynong, retired farmer, deceased (who died on 1st September, 1958), are requested to send particulars of their claims to Victoria Alberta Matthews, of Tynong, widow, the executor appointed by deceased's will, in care of the undersigned, by the 29th August, 1959, after which date she will distribute the assets, having regard only to the claims of which she shall then have had notice.

M. DAVINE, solicitor, Warragul. 6058

ERNEST EDWARD SHATTOCK, late of Seymour, farmer, DECEASED.

CREDITORS, next of kin, and others having claims in respect of the estate of the deceased (who died on the 28th day of March, 1959) are required by the administrator, Norman Stanley Bjorksten, to send particulars to the undersigned solicitors, by the 1st day of September, 1959, after which date the administrator may convey or distribute the assets, having regard only to the claims of which he then has had notice.

WILFRID J. OSBORNE & OSBORNE, solicitors, Seymour. 6059

CREDITORS, next of kin, and others having claims in respect of the estate of Robert Hugh Chaffey, late of Chaffey-avenue, Mildura, licensed real estate agent, deceased (who died on the 23rd April, 1958), are required by The Perpetual Executors and Trustees Association of Australia Limited, of Nos. 100-104 Queen-street, Melbourne, and Dorothy Chaffey, of Chaffey-avenue, Mildura, widow, the executors of the will of the said deceased, to send particulars of their claims to the said executors, in the care of the said association, on or before the 7th August, 1959, after which date the said executors will distribute the assets, having regard only to the claims of which they shall have had notice.

HILLARD, RICE & GARDE, solicitors, Mildura. 6074

RICHARD CHRISTMAS ANDERSON, late of "Ellisdale", Gainsborough, farmer, DECEASED.

CREDITORS, next of kin, and others having claims in respect of the estate of the deceased (who died on the 5th day of March, 1959) are required by the trustees, Richard Ralph Anderson, of Gainsborough, Florence Fay Petschack, of Jindivick, and Noel Cropley, of Ellenbank, to send particulars to them, by the 28th day of August, 1959, after which date the trustees may convey or distribute the assets, having regard only to the claims of which they then have notice.

GRAY, FRIEND & LONG, solicitors, Warragul. 6076

CREDITORS, next of kin, and others having claims in respect of the estate of Lillian Maud Rutherford, late of 78 Albert-street, Geelong West, widow, deceased (who died on the 24th day of November, 1958, and probate of whose will was issued by the Supreme Court of Victoria on the 3rd day of March, 1959, to The Fidelity Trustee Company Limited, of 101 Lydiard-street north, Ballarat, the executor named in the said will), are to send particulars of their claims to the said executor, at its branch office, situated at The Trustee Chambers, Malop-street, Geelong, by the 19th day of August, 1959, after which date the said executor will distribute the assets, having regard only to the claims of which it then has notice.

CRAWCOUR & HOLLYHOKE, solicitors, Yarra-street, Geelong. 6079

PETER FRANCIS MORRISON, late of Drouin, carpenter,
DECEASED.

CREDITORS, next of kin, and others having claims in respect of the estate of the deceased (who died on the 22nd day of August, 1958) are required by the trustees, James Walter Clark McKindlay, of Weebar-road, Drouin, and Alan William Rogers, of 178 Princes Highway, Drouin, to send particulars to them, by the 28th day of August, 1959, after which date the trustees may convey or distribute the assets, having regard only to the claims of which they then have notice.

GRAY, FRIEND & LONG, solicitors, Warragul. 6077

CREDITORS, next of kin, and others having claims in respect of the estate of Victoria Louisa Sheppard (also known as Louisa Sheppard), late of Dr. Singleton's Home for Women, 18 Islington-street, Collingwood, deceased (who died on 1st March, 1959), are to send particulars of their claims to the Union Trustee Company of Australia Limited, of 333 Collins-street, Melbourne, the executor of the estate of the deceased, by 24th August, 1959, after which date the executor will distribute the assets, having regard only to the claims of which it then has notice.

FREDERICK OWEN & ASSOCIATES, solicitors, 84 William-street, Melbourne. 6130

AXEL CHRISTIAN PETERSEN, formerly of Grovedale, but late of 8 Elizabeth-street, Belmont, Geelong, farmer,
DECEASED.

CREDITORS, next of kin, and others having claims in respect of the estate of the above-named deceased (who died on the 9th day of January, 1959), are required by the personal representative, The Union Trustee Company of Australia Limited, of 333 Collins-street, Melbourne, to send particulars to the said company, in the care of the under-mentioned solicitors, by the 27th day of August, 1959, after which date the personal representative may convey or distribute the assets, having regard only to the claims of which it then has notice.

Dated this 19th day of June, 1959.

HARDWOOD & PINCOTT, solicitors, 77 Moorabool-street, Geelong. 6103

EADITH ROSAMUND LACEY, late of York-street, Sale, spinster (who died 11th October, 1957).

CREDITORS, next of kin, and all other persons having claims against the estate of the deceased, are required by the executor of the will, Samuel Lachlan Lacey, of Raglan-street, Sale, engineer, to send particulars to him, care of the undersigned, on or before 22nd August, 1959, after which date he will distribute the assets, having regard only to the claims of which he then has notice.

R. M. ROLLAND, solicitor, 57c Raymond-street, Sale. 6091

EDWIN JOHN DAVIDSON, late of Bishopcourt, Raglan-street, Sale, Bishop (who died 1st April, 1958).

CREDITORS, next of kin, and all other persons having claims against the estate of the deceased, are required by the executrix of the will, Doris Evelyn Davidson, of Baroona-avenue, Church Point, Pittwater, New South Wales, widow, to send particulars to her, care of the undersigned, on or before 22nd August, 1959, after which date she will distribute the assets, having regard only to the claims of which she then has notice.

R. M. ROLLAND, solicitor, 57c Raymond-street, Sale. 6092

MARIA GRATZIA (in the will called Grazia) CANESTRA, late of 268 Inkerman-street, St. Kilda, in the State of Victoria, widow, DECEASED.

CREDITORS, next of kin, and others having claims against the estate of deceased (who died on the 30th day of September, 1958), are required to send particulars thereof to John Canestra, of Bull-road, Moorabin, fruiterer's assistant, Robert Canestra, of 23 Lewisham-road, Windsor, postal employee, Mary Canestra, of 268 Inkerman-street, Windsor, portress, and Rosina Silcot, of 45 Airlie-avenue, Armadale, married woman, care of the undersigned solicitor, by the 25th day of August, 1959, after which date they will distribute the assets of the deceased, having regard only to the claims of which they then have notice.

E. K. O'DONNELL, solicitor, 173 Greville-street, Prahran. 6152

CREDITORS, next of kin, and others having claims in respect of the estate of Rose Lillian Smith, late of 52 Martin-street, Elwood, married woman, deceased (who died on the 17th day of May, 1958, and probate of whose will has been granted to Leslie Edward Smith, of 52 Martin-street, Elwood, clerk, Lorraine Wilson Cherry, of 17 Parkland-crescent, East Brighton, married woman, and Elizabeth Alice MacGregor, of 217 Were-street, East Brighton, married woman), are to send in particulars of their claims to the said executors, care of the under-mentioned solicitors, by the 27th day of August, 1959, after which date they will distribute the assets, having regard only to the claims of which they then have notice.

PEARCE & WEBSTER, solicitors, 430 Little Collins-street, Melbourne. 6083

CREDITORS, next of kin, and others having claims in respect of the estate of Mary Isabel Aitken, late of "Beath", 14 Gaynor Court Park, Malvern, in Victoria, spinster (who died on the 18th day of March, 1959), are required by the executors, Suetonius Arthur Aitken, gentleman, and David Angus Aitken, engineer, both of 28 Belson-street, East Malvern aforesaid, to send particulars to them, care of the under-mentioned solicitors, by the 26th day of August, 1959, after which date they may convey or distribute the assets, having regard only to the claims of which they then have notice.

AITKEN, WALKER & STRACHAN, solicitors, 123 William-street, Melbourne. 6149

CREDITORS, next of kin, and others having claims in respect of the estate of Lorraine Scarlett Montiford-O'Brien, also known as Lorraine Scarlett Montiford O'Brien, Lorraine Scarlett Montiford, and Lorraine Scarlett O'Brien, late of 390 Dorcas-street, South Melbourne, retired railway employee, deceased (who died on 26th September, 1958), are hereby required to send particulars of their claims to The Equity Trustees, Executors, and Agency Company Limited, of 472 Bourke-street, Melbourne, by the 30th day of September, 1959, after which date it will distribute the assets, having regard only to the claims of which it has then had notice.

L'ESTRANGE & KENNEDY, solicitors, of 291 Bridge-road, Richmond. 6150

CREDITORS, next of kin, and others having claims against the estate of Grace Clark (also known as Grace McChesney Clark), formerly of 7 Fitzgibbon-crescent, Caulfield, in the State of Victoria, and of Bala Lodge, Chapel Hill, Indooroopilly, in the State of Queensland, but late of Bayview Private Hospital, Wellington Point, in the State of Queensland, widow, deceased (who died on the 18th day of February, 1959), are to send particulars of their claims to The Union Trustee Company of Australia Limited, of 333 Collins-street, Melbourne, by the 24th day of August, 1959, after which day the company will distribute the assets, having regard only to the claims of which it then has notice.

R. R. RENOWDEN & CO., solicitors, 80 Swanston-street, Melbourne. 6106

MARY BELL, late of Colaba Hospital, 88 Orrong-road, Elsternwick, in the State of Victoria, widow, DECEASED.

CREDITORS, next of kin, and others having claims against the estate of deceased (who died on the 24th day of January, 1959), are required to send particulars thereof to Charles Thomas Ashby, of Moolton-avenue, Thornbury, care of the undersigned solicitor, by the 25th day of August, 1959, after which date he will distribute the assets of the deceased, having regard only to the claims of which he then has notice.

E. K. O'DONNELL, solicitor, 173 Greville-street, Prahran. 6153

ETHEL SARAH TWEDDLE, late of 111 Bay-road, Sandringham, spinster, DECEASED.

CREDITORS, next of kin, and others having claims in respect of the estate of the above-named deceased (who died on the 11th April, 1959), are required by the executors, James Clifford Tweddle, of Henty, New South Wales, and Lester Quintus Permezel, of 379 Collins-street, Melbourne, solicitor, to send particulars to them, in care of their under-mentioned solicitors, by the 26th August, 1959, after which date the executors may convey or distribute the assets, having regard only to the claims of which they then have notice.

W. H. FLOOD & PERMEZEL, 379 Collins-street, Melbourne, solicitors for the executors. 6140

HENRY GEORGE LACEY, late of Stawell-street, Sale, engineer (who died 31st August, 1957).

CREDITORS, next of kin, and all other persons having claims against the estate of the deceased, are required by the executrix of the will, Eva Lacey, of Stawell-street, Sale, widow, to send particulars to her, care of the undersigned, on or before 22nd August, 1959, after which date she will distribute the assets, having regard only to the claims of which she then has notice.

R. M. ROLLAND, solicitor, 57c Raymond-street, Sale. 6093

CREDITORS, next of kin, and others having claims in respect of the estate of Harry Selby Rickards, late of "The Crib", 34 Jolimont-terrace, Jolimont, in the State of Victoria, retired warehouseman, deceased (who died on the 17th day of August, 1958), are to send the particulars of their claims to The Union Trustee Company of Australia Limited, of 333 Collins-street, Melbourne, by the 27th day of August, 1959, after which date it will distribute the assets, having regard only to the claims of which it then has notice.

RICKARDS & RICKARDS, solicitors, 324A Montague-street, Albert Park. 6151

ANN COLVILLE, formerly of Crimea-street, Caulfield, but late of Sherwood Hospital, 52 Northcote-avenue, Caulfield, spinster, DECEASED.

CREDITORS, next of kin, and others having claims in respect of the estate of the deceased (who died on the 15th October, 1958), are required by the executor, Lester Quintus Permezal, of 379 Collins-street, Melbourne, solicitor, to send particulars to him, in care of his under-mentioned solicitors, by the 26th August, 1959, after which date the executor may convey or distribute the assets, having regard only to the claims of which he then has notice.

W. H. FLOOD & PERMEZEL, 379 Collins-street, Melbourne, solicitors for the executor. 6141

CREDITORS, next of kin, and others having claims in respect of the estate of Arthur Percy Mason, late of 4 Baynton-avenue, North Sunshine, in the State of Victoria, storeman, deceased (who died on the 31st day of January, 1959), are required by the administratrix, Rose Maud Mason, of 4 Baynton-avenue, North Sunshine aforesaid, widow, to send particulars of their claims to her, care of Rogers and Gaylard, solicitors, of 281 Collins-street, Melbourne, by the 2nd day of September, 1959, after which date the said administratrix will distribute the assets of the deceased, having regard only to the claims of which she then shall have had notice.

ROGERS & GAYLARD, solicitors, 281 Collins-street, Melbourne. 6143

MIROSLAV CHARVAT, late of 3 Gladstone-street, Windsor, draughtsman (who died on the 8th July, 1957).

CREDITORS, next of kin, and all other persons having claims against the estate of the deceased, are required by the administrator of his estate, to send particulars to the administrator, care of the under-mentioned solicitors, on or before the 31st day of August, 1959, after which date distribution of the assets shall be made, having regard only to the claims of which the administrator then has notice.

GRAY & GRAY, solicitors, 340 Collins-street, Melbourne. 6144

CREDITORS, next of kin, and others having claims in respect of the estate of Victor Gordon Jack Sing, late of 3 Boardman-street, East Malvern, horse trainer, deceased (who died on the 22nd day of May, 1956), are to send particulars of claims to Mabel Adelaide Sing, of 5A Mary-street, Adelaide, South Australia, the executrix appointed by the deceased's will, by the 28th day of August, 1959, after which date she will distribute the assets, having regard only to the claims of which she then has notice.

GODFREY STEWART, MARTIN, & CO., solicitors, 20 Bank-place, Melbourne. 6124

CREDITORS, next of kin and others having claims in respect of the estate of Agnes Josephine Kelly (sometimes known as Aileen Agnes Kelly), late of 33 Bay-road, Sandringham, spinster (who died on the 23rd October, 1958), are to send particulars of their claims to John Mahony, of 20 Queen-street, Melbourne, by the 1st day of September, 1959, after which date he will distribute the assets, having regard only to the claims of which he then has notice.

MAHONY, O'BRIEN & DUGGAN, solicitors, 20 Queen-street, Melbourne. 6128

ELLEN MCKERNAN, late of 11 Compton-street, Reservoir, widow, DECEASED.

CREDITORS, next of kin and others having claims in respect of the estate of the above-named deceased (who died on 12th February, 1959), are required to send the particulars of their claims to the executors, James Edward McKernan and Teresa Florence McKenna, care of the under-named solicitors by the 26th day of August, 1959, after which date they will distribute the assets, having regard only to those claims of which they then have notice.

NORRIS, COATES & HEARLE, of 422 Collins-street, Melbourne, solicitors. 6133

CREDITORS, next of kin, and others having claims in respect of the estate of Grace Emily Atkin, late of 6 George-street, Bacchus March, married woman, deceased (who died on the 10th day of December, 1958, and probate of whose will has been granted to Oliver Stanley Atkin, of 6 George-street, Bacchus Marsh, retired farmer), are to send in particulars of their claims to the said executor, care of the under-mentioned solicitors by the 27th day of August, 1959, after which date he will distribute the assets, having regard only to the claims of which he then has notice.

PEARCE & WEBSTER, solicitors, 430 Little Collins-street, Melbourne. 6082

TIMOTHY FRANCIS MCKAY, late of 24 Perry-street, Seddon, retired, DECEASED.

CREDITORS, next of kin, and others having claims in respect of the above-named deceased (who died on the 8th October, 1958), are required to send particulars of their claims to the executrix, Sheila Veronica Barr, of 5 Prentice-street, Kingsville, married woman, care of the under-mentioned solicitor, by the 7th day of September, 1959, after which date she will distribute the assets, having regard only to the claims of which she shall have had notice.

JOHN GINNANE, solicitor, of 153A Barkly-street, Footscray. 6084

CREDITORS, next of kin, and others having claims in respect of the estate of Bertha Mary Lowry, late of 36 Kent-grove, Caulfield North, spinster, deceased (who died on the 24th day of April, 1959), are to send particulars of their claims to The Trustees, Executors and Agency Company Limited, of 401 Collins-street, Melbourne, by the 11th day of September, 1959, after which date it will distribute the assets, having regard only to the claims of which it then has notice.

DAVID THOMAS, of 140 Queen-street, Melbourne, solicitors for the said company. 6085

CHARLES BEATTY, late of 7 Mair-street, Hampton, retired farmer, DECEASED.

CREDITORS, next of kin, and others having claims in respect of the estate of the deceased (who died on the 12th day of January, 1959), are required by the trustee, The Equity Trustees, Executors and Agency Company Limited, of 472 Bourke-street, Melbourne, to send particulars of their claims to the said company by the 31st day of August, 1959, after which the executors may convey or distribute the assets, having regard only to the claims of which the company shall then have had notice.

Dated this 22nd day of June, 1959.

DUGDALE, SIMMONS & STEVENS, 486 Bourke-street, Melbourne, solicitors. 6086

CREDITORS, next of kin, and others having claims in respect of the estate of Ellen Burns, late of 5 Armfield-street, Middle Brighton, widow, deceased, intestate (who died on the 9th January, 1959, and letters of administration of whose estate have been granted to William James Burns, of 1092 Nepean Highway, Highbett), are to send in particulars of their claims to the said administrator, care of the under-mentioned solicitors, by the 1st September, 1959, after which date he will distribute the assets, having regard only to the claims of which he then has notice.

GERALD E. DELANY & CO., 452 Lonsdale-street, Melbourne. 6147

ROBERT HENRY MARSHALL, late of Beverford, in the State of Victoria, orchardist, DECEASED (who died on the 16th day of October, 1958).

CREDITORS, next of kin, and all other persons having claims against the estate of the deceased, are required by the executors of the will, Reginald Clyde Polkinghorne, of Worrinen, in the said State, fruitgrower, and Thomas Bridson Green, of Swan Hill, in the said State, solicitor, to send particulars to them, care of the undersigned, on or before the 19th day of September, 1959, after which date they will distribute the assets, having regard only to the claims of which they then have notice.

GARDEN & GREEN, solicitors, McCallum-street, Swan Hill. 6113

WILLEM JACOBUS ANDRIAAN HENRI VENEMA, late of 18 Valonia-avenue, Surrey Hills, marine engineer, DECEASED.

CREDITORS, next of kin, and others having claims against the estate of the deceased (who died on 14th November, 1958), are required by the executors, Decima Violet Venema and Bernard Gore Brett, care of 120 William-street, Melbourne, to send particulars to them by 28th August, 1959, after which date the executors may convey and distribute the assets, having regard only to the claims of which they then have notice.

BLAKE & RIGGALL, 120 William-street, Melbourne, solicitors. 6138

ELIZABETH SIPTHORP, late of 3 Ann-street, Footscray, spinster (who died on the 14th November, 1958).

CREDITORS, next of kin, and all other persons having claims against the estate of the said deceased are required by the executor of the will, National Trustees, Executors and Agency Company of Australasia Limited, of 95 Queen-street, Melbourne, to send particulars to the said executor, on or before the 31st day of August, 1959, after which date it will distribute the assets, having regard only to the claims of which it then has notice.

GRAY & GRAY, solicitors, 340 Collins-street, Melbourne. 6145

JAMES BOWEN PAIN, formerly of 70 Collins-street, Melbourne, but late of 128w Toorak-road, South Yarra, gentleman, DECEASED.

CREDITORS, next of kin, and others having claims against the estate of the deceased (who died on 19th November, 1958), are required by the executors, Janet Bowen Pain, John Ralph Burt, and Gerald Mansfield Niall, all care of 120 William-street, Melbourne, to send particulars to them by 28th August, 1959, after which date the executors may convey and distribute the assets, having regard only to the claims of which they then have notice.

BLAKE & RIGGALL, 120 William-street, Melbourne, solicitors. 6137

ALBERT FRANK BLOOD, formerly of "Lyndale," Gladstone-road, Dandenong, but late of "Holly Green," Webb-street, Narre Warren, in the State of Victoria, grazier, DECEASED.

CREDITORS, next of kin and others having claims in respect of the estate of the above-named deceased (who died on the 4th day of May, 1959), are required by Thomas Leach, of 580 Station-street, Box Hill, to send particulars to the said executor, of their claims by the 30th day of August, 1959, after which date the trustee may convey or distribute the assets, having regard only to the claims of which he then has notice.

Dated the 17th day of June, 1959.

HOLT, GRAHAM & NEWMAN, 178 Collins-street, Melbourne, solicitors for the executor. 6134

CREDITORS, next of kin and others having claims in respect to the estate of Rubina Isabel James, late of 17 Doulfon-road, Blackburn, married woman, deceased (who died on the 7th day of November, 1958), are to send particulars to The Fidelity Trustee Company Limited, whose registered office is situate at 101 Lydiard-street north, Ballarat, by the 31st day of August, 1959, after which date the said company will distribute the estate of the said deceased, having regard only to the claims of which it then has notice.

GILLOTT, MOIR & AHERN, solicitors, 95 Queen-street, Melbourne. 6136

NORMAN NORRIS DUTNEALL, of 24 Hillcrest-avenue, Kew, accountant, the executor to whom probate of the will of Florence Gertrude Dutneall, late of 58 Hillview-road, Mount Waverley, widow, deceased (who died on 14th August, 1958, was granted by the Supreme Court of Victoria on 2nd March, 1959, requires all creditors, next of kin and others having claims against the property or estate of the said deceased to send to the said executor, care of Norval H. Dooley and Breen, of 31 Queen-street, Melbourne, on or before 26th August, 1959, particulars in writing of their claims, after which date the executor intends to convey or distribute such property or estate to or among the persons entitled thereto, having regard only to the claims of which he shall then have had notice.

Dated the 18th June, 1959.

NORVAL H. DOOLEY & BREEN, solicitors, 31 Queen-street, Melbourne. 6081

CREDITORS, next of kin and others having claims in respect of the estate of Kate Billingham, formerly of 275 Hawthorn-road, Caulfield, in the State of Victoria, but late of 15 Maroo-street, Hughesdale, in the said State, spinster, deceased (who died on the 11th day of March, 1959), are to send particulars of their claims to The Trustees, Executors and Agency Company Limited, of 401 Collins-street, Melbourne, in the said State, the executor of the will of the said deceased, by the 17th August, 1959, after which date the said executor will distribute the assets, having regard only to the claims of which it shall then have had notice.

H. L. YUNCKEN & YUNCKEN, solicitors, of 443 Little Collins-street, Melbourne. 6123

BARBARA JANE ASSENDER, late of 140 Collins-street, Mentone, widow, DECEASED.

CREDITORS, next of kin, and others having claims in respect of the estate of the deceased (who died on 21st March, 1959), are required by the administrator, The Equity Trustees, Executors and Agency Company Limited, of 472 Bourke-street, Melbourne, to send particulars of their claims to the said company, by the 31st day of August, 1959, after which date the company may convey or distribute the assets, having regard only to the claims of which it shall then have had notice.

Dated this 22nd day of June, 1959.

DUGGLE, SIMMONS & STEVENS, 486 Bourke-street, Melbourne, solicitors. 6087

EDGAR GARFIELD FINLAY, formerly of 12 Vautier-street, Elwood, and 183 Nelson-place, Williamstown, but late of Kangaroo Grounds-road, Warrandyte, in the State of Victoria, nut food manufacturer, DECEASED.

CREDITORS, next of kin and others having claims in respect of the estate of the above-named deceased (who died on the 18th day of April, 1958), are required by Emily Elizabeth Finlay, of Kangaroo Grounds-road, Warrandyte, to send particulars to the said executrix of their claims by the 30th day of August, 1959, after which date the trustees may convey or distribute the assets, having regard only to the claims of which they then have notice.

Dated the 16th day of June, 1959.

HOLT, GRAHAM & NEWMAN, 178 Collins-street, Melbourne, solicitors for the executrix. 6135

In the Supreme Court of the State of Victoria.

SALE BY THE SHERIFF.

ON Wednesday, the 5th of August, 1959, at Eleven o'clock a.m., at Police Station, 110 North-road, Newport (unless process be stayed or satisfied):—

All the estate and interest (if any) of Milan Klobucar, formerly of 267 Monteith-street, Newport West, but now of parts unknown, as proprietor of an estate in fee-simple in the land described in certificate of title, volume 8159, folio 286, excepting thereout of the said certificate of title the land described in transfer No. A289383 in the Register Book, upon which is erected a four-bedroomed weatherboard dwelling house with an iron roof. Such property is known as No. 267 Monteith-street, Newport West.

Registered mortgage No. A542819 and caveat No. A555250 affect the said estate and interest.

Terms: Cash only.

D. K. PARK, Sheriff's Officer.

17th June, 1959.

6122

MINING NOTICE

TAWONGA GOLD MINING COMPANY NO LIABILITY (IN VOLUNTARY LIQUIDATION).

NOTICE is hereby given in pursuance of section 210 (2) of the Companies Act 1958 that a General Meeting of the members of Tawonga Gold Mining Company No Liability (in Voluntary Liquidation) will be held at my office, 247 Collins-street, Melbourne, on Tuesday, the 11th day of August, 1959, at the hour of Twelve o'clock noon, for the purpose of laying before the meeting an account of the winding up of the company and to give any explanations required thereof.

Dated this 22nd day of June, 1959.

6099 GILBERT JEFFERY, Liquidator.

IMPOUNDINGS

BROADMEADOWS.—Impounded in Campbellfield Pound.

1 bay gelding, 14.2 hands, off front and two hind legs white

If not claimed and expenses paid, to be sold on 9th July, 1959.

E. F. SMILEY,
Town Clerk.

6156—12/

EPPING.—Impounded in Epping Pound, by Janefield Mental Hospital, Bundoora.

2 sheep, V in left ear, no visible brand

If not claimed and expenses paid, to be sold on 10th July, 1959.

J. HEARD,
Poundkeeper.

6116—10/6

HAMILTON.—Impounded in Hamilton Pound, from Digby-road, by Shire Ranger.

1 brown gelding, thoroughbred type, indistinct brand

If not claimed and expenses paid, to be sold on 27th June, 1959.

I. FYFE,
Poundkeeper.

6115—10/6

LANCEFIELD.—Impounded in Lancefield Pound, from Main-road, between Romsey and Lancefield, on 14th June, by Shire Ranger.

4 Shorthorn cross steers, approximately 2 years, no visible brand

2 Shorthorn cross steers, yearlings, no visible brand

If not claimed and expenses paid, to be sold on 3rd July, 1959.

C. O. HORNER,
Poundkeeper.

6121—15/

WARRNAMBOOL.—Impounded in Warrnambool Pound.

1 brown yearling Jersey heifer, no visible brand

If not claimed and expenses paid, to be sold on 8th July, 1959.

V. MCKAY,
Poundkeeper.

6155—9/

STATE ACTS, 1958.

COPIES of the following Acts of Parliament of Victoria may be obtained at the Government Printing Office, or from any bookseller, at the price set opposite to each:—

No.	Price.
	s. d.
6171. Milk Board (Members)	0 6
6172. Consolidated Revenue	0 6
6173. Footscray (Lawson-street) Land	0 6
6174. Railways (Contracts)	0 6
6175. Game (Destruction)	0 6
6176. Western Metropolitan Market (Amendment)	0 6
6177. Local Government (Portland)	0 6
6178. Melbourne (Flinders-street) Land	0 6
6179. Public Account Advances (Home Builders' Account)	0 6
6180. Snowy Mountains Hydro-electric Agreements	2 6
6181. Gas and Fuel Corporation (Bendigo Undertaking)	1 0
6182. Acts Interpretation	0 6
6183. Railways (Employés)	0 6

STATE ACTS, 1958—continued.

No.	Price.
	s. d.
6184. Monash University	1 9
6185. University (Council)	0 6
6186. Marriage (Amendment)	0 6
6187. Consolidated Revenue	0 6
6188 } Consolidated Acts 1958.	
6421. }	
6422. Amendments Incorporation	0 6
6423. Police Offences (Trespass to Farms)	0 6
6424. Fern Tree Gully and Gembrook Railway (Reconstruction) Amendment	0 6
6425. Kew and Heidelberg Lands	0 6
6426. Gas and Fuel Corporation (Maryborough Undertaking)	0 6
6427. Local Government (Dandenong)	0 6
6428. Responsible Ministers	0 6
6429. Supreme Court and County Court (Judges)	0 6
6430. Melbourne and Metropolitan Board of Works (Borrowing Powers and Debentures)	0 6
6431. Consolidated Revenue	0 6
6432. Fences (Amendment)	0 6
6433. Contracts of Sale (Payments)	0 6
6434. Metropolitan Fire Brigades (Board)	0 6
6435. Process Servers and Inquiry Agents (Repossessions)	0 6
6436. Housing (Broadmeadows Land)	0 6
6437. Consolidated Revenue	0 6
6438. Instruments (Bills of Sale)	0 6
6439. Churches of Christ, Scientist Incorporation	0 9
6440. Wheat Industry Stabilization	1 0
6441. Dog (Guides for the Blind)	0 6
6442. Monash University (Acquisition of Land)	0 6
6443. Soldier Settlement (Loan)	0 6
6444. Home Finance (Amendment)	0 6
6445. Friendly Societies (Amendment)	0 6
6446. Co-operative Housing Societies (Guarantees)	0 6
6447. Land Tax (Exemptions and Rates)	0 6
6448. River Murray Waters	0 9
6449. Victorian Inland Meat Authority (Advances)	0 6
6450. Stamps (Amendment)	1 3
6451. Superannuation (Amendment)	0 6
6452. Grain Elevators (Amendment)	0 6
6453. Geelong Harbor Trust Lands	1 0
6454. Melbourne Cricket Club (Guarantee)	0 6
6455. Companies	15 0
6456. Local Government (City of Oakleigh)	0 6
6457. Co-operative Housing Societies (Residential Flats)	0 6
6458. Transport Regulation (Fund)	0 6
6459. Railways (Standardization Agreement)	1 0
6460. Water Supply Loan Application	1 3
6461. Co-operative Housing Societies (Insurance)	0 6
6462. Racing (Amendment)	0 6
6463. Motor Car (Third-party Insurance)	0 6
6464. Firearms (Amendment)	0 6
6465. Hawthorn and Kew Railway (Dismantling)	0 6
6466. Juries (Amendment)	0 9
6467. Tourist (Amendment)	0 6
6468. Filled Milk	0 9
6469. St. Kilda and Brighton Electric Street Railway (Dismantling)	0 6
6470. Judges Salaries	0 6
6471. Public Officers Salaries and Allowances	0 6
6472. Ballaarat Railway Land	0 6
6473. Game (Licences)	0 6
6474. Geelong Waterworks and Sewerage (Amendment)	0 6
6475. Coal Mine Workers Pensions (Early Retirement)	0 6
6476. Revenue Deficit Funding	0 6
6477. Railway Loan Application	1 3
6478. Administration and Probate (Amendment)	0 9
6479. Local Government Department	0 6
6480. Police Offences (Gaming)	0 6
6481. Marine (Amendment)	0 6
6482. Public Works Loan Application	0 9
6483. Motor Car (Amendment)	0 6
6484. Appropriation of Revenue, 1957-58	6 9
6485. Water (Valuations)	0 6
6486. Police Regulation (Amendment)	0 6
6487. State Forests Loan Application	0 6
6488. Police Offences (Trap Shooting)	0 6
6489. Sessional Acts Revision	1 3

Table of Acts and Enactments passed, date of operation, &c. 0 6

A. C. BROOKS,
Government Printer.

STATE ACTS, 1959.

COPIES of the following Acts of Parliament of Victoria may be obtained at the Government Printing Office, or from any bookseller, at the price set opposite to each:—

No.	Price.
	s. d.
6490. Water (Contracts)	0 6
6491. Property Law (Amendment)	0 6
6492. Agricultural Education (Amendment)	0 6
6493. Swan Hill Railway Land	0 6
6494. Stamps (Amendment)	0 6
6495. Justices (Amendment)	0 6
6496. Consolidated Revenue	0 6
6497. State Electricity Commission (Tourist Areas)	0 6
6498. Aborigines (Houses)	0 6
6499. Superannuation (Amendment)	0 6
6500. Country Roads (Amendment)	0 6
6501. Bendigo Land	0 6
6502. University (Honorary Degrees)	0 6
6503. Melbourne and Metropolitan Board of Works (Reconstitution)	0 9
6504. Land (Charges)	0 6
6505. Statute Law Revision	1 0
6506. Legal Profession Practice (Amendment)	0 6
6507. Health	0 9
6508. Fisheries (Amendment)	0 6
6509. Water (Irrigation Districts)	0 6
6510. Broadmeadows (Rating on Unimproved Values)	0 6
6511. Trustee (Amendment)	0 6
6512. Nurses	0 6
6513. Hairdressers Registration (Amendment)	0 6
6514. Labour and Industry (Retail Trading Hours)	0 6
6515. Milk Board (Amendment)	0 6
6516. Stock Diseases (Amendment)	0 9
6517. Hepburn Springs Land	0 9
6518. Vermin and Noxious Weeds	1 0
6519. The Constitution Act Amendment (Parliamentary Salaries)	0 9
6520. Public Works Committee (Amendment)	0 6
6521. Land (Plantation Areas)	0 6
6522. National Art Gallery and Cultural Centre (Amendment)	0 6
6523. Portland Harbor Trust (Amendment)	0 6
6524. Revocation and Excision of Crown Reservations	1 9
6525. Tourist (Amendment)	0 6
6526. Town and Country Planning (Amendment)	0 6
6527. Vegetation and Vine Diseases (Amendment)	0 6
6528. Medical	0 9
6529. Bread Industry	1 0
6530. Cemeteries	0 9
6531. Hire-Purchase	2 3
6532. Motor Car (Amendment)	0 9
6533. Motor Car (Hours of Driving)	0 6
6534. Land Settlement	1 9
6535. Local Government (Amendment)	1 6
6536. Melbourne and Metropolitan Board of Works (Amendment)	1 3

AGENTS FOR THE "VICTORIA GOVERNMENT GAZETTE".

THE following have been appointed agents to receive Advertisements and Subscriptions for the *Victoria Government Gazette*:—

- ARMSTRONG'S AGENCY, 205 Queen-street, Melbourne.
- ARMSTRONG BROS., Kyneton.
- MESSRS. ARNALL & JACKSON, 115 Barkly-street, West Brunswick.
- MR. WM. DAVIS, Mildura.
- A. J. DIGBY (B. S. and N. W. Cash), Main-street, Balrnedale.
- EDGAR'S NEWS AGENCY, Hargreaves-street, Bendigo.
- MESSRS. HENRY FRANKS & CO., Booksellers and Stationers, Market-square, Geelong.
- MESSRS. GORDON & GOTCH, News Agents, 511 Little Collins-street, Melbourne; and corner Barrack and Clarence streets, Sydney.
- GULLAN'S NEWSAGENCY, 88 Bridge-street, Ballarat.

- A. C. HAMPTON, 243 Mitchell-street, Bendigo.
 - MESSRS. HARSTON, PARTRIDGE, & CO., 455 Little Collins-street, Melbourne.
 - MR. C. F. LATIMER, News Agent, Casterton.
 - MCARTHUR'S AUTHORIZED NEWSAGENCY, 343 Wyndham-street, Shepparton.
 - MESSRS. R. H. & W. M. PETTY, News Agent, Wangaratta.
 - MESSRS. POWELL & DIXON, 89 Firebrace-street, Horsham.
 - J. PURDIE & CO., 138 Moorabool-street, Geelong.
 - F. W. RASHLEIGH & SON, Nunn-street, Benalla.
 - ROBERTSON & MULLENS LTD., Elizabeth-street, Melbourne.
 - SALE AUTHORIZED NEWSAGENCY, 142 Raymond-street, Sale.
 - SKINNER'S AUTHORIZED NEWSAGENCY, 49-51 Franklin-street, Traralgon.
 - MESSRS. SMITH & DUNNON, Hamilton.
 - THE MERCANTILE EXCHANGE, 380 Collins-street, Melbourne.
 - TUFF'S SHEPPARTON NEWSAGENCY, 246 Wyndham-street, Shepparton.
 - C. F. & H. J. VERNON, 162 Bridge-road, Richmond.
 - VIEW POINT AUTHORIZED NEWSAGENCY, 4 View Point, Bendigo.
 - E. W. B. WELSH, Hogan-street, Tatura.
- A copy of the *Gazette* filed at each place for public reference.
- A. C. BROOKS,
Government Printer.

CONTENTS

	PAGE
Acts of Parliament on sale at the Government Printing Office	1822
Appointments	1786
Cemetery—Scale of Fees	1783
Contracts	1782
Country Roads Board	1790
Courts	1784
Estates of Deceased Persons	1783
Government Notices	1771
Impoundings	1822
Lands	1800
Licences to Occupy Unused Roads	1775
Licences to Occupy Water Frontages	1773
Melbourne and Metropolitan Board of Works—Notices	1771
Mining	1777, 1822
Ministers of Religion Registered to Celebrate Marriages in Victoria	1772
Money Lenders Act 1958—Supplementary List	1774
Orders in Council	1787
Private Advertisements	1810
Proclamations	1769
Public Half-Holiday	1771
Public Service Notices	1806
Resignations	1787
State Rivers and Water Supply Commission	1772
Tenders	1804
Transport Regulation Board—Public Hearings	1779
Waterworks Trusts	1777

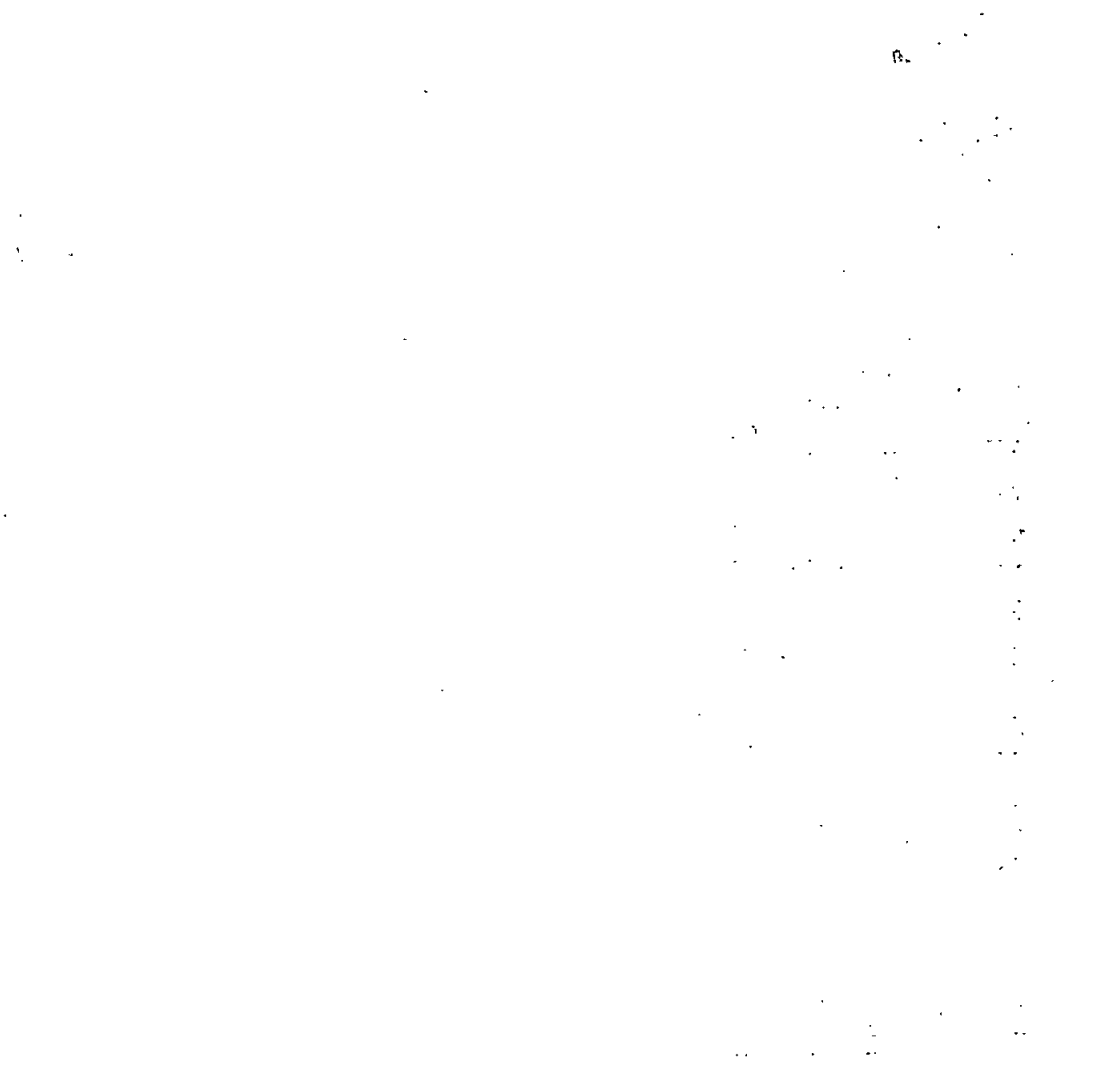

Figure 1: Scatter plot showing the relationship between X and Y.