



VICTORIA GOVERNMENT GAZETTE

Published by Authority

[Registered at the General Post Office, Melbourne, for transmission by post as a newspaper.]

No. 25]

FRIDAY, APRIL 7

[1961

Land Act 1958.

UNALIENATED CROWN LAND AVAILABLE FOR SETTLEMENT UNDER IMPROVEMENT PURCHASE LEASES.

PROCLAMATION

By His Excellency the Administrator of the Government of the State of Victoria and its dependencies in the Commonwealth of Australia &c., &c., &c.

IN pursuance of the provisions of section 153 of the *Land Act 1958*, I, the Administrator of the Government of the State of Victoria, in the Commonwealth of Australia, by and with the advice of the Executive Council of the said State, do by this proclamation declare the unalienated Crown lands mentioned in the sub-joined schedule, to be available for settlement under improvement purchase leases.

SCHEDULE.

County.	Parish.	Allotment.	Section.	Area.			Land Valuation.
				A.	R.	P.	
Normanby	Mouzie	12	10	116	0	16±	£1 5s. per acre.
Normanby	Mouzie	1	10	193	0	4±	£1 10s. per acre.
Normanby	Mouzie	13	10	135	0	25±	£1 5s. per acre.
Normanby	Killara	12B	C	190	0	0±	£2 per acre.

Given under my Hand and the Seal of the State of Victoria aforesaid, at Melbourne this twenty-eighth day of March, in the year of our Lord One thousand nine hundred and sixty-one, and in the tenth year of the reign of Her Majesty Queen Elizabeth II.

(L.S.)

CHARLES J. LOWE.

By His Excellency's Command,

KEITH TURNBULL,
Commissioner of Crown Lands and Survey.

GOD SAVE THE QUEEN!

Marketing of Primary Products Act 1958 (No. 6304).

DECLARING THAT MAIZE SHALL BECOME THE
PROPERTY OF THE MAIZE MARKETING BOARD.

PROCLAMATION

By His Excellency the Administrator of the Government of the State of Victoria and its Dependencies in the Commonwealth of Australia, &c., &c., &c.

WHEREAS by sub-section (1) of section 17 of the *Marketing of Primary Products Act 1958*, it is enacted that when a product has been declared a commodity and a board has been appointed in relation thereto, the Governor in Council may by Proclamation—

- (a) provide and declare that the commodity shall forthwith upon the date of publication of the Proclamation or on from and after a later date specified in the Proclamation, be divested from the producers of the commodity and become vested in and be the absolute property of the board as the owner thereof, and that upon any of the commodity coming into existence within a time specified in the same or a subsequent Proclamation it shall by virtue of this Act become vested in and be the absolute property of the board as the owner thereof; and
- (b) make such further provision as will enable the board effectively to obtain possession of the commodity as such owner and to deal with the same: And whereas by a Proclamation made on the 5th day of May, 1936, under the provisions of section 6 of the *Marketing of Primary Products Act 1935*, the Governor in Council declared maize to be a commodity under and for the purposes of the said Act: And whereas by an Order made on the 2nd November, 1936, the Governor in Council appointed a marketing board in relation to maize and assigned to such board the name of the "Maize Marketing Board": Now therefore, I, the Administrator of the Government of the State of Victoria, in the Commonwealth of Australia, by and with the advice of the Executive Council of the said State, do by this my Proclamation hereby provide and declare that on and from the second day of May, One thousand nine hundred and sixty-one all maize shall subject to and in accordance with the *Marketing of Primary Products Act 1958* be divested from the producers of maize and become vested in and be the absolute property of the Maize Marketing Board as the owner thereof and that upon any maize coming into existence within two (2) years from the second day of May, One thousand nine hundred and sixty-one, it shall by virtue of and subject to and in accordance with the said Act become vested in and be the absolute property of the Maize Marketing Board as the owner thereof and to enable the Maize Marketing Board as owners of the above-mentioned commodity effectively to obtain possession thereof and to deal with the same I do further provide that all such maize shall subject to and in accordance with the provisions of the said Act be delivered by the producers thereof to the Maize Marketing Board or its authorized agent within such times at such places and in such manner as the Maize Marketing Board by public notice, or in a particular case in writing, directs or as are prescribed by Regulations made under the said Act.

Given under my Hand and the Seal of the State of Victoria aforesaid, at Melbourne, this twenty-eighth day of March, in the year of our Lord One thousand nine hundred and sixty-one, and in the tenth year of the reign of Her Majesty Queen Elizabeth II.

(L.S.) CHARLES J. LOWE.

By His Excellency's Command,

G. L. CHANDLER,
Minister of Agriculture.

GOD SAVE THE QUEEN!

PUBLIC HOLIDAYS.

PROCLAMATION

By His Excellency the Administrator of the Government of the State of Victoria and its Dependencies in the Commonwealth of Australia, &c., &c., &c.

IN pursuance of the provisions contained in Part III. of the *Public Service Act 1958*, I, the Administrator of the Government of the State of Victoria, in the Commonwealth of Australia, by and with the advice of the Executive Council of the said State, do by this my Proclamation appoint the days and dates hereunder mentioned to be observed as Public Holidays or Public Half-Holidays (as the case may be) at the places respectively specified, viz.:—

Public Holiday:—

SATURDAY, THE 6TH MAY, 1961, throughout the Borough of Maryborough.

Public Half-Holiday from the Hour of Twelve o'clock noon:—

THURSDAY, THE 4TH MAY, 1961, throughout the City of Warrnambool.

Given under my Hand and the Seal of the State of Victoria aforesaid, at Melbourne, this 28th day of March, in the year of our Lord One thousand nine hundred and sixty-one, and in the tenth year of the reign of Her Majesty Queen Elizabeth II.

(L.S.)

CHARLES J. LOWE.

By His Excellency's Command,

L. H. S. THOMPSON,
Chief Secretary.

GOD SAVE THE QUEEN!

ANZAC DAY HOLIDAY.

IT is hereby notified that on—

TUESDAY, THE 25TH APRIL, 1961,

the Public Offices will be closed, such day having been appointed by the *Public Service Act 1958*, to be observed as a holiday in the Public Offices throughout the State of Victoria.

This notice relates only to the closing of the State Public Offices. All inquiries regarding the holiday in other offices and in shops and industry should be directed to the Department of Labour and Industry, Old Treasury Building, Spring-street, Melbourne, C.1. (Telephone 63 0321, Extension 6158 or 6382.)

A. G. RYLAH,
Chief Secretary.

Chief Secretary's Office,
Melbourne, C.1, 7th April, 1961.

DEPARTMENT OF MINES.

TAILINGS LICENCES GRANTED.

- 3083, Tailings Licence; The President, Councillors, and Ratepayers of the Shire of Yarrowonga, Parish of Chiltern West (in lieu of Tailings Licence No. 2819, expired).
- 3086, Tailings Licence; The Mayor, Councillors, and Citizens of the City of Bendigo, at Bendigo (in lieu of Tailings Licence No. 2842, expired).
- 3087, Tailings Licence; Country Roads Board, at Bendigo.

W. J. MIBUS,
Minister of Mines.

A LICENCE to carry on assurance and insurance business in Victoria from 22nd March, 1961 to 31st December, 1961, has been issued to the under-mentioned insurer:—

AUSTRALIAN AND OVERSEAS LIFE ASSURANCE COMPANY
LIMITED.

D. G. RICHARDS,
Comptroller of Stamps.

A LICENCE to carry on assurance and insurance business in Victoria from 1st January, 1961, to 31st December, 1961, has been issued to the under-mentioned insurer:—

LEP INSURANCE BROKERS PTY. LTD.

D. G. RICHARDS,
Comptroller of Stamps.

State Electricity Commission Acts.
ELECTRICAL APPROVALS BOARD.

PURSUANT to Regulation 16 of the Electrical Approvals Regulations—Approval of Equipment, 1953, the State Electricity Commission of Victoria hereby gives notice that it withdraws approval of the articles described hereunder on the dates as specified:—

Name of Applicant.	Article.	Reference Number.	Date of Certificate of Approval.	Date of Withdrawal of Approval.
R. V. Nathan	Razor, Trade Name "B.U.K."	AW/IG/01	15.3.48	23.2.61
Indelco Pty. Ltd.	Flexible Cord, twin flat 23/-0076", V.R.I. ..	AH/JG/02	6.10.49	10.2.61
Indelco Pty. Ltd.	Flexible Cord, twin twisted 9/-012", V.R.I., cotton covered	AH/JG/04	30.5.50	10.2.61
Indelco Pty. Ltd.	Flexible Cord, three core 28/-012", V.R.I., cotton covered	AH/JG/07	10.11.50	10.2.61
Indelco Pty. Ltd.	Flexible Cord, three core, 23/-0076", V.R.I., T.R.S.	AH/JG/09	8.3.51	10.2.61
Indelco Pty. Ltd.	Flexible Cord, twin twisted, 23/-0076", V.R.I., cotton braided	AH/JG/13	12.10.51	10.2.61
Indelco Pty. Ltd.	Flexible Cord, three core, 23/-0076", V.R.I., T.R.S.	AH/JG/14	7.12.51	10.2.61
Indelco Pty. Ltd.	Flexible Cord, three core, 70/-0076", V.R.I., T.R.S.	AH/JG/16	5.12.51	23.2.61

Dated the sixth day of April, 1961.

L. G. MORRISON, Acting Secretary.

State Electricity Commission Acts.
ELECTRICAL APPROVALS BOARD.

PURSUANT to Regulation 16 of the Electrical Approvals Regulations—Approval of Equipment, 1953, the State Electricity Commission of Victoria hereby gives notice that it withdraws approval of the articles described hereunder on the dates as specified.

Name of Applicant.	Article.	Reference Number.	Date of Certificate of Approval.	Date of Withdrawal of Approval.
Hapco Pty. Ltd.	Flexible Cord, three core 23/-0076" V.R.I., cotton braided	AH/KJ/02	17.11.49	9.3.61
International Radio Co. Pty. Ltd.	Flexible Cord, figure 8, 23/-0076" P.V.C. in- sulated	AH/GF/08	7.6.51	9.3.61
International Radio Co. Pty. Ltd.	Flexible Cord, Trade Name "Radion", three core, vacuum cleaner type, 23/-0076" P.V.C. insulated and sheathed.	AH/GF/09	11.3.54	9.3.61
International Radio Co. Pty. Ltd.	Flexible Cord, Trade Name "Radion", three core 23/-0076" P.V.C. insulated and sheathed	AH/GF/10	25/3/54	9.3.61

Dated the sixth day of April, 1961.

L. G. MORRISON, Acting Secretary.

AVENEL WATERWORKS TRUST.
RATING BY-LAW 1961.

THE Avenel Waterworks Trust, in pursuance and exercise of the powers conferred by the Water Acts, doth hereby make a rate for the supply of water for domestic purposes of Two shillings in the pound of the annual municipal valuation of lands and tenements liable to be rated within the Avenel Urban District.

Provided that in no case shall the amount of rate payable per annum in respect of any property (other than on land on which there is no building) be less than One hundred shillings and in respect of land on which there is no building be less than Fifteen shillings.

Such rates are made and shall be levied on the occupiers or owners of the lands and tenements for the year commencing the 1st day of January, 1961, and shall be payable on the 28th day of April, 1961, at the office of the said Trust.

The maximum quantity of water to be supplied in any one year without further charge to any property rated by the Trust is hereby fixed at the quantity which, at a charge of One shilling and six pence per 1,000 gallons, would produce an amount equal to the amount of rate levied on such property for the said year.

The charge for water supplied by measure to any property rated by the Trust in excess of such maximum quantity, computed as in the last preceding clause is hereby fixed at One shilling and six pence per 1,000 gallons.

Water troughs will be supplied as follows:—For each trough in an allotment of 5 acres or under One pound two shillings and six pence per annum, more than 5 acres a charge of One pound two shillings and six pence for the first 5 acres and One shilling and six pence for each additional acre.

The charge for water supplied by measure shall be payable, on demand, at the office of the said Trust.

Passed the 10th day of January, 1961.

The common seal of the Avenel Waterworks Trust was hereunto affixed, in the presence of—

(SEAL) MARTIN MORAN, Chairman.
P. KELLY, Secretary.

Approved, 23rd March, 1961.—W. J. MIBUS, Minister of Water Supply.

BARNAWARTHA WATERWORKS TRUST.
RATING BY-LAW FOR THE YEAR 1961.

THE Barnawartha Waterworks Trust, in pursuance and exercise of the powers conferred by the Water Acts, doth hereby make a rate for the supply of water for domestic purposes of Four shillings and three pence in the pound on the annual municipal valuation of lands and tenements liable to be rated within the Barnawartha Urban District.

Provided that in no case shall the amount of rate payable per annum in respect of any tenement (other than land on which there is not a building) be less than Six pounds fifteen shillings, and in respect of land on which there is no building less than One pound ten shillings.

Such rates are made and shall be levied upon the occupiers or owners of the said lands and tenements for the year commencing 1st January and ending 31st December, 1961, and shall be payable in one amount on the 1st day of May, 1961, at the office of the said Trust.

The maximum quantity of water to be supplied for the year without further charge to any property rated by the Trust is hereby fixed at the quantity which, at a charge of Two shillings per 1,000 gallons, would produce an amount equal to the amount of the rate levied on such property for the said year.

The charge for water supplied by measure to any property rated by the Trust in excess of such maximum quantity, computed as in the last preceding clause, is hereby fixed at Two shillings per 1,000 gallons.

The charge for water supplied to any property not rated by the Trust is hereby fixed at Two shillings per 1,000 gallons, and the minimum quantity of water to be charged for in cases where water is so supplied is hereby fixed at 1,000 gallons.

The charge for water supplied by measure shall be payable, on demand at the office of the Trust in Chiltern.

The seal of the Barnawartha Waterworks Trust was hereto affixed this 22nd day of March, 1961, in the presence of—

(SEAL) R. D. OATES, Chairman.
R. DOUGLAS, Commissioner.
N. M. SIMMONS, Secretary.

Approved, 29th March, 1961.—W. J. MIBUS, Minister of Water Supply.

OMEQ WATERWORKS TRUST.

RATING BY-LAW 1961.

THE Omeo Waterworks Trust, in pursuance and exercise of the powers conferred by the Water Acts, doth hereby make a rate of Three shillings and six pence in the pound on the annual municipal valuation of lands and tenements liable to be rated in the Omeo Urban District.

Provided that in no case shall the amount of rate payable per annum of any tenement (other than land on which there is no building) be less than Six pounds fifteen shillings, and in respect of land on which there is no building less than the sum of One pound ten shillings.

Such rates are made and shall be levied upon the occupiers or owners of the said lands and tenements for the year commencing on the 1st day of January, 1961, and shall be due and payable on the 14th day of April, 1961, at the office of the said Trust.

Passed this 18th day of March, 1961.

(SEAL) E. E. FOSTER, Chairman.
STAN A. HARRIS, Secretary.

Approved, 23rd March, 1961.—W. J. MIBUS, Minister of Water Supply.

SHIRE OF CRESWICK.

SMEATON WATER SUPPLY DISTRICT.

Rating By-law for the Year Ending 30th September, 1961.

THE Council of the Shire of Creswick, in pursuance and exercise of the powers conferred by the Water Acts, doth hereby make the following rates for the supply of water for domestic purposes on lands and tenements liable to be rated within the Smeaton Water Supply District in the Shire of Creswick.

On such lands and tenements a rate of Forty-two pence in the pound of the amount of the annual municipal value.

Provided that in no case shall the amount of the rate payable in respect of any tenement (other than land on which there is no building) be less than Six pounds fifteen shillings, and in respect of any land on which there is no building less than Forty shillings.

Such rates are made and levied upon the occupiers or owners of the said lands and tenements for the year commencing 1st October, 1960, and shall be payable on Monday, 8th May, 1961, at the office of the Council.

The maximum quantity of water to be supplied, without further charge to any property rated by the Authority, is hereby fixed at the quantity which, at a charge of Thirty-nine pence per 1,000 gallons, would produce an amount equal to the amount of the rate levied on such property for the said year.

The charge for water supplied by measure to any property rated by the Authority in excess of such maximum quantity, computed as in the last preceding clause, is hereby fixed at Thirty-nine pence per 1,000 gallons.

The charge for water supplied by measure to any property not rated by the Authority is hereby fixed at Thirty-nine pence per 1,000 gallons, and the minimum quantity of water to be charged for in cases where water is so supplied is hereby fixed at 10,000 gallons.

The charge for water supplied by measure shall be payable, on demand, at the office of the Council.

Passed by the Council of the Shire of Creswick on Monday, 20th March, 1961.

The common seal of the President, Councillors, and Ratepayers of the Shire of Creswick was affixed hereto, in the presence of—

(SEAL) J. A. S. GEDDES, President.
R. A. H. BRADSHAW, Councillor.
J. B. WILKIE, Shire Secretary.

Approved, 28th March, 1961.—W. J. MIBUS, Minister of Water Supply.

TOORA WATERWORKS TRUST.

RATING BY-LAW FOR THE YEAR 1961.

THE Toora Waterworks Trust, in pursuance and exercise of the powers conferred by the Water Acts, doth hereby make the following rates for the supply of water for domestic and ordinary purposes on land and tenements liable to be rated within the Welshpool Urban District.

On such lands and tenements a rate of Three shillings in the pound on the amount of the annual municipal valuation.

Provided that in no case shall the amount of rate payable in respect of any tenement (other than land on which there is no building) be less than Five pounds, and in respect of any land on which there is no building be less than One pound.

Such rates are made and levied upon the occupiers or owners of such lands and tenements for the year commencing on the 1st day of January, 1961, and shall be payable on the 14th day of April, 1961, at the office of the Trust.

The maximum quantity of water to be supplied without any further charge to any property rated by the Trust, is hereby fixed at the quantity which, at a charge of Two shillings per 1,000 gallons, would produce an amount equal to the amount of the rate levied on such property for the said year.

The charge for water supplied by measure to any property rated by the Trust in excess of such maximum quantity, computed as in the last preceding clause, is hereby fixed at Two shillings per 1,000 gallons.

The charge for water supplied by measure to any property not rated by the Trust is hereby fixed at Two shillings per 1,000 gallons, and the minimum quantity of water to be charged for in cases where water is so supplied is fixed at 5,000 gallons.

The charge for water supplied by measure shall be payable, on demand, at the office of the Trust.

Passed this 17th day of March, 1961.

(SEAL) WALTER IRELAND, Chairman.
B. V. CUMMINGS, Secretary.

Approved, 29th March, 1961.—W. J. MIBUS, Minister of Water Supply.

TOORA WATERWORKS TRUST.

RATING BY-LAW FOR THE YEAR 1961.

THE Toora Waterworks Trust, in pursuance and exercise of the powers conferred by the Water Acts, hereby make the following rates for the supply of water for domestic and ordinary purposes on lands and tenements liable to be rated within the Port Welshpool Urban District.

On such lands and tenements a rate of Three shillings in the pound on the amount of the annual municipal valuation.

Provided that in no case shall the amount of rate payable in respect of any tenement (other than land on which there is no building) be less than Five pounds, and in respect of any land on which there is no building be less than One pound.

Such rates are made and shall be levied upon the occupiers or owners of such lands and tenements for the year commencing on the 1st day of January, 1961, and ending on the 31st day of December, 1961, and shall be payable on the 14th day of April, at the office of the Trust.

The maximum quantity of water to be supplied without any further charge to any property rated by the Trust, is hereby fixed at the quantity which, at a charge of Two shillings per 1,000 gallons, would produce an amount equal to the amount of the rate levied on such property for the said year.

The charge for water supplied by measure to any property rated by the Trust in excess of such maximum quantity, computed as in the last preceding clause, is hereby fixed at Two shillings per 1,000 gallons.

The charge for water supplied by measure to any property not rated by the Trust is hereby fixed at Two shillings per 1,000 gallons, and the minimum quantity of water to be charged for in cases where water is so supplied is fixed at 5,000 gallons.

The charge for water supplied by measure shall be payable, on demand, at the office of the Trust.

Passed this 17th day of March, 1961.

(SEAL) WALTER IRELAND, Chairman.
B. V. CUMMINGS, Secretary.

Approved, 29th March, 1961.—W. J. MIBUS, Minister of Water Supply.

TOORA WATERWORKS TRUST.

RATING BY-LAW FOR THE YEAR 1961.

THE Toora Waterworks Trust, in pursuance and exercise of the powers conferred by the Water Acts, doth hereby make the following rates for the supply of water for domestic and ordinary purposes on the land and tenements liable to be rated within the Toora Urban District.

On such lands and tenements a rate of Two shillings in the pound on the amount of the annual municipal valuation.

Provided that in no case shall the amount of rate payable in respect of any tenement (other than land on which there is no building) be less than Two pounds, and in respect of any land on which there is no building be less than One pound.

Such rates are made and shall be levied upon the occupiers or owners of such lands and tenements for the year commencing on the 1st day of January, 1961, and ending on the 31st day of December, 1961, shall be payable on the 14th day of April, 1961, at the office of the Trust.

The maximum quantity of water to be supplied in any one year without any further charge to any property rated by the Trust, is hereby fixed at the quantity which, at a charge of One shilling and six pence per 1,000 gallons, would produce an amount equal to the amount of the rate levied on such property for the said year.

The charge for water supplied by measure to any property rated by the Trust in excess of such maximum quantity, computed as in the last preceding clause, is hereby fixed at One shilling and six pence per 1,000 gallons.

The charge for water supplied by measure to any property not rated by the Trust is hereby fixed at One shilling and six pence per 1,000 gallons, and the minimum quantity of water to be charged is fixed at 5,000 gallons.

The charge for water supplied by measure shall be payable, on demand, at the office of the Trust.

Passed this 17th day of March, 1961.

(SEAL) WALTER IRELAND, Chairman.
B. V. CUMMINGS, Secretary.

Approved, 29th March, 1961.—W. J. MIBUS, Minister of Water Supply.

REGISTRATION OF BIRTHS DEATHS AND MARRIAGES ACT 1959.—SECTION 7 (2).

IN accordance with the provisions of sub-section (2) of section 7 of the *Registration of Births Deaths and Marriages Act 1959*, notice is hereby given that on the thirtieth day of March, 1961, I, Arthur Gordon Rylah, Chief Secretary of the State of Victoria, appointed WILLIAM JOSEPH JEFFREY as a Collecting Agent at Shepparton, *vice* Kenneth Brian Curtis, resigned.

A. G. RYLAH,
Chief Secretary.

Chief Secretary's Office,
Melbourne, 30th March, 1961.

Country Fire Authority Act 1958.

VARIATION OF SUMMER PERIOD IN RESPECT OF SPECIFIED PARTS OF THE COUNTRY AREA OF VICTORIA.

WHEREAS by section 4 of the *Country Fire Authority Act 1958* it is enacted that the Chief Secretary of Victoria, after consultation with the Minister of Forests, may from time to time by declaration published in the *Government Gazette* declare any period to be the summer period in respect of the country area of Victoria, or any specified part of parts thereof and, without affecting the generality of the foregoing, may declare different periods to be the summer period in respect of different parts of the said country area:

And whereas by the said sub-section it is further enacted that any declaration so published may be revoked, amended, or varied by a subsequent declaration so published:

And whereas by declarations issued on the thirtieth day of November, 1960, the twelfth day of December, 1960, and the nineteenth day of December, 1960, and published in the *Government Gazette* of the thirtieth day of November, 1960, the fourteenth day of December, 1960, and the twenty-first day of December, 1960, respectively, different summer periods expiring on the fifteenth day of April, 1961, were declared in respect of different parts of the country area of Victoria, including the parts of the said country area specified in the Schedule hereto:

And whereas it is deemed expedient that the aforesaid declarations should be varied in the manner hereinafter described:

And whereas the Chief Secretary and the Minister of Forests have consulted accordingly:

Now therefore I, Arthur Gordon Rylah, Chief Secretary of Victoria, do by this my declaration vary the aforesaid declarations by declaring that the summer period in respect of the parts of the country area of Victoria specified in the Schedule hereto shall end at midnight on the seventh day of April, 1961.

SCHEDULE.

The Second Fire Control Region comprising the municipal districts of the City of Bendigo, the Borough of Eaglehawk and those portions of the Shires of Marong and Strathfieldsaye not included in the Twenty-first Fire Control Region; the Thirteenth Fire Control Region comprising the municipal districts of the Shires of Fern Tree Gully, Healesville and Upper Yarra and those portions of the City of Heidelberg and the Shires of Doncaster and Templestowe, Eltham and Lillydale not included in the Metropolitan Fire District; the Nineteenth Fire Control Region comprising the municipal districts of the Town of St. Arnaud and the Shires of Bet Bet, Kara Kara and Korong; the Twenty-first Fire Control Region comprising the municipal districts of the Town of Castlemaine, the Shires of East Loddon, Huntly, Maldon and Metcalfe and those portions of the Shires of Marong and Strathfieldsaye not included in the Second Fire Control Region; those portions of the Twenty-second Fire Control Region comprised by the municipal districts of the City of Shepparton, the Boroughs of Echuca and Kyabram and the Shires of Deakin, Nathalia, Numurkah, Rodney, Shepparton and Waranga; those portions of the Twenty-third Fire Control Region comprised by the municipal districts of the Borough of Benalla and the Shires of Benalla, Mansfield, Oxley and Wangaratta; and the Twenty-fourth Fire Control Region comprising the municipal districts of the Shires of Beechworth, Bright, Chiltern, Myrtleford, Towong, Upper Murray, Wodonga and Yackandandah.

A. G. RYLAH,
Chief Secretary.

6th April, 1961.

Local Government Act 1958.

ROAD NO LONGER REQUIRED FOR PUBLIC TRAFFIC.

WHEREAS the road in the Parish of Corio shown by hachure in the plan annexed hereto is within the City of Geelong and surveyed:

And whereas it is alleged that the said road is no longer required for public traffic, and the question whether the said road is or is not required for public traffic has been

referred to the Council of the said City and to the Honorable Keith Hector Turnbull, M.L.A., in his capacity as the responsible Minister of the Crown for the time being administering section 553 of *The Local Government Act 1958*:

Now therefore the said Council and the said Keith Hector Turnbull as such Minister as aforesaid, having taken the said question into their consideration, do under the powers vested in them by this present instrument, under the common seal of the City of Geelong and the hand and seal of the said Keith Hector Turnbull as such Minister as aforesaid, hereby decide that the said road is no longer required for public traffic.

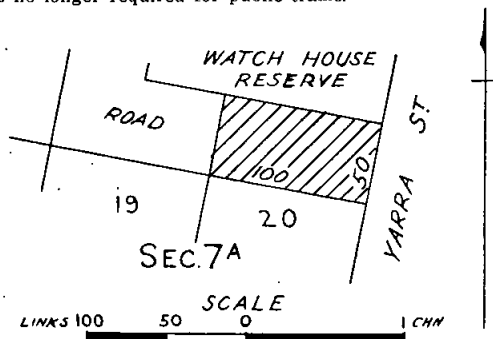

Dated the fifteenth day of March, in the year of our Lord, One thousand nine hundred and sixty-one.

The common seal of the City of Geelong was hereto affixed on the first day of March, 1961.

Signed, sealed, and delivered by the said City of Geelong, in the presence of—

(SEAL) VAUTIN H. ANDREWS, Mayor,
L. L. WALTER, Town Clerk.

Signed, sealed, and delivered by the said Keith Hector Turnbull, in the presence of E. TOOTELL, Clerk.

(SEAL) KEITH TURNBULL.

Housing Acts.

MUNICIPALITY OF KORUMBURRA.

DIRECTION, PURSUANT TO SECTION 8 (2) OF THE SLUM RECLAMATION AND HOUSING ACT NO. 4568, AS AMENDED BY SECTION 3 OF ACT NO. 5328, REQUIRING A HOUSE TO BE DEMOLISHED.

To Mrs. Margaret Ann Kroeger,
Executrix of Estate of Mary Margaret Egan.

TAKE notice that the Housing Commission, being of the opinion that it is impracticable to make the house or land described in the Schedule hereto comply with the regulations under section 8 of the Slum Reclamation and Housing Act No. 4568, as amended aforesaid hereby directs you to demolish such house within sixty (60) days after the date of service of this notice.

Dated the 13th day of February, 1961.

For and on behalf of the Housing Commission,

A. W. TAYLOUR,

An Officer of the Commission duly authorized to sign this notice.

SCHEDULE.

The house situate at Korumburra, and known as number 56 Princes-street, Korumburra, erected on land having a frontage of 40 feet or thereabouts to the said street.

NOTE.—Any owner who fails to comply with the direction above within the time specified shall be guilty of an offence against the above-mentioned Act.

If an owner fails to comply with the direction above within the time specified the Commission may—

- demolish the house;
- recover from the owner any expenses incurred;
- sell or dispose of any material taken from the house;
- apply proceeds of sale towards expenses of Commission and pay surplus (if any) to owner.

(See sub-section 5 of section 8 of Act 4568 as amended aforesaid.)

Housing Acts.

HOUSING COMMISSION.

VICTORIA.

Copy of Declaration of the Housing Commission, pursuant to Section 8 of Act No. 4568, as amended by Section 3 of Act No. 5328.

THE Housing Commission, after making due inquiries and obtaining all necessary reports, is satisfied that the house situate at and known as Number 56 Princes-street, Korumburra, does not comply with the regulations made under section 8 of the Slum Reclamation and Housing Act No. 4568, as amended, and the Housing Commission hereby declares such house to be unfit for human habitation.

Dated the 24th day of October, 1960.

The common seal of Housing Commission was hereto affixed, in the presence of—

(SEAL) J. P. GASKIN, Deputy Director.
G. G. BOLWELL, Secretary.

NOTE.—Any owner of a house or registered mortgagee of the land on which the house is situate, who feels aggrieved by any declaration of the Commission that such house is unfit for human habitation may, within fourteen days after the service of the declaration (endorsed hereon) that such house is unfit for human habitation, appeal therefrom to a Court of Petty Sessions consisting of a Police Magistrate sitting without any other justice or justices—see sub-section 6 of section 8 of Act No. 4568 as amended aforesaid.

Housing Act 1958 (No. 6275).—Section 99.

GENERAL NOTICE TO PARTIES EMPOWERED BY THE LANDS COMPENSATION ACT 1958 TO SELL AND CONVEY OR GRANT AND RELEASE, PURSUANT TO SECTION 99 OF ACT 6275.

GENERAL NOTICE TO TREAT FOR LAND IN A RECLAMATION AREA AT CARLTON.

IN pursuance of the provisions contained in the *Housing Act 1958* (No. 6275) and of the *Lands Compensation Act 1958* (No. 6286), the Housing Commission (hereinafter referred to as "the Commission") hereby doth give notice that the lands, tenements and hereditaments described in the Schedule hereto are required for the purpose of the Housing Acts and that the Commission is authorized by the provisions of section 68 of the said *Housing Act 1958* (No. 6275) to purchase or take compulsorily the said lands.

And the Commission accordingly hereby gives notice to all the parties interested in such land and to all the persons empowered by the *Lands Compensation Act 1958* to sell and convey or grant and release the land so required that it requires to take and purchase the land referred to in the said Schedule hereto and that it is willing to treat with such parties or persons for the purchase thereof and as to the compensation to be made and for the damage that may be sustained by reason of the execution of the works.

And further the Commission hereby requires such parties or persons, on or before the expiration of 21 days from the eighth day of April, 1961, to deliver to the offices of the Commission, at 179 Queen-street, Melbourne, a statement in writing of the particulars of the estate and interest in the said lands, tenements and hereditaments and of the claims made in respect thereof.

Dated the 20th day of March, 1961.

By order of the Commission,

G. G. BOLWELL,
Secretary.

SCHEDULE.

All that land situate within the municipality of the City of Melbourne being part of an area at Carlton bounded by Nicholson-street, Elgin-street, Station-street and Palmerston-street, and being all of the land comprised in Crown allotments 2, 3, 4 and 5 of section 70, at Carlton, in the Parish of Jika Jika, and so much of the land comprised in Crown allotment 1 of the said section 70 as is at present comprised in certificates of title, volume 4160, folio 801, volume 4923, folio 568, and volume 5867, folio 396.

Housing Acts.

MUNICIPALITY OF KORUMBURRA.

NOTICE, PURSUANT TO SECTION 8 (2) OF THE SLUM RECLAMATION AND HOUSING ACT No. 4568, AS AMENDED BY SECTION 3 OF ACT No. 5328, OF A DECLARATION BY THE HOUSING COMMISSION THAT A HOUSE IS UNFIT FOR HUMAN HABITATION.

To Mrs. Margaret Ann Kroeger,
Executrix of Estate of Mary Margaret Egan.

TAKE notice that the Housing Commission (hereinafter called "the Commission"), after making due inquiries and obtaining all necessary reports, is satisfied that the House (and/or land) described in the Schedule hereto does not comply with the Regulations made under section 8 of the above-mentioned Act as amended, and accordingly the Commission has declared such house to be unfit for human habitation.

A copy of the said declaration of the Commission is endorsed hereon and is served herewith: And take further notice that the following is a statement in writing setting out the particulars in respect of which the house or the land on which it is situated fails to comply with such Regulations, namely:

PARTICULARS.

Stump timbers decayed and defective. Sub-floor and structural timbers decayed and defective. Walls sagging out of line. Weatherboards split, decayed and defective. Cap and barge boards decayed and defective. Roof leaks, roof iron corroded, loose and out of shape. Spouting corroded, holed and missing. Downpipes corroded, defective and missing. Ridging corroded. Floors sunken, decayed and out of level. Flooring at ground level. T. and G. linings defective. T. and G. ceilings sagging and defective. Window frames, sashes and sills decayed and defective. Window sashes missing. Window glass fractured and missing. Glazing putty decayed. Doors missing and out of position. Evidence of weather damp. W.C. structure in disrepair. No stormwater or sullage water drains provided. Verandah structure in disrepair. Flooring boards decayed and missing, sub-floor timbers decayed. Walls and ceilings stained and discoloured. Fire place and stone hearths fractured and defective. Fuel stove defective. Cast iron copper defective, no flue provided. No troughs installed. No bath installed. No sink installed. Galvanized sheet iron chimney corroded and holed. Yard paving inadequate. Site overgrown with vegetation. Paintwork and putty perished. Fences in disrepair.

The Commission relies on each particular item of non-compliance separately as supporting its said declaration.

Dated the 13th day of February, 1961.

For and on behalf of the Housing Commission,

A. W. TAYLOUR,

An Officer of the Commission duly authorized to sign this notice.

SCHEDULE.

The house situate at Korumburra, and known as number 56 Princes-street, Korumburra, erected on land having a frontage of 40 feet or thereabouts to the said street.

PUBLIC TRUSTEE ACT 1958 (No. 6350).—SECTION 17.

I HEREBY give notice that on the 23rd March, 1961, the Public Trustee filed elections to administer the following deceased persons' estates, in accordance with section 17 of the *Public Trustee Act 1958*:—

BACK, FRANCES PAULINE, late of 93 Denistoun-avenue, Guildford, New South Wales, married woman, died 25th October, 1959, intestate.

*BROCK, NIGEL, formerly of 145A Hotham-street, East St. Kilda, but late of 10 Attley-grove, Ripponlea, agent, died 8th June, 1960.

RUSHTON, LAURENCE JAMES, late of Benalla, railway employee, died 16th June, 1960, intestate.

I HEREBY give notice that on the 24th March, 1961, the Public Trustee filed elections to administer the following deceased persons' estates, in accordance with section 17 of the *Public Trustee Act 1958*:—

MIELCAREK, HENRYK, late of 241 Moreland-road, Coburg, painter, died on or about 21st May, 1960, intestate.

*MUSTEY, THOMAS ERNEST, late of Rochester, clerk, died 22nd February, 1925.

PAUL, COLIN CLIVE, late of 32 Normanby-street, Middle Brighton, war pensioner, died 13th October, 1960, intestate.

PETERSON, VIOLET LOUISA, late of The Salvation Army, Cohuna-street, West Brunswick, pensioner, died 13th September, 1960, intestate.

PETERSSON, ERNST, also known as Ernest Julius Peterson, late of 245 Bank-street, South Melbourne, timber worker, died 10th December, 1960, intestate.

RYAN, DENIS, formerly of 11A Walkeley's-place, North Melbourne, but late of Mount Royal, Parkville, pensioner, died 24th October, 1959, intestate.

* According to the provisions of the will.

A. D. DUNCAN,

Public Trustee.

601 Little Collins-street, Melbourne, 29th March, 1961.

NOTICE.

ADMINISTRATION of the estate of each of the under-mentioned deceased persons has been granted to the Public Trustee, and creditors, next of kin, and all others having claims against the estate of any of the persons so mentioned are required to send particulars of their claims to the Public Trustee, 7th Floor, 601 Little Collins-street, Melbourne, on or before the 8th June, 1961, or they will be excluded from the distribution of the estate when the assets are being distributed:—

BACK, FRANCES PAULINE, late of 93 Denistoun-avenue, Guildford, New South Wales, married woman, died 25th October, 1959, intestate.

*BARRY, BERESFORD ROBERT WILLIAM, late of 9 Sherwood-road, Ivanhoe, retired director and secretary, died 4th January, 1961.

†BROCK, NIGEL, formerly of 145A Hotham-street, East St. Kilda, but late of 10 Attley-grove, Ripponlea, agent, died 8th June, 1960.

*CHERRY, MARY AGNES, formerly of 50 Barnett-street, Kensington, but late of Kew, spinster, died 8th August, 1960.

*CHERRY, ROBERT WILLIAM, formerly of 50 Barnett-street, Kensington, but late of Mt. Royal, Parkville, drover, died 19th May, 1959.

*FLOCKHART, ADA, late of 6 Sylverly-grove, Caulfield, widow, died 18th November, 1960.

*FORD, ANNIE, late of King-street, Yarra Glen, widow, died 18th February, 1960.

*GRACE, JOSEPH THOMAS, late of 34 Leura-grove, Hawthorn East, clerk of works, died 24th September, 1960.

*HENSELL, VIOLET ELLEN, late of 18 Myrose-avenue, Ascot Vale West, married woman, died 2nd January, 1961.

*HILL, ALICE EVA MARIA, late of "Whiteways", Eayling-street, Keilor, widow, died 11th November, 1960.

*JARVIS, HENRY HERBERT, late of 46 Gordon-grove, Preston, retired hospital attendant, died 26th August, 1960.

*KING, LILIAN MAY, formerly of 325 Hawthorn-road, Caulfield, but late of Flat 30, 78 Queens-road, St. Kilda, widow, died 29th November, 1960.

*MARKS, MALITA ETHEL, late of 62 Hargreaves-street, Castlemaine, spinster, died 10th August, 1960.

MIELCAREK, HENRYK, late of 241 Moreland-road, Coburg, painter, died on or about 21st May, 1960, intestate.

†MUSTEY, THOMAS ERNEST, late of Rochester, clerk, died 22nd February, 1925.

*NOCKELS, FLORENCE MAY, late of 16 Malleson-street, Richmond, married woman, died 9th July, 1959.

PAUL, COLIN CLIVE, late of 32 Normanby-street, Middle Brighton, war pensioner, died 13th October, 1960, intestate.

PETERSON, VIOLET LOUISA, late of The Salvation Army, Cohuna-street, West Brunswick, pensioner, died 13th September, 1960, intestate.

PETERSSON, ERNST, also known as Ernest Julius Peterson, late of 245 Bank-street, South Melbourne, timber worker, died 10th December, 1960, intestate.

RUSHTON, LAURENCE JAMES, late of Benalla, railway employee, died 16th June, 1960, intestate.

RYAN, DENIS, formerly of 11A Walkeley's-place, North Melbourne, but late of Mount Royal, Parkville, pensioner, died 24th October, 1959, intestate.

* With the will annexed.

† According to the provisions of the will.

A. D. DUNCAN,

Public Trustee.

Melbourne, 29th March, 1961.

CONTRACTS ACCEPTED.—(Series 1960-61.)**PUBLIC WORKS.**

3091. Various Schools, erection of timber-framed classrooms, section XXVIII., Sub-District Contract "A"—Metropolitan, £1,534.—S. & S. Constructions Pty. Ltd.
3092. Various Schools, erection of timber-framed classrooms, section XXVIII., Sub-District Contract "B"—Northern, £5,296.—A. V. Jennings Construction Co. Pty. Ltd.
3093. Various Schools, erection of timber-framed classrooms, section XXVIII., Sub-District Contract "C"—Northern, £9,367 8s.—Robert Poulston.
3094. Various Schools, erection of timber-framed classrooms, section XXVIII., Sub-District Contract "D"—Northern, £3,729.—A. V. Jennings Construction Co. Pty. Ltd.
3095. Various Schools, erection of timber-framed classrooms, section XXVIII., Sub-District Contract "E"—North-Eastern, £1,520.—Winston A. Churchill.
3096. Various Schools, erection of timber-framed classrooms, section XXVIII., Sub-District Contract "F"—North-Eastern, £6,260.—A. V. Steele.
3097. Various Schools, erection of timber-framed classrooms, section XXVIII., Sub-District Contract "G"—North-Eastern, £1,617.—K. Everson.
3098. Various Schools, erection of timber-framed classrooms, section XXVIII., Sub-District Contract "H"—Northern, £1,843.—A. V. Jennings Construction Co. Pty. Ltd.
3099. Various Schools, erection of timber-framed classrooms, section XXVIII., Sub-District Contract "I"—North-Eastern, £7,818.—A. V. Jennings Construction Co. Pty. Ltd.
3100. Various Schools, erection of timber-framed classrooms, section XXVIII., Sub-District Contract "J"—South-Eastern, £14,288.—A. V. Jennings Construction Co. Pty. Ltd.
3101. Various Schools, erection of timber-framed classrooms, section XXVIII., Sub-District Contract "K"—South-Eastern, £6,036.—S. & S. Constructions Pty. Ltd.
3102. Various Schools, erection of timber-framed classrooms, section XXVIII., Sub-District Contract "L"—South-Eastern, £5,470.—G. L. Mackie.
3103. Various Schools, erection of timber-framed classrooms, section XXVIII., Sub-District Contract "M"—South-Eastern, £6,300.—K. D. Sewell.
3104. Various Schools, erection of timber-framed classrooms, section XXVIII., Sub-District Contract "N"—Western, £3,396.—A. V. Jennings Construction Co. Pty. Ltd.
3105. Various Schools, erection of timber-framed classrooms, section XXVIII., Sub-District Contract "O"—Western, £10,616.—A. V. Jennings Construction Co. Pty. Ltd.
3106. Various Schools, erection of timber-framed classrooms, section XXVIII., Sub-District Contract "P"—South-Western, £2,318.—A. V. Jennings Construction Co. Pty. Ltd.
3107. Various Schools, erection of timber-framed classrooms, section XXVIII., Sub-District Contract "Q"—South-Western, £1,627.—A. V. Jennings Construction Co. Pty. Ltd.
3108. Various Schools, erection of timber-framed classrooms, section XXVIII., Sub-District Contract "R"—South-Western, £9,377.—A. V. Jennings Construction Co. Pty. Ltd.
3109. Various Schools, erection of timber-framed classrooms, section XXVIII., Sub-District Contract "S"—South-Western, £6,987.—A. V. Jennings Construction Co. Pty. Ltd.
3110. Various Schools, erection of timber-framed classrooms, section XXVIII., Sub-District Contract "T"—South-Eastern, £5,325.—A. V. Jennings Construction Co. Pty. Ltd.
3111. Corio, State School No. 124, additional toilets, lay drains and raising mains, &c., to connect to sewer, £1,949.—Nott & Drew Pty. Ltd.
3112. Croydon, Central State School No. 2900, supply and installation of effluent pumps in septic tanks, £570.—Full Range Pump Service Pty. Ltd.
3113. Deer Park, State School No. 1434, provision of chlorination unit, extension of water supply, &c., £393 10s.—R. Rivett.
3114. Dunkeld, State School No. 183, erection of new residence (Ellinbank type), £3,990.—W. J. Coates.
3115. Eltham, State School No. 209, installation of skylights, £355.—H. I. Johnson & W. H. Johnson.
3116. North Fitzroy, State School No. 1490, renovations to two (2) rooms, £289.—J. Lynch.
3117. Flemington, Travancore Developmental Centre, water supply, &c., £1,229 17s.—Raymond Rivett.
3118. Footscray, Girls' Secondary School, attention to toilets and water services, £341 15s.—R. Rivett.

3119. Frankston, High School, electrical installation in additional change room, stores, toilets, &c., £390 10s.—E. W. Horsington.
3120. Geelong, Teachers' College, heavy-duty asphalt paving, £5,352 5s.—J. H. Lewis & Son.
3121. Geelong, Junior Technical School, provision of sick bay, £333 18s. 6d.—R. Doolan.
3122. Geelong, Gordon Institute of Technology, painting and repairs (section B), £5,100.—Light and Blankley.
3123. Greythorn, State School No. 4694, stormwater drainage, £492 12s.—R. J. Oats.
3124. Hamilton, State School No. 4777, extension of plenum heating to two additional classrooms, £315.—Gray and Wood.
3125. Inglewood, Lands and Survey Department, residence, new timber-framed toilet and septic tank system, £275 10s.—P. E. Dunstan.
3126. Lake Bolac, High School, electrical installation in modified second section, £3,559.—I. J. McWilliams.
3127. Lake Tyers, Aboriginal Station, renovations to cottages (4), £2,245.—T. A. Thaxton.
3128. Little River, State School No. 1961, interior and exterior painting, £421 10s.—B. G. Jarvis.
3129. Macleod, Technical School, erection of shelter pavilions and storeroom, £1,195.—H. I. and W. H. Johnson.
3130. Malvern, Girls' School, exterior and interior painting to Domestic Arts Section, &c., £530.—Donovan and Brown.
3131. Mandurang, State School No. 1952, new combined out-office block and septic closet at school; septic closet at residence, £675 10s.—P. E. Dunstan.
3132. Melbourne, Government House, improvements to passenger lift, £1,845.—Alpha Electric Co.
3133. Melbourne, Technical College, painting steel window frames, £555.—M. Mulvey.
3134. Melbourne, Cancer Institute, erection of central block, section 1, £130,396.—Prentice Builders Pty. Ltd.
- T. K. MALTBY, Commissioner of Public Works. 28.3.61.

ORDERS IN COUNCIL.—(Series 1960-61.)**PUBLIC WORKS.**

3135. Essendon Technical School, special grant by Education Department as contribution towards the erection of an assembly hall, £16,500. (W.199222.)
- Approved by the Governor in Council, 15th March, 1961.—A. MAHLSTEDT, Clerk of the Executive Council.

STATE ELECTRICITY COMMISSION.

3136. The supply of galvanized steel strand for transmission and distribution lines, for a period of two years, to Specification No. 60-61/208, at Schedule Rates.—Australian Wire Rope Works Pty. Ltd.
3137. The supply of 100 amp. porcelain service fuses for consumers' services, for a period of two years, to Specification No. 60-61/180, at Schedule Rates.—Gordon Faine and Sons Pty. Ltd.
3138. The erection of brick and timber amenities block, stationery store, offices, &c., in existing steel buildings at Brooklyn Storage Depot, to Specification 60-61/236, £22,032.—G. Harris (Builders) Pty. Ltd.
3139. The supply of Diesel fuel oil for stationary engines, for a period of two years, to Specification No. 60-61/157, at Schedule Rates.—The Shell Co. of Australia Ltd.
3140. The supply of galvanized malleable iron castings, comprising socket clevis and eyes, and strain and suspension clamps, for a period of two years, to Specification No. 60-61/114, at Schedule Rates.—Stewarts and Lloyds (Distributors) Pty. Ltd.
3141. The supply of tractor and general replacement parts for International tractors and associated equipment, for a period of two years, to Specification No. 60-61/223, at Schedule Rates.—Victorian Industrial Sales and Service Pty. Ltd.
3142. The supply of 6.6-11 kV indoor metalclad switchgear and accessories for new substation in Albert Park area, to Specification No. 60-61/167, £22,086.—Westinghouse Rosebery Pty. Ltd.
3143. The supply of encapsulated ring type current transformers for consumers' metering, for a period of two years, to Specification No. 60-61/143, at Schedule Rates.—Godfrey Electrical Industries Pty. Ltd.
3144. The supply of encapsulated ring type current transformers and clamps for consumers' metering, for a period of two years, to Specification No. 60-61/143, at Schedule Rates.—Oliver J. Nilsen and Co. Pty. Ltd.
3145. The supply of conduit and conduit fittings for a period of six months, to Specification No. 60-61/216, at Schedule Rates.—British General Electric Co. Pty. Ltd.

3146. The supply of household installation fittings, for a period of six months, to Specification No. 60-61/216, at Schedule Rates.—Lawrence and Hanson Electrical (Vic.) Pty. Ltd.

3147. The supply of fuse units and switches for a period of six months, to Specification No. 60-61/216, at Schedule Rates.—Vealls Electrical and Radio Pty. Ltd.

PUBLIC WORKS.

3148. State School, Tottenham North, removal of debris after fire damage, £565.—A. H. Philip (W.257863.)

3149. Explosives Lighter, "Tarneit," Ports and Harbours Branch, docking, cleaning, scrubbing and painting from keel to waterline, £359.—Hobson's Bay Dock and Engineering Co. Pty. Ltd. (M.207094.)

3150. Bendigo Gaol, supply of one (1) John Heine model No. 106B power-g geared guillotine shear, £1,395.—McPherson's Ltd. (N.244457.)

3151. State School No. 4158, Westbreen, repairs after fire damage, £1,596.—F. J. Free and Co. (N.255878.)

3152. Horsham High School, special grant to school advisory council towards cost of erection of fencing, £1,368. (W.247486.)

3153. State School No. 4650, Newborough, replacement of overhead service by underground cable, £525 15s.—Colmax Electric Pty. Ltd. (S.E.252780.)

Approved by the Governor in Council, 21st March, 1961.—A. MAHLSTEDT, Clerk of the Executive Council.

LAW DEPARTMENT.

APPOINTMENT AMENDED.

HIS Excellency the Administrator of the Government of the State of Victoria, by and with the advice of the Executive Council thereof, doth by Order made on the 28th March, 1961, amend the Order in Council approved on the 28th February, 1961, appointing certain persons to Keep the Peace in the Eastern, Midland, and Southern Bailiwicks of the State of Victoria by the substitution of the name KELLAWAY DUDLEY ANDREW for that of Dudley Andrew Kellaway appearing therein.

A. MAHLSTEDT,
Clerk of the Executive Council.

APPOINTMENTS.

HIS Excellency the Administrator of the Government of the State of Victoria, by and with the advice of the Executive Council thereof, has, by Orders made on the 28th March, 1961, been pleased to make the under-mentioned appointments, viz.:

DEPARTMENT OF AGRICULTURE.

Inspectors Authorized to Take Proceedings under Part II. of the Fruit and Vegetables Act.

GERALD STANLEY BARTON,
HENRY JOHN BUGG,
THOMAS ANDREW CARMODY,
CLIFFORD CROUCH,
NORMAN COLIN JONES, and
NORMAN JOHN KLINGE,

pursuant to section 48 of the *Fruit and Vegetables Act 1958*, the persons named above who are Inspectors under the said Act, to take proceedings in respect of offences against Part II. of the said Act or the Regulations thereunder.

CHIEF SECRETARY'S DEPARTMENT.

Electoral Registrar.

OWEN PATRICK GRIFFIN
to be Electoral Registrar for the Drysdale, Geelong, Newtown and Chilwell and Queenscliff Subdivisions of the Electoral District of Geelong; and for the Bannockburn, Geelong North, Geelong West, Meredith and Sutherland Subdivisions of the Electoral District of Geelong West, to take effect on and from the 14th March, 1961, vice Michael Francis McSherry, resigned.

Electoral Registrars (Acting).

WILLIAM DAVID MILLAR
to be Electoral Registrar (Acting) for the Caulfield West, Elsternwick North, Ripponlea and St. Kilda North Subdivisions of the Electoral District of Ripponlea; and for the St. Kilda, St. Kilda Park and St. Kilda West Subdivisions of the Electoral District of St. Kilda, to take effect on and from the 13th March, 1961, during the absence, on leave, of James Edwin Moses.

ATHOL HERBERT THOMPSON
to be Electoral Registrar (Acting) for the Caulfield, Caulfield East, Malvern East and Malvern South Subdivisions of the Electoral District of Caulfield; and for

the Darling, Malvern and Malvern West Subdivisions of the Electoral District of Malvern, to take effect on and from the 15th March, 1961, during the absence, on leave, of Clive Edward Gustav Warmbrunn; and

PATRICK JOSEPH MCNAMARA
to be Electoral Registrar (Acting) for the Alphington, Ivanhoe and Thornbury East Subdivisions of the Electoral District of Ivanhoe; and for the Northcote and Thornbury Subdivisions of the Electoral District of Northcote, to take effect on and from the 22nd March, 1961, during the absence, on leave, of Norman Clifford Erwin.

Member of the Metropolitan Fire Brigades Appeal Tribunal.

FRANK EDWARD TUENO,
pursuant to the provisions of the *Metropolitan Fire Brigades Act 1958*, to be a member of the Metropolitan Fire Brigades Appeal Tribunal, for a period of two years, vice John Paterson, resigned.

Members of the Street Traders Licences Board.

JAMES CHRISTIE HOLLAND,
pursuant to the provisions of section 5 of the *Street Trading Act 1958*, to be a member of the Street Traders Licences Board, for a period of two years from the 1st April, 1961; and

WILLIAM RICHARD STEVENSON,
pursuant to the provisions of section 5 of the *Street Trading Act 1958*, to be a member of the Street Traders Licences Board, for the period from 4th April, 1961, up to and inclusive of the 3rd September, 1961.

Member of the Aborigines Welfare Board.

ARTHUR GODFREY HOLDEN,
pursuant to the provisions of section 4 of the *Aborigines Act 1958*, to be a member of the Aborigines Welfare Board, for the period ending the 22nd July, 1963.

LAW DEPARTMENT.

Justices of the Peace.

COLIN WILLIAM MACGILL, Martley-street, Porepunkah, to Keep the Peace in the Northern Bailiwick of the State of Victoria;

JOSEPH JAMES NEWTON O'BRIEN, 123 Main-road, Lower Plenty,

FREDERIC LESLIE PEMBERTON, 12 Kananook-avenue, Seaford,

ALEXANDER STEPHAN MARTONFFY, 1 Park-street, Moonee Ponds, and

CLARENCE EDWIN BURNS, 80 Main-road, Lower Plenty, to Keep the Peace in the Central Bailiwick of the State of Victoria.

Commissioners for Taking Declarations, &c.

LEONARD NOEL FLANNAGAN, 7 Ramona-avenue, Chadstone,

ALBERT FRANCIS MOSS, 37 Sparkes-avenue, Fairfield,

GEORGE IOANNIDIS, 86 Brunswick-street, Fitzroy,

LIONEL HENRY DILLON, care of Australian Consolidated Industries Limited, 500 Bourke-street, Melbourne, and

WALTER DE BONA, care of New Australian Centre, 366 Bourke-street, Melbourne,
to be Commissioners for taking Declarations and Affidavits, pursuant to the provisions of the *Evidence Act 1958*, to resign upon removing from the neighbourhood of the addresses stated.

DEPARTMENT OF TREASURER.

Receivers of Revenue.

WILLIAM EDWARD GUY
to act temporarily as Receiver of Revenue, Ballarat, during the absence of E. N. Kinchington, on leave; and

GREGORY JAMES FINDLAY
to act temporarily as Receiver of Revenue, Shepparton, during the absence of A. E. Thompson, on leave.

Collector of Imposts.

JAMES TALBOT JONES
to act temporarily as Collector of Imposts, Workers Compensation Board, during the absence of G. T. Smith, on leave.

A. MAHLSTEDT,
Clerk of the Executive Council.

At the Executive Council Chamber,
Melbourne, 28th March, 1961.

RESIGNATIONS.

HIS Excellency the Administrator of the Government of the State of Victoria, by and with the advice of the Executive Council thereof, has, by Orders made on the 28th March, 1961, accepted the resignations of the persons named hereunder of the offices mentioned, viz.:-

CHIEF SECRETARY'S DEPARTMENT.

JOHN PATERSON
as a member of the Metropolitan Fire Brigades Appeal Tribunal;

HENRY MILLS
as a Licensing Inspector for the purposes of the *Licensing Act 1958*, from and inclusive of the 14th March, 1961; and

MICHAEL FRANCIS MCSHERRY
as Electoral Registrar for the Drysdale, Geelong, Newtown and Chilwell and Queenscliff Subdivisions of the Electoral District of Geelong; and for the Bannockburn, Geelong North, Geelong West, Meredith and Sutherland Subdivisions of the Electoral District of Geelong West, from and inclusive of the 14th March, 1961.

A. MAHLSTEDT,
Clerk of the Executive Council.

At the Executive Council Chamber,
Melbourne, 28th March, 1961.

DEPARTMENT OF CROWN LANDS AND SURVEY.

At the Executive Council Chamber, Melbourne, the twenty-eighth day of March, 1961.

PRESENT:

His Excellency the Administrator of the Government of Victoria.

Sir Ewen Cameron | Mr. Mibus.
Mr. Fraser

LANDS TEMPORARILY RESERVED AS SITES.

HIS Excellency the Administrator of the Government of the State of Victoria, by and with the advice of the Executive Council thereof, doth hereby, in pursuance of the provisions of the *Land Act 1958*, reserve, temporarily, and also except from occupation for mining purposes, under any miner's right, the lands hereinafter described:-

AVOCA.—Site for Public Recreation and Tourist Camping, 72 acres, more or less, Township of Avoca, Parish of Avoca, Counties of Gladstone and Kara Kara, as indicated by hachure on plan hereunder.—(A.86(s) (Rs.405).

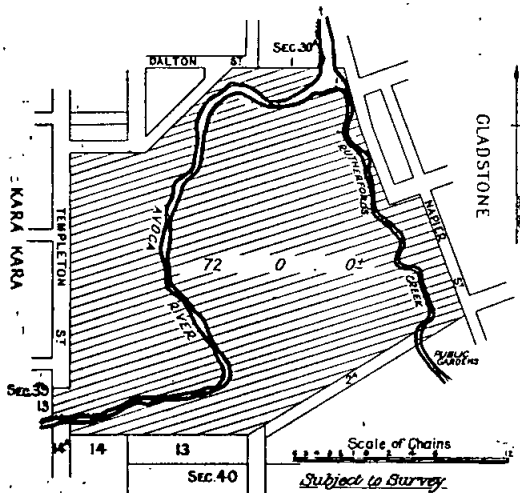

BRIGHT.—Site for the purposes of the Forests Commission, 16 perches, Township of Bright, Parish of Bright, County of Delatite, as indicated by hachure on plan hereunder.—(B.573(s) (Rs.8031).

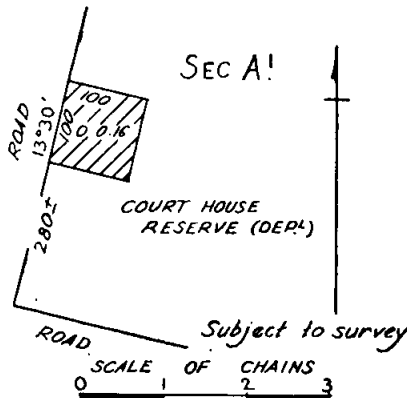

BROADLANDS.—Site for Preservation of Wildlife, 100-acres, more or less, Parish of Broadlands, County of Dargo, as indicated by hachure on plan hereunder.—(B.91(2) (Rs.8032).

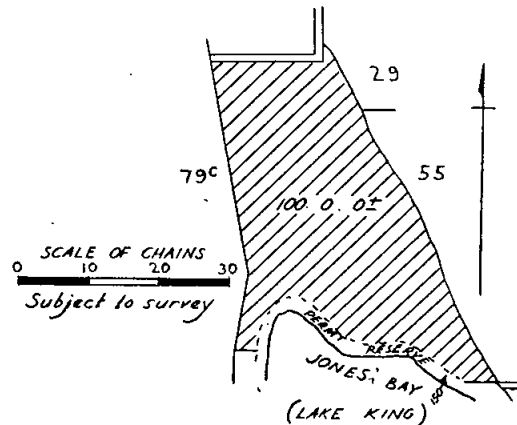

And the Honorable Keith Hector Turnbull, Her Majesty's Commissioner of Crown Lands and Survey for the State of Victoria, shall give the necessary directions herein accordingly.

A. MAHLSTEDT,
Clerk of the Executive Council.

DEPARTMENT OF CROWN LANDS AND SURVEY.

At the Executive Council Chamber, Melbourne, the twenty-eighth day of March, 1961.

PRESENT:

His Excellency the Administrator of the Government of Victoria.

Sir Ewen Cameron | Mr. Mibus.
Mr. Fraser

LAND PERMANENTLY RESERVED AS A SITE.

HIS Excellency the Administrator of the Government of the State of Victoria, by and with the advice of the Executive Council thereof, doth hereby, in pursuance of the provisions of the *Land Act 1958*, permanently reserve in the Parish of Moorabbin, as a site for a Cemetery, 3 acres 0 roods 37 perches of land in the two separate portions, as defined by description and hachure on plan published in the *Government Gazette* of 22nd February, 1961, in addition to and adjoining the site permanently reserved therefor by Orders in Council of the 28th April, 1936, and 26th May, 1953.—(Rs.4547.)

And the Honorable Keith Hector Turnbull, Her Majesty's Commissioner of Crown Lands and Survey for the State of Victoria, shall give the necessary directions herein accordingly.

A. MAHLSTEDT,
Clerk of the Executive Council.

DEPARTMENT OF CROWN LANDS AND SURVEY.

At the Executive Council Chamber, Melbourne, the twenty-eighth day of March, 1961.

PRESENT:

His Excellency the Administrator of the Government of Victoria.

Sir Ewen Cameron | Mr. Mibus.
Mr. Fraser

UNUSED ROADS CLOSED.

HIS Excellency the Administrator of the Government of the State of Victoria, by and with the advice of the Executive Council thereof, doth hereby direct that, in pursuance of the provisions of section 349 of the Land Act 1958, the unused roads referred to hereunder be closed, viz.:-

Township of Durham, Parish of Chiltern West, County of Bogong, being the road between allotment 16, Township of Durham, and allotment 45, Parish of Chiltern West.—(D.226(1) (H.023984).

Parish of Carngham, County of Grenville, being the road within allotment 73, section 26.—(C.111(6) (J.29892).

Township of Lockington, Parish of Bamawm, County of Bendigo, being the roads indicated by hachure on plan hereunder.—(B.94(E²) (W.68230).

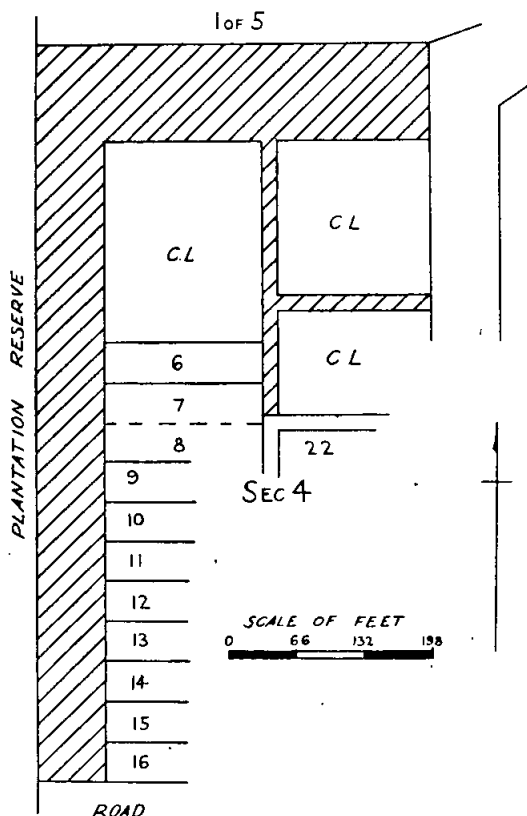

Parish of Dueran, County of Delatite, being the roads indicated by hachure on plan hereunder.—(D.174(6) (H.024748).

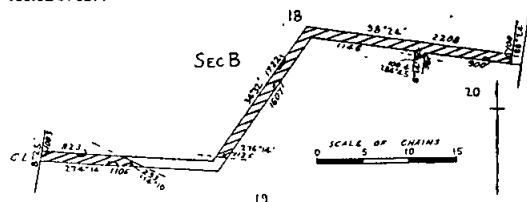

Parish of Moorarbool East, County of Bourke, being the road indicated by hachure on plan hereunder.—(M.137(6) (J.28678).

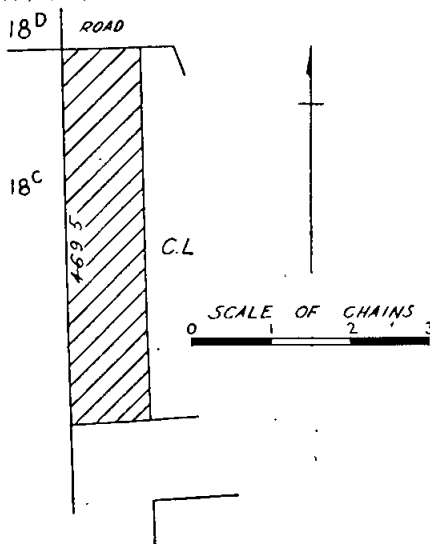

Parish of Beenak, County of Evelyn, being—(a) the road between allotment 90c and allotment 90d; (b) the road indicated by hachure on plan hereunder.—(B.680(6) (Misc.3184).

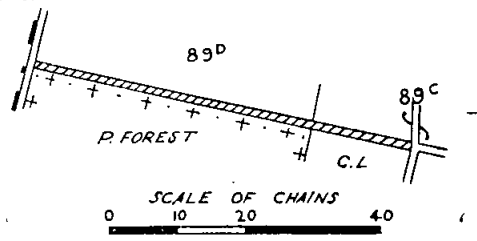

And the Honorable Keith Hector Turnbull, Her Majesty's Commissioner of Crown Lands and Survey for the State of Victoria, shall give the necessary directions herein accordingly.

A. MAHLSTEDT,
Clerk of the Executive Council.

DEPARTMENT OF CROWN LANDS AND SURVEY.

At the Executive Council Chamber, Melbourne, the twenty-eighth day of March, 1961.

PRESENT:

His Excellency the Administrator of the Government of Victoria.

Sir Ewen Cameron | Mr. Mibus.
Mr. Fraser

REVOCATIONS OF TEMPORARY RESERVATIONS OF LANDS BY ORDERS IN COUNCIL.

HIS Excellency the Administrator of the Government of the State of Victoria, by and with the advice of the Executive Council thereof, doth hereby, in pursuance of the provisions of the Land Act 1958, revoke the temporary reservations of lands by Orders in Council hereinafter referred to, viz.:-

ECHUCA NORTH.—Order in Council of 13th January, 1930, of 20 acres of land in the Parish of Echuca North, as a site for Cattle Yards and Abattoirs.—(Rs.3944.)

ST. ARNAUD.—Order in Council of 14th December, 1926, of 27 2/10 perches of land in the Township of St. Arnaud, as a site for Drainage purposes.—(Rs.3398.)

And the Honorable Keith Hector Turnbull, Her Majesty's Commissioner of Crown Lands and Survey for the State of Victoria, shall give the necessary directions herein accordingly.

A. MAHLSTEDT,
Clerk of the Executive Council.

EDUCATION ACT 1958.

At the Executive Council Chamber, Melbourne, the
twenty-eighth day of March, 1961.

PRESENT:

His Excellency the Administrator of the Government of Victoria.
Sir Ewen Cameron | Mr. Mibus.
Mr. Fraser

ADULT EDUCATION REGULATIONS (1961).

PURSUANT to the powers conferred on him by the *Education Act 1958* and all other powers him thereunto enabling, His Excellency the Administrator of the Government of the State of Victoria, by and with the advice of the Executive Council of the said State, doth hereby make the Regulations following, that is to say:—

1. These Regulations may be cited as the Adult Education Regulations (1961) and shall be read and construed as one with the Adult Education Regulations (1955) (hereinafter called the Principal Regulations).

2. (1) For Item 2 of Part A of the Second Schedule to the Principal Regulations there shall be substituted the following item:—

2. Juniors (Female).

Age	Under					
	16 Years	16 Years	17 Years	18 Years	19 Years	20 Years
Rate	£ 166	£ 197	£ 228	£ 272	£ 316	£ 355

(2) This amendment shall take effect as on and from the 2nd April, 1961.

And the Honorable John Stoughton Bloomfield, Her Majesty's Minister of Education for the State of Victoria, shall give the necessary directions herein accordingly.

A. MAHLSTEDT,
Clerk of the Executive Council.

LIBRARIES ACT 1958.

At the Executive Council Chamber, Melbourne, the
twenty-eighth day of March, 1961.

PRESENT:

His Excellency the Administrator of the Government of Victoria.
Sir Ewen Cameron | Mr. Mibus.
Mr. Fraser

AMENDMENT OF REGULATIONS.

IN pursuance of the powers conferred by the *Libraries Act 1958* and all other powers him thereunto enabling, His Excellency the Administrator of the Government of the State of Victoria, in the Commonwealth of Australia, by and with the advice of the Executive Council of the said State, doth hereby further amend the "Free Library Service Board Regulations 1950" (that is to say):—

1. In clause five, for the words "Forty-eight shillings", there shall be substituted the words "Fifty-two shillings".

2. In clause seven, for the expression "14.2 pence", there shall be substituted the expression "11.9 pence".

And the Honorable Arthur Gordon Rylah, Her Majesty's Chief Secretary for the State of Victoria, shall give the necessary directions herein accordingly.

A. MAHLSTEDT,
Clerk of the Executive Council.

METROPOLITAN FIRE BRIGADES ACT 1958.

*At the Executive Council Chamber, Melbourne, the
twenty-eighth day of March, 1961.*

PRESENT:

His Excellency the Administrator of the Government of Victoria.

Sir Ewen Cameron
Mr. Fraser

Mr. Mibus.

AMENDMENT OF REGULATIONS.

WHEREAS by the *Metropolitan Fire Brigades Act 1958* it is amongst other things enacted that the Governor in Council may make Regulations for all or any of the purposes set forth in the said Act:

And whereas by section 35 of the said Act it is further enacted that all Regulations as to the metropolitan district shall be prepared by the Metropolitan Fire Brigades Board and submitted to the Minister for approval prior to being made by the Governor in Council:

And whereas the Regulations set forth hereunder were prepared by the Metropolitan Fire Brigades Board and submitted to the Minister for his approval:

And whereas such Regulations have been approved by the Minister:

Now therefore, His Excellency the Administrator of the Government of the State of Victoria, in the Commonwealth of Australia, by and with the advice of the Executive Council of the said State, and in pursuance of the powers conferred by the said Act, doth hereby make the Regulations following (that is to say):—

The Metropolitan Fire Brigades General Regulations 1951 are hereby amended as follows:—

1. For clause 58, there shall be substituted the following clause:—

“58. All payments of £1 or upwards shall be made by cheques upon the bankers of the Board and unless the Board shall with regard to cheques drawn for a particular purpose otherwise direct, be signed by one member of the Finance Committee, and countersigned by the Secretary or by any other officer authorized by the Board.”

And the Honorable Arthur Gordon Rylah, Her Majesty's Chief Secretary for the State of Victoria, shall give the necessary directions herein accordingly.

A. MAHLSTEDT,
Clerk of the Executive Council.

ARCHITECTS ACTS.

*At the Executive Council Chamber, Melbourne, the
twenty-eighth day of March, 1961.*

PRESENT:

His Excellency the Administrator of the Government
of Victoria.

Sir Ewen Cameron | Mr. Mibus.
Mr. Fraser

APPOINTMENT OF MEMBERS OF THE ARCHITECTS
REGISTRATION BOARD OF VICTORIA.

PURSUANT to the provisions of the Architects Acts, His Excellency the Administrator of the Government of the State of Victoria, by and with the advice of the Executive Council thereof, by this Order appoints—

RAYMOND CLAYTON DAVEY,
ARTHUR CHARLES COLLINS, and
HARRY STEPHEN WINBUSH

to be Members of the Architects Registration Board of Victoria, for a period of two years ending on the 8th April, 1963.

And the Honorable Sir Thomas Karran Maltby, Her Majesty's Commissioner of Public Works for the State of Victoria, shall give the necessary directions herein accordingly.

A. MAHLSTEDT,
Clerk of the Executive Council.

LIBRARIES ACT 1958.

*At the Executive Council Chamber, Melbourne, the
twenty-eighth day of March, 1961.*

PRESENT:

His Excellency the Administrator of the Government
of Victoria.

Sir Ewen Cameron | Mr. Mibus.
Mr. Fraser

ORDER APPROVING TRANSFER OF LAND TO THE
MUNICIPALITY OF THE SHIRE OF KARKAROOC.**W**HEREAS:

1. The land described in the Schedule hereto is vested in trustees in trust that it may be used as a site for a Mechanics' Institute at Lascelles, in the State of Victoria.

2. The said land is no longer required for that purpose.

3. The trustees for the time being of the said land and the Council of the municipality of the Shire of Karkarooc within the municipal district of which the said land is situate have petitioned the Governor in Council, in writing, pursuant to section 23 of the *Libraries Act 1958*, to grant authority for the said trustees to transfer the said land to the said municipality.

4. No lessee, mortgagee or other person holds any interest in or right over the said land.

Now, therefore, in pursuance of the powers conferred by the said Act, His Excellency the Administrator of the Government of the State of Victoria, by and with the advice of the Executive Council thereof, doth hereby authorize the said trustees for the time being of the said land, notwithstanding any trusts, conditions, restrictions, or limitations contained in any document of title concerning the said land, to transfer the said land to the municipality aforesaid.

SCHEDULE.

All that piece of land, being lot 190 on plan of subdivision No. 6219, lodged in the Office of Titles, and being part of Crown allotment 1, Parish of Minapre, and being the land comprised in certificate of title, volume 3780, folio 826.

And the Honorable Arthur Gordon Rylah, Her Majesty's Chief Secretary for the State of Victoria, shall give the necessary directions herein accordingly.

A. MAHLSTEDT,
Clerk of the Executive Council.

HOSPITALS AND CHARITIES ACT 1958 (No. 6274).—
SECTION 46.

*At the Executive Council Chamber, Melbourne, the
twenty-eighth day of March, 1961.*

PRESENT:

His Excellency the Administrator of the Government
of Victoria.

Sir Ewen Cameron	Mr. Mibus.
Mr. Fraser	

INCORPORATION OF WARANGA MEMORIAL
HOSPITAL.

WHEREAS a petition signed by not less than 25 contributors to Waranga Memorial Hospital, an institution capable of incorporation under the *Hospitals and Charities Act 1958*, praying that that institution be incorporated has been received by the Hospitals and Charities Commission:

And whereas the substance or prayer of the said petition has been published in the *Government Gazette*:

And whereas no counter petition signed by an equal or greater number of contributors to the said institution has been lodged with the Hospitals and Charities Commission within one month after the date of such publication:

Now therefore, His Excellency the Administrator of the Government of the State of Victoria, by and with the advice of the Executive Council thereof, doth hereby declare that the contributors for the time being to Waranga Memorial Hospital shall be a body corporate by the name of "Waranga Memorial Hospital".

And the Honorable Sir Ewen Paul Cameron, Her Majesty's Minister of Health for the State of Victoria, shall give the necessary directions herein accordingly.

A. MAHLSTEDT,
Clerk of the Executive Council.

HOSPITALS AND CHARITIES ACT 1958 (No. 6274).—
SECTION 52.

*At the Executive Council Chamber, Melbourne, the
twenty-eighth day of March, 1961.*

PRESENT:

His Excellency the Administrator of the Government
of Victoria.

Sir Ewen Cameron	Mr. Mibus.
Mr. Fraser	

EXTENSION OF THE OBJECTS OR PURPOSES OF
ECHUCA DISTRICT HOSPITAL.

WHEREAS Echuca District Hospital is an incorporated institution within the meaning of the *Hospitals and Charities Act 1958*:

And whereas the Committee of the said hospital has requested that the objects or purposes of the hospital should be extended:

And whereas the Hospitals and Charities Commission after inquiry and report has recommended that the objects or purposes of the said hospital should be extended:

Now therefore His Excellency the Administrator of the Government of the State of Victoria, by and with the advice of the Executive Council thereof, doth hereby extend the objects or purposes of Echuca District Hospital to include the following objects or purposes:—

To afford medical and surgical aid in cases of destitution or to other persons entitled thereto under the Act or in such circumstances as the Committee may determine.

To provide facilities for the treatment of intermediate and private patients or either of them.

To provide facilities for the carrying out of investigations into ailments, diseases, injuries or other matters affecting the human body.

To provide instruction and training facilities for nurses.

And the Honorable Sir Ewen Paul Cameron, Her Majesty's Minister of Health for the State of Victoria, shall give the necessary directions herein accordingly.

A. MAHLSTEDT,
Clerk of the Executive Council.

HOSPITALS AND CHARITIES ACT 1958 (No. 6274).—
SECTION 52.

*At the Executive Council Chamber, Melbourne, the
twenty-eighth day of March, 1961.*

PRESENT:

His Excellency the Administrator of the Government
of Victoria.

Sir Ewen Cameron	Mr. Mibus.
Mr. Fraser	

WHEREAS Ouyen and District Hospital is an incorporated institution within the meaning of the *Hospitals and Charities Act 1958*:

And whereas the Committee of the said hospital has requested that the objects or purposes of the hospital should be extended:

And whereas the Hospitals and Charities Commission after inquiry and report has recommended that the objects or purposes of the said hospital should be extended:

Now therefore His Excellency the Administrator of the Government of the State of Victoria, by and with the advice of the Executive Council thereof, doth hereby extend the objects or purposes of Ouyen and District Hospital to include the following objects or purposes:—

To provide facilities for the treatment of intermediate and private patients, or either of them.

And the Honorable Sir Ewen Paul Cameron, Her Majesty's Minister of Health for the State of Victoria, shall give the necessary directions herein accordingly.

A. MAHLSTEDT,
Clerk of the Executive Council.

HOSPITALS AND CHARITIES ACT 1958 (No. 6274).—
SECTION 52.

*At the Executive Council Chamber, Melbourne, the
twenty-eighth day of March, 1961.*

PRESENT:

His Excellency the Administrator of the Government
of Victoria.

Sir Ewen Cameron	Mr. Mibus.
Mr. Fraser	

EXTENSION OF THE OBJECTS OR PURPOSES OF
YARRAM AND DISTRICT HOSPITAL.

WHEREAS Yarram and District Hospital is an incorporated institution within the meaning of the *Hospitals and Charities Act 1958*:

And whereas the Committee of the said hospital has requested that the objects or purposes of the hospital should be extended:

And whereas the Hospitals and Charities Commission after inquiry and report has recommended that the objects or purposes of the said hospital should be extended:

Now therefore His Excellency the Administrator of the Government of the State of Victoria, by and with the advice of the Executive Council thereof, doth hereby extend the objects or purposes of Yarram and District Hospital to include the following objects or purposes:—

To afford surgical and medical aid to sick persons in destitute circumstances, or other persons entitled thereto under the Act.

To provide facilities for the treatment of intermediate and private patients or either of them.

And the Honorable Sir Ewen Paul Cameron, Her Majesty's Minister of Health for the State of Victoria, shall give the necessary directions herein accordingly.

A. MAHLSTEDT,
Clerk of the Executive Council.

HOSPITALS AND CHARITIES ACT 1958 (No. 6274).—
SECTION 46.

*At the Executive Council Chamber, Melbourne, the
twenty-eighth day of March, 1961.*

PRESENT:

His Excellency the Administrator of the Government
of Victoria.

Sir Ewen Cameron		Mr. Mibus.
Mr. Fraser		

INCORPORATION OF RUPANYUP AND DISTRICT
HOSPITAL.

WHEREAS a petition signed by not less than 25 contributors to Rupanyup and District Hospital, an institution capable of incorporation under the *Hospitals and Charities Act 1958*, praying that that institution be incorporated has been received by the Hospitals and Charities Commission:

And whereas the substance or prayer of the said petition has been published in the *Government Gazette*:

And whereas no counter petition signed by an equal or greater number of contributors to the said institution has been lodged with the Hospitals and Charities Commission within one month after the date of such publication:

Now therefore, His Excellency the Administrator of the Government of the State of Victoria, by and with the advice of the Executive Council thereof, doth hereby declare that the contributors for the time being to Rupanyup and District Hospital shall be a body corporate by the name of "Rupanyup and District Hospital".

And the Honorable Sir Ewen Paul Cameron, Her Majesty's Minister of Health for the State of Victoria, shall give the necessary directions herein accordingly.

A. MAHLSTEDT,
Clerk of the Executive Council.

HOSPITALS AND CHARITIES ACT 1958 (No. 6274).—
SECTION 46.

*At the Executive Council Chamber, Melbourne, the
twenty-eighth day of March, 1961.*

PRESENT:

His Excellency the Administrator of the Government
of Victoria.

Sir Ewen Cameron		Mr. Mibus.
Mr. Fraser		

INCORPORATION OF DIMBOOLA DISTRICT
HOSPITAL.

WHEREAS a petition signed by not less than 25 contributors to Dimboola District Hospital, an institution capable of incorporation under the *Hospitals and Charities Act 1958*, praying that that institution be incorporated has been received by the Hospitals and Charities Commission:

And whereas the substance or prayer of the said petition has been published in the *Government Gazette*:

And whereas no counter petition signed by an equal or greater number of contributors to the said institution has been lodged with the Hospitals and Charities Commission within one month after the date of such publication:

Now therefore, His Excellency the Administrator of the Government of the State of Victoria, by and with the advice of the Executive Council thereof, doth hereby declare that the contributors for the time being to Dimboola District Hospital shall be a body corporate by the name of "Dimboola District Hospital".

And the Honorable Sir Ewen Paul Cameron, Her Majesty's Minister of Health for the State of Victoria, shall give the necessary directions herein accordingly.

A. MAHLSTEDT,
Clerk of the Executive Council.

LOCAL GOVERNMENT ACT 1958.

*At the Executive Council Chamber, Melbourne, the
twenty-eighth day of March, 1961.*

PRESENT:

His Excellency the Administrator of the Government
of Victoria.

Sir Ewen Cameron		Mr. Mibus.
Mr. Fraser		

BREADTHS OF A CARRIAGEWAY AND FOOTWAYS
DECLARED.—CITY OF NORTHCOTE.

IN pursuance of the provisions of section 520 of the *Local Government Act 1958*, His Excellency the Administrator of the Government of the State of Victoria, by and with the advice of the Executive Council thereof, and in compliance with a request of the Council of the City of Northcote, orders as follows:—

(1) The breadths of the carriageway and footways of that portion of Tharratt-street, between Collins and Pender streets, fixed and declared by an Order published in the *Government Gazette* on the 10th August, 1960, shall be altered; and

(2) the breadths of the carriageway and footways for the whole length of the said Tharratt-street—between Dundas-street and Flinders-street—are hereby fixed and declared to be the following:—

Width of footways on both sides—21 ft. 6 in.
Width of carriageway—23 feet.

And the Honorable Murray Victor Porter, Her Majesty's Minister for Local Government for the State of Victoria, shall give the necessary directions herein accordingly.

A. MAHLSTEDT,
Clerk of the Executive Council.

LOCAL GOVERNMENT ACT 1958.

*At the Executive Council Chamber, Melbourne, the
twenty-eighth day of March, 1961.*

PRESENT:

His Excellency the Administrator of the Government
of Victoria.

Sir Ewen Cameron		Mr. Mibus.
Mr. Fraser		

ROAD DISCONTINUED.—CITY OF CAMBERWELL.

WHEREAS it is provided in section 528 (2) of the *Local Government Act 1958* that where a road (whether or not a public highway but not being a road set out on land of the Crown) or any part thereof is not required for public use, the Governor in Council, on the request of the council of the municipality in which such road is situated, made not less than one month after publishing in a newspaper generally circulating in the district and posting to the registered proprietor (if any) of the land and any person known to have an interest in the land, notice of intention to make such a request, may, by Order published in the *Government Gazette*, direct that such road or part shall be discontinued and thereupon such road or part shall be discontinued accordingly:

And whereas the Council of the City of Camberwell has requested that the Governor in Council direct that the road described hereunder be discontinued, and, not less than one month previously, has published in a newspaper generally circulating in the district and posted to the registered proprietors of the land described hereunder and to all persons known to have an interest in the said road notice of intention to make such request:

Now, therefore, His Excellency the Administrator of the Government of the State of Victoria, by and with the advice of the Executive Council thereof, hereby directs that the road described hereunder shall be discontinued, and that the land and soil thereof may be sold by the Council of the City of Camberwell in such manner as the Council shall direct:—

The eastern 120 feet of a road 10 feet in width, between Victoria and Hopetoun avenues, in the municipal district of the City of Camberwell, being a road set out on lodged plan of subdivision No. 4100, and having its southern alignment parallel to and distant 170 feet from Canterbury-road.

And the Honorable Murray Victor Porter, Her Majesty's Minister for Local Government for the State of Victoria, shall give the necessary directions herein accordingly.

A. MAHLSTEDT,
Clerk of the Executive Council.

COUNTRY ROADS BOARD.

At the Executive Council Chamber, Melbourne, the twenty-eighth day of March, 1961.

PRESENT:

His Excellency the Administrator of the Government of Victoria.

Sir Ewen Cameron | Mr. Mibus.
Mr. Fraser

ORDER APPROVING OF WIDENING AN EXISTING MAIN ROAD IN THE SHIRE OF ALBERTON.

WHEREAS the Country Roads Board constituted under the *Country Roads Act 1958* (No. 6229) has represented to His Excellency the Governor in Council that it appears to it desirable that the existing Bulga Park-road in the Shire of Alberton (declared to be a main road under the said Act which declarations was confirmed by the Order in Council published in the *Government Gazette* of the 10th September, 1952, on page 5305) should be widened by the said Board: And whereas the said Board in accordance with the requirements of section 19 of the said cited Act has caused to be prepared a map plan and estimate showing the points between which and on and through what land the said widening is proposed to be made and the cost of acquiring the land: And whereas on an inspection of the said map and plan and a consideration of the said estimate His Excellency the Governor in Council is satisfied that there are funds legally available for acquiring the land: Now therefore be it known by this present Order that His Excellency the Administrator of the Government of the State of Victoria with the advice of the Executive Council thereof doth hereby approve of the said road being widened, that is to say:—

All that piece of land in the Parish of Wonwron, the boundaries of which are as follow:—Commencing at a point on the northern boundary of allotment 71 of the said parish distant 228 deg. 56 min. 2,799 links and 224 deg. 49 min. 3,802.1 links from the north-eastern angle of the said allotment; thence by lines bearing respectively 212 deg. 50 min. 571.9 links, 192 deg. 40 min. 397.4 links, 359 deg. 0 min. 460.5 links, and 44 deg. 49 min. 574.9 links to the point of commencement—which said piece of land is particularly delineated and shown coloured red on survey plan numbered 7794, lodged in the office of the Country Roads Board.

And the Honorable Sir Thomas Karran Maltby, Her Majesty's Commissioner of Public Works for the State of Victoria, shall give the necessary directions herein accordingly.

A. MAHLSTEDT,
Clerk of the Executive Council.

COUNTRY ROADS BOARD.

At the Executive Council Chamber, Melbourne, the twenty-eighth day of March, 1961.

PRESENT:

His Excellency the Administrator of the Government of Victoria.

Sir Ewen Cameron | Mr. Mibus.
Mr. Fraser

ORDER APPROVING OF WIDENING AN EXISTING MAIN ROAD IN THE SHIRE OF HEALESVILLE.

WHEREAS the Country Roads Board constituted under the *Country Roads Act 1958* (No. 6229) has represented to His Excellency the Governor in Council that it appears to it desirable that the existing Badger Creek-road in the Shire of Healesville (declared to be a main road under the said Act which declarations was confirmed by the Order in Council published in the *Government Gazette* of the 19th February, 1941, on page 910) should be widened by the said Board: And whereas the said Board in accordance with the requirements of section 19 of the said cited Act has caused to be prepared a map plan and estimate showing the points between which and on and through what land the said widening is proposed to be made and the cost of acquiring the land: And whereas on an inspection of the said map and plan and a consideration of the said estimate His Excellency the Governor in Council is satisfied that there are funds legally available for acquiring the land: Now therefore be it known by this present Order that His Excellency the Administrator of the Government of the State of Victoria with the advice of the Executive Council thereof doth hereby approve of the said road being widened, that is to say:—

All that piece of land in the Parish of Gracedale, the boundaries of which are as follow:—Commencing at the south-western angle of allotment 106 of the said parish; thence by lines bearing respectively 315 deg. 19 min. 289 ft. 9 in., 295 deg. 28 min. 245 ft. 2 in., 343 deg. 38 min. 93 ft. 8 in., 48 deg. 28 min. 174 ft. 1½ in., 64 deg. 47 min. 96 ft. 2 in., 181 deg. 11½ min. 200 feet, 157 deg. 57 min. 200 feet, 127 deg. 26 min. 200 feet, 100 deg. 22 min. 184 ft. 8 in., and 264 deg. 20 min. 178 feet to the point of commencement—which said piece of land is particularly delineated and shown coloured red on survey plan numbered 7871, lodged in the office of the Country Roads Board.

And the Honorable Sir Thomas Karran Maltby, Her Majesty's Commissioner of Public Works for the State of Victoria, shall give the necessary directions herein accordingly.

A. MAHLSTEDT,
Clerk of the Executive Council.

COUNTRY ROADS BOARD.

At the Executive Council Chamber, Melbourne, the twenty-eighth day of March, 1961.

PRESENT:

His Excellency the Administrator of the Government of Victoria.

Sir Ewen Cameron | Mr. Mibus.
Mr. Fraser

ORDER APPROVING OF WIDENING AN EXISTING MAIN ROAD IN THE SHIRE OF WANGARATTA.

WHEREAS the Country Roads Board constituted under the *Country Roads Act 1958* (No. 6229) has represented to His Excellency the Governor in Council that it appears to it desirable that the existing Boorhaman-road in the Shire of Wangaratta (declared to be a main road under the said Act which declarations was confirmed by the Order in Council published in the *Government Gazette* of the 12th March, 1941, on page 1248) should be widened by the said Board: And whereas the said Board in accordance with the requirements of section 19 of the said cited Act has caused to be prepared a map plan and estimate showing the points between which and on and through what land the said widening is proposed to be made and the cost of acquiring the land: And whereas on an inspection of the said map and plan and a consideration of the said estimate His

Excellency the Governor in Council is satisfied that there are funds legally available for acquiring the land: Now therefore be it known by this present Order that His Excellency the Administrator of the Government of the State of Victoria with the advice of the Executive Council thereof doth hereby approve of the said road being widened, that is to say:—

All that piece of land in the Parish of Boorhaman, the boundaries of which are as follow:—Commencing at the western angle of allotment 80A of the said parish; thence by lines bearing respectively 352 deg. 8 min. 465.8 links, 158 deg. 32 min. 711.2 links, and 315 deg. 40 min. 280.4 links to the point of commencement—which said piece of land is particularly delineated and shown coloured red on survey plan numbered 7823, lodged in the office of the Country Roads Board.

And the Honorable Sir Thomas Karran Maltby, Her Majesty's Commissioner of Public Works for the State of Victoria, shall give the necessary directions herein accordingly.

A. MAHLSTEDT,
Clerk of the Executive Council.

COUNTRY ROADS BOARD.

At the Executive Council Chamber, Melbourne, the twenty-eighth day of March, 1961.

PRESENT:

His Excellency the Administrator of the Government of Victoria.

Sir Ewen Cameron | Mr. Mibus.
Mr. Fraser

ORDER APPROVING OF WIDENING AN EXISTING STATE HIGHWAY IN THE CITY OF BROADMEADOWS.

WHEREAS the Country Roads Board constituted under the *Country Roads Act 1958* (No. 6229) has represented to His Excellency the Governor in Council that it appears to it desirable that the existing Hume Highway in the City of Broadmeadows (declared to be a State highway under the said Act which declaration was confirmed by the Order in Council published in the *Government Gazette* of the 8th July, 1925, on page 2371) should be widened by the said Board: And whereas the said Board in accordance with the requirements of section 19 of the said cited Act has caused to be prepared a map plan and estimate showing the points between which and on and through what land the said widening is proposed to be made and the cost of acquiring the land: And whereas on an inspection of the said map and plan and a consideration of the said estimate His Excellency the Governor in Council is satisfied that there are funds legally available for acquiring the land: Now therefore be it known by this present Order that His Excellency the Administrator of the Government of the State of Victoria with the advice of the Executive Council thereof doth hereby approve of the said highway being widened, that is to say:—

All that piece of land in the Parish of Will Will Rook, the boundaries of which are as follow:—Commencing at the north-western angle of the land comprised in certificate of title, volume 8044, folio 786, registered at the Office of Titles, and being part of Crown portion 13 of the said parish; thence by lines bearing respectively 90 deg. 4 min. 14 ft. 7 in., 164 deg. 3 min. 627 ft. 6 in., 169 deg. 13 min. 68 ft. 10½ in., 254 deg. 4 min. 12 ft. 10½ in., 348 deg. 16 min. 68 ft. 9½ in., and 344 deg. 3 min. 631 ft. 6 in. to the point of commencement—which said piece of land is particularly delineated and shown coloured red on survey plan numbered 7879, lodged in the office of the Country Roads Board.

And the Honorable Sir Thomas Karran Maltby, Her Majesty's Commissioner of Public Works for the State of Victoria, shall give the necessary directions herein accordingly.

A. MAHLSTEDT,
Clerk of the Executive Council.

COUNTRY ROADS BOARD.

At the Executive Council Chamber, Melbourne, the twenty-eighth day of March, 1961.

PRESENT:

His Excellency the Administrator of the Government of Victoria.

Sir Ewen Cameron | Mr. Mibus.
Mr. Fraser

ORDER APPROVING OF WIDENING AN EXISTING STATE HIGHWAY IN THE CITY OF DANDENONG.

WHEREAS the Country Roads Board constituted under the *Country Roads Act 1958* (No. 6229) has represented to His Excellency the Governor in Council that it appears to it desirable that the existing Princes Highway in the City of Dandenong (declared to be a State highway under the said Act which declaration was confirmed by the Order in Council published in the *Government Gazette* of the 11th December, 1935, on page 3245) should be widened by the said Board: And whereas the said Board in accordance with the requirements of section 19 of the said cited Act has caused to be prepared a map plan and estimate showing the points between which and on and through what land the said widening is proposed to be made and the cost of acquiring the land: And whereas on an inspection of the said map and plan and a consideration of the said estimate His Excellency the Governor in Council is satisfied that there are funds legally available for acquiring the land: Now therefore be it known by this present Order that His Excellency the Administrator of the Government of the State of Victoria with the advice of the Executive Council thereof doth hereby approve of the said highway being widened, that is to say:—

All that piece of land in the Parish of Eumemmerring, the boundaries of which are as follow:—Commencing at the south-western angle of lot 127 on plan of subdivision numbered 10380, lodged in the Office of Titles, and being part of allotment 7, section 25, of the said parish; thence by lines bearing respectively 295 deg. 42 min. 57 ft. 11 in., 359 deg. 33 min. 15 feet, 142 deg. 52 min. 16 ft. 0½ in., 106 deg. 11 min. 44 ft. 3 in., 104 deg. 38 min. 56 ft. 11½ in., and 269 deg. 22 min. 55 feet to the point of commencement—which said piece of land is particularly delineated and shown coloured red on survey plan numbered 7854, lodged in the office of the Country Roads Board.

And the Honorable Sir Thomas Karran Maltby, Her Majesty's Commissioner of Public Works for the State of Victoria, shall give the necessary directions herein accordingly.

A. MAHLSTEDT,
Clerk of the Executive Council.

COUNTRY ROADS BOARD.

At the Executive Council Chamber, Melbourne, the twenty-eighth day of March, 1961.

PRESENT:

His Excellency the Administrator of the Government of Victoria.

Sir Ewen Cameron | Mr. Mibus.
Mr. Fraser

DECLARATION OF A DEVIATION FROM THE GLENELG HIGHWAY IN THE SHIRE OF GRENVILLE.

WHEREAS by sections 74 and 58 of the *Country Roads Act 1958* (No. 6229) it is amongst other things enacted that when the Country Roads Board under the provisions of the Country Roads Act has by Resolution declared a deviation to be a State highway the said Board may also declare that such deviation shall be in lieu of any existing highway or part thereof named in such Resolution and that on publication in the *Government Gazette* of the Order confirming such Resolution the existing highway or part thereof shall cease to be a State highway or be discontinued as provided in the Resolution: And whereas the said Board has by Resolution declared the deviation on the land described in the First Schedule to such Resolution to be a State highway and has also declared that such deviation shall be in lieu of the part of the existing highway being the land described in the Second Schedule to the said Resolution

and that such part of the said existing highway shall be discontinued: Now therefore His Excellency the Administrator of the Government of the State of Victoria by and with the advice of the Executive Council thereof doth hereby confirm the said Resolution.

Resolution for Declaration of a Deviation of a State Highway under the Country Roads Act.

Whereas the land the site of the highway the course of which is below set out was taken by the Board under the provisions of the *Country Roads Act 1958* for the purpose of constructing such highway deviation which highway deviation has now been laid out and formed on the same: And whereas the said Board (being the Country Roads Board incorporated under the said Act) thinks that the highway aforesaid is fit to be used as a public highway such Board at a meeting now holden acting under the authority conferred upon it by sections 74 and 58 of the said Act doth by this present Resolution hereby declare the said highway deviation the course of which is described in the First Schedule hereto with the commencing and terminating points thereof respectively specified to be part of a State highway within the meaning and for the purposes of the *Country Roads Act 1958*: And the said Board doth also declare that such deviation shall be in lieu of the existing highway or part thereof described in the Second Schedule hereto and that such part of the said existing highway shall be discontinued.

FIRST SCHEDULE.
Shire of Grenville.

17. *Glenelg Highway*.—All those pieces of land in the Parish of Argyle, the boundaries of which are as follow:—

- (a) Commencing at the north-western angle of allotment D3 of the said parish; thence by lines bearing respectively 74 deg. 42 min. 350 links, 77 deg. 1 min. 1,706 links, 95 deg. 33 min. 999.9 links, 220 deg. 47 min. 183.5 links, 272 deg. 36 min. 794.2 links, 260 deg. 12 min. 728.1 links, 256 deg. 58½ min. 2,871.2 links, 260 deg. 52 min. 119.7 links, 295 deg. 23 min. 249.9 links, 79 deg. 15 min. 347 links, 77 deg. 1 min. 1,370.4 links and 71 deg. 10 min. 106.2 links to the point of commencement.
- (b) Commencing at the north-western angle of allotment 83 of the said parish; thence by lines bearing respectively 95 deg. 43 min. 974 links, 123 deg. 2 min. 909.1 links, 297 deg. 32 min. 861.8 links, 283 deg. 24 min. 550.2 links, 274 deg. 47 min. 458.2 links and 40 deg. 47 min. 37.7 links to the point of commencement—

which said pieces of land are particularly delineated and shown coloured red on survey plan numbered 7529, lodged in the office of the Country Roads Board.

SECOND SCHEDULE.
Shire of Grenville.

17. *Glenelg Highway*.—All that piece of land in the Parish of Argyle, the boundaries of which are as follow:—Commencing at the north-eastern angle of allotment 90 of the said parish; thence by lines bearing respectively 220 deg. 17 min. 839 links, 248 deg. 33 min. 173 links, 260 deg. 16 min. 1,480 links, 279 deg. 43 min. 1,407 links, 295 deg. 38 min. 1,004 links, 81 deg. 56 min. 270.4 links, 115 deg. 38 min. 758.2 links, 99 deg. 43 min. 756 links, 104 deg. 57 min. 100.8 links, 98 deg. 41 min. 504 links, 80 deg. 16 min. 1,439 links, 68 deg. 33 min. 120 links, 40 deg. 17 min. 801.2 links and 130 deg. 17 min. 150 links to the point of commencement—which said piece of land is particularly delineated and shown coloured blue on survey plan numbered 7529, lodged in the office of the Country Roads Board.

The common seal of the Country Roads Board was hereto affixed, at Kew, this twentieth day of March, One thousand nine hundred and sixty-one, in the presence of—

(SEAL) D. V. DARWIN, Chairman.
W. H. NEVILLE, Member.
N. L. ALLANSON, Acting Secretary.

And the Honorable Sir Thomas Karran Maltby, Her Majesty's Commissioner of Public Works for the State of Victoria, shall give the necessary directions herein accordingly.

A. MAHLSTEDT,
Clerk of the Executive Council.

COUNTRY ROADS BOARD.

At the Executive Council Chamber, Melbourne, the twenty-eighth day of March, 1961.

PRESENT:

His Excellency the Administrator of the Government of Victoria.

Sir Ewen Cameron | Mr. Mibus.
Mr. Fraser

ORDER APPROVING OF WIDENING AN EXISTING STATE HIGHWAY IN THE SHIRE OF FERN TREE GULLY.

WHEREAS the Country Roads Board constituted under the *Country Roads Act 1958* (No. 6229) has represented to His Excellency the Governor in Council that it appears to it desirable that the existing Burwood Highway in the Shire of Fern Tree Gully (declared to be a State highway under the said Act which declaration was confirmed by the Order in Council published in the *Government Gazette* of the 10th August, 1960, on pages 2743-6) should be widened by the said Board: And whereas the said Board in accordance with the requirements of section 19 of the said cited Act has caused to be prepared a map plan and estimate showing the points between which and on and through what land the said widening is proposed to be made and the cost of acquiring the land: And whereas on an inspection of the said map and plan and a consideration of the said estimate His Excellency the Governor in Council is satisfied that there are funds legally available for acquiring the land: Now therefore be it known by this present Order that His Excellency the Administrator of the Government of the State of Victoria with the advice of the Executive Council thereof doth hereby approve of the said highway being widened, that is to say:—

All those pieces of land in the Parish of Scoresby, the boundaries of which are as follow:—

- (a) Commencing at the south-western angle of lot 11 on plan of subdivision numbered 10471, lodged in the Office of Titles, and being part of allotment 53A of the said parish; thence by lines bearing respectively 2 deg. 40 min. 15 feet, 158 deg. 39 min. 27 ft. 5 in., and 314 deg. 38 min. 15 feet to the point of commencement.
- (b) Commencing at the southern angle of lot 7 on plan of subdivision numbered 10471, lodged in the Office of Titles, and being part of allotment 53A of the said parish; thence by lines bearing respectively 314 deg. 38 min. 15 feet, 89 deg. 38 min. 21 ft. 2½ in., and 224 deg. 38 min. 15 feet to the point of commencement.
- (c) Commencing at the western angle of lot 6 on plan of subdivision numbered 10471, lodged in the Office of Titles, and being part of allotment 53A of the said parish; thence by lines bearing respectively 44 deg. 38 min. 15 feet, 179 deg. 38 min. 21 ft. 2½ in., and 314 deg. 38 min. 15 feet to the point of commencement.
- (d) Commencing at the south-eastern angle of lot 1, block A, on plan of subdivision numbered 1437, lodged in the Office of Titles, and being part of allotment 53 of the said parish; thence by lines bearing respectively 314 deg. 35 min. 95 feet, 113 deg. 15 min. 22 feet, 83 deg. 45 min. 22 feet, 27 deg. 39 min. 67 ft. 2 in., and 182 deg. 40 min. 120 feet to the point of commencement.
- (e) Commencing at the south-eastern angle of lot 5 on plan of subdivision numbered 17274, lodged in the Office of Titles, and being part of allotment 53 of the said parish; thence by lines bearing respectively 288 deg. 50 min. 15 feet, 55 deg. 45 min. 18 ft. 0¼ in., and 182 deg. 40 min. 15 feet to the point of commencement.
- (f) Commencing at the south-western angle of lot 10, block F, on plan of subdivision numbered 1437, lodged in the Office of Titles, and being part of allotment 53 of the said parish; thence by lines bearing respectively 2 deg. 31 min. 15 feet, 145 deg. 40½ min. 24 feet, and 288 deg. 50 min. 15 feet to the point of commencement.
- (g) Commencing at the south-eastern angle of lot 9 on plan of subdivision numbered 12289, lodged in the Office of Titles, and being part of allotment 53 of the said parish; thence by lines bearing respectively 288 deg. 50 min. 14 feet, 53 deg. 2 min. 17 ft. 5 in., and 182 deg. 31 min. 15 feet to the point of commencement.

- (h) Commencing at a point on the northern boundary of Crown portion 50 of the said parish distant 108 deg. 52 min. 261 ft. 7½ in. from an angle in the said boundary formed by the intersection of lines bearing 81 deg. 1 min. and 108 deg. 52 min.; thence by lines bearing respectively 108 deg. 52 min. 15 feet, 197 deg. 28 min. 15 feet, and 333 deg. 10 min. 21 ft. 5¼ in. to the point of commencement.
- (i) Commencing at a point on the northern boundary of lot 1 on plan of subdivision numbered 11069, lodged in the Office of Titles, and being part of Crown portion 50 of the said parish the said point being distant 288 deg. 52 min. 50 feet from the north-eastern angle of the said lot; thence by lines bearing respectively 243 deg. 10 min. 20 ft. 11½ in., 17 deg. 28 min. 8 feet, 63 deg. 10 min. 9 ft. 11 in., and 108 deg. 52 min. 8 feet to the point of commencement.
- (j) Commencing at the north-eastern angle of lot 4 on plan of subdivision numbered 19850, lodged in the Office of Titles, and being part of Crown portion 50 of the said parish; thence by lines bearing respectively 192 deg. 50 min. 15 feet, 343 deg. 42½ min. 26 ft. 2½ in., and 134 deg. 35 min. 15 feet to the point of commencement.
- (k) Commencing at a point on the north-eastern boundary of Crown portion 50 of the said parish distant 314 deg. 35 min. 826 ft. 6 in. from an angle in the said boundary formed by the intersection of lines bearing 134 deg. 35 min. and 142 deg. 16 min.; thence by lines bearing respectively 268 deg. 39½ min. 20 ft. 10½ in., 42 deg. 44 min. 15 feet, and 134 deg. 35 min. 15 feet to the point of commencement—

which said pieces of land are particularly delineated and shown coloured red on survey plans numbered 7760 to 7768 (both inclusive), lodged in the office of the Country Roads Board.

And the Honorable Sir Thomas Karran Maltby, Her Majesty's Commissioner of Public Works for the State of Victoria, shall give the necessary directions herein accordingly.

A. MAHLSTEDT,
Clerk of the Executive Council.

COUNTRY ROADS BOARD.

At the Executive Council Chamber, Melbourne, the twenty-eighth day of March, 1961.

PRESENT:

His Excellency the Administrator of the Government of Victoria.

Sir Ewen Cameron		Mr. Mibus.
Mr. Fraser		

ORDER APPROVING OF WIDENING AN EXISTING STATE HIGHWAY IN THE SHIRE OF TOWONG.

WHEREAS the Country Roads Board constituted under the *Country Roads Act* 1958 (No. 6229) has represented to His Excellency the Governor in Council that it appears to it desirable that the existing Murray Valley Highway in the Shire of Towong (declared to be a State highway under the said Act which declaration was confirmed by the Order in Council published in the *Government Gazette* of the 15th February, 1933, on page 660) should be widened by the said Board: And whereas the said Board in accordance with the requirements of section 19 of the said cited Act has caused to be prepared a map plan and estimate showing the points between which and on and through what land the said widening is proposed to be made and the cost of acquiring the land: And whereas on an inspection of the said map and plan and a consideration of the said estimate His Excellency the Governor in Council is satisfied that there are funds legally available for acquiring the land: Now therefore be it known by this present Order that His Excellency the Administrator of the Government of the State of Victoria with the advice of the Executive Council thereof doth hereby approve of the said highway being widened, that is to say:—

All those pieces of land in the Parish of Bungil, the boundaries of which are as follow:—

- (a) Commencing at a point in allotment 5, section 1, of the said parish distant 81 deg. 26 min. 528.2 links and 232 deg. 18 min. 321.5 links

from the north-western angle of the said allotment; thence by lines bearing respectively 213 deg. 59 min. 292.4 links, 24 deg. 56 min. 200 links and 52 deg. 18 min. 100 links to the point of commencement.

- (b) Commencing at an angle in the eastern boundary of the existing Murray Valley Highway through allotment 5, section 1, of the said parish, formed by the intersection of lines bearing 202 deg. 48 min. and 175 deg. 15 min.; thence by lines bearing respectively 22 deg. 48 min. 412.5 links, 44 deg. 28 min. 61.3 links, 198 deg. 24 min. 603.5 links, and 355 deg. 15 min. 149.1 links to the point of commencement—

which said pieces of land are particularly delineated and shown coloured red on survey plan numbered 7828, lodged in the office of the Country Roads Board.

And the Honorable Sir Thomas Karran Maltby, Her Majesty's Commissioner of Public Works for the State of Victoria, shall give the necessary directions herein accordingly.

A. MAHLSTEDT,
Clerk of the Executive Council.

COUNTRY ROADS BOARD.

At the Executive Council Chamber, Melbourne, the twenty-eighth day of March, 1961.

PRESENT:

His Excellency the Administrator of the Government of Victoria.

Sir Ewen Cameron		Mr. Mibus.
Mr. Fraser		

DECLARATION OF THE WIDENING OF THE NATIMUK—HAMILTON ROAD, NHILL—JEPARIT ROAD AND WARRACKNABEAL—RAINBOW ROAD IN THE SHIRES OF ARAFILES AND DIMBOOLA RESPECTIVELY.

WHEREAS by section 21 of the *Country Roads Act* 1958 (No. 6229) it is amongst other things enacted that when the Country Roads Board under the provisions of the *Country Roads Act* has taken the land necessary for constructing the road or deviation or widening it shall as soon as it thinks such road or deviation or widening is fit to be used as a public highway by Resolution declare the road or deviation or widening to be a main road or part thereof and that upon publication in the *Government Gazette* of the Order of the Governor in Council confirming such Resolution such road or deviation or widening shall thereupon be a main road or a part thereof within the meaning of the said Act: And whereas the said Board has by Resolution declared the roads on the land described in the Schedules to such Resolution to be parts of main roads: Now therefore His Excellency the Administrator of the Government of the State of Victoria by and with the advice of the Executive Council thereof doth hereby confirm the said Resolution.

Resolution for Declaration of the Widening of Main Roads under the Country Roads Act.

Whereas the land the sites of the roads the courses of which are below set out was taken by the Board under the provisions of the *Country Roads Act* for the purpose of widening the main roads aforesaid which widenings have now been laid out and formed on the same: And whereas the said Board (being the Country Roads Board incorporated under the said Act) thinks that the widenings aforesaid are fit to be used as parts of public highways such Board at a meeting now holden doth by this Resolution hereby declare the same as described in the Schedules hereto with the commencing and terminating points thereof respectively specified to be parts of the main roads within the meaning and for the purposes of the *Country Roads Act*.

SCHEDULE.

Shire of Arapiles.

4. *Natimuk—Hamilton road* (304).—All that piece of land in the Parish of Darragan, the boundaries of which are as follow:—

Commencing at the south-western angle of allotment 14 of the said parish; thence by lines bearing respectively 0 deg. 1 min. 1,401 links, 343 deg. 3 min. 208 links, 140 deg. 32 min. 552 links, 169 deg. 3½ min. 493.2 links, 202 deg. 24 min. 746 links and 270 deg. 0 min. 100 links to the point of commencement.

Also, all that piece of land in the Parish of Lowan, the boundaries of which are as follow:—

Commencing at a point on the northern boundary of allotment 35c of the said parish, distant 270 deg. 0 min. 148.8 links from the north-eastern angle of the said allotment; thence by the arc of a circle of radius 3,830 links a distance of 1,071.8 links, the chord of which arc bears 171 deg. 58 min.; thence by lines bearing respectively 179 deg. 58 min. 1.136 links, 335 deg. 35½ min. 1.226.2 links, 352 deg. 25 min. 1.087 links and 90 deg. 0 min. 500 links to the point of commencement—

which said pieces of land are particularly delineated and shown coloured red on survey plan numbered 6762, lodged in the office of the Country Roads Board.

SCHEDULE.

Shire of Dimboola.

9. *Nhill-Jeparit road* (4609).—All that piece of land in the Parish of Ni Ni the boundaries of which are as follow:—

Commencing at the north-eastern angle of allotment 134A of the said parish; thence by lines bearing respectively 150 deg. 55 min. 346.3 links, 179 deg. 57 min. 492.6 links, 352 deg. 1 min. 483.4 links and 342 deg. 12 min. 332.4 links to the point of commencement.

Also, all that piece of land in the Parish of Tullyvea, the boundaries of which are as follow:—

Commencing at the south-western angle of allotment 27 of the said parish; thence by lines bearing respectively 331 deg. 5 min. 343.3 links, 360 deg. 0 min. 482.7 links, 172 deg. 36 min. 400.3 links and 163 deg. 30 min. 402.8 links to the point of commencement—

which said pieces of land are particularly delineated and shown coloured red on survey plan numbered 7059, lodged in the office of the Country Roads Board.

SCHEDULE.

Shire of Dimboola.

10. *Warracknabeal-Rainbow road* (4610).—All that piece of land in the Parish of Kenmare, the boundaries of which are as follow:—Commencing at the south-western angle of allotment 36 of the said parish; thence by lines bearing respectively 360 deg. 0 min. 1,449 links, 164 deg. 45 min. 783.5 links, 134 deg. 49 min. 697.6 links, 105 deg. 52 min. 731.6 links and 269 deg. 56½ min. 1,404.6 links to the point of commencement—which said piece of land is particularly delineated and shown coloured red on survey plan numbered 7285, lodged in the office of the Country Roads Board.

The common seal of the Country Roads Board was hereto affixed, at Kew, this twentieth day of March, One thousand nine hundred and sixty-one, in the presence of—

(SEAL) D. V. DARWIN, Chairman.
W. H. NEVILLE, Member.
N. L. ALLANSON, Acting Secretary.

And the Honorable Sir Thomas Karran Maltby, Her Majesty's Commissioner of Public Works for the State of Victoria, shall give the necessary directions herein accordingly.

A. MAHLSTEDT,
Clerk of the Executive Council.

COUNTRY ROADS BOARD.

At the Executive Council Chamber, Melbourne, the twenty-eighth day of March, 1961.

PRESENT:

His Excellency the Administrator of the Government of Victoria.

Sir Ewen Cameron | Mr. Mibus.
Mr. Fraser |

DECLARATION OF THE WIDENING OF PYRENEES HIGHWAY AND WARBURTON HIGHWAY IN THE CITY OF ARARAT AND THE SHIRE OF UPPER YARRA RESPECTIVELY.

WHEREAS by sections 21 and 74 of the *Country Roads Act* 1958 (No. 6229) it is amongst other things enacted that when the Country Roads Board under the

provisions of the Country Roads Act has taken the land necessary for constructing the highway or deviation or widening it shall as soon as it thinks such highway or deviation or widening is fit to be used as a public highway by Resolution declare the highway or deviation or widening to be a State highway or part thereof and that upon publication in the *Government Gazette* of the Order of the Governor in Council confirming such Resolution such highway or deviation or widening shall thereupon be a State highway or a part thereof within the meaning of the said Act: And whereas the said Board has by Resolution declared the highways on the land described in the Schedules to such Resolution to be parts of State highways: Now therefore His Excellency the Administrator of the Government of the State of Victoria by and with the advice of the Executive Council thereof doth hereby confirm the said Resolution.

Resolution for Declaration of the Widening of State Highways under the Country Roads Act.

Whereas the land the sites of the highways the courses of which are below set out was taken by the Board under the provisions of the Country Roads Act for the purpose of widening the State highways aforesaid which widenings have now been laid out and formed on the same: And whereas the said Board (being the Country Roads Board incorporated under the said Act) thinks that the widenings aforesaid are fit to be used as parts of public highways such Board at a meeting now holden doth by this Resolution hereby declare the same as described in the Schedules hereto with the commencing and terminating points thereof respectively specified to be parts of the State highways within the meaning and for the purposes of the Country Roads Act.

SCHEDULE.

City of Ararat.

24. *Pyrenees Highway*.—All that piece of land in the Town and Parish of Ararat, the boundaries of which are as follow:—Commencing at the north-western angle of allotment 4, section 59 of the said town; thence by lines bearing respectively 90 deg. 0 min. 225.1 links, 225 deg. 18½ min. 854.5 links, 304 deg. 4 min. 19.9 links and 34 deg. 4 min. 712 links to the point of commencement—which said piece of land is particularly delineated and shown coloured red on survey plan numbered 7131, lodged in the office of the Country Roads Board.

SCHEDULE.

Shire of Upper Yarra.

30. *Warburton Highway*.—All that piece of land in the Parish of Warburton, the boundaries of which are as follow:—Commencing at a point on the northern boundary of allotment 4e of the said parish, distant 81 deg. 57 min. 199.1 links from the north-western angle of the said allotment; thence by lines bearing respectively 81 deg. 57 min. 83.9 links, 98 deg. 43 min. 399 links, 101 deg. 36 min. 208 links, 88 deg. 57 min. 227 links, 89 deg. 19 min. 256.6 links, 258 deg. 27 min. 123.2 links, 266 deg. 18 min. 218.2 links, 271 deg. 27 min. 149.4 links, 277 deg. 41 min. 204.1 links, 279 deg. 6 min. 152.5 links, 294 deg. 40 min. 107.6 links, 261 deg. 46 min. 115.2 links, 316 deg. 13 min. 43.2 links and 272 deg. 11 min. 122.9 links to the point of commencement—which said piece of land is particularly delineated and shown coloured red and yellow on survey plan numbered 5752, lodged in the office of the Country Roads Board.

The common seal of the Country Roads Board was hereto affixed, at Kew, this twentieth day of March, One thousand nine hundred and sixty-one, in the presence of—

(SEAL) D. V. DARWIN, Chairman.
W. H. NEVILLE, Member.
N. L. ALLANSON, Acting Secretary.

And the Honorable Sir Thomas Karran Maltby, Her Majesty's Commissioner of Public Works for the State of Victoria, shall give the necessary directions herein accordingly.

A. MAHLSTEDT,
Clerk of the Executive Council.

COUNTRY ROADS BOARD.

At the Executive Council Chamber, Melbourne, the
twenty-eighth day of March, 1961.

PRESENT:

His Excellency the Administrator of the Government
of Victoria.

Sir Ewen Cameron | Mr. Mibus.
Mr. Fraser |

DECLARATION OF THE WIDENING OF
DAYLESFORD-TRENTHAM ROAD, DIGGERS REST-
COIMADAI ROAD AND WARRACKNABEAL-
RAINBOW ROAD IN THE SHIRES OF GLENLYON,
MELTON AND WARRACKNABEAL RESPECTIVELY.

WHEREAS by section 21 of the *Country Roads Act* 1958 (No. 6229) it is amongst other things enacted that when the Country Roads Board under the provisions of the Country Roads Act has taken the land necessary for constructing the road or deviation or widening it shall as soon as it thinks such road or deviation or widening is fit to be used as a public highway by Resolution declare the road or deviation or widening to be a main road or part thereof and that upon publication in the *Government Gazette* of the Order of the Governor in Council confirming such Resolution such road or deviation or widening shall thereupon be a main road or a part thereof within the meaning of the said Act: And whereas the said Board has by Resolution declared the roads on the land described in the Schedules to such Resolution to be parts of main roads: Now therefore His Excellency the Administrator of the Government of the State of Victoria by and with the advice of the Executive Council thereof doth hereby confirm the said Resolution.

Resolution for Declaration of the Widening of Main
Roads under the Country Roads Act.

Whereas the land sites of the roads the courses of which are below set out was taken by the Board under the provisions of the Country Roads Act for the purpose of widening the main roads aforesaid which widenings have now been laid out and formed on the same: And whereas the said Board (being the Country Roads Board incorporated under the said Act) thinks that the widenings aforesaid are fit to be used as parts of public highways such Board at a meeting now holden doth by this Resolution hereby declare the same as described in the Schedules hereto with the commencing and terminating points thereof respectively specified to be parts of the main roads within the meaning and for the purposes of the Country Roads Act.

SCHEDULE.

Shire of Glenlyon.

7. *Daylesford-Trentham road* (6607).—All that piece of land in the Parish of Bullarto, the boundaries of which are as follow:—Commencing at the south-eastern angle of allotment 13, section 4, Township of Bullarto North in the said parish; thence by lines bearing respectively 288 deg. 57 min. 61.4 links, 77 deg. 3 min. 81.4 links and 209 deg. 7 min. 43.7 links to the point of commencement— which said piece of land is particularly delineated and shown coloured red on survey plan numbered 6778, lodged in the office of the Country Roads Board.

SCHEDULE.

Shire of Melton.

7. *Diggers Rest-Coimadaí road* (10207).—All that piece of land in the Parish of Yangarook, the boundaries of which are as follow:—Commencing at the south-western angle of allotment 59A of the said parish; thence by lines bearing respectively 343 deg. 26 min. 250 links, 99 deg. 27½ min. 564.8 links and 253 deg. 11 min. 507.5 links to the point of commencement— which said piece of land is particularly delineated and shown coloured red on survey plan numbered 7122, lodged in the office of the Country Roads Board.

SCHEDULE.

Shire of Warracknabeal.

4. *Warracknabeal-Rainbow road* (17204).—All that piece of land in the Parish of Yellangip, the boundaries of which are as follow:—Commencing at a point on the southern boundary of allotment 80 of the said parish,

distant 270 deg. 16 min. 5,067.2 links from the south-eastern angle of the said allotment; thence by lines bearing respectively 270 deg. 16 min. 726.8 links, 306 deg. 19 min. 733.5 links and 108 deg. 22½ min. 1,388.6 links to the point of commencement— which said piece of land is particularly delineated and shown coloured red on survey plan numbered 7177, lodged in the office of the Country Roads Board.

The common seal of the Country Roads Board was hereto affixed, at Kew, this twentieth day of March, One thousand nine hundred and sixty-one, in the presence of—

(SEAL) D. V. DARWIN, Chairman.
W. H. NEVILLE, Member.
N. L. ALLANSON, Acting Secretary.

And the Honorable Sir Thomas Karran Maltby, Her Majesty's Commissioner of Public Works for the State of Victoria, shall give the necessary directions herein accordingly.

A. MAHLSTEDT,
Clerk of the Executive Council.

APPROACHING LAND SALES.

SALES of Crown lands, in fee-simple, will be held at the under-mentioned places and dates, viz:—

	No. of Gazette.
Ballarat.—Thursday, 18th May, 1961 ..	25
Bendigo.—Thursday, 13th April, 1961 ..	17
Echuca.—Monday, 17th April, 1961 ..	20
Kaniva.—Thursday, 13th April, 1961 ..	18
Leongatha.—Tuesday, 9th May, 1961 ..	24
Manangatang.—Wednesday, 19th April, 1961 ..	20
Merino.—Friday, 28th April, 1961 ..	21

SALE OF FREEHOLD LAND BY AUCTION.

Cohuna.—Monday, 17th April, 1961 ..	20
Koo-wee-rup.—Friday, 28th April, 1961 ..	21

SALE OF CLOSER SETTLEMENT LAND BY AUCTION.

Stanhope.—Wednesday, 17th May, 1961 ..	25
--	----

SALE OF CROWN LAND BY AUCTION.

The land will be offered for sale in fee-simple, and subject to the provisions of the Land Act and Regulations thereunder.

The upset price is the sum at which bidding will start, and no bid below that sum can be accepted. The highest bidder at or above that sum shall be the purchaser, subject to signature of contract and any necessary payment.

TERMS:

A deposit of at least 12½% of the purchase price must be paid at the sale, either in cash or by cheque.

The residue is payable in half-yearly instalments, in accordance with the following scale, or may be paid off at any earlier time.

£20 and under, 6 instalments.
Over £20, and not exceeding £50, 8 instalments.
Over £50, and not exceeding £100, 10 instalments.
Over £100, and not exceeding £200, 12 instalments.
Over £200, and not exceeding £300, 14 instalments.
Over £300, and not exceeding £400, 16 instalments.
Over £400, and not exceeding £500, 18 instalments.
Over £500, 20 instalments.

Interest at the rate of 5% per annum is payable with all payments of residue, and is computed for each instalment from the date of sale to the date of such payment. Additional interest is charged if any instalment is not paid on or before the due date.

If paid off within 30 days of sale, no interest is payable.

FEES, ETC.:

Also payable at the sale, in addition to the deposit, are the survey fee and the valuation of improvements (if purchaser be not the owner thereof).

Payable with balance of purchase money—

Crown Grant fee—50 acres and under ..	£1 10s.
Over 50 acres ..	£2
Purchase money £5 or under ..	£1

Assurance Fund contribution—One halfpenny for each £1 of purchase price. (This is a fund established to guarantee the validity of freehold titles.)

Transfer of interest prior to completion of payment may be allowed on payment of £1 fee and subject to stamp duty.

If unable to attend personally, a prospective purchaser may arrange for another person to bid as his agent.

KEITH TURNBULL,
Commissioner of Crown Lands and Survey.

Office of Crown Lands and Survey,
Melbourne, 7th April, 1961.

BALLARAT.—Sale (No. 11544) of Crown land in fee-simple, by auction, will be held at the LAND OFFICE, BALLARAT, on THURSDAY, the 18th MAY, 1961, at HALF-PAST TWO o'clock p.m. To be conducted by H. H. DODD, Land Officer, Ballarat.

Lot 1.

TOWNSHIP OF BALLAARAT, PARISH OF BALLAARAT, COUNTY OF GRENVILLE.

At the South-west Corner of Bell-street and Yarrowee-parade.

Upset price £250 the lot. Survey fee £5 10s.

Area 23 perches, subject to survey and any necessary easements disclosed thereby, allotment 3 of section 120.—(J.26222.)

Lot 2.

TOWNSHIP OF BALLAARAT EAST, PARISH OF BALLAARAT, COUNTY OF GRANT.

Fronting Canterbury-street, About 5½ Chains West of Lane-street.

Upset price £300 the lot. Survey fee £6.

Area 1 rood 10 perches, allotment 12 of section 63. Subject to sewerage easement 9 links wide. One month allowed for removal of improvements.—(J.30550.)

Lot 3.

TOWNSHIP OF SMYTHESDALE, PARISH OF SMYTHESDALE, COUNTY OF GRENVILLE.

Fronting the Main Road to Buninyong, in the South-east Corner of the Township.

Upset price £140 the lot. Survey fee £10 2s. 6d.

Area 11 acres, subject to survey and any necessary easements disclosed thereby, allotment 6 of section 30A. Valuation of improvements £705 (house, outbuildings, &c.) (D. N. McMaster.)

NOTE.—Allotment 6 as now offered is not as shown on current published plans, but also embraces additional land to the west and north.—(J.30014.)

Lot 4.

TOWNSHIP OF SMYTHESDALE, PARISH OF SMYTHESDALE, COUNTY OF GRENVILLE.

Fronting West Side of Railway Line About ½ Mile North-East of Railway Station.

Upset price £35 the lot. Survey fee £7 7s. 6d.

Area 3 acres, allotment 21A of section 35A. Valuation of improvements £500 (house and sheds) (B. Soufis).—(J.30498.)

Lot 5.

TOWNSHIP OF BAYUP, PARISH OF BLACKWOOD, COUNTY OF BOURKE.

At Barrys Reef, Fronting the Main Road from Blackwood to Trentham.

Upset price £25 the lot. Survey fee £7 12s. 6d.

Area 5 acres, allotment 9 of section 11A.—(J.28771.)

Lot 6.

TOWNSHIP OF BLACKWOOD, PARISH OF BLACKWOOD, COUNTY OF BOURKE.

At South-east Corner of Clarendon and Nolan streets.

Upset price £75 the lot. Survey fee £6 12s. 6d.

Area 1 acre, allotment 14 of section 1. Valuation of improvements £185. (Old weatherboard house.) (W. A. Wiltshire).—(J.30405.)

Lot 7.

PARISH OF LYNCHFIELD, COUNTY OF GRENVILLE.

Fronting Main Road from Smythesdale to Clarkesdale, Approximately 1½ Miles North of Berringa.

Upset price £10 the lot. Survey fee £7.

Area 3 roods 39 perches, allotment 8A of section B.—(J.28587.)

SALE OF CLOSER SETTLEMENT LAND BY AUCTION.

The land will be offered for sale in fee-simple, and subject to the provisions of the Closer Settlement Act and Regulations thereunder.

The upset price is the sum at which bidding will start, and no bid below that sum can be accepted. The highest bidder at or above that sum shall be the purchaser, subject to signature of contract and any necessary payment.

TERMS:

A deposit of at least 25% of the purchase price must be paid at the sale, either in cash or by cheque.

The residue is payable in twenty equal half-yearly instalments, or may be paid off at any earlier time.

Interest at the rate of 5% per annum is payable with all payments of residue, and is computed on the unpaid balance.

FEES, ETC.:

Also payable at the sale, in addition to the deposit, are the survey fee and the valuation of improvements (if purchaser be not the owner thereof).

Payable with balance of purchase money—

Crown Grant fee—50 acres and under	£1 10s.
Over 50 acres	£2
Purchase money £5 or under	£1

Assurance Fund contribution—One halfpenny for each £1 of purchase price. (This is a fund established to guarantee the validity of freehold titles.)

Transfer of interest prior to completion of payment may be allowed on payment of £1 fee and subject to stamp duty.

If unable to attend personally, a prospective purchaser may arrange for another person to bid as his agent.

KEITH TURNBULL,
Commissioner of Crown Lands and Survey.

Office of Crown Lands and Survey,
Melbourne, 7th April, 1961.

STANHOPE.—A sale of Closer Settlement land in fee-simple, by auction, will be held at the RETURNED SOLDIERS' HALL, STANHOPE, on WEDNESDAY, the 17th MAY, 1961, at ELEVEN o'clock a.m. To be conducted by G. E. HARPIN, Land Officer, Bendigo.

Lot 1.

PARISH OF GIRGARRE, COUNTY OF RODNEY.

Fronting East Side of Stanhope—Girgarre-road, Just North of the Township of Stanhope. Being the Site and Buildings of Former Lands Department Residence.

Upset price £1,860 the lot. Survey fee £7 7s. 6d.

Area 2a. 2r. 28p., allotment 20A of section B, together with all improvements thereon. (Improvements include weatherboard house and outbuildings).—(W.85098.)

PROPOSED REVOCATIONS OF TEMPORARY RESERVATIONS OF LAND BY ORDERS IN COUNCIL.

IN pursuance of the provisions of the Land Act 1958, notice is hereby given that it is the intention of the Governor in Council to revoke the temporary reservations of land by Orders in Council hereunder referred to, viz.:

The following Notices were published 1^o on the 15th March, 1961, pursuant to Orders of the 7th March, 1961.

ECHUCA.—The temporary reservation by Order in Council of the 21st December, 1921, of 7 acres 1 rood 17 perches of land in the Township of Echuca, as a site for Public purposes, revoked as to part by various Orders, so far only as the portion containing 21 perches indicated by hachure on plan hereunder are concerned.—(E3) (Rs.6175).

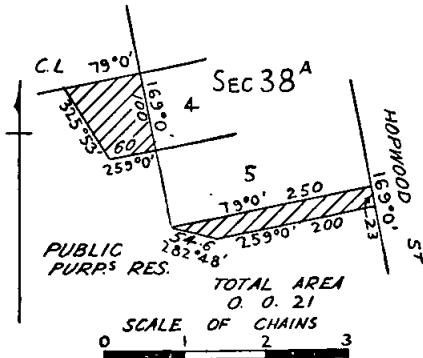

GLENMONA.—The temporary reservation, by Order in Council of the 18th August, 1908, of 44 acres 3 roods 13 perches of land in the Parish of Glenmona as a site for Watering purposes and for Supply of Gravel, revoked as to part by Order of the 14th April, 1915, so far only as the portion containing 1 rood 13 perches, indicated by hachure on plan hereunder, is concerned.—(G.155(3) (Rs.8026).

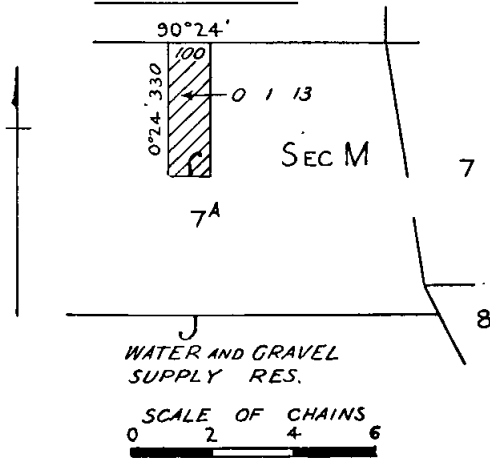

KEITH TURNBULL,
Commissioner of Crown Lands and Survey.

PROPOSED REVOCATIONS OF TEMPORARY RESERVATIONS OF LANDS BY ORDERS IN COUNCIL.

IN pursuance of the provisions of the *Land Act 1958*, notice is hereby given that it is the intention of the Governor in Council to revoke the temporary reservation of land by Order in Council hereunder referred to, viz.:-

The following Notices were published 1° on the 29th March, 1961, pursuant to Orders of the 15th March, 1961.

COMOORA.—The temporary reservation, by Order in Council of the 22nd November, 1869 (see *Government Gazette* 1869, page 1922), of 3 roods 23 perches of land in the Township of Comoora, as a site for Common School purposes.—(C.434(3) (Rs.6935).

HAMILTON.—The temporary reservation, by Order in Council of the 25th January, 1949, of 1 acre 2 roods 10 perches of land in the Township of Hamilton, as a site for Hospital purposes.—(H.45(2) (Rs.6321).

JANCOURT.—The temporary reservation, by Order in Council of the 14th April, 1959, of 34 acres 2 roods 34 perches of land in the Parish of Jancourt, as a site for the Supply of Gravel.—(J.24(G) (Rs.5027).

GLENMONA.—The temporary reservation, by Order in Council of the 14th February, 1961, of 1 rood, more or less, of land in the Parish of Glenmona, as a site for the Supply of Gravel.—(G.155(3) (Rs.3722).

JANCOURT.—The temporary reservation, by Order in Council of the 26th August, 1940, of 11 acres 0 roods 4 perches of land in the Parish of Jancourt, as a site for the Supply of Gravel.—(J.24(8) (Rs.5084).

GEMBROOK.—The temporary reservation, by Order in Council of the 16th July, 1940, of 7 acres 1 rood 16 perches of land in the Parish of Gembrook, as a site for Public Recreation, so far only as the portion containing 1 rood 12 perches, indicated by hachure on plan hereunder, is concerned.—(G.206(12) (Rs.5061).

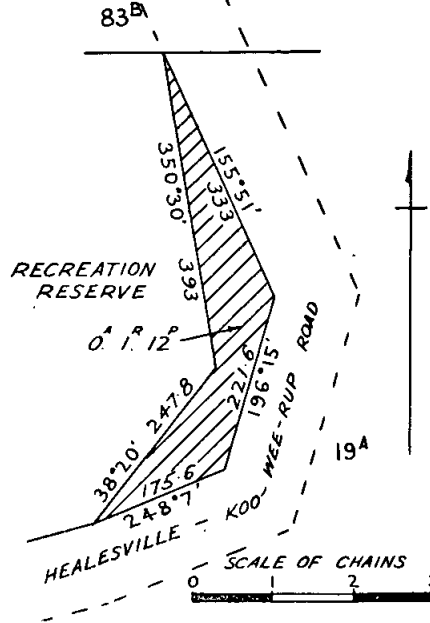

KEITH TURNBULL,
Commissioner of Crown Lands and Survey.

PROPOSED REVOCATION OF TEMPORARY RESERVATION OF LAND BY ORDER IN COUNCIL.

IN pursuance of the provisions of the *Land Act 1958*, notice is hereby given that it is the intention of the Governor in Council to revoke the temporary reservation of land by Order in Council hereunder referred to, viz.:-
The following Notice was published 1° on the 7th April, 1961, pursuant to Order of the 28th March, 1961.

GHERANG GHERANG (MODEWARRE).—The temporary reservation, by Order in Council of the 11th August, 1890, of 8 acres 2 roods 26 perches of land in the Parish of Gherang Gherang, as a site for Watering purposes, revoked as to part by Order of the 29th July, 1958, so far only as the portion containing 7 perches more or less, indicated by hachure on plan hereunder, is concerned.—(G.34(B) (Rs.3646).

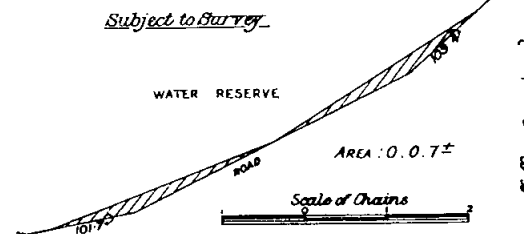

KEITH TURNBULL,
Commissioner of Crown Lands and Survey.

PROPOSED REVOCATION OF THE SETTING APART OF LAND BY ORDER IN COUNCIL.

IN pursuance of the provisions of the *Land Act 1958*, notice is hereby given that it is the intention of the Governor in Council to revoke the setting apart of land by Order in Council hereunder referred to, viz.:-

The following Notice was published 1° on the 22nd March, 1961, pursuant to Order of the 7th March, 1961.

AVOCA.—The setting apart, by Order in Council of the 9th January, 1860, of 2 acres of land in the Township of Avoca as a site for Market purposes.—(A.86(8) (Rs.5711).

KEITH TURNBULL,
Commissioner of Crown Lands and Survey.

Land Act 1958.

LEASE SURRENDERED.

NOTICE is hereby given that the Governor in Council has accepted the surrender of the Lease mentioned in the Schedule hereunder for the reason specified.

District.	Corr. No.	Name.	Section of Land Act under which Leased.	Parish.	Allotment.	Section.	Area.	Class.	Reason.
Mallee	P4008/218	Eva Irene Edelsten	241	Gaalanungah	Part 5..	..	A. R. P. 477 2 32	4th	Surrendered—Selection purchase lease to issue

Department of Crown Lands and Survey,
Melbourne, 27th March, 1961.

KEITH TURNBULL,
Commissioner of Crown Lands and Survey.

PROPOSED REVOCATION OF TEMPORARY RESERVATION OF LAND BY ORDER IN COUNCIL.

IN pursuance of the provisions of the Land Act 1958, notice is hereby given that it is the intention of the Governor in Council to revoke the temporary reservation of land by Order in Council hereunder referred to, viz.:-

The following Notice was published 1° on the 29th March, 1961, pursuant to Order of the 21st March, 1961.

FOSTER.—The temporary reservation, by Order in Council of the 28th June, 1915, of 2 roods 13 6/10 perches of land in the Township of Foster as a site for a Shire Hall, and the temporary reservation, by Order in Council of the 26th October, 1915, of 2 roods 13 6/10 perches of land as an addition thereto, are about to be revoked.—(F.100(*) (Rs.935).

KEITH TURNBULL,
Commissioner of Crown Lands and Survey.

PROPOSED REVOCATION OF THE TEMPORARY RESERVATION, AND THE WITHHOLDING FROM SALE, LEASING, AND LICENSING OF LAND BY ORDER IN COUNCIL.

IN pursuance of the provisions of the Land Act 1958, notice is hereby given that it is the intention of the Governor in Council to revoke the temporary reservation, and the withholding from sale, leasing and licensing, of land by Order in Council hereunder referred to, viz.:-

The following Notice was published 1° on the 22nd March, 1961, pursuant to Order of the 7th March, 1961.

INGLEWOOD.—The temporary reservation as a site for Municipal purposes and Public Gardens and the withholding from sale, leasing and licensing by Orders in Council of the 18th September, 1882, and 29th May, 1883 (see Government Gazette 1882, page 2319, and 1883, page 1117) of 1 acre 2 roods 3 1/2 perches of land in the Township of Inglewood, are about to be revoked.—(I4(*) (Rs.8006).

KEITH TURNBULL,
Commissioner of Crown Lands and Survey.

PROPOSED REVOCATION OF TEMPORARY RESERVATION, AND THE WITHHOLDING FROM SALE, LEASING, AND LICENSING OF LAND BY ORDER IN COUNCIL.

IN pursuance of the provisions of the Land Act 1958, notice is hereby given that it is the intention of the Governor in Council to revoke the temporary reservation, and the withholding from sale, leasing, and licensing, of land by Order in Council hereunder referred to, viz.:-

The following Notice was published 1° on the 7th April, 1961, pursuant to Order of the 28th March, 1961.

WARRACKNABEAL.—The temporary reservation as a site for Public purposes (State School) and the withholding from sale, leasing and licensing by Order in Council of the 1st April, 1878, of 3 acres of land in the Township of Warracknabeal, revoked as to part by Order of the 7th May, 1907, so far as the balance thereof, containing 2 acres 3 roods 31 perches, is concerned.—(W.293(*) (Rs.7948).

KEITH TURNBULL,
Commissioner of Crown Lands and Survey.

PROPOSED REVOCATION OF TEMPORARY RESERVATION OF LAND BY ORDER IN COUNCIL.

IN pursuance of the provisions of the Land Act 1958, notice is hereby given that it is the intention of the Governor in Council to revoke the temporary reservation of land by Order in Council hereunder referred to, viz.:-

The following Notice was published 1° on the 7th April, 1961, pursuant to Order of the 28th March, 1961.

HUNTLY.—The temporary reservation, by Order in Council of the 28th March, 1928, of 2 roods 4 perches of land in the Township of Huntly, as a site for a State School.—(H.107(*) (Rs.3656).

KEITH TURNBULL,
Commissioner of Crown Lands and Survey.

TENDERS—PUBLIC WORKS DEPARTMENT

TENDERS will be received at this Department until TEN a.m., on the days and for the purposes under mentioned.

Particulars may be learnt at the Department and also at places shown in parenthesis.

W.O. means Inspector of Works Office; P.S.—Police Station; T.S.—Technical School; H.E.S.—Higher Elementary School; S.S.—State School; H.S.—High School; C.S.—Consolidated School.

Tenders should be submitted on the Department's printed Tender Form. All tenders must be on a "Firm Tender" basis. The Board of Land and Works will not necessarily accept the lowest or any tender.

Tenders to be addressed to the Hon. the Commissioner of Public Works, and envelope containing tender to be marked "Tender for _____, closing _____".

NOTE.—No preliminary deposit is to be lodged with any tender, but a deposit in accordance with the prescribed Schedule, may be required from each successful tenderer.

Tuesday, 11th April, 1961.

Altona West.—New primary school building of eight class-rooms, S.S. 4862.

Ballarat North.—Electrical installation in extensions to Manual Arts Wing, Technical School. (W.O., Ballarat; T.S., Ballarat North.)

Belmont.—Internal and external renovations to residence, 40 Fyans-street, Chilwell, High School. (W.O., Geelong; H.S., Belmont.)

Bendigo.—Supply of refrigerator, Technical School, White Hills. (W.O., Bendigo.)

Beulah.—Repairs and painting, Police Station. (Amended specification.) (W.O., Warracknabeal; P.S., Beulah.)

Burnley.—Erection of Canteen and Recreation Room, Horticultural Gardens.

Burnley Gardens.—Electrical installation in new canteen and Recreation Room, Swan-street.

Camberwell.—New cupboards under chalkboards, S.S. 888.

Carlton.—Alteration to watchhouse with repairs and painting to all buildings, Police Station.

Carlton.—Chain-wire extension to fencing, S.S. 2605.

Carranballac.—Erection of timber-framed residence and garage, S.S. 3876. (W.O., Ararat and Ballarat; S.S., Carranballac.)

Caulfield.—Supply of tubular steel-framed tables, Technical School.

Frankston Heights.—Erection of new Primary School, S.S. 4815.

Geelong East.—Supply of refrigerator, Technical School. (W.O., Geelong.)

Hamilton.—Non-party fencing, S.S. 4777. (W.O., Hamilton; S.S., Hamilton.)

Hawthorn.—Repairs and painting, Court House.

Horsham.—Supply of refrigerator, Technical School. (W.O., Horsham.)

Kangaroo Flat.—Erection of new combined out-office and laundry block, S.S. 4728. (W.O., Bendigo; S.S., Kangaroo Flat.)

Kew.—Supply and lay rubber floor tiles, Nurses Hostel, Mental Hospital.

Kew.—Supply and erection of curtains, Mental Hospital.

Korong Vale.—New combined out-office block and septic tank installation, S.S. 1800. (W.O., Bendigo; S.S., Korong Vale.)

Manangatang.—Internal and external renovations, renewal of roof, repairs, &c., Consolidated School. (W.O., Swan Hill; C.S., Manangatang.)

Melbourne.—Alterations to store and provision of fire-escape exits, Head Office, Fisheries and Wildlife Department.

Melbourne.—Electrical installation, including new switchboards, &c., and rewiring of portion of First Floor, Titles Office, 283 Queen-street.

Melbourne.—Fire service, Supreme Court. (Amended specification.)

Melbourne.—Manufacture and supply of timber draughting benches, Institute of Technology.

Melbourne.—New concrete strong room, Registrar of Co-operative Housing Societies, 179 Queen-street.

Melbourne.—H.W.S. system and kitchen ventilating system, Teachers' Training College Hostel, "Warrwillah," 572 St. Kilda-road.

Mildura.—Erection of hostel and amenities block, Girls' High School Hostel. (W.O., Mildura.) (Quantities available.)

Mont Park.—Modifications to pipes, pumps, valves, &c., on soap and soda services, laundry, Larundel Mental Hospital. (W.O., Mont Park Mental Hospital.)

Mont Park.—Electrical installation in extensions to therapy block, Mental Hospital. (W.O., Mont Park Mental Hospital.)

Mont Park.—Supply and erection of curtains, Mental Hospital.

Moorabbin.—Repairs and painting to residence, S.S. 1111. (S.S., Moorabbin.)

Morwell.—Supply of refrigerator, Technical School.

Murrayville.—Repairs, internal and external painting, Court House. (W.O., Mildura; P.S., Murrayville.)

Neerim South.—New tapping from main and replacement of existing internal service and installation of new sinks in Science Room, Higher Elementary School and S.S. 2432. (W.O., Warragul; H.E.S. and S.S., Neerim South.)

Nhill.—Repairs and painting, Court House. (W.O., Horsham; P.S., Nhill.)

Redcliffs.—Mechanical services for new school, High School. (W.O., Mildura.)

Ringwood.—Additional lavatory accommodation, S.S. 2997. (S.S., Ringwood.)

Smythesdale.—Erection of out-office and woodshed block, install septic closets, S.S. 978. (Amended specification.) (W.O., Ballarat; S.S., Smythesdale.)

Tottenham North.—Electrical installation in new classrooms, &c., S.S. 4703. (S.S., Tottenham North.)

Warrawong.—Electrical installation, four additional L.T.C. class-rooms, &c., S.S. 4835. (S.S., Warrawong.)

Warrnambool.—Provision of new toilet and connexion of residence to town sewerage system, High School. (W.O., Warrnambool.)

Yarrowonga.—Plenum heating and H.W.S. installation to the extension of existing class-room wing, High School. (H.S., Yarrowonga.)

Tuesday, 18th April, 1961.

Altona North.—Joinery benches, racks, &c., Technical School.

Ararat.—Supply of steel cupboards, Mental Hospital. (W.O., Ararat, Ballarat.)

Bendigo.—Fence renewal, High School. (W.O., Bendigo.)

Carlton.—Water supply, S.S. 112.

Chelsea.—Repairs to roof and wall, S.S. 3729. (S.S., Chelsea.)

Cohuna.—General repairs to furniture, Consolidated School. (W.O., Bendigo.)

Croydon West.—New primary school building, S.S. 4879.

Dean's Marsh.—Additional out-office accommodation, drinking and washing facilities, S.S. 1642. (W.O., Camperdown; S.S., Dean's Marsh.)

Dunmunkle East.—Removal and re-erection building, ex Rich Avon East, S.S. 2691. (Amended specification.) (W.O., Warracknabeal; S.S., Dunmunkle East.)

Frankston Heights.—Electrical installation for new school of six (6) L.T.C. class-rooms, &c., S.S. 4815.

Genoa.—Internal and external renovations, S.S. 3112. (W.O., Bairnsdale; S.S., Genoa.)

Glen Waverley.—Purchase and removal of old residence, High School.

Jordanville.—Renewal of existing gas pipes and connexion of school to reticulated supply, Technical School.

Kew.—Plenum heating and hot-water service in Ward 22, Children's Cottages, Mental Hospital.

Kew.—Heating system, S.S. 4883.

Maryborough.—Supply of general furniture, Technical College. (W.O., Maryborough.)

Niddrie.—Supply of various furniture, Technical School.

Noble Park.—Connexion of residence, 9 Jasper-street, to sewer. Provision of new toilet on rear porch, S.S. 3675.

Preston.—Gas hot-water systems and gas wall heaters in therapy and toilet blocks, Therapy Annexe, 83 Hotham-street.

Rye.—Repairs and painting to residence, corner of Dundas-street and Point Nepean Highway, S.S. 1667.

Springvale.—New out-office block and external drains, S.S. 3507. (S.S., Springvale.)

Stawell.—New toilets and connect to town sewerage, Court House. (Amended specification.) (W.O., Ararat; Police Station, Stawell.)

Various.—Manufacture and supply of twenty-five (25) police signs, Police Stations.

Warracknabeal.—Improved drinking facilities, High School. (Amended specifications.) (W.O., Warracknabeal High School, Warracknabeal.)

Welshpool.—New out-office block and septic tank installation, &c., school and residence, S.S. 3011. (W.O., Korumburra; S.S., Welshpool.)

Werribee.—Erection of two grain silos, Research Station. (Research Station, Werribee.)

West Melbourne.—Electrical installation, garage, store and offices, Fisheries and Wildlife Department.

Williamstown.—Supply and delivery of two (2) double drum slipway winches, 3½ tons capacity, Slipways.

Yandoit.—Renovations to school and residence, S.S. 691. (W.O., Kyneton; S.S., Yandoit.)

Wednesday, 26th April, 1961.

Creswick.—Renovations to school and residence, S.S. 122. (W.O., Ballarat.) (Amended specifications.)

Daylesford.—Sheeting of spire to bell tower with copper, S.S. 1609. (W.O., Kyneton; S.S., Daylesford.)

Dookie.—Supply of 84 inner-spring mattresses, Agricultural College.

Dumbalk.—Construction of new out-offices for boys, woodshed and septic tank, and water supply installations at school and residence, S.S. 3415. (W.O., Korumburra; S.S., Dumbalk.)

Frankston Heights.—Plenum heating in six class-room unit, S.S. 4815.

Huntingdale.—Construction of reinforced concrete storm-water drain, High School.

Horsham.—Internal alterations, painting, provision of heaters, stainless steel sink, &c., Police Station. (W.O., Horsham.)

Irrewillipe East.—Out-office accommodation, drinking and washing facilities, S.S. 2357. (W.O., Camperdown; S.S., Irrewillipe East.) (Amended specification.)

Melbourne.—Sealing of cornice mold to east wing, New Treasury Buildings, Department of Lands and Survey.

Pira.—Construction of new timber out-office and septic tank installation, S.S. 4278. (W.O., Swan Hill; S.S., Pira.) (Amended specification.)

Port Fairy.—Erection of additional bedroom to residence, Consolidated School. (W.O., Warrnambool; Consolidated School, Port Fairy.)

Preston.—Aluminium windows, doors and curtain walling and sun hoods, Technical School.

Royal Park.—Plenum heating system and electric boiling water unit, Administrative Block, Mental Hospital.

Stawell.—Connexion of residence, 39 Houston-street, to town sewerage, Technical School. (W.O., Ararat.)

Stony Creek.—Resiting boys' and girls' out-offices, repairs and septic tank installations at school and residence, S.S. 3665. (W.O., Korumburra; S.S., Stony Creek.)

Wedderburn.—New out-office block, septic tank installation, wash basins, &c., Higher Elementary School. (W.O., Bendigo; Higher Elementary School, Wedderburn.) (Amended specification.)

T. K. MALTBY,

Commissioner of Public Works.

Public Works Department,

Melbourne, 5th April, 1961.

TENDERS FOR THE SERVICE, 1961-62.

GENERAL STORES.

TENDERS will be received until Eleven o'clock a.m. on Friday, 5th May, 1961, from persons willing to supply the under-mentioned articles in such quantities as may be ordered by the Victorian Government during the twelve months commencing 1st-July, 1961:—

Schedule No.

- 61. Packing—Engine, &c.
- 63. Piping, Ridging, Spouting, &c.
- 64. Polishes, Dusters, Cleansers, &c.
- 67. Soapmakers' Materials, &c.
- 71. Tents and Flvs.
- 74. Tools and Requisites—Shoemakers'.
- 75. Tires and Tubes, Pneumatic, for Motor Cars, Trucks, Buses, Motor Cycles and Side-cars, and Bicycles.
- 77. White Lead, Red Lead, and Linseed Oil.

The prices tendered must not include sales tax.

Security.—Five per cent. of total amount of tender accepted, but in no case will security of less than £3 be received.

Schedules as above, with full particulars, may be obtained from the Secretary to the Tender Board, by whom also the samples will be shown and any information afforded to persons tendering.

In all cases the total cost of each item must be extended in the columns provided.

Security will be required either in Commonwealth Treasury Bonds, or approved bank guarantee, fixed deposit receipt, Savings Bank deposit book, or non-negotiable cheque in favour of the Secretary to the Tender Board, as the tenderer may elect.

The security must be completed and the contract signed within five days of acceptance of the tender failing which the contract may be again advertised, or another tender accepted.

The lowest or any tender will not necessarily be accepted.

In the event of tenderers withdrawing or attempting to withdraw their tenders before notification of acceptance of same, or failing to take up their accepted tenders within the prescribed period after notification of acceptance, they may be disqualified from tendering or holding any future contracts for Government supplies for a period of twelve months, such disqualification to date from the notification of acceptance of tender. It is also stipulated that, if a tenderer be a member of a firm and such firm be interested in the contract, the tender shall be in the name of the firm and not in that of the individual and that, for a breach of this condition, the tender will be declared informal.

Tenders enclosed in a separate envelope, and having the words "Tender for ———" (as the case may be) written thereon, must be deposited in the Tender-box at the Tender Board Offices, Macarthur-street, Melbourne, or, if sent by post, postage must be prepaid, and the tenders addressed to the Chairman of the Tender Board, Tender Board Offices, Macarthur-street, Melbourne, C.2, which office they must reach not later than by first post on the date of closing of tenders.

The conditions of contract are those published in the Victoria Government Gazette, No. 24, dated 29th March, 1961, pages 1062 to 1064.

H. E. BOLTE,
Treasurer.

The Treasury,
Melbourne, 5th April, 1961.

PUBLIC SERVICE NOTICES

PUBLIC SERVICE (PUBLIC SERVICE BOARD) REGULATION 39.—RECLASSIFICATIONS.

THE Public Service Board has raised the classification of the under-mentioned offices as shown, and the Permanent Heads of the Departments have recommended the officers named for appointment.

Office and Present Classification.	Revised Classification.	Duties.	Qualifications.	Officer Recommended for Appointment.		
				Name.	Classification.	Date of Classification.

PROFESSIONAL DIVISION.

CHIEF SECRETARY'S DEPARTMENT.

Social Welfare Branch.

Chief Probation and Parole Officer, Class "B1"	Class "A1" (£2,175)	To be responsible to the Director-General of Social Welfare for the organization and control of probation and parole services pursuant to the Children's Court, Social Welfare and Crimes Acts	A Diploma of Social Studies or equivalent qualification; extensive experience in social work related to probation and parole, and capacity for administration and organization	Mathew, H. C.	Chief Probation and Parole Officer, Class "B1"	10.9.56
Probation and Parole Officer, Class "C"	Class "B"	To be responsible to the Chief Probation and Parole Officer for the organization and supervision of probation and parole services for females	A Diploma of Social Studies or equivalent qualification; experience in social work related to the organization of probation and parole services	Scrutton, Joan M. (Mrs.)	Probation and Parole Officer, Class "C"	29.6.58

TECHNICAL AND GENERAL DIVISION.

TREASURY.

Taxation (Land Tax) Office.

Assistant (Female), Grade III., Grades F14-F15 inclusive	Grade IV., Grades F17-F19 inclusive	To record and distribute inward and outward files and correspondence; to number and distribute change of ownership notices; to write and despatch queries to taxpayers as directed by the Valuers and other duties as required	A knowledge of Land Tax Office routine and procedure and of the geographical situation of all the various Shires, Parishes, Cities and Towns throughout the State. Ability to maintain a filing and recording system	Thomas, Valmai M.	Assistant (Female), Grade III.	16.11.53
--	-------------------------------------	--	--	-------------------	--------------------------------	----------

Appeals against such recommendations should be lodged with the Secretary to the Public Service Board not later than Monday, the 17th April, 1961.

Office of the Public Service Board,
Melbourne, 6th April, 1961.

By order,
V. P. SCULLY,
Secretary.

PUBLIC SERVICE (PUBLIC SERVICE BOARD) REGULATION 39.—VACANCY.

THE Permanent Head of the Department shown has recommended the officer named hereunder for appointment to the under-mentioned vacancy.

Office and Classification.	Duties.	Qualifications.	Officer Recommended for Appointment.		
			Name.	Classification.	Date of Classification.
TECHNICAL AND GENERAL DIVISION. DEPARTMENT OF CROWN LANDS AND SURVEY. <i>Royal Botanic Gardens.</i>					
Gardener, Grade II., Grades 17-19 inclusive	To have charge of a section of the Royal Botanic Gardens and carry out gardening as directed	A practical knowledge of the various activities and methods of gardening, including a knowledge of plants and their treatment; to have passed the proscribed examination as set out in Regulation 51(a) of the Public Service (Public Service Board) Regulations	Mitchell, J. P.	Mower and Carter, Grades 17-19 inclusive	17.11.55

Appeals against such recommendation should be lodged with the Secretary to the Public Service Board not later than Monday, 17th April, 1961.

Office of the Public Service Board,
Melbourne, 6th April, 1961.

By order,
V. P. SCULLY,
Secretary.

No. 1110. *Public Service Act 1958, Section 50.*

REGULATIONS.—PART III.—SALARIES, INCREMENTS AND ALLOWANCES.

THE Public Service Board, in pursuance of the powers conferred by the *Public Service Act 1958*, hereby amends its Regulations as shown below:—

SIXTH SCHEDULE.
TEMPORARY EMPLOYEES.

Designations of Positions and Rates of Salaries.

Department and Designation of Position.	Yearly Rate of Salary.		Increments (Annual).
	Minimum.	Maximum.	
GENERAL.	£	£	
Add— Labourer, Senior	350	..

A. GARRAN, Chairman.
V. P. SCULLY, Secretary.

Office of the Public Service Board,
Melbourne, 20th March, 1961.

No. 1109. *Public Service Act 1958, Section 50.*

REGULATIONS.—PART III.—SALARIES, INCREMENTS AND ALLOWANCES.

THE Public Service Board, in pursuance of the powers conferred by the *Public Service Act 1958*, hereby amends its Regulations as shown below:—

SIXTH SCHEDULE.
TEMPORARY EMPLOYEES.

Designations of Positions and Rates of Salaries.

Department and Designation of Position.	Yearly Rate of Salary.		Increments (Annual).
	Minimum.	Maximum.	
DEPARTMENT OF MINES	£	£	
Delete— Laboratory Attendant	366	..
Add— Laboratory Attendant— Junior— At 20 years of age	316	..
Adult	366	..

This Regulation shall have effect as on and from the 16th March, 1961.

A. GARRAN, Chairman.
V. P. SCULLY, Secretary.

Office of the Public Service Board,
Melbourne, 20th March, 1961.

No. 1107. *Public Service Act 1958, Section 39.*

REGULATIONS.—PART III.—SALARIES, INCREMENTS AND ALLOWANCES.

THE Public Service Board, in pursuance of the powers conferred by the *Public Service Act 1958*, hereby amends its Regulations as shown below:—

FIRST SCHEDULE.
PROFESSIONAL DIVISION.

Amount of Salary Assigned to Offices in Class "A1".

Office.	Yearly Rate of Salary.
DEPARTMENT OF CHIEF SECRETARY.	£
Delete— Deputy Director of Penal Services	2,425

A. GARRAN, Chairman.
V. P. SCULLY, Secretary.

Office of the Public Service Board,
Melbourne, 16th March, 1961.

No. 1106. PUBLIC SERVICE ACT 1958.

THE Public Service Board, in pursuance of the powers conferred by the *Public Service Act 1958*, hereby amends the Public Service (Public Service Board) Regulations as follows:—

PART I.—APPOINTMENTS TO THE ADMINISTRATIVE, PROFESSIONAL, AND TECHNICAL AND GENERAL DIVISIONS.

TECHNICAL AND GENERAL DIVISION.

In Regulation 31 "Department of Chief Secretary—Social Welfare Branch; Juvenile Schools" is substituted for "Department of Chief Secretary—Penal Establishments and Gaols; Juvenile Schools" in the heading and the words "Prisons Division, Social Welfare Branch" are substituted for the words "Penal and Gaols Branch" wherever appearing.

PART II.—PROMOTIONS AND TRANSFERS.

TECHNICAL AND GENERAL DIVISION.

In Regulation 48 "Department of Chief Secretary—Prisons Division, Social Welfare Branch" is substituted for "Department of Chief Secretary—Penal and Gaols Branch" in the heading and the words "Prisons Division, Social Welfare Branch" are substituted for the words "Penal and Gaols Branch" wherever appearing.

PART VI.—TRAVELLING EXPENSES.

DIVISION II.—REIMBURSEMENT OF CERTAIN OFFICERS FOR EXPENSES.

Department of Chief Secretary.

In Regulation 103 (3) the words "Prisons Division, Social Welfare Branch" are substituted for the words "Penal and Gaols Branch".

A. GARRAN, Chairman.
V. P. SCULLY, Secretary.

Office of the Public Service Board,
Melbourne, 16th March, 1961.

No. 1108.

Public Service Act 1958, Section 50.

REGULATIONS.—PART III.—SALARIES, INCREMENTS AND ALLOWANCES.

THE Public Service Board, in pursuance of the powers conferred by the *Public Service Act 1958*, hereby amends its Regulations as shown below:—

SIXTH SCHEDULE.

TEMPORARY EMPLOYEES.

Designations of Positions and Rates of Salaries.

Department and Designation of Position.	Yearly Rate of Salary.		Increments (Annual).
	Minimum.	Maximum.	
DEPARTMENT OF CHIEF SECRETARY.	£	£	
<i>Delete—</i>			
PENAL AND GAOLS.			
Dressmaking Instructor (Female)	444	..
Nurse	540	..
Penal Officer	402	558	3 of £32
Penal Officer (Female)	332	396	1 of £16, 1 of £32, and 1 of £16
Probation and Parole Officer (Female)	653	..
Probation and Parole Officer (Male)	710	..
<i>Add—</i>			
SOCIAL WELFARE.			
<i>Prisons Division.</i>			
Dressmaking Instructor (Female)	444	..
Nurse	540	..
Penal Officer	402	558	3 of £32
Penal Officer (Female)	332	396	1 of £16, 1 of £32, and 1 of £16
<i>Probation and Parole Division.</i>			
Probation and Parole Officer (Female)	653	803	3 of £50
Probation and Parole Officer (Male)	710	860	¶
DEPARTMENT OF LAW.			
<i>Delete—</i>			
Probation Officer (Male), Children's Courts	710	860	¶
Probation Officer (Female), Children's Courts	653	803	3 of £50

¶ Increments in accordance with the scale of rates of salaries as set out in the Third Schedule to these Regulations.

A. GARRAN, Chairman.
V. P. SCULLY, Secretary.

Office of the Public Service Board,
Melbourne, 16th March, 1961.

No. 1111.

Public Service Act 1958, Section 39.

REGULATIONS.—PART III.—SALARIES, INCREMENTS AND ALLOWANCES.

THE Public Service Board, in pursuance of the powers conferred by the *Public Service Act 1958*, hereby amends its Regulations as shown below:—

FIRST SCHEDULE.

PROFESSIONAL DIVISION.

Amount of Salary Assigned to Offices in Class "A1".

Office.	Yearly Rate of Salary.
DEPARTMENT OF HEALTH.	£
GENERAL HEALTH BRANCH.	
<i>Delete—</i>	
Senior Health Officer	3,525
<i>Add—</i>	
Assistant Chief Health Officer (Public Health)	3,525
MATERNAL AND CHILD WELFARE BRANCH.	
<i>Add—</i>	
Assistant Chief Health Officer (Child Health)	3,525

A. GARRAN, Chairman.
V. P. SCULLY, Secretary.

Office of the Public Service Board,
Melbourne, 29th March, 1961.

PUBLIC SERVICE OF VICTORIA.—VACANCIES.

APPLICATIONS will be received by the Public Service Board up to Friday, the 21st April, 1961, from persons employed in the Public Service of Victoria, who are eligible and qualified for appointment to the under-mentioned positions:—

ADMINISTRATIVE DIVISION.

Accountant, Accident Insurance Office, Class "A1", State Insurance Office, Chief Secretary's Department.

Yearly Salary.—£2,175.

Duties.—To act as Accountant, Collector of Imposts, and Certifying Officer of the State Accident and State Motor Car Insurance Offices.

Qualifications.—A qualified Accountant with a knowledge and experience of accounting procedure relating to Accident Insurance, including Agency, Re-insurance and Bonus Accounts. A good knowledge of the Workers Compensation Acts and the Motor Car Acts.

Class "C1", Department of Crown Lands and Survey.

Yearly Salary.—£960, minimum; £1,060, maximum.

Duties.—To supervise the drawing of diagrams on Crown grants and leases, and to check them with the record plans of the Department.

Qualifications.—Survey draughting experience; a good knowledge of the record plans, the Land and Closer Settlement Acts and Regulations, and the special conditions applicable to the alienation of Crown lands; to have passed the prescribed examination for Clerk and Draughtsman.

Class "C", Department of Crown Lands and Survey.

Yearly Salary.—£710, minimum; £860, maximum.

Duties.—To assist in the preparation and payment of salaries and wages and the keeping of records.

Qualifications.—Experience in the operation of a mechanized pay-roll; a knowledge of the Superannuation Acts and the applicable Regulations under the Public Service Act.

Class "C", Vermin and Noxious Weeds Branch, Department of Crown Lands and Survey.

Yearly Salary.—£710, minimum; £860, maximum.

Duties.—To examine claims for subsidies in respect of fumigants, poisons and weedicides, and deal with correspondence and keep records; to check chargings for hire of departmental equipment and expenses claims of field staff; to keep records of employees' leave.

Qualifications.—Experience in correspondence and accounts; a knowledge of the Land Acts and the *Vermin and Noxious Weeds Act 1958* and Regulations.

PROFESSIONAL DIVISION.

Senior District Health Officer, Class "A1", General Health Branch, Department of Health.

Yearly Salary.—£3,300.

Duties.—To be District Health Officer for the metropolitan health area; to advise medical officers of health and health inspectors in the discharge of their duties.

Qualifications.—A legally qualified medical practitioner of Victoria with a degree or diploma of public health; experience in administration of the Health and cognate Acts and the regulations.

Chief Structural Engineer, Class "A1", Public Works Department.

Yearly Salary.—£2,600.

Duties.—To be responsible for the preparation of detailed plans, computations, estimates, specifications and reports for structural works in connexion with all types of State buildings; to organize the essential plant and labour for the execution by day labour of structural works in connexion with buildings for structures of steel framing, reinforced concrete, brick masonry, timber construction and prefabricated units.

Qualifications.—A Degree or Diploma in Civil Engineering; experience in structural procedure; workshop practice, computations, designing, drafting specifications, reporting and estimating for a wide range of buildings and structures.

Principal Research Officer, Class "A1", Soil Conservation Authority, Premier's Department.

Yearly Salary.—£2,300.

Duties.—To be responsible to the Authority for the development and direction of the Research programme and the operations of the Research Division. (The work of the Division includes soil and ecological surveys, chemical and physical investigations into the properties of soils, agronomic, hydrologic and economic studies in relation to conservation, land use and erosion control).

Qualifications.—A Degree in Science or Agricultural Science and considerable research experience in several of the fields of study outlined above.

Computing Draughtsman (Geodetic), Classes "C"—"C1", Department of Crown Lands and Survey.

Yearly Salary.—£710, minimum; £1,060, maximum.

Duties.—Under direction to compute and record trigonometrical and photo-control survey data from original field observations.

Qualifications.—A competent geodetic computer with a knowledge of computations associated with the compilation of departmental maps on the Traverse Mercator Projection, and capable of recording Trigonometrical data. To possess the pre-requisite qualifications prescribed in paragraphs (a) and (b) of Public Service (Public Service Board) Regulation 23.

TECHNICAL AND GENERAL DIVISION.

Senior Inspector of Land Settlement, Vermin and Noxious Weeds Branch, Department of Crown Lands and Survey.

Yearly Salary.—£942, minimum; £1,038, maximum.

Duties.—To supervise the work of a group of Inspectors and to instruct them in the proper use and maintenance of power equipment; to inspect and furnish reports and valuations of land and improvements as required under the provisions of the Acts administered by the Department.

Qualifications.—A sound knowledge of the Vermin and Noxious Weeds Act, and to be familiar with other Acts administered by the Department; experience with modern power equipment and the latest fumigants and weedicides used by the Department for the control of vermin and noxious weeds; a sound knowledge of land valuations; ability to advise on farming methods generally.

Inspector of Land Settlement, Vermin and Noxious Weeds Branch, Department of Crown Lands and Survey.

Yearly Salary.—£622, minimum; £894, maximum.

Duties.—To administer the *Vermin and Noxious Weeds Act 1958*; to inspect and furnish reports and valuations on land and improvements as required under the Land, Closer Settlement, Wire Netting, and Agricultural Colleges Acts, and part of the Local Government Act (unused roads and water frontages); to furnish reports and valuations on land improvements as required by the Soldier Settlement Commission and the Rural Finance Corporation.

Qualifications.—A knowledge of the relevant provisions of the above-mentioned Acts; ability to make land valuations and to advise on farming methods generally, including the correct utilization of land.

Attendant, Grade I, National Gallery, National Museum and Institute of Applied Science, Chief Secretary's Department.

Yearly Salary.—£494, minimum; £510, maximum.

Duties.—To supervise the Office Cleaners, Labourers and Lavatory Attendants; to assist generally in the General Division work of the National Gallery and Museums; to perform the duties of Senior Attendant when required, and other duties as directed.

Qualifications.—Sound physique, good address, and suitability for attending to the Public; experience in a National Gallery or Museum; or other appropriate service.

NOTE.—Successful applicant will be required to undertake shift duties from 6 a.m. to 3 p.m.

NOTE.—The salary rates quoted above do not include the additional amount which is payable under Regulation 77A of the Board's Regulations.

By order,

V. P. SCULLY,

Secretary.

Office of the Public Service Board,
Melbourne, 6th April, 1961.

PUBLIC SERVICE OF VICTORIA.—VACANCY.

(TEMPORARY APPOINTMENT.)

APPLICATIONS will be received by the Public Service Board up to Friday, the 21st April, 1961, from persons who are qualified for appointment to the under-mentioned position:—

Photographic Assistant (Female), Department of Crown Lands and Survey.

Yearly Salary.—

Junior—Under 16 years of age, £127;
at 16 years of age, £153;
at 17 years of age, £166;
at 18 years of age, £197;
at 19 years of age, £241;
at 20 years of age, £285.

Adult—£316, minimum; £396, maximum.

Duties.—To assist in the Photographic Laboratory.

Qualifications.—Experience in the operation of continuous printers, and the washing, glazing and drying of prints.

The salary rates quoted above do not include the additional amount which is payable under Regulation 77A of the Board's Regulations.

By order,

V. P. SCULLY,

Secretary.

Office of the Public Service Board,
Melbourne, 6th April, 1961.

PUBLIC SERVICE OF VICTORIA.—VACANCIES.

DEPARTMENT OF HEALTH.

MENTAL HYGIENE BRANCH.

TECHNICAL AND GENERAL DIVISION.

APPLICATIONS will be received by the Public Service Board up to Friday, the 28th April, 1961, from persons employed in the Public Service of Victoria, who are eligible and qualified for appointment to the under-mentioned positions:—

Charge Nurse (Male), Beechworth Mental Hospital.

Yearly Salary.—£606, minimum; £654, maximum.

Duties.—To take charge or sub-charge of a ward in a Mental Hospital.

Qualifications.—A current practising certificate for Mental Nursing, and experience as a Deputy Charge Nurse in a Mental Hospital.

Tailor, Leading Hand, Sunbury Mental Hospital.

Yearly Salary.—£590.

Duties.—To be in charge of Tailor's Shop; to manufacture and repair clothing, &c.

Qualifications.—A qualified tailor able to cut, draft and manufacture the types of male clothing in use for mental patients.

Seamstress, Grade II, Beechworth Mental Hospital.

Yearly Salary.—£364, minimum; £396, maximum.

Duties.—To make up and repair clothing and bedding, and to supervise patients working in the sewing room.

Qualifications.—A competent needlewoman and machinist.

Cleaner and Labourer.

1 vacancy—Mont Park Mental Hospital.

1 vacancy—Kew Mental Hospital.

Yearly Salary.—£318, minimum; £334, maximum.

NOTE.—The salary rates quoted above do not include the additional amount which is payable under Regulation 77A of the Board's Regulations.

By order,

V. P. SCULLY,
Secretary.

Office of the Public Service Board,
Melbourne, 6th April, 1961.

PRIVATE ADVERTISEMENTS

CITY OF GEELONG WEST.

LOAN No. 46.

Notice of Intention to Borrow the Sum of £15,000 for Permanent Works and Undertakings.

NOTICE is hereby given that the Council of the City of Geelong West proposes to borrow the sum of Fifteen thousand pounds on the credit of the municipal revenues of the Mayor, Councillors and Citizens of the said City, such sum to be raised by the grant of mortgage in accordance with the provisions of the *Local Government Act 1958*.

1. The maximum rate of interest that may be paid is 5½ per cent. per annum.

2. The purpose for which the Loan is to be applied is:—

The execution of work under the provisions of sections 510 and 594 of the *Local Government Act 1946*, in pursuance of a scheme which was prepared by the Council; advertised in the *Government Gazette* on the 3rd of December, 1958 and approved by the Governor in Council on the 6th October, 1960, such approval being published in the *Government Gazette* on 19th October, 1960.

3. The period of the loan shall be five years.

4. Interest only will be paid half-yearly during the first eighteen months of the loan, and thereafter payment of interest and repayment of principal shall be made by seven equal half-yearly instalments of £2,396 5s. 4d. The first payment of interest shall be payable on the 1st January, 1962, and the first instalment covering interest and repayment of principal shall be payable on 1st July, 1963.

5. Such moneys shall be repayable at the Commonwealth Trading Bank of Australia, Melbourne.

The plans and specifications and the estimate of the cost of the proposed works and a statement showing the proposed expenditure of the moneys to be borrowed, are open for inspection at the Town Hall, Pakington-street, Geelong West.

13435

H. R. FRENCH, Town Clerk.

CITY OF MOORABBIN.

LOAN No. 112.

Notice of Intention to Borrow the Sum of Fifty thousand pounds (£50,000) for Permanent Works and Undertakings.

NOTICE is hereby given that the Council of the City of Moorabbin proposes to borrow the sum of Fifty thousand pounds (£50,000) on the credit of the municipal revenues of the Mayor, Councillors and Citizens of the said City, such sum to be raised by the grant of a mortgage, in accordance with the provisions of the *Local Government Act 1958*.

1. The maximum rate of interest that may be paid is 5½ per cent. per annum.

2. The purposes for which the loan is to be applied are:—

Construction of roads	£11,499
Purchase of land for recreational purposes	9,864
Construction and provision of workshops and nursery buildings at Council Depot—	
completion of works	28,637
	£50,000

3. The period of the loan shall be twenty years.

4. The loan shall be repaid by the creation of a sinking fund, and an appropriate amount will be set aside annually out of the municipal fund for such purpose.

5. The moneys borrowed shall be repayable at the Australia and New Zealand Bank Limited, 394 Collins-street, Melbourne, or at the Council's bankers for the time being in Melbourne.

6. The plans, specifications and estimate of the cost of the proposed works and undertakings and a statement showing the proposed expenditure of the moneys to be borrowed, are open for inspection at the Municipal Offices, Nepean Highway, Moorabbin, during office hours.

Dated this 30th day of March, 1961.

13447

V. A. SMITH, Town Clerk.

No. 480.

CITY OF NUNAWADING.

ALTERATION OF STREET NAME.

NOTICE is hereby given that, in pursuance of the powers conferred by the *Local Government Act*, the Council of the City of Nunawading did, at a meeting held on the 28th November, 1960, order that the following alteration be made in the name of the street as under, and that such Order take effect from the date of this publication in the *Victoria Government Gazette*:—

Old Name; New Name.

Northcote-street; Brunswick-road.

13477

A. ROY CHARLESWORTH, Town Clerk.

Dog Act 1958.

CITY OF NEWTOWN AND CHILWELL.

DECLARATION OF SHOPPING AREAS.

IN pursuance of the powers conferred by section 17 of the *Dog Act 1958*, the Council of the City of Newtown and Chilwell doth order that the portions of the streets described hereunder shall be Shopping Areas in the City of Newtown and Chilwell, for the purpose of the section aforementioned, viz:—

Pakington-street from Noble-street to Fyans-street; Latrobe-terrace from Noble-street to Sharp-street; Skene-street from Manning-street to west side of Cumberland-street; Stinton-avenue west side extending 100 feet south from Nicholas-street; Nicholas-street south side from Stinton-avenue to Daisy-street, Parish of Moorpanyal, County of Grant.

In witness whereof the common seal of the City of Newtown and Chilwell was affixed hereto this 29th day of March, 1961.

J. H. JEPSON, Mayor.

(SEAL) W. A. BODEY, Councillor.

13445

GEO. COCKS, Town Clerk.

CITY OF NEWTOWN AND CHILWELL.

BY-LAW No. 57.

A By-law of the City of Newtown and Chilwell made under section 65 of the *Health Act 1958*, as amended by the *Health (Amendment) Act 1960*, and numbered 57, for fixing a fee for the examination of plans, specifications, particulars and descriptions of proposed septic tank systems and any inspection of sites and installations.

THE Mayor, Councillors and Citizens of the City of Newtown and Chilwell, in pursuance of the powers conferred by the *Health Act 1958*, and of any and every other power enabling it in that behalf order as follows:—

1. The following fee is hereby fixed—

For the examination of plans, specifications, particulars and descriptions of proposed septic tank systems, and any inspection of sites and installations of septic tank systems	£4 0 0
--	--------

Resolution for passing this By-law agreed to by the Council of the City of Newtown and Chilwell on the 22nd day of February, 1961.

Confirmed on the 29th day of March, 1961.

In witness whereof the common seal of the Mayor, Councillors and Citizens of the City of Newtown and Chilwell was affixed hereto, in the presence of—

(SEAL) J. H. JEPSON, Mayor.
W. A. BODEY, Councillor.
GEO. COCKS, Town Clerk.

13444

CITY OF SUNSHINE.

LOAN No. 39.

Notice of Intention to Borrow the Sum of £10,000 for Permanent Works and Undertakings.

NOTICE is hereby given that the Council of the City of Sunshine proposes to borrow the sum of Ten thousand pounds on the credit of the municipal revenues of the Mayor, Councillors and Citizens of the said City, such sum to be raised by the grant of a mortgage, in accordance with the provisions of the *Local Government Act 1958*.

1. The maximum rate of interest that may be paid is 5½ per centum per annum.

2. The purpose for which the loan is to be applied is:—

(a) Construction of kerb, channels and foot-paths, Forrest-street	£6,000
(b) Construction of pavilion, Pennell Reserve	2,000
(c) Construction of sewerer conveniences, Maribyrnong Reserve	2,000

3. The period of the loan shall be fifteen years.

4. The moneys borrowed shall be repayable by providing out of the municipal fund 30 half-yearly payments of £493 16s. 11d. each, including principal and interest, on the 1st day of June and the 1st day of December during the currency of the loan. The first instalment shall be payable on the 1st day of December, 1961.

5. Such moneys shall be repayable at the Commonwealth Savings Bank of Australia, Melbourne.

The plans and specifications and the estimate of the cost of the proposed works and a statement showing the proposed expenditure of the moneys to be borrowed, are open for inspection at the Town Hall, Sunshine.

2nd March, 1961.

13446

T. W. DEUTSCHMANN, Town Clerk.

BOROUGH OF BENALLA.

NOTICE is hereby given that Charles Henry Wallace, of 1 Smythe-street, Benalla, has been appointed Poundkeeper in place of L. A. Hemley.

13453

L. A. HEMLEY, Town Clerk.

SHIRE OF BERWICK.

NOTICE is hereby given that the Council of the Shire of Berwick, in pursuance of the powers conferred by the *Local Government Acts*, has renamed the following road, namely:—

Old Name.—Fogarty-road.

New Name.—Hall-road.

Location.—Commencing at the junction with Woori Yallock-Pakenham-Koo-Wee-Rup road at the north-west corner of Crown allotment 47, section J, and continuing easterly to the north-east corner of Crown allotment 25, section H, Parish of Koo-Wee-Rup.

By order of the Council,

13478

BEATRICE THOMAS, Shire Secretary.

SHIRE OF CHARLTON.

BY-LAW No. 26.

A By-law of the Shire of Charlton made under section 65 of the *Health Act 1958*, as amended by the *Health (Amendment) Act 1960*, for fixing a fee for the examination of plans, specifications, particulars and descriptions of proposed septic tank systems and any inspection of sites and installations.

IN pursuance of the powers of the *Health Act 1958*, and of any and every other power it thereunto enabling the President, Councillors and Ratepayers of the Shire of Charlton, orders as follows:—

1. The following fee is hereby fixed—

For the examination of plans, specifications, particulars and descriptions of proposed septic tank installations, and any inspection of sites and installations of septic tank systems, Two pounds (£2).

Resolution for passing this By-law was agreed to by the Council of the Shire of Charlton on the 28th day of February, 1960, and confirmed on the 28th day of March, 1960.

The corporate seal of the President, Councillors and Ratepayers of the Shire of Charlton was hereunto affixed this 28th day of March, 1960, in the presence of—

13449

(SEAL) L. J. H. BARTLETT, President.
S. B. COSSAR, Councillor.
G. J. MORTON, Secretary.

SHIRE OF CRESWICK.

BY-LAW No. 24.

A By-law of the Shire of Creswick made under section 65 of the *Health Act 1958* as amended by the *Health (Amendment) Act 1960* and numbered twenty-four for fixing a fee for the examination of plans, specifications particulars and descriptions of proposed septic tank systems and any inspection of sites and installations.

IN pursuance of the powers of the *Health Act 1958* and of any and every other power it thereunto enabling the President, Councillors and Ratepayers of the Shire of Creswick order as follows:—

1. The following fee is hereby fixed:—

For the examination of plans, specifications particulars and descriptions of proposed septic tank systems, and any inspection of sites and installations of septic tank systems £1 (one pound).

Resolution for passing this By-law was agreed to by the Council of the Shire of Creswick on the twentieth day of March, 1961, and confirmed on the tenth day of April, 1961.

The corporate seal of the President, Councillors and Ratepayers of the Shire of Creswick was hereunto affixed in the presence of—

13443

(SEAL) J. A. S. GEDDES, President.
A. E. HOLTON, Councillor.
E. J. SEMMENS, Councillor.
J. B. WILKIE, Shire Secretary.

SHIRE OF HEALESVILLE.

BY-LAW No. 41.

NOTICE is hereby given that the Council of the Shire of Healesville has made a By-law, No. 41, for the purpose of fixing a fee of £2 2s. for the examination of plans and specifications, particulars and descriptions of proposed septic tank systems and any inspections of sites and installations.

A copy of the said By-law is available for inspection, free of charge, during office hours, at the Shire Office, Healesville.

13452

W. M. OLIVER, Shire Secretary.

SHIRE OF PYALONG.

NOTICE is hereby given that First Constable John Shirley has been duly appointed by the Council as Prosecuting Officer and Inspector of Nuisances.

13437

J. F. RYAN, Shire Secretary.

VICTORIA RACING CLUB ACT 1871.

NOTICE is hereby given that amendments to By-laws Nos. 3, 19, 20, 26, 26A, and 47 were duly passed by the Committee of the above club on the 17th day of February, 1961, and that, in accordance with section 15 of the said Act, such amendments were, on the 21st day of March, 1961, sent to the Chief Secretary and that such amendments have not been disallowed.

The said amendments read as follows:—

In By-law No. 3, after the words "for fifty years or over" appearing in the fourth line, the following words were added, viz.:—

"or who, in the opinion of the Committee, have rendered special services to the Club or to racing in Victoria or elsewhere or who for any other special reason the Committee decides it is desirable to appoint as Life Members."

In By-law No. 19, after the word "Secretary", the following words were added, viz.:—

"unless the Committee shall otherwise determine".

In By-law No. 20, the word "third" appearing in the second line was deleted and the word "fourth" substituted therefor.

By-law No. 26, as it now stands, was deleted and the following new By-law No. 26 substituted therefor, viz.:—

"26. Subject to the provisions of these By-laws all Members of the Club shall upon production of their tickets be admitted at all race-meetings conducted by the Club to all parts of the said land with the exception of such portions thereof or the stands and buildings erected thereon as the Committee may from time to time specifically allot for special purposes."

In By-law No. 26A, the word "Member" appearing in the first line of paragraph 1 thereof was deleted and the word "person" substituted therefor.

In By-law No. 47, the whole of the last two paragraphs beginning with the words "Provided subject" were deleted and the following paragraph substituted in their place, viz.:—

"Provided that all male Members of the Club shall upon production of their tickets be admitted without payment of any of the above tolls and charges to the racecourse in accordance with By-law No. 26. Lady Members and the holders of Members' Ladies' tickets shall be entitled to the same privileges except admission to such parts of the enclosures as are reserved for male Members."

T. C. MANIFOLD, Chairman, Victoria Racing Club.
13492

I, KEITH BRIAN LUCAS, of 47 Bendigo-street, Richmond, in the State of Victoria, purchasing officer, heretofore called and known by the name of Keith Brian Schlager, hereby give public notice that by a deed poll dated the 23rd March, 1961, duly executed and attested and deposited with the Registrar-General of the said State on the 28th March, 1961, I formally and absolutely renounced and abandoned the said surname of Schlager and declared that I have assumed and adopted and intended thenceforth upon all occasions whatsoever to use and subscribe the surname Lucas instead of the surname Schlager, and so as to be at all times thereafter known and described by the said name of Keith Brian Lucas.

Witness.—J. WISEMAN.
K. B. LUCAS.
13436

BENDIGO SEWERAGE AUTHORITY.

COMPULSORY ACQUISITION OF LANDS SITUATED OUTSIDE THE SEWERAGE DISTRICT.

NOTICE is hereby given that the Bendigo Sewerage Authority, under the powers conferred by the Sewerage Districts Acts, proposes to acquire by compulsory acquisition the lands described hereunder.

The land is proposed to be taken for the treatment of sewage and to form further portions of the Authority's Treatment Area.

A plan showing the lands to be acquired will be open for inspection at the Authority's Offices, "Civic Buildings", Hargreaves-street, Bendigo, between the hours of 10 a.m. and 4 p.m., Mondays to Fridays inclusive.

The land proposed to be acquired is the whole of Crown allotments 3, 12, and 16, no section, Parish of Huntly, County of Bendigo, as shown by red colour on a plan

approved by the Governor in Council on the 15th day of March, 1961, and deposited in the office of the State Rivers and Water Supply Commission, Melbourne.

13454 H. A. MOORS, Secretary.

DIMBOOLA SEWERAGE AUTHORITY.

DESCRIPTION OF SEWERAGE AREA No. 3 AS PROVIDED UNDER THE SIXTH SCHEDULE OF THE SEWERAGE DISTRICT ACT 1958.

THE above-mentioned Sewerage Authority, having made provision for carrying off the sewage from each and every property which, or any part of which, is within the sewerage area hereinafter described, doth hereby declare that on and after the 1st day of October, 1960, each and every property which, or any part of which, is within the said sewerage area shall be deemed to be a seweraged property within the meaning of the *Sewerage District Act 1958*.

The boundaries of the sewerage area hereinbefore referred to are as follows:—Commencing at a point on the existing boundary of Area No. 2, such point being the north-western corner of lot 10 on lodged plan 8337; thence in a north-easterly direction along the northern boundaries of lots 10, 11, and 12 on lodged plan 8337, and lots 1, 2, and 3 on lodged plan 12440 to the most north-eastern corner of lot 3 on lodged plan 12440; thence in a north-westerly direction by a line across a road to the south-eastern corner of lot 9 on lodged plan 12709; thence continuing in a straight line along the eastern boundary of the said lot 9 to the north-eastern corner of the said lot 9; thence by a line across a right-of-way to the south-eastern corner of lot 18 on lodged plan 12709; thence in a south-westerly direction along the southern boundaries of lots 18, 19, 20, 21, and 22 on lodged plan 12709 to the south-western corner of the said lot 22; thence in a south-westerly direction by a line across Emily-street to the south-eastern corner of lot 23 on lodged plan 12709; thence in a north-westerly direction along the eastern boundary of the said lot 23 to the north-eastern corner of the said lot 23; thence in a south-westerly direction along the northern boundary of the said lot 23 to the north-western corner of the said lot 23; thence in a south-easterly direction along the western boundary of the said lot 23 to the south-western corner of lot 23; thence continuing in a straight line by a line across a right-of-way to the intersection of the said line and the existing boundary of Area No. 2; thence generally in a north-easterly then south-easterly direction along the existing boundary of Area No. 2 to the point of commencement.

By order of the said Sewerage Authority.

13475 A. D. S. ANDERSON, Chairman.
T. MICHIE, Secretary.

NOTICE is hereby given that Philips Electrical Industries Pty. Limited, has applied for a lease under section 134 *Land Act 1958*, for a term of 50 years from 1st June, 1961, of allotments 16 and 17 of section E, City of South Melbourne, Parish of Melbourne South, containing 3 roods 24 perches, as a site for offices, warehouse and electrical merchandising.
13459

NOTICE OF DISSOLUTION.

NOTICE is hereby given that the partnership heretofore subsisting between Filomena Di Biase and Irma Scinetti, carrying on business as cafe proprietors, at 195 Williamson-street, Bendigo, under the style or firm of "Filomena Di Biase and Irma Scinetti", has been dissolved as from the 28th day of December, 1960, as far as concerns the said Filomena Di Biase. All debts due and owing by the said firm shall be received and paid by Irma Scinetti, who will continue to carry on the business at 195 Williamson-street, Bendigo.
13438

NOTICE is hereby given that the partnership heretofore subsisting between Walter Raymond Swaby and Ian David Swaby, carrying on business as optometrists, at 71 Kennedy-street, Hamilton, under the style or firm of W. R. & I. D. Swaby, has been dissolved as from the 1st day of January, 1961, so far as concerns the said Walter Raymond Swaby, who retires from the said firm. All debts due to and owing by the said firm will be received and paid respectively by Ian David Swaby, who will continue to carry on the said business under the style of "W. R. & I. D. Swaby."

Dated this 21st day of March, 1961.

13470 W. R. SWABY.
IAN D. SWABY.

NOTICE is hereby given that the partnership heretofore subsisting between Andrew Alexander Gray, Denis Roy Elam and Jerrold William Thomson, carrying on practice as medical practitioners, at 208 Maribyrnong-road, Moonee Ponds, and at 29 Military-road, Avondale Heights, under the style or firm name of Drs. Gray, Elam and Thomson, has been dissolved as from the 31st day of March, 1961, so far as concerns the said Jerrold William Thomson, who retires from the said firm. All accounts owing to the said firm should be forwarded to Drs. Gray and Elam, at 208 Maribyrnong-road, Moonee Ponds.

Dated the 31st day of March, 1961.

A. A. GRAY.

Signed by the said Andrew Alexander Gray, in the presence of—G. B. SEWELL, solicitor, Melbourne.

D. R. ELAM.

Signed by the said Denis Roy Elam, in the presence of—G. B. SEWELL,

J. W. THOMSON.

Signed by the said Jerrold William Thomson, in the presence of—G. B. SEWELL.

Sewell and Sewell, 422 Collins-street, Melbourne, 13491
solicitors.

NOTICE is hereby given that the partnership heretofore subsisting between Alan Lewis Mewkill and Phyllis Mary Mewkill, carrying on business as newsagents and stationers, at 68 Sackville-street, Port Fairy, under the style or firm of "Mewkills' Authorized Newsagency", has been dissolved by mutual consent as from the 3rd day of April, 1961. The business will be carried on at the same address under the same style or firm as heretofore by the said Alan Lewis Mewkill in partnership with Alan Charles Lucas.

Dated this 5th day of April, 1961.

A. L. MEWKILL.

P. M. MEWKILL.

A. C. LUCAS.

13476

The Companies Act 1958.—In the matter of **WHITEMAN'S GARAGES PROPRIETARY LIMITED.**—Notice *re* Meeting of Creditors, pursuant to section 201 (2).

NOTICE is hereby given that a Meeting of Creditors of the above-named company will be held at The Auction Room, Scotts Hotel, 444 Collins-street, Melbourne, on Monday, 17th April, 1961, at 10.30 a.m., the company having convened a meeting of its members for the same day for the purpose of considering a Resolution that the company be wound up voluntarily.

K. I. WHITEMAN, Director.

Ernest Fookes and Co., 339 Collins-street, Melbourne, C.1. 13441

The Companies Act 1958.—In the matter of **ANGLO AUSTRALIAN DISTRIBUTORS (VIC.) PROPRIETARY LIMITED.**—Notice of Meeting of Creditors, pursuant to section 201 (1) and (2).

NOTICE is hereby given that a Meeting of Creditors of the above-named company will be held in the "Burne Room", Room 409, Employers' Federation Building, 342 Flinders-street, Melbourne, on Friday, the 14th April, 1961, at Four p.m., the company having convened a meeting of its members for the same day for the purpose of considering, and if thought fit, approving a Resolution that the company be wound up voluntarily.

Dated this 30th day of March, 1961.

13434

M. COLLINS, Director.

Companies Act 1958.

THE LITTLE COLLINS STREET PROPRIETARY LIMITED.

Registered Office: The Office of Associated Pulp and Paper Mills Limited, 6th Floor, 360 Collins-street, Melbourne.

NOTICE is hereby given that at a General Meeting of the members of the above company held on the 28th March, 1961, the following Special Resolution was passed:—

"That the company be wound up voluntarily and that Charles Tonge Battersby be appointed liquidator for the purposes of such winding up."

Dated this 28th March, 1961.

13488

C. T. BATTERSBY, Liquidator.

No. 25—2680/61.—3

Companies Act 1958.

THE CENTRAL PROPRIETARY LIMITED.

Registered Office: The Office of Associated Pulp and Paper Mills Limited, 6th Floor, 360 Collins-street, Melbourne.

NOTICE is hereby given that at a General Meeting of the members of the above company held on the 28th March, 1961, the following Special Resolution was passed:—

"That the company be wound up voluntarily and that Charles Tonge Battersby be appointed liquidator for the purposes of such winding up."

Dated this 28th March, 1961.

13487

C. T. BATTERSBY, Liquidator.

The Companies Act 1958.—In the matter of **FIFTH AVENUE FASHIONS PROPRIETARY LIMITED.**—Notice *re* Meeting of Creditors, Pursuant to Section 201 (2).

NOTICE is hereby given that a Meeting of Creditors of the above-named company will be held in the offices of Kennedy, Smail and Middlemiss, 31 Queen-street, Melbourne, on Monday, 10th day of April, 1961, at 11.00 a.m. the company having convened a meeting of its members for the same day for the purpose of considering a Resolution that the company be wound up voluntarily.

Dated this 27th day of March, 1961.

L. F. GATES, Director.

Kennedy, Smail and Middlemiss, 31 Queen-street, Melbourne. 13464

The Companies Act 1958.—In the matter of **CHATHAM HARDWARE SUPPLIES PROPRIETARY LIMITED (in Liquidation).**

NOTICE is hereby given that at an Extraordinary Meeting of the members of the above-named company held on Wednesday, the 22nd day of March, 1961, it was resolved that the company be wound up voluntarily, and at a meeting of creditors held on the same day, pursuant to section 201, it was resolved that for such purpose George Roy Thompson and Norman Eric Stretton, of 31 Queen-street, Melbourne, accountants, be appointed liquidators.

Notice is also given that after 21 days from this date we shall proceed to distribute the assets. All creditors having any claims against the company should furnish particulars of same by that date, otherwise we shall proceed to distribute the assets without regard to their claim.

Dated this 30th day of March, 1961.

G. R. THOMPSON & N. E. STRETTON, Liquidators.

Kennedy, Smail and Middlemiss, 31 Queen-street, Melbourne. 13465

The Companies Act 1958.

LINDBERG FOSTER DISPLAYS PROPRIETARY LIMITED (IN VOLUNTARY LIQUIDATION).

NOTICE OF FINAL MEETING.

NOTICE is hereby given that, pursuant to section 210 of the *Companies Act 1958*, a General Meeting of the members and of the creditors of the above-named company will be held at 6th Floor, 83 William-street, Melbourne, on Monday, 8th day of May, 1961, at 11 o'clock in the forenoon, for the purpose of having an account laid before them showing the manner in which the winding up has been conducted and the property of the company disposed of, and of hearing any explanation that may be given by the liquidator.

13466

J. M. HILLIARD, Liquidator.

The Companies Act 1958, Section 210 (2).

RE AUSTRAL BABY CARRIAGES (VIC.) PROPRIETARY LIMITED (IN LIQUIDATION).

NOTICE is hereby given that a General Meeting of the members and the creditors of the above-named company will be held at 62 Wellington-parade, East Melbourne, on Friday, the 12th day of May, 1961, at 9.30 a.m. for the purpose of laying before them an account of my acts and dealings and of the conduct of the winding up during the preceding years.

Dated this 5th day of April, 1961.

13471

J. HENRY, Liquidator.

HOLDENSON AND NIELSON FRESH FOOD PTY. LTD.

REGISTER of Unclaimed Moneys Held by Holdenson and Nielson Fresh Food Pty. Ltd., 628 Bourke-street, Melbourne, C.I.

Name and Address of Owner on Books.	Total Amount Due to Owner.	Description of Unclaimed Money.	Date of Last Claim.
	£ s. d.		
H. and B. F. Elvery, Launching Place	1 13 8	Cheque	January, 1954
E. Lindner, Walla Walla	10 13 5	"	February, 1954
H. C. Moncrieff, North Berry Berry	1 5 0	"	February, 1954
W. A. Carron, Gerogery	5 11 10	"	April, 1954
D. Klimpsch, Yerong Creek	3 15 2	"	April, 1954
R. M. Beon, Temora	1 6 4	"	May, 1954
F. I. Severin, Burrumbuttock	1 6 4	"	June, 1954
J. E. Mackenzie, Henty	2 2 3	"	August, 1954
G. G. Graetz, Henty	3 1 5	"	September, 1954
M. Thomas, Osborne	1 5 10	"	September, 1954
I. Schneider, Ryan, via Henty	6 19 11	"	October, 1954
C. F. Gibbons, Wodonga	1 16 5	"	November, 1954
E. L. Glass, Wodonga	4 9 1	"	November, 1954
F. G. D. Johnson, Amphitheatre	1 2 8	"	May, 1954
J. Downing, Ballarat	3 9 7	"	March, 1954
A. Pearce, Massey	1 13 6	"	June, 1954
Modern Dairy, Ballarat	1 5 10	"	August, 1954
M. Gould, Kunnabulla	2 6 9	"	April, 1954
J. J. O'Sullivan, Runnymeade	1 4 8	"	May, 1954
T. Dillon, Wycheproof	2 0 4	"	June, 1954
E. V. McLean, Arnold	4 16 7	"	June, 1954
R. J. Harrison, Bridgewater	3 1 5	"	September, 1954
E. Wilson, Bendigo	4 5 1	"	November, 1954
R. G. Crighton, Macorna North	2 17 1	"	July, 1954
W. G. Sutfield, Wangaratta	0 8 7	"	March, 1954
E. G. Sutton, Yarrowonga North	15 15 2	"	November, 1954
H. T. Wright, Cobram	0 1 10	"	November, 1954
F. H. Henton, Derrinalium	9 9 3	"	August, 1954
E. G. Menzel, Tarrington	0 7 0	"	July, 1954
J. R. Saunders, Boosey	0 1 11	"	November, 1954
Holder of Cheque No. 6899	0 4 10	"	November, 1954
A. Yeoman, Streatham	0 19 2	"	May, 1954
M. M. Williams, Streatham	0 3 11	"	September, 1954
A. M. Bethune, Seville	5 5 3	"	March, 1954
W. C. Price, Baulkamaugh	0 5 9	"	June, 1954
H. Fisher, Numurkah	1 5 4	"	November, 1954
J. Ayson, Rochester	1 16 11	"	August, 1954
J. R. Waldron, Marionvale	3 0 8	"	November, 1954
W. Watson, Mooroopna	4 4 8	"	November, 1954
F. Pendergast, Shepparton	0 2 10	"	November, 1954
A. S. Fitzpatrick, Eden Park	2 16 3	"	August, 1954
L. Neumann, Katunga	1 14 7	"	November, 1954
A. Southern, Wangaratta	0 7 6	"	March, 1954
M. A. Williams, Bremin	0 16 10	"	May, 1954
Holder of Cheque No. 490	9 11 10	"	
	132 0 3		

13439

Companies Act 1938—Section 153(3).

WANGARATTA WOOLLEN MILLS LIMITED.

REGISTER of Unclaimed Moneys held by Wangaratta Woollen Mills Limited, as at 1st March, 1961.

Name of Owner on Books.	Total Amount Due to Owner.	Description of Unclaimed Money.	Date of Last Claim.
	£ s. d.		
Bell, J. R.	0 12 0	Dividends payable in respect of year ended 31st May, 1954	..
Dickson, W. J.	0 12 0	" " " " " "	..
Goonan, M. J.	4 4 0	" " " " " "	..
Hennessy, P. (Estate of)	0 18 0	" " " " " "	..
Hill, W. J.	0 18 0	" " " " " "	..
Lauenstein, M. (Estate of)	0 7 3	" " " " " "	..
Lawrence, J. F. (Estate of)	0 18 0	" " " " " "	..
Lenard, E. E.	1 7 0	" " " " " "	..
Lewis, J. T.	0 3 0	" " " " " "	..
Mason, G. G.	0 9 0	" " " " " "	..
Moore, F. T. (Estate of)	9 0 0	" " " " " "	..
Moroney, J. (Estate of)	0 12 0	" " " " " "	..
McPherson, C. J.	0 18 0	" " " " " "	..
Newton, R.	0 18 0	" " " " " "	..
Peterson, O.	1 10 0	" " " " " "	..
Plum, S.	1 10 0	" " " " " "	..
Smith, I. T.	6 0 0	" " " " " "	..
Slater, G.	2 14 0	" " " " " "	..
Walpole, A. A. (Estate of)	0 8 5	" " " " " "	..
Watt, I. C.	3 0 0	" " " " " "	..
Wright, C. S.	18 0 0	" " " " " "	..
	54 18 8		

13433

THE SHEPPARTON CO-OPERATIVE BUTTER FACTORY LTD.

REGISTER of Unclaimed Moneys held by the Shepparton Co-operative Butter Factory Ltd.

Name of Owner on Books.	Total Amount Due to Owner.	Description of Unclaimed Money.	Date of Last Claim.
	£ s. d.		
Anderson, Kate (deceased)	1 2 6	Dividends for year ended 30th June, 1954	No claim
Bowey, John (deceased)	1 2 6	" " " "	"
Brown, Edith	1 2 6	" " " "	"
Burns, Ellen (deceased)	1 10 0	" " " "	"
Darby, James S. (deceased)	2 12 6	" " " "	"
Heaton, J. W. (deceased)	1 2 6	" " " "	"
Kennedy, Edward (deceased)	1 13 0	" " " "	"
Kennedy, Donald (deceased)	1 2 6	" " " "	"
Kennedy, M. J.	1 2 6	" " " "	"
Kenny, M.	1 2 6	" " " "	"
Lane, Veronica	1 2 6	" " " "	"
Linnell, Charles	1 2 6	" " " "	"
Lupton, William (deceased)	1 2 6	" " " "	"
Moore, James A. (deceased)	0 7 6	" " " "	"
McKenzie, Robert (deceased)	1 10 0	" " " "	"
Ponsland, Thomas	1 2 6	" " " "	"
Reed, W. A. (deceased)	0 7 6	" " " "	"
Sheppard, Emma (deceased)	1 2 6	" " " "	"
Smith, Florence M.	0 7 6	" " " "	"
Stewart, Catherine K.	1 2 6	" " " "	"
Thompson, Hanna L. (deceased)	0 10 6	" " " "	"
Toohy, J.	1 2 6	" " " "	"
Turnbull, John (deceased)	1 17 6	" " " "	"
	26 11 0		

13469

Tenth Schedule.

GORDON AND GOTCH (AUSTRALASIA) LIMITED.

(Company No. 6858/8906.)

REGISTER of Unclaimed Moneys held by Gordon and Gotch (Australasia) Limited, 515 Little Collins-street, Melbourne, C.1, on 1st March, 1961.

Name and Address of Owner on Books.	Total Amount Due to Owner.	Description of Unclaimed Money.	Date of Last Claim.
	£ s. d.		
Jane Baxter McNeilly (deceased), c/o F. W. Beechag, Beechag's Chambers, Princes Highway, Rockdale	133 5 0	Dividends	No claim has been made in respect of such money
	133 5 0		

13474

Companies Act 1958—Tenth Schedule.

THE AUSTRALASIAN TEMPERANCE AND GENERAL MUTUAL LIFE ASSURANCE SOCIETY LIMITED.

REGISTER of Unclaimed Moneys held by The Australasian Temperance and General Mutual Life Assurance Society Limited.

Name and Address of Owner on Books.	Total Amount Due to Owner.	Description of Unclaimed Money.	Date of Last Claim.
	£ s. d.		
Curry, Mary Catherine, Cedar-street, Caulfield ..	3 0 0	Maturity Claim Policy Nod. 5854782	12.9.45
Curry, Mary Catherine, Cedar-street, Caulfield ..	2 6 0	Maturity Claim Policy Nod. 5854783	12.9.45
Johnson, Sydney Thomas, 5 Henry-street, Kensington	23 19 6	Maturity Claim Policy Nod. 5512781	6.9.45
Prebble, Bertha Kathleen, 297 Flemington-road, North Melbourne	3 15 9	Death Claim Policy Nod. 5809188	27.7.45

13450

ALLEN HOLDINGS LTD.

REGISTER of Unclaimed Moneys held by Allen Holdings Ltd.

Name of Owner on Books.	Total Amount Due to Owner.	Description of Unclaimed Money.	Date of Last Claim.
	£ s. d.		
Mrs. Pauline Maria Grenfeld	4 10 0	9% B Preference dividend	..
Miss Laura Lena Strachan	35 3 2	7½% Ordinary dividend
13440			

Companies Act 1958.

RE A. B. ELECTRICS PTY. LTD. (IN LIQUIDATION), of 274 Brunswick-street, Fitzroy.

NOTICE is hereby given that a Meeting of Creditors in the above estate will be held in the Board Room of Irwin, Widdows and Coakley, 4th Floor, 366 Bourke-street, Melbourne, on Wednesday, the 12th day of April, 1961, at 10.30 a.m.

Dated this 29th day of March, 1961.

A. J. IRWIN, Liquidator.
366 Bourke-street, Melbourne. 13462

ALL persons having claims against the estate of Mary Theresa Clairmonte, late of 1509 Sturt-street, Ballarat, widow, deceased, probate of whose will has been applied for by The Fidelity Trustee Company Limited, of 101 Lydiard-street north, Ballarat, the executor appointed by the said will, are hereby required to send particulars thereof, in writing, to the said company, on or before the 14th day of June, 1961, after which date the said company will proceed to distribute the assets of the said deceased, having regard only to the claims of which it shall then have had notice, and the said company will not be liable for the assets so distributed, or any part thereof, to any person of whose claim it shall not then have had notice.

R. G. DOBSON & Co., of 52 Lydiard-street, Ballarat, solicitors for the said company. 13455

CREDITORS, next of kin and others having claims against the estate of Geoffrey Laxton Jotham, formerly of 15 Orrong-grove, Caulfield, in Victoria, schoolmaster, late of Speen Hill, Somers, in Victoria, Paymaster-Commander, Royal Navy, deceased (who died on the 23rd day of November, 1960), are hereby required to send particulars of such claims to the executor, The Union Trustee Company of Australia Limited, of 333 Collins-street, Melbourne, on or before the 5th day of June, 1961, after which date the executor will proceed to distribute the assets of the said deceased amongst the persons entitled thereto, having regard only to the claims of which it shall have had notice.

Dated this 4th day of April, 1961.

A. P. AGG & ENGEL, solicitors, Bairnsdale. 13456

CREDITORS, next of kin and all others having claims against the estate of Alice Maud Murphy, late of Springmount, formerly married woman but later widow, deceased (who died on the 9th day of November, 1960), are requested to send particulars of their claims to the executor, John Dowling Nevett, of 216 Forest-street, Wendouree, solicitor, by the 5th day of June, 1961, after which date the executor will distribute the assets, having regard only to the claims of which he then has notice.

NEVETT, GLENN & TINNEY, solicitors, 205 Dana-street, Ballarat. 13457

BESSIE MAY BROWNRIGG, late of 1043 Dandenong-road, East Malvern, married woman, DECEASED (who died on the 9th November, 1960).

CREDITORS, next of kin and all other persons having claims against the estate of the deceased are required by the executors of her will, Leslie Josephine Vandermark, of Francis-street, Moe, married woman, and Ronald Ernest Brownrigg, of 16 Parkside-street, Blackburn, insurance clerk, to send particulars thereof to them, care of the under-mentioned solicitors, before the 14th June, 1961, after which date they may proceed to distribute the assets of the deceased, having regard only to the claims of which they then have notice.

COLTMAN, WYATT & ANDERSON, solicitors, 578 Bourke-street, Melbourne. 13481

GEORGE BULLEN, formerly of Eramosa-road, Somerville, in the State of Victoria, orchardist, but late of Swan Hill, in the said State, cafe proprietor, DECEASED.

CREDITORS, next of kin and other persons having claims against the estate of the deceased are required to send particulars of same to the executrix, Margaret Marie Bullen, in care of the undersigned, on or before the 15th day of June, 1961, after which date she will distribute the assets, having regard only to the claims of which she then has notice.

GERALD E. DELANY & Co., 270 Campbell-street, Swan Hill. 13482

ROBERT POTTS, formerly of Koraleigh, in the State of New South Wales, electrician, but late of Murray-street, Lake Boga, in the State of Victoria, naval pensioner, DECEASED, Intestate.

CREDITORS, next of kin and other persons having claims against the estate of the deceased are required to send particulars of same to the administrator, Ronald Potts, in care of the undersigned, on or before the 15th day of June, 1961, after which date they will distribute the assets, having regard only to the claims of which they then have notice.

GERALD E. DELANY & Co., solicitors, of 270 Campbell-street, Swan Hill. 13483

CREDITORS, next of kin and all others having claims in respect of the estate of Emily Winifred May Ricketts, late of number 16A Northcote-road, Armadale, in the State of Victoria, widow, deceased (who died on the 14th day of December, 1960), are to send the particulars of their claims to her executor, The Trustees, Executors and Agency Company Limited, of 401 Collins-street, Melbourne, in the said State, by the 8th day of June, 1961, after which date the said executor will distribute the assets, having regard only to the claims of which it then has notice.

HADEN SMITH & FITCHETT, solicitors, 405 Collins-street, Melbourne. 13460

CREDITORS, next of kin and others having claims against the estate of Gertrude Mary Rule, late of 39 Otter-street, Collingwood, widow, deceased (who died on the 28th day of February, 1961), are required to send particulars of their claims to Carlos Harold Rule, the executor of the will of the said deceased, care of the undersigned solicitor, before the 15th day of June, 1961, after which date the said executor will distribute the assets, having regard only to the claims of which he then has notice.

JOHN F. CARROLL, solicitor, 118 Queen-street, Melbourne. 13485

CREDITORS, next of kin and others having claims in respect of the estate of Alexander Frederick Lindsay Stewart, late of 5 Lara-street, Tooronga, gentleman, deceased (who died on the 29th day of November, 1960, and probate of whose will has been granted to Graham Lindsay Stewart, of 34 Angus-drive, Glen Waverley, railway employee, and Kathleen Georgie Stewart, of 34 Erica-avenue, Glen Iris, married woman), are to send in particulars of their claims to the said executors, care of the under-mentioned solicitors, by the 15th day of June, 1961, after which date they will distribute the assets, having regard only to the claims of which they then have notice.

PEARCE & WEBSTER, solicitors, 430 Little Collins-street, Melbourne. 13489

CREDITORS, next of kin and others having claims in respect of the estate of Elizabeth Agnes Toole, late of St. Joseph's Tower, 84 Princess-street, Kew, deceased (who died on the 21st day of December, 1960), are to send particulars of their claims to the National Trustees, Executors and Agency Company of Australasia Limited, whose registered office is situated at 95 Queen-street, Melbourne, by the 13th day of June, 1961, after which date it will distribute the assets, having regard only to the claims of which it then has notice.

WARMING & HAYES, of 422 Collins-street, Melbourne, solicitors, for the applicant. 13486

CREDITORS, next of kin and others having claims in respect of the estate of Robert Kidd Reid, late of 394 St. Kilda-road, Melbourne, gentleman, deceased (who died on the 11th day of December, 1960), are to send particulars of their claims to Leslie Bonna Hall, care of Henderson and Ball, solicitors, of 430 Little Collins-street, Melbourne, by the 26th day of June, 1961, after which date the said administratrix will distribute the assets, having regard only to claims of which she then has notice.

HENDERSON & BALL, solicitors, of 430 Little Collins-street, Melbourne. 13490

CREDITORS, next of kin and others having claims against the estate of Pearl Isabel Brewer, late of 42 Connell-street, Hawthorn, widow, deceased (who died on the 22nd day of January, 1961), are required to send particulars of their claims to Roy Thomas Brewer and Philip Charles Brewer, the executors of the will of the said deceased, care of the undersigned solicitor, before the 15th day of June, 1961, after which date the said executors will distribute the assets, having regard only to the claims of which he then has notice.

JOHN F. CARROLL, solicitor, 118 Queen-street, Melbourne. 13484

CHRISTINA MAY PEARSE, late of Nyah West, in the State of Victoria, married woman, DECEASED (who died on the 15th day of May, 1960).

CREDITORS, next of kin and all other persons having claims against the estate of the deceased are required by the executor of the will, Alexander Geddie Pearse, to send particulars to him, care of the undersigned, on or before the 28th day of June, 1961, after which date he will distribute the assets, having regard only to the claims of which they then have notice.

GARDEN & GREEN, solicitors, McCallum-street, Swan Hill. 13442

ANDREA MAIMONE, late of Duncans-road, Werribee South, market gardener, DECEASED, intestate.

CREDITORS, next of kin and others having claims against the estate of the deceased (who died on 4th December, 1960), are required by the administratrix, Grazia Marraffa, to send particulars to her care of 120 William-street, Melbourne, by the 8th June, 1961, after which date the administratrix may convey and distribute the assets, having regard only to the claims of which she then has notice.

BLAKE & RIGGALL, 120 William-street, Melbourne, solicitors. 13461

CREDITORS, next of kin and others having claims in respect of the estate of Richard Deeley Godby, late of 12 Chapel-street, St. Kilda, wharf labourer, deceased (who died on the 26th November, 1959), are to send particulars of their claims to National Trustees, Executors and Agency Company of Australasia Limited, whose registered office is at 95 Queen-street, Melbourne, by the 6th June, 1961, after which date it will distribute the assets, having regard only to the claims of which it then has notice. 13463

CREDITORS, next of kin and all other persons having claims against the estate of Lilian Sarah Staines, late of 5 Retreat-road, Hampton, widow, deceased (who died on the 18th day of February, 1961), are to send particulars of such claims to The Union Trustee Company of Australia Limited, of 333 Collins-street, Melbourne, by the 14th day of June, 1961, after which date the company will distribute the assets, having regard only to the claims of which it shall then have notice.

COOKE & CUSSEN, 383 Collins-street, Melbourne, solicitors. 13480

GORDON TIMARU DAWSON, formerly of 408 Toorak-road, Toorak, but late of Rodborough-avenue, Mt. Eliza, retired, DECEASED.

CREDITORS, next of kin and others having claims against the estate of the deceased (who died on 21st September, 1960), are required by the executors, John Ralph Burt and Bernard Gore Brett, of 120 William-street, Melbourne, solicitors, to send particulars to them by the 8th June, 1961, after which date the executors may convey and distribute the assets, having regard only to the claims of which they then have notice.

BLAKE & RIGGALL, 120 William-street, Melbourne, solicitors. 13468

CREDITORS, next of kin and other persons having claims against the estate of Michael Ernest Murphy, late of 25 Green-street, Windsor, gas worker, deceased (who died on the 27th day of February, 1961), are to send particulars of their claims to James Patrick Ogge, the executor of the will of the said deceased, care of James P. Ogge and Webb, of 165 Greville-street, Prahran, by the 8th day of June, 1961, after which date the said executor will distribute the assets, having regard only to the claims of which he shall have had notice.

JAMES P. OGGE & WEBB, of 165 Greville-street, Prahran, solicitors. 13472

AFTER fourteen clear days application will be made to the Supreme Court of Victoria that probate of the will dated the 18th day of February, 1953, of Annie Beatrice Edwards, late of 36 Murphy-street, South Yarra, in the State of Victoria, gentlewoman, deceased, be granted to Bessie Jenkins, of Rennison-street, Beaumaris, in the said State, spinster, and The Equity Trustees, Executors and Agency Company Limited, of 472 Bourke-street, Melbourne, in the said State, the executors named in the said will.

AITKEN, WALKER & STRACHAN, solicitors, 123 William-street, Melbourne. 13473

IMPOUNDINGS

BOORT.—Impounded in Boort Pound by C.R.B. Herdsmen.

1 sheep (lamb), ewe longtail, no visible brand or marks

If not claimed and expenses paid, to be sold on 12th April, 1961.

J. HUDSON,
13448—10/6 Poundkeeper.

KERANG.—Impounded in Kerang Pound.

1 dark-brown gelding hack or light harness, white spot on forehead; like Z low on left shoulder, all black points, short tail.

If not claimed and expenses paid, to be sold on 21st April, 1961.

J. NANCARROW,
13479—12/ Poundkeeper.

TERANG.—Impounded in Terang Pound, from Mc-Sween's-road, Noorat East.

1 aged black mare, no visible brand

If not claimed and expenses paid, to be sold on 17th April, 1961.

DORIS M. KIDD,
13451—10/6 Poundkeeper.

WARRNAMBOOL.—Impounded in Warrnambool Pound.

1 dark-brown Jersey cow, no visible brand
1 red vealer bull calf, no visible brand

If not claimed and expenses paid, to be sold on 19th April, 1961.

M. STONEHOUSE,
13493—10/6 Poundkeeper.

CONSOLIDATED ACTS.

COPIES of the following Consolidated Acts of the Parliament of Victoria may be obtained at the Government Printing Office, Melbourne, at the price set opposite to each, viz. :—

No.	Description	Price.		No.	Description	Price.	
		s.	d.			s.	d.
6188	Acts Enumeration and Revision Act 1958	1	9	6275	Housing Act 1958	6	3
6189	Acts Interpretation Act 1958	1	3	6276	Imprisonment of Fraudulent Debtors Act 1958	1	6
6190	Aborigines Act 1958	0	9	6277	Industrial and Provident Societies Act 1958	2	0
6191	Administration and Probate Act 1958	4	9	6278	Inebriates Act 1958	0	9
6192	Adoption of Children Act 1958	1	3	6279	Instruments Act 1958	3	9
6193	Agent-General's Act 1958	0	6	6280	Judicial Proceedings Reports Act 1958	0	9
6194	Agricultural Colleges Act 1958	1	0	6281	Juries Act 1958	2	0
6195	Agricultural Education Act 1958	0	9	6282	Justices Act 1958	11	3
6196	Agricultural Lime Act 1958	1	0	6283	Labour and Industry Act 1958	7	0
6197	Air Navigation Act 1958	0	6	6284	Land Act 1958	13	0
6198	Anzac Day Act 1958	0	6	6285	Landlord and Tenant Act 1958	4	6
6199	Apprenticeship Act 1958	1	9	6286	Lands Compensation Act 1958	1	9
6200	Arbitration Act 1958	0	9	6287	Land Settlement Act 1958	1	9
6201	Architects Act 1958	1	3	6288	Land Surveyors Act 1958	1	3
6202	Auction Sales Act 1958	1	3	6289	Land Tax Act 1958	2	9
6203	Audit Act 1958	2	3	6290	Latrobe Valley Act 1958	2	6
6204	Bakers and Millers Act 1958	0	9	6291	Legal Profession Practice Act 1958	3	9
6205	Bank Holidays Act 1958	0	9	6292	Libraries Act 1958	1	3
6206	Barley Marketing Act 1958	1	0	6293	Licensing Act 1958	8	9
6207	Bees Act 1958	0	9	6294	Lifts Regulation Act 1958	0	9
6208	Benefit Association Act 1958	1	9	6295	Limitation of Actions Act 1958	1	6
6209	Boilers Inspection Act 1958	1	6	6296	Liquified Petroleum Gas Act 1958	0	6
6210	Building Societies Act 1958	1	3	6297	Livery and Agistment Act 1958	0	9
6211	Business Investigations Act 1958	0	9	6298	Local Authorities Superannuation Act 1958	2	0
6212	Business Names Act 1958	1	3	6299	Local Government Act 1958	25	0
6213	Cancer Act 1958	1	9	6300	Maintenance Act 1958	3	6
6214	Carriers and Innkeepers Act 1958	1	0	6301	Margarine Act 1958	1	0
6215	Cattle Breeding Act 1958	0	9	6302	Marine Act 1958	7	9
6216	Cattle Compensation Act 1958	1	0	6303	Marine Stores and Old Metals Act 1958	1	6
6217	Cemeteries Act 1958	2	0	6304	Marketing of Primary Products Act 1958	2	9
6218	Children's Court Act 1958	2	0	6305	Markets Act 1958	1	0
6219	Children's Welfare Act 1958	2	3	6306	Marriage Act 1958	4	0
6220	Clean Air Act 1958	0	9	6307	Masseurs Act 1958	1	0
6221	Coal Mines Act 1958	7	9	6308	Master and Apprentice Act 1958	0	9
6222	Commercial Goods Vehicles Act 1958	1	6	6309	Medical Act 1958	3	6
6223	Commonwealth Arrangements Act 1958	0	6	6310	Melbourne and Metropolitan Board of Works Act 1958	8	0
6224	The Constitution Act Amendment Act 1958	16	0	6311	Melbourne and Metropolitan Tramways Act 1958	6	0
6225	Co-operation Act 1958	4	0	6312	Melbourne Harbor Trust Act 1958	4	0
6226	Co-operative Housing Societies Act 1958	3	6	6313	Mental Deficiency Act 1958	2	0
6227	Coroners Act 1958	1	3	6314	Mental Hygiene Act 1958	5	9
6228	Country Fire Authority Act 1958	3	6	6315	Metropolitan Fire Brigades Act 1958	2	6
6229	Country Roads Act 1958	3	9	6316	Mildura Irrigation and Water Trusts Act 1958	5	9
6230	County Court Act 1958	2	6	6317	Milk and Dairy Supervision Act 1958	3	9
6231	Crimes Act 1958	13	3	6318	Milk Board Act 1958	1	9
6232	Crown Proceedings Act 1958	1	0	6319	Milk Pasteurization Act 1958	0	9
6233	Dairy Products Act 1958	1	0	6320	Mines Act 1958	14	0
6234	Developmental Railways Act 1958	0	9	6321	Mining Development Act 1958	1	9
6235	Dietitians Registration Act 1958	1	3	6322	Ministry of Transport Act 1958	0	9
6236	Dog Act 1958	1	0	6323	Mint Act 1958	0	6
6237	Drainage Areas Act 1958	2	0	6324	Money Lenders Act 1958	2	3
6238	Drainage of Land Act 1958	1	0	6325	Motor Car Act 1958	5	3
6239	Dried Fruits Act 1958	1	6	6326	National Parks Act 1958	1	0
6240	Education Act 1958	3	0	6327	Newmarket Sheep Sales Act 1958	0	6
6241	Electric Light and Power Act 1958	2	0	6328	Nurses Act 1958	1	9
6242	Employers and Employees Act 1958	1	6	6329	Opticians Registration Act 1958	1	3
6243	Entertainments Tax Act 1958	1	3	6330	Partnership Act 1958	1	3
6244	Essential Services Act 1958	0	9	6331	Patriotic Funds Act 1958	1	6
6245	Estate Agents Act 1958	2	9	6332	Pawnbrokers Act 1958	1	6
6246	Evidence Act 1958	3	6	6333	Penalties Act 1958	0	6
6247	Explosives Act 1958	2	0	6334	Petroleum Act 1958	2	9
6248	Farm Produce Agents Act 1958	1	0	6335	Petrol Pumps Act 1958	0	9
6249	Fences Act 1958	1	3	6336	Poisons Act 1958	4	3
6250	Fertilizers Act 1958	1	6	6337	Police Offences Act 1958	7	6
6251	Firearms Act 1958	2	3	6338	Police Regulation Act 1958	3	9
6252	Fisheries Act 1958	2	3	6339	Poor Persons Legal Assistance Act 1958	0	9
6253	Footwear Regulation Act 1958	0	9	6340	Portland Harbor Trust Act 1958	2	0
6254	Forests Act 1958	4	3	6341	Pounds Act 1958	1	3
6255	Friendly Societies Act 1958	3	9	6342	Printers and Newspapers Act 1958	1	0
6256	Fruit and Vegetables Act 1958	1	9	6343	Process Servers and Inquiry Agents Act 1958	1	0
6257	Fungicides Act 1958	1	0	6344	Property Law Act 1958	9	0
6258	Game Act 1958	1	9	6345	Public Account Act 1958	1	0
6259	Goals Act 1958	1	6	6346	Public Authorities Marks Act 1958	0	9
6260	Gas and Fuel Corporation Act 1958	5	0	6347	Public Contracts Act 1958	0	6
6261	Gas Regulation Act 1958	1	9	6348	Public Safety Preservation Act 1958	0	9
6262	Geelong Harbor Trust Act 1958	3	3	6349	Public Service Act 1958	2	9
6263	Geelong Waterworks and Sewerage Act 1958	5	6	6350	Public Trustee Act 1958	3	3
6264	Gold Buyers Act 1958	2	3	6351	Public Works Act 1958	0	9
6265	Goods Act 1958	2	6	6352	Public Works Committee Act 1958	1	0
6266	Grain Elevators Act 1958	2	3	6353	Racing Act 1958	4	3
6267	Hairdressers Registration Act 1958	1	3	6354	Railway Lands Acquisition Act 1958	2	6
6268	Harbor Boards Act 1958	3	3	6355	Railways Act 1958	5	6
6269	Hawkers and Pedlars Act 1958	1	3	6356	Registration of Births Deaths and Marriages Act 1958	2	3
6270	Health Act 1958	14	0	6357	Religious Successory and Charitable Trusts Act 1958	2	0
6271	Home Finance Act 1958	0	9	6358	River Improvement Act 1958	2	0
6272	Horse Breeding Act 1958	1	3	6359	Road Traffic Act 1958	1	0
6273	Hospital Benefits Act 1958	0	9	6360	Rural Finance Corporation Act 1958	2	3
6274	Hospitals and Charities Act 1958	3	6	6361	Sale of Allotments of Land Act 1958	0	6
				6362	Seamen's Act 1958	0	9

CONSOLIDATED ACTS—*continued.*

No.		Price.
		s. d.
6363	Secondhand Dealers Act 1958	1 3
6364	Seeds Act 1958	1 3
6365	Senate Elections Act 1958	0 6
6366	Servants' Registry Offices Act 1958	0 9
6367	Settled Land Act 1958	4 0
6368	Sewerage Districts Act 1958	5 3
6369	Shearers Accommodation Act 1958	1 3
6370	Sheep Dipping Act 1958	0 9
6371	Sheep Owners Protection Act 1958	0 9
6372	Soil Conservation and Land Utilization Act 1958	1 6
6373	Soldier Settlement Act 1958	4 9
6374	Solicitor-General Act 1958	0 6
6375	Stamps Act 1958	6 0
6376	State Development Act 1958	1 0
6377	State Electricity Commission Act 1958	4 6
6378	State Relief Committee Act 1958	0 9
6379	State Savings Bank Act 1958	4 3
6380	Statistics Act 1958	0 9
6381	Stock and Share Brokers Act 1958	1 0
6382	Stock Diseases Act 1958	2 6
6383	Stock Foods Act 1958	1 3
6384	Stock Medicines Act 1958	1 0
6385	Street Trading Act 1958	0 9
6386	Superannuation Act 1958	3 0
6387	Supreme Court Act 1958	6 0
6388	Survey Co-ordination Act 1958	1 3
6389	Swine Act 1958	1 0
6390	Tattersall Consultations Act 1958	0 9
6391	Teaching Service Act 1958	2 3
6392	Temperance Halls Act 1958	0 6
6393	Theatres Act 1958	1 6
6394	Tobacco Sellers Act 1958	0 9
6395	Tourist Act 1958	0 9
6396	Town and Country Planning Act 1958	2 0
6397	Trade Unions Act 1958	1 0
6398	Tramways Act 1958	1 3
6399	Transfer of Land Act 1958	4 9
6400	Transport Regulation Act 1958	1 9
6401	Trustee Act 1958	3 9
6402	Trustee Companies Act 1958	1 9
6403	Unauthorized Documents Act 1958	0 6
6404	Unclaimed Moneys Act 1958	0 6
6405	University Act 1958	2 0
6406	Unlawful Assemblies and Processions Act 1958	1 3
6407	Vegetation and Vine Diseases Act 1958	1 6
6408	Venereal Diseases Act 1958	1 6
6409	Vermin and Noxious Weeds Act 1958	2 0
6410	Veterinary Surgeons Act 1958	1 0
6411	Victorian Inland Meat Authority Act 1958	1 0
6412	Warehousemen's Liens Act 1958	0 9
6413	Water Act 1958	12 9
6414	Weights and Measures Act 1958	3 0
6415	Wild Flowers and Native Plants Protection Act 1958	0 9
6416	Wills Act 1958	1 0
6417	Wire Netting Act 1958	1 9
6418	Women's Qualification Act 1958	0 6
6419	Workers Compensation Act 1958	4 9
6420	Wrongs Act 1958	1 3
6421	Youth Organizations Assistance Act 1958	0 6

A. C. BROOKS,
Government Printer.

AGENTS FOR THE "VICTORIA GOVERNMENT GAZETTE".

THE following have been appointed agents to receive Advertisements and Subscriptions for the *Victoria Government Gazette*—

- ARMSTRONG'S AGENCY, 205 Queen-street, Melbourne.
- ARMSTRONG BROS., Kyneton.
- MESSRS. ARNALL & JACKSON, 115 Barkly-street, West Brunswick.
- MR. WM. DAVIS, Mildura.
- A. J. DIGBY (B. S. and N. W. Cash), Main-street, Bairnsdale.

- EDGAR'S NEWSAGENCY, Hargreaves-street, Bendigo.
- MESSRS. HENRY FRANKS & CO., Booksellers and Stationers, Market-square, Geelong.
- MESSRS. GORDON & GOTCH, News Agents, 511 Little Collins-street, Melbourne; and corner Barrack and Clarence streets, Sydney.
- GULLAN'S NEWSAGENCY, 88 Bridge-street, Ballarat.
- A. C. HAMPTON, 243 Mitchell-street, Bendigo.
- MESSRS. HARSTON, PARTRIDGE, & CO., 455 Little Collins-street, Melbourne.
- MR. C. L. LATIMER, News Agent, Casterton.
- MCCARTHUR'S AUTHORIZED NEWSAGENCY, 345 Wyndham-street, Shepparton.
- MESSRS. R. H. & W. M. PETTY, News Agents, Wangaratta.
- MESSRS. POWELL & DIXON, 89 Firebrace-street, Horsham.
- J. PURDIE & CO., 138 Moorabool-street, Geelong.
- SALE AUTHORIZED NEWSAGENCY, 142 Raymond-street, Sale.
- SKINNER'S AUTHORIZED NEWSAGENCY, 49-51 Franklin-street, Traralgon.
- MESSRS. SMITH & DUNNON, Hamilton.
- THE MERCANTILE EXCHANGE, 380 Collins-street, Melbourne.
- A. C. THOMAS, 69 Bridge-street, Benalla.
- TUFF'S SHEPPARTON NEWSAGENCY, 246 Wyndham-street, Shepparton.
- C. F. & H. J. VERNON, 162 Bridge-road, Richmond.
- VIEW POINT AUTHORIZED NEWSAGENCY, 4 View Point, Bendigo.
- E. W. B. WELSH, Hogan-street, Tatura.

A copy of the *Gazette* filed at each place for public reference.

CONTENTS

	PAGE
Acts of Parliament on sale at the Government Printing Office	1131
Appointments	1101
Anzac Day Holiday	1094
Contracts	1100
Estates of Deceased Persons	1099
Government Notices	1094
Impoundings	1130
Lands	1113
Mining	1094
Orders in Council—	
Acts—Land	1102
Architects; Libraries; Hospitals and Charities; Local Government; Country Roads. <i>et seq</i>	1105
Private Advertisements	1122
Proclamations	1093
Public Holidays	1094
Public Service Notices	1118
Regulations—	
Acts—Education; Libraries; Metropolitan Fire Brigades. <i>et seq</i>	1104
Resignations	1102
Tenders	1116
Waterworks Trusts	1095