



VICTORIA GOVERNMENT GAZETTE

Published by Authority

[Registered at the General Post Office, Melbourne, for transmission by post as a newspaper.]

No. 55]

WEDNESDAY, JULY 5

[1961

Health Act 1958 (No. 6270).
CONSTITUTION OF THE COHUNA MEAT AREA.

PROCLAMATION

By His Excellency the Administrator of the Government of the State of Victoria, and its Dependencies in the Commonwealth of Australia, &c., &c., &c.

BY virtue of the powers conferred by the *Health Act 1958 (No. 6270)*, I, the Administrator of the Government of the State of Victoria, in the Commonwealth of Australia, on the recommendation of the Commission of Public Health and by and with the advice of the Executive Council of the said State, do by this my Proclamation constitute as a meat area, to be known as the Cohuna Meat Area, the area described hereunder:—

All that area of land contained within the boundaries of the Township of Cohuna as described in the *Victoria Gazette* No. 60 dated 9th May, 1934, together with lots 6 and 7 and 35, 36, 37 and 38 of Crown allotment I., section 1, Parish of Gunbower West.

Given under my Hand and the Seal of the State of Victoria aforesaid, at Melbourne, this twenty-seventh day of June, in the year of our Lord One thousand nine hundred and sixty-one, and in the tenth year of the reign of Her Majesty Queen Elizabeth II.

(L.S.)

CHARLES J. LOWE.

By His Excellency's Command,

E. P. CAMERON,
Minister of Health.

GOD SAVE THE QUEEN!

Health Act 1958 (No. 6270).
CONSTITUTION OF THE TRARALGON MEAT AREA.

PROCLAMATION

By His Excellency the Administrator of the Government of the State of Victoria, and its Dependencies in the Commonwealth of Australia, &c., &c., &c.

BY virtue of the powers conferred by the *Health Act 1958 (No. 6270)*, I, the Administrator of the Government of Victoria, in the Commonwealth of Australia, on the recommendation of the Commission of Public Health and by and with the advice of the Executive Council of the said State, do by this my Proclamation:—

1. Revoke the Proclamation dated 12th April, 1949, and published in the *Government Gazette* on the 13th April, 1949, whereby the Shire of Traralgon was constituted as a meat area; and

2. Declare the whole of the municipal district of the Shire of Traralgon and the whole of the municipal district of the Borough of Traralgon to be a meat area to be known as the Traralgon Meat Area.

Given under my Hand and the Seal of the State of Victoria aforesaid, at Melbourne, this twenty-seventh day of June, in the year of our Lord One thousand nine hundred and sixty-one, and in the tenth year of the reign of Her Majesty Queen Elizabeth II.

(L.S.)

CHARLES J. LOWE.

By His Excellency's Command,

E. P. CAMERON,
Minister of Health.

GOD SAVE THE QUEEN!

Game Act 1958.

REVOCATION OF PROCLAMATION OF CLOSE SEASON FOR NATIVE GAME OF ALL KINDS AT THE AREA RESERVED FOR WATER SUPPLY PURPOSES AND FOR PUBLIC RECREATION, ETC., PARISH OF TRAWALLA.

PROCLAMATION

By His Excellency the Administrator of the Government of the State of Victoria and its Dependencies in the Commonwealth of Australia, &c., &c., &c.

I THE Administrator of the Government of the State of Victoria, in the Commonwealth of Australia, by and with the advice of the Executive Council of the said State, and in pursuance of the provisions of the *Game Act 1958*, and all other powers me enabling in that behalf, do by this my Proclamation revoke the Proclamation made the eighth day of October, 1907, and published in the *Government Gazette* of the sixteenth day of October, 1907, respecting a close season for native game of all kinds at the area reserved for water supply purposes and for public recreation, &c., Parish of Trawalla.

Given under my Hand and the Seal of the State of Victoria aforesaid, at Melbourne, this fourth day of July, in the year of our Lord One thousand nine hundred and sixty-one, and in the tenth year of the reign of Her Majesty Queen Elizabeth II.

(L.S.)

CHARLES J. LOWE.

By His Excellency's Command,

A. G. RYLAH,
Chief Secretary.

GOD SAVE THE QUEEN!

BANK HALF-HOLIDAY.

PROCLAMATION

By His Excellency the Administrator of the Government of the State of Victoria and its Dependencies in the Commonwealth of Australia, &c., &c., &c.

IN pursuance of the provisions of the *Bank Holidays Act 1958*, I, the Administrator of the Government of the State of Victoria, in the Commonwealth of Australia, do by this my Proclamation appoint the day and date named hereunder a special day to be observed as a Bank Half-Holiday at the place mentioned, that is to say:—

Bank Half-Holiday from the Hour of Eleven a.m.:—
WEDNESDAY, THE 19TH JULY, 1961, at Heathcote.

Given under my Hand and the Seal of the State of Victoria aforesaid, at Melbourne, this fourth day of July, in the year of our Lord One thousand nine hundred and sixty-one, and in the tenth year of the reign of Her Majesty Queen Elizabeth II.

(L.S.) CHARLES J. LOWE.

By His Excellency's Command,
A. G. RYLAH,
Chief Secretary.

GOD SAVE THE QUEEN!

POLICE OFFENCES ACT 1958.

IN pursuance of the powers conferred upon the Chief Secretary by sub-section (3) of section 184 of the *Police Offences Act 1958*, I, Arthur Gordon Rylah, Her Majesty's Chief Secretary for the State of Victoria, do by this notice grant exemption from compliance with sub-sections (1) and (2) of section 184 of the said Act with respect to the publication "Fair Dinkum", distributed by Colorgravure Publications, 26-30 Flinders-street, Melbourne.

A. G. RYLAH,
Chief Secretary.

Chief Secretary's Office,
Melbourne, 30th June, 1961.

Vermin and Noxious Weeds Act 1958.

APPOINTMENT OF INSPECTOR.

IT is hereby notified that the Public Service Board, in exercise of its powers, has appointed the under-mentioned person as an Inspector under the provisions of section 4 of the *Vermin and Noxious Weeds Act 1958*, without additional salary:—

ALBERT JOHN DOUEAL.

F. H. KLENNER,
Secretary for Lands.

Melbourne, 3rd July, 1961.

A LICENCE to carry on assurance and insurance business in Victoria from 1st July, 1961, to 31st December, 1961, has been issued to the under-mentioned insurer:—

A.P.A. LIFE & GENERAL INSURANCE CO. LTD.

D. G. RICHARDS,
Comptroller of Stamps.

SHIRE OF WINCHELSEA.—PUBLIC HIGHWAY.

PURSUANT to the provisions of sections 522 and 526 of the *Local Government Act 1958*, the Council of the Shire of Winchelsea hereby directs that the land in the Parish of Bambra indicated by hatching in the diagram hereunder shall be a public highway on and from the date of publication of this order in the *Government Gazette* and declares that such land shall be a public highway in lieu of the land indicated by cross hatching on the said diagram.

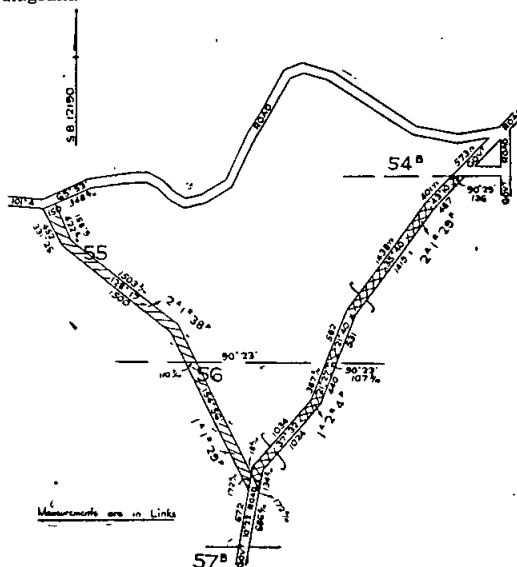

The common seal of the President, Councillors and Ratepayers of the Shire of Winchelsea was hereto affixed this 14th day of June, 1961, in the presence of—

(SEAL) CHARLES McDONALD, President.
COLIN F. NORLAND, Councillor.
W. W. WESTHORPE, Shire Secretary.

Approved by the Governor in Council, 27th June, 1961.
—A. MAHLSTEDT, Clerk of the Executive Council.

LOCAL GOVERNMENT DEPARTMENT.

ORDER CONFIRMED.—CITY OF BROADMEADOWS.

THE Minister of the Crown administering the *Local Government Act 1958*, as amended, on the 28th day of June, 1961, confirmed the Order hereinafter mentioned, in pursuance of the provisions of section 514 of the said Act, viz.:—

An Order of the Council of the Shire of Broadmeadows (which was on the 30th May, 1956, declared to be the City of Broadmeadows) made on the 29th August, 1949, for the purpose of widening Devon-road, Pascoe Vale, between Pascoe Vale-road and Northumberland-road, and for acquiring for such purpose all those portions of Crown portion 151, Parish of Jika Jika, indicated by hatching on the diagram hereunder:—

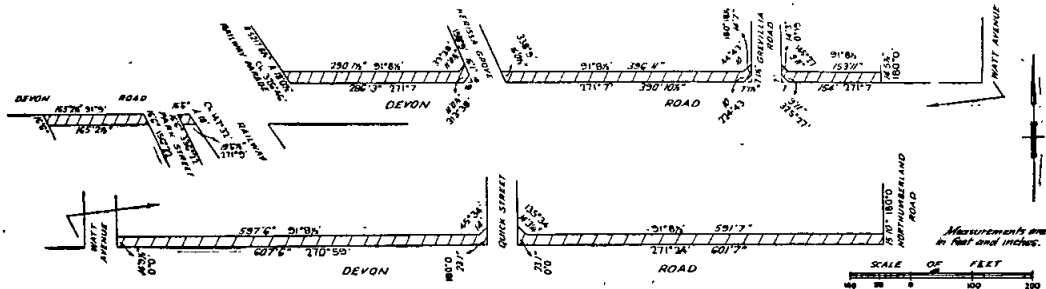

MURRAY PORTER,
Minister for Local Government.

Transport Regulation Act.
TRANSPORT REGULATION BOARD.
NOTICES OF PUBLIC HEARINGS.

NOTICE is hereby given that the applications made by the persons named below for licences to operate commercial passenger vehicles on the route or routes, or in the manner set out opposite their names, will be heard at a time and place to be communicated to the parties:—

Name and Address; Nature of Application.

- UNTHANK, R. F., 14 Curtis-street, Stawell; 1 commercial passenger vehicle, with seating capacity for 4 persons, to operate as follows:—(1) For the carriage of mails between Moyston and Ararat under contract to the Postmaster-General's Department, (2) for the carriage of 2 passengers between Moyston and Ararat. Fares and time-table as per application dated 21st June, 1961.
- PORTSEA PASSENGER SERVICE, Station-street, Frankston; 1 commercial passenger vehicle, with seating capacity for 60 persons, to operate for the carriage of—(1) school children only between Rosebud and Sorrento under contract to the Education Department, (2) mails under contract to the Postmaster-General's Department.
- CROYDON—MT. DANDENONG PASSENGER SERVICE, Main-road, Olinda; 1 commercial passenger vehicle, with seating capacity for 45 persons, to operate under the same terms and conditions as existing licences held by applicants.
- NICHOLS, E. C., 4 Selkirk-avenue, McKinnon; 1 commercial passenger vehicle, with seating capacity for 25 passengers, to operate as a substitute metropolitan omnibus on Route 24A (Gardiner—Caulfield—Chadstone) under the same terms and conditions as licences already held in the applicant's name.
- MAGUIRE, T. D., 215 Brunswick-road, East Brunswick; 1 commercial passenger vehicle, with seating capacity for 5 persons, to operate as a metropolitan taxi-cab, subject to the cancellation of metropolitan private hire licence No. M.H.1428, operated from Embassy Private Hire Service, 228 Elgin-street, Carlton, in the name of the applicant.

APPLICATION for a metropolitan private hire car licence by the person listed hereunder in respect of commercial passenger vehicles, with seating capacity for 5 persons, to operate under composite conditions from an approved depot in zone set out opposite his name:—

Name and Address; Zone.

- MANGLAVITI, A. A., 3 Sharpe-avenue, Merlynston; "E", "H", "G", "K", "N".

APPLICATIONS for renewal of licences by persons listed hereunder to operate under the same terms and conditions from the date of expiry:—

Name and Address; Licence Number; Classification; Expiry Date.

- SHERRY, F. P., 252 Pascoe Vale-road, Essendon; M.O. Sub. 14; metropolitan omnibus on Route 34 (Moonee Ponds—Westgarth); 30th September, 1961.
- SHERRY, F. P., 252 Pascoe Vale-road, Essendon; M.O.146; metropolitan omnibus on Route 34 (Moonee Ponds—Westgarth); 30th September, 1961.
- SHERRY, F. P., 252 Pascoe Vale-road, Essendon; M.O.395; metropolitan omnibus on Route 34 (Moonee Ponds—Westgarth); 30th September, 1961.
- KHANCOBAN SPRING CREEK SCHOOL, Box 16, Corryong; C.O.27; country omnibus; 15th September, 1961.
- KINGSTON, F. C., 19 Wimmera-street, Stawell; C.H.502; country hire, Stawell; 25th October, 1957.
- HIGHFIELD QUARRIES PTY. LTD., McDonald-road, Brooklyn; application for renewal of licence No. T.P.71 (expiring 16th October, 1961) to be operated as required for the carriage only, free of charge, of employees of the holder of this licence from or to Footscray to or from the premises of the holder of this licence in McDonald-road, Footscray.
- DIXON, R. M., M. R., & M. G. (trading as R. M. Dixon and Sons), Swann-street, Brim; application for renewal of licence No. T.P.104 (expiring 29th August, 1961) to be operated as a stage omnibus on the route between Brim West and the Brim State School as follows:—(a) No passenger other than school children, shall be carried along the said route, (b) teachers on the staff of the said school may also be carried on the vehicle along the route if authorized by the headmaster of the school.
- NOTICE is hereby given that the applications made by the persons named below for licences to operate the commercial goods vehicles on the route or routes, or in the manner set out opposite their names, will be heard at a time and place to be communicated to the persons concerned:—
- Name and Address; Nature of Application.*
- BAIN, J. A., 46A Goomalibee-street, Benalla; 1 commercial goods vehicle (approximately 200 cwt.) to operate—(a) within a radius of 50 miles from the post office at Benalla—plant the property of a contractor and required by him for use in connexion with the construction or maintenance of some specific, existing or proposed road, street, footpath, bridge, pier, wharf, weir or channel, and also the following materials, viz., metal, stones, screenings, ashes, gravel, sand, and earth, (b) within a radius of 20 miles from the site of any construction or maintenance work performed pursuant to paragraph (a) above, or from the railway station nearest thereto—any other materials required for such work, (c) within a radius of 20 miles from the post office at Benalla—general goods, excluding any plant or materials carried or to be carried pursuant to paragraphs (a) and (b) above.
- B.C.X. PURE FRUIT DRINKS PTY. LTD., Allingham-street, Golden Square; 1 commercial goods vehicle (118 cwt.) to operate—(a) aerated waters, cordials, and empty bottles and/or other containers for return, and also fresh citrus fruits in season for processing in the course of the applicant's business as "aerated water manufacturers and fruit processors" in the following area only, namely, within a radius of 100 miles from the chief post office in the City of Bendigo, but subject to the condition that no goods whatsoever shall be carried from or to any place situated within the metropolitan area of Melbourne, as defined in *Commercial Goods Vehicles Act 1958*, (b) from and to the premises of the applicant at Golden Square, Bendigo, to and from the premises at Murray Breweries Pty. Ltd. at Beechworth—own manufactured cordials and milk bar syrups in glass containers and empty glass containers.
- COLLIER, C. V., Best-street, Sea Lake; 1 commercial goods vehicle (93 cwt.) to operate within a radius of 50 miles of the post office at Sea Lake in the course of business as a "building contractor"—tools of trade, equipment, and small quantities of materials incidental to the completion of own contracts.
- COOK, E. G. L., Waterloo-road, Trafalgar; 1 commercial goods vehicle (137 cwt.) to operate within a radius of 50 miles from own quarry at Trafalgar—crushed metal, screenings, and sand, also replacement parts for use in own equipment.
- DEHNE, G. W., Dinglee; 1 commercial goods vehicle (80 cwt.) to operate—(a) within a radius of 20 miles of the post office at Dinglee—general goods, (b) within a radius of 50 miles of the post office at Dinglee—petroleum products in prescribed types of containers and empty return containers, on behalf of Caltex Oil (Aust.) Pty. Ltd., (c) from and to places within paragraph (a) to and from places within a radius of 50 miles of the post office at Dinglee—livestock.
- DEVILEE, J. J., 7 Sunnyside-avenue, Mildura; 1 commercial goods vehicle (12 cwt.) to operate within a radius of 100 miles of the post office at Mildura in the course of business as a "refrigeration engineer" for the purpose of servicing and repairing refrigerators and washing machines—tools of trade, spare parts, and refrigerators and washing machines for repair or having been repaired.
- DICK, R. P. & F. J., 3 Lawrence-grove, Traralgon; 1 commercial goods vehicle (10 cwt.) to operate throughout the State of Victoria in the course of business as a "signwriter"—tools of trade, scaffolding, and materials incidental to the completion of own contracts.
- DICKSON PRIMER TELEVISION SERVICES PTY. LTD., 25 Melbourne-road, North Geelong; 1 commercial goods vehicle (8 cwt.) to operate within an area bounded on the east by a north/south line drawn through the Township of Werribee, on the north by an east/west line drawn through the Township of Skipton, and on the west by a north/south line drawn throughout the Township of Camperdown for the purpose of installing, servicing, and maintaining television equipment—tools of trade, spare parts, and materials incidental to such installation and servicing.
- FORNERA, L., 58 O'Heas-road, Coburg; 1 commercial goods vehicle (113 cwt.) to operate—(a) within a radius of 95 miles of the post office at Cohuna and within a radius of 100 miles of the post office at Merbein (Bendigo Division of the Country Roads Board)—

- plant the property of a contractor and required for use in connexion with the construction of maintenance of some specific, existing or proposed road, street, footpath, bridge, wharf, pier, weir or channel, (b) within a radius of 20 miles from site of construction or maintenance work performed pursuant to paragraph (a) above, or from the railway station nearest thereto—metal, stones, screenings, ashes, gravel, sand, earth, and any other materials required for such work.
- FOWLER ROAD CONSTRUCTIONS PTY. LTD.**, corner of Power and Cavanagh streets, South Melbourne; 1 commercial goods vehicle (102 cwt.) to operate throughout the State of Victoria in the course of business as "road construction engineers" for the purpose of spraying road works—bitumen and tar for road spraying.
- FOXALL INSTRUMENTS PTY. LTD.**, 1213-1217 High-street, Armadale; 1 commercial goods vehicle (10 cwt.) to operate throughout the State of Victoria for the purpose of installing, servicing, and maintaining industrial instruments and machinery—tools of trade, spare parts, and materials incidental thereto.
- HALL, L. N.**, 13 Reviere-street, Long Gully; 1 commercial goods vehicle (8 cwt.) to operate within a radius of 100 miles of the post office at Bendigo in the course of business as a "tool cutter and grinder" for the purpose of collecting tools and cutting implements for sharpening and for repair—tools of trade, tools and cutting implements for sharpening and repair or having been sharpened or repaired.
- HUXTABLE, K.**, 202 Station-street, Koo-Wee-Rup; 1 commercial goods vehicle (106 cwt.) to operate—(a) within a radius of 20 miles of the post office at Koo-Wee-Rup—general goods, (b) within a radius of 50 miles of the post office at Koo-Wee-Rup—plant the property of a contractor and required by him for use in connexion with the construction or maintenance of some specific, existing or proposed road, street, footpath, bridge, pier, wharf, weir or channel, and also the following materials, viz., metal, stones, screenings, ashes, gravel, sand, and earth, (c) within a radius of 20 miles from the site of any construction or maintenance work performed pursuant to paragraph (a) above, or from the railway station nearest thereto—any other materials required for such work.
- LEAF, A. W. & W. J.**, Nathalia; 1 commercial goods vehicle (102 cwt.) to operate—(a) within a radius of 20 miles of the post office at Nathalia—general goods, (b) from and to places within paragraph (a) above and from places within a radius of 50 miles of the post office at Nathalia—livestock.
- MAMOUNEY, J. F., PTY. LTD.**, Williamson-street, Bendigo; 2 commercial goods vehicles (8 cwt. each) to operate within a radius of 100 miles of the chief post office in the City of Bendigo in the course of business as "home furnishers"—tools of trade, small items of furniture, carpets, linos, curtains, and blinds for laying or repairing, and materials incidental thereto.
- MELBOURNE TOWING SERVICE PTY. LTD.**, 169 City-road, South Melbourne; 1 commercial goods vehicle (68 cwt.) to operate throughout the State of Victoria for the purpose of towing and/or repairing wrecked and disabled vehicles—tools of trade, spare parts, and materials incidental thereto.
- MILEAGE TYRE SERVICE PTY. LTD.**, 55 Market-road, West Footscray; 1 commercial goods vehicle (56 cwt.) to operate within a radius of 50 miles of own premises at West Footscray in the course of business as "tire dealers"—tools of trade, tires, and tubes for repair or reconditioning and tires and tubes having been repaired or reconditioned, new tires and tubes and rims.
- MCLENNAN, D. G.**, Box 90, Wycheproof; application to vary the conditions of existing licence No. D.A.41551 by deleting from paragraph (c) Donald, and adding in lieu Wycheproof.
- NUGENT, J.**, 25 Fallon-street, Caulfield; 1 commercial goods vehicle (55 cwt.) to operate throughout the State of Victoria in the course of business as a "marine dealer"—marine goods as designated in the *Marine Stores and Old Metals Act 1958* (No. 6303).
- PATTINSON, R. J.**, Yarram-street, Yarram; 1 commercial goods vehicle (100 cwt.) to operate—(a) within a radius of 20 miles of the post office at Yarram—general goods, (b) within a radius of 50 miles of the Shell Company of Australia Ltd.'s depot at Traralgon—petroleum products in prescribed types of containers and empty return containers.
- READY MIXED CONCRETE (VIC.) PTY. LTD.**, 501 Swanston-street, Melbourne; application to vary the conditions of existing licence No. D.A.39437/6 by deleting Melbourne and adding in lieu Ballarat.
- RITCHIE, R. A. & A. E.**, Pyramid Hill; 1 commercial goods vehicle (127 cwt.) to operate—(a) within a radius of 20 miles of the post office at Pyramid Hill—general goods, (b) from and to places within paragraph (a) above, and from places within a radius of 50 miles of the post office at Pyramid Hill—livestock.
- SCOTT, K. E.**, Warburton; 1 commercial goods vehicle (266 cwt.) to operate—(a) from Foresta's forest landings in the Matlock area to Foresta's timber yards at North Fitzroy—logs, (b) from Yelland Bros.' sawmill at Matlock to State Seasoning Works yards at Newport, Australian Furniture Co.'s timber yards at Fishermen's Bend, St. Clair Timber Co.'s timber yards at Brunswick, Wright and Son's timber yards at Footscray, Miller's Trading Co.'s timber yards at South Melbourne, and to Raymond's timber yards at Port Melbourne—sawn timber.
- SCOTT, K. E.**, Warburton; 1 commercial goods vehicle (170 cwt.) to operate from Yelland Bros.' sawmill at Matlock to State Seasoning Works yards at Newport, Australian Furniture Co.'s timber yards at Fishermen's Bend, St. Clair Timber Co.'s timber yards at Brunswick, Wright and Son's timber yards at Footscray, Miller's Trading Co.'s timber yards at South Melbourne, and to Raymond timber yards at Port Melbourne—sawn timber.
- VICKERS ARMSTRONG (AUSTRALIA) PTY. LTD.**, 236 Princes Highway, Dandenong; 2 commercial goods vehicles (9 cwt. each) to operate—(a) within a radius of 50 miles of own premises at Dandenong in the course of business as earth-moving equipment engineers—own goods, (b) throughout the State of Victoria for the purpose of servicing earth-moving equipment and tractors—tools of trade, spare parts, and materials incidental thereto.
- WALLER, F. H.**, Box 164, Orbost; application to vary the conditions of existing licence No. T.T.D.409 by adding sawn timber from Waygara Sawmilling Co. at Sardine Creek to Waygara Sawmilling Co., Waygara.
- WATTS, T. H.**, 60 Arnold-street, Bendigo; application to vary the conditions of existing licence No. D.A.2256 by adding within a radius of 25 miles of the chief post office at Bendigo—general goods.
- WILSON, C. D.**, 4 Railway-crescent, Korumburra; application to vary the conditions of existing licence No. D.A.27928/2 by deleting the present conditions and adding in lieu throughout the State of Victoria in the course of business as a "house remover" houses and sheds for removal from site to site and for subsequent re-erection—tools of trade, equipment, and materials incidental to own contracts.
- WILSON, J. M.**, 42 Madden-street, Morwell; 1 commercial goods vehicle (108 cwt.) to operate—(a) within a radius of 20 miles of the post office at Morwell—general goods, (b) between Morwell and Quarry at Balook and within a radius of 20 miles of Balook—quarry plant, equipment, road-making plant, materials, and screenings, (c) between Morwell and quarry at Longford and within a radius of 20 miles of Longford—quarry plant, equipment, road-making plant, materials, and screenings.

NOTICE is hereby given that the applications made by the persons named below for renewal of licences to operate the commercial goods vehicles, on the route or routes or in the manner set out opposite their names, will be heard at a time and place to be communicated to the persons concerned:—

Name and Address; Present Franchise; Licence No.; Date of Expiry.

- BOWER, E. J.**, Glenburn; 1 commercial goods vehicle (71 cwt.) to operate—(a) from and to places situate within the corporate limits of the City of Melbourne and within a distance of 8 miles beyond thereof to and from places situate within a radius of 5 miles from the post office at Glenburn and to and from Murrindindi—general goods, (b) from and to places situate within a radius of 20 miles from the post office at Glenburn to and from places situate within a radius of 50 miles from the post office at Glenburn—livestock; D.A.30940; 23rd September, 1961.
- CAMPBELL, P. W.**, 6 Swinborne-street, Box Hill South; 1 commercial goods vehicle (8 cwt.) to operate throughout the State of Victoria in the course of business as "maintenance engineer" for the purpose of installing and repairing new and second-hand scales, cash registers and food processing machines—tools of trade and spare parts for use on own contracts; D.A.2602; 21st September, 1961.

CARTER, K. J., 4 Vauxhall-road, Northcote; 1 commercial goods vehicle (95 cwt.) to operate—(a) within a radius of 70 miles from the post office at Healesville (Dandenong Division of the Country Roads Board)—plant the property of a contractor and required for use in connexion with the construction or maintenance of some specific existing or proposed road, street, footpath, bridge, wharf, pier, weir or channel, (b) within a radius of 20 miles from site of construction or maintenance work performed pursuant to paragraph (a) above, or from the railway station nearest thereto—metal, stones, screenings, ashes, gravel, sand, earth and any other materials required for such work; D.A.30999; 23rd September, 1961.

COHN'S LIMITED, Bridge-street, Bendigo; 1 commercial goods vehicle (120 cwt.) to operate—(1) goods being the property of the holders of this licence in the course of their business as "aerated water, &c., sauces, &c., manufacturers, wine and spirit merchants" in the under-mentioned areas—(a) within a radius of 50 miles from the licensee's factory at Bendigo, (b) from and to licensee's factory at Bendigo to and from—(i) the Townships of Kyabram, Merrigum, Tatura, Mooroopna and Shepparton, (ii) places along the roads between the Townships of Gunbower and Cohuna, Boort and Quambatook, Charlton and Wycheproof, St. Arnaud and Donald, (2) from and to licensee's factory at Bendigo to and from licensee's factory at Swan Hill—licensee's own aerated waters, cordials and empty containers, (3) own aerated waters and cordials in glass containers and empty return containers in the course of business of the licensee as "aerated water and cordial manufacturers" as follows:—(a) From Bendigo to places along the route to and from Ballarat, (b) from Bendigo to places along the road between the Township of Avoca and the City of Hamilton, via the City of Ararat and the Township of Stawell; D.A.863; 5th September, 1961.

COHN'S LIMITED, Bridge-street, Bendigo; 1 commercial goods vehicle (207 cwt.) to operate—(1) goods being the property of the holders of this licence in the course of their business as "aerated water, &c., sauces, &c., manufacturers, wine and spirit merchants" in the under-mentioned areas—(a) within a radius of 50 miles from the licensee's factory at Bendigo, (b) from and to licensee's factory at Bendigo to and from—(i) the Townships of Kyabram, Merrigum, Tatura, Mooroopna and Shepparton, (ii) places along the roads between the Townships of Gunbower and Cohuna, Boort and Quambatook, Charlton and Wycheproof, St. Arnaud and Donald, (2) from and to licensee's factory at Bendigo to and from licensee's factory at Swan Hill—licensee's own aerated waters, cordials and empty containers; D.A.863/2; 5th September, 1961.

COHN'S LIMITED, Bridge-street, Bendigo; 1 commercial goods vehicle (118 cwt.) to operate—(1) goods being the property of the holders of this licence in the course of their business as "aerated water, cordial, tomato products and sauce manufacturers and wine and spirit merchants" in the under-mentioned areas:—(a) within a radius of 50 miles from the licensee's factory at Bendigo, (b) from and to licensee's factory at Bendigo to and from—(i) the Townships of Kyabram, Merrigum, Tatura, Mooroopna and Shepparton, (ii) places along the roads between the Townships of Gunbower and Cohuna, Boort and Quambatook, Charlton and Wycheproof, St. Arnaud and Donald, (2) own aerated waters and cordials in glass containers and empty return containers in the course of business of the licensee as "Aerated Water and Cordial manufacturers" as follows:—(i) from Bendigo to places along the route to and from Ballarat, (ii) from Bendigo to places along the route between the Township of Avoca and the City of Hamilton, via the City of Ararat and the Township of Stawell; D.A.863/3; 5th June, 1961.

COHN'S LIMITED, Bridge-street, Bendigo; 1 commercial goods vehicle (146 cwt.) to operate in the course of business of the licensee as "aerated water and sauce manufacturers, wine and spirit merchants"—own goods—(a) within a radius of 50 miles from own premises in the City of Bendigo, (b) from and to own premises in the City of Bendigo to and from—(i) the Townships of Kyabram, Merrigum, Tatura and Mooroopna and the City of Shepparton, (ii) places situated along the roads between and including the Townships of Gunbower and Cohuna, Boort and Quambatook, Charlton and Wycheproof, St. Arnaud and Donald; D.A.863/4; 5th September, 1961.

COUTTS, T. J., PTY. LTD., 54 Lydiard-street north, Ballarat; 1 commercial goods vehicle (8 cwt.) to operate throughout the State of Victoria from own premises in the City of Ballarat in the course of business as "electrical contractors and refrigeration engineers"—equipment, tools of trade, spare parts and materials incidental to the installation and servicing of electrical equipment and used solely for own contracts; D.A.7611/3; 21st September, 1961.

DARLOW, J. T., Box 82, Nathalia; 1 commercial goods vehicle (97 cwt.) to operate—(a) within a radius of 90 miles from the post office at Wangaratta (Benalla Division of the Country Roads Board)—road-contracting plant used in the construction or maintenance of a road, street, footpath, bridge, wharf, pier, weir or channel, (b) within a radius of 20 miles from site of construction or maintenance work performed pursuant to paragraph (a) above or from a railway station nearest thereto—materials required for such work, (c) within a radius of 20 miles from the post office at Nathalia—general goods; D.A.30626; 26th August, 1961.

THE ESKDALE BUTTER FACTORY CO. LTD., Eskdale; 1 commercial goods vehicle (100 cwt.) to operate within a radius of 35 miles from the post office at Eskdale in the course of business as "butter manufacturers and general storekeepers"—own cream, butter, bran, pollard, superphosphate, firewood, empty cream cans, petroleum products and goods incidental to business as butter manufacturers and storekeepers; D.A.5205; 21st September, 1961.

FLEETWAYS TRANSPORT & AGENCY PTY. LTD., 88-102 Normanby-road, South Melbourne; 3 commercial goods vehicles (185, 117 and 103 cwt.) to operate—(a) from the premises of motor vehicle distributors and dealers direct to consignees throughout the State of Victoria—complete motor vehicles, (b) between the Cities of Melbourne, Geelong and Dandenong—motor bodies; D.A.20028/12, D.A.20028/13; 16th September, 1961; D.A.20028/14; 23rd September, 1961.

GRAY, R. E., Wood-street, Stawell; 1 commercial goods vehicle (198 cwt.) to operate—(a) within a radius of 20 miles from the post office at Stawell—firewood, (b) bricks on behalf of the Stawell Brick Co. Pty. Ltd. in the under-mentioned areas only:—(i) On the north by a direct line from St. Arnaud through Donald and Hopetoun to the Victorian-South Australian border nearest to Serviceton, (ii) on the west by the South Australian border, (iii) on the south by the south coast from the Victorian-South Australian border to Warrnambool, thence by a direct line through Terang to Camperdown, (iv) on the east by a direct line from Camperdown through Derrinallum and Avoca to St. Arnaud; D.A.2574; 17th August, 1961.

HAMILTON, T., Box 26, Ararat; 1 commercial goods vehicle (89 cwt.) to operate—(a) within a radius of 20 miles from the post office at Ararat—general goods, (b) within a radius of 50 miles from the post office at Ararat—road-contracting plant and materials; D.A.1226; 31st May, 1961.

JACKSON, F. H., 117 Clyde-street, Box Hill; 1 commercial goods vehicle (146 cwt.) to operate within a radius of 70 miles from the premises of the Standard Brick Works (Box Hill) Pty. Ltd. at Box Hill—bricks on behalf of the said company; D.A.30890; 16th September, 1961.

KENNA, A. J., Spring-street, Mortlake; 1 commercial goods vehicle (142 cwt.) to operate within a radius of 70 miles from the post office at Mortlake—tools of trade and equipment incidental to licensee's own contracts in the course of business as "agricultural and earthmoving contractor"; D.A.30874; 16th September, 1961.

MAWSON, E. B. & SONS, Box 66, Post Office, Cohuna; 1 commercial goods vehicle (approximately 80 cwt.) to operate—(a) within a radius of 95 miles from the post office at Cohuna and within a radius of 100 miles from the post office at Merbein (Bendigo Division of the Country Roads Board)—plant the property of a contractor and required for use in connexion with the construction or maintenance of some specific existing or proposed road, street, footpath, bridge, wharf, pier, weir or channel, (b) within a radius of 20 miles from site of construction or maintenance work performed pursuant to paragraph (a) above, or from the railway station nearest thereto—metal, stones, screenings, ashes, gravel, sand, earth and any other materials required for such work, (c) within a radius of 20 miles of the post office at Cohuna—general goods; D.A.30119/2; 6th May, 1961.

MEADE, W. E., 422 Main-street, Bairnsdale; 1 commercial goods vehicle (17 cwt.) to operate from the railway stations at Sale, Bairnsdale and Orbost to retailers situate within that part of the State of Victoria east of a north/south line drawn through the City of Sale, in the course of licensee's business as "commercial agent"—cigarettes, tobacco, confectionery and potato chips; D.A.3617; 21st September, 1961.

MESSER, W., 727 Barkly-street, Ballarat; 1 commercial goods vehicle (8 cwt.) to operate within a radius of 50 miles from own premises at Ballarat and to and from Ararat in the course of business as "clothing and mercer"—own goods; D.A.30888; 16th September, 1961.

MOTOR TYRE SERVICE PTY. LTD., cnr. Deakin-avenue and Tenth-street, Mildura; 2 commercial goods vehicles (19 and 13 cwt.) to operate within a radius of 100 miles from Mildura in the course of business as "tire reconditioners"—new and second-hand tires and tubes, and tires and tubes for reconditioning or having been reconditioned, battery, oil and car accessories; D.A.31001/1, D.A.31001/3; 23th September, 1961.

MURRAY, W. A., 51 Watson-street, Wodonga; 1 commercial goods vehicle (60 cwt.) to operate—(a) within a radius of 90 miles from the post office at Wangaratta (Benalla Division of the Country Roads Board)—plant the property of a contractor and required for use in connexion with the construction or maintenance of some specific existing or proposed road, street, footpath, bridge, wharf, pier, weir or channel, (b) within a radius of 20 miles from site of construction or maintenance work performed pursuant to paragraph (a) above, or from the railway station nearest thereto—metal, stones, screenings, ashes, gravel, sand, earth and any other materials required for such work, (c) within a radius of 20 miles of the post office at Wodonga—general goods; D.A.1646; 9th September, 1961.

NEEDS, T. W., 17 Bourke-street, Kyneton; 1 commercial goods vehicle (105 cwt.) to operate—(a) within a radius of 20 miles from the post office at Kyneton—general goods, (b) within a radius of 50 miles from the post office at Kyneton—plant the property of a contractor and required by him for use in connexion with the construction or maintenance of some specific existing or proposed road, street, footpath, bridge, pier, wharf, weir or channel and also the following materials, viz., metal, stones, screenings, ashes, gravel and sand, (c) within a radius of 20 miles from the site of any construction work performed pursuant to paragraph (a) above, or from the railway station nearest thereto—any other materials required for such work; D.A.1708; 1st August, 1961.

O'DONNELL, J. P., J. H., & D. J. (trading as O'Donnell Bros. Tyre Service), Fairy-street, Warrnambool; 1 commercial goods vehicle (13 cwt.) to operate within a radius of 50 miles from own premises at Warrnambool, in the course of business as "new and second-hand tire and car accessory distributors"—tires and tubes for sale and delivery, used tires for repair, retreading or having been repaired or retreaded, batteries, oil and car accessories; D.A.30833; 16th September, 1961.

PETERS ICE CREAM (VIC.) LTD., 171-183 Burnley-street, Richmond; 1 commercial goods vehicle (50 cwt.) to operate throughout the State of Victoria for the purpose of installing and servicing refrigerators—refrigerators for installation, also tools of trade, spare parts and materials required in connexion with such installation and servicing; D.A.1813/10; 12th September, 1961.

SOUTHERN PENINSULA TRANSPORT SERVICE PTY. LTD., Post Office Box 4, Rosebud; 1 commercial goods vehicle (approximately 200 cwt.) to operate—(a) from and to the City of Melbourne to and from places on or within 3 miles distance from that portion of Nepean Highway situated between the Township of Portsea and the bridge over Dunn's Creek—general goods, (b) between the railway station at Mornington and places situated on or not more than 3 miles from that portion of the Nepean Highway between the Township of Portsea and the bridge over Dunn's Creek—general goods; D.A.2075/9; 21st September, 1961.

TAYLOR, L. R. & W. L. (trading as Taylor Bros.), 73 Forest-street, Castlemaine; 1 commercial goods vehicle (121 cwt.) to operate within a radius of 50 miles from the post office at Castlemaine in the course of business as "produce and wood merchants"—wheat, oats, chaff, hay and wood from farms and properties within the said radius to own stores at Castlemaine; D.A.4146; 21st September, 1961.

NOTICE is hereby given that the applications made by the persons named below for renewal with variation of licences to operate the commercial goods vehicles on the route or routes, or in the manner set out opposite their names, will be heard at a time and place to be communicated to the persons concerned:—

Name and Address; Present Franchise; Variation; Licence Number; Expiry Date.

COHNS LIMITED, Bridge-street, Bendigo; 1 commercial goods vehicle (163 cwt.) to operate—(1) goods being the property of the holders of this licence in the course of their business as "aerated water, &c., sauces, &c., manufacturers, wine and spirit merchants" in the under-mentioned areas—(a) within a radius of 50 miles from the licensee's factory at Bendigo, (b) from and to licensee's factory at Bendigo to and from—(1) the Townships of Kyabram, Merrigum, Tatura, Mooropna, and Shepparton, (ii) places along the roads between the Townships of Gunbower and Cohuna, Boort and Quambatook, Charlton and Wycheproof, St. Arnaud and Donald, (2) from and to licensee's factory at Bendigo to and from licensee's factory at Swan Hill—licensee's own aerated waters, cordials, and empty containers; by adding as paragraph 3—own aerated waters and cordials in glass containers and empty return containers in the course of business of the licensee as "aerated water and cordial manufacturers" as follows:—(a) from and to licensee's factory at Bendigo to and from licensee's factory at Wangaratta—licensee's own aerated waters, cordials, and empty returns, (b) from and to licensee's factory at Bendigo to and from licensee's factory at Yea—licensee's own aerated waters, cordials, and empty containers; D.A.863/1; 5th September, 1961.

COTTEE, G. A. & L., Kelsall-street, Warracknabeal; 1 commercial goods vehicle (209 cwt.) to operate—(a) within a radius of 20 miles of the post office at Warracknabeal—general goods, (b) within a radius of 50 miles of the post office aforesaid and to and from the Township of Patchewollock—petroleum products in prescribed types of containers and empty containers, on behalf of Caltex (Aust.) Pty. Ltd.; by adding to paragraph (b)—to and from Ouyen; D.A.30742; 23rd September, 1961.

Notice of any objection should be forwarded to reach the Secretary of the Board not later than Wednesday, 19th July, 1961.

B. P. KAY,
Secretary.

Exhibition Building, Rathdown-street, Carlton, N.3, 5th July, 1961.

Transport Regulation Act.

TRANSPORT REGULATION BOARD.

NOTICE No. 60.

Conditions of Operation of Certain Hire Stands for Taxi-cabs Situated in the City of Melbourne.

TAKE notice that, pursuant to the powers conferred on the Board by the provisions of Regulation 36 (i) of the Transport Consolidated Regulations 1960, the Board hereby specifies, in accordance with the provisions of Regulation 5 of Part I. of the said Regulations, the conditions of operation of certain taxi-cab hire stands situated within the City of Melbourne. These conditions shall take effect from and including midnight on 30th June, 1961.

1. Stands to which the said conditions shall apply are—

Hire Stand H.30 in Flinders-street on the south side, east for 105 feet from a point 45 feet east from the prolongation of the eastern building alignment of Degraeves-street.

Hire Stand H.47 in Swanston-street, west side, north for 45 feet from a point 30 feet north from the prolongation of the northern building alignment of Batman-avenue.

Hire Stand H.48 in Swanston-street, west side, south for 75 feet from a point 150 feet south from the southern building alignment of Flinders-street.

2. Notwithstanding the provisions of the Transport Consolidated Regulations 1960, and subject to the provisions of this notice, between the hours of 4.30 p.m. and 8.30 p.m. daily, it is a condition that these stands shall be used by commercial passenger vehicles the

licences issued in respect of which are classified as metropolitan taxi-cabs solely for the pick up of passengers intending to proceed to areas specified hereunder:—

(a) In respect of Hire Stand H.30, passengers proceeding to southern and western suburbs, including the following:—

Brighton, Caulfield, Malvern, Moorabbin, Oakleigh, Prahran, Sandringham, South Melbourne, St. Kilda, Essendon, Footscray, Sunshine and Williamstown, and other suburbs in the same general direction.

(b) In respect of Hire Stands H.47 and H.48, passengers proceeding to eastern and northern suburbs, including the following:—

Box Hill, Camberwell, Hawthorn, Kew, Brunswick, Fitzroy, Coburg, Collingwood, Heidelberg, Northcote, Preston, and other suburbs in the same general direction.

3. Notwithstanding the provisions contained in the previous paragraph drivers of taxi-cabs to which this notice is applicable shall at all times accept hirings from each of the stands aforesaid if such hirings are to terminate within the City of Melbourne.

By order of the Transport Regulation Board,

B. P. KAY,
Secretary.

PUBLIC TRUSTEE ACT 1958, No. 6350, SECTION 17.

I HEREBY give notice that, on the 19th June, 1961, the Public Trustee filed elections to administer the following deceased persons' estates, in accordance with section 17 of the *Public Trustee Act 1958*:—

OLSSSEN, PERCIVAL LESLIE, late of Sailor's Home, Siddley-street, Melbourne, wharf labourer, died 26th January, 1961.

SMITH, CHARLES RICHARD, late of Owens and Murray Home, Beechworth, pensioner, died 18th October, 1960.

I HEREBY give notice that, on the 20th June, 1961, the Public Trustee filed elections to administer the following deceased persons' estates, in accordance with section 17 of the *Public Trustee Act 1958*:—

HARRIS, LAWRENCE KEITH, late of 11 Shipley-street, South Yarra, fishmonger, died 23rd November, 1960.

KIRBY, GEORGE FREDERICK, formerly of Grandview-road, Warrandyte and Ringwood, but late of Sunbury, labourer, died 28th August, 1957.

ROBERTSON, LEWIS, late of Footscray Private Hospital, 10 Geelong-road, Footscray, pensioner, died 25th February, 1961.

WEEKES, HANNAH, late of "Hillandale", 62 Thompson-road, Upwey, pensioner, died 31st March, 1961.

WELSH, COLIN JOHN, late of 12 Southernhay-street, Regent, cross cut sawyer, died 29th March, 1961.

ZIMMERMAN, PETER, formerly of Minyip, but late of Ballarat, pensioner, died 24th March, 1961.

I HEREBY give notice that, on the 23rd June, 1961, the Public Trustee filed an election to administer the following deceased person's estate, in accordance with section 17 of the *Public Trustee Act 1958*:—

CHANTER, ARTHUR MABEY, formerly of "Ti Tree", New-street, Brighton Beach, and 11 Nepean Highway, Elsternwick, but late of Studley Park-road, Kew, professor of music, died 28th November, 1950.

A. D. DUNCAN,
Public Trustee.

601 Little Collins-street, Melbourne, C.1, 28th June, 1961.

NOTICE.

CREDITORS, next of kin and others having claims against the estate of any of the under-mentioned deceased persons are required to send particulars of their claims to the Public Trustee, 7th Floor, 601 Little Collins-street, Melbourne, the personal representative, on or before the 8th September, 1961, after which date the Public Trustee may convey or distribute the assets, having regard only to the claims of which the Public Trustee then has notice:—

BROWN, ALBERT GEORGE, formerly of 4 Fourth-avenue, Brunswick, but late of Mont Park, clerk, died 26th March, 1961.

DAVIDSON, CLARICE CONSTANCE, also known as Clarice Constance Mary Davidson, formerly of 58 York-street, South Yarra, but late of 8 Bletchley-road, Oakleigh, checker, died 25th February, 1961.

FEARY, ELSIE LYDIA, late of Kumara, New Zealand, widow, died 15th November, 1960.

FITZPATRICK, NORMAN GILLIES, formerly of 16 Ulupna-road, Carnegie, but late of 554 New-street, Elsternwick, clerk, died 7th April, 1961.

GOODWIN, ETHEL LOUISE, late of 16 Warner-street, Essendon, widow, died 30th March, 1961.

HARRIS, LAWRENCE KEITH, late of 11 Shipley-street, South Yarra, fishmonger, died 23rd November, 1960.

JUSTICE, HARRY, late of Ventnor, Phillip Island, farmer, died 24th July, 1959.

KIRBY, GEORGE FREDERICK, formerly of Grandview-road, Warrandyte and Ringwood, but late of Sunbury, labourer, died 28th August, 1957.

MACDONALD, MURDO SMITH, formerly of QX 7186, Unit 3rd Railway Construction Company, 2nd A.I.F., but late of 24 Sycamore-street, Chadstone, seaman, died 22nd September, 1960.

MCGREAL, PATRICK, late of Pakington-street, Geelong West, retired sergeant of police, died 21st June, 1961.

MCLEOD, ALLAN KEITH, late of South Purrumbete, farmer, died 12th May, 1961.

OLSSSEN, PERCIVAL LESLIE, late of Sailor's Home, Siddley-street, Melbourne, wharf labourer, died 26th January, 1961.

PICKERING, JAMES FARLEY, late of 49 Vasey-avenue, Lalor, bricklayer, died 11th April, 1961.

ROBERTSON, LEWIS, late of Footscray Private Hospital, 10 Geelong-road, Footscray, pensioner, died 25th February, 1961.

ROBINSON, HAROLD EDWARD, late of 117 Gordon-street, Balwyn, clerk, died 13th March, 1961.

SMITH, CHARLES RICHARD, late of Owens and Murray Home, Beechworth, pensioner, died 18th October, 1960.

WALPOLE, KATHLEEN LISSETTE, formerly of Bartels-street, McCrae, but late of 8 Kooringa-road, Ormond, widow, died 14th October, 1960.

WEEKES, HANNAH, late of "Hillandale", 62 Thompson-road, Upwey, pensioner, died 31st March, 1961.

WELSH, COLIN JOHN, late of 12 Southernhay-street, Regent, cross cut sawyer, died 29th March, 1961.

WHELAN, FREDRICK ARTHUR, also known as Frederick Arthur Whelan, late of 4 Laluma-street, Essendon, retired cleaner, died 18th April, 1961.

ZIMMERMAN, PETER, formerly of Minyip, but late of Ballarat, pensioner, died 24th March, 1961.

A. D. DUNCAN,
Public Trustee.

Melbourne, 28th June, 1961.

DEPARTMENT OF MINES.

SUBJECT to any necessary excisions, &c., it is proposed to grant the following mining leases:—

5596, Gippsland; Henry Lewis Rigbye and Kenneth Wright; 817a. 3r. 31p., Parish of Wollonaby.

5600, Gippsland; Robert George Johnston and Charlie Klingzot; 62a. 1r. 8p., Parishes of Waihalla and Numbruk.

7975, Mineral; Edward John Chaplin; 6a. 2r. 13p., Parish of Castlemaine.

7107, Maryborough; Oxide Gold No Liability; 11a. 2r. 13p., Parish of Woosang.

APPLICATION FOR LEASE DECLARED ABANDONED.

7965, Mineral; Ronald Brian Bell; 80 acres, Parish of Kosciusko.

APPLICATION FOR LEASE REFUSED.

7883, Mineral; William Henry Mildren; 50 acres, Parish of Berrigama.

EXTENSION OF TERM OF PETROLEUM PROSPECTING LICENCE.

157, Petroleum Prospecting Licence; Lakes Oil Limited; 200 square miles, Parishes of Stradbroke, Mullungdung, Darriman, Woodside, Wonwron, Boodyarn, Yarram Yarram, Woranga, Alberton East, Bruthen, Balloong and Tarra Tarra.

EXTENSION OF TERM OF PETROLEUM EXPLORATION PERMIT.

22, Petroleum Exploration Permit; Frome Broken Hill Company Proprietary Limited; 4,000 square miles, seaward a distance of 15 miles from the coast between Cape Schanck and the South Australian border.

W. J. MIBUS,
Minister of Mines.

AUCTION SALES ACT 1958.

LIST of Persons to whom Auctioneers' Licences have been issued during the month of May, 1961, and prior months.

Name.	Address.	Date of Issue.
Astbury, Neville Alfred	c/o Dennys Lascelles Ltd., Coleraine	26.5.61
Bannan, Paul	34 Jasper-terrace, Frankston	8.5.61
Barr, Robert James	45 Teak-street, Caulfield	30.5.61
Burden, Victor John	6 Glendale-street, Surrey Hills	23.5.61
Camm, Frank	80 Nepean Highway, Seaford	30.5.61
Coldbeck, David Edward	c/o Aust. Mercantile Land and Finance Co. Ltd., Benalla	1.5.61
Down, Graham Leslie	Gowangardie, via Violet Town	11.5.61
Farmer, John W.	9 Younger-street, Wangaratta	26.5.61
Finnis, Peter	307 Neil-street, Ballarat	1.1.61
Ford, William George	207 Walnut-avenue, Mildura	1.1.61
Hall, Lawrence George	Narracoote, South Australia	28.4.61
Hildebrand, Roy Kenneth	54 Melbourne-road, Norlane	31.5.61
Hiscock, Eric Tasman	7 Ashby Court, North Balwyn	10.5.61
Hudson, Robert Fairbairn	Kilmore	1.1.61
Knight, Bernard Hugh	Coleraine	1.5.61
McHugh, Raymond Thomas Jack	11 Dans-street, Ballarat	1.1.61
McPherson, Norman Henry	Nepean Highway, Dromana	9.5.61
Moran, Leo	Rushworth	9.2.61
Nulty, Francis Murray James	Mitchell-street, Ouyen	1.1.61
Nulty, Thomas James	Eleventh-street, Mildura	1.1.61
O'Shannessy, Thomas Joseph	P.B. 62, St. Arnaud	4.5.61
Portway, Colin	72 Xors-street, Frankston	12.5.61
Ray, Kevin John	9 Milton-street, Elwood	23.5.61
Ray, Lewis John	10 Heron-avenue, Mildura	1.1.61
Smith, Roy Douglas	Elmore	1.1.61
Steele, George Lunt	36 Crotonhurst-avenue, Caulfield	11.5.61
*Waring, Malcolm Howard	3 Norton-avenue, Shepparton	26.5.61
Whitmore, Roderick James	Nolan-street, Maryborough	1.1.61

* By transfer from K. E. Watts.

The Treasury,
Melbourne, C.2, 26th June, 1961.

E. W. COATES,
Director of Finance.

Marriage Act 1958.

MINISTERS OF RELIGION REGISTERED TO CELEBRATE MARRIAGES IN VICTORIA.

IT is hereby notified that in pursuance of the provisions of the *Marriage Act 1958*, No. 6306, Sec. 11, the under-mentioned Officiating Ministers of Religion have been registered at this Office for the celebration of marriages in Victoria:—

Number in Register.	Name.	Designation.	Denomination.	Residence.	Date of Registration.
12454	MacNab, Francis Auchline	Minister	Presbyterian	621 Punt-road, South Yarra	30.5.61
12455	Bouwmeester, Jacob Adrianus	Minister	Presbyterian	Rosedale	30.5.61
12456	Judd, Philip George	Elder	Re-organized Church of Jesus Christ of Latter Day Saints	7 Arabia-street, Frankston	1.6.61
12457	Popple, Alfred Matthias	Pastor	Methodist	Cudgewa	5.6.61
12458	Jones, John Thomas	Major	Salvation Army	73 Union-street, Armadale	5.6.61
12459	Sedlo, Henry	Minister	Presbyterian	Eddy-street, Rainbow	7.6.61
12460	Rigley, Peter Edwin	Captain	Salvation Army	16 Park-street, East Geelong	7.6.61
12461	Wardle, Thomas Moses	Minister	Congregational	123 Garden-street, Geelong	7.6.61
12462	Horwill, Frank Merrick	Minister	Baptist	Cohuna	15.6.61
12463	Baldwin, Cyril Donald Burdett	Minister	Baptist	Main-street, Koondrook	15.6.61
12464	Moore, Arthur Raymond	Minister	Baptist	Tavernor-street, Rainbow	19.6.61
12465	Hunter, Francis Edward	Priest	Roman Catholic	63 Wilfred-road, East Ivanhoe	21.6.61
12466	McDonald, Francis	Priest	Roman Catholic	Woodland-street, North Essendon	21.6.61
12467	Sharry, George Emmett	Priest	Roman Catholic	71 Somerville-road, Yarraville	21.6.61

Office of the Government Statist,
Melbourne, 23rd June, 1961.

F. W. CORRIE,
Assistant Government Statist.

Soil Conservation and Land Utilization Act 1958.

AMENDMENT OF APPOINTMENT OF A MEMBER OF THE DISTRICT ADVISORY COMMITTEE OF THE AVOCA RIVER SOIL CONSERVATION DISTRICT.

HIS Excellency the Administrator of the Government of the State of Victoria, by and with the advice of the Executive Council thereof, has, this day, amended the Order approved on the twenty-third of May, 1961, appointing Members of the District Advisory Committee of the Avoca River Soil Conservation District, by deleting the name JAMES FREDERICK ATKINSON appearing therein, and substituting therefor the name JAMES FREDERICK ALLINSON.

A. MAHLSTEDT,
Clerk of the Executive Council.

At the Executive Council Chamber,
Melbourne, 27th June, 1961.

LAW DEPARTMENT.

ADDITIONAL SITTINGS OF THE SUPREME COURT AT MILDURA.

HIS Excellency the Administrator of the Government of the State of Victoria, by and with the advice of the Executive Council thereof, doth by Order made on the 27th June, 1961, appoint Monday, the 24th July, 1961, for the Sittings of the Supreme Court at Mildura in addition to the days heretofore appointed.

L. H. S. THOMPSON,
for Attorney-General.

Approved by the Governor in Council,
27th June, 1961.

A. MAHLSTEDT,
Clerk of the Executive Council.

Police Regulation Act 1958.

POLICE FORCE OF VICTORIA.

DETERMINATION No. 92 OF THE POLICE CLASSIFICATION BOARD.

THE Police Classification Board, in pursuance of the powers in that behalf conferred by the *Police Regulation Act 1958*, hereby makes the following Determination, that is to say:—

1. The Determination No. 85 of the Police Classification Board of the 30th August, 1960, and published in the *Government Gazette* of the 25th October, 1960, as amended, is hereby further amended as follows:—

(a) By deleting paragraph 67 and substituting therefor the following:—

“67. If the duty to be performed by a member is of such a nature that it is reasonable to believe he will be detained for a period of several days away from his station or place of employment, he may receive, where practicable, an adequate advance of travelling expenses commensurate with the period of his absence.”

2. This Determination shall come into operation on the 27th day of June, 1961.

Dated at Melbourne this 26th day of June, 1961.

F. R. NELSON,

A Judge of the County Court of Victoria,
Deputy Chairman and Member of the
Police Classification Board.

D. S. RAMAGE,

Member of the Police Classification Board.

F. G. HOLLAND,

Member of the Police Classification Board.

Country Roads Acts.

COUNTRY ROADS BOARD.

NOTICE OF FIXING NEW ALIGNMENTS OF MIDLAND HIGHWAY
IN THE SHIRE OF HUNTLY AND THE CITY OF BENDIGO.

NOTICE is hereby given that the Country Roads Board, under the powers conferred upon it by the *Country Roads Act 1958* (No. 6229), has fixed new alignments for the east and west sides of the Midland Highway in the Shire of Huntly and City of Bendigo as described hereunder, that is to say:—

- (a) Commencing at a point in allotment 1, section 3, Parish of Huntly, distant 189 deg. 6½ min. 330 feet and 279 deg. 6½ min. 33 feet from the north-eastern angle of the said allotment; thence by lines bearing respectively 187 deg. 59½ min. 1,266 ft. 3 in., 188 deg. 48½ min. 2,432 ft. 5½ in., 233 deg. 48½ min. 21 ft. 2½ in., 98 deg. 48½ min. 15 feet, 188 deg. 48½ min. 81 ft. 1 in., 278 deg. 40½ min. 15 feet, 143 deg. 43 min. 21 ft. 2½ in. and 188 deg. 47 min. 1,595 ft. 5½ in. to a point on the eastern boundary of allotment 32, Township of Epsom, Parish of Sandhurst, distant 10 deg. 50 min. 262 ft. 1½ in. and 9 deg. 0½ min. 65 feet from the south-eastern angle of the said allotment 32.
- (b) Commencing at a point on the western boundary of allotment 8, section 6, Township of Epsom, Parish of Sandhurst, distant 188 deg. 36½ min. 121 feet from the north-western angle of the said allotment; thence by lines bearing respectively 187 deg. 49½ min. 640 feet, 190 deg. 50 min. 271 ft. 9 in., 144 deg. 49 min. 20 ft. 10 in., 278 deg. 46 min. 15 feet, 192 deg. 8 min. 66 ft. 1½ in., 98 deg. 46 min. 15 feet, 235 deg. 27½ min. 21 ft. 10 in., 192 deg. 8 min. 518 ft. 5 in., 192 deg. 32 min. 244 ft. 11½ in., 145 deg. 42½ min. 20 ft. 6½ in., 278 deg. 50½ min. 15 feet, 192 deg. 32 min. 66 ft. 1½ in., 98 deg. 50½ min. 15 feet, 235 deg. 42½ min. 21 ft. 10½ in. and 192 deg. 32 min. 228 ft. 2½ in. to the south-western angle of lot 3 on plan of subdivision numbered 43641, lodged in the Office of Titles, and being part of allotment 66, Township of Epsom, Parish of Sandhurst.
- (c) Commencing at the south-western angle of lot 50 on plan of subdivision numbered 43641, lodged in the Office of Titles, and being part of allotment 73, Township of Epsom, Parish of Sandhurst; thence by lines bearing respectively 191 deg. 28½ min. 336 ft. 11½ in., 121 deg. 14½ min. 26 ft. 3½ in., 231 deg. 32½ min. 37 ft. 10 in., 191 deg. 28½ min. 77 ft. 6½ in., 191 deg. 15 min. 447 ft. 0½ in., 190 deg. 54 min. 1,175 ft.

11 in. and 212 deg. 11½ min. 35 ft. 8 in. to a point on the north-western boundary of allotment 14, section 17, City of Bendigo, in the said parish, distant 190 deg. 53½ min. 27 ft. 8½ in. from the northern angle of the allotment last named.

- (d) Commencing at a point on the eastern boundary of allotment 24, Township of Epsom, Parish of Sandhurst, distant 190 deg. 34½ min. 295 ft. 5½ in. from the north-eastern angle of allotment 25 of the said township; thence by lines bearing 190 deg. 56½ min. 296 ft. 11½ in. and 191 deg. 28½ min. 452 ft. 1 in. to a point on the southern boundary of allotment 22 of the said township distant 278 deg. 45½ min. 9 ft. 0½ in. from the south-eastern angle thereof.—

which said new alignments are shown on survey plans numbered 7363, 7864, 7865, 7866, 7690 and 7691, lodged in the office of the Country Roads Board.

Copies of the said survey plans are lodged in the offices of the Country Roads Board, the municipalities of the Shire of Huntly and the City of Bendigo, the Registrar of Titles and the Registrar-General, respectively, and may be inspected by any person, without a fee, at any time at which such offices are open for business.

Dated the 29th day of June, 1961.

R. E. V. DONALDSON,
Secretary.

Country Roads Board, 60 Denmark-street, Kew, E.A.

Town and Country Planning Act 1958, as Amended.
SHIRE OF ALTONA PLANNING SCHEME 1958.

AMENDMENT No. 13.

Notice of Approval.

IN pursuance of the powers conferred by the *Town and Country Planning Act 1958*, as amended, the Governor in Council, by and with the advice of the Executive Council thereof, on the 6th June, 1961, approved a planning scheme entitled the Shire of Altona Planning Scheme 1958, Amendment No. 13, in respect of part of the municipal district of the Shire of Altona.

A copy of the planning scheme as approved may be inspected, during office hours, at the office of the Town and Country Planning Board, 61 Spring-street, Melbourne; at the office of the Shire of Altona, at Altona; and when available, at the Office of Titles, Melbourne, and at the Central Plan Office of the Department of Crown Lands and Survey, Melbourne.

W. H. CRAIG,
Secretary, Town and Country Planning Board.

STATE RIVERS AND WATER SUPPLY COMMISSION.

BY-LAW No. 5353.—FOR THE SALE AND DISTRIBUTION OF WATER FOR IRRIGATION—BACCHUS MARSH, GOULBURN-MURRAY, MACALISTER, MERBEIN, NYAH, REDCLIFFS, ROBINVALE, TRESKO AND WERRIBEE IRRIGATION DISTRICTS.

THE State Rivers and Water Supply Commission, in pursuance and exercise of the powers conferred by the Water Acts, doth hereby make the By-law following:—

1. This By-law shall apply to and have force in the Bacchus Marsh, Goulburn-Murray, Macalister, Merbein, Nyah, Redcliffs, Robinvale, Tresko and Werribee Irrigation Districts, except within any urban districts thereof, and shall come into operation on the 1st day of July, 1961.

2. By-laws Nos. 4868, 4869, 5121, 5141, 5227, 5229, 5230, 5231, 5232, 5233, 5234 and 5301 are hereby revoked.

3. For the purposes of this By-law, unless inconsistent with the context or subject-matter—

- (a) An "acre-foot" of water means such volume of water as would cover an area of 1 acre to a depth of 1 foot.
- (b) "Irrigation season" means in respect of any irrigation district or irrigation area thereof (as the case may be) a period for which an irrigation charge is made.
- (c) "Ordinary watering period" means, in respect of the Merbein, Nyah, Redcliffs, Robinvale or Tresko Irrigation District, any of such periods within an irrigation season as the Commission may fix from time to time after consultation with the appropriate Advisory Board as the periods during which, and only during which, water shall be supplied in respect of water rights.
- (d) A "watering" of any land means the volume of water supplied for any continuous application of water to such land for irrigation.

4. In respect of any irrigation district the Commission may, after consultation with the appropriate Advisory Board, fix the maximum quantity of water which may be taken under water right at or during any time or period by the owners or occupiers of lands in such district.

5. Ordinary watering periods in respect of the Merbein, Nyah, Redcliffs, Robinvale or Tresko Irrigation Districts may be fixed by the Commission from time to time after consultation with the appropriate Advisory Board.

6. All persons taking water from the works of the Commission shall take delivery thereof through such outlets, at such times, in such order, and in such manner as the Commission or its officers may direct.

7. Applications for the supply of water for irrigation shall be made in writing to the water bailiff in charge of that portion of the district in which the land to be irrigated is situated, or to such other officer as may be authorized by the Commission to receive applications.

8. All meters or other instruments for measurement of water supplied for irrigation shall be of a form and pattern approved by the Commission and shall be installed under the supervision of and to the satisfaction of the Commission.

9. All charges under this By-law for water supplied for irrigation of any land shall be payable on demand at the place at which irrigation charges in respect of lands in the same irrigation area or irrigation district are payable.

10. The charge per acre-foot for water supplied for irrigation other than in respect of any water right shall be as follows:—

- (a) *For water supplied to lands in the Goulburn-Murray, Macalister, Bacchus Marsh and Werribee Irrigation Districts*—the same as the irrigation charge per acre-foot last made for the district before the date on which such water is supplied: Provided that the charge per acre-foot for any water supplied for irrigation from any drain shall be, if the water is diverted by gravitation, one-half the amount of the irrigation charge per acre-foot last made for the district before such date, or, if the water is diverted by pumping, one-quarter the amount of the irrigation charge per acre-foot last made for the district before such date;
- (b) *For water supplied to lands in the Redcliffs and Merbein Irrigation Districts*—
 - (i) for water supplied during an ordinary watering period, the same as the irrigation charge per acre-foot last made for the district before the date on which such water is supplied,

- (ii) for water supplied at times other than during an ordinary watering period, but during a period in which water is supplied in respect of applications for the supply of water for the irrigation of a total area of not less than 300 acres within the district, one and one-half times the irrigation charge per acre-foot last made for the district before the date on which such water is supplied,

- (iii) for water supplied at times other than during an ordinary watering period, but during a period in which water is supplied in respect of applications for the supply of water for the irrigation of a total area of less than 300 acres within the district, twice the irrigation charge per acre-foot last made for the district before the date on which such water is supplied:

Provided that the minimum charge for a watering of any holding shall be the charge for one acre-foot of water so supplied;

(c) *For water supplied to lands in the Robinvale Irrigation District*—

- (i) for water supplied during an ordinary watering period, the same as the irrigation charge per acre-foot last made for the district before the date on which such water is supplied,

- (ii) for water supplied at times other than during an ordinary watering period, one and one-half times the irrigation charge per acre-foot last made for the district before the date on which such water is supplied:

Provided that the minimum charge for a watering of any holding shall be the charge for one acre-foot of water so supplied;

(d) *For water supplied to lands in the Nyah and Tresko Irrigation Districts*—the same as the irrigation charge per acre-foot last made for the district before the date on which such water is supplied: Provided that the minimum charge for a watering of any holding shall be the charge for one acre-foot of water so supplied.

11. In the absence of any specific means of measurement or during any period for which the meter or other instrument for measurement is deemed by the Commission to be inaccurate or not registering, a watering of any land shall be accounted as follows:—

(a) *For water supplied to land in the Merbein and Redcliffs Irrigation Districts*—a volume of water 6 inches in depth over such land: Provided that where application of water to the land is within an ordinary watering period and is by means of sprays a watering shall be accounted as a volume of water 3 inches in depth over such land;

(b) *For water supplied to land in the Nyah, Robinvale and Tresko Irrigation Districts*—a volume of water 5 inches in depth over such land: Provided that where application of water to the land is within an ordinary watering period and is by means of sprays a watering shall be accounted as a volume of water 3 inches in depth over such land;

(c) *For water supplied to land in the Goulburn-Murray, Macalister, Bacchus Marsh and Werribee Irrigation Districts*—a volume of water of such depth over the land as is set out in the Schedule hereunder according to the classification of the land and the crop thereon: Provided that—

- (i) a watering applied to any land by means of sprays shall be accounted as a volume of water 0.25 feet in depth over such land,

- (ii) a watering applied to an orchard within three years after planting shall be accounted as one-half the volume of a watering computed in accordance with the said Schedule,

- (iii) the volume of water supplied during any year ending 30th June for the irrigation of any land planted to tomatoes shall be accounted as a volume 2 feet in depth over such land or such lesser

depth as the Commission may decide in respect of any year during which the volume of water supplied is restricted because of shortage.
 (iv) the volume of water supplied during any year ending 30th June to any holding within which the area irrigated does

not exceed 5 acres shall be accounted as a volume 2 feet in depth over such area or such lesser depth as the Commission may decide in respect of any year during which the volume of water supplied is restricted because of shortage.

SCHEDULE.

Name of Irrigation District. Column 1.	Deemed Depth of a Watering over Land Irrigated.					
	Swamp Land. Column 2.	Ungraded Land.	Graded Land.		Orchards and Vineyards. Column 6.	Market Gardens. Column 7.
		Cereals and Native Pastures. Column 3.	Lucerne and Permanent and Annual Pastures. Column 4.	Annual Fodder Crops and Cereals. Column 5.		
Feet.	Feet.	Feet.	Feet.	Feet.	Feet.	Feet.
Goulburn-Murray	1.0	0.5	0.3	0.4	0.4	0.25
Macalister	1.0	0.5	0.4	0.5	0.5	0.25
Bacchus Marsh	1.0	0.5	0.5	0.5	0.5	0.4
Werribee	1.0	0.5	0.3	0.4	0.4	0.25

For the purposes of the above Schedule graded land means land which in the opinion of the Commission has been effectively laid out for the purpose of irrigation on the border, check or contour system.

The foregoing By-law was made by the State Rivers and Water Supply Commission on the 26th day of June, 1961, and the common seal of the said Commission was hereunto affixed the 30th day of June, 1961, in the presence of—

(SEAL) H. W. MCCAY, Commissioner.
 A. L. TISDALL, Commissioner.

Approved by the Governor in Council,
 4th July, 1961.

A. MAHLSTEDT,
 Clerk of the Executive Council.

STATE RIVERS AND WATER SUPPLY COMMISSION.
 BY-LAW No. 5354 REVOKING BY-LAW No. 5297 AND FIXING CHARGES FOR WATER SUPPLIED FROM THE COLIBAN SYSTEM OF WATERWORKS.

THE State Rivers and Water Supply Commission, in pursuance and exercise of the powers conferred by the Water Acts, doth hereby make the By-law following for the district supplied with water from the Coliban System of Waterworks:—

1. By-law No. 5297 made by the Commission on the 17th day of November, 1958, is hereby revoked as from the 1st day of July, 1961.

2. The charge to be paid for water supplied by measure from the pipes of the Commission after the 30th day of June, 1961, shall, except in cases of special agreement with the Commission and in the cases hereinafter specially mentioned, be Two shillings (2s.) per 1,000 gallons.

3. The maximum allowance of water to be supplied per annum without further charge to any properties rated by the Commission shall be the quantity which, if charged for at Two shillings (2s.) per 1,000 gallons, would give an amount equal to that payable per annum in respect of the property so supplied under the provisions of any By-law of the Commission for making and levying rates, and for all water supplied in excess of such allowance the charge shall be Twenty pence (1s. 8d.) per 1,000 gallons.

4. The maximum allowance of water to be supplied per annum without further charge to any property for which a minimum annual charge has been fixed by the Commission shall be the quantity which, if charged for at Two shillings (2s.) per 1,000 gallons, would give an amount equal to such minimum annual charge, and for all water supplied in excess of such allowance the charge shall be Twenty pence (1s. 8d.) per 1,000 gallons.

5. The charge to be paid for water supplied from the channels of the Commission shall be One and one-half pence (1½d.) per 1,000 gallons, except in the cases hereinafter mentioned—

- (a) For sluice mining, except for purposes directly connected with machinery in motion, One penny (1d.) per 1,000 gallons.
- (b) For steam boilers, condensers, air compressors and machinery for manufacturing purposes, Six pence (6d.) per 1,000 gallons.

The foregoing By-law was made by the State Rivers and Water Supply Commission on the 26th day of June, 1961, and the common seal of the said Commission was hereunto affixed the 30th day of June, 1961, in the presence of—

(SEAL) H. W. MCCAY, Commissioner.
 A. L. TISDALL, Commissioner.

Approved by the Governor in Council,
 4th July, 1961.

A. MAHLSTEDT,
 Clerk of the Executive Council.

APPOINTMENT OF COMMITTEE OF MANAGEMENT OF MT. BULLER ALPINE RESORT.

WHEREAS by section 50 of the Forests Act 1958 (No. 6254), it is provided that the Minister of Forests, may, on the recommendation of the Forests Commission, appoint any number of persons, not less than three, to be a Committee of Management of any land forming part of any reserved forest, such land being a place of natural beauty or interest or a health resort, and may remove any of such persons: Now, therefore, I, Alexander John Fraser, Her Majesty's Minister of Forests in the State of Victoria, on the recommendation of the Forests Commission, do hereby appoint—

J. B. HILTON-WOOD, of Melbourne, and
 K. G. HARROP, of Mansfield, in lieu of K. M. Gibson, as Members of the Committee of Management until the 23rd November, 1963, of the land forming part of the Reserved Forest in the Parish of Changue, County of Wonnangatta, described in the accompanying Schedule, and known as "Mt. Buller Alpine Resort", such land being a place of natural beauty or interest.

SCHEDULE ABOVE REFERRED TO.

Parish of Changue, County of Wonnangatta, 2,357 acres, more or less, being the area shown within pink border on plan marked 18.11.60 over 58/2260 in file of correspondence No. 58/2260 of the Forests Department.

Dated at Melbourne, the 27th day of June, 1961.

A. J. FRASER,
 Minister of Forests.

CONTRACTS ACCEPTED.—(Series 1960-61.)**VICTORIAN RAILWAYS.**

186. Liquid petroleum gas, at rates (Contract 61825).—John Thompson Combustion Engineering Pty. Ltd.
187. Insulation Ice Store House, for £1,787 10s. (Contract 61842).—W. H. Brewer Pty. Ltd.
188. Aluminium-faced plywood panels, for £42 6s. 8d. each (Contract 61856).—Ralph Symonds Ltd.

By order of the Victorian Railways Commissioners,
W. WALKER, Secretary for Railways. 30.6.61.

PUBLIC WORKS.

4022. Altona West, State School No. 4862, new primary school building of eight class-rooms, £27,868.—Rodney Construction Co. Pty. Ltd.

4023. Fawker, Technical School, erection of second and third sections, £45,873.—A. V. Jennings Construction Co. Pty. Ltd.

4024. Merbein, High School, new school, £66,800.—E. Mills and Sons.

4025. Redcliffs, High School, erection of high school in L.T.C., £66,600.—E. Mills and Sons.

4026. Templestowe South, State School No. 4861, new primary school, £28,700.—R. F. Hosie.

4027. Ararat, Mental Hospital, extension of steam radiators, carpenters' shop, £582.—Mech. Engineering Pty. Ltd.

4028. Ballarat, Mental Hospital, external painting to Ward M.4, £898 10s.—J. and W. and K. Walsh.

4029. Ballarat, Mental Hospital, external painting to Ward M.3, £898 10s.—J. and W. and K. Walsh.

4030. Belmont, High School, internal and external renovations to residence, £278 10s. 6d.—H. De Vries.

4031. Beulah, Police Station, repairs and painting, £350.—C. L. Hobson.

4032. Broadmeadows East, State School No. 4732, external lighting, £302.—Derjan Electrics.

4033. Camberwell, State School No. 888, new cupboards under chalkboards, £476 10s.—A. Williams Construction Co. Pty. Ltd.

4034. Carlton, Social Welfare Department, Prisons Division, 57 Palmerston-street, maintenance cleaning, period from 1st April, 1961, to 31st March, 1962, £324.—Linglow Cleaning Service.

4035. Carlton, State School No. 2605, chain wire extension to fencing, £195.—S. Macario and F. Donnini.

4036. Carlton, State School No. 112, renewal of water supply, £532.—F. Pullinger.

4037. Charlton, Clerk of Courts Residence, repairs and painting, £499.—R. House.

4038. Coburg, Pentridge Gaol, supply of overhead conveyor, paint spray booths and bake ovens, &c., £14,290.—Cameron and Jason.

4039. Cranbourne North, State School No. 4887, electrical installation in new school, £950.—Swift Electrical Services.

4040. Creswick, State School No. 122, renovations to school and residence, £4,900.—Ronald F. Hosie.

4041. Croydon North, State School No. 1992, installation of septic tank system, £1,065.—C. McCarthy.

4042. Dartmoor, Police Station, electrical installation, £508.—John L. Creek.

4043. Derrinallum, State School No. 2050, replacement of roofing with galvanized iron, £316 10s. 6d.—G. L. Breen.

4044. Dromana, Police Station, erection of (non-party) fencing, £270.—B. Bullen.

4045. East Loddon, Consolidated School, chalkboards and blinds, £308 18s.—R. House.

4046. Frankston Heights, State School No. 4815, plenum heating in six class-room unit, £2,038.—Thermic Heating and Ventilation.

4047. Geelong, Gordon Institute of Technology, extensions to the gas-heating system, £514 16s. 6d.—Nott and Drew Pty. Ltd.

4048. Heatherton, State School No. 938, renewal of flooring to two class-rooms, entrance hall, office and store, £387.—R. S. Burgess.

4049. Huntingdale, High School, construction of reinforced concrete stormwater drain, £1,064.—Boynton Plumbing Service Pty. Ltd.

4050. Jordanville, Technical School, renewal of existing gas pipes and connexion of school to reticulated supply, £398 2s. 2d.—Colonial Gas Holdings Ltd.

4051. Kangaroo Flat, State School No. 4728, erection of new combined out-office/laundry block, £1,239 8s.—J. G. Hibberd Pty. Ltd.

4052. Kew, Mental Hospital, provision of double-bowl stainless steel vegetable preparation bench, &c., £285 14s.—Ahearn Main and Stott Pty. Ltd.

4053. Koonwarra, State School No. 3177, installation of "Rein" type septic closets to school and residence, £1,023.—R. and J. Grant.

4054. Lake Bolac, State School No. 854, internal and external painting to school and residence, £2,505.—Newcomb Contractors.

4055. Lyndale, High School, heating and hot-water services for stages one and two, £11,855.—Gray and Wood.

4056. Melbourne, Titles Office, Queen-street, supply and installation of pump and return line, £347.—R. and G. Guymar.

4057. Moorabbin, State School No. 1111, repairs and painting to residence, £397.—A. Alaimo.

4058. Murrumbeena, Police Station, erection of police station and residence, £8,858.—J. Greenwood.

4059. Noble Park, State School No. 3675, connexion of residence, 9 Jasper-street, to sewer, provision of new toilet on rear porch, £290.—Boynton Plumbing Service Pty. Ltd.

4060. Noble Park, Technical School, connecting school to sewerage system, £3,335.—R. and G. Guymar.

4061. Parkmore, State School No. 4881, electrical installation of light, power and public address system for new school of eight L.T.C. class-rooms, &c., £1,300 12s. 6d.—Jennings Electrics.

4062. Preston, Early Treatment Centre, 83 Hotham-street, gas hot-water systems and gas wall heaters in therapy and toilet blocks, £685 14s. 4d.—G. and H. Snook.

4063. Raywood, Police Station, installation of septic tank, closets and drainage, £253 15s.—Campbell Connelly and Co. Pty. Ltd.

4064. Ringwood, State School No. 2997, additional lavatory accommodation, £2,400.—R. F. Hosie.

4065. Rye, State School No. 1667, cnr. Dundas-street and Point Nepean Highway, repairs and painting to residence, £565.—F. Freeman.

4066. Smythesdale, State School No. 978, erection of out-office, woodshed block, install septic closets, £787.—Penrice and Gercovich.

4067. Springvale, State School No. 3507, new out-office block and external drains, £3,361.—C. McCarthy.

4068. Strathmore, State School No. 4612, erection of new out-office block, £2,590 10s.—H. A. Bannister.

4069. Toolangi, Toolangi Potato Research Farm, installation of septic system to three (3) cottages, £475 10s.—D. W. Burch.

4070. Warrawong, State School No. 4835, electrical installation in four additional L.T.C. class-rooms, &c., £398 14s. 9d.—G. Anderson.

4071. Walpeup, Mallee Research Station, erection of toilet block, £1,585.—S. Sandor.

T. K. MALTBY, Commissioner of Public Works. 23.6.61.

ORDERS IN COUNCIL.—(Series 1960-61.)**EDUCATION DEPARTMENT.**

4000. One only Wulff's electroscope for Ballarat School of Mines, £151 8s.—Watson Victor Ltd.

4001. One only edge trimmer and jointer with accessories for Collingwood Technical School, £762 4s.—B.U. Supplies and Machinery Co.

4002. One only photographic composing machine for Melbourne School of Printing and Graphic Arts, £447 11s.—Filmopty Pty. Ltd.

4003. One only Standard electric typewriter for Gordon Institute of Technology, Geelong, £165.—I.B.M. Australia Pty. Ltd.

Approved by the Governor in Council, 27th June, 1961.—A. MAHLSTEDT, Clerk of the Executive Council.

PUBLIC WORKS.

4004. "Allambie", 70 Elgar-road, Elwood, Social Welfare Department, supply of electrical equipment as follows:—

Firm; Item; Price.

Singer Sewing Machine Coy.; two class 331K4 and three class 306K25 sewing machines; £359 15s. 10d. Lightburn and Co. Ltd.; six Lightburn Gold Seal twin-tub washing machines; £531 2s. 6d.

Warburton Franki Industries (Melb.) Pty. Ltd.; five 23-in. S.T.C. "Emperor" television sets and antennas; £692 19s. 2d.

Elanco Pty. Ltd.; six desk fans, five drying cabinets and twelve Hotpoint electric irons; £291 12s. 7d.

A.X. Refrigeration Installation and Maintenance Pty. Ltd.; eight refrigerators; £880. (N.E.265617.)

4005. Ararat Mental Hospital, installation of gas service and fittings for connexion to heavy-duty gas range, £395 15s.—The Gas Supply Co. Ltd. (W.190017 "C").

4006. Beaumaris State School, special grant for payment to School Committee as contribution towards the erection of a Library Room. (S.E.240055.)

4007. Ballarat Mental Hospital, provision of cabling to wards for P.A.X. system, £433 7s. 5d.—P.M.G.'s Department. (W.43279.)

4008. Christ the King Church School Temporary Buildings, Showgrounds, provision of washing and drinking facilities, £481 17s.—A. and R. Smith. (M.266945.)

4009. Frankston Technical College, fees for preparation of working drawings, £656.—Clive Steele Associates. (S.E.199883.)

4010. Government Printing Office, North Melbourne, preparing floor and supplying and laying Mastipave floor covering and supply of cafeteria equipment as follows:—

Firm; Item; Price.

A. Easton; preparing floor and supplying and laying Mastipave floor covering; £375.

K. G. Luke Pty. Ltd.; cafeteria equipment; £317 6d. 9d. (M.183465 "F").

4011. Government House, Melbourne, catering for garden party, £742 18s. 4d.—Turner's Catering Services Pty. Ltd. (M.162035.)

4012. Moonee Ponds West State School No. 2901, supply and erection of chain mesh fencing, £266.—Diamond Fence and Gate Co. Pty. Ltd. (W.245438.)

4013. Numurkah High School Advisory Council, special grant to Advisory Council towards cost of grading and levelling school grounds, £350. (N.E.237452.)

4014. Ports and Harbors Branch, supply of second-hand chain cable for buoyage purposes, £822 17s. 6d.—Dent Machinery Salvage Pty. Ltd. (M.206462.)

4015. Prison Farm, French Island, hire of formwork for circular tank, £530 10s. 4d.—Rapid Metal Developments (Aust.) Pty. Ltd. (S.E.164169.)

4016. Public Works Department Storeyard, Port Melbourne, supply of 5,000 feet of 3-in. diameter and 2,000 feet of 4-in. diameter agricultural pipes, £264 3s. 4d.—Victorian Stoneware Pipe Manufacturers' Association. (M.75131.)

4017. Public Works Department Depot, Port Melbourne, repairs to track wheels for Allen trencher, £276.—Maddison and Bowman Pty. Ltd. (M.35105.)

4018. Public Works Department Storeyard, Port Melbourne, supply of 10,000 feet of 2-in. diameter heavy-duty galvanized wrought iron pipes, £1,708 17s. 1d.—Stewarts and Lloyds (Distributors) Pty. Ltd. (M.69910.)

4019. State School No. 33, Dana-street, Ballarat, supply and installation of gas-heating equipment, £828 13s. 6d.—The Ballarat Gas Company. (W.252497.)

4020. Snob's Creek Fish Hatchery, installation of aerial reticulation for new water failure alarm siren and erect siren, £257.—M. Harrison. (N.E.11598 "A".)

4021. Tyabb Railway Station State School No. 3544, replacing floor, £257 19s. 8d.—W. N. Rogers. (S.E.264580.)

Approved by the Governor in Council, 20th June, 1961.—A. MAHLSTEDT, Clerk of the Executive Council.

FORESTS COMMISSION.

Loan Fund Act No. 6691, Item 1—

4072. To the purchase of part of Crown allotment 3, Town and Parish of Buchan, for forest purposes, £200.—Mesdames M. A. Kauffman and E. B. Moore, of Buchan.

Approved by the Governor in Council, 20th June, 1961.—A. MAHLSTEDT, Clerk of the Executive Council.

Loan Fund Act No. 6691, Item 1—

4073. To the purchase of parts of allotments 17A and 61, Parish of Coimadaí, containing 5 acres 0 roods 11 1/10 perches of land for forest purposes, £101 7s. 9d.—Edwin Holt, Bacchus Marsh.

Approved by the Governor in Council, 9th May, 1961.—A. MAHLSTEDT, Clerk of the Executive Council.

Loan Fund Act No. 6691, Item 1—

4074. To the purchase of allotment 78 and part of allotment 12E, Parish of Moorbanoool, County of Polwarth, containing 325 acres 1 rood 4 perches of land for forest purposes, £975 16s. 6d.—Charles Buchanan McKenzie and Ian Duncan McKenzie, of Gellibrand.

Approved by the Governor in Council, 27th June, 1961.—A. MAHLSTEDT, Clerk of the Executive Council.

PUBLIC WORKS.

4075. Bendigo Girls' Secondary School Advisory Council, special grant towards cost of erection of a canteen building at the school. (N.238979.)

4076. Chadstone Park State School Committee, special grant for payment towards the erection of a Library Room at the school. (M.230980.)

4077. Echuca High School, supply of 144 cubic yards of crushed rock, £345 12s.—D. Kennedy. (N.E.251576.)

4078. Edenhope High School, supply and installation of sliding doors, £296.—Geo. Lange and Sons Pty. Ltd. (W.260701.)

4079. Education Department, improved lighting, £729 12s.—J. Newall Pty. Ltd. ((M.266622.))

4080. Dredge *Matthew Flinders*, the under-mentioned works:—

Firm; Works; Price.

Buchanan and Brock Pty. Ltd.; overall repairs; £4,734 2s. 10d.

Duke's and Orr's Amalgamated Dry Docks Ltd.; docking and undocking, cleaning and painting, &c.; £4,608 14s. 7d. (M.206374.)

4081. Kew Mental Hospital, supply of glazed and flooring tiles, £345 12s. 8d.—The Australian Tesselated Tile Co. Pty. Ltd. (M.248687.)

4082. McLeod Penal Settlement, French Island, maintenance repairs to diesel-driven alternators and engine, £381 19s. 9d.—Southern Cross Machinery Pty. Ltd. (S.E.219842.)

4083. Norwood High School, bricklaying on retaining wall, £560.—John E. Peers. (S.E.192269.)

4084. Swinburne Technical College, diversion of storm-water drain, £2,199 0s. 7d.—Hawthorn City Council. (M.101422.)

Approved by the Governor in Council, 27th June, 1961.—A. MAHLSTEDT, Clerk of the Executive Council.

ORDERS IN COUNCIL.—(Series 1961-62.)

STATE ELECTRICITY COMMISSION.

81. For the supply of steel pipes and expansion joints, for fire and water services at Morwell Open Cut, to Specification No. 60-61/291, £7,488.—Cowley's Eureka Iron Works.

82. For the supply of high-speed twist drills, straight and taper shank hand taps, and hand dies, for a period of two years, to Specification No. 60-61/320, at Schedule Rates.—Ferrocast Engineers' Supplies Pty. Ltd.

83. For the supply of various files, for a period of two years, to Specification No. 60-61/322, at Schedule Rates.—Ferrocast Engineers' Supplies Pty. Ltd.

84. For the supply of five fluid couplings, for moveable conveyors at Yallourn Open Cut, to Specification No. 60-61/323, £13,105.—Moore Hydraulics Pty. Ltd.

85. For the supply of galvanized mild steel washers, for a period of two years, to Specification No. 60-61/292, at Schedule Rates.—West Footscray Engineering Works Pty. Ltd.

Approved by the Governor in Council, 20th June, 1961.—A. MAHLSTEDT, Clerk of the Executive Council.

VICTORIAN RAILWAYS.

BY-LAW NO. 382.

The Victorian Railways Commissioners in the exercise of the powers conferred upon them by the Railways Act do hereby make the following By-law, namely:—

Cash on Delivery Parcels Traffic.

On and after the first day of August, 1961, the amount of commission on the value of parcels consignments for carriage by passenger trains under the Cash on Delivery arrangement as declared by the sender on the consignment note which shall be deducted by the Comptroller of Accounts when arranging settlement with the sender shall be as follows:—

Declared Value	Amount of Commission
	s. d.
Not exceeding £3 0 0	2 0
Exceeding £3 0 0 but not exceeding £4 0 0	3 0
" £4 0 0 " " " "	4 0
" £5 0 0 " " " "	5 0
" £6 0 0 " " " "	6 0
" £7 0 0 " " " "	6 6
For each additional £1 0 0 up to a maximum of £125 0 0	0 6

Any subsisting By-law the provisions of which are inconsistent with the provisions of this By-law is to the extent of such inconsistency hereby repealed.

In witness whereof the common seal of the Victorian Railways Commissioners was affixed hereto this twenty-second day of June, One thousand nine hundred and sixty-one, in the presence of—

(SEAL) E. H. BROWNBILL } Victorian Railways
E. P. ROGAN } Commissioners.

Confirmed by the Governor in Council, the 27th day of June, 1961.—A. MAHLSTEDT, Clerk of the Executive Council.

Workers Compensation Act 1958.

LIST OF APPROVED INSURERS 1961-62.

- African Guarantee and Indemnity Company Limited.
 Ajax Insurance Company Limited.
 Albion Insurance Company Limited.
 Alliance Assurance Company Limited.
 American Home Assurance Company.
 Associated General Contractors Insurance Company Limited.
 Assurance and Thrift Association Limited.
 Atlas Assurance Company Limited.
 Australian Alliance Assurance Company.
 Australian and Eastern Insurance Company Limited.
 Australian Equitable Insurance Company Limited.
 Australian General Insurance Company Limited.
 Australian and International Insurances Limited.
 Australian Mutual Fire Insurance Society Limited.
 Australian National Assurance Company Limited.
 Australian Natives Association Insurance Company Limited.
 Automobile Fire and General Insurance Company of Australia Limited.
 A.M.P. Fire and General Insurance Company Limited.
 Baloise Marine Insurance Company Limited.
 Baltica Insurance Company Limited.
 Bankers and Traders Insurance Company Limited.
 British General Insurance Company of Australia Limited.
 British Traders Insurance Company Limited.
 Caledonian Insurance Company.
 Chamber of Manufactures Insurance Limited.
 Central Insurance Company Limited.
 Century Insurance Company Limited.
 Colonial Mutual Fire Insurance Company Limited.
 Commercial of Australia Insurance Company Limited.
 Commercial Union Assurance Company of Australia Limited.
 Commercial and General Insurance Limited.
 Consolidated Insurances of Australia Limited.
 Co-operative Insurance Company of Australia Limited.
 Cornhill Insurance Company Limited.
 C.M.L. Fire and General Insurance Company Limited.
 Derwent and Tamar Assurance Company Limited.
 Eagle Star Insurance Company Limited.
 Eastern United Assurance Corporation Limited.
 Economic Insurance Company Limited.
 Employers' Liability Assurance Corporation Limited.
 Farmers and Settlers Co-operative Insurance Company of Australia Limited.
 Federal Mutual Insurance Company of Australia Limited.
 Federation Insurance Limited.
 General Accident Fire and Life Assurance Corporation Limited.
 Gresham Fire and Accident Insurance Society Limited.
 Guardian Assurance Company Limited.
 Guildhall Insurance Company Limited.
 Hanover Insurance Company New York.
 Hartford Fire Insurance Company.
 Helvetia Swiss Fire Insurance Company Limited.
 Insurance Company of North America.
 Insurance Corporation of Ireland Limited.
 Insurance Office of Australia Limited.
 Interstate Steamship Insurance Company Proprietary Limited.
 Lancashire Insurance Company.
 Law Union and Rock Insurance Company Limited.
 Legal and General Assurance Society Limited.
 Licenses and General Insurance Company Limited.
 Liverpool and London and Globe Insurance Company Limited.
 Lombard Insurance Company Limited.
 London Assurance.
 London Guarantee and Accident Company Limited.
 London and Lancashire Insurance Company Limited.
 Manchester Unity Fire Insurance Company of Victoria Limited.
 Master Builders Insurance Company Limited.
 Melbourne Fire Office Limited.
 Mercantile Mutual Insurance Company Limited.
 Milford Insurance Company Limited.
 M.L.C. Fire and General Insurance Company Pty. Limited.
 National Employers Mutual General Insurance Association Limited.
 National and General Insurance Company Limited.
 National Alliance Insurance Company Limited.
 National Insurance Company of New Zealand Limited.
 New Zealand Insurance Company Limited.
 North British and Mercantile Insurance Company Limited.
 North Queensland Accident Insurance Company Limited.
 Northern Assurance Company Limited.
 Norwich Union Fire Insurance Society Limited.
 New India Assurance Company Limited.
 Northumberland Insurance Company Limited.
 Ocean Accident and Guarantee Corporation of Australia Limited.
 Orion Insurance Company Limited.
 Overseas Shipping Insurance Company Proprietary Limited.
 Pacific Insurance Company Limited.
 Palatine Insurance Company of Australia Limited.
 Patriotic Assurance Company Limited.
 Pearl Assurance Company Limited.
 Perpetual General Insurance and Guarantee Company Limited.
 Phoenix Assurance Company Limited.
 Provincial Insurance Company Limited.
 Provident Fire Insurance Company Limited.
 Prudential Assurance Company Limited.
 Queensland Insurance Company Limited.
 Riverina Insurance Company Limited.
 Royal Exchange Assurance of London.
 Royal Insurance Company Limited.
 Scottish Insurance Corporation Limited.
 Scottish Union and National Insurance Company.
 Sea Insurance Company Limited.
 Skandia Insurance Company.
 South African Fire and Accident Insurance Company Limited.
 South Australian Insurance Company Limited.
 South British Insurance Company Limited.
 Southern Pacific Insurance Company Limited.
 Southern Union Insurance Company of Australia Limited.
 Sphere Insurance Company Limited.
 State Assurance Company Limited.
 Steadfast Insurance Company Limited.
 Sun Insurance Office Limited.
 Switzerland General Insurance Company Limited.
 T. and G. Fire and General Insurance Company Limited.
 Transport and General Insurance Company Limited.
 Triton Insurance Company Limited.
 Union Assurance Society of Australia Limited.
 Union Insurance Society of Canton Limited.
 United Insurance Company Limited.
 Vanguard Insurance Company Limited.
 Victoria Insurance Company Limited.
 Victoria Racing Club.
 Victorian Automobile Chamber of Commerce Insurance Company Limited.
 Victorian Wheatgrowers Corporation Limited.
 Western Assurance Company.
 Western Australian Insurance Company (Canberra) Limited.
 World Auxiliary Insurance Corporation Limited.
 Yorkshire Insurance Company Limited.

Approved by the Governor in Council, 27th July, 1961.—
 A. MAHLSTEDT, Clerk of the Executive Council.

WODONGA WATERWORKS TRUST.
 AUTHORITY TO OBTAIN BANK OVERDRAFT.

HIS Excellency the Administrator of the Government of the State of Victoria, by and with the advice of the Executive Council thereof, doth by Order made on the 4th July, 1961, authorize the Wodonga Waterworks Trust to obtain, in pursuance of the provisions of section 286 of the *Water Act 1958* (No. 6413), an advance or advances during the year 1961 from the Commercial Banking Company of Sydney Limited, Wodonga, by overdraft of the Trust's current account thereat, such overdraft not to exceed at any one time the sum of Three thousand pounds (£3,000).

A. MAHLSTEDT,
 Clerk of the Executive Council.

At the Executive Council Chamber,
 Melbourne, 4th July, 1961.

LATROBE VALLEY WATER AND SEWERAGE BOARD.
BY-LAW NO. 2.—PREVENTION AND REGULATION OF DISCHARGE OF WASTE.

THE Latrobe Valley Water and Sewerage Board in pursuance and exercise of the powers conferred by the *Latrobe Valley Act 1958* hereby makes the following By-law:—

1. No person shall discharge any waste into the Latrobe River or into any place or in any manner whereby it flows or seeps or falls or passes by natural means into or may flow or seep or fall or so pass into the Latrobe River.

2. (1) In this By-law "waste" means—

- (a) Any sawdust, shavings, bark or other solid waste from a sawmill or wood-working establishment.
- (b) Any ash, dust, dirt, rubbish, garbage, nightsoil, manure, offal or any carcass or portion of a carcass of any animal.
- (c) Any grease, fat, oil, tar or radio-active material or any waste from a gas producer.
- (d) Any liquid which may impart to the Latrobe River at a point 40 chains below the point of entry a colour in excess of 50 parts per million measured on the Cobalt scale in excess of the colour of the Latrobe River measured on the Cobalt scale at a point 5 chains above the point of entry.
- (e) Any liquid of a temperature and quantity sufficient to increase the temperature of water in the Latrobe River above a temperature of 95° Fh. measured—

- (i) If at the point of entry the person discharging the liquid does not occupy both banks of the Latrobe River, at a distance of 20 chains below the point of entry; or
- (ii) if at the point of entry the person discharging the liquid does occupy both banks of the Latrobe River at—

- (a) a distance of 2 miles below the point of entry; or
- (b) a distance of 20 chains below the point (downstream of the point of entry) at which the person discharging the liquid ceases to occupy both banks—

whichever distance is the lesser.

Provided that during the period commencing on the date this By-law comes into operation and ending on the first day of July, 1965, any person discharging liquid into the Latrobe River who discharges similar liquid before this By-law came into operation shall be deemed to have complied with the requirements of this paragraph (e) if the temperature of water in the Latrobe River measured as aforesaid is not thereby increased above 97½° Fh. at any time and if the average temperature of water in the Latrobe River measured as aforesaid at hourly intervals throughout any one period of 24 hours does not exceed 95° Fh.

- (f) Any liquid which may increase the phenol content of any water in the Latrobe River above 0.5 parts per million by weight or the phenol content of any water in any tributary of the Latrobe River above 2 parts per million by weight or increase the chloro-phenol content of any water in the Latrobe River above .005 parts per million by weight. For the purposes of this paragraph "phenol" means phenol, cresol and xylenol.
- (g) Any liquid that may reduce the purity of any water in the Latrobe River beyond the standard set out in sub-clause (2) of this clause.

(2) The standard referred to in paragraph (g) of the previous sub-clause is that immediately on entering the Latrobe River no sample of liquid shall—

- (a) Contain more than 30 parts per million by weight of suspended matter.
- (b) When tested with its suspended matter included take up at a temperature of 65° Fh. more than 20 parts per million by weight of dissolved oxygen in five days.
- (c) Contain more than 0.15 parts per million by weight of cyanides.
- (d) Have a pH value of less than 6 or greater than 10.
- (e) Contain a total amount of zinc, chromium, arsenic, silver, copper, mercury, cadmium,

barium, selenium, lead and nickel in excess of one part per million by weight.

- (f) Contain free chlorine in excess of one part per million by weight.
- (g) In the case of a liquid containing domestic sewage or sewage effluent, when tested in amounts of 50 cubic centimetres contain any pathogenic organisms or any bacillus coli communis.

(3) Any person who contravenes or fails to comply with this By-law and is not liable to a penalty of not more than Five hundred pounds and to a further daily penalty of not more than One hundred pounds (as provided for in section 57 of the *Latrobe Valley Act 1958*) shall be liable to a penalty of not more than One hundred pounds and a further daily penalty of not more than Twenty pounds.

(4) In this By-law—

"Daily Penalty" means a penalty for each day on which an offence is continued or repeated—

- (a) after notice has been given to the offender of the commission of the offence; or
- (b) after a conviction or order of any court.

"Latrobe River" means the Latrobe River in Gippsland together with (unless the contrary intention appears) any tributaries, channels and defined water-courses which flow directly or indirectly into that river.

"Person" includes a corporation.

Expressions of distance shall be interpreted as meaning distance along the course of the Latrobe River and not necessarily distance in a straight line.

Words importing the singular shall be deemed to include the plural, and the plural the singular.

(5) This By-law shall come into operation on the date of the publication thereof in the *Government Gazette*.

The foregoing By-law No. 2 was made by the Latrobe Valley Water and Sewerage Board on the 13th day of June, 1961, and the common seal of the said Board was hereunto affixed the 13th day of June, 1961, in the presence of—

(SEAL) JOHN MULVANY, Chairman.
 A. D. SAMBELL, Member.
 T. J. PRIESTLEY, Secretary.

Approved by the Governor in Council,
 27th June, 1961.

A. MAHLSTEDT,
 Clerk of the Executive Council.

Cemeteries Act 1958.

SCALE OF FEES OF THE DIMBOOLA PUBLIC CEMETERY.

IN pursuance of the powers conferred upon them by the Cemeteries Acts, the Trustees of the Dimboola Public Cemetery hereby make the following scale of fees, which shall come into operation upon publication in the *Government Gazette*, and from and after such publication every scale of fees heretofore made by the said Trustees shall be and is hereby rescinded to the extent to which it conflicts with this scale:—

	£	s.	d.
Land 8 feet x 4 feet	4	10	0
Land 4 feet x 3 feet (Child's)	1	10	0
Number peg	0	10	0
Grave digging 4 feet	2	0	0
Grave digging 5 feet	4	0	0
Grave digging 6 feet	8	0	0
Grave digging 7 feet	9	10	0
Re-opening	5	0	0
Work under monument	1	0	0
Saturday work	1	10	0
Sunday and holiday work	2	0	0
Interment fee	2	0	0
Interment fee for re-opening	3	0	0
Monument fee—8 feet x 4 feet	2	0	0
Monument fee—8 feet x 8 feet	3	0	0
Monument fee—4 feet x 3 feet	1	0	0
Remove and replace ledger	3	0	0

L. A. MENZEL, Trustee.
 H. E. HIRTH, Trustee.
 E. G. JACKMAN, Trustee.

Approved by the Governor in Council,
 27th June, 1961.

A. MAHLSTEDT,
 Clerk of the Executive Council.

Cemeteries Act 1958.
PORT FAIRY PUBLIC CEMETERY.

IN pursuance of the powers conferred upon them by the *Cemeteries Act 1958*, the Trustees of the Port Fairy Public Cemetery hereby make the following Regulations, which shall come into operation upon publication in the *Government Gazette*, and from and after such publication every Regulation heretofore made by the said Trustees shall be and is hereby rescinded.

REGULATIONS GOVERNING LAWN CEMETERY, PORT FAIRY.

1. The new section of the Port Fairy Cemetery will be known as the New Lawn Cemetery, Port Fairy.
2. No interment must take place without the written authority of the Trust, and the fees paid in advance.
3. Public Graves: The interment will take place in the public non-denominational section and the fees will be that of digging the grave plus the interment fee.
4. Private Section: All graves in the private section must be purchased before any interment may take place, and the monumental fees paid with the purchase of the grave.
5. The Trust has the right to remove from graves any wreaths remaining after one month from the interment.

REGULATIONS APPERTAINING TO MONUMENTAL WORK IN THE NEW LAWN CEMETERY, PORT FAIRY.

1. All fees for the erection of new headstones are to be paid in advance by the owners of graves on their original application for ground.
2. Any person desiring to have erected a headstone on the grave of any relative or friend who is buried in the public ground may do so by application to the Trust and paying the prescribed monumental fee; and providing that a written guarantee will be given that the names of any subsequent person buried in the same grave will be included on the said headstone.
3. A fee shall be charged by the Trust for any alterations to existing headstone and shall be paid in advance with the application to carry out such alterations.
4. Written application must be made fourteen (14) days before proposed work is contemplated. Application must give full name of the owner of the grave, the name of the deceased person buried in such grave, the denomination of the section, and the work to be carried out.
5. No monumental work will be carried out without the written authority of the Trust which must be produced on application for the key to the Cemetery from the Secretary.
6. All surrounding lawns must be covered with a tarpaulin or some thick covering so as to prevent any cement or stone chippings remaining on the lawns.
7. On completion of the work the area must be left clean and tidy and all refuse deposited on rubbish heaps.
8. The Trust deems that any application for permission to construct, alter, or inscribe any grave in the Lawn Section of the Cemetery will only be approved on the understanding that the monumental mason will comply with these Regulations and Specifications, both of which have been laid down by the Trust and gazetted by the Governor in Council.
9. If any monumental work is found not to comply with the specifications laid down by the Trust the monumental mason responsible will be given thirty (30) days to have the same carried out to the satisfaction of the Trust at the monumental mason's own expense.

By Order of the Trustees, Port Fairy Cemetery.

T. A. CROWE, Chairman.
 A. G. HILL, Trustee.
 F. D. PEVITT, Trustee.
 T. DIGBY, Trustee.

APPENDIX A.

SCALE OF FEES.

<i>Lawn Cemetery, Port Fairy Cemetery.</i>		£	s.	d.
Purchase of land—8 feet x 4 feet	10	0	0
Purchase of land—8 feet x 8 feet	20	0	0
Certificate	0	15	0
Charge for each interment	3	10	0
Sinkings and re-openings	6	10	0
Interment on week-ends and holidays, including grave-digging on these days	3	3	0
Lawn maintenance charge with each interment	5	0	0
Monumental fees in advance on purchase ground—8 feet x 4 feet	3	0	0
Permission to inscribe or alter headstone	0	15	0

APPENDIX B.
SPECIFICATIONS FOR CONSTRUCTION OF HEADSTONES IN THE LAWN SECTION OF THE PORT FAIRY CEMETERY.

Materials.—Cement must be first quality Portland cement. Sand must be best quality red sand or washed river sand.

Reinforcing must be no less than 3/8 round reinforcing bars.

Headstones.—The height of the headstone must not be more than three (3) feet high above ground level.

The design will be selected by the owner.
 The headstone or desk must be of solid granite.

The headstone or desk will be securely fixed to the base.
 The headstone or ledger may be fixed at an angle providing that the headstone or ledger does not protrude past the back edge of the base stone.

Foundation Piers.—The foundation piers must be twelve (12) inches wide or must exceed the width of the base stone by six (6) inches.

All foundations must be sunk 3 feet.
 The piers must contain three (3) perpendicular reinforcing steel rods 5/16 inch thick which will protrude four (4) inches above so as to tie the base to the piers.

Base.—The base must be of solid granite or of concrete containing Portland cement, best quality sand and first quality blue metal, and plastered in synthetic granite rendering. Under no circumstances will scoria be allowed.

In the concrete bases four (4) reinforcing rods will run the length of the base and eight (8) rods will be spaced the width of the base at equal distances apart. The size of the reinforcing will be not less than 5/16 inch.

The width of the base will be the standard monumental width to correspond with grave width of four (4) feet.

All bases must be filled at back and sides to adjoining headstones with matching coloured cement.

The depth of the base will be twelve (12) inches.
 The height of the base will be eight (8) inches.

The base will be two (2) inches below ground level at the lowest point of the ground.

All bases must contain at least one Vase set in the granite or concrete.

Headstone.—The height of the headstone or ledger must not be more than three (3) feet from the top of the headstone to the bottom of the base.

The width must be not less than two (2) feet seven (7) inches.

Approved by the Governor in Council,
 27th June, 1961.

A. MAHLSTEDT,
 Clerk of the Executive Council.

MELBOURNE AND METROPOLITAN BOARD OF WORKS.

NOTICE TO THE OWNERS OF TENEMENTS IN THE UNDER-MENTIONED STREETS, AND THE PRIVATE STREETS, LANES, COURTS AND ALLEYS OPENING THERETO.

THE main pipe in the said streets being laid down, the owners of all tenements situated as under are hereby required, on or before the 7th August, 1961, to cause a proper pipe and stop cocks to be laid, so as to supply water within such tenements from the main pipe.

V. C. TREYVAUD,
 Secretary.

27th June, 1961.

STREET AND POSITION.

<i>Broadmeadows.</i>	
Railway-crescent, from Camp-road to Martell-street.	
Oxley-court, from Railway-crescent south-westwards 7½ chains.	
<i>Heidelberg.</i>	
Kathleen-road, from Berrima-road southwards 12½ chains.	
Clyde-court, from St. James-road southwards 5½ chains.	
Rowell-street, from Rosanna-road eastwards 12½ chains.	
<i>Keilor.</i>	
El Reno-crescent, from Fraser-street southwards 5½ chains.	
King-street, from Bowes-avenue eastwards 10 chains.	
Bowes-avenue, from King-street southwards 6 chains.	

Moorabbin.

Normanby-street, from Brady-road to Bignell-street.
Norville-street, from Normanby-street to Normdale-street.
Blamey-street, from Normanby-street to Normdale-street.

Nunawading.

Denman-street, from Northcote-road southwards 10½ chains.
Faulkner-street, from Blackburn-road eastwards 10½ chains.
Raleigh-street, from Blackburn-road eastwards 30½ chains.
Bindy-street, from Blackburn-road eastwards 29½ chains.

Oakleigh.

Westbrook-street, from Warrigal-road eastwards 3 chains.
Moore-avenue, from Rosebank-avenue northwards 9½ chains.

Springvale.

Chandler-road, from 4 chains south of Jellicoe-street southwards 3½ chains.
Princes-avenue, from St. James-avenue northwards 7½ chains.
Springvale-road, from Whitworth-avenue to Lenore-street.
Varden-street, from View-street to Billings-street.
Neale-street, from View-street to Billings-street.
Billings-street, from Neale-street southwards 1½ chains.
Billings-street, from Neale-street northwards 5 chains.
Jasper-street, from 20 chains north-west of Heatherton-road north-westwards 1 chain.

Sunshine.

Berkshire-road, from 1 chain west of Berry-street westwards 2½ chains.
Poole-street, from Byrne-street westwards 14½ chains.
Neimur-avenue, from Poole-street to Railway-parade.
Railway-parade, from Neimur-avenue to Vincent-street.
Vincent-street, from Railway-parade to Poole-street.

Waverley.

Waimarie-drive from Stevensons-road eastwards 16½ chains.

Whittlesea.

Settlement-road, from Epping-road eastwards 44 chains.

Housing Act 1958.

NOTICE OF RESOLUTION UNDER SECTION 99 (4) OF ACT No. 6275.

NOTICE is hereby given that Housing Commission, on the thirteenth day of June, 1961, resolved as follows:—

"Whereas Housing Commission in respect of the lands described in the Schedule hereto has given notice to the parties interested, under section 9 of the *Lands Compensation Act 1958*, as incorporated with the *Housing Act 1958*, Housing Commission hereby resolves that the lands described in the Schedule hereto are finally appropriated for the purposes of the *Housing Act 1958*."

SCHEDULE.

All that land situate within the municipality of the City of Collingwood and being the property known as No. 18 Harmsworth-street, and being the land more particularly described in a deed of conveyance memorialized in the office of the Registrar-General and therein numbered 209 of book 551.

G. G. BOLWELL,
Secretary.

Housing Act 1958, (Section 99 of Act 6275).

GENERAL NOTICE TO PARTIES EMPOWERED BY THE LANDS COMPENSATION ACT 1958, TO SELL AND CONVEY OR GRANT AND RELEASE, PURSUANT TO SECTION 99 OF ACT 6275.

GENERAL NOTICE TO TREAT FOR LAND IN A RECLAMATION AREA AT KENSINGTON.

IN pursuance of the provisions contained in the *Housing Act 1958*, and of the *Lands Compensation Act 1958*, the Housing Commission (hereinafter referred to as "the Commission") hereby doth give notice that the lands tenements and hereditaments described in the Schedule hereto are required for the purpose of the *Housing Act* and that the Commission is authorized by the provisions of section 68 of the *Housing Act 1958*, to purchase or take compulsorily, the said lands:

No. 55.—5337/61.—2

And the Commission accordingly hereby gives notice to all the parties interested in such land and to all persons empowered by the *Lands Compensation Act 1958*, to sell and convey or grant and release the land so required that it requires to take and purchase the land referred to in the said Schedule hereto and that it is willing to treat with such parties or persons for the purchase thereof and as to the compensation to be made and for the damage that may be sustained by reason of the execution of the works:

And further the Commission hereby requires such parties or persons on or before the expiration of twenty-one days from 22nd July, 1961, to deliver to the offices of the Commission, at 179 Queen-street, Melbourne, a statement in writing of the particulars of the estate and interest in the said lands tenements and hereditaments and of the claims made in respect thereof.

Dated the twenty-seventh day of June, 1961.

By order of the Commission,
G. G. BOLWELL,
Secretary.

SCHEDULE.

All those pieces of land situate within the Municipality of the City of Melbourne, being part of Crown allotment 20, of section 2, in the Parish of Doutta Galla, and being the lands more particularly described as follows:—

First.—All of the lands described in certificates of title, volume 891, folio 093, volume 932, folio 323, volume 1512, folio 392, volume 1530, folio 807, volume 1799, folio 783, volume 1951, folio 032, volume 2011, folio 140, volume 2255, folio 825, volume 2956, folio 112, volume 3431, folio 091, volume 3657, folio 300, volume 3924, folio 705, volume 4582, folio 373, volume 5208, folio 452, volume 5941, folio 091, volume 6796, folio 094 and 095, volume 7650, folio 074, volume 8151, folio 976 and volume 8220, folio 966.

Secondly.—So much of the land shown coloured red on the map in the margin of certificate of title, volume 2878, folio 599, as lies to the north-east of the north-westerly prolongation of the north-eastern boundary of the land shown coloured blue on the map in the margin of the said certificate of title, volume 2878, folio 599.

Plans are available for inspection at the Estates Branch of the Housing Commission situated on the Seventh Floor, at 179 Queen-street, Melbourne, and forms for the making of claims will also be available on application to the Commission.

Local Government Act 1958.

SHIRE OF ALTONA.

ORDER CONFIRMED.

THE Minister of the Crown administering the *Local Government Act 1958*, on the 22nd day of June, 1961, confirmed the Order hereinafter referred to, in pursuance of section 510 of the said Act, namely:

An Order of the Council of the Shire of Altona, made on the 9th May, 1961, for the purpose of providing an allotment having not less than a minimum width of frontage of 50 feet, and for compulsorily acquiring for such purpose all that piece of land, being lot 99 on plan of subdivision No. 11969.

M. V. PORTER,
Minister for Local Government.

Fisheries Act 1958.

NOTICE OF INTENTION TO REVOKE THE PROCLAMATION PRESCRIBING A CLOSE SEASON FOR MALE CRAYFISH.

IT is hereby notified for general information that it is intended, after the expiration of one month from the date of publication of this notice in the *Government Gazette*, to move His Excellency the Governor in Council to make a Proclamation revoking the Proclamation made on the twelfth day of April, 1960, and published in the *Government Gazette* of the thirteenth day of April, 1960, respecting a close season for male crayfish.

A. G. RYLAH,
Chief Secretary.

A. D. BUTCHER,
Director of Fisheries and Wildlife.

Fisheries Act 1958.

NOTICE OF INTENTION TO ALTER THE CLOSE SEASON FOR FEMALE CRAYFISH.

IT is hereby notified for general information that it is intended, after the expiration of one month from the date of publication of this notice in the *Government*

Gazette, to move His Excellency the Governor in Council to make a Proclamation revoking the Proclamation made the first day of June, 1960, and published in the *Government Gazette* of the eighth day of June, 1960, respecting the close season for female crayfish and prescribing the period from the first day of June to the thirtieth day of November, both days inclusive, in each year as a close season for female crayfish.

A. G. RYLAH,
Chief Secretary.

A. D. BUTCHER,
Director of Fisheries and Wildlife.

Fisheries Act 1958.

NOTICE OF INTENTION TO REVOKE THE
PROCLAMATION PRESCRIBING THE TERMS
AND CONDITIONS FOR THE SALE, ETC., OF
MALE CRAYFISH DURING THE CLOSE SEASON.

IT is hereby notified for general information that it is intended, after the expiration of one month from the date of publication of this notice in the *Government Gazette*, to move His Excellency the Governor in Council to make a Proclamation revoking the Proclamation made the twelfth day of April, 1960, and published in the *Government Gazette* of the thirteenth day of April, 1960, respecting the terms and conditions for the sale, &c., of male crayfish during the close season for such fish.

A. G. RYLAH,
Chief Secretary.

A. D. BUTCHER,
Director of Fisheries and Wildlife.

APPOINTMENTS.

HIS Excellency the Administrator of the Government of the State of Victoria, by and with the advice of the Executive Council thereof, has, by Orders made on the 27th day of June, 1961, been pleased to make the under-mentioned appointments, viz.:—

CHIEF SECRETARY'S DEPARTMENT.

Licensing Inspector.

REGINALD GEORGE WATSON, Chief Inspector of Police, to be a Licensing Inspector for the purposes of the *Licensing Act 1958*, *vice* Norman Rupert Briggs, resigned.

DEPARTMENT OF CROWN LANDS AND SURVEY.

Bailiffs of Crown Lands.

DENNIS FREDERICK PUFFETT to be a Bailiff of Crown Lands, without additional salary, and

ALBERT JOHN DOUEAL, an Inspector of Land Settlement, to be a Bailiff of Crown Lands, without additional salary.

DEPARTMENT OF HEALTH.

Trustees of Public Cemeteries.

SYDNEY JASON LANDERS to be a Trustee, Kiata Public Cemetery, *vice* A. W. Cole, resigned;

MAXWELL JOHN WALKER to be a Trustee, Kiata Public Cemetery, *vice* V. L. Collins, resigned;

IVAN KEVAN PILMORE to be a Trustee, Kiata Public Cemetery, *vice* A. R. Cole, resigned;

GORDON GEBART to be a Trustee, Rainbow Public Cemetery, *vice* A. J. Watt, deceased;

HECTOR FRANCIS KELLY to be a Trustee, Bright Public Cemetery, *vice* B. A. Blair, resigned;

WILLIAM HENRY ELSOM to be a Trustee, Dimboola Public Cemetery, *vice* E. Bending, resigned;

WILLIAM KNELLER FECHNER to be a Trustee, Dimboola Public Cemetery, *vice* J. Schultz, resigned;

JAMES WILLIAM HAEBICH to be a Trustee, Dimboola Public Cemetery, *vice* A. Herrman, resigned; and

HERBERT EDWARD TISCHLER,
GEORGE EDWARD WARD, and
IAN ALFRED WERNER,
to be Trustees, Dimboola Public Cemetery, additional Trustees.

Public Vaccinators.

JOHN JOSEPH BOURKE, M.B., B.S., to be a Public Vaccinator for the municipality of Hawthorn; and
JACK CASPAR CHERNY, M.B., B.S., to be a Public Vaccinator for the municipality of St. Kilda.

LAW DEPARTMENT.

Justices of the Peace.

HARRY GEOFFREY WELLS, 328 Flinders-street, Melbourne, and
DAVID BON LEWIS, 249c Belmore-road, Balwyn, to Keep the Peace in the Central Bailiwick of the State of Victoria.

Commissioners for Taking Declarations, &c.

ERNEST ALBERT SCHMIDT, 1 Vaughan-terrace, Buncle-street, North Melbourne,
COLIN MICHAEL KEITH, 118 St. James-road, Rosanna, and
FREDERICK ALBERT PEARSON, 18 Clements-street, Highett,
to be Commissioners for taking Declarations and Affidavits, pursuant to the provisions of the *Evidence Act 1958*, to resign upon removing from the neighbourhood of the addresses stated; and

KENNETH JOHN STOCKTON, Secretary, Valuers Qualification Board, Local Government Department, 61 Spring-street, Melbourne, and
ALBERT JOHN DOUEAL, Inspector of Land Settlement, Department of Crown Lands and Survey, Treasury-place, Melbourne,
to be Commissioners for taking Declarations and Affidavits, pursuant to the provisions of the *Evidence Act 1958*, to refrain from charging fees and to resign upon ceasing to occupy their present positions.

MINES DEPARTMENT.

Mining Registrars.

VINCENT GEORGE STAFFORD to act as Mining Registrar at Maryborough for the Maryborough-Carisbrook Division of the Maryborough Mining District, *vice* John Joseph Caven, transferred, fees received to be the only remuneration; and

JOHN JOSEPH CAVEN to act as District Mining Registrar for the Castlemaine Mining District and Mining Registrar for the Castlemaine Division of the Castlemaine Mining District, *vice* Vincent George Stafford, transferred, fees received to be the only remuneration.

DEPARTMENT OF THE TREASURER.

Collector of Imposts.

WILLIAM DOBINSON to act temporarily as Collector of Imposts, Milk Board, during the absence of R. D. Hall on leave.

A. MAHLSTEDT,
Clerk of the Executive Council.

At the Executive Council Chamber,
Melbourne, 27th June, 1961.

APPOINTMENTS.

HIS Excellency the Administrator of the Government of the State of Victoria, by and with the advice of the Executive Council thereof, has, by Orders made on the 4th day of July, 1961, been pleased to make the under-mentioned appointments, viz.:—

DEPARTMENT OF WATER SUPPLY.

Commissioners of Waterworks Trusts.

JAMES WILLIAM ELLIOTT to be a Commissioner of the Seymour Waterworks Trust for a period of four years from the date hereof, subject to the provisions of the Water Acts; and

FRANK CHARD MULLER and
JOHN BENJAMIN SWAFFIELD to be Commissioners of the Neerim South Waterworks Trust for a period of four years and three years respectively from the date hereof, subject to the provisions of the Water Acts.

A. MAHLSTEDT,
Clerk of the Executive Council.

At the Executive Council Chamber,
Melbourne, 4th July, 1961.

RESIGNATIONS.

HIS Excellency the Administrator of the Government of the State of Victoria, by and with the advice of the Executive Council thereof, has, by Orders made on the 27th day of June, 1961, accepted the resignations of the persons named hereunder of the offices mentioned, viz.:—

LAW DEPARTMENT.

ARTHUR EDWARD MANSFIELD, from the Commission of the Peace for the Central Bailiwick of the State of Victoria.

FRANK BRICE MCCARTHY, from the Commission of the Peace for the Central Bailiwick of the State of Victoria.

JOHN HENRY JONES, from the Commission of the Peace for the Southern Bailiwick of the State of Victoria.

ERIC WILLIAM BOYLE, from the Commission of the Peace for the Midland Bailiwick of the State of Victoria.

REGINALD GORDON JONES, as a Commissioner for taking Declarations and Affidavits, pursuant to the provisions of the *Evidence Act 1958*.

PERCY BRISTOW JAMES, as a Commissioner for taking Declarations and Affidavits, pursuant to the provisions of the *Evidence Act 1958*.

A. MAHLSTEDT,
Clerk of the Executive Council.

At the Executive Council Chamber,
Melbourne, 27th June, 1961.

STATE ELECTRICITY COMMISSION ACTS.

At the Executive Council Chamber, Melbourne, the
twenty-seventh day of June, 1961.

PRESENT:

His Excellency the Administrator of the Government of Victoria.

Sir Ewen Cameron | Mr. Thompson.

ELECTRICAL APPROVALS REGULATIONS.—APPROVAL OF EQUIPMENT,
1953—APPLIANCES TO BE SUBMITTED FOR APPROVAL.

PURSUANT to section 51 of the *State Electricity Commission Act 1958*, His Excellency the Administrator of the State of Victoria, by and with the advice of the Executive Council thereof, and on the recommendation of the State Electricity Commission of Victoria, doth hereby prescribe the following class and type of electrical appliance and apparatus intended, suggested, or designed for use in, or for the purpose of, or for connexion to, any electrical installation, and that electrical appliances or apparatus of the said class or type shall not after the 2nd January, 1963, be sold, hired or exposed for sale or hire, or advertised for sale or hire, unless the appliance or apparatus has been approved by the State Electricity Commission of Victoria, and is stamped or labelled as prescribed, that is to say:—

DOMESTIC ELECTRIC WASHING MACHINE.

A domestic electric washing machine being an appliance—other than an electric wash boiler—for operation at low or medium voltage, designed for domestic use and intended for washing clothing, household fabrics and the like and which may incorporate means for partially drying the wash load, and further orders and prescribes that the fees for examining, testing and reporting to be paid to the State Electricity Commission of Victoria on application for approval of any article shall be the respective fees set out in the Table hereunder; and, moreover, that any person applying for approval of any article shall deliver to the State Electricity Commission of Victoria, with his application for approval for the purpose of examination and testing, such number of samples of each article for which approval is sought as is set out in the said Table and such further samples of unassembled parts as the Commission may by notice, in writing, require, which samples shall be labelled in compliance with the Electrical Approvals Regulations—Approval of Equipment 1953.

TABLE ABOVE REFERRED TO.

Article.	Testing Fee.	Number of Samples to be Delivered to Commission.
	£ s. d.	
Washing Machine—Non-Automatic	19 0 0	2 (two)
Washing Machine—Automatic	22 0 0	2 (two)
Where a device is included in a washing machine and has not been approved under some other application—		
For each Motor Control Device (other than A.C. only)—an additional	9 10 0	2 (two)
For each Motor Control Device (A.C. only)—an additional	12 0 0	2 (two)
For each Thermal Protective Device—an additional	6 0 0	2 (two)

And the Honorable George Oswald Reid, Her Majesty's Minister of Electrical Undertakings for the State of Victoria, shall give the necessary directions herein accordingly.

A. MAHLSTEDT,
Clerk of the Executive Council.

DEPARTMENT OF CROWN LANDS AND SURVEY.

At the Executive Council Chamber, Melbourne, the twenty-seventh day of June, 1961.

PRESENT:

His Excellency the Administrator of the Government of Victoria.

Sir Ewen Cameron | Mr. Thompson.

LANDS TEMPORARILY RESERVED AS SITES.

HIS Excellency the Administrator of the Government of the State of Victoria, by and with the advice of the Executive Council thereof, doth hereby, in pursuance of the provisions of the Land Act 1958, reserve, temporarily, and also except from occupation for mining purposes, under any miner's right, the lands hereinafter described:—

BEULAH.—Site for Water Supply purposes, 8 acres, more or less, Township of Beulah, Parish of Galaquil, County of Karkaroc, as indicated by hachure on plan hereunder.—(B.729(?) (Rs.8045).

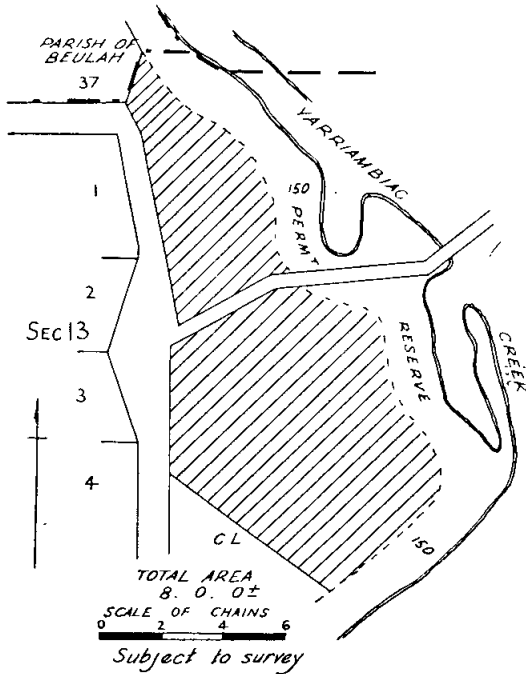

TRAWALLA (BEAUFORT).—Site for State School purposes, 1 rood, more or less, Parish of Trawalla, County of Ripon, as indicated by hachure on plan hereunder.—(T.140(?) (Rs.8042).

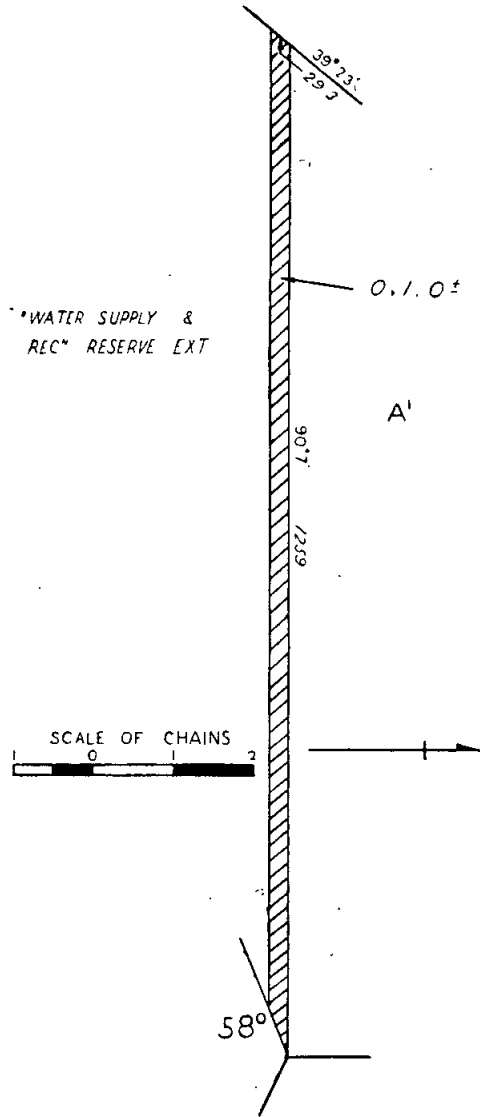

NUMURKAH.—Site for Educational purposes, 25 perches, Township of Numurkah, Parish of Katunga, County of Moira, as indicated by hachure on plan hereunder.—(N.119(?) (Rs.8046).

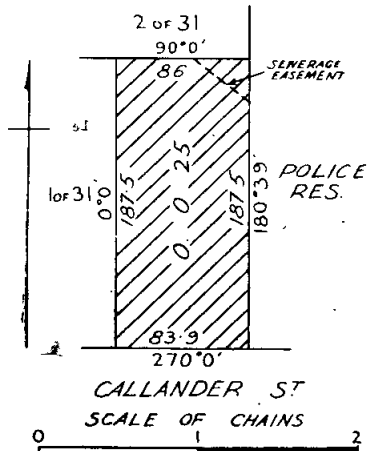

WARRACKNAEAL.—Site for a Civic Centre, 3 acres, Township of Warracknabeal, Parish of Werrigar, County of Borung, as indicated by hachure on plan hereunder.—(W.293(?) (Rs.7948).

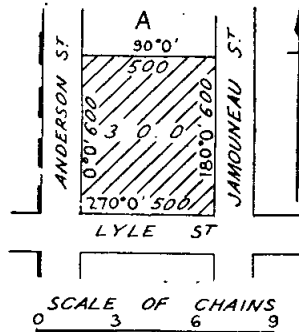

TRAWALLA (BEAUFORT).—Site for Water Supply purposes and Public Recreation in addition to and adjoining the site temporarily reserved therefor by Order in Council of the 3rd November, 1890, 3 roods 25 perches, more or less, Parish of Trawalla, County of Ripon, as indicated by hachure on plan hereunder.—(T.140^(s)) (Rs.295).

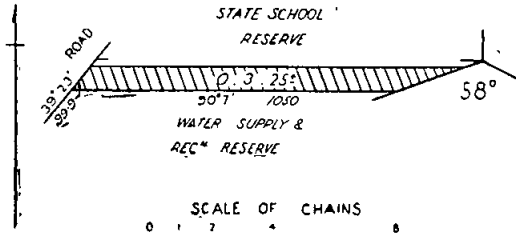

And the Honorable Keith Hector Turnbull, Her Majesty's Commissioner of Crown Lands and Survey for the State of Victoria, shall give the necessary directions herein accordingly.

A. MAHLSTEDT,
Clerk of the Executive Council.

DEPARTMENT OF CROWN LANDS AND SURVEY.

At the Executive Council Chamber, Melbourne, the twenty-seventh day of June, 1961.

PRESENT:

His Excellency the Administrator of the Government of Victoria.

Sir Ewen Cameron | Mr. Thompson.

UNUSED ROADS CLOSED.

HIS Excellency the Administrator of the Government of the State of Victoria, by and with the advice of the Executive Council thereof, doth hereby direct that, in pursuance of the provisions of section 349 of the Land Act 1958, the unused roads referred to hereunder be closed, viz.:

Parish of Walwa, County of Benambra, being the road between allotment 14, section 9, and the State School Reserve.—(W.296^(s)) (Rs.6990).

Parish of Welshpool, County of Buln Buln, being the road indicated by hachure on plan hereunder.—(W.127^(s)) (Misc. 1770).

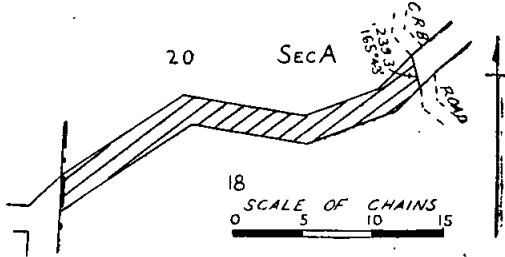

Parish of Taminick, County of Moira, being the portion of the width of the road indicated by hachure on plan hereunder.—(T.155^(s)) (H.023648).

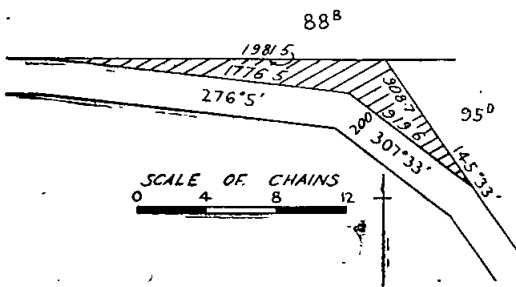

Parish of Telangatuk, County of Lowan, being the portions of the width of the road indicated by hachure on plan hereunder.—(T.195^(s)) (M.48645).

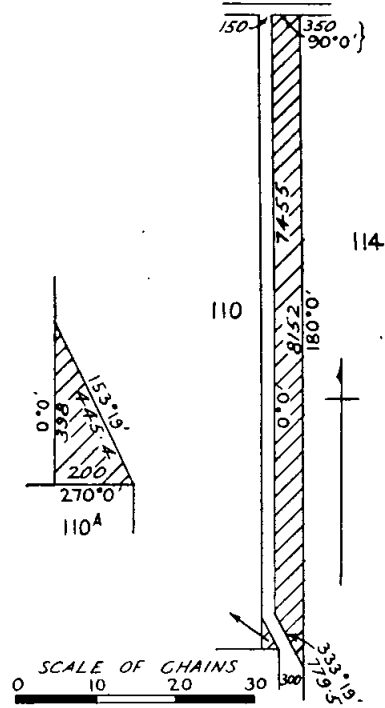

Township of Beaufort, Parish of Beaufort, County of Ripon, being the portion of the width of the road indicated by hachure on plan hereunder.—(B.304^(s)) (Rs.6754).

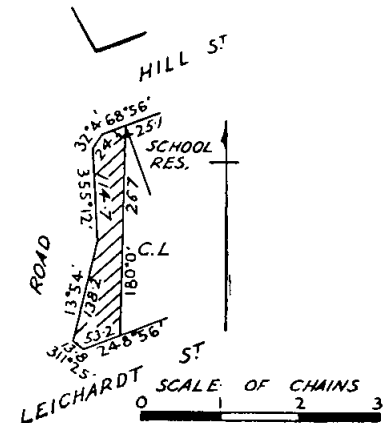

And the Honorable Keith Hector Turnbull, Her Majesty's Commissioner of Crown Lands and Survey for the State of Victoria, shall give the necessary directions herein accordingly.

A. MAHLSTEDT,
Clerk of the Executive Council.

NATIONAL PARKS ACT 1958.

At the Executive Council Chamber, Melbourne, the twenty-seventh day of June, 1961.

PRESENT:

His Excellency the Administrator of the Government of Victoria.

Sir Ewen Cameron | Mr. Thompson.

PURSUANT to the powers conferred by the National Parks Act 1958 (No. 6326) and all other powers thereunto enabling, His Excellency the Administrator of

the Government of the State of Victoria, by and with the advice of the Executive Council thereof, hereby makes the following regulations (that is to say):—

1. These regulations may be cited as the Mount Buffalo National Park (Fees, Tolls and Charges) Regulations 1961.

2. The following fees, tolls and charges are to be paid by persons using accommodation or amenities provided in the Mount Buffalo National Park:—

- (a) For admission to the National Park—
 (i) 2s. per car.
 (ii) 10s. per bus.
- (b) For use of the ski-tow—
 (i) 1s. per single ride ticket.
 (ii) 10s. per daily ticket.
- (c) For camping—
 2s. per night per person.

And the Honorable Henry Edward Bolte, Her Majesty's Premier for the State of Victoria, shall give the necessary directions herein accordingly.

A. MAHLSTEDT,
 Clerk of the Executive Council.

COUNTRY ROADS BOARD.

At the Executive Council Chamber, Melbourne, the twenty-seventh day of June, 1961.

PRESENT:

His Excellency the Administrator of the Government of Victoria.

Sir Ewen Cameron | Mr. Thompson.

ORDER APPROVING OF WIDENING AN EXISTING MAIN ROAD IN THE SHIRE OF MANSFIELD.

WHEREAS the Country Roads Board constituted under the *Country Roads Act 1958* (No. 6229) has represented to His Excellency the Governor in Council that it appears to it desirable that the existing Mansfield-Tolmie road in the Shire of Mansfield (declared to be a main road under the said Act which declaration was confirmed by the Order in Council published in the *Government Gazette* of the 5th October, 1932, on page 2256 and the *Government Gazette* of the 6th October, 1915, on page 3677) should be widened by the said Board: And whereas the said Board in accordance with the requirements of section 19 of the said cited Act has caused to be prepared a map plan and estimate showing the points between which and on and through what land the said widening is proposed to be made and the cost of acquiring the land: And whereas on an inspection of the said map and plan and a consideration of the said estimate His Excellency the Governor in Council is satisfied that there are funds legally available for acquiring the land: Now therefore be it known by this present Order that His Excellency the Administrator of the Government of the State of Victoria with the advice of the Executive Council thereof doth hereby approve of the said road being widened, that is to say:—

All that piece of land in the Parish of Dueran, the boundaries of which are as follow:—

Commencing at the south-western angle of allotment 15 of the said parish; thence by lines bearing respectively 360 deg. 0 min. 1,261 links, 174 deg. 43 min. 1,303 links and 286 deg. 52 min. 125.4 links to the point of commencement.

Also, all that piece of land in the Parish of Barwite, the boundaries of which are as follow:—

Commencing at the north-western angle of allotment 20A of the said parish; thence easterly by the south bank of the Broken River; thence by lines bearing 183 deg. 53 min. 1,365 links and 0 deg. 4 min. 1,360.5 links to the point of commencement—

which said pieces of land are particularly delineated and shown coloured red on survey plans numbered 8074 and 8075, lodged in the office of the Country Roads Board.

And the Honorable Sir Thomas Karran Maltby, Her Majesty's Commissioner of Public Works for the State of Victoria, shall give the necessary directions herein accordingly.

A. MAHLSTEDT,
 Clerk of the Executive Council.

COUNTRY ROADS BOARD.

At the Executive Council Chamber, Melbourne, the twenty-seventh day of June, 1961.

PRESENT:

His Excellency the Administrator of the Government of Victoria.

Sir Ewen Cameron | Mr. Thompson.

ORDER APPROVING OF WIDENING AN EXISTING STATE HIGHWAY IN THE CITY OF BROADMEADOWS.

WHEREAS the Country Roads Board constituted under the *Country Roads Act 1958* (No. 6229) has represented to His Excellency the Governor in Council that it appears to it desirable that the existing Hume Highway in the City of Broadmeadows (declared to be a State highway under the said Act which declaration was confirmed by the Order in Council published in the *Government Gazette* of the 7th August, 1946, on page 2471) should be widened by the said Board: And whereas the said Board in accordance with the requirements of section 19 of the said cited Act has caused to be prepared a map plan and estimate showing the points between which and on and through what land the said widening is proposed to be made and the cost of acquiring the land: And whereas on an inspection of the said map and plan and a consideration of the said estimate His Excellency the Governor in Council is satisfied that there are funds legally available for acquiring the land: Now therefore be it known by this present Order that His Excellency the Administrator of the Government of the State of Victoria with the advice of the Executive Council thereof doth hereby approve of the said highway being widened, that is to say:—

All that piece of land in the Parish of Will Will Rook, the boundaries of which are as follow:—Commencing at a point in Crown portion 3 of the said parish, the said point being the north-western angle of the land comprised in certificate of title, volume 7906, folio 180, entered in the register book; thence by lines bearing respectively 164 deg. 32 min. 2,554 ft. 10½ in., 164 deg. 58 min. 248 ft. 4½ in., 256 deg. 43 min. 10 feet, 344 deg. 58 min. 247 ft. 11½ in., 344 deg. 32 min. 2,527 ft. 6 in., 307 deg. 1 min. 47 ft. 7 in. and 89 deg. 30 min. 40 ft. 4 in. to the point of commencement—which said piece of land is particularly delineated and shown coloured red on survey plan numbered 7995, lodged in the office of the Country Roads Board.

And the Honorable Sir Thomas Karran Maltby, Her Majesty's Commissioner of Public Works for the State of Victoria, shall give the necessary directions herein accordingly.

A. MAHLSTEDT,
 Clerk of the Executive Council.

COUNTRY ROADS BOARD.

At the Executive Council Chamber, Melbourne, the twenty-seventh day of June, 1961.

PRESENT:

His Excellency the Administrator of the Government of Victoria.

Sir Ewen Cameron | Mr. Thompson.

ORDER APPROVING OF WIDENING AN EXISTING STATE HIGHWAY IN THE SHIRE OF KORONG.

WHEREAS the Country Roads Board constituted under the *Country Roads Act 1958* (No. 6229) has represented to His Excellency the Governor in Council that it appears to it desirable that the existing Calder Highway in the Shire of Korong (declared to be a State highway under the said Act which declaration was confirmed by the Order in Council published in the *Government Gazette* of the 6th December, 1944, on page 2948) should be widened by the said Board: And whereas the said Board in accordance with the requirements of section 19 of the said cited Act has caused to be prepared a map plan and estimate showing the points between which and on and through what land the said widening is proposed to be made and the cost of acquiring the land: And whereas on an inspection of the said map and plan and a consideration of the said estimate His Excellency the Governor in Council is satisfied that

there are funds legally available for acquiring the land: Now therefore be it known by this present Order that His Excellency the Administrator of the Government of the State of Victoria with the advice of the Executive Council thereof doth hereby approve of the said highway being widened, that is to say:—

All that piece of land in the Township and Parish of Inglewood, the boundaries of which are as follow:—Commencing at the eastern angle of allotment 4A, section 19A of the said township; thence by lines bearing respectively 147 deg. 43 min. 684.7 links, 318 deg. 58 min. 641 links, 308 deg. 34 min. 635.8 links, 114 deg. 56 min. 176.4 links and 120 deg. 1 min. 453 links to the point of commencement—which said piece of land is particularly delineated and shown coloured red on survey plan numbered 8135, lodged in the office of the Country Roads Board.

And the Honorable Sir Thomas Karran Maltby, Her Majesty's Commissioner of Public Works for the State of Victoria, shall give the necessary directions herein accordingly.

A. MAHLSTEDT,
Clerk of the Executive Council.

COUNTRY ROADS BOARD.

At the Executive Council Chamber, Melbourne, the twenty-seventh day of June, 1961.

PRESENT:

His Excellency the Administrator of the Government of Victoria.

Sir Ewen Cameron | Mr. Thompson.

ORDER APPROVING OF WIDENING AN EXISTING MAIN ROAD IN THE SHIRE OF ELTHAM.

WHEREAS the Country Roads Board constituted under the *Country Roads Act 1958* (No. 6229) has represented to His Excellency the Governor in Council that it appears to it desirable that the existing Heidelberg-Kinglake road in the Shire of Eltham (declared to be a main road under the said Act which declaration was confirmed by the Order in Council published in the *Government Gazette* of the 12th October, 1960, on pages 3305-6) should be widened by the said Board: And whereas the said Board in accordance with the requirements of section 19 of the said cited Act has caused to be prepared a map plan and estimate showing the points between which and on and through what land the said widening is proposed to be made and the cost of acquiring the land: And whereas on an inspection of the said map and plan and a consideration of the said estimate His Excellency the Governor in Council is satisfied that there are funds legally available for acquiring the land: Now therefore be it known by this present Order that His Excellency the Administrator of the Government of the State of Victoria with the advice of the Executive Council thereof doth hereby approve of the said road being widened, that is to say:—

All that piece of land in the Township and Parish of Queenstown, the boundaries of which are as follow:—

Commencing at a point on the northern boundary of the Heidelberg-Kinglake road through the said township, distant 102 deg. 0 min. 50.8 links from the south-eastern angle of allotment 46, Parish of Greensborough; thence by a line bearing 102 deg. 0 min. 188 links to Diamond Creek Reserve; thence south-easterly by the said reserve; thence by lines bearing 255 deg. 23 min. 85 links and 299 deg. 42 min. 278.9 links to the point of commencement.

Also, all those pieces of land in the Parish of Greensborough, the boundaries of which are as follow:—

- (a) Commencing at the south-western angle of a Cricket Reserve east of allotment 44B in the said parish; thence by lines bearing respectively 5 deg. 28 min. 7.1 links, 75 deg. 5 min. 754.6 links, 236 deg. 46 min. 342 links and 268 deg. 13 min. 444 links to the point of commencement.
- (b) Commencing at the south-western angle of allotment 44A of the said parish; thence by lines bearing respectively 315 deg. 39 min. 53.3 links, 66 deg. 11½ min. 597.9 links, 203 deg. 12 min. 55.9 links and 244 deg. 56 min. 538.5 links to the point of commencement.
- (c) Commencing at a point on the northern boundary of allotment 23, section C, of the said parish, distant 94 deg. 46 min. 456.2 links from the western angle of the said allotment; thence by lines bearing respectively 94 deg. 46 min.

326.5 links, 256 deg. 56 min. 434.6 links, 235 deg. 52 min. 165.8 links, 215 deg. 41½ min. 424.5 links, 199 deg. 0 min. 38.9 links, 317 deg. 37 min. 93.1 links, 342 deg. 35 min. 156.9 links, 27 deg. 32 min. 177.4 links, 76 deg. 56 min. 250.8 links, 319 deg. 26 min. 112.7 links and 76 deg. 56 min. 361.5 links to the point of commencement.

- (d) Commencing at the western angle of allotment 42A, section C, of the said parish; thence by lines bearing respectively 49 deg. 26 min. 216.8 links, 222 deg. 6½ min. 218.5 links, 200 deg. 43½ min. 652.5 links, 241 deg. 8 min. 413.1 links, 313 deg. 32½ min. 869.3 links, 86 deg. 8 min. 111.9 links, 122 deg. 7 min. 213 links, 144 deg. 12 min. 559 links, 53 deg. 0 min. 540 links and 18 deg. 20 min. 491 links to the point of commencement.

- (e) Commencing at the southern angle of allotment 40, section C, of the said parish; thence by lines bearing respectively 323 deg. 0 min. 170 links, 114 deg. 54 min. 192.7 links and 233 deg. 0 min. 90.8 links to the point of commencement—

which said pieces of land are particularly delineated and shown coloured red and yellow on survey plans numbered 8048, 8049, 8050 and 8051, lodged in the office of the Country Roads Board.

And the Honorable Sir Thomas Karran Maltby, Her Majesty's Commissioner of Public Works for the State of Victoria, shall give the necessary directions herein accordingly.

A. MAHLSTEDT,
Clerk of the Executive Council.

COUNTRY ROADS BOARD.

At the Executive Council Chamber, Melbourne, the twenty-seventh day of June, 1961.

PRESENT:

His Excellency the Administrator of the Government of Victoria.

Sir Ewen Cameron | Mr. Thompson.

ORDER APPROVING OF WIDENING AN EXISTING STATE HIGHWAY IN THE CITY OF BROADMEADOWS.

WHEREAS the Country Roads Board constituted under the *Country Roads Act 1958* (No. 6229) has represented to His Excellency the Governor in Council that it appears to it desirable that the existing Hume Highway in the City of Broadmeadows (declared to be a State highway under the said Act which declaration was confirmed by the Order in Council published in the *Government Gazette* of the 8th July, 1925, on page 2371) should be widened by the said Board: And whereas the said Board in accordance with the requirements of section 19 of the said cited Act has caused to be prepared a map plan and estimate showing the points between which and on and through what land the said widening is proposed to be made and the cost of acquiring the land: And whereas on an inspection of the said map and plan and a consideration of the said estimate His Excellency the Governor in Council is satisfied that there are funds legally available for acquiring the land: Now therefore be it known by this present Order that His Excellency the Administrator of the Government of the State of Victoria with the advice of the Executive Council thereof doth hereby approve of the said highway being widened, that is to say:—

All that piece of land in the Parish of Will Will Rook, the boundaries of which are as follow:—Commencing at the south-western angle of lot 1 on plan of subdivision numbered 25132, lodged in the Office of Titles, and being part of portion 13 of the said parish; thence by lines bearing respectively 344 deg. 3 min. 375 links, 346 deg. 58 min. 1,086 ft. 7 in., 30 deg. 8 min. 32 ft. 2 in., 166 deg. 58 min. 1,266 ft. 6½ in., 164 deg. 3 min. 221 ft. 7½ in. and 270 deg. 4 min. 14 ft. 7 in. to the point of commencement—which said piece of land is particularly delineated and shown coloured red on survey plan numbered 8130, lodged in the office of the Country Roads Board.

And the Honorable Sir Thomas Karran Maltby, Her Majesty's Commissioner of Public Works for the State of Victoria, shall give the necessary directions herein accordingly.

A. MAHLSTEDT,
Clerk of the Executive Council.

COUNTRY ROADS BOARD.

At the Executive Council Chamber, Melbourne, the twenty-seventh day of June, 1961.

PRESENT:

His Excellency the Administrator of the Government of Victoria.

Sir Ewen Cameron | Mr. Thompson.

ORDER APPROVING OF WIDENING AN EXISTING MAIN ROAD IN THE SHIRE OF FLINDERS.

WHEREAS the Country Roads Board constituted under the *Country Roads Act 1958* (No. 6229) has represented to His Excellency the Governor in Council that it appears to it desirable that the existing Mornington-Dromana road in the Shire of Flinders (declared to be a main road under the said Act which declaration was confirmed by the Order in Council published in the *Government Gazette* of the 5th October, 1932, on page 2256) should be widened by the said Board: And whereas the said Board in accordance with the requirements of section 19 of the said cited Act has caused to be prepared a map plan and estimate showing the points between which and on and through what land the said widening is proposed to be made and the cost of acquiring the land: And whereas on an inspection of the said map and plan and a consideration of the said estimate His Excellency the Governor in Council is satisfied that there are funds legally available for acquiring the land: Now therefore be it known by this present Order that His Excellency the Administrator of the Government of the State of Victoria with the advice of the Executive Council thereof doth hereby approve of the said road being widened, that is to say:—

All that piece of land in the Parish of Kangerong, the boundaries of which are as follow:—Commencing at a point on the south-western boundary of lot 12 on plan of subdivision numbered 5041, lodged in the Office of Titles, and being part of Jamieson's Crown Special Survey, in the said parish, the said point being distant 310 deg. 36 min. 206 feet from the southern angle of the said lot; thence by lines bearing respectively 36 deg. 2 min. 103 ft. 9 in., 40 deg. 36 min. 496 ft. 11 in., and 219 deg. 487 min. 600 ft. 43 in. to the point of commencement—which said piece of land is particularly delineated and shown coloured red on survey plan numbered 7997, lodged in the office of the Country Roads Board.

And the Honorable Sir Thomas Karran Maltby, Her Majesty's Commissioner of Public Works for the State of Victoria, shall give the necessary directions herein accordingly.

A. MAHLSTEDT,
Clerk of the Executive Council.

COUNTRY ROADS BOARD.

At the Executive Council Chamber, Melbourne, the twenty-seventh day of June, 1961.

PRESENT:

His Excellency the Administrator of the Government of Victoria.

Sir Ewen Cameron | Mr. Thompson.

DECLARATION OF THE WIDENING OF CRESSY-ROAD IN THE SHIRE OF GRENVILLE.

WHEREAS by section 21 of the *Country Roads Act 1958* (No. 6229) it is amongst other things enacted that when the Country Roads Board under the provisions of the *Country Roads Act* has taken the land necessary for constructing the road or deviation or widening it shall as soon as it thinks such road or deviation or widening is fit to be used as a public highway by Resolution declare the road or deviation or widening to be a main road or part thereof and that upon publication in the *Government Gazette* of the Order of the Governor in Council confirming such Resolution such road or deviation or widening shall thereupon be a main road or a part thereof within the meaning of the said Act: And whereas the said Board, has by Resolution declared the road on the land described in the Schedule to such Resolution to be part of a main road: Now therefore His Excellency the Administrator of the Government of the State of Victoria by and with the advice of the Executive Council thereof doth hereby confirm the said Resolution.

Resolution for Declaration of the Widening of a Main Road Under the Country Roads Act.

Whereas the land the site of the road the course of which is below set out was taken by the Board under the provisions of the *Country Roads Act* for the purpose of widening the main road aforesaid which widening has now been laid out and formed on the same: And whereas the said Board (being the Country Roads Board incorporated under the said Act) thinks that the widening aforesaid is fit to be used as part of a public highway such Board at a meeting now holden doth by this Resolution hereby declare the same as described in the Schedule hereto with the commencing and terminating points thereof respectively specified to be part of the main road within the meaning and for the purposes of the *Country Roads Act*.

SCHEDULE.

Shire of Grenville.

4. *Cressy-road* (6904).—All that piece of land in the Parish of Kuruc-a-ruc, the boundaries of which are as follow:—Commencing at a point on the western boundary of allotment 195 of the said parish, distant 180 deg. 0 min. 18 links from the north-western angle of the said allotment; thence by lines bearing respectively 175 deg. 35 min. 250.9 links 167 deg. 34 min. 661.7 links, 154 deg. 1 min. 663.5 links, 143 deg. 25 min. 570.7 links, 321 deg. 31 min. 1,273.7 links and 360 deg. 0 min. 954 links to the point of commencement—which said piece of land is particularly delineated and shown coloured red on survey plan numbered 6921, lodged in the office of the Country Roads Board.

The common seal of the Country Roads Board was hereto affixed at Kew this 19th day of June, One thousand nine hundred and sixty-one in the presence of—

(SEAL) D. V. DARWIN, Chairman.
W. H. NEVILLE, Member.
R. E. V. DONALDSON, Secretary.

And the Honorable Sir Thomas Karran Maltby, Her Majesty's Commissioner of Public Works for the State of Victoria, shall give the necessary directions herein accordingly.

A. MAHLSTEDT,
Clerk of the Executive Council.

COUNTRY ROADS BOARD.

At the Executive Council Chamber, Melbourne, the twenty-seventh day of June, 1961.

PRESENT:

His Excellency the Administrator of the Government of Victoria.

Sir Ewen Cameron | Mr. Thompson.

ORDER APPROVING OF WIDENING AN EXISTING STATE HIGHWAY IN THE SHIRE OF TAMBO.

WHEREAS the Country Roads Board constituted under the *Country Roads Act 1958* (No. 6229) has represented to His Excellency the Governor in Council that it appears to it desirable that the existing Princes Highway in the Shire of Tambo (declared to be a State highway under the said Act which declaration was confirmed by the Order in Council published in the *Government Gazette* of the 8th July, 1925, on pages 2371-3) should be widened by the said Board: And whereas the said Board in accordance with the requirements of section 19 of the said cited Act has caused to be prepared a map plan and estimate showing the points between which and on and through what land the said widening is proposed to be made and the cost of acquiring the land: And whereas on an inspection of the said map and plan and a consideration of the said estimate His Excellency the Governor in Council is satisfied that there are funds legally available for acquiring the land: Now therefore be it known by this present Order that His Excellency the Administrator of the Government of the State of Victoria with the advice of the Executive Council thereof doth hereby approve of the said highway being widened, that is to say:—

All those pieces of land in the Parish of Colquhoun, the boundaries of which are as follow:—

(a) Commencing at a point on the southern boundary of allotment 132 of the said parish distant 277 deg. 39 min. 2,078 links and 252 deg. 20 min. 105.2 links from the eastern angle of the said allotment; thence by lines bearing respectively

252 deg. 20 min. 48.3 links, 18 deg. 25 min. 339.5 links, 157 deg. 10 min. 97.2 links and 204 deg. 26 min. 239.3 links to the point of commencement.

- (b) Commencing at a point on the southern boundary of allotment 132 of the said parish distant 277 deg. 39 min. 1,903.5 links from the eastern angle of the said allotment; thence by lines bearing respectively 277 deg. 39 min. 99.3 links, 24 deg. 26 min. 212.6 links, 337 deg. 10 min. 1,114 links, 122 deg. 33 min. 410.9 links, 164 deg. 32 min. 378 links and 180 deg. 23 min. 648.1 links to the point of commencement—

which said pieces of land are particularly delineated and shown coloured red on survey plan numbered 7730, lodged in the office of the Country Roads Board.

And the Honorable Sir Thomas Karran Maltby, Her Majesty's Commissioner of Public Works for the State of Victoria, shall give the necessary directions herein accordingly.

A. MAHLSTEDT,
Clerk of the Executive Council.

LANDLORD AND TENANT ACT 1958.

At the Executive Council Chamber, Melbourne, the fourth day of July, 1961.

PRESENT:

His Excellency the Administrator of the Government of Victoria.

Mr. Chandler | Mr. Reid.

ORDER EXTENDING APPLICATION OF PART V. OF THE LANDLORD AND TENANT ACT 1958 TO CERTAIN PREMISES.

IN pursuance of the powers conferred by section 44 of the *Landlord and Tenant Act 1958*, His Excellency the Administrator of the Government of the State of Victoria, by and with the advice of the Executive Council thereof, doth hereby declare that the application of Part V. of the *Landlord and Tenant Act 1958* shall extend to each of the following premises:—

1. The premises known as No. 9 Upton-road, Windsor.
2. The premises known as No. 5 Upton-road, Windsor.
3. The premises known as No. 59 Peel-street, Windsor.
4. The premises known as No. 62 Chatsworth-road, Prahran.
5. The premises known as No. 236 Brunswick-road, West Brunswick.
6. The premises known as No. 442 Canning-street, North Carlton.
7. The premises known as No. 21 De Carle-street, Coburg.
8. The premises known as No. 114 Woolton-avenue, Thornbury, and all premises forming part of such premises.
9. The premises known as No. 445 Melbourne-road, Newport, and all premises forming part of such premises.
10. The premises known as No. 94 Victoria-avenue, Albert Park, and all premises forming part of such premises.
11. The premises known as No. 3 Hickford-street, Brunswick, and all premises forming part of such premises.
12. The premises known as No. 38 Argyle-street, Fawkner.
13. The premises known as No. 40 Argyle-street, Fawkner.
14. The premises known as No. 17 Anzac-crescent, Williamstown.
15. That part of the premises known as No. 12 Margaret-street, Moonee Ponds, which, on the 4th July, 1961, was let to Lubomar Majka.
16. That part of the premises known as No. 2 Shetland-avenue, West Brunswick, which, on the 4th July, 1961, was let to F. R. Warner.
17. That part of the premises known as No. 18 Stewart-street, Windsor, which, on the 4th July, 1961, was let to Shirley Hughes.

And the Honorable Arthur Gordon Rylah, Her Majesty's Attorney-General in and for the State of Victoria, shall give the necessary directions herein accordingly.

A. MAHLSTEDT,
Clerk of the Executive Council.

CO-OPERATION ACT 1958 (No. 6225).

At the Executive Council Chamber, Melbourne, the fourth day of July, 1961.

PRESENT:

His Excellency the Administrator of the Government of Victoria.

Mr. Chandler | Mr. Reid.

HIS Excellency the Administrator of the Government of the State of Victoria, by and with the advice of the Executive Council thereof, and in pursuance of the provisions of section 93 of the *Co-operation Act 1958* (No. 6225) and all other powers him thereunto enabling, doth hereby appoint—

JOHN JOYCE LYNCH, LL.B., and
LESLIE GEORGE NORMAN, J.P., chartered accountant (Aust.),

members of the Co-operative Societies Advisory Council for a period of three (3) years from and inclusive of 19th July, 1961.

And the Honorable Henry Edward Bolte, Her Majesty's Treasurer for the State of Victoria, shall give the necessary directions herein accordingly.

A. MAHLSTEDT,
Clerk of the Executive Council.

Apprenticeship Act 1958.

APPRENTICESHIP COMMISSION OF VICTORIA.

At the Executive Council Chamber, Melbourne, the fourth day of July, 1961.

PRESENT:

His Excellency the Administrator of the Government of Victoria.

Mr. Chandler | Mr. Reid.

APPOINTMENT OF PRESIDENT.

IN pursuance of the provisions of the *Apprenticeship Act 1958*, His Excellency the Administrator of the Government of the State of Victoria, by and with the advice of the Executive Council thereof, doth by this Order—

1. Appoint OLIVER EMANUEL NILSSON, B.Sc., Chief Inspector of Technical Schools, and a competent and impartial person of proved administrative ability and with a general knowledge of industrial matters and with teaching experience in a technical school, as a Member and President of the Apprenticeship Commission of Victoria from the seventh day of August, 1961, until the third day of November, 1961 (both dates inclusive).
2. Determine that the said OLIVER EMANUEL NILSSON shall be entitled to be paid a salary at the rate of Two hundred pounds per annum, in addition to the amount payable to him by way of salary as Chief Inspector of Technical Schools.

And the Honorable George Oswald Reid, Her Majesty's Minister of Labour and Industry for the State of Victoria, shall give the necessary directions herein accordingly.

A. MAHLSTEDT,
Clerk of the Executive Council.

SOIL CONSERVATION AND LAND UTILIZATION ACT.

At the Executive Council Chamber, Melbourne, the fourth day of July, 1961.

PRESENT:

His Excellency the Administrator of the Government of Victoria.

Mr. Chandler | Mr. Reid.

DISTRICT ADVISORY COMMITTEE.—BOGONG HIGH PLAINS SOIL CONSERVATION DISTRICT.

IN pursuance of the powers conferred by section 15 of the *Soil Conservation and Land Utilization Act*, His Excellency the Administrator of the Government of the State of Victoria, by and with the advice of the Executive Council thereof, doth hereby appoint the following persons

to be members of the District Advisory Committee of the Bogong High Plains Soil Conservation District for a term of three years:—

DONALD KNOX RICHARDSON, being a person elected to represent grazing, agricultural, and other relevant interests in the District.

RONALD FREDERICK BRIGGS, being a person elected to represent grazing, agricultural, and other relevant interests in the District.

JOHN FREDERICK ROPER, being a person elected to represent grazing, agricultural, and other relevant interests in the District.

HAROLD HOWARD WILLIAMS, being a person elected to represent grazing, agricultural, and other relevant interests in the District.

JOHN LAWRENCE MITCHELL, being the person representing the Department of Crown Lands and Survey.

MALCOLM STEPTO WOOD, being the person representing the Soil Conservation Authority.

And the Honorable Henry Edward Bolte, Her Majesty's Minister for Conservation in the State of Victoria, shall give the necessary directions herein accordingly.

A. MAHLSTEDT,
Clerk of the Executive Council.

WARRAGUL SEWERAGE AUTHORITY.

At the Executive Council Chamber, Melbourne, the fourth day of July, 1961.

PRESENT:

His Excellency the Administrator of the Government of Victoria.

Mr. Chandler | Mr. Reid.

EXTENT OF SEWERAGE DISTRICT INCREASED.

UNDER the powers conferred by the Sewerage Districts Acts and all other powers enabling him in that behalf, His Excellency the Administrator of the Government of the State of Victoria, by and with the advice of the Executive Council of the said State, doth hereby declare, order and direct as follows:—

That the extent of the Sewerage District of the Warragul Sewerage Authority be increased by adding to the same the land comprised within the boundaries described in the Schedule hereto, and as on and from the date hereof the extent of such District shall be deemed to be increased accordingly.

SCHEDULE.

Commencing at the intersection of the western boundary of the Warragul to Nayook Railway Reserve and the southern boundary of Crown allotment 75, Parish of Drouin East, County of Buln Buln, being a point on the eastern boundary of the existing Sewerage District; thence easterly along the southern boundaries of the said Crown allotment 75 and of Crown allotments 66 and 66A to a point in line with the western boundary of Crown allotment 12, section A; thence southerly by a line across a road to the north-western angle of the said Crown allotment 12; thence southerly along the western boundaries of the said Crown allotment 12 and of Crown allotment 11 to the south-western angle of the said Crown allotment 11; thence southerly by a line across a road to the north-western angle of Crown allotment 22b; thence southerly along the western boundary of the said Crown allotment 22b to a point in line with the northern boundary of Crown allotment 23; thence westerly by a line across a road to the north-eastern angle of the said Crown allotment 23; thence westerly along the northern boundaries of the said Crown allotment 23 and of Crown allotments 24, 25 and 26 to the north-western angle of the said Crown allotment 26, being a point on the eastern boundary of the existing Sewerage District; thence northerly along the eastern boundary of the existing Sewerage District to the point of commencement.

All of which boundaries are shown on a plan approved by the Governor in Council, and deposited in the office of the State Rivers and Water Supply Commission, Melbourne.—(Corres. 59/1215/66.)

And the Honorable Wilfred John Mibus, Her Majesty's Minister of Water Supply for the State of Victoria, shall give the necessary directions herein accordingly.

A. MAHLSTEDT,
Clerk of the Executive Council.

SPRINGVALE AND NOBLE PARK SEWERAGE AUTHORITY.

At the Executive Council Chamber, Melbourne, the fourth day of July, 1961.

PRESENT:

His Excellency the Administrator of the Government of Victoria.

Mr. Chandler | Mr. Reid.

AMENDMENT OF ORDER.

UNDER the powers conferred by the *Sewerage Districts Act 1958* and all other powers enabling him in that behalf, His Excellency the Administrator of the Government of the State of Victoria, by and with the advice of the Executive Council of the said State, doth hereby amend as follows the Order in Council proclaiming the Sewerage District and constituting the Springvale and Noble Park Sewerage Authority made the 13th November, 1948, and published in the *Victoria Government Gazette* dated 8th December, 1948:—

In clause (a) for the expression "One hundred and forty thousand pounds (£140,000)" there shall be substituted the expression "Seven hundred thousand pounds (£700,000)".

And the Honorable Wilfred John Mibus, Her Majesty's Minister of Water Supply for the State of Victoria, shall give the necessary directions herein accordingly.

A. MAHLSTEDT,
Clerk of the Executive Council.

AVON RIVER IMPROVEMENT TRUST.

At the Executive Council Chamber, Melbourne, the fourth day of July, 1961.

PRESENT:

His Excellency the Administrator of the Government of Victoria.

Mr. Chandler | Mr. Reid.

LOAN OF £6,971.

IN pursuance of the powers conferred by section 43 of the *River Improvement Act 1958* and all other powers enabling him in that behalf, His Excellency the Administrator of the Government of the State of Victoria, by and with the advice of the Executive Council of the said State, doth by this Order—

1. Make advance by way of loan to the Avon River Improvement Trust a sum of Six thousand nine hundred and seventy-one pounds (£6,971); and

2. Apply the following terms and conditions:—

(a) That the said sum shall be used for the carrying out of approved river improvement works within the boundaries of the Avon River Improvement District.

(b) That the Avon River Improvement Trust shall, in respect to such advance by way of loan, be subject to the powers, rights, duties and obligations conferred and imposed by—

(i) the provisions of sections 284, 285 and 287 to 294 of Part VII. of the *Water Act 1958*, so adapted that the word "Authority" therein shall mean "the Avon River Improvement Trust"; and

(ii) the provisions of section 295 of the said Part VII. of the *Water Act 1958*, so adapted as if for the expressions "any waterworks trust or local governing body" and "such waterworks trust or local governing body" there were substituted the expression "the Avon River Improvement Trust".

And the Honorable Wilfred John Mibus, Her Majesty's Minister of Water Supply for the State of Victoria, shall give the necessary directions herein accordingly.

A. MAHLSTEDT,
Clerk of the Executive Council.

LAKES ENTRANCE WATERWORKS TRUST.

At the Executive Council Chamber, Melbourne, the fourth day of July, 1961.

PRESENT:

His Excellency the Administrator of the Government of Victoria.

Mr. Chandler | Mr. Reid.

EXTENT OF DISTRICT INCREASED.

UNDER the powers conferred by the Water Acts and all other powers enabling him in that behalf, His Excellency the Administrator of the Government of the State of Victoria, by and with the advice of the Executive Council of the said State, doth hereby declare, order and direct as follows:—

That the extent of the Waterworks District of the Lakes Entrance Waterworks Trust be increased by adding to the same the land comprised within the boundaries described in the Schedule hereto, and as on and from the date hereof the extent of such District shall be deemed to be increased accordingly.

SCHEDULE.

Commencing at the north-western angle of Crown allotment 30a, Parish of Colquhoun, County of Tambo, being a point on the boundary of the existing Waterworks District; thence northerly along the eastern boundary of Crown allotment 30a to its north-eastern angle; thence westerly along the northern boundary of the said Crown allotment 30a to the south-eastern angle of Crown allotment 30b; thence westerly along the southern boundary of the said Crown allotment 30b and by a line being the continuation thereof through a Reserve to a point on the eastern shore of the North Arm; thence generally south-westerly and south-easterly along the said eastern shore of the North Arm to a point in line with the southern boundary of Crown allotment 30r, being a point on the boundary of the existing Waterworks District; thence generally easterly, northerly, easterly and northerly along the boundary of the existing Waterworks District to the point of commencement.

All of which boundaries are shown on a plan approved by the Governor in Council, and deposited in the office of the State Rivers and Water Supply Commission, Melbourne.—(Corres. 60/1790/42.)

And the Honorable Wilfred John Mibus, Her Majesty's Minister of Water Supply for the State of Victoria, shall give the necessary directions herein accordingly.

A. MAHLSTEDT,
Clerk of the Executive Council.

AVENEL WATERWORKS TRUST.

At the Executive Council Chamber, Melbourne, the fourth day of July, 1961.

PRESENT:

His Excellency the Administrator of the Government of Victoria.

Mr. Chandler | Mr. Reid.

AMENDMENT OF ORDER.

UNDER the powers conferred by the Water Acts and all other powers enabling him in that behalf, His Excellency the Administrator of the Government of the State of Victoria, by and with the advice of the Executive Council of the said State, doth hereby amend as follows the Order in Council appointing Commissioners of the Avenel Waterworks Trust made on the 6th June, 1961, and published in the *Victoria Government Gazette* of 14th June, 1961:—

For the name "Martin Morgan" there shall be substituted the name "Martin Moran".

And the Honorable Wilfred John Mibus, Her Majesty's Minister of Water Supply for the State of Victoria, shall give the necessary directions herein accordingly.

A. MAHLSTEDT,
Clerk of the Executive Council.

TRARALGON SEWERAGE AUTHORITY.

At the Executive Council Chamber, Melbourne, the fourth day of July, 1961.

PRESENT:

His Excellency the Administrator of the Government of Victoria.

Mr. Chandler | Mr. Reid.

AMENDMENT OF ORDER.

UNDER the powers conferred by the *Sewerage Districts Act 1958* and all other powers enabling him in that behalf, His Excellency the Administrator of the Government of the State of Victoria, by and with the advice of the Executive Council of the said State, doth hereby amend as follows the Order in Council proclaiming the Sewerage District and constituting the Traralgon Sewerage Authority made the 21st February, 1939, as amended by Orders in Council made the 4th October, 1955, 14th August, 1956, 12th April, 1960, and 11th October, 1960, and published in the *Victoria Government Gazettes* dated 1st March, 1939, 5th October, 1955, 15th August, 1956, 13th April, 1960, and 12th October, 1960, respectively:—

In clause (a) for the expression "Four hundred thousand pounds (£400,000)" there shall be substituted the expression "Six hundred thousand pounds (£600,000)".

And the Honorable Wilfred John Mibus, Her Majesty's Minister of Water Supply for the State of Victoria, shall give the necessary directions herein accordingly.

A. MAHLSTEDT,
Clerk of the Executive Council.

STRATHDOWNIE DRAINAGE TRUST.

At the Executive Council Chamber, Melbourne, the fourth day of July, 1961.

PRESENT:

His Excellency the Administrator of the Government of Victoria.

Mr. Chandler | Mr. Reid.

LOAN OF £5,000.

IN pursuance of the powers conferred by section 43 of the *River Improvement Act 1958* and all other powers enabling him in that behalf, His Excellency the Administrator of the Government of the State of Victoria, by and with the advice of the Executive Council of the said State, doth by this Order:—

1. Make advance by way of loan to the Strathdownie Drainage Trust of a sum of Five thousand pounds (£5,000); and

2. Apply the following terms and conditions:—

(a) That the said sum shall be used for the carrying out of approved river improvement works within the boundaries of the Strathdownie Drainage District.

(b) That the Strathdownie Drainage Trust shall, in respect to such advance by way of loan, be subject to the powers, rights, duties and obligations conferred and imposed by—

(i) the provisions of sections 284, 285 and 287 to 294 of Part VII of the *Water Act 1958*, so adapted that the word "Authority" therein shall mean "the Strathdownie Drainage Trust";

(ii) the provisions of section 295 of the said Part VII of the *Water Act 1958*, so adapted as if for the expressions "any waterworks trust or local governing body" and "such waterworks trust or local governing body" there were substituted the expression "the Strathdownie Drainage Trust".

And the Honorable Wilfred John Mibus, Her Majesty's Minister of Water Supply for the State of Victoria, shall give the necessary directions herein accordingly.

A. MAHLSTEDT,
Clerk of the Executive Council.

WHOROULY CREEK IMPROVEMENT TRUST.

At the Executive Council Chamber, Melbourne, the fourth day of July, 1961.

PRESENT:

His Excellency the Administrator of the Government of Victoria.

Mr. Chandler | Mr. Reid.

LOAN OF £3,124.

IN pursuance of the powers conferred by section 43 of the *River Improvement Act 1958* and all other powers enabling him in that behalf, His Excellency the Administrator of the Government of the State of Victoria, by and with the advice of the Executive Council of the said State, doth by this Order—

1. Make advance by way of loan to the Whorouly Creek Improvement Trust of a sum of Three thousand one hundred and twenty-four pounds (£3,124).

2. Apply the following terms and conditions:—

(a) That the said sum shall be used for the carrying out of approved river improvement works within the boundaries of the Whorouly Creek Improvement District.

(b) That the Whorouly Creek Improvement Trust shall in respect of such advance by way of loan, be subject to the powers, rights, duties and obligations conferred and imposed by—

(i) the provisions of sections 284, 285 and 287 to 294 of Part VII. of the *Water Act 1958*, so adapted that the word "Authority" therein shall mean "the Whorouly Creek Improvement Trust"; and

(ii) the provisions of section 295 of the said Part VII. of the *Water Act 1958*, so adapted as if for the expressions "any waterworks trust or local governing body" and "such waterworks trust or local governing body" there were substituted the expression "the Whorouly Creek Improvement Trust".

And the Honorable Wilfred John Mibus, Her Majesty's Minister of Water Supply for the State of Victoria, shall give the necessary directions herein accordingly.

A. MAHLSTEDT,
Clerk of the Executive Council.

APPROACHING LAND SALES.

SALES of Crown lands, in fee-simple, will be held at the under-mentioned places and dates, viz.:—

	No. of Gazette.
Beechworth.—Monday, 10th July, 1961	.. 47
Benalla.—Friday, 21st July, 1961	.. 47
Bendigo.—Thursday, 20th July, 1961	.. 47
Dunolly.—Friday, 4th August, 1961	.. 51
Geelong.—Thursday, 27th July, 1961	.. 50
Hopetoun.—Monday, 31st July, 1961	.. 51
Minyip.—Wednesday, 9th August, 1961	.. 51
Nhill.—Monday, 7th August, 1961	.. 51
Rainbow.—Monday, 31st July, 1961	.. 51
Shepparton.—Friday, 21st July, 1961	.. 47
Stawell.—Wednesday, 2nd August, 1961	.. 51
Wangaratta.—Thursday, 13th July, 1961	.. 47

SALE OF FREEHOLD LAND BY AUCTION.

Tallangatta.—Friday, 14th July, 1961 .. 47

PROPOSED REVOCATION OF PORTION OF TEMPORARY RESERVATION OF LAND BY ORDER IN COUNCIL.

IN pursuance of the provisions of the *Land Act 1958*, notice is hereby given that it is the intention of the

Governor in Council to revoke portion of the temporary reservation of land by Order in Council hereunder referred to, viz.:—

The following Notice was published 1° on the 14th June, 1961, pursuant to Order of the 6th June, 1961.

YAAPEET.—The temporary reservation, by Order in Council of the 4th July, 1917, of 3 acres 2 roods 9 2/10 perches of land in the Township of Yaapeet as a site for State School purposes, so far only as the portion containing 23 perches, indicated by hachure on plan hereunder, is concerned.—(Y.124(*) (Rs.1619).

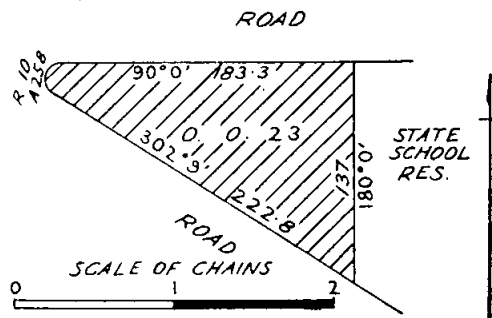

KEITH TURNBULL,
Commissioner of Crown Lands and Survey.

PROPOSED REVOCATION OF TEMPORARY RESERVATION, AND THE WITHHOLDING FROM SALE, LEASING, AND LICENSING OF LAND BY ORDER IN COUNCIL.

IN pursuance of the provisions of the *Land Act 1958*, notice is hereby given that it is the intention of the Governor in Council to revoke the temporary reservation, and the withholding from sale, leasing, and licensing of land by Order in Council hereunder referred to, viz.:—

The following Notice was published 1° on the 7th June, 1961, pursuant to Order of the 30th May, 1961.

YALONG SOUTH.—The temporary reservation as a site for Camping and for affording access to Water and the withholding from sale, leasing and licensing by Order in Council of the 25th August, 1884, of 37 acres more or less, in the Parish of Yalong South.—(Y.93(*) (Rs.5450).

KEITH TURNBULL,
Commissioner of Crown Lands and Survey.

PROPOSED REVOCATION OF TEMPORARY RESERVATION OF LAND BY ORDER IN COUNCIL.

IN pursuance of the provisions of the *Land Act 1958*, notice is hereby given that it is the intention of the Governor in Council to revoke the temporary reservation of land by Order in Council hereunder referred to, viz.:—

The following Notice was published 1° on the 14th June, 1961, pursuant to Order of the 6th June, 1961.

WOORARRA.—The temporary reservation, by Order in Council of the 21st May, 1907, of 1 rood 23 perches of land in the Parish of Woorarra, as a site for a Mechanics' Institute is about to be revoked.—(W.379(*) (Rs.459).

KEITH TURNBULL,
Commissioner of Crown Lands and Survey.

PROPOSED REVOCATION OF TEMPORARY RESERVATION OF LAND BY ORDER IN COUNCIL.

IN pursuance of the provisions of the *Land Act 1958*, notice is hereby given that it is the intention of the Governor in Council to revoke the temporary reservation of land by Order in Council hereunder referred to, viz.:—

The following Notice was published 1° on the 28th June, 1961, pursuant to Order of the 20th June, 1961.

GLENLOGIE.—The temporary reservation, by Order in Council of the 18th January, 1909, of 12 acres 0 roods 28 perches of land in the Parish of Glenlogie, as a site for the Supply of Gravel.—(G.65(*) (C.39166).

KEITH TURNBULL,
Commissioner of Crown Lands and Survey.

LIST OF CROWN LANDS AVAILABLE.

THE under-mentioned area is available for application as provided by various sections of the *Land Act 1958*, and all applications received on or before Wednesday, 2nd August, 1961, will be deemed to have been made simultaneously, but any application lodged after such date may be considered if received in time for inclusion in the advertisement of the cases to be heard at the Local Land Board. Applications on proper form, accompanied by 5s. duty stamp uncancelled (registration fee), may be delivered or forwarded by post to the Local Land Officer or to any Crown Lands Office in Victoria. Subject to the approval of the Secretary for Lands, when the survey fee exceeds £25 but does not exceed £50, a deposit of £25 may be paid, and when the fee exceeds £50, a deposit of 50 per cent. of the fee, the balance in either case being payable over six years in half-yearly instalments.

Marked plans of any particular area, application forms, and any further information may be obtained from the Crown Lands Department, Melbourne, and Land Office, Bairnsdale.

Department of Crown Lands and Survey,
Melbourne, 4th July, 1961.

KEITH TURNBULL,
Commissioner of Crown Lands and Survey.

* Improvements may be subject to re-valuation after land has been granted to an applicant.

Local Land Office.	County.	Township.	Allo- ment.	Section.	Area.	How Available.		Survey Fee.	Valuation of improvements (if any).	Location of Land, etc.	Nearest Railway Station or Township and Distance in miles therefrom.	How Accessible.	Water Supply.	General Description of Land— Soil, Timber, Suitability (Grazing, &c.).	
						Classi- cation.	Value per Acre.								
						A.	B.	C.	D.						
Bairnsdale	Tambo	Berrmarr..	8	A	500 0 0	4th	0 10 0	46 10 0	Nil	36 miles north of Buchanan by formed road	Nowa Nowa R.S., 56 miles	By road ..	From creeks travers- ing the area and by con- servation. Annual average rainfall about 25 inches.	Generally poor, stony and undulating with two well- grassed creek flats; soil is dark loam on flats and sandy loam on hills; mainly timbered with snow gum, box and peppermint. Suit- able sheep or cattle grazing.	

AGRICULTURAL AND GRAZING LANDS—SELECTION PURCHASE ALLOTMENTS.

DIVISION 4, PART I, LAND ACT 1958.

Land Act 1958.
LEASE SURRENDERED.

NOTICE is hereby given that the Governor in Council has accepted the surrender of the Lease mentioned in the Schedule hereunder for the reason specified.

District.	Corr. No.	Name.	Section of Land Act under which Leased.	Parish.	Allotment.	Section.	Area.	Class.	Reason.
Bairnsdale	419/44	Ellen Davies	44	Suggan Buggan	3	A	A. R. P. 1255 0 14		Surrendered

Department of Crown Lands and Survey,
Melbourne, 26th June, 1961.

KEITH TURNBULL,
Commissioner of Crown Lands and Survey.

COMMON ABOUT TO BE ABOLISHED.

IN pursuance of the provisions contained in the *Land Act 1958*, notice is hereby given that it is the intention of the Governor in Council to abolish the Common hereinafter mentioned, viz.:—

The following Notice was published 1° on the 14th June, 1961, pursuant to Order of the 6th June, 1961.

The Brankholme Town Common, proclaimed as such by the Governor in Council on the 26th November, 1860, 15th October, 1866 and the 15th June, 1875, is about to be abolished.—(Rs.414.)

KEITH TURNBULL,
Commissioner of Crown Lands and Survey.

LOCAL LAND BOARDS.

IN pursuance of the provisions of section 34 of the *Land Act 1958*, notice is hereby given that public hearings at the following place and time will be conducted by the persons respectively mentioned, being duly appointed in that behalf.

KEITH TURNBULL,
Commissioner of Crown Lands and Survey.

Department of Crown Lands and Survey,
Melbourne, 3rd July, 1961.

SCHEDULE.

DANDENONG, COURT HOUSE, Tuesday, 18th July, 1961, at 9.30 a.m.—W. M. Walsh and J. A. Murphy.

Public Service Act 1958.

PUBLIC SERVICE BOARD ELECTIONS.
MENTAL HYGIENE REPRESENTATIVE.

PURSUANT to the provisions of the Public Service Board Elections Regulations, I hereby announce that for the election of the Mental Hygiene Representative as a member of the Public Service Board, to be held on Thursday, the 3rd August, 1961, and also the election of a Deputy of such member, the following candidates have been duly nominated, namely:—

MEMBER.

Candidate; Department; Branch.

STANLEY JOSEPH BREW; Health Department; Mental Hygiene Branch (Larundel Mental Hospital).

DEPUTY MEMBER.

Candidate; Department; Branch.

JOSEPH HENRY RICHARDSON; Health Department; Mental Hygiene Branch (Mont Park Mental Hospital).
JOHN VICTOR SAUNDERS; Health Department; Mental Hygiene Branch (Mont Park Mental Hospital).

F. E. CAHILL,
Returning Officer.

Chief Secretary's Office, Spring-street,
Melbourne, C.1, 29th June, 1961.

Public Service Act 1958.

PUBLIC SERVICE BOARD ELECTIONS.
PUBLIC SERVICE REPRESENTATIVE.

PURSUANT to the provisions of the Public Service Board Elections Regulations, I hereby announce that for the election of the Public Service Representative

as a member of the Public Service Board, to be held on Thursday, the 3rd August, 1961, and also the election of a Deputy of such member, the following candidates have been duly nominated, namely:—

MEMBER.

Candidate; Department; Branch.

FREDERICK CHARLES MCARDLE; Education Department; Administrative Branch.

JOHN BRODY; Public Works Department; Accounts Branch.

DEPUTY MEMBER.

Candidate; Department; Branch.

JOHN BRODY; Public Works Department; Accounts Branch.

GEORGE WILLIAM ROGAN; Health Department; Mental Hygiene Branch.

F. E. CAHILL,
Returning Officer.

Chief Secretary's Office, Spring-street,
Melbourne, C.1, 29th June, 1961.

PUBLIC SERVICE NOTICES

No. 1132.

Public Service Act 1958, Section 50.

REGULATIONS—PART III.—SALARIES, INCREMENTS AND ALLOWANCES.

THE Public Service Board, in pursuance of the powers conferred by the *Public Service Act 1958*, hereby amends its Regulations as shown below:—

SIXTH SCHEDULE.

TEMPORARY EMPLOYEES.

Designations of Positions and Rates of Salaries.

Department and Designation of Position.	Yearly Rate of Salary.		Increments (Annual).
	Minimum.	Maximum.	
DEPARTMENT OF CHIEF SECRETARY.	£	£	
FISHERIES AND WILDLIFE.			
Add— Research Officer	710	1,280	†

† Increments in accordance with the scale of rates of salaries as set out in the Third Schedule to these Regulations.

A. GARRAN, Chairman.
V. P. SCULLY, Secretary.

Office of the Public Service Board,
Melbourne, 28th June, 1961.

PUBLIC SERVICE (PUBLIC SERVICE BOARD) REGULATION 39.—VACANCIES.

THE Permanent Heads of the Departments shown have recommended the officers named hereunder for appointment to the under-mentioned vacancies.

Office and Classification.	Duties.	Qualifications.	Officer Recommended for Appointment.		
			Name.	Classification.	Date of Classification.

PROFESSIONAL DIVISION.

LAW DEPARTMENT.

Office of Titles.

Chief Examiner of Titles, Class "A1" (£2,850)	To be responsible for the work of the Examiners of Titles and to advise on points of law and office practice.	A Barrister and Solicitor with sufficient conveying experience to perform the duties of the office	Allen, C. P. . .	Examiner of Titles, "A1" (£2,600)	29.6.58
---	---	--	------------------	-----------------------------------	---------

TECHNICAL AND GENERAL DIVISION.

STATE FORESTS DEPARTMENT.

Forest Overseer, Grade I, Grades 34-36 inclusive	To supervise operations of forest employees and licensees, and to carry out general and fire patrol duties	A good knowledge of the Victorian Forests Act and Regulations and of office procedure, and extensive practical experience of field methods and operation in the Forests Department	Stewart, N. A. J.	Forest Overseer, Grade II, Grades 32-33 inclusive	3.9.54
--	--	--	-------------------	---	--------

Appeals against such recommendations should be lodged with the Secretary to the Public Service Board not later than Saturday, the 15th July, 1961.

Office of the Public Service Board,
Melbourne, 4th July, 1961.

By order,
N. J. SIMMANCE,
Acting Secretary.

PUBLIC SERVICE (PUBLIC SERVICE BOARD) REGULATION 39.—RECLASSIFICATION.

THE Public Service Board has raised the classification of the under-mentioned office as shown, and the Permanent Head of the Department has recommended the officer named for appointment.

Office and Present Classification.	Revised Classification.	Duties.	Qualifications.	Officer Recommended for Appointment.		
				Name.	Classification.	Date of Classification.

ADMINISTRATIVE DIVISION.

CHIEF SECRETARY'S DEPARTMENT.

Social Welfare Branch.

Class "C2"	Class "B"	To be Staff Officer of the Social Welfare Branch	A good knowledge of the Public Service Act and Regulations and, preferably, of the staffing requirements of the institutions conducted by the Branch	Tovey, J. A.	Class "C2"	7.2.57
------------	-----------	--	--	--------------	------------	--------

Appeals against such recommendation should be lodged with the Secretary to the Public Service Board not later than Saturday, the 15th July, 1961.

Office of the Public Service Board,
Melbourne, 4th July, 1961.

By order,
N. J. SIMMANCE,
Acting Secretary.

PUBLIC SERVICE OF VICTORIA.—VACANCIES.

APPLICATIONS will be received by the Public Service Board up to Wednesday, the 19th July, 1961, from persons employed in the Public Service of Victoria, who are eligible and qualified for appointment to the under-mentioned positions:—

ADMINISTRATIVE DIVISION.

Chief Clerk, Class "A1", Department of Crown Lands and Survey.

Yearly Salary.—£2,300.

Duties.—To have general supervision of the work of the office and control the staff.

Qualifications.—A good knowledge of the Acts and Regulations administered in the Department; a knowledge of the Public Service Act and Regulations; ability to control a large staff.

Administration Officer, Class "A", Social Welfare Branch, Chief Secretary's Department.

Yearly Salary.—£1,920, minimum; £2,060, maximum.

Duties.—To be responsible for the central administration of the Social Welfare Branch, and for the co-ordination of the administrative work of the various divisions of the Branch.

Qualifications.—Administrative ability and preferably a knowledge of the provisions of the Social Welfare Act 1960.

Class "B1", Social Welfare Branch, Chief Secretary's Department.

Yearly Salary.—£1,630, minimum; £1,770, maximum.

Duties.—To manage the administration of the Youth Welfare Division.

Qualifications.—Administrative ability and preferably a knowledge of youth welfare provisions of the Social Welfare Act 1960.

Assistant Chief Inspector of Factories and Shops, Class "B1", Department of Labour and Industry.

Yearly Salary.—£1,630, minimum; £1,770, maximum.

Duties.—To assist generally in the direction and control of the Factory and Shops Inspectorate including the exercise of such statutory powers and functions as are assigned to him.

Qualifications.—Ability to initiate plans for inspection activities and to direct and control a large inspection staff. A wide knowledge of the industrial laws of Victoria and extensive experience in industrial matters generally.

Class "B1" (District Accounting Officer), Bendigo Centre, Water Supply Department.*Yearly Salary.*—£1,630, minimum; £1,770, maximum.*Qualifications.*—A good knowledge of the Water Acts, the Public Accounts and Stores Regulations and the incidence of rating; ability to control staff, to conduct negotiations and correspondence and to represent the Commission in proceedings for the recovery of rates; a good knowledge of the procedure regarding the purchase and control of stores; to be familiar with wages Awards and Determinations. Accountancy qualifications are desirable.

NOTE.—A house is available for the successful applicant, if married, for which a rental of 10 per cent. of standard salary, plus £16 a year will be charged. Particulars available from the Water Supply Department.

Class "B", Motor Registration Branch, Office of the Chief Commissioner of Police, Chief Secretary's Department.*Yearly Salary.*—£1,390, minimum; £1,500, maximum.*Duties.*—To act as Staff and Personnel Officer; to order and control stores and equipment.*Qualifications.*—Experience in handling staff; a good knowledge of the Public Service Act and Regulations; the Public Accounts and Stores Regulations and preferably the Motor Car Acts and Regulations.**Classes "C2"—"B", Office of the Public Trustee, Law Department.***Yearly Salary.*—£1,170, minimum; £1,500, maximum.*Duties.*—To act as Trust Officer dealing with estates of deceased persons and with agencies and trust estates.*Qualifications.*—A good knowledge of the Public Trustee Act and Regulations and the law affecting the administration of estates of deceased persons, trust and agencies, ability to administer such estates and experience in the management and conduct of estates and business.**Class "C2", Social Welfare Branch, Chief Secretary's Department.***Yearly Salary.*—£1,170, minimum; £1,280, maximum.*Duties.*—To be in charge of the records section of the Youth Welfare Division; as required to relieve the Chief Clerk.*Qualifications.*—Experience of correspondence and records systems and ability to draft correspondence. A knowledge of the Youth Welfare provisions of the *Social Welfare Act 1960* would be an advantage.**Class "C2" (District Accounting Officer), Maffra Centre, Water Supply Department.***Yearly Salary.*—£1,170, minimum; £1,280, maximum.*Qualifications.*—A good knowledge of the Water Acts; a knowledge of the incidence of rating, and experience in rate collecting; ability to conduct negotiations and correspondence and to represent the Commission in proceedings for recovery of rates.

NOTE.—A house is available for the successful applicant, if married, for which a rental of 10 per cent. of standard salary plus £16 a year will be charged. Particulars available from the Water Supply Department.

Classes "C1"—"C2", Geelong, Department of Crown Lands and Survey.*Yearly Salary.*—£960, minimum; £1,280, maximum.*Duties.*—To deal with Land Settlement applications and inquiries; to conduct Auction Sales of departmental lands; to hold Local Land Boards; to issue notices for payment of survey fees and to record orders for survey; to plot new surveys on office plans.*Qualifications.*—A general knowledge of the Land and Closer Settlement Acts and relevant portions of miscellaneous Acts and Regulations administered by the Department; experience in draughting and capable of charting on plans from surveyor's field notes.**Class "C1", Social Welfare Branch, Chief Secretary's Department.***Yearly Salary.*—£960, minimum; £1,060, maximum.*Duties.*—To assist in the ordering and receipt of stores. To maintain records of stores in use at departmental institutions.*Qualifications.*—A good knowledge of the Public Accounts and Stores Regulations, and experience in stores control.**Class "C1", Mines Department.***Yearly Salary.*—£960, minimum; £1,060, maximum.*Duties.*—To act as Secretary of the Sludge Abatement Board and of the Boards of Examiners of Mine Managers, Engine Drivers and Boiler Attendants; and to help administer the Gold Buyers Act.*Qualifications.*—A knowledge of the Gold Buyers Act and of the legislation governing the examination of candidates for certificates of competency under the Mines Act, Coal Mines Act and Regulations under the Labour and Industry Act would be an advantage.**Class "C1", Department of Labour and Industry.***Yearly Salary.*—£960, minimum; £1,060, maximum.*Duties.*—To assist in replying to inquiries by the public regarding wages, and to give advice concerning the application of State Wages Board Determinations and other Industrial Laws.*Qualifications.*—A good knowledge of the Labour and Industry Act and other Acts administered in the Department, the Regulations thereunder, Determinations of Wages Boards, and the procedure of the Department.**Class "C", Audit Office, Premier's Department.***Yearly Salary.*—£710, minimum; £860, maximum.*Duties.*—To assist in the audit and examination of accounts as required by the Auditor-General.*Qualifications.*—A knowledge of the Audit Act and Regulations; to have made progress in the study of accountancy.

NOTE.—The successful applicant will be required, initially, to perform audit duties at the Offices of the State Rivers and Water Supply Commission, Armadale.

Class "C", Social Welfare Branch, Chief Secretary's Department. (Four vacancies.)*Yearly Salary.*—£710, minimum; £860, maximum.*Position No. 1.**Duties.*—To assist generally in the State Wards Section in matters relating to children's institutions and wards placed therein.*Qualifications.*—A competent correspondence clerk, capable of dealing with the public and with voluntary child care organizations.*Position No. 2.**Duties.*—To assist in the Records Section of the Youth Welfare Division.*Qualifications.*—Experience in recording and filing systems.*Position No. 3.**Duties.*—Correspondence and recording duties in the Central Administration of the Branch.*Qualifications.*—Ability to draft correspondence and to maintain a records system.*Position No. 4.**Duties.*—To check, prepare and register accounts for payment and to assist generally.*Qualifications.*—A good knowledge of the Audit Act and of the Public Accounts and Stores Regulations.**Class "C", State Motor Car Insurance Office, Chief Secretary's Department. (Five vacancies.)***Yearly Salary.*—£710, minimum; £860, maximum.*Position No. 1.**Duties.*—To supervise and control staff dealing with members of the public and generally assist in the Policy Department.*Qualifications.*—A good knowledge of and practical experience in the underwriting of Comprehensive and Statutory Motor Vehicle Insurance. Ability to control staff and to provide information and service to the public generally.*Position No. 2.**Duties.*—To act as New Business and Endorsements Officer and assist generally in the Policy Department.*Qualifications.*—A good knowledge of and practical experience in the underwriting of Comprehensive and Statutory Motor Vehicle Insurance. Ability to control staff and conduct correspondence.*Positions Nos. 3, 4 and 5.**Duties.*—To supervise and control staff dealing with members of the public, conduct correspondence, assess negligence and outstanding liabilities in

relation to motor vehicle accidents and generally to assist in the Comprehensive Claims Department.

Qualifications.—A good knowledge of Comprehensive Motor Vehicle Insurance and experience in settlement of claims. Ability to conduct correspondence and control staff.

Class "C", Office of Titles, Law Department.

Yearly Salary.—£710, minimum; £860, maximum.

Duties.—To compile particulars of all dealings lodged for registration; to record the progress of each dealing and any attachments or detachments of dealings and to be responsible for their correct distribution.

Qualifications.—A knowledge of the Transfer of Land Act and cognate Acts and of the practice of the Office of Titles, and of the dealings dealt with by particular officers and an understanding of all requisitions.

Class "C", Department of Crown Lands and Survey.

Yearly Salary.—£710, minimum; £860, maximum.

Duties.—To keep the Accounts of Settlers on single-unit farms and of settlers under the Commonwealth Employment and Re-establishment Act.

Qualifications.—Good accounting experience.

PROFESSIONAL DIVISION.

Director, National Museum, Class "A1", Chief Secretary's Department.

Yearly Salary.—£2,600.

Duties.—To supervise the administration of the National Museum, and the work of the staff.

Qualifications.—A degree in science from an approved University; specialized knowledge of zoology, geology or anthropology; competent to supervise original research in these subjects and to edit scientific publications. Experience of museum administration and techniques, including the preservation and care of collections and the presentation of museum exhibits is desirable.

Senior Live Stock Research Officer, Class "A1", Department of Agriculture.

Yearly Salary.—£2,175.

Duties.—To undertake advanced research in the field of physiology of sheep and cattle.

Qualifications.—A degree in Agricultural Science or Veterinary Science of an Australian University; extensive experience in research in animal physiology.

Librarian (Male or Female), Class "C2", State Library, Chief Secretary's Department.

Yearly Salary.—Male—£1,170, minimum; £1,280, maximum. Female—£1,113, minimum; £1,223, maximum.

Duties.—To have sub-charge of the Lending Library with particular responsibility for rural services through the Country and Travelling Libraries.

Qualifications.—A University degree, or other special educational qualifications combined with long experience; to hold at least the Preliminary Certificate of the Library Association of Australia; experience in and extensive knowledge of modern lending library practices, both metropolitan and country, and capacity to direct and control staff.

Probation and Parole Officer (Male and Female), Classes "C"—"C2", Social Welfare Branch, Chief Secretary's Department. (Fifteen vacancies.)

Yearly Salary.—Male—£860, minimum; £1,280, maximum. Female—£803, minimum; £1,223, maximum.

(Commencing salary according to qualifications and experience.)

Duties.—To prepare pre-sentence investigation reports and to supervise probationers and parolees.

Qualifications.—Diploma of Social Studies or equivalent qualification.

NOTE.—Applications will be accepted from holders of an appropriate University Degree who are prepared, following appointment, to undertake on a part-time basis the additional study which would qualify them for the Diploma of Social Studies of the Melbourne University. Appointees will receive a commencing salary of £760 a year (Males) and £703 a year (Females); progression

beyond the rates of £860 and £803 a year, respectively, will be contingent upon their qualifying for the Diploma of Social Studies.

Social Worker (Male), Classes "C"—"C2", Social Welfare Branch, Chief Secretary's Department. (Four vacancies.)

Yearly Salary.—£860, minimum; £1,280, maximum. (Commencing salary according to qualifications and experience.)

POSITION Nos. 1-3.

Duties.—To do social case work with children or young persons, and with parents or foster parents; to prepare reports for administrative and clinical purposes; to undertake special project work.

Qualifications.—Diploma of Social Studies or equivalent qualification, preferably with experience in group work with children.

POSITION No. 4.

Duties.—To be responsible to the Director of Youth Welfare for duty on behalf of the Youth Advisory Council; to investigate and report on applications by voluntary organizations for grants from the Youth Organizations Assistance Fund and to perform other duties as required.

Qualifications.—Diploma of Social Studies or equivalent qualification, preferably with experience in youth welfare work.

NOTE.—Applications will be accepted from holders of an appropriate University Degree who are prepared, following appointment, to undertake on a part-time basis the additional study which would qualify them for the Diploma of Social Studies of the Melbourne University. Appointees will receive a commencing salary of £760 a year; progression beyond the rates of £860 a year will be contingent upon their qualifying for the Diploma of Social Studies.

Social Worker (Female), Classes "C"—"C2", Children's Welfare Branch, Chief Secretary's Department.

Yearly Salary.—£803, minimum; £1,223, maximum. (Commencing salary according to experience.)

Duties.—To supervise Family Group Homes. To advise Cottage Mothers in the care of children and in home management.

Qualifications.—Diploma of Social Studies or equivalent qualification; experience in child welfare work; organizing ability and capacity for the training and guidance of staff; an understanding of the problems of deprived children.

Assistant Geneticist, Classes "C"—"C2", Department of Agriculture.

Yearly Salary.—£960, minimum; £1,280, maximum—Agricultural Science Graduate. £860, minimum; £1,280, maximum—Science Graduate.

(Commencing salary according to experience.)

Duties.—To undertake a breeding programme for the production of superior strains of pasture legumes and other species for the Victorian wheat belt, and other duties in the Plant Breeding Branch as required.

Qualifications.—A Degree in Agricultural Science, or Science with Botany as a major subject, of the University of Melbourne or its equivalent.

NOTE.—The appointee will be stationed primarily at the State Research Farm, Werribee, but may later be required to transfer to a regional breeding station in a wheat-growing area. Board and lodging are available in the Staff Quarters for a single person.

TECHNICAL AND GENERAL DIVISION.

Assistant Senior Apprenticeship Supervisor, Apprenticeship Commission, Department of Labour and Industry.

Yearly Salary.—£1,086, minimum; £1,230, maximum.

Duties.—To assist in the direction and supervision of the work of Apprenticeship Supervisors, particularly in country districts.

Qualifications.—A good knowledge of the Apprenticeship Act and Regulations and of industrial conditions and labour laws, including Wages Board Determinations and Arbitration Court Awards, and experience as an Apprenticeship Supervisor.

Engineering Assessor, State Motor Car Insurance Office, Chief Secretary's Department.

Yearly Salary.—£798, minimum; £942, maximum.

Duties.—To act as Motor Car Claims Assessor.

Qualifications.—An Automotive Engineer possessing an "A" grade certificate; and capable of assessing motor car loss and damage claims and of compiling reports. A general knowledge of motor car insurance is desirable.

Inspector, Milk Board, Bendigo, Department of Agriculture.

Yearly Salary.—£750, minimum; £846, maximum.

Duties.—To examine and check records kept by dairy farmers, Authorized Agents of the Board, dairymen and milk carriers and to examine consignments of milk purchased by the Board; to inspect and report on premises and to perform other duties of an inspectorial nature.

Qualifications.—A qualified dairy supervisor; with a knowledge of the Milk Board Act and Regulations and the Health Regulations relative to food premises and food cleanliness.

Works Inspector, Coliban District, Water Supply Department.

Yearly Salary.—£686, minimum; £750, maximum.

Duties.—To assist in the supervision of water bailiffs in the Coliban District, the distribution and regulation of water from the channel system, the repair and maintenance of channels, and channel structures, channel lining, measuring weirs and outlet boxes. To be prepared to take over a vacant bailiff's section in an emergency.

Qualifications.—Experience in the distribution of irrigation water in a channel system; capable of supervising the work of gangs of men and setting out works, structures and channels from plans; competent to keep the necessary records and make arithmetical computations; a knowledge of water requirements for orchards, crops, pastures, and grasses grown under irrigation, and the method of preparing land for irrigation.

NOTE.—A house is available for the successful applicant, if married, for which a rental of 10 per cent. of standard salary plus £16 a year will be charged. Particulars available from the Water Supply Department.

Inspector (Wimmera-Mallee), Birchip Centre, Water Supply Department.

Yearly Salary.—£590, minimum; £638, maximum.

Duties.—To supervise the maintenance and repair of channels in the Birchip Centre and to take charge of gangs engaged on sand drift prevention and construction work. To control the regulation and distribution of water within the district.

Qualifications.—A knowledge of sand drift control and prevention, and experience in the maintenance and repair of channels and channel structures and in the regulation and distribution of water; capable of handling men and supervising gangs engaged on maintenance and repairs.

Assistant (Male), Grade I., Department of Agriculture.

Yearly Salary.—£542, minimum; £574, maximum.

Duties.—Under the Vegetation and Vine Diseases Act to collect from markets, railways, airways, shipping offices, &c., data on interstate imports of fruit, vegetables, &c.

Qualifications.—A knowledge of the Vegetation and Vine Diseases Act and the Regulations thereunder in so far as they relate to the payment of charges; experience in the collection and recording of statistics.

NOTE.—To be eligible to apply for this position, temporary employees or officers of the Technical and General Division other than Assistants (Male), must have passed the Board's examination for registration for appointment as Assistant (Male), Grade II., Technical and General Division.

Water Bailiff, Water Supply Department.

(One Vacancy Merbein Centre)
(One Vacancy Red Cliffs Centre)

Yearly Salary.—£430, minimum; £526, maximum.

Qualifications.—Ability to control and regulate the supply of water to irrigators and keep the necessary records and make arithmetical computations; a knowledge of water requirements for vines and citrus plantings and crops and grasses grown under irrigation, and methods of channel and drain construction and maintenance.

Mechanical Plant Operator, Ouyen Centre, Water Supply Department.

Yearly Salary.—£510.

Duties.—To operate mechanical plant as required; to carry out all operational services to the plant items, and keep records of plant performance.

Qualifications.—Ability to operate all types of tractors, hydraulic scoops, ditchers and other earth-moving equipment on construction and maintenance of earthen channels and other works.

Ranger, Horsham Centre, Water Supply Department. (Two Vacancies.)

Yearly Salary.—£430, minimum; £494, maximum.

Qualifications.—Competent to control and regulate the supply of water to landholders and supervise teams on channel cleaning; a knowledge of mechanical equipment used on sand cleaning and other works; ability to measure up channels for cleaning, and knowledge of the water requirements and channels in the district. Competent to measure up piecework and to perform clerical work involved in preparing time-book.

Messenger, Sheriff's Office, Law Department.

Yearly Salary.—£366, minimum; £430, maximum.

Duties.—To attend on the Supreme Court Judges and their Associates and generally to perform duties under the direction of the Senior Messenger.

Qualifications.—To be well mannered, active, and of neat appearance.

Labourer, Bendigo Public Offices, Public Works Department.

Yearly Salary.—£302, minimum; £318, maximum.

NOTE.—The salary rates quoted above do not include the additional amounts which are payable under Regulation 77A of the Board's Regulations.

By order,

N. J. SIMMANCE,
Acting Secretary.

Office of the Public Service Board,
Melbourne, 4th July, 1961.

**PUBLIC SERVICE OF VICTORIA.—VACANCY.
DEPARTMENT OF HEALTH.
MENTAL HYGIENE BRANCH.
TECHNICAL AND GENERAL DIVISION.**

APPLICATIONS will be received by the Public Service Board up to Wednesday, the 26th July, 1961, from persons employed in the Public Service of Victoria, who are eligible and qualified for appointment to the under-mentioned position:—

Supervisor of Catering, Grade I., Ballarat Mental Hospital.

Yearly Salary.—£718.

Duties.—To supervise the cooking and distribution of food for patients; to advise the Mess Committee in the cooking and distribution of food for staff and to control orders and supplies required for Staff Messes.

Qualifications.—Sound knowledge of large quantity cooking and general catering. Ability to supervise food distribution and service.

NOTE.—The salary rate quoted above does not include the additional amount which is payable under Regulation 77A of the Board's Regulations.

By order,

N. J. SIMMANCE,
Acting Secretary.

Office of the Public Service Board,
Melbourne, 4th July, 1961.

**PUBLIC SERVICE OF VICTORIA.—VACANCY.
(TEMPORARY APPOINTMENT.)**

APPLICATIONS will be received by the Public Service Board up to Wednesday, the 19th July, 1961, from persons who are qualified for appointment to the under-mentioned position:—

Mechanical Plant Operator, Ouyen Centre, Water Supply Department.

Yearly Salary.—£510.

Duties.—To operate mechanical plant as required; to carry out all operational services to the plant items, and keep records of plant performance.

Qualifications.—Ability to operate all types of tractors, hydraulic scoops, ditchers, and other earth-moving equipment on construction and maintenance of earthen channels and other works.

The salary rate quoted above does not include the additional amount which is payable under Regulation 77A of the Board's Regulations.

By order,
N. J. SIMMANCE,
Acting Secretary.

Office of the Public Service Board,
Melbourne, 4th July, 1961.

Public Service Act 1958.

THE Public Service Board, in pursuance of the powers conferred by the Public Service Act 1958, hereby amends the Public Service (Public Service Board) Regulations as follows:—

PART III.—SALARIES, INCREMENTS, AND ALLOWANCES.

REGULATION 77A.

In Regulation 77A the scale of amounts is deleted and the following scale inserted in lieu thereof:—

	Amount.	
(a) Adult Males and Married Male Minors ..	£523	
(b) Adult Females ..	£393	
(c) Minors other than Married Male Minors—		
	Amount.	
Age.	Male.	Female.
	£	£
At 16 years and under	262	262
At 17 years ..	314	262
At 18 years ..	366	275
At 19 years ..	418	314
At 20 years ..	471	353 "

This Regulation shall have effect as on and from the 9th July, 1961.

A. GARRAN, Chairman.
N. J. SIMMANCE, Acting Secretary.

PUBLIC SERVICE OF VICTORIA.

COMPETITIVE EXAMINATION FOR ADMISSION TO THE PUBLIC SERVICE (ADMINISTRATIVE DIVISION).

AN examination of male candidates for appointment to the Administrative Division of the Public Service of Victoria will be held on Saturday, the 19th August, 1961.

The examination is open to persons who have, or will, before the 31st January, 1962, have passed the School Leaving examination of the University of Melbourne or an equivalent examination, and who on the 19th August, 1961—

- (a) not being members of the Public Service are under 24 years of age; or
- (b) are temporary employees in the Public Service under 30 years of age; or
- (c) are officers of the Technical and General Division of the Public Service.

A candidate will be required to enter for competitive examination in the following subjects, viz.:—

- (1) English.
- (2) General Intelligence.

The English paper will include an essay, a test of comprehension which will include the requirements of a summary and a vocabulary test directed to requirements within the Public Service. In the essay, emphasis will be laid on clear thinking, sentence construction, spelling and punctuation.

In order to pass the examination, a candidate must obtain at least 50 per centum of the maximum number of marks in English and a scaled score of at least 95 in General Intelligence.

Appointments proposed to be made ..	150
Appointments reserved for officers of the Technical and General Division ..	20

Entries for the examination must be lodged at the Office of the Public Service Board, Public Offices, Treasury-place, Melbourne, C.2, (where the prescribed forms are obtainable) on or before Monday, the 31st July, 1961.

Reasonable facilities will be provided for candidates residing in country districts to sit for the examination in local centres.

By order,
N. J. SIMMANCE,
Acting Secretary.

Office of the Public Service Board,
Melbourne, 4th July, 1961.

PUBLIC SERVICE OF VICTORIA.

A COMPETITIVE examination of male and female candidates for appointment to the Professional Division of the Public Service of Victoria as Draughtsman or Draughtswoman will be held on Saturday, 19th August, 1961.

The examination is open to persons who, on the 19th August, 1961, are not less than 15 years of age and are under 24 years of age, and who have passed one of the following:—

- (a) The School Leaving examination, including English and any two of the following:— Mathematics A., Mathematics I., and Mathematics II., or
- (b) The School Intermediate examination, and, in addition, the School Leaving subjects of English and any two of the following:— Mathematics A., Mathematics I., and Mathematics II., or
- (c) An equivalent approved examination.

The subjects of the examination will be Practical Mathematics and Penmanship. To secure a pass a candidate must obtain at least 50 per centum of the marks allotted in each subject.

Practical Mathematics will be within the scope of School Leaving Mathematics A., I., and II., and will embrace simple problems in engineering, architecture and land surveying.

Penmanship will comprise the formation of letters and figures and the use of drawing instruments such as scale, set square, parallel ruler and protractor.

Entries for the examination must be lodged at the Office of the Public Service Board, Public Offices, Treasury-place, Melbourne, C.2 (where the prescribed forms are obtainable), on or before Monday, 31st July, 1961.

Reasonable facilities will be provided for candidates residing in country districts to sit for the examination in local centres.

By order,
N. J. SIMMANCE,
Acting Secretary.

Office of the Public Service Board,
Melbourne, 4th July, 1961.

PUBLIC SERVICE OF VICTORIA.

THE under-mentioned candidates passed in the order of merit indicated, the typing test at 42 words a minute held on 17th June, 1961:—

Order of Merit.	Candidate.
1 ..	McGraw, Marjorie Noelle
2 ..	Bowker, Heather Irene
3 ..	Herbert, Eunice Grace
4 ..	Jordon, Margaret Mary
5 ..	Neale, Joan Marjorie
6 ..	Talbot, Joy Patricia (Mrs.)
7 ..	Mansfield, Lynette Elisabeth
8 ..	Holschmacher, Ursula Ingeborg.
9 ..	Roberts, Margaret (Mrs.)
10 ..	Earl, Alice Doris (Mrs.)
11 ..	Webb, Elizabeth Grace (Mrs.)
12 ..	Whitley, Elva Blanche (Mrs.)
13 ..	Davis, Joan Maree (Mrs.)
14 ..	Kennedy, Maree
15 ..	McIntosh, Marlene Clarice
16 ..	Wessely, Edith (Mrs.)
17 ..	Cousins, Dorothy Anne
18 ..	Cummins, Carmel Patricia
19 ..	Duncan, Judith Lorraine
20 ..	Hall, Linda Jennifer
21 ..	Richards, Dianne Elizabeth
22 ..	Richardson, Agnes
23 ..	Courage, Linda Theresa
24 ..	Crouch, Olive Dawn
25 ..	Elliott, Valmai June
26 ..	Jackson, Marlene Ann
27 ..	Barlow, Elsie May (Mrs.)
28 ..	Brownbill, Janice Kathleen
29 ..	Cashen, Doris Muriel
30 ..	Forster, Letitia Joyce (Mrs.)
31 ..	Grainger, Kathleen Mary (Mrs.)
32 ..	Horwood, Barbara Nancy (Mrs.)
33 ..	Sinclair, Nellie Winifred
34 ..	Skinner, Frieda Marjorie (Mrs.)

By order,
N. J. SIMMANCE,
Acting Secretary.

Office of the Public Service Board,
Melbourne, 4th July, 1961.

EXAMINATION.—CLERKS OF COURTS.

NOTICE is hereby given that an examination of candidates desirous of qualifying for promotion to Class "C", Professional Division, as Clerk of Courts (Regulation 46, Public Service (Public Service Board Regulations)), will be held on Thursday and Friday, the 10th and 11th August, 1961, at the Law Courts, Melbourne.

Applications from officers desirous of being examined, addressed to the Secretary to the Public Service Board, Public Offices, Treasury Place, Melbourne, will be received up to Wednesday, the 2nd August, 1961.

By order,

N. J. SIMMANCE,

Acting Secretary.

Office of the Public Service Board,
Melbourne, 4th July, 1961.

TENDERS—PUBLIC WORKS DEPARTMENT

TENDERS will be received at this Department until TEN a.m. on the Tuesdays, and for the purposes, under mentioned.

Particulars may be learnt at the Department and also at places shown in parenthesis.

W.O. means Inspector of Works Office; P.S.—Police Station; T.S.—Technical School; H.E.S.—Higher Elementary School; S.S.—State School; H.S.—High School; C.S.—Consolidated School.

Tenders should be submitted on the Department's printed Tender Form. All tenders must be on a "Firm Tender" basis. The Board of Land and Works will not necessarily accept the lowest or any tender.

Tenders to be addressed to the Hon. the Commissioner of Public Works, and envelope containing tender to be marked "Tender for _____, closing _____".

NOTE.—No preliminary deposit is to be lodged with any tender, but a deposit in accordance with the prescribed Schedule, may be required from each successful tenderer.

Tuesday, 11th July, 1961.

Ararat.—Electrical installation in new Occupational Therapy Centre, Mental Hospital. (Second Amended Specification). (W.O., Ararat.)

Ballarat.—Supply of gas-heated drying cabinets, Teachers' College. (W.O., Ballarat.)

Bell Post Hill.—Electrical installation, additional four (4) L.T.C. class-rooms, &c., S.S. 4804. (W.O., Geelong; S.S., Bell Post Hill.)

Bell Post Hill.—Plenum heating in four additional class-rooms, S.S. 4804. (W.O., Geelong.)

Benalla.—Erection of brick Court House. (W.O., Benalla and Wangaratta.)

Benalla.—Electrical installation, Court House. (W.O., Benalla, Wangaratta, Shepparton.)

Benalla.—Air-conditioning and hot-water services and circulating fans, Court House. (W.O., Benalla.)

Benambra.—New out-offices and septic tank installations at school and residence, S.S. 1746. (W.O., Bairnsdale.)

Bundoora.—Replacement of existing heat exchangers, headers and pipe-work, Larundel Mental Hospital.

Camperdown.—Repairs and painting, Court House. (W.O., Camperdown; Court House, Camperdown.)

Coburg.—Supply and delivery of 24-in. stroke shaping machine and accessories, Pentridge Gaol.

Cudgewa.—Septic tank installations at school and residence, S.S. 1956. (W.O., Wangaratta; S.S., Cudgewa.)

Doveton.—Erection of two shelter pavilions and store, High School. (H.S., Doveton.)

Flemington.—Extensions in brick and concrete for fire escape stairway, Girls' Secondary School.

Frankston Forest.—Erection of two shelter pavilions, S.S. 4872.

Frankston.—Stainless steel benchwork for new residential section, Teachers' College.

Geelong.—Supply of 20 cubic feet refrigerator, Matthew Flinders Girls' Secondary School.

Healesville.—Alterations and additions, Installation of septic tank system, Court House. (Court House, Healesville.)

Horsham West.—Electrical installation in four (4) additional class-rooms, &c., S.S. 4697. (W.O., Horsham; S.S., Horsham West.)

Kew.—Supply of Mobile stainless steel food storage bins, Mental Hospital.

Leongatha.—Installation of sewerage, &c., S.S. 2981, Jeffrey-street. (W.O., Korumburra.)

Lockington.—New out-office block and sewerage treatment plant to school and two residences, Consolidated School. (W.O., Bendigo; C.S., Lockington.)

Mildura.—Supply of general furniture, Technical School.

Mont Park.—Supply and installation of lagging to existing condensate lines in laundry, alterations to pipework in Calorifier room and laundry, Larundel Mental Hospital.

Murrumbena.—Electrical installation, Police Station and residence. (Amended specification.)

Nhill.—Supply of 20 cubic feet refrigerator, High School.

North Brunswick.—Electrical installation, S.S. 3585.

Pinewood.—Erection of two shelter pavilions, S.S. 4874.

Port Melbourne.—Supply and delivery of fifty (50) only pneumatic tired, wooden handled, heavy duty concrete wheel-barrows, Public Works Department Depot. (Specifications to be submitted with tender.)

Queenscliff.—Supply and delivery of steel sheet piling (350 to 450 tons), Harbor, Public Works Department.

Rushworth.—Erection of six class-room primary school in concrete veneer, S.S. 1057. (W.O., Shepparton; S.S., Rushworth.)

St. Arnaud.—Electrical installation, Fisheries and Wildlife Department Office and residence. (W.O., Maryborough.)

Sale.—Domestic arts wing, concrete veneer, High School. (W.O., Traralgon; H.S., Sale.)

Sale.—Internal painting and painting front fence and garage, residence, 44 Lansdowne-street, S.S. 545. (W.O., Bairnsdale and Traralgon.)

Scoresby.—Septic tank installations at school and residence, &c., S.S. 1028. (S.S., Scoresby.)

Sebastopol.—Electrical installation, Girls' Technical School. (W.O., Ballarat.)

Snake Valley.—Erect out-office, woodshed block, and new toilet, residence, install septic tanks, S.S. 574. (W.O., Ballarat; S.S., Snake Valley.)

Stawell.—Electrical installation of new school of four (4) L.T.C. class-rooms, &c., S.S. 502. (W.O., Ararat and Horsham; P.S., Stawell.)

Sunbury.—Extension of staff kitchen, Mental Hospital. (Amended specification.)

Upper Yarra.—Supply and installation of an effluent pump for septic tank, High School.

Wallacedale North.—New out-offices and sanitary installation, S.S. 3332. (W.O., Warrnambool; S.S., Wallacedale North.)

Wonthaggi.—Remodelling of existing electrical wiring room, Technical School. (W.O., Korumburra.)

Tuesday, 18th July, 1961.

Axedale.—Provision of septic closet, Police Station. (W.O., Bendigo; P.S., Axedale.)

Ballarat.—Electrical installation for new dormitory and laundry, and additions to existing building, Female Teachers' Hostel, 1415 Sturt-street. (W.O., Ballarat; Teachers' College Hostel, 1415 Sturt-street, Ballarat.)

Balwyn North.—Internal renovations, S.S. 4638.

Bayswater.—Erection of two shelter pavilions and store-room, High School.

Bealiba.—Repairs and external painting, Court House. (W.O., Maryborough; Court House, Bealiba.)

Beechworth.—Supply of two steel frame buildings (hay sheds), Mental Hospital. (W.O., Wangaratta.)

Belmont.—Light asphalt paving, High School (W.O., Geelong.)

Benalla West.—Erection of two shelter pavilions, S.S. 4850. (W.O., Benalla; S.S., Benalla West.)

Blackburn South.—Repainting and re-fitting residence, installation of septic tank, High School. (H.S., Blackburn South.)

Boroondara.—New sanitary accommodation (Brick Toilet Block), S.S. 4724.

Braybrook.—Supply, delivery, installation and testing of liquid petroleum gas heating for portable class-rooms, Catholic School, corner of Riley-court and Athol-street.

Brookwood.—Supply and installation of an air heating unit to main workshop, Workshop Block, Forests Commission.

Coburg.—Roof repairs to "F" Division dormitory, Pentridge Gaol.

Cohuna.—Repairs and painting to residence at 2 Channel-street, Consolidated School. (W.O., Bendigo; C.S., Cohuna.)

Cranbourne.—Electrical installation, Police Station.

Ellinbank.—Supply and delivery and placing on site of 500 lb. capacity hydraulic hoist, Research Farm.

Flinders.—Purchase and removal of old Cable Station, Public Works Department.

Geelong.—Purchase and removal of two-storied brick building, corner of Fenwick and Little Malop streets, Public Offices. (W.O., Geelong.)

Geelong.—Purchase and removal of out-buildings at former Gordon Hostel, Public Offices, corner of Fenwick and Little Malop streets. (W.O., Geelong.)

Glen Waverley.—Erection of two shelter pavilions and storeroom, High School.

Golden Square.—Mechanical services, High School. (W.O., Bendigo.)

Great Western.—Erect out-office block, install septic tanks, S.S. 860 and residence. (Amended specification.) (W.O., Ararat; S.S., Great Western.)

Kew.—Supply of stainless steel food container, Mental Hospital.

Lakeside.—Erection of two shelter pavilions, S.S. 4882. (S.S., Lakeside.)

Macleod.—Erection of 2nd and 3rd sections, Technical School. (T.S., Macleod.)

Melbourne.—Supply and delivery of a mobile ice cream conservator, Teachers' College Hostel, "Warwillah", 572 St. Kilda-road.

Merrigum.—Internal and external renovations to residence and school, S.S. 1874. (W.O., Shepparton; P.S., Kyabram; S.S., Merrigum.)

Mildura South.—Additional out-offices for boys and girls, plus septic tank installation, S.S. 4389. (Amended specification.) (W.O., Mildura; S.S., Mildura South.)

Nathalia.—Internal and external renovations to main school building, H.E.S. 2060. (W.O., Shepparton; P.S., Echuca; H.E.S., Nathalia.)

Paynesville.—Purchase and removal of old residence and outbuildings, Public Works Department Slipway. (W.O., Bairnsdale.)

Romsey.—New sanitary accommodation at school and residence, S.S. 366. (W.O., Kyneton; S.S., Romsey.)

Rushworth.—Plenum heating in six class-room unit, S.S. 1057. (W.O., Shepparton.)

Rutherglen.—New High School Building. (W.O., Wangaratta; H.E.S., Rutherglen.)

Rutherglen.—Repairs and painting to residence, Research Station. (W.O., Wangaratta; Research Station, Rutherglen.)

Timor.—New toilet block to school and septic tanks to school and residence, S.S. 1207. (Amended specification.) (W.O., Maryborough; P.S., St. Arnaud; S.S., Timor.)

Traralgon.—Re-blocking, repairs to exterior concrete finish, internal and external painting residence, 56 Lafayette-street, S.S. 3584. (W.O., Traralgon.)

Wallup East.—Erect out-office, woodshed block, install septic closets, school and residence, S.S. 4640. (W.O., Horsham; S.S., Wallup East.)

Tuesday, 25th July, 1961.

Altona East.—Erection of concrete post and wire fencing, S.S. 4805. (S.S., Altona East.)

Aspendale.—Provision of septic tank system, S.S. 4193. (S.S., Aspendale.)

Avenel.—Septic tank installation, S.S. 8, and residence. (W.O., Alexandra; S.S., Avenel.)

Avoca Forest.—Removal of Wehla school buildings to Avoca Forest school site, S.S. 2014. (W.O., Maryborough.)

Ballarat.—External repairs and painting, residence, 12 Waller-avenue, Teachers' College. (W.O., Ballarat.)

Ballarat East.—Erection 3 additional class-rooms, High School. (W.O., Ballarat; H.S., Ballarat East.)

Beechworth.—Supply, delivery and fixing on site of new stainless steel washup benches for Wards F1, 2, 4, 5 and 12 of Mental Hospital. (W.O., Wangaratta; M.H., Beechworth.)

Benalla East.—Electrical installation four (4) additional L. T. C. class-rooms and new block of eight L.T.C. class-rooms, &c., S.S. 2256. (W.O., Benalla; S.S., Benalla East.)

Bethanga.—Purchase and removal of old school building, S.S. 1883. (W.O., Wangaratta.)

Casterton.—Erection of residence (Inspector of Works Type) High School. (W.O., Hamilton; High School, Casterton.)

Castlemaine.—Additional out-offices &c., High School. (W.O., Kyneton; High School, Castlemaine.)

Corryong.—Supply, delivery, installation and testing of liquid petroleum gas and central heating to new Manual Arts Wing and alterations to the existing "Bristol" Classroom Wing, High School. (W.O., Wangaratta.)

Cranbourne North.—Erection of two shelter pavilions, S.S. 4887.

Doncaster.—Erection of office, Police Station. (Police Station, Doncaster.)

Foster.—Conversion of cookery room to science room, High School. (Amended Specification.) (High School, Foster.)

Frankston.—Alterations to buildings for motor registration and licence testing purposes, Police Station. (Frankston Police Station.)

Haddon.—Erection of 16 ft. x 10 ft. shelter pavilion, S.S. 1076. (W.O., Ballarat; S.S. Haddon.)

Lake Bolac.—Erection of timber residence and "A" type Police Office, Police Station. (W.O., Ararat.)

Lilydale.—Supply and installation of central heating, Police Station, Castella-street.

Lucyvale.—Purchase and removal of old school buildings, S.S.3604. (W.O., Wangaratta.)

Lyndale.—Erection of two shelter pavilions and store, High School. (H.S., Lyndale.)

Macleod.—Electrical installation in stages 2 and 3, Technical School.

Manangatang.—Internal and external renovations, renewal of roof, repairs, &c., Consolidated School. (W.O., Swan Hill; C.S., Manangatang.)

Melbourne.—Installation of thermostatic fire alarms and fire Watchman's points, Parliament House.

Melbourne.—Installation of new main switchboard, distribution boards, sub-boards and sub-mains in Basement and Ground Floor, Parliament House. (Amended specification.)

Melbourne.—Alterations to existing heating system to suit remodelled tropical glasshouse, Royal Botanic Gardens, The Domain.

Melbourne.—Supply and installation of modifications to existing hot water system, Secondary Teachers' College Hostel, 19 Queens-road.

Meredith.—Erection of timber framed combined residence and "A" type office, Police Station (W.O., Geelong; Meredith Police Station.)

Ocean Grove.—Sewerage treatment plant installation, S.S. 3100. (W.O., Geelong; S.S., Ocean Grove.)

Roslyn.—Painting toilet block, Morrison Units and L.T.C. block, S.S. 4663. (W.O., Geelong and S.S., Roslyn.)

Rutherglen.—Supply and installation of Mechanical Services, High School. (W.O., Wangaratta.)

St. James.—Renovations and provision of septic closet, Police Station. (W.O., Benalla; P.S., St. James.)

Sale.—Electrical installation in modified Domestic Arts Wing, High School. (W.O., Bairnsdale.)

Sandringham.—Erection of Caretaker's residence, Technical School. (T.S., Sandringham.)

Sebastopol.—Supply, delivery, installation and testing of mechanical services, Girls' Technical School. (W.O., Ballarat.)

Seymour.—Purchase and removal of old class-room, S.S. 547. (W.O., Benalla; S.S., Seymour.)

Solway.—Supply, delivery and installation of oil firing equipment and alterations to existing heating, S.S. 4641.

Stawell.—Plenum heating in four class-room unit, S.S. 502. (W.O., Ballarat.)

Traralgon.—Erection of two shelter pavilions, S.S. 4700. (W.O., Traralgon.)

Werribee.—Repairs and painting to residence, Jellicoe-street, S.S. 649. (S.S., Werribee.) (Amended Specification.)

Werribee.—Remodelling and additions to toilet blocks at staff quarters, Research Farm. (Amended Specification.) (Research Farm, Werribee.)

Yarram.—Erection of timber framed residence, Fisheries and Wildlife Department. (W.O., Traralgon; P.S., Yarram.)

Tuesday, 1st August, 1961.

Yallourn.—Erection of trades block, Technical School. (W.O., Traralgon.)

T. K. MALTBY,

Commissioner of Public Works.

Public Works Department,
Melbourne, 4th July, 1961.

PRIVATE ADVERTISEMENTS

THE BALLARAT SEWERAGE AUTHORITY.

GENERAL NOTICE.

THE above-mentioned Sewerage Authority, having made provision for carrying off the sewage from each and every property which or any part of which is within the sewerage area hereinafter described, doth hereby declare that, on and after the 1st day of August, 1961, each and every property which, or any part of which, is within the said sewerage area shall be deemed to be a sewerage property within the meaning of the *Sewerage Districts Act 1958*.

The boundaries of the sewerage area hereinbefore referred to are:—

Sewerage Area No. 204.

Borough of Sebastopol.—Commencing at the south-west corner of No. 207 Albert-street being a point on the boundary of Sewerage Area No. 197; thence south-westerly to a point on the west building line of Albert-street about 310 feet south of Victoria-street, westerly about 150 feet by a line along a fence and prolongation thereof, north-westerly to a point on the eastern boundary of No. 7 Victoria-street being about 125 feet from Victoria-street

and about 172 feet from Albert-street, south-westerly to a point on the western boundary of No. 15 Victoria-street, northerly about 126 feet along the western boundary of the said No. 15 to the south building line of Victoria-street, north-westerly to the south-west corner of No. 16 Victoria-street, northerly to the north-west corner of the said No. 16, easterly to the south-west corner of No. 15 Birdwood-avenue, northerly along the western boundary of the said No. 15 to the south building line of Birdwood-avenue, northerly to the south-west corner of No. 140 Beverin-street, northerly to the north-west corner of No. 138 Beverin-street, westerly to the south-west corner of No. 136 Beverin-street, northerly to the south-east corner of No. 141 Spencer-street being a point on the boundary of Sewerage Area No. 190; thence northerly, generally easterly and southerly along the boundaries of Sewerage Areas Nos. 190, 189, 202 and 197 to the point of commencement.

Further particulars regarding the streets or parts of streets in which sewers have been laid may be ascertained on inquiry at the Authority's Office.

By order of the said Sewerage Authority.

14563 A. W. NICHOLSON, Chairman.
CHAS. H. CLAMP, Secretary.

GEELONG WATERWORKS AND SEWERAGE TRUST.

PURSUANT to section 60 (2) of the *Geelong Waterworks and Sewerage Act 1958*, (No. 6263), notice is hereby given of the intention of the Trust to construct sewers to provide for properties in and adjacent to:—

City of Geelong West.—Itkeston-street, Norwood-street, Kedleston-road and Bakewell-street, Joyce-parade, Matlock and Bakewell-streets, Minervaroad, Castleton-street;

City of Geelong.—Ormond-road;

City of Newtown and Chilwell.—Nicholas-street;

Shire of Corio.—Sheridan-street;

and more particularly as shown on maps which are open for inspection at the Trust's Offices, between the hours of 9 a.m. and 4 p.m. daily, from Monday to Friday inclusive.

Dated this 30th day of June, 1961.

14564 S. W. BIRRELL, Acting Secretary.

NOTICE is hereby given that the Numurkah Branch of the Country Women's Association of Victoria has applied for a lease, under section 134 of the *Land Act 1958*, for a term of 21 years from 1st September, 1961, of allotment 1, section 31, Township of Numurkah, containing 0 acres 0 roods 25 perches, as a site for a Hall and Rest Room. 14420

NOTICE is hereby given that Ansett Transport Industries Limited has applied for a lease under section 134 of the *Land Act 1958*, for a term of 65 years from 1st September, 1961, of allotments 12 and 13, section 1B, Parish of Doutta Galla, containing 12 acres 2 roods 16 perches for road transport depot and terminal, storage of goods and the assembly and maintenance of vehicles.

ALEXR. GRANT, DICKSON & KING, 119 William-street, Melbourne. 14580

CITY OF BROADMEADOWS.

BY-LAW No. 31.

A By-law of the City of Broadmeadows, made under section 65 of the *Health Act 1958*, as amended by the *Health (Amendment) Act 1960*, for fixing a fee for the examination of plans, specifications, particulars and descriptions of proposed septic tank systems, and any inspection of sites and installations.

IN pursuance of the powers of the *Health Act 1958* and of any and every other power it thereunto enabling, the Mayor, Councillors and Citizens of the City of Broadmeadows orders as follows:—

1. The following fee is hereby fixed for the examination of plans, specifications, particulars and descriptions of proposed septic tank systems, and any inspection of sites and installations of septic tank systems—Four pounds (£4).

The Resolution for passing this By-law was agreed to by the Council of the City of Broadmeadows on the 8th day of May, 1961, and confirmed on the 5th day of June, 1961.

In witness whereof the common seal of the Mayor, Councillors and Citizens of the City of Broadmeadows was hereunto affixed this 19th day of June, 1961, in the presence of—

(SEAL) COLIN B. SMITH, Mayor.
P. T. BRYANT, Councillor.
E. F. SMILEY, Town Clerk.

14550

CITY OF CAMBERWELL.

NOTICE is hereby given that the Council of the City of Camberwell has, under the provisions of the Local Government Acts, altered the name of the street as set forth in the subjoined schedule.

SCHEDULE.

New Name: Conway-crescent.

Old Name: Talbot-crescent.

Situation: Between Talbot-avenue and Northcote-avenue.

L. F. CHEFFERS, Chief Administrator.

Town Hall, Camberwell, 30th June, 1961. 14557

CITY OF COLAC.

BY-LAW No. 35.

Septic Tank Systems.

A By-law of the City of Colac, made under section 65 of the *Health Act 1958*, as amended by the *Health (Amendment) Act 1960*, for fixing a fee for the examination of plans, specifications, particulars and descriptions of proposed septic tank systems, and any inspection of sites and installations.

IN pursuance of the powers of the *Health Act 1958* and of any and every power it thereunto enabling, the Council of the City of Colac orders as follows:—

1. The following fee is hereby fixed:—

For the examination of plans, specifications, particulars and descriptions of proposed septic tank systems, and any inspection of sites and installations of septic tank systems—£2.

Resolution for passing this By-law was agreed to by the Council of the City of Colac on the 24th day of May, 1961, and confirmed on the 28th day of June, 1961.

The common seal of the Mayor, Councillors and Citizens of the City of Colac was hereunto affixed, in the presence of—

(SEAL) D. C. STALKER, Mayor.
L. G. ATYEO, Councillor.
F. M. KELLY, Town Clerk.

14588

CITY OF DANDENONG.

CHANGE OF STREET NAME.

NOTICE is hereby given that the Council of the City of Dandenong, at a meeting held on Monday, the 26th June, 1961, resolved that the following change of street name be made:—

Old Name: Park-road.

New Name: Box-street.

Description: Road and street shown on lodged plan No. 10380, between Plunkett-road and Claredale-road, as Plunkett-road, and known as Park-road.

14561 R. BOOTH, Town Clerk.

CITY OF MORDIALLOC.

BY-LAW No. 120.

A By-law of the City of Mordialloc, made under section 197 of the *Local Government Act 1958*, and numbered 120, for suppressing nuisances.

IN pursuance of the powers conferred by the *Local Government Act 1958* and of any and every other power it thereunto enabling, the Mayor, Councillors and Citizens of the City of Mordialloc order as follows:—

1. No person shall in any premises, between the hours of 10 p.m. to 6 a.m., use or work any machinery in such manner as to produce any objectionable noise audible to persons outside such premises.

2. This By-law shall apply to and have operation throughout the whole of the municipal district.

Resolution for passing this By-law was agreed to by the Council of the City of Mordialloc on the 10th day of April, 1961, and confirmed on the 22nd day of May, 1961.

The common seal of the Mayor, Councillors and Citizens of the City of Mordialloc was hereunto affixed, in the presence of—

(SEAL) ALLAN McLEAN, Mayor.
D. C. DENYER, Councillor.
J. GRUT, Town Clerk.

14589

CITY OF SANDRINGHAM.

BY-LAW No. 191.

A By-law of the City of Sandringham, made under sections 197 and 228 of the Local Government Acts, and numbered 191, for altering By-law No. 163, which amends By-law No. 127.

IN pursuance of the powers conferred by the Local Government Acts, and every other power thereunto it enabling the Mayor, Councillors and Citizens of the City of Sandringham with the approval of the Governor in Council hereby order as follows:—

1. The words and figures 286 ft. 11½ in. are substituted for the words and figures 236 ft. 11½ in. which appear in clause 2 of By-law 163.

Resolution for passing this By-law agreed to by the Council on the 4th day of October, 1960, and confirmed on the 2nd day of November, 1960.

The common seal of the Mayor, Councillors and Citizens of the City of Sandringham was hereto affixed the 2nd day of November, 1960, in the presence of—

(SEAL) W. JOHNSON, Mayor.
THOS. I. DUFF, Councillor.
FRED G. TRICKS, Town Clerk.

Approved by the Governor in Council this 16th day of May, 1961.—A. MAHLSTEDT, Clerk of the Executive Council.
14558

CITY OF SUNSHINE.

LOAN No. 40.

Notice of Intention to Borrow the Sum of £25,000 for Permanent Works and Undertakings.

NOTICE is hereby given that the Council of the City of Sunshine proposes to borrow the sum of Twenty-five thousand pounds on the credit of the municipal revenues of the Mayor, Councillors and Citizens of the said City, such sum to be raised by the grant of a mortgage in accordance with the provisions of the *Local Government Act 1958*.

1. The maximum rate of interest that may be paid is £5 17s. 6d. per cent. per annum.

2. The purpose for which the loan is to be applied is—

- (a) construction of Suffolk-street, Maidstone;
- (b) widening of shoulders of Devonshire-road, Sunshine;
- (c) construction of Furlong-road, North Sunshine.

3. The period of the loan shall be ten years.

4. The moneys borrowed shall be repayable by providing out of the municipal fund twenty half-yearly instalments of approximately £1,670 14s. during the currency of the loan. The first instalment shall be payable on the 1st day of March, 1962.

5. Such moneys shall be repayable at The State Savings Bank of Victoria, Melbourne.

The plans and specifications and the estimate of the cost of the proposed works, and a statement showing the proposed expenditure of the moneys to be borrowed, are open for inspection at the Town Hall, Sunshine.

14555 T. W. DEUTSCHMANN, Town Clerk.

CITY OF WAVERLEY.

NAME OF ROAD CHANGED.

IN accordance with the provisions of the *Local Government Act 1958*, notice is hereby given that the north-south section of Ricketts-road, Notting Hill, has been changed to Gilbey-street.

By order of the Council,

14549 F. S. BALES, Town Clerk.

TOWN OF PORTLAND.

BY-LAW No. 81.

A By-law of the Town of Portland, made under section 65 of the *Health Act 1958*, as amended by the *Health (Amendment) Act 1960*, for fixing a fee for the examination of plans, specifications, particulars and descriptions of proposed septic tank systems, and any inspection of sites and installations.

IN pursuance of the powers of the *Health Act 1958* and of any and every other power it thereunto enabling, the Council of the Town of Portland orders as follows:—

1. The following fee is hereby fixed:—

For the examination of plans, specifications, particulars and descriptions of proposed septic tank systems, and any inspection of sites and installations of septic tank systems—£1.

Resolution for passing this By-law was agreed to by the Council of the Town of Portland on the 6th day of June, 1961, and confirmed on the 20th day of June, 1961.

The common seal of the Mayor, Councillors and Burgesses of the Town of Portland was hereto affixed, in the presence of—

(SEAL) A. G. NICOL, Mayor.
14565 T. P. DUFTY, Councillor.
M. D. ALLARDICE, Acting Town Clerk.

SHIRE OF ALTONA.

SPECIAL ORDER.

Loan No. 20—£90,000—Private Streets Construction.

NOTICE is hereby given that the Council of the Shire of Altona has made a Special Order by adoption on 30th May, 1961, and confirmation on 27th June, 1961, of the following Resolution:—

"That the Council of the Shire of Altona borrows the sum of £90,000 on the credit of the municipal revenues of the President, Councillors and Ratepayers of the said shire, by the grant of a mortgage under the provisions of the *Local Government Act*.

1. The maximum rate of interest to be paid is £5 17s. 6d. per centum per annum.

2. The period of the Loan shall be ten years and such moneys shall be repayable at the Commonwealth Trading Bank of Australia, Williamstown, or at the Council's bankers for the time being in Melbourne.

3. The purpose of the Loan is for construction of private streets, £90,000.

4. The moneys borrowed shall be repayable by providing out of the municipal fund £3,612 15s. 9d. annually for ten years, to be invested in accordance with the said Act to form a sinking fund and interest to be paid half-yearly during the currency of the Loan".

14576 JAMES W. WATERS, Shire Secretary.

SHIRE OF AVOCA.

BY-LAW No. 26.

NOTICE is hereby given that the Council of the Shire of Avoca has made a By-law, No. 26, for the purpose of fixing a fee of £1 for the examination of plans, specifications, particulars and descriptions of proposed septic tank systems, and any inspections of sites and installations of septic tank systems.

A copy of the said By-law is available for inspection, free of charge, during office hours, at the Shire Office, Avoca.

14548 F. C. S. EDWARDS, Shire Secretary.

SHIRE OF DONCASTER AND TEMPLESTOWE.

LOAN No. 48.

Notice of Intention to Borrow the Sum of £44,500 for Permanent Works and Undertakings.

NOTICE is hereby given that the Council of the Shire of Doncaster and Templestowe proposes to borrow the sum of Forty-four thousand five hundred pounds (£44,500), on the credit of the municipal revenue of the President, Councillors and Ratepayers of the said Shire, such sum to be raised by the granting of a mortgage deed, in accordance with the provisions of the *Local Government Acts*.

1. The maximum rate of interest that may be paid is £5 17s. 6d. per centum per annum and shall be paid on the 1st day of February and the 1st day of August during the currency of the loan; the first payment shall be made on the 1st day of February, 1962.

2. The purposes for which the loan is to be applied are the following:—

- (i) Meters and time switches and metering equipment.
- (ii) Installation of new bulk supply station and systems.
- (iii) Installations of high tension reticulations.
- (iv) Installation of sub-stations.
- (v) Installation of protective switchgear.
- (vi) Installation of lightning protection.
- (vii) Installation of low tension mains.
- (viii) Plant purchase.
- (ix) Installation of additional circuit breaker, underground cable and out-going feeder circuit at W.D. Terminal—£44,500.

3. The period of the loan shall be eighteen years.

4. The loan shall be liquidated by investing from the municipal funds the sum of One thousand six hundred and fifty-seven pounds and ten pence per annum to form a sinking fund, pursuant to section 420 (1) (a) and (b) of the *Local Government Act 1958*.

5. Payments of principal and interest shall be made at The English, Scottish and Australian Bank Limited, Melbourne, or at the Council's bankers for the time being in Melbourne.

The plans, specifications and estimate of cost of the proposed works, and the statement showing the proposed expenditure of moneys to be borrowed, are open for inspection at the Municipal Offices, Doncaster.

14577 J. W. THOMSON, Shire Secretary.

SHIRE OF FRANKSTON.

By-LAW No. 103.

A By-law of the Shire of Frankston, made under section 65 of the *Health Act 1958*, as amended by the *Health (Amendment) Act 1960*, and numbered 103, for fixing a fee for the examination of plans, specifications, particulars and descriptions of proposed septic tank systems, and any inspection of sites and installations.

THE President, Councillors and Ratepayers of the Shire of Frankston, in pursuance of the powers conferred by the *Health Act 1958* and of any and every other power enabling in that behalf, order as follows:—

The following fee is hereby fixed:—

For the examination of plans, specifications, particulars and descriptions of proposed septic tank systems, and any inspection of sites and installations of septic tank systems—£4.

Resolution for passing this By-law agreed to by the Council of the Shire of Frankston on the 22nd day of May, 1961. Confirmed on the 26th day of June, 1961.

The common seal of the President, Councillors and Ratepayers of the Shire of Frankston was hereto affixed, in the presence of—

(SEAL) J. F. BOWES, President.
H. T. A. TAYLOR, Councillor.
14554 G. C. PENTLAND, Shire Secretary.

SHIRE OF METCALFE.

By-LAW No. 39.

A By-law of the Shire of Metcalfe, made under section 65 of the *Health Act 1958*, as amended by the *Health (Amendment) Act 1960*, for fixing a fee for the examination of plans, specifications, particulars and descriptions of proposed septic tank systems, and any inspection of sites and installations.

IN pursuance of the powers of the *Health Act 1958* and of any and every power it thereto enabling, the Council of the Shire of Metcalfe orders as follow:—

1. The following fee is hereby fixed:—

For examination of plans, specifications, particulars and descriptions of proposed septic tank systems, and any inspection of sites and installations of septic tank systems—One pound.

Resolution for passing this By-law was agreed to by the Council of the Shire of Metcalfe on the 28th day of February, 1961, and confirmed on the 28th day of March, 1961.

The common seal of the President, Councillors and Ratepayers of the Shire of Metcalfe was hereunto affixed, in the presence of—

(SEAL) F. D. PENNO, President.
IAN CAMPBELL, Councillor.
14566 W. T. HUTCHESON, Secretary.

SHIRE OF OXLEY.

Water Acts.

PROPOSED MOYHU WATERWORKS TRUST.

NOTICE is hereby given that the Oxley Shire Council has made application to the Honorable the Minister of Water Supply for the constitution of a Waterworks Trust, and for the proclamation of a Waterworks District at Moyhu, and the construction, maintenance and continuance of Water Supply Works within that district under the provisions of the Water Acts.

A general plan and description of the proposed works have been submitted with the application and copies of same may be seen at the Shire of Oxley Office, Reid-street, Wangaratta.

Dated at Wangaratta, the 21st day of June, 1961.

14479 D. REID, Shire Secretary.

SHIRE OF TULLAROOP.

By-LAW No. 21.

A By-law of the Shire of Tullaroop, made under section 65 of the *Health Act 1958*, as amended by the *Health (Amendment) Act 1960*, for fixing a fee for the

examination of plans, specifications, particulars and descriptions of proposed septic tank systems, and any inspections of sites and installations.

IN pursuance of the powers of the *Health Act 1958* and of any and every other power it thereto enabling, the Council of the Shire of Tullaroop orders as follows:—

1. The following fee is hereby fixed:—

For the examination of plans, specifications, particulars and descriptions of proposed septic tank systems, and any inspection of sites and installations of septic tank systems—£1.

The Resolution for passing this By-law was agreed to by the Council of the Shire of Tullaroop on the 11th day of April, 1961, and was confirmed on the 9th day of May, 1961.

The corporate seal of the Council of the Shire of Tullaroop was hereunto affixed, in the presence of—

(SEAL) F. F. ROBERTSON, President.
W. H. FREEMANTLE, Councillor.
14551 J. B. OGLE, Secretary.

SHIRE OF WARRACKNABEAL.

By-LAW No. 54.

A By-law of the Shire of Warracknabeal, made under section 65 of the *Health Act 1958*, as amended by the *Health (Amendment) Act 1960*, for fixing a fee for the examination of plans, specifications, particulars and descriptions of proposed septic tank systems, and any inspection of sites and installations.

IN pursuance of the powers of the *Health Act 1958* and of any and every other power it thereto enabling, the Council of the Shire of Warracknabeal order as follows:—

1. The following fee is hereby fixed:—

For the examination of plans, specifications, particulars and descriptions of proposed septic tank systems, and any inspection of sites and installations of septic tank systems—£2 10s.

Resolution for passing this By-law was agreed to by the Council of the Shire of Warracknabeal on the 19th day of May, 1961, and confirmed on the 23rd day of June, 1961.

The common seal of the President, Councillors and Ratepayers of the Shire of Warracknabeal was hereunto affixed, in the presence of—

(SEAL) W. F. WOODWARD, President.
MILES BOURKE, Councillor.
14552 S. FELL, Shire Secretary.

Town and Country Planning Act 1958, as Amended.

SHIRE OF WOORAYL.

INTERIM DEVELOPMENT ORDER.

Notice of Approval.

IN pursuance of the powers conferred by the *Town and Country Planning Act 1958*, as amended, the Administrator of the Government of the State of Victoria, by and with the advice of the Executive Council thereof, having taken into consideration a report of the Town and Country Planning Board, on the 4th day of July, 1961, approved an Interim Development Order by the Council of the Shire of Woorayl.

The Interim Development Order provides that the use or development of all that part of the Shire of Woorayl excepting the areas included in the Waratah Bay Planning Scheme and the erection, construction and carrying out of any buildings or other works thereon including the removal of trees in certain areas is prohibited except that the responsible authority may permit such uses, development, erection, constructions or other works as provided in the order.

A copy of the Interim Development Order and a map showing the areas affected may be inspected, free of charge, at the office of the Council of the Shire of Woorayl, at Leongatha, and at the office of the Town and Country Planning Board, 61 Spring-street, Melbourne.

14624 K. BRYDON, Acting Shire Secretary.

NOTICE is hereby given that the partnership previously subsisting between Sidney Bond Seymour, of 129 William-street, Melbourne, and Alan John Robinson, formerly of 129 William-street, Melbourne, but now of 465 Collins-street, Melbourne, in the practice of solicitors, under the firm name of "Williams and Matthews", at 129 William-street, Melbourne, was dissolved as at the 25th day of March, 1960.

14602

WE, Kenneth Alfred Evans, of 157 Bluff-road, Sandringham, and John David Evans, of 92 Grange-road, Toorak, hereby give notice that on the 30th day of June, 1961, the partnership between us in the legal practices carried on under the names or styles of Evans, Caradoc, Evans and Co., and K. A. Evans, was dissolved and that from such date the assets and liabilities of the legal practices conducted under the name Evans, Caradoc, Evans and Co., at 406 Lonsdale-street, Melbourne, 101 Main-street, Mornington, and High-street, Hastings, shall be under the sole ownership and be the sole responsibility respectively of the said John David Evans, and that from such date the assets and liabilities of the legal practice conducted under the name K. A. Evans, at 123 William-street, Melbourne, shall be under the sole ownership and be the sole responsibility respectively of the said Kenneth Alfred Evans.

Dated this 30th day of June, 1961.

14556

K. A. EVANS.
JOHN D. EVANS.

NOTICE is hereby given that the partnership heretofore subsisting between William Edward Stevenson and Dorothy May Stevenson, carrying on business as service station proprietors, at the corner of South-road and Nepean Highway, Moorabbin, under the firm name of W. E. and D. M. Stevenson, has been dissolved by mutual consent.

ADAMS & GARDE, solicitors, 959 Nepean Highway, Moorabbin, 14570

NOTICE is hereby given that the partnership heretofore subsisting between Peter Kirby and Maurice Clark, carrying on business as medical practitioners, at High-street, Kangaroo Flat, and at 98 Mitchell-street, Bendigo, under the style or firm of Dr. P. Kirby and Dr. M. Clark, has been dissolved as from 30th June, 1961, so far as concerns the said Maurice Clark. All debts due and owing by the said firm shall be received and paid by Peter Kirby, who will continue to carry on the business at High-street, Kangaroo Flat.

PETER KIRBY.
MAURICE CLARK.

HOGAN & HOGAN, solicitors, 68 Bull-street, Bendigo, 14559

The Companies Act 1958.—In the matter of J. and V. NICHOLLS PROPRIETARY LIMITED (in Liquidation).

NOTICE is hereby given that a First Dividend is intended to be declared in this matter. Creditors who have not proved their debts by the 20th July, 1961, will be excluded from the dividend.

Dated this 29th day of June, 1961.

E. R. SMAIL, Liquidator.

Kennedy, Smail and Middlemiss, 31 Queen-street, Melbourne, 14621

The Companies Act 1958.—In the matter of DAVID ANDERSON (NEWMARKET) PROPRIETARY LIMITED (in Liquidation).

NOTICE is hereby given that, pursuant to section 210 of the Companies Act 1958, a Final Meeting of the Creditors of the above company will be held at the offices of Kennedy, Smail and Middlemiss, 31 Queen-street, Melbourne, on Wednesday, 2nd August, 1961, at 10.00 a.m.

Business: To receive Liquidator's accounts.

Dated this 5th day of July, 1961.

E. R. SMAIL, Liquidator.

Kennedy, Smail and Middlemiss, 31 Queen-street, Melbourne, 14623

Companies Act 1958.—In the matter of MULTICASTERS PTY. LTD., of 85 Cambro-avenue, Clayton, and in the matter of the Companies Act 1958.

NOTICE is hereby given that, pursuant to section 201 that a Meeting of Creditors of the above-named company will be held at the office of Irwin, Widdows and Coakley, 4th Floor, 366 Bourke-street, Melbourne, on Wednesday, the 12th day of July, 1961, at 10.30 a.m. for the purposes set out in sections 201, 202 and 203 of the above Act.

By order of the Board,

E. BROWN, Director.

Dated this 27th day of June, 1961.

R. D. Widdows, public accountant, 366 Bourke-street, Melbourne, 14620

Companies Act 1958.

WANTIRNA SOUTH FRUIT PULPING CO-OPERATIVE LIMITED (IN LIQUIDATION).

NOTICE OF FINAL MEETING.

NOTICE is hereby given that, pursuant to section 210 of the above-named Act, a General Meeting of the members of the above-named company will be held at the offices of T. A. Stewart and Son, 34 Queen-street, Melbourne, on the 7th day of August, 1961, at 11.00 o'clock in the forenoon, for the purpose of having an account laid before them showing the manner in which the winding up has been conducted and the property of the company disposed of, and of hearing any explanation of the aforesaid account that may be given by the liquidator.

Dated this 23rd day of June, 1961.

14617

W. A. STEWART, Liquidator.

Companies Act 1958.—In the matter of RON CHARLTON WHOLESALERS PROPRIETARY LIMITED, of 15 Flinders-lane, Melbourne, and in the matter of the Companies Act 1958.

NOTICE is hereby given that, pursuant to section 201, a Meeting of Creditors of the above-named company will be held at the office of Irwin, Widdows and Coakley, 4th Floor, 366 Bourke-street, Melbourne, on Monday, the 17th day of July, 1961, at 10.30 o'clock in the forenoon, for the purposes set out in sections 201, 202 and 203 of the above Act.

By order of the Board,

R. G. CHARLTON, Director.

Dated this 29th June, 1961.

R. D. Widdows, public accountant, 366 Bourke-street, Melbourne, 14616

Companies Act 1958.

SAXON ENGINEERING & METAL CO. (1954) PROPRIETARY LIMITED (IN VOLUNTARY LIQUIDATION).

NOTICE is hereby given that pursuant to section 210 of the Companies Act 1958, a meeting of the members of the above-named company will be held at 280 Church-street, Richmond, on Wednesday, the 9th day of August, 1961, at Three o'clock p.m., for the purpose of having an account laid before them showing how the winding up of the company has been conducted and the property of the company disposed of.

Dated this 28th day of June, 1961.

K. L. PAROISSIEN, Liquidator.

280 Church-street, Richmond, E.I. 14601

The Companies Act 1958.

IVORY SEPTIC INSTALLATION SERVICE PTY. LTD.

PURSUANT TO SECTION 201 OF THE COMPANIES ACT 1958.

NOTICE is hereby given that a meeting of creditors of Ivory Septic Installation Service Pty. Ltd., will be held at the office of Hall and Rose, chartered accountants, 163 William-street, Melbourne, on Friday, the 7th day of July, 1961, at 10.30 a.m. in the forenoon, for the purpose of considering the company's affairs, the company having convened an Extraordinary General Meeting of its members to be held on the same day, and for the purposes of considering, and if thought fit, passing a Special Resolution that the company be wound up voluntarily.

Dated this 29th day of June, 1961.

14595

F. E. IVORY, Director.

COGHILL & SON PROPRIETARY LIMITED, of 267 Collins-street, Melbourne, a company incorporated under the provisions of the Companies Act 1938, hereby gives notice that by a Special Resolution passed by the members of the company on the 23rd day of June, 1961, it was resolved that the company be wound up voluntarily.

COLTMAN, WYATT & ANDERSON, solicitors, 578 Bourke-street, Melbourne, 14592

The Companies Act 1958.—In the matter of VANGUARD MOTORS MORWELL PTY. LTD. (in Voluntary Liquidation).

NOTICE is hereby given that a Second and Final Dividend is intended to be declared in this matter. Creditors who have not proved their debt by 19th July, 1961, will be excluded from the dividend.

Dated this 5th day of July, 1961.

14614

C. G. LANDY, Liquidator.

In the Supreme Court of Victoria.—In the matter of Part VI. of the *Companies Act 1958* and in the matter of S. and N. LEIGH PROPRIETARY LIMITED.

NOTICE is hereby given that a petition for the winding up of the above-named company by the Supreme Court was, on the 14th day of June, 1961, presented to the said Court by Tomasetti and Son Proprietary Limited. And that the said petition is directed to be heard before the Court sitting at Melbourne on the 27th day of July, 1961; and any creditors or contributory of the said company desirous to support or oppose the making of an order on the said petition may appear at the time of hearing by himself or his counsel for that purpose; and a copy of the petition will be furnished to any creditor or contributory of the said company requiring the same by the undersigned on payment of the regulated charge for the same. The petitioner's address is 279 Flinders-lane, Melbourne. The petitioner's solicitors are Norris, Coates and Hearle, of 422 Collins-street, Melbourne.

NORRIS, COATES & HEARLE.

NOTE.—Any person who intends to appear on the hearing of the said petition must serve on or send by post to the above-named solicitors, notice in writing of his intention so to do. The notice must state the name and address of the person, or, if a firm, the name and address of the firm, and must be signed by the person or firm, or his or their solicitor (if any) and must be served, or, if posted, must be sent by post in sufficient time to reach the above-named not later than Four o'clock in the afternoon of the 26th day of July, 1961.

The *Companies Act 1958*.

383 GILBERT ROAD PTY. LIMITED.

NOTICE OF MEETING OF CREDITORS, PURSUANT TO SECTION 201.

NOTICE is hereby given, pursuant to section 201 of the *Companies Act 1958*, that a meeting of the creditors of the above-named company will be held on the 2nd floor, 99 Queen-street, Melbourne, on Friday, the 7th day of July, 1961, at 10.30 o'clock in the forenoon, for the purposes mentioned in sections 202 and 203 of the said Act.

Dated this 3rd day of July, 1961.

By order of the Board,

14609

A. W. GUDGEON, Secretary.

In the matter of BILLY GRAHAM CRUSADE (MELBOURNE).

AT an Extraordinary General Meeting of the above-named company held at the St. Paul's Cathedral Buildings, Council Chamber, 2nd floor, Melbourne, at 4.30 p.m., on Friday, the 30th day of June, 1961, the following Resolution was passed as a Special Resolution:—

"That the company be wound up voluntarily and that Sydney Spencer Wallis, of 128 William-street, Melbourne, chartered accountant, be appointed liquidator for the purpose of the winding up of the company."

Dated this 1st day of July, 1961.

14607

JOHN ROBINSON, Secretary.

The *Companies Act 1958*.—In the matter of DEMO DISTRIBUTORS PROPRIETARY LIMITED, of 605 Lonsdale-street, Melbourne.—Notice *Re* Meeting of Creditors, pursuant to section 201 (2).

NOTICE is hereby given that a meeting of creditors of the above-named company will be held in the offices of Kennedy, Smail and Middlemiss, Lower Ground Floor, 31 Queen-street, Melbourne, on Friday, the 7th day of July, 1961, at Eleven a.m., the company having convened a meeting of its members for the same day for the purpose of considering a Resolution that the company be wound up voluntarily.

Dated this 29th day of June, 1961.

H. J. WEBSTER, Director.

Kennedy, Smail and Middlemiss, 31 Queen-street, Melbourne, C.1. 14615

CHAS. H. PAY PROPRIETARY LIMITED.

SPECIAL RESOLUTION TO WIND UP, PURSUANT TO SECTION 195.

AT an Extraordinary General Meeting of the above-named company, duly convened and held at 47 Norville-street, East Bentleigh, on the 28th day of June, 1961, the following Resolution was duly passed as a Special Resolution:—

"That the company be wound up voluntarily."

And at such last-mentioned meeting Charles William Pay, of 47 Norville-street, East Bentleigh, was appointed liquidator for the purpose of the winding up.

Dated this 28th day of June, 1961.

14571

CHAS. W. PAY, Chairman.

The *Companies Act 1958*.—In the matter of KAMAC INDUSTRIES PROPRIETARY LIMITED (in Voluntary Liquidation).

NOTICE is hereby given that at an Extraordinary Meeting of the members of the above-named company held on Wednesday, 14th day of June, 1961, it was resolved that the company be wound up voluntarily, and at a meeting of creditors held on the same day, pursuant to section 201, it was resolved that for such purpose Edward Ronald Smail, of 31 Queen-street, Melbourne, chartered accountant, be appointed liquidator. Notice is also given that after 21 days from this date I shall proceed to distribute the assets. All creditors having any claims against the company should furnish particulars of same by that date, otherwise I shall proceed to distribute the assets without regard to their claim.

Dated this 30th day of June, 1961.

E. R. SMAIL, Liquidator.

Kennedy, Smail and Middlemiss, 31 Queen-street, Melbourne. 14613

No. of Company 15619.

THANET ASSETS PROPRIETARY LIMITED.

NOTICE OF MEMBERS' VOLUNTARY WINDING UP OF A COMPANY REGISTERED UNDER THE COMPANIES ACT 1958.

Special Resolution.

AT an Extraordinary General Meeting of Members of Thanet Assets Proprietary Limited, duly convened and held at 422 Little Collins-street, Melbourne, on the 30th day of June, 1961, the following Special Resolution was duly passed:—

"That the company be wound up voluntarily under the provisions of the *Companies Act 1958*."

Walter Summerton, of 422 Little Collins-street, Melbourne, was duly appointed liquidator.

D. M. A. MCKENZIE, Chairman of Directors, 14575 Thanet Assets Proprietary Limited.

TRUSTEE ACT 1958.

CREDITORS, next of kin, and others having claims against any of the estates specified below, are required to send particulars in writing of such claims to the personal representatives of such estate in care of Morrison and Teare, solicitors, Numurkah, on or before 4th September, 1961, after which date the assets of the estate will be conveyed or distributed among the persons entitled thereto, having regard only to the claims to which the representatives shall then have had notice:—

Albert Edward Lawrence, late of Numurkah, retired farmer, deceased, died 14th August, 1960.

Margaret Rosina Lawrence, late of Numurkah, married woman, deceased, died 14th June, 1960.

William Thomas, late of Numurkah, retired farmer, deceased, died 19th January, 1961.

Roscor William Breen, late of Yarroweyah, dairy farmer, deceased, died 8th January, 1961.

John George Miller, late of Numurkah, farmer, deceased, died 21st December, 1960.

Walter Isaac Fowler, late of Katamatite, retired farmer, deceased, died 16th September, 1960.

Alvena Martin, late of Waai, widow, deceased, died 4th January, 1961.

John Smith, late of Strathmerton, labourer, deceased, died 31st August, 1960.

Frank Stevenson, late of 7 Prospect-street, Glenroy, pensioner, deceased, died 23rd December, 1960.

Sidney Harry Scott, late of Cobram, retired orchardist, deceased, died 9th May, 1960.

Rose Hatty, late of Numurkah, spinster, deceased, died 9th November, 1960.

Hector McLennan, late of 1 Lightfoot-street, Shepparton, retired farmer, deceased, died 11th June, 1960.

Elvie Mavis Thomas, late of Numurkah, married woman, deceased, died 30th June, 1960.

Thomas Caleb Southon, late of Katunga, retired farmer, deceased, died 1st January, 1961.

14553

M. A. RETALLICK.

CREDITORS, next of kin and others having claims in respect of the estate of Archibald George Hudson, late of Camperdown, agent, deceased (who died on the 5th February, 1961), are required to send particulars of their claims to the executor, care of the under-mentioned solicitors, by the 31st day of August, 1961, after which date the said executor will distribute the assets, having regard only to the claims of which he then has notice.

ARTHUR E. GEORGE & SONS, solicitors, Manifold-street, Camperdown. 14545

CREDITORS, next of kin, and others having claims against the estate of Henry Irving Pascoe, late of 240 Humfray-street north, Ballarat East, agent, deceased (who died on the 29th day of September, 1960), are requested to send particulars of their claims to the executor, Ord Howard Glenn, of 9 St. Aidans-drive, Ballarat, solicitor, by the 8th day of September, 1961, after which date the executor will distribute the assets, having regard only to the claims of which he then has notice.

NEVETT, GLENN & TINNEY, solicitors, 205 Dana-street, Ballarat. 14562

CREDITORS, next of kin, and others having claims in respect of the estate of William Ernest Norris, formerly of 291 McIntyre-street, Long Gully, Bendigo, but late of 18 Mount Korong-road, Bendigo, in the State of Victoria, cartage contractor, deceased (who died on the 3rd day of December, 1960), are to send the particulars of their claims to National Trustees, Executors and Agency Company of Australasia Limited, (Farmers and Citizens Division), of Charing Cross, Bendigo, by the 6th day of September, 1961, after which date it will distribute the assets, having regard only to the claims of which it then has notice.

Dated the 29th day of June, 1961.

WATSON, JAMES & ROGERS, of Bull-street, Bendigo, solicitors for the executor. 14560

FLORENCE MAUD BAIN, late of 278 St. Georges-road, Northcote, married woman, DECEASED.

CREDITORS, next of kin and others having claims in respect of the estate of the above-named deceased (who died on the 25th day of August, 1960) are required, by Francis John O'Connor, of 28 Flinders-street, Mentone, solicitor, the executor of the said deceased, to send particulars to the executor, care of Norman C. Phillips, of 732 High-street, Thornbury, by the 29th day of August, 1961, after which date the executor may convey or distribute the assets of the estate, having regard only to the claims of which he then has notice.

Dated the 29th day of June, 1961.

NORMAN C. PHILLIPS, solicitor, 732 High-street, Thornbury. 14546

IRENE MORVA PORCH, late of 29 Mercer-street, Malvern, spinster, DECEASED, intestate.

CREDITORS, next of kin and all other persons having claims against the estate are required by the administrator, Ivor James Porch, to send particulars of their claims to the said administrator, care of the undersigned solicitors, on or before the 15th day of September, 1961, after which date the administrator will distribute the assets, having regard only to the claims of which he then has notice.

GRAY, FRIEND & LONG, solicitors, Warragul. 14547

CREDITORS, next of kin, and others having claims in respect of the estate of Honora McCallum, formerly of 9 Craddock-avenue, Caulfield, but late of 4 Elizabeth-street, East Brighton, widow, deceased (who died on the 11th of May, 1960), are hereby required to send particulars of such claims, in writing, to August William Tonn and Agnes Tonn, care of Molomby and Molomby, solicitors, 99 Queen-street, Melbourne, on or before the 15th September, 1961, after which date they will proceed to distribute the assets of the said deceased which shall have come to their hands among the persons entitled thereto, having regard only to the claims of which they then shall have had notice.

MOLOMBY & MOLOMBY, 99 Queen-street, Melbourne, solicitors. 14598

CREDITORS, next of kin, and others having claims in respect of the estate of Albert Edward Harvey, formerly of 975 Mount Alexander-road, Essendon, and of Warragul, but late of 14 Combermere-street, Essendon, gentleman, deceased (who died on the 20th day of September, 1960), are to send particulars of their claims to the executors, Edward Lawrence Knyvett and Norman Walter McDonald, care of their solicitors, whose name and address is set out below, by the 29th day of August, 1961, after which date the executors will distribute the assets, having regard only to the claims of which they then have notice.

H. S. W. LAWSON, HUGHES & CO., 357 Little Collins-street, Melbourne, solicitors. 14597

ARCHIBALD FREDERICK SOUTHGATE, DECEASED.

PURSUANT to the *Trustee Act 1928*, notice is hereby given that all persons having claims against the estate of Archibald Frederick Southgate, late of Beaconsfield, in the State of Victoria, deceased (who died on the 28th February, 1961, and probate of whose will has been applied for by the Fidelity Trustee Company Limited, of 50 Market-street, Melbourne, in the said State), are hereby required to send particulars, in writing, of such claim to the said Fidelity Trustee Company Limited, at its above-mentioned address, on or before the 5th day of September, 1961, after which date the Fidelity Trustee Company Limited will proceed to distribute the assets of the said Archibald Frederick Southgate, deceased, which would have come to its hands, amongst the persons entitled thereto, having regard only to the claims of which it shall then have had notice. And notice is hereby further given that the said Fidelity Trustee Company Limited will not be liable for the assets so distributed or any part thereof to any person whose claims shall not have come to its notice as aforesaid.

Dated this 27th day of June, 1961.

BARNET ROCKMAN & CO., of 62a Young-street, Frankston, proctor for the said Fidelity Trustee Company Limited. 14603

CREDITORS, next of kin, and others having claims in respect of the estate of Harley Grover, formerly of 141 Bridge-street, Port Melbourne, but late of 13 Holmhurst-court, East Brighton, medical practitioner, deceased (who died on the 22nd April, 1961), are to send the particulars of their claims to The Equity Trustees, Executors and Agency Company Limited, whose registered office is situate at 472 Bourke-street, Melbourne, by the 11th September, 1961, after which date it will distribute the assets, having regard only to the claims of which it then has notice.

E. W. OLLEY, solicitor, 431 Bourke-street, Melbourne. 14600

CREDITORS, next of kin, and others having claims in respect of the estate of Gordon George Gluth, late of 2 Chrystobel-crescent, Hawthorn, in the State of Victoria, retired civil engineer (who died on the 3rd day of March, 1961), are to send the particulars of their claims to The Perpetual Executors and Trustees Association of Australia Limited, of 100-104 Queen-street, Melbourne, in the said State, by the 20th day of September, 1961, after which date it will distribute the assets, having regard only to the claims of which it then has notice.

HENDERSON & BALL, solicitors, of 430 Little Collins-street, Melbourne. 14596

CREDITORS, next of kin, and others having claims in respect of the estate of Jane Eliza Lynn, formerly of 440 Arden-street, Kensington, married woman, but late of Mental Hospital, Kew, widow, deceased (who died on the 15th May, 1961), are to send particulars of their claims to National Trustees, Executors and Agency Company of Australasia Limited, of 95 Queen-street, Melbourne, by the 1st September, 1961, after which date it will distribute the assets, having regard only to the claims of which it then has notice.

DOYLE & KERR, solicitors, 108 Queen-street, Melbourne. 14594

CREDITORS, next of kin, and others having claims in respect of the estate of Amy Strang, late of Flat 4, 27 Arnold-street, South Yarra, widow, deceased (who died on the 8th September, 1960), are to send particulars of their claims to James Desmond McCabe Doyle, at the address shown hereunder, by the 1st day of September, 1961, after which date he will distribute the assets, having regard only to the claims of which he then has notice.

DOYLE & KERR, solicitors, 108 Queen-street, Melbourne. 14593

CREDITORS, next of kin, and others having claims against the estate of Rosina Nolan, late of 53 Caroline-street, South Yarra, widow, deceased (who died on the 21st May, 1961), are to send particulars of their claims to the executor, National Trustees, Executors and Agency Company of Australasia Limited, of 95 Queen-street, Melbourne, by the 7th day of September, 1961, after which date the said company will distribute the estate of the said deceased, having regard only to the claims of which it then has notice.

BERNARD NOLAN, 595 Bourke-street, Melbourne, solicitor. 14599

Trustee Act 1958.
NOTICE TO CLAIMANTS.

PURSUANT to the *Trustee Act 1958*, creditors, next of kin, and all other persons having claims in respect of the estate of the deceased person named below are required to send particulars to the legal personal representative, at the address stated, after which date the representative will distribute the assets, having regard only to the claims of which notice has been received:—

Ferdinende Jeanne Hervey Lowe Houston-Lang, late of 59 Irvine-street, Mount Evelyn, widow, deceased, died 16th April, 1961.—Claims to the executor, Hugh Wray, of Mount Evelyn, estate agent, care of J. W. Glover, 422 Collins-street, Melbourne, by 12th September, 1961. J. W. Glover, L.L.B., 422 Collins-street, Melbourne. 14586

CREDITORS, next of kin, and others having claims in respect of the estate of Edward Perchard Dunn, late of Ferny Creek, in the State of Victoria, farmer and orchardist, deceased (who died on the 17th day of December, 1960), are to send particulars of their claims to the executors, The Union Trustee Company of Australia Limited and Keith Vannan Rintoul, care of the said company, at its registered office, 333 Collins-street, Melbourne, in the said State, by the 6th day of September, 1961, after which date they will distribute the assets, having regard only to the claims of which they then have notice.

BEST, HOOPER, RINTOUL & SHALLARD, solicitors,
100 Queen-street, Melbourne. 14618

HENRY WILLIAM THEODORE EMIL SCHAD, late of 25 Charnwood-road, St. Kilda, hairdresser, DECEASED.

CREDITORS, next of kin, and others having claims in respect of the estate of the deceased (who died on the 25th day of July, 1960) are required by the trustee, Philip Edington Rhoden, of 376 Collins-street, Melbourne, to send particulars to him, at his address aforesaid, by the 15th day of September, 1961, after which date the trustee may convey or distribute the assets, having regard only to the claims of which he then has notice.

Dated the 28th day of June, 1961.

JOHN P. RHODEN, solicitor, 376 Collins-street, Melbourne. 14619

CREDITORS, next of kin, and others having claims in respect of the estate of Donuill Kinloch, late of Auckland, in the Provincial District of Auckland, in New Zealand, insurance clerk, deceased (who died on the 23rd day of October, 1960), are to send the particulars of their claims to The Trustees, Executors and Agency Company Limited, whose registered office is situate at 401 Collins-street, Melbourne, by the 15th day of September, 1961, after which date it will distribute the assets, having regard only to the claims of which it then has notice.

Dated the 3rd day of July, 1961.

MADDEN, BUTLER, ELDER & GRAHAM, solicitors,
99 Queen-street, Melbourne. 14611

CREDITORS, next of kin, and others having claims in respect of the estate of Nance Isobel Reed, late of "Monomeith," Northbrook-avenue, Malvern, in the State of Victoria, widow, deceased (who died on the 2nd day of April, 1961), are to send particulars of their claims to The Trustees, Executors and Agency Company Limited, of 401 Collins-street, Melbourne, in the said State, and Archibald Simpson Anderson, of 9 Gaynor-court, Malvern, in the said State, medical practitioner, the executors of the will of the said deceased, by the 8th day of September, 1961, after which date the said executors will distribute the assets, having regard only to the claims of which it and he shall then have had notice.

H. L. YUNCKEN & YUNCKEN, solicitors, 443 Little Collins-street, Melbourne. 14604

CREDITORS, next of kin, and others having claims in respect of the estate of Reginald Talbot Gude, also called Reginald Talbot Goodie, late of 23 Woolcock-avenue, East Kew, garage proprietor, deceased (who died on the 1st day of October, 1960), are to send particulars of their claims to The Perpetual Executors and Trustees Association of Australia Limited, of 100-104 Queen-street, Melbourne, on or before the 6th September, 1961, after which date the said company will distribute the assets of the said deceased, having regard only to the claims of which it then has notice.

BEST, HOOPER, RINTOUL & SHALLARD, solicitors,
100 Queen-street, Melbourne. 14610

CREDITORS, next of kin, and others having claims in respect of the estate of Ann Maud Mary Higgins, late of 10 The Grange, East Malvern, spinster, deceased (who died on 26th January, 1961), are to send the particulars of their claims to The National Trustees Executors and Agency Company of Australasia Limited, of 95 Queen-street, Melbourne, by the 8th day of September, 1961, after which date it will distribute the assets, having regard only to the claims of which it then has notice.

PAUL C. NUNAN & BLOOM, solicitors, 422 Little Collins-street, Melbourne. 14622

CREDITORS, next of kin, and others having claims in respect of the estate of Ruth Vivian, late of 1 Clarke-avenue, Caulfield, widow, deceased (who died on the 4th day of March, 1961), are required to send particulars of their claims to the executor, The Equity Trustees, Executors and Agency Company Limited, of 472 Bourke-street, Melbourne, by the 15th day of September, 1961, after which date it will distribute the assets, having regard only to the claims of which it then has notice.

FREDERICK OWEN & ASSOCIATES, solicitors, 84 William-street, Melbourne. 14606

CREDITORS, next of kin, and others having claims in respect of the estate of Henry Baker Hyams, late of 70 Grosvenor-street, St. Kilda, gentleman, deceased (who died on the 17th day of April, 1961), are requested to send particulars of their claims to the executor, The Union Trustee Company of Australia Limited, of 333 Collins-street, Melbourne, by the 15th day of September, 1961, after which date it will distribute the assets, having regard only to the claims of which it then has notice.

FREDERICK OWEN & ASSOCIATES, solicitors, 84 William-street, Melbourne. 14605

CREDITORS, next of kin and others having claims in respect of the estate of Johanna Caroline Day, late of Penshurst, in the State of Victoria, widow, deceased (who died on the 22nd day of October, 1960, and probate of whose will was granted to James Edmund Day, of Penshurst, in the said State, farmer, the executor named in the said will), are to send particulars of their claims to the executor, care of the undersigned, at their address mentioned hereunder, by the 7th day of September, 1961, after which date the said executor will distribute the assets, having regard only to the claims of which he then has notice.

CAMERON & LOWENSTERN, solicitors, 62 Thompson-street, Hamilton. 14572

CREDITORS, next of kin and others having claims in respect of the estate of Richard Knott, late of Majorca, retired, deceased, intestate (who died on the 11th day of March, 1961), are to send the particulars of their claims to Kathleen May Hawke, of Kennedy-street, Maryborough, married woman, care of the under-mentioned solicitors, on or before the 1st day of October, 1961, after which date she will distribute the assets, having regard only to the claims of which she has notice.

HERRING, BATHURST & BRUCE, solicitors, Maryborough. 14569

CREDITORS, next of kin and others having claims in respect of the estate of George Edward Eastwood, formerly of 289 High-street, Prahran, greengrocer, but late of 77 Orrong-road, Elsternwick, retired, deceased (who died on the 4th day of April, 1960), are requested to send particulars of their claims to The National Trustees, Executors and Agency Company of Australasia Limited, of 95 Queen-street, Melbourne, the duly authorized administrator of the estate of the said deceased, in care of the said company, by the 15th day of September, 1961, after which date the administrator will distribute the assets, having regard only to the claims of which it has notice.

KENNETH J. CLEMENTS, 269 Glenhuntly-road-Elsternwick, solicitor for the administrator. 14568

CREDITORS, next of kin, and others having claims against the estate of Dorothy Agnes Massina, late of Flat 7, Brookfield-court, 97 Pleasant-road, Hawthorn East, in Victoria, married woman, deceased (who died on the 25th day of February, 1961), are to send particulars of their claims to The Union Trustee Company of Australia Limited, of 333 Collins-street, Melbourne, by the 6th day of September, 1961, after which date the company will distribute the assets, having regard only to the claims of which it then has notice.

AITKEN, WALKER & STRACHAN, solicitors, 123 William-street, Melbourne. 14584

CREDITORS, next of kin and others having claims in respect of the estate of Clarence Tasman King, late of 23 Park-street, Richmond, in the State of Victoria, retired, deceased (who died on the 16th day of September, 1960, and probate of whose will was granted to Robert Gibson Peart, of Glenthompson, in the said State, bank manager, the executor named in the said will), are to send particulars of their claims to the executor, care of the undersigned, at their address mentioned hereunder, by the 7th day of September, 1961, after which date the said executor will distribute the assets, having regard only to the claims of which he then has notice.

CAMERON & LOWENSTERN, solicitors, 62 Thompson-street, Hamilton. 14574

ANGUS GORDON MACDONALD, DECEASED.

CREDITORS, next of kin, and others having claims in respect of the estate of Angus Gordon Macdonald, late of Wellington, New Zealand, company director, deceased (who died on the 2nd January, 1961), are to send particulars of their claims to The Trustees, Executors and Agency Company Limited, of 401 Collins-street, Melbourne, by the 7th day of September, 1961, after which date the company will distribute the assets, having regard only to the claim of which it then has notice.

J. M. SMITH & EMMERTON, 480 Bourke-street, Melbourne, solicitors for the company. 14583

CREDITORS, next of kin, and others having claims in respect of the estate of Edith Ellen Emily Gillman, late of Birch Hotel, Haywards Heath, in the County of Sussex, England, spinster, deceased (who died on the 29th day of January, 1961), are required by The Trustees, Executors and Agency Company Limited, the registered office of which is situated at 401 Collins-street, Melbourne, the attorney under power of Bessie Eliza Gillman, of Birch Hotel, Haywards Heath aforesaid, the executrix of the will of the above-named deceased, to send particulars to the said company by the 6th day of August, 1961, after which date it may convey or distribute the assets, having regard only to the claims of which it then has notice.

AITKEN, WALKER & STRACHAN, 123 William-street, Melbourne, solicitors. 14585

MABEL FRANCIS DAVIS, late of 86 Wellington-parade, East Melbourne, widow, DECEASED, intestate.

CREDITORS, next of kin, and others having claims in respect of the estate of the deceased (who died on the 26th day of May, 1959), are required by the administrator, Harold Nicholas Brownless, of Shepparton-road, Euroa, grazier, to send particulars to him, care of the under-mentioned solicitor, by the 12th day of September, 1961, after which date the administrator may convey or distribute the assets, having regard only to the claims of which he then has notice.

J. E. SIEVERS, solicitor, 17 Sun-crescent, Sunshine. 14590

PEREGRINE JOSEPH STOCKDALE, late of 78 Fenwick-street, Carlton, wharf labourer, DECEASED, intestate.

CREDITORS, next of kin, and others having claims in respect of the estate of the deceased (who died on the 30th day of November, 1960), are required by the administrator, Ernest Stockdale, of 151 Duke-street, Sunshine, clerk, to send particulars to him, care of the under-mentioned solicitor, by the 12th day of September, 1961, after which date the administrator may convey or distribute the assets, having regard only to the claims of which he then has notice.

J. E. SIEVERS, solicitor, 17 Sun-crescent, Sunshine. 14591

CREDITORS, next of kin, and others having claims in respect of the estate of Doris Irene Adamson, late of Condah, in the State of Victoria, married woman, deceased, intestate (who died on the 21st day of December, 1960, and letters of administration of whose estate was granted to Norman Stuart Adamson, of Condah, in the said State, farmer, the administrator and next of kin of the said deceased), are to send particulars of their claims to the administrator, care of the undersigned, at their address mentioned hereunder, by the 7th day of September, 1961, after which date the said administrator will distribute the assets, having regard only to the claims of which he then has notice.

CAMERON & LOWENSTERN, solicitors, 62 Thompson-street, Hamilton. 14573

JOHN FRÉDÉRIC KLAERR, late of 10 Cecil-place, Prahran, manufacturer, DECEASED.

CREDITORS, next of kin, and others having claims in respect of the estate of the deceased (who died on 14th March, 1961) are required by the trustee, Clifford Buckley, of 20 Surrey-street, Box Hill, gentleman, to send particulars to him, care of the undersigned, by 7th September, 1961, after which date the trustee may convey or distribute the assets, having regard only to the claims of which he then has notice.

WHITING & BYRNE, solicitors, 166 Queen-street, Melbourne. 14582

JESSIE CALLAGHAN, late of Fingal, in the State of Victoria, married woman, DECEASED.

CREDITORS, next of kin, and others having claims in respect of the estate of the deceased (who died on the 3rd day of September, 1953) are required to send particulars of such claims to Straun Wright-Smith, of Rosebud, in the said State, solicitor, the sole surviving executor named in and appointed by the will of the deceased, on or before the 31st day of July, 1961, after which date the said Straun Wright-Smith may distribute the assets of the estate, having regard only to such claims as he may have had notice.

S. WRIGHT-SMITH, LLB., solicitor, Rosebud. 14581

In the Supreme Court of the State of Victoria.

SALE BY THE SHERIFF.

ON Tuesday, the 15th of August, 1961, at Eleven o'clock a.m., at the Police Station, Mount Waverley (unless process be stayed or satisfied):—

All the estate and interest (if any) of Hilton Homes Pty. Ltd., of 768 High-street, East Kew, as proprietor of an estate in fee-simple in the land described in certificate of title, volume 8149, folio 612, the land, which is vacant land situated on the west side of Petter-street, Glen Waverley, approximately 81 feet north of the intersection of Lincoln-avenue, formerly Carmichael-street, and Petter-street, Glen Waverley. The said land has a frontage of 60 feet to Petter-street and a depth of 137 feet, and is known as lot 74 Petter-street, Glen Waverley.

Terms: Cash only.

N. FROGLEY, Sheriff's Officer. 14579

29th June, 1961.

MINING NOTICE

NEW DAWN CONSOLIDATED NO LIABILITY.

A CALL (the 9th) of One shilling and nine pence per share has been made on the capital of the company in respect of the shares numbered 898821 to 908420, due and payable to the manager at the registered office, 379 Collins-street, Melbourne, on Wednesday, 12th July, 1961.

14608

H. L. STEWART, Manager.

IMPOUNDINGS

BOX HILL.—Impounded in Box Hill Pound, by Ranger.

2 red and white heifers, no visible brand
2 black and white heifers, no visible brand
4 brown heifers, no visible brand

If not claimed and expenses paid, to be sold on 20th July, 1961.

R. KENNEDY,
Poundkeeper.

14567—12/

SWAN HILL.—Impounded in Swan Hill Pound.

1 bay mare hack, white star on forehead, four black points, no visible brand

If not claimed and expenses paid, to be sold on 19th July, 1961.

C. RONCON,
Poundkeeper.

14578—10/6

TATURA.—Impounded in Tatura Pound.

3 Shorthorn Cross calves, no visible brand

If not claimed and expenses paid, to be sold on 20th July, 1961.

E. O'BRIEN,
Poundkeeper.

14587—9/

TONGALA.—Impounded in Tongala Pound, from Koyuga South.

1 Jersey heifer, approximately 1 year, golden colour, no visible brand

If not claimed and expenses paid, to be sold on 24th July, 1961.

B. PEARL,
Shire Secretary.

14625—12/

STATE ACTS, 1959.

COPIES of the following Acts of Parliament of Victoria may be obtained at the Government Printing Office, or from any bookseller, at the price set opposite to each:—

No.	Price.
	s. d.
6490. Water (Contracts)	0 6
6491. Property Law (Amendment)	0 6
6492. Agricultural Education (Amendment)	0 6
6493. Swan Hill Railway Land	0 6
6494. Stamps (Amendment)	0 6
6495. Justices (Amendment)	0 6
6496. Consolidated Revenue	0 6
6497. State Electricity Commission (Tourist Areas)	0 6
6498. Aborigines (Houses)	0 6
6499. Superannuation (Amendment)	0 6
6500. Country Roads (Amendment)	0 6
6501. Bendigo Land	0 6
6502. University (Honorary Degrees)	0 6
6503. Melbourne and Metropolitan Board of Works (Reconstitution)	0 9
6504. Land (Charges)	0 6
6505. Statute Law Revision	1 0
6506. Legal Profession Practice (Amendment)	0 6
6507. Health	0 9
6508. Fisheries (Amendment)	0 6
6509. Water (Irrigation Districts)	0 6
6510. Broadmeadows (Rating on Unimproved Values)	0 6
6511. Trustee (Amendment)	0 6
6512. Nurses	0 6
6513. Hairdressers Registration (Amendment)	0 6
6514. Labour and Industry (Retail Trading Hours)	0 6
6515. Milk Board (Amendment)	0 6
6516. Stock Diseases (Amendment)	0 9
6517. Hepburn Springs Land	0 9
6518. Vermin and Noxious Weeds	1 0
6519. The Constitution Act Amendment (Parliamentary Salaries)	0 9
6520. Public Works Committee (Amendment)	0 6
6521. Land (Plantation Areas)	0 6
6522. National Art Gallery and Cultural Centre (Amendment)	0 6
6523. Portland Harbor Trust (Amendment)	0 6
6524. Revocation and Excision of Crown Reservations	1 9
6525. Tourist (Amendment)	0 6
6526. Town and Country Planning (Amendment)	0 6
6527. Vegetation and Vine Diseases (Amendment)	0 6
6528. Medical	0 9
6529. Bread Industry	1 0
6530. Cemeteries	0 9
6531. Hire-Purchase	2 3
6532. Motor Car (Amendment)	0 9
6533. Motor Car (Hours of Driving)	0 6
6534. Land Settlement	1 9
6535. Local Government (Amendment)	1 6
6536. Melbourne and Metropolitan Board of Works (Amendment)	1 3
6537. Consolidated Revenue	0 6
6538. War Veterans' Homes Trust	1 3
6539. Frustrated Contracts	0 6
6540. Evidence (Amendment)	0 6
6541. Amendments Incorporation (Extension)	0 6
6542. Melbourne and Richmond Lands	0 9
6543. Local Government (Councillors' Declarations)	0 6
6544. Transfer of Land (Amendment)	0 6
6545. State Savings Bank (Amendment)	0 6
6546. Country Roads (Offices and Buildings)	0 6
6547. Statute Law Revision	0 6
6548. Marriage (Fees)	0 6
6549. State Electricity Commission (Hazelwood Power Station)	0 6
6550. Fences (Amendment)	0 6
6551. Coroners (Amendment)	0 6
6552. Stamps	0 6
6553. Motor Car (Insurance Surcharge)	0 6
6554. Entertainment Tax (Reduction)	0 6
6555. Melbourne and Metropolitan Tramways (Amendment)	0 9

STATE ACTS, 1959—continued.

No.	Price.
	s. d.
6556. Local Government (Municipalities Assistance Fund)	0 6
6557. Police Offences (Penalties)	0 6
6558. Consolidated Revenue	0 6
6559. Road Traffic (Infringements)	0 9
6560. Superannuation	0 6
6561. Crimes (Penalties)	0 6
6562. Alphington to East Preston Railway Construction (Housing)	0 6
6563. Motor Car	1 0
6564. Registration of Births, Deaths and Marriages	2 3
6565. Coal Mines (Pensions)	0 6
6566. Water Supply Loan Application	1 3
6567. Game (Amendment)	0 6
6568. Metropolitan Fire Brigades (Borrowing Powers)	0 6
6569. Health (Amendment)	0 6
6570. Police Regulation (Delegation of Powers)	0 6
6571. Imprisonment of Fraudulent Debtors (Depositions)	0 6
6572. Crimes (Sentences and Parole)	0 6
6573. Gas and Fuel Corporation (Colonial Gas Association Undertakings)	1 3
6574. Racing (Meetings)	0 6
6575. Landlord and Tenant (Amendment)	0 6
6576. Distribution of Population (Joint Committee)	0 6
6577. Lifts and Cranes	1 0
6578. Cemeteries (Investment of Funds)	0 6
6579. Public Service (Amendment)	0 6
6580. Trustee (Mortgages)	0 6
6581. Justices (Amendment)	0 6
6582. Water (Irrigation)	1 9
6583. Country Fire Authority (Amendment)	0 6
6584. Milk Board (Milk Shops)	0 6
6585. Forests (Pulpwood Agreement)	1 3
6586. Police Offences (Betting)	0 6
6587. Revenue Deficit Funding	0 6
6588. Geelong Trades Hall Council (Trustees)	0 6
6589. Melbourne Harbor Trust (Commissioners)	0 6
6590. Railway Loan Application	1 3
6591. State Forests Loan Application	0 6
6592. Land Tax (Rates)	0 6
6593. Teaching Service (Amendment)	0 6
6594. Land (Special Grants)	0 9
6595. Labour and Industry (Motor Car Shops)	0 6
6596. Home Finance (Financial)	0 6
6597. Dromana Land (Arthur's Seat Public Park)	0 6
6598. Money Lenders (Amendment)	0 6
6599. Landlord and Tenant (Fair Rents)	0 6
6600. Labour and Industry (Amendment)	0 6
6601. Local Government	0 9
6602. Public Works Loan Application	0 6
6603. Soldier Settlement (Amendment)	0 6
6604. Water (Land Reclamation)	0 6
6605. Mental Health	4 3
6606. Appropriation of Revenue	7 0

Table of Acts and Enactments passed date of operation, &c. 0 6

A. C. BROOKS,
Government Printer.

STATE ACTS, 1960.

COPIES of the following Acts of Parliament of Victoria may be obtained at the Government Printing Office, or from any bookseller, at the price set opposite to each:—

No.	Price.
	s. d.
6607. Anzac Day	1 0
6608. Agricultural Lime (Amendment)	0 6
6609. Motor Car (Commencement)	0 6
6610. Fisheries (Change of Title)	0 6
6611. Stamps (Amendment)	0 6
6612. Land (Public Authorities)	0 6
6613. Coal Canal Bridge	0 6
6614. Metropolitan Fire Brigades (Borrowing Powers)	0 6
6615. Wodonga Lands Exchange	0 6
6616. Licensing (Fees)	0 6
6617. Home Finance (Loans to Minors)	0 6
6618. Co-operative Housing Societies (Amendment)	0 6
6619. Racing (Totalizators Extension)	1 0
6620. Companies	0 6
6621. Judges Salaries and Allowances	0 6
6622. Coal Mines (Pensions Contributions)	0 6
6623. Landlord and Tenant (Further Amendment)	0 6
6624. Public Officers Salaries and Allowances	0 9
6625. Legal Profession Practice (Amendment)	0 6

STATE ACTS, 1960—continued.

No.	Price.	
	s.	d.
6626. Church of England in Australia Constitution	1	9
6627. Companies (Fees)	0	6
6628. Motor Car (Amendment)	1	0
6629. Geelong Waterworks and Sewerage (Amendment)	0	6
6630. Latrobe Valley (Financial)	0	6
6631. Labour and Industry (Amendment)	0	6
6632. Acts Interpretation	0	6
6633. Children's Court (Enforcement of Awards)	0	6
6634. Supreme Court (Proceedings before Master)	0	6
6635. Melbourne and Metropolitan Board of Works (Borrowing Powers)	0	6
6636. Electoral Provinces	0	9
6637. Town and Country Planning (Amendment)	0	6
6638. Racing (Dog Races)	0	6
6639. Industrial Safety Advisory Council	0	6
6640. Administration and Probate (Offices)	0	6
6641. Justices (Bail)	0	6
6642. National Parks (Amendment)	0	9
6643. Medical (Amendment)	0	6
6644. Melbourne Harbor Trust Lands	1	0
6645. Weights and Measures (Penalties)	0	6
6646. Transfer of Land (Stratum Estates)	0	6
6647. Local Government (Preston Streets Agreement)	0	9
6648. John Storey Memorial Fund	0	6
6649. Police Offences (Amendment)	0	6
6650. Motor Car (Third-Party Insurance)	0	6
6651. Social Welfare	2	9
6652. City of Melbourne Underground Railway Construction	1	0
6653. Valuation of Land	1	3
6654. Milk Board (Amendment)	0	6
6655. Victoria Racing Club (Amendment)	0	6
6656. Consolidated Revenue	0	6
6657. Consolidated Revenue	0	6
6658. Motor Car (Driving)	0	6
6659. Licensing (Amendment)	1	0
6660. Consolidated Revenue	0	6
6661. Consolidated Revenue	0	6
6662. Friendly Societies (Dental Clinics)	0	6
6663. Cancer (Amendment)	0	6
6664. Dried Fruits (Amendment)	0	6
6665. Barwon Heads Lands Exchange	0	6
6666. Revocation of Crown Reservations	0	6
6667. The Constitution Act Amendment (Expenses)	0	6
6668. Supreme Court (Orders)	0	6
6669. Gippsland Railway Deviation	0	9
6670. Hamilton Stockyards Railway Construction	0	6
6671. Nurses (Amendment)	0	6
6672. Ministry of Transport (Railway Officers)	0	6
6673. Fruit and Vegetables (Road Barriers)	0	6
6674. Transport Regulation (Qualifications of Chairman)	0	6
6675. Motor Car (Insurance Surcharge Continuance)	0	6
6676. Geelong Harbor Trust (Freezing Works Agreement)	0	9
6677. Western Metropolitan Market (Amendment)	0	6
6678. Racing (Trotting Races)	0	6
6679. Wattle Park Land	0	6
6680. Surplus Revenue	0	6
6681. Milk and Dairy Supervision (Research Contributions)	0	6
6682. Tourist (Amendment)	0	6
6683. Fisheries (Crayfish)	0	6
6684. Audit (Amendment)	0	6
6685. Sale of Allotments of Land (Amendment)	0	6
6686. Cattle Compensation (Amendment)	0	6
6687. Co-operative Housing Societies (Guarantees)	0	6
6688. State Library National Gallery National Museum and Institute of Applied Science	1	3
6689. Medical (Blood Transfusion)	0	6
6690. The Constitution Act Amendment (Treating)	0	6
6691. State Forests Loan Application	0	6
6692. Local Authorities Superannuation (Amendment)	0	9
6693. Local Government (Disqualification)	1	0
6694. Superannuation (Additions to Pensions)	0	6
6695. Police Regulation (Pensions)	0	6
6696. Trustee Companies (Amalgamation)	0	6
6697. Geelong and Colac Railway (Deviation)	0	6
6698. University Colleges Lands	0	6
6699. Local Government (Private Street)	0	6
6700. Northcote School	0	6
6701. Public Works Loan Application	0	9
6702. Tower Hill and Malmesbury Lands	0	6
6703. Coal Mines (Pensions)	0	6
6704. Vermin and Noxious Weeds (Financial)	0	6
6705. Navigable Waters (Oil Pollution)	1	0
6706. Business Names (Public Borrowings)	0	6
6707. Health (Tuberculosis Arrangement)	0	6

STATE ACTS, 1960.—continued.

No.	Price.	
	s.	d.
6708. Water Supply Loan Application	1	3
6709. Railway Loan Application	1	0
6710. Land Tax (Relief)	0	6
6711. Land Tax (Rates)	0	6
6712. Monash University (Amendment)	0	6
6713. National Fitness Council of Victoria	1	0
6714. Local Government (Keilor Waverley and Springvale)	0	6
6715. Explosives	2	3
6716. Statute Law Revision	0	9
6717. Motor Car (Abolition of Owners' Certificates)	0	6
6718. Road Traffic (Amendment)	0	6
6719. Milk Board (Powers)	0	6
6720. Marketing of Primary Products (Members)	0	6
6721. Melbourne and Geelong Mortgages	0	9
6722. Building Societies (Amendment)	0	9
6723. Local Government (Scaffolding Inspection)	0	9
6724. State Electricity Commission (Borrowing)	0	6
6725. Labour and Industry (Butchers' Shops)	0	6
6726. Country Fire Authority (Sawmill Burners)	0	6
6727. Sewerage Districts (Amendment)	1	0
6728. Water (Amendment)	1	3
6729. Housing (Powers)	0	6
6730. Entertainments Tax (Amendment)	0	6
6731. Crimes (Kidnapping)	0	6
6732. Health (Amendment)	0	6
6733. Game (Licences)	0	6
6734. Estate Agents (Amendment)	0	6
6735. Appropriation of Revenue	8	6

A. C. BROOKS,
Government Printer.

AGENTS FOR THE "VICTORIA GOVERNMENT GAZETTE".

THE following have been appointed agents to receive Advertisements and Subscriptions for the *Victoria Government Gazette*—

- ARMSTRONG'S AGENCY, 205 Queen-street, Melbourne.
- ARMSTRONG BROS., Kyneton.
- MESSRS. ARNALL & JACKSON, 115 Barkly-street, West Brunswick.
- MR. WM. DAVIS, Mildura.
- A. J. DIGBY (B. S. and N. W. Cash), Main-street, Bairnsdale.
- EDGAR'S NEWSAGENCY, Hargreaves-street, Bendigo.
- MESSRS. HENRY FRANKS & CO., Booksellers and Stationers, Market-square, Geelong.
- MESSRS. GORDON & GOTCH, News Agents, 511 Little Collins-street, Melbourne; and corner Barrack and Clarence streets, Sydney.
- GULLAN'S NEWSAGENCY, 88 Bridge-street, Ballarat.
- A. C. HAMPTON, 243 Mitchell-street, Bendigo.
- MESSRS. HARSTON, PARTRIDGE, & CO., 455 Little Collins-street, Melbourne.
- MR. C. L. LATIMER, News Agent, Casterton.
- MARTHUR'S AUTHORIZED NEWSAGENCY, 345 Wyndham-street, Shepparton.
- MESSRS. R. H. & W. M. PETTY, News Agents, Wangaratta.
- MESSRS. POWELL & DIXON, 89 Firebrace-street, Horsham.
- J. PURDIE & CO., 138 Moorabool-street, Geelong.
- SALE AUTHORIZED NEWSAGENCY, 142 Raymond-street, Sale.
- SKINNER'S AUTHORIZED NEWSAGENCY, 49-51 Franklin-street, Traralgon.
- MESSRS. SMITH & DUNNON, Hamilton.
- THE MERCANTILE EXCHANGE, 380 Collins-street, Melbourne.
- A. C. THOMAS, 69 Bridge-street, Benalla.
- TUFF'S SHEPPARTON NEWSAGENCY, 246 Wyndham-street, Shepparton.
- C. F. & H. J. VERNON, 162 Bridge-road, Richmond.
- VIEW POINT AUTHORIZED NEWSAGENCY, 4 View Point, Bendigo.
- E. W. B. WELSH, Hogan-street, Tatura.

A copy of the *Gazette* filed at each place for public reference.

PUBLICATION OF OFFICIAL MATTER.

ATENTION is invited to the following procedure in relation to the publication of official matter in the *Government Gazette*:—

1. Matter submitted to the Executive Council.

Matter submitted to the Executive Council which requires gazettal will normally be published in the issue of the following week.

Where urgent gazettal is required, special arrangements should be made with the *Gazette* Officer.

Publication will be facilitated by the submission of carbon copies for the use of the *Gazette* Officer.

2. Other matter.

(a) All other matter duly certified by a responsible officer for publication should be lodged with the *Gazette* Officer not later than half-past Ten a.m. on Tuesday.

(b) Lengthy or involved notices should be forwarded several days before publication.

(c) Proofs, which will be supplied only when specifically requested, or at the direction of the *Gazette* Officer, should be returned promptly to avoid delay in publication.

(d) No additions or amendments to matter for publication will be accepted by telephone.

THE "VICTORIA GOVERNMENT GAZETTE".

SUBSCRIPTIONS.—The subscription, including postage, is £2 15s. per annum, £1 7s. 6d. half-yearly, or 13s. 9d. per quarter, payable in advance.

Subscriptions are required to commence and terminate with a month.

A lesser period than three months cannot be subscribed for.

Subscribers do not receive the Acts of Parliament with the *GAZETTE*.

ADVERTISEMENTS are charged at the rate of 1s. 6d. per line single column, and 3s. per line double column.

The title (£5 Reward, Dissolution of Partnerships, &c.) forms one or more lines as a heading.

On an average, ten words make a line.

Every signature must likewise be counted as a line.

The final words of a paragraph, though only portion of a line, must be counted as one line.

SIGNATURES (in particular) and proper names must be written very plainly in the text; ONE SIDE ONLY of each slip of paper should be WRITTEN UPON.

ALL COMMUNICATIONS should be addressed to "The Government Printer, Melbourne".

ALL DOCUMENTS illegibly written will be returned unpublished, and where brands occur unprovided for by the ordinary letters of the alphabet, a worded explanatory description must be furnished.

THE VICTORIA GOVERNMENT GAZETTE is published on WEDNESDAY EVENING in each week, and Notices for insertion will be received by the Government Printer at

or before Two p.m. at ordinary rates, and late advertisements between Two p.m. and Five p.m. at double rates on the day preceding the day of publication.

Single copies of the *VICTORIA GOVERNMENT GAZETTE* are One shilling, posted One shilling and five pence.

No *GAZETTES* prior to January, 1950, in stock.

*****ALL PAYMENTS ARE REQUIRED IN ADVANCE.**—Remittances should be made by postal note, money order, or draft in favour of the Government Printer. Advertisements unaccompanied by a remittance sufficient to cover the cost of insertion will be returned unpublished.

CONTENTS

	PAGE
Acts of Parliament on sale at the Government Printing Office	2380
Appointments	2352
Auction Sales Act	2342
Bank Half-Holiday	2336
Cemeteries—Scale of Fees	2349
Contracts	2346
Country Roads Board	2343
Courts	2342
Estates of Deceased Persons	2341
Government Notices	2336
Impoundings	2379
Lands	2362
Melbourne and Metropolitan Board of Works— Notice	2350
Mining	2341, 2379
Ministers of Religion Registered to Celebrate Marriages in Victoria	2342
Orders in Council— Acts—Land; National Parks; Country Roads; Landlord and Tenant; Co-operation; Apprenticeship; Soil Conservation and Land Utilization; Sewerage Districts; River Improvement; Water.	2354 <i>et seq</i>
Private Advertisements	2371
Proclamations	2335
Public Service Notices	2364
Regulations— Acts—Police Regulation State Electricity Commission	2343 2353
Resignations	2353
State Rivers and Water Supply Commission	2344
Tenders	2370
Transport Regulation Board—Public Hearings	2337
Waterworks Trust	2348