



VICTORIA GOVERNMENT GAZETTE

Published by Authority

[Registered at the General Post Office, Melbourne, for transmission by post as a newspaper.]

No. 67]

TUESDAY, AUGUST 1

[1961

Process Servers and Inquiry Agents Act 1958.

DETAILS OF PERSONS LICENSED.

By direction of the Honorable the Chief Secretary, the subjoined lists of persons so far licensed as Inquiry Agents and Process Servers, pursuant to the above-mentioned Act, for the year ending on the 31st December, 1961, are published for general information.

C. W. PHILLIPS,
Registrar of Process Servers and Inquiry Agents.

Chief Secretary's Office,
Melbourne,
31st March, 1961.

INQUIRY AGENTS' LICENCES ISSUED FOR THE YEAR 1961.

Name of Licensee.	Business Address.	Registered Address.	Court of Issue.	Date of Issue.	Remarks. *(See footnote at end of list.)
Abberfield, Charles ..	136 Landells-road, Pascoe Vale	136 Landells-road, Pascoe Vale	Coburg ..	29.12.60	
Abel, Peter Maria ..	Commercial and General Acceptance Ltd., 51 Queen-street, Mel- bourne	64 Baden-Powell Drive, Frankston	Melbourne ..	16.12.60	
Abrehart, Charles Percival	Suite 9, 545 St. Kilda- road, Melbourne, S.C.3	Suite 9, 545 St. Kilda- road, Melbourne, S.C.3	Prahran ..	5.12.60	Director, Airlie Inquiry Agency, Suite 9, 545 St. Kilda-road, Mel- bourne
Abson, Colin Reginald ..	14 George-street, Moe ..	14 George-street, Moe ..	Moe ..	15.12.60	
Adams, Robert Valentine	55 Nunn-street, Benalla	55 Nunn-street, Benalla	Benalla ..	4.1.61	
Ahearn, Sylvester ..	M. A. Gibson (Speciali- ties) Pty. Ltd., 1087 High-street, Armadale, and Consumer Credit Corp. Pty. Ltd., 98 Collins-street, Mel- bourne	4 Seymour-road, Elstern- wick	Melbourne ..	16.12.60	c, e
Alderson, James Allan ..	Lot 46, Herbert-street, Mount Waverley	Lot 46, Herbert-street, Mount Waverley	Oakleigh ..	16.12.60	e
Allpress, Ian Walter ..	125 Rushall-crescent, North Fitzroy	125 Rushall-crescent, North Fitzroy	Fitzroy ..	15.12.60	a, b, c, e
Anderson, Thomas Donald	198 Moray-street, or Box 266, South Melbourne	66 Mentone-parade, Men- tone	South Mel- bourne	2.12.60	a, c, e
Anderson, William John	Eastern Star Mercantile Agency, 100 Denmark- street, Kew	100 Denmark-street, Kew	Kew ..	22.12.60	a, b, c, d, e
Arnold, Roger Andre ..	Major 8 Holdings, 95 Smith-street, Fitzroy	34 Walker-road, Carrum	Fitzroy ..	15.12.60	a, c, e

INQUIRY AGENTS' LICENCES ISSUED FOR THE YEAR 1961—continued.

Name of Licensee.	Business Address.	Registered Address.	Court of Issue.	Date of Issue.	Remarks. *(See footnote at end of list.)
Ash, Graham Alfred ..	Eastern Star Mercantile Agency, 100 Denmark-street, Kew	100 Denmark-street, Kew	Frankston ..	2.12.60	a, c, d, e
Ashfield, William Robert	8 Cyril-street, Box Hill South	8 Cyril-street, Box Hill South	Box Hill ..	16.12.60	a, b, c, d
Atkinson, John Richard	Alliance Acceptance Co., 636 St. Kilda-road, Melbourne	379 Alma-road, Caulfield	St. Kilda ..	6.12.60	e
Attwood, Peter ..	63 Deakin-avenue, Mildura	114 Etiwanda-avenue, Mildura	Mildura ..	23.2.61	a, b, c, d, e
Baker, Clarence James ..	134 Moorabool-street, Geelong	44 Iukeston-street, Herne Hill	..	7.12.60	e
Baldock, Clive Colin ..	15 Fitzgibbon-avenue, Brunswick West	15 Fitzgibbon-avenue, Brunswick West	Brunswick ..	14.12.60	
Barnden, Carlisle Victor	71 Deakin-avenue, Mildura	9 Chaffey-avenue, Mildura	Mildura ..	12.12.60	a, c, Director, R. H. Chaffey and Co. Pty. Ltd., 71 Deakin-avenue, Mildura
Barstow, Kenneth Frank	20 Elm-street, Surrey Hills	20 Elm-street, Surrey Hills	Box Hill ..	16.12.60	a, b, c, d, e
Batchelor, Henry Pennell	130 Smith-street, Collingwood	130 Smith-street, Collingwood	Collingwood ..	28.11.60	a, c, e
Begovic, Enver ..	Inge Detective Agency, 222 Victoria-parade, East Melbourne	222 Victoria-parade, East Melbourne	Melbourne ..	16.12.60	
Beissel, Barrie Edmund	336 Highett-road, Highett	336 Highett-road, Highett	Cheltenham ..	21.12.60	a, c, e
Belcher, George Frederick	146 Moorabool-street, Geelong	"Lilydale", Batesford	Geelong ..	7.12.60	e
Bennett, Frederick William	349 High-street, Preston	447 Plenty-road, East Preston	Preston ..	20.12.60	
Bennett, Theodore Robert	3 Liscard-street, Elsternwick	3 Liscard-street, Elsternwick	Elsternwick ..	30.11.60	e
Bentick, George Patrick	Lawrence Mercantile Agency, Mayfair Arcade, Dandenong	Mayfair Arcade, Dandenong	Dandenong ..	16.1.61	a, b, c, d, e
Berry, Raymond James McFarlane	9 Wilson-street, Swan Hill	9 Wilson-street, Swan Hill	Swan Hill ..	14.12.60	e
Berwick, Gilbert Auchterlonie	217 Tucker-road, McKinnon	217 Tucker-road, McKinnon	Cheltenham ..	21.12.60	
Bicknell, Gilmore Gerrard	35 Lithgow-street, Burwood	35 Lithgow-street, Burwood	Camberwell ..	1.12.60	
Birmingham, William Charles	366 Bridge-road, Richmond	3 Curzon-street, West Ivanhoe	Richmond ..	30.12.60	a, b, c, d, e
Blackmore, Charles Woodall	51 Queen-street, Melbourne	51 Queen-street, Melbourne	Melbourne ..	16.12.60	a, c, e
Blyth, Neil ..	103 Armstrong-street, Ballarat	103 Armstrong-street, Ballarat	Ballarat ..	24.11.60	a, b, c, d, e
Bocking, Selwyn George	c/o Universal Guarantee Pty. Ltd., 161 Sturt-street, South Melbourne	22 Gordon-street, Hampton, S.7	Brighton ..	23.12.60	a, b, c, d, e
Bonnick, Charles Barrymore	16 Clarendon-street, Frankston	16 Clarendon-street, Frankston	Frankston ..	2.12.60	
Bottomley, Alexander Foxcroft	130 Abbotsford-street, North Melbourne	130 Abbotsford-street, North Melbourne	Melbourne ..	8.12.60	Metropolitan Night Patrol Service Pty. Ltd., 343 Lt. Collins-street, Melbourne
Bottomley, William ..	130 Abbotsford-street, North Melbourne	130 Abbotsford-street, North Melbourne	Melbourne ..	8.12.60	Metropolitan Night Patrol Service Pty. Ltd., 343 Lt. Collins-street, Melbourne
Brennan, Ronald William	Kunyang-road, Mt. Eliza	Kunyang-road, Mt. Eliza	Frankston ..	2.12.60	e
Bricknall, William John	13 Woodmason-street, Malvern	13 Woodmason-street, Malvern	Malvern ..	25.11.60	a, b
Broccio, Francis John ..	29 Wheatley-road, Bentleigh	29 Wheatley-road, Bentleigh	Cheltenham ..	28.12.60	a, b, c, d, e
Brooks, Ronald George ..	Coronet Investments Pty. Ltd., 80 Waverley-road, East Malvern	80 Mollison-street, Noble Park	Malvern ..	25.11.60	a, c, d, e
Bromilow, Geoffrey Granville	132 Sturt-street, South Melbourne	132 Sturt-street, South Melbourne	South Melbourne ..	2.12.60	a, c, e
Bryant, George Edwin ..	149 Lonsdale-street, Dandenong	24 King George-parade, Dandenong	Dandenong ..	23.11.60	e
Brush, Richard Alan ..	cnr. Kingsway and South-road, Moorabbin	17 Stott-street, Box Hill	Box Hill ..	16.12.60	a, b, c, d, e
Bubniw, Victor ..	Acceptance Process Inquiry Service Co., 268 Albert-street, East Melbourne	14 Shaftesbury-street, Essendon	Melbourne ..	16.12.60	a, b, c, d, e
Cadeo, Kenneth Clarke ..	35 Como-street, Alphington	35 Como-street, Alphington	Heidelberg ..	16.12.60	a, b, c, d, e
Cain, John Douglas ..	Deakin-avenue, Mildura	Stuart and Harrison Pty. Ltd., Deakin-avenue, Mildura	Mildura ..	12.12.60	e
Campbell, Harold Frank	32 The Grove, Moreland	32 The Grove, Moreland	Brunswick ..	14.12.60	a, c, e
Cranston, Francis ..	546 Malvern-road, Prahran	18 Charnwood-road, St. Kilda	St. Kilda ..	5.1.61	a, c, d, e
Campi, Leslie Raymon ..	Linton Inquiry Agent, Bentleigh	9 Barnato-grove, Armadale	Malvern ..	25.11.60	e

INQUIRY AGENTS' LICENCES ISSUED FOR THE YEAR 1961—continued.

Name of Licensee.	Business Address.	Registered Address.	Court of Issue.	Date of Issue.	Remarks. *(See footnote at end of list.)
Cant, Anne	8 Bapaume-avenue, Edithvale, and 268 Albert-street, East Melbourne	8 Bapaume-avenue, Edithvale	Melbourne ..	16.12.60	a, b, c, d, e, Acceptance Process and Inquiry Service Co., 268 Albert-street, East Melbourne
Cant, John Henry ..	8 Bapaume-avenue, Edithvale, and 268 Albert-street, East Melbourne	8 Bapaume-avenue, Edithvale	Melbourne ..	16.12.60	Director, Acceptance Process and Inquiry Service Co., 268 Albert-street, East Melbourne
Capewell, Charles Brian	D. R. McDonald Pty. Ltd., 403A St. Kilda-road, Melbourne	403A St. Kilda-road, Melbourne	Prahran ..	5.12.60	c, e
Capuano, Arnold William	38 Darvall-street, Rosanna	38 Darvall-street, Rosanna	Heidelberg ..	16.12.60	e
Carroll, Dennis Malcolm	401 Church-street, Richmond, E.L., and 18 Cutter-street, Burnley, E.1	401 Church-street, Richmond, E.1	Richmond ..	13.12.60	
Carroll, Henry Malcolm	401 Church-street, Richmond, E.L., and 18 Cutter-street Burnley, E.1	401 Church-street, Richmond, E.1	Richmond ..	13.12.60	
Carroll, Thomas Henry ..	32 Glazebrook-street, Ballarat	32 Glazebrook-street, Ballarat	Ballarat ..	24.11.60	
Casey, Leslie Joseph ..	98 The Boulevard, Norlane	98 The Boulevard, Norlane	Geelong ..	23.1.61	a, b, c, d, e,
Cawsey, Geoffrey Myiel ..	284 Lonsdale-street, Melbourne	284 Lonsdale-street, Melbourne	Melbourne ..	16.12.60	
Chambers, Jack William	18 Thomas-street, East Brighton	18 Thomas-street, East Brighton	Brighton ..	16.12.60	a, b, c, d, e
Chapman, Henry Michael	3 Adele-street, Vermont	3 Adele-street, Vermont	Ringwood ..	6.12.60	a, c, d, e
Charles, Alan Blair ..	Commercial and General Acceptance Ltd., 3rd Floor, 51 Queen-street, Melbourne	51 Queen-street, Melbourne	Melbourne ..	16.12.60	a, c, e
Chesher, Robert James ..	17 Dobson-crescent, Braybrook	17 Dobson-crescent, Braybrook	Sunshine ..	6.12.60	a, b, c, d, e
Christiansen, Brian Jorgen	100 Denmark-street, Kew	100 Denmark-street, Kew	Kew ..	13.2.61	a, b, c, d, e
Clare, John Barlow ..	115 North-street, Glenroy, W.9	115 North-street, Glenroy, W.9	Glenroy ..	9.12.60	d
Clarke, Patrick ..	Room 13, St. James Building No. 4, William-street, Melbourne	32 Churchill-street, Glenroy	Glenroy ..	9.12.60	a, b, c, d, e
Clarke, Stanley Massam	5 King-street, Balwyn, E.8	5 King-street, Balwyn, E.8	Box Hill ..	16.12.60	
Clavant, William ..	15 David-road, Lilydale	15 David-road, Lilydale	Ringwood ..	6.12.60	a, d
Clayton, Raymond Edwin	228 Barkers-road, Hawthorn	228 Barkers-road, Hawthorn	..	30.12.60	e
Clegg, John Sydney ..	11 Crisp-street, Wangaratta	11 Crisp-street, Wangaratta	Wangaratta ..	15.12.60	e
Collins, Ronald John ..	47 Roberts-avenue, Box Hill South, and Namur Car Sales, 48 Swan-street, Richmond	47 Roberts-avenue, Box Hill South	Box Hill ..	15.11.60	a, e
Convery, Bernard Anthony	101 Lahinch-street, Broadmeadows	101 Lahinch-street, Broadmeadows	Glenroy ..	9.12.60	
Coad, William Francis ..	12 Fitzroy-street, Kerang	209 Boundary-street, Korang	Kerang ..	9.12.60	e
Coates, Barry Charles ..	5 Albert-street, Carnegie	14 King-street, Prahran	Oakleigh ..	20.2.61	
Cole, John Charles ..	Linton Inquiry Agency, 341 Centre-road, Bentleigh	Princes Highway, Garfield	Bunyip ..	7.12.60	a, c, e
Comber, Clifford Alan ..	Gippsland Acceptance Ltd., Dandenong	17 Bottlebrush-drive, Dandenong	Dandenong ..	23.11.60	
Conroy, Clement Edward	Commercial and General Acceptance Ltd., 51 Queen-street, Melbourne	51 Queen-street, Melbourne	Melbourne ..	16.12.60	a, e
Coombes, Walter Thomas	60 Collins-place, Melbourne	60 Collins-place, Melbourne	Melbourne ..	16.12.60	a, c, e
Corbett, Charles Reginald	60 Dudley-street, West Melbourne	60 Dudley-street, West Melbourne	Melbourne ..	16.12.60	a, b, c, d, e
Crawshaw, Frank Stephen	95 Ramu-parade, West Heidelberg	95 Ramu-parade, West Heidelberg	Heidelberg ..	16.12.60	a, b, c, d, e
Crockett, Francis Edgar	1 Railway Walk, Hampton	1 Railway Walk, Hampton	Sandringham ..	14.12.60	a, b, c, d, e
Cunningham, George David	Malcoe Mercantile Agency, 27 Nunns-road, Mornington	Princes Highway, Beaconsfield	Dandenong ..	23.11.60	a, b, c, d, e
Dance, Ronald Aleck ..	The Myor Emporium Ltd., Bourke-street, Melbourne	5 Thackeray-road, Reservoir	Melbourne ..	16.12.60	a, c, d, e
Davies, Harry William ..	Foy and Gibson, 130 Smith-street, Collingwood	22 Dromana-avenue, East Bentleigh	Collingwood ..	28.11.60	

INQUIRY AGENTS' LICENCES ISSUED FOR THE YEAR 1961—continued.

Name of Licensee.	Business Address.	Registered Address.	Court of Issue.	Date of Issue.	Remarks. *(See footnote at end of list.)
Davis, Clarence Robert ..	Carmichael-street, Casterton	Carmichael-street, Casterton	Casterton ..	22.12.60	a, b, c, d, e
Davis, Leslie Clarence ..	17 Penola-street, Preston, N.18	17 Penola-street, Preston, N.18	Preston ..	20.12.60	
Dawson, Ernest Edward	146 Thirteenth-street, Mildura	146 Thirteenth-street, Mildura	Mildura ..	12.12.60	a, c, e
Delahenty, Margaret Trevena	Lot 11, Alice-street, Mt. Waverley, and 453 Clayton-road, Clayton	Lot 11, Alice-street, Mt. Waverley	Oakleigh ..	13.1.61	
Delahenty, Patrick Awburn	Lot 11, Alice-street, Mt. Waverley, and 453 Clayton-road, Clayton	Lot 11, Alice-street, Mt. Waverley	Oakleigh ..	13.1.61	
Dick, Hugh William ..	15 Mimosa-avenue, Mildura	15 Mimosa-avenue, Mildura	Mildura ..	12.12.60	a, b, e
Dickman, Raymond Charles	441 Bay-street, Brighton	441 Bay-street, Brighton	Brighton ..	13.1.61	a, b, c, d, e
Digman, Henry Stephenson	Latec Finance (Vic.) Pty. Ltd., 505 St. Kilda-road, Melbourne, S.C.2	53 Princes-street, Prahran	Prahran ..	5.12.60	a, c, e
Dixon, Clifford ..	The Myer Emporium Ltd., Bourke-street, Melbourne	5 Wiltshire-street, Richmond	Melbourne ..	16.12.60	a, b, c, d, e
Dixon, Frank ..	33 Bird-avenue, Thornbury	33 Bird-avenue, Thornbury	Northcote ..	23.12.60	
Doody, Cyril Lawrence ..	Lawrence Mercantile Agency, 221 Lonsdale-street, Dandenong	57 Walker-street, Dandenong	Dandenong ..	23.11.60	c, e
Doody, Maxwell William	Lawrence Mercantile Agency, 221 Lonsdale-street, Dandenong	57 Walker-street, Dandenong	Dandenong ..	23.11.60	c, e
Douglas, Frank Edward	A.B.C. Investigating Agency, 21 Hillview-road, North Balwyn	21 Hillview-road, North Balwyn	Kew ..	29.11.60	A.B.C. Investigating Agency, 21 Hillview-road, North Balwyn
Dowdell, Bernard Paul ..	35 Como-street, Alphington	35 Como-street, Alphington	Heidelberg ..	13.1.61	
Dowling, Donald Julian	330 Lt. Collins-street, Melbourne	330 Lt. Collins-street, Melbourne	Melbourne ..	16.12.61	A.A. Investigations and Detective Agency, 330 Lt. Collins-street, Melbourne
Down, Graeme Leslie ..	7 Ely-street, Wangaratta	7 Ely-street, Wangaratta	Wangaratta ..	22.12.60	a, c, e
Downer, Arthur ..	11 Curlew-crescent, Norlane	11 Curlew-crescent, Norlane	Geelong ..	7.12.60	
Doyle, Glen William ..	146 Moorabool-street, Geelong	Leopold P.O., via Geelong	Geelong ..	7.12.60	e
Doyle, James ..	545 St. Kilda-road, Melbourne	545 St. Kilda-road, Melbourne	Prahran ..	5.12.60	a, b, c, d, e
Dunstan, Godfrey ..	"Kozlowski's", 55A Langtree-avenue, Mildura	139 Pasadene-grove, Mildura	Mildura ..	12.12.60	e
Easton, Rupert John ..	6 Boyd-street, Doncaster	6 Boyd-street, Doncaster	Kew ..	30.12.60	a, b, c, d, e
Ebbage, Alan Charles ..	244 Barkly-street, St. Kilda	244 Barkly-street, St. Kilda	St. Kilda ..	19.1.61	a, b, c, d, e
Edmonds, Archie Lambert	Room 16, 6th Floor, 37 Swanston-street, Melbourne	37 Swanston-street, Melbourne	Melbourne ..	16.12.60	a, c, e
Edwards, Ernest Charles	130 Abbotsford-street, North Melbourne	130 Abbotsford-street, North Melbourne	Melbourne ..	8.12.60	
Einsporn, John Albert ..	154 Minerva-road, Newtown, Geelong	154 Minerva-road, Newtown, Geelong	Geelong ..	7.12.60	a, b, c, d, e
Eldridge, Neville ..	26 Philip-street, Horsham	26 Philip-street, Horsham	Horsham ..	30.11.60	
Elvery, Stanley Gordon ..	c/o Miller's, Thompson's and Strachans	26 Bree-road, Hamilton	Hamilton ..	24.11.60	d
Emerson, Eric James ..	130 Abbotsford-street, North Melbourne	130 Abbotsford-street, North Melbourne	Melbourne ..	8.12.60	
Englander, Eric Simon ..	495 Collins-street, Melbourne	495 Collins-street, Melbourne	Melbourne ..	16.12.60	
Evans, Ernest ..	5 Pruden-street, Moe ..	5 Pruden-street, Moe ..	Moe ..	29.12.60	e
Fenton, John Mark ..	Dunn's Detective Agency, 119 Swanston-street, Melbourne	119 Swanston-street, Melbourne	Oakleigh ..	25.11.60	a, b, c, e
Fiddes, Lindsay Edward	57 Orange-avenue, Mildura	57 Orange-avenue, Mildura	Mildura ..	12.12.60	d, e
Finch, John William ..	Paul Strad Pty. Ltd. ..	67 Ormond-road, Moonee Ponds	Melbourne ..	16.12.60	e
Fleming, Malcolm Frank	540 Lt. Collins-street, Melbourne, Geronimo Investigation Service	540 Lt. Collins-street, Melbourne	Melbourne ..	16.12.60	a, b, c, d, e
Fletcher, Allan Richard ..	Eastern Star Mercantile Agency, 100 Denmark-street, Kew	100 Denmark-street, Kew	Frankston ..	27.1.61	
Flory, John Richard ..	5 Garnett-street, East Oakleigh, S.E.12	5 Garnett-street, East Oakleigh, S.E.12	Oakleigh ..	25.11.60	a, b, c, d, e
Fradkin, Raymond Harry	Lot 36, 16 Kallista-road, Springvale	16 Kallista-road, Springvale	Springvale ..	28.12.60	a, b, c, d, e
Fraser, Donald Alexander	Alliance Acceptance Co. Ltd., 636 St. Kilda-road, Melbourne	152 Oakleigh-road, Murrumbeena	St. Kilda ..	6.12.60	a, c, e

INQUIRY AGENTS' LICENCES ISSUED FOR THE YEAR 1961—continued.

Name of Licensee.	Business Address.	Registered Address.	Court of Issue.	Date of Issue.	Remarks. *(See footnote at end of list.)
Fraser, Noel Richard ..	Lawrence Mercantile Agency, Lonsdale-street, Dandenong	18 Essex-street, Glen Iris	Malvern ..	16.12.60	e
Freeland, Alan Bruce ..	10 Derby-crescent, Carnegie	10 Derby-crescent, Carnegie	Malvern ..	9.12.60	a, b, c, d, e
Fuller, Adrian Arthur Douglas	413A Elgar-road, Box Hill	413A Elgar-road, Box Hill	Box Hill ..	16.12.60	a, e
Fuller, William Kevin ..	College Mercantile Services, 60 Flinders-lane, Melbourne	Lot 74, Reilly-street, Ringwood	Box Hill ..	17.1.61	a, b, c, d, e
Fyfe, Alexander Wallace	264A Doncaster-road, North Balwyn	61 Flinders-lane, Melbourne	Box Hill ..	17.1.61	a, b, c, d, e, Director, Repossessions Incorporated
Garnaut, Louis Antony..	46 Bliburg-street, Broadmeadows	46 Bliburg-street, Broadmeadows	Broadmeadows	8.2.61	a, b, c, d, e
Gartner, David William Ross	130 Abbotsford-street, North Melbourne	130 Abbotsford-street, North Melbourne	North Melbourne	8.12.60	
Gidley, Thomas Henry ..	27 Mitchell-street, Northcote	27 Mitchell-street, Northcote	Northcote ..	9.12.60	a, b, c, d, e
Gillman, John Ernest ..	Suite 9 545 St. Kilda-road, Melbourne, S.C.3	Suite 9, 545 St. Kilda-road, Melbourne, S.C.3	Prahran ..	5.12.60	a, c, e, Director, Airlie Inquiry Agency, 545 St. Kilda-road, Melbourne
Godson, Peter Emile ..	71-73 Young-street, Frankston	Lot 41, Lloyd-street, Langwarrin	Frankston ..	9.12.60	e
Goldie, Sidney Jack ..	103 Hoddle-street, North Richmond	103 Hoddle-street, North Richmond	Richmond ..	13.12.60	a, c, e
Goodall, John Edward ..	1417 Malvern-road, Malvern	1417 Malvern-road, Malvern	Malvern ..	25.11.60	e
Goodwin, James ..	174 Kerferd-road, Albert Park	174 Kerferd-road, Albert Park	South Melbourne	19.12.60	d, e
Gourley, Albert Ronald..	35 Como-street, Alphington	14A Irving-place, Footscray	Heidelberg ..	16.12.60	a, b, c, d, e
Grant, Maxwell Gordon..	158 Barkly-street, Ararat	23 Hewitt-street, Ararat	Ararat ..	9.12.60	
Grant, Stuart Donald ..	540 Lt. Collins-street, Melbourne	540 Lt. Collins-street, Melbourne	Molbourne ..	31.1.61	
Gray, Dorothy Maae ..	340-342 Nicholson-street, Fitzroy, N.6	342 Nicholson-street, Fitzroy, N.6	Fitzroy ..	15.12.60	a, c, e, Gray's Mercantile Agency
Gray, Leon Allan ..	Lake Boga, Victoria	Lako Boga, Victoria ..	Swan Hill ..	14.12.60	d, e
Gray, Maurice George ..	7 Campbell-street, Frankston	7 Campbell-street, Frankston	Frankston ..	21.12.60	a, b, c, d, e
Green, Robert John ..	25 Bluff-road, Black Rock Coast Patrol Service, Torquay Golf Club	25 Bluff-road, Black Rock	Sandringham ..	14.12.60	a, b, c, d, e
Green, Vivian Bryan ..	18 Munday-street, Torquay	18 Munday-street, Torquay	Geelong ..	7.12.60	a, b, c, d, e, Coast Patrol Service
Gribben, Lloyd William ..	14 Knight-street, Shepparton	14 Knight-street, Shepparton	Shepparton ..	8.12.60	a, b, c, d, e
Grigg, William ..	49 Davies-street, Glenroy, W.9	49 Davies-street, Glenroy, W.9	Glenroy ..	9.12.60	a, c, d, e
Guyot, Keith Adrian ..	Alliance Acceptance Co. Ltd., 636 St. Kilda-road, Melbourne	38 Jack-road, Cheltenham	St. Kilda ..	6.12.60	e
Hackett, Thomas Henry	76 Lt. Malop-street, Geelong and 54 Malop-street, Geelong	Leopold-street, Geelong	Geelong ..	7.12.60	a, e
Hall, Eric William ..	177 Princes-highway, Dandenong	177 Princes-highway, Dandenong	Dandenong ..	23.11.60	e
Hall, George Felix ..	Piangil Garage, Piangil	Piangil Garage, Piangil	Nyah West ..	21.12.60	e
Hamilton, Ferguson ..	26 Melbourne-road, Norlane, and 35 Como-street, Alphington ..	26 Melbourne-road, Norlane	Geelong ..	7.12.60	e
Hankinson, John ..	13 Smith-road, Springvale North	13 Smith-road, Springvale North	Springvale ..	7.12.60	a, b, c, d, e
Hansen, Peter John ..	Purchase Credit Corp. Pty. Ltd., 157 Commercial-road South Yarra, S.E.1	157 Commercial-road, South Yarra, S.E.1	Prahran ..	13.1.61	
Harman, Graham George	441 Bay-street, Brighton	441 Bay-street, Brighton	Brighton ..	13.1.61	a, b, c, d, e
Harrison, John Joseph ..	366 Bridge-road, Richmond	17 Carnegie-avenue, North Kew	Richmond ..	21.12.60	a, b, c, d, e
Harrison, John William..	7 Hardwicke-street, Balwyn	7 Hardwicke-street, Balwyn	Camberwell ..	1.12.60	a, b, c, d, e
Hawkins, Raymond Alexander	21 Hillview-road, North Balwyn	c/o A.B.C. Investigating Agency, 21 Hillview-road, North Balwyn	Kew ..	24.11.60	a, b, c, d, e
Helps, Barbara Anne ..	117 Drummond-street, Carlton, N.3	117 Drummond-street, Carlton, N.3	Carlton ..	8.12.60	a, b, c, d, e
Helps, George ..	117 Drummond-street, Carlton, N.3	117 Drummond-street, Carlton, N.3	Carlton ..	8.12.60	a, b, c, d, e
Heywood, Stuart ..	H. G. Palmers, Bridge-road, Richmond	38 Clarendon-parade, West Footscray	Richmond ..	28.2.61	a, b, c, d, e
Hill, Benjamin Ashton ..	29 Myalla-street, Braybrook	29 Myalla-street, Braybrook	Sunshine ..	6.12.60	
Hinchliffe, James Anderson	21 Hillview-road, North Balwyn	21 Hillview-road, North Balwyn	Kew ..	28.11.60	
Hogben, George ..	63 Garsed-street, Bendigo	63 Garsed-street, Bendigo	Bendigo ..	14.12.60	
Holloway, Alan Murray..	c/o Laver's Pty. Ltd., Nyah West	O'Connor-street, Nyah West	Nyah West ..	21.12.60	a, b, c, d, e

INQUIRY AGENTS' LICENCES ISSUED FOR THE YEAR 1961—continued.

Name of Licensee.	Business Address.	Registered Address.	Court of Issue.	Date of Issue.	Remarks. *(See footnote at end of list.)
Holmberg, Amelia Janie ..	20 Manuka-street, South Oakleigh	20 Manuka-street, South Oakleigh	Oakleigh ..	25.11.60	
Hough, John Alexander	The Myer Emporium Ltd., Bourke-street, Melbourne	34 Walnut-street, Ormond	Melbourne ..	10.1.61	a, b, c, d, e
Houston, John Clarence	119 Swanston-street, Melbourne	119 Swanston-street, Melbourne	Melbourne ..	16.12.60	
Hughes, Anthony Joseph	33 Bird-avenue, Thornbury, N.17	33 Bird-avenue, Thornbury, N.17	Northcote ..	23.12.60	
Hughes, Evan Morris ..	31 Queen-street, Melbourne	31 Queen-street, Melbourne	Melbourne ..	16.12.60	a, b, c, d, e
Hughes, William ..	7 Pretoria-street, Deepdene	7 Pretoria-street, Deepdene	Camberwell ..	1.12.60	a, b, c, d, e
Humphreys, Bruce M. ..	12 Gardiner-street, North Melbourne	12 Gardiner-street, North Melbourne	North Melbourne	8.12.60	e
Humphrys, Charles ..	cnr. Kingsway and South-road, Moorabbin, S.20	cnr. Kingsway and South-road, Moorabbin, S.20	Brighton ..	16.12.60	Mercantile Recoveries
Hunter, Arthur James ..	c/o Eumcralla Finance Co., 164 Hawthorn-road, Caulfield, and Magnetic Motors, 634 South-road, Moorabbin	15 Veronica-street, Lower Ferntree Gully	Elsternwick ..	30.11.60	e
Humphreys, Francis George Marland	F. J. Marland Pty. Ltd., 12 Gardiner-street, North Melbourne	12 Gardiner-street, North Melbourne	North Melbourne	8.12.60	a, b, c, d, e
Hunter, William Watson	c/o Metropolitan Night Patrol Service Pty. Ltd., 130 Abbotsford-street, North Melbourne	130 Abbotsford-street, North Melbourne	North Melbourne	8.12.60	a, b, c, d, e
Hurley, James Sydney ..	36 McKellar-street, Benalla	36 McKellar-street, Benalla	Benalla ..	5.12.60	a, b, c, d, e
Hurley, Thomas Henry ..	8 Peak-street, Chadstone, S.E.10	8 Peak-street, Chadstone, S.E.10	Oakleigh ..	25.11.60	a, b, c, d, e
Hutchinson, Graham Ralph	130 Abbotsford-street, North Melbourne	130 Abbotsford-street, Melbourne	North Melbourne	8.12.60	
Huxtable, Albert Edward	Electrical Supply and Service, 163 Latrobe-street, Melbourne	3 Ararat-avenue, North Coburg	Melbourne ..	16.12.60	a, c, e
Jacobsen, Charles Edward	242 Barkly-street, Footscray	55 Geelong-road, Footscray	Footscray ..	14.12.60	
Jacobson, Eric William ..	Finsborough-street, Moorabbin	Finsborough-street, Moorabbin	Shepparton ..	8.12.60	e
Jacobsen, William Graham	Industrial Acceptance Corporation, 60 Collins-place, Melbourne	11 Haywood-street, Beaumaris	Melbourne ..	16.12.60	
James, Percy Alexander	1 Alce-street, Mt. Waverley	1 Alce-street, Mt. Waverley	Oakleigh ..	25.11.60	e
James, Rutland Evelynne	Karran House, 68 Yarra-street, Geelong	Karran House, 68 Yarra-street, Geelong	Geelong ..	7.12.60	a, c, e
Jamieson, James Harvey	Automatic Finance Co., 505 St. Kilda-road, Melbourne	505 St. Kilda-road, Melbourne	South Melbourne	2.12.60	a, c, d, e
Jensen, Ian Thomas ..	19 South-crescent, Westgarth	19 South-crescent, Westgarth	Northcote ..	9.12.60	a, b, c, d, e
Johansen, Loif Normann Ludvik	45 Loughnan-road, Ringwood	45 Loughnan-road, Ringwood	Ringwood ..	6.12.60	a, b, c, d, e
Johnstone, Robert Julian	Linton Inquiry Agency, Centre-road, Bentleigh	"Fairfields," Bayles, Victoria	Dandenong ..	23.11.60	e
Jones, Douglas Francis Godridge	35 Como-street, Alphington	35 Como-street, Alphington	Heidelberg ..	16.12.60	a, c, d, e
Jones, Francis William	35 Como-street, Alphington	35 Como-street, Alphington	Heidelberg ..	16.12.60	a, c, d, e
Jones, John Arthur ..	158 Charles-street, Abbotsford	158 Charles-street, Abbotsford	Collingwood ..	28.11.60	a, b, c, d, e
Jones, Ronald Gilbert ..	Modern General Electric, 280 Lonsdale-street, Melbourne	280 Lonsdale-street, Melbourne	Melbourne ..	16.12.60	e
Jones, Thomas Lloyd ..	30 Dunlop-avenue, Ascot Vale, Box 5139 AA, G.P.O., Melbourne	30 Dunlop-avenue, Ascot Vale	Melbourne ..	16.12.60	a, e
Kearns, Goerge Patrick ..	29 Chestnut-road, Doveton	29 Chestnut-road, Doveton	Dandenong ..	28.12.60	d
Kelly, Norman James ..	Linton Inquiry Agents, Box 27, Bentleigh	99 Hotham-street, East Melbourne	Richmond ..	13.12.60	e
Kelly, Richard Francis ..	744 High-street, Golden Square	744 High-street, Golden Square	Bendigo ..	14.12.60	a, b, c, d, e
King, Bryan Thomas ..	152 Boundary-road, Geelong	152 Boundary-road, Geelong	Geelong ..	7.12.60	
King, Raymond Ian ..	Grange Mercantile Agency, 19 Port Fairy-road, Hamilton	19 Port Fairy-road, Hamilton	Hamilton ..	1.12.60	a, c, e, Partner, Grange Mercantile Agency
Kirk, Joseph John ..	2 Boynton-street, East Bentleigh	2 Boynton-street, East Bentleigh	Cheltenham ..	21.12.60	a, b, c, e
Kirry, Mike ..	67 Kooyong-road, Caulfield	67 Kooyong-road, Caulfield	Melbourne ..	30.11.60	a, b, c, d, e, Mike's Detective Agency
Kirwan, Reginald Joseph	3 Nita-street, Geelong, W.9	3 Nita-street, Geelong, W.9	Geelong ..	9.12.60	a, b, c, d, e

INQUIRY AGENTS' LICENCES ISSUED FOR THE YEAR 1961—continued.

Name of Licensee.	Business Address.	Registered Address.	Court of Issue.	Date of Issue.	Remarks. *(See footnote at end of list.)
Laming, Wallace Arthur	21 Hillview-road, North Balwyn	24 Templestowe-road, Bulleen	Kew ..	22.12.60	
Lea, Thomas Flint ..	21 Hartington-street, Kew	21 Hartington-street, Kew	Kew ..	28.11.60	a, c, e
Leonard, John ..	441 Bay-street, Brighton	441 Bay-street, Brighton	Brighton ..	13.1.61	
Lewis, Ernest William ..	Echuca ..	Echuca P.O. ..	Echuca ..	3.1.61	a, c, d, e
Lewis, John Charles Brinley	540 Lt. Collins-street, Melbourne	540 Lt. Collins-street, Melbourne	Melbourne ..	8.3.61	
Lippegoes, Kevin John	151A McKinnon-road, McKinnon	4 Geum-street, Glenroy	Oakleigh ..	25.11.60	a, c, e
Lockhart, Eric John ..	Webb's Radio and Electrical Pty. Ltd., 525 North-road, Ormond	595 Glenhuntly-road, Elsternwick	Brighton ..	16.12.60	a, b, c, d, e
Lovell, Thomas Alexander	Lot 36, Japonica-grove, Frankston	Lot 36, Japonica-grove, Frankston	Frankston ..	9.12.60	e
Lowe, Victor Waldock ..	Flat 6, 1 Terrens-close, Moorabbin	Flat 6, 1 Terrens-close, Moorabbin	Brighton ..	16.12.60	a, b, c, e
Lynch, Kevin Francis ..	284 Lonsdale-street, Melbourne	284 Lonsdale-street, Melbourne	Melbourne ..	16.12.60	
Lyons, Neville William ..	53 Bourke-street, Melbourne	53 Bourke-street, Melbourne	Melbourne ..	16.12.60	a, b, c, d, e
McCleery, Robert Keith	161 Sturt-street, South Melbourne	161 Sturt-street, South Melbourne	South Melbourne ..	2.12.60	a, b, c, d, e
McConaghy, Robert Andrew	Grange Mercantile Agency, 19 Port Fairy-road, Hamilton	6 Riverview-terrace, Belmont	Hamilton ..	1.12.60	a, b, c, d, e
McConechy, Howard Norman	36A Hampton-street, Hampton	36A Hampton-street, Hampton	Cheltenham ..	21.12.60	e
McDonald, Donald Robert	699 North-road, Carnegie, and 403A St. Kilda-road, Melbourne	403A St. Kilda-road, Melbourne	Oakleigh ..	25.11.60	a, b, c, d, e
McDonald, Neil Alistair ..	45 Hughes-street, Upwey	45 Hughes-street, Upwey	Ferntree Gully ..	12.12.60	a, b, c, d, e
McDonald ..	414 Lonsdale-street, Melbourne	414 Lonsdale-street, Melbourne	Melbourne ..	16.12.60	a, c, e
McGeorge, Stanley John	Sunset Investigation Service, 25 Keith-street, Moorabbin	25 Keith-street, Moorabbin	Sandringham ..	14.12.60	e
McIntosh, James Edwin	8 Frederick-street, South Caulfield	8 Frederick-street, South Caulfield	Elsternwick ..	30.11.60	a, b, c, d, e
Mack, Bernard Harcourt	30 Koornang-road, Carnegie	22 Marma-road, Murrumbena	Oakleigh ..	25.11.60	
McKay, Kevin Joseph ..	46 Angliss-street, Kingsville, W.13	46 Angliss-street, Kingsville, W.13	Footscray ..	14.12.60	
MacKechnie, George Walter	Webb's Radio and Electrical Pty. Ltd., 525 North-road, Ormond	Aiden Flats, 2 Marine-parade, St. Kilda	St. Kilda ..	24.11.60	e
McKenzie, Donald Alexander	63 Midlothian-street, Chadstone	63 Midlothian-street, Chadstone	Oakleigh ..	30.12.60	
McKenzie, Marie Ellen ..	63 Midlothian-street, Chadstone	63 Midlothian-street, Chadstone	Oakleigh ..	30.12.60	
McLachlan, Ewan Lachlan	Lawrence Mercantile Agency	10 Deakin-crescent, Dandenong	Dandenong ..	23.11.60	c, e
McNulty, Bryan ..	Mailor's Flat, via Warrnambool, and Box 222, Warrnambool	Mailor's Flat, via Warrnambool	Warrnambool ..	31.12.60	
Macklan, Kevin Hugh ..	8 Church-street, Wodonga	8 Church-street, Wodonga	Wodonga ..	22.12.60	e
Maddison, Gilbert Tyndall	150 Fordham-avenue, Hartwell	150 Fordham-avenue, Hartwell	Camberwell ..	19.12.60	a, c, e
Martin, James ..	c/o Victor's Detective Bureau, 473 Bourke-street, Melbourne	c/o Victor's Detective Bureau, 473 Bourke-street, Melbourne	Melbourne ..	16.12.60	
Mason, Stanley Robert ..	9 Windsor-street, Pascoe Vale	9 Windsor-street, Pascoe Vale	Coburg ..	29.12.60	a, b, c, d, e
Massey, Alan William ..	W. H. and S. Massey Pty. Ltd., 377 Williamstown-road, Yarraville	377 Williamstown-road, Yarraville	Footscray ..	14.12.60	
Maydom, Frank Ross ..	420 St. Kilda-road, Melbourne	17 Devoy-street, South Oakleigh	Prahran ..	5.12.60	e
Medlyn, Kevin James ..	35 Como-street, Alphington	35 Como-street, Alphington	Heidelberg ..	16.12.60	a, b, c, d, e
Meredith, Lyn Edwin ..	55 Fawknor-street, St. Kilda	55 Fawknor-street, St. Kilda	St. Kilda ..	24.11.60	e
Merlin, Robert Tennant	13 Felicia-street, Mordialloc	13 Felicia-street, Mordialloc	Mordialloc ..	8.12.60	e
Miller, Alfred Fraser ..	The Myer Emporium Ltd., Bourke-street, Melbourne	110 South-road, Brighton	Melbourne ..	16.12.60	a, b, c, d, e
Mills, Edward John ..	Lot 11, Austin-road, Seaford	Lot 11, Austin-road, Seaford	Tecoma ..	2.12.60	e
Minchin, Devon George ..	Metropolitan Security Services Pty. Ltd., 82 Jolimont-street, Melbourne, C.2., and 71 New-street, Balgowlah, N.S.W.	82 Jolimont-street, Melbourne	Melbourne ..	16.12.60	

INQUIRY AGENTS' LICENCES ISSUED FOR THE YEAR 1961—continued.

Name of Licensee.	Business Address.	Registered Address.	Court of Issue.	Date of Issue.	Remarks. *(See footnote at end of list.)
Moon, Ronald Edward Kenneth	c/o 166-172 Mitchell-street, Bendigo	8 Somerville-street, Bendigo	Bendigo ..	14.12.60	a, e
Morey, William George ..	c/o Malcoe Mercantile Agency, 27 Nunns-road, Mornington	27 Nunns-road, Mornington	Mornington ..	7.12.60	a, b, c, d, e
Morley, Reginald Stanley	10 Church-street, Wodonga	10 Church-street, Wodonga	Wodonga ..	8.12.60	
Morris, Charles Philip ..	136 Johnston-street, Collingwood	98 Nicholson-street, Abbotsford	Collingwood ..	28.11.60	
Morris, Esther Jean ..	136 Johnston-street, Collingwood	98 Nicholson-street, Abbotsford	Collingwood ..	28.11.60	
Moss, Charles Manning ..	Burwood-road, Ferntree Gully	Burwood-road, Ferntree Gully	Ferntree Gully	12.12.60	e
Murnane, Albert John ..	10 Princess-street, Warrnambool	P.O. Box 207, Warrnambool	Warrnambool..	31.12.60	a, b, c, d, e
Murphy, John ..	171 Auburn-road, Auburn	171 Auburn-road, Auburn	Hawthorn ..	30.11.60	d
Murray, Donald Buchanan	Flat 1, 5 Inkerman-street, St. Kilda	Flat 1, 5 Inkerman-street, St. Kilda	St. Kilda ..	24.11.60	a, c, e
Murray, William John	Grange Mercantile Agency, 19 Port Fairy-road, Hamilton	Digby-road, Hamilton..	Hamilton ..	1.12.60	a, b, c, d, e
Myers, Allan G. ..	Geelong-road, Torquay	Geelong-road, Torquay	Geelong ..	7.12.60	
Myskowski, Edward ..	28 Watt-street, Spotswood, W.14	28 Watt-street, Spotswood, W.14	Footscray ..	14.12.60	
Nagel, Maxwell Edward ..	c/o Lawrence Mercantile, Lonsdale-street, Dandenong	28 Murray-drive, Burwood	Camberwell ..	12.12.60	e
Neale, Andrew Edward ..	427 Elizabeth-street, Melbourne, C.I.	427 Elizabeth-street, Melbourne, C.I.	Melbourne ..	16.12.60	a, e
Neary, Henry Paul ..	3 Patrick-street, Bendigo	3 Patrick-street, Bendigo	Bendigo ..	14.12.60	e
Nettleton, Robert Lindsay	38 Frome-avenue, Frankston	38 Frome-avenue, Frankston	Frankston ..	2.12.60	
Newman, Cyril Richard ..	Lot 23, Donald-street, Clayton	Lot 23, Donald-street, Clayton	Oakleigh ..	16.12.60	a, b, c, e
Newton, Gordon Alexander	Torquay-road, Grovedale	Torquay-road, Grovedale	Geelong ..	7.12.60	a, b, c, d, e
Nickelson, Robert George	16 Raleigh-street, Essendon	16 Raleigh-street, Essendon	Melbourne ..	16.12.60	
Nickelson, William James	16 Raleigh-street, Essendon	16 Raleigh-street, Essendon	Melbourne ..	16.12.60	
Nicolle, John Irvin ..	112 High-street, Preston, N.18	5 Ryde-street, Preston, N.18	Preston ..	20.12.60	a, b, c, d, e
Nicolle, Kathleen Mary ..	112 High-street, Preston, N.18	5 Ryde-street, Preston, N.18	Preston ..	20.12.60	a, b, c, d, e
Niland, Colin James ..	120 Beverley-road, Rosanna	120 Beverley-road, Rosanna	Hawthorn ..	30.12.60	e
Nixon, Frederick Elliott	163 Latrobe-street, Melbourne	99 Harold-street, Thornbury, N.17	Melbourne ..	16.12.60	e
O'Brien, Martin Francis	19 Bella Vista-road, Glen Iris	19 Bella Vista-road, Glen Iris	Malvern ..	16.12.60	a, b, c, d, e
Oldham, John Christopher Clark	51 Queen-street, Melbourne	2 Park-street, South Yarra	Melbourne ..	16.12.60	a, c, e
O'Neill, Kevin William ..	540 Lt. Collins-street, Melbourne	540 Lt. Collins-street, Melbourne	Melbourne ..	16.12.60	a, b, c, d, e
O'Shea, Anthony Francis	Ace Investigation Service, 28 Watt-street, Spotswood, W.14	28 Watt-street, Spotswood	Footscray ..	14.12.60	a, b, c, d, e
Osmond, Kenneth Russell	79 Hodder-street, East Brighton	79 Hodder-street, East Brighton	Brighton ..	24.2.61	a, b, c, d, e
Paroissien, Keith Lewis ..	130 Abbotsford-street, North Melbourne, and 343 Lt. Collins-street, Melbourne	19 Sherwood-street, Glen Iris	Melbourne ..	8.12.60	a, b, c, d, e, Metropolitan Night Patrol Service Pty. Ltd.
Pascoe, Thomas Marwood Russell	112A Armstrong-street, Ballarat	112A Armstrong-street, Ballarat	Ballarat ..	24.11.60	e
Patching, Allen Leo ..	7 Piper-street, Fawkner, and 77 Bourke-street, Melbourne	7 Piper-street, Fawkner	Coburg ..	13.12.60	a, b, c, d, e, Northern Security Agency
Patrick, David ..	3 Lysbeth-street, McKinnon	3 Lysbeth-street, McKinnon	Brighton ..	16.12.60	a, b, c, d, e
Patterson, Clifford Norman	Eastern Mercantile Agency, 100 Denmark-street, Kew	30 Raleigh-road, Maryborough	Kew ..	3.2.61	
Paull, Graham Charles ..	21 Lloyd-street, Moe, and Fowler-street, Moe	21 Lloyd-street, Moe ..	Moe ..	15.12.60	Paull's Complete Home Furnishers Pty. Ltd.
Percy, Hamilton Caldwell	38 Llaneast-street, Malvern	38 Llaneast-street, Malvern	Malvern ..	25.11.60	a, b, c, d, e
Perry, Beales Walter ..	Gippsland Acceptance Ltd., 221 Lonsdale-street, Dandenong	13 Percy-street, Dandenong	Dandenong ..	23.11.60	a, c, d, e
Pert, Charles Amos ..	Stawell ..	Stawell Security Service, 7 Allen-crescent, Stawell	Stawell ..	15.12.60	
Phelts, Donald Southwood	380 Somerville-road, West Footscray	380 Somerville-road, West Footscray	Footscray ..	14.12.60	

INQUIRY AGENTS' LICENCES ISSUED FOR THE YEAR 1961—*continued.*

Name of Licensee.	Business Address.	Registered Address.	Court of Issue.	Date of Issue.	Remarks. *(See footnote at end of list.)
Power, William Patrick ..	25 Khartoum-street, Burnley	Box 106, Camberwell ..	Richmond ..	13.12.60	
Primmer, John Allan ..	44p Purinuan-road, Reservoir, N.19	44p Purinuan-road, Reservoir, N.19	Preston ..	20.12.60	e
Proper, John William ..	459 Lt. Collins-street, Melbourne	47 Millswyn-street, South Yarra, S.E.1	Melbourne ..	16.12.60	a, b, c, d, e
Prowse, John Maurice ..	60 Dudley-street, West Melbourne	60 Dudley-street, West Melbourne	Melbourne ..	16.12.60	a, c, e
Rainford, Charles Ernest	Classic Radio and Television Pty. Ltd., and Coronot Investments Pty. Ltd.	80 Waverley-road, East Malvern	Malvern ..	25.11.60	a, b, c, e
Reid, Raymond Edward	Lonsdale General Electrics, 251 Swanston-street, Melbourne, C.1	22 Holland-street, Maidstone	Footscray ..	14.12.60	c, e
Renton, Raymond John	12 Devoy-street, South Oakleigh	12 Devoy-street, South Oakleigh	Oakleigh ..	25.11.60	a, b, c, d, e
Reynolds, Keith Basil ..	95 Johnston-street, Collingwood	76 Carlisle-street, St. Kilda	Collingwood ..	28.11.60	
Riddle, Reginald George	Lawrence Mercantile Agency, Mayfair Arcade, Dandenong	Mayfair Arcade, Dandenong	Dandenong ..	1.3.61	a, c, d, e
Rigby, Lawrence Valentine	739 Heidelberg-road, Alphington	739 Heidelberg-road, Alphington	Heidelberg ..	16.12.60	a, b, e
Riley, William Joseph ..	413A Elgar-road, Box Hill	413A Elgar-road, Box Hill	Box Hill ..	16.1.61	a, c, e
Roach, Frank ..	81 King-street, Bendigo	81 King-street, Bendigo	Bendigo ..	14.12.60	
Roberts, Gordon Lindsay	The Myer Emporium Ltd., Bourke-street, Melbourne	62 Hightt-road, Hampton	Melbourne ..	16.12.60	a, c, d, e
Robertson, William Kenneth	133 Bluff-road, Black Rock	28 Hotham-street, Beaumaris	Sandringham ..	14.12.60	e
Robson, Kenneth Milton	38 Cherry-avenue, Mildura	38 Cherry-avenue, Mildura	Mildura ..	15.12.60	a, b, c, d, e
Robson, William Victor ..	13 Kokoda-street, West Heidelberg	13 Kokoda-street, West Heidelberg	Heidelberg ..	16.12.60	a, b, c, d, e
Rodgers, Charles Edward	Sale ..	29 York-street, Sale ..	Sale ..	13.12.60	a, b, c, e
Roffey, Eric Francis ..	72 Benjamin-street, Sunshine	Box 67, P.O., Sunshine	Sunshine ..	6.12.60	e
Rohen, William Robert ..	289 Swanston-street, Melbourne	23 McLachlan-street, Westgarth	Melbourne ..	16.12.60	a, c, e
Rouda, Anwar Richard ..	308 Lygon-street, Carlton	308 Lygon-street, Carlton	Carlton ..	8.12.60	a, b, c, d, e, Anwar's Private Detective and Investigation Agency
Runting, Alan Lindsay ..	51 Queen-street, Melbourne	51 Queen-street, Melbourne	Melbourne ..	16.12.60	a, e
Scammell, Walter Ingram	540 Lt. Collins-street, Melbourne	540 Lt. Collins-street, Melbourne	Melbourne ..	16.12.60	
Schubert, Konrad ..	96 Malop-street, Geelong	14 Eureka-street, West Geelong	Geelong ..	7.12.60	
Scott, Edwin ..	471-473 South-road, Moorabbin	471-473 South-road, Moorabbin	Cheltenham ..	21.12.60	a, b, c, d, e
Scott, Ronald ..	19 Clifton-avenue, Clifton Hill	19 Clifton-avenue, Clifton Hill	Collingwood ..	15.12.60	
Scott, Russell Bray ..	81 The Boulevard, Ivanhoe	81 The Boulevard, Ivanhoe	Heidelberg ..	16.12.60	a, b, c, d, e
Seary, Dale ..	Metropolitan Night Patrol Service, 130 Abbotsford-street, North Melbourne	Flat 3, 119 Alma-road, East St. Kilda	Kew ..	24.11.60	e
Seers, Peter Frederick ..	Linton Inquiry Agency, 341 Centre-road, Dandenong	36 Melbourne-road, Dandenong	Dandenong ..	23.11.60	a, b, c, d, e
Selleck, Harold Edward	59 Decarle-street, Brunswick	59 Decarle-street, Brunswick	Brunswick ..	14.12.60	a, b, c, d, e
Selleck, James ..	59 Decarle-street, Brunswick	8 Lord-street, Fawkner	Brunswick ..	14.12.60	c, e
Shallcross, Eric Harry ..	1 Ringwood-street, Ringwood	1 Ringwood-street, Ringwood	Ringwood ..	6.12.60	e
Shanhun, Kevin James ..	211 Rathsay-road, Montmorency	211 Rathsay-road, Montmorency	Eltham ..	13.12.60	a, b, c, d, e
Sharman, Howard Alfred	8 Victoria-street, Warragul	8 Victoria-street, Warragul	Warragul ..	9.12.60	e
Sherren, Francis John Roy	5 Albert-road, Carnegie, and 76 Chaucer-street, St. Kilda	5 Albert-road, Carnegie	Elsternwick ..	30.11.60	
Shields, Ernest N. ..	416 Lydiard-street, Ballarat North	416 Lydiard-street, Ballarat North	Ballarat ..	24.11.60	a, b, c, e
Simmons, William John ..	27 Mars-crescent, Ararat	27 Mars-crescent, Ararat	Ararat ..	9.12.60	
Sinclair, Ronald Gordon	Childers-street, Cranbourne	Childers-street, Cranbourne	Cranbourne ..	7.12.60	
Skipworth, Alan William	11 Huon-grove, Ashburton	11 Huon-grove, Ashburton	Camberwell ..	1.12.60	
Sleeth, John Albert ..	6 Young-street, Ballarat	6 Young-street, Ballarat	Ballarat ..	24.11.60	e
Smith, Arthur Herbert ..	35 Como-street, Alphington	35 Como-street, Alphington	Heidelberg ..	16.12.60	c, e
Smith, Albert James ..	25 Bryant-road, Dandenong	25 Bryant-road, Dandenong	Dandenong ..	9.1.61	

INQUIRY AGENTS' LICENCES ISSUED FOR THE YEAR 1961—continued.

Name of Licensee.	Business Address.	Registered Address.	Court of Issue.	Date of Issue.	Remarks. *(See footnote at end of list.)
Smith, Charles Thomas ..	118 Wyndham-street, Shepparton	118 Wyndham-street, Shepparton	Shepparton ..	8.12.60	e
Smith, George Alexander (Jnr.)	87 Bulleen-road, North Balwyn	The Elite Detective Agency, 87 Bulleen-road, North Balwyn	Kew ..	24.11.60	
Smith, Kenneth Arthur	366 Bridge-road, Richmond	167 Victoria-parade, Fitzroy	Richmond ..	21.20.60	a, c, e
Smith, Robert Rodger ..	441 Bay-street, Brighton	441 Bay-street, Brighton	Brighton ..	13.1.61	a, b, c, d, e
Sonnberger, Graeme Gordon	130 Abbotsford-street, North Melbourne	130 Abbotsford-street, North Melbourne	North Melbourne	20.12.60	
Sonnberger, Joseph Ludwig	130 Abbotsford-street, North Melbourne	130 Abbotsford-street, North Melbourne	North Melbourne	8.12.60	Metropolitan Night Patrol Services Pty. Ltd., 343 Lt. Collins-street, Melbourne
Spearing, Kenneth Stanley	110 Landells-road, Pascoe Vale	110 Landells-road, Pascoe Vale	Coburg ..	10.1.61	a, c, d
Stanyer, John Keith ..	Travalley Motors Pty. Ltd., Princes-highway, Morwell	8 View-street, Moe ..	Morwell ..	13.12.60	a, b, c, d, e
Stapleton, Roger Patrick	Industrial Acceptance Corp., 60 Collins-place, Melbourne	8 Norville-street, East Bentleigh	Melbourne ..	16.12.60	e
Stevens, David Gordon ..	Gregory-street, Ouyen ..	Gregory-street, Ouyen	Ouyen ..	15.12.60	a, b, c, d, e
Stevens, Douglas Lloyd George	St. Albans Building Supplies Pty. Ltd., 20-22 East Esplanade, St. Albans, and 298 Main-road East, St. Albans	298 Main-road East, St. Albans	Sunshine ..	6.12.60	e
Sutherland, Frederick Thomas	"Morson Court", Main-street, Belgrave	"Morson Court", Main-street, Belgrave	Ferntree Gully	12.12.60	
Sutton, Lindsay Charles	Linton Inquiry Agency, 341 Centre-road, Bentleigh	341 Centre-road, Bentleigh	Brighton ..	16.12.60	a, b, c, d, e
Swenson, Peter Roy ..	36 Morinda-street, East Ringwood	36 Morinda-street, East Ringwood	Ringwood ..	6.12.60	a, b, c, e
Sykes, Robert Ernest ..	Industrial Security Service, 290A Coventry-street, South Melbourne, S.C.5	290 Coventry-street, South Melbourne	South Melbourne	2.12.60	
Tanner, Harold ..	27 Kellarny-road, Lower Templestowe	27 Kellarny-road, Lower Templestowe	Heidelberg ..	16.12.60	a, b, c, d
Tate, Andrew Ian ..	Victor's Detective Bureau, 473 Bourke-street, Melbourne, C.1	Victor's Detective Bureau, 473 Bourke-street, Melbourne, C.1	Melbourne ..	16.12.60	
Taylor, Harold Edwin ..	229 Barkly-avenue, Burnley, E.1	229 Barkly-avenue, Burnley, E.1	Richmond ..	20.12.60	
Thompson, Robert Jefferson	84 Whitlaw-street, Reservoir	84 Whitlaw-street, Reservoir	Preston ..	29.12.60	
Tresize, John Colin Maxwell	Laurence Mercantile Agency, Dandenong	Kidds-road, Dandenong	Dandenong ..	7.12.60	a, b, c, d, e
Trytell, Braham ..	363 Clarendon-street, South Melbourne	363 Clarendon-street, South Melbourne	South Melbourne	21.12.60	a, c, e
Turner, Constance Louisa	13A, 123 William-street, Melbourne	13A, 123 William-street, Melbourne	Melbourne ..	16.12.60	
Turner, Robert ..	13A, 123 William-street, Melbourne	13A, 123 William-street, Melbourne	Melbourne ..	16.12.60	a, b, c, d, e
Van-Es, Joseph Maria ..	Country Car Sales Pty. Ltd., 141-149 Lonsdale-street, Dandenong	24 Bryants-road, Dandenong	Dandenong ..	6.3.61	a, b, c, d, e
Vecens, Janis ..	24 Loch-street, St. Kilda West	24 Loch-street, St. Kilda West	St. Kilda ..	4.1.61	a, b, c, d, e
Vercoe, Bryant Henry ..	27 Nunns-road, Mornington	27 Nunns-road, Mornington	Mornington ..	7.12.60	b, c, d, e, Malcoe Agency
Vernon, James Frederick	92 Victoria-crescent, Mont Albert, E.10	92 Victoria-crescent, Mont Albert, E.10	Box Hill ..	16.12.60	a, b, c, d, e
Vincent, Ronald William	348 Lygon-street, East Brunswick	154 Blyth-street, East Brunswick	Brunswick ..	14.12.60	
Vincent, William Herbert Patrick	51 Queen-street, Melbourne	51 Queen-street, Melbourne	Melbourne ..	16.12.60	a, c, e
Walker, Geoffrey Ernest	9 Wimbleton-avenue, Elwood	9 Wimbleton-avenue, Elwood	St. Kilda ..	24.11.60	
Walton, John Andrew ..	Express Mercantile Agency, 151A McKinnon-road, McKinnon	151A McKinnon-road, McKinnon	Brighton ..	16.12.60	a, e, Express Mercantile Agency
Warner, Colleen ..	20 Ashlar-road, Moorabbin	20 Ashlar-road, Moorabbin	Cheltenham ..	21.12.60	
Watson, Robert George	365 Dandenong-road, Clayton, and 151A McKinnon-road, McKinnon	365 Dandenong-road, Clayton	Oakleigh ..	25.11.60	a, b, c, d, e
Weston, John Boaz ..	Flinders-road, Merricks, and 100 Denmark-street, Kew	Flinders-road, Merricks	Hastings ..	23.12.60	c, e
Wheeler, Alan Ronald ..	Waltons, Mack Furnishing Co., and Permewan Davis	16 Monash-street, Preston	Preston ..	20.12.60	e

INQUIRY AGENTS' LICENCES ISSUED FOR THE YEAR 1961—continued.

Name of Licensee.	Business Address.	Registered Address.	Court of Issue.	Date of Issue.	Remarks. *(See footnote at end of list.)
White, James Creighton	Brennan's Investigations, Kunyung-road, Mt. Eliza	56 Robert-street, Spotswood	Williamstown..	7.12.60	e
White, Rex	17 Carrington-road, Box Hill, 32 Milton-street, Nunawading, and 8 Cyril-street, Box Hill	17 Carrington-road, Box Hill	Box Hill ..	13.1.61	a, b, c, d, e
White, Richard Ernest Holland	Victoria Night Patrol Service, 8 Autumn-street, Coburg	13 Ridge-road, Oak Park	Coburg ..	13.12.60	a, b, c, e
Whiteside, John Siggins	8 Sandown-road, Ascot Vale	8 Sandown-road, Ascot Vale	Flemington ..	5.12.60	a, b, c, d, e
Whykes, Gordon John	807 Sturt-street, Ballarat	807 Sturt-street, Ballarat	Ballarat ..	24.11.60	e
Wilkinson, William Malcolm	403A St. Kilda-road, Melbourne	403A St. Kilda-road, Melbourne	South Melbourne	2.12.60	a, b, c, d, e
Williams, Alfred Harold	Lot 58, Leicester-street, Glen Waverley	Lot 58, Leicester-street, Glen Waverley	Oakleigh ..	25.11.60	a, c, e
Williams, John Maxwell ..	Ballarat Bureau of Investigation, 26 Lydiard-street South, Ballarat	26 Lydiard-street, South Ballarat	Ballarat ..	24.11.60	
Willsher, Malcolm David	15A Armstrong-street North Ballarat	15A Armstrong-street North Ballarat	Ballarat ..	24.11.60	a, c, e
Wines, Raymond Roy ..	44 Eastwood-street, Ballarat	44 Eastwood-street, Ballarat	Ballarat ..	24.11.60	c, e
Wise, Brian Patrick ..	Lot 85, Elsa-street, Fawkner	Lot 85, Elsa-street, Fawkner	Coburg ..	29.12.60	a, c, d, e
Wissell, John	Mercantile Recoveries, enr. Kingsway and South-road, Moorabbin and Box 108, P.O., Moorabbin	42 Thompsons-crescent, Research	Eltham ..	13.12.60	e
Woods, Carl Thornburn ..	Oakhill-road West, Pearceedale, and 100 Denmark-street, Kew	Oakhill-road West, Pearceedale	Frankston ..	2.12.60	a, c, d, e
Woods, Lloyd	158 Barkly-street, Ararat	21 Hewitt-street, Ararat	Ararat ..	9.12.60	a, b, c, d, e, Western Investigation and Debt Collections
Wright, Robert Henry ..	21 Cushing-avenue, Bentleigh	21 Cushing-avenue, Bentleigh	Cheltenham ..	28.12.60	
Young, Edward	9 Wimbledon-avenue, Elwood	9 Wimbledon-avenue, Elwood	Elwood ..	24.11.60	a, b, c, d, e
Young, Leonard William	214 Chapel-street, Prahran, and 169 Latrobe-street, Melbourne	8 Bowen-street, East St. Kilda	Prahran ..	5.12.60	

* The Process Servers and Inquiry Agents Regulations 1959, which operated from the 1st April, 1959, require applicants for Inquiry Agents' licences to specify which of the following functions they intend to perform, viz:—

- (a) obtaining and furnishing information as to the personal character or actions of any person or as to the character or nature of the business or occupation of any person;
- (b) obtaining, preparing or giving any evidence for the purposes of any proceedings under the *Marriage Act 1958* or *Maintenance Act 1958* whether such proceedings are already begun or are contemplated or prospective;
- (c) searching for missing persons;
- (d) furnishing guards or watchmen;
- (e) ascertaining the whereabouts of or repossessing any goods or chattels delivered pursuant to hire-purchase agreement.

Letters, a, b, c, d, e (as the case requires), have been inserted in the "Remarks" column to indicate which of the above functions the licensee intends to perform.

PROCESS SERVERS' LICENCES ISSUED FOR THE YEAR 1961.

Name of Licensee.	Business Address.	Registered Address.	Court of Issue.	Date of Issue.	Remarks.
Adams, Robert Valentine	55 Nunn-street, Benalla	55 Nunn-street, Benalla	Benalla ..	4.1.61	
Adams, Uzene Jessie ..	12 Osborne-street, Gardenvale	12 Osborne-street, Gardenvale	Brighton ..	16.12.60	
Ainsworth, Erwine ..	13 Powderham-road, Caulfield	13 Powderham-road, Caulfield	Malvern ..	25.11.60	
Alderson, James Allan ..	Lot 46, Herbert-street, Mt. Waverley	Lot 46, Herbert-street, Mt. Waverley	Oakleigh ..	16.12.60	
Allpress, Ian Walter ..	125 Rushall-crescent, North Fitzroy	125 Rushall-crescent, North Fitzroy	Fitzroy ..	15.12.60	
Archer, Brian Leslie ..	19 Fraser-street, Diamond Creek	19 Fraser-street, Diamond Creek	Eltham ..	13.12.60	
Archer, Kevin Douglas ..	10 Kokoda-street, Morwell	10 Kokoda-street, Morwell	Morwell ..	13.12.60	
Arthur-White, Ronald	258A Humffray-street north, Ballarat	258A Humffray-street north, Ballarat	Ballarat ..	24.11.60	
William					
Ashfield, William Robert	8 Cyril-street, Box Hill South	8 Cyril-street, Box Hill South	Box Hill ..	16.12.60	
Attwood, Peter ..	63 Deakin-avenue, Mildura	1114 Etiwanda-avenue, Mildura	Mildura ..	12.12.60	
Austen, Harry Leonard Cecil	Caltex Service Station, 319 Doncaster-road, North Balwyn	264A Doncaster-road, North Balwyn	Box Hill ..	16.1.61	
Bailey, Richard Walter ..	c/o E. S. Englander, 495 Collins-street, Mel- bourne	41 Rothersey-avenue, East Malvern	Melbourne ..	3.1.61	
Baldock, Clive Colin ..	15 Fitzgibbon-avenue, Brunswick West	15 Fitzgibbon-avenue, Brunswick West	Brunswick ..	14.12.60	
Barden, Carlisle Victor Irvine	71 Deakin-avenue, Mil- dura, and Indi-avenue, Red Cliffs	9 Chaffey-avenue, Mil- dura	Mildura ..	12.12.60	
Barnett, George Charles	Flat 1, 3 Verdant-avenue, Toorak	Flat 1, 3 Verdant-avenue, Toorak	Prahran ..	5.12.60	
Barstow, Kenneth Frank	20 Elm-street, Surrey Hills	20 Elm-street, Surrey Hills	Box Hill ..	16.12.60	
Beaton, George Murdoch	2 Evon-avenue, East Ringwood	2 Evon-avenue, East Ringwood	Ringwood ..	6.12.60	
Begovic, Enver ..	"Inge" Detective Agency, 222 Victoria- parade, East Mel- bourne	222 Victoria-parade, East Melbourne	Melbourne ..	16.12.60	
Belsky, Stan ..	57 Patty-street, Mentone	57 Patty-street, Mentone	Cheltenham ..	23.12.60	
Belleville, Kenneth ..	269 City-road, South Melbourne	269 City-road, South Melbourne	Melbourne ..	16.12.60	
Bennett, John Antcliff ..	Flat 5, 3 Cowderoy-street, West St. Kilda	Flat 5, 3 Cowderoy-street, West St. Kilda	St. Kilda ..	24.11.60	
Bent, Gary Lindsey ..	16 Grant-road, Newtown, Geelong	16 Grant-road, Newtown, Geelong	Geelong ..	7.12.60	
Berry, Keith Alwyn ..	Camellia-crescent, Nor- lane	Camellia-crescent, Nor- lane	Geelong ..	7.12.60	
Berry, Raymond James McFarlane	9 Wilson-street, Swan Hill	9 Wilson-street, Swan Hill	Swan Hill ..	19.12.60	
Birmingham, William Charles	366 Bridge-road, Rich- mond	3 Curzon-street, West Ivanhoe	Richmond ..	30.12.60	
Blackam, Donald Alfred	103 Armstrong-street south, Ballarat	732 Barkly-street, Bal- larat	Ballarat ..	24.11.60	
Blackmore, Charles Woodall	51 Queen-street, Mel- bourne	51 Queen-street, Mel- bourne	Melbourne ..	16.12.60	
Blyth, Neil ..	103 Armstrong-street south, Ballarat	103 Armstrong-street south, Ballarat	Ballarat ..	24.11.60	
Bottomley, Alexander Foxcraft	130 Abbotsford-street, North Melbourne	130 Abbotsford-street, North Melbourne	North Mel- bourne	8.12.60	
Bottomley, William ..	130 Abbotsford-street, North Melbourne	130 Abbotsford-street, North Melbourne	North Mel- bourne	8.12.60	
Boyd, James Douglas ..	3 Inverness-avenue, Burwood	3 Inverness-avenue, Burwood	Box Hill ..	16.12.60	
Bridgland, Harold Albert	35 Alamein-court, Golden Square	35 Alamein-court, Golden Square	Bendigo ..	14.12.60	
Briggs, John David ..	78 Vincent-road, Wanga- ratta	78 Vincent-road, Wanga- ratta	Wangaratta ..	15.12.60	
Brodrick, Leonard James	Shanns-avenue, Morning- ton Rural	Shanns-avenue, Morning- ton Rural	Mornington ..	7.12.60	
Bromilow, Geoffrey Granville	132 Sturt-street, South Melbourne	132 Sturt-street, South Melbourne	South Mel- bourne	2.12.60	
Brown, Kevin ..	Morson-court, Belgrave	Morson-court, Belgrave	Ferntree Gully	12.12.60	
Burgess, Bruce Munro ..	Commercial and General Acceptance Ltd., 51 Queen-street, Mel- bourne	8 Abbott-street, Sand- ringham	Melbourne ..	16.12.60	
Campbell, Archibald Colin	Nepean Highway, Mornington	Box 52, Mornington ..	Mornington ..	7.12.60	
Cant, Anne ..	8 Bapaume-avenue, Edithvale, and 268 Albert-street, East Melbourne	8 Bapaume-avenue, Edithvale	Melbourne ..	16.12.60	

PROCESS SERVERS' LICENCES ISSUED FOR THE YEAR 1961—continued.

Name of Licensee.	Business Address.	Registered Address.	Court of Issue.	Date of Issue.	Remarks.
Cant, John Henry ..	8 Bapaume-avenue, Edithvale, and 268 Albert-street, East Melbourne	8 Bapaume-avenue, Edithvale	Melbourne ..	16.12.60	
Carr, Graeme Neville ..	51 Greensborough-road, MacLeod	51 Greensborough-road, MacLeod	Heidelberg ..	16.12.60	
Carroll, Thomas Henry ..	32 Glazebrook-street, Ballarat	32 Glazebrook-street, Ballarat	Ballarat ..	24.11.60	
Cartwright, Arthur Herbert Leonard	8 Parer-street, Frankston	8 Parer-street, Frankston	Frankston ..	27.2.61	
Casey, Leslie Joseph ..	96 The Boulevard, Norlane	96 The Boulevard, Norlane	Geelong ..	23.1.61	
Chambeyron, John Joseph	6 Curie-avenue, Oak Park	6 Curie-avenue, Oak Park	Glenroy ..	9.12.60	
Charles, Alan Blair ..	c/o Commercial and General Acceptance Ltd., 3rd Floor, 51 Queen-street, Melbourne	51 Queen-street, Melbourne	Melbourne ..	16.12.60	
Charlesworth, William Harold	114 Nepean-highway, Aspendale, S.13	114 Nepean-highway, Aspendale, S.13	Mordialloc ..	29.12.60	
Chitty, George Arthur ..	A.B.C., 703 Burke-road, Camberwell	103A Mary-street, Richmond	Camberwell ..	19.12.60	
Clark, Margaret Elizabeth	F. Willing Pty. Ltd., 703 Burke-road, Camberwell	14 Wridgway-avenue, Burwood, E.13	Camberwell ..	1.12.60	
Clark, Peter Hall ..	F. Willing Pty. Ltd., 703 Burke-road, Camberwell	14 Wridgway-avenue, Burwood, E.13	Camberwell ..	1.12.60	
Clavant, William, Jnr. ..	15 David-road, Lilydale	15 David-road, Lilydale	Ringwood ..	6.12.60	
Clough, William ..	22 Churchill-street, Doncaster East	22 Churchill-street, Doncaster East	Box Hill ..	16.12.60	
Coakley, John ..	4th Floor, 366 Bourke-street, Melbourne	366 Bourke-street, Melbourne	Melbourne ..	16.12.60	
Coates, Barry Charles ..	5 Albert-street, Carnegie	14 King-street, Prahran	Oakleigh ..	20.2.61	
Condon, Shirley ..	11 Taunton-avenue, South Oakleigh	11 Taunton-avenue, South Oakleigh	Oakleigh ..	9.3.61	
Condon, Thomas William	2A George-street, West Preston	Sherren Investigations, 76 Chaucer-street, St. Kilda	Oakleigh ..	9.3.61	
Constable, Claude Wallace	16 Crammond-avenue, Wangaratta	16 Crammond-avenue, Wangaratta	Preston ..	20.12.60	
Covery, Bernard Anthony	101 Lahinch-street, Broadmeadows	101 Lahinch-street, Broadmeadows	Wangaratta ..	7.12.59	
Coombes, Allen Henry ..	F. Willing Pty. Ltd., 703 Burke-road, Camberwell	10 Hillside-road, Bulleen	Glenroy ..	9.12.60	
Corner, Robert Edwin ..	2 Mountain View-road, Nunawading	2 Mountain View-road, Nunawading	Heidelberg ..	16.12.60	
Cornish, Lance Percival ..	162A Barkly-street, Ararat	162A Barkly-street, Ararat	Box Hill ..	17.3.61	
Cox, Gerald Stewart ..	22 Lorac-avenue, Brighton	22 Lorac-avenue, Brighton	Ararat ..	10.3.61	
Crellin, Ronald William ..	Shackleton-street Belmont	Shackleton-street, Belmont	Brighton ..	16.12.60	
Crossley, Harry ..	16 McCrae-street, Dandenong	16 McCrae-street, Dandenong	Geelong ..	7.12.60	
Davis, John Edward ..	345 Hoddle-street, Collingwood	1128 Nepean-highway, Highett	Dandenong ..	23.11.60	
Davis, Leslie Clarence ..	17 Penola-street, Preston	17 Penola-street, Preston	Collingwood ..	28.11.60	
Davis, Thomas Charles ..	17 Penola-street, Preston	17 Penola-street, Preston	Preston ..	20.12.60	
Dawson, Ernest Edward	146 Thirteenth-street, Mildura, Box 375, Mildura	146 Thirteenth-street, Mildura	Preston ..	20.12.60	
Delahenty, Patrick Awburn	Lot 11, Alice-street, Mt. Waverley, and 453 Clayton-road, Clayton	Lot 11, Alice-street, Mt. Waverley	Mildura ..	12.12.60	
Denyer, Maurice Richard	Wattle-tree-road, Hurst-bridge	Wattle-tree-road, Hurst-bridge	Oakleigh ..	13.1.61	
Disher, Reginald Arthur	66 Gipps-street, East Melbourne	66 Gipps-street, East Melbourne	Eltham ..	13.12.60	
Dorz, Patricia Marie ..	9 Robert-street, Morwell	9 Robert-street, Morwell	Melbourne ..	16.12.60	
Doughty, Frederick William James	66 Tennyson-street, Norlane, Geelong	66 Tennyson-street, Norlane, Geelong	Morwell ..	13.12.60	
Dowling, Donald Julian	330 Lt. Collins-street, Melbourne	330 Lt. Collins-street, Melbourne	Geelong ..	3.2.61	
Downes, Arthur ..	11 Curlew-crescent, Norlane	11 Curlew-crescent, Norlane	Melbourne ..	16.12.60	
Dunkley, Larry George ..	20 Deschamps-avenue, Lilydale	20 Deschamps-avenue, Lilydale	Geelong ..	7.12.60	
Dunn, Cyril Frederick William	190 Bellair-street, Kensington	190 Bellair-street, Kensington	Geelong ..	7.12.60	
Dunn, William Thomas	44 Fulham-road, Alphington	44 Fulham-road, Alphington	Geelong ..	7.12.60	
Eardley, Thomas Henry	26 Beckett-street, Balwyn, E.8	26 Beckett-street, Balwyn, E.8	Flemington ..	6.3.61	
			Heidelberg ..	16.12.60	
			Camberwell ..	1.12.60	

PROCESS SERVERS' LICENCES ISSUED FOR THE YEAR 1961—continued.

Name of Licensee.	Business Address.	Registered Address.	Court of Issue.	Date of Issue.	Remarks.
Easton, Percy William ..	c/o Lawford Investment Co. Pty. Ltd., 690 Mt. Alexander-road, Moonee Ponds	9 Argyle-street, Moonee Ponds	Moonee Ponds	20.1.61	
Easton, Rupert John ...	6 Boyd street, Doncaster	6 Boyd-street, Doncaster	Kew	30.12.60	
Eddley, Leonard Harvey	7 Albert-street, Windsor	7 Albert-street, Windsor	Prahran	5.12.60	
Edgar, Kenneth G. ...	33 High-street, Nunawading	33 High-street, Nunawading	Box Hill	13.1.61	
Edmonds, Archie Lambert	Room 16, 6th Floor, 37 Swanston-street, Melbourne	37 Swanston-street, Melbourne	Melbourne	16.12.60	
Edwards, Bettina Joyce	13 Haigh-street, Moe ..	13 Haigh-street, Moe ..	Moe	26.1.61	
Edwards, Raymond Keith	13 Haigh-street, Moe ..	13 Haigh-street, Moe ..	Moe	15.12.60	
Eldridge, Neville ..	26 Philip-street, Horsham	26 Philip-street, Horsham	Horsham	30.11.60	
Englander, Beryl Emma	495 Collins-street, Melbourne	495 Collins-street, Melbourne	Melbourne	16.12.60	
Englander, Eric Simon ..	495 Collins-street, Melbourne	495 Collins-street, Melbourne	Melbourne	16.12.60	
Fesposito, Steven ...	20 Station-road, Footscray	20 Station-road, Footscray	Footscray	14.12.60	
Fisher, John Andrew ..	414 Lonsdale-street, Melbourne	13 Mountain View-road, North Balwyn	Melbourne	16.12.60	
Flavel, Charles Cameron	Lot 19, Park Lane, Croydon	Lot 19, Park Lane, Croydon	Ringwood	1.12.60	
Fleming, Malcolm Frank	540 Lt. Collins-street, Melbourne	540 Lt. Collins-street, Melbourne	Melbourne	16.12.60	
Foley, Sylvia ..	21 Hillview-road, North Balwyn	21 Hillview-road, North Balwyn	Kew	24.11.60	
Fradkin, Raymond	16 (Lot 36) Kallista-road, Springvale	16 (Lot 36) Kallista-road, Springvale	Springvale	28.12.60	
Freeland, Alan Bruce ..	10 Derby-crescent, Carnegie	10 Derby-crescent, Carnegie	Malvern	25.11.60	
French, Leslie Oswin ..	53 Queen-street, Melbourne	53 Queen-street, Melbourne	Melbourne	16.12.60	
Fuller, William Kevin ..	Mercantile College Services Pty. Ltd., 60 Flinders-lane, Melbourne	Lot 74, Reilly-street, Ringwood	Box Hill	17.1.61	
Fyfe, Alexander Wallace	264A Doncaster-road, North Balwyn	Lot 9, Ayr-street, Doncaster	Box Hill	17.1.61	
Gadsden, Eric Leslie ...	150 Lightwood-road, Noble Park	150 Lightwood-road, Noble Park	Dandenong	23.11.60	
Gandur, Raymond ..	Flat 5, 209 Brighton-road, Elwood	Flat 5, 209 Brighton-road, Elwood	Noble Park	10.3.61	
Garnaut, Louis Antony ..	46 Biliburg-street, Broadmeadows	46 Biliburg-street, Broadmeadows	Elsternwick	8.2.61	
Gartner, David William	130 Abbotsford-street, North Melbourne	130 Abbotsford-street, North Melbourne	Glenroy	8.12.60	
Ross	130 Abbotsford-street, North Melbourne	130 Abbotsford-street, North Melbourne	North Melbourne	8.12.60	
Cerkens, Maurice Patrick	Box 2, Daylesford	Box 2, Daylesford	Daylesford	13.12.60	
Gidley, Thomas Henry ..	27 Mitchell-street, Northcote	27 Mitchell-street, Northcote	Northcote	9.12.60	
Gillman, John Ernest ..	Airlie Inquiry Agency, Suite 9, 545 St. Kilda-road, Melbourne, S.C.3	Suite 9, 545 St. Kilda-road, Melbourne	Prahran	5.12.60	
Gladwin, Norman Howard	18 Hilda-street, Balwyn	703 Burke-road, Camberwell	Camberwell	1.12.60	
Goodall, John Edward ..	1417 Malvern-road, Malvern	1417 Malvern-road, Malvern	Malvern	25.11.60	
Grant, Maxwell Budge ..	35A Atkinson-street, Oakleigh	35A Atkinson-street, Oakleigh	Oakleigh	25.11.60	
Grant, Maxwell Gordon ..	158 Barkly-street, Ararat	23 Hewitt-street, Ararat	Ararat	9.12.60	
Grant, Neil Lugsdin ..	1 Blackshaw-street, East Ormond	1 Blackshaw-street, East Ormond	Oakleigh	16.12.60	
Grant, Stuart Donald ..	540 Lt. Collins-street, Melbourne	540 Lt. Collins-street, Melbourne	Melbourne	31.1.61	
Gray, Leon Allan ..	Lake Boga, Victoria ..	Lake Boga, Victoria ..	Swan Hill	14.12.60	
Gray, Maurice George ..	7 Campbell-street, Frankston	7 Campbell-street, Frankston	Frankston	21.12.60	
Green, David Roger ..	30 Woodlands-grove, Oakleigh	30 Woodlands-grove, Oakleigh	Oakleigh	16.12.60	
Green, Vivian Bryan ..	Coast Patrol Service, Torquay Golf Club	18 Munday-street, Torquay	Geelong	7.12.60	
Griffin, Brian James ..	414 Lonsdale-street, Melbourne	74 Hawthorn-road, Caulfield	Melbourne	16.12.60	
Guest, Joseph ..	41A Stawell-street, Sale	41A Stawell-street, Sale	Sale	13.12.60	
Gunston, Douglas Gerald	c/o E. S. Englander Pty. Ltd., 495 Collins-street, Melbourne	495 Collins-street, Melbourne	Footscray	14.12.60	
Hagger, Bruce Maxwell ..	20 Stephen-street, Newtown, Geelong	20 Stephen-street, Newtown, Geelong	Geelong	17.3.61	
Hamilton, Ferguson ...	26 Melbourne-road, Norlane, Geelong	26 Melbourne-road, Norlane, Geelong	Geelong	7.12.60	
Harrison, John Joseph ..	366 Bridge-road, Richmond	17 Carnegie-avenue, North Kew	Richmond	21.12.60	
Harrold, Charles Ernest	87 Como-parade, East Ivanhoe	87 Como-parade, East Ivanhoe	Mordialloc	8.12.60	
Harrold, Sidney Trevor	372 Station-street, Chelsea	372 Station-street, Chelsea	Chelsea	12.12.60	

PROCESS SERVERS' LICENCES ISSUED FOR THE YEAR 1961—continued.

Name of Licensee.	Business Address.	Registered Address.	Court of Issue.	Date of Issue.	Remarks.
Hartshorn, John Walter	Associated Process Bureau, 414 Lonsdale-street, Melbourne, and G. M. Flanagan Displays, 60 Buckhurst-street, South Melbourne	104 Hoffmans-road, West Essendon	Moonee Ponds	16.12.60	
Harvey, Coral Alice ..	441 Victoria-street, West Melbourne	441 Victoria-street, West Melbourne	North Melbourne	8.12.60	
Haymes, Kenneth Ralph	33 Ashted-road, Box Hill	33 Ashted-road, Box Hill	Box Hill	27.3.61	
Hem, Sydney Alexander	The Highway, West Newport	The Highway, West Newport	Williamstown ..	7.12.60	
Hession, Ronald Brendon	31 Closter-avenue, Ashwood	31 Closter-avenue, Ashwood	Oakleigh ..	25.11.60	
Heywood, Stuart ..	H. G. Palmers, Bridge-road, Richmond	38 Clarendon-parade, West Footscray	Richmond ..	28.2.61	
Hill, Benjamin Ashton ..	29 Myalla-street, Braybrook	29 Myalla-street, Braybrook	Sunshine ..	6.12.60	
Hinchliffe, Stephen Mark	South-road, Hamilton ..	South-road, Hamilton ..	Hamilton ..	1.12.60	
Hogben, George ..	62 Garsed-street, Bendigo	62 Garsed-street, Bendigo	Bendigo ..	14.12.60	
Holland, Noel Thomas ..	Associated Process Bureau, 414 Lonsdale-street, Melbourne	56 Balmoral-avenue, Pascoe Vale South	Coburg	13.12.60	
Holmberg, Amelia Janie	20 Manuka-street, South Oakleigh	20 Manuka-street, South Oakleigh	Oakleigh	25.11.60	
Honan, Geoffrey ..	8 Meredith-street, Elwood, S.3	8 Meredith-street, Elwood, S.3	St. Kilda ..	10.3.61	
Hookey, Geoffrey ..	29 Mostyn-street, Castlemaine	29 Mostyn-street, Castlemaine	Castlemaine ..	15.12.60	
Houston, John Clarence	119 Swanston-street, Melbourne	119 Swanston-street, Melbourne	Melbourne ..	16.12.60	
Howlett, Ivan Myles ..	17 Dundas-street, Sale	17 Dundas-street, Sale	Sale	13.12.60	
Hudson, John ..	5 Foy-avenue, Chelsea ..	5 Foy-avenue, Chelsea ..	Chelsea	12.12.60	
Hughes, Evan Morris ..	31 Queen-street, Melbourne	31 Queen-street, Melbourne	Melbourne ..	16.12.60	
Hughes, John Murray ..	76 Venice-street, Mentone	76 Venice-street, Mentone	Cheltenham ..	21.12.60	
Humphreys, Francis George Marland	F. J. Marland Pty. Ltd., 12 Gardiner-street, North Melbourne	12 Gardiner-street, North Melbourne	North Melbourne	22.12.60	
Humphrys, Charles ..	Box 108, Moorabbin ..	cnr. Kingsway and South-road, Moorabbin, S.20, Box 108, Moorabbin	Brighton ..	16.12.60	
Hundahl, Preben ..	c/o E. S. Englander, 495 Collins-street, Melbourne	274 Barkly-street, St. Kilda	Melbourne ..	2.1.60	
Hunter, William Watson	Metropolitan Night Patrol Service Pty. Ltd., 130 Abbotsford-street, North Melbourne	130 Abbotsford-street, North Melbourne	North Melbourne	8.12.60	
Hurley, James Sydney ..	36 McKellar-street, Benalla	36 McKellar-street, Benalla	Benalla ..	5.12.60	
Hurley, Thomas Henry ..	8 Peak-street, Chadstone, S.E.10	8 Peak-street, Chadstone, S.E.10	Oakleigh ..	25.11.60	
Hutchinson, Graham Ralph	130 Abbotsford-street, North Melbourne ..	130 Abbotsford-street, North Melbourne	North Melbourne	8.12.60	
James, Arthur Donald ..	11 Cherry-street, MacLeod West	11 Cherry-street, MacLeod West	Heidelberg ..	16.12.60	
James, Ida Dulcie ..	11 Cherry-street, MacLeod West	11 Cherry-street, MacLeod West	Heidelberg ..	4.1.61	
James, Percy Alexander	1 Alec-street, Mt. Waverley	1 Alec-street, Mt. Waverley	Richmond ..	13.12.60	
Johansen, Leif Normann Ludvik	45 Loughnan-road, Ringwood	45 Loughnan-road, Ringwood	Ringwood ..	31.1.61	
Johnson, John Martin ..	104 Monash-street, Sunshine	104 Monash-street, Sunshine	Sunshine ..	6.12.60	
Jones, David Campbell ..	c/o Laurens Collections Pty. Ltd., 414 Lonsdale-street, Melbourne	4 Leicester Square, Malvern	Melbourne ..	16.12.60	
Jones, Douglas Francis Godridge	35 Como-street, Alphington	35 Como-street, Alphington	Heidelberg ..	16.12.60	
Jones, Diana Joy ..	c/o Laurens Collections Pty. Ltd., 414 Lonsdale-street, Melbourne	"Runnymede," Leicester Square, Malvern	Melbourne ..	16.12.60	
Jones, Francis William ..	35 Como-street, Alphington	35 Como-street, Alphington	Heidelberg ..	16.12.60	
Jones, John Arthur ..	158 Charles-street, Abbotsford	158 Charles-street, Abbotsford	Melbourne ..	16.12.60	
Junck, Bernard ..	24 Prior-road, Chadstone	24 Prior-road, Chadstone	Oakleigh ..	25.11.60	
Kanake, Keith ..	22 Churchill-street, East Doncaster	22 Churchill-street, East Doncaster	Box Hill ..	16.12.60	
Kellow, William Henry ..	Franklin-street, Traralgon	Franklin-street, Traralgon	Traralgon ..	12.12.60	
Killin, William Ernest ..	495 Collins-street, Melbourne	495 Collins-street, Melbourne	Melbourne ..	16.12.60	

PROCESS SERVERS' LICENCES ISSUED FOR THE YEAR 1961—*continued.*

Name of Licensee.	Business Address.	Registered Address.	Court of Issue.	Date of Issue.	Remarks.
King, Allen R. ..	118 Synnott-street, Werribee	118 Synnott-street, Werribee	Werribee ..	16.1.61	
King, Bryan Thomas ..	152 Boundary-road, Geelong	152 Boundary-road, Geelong	Geelong ..	7.12.60	
King, Raymond Ian ..	Grange Mercantile Agency, 19 Port Fairy road, Hamilton	19 Port Fairy-road, Hamilton	Hamilton ..	1.12.60	
Kirry, Mike ..	67 Kooyong-road, Caulfield	67 Kooyong-road, Caulfield	Melbourne ..	30.11.60	
Knights, Ray McLaren ..	22 Nicholson-street, Warrnambool	22 Nicholson-street, Warrnambool	Warrnambool	31.12.60	
Knights, Ralph Simon Johnston	13 Bayview-road, Seddon	13 Bayview-road, Seddon	Footscray ..	14.12.60	
Knowles, George Alfred Slade	Coppin-road, Sorrento ..	Coppin-road, Sorrento ..	Sorrento ..	16.12.60	
Laurens, Beryl Adele ..	c/o Laurens Collections Pty. Ltd., 414 Lonsdale-street, Melbourne	31 Albany-road, Toorak	Melbourne ..	16.12.60	
Laurens, George Watson	c/o Laurens Collections Pty. Ltd., 414 Lonsdale-street, Melbourne	31 Albany-road, Toorak	Melbourne ..	16.12.60	
Laurens, William Albert John	A.B.C. Mercantile Agency, 703 Burke-road, Camberwell	10 Ross-street, Alphington	Camberwell ..	21.12.60	
Leake, Donald Ian ..	c/o G. Laurens, 38 Reid-street, Wangaratta	38 Reid-street, Wangaratta	Wangaratta ..	15.12.60	
Lewis, Ernest William ..	Echuca ..	Echuca P.O. ..	Echuca ..	3.1.61	
Lewis, John Charles ..	Geronimo Ives Service, 540 Lt. Collins-street, Melbourne	540 Lt. Collins-street, Melbourne	Melbourne ..	8.3.61	
Lewis, John Francis ..	24 Foley-street, Kew	24 Foley-street, Kew	Kew ..	24.11.60	
Littlejohn, Graeme Hunter	13 The Reserve, Ocean Grove	13 The Reserve, Ocean Grove	Geelong ..	7.12.60	
Lockhart, Eric John ..	Webb's Radio and Electrical Pty. Ltd., 525 North-road, Ormond	525 North-road, Ormond	Brighton ..	16.12.60	
Loh, Alan Norman ..	Reid-street, Wangaratta	Reid-street, Wangaratta	Wangaratta ..	15.12.60	
Loh, John Clement ..	4 Station-street, Hamilton	4 Station-street, Hamilton	Hamilton ..	30.12.60	
Long, James ..	48 Howard-street, North Melbourne	48 Howard-street, North Melbourne	North Melbourne	8.12.60	
Lotherington, Henry James	414 Lonsdale-street, Melbourne	414 Lonsdale-street, Melbourne	Sunshine ..	6.12.60	
Love, William George ..	George Laurens Pty. Ltd., 103 Armstrong-street South, Ballarat	412 Joseph-street, Canadian	Ballarat ..	24.11.60	
Lovell, Thomas Alexander	Lot 36, Japonica-grove, Frankston	Lot 36, Japonica-grove, Frankston	Frankston ..	2.12.60	
Lynch, Alan ..	414 Lonsdale-street, Melbourne	414 Lonsdale-street, Melbourne	Melbourne ..	31.12.60	
Lynch, Kevin Francis ..	284 Lonsdale-street, Melbourne	284 Lonsdale-street, Melbourne	Melbourne ..	16.12.60	
Maben, Geoffrey Gustav	Hunter-street, Lakes Entrance	Hunter-street, Lakes Entrance	Bairnsdale ..	21.12.60	
Macak, Jaroslav ..	5 Liddiard-street, Hawthorn	5 Liddiard-street, Hawthorn	Hawthorn ..	30.12.60	
McDonald, William ..	414 Lonsdale-street, Melbourne	414 Lonsdale-street, Melbourne	Melbourne ..	16.12.60	
McIntosh, James Edwin	8 Frederick-street, South Caulfield	8 Frederick-street, South Caulfield	Elsternwick ..	30.11.60	
McKenzie, Donald Alexander	63 Midlothian-street, Chadstone	63 Midlothian-street, Chadstone	Oakleigh ..	30.12.60	
McKenzie, Marie Ellen ..	63 Midlothian-street, Chadstone	63 Midlothian-street, Chadstone	Oakleigh ..	30.12.60	
MacMillan, James ..	83 Churchill-road, Morwell	83 Churchill-road, Morwell	Traralgon ..	12.12.60	
McNulty, Bryan ..	Mailors Flat, via Warrnambool	Mailors Flat, via Warrnambool	Warrnambool ..	31.12.60	
Mann, Murray Lyndon ..	Muir-street, Frankston	Muir-street, Frankston ..	Frankston ..	9.12.60	
Meikle, Alasdair John ..	327 Doncaster-road, North Balwyn	2 Louise-court, Doncaster	Box Hill ..	17.1.61	
Marsden, Robyn Ann ..	414 Lonsdale-street, Melbourne	414 Lonsdale-street, Melbourne	Melbourne ..	16.12.60	
Mason, Ian Arthur ..	294 Nell-street, Watsonia	294 Nell-street, Watsonia	Heidelberg ..	16.12.60	
Mattla, Allan Victor ..	120 Jenkins-street, Northcote	120 Jenkins-street, Northcote	Northcote ..	9.12.60	
Meadows, Denis Herbert	c/o E. S. Englander Pty. Ltd., 495 Collins-street, Melbourne	5 William-street, Hawthorn	Richmond ..	21.12.60	
Melville, Eric Thompson	495 Collins-street, Melbourne	495 Collins-street, Melbourne	Coburg ..	13.12.60	
Merlin, Robert Tennant	13 Felicia-street, Mordialloc	13 Felicia-street, Mordialloc	Mordialloc ..	8.12.60	
Miller, Clyde Albert ..	74 Moore-street, South Yarra	74 Moore-street, South Yarra	Prahran ..	5.12.60	
Mitchell, Harold ..	190 Bourke-street, Melbourne	24 Rothesay-avenue, Elwood	Melbourne ..	16.12.60	

PROCESS SERVERS' LICENCES ISSUED FOR THE YEAR 1961—*continued.*

Name of Licensee.	Business Address.	Registered Address.	Court of Issue.	Date of Issue.	Remarks.
Montgomery, Charles Norman	414 Lonsdale-street, Melbourne	414 Lonsdale-street, Melbourne	Melbourne ..	16.12.60	
Moore, Winsome Mae Blanche	12 Lang-street, South Yarra	12 Lang-street, South Yarra	Elsternwick ..	16.2.61	
Morey, William George..	27 Nunns-road, Mornington	Malcoe Mercantile Agency, 27 Nunns-road, Mornington	Mornington ..	7.12.60	
Morley, Reginald Stanley	10 Church-street, Wodonga	10 Church-street, Wodonga	Wodonga ..	8.12.60	
Morris, Charles Philip ..	136 Johnston-street, Collingwood	98 Nicholson-street, Abbotsford	Collingwood ..	28.11.60	
Morris, Esther Jean ..	136 Johnston-street, Collingwood	98 Nicholson-street, Abbotsford	Collingwood ..	28.11.60	
Morton, Albert Alexander.	36 Doris-street, Murrumbena	36 Doris-street, Murrumbena	Oakleigh ..	25.11.60	
Murdoch, Donald Kenneth	Lot 2, Kingston-road, Cheltenham, S.22	Lot 2, Kingston-road, Cheltenham, S.22	Cheltenham ..	21.12.60	
Murnane, Albert John ..	10 Princross-street, Warrnambool	P.O., Box 207, Warrnambool	Warrnambool..	31.12.60	
Murphy, Louis Dominic Patrick	Tarcombe-street, Euroa	P.O. Box 75, Euroa ..	Euroa ..	2.12.60	
Murphy, Stanley James	White Crow Ltd., 617 Spencer-street, West Melbourne	Lot 15, Macey-avenue, Avondale Heights ..	North Melbourne	8.12.60	
Murray, William John ..	Grange Mercantile Agency, 19 Port Fairy-road, Hamilton	Digby-road, Hamilton ..	Hamilton ..	1.12.60	
Mustey, Edward ..	52 Halpin-crescent, Shepparton	52 Halpin-crescent, Shepparton	Shepparton ..	8.12.60	
Myles, William ..	9 Anderson-avenue, East Bentleigh	9 Anderson-avenue, East Bentleigh	Oakleigh ..	30.12.60	
Myszkowski, Edward ..	28 Watt-street, Spotswood, W.14	28 Watt-street, Spotswood, W.14	Footscray ..	14.12.60	
Neal, William Richard ..	Hunter-street, Lakes Entrance	Hunter-street, Lakes Entrance	Bairnsdale ..	21.12.60	
Noale, Andrew Edward..	427 Elizabeth-street, Melbourne	427 Elizabeth-street, Melbourne	Melbourne ..	16.12.60	
Neary, Henry Paul ..	3 Patrick-street, Bendigo	3 Patrick-street, Bendigo	Bendigo ..	14.12.60	
Nettleton, Robert Lindsay	38 Frome-avenue, Frankston	38 Frome-avenue, Frankston	Frankston ..	2.12.60	
Newman, Cyril Richard	Lot 23, Donald-street, Clayton	Lot 23, Donald-street, Clayton	Oakleigh ..	16.12.60	
Nicolle, John Irvin ..	112 High-street, Preston	5 Ryde-street, Preston N.18	Preston ..	20.12.60	
Oldham, John Christopher Clarke	51 Queen-street, Melbourne	2 Park-street, South Yarra	Melbourne ..	16.12.60	
Oliver, Leon Julian ..	403A St. Kilda-road, Melbourne, and Leo Thorn and Co. Pty. Ltd.	7A Scotts-parade, Ivanhoe	Melbourne ..	16.12.60	
O'Shea, Anthony Francis	Acc Investigation Service, 28 Watt-street, Spotswood, W.14	28 Watt-street, Spotswood, W.14	Footscray ..	14.12.60	
Osmond, Kenneth Russell	79 Hodder-street, East Brighton	79 Hodder-street, East Brighton	Brighton ..	24.2.61	
Ould, Ronald Fitzgerald Graham	6 Campbell-street, Frankston	6 Campbell-street, Frankston	Frankston ..	2.12.60	
Paroissien, Keith Lewis ..	130 Abbotsford-street, North Melbourne, and 343 Lt. Collins-street, Melbourne	19 Sherwood-street, Glen Iris	Melbourne ..	8.12.60	
Patrick, David ..	3 Lysbeth-street, McKinnon	3 Lysbeth-street, McKinnon	Brighton ..	16.12.60	
Patterson, Frederick ..	"Morson Court", Main-street, Belgrave	"Morson Court", Main-street, Belgrave	Ferntree Gully	12.12.60	
Percy, Hamilton Caldwell	38 Laneast-street, Malvern	38 Laneast-street, Malvern	Malvern ..	25.11.60	
Perrin, Conrad Alex ..	91 Beach-street, Frankston	91 Beach-street, Frankston	Frankston ..	2.12.60	
Pert, Charles Amos ..	7 Allen-crescent, Stawell	Stawell Security Service, 7 Allen-crescent, Stawell	Stawell ..	15.12.60	
Phelts, Donald Southwood	380 Somerville-road, West Footscray	380 Somerville-road, West Footscray	Footscray ..	14.12.60	
Phillips, George ..	3 The Highway, West Newport	28 Ararat-street, West Newport	Williamstown..	21.12.60	
Power, William Patrick	25 Khartoum-street, Flat 1, 39 Alexandra-street, South Yarra	Box 106, Camberwell ..	Richmond ..	13.12.60	
Prior, Stanley George ..	Flat 1, 39 Alexandra-street, South Yarra	Flat 1, 39 Alexandra-street, South Yarra	Prahran ..	5.12.60	
Pritchard, Reginald James Owen	34 Patricia-street, East Bentleigh	34 Patricia-street, East Bentleigh	Cheltenham ..	11.1.61	
Proper, John William ..	459 Lt. Collins-street, Melbourne	47 Millsvyn-street, South Yarra, S.E.1	Melbourne ..	16.12.60	
Purser, Edward Thomas	Swansea-road, Montrose	Swansea-road, Montrose	Lilydale ..	30.12.60	
Quaife, Lambeth McDonald	Somerton-road, Oaklands Junction	Somerton-road, Oaklands Junction	Moonee Ponds	16.12.60	

PROCESS SERVERS' LICENCES ISSUED FOR THE YEAR 1961—continued.

Name of Licensee.	Business Address.	Registered Address.	Court of Issue.	Date of Issue.	Remarks.
Ratcliffe, Leslie Robert	Laurie Whitehead Pty. Ltd., 7 Brighton-road, St. Kilda	7 Brighton-road, St. Kilda	St. Kilda ..	6.12.60	
Raven, John ..	22 Brougham-street, Maryborough	22 Brougham-street, Maryborough	Maryborough ..	4.1.61	
Reddoch, Leonard James	14 Dixon-street, Pascoe Vale North	14 Dixon-street, Pascoe Vale North	Coburg ..	6.1.61	
Renton, Raymond John	12 Devoy-street, South Oakleigh	12 Devoy-street, South Oakleigh	Oakleigh ..	25.11.60	
Reynolds, Keith Basil ..	95 Johnston-street, Collingwood	76 Carlisle-street, St. Kilda	Collingwood ..	28.11.60	
Riley, William Joseph ..	413A Elgar-road, Box Hill	413A Elgar-road, Box Hill	Box Hill ..	16.1.61	
Ritchie, Barbara Lorraine	196 Bridport-street, Albert Park, S.C.6	196 Bridport-street, Albert Park, S.C.6	South Mel-bourne	16.12.60	
Rogerson, George Thomas	56 Comans-street, Morwell	56 Comans-street, Morwell	Morwell ..	28.2.61	
Russ, Donald Bogel ..	27 Yooringa-avenue, Norlane	27 Yooringa-avenue, Norlane	Geelong ..	7.12.60	
Salmon, Michael John ..	11 Meadow-crescent, Mt. Waverley	11 Meadow-crescent, Mt. Waverley	Oakleigh ..	16.12.60	
Sullivan, Kenneth Stuart	24 Dunscombe-avenue, Syndal	24 Dunscombe-avenue, Syndal	Oakleigh ..	16.12.60	
Seammell, Walter Ingram	540 Lt. Collins-street, Melbourne and 65A Franklin-street, Melbourne	540 Lt. Collins-street, Melbourne	Melbourne ..	16.12.60	
Scott, Nellie Agnes ..	34 Beech-street, South Caulfield	34 Beech-street, South Caulfield	Elsternwick ..	30.11.60	
Scott, Russell Bray ..	81 The Boulevard, Ivanhoe	81 The Boulevard, Ivanhoe	Heidelberg ..	16.12.60	
Seaborne, Frederick Osmond	Testro Bros., 222 Queen-street, Melbourne	124 Canterbury-road, Canterbury	Camberwell ..	1.12.60	
Senior, Maxwell Robert	462 Bell-street, Pascoe Vale	462 Bell-street, Pascoe Vale	Coburg ..	23.2.61	
Sherren, Francis John Roy	5 Albert-road, Carnegie, and 76 Chaucer-street, St. Kilda	5 Albert-road, Carnegie	Elsternwick ..	30.11.60	
Sinclair, Ronald Gordon	Childers-street, Cranbourne	Childers-street, Cranbourne	Cranbourne ..	7.12.60	
Sleeth, John Albert ..	6 Young-street, Ballarat	6 Young-street, Ballarat	Ballarat ..	24.11.60	
Smith, Albert Henry ..	90 Churchill-road, Morwell	90 Churchill-road, Morwell	Morwell ..	13.12.60	
Smith, Arthur Herbert ..	35 Como-street, Alphington	35 Como-street, Alphington	Heidelberg ..	16.12.60	
Smith, Albert James ..	25 Bryant-road, Dandenong	25 Bryant-road, Dandenong	Dandenong ..	9.1.61	
Smith, George Alexander (Jnr.)	87 Bulleen-road, North Balwyn	The Elite Detective Agency, 87 Bulleen-road, North Balwyn	Kew ..	24.11.60	
Smyth, Denis Augustine	122 Stanhope-street, Malvern	122 Stanhope-street, Malvern	Malvern ..	25.11.60	
Sonnberger, Graeme Gordon	130 Abbotsford-street, North Melbourne	130 Abbotsford-street, North Melbourne	North Mel-bourne	20.12.60	
Sonnberger, Joseph Ludwig	130 Abbotsford-street, North Melbourne	130 Abbotsford-street, North Melbourne	North Mel-bourne	18.12.60	
Souter, Henry Francis Joseph	Whiteheads Creek, Seymour	Whiteheads Creek, Seymour	Seymour ..	22.12.60	
Speed, Eric Ernest ..	5 Emu-street, North Maidstone	5 Emu-street, North Maidstone	Footscray ..	6.1.61	
Spiess, Wadim ..	6 Helene-street, Ardeer	6 Helene-street, Ardeer	Sunshine ..	6.12.60	
Spragge, Margaret Joan	18 Bayview-crescent, Black Rock	18 Bayview-crescent, Black Rock	Sandringham ..	25.1.61	
Stanley, Francis Herbert	379 North-road, Clayton	379 North-road, Clayton	Oakleigh ..	25.11.60	
Stanley, Joycelyn Olive	379 North-road, Clayton	379 North-road, Clayton	Oakleigh ..	25.11.60	
Stevens, Norman Maitland	23 Pleasant-street, Pascoe Vale	23 Pleasant-street, Pascoe Vale	Coburg ..	13.12.60	
Stevenson, Robert Thomas	9 Ferguson-street, Rosanna	9 Ferguson-street, Rosanna	Heidelberg ..	16.12.60	
Stockdale, Richard Eric	414 Lonsdale-street, Melbourne, (Associated Process Bureau)	38 Henry-street, Oakleigh, S.E.12	Melbourne ..	16.12.60	
Stuart, Harold Thomas	10 Karadoc-avenue, Pascoe Vale	10 Karadoc-avenue, Pascoe Vale	Coburg ..	13.12.60	
Sutherland, Frederick Thomas	"Morson Court", Main-street, Belgrave	"Morson Court", Main-street, Belgrave	Ferntree Gully	12.12.60	
Sutton, Joseph Henry ..	47 Sydney-road, Brunswick	47 Sydney-road, Brunswick	Brunswick ..	13.1.61	
Swift, Frederick Dean ..	Flat 5, 35 Lithgow-street, Burwood, E.13	Flat 5, 35 Lithgow-street, Burwood, E.13	Camberwell ..	1.12.60	
Sykes, Robert Ernest ..	Industrial Security Service, 200A Coventry-street, South Melbourne	290A Coventry-street, South Melbourne	South Mel-bourne	2.12.60	
Tanner, Harold ..	27 Killarny-road, Lower Templestowe	27 Killarny-road, Lower Templestowe	Heidelberg ..	16.12.60	
Taylor, Harold Edwin ..	229 Barkly-avenue, Burnley	229 Barkly-avenue, Burnley	Richmond ..	20.12.60	

PROCESS SERVERS' LICENCES ISSUED FOR THE YEAR 1961—continued.

Name of Licensee.	Business Address.	Registered Address.	Court of Issue.	Date of Issue.	Remarks.
Taylor, John Douglas ..	6 Allfrey-street, East Brighton, S.6	6 Allfrey-street, East Brighton, S.6	Brighton ..	7.2.61	
Taylor, Michael Charles	c/o E. S. Englander Pty. Ltd., 495 Collins-street, Melbourne	495 Collins-street, Melbourne	Melbourne ..	16.12.60	
Thomas, Francis Joseph	c/o George Laurens Pty. Ltd., Mitchell-street, Bendigo	29 Clarke street, Bendigo	Bendigo ..	14.12.60	
Thomas, Harold Joseph	5 Cricklewood-avenue, Frankston	5 Cricklewood-avenue, Frankston	Frankston ..	2.12.60	
Thompson, Robert Jefferson	84 Whitelaw-street, Reservoir	84 Whitelaw-street, Reservoir	Preston ..	29.12.60	
Thomas, Robert Victor George	9 Northgate-street, Mooroopna	9 Northgate-street, Mooroopna	Shepparton ..	8.12.60	
Thorp, Albert Charles ..	3 Leslie-court, Moe ..	3 Leslie-court, Moe ..	Moe ..	15.12.60	
Unworthy, Roy Lowell	99 Thompson-street, Hamilton	99 Thompson-street, Hamilton	Hamilton ..	1.12.60	
Van Every, Edward ..	8 William-street, Box Hill	8 William-street, Box Hill	Box Hill ..	16.12.60	
Vann, Clarence Leo ..	5 Mount-street, Ararat	162A Barkly-street, Ararat	Ararat ..	9.12.60	
Vecens, Janis ..	24 Loch-street, St. Kilda West	24 Loch-street, St. Kilda West	St. Kilda ..	4.1.61	
Verece, Bryant Henry ..	27 Nunns-road, Mornington	27 Nunns-road, Mornington	Mornington ..	7.12.60	
Vincent, Robert ..	68 Wyndham-street, Shepparton	68 Wyndham-street, Shepparton	Shepparton ..	8.12.60	
Vincent, William Herbert Patrick	51 Queen-street, Melbourne	51 Queen-street, Melbourne	Melbourne ..	16.12.60	
Waddell, John Leonard..	42 Melcombe-road, Ivanhoe	42 Melcombe-road, Ivanhoe	Heidelberg ..	27.2.61	
Walker, Geoffrey Ernest	9 Wimbledon-avenue, Elwood	9 Wimbledon-avenue, Elwood	St. Kilda ..	24.11.60	
Walters, Frederick Childs	Duke-street, Yarram ..	Duke-street, Yarram ..	Yarram ..	9.12.60	
Walters, Kenneth Joseph	Hazel Vale Dairy, Tecoma	81 Terns road, Upwey	Ferntree Gully	6.2.61	
Ward, Gordon Patrick ..	54 Beddoe avenue, North Clayton	54 Beddoe avenue, North Clayton	Oakleigh ..	25.11.60	
Warner, Colleen ..	20 Ashlar road, Moorabbin	20 Ashlar-road, Moorabbin	Cheltenham ..	21.12.60	
Watts, Frederick William	45 Barker-crescent, Traralgon	45 Barker-crescent, Traralgon	Traralgon ..	12.12.60	
Weir, Roy Emilton ..	40 Royal-parade, Pascoe Vale South	40 Royal-parade, Pascoe Vale South	Coburg ..	13.12.60	
Weyl, Herbert ..	323 Bourke-street, Melbourne, C.1	1 Meaden-court, Darling	Malvern ..	16.12.60	
White, Rex ..	17 Carrington-road, Box Hill, and 32 Milton-street, Nunawading, and 8 Cyril-street, Box Hill	17 Carrington-road, Box Hill	Box Hill ..	13.1.61	
Whitehouse, Alfred James	414 Lonsdale-street, Melbourne	28 Campbell-street, East Ringwood	Ringwood ..	6.12.60	
Whiteside, John Siggins	8 Sandown-road, Ascot Vale	8 Sandown-road, Ascot Vale	Flemington ..	5.12.60	
Wiebenga, Jack ..	16 Anderson-street, Frankston	16 Anderson-street, Frankston	Frankston ..	31.1.61	
Willett, George Albert ..	"Morson Court", Main-road, Belgrave	"Morson Court", Main-road, Belgrave	Ferntree Gully	12.12.60	
Williams, Alfred Harold	Lot 58, Leicester-street, Glen Waverley	Lot 58, Leicester-street, Glen Waverley	Oakleigh ..	25.11.60	
Williamson, John Edward	53 Shaftesbury-parade, Thornbury	53 Shaftesbury-parade, Thornbury	Northcote ..	13.1.61	
Williams, John Maxwell	Ballarat Bureau of Investigation, 26 Lydiard-street South, Ballarat	26 Lydiard-street South, Ballarat	Ballarat ..	24.11.60	
Williams, Lindsay Edwin	Lot 49, Eastfield-road, Croydon	Lot 49, Eastfield-road, Croydon	Ringwood ..	6.12.60	
Williamson, Melville James	4 Palm-avenue, Horsham	4 Palm-avenue, Horsham	Horsham ..	30.11.60	
Willing, Francis Laurence	703 Burke-road, Camberwell	703 Burke-road, Camberwell	Camberwell ..	1.12.60	
Woods, Lloyd ..	158 Barkly-street, Ararat	21 Hewitt-street, Ararat	Ararat ..	9.12.60	
Wyhoon, William James	3 David-street, Noble Park	3 David-street, Noble Park	Springvale ..	7.12.60	
Young, Clive Roland Emmott	Lot 30, Largs-street, Seaford	Lot 30, Largs-street, Seaford	Frankston ..	2.12.60	
Young, Leonard William	214 Chapel-street, Prahran, and 169 Latrobe-street, Melbourne	8 Bowen-street, East St. Kilda	Prahran ..	5.12.60	

1. The first part of the document discusses the importance of maintaining accurate records of all transactions and activities. It emphasizes that this is essential for ensuring transparency and accountability in the organization's operations.

2. The second part of the document outlines the specific procedures and protocols that must be followed to ensure that all records are properly maintained and updated. This includes details on how data should be collected, stored, and reviewed.

3. The third part of the document addresses the role of the management team in overseeing the implementation of these procedures and ensuring that they are followed consistently across all departments.

4. The fourth part of the document discusses the importance of regular audits and reviews to ensure that the record-keeping system is effective and compliant with all relevant regulations and standards.

5. The fifth part of the document provides a summary of the key points discussed and offers recommendations for how the organization can improve its record-keeping practices in the future.



VICTORIA GOVERNMENT GAZETTE

Published by Authority

[Registered at the General Post Office, Melbourne, for transmission by post as a newspaper.]

No. 68]

WEDNESDAY, AUGUST 2

[1961

Land Act 1958.

AREA OF LAND COMPRISED IN CERTAIN CLASSES DIMINISHED OR INCREASED.

PROCLAMATION

By His Excellency the Administrator of the Government of the State of Victoria and its dependencies in the Commonwealth of Australia, &c., &c., &c.

WHEREAS by the *Land Act 1958* it is amongst other things enacted that the Governor in Council may, by Proclamation to be published in the *Government Gazette*, at any time diminish or increase the area of land comprised in any of the classes mentioned in Part I., Division 1, Section 5, of the said *Land Act 1958*, but that the area of lands which may be sold by auction (Class 6), shall not be increased except as in certain cases in the said Act provided: Now therefore I, the Administrator of the Government of the State of Victoria, in the Commonwealth of Australia, by and with the advice of the Executive Council of the said State, and in accordance with the provisions of sections 94 and 117 of the *Land Act 1958* aforesaid, do hereby diminish or increase (as the case may be) the areas of Crown Lands comprised in Classes 6 and 7 of the classes mentioned in section 5 of the *Land Act 1958* aforesaid, to the extent set forth in the subjoined Schedule (that is to say):—

Schedule referred to.

CLASSES DIMINISHED OR INCREASED.

County.	Parish.	Allotment.	Section.	Area.	Diminished.	Increased.	Description.
					Class.	Class.	
				A. R. P.			
Bendigo ..	Nerring ..	3	7B	6 3 15	7	6	Approximately $\frac{1}{4}$ mile west of State School Reserve and approximately 5 chains south of Bendigo-Pyramid-road
Bendigo ..	Nerring ..	4	20B	12 3 26	7	6	Fronting south side of Bendigo-Pyramid-road approximately $\frac{1}{4}$ mile north of Sailors Gully-road
Bendigo ..	Nerring ..	5	20B	16 0 6	7	6	On the west of the southern portion of State School Reserve

Given under my Hand and the Seal of the State of Victoria, aforesaid, at Melbourne, this twenty-sixth day of July, in the year of our Lord One thousand nine hundred and sixty-one, and in the tenth year of the reign of Her Majesty Queen Elizabeth II.

(L.S.)

CHARLES J. LOWE.

By His Excellency's Command,

KEITH TURNBULL,
Commissioner of Crown Lands and Survey.

GOD SAVE THE QUEEN !

PROCLAMATION

By His Excellency the Lieutenant-General the Honorable Sir Edmund Francis Herring, K.C.M.G., K.B.E., D.S.O., M.C., E.D., Lieutenant-Governor of the State of Victoria and its Dependencies in the Commonwealth of Australia, &c., &c., &c.

WHEREAS by a Commission under the Royal Sign Manual and Signet, bearing date the Thirtieth day of July, One thousand nine hundred and forty-five, His Majesty King George VI. was graciously pleased to appoint me to be the Lieutenant-Governor of the State of Victoria and its Dependencies in the Commonwealth of Australia, with all the powers, rights, privileges, and advantages to the said Office belonging or appertaining; and further, in case of the death, incapacity, or removal of the Governor of the said State, or of his departure from the said State, or of his assuming the administration of the Government of the Commonwealth of Australia, to authorize and require me to administer the Government of the said State, with all and singular the powers and authorities contained in certain Letters Patent under the Great Seal of the United Kingdom of Great Britain and Ireland bearing date at Westminster the Twenty-ninth day of October, One thousand and nine hundred, constituting the office of Governor in and over the said State of Victoria and its dependencies as amended by Letters Patent under the Great Seal of the United Kingdom of Great Britain and Ireland, bearing date at Westminster the Thirtieth day of April, One thousand nine hundred and thirteen, making further provision for the administration of the Government of the State of Victoria and its Dependencies in certain events. And whereas the said Governor having assumed the Administration of the Government of the Commonwealth of Australia: Now therefore, I, Sir Edmund Francis Herring, the Lieutenant-Governor of the said State, do hereby proclaim that all the powers and authorities by the said Letters Patent granted to the Governor of the said State of Victoria and its dependencies and by virtue of all other powers and authorities thereunto me enabling, have become and are now vested in me as Lieutenant-Governor of the said State now residing therein, to be by me exercised and enjoyed in accordance with the terms of the said Commission.

Given under my Hand and the Seal of the State of Victoria aforesaid, at Melbourne, this second day of August in the year of our Lord One thousand nine hundred and sixty-one, and in the tenth year of the reign of Her Majesty Queen Elizabeth II.

(L.S.) E. F. HERRING.

By His Excellency's Command,
A. G. RYLAH,
Acting Premier.
GOD SAVE THE QUEEN!

Health Act 1958 (No. 6270).
CONSTITUTION OF A MEAT AREA.

PROCLAMATION

By His Excellency the Administrator of the Government of the State of Victoria and its Dependencies in the Commonwealth of Australia, &c., &c., &c.

BY virtue of the powers conferred by the *Health Act 1958 (No. 6270)*, I, the Administrator of the Government of the State of Victoria, in the Commonwealth of Australia, on the recommendation of the Commission of Public Health and by and with the advice of the Executive Council of the said State, do by this my Proclamation constitute the following as meat areas:—

Name of Meat Area; Description.

Frankston; the whole of the Municipal District of the Shire of Frankston.
Hastings; the whole of the Municipal District of the Shire of Hastings.

Given under my Hand and the Seal of the State of Victoria aforesaid, at Melbourne, this twenty-sixth day of July, in the year of our Lord One thousand nine hundred and sixty-one, and in the tenth year of the reign of Her Majesty Queen Elizabeth II.

(L.S.) CHARLES J. LOWE.

By His Excellency's Command,
E. P. CAMERON,
Minister of Health.
GOD SAVE THE QUEEN!

Health Act 1958 (No. 6270).

PROCLAMATION REVOKING THE CONSTITUTION OF A MEAT AREA.

PROCLAMATION

By His Excellency the Administrator of the Government of the State of Victoria and its Dependencies in the Commonwealth of Australia, &c., &c., &c.

BY virtue of the powers conferred by the *Health Act 1958 (No. 6270)*, I, the Administrator of the Government of the State of Victoria, in the Commonwealth of Australia, on the recommendation of the Commission of Public Health and by and with the advice of the Executive Council of the said State, do by this my Proclamation revoke the constitution of the Frankston Meat Area, as defined in the Proclamation published in the *Government Gazette* dated the 27th day of August, 1947, and amended by the Proclamation published in the *Government Gazette* of the 3rd day of November, 1954.

Given under my Hand and the Seal of the State of Victoria aforesaid, at Melbourne, this twenty-sixth day of July, in the year of our Lord One thousand nine hundred and sixty-one, and in the tenth year of the reign of Her Majesty Queen Elizabeth II.

(L.S.) CHARLES J. LOWE.

By His Excellency's Command,
E. P. CAMERON,
Minister of Health.
GOD SAVE THE QUEEN!

LOCAL GOVERNMENT DEPARTMENT.

PROCLAMATION EXTENDING THE OPERATION OF PART XLIII. OF THE LOCAL GOVERNMENT ACT 1958 (AS AMENDED) TO THE MUNICIPAL DISTRICTS OF THE CITY OF MARYBOROUGH, THE CITY OF SPRINGVALE AND THE CITY OF WAVERLEY.

By His Excellency the Administrator of the Government of Victoria and its Dependencies in the Commonwealth of Australia, &c., &c., &c.

WHEREAS section 824 of the *Local Government Act 1958 (as amended)* provides, *inter alia*, that the Governor in Council may, by Proclamation published in the *Government Gazette*, extend the operation of Part XLIII. of the Act to any city or town, or at the request of the council concerned, to any other municipality or part thereof.

Now, therefore, I, the Administrator of the Government of the State of Victoria, by and with the advice of the Executive Council thereof, by this my Proclamation do hereby extend the operation of Part XLIII. of the said Act to the municipal districts of the City of Maryborough, the City of Springvale and the City of Waverley.

Given under my Hand and the Seal of the State of Victoria aforesaid, at Melbourne, this twenty-sixth day of July, in the year of our Lord One thousand nine hundred and sixty-one, and in the tenth year of the reign of Her Majesty Queen Elizabeth II.

(L.S.) CHARLES J. LOWE.

By His Excellency's Command,
MURRAY PORTER,
Minister for Local Government.
GOD SAVE THE QUEEN!

BRANXHOLME TOWN COMMON ABOLISHED.

PROCLAMATION

By His Excellency the Administrator of the Government of the State of Victoria and its Dependencies in the Commonwealth of Australia, &c., &c., &c.

WHEREAS by Division 12 of Part I. of the *Land Act 1958* it is amongst other things enacted that the Governor in Council may from time to time increase, and after one month's notice in the *Government Gazette*, diminish, alter, or abolish any common, and may from time to time re-proclaim the whole or any part of any

such common for any of the purposes and subject to the provisions of the said Part of the said Act, and that nothing therein contained shall prevent the exercise of the powers conferred by the said Part of the said Act with respect to the leasing or licensing of any land comprised in any common: And whereas notice of the intention to abolish the Branxholme Town Common has been duly published in the *Government Gazette* for four consecutive weeks: Now therefore I, the Administrator of the Government of the State of Victoria, in the Commonwealth of Australia, by and with the advice of the Executive Council of the said State, do hereby abolish the Branxholme Town Common.

Given under my Hand and the Seal of the State of Victoria aforesaid, at Melbourne, this twenty-sixth day of July, in the year of our Lord One thousand nine hundred and sixty-one, and in the tenth year of the reign of Her Majesty Queen Elizabeth II.

(L.S.) CHARLES J. LOWE.

By His Excellency's Command,
KEITH TURNBULL,
Commissioner of Crown Lands and Survey.
GOD SAVE THE QUEEN!

PUBLIC HOLIDAYS.

PROCLAMATION

By His Excellency the Administrator of the Government of the State of Victoria and its Dependencies in the Commonwealth of Australia, &c., &c., &c.

IN pursuance of the provisions contained in Part III. of the *Public Service Act 1958*, I, the Governor of the State of Victoria, in the Commonwealth of Australia, by and with the advice of the Executive Council of the said State, do by this my Proclamation appoint the days and dates hereunder mentioned to be observed as Public Holidays or Public Half-Holidays (as the case may be) at the places respectively specified, viz.:—

Public Holiday:—

SATURDAY, THE 4TH NOVEMBER, 1961, throughout the Central Riding of the Shire of Kerang.

Public Half-Holidays from the Hour of Twelve o'clock noon:—

* THURSDAY, THE 17TH AUGUST, 1961, throughout the Balmoral Riding of the Shire of Wannon.

* THURSDAY, THE 31ST AUGUST, 1961, throughout the North Riding of the Shire of Arapiles.

* Agricultural Show.

Given under my Hand and the Seal of the State of Victoria aforesaid, at Melbourne, this twenty-sixth day of July, in the year of our Lord One thousand nine hundred and sixty-one, and in the tenth year of the reign of Her Majesty Queen Elizabeth II.

(L.S.) CHARLES J. LOWE.

By His Excellency's Command,
A. G. RYLAH,
Chief Secretary.
GOD SAVE THE QUEEN!

VEGETATION AND VINE DISEASES ACT 1958.

I, THE undersigned Gilbert Lawrence Chandler, being the responsible Minister of the Crown for the time being administering the *Vegetation and Vine Diseases Act 1958*, in accordance with the provisions of section 9 of the said Act, do hereby appoint the under-mentioned person to exercise with respect to any land whatsoever in that part of Victoria which lies within the limits of the Eastern, Western, Midland, Northern and Southern Bailiwicks of the Supreme Court of Victoria as defined in the Third Schedule to the *Supreme Court Act 1958*, the following powers, that is to say, to enter upon any such land whatsoever at any time with or without assistants to search for diseased trees, plants or vegetables and to remain thereon so long as may be reasonable for such purpose:—

SANDS, CLIFFORD FRANCIS PATEY.

Given under my Hand, at Melbourne, the 26th day of July, 1961.

G. L. CHANDLER,
Minister of Agriculture.

VEGETATION AND VINE DISEASES ACT 1958.

I, THE undersigned Gilbert Lawrence Chandler, being the responsible Minister of the Crown for the time being administering the *Vegetation and Vine Diseases Act 1958*, in accordance with the provisions of section 9 of the said Act, do hereby appoint the under-mentioned person to exercise with respect to any land whatsoever in that part of Victoria which lies within the limits of the Central Bailiwick of the Supreme Court of Victoria as defined in the Third Schedule to the *Supreme Court Act 1958*, the following powers, that is to say, to enter upon any such land whatsoever at any time with or without assistants to search for diseased trees, plants or vegetables and to remain thereon so long as may be reasonable for such purpose:—

SANDS, CLIFFORD FRANCIS PATEY.

Given under my Hand, at Melbourne, the 26th day of July, 1961.

G. L. CHANDLER,
Minister of Agriculture.

VEGETATION AND VINE DISEASES ACT 1958.

THE Public Service Board, by certificate dated the 14th July, 1961, has appointed the under-mentioned Farm Produce Inspectors, Grades 30-35 inclusive, Technical and General Division, Department of Agriculture, as Inspectors under the provisions of the *Vegetation and Vine Diseases Act 1958*, without additional salary:—

BRANFORD, IAIN CHARLES.
BUNNETT, CHARLES STUART.
DUNN, FRANCIS HENRY.
FOSTER, WILFRED HERBERT.
HENRY, ALBYN LYND.
POOLE, ERNEST GEORGE.
WHITTY, GRAHAM EDWARD.

FRANK M. READ,
Director of Agriculture.

Melbourne, 24th July, 1961.

NOTICE TO MARINERS.

[No. 12 of 1961.]

AUSTRALIA.—VICTORIA.

PORT PHILLIP.

1. Light Normal.
2. Light-beacon Construction Suspended.

1. Date.—On or about 8th August, 1961.

Former Notice.—No. 12 of 1959, T. hereby cancelled.

Position.—West Channel Pile Light, Lat. 38 deg. 11 min. 41 sec. S., Long. 144 deg. 45 min. 25 sec. E. (approx.).

Details.—The reconstruction of the West Channel Pile Light structure is completed and the light returned to normal.

2. Former Notice.—No. 8 of 1961, P. (2).

Position.—South Channel Pile Light, Lat. 38 deg. 19 min. 54 sec. S., Long. 144 deg. 51 min. 09 sec. E. (approx.).

Details.—Pile-driving operations for the construction of a light-beacon 285 degrees distant 8,250 feet from the above position have been suspended due to weather conditions. Further notice will issue on resumption.

Charts Affected.—B.A. Nos. 1171 and 2747.

Publications.—*Sailing Directions, Victoria*, 1959, pages 254 (1) and 230 (2). *List of Lights*, Vol. 10, 1960, No. 2232.

C. O'MALLEY,
Port Officer.

Ports and Harbors Branch,
Department of Public Works,
Melbourne, C.2, 27th July, 1961.

EDUCATION DEPARTMENT.

SUMMONING OFFICER.

UNDER section 5 of the *Education Act 1958*, I hereby appoint—

THOMAS EDWARD HEATH
to summon parents within the State of Victoria.

JOHN BLOOMFIELD,
Minister of Education.
Melbourne, 25th July, 1961.

Transport Regulation Acts.
TRANSPORT REGULATION BOARD.

NOTICES OF PUBLIC HEARINGS.

NOTICE is hereby given that the applications made by the persons named below for licences to operate the commercial goods vehicles on the route or routes, or in the manner set out opposite their names, will be heard at a time and place to be communicated to the persons concerned:—

Name and Address; Nature of Application.

- ATHANASIADIS, H., 97 Argyle-street, Traralgon; 1 commercial goods vehicle (130 cwt.) to operate—(a) within a radius of 70 miles of the post office at Yarram (Traralgon Division of the Country Roads Board)—plant the property of a contractor and required for use in connexion with the construction or maintenance of some specific, existing or proposed road, street, footpath, bridge, wharf, pier, weir or channel, (b) within a radius of 20 miles from site of construction or maintenance work performed pursuant to paragraph (a) above, or from the railway station nearest thereto—metal, stones, screenings, ashes, gravel, sand, earth and any other materials required for such work, (c) within a radius of 20 miles of the post office at Traralgon—general goods.
- BAKER, J. A. & G. E., Camp-street, Beechworth; 1 commercial goods vehicle (6 cwt.) to operate—(a) within a radius of 50 miles of Beechworth in the course of business as "plumbers"—own goods, (b) within a radius of 100 miles of Beechworth—tools of trade and equipment incidental to own contracts.
- ELLIOTT, I. & D. G. (trading as Bay Towing), 257 Bay-road, Cheltenham; 1 commercial goods vehicle (28 cwt.) to operate throughout the State of Victoria for the purpose of towing and/or repairing wrecked and disabled vehicles—tools of trade, spare parts and materials incidental thereto.
- BELL, S., Axedale; 1 commercial goods vehicle (12 cwt.) to operate—(a) within a radius of 20 miles of the post office at Axedale—general goods, (b) to and from places within a radius of 50 miles of the post office at Axedale, from and to places within paragraph (a) above—livestock, (c) within a radius of 50 miles of own depot at Axedale as an agent for B.P. Australia Ltd.—petroleum products in prescribed types of containers and empty return containers.
- BLENCOWE, R., Frankston-road, Dandenong; 1 commercial goods vehicle (142 cwt.) to operate—(a) within a radius of 25 miles of Melbourne—general goods, (b) from pits in the Cranbourne area to places within paragraph (a)—sand.
- BOYER, C. J. & SON, 9 Sturt-street, Kyneton; 1 commercial goods vehicle (100 cwt.) to operate within a radius of 30 miles of Kyneton in the course of business as "road contractor"—sand, gravel, screenings and firewood.
- CASEY, L. M., 3 Dundas-street, St. Arnaud; 1 commercial goods vehicle (8 cwt.) to operate—(a) within a radius of 20 miles of the post office at St. Arnaud—general goods, (b) between, St. Arnaud and Marnoo—mails and two (2) passengers.
- CLARKE, F. N., 9B Hall-street, Hawthorn; 1 commercial goods vehicle (97 cwt.) to operate—(a) within a radius of 25 miles of Melbourne—general goods, (b) within a radius of 70 miles of Auburn Brick Works, Auburn—bricks.
- CORIDAS, B. R., 96 McAdam-street, Maffra; 1 commercial goods vehicle (207 cwt.) to operate—(a) within a radius of 20 miles of Maffra—soil and gravel, (b) from Maffra to brick works situated at the Townships of Bairnsdale and Traralgon—gravel, (c) from brick works at Bairnsdale and Traralgon to Maffra—bricks.
- CRISERA, D., Post Office, Koorlong; 1 commercial goods vehicle (120 cwt.) to operate—(a) throughout the Shires of Mildura, Walpeup, Swan Hill, Wycheproof and Karkaroc—plant the property of a contractor and required for use in connexion with the construction or maintenance of some specific, existing or proposed road, street, footpath, bridge, wharf, pier, weir or channel, (b) within a radius of 20 miles from site of construction or maintenance work performed pursuant to paragraph (a) above, or from the railway station nearest thereto—metal, stones, screenings, ashes, gravel, sand, earth and any other materials required for such work, (c) within a radius of 20 miles of the post office at Koorlong—general goods.
- COSTELLO, C., care of Country Roads Board, Violet Town; 1 commercial goods vehicle (88 cwt.) to operate—(a) within a radius of 90 miles of the post office at Wangaratta (Benalla Division of the Country Roads Board)—plant the property of a Government authority, municipality or of a contractor and required for use in connexion with the construction or maintenance of some specific, existing or proposed road, street, footpath, bridge, wharf, pier, weir or channel, (b) within a radius of 20 miles from site of construction or maintenance work performed pursuant to paragraph (a) above, or from the railway station nearest thereto—metal, stones, screenings, ashes, gravel, sand, earth and any other materials required for such work.
- CURLEY, J. F., 144 Princes-street, Traralgon; 1 commercial goods vehicle (144 cwt.) to operate—(a) within a radius of 70 miles of the post office at Yarram (Traralgon Division of the Country Roads Board)—plant the property of a contractor and required for use in connexion with the construction or maintenance of some specific, existing or proposed road, street, footpath, bridge, wharf, pier, weir or channel, (b) within a radius of 20 miles from site of construction or maintenance work performed pursuant to paragraph (a) above, or from the railway station nearest thereto—metal, stones, screenings, ashes, gravel, sand, earth and any other materials required for such work.
- DAVIS, M. L., 31 Peace-avenue, Warragul; 1 commercial goods vehicle (85 cwt.) to operate within a radius of 40 miles from own quarry at Drouin—road-contracting plant and materials.
- DAY, E. E., & SONS PTY. LTD., 822 Howitt-street, Ballarat; 1 commercial goods vehicle (8 cwt.) to operate—(a) within a radius of 25 miles of Ballarat in the course of business as "machinery manufacturers and merchants"—own goods, (b) throughout the State of Victoria as a traveller's vehicle for the purpose of booking orders—samples of own goods, with the ability to leave a sample when required.
- DOWN, L., Murrindindi; application to vary the conditions of licences Nos. T.T.D.182 and T.T.D.182/1 by adding to timber yards and building sites within a radius of 25 miles of Melbourne.
- ERECTION ENGINEERS PTY. LTD., 13 Anderson-road, Thornbury; 1 commercial goods vehicle (37 cwt.) to operate—(a) within a radius of 50 miles of own premises at Thornbury in the course of business as "structural engineers"—own goods, (b) throughout the State of Victoria—tools of trade and erection equipment incidental to own contracts, (c) within a radius of 20 miles of any contract currently engaged upon or from the nearest railway station thereto—materials for use on such contract.
- FLETCHER, H. S., Nepean Highway, Rye; 1 commercial goods vehicle (approximately 120 cwt.) to operate between own hotel at Rye and the City of Melbourne in the course of business as "hotel proprietor"—own goods.
- FRASER, G. C., 68 Argyle-street, Traralgon; application to vary the conditions of existing licence No. T.T.D.198 by adding logs from S.E.C. forest landings in Yallourn North area to sawmills at Longwarry and Pakenham.
- THE GRASMERE BUTTER CO. LTD., 57 Fairy-street, Warrnambool; 1 commercial goods vehicle (108 cwt.) to operate, being the owner of the butter factory for the carriage of—(i) milk or cream to own butter factory at Koroit, (ii) empty milk cans or cream cans and goods to the premises of any primary producer from whose premises milk or cream is collected, (iii) goods and materials necessary for the working of own factory between own factory and the Koroit Railway Station, (iv) between local depot at Koroit and own factory at Koroit—own goods, (v) from own factory at Koroit to Borthwick's Cool Stores at Portland—own goods.
- HAMILTON, K., Orford; 1 commercial goods vehicle (115 cwt.) to operate—(a) within a radius of 20 miles of Orford—general goods, (b) from and to places within a radius of 50 miles of Orford, and to and from places within paragraph (a) above—livestock.
- HAYES & KYDD PTY. LTD., Auckland-street, Bega, New South Wales; 2 commercial goods vehicles (269 cwt. and approximately 200 cwt.) to operate from sawmills at Noorinbee and Cann River to the railway station at Orbst—sawn timber.
- LEE, L. (trading as H. K. and Co.), 311 Racecourse-road, Newmarket; 1 commercial goods vehicle (9 cwt.) to operate—(a) within a radius of 50 miles from own premises at Newmarket—own goods, (b) from own premises at Newmarket to Lorne and Military Camps at Puckapunyal—own chicken rolls and dim sims.
- THE HOFFMAN BRICK & POTTERIES LTD., Dawson-street, Brunswick; application to vary the conditions of existing licence No. D.A.35003/11 by deleting Brunswick and adding in lieu—Traralgon and Yallourn.

- HOGAN, M. M., 144 Perry-street, Alphington; 1 commercial goods vehicle (100 cwt.) to operate within a radius of 70 miles from the premises of the Northcote Brick Co. Pty. Ltd., at Northcote—bricks on behalf of the said company.
- KENNA, A. J., Spring-street, Mortlake; 1 commercial goods vehicle (166 cwt.) (low loader) to operate throughout the State of Victoria in the course of business as an "agricultural and earth-moving contractor"—tools of trade and equipment incidental only to own contracts.
- KUMMER, I., 12 John-street, Balwyn; 1 commercial goods vehicle (8 cwt.) to operate within a radius of 50 miles of Melbourne as a "service mechanic" on behalf of Turner Industries Ltd. for the purpose of servicing and installing washing machines, &c.—tools of trade, spare parts, washing machines, &c., for repair, having been repaired and for installation, and materials incidental thereto.
- VUKASINOVIC, M. (trading as Milos Motors), Melbourne-road, Wodonga; 1 commercial goods vehicle (9 cwt.) to operate within a radius of 100 miles of the post office at Wodonga for the purpose of towing and/or repairing wrecked and disabled vehicles—tools of trade, spare parts and materials incidental thereto.
- VUKASINOVIC, M. (trading as Milos Motors), Melbourne-road, Wodonga; 1 commercial goods vehicle (approximately 100 cwt.) to operate within a radius of 50 miles of the post office at Wodonga in a specially constructed vehicle—premixed concrete.
- MORAN, A. & D., PRY. LTD., 8 Buchanan-street, Ivanhoe; 1 commercial goods vehicle (8 cwt.) to operate—(a) within a radius of 50 miles of own premises in the course of business as "wholesale clothing manufacturer and distributor"—own goods, (b) throughout the State of Victoria for the purpose of booking orders and displaying samples—samples of clothing with the ability to leave a sample when required.
- MOSS, L. R. W. (ELECTRICAL) PRY. LTD., 12 Bank-place, Melbourne; application to vary the conditions of licence No. D.A.39901 by deleting present conditions and adding in lieu—(a) within a radius of 50 miles of Melbourne in the course of business as "electrical contractors"—own goods, (b) throughout the State of Victoria for the purpose of servicing and installing electrical equipment—tools of trade, spare parts and materials incidental thereto.
- MURRAY, A. A., Moama, New South Wales; 1 commercial goods vehicle (107 cwt.) to operate—(a) within a radius of 100 miles of the post office at Merbein and/or within a radius of 95 miles of the post office at Cohuna (Bendigo Division of the Country Roads Board)—plant, the property of a contractor and required for use in connexion with the construction or maintenance of some specific, existing or proposed road, street, footpath, bridge, wharf, pier, weir or channel, (b) within a radius of 20 miles from site of construction or maintenance work performed pursuant to paragraph (a) above, or from the railway station nearest thereto—metal, stones, screenings, ashes, gravel, sand, earth and any other materials required for such work.
- MCCORMICK, R., & SON, 3 Dixon-street, Wangaratta; 1 commercial goods vehicle (approximately 100 cwt.) to operate within a radius of 150 miles of the post office at Wangaratta for the purpose of towing and/or repairing wrecked and disabled vehicles—tools of trade, spare parts and materials incidental thereto.
- NAUGHTON, W., & J. CALLAHAN (trading at N. & C. Transport Co.), Bowen-road, Sorrento; 1 commercial goods vehicle (23 cwt.) to operate—(a) within a radius of 20 miles of Sorrento—general goods, (b) within a radius of 50 miles of Ampol Depot at Newport—petroleum products and empty containers on behalf of the said company.
- THE NESTLE COMPANY (AUSTRALIA) LTD., Foster-street, Maffra; 2 commercial goods vehicles (7 cwt. and 77 cwt.) to operate within a radius of 50 miles of own premises at Maffra in the course of business as "manufacturers of milk products"—own goods.
- PEEL, A. H., 50 O'Shannessy-street, Nunawading; 1 commercial goods vehicle (20 cwt.) to operate throughout the State of Victoria on behalf of the Australian Bible Gift Crusade for the purpose of distributing religious books, &c., free, to schools and ministers of religion, also with the ability to sell to householders only—religious publications and the New English Bible.
- PIEPER, G. C., Katunga; 1 commercial goods vehicle (10 cwt.) to operate—(a) between own premises at Katunga and the City of Shepparton and within a radius of 20 miles of the post office at Katunga in the course of business as a "general storekeeper"—own goods, (b) between Katunga and Sandmount—mails under contract to the P.M.G. Department and parcels.
- PORRECA, N., 25 Murphy-street, Richmond; 1 commercial goods vehicle (146 cwt.) to operate from pits at Garfield and Koo-Wee-Rup to depots at Dandenong and Murrumbena and to places in the eastern and southern suburbs of Melbourne on behalf of Plowright Albion Koo-Wee-Rup Washed Sand and Gravel Co. Pty. Ltd.—sand.
- MOYLE, K. M., & R. WATSON (trading as Rising Sun Towing Service), 2 Williamstown-road, West Footscray; 1 commercial goods vehicle (16 cwt.) to operate throughout the State of Victoria for the purpose of towing and/or repairing wrecked and disabled vehicles—tools of trade, spare parts and materials incidental thereto.
- SALTMARSH, E. M. (Mrs.), Box 1, Byawatha-road, Wangaratta; 1 commercial goods vehicle (400 cwt. low loader) to operate throughout the State of Victoria in the course of business as a "earth-moving contractor"—tools of trade and equipment incidental to own contracts.
- SHELLY, P. E., Bacchus Marsh; 1 commercial goods vehicle (approximately 240 cwt.) to operate solely on behalf of C. S. R. Fibreboard Groups' Factory at Bacchus Marsh to consignees within a radius of 50 miles of such factory for the carriage of all finished products, empty pallets and damaged products for claim.
- SIDES, W. L., & SON PRY. LTD., 422 Collins-street, Melbourne; 3 commercial goods vehicles (60, 52 and approximately 50 cwt.) to operate throughout the State of Victoria in the course of business as "boring contractors"—tools of trade, boring equipment and materials incidental to own contracts.
- SMITH, W. F. & J. B., 11 Gray-street, Leongatha; 1 commercial goods vehicle (120 cwt.) to operate—(a) within a radius of 20 miles of the post office at Leongatha—general goods, (b) from State Electricity Commission at Morwell to own yard at Leongatha—bagged briquettes.
- STAMP, J. W., PRY. LTD., 235 Cardigan-street, Carlton; 1 commercial goods vehicle (7 cwt.) to operate throughout the State of Victoria in the course of business as "abattoir machinery manufacturers"—tools of trade, spare parts and materials incidental to servicing own manufactured abattoir machinery.
- STEWART, K. J., 529 Burwood-road, Hawthorn; 1 commercial goods vehicle (35 cwt.) to operate throughout the State of Victoria for the purpose of towing and/or repairing wrecked and disabled vehicles—tools of trade, spare parts and materials incidental thereto.
- SWEENEY, K. W., 33 Bruce-street, Heyfield; application to vary the conditions of existing licence No. T.T.D.2050 by adding "from forest landings in Licola area to sawmills at Heyfield—logs".
- WADE, A. D., 9 Stewart-street, Horsham; 1 commercial goods vehicle (15 cwt.) to operate in the course of business as a "wholesale distributing agent" within a radius of 60 miles of Horsham and to Hopetoun and Birchlip—(a) on behalf of Phoenix Biscuit Co. Pty. Ltd. and Colvan Chips—goods on behalf of such firms. NOTE.—All goods to be railed to Horsham or a convenient railway station in the above area; (b) on behalf of Wimmera Pickle Co.—foodstuffs on behalf of such firm.
- YOUNG, W. H., & SONS, 182 High-street, Shepparton; 1 commercial goods vehicle (209 cwt.) to operate within a radius of 50 miles of own premises at Shepparton in a specially constructed vehicle in the course of business as "concrete manufacturers"—own premixed concrete.

NOTICE is hereby given that the applications made by the persons named below for renewal of licences to operate the commercial goods vehicles on the route or routes, or in the manner set out opposite their names, will be heard at a time and place to be communicated to the persons concerned:—

Name and Address; Present Franchise; Licence Number; Expiry Date.

BORGO, M., 451 Rathdown-street, Carlton; 1 commercial goods vehicle (73 cwt.) to operate as a specially constructed vehicle within a radius of 100 miles from the post office situated at the corner of Bourke and Elizabeth streets, in the City of Melbourne, in the course of business of the licence holder as "hawker"—licensee's own continental small goods, grocery lines and fruit and vegetables in season. *Special Condition.*—It is also a condition of this licence that any of the goods carried for resale shall not be supplied to retail stores; D.A.38773; 14th October, 1961.

FORD, F. T., 56 Bride-street west, Benalla; 1 commercial goods vehicle (8 cwt.) to operate throughout the State of Victoria in the course of business as "builder"—building materials incidental to and for use on licensee's own contracts; D.A.7271; 12th October, 1961.

HARRIS, E. S., & Co. PTY. LTD., 43 Kepler-street, Warrnambool; 1 commercial goods vehicle (250 cwt.) to operate in the course of licensee's business as "building contractors"—(a) within a radius of 20 miles from the main post office at Warrnambool—licensee's own goods, (b) from licensee's premises at Warrnambool to licensee's sawmill at Drik Drik—mill plant and mill supplies, returning with sawn timber for use in connexion with licensee's own building contracts, (c) from brickworks at Glenthompson, Stawell and Ararat to building sites within a radius of 20 miles from the main post office at Warrnambool—bricks; T.D.2836; 8th October, 1961.

HOWARTH, L. J., Ellingamite North; 1 commercial goods vehicle (80 cwt.) to operate—(a) within a radius of 50 miles from the post office at Ellingamite North in the course of business as "primary producer"—own goods, (b) within a radius of 20 miles from the post office at Ellingamite North—petroleum products in prescribed types of containers and empty containers on behalf of Ampol Petroleum Ltd.; D.A.31087; 14th October, 1961.

JUDD, G. E., B. E. & H. C. J. (trading as G. Judd and Sons), 40 Coghill-street, Yarrowonga; 1 commercial goods vehicle (215 cwt.) to operate—(a) within a radius of 20 miles from the post office at Yarrowonga—general goods, (b) within a radius of 50 miles from the post office at Yarrowonga—road-contracting plant and materials; D.A.1403/2; 14th October, 1961.

RAMSAY, W. M., Buchan; 1 commercial goods vehicle (9 cwt.) to operate—(1) parcels and mail only along the following routes, namely—(a) between Buchan and Bairnsdale, via Bruthen, subject to the special restrictions set out hereunder, (b) between Buchan and Wulgulmerang, via Butcher's Ridge and Gelantipy, (2) in addition to the carriage of parcels and mail along the above routes, the vehicle may also be operated along the above routes for the carriage of passengers, not exceeding two, at any time, subject to the special restriction set out hereunder in respect of Route (a) above, and subject also to the condition to operate—(i) between Buchan and Bairnsdale on Mondays, Wednesdays and Fridays, (ii) between Buchan and Wulgulmerang on Tuesdays, Thursdays and Saturdays, (3) special restrictions as to carriage of both passengers and parcels on Route (a)—(a) on journeys to Bairnsdale from Buchan along Route (a) above, passengers and/or parcels may be taken up and set down at any place between Buchan and Bruthen, but no passengers or parcels whatsoever consigned or bound for places along the route south of Bruthen shall be taken up at any point nearer to Bairnsdale than a point along the route 2 miles east of the Bruthen Post Office, (b) on journeys from Bairnsdale to Buchan along Route (a) above, passengers and parcels may be taken up at any point *en route*, but shall not be set down at any point nearer to Bairnsdale than a point along the route 2 miles east of the Bruthen Post Office; D.A.24429/1; 21st October, 1961.

RICKEY, A. H., 8 Symons-street, Ballarat; 1 commercial goods vehicle (120 cwt.) to operate—(a) throughout the State of Victoria in the course of business as "road and bridge construction and earth-moving contractor"—tools of trade and equipment incidental to own contracts, (b) within a radius of 20 miles from the site of any contract—any materials incidental to such contracts; D.A.5921/1; 19th October, 1961.

STANSFIELD & SMITH PTY. LTD., 327 Sturt-street, Ballarat; 1 commercial goods vehicle (10 cwt.) to operate throughout the State of Victoria—tools of trade and materials incidental to contracts entered into by the holders of this licence in the course of business as "painting and glazing contractors"; D.A.2097/4; 22nd July, 1961.

TEMPLETON, T. J., corner of Stawell and Elgin streets, Sale; 1 commercial goods vehicle (7 cwt.) to operate within a radius of 40 miles from the post office at Sale—new and second-hand sewing machines and accessories; D.A.31096; 21st October, 1961.

WHITE, C., 34 Elliot-avenue, Deepdene; 1 commercial goods vehicle (16 cwt.) to operate throughout the State of Victoria in the course of business as "electrical contractor"—tools of trade, spare parts and materials incidental to own contracts; D.A.9135; 26th October, 1961.

NOTICE is hereby given that the applications made by the persons named below for licences to operate commercial passenger vehicles, on the route or routes or in the manner set out opposite their names, will be heard at a time and place to be communicated to the parties:—

Name and Address; Nature of Application.

RODGERS, A. E., Gibson-street, Korong Vale; 1 commercial passenger vehicle, with seating capacity for 31 persons, to operate as follows:—(a) For the carriage of school children only between Boort and Wychitella, under contract to the Education Department, (b) as a country special service omnibus from Boort.

BURROWS, D. K., Box 1, Caramut; 1 commercial passenger vehicle, with seating capacity for five persons, to operate as follows:—(a) For the carriage of passengers between Caramut and Warrnambool, (b) for the carriage of mails between Caramut and Warrnambool, under contract to the Postmaster-General's Department, (c) for the carriage of parcels between Caramut and Warrnambool.

ANDERSON, E. M. & A. J., 19 Haverfield-street, Echuca; 1 commercial passenger vehicle, to be purchased, to operate as a town bus at Echuca. Fares and timetables as per application dated 26th June, 1961.

PRICE, L. W., Newtown, Beechworth; 1 commercial passenger vehicle, with seating capacity for five persons, to operate under the same terms and conditions as existing taxi-cabs licensed at Beechworth, subject to the cancellation of licence No. C.H.189.

MURRAY, H. E., & D. C. FRANCOMBE, Wattle-avenue, Werribee; 1 commercial passenger vehicle, with seating capacity for five persons, to operate for the carriage of passengers and mails between Werribee Post Office and Werribee South Post Office, via Duncans-road, Diggers-road and Whites-road, under contract to the Postmaster-General's Department.

LANG, J. & J., Ireland-street, Bright; 1 commercial passenger vehicle, with seating capacity for five persons, to operate under the same terms and conditions as licences Nos. T.O.1, T.O.2 and T.O.56 held by the applicants.

CORTO BUS LINES PTY. LTD., Box 191, Geelong; 26 commercial passenger vehicles, with large seating capacity, to operate as follows:—(a) Under the same terms and conditions as licences Nos. U.O.410, U.O.449, U.O.450, U.O.452, U.O.453, U.O.454, U.O.455, U.O.457, U.O.459, U.O.460, U.O.463, U.O.465, U.O.466, U.O.467, U.O.468, U.O.469, U.O.471, U.O.472, U.O.483, U.O.485, U.O.507, U.O.508, U.O.509, U.O.511, U.O.514 and U.O.570, (b) as urban stage omnibuses from the corner of Ryrie-street and Boundary-road, East Geelong, via Boundary-road, Carr-street, Swanston-street, Fyans-street, Moorabool-street, Francis-street, Spring-street, Torquay-road, Settlement-road, Colac-road, Roslyn-road, Valley-road, Barrabool-road, Princes Bridge, Shannon-avenue, Aberdeen-street, Minerva-road, Church-street, Vines-road, Anakie-road, Separation-street, Thompson-road, Sparks-road, to Station-street, Norlane.

TIME-TABLE.

Week Days.

Depart East Geelong.	Depart Norlane.
9.15 a.m.	9.15 a.m.
10.30 a.m.	10.30 a.m.
1.00 p.m.	1.00 p.m.
2.15 p.m.	2.15 p.m.

HOLBOROW, W., & H. S. COLLINS, 101 Bell-street, West Heidelberg; application for variation of all "M.O." licences on Route 87A (Heidelberg-Eltham) to provide an extension of service from the corner of Eltham-road and Panorama-avenue, via Panorama-avenue, Old Eltham, Bonds, Cleveland, Banyule and Rosanna roads, Burgundy-street and Studley-road to Heidelberg Station (with ability at later stage to deviate from Banyule-road via Beverley-road to Burgundy-street).

NOTE.—To be operated only when road condition permits and area sufficiently developed.

FISHER, A. (Mrs.), 332 Barkers-road, Hawthorn; 1 commercial passenger vehicle, with seating capacity for five passengers, to operate for the carriage of kindergarten children free of charge between the children's homes situated in the Hawthorn area and the kindergarten situated at 332 Barkers-road, Hawthorn.

DYSON'S, L. C. BUS SERVICE PTY. LTD., 753 Plenty-road, East Preston; application for variation of "C.O." licences on Route 263A (Regent-Whittlesea-Kinglake) to delete service between the corner of Whittlesea-Kinglake road and Jacks Creek-road and Kinglake West, via Whittlesea-Kinglake road, on all services to and from Kinglake and instead to—(a) operate between the corner of Whittlesea-Kinglake road and

Jacks Creek-road to Kinglake West, via Jacks Creek-road and Old Yea-road, (b) extend two trips daily (Mondays-Fridays) to Humevale from Whittlesea, i.e., depart Humevale 8.50 a.m. for Regent Station and depart Regent Station 3.05 p.m. for Humevale.

APPPLICATIONS for renewal of licences by persons listed hereunder to operate under the same terms and conditions from the date of expiry:—

Name and Address; Licence No.; Classification; Expiry Date.

COLE, J. H., Wood-street, Beaconsfield; C.H.318; country private hire car, Beaconsfield; 21st December, 1961.
 EWING, E. M. (Mrs.), Lyons-street, Newstead; C.H.85; country private hire car, Newstead; 1st December, 1961.

GILBERTSON, R. J., PTY. LTD., 591 Mt. Alexander-road, Moonee Ponds; application for renewal of licence No. T.P.13, expiring 31st December, 1961, to operate for the carriage only of employees of the holder of this licence free of charge and without reward from or to the Essendon Railway Station to or from the abattoirs of the holder of this licence situated in Kyle-road, West Newport.

ARCHIE'S CREEK DAIRY PRODUCE CO. LTD., Archie's Creek; application for renewal of licence No. T.P.4, expiring 1st November, 1961, to operate for the carriage of employees of the holder of this licence as required between Wonthaggi and the factory premises of the

holder of this licence at Archie's Creek, provided that each and all such employees shall be so carried on the vehicle free of charge and without reward.

BROOKS, T. E. & D., 1 Cobham-street, Terang; application for renewal of licence No. T.P.3, expiring 20th December, 1961, to operate as follows:—(a) For the carriage only of retarded children on the following routes:—(i) Between Camperdown and Terang, via Cobden, (ii) between Mortlake and Terang, (b) for the carriage of mails between Terang Post Office and Terang Railway Station, subject to contract to the Postmaster-General's Department, (c) for the carriage of parcels within a radius of 20 miles from the Terang Post Office.

KELLY, A. L., Toolangi; application for renewal of licence No. T.P.50, expiring 4th December, 1961, to operate as a stage omnibus along the following routes:— (a) Between Healesville and Badger Creek, via Don and Anderson roads, Fields Gate, Sir Colin McKenzie Wild Life Sanctuary, (b) between Healesville and Castella, via Chum Creek-road and Toolangi, returning via Myer's Creek-road, (c) mails may be carried along the above routes, (d) own goods of the holder of this licence may also be carried on the vehicle within a radius of 50 miles from the Toolangi Post Office.

Notice of any objection should be forwarded to reach the Secretary to the Board not later than Wednesday, 16th August, 1961.

B. P. KAY,
 Secretary.

Exhibition Buildings, Rathdown-street, Carlton, N.3.
 2nd August, 1961.

MONEY LENDERS ACT 1958.

IN accordance with the provisions of the above-mentioned Act the following is published for general information.

List of persons to whom Money Lenders' Licences have been issued for the year ending 30th June, 1961.

Name.	Authorized Name.	Authorized Address.	Date of Issue.
*Cambridge Credit (Vic.) Pty. Ltd. (R. McC. Park, appointee)	Cambridge Credit (Vic.) Pty. Ltd. ..	411-413 Lonsdale-street, Melbourne	22.5.61
Clyburn Finance Pty. Ltd. (R. M. Cole, appointee)	Clyburn Finance Pty. Ltd. ..	269 Williamstown-road, Port Melbourne	8.6.61
*Daws, Edward Adrian	Edward Adrian Daws	Kaloola, Ellen-grove, Templestowe	30.6.61
*Daws, May	May Daws	Kaloola, Ellen-grove, Templestowe	30.6.61
G.U.A. Finances Pty. Ltd. (K. J. O'Brien, appointee)	G.U.A. Finances Pty. Ltd. ..	"Tuerong Valley", Mornington ..	14.6.61
Jennings, Basil Raymond	Basil Raymond Jennings	Myrtleford	18.5.61
†Mutual Underwriting and Development Ltd. (Colin Halley Coghill, appointee)	Mutual Underwriting and Development Ltd.	37 Swanston-street, Melbourne ..	15.6.61
*Northumberland Insurance Co. Ltd. (W. E. Thomson, appointee)	Northumberland Insurance Co. Ltd. ..	411-413 Lonsdale-street, Melbourne	22.5.61
Reid Murray Acceptance Ltd. (D. K. Fidge, appointee)	Reid Murray Acceptance Ltd. ..	c/o Paynes Bon Marche Pty. Ltd., 83-85 Malop-street, Geelong	11.5.61
Reid Murray Acceptance Ltd. (D. K. Fidge, appointee)	Reid Murray Acceptance Ltd. ..	c/o Paynes Homemakers Store, The Mall, Heidelberg West	12.5.61
Reid Murray Acceptance Ltd. (D. K. Fidge, appointee)	Reid Murray Acceptance Ltd. ..	c/o Paynes Bon Marche Pty. Ltd., 156 Commercial-road, Morwell	28.6.61

State Treasury, Melbourne, C.2, 31st July, 1961. * New Authorized Address. † Transfer of Appointee. M. A. R. SYNNOT,
Registrar.

AUCTION SALES ACT 1958.

LIST of Persons to whom Auctioneers' Licences have been issued during the month of June, 1961, and prior months.

Name.	Address.	Date of Issue.
Bills, Richard Glenn	Steels Creek-road, Yarra Glen	27.6.61
Brooks, Eric Ross	Ouyen	4.5.61
Chammen, Harry Charles	26 Palmerston-street, Camberwell	8.6.61
Crane, Clive David Heathcote	Nathalia	9.6.61
Elliott, James Balfour	Yea	22.6.61
Jess, John Augustine	Telford-street, Yarrowonga	20.6.61
Johnstone, Bruce Robert	Lot 148, Bryan-avenue, Altona North	26.6.61
Lewington, Clement James	305 Dandenong-road, Clayton	13.6.61
McConchie, Neil Robert	2 Medowa-street, Wangaratta	8.6.61
Meaden, Alan Kenneth	Kialla	5.4.61
Miliklis, Jack Michael	8 McGregor-street, Canterbury	14.6.61
Oberin, Frederick Keith	Timmering, via Rochester	28.6.61
Obst, Barry Clifford	12 Anzac-road, Trafalgar	28.6.61
Turnbull, John Alexander	Yarrowonga	20.6.61

The Treasury, Melbourne, C.2, 31st July, 1961. E. W. COATES,
Director of Finance.

Local Government Act 1958, Part 48, Section 904.

LICENCES TO OCCUPY UNUSED ROADS.

NOTICE is hereby given that Licences to occupy Unused Roads have been issued to the following approved applicants, and that the Licence Fee specified in each case has been received by the Accountant, Department of Crown Lands and Survey, Melbourne, C.2.

Number of Licence.	Name and Address of Licensee.	Municipality.	Parish.	Abutting— Allotments and Sections.	Area.		Fee for Licence.	Date of Issue of Licence.	Date of Expiry of Licence.
					A. R. P.	£ s. d.			
41421	Rothus, A. G., Noradjuha	Arapiles ..	Darragan ..	South of 1A	9 2 0	2 7 6	1.1.59	31.12.61	
41422	Wallis, D. M., Miram	Lowan ..	Tarranginnie	North of 284	11 2 0	1 0 0	1.1.59	31.12.61	
41423	Goss, G. T., Adelaide	Kowree ..	Gymbowen	Eastern 3,350 links south of 78	3 1 8	1 0 0	1.1.59	31.12.61	
41424	Lyons, M. J. and V. R., Woomelang	Karkaroc	Byanga ..	East of 35	6 0 13	2 0 0	1.1.59	31.12.61	
41425	Brown, J. L., Swan Hill	Swan Hill..	Woorinen ..	West of 58 and 60 ..	17 2 0	3 1 3	1.1.59	31.12.61	
41426	Krause, T. O., Dadswell's Bridge	Wimmera	Ledcourt ..	South of 195	4 2 16	1 4 6	1.1.59	31.12.61	
41427	Ffrench, C. A., Landsborough	Avoca ..	Navarre ..	North of 307 and part of 284	11 2 0	2 3 6	1.1.59	31.12.61	
41428	Bolwell, E. J., Wallup East	Arapiles ..	Duchembegarra	Between 56 and 57, section A	32 2 0	1 0 0	1.1.59	31.12.61	
41429	Blake, R. H., Nicholls Point	Mildura ..	Mildura ..	Adjoining part A, section B, block F (Cureton-avenue)	0 2 0	1 0 0	1.1.59	31.12.61	
41430	Hunt, C. M., (Miss), Mildura	Mildura ..	Mildura ..	Adjoining part A, section 8, block F (Cureton-avenue)	0 3 0	1 0 0	1.1.59	31.12.61	
41431	Chine, P., Nicholls Point	Mildura ..	Mildura ..	Adjoining 5, 6, 7, section 84, block F (Cureton-avenue)	3 2 0	1 0 0	1.1.59	31.12.61	
41432	Conolly, J. A., Nicholls Point	Mildura ..	Mildura ..	Adjoining 12 and 13, part of 10, section 84, block F (Cureton-avenue)	4 0 0	1 0 0	1.1.59	31.12.61	
41433	Pahek, J., Nicholls Point..	Mildura ..	Mildura ..	Adjoining 8, section 8, block F (Cureton-avenue)	1 0 0	1 0 0	1.1.59	31.12.61	
41434	Ampt, L. W., 29 Frederick-street, Horsham	Arapiles ..	Kalingur ..	East of 26	4 2 0	1 0 0	1.1.59	31.12.61	
41435	Ampt, G. A., Gymbowen	Arapiles ..	Kalingur ..	East of 13	5 2 0	1 0 0	1.1.59	31.12.61	
41436	Davy, A. F., Nicholls Point	Mildura ..	Mildura ..	Adjoining 7, section 8, block F (Cureton-avenue)	1 0 0	1 0 0	1.1.59	31.12.61	
41437	Tassone, G., Nicholls Point	Mildura ..	Mildura ..	Adjoining 8 and 9, section 84, block F (Cureton-avenue)	3 0 0	1 0 0	1.1.59	31.12.61	
41438	Puls, A. B., Polkemmet ..	Wimmera	Quantong	East of 96B, 98, 97, 99, 100	45 0 0	6 10 0	1.1.59	31.12.61	
41440	Dumesny, J. G., Horsham	Wimmera	Quantong	East of 98A	7 0 0	2 5 0	1.1.59	31.12.61	
41441	Arnold, G. E., Nicholls Point	Mildura ..	Mildura ..	Adjoining part of 5, section 7 (Cureton-avenue)	0 1 0	1 0 0	1.1.59	31.12.61	
41442	Rawlins, R. E., Nicholls Point	Mildura ..	Mildura ..	Adjoining 2 and 4, section 84, block F (Cureton-avenue)	1 2 0	1 0 0	1.1.59	31.12.61	
41443	Callipari, G., Nicholls Point	Mildura ..	Mildura ..	Adjoining 6 and part of 5, section 7 (Cureton-avenue)	1 2 0	1 0 0	1.1.59	31.12.61	
41444	Oxley, M. E., (Mrs.), Mildura	Mildura ..	Mildura ..	Adjoining part of 1, section 9, block F (Cureton-avenue)	3 0 0	1 0 0	1.1.59	31.12.61	
41445	Tucker, D., Drung Drung	Wimmera	Longerenong	Western half of road through 23A	2 0 0	1 0 0	1.1.59	31.12.61	
41446	Jess, T., Glenorchy ..	Stawell ..	Gampola ..	Between 9A and 27	7 3 10	1 19 0	1.1.59	31.12.61	
41447	Lang, M. J., (Mrs.), Warracknabeal	Arapiles ..	Dollin ..	Northern half of road between 49 and 50, eastern half of road between 64A and 50	6 1 0	1 0 0	1.1.59	31.12.61	
41448	O'Beirne, J. and Sons, Horsham	Arapiles ..	Dollin ..	Southern half of road between 49 and 50, eastern half between 49 and 55, between 48 and 56, east of 48	18 0 0	2 14 0	1.1.59	31.12.61	
41449	Mibus, R. M., Horsham ..	Wimmera	Bungalally	Part of road fronting 165 and 166	16 0 0	4 0 0	1.1.59	31.12.61	
41450	Cameron, N. L., Toolondo	Kowree ..	Toolondo ..	From north-west corner of 105 to St. Rivers channel easement in 105A	4 0 0	2 0 0	1.1.59	31.12.61	
41451	Chettle, T. F., Nyah ..	Swan Hill..	Tyntynder North	West of 20	4 0 0	1 0 0	1.1.59	31.12.61	
41452	Okely, O. P. and J. J., Gymbowen	Arapiles ..	Kalingur ..	South of 15	6 2 0	1 0 0	1.1.59	31.12.61	
41453	Huff, C. E., Rainbow ..	Dimboola ..	Pullut ..	Between 5 and 6	51 1 10	1 16 9	1.1.59	31.12.61	
41454	Crockford, A., (Mrs.), Edenhope	Kowree ..	Karnak and Dopewora	West of 86 and between 86 (Parish of Dopewora) and 88 (Parish of Karnak) adjoining 7 and 8, section 7	26 0 0	3 18 3	1.1.60	31.12.62	
41455	Callipari, M. and A., Nicholls Point	Mildura ..	Mildura ..	Block F (Cureton-avenue)	2 0 0	1 0 0	1.1.59	31.12.61	
41456	Sleep, R. and F., Stawell, Pomona	Ararat ..	Boroka ..	South-east and north-west of 74 and east of 74A	18 2 0	1 17 0	1.1.59	31.12.61	

LICENCES TO OCCUPY UNUSED ROADS—continued.

Number of Licence.	Name and Address of Licensee.	Municipality.	Parish.	Abutting— Allotments and Sections.	Area.		Fee for Licence.		Date of Issue of Licence.	Date of Expiry of Licence.
					A. R. P.	£ s. d.	£	s. d.		
41457	Edgar, R. K., Speed ..	Wycheproof	Boorong ..	Between 48 and 48A ..	8 0 0	1 12 0	1 1 0	60	1.1.60	31.12.62
41458	Norman, D. L., Kaniva ..	Kaniva ..	Kaniva ..	Between the railway line and 1 and 2 (Township of Kaniva)	1 0 0	1 0 0	1 1 0	59	1.1.59	31.12.61
41459	Kent, R. and D., Serviceton	Kaniva ..	Leecor ..	Adjoining east, west and north boundaries of section 4 (Township of Serviceton)	5 0 0	1 10 0	1 1 0	60	1.1.60	31.12.62
41460	Turner, M., Horsham ..	Wimmera	Longerenong	22AA and 22AB ..	10 0 0	1 14 0	1 1 0	60	1.1.60	31.12.62
41461	Wilks, R. J., Apsley ..	Kowree ..	Tallageira	North and west of 56	14 3 0	4 8 6	1 1 0	60	1.1.60	31.12.62
41462	Beard, N. I., Merbein ..	Mildura ..	Merbein ..	East of 4, section A ..	2 0 0	1 0 0	1 0 0	60	1.1.60	31.12.62
41463	Punchard, A. F., Stawell	Stawell ..	Kirkella ..	East of 55B, 53 and north of 53, 54	11 0 20	1 4 0	1 1 0	60	1.1.60	31.12.62
41464	Bellinger, G. C., Hopetoun	Karkaroc	Goyurah and Gaalanungah	Between 44 and 75 (Parish of Goyurah) and 25 (Parish of Gaalanungah)	8 0 0	2 4 0	1 1 0	60	1.1.60	31.12.62
41465	Ladlow, V. C. McC., Horsham	Kowree ..	Toolondo ..	North of 121 and 121A	7 0 0	1 0 0	1 1 0	59	1.1.59	31.12.61
41466	Pickering, S. C., Dadswells Bridge	Stawell ..	Ledcourt ..	North and west of 279 and north of 280	16 0 0	1 0 0	1 0 0	60	1.1.60	31.12.62
41467	Rich, D. G. and R. L., Kaniva	Kowree ..	Toolondo ..	West of 41, 42, 43 ..	12 0 0	1 0 0	1 0 0	59	1.1.59	31.12.61
41468	Voigt, T. R., Horsham ..	Wimmera	Golton	Western part, south of 52	3 0 0	1 0 0	1 0 0	60	1.1.60	31.12.62
41469	Schulze, J. F., Dimboola	Dimboola ..	Dimboola ..	Between 55 and 56H, section B	3 0 0	1 1 0	1 1 0	59	1.1.59	31.12.61
41470	Matuschka, H. P., E. H. and K. J., Green Lake	Wimmera	Bungalally	Two chain strip of north/south road, west of 159A	8 0 0	4 0 0	1 1 0	60	1.1.60	31.12.62
41471	Tink, H. S. and E. D., Serviceton	Kaniva ..	Dinyarrak ..	East and west road (5 chains) between 59 and 59A	18 2 0	9 5 0	1 1 0	60	1.1.60	31.12.62
41472	Bull, F. R., Patyah ..	Kowree ..	Jallakin ..	South of 61A ..	5 2 0	1 7 6	1 1 0	60	1.1.60	31.12.62
41473	Farmers, C. H., Tarranginnie	Lowan ..	Tarranginnie	South of 38 ..	4 0 8	3 6 0	1 1 0	60	1.1.60	31.12.62
41474	Drendel, L. E., Rainbow ..	Dimboola ..	Kurnbrunin	Between 24 and 25 ..	30 0 0	11 5 0	1 1 0	60	1.1.60	31.12.62
41475	Sloan, A. H., Rainbow ..	Dimboola ..	Kurnbrunin	Southern part west of 10	9 0 0	2 5 0	1 1 0	60	1.1.60	31.12.62
41476	Albrecht, T. G., Gerang Gerung	Dimboola ..	Gerang	Between 16, 16A, and 39, 39A	5 2 0	1 4 9	1 1 0	60	1.1.60	31.12.62
41477	Gould, J. W. and A. W., Rainbow	Dimboola ..	Kurnbrunin	Northern part of road, west of 10	8 2 10	2 5 0	1 1 0	60	1.1.60	31.12.62
41478	Ingpen, T. E., Nhill ..	Lowan ..	Tarranginnie	South of 37A ..	4 0 0	3 4 0	1 1 0	60	1.1.60	31.12.62
41479	Koschmann, F. A. and D. E. Murtoa	Dunmunkle	Wirchilleba	Between 1, 48 and 2, 47	8 0 0	7 0 0	1 1 0	60	1.1.60	31.12.62
41480	Wilson, H. C., Lake View	Arapiles ..	Nurrabiel ..	North of 32 and Darragan Swamp	6 0 0	3 0 0	1 1 0	60	1.1.60	31.12.62
41481	Clarke, A. J., Rupanyup	Dunmunkle	Lallat ..	Between 181, part of 180 and 175, 176, part of 177	13 0 0	6 10 0	1 1 0	60	1.1.60	31.12.62
41482	Deppeler, K. A., Turriff	Karkaroc	Gorya ..	East of Turriff Station and south of 37	8 2 0	1 5 6	1 1 0	60	1.1.60	31.12.62
41483	Ey, E. R., Yaapeet ..	Karkaroc	Nypo ..	Between 27, 28 and 26, 25	15 0 0	1 17 6	1 1 0	60	1.1.60	31.12.62
41484	Werner, A. W., Ellam ..	Dimboola ..	Joop ..	West of 12 and 13 ..	16 0 0	4 0 0	1 1 0	60	1.1.60	31.12.62
41485	Heinrich, K. G., Rainbow	Dimboola ..	Pigick ..	Between 16 and 19, 20	18 0 0	6 15 0	1 1 0	60	1.1.60	31.12.62
41486	Wedding, H. B., Rainbow	Dimboola ..	Pigick ..	Between 9 and 13 ..	18 0 0	4 10 0	1 1 0	60	1.1.60	31.12.62
41487	McKenzie, L. R., Pullut ..	Dimboola ..	Joop ..	West of 3 ..	8 0 0	2 0 0	1 1 0	60	1.1.60	31.12.62
41488	Wedding, C. F. G., Rainbow	Dimboola ..	Pigick ..	Between 8 and 14 ..	18 0 0	4 10 0	1 1 0	60	1.1.60	31.12.62
41489	Gloster, A. J., G. E., R. W. and K. J., Underbool	Wycheproof	Towaninny	South of 34, section 4	5 0 0	1 0 0	1 1 0	60	1.1.60	31.12.62
41490	McLoughlin, J. P., Rupanyup	Dunmunkle	Lallat ..	Between part of 180 and 177, 179, 178	10 0 0	5 0 0	1 1 0	60	1.1.60	31.12.62
41491	Ryan, A. T., Galaquil ..	Warracknabeal	Batchica ..	South of 13 and eastern part of 12 (65 chains)	6 2 0	3 5 0	1 1 0	60	1.1.60	31.12.62
41492	Hayden, T. W., Jeparit ..	Dimboola ..	Hindmarsh	East of 50 ..	7 3 0	2 6 6	1 1 0	60	1.1.60	31.12.62
41493	Keller, A. R., Ellam ..	Dimboola ..	Joop ..	West of 14 ..	8 0 0	2 0 0	1 1 0	60	1.1.60	31.12.62
41494	Lush, H. J., Rainbow ..	Dimboola ..	Werrap ..	Between 30, 31 and 17	10 0 20	1 15 0	1 1 0	60	1.1.60	31.12.62
41495	Chaplin, S. L. and A. B., Rainbow	Dimboola ..	Werrap ..	Between 64 and 65 ..	6 2 0	2 0 0	1 1 0	60	1.1.60	31.12.62
41496	McIntosh, N. D. and J. P., Ellam	Dimboola ..	Hindmarsh	East of 36 ..	8 0 0	2 0 0	1 1 0	60	1.1.60	31.12.62

Department of Crown Lands and Survey,
Melbourne, 26th July, 1961.

KEITH TURNBULL,
Commissioner of Crown Lands and Survey.

COLERAINE AND CASTERTON WATERWORKS TRUST.

FIXING THE LIMIT OF A BANK OVERDRAFT.

HIS Excellency the Administrator of the Government of the State of Victoria, by and with the advice of the Executive Council thereof, doth by Order made on the 26th July, 1961, in pursuance of the provisions of section 288 of the *Water Act 1958* (No. 6413), fix the limit

of the overdraft to be obtained by the Coleraine and Casterton Waterworks Trust from the English, Scottish, and Australian Bank Limited, Coleraine, at an amount not to exceed at any one time the sum of Five thousand pounds (£5,000).

A. MAHLSTEDT,
Clerk of the Executive Council.

At the Executive Council Chamber,
Melbourne, 26th July, 1961.

KATAMATITE WATERWORKS TRUST.

AUTHORITY TO OBTAIN BANK OVERDRAFT.

HIS Excellency the Administrator of the Government of the State of Victoria, by and with the advice of the Executive Council thereof, doth by Order made on the 26th July, 1961, authorize the Katamatite Waterworks Trust to obtain, in pursuance of the provisions of section 286 of the *Water Act 1958* (No. 6413), an advance or advances during the year 1961 from the Australia and New Zealand Bank Limited, Katamatite, by overdraft of the Trust's current account thereat, such overdraft not to exceed at any one time the sum of Two hundred and fifty pounds (£250).

A. MAHLSTEDT,
Clerk of the Executive Council.

At the Executive Council Chamber,
Melbourne, 26th July, 1961.

YARRAM WATERWORKS TRUST.

AUTHORITY TO OBTAIN BANK OVERDRAFT.

HIS Excellency the Administrator of the Government of the State of Victoria, by and with the advice of the Executive Council thereof, doth by Order made on the 26th July, 1961, authorize the Yarram Waterworks Trust to obtain, in pursuance of the provisions of section 286 of the *Water Act 1958* (No. 6413), an advance or advances during the year 1961, from the Commercial Banking Company of Sydney Limited, Yarram, by overdraft of the Trust's current account thereat, such overdraft not to exceed at any one time the sum of Three hundred pounds (£300).

A. MAHLSTEDT,
Clerk of the Executive Council.

At the Executive Council Chamber,
Melbourne, 26th July, 1961.

ECHUCA SEWERAGE AUTHORITY.

ANNUAL BALANCE.

HIS Excellency the Administrator of the Government of the State of Victoria, by and with the advice of the Executive Council thereof, doth by Order made on the 26th July, 1961, in pursuance of the provisions of the Sewerage Districts Acts, fix the 30th day of September in each year as from the 1st January, 1962, as the day to which the accounts of the Echuca Sewerage Authority shall be balanced.

A. MAHLSTEDT,
Clerk of the Executive Council.

At the Executive Council Chamber,
Melbourne, 26th July, 1961.

Hospitals and Charities Act 1958 (No. 6274).—Section 46.
PETITION TO INCORPORATE GRACE BRUCE AND J. L. McMILLAN MEMORIAL HOME.

IT is notified, in accordance with the provisions of section 46 of Act No. 6274, that the Hospitals and Charities Commission has received a petition signed by not less than 25 contributors to Grace Bruce and J. L. McMillan Memorial Home praying that that institution be incorporated under the provisions of the said Act. The institution established in Traralgon will have for its objects—

- (a) to provide benevolent assistance to aged persons by providing permanent facilities for their daily accommodation and care, stipulating that, in premises for which a grant under the Aged Persons Homes Act has been received, only aged persons as defined in that Act will be admitted; special consideration to be given to persons in necessitous circumstances;
- (b) doing such other things which, in the Committee's opinion, will provide for the economic, recreational, and social well-being of the residents,

and is capable of being incorporated.

If a counter-petition signed by an equal or greater number of contributors is not lodged with the aforesaid Commission, at No. 1 Nicholson-street, Melbourne, within one calendar month of the publication of this notice, the Governor in Council may by Order made pursuant to Act No. 6274, declare the contributors for the time being to Grace Bruce and J. L. McMillan Memorial Home to be a body corporate by the name set forth in such Order.

E. P. CAMERON,
Minister of Health.

Department of Health,
Melbourne, 24th July, 1961.

LAW DEPARTMENT.

COURTS OF GENERAL SESSIONS OF THE PEACE—1961.

HIS Excellency the Administrator of the Government of the State of Victoria by and with the advice of the Executive Council thereof, doth hereby amend the Order in Council approved on the 15th November, 1960, appointing certain dates for holding Courts of General Sessions of the Peace during the year 1961 as indicated in the second column of the subjoined Schedule so far as the Court at the place named in the first column of such Schedule is concerned.

SCHEDULE.

Place.	Alteration of Date.
Kerang ..	From Tuesday the 10th October, 1961 to Tuesday the 3rd October, 1961.

A. MAHLSTEDT,
Clerk of the Executive Council.

At the Executive Council Chamber,
Melbourne, 26th July, 1961.

LAW DEPARTMENT.

HAWKERS' AND PEDLERS' LICENCES—CONSIDERATION OF APPLICATIONS.

HIS Excellency the Administrator of the Government of the State of Victoria by and with the advice of the Executive Council thereof, and in pursuance of the provisions of section 6 of the *Hawkers and Pedlers Act 1958*, doth hereby appoint in lieu of the days heretofore appointed, the days set forth in the third column of the Schedule below for holding General Meetings of Justices for the special purpose of taking into consideration applications for hawkers' and pedlers' licences at the Courts named in the first column of such Schedule in the Police District indicated—to take effect as from and inclusive of the dates shown.

SCHEDULE.

Court.	Police District.	Day Appointed.	Date of Commencement.
Tallangatta	Upper Murray	Every Friday at 10 a.m.	18th August, 1961
Corryong ..	Upper Murray	Every Thursday at 10 a.m.	17th August, 1961

A. MAHLSTEDT,
Clerk of the Executive Council.

At the Executive Council Chamber,
Melbourne, 26th July, 1961.

Teaching Service Act 1958 (No. 6391).

TEACHERS TRIBUNAL ELECTION.

PURSUANT to the provisions of the Teachers Tribunal Regulations, I hereby declare that the election conducted by me on the 24th of July, 1961, has resulted in DOUGLAS RANKING BROWN (Recruitment Branch, Education Department), being elected as a Member of the Teachers Tribunal, and ROBERT STANLEY NORRIS (State School No. 4316, Preston East), being elected as the Deputy of such Member.

R. H. BIGGS,
Returning Officer.

ANNUAL LICENCE.

I HEREBY notify that the necessary duty has been paid by the under-mentioned company for a Licence to carry on Assurance and Insurance business in Victoria during the year 1961, and that the Annual Licence has accordingly been issued.

BRITISH CROWN ASSURANCE CORPORATION LIMITED.

D. G. RICHARDS,
Comptroller of Stamps.

Chief Office for Stamp Duties,
Melbourne, 21st July, 1961.

STOCK DISEASES ACT 1958.

THE Public Service Board, by Certificate dated the 10th July, 1961, has appointed the under-mentioned officers and employees, Department of Agriculture, as Inspectors of Stock, under the provisions of Part I. of the *Stock Diseases Act 1958*, without additional salary:—

Name.	Position.
Bullock, Frederick James	Senior Orchard Inspector, Grades 42-44 inclusive
Clay, James Alfred Edward	Orchard Supervisor, Grade II., Grades 33-36 inclusive
McKimmie, Clive Frederick	Orchard Supervisor, Grade II., Grades 33-36 inclusive
Bloom, Arthur Albert	Orchard Inspector Grades 32-34 inclusive
Gibbs, John Freeland	Orchard Inspector Grades 32-34 inclusive
Jeremiah, Leslie Albert	Orchard Inspector Grades 32-34 inclusive
Manning, Harold Luke	Orchard Inspector Grades 32-34 inclusive
McLauchlan, William Allan	Orchard Inspector Grades 32-34 inclusive
Pump, Wilfred Hermann	Orchard Inspector Grades 32-34 inclusive
Addison, Hercules	Orchard Inspector
Alexander, Ralph William	Orchard Inspector
Anderson, James Gray	Orchard Inspector
Baker, Kevin John	Orchard Inspector
Barker, Harold Nelson	Orchard Inspector
Barlow, Alexander	Orchard Inspector
Barnham, Gordon Philip	Orchard Inspector
Barton, Gerald Stanley	Orchard Inspector
Bass, John St. Clare	Orchard Inspector
Beer, David George	Orchard Inspector
Bell, George Edward	Orchard Inspector
Berrett, Eric	Orchard Inspector
Bugg, Henry John	Orchard Inspector
Caffrey, Brian George	Orchard Inspector
Cameron, Charles Donald Lochiel McRae	Orchard Inspector
Carter, Keith Ferdinand Joseph	Orchard Inspector
Clay, John Clifford	Orchard Inspector
Cole, Douglas Charles	Orchard Inspector
Coles, Arthur	Orchard Inspector
Cooper, William Mirrylees	Orchard Inspector
Cornwell, William Cecil	Orchard Inspector
Crouch, Clifford	Orchard Inspector
Evans, Alan Rae	Orchard Inspector
Hickey, Patrick Gerard	Orchard Inspector
Hicks, Leonard Joseph	Orchard Inspector
Humfrey, Stanley	Orchard Inspector
Jesser, Robert Charles	Orchard Inspector
Jones, Norman Colin	Orchard Inspector
Klinge, Norman John	Orchard Inspector
Lahore, Ian Campbell	Orchard Inspector
Leahy, Francis John	Orchard Inspector
Lloyd, Arnold Gordon	Orchard Inspector
Lumb, John Albert	Orchard Inspector
Madigan, Michael William	Orchard Inspector
Martin, Walter Thomas	Orchard Inspector
McKeown, Joseph Michael	Orchard Inspector
Newton, William Wallace	Orchard Inspector
O'Callaghan, Herbert John	Orchard Inspector
Padgett, Alex Leslie	Orchard Inspector
Phillips, George Colles	Orchard Inspector
Potter, Jack	Orchard Inspector
Pump, George Hermann	Orchard Inspector
Riggs, Frederick Thomas	Orchard Inspector
Shone, Alan Stanton	Orchard Inspector
Simpson, George Bamford Horatio	Orchard Inspector
Stedman, Stuart Mac- Kenzie	Orchard Inspector
Van Veen, Nicolaas	Orchard Inspector
Weste, Hans Leopold	Orchard Inspector
Winnett, Raymond Victor	Orchard Inspector
Woolstencroft, John Sher- lock	Orchard Inspector

ELECTION OF A MEMBER OF THE COMMITTEE OF CLASSIFIERS FOR THE PRIMARY SCHOOLS DIVISION, EDUCATION DEPARTMENT.

I HEREBY give notice, pursuant to clause 7 of Regulation 2 of the Teaching Service (Teachers Tribunal) Regulations, that it is my intention to proceed to the election of a teacher to the Committee of Classifiers for the Primary Schools Division.

Nominations for the said election must be lodged with or delivered by post to me at the Teachers Tribunal, Observatory House, Birdwood-avenue, South Yarra, S.E.1, before noon on Monday, the 28th August, 1961.

In the event of more candidates than one being duly nominated, the poll for the said election will close at Four o'clock p.m. on Monday, the 23rd October, 1961.

G. FENNELL,
Returning Officer.

Office of the Teachers Tribunal,
Melbourne, 31st July, 1961.

Water Acts.

STATE RIVERS AND WATER SUPPLY COMMISSION.

CARRUM DOWNS AND SOUTH FRANKSTON URBAN DISTRICTS.

NOTICE to owners of tenements in the under-mentioned streets in the Carrum Downs and South Frankston Urban Districts, and the private streets, lanes, courts and alleys opening thereto:—

CARRUM DOWNS URBAN DISTRICT.

Bawden-street.

SOUTH FRANKSTON URBAN DISTRICT.

Oakfield-court.
Tavistock-road.

The main pipe in the said streets being laid down, the owners of all tenements situated as above are hereby required, on or before the 4th day of September next, to cause proper pipes and stop cocks to be laid, so as to supply water within such tenements from the main pipe.

E. BROWN, Secretary,
State Rivers and Water Supply Commission.
Melbourne, 28th July, 1961.

Water Acts.

STATE RIVERS AND WATER SUPPLY COMMISSION.

BARWON HEADS AND OCEAN GROVE, PORTARLINGTON AND ANGLESEA URBAN DISTRICTS.

NOTICE to owners of tenements in the under-mentioned streets in the Barwon Heads and Ocean Grove, Portarlington and Anglesea Urban Districts, and the private streets, lanes, courts and alleys opening thereto:—

BARWON HEADS AND OCEAN GROVE URBAN DISTRICT.

Ocean Grove.

Asbury-street, from end of existing main opposite lot 311 to lot 1, about $\frac{1}{2}$ chain easterly from Mann-street.

Field-street, from Madeley-street to a point opposite lot 238 on lodged plan of subdivision No. 1856, about $1\frac{1}{2}$ chains southerly from Epworth-street.

Madeley-street, from end of existing main opposite lot 268 to Field-street.

Powell-street, from (i) end of existing main opposite lot 274 to a point opposite lot 275, about 1 chain north-easterly; (ii) end of existing main opposite lot 300 to a point opposite lot 306, about 6 chains south-westerly.

Tuckfield-street, from Watkin-street to a point opposite lot 291, about 1 chain northerly.

Wyatt-street, from end of existing main opposite lot 571 to a point opposite lot 564, about 7 chains westerly.

PORTARLINGTON URBAN DISTRICT.

Newcombe-street, from end of existing main opposite lot 6, section 17A, to a point opposite lot 1, about $4\frac{1}{2}$ chains westerly.

ANGLESEA URBAN DISTRICT.

Baker-street, from McMillan-street to a point opposite lot 6, about $6\frac{1}{2}$ chains generally north-westerly.

The main pipe in the said streets being laid down, the owners of all tenements situated as above are hereby required, on or before the 4th day of September next, to cause proper pipes and stop cocks to be laid, so as to supply water within such tenements from the main pipe.

E. BROWN, Secretary,
State Rivers and Water Supply Commission.
Melbourne, 28th July, 1961.

CONTRACTS ACCEPTED.—(Series 1960-61.)**GENERAL STORES.**

Gazette No. 9, 1st February, 1961, Schedule No. 52. Tools (General).—For the rates shown opposite the following items, substitute the rates as set out hereunder, as from 18th July, 1961:—Item No. 273, 28s. 5d. each; Item No. 274, 40s. 11d. each; Item No. 275, 54s. 3d. each.

H. COUTTS, Secretary to the Tender Board. 1.8.61.

PUBLIC WORKS.

4225. Benalla East, State School No. 2256, new school building, £35,184.—Aif. Richardson Construction.

4226. Malvern, Girls' Secondary School, erection of two-storey brick Domestic Arts Block, £44,349.—T. W. Morris and Son Pty. Ltd.

4227. Melbourne, Stamp Duties Office, supply and erection of steel-framed building, &c., £11,003.—Anderson Construction Co. Pty. Ltd.

4228. Horsham West, State School No. 4697, additional class-rooms, £18,367 18s. 6d.—Francis and Stewart.

4229. Portland South, State School No. 4750, erection of eight-class-room primary school, £30,526.—Callagher and Power.

4230. St. Albans, Technical School, supply and installation of mechanical services to stage 1, £11,090.—Frederick W. Nielsen Pty. Ltd.

4231. Upper Yarra, High School, installation and testing of mechanical services, £10,780.—Thermic Heating and Ventilation.

4232. Altona West, State School No. 4862, electrical installation of new school of eight L.T.C. class-rooms, &c., £1,053 1s.—Swift Electrical Services.

4233. Bendigo, High School, fence renewal, £311 10s.—A. T. Keast.

4234. Berrybank, State School No. 3639, improved sanitation at school and residence, £297 15s.—Peter McBride and Co.

4235. Brighton, Technical School, new store, escape stairway, and alterations to class-rooms, £3,189.—A. Kilmas.

4236. Bundoora, Repatriation Hospital, supply and installation of an electric petrol bowser and 500-gallon underground storage tank, £540.—Engineering Products Pty. Ltd.

4237. Burnley, Horticultural Gardens, erection of canteen and recreation-room, £3,873.—V. Laizans and Son.

4238. Castlemaine, State School No. 119, re-blocking, repairs, and external painting residence, £372.—R. House.

4239. Clarkefield, State School No. 3035, erection of new shelter shed and repairs to existing shed, £394 15s.—A. C. Dawes.

4240. Corio, Technical School, heavy and light duty asphalt paving, £3,334 10s. 9d.—J. H. Lewis and Son.

4241. Croydon West, State School No. 4879, electrical installation of new school, £1,236 15s.—Derjan Electrics.

4242. Croydon West, State School No. 4879, Plenum heating, £2,197.—Lonsdale Sheet Metal and Steel Company Pty. Ltd.

4243. Donald, Court House, repairs and painting, £533.—William Nolan.

4244. Echuca, Court House, repairs and external painting, Court House; installation of flyscreens, flydoor, and woodshed, residence, £1,185 15s.—John M. Thomson.

4245. Fawkner, Technical School, electrical installations in stages 2 and 3, £3,937.—K. J. Dupuy.

4246. Fawkner, Technical School, mechanical services to stages 2 and 3, £3,665.—Belsair Pty. Ltd.

4247. Geelong, "Ariston", Teachers' College Hostel, additional bedrooms and sanitary accommodation, £4,620.—James Murray (trading as Murray and Rowe).

4248. Gorae West, State School No. 4556, installation of septic tanks and out-offices at school and residence, £1,210.—Conquest Constructions.

4249. Kennington, State School No. 3686, new out-office block and septic tank installation, £1,038 15s. 6d.—J. G. Hibberd Pty. Ltd.

4250. Kew, Mental Hospital, supply and fixing fibrous plaster ceilings to Ward "B", £559.—Major Fibrous Plaster Pty. Ltd.

4251. Lavers Hill, Consolidated School, erection of new out-office block, £4,986 2s.—Peter McBride and Co.

4252. Laverton, State School No. 4765, Plenum heating, £1,826.—Lonsdale Sheet Metal and Steel Co. Pty. Ltd.

4253. Lemnos, State School No. 4269, installation of septic tank to school and residence, £1,454 12s. 6d.—A. and H. E. McDougall.

4254. Melbourne, Police Headquarters, Russell-street, new stainless steel trough units, &c., in Forensic Laboratory, £339 15s.—Burwood Stainless Pty. Ltd.

4255. Millgrove, State School No. 3655, internal repairs and painting to school buildings, £393.—D. W. Wilson.

4256. Mulgrave, State School No. 2172, installation of septic tank and construction of new boys' out-offices, £1,140 8s. 6d.—H. and A. Tinsley Pty. Ltd.

4257. Murrayville, Court House, repairs, internal and external painting, £495 10s.—O. H. Wynne and Sons.

4258. Mysia, State School No. 1899, installation of septic tank system to school and residence, £391 12s.—D. J. Osborn Plumbing Service.

4259. Bacchus Marsh, High School, additional class-room and administration wings, £51,587.—A. V. Jennings Construction Co. Pty. Ltd.

4260. Braybrook, Christ the King Catholic School, erection of ten portable class-rooms, £24,165.—A. V. Jennings Construction Co. Pty. Ltd.

4261. Beeac, State School No. 482, new out-office block, installation of septic tank and chalkboards, £1,636 15s.—T. W. Fowler.

4262. Braeside, State School No. 3910, new out-office block and connect to main sewer, £2,037.—S. W. Biggs.

4263. Brunswick, Police Transport Depot, supply and erection of steelwork for car washes, £520.—Johns and Waygood Ltd.

4264. Dergholm, State School No. 1729, erection of out-office block and installation of septic closets, £523 8s.—Jeffrey McCombe.

4265. Digby, State School No. 2047 and residence, new out-house and septic tank installation at school and residence, £973 10s.—F. H. Porter.

4266. Dromana, State School No. 184, septic tank installation, £1,729 16s. 6d.—Neerim Plumbers Pty. Ltd.

4267. Hawksburn, State School No. 1467, internal renovations, main school, £3,000.—G. J. Little.

4268. Footscray, Court House, erection of additional rooms, £1,977 16s. 2d.—W. H. Langdon and Sons Pty. Ltd.

4269. Foxhow, State School No. 1600, septic sewerage system, school and residence, £261 14s.—Peter McBride and Co.

4270. Glenormiston, Department of Agriculture, supply and installation of dairy equipment, £1,460.—R. M. Wigg.

4271. Hepburn, State School No. 767, repairs and painting to school and residence, £395.—J. A. Jansen.

4272. Kernot, State School No. 4024, external painting and provision of drinking facilities, £258.—Strykert and Bellingham.

4273. Kinglake, National Park, erection of brick veneer residence, £5,410 14s. 6d.—Dixon and Essing.

4274. Labertouche, State School No. 2471, installation of septic tank and provision of new sanitary accommodation, £316 17s.—Backman and Ryan.

4275. Lismore, State School No. 1293, additional out-office accommodation, additional drinking and washing facilities, £672.—G. A. Noone and J. J. Boscarini.

4276. Lockington, Consolidated School, erection of boundary fencing, £633.—W. G. Blake.

4277. Melbourne, Public Service Board, New Treasury Building, modifications to electrical installation, 4th floor, western annexe, £496.—Marshall and Camerino.

4278. Nicholson, State School No. 1716, septic tank installation, £338 8s.—W. K. Reynolds.

4279. Port Fairy, Consolidated School, erection of additional bedroom to residence, £899 10s.—Kearney, Watts and Son.

4280. Sale, Technical School, electrical installation, re-wiring of Mechanics' Institute, £2,185 16s.—Yarram Sporting Goods and Electrical Pty. Ltd.

4281. Seymour, Police Station, electrical installation in new office building, £1,075 10s.—P. G. McDonald and A. B. Grey.

4282. Toolamba, State School No. 1455, repairs and painting, £1,734.—N. L. Pinder.

4283. Warragul, State School No. 2104, erection of new paling fencing and repairs to existing fences, £290.—Donald A. Joyce.

T. K. MALTBY, Commissioner of Public Works. 24.7.61.

CONTRACTS ACCEPTED.—(Series 1961-62.)**VICTORIAN RAILWAYS.**

24. Stockyards, Derrinallum, for £1,454 4s. (Contract 61791).—R. Loader. 25. Portable shelters, at £1,792 10s. each (Contract 61840).—Freighter Industries (Vic.) Pty. Ltd. 26. Overhead cranes at Spotswood, at £4,525 each (Contract 61871).—Wm. Reid Engineering Pty. Ltd. 27. Removal, &c., of cranes from Newport to Dynon, for £10,120 (Contract 61882).—Wm. Reid Engineering Pty. Ltd. 28. Septic tanks, &c., at Korong Vale, for £1,144 5s. 6d. (Contract 61891).—W. H. Ritchie. 29. Electric motors, at rates (Contract 61898).—Noyes Bros. Pty. Ltd. 30. Electric motors, at rates (Contract 61957).—Australian Electrical Industries Pty. Ltd. 31. Switch-gear, at rates (Contract 61806).—M.I. Australia Pty. Ltd.

By order of the Victorian Railways Commissioners,
W. WALKER, Secretary for Railways. 28.7.61.

CONTRACTS ACCEPTED.—(Series 1961-62.)**PUBLIC WORKS.**

291. Port Melbourne, Public Works Department Store-yard, supply of filing cabinets, £2,975 12s. 6d.—E. T. Brown Ltd.
292. Keon Park, Technical School, supply of crushed rock, £282 14s.—Pasa and Black Quarries Pty. Ltd.
293. Mont Park, Mental Hospital, supply of carpets, £252 15s.—W. P. Murison.
294. Sunbury, Mental Hospital, supply of curtains, £320.—Hoad Manufacturing Pty. Ltd.
295. Melbourne, Companies Registration Office, supply of office equipment, £799.—Duff Steel Industries Pty. Ltd.
296. Melbourne, Public Works Department Accounts Branch, supply of bookkeeping machine, £618 2s.—Burroughs Limited.
297. Lara, Children's Welfare Department, supply of chairs, £342 7s. 9d.—Sebel Sales Ltd.
298. Port Melbourne, Public Works Department Depot, supply of tractor, £288.—E. Hassett and Sons Pty. Ltd.
299. Hampton, Breakwater, supply of quarried stone, £790.—Standard Quarries Ltd.
300. Port Melbourne, Public Works Department Depot, supply of concrete mixers, £1,990.—Welling and Crossley Pty. Ltd.
301. Fairlea, Female Prison, supply of sewing machines, £355 3s. 10d.—Singer Sewing Machine Co.
302. Dookie, Agricultural College, supply of mattresses, £493 10s.—Yarra Bedding Co. Pty. Ltd.
303. Dookie, Agricultural College, supply of divan beds, £1,794 14s.—Kennett Bros. and Rayner Pty. Ltd.
304. Warrnambool, Mental Hospital, supply of food containers, £431.—E.G.A. (S. Cunningham) Pty. Ltd.
305. Williamstown, Marine Survey, supply of marine engine, £4,141.—Diesel Services Pty. Ltd.
306. Coburg, Her Majesty's Gaol, Pentridge, supply of composing machine, £678.—Addressograph-Multigraph of Aust. Pty. Ltd.
307. Doon, Longerenong Agricultural College, supply of limestone, £375.—M. Mintern and Sons.
308. West Melbourne, Government Cool Stores, supply of timber, £442.—Les. Grace.
309. Coburg, Her Majesty's Gaol, Pentridge, supply of laminex sheets, £457 10s.—A. V. Wehl and Co. Pty. Ltd.
310. Sunbury, Mental Hospital, supply of kitchen equipment, £1,326 10s.—E.G.A. (S. Cunningham) Pty. Ltd.
311. Broadford, High School (new), supply of crushed rock, £265 13s.—F. T. Webb.
312. South Melbourne, Public Works Department Store-yard, supply of canvas fire hose, £682 5s. 10d.—Fire Fighting Equipment Co.
313. Ballarat East, High School, supply of chairs, £278 8s.—D. F. Cowan Sales Pty. Ltd.
314. Morwell, Technical School, supply of workshop equipment, £459 10s. 6d.—McPhersons Ltd.
315. White Hills, Technical School (Bendigo), supply of planing and jointing machine, £345.—Hillston and Co.
316. Croydon, High School, supply of chairs, £292 10s.—Reed Engineering Pty. Ltd.
317. Mont Park, Mental Hospital, supply of chairs, £350 2s. 6d.—J. R. Dunstan.
318. Kew, Traffic Commission, supply of furniture, £483 6s. 6d.—Myer Teale (Brunswick) Pty. Ltd.
319. Coburg, Pentridge Gaol, supply of cisterns, £534.—John Danks and Son Pty. Ltd.
320. Bendigo (White Hills), Technical School, supply of circular saw bench, £260.—A. and S. Wolfenden.
321. Kew, Mental Hospital, supply of chairs, £340.—J. R. Dunstan.
322. Kew, Mental Hospital, supply of furniture, £2,422 13s. 6d.—G. G. Phillips.
323. Sunshine North, Technical School, supply of steel timber rack, £367 16s.—V.I.A. Ltd.
324. Melbourne, Teachers' College Hostel, supply of furniture, £1,019 12s.—Johnstone and Morrison Pty. Ltd.
325. Bundoora, Larundel Mental Hospital, supply of washing machines, £750 3s. 9d.—Lightburn and Co. Ltd.
326. North Melbourne, Government Printing Office, supply of cafeteria equipment, £317 6s. 9d.—K. G. Luke Pty. Ltd.
327. Port Melbourne, Public Works Department Depot, supply of parts for Allen trencher, £276.—Maddison and Bowman Pty. Ltd.

H. R. PETTY, Commissioner of Public Works. 28.7.61.

ORDERS IN COUNCIL.—(Series 1960-61.)**STATE ELECTRICITY COMMISSION.**

4284. For the supply of rubber insertion jointing, for a period of two years, to Specification 60-61/215, at Schedule rates.—Olympic General Products Pty. Ltd.

4285. For the supply and delivery of welded steel pipes and fittings for fire services, Morwell Open Cut, £13,008 10s. 1d.—Mephan Ferguson Pty. Ltd.

Approved by the Governor in Council, 18th July, 1961.—A. MAHLSTEDT, Clerk of the Executive Council.

ORDERS IN COUNCIL.—(Series 1961-62.)**EDUCATION DEPARTMENT.**

291. One only precision ammeter, £88; one only voltmeter, £88; one only current transformer, £41 5s., for Caulfield Technical College.—A. J. William.
292. One only e/m apparatus, for Caulfield Technical College, £145.—B.W.D. Electronics Pty. Ltd.
293. One only Universal hobbing machine, £2,500; plus milling attachment, £331, for Caulfield Technical College.—Herbert Osborne Pty. Ltd.
294. One only Universal resistance welding control, for Footscray Technical College, £430.—Sciaky Pty. Ltd.
295. One only single-pan rapid weighing analytical balance, for Emily McPherson College, £145.—Watson Victor Ltd.
296. One only photo-copying machine, for Gordon Institute of Technology, Geelong, £230 14s. 2d.—Kodak (Australasia) Pty. Ltd.
297. One only electric duplicator, for Gordon Institute of Technology, Geelong, £220.—Gestetner Pty. Ltd.
298. One only Sartorius damped analytical balance, £120; one only spark tester, £20; two resistances, £55, for Maryborough Technical College.—H. B. Selby and Co. Pty. Ltd.
299. One only Special electrical sewing machine, for Wangaratta Technical School, £116 10s.—Singer Sewing Machine Co.
300. One only Premo 5½-in. lathe, for Wangaratta Technical School, £383.—Goodall and Co. Pty. Ltd.
301. One only electronic wheeler balancer, for Warragul Technical School, £221 3s. 6d.—Replacement Parts Pty. Ltd.
302. One only glass-washing machine, for William Angliss Food Trades School, £195.—Atherton Benham Pty. Ltd.
303. Two dough mixers, for William Angliss Food Trades School, £390.—J. C. Revill.
304. One only programme recorder, for Caulfield Technical College, £195.—Medical Equipment Services Pty. Ltd.
305. One only honing head, £140; two plastic welding torches, £42 10s. 6d., for Richmond Technical School.—Replacement Parts Pty. Ltd.
306. Two gear boxes, £129; two final drive units, £136, for Richmond Technical School.—Ford Motor Co.
307. Two gear boxes, £100; two final drive units, £125, for Richmond Technical School.—British Motor Corp. (Aust.) Pty. Ltd.
308. One only Herald chassis, £430; four tension wrenches, £27 4s., for Richmond Technical School.—A.M.I. Parts Pty. Ltd.
309. One only Hercus 4½-in. lathe, £283; one only valve seat reaming kit, £61 19s., for Richmond Technical School.—McPhersons Ltd.
310. Three air conditioners, £56 6s. 6d.; one only welding equipment, £103 3s. 8d., for Richmond Technical School.—C.I.G. (Victoria) Pty. Ltd.

Approved by the Governor in Council, 26th July, 1961.—A. MAHLSTEDT, Clerk of the Executive Council.

MELBOURNE AND METROPOLITAN BOARD OF WORKS.

NOTICE TO THE OWNERS OF TENEMENTS IN THE UNDER-MENTIONED STREETS, AND THE PRIVATE STREETS, LANES, COURTS AND ALLEYS OPENING THEREON.

THE main pipe in the said streets being laid down, the owners of all tenements situated as under are hereby required on or before the 4th September, 1961, to cause a proper pipe and stop cocks to be laid so as to supply water within such tenements from the main pipe.

25th July, 1961.

V. C. TREYVAUD,
Secretary.

STREET AND POSITION.*Altona.*

Paringa-road, from Millers-road westwards 18½ chains.
Webb-street, from Paringa-road southwards 7½ chains.
Roe-street, from Paringa-road southwards 2½ chains.

Berwick.

Lacebark-street, from Power-road to Kidds-road.
 Tristania-street, from Power-road to Kidds-road, 24½ chains.
 Mimosa-street, from Lacebark-street to Tristania-street.
 Kathryn-street, from Tristania-street to Marie-street.
 Acacia-street, from Tristania-street to Kathryn-street.

Broadmeadows.

Eldorado-street, from Lebanon-street to Strelton-avenue.
 Strelton-avenue, from Eldorado-street westwards 9 chains.
 Wurruk-street, from Mutton-street eastwards 3 chains.

Doncaster.

Woodhouse-road, from Hunt-street westwards 11½ chains.

Eltham.

Davey-road, from Station-road to Ratray-road.
 Bridge-street, from Bible-street westwards 8 chains.

Keilor.

Woorite-place, from Milleara-road to Keilor-road.
 Wunnamurra-drive, from Milleara-road westwards 19½ chains.
 Wingara-avenue, from Woorite-place to Clark-road.
 Clark-road, from Shelley-street to Henry-street.
 Nyah-street, from Clark-road to Woorite-place.
 Wyong-street, from Woorite-place to Clark-road.
 The Centreway (north side), from Wyong-street to Wingara-avenue.
 The Centreway (south side), from Wyong-street to Wingara-avenue.
 McIntosh-street, from McNamara-avenue northwards 16½ chains.
 Laurence-avenue, from 8½ chains west of Lock-street westwards 4 chains.
 Clydesdale-road, from McNamara-avenue north-westwards 4½ chains.
 Lock-street, from Clydesdale-road to Laurence-avenue.
 Parer-road, from McNamara-avenue westwards 13½ chains.
 Parer-road, from McNamara-avenue eastwards 15½ chains.
 McNamara-avenue, from 3 chains north of McIntosh-street to Parer-road.
 McNamara-avenue, from Highridge-crescent southwards 12 chains.
 El Reno-crescent, from McNamara-avenue eastwards 1 chain.

Malvern.

Carrol-crescent, from Tooronga-road to Weir-street.

Moorabbin.

Normdale-road, from Brady-road to Bignell-road.
 Norville-street, from Normdale-road southwards 10 chains.
 Blamey-street, from Normdale-road southwards 10 chains.

Nunawading.

Springfield-road, from 6 chains north-east of McCulloch-street north-eastwards 4 chains.
 Sunnyside-avenue, from Springfield-road south-eastwards 12½ chains.

Oakleigh.

Marriott-street, from Dandenong-road to Baker-street.
 Albany-road, from Gordon-avenue eastwards 1½ chains.
 Voumard-street, from Guest-road to Elata-street.

Prahran.

Green-street, from Stewart-street eastwards 1½ chains.

Preston.

Albert-street, from Bell-street northwards 7 chains.
 Wood-street, from 1½ chains west of Hannah-street westwards 2 chains.
 Greenock-street, from Aberdeen-street south-eastwards 8½ chains.
 Dundee-street, from 7 chains north-east of Hickford-street to Argyle-street.
 Aberdeen-street, from 12 chains north-east of Hickford-street to Dumbarton-street.
 Dumbarton-street, from Aberdeen-street eastwards 13½ chains.
 Banff-street, from Hickford-street north-eastwards 14 chains.

Richmond.

Right-of-way (3 chains north of Barkly-avenue), from Gibdon-street westwards 2½ chains.

Ringwood.

Tweed-street, from Dublin-road to Illoura-avenue.
 Merry-street, from Tweed-street northwards 6 chains.
 Illoura-avenue, from 3½ chains north of Hilary-court to Nicholson-street.
 Nicholson-street, from Illoura-avenue westwards 5½ chains.
 Station-street, from 9½ chains east of Bedford Park-road eastwards 13 chains.
 Athol-grove, from Nicholson-street southwards 3½ chains.

Sunshine.

Market-place, from Duke-street eastwards 3½ chains.

Waverley.

Orchard-street, from High Street-road northwards 18½ chains.
 Kwinana-road, from Orchard-street eastwards 11½ chains.
 Subiaco-court, from Kwinana-road northwards 7½ chains.
 Medina-road, from High Street-road northwards 19 chains.
 Wembly-court, from Orchard-street eastwards 2½ chains.
 Floreat-court, from Medina-road eastwards 5½ chains.
 Morton-street, from Blackburn-road westwards 19½ chains.

PUBLIC TRUSTEE ACT 1958 (No. 6350), SECTION 17.

I HEREBY give notice that on the 17th July, 1961, the Public Trustee filed elections to administer the following deceased persons' estates, in accordance with section 17 of the *Public Trustee Act 1958*:—

FERGUSON, HAMILTON, late of Melbourne Home and Hospital for the Aged, Cheltenham, pensioner, died 17th November, 1959.

FIELDING, FRANK HEDLEY, formerly of 10 Wrixon-avenue, East Brighton, but late of Warrigal-road, Cheltenham, retired blacksmith, died 1st May, 1961.

FRANKISH, PERCY, late of 3 Alandale-road, Belgrave, pensioner, died 27th April, 1961.

NOBLE, ANDREW DORES, formerly of Regimental No. 2621, 3rd Pioneers, Australian Imperial Forces, and Bay-view Hotel, Cecil-street, South Melbourne, but late of 47 Bridport-street, South Melbourne, war pensioner, died 16th November, 1960.

PHELAN, JOHN PATRICK, late of 735 Nepean Highway, East Brighton, packer, died 19th April, 1961.

POHL, ADALBERT JOHANN, late of 3 Cranley-street, Springvale, toolmaker, died 23rd February, 1961.

I HEREBY give notice that on the 21st July, 1961, the Public Trustee filed an election to administer the following deceased person's estate, in accordance with section 17 of the *Public Trustee Act 1958*:—

CHAMPION, GEORGE ALEXANDER, late of 14 Kingsville-street, Footscray, gardener, died 31st May, 1961.

I HEREBY give notice that on the 18th July, 1961, the Public Trustee filed elections to administer the following deceased persons' estates, in accordance with section 17 of the *Public Trustee Act 1958*:—

ASHLEY, EDMUND, late of 155 Mitcham-road, Mitcham, labourer, died 3rd May, 1961.

BRYANT, WALTER FREDERICK, formerly of 832 Burke-road, Camberwell, but late of 46 Cleek-avenue, South Oakleigh, gallery attendant, died on or about the 27th November, 1960.

CONWAY, MICHAEL JOHN, late of Sheppard-street, Ballarat, labourer, died 27th December, 1937.

LANGRIDGE, ROBERT DAVID, late of Ovens and Murray Home, Beechworth, pensioner, died 23rd May, 1959.

MALLEY, WILLIAM, also known as William O'Malley, formerly of Yinnar, but late of Bundoora, war pensioner, died 18th March, 1961.

MATTHEWS, ALICE, late of 56 Widdop-crescent, Moorabbin, widow, died 17th May, 1961.

WROBEL, HELENA, late of 24 Sydenham-street, Footscray, pensioner, died 19th June, 1961.

A. D. DUNCAN,

Public Trustee.

601 Little Collins-street, Melbourne, C.1, 26th July, 1961.

NOTICE.

CREDITORS, next of kin and others having claims against the estate of any of the under-mentioned deceased persons are required to send particulars of their claims to the Public Trustee, 7th Floor, 601 Little Collins-street, Melbourne, the personal representative, on or before the 5th October, 1961, after which date the Public

Trustee may convey or distribute the assets, having regard only to the claims of which the Public Trustee then has notice:—

ABERCROMBIE, JENNIE ELSA, formerly of 27 Luxton-road, Hawksburn, but late of 132A Williams-road, Prahran, widow, died 11th May, 1961.

ASHLEY, EDMUND, late of 155 Mitcham-road, Mitcham, labourer, died 3rd May, 1961.

ATTRILL, KATE, late of 86 Powlett-street, East Melbourne, spinster, died 2nd May, 1961.

BRUCE, DOROTHY MARGUERITE, late of residence Bank of New South Wales, 190 Bourke-street, Melbourne, widow died on or about 21st September, 1960.

BRYANT, WALTER FREDERICK, formerly of 832 Burke-road, Camberwell, but late of 46 Cleek-avenue, South Oakleigh, gallery attendant, died on or about the 27th November, 1960.

CHAMPION, GEORGE ALEXANDER, late of 14 Kingsville-street, Footscray, gardener, died 31st May, 1961.

CODLING, WILLIAM DENTON, late of 1 Woodhead-street, North Fitzroy, retired electrician, died 18th May, 1961.

CONWAY, MICHAEL JOHN, late of Sheppard-street, Ballarat, labourer, died 27th December, 1937.

FERGUSON, HAMILTON, late of Melbourne Home and Hospital for the Aged, Cheltenham, pensioner, died 17th November, 1959.

FIELDING, FRANK HEDLEY, formerly of 10 Wrixon-avenue, East Brighton, but late of Warrigal-road, Cheltenham, retired blacksmith, died 1st May, 1961.

FRANKISH, PERCY, late of 3 Alandale-road, Belgrave, pensioner, died 27th April, 1961.

HAMILTON, REBECCA GERTRUDE, late of 31 Burton-crescent, East Ivanhoe, widow, died 29th April, 1961.

HOWELL, WILLIAM PHILIP, also known as William Phillip Howell, late of 95 McPherson-street, North Carlton, retired bread carter, died 1st July, 1960.

KOSTAL, MIROSLAV, late of Commonwealth Migrant Hostel, Nunawading, clerk, died 18th September, 1960.

KRIST, RICHARD, late of 13 Byron-street, Moonee Ponds, fitter and turner, died 22nd December, 1960.

LANGRIDGE, ROBERT DAVID, late of Ovens and Murray Home, Beechworth, pensioner, died 23rd May, 1959.

LEECH, VINCENT THOMAS, late of 356 Buckley-street, Essendon, foreman, died 8th May, 1961.

MALLEY, WILLIAM, also known as William O'Malley, formerly of Yinnar, but late of Bundoora, war pensioner, died 18th March, 1961.

MATTHEWS, ALICE, late of 56 Widdop-crescent, Moorabbin, widow, died 17th May, 1961.

NASH, GEORGE MOORE, late of 10 Osborne-street, Garden-vale, retired contractor, died 30th April, 1961.

NOBLE, ANDREW DORES, formerly of Regimental No. 2621, 3rd Pioneers, Australian Imperial Forces, and Bay-view Hotel, Cecil-street, South Melbourne, but late of 47 Bridport-street, South Melbourne, war pensioner, died 16th November, 1960.

OWEN, EDGAR HENRY, late of 483 Gore-street, Fitzroy, hairdresser, died 13th May, 1961.

PHELAN, JOHN PATRICK, late of 735 Nepean Highway, East Brighton, packer, died 19th April, 1961.

POHL, ADALBERT JOHANN, late of 3 Cranley-street, Springvale, toolmaker, died 23rd February, 1961.

SCHEWTSCHENKO, ALEX, late of 81 Fox-street, St. Albans, driver, died 30th December, 1960.

STEPHENSON, GEORGE ELSMIE LEOPOLD, late of 14 Railway-avenue, Armadale, retired general worker, died 13th March, 1961.

STILES, MELVYN CRAIG, late of Frederick-street, Doncaster, invalid pensioner, died 2nd May, 1961.

STUBBS, VIOLET MAY, formerly of Ryans-road, Clayton, late of 387 Neerim-road, Murrumbidgee, widow, died 27th April, 1961.

WROBEL, HELENA, late of 24 Sydenham-street, Footscray, pensioner, died 19th June, 1961.

A. D. DUNCAN,
Public Trustee.

Melbourne, 26th July, 1961.

DEPARTMENT OF MINES.

SUBJECT to any necessary excisions, &c., it is proposed to grant the following mining lease:—

7868, Mineral; John Leonard Williams and Charles Ross Williams; 16 acres, Parish of Langwarrin.

APPLICATION FOR LEASE DECLARED ABANDONED.

7814, Mineral; W. C. Findlay, J. R. McLaren, I. M. Johnstone and D. J. Johnstone; 2,377 acres, Parish of Allambee.

MINING LEASE EXPIRED.

11205, Bendigo; Edgar Charles Adams; 51a. 0r. 4p., Parish of Toolleen.

MINERAL SEARCH LICENCE EXPIRED.

230, Mineral Search Licence; Frederick Daniel Lloyd, Graham John King and Joseph Royston Harbridge.

EXTENSION OF TERM OF PETROLEUM PROSPECTING LICENCE.

246, Petroleum Prospecting Licence; Estate of A. E. Ekberg, deceased; 197 square miles, County of Tambo.

TAILINGS LICENCES GRANTED.

3095, Tailings Licence; Alan Heywood Sutherland; Parish of Toora (in lieu of Tailings Licence No. 3016, expired).

3097, Tailings Licence; John L. Ward; Parish of Chiltern West (in lieu of Tailings Licence No. 3012, expired).

3098, Tailings Licence; Allan Chan; at Bendigo (in lieu of Tailings Licence No. 3021, expired).

3100, Tailings Licence; Allan Chan; at Bendigo (in lieu of Tailings Licence No. 3023, expired).

3101, Tailings Licence; John Doyle and Robert Leo Doyle; Parish of Huntly (in lieu of Tailings Licence No. 3018, expired).

3102, Tailings Licence; James McDonald Richardson; Parishes of Numbruck and Moondarra (in lieu of Tailings Licence No. 3020, expired).

3110, Tailings Licence; William B. P. Henry; Parish of Maldon (in lieu of Tailings Licence No. 2993, expired).

3111, Tailings Licence; William B. P. Henry; Parish of Maldon (in lieu of Tailings Licence No. 3009, expired).

3112, Tailings Licence; William B. P. Henry; Parish of Maldon (in lieu of Tailings Licence No. 3010, expired).

3114, Tailings Licence; Ray L. Maltby; Parish of Yehrip (in lieu of Tailings Licence No. 3014, expired).

W. J. MIBUS,
Minister of Mines.

MINING LEASES DECLARED VOID.

9099, Castlemaine; John Joseph Hayes; 775a. 2r. 28p., Parish of Balnarring.

7770, Mineral; John Cern; 9a. 2r. 8p., Parishes of Faraday and Chewton.

E. CONDON,
Secretary for Mines.

WORKERS COMPENSATION ACTS.

NOTICE is hereby given that, pursuant to section 82 (7) of the *Workers Compensation Act 1958*, the Workers Compensation Board has fixed the under-mentioned days as the days upon which the respective quarterly instalments of the contributions to the Workers Compensation Board Fund for the financial year ending the 30th June, 1962, shall be paid:—

First quarterly instalment—15th August, 1961.
Second quarterly instalment—1st October, 1961.
Third quarterly instalment—1st January, 1962.
Fourth quarterly instalment—1st April, 1962.

By order of the Board,

GEO. T. SMITH,
Registrar, Workers Compensation Board.

Melbourne, 27th July, 1961.

APPOINTMENTS.

HIS Excellency the Administrator of the Government of the State of Victoria, by and with the advice of the Executive Council thereof, has, by Orders made on the 26th day of July, 1961, been pleased to make the under-mentioned appointments, viz.:—

CHIEF SECRETARY'S DEPARTMENT.

Electoral Registrar (Acting).

NORMAN RUSSELL ARNOLD

to be Electoral Registrar (Acting) for the Drysdale, Geelong, Newtown and Chilwell and Queenscliff Subdivisions of the Electoral District of Geelong; and for

the Bannockburn, Geelong North, Geelong West, Meredith and Sutherland Subdivisions of the Electoral District of Geelong West, to take effect on and from the 17th July, 1961, during the absence on leave of Owen Patrick Griffin.

Honorary Probation Officer.

DANIEL JOSEPH MCARDLE, 8 Norwood-avenue, Brighton Beach, pursuant to the provisions of section 507 (2) of the *Crimes Act 1958*, to be an Honorary Probation Officer for the purposes of the said Act.

Acting Governor of Training Prison.

ROY SEAMER VODDEN, pursuant to the provisions of the *Goals Act 1958*, to be Governor (Acting) of Her Majesty's Training Prison, Bendigo, from the 24th July, 1961, to the 8th August, 1961, both dates inclusive, during the absence on leave of Ian Gordon Grindlay.

EDUCATION DEPARTMENT.

Member of the Council of Public Education.

JOHN RAMSDEN LYALL, B.A., Dip.Ed. (as representing the Education Department), pursuant to section 8 of the *Education Act 1958*, to be a Member of the Council of Public Education for the period ending the 31st December, 1962, *vice* J. G. Greening, deceased.

DEPARTMENT OF HEALTH.

Government Representatives on Hospital Committees of Management.

RONALD HERBERT RANKIN to be Government Representative on the Committee of Management of Winchelsea Medical Centre, pursuant to the provisions of section 48 of the *Hospitals and Charities Act 1958*, for a period of three years, *vice* R. F. Richardson, resigned; and

NORMAN McLAREN YOUNG to be Government Representative on the Committee of Management of Bendigo and Northern District Base Hospital, pursuant to the provisions of section 48 of the *Hospitals and Charities Act 1958*, for a further period of three years from and inclusive of the 26th August, 1961.

Deputy Superintendent, Mental Hospital.

ZOLTAN BELA BOZAN to be Deputy Superintendent, Mental Hospital, Beechworth, pursuant to the provisions of section 39 of the *Mental Hygiene Act 1958*, as from and inclusive of the 17th July, 1961.

Trustees of Public Cemeteries.

LESLIE ARTHUR WOODFORD and LEONARD ALFRED EDGE to be Trustees, Hotspur Public Cemetery, as additional Trustees;

LAURENCE JOHN CLONAN to be a Trustee, Sheep Hills Public Cemetery, *vice* A. V. Parsons, deceased;

STANLEY CHILDS to be a Trustee, Sheep Hills Public Cemetery, *vice* A. Heath, deceased;

SYDNEY VINSON WRIGHT to be a Trustee, Sheep Hills Public Cemetery, *vice* G. Malcolm, resigned;

NORMAN WILFRED SCHULTZ to be a Trustee, Sheep Hills Public Cemetery, *vice* D. W. McAfee, resigned;

JOHN FREDERICK KENT to be a Trustee, Sheep Hills Public Cemetery, *vice* H. Bunge, resigned;

ARCHIBALD JAMES CAMPBELL to be a Trustee, Sheep Hills Public Cemetery, *vice* J. Stainthorpe, resigned;

JOHN DAVID ANDERSON to be a Trustee, Rochester Public Cemetery, *vice* J. Forsyth, deceased; and

JOHN EDWIN KAYE and THOMAS EDWARD CHESTER to be Trustees, Carisbrook Public Cemetery, as additional Trustees.

Public Vaccinator.

ALEXANDER NORMAN JONES, M.B., B.S., to be Public Vaccinator for the municipality of Camberwell.

LAW DEPARTMENT.

Justices of the Peace.

ALAN JAMES BOWES, Hawkesdale, and JACK MATTHEWS, Heywood, to Keep the Peace in the Western Bailiwick of the State of Victoria;

WILLIAM SCOTT STEEL, care of Country Roads Board, 60 Denmark-street, Kew, to Keep the Peace in all Bailiwicks of the State of Victoria; and

ARTHUR CAREY MATLOCK, 21 Tassell-street, Glenroy, JOHN ROSS RISCHBIETH, 60 The Esplanade, Mari-byrnong,

THOMAS LEONARD OSCAR HOLT, Hillview Farm, Christmas Hills, GERRARD MAHON GILLESPIE, R.A.A.F. Base, Laverton, RAYMOND CYRIL MITCHELL, Walnut-street, Whittlesea, and

SYDNEY AARONS, care of General Motors-Holden's Pty. Ltd., Port Melbourne, to Keep the Peace in the Central Bailiwick of the State of Victoria.

Commissioners for Taking Declarations, &c.

WALTER JOSEPH SUTTON, 3 Small-street, Hampton, PAUL JOSEPH COSAITIS, 2 Wedding-court, Broadmeadows.

EDGAR WAVERLEY LECHTE, 489 High Street-road, Mount Waverley,

RONALD EDWIN FARQUHARSON, 28 Pearl-street, Niddrie, and

JAMES OLIVER WHITE, Ninks-road, St. Andrews North, to be Commissioners for taking Declarations and Affidavits, pursuant to the provisions of the *Evidence Act 1958*, to resign upon removing from the neighbourhood of the addresses stated; and

MARIO LOPEZ, care of the New Zealand Insurance Company Limited, 491-493 Bourke-street, Melbourne, and

RONALD LETCHER, care of Felt and Textiles of Australia Limited, 8 Nicholson-street, Melbourne, to be Commissioners for taking Declarations and Affidavits, pursuant to the provisions of the *Evidence Act 1958*, to resign upon ceasing to occupy their present positions.

Deputy Clerk of Court of Petty Sessions.

JAMES RAY AITKEN to be a Deputy Clerk of the Court of Petty Sessions at Geelong, pursuant to the provisions of section 87 (2) (a) of the *Justices Act 1958*, for the period from the 3rd July, 1961, to the 15th September, 1961, both dates inclusive.

Sworn Valuator.

JAMES KENNETH BIGGS to be a Sworn Valuator, pursuant to the provisions of the *Transfer of Land Act 1958*, for the Counties of Evelyn, Mornington, Buln Buln, Tanjil, Dargo, Tambo and Croajingolong.

DEPARTMENT OF PUBLIC WORKS.

Wharf Manager.

Senior Constable RONALD ROBERT RAYNER, No. 10118, as on and from 8th June, 1961, to be Wharf Manager at Apollo Bay, to carry out that portion of Part II. of the *Marine Act 1958* which relates to the management of public wharves, and to be an officer under section 19 of such Act to levy and collect wharfage rates thereat, at a remuneration of £20 per annum, *vice* Senior Constable John Robert Sexton, No. 8412, retired.

DEPARTMENT OF THE TREASURER.

Member of the Bookmakers and Bookmakers' Clerks Registration Committee.

ALAN VINCENT DUNN, being a person nominated by the Trotting Control Board, pursuant to section 85 of the *Racing Act 1958*, to be a Member of the Bookmakers and Bookmakers' Clerks Registration Committee for the period 26th July, 1961, to 22nd February, 1963, both dates inclusive.

DEPARTMENT OF WATER SUPPLY.

Waterworks Trust Commissioners.

FORREST JOHN BLAY and HARRY VICTOR MARTIN to be Commissioners of the Beaufort Waterworks Trust, each for a period of four years from the date hereof, subject to the provisions of the Water Acts.

A. MAHLSTEDT,
Clerk of the Executive Council.

At the Executive Council Chamber,
Melbourne, 26th July, 1961.

RESIGNATION.

HIS Excellency the Administrator of the Government of the State of Victoria, by and with the advice of the Executive Council thereof, has, by Order made on the 26th day of July, 1961, accepted the resignation of the person named hereunder of the office mentioned, viz.:

LAW DEPARTMENT.

ARTHUR LIVINGSTONE JOYCE, as a Commissioner for taking Declarations and Affidavits, pursuant to the provisions of the Evidence Act 1958.

A. MAHLSTEDT,
Clerk of the Executive Council.

At the Executive Council Chamber,
Melbourne, 26th July, 1961.

DEPARTMENT OF CROWN LANDS AND SURVEY.

At the Executive Council Chamber, Melbourne, the twenty-sixth day of July, 1961.

PRESENT:

His Excellency the Administrator of the Government of Victoria.

- | | |
|------------|----------------|
| Mr. Bolte | Mr. Chandler |
| Mr. Mibus | Mr. Bloomfield |
| Mr. Petty | Mr. Turnbull |
| Mr. Reid | Mr. Porter |
| Mr. Fraser | Mr. Thompson. |

LANDS TEMPORARILY RESERVED AS SITES.

HIS Excellency the Administrator of the Government of the State of Victoria, by and with the advice of the Executive Council thereof, doth hereby, in pursuance of the provisions of the Land Act 1958, reserve, temporarily, and also except from occupation for mining purposes, under any miner's right, the lands hereinafter described:—

JAMIESON.—Site for Public purposes, 1 acre, more or less, Township of Jamieson, Parish of Jamieson, County of Wonnangatta, as indicated by hachure on plan hereunder.—(J.22(2) (Rs.8054).

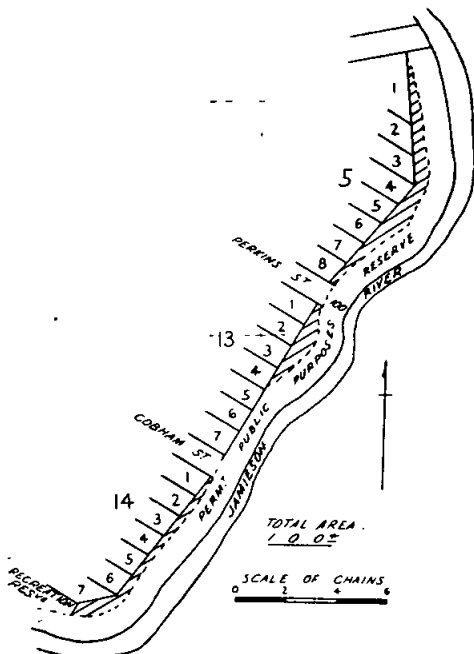

KIRRAK (INVERLOCH).—Site for Public purposes, 12 acres, more or less, Parish of Kirrak, County of Buln Buln, as indicated by hachure on plan hereunder.—(K.148(2) (Rs.771).

No. 68.—6267/61.—2

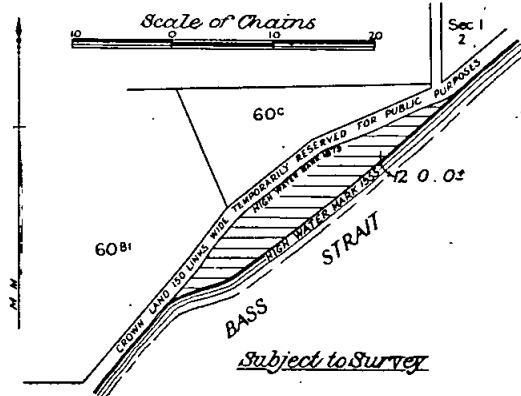

WERRIKOO (STRATHDOWNIE).—Site for Public Recreation, 6 acres 0 roods 32 perches, Parish of Werrikoo, County of Follett, as indicated by hachure on plan hereunder.—(W.333(2) (Rs.8047).

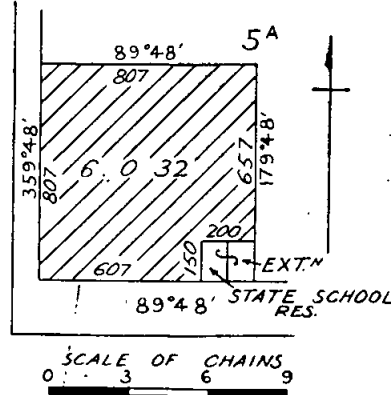

WHITFIELD (MYRRHEE).—Site for Public Recreation, 20 acres, more or less, Parish of Whitfield, County of Delatite, as indicated by hachure on plan hereunder.—(W.317(2) (Rs.8056).

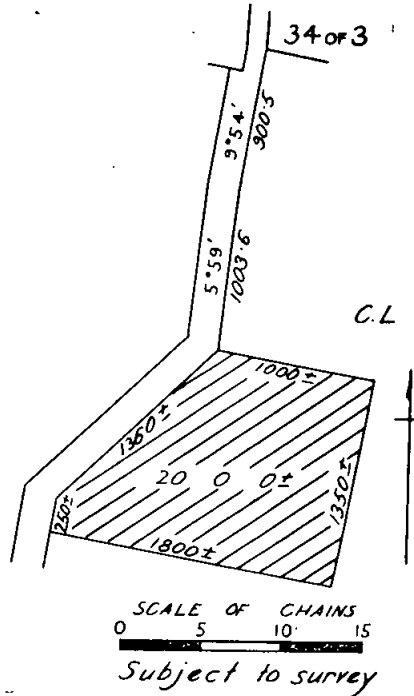

YARCK.—Site for State School purposes, 1 acre 3 roods 35 perches, Township of Yarck, Parish of Yarck, County of Anglesey, as indicated by hachure on plan hereunder.—(Y.84(?) (Rs.8036).

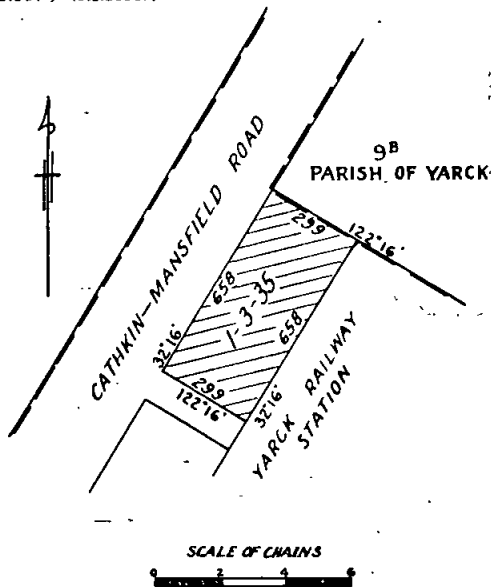

GLENROWEN.—Site for Water Supply purposes, in addition to and adjoining the site temporarily reserved therefor, by Order in Council of the 20th February, 1882, 3 acres, Township of Glenrowen, Parish of Glenrowen, County of Moira, as indicated by hachure on plan hereunder.—(G.92(*) (Rs.7046).

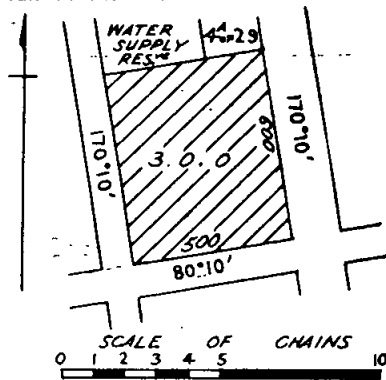

And the Honorable Keith Hector Turnbull, Her Majesty's Commissioner of Crown Lands and Survey for the State of Victoria, shall give the necessary directions herein accordingly.

A. MAHLSTEDT,
Clerk of the Executive Council.

DEPARTMENT OF CROWN LANDS AND SURVEY.

At the Executive Council Chamber, Melbourne, the twenty-sixth day of July, 1961.

PRESENT:

His Excellency the Administrator of the Government of Victoria.

- | | |
|------------|----------------|
| Mr. Bolte | Mr. Chandler |
| Mr. Mibus | Mr. Bloomfield |
| Mr. Petty | Mr. Turnbull |
| Mr. Reid | Mr. Porter |
| Mr. Fraser | Mr. Thompson. |

UNUSED ROADS CLOSED.

HIS Excellency the Administrator of the Government of the State of Victoria, by and with the advice of the Executive Council thereof, doth hereby direct that, in

pursuance of the provisions of section 349 of the Land Act 1958, the unused roads referred to hereunder be closed, viz.:—

Parish of Maldon, County of Talbot, being the road between allotments 6, 7, 8 and 9 and allotments 12A and 13B, section A1.—(M.449(*) (W.69031).

Parish of Stawell, County of Borung, being the road between allotment 26, section 4, and the State School Reserve.—(S.329(14) (C.98018).

And the Honorable Keith Hector Turnbull, Her Majesty's Commissioner of Crown Lands and Survey for the State of Victoria, shall give the necessary directions herein accordingly.

A. MAHLSTEDT,
Clerk of the Executive Council.

DEPARTMENT OF CROWN LANDS AND SURVEY.

At the Executive Council Chamber, Melbourne, the twenty-sixth day of July, 1961.

PRESENT:

His Excellency the Administrator of the Government of Victoria.

- | | |
|------------|----------------|
| Mr. Bolte | Mr. Chandler |
| Mr. Mibus | Mr. Bloomfield |
| Mr. Petty | Mr. Turnbull |
| Mr. Reid | Mr. Porter |
| Mr. Fraser | Mr. Thompson. |

REVOCATION OF TEMPORARY RESERVATION OF LAND BY ORDER IN COUNCIL.

HIS Excellency the Administrator of the Government of the State of Victoria, by and with the advice of the Executive Council thereof, doth hereby, in pursuance of the provisions of the Land Act 1958, revoke the temporary reservation of land by Order in Council hereinafter referred to, viz.:—

GLENLOGIE.—Order in Council of 18th January, 1909, of 12 acres 0 roods 28 perches of land in the Parish of Glenlogie as a site for the Supply of Gravel.—(C.39166.)

And the Honorable Keith Hector Turnbull, Her Majesty's Commissioner of Crown Lands and Survey for the State of Victoria, shall give the necessary directions herein accordingly.

A. MAHLSTEDT,
Clerk of the Executive Council.

COLERAINE AND CASTERTON WATERWORKS TRUST.

At the Executive Council Chamber, Melbourne, the twenty-sixth day of July, 1961.

PRESENT:

His Excellency the Administrator of the Government of Victoria.

- | | |
|------------|----------------|
| Mr. Bolte | Mr. Chandler |
| Mr. Mibus | Mr. Bloomfield |
| Mr. Petty | Mr. Turnbull |
| Mr. Reid | Mr. Porter |
| Mr. Fraser | Mr. Thompson. |

REPEAL OF ORDER.

UNDER the powers conferred by the Water Acts and all other powers enabling him in that behalf, His Excellency the Administrator of the Government of the State of Victoria, by and with the advice of the Executive Council of the said State, doth hereby repeal the Order made by the Governor in Council on 16th March, 1951, as amended by the Order in Council made on 14th May, 1958, fixing the limit of the overdraft to be obtained by the Coleraine and Casterton Waterworks Trust at Three thousand pounds (£3,000).

And as and on from the date hereof the said Order of the Governor in Council shall be deemed to be repealed accordingly.

And the Honorable Wilfred John Mibus, Her Majesty's Minister of Water Supply for the State of Victoria, shall give the necessary directions herein accordingly.

A. MAHLSTEDT,
Clerk of the Executive Council.

PUBLIC SERVICE ACT 1958.

At the Executive Council Chamber, Melbourne, the twenty-sixth day of July, 1961.

PRESENT:

His Excellency the Administrator of the Government of Victoria.

Mr. Bolte	Mr. Chandler
Mr. Mibus	Mr. Bloomfield
Mr. Petty	Mr. Turnbull
Mr. Reid	Mr. Porter
Mr. Fraser	Mr. Thompson.

REGULATIONS.

IN pursuance of the powers conferred by the *Public Service Act 1958*, His Excellency the Administrator of the Government of the State of Victoria, by and with the advice of the Executive Council thereof, doth hereby amend the Public Service (Governor in Council) Regulations in the manner following, that is to say:—

PART IV.—LEAVE OF ABSENCE.

Long Service Leave.

In Regulation 59, following the words "with the Victoria Police Force;" there shall be inserted the words—

"with the Soldier Settlement Commission;"

And the Honorable Henry Edward Bolte, Her Majesty's Premier for the State of Victoria, shall give the necessary directions herein accordingly.

A. MAHLSTEDT,
Clerk of the Executive Council.

LOCAL GOVERNMENT DEPARTMENT.

At the Executive Council Chamber, Melbourne, the twenty-sixth day of July, 1961.

PRESENT:

His Excellency the Administrator of the Government of Victoria.

Mr. Bolte	Mr. Chandler
Mr. Mibus	Mr. Bloomfield
Mr. Petty	Mr. Turnbull
Mr. Reid	Mr. Porter
Mr. Fraser	Mr. Thompson.

DRAINAGE AREAS ACT 1958.

At the Executive Council Chamber, Melbourne, the twenty-sixth day of July, 1961.

PRESENT:

His Excellency the Administrator of the Government of Victoria.

Mr. Bolte	Mr. Chandler
Mr. Mibus	Mr. Bloomfield
Mr. Petty	Mr. Turnbull
Mr. Reid	Mr. Porter
Mr. Fraser	Mr. Thompson.

APPLICATION TO ELECTIONS OF COUNCILLORS FOR THE BOROUGH OF SEBASTOPOL OF REGULATIONS RELATING TO COMPULSORY VOTING.

WHEREAS it is provided in section 149 of the *Local Government Act 1958* that the Governor in Council, on the petition of the Council of any municipality, may, by Order published in the *Government Gazette*, apply to elections of councillors for such municipality, with any modifications provided for in such Order, all or any of the Regulations relating to compulsory voting made under the said section 149:

Now, therefore, His Excellency the Administrator of the Government of the State of Victoria, by and with the advice of the Executive Council thereof, and in pursuance of a petition of the Council of the Borough of Sebastopol, doth hereby order that the Regulations relating to compulsory voting at municipal elections, made pursuant to the provisions of the said section 149, shall apply to elections of councillors for the municipality of the Borough of Sebastopol.

And the Honorable Murray Victor Porter, Her Majesty's Minister for Local Government for the State of Victoria, shall give the necessary directions herein accordingly.

A. MAHLSTEDT,
Clerk of the Executive Council.

CONSTITUTION OF THE CARLYLE DRAINAGE AREA.—SHIRE OF RUTHERGLEN.

PURSUANT to the provisions of the *Drainage Areas Act 1958*, and in compliance with the prayer of a petition presented by the President, Councillors, and Ratepayers of the Shire of Rutherglen, notice of which petition was duly published in the *Government Gazette* on the 15th March, 1961, His Excellency the Administrator of the Government of the State of Victoria, by and with the advice of the Executive Council thereof, by this Order directs that the portion of the said Shire described hereunder be constituted a Drainage Area within the meaning of the said Act, under the name of the Carlyle Drainage Area:—

Commencing at the north-east corner of Crown allotment 2, section P, Parish of Gooramadda; thence southerly along the road boundary to the north-east corner of Crown allotment 1, section S, Parish of Gooramadda; thence south-westerly along the road boundary to the Murdering Hut Creek and thence westerly by the roadway along the southern boundary of Crown allotment 10, section S, to a point opposite the north-east corner of Crown allotment 37, section 33, Parish of Carlyle; thence southerly to the northern boundary of Crown allotment 39, section 33; thence easterly, southerly and westerly around the boundary of this allotment; thence westerly along this roadway to the south-east corner of Crown

allotment 15b, section 31; thence northerly to the western boundary of Crown allotment 15, section 31; thence northerly, north-easterly and easterly around this boundary to the north-east corner of Crown allotment 15, section 31; thence northerly along the roadway to a point opposite the northern boundary of Crown allotment 3a¹; thence westerly through Crown allotment 3a, section 31, to the northern boundary of Crown allotment 3a¹, and along this boundary and that of Crown allotment 2a, section 31, to the north-west corner of Crown allotment 2b, section 31; thence southerly along the roadway to a point opposite the northern boundary of Crown allotment 4b¹, section 29; thence westerly to the eastern boundary of Crown allotment 4, section 29; thence southerly, westerly, southerly, westerly, and northerly around that allotment; thence northerly along the roadway to the north-west corner of Crown allotment 1, section 29; thence easterly along the roadway and north of easterly to the point of commencement at the north-east corner of Crown allotment 2, section P, in the Parish of Gooramadda, County of Bogong.

And the Honorable Murray Victor Porter, Her Majesty's Minister for Local Government for the State of Victoria, shall give the necessary directions herein accordingly.

A. MAHLSTEDT,
Clerk of the Executive Council.

DRAINAGE AREAS ACT 1958.

At the Executive Council Chamber, Melbourne, the twenty-sixth day of July, 1961.

PRESENT:

His Excellency the Administrator of the Government of Victoria.

Mr. Bolte	Mr. Chandler
Mr. Mibus	Mr. Bloomfield
Mr. Petty	Mr. Turnbull
Mr. Reid	Mr. Porter
Mr. Fraser	Mr. Thompson.

CONSTITUTION OF THE STONY CREEK DRAINAGE AREA.—SHIRE OF MORTLAKE.

PURSUANT to the provisions of the *Drainage Areas Act 1958*, and in compliance with the prayer of a petition presented by a majority of the owners owning at least half of the land described in the petition, notice of which petition was duly published in the *Government Gazette* of the 26th April, 1961, His Excellency the Administrator of the Government of the State of Victoria, by and with the advice of the Executive Council thereof, by this Order directs that the portion of the Shire of Mortlake described hereunder be constituted a Drainage Area within the meaning of the said Act, under the name of the Stony Creek Drainage Area:—

Commencing at the north-eastern corner of the Parish of Kolora; thence southerly by the eastern boundary of the said parish to the south-eastern corner thereof; thence south-westerly by the northern boundary of the three-chain road bearing south 67 deg. 46½ min. west 3,240 7/10 links; thence north-westerly by a line bearing north 22 deg. 13 min. west 4,002 links; thence westerly by a line bearing south 67 deg. 47 min. west 3,608 links to a road; thence northerly by a road bearing north 0 deg. 6 min. west 2,865 links; thence westerly by a line to the Terang and Mortlake railway; thence north-westerly by the said railway to the north-western corner of Crown allotment 2a section XI, Parish of Kolora; thence southerly by the eastern boundary of Crown allotment 2a and 2b, section X, Parish of Kolora, to the south-eastern corner of Crown allotment 2b aforesaid; thence westerly by the southern boundary of that allotment and of Crown allotment 1, section X, Parish of Kolora, to the south-western corner thereof; thence northerly by the western boundary of Crown allotment 1, section X, to the road at the north-western corner thereof; thence westerly by the said road on the northern boundaries of sections IX and VIII, Parish of Kolora, to the north-western corner of Crown allotment 1, section VIII, aforesaid; thence southerly by the road on the western boundaries of Crown allotments 1, 2, 3 and 8 of said section VIII, to the southern corner of Crown allotment-9, section VII, Parish of Kolora; thence northerly by a road and westerly by the southern boundary of Crown allotment B¹, section VII, Parish of Kolora; thence northerly by a road on the eastern boundaries of Crown allotments 4 and 5, section VI, Parish of Kolora, to the south-eastern corner of Crown allotment 2, section V, Parish of Kolora; thence westerly, northerly and easterly

by the boundaries of said Crown allotment 2 to the south-eastern corner of Crown allotment 3, section V, aforesaid; thence northerly, westerly, northerly and westerly by the eastern and northern boundaries of aforesaid Crown allotment 3 to the north-western corner thereof; thence northerly by the road on the western boundary of the Parish of Kolora to the road at the north-eastern corner of Crown allotment 45, Parish of Ellerslie; thence westerly by the road on the northern boundaries of Crown allotments 45, 44 and 43, Parish of Ellerslie; thence southerly and westerly by the road on the eastern and southern boundaries of Crown allotment 48, Parish of Ellerslie; thence southerly, westerly and northerly by the roads on the eastern, southern and western boundaries of Crown allotment 51, Parish of Ellerslie; thence northerly by the road on the western boundaries of Crown allotments 50 and 49, Parish of Ellerslie, to the C.R.B. main road on the north-western boundary of Crown allotment 49 aforesaid; thence north-easterly by the said C.R.B. main road through portion of the Parishes of Ellerslie and Mortlake to north-western corner of Crown allotment 1, section XXVII, Parish of Mortlake; thence easterly by the road on the north of the said Crown allotment 1 to the south-eastern corner of Crown allotment 25, section 11, Parish of Mortlake; thence northerly by the road on the eastern boundary of Crown allotment 25 aforesaid to the northern corner of the Pound Reserve; thence north-easterly by the road on the north of the Pound Reserve being the Hamilton Highway to the south-eastern corner of Crown allotment 2b, section XIII; thence northerly by the eastern boundaries of Crown allotments 2b, section XIII, Parish of Mortlake, and section XXV and XXIV, Parish of Toorak, to the road at the north-eastern corner thereof; thence easterly by the said road to the north-eastern corner of Crown allotment 57e, Parish of Darlington West; thence southerly and westerly by the eastern and southern boundaries of the said Crown allotment 57e to the north-eastern corner of Crown allotment 57d, Parish of Darlington West; thence southerly, easterly and southerly by the eastern boundary of the said Crown allotment 57d to the Hamilton Highway at the south-eastern corner thereof; thence south-westerly by the Hamilton Highway to the eastern boundary of the Parish of Toorak; thence southerly by the easterly boundary of the Parishes of Toorak and Mortlake to the south-eastern corner of Crown allotment 2, section XXI, Parish of Mortlake; thence by the road on the southern boundary of Crown allotment 2 aforesaid south-easterly to the north-eastern corner of Crown allotment 63a, Parish of Wooriwyrite; thence southerly by the C.R.B. main road on the eastern boundary of Crown allotments 63a, 63b, Parish of Wooriwyrite, to the southern boundary of the Parish of Wooriwyrite; thence westerly by the said boundary to the point of commencement.

And the Honorable Murray Victor Porter, Her Majesty's Minister for Local Government for the State of Victoria, shall give the necessary directions herein accordingly.

A. MAHLSTEDT,
Clerk of the Executive Council.

COUNTRY ROADS BOARD.

At the Executive Council Chamber, Melbourne, the twenty-sixth day of July, 1961.

PRESENT:

His Excellency the Administrator of the Government of Victoria.

Mr. Bolte	Mr. Chandler
Mr. Mibus	Mr. Bloomfield
Mr. Petty	Mr. Turnbull
Mr. Reid	Mr. Porter
Mr. Fraser	Mr. Thompson.

ORDER APPROVING OF WIDENING AN EXISTING MAIN ROAD IN THE SHIRE OF COLAC.

WHEREAS the Country Roads Board constituted under the *Country Roads Act 1958* (No. 6229) has represented to His Excellency the Governor in Council that it appears to it desirable that the existing Colac-Forrest road in the Shire of Colac (declared to be a main road under the said Act which declaration was confirmed by the Order in Council published in the *Government Gazette* of the 5th October, 1932, on page 2256) should be widened by the said Board; And whereas the said Board in accordance with the requirements of section 19 of the said cited Act has caused

to be prepared a map plan and estimate showing the points between which and on and through what land the said widening is proposed to be made and the cost of acquiring the land: And whereas on an inspection of the said map and plan and a consideration of the said estimate His Excellency the Governor in Council is satisfied that there are funds legally available for acquiring the land: Now therefore be it known by this present Order that His Excellency the Administrator of the Government of the State of Victoria with the advice of the Executive Council thereof doth hereby approve of the said road being widened, that is to say:—

All that piece of land in the Parishes of Yeo and Gerangamete, the boundaries of which are as follow:—Commencing at the south-eastern angle of allotment 50B, Parish of Yeo; thence by lines bearing respectively 211 deg. 0 min. 300 links, 13 deg. 14 min. 675.1 links and 180 deg. 0 min. 400 links to the point of commencement—which said piece of land is particularly delineated and shown coloured red on survey plan numbered 8087, lodged in the office of the Country Roads Board.

And the Honorable Sir Thomas Karran Maltby, Her Majesty's Commissioner of Public Works for the State of Victoria, shall give the necessary directions herein accordingly.

A. MAHLSTEDT,
Clerk of the Executive Council.

COUNTRY ROADS BOARD.

At the Executive Council Chamber, Melbourne, the twenty-sixth day of July, 1961.

PRESENT:

His Excellency the Administrator of the Government of Victoria.

Mr. Bolte	Mr. Chandler
Mr. Mibus	Mr. Bloomfield
Mr. Petty	Mr. Turnbull
Mr. Reid	Mr. Porter
Mr. Fraser	Mr. Thompson.

ORDER APPROVING OF WIDENING AN EXISTING MAIN ROAD IN THE SHIRE OF BUNINYONG.

WHEREAS the Country Roads Board constituted under the *Country Roads Act 1958* (No. 6229) has represented to His Excellency the Governor in Council that it appears to it desirable that the existing Old Melbourne-road in the Shire of Buninyong (declared to be a main road under the said Act which declaration was confirmed by the Order in Council published in the *Government Gazette* of the 4th June, 1947, on page 2820) should be widened by the said Board: And whereas the said Board in accordance with the requirements of section 19 of the said cited Act has caused to be prepared a map plan and estimate showing the points between which and on and through what land the said widening is proposed to be made and the cost of acquiring the land: And whereas on an inspection of the said map and plan and a consideration of the said estimate His Excellency the Governor in Council is satisfied that there are funds legally available for acquiring the land: Now therefore be it known by this present Order that His Excellency the Administrator of the Government of the State of Victoria with the advice of the Executive Council thereof doth hereby approve of the said road being widened, that is to say:—

All that piece of land in the Parish of Warrenheip, the boundaries of which are as follow:—Commencing at the south-western angle of allotment 24, section 1, of the said parish; thence by lines bearing respectively 350 deg. 51 min. 752.4 links, 152 deg. 0 min. 477.6 links, 139 deg. 38 min. 499 links, 127 deg. 25 min. 566.9 links and 294 deg. 41 min. 966 links to the point of commencement—which said piece of land is particularly delineated and shown coloured red and blue on survey plan numbered 7885, lodged in the office of the Country Roads Board.

And the Honorable Sir Thomas Karran Maltby, Her Majesty's Commissioner of Public Works for the State of Victoria, shall give the necessary directions herein accordingly.

A. MAHLSTEDT,
Clerk of the Executive Council.

COUNTRY ROADS BOARD.

At the Executive Council Chamber, Melbourne, the twenty-sixth day of July, 1961.

PRESENT:

His Excellency the Administrator of the Government of Victoria.

Mr. Bolte	Mr. Chandler
Mr. Mibus	Mr. Bloomfield
Mr. Petty	Mr. Turnbull
Mr. Reid	Mr. Porter
Mr. Fraser	Mr. Thompson.

ORDER APPROVING OF WIDENING AN EXISTING STATE HIGHWAY IN THE SHIRE OF SEYMOUR.

WHEREAS the Country Roads Board constituted under the *Country Roads Act 1958* (No. 6229) has represented to His Excellency the Governor in Council that it appears to it desirable that the existing Hume Highway in the Shire of Seymour (declared to be a State highway under the said Act which declaration was confirmed by the Order in Council published in the *Government Gazette* of the 8th July, 1925, on pages 2371-3) should be widened by the said Board: And whereas the said Board in accordance with the requirements of section 19 of the said cited Act has caused to be prepared a map plan and estimate showing the points between which and on and through what land the said widening is proposed to be made and the cost of acquiring the land: And whereas on an inspection of the said map and plan and a consideration of the said estimate His Excellency the Governor in Council is satisfied that there are funds legally available for acquiring the land: Now therefore be it known by this present Order that His Excellency the Administrator of the Government of the State of Victoria with the advice of the Executive Council thereof doth hereby approve of the said highway being widened, that is to say:—

All that piece of land in the Parishes of Avenel and Mangalore, the boundaries of which are as follow:—Commencing at the south-western angle of allotment 1B, section E, Parish of Avenel; thence by lines bearing respectively 36 deg. 52 min. 2,503.6 links, 62 deg. 47 min. 227.8 links, 216 deg. 52 min. 3,857.1 links, 308 deg. 28 min. 103 links, 42 deg. 18 min. 36.0 links and 36 deg. 52 min. 1,109.9 links to the point of commencement—which said piece of land is particularly delineated and shown coloured red, yellow and blue on survey plan numbered 8147, lodged in the office of the Country Roads Board.

And the Honorable Sir Thomas Karran Maltby, Her Majesty's Commissioner of Public Works for the State of Victoria, shall give the necessary directions herein accordingly.

A. MAHLSTEDT,
Clerk of the Executive Council.

COUNTRY ROADS BOARD.

At the Executive Council Chamber, Melbourne, the twenty-sixth day of July, 1961.

PRESENT:

His Excellency the Administrator of the Government of Victoria.

Mr. Bolte	Mr. Chandler
Mr. Mibus	Mr. Bloomfield
Mr. Petty	Mr. Turnbull
Mr. Reid	Mr. Porter
Mr. Fraser	Mr. Thompson.

DECLARATION OF THE WIDENING OF BRIGHT-ROAD IN THE SHIRE OF OXLEY.

WHEREAS by section 21 of the *Country Roads Act 1958* (No. 6229) it is amongst other things enacted that when the Country Roads Board under the provisions of the Country Roads Act has taken the land necessary for constructing the road or deviation or widening it shall as soon as it thinks such road or deviation or widening is fit to be used as a public highway by Resolution declare the road or deviation or widening to be a main road or part thereof and that upon publication in the *Government Gazette* of the Order of the Governor in Council confirming such Resolution such road or

deviation or widening shall thereupon be a main road or a part thereof within the meaning of the said Act: And whereas the said Board has by Resolution declared the road on the land described in the Schedule to such Resolution to be part of a main road: Now therefore His Excellency the Administrator of the Government of the State of Victoria by and with the advice of the Executive Council thereof doth hereby confirm the said Resolution.

Resolution for Declaration of the Widening of a Main Road under the Country Roads Act.

Whereas the land the site of the road the course of which is below set out was taken by the Board under the provisions of the Country Roads Act for the purpose of widening the main road aforesaid which widening has now been laid out and formed on the same: And whereas the said Board (being the Country Roads Board incorporated under the said Act) thinks that the widening aforesaid is fit to be used as part of a public highway such Board at a meeting now holden doth by this Resolution hereby declare the same as described in the Schedule hereto with the commencing and terminating points thereof respectively specified to be part of the main road within the meaning and for the purposes of the Country Roads Act.

SCHEDULE.

Shire of Oxley.

4. *Bright-road* (12904).—All that piece of land in the Parish of Whorouly, the boundaries of which are as follow:—Commencing at the southern angle of allotment 51 of the said parish: thence by lines bearing respectively 298 deg. 47 min. 729.2 links, 91 deg. 54 min. 610.2 links, 71 deg. 4 min. 520.9 links and 222 deg. 51 min. 681.8 links to the point of commencement—which said piece of land is particularly delineated and shown coloured red on survey plan numbered 7379, lodged in the office of the Country Roads Board.

The common seal of the Country Roads Board was hereto affixed, at Kew, this seventeenth day of July, One thousand nine hundred and sixty-one, in the presence of—

(SEAL) D. V. DARWIN, Chairman.
W. H. NEVILLE, Member.
R. E. V. DONALDSON, Secretary.

And the Honorable Sir Thomas Karran Maltby, Her Majesty's Commissioner of Public Works for the State of Victoria, shall give the necessary directions herein accordingly.

A. MAHLSTEDT,
Clerk of the Executive Council.

COUNTRY ROADS BOARD.

At the Executive Council Chamber, Melbourne, the twenty-sixth day of July, 1961.

PRESENT:

His Excellency the Administrator of the Government of Victoria.

Mr. Bolte	Mr. Chandler
Mr. Mibus	Mr. Bloomfield
Mr. Petty	Mr. Turnbull
Mr. Reid	Mr. Porter
Mr. Fraser	Mr. Thompson.

DECLARATION OF A DEVIATION FROM THE HUME HIGHWAY IN THE SHIRE OF SEYMOUR.

WHEREAS by sections 74 and 58 of the *Country Roads Act 1958* (No. 6229) it is amongst other things enacted that when the Country Roads Board under the provisions of the Country Roads Act has by Resolution declared a deviation to be a State highway the said Board may also declare that such deviation shall be in lieu of any existing highway or part thereof named in such Resolution and that on publication in the *Government Gazette* of the Order confirming such Resolution the existing highway or part thereof shall cease to be a State highway or be discontinued as provided in the Resolution: And whereas the said Board has by Resolution declared the deviation on the land described in the First Schedule to such Resolution to be a State highway and has also declared that such deviation shall be in lieu of the part of the existing highway being the

land described in the Second Schedule to the said Resolution and that such part of the said existing highway shall be discontinued: Now therefore His Excellency the Administrator of the Government of the State of Victoria by and with the advice of the Executive Council thereof doth hereby confirm the said Resolution.

Resolution for Declaration of a Deviation of a State Highway under the Country Roads Act.

Whereas the land the site of the highway the course of which is below set out was taken by the Board under the provisions of the *Country Roads Act 1958* for the purpose of constructing such highway deviation which highway deviation has now been laid out and formed on the same: And whereas the said Board (being the Country Roads Board incorporated under the said Act) thinks that the highway aforesaid is fit to be used as a public highway such Board at a meeting now holden acting under the authority conferred upon it by sections 74 and 58 of the said Act doth by this present Resolution hereby declare the said highway deviation the course of which is described in the First Schedule hereto with the commencing and terminating points thereof respectively specified to be part of a State highway within the meaning and for the purposes of the *Country Roads Act 1958*: And the said Board doth also declare that such deviation shall be in lieu of the existing highway or part thereof described in the Second Schedule hereto and that such part of the said existing highway shall be discontinued.

FIRST SCHEDULE.

Shire of Seymour.

5. *Hume Highway*.—All that piece of land in the Town and Parish of Avenel, the boundaries of which are as follow:—Commencing at the north-western angle of allotment 1, section 30, of the said town; thence by lines bearing respectively 251 deg. 24 min. 112.7 links, 237 deg. 7 min. 828.2 links, 230 deg. 27 min. 1,055.5 links, 242 deg. 42 min. 826.1 links, 36 deg. 53 min. 256.4 links, 50 deg. 27 min. 2,211 links, 70 deg. 19 min. 566.9 links, 83 deg. 5 min. 461.9 links, 99 deg. 42 min. 566.3 links, 118 deg. 2 min. 520.9 links, 131 deg. 23 min. 1,345.7 links, 120 deg. 18 min. 467.8 links, 163 deg. 9 min. 98 links, 299 deg. 37 min. 660.2 links, 314 deg. 3 min. 1,053 links, 305 deg. 19 min. 227.6 links, 291 deg. 6 min. 221.1 links, 278 deg. 47 min. 241 links, 255 deg. 33 min. 308.9 links and 270 deg. 37½ min. 700.7 links to the point of commencement—which said piece of land is particularly delineated and shown coloured red and yellow on survey plan numbered 6285, lodged in the office of the Country Roads Board.

SECOND SCHEDULE.

Shire of Seymour.

5. *Hume Highway*.—All those pieces of land in the Parish of Avenel, the boundaries of which are as follow:—

- (a) Commencing at a point on the eastern boundary of allotment 1b, section E, of the said parish, distant 189 deg. 4 min. 429.8 links from the north-eastern angle of the said allotment; thence by lines bearing respectively 189 deg. 4 min. 248.1 links, 242 deg. 47 min. 2,035.6 links, 42 deg. 54 min. 588 links and 242 deg. 47 min. 1,629.4 links to the point of commencement.
 - (b) Commencing at a point on the western boundary of allotment 1, section 30, Township of Avenel, in the said parish, distant 188 deg. 59 min. 356.4 links from the north-western angle of the said allotment; thence by lines bearing respectively 62 deg. 42 min. 604.7 links, 98 deg. 50 min. 480 links, 255 deg. 33 min. 373 links, 242 deg. 42 min. 775.3 links and 8 deg. 59 min. 248.1 links to the point of commencement—
- which said pieces of land are particularly delineated and shown coloured blue on survey plan numbered 6285, lodged in the office of the Country Roads Board.

The common seal of the Country Roads Board was hereto affixed, at Kew, this seventeenth day of July, One thousand nine hundred and sixty-one, in the presence of—

(SEAL) D. V. DARWIN, Chairman.
W. H. NEVILLE, Member.
R. E. V. DONALDSON, Secretary.

And the Honorable Sir Thomas Karran Maltby, Her Majesty's Commissioner of Public Works for the State of Victoria, shall give the necessary directions herein accordingly.

A. MAHLSTEDT,
Clerk of the Executive Council.

COUNTRY ROADS BOARD.

At the Executive Council Chamber, Melbourne, the twenty-sixth day of July, 1961.

PRESENT:

His Excellency the Administrator of the Government of Victoria.

- | | |
|------------|----------------|
| Mr. Bolte | Mr. Chandler |
| Mr. Mibus | Mr. Bloomfield |
| Mr. Petty | Mr. Turnbull |
| Mr. Reid | Mr. Porter |
| Mr. Fraser | Mr. Thompson. |

DECLARATION OF THE WIDENING OF THE GLENELG HIGHWAY IN THE SHIRE OF WANNON.

WHEREAS by sections 21 and 74 of the *Country Roads Act 1958* (No. 6229) it is amongst other things enacted that when the Country Roads Board under the provisions of the Country Roads Act has taken the land necessary for constructing the highway or deviation or widening it shall as soon as it thinks such highway or deviation or widening is fit to be used as a public highway by Resolution declare the highway or deviation or widening to be a State highway or part thereof and that upon publication in the *Government Gazette* of the Order of the Governor in Council confirming such Resolution such highway or deviation or widening shall thereupon be a State highway or a part thereof within the meaning of the said Act: And whereas the said Board has by Resolution declared the highway on the land described in the Schedule to such Resolution to be part of a State highway: Now therefore His Excellency the Administrator of the Government of the State of Victoria by and with the advice of the Executive Council thereof doth hereby confirm the said Resolution.

Resolution for Declaration of the Widening of a State Highway under the Country Roads Act.

Whereas the land the site of the highway the course of which is below set out was taken by the Board under the provisions of the Country Roads Act for the purpose of widening the State highway aforesaid which widening has now been laid out and formed on the same: And whereas the said Board (being the Country Roads Board incorporated under the said Act) thinks that the widening aforesaid is fit to be used as part of a public highway such Board at a meeting now holden doth by this Resolution hereby declare the same as described in the Schedule hereto with the commencing and terminating points thereof respectively specified to be part of the State highway within the meaning and for the purposes of the Country Roads Act.

SCHEDULE.

Shire of Wannon.

17. *Glenelg Highway*.—All those pieces of land in the Parish of Muntham, the boundaries of which are as follow:—

- (a) Commencing at the western angle of lot 41 on plan of subdivision numbered 4440, lodged in the Office of Titles, and being part of subdivision A, of allotment 3, section 8, of the said parish; thence by lines bearing respectively 315 deg. 27 min. 42.1 links, 129 deg. 45 min. 614.5 links and 297 deg. 41 min. 200 links to the point of commencement.
- (b) Commencing at a point on the southern boundary of lot 33 on plan of subdivision numbered 4440, lodged in the Office of Titles, and being part of subdivisions A and B of allotment 3, section 9, of the said parish, the said point being distant 114 deg. 10 min. 1,685.4 links from the south-western angle of the said lot; thence by lines bearing respectively 104 deg. 3 min. 493.6 links, 275 deg. 38 min. 272.7 links and 294 deg. 10 min. 227.3 links to the point of commencement.
- (c) Commencing at a point on the southern boundary of lot 23 on plan of subdivision numbered 4440, lodged in the Office of Titles, and being part of subdivision B, of allotment 5, section 9, of the said parish, the said point being distant 119 deg. 19 min. 148.5 links from the south-western angle of the said lot; thence by lines bearing respectively 110 deg. 8 min. 237.2 links, 274 deg. 40 min. 90.9 links and 299 deg. 19 min. 151.5 links to the point of commencement—

which said pieces of land are particularly delineated and shown coloured red on survey plans numbered 6240 and 6358, lodged in the office of the Country Roads Board.

The common seal of the Country Roads Board was hereto affixed, at Kew, this seventeenth day of July, One thousand nine hundred and sixty-one, in the presence of—

- (SEAL) D. V. DARWIN, Chairman.
W. H. NEVILLE, Member.
R. E. V. DONALDSON, Secretary.

And the Honorable Sir Thomas Karran Maltby, Her Majesty's Commissioner of Public Works for the State of Victoria, shall give the necessary directions herein accordingly.

A. MAHLSTEDT,
Clerk of the Executive Council.

APPROACHING LAND SALES.

SALES of Crown lands, in fee-simple, will be held at the under-mentioned places and dates, viz.:—

	No. of Gazette.
Berrwillock.—Monday, 28th August, 1961 ..	57
Geelong.—Thursday, 27th July, 1961 ..	50
Maryborough.—Friday, 25th August, 1961 ..	57
Minyip.—Wednesday, 9th August, 1961 ..	51
Nhill.—Monday, 7th August, 1961 ..	51
Redcliffs.—Thursday, 24th August, 1961 ..	57
Shepparton.—Friday, 1st September, 1961 ..	59
Speed.—Tuesday, 29th August, 1961 ..	57

SALE OF CLOSER SETTLEMENT LAND BY AUCTION.

Redcliffs.—Thursday, 24th August, 1961 .. 57

PROPOSED REVOCATIONS OF TEMPORARY RESERVATIONS OF LANDS BY ORDERS IN COUNCIL.

IN pursuance of the provisions of the *Land Act 1958*, notice is hereby given that it is the intention of the Governor in Council to revoke the temporary reservations of lands by Orders in Council hereunder referred to, viz.:—

The following Notices were published 1^o on the 2nd August, 1961, pursuant to Orders of the 26th July, 1961.

BOIGBEAT.—The temporary reservation, by Order in Council of the 5th December, 1911, of 2 acres of land in the Township of Boigbeat, as a site for a State School, and the temporary reservation by Order of the 20th September, 1920, of 1 acre of land, as an extension thereto.—(B.747⁽³⁾) (Rs.2208).

MERRINEE.—The temporary reservation, by Order in Council of the 2nd February, 1934, of 3 acres 2 roods of land in the Parish of Merrinee, as a site for State School purposes.—M.590⁽¹⁾ (Rs.4367).

TRUGANINA.—The temporary reservation, by Order in Council of the 24th November, 1959, of 190 acres, more or less, of land in the Parish of Truganina, as a site for Public Recreation.—(T.109⁽⁶⁾) (Rs.245).

MOORABBIN (CHELTENHAM).—The temporary reservation, by Order in Council of the 23rd January, 1912, of 7 acres 3 roods 25 perches of land in the Parish of Moorabbin, as a site for a Public Park, so far only as the portion containing 20 perches, indicated by hachure on plan hereunder, is concerned.—(M.164⁽³⁾) (Rs.2943).

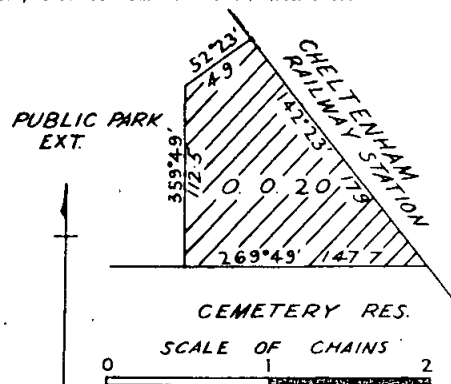

SEA LAKE.—The temporary reservation, by Order in Council of the 25th October, 1960, of 1 acre 1 rood 10 perches, more or less, of land in the Township of Sea Lake, as a site for a Swimming Pool, so far only as the portion containing 32 perches, indicated by hachure on plan hereunder, is concerned.—(S.452⁽²⁾) (Rs.7951).

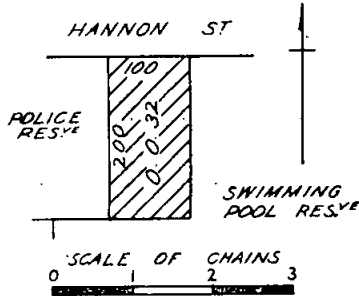

WODONGA.—The temporary reservation, by Order in Council of the 16th May, 1939, of 5 acres 1 rood 30 perches of land in the Township of Wodonga, as a site for Public Recreation and Plantation purposes, so far only as the portion containing 3 acres, more or less, indicated by hachure on plan hereunder, is concerned.—(W.308 (S²)) (Rs.4924).

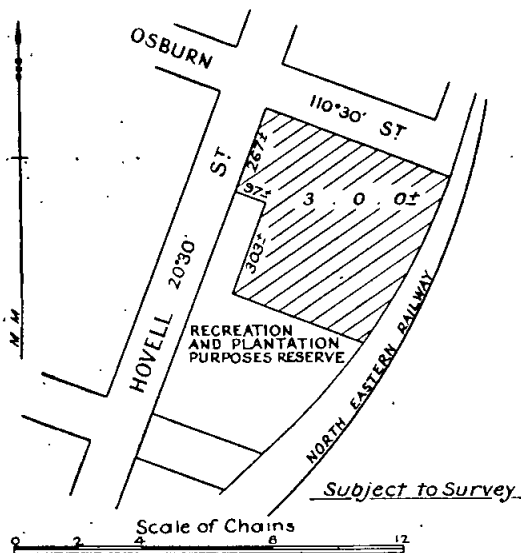

KEITH TURNBULL,
Commissioner of Crown Lands and Survey.

WAYGARA.—The temporary reservation, by Order in Council of the 28th January, 1910, of 3 acres 1 rood 15 perches of land in the Parish of Waygara, as a site for the Supply of Gravel.—(W.395^(a)) (H.028011).

BONNIE DOON.—The temporary reservation, by Order in Council of the 30th May, 1892, of 1 acre of land in the Township of Bonnie Doon, as a site for Water Supply purposes revoked as to part by Order of the 18th February, 1958, so far as the balance thereof containing 3 roods 35 perches is concerned.—(D.164⁽²⁾) (Rs.4243).

KEITH TURNBULL,
Commissioner of Crown Lands and Survey.

PROPOSED REVOCATIONS OF TEMPORARY RESERVATIONS OF LANDS BY ORDERS IN COUNCIL.

IN pursuance of the provisions of the *Land Act 1958*, notice is hereby given that it is the intention of the Governor in Council to revoke the temporary reservations of lands by Orders in Council hereunder referred to, viz.:—

The following Notices were published 1^o on the 26th July, 1961, pursuant to Orders of the 19th July, 1961.

SANDHURST (BENDIGO).—The temporary reservation, by Order in Council of the 22nd March, 1949, of 4 acres 1 rood of land at Bendigo, in the Parish of Sandhurst, as a site for Cricket Ground and Public Recreation, and the temporary reservation by Order of the 29th August, 1950, of 1 rood 15 perches, more or less, of land as an extension thereto, so far only as the respective portions containing 30 perches, more or less, and 8 perches, more or less, indicated by hachure on the plan hereunder, are concerned.—(S.372^(a)) (Rs.5074).

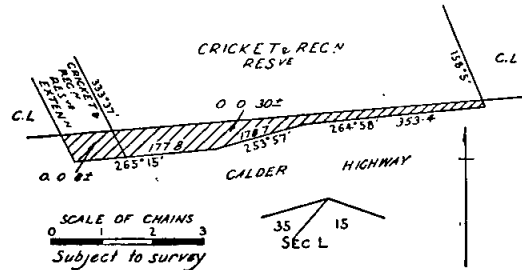

CONEWARRE.—The temporary reservation, by Order in Council of the 4th August, 1873, of 36 acres 3 roods 17 perches of land in the Parish of Conewarre as a site for Park and Recreation purposes, revoked as to part by Order of the 25th February, 1904, and the temporary reservation by Order of the 26th August, 1947, of the balance of 16 acres 3 roods 17 perches for the additional purpose of a Public Hall, so far only as the portion containing 1 rood, more or less, indicated by hachure on plan hereunder, is concerned.—(C.261^(a)) (Rs.1367).

PROPOSED REVOCATIONS OF TEMPORARY RESERVATIONS OF LANDS BY ORDERS IN COUNCIL.

IN pursuance of the provisions of the *Land Act 1958*, notice is hereby given that it is the intention of the Governor in Council to revoke the temporary reservations of lands by Orders in Council hereunder referred to, viz.:—

The following Notices were published 1^o on the 12th July, 1961, pursuant to Orders of the 4th July, 1961.

CUDGEWA.—The temporary reservation, by Order in Council of the 1st April, 1941, of 2 acres 1 rood 8 perches of land in the Parish of Cudgewa, as a site for State School purposes.—(C.358⁽¹⁾) (Rs.5189).

WAPPAN.—The temporary reservation, by Order in Council of the 19th September, 1887, (see *Government Gazette 1887*, page 2760) of 6 acres 0 roods 21 perches of land in the Parish of Wappan, as a site for Water Supply purposes.—(W.328⁽⁴⁾) (C.98470).

RESERVE ROAD

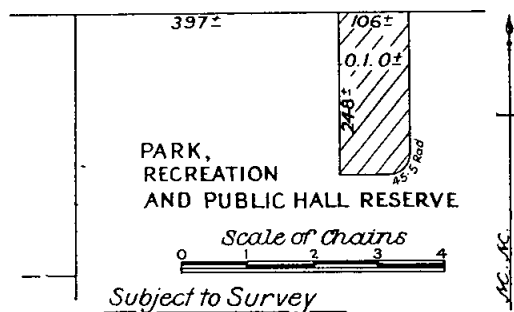

KEITH TURNBULL,
Commissioner of Crown Lands and Survey.

Land Act 1958.

LICENCES UNDER THE LAND ACTS 1928 AND 1958 DECLARED VOID.

NOTICE is hereby given that the Licences in the Schedule hereunder have been Declared Void for the reason specified in each case.

District.	Corr. No.	Name of Licensee.	Section of Land Act under which Licensed.	Parish.	Allotment.	Section.	Area.		Annual Rental.	Reasons for Voiding.
							A. R. P.	£ s. d.		
Castlemaine	0364/129	Wudy, Franz ..	129	Faraday ..	13A	A2	2 1 26	1 0 0	Surrendered.	
Castlemaine	0306/129	Prosser, Mary Ellen	129	Glenalbyn ..	32	B	1 0 0	1 0 0	Surrendered.	

Department of Crown Lands and Survey,
Melbourne, 1st August, 1961.

KEITH TURNBULL,
Commissioner of Crown Lands and Survey.

LOCAL LAND BOARDS.

IN pursuance of the provisions of section 34 of the *Land Act 1958*, notice is hereby given that public hearings at the following places and times will be conducted by the person respectively mentioned, being duly appointed in that behalf.

KEITH TURNBULL,
Commissioner of Crown Lands and Survey.

Department of Crown Lands and Survey,
Melbourne, 1st August, 1961.

SCHEDULE.

PORTLAND LAND INSPECTOR'S OFFICE, Tuesday,
15th August, 1961, at 9 a.m.—H. E. Michell.
PORT FAIRY COURT HOUSE, Thursday, 24th, and
Friday, 25th August, 1961, at 9 a.m. each day.—
H. E. Michell.
CASTERTON LAND INSPECTOR'S OFFICE, Thursday,
17th August, 1961, at 9 a.m.—H. E. Michell.

REGULATIONS FOR THE CARE, PROTECTION, AND MANAGEMENT OF THE "YANAKIE LANDING FORESHORE RESERVE".

WHEREAS by section 218 of the *Land Act 1958*, power is given to the Board of Land and Works to make Regulations in respect of the care, protection, and management of any Crown land which has been reserved under the *Land Acts* for any public purpose whatsoever and which has not been conveyed to or vested in trustees, and for the further purposes as enacted: Now therefore the Board of Land and Works, in pursuance of the power conferred aforesaid, doth hereby make the following Regulations in respect of the reserved Crown land in the Parish of Yanakie as is indicated by hachure on plan marked Y/13.12.1960 attached to Lands Department correspondence Rs.7942, and known as the "Yanakie Landing Foreshore Reserve", hereinafter referred to as the "Reserve".

The Reserve has been placed under the control of a Committee of Management (hereinafter referred to as the "Committee"), with full power and authority to enforce these Regulations.

REGULATIONS.

1. No person shall enter or remain on the Reserve who may offend against decency as regards dress, language or conduct.
2. No person shall bathe from the Reserve, unless decently attired in a suitable bathing costume.
3. No person shall enter or leave the Reserve, except by means of the ramps or other openings provided, and no person shall climb the cliffs in the Reserve.
4. No person shall damage or interfere in any way with the trees, shrubs, marram grass or flowers in the Reserve.
5. No person shall in any way injure any of the buildings, fences, or seats in the Reserve, nor leave or deposit any glass, paper or rubbish in the Reserve.
6. No person shall remove from the Reserve any gravel, stone, shell-grit, sand or loam.
7. No person shall cut, saw, dig, move or displace any tree, bough, live or dead timber, wood or other material which may be in or around the Reserve without the consent, in writing, of the Committee.
8. No person shall commit a nuisance in any public or private bathing-box, boat-shed, or other building or erection on the Reserve.

9. No person shall carry or discharge firearms or air-guns in the Reserve.

10. No person shall shoot, trap or destroy any birds or native game within the Reserve.

11. No person shall bring into the Reserve any cattle, horses, sheep or other animals without the permission, in writing, of the Committee first obtained.

12. (a) No person, without the consent, in writing, of the Committee shall cause or suffer, or knowingly permit any dog belonging to him or in his charge, to enter or remain in the Reserve, unless such dog be and continue to be under proper control on a chain, cord or leash, and be effectively restrained from causing annoyance to any person or from damaging or interfering in any way with the property of the said Committee, or bring into the Reserve any dog for training or exercising for coursing, or other purposes of sport.

(b) Any dog found in the Reserve, except as provided in these Regulations, shall be liable to be seized and/or destroyed by the Committee, and the owner or any person having the custody of any dog so found shall be guilty of an offence against these Regulations, and may be required to make compensation for any damage done to the property of the said Committee by such dog.

13. (a) No person shall drive on to the Reserve or park thereon any motor car or other vehicle, except at such places as are set apart for this purpose by the Committee.

(b) No person shall drive or ride a motor cycle, motor car, bicycle, or other vehicle on the sands of the beach without the permission, in writing, of the Committee first obtained.

14. No person shall park or leave any motor car or other vehicle on any part of the Reserve, except in an area set apart for the purpose by the Committee.

15. No persons, except labourers and workmen employed in the reserve and authorized officers of the Committee, shall enter any plots therein which may be enclosed for plantations of young trees or shrubs.

16. The Committee may set apart portion of the Reserve as and for the purposes of a children's playground.

17. No person shall drive or park a motor vehicle of any kind within 25 yards of the children's playground.

18. No person above the age of fourteen years shall use, play with or damage any of the swings, fixtures or other equipment erected or provided in the children's playground.

19. No person shall leave or deposit any fish or fish offal on the Reserve.

20. No person shall, in the Reserve—

(a) light or use fires save in fireplaces which may be provided by the Committee, except by special permission or direction of the Committee;

(b) break glass of any kind; and

(c) deposit or leave any bottle, glass, tin can, orange peel, waste paper, garbage or litter of any kind, except in a receptacle provided for that purpose by the Committee.

21. No person shall on any portion of the Reserve cause or permit any outcry, sound or noise to be emitted from an amplifier, loud speaker, public address system or like instrument without first obtaining the written permission of the Committee, and such permission may be granted subject to such terms, conditions and restrictions as may be imposed by the Committee.

22. No person shall play or perform in any band or deliver or read any public speech, prayer or address of any kind, sing any song or enter into any public discussion on the Reserve without the permission of the Committee first obtained.

23. No person shall bet publicly on any part of the Reserve, and every person infringing this Regulation shall be liable to expulsion from the enclosures and the Reserve.

24. No person shall erect in the Reserve any building, booth or other structure for the purpose of offering for sale or hire any article without the permission, in writing, of the Committee first obtained.

25. No person shall take part in any public entertainment of any sort in the Reserve without the permission, in writing, of the Committee first obtained.

26. No person shall play, practise, or engage in any organized game or sport within the Reserve, unless by consent of the Committee.

27. No person shall erect any bathing-box, boat-house, shed, or any other building, structure or erection or booth on any site in the Reserve without the permission, in writing, of the Committee first obtained, and such permission may be granted subject to such terms, fees and conditions as may be deemed reasonable and advisable by the Committee consistent with these Regulations, but no person shall use or cause to be used or knowingly permit to be used any such bathing-box, boat-house, shed or any other building, structure or erection or booth for residential purposes.

28. The Committee may, subject to the payment of a fee prescribed by it, allow the transfer of any permit, but no person shall sublet any site or structure without the permission, in writing, of the Committee first obtained.

29. The granting, withdrawal, renewal, or allowance of the transfer of any permit or the subletting of any site or structure shall at all times be at the absolute discretion of the Committee.

30. If the owner of any bathing-box, boat-house, shed or any other building, structure, erection or booth erected on any site on the Reserve neglects for a period exceeding twelve months to pay to the Committee the fee payable in respect thereof, then and in any such case it shall be lawful for the Committee in such manner as it thinks fit to sell such bathing-box, boat-house, shed or other building, structure, erection or booth, and to recover from the proceeds of such sale the arrears of rent and the costs and expenses of such sale.

31. The Committee shall have full power to order the removal from the Reserve of any bathing-box, boat-house, shed or any other building, structure, erection or booth which has been placed, erected or established without its consent, or which has not been properly erected or properly painted, or which in its opinion has not been satisfactorily maintained or kept in repair, or in respect of which the term of permission for the use of the site has expired or the permission to use the site for a building or buildings has expired or been withdrawn.

32. No person shall neglect or refuse to remove any bathing-box, boat-house, shed or other building, structure, erection or booth, erected or placed by him on any site in or on the Reserve within fourteen (14) days after the Committee has sent by registered post to his last-known address, a notice requiring such person to remove such bathing-box, boat-house, shed or any other building, structure, erection or booth. Such notice may be signed by either the chairman or secretary for the time being of the said Committee.

33. In the event of any such neglect or refusal as above mentioned continuing after the expiration of the said fourteen (14) days, the Committee may pull down and/or remove and/or sell such bathing-box, boat-house, shed or any other building, structure, erection or booth, and recover the costs and expenses thereof from the person so neglecting or refusing to remove the same, but without prejudice to proceedings by way of information for breach of these Regulations being taken against such person so neglecting or refusing.

34. Persons renting or hiring any stand, building, erection or enclosure on the occasions of any fêtes, sports or holiday amusements may be required to deposit any sum which the Committee may at any time determine not exceeding Ten pounds, by way of guarantee that due care shall be taken of such stand, building, erection or enclosure, and such Committee, in its absolute discretion, may make good any damage or injury sustained by such stand, building, erection or enclosure or anything contained therein during such occupancy or hiring and deduct the cost of making good such loss or damage from the sum of money deposited by way of guarantee and all persons so renting or hiring shall abide by these Regulations, and by any order given by the Committee.

35. No person shall offer for sale or hire any article within the Reserve or within any structure thereon without the permission of the Committee first obtained.

36. No person shall drive or ride any animal or motor vehicle within the Reserve in a manner likely to cause injury to any person.

37. All persons using any conveniences provided on the Reserve by the Committee shall, on demand, pay to such Committee a fee which shall from time to time be indicated.

38. No person shall use the water closets or urinals in the Reserve or any portion of such water closets or urinals for any purpose other than that for which the same are constructed.

39. The Committee may set apart a portion or portions of the Reserve as and for the purpose of a camping area, and may fix and collect fees or other charges for entering and use of any such area.

40. No person shall camp or erect any tent or other structure on any site on any portion of the Reserve, except on such portion or portions thereof as may be specially set apart for the purpose by the Committee, and then only with the consent, in writing, of such Committee and on payment of such fees and subject to such conditions as such Committee may determine.

41. Any person entering any structure, tent or shelter or parking a caravan in any camping area shall abide by such directions as may be given by the Committee or its duly appointed officer.

42. No person, other than a person desirous of holidaying on any area set apart for camping in the Reserve, shall bring a caravan therein or erect a tent thereon and then only for a period of not more than four weeks at any one time, nor shall any person sublet such caravans, such tent, or camping site.

43. The person to whom permission is issued by the Committee or its authorized officer to use a site in a camping area shall be deemed to be the person who erected on such site any structure, tent or shelter or who parked a caravan pursuant to such permission, and such person shall keep the site thus occupied in such camping area in a clean, sanitary and tidy condition, and before vacating such site shall collect and place in the receptacle provided for the purpose all refuse, litter or garbage from the site.

44. Any permission issued by the Committee or its authorized officer to a person for use of a camping area may be cancelled or withdrawn by such Committee or its authorized officer, and subsequent to such cancellation or withdrawal a proportionate refund of any fees or charges paid in advance shall be refunded, and such Committee or its authorized officer at its or his discretion may deduct and retain from any such proportionate refund a sum as it or he determines will be necessary to clear up and put in order the site vacated.

45. Every person holding or purporting to hold any receipt or permission, in writing, issued by the Committee shall on demand by any member of the Committee or the properly appointed servant of such Committee or any member of the Police Force, or any bailiff of Crown lands, produce such receipt or permission in writing.—(Rs.7942.)

The common seal of the Board of Land and Works was hereto affixed this 26th day of July, 1961, in the presence of—

(SEAL) KEITH TURNBULL, President.
F. KLENNER, Member.

Every person who contravenes or fails to comply with these Regulations shall, in accordance with the provisions of section 218 of the *Land Act* 1958, for each offence be liable to a penalty or not more than Five pounds, and every person who contravenes or fails to comply with any such Regulations, and who, after he has been warned by any bailiff of Crown lands or by any member of the Police Force, does not desist therefrom, may be forthwith apprehended by such bailiff or member of the Police Force and taken before some justice to be dealt with according to law and shall be liable to a penalty of not more than Ten pounds.

REGULATIONS FOR THE CARE, PROTECTION AND MANAGEMENT OF THE "ALTONA FORESHORE RESERVE."

WHEREAS by section 218 of the *Land Act* 1958, power is given to the Board of Land and Works to make Regulations in respect of the care, protection and management of any Crown land which has been reserved under the *Land Acts* for any public purpose whatsoever and

which has not been conveyed to or vested in trustees, and for the further purposes as enacted: Now therefore the Board of Land and Works, in pursuance of the power conferred aforesaid, doth hereby make the following Regulations in respect of such portion of the Foreshore Reserve in the Parish of Truganina as is indicated by red colour on plan marked T over 9.12.57 attached to Lands Department correspondence S.70845 and known as the "Altona Foreshore Reserve" (hereinafter referred to as the "Reserve").

The Reserve has been placed under the control of the Council of the Shire of Altona as a Committee of Management, (hereinafter referred to as the "Committee"), with full power and authority to enforce these Regulations.

The Regulations made by the Board of Land and Works on 13th June, 1930, in respect of the Reserve are hereby revoked.

REGULATIONS.

1. The Committee may set apart any portion of the Reserve for the purpose of any lawful games or sports and from time to time grant to any club or association of clubs the use of the grounds so set apart upon such terms and conditions as it may deem to be reasonable and consistent with the Regulations.

2. (a) No person shall enter or remain in the Reserve who may offend against decency as regards dress, language or conduct.

(b) No person shall in the Reserve wilfully obstruct, disturb, or annoy any other person in the proper use of the Reserve, or any part thereof, or wilfully obstruct or interrupt any servant of the Committee of Management in the proper execution of his duty or work.

3. No person shall damage in any way the trees, shrubs, lawns, or flowers in the Reserve, nor shall fires be lighted therein, excepting in the places provided for the purpose by the Committee.

4. No person shall climb, or jump over the gates or fences in or around the Reserve, stick bills thereon, or cut names on or in any way damage or injure any of the buildings, gates, fences, seats or trees in the Reserve, nor leave or deposit any glass, paper or rubbish nor roll or throw stones or any missiles of any kind therein.

5. No person shall put in the Reserve any cattle, horses, sheep, goats or other animals without the permission, in writing, of the Committee first obtained, excepting that horses may be bathed or exercised in the area designated for the purpose north of the Nellie-street outfall drain.

6. The Committee may debar any person from bringing into the Reserve any dog unless such dog is controlled by a leash.

7. No person shall camp in the Reserve.

8. No person shall erect in the Reserve any structure for the purpose of offering for sale any article without the permission, in writing, of the Committee first obtained.

9. No person shall take part in any public meeting, nor shall any band perform in the Reserve without the permission, in writing, of the Committee first obtained.

10. No person shall bet publicly in any part of the Reserve, and every person infringing this Regulation shall be liable to expulsion from the enclosures and Reserve.

11. No person shall hawk or offer for sale in the Reserve any goods, chattels, articles or provisions of any description without the permission, in writing, of the Committee first obtained.

12. No person, not being a player or official, shall trespass on any area set aside for use by lifesavers, or other authorized club or organization for practice, demonstration or competition, during the progress of any match, practice, demonstration or competition.

13. No person shall play cricket, hockey, rounders, golf (or any other similar game), with a hard or solid ball, nor play football on the Reserve other than in the areas set apart for such games or sports.

14. No person shall in the Reserve wilfully obstruct, disturb or annoy any other person in the proper use of the Reserve, or any part thereof, or wilfully obstruct or interrupt any servant of the Committee in the proper execution of his duty or work.

15. No person, except labourers or workmen employed in the Reserve, shall enter any plots therein which may be enclosed for plantations of young trees or shrubs.

16. No person shall remove any sea-weed or other material from the Reserve without the permission, in writing, of the Committee of Management first obtained, and subject to the payment of such charges as shall from time to time be deemed reasonable by the Committee of Management.

17. No person shall remove or displace or damage or deface any board, plate, fitting or written notice for the exhibition of any Regulations, or any notice fixed or set up by the Committee of the Reserve.

18. All persons using the conveniences, dressing-sheds, or other facilities provided by the Committee of Management on the Foreshore shall pay such charges for the use of same, as shall from time to time be deemed by the Committee of Management reasonable and consistent with these Regulations.

19. No person shall park motor cars or other vehicles within the Reserve excepting at such places as are set apart by the Committee of Management for that purpose, and the Committee of Management may charge and take a fee not exceeding two shillings per motor car or other vehicle per day for use of such area.—(C.70845.)

The common seal of the Board of Land and Works was hereto affixed this 26th day of July, 1961, in the presence of—

(SEAL) KEITH TURNBULL, President.
F. KLENNER, Member.

Every person who contravenes or fails to comply with these Regulations shall, in accordance with the provisions of section 218 of the *Land Act* 1958, for each offence be liable to a penalty of not more than Five pounds, and every person who contravenes or fails to comply with any such Regulations, and who, after he has been warned by any bailiff of Crown lands or by any member of the Police Force, does not desist therefrom, may be forthwith apprehended by such bailiff or member of the Police Force and taken before some justice to be dealt with according to law and shall be liable to a penalty of not more than Ten pounds.

REGULATIONS FOR THE CARE, PROTECTION AND MANAGEMENT OF THE "LAKE ALBACUTYA FRONTAGE RESERVES".

WHEREAS by section 218 of the *Land Act* 1958 power is given to the Board of Land and Works to make Regulations in respect of the care, protection and management of any Crown land which has been reserved under the Land Acts for any public purpose whatsoever and which has not been conveyed to or vested in trustees, and for the further purposes as enacted: Now therefore the Board of Land and Works, in pursuance of the power conferred aforesaid, doth hereby make the following Regulations in respect of the land in the Parishes of Albacutya and Kurnbrunnin temporarily reserved by Orders in Council of 26th April, 1961, as sites for Public purposes and those portions of the land permanently reserved for public purposes adjoining thereto, together known as the "Lake Albacutya Frontage Reserves", hereinafter referred to as the "Reserve".

The Reserve has been placed under the control of a Committee of Management (hereinafter referred to as the "Committee"), with full power and authority to enforce these Regulations.

REGULATIONS.

1. The Reserve shall be open to the public at all times, free of charge, except on such days not exceeding twenty-six (26) in any one year as any portion of the Reserve, inclusive of the beach, may be set aside for purposes consistent with the reservation and with the consent of the Committee.

2. No person shall enter or remain in the Reserve who may offend against decency as regards dress, language, or conduct.

3. No person shall damage or interfere in any way with the trees, shrubs, marram grass or flowers in the Reserve, nor shall fires be lighted therein except with the written consent of the Committee.

4. No person shall in any way injure any of the buildings, fences or seats in the Reserve, nor leave or deposit any glass, paper, or rubbish in the Reserve.

5. No person shall remove from the Reserve any gravel, stone, shellgrit, sand or loam.

6. No person shall cut, saw, dig, move or displace any tree, bough, live or dead timber, wood or other material which may be in or around the Reserve without the consent, in writing, of the Committee.

7. No person shall put or graze in the Reserve any cattle, goats, pigs, horses, sheep or any other animals without the permission, in writing, of the Committee being first obtained, except grazing rights being held from the Crown.

8. (i) No person without the consent, in writing, of the Committee shall cause or suffer or knowingly permit any dog belonging to him, or in his charge, to enter or remain in the Reserve unless such dog be and continues to be under proper control on a chain, cord or leash, and be effectively restrained from causing annoyance to any person, or from damaging or interfering in any way with the property of the said Committee, or bring into the Reserve any dog for training or exercising for coursing or other purposes of sport.

(ii) Any dog found in the Reserve, except as provided in these Regulations, shall be liable to be seized and/or destroyed by the Committee and the owner or any person having the custody of any dog so found shall be guilty of an offence against these Regulations and may be required to make compensation for any damage done to the property of the said Committee by such dog.

9. No person shall camp or erect any tent or other structure on any site on any portion of the Reserve, except on such portion as may be specially set apart for the purpose in the Reserve, and then only with the consent, in writing, of the Committee and on payment of such fees and subject to such conditions as the Committee may determine.

10. No person shall erect any bathing-box, boathouse, shed, or any other building, structure, or erection or booth on any site on the Reserve without the permission, in writing, of the Committee first obtained, and such permission may be granted subject to such terms, fees, and conditions as may be deemed reasonable and advisable by the Committee consistent with these Regulations, but no person shall use or cause to be used or knowingly permit to be used any such bathing-box, boathouse, shed, or any other building, structure, or erection or booth for residential purposes.

11. The Committee shall have full power to order the removal from the Reserve of any bathing-box, boathouse, shed or any other building, structure, or erection or booth which has been placed, erected, or established without its consent or which has not been properly erected or properly painted or which in its opinion has not been satisfactorily maintained or kept in repair or in respect of which the term of the permission for the use of the site has expired or the permission to use the site for a building or buildings has expired or been withdrawn.

12. No person shall neglect or refuse to remove any bathing-box, boathouse, shed or other building, structure or erection or booth erected or placed by him on any site in or on the Reserve within fourteen (14) days after the Committee has sent by registered post to his last known address a notice requiring such person to remove such bathing-box, boathouse, shed or any other building, structure, or erection or booth. Such notice may be signed by either the chairman or secretary for the time being of the said Committee.

13. In the event of any such neglect or refusal as above mentioned continuing after the expiration of the said fourteen (14) days, the Committee may remove such bathing-box, boathouse, shed, or any other building, structure, or erection or booth and recover the cost and/or expense of such removal from the person so neglecting or refusing to remove the same, but without prejudice to proceedings by way of information for breach of these Regulations being taken against such person so neglecting or refusing.

14. No person shall deposit or cause to be deposited waste paper, bottles, or any other litter on any part of the Reserve, except in the receptacles provided for the purpose.

15. Persons renting or hiring any stand, building, erection, or enclosure, on the occasions of any fêtes, sports or holiday amusements, may be required to deposit any sum which the Committee may at any time determine, not exceeding £10, by way of guarantee that due care shall be taken of such stand, building, erection or enclosure, and such Committee, in its absolute discretion, may make good any damage or injury sustained by such stand, building, erection or enclosure or anything contained therein, during such occupancy or hiring, and deduct the cost of making good such loss or damage from the sum deposited by way of guarantee, and all persons so renting or hiring shall abide by these Regulations and by any order given by the Committee.

16. No person shall play, practice, or engage in any organized game or sport within the Reserve, unless by consent of the Committee.

17. Every person holding or purporting to hold any receipt or permission, in writing, issued by the Committee shall, on demand by any member of the Committee

or the properly appointed servant of such Committee or any member of the Police Force, or any bailiff of Crown lands, produce such receipt or permission in writing.

18. The Committee may set apart any portion or portions of the Reserve as a place for the parking of vehicles.

19. No person shall park a vehicle within the Reserve, except in places set apart by the Committee for the parking of vehicles.

20. The Committee may fix such fee as it thinks fit as the fee for the parking of vehicles in any place set apart within the Reserve for the parking of vehicles.

21. Every person who parks a vehicle in the place set apart for the parking of vehicles shall pay to the Committee or its authorized representatives on demand such fee as has been fixed by the Committee pursuant to these Regulations as the fee for parking in such place.

22. Every person bringing a vehicle into the Reserve shall obey the reasonable direction of the Committee or its authorized representatives in relation to the driving or parking of such vehicles within the Reserve.—(Rs.8033.)

The common seal of the Board of Land and Works was hereto affixed this 26th day of July, 1961, in the presence of—

(SEAL)

KEITH TURNBULL, President.
F. KLENNER, Member.

Every person who contravenes or fails to comply with these Regulations shall, in accordance with the provisions of section 218 of the *Land Act 1958*, for each offence be liable to a penalty of not more than Five pounds, and every person who contravenes or fails to comply with any such Regulations, and who, after he has been warned by any bailiff of Crown lands or by any member of the Police Force, does not desist therefrom, may be forthwith apprehended by such bailiff or member of the Police Force and taken before some justice to be dealt with according to law and shall be liable to a penalty of not more than Ten pounds.

COMMITTEES OF MANAGEMENT OF RESERVES. APPOINTMENTS.

WHEREAS by section 221 of the *Land Act 1958* it is provided that it shall be lawful for the Governor in Council or the Board of Land and Works to appoint and remove any number of persons, not less than three, or any municipal council, or the governing body of any corporation to be a Committee of Management of any specified Crown land reserved either temporarily or permanently for any of the purposes set out in section 14 of the *Land Act 1958*, and not conveyed to or vested in trustees: Now therefore the Board of Land and Works doth hereby appoint the under-mentioned persons to be members of the Committee of Management of the Reserves named:—

"KIAMAL PUBLIC HALL RESERVE."

Herbert Edward Dean, Walter Charles Dixon, Valentine John Pearson, Archibald Murdock Munro, Norman Stanly Vallance, Alex Maxwell Jardine and Francis Alan Hickmott as the Committee of Management for a period of three (3) years of the land temporarily reserved by Order in Council dated the 10th February, 1920, as a site for Public Hall in the Township of Kiamal, and known as the "Kiamal Public Hall Reserve".—(Corres. Rs.2093.)

"PATHO RECREATION RESERVE."

James Geoffrey Russell, Albert Leslie Forster, Michael James Maher, Thomas Henry Forster, Douglas McDonald Russell, Ernest Murray Rae and Delroy Peter Phyland as a Committee of Management for a period of three (3) years of the land in the Parish of Patho temporarily reserved by Order in Council of the 5th February, 1924, as a site for Public Recreation, and known as the "Patho Recreation Reserve".—(Corres. Rs.3140.)

"BERRIWILLOCK PUBLIC HALL RESERVE."

Brian O'Bryan Hernon, John Nicholas Corbett, William Wilson, Roy Cornelius McNally, Walter John Renney, William Leonard Rogers, Maxwell Thomas Gleeson, Stanley William Twigg and John Crothers McClelland as a Committee of Management for a period of three (3) years of the land in the Township of Berriwillock temporarily reserved by Order in Council of 4th September, 1956, as a site for a Mechanics' Institute, in addition to and adjoining the site temporarily reserved therefor by Order in Council of 21st January, 1897, both areas together being known as "Berriwillock Public Hall Reserve".—(Corres. Rs.1487.)

"BAYLES PUBLIC GARDENS AND PARK RESERVE."

William Edward H. Huntingford, Frank Williams, Daniel William Feild, James Ledingham McDonald, Keith Gerald Quigley, Raymond Percy Fechner, Keith C. Bethune, Ian Stanton Tyrrell, Henry Evans and Robert William Hayward as a Committee of Management for a period of three (3) years from 31st July, 1961, of the remaining portion of the land temporarily reserved by Order in Council dated 20th June, 1932, as a site for Public Gardens and Plantation in the Parish of Yallock at Bayles, and known as the "Bayles Public Gardens and Park Reserve".—(Corres. Rs.4214.)

"WINNAP PUBLIC HALL AND RECREATION RESERVE."

Ronald Keith McClure, George Edward Malseed, Harold Crawford Kerr, Colin Murray McLean, Arthur Stanley Holmes, Ian Joseph Emerson, Raymond George Malseed, Warren James Kerr, Charlton Read Malseed, Basil George Emerson Liddle, Mervyn John Kerr, Trevor Spencer, Samuel David Malseed, Reginald Frederick Holmes and John Lyall McEachern as a Committee of Management for a period of three (3) years of the land in the Parish of Drik Drik temporarily reserved as a site for Public Recreation and Public Hall by Order in Council dated 5th February, 1952, and known as the "Winnap Public Hall and Recreation Reserve".—(Corres. Rs.6784.)

"BAYLES PUBLIC HALL RESERVE."

William Edward H. Huntingford, Daniel William Feild, Henry Evans, Keith Gerald Quigley, Raymond Percy Fechner, Keith C. Bethune, Robert William Hayward, Samuel R. McKay, James Ledingham McDonald and Harold Edgar Ridgway as a Committee of Management for a period of three (3) years from 31st July, 1961, of the land temporarily reserved by Order in Council dated 20th June, 1932, as a site for a Public Hall in the Parish of Yallock, and known as the "Bayles Public Hall Reserve".—(Corres. Rs.4213.)

"COLAC RACECOURSE AND RECREATION RESERVE."

George Slater and Thomas Vincent Walsh, in the place of Francis Henry Scullion and Thomas Stephen (both resigned), as members of the Committee of Management for the period ending 5th April, 1963, of the land in the Parish of Elliminyt temporarily reserved by Order in Council dated 16th January, 1934, as a site for Racing and other purposes of Public Recreation, and known as the "Colac Racecourse and Recreation Reserve".—(Corres. Rs.467.)

"MINYIP RECREATION RESERVE."

Roderick John McKenzie Boyd, George Samuel Padgett, George Roy Penny, Alex Harold Penny, John Padgett, Hugh Alan Midgley and Edgar Arthur Westrop Waller as a Committee of Management for a period of three (3) years, of the land temporarily reserved by Order in Council dated the 5th November, 1924, as a site for Public Recreation in the Township of Minyip, and known as the "Minyip Recreation Reserve".—(Corres. Rs.3027.)

"KOONWARRA MEMORIAL PARK."

Gordon Alwyn Silk, Albert Victor Arnold, William John Hinds, Donald Keith Cook, Wilfred Bruce Trew, Harry Chapple Arnold, Norman William Caithness, Eric George Smith and Frederick John Holt as a Committee of Management for a period of three (3) years of the land in the Township of Koonwarra temporarily reserved by Order in Council dated the 2nd February, 1955, as a site for Memorial Park, and known as the "Koonwarra Memorial Park".—(Corres. Rs.7330.)

"BAYLES RECREATION RESERVE."

Henry Evans, Frank Williams, Daniel William Feild, James Ledingham McDonald, Raymond Percy Fechner, Keith C. Bethune, Ian Stanton Tyrrell, Keith Gerald Quigley, William Edward H. Huntingford and Harold Edgar Ridgway as a Committee of Management for a period of three (3) years from 31st July, 1961, of the land temporarily reserved by Order in Council dated 30th October, 1923, as a site for Public Recreation in the Parish of Koo-wee-rup East, at Bayles, and known as the "Bayles Recreation Reserve".—(Corres. Rs.2844.)

In witness whereof the common seal of the Board of Land and Works was hereunto affixed this twenty-sixth day of July, One thousand nine hundred and sixty-one, in the presence of—

(SEAL) KEITH TURNBULL, President.
F. KLENNER, Member.

TENDERS—PUBLIC WORKS DEPARTMENT

TENDERS will be received at this Department until TEN a.m. on the Tuesdays, and for the purposes, under mentioned.

Particulars may be learnt at the Department and also at places shown in parenthesis.

W.O. means Inspector of Works Office; P.S.—Police Station; T.S.—Technical School; H.E.S.—Higher Elementary School; S.S.—State School; H.S.—High School; C.S.—Consolidated School.

Tenders should be submitted on the Department's printed Tender Form. All tenders must be on a "Firm Tender" basis. The Board of Land and Works will not necessarily accept the lowest or any tender.

Tenders to be addressed to the Hon. the Commissioner of Public Works, and envelope containing tender to be marked "Tender for _____, closing _____".

NOTE.—No preliminary deposit is to be lodged with any tender, but a deposit in accordance with the prescribed Schedule may be required from each successful tenderer.

Tuesday, 8th August, 1961.

- Altona.—Septic tank installation, S.S. 3923.
Ararat.—Supply and installation of one milking machine, Mental Hospital. (W.O., Ararat.)
Ardmona.—Out-office block and septic tank installation, &c., S.S. 1563. (W.O., Shepparton; S.S., Ardmona.)
Ballarat.—Erection of Occupational Therapy Centre, Mental Hospital. (W.O., Ballarat; Mental Hospital, Ballarat.)
Ballarat East.—Erect shelter pavilion and minor repairs, S.S. 1998. (W.O., Ballarat; S.S., Ballarat East.)
Beechworth.—Construction of four (4) additional out-offices for girls and septic tank installation, S.S. 1560. (W.O., Wangaratta; S.S., Beechworth.)
Beechworth.—Connecting link between Ward F.6 and L.T.C. Therapy Ward, Mental Hospital. (W.O., Wangaratta; Mental Hospital, Beechworth.)
Beechworth.—Installation of liquid petroleum gas, High School.
Bell Post Hill.—Electrical installation, additional four (4) L.T.C. class-rooms, &c., S.S. 4804. (W.O., Geelong; S.S., Bell Post Hill.)
Benambra.—New out-offices and septic tank installations at school and residence, S.S. 1746. (W.O., Bairnsdale.)
Bendigo—Swan Hill District.—Maintenance of oil burners and other mechanical equipment, period, July, 1961, to June, 1962, Schools Various. (W.O., Bendigo and Swan Hill.)
Boundary Bend.—Erection of a new out-office block and septic tanks, S.S. 4089. (Amended specification.) (W.O., Swan Hill; S.S., Boundary Bend.)
Broadmeadows.—Erection of two shelter pavilions, S.S. 4875.
Broadmeadows.—Heating and hot water systems to Section 1, Technical School.
Campbellfield.—Erection of one 32 ft. x 16 ft. shelter pavilion, S.S. 143. (S.S., Campbellfield.)
Carlton.—Supply of equipment for Shop, Secondary Teachers' College.
Carrum.—Septic tank installation and additional closets, S.S. 3385. (S.S., Carrum.)
Caulfield.—Erection of new Junior Technical School in brick.
Clayton North.—Septic tank installation, S.S. 734. (S.S., Clayton North.)
Daylesford.—Sheeting of spire to bell tower with copper, S.S. 1609. (W.O., Kyneton; S.S., Daylesford.)
Dunkeld.—New sanitary accommodation at teachers' flats, Consolidated School. (W.O., Hamilton.)
Essendon.—Electrical installation alterations, Technical School, corner of Hoddle and Buckley streets. (T.S., Essendon.)
Fawkner East.—Erection of two shelter pavilions, S.S. 4846. (S.S., Fawkner East.)
Geelong.—Internal renovations, Police Station. (P.S., Geelong.)
Gresswell.—Renovations and repainting to mortuary building, Sanatorium. (Sanatorium, Gresswell.)
Gunbower Island.—New out-office block and septic tank installation at school and residence, S.S. 3503. (W.O., Bendigo; S.S., Gunbower Island.)
Hawthorn.—Purchase and removal of old brick residences, Swinburne Technical School.
Healesville.—Installation of liquid petroleum gas, High School.
Hernes Oak.—Septic tank installation and water service, S.S. 4636. (W.O., Traralgon.)
Irymple South.—Installation of septic tank, S.S. 3702. (W.O., Mildura; S.S., Irymple South.)

Kanumbra.—Erection of one new shelter pavilion, S.S. 1932. (W.O., Alexandra; S.S., Kanumbra.)

Lake Tyers.—Removal of sleep-outs and re-erection, Aboriginal Station. (W.O., Bairnsdale.)

Lismore.—External painting and fence repairs, Police Station. (W.O., Camperdown; P.S., Lismore.)

Malvern.—External renovations, Toorak Teachers' College.

Melbourne.—Supplying steel shelving, dismantling and re-erecting existing steel shelving, Titles Office.

Metropolitan.—Maintenance of oil burners and mechanical equipment for period, July, 1961, to June, 1962, Schools Various.

Mildura District.—Maintenance of oil burners and other mechanical equipment, period, July, 1961, to June, 1962, Schools Various. (W.O., Mildura.)

Mitiamo.—General repairs and renovations, S.S. 2657. (W.O., Bendigo; S.S., Mitiamo.) (Amended specification.)

Mont Park.—Installation of an electric petrol pump, Mental Hospital.

Moomba Park.—Erection of shelter pavilions, S.S. 4876.

Murtoa.—Demolition of existing shelters, erection No. 2—shelter pavilions with attached woodshed, S.S. 1549. (W.O., Warracknabeal; S.S., Murtoa.)

Neerim East.—Renovations to school and residence and new septic closets, S.S. 3158. (W.O., Warragul; S.S., Neerim East.)

Niddrie.—Erect third section plus No. 3 additional classrooms, High School.

Noble Park.—New toilet and connexion to town sewerage system, Technical School residence.

North-Eastern District (Inner).—Maintenance of oil burners and mechanical equipment for period, July, 1961, to June, 1962, Schools Various.

North-Eastern District (Outer).—Maintenance of oil burners and mechanical equipment for period, July, 1961, to June, 1962, Schools Various.

Numurkah.—Additional offices and insulation to roof, Police Station. (W.O., Shepparton; P.S., Numurkah.)

Oak Park.—Connexion to sewer and installation of a fire service, S.S. 4721.

Orbost.—Installation of sewerage treatment plant, S.S. 2744. (W.O., Bairnsdale; S.S., Orbost.)

Penshurst.—Erection of one shelter pavilion, S.S. 486. (W.O., Hamilton; S.S., Penshurst.)

Prahran.—Supply various items of joinery, Technical School.

Preston East.—Erection of 2nd and 3rd sections of timber-framed concrete veneer school buildings, Technical School.

Redcliffs.—Installation of liquid petroleum gas, High School. (W.O., Mildura.)

Robinvale.—Repairs and painting to women teachers' residence, No. 2 Bromley-road, Consolidated School. (W.O., Swan Hill; C.S., Robinvale.)

Robinvale.—General repairs and renovations with provision of concrete paths to residence, Leonora-street, Consolidated School. (W.O., Swan Hill; C.S., Robinvale.)

Rosedale.—Resiting existing out-offices, &c., septic tank installations, &c., school and residence, S.S. 770. (W.O., Traralgon; S.S., Rosedale.)

Rutherglen.—Installation of liquid petroleum gas, High School.

Sale.—Mechanical services for Domestic Arts Wing, High School, corner Desailly-street and Raymond-street. (W.O., Bairnsdale; H.S., Sale.)

Snake Valley.—Erect out-office, woodshed block and new toilet, residence, install septic tanks, S.S. 574 and residence. (W.O., Ballarat; S.S., Snake Valley.)

South-Eastern District (Inner).—Maintenance of oil burners and mechanical equipment for period, July, 1961, to June, 1962, Schools Various.

South-Eastern District (Outer).—Maintenance of oil burners and mechanical equipment for period, July, 1961, to June, 1962, Schools Various.

South-Western Victoria.—Maintenance of oil burners and other mechanical equipment, period, July, 1961, to June, 1962, Schools Various. (W.O., Warrnambool.)

Walwa.—Renovations, Police Station. (W.O., Wangaratta; P.S., Tallangatta and Walwa.)

Warrnambool.—Erection of an occupational therapy centre, Mental Hospital. (W.O., Warrnambool.)

Warrnambool.—Fencing and painting to residence and out-buildings, Inspector of Works residence, Public Works Department. (W.O., Warrnambool.)

Watsonia.—1st and 2nd sections of new building, High School.

Western Metropolitan (Geelong-Ballararat).—Maintenance of oil burners and mechanical equipment, period, July, 1961, to June, 1962. Schools Various. (W.O., Geelong and Ballarat.)

West Melbourne.—Manufacture, supply and delivery of pre-cast, pre-stressed concrete grillage beams, Government Cool Stores.

West Melbourne.—Manufacture, supply and delivery of six (6) steel roof trusses, Government Cool Stores.

Williamstown.—Additional sanitary accommodation for girls and alterations to boys' out-offices, High School. (H.S., Williamstown.)

Wimmera District.—Maintenance of oil burners and other mechanical equipment, period, July, 1961, to June, 1962, Schools Various. (W.O., Horsham.)

Yarck.—Septic tank installation, &c., S.S. 1331. (W.O., Alexandra; S.S., Yarck.)

Tuesday, 15th August, 1961.

Altona East.—Septic tank installation, S.S. 4805.

Ararat.—Supply and installation of unit heaters in main kitchen building and sewing building, Mental Hospital. (W.O., Ararat.)

Ardeer.—Erection of No. 4 additional class-rooms, S.S. 4848. (S.S., Ardeer.)

Ardeer.—Electrical installation of four (4) additional L.T.C. class-rooms, S.S. 4848. (S.S., Ardeer.)

Ballarat.—Repairs and external painting, Girls' Secondary School. (W.O., Ballarat; Girls' Secondary School, Ballarat.)

Ballarat.—Re-blocking and repairs to sub-floor timbers, Special School 4762. (W.O., Ballarat; Special School, Ballarat.)

Ballarat.—Supply and delivery of sixty (60) gallons steam jacketted fixed boiling kettle, Mental Hospital.

Beechworth.—Supply and delivery of stainless steel ovens unit, Mental Hospital.

Birchip.—Erection of "A" type office and residence, &c., Police Station. (Amended Specification.) (W.O., Warracknabeal; P.S., Birchip.)

Bolinda.—New sanitary accommodation, S.S. 1070. (W.O., Kyneton.) (Amended Specification.)

Brunswick.—Enclosing balconies, Girls' Secondary School.

Carisbrook.—New out-offices and installation of septic tank, S.S. 1030. (W.O., Maryborough; S.S., Carisbrook.)

Cheltenham.—Erection of 3rd section, High School.

Doveton.—Electrical installation, main electrical supply cable, High School.

Essendon.—Renewal of quadrangle veranda roofing, High School. (H.S., Essendon.)

Fern Tree Gully.—Forming, grading and paving of parking area in the National Park.

Flinders.—Purchase and removal of old Cable Station, Public Works Department.

Frankston.—Purchase and removal of old weatherboard building, Technical School. (T.S., Frankston.)

Geelong.—Upholstered unit furniture, Teachers' College, 60 Vines-road.

Heathcote.—Repairs and painting, Police Station. (W.O., Bendigo; P.S., Heathcote.)

Heathcote.—Repairs to walls, Court House. (W.O., Bendigo; P.S., Heathcote.)

Jacana.—Installation of septic tank, filter bed, and pump house, S.S. 4839. (S.S., Jacana.)

Janefield.—Supply and delivery of Mobile Stainless Steel Food Bins, Mental Hospital.

Kangaroo Flat.—Erection of "A" type office, Police Station. (W.O., Bendigo.)

Leitchville.—New out-office block and septic tank installations at school and residence, S.S. 2087. (W.O., Bendigo; S.S., Leitchville.)

Lexton.—School and residence: new out-office block with septic tank, S.S. 1569. (W.O., Maryborough; S.S., Lexton.)

Lucknow.—Repairs and painting, S.S. 1231. (W.O., Bairnsdale; S.S., Lucknow.)

Melbourne.—Rewiring and additions in Strong Room, Titles Office, 283 Queen-street.

Melbourne.—Repairs and painting of office, Hairdressing School of C.R.T.S. Annexe.

Melbourne.—Rewire of 3rd, 4th, 7th and 15th Courts and environs, Law Courts.

Melbourne.—Supply and lay rubber tiles, Companies Registration Office, Crown Law Department, 453 Latrobe-street.

Melbourne.—Supply 6 x 28 drawer Punch Card Cabinets, State Accident Insurance Office.

Melbourne.—Supply and installation of one air conditioning unit and all relevant ductwork, air registers, &c., and removal of existing ventilation system in Board Room, State Offices, Forests Commission, 453 Latrobe-street.

Moorabbin West.—New sanitary accommodation, S.S. 4643. (S.S., Moorabbin West.)

Newlands.—Erection of extended third section, High School.

Newport.—Repairs and renovations to residence and office, Police Station.

Numurkah.—New internal toilet and septic tank, repairs, internal and external painting, Court House. (W.O., Shepparton; P.S., Numurkah.)

Oakleigh.—Sanitary accommodation, S.S. 4214, Nursery, Paynesville.—Purchase and removal of old residence and out-buildings, Slipway, Public Works Department. (W.O., Bairnsdale.)

Portarlington.—Erection of timber-framed combined residence and "A" type office, Police Station. (W.O., Geelong; P.S., Portarlington.)

Redcliffs East.—Replacement of existing water service, S.S. 4123. (W.O., Mildura; S.S., Redcliffs East.)

Riverslea.—New out-office block and septic tank installation, S.S. 3667. (W.O., Bairnsdale; S.S., Riverslea.)

Royal Park.—Supply and lay vinyl tiles, Receiving House.

Sunbury.—New fire doors, new openings and linings to Wards M.2 and F.2, Mental Hospital. (Mental Hospital, Sunbury.)

Swan Hill.—Supply of general furniture (install part thereof), Technical School. (W.O., Swan Hill.)

Traralgon.—Sewerage reticulation within hospital grounds, Mental Hospital. (W.O., Traralgon.)

Traralgon.—Electrical installation in Early Treatment Centre, Mental Hospital. (W.O., Traralgon.)

Wandiligong.—Septic tank installation, new out-office block, S.S. 275. (W.O., Benalla; S.S., Wandiligong.)

Tuesday, 22nd August, 1961.

Ararat.—Supply of mattress covers, Mental Hospital. Ararat.—Supply of curtain material, Mental Hospital. (W.O., Ararat.)

Ballarat.—Supply of Art Room furniture, School of Mines. (W.O., Ballarat.)

Ballarat.—Provision of stainless steel sinks, School of Mines. (W.O., Ballarat; School of Mines, Ballarat.)

Ballarat North.—External painting of school and out-buildings, Technical School. (W.O., Ballarat; T.S., Ballarat North.)

Baynton East.—Chalkboards, septic closets, &c., S.S. 4239. (W.O., Kyneton; S.S., Baynton East.)

Beechworth.—Supply, delivery and installation of ventilation equipment in main kitchen, Mental Hospital. (W.O., Wangaratta.)

Bendigo.—Repairs and external painting, Public Offices. (Amended specification.) (W.O., Bendigo.)

Box Hill.—Electrical installation, Assembly Hall, High School.

Box Hill.—Heating and ventilation for Assembly Hall, High School.

Chelsea.—Septic tank installation, &c., S.S. 3729. (S.S., Chelsea.)

Coburg.—Supply only of 20 tube steel table 4 ft. x 2 ft. 6 in. and 100 tube steel upholstered chairs, Pentridge Gaol.

Coburg.—Supply only of 20 tube steel tables 4 ft. x lockers, 72 in. x 18 in. x 15 in., Pentridge Gaol.

Colac.—Supply and installation of additional heaters, High School. (W.O., Warrnambool.)

Colac.—Provision of sanitary accommodation, Lands and Survey Department Depot. (W.O., Camperdown.)

Colac.—Various benches and cabinets, Technical School. (W.O., Camperdown and Warrnambool.)

East Oakleigh.—Sanitary accommodation for female staff, S.S. 4327. (S.S., East Oakleigh.)

Golden Square.—Erection of brick veneer office, Police Station. (W.O., Bendigo.)

Hawthorn.—Brick additions, Milk Board, Domville-avenue.

Melbourne.—Supply, delivery, installation and testing of ventilation system to First Floor Lecture Theatre, Pharmacy College, Royal Melbourne Institute of Technology.

Melbourne.—Supply, delivery and installation of air conditioning unit in Caretaker's Flat, State Offices, 179 Queen-street.

Mildura.—Internal and external repairs and painting, Court House. (W.O., Mildura; Court House, Mildura.)

Mont Park.—Laundry and Flat Ironer materials, Larundel Mental Hospital.

Myrtleford.—New open-sided Hay Shed, Tobacco Research Station. (W.O., Benalla.)

Nhill.—Enclosing class-room verandah, S.S. 2411. (W.O., Horsham.)

Northcote.—Repairs and internal painting, Police Station.

Nunawading.—Connexion to sewer, abolishing septic tank system, High School.

Redcliffs.—Internal repairs and painting, Court House. (W.O., Mildura; Court House, Redcliffs.)

Rochester.—Sewerage treatment plant to serve High and State Schools. (W.O., Bendigo; H.S., Rochester.)

Royal Park.—Provision of Isolation Block at "Kurrajong", "Turana", Social Welfare Department.

Rutherglen.—Electrical installation in new type "300", High School. (W.O., Wangaratta; P.S., Beechworth, Myrtleford and Rutherglen.)

St. Albans.—Supply of various items of furniture, Technical School.

Sebastopol.—Erection of No. 2 shelter pavilions, and 16 ft. x 12 ft. Store, Girls' Technical School. (W.O., Ballarat.)

Seaholme.—Installation of septic tank, washing and drinking facilities, S.S. 4440. (S.S., Seaholme.)

Stonehaven.—Construction of a new timber out-office and septic closet installations, S.S. 2199. (Amended Specification.) (W.O., Geelong.)

Swan Hill.—Erection of a modified domestic arts wing in concrete veneer, High School. (W.O., Swan Hill and Bendigo.)

Swan Hill.—Electrical installation, Girls' Hostel, High School. (W.O., Swan Hill; H.S., Swan Hill.)

Swan Hill.—Erection of additional Hostel accommodation for girls, High School. (W.O., Swan Hill and Bendigo.)

Thomastown.—Sewerage installation, S.S. 631. (S.S., Thomastown.)

Toolangi.—Supply, delivery and installation of mechanical services, Potato Research Centre.

Yallourn North.—Erection of one shelter pavilion, S.S. 3967. (W.O., Traralgon; S.S., Yallourn North.)

Tuesday, 29th August, 1961.

Melbourne.—Rewiring and additions to electrical installation, Crown Law Offices, Lonsdale-street.

Tuesday, 19th September, 1961.

Melbourne.—Supply and delivery to Melbourne, Victoria, of one 12-in. Cutter Suction Dredge, together with floating and shore discharge pipe-lines, Ports and Harbors, Public Works Department.

H. R. PETTY,
Commissioner of Public Works.

Public Works Department,
Melbourne, 1st August, 1961.

TENDERS FOR THE SERVICE, 1961-62.

REQUISITES FOR EDUCATION DEPARTMENT.

TENDERS will be received until Eleven o'clock a.m. on Friday, 11th August, 1961, from persons willing to supply the under-mentioned articles, in such quantities as may be ordered by the Victorian Government, from the 1st September, 1961, to the 31st August, 1962:—

Schedule No.:

1. Requisites (Junior School).
2. Exercise Books and Requisites.

The prices tendered must not include sales tax.

Security.—Five per cent. of total amount of tender accepted, but in no case will security of less than £3 be received.

Schedules as above, with full particulars, may be obtained from the Secretary to the Tender Board, by whom also the samples will be shown and any information afforded to persons tendering.

Should the tenderer be in a position to supply a suitable substitute of Commonwealth production or manufacture in place of any sample exhibited that may be of imported origin, he may tender for such substitute, but must submit with his tender a sample of the article offered.

In all cases the country of origin of the articles tendered must be stated, and the total cost of each item extended in the columns provided.

Security will be required either in Commonwealth Treasury Bonds, or approved bank guarantee, fixed deposit receipt, Savings Bank deposit book, or non-negotiable cheque in favour of the Secretary to the Tender Board, as the tenderer may elect.

The security must be completed and the contract signed within five days of acceptance of the tender, failing which the contract may be again advertised, or another tender accepted.

The lowest or any tender will not necessarily be accepted.

In the event of tenderers withdrawing or attempting to withdraw their tenders before notification of acceptance of same, or failing to take up their accepted tenders within the prescribed period after notification of acceptance, they may be disqualified from tendering or holding any future contracts for Government supplies for a period of one year, such disqualification to date from the notification of acceptance of tender. It is also stipulated that, if a tenderer be a member of a firm and such firm be interested in the contract, the tender shall be in the name of the firm and not in that of the individual and that, for a breach of this condition the tender will be declared informal.

Tenders enclosed in a separate envelope, and having the words "Tender for ————" (as the case may be) written thereon, must be deposited in the Tender-box at the Tender Board Offices, Macarthur-street, Melbourne, or if sent by post, postage must be prepaid, and the tenders addressed to the Chairman of the Tender Board, Tender Board Offices, Macarthur-street, Melbourne, C.2, which office they must reach not later than by first post on the date of closing of tenders.

CONDITIONS OF CONTRACT.

1. Except where definite quantities are specified the Government will not be bound to order from the contractor all the articles enumerated in the schedule, but only those articles, and such quantities of those articles, as it may be found necessary to order. Should the Government, however, require a larger supply of any article than the estimated quantity stated in the schedules, the contractor will nevertheless be bound to supply the same at contract rates.

The Government reserves the right to purchase otherwise than from the contractor articles of any of the several kinds enumerated in the schedules the purchase of which is, in the opinion of the Tender Board, necessary in order to meet special circumstances or special requirements.

2. The supplies are to be the same as sample where so stated, and of the particular manufacture indicated in the schedule of tenders. In the case of different makers' goods, the contractor will be required to supply the kind ordered. *The supplies are to be the best quality of their several kinds or manufacture.* In the event of the tender having been accepted for goods manufactured within the Commonwealth or manufactured within any other part of the British Empire (as the case may be), all such goods supplied shall, if required by the Government, bear evidence that they are of the particular manufacture tendered for, and, in addition, the contractor may at any time during the currency of the contract be called on to furnish a statutory declaration as to the country or origin of the goods supplied.

3. Except where otherwise stated in the schedule, the value of all packages, cases, casks, &c., whether bulk be broken or not, must be included in the prices stated in the contractor's tender; all such packages, &c., to be considered the property of the Government, and no charges or expenses whatsoever beyond the price tendered and set out in the schedule will be allowed to the contractor for any articles or packages, cases, casks, &c. The net weight or quantity only will be paid for. Contractors must provide, without extra charge, whatever labour may be required in the packing of stores, and the stores shall be packed in such a manner as shall secure them from injury during transit, and until delivery such stores shall be at the risk of the contractor.

4. All orders for supplies will emanate from the Education Department. The goods shall be delivered as may be directed by the officer ordering the supply.

5. Supplies ordered for delivery in the Melbourne District are to be delivered free of all charges (whether cartage, freight, &c.), and, for the purposes of these contracts, Melbourne District will include a radius of 12 miles from the Elizabeth-street Post Office. For supplies outside that radius the goods must be delivered free on rails at Flinders-street or Spencer-street Railway Stations as required.

6. Arrangements as to time of delivery and inspection of goods will be made by the Secretary, Education Department, or such other officer whom he may appoint.

7. Orders must receive prompt execution; and in the event of the goods not being delivered within forty-eight hours after the contractor shall have received the order, or within such other time as the order may specify for delivery, it will be competent for the officer named in clause 6, or the head of the department to whom the goods are to be supplied, on giving the contractor twenty-four hours' notice to purchase the supplies, or any like supplies that are suitable for the service, at the contractor's risk, and the extra expense incurred over and above the contract price (if any) will be deducted from the contractor's account or from the security money.

8. Delivery will not be deemed to have been made until the goods have been approved. In case of the rejection or return of any supplies, the contractor shall bear the whole cost of replacing the supplies rejected or returned, otherwise purchases will be effected at the contractor's risk and the extra expense deducted as in clause 7.

9. The official order issued by the Education Department shall be forwarded by the contractor to the officer authorized to accept delivery, who shall acknowledge thereon the receipt of the goods accepted and return the order to the contractor, who will attach same to his claim for payment.

10. All orders, duly received, shall be returned to the Education Department at the end of each month, accompanied by an account in the prescribed form for the articles supplied during the month, and, on receipt of same, the contractor shall be entitled to payment, due time to be allowed for the examination and verification of the claim.

11. The acceptance of the supplies shall be subject to the approval of the officer authorized to take delivery of the stores, or such other officer as shall be named in the schedules. Delivery of the articles will not be deemed to have been made until they have been handed in good order and condition to the head teacher of the school or such other person as may be authorized to accept delivery, &c. The contractor may, however, claim a survey on any goods objected to; but in that case he must, within twenty-four hours after objection is made give notice thereof, in writing, to the officer rejecting the goods. If, after the delivery of the supplies has been taken, any deficiency or defect is discovered therein, such deficient or defective stores may be returned to the contractor.

12. The members of Boards of survey will be appointed by the Treasurer of the State for the time being, and the decision of the Board is to be considered as final. If the Board shall decide that the article is not of proper quality it must be immediately replaced by the contractor, failing which it, or any like supply that is suitable for the service, will be procured elsewhere, and the survey fees and extra expense (if any) will be deducted as in clause 7.

13. All goods forwarded under these contracts shall, where practicable, be forwarded by rail, and all consignments shall bear the number of the consignment notes under which they are forwarded, and also the name of the contractor by whom consigned, on a legibly-written business label.

14. When the contractor is required to make delivery of goods at a railway station for transmission by rail, he shall obtain a receipt for the goods in duplicate on the Stores and Transport consignment note, at the same time handing in a triplicate and quadruplicate of the form as an authority for the Railways to act as agent for, and charge the freight to, the Stores and Transport Office or such other Department as shall be named therein. He shall as soon as possible, and not later than twenty-four hours thereafter, deliver the original at the Tender Board Offices, the duplicate to be forwarded to consignee in accordance with clause 15, and the quintuplicate to be retained by himself. Should the goods thus forwarded be rejected, the contractor must bear the cost of replacing such goods, for which service the departmental consignment note is not to be used. Any infringement of this condition will subject the contractor to such mulct as the Tender Board may recommend under clause 17 of these conditions. Such mulct may be deducted as in clause 7.

15. *Immediately after the consignment of the goods, the officer to whom they are forwarded shall be notified by the contractor, on the duplicate consignment note provided for the purpose, that the goods have been sent. On receipt of this document, the officer to whom it has been forwarded shall acknowledge thereon the receipt of the goods without delay to the Stores and Transport Office. In the event of loss through failure on the part of the contractor to comply with this condition he will be held responsible, and the amount of the loss incurred for same will be deducted as in clause 7.*

16. Should the order on the contractor specially provide that goods of a fragile character, or such as are liable to suffer loss by leakage, shall be consigned at the risk of the Railways Commissioners under special freight conditions, the contractor shall in such instance provide, in writing, on the consignment note an intimation to that effect, failing which, in the event of loss, he shall bear the whole cost of replacing the goods, the amount being deducted from the contractor's account or the security money.

17. A refusal to execute orders, irregularity in the quantity or quality of the supplies, delay in delivering or replacing them when required, or non-compliance with the terms of clauses 14 and 15 of these conditions respecting the forwarding of consignment notes, &c., will subject the contractor, upon report from the Tender Board, to such mulct not exceeding Fifty pounds as the said Treasurer may direct and the amount may be deducted as in clause 7. It will also be in the power of the said Treasurer upon such refusal, irregularity, or delay, to terminate the contract forthwith, and declare forfeit the whole or any portion of the security money; and, in addition, the contractor will be disqualified from tendering or holding any future contract or contracts for a period of one year from the date of such disqualification.

18. Contractors are not at liberty to transfer their contracts under cover of power of attorney, coupled with an interest or otherwise; and no such transfer will be recognized by the Government. If it is found during the currency of the contract that the contractor has not con-

formed to the condition of advertisement—which stipulates that if a tenderer be a member of a firm, and such firm be interested in the contract, the tender shall be in the name of the firm, and not in that of the individual—then the said Treasurer may, on the recommendation of the Tender Board, determine the contract, and forfeit the security money.

19. The contracts entered into under these conditions are not to be considered as being broken, infringed, or vitiated by the importation of stores for the Government service, or by any contracts or purchases made by the Agent-General for Victoria, or by any contracts or agreements made for supplies to Technical Schools, or by any article being made at any Government establishment and supplied for the use of the Education Department, or by the consumption of the surplus stock of any Government establishment.

20. Notwithstanding anything contained to the contrary in section 152 of the *Customs Act 1901-36*, it is hereby expressly provided that upon any alteration of the duty collected affecting the goods included in this contract, the contract price shall not be altered, and the contract may be terminated at the opinion of either party by two months' notice in writing from the first day of the calendar month next ensuing, and within the period for which the contract is made. The contract for the unaffected items shall remain in full force and effect. Any notice to be served under this condition shall be deemed to have been duly served if sent to the contractor in a registered letter to his last-known place of business or abode.

21. *Under no circumstances, other than those mentioned in clause 20, will a contractor be permitted to abandon his contract.* In the event of the contractor failing to carry on the contract, the contract security money will in that case be absolutely forfeited; and, in addition, the contractor will be held liable for any loss which the Government may sustain in consequence of such failure.

22. Should the Minister of Education for the time being decide to discontinue the use of any book, map, or any other article in the schedule, or to direct that any book, map, or any other article other than those enumerated therein be taken into use, he shall at any time give six months' notice of such intention or decision to the contractor, and after the expiration of the period of such notice the Education Department shall not be bound to take any further supply of such book, map, or any other article, nor shall the contractor be bound to supply the same, and all books or maps not in the schedule, but which it may be decided to introduce, shall be supplied by the contractor after expiration of such notice at a price to be agreed on between the Minister of Education for the time being and the contractor.

H. E. BOLTE,
Treasurer.

The Treasury,
Melbourne, 1st August, 1961.

TENDERS FOR THE SERVICE, 1961-62.
GENERAL STORES.

TENDERS will be received until Eleven o'clock a.m. on Friday, 11th August, 1961, from persons willing to supply the under-mentioned articles in such quantities as may be ordered by the Victorian Government, from the 1st September, 1961, to the 31st August, 1962:—

Schedules as above, with full particulars, may be obtained from the Secretary to the Tender Board, by whom also the samples will be shown and any information afforded to persons tendering.

In all cases the total cost of each item must be extended in the columns provided.

Schedule No.

- 68. Stamps, Rubber.
- 69. Stationery (General) and Typewriters.

The prices tendered must not include sales tax.

Security.—Five per cent. of total amount of tender accepted, but in no case will security of less than £3 be received.

Security will be required either in Commonwealth Treasury Bonds, or approved bank guarantee, fixed deposit receipt, Savings Bank deposit book, or non-negotiable cheque in favour of the Secretary to the Tender Board, as the tenderer may elect.

The security must be completed and the contract signed within five days of acceptance of the tender, failing which the contract may be again advertised, or another tender accepted.

The lowest or any tender will not necessarily be accepted.

In the event of tenderers withdrawing or attempting to withdraw their tenders before notification of acceptance of same, or failing to take up their accepted tenders

within the prescribed period after notification of acceptance, they may be disqualified from tendering or holding any future contracts for Government supplies for a period of twelve months, such disqualification to date from the notification of acceptance of tender. It is also stipulated that, if a tenderer be a member of a firm and such firm be interested in the contract, the tender shall be in the name of the firm and not in that of the individual and that, for a breach of this condition, the tender will be declared informal.

Tenders enclosed in a separate envelope, and having the words "Tender for ————" (as the case may be) written thereon, must be deposited in the Tender-box at the Tender Board Offices, Macarthur-street, Melbourne, or if sent by post, postage must be prepaid, and the tenders addressed to the Chairman of the Tender Board, Tender Board Offices, Macarthur-street, Melbourne, C.2, which office they must reach not later than by first post on the date of closing of tenders.

The conditions of contract are those published in the *Victoria Government Gazette*, No. 24, dated 29th March, 1961, pages 1062 to 1064.

H. E. BOLTE,
Treasurer.

The Treasury,
Melbourne, 1st August, 1961.

PUBLIC SERVICE NOTICES

No. 1138.

Public Service Act 1958.

REGULATIONS.—PART III.—SALARIES, INCREMENTS, AND ALLOWANCES.

THE Public Service Board, in pursuance of the powers conferred by the *Public Service Act 1958*, hereby amends its Regulations as shown below:—

FOURTH SCHEDULE.

ADMINISTRATIVE DIVISION.

Amount of Salary Assigned to Offices in Class "A1".

Office.	Yearly Rate of Salary.
DEPARTMENT OF CHIEF SECRETARY.	£
<i>Add—</i> Assistant Insurance Commissioner	2,600

A. GARRAN, Chairman.
V. P. SCULLY, Secretary.

Office of the Public Service Board,
Melbourne, 25th July, 1961.

No. 1140.

Public Service Act 1958, Section 39.

REGULATIONS.—PART III.—SALARIES, INCREMENTS AND ALLOWANCES.

THE Public Service Board, in pursuance of the powers conferred by the *Public Service Act 1958*, hereby amends its Regulations as shown below:—

FIRST SCHEDULE.

PROFESSIONAL DIVISION.

Amount of Salary Assigned to Offices in Class "A1".

Office.	Yearly Rate of Salary.
DEPARTMENT OF LAW.	£
<i>Add—</i> Solicitor to the Public Trustee	2,300
DEPARTMENT OF AGRICULTURE.	
<i>Add—</i> Veterinary Officer	2,175

A. GARRAN, Chairman.
V. P. SCULLY, Secretary.

Office of the Public Service Board,
Melbourne, 24th July, 1961.

No. 1139.

Public Service Act 1958, Section 50.

REGULATIONS.—PART III.—SALARIES, INCREMENTS AND ALLOWANCES.

THE Public Service Board, in pursuance of the powers conferred by the *Public Service Act 1958*, hereby amends its Regulations as shown below:—

SIXTH SCHEDULE.

TEMPORARY EMPLOYEES.

Designations of Positions and Rates of Salaries.

Department and Designation of Position.	Yearly Rate of Salary.		Increments (Annual).
	Minimum.	Maximum.	
	£	£	
DEPARTMENT OF AGRICULTURE.			
<i>Delete</i> — Field Officer (Female)	524	636	3 of £32 and 1 of £16
<i>Add</i> — Field Officer (Female)— Junior— At 18 years of age At 19 years of age At 20 years of age Adult 524	272 316 355 636 3 of £32 and 1 of £16

A. GARRAN, Chairman.
V. P. SCULLY, Secretary.

Office of the Public Service Board,
Melbourne, 17th July, 1961.

PUBLIC SERVICE OF VICTORIA.—VACANCIES.

APPLICATIONS will be received by the Public Service Board up to Wednesday, the 16th August, 1961, from persons employed in the Public Service of Victoria, who are eligible and qualified, for appointment to the under-mentioned positions:—

ADMINISTRATIVE DIVISION.

Chief Finance Officer, Class "A1", Office of the Housing Commission, Treasury.

Yearly Salary.—£2,600.

Duties.—Responsibility for Budget control of capital and maintenance expenditure, continuous review of capital commitments, financial planning under Commonwealth and State Housing Agreements, supervision of borrowings and investments by the Commission and all financial matters in connexion with the activities of the Housing Commission, including the Concrete House Project.

Qualifications.—A qualified Accountant with wide practical experience and ability in financial planning and in carrying out special investigations. A good knowledge of financial matters under the Housing Act and the Commonwealth and State Housing Agreements.

Assistant Accountant, Class "A1", Office of the Housing Commission, Treasury.

Yearly Salary.—£2,175.

Duties.—To act as Deputy to the Chief Accountant, and under his direction to be responsible for the operation of the Accounts Division of the Commission.

Qualifications.—A qualified Accountant with a good knowledge of the Public Accounts and Stores Regulations and Treasury and Audit practice.

Accountant, Class "A", Office of the Chief Commissioner of Police, Chief Secretary's Department.

Yearly Salary.—£1,920, minimum; £2,060, maximum.

Duties.—To direct and control the work of the Accounts Branch and to advise in financial matters relating to the activities of the Police Department.

Qualifications.—A qualified Accountant with a good knowledge of the *Audit Act 1958*, the Public Accounts and Stores Regulations 1958 and Treasury procedures.

Officer in Charge, State Motor Car Insurance Office, Class "A", Chief Secretary's Department.

Yearly Salary.—£1,920, minimum; £2,060, maximum.

Duties.—To act as Officer in Charge of the State Motor Car Insurance Office.

Qualifications.—A specialized knowledge of comprehensive and statutory motor vehicle insurance with practical experience in underwriting and settlement of claims; a good knowledge of the Motor Car Acts and the Law as affecting insurance contracts; ability to develop business and to direct and control a large staff.

Class "B1", Accounts Branch, Education Department.

Yearly Salary.—£1,630, minimum; £1,770, maximum.

Duties.—To act as Officer in Charge of the Ledger and Miscellaneous Accounts Section; to control ledger postings and the dissection of revenue and expenditure vouchers; to assist in dealing with special correspondence and in the general administration of the Branch.

Qualifications.—A qualified Accountant with a good knowledge of the Public Accounts and Stores Regulations.

Class "C1", Social Welfare Branch, Chief Secretary's Department. (Three vacancies.)

Yearly Salary.—£960, minimum; £1,060, maximum.

POSITION No. 1.

Duties.—To act as Secretary to the Youth Parole Board and to assist generally in the administration of the Probation and Parole Division.

Qualifications.—A good knowledge of the parole provisions of the *Social Welfare Act 1960*, and experience in drafting correspondence.

POSITION No. 2.

Duties.—To be responsible to the Chief Probation and Parole Officer for the preparation of Court actions for breaches of probation.

Qualifications.—A good knowledge of Court procedure and of the probation provisions of the Social Welfare and Crimes Acts.

POSITION No. 3.

Duties.—To be in charge of the correspondence and records section of the Central Administration of the Branch.

Qualifications.—Experience of correspondence and records systems and ability to draft correspondence.

Class "C", Taxation (Land Tax) Office, Treasury.

Yearly Salary.—£710, minimum; £860, maximum.

Duties.—To assist the Senior Assessor; to prepare assessment of arrears and default cases; to investigate assessments under section 45 of the *Land Tax Act 1958*, and cases of primary production land which are exempt under section 7 of the *Land Tax Act 1958*.

Qualifications.—Experience in assessing duties; a good knowledge of the *Land Tax Act and Regulations*; to be familiar with the methods by which interests in land are transferred.

Class "C", Office of the Housing Commission, Treasury.

Yearly Salary.—£710, minimum; £860, maximum.

Duties.—To act as Section Leader of the Land Sales and Statistical Section of the House Sales Department, to be responsible to the Accountant for preparation of House Sales files, registers and summary working sheets; to account for Miscellaneous House Sales, Sales of Land, and to prepare returns as required under the Commonwealth and State Housing Agreements.

Qualifications.—A knowledge of the provisions of the Housing Act and Commonwealth and State Housing Agreements, and of the Commission's accounting procedures relating to the sale of land and houses.

Class "C", Public Works Department.

Yearly Salary.—£710, minimum; £860, maximum.

Duties.—To assist in the examination of proposals to commence new works and the preparation of submissions to the Board of Land and Works.

Qualifications.—Capacity to deal with requisitions, tenders and contracts.

Class "C", Department of Agriculture.

Yearly Salary.—£710, minimum; £860, maximum.

Duties.—To maintain and control the records of the Internal Audit Section; to assist the Internal Auditor as required.

Qualifications.—To be familiar with audit procedures; a good knowledge of the *Audit Act and Regulations*.

Class "C", Water Supply Department.

Yearly Salary.—£710, minimum; £860, maximum.

Duties.—To issue Expenditure Authorities covering funds controlled by the Commission and to record loan commitments; to reconcile machines cost postings with financial records; to prepare financial statements as required.

Qualifications.—Preferably a knowledge of the Commission's activities and its system of accounts, and of the Public Accounts and Stores Regulations.

PROFESSIONAL DIVISION.**Assistant Press Relations Officer, Classes "B"—"B1", Premier's Office, Premier's Department.**

Yearly Salary.—£1,390, minimum; £1,770, maximum. (Commencing salary according to experience.)

Duties.—To assist in the preparation of articles concerning the work of the Government, and the activities of Government Departments, for publication in the Press and for Broadcasting and Television purposes.

Qualifications.—Satisfactory experience as a press journalist and in the type of work outlined above.

Senior Quantity Surveyor, Class "B", Public Works Department. (Two vacancies.)

Yearly Salary.—£1,390, minimum; £1,500, maximum.

Duties.—The supervision of a section of the staff in the preparation of bills of quantities, variations, estimates, schedules of dilapidations, measurements of works for progress payments, schedules of materials for day labour contracts, analysis of building costs and relevant investigation, survey and reports.

Qualifications.—A fully qualified Quantity Surveyor holding or being eligible for corporate membership of a professional association of Quantity Surveyors; experience in all branches of the profession, and capable of supervising staff.

Surveyor, Classes "C1" or "C2", Water Supply Department. (Two vacancies.)

Yearly Salary.—Class "C1"—£960, minimum; £1,060, maximum. Class "C2"—£1,170, minimum; £1,280, maximum.

Duties.—To effect title surveys in accordance with regulations under the Transfer of Land Act, and to carry out general engineering surveys in connexion with investigations of reservoir sites and foundations of channel systems and other water supply undertakings.

Qualifications.—Class "C1"—a Licensed Surveyor. Class "C2"—a Licensed Surveyor with at least three years' experience as such.

Assistant Engineer, Classes "C"—"C2", Architectural Branch (Sewerage Section), Public Works Department.

Yearly Salary.—£1,049, minimum; £1,709, maximum—Graduate. £909, minimum; £1,709, maximum—Diplomate. (Commencing salary according to experience.)

Duties.—To prepare plans and specifications for water supply, stormwater and sewerage installations to public buildings and institutions.

Qualifications.—To possess a University Degree or Diploma in Civil Engineering, or other recognized qualifications.

Assistant Livestock Research Officer, Classes "C"—"C2", Department of Agriculture.

Yearly Salary.—£960, minimum; £1,280, maximum. (Commencing salary according to experience.)

Duties.—Under direction to undertake investigations in animal husbandry at the Animal Husbandry Research Centre, Werribee.

Qualifications.—A degree in Agricultural Science of an Australian University or equivalent qualifications; experience with livestock is desirable.

Social Worker (Male or Female), Classes "C"—"C2", Tuberculosis Branch, Department of Health.

Yearly Salary.—Male—£860, minimum; £1,280, maximum. Female—£803, minimum; £1,223, maximum. (Commencing salary according to experience.)

Duties.—To undertake social work associated with patients under the control of the Tuberculosis Branch.

Qualifications.—Diploma of Social Studies or equivalent qualification.

Social Worker (Female), Classes "C"—"C2", Social Welfare Branch, Chief Secretary's Department.

Yearly Salary.—£803, minimum; £1,223, maximum. (Commencing salary according to experience.)

Duties.—Under direction, to do social case work in the Family Welfare Division; to prepare reports for administrative and clinical purposes; to undertake special project work as required.

Qualifications.—Diploma of Social Studies of the Melbourne University or equivalent qualification.

NOTE.—Applications will be accepted from holders of an appropriate University Degree who are prepared, following appointment, to undertake on a part-time basis the additional study which would qualify them for the Diploma of Social Studies of the Melbourne University. These appointees will receive a commencing salary of £703 a year and progression beyond the rate of £803 a year will be contingent upon their qualifying for the Diploma of Social Studies.

Draughtsman, Classes "C"—"C1", Public Works Department.

Yearly Salary.—£710, minimum; £1,060, maximum.

Duties.—To prepare plans and designs of Civil Engineering projects including tourists' works, drainage, roadways, water supply construction, steel and reinforced concrete structures, and construction of asphalt paving.

Qualifications.—A competent survey and engineering draughtsman with technical school training in Civil Engineering; to be experienced in Civil Engineering practice and design and to possess the pre-requisite qualifications prescribed in paragraphs (a) and (b) of the Public Service (Public Service Board) Regulation 23.

TECHNICAL AND GENERAL DIVISION.**Assessment Officer, Registry of Co-operative Societies, Treasury.**

Yearly Salary.—£1,038, minimum; £1,134, maximum.

Duties.—To inspect dwellings during construction and to assess the value of work done.

Qualifications.—A sound knowledge of building principles and practice; practical experience in building construction.

Engineering Assistant (Mechanical), Water Supply Department.

Yearly Salary.—£798, minimum; £846, maximum.

Duties.—On a construction project, to be responsible to the Resident Engineer for the supervision of maintenance and repair of construction plant, including earth-moving equipment and motor vehicles; to supervise miscellaneous mechanical and electrical installations.

Qualifications.—A good knowledge of the maintenance and repair of construction plant, including motor vehicles, with satisfactory experience in this field including the control of labour; a good technical education.

Orchard Supervisor, Grade II., Department of Agriculture.

Yearly Salary.—£718, minimum; £846, maximum.

Duties.—To inspect, pursuant to the Vegetation and Vine Diseases Act and *Fruit and Vegetables Act* 1958, orchards, nurseries, markets, &c., and to advise growers on all phases of orchard work.

Qualifications.—To have passed the Orchard Supervisor's examination; a good practical knowledge of fruit growing and experience in orchard supervision work.

Poultry Instructor, Assistant, Dookie Agricultural College, Department of Agriculture.

Yearly Salary.—£686, minimum; £846, maximum.

Duties.—To assist the Poultry Instructor in the work and management of the Poultry Branch, and in the supervision of students working in the Branch; to perform other duties as required.

Qualifications.—Diploma of a recognized Agricultural College; experience in poultry farming.

Field Officer, Department of Agriculture. (Three vacancies.)

Yearly Salary.—£654, minimum; £798, maximum. (Commencing salary will be determined within this initial range according to experience, but advancement is not limited to the maximum quoted.)

Position No. 1.

Duties.—To carry out field work in connexion with animal husbandry research projects.

Qualifications.—Diploma of an approved Agricultural College (Australian) or its equivalent.

Position No. 2.

Duties.—To assist with the experimental work conducted by the Biology Branch and any other work required by the Chief Biologist.

Qualifications.—Diploma of an Agricultural or Horticultural College or equivalent.

Position No. 3.

Duties.—With headquarters at State Research Farm, Werribee, to assist in the field work associated with plant breeding, including the sowing and maintenance of nurseries and the segregation of plant materials.

Qualifications.—Diploma or Certificate of an approved Agricultural College.

Note.—Field Officers are eligible for appointment to the position of Field Officer, Senior—salary range, £846-£942; and on passing a qualifying examination for appointment to the Professional Division as Experimental Officer—salary, £810-£1,280.

Fruit Inspector, Department of Agriculture.

Yearly Salary.—£654, minimum; £798, maximum.

Duties.—To examine fresh fruit, seed, timber, plants, &c., and to issue certificates under the Vegetation and Vine Diseases, Fruit and Vegetable, Health, Seeds Commerce and Quarantine Acts.

Qualifications.—A general knowledge of economic entomology, vegetable pathology, seeds of economic plants, weed seeds, and the above-mentioned Acts and Regulations thereunder. To have passed the prescribed examination.

Orchard Inspector, Department of Agriculture. (Three vacancies.)

Yearly Salary.—£686, minimum; £750, maximum.

Duties.—To assist in fruit fly control and eradication; to inspect fruit in shops, markets and orchards for the presence of plant diseases; and to assist Orchard Supervisors as required.

Qualifications.—A good practical knowledge of fruit growing; at least two years' experience in fruit fly eradication with the Department of Agriculture.

Note.—Candidates will be required to undergo an examination, to be held at the Burnley Horticultural College at a date to be fixed.

Mechanical Supervisor, Robinvale Pumping Station, Water Supply Department.

Yearly Salary.—£654, minimum; £750, maximum.

Duties.—Repair and maintenance of steam boilers, steam and diesel engine driven pumps, and auxiliary mechanical plant at the Robinvale pumping station, and the supervision of persons employed on the operation and maintenance of such plant.

Qualifications.—To have served an apprenticeship as a fitter and turner, with not less than ten years' subsequent experience in the repair and maintenance of steam and diesel engines and associated plant.

Note.—A house is available for the successful applicant, if married, subject to a formal tenancy agreement being entered into, for which a rental of 10 per cent. of standard salary plus £16 a year will be charged. Particulars available from the Water Supply Department.

Penal Officer, Prisons Division, Social Welfare Branch, Chief Secretary's Department. (Sixty-six vacancies.)

Yearly Salary.—£462, minimum; £622, maximum.

Duties.—To control and supervise male prisoners and to perform other duties as required.

Qualifications.—As required by Regulation 31 of the Public Service (Public Service Board) Regulations.

Shorthand Writer and Typist (Female), Senior, Public Works Department.

Yearly Salary.—£572, minimum; £604, maximum.

Duties.—To be personal stenographer to the Minister of Public Works.

Qualifications.—An experienced shorthand writer and typist capable of writing shorthand at the rate of 120 words a minute and of taking dictation and notes at deputations.

Reservoir Keeper (Glenmaggie), Grade III., Water Supply Department.

Yearly Salary.—£510, minimum; £590, maximum.

Duties.—Under the Reservoir Keeper, to assist in the maintenance and operation of the reservoir and outlet structures, the improvements on adjoining lands, and the regulation of the outflow from the reservoir, taking of gaugings and keeping of records.

Qualifications.—Experience in the construction and maintenance of works involving the use of concrete earth and rock, in the operation and maintenance of outlet works and flood gates and their operating machinery, and in the establishment and care of ornamental trees and plantations; to be physically capable of carrying out this class of work and be competent to supervise casual labour, keep records and make reports in connexion with specified duties.

Note.—A house is available for the successful applicant, if married, for which a rental of 10 per cent. of standard salary, plus £16 a year will be charged, subject to a formal tenancy agreement being entered into. Particulars available from the Water Supply Department.

Senior Water Bailiff, Cohuna Centre, Water Supply Department.

Yearly Salary.—£574.

Qualifications.—Experience in the regulation and distribution of water through channels and natural streams to private diverters; to be familiar with the use and performance of small pumping plants for irrigation; a good knowledge of water requirements for orchards, crops pastures and grasses grown under irrigation in the area; experience in channel construction and maintenance.

Note.—A house is available for the successful applicant, if married, for which a rental of 10 per cent. of standard salary plus £16 a year will be charged, subject to a formal tenancy agreement being entered into. Particulars available from the Water Supply Department.

Carpenter, Dookie Agricultural College, Department of Agriculture. (Three vacancies.)

Yearly Salary.—£510, minimum; £538, maximum.

Duties.—General carpentry constructional and maintenance work; to assist with the supervision of the practical carpentry work of students; other duties as required.

Qualifications.—A competent carpenter experienced in timber farming, finishing and fixing, carpentry maintenance and repair work.

Estate Officer (Female), Grade IV., Office of the Housing Commission, Treasury.

Yearly Salary.—£492, minimum; £556, maximum.

Duties.—To perform housing estate duties as required in respect of a section of a district, including revenue collections, interviewing of tenants regarding rental arrears, advising tenants on matters affecting their tenancy, and inspecting and reporting on houses and various phases of estate management.

Qualifications.—To be educated to Intermediate Certificate standard or to be already an officer of the Commission; suitable experience in aspects of estate management or social work; a current driver's licence; preferably between the ages of 24 and 45.

Note.—After completing three years' satisfactory service as Estate Officer (Female), Grade IV., will be eligible for progression to Estate Officer (Female), Grade III., (£588-£620).

Despatch Officer, State Film Centre, Premier's Department.

Yearly Salary.—£430, minimum; £446, maximum.

Duties.—To supervise the packing and rail despatch of films from the State Film Centre to country areas, to supervise the storage of films in numbered racks, to keep simple records of films despatched from and returned to the Centre, and to drive a light delivery van. To supervise the work of the Assistant Film Despatch Officer.

Qualifications.—A current car driver's licence; sound physique; experience in despatch records.

Note.—The salary rates quoted above do not include the additional amount which is payable under Regulation 77A of the Board's Regulations.

By 'order,

V. P. SCULLY,

Office of the Public Service Board,
Melbourne, 1st August, 1961. Secretary.

PUBLIC SERVICE OF VICTORIA.—VACANCIES.
(TEMPORARY APPOINTMENTS.)

APPLICATIONS will be received by the Public Service Board up to Wednesday, the 16th August, 1961, from persons who are qualified for appointment to the under-mentioned positions:—

PUBLIC WORKS DEPARTMENT.

Quantity Surveyor. (Four vacancies.)

Yearly Salary.—£1,170, minimum; £1,280, maximum.
Duties.—Preparation of bills of quantities, variations, estimates, schedules, reports and site survey in connexion with tasks generally executed in the Quantity Survey Section.

Qualifications.—A fully qualified Quantity Surveyor holding or being eligible for corporate membership of a professional association of Quantity Surveyors; experience in the various branches of the profession.

Assistant Quantity Surveyor, Grade I.

Yearly Salary.—£710, minimum; £810, maximum.
Duties.—To assist in preparing bills of quantities, variations, estimates, schedules, reports and site survey in connexion with tasks generally executed in the Quantity Survey Section.

Qualifications.—To have completed three years study at a professional or technical centre in preparation for eligibility for corporate membership of a professional association of quantity surveyors; three years practical experience and training in an established office.

The salary rates quoted above do not include the additional amount which is payable under Regulation 77A of the Board's Regulations.

By order,
V. P. SCULLY,
Office of the Public Service Board,
Melbourne, 1st August, 1961. Secretary.

PUBLIC SERVICE OF VICTORIA.—VACANCIES.
DEPARTMENT OF HEALTH.
MENTAL HYGIENE BRANCH.
TECHNICAL AND GENERAL DIVISION.

APPLICATIONS will be received by the Public Service Board up to Wednesday, the 23rd August, 1961, from persons employed in the Public Service of Victoria, who are eligible and qualified for appointment to the under-mentioned positions:—

Principal Nurse (Male), Ballarat Mental Hospital.

Yearly Salary.—£894, minimum; £942, maximum.
Duties.—Under direction of the Psychiatrist Superintendent to have charge of Male Division—Staff and Patients.

Qualifications.—Current practising certificate for Mental Nursing. Experience in a senior position in a Mental Hospital, ability to control patients and staff, compile reports and records relating to these duties, and give lectures to Student Nurses.

Deputy Charge Nurse (Male), Warrnambool Mental Hospital.

Yearly Salary.—£542, minimum; £574, maximum.
Duties.—To be second in charge of a ward.
Qualifications.—A current practising certificate for Mental Nursing and approved experience.

Cleaner and Labourer, Mont Park Mental Hospital.

Yearly Salary.—£318, minimum; £334, maximum.

NOTE.—The salary rates quoted above do not include the additional amount which is payable under Regulation 77A of the Board's Regulations.

By order,
V. P. SCULLY,
Office of the Public Service Board,
Melbourne, 1st August, 1961. Secretary.

PUBLIC SERVICE (PUBLIC SERVICE BOARD) REGULATION 39.—VACANCIES.

THE Permanent Heads of the Departments shown have recommended the officers named hereunder for appointment to the under-mentioned vacancies.

Office and Classification.	Duties.	Qualifications.	Officer Recommended for Appointment.		
			Name.	Classification.	Date of Classification.
PROFESSIONAL DIVISION.					
DEPARTMENT OF AGRICULTURE.					
Superintendent of Agriculture, Class "A1" (£3,300)	To be Head of the Agricultural Division of the Department	A University Degree in Agricultural Science; a detailed knowledge of the activities of the Division; administrative ability; a sound knowledge of modern research methods, and experience in the conduct of research and advisory work	McDonald, W. J. B.	Senior Inspector of Agriculture, Class "A1" (£2,600)	5.12.57
TECHNICAL AND GENERAL DIVISION.					
CHIEF SECRETARY'S DEPARTMENT.					
<i>Social Welfare—Prisons Division.</i>					
Penal Officer, Chief, Grade II., Grades 37-38 inclusive (two offices)	To be officer in charge Corrimungle Prison Farm or to fill any position of equivalent rank in the Division as directed	A Senior Penal Officer who has passed the examination under Regulation 48 (2) of the Public Service (Public Service Board) Regulations for promotion to Chief Penal Officer; a good knowledge of penal problems and modern developments	Fellows, J. H. . .	Penal Officer, Senior, Grades 33-35 inclusive	24.9.58
	To be officer in charge Classification Centre, Her Majesty's Prison, Pentridge, or to fill any position of equivalent rank in the Division as directed	A Senior Penal Officer who has passed the examination under Regulation 48 (2) of the Public Service (Public Service Board) Regulations for promotion to Chief Penal Officer; a good knowledge of penal problems and modern developments; a knowledge of classification procedures and requirements	Edmonds, F. J.	Penal Officer, Senior, Grades 33-35 inclusive	6.9.48

Appeals against such recommendations should be lodged with the Secretary to the Public Service Board not later than Saturday, the 12th August, 1961.

Office of the Public Service Board,
Melbourne, 1st August, 1961.

By order,
V. P. SCULLY,
Secretary.

PUBLIC SERVICE (PUBLIC SERVICE BOARD) REGULATION 39.—RECLASSIFICATIONS.

THE Public Service Board has raised the classification of the under-mentioned offices as shown, and the Permanent Heads of the Departments have recommended the officers named for appointment.

Office and Present Classification.	Revised Classification.	Duties.	Qualifications.	Officer Recommended for Appointment.		
				Name.	Classification.	Date of Classification.
PROFESSIONAL DIVISION.						
PREMIER'S DEPARTMENT.						
<i>Soil Conservation Authority.</i>						
Senior Research Officer, Class "B1"	Class "A"	The direction, supervision, and carrying out of investigations of those phases of economics which are important in relation to soil conservation and land use	A degree in Agricultural Science or Economics or equivalent qualification; extensive training and experience in the economics of agriculture	Molnar, I. . .	Senior Research Officer, Class "B1"	12.3.57
TECHNICAL AND GENERAL DIVISION.						
DEPARTMENT OF CROWN LANDS AND SURVEY.						
Assistant (Male), Grade II., Grades 16-21 inclusive (two offices)	Grade I., Grades 23-25 inclusive (two offices)	To be in charge of the Survey and Photographic Store at Russell-street Annexe	A knowledge of the departmental system of recording; capable of handling heavy parcels; a current car driver's licence	Graf, S. J. . .	Assistant (Male), Grade II.	27.4.59
		To purchase and distribute various materials for making surveys and to supervise daily checks and keep records of sensitized paper and films	A knowledge of the appropriate departmental procedures	Madarassy, O.	Assistant (Male), Grade II.	27.4.59
DEPARTMENT OF HEALTH.						
MENTAL HYGIENE BRANCH.						
<i>Pleasant Creek Special School, Stawell.</i>						
Cook (Male), Grade II., Grades 19-20 inclusive	Grade I., Grades 22-24 inclusive	To be in charge of the kitchen and staff therein	A competent Cook with experience in large quantity preparation and cooking of foodstuffs and ability to control staff	Jeanes, R. O.	Cook (Male), Grade II.	10.6.59

Appeals against such recommendations should be lodged with the Secretary to the Public Service Board not later than Saturday, the 12th August, 1961.

Office of the Public Service Board,
Melbourne, 1st August, 1961.

By order,
V. P. SCULLY,
Secretary.

APPOINTMENT OF A DEPUTY TO A MEMBER OF THE PUBLIC SERVICE BOARD.

WHEREAS in the manner prescribed by the Regulations and at an election held in conjunction with the election of Frederick Charles McArdle as the Public Service representative on the Public Service Board, George William Rogan was elected to be his deputy in the case of his suspension, illness or absence:

And whereas the said Frederick Charles McArdle is unable by reason of illness to attend the meeting of the Board on Wednesday, the 26th July, 1961:

Now therefore, at the request of the said Frederick Charles McArdle and in pursuance of the powers conferred by section 2 of the *Public Service (Amendment) Act 1959* (No. 6579), I do hereby appoint the said George William Rogan to be the deputy of Frederick Charles McArdle on that day.

Given under my Hand, at Melbourne, this twenty-sixth day of July, 1961.

A. GARRAN,
Chairman.

PRIVATE ADVERTISEMENTS

Dog Act 1958.
CITY OF COBURG.

THE Council of the City of Coburg hereby specifies for the purposes of section 17 of the *Dog Act 1958* the following shopping areas in which the owner of any dog (other than a dog being used in the droving of stock) which is found in or on any such shopping area, and

which is not under the effective control of some person by means of a chain or cord or leash, shall be liable for a first offence to a penalty of not more than Four pounds, and for a second or any subsequent offence to a penalty of not more than Ten pounds:—

- Pascoe-street, south side, from West-street to Northumberland-road.
- Kent-road, north side, from Cumberland-road eastwards a distance of approximately 213 feet.
- Sussex-street, east side, from Shorts-road to Rollo-street.
- Sussex-street, west side, from Heather-avenue northward a distance of approximately 45 feet.
- Sussex-street, west side, from Heather-avenue southward a distance of approximately 45 feet.
- Gaffney-street, south side, from Parker-street to the Pascoe Vale railway line.
- Gaffney-street, south side, from Molesworth-street to Higinbotham-street.
- Cumberland-road, east side, from Gaffney-street northward a distance of approximately 270 feet.
- Cumberland-road, east side, from Gaffney-street to Bradley-street.
- Melville-road, west side, from Bell-street southward a distance of approximately 246 feet.
- Melville-road, west side, from Woodlands-avenue northward a distance of approximately 132 feet.
- Bell-street, north side, from Greenwood-street to Turner-street.
- Bell-street, north side, from Sussex-street eastward a distance of approximately 90 feet.
- Bell-street, north side, from York-street to Wills-street.
- Bell-street, north side, from York-street eastward a distance of approximately 72 feet.
- Bell-street, north side, from Sydney-road to Main-street.
- Bell-street, north side, from Clifton-grove to Suffolk-avenue.

Bell-street, north side, from Suffolk-avenue westward a distance of approximately 87 feet.
 Bell-street, south side, from Royal-parade to Springhall-parade.
 Bell-street, south side, from Sydney-road to the Coburg railway line.
 Coonans-road, west side, from Parkstone-avenue to Brentwood-avenue.
 Moreland-road, north side, from Sydney-road to Cameron-street.
 Moreland-road, north side, from Nicholson-street to East-street.
 Sydney-road, east side, from Moreland-road to Moore-street.
 Sydney-road, east side, from The Avenue to Rennie-street.
 Sydney-road, east side, from Sheffield-street to Bell-street.
 Sydney-road, east side, from Gaffney-street northward a distance of approximately 120 feet.
 Sydney-road, east side, from Bakers-road southward a distance of approximately 138 feet.
 Sydney-road, east side, from Mathieson-street southward a distance of approximately 63 feet.
 Sydney-road, west side, from Moreland-road northward a distance of approximately 310 feet.
 Sydney-road, west side, from The Avenue to Norman-street.
 Sydney-road, west side, from Munro-street to Bell-street.
 Sydney-road, west side, from Bell-street northward a distance of approximately 128 feet.
 Sydney-road, west side, from Bakers-road to Spry-street.
 Sydney-road, west side, from Plaisted-street to Boundary-road.
 Elizabeth-street, east side, from McNamara-street northward a distance of approximately 114 feet.
 Elizabeth-street, east side, from McNamara-street southward a distance of approximately 130 feet.
 Elizabeth-street, west side, from Murray-road northward a distance of approximately 382 feet.
 Merlyn-street, west side, from Orvieto-street to Novian-street.
 Lorensen-avenue, west side, from Delta-avenue northward a distance of approximately 120 feet.
 Orvieto-street, south side, from a point 110 feet west of Lorensen-avenue westward a distance of approximately 72 feet.
 Derby-street, west side, from Windsor-street to Warwick-street.
 Munro-street, south side, from Liverpool-street to Jamieson-street.
 Reynard-street, north side, from Phillips-street to Preston-street.
 Reynard-street, south side, from Queen-street to Donne-street.
 Harding-street, north side, from Salisbury-street to Gladstone-street.
 Anderson-street, west side, from Westgate-street northward a distance of approximately 130 feet.
 Newlands-road, east side, from a point 530 feet north of Nola-street northward a distance of approximately 450 feet.

14953

G. A. BRIDGES, Town Clerk.

CITY OF KEW.

ORDER CHANGING NAME OF STREET.

NOTICE is hereby given that at a meeting of the Council of the City of Kew held on the 25th day of July, 1961, the said Council, in pursuance of the powers conferred by the *Local Government Act 1958*, did make an Order changing the name of the street set out hereunder:—

Old Name; New Name.

Fenton-arcade; Fenton-way.

By order,

14954

W. D. BIRRELL, Town Clerk.

TOWN OF CASTLEMAINE.

BY-LAW No. 115 made under the Local Government Acts prohibiting the leaving standing of derelict or unregistered motor cars on streets or roads is now in force, and a copy is open for inspection, free of charge, at the Town Hall, during office hours.

14922

G. R. GOUGH, Town Clerk.

SHIRE OF BAIRNSDALE.

ALTERATION IN STREET NAME.

NOTICE is hereby given that in pursuance of the powers conferred by the Local Government Acts, the Council of the Shire of Bairnsdale at a meeting held on the

11th day of July, 1961, did resolve on the following change in a street name, viz.:—

Location and Previous Name; New Name.

In the Township of Paynesville, westerly from the corner of the Bairnsdale-Paynesville road. Formerly known as Government-road or Newlands Backwater-road; Newlands-drive.

14961

E. LLOYD BRINDLEY, Shire Secretary.

SHIRE OF BAIRNSDALE.

SPECIAL ORDER.

Private Streets Construction—Loan No. 37.

NOTICE is hereby given that at a Special Meeting of the Council held on the 27th day of June, 1961, the following Resolution was adopted:—

That the Council hereby makes a Special Order to borrow on the credit of the President, Councillors and Ratepayers of the Shire of Bairnsdale, the sum of Fifteen thousand pounds (£15,000) such sum to be secured by a grant of mortgage in accordance with the provisions of the Local Government Act and that the following provisions apply to such loan, namely:—

The rate of interest to be paid in respect of such loan be £5 17s. 6d. per centum per annum.

Such loan with interest thereon be repayable in 30 equal half-yearly instalments at the Bank of New South Wales Savings Bank, Melbourne, the first of such payments to be made on the 1st day of January, 1962 and the final payment on the 1st day of July, 1976.

The proceeds of such loan be applied to the cost of constructing private streets named Tomkins and High streets, as set out in lodged plan of subdivision No. 20518, and the private street, known as Power-street, set out in lodged plan of subdivision No. 10945, in accordance with construction schemes as finally settled under the provisions of Division 10 of Part XIX. of the *Local Government Act 1958*.

The loan to be liquidated from the receipts of money payable under the said private street schemes—any insufficiency being advanced out of the municipal fund in accordance with the provisions of the *Local Government Act 1958*.

And it is hereby further notified that at a Special Meeting of the Council held on Monday, 24th July, 1961, the above Resolution was confirmed.

14960

E. LLOYD BRINDLEY, Shire Secretary.

SHIRE OF BERWICK.

BY-LAW No. 40.

A By-law of the Shire of Berwick, made under section 65 of the *Health Act 1958* as amended by the *Health (Amendment) Act 1960*, for fixing a fee for the examination of plans, specifications, particulars and descriptions of proposed septic tank systems and any inspections of sites and installations.

IN pursuance of the powers of the *Health Act 1958* and of any and every other power it thereunto enabling the President, Councillors and Ratepayers of the Shire of Berwick orders as follows:—

1. The following fee is hereby fixed:—

For the examination of plans, specifications, particulars and descriptions of proposed septic tank systems, and any inspections of sites and installations of septic tank systems—£3.

Resolution for passing this By-law was agreed to by the Council of the Shire of Berwick on the 17th day of April, 1961, and confirmed on the 19th day of June, 1961.

The common seal of the President, Councillors and Ratepayers of the Shire of Berwick was hereunto affixed in the presence of—

(SEAL) R. H. TEMPLETON, President.
 P. B. RONALD, Councillor.
 A. E. TOWT, Councillor.
 BEATRICE THOMAS, Secretary.

14959

SHIRE OF GISBORNE.

NOTICE is hereby given that the Council of the Shire of Gisborne has made a By-law No. 35 for the purpose of fixing a fee of £2 for the examination of plans and specifications, particulars and descriptions of proposed septic tank systems and any inspections of sites and installations.

A copy of the By-law is available for inspection, during office hours, at the Shire Office, Gisborne.

14951

K. V. ROBINSON, Shire Secretary.

SHIRE OF GISBORNE.

ORDER CHANGING THE NAME OF A STREET.

NOTICE is hereby given that at a meeting of the Council of the Shire of Gisborne held on 3rd July, 1961, the said Council, in pursuance of the powers conferred by the *Local Government Act 1958*, did make an Order changing the name of the street as set out hereunder:—

Old Name.—Back-road or Slocombes-road.

New Name.—Hobbs-road.

Location.—Westerly of allotments 18, 21 and 27, section M, Parish of Gisborne.

14952 K. V. ROBINSON, Shire Secretary.

SHIRE OF KILMORE.

LOAN No. 24.

Notice of Intention to Borrow the Sum of £15,000 for Permanent Works and Undertakings.

NOTICE is hereby given that the Council of the Shire of Kilmore proposes to borrow the sum of Fifteen thousand pounds on the credit of the municipal revenues of the President, Councillors and Ratepayers of the said Shire of Kilmore, such sum to be raised by the grant of a mortgage, in accordance with the provisions of the *Local Government Act 1958*.

1. The maximum rate of interest that may be paid is 13/16 per cent. per annum.

2. The purposes for which the loan is to be applied are:—

(a) Construction of kerbing and channelling and associated works.

(b) Purchase of road-making plant.

3. The period of the loan shall be seven years.

4. The moneys borrowed shall be repayable by providing out of the Municipal Fund fourteen half-yearly instalments of approximately £1,319 8s. 6d. each, including principal and interest, on the 1st day of May and the 1st day of November during the currency of the loan. The first instalment shall be payable on the 1st day of May, 1962.

5. Such moneys shall be repayable at the State Savings Bank of Victoria, Melbourne.

The plans and specifications and the estimate of the cost of the proposed works, and a statement showing the proposed expenditure of the moneys borrowed, shall be open for inspection at the Shire Offices, Kilmore.

14930 J. T. LEDWIDGE, Acting Shire Secretary.

SHIRE OF KORUMBURRA.

BY-LAW No. 40.

A By-law of the Shire of Korumburra, made under the *Local Government Act 1958* and the Uniform Building Regulations, Victoria, and numbered 40, for prescribing areas in which off-street accommodation for stationary vehicles shall be provided in or within a specified distance of every building thereafter constructed within such areas.

IN pursuance of the powers conferred by the *Local Government Act 1958* and the Uniform Building Regulations, Victoria, and of any other power thereunto enabling them in that behalf, the President, Councillors, and Ratepayers of the Shire of Korumburra order as follows:—

1. (a) Subject to paragraphs (b) and (c) hereof, upon the land set out and described in the First Schedule hereto and used or intended to be used for any purpose specified in column 1 in the Table to this clause, provision shall be made for the accommodation of stationary vehicles in the ratio set forth in column 2 of such Table, but so that the number of car spaces so provided shall be not less than the nearest whole number to the number arrived at when the ratio is applied.

(b) So long as any existing accommodation for stationary vehicles is not diminished regard shall be had when applying the ratio set forth in column 2 of the Table to this clause only to such buildings or to such parts of buildings (as the circumstances require) constructed after the commencing date.

(c) Where land is insufficient in area to enable provision for the accommodation of stationary vehicles to be made in accordance with the Table to this clause additional provision shall be made upon other land in the vicinity for the accommodation of such vehicles so that the total area so provided complies with the requirements of the said Table.

(d) Save where access to a car space is obtained directly from a street or road an access lane or lanes of sufficient dimensions shall be provided.

(e) The area of each car space shall not be less than 140 square feet, and—

(i) where entrance to a car space is obtained from the side the combined width of the car space and the access lane shall not be less than 15 feet. Where access is obtained as aforesaid if the combined width of the car space and the access lane is not more than 16 feet the length of the car space shall be not less than 24 feet; if such combined width is more than 16 feet but less than 17 feet the length of the car space shall be not less than 22 feet; and if such combined width is more than 17 feet the length of the car space shall be not less than 20 feet;

(ii) where entrance to a car space is from an end and such car space is at right angles to the access lane, the length of the car space shall be not less than 16 ft. 6 in. and the width of the access lane shall be not less than 20 feet;

(iii) where entrance to the car space is from an end and such car space is at an angle of 45 degrees to the access lane the length of the car space shall be not less than 16 ft. 6 in. and the width of the access lane shall be not less than 12 feet.

(f) The occupier of land wherein provision is or is to be made for the accommodation of stationary vehicles in conformity with this clause shall before any building or work is constructed or enlarged, rebuilt or extended on such land, lodge with the Council a plan upon which shall be delineated all car spaces and access lanes constituting such accommodation and shall at all times in conformity with such plan clearly indicate on the ground the boundaries of all such car spaces and access lanes.

TABLE TO CLAUSE 2.

Column 1.	Column 2.
Residential building ..	one car space to each five lodging-rooms.
Flats	three car spaces to each four flats.
Factories	one car space to each 1,000 square feet of floor area of the building.
Warehouse or Store ..	one car space to each 2,000 square feet of floor area of the building.
Office	one car space to each 500 square feet of floor area of the building.
Place of assembly—other than a public hall	one car space to each 200 square feet of floor area of the building.
Place of worship or public hall	one car space to each ten seats.
Hotel	one car space to each 20 square feet of bar floor space available to the public and one car space to each 60 square feet of lounge or beer garden floor space available to the public.
Shops	one car space to every 80 square feet of floor space available to the public.

2. (a) Where under or pursuant to this By-law provision is required to be made for the accommodation of vehicles such provision shall at all times continue to be made.

(b) Where under or pursuant to this By-law provision is made on land for the accommodation of stationary vehicles such land shall not, without the consent of the Council, be used so as to reduce such accommodation.

FIRST SCHEDULE.

Such portions of the municipality as are included in the areas described hereunder, namely:—

The whole of the Korumburra Riding of the Shire of Korumburra as is now or may hereafter be defined.

The Resolution for making and passing this By-law was agreed to by the Council at its meeting held on the 19th day of April, 1961, and confirmed on the 17th day of May, 1961.

The common seal of the President, Councillors, and Ratepayers of the Shire of Korumburra was hereunto affixed, in the presence of—

(SEAL) J. ANDERSON, President.
H. C. GOAD, Councillor.
M. H. GARDNER, Secretary.

Approved by the Governor in Council, 11th July, 1961.
—A. MAHLSTEDT, Clerk of the Executive Council. 14931

SHIRE OF KOWREE.

BY-LAW No. 36.

A By-law of the Shire of Kowree made under the Local Government Acts and the Uniform Building Regulations, Victoria, and numbered 36 for determining, applying, dispensing with or regulating such matters or things as are left to be determined, applied, dispensed with or regulated by the Council of the said Shire under the Uniform Building Regulations, Victoria.

IN pursuance of the powers conferred by the Local Government Acts and the Uniform Building Regulations, Victoria, and of any and every other power it thereunto enabling the President, Councillors and Ratepayers of the Shire of Kowree, doth order as follows:—

1. Clause 3 of By-law No. 31 of the Shire of Kowree, is hereby repealed.

2. For Clause 3 of By-law No. 31 so repealed there shall be substituted the following:—

3. The minimum area depth and width of frontage specified in Column 3 of Table 804 of the Uniform Building Regulations 1959, as amended by Uniform Building Regulations Amending Regulations No. 2, 1959 (hereinafter called the Regulations), are hereby adopted as the minimum area, depth and width of frontage of land on which a building of Class I. or Class II. Occupancy shall be constructed throughout those portions of the said Shire to which the operation of the said Regulations has been or shall hereafter be extended.

3. Clause 5 of By-law No. 31 is hereby repealed.

4. For Clause 5 of By-law No. 31 repealed by this By-law there shall be substituted the following clause:—

5. In the case of a building on any land forming part of a subdivision approved by the Council and lodged with the Office of Titles prior to the date of commencement of the Regulations the requirements of Clause 813 of the Regulations requiring rear access to buildings of Class IV. Occupancy, are hereby dispensed with.

5. This By-law shall apply to and have operation throughout those portions of the municipal district to which the operation of the said Regulations were extended by Proclamation of 15th April, 1955.

The Resolution for passing this By-law was agreed to by the Council of the Shire of Kowree on the 4th day of October, 1960, and confirmed by Resolution of the Council of the Shire of Kowree on the 10th day of April, 1961.

The common seal of the President, Councillors and Ratepayers of the Shire of Kowree was hereto affixed the 10th day of April, 1961, in the presence of—

(SEAL) R. G. WALKER, President.
R. L. AMPT, Councillor.
H. ERNEST WALKER, Secretary.

Approved by the Governor in Council, the 11th day of July, 1961.—A. MAHLSTEDT, Clerk of the Executive Council. 14927

SHIRE OF LOWAN.

BY-LAW No. 58.

A By-law of the Shire of Lowan, made under section 65 of the *Health Act 1958*, as amended by the *Health (Amendment) Act 1960*, for fixing a fee for the examination of plans, specifications, particulars and descriptions of proposed septic tank systems, and any inspection of sites and installations.

IN pursuance of the powers of the *Health Act 1958* and of any and every other power it thereunto enabling, the Council of the Shire of Lowan orders as follows:—

1. The following fee is hereby fixed:—

For the examination of plans, specifications, particulars and descriptions of proposed septic tank systems, and any inspection of sites and installations of septic tank systems—£2 10s.

Resolution for passing this By-law was agreed to by the Council of the Shire of Lowan on the 20th day of June, 1961, and confirmed on the 18th day of July, 1961.

The common seal of the President, Councillors and Ratepayers of the Shire of Lowan was hereunto affixed the 28th day of July, 1961, in the presence of—

(SEAL) G. J. PILGRIM, President.
M. J. MEEK, Councillor.
F. W. FRITSCH, Secretary.

14947

SHIRE OF LOWAN.

BY-LAW No. 59.

A By-law of the Shire of Lowan, made under the Local Government Acts, and numbered 59 for regulating the writing, painting, printing, stencilling, placing or affixing any letter, figure, device, poster, sign or advertisement upon any footpath, street or road or upon any building, fence, or other property vested in the Shire of Lowan or under the control and management of the Council thereof.

IN pursuance of the powers conferred by the Local Government Acts and of every and any other power it thereunto enabling the President, Councillors and Ratepayers of the Shire of Lowan order as follows:—

1. No person shall without the consent of the said Council or an Officer thereof duly authorized in that behalf first had and obtained write, paint, print, stencil, place or affix any letter, figure, device, poster, sign or advertisement upon any footpath, street or road or upon any building, fence or other property vested in the municipality or under the control and management of the Council thereof.

2. The said Council may obliterate, abolish or remove any letter, figure, device, poster, sign or advertisement effected in breach of this By-law.

3. Any person who shall be guilty of any wilful breach of any of the provisions of this By-law shall be liable for each and every offence to a penalty not exceeding Twenty pounds, and, if such offence is continued, to a further penalty not exceeding £2 for each day during which such offence is continued, and shall also be liable to repay any expense incurred by the Council, in pursuance of clause 2 hereof.

4. This By-law shall apply and have operation throughout the Nhill Riding of the municipal district of the Shire of Lowan.

Resolution for passing this By-law agreed to by the Council of the Shire of Lowan the 20th day of June, 1961, and confirmed on the 18th day of July, 1961.

The common seal of the President, Councillors and Ratepayers of the Shire of Lowan was hereunto affixed the 28th day of July, 1961, in the presence of—

(SEAL) G. J. PILGRIM, President.
M. J. MEEK, Councillor.
F. W. FRITSCH, Secretary.

14948

SHIRE OF ORBOST.

BY-LAW No. 48.

NOTICE is hereby given that in pursuance of powers conferred by the *Local Government Act 1958*, the Council of the Shire of Orbost has made By-law No. 48, for the purpose of prohibiting the leaving, standing of derelict or unregistered motor cars on streets or roads in the Shire, and providing for the removal and disposal of such motor cars and the imposition of charges for such removal and disposal.

The approval of the Governor in Council was granted on the 4th day of July, 1961.

Copy of the By-law may be inspected, free of charge, at the Shire Office, Orbost.

27th July, 1961.

14955 JAMES H. MITCHELL, Shire Secretary.

SHIRE OF RODNEY.

ORDER CHANGING NAMES OF STREETS IN THE TOWNSHIP OF MERRIGUM.

IN pursuance of the powers conferred on it by the provisions of the *Local Government Act 1958*, the President, Councillors and Ratepayers of the Shire of Rodney do hereby Order that the names of streets in the Township of Merrigum set out hereunder, be altered to the new names hereinafter appearing—

Old Name; New Name; Location.

Tatura-Byrneside-Kyabram road; Waverley-avenue; that portion within the boundary of the Township of

Merrigum, being the north-south road between Crown allotments 86 and 68, Parish of Mooropna West and 84 and 83, Parish of Kyabram East.

Merrigum—Cooma and Merrigum—Ardmona roads; Morrissey-street; that portion within the boundary of the Township of Merrigum, being the east-west road between Crown allotments 86 and 68, Parish of Mooropna West and 84 and 83, Parish of Kyabram East.

(Unnamed); Lifford-street; Cul-de-sac, commencing at the Merrigum—Ardmona road (as altered by this Order to Morrissey-street), proceeding in a south-easterly direction approximately parallel with the railway line.

School-road; Judd-avenue; from the Tatura—Byrneside—Kyabram road (as altered by this Order to Waverley-avenue) west to the railway line.

Dated this 26th day of June, 1961.

The common seal of the President, Councillors and Ratepayers of the Shire of Rodney was hereto affixed in the presence of—

(SEAL) O. F. YOUNG, President.
A. T. CALDER, Councillor.
14949 R. PERRY, Secretary.

SHIRE OF WARANGA.

LOAN No. 24.

Notice of Intention to Borrow the Sum of Five Thousand Pounds (£5,000) for Permanent Works and Undertakings.

NOTICE is hereby given that the Council of the Shire of Waranga proposes to borrow on the credit of the municipal revenues of the President, Councillors and Ratepayers of the said Shire, the sum of Five thousand pounds (£5,000) such sum to be raised by the grant of a mortgage, in accordance with the provisions of the *Local Government Act 1958*.

1. The maximum rate of interest that may be paid is £5 17s. 6d. per centum per annum.

2. The purpose for which the loan is to be applied is for the completion and equipping of the Civic Centre at Rushworth.

3. The period of the loan shall be ten years.

4. The moneys borrowed shall be repayable by providing out of the municipal fund twenty half-yearly instalments of approximately £334 3s. each, including principal and interest, on the 1st day of April and the 1st day of October during the currency of the loan. The first instalment shall be payable on the 1st day of April, 1962.

5. Such moneys shall be repayable at the State Savings Bank of Victoria, Melbourne.

The plans and specifications and the estimate of the proposed works and a statement showing the proposed expenditure of the money to be borrowed, are open for inspection at the offices of the Council, High-street, Rushworth.

14956 B. E. LEACH, Shire Secretary.

SHIRE OF WARRAGUL.

By-LAW No. 67.

A By-law of the Shire of Warragul, made under the *Health Act 1958*, and numbered 67, for the purpose of providing for the collection and disposal of nightsoil.

IN pursuance of the powers contained in the *Health Act 1958* and of any other power thereunto enabling them in that behalf, the Council of the Shire of Warragul, in the name and on behalf of the President, Councillors and Ratepayers of the said Shire, for the purpose of carrying the said Act into execution within their jurisdiction, make the following By-law (that is to say):—

1. All former By-laws so far as they relate to the matters and things provided for in this By-law are hereby repealed.

2. This By-law shall come into full force and operation on its approval by the Governor in Council and immediately after its publication in the *Government Gazette*.

3. This By-law shall apply to and have operation in the areas described and set out in the Schedule to this By-law.

4. In this By-law, unless inconsistent with the context or subject-matter—

“Inspector” means any officer authorized by the Commission or Council, and includes any acting or assistant inspector.

“Proprietor” means the proprietor of any premises, and includes the owner, the occupier, or any person having the management or control thereof.

“The Commission” means the Commission of Public Health.

“Officer of the Council” means any regularly and duly appointed officer of the Council.

5. The proprietor of any premises on which there is erected a pan-closet shall cause the space under the seat of each pan-closet on such premises to be prepared for the accommodation of a pan as described herein, and shall permit the same to be used for the double-pan service hereinafter provided for and shall cause each pan-closet to be kept in a fit state for such service.

6. The proprietor shall cause every pan-closet to be supplied by the Council or otherwise with a pan for the reception of nightsoil, and shall cause such pan (except when being exchanged) to be always kept in proper position under the seat of each pan-closet, and shall also provide a lid capable of being fitted tightly to such pan when being removed from the premises to the depot, so as to prevent the spilling of the contents and the emission of offensive vapours, gases, or effluvia from the contents of such pan.

7. Such pan shall be cylindrical in shape and formed of galvanized iron of not less than 22-gauge or other approved materials or materials presenting on the inside and outside an impervious hard, smooth, and durable surface, and those surfaces which come into contact with nightsoil shall also be free from any projections. It shall be water-tight, strongly constructed, reinforced with metal bands where necessary, and provided with properly attached side-lifting handles. Each pan shall have a capacity of 1½ cubic feet, and shall have an internal depth of 14 inches, a diameter of not less than 14 inches, and a suitable rim or lugs to permit an air-tight lid to be affixed. The seams of the pan shall be folded, grooved, and sweated with solder.

8. The proprietor of the premises shall cause to be kept in every closet belonging thereto a supply of liquid deodorant or lime, sawdust, or some other dry material efficient for deodorizing nightsoil, and shall cause all nightsoil which may be deposited in the pan in such pan-closet to be immediately on the deposit thereof covered with a quantity of deodorizing material sufficient to thoroughly and effectually deodorize the contents of such pan.

9. The proprietor shall provide every urinal with an approved apparatus for the regulated automatic discharge into such urinal of sufficient approved deodorant for the purpose of keeping such urinal constantly deodorized.

10. No person shall place, or cause or permit to be placed, any slops, water, or rubbish in any pan.

11. The proprietor of any premises whereon there is a pan-closet or urinal shall—

(a) maintain such pan-closet and urinal in good repair and in a cleanly condition; and

(b) when required by an inspector effectually disinfect such pan-closet and urinal and/or the contents thereof, and effect any repairs thereto that such inspector may deem necessary.

12. At least once a week, and in any case as often as may be necessary to prevent the level of the contents of such pan approaching within 2½ inches of the brim thereof, the pan in use shall be closed with a lid and removed by the contractor or person authorized or employed in that behalf by the Council with its contents from the premises and another pan, thoroughly cleansed and in good order, shall be left in its place.

13. Such contractor or person removing such pans shall report to the Council at the earliest available opportunity the discovery of any pan found to be overflowing or leaking, and shall forthwith cause the place whereon the contents have been dropped or spilled to be properly cleaned.

14. The contractor or person authorized or employed by the Council for that purpose shall cause all pans to be removed in a suitable covered vehicle in such a manner as not to cause nuisance, danger to health, or offensiveness, and forthwith cause such vehicle to be removed to the approved depot.

15. The contractor or person or persons authorized or employed by the Council for the removal of nightsoil shall cause it to be properly, efficiently, and sanitariously disposed of—

(a) at a depot provided by the Council or a Sewerage Authority in accordance with the requirements of the *Health Act and Regulations*; or

(b) at a depot provided by the contractor or authorized person and registered with the Council; or

- (c) by means of desiccation, incineration, destructive distillation, or by treatment with absorbent substances or chemicals, or by discharging into a sewer of a Sewerage Authority, or by connecting with an approved septic tank system, or by any other method authorized by the Council with the approval of the Commission of Public Health.
16. If such nightsoil be disposed of in trenches, then—
- such trenches shall not be more than 18 inches wide and shall be excavated to a regular plan;
 - no trench shall be more than 18 inches nor less than 9 inches deep and the depth of any one trench shall be sensibly uniform throughout its length;
 - every trench shall be so located in relation to the slopes of the land that its bottom shall be at the same level throughout its length;
 - the first trench in every depot or unit shall be excavated (subject to compliance with Regulation 27 (b) of the General Sanitary Regulations 1950) near the lowest part of such depot or section and each subsequent trench shall be higher than its predecessor until the depot or unit has been used;
 - in all cases where the soil is such that liquid is not readily absorbed the bottom of the trench shall be broken up roughly so that liquid from the nightsoil may drain rapidly into the spaces between the clots, provided that no trench shall be so used where the bottom consists of rock or other impermeable material.
17. Nightsoil shall be emptied into trenches in such a manner as to avoid splashing and so that no nightsoil shall be less than 6 inches below the surface of the undisturbed soil; and it shall be covered immediately with soil to a depth of at least 6 inches. Covering of nightsoil shall be done so as not to cause overflowing or to raise the surface of the nightsoil closer to ground level than 3 inches, and any soakage to the surface shall be immediately covered with clean earth, the necessary filling to be obtained by excavation of another trench in a parallel position to but not less than 12 inches from the aforesaid trench required to be filled in.
18. Spilled nightsoil shall be forthwith collected and buried as described in the foregoing and the soiled ground shall be immediately covered with clean earth.
19. Every depot as a whole and in large depots where the slope of the surface or character of the soil so requires, every section shall be protected from ingress of water from neighbouring land; and provision shall be made by means of check banks, trenches, and/or apparatus to prevent the escape of polluted drainage from such depot, and it shall be the responsibility of the contractor or persons authorized to ensure that such escape of polluted drainage shall be prevented.
20. Such contractor or persons authorized by the Council for that purpose shall immediately report to the Council any escape of polluted drainage from a depot however caused.
21. Every pan used for the reception or conveyance of nightsoil shall immediately on being emptied be thoroughly washed or otherwise cleansed. The resultant washings or other filth shall be disposed of in a similar manner as the nightsoil.
22. Every pan after the disposal of its contents and after being cleansed in manner aforesaid and before it again leaves the depot or disposal ground shall on every such occasion be thoroughly cleansed and disinfected by—
- immediately after washing and scrubbing with water subjecting the pan to a current of steam from a boiler at 60-lb. pressure to the square inch for not less than two minutes in a steam-tight box or chamber; or
 - thorough washing and scrubbing in water then rinsing in clean water and finally submerging for not less than five minutes in an aqueous solution containing not less than 1 per cent. of accol, cyllin, kerol, izal, hycol, or other disinfectant of equal efficiency; or
 - thorough washing and scrubbing in water and afterwards submerging for not less than five minutes in boiling water; or
 - any other method approved in writing from time to time by the Commission.
23. The internal surface of every pan before it is first used shall be properly coated with well-boiled tar, crude creosote, or other approved material, and such coating shall thereafter be renewed when deemed necessary by the Council, but not less than once a month.

24. The contractor or person authorized or employed by the Council for the removal of nightsoil shall cause all vehicles used for the transport of pans to the depot to be properly constructed, kept clean, and disinfected daily at the depot and maintained in a proper state of repair.

25. The proprietor or any other person shall not remove any nightsoil from any premises except in accordance with this By-law.

26. The proprietor or any other person within the area defined by this By-law shall not bury nor cause to be buried any nightsoil in any yard, garden, or other place not being a place set apart for such purpose by the Council.

27. The inspector or any other officer or officers duly appointed by the Council shall have full power to enter into or upon any premises, yards, or lands at any time for the purpose of inspecting closets, urinals, pans, receptacles, vehicles, plant, and all other things and places therein and thereon, and for the purpose of carrying out the provisions of this By-law.

28. If any person or the Council commit a breach of this By-law he or they shall for every breach be liable to a penalty of not more than Twenty pounds, and in the case of a continuing offence to a further daily penalty of not more than Five pounds.

29. All complaints and infringements against this By-law shall be reported to the Council, in writing, within 24 hours after such occurrence of infringement.

THE SCHEDULE ABOVE REFERRED TO.

Township of Darnum.—All that piece of land being parts of the Township of Darnum, Parish of Darnum, comprising sections 1-8 inclusive of the Town of Darnum; C.A.'s 6-8, sections 10, 11, and 14, section 12; 4 and 5, section 13; 4, section 15; State School and Recreation Reserve.

Town of Nilma.—All that piece of land being all the Township of Nilma, Parish of Drouin East, together with C.A. 79B, Parish of Drouin East, and State School; C.A.'s 16 and 16A, Parish of Darnum.

Town of Rokeby.—All that piece of land being the whole of the Township of Rokeby, Parish of Drouin East, together with C.A.'s 20 and 20B, Parish of Drouin East.

Town of Buln Buln.—All that piece of land being part of the Parish of Drouin East, being C.A.'s 35A, 35B, 36, pt. 42A and 43 and pt. 44, Parish of Drouin East.

Town of Warragul.—All that piece of land being the Town of Warragul and part Parish of Drouin East, comprising the whole of sections 1-12, Town of Warragul, together with C.A.'s 103, 102, 101, 100, 99, 93, 89, 87, 86, 82, 78, 78A, 77, 75, 73 and 71, Parish of Drouin East, the whole of section A and Bona Vista Estate, section B, Parish of Drouin East, and pt. C.A.'s 92, 84, 70 and 61, Parish of Drouin East.

Resolution for passing this By-law agreed to by the Council on the 14th March, 1961, and confirmed on the 11th April, 1961.

The common seal of the President, Councillors and Ratepayers of the Shire of Warragul was affixed hereto this 11th April, 1961—

(SEAL) W. A. GREEN, President.
ROY MCKAY, Councillor.
D. McADIE, Shire Secretary.

Submitted to the Commission of Public Health, on the 30th day of May, 1961.—A. GARDNER, Secretary, Commission of Public Health.

Approved by the Governor in Council, on the 14th day of June, 1961.—A. MAHLSTEDT, Clerk of the Executive Council. 14950

SHIRE OF WINCHELSEA.

BY-LAW No. 55.

A By-law of the Shire of Winchelsea made under section 65 of the *Health Act 1958* as amended by the *Health (Amendment) Act 1960*, and numbered 55 for the purpose of fixing a fee for the examination of plans, specifications, particulars and descriptions of proposed septic tank systems and any inspection of sites and installations.

IN pursuance of the powers conferred by the *Health Act 1958*, and every other power enabling it in that behalf, the President, Councillors and Ratepayers of the Shire of Winchelsea order as follows:—

1. The following fee is hereby fixed:—

For the examination of plans, specifications, particulars and descriptions of proposed septic tank systems and any inspection of sites and installations of septic tank systems—£2.

Resolution for passing this By-law agreed to by the Council of the Shire of Winchelsea on the 14th day of June, 1961, and confirmed on the 12th day of July, 1961.

The common seal of the President, Councillors and Ratepayers of the Shire of Winchelsea was affixed hereto in the presence of—

(SEAL) CHARLES McDONALD, President.
14958 J. S. CALDOW, Councillor.
W. W. WESTHORPE, Shire Secretary.

SHIRE OF WOORAYL.

BY-LAW No. 44.

NOTICE is hereby given that the Council of the Shire of Woorayl has made By-law No. 44 for prohibiting or regulating the use on any road of any vehicle having projections on its wheels or which moves wholly or partly on crawler or revolving tracks and for other purposes.

A copy of the said By-law No. 44 is available for inspection at the Shire Office, Leongatha.

14944 A. BEANLAND, Shire Secretary.

SHIRE OF WOORAYL.

BY-LAW No. 45.

NOTICE is hereby given that the Council of the Shire of Woorayl has made By-law No. 45 for fixing a fee for the examination of plans, specifications, particulars and descriptions of proposed septic tank systems and any inspections of sites and installations.

A copy of the said By-law No. 45 is available for inspection at the Shire Office, Leongatha.

14945 A. BEANLAND, Shire Secretary.

SHIRE OF WOORAYL.

NOTICE is hereby given that Senior Constable Percival Noah Dennis Ball, No. 10515, has been appointed Prosecuting Officer to the Shire of Woorayl.

14946 A. BEANLAND, Shire Secretary.

NOTICE is hereby given that the Castlemaine Lawn Tennis Club has applied for a lease for a term of 21 years under section 134 of the *Land Act 1958*, in respect of an area of Crown lands, containing approximately 3a. 2r. 39p., being allotment 11, section 85, Township of Castlemaine, as a site for purposes of Amusement and Recreation (Tennis Courts and Club Rooms). 14826

TRARALGON SEWERAGE AUTHORITY.

THE above-mentioned Sewerage Authority, having made provision for the carrying off of sewage from each and every property which or any part of which is within the Sewerage Area hereinafter described, doth hereby declare that on and after the 1st day of August, 1961, each and every property which or any part of which is within the said Sewerage Area shall be deemed to be a sewered property within the meaning of the *Sewerage Districts Act 1958*.

The boundaries of the Sewerage Area hereinbefore referred to are as follows:—

SEWERAGE AREA No. 19.

Commencing at the north-western angle of lot 198, lodged plan of subdivision No. 23924, Township and Parish of Traralgon, being a point on the eastern building line of Doyne-crescent and a point on the boundary of Sewerage Area No. 15; thence easterly along the northern boundary of the said lots 198 and 214 to Stockdale-road, easterly across Stockdale-road to a point on the eastern building line of Stockdale-road, southerly along the eastern building line of Stockdale-road to Grey-street, westerly along the southern building line of Grey-street to a point on the southern building line of Grey-street 24 feet west of the eastern building line of Doherty-court, northerly across Grey-street and northerly along the western boundary and easterly along the northern boundary of the land occupied by a Technical School to the south-western angle of lot 36, lodged plan of subdivision No. 23924, northerly along the western boundaries of lots 36, 35, 34, 33, 32, 31, 30, 29, 28, 27, 26, 25, 22, 21, 19, 18, 17, 16, 15, and 13, plan of subdivision No. 23924, to a point on the southern building line of Crambling-street easterly along the southern building line of Crambling-street to its intersection with Gilmour-street, southerly along the western building line of Gilmour-street to a point opposite the southern building line of Johnson-crescent, easterly along the southern building line of Johnson-crescent to a point opposite the western building line of Doyne-crescent, northerly across Johnson-crescent and northerly along the western building line of Doyne-crescent to Holden-crescent westerly

along the northern building line of Holden-crescent to Wallace-court, northerly along the eastern building line of Wallace-court to the south-western angle of lot 152, plan of subdivision No. 23924, such angle being a point on the boundary of Sewerage Area No. 15; thence easterly, northerly and easterly along part of the boundary of Sewerage Area No. 15 to the point of commencement.

All of which boundaries are shown on a plan which is open for inspection at the office of the Sewage Authority.

14932 (SEAL) DONALD DUNBAR, Chairman.
CLEM LITTLE, Commissioner.
I. H. PATON, Secretary.

NOTICE is hereby given that the partnership heretofore subsisting between the undersigned, Walter Richard Penberthy and Frank Lowry, carrying on business as builders and contractors under the name of "W. R. Penberthy and F. Lowry", has been dissolved by mutual consent as from the 22nd day of May, 1961. All debts due and owing by the said late firm will be received and paid by the said Frank Lowry and Walter Richard Penberthy.

Dated at Geelong, this 25th day of July, 1961.

W. R. PENBERTHY.
F. LOWRY.

Witness—D. L. SCENEY, law clerk, Geelong. 14923

NOTICE is hereby given that the partnership heretofore subsisting between James Wills and Ian Robert Wills, both of Lake Bolac, carrying on business under the name of "James Wills and Son" has been dissolved as from the 30th day of June, 1961.

Dated the 30th day of June, 1961.

JAMES WILLS.
IAN ROBERT WILLS.

Briggs and O'Driscoll, solicitors, Ararat. 14929

NOTICE is hereby given that the partnership heretofore subsisting between John Maxwell Ryan, Ian Gifford McDonald and Noel Wealands, carrying on the business of the retailing and servicing of gas, electrical and other goods and equipment at Yarrowonga under the style or firm name of Yarrowonga Gas and Electric Centre, has been dissolved as from 30th June, 1961, so far as concerns the said Noel Wealands, who retires from the said firm.

Dated 26th July, 1961.

JOHN M. RYAN.
IAN G. McDONALD.
N. WEALANDS.

Witness:—W. W. HARGRAVE. 14957

ROSHEL FLATS PROPRIETARY LIMITED.

NOTICE is hereby given that the Final General Meeting of the members of the above-named company will be held at the office of H. Guest, public accountant, 207B Balaclava-road, Caulfield, on Wednesday, 13th September, 1961, at 2 p.m., for the purpose of laying before the meeting the account of the liquidator of the company showing how the winding up has been conducted and the property of the company has been disposed of.

Dated this 25th day of July, 1961.

14934 H. GUEST, Liquidator.

The Companies Act 1958.

ESPRESSO PTY. LIMITED.

AT an Extraordinary General Meeting of the members of the above company duly convened and held at the registered office of the company, 40 Little Latrobe-street, Melbourne, on Thursday, the 27th July, 1961, the following Special Resolution was duly passed:—

"That a declaration of solvency in a members' voluntarily winding up having been made by the directors, pursuant to section 198 of the *Companies Act 1958*, it now be resolved that the company be voluntarily wound up and that R. P. Orr, chartered accountant, be appointed liquidator."

Dated this 27th day of July, 1961.

14935 J. W. G. PALLISER, Director.

In the matter of the *Partnership Act 1958*, and in the matter of F. C. WADE AND SONS (a firm).

NOTICE is hereby given that the partnership heretofore subsisting between Frederick Charles Wade (the elder) of lot 6, High-street, Epping, and Percival James Wade, now of Maralinga, in the State of South Australia, and Frederick Charles Wade (the younger), of lot 4,

High-street, Epping, carrying on business at lot 6, High-street, Epping, under the style or firm of F. C. Wade and Sons, has been dissolved as from the 20th day of May, 1961, and all debts due and owing by the said late firm will be received and paid respectively by the said Frederick Charles Wade (the elder), at his above address.

Dated the 25th day of July, 1961.

FREDERICK CHARLES WADE.
PERCIVAL J. WADE.
FREDERICK CHARLES WADE.

14990

COGHILL & SON PROPRIETARY LIMITED (IN VOLUNTARY LIQUIDATION).

NOTICE is hereby given that a General Meeting of the members of Coghill and Son Proprietary Limited (in Voluntary Liquidation), will be held at the office of the liquidator, L. N. Jupp, chartered accountant, 360 Collins-street, Melbourne, on the 11th day of September, 1961, at the hour of Ten a.m., for the purpose of laying before the members an account showing how the winding up has been conducted and how the property of the company has been disposed of and giving an explanation thereof.

Dated this 2nd day of August, 1961.

L. N. JUPP, Liquidator.

Coltman, Wyatt and Anderson, solicitors, 578 Bourke-street, Melbourne. 14985

The Companies Act 1958.

ROBERT B. SENIOR & SONS PROPRIETARY LIMITED (IN LIQUIDATION).

NOTICE is hereby given that a First Dividend is intended to be declared in the above matter.

Creditors who have not proved their debts by the 18th day of August, 1961, may be excluded from this dividend.

Dated this 31st day of July, 1961.

J. K. HALL, Liquidator.

Hall and Rose, chartered accountants, 163 William-street, Melbourne. 14989

Companies Act 1958.—Victoria.

ENTERPRISE BUILDING CO. PROPRIETARY LIMITED (IN VOLUNTARY LIQUIDATION).

NOTICE CONVENING FINAL MEETING, PURSUANT TO SECTION 210.

NOTICE is hereby given, in pursuance of section 210 of the Companies Act 1958, that a General Meeting of the members of the above-named company will be held at 11 Queen-street, Melbourne, on the 11th day of September, 1961, at Ten o'clock in the forenoon, for the purpose of having an account laid before them showing the manner in which the winding up has been conducted and the property of the company disposed of and of hearing any explanation that may be given by the liquidator.

B. M. COOK, Liquidator.

11 Queen-street, Melbourne. 14988

HALES FLOATE PTY. LTD (IN VOLUNTARY LIQUIDATION).

NOTICE CONVENING FINAL MEETING, PURSUANT TO SECTION 210.

NOTICE is hereby given, in pursuance of section 210 of the Companies Act 1958, that a General Meeting of the members of the above-named company will be held at the office of the liquidator, 3rd Floor, 358 Collins-street, Melbourne, on Tuesday, 5th September, 1961, at half past Two o'clock in the afternoon, for the purpose of having an account laid before them showing the manner in which the winding up has been conducted and the property of the company disposed of and of hearing any explanation that may be given by the liquidator.

V. S. RANKIN, Liquidator.

358 Collins-street, Melbourne, C.1, 26th July, 1961. 14988

The Companies Act 1958.—In the matter of JAMES McLAREN PTY. LTD.

NOTICE is hereby given that, pursuant to section 210 of the Companies Act, a Final Meeting of the members of the above company will be held at the residence of James C. McLaren, 45 Outlook-drive, Burwood, on Thursday, 31st August, 1961, at Eight p.m.

Business: To receive the liquidator's accounts.

Dated this 25th day of July, 1961.

F. J. WATTY, Liquidator.

130 High-street, Kew. 14964

The Companies Act 1958.

WESTWAY PROPRIETARY LIMITED (IN VOLUNTARY LIQUIDATION).

NOTICE is hereby given that, pursuant to section 210 of the Companies Act 1958, a Final Meeting of the members of the above-named company will be held at 22 Mitchell-street, Seaford, on Saturday, the 9th day of September, 1961, at Eleven o'clock in the forenoon, for the purpose of having an account laid before them showing the manner in which the winding up has been conducted and the property of the company disposed of, and of hearing any explanation that may be given by the liquidator.

Dated this 29th day of July, 1961.

14962 D. J. MILLER, Liquidator.

In the matter of ASSOCIATED PLASTER AND GYPSUM COMPANY PROPRIETARY LIMITED (IN LIQUIDATION).

BY order of the Court dated the 21st day of July, 1961, Guy Newton Moore, the liquidator of the said company, was granted his release as such liquidator.

Dated the 25th day of July, 1961.

BLAKE & RIGGALL, 120 William-street, Melbourne, solicitors for the liquidator. 14983

Companies Act 1958.—In the matter of G. B. FITZGERALD PROPRIETARY LIMITED.

NOTICE is hereby given that at an Extraordinary General Meeting of the above-named company duly convened and held at 366 Bourke-street, Melbourne, at a quarter past Three o'clock in the afternoon, on the 24th day of July, 1961, the following Special Resolution was duly passed:—

“That it has been proved to the satisfaction of this meeting that the company cannot by reason of its liabilities continue in business and it is advisable to wind up and accordingly that the company be wound up voluntarily and that Allan John Irwin, of Suite 16, Somerset House, 553 St. Kilda-road, Melbourne, be appointed liquidator for the purpose of the winding up.”

Dated this 26th day of July, 1961.

A. J. IRWIN, Liquidator.

Suite 16, Somerset House, 553 St. Kilda-road, Melbourne, C.1. 14980

In the Supreme Court of the State of Victoria.—In the matter of the Companies Act 1958, and in the matter of R. COSTANZA PTY. LTD., a company duly incorporated under the provisions of the Companies Act 1958, of the State of Victoria.

NOTICE is hereby given that a petition for the winding up of the above-named company by the Supreme Court of Victoria was on the 28th day of June, 1961, presented to the said Court by W. Len Johnson Pty. Ltd., of 26 O'Connell-street, Sydney, New South Wales, a creditor (hereinafter called “the petitioning company”) and that the said petition is now directed to be heard before the Court on the 24th day of August, 1961, at the Practice Court, Law Courts, William-street, Melbourne, at half past Ten o'clock in the forenoon, and any creditor or contributory of the said R. Costanza Pty. Ltd. desiring to support or oppose the making of an order on the said petition may appear at the time of hearing in person or by his counsel for that purpose; and a copy of the petition will be furnished to any director or contributory of the said R. Costanza Pty. Ltd., requiring the same by the undersigned solicitors on payment of the regulated charge for the same.

ELLISON, HEWISON & WHITEHEAD, 421 Bourke-street, Melbourne, solicitors for the petitioning company.

NOTE.—Any person who intends to appear on the hearing of the said petition must serve on or send by post to the above-named petitioning company or its solicitors notice, in writing, of his intention to do so. The notice must state the name and address of the person or, if a firm or company, the name and address of the firm or company, and must be signed by the person, firm or company, or his, their or its solicitor (if any) and must be served, or if posted, must be sent by post in sufficient time to reach the above-named petitioning company or its solicitors not later than Twelve o'clock mid-day on Saturday, the 26th day of August, 1961. 14981

In the matter of LUX FOUNDRY PROPRIETARY LIMITED (in Voluntary Liquidation).—Creditors' winding up.

NOTICE is hereby given that at an Extraordinary General Meeting of the above-named company, duly convened and held at 177 Collins-street, Melbourne, at

a quarter to Ten o'clock in the forenoon, on the 25th day of July, 1961, the following Special Resolution was duly passed:—

"That it has been proved to the satisfaction of this meeting that the company by reason of its liabilities cannot continue its business and that it is advisable to wind up and accordingly that the company be wound up voluntarily."

Dated the 28th day of July, 1961.

14976 S. J. FERRIER, Chairman.

NOTICE OF WINDING UP ORDER.

IN the matter of Diamond Creek Meat Co. Pty. Limited, winding up order, made 28th day of July, 1961.

Name and address of official liquidator: John Kenneth Hall, of 163 William-street, Melbourne.

New Zealand Loan and Mercantile Agency Company Limited: petitioner. 14975

TAMMY FASHIONS PROPRIETARY LIMITED.

VOLUNTARY WINDING UP.

NOTICE is hereby given that a Meeting of Creditors of Tammy Fashions Pty. Ltd., will be held at the office of the company situated at 36-50 Flinders-lane, on Friday, 4th August, 1961, at Three o'clock p.m.

14965 G. H. WILSON, Managing Director.

RE PORT PHILLIP CONSTRUCTIONS PTY. LTD. (IN LIQUIDATION).

CREDITORS are advised that, in accordance with section 210 of the Victorian Companies Act a Final Meeting of Creditors will be held at Employers Federation Building, 342 Flinders-street, Melbourne, on Monday, 28th August, 1961, at Ten o'clock a.m.

14921 B. H. WHITAKER, Liquidator.

OWEN O'BRIEN PROPRIETARY LIMITED (IN VOLUNTARY LIQUIDATION).

NOTICE is hereby given that the Final General Meeting of Shareholders of the above company will be held at the office of Miles O'Neill and Heffernan, 82 Mackay-street, Rochester, on 28th day of August, 1961, at Ten o'clock in the forenoon, for the purpose of laying before the meeting the account of the liquidator of the company showing how the winding up has been conducted and the property of the company disposed of, and giving an explanation thereof.

Dated the 20th day of July, 1961.

14920 J. A. HEFFERNAN, Liquidator.

JOHN GOOLD WALKER, late of Cobram, in the State of Victoria, grazier, DECEASED.

CREDITORS, next of kin and others having claims in respect of the estate of the deceased (who died on the 24th day of February, 1961) are required by the executors, Reginald Goold Walker, of Barooga, in the State of New South Wales, channel attendant, and Bertha Joan de Freitas, of 14 Poath-road, Hughesdale, in the State of Victoria, married woman, to send particulars to them care of the undersigned by the 10th day of October, 1961, after which date the executors may convey or distribute the assets, having regard only to the claims of which they then have notice.

Dated this 28th day of July, 1961.

ALEC M. HAYES, solicitor, 199 Campbell-street, Swan Hill. 14942

ALBERT ERNEST PILLOW, late of 19 Stephen-street, Newtown, Geelong, in the State of Victoria, company director and general manager, DECEASED.

CREDITORS, next of kin and others having claims in respect of the estate of the deceased (who died on the 24th day of September, 1960), are required by the personal representatives, The Fidelity Trustee Company Limited, of 101 Lydiard-street north, Ballarat, in the said State, and Albert Fenton Pillow, of 52 Anewendrive, Toronto 16, Ontario, Canada, professor of mathematics, to send particulars to them, at the office of the said company, at 8 Malop-street, Geelong aforesaid, by the 15th day of October, 1961, after which date the personal representatives may convey or distribute the assets, having regard only to the claims of which they then have notice.

Dated the 25th day of July, 1961.

FREEMAN & FALLAW, solicitors, 41 Yarra-street, Geelong. 14924

CREDITORS, next of kin and others having claims in respect of the estate of Matthew John Webb, late of 57 Seaview-avenue, North Shore, in the State of Victoria, engineer, deceased (who died on the 23rd day of November, 1960), are to send the particulars of their claims to The Fidelity Trustee Company Limited, at its office at 8 Malop-street, Geelong, in the said State, by the 15th day of October, 1961, after which date it will distribute the assets, having regard only to the claims of which it then has notice.

FREEMAN & FALLAW, solicitors, 41 Yarra-street, Geelong. 14925

LYDIA ALVINA ELIZA CAROLINE LEWIS, late of Nyah, in the State of Victoria, widow, DECEASED (who died on 25th December, 1960).

CREDITORS, next of kin and all other persons having claims against the estate of the deceased, are required by the executors of the will, Thomas Roy Limon and Robert William Coburn, to send particulars to them, care of the undersigned, on or before the 17th day of October, 1961, after which date they will distribute the assets, having regard only to the claims of which they then have notice.

GARDEN & GREEN, solicitors, Nyahwest. 14919

ELLEN KEATING, formerly of Macedon, in the State of Victoria, but late of Noonan-grove, Woodend, in the said State, widow, DECEASED.

CREDITORS, next of kin and others having claims in respect of the deceased (who died on the 23rd day of May, 1961), are required by the executor, The Equity Trustees, Executors, and Agency Company Limited, of 472 Bourke-street, Melbourne, in the said State, to send particulars, in writing, to it at the office of the undersigned at Kyneton by the 31st day of October, 1961, after which date the executor may convey or distribute the assets, having regard only to the claims of which it then has notice.

H. HURRY & SON, solicitors, Kyneton, and at Woodend and Gisborne. 14936

CREDITORS, next of kin and others having claims against the estate of Clarence Albert Norman, late of 615 Neil-street, Ballarat, blacksmith, deceased (who died on the 18th day of April, 1961), are requested to send particulars of their claims to the executor, The Fidelity Trustee Company Limited, of 101 Lydiard-street north, Ballarat, by the 9th day of October, 1961, after which date the executor will distribute the assets, having regard only to the claims of which it then has notice.

NEVETT, GLENN & TINNEY, solicitors, 205 Dana-street, Ballarat. 14997

CREDITORS, next of kin and others having claims in respect of the estate of David McClure, late of "Overton Lodge", 275 Lennox-street, Richmond, architect, deceased (who died on 4th February, 1961), are to send particulars of their claims to The Trustees Executors and Agency Company Limited and Robert Tweeddale Breen, the executors, care of the said company at its registered office, 401 Collins-street, Melbourne, by the 6th day of October, 1961, after which date the said executors will distribute the assets, having regard only to the claims of which they then have notice.

R. T. BREEN, L.L.B., solicitor, Railway-walk, Middle Brighton. 14999

AUSTIN ALEXANDER PEARSE, late of Nyahwest, in the State of Victoria, farmer, DECEASED (who died on the 11th day of February, 1961).

CREDITORS, next of kin and all other persons having claims against the estate of the deceased are required by the executor, Dalney Thomas Pearse, to send particulars to him, care of the undersigned, on or before the 21st day of October, 1961, after which date he will distribute the assets, having regard only to the claims of which he then has notice.

GARDEN & GREEN, solicitors, Nyahwest. 14943

NELLIE CHARLOTTE BENNETT, late of 12 Holden-street, Camperdown, widow, DECEASED, intestate.

CREDITORS, next of kin and others having claims in respect of the estate of the above-named deceased (who died on the 22nd day of June, 1961) are required to send particulars of their claims to the administratrix, Hettie Muriel Cook, of Laang, married woman, care of the undersigned solicitor, on or before the 2nd day of October, 1961, after which date she will distribute the assets, having regard only to the claims of which she then has notice.

DAVID E. TRICKETT, High-street, Terang. 14963

CREDITORS, next of kin and all others having claims against the estate of Alfred Blakeley Mackay, late of 189 Auburn-road, Auburn, secretary, deceased (who died on 25th September, 1960), are required to send particulars thereof to the Union Trustee Company of Australia Limited, of 333 Collins-street, Melbourne, the executor appointed by the deceased's will, on or before the 6th day of October, 1961, after which date it will distribute the assets, having regard only to the claims of which it then has notice.

ARTHUR L. ROW & MACKAY, solicitors, 221 Balaclava-road, Caulfield. 14933

HENRY KENNEDY, late of 8 Everingham-street, Swan Hill, in the State of Victoria, retired watchmaker, DECEASED (who died on 27th April, 1961).

CREDITORS, next of kin and all other persons having claims against the estate of the deceased are required by the executors of the will, John Searle Kennedy and Robert James Kennedy, to send particulars to them, care of the undersigned on or before the 24th day of October, 1961, after which date they will distribute the assets, having regard only to the claims of which they then have notice.

GARDEN & GREEN, solicitors, McCallum-street, Swan Hill. 14928

THOMAS LAMB, late of 15 Pender-street, Thornbury, bank officer, DECEASED (who died on the 3rd day of December, 1952).

CREDITORS, next of kin and all other persons having claims against the estate of the deceased, are required by the executrix of his will, Mary Lamb, of 15 Pender-street, Thornbury, spinster, to send particulars thereof to her, care of the under-mentioned solicitors, on or before the 11th day of October, 1961, after which date she may proceed to distribute the assets of the deceased, having regard only to the claims of which she then had notice.

COLTMAN, WYATT & ANDERSON, solicitors, 578 Bourke-street, Melbourne. 14987

HENRY ERNEST HARVEY, late of 163 Westgarth-street, Northcote, managing director, DECEASED (who died on the 7th day of February, 1961).

CREDITORS, next of kin and all other persons having claims against the estate of the said deceased, are required by the executor of his will, William Edward Harvey, of 14 Barker-street, Cheltenham, general manager, to send particulars thereof to him, care of the under-mentioned solicitors, on or before the 31st day of October, 1961, after which date he may proceed to distribute the assets of the deceased, having regard only to the claims of which he then has notice.

COLTMAN, WYATT & ANDERSON, solicitors, 578 Bourke-street, Melbourne. 14986

CREDITORS, next of kin and others having claims in respect of the estate of Leslie Gilbert Arthur, late of 34 Mitchell-street, Glenroy, labourer, deceased (who died on the 20th day of September, 1960), are hereby required to send particulars of such claims, in writing, to John Matthew Arthur, care of Molomy and Molomy, solicitors, 99 Queen-street, Melbourne, on or before the 15th day of October, 1961, after which date he will proceed to distribute the assets of the said deceased, which shall have come to his hands, among the persons entitled thereto, having regard only to the claims of which he then shall have had notice.

MOLOMBY & MOLOMBY, solicitors, 99 Queen-street, Melbourne. 14991

CREDITORS, next of kin and others having claims in respect of the estate of Doris Lillian Booth, late of 174 Amess-street, North Carlton, widow, deceased (who died on the 21st day of September, 1959), are to send particulars of their claims to Victor Clarence Truman, Vera Clair Clucas and Emily Louise Truman, in care of the under-mentioned solicitors, on or before the 7th day of October, 1961, after which date they will distribute the assets, having regard only to the claims of which they then have notice.

MORRISON, TEARE & PURNELL, solicitors, 164 Flinders-street, Melbourne. 14992

THOMAS HENRY MUSCROFT, late of 26 North-road Newport, retired blacksmith, DECEASED.

CREDITORS, next of kin and others having claims in respect of the estate of the above-named deceased (who died on 16th May, 1961), are required by The

Trustees Executors and Agency Company Limited, of 401 Collins-street, Melbourne, to send particulars to it by the 18th October, 1961, after which date the executor may convey or distribute the asset, having regard only to the claims of which it then has notice.

Dated the 28th day of July, 1961.

W. B. & O. McCUTCHEON, solicitors, 150 Queen-street, Melbourne. 14993

CREDITORS, next of kin and others having claims against the estate of Elsie Ethel Isherwood, late of 20 McConchie-avenue, North Kew, widow, deceased (who died on the 22nd May, 1961), are to send particulars of their claims to the executor, National Trustees, Executors and Agency Company of Australasia Limited, at its registered address, 95 Queen-street, Melbourne, by the 4th day of October, 1961, after which date the said company will distribute the estate of the said deceased, having regard only to the claims of which it then has notice.

BERNARD NOLAN, solicitor, 595 Bourke-street, Melbourne. 14994

MALVA FRANCES ZETLAND, late of 94 Andrew-street, Brighton, in the State of Victoria, widow.

CREDITORS, next of kin and others having claims in respect of the estate of the deceased (who died on the 24th of August, 1960), are required to send particulars of their claims to J. Okno, of 390 Lonsdale-street, Melbourne, the executor of the estate, by the 10th of October, 1961, after which date he may convey or distribute the assets, having regard only to the claims of which he then has notice.

J. OKNO & CO., solicitors, of 390 Lonsdale-street, Melbourne. 14995

CREDITORS, next of kin and others having claims in respect of the estate of William Bernard Mangan, late of "St. Colmans", 293 Carlisle-street, Balaclava, parish priest, deceased (who died on the 17th day of October, 1960), are required by Mary Margaret Munnerly and William Fawcner Lucas, the executors, to send particulars of their claims to the under-mentioned solicitors, by the 30th day of September, 1961, after which date they will distribute the assets, having regard only to the claims of which they then have notice.

STRONGMAN & CROUCH, solicitors, 118 Queen-street, Melbourne. 14996

CREDITORS, next of kin and others having claims in respect of the estate of Robert Johann Rathmann, late of Strathbogie, grazier, deceased (who died on the 23rd day of April, 1961), are required by the executor, The Trustees Executors and Agency Company Limited, whose registered office is at 401 Collins-street, Melbourne, to send particulars of their claims to the said executor, at its address aforesaid, by the 10th day of October, 1961, after which date the executor may convey or distribute the assets, having regard only to the claims of which it then has notice.

J. J. TEHAN & CO., Binney-street, Euroa, solicitors for the executor. 15002

CREDITORS, next of kin and others having claims in respect of the estate of Charles Tognini, late of 8 May-street, Gardenvale, in the State of Victoria, gentleman, deceased (who died on the 11th day of November, 1960), are to send particulars of their claims to Royston T. Cahir, solicitor, of 475 Collins-street, Melbourne, by the 4th day of October, 1961, after which date the executors will distribute the assets of the said estate, having regard only to claims of which they then have notice.

ROYSTON T. CAHIR, solicitor, 475 Collins-street, Melbourne, C.I. 14984

GEORGINA VIOLET HOILE, late of 694 Whitehorse-road, Mont Albert, widow, DECEASED.

CREDITORS, next of kin and others having claims in respect of the estate of the above-named deceased (who died on 16th January, 1961), are required to send the particulars of their claims to the executor, Thomas Keith Davies, care of the under-named solicitors, by the 5th day of October, 1961, after which date he will distribute the assets, having regard only to those claims of which he then has notice.

NORRIS, COATES & HEARLE, solicitors, of 422 Collins-street, Melbourne. 14979

VICTOR WILLIAM HISCOCK, late of Kilsyth, in the State of Victoria, real estate agent, DECEASED (who died on the 7th day of May, 1961).

CREDITORS, next of kin and all other persons having claims against the estate of the deceased, are required by the executrix of the will of the deceased, Catherine Hiscock, of Kilsyth aforesaid, widow, to send particulars to her, care of the undersigned, on or before the 25th day of October, 1961, after which date she will distribute the assets, having regard only to the claims of which she then has notice.

HALL & WILCOX, solicitors, 20 Queen-street, Melbourne. 14978

CREDITORS, next of kin and others having claims in respect of the estate of James Cook Kelt, formerly of Welshpool, farmer, but late of 4 Merville-avenue, East Malvern, gentleman, deceased (who died on the 13th day of March, 1961), are required by the trustees, The Trustees Executors and Agency Company Limited, of 401 Collins-street, Melbourne, and Dorothy Maud Kelt, of 4 Merville-avenue, East Malvern, widow, to send particulars of their claims to the said, The Trustees, Executors and Agency Company Limited, at 401 Collins-street, Melbourne, by the 6th day of October, 1961, after which date the trustees may convey or distribute the assets, having regard only to the claims of which they then have notice.

PURVES & PURVES, solicitors, 90 William-street, Melbourne. 14972

CREDITORS, next of kin and others having claims in respect of the estate of Alexander Lawson Austin, late of 18 Morrice-street, Caulfield, stevedoring superintendent, deceased (who died on the 26th day of January, 1961), are required by the administratrix, Bette Rosalie Austin, of 18 Morrice-street, Caulfield, widow, to send particulars of their claims to her, care of Rogers and Gaylard, solicitors, 281 Collins-street, Melbourne, by the 11th day of October, 1961, after which date the said administratrix will distribute the assets of the deceased, having regard only to the claims of which she then shall have had notice.

ROGERS & GAYLARD, solicitors, 281 Collins-street, Melbourne. 14973

RUTH CRISP, late of Fendalton, Christchurch, New Zealand, Feme Sole, DECEASED.

CREDITORS, next of kin and others having claims against the estate of the said deceased (who died on 27th February, 1959), are to send particulars of their claims to The Union Trustee Company of Australia Limited, the registered office of which is situate at 333 Collins-street, Melbourne, by the 5th day of October, 1961, after which date it will distribute the assets, having regard only to the claims of which it then has notice.

BLAKE & RIGGALL, solicitors, 120 William-street, Melbourne. 14974

CREDITORS, next of kin and others having claims in respect of the estate of Julia Lilian Jutson, late of Kenilworth Private Hospital, 3 Kenilworth-parade, widow, deceased (who died on the 13th day of February, 1961), are to send particulars of their claims to the Equity Trustees and Agency Company Limited, of 472 Bourke-street, Melbourne, by the 28th day of September, 1961, after which date it will distribute the assets, having regard only to the claims of which it then has notice.

HALL & WILCOX, solicitors, 20 Queen-street, Melbourne. 14977

CREDITORS, next of kin, and others having claims in respect of the estate of Thomas Edward Quinhampton, late of Coreen, near Corowa, in the State of New South Wales, farmer, deceased (who died on the 20th day of June, 1960), are to send particulars of their claims to the executors appointed by deceased's will to the care of Frank B. Lethbridge, solicitor, Rutherglen, by the 10th day of October, 1961, after which date the said executors will distribute the assets, having regard only to the claims of which they shall then have had notice.

Dated the 27th day of July, 1961.

FRANK B. LETHBRIDGE, solicitor, Rutherglen, solicitor for the executors. 14966

CREDITORS, next of kin, and others having claims in respect of the estate of John Lawrence Godde, formerly of Rand, in the State of New South Wales, farmer, but late of Yarrowonga, in the State of Victoria,

retired farmer, deceased (who died on the 8th day of April, 1960), are to send particulars of their claims to the executors, Leonard Joseph Godde, of Box 250, Kyabram, in the State of Victoria, dealer, and Arthur Lawrence Godde, of Box 77, Rand, in the State of New South Wales, agent, to the care of Frank B. Lethbridge, solicitor, Rutherglen, by the 10th day of October, 1961, after which date the said executors will distribute the assets, having regard only to the claims of which they shall then have had notice.

Dated the 27th day of July, 1961.

FRANK B. LETHBRIDGE, solicitor, Rutherglen, solicitor for the executors. 14967

RE ESTATE MYRTLE IVY LANE, DECEASED.

CREDITORS, next of kin, and others having claims in respect of the estate of Myrtle Ivy Lane, late of Portland, married woman, deceased (who died on the 25th day of May, 1960), are to send particulars of their claims to Thelma May Dipalo, care of the under-mentioned solicitor, the executrix appointed by the deceased's will, by the 3rd day of October, 1961, after which date the said Thelma May Dipalo will distribute the assets, having regard only to the claims of which she then has notice.

DOUGLAS R. GREY, LL.B., solicitor, 18 Henty-street, Portland. 14940

CREDITORS, next of kin, and others having claims in respect of the estate of Lynda Grace Benbow, late of Heywood, in the State of Victoria, widow, deceased (who died on the 19th day of April, 1961, and probate of whose will was granted to The Fidelity Trustee Company Limited, of 101 Lydiard-street north, Ballarat, in the said State, the executor named in the said will), are to send particulars of their claims to the executor, care of the undersigned, at their address mentioned hereunder, by the 5th day of October, 1961, after which date the said executor will distribute the assets, having regard only to the claims of which it then has notice.

CAMERON & LOWENSTERN, solicitors, Hamilton. 14968

JOHN KAY POLINELLI, late of Ultima, in the State of Victoria, farmer, DECEASED.

CREDITORS, next of kin, and others having claims in respect of the estate of deceased (who died on the 14th day of March, 1961), are required by the executors, Edward Power, of 113 Wattle-street, Bendigo, in the State of Victoria, gardener, and Lavena Mary Polinelli, of Ultima, in the said State, widow, to send particulars to them, care of the undersigned, by the 10th day of October, 1961, after which date the executors may convey or distribute the assets, having regard only to the claims of which they then have notice.

Dated this 28th day of July, 1961.

ALEC M. HAYES, solicitor, 199 Campbell-street, Swan Hill. 14941

CREDITORS, next of kin, and others having claims in respect of the estate of Charles Frederick Best, late of Ararat, retired auctioneer, deceased (who died on the 2nd May, 1961), are required by The Fidelity Trustee Company Limited, of 101 Lydiard-street north, Ballarat, and Joseph Best, of 413 Lydiard-street, Ballarat, retired Archdeacon, the executors of the will of the said deceased, to send particulars, in writing, of their claims to the said company, at its above address, on or before the 3rd October, 1961, after which date they will distribute the assets, having regard only to the claims of which they then have notice.

BRUCE R. TIVEY, solicitor, Ararat. 14939

CREDITORS, next of kin, and others having claims against the estate of Margaret Alice Barnes, late of 220 Wattle-tree-road, Malvern, spinster, deceased (who died on the 17th day of May, 1961), are to send particulars of their claims to the National Trustees, Executors and Agency Company of Australasia Limited, of 95 Queen-street, Melbourne, the executors named in the will of the said deceased, by the 5th day of October, 1961, after which date the said executor will distribute the assets, having regard only to the claims of which he shall have had notice.

JAMES P. OGGIE & WEBB, solicitors, of 165 Greville-street, Prahran. 14971

CREDITORS, next of kin, and others having claims against the estate of Claude Hamilton O'Meara, late of St. Clair, via Wonthaggi, grazier, deceased (who died on the 6th day of April, 1961), are required by Leslie Hamilton O'Meara and Susannah Carlie O'Meara, the executors of the will of deceased, to send to them addressed to the care of the undersigned solicitors, particulars thereof, on or before the 17th day of October, 1961, after which date they will distribute the estate of deceased, having regard only to the claims of which they shall then have notice.

BIRCH, ROSS & ATKINSON, solicitors, Wonthaggi.
14969

In the Supreme Court of the State of Victoria.
SALE BY THE SHERIFF.

ON Monday, the 11th day of September, 1961, at Eleven a.m., at the Police Station, Glenhuntly (unless process be stayed or satisfied):—

All the estate and interest (if any) of L. Bamford, of 2 Miriam-street, Caulfield, plumber, as proprietor of an estate in fee-simple in the land described in certificate of title, volume 5589, folio 751, upon which is erected a weatherboard dwelling house of six main rooms with garage and out-buildings, known as No. 2 Miriam-street, Caulfield.

Registered mortgage No. B87229, for approximately £3,000, affects the said estate and interest.

Terms: Cash only.

DAVID J. JOHNSTON, Sheriff's Officer.

27th July, 1961. 14970

MINING NOTICE

MORNING STAR MINES NO LIABILITY.

NOTICE is hereby given that a Call (the Fifth) of Three pence (3d.) per share on the increased capital of all issued shares as approved at the Extraordinary General Meeting of the company held on Thursday, 19th May, 1960, has been made due and payable to the secretary, at the registered office of the company, 422 Collins-street, Melbourne, on Wednesday, the 9th day of August, 1961.

This Call will make the shares paid to 5s. 3d. each.

By order of the Board,

K. H. GRANT, Secretary.

Registered Office, 422 Collins-street, Melbourne.

26th July, 1961. 14982

IMPOUNDINGS

DANDENONG.—Impounded in Dandenong Pound, by Ranger, off Frankston-road.

1 bay gelding, 15 hands, white off hind fetlock, white dot on nose, no visible brand

If not claimed and expenses paid, to be sold at Dandenong Market, on 18th August, 1961.

14998—12/ A. WALKER, Poundkeeper.

ELTHAM.—Impounded in Eltham Pound, by Ranger.

1 black and white cow, no visible brand
3 heifers, one red and white, two black, no visible brand

If not claimed and expenses paid, to be sold on 19th August, 1961.

15000—10/6 A. GRAHAM, Poundkeeper.

LARA.—Impounded in Lara Pound, from You Yangs.

1 dark-bay mare, no visible brand

If not claimed and expenses paid, to be sold on 19th August, 1961.

15001—9/ RONALD W. ELLIS, Poundkeeper.

CONSOLIDATED ACTS.

COPIES of the following Consolidated Acts of the Parliament of Victoria may be obtained at the Government Printing Office, Melbourne, at the price set opposite to each, viz. :—

No.		Price. s. d.
6188	Acts Enumeration and Revision Act 1958	1 9
6189	Acts Interpretation Act 1958	1 3
6190	Aborigines Act 1958	0 9
6191	Administration and Probate Act 1958	4 9
6192	Adoption of Children Act 1958	1 3
6193	Agent-General's Act 1958	0 6
6194	Agricultural Colleges Act 1958	1 0
6195	Agricultural Education Act 1958	0 9
6196	Agricultural Lime Act 1958	1 0
6197	Air Navigation Act 1958	0 6
6198	Anzac Day Act 1958	0 6
6199	Apprenticeship Act 1958	1 9
6200	Arbitration Act 1958	0 9
6201	Architects Act 1958	1 3
6202	Auction Sales Act 1958	1 3
6203	Audit Act 1958	2 3
6204	Bakers and Millers Act 1958	0 9
6205	Bank Holidays Act 1958	0 9
6206	Barley Marketing Act 1958	1 0
6207	Bees Act 1958	0 9
6208	Benefit Association Act 1958	1 9
6209	Boilers Inspection Act 1958	1 6
6210	Building Societies Act 1958	1 3
6211	Business Investigations Act 1958	0 9
6212	Business Names Act 1958	1 3
6213	Cancer Act 1958	1 9
6214	Carriers and Innkeepers Act 1958	1 0
6215	Cattle Breeding Act 1958	0 9
6216	Cattle Compensation Act 1958	1 0
6217	Cemeteries Act 1958	2 0
6218	Children's Court Act 1958	2 0
6219	Children's Welfare Act 1958	2 3
6220	Clean Air Act 1958	0 9
6221	Coal Mines Act 1958	7 9
6222	Commercial Goods Vehicles Act 1958	1 6
6223	Commonwealth Arrangements Act 1958	0 6
6224	The Constitution Act Amendment Act 1958	16 0
6225	Co-operation Act 1958	4 0
6226	Co-operative Housing Societies Act 1958	3 6
6227	Coroners Act 1958	1 3
6228	Country Fire Authority Act 1958	3 6
6229	Country Roads Act 1958	3 9
6230	County Court Act 1958	2 6
6231	Crimes Act 1958	13 3
6232	Crown Proceedings Act 1958	1 0
6233	Dairy Products Act 1958	1 0
6234	Developmental Railways Act 1958	0 9
6235	Dietitians Registration Act 1958	1 3
6236	Dog Act 1958	1 0
6237	Drainage Areas Act 1958	2 0
6238	Drainage of Land Act 1958	1 0
6239	Dried Fruits Act 1958	1 6
6240	Education Act 1958	3 0
6241	Electric Light and Power Act 1958	2 0
6242	Employers and Employees Act 1958	1 6
6243	Entertainments Tax Act 1958	1 3
6244	Essential Services Act 1958	0 9
6245	Estate Agents Act 1958	2 9
6246	Evidence Act 1958	3 6
6247	Explosives Act 1958	2 0
6248	Farm Produce Agents Act 1958	1 0
6249	Fences Act 1958	1 3
6250	Fertilizers Act 1958	1 6
6251	Firearms Act 1958	2 3
6252	Fisheries Act 1958	2 3
6253	Footwear Regulation Act 1958	0 9
6254	Forests Act 1958	4 3
6255	Friendly Societies Act 1958	3 9
6256	Fruit and Vegetables Act 1958	1 9
6257	Fungicides Act 1958	1 0
6258	Game Act 1958	1 9
6259	Gaols Act 1958	1 6
6260	Gas and Fuel Corporation Act 1958	5 0
6261	Gas Regulation Act 1958	1 9
6262	Geelong Harbor Trust Act 1958	3 3
6263	Geelong Waterworks and Sewerage Act 1958	5 6
6264	Gold Buyers Act 1958	2 3
6265	Goods Act 1958	2 6
6266	Grain Elevators Act 1958	2 3
6267	Hairdressers Registration Act 1958	1 3
6268	Harbor Boards Act 1958	3 3
6269	Hawkers and Pedlers Act 1958	1 3
6270	Health Act 1958	14 0
6271	Home Finance Act 1958	0 9
6272	Horse Breeding Act 1958	1 3
6273	Hospital Benefits Act 1958	0 9
6274	Hospitals and Charities Act 1958	3 6

CONSOLIDATED ACTS—*continued.*

No.	Description	Price.	
		s.	d.
6275	Housing Act 1958	6	3
6276	Imprisonment of Fraudulent Debtors Act 1958 .. .	1	6
6277	Industrial and Provident Societies Act 1958 .. .	2	0
6278	Inebriates Act 1958	0	9
6279	Instruments Act 1958	3	9
6280	Judicial Proceedings Reports Act 1958	0	9
6281	Juries Act 1958	2	0
6282	Justices Act 1958	11	3
6283	Labour and Industry Act 1958	7	0
6284	Land Act 1958	13	0
6285	Landlord and Tenant Act 1958	4	6
6286	Lands Compensation Act 1958	1	9
6287	Land Settlement Act 1958	1	9
6288	Land Surveyors Act 1958	1	3
6289	Land Tax Act 1958	2	9
6290	Latrobe Valley Act 1958	2	6
6291	Legal Profession Practice Act 1958	3	9
6292	Libraries Act 1958	1	3
6293	Licensing Act 1958	8	9
6294	Lifts Regulation Act 1958	0	9
6295	Limitation of Actions Act 1958	1	6
6296	Liquified Petroleum Gas Act 1958	0	6
6297	Livery and Agistment Act 1958	0	9
6298	Local Authorities Superannuation Act 1958 .. .	2	0
6299	Local Government Act 1958	25	0
6300	Maintenance Act 1958	3	6
6301	Margarine Act 1958	1	0
6302	Marine Act 1958	7	9
6303	Marine Stores and Old Metals Act 1958 .. .	1	6
6304	Marketing of Primary Products Act 1958 .. .	2	9
6305	Markets Act 1958	1	0
6306	Marriage Act 1958	4	0
6307	Masseurs Act 1958	1	0
6308	Master and Apprentice Act 1958	0	9
6309	Medical Act 1958	3	6
6310	Melbourne and Metropolitan Board of Works Act 1958	8	0
6311	Melbourne and Metropolitan Tramways Act 1958	6	0
6312	Melbourne Harbor Trust Act 1958	4	0
6313	Mental Deficiency Act 1958	2	0
6314	Mental Hygiene Act 1958	5	9
6315	Metropolitan Fire Brigades Act 1958	2	6
6316	Mildura Irrigation and Water Trusts Act 1958 .. .	5	9
6317	Milk and Dairy Supervision Act 1958	3	9
6318	Milk Board Act 1958	1	9
6319	Milk Pasteurization Act 1958	0	9
6320	Mines Act 1958	14	0
6321	Mining Development Act 1958	1	9
6322	Ministry of Transport Act 1958	0	9
6323	Mint Act 1958	0	6
6324	Money Lenders Act 1958	2	3
6325	Motor Car Act 1958	5	3
6326	National Parks Act 1958	1	0
6327	Newmarket Sheep Sales Act 1958	0	6
6328	Nurses Act 1958	1	9
6329	Opticians Registration Act 1958	1	3
6330	Partnership Act 1958	1	3
6331	Patriotic Funds Act 1958	1	6
6332	Pawnbrokers Act 1958	1	6
6333	Penalties Act 1958	0	6
6334	Petroleum Act 1958	2	9
6335	Petrol Pumps Act 1958	0	9
6336	Poisons Act 1958	4	3
6337	Police Offences Act 1958	7	6
6338	Police Regulation Act 1958	3	9
6339	Poor Persons Legal Assistance Act 1958	0	9
6340	Portland Harbor Trust Act 1958	2	0
6341	Pounds Act 1958	1	3
6342	Printers and Newspapers Act 1958	1	0
6343	Process Servers and Inquiry Agents Act 1958 .. .	1	0
6344	Property Law Act 1958	9	0
6345	Public Account Act 1958	1	0
6346	Public Authorities Marks Act 1958	0	9
6347	Public Contracts Act 1958	0	6
6348	Public Safety Preservation Act 1958	0	9
6349	Public Service Act 1958	2	9
6350	Public Trustee Act 1958	3	3
6351	Public Works Act 1958	0	9
6352	Public Works Committee Act 1958	1	0
6353	Racing Act 1958	4	3
6354	Railway Lands Acquisition Act 1958	2	6
6355	Railways Act 1958	5	6
6356	Registration of Births Deaths and Marriages Act 1958	2	3
6357	Religious Successory and Charitable Trusts Act 1958	2	0
6358	River Improvement Act 1958	2	0
6359	Road Traffic Act 1958	1	0
6360	Rural Finance Corporation Act 1958	2	3
6361	Sale of Allotments of Land Act 1958	0	6
6362	Seamen's Act 1958	0	9

CONSOLIDATED ACTS—*continued.*

No.	Description	Price.	
		s.	d.
6363	Secondhand Dealers Act 1958	1	3
6364	Seeds Act 1958	1	3
6365	Senate Elections Act 1958	0	6
6366	Servants' Registry Offices Act 1958	0	9
6367	Settled Land Act 1958	4	0
6368	Sewerage Districts Act 1958	5	3
6369	Shearers Accommodation Act 1958	1	3
6370	Sheep Dipping Act 1958	0	9
6371	Sheep Owners Protection Act 1958	0	9
6372	Soil Conservation and Land Utilization Act 1958	1	6
6373	Soldier Settlement Act 1958	4	9
6374	Solicitor-General Act 1958	0	6
6375	Stamps Act 1958	6	0
6376	State Development Act 1958	1	0
6377	State Electricity Commission Act 1958	4	6
6378	State Relief Committee Act 1958	0	9
6379	State Savings Bank Act 1958	4	3
6380	Statistics Act 1958	0	9
6381	Stock and Share Brokers Act 1958	1	0
6382	Stock Diseases Act 1958	2	6
6383	Stock Foods Act 1958	1	3
6384	Stock Medicines Act 1958	1	0
6385	Street Trading Act 1958	0	9
6386	Superannuation Act 1958	3	0
6387	Supreme Court Act 1958	6	0
6388	Survey Co-ordination Act 1958	1	3
6389	Swine Act 1958	1	0
6390	Tattersall Consultations Act 1958	0	9
6391	Teaching Service Act 1958	2	3
6392	Temperance Halls Act 1958	0	6
6393	Theatres Act 1958	1	6
6394	Tobacco Sellers Act 1958	0	9
6395	Tourist Act 1958	0	9
6396	Town and Country Planning Act 1958	2	0
6397	Trade Unions Act 1958	1	0
6398	Tramways Act 1958	1	3
6399	Transfer of Land Act 1958	4	9
6400	Transport Regulation Act 1958	1	9
6401	Trustee Act 1958	3	9
6402	Trustee Companies Act 1958	1	9
6403	Unauthorized Documents Act 1958	0	6
6404	Unclaimed Moneys Act 1958	0	6
6405	University Act 1958	2	0
6406	Unlawful Assemblies and Processions Act 1958 .. .	1	3
6407	Vegetation and Vine Diseases Act 1958	1	6
6408	Veneral Diseases Act 1958	1	6
6409	Vermin and Noxious Weeds Act 1958	2	0
6410	Veterinary Surgeons Act 1958	1	0
6411	Victorian Inland Meat Authority Act 1958 .. .	1	0
6412	Warehousemen's Liens Act 1958	0	9
6413	Water Act 1958	12	9
6414	Weights and Measures Act 1958	3	0
6415	Wild Flowers and Native Plants Protection Act 1958	0	9
6416	Wills Act 1958	1	0
6417	Wire Netting Act 1958	1	9
6418	Women's Qualification Act 1958	0	6
6419	Workers Compensation Act 1958	4	9
6420	Wrongs Act 1958	1	3
6421	Youth Organizations Assistance Act 1958	0	6

A. C. Brooks,
Government Printer.

STATE ACTS, 1959.

COPIES of the following Acts of Parliament of Victoria may be obtained at the Government Printing Office, or from any bookseller, at the price set opposite to each:—

No.	Description	Price.	
		s.	d.
6490.	Water (Contracts)	0	6
6491.	Property Law (Amendment)	0	6
6492.	Agricultural Education (Amendment)	0	6
6493.	Swan Hill Railway Land	0	6
6494.	Stamps (Amendment)	0	6
6495.	Justices (Amendment)	0	6
6496.	Consolidated Revenue	0	6
6497.	State Electricity Commission (Tourist Areas) .. .	0	6
6498.	Aborigines (Houses)	0	6
6499.	Superannuation (Amendment)	0	6
6500.	Country Roads (Amendment)	0	6
6501.	Bendigo Land	0	6
6502.	University (Honorary Degrees)	0	6
6503.	Melbourne and Metropolitan Board of Works (Reconstitution)	0	9
6504.	Land (Charges)	0	6
6505.	Statute Law Revision	1	0
6506.	Legal Profession Practice (Amendment)	0	6

STATE ACTS, 1959—continued.

No.		Price.
		s. d.
6507.	Health	0 9
6508.	Fisheries (Amendment)	0 6
6509.	Water (Irrigation Districts)	0 6
6510.	Broadmeadows (Rating on Unimproved Values)	0 6
6511.	Trustee (Amendment)	0 6
6512.	Nurses	0 6
6513.	Hairdressers Registration (Amendment)	0 6
6514.	Labour and Industry (Retail Trading Hours)	0 6
6515.	Milk Board (Amendment)	0 6
6516.	Stock Diseases (Amendment)	0 9
6517.	Hepburn Springs Land	0 9
6518.	Vermin and Noxious Weeds	1 0
6519.	The Constitution Act Amendment (Parliamentary Salaries)	0 9
6520.	Public Works Committee (Amendment)	0 6
6521.	Land (Plantation Areas)	0 6
6522.	National Art Gallery and Cultural Centre (Amendment)	0 6
6523.	Portland Harbor Trust (Amendment)	0 6
6524.	Revocation and Excision of Crown Reservations	1 9
6525.	Tourist (Amendment)	0 6
6526.	Town and Country Planning (Amendment)	0 6
6527.	Vegetation and Vine Diseases (Amendment)	0 6
6528.	Medical	0 9
6529.	Bread Industry	1 0
6530.	Cemeteries	0 9
6531.	Hire-Purchase	2 3
6532.	Motor Car (Amendment)	0 9
6533.	Motor Car (Hours of Driving)	0 6
6534.	Land Settlement	1 9
6535.	Local Government (Amendment)	1 6
6536.	Melbourne and Metropolitan Board of Works (Amendment)	1 3
6537.	Consolidated Revenue	0 6
6538.	War Veterans' Homes Trust	1 3
6539.	Frustrated Contracts	0 6
6540.	Evidence (Amendment)	0 6
6541.	Amendments Incorporation (Extension)	0 6
6542.	Melbourne and Richmond Lands	0 9
6543.	Local Government (Councillors' Declarations)	0 6
6544.	Transfer of Land (Amendment)	0 6
6545.	State Savings Bank (Amendment)	0 6
6546.	Country Roads (Offices and Buildings)	0 6
6547.	Statute Law Revision	0 6
6548.	Marriage (Fees)	0 6
6549.	State Electricity Commission (Hazelwood Power Station)	0 6
6550.	Fences (Amendment)	0 6
6551.	Coroners (Amendment)	0 6
6552.	Stamps	0 6
6553.	Motor Car (Insurance Surcharge)	0 6
6554.	Entertainments Tax (Reduction)	0 6
6555.	Melbourne and Metropolitan Tramways (Amendment)	0 9
6556.	Local Government (Municipalities Assistance Fund)	0 6
6557.	Police Offences (Penalties)	0 6
6558.	Consolidated Revenue	0 6
6559.	Road Traffic (Infringements)	0 9
6560.	Superannuation	0 6
6561.	Crimes (Penalties)	0 6
6562.	Alphington to East Preston Railway Construction (Housing)	0 6
6563.	Motor Car	1 0
6564.	Registration of Births, Deaths and Marriages	2 3
6565.	Coal Mines (Pensions)	0 6
6566.	Water Supply Loan Application	1 3
6567.	Game (Amendment)	0 6
6568.	Metropolitan Fire Brigades (Borrowing Powers)	0 6
6569.	Health (Amendment)	0 6
6570.	Police Regulation (Delegation of Powers)	0 6
6571.	Imprisonment of Fraudulent Debtors (Depositions)	0 6
6572.	Crimes (Sentences and Parole)	0 6
6573.	Gas and Fuel Corporation (Colonial Gas Association Undertakings)	1 3
6574.	Racing (Meetings)	0 6
6575.	Landlord and Tenant (Amendment)	0 6
6576.	Distribution of Population (Joint Committee)	0 6
6577.	Lifts and Cranes	1 0
6578.	Cemeteries (Investment of Funds)	0 6
6579.	Public Service (Amendment)	0 6
6580.	Trustee (Mortgages)	0 6
6581.	Justices (Amendment)	0 6
6582.	Water (Irrigation)	1 9
6583.	Country Fire Authority (Amendment)	0 6
6584.	Milk Board (Milk Shops)	0 6
6585.	Forests (Pulpwood Agreement)	1 3

STATE ACTS, 1959—continued.

No.		Price.
		s. d.
6586.	Police Offences (Betting)	0 6
6587.	Revenue Deficit Funding	0 6
6588.	Geelong Trades Hall Council (Trustees)	0 6
6589.	Melbourne Harbor Trust (Commissioners)	0 6
6590.	Railway Loan Application	1 3
6591.	State Forests Loan Application	0 6
6592.	Land Tax (Rates)	0 6
6593.	Teaching Service (Amendment)	0 6
6594.	Land (Special Grants)	0 9
6595.	Labour and Industry (Motor Car Shops)	0 6
6596.	Home Finance (Financial)	0 6
6597.	Dromana Land (Arthur's Seat Public Park)	0 6
6598.	Money Lenders (Amendment)	0 6
6599.	Landlord and Tenant (Fair Rents)	0 6
6600.	Labour and Industry (Amendment)	0 6
6601.	Local Government	0 9
6602.	Public Works Loan Application	0 6
6603.	Soldier Settlement (Amendment)	0 6
6604.	Water (Land Reclamation)	0 6
6605.	Mental Health	4 3
6606.	Appropriation of Revenue	7 0

Table of Acts and Enactments passed date of operation, &c. 0 6

A. C. BROOKS,
Government Printer.

STATE ACTS, 1960.

COPIES of the following Acts of Parliament of Victoria may be obtained at the Government Printing Office, or from any bookseller, at the price set opposite to each:—

No.		Price.
		s. d.
6607.	Anzac Day	1 0
6608.	Agricultural Lime (Amendment)	0 6
6609.	Motor Car (Commencement)	0 6
6610.	Fisheries (Change of Title)	0 6
6611.	Stamps (Amendment)	0 6
6612.	Land (Public Authorities)	0 6
6613.	Coal Canal Bridge	0 6
6614.	Metropolitan Fire Brigades (Borrowing Powers)	0 6
6615.	Wodonga Lands Exchange	0 6
6616.	Licensing (Fees)	0 6
6617.	Home Finance (Loans to Minors)	0 6
6618.	Co-operative Housing Societies (Amendment)	0 6
6619.	Racing (Totalizators Extension)	1 0
6620.	Companies	0 6
6621.	Judges Salaries and Allowances	0 6
6622.	Coal Mines (Pensions Contributions)	0 6
6623.	Landlord and Tenant (Further Amendment)	0 6
6624.	Public Officers Salaries and Allowances	0 9
6625.	Legal Profession Practice (Amendment)	0 6
6626.	Church of England in Australia Constitution	1 9
6627.	Companies (Fees)	0 6
6628.	Motor Car (Amendment)	1 0
6629.	Geelong Waterworks and Sewerage (Amendment)	0 6
6630.	Latrobe Valley (Financial)	0 6
6631.	Labour and Industry (Amendment)	0 6
6632.	Acts Interpretation	0 6
6633.	Children's Court (Enforcement of Awards)	0 6
6634.	Supreme Court (Proceedings before Master)	0 6
6635.	Melbourne and Metropolitan Board of Works (Borrowing Powers)	0 6
6636.	Electoral Provinces	0 9
6637.	Town and Country Planning (Amendment)	0 6
6638.	Racing (Dog Races)	0 6
6639.	Industrial Safety Advisory Council	0 6
6640.	Administration and Probate (Offices)	0 6
6641.	Justices (Bail)	0 6
6642.	National Parks (Amendment)	0 9
6643.	Medical (Amendment)	0 6
6644.	Melbourne Harbor Trust Lands	1 0
6645.	Weights and Measures (Penalties)	0 6
6646.	Transfer of Land (Stratum Estates)	0 6
6647.	Local Government (Preston Streets Agreement)	0 9
6648.	John Storey Memorial Fund	0 6
6649.	Police Offences (Amendment)	0 6
6650.	Motor Car (Third-Party Insurance)	0 6
6651.	Social Welfare	2 9
6652.	City of Melbourne Underground Railway Construction	1 0
6653.	Valuation of Land	1 3
6654.	Milk Board (Amendment)	0 6
6655.	Victoria Racing Club (Amendment)	0 6

STATE ACTS, 1960—continued.

No.		Price. s. d.
6656.	Consolidated Revenue	0 6
6657.	Consolidated Revenue	0 6
6658.	Motor Car (Driving)	0 6
6659.	Licensing (Amendment)	1 0
6660.	Consolidated Revenue	0 6
6661.	Consolidated Revenue	0 6
6662.	Friendly Societies (Dental Clinics)	0 6
6663.	Cancer (Amendment)	0 6
6664.	Dried Fruits (Amendment)	0 6
6665.	Barwon Heads Lands Exchange	0 6
6666.	Revocation of Crown Reservations	0 6
6667.	The Constitution Act Amendment (Expenses)	0 6
6668.	Supreme Court (Orders)	0 6
6669.	Gippsland Railw. Deviation	0 9
6670.	Hamilton Stockyards Railway Construction	0 6
6671.	Nurses (Amendment)	0 6
6672.	Ministry of Transport (Railway Officers)	0 6
6673.	Fruit and Vegetables (Road Barriers)	0 6
6674.	Transport Regulation (Qualifications of Chair- man)	0 6
6675.	Motor Car (Insurance Surcharge Continuance)	0 6
6676.	Geelong Harbor Trust (Freezing Works Agreement)	0 9
6677.	Western Metropolitan Market (Amendment)	0 6
6678.	Racing (Trotting Races)	0 6
6679.	Wattle Park Land	0 6
6680.	Surplus Revenue	0 6
6681.	Milk and Dairy Supervision (Research Con- tributions)	0 6
6682.	Tourist (Amendment)	0 6
6683.	Fisheries (Crayfish)	0 6
6684.	Audit (Amendment)	0 6
6685.	Sale of Allotments of Land (Amendment)	0 6
6686.	Cattle Compensation (Amendment)	0 6
6687.	Co-operative Housing Societies (Guarantees)	0 6
6688.	State Library National Gallery National Museum and Institute of Applied Science	1 3
6689.	Medical (Blood Transfusion)	0 6
6690.	The Constitution Act Amendment (Treating)	0 6
6691.	State Forests Loan Application	0 6
6692.	Local Authorities Superannuation (Amend- ment)	0 9
6693.	Local Government (Disqualification)	1 0
6694.	Superannuation (Additions to Pensions)	0 6
6695.	Police Regulation (Pensions)	0 6
6696.	Trustee Companies (Amalgamation)	0 6
6697.	Geelong and Colac Railway (Deviation)	0 6
6698.	University Colleges Lands	0 6
6699.	Local Government (Private Street)	0 6
6700.	Northcote School	0 6
6701.	Public Works Loan Application	0 9
6702.	Tower Hill and Malmsbury Lands	0 6
6703.	Coal Mines (Pensions)	0 6
6704.	Vermin and Noxious Weeds (Financial)	0 6
6705.	Navigable Waters (Oil Pollution)	1 0
6706.	Business Names (Public Borrowings)	0 6
6707.	Health (Tuberculosis Arrangement)	0 6
6708.	Water Supply Loan Application	1 3
6709.	Railway Loan Application	1 0
6710.	Land Tax (Relief)	0 6
6711.	Land Tax (Rates)	0 6
6712.	Monash University (Amendment)	0 6
6713.	National Fitness Council of Victoria	1 0
6714.	Local Government (Keilor Waverley and Springvale)	0 6
6715.	Explosives	2 3
6716.	Statute Law Revision	0 9
6717.	Motor Car (Abolition of Owners' Certificates)	0 6
6718.	Road Traffic (Amendment)	0 6
6719.	Milk Board (Powers)	0 6
6720.	Marketing of Primary Products (Members)	0 6
6721.	Melbourne and Geelong Mortgages	0 9
6722.	Building Societies (Amendment)	0 9
6723.	Local Government (Scaffolding Inspection)	0 9
6724.	State Electricity Commission (Borrowing)	0 6
6725.	Labour and Industry (Butchers' Shops)	0 6
6726.	Country Fire Authority (Sawmill Burners)	0 6
6727.	Sewerage Districts (Amendment)	1 0
6728.	Water (Amendment)	1 3
6729.	Housing (Powers)	0 6
6730.	Entertainments Tax (Amendment)	0 6
6731.	Crimes (Kidnapping)	0 6
6732.	Health (Amendment)	0 6
6733.	Game (Licences)	0 6
6734.	Estate Agents (Amendment)	0 6
6735.	Appropriation of Revenue	8 6

A. C. BROOKS,
Government Printer.

STATE ACTS, 1961.

No.		Price. s. d.
6736.	Public Works Committee (Special Exemption)	0 6
6737.	Railways (Permanent Service)	0 6
6738.	Superannuation (Railway Service)	0 6
6739.	Stamps (Amendment)	0 6
6740.	Employers and Employés (Attachment of Wages)	0 6
6741.	St. Kilda (Goldsmith and Shelley Streets) Land	0 6
6742.	Municipal Association (Amendment)	0 6
6743.	Wormbete Land	0 6
6744.	Grain Elevators (Borrowing)	0 6
6745.	Housing (Amendment)	0 6
6746.	Land (North-West Mallee Settlement Areas)	0 9
6747.	Ripon Peace Memorial Hospital Trust	0 6
6748.	Road Traffic (Parking on Railway and Municipal Property)	0 6
6749.	Co-operation (Amendment)	0 6
6750.	Heidelberg and Toolamba Lands Exchange	0 6
6751.	Town and Country Planning (Amendment)	0 6
6752.	Janet Clarke Hall	0 6
6753.	Transport Regulation (Compensation)	0 6
6754.	Bread Industry (Legal Proceedings)	0 6
6755.	Milk Pasteurization (Licences)	0 6
6756.	Health (Proprietary Medicines)	0 6
6757.	Police Offences (False Reports to Police)	0 6
6758.	Evidence (Children)	0 6
6759.	Statute Law Revision	0 6
6760.	Transport Regulation (Term of Office)	0 6
6761.	Prostitution	0 6
6762.	Motor Car (Amendment)	1 0
6763.	Game (Amendment)	0 6
6764.	The Constitution Act Amendment (Electoral)	0 9
6765.	Building Societies (Amendment)	1 3
6766.	Juries (Amendment)	0 6
6767.	Gas and Fuel Corporation (Borrowing)	0 6
6768.	Clean Air (Sub-committees)	0 6
6769.	Housing (Home Builders' Account)	0 6
6770.	Police Offences (Pinball Machines)	0 6
6771.	Fisheries (Commercial Council)	0 6
6772.	Consolidated Revenue	0 6
6773.	Consolidated Revenue	0 6

A. C. BROOKS,
Government Printer.

CONTENTS

	PAGE
Acts of Parliament on sale at the Government	2693
Printing Office	2659
Appointments	2651
Auction Sales Act	2656
Contracts	2654
Courts	2658
Estates of Deceased Persons	2647
Government Notices	2693
Impoundings	2667
Lands	2652
Licences to Occupy Unused Roads	2657
Melbourne and Metropolitan Board of Works— Notice	2659, 2693
Mining	2651
Money Lenders Act 1958—Supplementary List	2647
Notice to Mariners	2661
Orders in Council— Acts—Land; Water	et seq 2663
Local Government; Drainage Areas; Country Roads.	et seq 2682
Private Advertisements	2645
Proclamations	2647
Public Holidays	2677
Public Service Notices	2663
Regulations— Acts—Public Service	2661
Resignation	2655
State Rivers and Water Supply Commission	2673
Tenders	2648
Transport Regulation Board—Public Hearings	2653
Waterworks Trusts	2653

[2697]



VICTORIA GOVERNMENT GAZETTE

Published by Authority

[Registered at the General Post Office, Melbourne, for transmission by post as a newspaper.]

No. 69]

WEDNESDAY, AUGUST 2

[1961

LANDLORD AND TENANT ACT 1958.

At the Executive Council Chamber, Melbourne, the second day of August, 1961.

PRESENT:

His Excellency the Lieutenant-Governor of Victoria.
Mr. Chandler | Mr. Reid.
Mr. Thompson

ORDER EXTENDING APPLICATION OF PART V. OF THE LANDLORD AND TENANT ACT 1958 TO CERTAIN PREMISES.

IN pursuance of the powers conferred by section 44 of the *Landlord and Tenant Act 1958*, His Excellency the Lieutenant-Governor of Victoria, by and with the advice of the Executive Council thereof, doth hereby declare that the application of Part V. of the *Landlord and Tenant Act 1958* shall extend to each of the following premises:—

1. The premises known as Number 13 Wondah-street, Cobram.
2. The premises known as Number 15 Wondah-street, Cobram.
3. The premises known as Number 53 Howe-crescent, South Melbourne.
4. The premises known as Number 367 Station-street, North Carlton.
5. The premises known as Number 6 Arthur-street, South Yarra.
6. The premises known as "Roslyn", Toorac-road, Upwey.
7. The premises known as Flat No. 1 at 283 High-street, Preston.
8. The premises known as Flat No. 2 at 283 High-street, Preston.
9. The premises known as Number 31 Simpson-street, Yarraville.
10. The premises known as Number 43 Coronation-street, West Footscray.
11. The premises known as No. 11 O'Shannassy-street, North Melbourne.

And the Honorable Arthur Gordon Rylah, Her Majesty's Attorney-General in and for the State of Victoria, shall give the necessary directions herein accordingly.

A. MAHLSTEDT,
Clerk of the Executive Council.

No. 69.—6512/61.

LANDLORD AND TENANT ACT 1958.

At the Executive Council Chamber, Melbourne, the second day of August, 1961.

PRESENT:

His Excellency the Lieutenant-Governor of Victoria.
Mr. Chandler | Mr. Reid.
Mr. Thompson

ORDER EXCLUDING CERTAIN PREMISES FROM THE OPERATION OF CERTAIN PROVISIONS CONTAINED IN PART V. OF THE LANDLORD AND TENANT ACT 1958.

IN pursuance of the powers conferred upon him by the *Landlord and Tenant Act 1958*, His Excellency the Lieutenant-Governor of Victoria, by and with the advice of the Executive Council thereof, doth hereby declare that the premises situated at Number 128 Boundary-road, North Melbourne, shall be excluded from the operation of the whole of the provisions contained in Division 2 and 3 of Part V. of the *Landlord and Tenant Act 1958*.

And the Honorable Arthur Gordon Rylah, Her Majesty's Attorney-General in and for the State of Victoria, shall give the necessary directions herein accordingly.

A. MAHLSTEDT,
Clerk of the Executive Council.

Town and Country Planning Act 1958 (As Amended).

SHIRE OF MYRTLEFORD.

INTERIM DEVELOPMENT ORDER.

BY virtue of the powers conferred by the *Town and Country Planning Act 1958*, as amended, and of every other power enabling it in that behalf, the Shire of Myrtleford (hereinafter referred to as the Responsible Authority) having commenced the preparation of a Planning Scheme in accordance with the said Act on the 22nd day of June, 1961, hereby makes the following Interim Development Order for the purpose of regulating, restricting, restraining or prohibiting the use or development of any land or the erection, construction or carrying out of any buildings or works on any land within the area described in the Schedule hereto.

1. After the coming into operation of this Interim Development Order no person shall use or develop any land or erect, construct or carry out any buildings or

works on any land within the area included in the Schedule, except in accordance with the provisions of a permit issued by the Responsible Authority.

2. Any application for a permit to use or develop any land or to erect, construct or carry out any buildings or works shall be accompanied by a sketch plan or copy of Certificate of Title of the land and a description of the proposed use or development and type and construction of any buildings or works proposed to be erected, constructed or carried out, and such other particulars relating to the application as the Responsible Authority may require.

3. This Interim Development Order shall not prevent the continuance of the use of any land or buildings for the purposes for which such lands or buildings were lawfully used immediately before the coming into operation of this Order.

4. Schedule.—All that area of land contained within the following boundary:—

In the Parish of Myrtleford commencing at the junction of the Barwidgee Creek with the Ovens River; thence generally north-easterly along the Barwidgee Creek to the point opposite the western corner of C.A. 8, section 7; thence by a line generally south-easterly along the south-western boundary of C.A. 8 and part C.A. 6 to the eastern corner of C.A. 7A, all of section 7; thence along the permanent forest boundary generally southerly to the southernmost corner of C.A. 9C, section 9A; thence by a straight line generally southerly to the north-east corner of C.A. 4, section 0; thence southerly along the eastern boundary of that allotment to the road reserve; thence along the road reserve generally south-easterly and southerly to the Ovens River; thence along that river generally north-westerly to the commencing point.

(SEAL) W. R. SELZER, Shire President.
KEVIN A. WELLES, Councillor.
K. S. LANE, Shire Secretary.

Report by the Town and Country Planning Board on the 31st day of July, 1961. Recommended for approval.—
FRED. C. COOK, Chairman.

Approved by the Governor in Council on the 2nd day of August, 1961.

A. MAHLSTEDT,
Clerk of the Executive Council.

Town and Country Planning Act 1958 (As Amended).

SHIRE OF BARRABOOL.

INTERIM DEVELOPMENT ORDER.

BY virtue of the powers conferred by the *Town and Country Planning Act 1958*, as amended, and of every other power enabling it in that behalf, the Shire of Barrabool (hereinafter referred to as the Responsible Authority) having commenced the preparation of a Planning Scheme in accordance with the said Act on the 16th day of March, 1961, hereby makes the following Interim Development Order for the purpose of regulating, restricting, restraining or prohibiting the use or development of any land or the erection, construction or carrying out of any buildings or works, that is to say:—

1. Except in accordance with the provisions of a permit issued by the Responsible Authority, no person shall use, subdivide or otherwise develop any land or erect, construct or carry out any buildings or works on any land within the area described in the First and Second Schedules hereto.

2. After the coming into operation of this Interim Development Order:—

- (a) No person shall subdivide any land in that part of the Shire of Barrabool described in the First Schedule hereto into allotments having an area of less than 10 acres.

- (b) No person shall subdivide into allotments any land in that part of the Shire of Barrabool described in the Second Schedule hereto except in accordance with the provisions of a permit issued by the Responsible Authority.

3. Notwithstanding the provisions of clause 2 (a) hereof the Responsible Authority may permit a parcel of land lesser in area than is prescribed to be excised for the purpose of—

- (a) increasing the area of an existing allotment,
(b) erecting one only additional dwelling house,
(c) erecting a hall, church and building principally used for religious purposes,
(d) erecting a school and buildings principally used for educational purposes, and
(e) erecting a utility service structure, depot or works, constructed by a Government Department or Public Authority.

4. This Interim Development Order shall not prohibit the continuance of the use of any land or buildings for the purposes for which such land or buildings were lawfully used immediately before the coming into operation of this Order.

5. Every application for a permit under the provisions of this Order shall be made on the prescribed form, copies of which may be obtained from the office of the Responsible Authority at 441 Moorabool-street, Geelong.

FIRST SCHEDULE.

All land in the municipal district of the Shire of Barrabool except—

- (a) that part of the municipal district within the area of the Interim Development Order made by the Geelong and District Town Planning Committee and approved by the Governor in Council on the 17th day of December, 1946;
(b) that part of the municipal district within the boundary of the Ocean Road Planning Scheme 1955 approved by the Governor in Council on the 15th day of April, 1958; and
(c) the areas of land described in the Second Schedule hereto.

SECOND SCHEDULE.

All land in the Shire of Barrabool comprising—

- (a) that part of the areas of the towns and districts of Torquay, Anglesea, Airey's Inlet and Lorne excluded from the provisions of the Ocean Road Planning Scheme, 1955;
(b) the Crown allotments listed hereunder—
Parish of Duneed—
Crown allotments 1, 2, 3, 4, 5, 6 (g), (h) and (i) of section VI.;
N, M, M¹, O, P, Q and R, section VII.;
Q, R, S, T, U, V, and W, section VIII.;
9A, 9B, 9C, W, X, Y, and Z, section IX.;
(c) that part of the Crown allotments within the Parish of Duneed as defined hereunder—
(i) that portion of Crown allotment B, section V, south of the Princes Highway.

(SEAL) G. M. COCHRANE, President.
G. W. F. McINTYRE, Councillor.
T. GOODALL, Municipal Clerk.

Dated this 21st day of July, 1961.

Report by the Town and Country Planning Board on the 28th day of July, 1961. Recommended for approval.—
FRED. C. COOK, Chairman.

Approved by the Governor in Council on the 2nd day of August, 1961.

A. MAHLSTEDT,
Clerk of the Executive Council.