



# VICTORIA GOVERNMENT GAZETTE

Published by Authority

[Registered at the General Post Office, Melbourne, for transmission by post as a newspaper.]

No. 117]

WEDNESDAY, NOVEMBER 14

[1962

## ACTS OF PARLIAMENT.

### PROCLAMATION

By His Excellency the Governor of the State of Victoria and its Dependencies in the Commonwealth of Australia, &c., &c., &c.

I, THE Governor of the State of Victoria, in the Commonwealth of Australia, do hereby declare that I have this day assented, in Her Majesty's name, to the Bills passed by the Parliament of the said State, the titles whereof are hereunder set forth, that is to say:—

- No. 6903. An Act to amend the *Entertainments Tax Act 1958* and for other purposes.
- No. 6904. An Act to amend Section Sixty-six of the *Education Act 1958*.
- No. 6905. An Act to alter certain Requirements necessary for Membership of the Marine Board of Victoria and for other purposes.
- No. 6906. An Act to increase the Maximum Sum which may be borrowed by the Grain Elevators Board.
- No. 6907. An Act to regulate Matters with respect to Residences allocated to Members of the Teaching Service.
- No. 6908. An Act to provide for the Closing of a certain Street in the City of Brighton known as Cramer-street and for the Opening in lieu thereof of a Public Footway and for the Vesting in Brighton Grammar School of Part of the Land on which the said Street is formed and for other purposes.
- No. 6909. An Act to amend the *Co-operative Housing Societies Act 1958*, and for other purposes.
- No. 6910. An Act to amend the *Stamps Act 1958* and for purposes connected therewith.
- No. 6911. An Act to amend the *Soil Conservation and Land Utilization Act 1958*, and for other purposes.
- No. 6912. An Act to provide, upon the Surrender to Her Majesty of certain Land in the Parish of Beaufort for the Reservation thereof as a Site for Municipal Purposes, and for the Revocation of the Reservation of certain other Land in the said Parish temporarily reserved as a Site for the Carngham and Beaufort District Road Board's

Offices and for the Grant thereof to the President Councillors and Ratepayers of the Shire of Ripon, and for other purposes.

- No. 6913. An Act to make Provision for the Licensing of Bodies Corporate under the *Second-hand Dealers Act 1958*, to increase the Fees payable for Licences issued under the said Act, and for other purposes.

Given under my Hand and the Seal of the State of Victoria aforesaid, at Melbourne, this seventh day of November, in the year of our Lord One thousand nine hundred and sixty-two, and in the eleventh year of the reign of Her Majesty Queen Elizabeth II.

(L.S.)

DALLAS BROOKS.

By His Excellency's Command,

HENRY E. BOLTE,  
Premier.

GOD SAVE THE QUEEN!

*Milk and Dairy Supervision Act 1958* (No. 6317).

## MUNICIPALITIES DEFINED AS URBAN DISTRICTS.

### PROCLAMATION

By His Excellency the Governor of the State of Victoria and its Dependencies in the Commonwealth of Australia, &c., &c., &c.

I, IN pursuance of the provisions contained in Part III. of the *Milk and Dairy Supervision Act 1958* (No. 6317), I, the Governor of the State of Victoria, in the Commonwealth of Australia, by and with the advice of the Executive Council of the said State, do by this my Proclamation hereby define for the purpose of the said Act the Municipal Districts the names of which appear in the Schedule hereto as urban districts as on and from the first day of December, One thousand nine hundred and sixty-two.

### SCHEDULE.

Shire of Bass.  
Shire of Korumburra.

Given under my Hand and the Seal of the State of Victoria aforesaid, at Melbourne, this seventh day of November, in the year of our Lord One thousand nine hundred and sixty-two, and in the eleventh year of the reign of Her Majesty Queen Elizabeth II.

(L.S.) DALLAS BROOKS.

By His Excellency's Command,  
G. L. CHANDLER,  
Minister of Agriculture.  
GOD SAVE THE QUEEN!

Given under my Hand and the Seal of the State of Victoria aforesaid, at Melbourne, this seventh day of November, in the year of our Lord One thousand nine hundred and sixty-two, and in the eleventh year of the reign of Her Majesty Queen Elizabeth II.

(L.S.) DALLAS BROOKS.

By His Excellency's Command,  
R. J. HAMER,  
for Chief Secretary.  
GOD SAVE THE QUEEN!

#### PUBLIC HIGHWAY.—SHIRE OF LILLYDALE.

##### PROCLAMATION

By His Excellency the Governor of the State of Victoria and its Dependencies in the Commonwealth of Australia, &c., &c., &c.

WHEREAS by the Local Government Act 1958, as amended, section 519, it is amongst other things enacted that it shall be lawful for the Governor in Council at any time, and from time to time, upon request of the Council of any municipality, by notice in the *Government Gazette*, to proclaim any land reserved, used or by purchase or exchange acquired for a street, road, highway, thoroughfare, bridge, square, court, alley or right-of-way or any street, road, lane, or passage made or laid out or proposed to be made or laid out on any land of which a plan delineating that street, road, lane or passage has been lodged with the Registrar of Titles, pursuant to sub-section (11) of section 569 of the said Act to be a public highway, and that such land shall thereupon and thenceforth from the date of such Proclamation become and be absolutely dedicated to the public as a public highway within the meaning of any law then or thereafter in force:

And whereas the Council of the Shire of Lillydale has requested that the land hereinafter mentioned, which has been used for a street within the said Shire, be so declared to be a public highway:

Now, therefore, I, the Governor of the State of Victoria in the Commonwealth of Australia, by and with the advice of the Executive Council of the said State, do by this Proclamation declare that all that piece of land being Cherylne-court as shown on plan of subdivision No. 41376, lodged in the Office of Titles and thereon coloured brown, shall be a public highway within the meaning of the said Act.

Given under my Hand and the Seal of the State of Victoria aforesaid at Melbourne, this seventh day of November in the year of our Lord One thousand nine hundred and sixty-two, and in the eleventh year of the reign of Her Majesty Queen Elizabeth II.

(L.S.) DALLAS BROOKS.

By His Excellency's Command,  
MURRAY PORTER,  
Minister for Local Government.  
GOD SAVE THE QUEEN!

#### PUBLIC HOLIDAYS.

##### PROCLAMATION

By His Excellency the Governor of the State of Victoria and its Dependencies in the Commonwealth of Australia, &c., &c., &c.

IN pursuance of the provisions contained in Part III. of the *Public Service Act 1958*, I, the Governor of the State of Victoria, in the Commonwealth of Australia, by and with the advice of the Executive Council of the said State, do by this my Proclamation appoint the days and dates hereunder mentioned to be observed as a Public Holiday or Public Half-Holiday (as the case may be) at the places respectively specified, viz.:—

##### *Public Holiday*:—

\*SATURDAY, THE 2ND FEBRUARY, 1963, throughout the Shire of South Gippsland.

*Public Half-Holiday from the Hour of Twelve o'clock noon*:—

\*THURSDAY, THE 15TH NOVEMBER, 1962, throughout the City of Hamilton.

\*Agricultural Show.

#### PUBLIC HALF-HOLIDAY.

##### PROCLAMATION

By His Excellency the Governor of the State of Victoria and its Dependencies in the Commonwealth of Australia, &c., &c., &c.

IN pursuance of the provisions contained in Part III. of the *Public Service Act 1958*, I, the Governor of the State of Victoria, in the Commonwealth of Australia, by and with the advice of the Executive Council of the said State, do by this my Proclamation appoint the day and date hereunder mentioned to be observed as a Public Half-Holiday at the place specified, viz.:—

*Public Half-Holiday from the Hour of Twelve o'clock noon*:—

\*THURSDAY, THE 15TH NOVEMBER, 1962, throughout the Shire of Dundas.

\*Agricultural Show.

Given under my Hand and the Seal of the State of Victoria aforesaid, at Melbourne, this thirteenth day of November, in the year of our Lord One thousand nine hundred and sixty-two, and in the eleventh year of the reign of Her Majesty Queen Elizabeth II.

(L.S.) DALLAS BROOKS.

By His Excellency's Command,  
R. J. HAMER,  
for Chief Secretary.  
GOD SAVE THE QUEEN!

#### BANK HALF-HOLIDAY.

##### PROCLAMATION

By His Excellency the Governor of the State of Victoria and its Dependencies in the Commonwealth of Australia, &c., &c., &c.

IN pursuance of the provisions of the *Bank Holidays Act 1958*, I, the Governor of the State of Victoria, in the Commonwealth of Australia, do by this my Proclamation appoint the day and date named hereunder a special day to be observed as a Bank Half-Holiday at the place mentioned, that is to say:—

*Bank Half-Holiday from the Hour of Eleven a.m.*:—

TUESDAY, THE 27TH NOVEMBER, 1962, at the Shire of Newham and Woodend.

Given under my Hand and the Seal of the State of Victoria aforesaid, at Melbourne, this thirteenth day of November, in the year of our Lord One thousand nine hundred and sixty-two, and in the eleventh year of the reign of Her Majesty Queen Elizabeth II.

(L.S.) DALLAS BROOKS.

By His Excellency's Command,  
R. J. HAMER,  
for Chief Secretary.  
GOD SAVE THE QUEEN!

#### BANK HALF-HOLIDAYS.

##### PROCLAMATION

By His Excellency the Governor of the State of Victoria and its Dependencies in the Commonwealth of Australia, &c., &c., &c.

IN pursuance of the provisions of the *Bank Holidays Act 1958*, I, the Governor of the State of Victoria, in the Commonwealth of Australia, do by this my Proclamation

appoint the days and dates named hereunder special days to be observed as Bank Half-Holidays at the places respectively mentioned, that is to say:—

*Bank Half-Holidays from the Hour of Eleven o'clock a.m.:—*

WEDNESDAY, THE 21ST NOVEMBER, 1962, at Learmonth.

THURSDAY, THE 15TH NOVEMBER, 1962, at Dunkeld.

Given under my Hand and the Seal of the State of Victoria aforesaid, at Melbourne, this seventh day of November, in the year of our Lord One thousand nine hundred and sixty-two, and in the eleventh year of the reign of Her Majesty Queen Elizabeth II.

(L.S.) DALLAS BROOKS.

By His Excellency's Command,  
R. J. HAMER,  
for Chief Secretary.  
GOD SAVE THE QUEEN!

Melbourne and Metropolitan  
BOARD OF WORKS.

GENERAL NOTICE.

THE Melbourne and Metropolitan Board of Works, having made sewers for carrying off the sewage from each and every property which, or any part of which, abuts on the streets or parts of streets in which such sewers are laid, and which are included within the sewerage areas hereinafter described, doth hereby declare that on and after the 14th December, 1962, each and every property which, or any part of which, abuts on the said streets or parts of streets, shall be deemed to be a sewer property within the meaning of the *Melbourne and Metropolitan Board of Works Act 1958*.

The Sewerage Areas hereinbefore referred to are:—

*Sewerage Area No. 1784.*

*City of Sunshine.*—Commencing at the junction of Ballarat-road and Lacy-street; thence northerly along Lacy-street, easterly along Cranwell-street, northerly along Evans-street, easterly along Airley-street, southerly along the eastern boundaries of lots 4 to 1 Evans-street, easterly along Chewton-street, southerly along Ashley-street, westerly along Ballarat-road to the commencing point.

*Sewerage Area No. 1785.*

*City of Broadmeadows.*—Commencing at the junction of Pascoe Vale-road and Willet-avenue; thence westerly along Willet-avenue, northerly along Summit-avenue, westerly along New-road, northerly along Kennedy-street, westerly along Loongana-avenue, northerly and north-westerly along Palana-street, north-easterly along Dromana-street to the boundary of Sewerage Area No. 1712 in William-street, south-easterly and north-easterly following the said boundary to the junction of Kennedy-street and Pascoe Vale-road, southerly along Pascoe Vale-road to the commencing point.

*Sewerage Area No. 1786.*

*City of Moorabbin.*—Commencing at the intersection of Brooks-street and Manuka-street, on the boundary of Sewerage Area No. 1597; thence northerly along Manuka-street, easterly along Gowrie-street to the boundary of Sewerage Area No. 1366, southerly and easterly following the said boundary to Warrigal-road, southerly along Warrigal-road, westerly along Tudor-street, northerly along the western boundaries of lots 34 Tudor-street and 1 Orange-street, easterly along Orange-street, northerly along the western boundary of lot 5 Orange-street, westerly along the southern boundaries of lots 45 to 30 Brooks-street, northerly along the western boundary of the said lot 30 to the boundary of Sewerage Area No. 1597, easterly, northerly and easterly following the said boundary to the commencing point.

*Sewerage Area No. 1787.*

*City of Broadmeadows.*—Commencing at the junction of Barry-road and Blair-street; thence southerly along Blair-street, easterly along Lismore-street, north-easterly and northerly along Dallas-drive, westerly along Barry-road to the commencing point.

*Sewerage Area No. 1788.*

*City of Box Hill.*—Commencing at the junction of Ferris-avenue and Woodhouse-grove, on the boundary of Sewerage Area No. 1743; thence south-westerly, southerly, easterly and southerly following the said boundary to the junction of the eastern part of Olympiad-crescent and

Shannon-street, easterly along Shannon-street, northerly along the eastern boundary of lot 46 Shannon-street and portion of the eastern boundary of lot 47. Olympiad-crescent, easterly along the southern boundaries of lots 7 and 30 Saxton-street, 37 to 39 Mitta-street and 41 Simmons-street, southerly along Simmons-street, easterly along Shannon-street, northerly along the eastern boundary of lot 2 Shannon-street, westerly and north-westerly along the northern boundaries of the said lots 2 and 3 Shannon-street, northerly along the eastern boundaries of lots 129 to 138 Ovens-street, easterly along the southern boundary of lot 142 Station-street, northerly along Station-street, westerly, southerly and south-westerly along Woodhouse-grove to the commencing point.

*Sewerage Area No. 1789.*

*City of Camberwell.*—Commencing at the junction of Jacka-street and Dunstan-street; thence easterly along Dunstan-street, south-westerly and southerly along Hosken-street, westerly along Burton-street, further westerly along the southern boundary of lot 701 Jacka-street, northerly along the western boundaries of lots 701 to 693 Jacka-street and a line in continuation to the boundary of Sewerage Area No. 1770, easterly and southerly following the said boundary to the commencing point.

*Sewerage Area No. 1790.*

*City of Moorabbin.*—Commencing at the junction of Mathieson-street and Tennyson-street; thence easterly and south-easterly along Tennyson-street, south-westerly along Karen-street, north-westerly along Mathieson-street, south-westerly along the south-eastern boundaries of lots 26 Mathieson-street and 25 Nepean Highway, westerly by a line to and along Bay-road, northerly along the western boundary of lot 2 Bay-road, north-easterly along the north-western boundary of the said lot 2 and a line in continuation to Nepean Highway, north-westerly along Nepean Highway to the boundary of Sewerage Area No. 1543, north-easterly and north-westerly following the said boundary to the commencing point.

Further particulars regarding the streets or parts of streets in which sewers have been laid may be ascertained on inquiry at the Board's office.

By order of the Board,

H. J. SNADDEN,  
Secretary.

110 Spencer-street, Melbourne, C.1, 13th November, 1962.

*Electric Light and Power Act 1958.*

ORDER GRANTED BY THE GOVERNOR IN COUNCIL.

IT is hereby notified that an Order, pursuant to the provisions of the *Electric Light and Power Act 1958* (No. 6241), as hereunder mentioned, has been granted by His Excellency the Governor in Council, viz.:—

Order No. 329.—Order under section 10 of the above-mentioned Act granted to the City of Footscray in respect of South Kingsville.

G. O. REID,  
Minister of Electrical Undertakings.

State Electricity Commission of Victoria,  
7th November, 1962.

COMPANIES ACT 1961.

NOTICE is hereby given, in pursuance of section 308 (2) and 308 (3) of the *Companies Act 1961*, that at the expiration of three months from the date hereof the name of the following company will, unless cause is shown to the contrary, be struck off the Register and the said company will be dissolved.

Dated this 28th day of November, 1962.

T. S. WELSH,  
Registrar of Companies.

Companies Registration Office,  
Melbourne.

COMPANY ABOVE REFERRED TO.

Name of Company.

Number of  
Registration.

The Merrigum Bakery Company Limited .. 5015

Soil Conservation and Land Utilization Act 1958.

EPPALOCK WATER SUPPLY CATCHMENT PROCLAIMED 20TH JULY, 1960, "VICTORIA GOVERNMENT GAZETTE", No. 71.

NOTICE OF DETERMINATION OF LAND-USE IN PART OF EPPALOCK CATCHMENT, PLAN No. 1123.

Pursuant to Section 22 of the "Soil Conservation and Land Utilization Act 1958" (No. 6372).

IN pursuance of the provisions of section 23, sub-section 1, of the Soil Conservation and Land Utilization Act 1958 (No. 6372), the Soil Conservation Authority has determined land-use for all that area of land in the Parish of Newham within the Eppalock catchment delineated and distinctively marked on plan No. 1123, the original of which is lodged at the head office of the Soil Conservation Authority. All land within this area shall be used in accordance with the provisions of the particular category of land-use to which each area has been assigned.

The provisions of each of the land-use categories determined for this area are set out hereunder:—

 Land to be permanently used for forest purposes where forestry operations may be carried out under the supervision and control of the Forests Commission acting as agent for the Authority and where no subdivision for residential purposes shall be permitted.

 Land which may be used for forest purposes, but which, if approved by the Authority, may be developed for grazing or agricultural purposes or, if warranted, for residential purposes, subject to conditions imposed according to the particular circumstances, such conditions to include—

- (a) the degree of clearing permissible;
- (b) the specification of those areas where timber shall be retained;
- (c) the specification of those areas where subdivision for residential purposes would be permitted.

 Land which may be used for grazing or agricultural purposes, but where, if warranted, subdivision for residential purposes will be considered subject to conditions approved by the Soil Conservation Authority.

 Land within a minimum of 1 chain or such greater distance as the Authority may require from specified streams, springs, oftakes or storages, on which land-use shall be subject to conditions imposed by the Soil Conservation Authority, but in no circumstances shall permission be given for—

- (a) cropping, and
- (b) erection of buildings.

 Land reserved for roads and other public purposes on which any changes from the existing nature and conditions shall be made only after consultation with the Authority.

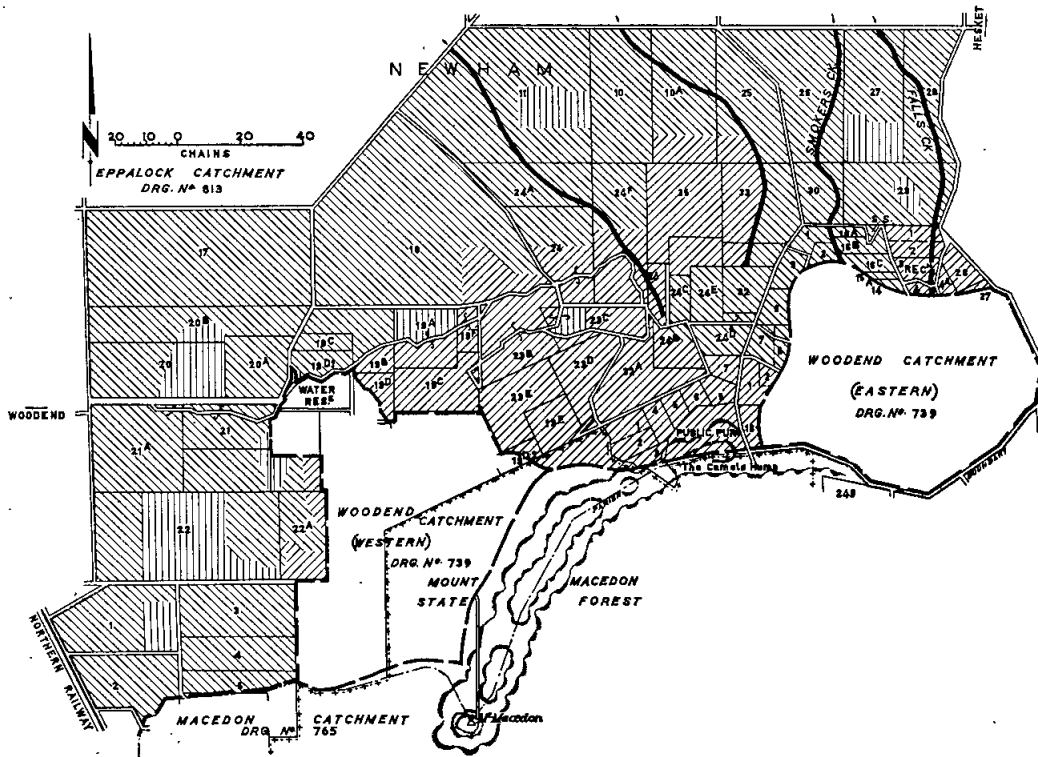

1123

I. S. HANCOCK,  
Acting Secretary.

Transport Regulation Act.  
TRANSPORT REGULATION BOARD.

## NOTICES OF PUBLIC HEARINGS.

NOTICE is hereby given that the applications made by the persons named below for licences to operate commercial passenger vehicles on the route or routes, or in the manner set out opposite their names, will be heard at a time and place to be communicated to the parties:—

*Name and Address; Nature of Application.*

- HICKS, G. R., PTY. LTD., Ouyen; 1 commercial passenger vehicle, with seating capacity for 33 persons, to operate under the same terms and conditions as licence No. T.P.74 in the name of the applicant company.
- BELL STREET BUS CO. PTY. LTD., 326 Bell-street, Preston; application for variation of Route 112A (Coburg-Merlynston) to operate the following turning procedure from Kent-road, via Cornwall-street, Boundary-road and Cumberland-road to normal route.  
(No extra fare for passengers who travel on the route covered by the proposed new turning procedure.)  
NOTE.—This application replaced application gazetted 7th November, 1962.
- CHRISTE, J. C., 612 Ascot-street, Ballarat; application for renewal of licences Nos. C.O.186 and C.O.208 (expiring 2nd February, 1963), authorizing operations under the same terms and conditions.
- HORE, J. S., 70 High-street, Wodonga; application for renewal of licence No. C.T.331 (expiring 7th February, 1963), authorizing operations as a country taxi from Wodonga.
- O'NEILL, Rev. Father, St. Patrick's Catholic Church, Princes Highway, Pakenham; application for renewal of licence No. T.P.66 (expiring 6th February, 1963), authorizing operations under the same terms and conditions.
- QANTAS EMPIRE AIRWAYS LTD., Beach-road, Avalon; application for renewal of licences Nos. T.P.61, T.P.97 and T.P.111 (expiring 28th February, 1963), authorizing operations under the same terms and conditions.
- FISHER, L. J. (trading as Westport Roadlines), Fisherterrace, Lang Lang; application for renewal of licence No. T.P.119 (expiring 31st March, 1963), authorizing operations under the same terms and conditions.
- NOLAN, J., Rev. Father, St. Joseph's Catholic School, Sorrento; application for renewal of licence No. T.P.36 (expiring 18th March, 1963), authorizing operations under the same terms and conditions.
- TURNER, K., T. & M., 35 Woonah-street, Chadstone; application for renewal of licence No. T.P.18 (expiring 10th February, 1963), authorizing operations under the same terms and conditions.

APPLICATIONS for metropolitan private hire car licences by the persons listed hereunder in respect of commercial passenger vehicles, with seating capacity for five persons, to operate under composite conditions from an approved depot in zone set out opposite their names:—

*Name and Address; Zone.*

- BERGER, M., 48 Hudson-street, Fawkner; "G".
- BENNETT, H., 5 Thompson-street, Watsonia; "G".
- DE BATTISTA, J., 54 McView-road, Thomastown; "G".
- JACKSON, J. W., 142 Sackville-street, Collingwood; "G".
- PAULING, T., care of 8 Keith-street, Huntingdale; "G".
- RACOVALIS, G. P., 15 Princess-street, Fawkner; "G".
- SIDNEY, B. D., Lot 40, Duff-parade, Lower Plenty; "G".
- LACEY, H., 284 Nell-street, Watsonia; "G".
- WILLIAMS, L. A., 2 Lawson-parade, Heidelberg; "G".
- HIPPOCRATES, G., 20 Margaret-street, Footscray; "G".

NOTICE is hereby given that the applications made by the persons named below for licences to operate the commercial goods vehicles, on the route or routes or in the manner set out opposite their names, will be held at a time and place to be communicated to the persons concerned:—

*Name and Address; Nature of Application.*

- BOWERS, L. A., 110 Gordon-street, Balwyn; 1 commercial goods vehicle (8 cwt.) to operate within a radius of 50 miles of the premises of the Myer Emporium at Melbourne in the course of business as a "floor covering layer" on behalf of the said company—floor coverings for laying, tools of trade and materials incidental thereto.
- BROWN, M. J., 38 Mountain View-avenue, Boronia; 1 commercial goods vehicle (8 cwt.) to operate within a radius of 50 miles of the premises of the Myer Emporium at Melbourne in the course of business as

a "floor covering layer" on behalf of the said company—floor coverings for laying, tools of trade and materials incidental thereto.

- BURGESS & NOYES PTY. LTD., Kepler-street, Warrnambool; 1 commercial goods vehicle (42 cwt.) to operate within a radius of 50 miles of own premises at Warrnambool in the course of business as "agricultural machinery dealers and repairers"—own goods, and agricultural machinery for repair or having been repaired.
- BUTTERWORTH, J. C., 44 Highridge-crescent, Airport West; 1 commercial goods vehicle (9 cwt.) to operate throughout the State of Victoria in the course of business as a "well drilling contractor"—tools of trade, equipment and materials incidental to the completion of own contracts.
- DALE, K. J., Hunter-street, Mansfield; 1 commercial goods vehicle (271 cwt.) to operate from forest landings in the Jamieson area to J. D. Walker's sawmill at Mansfield and J. A. Terrett's sawmill at Benalla—logs.
- DOODR, NORM, & SONS PTY. LTD., 401 Drummond-street north, Ballarat; 1 commercial goods vehicle (approximately 160 cwt.) to operate—(a) within a radius of 25 miles from the chief post office in the City of Ballarat—general goods, (b) within a radius of 70 miles from the chief post office in the City of Ballarat on behalf of the Eureka Terra Cotta & Tile Co. of Aust. Ltd. and Martins Stoneware Pipes Ltd.—(i) roofing tiles, roof battens and tile fixing materials, (ii) glazed bricks, bricks and glazed earthenware pipes.
- DRUMMOND, I. M. & W. R. M., 12 Chapman-street, Swan Hill; 1 commercial goods vehicle (111 cwt.) to operate in the course of business as "concrete contractors" within a radius of 50 miles of the post office at Swan Hill—tools of trade and materials incidental to own contracts.
- EVANS, C. R., Middle-street, Lakes Entrance; application to vary the conditions of existing licence No. T.T.D.479 by deleting present conditions and adding in lieu—(a) from forest landings in the Nunnet-Gillingall area to N. Putt's sawmill at Nowa Nowa—logs, (b) from forest landings within a radius of 10 miles of Nowa Nowa to N. Putt's sawmill at Nowa Nowa—logs.
- F.B.N. DISTRIBUTORS, 176 High-street, Maryborough; 1 commercial goods vehicle (130 cwt.) to operate within a radius of 50 miles of own premises at Maryborough in the course of business as "aerated water distributors"—aerated waters in glass containers and empty return containers.
- FLINN, W., Omeo Highway, Bruthen; application to vary the conditions of existing licence No. T.T.D.195/1 by deleting present conditions and adding in lieu—(a) from forest landings in the Cobbanah district to A. F. Collins' sawmill at Bairnsdale and from forest landings at Ensay North to Collins' sawmill at Ensay—logs, (b) from sawmills at Ensay to Bruthen Railway Station—sawn timber.
- HALL, J. B., 10 President-street, Seymour; application to vary the conditions of existing licences Nos. D.A.42004/2 and D.A.42004/4 by deleting present conditions and adding in lieu—(a) within a radius of 20 miles of the post office at Seymour—general goods, (b) from site to site as required by the Victorian Railways for maintenance of the railway lines between Melbourne and Wodonga—metal, stone, screenings, ashes, gravel, sand, earth and any other materials required for use on the maintenance of the said lines, also tools and equipment incidental thereto, (c) within a radius of 20 miles of any site under current construction or maintenance along the aforesaid lines—materials and equipment for use on such project.
- HUME BOTTLERS PTY. LTD., Tone-road, Wangaratta; 1 commercial goods vehicle (8 cwt.) to operate within a radius of 50 miles of the post office at Shepparton and to Wangaratta in the course of business as "soft drink manufacturers"—aerated waters in glass containers and empty return containers.
- HUTCHINSON, A. W., Nurrabiel; 1 commercial goods vehicle (111 cwt.) to operate—(a) within a radius of 20 miles of the post office at Nurrabiel—general goods, (b) from the depot of Shell Co. of Aust. Ltd. at Horsham to own depot at Nurrabiel—petroleum products and empty return containers, (c) from own depot at Nurrabiel to consignees within a radius of 25 miles thereof—petroleum products and empty return containers.
- JEFFREY, J., & SONS PTY. LTD., Wegner-street, Morwell; 1 commercial goods vehicle (200 cwt. approximately) to operate—(a) within a radius of 70 miles of the post office at Yarram (Traralgon Division of the Country Roads Board)—plant the property of a contractor and required for use in connexion with the construction or maintenance of some specific, existing or proposed road, street, footpath, bridge, wharf, pier,

- weir or channel, (b) within a radius of 20 miles from the site of construction or maintenance work performed pursuant to paragraph (a) above, or from the railway station nearest thereto—metal, stones, screenings, ashes, gravel, sand, earth and any other materials required for such work, (c) within a radius of 20 miles of the post office at Morwell—general goods.
- JACOB & JOHNSTONE, Clifton-street, Euroa; 1 commercial goods vehicle (5 cwt.) to operate—(a) throughout the State of Victoria in the course of business as "carrier" for the purpose of servicing and repairing own vehicles—own spare parts, tools and equipment incidental to such servicing and repair, (b) within a radius of 20 miles of the post office at Euroa—general goods.
- JAMES, G. E., Sutcliffe-street, Sea Lake; 1 commercial goods vehicle (63 cwt.) to operate—(a) within a radius of 20 miles from the Sea Lake Post Office—general goods, (b) within a radius of 50 miles from the Sea Lake Post Office—goods on behalf of the Sea Lake Timber & Hardware Co. Pty. Ltd. subject to the condition that no goods shall be carried on the route between Sea Lake and Charlton outside the radius defined in part (a) above, other than crushed rock from Wycheproof to Sea Lake, (c) from Koondrook to Sea Lake—sawn redgum timber.
- LIVERSIDGE, W. J., Mount Franklin; 1 commercial goods vehicle (approximately 100 cwt.) to operate from bush sites in the Daylesford district to Bacchus Marsh, via Ballan—pulpwood.
- THE NORTHCOTE BRICK CO. LTD., Robbs-parade, Northcote; 2 commercial goods vehicles (125 and 124 cwt.) to operate within a radius of 75 miles from own premises at Northcote in the course of business as "brick manufacturers"—own bricks.
- PALMER, H. G., PTY. LTD., 491-493 Bourke-street, Melbourne; 3 commercial goods vehicles (16, 16 and 16 cwt.) to operate within a radius of 50 miles of own branch premises at Horsham in the course of business as "electrical appliance retailers and servicemen"—tools of trade, spare parts, appliances for repair, having been repaired and for installation and materials incidental thereto.
- PETERS ICE CREAM (VIC.) LTD., 171-183 Burnley-street, Richmond; 1 commercial goods vehicle (180 cwt.) to operate throughout the State of Victoria as a specially constructed, insulated and refrigerated van for the purpose of supplying own distributors with ice-cream and frozen foods at a temperature not exceeding 10° F.
- PHELAN, W., & SONS PTY. LTD., 157 High-street, Maryborough; 1 commercial goods vehicle (12 cwt.) to operate throughout the State of Victoria, in the course of business as "builders and contractors" for the purpose of supervising own contracts—tools of trade, and materials incidental to the repair or completion of own contracts.
- RENKIN, J. G., Minnera; 1 commercial goods vehicle (119 cwt.) to operate—(a) within a radius of 50 miles of own premises at Minnera, in the course of business as "grain merchant"—own goods, (b) from BP Australia Ltd. depot at Ballarat to own depot at Minnera and to places situated within a radius of 20 miles of own depot—petroleum products in prescribed types of containers and empty return containers.
- RICE, E. J., 48 Smith-street, Collingwood; 1 commercial goods vehicle (7 cwt.) to operate within a radius of 50 miles of own premises at Collingwood and between Collingwood and the Warragul Market as a "stallholder"—own children's clothing.
- ROWBOTTOM, L. C., Minhamite; 1 commercial goods vehicle (71 cwt.) to operate—(a) within a radius of 20 miles of the post office at Minhamite and from Warrnambool and Hamilton to Minhamite—general goods, (b) to and from places within a radius of 50 miles of the post office at Minhamite from and to places situated within paragraph (a)—livestock.
- RUDD, F. G., 6 Somer-avenue, Shepparton; 1 commercial goods vehicle (90 cwt.) to operate—(a) from site to site as required by the Victorian Railways for maintenance of the railway lines between Glenrowan and Wodonga—metal, stones, screenings, ashes, gravel, sand, earth and any other materials required for use on the maintenance of the said lines; also tools and equipment incidental thereto, (b) within a radius of 20 miles of any site under current construction or maintenance along the aforesaid lines—materials and equipment for use on such project.
- SINCLAIR, H. R., 35 Devon-street, Cheltenham; 1 commercial goods vehicle (135 cwt.) to operate—(a) within a radius of 25 miles of the G.P.O., Melbourne—general goods, (b) within a radius of 70 miles of Evans Brothers Pty. Ltd. at Scoresby—bricks on behalf of the said company.
- SINCLAIR, T. G., 35 Devon-street, Cheltenham; 1 commercial goods vehicle (134 cwt.) to operate—(a) within a radius of 25 miles of the G.P.O., Melbourne—general goods, (b) within a radius of 70 miles of Evans Brothers Pty. Ltd. at Scoresby—bricks on behalf of the said company.
- SOUTHERN PLANT HIRE CO. PTY. LTD., 1-3 Margaret-street, Huntingdale; 1 commercial goods vehicle (195 cwt.) to operate—(a) within a radius of 20 miles of own premises at Huntingdale, in the course of business as "earth-moving contractors and engineers"—own goods, (b) throughout the State of Victoria as a low loader—own tools of trade and earth-moving equipment incidental to own contracts.
- SWEDA (VICTORIA) PTY. LTD., 34 Queens-road, Melbourne; 1 commercial goods vehicle (6 cwt.) to operate—(a) within a radius of 50 miles of the G.P.O., Melbourne, in the course of business as "cash register manufacturers"—own goods, (b) throughout the State of Victoria for the purpose of servicing cash registers—tools of trade, spare parts, cash registers for repair and having been repaired and materials incidental thereto.
- TAYLOR, I. G., Apsley; 1 commercial goods vehicle (232 cwt.) to operate—(a) within a radius of 10 miles of the post office at Apsley and to and from the railway stations at Goroke and Carpolac—general goods, (b) from the railway stations at Goroke and Carpolac to places situate within a radius of 25 miles from the post office at Apsley—superphosphate.
- TOPPA ICE CREAM PTY. LTD., corner Stewart and Ryan streets, East Brunswick; 1 commercial goods vehicle (8 cwt.) to operate—(a) within a radius of 50 miles of own premises at East Brunswick, in the course of business as "ice-cream and milk products manufacturers"—own goods, (b) throughout the State of Victoria for the purpose of maintaining own refrigeration processing plants and own vehicles and equipment—tools of trade, spare parts, equipment for repair, having been repaired and materials incidental thereto.

NOTICE is hereby given that the applications made by the persons named below for renewal of licence to operate the commercial goods vehicles on the route or routes, or in the manner set out opposite their names, will be heard at a time and place to be communicated to the persons concerned.

*Name and Address; Present Franchise; Licence No.; Date of Expiry.*

COOMBS, A. G., PTY. LTD., 26 Cochranes-road, Moorabbin; 1 commercial goods vehicle (73 cwt.) to operate throughout the State of Victoria in the course of business of the holders of this licence as "heating engineers" for the purposes of installing and servicing air conditioning units and heating systems—tools of trade, spare parts and equipment incidental to the completion of licensees' own contracts; D.A.891; 28th January, 1963.

HURST, R. E. & F. A., Williams-crescent, Tallangatta; 1 commercial goods vehicle (170 cwt.) to operate—(a) within a radius of 50 miles from the post office at Tallangatta—earth-moving equipment the property of the holders of this licence in the course of business as "earth-moving contractors", (b) within a radius of 90 miles from the post office at Wangaratta—earth-moving and road contracting equipment on behalf of the Forests Commission of Victoria, State Electricity Commission of Victoria and the Country Roads Board; D.A.34871; 14th January, 1963.

#### TOW TRUCK RENEWALS.

*Name and Address; Present Franchise; Licence No.; Date of Expiry.*

BAIRNSDALE G.P. MOTORS (ORBOST) PTY. LTD., Nicholson-street, Orbst; 1 commercial goods vehicle (14 cwt.) to operate throughout the State of Victoria for the purpose of repairing or towing disabled or wrecked vehicles—tools, spare parts and materials incidental to trade; D.A.582; 3rd July, 1962.

BROWN, H. M., Harris-street, Corryong; 1 commercial goods vehicle (32 cwt.) to operate throughout the State of Victoria for the purposes of repairing or towing disabled or wrecked vehicles—tools, spare parts and materials incidental to trade; D.A.34160; 20th October, 1962.

DEUTSCHER, G. H. (trading as Dandy Towing Service), 51 Lonsdale-street, Dandenong; 1 commercial goods vehicle (55 cwt.) to operate throughout the State of Victoria for the purposes of repairing or towing disabled or wrecked vehicles—tools, spare parts and materials incidental to trade; D.A.32509/6; 18th August, 1962.

EAST BRUNSWICK USED CARS PTY. LTD., 303 Lygon-street, East Brunswick; 1 commercial goods vehicle (60 cwt.) to operate throughout the State of Victoria for the purpose of towing or repairing disabled or wrecked vehicles to or from licensee's premises at East Brunswick—tools of trade, spare parts and materials incidental to trade; D.A.17361; 25th October, 1962.

EDNEY'S GARAGE, 1 Bair-street, Leongatha; 1 commercial goods vehicle (68 cwt.) to operate within a radius of 50 miles from the post office at Leongatha, for the purposes of repairing or towing disabled or wrecked vehicles—tools, spare parts and materials incidental to trade; D.A.1025; 20th December, 1962.

JONES, C. H. & O. E. (trading as Glebe Engineering, Kyneton), High-street, Kyneton; 1 commercial goods vehicle (68 cwt.) to operate throughout the State of Victoria as a tow truck for the purpose of repairing or towing disabled or wrecked vehicles; D.A.33308/1; 13th October, 1962.

HUNTER, B. H., 11 Warncliffe-grove, Ivanhoe; 1 commercial goods vehicle (60 cwt.) to operate throughout the State of Victoria for the purpose of repairing or towing disabled or wrecked vehicles—tools, spare parts and materials incidental to trade; D.A.34419; 4th November, 1962.

HUNTER, N. & M., 325 Darebin-road, Thornbury; 1 commercial goods vehicle (32 cwt.) to operate throughout the State of Victoria as a "tow truck" for the purpose of repairing or towing disabled or wrecked vehicles—tools of trade, spare parts and materials incidental thereto; D.A.34513; 20th October, 1962.

JACOBSON, E. W., Main-street, Mooroopna; 1 commercial goods vehicle (84 cwt.) to operate throughout the State of Victoria as a tow truck for the purpose of repairing or towing disabled or wrecked vehicles—tools, spare parts and materials incidental to trade; D.A.16089; 20th October, 1962.

LANES MOTORS (SALES) PTY. LTD., Frankston Branch, 30-44 Young-street, Frankston; 1 commercial goods vehicle (60 cwt.) to operate throughout the State of Victoria for the purposes of repairing or towing disabled or wrecked vehicles—tools, spare parts and materials incidental to trade; D.A.32487; 26th May, 1962.

MODERN TOWING AND SALVAGE PTY. LTD., 378 Barkly-street, Footscray; 1 commercial goods vehicle (Mobile Crane) to operate throughout the State of Victoria as a tow truck for the purpose of repairing or towing disabled or wrecked vehicles—tools of trade, spare parts and materials incidental thereto; D.A.28588/4; 20th October, 1962.

RANLEY PANELS PTY. LTD., 22 O'Callaghan-parade, Horsham; 1 commercial goods vehicle (18 cwt.) to operate throughout the State of Victoria as a tow truck for the purpose of repairing or towing disabled or wrecked vehicles—tools of trade, spare parts and materials incidental thereto; D.A.35033; 14th January, 1963.

WATERS, T. S. & COCKS, W. D. (trading as Stanbil Motors), Charing Cross, Bendigo; 1 commercial goods vehicle (62 cwt.) to operate within a radius of 100 miles from the chief post office in the City of Bendigo for the purpose of repairing or towing disabled or wrecked vehicles—tools, spare parts and materials incidental to trade; D.A.2092/1; 17th November, 1962.

TOOLES MOTORS PTY. LTD., High-street, Wodonga; 2 commercial goods vehicles (79 and 52 cwt.) to operate throughout the State of Victoria for the purposes of repairing or towing disabled or wrecked vehicles—tools, spare parts and materials incidental to trade; D.A.2173/2, D.A.2173/6; 20th October, 1962.

TYRRELL MOTORS PTY. LTD., Thompson-avenue, Cowes; 1 commercial goods vehicle (13 cwt.) to operate throughout the State of Victoria as a tow truck for the purpose of repairing or towing disabled or wrecked vehicles; D.A.34652; 1st December, 1962.

Notice of any objection should be forwarded to reach the Secretary of the Board not later than Wednesday, 28th November, 1962.

A. V. C. COOK,  
Acting Secretary.

Exhibition Buildings, Rathdowne-street, Carlton, N.3,  
14th November, 1962.

## DEPARTMENT OF MINES.

SUBJECT to any necessary excisions, &c., it is proposed to grant the following mining leases:—

9202, Ballarat; Farrel Alfred Kiernan; 793 acres, Parish of Ballarat.

8073, Mineral; Leslie Ernest Swift; 1a. 3r. 20p., Parish of Castlemaine.

## APPLICATION FOR LEASE DECLARED ABANDONED.

2826, Ararat; John Ford Paterson and Norman Fittock; 756a. 3r. 36p., Parish of Landsborough.

## MINING LEASES GRANTED.

8348, Beechworth; Donald Brian Bell; 33a. 2r. 27p., Parish of Malkara.

5607, Gippsland; Ronald Brian Bell; 54a. 0r. 14p., Parish of Mowamba.

## TAILINGS LICENCE GRANTED.

3209, Tailings Licence; Antonio Sist; Parish of Langi-Kal-Kal (in lieu of Tailings Licence No. 3142, expired).

## TAILINGS LICENCE EXPIRED.

3118, Tailings Licence; Henry Lewis Rigbye; Parish of Huntly.

## MINERAL SEARCH LICENCE GRANTED.

411, Mineral Search Licence; John S. Mellington and Helen H. Mellington; 50 acres, Parish of Wyperfield.

## MINERAL SEARCH LICENCE EXPIRED.

295, Mineral Search Licence; C. M. Armstrong, M. J. Tuddenham, H. P. Armstrong, A. R. Rowe, J. D. Shedden; 100 acres, Parish of Bungal.

## TERM OF PETROLEUM PROSPECTING LICENCE EXTENDED.

210, Petroleum Prospecting Licence; Westralian Oil Ltd.; 191 square miles, Parishes of Doomburrim, Meenyan, Dumbalk, Mirboo South, Wonga Wonga South, Wonga Wonga, Toora, Woorarra, Bingin-warri, Wonyip, Devon, and Welshpool.

W. J. MIBUS,  
Minister of Mines.

## MINING LEASES DECLARED VOID.

7844, Mineral; Harold Hanrahan and Frank Robert Yates; 54a. 2r. 21p., Parish of Piangil West.

7950, Mineral; Douglas James Wade; 9a. 2r. 20p., Parish of Tarrawarra North.

E. CONDON,  
Secretary for Mines.

## SOCIAL WELFARE ACT 1960.

IN pursuance of the powers conferred by the *Social Welfare Act 1960*, I, Her Majesty's Chief Secretary for the State of Victoria, do hereby appoint GEORGE STEWART SMALE, to be the Chairman of the Social Welfare Training Council for a period of twelve months commencing on the 20th day of November, 1962.

Given under my Hand at Melbourne, this 10th day of October, 1962—

R. J. HAMER,  
for Chief Secretary.

Licensing Act 1958.—Section 54.

VICTORIAN LICENSING COURT.

NOTICE is hereby given that the Victorian Licensing Court will be held during the year 1963 for the Licensing areas of Central Metropolitan, Eastern Metropolitan, Northern Metropolitan, Southern Metropolitan, Western Metropolitan, Bairnsdale, Ballarat, Bendigo, Geelong, Hamilton, Mildura, Shepparton, Wangaratta, Warragul and Warrnambool at the under-mentioned place on the days and time hereunder mentioned:—

Place.	Date of Sitting.	Time.
Melbourne ..	Tuesday, 29th January ..	10.45 a.m.
" ..	Monday, 4th February ..	"
" ..	Monday, 11th February ..	"
" ..	Monday, 18th February ..	"
" ..	Monday, 25th February ..	"
" ..	Monday, 4th March ..	"
" ..	Tuesday, 12th March ..	"
" ..	Monday, 18th March ..	"
" ..	Monday, 25th March ..	"
" ..	Monday, 1st April ..	"
" ..	Monday, 8th April ..	"
" ..	Monday, 22nd April ..	"
" ..	Monday, 29th April ..	"
" ..	Monday, 6th May ..	"
" ..	Monday, 13th May ..	"
" ..	Monday, 20th May ..	"
" ..	Monday, 27th May ..	"
" ..	Monday, 3rd June ..	"
" ..	Tuesday, 11th June ..	"
" ..	Monday, 17th June ..	"
" ..	Monday, 24th June ..	"
" ..	Monday, 1st July ..	"
" ..	Monday, 8th July ..	"
" ..	Monday, 15th July ..	"
" ..	Monday, 22nd July ..	"
" ..	Monday, 29th July ..	"
" ..	Monday, 5th August ..	"
" ..	Monday, 12th August ..	"
" ..	Monday, 19th August ..	"
" ..	Monday, 26th August ..	"
" ..	Monday, 2nd September ..	"
" ..	Monday, 9th September ..	"
" ..	Monday, 16th September ..	"
" ..	Monday, 23rd September ..	"
" ..	Monday, 30th September ..	"
" ..	Monday, 7th October ..	"
" ..	Monday, 14th October ..	"
" ..	Monday, 21st October ..	"
" ..	Monday, 28th October ..	"
" ..	Monday, 4th November ..	"
" ..	Monday, 11th November ..	"
" ..	Monday, 18th November ..	"
" ..	Monday, 25th November ..	"
" ..	Monday, 2nd December ..	"
" ..	Monday, 9th December ..	"
" ..	Monday, 16th December ..	"

Dated at Melbourne this Eighth day of November, 1962.

A. M. FRASER, J., Chairman,  
Victorian Licensing Court.

Licensing Act 1958.—Section 54.

VICTORIAN LICENSING COURT.

NOTICE is hereby given that sittings of the Victorian Licensing Court for the purpose of urgent business only for the Licensing Areas of Central Metropolitan, Eastern Metropolitan, Northern Metropolitan, Southern Metropolitan, Western Metropolitan, Bairnsdale, Ballarat, Bendigo, Geelong, Hamilton, Mildura, Shepparton, Wangaratta, Warragul and Warrnambool are hereby appointed at the under-mentioned place on the days and time hereunder mentioned:—

Place.	Date of Sitting.	Time.
Melbourne ..	Monday, 7th January, 1963 ..	10.45 a.m.
" ..	Monday, 14th January, 1963 ..	"

Dated at Melbourne this Eighth day of November, 1962.

A. M. FRASER, J., Chairman,  
Victorian Licensing Court.

LAW DEPARTMENT.—ATTORNEY-GENERAL.

CHILDREN'S COURTS—DAYS AND HOURS APPOINTED.

HIS Excellency the Governor of the State of Victoria, by and with the advice of the Executive Council thereof, doth, by Order made on the 7th day of November, 1962, pursuant to the provisions of section 8 (1) of the *Children's Court Act 1953*, appoint the days and hours contained in the Schedule below for the holding of Children's Courts at the places named in such Schedule in lieu of the days and hours heretofore appointed—to take effect from the 1st January, 1963.

SCHEDULE.

Place.	Days and Hours.
Moe ..	Every Tuesday in each month at 10.30 a.m.
Morwell ..	Every Thursday in each month at 10.30 a.m.

N. G. WISHART,  
Clerk of the Executive Council.

At Government House,  
Melbourne, 7th November, 1962.

Country Fire Authority Act 1958.

SUMMER PERIOD IN RESPECT OF SPECIFIED PARTS OF THE COUNTRY AREA OF VICTORIA.

WHEREAS by section 4 of the *Country Fire Authority Act 1958* it is enacted that the Chief Secretary of Victoria, after consultation with the Minister of Forests, may from time to time by declaration published in the *Government Gazette* declare any period to be the summer period in respect of the country area of Victoria, or any specified part or parts thereof and, without affecting the generality of the foregoing, may declare different periods to be the summer period in respect of different parts of the said country area:

And whereas the Chief Secretary and the Minister of Forests have consulted accordingly:

Now therefore, I, the Chief Secretary of Victoria, do hereby declare the period commencing at midnight on the 16th day of November, 1962, and ending at midnight on the 15th day of April, 1963, to be the summer period in respect of the parts hereinafter specified of the country area of Victoria, that is to say:—

Those portions of the Eighteenth Fire Control Region comprised by the municipal district of the Shire of Mildura excluding those portions of the aforesaid shire which lie within the Parishes of Mildura and Merbein.

R. J. HAMER,  
for Chief Secretary.

Chief Secretary's Office,  
Melbourne, 12th November, 1962.

Licensing Act 1958.

REGISTRATION OF A BREWER.

CARLTON AND UNITED BREWERIES LTD., has this day caused to be registered its name and a particular description of its premises situate 101 Corio-terrace, Geelong, where it proposes to carry on the business of a brewer during the year 1963.

Dated this 1st day of November, 1962.

J. MILLS,  
Clerk of the Licensing Court  
for the Licensing Area of Geelong.

SALE OF MOTOR VEHICLE.

AN owner is required for a 1948 model Studebaker sedan, engine No. CSP265PH21.6., registered as Queensland vehicle No. NGY-956.

The motor vehicle came into the possession of the Police on 14th May, 1962, and, if not claimed, will be sold by public auction at the Gardenvale Police Station, at 3 p.m., on Wednesday, 5th December, 1962.

S. H. PORTER,  
Chief Commissioner of Police.

Stamps Act 1958.

ANNUAL LICENCE.

A LICENCE to carry on assurance and insurance business in Victoria, from 19th September, 1962, to 31st December, 1962, has been issued to the under-mentioned company:—

TATCHELL & DANIELL PROPRIETARY LIMITED.

D. G. RICHARDS,  
Comptroller of Stamps.



## Dietitians Registration Act 1958.

## LIST OF REGISTERED DIETITIANS YEAR ENDED 30TH JUNE, 1962.

Number of Certificate	Date of Registration.	Name.	Address.	Qualifications.	Further Particulars.
115	28.4.44	Abramovitch, Flora Dalwood (now Flora Dalwood)	2 Lowther-street, Alphington	Registered under Sec. 7 of the <i>Dietitians Registration Act 1942</i>	..
60	17.3.44	Ackroyd, Ellen Beatrice ..	15 Vincent-street, East Malvern	Registered under Sec. 6 of the <i>Dietitians Registration Act 1942</i>	..
321	21.2.56	Aikman, Rosemary (Mrs. Perdriau)	56 Alice-street, Mount Waverley	Registered under Sec. 7 of the <i>Dietitians Registration Act 1942</i>	..
62	17.3.44	Aitken, Lynly Sheila ..	c/o Royal Melbourne Hospital	Registered under Sec. 7 of the <i>Dietitians Registration Act 1942</i>	..
154	19.5.44	Akerman, Emil ..	144 Wickham-road, Moorabbin	Registered under Sec. 7 of the <i>Dietitians Registration Act 1942</i>	..
142	19.5.44	Akerman, Muriel Alice (Mrs.) ..	" " "	" " "	..
12	18.2.44	Armstrong, Lawrence ..	Block Arcade, 98 Elizabeth-street, Melb., (P.O. Box 430-C)	" " "	..
13	18.2.44	Armstrong, Margaret Matilda (Mrs.)	" " "	" " "	..
81	31.3.44	Armstrong, Myra Margaret (Mrs. H. W. Lee)	2 Kennealy-street, Surrey Hills	" " "	..
149	19.5.44	Backwell, Elizabeth Marion ..	"Leaton" 57 Maude-street, South Geelong	Registered under Sec. 6 of the <i>Dietitians Registration Act 1942</i>	..
195	6.9.46	Barker, George Ralph ..	Bogong Chambers, 603 Dean-street, Albury, N.S.W.	Registered under Sec. 7 of the <i>Dietitians Registration Act 1942</i>	..
286	8.10.54	Barnes, Patricia Anne ..	6 Williams-road, Windsor ..	Registered under Sec. 6 of the <i>Dietitians Registration Act 1942</i>	..
196	21.2.47	Beard, Sara Constance ..	36 Nanson-street, Wembley, W.A.	" " "	..
212	28.6.48	Beaumont, Marjorie Elizabeth (Mrs.)	6 Woodlands-grove, Oakleigh, S.E.12	" " "	..
250	30.3.51	Belfrage, Marion Grace ..	21 Sydenham-avenue, Manifold Heights, Geelong	" " "	..
23	18.2.44	Bennett, Alfred Gordon ..	25 Seaford-road, Seaford ..	Registered under Sec. 7 of the <i>Dietitians Registration Act 1942</i>	..
54	17.3.44	Bevan, Lorna Lesley (Mrs. W. C. Dwyer)	915 Dandenong-road, East Malvern	Registered under Sec. 6 of the <i>Dietitians Registration Act 1942</i>	..
239	24.3.50	Blanton, Wilga Margaret (Mrs. McKay)	"Luprena" Pleasant View-crescent, Glen Waverley	" " "	..
300	4.5.56	Bolton, Margaret Ellen (Mrs. M. E. Grant)	29 Iona-avenue, Belmont Geelong	" " "	..
143	19.5.44	Boughton, Frank ..	340 Albert-street, East Melbourne	Registered under Sec. 7 of the <i>Dietitians Registration Act 1942</i>	..
42	17.3.44	Bowring, Heather MacLeod (Mrs. A. Cameron)	43 Kennealy-street, Surrey Hills	Registered under Sec. 6 of the <i>Dietitians Registration Act 1942</i>	..
146	19.5.44	Brewer, Asheton Cobb ..	17 Park-crescent, Fairfield N.20	Registered under Sec. 7 of the <i>Dietitians Registration Act 1942</i>	..
184	3.8.45	Bruce, Harold John ..	27 Albury-road, North Balwyn, E.9	" " "	..
280	26.3.54	Burke, June Lynette (Mrs. McVilly)	100 Dorrigo-street, Kedian, Brisbane	Registered under Sec. 6 of the <i>Dietitians Registration Act 1942</i>	..
119	28.4.44	Cahn, Audrey Josephine (Mrs.)	"White Cottage" Osborne-road, Warrandyte	Registered under Secs. 6 and 7 of the <i>Dietitians Registration Act 1942</i>	Diploma of Dietetics, Univ. of Melbourne 9th April, 1938
153	19.5.44	Campbell, Wilma Mary ..	24 Clyde-street, Box Hill, E.12	Registered under Sec. 6 of the <i>Dietitians Registration Act 1942</i>	..
100	31.3.44	Carrington, Elizabeth May ..	34 Bridge-street, Ballarat ..	Registered under Sec. 7 of the <i>Dietitians Registration Act 1942</i>	..
213	28.6.48	Christian, Patricia Ellen (Mrs. Samson)	c/o Royal Womens Hospital, 720 Swanston-street, Carlton N.3	Registered under Sec. 6 of the <i>Dietitians Registration Act 1942</i>	..
34	17.3.44	Chisholm, Royena Strathy ..	P.O., Box, 17 Macedon ..	" " "	..
182	27.4.45	Chomley, Shirley Olive Joyce (Mrs.)	Barwon-avenue, Chillwell, Geelong	" " "	..
111	28.4.44	Clarke, Archibald William Bernard	15 Inverloch-street, East Preston, N.18	Registered under Sec. 7 of the <i>Dietitians Registration Act 1942</i>	..
173	25.8.44	Clegg, Marjorie Lillian (Mrs. W. G. McQuarrie)	1A Ranfurly-crescent, Glen Iris	Registered under Sec. 6 of the <i>Dietitians Registration Act 1942</i>	..
47	17.3.44	Cock, Hainsworth Thomas ..	71 Collins-street, Melbourne, C.1	Registered under Sec. 7 of the <i>Dietitians Registration Act 1942</i>	..
324	21.2.58	Cocks, Maureen Margaret ..	27 St. James-parade, Elsternwick, S.4	Registered under Sec. 6 of the <i>Dietitians Registration Act 1942</i>	..
79	31.3.44	Cogan, Agnes Marie (Mrs.) ..	34 Bridge-street, Ballarat ..	Registered under Sec. 7 of the <i>Dietitians Registration Act 1942</i>	..
123	28.4.44	Coleman, Dora Lillian ..	120 Marshall-street, Ivanhoe, N.21	" " "	..
259	1.2.52	Collie, Wilma Catherine ..	"Allambie" Montana-road, Croydon	Registered under Sec. 6 of the <i>Dietitians Registration Act 1942</i>	..
50	17.3.44	Coltman, Mrs. Winifred Hawthorne	100 Oxford-road, Croydon ..	Registered under Secs. 6 and 7 of the <i>Dietitians Registration Act 1942</i>	..
137	19.5.44	Condon, Patrick John ..	Argyle Hotel, Hamilton ..	Registered under Sec. 7 of the <i>Dietitians Registration Act 1942</i>	..
208	23.2.48	Cooper, Lorna (Mrs. Johnston)	43 Tulip-grove, Cheltenham	Registered under Sec. 6 of the <i>Dietitians Registration Act 1942</i>	..

## LIST OF REGISTERED DIETITIANS—continued.

Number of Certificate.	Date of Registration.	Name.	Address.	Qualifications.	Further Particulars.
254	29.6.61	Coubrough, June Roberts (Mrs. F. J. Thomann)	56 Best-street, Devonport, Tasmania	Registered under Sec. 6 of the <i>Dietitians Registration Act 1942</i>	Diploma of Dietetics, Univ. of Melb. 3rd Sept., 1951
339	6.2.61	Coutts, Jennifer .. ..	Footscray District Hospital, Eleanor-street, Footscray	Registered under Sec. 7 of the <i>Dietitians Registration Act 1958</i>	.. ..
205	24.11.47	Crang, Alison Caldwell (Mrs. Nimmo)	78 Railway-road, Carnegie	Registered under Sec. 6 of the <i>Dietitians Registration Act 1942</i>	.. ..
344	8.3.61	Creelman, Annette Elizabeth ..	910 Station-street, Box Hill North	Registered under Sec. 7 of the <i>Dietitians Registration Act 1958</i>	.. ..
17	18.2.44	Cutting, Charles Kilburn ..	372 Mont Albert-road, Mont Albert	Registered under Sec. 7 of the <i>Dietitians Registration Act 1942</i>	.. ..
125	28.4.44	Davey, Lois Joan .. ..	8 Christowel-street, East Camberwell, E.6	Registered under Sec. 6 of the <i>Dietitians Registration Act 1942</i>	.. ..
355	28.2.62	Deeble, Janice Inez .. ..	33 Ropley-avenue, Balwyn, E.8	Registered under Sec. 7 of the <i>Dietitians Registration Act 1958</i>	.. ..
28	17.3.44	D'Orr, Edward Thomas .. ..	59 Hambleton-street, Albert Park	Registered under Sec. 7 of the <i>Dietitians Registration Act 1942</i>	.. ..
103	31.3.44	Doyle, James Edward .. ..	1012 Sturt-street, Ballarat ..	Registered under Sec. 6 of the <i>Dietitians Registration Act 1942</i>	.. ..
311	29.4.57	Duggan, Isabel Bridget .. ..	54 Ross-street, Coburg	Registered under Sec. 6 of the <i>Dietitians Registration Act 1942</i>	.. ..
64	17.3.44	Duigan, Gwynne Elizabeth (Mrs.)	13 Chester-street, Herne Hill, Geelong	" " "	.. ..
114	28.4.44	Dunne, Mary Josephine .. ..	3 Riversdale-road, Hawthorn	" " "	.. ..
139	19.5.44	Earle, M. Philomena .. ..	St. John of God Hospital, Subiaco, W.A.	" " "	.. ..
227	29.4.49	Edgar, Sadie Ross (Mrs. Hope)	c/o Post Office, Harrow, Vic.	Registered under Sec. 7 of the <i>Dietitians Registration Act 1958</i>	.. ..
353	16.2.62	Efron, Carole Ray	28 Kambea-grove, Caulfield, S.E.7	Registered under Secs. 6 and 7 of the <i>Dietitians Registration Act 1942</i>	.. ..
26	17.3.44	Elliott, Jessie May .. ..	c/o Firbank C.E.G.G.S., 24 Middle-crescent, Brighton S.5	Registered under Sec. 6 of the <i>Dietitians Registration Act 1942</i>	.. ..
272	13.2.53	Everard, Betty Claire (Mrs. John Lynch)	Wellington-road, Clematis	Registered under Sec. 6 of the <i>Dietitians Registration Act 1942</i>	.. ..
336	13.5.60	Fallon, Kerry Ann .. ..	Branch-road, Croydon ..	Registered under Sec. 7 of the <i>Dietitians Registration Act 1958</i>	.. ..
221	4.3.49	Fawckner, Olive Dorothy (Mrs. D. Hammon)	51 Whittens-lane, Doncaster	Registered under Sec. 6 of the <i>Dietitians Registration Act 1942</i>	.. ..
74	31.3.44	Findlay, Frank Torrens .. ..	849 Burwood-road, Upper Hawthorn, E.6	Registered under Sec. 7 of the <i>Dietitians Registration Act 1942</i>	.. ..
19	18.2.44	Forbes, Eleanor Frances (Mrs. Davis)	cnr. Rau and Hanel streets, Albury, N.S.W.	" " "	.. ..
102	31.3.44	Forster, Katherine Spears (Mrs.)	38 Ormond-road, Elwood ..	Registered under Sec. 6 of the <i>Dietitians Registration Act 1942</i>	.. ..
209	23.2.48	Fowler, Reginald Thomas .. ..	28 North-road, Newport, W.15	" " "	.. ..
334	31.3.60	Francis, Dorothy Edna May	6 Fern-street, Oakleigh ..	Registered under Sec. 7 of the <i>Dietitians Registration Act 1958</i>	.. ..
198	18.4.47	Gardner, Marie Theresa (Mrs. Hooper)	81 Darley-road, Randwick, N.S.W.	Registered under Sec. 6 of the <i>Dietitians Registration Act 1942</i>	.. ..
68	31.3.44	Glascodine, Helen Delamain ..	275 Mont Albert-road, Surrey Hills, E.10	Registered under Secs. 6 and 7 of the <i>Dietitians Registration Act 1942</i>	.. ..
315	15.2.57	Glass, Pauline (Mrs.) .. ..	c/o 46 Derby-street, Kew, E.4	Registered under Sec. 6 of the <i>Dietitians Registration Act 1942</i>	.. ..
293	10.6.55	Goddard, Maxine Theresa (Mrs. Cadzow)	1 Campaspe-street, Box Hill North, E.12	" " "	.. ..
352	16.2.62	Goldhar, Bertha .. ..	c/o Dietary Dept., Repat. Gen. Hospital, Heidelberg	Registered under Sec. 7 of the <i>Dietitians Registration Act 1958</i>	.. ..
5	28.1.44	Gomarsall, Alice Louise .. ..	10 Trentham-street, Sandringham, S.8	Registered under Sec. 7 of the <i>Dietitians Registration Act 1942</i>	.. ..
333	31.2.60	Gooley, Frances (Mrs. Cheong)	63 Lade-street, Cooraroo, Brisbane, Queensland	Registered under Sec. 7 of the <i>Dietitians Registration Act 1958</i>	.. ..
354	21.2.62	Gorway, Beverley Jill .. ..	22 Anderson-street, Torquay	" " "	.. ..
222	4.3.49	Braham, Elizabeth Joyce (Mrs. Young)	63 Stafford-street, Artarmon, N.S.W.	Registered under Sec. 6 of the <i>Dietitians Registration Act 1942</i>	.. ..
247	21.7.50	Graham, Marjorie Allison (Mrs. Baulch)	10 Drysdale-avenue, Malvern	" " "	.. ..
106	31.3.44	Grimes, Gladys Ellen (Mrs. Newitt)	289 Malvern-road, South Yarra, S.E.1	Registered under Sec. 7 of the <i>Dietitians Registration Act 1942</i>	.. ..
89	31.3.44	Grimes, Harold Samuel .. ..	127 Anzac Highway, Glenelg, S.A.	" " "	.. ..
194	6.9.46	Guice, Edna Mavis .. ..	193 George-street, East Melbourne, E.7	Registered under Sec. 6 of the <i>Dietitians Registration Act 1942</i>	.. ..
348	25.8.61	Haines, Eileen Florence .. ..	Warrigal-road, Surrey Hills	Registered under Sec. 7 of the <i>Dietitians Registration Act 1958</i>	.. ..
147	19.5.44	Healy, Eileen Ann .. ..	Pallotine Mission Centre Fifth-avenue, Riverton, W.A.	Registered under Secs. 6 and 7 of the <i>Dietitians Registration Act 1942</i>	.. ..
180	27.4.45	Heckrath, Patricia Mary .. ..	2 Enfield-road, North Brighton, S.5	Registered under Sec. 7 of the <i>Dietitians Registration Act 1942</i>	.. ..
179	16.2.45	Hennesy, Catherine Agnes (Mrs. Howe)	10 Bethune-street, Queens-cliff	Registered under Sec. 6 of the <i>Dietitians Registration Act 1942</i>	.. ..
32	18.2.44	Herzog, Richard Frederick .. ..	498 Victoria-parade, East Melbourne	Registered under Sec. 7 of the <i>Dietitians Registration Act 1942</i>	.. ..
61	17.3.44	Hogan, Shirley Gertrude Honora Mary	Royal Perth Hospital, Perth, W.A.	Registered under Sec. 6 of the <i>Dietitians Registration Act 1942</i>	.. ..
280	1.2.52	Holden, Pauline Marjory .. ..	19 Howitt-street, Glen Iris, S.E.6	" " "	.. ..

## LIST OF REGISTERED DIETITIANS—continued.

Number of Certificate	Date of Registration.	Name.	Address.	Qualifications.	Further Particulars.
83	31.3.44	Holmes, Percival Leonard ..	300 Little Collins-street, Melb.	Registered under Sec. 7 of the <i>Dietitians Registration Act 1942</i>	..
345	4.5.61	Holmes, Susan Elizabeth (Mrs. Jenkins)	Flat 6, 29 Albert-street, East Melbourne	Registered under Sec. 7 of the <i>Dietitians Registration Act 1958</i>	..
233	14.10.49	Ince, Elizabeth Gertrude (Mrs. Lloyd)	40 Westgarth-street, Oakleigh	Registered under Sec. 6 of the <i>Dietitians Registration Act 1942</i>	..
88	16.2.45	Inches, Rosemary Barton (Mrs. Hepburn)	18 Birdwood-street, Balwyn, E.8	" " "	..
89	17.3.44	Jackson, Dorothy Jean (Mrs. Sumner)	8 Alison-street, Moorabbin..	" " "	..
273	13.2.53	Jackson, Muriel Amy (Mrs. Williams)	24 Park-street, Newtown, Geelong	" " "	..
91	4.4.55	Jessop, Gwen Lorraine ..	11 Bringa-avenue, Camberwell, E.6	" " "	..
63	17.3.44	Johns, Gladys Kathleen ..	52 Esmond-street, Hyde Park, S.A.	" " "	..
342	23.2.61	Jones, Margaret Amelia ..	12 Maxwell-street, Turramurra, N.S.W.	Registered under Sec. 7 of the <i>Dietitians Registration Act 1958</i>	..
351	3.1.62	Knubley, Gillian Lorraine ..	c/o Royal Melbourne Hospital, Parkville, N.2	" " "	..
214	28.6.48	Laidler, Margaret Anne (Mrs. Gulbis)	70 Kerford-street, East Malvern	Registered under Sec. 6 of the <i>Dietitians Registration Act 1942</i>	..
4	28.1.44	Lelean, Arthur Drew ..	"Sunways" 418 Wendouree-parade, Ballarat	Registered under Sec. 7 of the <i>Dietitians Registration Act 1942</i>	..
274	13.2.53	Lewis, Agnes Tuohy (Mrs.) ..	Flat 9, 34 Grey-street, St. Kilda, S.2	Registered under Sec. 6 of the <i>Dietitians Registration Act 1942</i>	..
245	21.7.50	Linton-Smith, Lois Sydney ..	Box 147, Horsham ..	" " "	..
200	24.4.47	Livingston, Mary Elizabeth (Mrs. Fleming)	9 Oban-street, Wadestown, Wellington, N.Z.	" " "	..
41	17.3.44	Long, Matthew Leonard ..	596 Burke-road, Camberwell	Registered under Sec. 7 of the <i>Dietitians Registration Act 1942</i>	..
112	28.4.44	Longfield, Bruce Anthony ..	230 Collins-street, Melbourne, C.1	" " "	..
299	20.2.56	Longson, Joan Margaret ..	17 Cornwell-road, Sunshine	Registered under Sec. 6 of the <i>Dietitians Registration Act 1942</i>	..
166	9.6.44	Lucas, Edward Ralph ..	10 Grange-road, West Preston, N.18	Registered under Sec. 7 of the <i>Dietitians Registration Act 1942</i>	..
45	17.3.44	Lyell, Doreen Mande ..	4A Fairview-street, Hawthorn, E.2	Registered under Secs. 6 and 7 of the <i>Dietitians Registration Act 1942</i>	..
93	31.3.44	Mackintosh, Alexander Watson	153 Shaftesbury-parade, Thornbury, N.17	Registered under Sec. 7 of the <i>Dietitians Registration Act 1942</i>	..
92	31.3.44	Mackintosh, Winifred Laurie (Mrs.)	" " "	" " "	..
241	24.3.50	Malcolm, Sheila Humphreys ..	Lot 26, Prince Alfred-parade, Newport, Sydney	Registered under Sec. 6 of the <i>Dietitians Registration Act 1942</i>	..
229	29.4.49	Marshall, Elsie Hannah ..	c/o Commonwealth Savings Bank of Australia, Aldwych Branch London	" " "	..
230	29.4.49	Mason, Elizabeth Therese ..	112 Robert-street, Northcote, N.6	" " "	..
144	19.5.44	Mayor-Kollosche, Lurline Helen (Mrs.)	33 Olive-grove, Boronia ..	Registered under Sec. 7 of the <i>Dietitians Registration Act 1942</i>	..
346	1.7.61	Meyer, Suzanne Lina ..	c/o Queen Victoria Memorial Hospital, Lonsdale-street, Melbourne	Registered under Sec. 7 of the <i>Dietitians Registration Act 1958</i>	..
297	9.9.55	Milkins, Shirley June (Mrs. Gordon Perret)	616 18th-avenue, Calgary, Alberta, Canada	Registered under Sec. 6 of the <i>Dietitians Registration Act 1942</i>	..
131	19.5.44	Miller, James Raeburn ..	29th-crescent, Vaulchuse, Sydney, N.S.W.	Registered under Sec. 7 of the <i>Dietitians Registration Act 1942</i>	..
99	31.3.44	Milne, Charles King ..	167 Collins-street, Melbourne, C.1	" " "	..
48	19.5.44	Moore, Winifred May (Mrs.) ..	44 Bowen-street, Camberwell, E.6	" " "	..
216	20.8.48	McDonald, Shirley ..	Dietitian, c/o Base Hospital, Ballarat	Registered under Sec. 6 of the <i>Dietitians Registration Act 1942</i>	..
340	20.2.61	McGill, Patricia (nee Clayton)	72 Vigeons-road, Reservoir	Registered under Sec. 7 of the <i>Dietitians Registration Act 1958</i>	..
262	5.2.52	McNaughton, Eleanor Hamilton (Mrs. Welch)	Dwyer-street, Macleod ..	Registered under Sec. 6 of the <i>Dietitians Registration Act 1942</i>	..
242	24.3.50	McNaughton, Jean Wise ..	Flat 1, 119 Alexander-avenue, South Yarra, S.E.1	" " "	..
70	31.3.44	Nesbitt, Laura Evelyn ..	105 Collins-street, Melbourne, C.1	Registered under Sec. 7 of the <i>Dietitians Registration Act 1942</i>	..
18	18.2.44	Newman, Kenneth Fossey ..	The Farmhouse, Pembroke-road, Mooroolbark	" " "	..
52	17.3.44	Nicolson, Duncan Peter ..	141 Alexander-avenue, South Yarra	" " "	..
193	5.7.46	Nicolson, Norman Duncan Gayner	131 Nicholson-street, East Coburg	" " "	..
1	28.1.44	Nissen, Elizabeth Eleanor (Mrs.)	25 Male-street, Middle Brighton, S.5	Registered under Sec. 6 of the <i>Dietitians Registration Act 1942</i>	..
105	31.3.44	O'Brien, Leslie Michael ..	225 Beaconsfield-parade Middle Park	Registered under Sec. 7 of the <i>Dietitians Registration Act 1942</i>	..
329	23.1.59	Oldham, Patricia Margaret Anne	Dietary Department, Repat. General Hospital, Heidelberg	Registered under Sec. 7 of the <i>Dietitians Registration Act 1958</i>	..
284	26.3.54	Paterson, Elise Esther (Mrs. Stock)	16 Jess-street, Reservoir, N.19	Registered under Sec. 6 of the <i>Dietitians Registration Act 1942</i>	..

## LIST OF REGISTERED DIETITIANS—continued.

Number of Certificate.	Date of Registration.	Name.	Address.	Qualifications.	Further Particulars.
69	31.3.44	Paterson, Mrs. Nancy Brodribb	229 Belmore-road, North Balwyn	Registered under Sec. 7 of the <i>Dietitians Registration Act 1942</i>	..
76	21.3.44	Perrin, Ralph Harold ..	398 Sydney-road, Coburg, N.13	" " "	..
303	10.8.56	Pope, Joan Margaret (Mrs. J. M. Swain)	61 Ranfurly-court, Nunawading	Registered under Sec. 6 of the <i>Dietitians Registration Act 1942</i>	..
156	19.5.49	Phillips, Mrs. Edith ..	80 Stevenson-street, Kew, E.4	Registered under Sec. 7 of the <i>Dietitians Registration Act 1942</i>	..
349	26.10.61	Prider, Clarene Mary ..	c/o Dietary Department, Alfred Hospital, Commercial-road, Prahran	Registered under Sec. 7 of the <i>Dietitians Registration Act 1958</i>	..
338	27.6.60	Primrose, Diana Marjorie Manners	Wallington, via Geelong ..	" " "	..
320	21.2.58	Pyper, Alison Priscilla ..	Westbury, Tasmania ..	Registered under Sec. 6 of the <i>Dietitians Registration Act 1942</i>	..
86	31.3.44	Quinsey, Alma Irene (Mrs. Manhire)	"Koorungal" Lot 6 Britnell's-road, Briar Hill	" " "	..
192	5.7.46	Radford, Denise Viola (Mrs. Runting)	26 Coreen-avenue, Beaumaris, S.10	" " "	..
27	17.3.44	Ramsay, Elizabeth Sidney ..	7 Grange-road, Canterbury, E.7	" " "	..
341	22.2.61	Reilly, Janet Laura (Mrs. Woods)	Flat 23, 600 St. Kilda-road, Melbourne	Registered under Sec. 7 of the <i>Dietitians Registration Act 1958</i>	..
9	28.1.44	Roberts, Frederick George ..	289 Malvern-road, South Yarra, S.E.1	Registered under Sec. 7 of the <i>Dietitians Registration Act 1942</i>	..
14	28.1.44	Roberts, Gladys Maude (Mrs.)	" " "	" " "	..
317	5.7.57	Rogers, Margaret Sutherland ..	4 Bay Vista Court, 137 Beach-road, Parkdale	Registered under Sec. 6 of the <i>Dietitians Registration Act 1942</i>	..
288	8.10.54	Rousseau, Joan Elaine (Mrs. Sudholz)	14 Varden-street, Springvale	" " "	..
167	9.6.44	Russell, Garret Victor James	6 Elizabeth-street, Melbourne, C.1	Registered under Sec. 7 of the <i>Dietitians Registration Act 1942</i>	..
133	19.5.44	Schattner, Bernhard ..	117 Collins-street, Melbourne, C.1	" " "	..
224	4.3.49	Scott, Alison Mary ..	c/o 23 Princess-street, Kew, E.4	Registered under Sec. 6 of the <i>Dietitians Registration Act 1942</i>	..
302	4.5.56	Sharp, Jeanette (Mrs. Delatycki)	Flat 2, 68 Alexandra-street, East St. Kilda	" " "	..
312	15.2.57	Shields, Brenda Desmond (Mrs.)	2a Summerhill-grove, Hawthorn	" " "	..
121	28.4.44	Silberstein, Maria Margaret (Mrs. T. D. Fisher)	99 Manning-road, East Malvern, S.E.5	Registered under Sec. 7 of the <i>Dietitians Registration Act 1942</i>	..
104	31.3.44	Sim, Elsie Lilian ..	c/o Royal Melbourne Hospital	Registered under Sec. 6 of the <i>Dietitians Registration Act 1942</i>	..
21	18.2.44	Simon, Ilse (Mrs.) (now Mrs. Synnot)	Gray Court, Beaumaris, S.10	Registered under Sec. 7 of the <i>Dietitians Registration Act 1942</i>	..
177	6.10.44	Sleeman, David Beatty ..	32 View-street, Bendigo ..	" " "	..
155	19.5.44	Smith, Lilian Fraser (Mrs.) ..	St. Vincent's Hospital, Victoria-parade, Fitzroy, N.6	Registered under Secs. 6 and 7 of the <i>Dietitians Registration Act 1942</i>	..
85	31.3.44	Spigelman, Harry ..	83 Acland-street, St. Kilda, S.2	Registered under Sec. 7 of the <i>Dietitians Registration Act 1942</i>	..
204	20.6.47	Spring, Christian Isabel (Mrs. Dunstone)	29 Boreham-street, Sunshine, W.20	Registered under Sec. 6 of the <i>Dietitians Registration Act 1942</i>	..
252	30.3.51	Steedman, Rhona Mary (Sister Mary Immaculata)	Convent of Mercy, Rosanna-road, Rosanna	" " "	..
261	1.2.52	Steward, Margaret Anne ..	c/o Royal Melbourne Hospital	" " "	..
91	31.3.44	Suss, Edith (Mrs.) ..	21 Grandview-grove, East Prahran, S.1	Registered under Sec. 7 of the <i>Dietitians Registration Act 1942</i>	..
7	28.1.44	Sutherland, Sheila Maude ..	78 Walpole-street, Kow, E.4	Registered under Sec. 6 of the <i>Dietitians Registration Act 1942</i>	..
347	29.7.61	Tabley, Jennifer Dorothy ..	c/o Queen Victoria Hospital, Melbourne	Registered under Sec. 7 of the <i>Dietitians Registration Act 1958</i>	..
162	9.6.44	Tate, John Thomas ..	"Staff" Repatriation Gen. Hospital, Heidelberg, N.23	Registered under Sec. 7 of the <i>Dietitians Registration Act 1942</i>	..
350	4.12.61	Till, Margaret Rose ..	c/o Royal Melbourne Hospital	Registered under Sec. 7 of the <i>Dietitians Registration Act 1958</i>	..
357	22.6.62	Tinney, Ruth Kingsley ..	c/o Nurses Home, Royal Melbourne Hospital	" " "	..
88	31.3.44	Topp, Elsie Marie ..	864 Toorak-road, East Hawthorn	Registered under Secs. 6 and 7 of the <i>Dietitians Registration Act 1942</i>	..
303	4.5.56	Topping, Joan ..	1985 Malvern-road, East Malvern	Registered under Sec. 6 of the <i>Dietitians Registration Act 1942</i>	..
36	17.3.44	Turner, Caroline Nancy ..	266 Dorset-road, Croydon ..	Registered under Secs. 6 and 7 of the <i>Dietitians Registration Act 1942</i>	Diploma of Dietetics Univ. of Melbourne 7th Oct. 1940
96	31.3.44	Turner, Emily Marion ..	Alfred Hospital, Commercial-road, Prahran	" " "	..
80	31.3.44	Underwood, Mary Elizabeth (Sister Emeric)	c/o St. Vincent's Hospital, Fitzroy	" " "	..
335	13.5.60	Urquhart, Robin Mather ..	c/o Royal Melbourne Hospital	Registered under Sec. 7 of the <i>Dietitians Registration Act 1958</i>	..
304	6.6.56	Van Der Kloos, Dorothea Amalia	c/o Repatriation General Hospital, Springbank, S.A.	Registered under Sec. 6 of the <i>Dietitians Registration Act 1942</i>	..

LIST OF REGISTERED DIETITIANS—continued.

Number of Certificate	Date of Registration.	Name.	Address.	Qualifications.	Further Particulars.
343	24.2.61	Venn-Brown, Una Mary (Mrs.)	76 Elgin-street, Gordon, N.S.W.	Registered under Sec. 7 of the Dietitians Registration Act 1958	..
318	21.2.58	Voet, Wilhelmina (Mrs. W. H. Schoenmaker)	Native Mission Farm, Rolelands, W.A.	Registered under Sec. 6 of the Dietitians Registration Act 1942	..
275	29.5.53	Wade, Jacqueline (Mrs. Pead)	c/o Mr. W. A. Pead, Box 876J, G.P.O. Hobart, Tasmania	" " "	..
35	17.3.44	Walker, Denise Ann (Mrs. McKinnon)	12 Neville-avenue, Clarence Gardens, S.A.	" " "	..
218	20.8.48	White, Jocelyn Slade ..	3 Brain-terrace, Launceston, Tasmania	" " "	..
204	10.6.55	Williams, Margaret Kathleen (Mrs. B. R. Curtis)	39 Richardson-avenue, North Glenelg	" " "	..
308	5.10.56	Williams, Marjorie Christine (Mrs. Mollard)	Flat 11, 199 Brighton-road, Elwood	" " "	..
285	26.3.54	Wishart, Alison Mary (Mrs. R. J. Mittag)	5 Ellendale-street, North Balwyn, E.9	" " "	..
327	27.5.60	Wolf, Hanna Margot	c/o 9 Coronation-street, East Brighton, S.6	Registered under Sec. 7 of the Dietitians Registration Act 1948	..
356	28.2.62	Wood, Margaret Beverley ..	19 Mercer-parade, Geelong ..	" " "	..
16	18.2.44	Wood, Rupert Edmond ..	234 Collins-street, Melbourne, C.1	Registered under Sec. 7 of the Dietitians Registration Act 1942	..

30th June, 1962.  
"Anzac House",  
4 Collins-street,  
Melbourne, C.1.

VERA M. SUTTON,  
Registrar.

STATE RIVERS AND WATER SUPPLY COMMISSION.  
By-LAW No. 5400.

Drainage Rates.—Irrigation Districts.

THE State Rivers and Water Supply Commission, in pursuance and exercise of the powers conferred by the Water Acts, doth hereby make the By-law following:—

1. The following Drainage Rates for the drainage of land are hereby made and levied upon the occupiers or owners of all lands within the Irrigation Districts set out in the Schedule hereto:—

- (1) In respect of all lands in the First drainage Rating Division (being the lands against which the number 1 is shown in the column designated "Rating Division—Drainage Rate" (hereinafter called the "said column") incorporated in the Register of Lands for the appropriate Irrigation District sealed by the Commissioner), a Drainage Rate of the amount in the pound shown in column 1 of the said Schedule of the unimproved capital value of all such lands.
- (2) In respect of all lands in the Second Drainage Rating Division (being the lands against which the number 2 is shown in the said column), a Drainage Rate of the amount in the pound shown in column 2 of the said Schedule of the unimproved capital value of all such lands.
- (3) In respect of all lands in the Third Drainage Rating Division (being the lands against which the number 3 is shown in the said column), a

Drainage Rate of the amount in the pound shown in column 3 of the said Schedule of the unimproved capital value of all such lands.

- (4) In respect of all lands in the Fourth Drainage Rating Division (being the lands against which the number 4 is shown in the said column), a Drainage Rate of the amount in the pound shown in column 4 of the said Schedule of the unimproved capital value of all such lands.

Provided that in respect of the lands in the Fifth Drainage Rating Division (being the lands against which the number 5 is shown in the said column and all lands within any urban district) no Rate is made or levied.

2. Such Drainage Rates are made and levied for the year ending 30th June, 1963, and shall be payable on 16th November, 1962, at the offices of the Commission at the places named in column 6 of the said Schedule opposite the names of the respective Irrigation Districts or Irrigation Areas thereof (as the case may be).

3. Interest will be chargeable as from the date such Rates become payable on all Rates not paid within six months from the said date.

4. For making and levying such Drainage Rates the unimproved capital valuations returned by valuers appointed by the Commission and adopted from time to time by the Commission and currently in force shall be deemed and taken to be the rateable value of such lands, subject to the Water (Irrigation Districts) Act 1959.

SCHEDULE.

Name of Irrigation District.	Amount of Rates in the £ of the Unimproved Capital Values of the Lands in such Districts.				Date on which Register of Lands Sealed by the Commission.	Places at which Rates shall be Payable.
	1st Division.	2nd Division.	3rd Division.	4th Division.		
	Column 1.	Column 2.	Column 3.	Column 4.		
Merbein Irrigation District .. .. .	6-00	4-50	3-00	1-50	7.9.62	Merbein
Nyah Irrigation District .. .. .	7-00	5-25	3-50	1-75	"	Nyah West
Red Cliffs Irrigation District .. .. .	6-00	4-50	3-00	1-50	"	Red Cliffs
Robinvale Irrigation District .. .. .	7-00	5-25	3-50	1-75	"	Robinvale
Tresco Irrigation District .. .. .	7-00	5-25	3-50	1-75	"	Swan Hill

The foregoing By-law was made by the State Rivers and Water Supply Commission on the 8th day of October, 1962, and the common seal of the said Commission was hereunto affixed the 9th day of November, 1962, in the presence of—

(SEAL)

L. R. EAST, Commissioner.  
H. W. McCAY, Commissioner.

Approved by the Governor in Council, 13th of November, 1962.—N. G. WISHART, Clerk of the Executive Council.

STATE RIVERS AND WATER SUPPLY COMMISSION.

IRRIGATION CHARGES—IRRIGATION DISTRICTS SUPPLIED BY PUMPING.

PURSUANT to the provisions of section 67 of the *Water Act 1958* (as amended) NOTICE IS HEREBY GIVEN THAT:—

1. Under the powers conferred by the *Water Acts*, the State Rivers and Water Supply Commission has made and levied upon the occupiers or owners of lands within the districts named in the Schedule hereto IRRIGATION CHARGES of the amounts shown in column 1 of the said Schedule opposite the names of the respective districts for each and every acre-foot of water apportioned to such lands as water rights.
2. Such Irrigation Charges are made and levied for the periods shown in column 2 of the said Schedule and shall be payable on the dates shown in column 3 and at the offices of the Commission at the places shown in column 4 thereof.
3. Interest will be chargeable as from the date such charges become payable on all charges not paid within six months from the said date.

SCHEDULE.

Name of Irrigation District.	Amount of Irrigation Charge for each and every acre-foot of water apportioned as Water Rights. Column 1	Period for which the Irrigation Charge is made. Column 2	Date on which Irrigation Charges shall be payable. Column 3	Places at which Irrigation Charges shall be payable. Column 4
	Shillings			
Merbein Irrigation District .. .. .	70	1st July, 1962 to 30th June, 1963	16th November, 1962	Merbein
Nyah Irrigation District .. .. .	60	" "	"	Nyah West
Red Cliffs Irrigation District .. .. .	70	" "	"	Red Cliffs
Robinvale Irrigation District .. .. .	80	" "	"	Robinvale
Tresco Irrigation District .. .. .	60	1st September, 1962 to 15th May, 1963	"	Swan Hill

The foregoing notice was adopted by the State Rivers and Water Supply Commission on the 8th day of October, 1962, and the common seal of the said Commission was hereunto affixed the 9th day of November, 1962.

(SEAL)

L. R. EAST, Commissioner.

H. W. McCAY, Commissioner.

Approved by the Governor in Council, 13th of November, 1962.—N. G. WISHART, Clerk of the Executive Council.

STATE RIVERS AND WATER SUPPLY COMMISSION.

IRRIGATION DISTRICTS—GENERAL RATES.

PURSUANT to the provisions of section 66 of the *Water Act 1958* (as amended) notice is hereby given that:—

1. The State Rivers and Water Supply Commission has levied upon the occupiers or owners of all lands within the irrigation districts named in the Schedule hereto, a general rate in respect of the financial year ending 30th June, 1963, of 1d. in the pound of the unimproved capital value of such land, except that in any district the lands whereof have been arranged in divisions the general rate in respect of lands in the Second Division shall be one-half of the general rate for the district and the general rate in respect of lands in the Third Division shall be one-fourth of the general rate for the district and no rate shall be levied in respect of lands in the Fourth Division.

2. The lands within the said irrigation districts have been arranged in divisions as shown by the numbers in the column designated "Rating Division—General Rate" incorporated in the register of lands for the said districts sealed by the Commission. A copy of the appropriate register of lands in respect of any land may be inspected during office hours at the Commission's head office at Melbourne or at the place shown opposite the name of the appropriate irrigation district in column 3 of the Schedule hereto.

3. Such general rate in respect of any land shall be payable at the Commission's office at the place shown opposite the appropriate irrigation district in column 3 of the Schedule hereto.

4. Such general rate shall be payable on 16th November, 1962.

5. Interest will be chargeable as from the date such rates become payable on all rates not paid within six months.

SCHEDULE.

Name of Irrigation District. Column 1	Date on which Register of Lands Sealed by the Commission. Column 2	Places at which the rates shall be payable. Column 3
Merbein Irrigation District .. .. .	7.9.62	Merbein
Nyah Irrigation District .. .. .	"	Nyah West
Red Cliffs Irrigation District .. .. .	"	Red Cliffs
Robinvale Irrigation District .. .. .	"	Robinvale
Tresco Irrigation District .. .. .	"	Swan Hill

Melbourne, 9th November, 1962.

By Order of the Commission,

A. H. RIGG,  
Secretary.

**CONTRACTS ACCEPTED.**—(Series 1962-63.)**VICTORIAN RAILWAYS.**

52. Lead acid batteries (2nd lot), at £51 10s. per set (Contract 62234).—Dunlop Oldham Pty. Ltd. 53. Guillotine machine for £7,699 (Contract 62238).—Goodall & Co. Pty. Ltd. 54. Wooden electric light poles, at rates (Contract 62240).—Alex. Sturrock & Sons Pty. Ltd. as agents for K. B. Varney.

By order of the Victorian Railways Commissioners,  
W. WALKER, Secretary. 9.11.62.

**GENERAL STORES.**

Gazette No. 38, 11th April, 1962, Schedule No. 52, Tools, General.—For Item No. 33 substitute 11d. each, as from 19th October, 1962.

H. COUTTS, Secretary to the Tender Board. 13.11.62.

**ORDERS IN COUNCIL.**—(Series 1962-63.)**FORESTS COMMISSION.**

Loan Fund Act No. 6817, Item 6, Project PX—

1754. To the purchase of that part of allotment 1, section 1, Parish of Berringama, County of Benambra, comprising approximately 2 roods, for forest purposes, £15.—A. W. Holloway.

Approved by the Governor in Council, 25th September, 1962.—N. G. WISHART, Clerk of the Executive Council.

**EDUCATION DEPARTMENT.**

1755. One only air compressor with receiver, for Box Hill Technical School, £101.—Bennie Teare Pty. Ltd.

Approved by the Governor in Council, 7th November, 1962.—N. G. WISHART, Clerk of the Executive Council.

**PUBLIC WORKS.**

1756. Ararat, Mental Hospital, supply and installation of an S.T.C. alarm system in "J" Ward, £485.—Standard Telephones and Cables Pty. Ltd. (W.301237).

1757. Arthur's Creek, State School, erection of one (1) only 24 ft. x 24 ft. class-room with corridor and porch, £1,668.—A. V. Jennings Industries (Aust.) Limited (N.W.309975).

1758. Footscray, Technical School, special grant authorized by the Education Department towards cost of erection of a sports pavilion at the school, £6,973 5s.—Footscray Technical School Advisory Council (S.W.278850).

1759. Karingal, High School, special grant authorized by the Education Department towards cost of construction of a sports oval, &c., at the school, £1,385 17s. 6d.—Karingal High School Advisory Council (S.E.277599).

1760. Melbourne, Law Courts, repairs to downpipes inside dome, £508 1s. 8d.—A. Crewther and Son Pty. Ltd. (M.296586).

1761. Melbourne, Accounts Branch, Public Works Department, supply of one (1) only Burroughs Typing Sensimatic Accounting Machine, £2,721 2s. (including £50 trade-in on existing Mercedes machine).—Burroughs Limited (M.254269).

1762. Templestowe, High School, special grant authorized by the Education Department towards cost of erection of a canteen at the school, £690.—Templestowe High School Advisory Council (N.E.284969).

Approved by the Governor in Council, 7th November, 1962.—N. G. WISHART, Clerk of the Executive Council.

**STATE ELECTRICITY COMMISSION.**

1763. For the construction of civil engineering works for coal conveyors to Hazelwood Power Station, to Specification No. 62-63/79, £36,360 (plus items at schedule rates).—S. Haunstrup & Co. Pty. Ltd.

Approved by the Governor in Council, 16th October, 1962.—N. G. WISHART, Clerk of the Executive Council.

1764. For the construction of concrete anchorages for towers on Kiewa/Melbourne transmission line, to Specification No. 62-63/116, £126,436.—Ascom Pty. Ltd.

1765. For the purchase of approximately 150 acres 18 perches of land situate Fraser's-road, Hazelwood, being whole of land comprising certificate of title 7342, folio 299, for Hazelwood Cooling Pondage, £40,000.—William Francis Daly.

1766. For the construction of roads, paths and drains, Morwell Project, to Specification No. 62-63/127, £17,750.—Gippsland Plant Hire.

1767. For the dismantling of No. 3 dredger, Morwell Open Cut, for repairs, to Quotation No. 1798, £4,500.—Jacobson & Dalton Pty. Ltd.

1768. For the supply of spare parts for coal crushing and screening plant, Yallourn "E" Power Station, to Quotation No. 38, £8,701 13s. 9d.—Klockner-Humboldt-Deutz A. G.

1769. For the supply and installation of high temperature hot water plant for district heating scheme, William-street, Melbourne, to Specification No. 62-63/172, £44,754.—Thos. Walker & Sons Pty. Ltd.

1770. For the conversion of eight 6.6 kV transformers at Cheltenham for use at 11 kV, to Quotation No. 1877, £7,200.—Wilson Electric Transformer Co. Pty. Ltd.

Approved by the Governor in Council, 30th October, 1962.—N. G. WISHART, Clerk of the Executive Council.

*Town and Country Planning Act 1961.***CITY OF MOORABBIN PLANNING SCHEME 1952.****AMENDMENT No. 13, 1962.***Notice of Approval.*

IN pursuance of the powers conferred by the *Town and Country Planning Act 1961*, the Governor in Council on the 13th November, 1962, approved a planning scheme entitled the City of Moorabbin Planning Scheme 1952, Amendment No. 13, 1962, in respect of part of the municipal district of the City of Moorabbin.

A copy of the planning scheme as approved may be inspected during office hours at the office of the Town and Country Planning Board, 61 Spring-street, Melbourne; at the office of the Council of the City of Moorabbin; and when available, at the Office of Titles, Melbourne, and at the Central Plan Office of the Department of Crown Lands and Survey, Melbourne.

W. H. CRAIG, Secretary,  
Town and Country Planning Board.

*Town and Country Planning Act 1961.***SHIRE OF FRANKSTON PLANNING SCHEME 1959.****AMENDMENT No. 1, 1962.***Notice of Approval.*

IN pursuance of the powers conferred by the *Town and Country Planning Act 1961*, the Governor in Council on the 13th November, 1962, approved a planning scheme entitled the Shire of Frankston Planning Scheme 1959, Amendment No. 1, 1962, in respect of part of the municipal district of the Shire of Frankston.

A copy of the planning scheme as approved may be inspected during office hours at the office of the Town and Country Planning Board, 61 Spring-street, Melbourne; at the office of the Council of the Shire of Frankston; and when available, at the Office of Titles, Melbourne, and at the Central Plan Office of the Department of Crown Lands and Survey, Melbourne.

W. H. CRAIG, Secretary,  
Town and Country Planning Board.

*Town and Country Planning Act 1961.***SHIRE OF ROSEDALE.****INTERIM DEVELOPMENT ORDER.***Notice of Approval.*

IN pursuance of the powers conferred by the *Town and Country Planning Act 1961*, the Governor in Council by and with the advice of the Executive Council thereof, on the 13th day of November, 1962, approved an Interim Development Order by the Council of the Shire of Rosedale.

The Interim Development Order provides that the use or development of the whole of the Shire of Rosedale excepting the areas included in the Latrobe Valley Sub-Regional Planning Scheme 1949 which was approved by the Governor in Council on the 24th day of July, 1951, and the erection, construction and carrying out of any buildings, roads or other works thereon is prohibited except that the responsible authority may permit such uses, development, erection, constructions or other works as provided in the order.

A copy of the Interim Development Order and a map showing the areas affected may be inspected free of charge at the office of the Council of the Shire of Rosedale, at Rosedale, and at the office of the Town and Country Planning Board, 61 Spring-street, Melbourne.

G. W. THOMSON, Shire Secretary.

*Town and Country Planning Act 1958, as Amended.*

CITY OF RICHMOND.

INTERIM DEVELOPMENT ORDER.

BY virtue of the powers conferred by the *Town and Country Planning Act 1958*, as amended, and of every other power enabling it in that behalf, the Council of the City of Richmond (hereinafter referred to as the Responsible Authority), having commenced the preparation of a planning scheme in accordance with the said Act hereby makes the following Interim Development Order for the purpose of regulating, restricting, restraining or prohibiting the use or development of any land or the erection, construction or carrying out of any buildings or works on any land within the area described or shown on the map as the Schedule hereto.

1. After the coming into operation of this Interim Development Order no person shall use or develop any land or erect, construct, or carry out any buildings or works on any land within the area included in the Schedule, except in accordance with the provisions of a permit issued by the Responsible Authority.

2. Any application for a permit to use or develop any land or to erect, construct or carry out any buildings or works, shall be accompanied by a sketch plan or copy of certificate of title of the land and a description of the proposed use or development, and type of construction of any buildings or works proposed to be erected, constructed or carried out and such other particulars relating to the application as the Responsible Authority may require.

3. This Interim Development Order shall not prevent the continuance of the use of any land or buildings for the purposes for which such land or buildings were lawfully used immediately before the coming into operation of this Order.

4. Schedule—the whole of the municipal district of the City of Richmond.

Sealed with the common seal of the Mayor, Councillors and Citizens of the City of Richmond this first day of September, 1960, in the presence of—

(SEAL) D. LEWIS, Mayor,  
TOM PELUSO, Councillor.  
CHAS. C. EYRES, Town Clerk.

Report by the Town and Country Planning Board, on the 19th day of September, 1960.—Recommended for approval.—FRED. C. COOK, Chairman.

Approved by the Governor in Council on the 25th day of October, 1960.—A. MAHLSTEDT, Clerk of the Executive Council.

Report by the Town and Country Planning Board, on the 4th day of October, 1961.—Recommended for approval.—FRED. C. COOK, Chairman.

Approved by the Governor in Council on the 17th day of October, 1961.—N. G. WISHART, Acting Clerk of the Executive Council.

Report by the Town and Country Planning Board on the 17th day of October, 1962.—Recommended for approval.—FRED. C. COOK, Chairman.

Approved by the Governor in Council on the 30th day of October, 1962.—N. G. WISHART, Clerk of the Executive Council.

PLENTY-YARRAMBAT WATERWORKS TRUST.

RATING BY-LAW FOR THE YEAR 1962-63.

THE Plenty-Yarrambat Waterworks Trust, in pursuance and exercise of the powers conferred by the Water Acts, doth hereby make a rate for the supply of water for domestic purposes of Three shillings and six pence in the pound on the net annual valuation of lands and tenements liable to be rated within the Plenty-Yarrambat Urban District.

Provided that in no case shall the amount of the rate payable per annum in respect of any tenement (other than the land on which there is no building) be less than Six pounds fifteen shillings, and in respect of any land where there is no building less than Two pounds.

Such rates are made and shall be levied upon occupiers or owners of the said land and tenements for the year commencing on the 1st October, 1962, and shall be due and payable on the 10th December, 1962, at the office of the Trust, Town Hall, Ivanhoe.

The maximum quantity of water to be supplied in any one year without further charge to any property rated by the Trust is hereby fixed at the quantity which, at a charge of Three shillings and six pence per 1,000 gallons, would produce an amount equal to the amount of the rate levied on such property for the said year.

The charge for water supplied to any property rated by the Trust in excess of such maximum quantity, computed as in the last clause, is hereby fixed at Three shillings and six pence per 1,000 gallons.

The charge for water supplied by measure shall be payable, on demand, at the office of the Trust.

Dated this 3rd day of October, 1962.

(SEAL) G. T. UPTON, Chairman,  
A. K. LINES, Commissioner.  
F. PHILLIPS, Secretary.

Approved 5th November, 1962.—W. J. MIBUS, Minister of Water Supply.

BENALLA SEWERAGE AUTHORITY.

ANNUAL BALANCE.

HIS Excellency the Governor of the State of Victoria, by and with the advice of the Executive Council thereof, doth by Order made on the 13th day of November, 1962, in pursuance of the provisions of the Sewerage Districts Acts fix the 30th day of September in each year as from 1st January, 1963, as the day to which the accounts of the Benalla Sewerage Authority shall be balanced.

N. G. WISHART,  
Clerk of the Executive Council.

At Government House,  
Melbourne, 13th November, 1962.

*Cemeteries Act 1958.*

SCALE OF FEES OF THE DIGBY PUBLIC CEMETERY.

IN pursuance of the powers conferred upon them by the Cemeteries Acts the trustees of the Digby Public Cemetery hereby make the following scale of fees, which shall come into operation upon publication in the *Government Gazette*, and from and after such publication every scale of fees heretofore made by the said trustees shall be and is hereby rescinded to the extent to which it conflicts with this scale:—

	£	s.	d.
Interment of Ashes.			
Adults .. .. .	3	10	0
Children—			
Under 12 years .. .. .	2	0	0
Stillborn .. .. .	1	10	0

A. J. HEENAN, Trustee.  
A. MCCALLUM, Trustee.  
A. G. MCINTOSH, Trustee.

Approved by the Governor in Council, 7th November, 1962.—N. G. WISHART, Clerk of the Executive Council.

*Cemeteries Act 1958.*

SCALE OF FEES OF THE TALGARNO PUBLIC CEMETERY.

IN pursuance of the powers conferred upon them by the Cemeteries Acts the trustees of the Talgarno Public Cemetery hereby make the following scale of fees, which shall come into operation upon publication in the *Government Gazette*, and from and after such publication every scale of fees heretofore made by the said trustees shall be and is hereby rescinded to the extent to which it conflicts with this scale:—

	£	s.	d.
Land for Private Graves.			
8 feet by 4 feet .. .. .	4	0	0
8 feet by 8 feet .. .. .	8	0	0

Miscellaneous.  
Interment fee .. .. . 1 0 0

WILLIAM SAUNDERS, Trustee.  
L. W. COLE, Trustee.  
W. ERIC ELLWOOD, Trustee.

Approved by the Governor in Council, 7th November, 1962.—N. G. WISHART, Clerk of the Executive Council.



*Cemeteries Act 1958.*

## SCALE OF FEES OF THE BURWOOD PUBLIC CEMETERY.

IN pursuance of the powers conferred upon them by the Cemeteries Acts the trustees of the Burwood Public Cemetery hereby make the following scale of fees, which shall come into operation upon publication in the *Government Gazette*, and from and after such publication every scale of fees heretofore made by the said trustees shall be and is hereby rescinded to the extent to which it conflicts with this scale:—

	£	s.	d.
Re-opening grave .. .. .	10	0	0
Re-opening grave to take oversize casket ..	16	0	0

*Miscellaneous.*

Permission to put concrete top on grave ..	0	5	0
Permission to re-gild inscription ..	0	5	0

*Lawn graves.*

Land 8 feet by 4 feet .. .. .	25	0	0
Sinking grave 7 feet .. .. .	12	0	0
Bronze plaque .. .. .	9	0	0
Re-opening grave for second burial ..	12	0	0
Flower container for plaque .. .. .	3	10	0

W. MOLD, Trustee.  
W. S. PETERSON, Trustee.  
S. B. WISEMAN, Trustee.

Approved by the Governor in Council, 7th November, 1962.—N. G. WISHART, Clerk of the Executive Council.

*Cemeteries Act 1958.*

## SCALE OF FEES OF THE SPRINGVALE PUBLIC CEMETERY.

IN pursuance of the powers conferred upon them by the Cemeteries Acts the trustees of the Springvale Public Cemetery hereby make the following scale of fees, which shall come into operation upon publication in the *Government Gazette*, and from and after such publication every scale of fees heretofore made by the said trustees shall be and is hereby rescinded to the extent to which it conflicts with this scale:—

	£	s.	d.
Gate niches .. .. .	7	0	0
New wall niches, "Cassia" area ..	15	0	0
Ground niches .. .. .	20	0	0
Tenure 50 years.			

In accordance with the Resolution passed at the meeting of trustees on the 21st August, 1962, the common seal of the trustees of The Necropolis, Springvale, was hereto affixed, in the presence of—

L. G. WILSON, Trustee.  
(SEAL) T. A. BLAIR, Trustee.  
E. H. R. EBBS, Trustee.

17th September, 1962.

Approved by the Governor in Council, 7th November, 1962.—N. G. WISHART, Clerk of the Executive Council.

## APPOINTMENTS.

HIS Excellency the Governor of the State of Victoria, by and with the advice of the Executive Council thereof, has, by Orders made on the 7th day of November, 1962, been pleased to make the under-mentioned appointments, viz:—

## DEPARTMENT OF AGRICULTURE.

*Member of Milk Board.*

CYRIL JOHN BENNETT MCPHERSON to be a Member of the Milk Board for a period of three (3) years, from and inclusive of the 14th December, 1962, pursuant to the provisions of the *Milk Board Act 1958*.

## CHIEF SECRETARY'S DEPARTMENT.

*Deputy Insurance Commissioner.*

ALBERT KEVIN CLARKE, pursuant to the provisions of the *Workers Compensation Act 1958*, to be the Deputy Insurance Commissioner from the 19th October, 1962, *vice* Leslie William Carver, resigned; and

ALBERT KEVIN CLARKE (the Deputy Insurance Commissioner under the *Workers Compensation Act 1958*),

pursuant to the provisions of the *Motor Car Act 1958*, to be the Deputy Insurance Commissioner under the said Act, from the 19th October, 1962, *vice* Leslie William Carver, resigned.

*Electoral Registrar (Acting).*

## GORDON EDWIN HUTH

to be Electoral Registrar (Acting) for the Brighton and Hampton Subdivisions of the Electoral District of Brighton; and for the Brighton East and Elsternwick Subdivisions of the Electoral District of Elsternwick; to take effect on and from the 22nd October, 1962, during the absence on leave of Frederick Macaulay.

*Governor (Acting) of Prison.*

## ARNOLD WILLIAM PECK,

pursuant to the provisions of the *Gaols Act 1958*, to be Governor (Acting) of Her Majesty's Prison, Sale, from the 3rd December, 1962, to 16th December, 1962, both dates inclusive, during the absence on leave of Lionel John Jackson.

*Honorary Probation Officer.*

Major LESLIE ROY WRIGHT, Salvation Army Headquarters, 69 Bourke-street, Melbourne, to be an Honorary Probation Officer, pursuant to the provisions of section 10 (1) of the *Children's Court Act 1958*, for all Children's Courts in Victoria.

## DEPARTMENT OF CROWN LANDS AND SURVEY.

*Committee of Management.*

## CLARENCE JAMES EDWARD POLLOCK,

## RICHARD EUSTACE TRACEY,

## FRANCIS HAROLD KLENNER,

## ALBERT RICHARD ROBERTS,

## ERNEST HENRY WAGSTAFF, and

## ALEXANDER WILLIAM MCLIESH,

to be members of the Committee of Management of Elsternwick Park, provided nevertheless that the said Albert Richard Roberts, Ernest Henry Wagstaff and Alexander William McLiesh shall hold office as members of the Committee of Management for so long only as they respectively continue to be Councillors and the elect of the Council of the City of Brighton.

*Trustee of Site.*

## ALBERT JOSEPH MERRICK

to be a Trustee of the land permanently reserved on the 18th October, 1886, as a site for public recreation at Ballaarat, in place of Oscar William Curnow, deceased.

## LAW DEPARTMENT.

*Assistant Registrar.*

## MICHAEL JAMES TERENCE QUIRK

to be an Assistant Registrar, pursuant to the provisions of sections 20 and 21 of the *County Court Act 1958*, for the County Court at Warrnambool, during the absence of G. G. Moon on annual leave, to take effect from the date of commencement of duty.

*Clerk of Petty Sessions, &c.*

## MICHAEL JAMES TERENCE QUIRK

to be Clerk of Petty Sessions and Clerk of the Children's Court at Camperdown, Cobden, Lismore, Mortlake and Terang during the absence of G. G. Moon on annual leave, to take effect from the date of commencement of duty.

*Clerk of Children's Court.*

## LINDSAY THOMAS GOULD

to be Clerk of the Children's Court at Frankston, *vice* J. C. Tobin, relieved, to take effect from the date of commencement of duty.

*Commissioners for Taking Declarations, &c.*

## HENRY STRAKATY,

## JAMES ALLEN PHILLIP BICKWELL,

## PATRICK ALDWORTH HURLEY,

## WADIM SPIESS,

## NEIL BERNARD WALTERS,

## TREVOR MAGNUS LAGSTROM and

## IAN ROBERT WISE, Officers of Department of Labour

## and Industry, Spring-street, Melbourne; and

## GEORGE LINDSAY BUGGE,

## PETER DESMOND CHARLESTON,

## RAYMOND JOHN DAVIS,

## WILLIAM HARVEY GOLDSBURY,

GARRY NICHOLAS ANTHONY O'DONOHUE,  
ALFRED MICHAEL RILEY and  
GERARD ARTHUR NINIAN WILSON, Officers of Housing  
Commission of Victoria, 179 Queen-street, Mel-  
bourne.

to be Commissioners for taking Declarations and Affidavits, pursuant to the provisions of the *Evidence Act 1958*, to refrain from charging fees and to resign upon ceasing to be officers of the Department of Labour and Industry and Housing Commission, respectively;

CHARLES HENRY QUIN, Inspector Personnel, Re-  
patriation Department,  
PETER JOHN ADAMS, Clerk and Treasurer, Shire of  
Mansfield, Shire Hall, Mansfield, and  
MARK S. MOUTAFIS, care of Photo Lithographers Pty.  
Ltd, 170 Cardigan-street, Carlton, N.3.

to be Commissioners for taking Declarations and Affidavits, pursuant to the provisions of the *Evidence Act 1958*, to resign upon ceasing to occupy their present positions; and

GEORGE PARDAVY, 8 Henry-street, East Brighton,  
LAURA MADDERN, care of 215 Barker-street, Castle-  
maine,  
BERNARD ABRAHAM BOAS, 374 Waverley-road, East  
Malvern, and  
GRAEME PATRICK THOMAS SWEENEY, The Warden,  
Monash University,

to be Commissioners for taking Declarations and Affidavits, pursuant to the provisions of the *Evidence Act 1958*, to resign upon removing from the neighbourhood of the addresses stated.

#### *Justices of the Peace.*

ROBERT LESLIE CLAY, Huntly,  
to Keep the Peace in the Midland Bailiwick of the State of Victoria;

MORTON HENRY HORMAN, Noojee,  
to Keep the Peace in the Eastern Bailiwick of the State of Victoria; and

THORA MARY KINNIBURGH, 45 Justin-avenue, Glenroy,  
and

BRUCE IAN LADE, Highlands, via Seymour,  
to Keep the Peace in the Central Bailiwick of the State of Victoria.

#### *Judges of County Courts, &c.*

HUBERT THEODORE FREDERICO, LL.B., Q.C., a Barrister at Law, who has practised as a barrister in Victoria for a period of seven years, and

NORMAN ALFRED VICKERY, M.B.E., M.C., E.D., B.Ec. (Sydney), LL.B. (Melb.), a Barrister at Law, who has practised as a barrister in Victoria for a period of seven years,

to be Judges of the County Court and Judges of the Courts of Mines, under the provisions of the County Court Acts, to take effect from the date of commencement of duty.

#### *Chairmen of General Sessions.*

HUBERT THEODORE FREDERICO, LL.B., Q.C., a Barrister at Law of Victoria, who has practised for a period of five years, and

NORMAN ALFRED VICKERY, M.B.E., M.C., E.D., B.Ec. (Sydney), LL.B. (Melb.), a Barrister at Law of Victoria, who has practised for a period of five years,

to be Chairmen of General Sessions under the provisions of the *Justices Act 1958*, to take effect from the date of commencement of duty.

#### DEPARTMENT OF PUBLIC WORKS.

##### *Wharf Managers.*

First Constable ERNEST WILLIAM LEE, No. 9935,  
to be Wharf Manager at Cowes, Rhyll and Tankerton, as from 10th October, 1962, to carry out that portion of Part II. of the *Marine Act 1958* which relates to the management of Public Wharves, and to be an officer under section 19 of such Act to levy and collect wharfage rates thereat, at a remuneration of £25 per annum, *vice* First Constable Joshua Robert Gray, No. 8750, transferred.

Senior Constable FRANK JAMES MCCLINTOCK, No. 9276,  
to be Wharf Manager at Black Rock as on and from 25th July, 1962, to carry out that portion of Part II. of the *Marine Act 1958*, which relates to the management of Public Wharves, and to be an officer under section 19 of such Act to levy and collect wharfage rates thereat, at a remuneration of £12 10s. per annum, *vice* Senior Constable John Smith, No. 8900, transferred.

Senior Constable JOHN STANLEY MCGOUGH, No. 9214,  
as Wharf Manager at Rosebud, Rye and Flinders, as on and from 30th August, 1962, to carry out that portion of Part II. of the *Marine Act 1958*, which relates to

the management of Public Wharves, and to be an officer under section 19 of such Act, to levy and collect wharfage rates thereat, at a remuneration of £25 per annum, *vice* Senior Constable Frank James McClintock, No. 9276, transferred.

Senior Constable BRUCE DANIEL NOEL O'SULLIVAN,  
No. 10645,

as Wharf Manager at Werribee, as on and from 1st September, 1962, to carry out that portion of Part II. of the *Marine Act 1958*, which relates to the management of Public Wharves, and to be an officer under section 19 of such Act, to levy and collect wharfage rates thereat, at a remuneration of £12 10s. per annum, *vice* First Constable Bernard Daniel O'Keefe, No. 10159, transferred.

#### DEPARTMENT OF THE TREASURER.

##### *Receivers of Revenue (Acting).*

FRANCIS WILLIAM HENRY TOLL

to act temporarily as Receiver of Revenue, Motor Registration Branch, Chief Secretary's Department, *vice* W. S. Kruger.

FREDERICK JOHN DUTHIE

to act temporarily as Receiver of Revenue, Kerang, during the absence of R. J. Canning, on leave.

#### DEPARTMENT OF WATER SUPPLY.

##### *Water Commissioner.*

ALAN GUYE

to be a Commissioner of the Ballarat Water Commissioners, pursuant to the provisions of the Water Acts, to hold office as such for a period of four years from 9th November, 1962, his present term of office expiring on 8th November, 1962.

N. G. WISHART,

Clerk of the Executive Council.

At Government House,  
Melbourne, 7th November, 1962.

#### APPOINTMENTS.

HIS Excellency the Governor of the State of Victoria, by and with the advice of the Executive Council thereof, has, by Order made on the 13th day of November, 1962, been pleased to make the under-mentioned appointments, viz.:—

#### STATE ELECTRICITY COMMISSION.

*Chairman and Members of the Yallourn Town Advisory Council.*

THOMAS FORRISTAL,

pursuant to the provisions of the *State Electricity Commission Act 1958*, to be a Member and Chairman of the Yallourn Town Advisory Council for a term of three (3) years as from the 7th January, 1963;

THOMAS BROUGHTON JENSEN,

JOSEPH PHIL ASHMEAD, and

AUSTIN LYNCH,

pursuant to the provisions of the *State Electricity Commission Act 1958*, to be Members of the Yallourn Town Advisory Council for a term of three (3) years as from the 7th January, 1963.

N. G. WISHART,

Clerk of the Executive Council.

At Government House,  
Melbourne, 13th November, 1962.

#### RESIGNATIONS.

HIS Excellency the Governor of the State of Victoria, by and with the advice of the Executive Council thereof, has, by Orders made on the 7th day of November, 1962, accepted the resignations of the persons named hereunder of the offices mentioned, viz.:—

#### CHIEF SECRETARY'S DEPARTMENT.

RONALD ROSS COX, as a Licensing Inspector for the purposes of the *Licensing Act 1958*, from and inclusive of the 24th October, 1962.

LESLIE WILLIAM CARVER, as Deputy Insurance Commissioner, pursuant to the provisions of the *Workers Compensation Act 1958*, from and inclusive of the 19th October, 1962.

LESLIE WILLIAM CARVER, as Deputy Insurance Commissioner, pursuant to the provisions of the *Motor Car Act 1958*, from and inclusive of the 19th October, 1962.

LAW DEPARTMENT.

CHARLES DUNN, KEITH FRANK ALLISON MYERS and JOHN CHARLES SEXTON, as Commissioners for taking Declarations and Affidavits, pursuant to the provisions of the *Evidence Act 1958*.  
 ANDREW ROBERT CROFTS, from the Commission of the Peace for the Eastern Bailiwick of the State of Victoria.  
 RANDOLPH JOHN EDDY, from the Commission of the Peace for the Central Bailiwick of the State of Victoria.  
 LEONARD JOHN HERBERT JOSEPH MORRISON, from the Commission of the Peace for the Western Bailiwick of the State of Victoria.  
 REGINALD HARRY PRIESTLEY and LESLIE CHARLES ANDERS, from the Commission of the Peace for the Midland Bailiwick of the State of Victoria.

N. G. WISHART,  
 Clerk of the Executive Council.

At Government House,  
 Melbourne, 7th November, 1962.

EXPLOSIVES ACT 1958.

At Government House, Melbourne, the seventh day of November, 1962.

PRESENT:  
 His Excellency the Governor of Victoria.  
 Mr. Petty | Mr. Porter.

CLASSIFICATION OF EXPLOSIVES.

HIS Excellency the Governor of the State of Victoria, by and with the advice of the Executive Council thereof, and in pursuance of the provisions of section 53 of the *Explosives Act 1958*, doth by this Order classify the under-mentioned explosives as follows:—

CLASS 6—AMMUNITION.

Division 1.

"Imperial" No. 2 Shotgun Caps. (Not for general sale.) (X)

Division 2.

Waterwork Boosters. (Not for general sale.) (Z)

And the Honorable Arthur Gordon Rylah, Her Majesty's Chief Secretary for the State of Victoria, shall give the necessary directions herein accordingly.

N. G. WISHART,  
 Clerk of the Executive Council.

LANDLORD AND TENANT ACT 1958.

At Government House, Melbourne, the seventh day of November, 1962.

PRESENT:  
 His Excellency the Governor of Victoria.  
 Mr. Petty | Mr. Porter.

ORDER EXCLUDING CERTAIN PREMISES FROM THE OPERATION OF CERTAIN PROVISIONS OF PART V. OF THE LANDLORD AND TENANT ACT 1958.

IN pursuance of the powers conferred by section 44 of the *Landlord and Tenant Act 1958*, His Excellency the Governor of the State of Victoria, by and with the advice of the Executive Council thereof, doth hereby declare that each of the following premises shall be excluded from the operation of the whole of the provisions contained in Divisions 2 and 3 of Part V. of the Act, viz.:—

1. The premises known as Number 72 Southey-street, Elwood.
2. The premises known as Number 30 Lyonsville-avenue, East Preston.

And the Honorable Arthur Gordon Rylah, Her Majesty's Attorney-General for the State of Victoria, shall give the necessary directions herein accordingly.

N. G. WISHART,  
 Clerk of the Executive Council.

DEPARTMENT OF CROWN LANDS AND SURVEY.

At Government House, Melbourne, the seventh day of November, 1962.

PRESENT:  
 His Excellency the Governor of Victoria.  
 Mr. Petty | Mr. Porter.

UNUSED ROADS CLOSED.

HIS Excellency the Governor of the State of Victoria, by and with the advice of the Executive Council thereof, doth hereby direct that, in pursuance of the provisions of section 349 of the *Land Act 1958*, the unused roads referred to hereunder be closed, viz.:—

At Bendigo, Parish of Sandhurst, County of Bendigo, being the roads indicated by hachure on plan hereunder.—(S.372(121, 122) (W.84356).

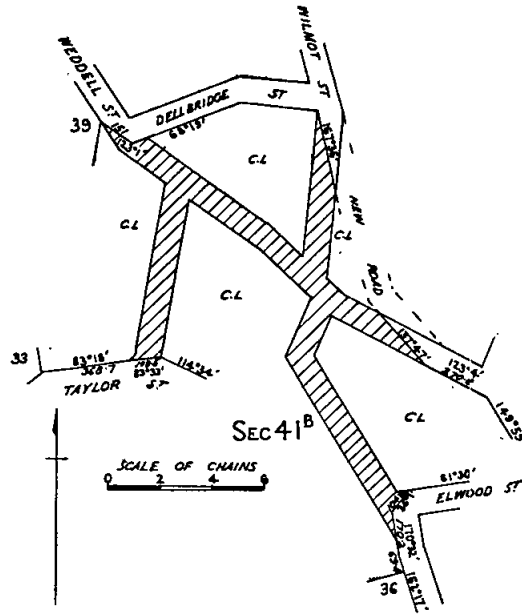

Parish of Orbost East, County of Croajingolong, being the road indicated by hachure on plan hereunder.—(O.23(11) (H.026689).

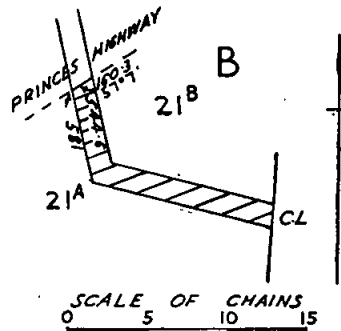

Parish of Warrenbayne, County of Delatite, being the road between allotment 42b and allotment 42b.—(W.109(4) (H.027589).

And the Honorable Keith Hector Turnbull, Her Majesty's Commissioner of Crown Lands and Survey for the State of Victoria, shall give the necessary directions herein accordingly.

N. G. WISHART,  
 Clerk of the Executive Council.

ROAD TRAFFIC ACT 1958.

At Government House, Melbourne, the seventh day of November, 1962.

PRESENT:

His Excellency the Governor of Victoria.  
Mr. Petty | Mr. Porter.

ORDER EXTENDING APPLICATION OF ACT TO CERTAIN LAND OR PREMISES VESTED IN OR UNDER THE CONTROL OF THE CITY OF BRIGHTON.

IN pursuance of the powers conferred by the *Road Traffic Act 1958*, and all other powers him thereunto enabling, His Excellency the Governor of the State of Victoria in the Commonwealth of Australia, by and with the advice of the Executive Council of the said State, and at the request of the Council of the City of Brighton, doth by this Order extend the application of the provisions of the said Act to that land or premises vested in or under the control of the City of Brighton as is shown delineated and hachured on the plan annexed hereto.

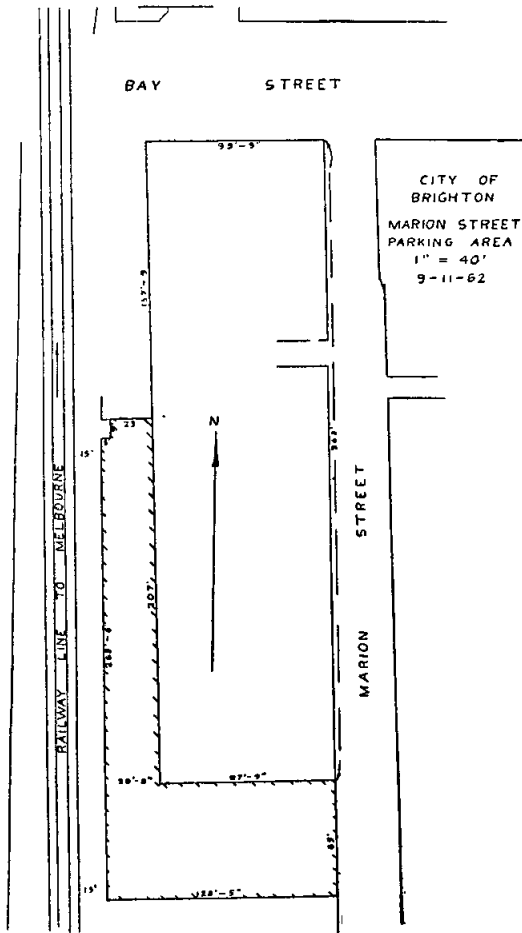

And the Honorable Arthur Gordon Rylah, Her Majesty's Chief Secretary for the State of Victoria, shall give the necessary directions herein accordingly.

N. G. WISHART,  
Clerk of the Executive Council.

MENTAL HEALTH ACT 1959 (No. 6605), SECTION 59.

At Government House, Melbourne, the seventh day of November, 1962.

PRESENT:

His Excellency the Governor of Victoria.  
Mr. Petty | Mr. Porter.

PURSUANT to the provisions of the *Mental Health Act 1959*, His Excellency the Governor of the State of Victoria, by and with the advice of the Executive Council of the said State, doth hereby proclaim the hostilities in which Her Majesty was engaged in Malaya after the 28th day of June, 1950, to be hostilities for the purposes of section 59 of the *Mental Health Act 1959*.

And the Honorable Ronald William Mack, Her Majesty's Minister of Health for the State of Victoria, shall give the necessary directions herein accordingly.

N. G. WISHART,  
Clerk of the Executive Council.

GEELONG WATERWORKS AND SEWERAGE TRUST.

At Government House, Melbourne, the seventh day of November, 1962.

PRESENT:

His Excellency the Governor of Victoria.  
Mr. Petty | Mr. Porter.

CONSENT TO BORROWING £200,000.

UNDER the powers conferred by the Geelong Waterworks and Sewerage Acts and all other powers enabling him in that behalf, His Excellency the Governor of the State of Victoria, by and with the advice of the Executive Council of the said State, doth hereby consent to the Geelong Waterworks and Sewerage Trust borrowing, at interest, subject to the Geelong Waterworks and Sewerage Acts the sum of Two hundred thousand pounds (£200,000) in two amounts of One hundred and fifty thousand pounds (£150,000) and Fifty thousand pounds (£50,000) respectively, to meet the cost of water supply works.

And the Honorable Wilfred John Mibus, Her Majesty's Minister of Water Supply for the State of Victoria, shall give the necessary directions herein accordingly.

N. G. WISHART,  
Clerk of the Executive Council.

CASTLEMAINE SEWERAGE AUTHORITY.

At Government House, Melbourne, the seventh day of November, 1962.

PRESENT:

His Excellency the Governor of Victoria.  
Mr. Petty | Mr. Porter.

CONSENT TO BORROWING £20,000.

UNDER the powers conferred by the Sewerage Districts Acts and all other powers enabling him in that behalf, His Excellency the Governor of the State of Victoria, by and with the advice of the Executive Council of the said State, doth hereby consent to the Castlemaine Sewerage Authority borrowing by the assignment of the General Fund a sum of Twenty thousand pounds (£20,000) to meet the cost of sewerage works as set forth in the detailed statement bearing date the 2nd November, 1962.

And the Honorable Wilfred John Mibus, Her Majesty's Minister of Water Supply for the State of Victoria, shall give the necessary directions herein accordingly.

N. G. WISHART,  
Clerk of the Executive Council.

## STAWELL SEWERAGE AUTHORITY.

*At Government House, Melbourne, the seventh day of November, 1962.*

PRESENT:

His Excellency the Governor of Victoria.  
Mr. Petty | Mr. Porter.

## CONSENT TO BORROWING £25,000.

UNDER the powers conferred by the Sewerage Districts Acts and all other powers enabling him in that behalf, His Excellency the Governor of the State of Victoria, by and with the advice of the Executive Council of the said State, doth hereby consent to the Stawell Sewerage Authority borrowing by the assignment of the General Fund the sum of Twenty-five thousand pounds (£25,000) for the conversion of loans numbered 1, 2 and 3.

And the Honorable Wilfred John Mibus, Her Majesty's Minister of Water Supply for the State of Victoria, shall give the necessary directions herein accordingly.

N. G. WISHART,  
Clerk of the Executive Council.

## BACCHUS MARSH SEWERAGE AUTHORITY.

*At Government House, Melbourne, the seventh day of November, 1962.*

PRESENT:

His Excellency the Governor of Victoria.  
Mr. Petty | Mr. Porter.

## POWER TO BORROW £15,000.

UNDER the powers conferred by the Sewerage Districts Acts and all other powers enabling him in that behalf, His Excellency the Governor of the State of Victoria, by and with the advice of the Executive Council of the said State, doth hereby consent to the Bacchus Marsh Sewerage Authority borrowing by the assignment of the General Fund a sum of Fifteen thousand pounds (£15,000) for the carrying out of works in accordance with the provisions of sections 95, 130 and 137 of the *Sewerage Districts Act 1958*. All moneys received by the said Authority in payment of costs and expenses of the said works, or any of them, shall be set aside for the purpose of and applied in repayment of the said sum so borrowed.

And the Honorable Wilfred John Mibus, Her Majesty's Minister of Water Supply for the State of Victoria, shall give the necessary directions herein accordingly.

N. G. WISHART,  
Clerk of the Executive Council.

## MORNINGTON SEWERAGE AUTHORITY.

*At Government House, Melbourne, the seventh day of November, 1962.*

PRESENT:

His Excellency the Governor of Victoria.  
Mr. Petty | Mr. Porter.

## CONSENT TO BORROWING £30,000.

UNDER the powers conferred by the Sewerage Districts Acts and all other powers enabling him in that behalf, His Excellency the Governor of the State of Victoria, by and with the advice of the Executive Council of the said State, doth hereby consent to the Mornington Sewerage Authority borrowing by the assignment of the General Fund a sum of Thirty thousand pounds (£30,000) to meet the cost of sewerage works as set forth in the detailed statement bearing date the 2nd November, 1962.

And the Honorable Wilfred John Mibus, Her Majesty's Minister of Water Supply for the State of Victoria, shall give the necessary directions herein accordingly.

N. G. WISHART,  
Clerk of the Executive Council.

## SHEPPARTON SEWERAGE AUTHORITY.

*At Government House, Melbourne, the seventh day of November, 1962.*

PRESENT:

His Excellency the Governor of Victoria.  
Mr. Petty | Mr. Porter.

## CONSENT TO BORROWING £50,000.

UNDER the powers conferred by the Sewerage Districts Acts and all other powers enabling him in that behalf, His Excellency the Governor of the State of Victoria, by and with the advice of the Executive Council of the said State, doth hereby consent to the Shepparton Sewerage Authority borrowing by the assignment of the General Fund the sum of Fifty thousand pounds (£50,000) to meet the cost of sewerage works as set forth in the detailed statement bearing date 2nd November, 1962.

And the Honorable Wilfred John Mibus, Her Majesty's Minister of Water Supply for the State of Victoria, shall give the necessary directions herein accordingly.

N. G. WISHART,  
Clerk of the Executive Council.

## MILDURA SEWERAGE AUTHORITY.

*At Government House, Melbourne, the seventh day of November, 1962.*

PRESENT:

His Excellency the Governor of Victoria.  
Mr. Petty | Mr. Porter.

## CONSENT TO BORROWING £25,000.

UNDER the powers conferred by the Sewerage Districts Acts and all other powers enabling him in that behalf, His Excellency the Governor of the State of Victoria, by and with the advice of the Executive Council of the said State, doth hereby consent to the Mildura Sewerage Authority borrowing by the assignment of the General Fund the sum of Twenty-five thousand pounds (£25,000) in two amounts of Fifteen thousand pounds (£15,000) and Ten thousand pounds (£10,000) respectively, to meet the cost of sewerage works as set forth in the detailed statement bearing date the 2nd November, 1962.

And the Honorable Wilfred John Mibus, Her Majesty's Minister of Water Supply for the State of Victoria, shall give the necessary directions herein accordingly.

N. G. WISHART,  
Clerk of the Executive Council.

## WATER ACTS.

*At Government House, Melbourne, the seventh day of November, 1962.*

PRESENT:

His Excellency the Governor of Victoria.  
Mr. Petty | Mr. Porter.

## FORREST WATERWORKS TRUST CONSTITUTED.

UNDER the powers conferred by the Water Acts and all other powers enabling him in that behalf, His Excellency the Governor of the State of Victoria, by and with the advice of the Executive Council of the said State, doth hereby approve of the application of the Councillors of the Shire of Otway for the constitution of a Waterworks Trust, subject to the provisions of the said Acts, to construct, manage and maintain the works for the supply of water to the Township of Forrest, and doth hereby order and appoint as follows:—

1. That the name of the Trust shall be Forrest Waterworks Trust.

2. That the Commissioners of the Trust shall be six members to be elected directly by the ratepayers of the proposed Waterworks District, together with one other person appointed by the Governor in Council.

3. That the estimated cost of carrying out the proposed waterworks shall be Sixteen thousand pounds (£16,000).

4. That the principal works to be constructed or carried out by the Trust shall consist of a pumping station, rising main, service basin, supply main and the reticulation of the Forrest Township.

5. That the limits of the land within which the said Waterworks Trust shall have authority shall be those within the following boundaries:—

#### PORTION 1.

Commencing at the north-eastern angle of Crown allotment 5z, Parish of Yaughar, County of Polwarth; thence due east by a line across a road to a point on the western boundary of Crown allotment 5b; thence southerly along the said western boundary of Crown allotment 5b to its south-western angle; thence easterly along the southern boundary of the said Crown allotment 5b and by a line being the continuation thereof across a Reserve to a point on the centre line of a Permanent Railway Survey from Birregurra to Barramunga; thence generally south-easterly along the said centre line to a point in line with the south-eastern boundary of lot 12, section E, Township of Forrest; thence south-westerly by a line across the aforesaid Reserve and a road and along the south-eastern boundaries of the said lot 12 and of lots 13A and 13B to the southernmost angle of the said lot 13B; thence south-easterly along the north-eastern boundary of lot 4 to its easternmost angle; thence westerly along the southern boundary of the said lot 4 and by a line being the continuation thereof across a road to a point on the eastern boundary of Crown allotment 5j, Parish of Yaughar; thence northerly along the said eastern boundary of Crown allotment 5j, by a line across a road and along the eastern boundary of Crown allotment 15 to a point in line with the northern boundary of lot 1, section E, Township of Forrest; thence due west by a line through the aforesaid Crown allotment 15 a distance of 250 links to a point in line with the western boundary of lot 2 shown on lodged plan of subdivision No. 20757; thence northerly by a line through the said Crown allotment 15 and along the western boundary of the said lot 2 and lots 1, 14, 13, 12, 11 and 10 to the north-western angle of the said lot 10; thence north-westerly by a line through Crown allotment 5 shown on lodged plan of subdivision No. 10064 to the southernmost angle of the lands described in certificate of title, volume 8040, folio 325, lodged in the Office of Titles, Melbourne; thence north-westerly along the south-western boundary of the said lands described in certificate of title, volume 8040, folio 325 and in volume 8040, folio 326 to the westernmost angle of the land described in the said certificate of title, volume 8040, folio 326; thence north-westerly by a line through Crown allotment 9 to the south-eastern angle of the lands described in certificate of title, volume 8163, folio 635; thence westerly along the southern boundary of the said lands to its south-western angle; thence northerly along the western boundary of the said lands to its north-western angle; thence northerly by a line across a road to the southernmost angle of lot 7 shown on lodged plan of subdivision No. 10064; thence northerly along the eastern boundary of the said lot 7 for a distance of 208.3 links; thence easterly by a line across a road to the north-western angle of lot 1 shown on lodged plan of subdivision No. 40065; thence easterly along the northern boundaries of the said lot 1 and of lots 2, 3, 4 and 5 and the lands shown on miscellaneous plan No. G/177 to its north-eastern angle; thence northerly by a line through Crown allotment 6, a State School Reserve and across a road to the southernmost angle of Crown allotment 5x; thence easterly along the southern boundary of the said Crown allotment 5x and of Crown allotment 5y to the south-western angle of Crown allotment 5z; thence northerly along the western boundary of the said Crown allotment 5z to its north-western angle; thence easterly along the northern boundary of the said Crown allotment 5z to its north-eastern angle being the point of commencement.

#### PORTION 2.

##### Site of Pumping Station.

The site of the pumping station shall be the land occupied by the said pumping station in River Reserve, Gazette No. 81-1389, Parish of Yaughar, County of Polwarth, being on the west branch of the Barwon River.

#### PORTION 3.

##### Site of Rising Main.

The site of the rising main being the strip of land 50 links in width, being 25 links on each side of the centreline of the said rising main, commencing at a point in River Reserve, Gazette No. 81-1389, Parish of Yaughar, County of Polwarth, being a point on the site of the pumping station as described in Portion 2; thence north-westerly across the said River Reserve and through Crown allotment 4A to a point on the site of the service basin as described in Portion 4.

#### PORTION 4.

##### Site of Service Basin.

The site of the service basin shall be the land occupied by the said service basin in Crown allotment 4A, Parish of Yaughar, County of Polwarth.

#### PORTION 5.

##### Site of Supply Main.

The site of the supply main being a strip of land 50 links in width, being 25 links on each side of the centreline of the said supply main, commencing at a point in Crown allotment 4A, Parish of Yaughar, County of Polwarth, being a point on the boundary of the site of the service basin as described in Portion 4; thence north-westerly through the aforesaid Crown allotment 4A, across a road reserve and northerly along a road reserve to a point on the southern boundary of the Waterworks District as described in Portion 1.

All of which boundaries are shown on a plan approved by the Governor in Council and deposited in the office of the State Rivers and Water Supply Commission, Melbourne.—(Corres. 59/4349/19.)

And the Honorable Wilfred John Mibus, Her Majesty's Minister of Water Supply for the State of Victoria, shall give the necessary directions herein accordingly.

N. G. WISHART,  
Clerk of the Executive Council.

#### PAYNESVILLE WATERWORKS TRUST.

At Government House, Melbourne, the seventh day of November, 1962.

PRESENT:

His Excellency the Governor of Victoria.  
Mr. Petty | Mr. Porter.

#### EXTENT OF DISTRICT INCREASED.

UNDER the powers conferred by the Water Acts and all other powers enabling him in that behalf, His Excellency the Governor of the State of Victoria, by and with the advice of the Executive Council of the said State, doth hereby declare, order and direct as follows:—

That the extent of the Waterworks and Urban Districts of the Paynesville Waterworks Trust be increased by adding to the same the land comprised within the boundaries described in the Schedule hereto, and as on and from the date hereof, the extent of such Districts shall be deemed to be increased accordingly.

#### SCHEDULE.

Commencing at a point on the southern boundary of Crown allotment 146, Parish of Bairnsdale, County of Tanjil, in line with the western boundary of lot 1 on lodged plan of subdivision No. 55232, being a point on the boundary of the existing Waterworks District; thence easterly along the aforesaid southern boundary of Crown allotment 146 to its south-eastern angle; thence northerly along the eastern boundary of the said Crown allotment 146 to its north-eastern angle; thence westerly along the northern boundary of the said Crown allotment 146 to a point in line with the eastern boundary of Crown allotment 146c; thence northerly by a line across a road and along the said eastern boundary of Crown allotment 146c to a point in line with the southern boundary of Crown allotment 146b; thence easterly by a line across a road and along the southern boundaries of the said Crown allotment 146b and of Crown allotment 146e and by a line being the continuation across a reserve to a point on the western shoreline of McMillan's Strait; thence

generally southerly along the said western shoreline of McMillan's Strait to the north-eastern angle of Crown allotment 147d being a point on the boundary of the existing Waterworks District; thence westerly, south-easterly, south-westerly, westerly and northerly along the boundary of the existing Waterworks District to the point of commencement.

All of which boundaries are shown on a plan approved by the Governor in Council and deposited in the office of the State Rivers and Water Supply Commission, Melbourne.—(Corres. 59/2747/73.)

And the Honorable Wilfred John Mibus, Her Majesty's Minister of Water Supply for the State of Victoria, shall give the necessary directions herein accordingly.

N. G. WISHART,  
Clerk of the Executive Council.

#### WARRAGUL WATERWORKS TRUST.

At Government House, Melbourne, the seventh day of November, 1962.

PRESENT:

His Excellency the Governor of Victoria.  
Mr. Petty | Mr. Porter.

#### AMENDMENT OF ORDER.

UNDER the powers conferred by the Water Acts and all other powers enabling him in that behalf, His Excellency the Governor of the State of Victoria, by and with the advice of the Executive Council of the said State, doth hereby amend as follows the Order in Council made the 6th day of March, 1962, and published in the *Victoria Government Gazette* dated 7th March, 1962, approving of a plan of main pipe-line and off-take weir to be constructed by the Warragul Waterworks Trust.

In Portion I.—Site for Main Pipe-line—in lines 25 and 26 for the words "Crown land and through a Reserve on the right bank of the right branch of the Tarago River and State Forest to" there shall be substituted the following:—

"Crown land and through State Forest to."

All of which lands are shown on an amending plan marked "B" approved by the Governor in Council and deposited in the office of the State Rivers and Water Supply Commission, Melbourne.—(Corres. 59/1073/201.)

And the Honorable Wilfred John Mibus, Her Majesty's Minister of Water Supply for the State of Victoria, shall give the necessary directions herein accordingly.

N. G. WISHART,  
Clerk of the Executive Council.

#### WATER ACTS.

At Government House, Melbourne, the seventh day of November, 1962.

PRESENT:

His Excellency the Governor of Victoria.  
Mr. Petty | Mr. Porter.

#### THORPDALE WATERWORKS TRUST CONSTITUTED.

UNDER the powers conferred by the Water Acts and all other powers enabling him in that behalf, His Excellency the Governor of the State of Victoria, by and with the advice of the Executive Council of the said State, doth hereby approve of the application of the Councillors of the Shire of Narracan for the constitution of a Waterworks Trust, subject to the provisions of the said Acts, to construct, manage and maintain the works for the supply of water to the Township of Thorpdale, and doth hereby order and appoint as follows:—

1. That the name of the Trust shall be Thorpdale Waterworks Trust.

2. That the Commissioners of the Trust shall comprise six persons to be elected directly by the ratepayers of the proposed Waterworks Trust together with one other person appointed by the Governor in Council.

3. That the estimated cost of carrying out the proposed waterworks shall be Eleven thousand eight hundred pounds (£11,800).

4. That the principal works to be constructed or carried out by the Trust shall consist of a storage basin, pumping station, rising main, and reticulation mains at the Township of Thorpdale.

5. That the limits of the land within which the said Waterworks Trust shall have authority shall be those within the boundaries described in the Schedule hereto.

#### SCHEDULE.

##### PORTION I.

###### *Site of Off-take Weir.*

The site of the off-take weir shall be the land occupied by the said off-take weir on Easterbrook Creek in Crown allotment 138, Parish of Moe, County of Buln Buln.

##### PORTION II.

###### *Site of Pumping Station.*

The site of the pumping station shall be the land occupied by the said pumping station in Crown allotment 138, Parish of Moe, County of Buln Buln, adjacent to the off-take weir as described in Portion I.

##### PORTION III.

###### *Site of Rising Main.*

The site of the rising main being a strip of land 50 links in width being 25 links on each side of the centreline of the said rising main commencing at a point on the site of the pumping station as described in Portion II; thence generally south-easterly through Crown allotment 138, Parish of Moe, County of Buln Buln, to a point on the boundary of the Thorpdale Reticulation Area as described in Portion IV.

##### PORTION IV.

###### *Reticulation Area.*

Commencing at the intersection of the northern boundary of Graham-street, on lodged plan of subdivision No. 2393, being part of Crown allotment 82, Township of Thorpdale, Parish of Moe, County of Buln Buln, with the eastern boundary of Hamilton-street; thence southerly along the said eastern boundary of Hamilton-street to a point in line with the northern boundary of Railway-road; thence easterly by the prolongation of the said northern boundary of Railway-road to a point in line with the eastern boundary of Douglas-street, on lodged plan of subdivision No. 3387; thence southerly by a line through Crown allotments 82 and 138 and along the said eastern boundary of Douglas-street to a point on the southern boundary of Tait-street; thence westerly along the said southern boundary of Tait-street and by a line being the continuation thereof through Crown allotment 138 to a point on a line parallel to and distant 200 feet westerly from the western boundary of Thorpdale-road; thence by a line bearing north 7 deg. 42 min. east a distance of approximately 650 feet to a point on the southern boundary of Childers-road; thence westerly along the said southern boundary of Childers-road to a point in line with the centreline of the Moe-Thorpdale Railway; thence northerly by a line across a road and along the said centreline of the Moe-Thorpdale Railway to a point in line with the northern boundary of Graham-street; thence easterly by a line through Crown allotment 82, across Station-street and along the aforesaid northern boundary of Graham-street to its intersection with the eastern boundary of Hamilton-street being the point of commencement.

All of which boundaries are shown on a plan approved by the Governor in Council and deposited in the office of the State Rivers and Water Supply Commission, Melbourne.—(Corres. 59/8794/28.)

And the Honorable Wilfred John Mibus, Her Majesty's Minister of Water Supply for the State of Victoria, shall give the necessary directions herein accordingly.

N. G. WISHART,  
Clerk of the Executive Council.

## HOUSING ACT 1958.

At Government House, Melbourne, the seventh day of November, 1962.

PRESENT:

His Excellency the Governor of the State of Victoria.

Mr. Petty | Mr. Porter.

## CLOSING OF ROADS AND THE EXTINGUISHMENT OF AN EASEMENT.—SHIRE OF FRANKSTON..

WHEREAS by virtue and in exercise of the powers contained in the *Housing Act 1958* (No. 6275), the Housing Commission has recommended to the Governor in Council that the roads and easement described in the Schedule hereto be closed and extinguished:

Now therefore, His Excellency the Governor of the State of Victoria, in the Commonwealth of Australia, by and with the advice of the Executive Council of the said State, doth in pursuance of the powers conferred by the said Act and upon such recommendation, consent and by this Order hereby close and extinguish such roads and easement.

## SCHEDULE.

First.—So much of the roads shown coloured brown on plan of subdivision No. 2997, lodged in the Office of Titles, as is delineated and hachured on the plan hereunder.

Secondly.—The drainage easement affecting lot No. 3 on plan of subdivision No. 19280, lodged in the Office of Titles.

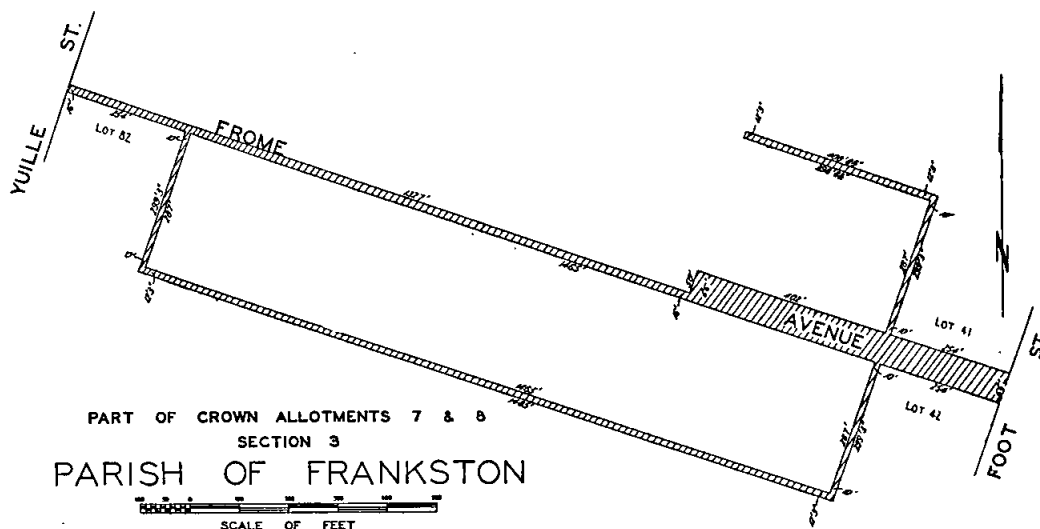

And the Honorable Lindsay Hamilton Simpson Thompson, Her Majesty's Minister of Housing for the State of Victoria, shall give the necessary directions herein accordingly.

N. G. WISHART,  
Clerk of the Executive Council.

## COUNTRY ROADS BOARD.

At Government House, Melbourne, the seventh day of November, 1962.

PRESENT:

His Excellency the Governor of Victoria.

Mr. Petty | Mr. Porter.

## ORDER APPROVING OF WIDENING AN EXISTING MAIN ROAD IN THE SHIRE OF DUNDAS.

WHEREAS the Country Roads Board constituted under the *Country Roads Act 1958* (No. 6229) has represented to His Excellency the Governor in Council that it appears to it desirable that the existing Macarthur-Penshurst road in the Shire of Dundas (declared to be a main road under the said Act which declaration was confirmed by the Order in Council published in the *Government Gazette* of the 2nd July, 1947, on page 3354) should be widened by the said Board: And whereas the said Board in accordance with the requirements of section 19 of the said cited Act has caused to be prepared a map plan and estimate showing the points between which and on and through what land the said widening is proposed to be made and the cost of acquiring the land: And whereas on an inspection of the said map and plan and a consideration of the said estimate His Excellency the Governor in Council is satisfied that there are funds

legally available for acquiring the land: Now therefore be it known by this present Order that His Excellency the Governor of the State of Victoria with the advice of the Executive Council thereof doth hereby approve of the said road being widened, that is to say:—

All those pieces of land in the Parish of Warrabkook, the boundaries of which are as follow:—

- (a) Commencing at the north-western angle of allotment 1A, section 6, of the said parish; thence by lines bearing respectively 90 deg. 0 min. 247.3 links, 250 deg. 19 min. 331.5 links and 210 deg. 7 min. 129.1 links to the point of commencement.
- (b) Commencing at an angle in the eastern boundary of allotment 2a, section 7, of the said parish, formed by the intersection of lines bearing 70 deg. 0 min. and 30 deg. 8½ min.; thence by lines bearing respectively 250 deg. 0 min. 500 links, 60 deg. 38 min. 478 links, 41 deg. 58 min. 379.8 links and 210 deg. 8½ min. 400 links to the point of commencement—

which said pieces of land are particularly delineated and shown coloured red on survey plan numbered 8640, lodged in the office of the Country Roads Board.

And the Honorable Horace Rostill Petty, Her Majesty's Commissioner of Public Works for the State of Victoria, shall give the necessary directions herein accordingly.

N. G. WISHART,  
Clerk of the Executive Council.



## COUNTRY ROADS BOARD.

At Government House, Melbourne, the  
seventh day of November, 1962.

PRESENT:

His Excellency the Governor of Victoria.  
Mr. Petty | Mr. Porter.

## ORDER APPROVING OF A DEVIATION FROM A MAIN ROAD IN THE SHIRE OF MYRTLEFORD.

WHEREAS the Country Roads Board constituted under the *Country Roads Act 1958* (No. 6229) has represented to His Excellency the Governor in Council that it appears to it desirable that the deviation hereinafter referred to from the existing Buffalo River-road in the Shire of Myrtleford (declared to be a main road under the said Act which declaration was confirmed by the Order in Council published in the *Government Gazette* of the 26th April 1939, on page 1388) should be made by the said Board: And whereas the said Board in accordance with the requirements of section 19 of the said cited Act has caused to be prepared a map plan and estimate showing the points between which and on and through what land the said deviation is proposed to be made and the cost of acquiring the land: And whereas on an inspection of the said map and plan and a consideration of the said estimate His Excellency the Governor in Council is satisfied that there are funds legally available for acquiring the land: Now therefore be it known by this present Order that His Excellency the Governor of the State of Victoria with the advice of the Executive Council thereof doth hereby approve of the said road being made, that is to say:—

All those pieces of land in the Parish of Eurandelong, the boundaries of which are as follow:—

- (a) Commencing at a point on the eastern boundary of allotment 5A, section 12, of the said parish, distant 200 deg. 16 min. 778.1 links from the north-eastern angle of the said allotment; thence by lines bearing respectively 200 deg. 16 min. 998.4 links, 14 deg. 8 min. 596.7 links and 29 deg. 12 min. 140.1 links to the point of commencement.
- (b) Commencing at a point on the northern boundary of allotment 6, section 12, of the said parish, distant 68 deg. 13 min. 204.3 links from the north-western angle of the said allotment; thence by lines bearing respectively 68 deg. 13 min. 175.1 links, 189 deg. 17 min. 494.8 links, 230 deg. 34 min. 745.5 links, 20 deg. 16 min. 297.4 links, 50 deg. 34 min. 432.2 links and 9 deg. 17 min. 347.9 links to the point of commencement.
- (c) Commencing at the south-western angle of allotment 3B, section 12, of the said parish; thence by lines bearing respectively 42 deg. 11 min. 339.6 links, 132 deg. 37 min. 165.2 links and 248 deg. 13 min. 376.5 links to the point of commencement—

which said pieces of land are particularly delineated and shown coloured red on survey plan numbered 8692, lodged in the office of the Country Roads Board.

And the Honorable Horace Rostill Petty, Her Majesty's Commissioner of Public Works for the State of Victoria, shall give the necessary directions herein accordingly.

N. G. WISHART,  
Clerk of the Executive Council.

## COUNTRY ROADS BOARD.

At Government House, Melbourne, the  
seventh day of November, 1962.

PRESENT:

His Excellency the Governor of Victoria.  
Mr. Petty | Mr. Porter.

## ORDER APPROVING OF WIDENING AN EXISTING MAIN ROAD IN THE SHIRE OF MIRBOO.

WHEREAS the Country Roads Board constituted under the *Country Roads Act 1958* (No. 6229) has represented to His Excellency the Governor in Council that it appears to it desirable that the existing Grand Ridge-road in the Shire of Mirboo (declared to be a main road

under the said Act which declaration was confirmed by the Order in Council published in the *Government Gazette* of the 23rd November, 1932, on page 2618) should be widened by the said Board: And whereas the said Board in accordance with the requirements of section 19 of the said cited Act has caused to be prepared a map plan and estimate showing the points between which and on and through what land the said widening is proposed to be made and the cost of acquiring the land: And whereas on an inspection of the said map and plan and a consideration of the said estimate His Excellency the Governor in Council is satisfied that there are funds legally available for acquiring the land: Now therefore be it known by this present Order that His Excellency the Governor of the State of Victoria with the advice of the Executive Council thereof doth hereby approve of the said road being widened, that is to say:—

All that piece of land in the Township of Mirboo North, Parish of Mirboo, the boundaries of which are as follow:— Commencing at a point on the northern boundary of allotment 39, section 3, of the said township distant 98 deg. 40 min. 67 ft. 11½ in. from the north-western angle of the said allotment; thence by lines bearing respectively 98 deg. 40 min. 59 ft. 4½ in., 130 deg. 15 min. 99 feet, 162 deg. 40 min. 58 ft. 1 in., 175 deg. 32 min. 16 ft. 11 in., 317 deg. 44 min. 92 ft. 6 in. and 310 deg. 15 min. 118 ft. 9½ in. to the point of commencement—which said piece of land is particularly delineated and shown coloured red on survey plan numbered 8688A, lodged in the office of the Country Roads Board.

And the Honorable Horace Rostill Petty, Her Majesty's Commissioner of Public Works for the State of Victoria, shall give the necessary directions herein accordingly.

N. G. WISHART,  
Clerk of the Executive Council.

## COUNTRY ROADS BOARD.

At Government House, Melbourne, the  
seventh day of November, 1962.

PRESENT:

His Excellency the Governor of Victoria.  
Mr. Petty | Mr. Porter.

## ORDER APPROVING OF WIDENING AN EXISTING MAIN ROAD IN THE SHIRE OF HEYTESBURY.

WHEREAS the Country Roads Board constituted under the *Country Roads Act 1958* (No. 6229) has represented to His Excellency the Governor in Council that it appears to it desirable that the existing Timboon-Nullawarre road in the Shire of Heytesbury (declared to be a main road under the said Act which declaration was confirmed by the Order in Council published in the *Government Gazette* of the 17th September, 1958, on page 3126) should be widened by the said Board: And whereas the said Board in accordance with the requirements of section 19 of the said cited Act has caused to be prepared a map plan and estimate showing the points between which and on and through what land the said widening is proposed to be made and the cost of acquiring the land: And whereas on an inspection of the said map and plan and a consideration of the said estimate His Excellency the Governor in Council is satisfied that there are funds legally available for acquiring the land: Now therefore be it known by this present Order that His Excellency the Governor of the State of Victoria with the advice of the Executive Council thereof doth hereby approve of the said road being widened, that is to say:—

All those pieces of land in the Parish of Timboon, the boundaries of which are as follow:—

- (a) Commencing at an angle in the north-eastern boundary of the existing Timboon-Nullawarre road through allotment 70A of the said parish, formed by the intersection of lines bearing 0 deg. 32 min. and 329 deg. 26 min.; thence by lines bearing respectively 158 deg. 20 min. 665 links, 140 deg. 16 min. 309.7 links, 131 deg. 48 min. 266.5 links, 307 deg. 36 min. 432.3 links, 316 deg. 30 min. 381.9 links, 341 deg. 4 min. 123.9 links and 0 deg. 32 min. 375.9 links to the point of commencement.
- (b) Commencing at an angle in the northern boundary of allotment 81A of the said parish formed by the intersection of lines bearing 290 deg. 48 min. and 268 deg. 0 min.; thence by lines bearing respectively 110 deg. 48 min. 198 links, 103 deg.

- 21 min. 334 links, 278 deg. 28 min. 484 links, 284 deg. 30 min. 272 links and 88 deg. 0 min. 232 links to the point of commencement.
- (c) Commencing at an angle in the northern boundary of allotment 81A of the said parish, formed by the intersection of lines bearing 72 deg. 54 min. and 40 deg. 16 min.; thence by lines bearing respectively 40 deg. 16 min. 344 links, 88 deg. 0 min. 146 links, 222 deg. 36 min. 202.2 links and 242 deg. 50 min. 260 links to the point of commencement.
- (d) Commencing at the south-eastern angle of allotment 81B of the said parish; thence by lines bearing respectively 275 deg. 22 min. 59 links, 277 deg. 59 min. 377 links, 283 deg. 21 min. 323 links, 296 deg. 21 min. 131 links, 102 deg. 42 min. 442 links, 99 deg. 28 min. 405 links, 93 deg. 28 min. 33.2 links and 179 deg. 57 min. 24.7 links to the point of commencement.
- (e) Commencing at the south-western angle of allotment 80G of the said parish; thence by lines bearing respectively 0 deg. 13 min. 27.5 links, 93 deg. 44 min. 313 links, 246 deg. 58 min. 76.5 links and 275 deg. 25 min. 243 links to the point of commencement.
- (f) Commencing at a point on the northern boundary of allotment 80G<sup>(1)</sup> of the said parish distant 95 deg. 25 min. 259 links from the north-western angle of the said allotment; thence by lines bearing respectively 66 deg. 58 min. 223 links, 105 deg. 32 min. 131 links, 135 deg. 16 min. 149 links and 277 deg. 0 min. 439.5 links to the point of commencement.
- (g) Commencing at the north-eastern angle of allotment 80G<sup>(1)</sup> of the said parish; thence by lines bearing respectively 126 deg. 53 min. 222.1 links, 158 deg. 39 min. 409 links, 143 deg. 19 min. 96.5 links, 283 deg. 8 min. 21.8 links, 311 deg. 28 min. 161.6 links, 332 deg. 46 min. 419.5 links, 318 deg. 50 min. 211 links, 300 deg. 10 min. 257 links, 110 deg. 23 min. 147 links and 126 deg. 53 min. 217 links to the point of commencement—

which said pieces of land are particularly delineated and shown coloured red and yellow on survey plans numbered 8612, 8613, 8614 and 8615, lodged in the office of the Country Roads Board.

And the Honorable Horace Rostill Petty, Her Majesty's Commissioner of Public Works for the State of Victoria, shall give the necessary directions herein accordingly.

N. G. WISHART,  
Clerk of the Executive Council.

#### COUNTRY ROADS BOARD.

At Government House, Melbourne, the  
seventh day of November, 1962.

#### PRESENT:

His Excellency the Governor of Victoria.  
Mr. Petty | Mr. Porter.

#### ORDER APPROVING THE MAKING OF A BY-PASS IN THE SHIRE OF CRANBOURNE.

#### WHEREAS:

I. Section 114 of the *Country Roads Act* 1958 (herein called "the Act") provides (*inter alia*) in—

- (a) sub-section (1) thereof that the powers conferred upon municipal councils by Division fourteen of Part XIX. of the *Local Government Act* 1958 shall so far as applicable be conferred upon the Country Roads Board (herein called "the Board") so far as relates to the declaration of the alignment the widening and opening up of by-pass roads and that the provisions of the said Division shall with certain modifications extend and apply accordingly; and
- (b) sub-section (2) thereof that no by-pass road shall be widened or opened up pursuant to the said section unless the Governor in Council has by Order published in the *Government Gazette* approved such widening or opening up.

II. Section 101 of the Act provides (*inter alia*) that for the purposes of Part VII. of the Act sections 19 to 21 of the Act shall so far as applicable and with such adaptations as are necessary extend and apply with respect to by-pass roads.

#### III. The Board has—

- (a) in exercise of the powers conferred upon it by the said section 114 and for the purpose of opening up a by-pass road in the Shire of Cranbourne under the name "Dingley By-pass road" by Resolution dated the twenty-first day of August, 1961, fixed alignments for each side of the said road;
- (b) in accordance with the provisions of section 19 of the Act caused to be prepared a map, plan and estimate showing—
- (i) the points between which and the lands on and through which the said road is proposed to be made; and
- (ii) the cost of acquiring the land.

IV. The Governor in Council is satisfied that there are funds legally available for acquiring the said land.

Now therefore, His Excellency the Governor of the State of Victoria, with the advice of the Executive Council thereof by this Order approves, for the purposes of section 20 (as applied by the said section 101) and of section 114 of the Act, the acquisition of the said land (being the land described in the Schedule hereto) and the making of the said road.

#### SCHEDULE.

All that piece of land in the Parish of Eumemmerring, the boundaries of which are as follow:—Commencing at the north-eastern angle of allotment 20, section 25, of the said parish; thence by lines bearing respectively 358 deg. 55½ min. 34 ft. 2 in., 131 deg. 50 min. 465 ft. 1½ in., 127 deg. 15 min. 465 ft. 7 in., 121 deg. 26 min. 367 feet, 114 deg. 50 min. 475 feet, 107 deg. 25 min. 562 feet, 103 deg. 39 min. 593 ft. 1 in., 105 deg. 22 min. 509 ft. 11½ in., 102 deg. 7 min. 302 feet, 83 deg. 40 min. 295 feet, 65 deg. 31 min. 238 ft. 6 in., 46 deg. 20 min. 242 ft. 1½ in., 24 deg. 23 min. 333 feet, 180 deg. 52½ min. 1,536 ft. 10 in., 323 deg. 58 min. 309 feet, 303 deg. 9 min. 251 ft. 4 in., 292 deg. 48 min. 203 feet, 291 deg. 0 min. 977 ft. 4 in., 288 deg. 25 min. 636 feet, 286 deg. 7 min. 346 ft. 3 in., 285 deg. 23 min. 224 ft. 2 in., 293 deg. 8 min. 505 ft. 10 in., 297 deg. 55 min. 418 ft. 9 in., 306 deg. 21 min. 440 ft. 6 in., 311 deg. 50 min. 430 ft. 3 in., and 358 deg. 55½ min. 274 ft. 9½ in. to the point of commencement—which said piece of land is particularly delineated and shown coloured red and yellow on survey plan numbered 8008, lodged in the office of the Country Roads Board.

And the Honorable Horace Rostill Petty, Her Majesty's Commissioner of Public Works for the State of Victoria, shall give the necessary directions herein accordingly.

N. G. WISHART,  
Clerk of the Executive Council.

#### COUNTRY ROADS BOARD.

At Government House, Melbourne, the  
seventh day of November, 1962.

#### PRESENT:

His Excellency the Governor of Victoria.  
Mr. Petty | Mr. Porter.

#### ORDER APPROVING OF A DEVIATION FROM A MAIN ROAD IN THE SHIRE OF STAWELL.

WHEREAS the Country Roads Board constituted under the *Country Roads Act* 1958 (No. 6229) has represented to His Excellency the Governor in Council that it appears to it desirable that the deviation hereinafter referred to from the existing Landsborough-road in the Shire of Stawell (declared to be a main road under the said Act which declaration was confirmed by the Order in Council published in the *Government Gazette* of the 19th February, 1941, on page 909) should be made by the said Board: And whereas the said Board in accordance with the requirements of section 19 of the said cited Act has caused to be prepared a map plan and estimate showing the points between which and on and through what land the said deviation is proposed to be made and

the cost of acquiring the land: And whereas on an inspection of the said map and plan and a consideration of the said estimate His Excellency the Governor in Council is satisfied that there are funds legally available for acquiring the land: Now therefore be it known by this present Order that His Excellency the Governor of the State of Victoria with the advice of the Executive Council thereof doth hereby approve of the said road being made, that is to say:—

All those pieces of land in the Parish of Stawell, the boundaries of which are as follow:—

- (a) Commencing at the south-western angle of allotment 79 of the said parish; thence by lines bearing respectively 6 deg. 15 min. 134.7 links, 91 deg. 14 min. 634.3 links and 259 deg. 30 min. 660 links to the point of commencement.
- (b) Commencing at the southern angle of allotment 15c of the said parish; thence by lines bearing respectively 316 deg. 11 min. 328.7 links, 103 deg. 52 min. 292.7 links, 186 deg. 10 min. 154.3 links and 251 deg. 11 min. 42.2 links to the point of commencement.
- (c) Commencing at the north-eastern angle of allotment 18 of the said parish; thence by lines bearing respectively 89 deg. 30 min. 25.5 links, 103 deg. 52 min. 1,241.2 links, 136 deg. 9 min. 374.5 links, 283 deg. 52 min. 989.2 links, 181 deg. 27 min. 176.7 links, 331 deg. 48 min. 197.4 links, 283 deg. 52 min. 1,249.4 links and 89 deg. 30 min. 780.5 links to the point of commencement—

which said pieces of land are particularly delineated and shown coloured red and yellow on survey plan numbered 8828, lodged in the office of the Country Roads Board.

And the Honorable Horace Rostill Petty, Her Majesty's Commissioner of Public Works for the State of Victoria, shall give the necessary directions herein accordingly.

N. G. WISHART,  
Clerk of the Executive Council.

#### COUNTRY ROADS BOARD.

*At Government House, Melbourne, the seventh day of November, 1962.*

PRESENT:

His Excellency the Governor of Victoria.  
Mr. Petty | Mr. Porter.

#### ORDER APPROVING OF WIDENING AN EXISTING STATE HIGHWAY IN THE SHIRE OF McIVOR.

WHEREAS the Country Roads Board constituted under the *Country Roads Act 1958* (No. 6229) has represented to His Excellency the Governor in Council that it appears to it desirable that the existing Northern Highway in the Shire of McIvor (declared to be a State highway under the said Act which declaration was confirmed by the Order in Council published in the *Government Gazette* of the 31st January, 1945, on page 252) should be widened by the said Board; And whereas the said Board in accordance with the requirements of section 19 of the said cited Act has caused to be prepared a map plan and estimate showing the points between which and on and through what land the said widening is proposed to be made and the cost of acquiring the land: And whereas on an inspection of the said map and plan and a consideration of the said estimate His Excellency the Governor in Council is satisfied that there are funds legally available for acquiring the land: Now therefore be it known by this present Order that His Excellency the Governor of the State of Victoria with the advice of the Executive Council thereof doth hereby approve of the said highway being widened, that is to say:—

All those pieces of land in the Parish of Knowsley East, the boundaries of which are as follow:—

- (a) Commencing at the western angle of allotment 20 of the said parish; thence by lines bearing respectively 7 deg. 58 min. 250 links, 167 deg. 55 min. 469.7 links and 327 deg. 52 min. 250 links to the point of commencement.
- (b) Commencing at the north-eastern angle of allotment 24E of the said parish; thence by lines bearing respectively 149 deg. 54 min. 490.8 links, 189 deg. 34 min. 664 links, 231 deg. 52½ min. 465.3 links, 344 deg. 43 min. 967.5 links, 341 deg. 43 min. 552.2 links, 331 deg. 49 min. 532.4

links, 321 deg. 29½ min. 423.2 links and 127 deg. 13 min. 1,473.6 links to the point of commencement.

Also all that piece of land in the Parish of Crosbie, the boundaries of which are as follow:—

Commencing at the south-eastern angle of allotment 15, section C, of the said parish; thence by lines bearing respectively 270 deg. 2 min. 27 links, 355 deg. 32 min. 517.8 links, 339 deg. 52 min. 600 links, 154 deg. 27 min. 684 links, and 182 deg. 37 min. 463 links to the point of commencement—

which said pieces of land are particularly delineated and shown coloured red and yellow on survey plans numbered 8778 and 8812, lodged in the office of the Country Roads Board.

And the Honorable Horace Rostill Petty, Her Majesty's Commissioner of Public Works for the State of Victoria, shall give the necessary directions herein accordingly.

N. G. WISHART,  
Clerk of the Executive Council.

#### WATER ACTS.

*At Government House, Melbourne, the thirteenth day of November, 1962.*

PRESENT:

His Excellency the Governor of Victoria.  
Mr. Turnbull | Mr. Reid.  
Mr. Hamer

#### GEMBROOK, COCKATOO, AND EMERALD WATERWORKS TRUST CONSTITUTED.

UNDER the powers conferred by the Water Acts and all other powers enabling him in that behalf, His Excellency the Governor of the State of Victoria, by and with the advice of the Executive Council of the said State, doth hereby approve of the application of the Councillors of the Shires of Fern Tree Gully and Berwick for the constitution of a Waterworks Trust, subject to the provisions of the said Acts, to construct, manage and maintain the works for the supply of water to the Townships of Gembrook, Cockatoo and Emerald, and doth hereby order and appoint as follows:—

1. That the name of the Trust shall be Gembrook, Cockatoo and Emerald Waterworks Trust.
2. That the Commissioners of the Trust shall comprise three members to be elected by the Fern Tree Gully Shire Council, and three members elected by the Berwick Shire Council, together with one other person appointed by the Governor in Council.
3. That the estimated cost of carrying out the proposed waterworks shall be Two hundred and fifty thousand pounds (£250,000).
4. That the principal works to be constructed or carried out by the Trust shall consist of an offtake weir, approximately 18 miles of main pipeline, two service basins, and the reticulation of the Townships of Gembrook, Cockatoo, and Emerald.
5. That the limits of the land within which the said Waterworks Trust shall have authority shall be those within the following boundaries:—

##### *Portion 1.—Site of Catchment Area.*

Commencing at a point on the northern boundary of Crown allotment 17, Parish of Beenak, County of Evelyn, such point being 1,000 links westerly from the north-eastern angle of the said Crown allotment 17; thence easterly along the northern boundaries of the said Crown allotment 17 and of Crown allotments 18 and 19, a Permanent Forest Reserve, and Crown allotment 23<sup>a</sup> to the north-eastern angle of the said Crown allotment 23<sup>a</sup>; thence southerly along the eastern boundary of the said Crown allotment 23<sup>a</sup> to a point on the northern boundary of Crown allotment 22; thence easterly along the northern boundary of the said Crown allotment 22 to its north-eastern angle; thence generally southerly and south-westerly along the western boundaries of the said Crown allotment 22 and of Crown allotments 21 and 20 to the south-western angle of the said Crown allotment 20; thence south-westerly by a line across a road to the south-eastern angle of Crown allotment 86<sup>e</sup>; thence westerly and south-westerly along the south-eastern boundary of the said Crown allotment 86<sup>e</sup> to its southernmost angle, by a line across a road to the

easternmost angle of Crown allotment 1, section 1A, and along the south-eastern boundaries of the said Crown allotment 1 and of Crown allotments 2, 3, 4, 5 and 6 to the southernmost angle of the said Crown allotment 6; thence north-westerly along the south-western boundaries of Crown allotments 6A, 5A and a water reserve to the westernmost angle of the said reserve; thence generally westerly along the southern boundary of the aforesaid Crown allotment 86E and Crown allotment 86D to its south-western angle; thence northerly, easterly and north-easterly along the western and north-western boundary of the said Crown allotment 86D to its northernmost angle; thence northerly by a line across McCraes Creek Reserve to the most south-western angle of Crown allotment 18; thence generally westerly along the southern boundary of Crown allotment 17 to a point on a line parallel to and distant 1,000 links westerly from the eastern boundary of the said Crown allotment 17; thence northerly by the said line through the said Crown allotment 17 to a point on its northern boundary being the point of commencement.

*Portion II.—Site of Supply Main.*

The site of the supply main being a strip of land 50 links in width, being 25 links on each side of the centre-line of the said supply main, commencing at the northernmost angle of Crown allotment 86D, Parish of Beenak, County of Evelyn, being a point on the western boundary of the catchment area as described in Portion I; thence generally westerly through the McCraes Creek Reserve, Crown allotments 83, 83C, 83A, and across a road; thence north-westerly and south-westerly through the Township of Beenak; thence generally southerly and south-westerly across a road, through Crown allotments 4 and 89E, across a road, through Crown allotment 90C, across a road, through Crown allotments 90A, 90B, Crown allotments 1 and 102, Parish of Gembrook, across a road, through Crown allotment 103, across a road, through a Permanent Forest Reserve, across a road, through Crown allotments 15 and 14 to a point on the eastern boundary of the Waterworks District as described in Portion III.

*Portion III.—Waterworks District.*

Commencing at the north-eastern angle of lot 3 on lodged plan of subdivision No. 4383, Parish of Gembrook, County of Evelyn; thence easterly by a line across a road, along the southern boundary of lot 5 on lodged plan of subdivision No. 7641, Township of Emerald, across a road and along the southern boundary of lot 6 to its south-eastern angle; thence northerly along the eastern boundaries of the said lot 6 and of lot 7 to the south-western angle of Crown allotment 20, section A; thence easterly along the southern boundary of the said Crown allotment 20 to a point on the western boundary of Crown allotment 13; thence northerly along the said western boundary of Crown allotment 13 to its north-western angle; thence easterly along the northern boundary of the said Crown allotment 13 to the south-western angle of Crown allotment 14; thence northerly along the western boundary of the said Crown allotment 14 and by a line being the continuation thereof across a road to a point on the southern boundary of Crown allotment 54, Parish of Gembrook; thence easterly along the southern boundary of the said Crown allotment 54 to its south-eastern angle; thence south-easterly by a line across a road to the westernmost angle of Crown allotment 53A; thence south-easterly and southerly along the south-western and western boundaries of the said Crown allotment 53A to the north-western angle of lot 1 on lodged plan of subdivision No. 36226; thence generally north-easterly along the north-western boundaries of the said lot 1 and of lots 2 and 12 to the northernmost angle of the said lot 12, being a point on the eastern boundary of Crown allotment 53A; thence southerly along the said eastern boundary of Crown allotment 53A to the southernmost angle of lot 1 on lodged plan of subdivision No. 26904; thence north-easterly along the south-eastern boundaries of the said lot 1 and of lot 2 to the south-western angle of the said lot 3; thence easterly along the southern boundary of the said lot 3, by a line across a road and along the southern boundary of lot 5 and by a line being the continuation thereof through Crown allotment 53 to a point on the western boundary of plan of survey J/581; thence northerly along the said western boundary of plan of survey J/581 to its north-western angle; thence easterly along the northern boundary of the said plan of survey No. J/581 to a point on the western boundary of plan of survey No. G/334; thence northerly along the said western boundary of plan of survey No. G/334 to its north-western angle; thence easterly along the northern boundary of the said plan of survey No. G/334 to its north-eastern angle; thence north-westerly along the eastern boundary of Crown allotment 40E, Parish of Nangana, to a point in line with the

northern boundary of lot 22 on lodged plan of subdivision No. 9558; thence easterly by a line across a road and along the northern boundaries of the said lot 22 and of lots 21, 20, 19, 18, 17, 16 and 15, and by a line being the continuation thereof across a road to a point on the western boundary of Crown allotment 55, Parish of Gembrook; thence southerly along the said western boundary of Crown allotment 55 to the north-western angle of lot 10 on lodged plan of subdivision No. 10294; thence south-easterly along the north-eastern boundary of the said lot 10 and of lot 11 by a line across a road and along the south-western boundary of the land shown on lodged plan of subdivision No. 51616 to its south-eastern angle; thence north-easterly along the south-eastern boundary of the aforesaid Crown allotment 55 to a point in line with the north-eastern boundary of lot 1 on lodged plan of subdivision No. 5939; thence south-easterly by a line across a road and along the said north-eastern boundary of lot 1, by a line across a road and along the north-eastern boundary of lot 25 to its easternmost angle; thence south-westerly along the south-eastern boundaries of the said lot 25 and of lots 24, 23, 22, 21, 20, 19, 18, 17 and 16 to the south-eastern angle of the said lot 16, being a point on the south-western boundary of Crown allotment 56; thence south-easterly along the south-western boundaries of the said Crown allotment 56 and of Crown allotment 60A to the southernmost angle of the said Crown allotment 60A; thence generally north-easterly along the south-eastern boundary of the said Crown allotment 60A to a point in line with the south-western boundary of Crown allotment 62B; thence south-easterly by a line across a road and along the said south-western boundary of Crown allotment 62B to a point on the north-western boundary of Crown allotment 63; thence south-westerly along the said north-western boundary of Crown allotment 63 to its westernmost angle; thence south-easterly along the south-western boundaries of the said Crown allotment 63 and of Crown allotment 63A to the southernmost angle of the said Crown allotment 63A; thence south-easterly by a line across the Cockatoo Creek Reserve to the westernmost angle of lot 23 on lodged plan of subdivision No. 7753, being a point on the north-western boundary of Crown allotment 127E; thence generally north-easterly along the said north-western boundary of Crown allotment 127E and by a line being the continuation thereof across a road to a point on the right boundary of the said Cockatoo Creek Reserve; thence generally south-easterly and north-easterly along the said right boundary of the Cockatoo Creek Reserve to a point on a line parallel to and distant 500 links northerly from the southern boundary of Crown allotment 6; thence easterly by the said line across the aforesaid Cockatoo Creek Reserve through the said Crown allotment 6 and Crown allotment 123B<sup>2</sup> to a point in line with the western boundary of Crown allotment 127B; thence generally southerly by a line through the said Crown allotment 123B<sup>2</sup>, across a road, along the western boundary of Crown allotment 127B and the western and south-western boundaries of Crown allotment 125A to its southernmost angle; thence generally north-easterly and easterly along the south-eastern boundary of Crown allotment 125B to its south-eastern angle; thence generally south-easterly along the south-western boundaries of Crown allotment 125C and Crown allotment 86 and by a line across a road to the southernmost angle of Crown allotment 86B; thence easterly along the southern boundary of the said Crown allotment 86B to its south-eastern angle; thence north-easterly by a line across a road to the south-western angle of Crown allotment A13; thence south-easterly along the south-western boundary of the said Crown allotment A13 to its southernmost angle; thence easterly along the southern boundary of lot 2 on lodged plan of subdivision No. 4229 and by a line being the continuation thereof across a road to a point on the western boundary of Crown allotment 72; thence southerly along the said western boundary of Crown allotment 72 to its south-western angle; thence south-easterly along the south-western boundary of lot 4 on lodged plan of subdivision No. 4229 by a line across the Fern Tree Gully-Gembrook Railway Reserve to a point on its southern boundary; thence generally easterly along the said southern boundary of the railway reserve to a point in line with the western boundary of lot 29 on lodged plan of subdivision No. 4229; thence northerly by a line across the said railway reserve and a road and along the western boundaries of the said lot 29 and of Crown allotment 93B to its north-western angle; thence generally north-easterly along the northern boundary of the said Crown allotment 93B and by a line being the continuation thereof across a road to a point on the north-western boundary of Crown allotment 96A; thence generally south-westerly along the said north-western boundary of Crown allotment 96A to its south-western angle; thence south-easterly along the south-western boundary of the said Crown allotment 96A by a line

across a mining reserve, along the south-western boundary of Crown allotment 96A and by a line being the continuation thereof across a road to a point on the western boundary of Crown allotment 98; thence south-westerly along the said north-western boundary of Crown allotment 98 to its westernmost angle; thence south-easterly along the south-western boundary of the said Crown allotment 98 and by a line being the continuation thereof across a road to a point on the north-western boundary of Crown allotment 14; thence south-westerly along the said north-western boundary of Crown allotment 14 and by a line being the continuation thereof to a point on the south-eastern boundary of a road, *Gazette* 93-4422; thence generally south-westerly along the south-eastern boundary of the said road and by a line being the continuation thereof across a road to a point on the north-eastern boundary of Crown allotment 25; thence generally northerly by a line across a road and along the eastern boundaries of Crown allotments 27, 28, 29, 30, 31 and 32A to the easternmost angle of the said Crown allotment 32A; thence westerly along the southern boundary of Crown allotment A10 by a line across a road and along the southern boundary of Crown allotment A11 to its south-western angle; thence southerly along the western boundary of a Public Park Reserve and by a line being the continuation thereof to a point in line with the northern boundary of lot 41 on lodged plan of subdivision No. 9547; thence generally westerly by a line across a road and along the northern boundary of the said lot 41 and of lot 42 to the north-western angle of the said lot 42; thence by a line across a road and through lot 47 to a point on its northern boundary such point being 867.1 links from the north-western angle of the said lot 47; thence westerly along the northern boundary of the said lot 47 and by a line being the continuation thereof across a road to a point on the north-eastern boundary of lot 46; thence north-westerly along the said north-eastern boundary of lot 46 and by a line being the continuation thereof through the said lot 46, across a road and through lot 51 to a point on the southern boundary of the Fern Tree Gully-Gembrook Railway Reserve; thence generally north-westerly along the southern boundary of the said railway reserve to a point on the eastern boundary of Crown allotment 126L; thence southerly and westerly along the eastern and southern boundaries of the said Crown allotment 126L to a point on the southern boundary of the aforesaid Fern Tree Gully-Gembrook Railway Reserve; thence generally south-westerly along the said southern boundary of the railway reserve to the westernmost angle of Crown allotment 126H; thence easterly along the southern boundary of the said Crown allotment 126H to its south-eastern angle; thence southerly by a line across a road to the north-western angle of lot 3 on lodged plan of subdivision No. 4539; thence southerly and easterly along the western and southern boundaries of the said lot 3 to a point in line with the eastern boundary of lot 6B; thence southerly by a line across a road and along the said eastern boundary of lot 6B to its south-eastern angle being a point on the centreline of the Cockatoo Creek; thence generally north-westerly along the said centreline of the Cockatoo Creek and along the northern boundary of Crown allotment 78 to a point on the eastern boundary of Crown allotment 79; thence generally northerly along the said eastern boundary of Crown allotment 79 to its northernmost angle; thence by a line south-westerly along the south-eastern boundaries of lots 22, 23, 59, 60, 89, 90 and 110 to the southernmost angle of the said lot 110; thence north-westerly along the south-western boundaries of the said lot 110 and of lots 109, 108, 107, 106, 105, 104, 103 and 102 and by a line being the continuation thereof across a road and through lot 3 on lodged plan of subdivision No. 27146 to a point on a line parallel to and distant 260 links from the eastern boundary of the said Crown allotment 3; thence generally northerly, north-westerly and south-westerly by lines parallel to and distant 260 links from the eastern, north-eastern and north-western boundaries of the lands shown on the said lodged plan of subdivision No. 27146, through the said lands shown on lodged plan of subdivision No. 27146 to the easternmost angle of lot 29 on lodged plan of subdivision No. 56036; thence south-westerly along the south-eastern boundaries of the said lot 29 and of lots 30, 31, 32, 33, 34 and 35 to the southernmost angle of the said lot 35; thence south-westerly by a line across a road to the easternmost angle of lot 36; thence southerly along the eastern boundary of the said lot 36 to its south-eastern angle; thence westerly along the southern boundaries of the said lot 36 and of lots 37, 38, 39 and 43 and by a line being the continuation thereof across a road and along the northern boundary of Crown allotment 35 and by a line being the continuation thereof, across a road and along the southern boundary of Crown allotment B, Parish of Gembrook, County of Mornington, to a point on a line parallel to and distant 500 links south-

westerly from the north-eastern boundary of the said Crown allotment B; thence north-easterly by the said line through the said Crown allotment B to a point on its northern boundary; thence generally easterly along the said northern boundary of Crown allotment B to the easternmost angle of lot 62 on lodged plan of subdivision No. 5068, Parish of Gembrook, County of Evelyn; thence by a line north-westerly along the north-eastern boundaries of the said lot 62 and of lots 63, 64, 65, 66, 67, 68, 69, 70, 71, 72, 73, 74 and 49, and by a line being the continuation thereof across a road to a point on the south-eastern boundary of Crown allotment 21; thence north-easterly along the said south-eastern boundary of Crown allotment 21 and by a line being the continuation thereof across a road to a point on the southern boundary of Crown allotment 18; thence south-easterly and north-easterly along the said southern boundary of Crown allotment 18 to its easternmost angle; thence north-easterly along the south-eastern boundaries of Crown allotments 31, 30, 29, 28, 27 and 26, Township of Cockatoo, to the easternmost angle of the said Crown allotment 26; thence north-easterly, northerly and north-westerly along the south-eastern and north-eastern boundaries of Crown allotments 25 and 24 to a point on the north-eastern boundary of the said Crown allotment 24 in line with the south-eastern boundary of Crown allotment 23; thence north-easterly by a line across a road and along the south-eastern boundary of the said Crown allotment 23 and of Crown allotments 22, 21 and 20 to the easternmost angle of the said Crown allotment 20; thence north-westerly along the north-eastern boundaries of the said Crown allotment 20 and Crown allotments 19 and 18 to the northernmost angle of the said Crown allotment 18; thence westerly along the southern boundary of Crown allotment 61, Parish of Gembrook, County of Evelyn, to its southernmost angle; thence north-westerly along the south-western boundary of the said Crown allotment 61 to the easternmost angle of Crown allotment 59; thence westerly and south-westerly along the southern boundary of the said Crown allotment 59 to the north-eastern angle of Crown allotment 59B; thence westerly along the southern boundary of the said Crown allotment 59B and of Crown allotment 58B by a line across a reserve and along the southern boundaries of Crown allotments 58A and Crown allotment 1 to a point on the eastern boundary of Crown allotment 52; thence north-easterly along the said eastern boundary of Crown allotment 52 by a line across the aforesaid railway reserve to a point on its north-eastern boundary; thence north-westerly, westerly and south-westerly along the north-eastern, northern and north-western boundaries of the said railway reserve to the easternmost angle of lot 64 on lodged plan of subdivision No. 13262; thence south-westerly and north-westerly along the northern boundary of the said lot 64 and by a line being the continuation thereof across a road to a point on the south-eastern boundary of lot 53; thence north-easterly along the south-eastern boundaries of the said lot 53 and of lot 54 to the easternmost angle of the said lot 54; thence north-westerly along the north-eastern boundary of the said lot 54 to its northernmost angle; thence generally westerly along the north-western boundaries of the said lot 54 and of lots 53, 52, 51, 50, 49, 48, 47, 46, 45, 44, 43 and 42 to the north-western angle of the said lot 42; thence southerly along the western boundaries of the said lot 42 and of lot 89 and by a line being the continuation thereof across a road and the aforesaid railway reserve to a point on its southern boundary; thence generally south-easterly and southerly along the southern and western boundaries of the railway reserve to the northernmost angle of lot 44 on lodged plan of subdivision No. 13266, and by a line being the continuation thereof across a road to a point on the north-eastern boundary of lot 2 on lodged plan of subdivision No. 11961; thence generally south-easterly along the said north-eastern boundary of lot 2 to its easternmost angle; thence westerly along the northern boundary of lot 3 to a point on the western boundary of Crown allotment 44; thence southerly along the said western boundary of Crown allotment 44 to a point in line with the southern boundary of Crown allotment 45; thence westerly by a line across a road and along the said southern boundary of Crown allotment 45 by a line across a road and along the northern boundaries of Crown allotments 49A, 141B, 141D and 141A to the south-western angle of lot 58 on lodged plan of subdivision No. 11259; thence northerly along the western boundary of lot 58, along the boundary of a road and along the western boundaries of lots 57, 56, 55, 54, 53 and 46, by a line being the continuation thereof across a road to a point on the north-western boundary of Westland-road; thence north-easterly along the said north-western boundary of Westland-road to the easternmost angle of lot 6, section B, Township of Emerald; thence north-westerly along the north-eastern boundary of the said lot 6 to the northernmost angle, being a point

on the western boundary of the Township of Emerald; thence generally northerly along the said township boundary to the north-eastern angle of lot 3 on lodged plan of subdivision No. 4383, being the point of commencement—all of which boundaries are shown on plans marked "A", "B", and "C" approved by the Governor in Council and deposited in the office of the State Rivers and Water Supply Commission, Melbourne (Corres. 60/6606/29).

And the Honorable Wilfred John Mibus, Her Majesty's Minister of Water Supply for the State of Victoria, shall give the necessary directions herein accordingly.

N. G. WISHART,  
Clerk of the Executive Council.

#### WARRAGUL SEWERAGE AUTHORITY.

*At Government House, Melbourne, the thirteenth day of November, 1962.*

PRESENT:

His Excellency the Governor of Victoria.	
Mr. Turnbull	Mr. Reid.
Mr. Hamer	

#### CONSENT TO BORROWING £15,000.

UNDER the powers conferred by the Sewerage Districts Acts and all other powers enabling him in that behalf, His Excellency the Governor of the State of Victoria, by and with the advice of the Executive Council of the said State, doth hereby consent to the Warragul Sewerage Authority borrowing by the assignment of the General Fund the sum of Fifteen thousand pounds (£15,000) to meet the cost of sewerage works as set forth in the detailed statement bearing date 9th November, 1962.

And the Honorable Wilfred John Mibus, Her Majesty's Minister of Water Supply for the State of Victoria, shall give the necessary directions herein accordingly.

N. G. WISHART,  
Clerk of the Executive Council.

#### WODONGA SEWERAGE AUTHORITY.

*At Government House, Melbourne, the thirteenth day of November, 1962.*

PRESENT:

His Excellency the Governor of Victoria.	
Mr. Turnbull	Mr. Reid.
Mr. Hamer	

#### CONSENT TO BORROWING £25,000.

UNDER the powers conferred by the Sewerage Districts Acts and all other powers enabling him in that behalf, His Excellency the Governor of the State of Victoria, by and with the advice of the Executive Council of the said State, doth hereby consent to the Wodonga Sewerage Authority borrowing by the assignment of the General Fund the sum of Twenty-five thousand pounds (£25,000) to meet the cost of sewerage works as set forth in the detailed statement bearing date the 9th November, 1962.

And the Honorable Wilfred John Mibus, Her Majesty's Minister of Water Supply for the State of Victoria, shall give the necessary directions herein accordingly.

N. G. WISHART,  
Clerk of the Executive Council.

#### LANDLORD AND TENANT ACT 1958.

*At Government House, Melbourne, the thirteenth day of November, 1962.*

PRESENT:

His Excellency the Governor of Victoria.	
Mr. Turnbull	Mr. Reid.
Mr. Hamer	

#### ORDER EXCLUDING CERTAIN PREMISES FROM THE OPERATION OF CERTAIN PROVISIONS OF PART V. OF THE LANDLORD AND TENANT ACT 1958.

IN pursuance of the powers conferred by section 44 of the *Landlord and Tenant Act 1958*, His Excellency the Governor of the State of Victoria, by and with the advice of the Executive Council thereof, doth hereby declare that the following premises shall be excluded from the operation of the whole of the provisions contained in Divisions 2 and 3 of Part V. of the Act, viz.:

The premises known as "Roslyn" in Toorac-road, Upwey.

And the Honorable Arthur Gordon Rylah, Her Majesty's Attorney-General for the State of Victoria, shall give the necessary directions herein accordingly.

N. G. WISHART,  
Clerk of the Executive Council.

#### STATE ELECTRICITY COMMISSION ACTS.

*At Government House, Melbourne, the thirteenth day of November, 1962.*

PRESENT:

His Excellency the Governor of Victoria.	
Mr. Turnbull	Mr. Reid.
Mr. Hamer	

#### ELECTRICITY SUPPLY.—BEULAH.

WHEREAS the President, Councillors and Ratepayers of the Shire of Karkaroc on the 14th day of October, 1962, applied to the State Electricity Commission of Victoria for the supply of electricity by the Commission pursuant to section 45 of the *State Electricity Commission Act 1958* in bulk or otherwise to persons and bodies of persons corporate or unincorporate other than undertakers or public statutory corporations in the area in and near the Township of Beulah, being the area in which the Shire of Karkaroc is for the time being authorized to supply electricity by virtue of an Order in Council made under the *Electric Light and Power Act 1958* and cited as the Shire of Karkaroc Lighting Order No. 72-1912: And whereas the Commission has made the enquiry, determination and report in sub-section 3 of the said section 45 referred to: And whereas the Commission upon such enquiry is satisfied that the probable demand for electricity within the said area will be such that the annual revenue obtainable from the supply of electricity according to the scale of charges determined by it as by that section required will be sufficient to pay the annual cost to the Commission of or incidental to the supply: Now therefore His Excellency the Governor of the State of Victoria, by and with the advice of the Executive Council thereof, doth hereby authorize the necessary works to be provided and constructed by the Commission for such supply to be given including the purchase by the Commission of the assets of the Shire of Karkaroc pertaining to the supply of electricity by the said Shire in the said area.

And the Honorable George Oswald Reid, Her Majesty's Minister of Electrical Undertakings for the State of Victoria, shall give the necessary directions herein accordingly.

N. G. WISHART,  
Clerk of the Executive Council.

## HOUSING ACT 1958.

At Government House, Melbourne, the thirteenth day of November, 1962.

## PRESENT:

His Excellency the Governor of Victoria.	
Mr. Turnbull	Mr. Reid.
Mr. Hamer	

## DECLARATION OF A RECLAMATION AREA AT KENSINGTON.

WHEREAS within an area in the City of Melbourne described in the Schedule hereto there are houses which—

- (a) are unfit for human habitation; and
- (b) are in the opinion of the Housing Commission insanitary or unhealthy by reason of—
  - (i) the excessive number of buildings within the area;
  - (ii) the bad arrangement of buildings within the area; and
  - (iii) the bad arrangement or narrowness of streets within the area.

And whereas the Housing Commission considers that housing conditions within the area cannot satisfactorily be dealt with unless the said area is dealt with under Part III. of the *Housing Act 1958* (No. 6275) as a Reclamation Area and has recommended that the said area should be constituted a Reclamation Area:

And whereas the Housing Commission having duly complied with the provisions of sub-section (3) of section 67 of the said Act has submitted to the Governor in Council its recommendation that the said area should be constituted a Reclamation Area:

Now therefore I, the Governor of the State of Victoria, in the Commonwealth of Australia, by and with the advice of the Executive Council of the said State do hereby declare the said area to be a Reclamation Area.

## SCHEDULE.

All that piece of land situate within the Municipality of the City of Melbourne, being part of Crown allotment 20, section 2, Parish of Doutta Galla, and being the land bounded by a line commencing at the most northerly corner of the land comprised in certificate of title, volume 6931, folio 120, being a point on the south-western alignment of Derby-street; thence south-westerly by the north-western boundary of the land comprised in the said certificate of title, volume 6931, folio 120, and the prolongation of such boundary, to the south-western alignment of Gloster-road; thence south-easterly by the said south-western alignment of Gloster-road to the intersection thereof with the boundary between Crown allotments 19 and 20 of section 2, Parish of Doutta Galla; thence north-easterly by the said Crown allotment boundary to the intersection thereof with the south-western alignment of Derby-street; and thence north-westerly by the said south-western alignment of Derby-street to the point of commencement.

And the Honorable Lindsay Hamilton Simpson Thompson, Her Majesty's Minister of Housing for the State of Victoria, shall give the necessary directions herein accordingly.

N. G. WISHART,  
Clerk of the Executive Council.

## STAMPS ACT 1958 (No. 6375).

At Government House, Melbourne, the thirteenth day of November, 1962.

## PRESENT:

His Excellency the Governor of Victoria.	
Mr. Turnbull	Mr. Reid.
Mr. Hamer	

## REVOCATION OF DECLARATION OF APPROVED VENDORS.

HIS Excellency the Governor of the State of Victoria, by and with the advice of the Executive Council thereof, doth by this Order made pursuant to section 131c of the *Stamps Act 1958* (No. 6375), revoke the

declaration made on the 9th December, 1958, and published in the *Government Gazette* of 10th December, 1958, declaring certain persons to be "approved vendors" for the purposes of subdivision (14) of Division 3 of Part II. of the *Stamps Act 1958* in so far as the said declaration refers to the under-mentioned person—

7. City of Footscray.

And the Honorable Henry Edward Bolte, Her Majesty's Treasurer for the State of Victoria, shall give the necessary directions herein accordingly.

N. G. WISHART,  
Clerk of the Executive Council.

## STAMPS ACT 1958 (No. 6375).

At Government House, Melbourne, the thirteenth day of November, 1962.

## PRESENT:

His Excellency the Governor of Victoria.	
Mr. Turnbull	Mr. Reid.
Mr. Hamer	

## REVOCATION OF DECLARATION OF APPROVED VENDORS.

HIS Excellency the Governor of the State of Victoria, by and with the advice of the Executive Council thereof, doth by this Order made pursuant to section 131c of the *Stamps Act 1958* (No. 6375), revoke the declaration made on the 14th July, 1959, and published in the *Government Gazette* of the 22nd July, 1959, declaring certain persons to be "approved vendors" for the purposes of subdivision (14) of Division 3 of Part II. of the *Stamps Act 1958* in so far as the said declaration refers to the under-mentioned person—

92. Confidential Investments Proprietary Limited.

And the Honorable Henry Edward Bolte, Her Majesty's Treasurer for the State of Victoria, shall give the necessary directions herein accordingly.

N. G. WISHART,  
Clerk of the Executive Council.

## TOWN AND COUNTRY PLANNING ACT 1961.

At Government House, Melbourne, the thirteenth day of November, 1962.

## PRESENT:

His Excellency the Governor of Victoria.	
Mr. Turnbull	Mr. Reid.
Mr. Hamer	

## CONTINUANCE OF PREPARATION OF THE CITY OF HEIDELBERG PLANNING SCHEME.

WHEREAS it is provided by section 51 of the *Town and Country Planning Act 1961* that where by reason of the exercise of any power contained in section 16 of the *Local Government Act 1958* any part of any land which is within the area of a planning scheme in course of preparation becomes the whole or a part of any new or different municipal district the Governor in Council on the application of the Council of any municipality concerned may by Order make provision for the preparation of the scheme to be continued:

And whereas the Council of the City of Heidelberg on the 25th day of August, 1952, commenced the preparation of a planning scheme for the whole of the City of Heidelberg as then constituted:

And whereas pursuant to section 16 of the *Local Government Act 1958* the City of Heidelberg was on the 1st day of October, 1962, reduced by reason of the severance of portion of its municipality and the annexation of that portion to the City of Northcote:

And whereas an application has been made by the Council of the City of Northcote advising that it does not desire to continue with the preparation of that part of the City of Heidelberg Planning Scheme in respect of land now within the municipal district of the City of Northcote:

And whereas it is provided by section 52 of the *Town and Country Planning Act 1961* that an interim development order in force immediately before any alteration in a municipal district shall continue to have the same force and effect after the alteration but that the responsible authority after any Order is made, pursuant to section 51 of the said Act, shall be specified for that purpose in the said Order:

And whereas an interim development order was made by the Council of the City of Heidelberg and approved by the Governor in Council on the 7th day of March, 1961, and published in the *Victoria Government Gazette* No. 18, dated the 8th day of March, 1961:

And whereas the said interim development order was submitted for re-approval by the Council of the City of Heidelberg and re-approved by the Governor in Council on the 6th day of June, 1962, and published in the *Victoria Government Gazette* No. 57, dated the 7th day of June, 1962:

Now therefore His Excellency the Governor of the State of Victoria by and with the advice of the Executive Council doth hereby make the following Order, that is to say:—

1. That the planning scheme commenced by the Council of the City of Heidelberg on the 25th day of August, 1952, is divided into two parts, first that part being the area of the scheme within the municipal district of the City of Heidelberg, the boundaries of such municipality being defined in the *Victoria Government Gazette* No. 78, dated the 25th day of July, 1962, and secondly that part being the area of the scheme within the municipal district of the City of Northcote the boundaries of such municipality being defined in the *Victoria Government Gazette* No. 78, dated the 25th day of July, 1962.

2. That the Council of the City of Heidelberg is hereby authorized to continue the preparation of the said planning scheme for that part of the scheme within its municipal district and the said Council shall be deemed always to have been the responsible authority in relation to the said part of the scheme and no act, matter or proceeding relating to the preparation of the scheme or the relevant part thereof shall be affected or abated by reason of the alteration in the municipal district.

3. That the responsible authority for the purpose of the subsequent operation and effect of the hereinbefore cited interim development order shall after the making of this Order by the Council of the City of Heidelberg in respect of that part of the area of the planning scheme within the municipal district of the City of Heidelberg.

And the Honorable Murray Victor Porter, Her Majesty's Minister for Local Government for the State of Victoria, shall give the necessary direction herein accordingly.

N. G. WISHART,  
Clerk of the Executive Council.

#### APPROACHING LAND SALES.

SALES of Crown lands, in fee-simple, will be held at the under-mentioned places and dates, viz.:—

	No. of Gazette.
Avoca.—Friday, 14th December, 1962 ..	117
Ballarat.—Tuesday, 18th December, 1962 ..	116
Bendigo.—Thursday, 29th November, 1962 ..	112
Dartmoor.—Monday, 19th November, 1962 ..	111
Hamilton.—Wednesday, 28th November, 1962 ..	114
Maryborough.—Friday, 14th December, 1962 ..	117
Portland.—Monday, 19th November, 1962 ..	111
Red Cliffs.—Tuesday, 11th December, 1962 ..	115
Red Cliffs.—Tuesday, 11th December, 1962 ..	116

#### SALE OF FREEHOLD LAND BY AUCTION.

Wallan.—Wednesday, 28th November, 1962 .. 114

#### AUCTION OF RIGHT TO LEASE CROWN LAND.

Melbourne.—Wednesday, 19th December, 1962 117

#### SALES OF CROWN LAND BY AUCTION.

The land will be offered for sale in fee-simple, and subject to the provisions of the Land Act and Regulations thereunder.

The upset price is the sum at which bidding will start, and no bid below that sum can be accepted. The highest bidder at or above that sum shall be the purchaser, subject to signature of contract and any necessary payment.

#### TERMS:

A deposit of at least 12½% of the purchase price must be paid at the sale, either in cash or by cheque.

The residue is payable in half-yearly instalments, in accordance with the following scale, or may be paid off at any earlier time.

£20 and under, 6 instalments.
Over £20, and not exceeding £50, 8 instalments.
Over £50, and not exceeding £100, 10 instalments.
Over £100, and not exceeding £200, 12 instalments.
Over £200, and not exceeding £300, 14 instalments.
Over £300, and not exceeding £400, 16 instalments.
Over £400, and not exceeding £500, 18 instalments.
Over £500, 20 instalments.

Interest at the rate of 5% per annum is payable with all payments of residue, and is computed for each instalment from the date of sale to the date of such payment. Additional interest is charged if any instalment is not paid on or before the due date.

If paid off within 30 days of sale, no interest is payable.

#### FEES, ETC.:

Also payable at the sale, in addition to the deposit, are the survey fee and, if applicable, the valuation of improvements (if purchaser be not the owner thereof).

#### Payable with balance of purchase money—

Crown Grant fee—50 acres and under ..	£1 10s.
Over 50 acres ..	£2
Purchase money £5 or under ..	£1

Assurance Fund contribution—One halfpenny for each £1 of purchase price. (This is a fund established to guarantee the validity of freehold titles.)

Transfer of interest prior to completion of payment may be allowed on payment of £1 fee and subject to stamp duty.

If unable to attend personally, a prospective purchaser may arrange for another person to bid as his agent.

KEITH TURNBULL,  
Commissioner of Crown Lands and Survey.

Office of Crown Lands and Survey,  
Melbourne, 14th November, 1962.

AVOCA.—Sale (No. 11643) of Crown land in fee-simple, by auction, will be held at the LAND INSPECTOR'S OFFICE, AVOCA, on FRIDAY, the 14th DECEMBER, 1962, at HALF-PAST NINE o'clock a.m. To be conducted by D. J. YURCINA, Land Officer, St. Arnaud.

TOWNSHIP OF AVOCA, PARISH OF AVOCA, COUNTY OF GLADSTONE.

#### Lot 1.

At the South-east corner of Rutherford and Hart streets. (Extending back to Barnett-street.)

Upset price £40 the lot. Survey fee £5 10s.

Area 0a. 1r. 0p., allotment 1 of section 15a. One month allowed for removal of improvements.

#### Lot 2.

Fronting the East side of Rutherford-street about 3 chains South of Hart-street. (Extending back to Barnett-street.)

Upset price £30 the lot. Survey fee £5 10s.

Area 0a. 1r. 0p., allotment 4 of section 15a.—(W.86087.)

#### Lot 3.

PARISH OF BARKLY, COUNTY OF KARA KARA.

About 2½ miles South-east of the Township of Barkly. Bounded on the West and South by unused and unmarked roads.

Upset price £10 the lot. Survey fee £7 12s. 6d.

Area 4a. 1r. 19p., allotment 33a of section C.—(W.71139.)



**MARYBOROUGH.**—Sale (No. 11644) of Crown land in fee-simple, by auction, will be held at the LAND OFFICE, 80 HIGH-STREET, MARYBOROUGH, on FRIDAY, the 14th DECEMBER, 1962, at TWO o'clock p.m. To be conducted by D. J. YURCINA, Land Officer, St. Arnaud.

PARISH OF MARYBOROUGH, COUNTY OF TALBOT.

Lot 1.

*Fronting South side of Churchill-street about 1½ chains West of Mariner Reef-road.*

Upset price £65 the lot. Survey fee £6 10s.

Area 0a. 1r. 16p., subject to survey, allotment 36 of section 23A. Subject to drainage easement 10 links wide along southern and eastern boundaries.—(W.80496.)

Lot 2.

*About 3 miles West of Maryborough, about ½ mile North of Maryborough-Ararat railway line and about 3 chains East of Timor Creek.*

Upset price £32 the lot. Survey fee £8 17s. 6d.

Area 22a. 0r. 21p., allotment 17 of section 19. Grantee shall not be entitled to compensation for any damage to be done by mining. (Section 81 Land Act 1958).—(W.82507.)

#### AUCTION OF RIGHT TO LEASE CROWN LAND.

**MELBOURNE.**—A Sale by Auction of the right to lease a Crown allotment will be held at KELVIN HALL, 55 COLLINS-PLACE, MELBOURNE, on WEDNESDAY, the 19th DECEMBER, 1962, at ELEVEN o'clock a.m. To be conducted by J. A. MURPHY, Land Officer, Melbourne. Auctioneers: BAILLIEU ALLARD REAL ESTATE PTY. LTD., 360 Collins-street, Melbourne.

The right to lease will be offered, pursuant to section 134 of the Land Act 1958, for any purpose or purposes which may be authorized under the provisions of the Land Acts, subject to the provisions summarized hereunder:—

All mineral rights will be reserved under the provisions of the Mines Act 1958 and all petroleum rights under the provisions of the Petroleum Act 1958.

The lease will commence on 20th December, 1962, the rent therefor will be the highest offer (not less than the upset rent) accepted at the sale, subject to re-appraisal at the end of each ten years' period if the lease be for a longer term than ten years. The rent will be payable quarterly in advance, and the first quarter's rent must be paid at the time of the sale, together with the lease fee of £2.

The lessee shall pay all taxes, rates, duties, charges, assessments, &c., and discharge all obligations under any Act in respect of the leased premises.

The land shall not (unless with the consent of the Board of Land and Works (hereinafter called "the Board")) be used for any other purpose than that declared by the purchaser and approved.

Plans of all buildings proposed to be erected on the land shall be submitted to the Board for its consideration, and work shall not be commenced until approval is given.

The buildings and other improvements shall be maintained throughout the term of the lease in good order and repair to the satisfaction of the Board.

The lessee shall adopt such sanitary measures as the Board requires and carry out all requirements of the Melbourne and Metropolitan Board of Works.

The lessee shall keep all buildings insured in the name of the Secretary for Lands for an amount fixed by him, and the policy and the renewal receipts in respect thereof shall be deposited with the Secretary for Lands, Melbourne.

The Board or its servants shall have the right of entry for inspection purposes, and, in case of default with regard to maintenance, to make good any defects at lessee's expense.

Arrangements must be made for the prevention of nuisance.

No advertising matter or medium will be permitted on the land or premises or fencing, provided, however, that the Board may permit a sign or other advertisement which refers solely to the purpose for which the lease is granted.

The site shall not be used for the storage of any explosive combustible or inflammable materials unless and until an application has been submitted and consented to by the Board.

No. 117.—9759/62.—3

The lessee shall not assign, sub-let, mortgage, or transfer the land, or any part thereof, without the consent of the Board.

The lessee shall at the expiry, or sooner determination of the lease, yield and deliver the land and premises to Her Majesty, her heirs and successors in good order and condition.

The lessee shall observe any other conditions and provisions agreed upon before the issue of the lease.

The lease shall be voidable for failure to use the land bona fide for the purpose for which it has been demised, or for non-payment of rent or interest on rent in arrear, or for breach of any condition, or if the affairs of the lessee be wound up, or in the event of bankruptcy of the lessee. In the event of the lease being declared void, it shall be lawful for the Crown to enter into and take full possession of the land and premises.

At the expiration or sooner determination of the term of the lease, the land and all improvements (except machinery, and appliances which can be removed without material injury to the land or buildings) shall revert to the Crown.

The land is subject to resumption for mining purposes under section 205 of the Land Act 1958.

The Governor in Council has the right to resume the whole or any part of the land for public purposes on payment of compensation for the lessee's interest in the unexpired term of the lease in respect of the resumed area.

The lessee shall contribute to the cost incurred by the local municipality for the construction of any roadway, footpath, and channel on any road abutting on the leased land, or in the drainage of such land, in the same way as if liable under the Local Government Act 1958.

The lessee shall, within the time specified hereunder, have erected buildings (the walls of which shall be of brick, concrete, or other material agreed to by the Board) and/or other permanent improvements on the land of not less than the values stated hereunder, in accordance with plans and specifications approved by the Board. It will be the lessee's obligation to ensure compliance with the building covenant notwithstanding any restrictions on capital issues.

No buildings or other structures shall be erected at a level lower than that required for proper and effective drainage of the leased land.

If the purchaser covenants to erect improvements substantially in excess of the minimum required, the term of the lease may be fixed by the Board for a longer term, to be determined by it within the provisions of the Land Acts.

Printed forms of the general conditions of the lease, in full, may be inspected at the Crown Lands Department, State Public Offices, Melbourne. Phone 63 0321, Ext. 205.)

F. H. KLENNER,  
Secretary for Lands.

Melbourne, 14th November, 1962.

Lot 1.

CITY OF PORT MELBOURNE, PARISH OF MELBOURNE SOUTH,  
COUNTY OF BURKE.

*Fronting North side of Plummer-street about 2 chains West of Salmon-street. Having a frontage of 6 chains by a depth of about 6 chains. Formerly occupied by C.R.B. Storeyard.*

Upset rental £2,768 per annum for first ten years.

Term of lease 50 years.

Area 3a. 2r. 15p., allotment 6 of section 67E, subject to drainage easement 15 links wide along northern boundary. Valuation of £4,000 to be paid within seven days in respect of existing improvements, comprising various galvanized iron buildings.

#### NOTES.

1. This land is subject to the Melbourne and Metropolitan Board of Works Interim Development Order 1959, and it is understood that action is being taken to re-zone the allotment as general industrial.

2. Inspection may be arranged by contacting the C.R.B. Depot, Brady-street, South Melbourne (Mr. Cullen) (Telephone 64 3694).—(02368/129.)

*Land Act 1958.*

## LICENCES UNDER THE LAND ACTS 1928 AND 1958 DECLARED VOID.

NOTICE is hereby given that the Licence in the Schedule hereunder has been Declared Void for the reason specified.

District.	Corr. No.	Name of Licensee.	Section of Land Act under which Licensed.	Parish.	Allotment.	Section.	Area.	Annual Rental.	Reasons for Voiding.
							A. R. P.	£ s. d.	
Bendigo	01064/138	Estate of S. Cheong deceased	138	Sandhurst ..	306D	K	0 0 22	1 0 0	Non payment of Rental

Department of Crown Lands and Survey,  
Melbourne, 12th November, 1962.

KEITH TURNBULL,  
Commissioner of Crown Lands and Survey.

*Land Act 1958.*

## LEASE SURRENDERED.

NOTICE is hereby given that the Governor in Council has accepted the surrender of the Lease mentioned in the Schedule hereunder for the reason specified.

District.	Corr. No.	Name.	Section of Land Act under which Leased.	Parish.	Allotment.	Section.	Area.	Class.	Reason.
							A. R. P.		
Mallee ..	4818P/218	M. A. J. Cameron ..	241	Budgerium East	15	2	142 0 11	..	Surrendered — Selection Purchase Lease to issue

Department of Crown Lands and Survey,  
Melbourne, 30th October, 1962.

KEITH TURNBULL,  
Commissioner of Crown Lands and Survey.

*Land Act 1958.*

## LICENCE UNDER THE LAND ACTS 1928 AND 1958 DECLARED VOID.

NOTICE is hereby given that the Licence in the Schedule hereunder has been declared Void for the reason specified.

District.	Corr. No.	Name of Licensee.	Section of Land Act under which Licensed.	Parish.	Allotment.	Section.	Area.	Annual Rental.	Reasons for Voiding.
							A. R. P.	£ s. d.	
Bairnsdale	151/129	Herbert William Griffiths	129	Wat Wat ..	11	..	3 0 0	1 0 0	Cancelled

Department of Crown Lands and Survey,  
Melbourne, 12th November, 1962

KEITH TURNBULL,  
Commissioner of Crown Lands and Survey.

## Soldier Settlement Acts.

## LEASE SURRENDERED.

NOTICE is hereby given that the Rural Finance and Settlement Commission, pursuant to the powers conferred upon it by the Soldier Settlement Acts, has accepted the surrender of the lease mentioned in the Schedule hereunder for the reason specified.

## SCHEDULE.

Corr. No.	Name.	Section of Act No. 5179 under which Leased.	Parish.	Allotment.	Area.	Reason.
					A. R. P.	
1049/27	H. E. Mortimore ..	27	Bumbang ..	..	21, Section C	28 1 7 New lease to issue

Rural Finance and Settlement Commission,  
7th November, 1962.

M. J. CRONIN,  
Deputy Secretary,  
(Settlement Branch).

LIST OF CROWN LANDS AVAILABLE.

THE under-mentioned areas are available for application as provided by various sections of the *Land Act 1958*, and all applications received on or before Wednesday, 12th December, 1962, will be deemed to have been made simultaneously, but any application lodged after such date may be considered if received in time for inclusion in the advertisement of the cases to be heard at the Local Land Board. Applications on proper form, accompanied by 5s. duty stamp unaccompanied (registration fee), may be delivered or forwarded by post to the Local Land Officer or to any Crown Lands Office in Victoria. Subject to the approval of the Secretary for Lands, when the survey fee exceeds £25 but does not exceed £50, a deposit of £25 may be paid, and when the fee exceeds £50, a deposit of 50 per cent. of the fee, the balance in either case being payable over six years in half-yearly instalments.

Marked plans of any particular area, application forms, and any further information may be obtained from the Crown Lands Department, Melbourne, and Land Offices, Horsham and Alexandria.

Department of Crown Lands and Survey,  
Melbourne, 12th November, 1962.

KEITH TURNBULL,  
Commissioner of Crown Lands and Survey.

\* Improvements may be subject to re-valuation after land has been granted to an applicant.

Local Land Office.	County.	Parish.	Allotment.	Section.	Area.	How Available.		Survey Fee.	Valuation of Improvements (if any).	Location of Land, &c.	Nearest Railway Station, and Distance in miles therefrom.	How Accessible.	Water Supply.	General Description of Land—Soil, Timber, Suitability (Grazing, &c.).
						Classification.	Value per Acre.							
						A. B. P.		£ s. d.						
AVAILABLE UNDER SECTION 44 OF THE LAND ACT 1958.														
Horsham ..	Lowan ..	Carehap ..	128, 130	..	1,000 0 0 ± (Subject to survey)	4th	1 15 0	78 15 0	..	In the south-west of the Parish	8 miles west of the Township of Toolondo	Access by track from the west	To be conserved	Undulating sandy loam with low sand rises covered by Redgum, Black Box, White Iron Bark, Manna Gum, Brown Stringybark, Heath and Desert Banksia. Suitable for grazing.
AVAILABLE UNDER SECTION 133 OF THE LAND ACT 1958.														
Alexandria	Anglesey ..	Township of Marysville, Parish of Steavenson	14	2	0 1 0 ±	..	Rental to be fixed	6 0 0	Nil	About 4 chains west of Lyell-street fronting the southern side of a road which is the continuation of Kings-road	Township block	By road ..	To be conserved	Gently sloping land, mountain loam soil. Suitable for residence

**PROPOSED REVOCATIONS OF TEMPORARY RESERVATIONS OF LANDS BY ORDERS IN COUNCIL.**

IN pursuance of the provisions of the *Land Act 1958*, notice is hereby given that it is the intention of the Governor in Council to revoke the temporary reservations of lands by Orders in Council hereunder referred to, viz.:-

The following Notices were published 1° on the 14th November, 1962, pursuant to Orders of the 7th November, 1962.

**CARBOOR.**—The temporary reservation, by Order in Council of the 29th June, 1885 (see *Government Gazette* of the 3rd July, 1885, page 1897) of 51 acres 11 perches of land in the Parish of Carboor as a site for Watering purposes, revoked as to part by Order of the 20th November, 1916, is about to be revoked so far as the balance thereof, containing 24 acres 2 roods 15 perches, is concerned.—(C.410(°)) (H.028863).

**OAKLEIGH.**—The temporary reservation, by Order in Council of the 12th May, 1925, of 3 acres 1 rood 24 6/10 perches of land in the Township of Oakleigh, as a site for Public Gardens, revoked as to part by Order of the 10th November, 1959, is about to be revoked so far only as the portions containing 1 acre 1 rood 10 3/10 perches, indicated by hachure on plan hereunder, are concerned.—(O.1(2)) (Rs.3100).

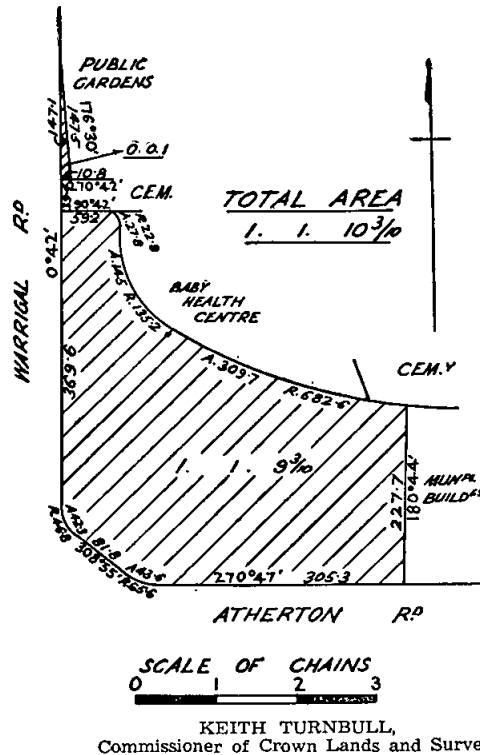

**PROPOSED REVOCATIONS OF TEMPORARY RESERVATIONS OF LANDS BY ORDERS IN COUNCIL.**

IN pursuance of the provisions of the *Land Act 1958*, notice is hereby given that it is the intention of the Governor in Council to revoke the temporary reservations of lands by Orders in Council hereunder referred to, viz.:-

The following Notices were published 1° on the 24th October, 1962, pursuant to Orders of the 16th October, 1962.

**LLANELLY.**—The temporary reservation, by Order in Council of the 12th September, 1870 (see *Government Gazette* of the 16th September, 1870, page 1371), of 1 acre of land in the Township of Llanelly, as a site for Common School purposes.—(L.130(2)) (C.98812).

**SHELFORD.**—The temporary reservation, by Order in Council of the 1st August, 1864, of 1 rood of land in the Township of Shelford, as a site for a Mechanics' In-

stitute, and the temporary reservation by Order in Council of the 23rd October, 1945, of 1 rood of land as an extension thereto.—(S.279(3)) (Rs.2561).

**WALPEUP.**—The temporary reservation, by Order in Council of the 31st March, 1913, of 2 roods of land in the Township of Walpeup, as a site for Police purposes.—(W.406(E1)) (C.58050).

**SALISBURY WEST.**—The temporary reservation, by Order in Council of the 26th March, 1901, of 10,700 acres of unappropriated Crown land in the Parishes of Kurting, Salisbury West, Glenalbyn, Inglewood and Tarnagulla, as a site for the Growth of Timber for the purpose of the manufacture or production of eucalyptus oil, revoked as to part by various Orders, is about to be revoked so far only as the portion in the Parish of Salisbury West containing 500 acres, more or less, indicated by hachure on plan hereunder, is concerned.—(S.441(°)) (Rs.1614).

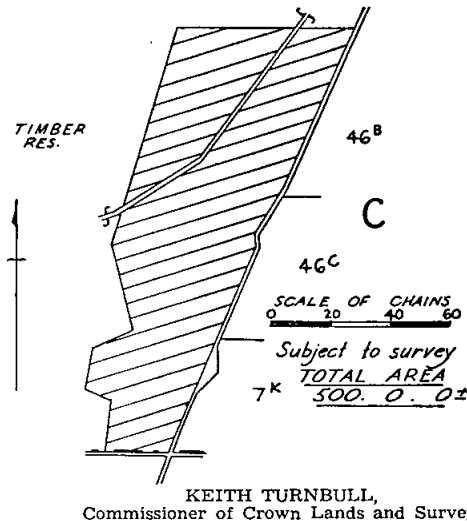

**PROPOSED REVOCATIONS OF TEMPORARY RESERVATIONS OF LANDS BY ORDERS IN COUNCIL.**

IN pursuance of the provisions of the *Land Act 1958*, notice is hereby given that it is the intention of the Governor in Council to revoke the temporary reservations of lands by Orders in Council hereunder referred to, viz.:-

The following Notices were published 1° on the 31st October, 1962, pursuant to Orders of the 23rd October, 1962.

**BENALLA.**—The temporary reservation, by Order in Council of the 26th January, 1886, of 16 acres of land, being allotments 7 and 8, section F, in the Parish of Benalla, as a site for the Supply of Loam and Gravel, revoked as to part by Order in Council of the 6th December, 1904, so far as the balance thereof, containing 15 acres 3 roods 9 perches is concerned.—(B.392(°)) (C.26144).

**GOORNONG.**—The temporary reservation, by Order in Council of the 13th February, 1894 (see *Government Gazette* of the 16th February, 1894, page 865), of 14 acres 30 perches of land in the Parish of Goornong, as a site for Supply of Gravel, so far only as the portion containing 3 acres 1 rood 23 perches, indicated by hachure on plan hereunder, is concerned.—(G.98(°)) (Rs.3162).

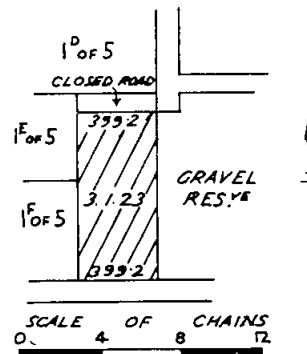

OAKLEIGH.—The temporary reservation, by Order in Council of the 10th December, 1923, of 1 rood 36 perches of land in the Township of Oakleigh, as a site for a Baby Health Centre.—(O.1<sup>(2)</sup>) (Rs.3801).

OAKLEIGH.—The temporary reservation, by Order in Council of the 25th June, 1919, of 1 rood 15 perches of land in the Township of Oakleigh, as a site for Municipal Buildings.—(O.1<sup>(2)</sup>) (Rs.1936).

KEITH TURNBULL,  
Commissioner of Crown Lands and Survey.

**PROPOSED REVOCATION OF TEMPORARY RESERVATION, AND THE WITHHOLDING FROM SALE, LEASING, AND LICENSING OF LAND BY ORDER IN COUNCIL.**

IN pursuance of the provisions of the *Land Act 1958*, notice is hereby given that it is the intention of the Governor in Council to revoke the temporary reservation, and the withholding from sale, leasing, and licensing, of land by Order in Council hereunder referred to, viz.:

The following Notice was published 1° on the 24th October, 1962, pursuant to Order of the 16th October, 1962.

GANOO GANOO.—The temporary reservation as a site for Camping and Affording Access to Water, and the withholding from sale, leasing and licensing by Order in Council of the 13th November, 1882, of 20 acres of land in the Parish of Ganoo Ganoo, so far only as the portion containing 1 acre 3 roods 34 perches, indicated by hachure on plan hereunder, is concerned.—(G.190<sup>(1)</sup>) (C.98341).

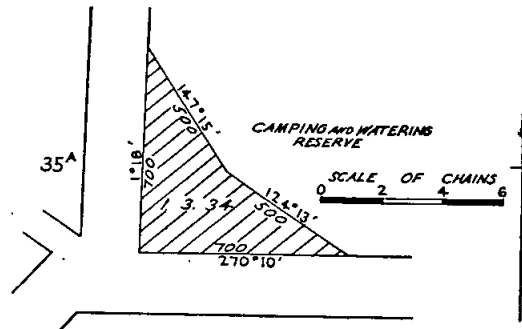

KEITH TURNBULL,  
Commissioner of Crown Lands and Survey.

**PROPOSED REVOCATIONS OF TEMPORARY RESERVATIONS OF LAND BY ORDERS IN COUNCIL**

IN pursuance of the provisions of the *Land Act 1958*, notice is hereby given that it is the intention of the Governor in Council to revoke the temporary reservations of land by Orders in Council hereunder referred to, viz.:

The following Notices were published 1° on the 7th November, 1962, pursuant to Orders of the 30th October, 1962.

BULLEEN (DONCASTER).—The temporary reservation, by Order in Council of the 24th July, 1951, of 31 perches of land in the Parish of Bulleen, as a site for Police purposes, so far only as the portion containing 1 3/10 perches indicated by hachure on plan hereunder is concerned.—(B.526<sup>(2)</sup>) (Rs.6679).

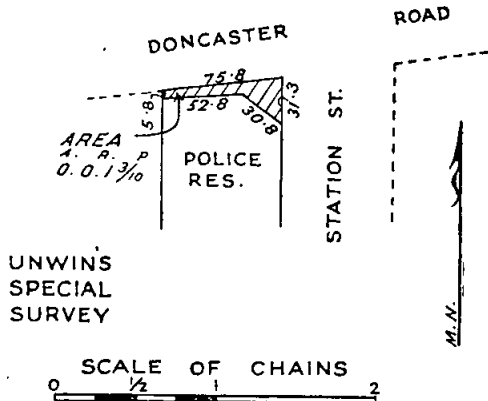

GLENMAGGIE.—The temporary reservation, by Order in Council of the 4th September, 1893, of 10 acres of land in the Parish of Glenmaggie, as a site for Supply of Gravel.—(G.178<sup>(9)</sup>) (Rs.2531).

KEITH TURNBULL,  
Commissioner of Crown Lands and Survey.

**COMMON ABOUT TO BE ABOLISHED.**

IN pursuance of the provisions contained in the *Land Act 1958*, notice is hereby given that it is the intention of the Governor in Council to abolish the common hereinafter mentioned, viz.:

The following Notice was published 1° on the 24th October, 1962, pursuant to Order of the 16th October, 1962.

The Darlington Town Common, proclaimed as such by the Governor in Council on the 30th April, 1866, and the 19th August, 1867.—(Rs.2236.)

KEITH TURNBULL,  
Commissioner of Crown Lands and Survey.

**COMMITTEES OF MANAGEMENT OF RESERVES.**

**APPOINTMENTS.**

WHEREAS by section 221 of the *Land Act 1958* it is provided that it shall be lawful for the Governor in Council or the Board of Land and Works to appoint and remove any number of persons, not less than three, or any municipal council, or the governing body of any corporation, to be a Committee of Management of any specified Crown land reserved either temporarily or permanently for any of the purposes set out in section 14 of the *Land Act 1958*, and not conveyed to or vested in trustees: Now therefore the Board of Land and Works doth hereby appoint the under-mentioned persons to be members of the Committee of Management of the Reserves named:—

**"COBDEN RECREATION RESERVE."**

James Michael McCabe, Clifford John Biesse, Cyril John Spall, Gordon Smith, Michael Francis Daffy, Henry Nicholas Thornton, Allen Gilbert Adkins, Patrick Francis Pekin, Davy Edward Wedge and James Mathieson as the Committee of Management for a period of three (3) years of the land temporarily reserved by Order in Council dated 8th November, 1886, as a site for Public Recreation in the Township of Cobden and known as the "Cobden Recreation Reserve".—(Corres. Rs.683.)

**"KINGOWER CRICKET AND RECREATION RESERVE."**

Ronald James Gilmore, Mervyn Henry Gilmore, John Salathiel Gillespie, Geoffrey James Catto and Albert John Fishlock as a Committee of Management for a period of three (3) years of the land temporarily reserved by Order in Council dated 24th August, 1896, as a site for Cricket and other purposes of Public Recreation in the Parish of Kingower and known as the "Kingower Cricket and Recreation Reserve".—(Corres. Rs.4687.)

**"MOORNGAG PUBLIC HALL AND RECREATION RESERVE."**

Leo Ginnivan, Frederick J. Horsburgh, Leonard J. Sawyer, Francis R. McCauley, Daniel E. Ginnivan, Dennis K. McCauley, George H. Exton, Charles Smales, John T. Duffy and Robert J. Akeroyd as a Committee of Management for a period of three (3) years of the land temporarily reserved by Order in Council dated 21st November, 1887, as a site for Public Recreation, and by Order in Council dated 7th September, 1948, as a site for additional purpose of a Public Hall in the Parish of Rothesay, and known as the "Mooringag Public Hall and Recreation Reserve".—(Corres. Rs.2741.)

**"PORT WELSHPOOL FORESHORE RESERVE AND PORT WELSHPOOL CAMPING AND RECREATION RESERVE."**

Arthur Charles Bickerton, Per Conrad Peterson, Edward James Telling, Thomas Henry Miller, Robin Bjorksten, Lillie Margaret Peterson, John Acutt Blayney, John Bernard Brewer, Godfrey MacLeod, Norman Frank Daff, Albert Charles Snell and Berend Berends for a period of three (3) years, together with Vivian Walter Bennett-Wood (for so long only as he remains a Councillor and the elect of the Council of the Shire of South Gippsland) as the Committee of Management of such portions of the area temporarily reserved by Order in Council dated 3rd August, 1936, as a site for Public purposes in the Parish of Welshpool as indicated by red colour on plan marked P.W./15.12.36 with Lands Department correspondence No. Rs.4589 and known as the "Port Welshpool Foreshore Reserve".—(Corres. Rs.4589.)

**"SEAFORD FORESHORE RESERVE."**

John McCulloch, Bruce Aitken and Ian Robert Evans (for so long only as they are Councillors and the elect of the Council of the Shire of Frankston) in the place of Clarence Theodore Coates, James Robert Lee Ellis and Frederic Leslie Pemberton (no longer Councillors) as members of the Committee of Management of such portions of the Reserve for Public purposes in the Parishes of Frankston and Lyndhurst as are indicated by red colour on plans marked S.29/4/37 and A.10/12/1957 attached to Lands Department correspondence Rs.4674, together with the area between high and low water mark bordering such portions, all of which is known as the "Seaford Foreshore Reserve".—(Corres. Rs.4674.)

**"WARRNAMBOOL FORESHORE RESERVE."**

Henry James Beardsley and Harold Ivor Stephenson (for so long only as they continue to be Councillors and the elect of the Council of the City of Warrnambool) and Henry James McGennan, Stewart Archibald Lindsay, Jens Michael Flaherty, James Norman Abbott, Patrick O'Sullivan, James Francis Thompson, James Stoddart Low, Ernest John Saywell and John Beynon Dwyer as a Committee of Management for a period of three (3) years of that portion of the reserved land in the City of Warrnambool, Parish of Wangoom, as is bordered blue on plan marked W/31.10.62 on Lands Department correspondence Rs.6255 and known as the "Warrnambool Foreshore Reserve".—(Corres. Rs.6255.)

In witness whereof the common seal of the Board of Land and Works was hereunto affixed this eighth day of November, One thousand nine hundred and sixty-two in the presence of—

(SEAL) KEITH TURNBULL, President.  
F. KLENNER, Member.

**LOCAL LAND BOARD.**

IN pursuance of the provisions of section 34 of the Land Act 1958, notice is hereby given that a public hearing at the following place and time, will be conducted by the person mentioned, being duly appointed in that behalf.

KEITH TURNBULL,  
Commissioner of Crown Lands and Survey.  
Department of Crown Lands and Survey,  
Melbourne.

SEYMOUR LAND OFFICE, Friday, 23rd November, 1962,  
at 11 a.m.—K. C. Gittins.

**TENDERS—PUBLIC WORKS DEPARTMENT**

TENDERS will be received at this Department's Head Office, Treasury-place, Melbourne, until TEN a.m. on the dates, and for the purposes under mentioned.

Particulars may be learnt at the Department and also at places shown in parentheses.

W.O. means Inspector of Works Office; P.S.—Police Station; T.S.—Technical School; H.E.S.—Higher Elementary School; S.S.—State School; H.S.—High School; C.S.—Consolidated School.

Tenders should be submitted on the Department's printed Tender Form and will not be received by telephone. All tenders must be on a "Firm Tender" basis. The Board of Land and Works will not necessarily accept the lowest or any tender.

Tenders to be addressed to the Hon. the Commissioner of Public Works, and envelope containing tender to be marked "Tender for \_\_\_\_\_, closing Tuesday."

NOTE.—No preliminary deposit is to be lodged with any tender, but a deposit in accordance with the prescribed Schedule may be required from each successful tenderer.

**Tuesday, 20th November, 1962.**

Alfredton.—Repairs and painting to residence, 18 Junction-street, Ballarat, S.S. 1091. (W.O., Ballarat; S.S., Alfredton.)

Ararat.—Repairs and painting, Court House. (W.O., Ararat.)

Ballarat.—Supply and installation of electricity meters, in residences, Mental Hospital. (W.O., Ballarat.)

Bay View.—Plenum heating in new six (6) additional class-rooms, S.S. 4752.

Bay View.—Electrical installation in six (6) additional L.T.C. class-rooms, &c., S.S. 4752.

Blackburn South.—Supply, delivery, installation and testing of the Mechanical Services, stage 3, High School.

Blackburn South.—Electrical installation in extended stage 3, Standard High School.

Brimpaen.—Erect out-office, shelter shed, install septic tanks, S.S. 2525. (W.O., Horsham; S.S., Brimpaen.)

Broadmeadows.—Internal and external repairs to residence, Police Stud Depot.

Buckley.—Septic tank installations, S.S. 1481 and residence. (W.O., Geelong; S.S., Buckley.)

Burwood.—Supply and installation of food lift to "Sunny Side" Cottage, "Allambie", Social Welfare Department.

Campmeadows.—Plenum heating in new four additional class-rooms, S.S. 4833.

Campmeadows.—Electrical installation in four (4) additional L.T.C. class-rooms, &c., S.S. 4833.

Carlton.—Supply of index card cabinets, Motor Registration Branch.

Cheltenham East.—Plenum heating in new four (4) additional class-rooms, S.S. 4754.

Cheltenham East.—Electrical installation in four (4) additional L.T.C. class-rooms, &c., S.S.4754.

Dingley.—Repairs and painting to school buildings, out-buildings and Bristol class-rooms, S.S. 4257.

Dooen.—Supply of pressure-treated impregnated round hardwood posts, Longerenong Agricultural College.

Doveton.—Supply, delivery, installation and testing of the Mechanical Service, stage 3, High School.

Doveton.—Electrical installation in extended stage 3, Standard High School.

Doveton West.—Electrical installation in four (4) additional L.T.C. class-rooms, S.S. 4820.

Doveton West.—Plenum heating in new four (4) additional class-rooms, S.S. 4820.

Driffield.—Septic tank installation, school and residence, S.S. 2433. (W.O., Traralgon; S.S., Driffield.)

Drysdale.—Internal renovations and painting to school residence, 2 Princess-street, S.S. 1645. (W.O., Geelong; S.S., Drysdale.)

Dumbalk East.—Repairs and painting, S.S. 3172. (W.O., Korumburra; S.S., Dumbalk East.)

Echuca.—Internal repairs and painting, Court House. (W.O., Shepparton; P.S., Echuca.)

Essendon.—External repairs and painting, Technical School. (Amended specification.)

Geelong.—Installation of mezzanine floor, Gordon Institute of Technology. (W.O., Geelong.)

Glen Waverley.—Electrical installation in extended stage 3, High School.

Glen Waverley.—Supply, delivery, installation and testing of the mechanical services, stage 3, High School.

Hamilton.—Electrical installation in modified stages 1, 2 and 3, Technical School. (W.O., Hamilton, Geelong and Warrnambool.)

Hamilton.—Erection of first, second and third sections, Technical School. (W.O., Hamilton, Warrnambool.)

Hamilton.—Extension of mechanical services, Technical School. (W.O., Ballarat.)

Heywood.—Installation of liquid petroleum gas, High School.

Hopetoun.—Repairs and painting, Police Station. (W.O., Warracknabeal; P.S., Hopetoun.)

Jamieson.—Installation of septic tank, new toilets and water supply at school and residence, S.S. 814. (W.O., Alexandra; S.S., Jamieson.)

Karingal.—Supply, delivery, installation and testing of the mechanical services, stage 3, High School.

Karingal.—Electrical installation in extended stage 3, High School.

Keilor Heights.—Erect Primary School No. 8 class-rooms, S.S. 4877.

Keilor Heights.—Electrical installation in new school of eight (8) class-rooms, S.S. 4877.

Keilor Heights.—Plenum heating to new eight (8) class-room unit, S.S. 4877.

Kew.—Supply and fix fibrous plaster ceilings to wards 5 and 6 (C and C1), Mental Hospital. (W.O., Mental Hospital, Kew.)

Lysterfield.—Installation of septic tanks at school and residence, S.S. 1866. (S.S., Lysterfield.)

Maffra.—Renovations, High School. (W.O., Traralgon; H.S., Maffra.)

Melbourne.—New reinforced concrete paving to floor and step of "The Temple of the Winds", Royal Botanic Gardens.

Melbourne.—Supply, make and erect curtains for police bedrooms, Police Headquarters, Russell-street.

Melbourne.—Supply and fixing new double-hung aluminium windows, Police Headquarters, Russell-street.

Mont Park.—Replacement of existing glazing with adjustable louvres to sawtooth roof trusses, Larundel Mental Hospital.

Mont Park.—Supply and laying of seamless vinyl floor and wall surfacing to toilet areas, M.I. Mental Hospital.

Mont Park.—Supply, delivery and fixing on site of new stainless steel benchwork, M.S.U. Mental Hospital.

Moorillim.—Repairs and painting, S.S. 1524. (W.O., Alexandra; S.S., Moorillim.)

Mornington.—Renovations to residence, Police Station. (P.S., Mornington.)

Mornington.—Repairs and painting to residence, High School. (H.S., Mornington.)

Morwell.—Attention to sub-floor ventilation, Court House. (W.O., Traralgon; P.S., Morwell.)

Newborough East.—Repairs and painting, S.S. 4670. (W.O., Traralgon; S.S., Newborough East.)

Nhill.—Roof repairs to "Bristol" building, High School. (W.O., Horsham; H.S., Nhill.)

Pascoe Vale.—Asphalt repairs and associated work, S.S. 3081.

Pascoe Vale.—Installation of fire service, Girls' Secondary School.

Port Melbourne.—Supply and delivery of Pile Shoes, Public Works Depot, Salmon-street.

Port Melbourne.—Supply and fitting of all-weather lockup cabins to three (3) existing Departmental Ferguson 35 tractors, Public Works Department Depot.

Royal Park.—Supply and delivery of fabricated structural steel, Mental Hospital.

Royal Park.—Supply of pneumatic-tired, petrol-driven tractor and associated equipment (Ferguson tractor, model T.E.A., to be accepted as trade-in), Youth Welfare Division, "Turana".

Sea Lake.—Provision of asphalt areas, drainage, concrete beautification and associated works, High School. (W.O., Swan Hill; H.S., Sea Lake.)

Sebastopol.—Earthworks, gravelling, asphalt, road-works, concreting, drainage and landscaping, Technical School. (W.O., Ballarat and Geelong.)

Speed.—Repairs and painting to residence, S.S., 3861. (W.O., Warracknabeal; S.S., Speed.)

Sunbury.—Sub-floor ventilation in bluestone walls, Wards M4, M6 and M7, Mental Hospital. (Mental Hospital, Sunbury.)

Sunshine.—Completion of shelter pavilions, Technical School. (Amended specification.)

Sunshine North.—Site works, including asphalt, concrete and gravel paving and drainage, Girls' Technical School.

Swan Hill.—Installation of septic tank and connexion to sewerage, Technical School. (W.O., Swan Hill; T.S., Swan Hill.)

Tongala.—Removal of hedge and erection of new fence, Consolidated School Residence. (W.O., Shepparton; C.S., Tongala.)

Various.—Extended third sections to timber-framed High Schools at Doveton, Karingal, Blackburn South and Glen Waverley.

Victoria Park.—Internal renovations, S.S. 2957.

Yallourn.—Supply and delivery of equipment for Diploma School, Technical School.

### Tuesday, 27th November, 1962.

Armada.—Exterior renovations, "Sebroff", Domestic Arts Teachers' College Hostel, 10 Orrong-road.

Armada.—Provision of a new change room, Domestic Arts Teachers' College, "Larnook".

Bairnsdale.—Additional room, &c., Transport Regulation Board Residence. (W.O., Bairnsdale.)

Ballarat North.—Install fire service, Technical School. (W.O., Ballarat.)

Bentleigh.—General repairs and painting, High School.

Boralma.—Exterior and interior painting and repairs, S.S. 2574. (W.O., Wangaratta; S.S., Boralma.)

Burrum.—Repairs and painting, S.S. 4442. (W.O., Warracknabeal; S.S., Burrum.)

Castlemaine.—Repairs, internal and external painting and provision of new stainless steel wash troughs, High School. (W.O., Kyneton; H.S., Castlemaine.)

Caulfield.—Repairs and renovations to Senior School, S.S., 773.

Caulfield.—New tile roof to Junior School, S.S. 773.

Chelsea.—Repairs, painting, &c., Police Station.

Chiltern.—Repairs and painting to residence, office and out-buildings, Police Station. (W.O., Wangaratta.)

Clyde.—Additional drinking and washing facilities, S.S. 3664. (S.S., Clyde.)

Corio.—Erection of second and third sections, Technical School. (W.O., Geelong.)

Corio.—Supply, delivery, installation and testing of extensions to mechanical services, stages 2 and 3, Technical School. (W.O., Geelong.)

Corio.—Electrical installation in extensions to stages 2 and 3, Technical School. (W.O., Geelong.)

Croydon.—Erection of craft room, S.S. 2900.

Dandenong.—Aluminium windows and glazing, Psychiatric Unit, Mental Hygiene Authority.

Darnum.—Reblocking, repairs and painting, S.S. 2319 and residence. (W.O., Warragul; S.S., Darnum.)

Donald.—Repairs and painting to Court House. (W.O., Maryborough; P.S., Donald.)

Echuca.—Conversion of Art Room into Science Room, High School. (W.O., Shepparton; H.S., Echuca.)

Echuca.—Conversion of locker room to staff room, High School. (W.O., Shepparton; H.S., Echuca.)

Essendon.—Provision of steel fire escape stairs, S.S. 483. Fern Tree Gully North.—Four additional class-rooms, S.S. 4718.

Fern Tree Gully North.—Plenum heating in new four (4) class-room unit, S.S. 4718.

Geelong.—Supply and delivery of 1,600 cubic yards of loam, (20 lb. sample to be delivered to P.W.D. Office, Geelong), Teachers' College.

Glen Forbes.—New toilet block and installation of septic tank, S.S. 4008. (W.O., Korumburra; S.S., Glen Forbes.)

Irrewarra.—Supply and installation of electric bore pump, S.S. 4099.

Koorooman East.—New toilets and septic tank, S.S. 3389. (W.O., Korumburra; S.S., Koorooman East.)

Laburnum.—Electrical installation in new eight (8) class-room L.T.C. School, S.S. 4863.

Laburnum.—New primary school of eight (8) class-rooms, S.S. 4863.

Laburnum.—Plenum heating in new eight (8) class-room unit, S.S. 4863.

Lilliput.—Repairs and painting, S.S. 1015. (W.O., Wangaratta; S.S., Lilliput.)

Little River.—Reblocking, internal painting and repairs, residence, S.S. 1961. (W.O., Geelong; S.S., Little River.)

Malvern.—Pipe and chain mesh fencing, S.S. 2586.

Maryborough.—New sleepout in timber and renovations, P.W.D., Inspector's residence. (W.O., Maryborough.)

Maryborough.—Supply of general furniture for Workshop Block, Technical College.

Macleod.—Construction of four porous tennis courts and fencing, High School.

Melton South.—Supply and installation of an electric bore pump, S.S. 3717.

Montague.—New accommodation for kitchen and laundry, Special School 2784.

Mont Park.—Supply and erection of a new copper roof over destructor unit, Mental Hospital.

Moonee Ponds Central.—Repairs and painting, Cleaner's Residence, S.S. 3987.

Morwell.—Supply and delivery of one 14-in. shaping machine, Technical School.

Mt. Best.—New toilets and septic tank installation, S.S. 3429 and residence. (W.O., Korumburra; S.S., Mt. Best.)

Mystic Park.—Septic tank installation, S.S. 3366. (Amended specification.) (W.O., Swan Hill; S.S., Mystic Park.)

Nunawading.—Painting and repairs, S.S. 4190.

Oak Park.—Minor repairs and external painting, S.S., 4721.

Olympic Village.—Six (6) additional class-rooms, S.S. 4713.

Olympic Village.—Plenum heating to new six (6) additional class-rooms, S.S. 4713.

Olympic Village.—Electrical installation in six (6) additional L.T.C. class-rooms, &c., S.S. 4713.

Panmure.—Installation of additional out-offices and bore water supply, S.S. 1079 and residence. (W.O., Warrnambool; S.S., Panmure.)

Parkdale.—Repairs to out-offices, S.S. 4171.

Pascoe Vale.—External repairs and painting, Girls' Secondary School. (Amended specification.)

Preston North-East.—New office for infant mistress and staff toilets, S.S. 4764.

Redesdale.—New toilets and septic tank installation, S.S. 2571. (W.O., Kyneton; S.S., Redesdale.)

Robinvale.—Repairs and painting, Consolidated School. (W.O., Swan Hill; C.S., Robinvale.)

Shepparton Park.—Purchase and removal of old school building, S.S. 3264. (W.O., Shepparton.)

Somers.—Removal of a building from Coolart Estates to Somers School Camp, S.S. 4647. (S.S., Somers.)

Snobs Creek.—Supply and installation of pumping plant, Fish Research Station and Hatchery.

Sunbury.—Additional septic tank on existing drain to residences at Mental Hospital. (M.H., Sunbury.)

Sunshine North.—Electrical installation in extensions to stages 2 and 3, Technical School.

Sunshine North.—Supply, delivery, installation and testing of extension to mechanical services, stages 2 and 3, Technical School.

Sunshine North.—Erection of second and third sections, Technical School.

Swan Hill.—Repairs and painting to residence, 1 Chisholm-street, S.S. 1142. (W.O., Swan Hill.)

Teesdale.—Out-office block and septic tank installation, S.S. 2065 and residence. (W.O., Geelong; S.S., Teesdale.)

Thornton.—Installation of septic tanks and water supply at school and residence, S.S. 1371. (W.O., Alexandra; S.S., Thornton.)

Tongala.—Repairs and painting to school buildings, Consolidated School. (W.O., Shepparton; C.S., Tongala.)  
Wattle Park.—Erection of fencing (non-party) and field gates, High School.

West Melbourne.—New timber and chain-mesh boundary fencing, Government Cool Stores.

West Melbourne.—Supply and delivery of Coolroom Door Fittings, Government Cool Stores.

West Melbourne.—Supply and delivery of 63,000 lineal feet of 5½ in. x ¾ in. select T. and G. Hardwood Flooring, Cool Stores, Dudley-street.

West Melbourne.—Supply and delivery of Corkboard, Government Cool Stores, Dudley-street.

West Melbourne.—Electrical installation in cooling chambers, Government Cool Stores.

Winton.—Out-office block and septic tank installation at S.S. 1870 and residence. (W.O., Benalla; S.S., Winton.)

Wodonga.—Sewerage installation and fire service at school and residence, S.S., 37. (W.O., Wangaratta; S.S., Wodonga.)

Woodbourne.—Installation of septic tanks, new toilets and bore water supply at S.S. 2875 and residence. (W.O., Alexandra; S.S., Woodbourne.)

### Tuesday, 4th December, 1962.

Avoca.—Erection of combined brick veneer residence, office and garage with fuel room, Police Station. (W.O., Maryborough.)

Avoca.—Electrical installation, Police Station and residence. (W.O., Maryborough.)

Barkstead.—Purchase and removal old building, S.S. 985. (W.O., Ballarat; S.S., Barkstead.)

Bell Park.—Erection of third section, High School. (W.O., Geelong; H.S., Bell Park.)

Bell Park.—Electrical installation in extended stage (3), High School. (W.O., Geelong; H.S., Bell Park.)

Bell Park.—Supply, delivery, installation and testing of the mechanical services, stage 3, High School.

Beveridge.—Purchase and removal of old residence, S.S. 1476. (W.O., Alexandra.)

Blackburn South.—Repairs and painting, S.S. 4035. Clarkefield.—Installation of septic tank, new toilets and bore water supply, S.S. 3035. (W.O., Kyneton; S.S., Clarkefield.)

Deepdene.—Repairs and painting, S.S. 3680. (Amended specification.)

Frankston Forest.—Six (6) additional class-rooms, S.S. 4872.

Frankston Forest.—Plenum heating in new six class-room unit, S.S. 4872.

Glenburn.—Installation of septic tanks and water supply at school and residence, S.S. 3344. (W.O., Alexandra; S.S., Glenburn.)

Grantville.—Septic tank installation, S.S. 1414. (W.O., Korumburra; S.S., Grantville.)

Grassy Spur.—New out-office block and septic tank installations, &c., S.S. 3450. (W.O., Korumburra; S.S., Grassy Spur.)

Greythorn.—New sanitary accommodation, &c., S.S. 4694.

Hallora.—Toilet block and septic tank installation, S.S. 2377. (W.O., Warragul; S.S., Hallora.)

Homewood.—Installation of septic tank, new toilets, woodshed and water supply, S.S. 1433. (W.O., Alexandra; S.S., Homewood.)

Katunga South.—Purchase and removal of old windmill, S.S. 2269. (W.O., Shepparton; S.S., Katunga South.)

Macedon.—Repairs and painting, S.S. 1660. (W.O., Kyneton; S.S., Macedon.)

Mont Park.—Supply, delivery and fixing on site of new stainless steel benchwork, &c., M.S.U., Isolation Block, Mental Hospital.

Northcote.—Renovations to flooring, High School. (Amended specification.) (H.S., Northcote.)

Oberon.—Supply and installation of an effluent pump for septic tank, High School.

Pyalong.—Repairs, renewal and external painting, S.S. 2005. (W.O., Kyneton; S.S., Pyalong.)

Richmond.—Interior and exterior renovations and painting, S.S. 1396.

Royal Park.—Supply, delivery and installation of automatic food lift, "Turana", Children's Remand Centre.

Sunbury.—Supply and installation of electricity meters in residences, Mental Hospital.

Tylden.—Installation of septic tanks, new toilets and bore water supply, S.S. 621. (W.O., Kyneton; S.S., Tylden.)

Upper Yarra.—Supply and erection of 16 ft. x 12 ft. store shed, High School. (H.S., Upper Yarra.)

H. R. PETTY,  
Commissioner of Public Works.

Public Works Department,  
Melbourne, 13th November, 1962.

## PUBLIC SERVICE NOTICES

### PUBLIC SERVICE OF VICTORIA.—VACANCIES.

APPLICATIONS will be received by the Public Service Board up to Wednesday, the 28th November, 1962, from persons employed in the Public Service of Victoria, who are eligible and qualified for appointment to the under-mentioned positions:—

#### ADMINISTRATIVE DIVISION.

##### Class "B", Water Supply Department.

Yearly Salary.—£1,390, minimum; £1,500, maximum.

Duties.—To conduct research into and report on economic aspects of irrigation and water supply undertakings and projects. To carry out statistical investigations in regard to water supply and associated activities, including the nature, extent and value of production in irrigation and water supply districts. To undertake special assignments as required.

Qualifications.—Preferably to hold a Degree or Diploma including Economics as a major subject or to be a qualified Accountant. Ability in research into economic and general statistical problems. An interest in rural economics would be an advantage.

##### Class "C2", Accounts Branch, Treasury.

Yearly Salary.—£1,170, minimum; £1,280, maximum.

Duties.—To keep the Trust Fund ledger and to prepare statements in connexion with the various trust accounts therein; to be Deputy Registrar of Unclaimed Moneys and responsible for the keeping of the Register of Unclaimed Moneys; to deal with claims to moneys held in the trust accounts with particular reference to the Companies Liquidation Account, Testamentary and Trust Fund, Unclaimed Moneys Fund and the Totalizer Unclaimed Dividends Fund.

Qualifications.—A qualified Accountant with a good knowledge of the Audit Act, Unclaimed Moneys and other Acts as far as they relate to the various trust accounts and of the Treasury system of accounts and the Public Accounts and Stores Regulations.

##### Class "C", Social Welfare Branch, Youth Welfare Division, Chief Secretary's Department.

Yearly Salary.—£710, minimum; £860, maximum.

Duties.—To act as administrative officer in the Hostels and Employment Section of the Youth Welfare Division.

Qualifications.—Experience in correspondence, recording and simple accounting.

#### PROFESSIONAL DIVISION.

##### Assistant Research Officer, Classes "C"—"C2", Soil Conservation Authority, Premier's Department.

Yearly Salary.—£960, minimum; £1,280, maximum—  
Agricultural Science.

£860, minimum; £1,280, maximum—  
Science.

(Commencing salary according to experience.)

Duties.—To undertake conservation research and investigation as directed.

Qualifications.—A Degree in Agricultural Science, Science, or equivalent.

NOTE.—The officer appointed to this position will be engaged primarily on soil chemical investigations to supplement soil and ecological survey data to elucidate problems of soil conservation.

##### Assistant Architect, Classes "C"—"C2", Public Works Department.

Yearly Salary.—£960, minimum; £1,280, maximum—  
Graduate.

£860, minimum; £1,280, maximum—  
Diplomate.

(Commencing salary according to experience.)

Duties.—To prepare preliminary and contract plans, details, specifications, reports and estimates for modern buildings.

Qualifications.—A Degree or Diploma in Architecture or to be qualified by examination for registration as an Architect, or equivalent qualifications.



**Draughtsman, Classes "C"—"C1", Public Works Department.**

*Yearly Salary.*—£710, minimum; £1,060, maximum.

*Duties.*—To prepare preliminary sketches and structural drawings, contract plans, details and specifications for modern structures including timber, reinforced concrete and steel.

*Qualifications.*—To be qualified in building construction and capable of designing simple structures in timber, reinforced concrete and steel; to possess the pre-requisite qualifications prescribed in paragraphs (a) or (b) in Public Service (Public Service Board) Regulation 23.

TECHNICAL AND GENERAL DIVISION.

**Inspector of Land Settlement, Department of Crown Lands and Survey.**

*Yearly Salary.*—£622, minimum; £894, maximum.

*Duties.*—To administer the *Vermin and Noxious Weeds Act 1958*; to inspect and furnish reports and valuations on land and improvements as required under the provisions of the Land, Closer Settlement, Wire Netting and Agricultural Colleges Acts and part of the Local Government Act (unused roads and water frontages); to furnish reports and valuations on land improvements as required by the Rural Finance and Settlement Commission.

*Qualifications.*—A knowledge of the relevant provisions of the above-mentioned Acts; ability to make land valuations and to advise on farming methods generally, including the correct utilization of land; to have passed the prescribed examination as set out in Regulation 36 of the Public Service (Public Service Board) Regulations.

**Assistant Overseer, Wire-netting Factory, Prisons Division, Social Welfare Branch, Chief Secretary's Department.**

*Yearly Salary.*—£622, minimum; £750, maximum.

*Duties.*—To assist the Overseer of the Wire Netting Factory in the care and management of the factory, and in instructing the men under his supervision in the manufacture of wire netting.

*Qualifications.*—Ability to control and instruct men and to maintain and keep in good condition wire-weaving machines, bobbin and tube machines, and galvanizing plant.

**Fisheries and Wildlife Officer, Grade II, Fisheries and Wildlife Branch, Chief Secretary's Department.**

*Yearly Salary.*—£478, minimum; £574, maximum.

*Duties.*—To enforce the provisions of the Fisheries and Game Acts and Regulations and generally to assist in the outside work of the Branch.

*Qualifications.*—To be strong, healthy and active, able to drive a motor vehicle and to manage a motor boat. A good knowledge of and ability to effect running repairs to motor vehicles and marine engines. A knowledge of all classes of fish and native game and the methods of fishermen and shooters would be an advantage. An education to intermediate standard is desirable. Applicants should be under forty (40) years of age.

*NOTE.*—An allowance of £150 a year for overtime and week-end duty is payable, plus an additional week's leave.

**Laundry Foreman, "Turana" Youth Training Centre, Social Welfare Branch, Chief Secretary's Department.**

*Yearly Salary.*—£510, minimum; £558, maximum.

*Duties.*—To be responsible for all departments of the laundry and to have charge of all laundry machinery.

*Qualifications.*—Experience in the use of laundry equipment; ability to control staff and trainees.

**Carpenter, "Turana" Youth Welfare Division, Social Welfare Branch, Chief Secretary's Department.**

*Yearly Salary.*—£510, minimum; £558, maximum.

*Duties.*—To carry out, as directed, carpentry work and general maintenance of woodwork, furniture, glazing and fencing; to assist occasionally, if required, other artisan staff.

*Qualifications.*—A competent and experienced carpenter.

*NOTE.*—The salary rates quoted above do not include the additional amount which is payable under Regulation 74 of the Board's Regulations.

By order,  
V. P. SCULLY,  
Secretary.

Office of the Public Service Board,  
Melbourne, 13th November, 1962.

PUBLIC SERVICE OF VICTORIA.—VACANCIES.

DEPARTMENT OF HEALTH.

MENTAL HYGIENE BRANCH.

TECHNICAL AND GENERAL DIVISION.

APPLICATIONS will be received by the Public Service Board up to Wednesday, the 5th December, 1962, from persons employed in the Public Service of Victoria, who are eligible and qualified for appointment to the under-mentioned positions:—

**Carpenter, Leading Hand, Kew.**

*Yearly Salary.*—£590.

*Qualifications.*—A competent and experienced carpenter.

**Laundry Foreman, Beechworth.**

*Yearly Salary.*—£542, minimum; £590, maximum.

*Duties.*—To be responsible for control of all departments of the laundry.

*Qualifications.*—Experience in the use of all laundry equipment, ability to direct laundry staff and patients employed, and a knowledge of modern laundry processes.

**Deputy Charge Nurse (Male), Ararat.**

*Yearly Salary.*—£542, minimum; £574, maximum.

*Duties.*—To be second in charge of a ward.

*Qualifications.*—A current practising certificate for Mental Nursing and approved experience.

**Storekeeper, Grade II, Hobson Park Hospital, Traralgon.**

*Yearly Salary.*—£526, minimum; £558, maximum.

*Duties.*—Under the direction of the Secretary, to be responsible for the receipt, issue and safe custody of stores, materials and provisions, and for the records relating thereto.

*Qualifications.*—A good knowledge of stores, materials and provisions, and experience in the control and distribution thereof; clerical ability with general knowledge of bookkeeping methods relating to stores records.

**Gardener, Grade I, Hobson Park Hospital, Traralgon.**

*Yearly Salary.*—£478, minimum; £510, maximum.

*Duties.*—To be in charge of Ornamental Garden.

*Qualifications.*—Sound knowledge of ornamental gardening with ability to design and plant out new ground; ability to propagate plants from seeds and cuttings, and to prune trees and shrubs.

**Motor Truck Driver, Larundel.**

*Yearly Salary.*—£446, minimum; £462, maximum.

*Duties.*—To distribute laundry, provisions, heavy and light goods, &c., throughout Larundel and adjoining hospitals.

*Qualifications.*—A licensed motor truck driver.

**General Assistant, Hobson Park Hospital, Traralgon.**

*Yearly Salary.*—£382, minimum; £414, maximum.

*Duties.*—To give general assistance in the various artisan activities connected with the Hospital services and maintenance.

*Qualifications.*—A semi-skilled worker in good physical condition. Knowledge of some trade desirable.

**Kitchenman. (Two vacancies.)**

One vacancy—Mont Park.

One vacancy—Ararat.

*Yearly Salary.*—£366.

*Duties.*—To assist Cooks generally, preparation of vegetables and other foodstuffs. Attending to cleanliness of kitchen.

*Qualifications.*—Some knowledge of cooking is desirable.

*NOTE.*—Separate applications must be submitted for the above positions.

**Cleaner and Labourer, Hobson Park Hospital, Traralgon.**

*Yearly Salary.*—£318, minimum; £334, maximum.

*NOTE.*—The salary rates quoted above do not include the additional amount which is payable under Regulation 74 of the Board's Regulations.

By order,  
V. P. SCULLY,  
Secretary.

Office of the Public Service Board,  
Melbourne, 13th November, 1962.

PUBLIC SERVICE (PUBLIC SERVICE BOARD) REGULATION 52.—RECLASSIFICATIONS.

THE Public Service Board has raised the classification of the under-mentioned offices as shown, and the Permanent Heads of the Departments have recommended the officers named for appointment.

Office and Present Classification.	Revised Classification.	Duties.	Qualifications.	Officer Recommended for Appointment.		
				Name.	Classification.	Date of Classification.

ADMINISTRATIVE DIVISION.

DEPARTMENT OF HEALTH.

*Mental Hygiene Branch—Children's Cottages, Kew.*

Class "C2"	Classes "C2" —"B"	To be secretary of the Hospital	Experience in organization of a Mental Hospital, including control of stores, clothing, provisions, &c. and artisan activities. A good knowledge of the Mental Hygiene Acts and Regulations; ability to control staff.	Nugent, D. . .	Class "C2"	5.12.57
------------	----------------------	---------------------------------	--	----------------	------------	---------

PROFESSIONAL DIVISION.

DEPARTMENT OF AGRICULTURE.

Science Master, Burnley Horticultural College, Class "C1"	Classes "C2" —"B"	To teach sciences related to horticulture to diploma level and Agricultural Science to Matriculation standard; to engage in other activities of the College as required	A qualified and experienced teacher, with sound training and experience in the teaching of biological and physical sciences to matriculation level	Farrance, A. J.	Science Master, Burnley Horticultural College, Class "C1"	21.11.58
---	----------------------	---	--	-----------------	---	----------

CHIEF SECRETARY'S DEPARTMENT.

*Explosives and Gas Examining Branch.*

Senior Chemist, Class "B1"	Class "A"	To have charge of the laboratories; to be responsible for the maintenance of standards of accuracy of gas measuring and testing equipment for town's gas and liquefied petroleum gas; to inspect explosives factories; to investigate explosions and fires involving explosives or other dangerous substances; other inspectional and technical duties as directed	A Degree in Science with Chemistry as a major subject or a Diploma of Applied Chemistry from an approved technical college and to be an Associate of the Royal Australian Chemical Institute; special training and experience in explosives factory procedure and in the chemistry, examination and testing of explosives and other hazardous materials; a good knowledge of the Explosives Act, the Gas Regulation Act and the Liquefied Petroleum Gas Act and Regulations and of the standard procedure for calibrating gas measuring and testing equipment for town's gas and liquefied petroleum gas; ability to control staff and supervise laboratory work	Buckley, R. F.	Senior Chemist, Class "B1"	30.11.59
----------------------------	-----------	--	--	----------------	----------------------------	----------

LAW DEPARTMENT.

*Courts Branch—Moe.*

Clerk of Courts, Grade III., Class "C"	Grade II., Classes "C1"—"C2"		As prescribed by Public Service (Public Service Board) Regulation 58	Ryan, K. T. . .	Clerk of Courts, Grade III., Class "C"	16.6.59
--	------------------------------	--	--	-----------------	--	---------

TECHNICAL AND GENERAL DIVISION.

PUBLIC WORKS DEPARTMENT.

Typist (Female), Grade I., Grades F10-F14 inclusive	Assistant (Female) Senior, Grades F23-F26 inclusive	Under the direction of the Officer in Charge, Accounts Payable Section, to supervise staff engaged on the preparation and checking of schedules, payee advices, cheques and reimbursements in respect of accounts payable	A good knowledge of procedures associated with the preparation of claims for payment including mechanized processing, a knowledge of the department's accounting records system and of Treasury funds.	Booth, Constance M.	Typist (Female), Grade I.	23.11.61
---	---	---	--	---------------------	---------------------------	----------

Appeals against such recommendations should be lodged with the Secretary to the Public Service Board not later than Saturday, the 24th November, 1962.

Office of the Public Service Board,  
Melbourne, 13th November, 1962.

By order,  
V. P. SCULLY,  
Secretary.

No. 1249.

*Public Service Act 1958, Section 50.*

## REGULATIONS—PART IV.—SALARIES AND INCREMENTS.

THE Public Service Board, in pursuance of the powers conferred by the *Public Service Act 1958*, hereby amends its Regulations as shown below :—

## SIXTH SCHEDULE.

## TEMPORARY EMPLOYEES.

*Designations of Positions and Rates of Salaries.*

Department and Designation of Position.	Yearly Rate of Salary.		Increments (Annual).
	Minimum.	Maximum.	
DEPARTMENT OF LAW	£	£	
Delete— Mortuary Attendant, Morgue	..	478	..
Add— Mortuary Attendant, Assistant, Morgue	..	478	..

A. GARRAN, Chairman.  
V. P. SCULLY, Secretary.

Office of the Public Service Board,  
Melbourne, 31st October, 1962.

## CLERK, TOWN AND COUNTRY PLANNING BOARD.

APPLICATIONS are invited from persons suitably qualified and experienced for the position of Clerk, Grade 4, on the staff of the Board.

*Salary Range.*—(Actual) £1,693 to £1,803 per annum.

*Duties.*—The successful applicant will be required under the direction of the Secretary to be responsible for the supervision and co-ordination of the work of the administrative and co-ordination of the work of the administrative and typing staff and to undertake secretarial duties to the Board in the absence of the Secretary.

*Qualifications.*—Qualifications should include experience in office administration and ability to carry out investigations and prepare reports. Secretarial experience and a knowledge of the scope and operation of planning and other allied legislation would be an advantage.

*General Conditions.*—Superannuation, recreation, sick and long service leave are similar to those applying to the State Public Service.

Applications, stating age, qualifications and experience will be received up to and including the 24th November, 1962, and should be addressed to the Secretary, Town and Country Planning Board, 61 Spring-street, Melbourne, C.1.

## PRIVATE ADVERTISEMENTS

## CITY OF CAMBERWELL.

## BY-LAW No. 125.

A By-law of the City of Camberwell made under Part XXXV. of the *Local Government Act 1958* and numbered 125 for the purpose of repealing By-laws Nos. 65, 106 and 114, and for imposing, collecting and receiving charges or entrance fees for clubs, associations, or persons using or entering in or upon any lands purchased or rented or otherwise provided by or granted or given by any person to the Council of the Municipality of the City of Camberwell for the providing of pleasure grounds or places of public resort or public recreation and also for regulating the conduct of persons using or being upon or in any such grounds or places.

IN pursuance of the powers conferred by the *Local Government Act 1958*, the Mayor, Councillors and Citizens of the City of Camberwell order as follows:—

*Repeal.*

By-laws Nos. 65, 106 and 114 made by the City of Camberwell under the *Local Government Acts 1928* and 1958 are hereby repealed.

*Operation.*

This By-law shall apply to and have operation throughout the whole of the Municipal District of the City of Camberwell, and shall come into operation and have effect immediately upon its publication in the *Victoria Government Gazette*.

*Definitions.*

"Council" means the Council of the City of Camberwell.

"Management Committee" means an Honorary Committee elected in accordance with rules applying to the constitution of Committees of Management of pleasure grounds or places of public resort or public recreation as laid down by the Council from time to time.

The definition "Lands" without limiting the generality hereof includes any building or other structure erected in on or over the soil.

1. The Council may from time to time appoint local Management Committees to manage such lands as have been or at any future time shall be purchased or rented or otherwise provided by or granted or given by any person to the Council for the providing of pleasure grounds or places of public resort or public recreation, and may prescribe Rules and Regulations for the appointment of such Committees and the manner in which such management shall be carried out.

2. The Council shall have power to hold entertainments, performances, sports meetings, cricket or football matches or other forms of sport on any of such lands and to make a charge for admission thereto.

3. No charge or fee for admission shall exceed Two shillings for each adult person and One shilling for each child under the age of fourteen years unless the Council has previously authorized a higher charge.

4. No person except members of the Council or of the Management Committee, the Town Clerk, the City Engineer, and employees of the Council or Management Committee on duty shall enter any portion of such lands when a charge is made for admission thereto without first paying the fee charged unless otherwise authorized by the Council or Management Committee.

5. No person unless he be guilty of an offence under this By-law shall be required to leave during any such entertainment or sports after he has paid for admission until he has been tendered the amount of the admission fee paid by him.

6. All such lands shall be open to the public free of charge except on such days and at such hours as the Council shall appoint or when a charge is made for admission under the authority of the Council.

7. (i) No person shall interfere with or break or damage any of the trees, plants, or shrubs or pluck any flowers or walk on the beds or borders or climb, jump, or get upon or over any of the fences or gates or cut or in any way damage any of the fences, gates, seats, or other structures, or post bills or advertisements on any of the fences, gates, seats, or other structures or roll or throw stones or other missiles, or leave therein any bottles, broken glass, paper, fruit skins or peel, or any refuse or rubbish whatsoever except in the receptacles provided, or spit or expectorate upon any of the paths or structures, or remove, displace, or damage any notice board within any of such lands.

(ii) No person shall damage any building or post, bills or advertisements on or in any building or leave therein any bottles, broken glass, paper, fruit skins or peel or any refuse or rubbish whatsoever except in the receptacles provided nor spit or expectorate in any building or damage any notice board within any building.

8. No person shall carry firearms in or through such lands or shoot, snare or destroy any birds therein except by the authority of the Council.

9. No person shall without permission of the Council, play, practice or engage in any game or sport within such lands on a Sunday.

10. No person shall engage in cricket, football, bowls, tennis, lacrosse, or any like games in any of such lands without the authority of the Council or Management Committee and then only on payment of any fees or charges that may be prescribed from time to time.

11. No motor car, truck, motor scooter, motor bicycle, bicycle, scooter, cart or any other vehicle whether propelled by mechanical, human or animal power shall be driven or ridden on any footpath or on any or through any such land except any areas set aside for the parking of vehicles without the authority of the proper officer of the Council having first been obtained.

12. No person shall play any unlawful game or make any wager for money or carry on any form of gambling or by any unseemly conduct or otherwise interfere with the comfort and enjoyment of other persons within such lands.

13. No person shall interfere with or in any way hinder or interrupt any employees of the Council or Management Committee engaged in any of such lands.

14. No person shall sell or offer for sale within any of such lands any articles of food or drink or any other commodity or operate any money-making amusement or make any collection of money for any purpose without the written permission of the Council or Management Committee.

15. No person shall behave in a disorderly manner or create or take part in any disturbance or use indecent or abusive language or commit any nuisance or in any way offend against decency as regards dress, language or conduct in any of such lands.

16. No person except employees of the Council or of the Management Committee shall enter any plots in any of such lands which may be enclosed for plantation of trees or shrubs.

17. No person other than players or officials or competitors at any sports gathering duly authorized as aforesaid, shall enter or remain within or upon the playing arena in such lands during the progress of any cricket, football, tennis, bowls, or lacrosse match, or sports gathering, nor interrupt nor interfere with any employee of the Council or Management Committee in the proper execution of his duty or work.

18. No person shall cross or trespass on the playing ground during any cricket, football, tennis, bowls or lacrosse match or sports gathering in such lands when such crossing or trespassing would cause undue interference with the progress of a match or sports gathering.

19. No person shall remain in any of such lands at any time when lawfully directed by any policy officer or officer or employee of the Council to leave the same.

20. (i) No person shall put in any of the said lands any cattle, horses, sheep, goats, or other animals without the permission of the Council or Management Committee, and any animals found so trespassing on any such lands may be seized by the proper officer of the Council, and the owner proceeded against for such trespass.

(ii) No horses, cattle, sheep, goats or other animals shall be driven or ridden on any footpath or in or through any such land without authority of the proper officer of the Council having first been obtained.

21. No person shall bring or have any dog in any of such lands unless such dog is controlled by a chain or cord.

22. No person shall park or leave any motor car or other vehicle in any of such lands excepting at such places and at such times as are provided for that purpose by the Council and the Council may make a charge not exceeding Two shillings a day or part of a day for every motor car or other vehicle so parked or left.

23. No person shall dig or remove any sand, gravel, soil, or other material from any of such lands unless authorized in writing by the Council so to do.

24. Where any area in such lands has been set apart as a children's playground and swings and other appliances have been provided, the following rules shall apply—

- (a) No person above the age of fourteen years shall enter upon or remain on such area or use any of the swings or other appliances therein, provided, however, that this condition shall not apply to parents or other persons in charge of children who shall be at liberty to enter or remain on such area to watch over children who are in their charge.
- (b) The swings or other appliances erected in such area shall not be used by any child or children for a longer period than five minutes consecutively if any other child or children is or are waiting to use them.
- (c) Every person being lawfully on such area shall obey the directions of any officer of the Council or of any police officer or any member of the Management Committee in respect of his or her conduct therein.
- (d) The Council and/or Management Committee shall not be responsible for any accident occurring on any portion of such area or arising from the use of any of the swings or other appliances therein.

(e) Children's playgrounds shall not be open for use after the hour of sunset.

25. No person or persons without the written permission of the Council and a permit to sell, supply or consume liquor issued pursuant to the Licensing Act, shall—

- (a) bring into or consume in any such lands,
- (b) supply to any person or persons in any such lands,
- (c) have in his or her possession or under his or her control in any such lands,

any alcoholic liquor.

26. None of the powers conferred on the Management Committee of any recreation reserve by the constitution and rules of such Management Committee shall be exercised in the event of the Council having passed a Resolution forbidding the exercise of such powers or any of them.

27. Penalties—Every person who is guilty of any wilful act or default contrary to any of the provisions of this By-law shall be liable on conviction to a penalty not exceeding Twenty pounds (£20).

Resolution for passing this By-law agreed to by the Council the 20th day of August, 1962.

Confirmed the 17th day of September, 1962.

The common seal of the Mayor, Councillors and Citizens of the City of Camberwell was hereto affixed, by Order of the Council this 17th day of September, 1962, in the presence of—

(SEAL) RALPH L. DEAR, Mayor.  
W. FORDHAM, Councillor.  
H. L. POLGLASE, Acting Town Clerk.

Approved by the Governor in Council on the 23rd day of October, 1962—N. G. WISHART, Clerk of the Executive Council. 3393

#### CITY OF CAMBERWELL.

##### LOAN No 54.

*Notice of Intention to Borrow the Sum of £10,000 for Permanent Works and Undertakings.*

NOTICE is hereby given that the Council of the City of Camberwell proposes to borrow the sum of Ten thousand pounds on the credit of the municipal revenues of the Mayor, Councillors and Citizens of the said City, by the issue of a mortgage, in accordance with the provisions of the *Local Government Act 1958*.

1. The maximum rate of interest that may be paid is 5½ per cent. per annum.
2. The purpose for which the loan is to be applied is road reconstruction and drainage works.
3. The period of the loan shall be ten years.
4. The money borrowed shall be repayable by providing out of the municipal fund twenty half-yearly instalments of approximately £656 14s. 5d. each, including principal and interest, on the 1st day of October and the 1st day of March during the currency of the loan. The first instalment shall be payable on the 1st day of October, 1963.
5. Such moneys shall be repayable at the Head Office of the Commonwealth Savings Bank, Melbourne.

The plans and specifications and the estimate of the cost of the proposed works and a statement showing the proposed expenditure of the moneys to be borrowed, are open for inspection at the office of the Council, Municipal Chambers, Camberwell, during office hours.

Dated this 13th day of November, 1962.

3443 L. F. CHEFFERS, Chief Administrator.

#### CITY OF CAMBERWELL.

##### LOAN No. 55.

*Notice of Intention to Borrow the Sum of £25,000 for Permanent Works and Undertakings.*

NOTICE is hereby given that the Council of the City of Camberwell proposes to borrow the sum of Twenty-five thousand pounds on the credit of the municipal revenues of the Mayor, Councillors and Citizens of the said City, by the issue of debentures, in accordance with the provisions of the *Local Government Act 1958*.

1. The maximum rate of interest that may be paid is 5½ per cent. per annum.
2. The purpose for which the loan is to be applied is road reconstruction and drainage works.
3. The period of the loan shall be ten years.

4. The money borrowed shall be repayable by providing out of the municipal fund twenty half-yearly instalments of approximately £1,641 15s. 11d. each, including principal and interest, on the 1st day of October and the 1st day of March during the currency of the loan. The first instalment shall be payable on the 1st day of October, 1963.

5. Such money shall be repayable at the Head Office of the Commercial Bank of Australia Ltd., Melbourne, or at the Head Office of the Council's bankers for the time being in Melbourne.

Dated this 13th day of November, 1962.

3442 L. F. CHEFFERS, Chief Administrator.

CITY OF DANENONG.

LOAN No. 25.

*Notice of Intention to Borrow the Sum of £15,000 for Permanent Works and Undertakings.*

NOTICE is hereby given that the Council of the City of Dandenong proposes to borrow the sum of £15,000 on the credit of the municipal revenues of the Mayor, Councillors and Citizens of the said City, such sum to be raised by the grant of a mortgage, in accordance with the provisions of the *Local Government Act 1958*.

1. The amount of principal moneys which it is proposed to borrow is £15,000.

2. The maximum rate of interest that may be paid is 5 10s. per centum per annum.

3. The period of the loan will be ten years and the time or times at which the moneys borrowed are to be repayable are the 1st day of March and the 1st day of September in each year during the currency of the loan, commencing on the 1st day of September, 1963. The place of repayment will be the Commercial Bank of Australia Ltd., Melbourne, or at the Council's bankers for the time being in Melbourne.

4. The purpose for which the loan is to be applied is for permanent works and undertakings, viz.:—

Construction works Cattle Market, Cheltenham-road, Dandenong.

Construction of—

(a) Underground drain, levelling area for concrete paving and erection cattle selling pens.

(b) Roadway on northern side of land under lease.

(c) Water reticulation to some existing and new cattle pens.

(d) Brick washing and manure collection areas.

The loan is to be liquidated by twenty half-yearly payments of approximately £985 1s. 6d. each, including principal and interest, payable out of the municipal fund.

Plans and specifications and an estimate of the cost of such works and undertakings and a statement showing the proposed expenditure of the money to be borrowed, are open for inspection of ratepayers during office hours at the Town Hall, Lonsdale-street, Dandenong.

Dated at Dandenong this 14th day of November, 1962.

3401 C. A. ELLIOTT, Town Clerk.

CITY OF HEIDELBERG.

*Local Government Act 1958.*

NOTICE TO ALL WHOM IT MAY CONCERN.

WHEREAS the Council of the Municipality of the City of Heidelberg in the State of Victoria deems it expedient to execute a certain work or undertaking for the purpose of providing an off-street parking area, for the purposes whereof it is in the opinion of the said Council necessary and desirable that the said Council exercise its power of taking land compulsorily within the municipal district of the said Council, as provided by the *Local Government Act, 1958*, and the said Council has caused its surveyor to prepare a plan of the said work or undertaking as is necessary and in which is expressed the nature and extent of such work or undertaking and the exact site and admeasurements thereof and on and through what land the said work or undertaking is proposed to be placed and the names of the owners or reputed owners, lessees or reputed lessees and the occupiers of such land so proposed to be taken so far as known and the said plan so prepared has been approved by the said Council.

In pursuance of the provisions of the *Local Government Act 1958*, the said Council doth hereby publish and give notice that the description shortly of the purport of the said work or undertaking and of the said plan is as follows:—

The provision of an off-street parking area for Heidelberg shopping centre, Burgundy-street.

And the said Council doth hereby give further notice that the said plan is deposited at the office of the said Council, Town Hall, Ivanhoe, and is there open for inspection and perusal on all the days and between the hours the Municipal Office is appointed to be open for the space of 40 clear days from the date of the publication of this notice in the *Government Gazette*.

And the said Council doth hereby call upon all persons interested in or affected by the said proposed work or undertaking to set forth in writing, addressed to the said Council or the Town Clerk thereof, at the Town Hall, Ivanhoe, within 40 clear days from the date of the publication of this notice as aforesaid all objections which they may have to the said work or undertaking.

Dated this 5th day of November, 1962.

The common seal of the Mayor, Councillors and Citizens of the City of Heidelberg was hereto affixed, by me—

F. PHILLIPS, Town Clerk.

in the presence of—

(SEAL)

ARTHUR C. WEALES, Mayor.  
FRANK T. ROJO, Councillor.

3402

CITY OF MELBOURNE.

BY-LAW No. 430.

A By-law of the City of Melbourne, made under Part VII, Division 1, of the *Local Government Act 1958* and numbered 430 to amend and add to By-law No. 418.

IN pursuance of the powers conferred by Part VII, Division 1, of the *Local Government Act 1958* and every other Act or power enabling it in that behalf, the Council of the City of Melbourne doth order as follows:—

1. Clause 14 of By-law No. 418 shall be repealed and the following clause substituted therefor, viz.:—

"14. (1) No person shall deposit or leave any refuse or rubbish on any street, road, lane or passage in the City.

(2) No person shall, without the consent, in writing, of the City Engineer in that behalf deposit or leave any refuse or rubbish on any land in the City.

(3) Every person who by any wilful act or default contravenes either of the provisions of this clause shall be liable on conviction to a penalty of not more than One hundred pounds."

2. By-law No. 418 shall be further amended by inserting after clause 15 the following new clause, viz.:—

"15A. Any land in the City which the Council by notice, in writing, to the owner or occupier has declared to be unsightly or destructive of the amenity of the neighbourhood shall within a period stated in the notice, not being less than 60 days, be enclosed with a sufficient fence of iron, timber, brick or other suitable material approved by the building surveyor to a height of 6 feet at the least and in such manner as to conceal the land from the view of passers-by."

3. After sub-clause (2) of clause 24, there shall be added the following sub-clauses:—

"(3) No person shall place or leave on any street or footway any placard, board or other thing by way of advertisement.

(4) No person shall on any street or footway carry or cause to be otherwise displayed for the primary purpose of advertising any placard, board or other thing."

4. In clause 29 the word "of" where secondly appearing shall be repealed.

5. In clause 37 after the words "any veranda" there shall be added the words "or upon any shop front or any outside wall abutting any street or public place."

6. (a) After clause 27 the following new clause shall be added:—

"27A. Unless otherwise expressly provided no person shall obstruct any street or footway by standing or loitering therein or thereon whether for the purpose of selling or offering for sale any goods or otherwise."

(b) In clause 28 the words and figures "clauses 25, 26 and 27" shall be repealed and the following words and figures substituted therefor, viz.:—

"Clauses 25, 26, 27 and 27A."

Resolution for passing this By-law agreed to by the Council of the City of Melbourne the fifteenth day of October, 1962, and confirmed the twelfth day of November, 1962.

3450

M. A. NATHAN, Lord Mayor.  
F. N. ROGAN, Town Clerk.

**CITY OF MOORABBIN.**

**ORDERS CHANGING NAMES OF STREETS.**

**NOTICE** is hereby given that at meetings of the Council of the City of Moorabbin held on the 15th October, 1962, and 5th November, 1962, the said Council, in pursuance of the powers conferred by the *Local Government Act 1958*, did make orders changing the names of the following streets:—

*Old Name; New Name; Location.*

Halley-street; Jeffrey-street; off the north side of Lawson-street, Bentleigh, to connect with the existing Jeffrey-street.

Pine-lane (east-west section) and Tattersson-road; Madden-road; off west side of Old Dandenong-road, Heatherton.

By order of the Council,

3403 V. A. SMITH, Town Clerk.

**Town and Country Planning Acts.**

**CITY OF NEWTOWN AND CHILWELL.—EIGHTH SCHEDULE.**

**GEELONG PLANNING SCHEME 1959.—CITY OF NEWTOWN AND CHILWELL.**

*Amendment No. 1, 1962.*

**NOTICE** is hereby given that the Council of the City of Newtown and Chilwell in pursuance of its powers under the Town and Country Planning Acts has prepared a Planning Scheme for—All that piece of land bounded by Pakington-street on the West, Saffron-street on the North, Clarendon-street on the South and right-of-way approximately 91 feet East from Pakington-street, Chilwell.

For the purpose of varying the principal scheme by changing the area stated from Commercial "B" to Residential "A".

All maps, plans, descriptions and other data fully setting out and explaining the planning scheme have been deposited at the City Hall, Pakington-street, Newtown, and at the office of the Town and Country Planning Board, Melbourne, and will be open for inspection without payment of any fee by all persons affected, between the hours of 9 a.m. and 4 p.m., on all days of the week except Saturdays, Sundays and Public Holidays, until and including the 21st day of December, 1962.

Any persons affected by the Planning Scheme are required to set forth in writing all objections they may have, addressed to The Town Clerk, Newtown and Chilwell City Council, Pakington-street, Newtown, on or before the 21st day of December, 1962.

6th November, 1962

3381 GEO. COCKS, J.P., Town Clerk.

**CITY OF RINGWOOD.**

**LOAN No. 47.**

*Notice of Intention to Borrow the Sum of £15,000 for Permanent Works and Undertakings.*

**NOTICE** is hereby given that the Council of the City of Ringwood proposes to borrow the sum of Fifteen thousand pounds on the credit of the municipal revenues of the Mayor, Councillors and Citizens of the said City, such sum to be raised by the grant of a mortgage in accordance with the provisions of the *Local Government Act 1958*.

1. The maximum rate of interest that may be paid is 5½ per cent. per annum.

2. The purposes for which the loan is to be applied are:—

(a) Purchase of Office Equipment—Accounting Machine	£1,900
(b) Purchase of Road Making Plant—Front End Loader	2,000
(c) Road Construction—Oban-road—Maroon-dah Highway, Warrandyte-road	10,400
(d) Footpath construction—Various	700
	£15,000

3. The period of the loan shall be ten years.

4. The moneys borrowed shall be repayable by providing out of the municipal fund twenty half-yearly instalments of approximately £985 1s. 6d. each, including principal and interest, on the 1st day of March and September during the currency of the loan. The first instalment shall be payable on the 1st day of September, 1963.

5. Such moneys shall be repayable at the Bank of New South Wales, Maroon-dah Highway, Ringwood.

The plans and specifications and the estimate of the cost of the proposed works and a statement showing the proposed expenditure of the moneys to be borrowed, are open for inspection at the Town Hall, Ringwood.

F. P. DWERRYHOUSE, Town Clerk.

Town Hall, Ringwood, 5th November, 1962. 3364

*Local Government Act 1958.*

**CITY OF SPRINGVALE.**

**NOTICE OF INTENTION TO TAKE LAND COMPULSORILY.**

**NOTICE** is given that it is the intention of the Council of the City of Springvale, in exercise of the powers conferred on it by the *Local Government Act 1958*, to take compulsorily the following land:—

All that piece of land on the eastern boundary of lot 56, Corrigan-road, lodged plan No. 9395, thus:—Commencing at the south-west corner of lot 56; thence easterly by the southern boundary of the said lot for a distance of 2 ft. 11 in.; thence northerly for a distance of 50 feet; thence westerly by the northern boundary for a distance of 5 ft. 10 in.; thence southerly to the point of commencement.

And all that piece of land on the eastern boundary of lot 55, Corrigan-road, lodged plan No. 9395, thus:—Commencing at the south-west corner of the said lot; thence easterly by the southern boundary for a distance of 5 ft. 10 in.; thence northerly along the eastern boundary of the said lot for a distance of 50 ft. 9 in.; thence westerly by the northern boundary for a distance of 8 ft. 9 in.; thence generally southerly to the point of commencement.

The said land is required for and being taken for the following work or undertaking by the said Council:—

For the purpose of widening Corrigan-road, Noble Park, within its municipal district.

The Council has caused to be prepared specification, map and plan showing the nature and extent of such work or undertaking and more particularly describing the said land and the exact site and measurements thereof and stating that the names of the owners or reputed owners of the said lands are Gerald E. Bell and Leslie R. Cowen, and the names of the occupiers thereof are the said Gerald E. Bell and Leslie R. Cowen.

The said specification, map and plan have been approved by the Council and are now deposited for inspection by all persons interested at the offices of the City of Springvale, situated at Springvale-road, Springvale, and may be inspected there during office hours.

All persons affected by the proposed works or undertaking are hereby required to set forth, in writing, addressed to the said Council or to the Municipal Clerk within forty (40) clear days from the publication of this notice in the *Government Gazette*, all objections which they may have to such work or undertaking.

Dated the 8th day of November, 1962.

By order of the Council,

H. L. WILLIAMS, Town Clerk and Municipal Clerk.

3426

**CITY OF SPRINGVALE.**

**LOAN No. 96.**

*Special Order to Borrow the Sum of £3,500.*

**NOTICE** is hereby given that the Council at an Ordinary Meeting held on Monday, 5th November, 1962, at 7.00 p.m. passed the following Resolution as a Special Order.

That—

1. (a) This Council borrow moneys by the grant of a mortgage upon the credit of the Municipality pursuant to section 585 of the *Local Government Act 1958*.

(b) The amount of the principal moneys to be borrowed be £3,500.

(c) The rate of interest to be paid be £5 10s. per centum per annum.

(d) The moneys borrowed be repayable by twenty equal instalments payable respectively on the 15th day of January, and on the 15th day of July of each year, the first such instalment being repayable on the 15th day of July, 1963.

(e) The moneys borrowed be repayable at the Australia and New Zealand Bank Limited, Lonsdale and Scott streets, Dandenong.

(f) The loan be applied for the purposes of liquidating or of partly liquidating the amount due on overdraft of current account to the Council's Bankers in respect of the execution of private street construction schemes pursuant to Division 10 of Part XIX. of the *Local Government Acts*.

(g) The loan be liquidated by providing out of the municipal fund on the 15th day of January, and on the 15th day of July of each year, the sum necessary to pay the half-yearly instalment and the interest then due in respect of the loan.

2. The Council directs that this Resolution be brought forward for confirmation as a Special Order at a meeting of the Council to be held on the 3rd day of December, 1962, at seven o'clock in the afternoon.

Notice is hereby further given that the said Resolution will be submitted for confirmation at the Ordinary Meeting of the Council to be held on Monday, 3rd December, 1962, at 7.00 p.m. in the Council Chambers, City Offices, Springvale.

3391

H. L. WILLIAMS Town Clerk.

## CITY OF SPRINGVALE.

## LOAN No. 98.

*Special Order to Borrow the Sum of £50,000.*

NOTICE is hereby given that the Council at an Ordinary Meeting held on Monday, 5th November, 1962, at 7.00 p.m. passed the following Resolution as a Special Order.

That—

1. (a) This Council borrow moneys by the grant of a mortgage upon the credit of the Municipality pursuant to section 585 of the *Local Government Act 1958*.

(b) The amount of the principal moneys to be borrowed be £50,000.

(c) The rate of interest to be paid be £5 10s. per centum per annum.

(d) The moneys borrowed be repayable by twenty equal instalments payable respectively on the first day of April, and on the first day of October of each year, the first such instalment being repayable on the first day of October, 1963.

(e) The moneys borrowed be repayable at the Australia and New Zealand Bank Limited, Lonsdale and Scott streets, Dandenong.

(f) The loan be applied for the purposes of liquidating or of partly liquidating the amount due on overdraft of current account to the Council's Bankers in respect of the execution of private street construction schemes pursuant to Division 10 of Part XIX. of the *Local Government Acts*.

(g) The loan be liquidated by providing out of the municipal fund on the first day of April, and on the first day of October of each year, the sum necessary to pay the half-yearly instalment and the interest then due in respect of the loan.

2. The Council directs that this Resolution be brought forward for confirmation as a Special Order at a meeting of the Council to be held on the 3rd day of December, 1962, at seven o'clock in the afternoon.

Notice is hereby further given that the said Resolution will be submitted for confirmation at the Ordinary Meeting of the Council to be held on Monday, 3rd December, 1962, at 7.00 p.m. in the Council Chambers, City Offices, Springvale.

3392

H. L. WILLIAMS Town Clerk.

## TOWN OF STAWELL.

## LOAN No. 26.

*Notice of Intention to Borrow the Sum of £12,000 for Permanent Works and Undertakings.*

NOTICE is hereby given that the Council of the Town of Stawell proposes to borrow the sum of Twelve thousand pounds on the credit of the municipal revenues of the Mayor, Councillors and Citizens of the said Town of Stawell, other than such revenue as set out in subsection (3) of section 397 of the *Local Government Act 1958*, such sum to be raised by the grant of a mortgage, in accordance with the provisions of the *Local Government Act 1958*.

1. The maximum rate of interest that may be paid is 5½ per cent. per annum or the rate prevailing at date of settlement.

2. The purpose for which the loan is to be applied is—  
Construction of extensions to electricity reticulation. Additional generating equipment.

3. The period of the loan shall be ten years.

4. The moneys borrowed shall be repayable by providing out of the municipal fund twenty half-yearly instalments of approximately £788 1s. 4d. each, including principal and interest, on the 1st day of September and the

1st day of March during the currency of the loan. The first instalment shall be payable on the 1st day of September, 1963.

5. Such moneys shall be repayable at The Australia and New Zealand Savings Bank Limited, Melbourne.

The plans and specifications and the estimate of the cost of the proposed works, and a statement showing the proposed expenditure of the moneys to be borrowed, are open for inspection at the Municipal Offices, Stawell.

Dated 9th November, 1962.

3404

L. L. SMITH, Town Clerk.

## BOROUGH OF MOE.

## LOAN No. 24.

*Notice of Intention to Borrow the sum of £5,000 for Permanent Works and Undertakings.*

NOTICE is hereby given that the Council of the Borough of Moe proposes to borrow the sum of Five thousand pounds on the credit of the municipal revenues of the Mayor, Councillors and Burgesses of the said Borough, such sum to be raised by the grant of a mortgage in accordance with the provisions of the *Local Government Act 1958*.

1. The maximum rate of interest that may be paid is £5 10s. per cent. per annum.

2. The purpose for which the loan is to be applied is—

	£
(a) Purchase of Plant and Equipment ..	2,000
(b) Drainage, Administration Building area ..	1,610
(c) Drain, corner of Murray-road and Shanahan-parade ..	520
(d) Albert-street paths ..	450
(e) Street Construction, Murray-road Reserve	420
	£5,000

3. The period of the loan shall be ten years.

4. The moneys borrowed shall be repayable by providing out of the municipal fund twenty half-yearly instalments of approximately £328 10s. each, including principal and interest, on the 1st day of August and the 1st day of February during the currency of the loan. The first instalment shall be payable on the 1st day of August, 1963.

5. Such moneys shall be repayable at The State Savings Bank of Victoria, Melbourne.

The plans and specifications and the estimate of the cost of the proposed works, and a statement showing the proposed expenditure of the moneys to be borrowed, are open for inspection at the Borough Office, Moe, during office hours.

Dated 7th November, 1962.

3365

F. E. BARTLETT, Town Clerk.

## BOROUGH OF MOE.

## LOAN No. 25.

*Notice of Intention to Borrow the sum of £8,000 for Permanent Works and Undertakings.*

NOTICE is hereby given that the Council of the Borough of Moe proposes to borrow the sum of Eight thousand pounds on the credit of the municipal revenues of the Mayor, Councillors and Burgesses of the said Borough, such sum to be raised by the grant of a mortgage in accordance with the provisions of the *Local Government Act 1958*.

1. The maximum rate of interest that may be paid is £5 10s. per cent. per annum.

2. The purpose for which the loan is to be applied is—  
Council contribution to C.R.B. works.

3. The period of the loan shall be 40 years.

4. The loan is to be liquidated by the creation of a sinking fund, pursuant to section 423A of the *Local Government Act 1958*. Interest on the amount of the loan shall be payable half-yearly.

5. Such moneys shall be repayable at the State Superannuation Board, Treasury Gardens, Melbourne, C2, or at the Council's bankers for the time being in the City of Melbourne, or at such other place or places as the lender from time to time may require.

The plans and specifications and the estimate of the cost of the proposed works, and a statement showing the proposed expenditure of the moneys to be borrowed, are open for inspection at the Borough Office, Moe.

Dated this 7th day of November, 1962.

3367

F. E. BARTLETT, Town Clerk.

## BOROUGH OF MOE.

## LOAN No. 26.

*Notice of Intention to Borrow the sum of £5,000 for Permanent Works and Undertakings.*

**N**OTICE is hereby given that the Council of the Borough of Moe proposes to borrow the sum of Five thousand pounds on the credit of the municipal revenues of the Mayor, Councillors and Burgesses of the said Borough, such sum to be raised by the grant of a mortgage in accordance with the provisions of the *Local Government Act 1958*.

1. The maximum rate of interest that may be paid is £5 10s. per cent. per annum.
2. The purpose for which the loan is to be applied is—  
The purchase of a staff residence in Newborough.
3. The period of the loan shall be 40 years.
4. The moneys borrowed shall be repayable by providing out of the municipal fund 80 half-yearly instalments of approximately £155 4s. 4d. each, including principal and interest, on the 1st day of August and the 1st day of February during the currency of the loan. The first instalment shall be payable on the 1st day of August, 1963.
5. Such moneys shall be repayable at the National Bank of Australasia, Melbourne, or at the Council's bankers for the time being in Melbourne.

The plans and specifications and the estimate of the cost of the proposed works, and a statement showing the proposed expenditure of the moneys to be borrowed, are open for inspection at the Borough Office, Moe, during office hours.

Dated 7th November, 1962.

3366

F. E. BARTLETT, Town Clerk.

## SHIRE OF BAIRNSDALE.

## LOAN No. 43.

*Notice of Intention to Borrow the Sum of £11,000 for Permanent Works and Undertakings.*

**N**OTICE is hereby given that the Council of the Shire of Bairnsdale proposes to borrow the sum of Eleven thousand pounds on the credit of the municipal revenues of the President, Councillors and Ratepayers of the said Shire, such sum to be raised by the grant of a mortgage, in accordance with the provisions of the *Local Government Act 1958*.

1. The maximum rate of interest that may be paid is £5 7s. 6d. per cent. per annum.
2. The purposes for which the loan is to be applied are—  
Purchase of road-making plant.
3. The period of the loan shall be six years.
4. The moneys borrowed shall be repayable by providing out of the municipal fund twelve half-yearly instalments of £1,084 11s. 4d. each, including principal and interest, on the 1st day of March and the 1st day of September during the currency of the loan, the first instalment to be repayable on the 1st day of September, 1963.
5. Such moneys shall be repayable at the Bank of New South Wales, Bairnsdale.

The plans and specifications and the estimate of the cost of the proposed works, and a statement showing the proposed expenditure of the moneys to be borrowed, are open for inspection at the Shire Office, Nicholson-street, Bairnsdale during office hours.

3448

E. LLOYD BRINDLEY, Shire Secretary.

## SHIRE OF BAIRNSDALE.

## LOAN No. 44.

*Notice of Intention to Borrow the Sum of £15,000 for Permanent Works and Undertakings.*

**N**OTICE is hereby given that the Council of the Shire of Bairnsdale proposes to borrow the sum of Fifteen thousand pounds on the credit of the municipal revenues of the President, Councillors and Ratepayers of the said Shire, such sum to be raised by the grant of a mortgage, in accordance with the provisions of the *Local Government Act 1958*.

1. The maximum rate of interest that may be paid is £5 10s. per cent. per annum.
2. The purposes for which the loan is to be applied are—  
Road construction and drainage.

3. The period of the loan shall be fifteen years.

4. The moneys borrowed shall be repayable by providing out of the municipal fund 30 half-yearly instalments of £740 15s. 4d. each, including principal and interest, on the 1st day of March and the 1st day of September during the currency of the loan, the first instalment to be repayable on the 1st day of September, 1963.

5. Such moneys shall be repayable at the Bank of New South Wales, Bairnsdale.

The plans and specifications and the estimate of the cost of the proposed works, and a statement showing the proposed expenditure of the moneys to be borrowed, are open for inspection at the Shire Office, Nicholson-street, Bairnsdale during office hours.

3447

E. LLOYD BRINDLEY, Shire Secretary.

## SHIRE OF BALLARAT.

## BY-LAW No. 35.

**N**OTICE is hereby given that, in pursuance of powers conferred by the Local Government Acts, the President, Councillors and Ratepayers of the Shire of Ballarat have made By-law No. 35 for prohibiting or regulating the leaving standing of derelict or unregistered motor cars on streets or roads and providing for the removal and disposal of such motor cars and the imposition of charges for such removal and disposal.

A copy of the By-law is open for inspection, free of charge, during office hours at the Office of the Council, Gillies-street, Wendouree.

3421

JAMES H. MITCHELL, Shire Secretary.

## SHIRE OF BALLARAT.

## BY-LAW No. 36.

**N**OTICE is hereby given that, in pursuance of powers conferred by the Local Government Acts, the President, Councillors and Ratepayers of the Shire of Ballarat have made a By-law No. 36 for prohibiting or regulating the leaving standing of caravans on streets or roads and the placing of caravans on private property.

A copy of the By-law is open for inspection, free of charge, during office hours at the Office of the Council, Gillies-street, Wendouree.

3420

JAMES H. MITCHELL, Shire Secretary.

## SHIRE OF BUNINYONG.

## BY-LAW No. 23.

A By-law of the Shire of Buninyong made under section 197 (1) (XX.) of the *Local Government Act 1958* as amended by any Act, and numbered 23 for prohibiting the use on any road of any vehicle having on its wheels any bars, spikes, flanges or other projections or of any vehicle which moves wholly or partly on crawler or revolving tracks.

**I**N pursuance of the powers conferred by the *Local Government Act 1958* as amended by any Act, the President, Councillors and Ratepayers of the Shire of Buninyong, order as follows:—

1. No person shall use on any road any vehicle having on its wheels any bars, spikes, flanges or other projections or any vehicle which moves wholly or partly on crawler or revolving tracks.
2. This By-law shall apply to and have operation throughout the whole of the municipal district of the Shire of Buninyong.

Resolution for passing this By-law agreed to by the Council of the Shire of Buninyong on the 2nd day of August, 1962, and confirmed on the 31st day of August, 1962.

The common seal of the Corporation, styled the President, Councillors and Ratepayers of the Shire of Buninyong was affixed hereto, in the presence of—

3383

(L.S.)

D. L. COXALL, President.

A. F. TURNER, Councillor.

A. C. LORD, Shire Secretary.

## SHIRE OF CROYDON.

**W**HETHERAS the Council of the Shire of Croydon deems it expedient to provide the work of undertaking the constructing of a drain on the land described in the Schedule hereto: And whereas for the purpose thereof the exercise of the compulsory power of taking the said easement will in the Council's opinion be necessary and desirable: And whereas the Council has caused to be prepared maps, plans, sections and elevations setting out and describing such work or undertaking and the exact



site and admeasurements thereof and the names of the owners or reputed owners, lessees or reputed lessees and the occupiers thereof as far as such names be ascertained by the Council: And whereas such maps, plans, sections and elevations are deposited at the office of the Council at Croydon and are and shall be open for inspection by all persons interested at all reasonable hours for the space of 40 clear days after publication of this notice in the *Government Gazette*: Now notice is hereby given to all persons affected by the proposed work and undertaking and they are hereby called upon to set forth, in writing, addressed to the said Council or the President of the Shire of Croydon within 40 clear days from the publication of this notice in the *Government Gazette* all objections which they may have to the said work or undertaking.

SCHEDULE HEREINBEFORE REFERRED TO:

All that piece of land being 6 feet wide along the northern boundary of lot 1, lodged plan 23011, corner of Canterbury-road and Gracedale-avenue, Bayswater.

3369 K. A. MCKAY, Shire Secretary.

SHIRE OF FLINDERS.

LOAN NO. 32.

*Notice of Intention to Borrow the Sum of £30,000 for Permanent Works and Undertakings.*

NOTICE is hereby given that the Council of the Shire of Flinders proposes to borrow the sum of £30,000 upon the credit of the municipal revenues of the President, Councillors and Ratepayers of the Shire of Flinders, such sum to be raised by grant of a mortgage, in accordance with the provisions of the *Local Government Act 1958*.

1. The maximum rate of interest that may be paid is £5 10s. per centum per annum.

2. The purpose for which the loan is to be applied is—

Purchase of accounting machine ..	£2,000
Construction of Rosebud Olympic Oval ..	8,000
Construction of streets ..	20,000

£30,000

3. The period of the loan shall be ten years.

4. The loan shall be repaid by twenty half-yearly instalments of £1,970 3s. each by provision out of the Municipal Fund of the amount during the currency of the loan. The first instalment shall be due and payable on the 1st August, 1963.

5. Such money shall be repayable at the National Bank of Australasia Ltd., Melbourne.

The plans, specifications and an estimate of the cost of the proposed works, and a statement showing the proposed expenditure of the moneys to be borrowed, are open for inspection at the Shire Office, Dromana, during office hours.

3422 S. WILLIAMS, Shire Secretary.

SHIRE OF GLENELG.

APPOINTMENT OF PROSECUTING OFFICER.

NOTICE is hereby given that Senior Constable Eric William Brewer, No. 10926, has been appointed as Prosecuting Officer in place of Sergeant Alan Coysh, No. 10150.

3445 J. B. HANSEN, Shire Secretary.

SHIRE OF HAMPDEN.

PROSECUTING OFFICER.

NOTICE is hereby given that Senior Constable Reginald George Brown, No. 10772, has been appointed Prosecuting Officer to the Shire of Hampden, in lieu of Sergeant T. P. Gilmore, resigned.

3368 S. J. GRIMMER, Shire Secretary.

SHIRE OF KOWREE.

IN pursuance of the powers conferred by section 522 of the *Local Government Act 1958*, the Council of the Shire of Kowree doth hereby direct that the land in the Parish of Jallakin more particularly described hereunder which has been taken purchased or acquired by it shall be a public highway from and after the date of publication of this Order in the *Government Gazette*:—

All that piece of land being the surface and down to a depth of 50 feet below the surface of that part of allotment 17A, Parish of Jallakin, County of Lowan, containing 17 perches bounded as follows:—Commencing at the south-

east corner of the said allotment; thence north 89 deg. 43 min. west 450 links; thence north 37 deg. 9 min. west 285 5/10 links; thence south 52 deg. 4 min. east 242 links; thence south 18 deg. 28 min. east 83 links to the commencing point.

The common seal of the President, Councillors and Ratepayers of the Shire of Kowree was hereto affixed this 5th day of October, 1959, in the presence of—

(SEAL) R. S. HARKNESS, President.  
A. M. HOBBS, Councillor.  
3406 H. ERNEST WALKER, Secretary.

SHIRE OF KOWREE.

IN pursuance of the powers conferred by section 522 of the *Local Government Act 1958*, the Council of the Shire of Kowree doth hereby direct that the land in the Parish of Edenhope being all that piece of land containing 1 acre 2 roods 8 perches or thereabouts, being part of Crown section A, Parish of Edenhope, commencing at a point on the southern boundary thereof distant 2,071 6/10 links from the south-west corner thereof; thence north 600 links west, 400 links north, 100 links east, 400 links north, 453.4 links east, 100 links south, 1,153.4 links west, 100 links to the commencing point, which has been taken purchased or acquired by it, shall be a public highway from and after the date of publication of this Order in the *Government Gazette*.

The common seal of the President, Councillors and Ratepayers of the Shire of Kowree was hereunto affixed this 5th day of September, 1960, in the presence of—

(SEAL) R. G. WALKER, President.  
A. M. HOBBS, Councillor.  
3407 H. ERNEST WALKER, Secretary.

SHIRE OF KOWREE.

IN pursuance of the powers conferred by section 522 of the *Local Government Act 1958*, the Council of the Shire of Kowree doth hereby direct that the land in the Parish of Boorookpi containing 3 roods 32 5/10 perches or thereabouts, being part of Crown allotment 7, commencing at the north-east corner of the said allotment bearing south 0 deg. 25 min. east 228 1/10 links; thence north 75 deg. 9 min. west; thence north 89 deg. 35 min. east 835 6/10 links to the commencing point, which has been taken purchased or acquired by it, shall be a public highway from and after the date of publication of this Order in the *Government Gazette*.

The common seal of the President, Councillors and Ratepayers of the Shire of Kowree was hereunto affixed this 5th day of November, 1962, in the presence of—

(SEAL) A. M. HOBBS, President.  
S. C. HOBBS, Councillor.  
3408 H. ERNEST WALKER, Secretary.

SHIRE OF KOWREE.

IN pursuance of the powers conferred by section 522 of the *Local Government Act 1958*, the Council of the Shire of Kowree doth hereby direct that the land in the Parish of Boorookpi containing 11 8/10 perches being part of Crown allotment 8A, commencing at the northern most corner of the said allotment; thence south 56 deg. 48 min. east 104 4/10 links; thence north 80 deg. 50 min. west 374 4/10 links; thence south 89 deg. 35 min. west 255 6/10 links to the commencing point limited as to depth to the surface and down to a depth of 50 feet below the surface hereof, which has been taken purchased or acquired by it, shall be a public highway from and after the date of publication of this Order in the *Government Gazette*.

The common seal of the President, Councillors and Ratepayers of the Shire of Kowree was hereunto affixed this 5th day of November, 1962, in the presence of—

(SEAL) A. M. HOBBS, President.  
S. C. HOBBS, Councillor.  
3409 H. ERNEST WALKER, Secretary.

SHIRE OF KOWREE.

IN pursuance of the powers conferred by sections 522 and 526 of the *Local Government Act 1958*, the Council of the Shire of Kowree doth hereby direct that the land in the Parish of Awonga being part of Crown allotment G, commencing at the north-east angle of the said allotment; thence south 59 deg. 21 min. west 171 7/10 links; thence north 36 deg. 6 min. east 107 1/10 links; thence north 89 deg. 22 min. east 84 6/10 links to the commencing point

containing 5 8/10 perches or thereabouts, which has been taken purchased or acquired by it, shall be a public highway from and after the date of publication of this Order in the *Government Gazette*.

The common seal of the President, Councillors and Ratepayers of the Shire of Kowree was hereunto affixed this 5th day of November, 1962, in the presence of—

(SEAL) A. M. HOBBS, President.  
S. C. HOBBS, Councillor.  
3410 H. ERNEST WALKEAR, Secretary.

## SHIRE OF KOWREE.

IN pursuance of the powers conferred by sections 522 and 526 of the *Local Government Act 1958*, the Council of the Shire of Kowree doth hereby direct that the land in the Parish of Awonga being part of Crown allotment 86 commencing at the south-east angle of the said allotment; thence north 17 deg. 2 min. east 207 5/10 links; thence south 36 deg. 6 min. east 246 7/10 links; thence north 89 deg. 21 min. east 84 6/10 links to the commencing point containing 13 4/10 perches or thereabouts which has been taken purchased or acquired by it, shall be a public highway from and after the date of publication of this Order in the *Government Gazette*.

The common seal of the President, Councillors and Ratepayers of the Shire of Kowree was hereunto affixed this 5th day of November, 1962, in the presence of—

(SEAL) A. M. HOBBS, President.  
S. C. HOBBS, Councillor.  
3411 H. ERNEST WALKEAR, Secretary.

## SHIRE OF KOWREE.

IN pursuance of the powers conferred by sections 522 and 526 of the *Local Government Act 1958*, the Council of the Shire of Kowree doth hereby direct that the land in the Parish of Yallakar being—

Firstly, all that piece of land commencing at the north-east corner of allotment 6c section A, said Parish; thence south 0 deg. 46 min. east 110 links; thence south 89 deg. 15 min. west 1,497.1 links; thence north 0 deg. 46 min. west 110 links; thence north 89 deg. 15 min. east 1,497.1 links to the commencing point containing 1 acre 2 roods 23 perches.

Secondly, all that piece of land commencing at the north-west corner of allotment 19 section A, said Parish; thence north 89 deg. 15 min. east 100 links; thence south 0 deg. 46 min. east 2,205.9 links; thence south 11 deg. 19 min. west 477.8 links; thence north 0 deg. 46 min. west 2,673.1 links to the commencing point containing 2 acres 1 rood 30 perches—

which has been taken purchased or acquired by it shall be a public highway from and after the date of publication of this Order in the *Government Gazette*.

The common seal of the President, Councillors and Ratepayers of the Shire of Kowree was hereto affixed the 8th day of February, 1960, in the presence of—

(SEAL) R. S. HARKNESS, President.  
J. FINN KIRBY, Councillor.  
3412 H. ERNEST WALKEAR, Secretary.

## SHIRE OF KOWREE.

IN pursuance of the powers conferred by sections 522 and 526 of the *Local Government Act 1958*, the Council of the Shire of Kowree doth hereby direct that the land in the Parish of Nuncoung being part of Crown allotment 64 containing 1 acre 3 roods 8 2/10 perches, commencing at a point on the eastern boundary of the said allotment, distant south 0 deg. 45 min. east 181 4/10 links from the south-east corner of the land in certificate of title, volume 7157, fol. 282; thence south 0 deg. 45 min. east 818 6/10 links; thence north 89 deg. 58 min. west 656 2/10 links; thence north 55 deg. 14 min. east 591 1/10 links; thence north 19 deg. 22 min. east 510 8/10 links to the point of commencement, which has been taken purchased or acquired by it, shall be a public highway from and after the date of publication of this Order in the *Government Gazette*.

The common seal of the President, Councillors and Ratepayers of the Shire of Kowree was hereunto affixed this 5th day of November, 1962, in the presence of—

(SEAL) A. M. HOBBS, President.  
S. C. HOBBS, Councillor.  
3413 H. ERNEST WALKEAR, Secretary.

## SHIRE OF KOWREE.

IN pursuance of the powers conferred by section 522 of the *Local Government Act 1958*, the Council of the Shire of Kowree doth hereby direct that the land in the Parish of Awonga County of Lowan being the surface and down to a depth of 50 feet below the surface of that part of Crown allotment 110, commencing at the south-east corner of the said allotment; thence south 89 deg. 52 min. east 1,159 links; thence north 59 deg. 20 min. east 116 1/10 links; thence north 89 deg. 52 min. east 1,059 1/10 links; thence south 0 deg. 1 min. east 59 links to the commencing point, which has been taken purchased or acquired by it, shall be a public highway from and after the date of publication of this Order in the *Government Gazette*.

The common seal of the President, Councillors and Ratepayers of the Shire of Kowree was hereunto affixed this 5th day of November, 1962, in the presence of—

(SEAL) A. M. HOBBS, President.  
S. C. HOBBS, Councillor.  
3414 H. ERNEST WALKEAR, Secretary.

## SHIRE OF KOWREE.

IN pursuance of the powers conferred by section 522 of the *Local Government Act 1958*, the Council of the Shire of Kowree doth hereby direct that the land in the Parish of Awonga County of Lowan being part of Crown allotment 49, commencing at the north-west corner of the said allotment; thence north 89 deg. 53 min. east distant 938.2 links; thence south 67 deg. 14 min. west distant 551 links; thence south 38 deg. 45 min. west distant 508.8 links; thence south 13 deg. 01 min. west distant 491.5 links; thence north 0 deg. 3 min. west distant 1,087 links to the commencing point containing 2 acres 3 roods 6 3/10 perches or thereabouts, which has been taken purchased or acquired by it, shall be a public highway from and after the date of publication of this Order in the *Government Gazette*.

The common seal of the President, Councillors and Ratepayers of the Shire of Kowree was hereunto affixed this 5th day of November, 1962, in the presence of—

(SEAL) A. M. HOBBS, President.  
S. C. HOBBS, Councillor.  
3415 H. ERNEST WALKEAR, Secretary.

## SHIRE OF KOWREE.

IN pursuance of the powers conferred by section 522 of the *Local Government Act 1958*, the Council of the Shire of Kowree doth hereby direct that the land in the Parish of Awonga County of Lowan being part of Crown allotment 49c, commencing at the south-west corner of the said allotment; thence north 0 deg. 3 min. west distant 500 links; thence south 3 deg. 02 min. east distant 500.7 links; thence 589 deg. 57 min. west distant 26 links to the commencing point containing 10 4/10 perches or thereabouts, which has been taken purchased or acquired by it, shall be a public highway from and after the date of publication of this Order in the *Government Gazette*.

The common seal of the President, Councillors and Ratepayers of the Shire of Kowree was hereunto affixed this 5th day of November, 1962, in the presence of—

(SEAL) A. M. HOBBS, President.  
S. C. HOBBS, Councillor.  
3416 H. ERNEST WALKEAR, Secretary.

## SHIRE OF KOWREE.

IN pursuance of the powers conferred by section 522 of the *Local Government Act 1958*, the Council of the Shire of Kowree doth hereby direct that the land in the Parish of Awonga County of Lowan being part of Crown allotment 30, commencing at the south-west corner of the said allotment; thence north 0 deg. 1 min. east distant 59 links; thence north 89 deg. 52 min. east distant 1,402.8 links; thence south 5 deg. 34 min. east distant 59.3 links; thence south 89 deg. 52 min. east distant 1,397 links to the commencing point containing 3 roods 12 2/10 perches or thereabouts, which has been taken purchased or acquired by it, shall be a public highway from and after the date of publication of this Order in the *Government Gazette*.

The common seal of the President, Councillors and Ratepayers of the Shire of Kowree was hereunto affixed this 5th day of November, 1962, in the presence of—

(SEAL) A. M. HOBBS, President.  
S. C. HOBBS, Councillor.  
3417 H. ERNEST WALKEAR, Secretary.

## SHIRE OF MALDON.

## LOAN No. 13.

*Notice of Intention to Borrow the Sum of £1,400 for Permanent Works and Undertakings.*

NOTICE is hereby given that the Council of the Shire of Maldon proposes to borrow the sum of One thousand four hundred pounds on the credit of the municipal revenues of the President, Councillors and Ratepayers of the said Shire, such sum to be raised by the grant of a mortgage, in accordance with the provisions of the *Local Government Act 1958*.

1. The maximum rate of interest that may be paid is 5½ per cent. per annum.

2. The purpose for which the loan is to be applied is for renovations and improvements to Maldon Swimming Pool.

3. The period of the loan shall be ten years.

4. The moneys borrowed shall be repayable by providing out of the Municipal Fund twenty half-yearly instalments of approximately £91 19s. each, including principal and interest, on the 1st day of September and the 1st day of March during the currency of the loan. The first instalment shall be payable on the 1st day of September, 1963.

5. Such moneys shall be repayable at the State Savings Bank of Victoria, Melbourne.

The plans and specifications and the estimate of the cost of the proposed works, and a statement showing the proposed expenditure of the moneys to be borrowed, are open for inspection at the Shire Office, Maldon.

Dated the 9th November, 1962.

3423

S. R. BEACH, Shire Secretary.

## SHIRE OF MANSFIELD.

## LOAN No. 40.

*Notice of Intention to Borrow the Sum of £1,630 for Permanent Works and Undertakings.*

NOTICE is hereby given that the Council of the Shire of Mansfield proposes to borrow the sum of Sixteen hundred and thirty pounds on the credit of the municipal revenues of the President, Councillors and Ratepayers of the said Shire, such sum to be raised by the grant of a mortgage, in accordance with the provisions of the *Local Government Act 1958*.

1. The maximum rate of interest that may be paid is 5½ per centum per annum.

2. The purpose for which the loan is to be applied is construction of caravan park at Mansfield and construction of launching ramps, approach roads and turning bays at Goughs Bay.

3. The period of the loan shall be ten years.

4. The moneys borrowed shall be repayable by providing out of the Municipal Fund twenty half-yearly instalments of approximately One hundred and seven pounds one shilling (£107 1s.) each, including principal and interest, on the 1st day of February and the 1st day of August during the currency of the loan. The first instalment shall be payable on the 1st day of August, 1963.

5. Such moneys shall be repayable at the State Savings Bank of Victoria, Melbourne.

6. The plans and specifications and the estimate of the cost of the proposed works, and a statement showing the proposed expenditure of the moneys to be borrowed, are open for inspection at the Shire Office, Mansfield.

Dated the 7th day of November, 1962.

3390

R. WOMERSLEY, Shire Secretary.

## SHIRE OF MILDURA.

## BY-LAW No. 102.

NOTICE is hereby given that, in pursuance of the powers conferred by the Dog Acts and the Local Government Acts, the President, Councillors and Ratepayers of the Shire of Mildura have made By-law No. 102 for prescribing fees and for providing that any person who is the owner of a dog, and who is in necessitous circumstances, shall be entitled to register the dog without fee.

A copy of the By-law is open for inspection, free of charge, during office hours at the office of the Council, Deakin-avenue, Mildura.

3405

A. D. HARVEY, Shire Secretary.

## Sewerage Districts Acts.

## SHIRE OF MORNINGTON.

## PROPOSED MOUNT ELIZA SEWERAGE AUTHORITY.

NOTICE is hereby given that the Mornington Shire Council has made application to the Honorable the Minister of Water Supply for the constitution of a Sewerage Authority and for the Proclamation of a sewerage district at Mount Eliza, and for the construction, maintenance and continuance of sewerage works within that district under the provisions of the Sewerage Districts Acts.

A general plan and description of the proposed works have been submitted with the application, and copies of same may be seen at—

- (i) The Mornington Civic Centre, Queen-street, Mornington.
- (ii) The offices of the State Rivers and Water Supply Commission, 90 Orrong-road, Armadale.
- (iii) The offices of the Commission of Public Health, 295 Queen-street, Melbourne.

Dated at Mornington the 9th day of November, 1962.

3418

D. G. COLLINGS, Shire Secretary.

## SHIRE OF PHILLIP ISLAND.

## PROSECUTING OFFICER, PHILLIP ISLAND.

NOTICE is hereby given that First Constable Ernest William Lee, No. 9935, of Cowes, has been appointed Prosecuting Officer for the Shire of Phillip Island.

3425

STAN A. HARRIS, Shire Secretary.

## SHIRE OF SOUTH GIPPSLAND.

## By-LAW No. 37.

A By-law of the Shire of South Gippsland made under the provisions of the *Health Act 1958* and numbered 37 relating to the collection and disposal of nightsoil.

IN pursuance of the powers conferred by the *Health Act 1958* and of every other power enabling them in that behalf the President, Councillors and Ratepayers of the Shire of South Gippsland with the approval of the Governor in Council do hereby order as follows:—

1. The provisions of By-law No. 14 shall cease to apply to and have operation in the Townships of Welshpool, Port Welshpool and Port Franklin within the boundaries set out in the following descriptions:—

*Welshpool.*

Commencing at the south-west corner of Crown allotment 6 of A. Parish of Welshpool; thence northerly along the western boundary of said Crown allotment to north side of Sidney-street, being north boundary of lodged plan 3299; thence in an easterly direction along the north side of Sidney-street, across Welshpool-Boolarra road, and along north boundary of lodged plan 4360 to most northerly corner of said lodged plan; thence south-easterly along the eastern boundary of said lodged plan to most easterly corner of said lodged plan, being a point on the northern side of Government road; thence by a line in a south-easterly direction across Government road, railway station, and Railway-avenue to north-east corner of lodged plan 4764; thence southerly along eastern boundary of said lodged plan and part of eastern boundary of lodged plan 5441 to the north side of Pedersen-street; thence south-westerly along the north side of said street to the north-east corner of lot 30, lodged plan 5441; thence westerly along north boundary of said lot to point on the eastern side of Government road; thence by line in a north-westerly direction across Government road to south-east corner of lodged plan 4756; thence westerly along south boundary and northerly along west boundary of portion of lodged plan 4756, south of railway, to railway line; thence by line across railway to most westerly point of lodged plan 4756; thence south-westerly along north boundary of railway line to west boundary of Crown allotment 14A; thence north-westerly along west boundary of said allotment to north-east corner of allotment 13; thence by a line in a northerly direction across Government road to point of commencement.

*Port Welshpool.*

All of section 1 to 17, allotments 1 to 7 of section 18 and allotments 1 to 10 and 14 and 15 of section 19 in the Township of Welshpool.

*Port Franklin.*

All that part of the Township of Bowen on the west side of the Franklin river and all of section E in the Parish of Toora.

2. This by-law shall come into force and operation on its approval by the Governor in Council and immediately after its publication in the *Government Gazette*.

Resolution for passing this By-law agreed to by the Council on the 12th day of July, 1962, and confirmed on the 9th day of August, 1962.

The common seal of the President, Councillors and Ratepayers of the Shire of South Gippsland was hereunto affixed, in the presence of—

(SEAL) J. H. McDONALD, President.  
T. R. MORRIS, Councillor.  
V. W. B. WOOD, Councillor.  
J. RENNICK, Secretary.

Submitted to the Commission of Public Health on 21st August, 1962.—J. F. RAYNER, Acting Secretary, Commission of Public Health.

Approved by the Governor in Council on the 11th day of September, 1962.—N. G. WISHART, Clerk of the Executive Council. 3389

## SHIRE OF WODONGA.

## BY-LAW No. 52.

A By-law of the Shire of Wodonga, made under the Dog Acts, and numbered 52, for fixing registration and other fees thereunder.

IN pursuance of the powers conferred by the Dog Acts and of any and every other power it thereunto enabling, the President, Councillors and Ratepayers of the Shire of Wodonga order as follows:—

1. By-law No. 41 is hereby repealed.
2. The following fees and sums are hereby fixed, pursuant to the Dog Acts:—
  - (a) For registration, pursuant to section 6 of *Dog Act 1958*, as amended by any Act—Ten to Twenty shillings.
  - (b) For particulars of any dog or the name of the registered owner thereof or for a certified copy of the receipt mentioned in section 12 of the *Dog Act 1958*, as amended by any Act—Two shillings and six pence.
  - (c) Sum payable to the Registration Officer, pursuant to section 15 of the *Dog Act 1958*, as amended by any Act—£3.
  - (d) Sum payable to the Registration Officer, pursuant to section 16 of the *Dog Act 1958*, as amended by any Act—£3.
3. This By-law shall apply to and have operation throughout the whole of the municipal district.

Resolution for passing this By-law agreed to by the Council on the 3rd day of October, 1962, and confirmed on the 7th day of November, 1962.

The common seal of the President, Councillors and Ratepayers of the Shire of Wodonga was hereunto affixed, in the presence of—

(SEAL) A. G. RICHARDSON, President.  
R. G. SNOWDON, Councillor.  
H. McK. SILKE, Shire Secretary.

3424

## NOTICE OF INTENTION TO APPLY FOR AN ORDER IN COUNCIL UNDER THE ELECTRIC LIGHT AND POWER ACT 1958.

NOTICE is hereby given that J. H. Ferris and A. J. Thomson intend to apply to the Governor in Council of the State of Victoria for an Order under section 10 of the *Electric Light and Power Act 1958* authorizing them to supply electricity for public and private purposes within an area comprising the Township of Walwa.

There are no tramways or railways which the applicant proposed to break up or interfere with in accordance with the special power to be inserted in that behalf in the proposed Order.

Copies of the draft Order and of the Order when made can be obtained by any person at the price of Ten shillings each at J. H. Ferris and A. J. Thomson, Walwa, and at the office of the State Electricity Commission of Victoria, at Nos. 22-32 William-street, Melbourne.

Notices of objection and other documents may be served at the office of the applicant as aforesaid.

Every council, company, person or persons desirous of bringing before the State Electricity Commission of Victoria, by whom the *Electric Light and Power Act 1958* is administered, any objection respecting the application must do so within three months from the date of the *Government Gazette* containing this advertisement, by

notice addressed to the Secretary, State Electricity Commission of Victoria, 22-32 William-street, Melbourne, marked on the outside of the cover enclosing it: "*Electric Light and Power Act 1958*". A copy of every such notice must also be forwarded to the applicant for the Order.

Dated this 1st day of November, 1962.

J. H. FERRIS.  
A. J. THOMSON.

3400

NOTICE is hereby given that the Harrow Golf Club has applied for a lease of allotment 71A, Parish of Harrow, containing 180 acres 0 roods 30 perches, pursuant to section 134 of the *Land Act 1958*, for the purpose of amusement and recreation for a term of 21 years. 3235

NOTICE is hereby given that San Remo Fishermen's Co-operative Society Limited of San Remo has applied for a lease under section 134 of the *Land Act 1958*, for a term of 20 years, of allotment 1F, section A, Township of San Remo, Parish of Woolamai, as a site for Fish Freezing Works. 3224

NOTICE is hereby given that the Yackandandah and District Bowling Club has applied for a lease for a term of 21 years, under section 134 of the *Land Act 1958*, of 1 acre and 25 perches being allotment 6, section 10, Township of Yackandandah, for purposes of Amusement and Recreation (bowling green). 3277

## WARRAGUL WATERWORKS TRUST.

## PROPOSED DARNUM URBAN DISTRICT.

NOTICE is hereby given that the Warragul Waterworks Trust has made application to the Honorable the Minister of Water Supply for the proclamation of an Urban District at Darnum, and the construction, maintenance, and continuance of water supply works within that district under the provisions of the Water Acts.

A general plan and description of the proposed works have been submitted with the application, and copies of the same may be seen at the Trust's office at Warragul.

Dated at Warragul the 29th day of October, 1962.

3294 R. W. LEASK, Secretary.

## GEELONG WATERWORKS AND SEWERAGE TRUST.

PURSUANT to section 60 (2) of the *Geelong Waterworks and Sewerage Act 1958* (No. 6263), notice is hereby given of the intention of the Trust to construct sewers to provide for properties in and adjacent to:—

*Shire of South Barwon*.—Lower Spring-street, Maxwell-avenue, Bailey-street, Glen-avenue and Barwon Heads-road, East Belmont.

*Shire of Corio*.—McCurdy-road and Oak-street, Herne Hill; Macarthur-avenue, Bell Park.

*City of Geelong*.—Oxford-street, Whittington. Wood-street and Strong-street, Breakwater—

and more particularly as shown on maps which are open for inspection at the Trust's Offices, between the hours of 9 a.m. and 4 p.m. daily, from Monday to Friday inclusive.

Dated this 5th day of November, 1962.

3376 B. C. HENSHAW, Secretary.

## BALLARAT SEWERAGE AUTHORITY.

PURSUANT to section 119 (2) of the *Sewerage Districts Act 1958* (No. 6368), notice is hereby given of the intention to construct sewers to provide for properties situated in portions of the areas bounded approximately by:—

*City of Ballarat*.—Lovenear-grove including lots Nos. 35 to 49 and 13 to 17; Rubicon-street north side from about 5 chains east of Skipton-street easterly about 2½ chains.

*Borough of Sebastopol*.—Sayle, Yarrowee, Rubicon and Orion-streets—

more particularly as shown on maps which are open for inspection at this office between the hours of 9 a.m. and 4 p.m., Monday to Friday inclusive.

Dated this 8th day of November, 1962.

3427 CHAS. H. CLAMP, Secretary.

## NOTICE OF INTENTION TO APPLY FOR A LICENCE TO DIVERT WATER AND CUT RACE FROM THE RIVER MURRAY, AT BARMAN.

I HEREBY give notice that I intend to apply for a licence empowering me to divert water for a term of fifteen years to the extent of 100 acre-feet per annum at

a maximum rate of 5 acre-feet per day of 24 hours for the irrigation, being part of allotment 1-10 and 36, section 13, Parish of Barmah, and to occupy certain Crown lands for works of diversion, and to cut a race thereon.

Any objection to such application must be forwarded, in writing, to reach the State Rivers and Water Supply Commission, Melbourne, before 17th December, 1962, being 30 days from the first publication of this notice.

IRENE MARY MALONEY.

48 High-street, Echuca. 3441

NOTICE OF INTENTION TO APPLY FOR A LICENCE TO DIVERT WATER AND CUT RACE FROM THE RIVER MURRAY, AT ROBINVALE.

I HEREBY give notice that I intend to apply for a licence empowering me to divert water for a term of seven and one-half years to the extent of 9 acre-feet per annum at a maximum rate of  $\frac{1}{2}$  acre-foot per day of 24 hours for the irrigation of vines, being part of allotment 60, Parish of Bumbang, and to occupy certain Crown lands for works of diversion and to cut a race thereon.

Any objection to such application must be forwarded, in writing, to reach the State Rivers and Water Supply Commission, Melbourne, before 9th December, 1962, being 30 days from the first publication of this notice.

GIUSIPEPPE GARAFALO.

Box 222, Robinvale. 3439

NOTICE OF INTENTION TO APPLY FOR A LICENCE TO DIVERT WATER AND CUT RACE FROM THE RIVER MURRAY, AT ROBINVALE.

WE hereby give notice that we intend to apply for a licence empowering me to divert water for a term of seven and one-half years to the extent of  $7\frac{1}{2}$  acre-feet per annum at a maximum rate of 2 acre-feet per day of 24 hours for the irrigation of vines and pasture, being part of allotment 71, Parish of Bumbang, and to occupy certain Crown lands for works of diversion and to cut a race thereon.

Any objection to such application must be forwarded, in writing, to reach the State Rivers and Water Supply Commission, Melbourne, before 9th December, 1962, being 30 days from the first publication of this notice.

BRUNO NAGL.  
JOY NAGL.

Box 407, Robinvale. 3436

NOTICE OF INTENTION TO APPLY FOR A LICENCE TO DIVERT WATER AND CUT RACE FROM THE RIVER MURRAY, AT BOUNDARY BEND.

I HEREBY give notice that I intend to apply for a licence empowering me to divert water for a term of seven years to the extent of 27 acre-feet per annum at a maximum rate of 2-25 acre-feet per day of 24 hours for the irrigation of 9 acres, being part of allotment 2, section A, Parish of Yungera, and to occupy certain Crown lands for works of diversion and to cut a race thereon.

Any objection to such application must be forwarded, in writing, to reach the State Rivers and Water Supply Commission, Melbourne, before 9th November, 1962, being 30 days from the first publication of this notice.

FRANCIS JOHN ROBERT O'BREE.

Boundary Bend. 3437

NOTICE OF INTENTION TO APPLY FOR A LICENCE TO DIVERT WATER AND CUT RACE FROM THE RIVER MURRAY, AT ROBINVALE.

I HEREBY give notice that I intend to apply for a licence empowering me to divert water for a term of seven years to the extent of 9 acre-feet per annum at a maximum rate of 100,000 acre-feet per day of 24 hours for the orchard and garden, being part of allotment 58, Parish of Bumbang, and to occupy certain Crown lands for works of diversion and to cut a race thereon.

Any objection to such application must be forwarded, in writing, to reach the State Rivers and Water Supply Commission, Melbourne, before 14th December, 1962, being 30 days from the first publication of this notice.

VERNON ALBERT RIDLEY.

Box 98, Robinvale. 3433

NOTICE OF INTENTION TO APPLY FOR A LICENCE TO DIVERT WATER AND CUT RACE FROM THE RIVER MURRAY, AT ROBINVALE.

I HEREBY give notice that I intend to apply for a licence empowering me to divert water for a term of seven years to the extent of 9 acre-feet per annum at a Commission, Melbourne, before 14th December, 1962, being

24 hours for the orchard and garden, being part of allotment 57, Parish of Bumbang, and to occupy certain Crown lands for works of diversion and to cut a race thereon.

Any objection to such application must be forwarded, in writing, to reach the State Rivers and Water Supply Commission, Melbourne, before 14th December, 1962, being 30 days from the first publication of this notice.

ALBERT WILLIAM RIDLEY.

Box 98, Robinvale. 3434

NOTICE OF INTENTION TO APPLY FOR A LICENCE TO DIVERT WATER AND CUT RACE FROM THE RIVER MURRAY, AT ROBINVALE.

I HEREBY give notice that I intend to apply for a licence empowering me to divert water for a term of seven years to the extent of 9 acre-feet per annum at a maximum rate of 100,000 acre-feet per day of 24 hours for the garden and orchard, being part of allotment 67, Parish of Bumbang, and to occupy certain Crown lands for works of diversion and to cut a race thereon.

Any objection to such application must be forwarded, in writing, to reach the State Rivers and Water Supply Commission, Melbourne, before 14th December, 1962, being 30 days from the first publication of this notice.

FRANCESCO COSTANTINO.

Box 228, Robinvale. 3435

NOTICE OF INTENTION TO APPLY FOR A LICENCE TO DIVERT WATER AND CUT RACE FROM THE RIVER MURRAY, AT ROBINVALE.

I HEREBY give notice that I intend to apply for a licence empowering me to divert water for a term of seven and one-half years to the extent of 9 acre-feet per annum at a maximum rate of  $\frac{1}{2}$  acre-feet per day of 24 hours for the irrigation of market garden, being part of allotment 44, Parish of Bumbang, and to occupy certain Crown lands for works of diversion and to cut a race thereon.

Any objection to such application must be forwarded, in writing, to reach the State Rivers and Water Supply Commission, Melbourne, before 9th December, 1962, being 30 days from the first publication of this notice.

GESUALDO LAZZARA.

Box 358, Robinvale. 3431

NOTICE OF INTENTION TO APPLY FOR A LICENCE TO DIVERT WATER AND CUT RACE FROM THE RIVER MURRAY, AT ROBINVALE.

I HEREBY give notice that I intend to apply for a licence empowering me to divert water for a term of seven and a half years to the extent of 9 acre-feet per annum at a maximum rate of  $\frac{1}{2}$  acre-feet per day of 24 hours for the irrigation of 3 acres, market garden, being part of allotment 15, Parish of Bumbang, and to occupy certain Crown lands for works of diversion, and to cut a race thereon.

Any objection to such application must be forwarded, in writing, to reach the State Rivers and Water Supply Commission, Melbourne, before 9th December, 1962, being 30 days from the first publication of this notice.

MABEL GERTRUDE FERGUSON.

Box 337, Robinvale. 3374

NOTICE OF INTENTION TO APPLY FOR A LICENCE TO DIVERT WATER AND CUT RACE FROM THE RIVER MURRAY, AT YARRAWONGA.

I HEREBY give notice that I intend to apply for a licence empowering me to divert water for a term of eight years to the extent of 100 acre-feet per annum at a maximum rate of 5 acre-feet per day of 24 hours for the irrigation of 100 acres of pasture, being part of allotments 6 and 7, Parish of Yarrowonga, and to occupy certain Crown lands for works of diversion, and to cut a race thereon.

Any objection to such application must be forwarded, in writing, to reach the State Rivers and Water Supply Commission, Melbourne, before 14th December, 1962, being 30 days from the first publication of this notice.

JAMES BRUCE FORGE.

"Yarramine", Yarrowonga. 3378

NOTICE OF INTENTION TO APPLY FOR A LICENCE TO DIVERT WATER AND CUT RACE FROM THE RIVER MURRAY, AT ECHUCA NORTH.

WE hereby give notice that we intend to apply for a licence empowering us to divert water for a term of eight years to the extent of 60 acre-feet per annum

at a maximum rate of 3 acre-feet per day of 24 hours for the irrigation of 30 acres, being allotments 37-40, 40A, 41 and 42 and part of 35, Township of Glanville, Parish of Echuca North, and to occupy certain Crown lands for works of diversion, and to cut a race thereon.

Any objection to such application must be forwarded, in writing, to reach the State Rivers and Water Supply Commission, Melbourne, before 10th day of December, 1962, being 30 days from the first publication of this notice.

RALPH EDWARD BUEGGE.  
ALMA LOIS BUEGGE.

R.M.D., Box 53, Echuca Village. 3385

NOTICE OF INTENTION TO APPLY FOR A LICENCE TO DIVERT WATER AND CUT RACE FROM THE RIVER MURRAY, AT TORRUMBARRY.

I HEREBY give notice that I intend to apply for a licence empowering me to divert water for a term of eight years to the extent of 40 acre-feet per annum at a maximum rate of 2 acre-feet per day of 24 hours for the irrigation of 20 acres for tobacco, being part of allotments 12 and 13, section 8, Parish of Torrumbarry North, and to occupy certain Crown lands for works of diversion, and to cut a race thereon.

Any objection to such application must be forwarded, in writing, to reach the State Rivers and Water Supply Commission, Melbourne, before 4th December, 1962, being 30 days from the first publication of this notice.

DOMENICO NINO RIGONI.  
RONALD ANTHONY RIGONI.

Torrumbarry P.O., Victoria. 3386

NOTICE OF INTENTION TO APPLY FOR A LICENCE TO DIVERT WATER AND CUT RACE FROM THE RIVER MURRAY, AT ROBINVALE.

I HEREBY give notice that I intend to apply for a licence empowering me to divert water for a term of eight years to the extent of 18 acre-feet per annum at a maximum rate of 5 acre-feet per day of 24 hours for the irrigation of 6 acres, being part of allotments 10 and 12, section A, Parish of Bumbang, County of Karkarook, and to occupy certain Crown lands for works of diversion, and to cut a race thereon.

Any objection to such application must be forwarded, in writing, to reach the State Rivers and Water Supply Commission, Melbourne, before 12th December, 1962, being 30 days from the first publication of this notice.

ROSARIO MAMMONE.

Robinvale. 3387

NOTICE OF INTENTION TO APPLY FOR A LICENCE TO DIVERT WATER AND CUT RACE FROM THE RIVER MURRAY, AT ECHUCA.

WE hereby give notice that we intend to apply for a licence empowering us to divert water for a term expiring on 30th June, 1970, to the extent of 50 acre-feet per annum at a maximum rate of 3 acre-feet per day of 24 hours for the irrigation of 25 acres, being Crown allotments 5, 6, 7, 8, 9, 10, 11, 12, 11A, 13, 57, 58 and 59, Township of Glanville, and allotment 23, all Parish of Echuca North, and to occupy certain Crown lands for works of diversion, and to cut a race thereon.

Any objection to such application must be forwarded, in writing, to reach the State Rivers and Water Supply Commission, Melbourne, before 17th December, 1962, being 30 days from the first publication of this notice.

WILLIAM JAMES McLEOD.  
ELLEN MURIEL McLEOD.  
EMMA ELIZABETH FELMINGHAM.

76 Pakenham-street, Echuca. 3388

NOTICE OF INTENTION TO APPLY FOR A LICENCE TO DIVERT WATER AND CUT RACE (RE-ISSUE) FROM THE RIVER MURRAY, AT WEMEN.

I HEREBY give notice that I intend to apply for a licence empowering me to divert water for a term of eight years to the extent of 48 acre-feet per annum at a maximum rate of 2 acre-feet per day of 24 hours for the irrigation of 16 acres of market garden and citrus trees, being part of allotment part 7 (part lot 2), Parish of Wemen, and to occupy certain Crown lands for works of diversion, and to cut a race thereon.

Any objection to such application must be forwarded, in writing, to reach the State Rivers and Water Supply Commission, Melbourne, before 5th December, 1962, being 30 days from the first publication of this notice.

DONALD WALTER LAMPARD.

Hattah. 3394

NOTICE OF INTENTION TO APPLY FOR A LICENCE TO DIVERT WATER AND CUT RACE FROM THE RIVER MURRAY, AT ROBINVALE.

I HEREBY give notice that I intend to apply for a licence empowering me to divert water for a term of seven and a half years to the extent of 45 acre-feet per annum at a maximum rate of 1 acre-foot per day of 24 hours for the irrigation of 3 acres of citrus and 12 acres of market garden, being part of allotments 23, 26 and 52, Parish of Bumbang, and to occupy certain Crown lands for works of diversion, and to cut a race thereon.

Any objection to such application must be forwarded, in writing, to reach the State Rivers and Water Supply Commission, Melbourne, before 9th December, 1962, being 30 days from the first publication of this notice.

SALAVATORE MEZZATESTA.

Box 278, Robinvale. 3395

NOTICE is hereby given that the partnership heretofore subsisting between Keith Edward Merrall and Trevlyn Victor Fleming carrying on business as glass merchants, at 66 Foster-street, Dandenong, under the name of "Dandy Glass Works" has been dissolved by mutual consent as from 30th June, 1962. All debts due to and owing by the partnership will be received and paid by the said Keith Edward Merrall, who will continue to carry on the business at the same place in partnership with Emily June Merrall.

Dated the 2nd day of October, 1962.

T. V. FLEMING.  
K. E. MERRALL.

Gordon, Rennick and Gaynor, solicitors, 473 Bourke-street, Melbourne. 3476

#### PARTNERSHIP.

STOKES AND MARGGRAFF (trading as E. J. Stokes and G. Marggraff), butchers, trading at 69B Hotham-road, Niddrie. Dissolved 1st November, 1962.

3446 G. MARGGRAFF.

The Companies Act 1961.—In the matter of VENEZIA RESTAURANT PTY. LIMITED—Notice re Meeting of Creditors, Pursuant to Section 260.

NOTICE is hereby given that a Meeting of Creditors of the above-named company will be held at Room 516, 5th Floor, 342 Flinders-street, Melbourne, on Monday, 26th November, 1962, at Eleven a.m., the company having convened a meeting of its members for the same day for the purpose of considering a Resolution that the company be wound up voluntarily.

Dated this 2nd day of November, 1962.

3398 W. DE BONA, Director.  
K. C. ELLIS, Director.

#### Companies Act 1961.

REX INDUSTRIES PROPRIETARY LIMITED.

NOTICE OF RESOLUTION FOR VOLUNTARY WINDING UP.

NOTICE is hereby given that on 2nd November, 1962, the following was duly passed as a Special Resolution:—

"That the company be placed in voluntary liquidation and that Cecil Paul Stephens, 20 Collins-street, Melbourne, be appointed liquidator."

Dated 9th November, 1962.

3399 R. J. HOOD, Chairman.

In the matter of RICHARD WILDRIDGE (VIC.) PROPRIETARY LIMITED.

AT an Extraordinary General Meeting of the above-named company held at 247 George-street, Sydney, on the 5th day of November, 1962, the following Special Resolution was duly passed:—

"That the company be wound up voluntarily."

And at such last-mentioned meeting Sydney Spencer Wallis of care of Price Waterhouse and Co., 128 William-street, Melbourne, was appointed liquidator for the purpose of the winding up.

A. J. COLLINSON, Secretary.

Davies, Campbell and Piesse, solicitors, 401 Collins-street, Melbourne. 3458

The Companies Act 1958.—In the matter of THORNBURY MOTOR SERVICE PTY. LIMITED (in Voluntary Liquidation).

THE affairs of the above-named company having been fully wound up and an account having been made up showing how the winding up has been conducted and the property of the company disposed of, notice is hereby given that the adjourned General Meeting of the members of the company will be held at Eleven a.m. on the 7th day of December, 1962, at 131 Queen-street, Melbourne, for the purpose of laying before it the account and giving any explanation thereof.

Dated the 9th day of November, 1962.

3454 J. H. ROWLAND, Liquidator.

Companies Act 1961.

THE WARRACKNABEAL ELECTRIC LIGHT COMPANY LIMITED (IN VOLUNTARY LIQUIDATION).

NOTICE is hereby given that the Final Meeting of members of the Warracknabeal Electric Light Company Limited (in Voluntary Liquidation) will be held at the office of F. R. Pomeroy, 102 Scott-street, Warracknabeal, on 14th December, 1962, at Ten a.m., for the purposes of section 272 of the Act.

Dated this 14th day of November, 1962.

3438 F. R. POMEROY, Liquidator.

Companies Act 1961.

NOTICE OF SPECIAL RESOLUTION TO WIND UP, PURSUANT TO SECTION 254 (2).

CEMENT DISTRIBUTORS PROPRIETARY LIMITED.

AT a General Meeting of the members of Cement Distributors Proprietary Limited, duly convened and held at the registered office of the company, 51 Queen-street, Melbourne, on the 7th day of November, 1962, the Special Resolution set out below was duly passed:—

"That the company be wound up voluntarily."

Dated this 7th day of November, 1962.

3475 L. T. NETTLEFOLD, Chairman of Directors.

Companies Act 1961.—In the matter of HILLDENE PROPRIETARY LIMITED.

AT a General Meeting of the above-named company duly convened and held at 95 Queen-street, Melbourne, on Friday, the 2nd day of November, 1962, the Following Resolution was duly passed as a Special Resolution:—

"That the company be wound up voluntarily."

Dated the 8th day of November, 1962.

3473 DESMOND KELLY, Secretary.

CREDITORS, next of kin and others having claims in respect of the estates of the under-mentioned persons, who died on the under-mentioned dates, are required by the under-mentioned executors to send particulars of their claims to the respective executors named hereunder, in care of the solicitors named hereunder, by 16th January, 1963, after which date the respective executors will distribute the assets in the respective estates, having regard only to the claims of which they then have notice:—

Name of Deceased; Date of Death; Name of Executors.

Arthur Robert Smith, late of Ridge-road, Kalorama; 17th August, 1962; William Arthur Prendergast.

Harriette Hodges, late of 29 Norwood-road, North Caulfield; 11th August, 1962; Charlotte Ethel Nind.

Violet Maud Gibson, late of 283 Upper Heidelberg-road, Ivanhoe; 3rd July, 1962; William Gibson and Joyce Gibson.

Leonard James Byers, late of 16 Third-avenue, Brunswick; 10th September, 1962; Mona Noreen Byers.

Sarah Ann Wood, late of 26 Burroughs-road, Balwyn; 14th September, 1962; William Wood and Phyllis Geddes.

Victor Edward Charnley, late of Royle-avenue, Kallista; 17th July, 1962; Winifred Anne Charnley.

William Henry Gosch, late of 129 Willsmere-road, North Kew; 11th November, 1961; Ethel Gosch, Leonard William Gosch and Alice Beryl O'Farrell.

W. A. PRENDERGAST & ROBINSON, solicitors, 406 Lonsdale-street, Melbourne. 3453

MYLES DILLON O'CALLAGHAN, late of 9 Glenvale-road, Glen Iris, in the State of Victoria, gentleman, DECEASED.

CREDITORS, next of kin and others having claims in respect of the estate of the deceased (who died on the 28th day of May, 1962), are required by the trustee,

The Trustees, Executors and Agency Company Limited, of 401 Collins-street in the said State, to send particulars of their claims to it by the 9th day of January, 1963, after which date the trustee may convey or distribute the assets, having regard only to the claims of which it then has notice.

H. L. YUNCKEN & YUNCKEN, solicitors, 443 Little Collins-street, Melbourne. 3456

CREDITORS, next of kin and others having claims against the estate of Anne Josephine Murnane, late of 76 Octavia-street, St. Kilda, home duties, deceased (who died on the 15th day of December, 1961), are required by Joseph Clyde Mulholland, the executor of the will of the deceased, to send to him, care of the undersigned solicitors, particulars thereof on or before the 20th January, 1963, after which date he will distribute the assets, having regard only to the claims of which he shall then have notice.

J. H. TROTTER, & Co., solicitors, 37 Queen-street, Melbourne. 3472

CREDITORS, next of kin and others having claims against the estate of Charlotte Johanna Byriell, of 36 High-street, Kew, spinster, deceased (who died on 22nd July, 1962), are to send particulars of their claims to The Union Trustee, Company of Australia Limited, the registered office of which is situate at 333 Collins-street, Melbourne, in the State of Victoria, by the 2nd day of January, 1963, after which date it will distribute the assets, having regard only to the claims of which it then has notice.

BLAKE & RIGGALL, solicitors, 120 William-street, Melbourne. 3471

NOTICE TO CREDITORS.

CREDITORS, next of kin and others having claims in respect of the estate of Percy Claude Butler, late of 2 Goathlands-street, East St. Kilda, financial agent, deceased (who died on the 5th of May, 1959, and probate of whose will and two codicils has been granted to Victor Albert Butler, of 54 Park-crescent, Fairfield, financial agent), are to send particulars, in writing, of their claims to the said executor, care of the under-mentioned solicitors, by the 16th day of January, 1963, after which date he will distribute the assets, having regard only to the claims of which he then has notice.

FREDERICK W. COX & SON, solicitors, 452 Lonsdale-street, Melbourne. 3470

LEILA MILDRED MACKAY, late of 472 Glenferrie-road, Hawthorn, widow, DECEASED.

CREDITORS, next of kin and others having claims in respect of the estate of the deceased (who died on 27th July, 1962), are required by the trustee, The Equity Trustees, Executors and Agency Company Limited, of 472 Bourke-street, Melbourne, to send particulars to it by the 20th January, 1963, after which date the trustees may convey or distribute the assets, having regard only to the claims of which it then has notice.

Dated this 6th day of November, 1962.

WEIGALL & CROWTHER, solicitors, of 459 Little Collins-street, Melbourne. 3467

CREDITORS, next of kin and others having claims in respect of the estate of George William Archie Smith, formerly of Moomboldool, in New South Wales, but late of Tallangatta, in Victoria, retired, deceased (who died on the 30th day of March, 1962), are required by the executors, Aileen Monica Trembath, of Moomboldool, aforesaid, and Mary Patricia Osborne, of Tallangatta, aforesaid married women, to send particulars to them, care of the under-mentioned solicitors, by the 8th day of January, 1963, after which date they may convey or distribute the assets, having regard only to the claims of which they then have notice.

AITKEN, WALKER & STRACHAN, solicitors, 123 William-street, Melbourne. 3466

CREDITORS, next of kin and others having claims in respect of the estate of Wilhelmina Christina Ada Zeising, late of Boronia-road, Boronia, in the State of Victoria, spinster, deceased (who died on the 5th day of May, 1962), are required by the trustee, Albert Ernest Zeising, of Boronia-road, Boronia, to send particulars of their claims to him, care of the undersigned, by the 15th day of February, 1963, after which date the trustee may convey or distribute the assets, having regard only to the claims of which he then has notice.

R. E. LEWIS, ORR & GIBSON, solicitors, 406 Lonsdale-street, Melbourne. 3463

*Trustee Act 1958.*

## NOTICE TO CLAIMANTS.

**P**URSUANT to the *Trustee Act 1958*, creditors, next of kin and all other persons having claims in respect of the estate of any deceased person named below are required to send particulars to the legal personal representative or representatives at the address stated, after which date the representative or representatives will distribute the assets, having regard only to the claims of which notice has been received:—

Thomas Patrick Sinnott, late of Yambuk, farmer, deceased, died 13th December, 1961.—Claims to the executors, William Bernard Sinnott, of "Oakvale," Port Fairy, and William Gregory Gleeson, of Killarney, farmers, care of Conlan and Leishman, solicitors, 38 Bank-street, Port Fairy, by 14th January, 1963. 3370

Ann Jane McKinney late of Black-street, Koroit, widow, deceased, died 13th September, 1960.—Claims to the executor, Stanley Cecil Bence, of 25 Hunter-street, Syndal, railway employee, care of Conlan and Leishman, solicitors, 38 Bank-street, Port Fairy, by 21st January, 1963. 3371

James Sholto Douglass, formerly of Yambuk, but late of 75 Regent-street, Port Fairy, farmer, deceased, died 15th May, 1962.—Claims to the executors, Frances Ann Douglass, of 75 Regent-street, Port Fairy, widow, and Galety William Cathels, of Flat 4, 10 Barnsbury-road, South Yarra, surveyor, care of Conlan and Leishman, solicitors, 38 Bank-street, Port Fairy, by 21st January, 1963. 3372

Ada Hasell, late of Yambuk, formerly married woman, but latterly widow, deceased, died 25th December, 1961.—Claims to the executors, James Allen Hasell, of 7 Bartlett-street, Colac, clerk and Arthur Stewart Hasell, of 12 Murray-street, Warrnambool, foreman, care of Conlan and Leishman, solicitors, 38 Bank-street, Port Fairy, by 21st January, 1963. 3432

**C**REDITORS, next of kin and other having claims in respect of the estate of Freda Marcell Scott, late of Cornerways, Upperfield, Midhurst, Sussex, in England, married woman, deceased (who died on the 18th day of December, 1961), are required by Ross Gibson Macfarlan and Philip Edginton Aitken, both of 123 William-street, Melbourne, in the State of Victoria, solicitors, the attorneys under power of Patrick Tindle Keith Anderson, of Petworth, Sussex, aforesaid solicitor, the executor to whom probate of the will of the above-named deceased was granted, to send particulars to them, care of the under-mentioned solicitors, by the 8th day of January, 1963, after which date they may convey or distribute the assets, having regard only to the claims of which they then have notice.

AITKEN, WALKER & STRACHAN, solicitors, 123 William-street, Melbourne. 3465

**C**REDITORS, next of kin and others having claims in respect of the estate of Alice May Hunter (also known as Alice Mary Hunter), late of 83 Cromwell-road, South Yarra, apartment-house keeper, deceased (who died on the 11th day of August, 1962), are to send particulars of their claims to Jean Alice Smith, care of Best, Hooper, Rintoul and Shallard, solicitors, 100 Queen-street, Melbourne, on or before the 15th day of January, 1963, after which date the said Jean Alice Smith will distribute the assets of the said deceased, having regard only to claims of which she then has notice.

BEST, HOOPER, RINTOUL & SHALLARD, solicitors, 100 Queen-street, Melbourne. 3479

**T**HE PERPETUAL EXECUTORS AND TRUSTEES ASSOCIATION OF AUSTRALIA LIMITED, of 100-104 Queen-street, Melbourne, Victoria, the administrators of the estate of Winifred Alma Ellis, formerly of Balranald, New South Wales, but late of Brunel-street, East Malvern, Victoria, deceased (who died on the 13th day of March, 1926), require all creditors, next of kin and others having claims against the property or estate of the said deceased to send to the said company, on or before the 18th day of January, 1963, particulars, in writing, of such claims, after which date the said executors intend to convey or distribute such property or estate to or among the persons entitled thereto, having regard only to the claims of which they shall have had notice.

HEDDERWICK, FOOKES & ALSTON, 103 William-street, Melbourne. 3480

**C**REDITORS, next of kin and others having claims in respect of the estate of Mary Alice Hooker, late of 12 Veronica-street, South Oakleigh, in the State of Victoria, widow, deceased (who died on the 24th day of April, 1960), are required by the trustees, Doris Mary Hooker, of 263 Domain-road, South Yarra, and William Graham Orr, of 406 Lonsdale-street, Melbourne, to send particulars of their claims to them, care of the undersigned, by the 15th day of February, 1963, after which date the trustees may convey or distribute the assets, having regard only to the claims of which they then have notice.

R. E. LEWIS, ORR & GIBSON, solicitors, 406 Lonsdale-street, Melbourne. 3461

**C**REDITORS, next of kin and others having claims in respect of the estate of Ellen Anna Rosa Paull, late of 53 Kerford-street, East Malvern, in the State of Victoria, spinster, deceased (who died on the 10th day of July, 1962), are required by the trustee, William Graham Orr, of 406 Lonsdale-street, Melbourne, to send particulars of their claims to him care of the undersigned, by the 15th day of February, 1963, after which date, the trustee may convey or distribute the assets, having regard only to the claims of which he then has notice.

R. E. LEWIS, ORR & GIBSON, solicitors, 406 Lonsdale-street, Melbourne. 3462

**C**REDITORS, next of kin and others having claims in respect of the estate of Bessie Roadknight, late of 84 Rathmines-road, Fairfield, widow, deceased (who died on the 25th day of July, 1962), are required by the trustee, Gladys Bessie Annie DeKing, of 4 Orange-court, Heidelberg West, to send particulars of their claims to her, care of the undersigned, by the 15th day of February, 1963, after which date the trustee may convey or distribute the assets, having regard only to the claims of which she then has notice.

R. E. LEWIS, ORR & GIBSON, solicitors, 406 Lonsdale-street, Melbourne. 3464

**C**REDITORS, next of kin and others having claims in respect of the estate of Margaret Fife Looker, late of 18 Grant-street, East Malvern, in the State of Victoria, spinster (who died on the 23rd day of July, 1962), are to send the particulars of their claims to The Trustees, Executors and Agency Company Limited, whose registered office is at No. 401 Collins-street, Melbourne, in the said State, by the 14th day of January, 1963, after which date it will distribute the assets, having regard only to the claims of which it then has notice.

Dated the 7th day of November, 1962.

BOOTHBY & BOOTHBY, solicitors, 883 Dandenong-road, Caulfield East, and at Korumburra. 3460

## CHRISTINA MAUDE ADAMSON.

**C**REDITORS, next of kin and others having claims in respect of the estate of Christina Maude Adamson, late of Surrey Hall, 564 St. Kilda-road, Melbourne, widow (who died on the 25th December, 1961), are to send particulars of their claims to Marjorie Evelyn Stebbing and Cecil Neweyn John Millen (the executors of the will of the said deceased), care of Cole and O'Heare, solicitors, 465 Collins-street, Melbourne, by the 24th January, 1963, after which date the said executors will distribute the assets, having regard only to the claims of which they then have notice.

COLE & O'HEARE, solicitors, 465 Collins-street, Melbourne. 3457

**C**REDITORS, next of kin and others having claims in respect of the estate of John Edward Wheeler, late of Dunedin, in the Provincial District of Otago, in the Dominion of New Zealand, company director, deceased (who died on or about 2nd February, 1961), are to send particulars of their claims to The Trustees Executors and Agency Company Limited, of 401 Collins-street, Melbourne, in the State of Victoria, the duly appointed attorney under power from The Trustees Executors and Agency Company of New Zealand Limited, the executors of the will and codicil of the said deceased, by the 17th day of January, 1963, after which date the said attorney will distribute the assets, having regard only to the claims of which it shall then have had notice.

H. L. YUNCKEN & YUNCKEN, solicitors, 443 Little Collins-street, Melbourne. 3452



**CREDITORS**, next of kin and others having claims in respect of the estate of William Squires Holbern, late of 57 Martin-street, Belgrave, retired electrician (who died on 28th April, 1962), are to send the particulars of their claims to The Perpetual Executors and Trustees Association of Australia Limited, of 100-104 Queen-street, Melbourne, by the 18th day of January, 1963, after which date it will distribute the assets, having regard only to the claims of which it then has notice.

DUNCAN MACKINNON & CO., solicitors, 379 Collins-street, Melbourne. 3474

**CREDITORS**, next of kin and others having claims against the estate of Alice Charlotte Romeril, late of Cherry Farm, near Waikouaiti, in the Provincial District of Otago, New Zealand, spinster, deceased (who died on or about the 20th November, 1961), are to send particulars of their claims to The Trustees, Executors and Agency Company Limited, of 401 Collins-street, Melbourne, as attorneys for The Trustees, Executors and Agency Company of New Zealand Limited, of 24 Water-street, Dunedin, in Otago, New Zealand (under power of attorney dated 22nd March, 1962), by the 16th day of January, 1963, after which date the company will distribute the assets, having regard only to the claims of which it then has notice. 3481

**CREDITORS**, next of kin and others having claims in respect of the estate of Thomas Veale, late of Beechworth Mental Hospital, in the State of Victoria, gentleman, deceased, intestate (who died on 23rd October, 1960), are required to send particulars of their claims to the administratrix, care of the under-mentioned solicitor, by the 21st day of January, 1963, after which date the administratrix will distribute the assets, having regard only to the claims of which she then has notice.

K. P. REES, B.A., LL.B., solicitor, 89 Queen-street, Melbourne. 3478

CHARLES JOHN GORDON GILLIES, late of 86 May-street, Preston, retired dentist, DECEASED (who died on 2nd September, 1962).

**CREDITORS**, next of kin and all other persons having claims against the estate of the deceased are required by the executor, The Trustees, Executors and Agency Company Limited, of 401 Collins-street, Melbourne, to send particulars of their claims to the said company, on or before the 16th day of January, 1963, after which date the said company will distribute the assets, having regard only to the claims of which it then has notice.

HOME, WILKINSON & LOWRY, solicitors, 401 Collins-street, Melbourne. 3477

JOHN ALFRED THOMPSON, late of 14 Turnbull-street, Mornington, DECEASED.

**CREDITORS**, next of kin and others having claims in respect of the deceased (who died on the 28th day of July, 1962) are required by his trustees, Albert Cleland, of Curia-street, Mansfield, builder, Alfred John Thompson, of Kinglake West, carrier, and Robert John Forsyth, of 21 Turnbull-street, Mornington, surveyor, to send particulars to them care of the under-mentioned firm of solicitors by the 21st day of January, 1963, after which date the trustees may convey and distribute the assets, having regard only to the claims of which they then have notice.

MAL RYAN & GLEN, High-street, Mansfield, solicitors for the trustees. 3373

MURIEL HUTTON ALEXANDER, late of Euston-road, Hughesdale, spinster, DECEASED.

**CREDITORS**, next of kin and others having claims in respect of the estate of the deceased (who died on the 21st day of August, 1962) are required by the personal representatives, John Welford Stubbs and Niel Lindsay Davidson, both of Malop-street, Geelong, solicitors, to send particulars to them, care of the under-mentioned solicitors, by the 22nd day of January, 1963, after which date the personal representatives may convey or distribute the assets, having regard only to the claims of which they then have notice.

WHYTE, JUST & MOORE, solicitors, 27 Malop-street, Geelong. 3375

CHARLES MONTGOMERY EWART, late of Nicholson-street Healesville, gentleman, DECEASED.

**CREDITORS**, next of kin and others having claims in respect of the estate of the deceased (who died on the 19th day of April, 1962) are required by the executors, The Trustees, Executors and Agency Company

Limited, of 401 Collins-street, Melbourne, and Alma Irene Ewart, of Nicholson-street, Healesville, widow, to send particulars of their claims to them, care of the under-mentioned solicitors, by the 15th day of January, 1963, after which date they will distribute the assets, having regard only to the claims of which they then have notice.

R. P. BAYLOR & CO., solicitors, Healesville. 3377

**CREDITORS**, next of kin and others having claims in respect of the Will and unadministered estate of Catherine Wilson, late of 14 Golding-street, Canterbury, in the State of Victoria, widow, deceased (who died on the 10th January, 1930), are requested to send particulars of their claims to her administrator, George Francis Wilson, of 58 Victory-road Airport West, in the said State, public servant, in the care of the undersigned solicitor, by the 24th day of January, 1963, after which date the administrator will distribute the assets, having regard only to the claims of which he has notice.

BRIAN O'KEEFFE, solicitor, 800 Burke-road, Camberwell. 3379

**CREDITORS**, next of kin and others having claims in respect of the estate of Roy Desmond Wilson, late of 14 Golding-street, Canterbury, in the State of Victoria, postman, deceased (who died on the 11th day of March, 1962), are requested to send particulars of their claims to his administrator, George Francis Wilson, of 58 Victory-road, Airport West, in the said State, public servant, in the care of the undersigned solicitor, by the 24th day of January, 1963, after which date the administrator will distribute the assets, having regard only to the claims of which he has notice.

BRIAN O'KEEFFE, solicitor, 800 Burke-road, Camberwell. 3380

**CREDITORS**, next of kin and others having claims in respect of the estate of Alfred John Maier, late of "Imina," Brisbane-street, Berwick, in the State of Victoria, clerk in Holy Orders, deceased (who died on the 24th day of May, 1962) and probate of whose will was granted by the Supreme Court of Victoria on the 1st day of November, 1962, to Thomas Geoffrey Littleton, of Traralgon, in the said State, solicitor, are to send particulars of their claims to the executor, care of the below-mentioned solicitors, by the 31st day of January, 1963, after which date they will distribute the assets of the deceased, having regard only to the claims of which they then have notice.

Dated the 7th day of November, 1962.

BRUCE & LITTLETON, solicitors, Traralgon. 3382

HERBERT READY ALGERNON DELLAR, late of Swan Hill, in the State of Victoria, labourer, DECEASED (who died on the 22nd July, 1962).

**CREDITORS**, next of kin and all other persons having claims against the estate of the deceased are required by the executors of the will, William Morris Dellar and Mary Ann Parfrey, to send particulars to them, care of the undersigned, on or before the 7th day of February, 1963, after which date they will distribute the assets, having regard only to the claims of which they then have notice.

GARDEN & GREEN, solicitors, McCallum-street, Swan Hill. 3396

#### NOTICE TO CREDITORS.

**THE UNION TRUSTEE COMPANY OF AUSTRALIA LIMITED**, of 333 Collins-street, Melbourne, the executor of the will of Franzisca Marea Crawley, formerly of 31 Wordsworth-street, Moonee Ponds, but late of 2 The Highway, Bentleigh, widow, deceased (who died on the 19th August, 1962), requires all creditors, next of kin and others having claims against the property or estate of the said deceased to send to the said executor, at its address aforementioned, on or before the 15th day of January, 1963, particulars, in writing, of such claims, after which date the said executor intends to convey or distribute such property or estate to or among the persons entitled thereto, having regard only to the claims of which it shall have had notice.

RODDA, BALLARD & VROLAND, solicitors of 430 Little Collins-street, Melbourne. 3397

**CREDITORS**, next of kin and others having claims against the estate of Herbert Baliff Stranger, formerly of 28 Tress-street, Mt. Pleasant, Ballarat, in the State of Victoria, pattern maker, but late of 818 Bond-street,

Ballarat, in the said State, pensioner, deceased (who died on the 27th day of September, 1962), are to send particulars of their claims to The Fidelity Trustee Company Limited, of 101 Lydiard-street north, Ballarat, by the 15th day of January, 1963, after which date the company will distribute the assets, having regard only to the claims of which it then has notice.

THE FIDELITY TRUSTEE COMPANY LIMITED, 101  
Lydiard-street north, Ballarat. 3428

**CREDITORS**, next of kin and others having claims against the estate of William Archibald Warren, late of 104 Twelfth-street, Mildura, in the State of Victoria, retired grazier (who died on the 8th day of September, 1961), are required to send particulars of their claims to Bagot's Executor and Trustee Company Limited, the executor of the will of the said deceased, at its registered office, 198 North-terrace, Adelaide, in the State of South Australia, by the 31st day of January, 1963, after which date it will distribute the assets, having regard only to the claims of which it shall then have notice.

JOHN C. ARNOLD, solicitor, Bowrings' Buildings,  
Eighth-street, Mildura. 3429

**CREDITORS**, next of kin and others having claims against the estate of Alma Murtle Byrnes, late of 1 Tamarisk-grove, Mildura, in the State of Victoria, widow (who died on the 17th day of July, 1961), are required to send particulars of their claims to Elder's Trustee and Executor Company Limited, the executor of the will of the said deceased, at its registered office, 37-39 Currie-street, Adelaide, in the State of South Australia, by the 31st day of January, 1963, after which date it will distribute the assets, having regard only to the claims of which it shall then have notice.

JOHN C. ARNOLD, solicitor, Bowrings' Buildings,  
Eighth-street, Mildura. 3430

GEORGE ALEXANDER BLUETT, late of 126 Summer-hill-road, Footscray, retired, DECEASED.

**CREDITORS**, next of kin and others having claims against the estate of the said deceased (who died on the 8th day of August, 1962), are required by the executor, Kevin William Bluett, of 41 Devon-street, Cheltenham, to send particulars thereof to him, care of the under-named solicitor, by the 31st day of January, 1963, after which date he will distribute the assets, having regard only to the claims of which he then has notice.

JOHN GINNANE, LL.B., solicitor, 153A Barkly-street,  
Footscray. 3455

**CREDITORS**, next of kin and others having claims in respect of the estate of Dorothy Hurford, late of 54 Church-street, Hawthorn, florist, deceased (who died on the 22nd day of September, 1962), are to send particulars of their claims to The Equity Trustees, Executors and Agency Company Limited, at 472 Bourke-street, Melbourne, by the 22nd day of January, 1963, after which date it will distribute the assets, having regard only to the claims of which it then has notice.

LEACH & THOMSON, solicitors, 472 Bourke-street,  
Melbourne. 3451

In the Supreme Court of the State of Victoria.

SALE BY THE SHERIFF:

ON Wednesday, the 16th of January, 1963, at Eleven o'clock a.m., at the Police Station, Ringwood (unless process be stayed or satisfied):—

All the estate and interest (if any) of Kevin Alexander Green and Valerie May Green, formerly of 139 Bedford-road, Ringwood, but now of 21 Roberts-street, Traralgon, truck driver and married woman respectively, as joint proprietors of an estate in fee-simple in the land described in certificate of title, volume 8258, folio 444, upon which is erected a four-room weatherboard house with kitchen, conveniences and a garage, known as No. 139 Bedford-road, Ringwood.

Registered mortgage, No. A.944998, affects the said estate and interest.

Terms: Cash only.

DAVID J. JOHNSTON, Sheriff's Officer.

8th November, 1962.

3459

## INSOLVENCY NOTICES

Commonwealth of Australia.—The Bankruptcy Act 1924-60, Part XII.—In the matter of Assigned Estate of KEVIN FRANCIS DAVERN, of 71 Strathalbyn-street, East Kew (trading as DAVENITE PLATE CO. & WHITVERN DISTRIBUTORS, of 70 Faraday-street, Carlton).—No. 73 of 1961.

NOTICE is hereby given that a First Dividend is intended to be declared in the above matter. Creditors who have not proved their debts by the 6th day of December, 1962, will be excluded therefrom.

Dated this 7th day of November, 1962.

R. D. WIDDOWS, Trustee.

125 William-street, Melbourne.

3468

Commonwealth of Australia.—The Bankruptcy Act 1924-60, Part XII.—In the matter of Assigned Estate of KEVIN FRANCIS DAVERN and WARWICK JOSEPH WHITE, both of 71 Strathalbyn-street, East Kew (trading as DAVENITE PLATE CO. & WHITVERN DISTRIBUTORS, of 70 Faraday-street, Carlton).—No. 73 of 1961.

NOTICE is hereby given that a Second Dividend is intended to be declared in the above matter. Creditors who have not proved their debts by the 6th day of December, 1962, will be excluded therefrom.

Dated this 7th day of November, 1962.

R. D. WIDDOWS, Trustee.

125 William-street, Melbourne.

3469

## IMPOUNDINGS

**COLBINABBIN**.—Impounded in Colbinabbin Pound, by J. McEvoy.

1 Border Leicester ram, 6 years, full wool, ear tag, I. S. Weaver, tattooed both ears, no visible brand.

If not claimed and expenses paid, to be sold on 30th November, 1962.

B. E. LEACH,

Shire Secretary.

3444—12/

**COBDEN**.—Impounded in Cobden Pound.

1 dark Jersey yearling calf, no visible brand

1 brown Jersey yearling calf, no visible brand

2 yellow Jersey yearling calves, no visible brand

If not claimed and expenses paid, to be sold on 24th November, 1962.

J. S. BRADD,

Poundkeeper.

3384—12/

**DEDERANG**.—Impounded in Dederang Pound, Gundowring.

1 Black Poll-cross steer, piece out under right ear, no visible brand

If not claimed and expenses paid, to be sold on 27th November, 1962.

H. T. SEYMOUR,

Poundkeeper.

3449—12/

**NUMURKAH**.—Impounded in Numurkah Pound, on 8th November, 1962.

2 wethers, shorn, no visible brand

3 lambs, shorn, no visible brand

7 ewes, shorn, no visible brand

If not claimed and expenses paid, to be sold on 30th November, 1962.

G. A. TAYLOR,

Poundkeeper.

3419—13/6

**TRARALGON**.—Impounded in Traralgon Stock Pound, Hickox-street, Traralgon, from borough roads, on 8th November, 1962.

1 white common billy goat, collar around neck, no visible brand

If not claimed and expenses paid, to be sold on 30th November, 1962.

J. LINDSAY,

Poundkeeper.

3440—13/6

**STATE ACTS, 1961**

STATE ACTS, 1961.—*continued.*

COPIES of the following Acts of Parliament of Victoria may be obtained at the Government Printing Office, or from any bookseller, at the price set opposite to each:—

No.	Price.
No.	s. d.
6736. Public Works Committee (Special Exemption)	0 6
6737. Railways (Permanent Service)	0 6
6738. Superannuation (Railway Service)	0 6
6739. Stamps (Amendment)	0 6
6740. Employers and Employés (Attachment of Wages)	0 6
6741. St. Kilda (Goldsmith and Shelley Streets) Land	0 6
6742. Municipal Association (Amendment)	0 6
6743. Wormbete Land	0 6
6744. Grain Elevators (Borrowing)	0 6
6745. Housing (Amendment)	0 6
6746. Land (North-West Mallee Settlement Areas)	0 9
6747. Ripon Peace Memorial Hospital Trust	0 6
6748. Road Traffic (Parking on Railway and Municipal Property)	0 6
6749. Co-operation (Amendment)	0 6
6750. Heidelberg and Toolamba Lands Exchange	0 6
6751. Town and Country Planning (Amendment)	0 6
6752. Janet Clarke Hall	0 6
6753. Transport Regulation (Compensation)	0 6
6754. Bread Industry (Legal Proceedings)	0 6
6755. Milk Pasteurization (Licences)	0 6
6756. Health (Proprietary Medicines)	0 6
6757. Police Offences (False Reports to Police)	0 6
6758. Evidence (Children)	0 6
6759. Statute Law Revision	0 6
6760. Transport Regulation (Term of Office)	0 6
6761. Prostitution	0 6
6762. Motor Car (Amendment)	1 0
6763. Game (Amendment)	0 6
6764. The Constitution Act Amendment (Electoral)	0 9
6765. Building Societies (Amendment)	1 3
6766. Juries (Amendment)	0 6
6767. Gas and Fuel Corporation (Borrowing)	0 6
6768. Clean Air (Sub-committees)	0 6
6769. Housing (Home Builders' Account)	0 6
6770. Public Offences (Pinball Machines)	0 6
6771. Fisheries (Commercial Council)	0 6
6772. Consolidated Revenue	0 6
6773. Consolidated Revenue	0 6
6774. Consolidated Revenue	0 6
6775. Game (Black Swans)	0 6
6776. Distribution of Population (Joint Committee)	0 9
6777. Public Works Interim Loan Application	0 6
6778. Legal Profession Practice (Amendment)	0 6
6779. Home Finance (Amendment)	0 6
6780. Cancer (Amendment)	0 6
6781. Tourist (Amendment)	0 6
6782. Water (Ballarat Water Commissioners)	0 6
6783. Commercial Goods Vehicles (Tow Trucks)	0 6
6784. Consolidated Revenue	0 6
6785. Local Government (Municipal Assistance Fund)	0 6
6786. Agricultural Colleges (Leases)	0 6
6787. United Lutheran Church Incorporation	1 3
6788. West Melbourne Market Land (Amendment)	0 6
6789. Portland Harbor Trust (Quarrying)	0 6
6790. Racing (Bookmakers' Course Agents)	0 9
6791. Stamps (Further Amendment)	1 0
6792. North Geelong to Fyansford Railway Deviation	0 6
6793. Apprenticeship (Amendment)	0 6
6794. Land (Unused Roads and Water Frontages)	0 9
6795. Motor Car (Insurance Surcharge)	0 6
6796. Forests (Wood Pulp Agreement)	2 0
6797. Dandenong Lands	0 9
6798. Local Authorities Superannuation (Amendment)	0 6
6799. R.S.L. Welfare Trust Fund	0 9
6800. The Zinc Corporation Limited	0 9
6801. Mines (Explosives)	0 6
6802. University (Officers)	0 6
6803. State Accident Insurance Office	0 6
6804. Melbourne and Metropolitan Board of Works (Yarra River)	0 6
6805. Legal Aid	0 9
6806. Crimes (Breath Test Evidence)	0 6
6807. Consolidated Revenue	0 6
6808. Civil Aviation (Carriers' Liability)	0 6
6809. Sheep Owners Protection	1 0
6810. Entertainments Tax (Amendment)	0 6
6811. Exhibition (Borrowing Powers)	0 6
6812. Children's Welfare (Appeals)	0 6
6813. Pawnbrokers (Amendment)	0 6
6814. Property Law (Loans to Minors)	0 6
6815. Disposal of Uncollected Goods	1 0
6816. Milk and Dairy Supervision (Amendment)	0 6
6817. State Forests Loan Application	0 6

No.	Price.
No.	s. d.
6818. Health (Dangerous Substances)	0 6
6819. Money Lenders (Amendment)	0 6
6820. Water Supply Loan Application	1 0
6821. Co-operative Housing Societies (Amendment)	0 6
6822. Legal Profession Practice (Further Amendment)	0 6
6823. Labour and Industry (Women's Hairdressing)	0 6
6824. Co-operation (Amendment)	0 6
6825. Valuation of Land (Amendment)	1 0
6826. Public Works Loan Application	0 6
6827. Land Tax (Exemptions and Rates)	0 9
6828. Landlord and Tenant (Amendment)	0 9
6829. Mines (Aluminium Agreement)	1 3
6830. Railway Loan Application	1 0
6831. Railways (Funds)	0 6
6832. Motor Boating	1 3
6833. Police Regulation (Amendment)	0 6
6834. Housing (Commonwealth and State Agreement)	0 9
6835. Education (Amendment)	0 6
6836. Racing (Off-course Doubles Totalizators)	1 0
6837. Medical (Amendment)	0 6
6838. Water and Sewerage Authorities (Proceedings and Finances)	1 3
6839. Companies	21 0
6840. The Constitution Act Amendment	0 6
6841. Local Government (Streets and Abattoirs)	0 6
6842. Crown Leases	0 6
6843. Church of England (Greensborough Land)	0 6
6844. Juries (Fees)	0 6
6845. Limitation of Actions (Recovery of Imposts)	0 6
6846. Rural Finance and Settlement Commission	1 3
6847. Marine (Amendment)	1 6
6848. Dog	0 9
6849. Town and Country Planning	3 3
6850. Appropriation of Revenue, 1960-61	8 9

A. C. BROOKS,  
Government Printer.

**STATE ACTS, 1962**

COPIES of the following Acts of Parliament of Victoria may be obtained at the Government Printing Office, or from any bookseller, at the price set opposite to each:—

No.	Price.
No.	s. d.
6851. Racing (Anzac Day)	0 6
6852. Railways (Thomson River Bridge)	0 6
6853. Business Names	1 9
6854. Melbourne Cricket Ground	0 6
6855. Evidence (Amendment)	0 6
6856. Railways (Industrial Awards)	0 6
6857. Children's Welfare (Assistance)	0 6
6858. National Parks	0 6
6859. Consolidated Revenue	0 6
6860. Land (Industrial Grants)	0 6
6861. Revocation and Excision of Crown Reservations	1 0
6862. Standard Insurance Company Limited	0 6
6863. The Constitution Act Amendment (Statute Law Revision Committee)	0 6
6864. Dog (Registration Discs)	0 6
6865. Game (Black Swans) Amendment	0 6
6866. Administration and Probate (Amendment)	0 6
6867. Statute Law Revision	0 9
6868. Tottenham to Brooklyn Railway Construction	0 6
6869. Kerang (Alexandra Park) Land	0 6
6870. Forests (Amendment)	0 6
6871. Melbourne Harbor Trust Lands	1 6
6872. Dried Fruits (Expenses and Finances)	0 6
6873. Housing (Home Builders' Account)	0 6
6874. Supreme Court (Interest on Judgments)	0 6
6875. The Constitution Act Amendment (Postal Voting)	0 6
6876. Melbourne and Metropolitan Board of Works (Government Guarantee)	0 6
6877. Stock (Artificial Breeding)	0 9
6878. Tattooing	0 6
6879. Unclaimed Moneys	1 0
6880. Cancer (Facilities)	0 6
6881. Road Traffic (Traffic Control Items)	0 6
6882. Consolidated Revenue	0 6
6883. Health (Sampling of Foods)	0 6
6884. Crimes (Detention)	0 6
6885. Fisheries (Noxious Fish)	0 9
6886. Subordinate Legislation	1 3
6887. Country Fire Authority (Amendment)	0 6
6888. Local Government (Amendment)	1 3

STATE ACTS, 1962—*continued.*

No.	Price. s. d.
6889. Poisons .. .. .	3 3
6890. Probate Duty .. .. .	3 6
Table of Acts and Enactments passed, date of operation, &c. .. .. .	0 3

A. C. BROOKS,  
Government Printer.

ACTS REPRINTED IN ACCORDANCE WITH THE AMENDMENTS INCORPORATION ACT 1958 (No. 6422).

No.	Price. s. d.
6191. Administration and Probate Act .. .. .	4 9
6219. Children's Welfare Act .. .. .	2 6
6225. Co-operation Act .. .. .	4 0
6246. Evidence Act .. .. .	3 6
6249. Fences Act .. .. .	1 3
6251. Firearms Act .. .. .	2 3
6274. Hospitals and Charities Act .. .. .	3 6
6283. Labour and Industry Act .. .. .	7 3
6285. Landlord and Tenant Act .. .. .	4 6
6293. Licensing Act .. .. .	9 3
6299. Local Government Act .. .. .	25 0
6325. Motor Car Act .. .. .	6 6
6328. Nurses Act .. .. .	2 0
6330. Partnership Act .. .. .	1 3
6363. Second-hand Dealers Act .. .. .	1 3
6367. Settled Land Act .. .. .	4 0
6375. Stamps Act .. .. .	6 0
6399. Transfer of Land Act .. .. .	5 0
6401. Trustee Act .. .. .	4 0
6419. Workers Compensation Act .. .. .	4 9
6455. Companies Act (2nd reprint) .. .. .	15 0

A. C. BROOKS,  
Government Printer.

FRANKS, H., & CO., 184 Ryrie-street, Geelong.  
 GORDON & GOTCH AUSTRALASIA LTD., 511 Little Collins-street, Melbourne.  
 GULLAN'S NEWSAGENCY, 88 Bridge-street, Ballarat.  
 HALES, D. & N., Henty-street, Casterton.  
 HAMPTON, A. C., 243 Mitchell-street, Bendigo.  
 HARSTON, PARTRIDGE & CO. PTY. LTD., 455 Little Collins-street, Melbourne.  
 THE MERCANTILE EXCHANGE, 90 Queen-street, Melbourne.  
 MCGILL'S AUTHORIZED NEWSAGENCY, 183-5 Elizabeth-street, Melbourne.  
 PETTY, R. H. & W. M., 83 Murphy-street, Wangaratta.  
 PURDIE, J., & CO., 138 Moorabool-street, Geelong.  
 SALE AUTHORIZED NEWSAGENCY, 142 Raymond-street, Sale.  
 SKINNER'S AUTHORIZED NEWSAGENCY, 49-51 Franklin-street, Traralgon.  
 SMITH & DUNNON, 112-114 Gray-street, Hamilton.  
 TUFF'S SHEPPARTON NEWSAGENCY, 246 Wyndham-street, Shepparton.  
 VERNON, C. F. & H. J., 162 Bridge-road, Richmond.  
 VIEW POINT AUTHORIZED NEWSAGENCY, 4 View Point, Bendigo.

A copy of the *Gazette* filed at each place for public reference.

**CONTENTS**

*Subordinate Legislation Act 1962.*

NOTICE OF MAKING OF STATUTORY RULES.

IN pursuance of the provisions of the *Subordinate Legislation Act 1962* and the Regulations made thereunder, notice is given of the making of the following statutory rules:—

No.	Companies Act 1961. s. d.	Price. s. d.
34/1962. Companies (Auditors) Regulations 1962 ..	0 6	0 6
<i>Companies Act 1961.</i>		
35/1962. Amendment of Regulations — Official Liquidator's Bond .. .. .	0 6	0 6
<i>Stamps Act 1958.</i>		
36/1962. Stamps (Amendment) Regulations 1962 ..	0 3	0 3

Copies of these statutory rules may be purchased at the Sale of Publications Office, Government Printing Office, Macarthur-street, Melbourne.

A. C. BROOKS,  
Government Printer.

AGENTS FOR THE "VICTORIA GOVERNMENT GAZETTE".

THE following have been appointed agents to receive Advertisements and Subscriptions for the *Victoria Government Gazette*:—

ANGUS & ROBERTSON LTD., 66-68 Elizabeth-street, Melbourne.  
 ARMSTRONG BROS. PTY. LTD., Mollison-street, Kyneton.  
 ARMSTRONG'S AGENCY, 205 Queen-street, Melbourne.  
 ARNALL & JACKSON, 390 Barkly-street, Brunswick, N.10.  
 BAIRNSDALE AUTHORIZED NEWSAGENCY, 132 Main-street, Bairnsdale.  
 COOKE, F. R. & E. M., & SONS, 69 Bridge-street, Benalla.  
 DAVIS, WM. (MILDURA) PTY. LTD., 126 Eighth-street, Mildura.  
 DIXON'S NEWSAGENCY, 89 Firebrace-street, Horsham.  
 EDGAR'S NEWSAGENCY. PTY. LTD., 293 Hargreaves-street, Bendigo.

	PAGE
Acts of Parliament .. .. .	3739
Acts of Parliament on sale at the Government Printing Office .. .. .	3797
Appointments .. .. .	3755
Bank Half-Holidays .. .. .	3740
Cemeteries—Scale of Fees .. .. .	3754
Clerk, Town and Country Planning Board .. .. .	3781
Companies Act 1961—Notice .. .. .	3741
Contracts .. .. .	3753
Courts .. .. .	3746
Government Notices .. .. .	3741
Impoundings .. .. .	3796
Insolvency Notices .. .. .	3796
Lands .. .. .	3770
List of Registered Dietitians .. .. .	3747
Melbourne and Metropolitan Board of Works—Notice .. .. .	3741
Mining .. .. .	3745
Notice of Making of Statutory Rules .. .. .	3798
Orders in Council—	
Acts—Explosives; Landlord and Tenant; Land; Road Traffic; Mental Health; Geelong Waterworks and Sewerage; Sewerage Districts; Water; Housing; Country Roads; State Electricity Commission; Stamps; Town and Country Planning.	3757 et seq
Police Sale .. .. .	3746
Private Advertisements .. .. .	3781
Proclamations .. .. .	3739
Public Half-Holiday .. .. .	3740
Public Holidays .. .. .	3740
Public Service Notices .. .. .	3778
Resignations .. .. .	3756
State Rivers and Water Supply Commission .. .. .	3751
Tenders .. .. .	3776
Transport Regulation Board—Public Hearings .. .. .	3743
Waterworks Trust .. .. .	3754



**VICTORIA**  
**GOVERNMENT GAZETTE**

Published by Authority

[Registered at the General Post Office, Melbourne, for transmission by post as a newspaper.]

No. 118]

WEDNESDAY, NOVEMBER 14

[1962

*County Court Act 1958.*

RULES OF COURT.

**WE**, a majority of the Judges for the time being of the County Court, in exercise of the powers vested in us by section 78 of the *County Court Act 1958* do hereby amend the County Court Rules 1930 as follows and have fixed the following scale of fees costs and expenses to be paid to counsel practitioners and witnesses.

1. For paragraph (d) of Rule 2 of Order LI. there shall be substituted the following paragraph :—

(d) Subject to the provisions of these rules, all costs taxed by the Registrar shall be taxed as follows :—

(i) As to all business done on or after the fifteenth day of November, 1962 according to the Schedule hereto of Scale of Costs.

(ii) As to all business done on or after the first day of July, 1957, and before the fifteenth day of November, 1962, according to the Schedule of Scale of Costs which came into force on the sixth day of May, 1953, with the addition thereto of fifty per centum on all allowances set forth in that scale, (other than for Counsel's fees and other disbursements and payments).

(iii) As to all business done on or after the sixth day of May, 1953, but before the first day of July, 1957, according to the Schedule of Scale of Costs which came into force on the sixth day of May, 1953.

2. After paragraph (b) of Rule 15 of Order LI. there shall be inserted the following paragraphs :—

(c) Where the amount recovered or sought to be recovered or the value of the property in litigation regulating the scale of costs exceeds £2,500, then notwithstanding anything contained in the rules or in the scale of costs the fees to be allowed to counsel (including if the Judge thinks fit more than one counsel) shall be such fees as the Judge shall certify.

(d) Where in such case the Judge certifies for more than one counsel all reasonable and necessary attendances and copies additional to those which would have been necessary had only one counsel been employed shall be allowed.

3. For the Schedule of Scale of Costs at the end of the said Rules, there shall be substituted the Schedule of Scale of Costs annexed thereto.

And we do hereby certify the same under our hands to a law officer of the Crown, namely, the Honorable Arthur Gordon Rylah, Attorney-General, this 31st day of October, One thousand nine hundred and sixty-two.

A. L. READ  
J. H. MOORE  
G. L. DETHRIDGE  
J. G. NORRIS  
BEN. J. DUNN  
E. H. E. BARBER  
S. H. Z. WOJNARSKI  
TREVOR RAPKE  
E. O. MOODIE-HEDDLE

} Judges of County Courts.

I hereby certify that this is a true and proper copy of the original amendment of which it purports to be a copy.

R. A. W. BURNS,  
Secretary to the Law Department.  
5th November, 1962.

SCHEDULE OF SCALE OF COSTS.

SCALE of Fees and Costs to be paid to Counsel and Practitioners as well between party and party as between Practitioner and Client save that as between Practitioner and Client the Registrar or other taxing officer may allow any disbursements reasonably made in excess of any item of disbursement herein provided either wholly or in part as he may think fit.

No. of Item.	Subject Matter.	" A "	" B "	" C "	" D "	" E "
		Under £100.	£100 and under £250.	£250 and under £500.	£500 and under £1,000.	£1,000 and Upwards.
		£ s. d.	£ s. d.	£ s. d.	£ s. d.	£ s. d.
1	Preparation of Plaintiff Note, Summonses, particulars (and further particulars) of claim, including one copy for service, attendance on—Registrar to issue, and affidavit of service .. .. .	1 17 6	3 0 0	4 0 0	6 0 0	6 0 0
2	(a) Preparation of particulars of Counter-Claim, including notice thereof, copy to file one copy for service, and attendance filing .. .. .	1 17 6	3 0 0	4 0 0	4 0 0	4 0 0
	(b) Preparation of Third Party notice or notice claiming contribution or indemnity copy to file, one copy for Service and attendance filing .. .. .	1 17 6	3 0 0	4 0 0	4 0 0	4 0 0
3	(a) Summonses for witness AD test for any number of persons, including praecipies and attendances to issue .. .. .	0 18 0	1 4 0	1 10 0	1 10 0	1 10 0
	For each copy after the first witness.					
	(b) Summonses to witness duces tecum, including all copies praecipies and attendances to issue .. .. .	0 18 0	1 4 0	1 10 0	1 10 0	1 10 0
4	Summonses in Chambers, including attendance to issue and copy for service .. .. .	1 10 0	2 0 0	2 0 0	2 0 0	2 0 0
	Notices, Consents and Other Memoranda.					
5	Notice before action in all cases where required by any Act, including copy .. .. .	1 10 0	2 0 0	3 0 0	3 0 0	4 0 0
6	Notice to admit or produce, including copy and service .. .. .	1 2 6	2 0 0	2 0 0	3 0 0	3 0 0
7	If special or necessarily long, such allowance for drawing as the Judge or Registrar shall think proper (in addition to allowance under items 18 and 21 for service), not exceeding per folio .. .. .	0 3 0	0 4 0	0 4 0	0 4 0	0 4 0
8	For each further notice to produce or admit considered necessary by the Judge, or Registrar on taxation, including copy and service .. .. .	1 2 6	1 10 0	2 0 0	2 0 0	2 0 0
9	Any necessary or proper consent or admission, including attendance to obtain or give and copy for opposite party, except where otherwise provided .. .. .	1 2 6	1 10 0	1 10 0	1 10 0	1 10 0
10	Notice under Order XXIII., of intention to defend, including attendance to file .. .. .	0 15 0	1 0 0	1 0 0	1 0 0	1 0 0
11	Notice of special Defence (including particulars); copy to file, one copy for service, and attending to file .. .. .	1 10 0	2 0 0	3 0 0	3 0 0	3 0 0
12	Or for drawing such notice per folio .. .. .	0 3 0	0 4 0	0 4 0	0 4 0	0 4 0
13	Preparing consent to judgment under Order XXVII., and obtaining execution thereof .. .. .	1 10 0	2 0 0	3 0 0	3 0 0	3 0 0
14	In actions remitted by Supreme Court (or in actions tried by consent in the Court) preparing documents as required by Rules, including copies and attending Registrar, to file documents under Order XXXV. .. .. .	1 10 0	2 0 0	3 0 0	3 0 0	3 0 0
15	Any necessary or proper notice undertaking or memorandum not otherwise provided for, including copies to file and serve attending filing and service .. .. .	1 2 6	2 0 0	2 0 0	2 0 0	2 0 0
16	If special or necessarily exceeding three folios, for drawing each additional folio .. .. .	0 3 0	0 4 0	0 4 0	0 4 0	0 4 0
SERVICE.						
(NOTE.—Where two or more documents have or could have been served together, one fee only for service of all such documents is to be allowed.)						
17	Service of Plaintiff Summonses or any originating proceeding on a party .. .. .	1 2 6	1 10 0	1 10 0	1 10 0	1 10 0
18	Service of any necessary document on a party or his practitioner or on the Registrar if not authorized to be served by post .. .. .	0 15 0	1 0 0	1 0 0	1 0 0	1 0 0
19	If authorized to be served by post .. .. .	0 6 0	0 8 0	0 8 0	0 8 0	0 8 0
20	Service of Summonses on witness .. .. .	1 2 6	1 10 0	1 10 0	1 10 0	1 10 0
21	If any document herein mentioned be served beyond 2 miles from the Registrar's office a reasonable amount to be fixed by the Registrar.					
22	When substituted service is ordered, in addition all costs of attendances, making appointments to serve, drawing, engrossing, attending to swear affidavits and to obtain order (in addition to oaths and Court fees) not exceeding .. .. .	4 14 6	8 8 0	8 8 0	8 8 0	8 8 0
23	In addition where substituted service by way of advertisement is ordered, for drawing and engrossing, advertisement, and attending to insert same (together with advertising fees paid) .. .. .	1 10 0	2 10 0	2 10 0	2 10 0	2 10 0
INSTRUCTIONS.						
24	Instructions to sue or defend (including counter-claim) or for any originating proceeding .. .. .	3 3 0	5 0 0	6 0 0	7 10 0	9 0 0
25	If no amount be allowed under Item 28, then an additional sum may be allowed in respect to this item if thought proper by the Registrar on taxation, not exceeding .. .. .	2 5 0	5 0 0	6 0 0	8 0 0	10 0 0
26	Instructions for special affidavits including answers to interrogatories and affidavits in answer to notice for discovery (subject to Order 51, Rule 9) .. .. .	1 17 6	2 10 0	3 10 0	3 10 0	3 10 0

## SCHEDULE OF SCALE OF COSTS—continued.

No. of Item.	Subject Matter.	" A "	" B "	" C "	" D "	" E "
		Under £100.	£100 and under £250.	£250 and under £500.	£500 and under £1,000.	£1,000 and Upwards.
		£ s. d.	£ s. d.	£ s. d.	£ s. d.	£ s. d.
27	Instructions for any special application to the Court or a Judge .. .. .	1 2 6	1 10 0	1 10 0	2 5 0	2 5 0
28	Instructions for Brief for Counsel or Brief Notes for practitioner where no Counsel employed on trial including all attendances on and correspondence with the party and his witnesses and all necessary perusals and/or work in connexion with the preparation for hearing (with discretionary power to the Registrar to allow in addition any necessary out-of-pocket expenses) not exceeding ..	12 12 0	21 0 0	31 10 0	42 0 0	63 0 0
	If by reason of special circumstances, any party considers that the maximum allowance under this Item is not sufficient remuneration for the work actually done, then such party may apply to the trial Judge at or after trial to order an increase in such maximum amount, and such judge may fix such amount as he thinks proper in all the circumstances.					
29	Instructions for Counsel to advise on evidence or to furnish an opinion (including attendance on Counsel) when allowed on taxation .. .. .	..	4 0 0	4 0 0	4 10 0	4 10 0
	<i>Drawing.</i>					
	(NOTE—(a) The matter of all documents should be necessary and relevant, and expressed without prolixity and the costs of all unnecessary, irrelevant or prolix matter must be disallowed.) (b) No allowance shall be made to a Practitioner for drawing a document actually drawn by Counsel. (c) The allowance for drawing Brief shall not exceed .. .. .	9 0 0	20 0 0	40 0 0	40 0 0	40 0 0
30	Drawing Brief on trial or on hearing before arbitrator or referee where Counsel employed per folio .. .. .	0 3 0	0 4 0	0 4 0	0 4 0	0 4 0
31	Preparing Brief Notes for practitioner where no Counsel employed, including copy—per folio .. .. .	0 3 0	0 4 0	0 4 0	0 4 0	0 4 0
32	Drawing and copying Brief for Counsel on examination of witnesses or to support or oppose any motion or application, where not otherwise provided for, not exceeding .. .. .	3 0 0	5 0 0	6 0 0	6 0 0	6 0 0
33	Drawing affidavits, accounts, and any document including request for further particulars allowed as necessary on taxation not otherwise provided for—per folio .. .. .	0 3 0	0 4 0	0 4 0	0 4 0	0 4 0
34	Drawing affidavit of service of any document, other than plaint summons, when deemed necessary (including copy and attendance to swear and file) in addition to oaths and fees .. .. .	1 2 6	1 10 0	1 10 0	1 10 0	1 10 0
	<i>Copies.</i>					
	(NOTE.—No copies are to be allowed for unless the Registrar is satisfied that they were necessary and that copies previously prepared were not available.)					
35	All engrossments and copies where no provision is made herein that the fee for preparing and drawing is to include engrossments or copies, for each engrossment and for each copy except otherwise provided for which the Registrar may consider necessary, per folio .. .. .	0 1 6	0 2 0	0 2 0	0 2 0	0 2 0
36	Carbon or machine-made copies, per folio .. .. .	0 0 9	0 1 0	0 1 0	0 1 0	0 1 0
	(NOTE.—Where two or more copies could have been made by typewriter by the same impression, the Registrar shall allow for each copy, however made, the same rate only as for carbon copies.)					
	<i>Perusals.</i>					
37	Perusing deeds, correspondence, accounts, and documents when long and thought necessary on taxation, if the Registrar considers that such allowances should be made in addition to Item 28, per folio 6d., but not exceeding .. .. .	6 6 0	8 8 0	12 12 0	12 12 0	12 12 0
38	Perusing and advising on Notice to produce or admit, admission of facts, special defence, counter-claim, further particulars, answers to interrogatories, affidavit in obedience to order for discovery—if ten folios or less ..	1 2 6	1 10 0	1 10 0	1 10 0	1 10 0
39	For every extra folio .. .. .	0 1 6	0 2 0	0 2 0	0 2 0	0 2 0
	<i>Attendances.</i>					
	(NOTE.—Order LI., Rule 16—More than one attendance at the Office of the Registrar in an action or matter shall not be allowed unless the Registrar on taxation is satisfied that each separate attendance was necessary.)					
40	Attendance to enter up final judgment under Order XXIII. including taxing costs where final judgment is entered .. .. .	2 0 0	2 0 0	2 0 0	2 0 0	2 0 0
41	Attendance at the Office of the Registrar Bailiff or on opposite party, where not otherwise provided for .. .. .	0 15 0	1 0 0	1 0 0	1 0 0	1 0 0
42	Where the attendance requires the personal attendance of the Solicitor or Managing Clerk, and involves the exercise of skill or legal knowledge per hour or part thereof ..	1 2 6	2 0 0	2 0 0	2 10 0	2 10 0
43	Attending to inspect documents, pursuant to a notice to admit, or to an order or to a notice under any rule .. ..	1 2 6	1 10 0	1 10 0	2 0 0	2 0 0
44	Each hour after the first or part thereof in the opinion of the Registrar necessarily occupied .. .. .	1 2 6	1 10 0	1 10 0	1 10 0	1 10 0

SCHEDULE OF SCALE OF COSTS—continued.

No. of Item.	Subject Matter.	" A "	" B "	" C "	" D "	" E "
		Under £100.	£100 and under £250.	£250 and under £500.	£500 and under £1,000.	£1,000 and Upwards.
		£ s. d.	£ s. d.	£ s. d.	£ s. d.	£ s. d.
45	Attending to produce documents for inspection for each necessary attendance .. .. .	0 15 0	1 0 0	1 0 0	1 0 0	1 0 0
46	On Deponent to be sworn to an affidavit in answer to interrogatories or notice for discovery or other special affidavit .. .. .	0 15 0	1 0 0	1 0 0	1 0 0	1 0 0
47	Inspection under Order XVI. of property not exceeding per hour .. .. .	1 2 6	1 10 0	1 10 0	1 10 0	1 10 0
48	Attendance of Solicitor or managing clerk to inspect works or <i>locus in quo</i> or for any other similar purpose where considered necessary by Registrar not exceeding per hour .. .. .	1 2 6	1 10 0	1 10 0	1 10 0	1 10 0
49	Where it becomes necessary to advise or receive instructions from a client in the progress of an action or matter, and not for a purpose which could have been effected at any previous or subsequent attendance, and if an attendance was necessary, and has not been provided for herein .. .. .	0 15 0	1 10 0	1 10 0	2 0 0	2 0 0
50	Attendance on Counsel with Brief or with Notice of Appeal or other document to settle—where fee to Counsel is £5 10s. or less .. .. .	0 15 0	1 0 0	1 0 0	1 0 0	1 0 0
	Where fee exceeds £5 10s. .. .. .	1 2 6	1 10 0	1 10 0	1 10 0	1 10 0
51	If conference allowed by Judge or Registrar, appointing and attending same .. .. .	1 10 0	3 0 0	4 0 0	4 0 0	4 0 0
52	Attending Court or Judge to support or oppose any motion or application, when no Counsel employed, when not otherwise provided for .. .. .	2 5 0	3 0 0	4 0 0	4 0 0	4 0 0
53	Attending same with Counsel .. .. .	1 10 0	2 0 0	2 0 0	2 0 0	2 0 0
54	All necessary unopposed applications to the Judge in Chambers, where not otherwise provided for .. .. .	1 10 0	2 0 0	2 0 0	2 0 0	2 0 0
55	(a) Attending Court on calling over list or on pre-trial investigation .. .. .	2 0 0	2 0 0	2 0 0	2 0 0	2 0 0
	(b) If principal or managing clerk attends .. .. .	3 10 0	3 10 0	3 10 0	3 10 0	3 10 0
56	Attending Court cause in list before trial, per day, allowance in any case not to exceed three days .. .. .	1 11 6	2 2 0	2 2 0	2 2 0	2 2 0
57	Attending Court on trial, or before arbitrator or referee, with Counsel, per day .. .. .	6 6 0	8 8 0	12 12 0	14 14 0	16 16 0
	If solicitor does not give substantial attendance .. .. .	3 0 0	4 0 0	4 0 0	6 0 0	10 0 0
58	Solicitor attending Court or arbitrator or referee and conducting trial or hearing where no Counsel employed per day .. .. .	9 9 0	16 16 0	21 0 0	25 4 0	29 8 0
	Where the Solicitor or clerk (whether Counsel employed or not) does not reside or carry on business within 15 miles of the town in which the trial or hearing takes place, in addition to the sum reasonably paid for travelling and for hotel expenses to attend the trial or hearing, such amount as may be ordered by the Judge or allowed by the Registrar.					
59	Attending before Judge with or without Counsel to hear deferred judgment when certified for by Judge or allowed by Registrar .. .. .	1 2 6	1 10 0	2 0 0	2 0 0	2 0 0
60	Obtaining appointment to tax costs, and making and serving copy on opposite party .. .. .	0 15 0	1 0 0	1 0 0	1 0 0	1 0 0
61	Attending taxing costs other than costs where final judgment entered under Order XXIII. for each hour or part of an hour .. .. .	1 10 0	2 0 0	2 0 0	2 0 0	2 0 0
62	Attendance to make search for insolvencies, bankruptcies, incorporation of companies (and obtaining certificates of same), births, marriages, deaths, registration of firms, against lands, at Master of the Supreme Court's or Registrar of Probate's office or any like searches where thought necessary by Judge or Registrar, and not covered by any item of instructions allowed in addition to fee paid .. .. .	1 2 6	1 10 0	1 10 0	1 10 0	1 10 0
63	Attending witness arranging at Court without subpoena .. .. .	0 15 0	1 0 0	1 0 0	1 0 0	1 0 0
	<i>Costs of Appeal.</i>					
64	Instructions to appeal or to oppose appeal .. .. .	1 10 0	2 0 0	2 0 0	3 0 0	3 0 0
65	Application for copy Judge's notes .. .. .	0 15 0	1 0 0	1 0 0	1 0 0	1 0 0
66	Paid for same, amount actually paid, not exceeding per folio, as per Order XXXIII., Rule 7 .. .. .	0 3 0	0 3 0	0 3 0	0 3 0	0 3 0
67	Preparing notice of appeal including copies not exceeding .. .. .	1 10 0	4 0 0	4 0 0	4 0 0	4 0 0
68	Paying money into Court as deposit on appeal, including notice and service .. .. .	1 2 6	2 0 0	2 0 0	2 0 0	2 0 0
69	Notice of nature and particulars of proposed security, including copies and service .. .. .	1 2 6	1 10 0	1 10 0	1 10 0	1 10 0
70	Fair copy Case, per folio .. .. .	0 1 6	0 2 0	0 2 0	0 2 0	0 2 0
71	Respondent perusing, settling, and making copy draft appeal case, per folio .. .. .	0 1 6	0 2 0	0 2 0	0 2 0	0 2 0
72	Attendances on printer, and examining proof print, per folio .. .. .	0 0 6	0 0 8	0 0 8	0 0 8	0 0 8
73	Clean copy, to file in Supreme Court, per folio .. .. .	0 1 6	0 2 0	0 2 0	0 2 0	0 2 0
74	Paid (price paid) for six copies type-written or printed, per folio not exceeding. The Registrar may nevertheless where an amount in excess of the sum fixed has been necessarily paid by the practitioner allow the same either wholly or in part as he may think fit .. .. .	0 4 0	0 4 0	0 4 0	0 4 0	0 4 0



## SCHEDULE OF SCALE OF COSTS—continued.

No. of Item.	Subject Matter.	" A "	" B "	" C "	" D "	" E "
		Under £100.	£100 and under £250.	£250 and under £500.	£500 and under £1,000.	£1,000 and upwards.
		£ s. d.	£ s. d.	£ s. d.	£ s. d.	£ s. d.
75	Attending Judge, with or without Counsel, to settle case Costs of preparation of necessary affidavits, and swearing and filing same, and attendances on opposite party or Registrar, and letters, when necessary, and allowed by the Registrar, may be allowed in accordance with appropriate items in general scale.	1 2 6	1 10 0	2 0 0	2 0 0	2 0 0
	<i>Fees to Counsel.</i>					
	(NOTE.—No fee to Counsel is to be allowed unless vouched by Counsel's signature (Order LI., Rule 23.)					
76	To settle notice before action, if allowed by Judge or Registrar, and actually paid, not exceeding	2 4 6	2 4 6	4 6 6	4 6 6	4 6 6
77	On application for final judgment, where certified for and actually paid, not exceeding	2 4 6	4 6 6	4 6 6	5 10 0	5 10 0
78	(a) On trial, or hearing before Arbitrator or Referee, amount actually paid, not exceeding	11 0 0	13 2 0	19 8 0	27 0 0	32 10 0
	(b) In circuit cases a further fee may be allowed and the amount thereof fixed by order of the Judge if, in his opinion (having regard to all the circumstances, including travelling expenses, living expenses and absence from Chambers) the scale fee is insufficient, but the total amount of the scale fee and the further fee shall not exceed the fee marked on the brief.					
79	On conference, amount actually paid, not exceeding	2 7 0	2 7 0	2 7 0	3 8 0	3 8 0
80	Refresher fee	8 13 0	9 14 0	13 2 0	17 6 0	21 15 0
81	To hear deferred judgment, when certified for by Judge, or allowed by Registrar	2 4 6	2 4 6	3 5 6	3 5 6	4 6 6
82	To support or oppose any motion or oppose any motion or application, amount actually paid, not exceeding	2 4 6	3 5 6	4 6 6	5 10 0	5 10 0
83	To settle interrogatories or answers thereto, when allowed on taxation amount actually paid, not exceeding	2 4 6	3 5 6	3 5 6	4 6 6	5 10 0
84	To settle Particulars of Claim, Counter-Claim, Set Off, Special Defence, or further particulars of foregoing, or to settle special case, answer or award	2 4 6	3 5 6	4 6 6	5 10 0	5 10 0
85	On Examination under Imprisonment of Fraudulent Debtors Act, not exceeding	2 4 6	3 5 6	4 6 6	4 6 6	5 10 0
86	To settle Notice of Appeal, when allowed on taxation	2 4 6	3 5 6	3 5 6	4 6 6	5 10 0
87	To settle draft Appeal Case, when allowed on taxation	2 4 6	3 5 6	3 5 6	4 6 6	5 10 0
88	Fee on settling Appeal Case before Judge, when allowed on taxation	2 4 6	3 5 6	3 5 6	4 6 6	5 10 0
89	To advise on evidence or to furnish an opinion when certified for by Judge or allowed by Registrar		4 6 6	4 6 6	4 6 6	5 10 0
90	Plaintiff's costs of final judgment, including summons and affidavit in support, in addition to disbursements	4 14 6	8 8 0	8 8 0	8 8 0	8 8 0
91	An allowance under item 90 shall, in addition, be made at the discretion of the Registrar, but subject to Order LI., Rule 24, if summons for final judgment be necessarily served beyond 2 miles of the Registrar's Office.					
92	Defendant's costs of a similar application, in addition to disbursements	3 3 0	6 6 0	6 6 0	8 8 0	8 8 0
93	If Counsel certified for, brief to Counsel and copy of documents to accompany and attending him therewith, not exceeding	2 5 0	3 0 0	3 0 0	4 10 0	6 0 0
	<i>Costs of the Day.</i>					
94	Costs of the day (if allowed by the Judge at the trial), where the trial lasts more than one day, or is adjourned for want of time, or upon payment of the costs of the day, as follows:—					
	(a) Practitioner for attending Court where no Counsel employed, not exceeding	3 3 0	4 4 0	8 8 0	8 8 0	8 8 0
	(b) Attending with Counsel, not exceeding	1 10 0	2 0 0	4 0 0	4 0 0	4 0 0
	(c) Counsel's fee	7 12 0	8 13 0	11 0 0	14 3 0	18 12 0
	(d) Expenses of witnesses in attendance at Court					
	<i>Execution.</i>					
95	Preparing execution and attending to issue and for Return	1 10 0	2 0 0	2 0 0	2 0 0	2 0 0
	<i>Imprisonment of Fraudulent Debtors Act 1928.</i>					
96	(a) Instructions for and bespeaking certified copy judgment and service thereof, and also preparation of judgment summons and affidavit in support, including copy and service	6 0 0	10 0 0	10 0 0	10 0 0	10 0 0
	(b) If served beyond 2 miles from the Registrar's Office, an additional amount, to be fixed by the Registrar.					
97	Attending Court on examination, where no Counsel employed, not exceeding	3 0 0	6 0 0	6 0 0	8 0 0	8 0 0

SCHEDULE OF SCALE OF COSTS—continued.

No. of Item.	Subject Matter.	" A "	" B "	" C "	" D "	" E "
		Under £100.	£100 and under £250.	£250 and under £500.	£500 and under £1,000.	£1,000 and Upwards.
		£ s. d.	£ s. d.	£ s. d.	£ s. d.	£ s. d.
98	Attending with Counsel .. .. .	1 10 0	2 0 0	2 0 0	3 0 0	3 0 0
99	When Counsel employed drawing and engrossing brief, not exceeding .. .. .	1 10 0	3 0 0	3 0 0	4 0 0	4 0 0
100	(a) Drawing and engrossing order, attending to issue, copy for service, and service, in addition to fees paid .. .. . (b) If served beyond 2 miles from the Registrar's Office, an additional amount, to be fixed by the Registrar.	2 5 0	4 0 0	4 0 0	4 0 0	4 0 0
	<i>Letters and Miscellaneous.</i>					
101	(a) Letter before action or special letter .. .. . (b) Any necessary letter, including agency correspondence .. .. . (c) Circular letters, after the first .. .. .	1 0 0 0 10 0 0 1 6	1 0 0 0 10 0 0 3 0	1 0 0 0 10 0 0 3 0	1 0 0 0 10 0 0 3 0	1 0 0 0 10 0 0 3 0
102	Plans, charts, photographs, or models, where necessary for use at hearing, and certified by the Judge, or allowed by Registrar, not exceeding .. .. . (The Registrar may nevertheless where an amount in excess of the sum fixed has been necessarily paid by the practitioner allow the same either wholly or in part as he may think fit.)	4 4 0	4 4 0	6 6 0	8 8 0	10 10 0
103	Practitioner's clerk's fee .. .. .	0 15 0	0 15 0	1 0 0	1 0 0	1 10 0
	<i>Conveyancing Business.</i>					
104	The charges prescribed by any Solicitors' Remuneration Order or Orders for the time being in force.					
	<i>Rating Appeals.</i>					
105	Instructions for appeal, or to support assessment, including preparation of notice of appeal, and copy for service, and filing with Registrar. Where annual value appealed against is under £100—£8. Where annual value appealed against is over £100—£10.					

RATING APPEALS.

As to all other items and charges under this heading, as far as practicable Scale A shall apply where the annual value appealed against is under £100, and Scale B where the annual value appealed against is over £100.

Whenever any rating appeal case is, in the opinion of the presiding Judge, of such a special and important nature that the fees above specified would not be a fair and reasonable remuneration for the trouble, care, skill, and expense necessarily involved in the proper preparation and conduct of such appeal case, he may allow such lump sum as, in his opinion, would amount to such fair and reasonable remuneration.

Provided that nothing herein stated with regard to costs of rating appeals shall prevent the Judge from making such order as to costs or fixing the same at such sum as he shall think fit.

WITNESSES' EXPENSES.

Professional men, including—	<i>Allowance.</i>
Medical practitioners .. .. .	} £5 5s. per hour or part thereof necessarily absent from professional rooms or place of business but not in any event to exceed £42 for any one day.
Legal practitioners .. .. .	
Architects .. .. .	
Engineers or surveyors .. .. .	
Dentists .. .. .	
Veterinary surgeons .. .. .	
University professors .. .. .	
Accountants (carrying on business as principals) .. .. .	
Patent Attorneys .. .. .	
Merchants, auctioneers, estate agents, sharebrokers, bank managers .. .. .	<i>Allowances per day.</i>
Company managers .. .. .	} £5
Farmers or Graziers .. .. .	
Master tradesmen .. .. .	
Persons carrying on business, such as hotelkeepers, shopkeepers, commission agents, &c. .. .. .	
Gentlemen .. .. .	} £3 or amount of salary or wages actually lost by witness whichever is the greater but not exceeding in any event £5
Persons in receipt of salary or wages .. .. .	
All other witnesses .. .. .	£3.

Interpreter—

- (a) Attending professional scientific or expert witnesses qualifying to give evidence—£3 3s. per day.
- (b) Attending conference with Counsel—£3 3s.
- (c) Attending Court—£6 6s. per day.

Travelling expenses, if witness's residence or place of business is more than 4 miles from place of hearing, the sum reasonably and actually paid.

Witnesses attending in more than one cause will be entitled to a proportionate part only in each cause.

Professional, scientific, or expert witnesses, for each day necessarily occupied in qualifying to give evidence, when certified to by the Judge, to be allowed the sum actually paid, but not exceeding £7 7s.

In cases in which witnesses are compelled to be absent from home over night, a reasonable sum not exceeding £3 for each night of absence of each witness to be allowed as sustenance fee in addition to above allowances.

In cases in which it is considered reasonable to bring heavy or bulky articles to Court or the precincts of the Court as exhibits or for inspection by Judge or Jury, a reasonable sum may be allowed for the costs of conveyance or transport.



# VICTORIA GOVERNMENT GAZETTE

Published by Authority

[Registered at the General Post Office, Melbourne, for transmission by post as a newspaper.]

No. 119]

WEDNESDAY, NOVEMBER 21

[1962

*Forests Act 1958 (No. 6254).*

## PROCLAMATION OF PROHIBITED PERIOD.

### PROCLAMATION

By His Excellency the Governor of the State of Victoria and its Dependencies in the Commonwealth of Australia, &c., &c., &c.

IN pursuance of the powers conferred by section 3 of the *Forests Act 1958*, I, the Governor of the State of Victoria in the Commonwealth of Australia, by and with the advice of the Executive Council of the said State, do by this my Proclamation proclaim the period commencing at midnight between the twenty-third and twenty-fourth days of November, 1962, and ending at midnight between the thirtieth day of April and the first day of May, 1963, to be the prohibited period in respect to any fire-protected area other than a State forest or national park in the State of Victoria situated in such municipalities as are specified in the Schedule hereto.

### SCHEDULE.

The Shires of Alexandra, Ararat, Arapiles, Avon, Bairnsdale, Beechworth, Belfast, Berwick, Broadford, Bulla, Chiltern, Dimboola, Dundas, Dunmunkle, Eltham, Glenelg, Healesville, Kaniva, Kowree, Kilmore, Lowan, Minhamite, Mt. Rouse, Omeo, Orbost, Portland, Rosedale, Seymour, Stawell, Tambo, Upper Yarra, Wannon, Warracknabeal, Whittlesea, Wimmera, Wodonga, Yackandandah, Yea.

The Cities of Broadmeadows, Kellor.

Given under my Hand and the Seal of the State of Victoria aforesaid, at Melbourne, this twentieth day of November, in the year of our Lord One thousand nine hundred and sixty-two, and in the eleventh year of the reign of Her Majesty Queen Elizabeth II.

(L.S.)

DALLAS BROOKS.

By His Excellency's Command,

L. H. S. THOMPSON,  
Minister of Forests.

GOD SAVE THE QUEEN!

*Country Fire Authority Act 1958.*

## SUMMER PERIOD IN RESPECT OF SPECIFIED PARTS OF THE COUNTRY AREA OF VICTORIA.

WHEREAS by section 4 of the *Country Fire Authority Act 1958* it is enacted that the Chief Secretary of Victoria, after consultation with the Minister of Forests, may from time to time by declaration published in the *Government Gazette* declare any period to be the summer period in respect of the country area of Victoria, or any specified part or parts thereof and, without affecting the generality of the foregoing, may declare different periods to be the summer period in respect of different parts of the said country area:

And whereas the Chief Secretary and the Minister of Forests have consulted accordingly:

Now therefore I, the Chief Secretary of Victoria, do hereby declare the period commencing at midnight on the twenty-third day of November, 1962, and ending at midnight on the fifteenth day of April, 1963, to be the summer period in respect of the parts hereinafter specified of the country area of Victoria, that is to say:—

Those portions of the Eighteenth Fire Control Region comprised by the municipal districts of the Shire of Walpeup and those portions of the Shire of Swan Hill which lie north from the under-mentioned boundary that is to say:—Commencing at the south-western angle of Crown allotment 31, no section, Parish of Kulwin; thence easterly by a road and a line to a point on the west bank of the River Murray distant approximately 5,500 links easterly from the most eastern angle of Crown allotment 79, no section, Parish of Piangil and excluding those portions thereof described in the First Schedule to this declaration.

### FIRST SCHEDULE.

Those portions of the municipal district of the Shire of Swan Hill to which this declaration does not apply:—

Robinvale Irrigation District—Soldier Settlement. Subdivision—sections D and E and those portions of section C south of the Happy Valley-road and those portions of section B south of Belar-avenue (excepting Crown lands).

R. J. HAMER,  
for Chief Secretary.

Chief Secretary's Office,  
Melbourne, 20th November, 1962.

Transport Regulation Acts.  
TRANSPORT REGULATION BOARD.

## NOTICES OF PUBLIC HEARINGS.

NOTICE is hereby given that the applications made by the persons named below for licences to operate commercial passenger vehicles on route or routes, or in the manner set out opposite their names, will be heard at a time and place to be communicated to the parties.

*Name and Address; Nature of Application.*

BALSARINI, B. R., Ultima; 1 commercial passenger vehicle with seating capacity for ten (10) persons to operate as follows—(a) for the carriage of school children only between Ultima—South and West Ultima—Ultima under subsidy to the parents of the children and the Education Department, (b) as a country special service omnibus within a radius of 50 miles of Ultima.

TRANS OTWAY LTD., Corner Ryrie and Fenwick streets, Geelong; for variation of C.O. licences to amend the mail, parcels, medicines and spare parts for motor vehicles and newspaper rights on the Geelong—Lorne—Apollo Bay service and instead carry such goods without restriction as to weight but subject to the following condition—That such goods are carried in a compartment or space in the vehicle/s reserved for that purpose to the satisfaction of the Board's Regional Officer at Geelong, and not on any seats or in any areas available for passenger accommodation.

TRANS OTWAY LTD., Corner Ryrie and Fenwick streets, Geelong; for variation of C.O. licences to amend the parcel carrying rights of the Melbourne—Lorne—Apollo Bay services (Part 3 (b) (1) which relates to weight of parcels carried) and in lieu operate as follows—"That parcels and/or newspapers are carried in a compartment or space reserved for that purpose to the satisfaction of the Board's Regional Officer at Geelong, and not on any seats or in any areas available for passenger accommodation."

NOTE.—The present restriction as to the area that parcels and newspapers may be carried to/or from is to remain un-altered.

COOK, I. J., & SONS, 21 Fyansford-road, Herne Hill, Geelong; 1 commercial passenger vehicle with seating capacity for 11 persons to operate as follows—(a) for the carriage of pupils attending the Karinal Mentally Handicapped Children's School as and when required, (b) on the industrial services operated by the applicant, (c) as an urban special service omnibus from Geelong.

BURGE, C. W., Inverloch-road, Wonthaggi; 1 commercial passenger vehicle with seating capacity for 33 persons to operate for the carriage of school children only between Cowes and Wonthaggi High School under contract to the Education Department.

MASON, N. O., 414 Riversdale-road, Surrey Hills; 1 commercial passenger vehicle with large seating capacity to operate as an additional metropolitan route omnibus on Route 89A (Canterbury—Box Hill) under the same terms and conditions as all M.O. licences at present held by the applicant.

ARMSTRONG, S. W., 33 Cummins-road, East Brighton; application for permit authority to operate any one of vehicles, licence Nos. M.C.513, M.C.606 or M.C.609, under contract to the Victoria Police Department—(a) from and to the police traffic school in Albion-street, Essendon, to and from various schools within a radius of five (5) miles of the school via the most direct route, (b) from and to the police traffic school in Cotham-road, Kew, to and from various schools within a radius of five (5) miles of the school via the most direct route.

*Time-table (Mondays—Fridays).*

Depart Schools 9.30 a.m.—11.30 a.m.

Depart Schools 1.00 p.m.—2.45 p.m.

APPLICATIONS for renewal of licences by persons listed hereunder to operate under the same terms and conditions from the date of expiry.

*Name and Address; Licence Number; Classification; Expiry date.*

B. P. AUSTRALIA LTD., 191 Queen-street, Melbourne; T.P.150; temporary passenger licence; 18th March, 1963.

MCCALLUM, A. M. (on behalf of Victoria Hall Sunday School), 11 Coronation-street, West Footscray; T.P.22; temporary passenger licence; 12th February, 1963.

BRUK-BRUK BUS SERVICE PTY. LTD., Private Bag 172, Casterton; T.P.148; temporary passenger licence; 26th February, 1963.

HOGAN, REV. FATHER, The Holy Rosary School, Heathcote; T.P.27; temporary passenger licence, 26th February, 1963.

SMORGAN, NORMAN, & SONS PTY. LTD., Somerville-road, Brooklyn; T.P.158; temporary passenger licence; 5th March, 1963.

GOULDING, R. (trading as Golden Creche, 1 Cornwall-street, South Blackburn; T.P.143; temporary passenger licence; 6th February, 1963.

BAU, M., Kingwak Butter Factory, 9 King-street, Wonthaggi; T.P.149; temporary passenger licence; 26th February, 1963.

MCPHERSON, K., 52 Margaret-street, Werribee; C.T.184; country taxi, Werribee; 27th March, 1963.

RATTEN, G. D., 121 Elgin-street, Morwell; C.T.161; country taxi, Morwell; 27th February, 1963.

CUNNINGHAM, A. W., Pty. Ltd., 40 Manifold-street, Colac; C.O.156; country omnibus; 3rd March, 1963.

APPLICATIONS for metropolitan private hire-car licences by the persons listed hereunder in respect of commercial passenger vehicles with seating capacity for five persons to operate under composite conditions from an approved depot in zone set out opposite their names.

*Name and Address; Zone.*

FILES, J. F., 18 Drysdale-street, Reservoir; "G".

WIMBORNE, H., 5 Walsh-street, Ormond; "G".

DRONE, A., 7 Short-street, Vermont; "G".

MALACRIA, V., 48 Fenwick-street, Clifton Hill; "G".

GRAYS MOTORS PTY. LTD., 7 Woodstock-street, Chillwell, Geelong; application for full term urban taxi-cab licences authorizing operations as urban taxi-cabs within the urban area of Geelong subject to the cancellation of temporary licences U.T.416 and U.T.470 expiring 17th March, 1963, and 7th February, 1963, respectively in the name of the applicant company.

POULTON, A. V., 67 Beauford-street, Huntingdale; application for renewal of metropolitan private hire car licence No. M.H.2407, expiry date, 8th February, 1963, authorizing operations from the depot of Luxury Cars Ltd., corner Nicholson and Carlton streets, Carlton.

## Commercial Goods Vehicles Acts.

## TRANSPORT REGULATION BOARD.

## NOTICE OF PUBLIC HEARINGS.

NOTICE is hereby given that the application made by the person named below for renewal of licence with variation to operate the commercial goods vehicle on the route or routes, or in the manner set out opposite the name, will be heard at a time and place to be communicated to the person concerned:—

*Name and Address; Present Franchise; Variation; Licence No.; Date of Expiry.*

PENINSULA HAULAGE PTY. LTD., 506 Nepean Highway, Frankston; 1 commercial goods vehicle (262 cwt.) to operate—(a) within a radius of 20 miles from the post office at Frankston—general goods, (b) within a radius of 40 miles from the post office at Frankston—bricks on behalf of the Colortone Brick Ltd., at Frankston; by deleting 40 miles from paragraph (b) and adding in lieu 100 miles; D.A.1801; 28th February, 1963.

NOTICE is hereby given that the applications made by the persons named below for renewal of licences to operate the commercial goods vehicles on the route or routes, or in the manner set out opposite their names, will be heard at a time and place to be communicated to the persons concerned:—

*Name and Address; Present Franchise; Licence No.; Date of Expiry.*

AGENCIES, A. H., & SALES PTY. LTD., 519 High-street, East Prahran; 2 commercial goods vehicles (16 cwt. each) to operate throughout the State of Victoria, in the course of business as an "automotive accessory supplier" for the purpose of sales promotion and booking of orders with the ability to leave an occasional urgent order—automotive accessory lines, chamois, Karinna products, &c. NOTE.—All orders to be consigned by rail; T.D.A.45101, T.D.A.45101/1; 8th January, 1963.

**CITY GUIDE SYSTEM (VIC.) PTY. LTD.**, 159-161 Eastern-road, South Melbourne; 1 commercial goods vehicle (17 cwt.) to operate throughout the State of Victoria for the purpose of repairing, servicing and installing City guide systems—tools of trade and City guides for repair or having been repaired for installation; D.A.34980; 28th January, 1963.

**DINSDALE, F. H. & G.**, Station-street, Fern Tree Gully; 2 commercial goods vehicles (100 and 88 cwt.) to operate—(a) within a radius of 20 miles from the post office at Fern Tree Gully—general goods, (b) within a radius of 70 miles from the premises of the City Brick Works Co. Pty. Ltd., at East Hawthorn—bricks on behalf of the said company; D.A.33629, D.A.33629/1; 11th August, 1962.

**FOX, ALBERT H. PTY. LTD.**, 493 Mt. Alexander-road, Moonee Ponds; 1 commercial goods vehicle (10 cwt.) to operate—(a) within a radius of 50 miles from the premises of the holders of this licence at Moonee Ponds—licensee's own goods, in the course of business as "piano tuners, radio and electrical retailers", (b) throughout the State of Victoria—tools of trade, pianos for repair or having been repaired and pianos for demonstration, in the course of business of the holders of this licence as "piano tuners and dealers"; D.A.35038; 28th January, 1963.

**JAQUES BROS. LIMITED**, corner Griffiths and Palmer streets, Richmond; 1 commercial goods vehicle (8 cwt.) to operate throughout the State of Victoria, in the course of licensee's business as "earth-moving machinery manufacturers"—tools of trade, materials and equipment incidental to the servicing and repair of such machines; D.A.20624/1; 28th February, 1963.

**KENNEDY, J. W.**, 82 Wakeham-street, Stawell; 1 commercial goods vehicle (7 cwt.) to operate throughout the State of Victoria—tools of trade and materials incidental to the completion of contracts entered into by the holder of this licence, in the course of business as "bricklayer and builder"; D.A.33741; 22nd September, 1962.

**MAPLES PTY. LTD.**, 253 Clarendon-street, South Melbourne; 1 commercial goods vehicle (11 cwt.) to operate—(a) within a radius of 100 miles from the post office at Mildura in the State of Victoria, in the course of business as "home furnishers"—own goods for display and delivery to clients also tools of trade incidental to the servicing and maintenance of goods already sold by the licensees, (b) from the railway station at Mildura to own store at Mildura—own goods; D.A.30136/4; 28th February, 1963.

**PATERSON'S PTY. LTD.**, 152 Bourke-street, Melbourne; 1 commercial goods vehicle (50 cwt.) to operate within a radius of 50 miles from the post office at Echuca, in the course of business as "home furnishers"—furniture and furnishings being the property of the licensee; D.A.1782/8; 28th February, 1963.

**PETERS ICE CREAM (VIC.) LTD.**, 171-183 Burnley-street, Richmond; 5 commercial goods vehicles (208, 175, 150, 202 and 173 cwt.) to operate throughout the State of Victoria as a specially constructed, insulated and refrigerated van for the purpose of supplying our own distributing depots with ice cream and frozen foods at a temperature not exceeding 10° F., and when returning from Traralgon, the transport of Yoghurt from our milk factories at Trafalgar and Yarragon to own distributor's refrigerated depot at Clayton; T.D.A.1813/26, T.D.A.1813/27, T.D.A.1813/28, T.D.A.1813/29, T.D.A.1813/30; 19th February, 1963.

**PULLING, F. T., & SONS PTY. LTD.**, 8 Lord-street, Richmond; 1 commercial goods vehicle (9 cwt.) to operate throughout the State of Victoria in the course of business as "builders and contractors" in a supervisory capacity, with the ability to carry tools of trade and incidental items of components for replacement or completion or work in hand, all other materials having been transported by rail; D.A.1870/1; 23rd February, 1963.

**RUSSELL, E. A. C., PTY. LTD.**, Main-street, Gembrook; 3 commercial goods vehicles (103, 138 and 115 cwt.) to operate—(a) from or to places situate within a radius of 9 miles from the post office at Gembrook to or from the City of Melbourne, via Fern Tree Gully or alternatively via the main road to Pakenham and thence via Princes Highway—general goods, (b) within a radius of 20 miles from the post office at Gembrook—general goods confined to that area, that is to say, general goods taken up within the said radius for delivery within that radius and not elsewhere, (c) from or to places situate within a radius of 5 miles from the depot of the licence holder at Fern Tree Gully and serving places adjacent to the road between Fern Tree Gully and Gembrook to and from the City of Melbourne—general goods, (d) within a radius of 30 miles from the depot of the

licence holder at Fern Tree Gully—petroleum products in bulk tanks and prescribed types of containers and empty return containers; D.A.4901, D.A.4901/1, D.A.4901/2; 28th February, 1963.

**SHELL Co. of AUSTR. LTD.**, 163 William-street, Melbourne; 1 commercial goods vehicle (15 cwt.) to operate throughout the State of Victoria for the installation and maintenance of licensee's own petrol pumps, tanks and bowsers—petrol pumps, tanks, bowsers, fittings, tools of trade, equipment and materials incidental to such installations and maintenance; D.A.2020/7; 23rd February, 1963.

**SOUTHERN STATES DRILLING Co. PTY. LTD.**, 357 Little Collins-street, Melbourne; 1 commercial goods vehicle (71 cwt.) to operate throughout the State of Victoria—tools of trade and equipment incidental to contracts entered into by the holders of this licence in the course of business as "water-boring contractors"; D.A.33737; 18th August, 1962.

**STEVENSON, H. F., PTY. LTD.**, 10 Duffy-street, Burwood; 1 commercial goods vehicle (79 cwt.) to operate—(a) within a radius of 25 miles from the post office situated at the corner of Bourke-street and Elizabeth-street in the City of Melbourne—general goods, (b) from and to the premises of Thermal Traders Pty. Ltd., at Lara, to and from places situated within the radius as defined in paragraph (a) above and to and from places situated on the Mornington Peninsula—liquid petroleum gas, gas appliances and empty return containers solely on behalf of the said company; T.D.A.2111/5; 19th February, 1963.

**WILLIAMSON, WILLIAM J.**, 17 Oak-street, Seymour; 1 commercial goods vehicle (142 cwt.) to operate—(a) within a radius of 70 miles from the Seymour Post Office on behalf of the Country Roads Board and local shires—plant the property of a contractor and required by him for use in connexion with the construction or maintenance of some specific, existing or proposed road, street, footpath, bridge, pier, wharf, weir or channel and also the following materials, viz., metal, screenings, ashes, gravel, stones and sand, (b) within a radius of 20 miles from the site of any construction or maintenance work performed pursuant to paragraph (a) above, or from the railway station nearest thereto—any other materials required for such work; D.A.41641/2; 4th December, 1962.

**NOTICE** is hereby given that the applications made by the persons named below for licences to operate the commercial goods vehicles on the route or routes, or in the manner set out opposite their names, will be held at a time and place to be communicated to the persons concerned:—

*Name and Address; Nature of Application.*

**ALBION QUARRYING Co. PTY. LTD.**, Arden-street, North Melbourne; application to vary the conditions of existing licences Nos. D.A.520/30 and D.A.520/52, by deleting North Melbourne and adding in lieu "Geelong" and by adding as paragraph (b) within a radius of 150 miles of Geelong as a bulk bitumen and tar unit—bulk hot and cold tar, bitumen and spraying materials incidental to own contracts, and as paragraph (c) within a radius of 150 miles of Geelong, own spreading equipment and within a radius of 30 miles of any road construction contract, spreading materials incidental to such contract.

**ALBION QUARRYING Co. PTY. LTD.**, Arden-street, North Melbourne; application to vary the conditions of existing licences Nos. D.A.520/30, D.A.520/52 and D.A.520/64 by adding "and in the course of business as road-contracting materials suppliers".

**BARLING, LEONARD**, Lyons-street, Cressy; application to vary the conditions of existing licences Nos. D.A.12902 and D.A.12902/1 by adding as paragraph (c) from the City of Geelong to the Township of Cressy—petroleum products in prescribed types of containers and empty containers on the return journey.

**BURGESS, C. M.**, 28 Albion-road, Box Hill; 1 commercial goods vehicle (107 cwt.) to operate within a radius of 50 miles of Passiona Botling Co. (Melb.) Ltd., Moorabbin, as a contract carrier under contract to the said company—aerated waters, cordials and empty return containers.

**CLEELAND, W. R.**, 12 Royal-avenue, Benalla; application to vary the conditions of existing licence No. T.T.D.545 by adding "from forest landings in the Mt. Buller and Jamieson areas to sawmills at Mansfield and Benalla".

**CORTTES LTD.**, 160 Whitehorse-road, Blackburn; 1 commercial goods vehicle (8 cwt.) to operate throughout the State of Victoria, in the course of business as "cordial

- manufacturers" as a servicing vehicle for the repair and maintenance of own fruit drink dispensing machines—tools of trade, spare parts and materials incidental to such repair and maintenance.
- CASHMAN, S. J., & G. R. BLUNDELL** (trading as Crystal Cordial Co.), 34 Macalister-street, Sale; 1 commercial goods vehicle (42 cwt.) to operate to and from depot at Sale to and from the Townships of Maffra, Stratford, Lindenow, Bairnsdale, Paynesville, Metung, Lakes Entrance, Nowa Nowa, Orbost, Newmerella, Briagolong, Boisdale, Munro, Rosedale, Cowwarr, Heyfield, Tinambra, Newry, Woodside and Yarram, in the course of business as "aerated waters and cordial manufacturers"—own aerated waters and cordials in glass containers and empty returns.
- DALTON, M. A.**, Princes Highway, Warrnambool; 1 commercial goods vehicle (8 cwt.) to operate—(a) within a radius of 50 miles of own premises at Warrnambool, in the course of business as "a panel beater"—own goods, (b) within a radius of 50 miles of own premises at Warrnambool, in the course of business as "a panel beater on a low loader trailer" for the purpose of lifting and carrying or towing, repairing and/or disposing of disabled or wrecked motor vehicles from garage to garage or from premises to licence holder's premises, in the course of business as "a buyer and repairer of wrecked motor vehicles" on behalf of insurance companies or other interested parties—disabled or wrecked motor vehicles, tools of trade, spare parts and materials incidental thereto, subject to the condition that the vehicle shall not be used to tow away any wrecked or damaged vehicle from the scene or area of collision or point of impact at which the damage was caused to any such vehicle and that all towing, pursuant to this licence shall be confined wholly to the subsequent disposal or repair of such vehicle after its initial towing to a garage by a properly authorized tow truck operator.
- DOYLE, W. K.**, 1 Oxford-close, Moorabbin; application to vary the conditions of existing licence No. D.A.37591, by deleting present conditions and adding in lieu "throughout the State of Victoria in a specially constructed insulated unit on behalf of Fowler Asphalt Pty. Ltd.—hot asphalt and premix at a temperature of 360° F."
- GLARE, L. H., & R. G. DUNN**, 9 Ashton-street, Swan Hill; 2 commercial goods vehicles (146 and 147 cwt.) to operate—(a) within a radius of 95 miles of the post office at Cohuna and/or within a radius of 100 miles of the post office at Merbein (Bendigo Division of the Country Roads Board)—plant the property of a contractor and required for use in connexion with the construction or maintenance of some specific, existing or proposed road, street, footpath, bridge, wharf, pier, weir or channel, (b) within a radius of 20 miles from site of construction or maintenance work performed pursuant to paragraph (a) above, or from the railway station nearest thereto—metal, stones, screenings, ashes, gravel, sand, earth and any other materials required for such work, (c) within a radius of 20 miles of the post office at Swan Hill—general goods.
- HODSON, J. G.**, Wingan River, via Cann River; application to vary the conditions of existing licence No. T.T.D.596 by deleting present conditions and adding in lieu "from forest landings in that part of Victoria east of a north/south line drawn through Cann River to sawmills at Genoa—logs, from Parker and Morrison's sawmill at Genoa to Orbost Railway Station—sawn timber".
- HUTCHINSON, ROBERT, LTD.**, Hartington-street, Glenroy; 1 commercial goods vehicle (233 cwt.) to operate within a radius of 50 miles of own premises at Glenroy, in the course of business as "flour millers and stockfeed manufacturers"—own goods.
- NOTE**—Excluding all operations to the City of Geelong.
- HUTTON, J. C. PTY. LTD.**, 65 High-street, Preston; 2 commercial goods vehicles (123 and 125 cwt.) to operate between own premises at Preston and Bendigo and/or Wangaratta and places *en route*, in the course of business as "bacon and smallgoods manufacturers" in specially constructed refrigerated vehicles—fresh meat, cooked meat, sausages, smallgoods and up to 3 cwt. of dripping, lard and cheese and the ability to carry canned hams not to exceed 20 cwt. in any one week. All goods carried at a temperature not exceeding 40° F.
- HUTTON, J. C. PTY. LTD.**, 65 High-street, Preston; 9 commercial goods vehicles (44, 21, 104, 50, 53, 60, 21, 97 and 90 cwt.) to operate throughout the State of Victoria, in the course of business as "bacon and smallgoods manufacturers" in a specially constructed insulated and iced vehicle—fresh meat, cooked meat, sausages and smallgoods with the ability to carry up to 3 cwt. of lard, dripping, cheese and canned hams.
- JACKSON, G. E.**, 3 Hirst-street, Blackburn; 1 commercial goods vehicle (140 cwt.) to operate—(a) within a radius of 25 miles from the post office situate at the corner of Bourke and Elizabeth streets in the City of Melbourne—general goods, (b) within a radius of 70 miles from the premises of the Standard Brick Works (Box Hill) Pty. Ltd. at Box Hill—bricks on behalf of the said company.
- LANSSELL, R. H.**, 47 Bakewell-street, Bendigo; 1 commercial goods vehicle (8 cwt.) to operate within a radius of 100 miles from the chief post office in the City of Bendigo, in the course of business as "plumber"—tools of trade and equipment and small quantities of materials used in the execution of own contracts.
- NOTE**—No goods whatsoever shall be carried from Melbourne to Bendigo.
- LOVE, J. R.**, Cassilis, via Omeo; 1 commercial goods vehicle (110 cwt.) to operate from own lime pit at Bindi Station to places within the Shires of Omeo and Tambo in the course of business as an "agricultural contractor and quarrymaster"—bulk agricultural lime and bagged lime.
- MARSDEN, N. E. & J. M.**, High-street, Mansfield; 1 commercial goods vehicle (220 cwt.) to operate from forest landings in the Mt. Buller area to Mt. Buller Timber Co., at Mansfield—logs.
- MILNES, J. B.** Lot 8, Princes Highway, Narre Warren; application to vary the conditions of existing licence No. D.A.29530, by deleting "Inverloch" from paragraph (c) and adding in lieu "Narre Warren".
- MCLEAN, M. I.**, Oaks-street, Orbost; 1 commercial goods vehicle (approximately 195 cwt.) to operate—(a) from forest landings within a radius of 10 miles of Bemm river to E. T. Brunt & Sons sawmill at Bemm river—logs, (b) from E. T. Brunt & Sons sawmill at Bemm river to Orbost railway station—sawn timber.
- MCMAHON, M.**, 98 Banyan-street, Warrnambool; 1 commercial goods vehicle (80 cwt.) to operate within a radius of 50 miles of the chief post office in the City of Warrnambool on behalf of R. A. Steel Constructions of Warrnambool—structural steel and prefabricated farm buildings.
- THE NORTHCOTE BRICK CO. LTD.**, Robbs-parade, Northcote; 1 commercial goods vehicle (125 cwt.) to operate within a radius of 75 miles of own premises at Northcote in the course of business as "brick manufacturers"—own bricks.
- PARSONS, P. D.**, 47 Pye-street, Swan Hill; 1 commercial goods vehicle (251 cwt.) to operate—(a) within a radius of 50 miles from the post office at Swan Hill—plant the property of a contractor and required by him for use in connexion with the construction or maintenance of some specific, existing or proposed road, street, footpath, bridge, pier, wharf, weir or channel and also the following materials, viz., metal, stones, screenings, ashes, gravel, sand and earth, (b) within a radius of 20 miles from the site of any construction or maintenance work performed pursuant to paragraph (a) above, or from the railway station nearest thereto—any other materials required for such work, (c) within a radius of 20 miles from the post office at Swan Hill—general goods excluding any plant or materials carried or to be carried pursuant to paragraph (a) and (b) above.
- PATERSONS PTY. LTD.**, 152 Bourke-street, Melbourne, C.1; 1 commercial goods vehicle (11 cwt.) to operate within a radius of 50 miles from the chief post office in the City of Ballarat, in the course of business as "furniture warehouseman"—own soft furnishings and furniture.
- PEARCE, N. C., & P. W.**, 4 Heather-avenue, Pascoe Vale; 1 commercial goods vehicle (260 cwt.) to operate from own forest landings in the Nagambie, Murrindindi and Euroa areas to Hollenson Bros. saw millers at Nunawading—logs.
- POPE, S. A.**, 33 Hopkins-road, Warrnambool; 1 commercial goods vehicle (12 cwt.) to operate within a radius of 50 miles of post office at Warrnambool on behalf of E.I.L. Service, of 48 Kepler-street, Warrnambool, for the purpose of servicing and installing refrigeration equipment, washing machines, television sets, radios and electrical appliances—tools of trade, spare parts and materials incidental to such installation and servicing also refrigeration equipment, washing machines, television sets, radios and electrical appliances for installation, repair or having been repaired.

- PRICE, K. A., Lot 9, Tatiara-avenue, Croydon; 1 commercial goods vehicle (10 cwt.) to operate within a radius of 50 miles of the premises of Turner Manufacturing Co. Pty. Ltd., at Nunawading, solely on behalf of the said company, for the purpose of installing, servicing and repairing electrical appliances and lawn mowers—tools of trade, spare parts, electrical appliances and lawn mowers for installation and repair or having been repaired.
- RENKIN, J. G., Mininera; 1 commercial goods vehicle (119 cwt.) to operate—(a) within a radius of 20 miles of the post office at Mininera—general goods, (b) to and from B.P. Australia Ltd.'s depot at Ballarat to own depot at Mininera—petroleum products in prescribed types of containers and empty return containers, (c) from places situated in paragraph (a) to the districts of Colac, Camperdown, Terang and Warrnambool in the course of business as a "grain merchant"—grain.
- R.M.C. TRANSPORT (N.S.W.) PTY. LTD., 501 Swanston-street, Melbourne; application to vary the conditions of existing licence No. D.A.39437/5 by deleting "Ballarat" and adding in lieu "North Melbourne".
- SCHWEPPE (AUST.) LTD., 137 Chesterville-road, Highett; 1 commercial goods vehicle (140 cwt.) to operate within a radius of 50 miles of own premises at Moorabbin in course of business as "aerated water and cordial manufacturer"—own goods but excluding all operations to the City of Geelong.
- SUPER SPREAD AVIATION PTY. LTD., Hangar 7, Moorabbin Airport, Cheltenham; application to vary the conditions of existing licence No. D.A.32408/4 by deleting present conditions and adding in lieu—"Throughout the State of Victoria in the course of business as 'aerial crop dusters' for loading of superphosphate into aircraft for dusting purposes; also weedicide sprays and equipment and aviation fuel in a bulk tank, water traps for refueling, such equipment approved by the Department of Civil Aviation."
- SUPER SPREAD AVIATION PTY. LTD., Hangar 7, Moorabbin Airport, Cheltenham; 1 commercial goods vehicle (50 cwt.) to operate throughout the State of Victoria in the course of business as "aerial crop dusters" as a crane truck for the purpose of loading superphosphate into aircraft for dusting purposes and with the ability to carry aviation fuel in a bulk tank and water traps for refuelling, such equipment approved by the Department of Civil Aviation.
- SUPER SPREAD AVIATION PTY. LTD., Hangar 7, Moorabbin Airport, Cheltenham; 5 commercial goods vehicles (11, 11, 7, 7, and 9 cwt.) to operate throughout the State of Victoria in the course of business as "aerial crop dusters"—tools of trade, spare parts and small quantities of weedicide sprays and aviation fuel in containers.
- WILSON, H. W. PTY. LTD., Nepean Highway, Dromana; application to vary the conditions of existing licence No. D.A.35776 by adding to part (ii) paragraph (b) "from and to Dromana to and from own shops at Traralgon, Morwell, Warragul and Newborough".
- WILSON, W. D., Curdies River, via Timboon; 1 commercial goods vehicle (100 cwt.) to operate—(a) within a radius of 75 miles of the post office at Peshurst (Warrnambool Division of the Country Roads Board)—plant the property of a contractor and required for use in connexion with the construction or maintenance of some specific existing or proposed road, street, foot-path, bridge, wharf, pier, weir or channel, (b) within a radius of 20 miles from site of construction or maintenance work performed pursuant to paragraph (a) above, or from the railway station nearest thereto—metal, stones, screenings, ashes, gravel, sand, earth and any other materials required for such work, (c) within a radius of 20 miles of the post office at Curdies River—general goods.
- BISSETT, WILLIAM ALAN, Cormandale; 1 commercial goods vehicle (76 cwt.) to operate throughout the State of Victoria as a tow truck for the purpose of lifting and carrying or towing and/or repairing wrecked or disabled vehicles—tools of trade, spare parts and materials incidental thereto.
- BLAIR, J. F., & J. R. BROWNE (trading as Esplanade Motors), 133 Ormond Esplanade, Elwood; 1 commercial goods vehicle (21 cwt.) to operate within a radius of 25 miles of G.P.O., Melbourne, as a tow truck for the purpose of lifting and carrying or towing and/or repairing wrecked or disabled vehicles—tools of trade, spare parts and materials incidental thereto.
- CHELTON MOTOR BODY WORKS, 1238 Nepean Highway, Cheltenham; 1 commercial vehicle (75 cwt.) to operate within a radius of 20 miles of post office at Cheltenham as a tow truck for the purpose of lifting and carrying or towing and/or repairing wrecked or disabled vehicles—tools of trade, spare parts and materials incidental thereto.
- DYER, KEVIN FRANCIS, 58 Byron-street, North Melbourne; 1 commercial goods vehicle (40 cwt.) to operate within a radius of 25 miles of G.P.O., Melbourne, as a tow truck for the purpose of lifting and carrying or towing and/or repairing wrecked or disabled vehicles—tools of trade, spare parts and materials incidental thereto.
- ESKDALE MOTORS PTY. LTD., 153-159 Hawthorn-road, Caulfield; 1 commercial goods vehicle (29 cwt.) to operate within a radius of 25 miles of the G.P.O., Melbourne, as a tow truck for the purpose of lifting and carrying or towing and/or repairing wrecked or disabled vehicles—tools of trade, spare parts and materials incidental thereto.
- FLAMINI'S MOTORS, 50 Reid-street, North Fitzroy; 1 commercial goods vehicle (13 cwt.) to operate within a radius of 25 miles of the G.P.O., Melbourne, as a tow truck for the purpose of lifting and carrying or towing and/or repairing wrecked or disabled vehicles—tools of trade, spare parts and materials incidental thereto.
- HAA, M. R., & A. L. YOUNG, Warburton-road, Wandin North; 1 commercial goods vehicle (12 cwt.) to operate within a radius of 20 miles of post office at Wandin North as a tow truck for the purpose of lifting and carrying or towing and/or repairing wrecked or disabled vehicles—tools of trade, spare parts and materials incidental thereto.
- HAMMERSLEY, ALBAN, 79c Lexton-road, Box Hill; 1 commercial goods vehicle (28 cwt.) to operate within a radius of 25 miles of G.P.O., Melbourne, as a tow truck for the purpose of lifting and carrying or towing and/or repairing wrecked or disabled vehicles—tools of trade, spare parts and materials incidental thereto.
- JEREMIAH, GEORGE, Main-road, Tyabb; 1 commercial goods vehicle (3 tons) to operate within a radius of 20 miles of the post office at Tyabb as a tow truck for the purpose of lifting and carrying or towing and/or repairing wrecked or disabled vehicles—tools of trade, spare parts and materials incidental thereto.
- JEREMIAH, GEORGE, Main-road, Tyabb; 1 commercial goods vehicle (71 cwt.) to operate within a radius of 20 miles of post office at Tyabb as a tow truck for the purpose of lifting and carrying or towing and/or repairing wrecked or disabled vehicles—tools of trade, spare parts and materials incidental thereto.
- LEVINS, A. W. H., 9 Main-road, Seville; 1 commercial goods vehicle (60 cwt.) to operate within a radius of 20 miles of the post office at Seville as a tow truck for the purpose of lifting and carrying or towing and/or repairing wrecked or disabled vehicles—tools of trade, spare parts and materials incidental thereto.
- LILYDALE PANEL WORKS, 58 Cave Hill-road, Lilydale; 1 commercial goods vehicle (36 cwt.) to operate within a radius of 20 miles of the post office at Lilydale as a tow truck for the purpose of lifting and carrying or towing and/or repairing wrecked or disabled vehicles—tools of trade, spare parts and materials incidental thereto.
- MITCHELL, LINDSAY GORDON, Hume Highway, Glenrowan; 1 commercial goods vehicle (34 cwt.) to operate throughout the State of Victoria as a tow truck for the purpose of lifting and carrying or towing and/or repairing wrecked or disabled vehicles—tools of trade, spare parts and materials incidental thereto.
- MACDERMID, LINDSAY WALTER, 10 Kirkham-road, Dandenong; 1 commercial goods vehicle (6 cwt.) to operate within a radius of 50 miles of own premises at Dandenong as a tow truck for the purpose of lifting

## TOW TRUCKS.

*Name and Address; Nature of Application.*

- ALLAN, NORMAN FRANKLIN, 93 Highbury-road, Burwood; 1 commercial goods vehicle (25 cwt.) to operate throughout the State of Victoria as a tow truck for the purpose of lifting and carrying or towing and/or repairing wrecked or disabled vehicles—tools of trade, spare parts and materials incidental thereto.
- ANDERSON, J. F. & D. E., 14 Gellibrand-crescent, Reservoir; 1 commercial goods vehicle (69 cwt.) to operate within a radius of 20 miles of post office at Reservoir as a tow truck for the purpose of lifting and carrying or towing and/or repairing wrecked or disabled vehicles—tools of trade, spare parts and materials incidental thereto.

and carrying or towing and/or repairing wrecked or disabled vehicles—tools of trade, spare parts and materials incidental thereto.

**PRESSWELL, RICHARD FRANCIS**, corner of Main-road and Beard-street, Eltham East; 1 commercial goods vehicle (42 cwt.) to operate within a radius of 50 miles of post office at Eltham East as a tow truck for the purpose of lifting and carrying or towing and/or repairing wrecked or disabled vehicles—tools of trade, spare parts and materials incidental thereto.

**RAPID PANEL WORKS**, 64 High-street, Kew; 1 commercial goods vehicle (79 cwt.) to operate within a radius of 25 miles of the G.P.O., Melbourne, as a tow truck for the purpose of lifting and carrying or towing and/or repairing wrecked or disabled vehicles—tools of trade, spare parts and materials incidental thereto.

**SUNRAYSA MOTOR & TRACTOR SERVICE**, Eighth-street, Mildura; 1 commercial goods vehicle (20 cwt.) to operate within a radius of 20 miles of post office at Mildura as a tow truck for the purpose of lifting and carrying or towing and/or repairing wrecked or disabled vehicles—tools of trade, spare parts and materials incidental thereto.

**TREVASKIS, R. S. & A. R.**, 1 Benalla-road, Shepparton; 1 commercial goods vehicle (27 cwt.) to operate within a radius of 20 miles of post office at Shepparton as a tow truck for the purpose of lifting and carrying or towing and/or repairing wrecked or disabled vehicles—tools of trade, spare parts and materials incidental thereto.

**WHEELDON, NOEL JOHN**, 67 McLeod-street, Bairnsdale; 1 commercial goods vehicle (35 cwt.) to operate within a radius of 20 miles of post office at Bairnsdale as a tow truck for the purpose of lifting and carrying or towing and/or repairing wrecked or disabled vehicles—tools of trade, spare parts and materials incidental thereto.

**YARRA GLEN MOTORS PTY. LTD.**, Bell-street, Yarra Glen; 1 commercial goods vehicle (65 cwt.) to operate within a radius of 20 miles of post office at Yarra Glen as a tow truck for the purpose of lifting and carrying or towing and/or repairing wrecked or disabled vehicles—tools of trade, spare parts and materials incidental thereto.

Notice of any objection should be forwarded to reach the Secretary of the Board not later than Wednesday, 5th December, 1962.

A. V. C. COOK,  
Acting Secretary.

Exhibition Buildings, Rathdowne-street, Carlton, N.3,  
Wednesday, 21st November, 1962.

#### MOE WATERWORKS TRUST.

##### RATING BY-LAW FOR THE YEAR 1963.

**THE** Moe Waterworks Trust, in pursuance and exercise of powers conferred by the Water Acts, hereby makes a rate for the supply of water for domestic purposes of One shilling and two pence in the £1 of the net annual valuation (municipal) of lands and tenements liable to be rated within the Moe Urban District.

Provided that in no case shall the amount of the rate payable per annum in respect of any tenement (other than land on which there is no building) be less than Five pounds, and in respect of any land on which there is no building, less than Two pounds.

Such rates are made and shall be levied upon the occupiers or owners of said lands and tenements for the year commencing the 1st day of January, 1963, and shall be due and payable on the 3rd day of January, 1963, at the office of the said Trust.

The maximum quantity of water to be supplied in any one year without further charge to any property rated by the Trust is hereby fixed at the quantity which at a charge of One shilling and three pence per 1,000 gallons would produce an amount equal to the amount of the rate levied on such property for the said year.

The charge for water supplied by measure to any property rated by the Trust in excess of such maximum quantity, computed as in the preceding clause, is hereby fixed at One shilling and three pence per 1,000 gallons. The charge for water supplied by measure shall be payable, on demand, at the office of the Trust.

Passed this 22nd day of October, 1962.

(SEAL) J. S. TABUTEAU, Chairman.  
T. B. DREW, Commissioner.  
D. G. TIMMINS, Commissioner.  
W. H. BURRAGE, Secretary.

Approved, 13th November, 1962.—W. J. MIBUS, Minister of Water Supply.

#### LINTON WATERWORKS TRUST.

##### RATING BY-LAW FOR THE YEAR 1963, No. 8.

**THE** Linton Waterworks Trust, in pursuance and exercise of its powers conferred by the Water Acts, doth hereby make a rate for the supply of water for domestic purposes of Three shillings in the £1 on the net annual valuation of lands and tenements liable to be rated within the Linton Urban District.

Provided that in no case shall the amount of the rate payable per annum in respect of any tenement (other than the land on which there is no building) be less than Six pounds fifteen shillings, and in respect of any land where there is no building, less than One pound.

Such rates are made and shall be levied upon the occupiers or owners of the said lands and tenements for the year commencing on the 1st day of January, 1963, and shall be due and payable on the 1st day of February, 1963, at the office of the said Trust.

The maximum quantity of water to be supplied in any one year without further charge to any property rated by the Trust is hereby fixed at the quantity which, at a charge of Two shillings per 1,000 gallons, would produce an amount equal to the amount of the rate levied on such property for the said year.

The charge for water supplied by measure to any property rated by the Trust in excess of such maximum quantity, computed as in the last preceding clause, is hereby fixed at Two shillings per 1,000 gallons.

The charge for water supplied by measure shall be payable, on demand, at the office of the Trust.

Such person or persons as the Trust may appoint for the purpose, are hereby authorized to demand, receive, collect and recover the said rates and charges.

Passed this 8th day of November, 1962.

(SEAL) H. O'C. KENNEDY, Chairman.  
S. E. MORGAN, Commissioner.  
A. F. NICOL, Commissioner.  
L. OLDHAM, Secretary.

Approved, 13th November, 1962.—W. J. MIBUS, Minister of Water Supply.

#### COBRAM WATERWORKS TRUST.

##### RATING BY-LAW FOR THE YEAR 1962-63.

**THE** Cobram Waterworks Trust, in pursuance and exercise of the powers conferred by the Water Acts, doth hereby make a rate for the supply of water for domestic purposes of Thirteen pence in the £1 on the annual municipal value of lands and tenements liable to be rated within the Cobram Urban District.

Provided that in no case shall the amount of rate payable per annum in respect of any tenement (other than land on which there is no building) be less than Thirty shillings, and in respect of any land on which there is no building less than fifteen shillings.

Such rate is made for the year commencing on the 1st day of October, 1962, and shall be payable on the 10th day of April, 1963, at the office of the said Trust.

Dated this 22nd day of October, 1962.

(SEAL) JOHN E. C. RADCLIFFE, Chairman.  
W. NEVILL, Commissioner.  
RONALD T. CUTTS, Secretary.

Approved, 13th November, 1962.—W. J. MIBUS, Minister of Water Supply.

#### ALEXANDRA WATERWORKS TRUST.

##### RATING BY-LAW FOR THE YEAR 1963.

**THE** Alexandra Waterworks Trust, in pursuance and exercise of the powers conferred by the Water Acts, doth hereby make a rate for the supply of water for domestic purposes of Fourteen pence in the £1 on the annual municipal valuation of lands and tenements liable to be rated within the Alexandra Urban District.

Provided that in no case shall the amount of rate payable per annum in respect of any tenement (other than land on which there is no building) be less than Forty-five shillings, and in respect of land on which there is no building be less than Twenty shillings.

Such rates are made and shall be levied upon the occupiers or owners of the said lands and tenements for the year commencing on the 1st day of January, 1963, and shall be due and payable on the 3rd day of January,



1963, at the office of the said Trust, and if unpaid by the 3rd day of May, 1963, shall bear interest at 6 per cent. per annum from the day on which it became payable.

The maximum quantity of water to be supplied in any one year, without any further charge to any property rated by the Trust, is hereby fixed at the quantity which, at a charge of Eighteen pence per 1,000 gallons, would produce the amount equal to the amount of rate levied on such property for the said year.

The charge for water supplied by measure to any property rated by the Trust in excess of such maximum quantity, computed as in the last preceding clause, is hereby fixed at One shilling and six pence per 1,000 gallons.

The charge for water supplied by measure to any property not rated by the Trust is hereby fixed at One shilling and seven pence per 1,000 gallons, and the minimum quantity of water to be charged for in any case where water is so supplied is hereby fixed at 30,000 gallons.

The charge for water supplied by measure shall be payable, on demand, at the office of the Trust.

Passed by the Alexandra Waterworks Trust this 29th day of October, 1962.

(SEAL) B. J. O'BRIEN, Chairman.  
H. C. FITZROY, Commissioner.  
R. G. HATFIELD, Secretary.

Approved, 13th November, 1962.—W. J. MIBUS, Minister of Water Supply.

#### BROADFORD WATERWORKS TRUST.

##### RATING BY-LAW FOR THE YEAR 1963.

**T**HE Broadford Waterworks Trust, in pursuance and exercise of the powers conferred by the Water Acts, doth hereby make a rate for the supply of water for domestic purposes of Two shillings and four pence in the pound on the net annual value of lands and tenements liable to be rated within the Broadford Urban District, provided that in no case shall the amount of rate payable per annum in respect of any tenement (other than land on which there is no building) be less than One hundred and twenty shillings, and in respect of any land on which there is no building less than Forty shillings.

Such rates are made and shall be levied upon the occupiers or owners of the said lands and tenements for the year commencing on the 1st day of January, 1963, and shall be payable on the 10th day of January, 1963, at the office of the said Trust.

The maximum quantity of water to be supplied in any one year, without further charge to any property rated by the Trust, is hereby fixed at the quantity produced by a charge of One shilling and six pence per 1,000 gallons on the first Twenty pounds of the rate and One shilling per 1,000 gallons on the amount of rate exceeding Twenty pounds.

The charge for water supplied to any property by the Trust in excess of such maximum quantity is hereby fixed at Six pence per 1,000 gallons.

The charge for water supplied by measure shall be payable, on demand, at the office of the Trust.

Passed this 1st day of November, 1962.

(SEAL) H. C. REID, Chairman.  
M. D. WADE, Secretary.

Approved, 13th November, 1962.—W. J. MIBUS, Minister of Water Supply.

#### AVOCA TOWNSHIP WATERWORKS TRUST.

##### RATING BY-LAW FOR THE YEAR 1963.

**T**HE Avoca Township Waterworks Trust, in pursuance and exercise of the powers conferred by the Water Acts, doth hereby make a rate for the supply of water for domestic purposes of Two shillings in the pound on the annual municipal valuation of lands and tenements liable to be rated within the Avoca Township Waterworks Trust Urban District.

Provided that in no case shall the amount of the rate payable per annum in respect of any tenement (other than land on which there is no building) be less than Three pounds, and in respect of any land on which there is no building less than Two pounds.

Such rates are made and shall be levied upon the occupiers or owners of the said lands and tenements for the year commencing on the 1st day of January, 1963, and shall be payable on the 4th day of January, 1963, at the office of the said Trust.

The maximum quantity of water to be supplied in any one year, without further charge to any property rated by the Trust, is hereby fixed at the quantity which, at a charge of Two shillings per 1,000 gallons, would produce an amount equal to the amount of the rate levied on such property for the said year.

The charge for water supplied by measure to any property rated by the Trust in excess of such maximum quantity, computed as in the preceding clause, is hereby fixed at Two shillings per 1,000 gallons.

The charge for water supplied by measure to any property not rated by the Trust is hereby fixed at Four shillings per 1,000 gallons for a supply up to 60,000 gallons, and Two shillings per 1,000 gallons thereafter, and the minimum quantity of water to be charged for in cases where water is so supplied is hereby fixed at 15,000 gallons.

The charge for water supplied by measure shall be payable, on demand, at the office of the said Trust.

Passed this 5th day of November, 1962.

The corporate seal of the Avoca Township Waterworks Trust was hereunto affixed this 5th day of November, 1962, in the presence of—

(SEAL) WILLIAM GLEDHILL, Chairman.  
H. F. CHAPMAN, Commissioner.  
C. T. SQUIRES, Commissioner.  
F. C. S. EDWARDS, Secretary.

Approved, 13th November, 1962.—W. J. MIBUS, Minister of Water Supply.

#### HEALESVILLE WATERWORKS TRUST.

##### RATING BY-LAW 1963.

**T**HE Healesville Waterworks Trust, in pursuance and exercise of the powers conferred by the Water Acts, doth hereby make a rate for the supply of water for domestic purposes of One shilling in the pound on the net annual valuation of lands and tenements liable to be rated within the Healesville Urban District.

Provided that in no case shall the amount of rate payable per annum in respect of any tenement be less than Two pounds.

Such rates are made and shall be levied upon the occupiers or owners of the said lands and tenements for the year commencing on the 1st day of January, 1963, and shall be payable on the 2nd day of January, 1963, at the office of the said Trust.

The maximum quantity of water to be supplied in any one year without further charge to any property rated by the Trust is hereby fixed at the quantity which, at a charge of One shilling per 1,000 gallons, would produce an amount equal to the amount of rate levied on such property for the said year.

The charge for water supplied by measure to any property rated by the Trust in excess of such maximum quantity, computed as in the last preceding clause, is hereby fixed at One shilling per 1,000 gallons.

The charge for water supplied by measure to any property not rated by the Trust is hereby fixed at One shilling per 1,000 gallons.

The charge for water supplied by measure shall be payable, on demand, at the office of the Trust.

Passed this 30th day of October, 1962.

(SEAL) J. F. SLATTER, Chairman.  
W. M. OLIVER, Secretary.

Approved, 13th November, 1962.—W. J. MIBUS, Minister of Water Supply.

#### KYNETON SHIRE WATERWORKS TRUST.

##### RATING BY-LAW FOR THE YEAR 1962-63.

**T**HE Kyneton Shire Waterworks Trust, in pursuance and exercise of the powers conferred by the Water Acts, doth hereby make a rate for the supply of water for domestic purposes of Eleven pence, in the pound on the annual municipal valuation of lands and tenements liable to be rated within the Kyneton Shire Waterworks Trust Urban District.

Provided that in no case shall the amount of rate payable per annum in respect of any tenement (other than land on which there is no building) be less than Sixty shillings, and in respect of any land on which there is no building less than Thirty shillings.

Such rates are made and shall be levied upon the occupiers or owners of the said lands and tenements for the year commencing the 1st day of October, 1962, and shall be due and payable on the 21st day of January, 1963, at the office of the said Trust.

The maximum quantity of water to be supplied in any one year without further charge to any property rated by the Trust is hereby fixed at the quantity which, at a charge of One shilling and six pence per 1,000 gallons, would produce an amount equal to the amount of rate levied on such property for the said year.

The charge for water supplied by measure to any property rated by the Trust in excess of such maximum quantity, computed as in the last preceding clause, is hereby fixed at One shilling and six pence per 1,000 gallons.

The charge for water supplied by measure shall be payable, on demand, at the office of the Trust.

Passed this 7th day of November, 1962.

(SEAL) M. N. MURPHY, Chairman.  
S. G. PORTER, Secretary.

Approved, 13th November, 1962.—W. J. MIBUS, Minister of Water Supply.

#### KOO-WEE-RUP WATERWORKS TRUST.

##### RATING BY-LAW No. 34 FOR THE YEAR 1963.

THE Koo-Wee-Rup Waterworks Trust, in pursuance and exercise of the powers conferred by the Water Acts, doth hereby make a rate for the supply of water for domestic purposes of One shilling and six pence in the pound of municipal valuation of lands and tenements to be rated within the Koo-Wee-Rup Urban District.

Provided that in no case shall the amount of rate payable per annum in respect of any tenement (other than land on which there is no building) be less than Seven pounds, and in respect of land on which there is no building Thirty shillings.

Such rates are made and shall be levied on the occupiers or owners of said lands and tenements for the year commencing the first day of January, 1963, and shall be payable on the seventh day of January, 1963, at the office of the Trust.

The maximum quantity of water to be supplied in any one year without further charge to any property rated by the trust is hereby fixed at the quantity which at a charge of Two shillings per 1,000 gallons, would produce an amount equal to the amount of rate levied on such property for the said year.

The charge for water supplied by measure to any property rated by the Trust in excess of such maximum quantity, computed as in the last preceding clause, is hereby fixed at Two shillings per 1,000 gallons.

The charge for water supplied by measure shall be payable, on demand, at the office of the Trust.

The Secretary of the Trust for the time being is hereby authorized to demand, collect, and recover on behalf of the Trust the rates and charges imposed by this By-law.

Passed this 5th day of November, 1962.

(SEAL) L. J. COCHRANE, Chairman.  
W. J. POLLOCK, Secretary.

Approved, 13th November, 1962.—W. J. MIBUS, Minister of Water Supply.

#### HORSHAM WATERWORKS TRUST.

##### RATING BY-LAW FOR THE PERIOD 1ST OCTOBER, 1962, TO 30TH SEPTEMBER, 1963.

THE Commissioners of the Horsham Waterworks Trust, in pursuance of the provisions of the Water Acts, do hereby make the following By-law:—

1. The water rate for the year ending 30th September, 1963, on all lands and tenements liable to be rated within the Horsham Waterworks Trust District shall be Seven pence in the pound on the municipal valuation of the City of Horsham for the year 1962-63.

Provided that in no case shall the amount of rate payable in respect of any property on which there is a building be less than Three pounds ten shillings, and in respect of any property on which there is no building less than Two pounds.

2. (a) The maximum quantity of water to be supplied during the year ending 30th September, 1963, without further charge to any property rated by the Trust, is hereby fixed at the quantity which, at a charge of One shilling per 1,000 gallons, would produce an amount equal to the amount of the rate levied on such property for the said period.

(b) The charge for water supplied by measure to any property rated by the Trust in excess of such maximum quantity, computed as in the preceding sub-clause, is hereby fixed at Nine pence per 1,000 gallons.

(c) The charge for water supplied by measure to any property not rated by the Trust, excepting water supplied from the Mount Zero pipe-line, is hereby fixed at Nine pence per 1,000 gallons, and the minimum quantity of water to be charged for in cases where water is so supplied is hereby fixed at 27,000 gallons.

(d) The charge for water supplied by measure from the Mount Zero pipe-line to any property not rated by the Trust is hereby fixed at One shilling and six pence per 1,000 gallons, and the minimum quantity of water to be charged for in cases where water is so supplied is hereby fixed at 47,000 gallons.

(e) The charge for water supplied by measure shall be payable, on demand, at the office of the Trust.

3. All water rates shall be payable on the 4th day of January, 1963, at the office of the Trust, Wilson-street, Horsham, where payments will be received during office hours.

4. Such officers as the Trust may from time to time appoint for the purpose are hereby authorized to demand, receive, and recover the said charges.

The foregoing By-law was passed by the Commissioners of the Horsham Waterworks Trust, on the 5th day of November, 1962, and the common seal hereunder affixed, in the presence of—

(SEAL) MARIE V. LANDT, Chairman.  
T. E. CONROY, Commissioner.  
A. R. O'CONN, Secretary.

Approved, 13th November, 1962.—W. J. MIBUS, Minister of Water Supply.

#### BALLARAT WATER COMMISSIONERS.

##### RATING BY-LAW FOR YEAR 1963, No. 66.

THE Ballarat Water Commissioners, in pursuance and exercise of the powers conferred by the Water Acts, doth hereby make a rate for the supply of water for domestic purposes of One shilling in the pound of the annual municipal valuation of lands and tenements liable to be rated within the Ballarat Water Supply District.

Provided that in no case shall the amount of water rate payable annually be less than One pound ten shillings in respect of any rateable property.

Such rates are made and shall be levied upon the occupiers or owners of the said lands and tenements for the year commencing the 1st day of January, 1963, and shall be payable on the 30th day of March, 1963, at the office of the Ballarat Water Commissioners.

The maximum quantity of water to be supplied in any one year without further charge to any property rated by the Commissioners is hereby fixed at the quantity which, at a charge of One shilling and four pence per 1,000 gallons, would produce an amount equal to the amount of the rate levied on such property for the said year.

The charge for water supplied by measure to any property rated by the Commissioners in excess of such maximum quantity, computed as in the last preceding clause, is hereby fixed at One shilling and four pence per 1,000 gallons.

The charge for water supplied by measure shall be payable, on demand, at the office of the Commissioners.

Passed this 8th day of November, 1962.

(SEAL) ARTHUR W. NICHOLSON, Chairman.  
A. GUYE, Commissioner.  
CHAS. H. CLAMP, Secretary.

Approved, 13th November, 1962.—W. J. MIBUS, Minister of Water Supply.

## MARYSVILLE WATERWORKS TRUST.

## BY-LAW No. 3.

**T**HE Marysville Waterworks Trust (hereinafter referred to as "the Trust") in pursuance and exercise of the powers conferred by the Water Acts doth hereby make a By-law for restricting the use of water supplied by the Trust for other than domestic purposes.

1. This By-law shall come into operation at such time as the Trust from time to time directs by notice published in a newspaper circulating generally within the Marysville Waterworks District and cease to have operation at such time as the Trust from time to time directs by notice so published.

2. No person shall use or permit or suffer to be used any water supplied by the Trust to water or irrigate any land, orchard, grass, lawn, garden, tree, shrub, plant, plantation or any vegetation whatsoever unless the water is used—

- (a) by means of a hose held and controlled in the hand within eighteen inches of the outlet of such hose and during the whole of the use by the person so using the water; or
- (b) by means of a container of a capacity not exceeding 4 gallons (imp.) held in the hand of the person using such water.

3. Upon application for exemption being made, in writing, by any water user in the Marysville Waterworks Trust District to the Trust, the Trust if it thinks fit may grant a written exemption to any such water user from the operation of this By-law in whole or in part and for such period and upon such terms and conditions as the Trust may see fit to impose or the Trust may refuse to grant such application without giving any reason for such refusal.

4. This By-law shall have effect throughout the whole of the Marysville Waterworks Trust District.

5. Every person guilty of an offence against this By-law shall for every such offence be liable to a penalty not exceeding Fifty pounds and in the case of a continuing offence a further penalty not exceeding Five pounds for every day after notice of the offence from the Trust.

The foregoing By-law was made the 13th day of April, 1962, and the seal of the Trust affixed hereto in the presence of—

(SEAL) J. A. GRIEVE, Chairman.  
J. L. GOULD, Commissioner.  
W. MASSEY, Secretary.

Approved by the Governor in Council, 13th November, 1962.—N. G. WISHART, Clerk of the Executive Council.

## CITY OF WARRNAMBOOL.

## RATING BY-LAW FOR THE YEAR 1962-63 (BY-LAW No. 78).

**T**HE Municipal Council of the City of Warrnambool, in pursuance and exercise of the powers conferred by the Water Acts, doth make a rate for the supply of water for domestic purposes of Eighteen pence (18d.) in the £1 on the net annual valuation of lands and tenements liable to be rated within the Warrnambool Water Supply District.

Provided that in no case shall the amount of the rate payable per annum in respect of any tenement (other than land on which there is no building) be less than One hundred shillings, and in respect of any land on which there is no building less than Sixty shillings.

Such rates are made and shall be levied upon the occupiers or owners of the said lands and tenements for the year commencing on the 1st day of October, 1962, and shall be payable on the 10th day of December, 1962, at the office of the said local governing body, Municipal Chambers, Warrnambool.

The maximum quantity of water to be supplied in any one year without further charge to any property rated by the Council is hereby fixed at the quantity which at a charge of Twenty-six pence per 1,000 gallons, would produce an amount equal to the amount of the rate levied on such property for the said year.

The charge for water supplied by measure to any property rated by the Council in excess of such maximum quantity, computed as in the last preceding clause, is hereby fixed at Twenty-four pence per 1,000 gallons.

The charge for water supplied by measure to any property not rated by the Council is hereby fixed at Twenty-one pence per 1,000 gallons, and the minimum quantity of water to be charged in cases where water is so supplied is hereby fixed at 45,000 gallons.

Such person or persons as the Council may appoint from time to time for the purpose shall be authorized to demand, receive, and collect the said rates and charges.

The foregoing was made and adopted by the Municipal Council of the City of Warrnambool on the 30th October, 1962, and the common seal of the City of Warrnambool was hereto affixed by order of the said Council, in the presence of—

(SEAL) P. O'SULLIVAN, Mayor.  
E. P. GIBBONS, Councillor.  
J. A. WELSH, Councillor.  
K. L. ARNEL, Town Clerk.

Approved, 13th November, 1962.—W. J. MIBUS, Minister of Water Supply.

## WARBURTON WATERWORKS TRUST.

## RATING BY-LAW FOR YEAR 1963.

**T**HE Warburton Waterworks Trust, in pursuance and exercise of the powers conferred by the Water Acts, doth hereby make a rate for the supply of water for domestic purposes of One shilling and three pence in the £1 of the annual municipal valuation of the lands and tenements liable to be rated in the Warburton Urban District.

Provided that in no case shall the amount of rate payable per annum in respect of any tenement (other than land on which there is no building) be less than £1 and on land where there is no building be less than Ten shillings.

Such rates are made and shall be levied upon the occupiers or owners of the said lands and tenements for the year commencing 1st day of January, 1963, and shall be payable on the 31st day of January, 1963, at the office of the said Trust.

The maximum quantity of water to be supplied in any one year without further charge to any property rated by the Trust is hereby fixed at a quantity which, at a charge of One shilling and three pence per 1,000 gallons, would produce an amount equal to the amount of rate levied on such property for the said year.

The charge for water supplied by measure to any property rated by the Trust in excess of such maximum quantity computed as in the last preceding clause, is hereby fixed at One shilling and three pence per 1,000 gallons.

The charge for water supplied by measure shall be payable, on demand, at the office of the said Trust.

Passed this 23rd day of October, 1962.

(SEAL) THOMAS F. BRENT, Chairman.  
F. A. MAXWELL, Secretary.

Approved, 13th November, 1962.—W. J. MIBUS, Minister of Water Supply.

## ST. ARNAUD WATERWORKS TRUST.

## RATING BY-LAW FOR THE YEAR 1963.

**T**HE St. Arnaud Waterworks Trust, in pursuance and exercise of the powers conferred by the Water Acts, doth hereby make a rate for the supply of water for domestic purposes of Two shillings and three pence in the £1 of the annual municipal valuation of the lands and tenements liable to be rated within the St. Arnaud Waterworks Trust Urban District.

Provided that in no case shall the amount of rate payable per annum in respect of any tenement (other than land on which there is no building) be less than Three pounds, and in respect of land on which there is no building less than Ten shillings.

Such rates are made and shall be levied upon the occupiers or owners of the said lands and tenements for the year commencing the 1st day of January, 1963, and shall be payable on the 1st day of February, 1963, at the offices of the said Trust, Town Hall, St. Arnaud.

The maximum quantity of water to be supplied in any one year without further charge to any property rated by the Trust is hereby fixed at a quantity which, at a charge of Two shillings per 1,000 gallons, would produce an amount equal to the amount of the rate levied on such property for the said year.

The charge for water supplied by measure to any property rated by the Trust in excess of such maximum quantity, computed as in the last preceding clause, is hereby fixed at Two shillings per 1,000 gallons.

The charge for water supplied by measure, shall be payable, on demand, at the office of the Trust.

Passed this 5th day of November, 1962.

(SEAL) G. A. HUNT, Chairman.  
G. A. ANDERSON, Commissioner.  
PAUL JAMES, Secretary.

Approved, 13th November, 1962.—W. J. MIBUS, Minister of Water Supply.

#### SHIRE OF KOWREE WATERWORKS TRUST.

GOROKE URBAN DISTRICT.

*Rating By-law for the Year 1963.*

**T**HE Shire of Kowree Waterworks Trust, in pursuance and exercise of the powers conferred by the Water Acts, doth hereby make a rate for the supply of water for domestic purposes for Two shillings and eight pence in the pound on the annual municipal valuation of lands and tenements liable to be rated within the Goroke Urban District.

Provided that in no case shall the amount of rate payable per annum in respect of any tenement (other than land on which there is no building) be less than Four pounds seven shillings and six pence, and in respect of any land on which there is no building less than Four pounds seven shillings and six pence.

Such rates are made and shall be levied upon the occupiers or owners of the said lands and tenements for the year commencing on the 1st day of January, 1963, and shall be payable on the 10th day of April, 1963, at the office of the said Trust.

The maximum quantity of water to be supplied in any one year without further charge to any property rated by the Trust is hereby fixed at the quantity which, at a charge of Two shillings per 1,000 gallons, would produce an amount equal to the amount of the rate levied on such property for the said year.

The charge for water supplied by measure to any property rated by the Trust in excess of such maximum quantity, computed as in the last preceding clause, is hereby fixed at Two shillings per 1,000 gallons.

The charge for water supplied by measure to any property not rated by the Trust is hereby fixed at Two shillings per 1,000 gallons, and the minimum quantity of water to be charged for in cases where water is so supplied is hereby fixed at 20,000 gallons.

The charge for water supplied by measure shall be payable, on demand, at the office of the Trust.

Passed this 5th day of November, 1962.

(SEAL) RAYMOND L. AMPT, Chairman.  
H. ERNEST WALKER, Secretary.

Approved, 13th November, 1962.—W. J. MIBUS, Minister of Water Supply.

#### SHIRE OF KOWREE WATERWORKS TRUST.

EDENHOPE URBAN DISTRICT.

*Rating By-law for the Year 1963.*

**T**HE Shire of Kowree Waterworks Trust, in pursuance and exercise of the powers conferred by the Water Acts, doth hereby make a rate for the supply of water for domestic purposes of Two shillings and three pence (2s. 3d.) in the pound on the annual municipal valuation of lands and tenements liable to be rated within the Edenhope Urban District.

Provided that in no case shall the amount of rate payable per annum in respect of any tenement (other than land on which there is no building) be less than Four pounds, and in respect of any land on which there is no building less than Four pounds.

Such rates are made and shall be levied upon the occupiers or owners of the said lands and tenements for the year commencing on the 1st day of January, 1963, and shall be payable on the 10th day of April, 1963, at the office of the said Trust.

The maximum quantity of water to be supplied in any one year without further charge to any property rated by the Trust is hereby fixed at the quantity which, at a charge of Two shillings per 1,000 gallons, would produce an amount equal to the amount of the rate levied on such property for the said year.

The charge for water supplied by measure to any property rated by the Trust in excess of such maximum quantity, computed as in the last preceding clause, is hereby fixed at Two shillings per 1,000 gallons.

The charge for water supplied by measure to any property not rated by the Trust is hereby fixed at Two shillings per 1,000 gallons, and the minimum quantity of water to be charged for in cases where water is so supplied is hereby fixed at 20,000 gallons.

The charge for water supplied by measure shall be payable, on demand, at the office of the Trust.

Passed this 5th day of November, 1962.

(SEAL) RAYMOND L. AMPT, Chairman.  
H. ERNEST WALKER, Secretary.

Approved, 13th November, 1962.—W. J. MIBUS, Minister of Water Supply.

#### COLAC WATERWORKS TRUST.

RATING BY-LAW FOR THE YEAR 1ST OCTOBER, 1962, TO 30TH SEPTEMBER, 1963.

*Cororooke, Coragulac, Alvie, Warrion, Beeac and Cressy Urban Districts.*

**T**HE Colac Waterworks Trust, in pursuance and exercise of powers conferred by the Water Acts, doth hereby make a rate for the supply of water for domestic purposes of Two shillings and six pence in the pound on the annual municipal valuations of lands and tenements liable to be rated within the Cororooke, Coragulac, Alvie, Warrion, Beeac and Cressy Urban Districts.

Provided that in no case shall the amount of rate payable per annum in respect of any tenement (other than land on which there is no building) be less than One hundred and fifty shillings, and in respect of land on which there is no building less than Forty shillings.

Such rates are made and shall be levied upon the occupiers or owners of the said lands and tenements for the period commencing the 1st day of October, 1962, and shall be payable in one sum on the 31st day of January, 1963, at the office of the said Trust, and if not paid within four months from the date made payable will bear interest at the rate of 6 per cent. per annum from the date made payable until paid.

The maximum quantity of water to be supplied in the aforementioned period, without further charge to any property rated by the Trust, is hereby fixed at the quantity which, at a charge of Two shillings per 1,000 gallons, would produce an amount equal to the amount of rate levied on such property for the said period.

The charge for water supplied by measure to any property rated by the Trust in excess of such maximum quantity, computed as in the last preceding clause, is hereby fixed at Two shillings per 1,000 gallons.

The above charge for water supplied by measure to any property shall be payable, on demand, at the office of the said Trust.

Signed and Sealed this 24th day of September, 1962.

(SEAL) ARTHUR F. POTTER, Chairman.  
A. O. BILSON, Commissioner.  
E. J. ROBBINS, Secretary.

Approved, 13th November, 1962.—W. J. MIBUS, Minister of Water Supply.

#### COLAC WATERWORKS TRUST.

RATING BY-LAW FOR THE YEAR 1ST OCTOBER, 1962, TO 30TH SEPTEMBER, 1963.

*Colac Urban District.*

**T**HE Colac Waterworks Trust, in pursuance and exercise of powers conferred by the Water Acts, doth hereby make a rate for the supply of water for domestic purposes of Eleven pence in the pound on the annual municipal valuations of lands and tenements liable to be rated within the Colac Urban District.

Provided that in no case shall the amount of rate payable per annum in respect of any tenement (other than land on which there is no building) be less than Eighty shillings, and in respect of land on which there is no building less than Forty shillings.

Such rates are made and shall be levied upon the occupiers or owners of the said lands and tenements for the period commencing the 1st day of October, 1962, and shall be payable in one sum on the 31st day of January, 1963, at the office of the said Trust, and if not paid within

four months from the date made payable will bear interest at the rate of 6 per cent. per annum from the date made payable until paid.

The maximum quantity of water to be supplied in the aforementioned period, without further charge to any property rated by the Trust, is hereby fixed at the quantity which, at a charge of Two shillings per 1,000 gallons, would produce an amount equal to the amount of rate levied on such property for the said period.

The charge for water supplied by measure to any property rated by the Trust in excess of such maximum quantity, computed as in the last preceding clause, is hereby fixed at Two shillings per 1,000 gallons.

The above charge for water supplied by measure to any property shall be payable, on demand, at the office of the said Trust.

Signed and Sealed this 24th day of September, 1962.

(SEAL) ARTHUR F. POTTER, Chairman.  
A. O. BILSON, Commissioner.  
E. J. ROBBINS, Secretary.

Approved, 13th November, 1962.—W. J. MIBUS, Minister of Water Supply.

#### CITY OF ARARAT WATER SUPPLY DISTRICT.

BY-LAW No. 69.

*Rating By-law for the Year Ending 30th September, 1963.*

THE Council of the City of Ararat, in pursuance and exercise of the powers conferred by the Water Acts, doth hereby make a rate for the supply of water for domestic purposes of Two shillings in the £1 of the annual municipal valuation of lands and tenements liable to be rated within the City of Ararat Water Supply District.

Provided that in no case shall the amount of rate payable per annum in respect of any tenement be less than Eight pounds, and in respect of any land on which there is no building, less than Five pounds.

Such rates are made and shall be levied upon the occupiers or owners of the said lands and tenements for the year ending the 30th day of September, 1963, and shall be payable on the 2nd day of January, 1963, at the office of the said Council.

The maximum quantity to be supplied in any one year without further charge to any property rated by the Council is hereby fixed at the quantity which, at a charge of Thirty pence per 1,000 gallons supplied, would produce an amount equal to the amount of the rate levied on such property for the said year.

The charge for water supplied by measure to any property rated by the Council in excess of such maximum quantity, computed as in the preceding clause is hereby fixed at Two shillings per 1,000 gallons.

The charge for water supplied by measure shall be payable, on demand, at the office of the Council.

All water rates levied shall bear interest at the rate of 6 per cent. per annum from the date when such rates become payable until the said rates are paid, but interest shall not be payable in respect of any such rates if such rates are paid on or before 7th June, 1963.

Passed this 29th day of October, 1962.

(SEAL) ERIC W. JAMES, Mayor.  
GEOFFREY E. MARX, Councillor.  
J. I. GRENFELL, Town Clerk.

Approved, 13th November, 1962.—W. J. MIBUS, Minister of Water Supply.

#### NHILL WATERWORKS TRUST.

RATING BY-LAW FOR THE YEAR 1963.

THE Nhill Waterworks Trust, in pursuance and exercise of the powers conferred by the Water Acts, doth hereby make a rate for the supply of water used for domestic purposes of Two shillings and six pence in the £1 on the annual municipal valuation of lands and tenements liable to be rated within the Nhill Urban District.

1. Provided that in no case shall the amount of rate payable per annum in respect to any tenement be less than Forty shillings.

2. Such rates are made and shall be levied upon the occupiers or owners of the said lands and tenements for the year commencing 1st January, 1963, and shall be payable on the 1st day of February, 1963, at the office of the said Trust.

3. The maximum quantity of water to be supplied in any one year without further charge shall be the quantity which, at a rate of Twenty pence per 1,000 gallons, would produce an amount equal to the amount of rate levied on such property for the said year.

4. The charge for water supplied by measure to any property rated by the Trust in excess of such maximum quantity, computed as in the last preceding clause, is hereby fixed at Fifteen pence per 1,000 gallons.

5. The charge for water supplied by measure to any property not rated by the Trust is hereby fixed at Two shillings and six pence per 1,000 gallons.

6. The charge for water supplied by measure shall be payable, on demand, at the office of the said Trust.

7. *Public Institutions and Others.*—Water supplied to the Government Departments, charitable or other institutions, religious denominations, shall be by measure at One shilling and three pence per 1,000 gallons or by special arrangement.

8. *Water Troughs.*—Private water troughs will be charged for at the rate of Thirty shillings per annum each, except where, in the opinion of the Trust, a meter shall be necessary, in which case the minimum charge shall be for 24,000 gallons at One shilling and three pence per 1,000 gallons.

Such person or persons as the Commissioners of the Trust may from time to time appoint for that purpose shall be authorized to demand and receive and collect and recover the said rates and charges.

Passed this 6th day of November, 1962.

(SEAL) R. HARRY FISCHER, Chairman.  
H. L. BOND, Secretary.

Approved, 13th November, 1962.—W. J. MIBUS, Minister of Water Supply.

#### MOOROOPNA WATERWORKS TRUST.

RATING BY-LAW FOR THE YEAR 1963.

THE Mooroopna Waterworks Trust, in pursuance and exercise of the powers conferred by the Water Acts, doth hereby make a rate for the supply of water for domestic purposes of One shilling and six pence in the £1 of the annual municipal valuation of the lands and tenements liable to be rated within the Mooroopna Urban District.

Provided that in no case shall the amount of the rate payable per annum in respect of any tenement (other than land on which there is no building) be less than Three pounds ten shillings, and in respect of any land on which there is no building, less than Two pounds.

Such rates are made and shall be levied upon the occupiers or owners of the said lands and tenements for the year commencing on the 1st day of January, 1963, and shall be payable on the 24th day of January, 1963, at the office of the Trust.

The maximum quantity of water to be supplied in any one year without further charge to any property rated by the Trust is hereby fixed at the quantity which, at a charge of One shilling and six pence per 1,000 gallons, would produce an amount equal to the amount of the rate levied on such property for the said year.

The charge for water supplied by measure to any property rated by the Trust in excess of such maximum quantity, computed as in the last preceding clause, is hereby fixed at One shilling and six pence per 1,000 gallons.

The charge for water supplied by measure to any property not rated by the Trust is hereby fixed at One shilling and six pence per 1,000 gallons, except in the case of the Mooroopna Hospital, the charge for which is hereby fixed at One shilling and two pence half-penny per 1,000 gallons, and the minimum quantity of water to be charged for in cases where water is so supplied is hereby fixed at 20,000 gallons.

For each public trough supplied with water by the Trust, the sum of One pound per annum shall be charged.

The charge for water supplied by measure shall be payable, on demand, at the office of the Trust.

Passed this 25th day of October, 1962.

(SEAL) M. G. O'BRIEN, Chairman.  
ROY A. CLYDESDALE, Secretary.

Approved, 13th November, 1962.—W. J. MIBUS, Minister of Water Supply.

## THE BALLARAT WATER COMMISSIONERS.

## AUTHORITY TO OBTAIN A BANK OVERDRAFT.

HIS Excellency the Governor of the State of Victoria, by and with the advice of the Executive Council thereof, doth by Order made on the 20th day of November, 1962, authorize the Ballarat Water Commissioners to obtain, in pursuance of the provisions of section 286 of the *Water Act 1958* (No. 6413), an advance or advances during the year 1963 from the Commonwealth Bank of Australia, Ballarat, by overdraft of the Commissioners current account thereat, such overdraft not to exceed at any one time the sum of Fifteen thousand pounds (£15,000).

N. G. WISHART,  
Clerk of the Executive Council.

At Government House,  
Melbourne, 20th November, 1962.

## METUNG WATERWORKS TRUST.

## AUTHORITY TO OBTAIN A BANK OVERDRAFT.

HIS Excellency the Governor of the State of Victoria, by and with the advice of the Executive Council thereof, doth by Order made on the 20th day of November, 1962, authorize the Metung Waterworks Trust to obtain, in pursuance of the provisions of section 286 of the *Water Act 1958* an advance or advances during the year 1962 from the Commercial Banking Company of Sydney Limited, Bairnsdale, by overdraft of the Trust's current account thereat, such overdraft not to exceed at any one time the sum of Three hundred pounds (£300).

N. G. WISHART,  
Clerk of the Executive Council.

At Government House,  
Melbourne, 20th November, 1962.

## COHUNA WATERWORKS TRUST.

## FIXING THE LIMIT OF BANK OVERDRAFT.

HIS Excellency the Governor of the State of Victoria, by and with the advice of the Executive Council thereof, doth by Order made on the 20th day of November, 1962, in pursuance of the provisions of section 288 of the *Water Act 1958* (No. 6413), fix the limit of the overdraft to be obtained by the Cohuna Waterworks Trust from the Australia and New Zealand Bank Limited, Cohuna, at an amount not to exceed at any one time the sum of Five thousand pounds (£5,000).

N. G. WISHART,  
Clerk of the Executive Council.

At Government House,  
Melbourne, 20th November, 1962.

## FORREST WATERWORKS TRUST.

## FIRST ELECTION OF COMMISSIONERS.

HIS Excellency the Governor of the State of Victoria, by and with the advice of the Executive Council thereof, doth by Order made on the 20th day of November, 1962, in pursuance of the provisions of the *Water Acts*, fix Thursday, 6th December, 1962, as the day for holding, at the Public Hall, Forrest, the first election of Commissioners of the Forrest Waterworks Trust.

N. G. WISHART,  
Clerk of the Executive Council.

At Government House,  
Melbourne, 20th November, 1962.

## THORPDALE WATERWORKS TRUST.

## FIRST ELECTION OF COMMISSIONERS.

HIS Excellency the Governor of the State of Victoria, by and with the advice of the Executive Council thereof, doth by Order made on the 20th day of November, 1962, in pursuance of the provisions of the *Water Acts*, fix Thursday, the 6th December, 1962, as the day for holding, at the Public Hall, Thorpdale, the first election of Commissioners of the Thorpdale Waterworks Trust.

N. G. WISHART,  
Clerk of the Executive Council.

At Government House,  
Melbourne, 20th November, 1962.

## HAMILTON SEWERAGE AUTHORITY.

## ANNUAL BALANCE.

HIS Excellency the Governor of the State of Victoria, by and with the advice of the Executive Council thereof, doth by Order made on the 20th day of November, 1962, in pursuance of the provisions of the *Sewerage Districts Acts*, fix the 30th day of September in each year, as from 1st January, 1963, as the day to which the accounts of the Hamilton Sewerage Authority shall be balanced.

N. G. WISHART,  
Clerk of the Executive Council.

At Government House,  
Melbourne, 20th November, 1962.

## STATE RIVERS AND WATER SUPPLY COMMISSION.

## BY-LAW No. 5416.

*Prohibiting the Clearing or Fallowing or Burning Off of Lands Adjacent to Channels in Certain Allotments of Lands Within the Northern Mallee Waterworks District.*

THE State Rivers and Water Supply Commission, pursuant to and in exercise of the powers conferred by the *Water Acts*, doth hereby make the By-law following:—

1. By-law No. 5398 is hereby revoked.
2. The clearing or fallowing or burning off of any land within 3 chains of any channel under the control of the State Rivers and Water Supply Commission, within the allotments set out hereunder, is prohibited.

## OUYEN SUBDIVISION.

*Parish of Paignie.*

Allotments 32, 45, 46, 47, 52.

*Parish of Wymlet.*

Allotments 23, 26, 36, 37, 39, 40, 42, 43.

## TYRRELL SUBDIVISION.

*Parish of Kulwin.*

Allotments 13, 13A.

*Parish of Winnambool.*

Allotments 9, 10, 15A, 17, 18, 19, 23.

## TYRRELL WEST SUBDIVISION.

*Parish of Dering.*

Allotment 27.

*Parish of Pirro.*

Allotment 76.

3. Any person who clears or fallows or burns off, or causes or permits to be cleared or to be fallowed or to be burnt off, any portion of such land within 3 chains of any channel under the control of the Commission (unless he has first obtained the written consent of the Commission or its Authorized Officer), shall be guilty of an offence against this By-law and liable to a penalty not exceeding Fifty pounds.

The foregoing By-law was made by the State Rivers and Water Supply Commission on the 19th day of November, 1962, and the common seal of the said Commission was hereunto affixed on the 19th day of November, 1962, in the presence of—

(SEAL) H. W. MCCAY, Commissioner.  
A. L. TISDALL, Commissioner.

Approved by the Governor in Council, 20th November, 1962.—N. G. WISHART, Clerk of the Executive Council.

## FARM PRODUCE AGENTS ACT 1958 (No. 6248).

A FURTHER list of persons to whom Farm Produce Agents' licences have been issued for the year ending 31st December, 1962, all of whom are exempt from the provisions of paragraphs (a) and (b) of sub-section (1) of section (10) of the *Farm Produce Agents Act 1958*, in regard to lodging a fidelity bond.

*Name; Principal Place of Business.*

Colac and District Wholesale Fruit Distributing Co.; Murray-street, Colac.  
Hope, Robert Thomas; 172 Tucker-road, Bentleigh.  
Sau, Ignacij; 54 Lambie-street, Cooma, New South Wales.  
Taylor, John Francis; Main-road, Marysville.

## FARM PRODUCE AGENTS ACT 1958 (No. 6248).

**A** FURTHER list of persons to whom Farm Produce Agents' licences have been issued for the year ending 31st December, 1962, each of whom has lodged a fidelity bond in accordance with the requirements of the Act:—

*Name; Address.*

Alderuccio, Antonio; 60A Chapman-street, North Melbourne.  
 Amalfi, Frank; 30 Elizabeth-street, Fawkner.  
 Amalfi, John; 107 Thomsons-road, Bulleen.  
 Archibald Honey Co.; 44 McIndoe-parade, Parkdale.  
 Barylak, Robert; 14 Mackie-grove, East Brighton.  
 Bendigo Quick Frozen Foods Pty. Ltd.; Aspinall-street, Golden Square.  
 Bowyer, Henry Joseph; 219 O'Heas-road, Pascoe Vale.  
 Carmody, Edward Patrick; Coragulac, Victoria.  
 Crema & Co.; 31 Alice-street, Coburg.  
 Cutrale, Antonio; 112 Leveson-street, North Melbourne.  
 D'Aloisio, Panfilo; 29 Clyde-street, Lilydale.  
 D'Aloisio, V. and D.; Chapman-street, Silvan.  
 Di Pietro, Guiseppe Antonio; 110 Peel-street, North Melbourne.  
 Hunscha, August Ronald; Jeparit, Victoria.  
 Jackson Shands Pty. Ltd.; 540 Little Collins-street, Melbourne.  
 Jonas Wholesale Pty. Ltd.; 146 Dudley-street, Melbourne.  
 Latorre, Francesco; 63 Davies-street, Brunswick.  
 Madafferi, Vincent; 10 Errol-avenue, East Brunswick.  
 Merlino, Frank; 105 Leonards-road, Ascot Vale.  
 Mentiplay, D. & Co. (Vegetables) Pty. Ltd.; 27 Wholesale Fruit Market, Melbourne.  
 McKeddie Orchards; Main Ridge, Victoria.  
 Nichols, John Frederick; Lalors-road, Healesville.

Petrucelle, Antonio; 396 Wellington-street, Collingwood.  
 Quong Hoong Wah Pty. Ltd.; 41 Wholesale Fruit Market, Melbourne.  
 Renown and Pearlite Pty. Ltd.; 171 Stawell-street, Burnley.  
 Sanitarium Health Food Co.; 118 Union-street, Windsor.  
 Sesto, John; 117A Nepean Highway, Aspendale.  
 Silks Vegetables Pty. Ltd.; 24 Wholesale Fruit Market, Melbourne.  
 Smith, William John; 1116 Howitt-street, Ballarat.  
 Tassone, Guiseppe; 252 Mary-street, Richmond.  
 Tassone, Pasquale; 40 South-street, Ascot Vale.  
 Tonkin Bros. Midland Apiaries; Talbot-road, Maryborough.  
 Wiffen, W. & Sons; Willis-street, Portarlington.  
 Wills, L. & Co. Pty. Ltd.; 793 Whitehorse-road, Mont Albert.

## DEPARTMENT OF CROWN LANDS AND SURVEY.

## ORDER IN COUNCIL CANCELLED.

**H**IS Excellency the Governor of the State of Victoria, by and with the advice of the Executive Council thereof, doth by Order made on the 13th day of November, 1962, cancel the Order in Council made on the 23rd day of October, 1962, revoking the Order in Council of the 15th August, 1922, permanently reserving a site for the purpose of a Cemetery in the Township of Oskleigh, containing 4 acres 2 roods 30 perches.

N. G. WISHART,  
 Clerk of the Executive Council.

At Government House,  
 Melbourne, 13th November, 1962.

*Police Regulation Act 1958.*

## POLICE FORCE OF VICTORIA.

## DETERMINATION NO. 102 OF THE POLICE CLASSIFICATION BOARD.

**T**HE Police Classification Board, in pursuance of the powers in that behalf conferred by the *Police Regulation Act 1958*, hereby makes the following Determination, that is to say:—

1. The Determination No. 85 of the Police Classification Board of the 30th August, 1960, and published in the *Government Gazette* of the 25th October, 1960 (as amended), is hereby further amended as follows:—

(a) In paragraph 9 by inserting immediately after the expression—

“Editor, Police Life . . . 63.18.6” the expression—

“Sub-officers performing duties at the Companies Registration Branch of the Law Department . . . 63.18.6”

and after the expression—“Assistant Editor, Police Life . . . 36.10.6” the expression—

“First Constables and Constables performing duties at the Companies Registration Branch of the Law Department . . . 36.10.6”.

(b) In paragraph 15 by deleting the expression—“Sub-officers, First Constables and Constables of Mobile Section of Branch while performing active patrol duties . . . 2.0”—and substituting therefor the following:—

“Sub-officers, First Constables and Constables of Mobile Section of Branch while performing active patrol duties—

During third and subsequent years . . . . 4.0.

During first and second years . . . . 2.6.”

2. This Determination shall come into operation upon the 14th day of November, 1962.

Dated at Melbourne this 14th day of November, 1962.

J. F. MULVANY,  
 A Judge of the County Court of Victoria,  
 Chairman and Member of the Police  
 Classification Board.

D. S. RAMAGE,  
 Member of the Police Classification Board.

W. J. McLAREN,  
 Member of the Police Classification Board.

Melbourne and Metropolitan  
BOARD OF WORKS.

NOTICE TO THE OWNERS OF TENEMENTS IN THE UNDER-MENTIONED STREETS, AND THE PRIVATE STREETS, LANES, COURTS AND ALLEYS OPENING THERETO.

THE main pipe in the said streets being laid down, the owners of all tenements situated as under are hereby required on or before the 24th December, 1962, to cause a proper pipe and stop cocks to be laid so as to supply water within such tenements from the main pipe.

H. J. SNADDEN,  
Secretary.

13th November, 1962.

STREET AND POSITION.

*Box Hill.*

Valda-avenue, from 2½ chains east of Lincoln-avenue eastwards 8½ chains.  
Vivianne-avenue, from Chessell-road to Valda-avenue.  
Milne-road, from Chessell-road to Valda-avenue.

*Broadmeadows.*

Angustine-terrace, from Finchley-street to Cherwell-avenue.

*Dandenong.*

Boyd-street, from Avril-street northwards and westwards 18½ chains.  
Phillip-street, from Boyd-street southwards 6½ chains.  
Barton-street, from Boyd-street to McFees-road.  
Boyd-court, from Boyd-street south-westwards 5½ chains.

*Kew.*

Annadale-street, from Maxwell-street to Mortimer-street.

*Melbourne.*

Right of Way, from 3 chains south of Grattan-street from Berkley-street eastwards 1½ chains.

*Moorabbin.*

Matilda-street, from 10 chains south of Bulli-street to Genoa-street.  
Genoa-street, from Matilda-street westwards 1½ chains.

*Preston.*

Lambassa-grove, from 3 chains south of Lloyd-avenue southwards 1½ chains.  
Lloyd-avenue, from 1½ chains east of Lambassa-grove to Cheddar-road west.  
Cheddar-road west, from Lloyd-avenue north-eastwards 2½ chains.

*Springvale.*

Tyree-avenue, from Hillcrest-grove southwards 7½ chains.

*Waverley.*

Pinewood-drive, from Blackburn-road to Illuka-crescent.  
Clarke-street, from Waimarie-drive to Amber-grove 9½ chains.  
Amber-grove, from Clarke-street westwards 10 chains.  
Kunzea-court, from Amber-grove southwards 5 chains.  
Saniky-street, from Westerfield-drive westwards 20½ chains.  
Darcey-court, from Saniky-street northwards 3½ chains.  
Linden-court, from Saniky-street northwards.  
Westerfield-drive, from Fern Tree Gully-road to Pemberley-drive.  
Pemberley-drive, from Westerfield-drive eastwards 9 chains.  
Longbourne-avenue, from Westerfield-drive to Pemberley-drive.  
Rosing-court, from Longbourne-avenue northwards 6½ chains.

LAW DEPARTMENT.

APPOINTMENT AMENDED.

HIS Excellency the Governor of the State of Victoria, by and with the advice of the Executive Council thereof, doth by Order made on the 13th November, 1962, amend the Order made on 25th September, 1951, appointing Joseph Jeremiah O'Sullivan to Keep the Peace in the Southern Bailiwick of the State of Victoria by the deletion of the words "Southern Bailiwick" and the substitution therefor of the words "Southern and Western Bailiwicks."

N. G. WISHART,  
Clerk of the Executive Council.

At Government House,  
Melbourne, 13th November, 1962.

COMPANIES ACT 1961.

NOTICE is hereby given in pursuance of section 308 (2) and 308 (3) of the Companies Act 1961 that at the expiration of three months from the date hereof the names of the following companies will, unless cause is shown to the contrary, be struck off the Register and the said Companies will be dissolved.

Dated this 16th day of November, 1962.

T. S. WELSH,  
Registrar of Companies.

Companies Registration Office,  
Melbourne.

COMPANIES ABOVE REFERRED TO.

Name of Company.	No. of Registration.
Rubber Company of Australia Proprietary Limited	13994
Airdok Radio Valve Company Proprietary Limited	19391
Henry G. Small & Company Proprietary Limited	19506
The Grit Company of Australia Proprietary Limited	22806
Southern Electric Company Proprietary Limited	22857
Fullscroll Pty. Limited	23573
Star Express Carrying Company Proprietary Limited	27428
R. M. Harrison Proprietary Limited	27539
Regent-street Productions Proprietary Limited	32171
R. M. Carson and Company Proprietary Limited	33290
Lewco Industries Proprietary Limited	34034
Chemical Cleaning Services Proprietary Limited	34892
G. W. Friend & Co. Pty. Limited	35179
G. W. Investments Proprietary Limited	35621
Tecoma Investments Proprietary Limited	35650
Corona Appliances Distribution Proprietary Limited	35658
L. E. Samblebe Proprietary Limited	35718
Braxley Industries Proprietary Limited	35856
Speed & Maher Proprietary Limited	36494
Mitcham Glass Service Proprietary Limited	36833
Venice Decorating Coy. Proprietary Limited	38156
Blue Top & Cream Taxi Company Limited	38322
Batman Centre Proprietary Limited	38379
Heatherdale Fibrous Plaster Pty. Limited	39797
Melstream Nominees Proprietary Limited	39935
Giplec Proprietary Limited	41265
Super Market Television Proprietary Limited	41811
Relimass Pty. Limited	41992
Diamond Creek Meat Co. Pty. Limited	42489
Aboriginal Enterprises Proprietary Limited	43173
Clarmo Proprietary Limited	44143
Roy Neon Illuminated Signs (Victoria) Proprietary Limited	45692
Provisas Proprietary Limited	45771
Solid Constructions Pty. Limited	48169
J. O'Loughlin and Co. Pty. Limited	49566
Gunn's Gully Development Proprietary Limited	49740

Milk Board Act 1958.

SPECIFIED DAIRIES.

AFTER inquiry conducted, pursuant to section 22 of the Milk Board Act, the Milk Board doth, by this notice—

(1) Hereby specify the dairies shown in Schedule A herein as dairies from which milk may be sold or distributed within the South Gippsland Milk District.

(2) Hereby specify the dairies shown in Schedule B herein as dairies at which milk may be sold by retail for delivery only at those dairies.

(3) Hereby cancel, as from the date hereof, the licences held under Part II. of the Milk and Dairy Supervision Act 1958 in respect of such dairies within the South Gippsland Milk District as are not specified in this notice.

SCHEDULE A.

Dairies in the South Gippsland Milk District from which milk may be sold or distributed within that district.

MUNICIPAL DISTRICT—BASS.

DAIRIES—DELIVERY.

Present Holder of Licence; Location.

Phillip Island Dairies Pty. Ltd.; Edgar-avenue, San Remo.

MUNICIPAL DISTRICT—KORUMBURRA.

DAIRIES—DELIVERY.

Present Holder of Licence; Location.

E. W. Gallus Pty. Ltd.; 40 Victoria-street, Korumburra.  
Myors, J. and M.; Gordon-street, Korumburra.  
Weir, G. H. and J. M.; Victoria-street, Loch.



## DAIRIES—DAIRY FARM AND DELIVERY.

*Present Holder of Licence; Location.*

Fowles, J. H.; Bass Valley-road, Bena.

Hewson, F. J.; Main-road, Nyora.

Lawrence, K. A.; 14 Warragul-road, Korumburra.

## MUNICIPAL DISTRICT WONTHAGGI.

## DAIRIES—DELIVERY.

*Present Holder of Licence; Location.*

E. W. Gallus Pty. Ltd.; 6 Bent-street, Wonthaggi.

Hanley, N. and S.; 100 McKenzie-street, Wonthaggi.

Dairies outside the South Gippsland Milk District from which milk may be sold or distributed within that district.

*Present Holder of Licence; Location.*

Arthur Bros. Dairies Pty. Ltd.; 146 Beach-street, Frankston.

Holdenson &amp; Nielson Fresh Food Pty. Ltd.; Queen-street, Warragul.

## SCHEDULE B.

Dairies within the South Gippsland Milk District at which milk may be sold by retail for delivery only at those dairies.

## MUNICIPAL DISTRICT—BASS.

## DAIRIES—HOUSE TRADE.

*Present Holder of Licence; Location.*

Archie's Creek Dairy Produce Co. Ltd.; Archie's Creek.

## DAIRIES—DAIRY FARM AND HOUSE TRADE.

*Present Holder of Licence; Location.*

Asquith, E. F. and P. M.; Hicksborough.

Park, C. E.; Edison-street, North Wonthaggi.

## MUNICIPAL DISTRICT—KORUMBURRA.

## DAIRIES—HOUSE TRADE.

*Present Holder of Licence; Location.*

Kongwak Co-operative Butter Factory Co. Ltd.; Kongwak.

Korumburra &amp; District Co-operative Butter Factory &amp; Trading Co. Ltd.; 47 Station-street, Korumburra.

Poowong Butter Factory Pty. Ltd.; Main-street, Poowong.

By order of the Milk Board,

R. D. HALL,  
Secretary.

## STATE FORESTS DEPARTMENT.

## APPOINTMENT OF COMMITTEE OF MANAGEMENT OF "STEAVENSON FALLS SCENIC RESERVE".

WHEREAS by section 50 of the *Forests Act 1958*, it is provided that the Minister of Forests may, on the recommendation of the Forests Commission, appoint any number of persons, not less than three, to be a Committee of Management of any land forming part of any Reserved Forest, such land being a place of natural beauty or interest or a health resort, and may remove any such persons: Now therefore, I, Lindsay Hamilton Simpson Thompson, Her Majesty's Minister of Forests for the State of Victoria, on the recommendation of the Forests Commission, do hereby appoint—

Councillor G. G. Cuzens  
F. Fiske  
J. Haycraft  
J. Grieve, and  
F. J. May

as Members of the Committee of Management for a period of three years from the 15th October, 1962, of the land forming part of the Reserved Forest in the Parish of Steavenson, County of Anglesey, described in the accompanying Schedule, and known as "Steavenson Falls Scenic Reserve", such land being a place of natural beauty and interest.

## SCHEDULE ABOVE REFERRED TO.

Parish of Steavenson, County of Anglesey, 469 acres, more or less, being the area shown by pink colour on plan marked A.58/613 over 15/10/59 on file of correspondence No. 60/778 of the Forests Department.

Dated at Melbourne the 15th day of November, 1962.

L. H. S. THOMPSON,  
Minister of Forests.

## PUBLIC TRUSTEE ACT 1958, No. 6350, SECTION 17.

I HEREBY give notice that on the 26th October, 1962, the Public Trustee filed elections to administer the following deceased persons' estates in accordance with section 17 of the *Public Trustee Act 1958*:—

FERGUSON, CLAUDE ROBERT, also known as Robert Claude Ferguson, late of 38 Poplar-street, Caulfield, municipal labourer, died 22nd August, 1962.

FITZGERALD, WILLIAM DEGLAN, late of 47 Harrow-street, Preston, retired council employee, died 5th August, 1962.

I HEREBY give notice that on the 25th October, 1962, the Public Trustee filed elections to administer the following deceased persons' estates in accordance with section 17 of the *Public Trustee Act 1958*:—

KARSLAKE, WILLIAM, late of 188 Albert-street, Port Melbourne, pensioner, died on or about 13th April, 1962.

MCWILLIAM, GLEN THOMAS, also known as Thomas Glenore Morrison McWilliam, late of Flat 1, 15 Small-street, Hampton, railway employee, died 9th August, 1962.

I HEREBY give notice that on the 5th November, 1962, the Public Trustee filed elections to administer the following deceased persons' estates in accordance with section 17 of the *Public Trustee Act 1958*:—

ANDREWS, WILLIAM, formerly known as Walter Watson, late of West Camp, Yallourn, trades assistant, died 11th August, 1962.

HALL, FREDERICK ARTHUR LAURENCE, formerly of 323 Glenlyon-road, East Brunswick, late of "Alexander", Castlemaine, compositor, died 25th November, 1960.

HIND, ROBERT, late of 63 Cardigan-street, Carlton, pensioner, died 13th September, 1962.

RYAN, MARY, called in religion Sister Mary Clement, formerly of Sacred Heart Presentation Convent, Wagga Wagga, New South Wales, but late of Mount-street, Margarets Ryde, New South Wales, Sister in Religion, died 19th January, 1948.

WARD, JOHN, late of Mont Park, retired bootmaker, died 23rd May, 1962.

WHITTY, MARION ELIZABETH ETHEL, late of Ballarat, widow, died 7th August, 1962.

WILLIAMS, SUSIE, late of 231 Autumn-street, Geelong West, spinster, died 10th July, 1962.

I HEREBY give notice that on the 8th November, 1962, the Public Trustee filed an election to administer the following deceased person's estate in accordance with section 17 of the *Public Trustee Act 1958*:—

MCDONALD, DAISY EILEEN HILDA, late of 92 Melbourne-road, North Williamstown, married woman, died 6th July, 1962.

I HEREBY give notice that on the 2nd November, 1962, the Public Trustee filed an election to administer the following deceased person's estate in accordance with section 17 of the *Public Trustee Act 1958*:—

SHANNAN, ALEXANDER, late of 74 Third-avenue, North Altona, storeman, died 19th May, 1962.

A. D. DUNCAN,  
Public Trustee.

21 Degraves-street, Melbourne, 14th November, 1962.

## NOTICE.

CREDITORS, next of kin and others having claims against the estate of any of the under-mentioned deceased persons are required to send particulars of their claims to the Public Trustee, 21 Degraves-street, Melbourne, the personal representative, on or before the 24th January, 1963, after which date the Public Trustee may convey or distribute the assets, having regard only to the claims of which the Public Trustee then has notice:—

ANDREWS, WILLIAM, formerly known as Walter Watson, late of West Camp, Yallourn, trades assistant, died 11th August, 1962.

BARNES, ELIZABETH, formerly of Lot 14, corner of Weaponess and Purdom roads, Wembly Downs, Western Australia, but late of 1 Sefton-place, East Camberwell, widow, died 28th June, 1962.

CRAMPTON, EDITH ELIZA EVA, late of 11 Jackson-street, St. Kilda, married woman, died 5th June, 1962.

D'OLIVEIRA, ALBERT, late of 13 Arundel-avenue, Keon Park, retired storeman, died 22nd August, 1962.

DOWDING, FREDERICK WILLIAM, late of 36 Rotherwood-street, Richmond, bootmaker, died 19th September, 1941.

EGGLESTONE, SARAH ELIZABETH, late of Jerusalem, near Kadina, South Australia, widow, died 18th November, 1934.

FAIRWEATHER, LINDON CREIGHTON JAMES, late of 2 Kynoch-street, Deer Park, foreman, died 24th July, 1962.

FERGUSON, CLAUDE ROBERT, also known as Robert Claude Ferguson, late of 38 Poplar-street, Caulfield, municipal labourer, died 22nd August, 1962.

FIELDER, ALFRED, late of Myall, Lake Mundi, via Penola, station hand, died 14th June, 1962.

FITZGERALD, WILLIAM DEGLAN, late of 47 Harrow-street, Preston, retired council employee, died 5th August, 1962.

GRAY, CHARLES WILLIAM, late of 35 Greig-street, Seddon, storeman, died 29th July, 1962.

HALL, FREDERICK ARTHUR LAURENCE, formerly of 323 Glenlyon-road, East Brunswick, late of "Alexander", Castlemaine, compositor, died 25th November, 1960.

HANMER, ALICE WENSLEY, late of 58 Helen-street, Northcote, widow, died 26th July, 1962.

HIGGINS, HERBERT SAMUEL, late of 33 Toolangi-road, Alphington, retired signwriter, died 8th July, 1962.

HIND, ROBERT, late of 63 Cardigan-street, Carlton, pensioner, died 13th September, 1962.

JONES, WILLIAM MAITLAND, formerly of 125 Paisley-street, Footscray, but late of Auckland, New Zealand, builder, died 7th March, 1961.

KARSLAKE, WILLIAM, late of 188 Albert-street, Port Melbourne, pensioner, died on or about 13th April, 1962.

LEATHER, GEORGE JAMES, late of 4 Talota-avenue, Ringwood East, toolmaker, died 13th July, 1962.

MCCROHAN, WILLIAM, formerly of 28 Victoria-road, South Northcote, late of 36 Kooyong-road, Caulfield, gentleman, died 9th August, 1962.

MCCASH, McDONALD JOHN, late of 217 Page-street, Middle Park, market inspector, died 21st July, 1962.

MCDONALD, DAISY EILEEN HILDA, late of 92 Melbourne-road, North Williamstown, married woman, died 6th July, 1962.

MCWILLIAM, GLEN THOMAS, also known as Thomas Glenore Morrison McWilliam, late of Flat 1, 15 Small-street, Hampton, railway employee, died 9th August, 1962.

RYAN, MARY, called in religion Sister Mary Clement, formerly of Sacred Heart Presentation Convent, Wagga Wagga, New South Wales, but late of Mount-street, Margarets Ryde, New South Wales, Sister in Religion, died 19th January, 1948.

SCHMIDT, ALBERT EDWIN, late of Sonoma-street, Collingville, Queensland, pastry cook, died 16th February, 1962.

SHANNAN, ALEXANDER, late of 74 Third-avenue, North Altona, storeman, died 19th May, 1962.

WARD, JOHN, late of Mont Park, retired bootmaker, died 23rd May, 1962.

WHEELER, HENRY RICHARD THOMAS, late of 10 Garden Cottages, Leigh, Kent, England, died 30th April, 1954.

WHITTY, MARION ELIZABETH ETHEL, late of Ballarat, widow, died 7th August, 1962.

WILLIAMS, SUSIE, late of 231 Autumn-street, Geelong West, spinster, died 10th July, 1962.

WOODHEAD, CAROLINE, late of South-street, Glenroy, married woman, died 27th July, 1961.

A. D. DUNCAN,  
Public Trustee.

Melbourne, 14th November, 1962.

NOTICE TO MARINERS.  
[No. 12 OF 1962.]

AUSTRALIA.—VICTORIA.

1. Port Phillip.—Buoy Established.
2. Corner Inlet Approach.—Buoy Restationed.
3. Port Albert Approach.—Buoy Restationed.

1. Date.—On or about 23rd November, 1962.

Position.—Gellibrand Pile Light, lat. 37 deg. 52 min. 43 sec. S., long. 144 deg. 54 min. 45 sec. E. (approx.).

Position of Buoy.—1.33 miles 226 deg. from above position, in lat. 37 deg. 53 min. 40 sec. S., long. 143 deg. 53 min. 40 sec. E. (approx.).

Details.—A red, dome shaped aircraft mooring buoy with a 6 foot pole surmounted by a radar reflector will be established.

2. Former Notice.—No. 4 of 1961 hereby cancelled.

Position.—Front Light, leading line 272 deg. 20 min., Wilson's Promontory, lat. 38 deg. 50 min. 40 sec. S., long. 146 deg. 28 min. 19 sec. E. (approx.).

Details.—The 1st class steel nun buoy, black, No. 2 has been restationed 5.83 miles 091 deg. 16 min. from the above position.

3. Former Notice.—No. 15 of 1961 hereby cancelled.

Position.—Front Light, leading line, Port Albert, lat. 38 deg. 44 min. 37 sec. S., long. 146 deg. 39 min. 27 sec. E. (approx.).

Details.—The 1st class steel can buoy, No. 2 Fairway, has been restationed 2.47 miles 137 deg. 42 min. from above position.

Charts Affected.—(1) B.A. 1171, 624, Aust. 153 (2 and 3) E.A. 1703, Aust. 145 (3) Aust. 199.

Publications.—Sailing Directions, Victoria, 1959, pages 316, 503 and 555.

C. O'MALLEY,  
Port Officer.

Ports and Harbors Branch,  
Department of Public Works,  
Melbourne, C.2., 15th November, 1962.

DEPARTMENT OF MINES.

SUBJECT to any necessary excisions, &c., it is proposed to grant the following mining leases:—

- 8345, Beechworth; Mervyn Raymore Cocks; 4a. 2r. 4p., Parish of Bungil.
- 8369, Beechworth; Gordon Robert Smith; 25a. 0r. 20p., Parish of Carlyle.
- 8382, Beechworth; Ronald Brian Bell; 36 acres, Parish of Burrungabugge.

MINING LEASES GRANTED.

- 7111, Maryborough; Welcome Sutton; 667a. 2r. 20p., Parishes of Tchuterr and Wehla.
- 7821, Mineral; Sulphates Limited; 14a. 1r. 22p., Parish of Allambee East.
- 8087, Mineral; Charles Thomas Manuell and Joseph Ernest Manuell; 18a. 1r. 17p., Parish of Tanjil East.

TAILINGS LICENCES GRANTED.

- 3174, Tailings Licence; Frank Edward Evans; 9a. 0r. 36p., Parish of Sandhurst.
- 3212, Tailings Licence; James Harold Jackson; Parish of Faraday (in lieu of Tailings Licence No. 3152, expired).
- 3213, Tailings Licence; Giuseppe Mioni; at Korumburra East (in lieu of Tailings Licence No. 3161, expired).
- 3215, Tailings Licence; Ray L. Maltby; Parish of Yehrip (in lieu of Tailings Licence No. 3114, expired).

WATER RIGHT LICENCE GRANTED.

- 1234, Water Right Licence; Kenneth Wright; 2a. 3r. 30p., Parish of Wollonaby.

W. J. MIBUS,  
Minister of Mines.

MINING LEASES DECLARED VOID.

- 7256, Mineral; William Arthur Vickery; 69a. 1r. 32p., Parish of Burrowye.
- 7421, Mineral; Max Harold Jackson; 40a. 2r. 14p., Parish of Bullengarook.
- 7634, Mineral; Ceramic Kaolin Mines Proprietary Limited; 19a. 2r. 36p., Parish of Lal Lal.

E. CONDON,  
Secretary for Mines.

CORRIGENDUM.

On page 3745 of the *Government Gazette* of 14th November, 1962, under the heading "Mining Leases Granted", the reference to 8348, Beechworth; Donald Brian Bell should read 8348, Beechworth; Ronald Brian Bell.

**CONTRACTS ACCEPTED.—(Series 1962-63.)****CEREALS.**

Requirements under Sub-schedule No. 7 of Schedule No. 1 for the month of December, 1962, are to be purchased from the under-mentioned firms at the rates per cwt. respectively indicated, viz.:—Robert Harper and Co. Ltd., Barley, pearl, 35s.; Peas, split, yellow, 53s. 9d.; Rice, dressed, 91s.; Rice, unpolished, 91s.; Tapioca, seed, 11d. per lb., less 3 per cent. 14 days or 2½ per cent. 30 days. H. S. K. Ward Pty. Ltd., Oatmeal, plain, 47s. 6d.; Oatmeal, flaked, 48s.

**GENERAL STORES.****CONTRACT CANCELLED.**

*Gazette* No. 83, 3rd August, 1962, Schedule No. 37, Electric Lamps, Accessories, &c. Contract No. 1962/371, Brooks Robinson Pty. Ltd., is hereby cancelled.

**CONTRACT ACCEPTED.**

*Gazette* No. 83, 3rd August, 1962, Schedule No. 37, Electric Lamps, Accessories, &c. For the supply of Conduit and Fittings, &c. Sub-schedule F, Item Nos. 126 to 154, Warburton Franki Industries (Melbourne) Pty. Ltd., as from 1st November, 1962.

*Gazette* No. 83, 3rd August, 1962, Schedule No. 37, Electric Lamps, Accessories, &c. For the rates shown opposite the following items, substitute the rates as set out hereunder as from 1st November, 1962.

Item No. 126, £3 7s. 8d.; Item No. 127, £4 3s.; Item No. 148, £1 3s. 1d. per 100 feet.

H. COUTTS, Secretary to the Tender Board. 19.11.62.

**SOIL CONSERVATION AUTHORITY.****EPPALOCK CATCHMENT PROJECT.**

1771. Erection of 3-bedroom residence fitted with hot water service and electric booster, built-in cupboards and robes, rotary clothes hoist, septic tank system, 1,500 gallon tank on steel stand, Holland blinds, stormwater and sillage drains, concrete paving, connexion to town water supply, £3,954 19s. 3d.—W. M. Phelan & Sons, Maryborough.

I. S. HANCOCK, Acting Secretary.

**EDUCATION DEPARTMENT.**

1772. One only electric duplicator, for Ringwood Technical School, (£185 10s. less trade-in on old machine £50), £135 10s.—Roneo Co. (Melb.) Pty. Ltd.

Approved by the Governor in Council, 13th November, 1962.—N. G. WISHART, Clerk of the Executive Council.

**PUBLIC WORKS.**

1777. Royal Park, Mental Hospital, supply deep fryer, sterilizer press, £1,137 5s.—E.G.A. (S. Cunningham) Pty. Ltd.

1778. Royal Park, Mental Hospital, supply food mixing machine, £495.—Brice Scale & Slicer Co. Pty. Ltd.

1779. Royal Park, Mental Hospital, supply steam jacketed tilting pot, £850.—J. Curtain & Son Pty. Ltd.

1780. Burwood, Technical School, lathes and equipment, £2,506 14s. 5d.—Stockdale Newall Machine Tools Pty. Ltd.

1781. Frankston, Technical School, supply Triumph Herald CJASSOS, £537 10s.—Australian Motor Ind. Ltd.

1782. Burwood, "Allambie", Children's Welfare Department, supply 50 cub. ft. refrigerator, £983.—Ahearn, Main and Stott Pty. Ltd.

1783. Benalla, Technical School, supply gravel, £510.—Abley Brothers.

1784. Kew, Mental Hospital, supply steam heated urn, press and grill, £601 1s.—E.G.A. (S. Cunningham) Pty. Ltd.

1785. Traralgon, Mental Hospital, supply stainless steel cool room, £2,214 16s.—Ahearn, Main & Stott Pty. Ltd.

1786. Burwood, "Allambie", supply tables and chairs, £457.—Aristoc Industries Pty. Ltd.

1787. Kew, Mental Hospital, supply gas ovens, £1,511.—Ahearn, Main & Stott Pty. Ltd.

1788. Kew, Mental Hospital, supply thermo radiant ovens, £2,344 10s.—Thermo Radiant Ovens Sales Pty. Ltd.

1789. Beechworth, Mental Hospital, supply foam pillows and mattress covers, £595.—Dunlopillo Pty. Ltd.

No. 119.—9975/62.—2

1790. Ararat, Mental Hospital, supply and fix curtains, £320.—Hoad Manufacturing Pty. Ltd.

1791. Bendigo, Technical School, supply commercial refrigerator, £252.—Warburton Franki Ind. Pty. Ltd.

1792. Banyule, High School, lay, seal and polish linoleum, £280 10s.—A. Easton.

1793. Donald, High School, supply commercial refrigerator, £252.—Warburton Franki Ind. Pty. Ltd.

1794. Daylesford, Technical School, supply furniture, &c., 1,068 13s.—Kennett Bros. & Rayner Pty. Ltd.

1795. Hawthorn, Court House, alteration to benches, tables, jury box, &c., £295 10s.—F. G. Haynes.

1796. San Remo, San Remo Foreshore, supply stone spalls, £685.—W. F. Evans.

1797. Mont Park, Mental Hospital, supply dining chairs, £567.—D. F. Cowan Sales Pty. Ltd.

1798. Bendigo, Kangaroo Flat Technical School, supply refrigerator, £252.—Warburton Franki Ind. (Melb.) Pty. Ltd.

1799. Mont Park, Mental Hospital, supply curtains, £325 10s.—Moonee Furnishing Pty. Ltd.

1800. Burnley, Plant Research Laboratory, supply furniture, £860.—P. H. Williams.

1801. Frankston, Technical School, supply fitting and turning equipment, £1,666 17s. 5d.—Stockdale Newall Machine Tools Pty. Ltd.

1802. Frankston, Technical School, supply swing model lathe and electric motor, £281 2s.—McPhersons Limited.

1803. Maidstone, High School, Maribyrnong, supply lathes, &c., £647 16s.—Demco Machinery Co. (Vic.) Pty. Ltd.

1804. Werribee, Animal Husbandry Research Centre, supply timber, £260 19s. 5d.—Charles Rouch Pty. Ltd.

1805. Sebastopol, Technical School, supply bandsaw machine—£374.—A. & S. Wolfenden.

1806. Morwell, Technical School, supply various items joinery, £1,175 14s. 6d.—Kennett Bros. & Rayner Pty. Ltd.

H. R. PETTY, Commissioner of Public Works. 16.11.62.

**PUBLIC WORKS.**

1811. Langi Kal Kal, Social Welfare Department, Training Centre, main switchboard, modifications, £675.—R. Lonsdale.

1812. Lexton, Police Station, electrical installation, office and residence, £310.—Avoca Electrical Service.

1813. Lima East, State School No. 2889, septic tank installation, water supply, &c., £1,060.—A. E. Ogden and R. A. Beer.

1814. Macedon, Police Station, general repairs and painting to residence and fencing, £522 16s.—J. E. Acott and G. A. McFarlane.

1815. Merrivale, State School No. 4215, erection of timber residence and timber garage (prefabricated), £4,329.—H. & C. Mathrick.

1816. Middle Indigo, State School No. 1115, erection of one (1) new shelter pavilion, £340 9s.—Roy O. Tobias.

1817. Robinvale, Consolidated School, improvements in ventilation of L.T.C. class-rooms, £560.—North-West Trading Co. Pty. Ltd.

1818. Rutherglen, Agriculture Department, Research Station, erection of entrance gates and cattle grid, £1,112.—R. Baring & Sons.

1819. Stanhope South, State School No. 4325 and Residence, new out-offices and septic tank installations, £1,459.—P. R. Pinder.

1820. Tabilk, State School No. 951, repairs and painting to school and residence, £929 10s.—W. J. Lyons.

1821. Timboon, High School, installation of L.F. gas to science room and general metalwork room, £300.—The Gas Supply Co. Ltd.

1822. Tongala, Consolidated School, electrical installation in new residence, £277 2s.—Tongala Electrical Services.

1823. Tottenham, State School No. 4707, repairs and external painting, £498 10s.—"V.P.S." Renovations & Painting Service.

1824. Traralgon, Technical School, erection of chain mesh fencing, £938.—Diamond Fence & Gate Co. Pty. Ltd.

1825. Tyabb Railway Station, State School No. 3544, septic tank installation, school and residence, £820.—W. J. Gaza Shaw.

1826. Warragul, High School, erection of bicycle shelter, £343 13s.—E. Elliott.

1827. Wonthaggi, Technical School, erection No. 2 new shelter pavilions, 32 ft. x 16 ft., £1,098.—M. Akkerman.

1828. Apsley, Police Station, electrical installation of light and power, residence and office, £295 10s.—J. W. McDowell.

1829. Apsley, Police Station, erection of timber residence and "A" type office, &c., £7,585 10s.—C. R. Ballinger & Sons.

1830. Ballarat, School of Mines, repairs and sanding floors, Art School, £708 15s.—Ballarat Colour Centre.
1831. Ballarat, Ewing House, School for Deaf Children, S.S. No. 4843, supply, delivery, installation and testing of gas heating and hot-water supply, £506 10s.—The Ballarat Gas Company.
1832. Ballarat, Ballarat S.S. No. 4762, supply, delivery, installation and testing of plenum heating and hot-water services, £3,399 10s. 6d.—Lonsdale Sheet Metal & Steel Co. Pty. Ltd.
1833. Bayswater, Bayswater S.S. No. 2163, alterations and renovations, £1,110.—C. McCarthy.
1834. Bendigo, Bendigo Technical College, external painting to Trades School Block, £978.—Light & Blankley.
1835. Birchip, Lands and Survey Department, residence, repairs and painting, £1,045.—W. E. White & Sons Pty. Ltd.
1836. Boolite, Boolite S.S. No. 2170, erect out-office block, install septic closets, £722 10s.—H. J. & K. M. Onley.
1837. Brunswick North-West, State School No. 4399, earthwork, gravelling, concrete kerb and channels and drainage work, £2,918.—W. N. Kirkpatrick.
1838. Bulleen, State School No. 4869, plenum heating, extension from six to twelve class-rooms, £1,798.—Bruce Sheet Metal Service.
1839. Camperdown, Court House, addition of new store and toilet unit, £879.—J. A. Macpherson.
1840. Catani, State School No. 4154, septic tank and bore-water supply installations, £1,136 14s. 11d.—W. H. MacGibbon & Son.
1841. Charlton, Higher Elementary School, No. 1480, internal and external repairs and painting to residence, 3 View-street, £991.—Light and Blankley.
1842. Coatesville, State School No. 4712, additional entrance and roof alterations, £588.—D. B. Tincknell Pty. Ltd.
1843. Coimadai, State School No. 716, repairs and painting to school and residence, £1,662 14s. 6d.—Goodwood Decorating Service.
1844. Collingwood, Technical School, electrical installation, improved lighting for woodwork block, £1,975.—J. & B. Ranking.
1845. Cranbourne, Police Station, resiting old office, £288 10s.—G. J. Hermans.
1846. Dalmore, State School No. 4002, out-office block, septic tank and bore-water supply installations, £1,370 10s.—W. & D. Pitts & Sons Pty. Ltd.
1847. Daylesford, State School No. 1609, minor repairs with internal and external painting to residence, 41 Jamieson-street, £298.—Mawby & Rixon.
1848. Dimboola, State School No. 1372, repairs and painting, £260.—Geo. Lange & Sons Pty. Ltd.
1849. Doon, Longerenong Agricultural College, electrical installations in main building, £9,895 15s. 6d.—T. J. Coultis Pty. Ltd.
1850. Dousta Galla, State School No. 4708, provision of additional toilet, £387.—L. F. Murray Pty. Ltd.
1851. Drouin South, State School No. 2313, out-office block and septic tank, £1,045.—A. P. Backman & Sons.
1852. Drummond, State School No. 1848, repairs and painting to school and residence, £625.—Mawby & Rixon.
1853. Eaglehawk, State School No. 210, connexion to town sewerage, £1,069 15s.—V. G. Allen.
1854. Eltham, State school No. 209, renovations, £1,555.—Pettigrews Pty. Ltd.
1855. Eltham East State School No. 4897, electrical installation, new school of six (6) L.T.C. class-rooms, £1,113.—J. & B. Ranking.
1856. Eltham East, State School No. 4897, plenum heating to new six (6) class-room unit, £1,898.—Bruce Sheet Metal Service.
1857. Essendon, Technical School, extension of heating and modifications to boiler room, £3,295.—W. S. Atherton & Co.
1858. Fairholm, State School No. 3972, new out-office block and septic closet installations, £911.—Peter McBride & Co.
1859. Geelong North, State School No. 1889, roofing repairs, external and internal painting, £629 18s. 6d.—W. C. Freeman Pty. Ltd.
1860. Glenroy, High School, painting exterior woodwork and guttering, £784.—Frederick Thomas.
1861. Golden Square, State School No. 1189, additions to out-office block and drinking and washing facilities, £462 15s. 3d.—V. G. Allen.
1862. Hamilton, Inspector of Works Residence, internal and external renovations, £455.—J. & M. Wilkinson Pty. Ltd.
1863. Harrow, Lands and Survey Department, residence and depot, installation of septic closets, £534 10s.—Geo. Lange & Sons Pty. Ltd.
1864. Hughesdale, State School No. 4176, internal repairs and painting, £2,372.—W. D. Pitts & Sons Pty. Ltd.
1865. Kew, Mental Hospital, internal and external renovations and repairs to residence, Wills-street, £392.—Pettigrews Pty. Ltd.
1866. Kew, Mental Hospital, electrical installation for new boiler house, Children's Cottages, £756.—J. & B. Ranking.
1867. Kew, Mental Hospital, site work, drainage works and landscaping, Nurses' Home, Children's Cottages, £3,047.—R. Lambert.
1868. Kew, Mental Hospital, new aluminium flywire screens to existing timber windows, Children's Cottages, £1,015.—James Aluminium Industries Pty. Ltd.
1869. King Valley, State School No. 2894, new out-office block, drinking, ablution trough and septic tank installation for school and residence, £1,191 18s.—C. G. Haynes.
1870. Kooroocheang, State School No. 1055, renovations and painting to residence, £725 10s.—K. Helstrup.
1871. Kyabram, State School No. 2902, new out-office block, sewer drains &c., £2,723.—Norman L. Pinder.
1872. Kyabram, State School No. 2902, renovations to residence, 26 Union-street, £397.—Peter R. Pinder.
1873. Lake Tyers, State School No. 1319, erection of 20 feet by 10 feet shelter pavilion, £318.—T. A. Thaxton.
1874. Lilydale, High School, supply and installation of external fluorescent lighting, £363.—N. G. Johnston.
1875. Lyndale, High School, erection of chain mesh and pipe post fence, £1,151 10s.—A. Arnold's Fences Pty. Ltd.
1876. Macleod, State School No. 4246, construction boys out-office block, additions girls out-offices, connexion to sewer, septic tank, &c., £4,998.—Neerim Plumbers Pty. Ltd.
1877. Melbourne, Parliament Place, Public Offices, installation of main switchboard, £1,904.—C. W. Norris & Co. Pty. Ltd.
1878. Majorca, State School No. 764, repairs and painting residence, £550.—R. J. Coghlan.
1879. Mallacoota, State School No. 3515, repairs and painting to residence, L.T.C. shelter pavilion and out-offices, £490 12s.—John W. Bruce.
1880. Mallacoota, State School No. 3515, construction of toilets, septic tank and water supply installations, £2,375.—N. F. Mann.
1881. Malvern, Girls' Secondary School, external and internal repairs and painting to cleaners residence, £699.—Hans Hieber.
1882. Malvern, "Stonington", Toorak Teachers' College, alterations and renovations, caretakers residence, £1,850.—K. B. Morrow.
1883. Malvern, State School No. 1604, internal painting and renovations to Infants School, £1,201 17s.—W. & D. Pitts & Sons Pty. Ltd.
1884. Mansfield, High School, supply and installation of liquid petroleum gas, £331 12s.—I. D. McGuffie.
1885. Mardan South, State School No. 3166, septic tank and new out-offices, &c., £1,098.—A. J. Avage & Son Pty. Ltd.
1886. Marlo, State School No. 3433, septic tank installations, &c., £862 11s.—R. J. Prowd.
1887. Melbourne, State Offices, 453 Latrobe-street, supply and installation of roof ventilation, £476.—Bruce Sheet Metal Service.
1888. Melbourne, Old Treasury Building, Spring-street, maintenance cleaning, 1st October 1962 to 30th September, 1963, £3,060.—Utility Office Cleaning Services Pty. Ltd.
1889. Mont Park, Larundel Mental Hospital, Supply and installation of exhaust hood over urns in six (6) female wards, £1,076.—Bruce Sheet Metal Service.
1890. Mont Park, Larundel Mental Hospital, supply and installation of draught regulators in flues from boilers in No. 1 boilerhouse, £580.—S.P.Q.R. Trading Pty. Ltd.
1891. Mooroopna North, State School No. 1612, general repairs and external painting to all school buildings and provision of new out-offices with septic closets, £1,025 4s.—P. M. & Keith Everson.
1892. Myrtleford, Consolidated School, repairs and painting to residence, Power-street, £360 4s.—H. Matthes & H. Castens.
1893. Nayook, State School No. 3227 and residence, installation of septic tank, £975 18s. 11d.—W. H. MacGibbon & Son.
1894. Neerim, State School No. 2666, septic tank installation at school and residence, £842.—A. P. Backman & Sons.
1895. Nilma North, State School No. 4428, septic tank installations, £568 10s.—A. P. Backman & Sons.
1896. Nirranda, State School No. 1130, erection of shelter pavilion, £367 18s.—F. Bos.
1897. Overport, State School No. 4780, erection of filter bed, humus tank pump chamber and pump house, £1,111.—D. B. Tincknell Pty. Ltd.
1898. Prahran, Technical School, supply, delivery, installation and testing of the plenum heating, hot water and ventilating systems, £7,829.—Ford-Swinton Industries Pty. Ltd.

7899. Royal Park, Receiving House, supply and erection of pipe, timber and chain mesh boundary fencing, £907.—A. Arnold's Fences Pty. Ltd.

1900. Rushworth, State School No. 1057, provision of asphalt, concrete, drainage, beautification and associated works, £5,724 15s.—J. H. Nichols.

1901. Rutherglen, Agriculture Department, Research Station, septic tank installations to No. 3 staff residences, £425.—Colin G. Haynes.

1902. South Melbourne, Secondary Teachers' College Hostel, 19 Queen's-road, internal and external repairs and renovations, £6,428.—D. B. Tincknell Pty. Ltd.

1903. Southmoor, State School No. 4910, Plenum heating in new Primary School, £3,612.—Centerclime Pty. Ltd.

1904. Stanhope South, State School No. 4325, renovations to school buildings, £750.—L. A. Skelton.

1905. Sunbury, State School No. 1002, erection of shelter pavilion, £609.—V. Laizans & Son.

1906. Swan Hill, Technical School, installation of fire service water supply, £1,342 14s. 2d.—F. A. Petzke & Co.

1907. Tarranyurk, State School No. 3000, new out-office block, install septic tank, £1,084 10s.—Geo. Lange & Sons Pty. Ltd.

1908. Trafalgar, State School No. 2185, external repairs and painting to residence, out-buildings and fencing, £320.—D. Joyce.

1909. Traralgon, Mental Hygiene Authority, Day Centre, external painting and repairs, £372.—John Corser Pty. Ltd.

1910. Trida, State School No. 3405, septic tank and water supply installations, £673 18s.—Joseph White.

1911. Tylden, State School No. 621, repairs and painting, £775 10s.—A. J. Kleinsma.

1912. Warrnambool, Mental Hospital, supply of windows, £272 6s. 9d.—W. Pheelan & Sons Pty. Ltd.

1913. Wonga Park, State School No. 3241, painting and repairs to residence, £881.—W. & D. Pitts & Sons Pty. Ltd.

1914. Wonthaggi, Technical School, extension of heating, £279 5s.—R. J. Wilson.

1915. Woori Yallock, State School No. 1259 and residence, proposed out-office and woodshed block, septic tanks and water supply installations, £1,684.—L. G. Aldous.

1916. Wooreen, State School No. 3723, new out-office block, septic tank and water supply installations, £980.—A. J. Avage & Son Pty. Ltd.

1917. Yarrambat, State School No. 2054, construction of out-office block, installation of septic tank, filter, &c., and water supply at school and residence, £2,670.—L. W. Booth.

1918. Dallas, State School No. 4900, erection of concrete veneer timber-framed Primary School, £39,975.—A. V. Jennings Industries (Aust.) Ltd.

1919. Dooen, Longerenong Agricultural College, supply and installation of heating, hot water and ventilation services, £17,491 10s.—Frederick W. Nielsen Pty. Ltd.

1920. Dooen, Longerenong Agricultural College, New Dormitory wing, Administration wing, Assembly Hall, &c., £157,400.—A. R. P. Crow & Sons Pty. Ltd.

1921. Dookie, Agricultural College, provision of asphalt areas, drainage, concrete paving, &c., &c., £14,551.—K. P. Lakeman.

1922. Eltham East, State School No. 4897, erection of a six class-room Primary School, £38,200.—A. V. Jennings Industries (Aust.) Ltd.

1923. Moorabbin Heights, State School No. 4837, erection of six (6) additional class-rooms, £14,395.—A. V. Jennings Industries (Aust.) Ltd.

1924. Oberon, High School, erection of first and second sections, £78,265.—A. V. Jennings Industries (Aust.) Ltd.

1925. Southmoor, State School No. 4910, erection of new Primary School, £36,375.—A. P. Vincent (Builders) Pty. Ltd.

1926. Western, Sub-district Contract "24", various, erection of timber class-rooms, &c., £7,124.—A. V. Jennings Construction Co. Pty. Ltd.

1927. Various, High Schools, erection of three (3) timber framed residences (with garages), at the following High Schools, Blackburn, Rosanna and Oakleigh, £14,188.—Vanvliet & Gardner.

H. R. PETTY, Commissioner of Public Works. 19.11.62.

#### ORDERS IN COUNCIL.—(Series 1962-63.)

##### PUBLIC WORKS.

1773. Golden Square, High School, brickwork as specified, at rates, estimated total cost, £2,691 4s.—R. Crawford. (N.W.261284).

1774. Melbourne, Health Department, for electrical installation, for heating system, as specified, £338 13s.—J. Newall Pty. Ltd. (M.213343 "A").

1775. Melbourne, Parliament House, maintenance of dining room passenger lift, for period 1st July, 1962, to 30th June, 1963, £284 4s.—Otis Elevator Co. Pty. Ltd. (M.102805.)

1776. Wattle Park, High School, erection of electricity supply line, £385.—City of Box Hill, Electrical Engineer's Department. (N.E.282340 "A").

Approved by the Governor in Council, 13th November, 1962.—N. G. WISHART, Clerk of the Executive Council.

##### STATE ELECTRICITY COMMISSION.

1807. For the erection of brick offices, showroom and timber-framed store at Lilydale, to Specification No. 62-63/44/5, £11,350.—Gonelli Bros. Pty. Ltd.

Approved by the Governor in Council, 30th October, 1962.—N. G. WISHART, Clerk of the Executive Council.

1808. For the transportation of briquettes from the Red Cliffs Railway Siding to the Red Cliffs Power Station, for a period of seven months, to Specification No. 59-60/199, at schedule rates.—R. M. Eastmond Pty. Ltd.

1809. For the supply of three fork-lift trucks for briquette depots, to Specification No. 62-63/106, £8,229.—Production Plant Ltd.

1810. For the construction of power supply and pump control centre for ash and sludge disposal, Morwell, to Specification No. 62-63/54A, £6,850, plus items at schedule rates.—Slade Betts Pty. Ltd.

Approved by the Governor in Council, 7th November, 1962.—N. G. WISHART, Clerk of the Executive Council.

##### Country Fire Authority Act.

##### PERMISSION TO HOLD FIRE BRIGADE DEMONSTRATION.

IN pursuance with the provisions of section 103 of the Country Fire Authority Act 1958, the Country Fire Authority has granted permission for the holding of a fire brigade demonstration as under:—

##### RURAL FIRE BRIGADES.

At Stuart Mill on Saturday, 23rd March, 1963.

J. L. ALLEN,  
Secretary.

19th November, 1962.

##### APPOINTMENTS.

HIS Excellency the Governor of the State of Victoria, by and with the advice of the Executive Council thereof, has, by Orders made on the 13th day of November, 1962, been pleased to make the under-mentioned appointments, viz:—

##### CHIEF SECRETARY'S DEPARTMENT.

##### Chaplain of Prison.

PETER HARRIS (The Reverend Father) to be Roman Catholic Chaplain (part-time) to Morwell River Reforestation Prison.

##### Electoral Registrars (Acting).

HAROLD BURTON FITZGIBBE to be Electoral Registrar (Acting) for the Drysdale, Geelong, Newtown and Chilwell and Queenscliff Subdivisions of the Electoral District of Geelong; and for the Bannockburn, Geelong North, Geelong West, Meredith and Sutherland Subdivisions of the Electoral District of Geelong West, to take effect on and from the 19th November, 1962, during the absence on leave of Owen Patrick Griffin.

ALFRED LAURENCE SOLOMONS to be Electoral Registrar (Acting) for the Burnley, Hawthorn and Richmond South Subdivisions of the Electoral District of Hawthorn; and for the Abbotsford, Collingwood and Richmond Subdivisions of the Electoral District of Richmond, to take effect on and from the 5th November, 1962, during the absence on leave of Leonard John Lubcke.

##### Honorary Probation Officers.

JANICE MARY WADDELL (Mrs.) pursuant to the provisions of section 507 (2) of the Crimes Act 1958, to be an Honorary Probation Officer for the purposes of the said Act.

KENNETH WILLIAM BRADFIELD, EDGAR ORBOST KNIGHT (The Reverend), DONALD CHARLES LEWIS (The Reverend), KEITH ROBERTS MURRAY, JANICE MARY WADDELL (Mrs.), and IAN HAMILTON WELCH, to be Honorary Probation Officers, pursuant to the provisions of section 10 (1) of the Children's Court Act 1958, for all Children's Courts in Victoria.

## MINISTRY OF HEALTH.

*Government Representatives on Hospitals Committees.*

FRANCIS ALBERT ROWELL  
to be Government Representative on the Committee of Management of Heathcote District Hospital, pursuant to the provisions of section 48 of the *Hospitals and Charities Act 1958* for a further term of three years from 12th December, 1962; and

DAVID LLOYD LEWIS  
to be Government Representative on the Committee of Management of Frankston Community Hospital, pursuant to the provisions of section 48 of the *Hospitals and Charities Act 1958*, for a period of three years, *vice* A. R. Millis, resigned.

## LAW DEPARTMENT.

*Assistant Registrar.*

JOHN CHARLES TOBIN  
to be an Assistant Registrar, pursuant to the provisions of sections 20 and 21 of the *County Court Act 1958*, for the County Court at Wangaratta, during the absence of A. F. Spencer on annual leave, to take effect from the date of commencement of duty.

*Clerks of Petty Sessions, &c.*

JOHN CHARLES TOBIN  
to be Clerk of Petty Sessions and Clerk of the Children's Court at Beechworth, Bright, Myrtleford and Yackandandah, during the absence of A. F. Spencer on annual leave, to take effect from the date of commencement of duty; and

JOHN GERALD DENAHY  
to be Clerk of Petty Sessions at Port Melbourne and Williamstown and Clerk of Petty Sessions and Clerk of the Children's Court at Lilydale during the absence of A. J. Johnson, on approved leave, to take effect from the date of commencement of duty.

*Commissioners for Taking Declarations, &c.*

HAROLD WILLIAM COLLINS, Office Manager, Rheem Australia Pty. Ltd., Geelong-road, Brooklyn,  
GRAHAM JOHN UNITT, General Manager, Daniel Harvey Ltd., Whitehorse-road, Nunawading, and  
JOHN STANLEY NYE, Partner, Young & Outhwaite, 51 Queen street, Melbourne,  
to be Commissioners for taking Declarations and Affidavits pursuant to the provisions of the *Evidence Act 1958*, to resign upon ceasing to occupy their present positions.

GRAHAM ALFRED HUMPHREY JAMES, 79 Cumberland-road, Pascoe Vale,  
GEORGE TRAUMANIS, 228 St. Georges-road, North Fitzroy, and  
ERNEST ARTHUR ROLAND LEWIN, 159 Gertrude-street, Fitzroy, N.6,  
to be Commissioners for taking Declarations and Affidavits pursuant to the provisions of the *Evidence Act 1958*, to resign upon removing from the neighbourhood of the addresses stated.

*Deputy Clerk of the Peace, &c.*

FREDERICK JOHN DUTHIE  
to be Deputy Clerk of the Peace, Registrar of the County Court, Clerk of Petty Sessions and Clerk of the Children's Court at Kerang and Clerk of Petty Sessions and Clerk of the Children's Court at Boort, Cohuna, Koondrook and Quambatook, during the absence of R. J. Canning on annual leave, to take effect from the date of commencement of duty.

*Deputy Prothonotary, &c.*

PERCIVAL JOHN MENKHORST  
to be Deputy Prothonotary, Clerk of the Peace for the Western Bailiwick, Registrar of the County Court, Clerk of Petty Sessions and Clerk of the Children's Court at Warrnambool, and Clerk of Petty Sessions and Clerk of the Children's Court at Koroit and Port Fairy, during the absence of J. F. O'Hara, on annual leave, to take effect from the date of commencement of duty.

*Judge of County Court, &c.*

ARTHUR CHARLES ADAMS, LL.M., a Barrister at Law, who has practised as a Barrister in Victoria for a period of seven years,  
to be a Judge of the County Court and a Judge of Courts of Mines, under the provisions of the County Court Acts, to take effect from the date of commencement of duty.

*Chairman of General Sessions.*

ARTHUR CHARLES ADAMS, LL.M., a Barrister at Law of Victoria who has practised for a period of five years,  
to be a Chairman of General Sessions under the provisions of the *Justices Act 1958*, to take effect from the date of commencement of duty.

*Justices of the Peace.*

EDWIN STANLEY WENN, Drouin-road, Longwarry,  
to Keep the Peace in the Eastern and Central Bailiwicks of the State of Victoria.

RONALD HARRY OSBORNE, Acting Works Accountant, State Electricity Commission, Morwell,  
to Keep the Peace in the Eastern Bailiwick of the State of Victoria.

## DEPARTMENT OF PUBLIC WORKS.

*Wharf Manager.*

Sergeant NEIL GEMMILL, No. 9943,  
to be Wharf Manager at Sale, as on and from 2nd October, 1962, to carry out that portion of Part II. of the *Marine Act 1958*, which relates to the Management of Public Wharves, and to be an officer under section 19 of such Act to levy and collect wharfage rates thereat, at a remuneration of £12 10s. per annum, *vice* Inspector Ewan Leslie Howlett, No. 8961, transferred.

N. G. WISHART,  
Clerk of the Executive Council.

At Government House,  
Melbourne, 13th November, 1962.

## APPOINTMENTS.

HIS Excellency the Governor of the State of Victoria, by and with the advice of the Executive Council thereof, has, by Orders made on the 20th day of November, 1962, been pleased to make the under-mentioned appointments, *viz.*:—

## DEPARTMENT OF WATER SUPPLY.

*River Improvement Trust Commissioners.*

RAYMOND TOMAS CASHIN,  
DONALD WILLIAM LYNDON,  
JOHN MCLLWAIN,  
EDWARD PETER HANILY, and  
JOHN GORDON MCGREGOR BLACK  
to be Commissioners of the Tarwin River Improvement Trust, to hold office as such from the date hereof until the 12th December, 1962, subject to the provisions of the Water Acts.

*Members of Sewerage Authority.*

ARTHUR ROYAL ANDERSON,  
JOHN FREDERICK KING-CHURCH, and  
HERBERT GLADSTONE PRICE  
to be Members of the Yarram Sewerage Authority, each to hold office for a period of four years from the date hereof, subject to the provisions of the Sewerage Districts Acts.

*Waterworks Trust Commissioner.*

TREVERTHERN WILLIAMS  
to be a Commissioner of the Tongala Waterworks Trust, to hold office as such from the date hereof until the 21st September, 1963, subject to the provisions of the Water Acts.

N. G. WISHART,  
Clerk of the Executive Council.

At Government House,  
Melbourne, 20th November, 1962.

## RESIGNATION.

HIS Excellency the Governor of the State of Victoria, by and with the advice of the Executive Council thereof, has, by Order made on the 13th day of November, 1962, accepted the resignation of the person named hereunder of the office mentioned, *viz.*:—

## LAW DEPARTMENT.

MAURICE COWLISHAW, from the Commission of the Peace for the Central Bailiwick of the State of Victoria.

N. G. WISHART,  
Clerk of the Executive Council.

At Government House,  
Melbourne, 13th November, 1962.

## MENTAL HEALTH ACT 1959, SECTION 26.

At Government House, Melbourne, the seventh day of November, 1962.

## PRESENT:

His Excellency the Governor of Victoria,  
Mr. Petty | Mr. Porter.

## APPOINTMENT OF OFFICERS OF MENTAL HEALTH INSTITUTIONS.

UNDER the powers conferred by section 26 of the *Mental Health Act 1959* and all other powers enabling him in that behalf, His Excellency the Governor of the State of Victoria, by and with the advice of the Executive Council of the said State, doth hereby make the following appointments, as from and inclusive of the 1st November, 1962, namely:—

*Institution; Office; Name of Person Appointed.**Ballarat Psychiatric Hospital*

Superintendent: EDGAR LEONARD ROBERTS, M.B., B.S.,  
Deputy Superintendent: CHARLES STEELE HAUGHTON,  
M.B., B.S.

Secretary: KELVIN CHARLES TURNER.  
Deputy Secretary: JAMES WILLIAM HAYES.

*Larundel Psychiatric Hospital*

Superintendent: HAROLD CROWCOMBE STONE, M.B., B.S.  
Deputy Superintendent: NORMAN CHARLES CONNELL,  
M.R.C.S., L.R.C.P.

Secretary: JOHN THOMAS GARVEY.  
Deputy Secretary: JAMES JOSEPH DURMAN.

*Pleasant View Psychiatric Hospital*

Superintendent: JOHN FREDERICK JOSEPH CADE, M.B.,  
B.S., M.D.

Deputy Superintendent: ARCHIE SAMUEL ELLIS, M.B.,  
B.S.  
Secretary: FRANK BENJAMIN HOWELL.  
Deputy Secretary: ALLAN JOSEPH McDONALD.

*Royal Park Psychiatric Hospital*

Superintendent: JOHN FREDERICK JOSEPH CADE, M.B.,  
B.S., M.D.

Deputy Superintendent: ARCHIE SAMUEL ELLIS, M.B.,  
B.S.  
Secretary: FRANK BENJAMIN HOWELL.  
Deputy Secretary: ALLAN JOSEPH McDONALD.

*Ararat Mental Hospital*

Superintendent: HAROLD STANLEY PAULL, M.B., Ch.B.,  
D.P.M.

Deputy Superintendent: DENYS BERRANGE BRINK,  
M.B., Ch.B.  
Deputy Secretary: LAURENCE O'KEANE.

*Ballarat Mental Hospital*

Superintendent: EDGAR LEONARD ROBERTS, M.B., B.S.  
Deputy Superintendent: CHARLES STEELE HAUGHTON,  
M.B., B.S.

Secretary: KELVIN CHARLES TURNER.  
Deputy Secretary: JAMES WILLIAM HAYES.

*Beechworth Mental Hospital*

Superintendent: LAURENCE FREDERICK DONNAN,  
L.M.S.S.A., L.R.C.P., D.P.M.

Deputy Superintendent: ZOLTAN BELA BOZAN, M.B.,  
B.S.  
Secretary: GORDON READ SLEEMAN.  
Deputy Secretary: RICHARD EDGAR LADSON.

*Kew Mental Hospital*

Superintendent: HERBERT MICHAEL BOWER, M.B., B.S.,  
D.P.M.

Deputy Superintendent: LYAL LONGHURST LOVETT,  
M.B., B.S.  
Secretary: JOHN PERCIVAL BATTISCOMBE.  
Deputy Secretary: ROBERT JOHN DRISCOLL.

*Larundel Mental Hospital*

Superintendent: HAROLD CROWCOMBE STONE, M.B., B.S.  
Deputy Superintendent: NORMAN CHARLES CONNELL,  
M.R.C.S., L.R.C.P., D.P.M.

Secretary: JOHN THOMAS GARVEY.  
Deputy Secretary: JAMES JOSEPH DURMAN.

*Mont Park Mental Hospital*

Superintendent: GRANTLEY ALAN WRIGHT, M.B., B.S.  
Deputy Superintendent: JOHN MALCOLM COLLINS, M.B.,  
B.S., D.P.M.

Secretary: ERNEST HENRY GUPPY.  
Deputy Secretary: DESMOND FLYNN.

*Sunbury Mental Hospital*

Superintendent: ALASTAIR ARNAUD REID, M.B., B.S.,  
D.P.M.

Deputy Superintendent: GEORGE EDWARD COOK, M.B.,  
B.Ch., D.P.M.  
Secretary: KENNETH MILTON BAIRD.  
Deputy Secretary: FRANCIS STEPHEN CLAREBROUGH.

*Warrnambool Mental Hospital*

Superintendent: HAROLD STANLEY PAULL, M.B., Ch.B.,  
D.P.M.

Deputy Superintendent: DENYS BERRANGE BRINK,  
M.B., Ch.B.  
Secretary: COLIN EUSTACE HAY.  
Deputy Secretary: IAN LITCHFIELD ARNEL.

*Janefield Training Centre*

Superintendent: THOMAS GRENVILLE CLARENCE  
RETALICK, M.B., B.S.

Deputy Superintendent: MARGARET HEGGIE TROUP,  
M.B., B.S.  
Secretary: COLIN HENRY FELLOW-SMITH.  
Deputy Secretary: JOHN WARWICK BARTLETT.

*Kew Cottages Training Centre*

Superintendent: WILFRED ARTHUR JOSEPH BRADY, M.B.,  
B.S.

Deputy Superintendent: DAVID BUXTON PITT, M.B.,  
B.S.  
Secretary: DESMOND NUGENT.  
Deputy Secretary: BAYLEE WILLIAM ROGERS.

*Sunbury Training Centre*

Superintendent: ALASTAIR ARNAUD REID, M.B., B.S.,  
D.P.M.

Deputy Superintendent: GEORGE EDWARD COOK, M.B.,  
B.Ch., D.P.M.  
Secretary: KENNETH MILTON BAIRD.  
Deputy Secretary: FRANCIS STEPHEN CLAREBROUGH.

*Repatriation Mental Hospital Bundoora*

Superintendent: THOMAS GRENVILLE CLARENCE  
RETALICK, M.B., B.S.

Deputy Superintendent: KENNETH HYETT BRYANT,  
M.B., B.S., D.P.M.  
Secretary: KENNETH AUSTIN BOYD.  
Deputy Secretary: JOHN WARWICK BARTLETT.

And the Honorable Ronald William Mack, Her Majesty's Minister of Health for the State of Victoria, shall give the necessary directions herein accordingly.

N. G. WISHART,  
Clerk of the Executive Council.

## DEPARTMENT OF CROWN LANDS AND SURVEY.

At Government House, Melbourne, the thirteenth day of November, 1962.

## PRESENT:

His Excellency the Governor of Victoria.  
Mr. Turnbull | Mr. Reid.  
Mr. Hamer

## REVOCATION OF PERMANENT RESERVATION OF LAND BY ORDER IN COUNCIL.

HIS Excellency the Governor of the State of Victoria, by and with the advice of the Executive Council thereof, doth hereby, in pursuance of the provisions of section 3 (1) of the *Revocation and Excision of Crown Reservations Act 1959* (No. 6524), revoke the permanent reservation of land by Order in Council hereinafter referred to, viz.:—

OAKLEIGH.—The Order in Council of the 15th August, 1922, permanently reserving 4 acres 2 roods 30 perches of land in the Township of Oakleigh as a site for a Cemetery.—(O1<sup>(2)</sup> (Rs.3802).

And the Honorable Keith Hector Turnbull, Her Majesty's Commissioner of Crown Lands and Survey for the State of Victoria, shall give the necessary directions herein accordingly.

N. G. WISHART,  
Clerk of the Executive Council.

DEPARTMENT OF CROWN LANDS AND SURVEY.

At Government House, Melbourne, the thirteenth day of November, 1962.

PRESENT:

His Excellency the Governor of Victoria.  
Mr. Turnbull | Mr. Reid.  
Mr. Hamer

UNUSED ROADS CLOSED.

HIS Excellency the Governor of the State of Victoria, by and with the advice of the Executive Council thereof, doth hereby direct that, in pursuance of the provisions of section 349 of the Land Act 1958, the unused roads referred to hereunder be closed, viz.:—

Parish of Charlton West, County of Kara Kara being the road indicated by hachure on plan hereunder.—(C.377(\*) (C.96731).

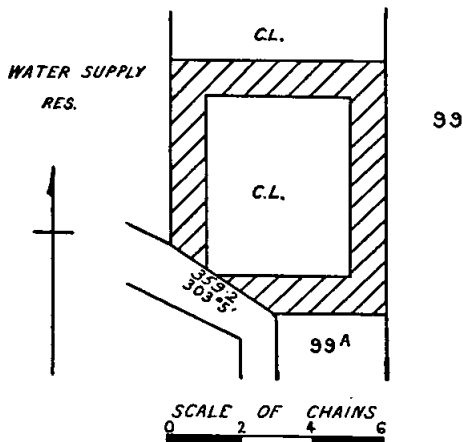

Parish of Parwan, County of Grant, being the portion of the width of the road indicated by hachure on plan hereunder.—(P.8(\*) (G.66065).

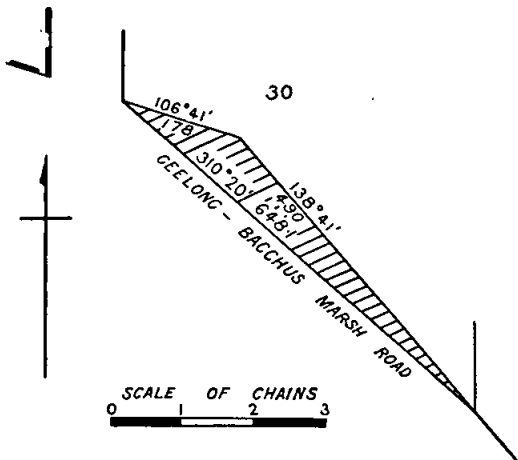

Township of Yellingbo, Parish of Woori Yallock, County of Evelyn, being the road between allotment 53 and allotment 54.—(Y.120(\*) (G.65995).

And the Honorable Keith Hector Turnbull, Her Majesty's Commissioner of Crown Lands and Survey for the State of Victoria, shall give the necessary directions herein accordingly.

N. G. WISHART,  
Clerk of the Executive Council.

DEPARTMENT OF CROWN LANDS AND SURVEY.

At Government House, Melbourne, the thirteenth day of November, 1962.

PRESENT:

His Excellency the Governor of Victoria.  
Mr. Turnbull | Mr. Reid.  
Mr. Hamer

LANDS TEMPORARILY RESERVED AS SITES.

HIS Excellency the Governor of the State of Victoria, by and with the advice of the Executive Council thereof, doth hereby, in pursuance of the provisions of the Land Act 1958, reserve, temporarily, and also except from occupation for mining purposes, under any miner's right, the lands hereinafter described:—

KARNAK.—Site for Public Recreation, 314 acres more or less, Parish of Karnak, County of Lowan, as indicated by hachure on plan hereunder.—(K.132(\*) (Rs.7702).

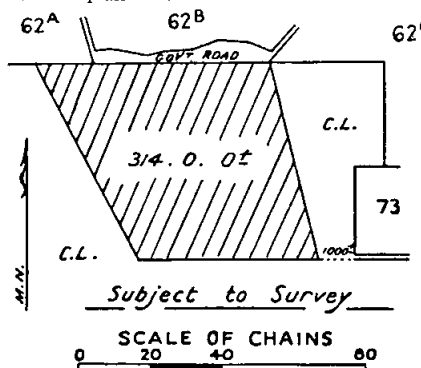

YANDOLT.—Site for a Public Hall, 2 roods 20 perches more or less, Parish of Yandolt, County of Talbot, as indicated by hachure on plan hereunder.—(Y.6(\*) (Rs.8173).

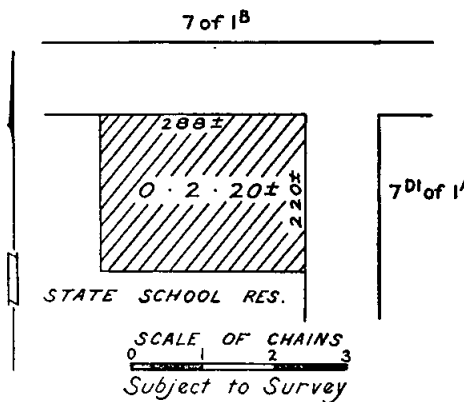

And the Honorable Keith Hector Turnbull, Her Majesty's Commissioner of Crown Lands and Survey for the State of Victoria, shall give the necessary directions herein accordingly.

N. G. WISHART,  
Clerk of the Executive Council.

COUNTRY ROADS BOARD.

At Government House, Melbourne, the thirteenth day of November, 1962.

PRESENT:

His Excellency the Governor of Victoria.  
Mr. Turnbull | Mr. Reid.  
Mr. Hamer

ORDER APPROVING OF WIDENING AN EXISTING MAIN ROAD IN THE SHIRE OF MYRTLEFORD.

WHEREAS the Country Roads Board constituted under the Country Roads Act 1958 (No. 6229) has represented to His Excellency the Governor in Council that it



appears to it desirable that the existing Myrtleford-Yackandandah road in the Shire of Myrtleford (declared to be a main road under the said Act which declaration was confirmed by the Order in Council published in the *Government Gazette* of the 21st September, 1932, on page 2177) should be widened by the said Board: And whereas the said Board in accordance with the requirements of section 19 of the said cited Act has caused to be prepared a map plan and estimate showing the points between which and on and through what land the said widening is proposed to be made and the cost of acquiring the land: And whereas on an inspection of the said map and plan and a consideration of the said estimate His Excellency the Governor in Council is satisfied that there are funds legally available for acquiring the land: Now therefore be it known by this present Order that His Excellency the Governor of the State of Victoria with the advice of the Executive Council thereof doth hereby approve of the said road being widened, that is to say:—All that piece of land in the Parish of Barwidgee, the boundaries of which are as follow:—Commencing at a point on the western boundary of allotment 32, section A, of the said parish, distant 182 deg. 2 min. 589 links from the north-western angle of the said allotment; thence by lines bearing respectively 28 deg. 23 min. 337 links, 190 deg. 13 min. 1,054.7 links and 2 deg. 2 min. 742.2 links to the point of commencement—which said piece of land is particularly delineated and shown coloured red on survey plan numbered 8691, lodged in the office of the Country Roads Board.

And the Honorable Horace Rostill Petty, Her Majesty's Commissioner of Public Works for the State of Victoria shall give the necessary directions herein accordingly.

N. G. WISHART,  
Clerk of the Executive Council.

#### COUNTRY ROADS BOARD.

At Government House, Melbourne, the thirteenth day of November, 1962.

PRESENT:

His Excellency the Governor of Victoria.  
Mr. Turnbull | Mr. Reid.  
Mr. Hamer |

ORDER APPROVING OF WIDENING AN EXISTING MAIN ROAD IN THE SHIRE OF KILMORE.

WHEREAS the Country Roads Board constituted under the *Country Roads Act 1958* (No. 6229) has represented to His Excellency the Governor in Council that it appears to it desirable that the existing Broadford-Wallan road in the Shire of Kilmore (declared to be a main road under the said Act which declaration was confirmed by the Order in Council published in the *Government Gazette* of the 18th June, 1947, on pages 2949-51) should be widened by the said Board: And whereas the said Board in accordance with the requirements of section 19 of the said cited Act has caused to be prepared a map plan and estimate showing the points between which and on and through what land the said widening is proposed to be made and the cost of acquiring the land: And whereas on an inspection of the said map and plan and a consideration of the said estimate His Excellency the Governor in Council is satisfied that there are funds legally available for acquiring the land: Now therefore be it known by this present Order that His Excellency the Governor of the State of Victoria with the advice of the Executive Council thereof doth hereby approve of the said road being widened, that is to say:—All that piece of land in the Parish of Wallan Wallan, the boundaries of which are as follow:—Commencing at a point on the eastern boundary of portion 41 of the said parish, distant 359 deg. 56 min. 1,259 feet from the south-eastern angle of the said portion; thence by lines bearing respectively 353 deg. 25 min. 386 ft. 4½ in., 340 deg. 24 min. 311 ft. 5½ in., 328 deg. 14 min. 379 ft. 4 in., 141 deg. 55 min. 563 ft. 11½ in. and 179 deg. 56 min. 555 ft. 10 in. to the point of commencement—which said piece of land is particularly delineated and shown coloured red on survey plan numbered 8476 lodged in the office of the Country Roads Board.

And the Honorable Horace Rostill Petty, Her Majesty's Commissioner of Public Works for the State of Victoria shall give the necessary directions herein accordingly.

N. G. WISHART,  
Clerk of the Executive Council.

#### COUNTRY ROADS BOARD.

At Government House, Melbourne, the thirteenth day of November, 1962.

PRESENT:

His Excellency the Governor of Victoria.  
Mr. Turnbull | Mr. Reid.  
Mr. Hamer |

ORDER APPROVING OF WIDENING AN EXISTING MAIN ROAD IN THE SHIRE OF DONCASTER AND TEMPLESTOWE.

WHEREAS the Country Roads Board constituted under the *Country Roads Act 1958* (No. 6229) has represented to His Excellency the Governor in Council that it appears to it desirable that the existing Heidelberg-Doncaster road in the Shire of Doncaster and Templestowe (declared to be a main road under the said Act which declaration was confirmed by the Order in Council published in the *Government Gazette* of the 7th September, 1960, on pages 2977-81) should be widened by the said Board: And whereas the said Board in accordance with the requirements of section 19 of the said cited Act has caused to be prepared a map plan and estimate showing the points between which and on and through what land the said widening is proposed to be made and the cost of acquiring the land: And whereas on an inspection of the said map and plan and a consideration of the said estimate His Excellency the Governor in Council is satisfied that there are funds legally available for acquiring the land: Now therefore be it known by this present Order that His Excellency the Governor of the State of Victoria with the advice of the Executive Council thereof doth hereby approve of the said road being widened, that is to say:—

All that piece of land in the Parish of Bulleen, the boundaries of which are as follow:—Commencing at a point in Unwins Crown Special Survey in the said parish formed by the intersection of the eastern boundary of High-street and the southern boundary of Heidelberg-Doncaster road; thence by lines bearing respectively 120 deg. 26 min. 764 ft. 7 in., 179 deg. 39½ min. 23 ft. 3½ in., 300 deg. 26 min. 764 ft. 9 in. and 360 deg. 0 min. 23 ft. 2½ in. to the point of commencement—which said piece of land is particularly delineated and shown coloured red on survey plan numbered 8791, lodged in the office of the Country Roads Board.

And the Honorable Horace Rostill Petty, Her Majesty's Commissioner of Public Works for the State of Victoria shall give the necessary directions herein accordingly.

N. G. WISHART,  
Clerk of the Executive Council.

#### COUNTRY ROADS BOARD.

At Government House, Melbourne, the thirteenth day of November, 1962.

PRESENT:

His Excellency the Governor of Victoria.  
Mr. Turnbull | Mr. Reid.  
Mr. Hamer |

ORDER APPROVING OF WIDENING AN EXISTING STATE HIGHWAY IN THE SHIRE OF ARARAT.

WHEREAS the Country Roads Board constituted under the *Country Roads Act 1958* (No. 6229) has represented to His Excellency the Governor in Council that it appears to it desirable that the existing Glenelg Highway in the Shire of Ararat (declared to be a State highway under the said Act which declaration was confirmed by the Order in Council published in the *Government Gazette* of the 29th October, 1947, on pages 5573-5) should be widened by the said Board: And whereas the said Board in accordance with the requirements of section 19 of the said cited Act has caused to be prepared a map plan and estimate showing the points between which and on

and through what land the said widening is proposed to be made and the cost of acquiring the land: And whereas on an inspection of the said map and plan and a consideration of the said estimate His Excellency the Governor in Council is satisfied that there are funds legally available for acquiring the land: Now therefore be it known by this present Order that His Excellency the Governor of the State of Victoria with the advice of the Executive Council thereof doth hereby approve of the said highway being widened that is to say:—

All that piece of land in the Township of Wickliffe, Parish of Wickliffe South, the boundaries of which are as follow:—Commencing at the south-western angle of allotment 3 of the said township; thence by lines bearing respectively 359 deg. 8 min. 165.1 links, 162 deg. 56 min. 276.1 links, 157 deg. 36 min. 1,038.8 links, 146 deg. 19 min. 294.1 links, 269 deg. 20 min. 544.1 links, 330 deg. 9 min. 105.3 links and 358 deg. 0 min. 1,219.6 links to the point of commencement—which said piece of land is particularly delineated and shown coloured red and yellow on survey plan numbered 8847, lodged in the office of the Country Roads Board.

And the Honorable Horace Rostill Petty, Her Majesty's Commissioner of Public Works for the State of Victoria shall give the necessary directions herein accordingly.

N. G. WISHART,  
Clerk of the Executive Council.

#### COUNTRY ROADS BOARD.

*At Government House, Melbourne, the thirteenth day of November, 1962.*

PRESENT:

His Excellency the Governor of Victoria.  
Mr. Turnbull | Mr. Reid.  
Mr. Hamer |

#### ORDER APPROVING OF WIDENING AN EXISTING STATE HIGHWAY IN THE SHIRE OF KYNETON.

WHEREAS the Country Roads Board constituted under the *Country Roads Act 1958* (No. 6229) has represented to His Excellency the Governor in Council that it appears to it desirable that the existing Calder Highway in the Shire of Kyneton (declared to be a State highway under the said Act which declaration was confirmed by the Order in Council published in the *Government Gazette* of the 28th December, 1928, on page 3439) should be widened by the said Board: And whereas the said Board in accordance with the requirements of section 19 of the said cited Act has caused to be prepared a map plan and estimate showing the points between which and on and through what land the said widening is proposed to be made and the cost of acquiring the land: And whereas on an inspection of the said map and plan and a consideration of the said estimate His Excellency the Governor in Council is satisfied that there are funds legally available for acquiring the land: Now therefore be it known by this present Order that His Excellency the Governor of the State of Victoria with the advice of the Executive Council thereof doth hereby approve of the said highway being widened that is to say:—

All that piece of land in the Parish of Lauriston the boundaries of which are as follow:—Commencing at an angle in the southern boundary of portion 80 of the said parish, formed by the intersection of lines bearing 94 deg. 55 min. and 106 deg. 28 min.; thence by lines bearing respectively 274 deg. 55 min. 1,492 links, 278 deg. 9 min. 4,315 links, 282 deg. 13 min. 189 links, 18 deg. 54 min. 45.7 links, 98 deg. 9 min. 5,070.6 links, 95 deg. 49 min. 961.7 links, 107 deg. 20 min. 513.4 links, 109 deg. 53 min. 193.4 links and 286 deg. 28 min. 751 links to the point of commencement—which said piece of land is particularly delineated and shown coloured red and blue on survey plan numbered 8833, lodged in the office of the Country Roads Board.

And the Honorable Horace Rostill Petty, Her Majesty's Commissioner of Public Works for the State of Victoria shall give the necessary directions herein accordingly.

N. G. WISHART,  
Clerk of the Executive Council.

#### BALLARAT SEWERAGE AUTHORITY.

*At Government House, Melbourne, the twentieth day of November, 1962.*

PRESENT:

His Excellency the Governor of Victoria.  
Mr. Bloomfield | Mr. Thompson.

#### AMENDMENT OF ORDER.

UNDER the powers conferred by the Sewerage Districts Acts and all other powers enabling him in that behalf, His Excellency the Governor of the State of Victoria, by and with the advice of the Executive Council of the said State, doth hereby amend as follows the Order in Council proclaiming the Sewerage District and constituting the Ballarat Sewerage Authority, made on the 30th November, 1920, as amended by Orders in Council made on the 9th November, 1936, 3rd July, 1956, and 1st March, 1960, and published in the *Victoria Government Gazette* dated 8th December, 1920, 11th November, 1936, 11th July, 1956, and 2nd March, 1960, respectively:—

In clause (a) for the expression "One million five hundred thousand pounds (£1,500,000)" there shall be substituted the expression "Two million pounds (£2,000,000)".

And the Honorable Wilfred John Mibus, Her Majesty's Minister of Water Supply for the State of Victoria, shall give the necessary directions herein accordingly.

N. G. WISHART,  
Clerk of the Executive Council.

#### MORWELL SEWERAGE AUTHORITY.

*At Government House, Melbourne, the twentieth day of November, 1962.*

PRESENT:

His Excellency the Governor of Victoria.  
Mr. Bloomfield | Mr. Thompson.

#### CONSENT TO BORROWING £20,000.

UNDER the powers conferred by the Sewerage Districts Acts and all other powers enabling him in that behalf, His Excellency the Governor of the State of Victoria, by and with the advice of the Executive Council of the said State doth hereby consent to the Morwell Sewerage Authority borrowing by the assignment of the General Fund the sum of Twenty thousand pounds (£20,000) to meet the cost of sewerage works as set forth in the detailed statement bearing date the 16th November, 1962.

And the Honorable Wilfred John Mibus, Her Majesty's Minister of Water Supply for the State of Victoria, shall give the necessary directions herein accordingly.

N. G. WISHART,  
Clerk of the Executive Council.

#### BALLARAT SEWERAGE AUTHORITY.

*At Government House, Melbourne, the twentieth day of November, 1962.*

PRESENT:

His Excellency the Governor of Victoria.  
Mr. Bloomfield | Mr. Thompson.

#### POWER TO BORROW £20,000.

UNDER the powers conferred by the Sewerage Districts Acts and all other powers enabling him in that behalf, His Excellency the Governor of the State of Victoria, by and with the advice of the Executive Council of the said State, doth hereby consent to the Ballarat Sewerage Authority borrowing by the assignment of the General Fund a sum of Twenty thousand pounds (£20,000) for the carrying out of works in accordance with the provisions of sections 95, 130 and 137 of the *Sewerage Districts Act 1958*. All moneys received by the said

Authority in payment of costs and expenses of the said works, or any of them, shall be set aside for the purpose of and applied in repayment of the said sum so borrowed.

And the Honorable Wilfred John Mibus, Her Majesty's Minister of Water Supply for the State of Victoria, shall give the necessary directions herein accordingly.

N. G. WISHART,  
Clerk of the Executive Council.

#### GEELONG WATERWORKS AND SEWERAGE TRUST.

*At Government House, Melbourne, the  
twentieth day of November, 1962.*

PRESENT:

His Excellency the Governor of Victoria.  
Mr. Bloomfield | Mr. Thompson.

CONSENT TO BORROWING £50,000.

UNDER the powers conferred by the Geelong Waterworks and Sewerage Acts and all other powers enabling him in that behalf, His Excellency the Governor of the State of Victoria, by and with the advice of the Executive Council of the said State, doth hereby consent to the Geelong Waterworks and Sewerage Trust borrowing at interest, subject to the Geelong Waterworks and Sewerage Acts, the sum of Fifty thousand pounds (£50,000) to meet the cost of sewerage works.

And the Honorable Wilfred John Mibus, Her Majesty's Minister of Water Supply for the State of Victoria, shall give the necessary directions herein accordingly.

N. G. WISHART,  
Clerk of the Executive Council.

#### GEELONG WATERWORKS AND SEWERAGE TRUST.

*At Government House, Melbourne, the twentieth day of  
November, 1962.*

PRESENT:

His Excellency the Governor of Victoria.  
Mr. Bloomfield | Mr. Thompson.

CONSENT TO BORROWING £200,000.

UNDER the powers conferred by the Geelong Waterworks and Sewerage Acts and all other powers enabling him in that behalf, His Excellency the Governor of the State of Victoria, by and with the advice of the Executive Council of the said State, doth hereby consent to the Geelong Waterworks and Sewerage Trust borrowing at interest subject to the Geelong Waterworks and Sewerage Acts the sum of Two hundred thousand pounds (£200,000) to meet the cost of water supply works.

And the Honorable Wilfred John Mibus, Her Majesty's Minister of Water Supply for the State of Victoria, shall give the necessary directions herein accordingly.

N. G. WISHART,  
Clerk of the Executive Council.

#### BALLARAT WATER COMMISSIONERS.

*At Government House, Melbourne, the twentieth day of  
November, 1962.*

PRESENT:

His Excellency the Governor of Victoria.  
Mr. Bloomfield | Mr. Thompson.

#### SALE OF EASEMENT RIGHTS.

HIS Excellency the Governor of the State of Victoria, by and with the advice of the Executive Council thereof, doth hereby, under the provisions of the Water Acts approve of the sale of easement rights by the Ballarat Water Commissioners of approximately 12 acres of land being part of Water Reserves, Parishes of Bungaree and Warrenheip, County of Grant, and part of

Crown allotment 3, section 10, Parish of Bungaree, Counties of Grenville and Grant, as shown by red colour on plans marked "A" and "B" approved by the Governor in Council and deposited in the office of the State Rivers and Water Supply Commission, Melbourne. —(Corres. 62/1692/33.)

And the Honorable Wilfred John Mibus, Her Majesty's Minister of Water Supply for the State of Victoria, shall give the necessary directions herein accordingly.

N. G. WISHART,  
Clerk of the Executive Council.

#### GEELONG WATERWORKS AND SEWERAGE TRUST.

*At Government House, Melbourne, the twentieth day of  
November, 1962.*

PRESENT:

His Excellency the Governor of Victoria.  
Mr. Bloomfield | Mr. Thompson.

#### WITHDRAWAL OF PERMISSION TO OCCUPY LANDS.

WHEREAS the approval of the Minister of Water Supply was given on 6th January, 1888, to the terms of the permission given to the society known as the Geelong and Western District Fish Acclimatizing Society and unless and until the permission is withdrawn by the Governor in Council the society may continue to occupy for fish-breeding purposes so much of the land situate at the Lovely Banks service basin as on the 25th January, 1908, was occupied by the society under the permission.

And whereas the Geelong Waterworks and Sewerage Trust has advised that the society which has not occupied the land for many years, is now defunct and requests that the necessary approval be sought to withdraw the permission granted to the society.

Now therefore, His Excellency the Governor of the State of Victoria, by and with the advice of the Executive Council of the said State, in accordance with the provisions of section 37 of the *Geelong Waterworks and Sewerage Act 1958* (No. 6263) doth hereby withdraw permission for the Geelong and Western District Fish Acclimatizing Society to occupy the said lands.

And the Honorable Wilfred John Mibus, Her Majesty's Minister of Water Supply for the State of Victoria, shall give the necessary directions herein accordingly.

N. G. WISHART,  
Clerk of the Executive Council.

#### WATER ACTS.

*At Government House, Melbourne, the twentieth day of  
November, 1962.*

PRESENT:

His Excellency the Governor of Victoria.  
Mr. Bloomfield | Mr. Thompson.

#### HEYWOOD WATERWORKS TRUST CONSTITUTED.

UNDER the powers conferred by the Water Acts and all other powers enabling him in that behalf, His Excellency the Governor of the State of Victoria, by and with the advice of the Executive Council of the said State, doth hereby approve of the application of the Councillors of the Shire of Portland for the constitution of a Waterworks Trust, subject to the provisions of the said Acts, to construct, manage and maintain the works for the supply of water to the Township of Heywood and doth hereby order and appoint as follows:—

1. That the name of the Trust shall be Heywood Waterworks Trust.
2. That the Commissioners of the Trust shall be the three Riding Councillors for the time being of the Central Riding of the Shire of Portland, together with three other persons appointed by the Governor in Council.
3. That the estimated cost of carrying out the proposed waterworks shall be Fifty-five thousand pounds (£55,000).

4. That the principal works to be constructed or carried out by the Trust shall consist of a pumping station, bore, ground level basin, elevated storage and the reticulation of the Heywood township.

5. That the limits of the land within which the said Waterworks Trust shall have authority shall be those within the following boundaries:—Commencing at a point on the southern boundary of Crown allotment 11, section 2, Parish of Heywood, County of Normanby, such point being 300 links distant westerly from the south-eastern angle of the said Crown allotment 11; thence northerly by a line parallel to and distant 300 links westerly from the eastern boundaries of the said Crown allotment 11 and of Crown allotment 10 through the said Crown allotments 11 and 10, across a road, through Crown allotments 4 and 3, across a road and through Crown allotments 1 and 2, section 1 to a point on the northern boundary of the said Crown allotment 2; thence easterly along the said northern boundary of Crown allotment 2 to its north-eastern angle; thence south-easterly by a line across a road to the north-western angle of allotment 5, section 34, Township of Heywood; thence easterly along the northern boundaries of the said allotment 5 and of allotments 4 and 3 to the north-eastern angle of the said allotment 3; thence northerly along the eastern boundary of allotment 2 and by a line being the continuation thereof across a reserve and the Fitzroy River to a point on its left bank; thence generally easterly along the said left bank of the Fitzroy River to a point in line with the eastern boundary of allotment 38, Township of Heywood, Parish of Drumborg; thence northerly by the said line across a reserve and along the eastern boundary of the aforesaid allotment 38 to its north-eastern angle; thence north-easterly by a line across a road to the south-eastern angle of allotment 16; thence northerly along the eastern boundaries of the said allotment 16 and of allotments 15, 14 and 13 to the north-eastern angle of the said allotment 13; thence north-easterly by a line across a road to the south-eastern angle of allotment 12; thence northerly along the eastern boundary of the said allotment 12 and of allotment 11 and by a line being the continuation thereof across a road to a point on the southern boundary of Crown allotment 13, section 3, Parish of Drumborg; thence easterly along the said southern boundary of Crown allotment 13 and by a line being the continuation thereof across a road to the south-western angle of Crown allotment 25B, Parish of Homerton; thence easterly along the southern boundary of the said Crown allotment 25B to a point in line with the western boundary of allotment 1, Township of Heywood, Parish of Heywood; thence southerly by a line across a road and along the western boundaries of the said allotment 1 and of allotment 2, by a line across a road and along the western boundary of allotment 25 to its south-western angle; thence easterly along the southern boundary of the said allotment 25 and by a line being the continuation thereof across a road to a point on the western boundary of Crown allotment 26, Parish of Homerton; thence southerly along the said western boundary of Crown allotment 26 to the north-western angle of Crown allotment 107; thence southerly along the western boundary of the said Crown allotment 107 to a point on the north-western boundary of the Portland-Ararat Railway Reserve; thence south-westerly along the said Railway Reserve by a line bearing south 32 deg. 45 min. west for a distance of 500 links to a point on the southern boundary of allotment 27, Township of Heywood, Parish of Drumborg; thence westerly along the southern boundaries of allotments 27 and 28 to the easternmost angle of allotment 32; thence south-westerly along the south-eastern boundaries of allotments 32 and 33 and by a line being the continuation thereof across a road a public reserve and the Fitzroy River Reserve to its intersection with the prolongation of the south-western boundary of lot 1, section 22B, Township of Heywood, Parish of Heywood; thence south-easterly by a line across a road, the Portland and Ararat Railway Reserve and through a public reserve to the westernmost angle of the aforesaid lot 1; thence easterly along the northern boundary of the said lot 1 to its northernmost angle; thence south-easterly along the north-eastern boundaries of the said lot 1 and of lot 2 to the north-eastern angle of the said lot 2; thence south-easterly by a line across a road to the north-western angle of Crown allotment 1, section 4; thence south-easterly along the north-eastern boundary of the said Crown allotment 1 for a distance of approximately 341.7 links; thence southerly by a line parallel to and distant 300 links easterly from the western boundary of the said Crown allotment 1, through the said Crown allotment 1, across a road, through Crown allotments 3 and 4 to the intersection of the said line and a line parallel to and distant 300 links southerly from the northern boundary of

Crown allotment 11, section 3; thence westerly by the said line through the aforesaid Crown allotment 4, across a road, through Crown allotments 11 and 10 and across the Portland and Ararat Railway Reserve to a point on its western boundary; thence along the said Railway Reserve boundaries by a line bearing south 5 deg. 15 min. west a distance of 3,030 links; thence by a line bearing north 84 deg. 45 min. west a distance of 500 links across a road and through Crown allotment 1, section A to a point in the said Crown allotment 1; thence northerly by a line parallel to and distant 300 links westerly from the eastern boundary of the said Crown allotment 1, through the said Crown allotment 1, across a road and through Crown allotments 8 and 7, section 3 to the intersection of the said line and a line parallel to and distant 300 links southerly from the northern boundary of Crown allotment 7; thence westerly by the said line through the said Crown allotment 7 and Crown allotments 6, 5, 2 and 1 to a point on the western boundary of the said Crown allotment 1; thence south-westerly by a line across a road to a point on the eastern boundary of Crown allotment 12 such point being distant 300 links southerly from the northern boundary of the said Crown allotment 12; thence westerly by a line parallel to and distant 300 links southerly from the said northern boundary of Crown allotment 12; through the said Crown allotment 12 to its intersection with a line parallel to and distant 300 links westerly from the eastern boundary of the said Crown allotment 12; thence northerly by the said line through the said Crown allotment 12 and across a road to a point on the southern boundary of Crown allotment 11 being the point of commencement—all of which boundaries are shown on a plan approved by the Governor in Council and deposited in the office of the State Rivers and Water Supply Commission, Melbourne. (Corres. 60/385/13.)

And the Honorable Wilfred John Mibus, Her Majesty's Minister of Water Supply for the State of Victoria, shall give the necessary directions herein accordingly.

N. G. WISHART,  
Clerk of the Executive Council.

#### STATE RIVERS AND WATER SUPPLY COMMISSION.

*At Government House, Melbourne, the  
twentieth day of November, 1962.*

PRESENT:

His Excellency the Governor of Victoria.  
Mr. Bloomfield | Mr. Thompson.

#### LANG LANG SEWERAGE AUTHORITY.—SEWERAGE DISTRICT PROCLAIMED AND AUTHORITY CONSTITUTED.

UNDER the powers conferred by the Sewerage Districts Acts and all other powers enabling him in that behalf, His Excellency the Governor of the State of Victoria, by and with the advice of the Executive Council of the said State, doth hereby approve of the application of the Lang Lang Waterworks Trust for the proclamation of a Sewerage District and for the constitution of a Sewerage Authority to carry out works for the sewerage of Lang Lang in accordance with the provisions of the said Acts, and doth hereby appoint as follows:—

- (a) That the amount of loan moneys which may be borrowed by such Authority shall be Thirty-five thousand pounds (£35,000);
- (b) that the principal works to be constructed or carried out by the Sewerage Authority shall consist of reticulation and branch sewers, main sewers, pumping station, gravity main and treatment works;
- (c) that the limits of the land within which the said Sewerage Authority shall have authority shall be those within the following boundaries:—

##### *Portion I.—Sewerage District.*

Commencing at the southernmost angle of lot 51 on lodged plan of subdivision No. 3250, Parish of Lang Lang, County of Mornington; thence north-easterly along the south-eastern boundary of the said lot 51 to its easternmost angle; thence north-westerly along the north-eastern boundary of the said lot 51 to its northernmost angle; thence north-easterly along the north-western boundary of lot 74, by a line across a road, along the north-western boundary of lots

125 and 147, by a line across a road, along the north-western boundaries of lots 198 and 222, by a line across a road and along the north-western boundaries of lots 262 and 286 to the northernmost angle of the said lot 286; thence south-easterly along the north-eastern boundary of the said lot 286 to its easternmost angle; thence south-easterly by a line across a road to the westernmost angle of lot 285; thence south-easterly along the south-western boundary of the said lot 285 to its southernmost angle; thence north-easterly along the south-eastern boundary of the said lot 285 and by a line being the continuation thereof across a road to a point on the north-eastern boundary of Oxford-street; thence south-easterly along the said north-eastern boundary of Oxford-street to a point in line with the north-western boundary of the lands shown on lodged plan of subdivision No. 22800; thence north-easterly by a line across the South-Eastern Railway Reserve, through Crown allotments 5 and 4 and along the said north-western boundary of the lands shown on lodged plan of subdivision No. 22800 and by a line being the continuation thereof through the said Crown allotment 4 to its intersection with the prolongation of the north-eastern boundary of an Education Department Reserve; thence south-easterly by a line through the said Crown allotment 4 across a road and along the said north-eastern boundary of the Education Department Reserve to its easternmost angle; thence south-westerly along the south-eastern boundary of the said Reserve to its intersection with a line parallel to and distant 250 links north-easterly from the north-eastern boundary of James-street; thence south-easterly by a line through Crown allotment 13A to its intersection with a line parallel to and distant 350 links south-easterly from the south-eastern boundary of the lands shown on lodged plan of subdivision No. 2096; thence south-westerly by the said line parallel to and distant 350 links from the south-eastern boundary of the lands shown on lodged plan of subdivision No. 2096 through the said Crown allotment 13A, across the South-Eastern Railway Reserve and through the aforesaid Crown allotment 13A to a point on the north-eastern boundary of McDonald's-road; thence south-easterly along the said north-eastern boundary of McDonald's-road to a point in line with the south-eastern boundary of lot 9 on lodged plan of subdivision No. 22888; thence south-westerly by a line across a road and along the aforesaid south-eastern boundary of lot 9 to its southernmost angle; thence north-westerly along the south-western boundary of the said lot 9 and of lots 8, 7, 6, 5, 4, 3, 2 and 1 and by a line being the continuation thereof through Crown allotment 12, across a road and through the said Crown allotment 12 to a point on the south-western boundary of lot 3 on lodged plan of subdivision No. 3975; thence south-westerly along the said south-eastern boundary of lot 3 to its southernmost angle; thence north-westerly along the south-western boundaries of the said lot 3 and of lot 2 to the westernmost angle of the said lot 2; thence north-easterly by a line across a road to the southernmost angle of lot 1 on lodged plan of subdivision No. 50212; thence north-westerly along the south-western boundaries of the said lot 1 and of lots 2 and 3 to the westernmost angle of the said lot 3; thence north-easterly along the north-western boundary of the said lot 3 for a distance of 106 links; thence north-easterly by a line through Crown allotment 6 to a point on the south-western boundary of McDonald's-road, such point being distant 120 links north-westerly from the northernmost angle of the aforesaid lot 3; thence north-westerly along the aforesaid south-western boundary of McDonald's-road to a point in line with the north-western boundary of lot 52 on lodged plan of subdivision No. 3250; thence north-easterly by a line across a road to the southernmost angle of lot 51 being the point of commencement.

*Portion II.—Site of Treatment Works.*

Commencing at the northernmost angle of Crown allotment 11, Parish of Lang Lang, County of Mornington; thence south-westerly along the eastern boundary of the said Crown

allotment 11 for a distance of 3,380 links; thence by a line bearing south 59 degrees west through the said Crown allotment 11 for a distance of 1,160 links; thence north-easterly by a line parallel to the eastern boundary of the said Crown allotment 11 through the said Crown allotment 11 to a point on its northern boundary; thence north-easterly along the said northern boundary of Crown allotment 11 to its northernmost angle being the point of commencement.

*Portion III.—Site of Gravity Main.*

The site of the gravity main being a strip of land 50 links in width, being 25 links on each side of the centreline of the said gravity main, commencing at a point on the boundary of the Sewerage District as described in Portion I., Parish of Lang Lang, County of Mornington, being also a point on the south-western boundary of lot 3 of the lands shown on lodged plan of subdivision No. 50212; thence south-westerly through Crown allotment 6 and along the Westernport-road Reserve to a point on the boundary of the site of the treatment works as described in Portion II.

All of which boundaries are shown on a plan approved by the Governor in Council and deposited in the office of the State Rivers and Water Supply Commission, Melbourne.—(Correspondence No. 61/3737/22.)

- (d) That the Commissioners for the time being of the Lang Lang Waterworks Trust shall be the members of the Sewerage Authority;
- (e) that the name of the Authority shall be Lang Lang Sewerage Authority.

And the Honorable Wilfred John Mibus, Her Majesty's Minister of Water Supply for the State of Victoria, shall give the necessary directions herein accordingly.

N. G. WISHART,  
Clerk of the Executive Council.

RIVER IMPROVEMENT ACT 1958.

*At Government House, Melbourne, the twentieth day of November, 1962.*

PRESENT:

His Excellency the Governor of Victoria.  
Mr. Bloomfield | Mr. Thompson.

LATROBE RIVER IMPROVEMENT TRUST.—RATING DIVISIONS 1962.

UNDER the powers conferred by the *River Improvement Act 1958*, and all other powers enabling him in that behalf, His Excellency the Governor of the State of Victoria, by and with the advice of the Executive Council of the said State, doth by this Order repeal the Order made on the 31st October, 1961, determining rating divisions in the Latrobe River Improvement District, and doth hereby determine that the properties within the Latrobe River Improvement District shall be arranged in ten divisions in the manner hereinafter provided:—

- (1) That the said divisions shall be known as the First, Second, Third, Fourth, Fifth, Sixth, Seventh, Eighth, Ninth and Tenth Divisions.
- (2) That the First Division shall comprise those lands shown coloured orange on the plan titled "Latrobe River Improvement District Rating Divisions 1962" approved by the Governor in Council and deposited at the office of the State Rivers and Water Supply Commission, Melbourne.—(Corres. No. 59/1585/27.)
- (3) That the Second Division shall comprise all those lands shown coloured purple on the said plan.
- (4) That the Third Division shall comprise all those lands shown coloured red on the said plan.
- (5) That the Fourth Division shall comprise all those lands shown coloured brown on the said plan.
- (6) That the Fifth Division shall comprise all those lands shown coloured light-blue on the said plan.

- (7) That the Sixth Division shall comprise all those lands shown coloured yellow on the said plan.
- (8) That the Seventh Division shall comprise all those lands shown coloured green on the said plan.
- (9) That the Eighth Division shall comprise all those lands shown coloured pink on the said plan.
- (10) That the Ninth Division shall comprise all those lands shown coloured dark-blue on the said plan.
- (11) That the Tenth Division shall comprise all those lands shown uncoloured on the said plan.

And the Honorable Wilfred John Mibus, Her Majesty's Minister of Water Supply for the State of Victoria, shall give the necessary directions herein accordingly.

N. G. WISHART,  
Clerk of the Executive Council.

LANDLORD AND TENANT ACT 1958.

At Government House, Melbourne, the twentieth day of November, 1962.

PRESENT:

His Excellency the Governor of Victoria.  
Mr. Bloomfield | Mr. Thompson.

ORDER EXTENDING APPLICATION OF PART V. OF THE LANDLORD AND TENANT ACT 1958 TO CERTAIN PREMISES.

IN pursuance of the powers conferred by section 44 of the *Landlord and Tenant Act 1958*, His Excellency the Governor of the State of Victoria, by and with the advice of the Executive Council thereof, doth hereby declare that the application of Part V. of the *Landlord and Tenant Act 1958* shall extend to each of the following premises:—

1. The premises known as No. 41 Westgarth-street, Northcote.
2. The premises known as No. 269 Malvern-road, South Yarra.
3. The premises known as Flat No. 2 at No. 10 Rose-street, Armadale.

And the Honorable Arthur Gordon Rylah, Her Majesty's Attorney-General for the State of Victoria, shall give the necessary direction herein accordingly.

N. G. WISHART,  
Clerk of the Executive Council.

STAMPS ACT 1958 (No. 6375).

At Government House, Melbourne, the twentieth day of November, 1962.

PRESENT:

His Excellency the Governor of Victoria.  
Mr. Bloomfield | Mr. Thompson.

REVOCATION OF DECLARATION OF APPROVED VENDORS.

HIS Excellency the Governor of the State of Victoria, by and with the advice of the Executive Council thereof, doth by this Order, made pursuant to section 131c of the *Stamps Act 1958* (No. 6375), revoke the declaration made on the 10th February, 1959, and published in the *Government Gazette* of 11th February, 1959, declaring certain persons to be "approved vendors" for the purposes of subdivision (14) of Division three of Part II. of the *Stamps Act 1958* in so far as the said declaration refers to the under-mentioned persons:—

72. Tremayne Investments Limited.
73. William, Graham & Boyd Limited.

And the Honorable Henry Edward Bolte, Her Majesty's Treasurer for the State of Victoria, shall give the necessary directions herein accordingly.

N. G. WISHART,  
Clerk of the Executive Council.

STAMPS ACT 1958 (No. 6375).

At Government House, Melbourne, the twentieth day of November, 1962.

PRESENT:

His Excellency the Governor of Victoria.  
Mr. Bloomfield | Mr. Thompson.

DECLARATION OF APPROVED VENDOR.

HIS Excellency the Governor of the State of Victoria, by and with the advice of the Executive Council thereof, doth by this Order, made pursuant to section 131c (1) of the *Stamps Act 1958*, declare the under-mentioned person carrying on business as a vendor of goods under instalment purchase agreements to be an "approved vendor" for the purposes of subdivision (14) of Division three of Part II. of the *Stamps Act 1958*.

203. Retreat Holding Co. Pty. Ltd.

And the Honorable Henry Edward Bolte, Her Majesty's Treasurer for the State of Victoria, shall give the necessary directions herein accordingly.

N. G. WISHART,  
Clerk of the Executive Council.

APPROACHING LAND SALES.

SALES of Crown lands, in fee-simple, will be held at the under-mentioned places and dates, viz.:—

	No. of Gazette.
Avoca.—Friday, 14th December, 1962 ..	117
Ballarat.—Tuesday, 18th December, 1962 ..	116
Bendigo.—Thursday, 29th November, 1962 ..	112
Hamilton.—Wednesday, 28th November, 1962 ..	114
Maryborough.—Friday, 14th December, 1962 ..	117
Red Cliffs.—Tuesday, 11th December, 1962 ..	115
Red Cliffs.—Tuesday, 11th December, 1962 ..	116

SALE OF FREEHOLD LAND BY AUCTION.

Wallan.—Wednesday, 28th November, 1962 .. 114

AUCTION OF RIGHT TO LEASE CROWN LAND.

Melbourne.—Wednesday, 19th December, 1962 117

PROPOSED REVOCATIONS OF TEMPORARY RESERVATIONS OF LAND BY ORDERS IN COUNCIL

IN pursuance of the provisions of the *Land Act 1958*, notice is hereby given that it is the intention of the Governor in Council to revoke the temporary reservations of land by Orders in Council hereunder referred to, viz.:—  
*The following Notices were published 1° on the 7th November, 1962, pursuant to Orders of the 30th October, 1962.*

BULLEEN (DONCASTER).—The temporary reservation, by Order in Council of the 24th July, 1951, of 31 perches of land in the Parish of Bulleen, as a site for Police purposes, so far only as the portion containing 1 3/10 perches indicated by hachure on plan hereunder is concerned.—(B.526<sup>(2)</sup>) (Rs.6679).

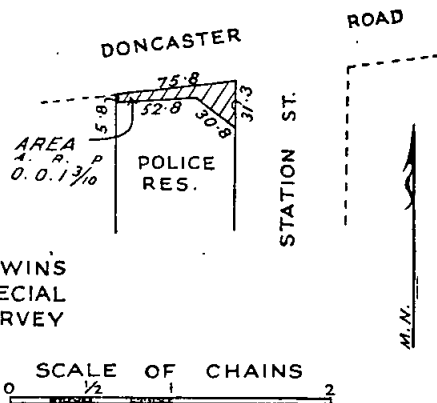

GLENMAGGIE.—The temporary reservation, by Order in Council of the 4th September, 1893, of 10 acres of land in the Parish of Glenmaggie, as a site for Supply of Gravel.—(G.178<sup>(a)</sup>) (Rs.2531).

KEITH TURNBULL,  
Commissioner of Crown Lands and Survey.

PROPOSED REVOCATIONS OF TEMPORARY RESERVATIONS OF LANDS BY ORDERS IN COUNCIL.

IN pursuance of the provisions of the *Land Act 1958*, notice is hereby given that it is the intention of the Governor in Council to revoke the temporary reservations of lands by Orders in Council hereunder referred to, viz.:-

The following Notices were published 1° on the 14th November, 1962, pursuant to Orders of the 7th November, 1962.

CARBOOR.—The temporary reservation, by Order in Council of the 29th June, 1885 (see *Government Gazette* of the 3rd July, 1885, page 1897) of 51 acres 11 perches of land in the Parish of Carboor as a site for Watering purposes, revoked as to part by Order of the 20th November, 1916, is about to be revoked so far as the balance thereof, containing 24 acres 2 roods 15 perches, is concerned.—(C.410<sup>(b)</sup>) (H.028863).

OAKLEIGH.—The temporary reservation, by Order in Council of the 12th May, 1925, of 3 acres 1 rood 24 6/10 perches of land in the Township of Oakleigh, as a site for Public Gardens, revoked as to part by Order of the 10th November, 1959, is about to be revoked so far only as the portions containing 1 acre 1 rood 10 3/10 perches, indicated by hachure on plan hereunder, are concerned.—(O.1<sup>(2)</sup>) (Rs.3100).

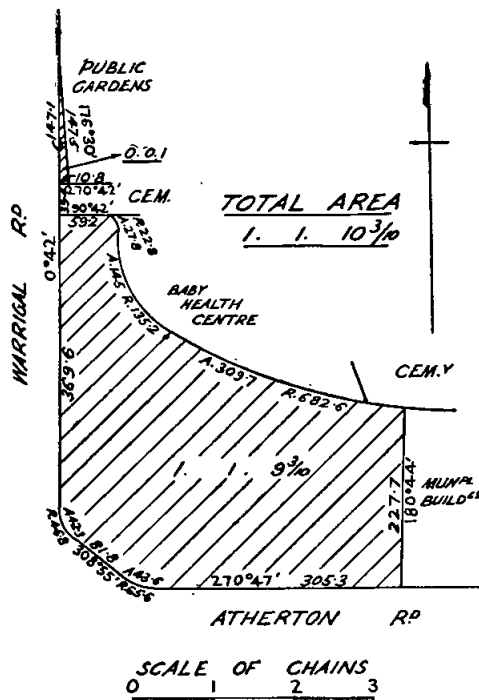

KEITH TURNBULL,  
Commissioner of Crown Lands and Survey.

PROPOSED REVOCATIONS OF TEMPORARY RESERVATIONS OF LANDS BY ORDERS IN COUNCIL.

IN pursuance of the provisions of the *Land Act 1958*, notice is hereby given that it is the intention of the Governor in Council to revoke the temporary reservations of lands by Orders in Council hereunder referred to, viz.:-

The following Notices were published 1° on the 31st October, 1962, pursuant to Orders of the 23rd October, 1962.

BENALLA.—The temporary reservation, by Order in Council of the 26th January, 1886, of 16 acres of land, being allotments 7 and 8, section F, in the Parish of

Benalla, as a site for the Supply of Loam and Gravel, revoked as to part by Order in Council of the 6th December, 1904, so far as the balance thereof, containing 15 acres 3 roods 9 perches is concerned.—(B.392<sup>(b)</sup>) (C.26144).

GOORNONG.—The temporary reservation, by Order in Council of the 13th February, 1894 (see *Government Gazette* of the 16th February, 1894, page 865), of 14 acres 30 perches of land in the Parish of Goornong, as a site for Supply of Gravel, so far only as the portion containing 3 acres 1 rood 23 perches, indicated by hachure on plan hereunder, is concerned.—(G.98<sup>(2)</sup>) (Rs.8162).

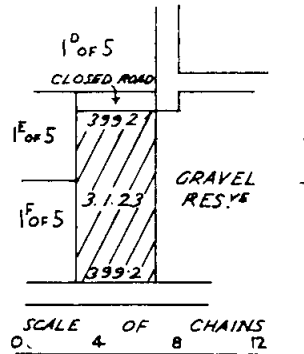

OAKLEIGH.—The temporary reservation, by Order in Council of the 10th December, 1928, of 1 rood 36 perches of land in the Township of Oakleigh, as a site for a Baby Health Centre.—(O.1<sup>(2)</sup>) (Rs.3801).

OAKLEIGH.—The temporary reservation, by Order in Council of the 25th June, 1919, of 1 rood 15 perches of land in the Township of Oakleigh, as a site for Municipal Buildings.—(O.1<sup>(2)</sup>) (Rs.1936).

KEITH TURNBULL,  
Commissioner of Crown Lands and Survey.

PROPOSED REVOCATION OF TEMPORARY RESERVATION OF LAND BY ORDER IN COUNCIL.

IN pursuance of the provisions of the *Land Act 1958*, notice is hereby given that it is the intention of the Governor in Council to revoke the temporary reservation of land by Order in Council hereunder referred to, viz.:-

The following Notice was published 1° on the 21st November, 1962, pursuant to Order of the 13th November, 1962.

WANDIN YALLOCK.—The temporary reservation, by Order in Council of the 31st January, 1922, of 10 acres of land in the Township of Wandin Yallock, as a site for a Cemetery.—(W.295<sup>(B<sup>8</sup>)</sup>) (Rs.7009).

KEITH TURNBULL,  
Commissioner of Crown Lands and Survey.

REGULATIONS FOR THE CARE, PROTECTION AND MANAGEMENT OF THE "ANZAC MEMORIAL PARK", WARRACKNABEAL.

WHEREAS by section 218 of the *Land Act 1958* power is given to the Board of Land and Works to make Regulations in respect of the care, protection and management of any Crown land which has been reserved under the Land Acts for any public purpose whatsoever and which has not been conveyed to or vested in trustees, and for the further purposes as enacted: Now therefore the Board of Land and Works in pursuance of the power conferred aforesaid, doth hereby make the following Regulations in respect of the land in the Township of Warracknabeal temporarily reserved by Order in Council dated the 7th September, 1903, as a site for Public Recreation and known as "Anzac Memorial Park", Warracknabeal, (hereinafter referred to as the "Reserve").

The Reserve has been placed under control of a Committee of Management with power and authority to enforce these Regulations.

REGULATIONS.

1. The Regulations made by the Board in respect of the Reserve on the 9th July, 1937, are hereby rescinded.
2. The Reserve shall be open to the public from sunrise to sunset, free of charge, except on such days as the Reserve may be set apart for cricket or football

matches, fêtes, tennis, sports, shows, gymkhanas, or holiday amusements, on any of which occasions the fees provided hereinafter may be charged and taken for the admission of every adult.

3. For admission of each adult on such days as the Reserve may be set apart for cricket or football matches, fêtes, sports, shows, gymkhanas, tennis or holiday amusements, a sum not exceeding 5s. (five shillings).

4. No person shall be allowed to cart any material through or within the Reserve, nor shall any loaded dray, cart, or wagon be driven through or within the Reserve without the permission of the Committee of Management first obtained.

5. No person, unless authorized by the Committee of Management, shall drive or ride any animal with or without vehicles, upon that part of the Reserve used for athletic or racing purposes or games.

6. No person, not being a player or official, shall trespass on the playing arena or racing track during the progress of any football or cricket match, tennis, or any sports gathering or race-meeting, nor wilfully obstruct or interrupt or in any way interfere with any servant of the Committee of Management in the proper execution of his work or duty.

7. The Committee of Management may let the Reserve on such terms and conditions as it may deem reasonable and consistent with these Regulations, but the maximum fee shall not exceed the sum of £50 per day for each function.

8. The Committee of Management may set apart any portion of the Reserve for the purpose of any lawful game, gymkhana, or sports, and from time to time grant to any club or association of clubs, upon such terms and conditions as the Committee of Management may determine, the use of the grounds so set apart.

9. The Committee of Management may from time to time select portions of the Reserve for the parking of cars, and vehicles, and for the tethering of horses, and no cars, vehicles, or horses shall be parked or tethered in any portions of the Reserve other than in the portions set apart for the purposes. A charge of Two shillings per day may be made for the admission of any vehicle to the Reserve, on such days on which a charge for admission is being made, as provided by clause 2 of these Regulations.

10. No person shall damage in any way the trees, shrubs or flowers in the Reserve, nor shall fires be lighted thereon without the permission, in writing, of the Committee of Management first obtained.

11. No person shall climb or jump through over or under the gates or fences in or around the Reserve, stick bills thereon, cut names on or in any way damage or injure any of the buildings, gates, fences, seats, or trees in the Reserve, nor leave or deposit any glass, paper, or rubbish, nor roll or throw stones or any missiles therein.

12. No person shall put in the Reserve any cattle, horses, sheep, goats, pigs, or other animals without the permission in writing of the Committee of Management first obtained, provided always that the money received for agistment shall be expended in the maintenance and improvement of the Reserve, and that an account thereof shall be furnished annually to the Board of Land and Works.

13. No persons shall camp in the Reserve, nor erect therein any buildings, or any booth or other structure for the purpose of offering for sale any article, without the permission in writing of the Committee of Management first obtained.

14. No person shall behave in a disorderly manner, or create or take part in any disturbance, or use indecent or abusive language or commit any nuisance, or in any way offend against decency in the Reserve, or the buildings or structures therein, and any person found in a state of intoxication or otherwise offending against this Regulation, shall be liable to be forthwith removed from the Reserve, notwithstanding that such person shall have a ticket for admission thereto, and shall be liable to the penalty hereinafter provided.

15. No person shall remain in the Reserve at any time when lawfully directed by any officer or employee of the Committee of Management to leave the same.

16. No club, association, or person shall hold or take part in any game of golf, or any games of any description, entertainment, performance, show, or ceremony in any part of the Reserve without the written authority of the Committee of Management first obtained.

17. No club or association of any kind having for its object physical recreation, or any members or member of any club or association, nor any other person shall play,

practise, train or engage in any game of sport or athletic exercise within the Reserve without the permission of the Committee of Management, in writing, first obtained, unless any such person is at the time of playing a member of any club which is duly authorized to play in the Reserve at such time. Provided that any person not otherwise offending against these Regulations may enter on the Reserve and play golf thereon, on paying to the club or association for the time being leasing the Reserve or the Committee of Management, a green fee of Two shillings and sixpence per day, or part thereof, or of Five shillings per week.

18. No person shall carry firearms in or through the Reserve, or shoot, snare or destroy any birds or animals therein, or take, injure or destroy any bird's egg, either in the Reserve or in or on any water therein, or bathe in any such water, unless by the authority of the Committee of Management first obtained.

19. No person shall sell or offer for sale within the Reserve any article of food or drink or other commodity or operate any money making amusement without the written permission of the Committee of Management.

20. No person shall spit or expectorate on the paths or on any structure or erection in the Reserve.

21. No person shall carry on the trade, business, or calling of a bookmaker except in or on such portions of the Reserve as may be set apart for that purpose and then only when he shall have complied with the conditions imposed by the Committee of Management, viz.:— That he shall be duly registered as a bookmaker and pay to the Committee of Management such fee as the Committee of Management may determine. That during the time that he shall be in or upon the Reserve carrying on his trade, business, or calling of a bookmaker he shall wear a ticket to be supplied to him by the Committee of Management which shall be visible to the public and shall have thereon his name.

22. Persons renting or hiring any stand, building, erection or enclosure on the occasions of any fêtes, sports, race-meetings, or holiday amusements, may be required to deposit any sum which the Committee of Management may at any time determine, not exceeding Ten pounds, by way of guarantee that due care shall be taken of such stand, building, erection, or enclosure and such Committee, in its absolute discretion, may make good any damage or injury sustained by such stand, building, erection, or enclosure, or anything contained therein during occupancy or hiring and deduct the cost of making good such loss or damage from the sum of money deposited by way of guarantee, and all persons so renting or hiring shall abide by these Regulations, and by any order given by the Committee of Management.

23. No person, except labourers and workmen employed in the Reserve, shall enter any plots therein which may be enclosed for plantations of young trees or shrubs.

The common seal of the Board of Land and Works was hereto affixed this 15th day of November, 1962, in the presence of—

(SEAL) KEITH TURNBULL, President.  
F. KLENNER, Member.

Every person who contravenes or fails to comply with these Regulations shall, in accordance with the provisions of section 218 of the *Land Act 1958*, for each offence be liable to a penalty of not more than Five pounds, and every person who contravenes or fails to comply with any such Regulations, and who, after he has been warned by any bailiff of Crown lands or by any member of the Police Force, does not desist therefrom, may be forthwith apprehended by such Bailiff or member of the Police Force and taken before some justice to be dealt with according to law and shall be liable to a penalty of not more than Ten pounds.

#### AMENDMENT OF REGULATIONS FOR THE CARE, PROTECTION AND MANAGEMENT OF "VICTORIA PARK", RECREATION RESERVE, BANNOCKBURN.

THE Board of Land and Works in pursuance of the powers conferred on it, doth hereby amend the Regulations made by it on the 27th May, 1925 for the care, protection and management of the land temporarily reserved by Order in Council dated the 9th August, 1881, as a site for Cricket and other purposes of Public Recreation in the Parish of Wabdallah, and known as the



"Victoria Park Reserve", Bannockburn, by rescinding regulation number 1 and substituting therefor under the same number the following regulation:—

## REGULATION.

1. The Reserve shall be open to the public from sunrise to sunset and such other hours as may be approved by the Committee of Management, free of charge, excepting on such days as the Reserve may be set apart for cricket or football matches, fêtes, sports or holiday amusements, on any of which occasions a sum not exceeding Seven shillings and sixpence may be charged and taken for the admission of every adult to the Reserve.—(Rs.584.)

The common seal of the Board of Land and Works was hereto affixed this 15th day of November, 1962, in the presence of—

(SEAL) KEITH TURNBULL, President.  
F. KLENNER, Member.

Every person who contravenes or fails to comply with these Regulations shall, in accordance with the provisions of section 218 of the *Land Act 1958*, for each offence be liable to a penalty of not more than Five pounds, and every person who contravenes or fails to comply with any such Regulations, and who, after he has been warned by any bailiff of Crown lands or by any member of the Police Force, does not desist therefrom, may be forthwith apprehended by such Bailiff or member of the Police Force and taken before some justice to be dealt with according to law and shall be liable to a penalty of not more than Ten pounds.

## REGULATIONS FOR THE CARE, PROTECTION, AND MANAGEMENT OF THE "LAANECOORIE RECREATION RESERVE".

THE Board of Land and Works in pursuance of the powers conferred on it, doth hereby make the following Regulations:—

The Regulations made by the Board on the 25th July, 1935, for the care, protection and management of the land temporarily reserved by Order in Council dated the 7th June, 1905, as a site for Public Recreation in the Township of Laanecoorie are hereby applied to the land temporarily reserved by Order in Council dated the 16th October, 1962, as a site for Public Recreation in addition to and adjoining the first mentioned site.—(Rs.2004.)

The common seal of the Board of Land and Works was hereto affixed this 15th day of November, 1962, in the presence of—

(SEAL) KEITH TURNBULL, President.  
F. KLENNER, Member.

COMMITTEES OF MANAGEMENT OF RESERVES.  
APPOINTMENTS.

WHEREAS by section 221 of the *Land Act 1958* it is provided that it shall be lawful for the Governor in Council or the Board of Land and Works to appoint and remove any number of persons, not less than three, or any municipal council, or the governing body of any corporation, to be a Committee of Management of any specified Crown land reserved either temporarily or permanently for any of the purposes set out in section 14 of the *Land Act 1958*, and not conveyed to or vested in trustees: Now therefore the Board of Land and Works doth hereby appoint the under-mentioned persons to be members of the Committee of Management of the Reserves named:—

## "GLENELG-CASTERTON RIVER FRONTAGE RESERVE."

Charles Arthur Anderson, Murray McAllister, Stanley Stooke, Malcolm Heslop Stott and Herbert David Mitchell as a Committee of Management for a period of three (3) years of such portions of the River Frontages Reserve in the Township of Casterton, Parish of Casterton, as are indicated by pink colour on plan marked C.16.10.31 with Lands Department Correspondence C.80160, and known as the "Glenelg-Casterton River Frontages Reserve".—(Corres. C.80160.)

## "LAKE ROWAN RECREATION RESERVE."

Arthur Charles McQualter, Andrew John Henry McQualter, Murray Maxwell Ralph, Ian Gilbert Holmes, George Albert Irvine, David William Reid and Henry William Irvine as a Committee of Management for a period of three (3) years of the land temporarily reserved by Order in Council dated 25th July, 1892, as a site for Public Recreation in the Town of Karrabumet, and known as the "Lake Rowan Recreation Reserve".—(Corres. Rs.1971.)

## "MERRIGUM PARK."

Colin David Young, Cyril Francis Brock, Kenneth Laurence Duhring, Reginald Kitchener Younger, Leslie Herbert Pell, John Joseph Sweeney and Neil Alexander Lanyon as a Committee of Management for a period of three (3) years of the land in the Parish of Kyabram temporarily reserved by Order in Council dated the 23rd October, 1962, as a site for Public Park and Recreation, and known as "Merrigum Park".—(Corres. Rs.8165.)

## "TATONG RECREATION RESERVE."

Keith Martin Muller, John Wilfred Mitchell, Allan Evan Lewis, Albie Henderson, Dennis Harrison and William Alexander McCauley as a Committee of Management for a period of three (3) years of the lands temporarily reserved by Orders in Council dated 19th March, 1906, and 8th July, 1935, as sites for Public Recreation in the Parish of Rothesay, Township of Tatong, which are known as "Tatong Recreation Reserve".—(Corres. Rs.101.)

## PORTION OF THE RESERVE FOR CAMPING AND WATERING PURPOSES IN THE PARISH OF BARONGAROOK.

The Forests Commission as a Committee of Management of such portion of the land in the Parish of Barongarook, temporarily reserved by Order in Council dated the 7th November, 1900, as is indicated by red colour on plan marked B.28.8.62, attached to Lands Department Correspondence Rs. 5217.—(Corres. Rs.5217.)

## MUNICIPAL AND PUBLIC PURPOSES RESERVE IN THE PARISH OF BALLAARAT, TOWNSHIP OF BALLAARAT EAST.

The Council of the City of Ballaarat as a Committee of Management of the land in the Parish of Ballaarat, Township of Ballaarat East, temporarily reserved by Order in Council dated the 30th October, 1962, as a site for Municipal and Public purposes.—(Corres. 8178.)

## "ELDORADO CENTENNIAL PARK" AND "MONUMENT HILL" RESERVES.

James William Milne, John Colin Angus, Stanley George Ramsay, John Bloor Dent, Robert Charles Allen, Francis Edward Grealy, Harry William Ralph Lonie, Keith Saltmarsh, Geoffrey James Milne and Desmond George Dent as a Committee of Management for a period of three (3) years of the lands temporarily reserved by Orders in Council dated the 8th April, 1889, 22nd December, 1891, and 14th August, 1939, as sites for a Public Park in the Parishes of Byawatha and Tarrawingee, and known as the "Eldorado Centennial Park" and "Monument Hill" Reserves.—(Corres. Rs.1926, Rs.4972.)

## "BUDGERUM WEST PUBLIC PURPOSES RESERVE."

James Barrett Mann, Robert Williamson, Gregor Knight, Keith Williamson and Edmund Alfred Adamthwaite as a Committee of Management for a period of three (3) years of those portions of the reserved Crown lands in the Parish of Budgerum West as are indicated in red and blue colours on plan marked B.18.5.39 attached to Lands Department Correspondence Rs. 4915, and known as the "Budgerum West Public Purposes Reserve".—(Corres. Rs.4915.)

## "Corryong Racecourse, Show Yards and Recreation Reserve."

Percy William Attree (for so long only as he continues to be a Councillor and the elect of the Council of the Shire of Upper Murray) and Gordon Corrigan Hamilton, Herbert Arthur Nankervis, William Hugh Whitehead, Ronald John Macnamara, John Robert McCarry, Thomas Bruce Harris, Colin Andrew Whitsed, Douglas Christjohn Schintler, Leo Clarence Lloyd and Colin William John McClure as a Committee of Management for a period of three (3) years of the land temporarily reserved for a Racecourse and Other purposes of Public Recreation and for Showgrounds in the Township of Corryong, and known as the "Corryong Racecourse, Show Yards and Recreation Reserve".—(Corres. Rs.1930.)

## "GLENTHOMPSON PARK AND RECREATION RESERVE."

Elliot David Osmond Mitchell, Clarence Edward Barker, Joseph Ernest Dolman, Rex Wesley Mitchell, Francis Bowman Turner, R. J. Kelly and A. E. Fountain as a Committee of Management for a period of three (3) years of the land temporarily reserved by Order in Council dated 8th November, 1910, as a site for Public Recreation in the Township of Glenthompson, and known as the "Glenthompson Public Park and Recreation Reserve".—(Corres. Rs.4776.)

**RESERVE FOR PUBLIC PARK IN THE PARISH OF BEECHWORTH.**

The Council of the Shire of Beechworth as a Committee of Management of the land in the Parish of Beechworth, temporarily reserved by Orders in Council dated the 13th January, 1913, and the 16th October, 1963, as a site for a Public Park. This appointment is in lieu of that appointment made on the 3rd April, 1913, which is hereby revoked.—(Corres. Rs.271.)

**RESERVE FOR SEWERAGE PURPOSES IN THE PARISH OF DOWLING FOREST.**

The Ballarat Sewerage Authority as a Committee of Management of the land in the Parish of Dowling Forest temporarily reserved by Order in Council dated the 23rd October, 1962, as a site for Sewerage purposes.—(Corres. Rs.8175.)

**"MERINGUR RECREATION RESERVE."**

Percival Weinert, Raymond Summerhayes, John Henry Dunning, Andrew John Kelly, Thomas Malcolm Bahr, Alfred C. Summerhayes, Alva Christian Kelly, Donald D. Meyer, Stanley Desmond Bahr and Arnold Elmo Harmer as a Committee of Management for a period of three (3) years of the land in the Township of Meringur temporarily reserved by Orders in Council dated the 29th May, 1928, 10th December, 1929, and 30th October, 1951, as sites for Public Recreation, and together known as the "Meringur Recreation Reserve".—(Corres. Rs.3682.)

**"LEITCHVILLE RECREATION RESERVE."**

Jack T. Burke, Hector M. Brown, Eric Lunghusen, Ernest T. O'Rourke, Neil F. Goulding, Alan O. Opie and Francis C. Hawken as a Committee of Management for a period of three (3) years of the land temporarily reserved by Orders in Council dated the 4th July, 1938, and 1st November, 1943, as sites for Public Recreation in the Parish of Gunbower West, and known as the "Leitchville Recreation Reserve".—(Corres. Rs.3361.)

**"WERRIBEE RACECOURSE AND RECREATION RESERVE."**

David Henry Macknamara, Warwick Calmady Cayley, J. O'Toole and Aloysius Joseph Louis Hayes (as representatives of the Werribee Racing Club), Ernest Henry Fisher and Leonard Charles Grant (as representatives of the Werribee Golf Club), and Joseph Lawrence Callanan, Denis Phelan, Walter Carter and Alfred Samuel Nutter as a Committee of Management for a period of three (3) years of the land temporarily reserved by Order in Council dated the 22nd April, 1861, as a site for a Racecourse and General Recreation purposes in the Township of Wyndham (now Werribee), and known as the "Werribee Racecourse and Recreation Reserve".—(Corres. Rs.925.)

**"MORNINGTON FORESHORE RESERVES" AND "MOUNT MARTHA CAMPING RESERVE."**

Cornelius Edmund Brownbill, William Lyndhurst Hawkins and George Anthony Fairbairn for a period of three years from the 31st October, 1962, and Ralph Hope Street, Donald Rutherford Morell, Allan Bruce Cameron and Charles Bowman Wilson (for so long only as they continue to be Councillors and the elect of the Council of the Shire of Mornington) as a Committee of Management of the land in the Township of Mornington, temporarily reserved as a site for a Public Park and for Public Recreation by Order in Council dated 3rd November, 1954, and of the reserved Crown lands in the Township of Mornington and Parish of Moorooduc as are indicated by red colour on plans marked M.27/4/31 and M.22/4/36 attached to Lands Department correspondence C.68905, and the land in the Parish of Moorooduc temporarily reserved by Order in Council dated 22nd December, 1938, as a site for Camping purposes, and known as the "Mornington Foreshore Reserves" and "Mount Martha Camping Reserve".—(Corres. Rs.5207, Rs.4898, Rs.5921.)

**"TATURA SHOW YARDS AND RECREATION RESERVE."**

Arthur George Knee and Thomas Vincent Deane for a period of three (3) years, and Patrick Mortimer Kerrins, Ronald Bruce Donaldson, Thomas John Edgar Hastie, Joseph Sampson Carlyon and William John Williams (as representatives and the elect of the Tatura Agricultural Society) as a Committee of Management of the land in the Township of Tatura temporarily reserved by Order in Council dated the 21st July, 1959, as a site for Show Yards and Public Recreation, and known as the "Tatura Show Yards and Recreation Reserve".—(Corres. Rs.1111.)

**"YARROWEYAH PARK."**

Russell Keith McDonald, Douglas Haig McDonald, Charles Henry Morton, Thomas George Edmund Reilly, Louis Campbell Jones, Gerald Joseph Cooper and Eric Lindsay Gemmill as a Committee of Management for a period of three (3) years of the land in the Parish of Yarroweyah temporarily reserved by Order in Council dated 21st July, 1953, as a site for Public Recreation, and known as "Yarroweyah Park".—(Corres. Rs.7137.)

**"LAANECOORIE RECREATION RESERVE."**

Edward J. Scholes, Thomas A. Smith, Brendon Lyon, Ronald L. Grimmett, George A. Scholes, James A. Curnow, Graham A. Brownbill, Roy Cain, Allen Brownbill and Gavin Trimble as a Committee of Management for a period ending the 17th July, 1964, of the land temporarily reserved by Orders in Council dated the 7th June, 1905, and the 16th October, 1962, as a site for Public Recreation in the Township of Laanecoorie, and known as the "Laanecoorie Recreation Reserve".—(Corres. Rs. 2004.)

This appointment is in lieu of all previous appointments in respect of the said land which are hereby revoked.

**"INVERLEIGH MECHANICS' INSTITUTE RESERVE."**

Eric Thomas Peel, John MacNaughton and John McMahan as a Committee of Management for a period of three (3) years of the land permanently reserved by Order in Council dated the 2nd September, 1902, as a site for a Mechanics' Institute and Free Library at Inverleigh, and known as the "Inverleigh Mechanics' Institute Reserve".—(Corres. Rs.5110.)

In witness whereof the common seal of the Board of Land and Works was hereunto affixed this fifteenth day of November, One thousand nine hundred and sixty-two, in the presence of—

(SEAL) KEITH TURNBULL, President.  
F. KLENNER, Member.

*Land Settlement Act 1959.*

**LAND AVAILABLE FOR APPLICATION.**

NOTIFICATION is hereby given in accordance with section 7 of the *Land Settlement Act 1959*, that the under-mentioned holdings are available for settlement.

Any male person who is not less than 21 years of age and who is a British subject may apply on the prescribed form for settlement on any holding or holdings, indicating where he applies in respect of more than one holding his order of preference therefor.

Prescribed application forms, plans, and further details may be obtained from the Settlement Branch, Rural Finance and Settlement Commission, State Public Offices, Melbourne, C.2.

Closing date for receipt of completed application forms for settlement on these holdings is the 17th December, 1962, such applications to be in the hands of the Deputy Secretary, Rural Finance and Settlement Commission, on or before that date.

M. J. CRONIN,  
Deputy Secretary.

Rural Finance and Settlement Commission,  
Melbourne, C.2, 19th November, 1962.

**SCHEDULE OF ALLOTMENTS.**

**SUBDIVISION OF FIFTH PORTION OF EAST GOULBURN IRRIGATION SETTLEMENT AREA.**

PARISH OF DUNBULBALANE—COUNTY OF MOIRA.  
*Suitable for the Growing of Soft Fruits under Irrigation.*

Lot Number on Plan of Subdivision.	Approximate Area in Acres (Subject to Survey).
18	42
55	45
59	47
61	51
64	49
65	49
66	42
68	40
70	46
74	41
75	44
77	42
81	45

## Land Act 1958.

## LICENCE UNDER THE LAND ACTS 1928 AND 1958 DECLARED VOID.

NOTICE is hereby given that the Licence in the Schedule hereunder has been Declared Void for the reason specified.

District.	Corr. No.	Name of Licensee.	Section of Land Act under which Licensed.	Parish.	Allotment.	Section.	Area.	Annual Rental.	Reason for Voiding.
Castlemaine	0426/138	Francis Xavier Dilks	138	Castlemaine	54	B1	A. R. P. 2 0 11 <sup>7</sup> / <sub>10</sub>	£ s. d. 2 10 0	Surrendered

Department of Crown Lands and Survey,  
Melbourne, 19th November, 1962.

KEITH TURNBULL,  
Commissioner of Crown Lands and Survey.

## Land Act 1958.

## LEASE SURRENDERED.

NOTICE is hereby given that the Governor in Council has accepted the surrender of the Lease mentioned in the Schedule hereunder for the reason specified.

District.	Corr. No.	Name.	Section of Land Act under which Leased	Parish.	Allotment.	Section.	Area.	Class.	Reason.
Geelong	515/44	Mr. Josef Heilers	44	Wangerrip	92	..	A. R. P. 113 0 0	..	Non-compliance with lease conditions

Department of Crown Lands and Survey,  
Melbourne, 5th November, 1962.

KEITH TURNBULL,  
Commissioner of Crown Lands and Survey.

## TENDERS—PUBLIC WORKS DEPARTMENT

TENDERS will be received at this Department's Head Office, Treasury-place, Melbourne, until TEN a.m. on the dates, and for the purposes under mentioned.

Particulars may be learnt at the Department and also at places shown in parentheses.

W.O. means Inspector of Works Office; P.S.—Police Station; T.S.—Technical School; H.E.S.—Higher Elementary School; S.S.—State School; H.S.—High School; C.S.—Consolidated School.

Tenders should be submitted on the Department's printed Tender Form and will not be received by telephone. All tenders must be on a "Firm Tender" basis. The Board of Land and Works will not necessarily accept the lowest or any tender.

Tenders to be addressed to the Hon. the Commissioner of Public Works, and envelope containing tender to be marked "Tender for \_\_\_\_\_, closing Tuesday, \_\_\_\_\_".

NOTE.—No preliminary deposit is to be lodged with any tender, but a deposit in accordance with the prescribed Schedule may be required from each successful tenderer.

Tuesday, 27th November, 1962.

Armada.—Exterior renovations, "Sebroff", Domestic Arts Teachers' College Hostel, 10 Orrong-road.

Armada.—Provision of a new change room, Domestic Arts Teachers' College, "Larnook".

Bairnsdale.—Additional room, &c., Transport Regulation Board Residence. (W.O., Bairnsdale.)

Ballarat North.—Install fire service, Technical School. (W.O., Ballarat.)

Bentleigh.—General repairs and painting, High School. Boralma.—Exterior and interior painting and repairs, S.S. 2574. (W.O., Wangaratta; S.S., Boralma.)

Burrum.—Repairs and painting, S.S. 4442. (W.O., Warracknabeal; S.S., Burrum.)

Castlemaine.—Repairs, internal and external painting and provision of new stainless steel wash troughs, High School. (W.O., Kyneton; H.S., Castlemaine.)

Caulfield.—Repairs and renovations to Senior School, S.S., 773.

Caulfield.—New tile roof to Junior School, S.S. 773.

Chelsea.—Repairs, painting, &c., Police Station.

No. 119.—9975/62.—3

Chiltern.—Repairs and painting to residence, office and out-buildings, Police Station. (W.O., Wangaratta.)

Clyde.—Additional drinking and washing facilities, S.S. 3664. (S.S., Clyde.)

Corio.—Erection of second and third sections, Technical School. (W.O., Geelong.)

Corio.—Supply, delivery, installation and testing of extensions to mechanical services, stages 2 and 3, Technical School. (W.O., Geelong.)

Corio.—Electrical installation in extensions to stages 2 and 3, Technical School. (W.O., Geelong.)

Croydon.—Erection of craft room, S.S. 2900.

Dandenong.—Aluminium windows and glazing, Psychiatric Unit, Mental Hygiene Authority.

Darnum.—Reblocking, repairs and painting, S.S. 2319 and residence. (W.O., Warragul; S.S., Darnum.)

Donald.—Repairs and painting to Court House. (W.O., Maryborough; P.S., Donald.)

Echuca.—Conversion of Art Room into Science Room, High School. (W.O., Shepparton; H.S., Echuca.)

Echuca.—Conversion of locker room to staff room, High School. (W.O., Shepparton; H.S., Echuca.)

Essendon.—Provision of steel fire escape stairs, S.S. 483.

Fern Tree Gully North.—Four additional class-rooms, S.S. 4718.

Fern Tree Gully North.—Plenum heating in new four (4) class-room unit, S.S. 4718.

Geelong.—Supply and delivery of 1,600 cubic yards of loam, (20 lb. sample to be delivered to P.W.D. Office, Geelong), Teachers' College.

Glen Forbes.—New toilet block and installation of septic tank, S.S. 4008. (W.O., Korumburra; S.S., Glen Forbes.)

Glenroy.—Connexion to M.M.B.W. sewerage line, Police Station. (Amended specification.) (P.S., Glenroy.)

Irrewarra.—Supply and installation of electric bore pump, S.S. 4099.

Koorooman East.—New toilets and septic tank, S.S. 3389. (W.O., Korumburra; S.S., Koorooman East.)

Laburnum.—Electrical installation in new eight (8) class-room L.T.C. School, S.S. 4863.

Laburnum.—New primary school of eight (8) class-rooms, S.S. 4863.

Laburnum.—Plenum heating in new eight (8) class-room unit, S.S. 4863.

Lilliput.—Repairs and painting, S.S. 1015. (W.O., Wangaratta; S.S., Lilliput.)

Little River.—Reblocking, internal painting and repairs, residence, S.S. 1961. (W.O., Geelong; S.S., Little River.)

Maidstone.—Provision of chain-mesh screens to out-offices, S.S. 4658.

Malvern.—Pipe and chain mesh fencing, S.S. 2586.

Maryborough.—New sleepout in timber and renovations, P.W.D., Inspector's residence. (W.O., Maryborough.)

Maryborough.—Supply of general furniture for Workshop Block, Technical College.

Macleod.—Construction of four porous tennis courts and fencing, High School.

Melbourne.—Maintenance cleaning, 1st January, 1963, to 30th April, 1963, with possible extension on a monthly basis, State Offices Annexe, 107 Russell-street.

Melbourne.—Supply of refrigerator for canteen (Special Pattern), State Accident Insurance Office.

Melton South.—Supply and installation of an electric bore pump, S.S. 3717.

Montague.—New accommodation for kitchen and laundry, Special School 2784.

Mont Park.—Supply and erection of a new copper roof over destructor unit, Mental Hospital.

Moonee Ponds Central.—Repairs and painting, Cleaner's Residence, S.S. 3987.

Morwell.—Supply and delivery of one 14-in. shaping machine, Technical School.

Mt. Best.—New toilets and septic tank installation, S.S. 3429 and residence. (W.O., Korumburra; S.S., Mt. Best.)

Mystic Park.—Septic tank installation, S.S. 3366. (Amended specification.) (W.O., Swan Hill; S.S., Mystic Park.)

Nunawading.—Painting and repairs, S.S. 4190.

Oak Park.—Minor repairs and external painting, S.S. 4721.

Olympic Village.—Six (6) additional class-rooms, S.S. 4713.

Olympic Village.—Plenum heating to new six (6) additional class-rooms, S.S. 4713.

Olympic Village.—Electrical installation in six (6) additional L.T.C. class-rooms, &c.; S.S. 4713.

Panmure.—Installation of additional out-offices and bore water supply, S.S. 1079 and residence. (W.O., Warrnambool; S.S., Panmure.)

Parkdale.—Repairs to out-offices, S.S. 4171.

Pascoe Vale.—External repairs and painting, Girls' Secondary School. (Amended specification.)

Preston North-East.—New office for infant mistress and staff toilets, S.S. 4764.

Redesdale.—New toilets and septic tank installation, S.S. 2571. (W.O., Kyneton; S.S., Redesdale.)

Robinvale.—Repairs and painting, Consolidated School. (W.O., Swan Hill; C.S., Robinvale.)

Shepparton Park.—Purchase and removal of old school building, S.S. 3264. (W.O., Shepparton.)

Somers.—Removal of a building from Coolart Estates to Somers School Camp, S.S. 4647. (S.S., Somers.)

Snobs Creek.—Supply and installation of pumping plant, Fish Research Station and Hatchery.

Sunbury.—Additional septic tank on existing drain to residences at Mental Hospital. (M.H., Sunbury.)

Sunbury.—Supply and delivery of timber, &c., Mental Hospital.

Sunshine North.—Electrical installation in extensions to stages 2 and 3, Technical School.

Sunshine North.—Supply, delivery, installation and testing of extension to mechanical services, stages 2 and 3, Technical School.

Sunshine North.—Erection of second and third sections, Technical School.

Swan Hill.—Repairs and painting to residence, 1 Chisholm-street, S.S. 1142. (W.O., Swan Hill.)

Teesdale.—Out-office block and septic tank installation, S.S. 2065 and residence. (W.O., Geelong; S.S., Teesdale.)

Thornton.—Installation of septic tanks and water supply at school and residence, S.S. 1371. (W.O., Alexandra; S.S., Thornton.)

Tongala.—Repairs and painting to school buildings, Consolidated School. (W.O., Shepparton; C.S., Tongala.)

Wattle Park.—Erection of fencing (non-party) and field gates, High School.

West Melbourne.—New timber and chain-mesh boundary fencing, Government Cool Stores.

West Melbourne.—Supply and delivery of Coolroom Door Fittings, Government Cool Stores.

West Melbourne.—Supply and delivery of 63,000 lineal feet of 5½ in. x ¾ in. select T. and G. Hardwood Flooring, Cool Stores, Dudley-street.

West Melbourne.—Supply and delivery of Corkboard, Government Cool Stores, Dudley-street.

West Melbourne.—Electrical installation in cooling chambers, Government Cool Stores.

Winton.—Out-office block and septic tank installation at S.S. 1870 and residence. (W.O., Benalla; S.S., Winton.)

Wodonga.—Sewerage installation and fire service at school and residence, S.S. 37. (W.O., Wangaratta; S.S., Wodonga.)

Woodbourne.—Installation of septic tanks, new toilets and bore water supply at S.S. 2875 and residence. (W.O., Alexandra; S.S., Woodbourne.)

#### Tuesday, 4th December, 1962.

Avoca.—Erection of combined brick veneer residence, office and garage with fuel room, Police Station. (W.O., Maryborough.)

Avoca.—Electrical installation, Police Station and residence. (W.O., Maryborough.)

Bairnsdale.—Supply of turpentine piles for Lakes Entrance Jetty, Ports and Harbors.

Barkstead.—Purchase and removal old building, S.S. 985. (W.O., Ballarat; S.S., Barkstead.)

Bell Park.—Erection of third section, High School. (W.O., Geelong; H.S., Bell Park.)

Bell Park.—Electrical installation in extended stage (3), High School. (W.O., Geelong; H.S., Bell Park.)

Bell Park.—Supply, delivery, installation and testing of the mechanical services, stage 3, High School.

Bendigo.—Removal of rubbish, general grading, supply and spread topsoil, provision of water supply and grassing, Teachers' Training College. (Amended specification.) (W.O., Bendigo.)

Beveridge.—Purchase and removal of old residence, S.S. 1476. (W.O., Alexandra.)

Blackburn South.—Repairs and painting, S.S. 4035.

Carrum.—Construction of concrete and asphalt paving, paving repairs and drainage, S.S. 3385.

Clarkefield.—Installation of septic tank, new toilets and bore water supply, S.S. 3035. (W.O., Kyneton; S.S., Clarkefield.)

Deepdene.—Repairs and painting, S.S. 3680. (Amended specification.)

Frankston Forest.—Electrical installation in new block of six (6) class-rooms, S.S. 4872.

Frankston Forest.—Six (6) additional class-rooms, S.S. 4872.

Frankston Forest.—Plenum heating in new six class-room unit, S.S. 4872.

Geelong.—Supply of art desks, Gordon Institute of Technology.

Glenburn.—Installation of septic tanks and water supply at school and residence, S.S. 3344. (W.O., Alexandra; S.S., Glenburn.)

Grantville.—Septic tank installation, S.S. 1414. (W.O., Korumburra; S.S., Grantville.)

Grassy Spur.—New out-office block and septic tank installations, &c., S.S. 3450. (W.O., Korumburra; S.S., Grassy Spur.)

Greythorn.—New sanitary accommodation, &c., S.S. 4694.

Hallora.—Toilet block and septic tank installation, S.S. 2377. (W.O., Warragul; S.S., Hallora.)

Homewood.—Installation of septic tank, new toilets, woodshed and water supply, S.S. 1433. (W.O., Alexandra; S.S., Homewood.)

Katunga South.—Purchase and removal of old windmill, S.S. 2269. (W.O., Shepparton; S.S., Katunga South.)

Macedon.—Repairs and painting, S.S. 1660. (W.O., Kyneton; S.S., Macedon.)

Malmsbury.—Construction of a gravel road and provision of culverts, Training Centre, Social Welfare Department. (W.O., Kyneton.)

Mansfield.—Supply of refrigerator, High School.

Mont Park.—Supply, delivery and fixing on site of new stainless steel benchwork, &c., M.S.U., Isolation Block, Mental Hospital.

Northcote.—Renovations to flooring, High School. (Amended specification.) (H.S., Northcote.)

Oberon.—Supply and installation of an effluent pump for septic tank, High School.

Pyalong.—Repairs, renewal and external painting, S.S. 2005. (W.O., Kyneton; S.S., Pyalong.)

Richmond.—Interior and exterior renovations and painting, S.S. 1396.

Royal Park.—Supply, delivery and installation of automatic food lift, "Turana", Children's Remand Centre.

Sunbury.—Supply and installation of electricity meters in residences, Mental Hospital.

Tylden.—Installation of septic tanks, new toilets and bore water supply, S.S. 621. (W.O., Kyneton; S.S., Tylden.)

Upper Yarra.—Supply and erection of 16 ft. x 12 ft. store shed, High School. (H.S., Upper Yarra.)

Various.—Laying, sealing and polishing linoleum in various State buildings in the State of Victoria, 1st January, 1963, to 31st December, 1963. (W.O., Ararat, Ballarat, Bendigo, Geelong, Mildura, Shepparton and Warrnambool.)

Williamstown.—Recharging, acetoneing and inspection of acetylene navigation light cylinders from 1st January, 1963, to 31st December, 1963, Ports and Harbors Dredging Depot.

Woodside.—Supply and installation of an electric bore pump, S.S. 1176. (Amended specification.)

#### Tuesday, 11th December, 1962.

Ballarat.—Supply of 20 single art desks and 30 chairs, School of Mines.

Bendigo.—Internal and external renovations, Teachers' College Hostel. (W.O., Bendigo.)

Bendigo.—Renovations to library, Technical College. (W.O., Bendigo; Technical College, Bendigo.)

Coatesville.—Installation of additional drinking and ablation troughs and water supply, S.S. 4712.

Essendon.—Repairs and repainting of school lockers, High School.

Foster.—Repairs and painting to residence, 7 Hoddle-street, High School. (W.O., Korumburra.)

Geelong.—Alterations to woodwork and welding workshops, Gordon Institute of Technology. (W.O., Geelong.)

Gooram.—New toilet block and septic tank installation at S.S. 1755. (W.O., Alexandra.)

Jamieson.—Repairs, repainting and fencing, Court House. (W.O., Alexandra; P.S., Jamieson.)

Kew.—Aluminium curtain walling and windows, &c., High School.

Kew.—Construction of asphalt paving with drainage, concrete paths and landscaping, Children's Cottages, Mental Hospital.

Kingsville.—Erection of two (2) shelter pavilions and a 16 feet x 12 feet store, S.S. 3988.

Lake Boga.—Erection of combined brick veneer residence, office and garage with fuel room, Police Station. (W.O., Swan Hill.)

Lake Boga.—Supply and installation of hot-water service, electric pump, hand pump, sink heater and installation of slow combustion stove, Police Station and residence. (W.O., Swan Hill.)

Melbourne.—Supply and lay linoleum tiles, Hairdressing School, Latrobe-street.

Melbourne.—Supply and installation of one new central heating boiler, new central heating mains and the replacement of one gas-fired warm air furnace, Royal Melbourne Institute of Technology.

Moe.—Repair of asphalt paving and construction of light-duty asphalt pavement, High School. (W.O., Warragul and Traralgon; H.S., Moe.)

Morwell.—Two-storied solid brick office block, Police Station. (W.O., Traralgon.)

Morwell.—Electrical installation, Police Station.

Morwell.—Supply, delivery, installation and testing of central heating and hot-water systems and electric circulating fans, Police Station. (W.O., Traralgon.)

Panton Hill.—Repairs and painting, S.S. 1134. (S.S., Panton Hill.)

Prahran.—Supply and fixing glazed aluminium windows, doors, curtain walling and sun visors, New Workshop Block, Technical School.

St. Albans.—Repairs and painting, S.S. 2969. (Amended specification.)

Tetoora-road.—Completion of installation of septic sewerage, S.S. 3860. (W.O., Warragul; S.S., Tetoora-road.)

Timboon.—Extension of school building by four additional class-rooms, Consolidated School. (W.O., Warrnambool.)

Timboon.—Electrical installation in new block of four (4) class-rooms, Consolidated School. (W.O., Camperdown and Warrnambool; C.S., Timboon.)

Timboon.—Plenum heating in new four (4) additional class-rooms, Consolidated School.

Upwey.—Additional toilet accommodation at S.S. 4530. (S.S., Upwey.)

Various.—Maintenance of oil burners in schools, North-east Inner, 1st January, 1963, to 31st December, 1963.

Various.—Maintenance of oil burners in schools, North-east Outer, 1st January, 1963, to 31st December, 1963.

Various.—Maintenance of oil burners and other mechanical equipment, 1st January, 1963, to 31st December, 1963, schools, Western Metropolitan, Geelong-Ballarat area. (W.O., Geelong and Ballarat.)

Various.—Maintenance of oil burners and other mechanical equipment, 1st January, 1963, to 31st December, 1963, schools, South-west Victoria area. (W.O., Warrnambool.)

Various.—Maintenance of oil burners and other mechanical equipment, 1st January, 1963, to 31st December, 1963, schools, Mildura area. (W.O., Mildura.)

Various.—Maintenance of oil burners and other mechanical equipment, 1st January, 1963, to 31st December, 1963, schools, Bendigo-Swan Hill-Wimmera area. (W.O., Bendigo, Swan Hill and Horsham.)

Various.—Maintenance of oil burners in schools, South-east Inner, 1st January, 1963, to 31st December, 1963.

Various.—Maintenance of oil burners in schools, South-east Outer, 1st January, 1963, to 31st December, 1963.

Various.—Maintenance of oil burners and other mechanical equipment in schools, Metropolitan District, 1st January, 1963, to 31st December, 1963.

Woomelang.—Erection of pipe-rail fencing, Court House. (W.O., Warracknabeal; P.S., Woomelang.)

Yarram.—General repairs, Court House. (W.O., Traralgon; P.S., Yarram.)

#### Tuesday, 18th December, 1962.

Footscray.—Erection of new Junior School in concrete and prestressed concrete, Technical School.

Prahran.—Repairs to slate roof, S.S. 2855.

H. R. PETTY,

Commissioner of Public Works.

Public Works Department,

Melbourne, 20th November, 1962.

#### TENDERS FOR THE SERVICE, 1962-63.

##### GENERAL STORES.

TENDERS will be received until Eleven o'clock a.m. on Friday, 14th December, 1962, from persons willing to supply the under-mentioned articles in such quantities as may be ordered by the Victorian Government, from the 1st January, 1963, to the 30th June, 1964.

Schedules as above, with full particulars, may be obtained from the Secretary to the Tender Board, by whom also the samples will be shown and any information afforded to persons tendering.

In all cases the total cost of each item must be extended in the columns provided.

##### Schedule No.

##### 62. Paints and Enamels.

The prices tendered must not include sales tax.

Security.—Five per cent. of total amount of tender accepted, but in no case will security of less than £3 be received.

Security will be required either in Commonwealth Treasury Bonds, or approved bank guarantee, fixed deposit receipt, Savings Bank deposit book, or non-negotiable cheque in favour of the Secretary to the Tender Board, as the tenderer may elect.

The security must be completed and the contract signed within five days of acceptance of the tender, failing which the contract may be again advertised, or another tender accepted.

The lowest or any tender will not necessarily be accepted.

In the event of tenderers withdrawing or attempting to withdraw their tenders before notification of acceptance of same, or failing to take up their accepted tenders within the prescribed period after notification of acceptance, they may be disqualified from tendering or holding any future contracts for Government supplies for a period of twelve months, such disqualification to date from the notification of acceptance of tender. It is also stipulated that, if a tenderer be a member of a firm and such firm be interested in the contract, the tender shall be in the name of the firm and not in that of the individual and that, for a breach of this condition, the tender will be declared informal.

Tenders enclosed in a separate envelope, and having the words "Tender for Paints and Enamels" (as the case may be) written thereon, must be deposited in the Tender-box at the Tender Board Offices, Macarthur-street, Melbourne, or if sent by post, postage must be prepaid, and the tenders addressed to the Chairman of the Tender Board, Tender Board Offices, Macarthur-street, Melbourne, C.2, which office they must reach not later than by first post on the date of closing of tenders.

The conditions of contract are those published in the *Victoria Government Gazette*, No. 38, dated 11th April, 1962, pages 1051 to 1052.

H. E. BOLTE,

Treasurer.

The Treasury,

Melbourne, 20th November, 1962.

**PUBLIC SERVICE NOTICES**

No. 1250.

**PUBLIC SERVICE ACT 1958.**

THE Public Service Board, in pursuance of the powers conferred by the *Public Service Act 1958*, hereby amends the Public Service (Public Service Board) Regulations as follows:—

**PART V.—ALLOWANCES.**

**DIVISION I.—ALLOWANCES FOR QUALIFICATIONS OR EFFICIENCY.**

**TECHNICAL AND GENERAL DIVISION.**

*General—Shorthand Writers and Typists (Female).*

**Regulation 97.**

Sub-regulation (2) is revoked and the following sub-regulation is substituted therefor:—

“(2) Any person, who is in receipt of a salary under the provisions of sub-regulation (1) of this Regulation and who satisfies the Board, by test, of her ability to write shorthand at the rate of 120 words a minute shall be paid, from the date of the test, an allowance at the rate of £16 a year.”

A. GARRAN, Chairman.  
V. P. SCULLY, Secretary.

Office of the Public Service Board,  
Melbourne, 5th November, 1962.

No. 1253.

*Public Service Act 1958, Section 39.*

**REGULATIONS.—PART IV.—SALARIES AND INCREMENTS.**

THE Public Service Board, in pursuance of the powers conferred by the *Public Service Act 1958*, hereby amends its Regulations as shown below:—

**FIRST SCHEDULE.**

**PROFESSIONAL DIVISION.**

*Amount of Salary Assigned to Offices in Class “A1”.*

Office.	Yearly Rate of Salary.
£	
<i>Delete—</i> Assistant Chief Mechanical Engineer .. .. .	2,850

*This Regulation shall have effect as on and from the 2nd September, 1962.*

A. GARRAN, Chairman.  
V. P. SCULLY, Secretary.

Office of the Public Service Board,  
Melbourne, 5th November, 1962.

No. 1251.

*Public Service Act 1946, Section 50.*

**REGULATIONS.—PART IV.—SALARIES AND INCREMENTS.**

THE Public Service Board, in pursuance of the powers conferred by the *Public Service Act 1958*, hereby amends its Regulations as shown below:—

**SIXTH SCHEDULE.**

**TEMPORARY EMPLOYEES.**

*Designations of Positions and Rates of Salaries.*

Department and Designation of Position.	Yearly Rate of Salary.		Increments (Annual).
	Minimum.	Maximum.	
	£	£	
DEPARTMENT OF AGRICULTURE.			
<i>Add—</i> Caretaker, Milk Board .. .. .	..	382	..

*This Regulation shall have effect as on and from the 20th August, 1962.*

A. GARRAN, Chairman.  
V. P. SCULLY, Secretary.

Office of the Public Service Board,  
Melbourne, 12th November, 1962.

No. 1254.

*Public Service Act 1958.*

**REGULATIONS.—PART IV.—SALARIES AND INCREMENTS.**

THE Public Service Board, in pursuance of the powers conferred by the *Public Service Act 1958*, hereby amends the Public Service (Public Service Board) Regulations as follows:—

**SECOND SCHEDULE.**

**TECHNICAL AND GENERAL DIVISION.**

*Grades and Salary Scales—Females.*

The following Grades are added:—

Grade Number.	Yearly Rate of Salary.
£	
F43 .. .. .	1,196
F44 .. .. .	1,244
F45 .. .. .	1,299
F46 .. .. .	1,354
F47 .. .. .	1,409
F48 .. .. .	1,464

A. GARRAN, Chairman.  
V. P. SCULLY, Secretary.

Office of the Public Service Board,  
Melbourne, 12th November, 1962.

No. 1252.

*Public Service Act 1958, Section 50.*

**REGULATIONS.—PART IV.—SALARIES AND INCREMENTS.**

THE Public Service Board, in pursuance of the powers conferred by the *Public Service Act 1958*, hereby amends its Regulations as shown below:—

**SIXTH SCHEDULE.**

**TEMPORARY EMPLOYEES.**

*Designations of Positions and Rates of Salaries.*

Department and Designation of Position.	Yearly Rate of Salary.		Increments (Annual).
	Minimum.	Maximum.	
	£	£	
DEPARTMENT OF CHIEF SECRETARY.			
<i>Add—</i> Farm Foreman Aboriginal Station, Lake Tyers	..	478	..
Nurse, Aboriginal Station, Lake Tyers	524	556	1 of £32

A. GARRAN, Chairman.  
V. P. SCULLY, Secretary.

Office of the Public Service Board,  
Melbourne, 12th November, 1962.

No. 1255.

**PUBLIC SERVICE ACT 1958.**

THE Public Service Board, in pursuance of the powers conferred by the *Public Service Act 1958*, hereby amends the Public Service (Public Service Board) Regulations as follows:—

**PART IV.—SALARIES AND INCREMENTS.**

**DIVISION IV.—TECHNICAL AND GENERAL DIVISION.**

*Regulation 83.*

In sub-regulation (2) under the heading “Females—” add the following:—

“1,148 to 1,409 55.”

A. GARRAN, Chairman.  
V. P. SCULLY, Secretary.

Office of the Public Service Board,  
Melbourne, 12th November, 1962.

## PUBLIC SERVICE (PUBLIC SERVICE BOARD) REGULATION 52.—RECLASSIFICATION.

THE Public Service Board has raised the classification of the under-mentioned office as shown, and the Permanent Head of the Department has recommended the officer named for appointment.

Office and Present Classification.	Revised Classification.	Duties.	Qualifications.	Officer Recommended for Appointment.		
				Name.	Classification.	Date of Classification.

## TECHNICAL AND GENERAL DIVISION.

## DEPARTMENT OF HEALTH.

## Mental Hygiene Branch—Mont Park.

Telephonist (Female), Grade I., Grades F10-F14 inclusive	Grade II., Grades F15-F16 inclusive		A competent operator of a P.A.B.X. telephone system, with a knowledge of hospital routine	Pinches, Martha J.	Telephonist (Female), Grade I.	16.7.53
--	-------------------------------------	--	---	--------------------	--------------------------------	---------

Appeals against such recommendation should be lodged with the Secretary to the Public Service Board not later than Saturday, the 1st December, 1962.

By order,

V. P. SCULLY,

Secretary.

Office of the Public Service Board,  
Melbourne, 20th November, 1962.

## PUBLIC SERVICE OF VICTORIA.—VACANCIES.

APPLICATIONS will be received by the Public Service Board up to Wednesday, the 5th December, 1962, from persons employed in the Public Service of Victoria, who are eligible and qualified for appointment to the under-mentioned positions.

## ADMINISTRATIVE DIVISION.

## Class "B1", Department of Crown Lands and Survey.

Yearly Salary.—£1,630, minimum; £1,770, maximum.

Duties.—To have charge of one of the divisions of the State; to deal with correspondence from persons holding or seeking land under the Land Act, the Closer Settlement Acts and Agricultural Colleges Acts; to deal with applications for advances under the Wire Netting Act.

Qualifications.—A good knowledge of the Land Act, the Closer Settlement Acts, the Agricultural Colleges Acts, the Wire Netting Act and Part 48 of the Local Government Act and of the Regulations, procedure and practice thereunder.

## Class "B1", Registry of Co-operative Housing Societies and Co-operative Societies Branch, Treasury.

Yearly Salary.—£1,630, minimum; £1,770, maximum.

Duties.—To act as accountant to the Registry of Co-operative Housing Societies and the Home Finance Trust.

Qualifications.—A qualified accountant, preferably with a knowledge of the Co-operative Housing Societies Act, the Home Finance Act, the Commonwealth—States Housing Agreement and the operations of co-operative housing societies.

## Secretary, Classes "C2"—"B", Janefield Training Centre, Mental Hygiene Branch, Department of Health.

Yearly Salary.—£1,170, minimum; £1,500, maximum.

Qualifications.—Experience in the organization and administration of a Mental Hospital or training Centre including control of stores, clothing and provisions; a good knowledge of the Mental Health Act and regulations; ability to control staff.

## Class "C1", General Health Branch, Department of Health.

Yearly Salary.—£960, minimum; £1,060, maximum.

Duties.—To assist the Secretary to the Poisons Advisory Committee in the administration of the Poisons Act 1962.

Qualifications.—A knowledge of the Poisons Act, Health Act and other legislation administered by the General Health Branch.

## Class "C", Mental Hygiene Branch, Department of Health.

Yearly Salary.—£710, minimum; £860, maximum.

Duties.—To have charge of a salaries sub-section and supervise the preparation of pay-rolls for Mental Hospitals and Clinics.

Qualifications.—A good knowledge of the relevant sections of the Public Service, Superannuation, and Mental Health Acts and Regulations.

## Class "C", Office of the Housing Commission, Treasury.

Yearly Salary.—£710, minimum; £860, maximum.

Duties.—To act as Section Leader of the Collections Section of the House Sales Department; to be responsible to the Accountant for the recording and balancing of all receipts and to prepare monthly schedules of arrears of instalments.

Qualifications.—A knowledge of the provisions of the Housing Act and Commonwealth and State Housing Agreements, and of the Commission's accounting procedures relating to sales of houses; ability to control staff.

## PROFESSIONAL DIVISION.

## School Medical Officer, Classes "A"—"A1", (Male or Female), Maternal and Child Welfare Branch, Department of Health. (Two vacancies.)

Yearly Salary.—

Male—£1,920, minimum; £2,600, maximum.

Female—£1,863, minimum; £2,543, maximum.

Duties.—To carry out medical inspections of school children and other medical duties as directed by the Director of Child Health (Medical).

Qualifications.—A legally qualified medical practitioner of Victoria. Applicants must be prepared to undertake country duties, and should forward evidence of hospital and other experience.

## Senior Chemist, Class "A", General Health Branch, Department of Health.

Yearly Salary.—£1,920, minimum; £2,060, maximum.

Duties.—Subject to the direction of the Chief Health Officer, to be responsible for the professional and technical administration of the Poisons Act 1962.

Qualifications.—A registered pharmaceutical chemist with approved post-graduate qualification or experience in pharmaceutical practice; A good knowledge of the classification of poisons and deleterious substances.

## Reporter, Grade I, Classes "C2"—"B1", Government Shorthand Writer's Office, Chief Secretary's Department.

Yearly Salary.—£1,170, minimum; £1,770, maximum.

Duties.—To report proceedings before Commissions, Boards of Inquiry, Industrial Appeals Court, Inquisitions and various other tribunals, and to furnish transcripts thereof in verbatim, narrative or précis form, as required.

**Qualifications.**—A licensed shorthand writer under the provisions of the *Evidence Act 1958*, with satisfactory experience in duties of the kind mentioned.

**Valuer, Class "B", Taxation (Land Tax) Office, Treasury.**

**Yearly Salary.**—£1,390, minimum; £1,500, maximum.

**Duties.**—To carry out inspections and make valuations for Land Tax, Probate Duty and Stamp Duty purposes of all classes of real estate, including hotels, shops, factories, residential properties and broad acres.

**Qualifications.**—To be a member of, or qualified for admission to, the Commonwealth Institute of Valuers, or to be entitled to an unrestricted certificate from the Valuers' Qualification Board. A good knowledge of the principles governing valuation of land and improvements and ability to discuss valuations with taxpayers or their representatives.

**Lecturer in Agricultural Engineering, Classes "C2"—"B", Dookie Agricultural College, Department of Agriculture.**

**Yearly Salary.**—£1,170, minimum; £1,500, maximum.

**Duties.**—To lecture to students in the machinery aspects of the subject of General Farm Practice, in Farm Mechanics and in one or both of the subjects of Physics and Surveying and to organize demonstrations; to share house duty; other duties as required.

**Qualifications.**—A degree in Agricultural Science with some experience in the use and design of agricultural machinery and tractors; or a degree in Agricultural Engineering with some experience in agricultural matters; ability to instruct students.

**Children's Librarian (Female), Class "C2", Free Library Service Board, Chief Secretary's Department.**

**Yearly Salary.**—£1,113, minimum; £1,223, maximum.

**Duties.**—To advise the Board and Municipal Libraries on all aspects of Children's Library development; to prepare suitable reading lists for Children's Libraries; to inspect regularly all Municipal Children's Libraries to ensure that they are of adequate standard; to arrange displays of Children's Library activity as directed by the Secretary; to address public meetings and interested organizations of Children's Library activities.

**Qualifications.**—Registration Certificate of the Library Association of Australia or equivalent qualification; experience in Children's Library work and a knowledge of general library practice.

**Professional Assistant, Classes "C"—"C2", Crown Solicitor's Office, Law Department.**

**Yearly Salary.**—£710, minimum; £1,280, maximum.

**Duties.**—To assist in the work of the Crown Solicitor's Office.

**Qualifications.**—To have passed in not less than five subjects of the course for the L.L.B.

**Technical Officer, Classes "C"—"C2", National Parks Authority, Premier's Department.**

**Yearly Salary—**

£960, minimum; £1,280, maximum—Agricultural Science Graduate.

£860, minimum; £1,280, maximum—Science Graduate. (Commencing salary according to experience.)

**Duties.**—To inspect and report upon the condition of national parks, to organize and instruct field staff, to undertake liaison work with the Committees of Management and constructing authorities, to assist in botanical and zoological surveys and in the development of public relations; other duties as required.

**Qualifications.**—A degree in Forestry, Agricultural Science or Science of an approved University; or the diploma of an approved forestry or agricultural college, together with special aptitude and qualifications; or equivalent qualifications; preferably a knowledge of Australian flora and fauna and of conservation practices. Experience in public relations work is desirable.

#### TECHNICAL AND GENERAL DIVISION.

**Estate Officer, Grade IV., Office of the Housing Commission, Treasury.**

**Yearly Salary.**—£590, minimum; £654, maximum.

**Duties.**—To perform Housing Estate Duties in respect of a section of a district including Revenue Collection, interviewing tenants regarding rental arrears, advising tenants on matters affecting their tenancy, and inspecting and reporting on dwelling and various phases of Estate Management.

**Qualifications.**—To be educated to Intermediate Certificate standard and able to make investigations and prepare reports. Experience in dealing with the public and capable of handling public moneys; a car driver's licence.

**NOTE.**—After completing three years' satisfactory service as Estate Officer, Grade IV., will be eligible for progression to Estate Officer, Grade III, (£686-£718).

**Shorthand Writer and Typist (Female) Senior, Explosives and Gas Examining Branch, Chief Secretary's Department.**

**Yearly Salary.**—£572, minimum; £604, maximum.

**Duties.**—To prepare correspondence and scientific reports from dictation, take shorthand notes of conferences, file technical records and assist generally.

**Qualifications.**—A competent typist, capable of writing shorthand at the rate of 120 words a minute and of preparing scientific reports and correspondence from dictation.

**Shorthand Writer and Typist (Female) Senior, Education Department.**

**Yearly Salary.**—£572, minimum; £604, maximum.

**Duties.**—To be private secretary to the Director of Education.

**Qualifications.**—A competent typist and capable of writing shorthand at the rate of 120 words per minute; to be experienced in secretarial duties.

**Senior Water Bailiff, Water Supply Department. (Two vacancies.)**

**Yearly Salary.**—£574.

**Position No. 1.—ROCHESTER CENTRE.**

**Duties.**—To control a section of the main channel and subsidiary channels; to supervise water distribution, repairs and maintenance of channels within the section, and to allocate water as required.

**Qualifications.**—Experience in the regulation and distribution of water and in channel and drain construction and maintenance; a good knowledge of water requirements for crops and grasses grown under irrigation.

**Position No. 2.—SECTION 14, TONGALA CENTRE.**

**Duties.**—To control a section of the main channel and subsidiary channels; to regulate supplies between water bailiffs; to supervise water distribution, repairs and maintenance of channels within the section.

**Qualifications.**—Experience in the regulation and distribution of water; a good knowledge of water requirements for orchards, crops, pastures and grasses grown under irrigation in the district; experience in channel and drain construction and maintenance.

**NOTE.**—Houses are available for the successful applicants, if married, for which a rental of 10 per cent. of standard salary, plus £16 a year, will be charged. Occupancy will be subject to a formal tenancy agreement being entered into. Particulars are available from the Water Supply Department.

**Assistant (Male), Grade I, Social Welfare Branch, Central Administration, Chief Secretary's Department.**

**Yearly Salary.**—£542, minimum; £574, maximum.

**Duties.**—To prepare reconciliations of bank statements and cash books and perform duties incidental thereto; to assist generally as required.

**Qualifications.**—Accuracy in dealing with figures. Preferably experience in large bank and cash book reconciliations.



**Water Bailiff, Swan Hill Centre, Water Supply Department.**  
*Yearly Salary.*—£430, minimum; £526, maximum.

*Qualifications.*—Ability to control and regulate the supply of water to irrigators, to keep the necessary records, and make arithmetical computations; a knowledge of water supply requirements of vines, citrus plantings, and crops grown under irrigation, the methods of preparation of land for irrigation and methods of channel and drain construction and maintenance.

*NOTE.*—A house is available for the successful applicant, if married, for which a rental of 10 per cent. of standard salary, plus £16 a year, will be charged. Occupancy will be subject to a formal tenancy agreement being entered into. Particulars are available from the Water Supply Department.

**Attendant, Grade I, National Gallery, National Museum and Institute of Applied Science, Chief Secretary's Department.**

*Yearly Salary.*—£494, minimum; £510, maximum.

*Duties.*—To assist generally in the General Division work of the National Gallery, National Museum and Institute of Applied Science; to perform the duties of Senior Attendant when required, and other duties as directed.

*Qualifications.*—Sound physique, good address, and suitability for attending to the public; experience in a National Gallery or Museum, or other appropriate Service.

*NOTE.*—Successful applicant may be required to undertake shift duties.

**Assistant Superintendent (Female), "The Gables", Children's Home, Kew, Social Welfare Branch, (Family Welfare Division), Chief Secretary's Department.**

*Yearly Salary.*—£476, minimum; £492, maximum.

*Duties.*—To assist the Superintendent in the care of young children and in the supervision of a small staff.

*Qualifications.*—Good personality and understanding and capacity for the care of emotionally disturbed children. Competent to direct and supervise staff.

*NOTE.*—The salary rates quoted above do not include the additional amounts which are payable under Regulation 74 of the Board's Regulations.

By order,

V. P. SCULLY,

Office of the Public Service Board, Secretary,  
 Melbourne, 20th November, 1962.

**PUBLIC SERVICE OF VICTORIA.—VACANCIES.**

**DEPARTMENT OF HEALTH**

**MENTAL HYGIENE BRANCH**

**TECHNICAL AND GENERAL DIVISION.**

**A**PPPLICATIONS will be received by the Public Service Board up to Wednesday, the 12th December, 1962, from persons employed in the Public Service of Victoria who are eligible and qualified for appointment to the under-mentioned positions:—

**Assistant Head Nurse (Male), Hobson Park Hospital, Traralgon.**

*Yearly Salary.*—£750, minimum; £798, maximum.

*Duties.*—To act as deputy to Principal Nurse (Female) in the supervision, organization and management of the nursing services; to participate in the community psychiatric activities as required and to take an active part in both practical and theoretical training of nursing and other ward personnel.

*Qualifications.*—A current practising certificate for mental nursing and preferably experience in the early treatment of psychiatric illness.

**Fireman, Sunbury.**

*Yearly Salary.*—£430, minimum; £462, maximum.

*Duties.*—To fire boilers and to assist Engineer Mechanic.

*Qualifications.*—Boiler Attendant's Certificate or higher qualification.

*NOTE.*—The salary rates quoted above do not include the additional amount which is payable under Regulation 74 of the Board's Regulations.

By order,

V. P. SCULLY,

Office of the Public Service Board, Secretary,  
 Melbourne, 20th November, 1962.

**PUBLIC SERVICE OF VICTORIA.—VACANCY.**

(TEMPORARY APPOINTMENT).

**A**PPPLICATIONS will be received by the Public Service Board up to Wednesday, the 5th December, 1962, from persons who are qualified for appointment to the under-mentioned position:—

*Field Officer, Live Stock, Department of Agriculture.*

*Yearly Salary.*—Junior—at 18 years of age—£324.  
 at 19 years of age—£368.  
 at 20 years of age—£420.  
 Adult—£654, minimum, £718, maximum.

*Duties.*—To assist the veterinary staff in the control of stock diseases, Strain 19 Brucella abortus vaccinations, the rapid field antigen test for Pullorum disease and other duties as directed.

*Qualifications.*—A Dookie or Longerenong Diploma of Agriculture or its equivalent and a practical knowledge of livestock and their management.

The salary rates quoted above do not include the additional amount which is payable under Regulation 74 of the Board's Regulations.

By order,

V. P. SCULLY,

Office of the Public Service Board, Secretary,  
 Melbourne, 20th November, 1962.

**PUBLIC SERVICE OF VICTORIA.**

**SPEED TESTS FOR SHORTHAND WRITERS AND TYPISTS (FEMALE).**

**A**T the tests held on the 17th November, 1962, the under-mentioned candidates passed at the required standards:—

**TEST AT 120 WORDS PER MINUTE.**

DEPARTMENT OF AGRICULTURE.

*Milk Board.*

Joachimsman, Florence (Mrs.).

**TEST AT 100 WORDS PER MINUTE.**

CHIEF SECRETARY'S DEPARTMENT.

*Social Welfare Branch.*

Andrews, Nancy Beryl (Mrs.).

Gooding, Wanita Elizabeth.

Schrappel, Ann.

EDUCATION DEPARTMENT.

Benn, Pearl (Mrs.).

PUBLIC WORKS DEPARTMENT.

Dyson, Myra Jean.

DEPARTMENT OF STATE FORESTS.

Prince, Violet Irene.

TREASURY.

*Office of the Housing Commission.*

Allen, Elaine (Mrs.).

Hinrichsen, Lynette Maree.

Morrison, Miriam Grace (Mrs.).

By order,

V. P. SCULLY,

Office of the Public Service Board, Secretary,  
 Melbourne, 20th November, 1962.

**APPOINTMENT OF A DEPUTY TO A MEMBER OF THE PUBLIC SERVICE BOARD.**

**W**HEREAS in the manner prescribed by the Regulations and at an election held in conjunction with the election of Stanley Joseph Brew as the Mental Hygiene representative on the Public Service Board, Joseph Henry Richardson was elected to be his deputy in the case of his suspension, illness or absence:

And whereas the said Stanley Joseph Brew is unable by reason of absence to attend a meeting of the Board to be held on the 19th November, 1962:

Now therefore, at the request of the said Stanley Joseph Brew and in pursuance of the powers conferred by section 2 of the *Public Service (Amendment) Act 1959* (No. 6579), I do hereby appoint the said Joseph Henry Richardson to be the deputy of Stanley Joseph Brew on the above-mentioned date.

Given under my Hand, at Melbourne, this nineteenth day of November, 1962.

A. GARRAN,

Office of the Public Service Board, Chairman,  
 Treasury-place, Melbourne.

*Teaching Service Act 1958.*

## TEACHING SERVICE (TEACHERS TRIBUNAL) REGULATIONS.

## AMENDMENT No. 38.

THE Teachers Tribunal, in pursuance of the powers conferred by the *Teaching Service Act 1958*, hereby amends Regulation 3 of the Teaching Service (Teachers Tribunal) Regulations in the manner following, that is to say:—

## REGULATION 3.

1. In clause 6, after the expression "having regard to—", insert the following new paragraph:—

"(a) first, the amount of the allowances payable to the Principals of the schools listed in clause 31 (A) of Part XII. of the Teaching Service (Classification, Salaries and Allowances);  
and".

2. Paragraphs (a) and (b) to be relettered (b) and (c), respectively.

LOUIS F. C. GARLICK, Chairman.  
G. FENNELL, Secretary.

Office of the Teachers Tribunal,  
Melbourne, 13th November, 1962.

## PRIVATE ADVERTISEMENTS

Town and Country Planning Acts.  
CITY OF ARARAT.  
EIGHTH SCHEDULE.

NOTICE is hereby given that the City of Ararat, in pursuance of its powers under the Town and Country Planning Acts, has prepared a Planning Scheme for the following land:—

(a) Land corner Port Fairy-road and Churchill-avenue, being Crown allotments 21, 22 and 23, section O, Town and Parish of Ararat, containing approximately 6 acres, 0 roods, 15 perches, for the purpose of altering the zone from light industrial to residential.

(b) Land corner Palmerston and Queen streets, being Crown allotments 8 and 9, section 2, Town and Parish of Ararat, for the purpose of altering the zone from residential to business and commercial.

(c) Land north side of High-street, being Crown allotment 2, section 33, Town and Parish of Ararat, containing approximately 1 acre, 0 roods, 21 and 9/10 perches, for the purpose of altering the zone from light industrial to heavy industrial.

(d) Land corner Barkly and Alfred streets, being Crown allotment 11 and part 12, section 20, having a frontage of 132 feet to Barkly-street by a depth of 105 feet along Alfred-street, for the purpose of altering the zone from residential to business and commercial.

All maps, plans, descriptions and other data fully setting out and explaining the Planning Scheme have been deposited at the Town Hall Office, Ararat, and at the office of the Town and Country Planning Board, Melbourne, and will be open for inspection without payment of any fee by all persons affected, between the hours of 10 a.m. and 4 p.m. on all days of the week except Saturdays, Sundays and Public Holidays until and including the 21st day of December, 1962.

Any persons affected by the Planning Scheme are required to set forth, in writing, all objections they may have, addressed to the Town Clerk, Town Hall, Ararat, on or before the 21st day of December, 1962.

3513

J. I. GRENFELL, Town Clerk.

## CITY OF BOX HILL.

## LOAN No. 148.

*Notice of Intention to Borrow the Sum of £50,000 for Permanent Works and Undertakings in the City of Box Hill.*

NOTICE is hereby given that the Council of the City of Box Hill proposes to borrow on the credit of the municipal revenues of the Mayor, Councillors and Citizens of the City of Box Hill the sum of Fifty thousand pounds such sum to be raised by the grant of a mortgage in accordance with the provisions of the Local Government Acts.

The maximum rate of interest that may be paid is 5½ per centum per annum.

The money borrowed shall be repayable at the office of the Local Authorities Superannuation Board, Rigby House, 15 Queens-road, Melbourne, or such other place or places as the Board from time to time may require. The loan shall have a currency of 40 years and interest thereon shall be payable half-yearly on the 1st days of April and October in each year, the first payment to be made on 1st October, 1963, and the final payment together with the repayment of principal (in full) on the 1st day of April, 2003.

The purpose for which the loan is to be applied shall be—

Capital works in the electric supply undertaking.

The loan is to be liquidated by a sinking fund which shall be created in accordance with the provisions of the Local Government Acts by the half-yearly investment of such amount, as the Auditor-General certifies will be sufficient to repay the principal moneys secured by the mortgage within the currency of the loan, in such manner as the Treasurer of Victoria shall direct.

The plans, specifications and estimates of cost of the works referred to above and statement showing the proposed expenditure of the money to be borrowed, are open for inspection during office hours of the Council, Town Hall, Box Hill.

Dated this 20th day of November, 1962.

3524

A. N. WALLS, Town Clerk.

## CITY OF BROADMEADOWS.

## PRIVATE STREETS LOAN No. 28.

*Construction of Private Streets.*

NOTICE is hereby given that at a meeting of the Council of the City of Broadmeadows held at the Town Hall, Broadmeadows, on 15th October, 1962, the said Council did agree to the following Resolution, i.e., that the Council do by Special Order and it does hereby resolve to borrow the sum of £25,000 by the grant of a mortgage on the credit of the Mayor, Councillors and Citizens of the City of Broadmeadows in accordance with the provisions of the *Local Government Act 1958* and amendments.

The rate of interest shall be £5 10s. per centum per annum.

The moneys borrowed shall be repayable by providing twenty half-yearly instalments of £1,641 10s., including principal and interest, on the 1st day of June and the 1st day of December during the currency of the loan and the first payment shall be payable on the 1st day of June, 1963.

Such moneys shall be repayable at the Commonwealth Bank of Australia, Glenroy.

The purpose for which the said loan shall be applied is for the construction of Augusta-avenue under the provisions of Division 10 of Part XIX. of the Local Government Act and amendments and the said loan shall be liquidated from the receipt of moneys payable under the said Division.

Notice is hereby further given that at a meeting of the said Council held at the Town Hall, Broadmeadows, on the 12th day of November, 1962, the said Resolution was confirmed.

Dated this 15th day of November, 1962.

E. F. SMILEY, Town Clerk.

Town Hall, Broadmeadows. 3525

#### CITY OF COBURG.

##### LOAN No. 81.

*Notice of Intention to Borrow the Sum of £50,000 for Permanent Works and Undertakings.*

NOTICE is hereby given that the Council of the City of Coburg proposes to borrow the sum of Fifty thousand pounds on the credit of the municipal revenues of the Mayor, Councillors and Citizens of the said City, such sum to be raised by the grant of a mortgage, in accordance with the provisions of the *Local Government Act 1958*.

1. The maximum rate of interest that may be paid is £5 10s. per centum per annum.

2. The interest is to be payable half-yearly during the currency of the loan.

3. The period of the loan shall be 40 years.

4. The moneys borrowed shall be repayable to the Local Authorities Superannuation Board at the office of the Board, "Rigby House", 15 Queens-road, Melbourne or at such other place as the Board may require on 31st March, 2003.

5. The loan is to be liquidated by the creation of a sinking fund, pursuant to section 428A of the *Local Government Act 1958*.

6. The purpose for which the loan is to be applied is electric supply capital expenditure.

The plans and specifications and the estimate of the cost of the proposed works and a statement showing the proposed expenditure of the moneys to be borrowed, are open for inspection at the Town Hall, Coburg, during office hours.

Dated the 15th November, 1962.

3514 G. A. BRIDGES, Town Clerk.

#### CITY OF ESSENDON.

##### BY-LAW No. 157.

##### *Dog Fees By-law.*

A by-law of the City of Essendon made under section 6 of the *Dog Act 1958* and numbered 157 for fixing registration and other fees for dogs.

IN pursuance of the powers conferred by the *Dog Act 1958* and of any and every other Act it thereunto enabling the Mayor, Councillors and Citizens of the City of Essendon orders as follows:—

1. This By-law shall be known as the Dog Fees By-law.

2. By-law No. 148 of the City of Essendon for fixing registration and other fees under the *Dog Act* is hereby repealed.

3. The registration fee for dogs under section 6 of the *Dog Act* is hereby fixed at the amount of Ten shillings.

4. The amount of One pound is hereby fixed as the amount payable to the Registration Office, pursuant to sub-section (4) of section 15 of the *Dog Act 1958* for the reclaiming of a dog under that section.

5. The amount of One pound is hereby fixed as the amount payable under section 16 of the *Dog Act 1958* for the cost of keeping a dog.

6. This by-law shall apply to and have operation throughout the whole of the municipal district.

Resolution for passing this By-law agreed to by the Council of the City of Essendon on the 27th day of August 1962, and confirmed on the 24th day of September, 1962.

The corporate seal of the Mayor, Councillors and Citizens of the City of Essendon was hereunto affixed in the presence of—

(SEAL) J. A. FULLARTON, Mayor.  
G. S. IRELAND, Councillor.  
K. LISTER, Town Clerk.

3500

#### CITY OF MELBOURNE.

##### BY-LAW No. 432.

A By-law of the City of Melbourne made under Part VII., Division 1 of the *Local Government Act 1958*, and numbered 432 to amend and add to By-law No. 391.

IN pursuance of the powers conferred by Part VII., Division 1 of the *Local Government Act 1958* and every other Act or power enabling it in that behalf, the Council of the City of Melbourne doth order as follows:—

1. Clause 1 of By-law No. 391 shall be and is hereby repealed.

2. After clause 6 of By-law No. 391, there shall be inserted the following new clause:—

"6A. In any street or road or part of a street or road in which the distance between the building lines is less than 20 feet or in which the footpaths are less than 3 feet in width and in any other street or road or part of a street or road approved by the Minister for the purposes of this clause, it shall be lawful for the Council from time to time to cause any signs authorized to be displayed pursuant to regulations made under the *Road Traffic Act 1958* or to section 555A of the *Local Government Act 1958* or any Resolution thereunder to be painted or affixed on any appropriate part of any house or building abutting on or adjacent or in close proximity to the street or road.

For the purposes of this clause the words 'the Minister' shall have the same meaning as in section 3 of the *Local Government Act 1958*".

Resolution for passing this By-law agreed to by the Council of the City of Melbourne the 15th day of October, 1962, and confirmed the 12th day of November, 1962.

3570 M. NATHAN, Lord Mayor.  
F. H. ROGAN, Town Clerk.

#### CITY OF MELBOURNE.

##### BY-LAW No. 433.

NOTICE is hereby given that at meetings of the Council of the City of Melbourne, held on the 15th day of October, 1962, and the 12th day of November, 1962, the said Council did make, pass and confirm a By-law intitled "A By-law of the City of Melbourne made under section 805 of the *Local Government Act 1958*, and numbered 433 with respect to the control and management of car parking areas and for fixing and collecting charges for the use thereof and for other purposes", summary of which is set out hereunder, viz.:—

The By-law which re-enacts in amended form By-law No. 409 provides for the control and management of all Council off-street car parking areas in the City.

The By-law—

- Describes in the Schedule thereto the areas of land set aside for car parking purposes.
- Sets out the times during which cars may be parked in the areas.
- Sets out the relevant fees to be paid, or, in the case of parking meters being installed, stipulates that the prescribed fee shall be paid in accordance with the instructions set out on the parking meter.
- Provides for the use of ticket-dispensing machines in off-street parking areas.
- Provides for the appointment of officers to receive fees, &c., and stipulates the duties and powers of such officers.
- Sets out matters which are offences against the By-law.
- Provides that the By-law is not applicable to the areas concerned whilst they may be leased by the Council to any person.

3569

F. H. ROGAN, Town Clerk.

#### CITY OF OAKLEIGH.

##### LOAN No. 81.

NOTICE is hereby given that at a meeting held on the 15th October, 1962, the Council of the City of Oakleigh adopted the following Resolution:—

That this Council borrow the sum of One hundred thousand pounds (£100,000) by the grant of a mortgage upon the credit of the municipality in accordance with the provisions of the *Local Government Acts*.

That the rate of interest to be paid shall be Five pounds ten shillings (£5 10s.) per centum per annum.

That the loan be repaid by twenty half-yearly instalments of principal and interest each of £6,567 3s. 6d. on the 1st day of February and the 1st day of August in each year at the C.B.C. Savings Bank Limited, Melbourne.

The purpose for which the loan is to be applied is the construction of private streets in accordance with the provisions of Division 10 of Part XIX. of the Local Government Act.

Notice is also given that at a meeting of the Council held on the 19th November, 1962, the above Resolution was confirmed.

Dated this 20th day of November, 1962.

3546

A. E. RAVEN, Town Clerk.

CITY OF PORT MELBOURNE.

BY-LAW NO. 147.

A By-law of the City of Port Melbourne made under section 326 of the *Health Act 1958*, for fixing fees for examining and branding carcasses of animals or meat slaughtered at any abattoir situated within the limits of the meat area as at present constituted and as may be constituted from time to time, within the City of Port Melbourne, and of any carcasses of animals or meat slaughtered outside such meat area and brought within such area for examination and branding.

PURSUANT to the powers conferred by section 326 of the *Health Act 1958*, the Mayor, Councillors and Citizens of the City of Port Melbourne order as follows:—

1. As from the 1st day of October, 1962, the fees payable shall be—

For examining and branding carcasses or parts of carcasses of or meat derived from any—

	s. d.
(a) bull, cow, calf (other than a bobby calf) heifer, ox or steer .. .. .	6 0
(b) bobby calf, goat, kid, lamb or sheep .. .. .	1 6
(c) swine .. .. .	2 0

Any quantity of meat (not including offal) fresh or cured in pieces less than a side, per cwt. or part thereof .. .. .

Any offal, per piece .. .. .

For every certificate as to an examination made by a meat inspector .. .. .

In this By-law "bobby calf" means a calf not more than six weeks old.

Resolution for passing this By-law agreed to by the Council of the City of Port Melbourne this 24th day of July, 1962, and confirmed the 21st day of August, 1962.

The common seal of the Mayor, Councillors and Citizens of the City of Port Melbourne was hereunto affixed this 22nd day of August, 1962, in the presence of—

(SEAL) M. H. FENNELL, Mayor  
L. S. TURNER, Councillor.  
A. T. AANENSEN, Town Clerk.

Submitted to the Commission of Public Health on the 2nd day of October, 1962.—A. T. GARDNER, Secretary, Commission of Public Health.

Approved by the Governor in Council on the 7th day of November, 1962.—N. G. WISHART, Clerk of the Executive Council. 3529

CITY OF OAKLEIGH.

BY-LAW NO. 161.

A By-law of the City of Oakleigh made under the provisions of section 326 of the *Health Act 1958* and numbered 161 for the purposes of fixing the rates of fees or dues payable to the Council under Part XV. of the said Act and for repealing certain By-laws of the City of Oakleigh.

IN pursuance of the powers conferred by the *Health Act 1958*, the Mayor, Councillors and Citizens of the City of Oakleigh order as follows:—

1. The whole of each of the By-laws listed in the Schedule hereto are hereby repealed.

2. Clause 7 of the By-law No. 63 of the City of Oakleigh is hereby repealed and the following substituted therefor:—

"The fees which are payable to the Council shall be as follows:—

For the use of a public abattoir for slaughtering any—

	£ s. d.
(a) bull, cow, calf exceeding 250 lb., heifer, ox or steer .. .. .	5 0
(b) calf over 150 lb. but not exceeding 250 lb. .. .. .	4 0
(c) calf not exceeding 150 lb. and any bobby calf .. .. .	1 0
(d) goat, kid, lamb or sheep .. .. .	1 0
(e) pig not exceeding 150 lb. .. .. .	1 6
(f) pig over 150 lb. .. .. .	2 0

For examining any—

(a) bull, cow, calf exceeding 250 lb., heifer, ox or steer .. .. .	2 0
(b) calf over 150 lb. but not exceeding 250 lb. .. .. .	2 0
(c) calf not exceeding 150 lb. and any bobby calf .. .. .	0 6
(d) goat, kid, lamb or sheep .. .. .	0 6
(e) pig not exceeding 150 lb. .. .. .	1 0
(f) pig over 150 lb. .. .. .	2 0

For examining and branding—

1. Any carcass or side of—

(a) bull, cow, calf exceeding 250 lb., heifer, ox or steer .. .. .	4 0
(b) calf over 150 lb. but not exceeding 250 lb. .. .. .	2 0
(c) calf not exceeding 150 lb. and any bobby calf .. .. .	1 0
(d) goat, kid, lamb or sheep .. .. .	0 6
(e) pig not exceeding 150 lb. .. .. .	1 0
(f) pig over 150 lb. .. .. .	2 0

2. Any quantity of meat (not including offal), fresh or cured in pieces less than a side per hundredweight or part thereof .. .. .

3. Any offal—per piece .. .. .

For any certificate as to an examination made by a meat inspector .. .. .

For the slaughtering and dressing by any slaughterman employed by the Council of any—

(a) bull, cow, calf (other than a bobby calf), heifer, ox or steer .. .. .	2 0 0
(b) bobby calf, goat, kid, lamb or sheep .. .. .	5 0
(c) swine .. .. .	1 0 0

For chilling for 48 hours from time of slaughter not including Saturdays, Sundays or Public Holidays any—

(a) bull, cow, calf exceeding 250 lb., heifer ox or steer .. .. .	6 6
(b) calf over 150 lb. but not exceeding 250 lb. .. .. .	4 6
(c) calf not exceeding 150 lb. and any bobby calf .. .. .	1 0
(d) goat, kid, lamb or sheep .. .. .	1 0
(e) pig not exceeding 150 lb. .. .. .	1 0
(f) pig over 150 lb. .. .. .	3 0

If carcass is left in chilling chamber for a period longer than 48 hours from time of slaughter not including Saturdays, Sundays and Public Holidays a charge of—

(a) bull, cow, calf exceeding 250 lb., heifer ox or steer .. .. .	6 6
(b) calf over 150 lb. but not exceeding 250 lb. .. .. .	4 6
(c) calf not exceeding 150 lb. and any bobby calf .. .. .	1 0
(d) goat, kid, lamb or sheep .. .. .	1 0
(e) pig not exceeding 150 lb. .. .. .	1 0
(f) pig over 150 lb. .. .. .	3 0

for each period of 24 hours or part thereof in excess of 48 hours."

In this By-law "bobby calf" means a calf not more than six weeks old.

SCHEDULE OF BY-LAWS REPEALED.

Description of By-law; Extent of Repeal.

By-law No. 86 of the City of Oakleigh; The whole.
By-law No. 111 of the City of Oakleigh; The whole.
By-law No. 123 of the City of Oakleigh; The whole.
By-law No. 127 of the City of Oakleigh; The whole.
By-law No. 141 of the City of Oakleigh; The whole.
By-law No. 149 of the City of Oakleigh; The whole.
By-law No. 160 of the City of Oakleigh; The whole.

Resolution for passing this By-law agreed to by the Council, the 6th day of August, 1962, and confirmed on the 3rd day of September, 1962.

W. G. COLE, Mayor.  
F. E. HUNT, Councillor.  
A. E. RAVEN, Town Clerk.

Submitted to the Commission of Public Health on the 18th day of September, 1962.—A. T. GARDNER, Secretary, Commission of Public Health.

Approved by the Governor in Council on the 7th day of November, 1962.—N. G. WISHART, Clerk of the Executive Council. 3510

## CITY OF PRESTON.

## LOAN No. 27.

*Private Street Construction.*

NOTICE is hereby given that the following Special Order was passed by the Council at a meeting held on the 15th October, 1962, and was, after due publication and notice, confirmed at a meeting of the Council of the City of Preston held on the 19th November, 1962.

1. That this Council, by Special Order, resolves to borrow on the credit of the Mayor, Councillors and Citizens of the City of Preston the sum of £50,000 (Fifty thousand pounds) such sum to be secured by the grant of a mortgage in accordance with the provisions of the Local Government Act.

2. The rate of interest to be paid is £5 10s. per centum per annum.

3. The times which the moneys borrowed are to be repayable are on the 1st day of December and the 1st day of June in each year, the loan to have a currency of fifteen years, the first payment to be made on the 1st day of June, 1963, and the final payment on the 1st day of December, 1977, and that the place the moneys shall be repayable is at the Bank of New South Wales, Preston.

4. The purpose for which the loan is to be applied is the repayment of principal moneys owing by the municipality on account of a previous loan on overdraft of current account from the Bank of New South Wales, such overdraft having been obtained in terms of section 583 of the *Local Government Act 1958* for the purpose of financing schemes of private street construction.

5. The manner in which the loan is to be liquidated is by provision out of the municipal fund in each half-year during the currency of the loan the sum of £2,469 4s. 7d. which includes principal and interest.

3526

J. C. DONATH, Town Clerk.

## CITY OF PRESTON.

## LOAN No. 26.

*Private Street Construction.*

NOTICE is hereby given that the following Special Order was passed by the Council at a meeting held on the 15th October, 1962, and was, after due publication and notice, confirmed at a meeting of the Council of the City of Preston held on the 19th November, 1962.

1. That this Council, by Special Order, resolves to borrow on the credit of the Mayor, Councillors and Citizens of the City of Preston the sum of £25,000 (Twenty-five thousand pounds) such sum to be secured by the grant of a mortgage in accordance with the provisions of the Local Government Act.

2. The rate of interest to be paid is £5 10s. per centum per annum.

3. The times which the moneys borrowed are to be repayable are on the 1st day of December and the 1st day of June in each year, the loan to have a currency of ten years, the first payment to be made on the 1st day of June, 1963, and the final payment on the 1st day of December, 1972, and that the place the moneys shall be repayable is at the State Savings Bank of Victoria, Melbourne.

4. The purpose for which the loan is to be applied is the repayment of principal moneys owing by the municipality on account of a previous loan on overdraft of current account from the Bank of New South Wales, such overdraft having been obtained in terms of section 583 of the *Local Government Act 1958* for the purpose of financing schemes of private street construction.

5. The manner in which the loan is to be liquidated is by provision out of the municipal fund in each half-year during the currency of the loan the sum of approximately £1,641 16s. which includes principal and interest.

3527

J. C. DONATH, Town Clerk.

## CITY OF PRESTON.

## LOAN No. 25.

*Private Street Construction.*

NOTICE is hereby given that the following Special Order was passed by the Council at a meeting held on the 15th October, 1962, and was, after due publication and notice, confirmed at a meeting of the Council of the City of Preston held on the 19th November, 1962.

1. That this Council, by Special Order, resolves to borrow on the credit of the Mayor, Councillors and Citizens of the City of Preston the sum of £50,000 (Fifty thousand pounds) such sum to be secured by the grant of a mortgage in accordance with the provisions of the Local Government Act.

2. The rate of interest to be paid is £5 10s. per centum per annum.

3. The times which the moneys borrowed are to be repayable are on the 1st day of December and the 1st day of June in each year, the loan to have a currency of fifteen years, the first payment to be made on the 1st day of June, 1963, and the final payment on the 1st day of December, 1977, and that the place the moneys shall be repayable is at the Bank of New South Wales, Preston.

4. The purpose for which the loan is to be applied is the repayment of principal moneys owing by the municipality on account of a previous loan on overdraft of current account from the Bank of New South Wales, such overdraft having been obtained in terms of section 583 of the *Local Government Act 1958* for the purpose of financing schemes of private street construction.

5. The manner in which the loan is to be liquidated is by provision out of the municipal fund in each half-year during the currency of the loan the sum of £2,469 4s. 7d. which includes principal and interest.

3528

J. C. DONATH, Town Clerk.

## CITY OF WARRNAMBOOL.

NOTICE is hereby given, in accordance with section 587 (3) of the *Local Government Act 1958*, that the Council of the City of Warrnambool, having received a request from the Housing Commission, Victoria, so to do, hereby declare—

## ALISON-AVENUE.

in the City of Warrnambool, to be dedicated to the public as a public highway, the said street having been constructed to the satisfaction of the Council.

3512

K. L. ARNEL, Town Clerk.

## BOROUGH OF CLUNES.

## BY-LAW No. 56.

A By-law of the Borough of Clunes made under section 93 of the Health Act and section 197 of the *Local Government Act 1958*, and numbered 56, for regulating the keeping of animals (including birds) and for regulating or prohibiting the keeping of any place which, in the opinion of the Council, may be offensive, injurious to health or dangerous.

IN pursuance of the powers conferred by the above-mentioned Acts, the Mayor, Councillors and Burgesses of the Borough of Clunes order as follows:—

1. All existing By-laws of the Council, so far as they relate to matters and things provided for in this By-law, shall be and are hereby repealed.

2. This By-law shall come into force and operation immediately after its approval by the Governor in Council and publication in the *Government Gazette*.

3. This By-law shall apply and have operation throughout the whole of the municipal district, except to premises registered as poultry-killing premises and poultry saleyards, when so exempt, in writing, by the Council.

4. In this By-law, unless inconsistent with the context or subject-matter—

“Council” means the Council of the Borough of Clunes.

“Approved materials” means materials approved by the Council.

“Dwelling” shall include a living room, sleepout, cabin or hut, and any room used for sleeping, living or cooking.

“Poultry” includes fowls, turkeys, ducks and geese.

“Person” includes the owner or occupier or person in charge of any premises to which this By-law may apply.

“Litter” includes wood shavings, tan bark, straw, dry grass clippings or other suitable clean, dry material.

"Battery cage" means a wire and metal mesh cage divided into one or more compartments, whether portable or not, in which poultry is kept.

"Property" means any tenement or land in separate occupation.

"Fowl-house" means any enclosed structure used for the purpose of keeping poultry.

5. No person shall keep or cause or permit to be kept on any property more than two (2) turkeys, ducks or geese.

6. No person shall allow, cause, permit, or suffer poultry to wander, either at large or under control, in or upon any street, road, vacant land, or watercourse within the Borough.

7. No person shall keep in any fowl-house a number of fowls greater than the number produced by dividing the area in square feet of such fowl-house by four.

8. No person shall keep, cause, permit or allow to be kept on any property, more than twenty (20) fowls, without the written permission of the Council being first obtained, and such permission shall only be granted if the Council has satisfied itself that the accommodation provided for the housing and yarding of such fowls is adequate and is not likely to be offensive or injurious to health.

9. No person shall keep any poultry on any premises other than in a fowl-house or battery cage and unless such fowl-house or battery cage is—

- (a) Distant at least 75 feet from the boundary of any street or road to which the principal building on such property faces.
- (b) Distant at least 10 feet from any other street or road of a greater width than 25 feet.
- (c) Distant at least 5 feet from any street or road or right-of-way of a lesser width than 25 feet.
- (d) Distant at least 5 feet from any adjoining allotment of land.
- (e) Distant at least 40 feet from any dwelling, whether on the same or adjoining land.

10. Every fowl-house or battery cage, if immobile, shall be roofed with approved materials and the surface level of the floor thereof shall be at least 3 inches above the level of the surrounding ground, and shall be so constructed so as to hold at least 6 inches in depth of litter.

11. Every fowl-house or battery cage, if immobile, shall be rendered rat-proof by placing galvanised iron, jointed brickwork, cement sheeting, or concrete around the outer foundations to a depth of at least 18 inches below the surface level of the floor, and all walls shall be constructed of approved rat-proof materials.

12. No person shall keep or store, or cause or permit to be kept or stored on any property where poultry are kept, any food for consumption by poultry, unless such food is kept or stored in rat-proof receptacles.

13. The owner, occupier, or person in charge of any property on which poultry are kept, shall cause the fowl-house, immobile battery cage, mobile battery cage, and any attached fowl-run or yard, to be thoroughly cleansed from time to time, as often as may be necessary, or at the direction of the Council, and shall keep the same in a clean, wholesome, and sanitary condition at all times, with particular regard to drainage.

14. Poultry droppings, litter, and refuse shall be removed from the premises from time to time, or at the direction of the Council, so as not to cause a nuisance or conditions likely to be offensive.

15. Any person guilty of contravention of any provisions of this By-law shall be liable, on conviction, to a penalty not exceeding Twenty pounds, and, in the case of any offence continuing after such conviction, to a further daily penalty of not more than Five pounds, but so that the total of such penalties shall not exceed One hundred pounds.

The Resolution adopting By-law No. 56 was agreed to at a meeting of the Council held on the 8th November, 1961, and confirmed on 13th December, 1961.

As witness, the common seal of the Mayor, Councillors and Burgesses of the Borough of Clunes was hereto affixed this 13th December, 1961, in the presence of—

(SEAL) W. C. FOULKES, Mayor.  
C. BLACKMORE, Councillor.  
R. J. PRYOR, Town Clerk.

Submitted to the Commission of Public Health on 21st August, 1962.

Approved by the Governor in Council on the 11th day of September, 1962. 3515

SHIRE OF BANNOCKBURN.

LOAN No. 8.

Notice of Intention to Borrow the Sum of £6,000 for Permanent Works and Undertakings.

NOTICE is hereby given that the Council of the Shire of Bannockburn proposes to borrow the sum of £6,000 on the credit of the municipal revenues of the President, Councillors and Ratepayers of the said Shire, such sum to be raised by the grant of a mortgage in accordance with the provisions of the *Local Government Act 1958*.

1. The maximum rate of interest that may be paid is 5½ per cent. per annum.

2. The purposes for which the loan is to be applied are:—

Purchase of plant .. .. .	£2,300
Improvements to Shire Hall, erection of machinery shed, purchase of office equipment .. .. .	1,800
Sealing service roads in the Meredith, Inverleigh and Bannockburn townships ..	1,900
	<hr/>
	£6,000

3. The period of the loan shall be five years.

4. The moneys borrowed shall be repayable by providing out of the municipal fund ten half-yearly instalments of approximately £692 4s. each, including principal and interest on the 1st day of September and the 1st day of March, during the currency of the loan. The first instalment shall be payable on the 1st day of September, 1963.

5. Such moneys shall be repayable at the State Savings Bank of Victoria, Melbourne.

The plans and specifications and the estimate of the cost of the proposed works and a statement showing the proposed expenditure of the moneys to be borrowed, are open for inspection at the Shire Hall, Bannockburn.

Dated 20th November, 1962.

3558 W. L. MOUNTJOY, Shire Secretary.

SHIRE OF COLAC.

BY-LAW No. 127.

A By-law of the Shire of Colac made under sections 317 and 326 of the *Health Act 1958*, and numbered 127, for the purpose of amending By-laws Nos. 114, 115 and 125 of the said Shire, and altering the rates of fees and dues payable to the Council of the Shire of Colac under Part XV. of the said Act.

IN pursuance of the powers conferred by the *Health Act 1958* and the *Local Government Act 1958*, and the amendments thereof, and every other power enabling them in this behalf, the President, Councillors and Ratepayers of the Shire of Colac order as follows:—

1. This By-law shall come into operation on the day after the day of the publication hereof in the *Victoria Government Gazette*.

2. The whole of clause 6 of By-law No. 99 of the Shire of Colac (as amended) is hereby repealed and the following clause inserted in lieu thereof.

3. The fees and dues payable to the Council of the Shire of Colac under Part XV. of the *Health Act 1958* shall be as follows:—

	Per head.
(a) For the use of the Colac Municipal Abattoirs for slaughtering any—	s. d.
Bull, cow, heifer, ox or steer ..	4 0
Sheep, lamb, goat or kid ..	1 0
Swine .. .. .	2 0
Calf (100 lb. dead weight or under)	1 0
Calf (over 100 lb. dead weight) ..	3 0
(b) For examining any—	
Bull, cow, heifer, ox or steer ..	2 6
Sheep, lamb, goat or kid ..	0 6
Swine .. .. .	2 0
Calf (100 lb. dead weight or under)	0 6
Calf (over 100 lb. dead weight) ..	2 0
(c) For examining and branding any carcass of, or side of—	
Bull, cow, heifer, ox or steer ..	4 0
Sheep, lamb, goat or kid ..	0 9
Swine .. .. .	2 0
Calf (100 lb. dead weight or under)	0 6
Calf (over 100 lb. dead weight) ..	2 0
Any quantity of meat (not including offal), fresh or cured in pieces less than a side—per hundred-weight or part thereof ..	1 0

(d) For any certificate as to an examination made by a meat inspector ..	s. d.
	4 0
(e) For chilling a carcass of any—	
Bull, cow, heifer, ox or steer ..	5 6
Sheep, lamb, goat or kid ..	0 3
Swine not exceeding 150 lb. in weight ..	1 0
Swine exceeding 150 lb. in weight ..	3 0
Calf (100 lb. dead weight or under) ..	1 0
Calf (over 100 lb. dead weight) ..	3 0

Resolution for passing this By-law agreed to by the Council on the 9th day of July, 1962, and confirmed on the 13th day of August, 1962.

The common seal of the President, Councillors and Ratepayers of the Shire of Colac was hereto affixed by order of the Council, in the presence of—

(SEAL) H. L. MARTIN, President.  
T. SHELTON, Councillor.  
J. W. TAYLOR, Secretary.

Submitted to the Commission of Public Health on the 18th day of September, 1962.—A. T. GARDNER, Secretary, Commission of Public Health.

Approved by the Governor in Council on the 7th day of November, 1962.—N. G. WISHART, Clerk of the Executive Council. 3507

## SHIRE OF CORIO.

## LOAN No. 49.

*Notice of Intention to Borrow the Sum of £25,000 for Permanent Works and Undertakings.*

NOTICE is hereby given that the Council of the Shire of Corio proposes to borrow the sum of Twenty-five thousand pounds (£25,000) on the credit of the municipal revenues of the President, Councillors and Ratepayers of the said Council, such sum to be raised by a grant of a mortgage in accordance with the provisions of the *Local Government Act 1958*.

1. The maximum rate of interest that may be paid is £5 10s. (5½) per cent. per annum.

2. The purposes for which the loan is to be applied is for permanent works and undertakings, reconstruction of part of Anakie-road.

3. The period of the loan shall be ten years.

4. The moneys borrowed shall be repayable by providing out of the municipal fund twenty half-yearly instalments of approximately £1,641 16s. each, including principal and interest on the 1st day of March and the 1st day of September, during the currency of the loan. The first instalment shall be payable on the 1st day of September, 1963.

5. Such moneys shall be repayable at the State Savings Bank of Victoria, Melbourne.

The plans and specifications and the estimate of the cost of the proposed works and a statement showing the proposed expenditure of the moneys to be borrowed, are open for inspection at the Shire Office, Osborne House, North Geelong.

Dated 19th November, 1962.

3544 W. H. MYERS, Shire Secretary.

## Water Acts.

## SHIRE OF CRESWICK.

## PROPOSED URBAN DISTRICT.

NOTICE is hereby given that the Creswick Shire Council has made application to the Honorable the Minister of Water Supply for the Proclamation of an urban district at Kingston, Springmount, Allendale, Broomfield, Newlyn and Newlyn North, and the construction, maintenance, and continuance of water supply works within that district under the provisions of the Water Acts.

A general plan and description of the proposed works have been submitted with the application, and copies of same may be seen at the Shire Office at Creswick.

Dated at Creswick the 13th day of November, 1962.

3483 J. B. WILKIE, Shire Secretary.

## SHIRE OF ELTHAM.

## NAMING OF ROAD.

NOTICE is hereby given that the un-named Government road east of Crown allotments 45, 47, 48 and 49, section B, Parish of Greensborough, has been named Chariber-lane.

3543 M. B. WATSON, Shire Secretary.

## SHIRE OF FERN TREE GULLY.

## BY-LAW No. 127.

NOTICE is hereby given that the Shire of Fern Tree Gully has made a By-law No. 127 for regulating drainage.

This By-law makes the installation of approved grease traps compulsory where drainage from private premises is discharged into any road drain public land or waterway.

Notice is further given that a copy of this By-law is open for inspection, free of charge, during office hours at the office of the Council.

3501 R. B. WEBB, Municipal Manager.

## SHIRE OF FERN TREE GULLY.

## NOTICE OF INTENTION TO TAKE LAND COMPULSORILY.

NOTICE is hereby given as follows:—

1. The Council has caused to be prepared and has approved such specifications, maps, plans, sections and elevations as may be necessary providing for the compulsory acquisition by the said Shire of the land described below for the purpose of providing a place of public resort and recreation.

2. Such specifications, maps, plans, sections and elevations, which contain full particulars of the works to be undertaken and of the exact site and admeasurements thereof and of all other matters required under section 512 (1) of the *Local Government Act 1958*, have been deposited at the Shire Offices, Fern Tree Gully, Victoria, where they are and will remain open for inspection by all persons interested for the space of 40 clear days after publication of this notice at all times during the ordinary hours when such office is open.

3. The land proposed to be acquired comprises all that piece of land described in certificate of title, volume 5467, folio 1093348, and comprising 5 acres 2 roods 13 perches or thereabouts and being part of Crown allotment 70J, Parish of Narree Worrان, County of Mornington, commonly known as the "Belgrave Reservoir" and located in Belgrave-Hallam road, Belgrave.

4. All persons affected by the proposed undertaking are required within 40 clear days after publication hereof in the *Government Gazette* to set forth, in writing, addressed to the said Council or its municipal clerk, all objections which they may have to the undertaking.

Dated this 16th day of November, 1962.

By order of the Council,

R. B. WEBB,

3540 Acting Shire Secretary and Municipal Clerk.

## SHIRE OF FRANKSTON.

## LOAN No. 74 (£25,000).

*Special Order.*

NOTICE is hereby given that the Council of the Shire of Frankston did, at a Meeting held on Monday, 8th October, 1962, agree to the following Resolution:—

1. That this Council borrow the sum of £25,000 by the grant of mortgage for such amount secured on the credit of the President, Councillors and Ratepayers of the municipality, in accordance with the provisions of section 585 of the *Local Government Act 1958* (as amended).

2. That the rate of interest to be paid be £5 10s. per centum per annum.

3. That the period of loan be ten (10) years, and that the moneys borrowed be repayable by half-yearly instalments of £1,641 16s. approximately, including principal and interest, on the 1st day of June and the 1st day of December during the currency of the loan, the first instalment being payable on the 1st day of June, 1963.

4. That such moneys be repayable at the State Savings Bank of Victoria, Melbourne.

5. That the loan be applied for the purpose of constructing private streets within the Shire of Frankston, in pursuance of and in accordance with the provisions of Division 10 of Part XIX. of the *Local Government Act 1958*.

And notice is hereby further given that the said Council did, at a Meeting held at 8 p.m. on Monday, 12th November, 1962, confirm such Resolution.

G. C. PENTLAND, Shire Secretary.

Shire Office, Frankston.

3482

## SHIRE OF FRANKSTON.

## LOAN No. 76.

*Notice of Intention to Borrow the Sum of £10,000 for Permanent Works and Undertakings.*

NOTICE is hereby given that the Council of the Shire of Frankston proposes to borrow the sum of Ten thousand pounds on the credit of the municipal revenues of the President, Councillors and Ratepayers of the said Shire, such sum to be raised by the grant of a mortgage, in accordance with the provisions of the *Local Government Act 1958*.

1. The maximum rate of interest that may be paid is £5 10s. 5d. per centum per annum.
2. The purpose for which the loan is to be applied is drainage works, £10,000.
3. The period of the loan shall be fifteen years.
4. The moneys borrowed shall be repayable by providing out of the Municipal Fund 30 half-yearly instalments of £493 16s. 11d., including principal and interest, on the 1st day of September and the 1st day of March during the currency of the loan. The first instalment shall be payable on the 1st day of September, 1963.
5. Such moneys shall be repayable at the Commonwealth Savings Bank of Australia, Melbourne.

The plans and specifications and the estimates of the cost of the proposed works, and a statement showing the proposed expenditure of the money to be borrowed, are open for inspection at the Municipal Offices, Frankston.

3545

G. C. PENTLAND, Shire Secretary.

## SHIRE OF HEALESVILLE.

## BY-LAW No. 45.

*Rubbish and Tips, &c.*

A By-law of the Shire of Healesville, made under section 197 of the *Local Government Act 1958* and section 93 of the *Health Act 1958*, and numbered 45.

IN pursuance of the powers conferred by the above-mentioned Acts, the President, Councillors and Ratepayers of the Shire of Healesville order as follows:—

1. By-law No. 20 of the Shire of Healesville is hereby repealed.
2. No person shall deposit or leave any refuse or rubbish on any land other than a rubbish tip established by the said Shire.
3. No person shall deposit or leave any refuse or rubbish on streets, roads, lanes or passages other than in authorized bins or tins.
4. The owner or occupier of any land on which any refuse or rubbish (other than refuse or rubbish the removal of which the Council of the Shire of Healesville has undertaken or contracted for under section 48 of the *Health Act 1958*) is deposited or left on receiving written notice from such Council under the hand of its Shire Secretary (or such other officer of the municipality who may for the time being be acting on behalf of the Shire Secretary) requiring such owner or occupier to remove or effectually destroy any such refuse or rubbish shall comply with any such notice within seven days after receipt thereof.
5. No person shall do or suffer to be done any of the following matters at any refuse tip or incinerator under the control of the Council of the Shire of Healesville:—
  - (a) Trespass on any part of such land.
  - (b) Obstruct, disturb, interrupt or annoy any person lawfully using such area.
  - (c) Neglect or refuse to obey the lawful directions of the Council's Engineer or other officer or employee in charge of any such area.
  - (d) Deposit or leave any rubbish, refuse, waste or any other material which, in the opinion of the Council's Engineer or other officer in charge of such area is liable to ignite spontaneously or if ignited to cause smoke or fumes of a nature dangerous to the public provided that this prohibition shall apply for only such period of the year as the Council or its Engineer or other officer in charge of any such area shall determine.
  - (e) Bring, deposit or leave any refuse or rubbish obtained from any place outside the municipal district of the Shire of Healesville without the written authority of the Shire Secretary of the said Shire.
  - (f) Light any fire in any part of the tip.
  - (g) Interfere with the surface of the tip or with any materials deposited or about to be deposited at the tip.

(h) Disfigure, damage, destroy or interfere with any notice-board, fence, building, appliance, machine, tree, gate or other equipment at the tip.

6. No person in or upon any road, street, footway or public place within the municipal district of the Shire of Healesville shall drive any vehicle laden with rubbish or refuse which may drop or be blown about unless such vehicle is provided with adequate sides and where necessary enclosed to the satisfaction of the Council.

7. Any person guilty of a contravention of the provisions of this By-law shall be liable, on conviction, to a penalty not exceeding Twenty pounds, and in the case of any offence continuing after such conviction to a further daily penalty of not more than One pound, but so that the total of such penalties shall not exceed One hundred pounds.

8. This By-law shall apply to and have effect throughout the whole of the municipal district of the Shire of Healesville.

Resolution adopting this By-law agreed to by the Council on 31st July, 1962, and confirmed on 28th August, 1962.

The common seal of the President, Councillors and Ratepayers of the Shire of Healesville was hereto affixed the 28th day of August, 1962, in the presence of—

(SEAL) R. J. RICHARDS, President.  
ERNEST N. LYNE, Councillor.  
W. M. OLIVER, Secretary.

Submitted to the Commission of Public Health on the 18th day of September, 1962.—A. T. GARDINER, Secretary, Commission of Public Health.

Approved by the Governor in Council on the 7th day of November, 1962.—N. G. WISHART, Clerk of the Executive Council. 3508

## SHIRE OF KERANG.

## LOAN No. 52.

NOTICE is hereby given that the Council of the Shire of Kerang proposes to borrow the sum of Fifteen thousand pounds (£15,000) on the credit of the municipal revenues of the President, Councillors and Ratepayers of the Shire of Kerang, such sum to be raised by the grant of a mortgage in accordance with the provisions of the *Local Government Acts*.

1. The maximum rate of interest that may be paid is 5½ per cent. per annum.
2. The purpose for which the loan is to be applied is part of cost of Kerang Swimming Pool.
3. The period of the loan shall be fifteen years.
4. The moneys borrowed shall be repayable by providing out of the municipal fund 30 half-yearly instalments of approximately £740 15s. 4d. each, including principal and interest on the 14th day of January and 14th day of July during the currency of the loan. The first instalment shall be payable on the 14th July, 1963.
5. Such moneys shall be repayable at the C.B.C. Savings Bank Limited, Melbourne.

The plans and specifications and the estimate of the cost of the proposed works, and a statement showing the proposed expenditure of the moneys to be borrowed, are open for inspection at the Memorial Municipal Chambers, Kerang.

Dated at Kerang, this 6th day of November, 1962.

3531

L. R. RUNDLE, Shire Secretary.

## SHIRE OF MALDON.

## BY-LAW No. 20.

A By-law of the Shire of Maldon, made under the *Health Act 1958*, and numbered 20, for the purpose of prescribing fees to be charged for the registration of premises required under the said Act, to be registered, and for the renewal of such registrations and for the transfer of registration thereof, pursuant to the said Act.

IN pursuance of the powers conferred by the *Health Act 1958*, and by every Act or power enabling it in that behalf the President, Councillors and Ratepayers of the Shire of Maldon make this By-law and order as follows:—

1. By-law No. 12 of the Shire of Maldon is hereby repealed.
2. The fees to be charged, received and taken by the Council of the Shire of Maldon for the registration of premises described in the Schedule hereto, and for the annual renewals thereof and for any transfers of such



registrations respectively, pursuant to the provisions of the *Health Act 1958*, shall be as set out in the Schedule hereto.

3. Such fees shall be paid to the Shire Secretary by any person making application for such registration, renewals or transfer respectively.

4. This By-law shall apply to and have operation throughout the whole of the municipal district of the Shire of Maldon.

SCHEDULE REFERRED TO IN THIS BY-LAW.

(a) For every registration and for every annual renewal of registration of premises:—

Nature of Premises.	Fees Payable.	
	£	s. d.
Offensive Trade Premises (other than those referred to below) .. .. .	2	10 0
Offensive Trade Premises, being fat extracting or melting or rendering works which are conducted at premises occupied principally as a butcher's shop and at which fat is extracted, melted or rendered from materials derived from such shop .. .. .	1	0 0
Offensive Trade Premises—Poultry killing or cleaning or dressing .. .. .	2	2 0
Cattle Sale-yards .. .. .	1	0 0
Boarding-houses .. .. .	1	0 0
Common Lodging-houses .. .. .	1	0 0
Eating-houses .. .. .	1	0 0
Apartment-houses—containing not more than one apartment .. .. .	0	10 0
Containing more than one apartment .. .. .	1	0 0
Camping areas .. .. .	1	0 0
Food Premises—		
(i) where five or less than five persons are employed .. .. .	0	10 0
(ii) where from six to twenty persons are employed .. .. .	1	0 0
(iii) where from 21 to 50 persons are employed .. .. .	2	0 0
(iv) where more than 50 persons are employed .. .. .	5	0 0
Premises at or in any part of which eggs for sale are received or stored for the purpose of being chilled .. .. .	1	0 0
Hairdresser's Beauty Parlours and Chiropodist's Establishments .. .. .	1	0 0

(b) For any transfer of registration of any of the said premises the fee shall be Two shillings and six pence.

(c) Applications for renewal of registration shall be lodged with the Shire Secretary on or before the 15th day of November in each year, and the Certificate of Registration then in force shall be lodged with each application.

(d) Where application for renewal is not lodged with the Council until after such date an additional fee of one half of the relevant prescribed fee otherwise payable shall be paid.

Resolution for passing this By-law agreed to by the Council of the Shire of Maldon, the 5th day of July, 1962, and confirmed the 2nd day of August, 1962.

The common seal of the President, Councillors and Ratepayers of the Shire of Maldon was affixed hereto in the presence of—

(SEAL) R. S. STEELE, President.  
A. E. WOOD, Councillor.  
S. R. BEACH, Shire Secretary.

Submitted to the Commission of Public Health on the 2nd day of October, 1962.—A. T. GARDNER, Secretary to the Commission.

Approved by the Governor in Council on the 7th day of November, 1962.—N. G. WISHART, Clerk of the Executive Council. 3532

Sewerage Districts Acts.

SHIRE OF MORNINGTON.

PROPOSED MOUNT ELIZA SEWERAGE AUTHORITY.

NOTICE is hereby given that the Mornington Shire Council has made application to the Honorable the Minister of Water Supply for the constitution of a Sewerage Authority and for the Proclamation of a sewerage district at Mount Eliza, and for the construction, maintenance and continuance of sewerage works within that district under the provisions of the Sewerage Districts Acts.

A general plan and description of the proposed works have been submitted with the application, and copies of same may be seen at—

- (i) The Mornington Civic Centre, Queen-street, Mornington.
- (ii) The offices of the State Rivers and Water Supply Commission, 90 Orrong-road, Armadale.
- (iii) The offices of the Commission of Public Health, 295 Queen-street, Melbourne.

Dated at Mornington the 9th day of November, 1962,  
3418 D. G. COLLINGS, Shire Secretary.

SHIRE OF RODNEY.

NOTICE is hereby given that Senior Constable Ira Vendor Smith, No. 9826, has been appointed Prosecuting Officer for the Shire of Rodney in the Merrigum Riding, vice First Constable R. J. Blain, transferred.

3485 R. PERRY, Shire Secretary.

SHIRE OF RODNEY.

BY-LAW No. 67.

A By-law of the Shire of Rodney made under section 65 of the *Health Act 1958* as amended by the *Health (Amendment) Act 1960* and numbered 67 for fixing a fee for the examination of plans, specifications, particulars and descriptions of proposed septic tank systems and any inspection of sites and installations.

IN pursuance of the powers of the *Health Act 1958* and of any and every other power it thereunto enabling the President, Councillors and Ratepayers of the Shire of Rodney order as follows:—

1. The following fee is hereby fixed:—

For the examination of plans, specifications, particulars and descriptions of proposed septic tank systems, and any inspection of sites and installations of septic tank systems—£1 (One pound).

Resolution for passing this By-law was agreed to by the Council of the Shire of Rodney on the 3rd day of September, 1962, and confirmed on the 29th day of October, 1962.

The corporate seal of the President, Councillors and Ratepayers of the Shire of Rodney was hereunto affixed in the presence of—

(SEAL) S. YOULDEN, President.  
T. HASTIE, Councillor.  
3484 REUBEN PERRY, Shire Secretary.

SHIRE OF RUTHERGLEN.

ORDER OF THE COUNCIL SPECIFYING SHOPPING AREAS.

IN pursuance of the powers conferred by the Dog Acts, the Council of the Shire of Rutherglen, at a meeting held on the 2nd day of November, 1962, did order that the shopping areas defined in the Schedule hereto, be specified for the purposes of section 17 of the *Dog Act 1958* (No. 6236) as amended by section 10 of the *Dog Act 1961* (No. 6848).

SCHEDULE OF SHOPPING AREAS.

1. Main-street, Rutherglen, between railway crossing north-east of Fortune-street and the easterly side of right-of-way on west of section C, Township of Rutherglen, Parish of Carlyle.

2. Foord-street, Wahgunyah, northward from the northern side of Blanche-street to the Murray River.  
3504 C. A. RICKETTS, Shire Secretary.

SHIRE OF WHITTLESEA.

LOAN No. P.S. 7.

Private Streets Account.

NOTICE is hereby given that at the meeting of the Council of the Shire of Whittlesea, held at the Shire Office, Epping, on 1st October, 1962, the said Council did agree to the following Resolution, that is to say:—

“That—

- (a) This Council borrow moneys by the grant of a mortgage upon the credit of the municipality, pursuant to section 585 of the Local Government Acts.
- (b) The amount of the principal moneys to be borrowed be £20,000.
- (c) The rate of interest to be paid be 5½ per cent. per annum.

- (d) The moneys borrowed be repayable by twenty instalments of £1,313 8s. 8d. each, payable respectively on the 1st day of June and on the 1st day of December of each year. The first such instalment being repayable on the 1st day of June, 1963.
- (e) The moneys borrowed be repayable at the Commercial Savings Bank of Australia Limited, Melbourne.
- (f) The loan be applied for the purpose of defraying part of the cost of the execution of schemes for the construction of private streets, pursuant to Division 10 of Part XIX. of the Local Government Acts.
- (g) The loan be liquidated by providing out of the receipts from owners made liable under the schemes, or, in case such receipts are insufficient, then by providing from the municipal fund, in each half-year during the currency of the loan the sum of £1,313 8s. 8d., which sum includes principal and interest."

And notice is hereby further given that, at the meeting of the said Council held at the Shire Office, Epping, on 19th November, 1962, the said Resolution was confirmed.

3533

R. G. C. COOK, Shire Secretary.

SHIRE OF WODONGA.

BY-LAW No. 52.

A By-law of the Shire of Wodonga, made under the Dog Acts, and numbered 52, for fixing registration and other fees thereunder.

IN pursuance of the powers conferred by the Dog Acts and of any and every other power it thereunto enabling, the President, Councillors and Ratepayers of the Shire of Wodonga order as follows:—

1. By-law No. 41 is hereby repealed.
2. The following fees and sums are hereby fixed, pursuant to the Dog Acts:—
 

	£	s.	d.
(a) For registration, pursuant to section 6 of Dog Act 1958, as amended by any Act	0	10	0
(b) For particulars of any dog or the name of the registered owner thereof or for a certified copy of the receipt mentioned in section 12 of the Dog Act 1958, as amended by any Act	0	2	6
(c) Sum payable to the Registration Officer, pursuant to section 15 of the Dog Act 1958, as amended by any Act	3	0	0
(d) Sum payable to the Registration Officer, pursuant to section 16 of the Dog Act 1958, as amended by any Act	3	0	0

3. This By-law shall apply to and have operation throughout the whole of the municipal district.

Resolution for passing this By-law agreed to by the Council on the 3rd day of October, 1962, and confirmed on the 7th day of November, 1962.

The common seal of the President, Councillors and Ratepayers of the Shire of Wodonga was hereunto affixed, in the presence of—

(SEAL) A. G. RICHARDSON, President.  
 J. P. MYLON, Councillor.  
 3539 H. MCK. SILKE, Shire Secretary.

THE BALLARAT SEWERAGE AUTHORITY.

GENERAL NOTICE.

THE above-mentioned Sewerage Authority having made provision for carrying off the sewage from each and every property which or any part of which is within the Sewerage Area hereinafter described, doth hereby declare that on and after the 1st day of December, 1962, each and every property which or any part of which is within the said Sewerage Area shall be deemed to be a seweraged property within the meaning of the *Sewerage Districts Act 1958*.

The boundaries of the Sewerage Area hereinbefore referred to are:—

*Sewerage Area No. 216.*

*Shire of Ballarat.*—Commencing at the north-east corner of a vacant allotment, lot No. 499, being a point on the south building line of Willow-grove and about 173 feet west of Marigold-street, and being a point on the boundary of Sewerage Area No. 209; thence northerly across Willow-grove to the south-west corner of a vacant allotment, lot No. 505, being about 153 feet west of Marigold-street, north-westerly to the north-

west corner of the said lot No. 505, north-easterly along the southern boundary of a Reserve for recreation, drainage and sewerage to the north-west corner of a vacant allotment, lot No. 526, being about 145 feet east of Marigold-street, south-easterly and southerly along the northern and eastern boundaries of the said lot No. 526 to the south-east corner of the said lot No. 526, being a point on the north building line of Willow-grove, south-easterly across Willow-grove to the north-east corner of a vacant allotment, lot No. 407, generally south-easterly along the west building line of Willow-grove to the south-west corner of Willow-grove and Gillies-street, southerly along the west building line of Gillies-street to the north-west corner of Gillies and Aster streets, generally westerly along the north building line of Aster-street to the north-east corner of Aster-street and Maple-avenue, westerly across Maple-avenue to the north-east corner of No. 43 Maple-avenue, being a point on the boundary of Sewerage Area No. 211; thence northerly, easterly, northerly, north-westerly and south-westerly along the boundaries of Sewerage Areas Nos. 211 and 209 to the point of commencement.

Further particulars regarding the streets or parts of streets in which sewers have been laid may be ascertained on inquiry at the Authority's office.

By order of the said Sewerage Authority.

3536

A. W. NICHOLSON, Chairman.  
 CHAS. H. CLAMP, Secretary.

HAMILTON SEWERAGE AUTHORITY.

GENERAL NOTICE.

THE above-mentioned Sewerage Authority, having made provision for carrying off the sewage from each and every property which, or any part of which, is within the Sewerage Areas hereinafter described, doth hereby declare that on and after the 20th day of December, 1962, each and every property which, or any part of which, is within the said Sewerage Areas shall be deemed to be a seweraged property within the meaning of the *Sewerage Districts Act 1958*.

The boundaries of the Sewerage Areas hereinbefore referred to are:—

*Sewerage Area No. 13.*

Commencing at a point on the eastern building line of George-street, being the north-western corner of Crown allotment 5, section 11, Parish of South Hamilton, at Hamilton, being a point on the boundary of Sewerage Area No. 10; thence easterly along the boundary of Sewerage Area No. 10 to a point distant 120 feet from the eastern building line of George-street; thence northerly by a line parallel to the eastern building line of George-street and distant 120 feet therefrom to the point of intersection with the boundary of Sewerage Area No. 6; thence westerly, southerly, easterly and northerly along the boundaries of Sewerage Areas No. 6 and No. 10 to the point of commencement.

*Sewerage Area No. 14.*

Commencing at a point on the western boundary of Crown allotment 7, section A, Parish of North Hamilton, County of Dundas, distant 132 feet south of the southern building line of Kenny-street, being a point on the western boundary of Sewerage Area No. 4; thence westerly by a line parallel to the southern boundary of Kenny-street and distant 132 feet therefrom to the north-eastern corner of lot 29 on lodged plan of subdivision 40731; thence southerly along the eastern boundaries of lots 29 to 41 inclusive to the south-eastern corner of lot 41 on the said lodged plan of subdivision 40731; thence westerly along the southern boundary of the said lot 41 to its south-western corner; thence northerly along the western boundaries of lots 41 to 32 on the said lodged plan 40731 to the north-western corner of lot 32; thence westerly across Queen-street to the north-western corner of Queen and Prince streets; thence westerly along the northern building line of Prince-street to the north-western corner of Prince and Elizabeth streets; thence southerly along the western building line of Elizabeth-street to the south-eastern corner of Elizabeth and Charles streets; thence south-westerly by a line across Charles-street to the north-eastern corner of lot 72 on lodged plan of subdivision 40731; thence southerly to the south-eastern corner of the said lot 72; thence westerly along the southern boundaries of lots 72, 71 and 70 to the eastern building line of McPhee-street; thence northerly along the eastern building line of McPhee-street to the south-eastern corner of McPhee and Kenny streets; thence westerly across McPhee-street and along the southern building line of Kenny-street to the north-western corner of Crown allotment 11, section A, Parish of North Hamilton; thence north-westerly across Kenny-street to the south-western

corner of lot 52 on lodged plan of subdivision 33854; thence northerly, north-easterly and south-easterly along the boundaries of lot 52 and lot 53 on the said lodged plan 33854 to the western building line of Walls-crescent; thence due east to the eastern building line of Walls-crescent; thence northerly along the eastern building line of Walls-crescent to the north-western corner of lot 58 on lodged plan of subdivision 33854; thence easterly and southerly along the boundaries of lots 58, 57 and 56 to the south-eastern corner of lot 56; thence easterly by a line parallel to the northern building line of Kenny-street and distant 116 ft. 1½ in. therefrom to the western boundary of Crown allotment 49, section A, Parish of North Hamilton; thence southerly, easterly, northerly and westerly along the western, southern, eastern and northern boundaries of Crown allotment 49 and along the southern boundary of Crown allotment 39 of the said section A, to a point distant 150 feet west of the south-eastern corner of Crown allotment 39; thence northerly by a line parallel to the eastern boundary of Crown allotment 39 to the southern building line of Lewis-street; thence easterly along the southern building line of Lewis-street to its intersection with the south-western building line of Coleraine-road; thence north-westerly across Coleraine-road to the corner of King and Hammond streets; thence northerly along the eastern building line of Hammond-street to a point distant 330 feet north of the north-western boundary of Crown allotment 59, section A, Parish of North Hamilton; thence easterly by a line parallel to the northern boundary of Crown allotment 59 for a distance of 150 feet; thence southerly by a line parallel to the eastern building line of Hammond-street and distant 150 feet therefrom to a point on the northern boundary of the said Crown allotment 59; thence easterly and southerly along the northern and eastern boundaries and eastern boundary produced, of the said Crown allotment 59 to the southern building line of King-street; thence easterly along the southern building line to the south-western corner of King and Lindsay streets; thence due north across King-street to a point 200 feet north of the northern building line of King-street; thence easterly by a line parallel to and distant 200 feet northerly of the northern building line of King-street to a point 200 feet west of the western building line of Mt. Baimbridge-road; thence northerly by a line parallel to and 200 feet westerly of the western building line of Mt. Baimbridge-road to a point 450 feet south of the southern building line of Kent-road; thence easterly by a line parallel to and distant 450 feet southerly of the southern building line of Kent-road to the western building line of Mt. Baimbridge-road and across Mt. Baimbridge-road to a point on its eastern building line; thence northerly along the eastern building line of Mt. Baimbridge-road to a point distant 132 feet south of the southern building line of Kent-road; thence due east for a distance of 165 feet; thence southerly by a line parallel to and distant 165 feet easterly of the eastern building line of Mt. Baimbridge-road to a point distant 150 feet north of the northern building line of King-street; thence easterly by a line parallel to and distant 150 feet northerly of the northern building line of King-street to a point on the western boundary of Crown allotment 40, section C, Parish of North Hamilton; thence northerly along the western boundaries of Crown allotments 40 and 39 to the southern building line of Kent-road; thence easterly along the southern building line of Kent-road to a point distant 120 feet west of the western building line of Gordon-street; thence northerly across Kent-road to the south-western corner of lot 2 on lodged plan of subdivision 30961; thence northerly along the western boundaries of lots 2 and 3 of the said lodged plan to the north-western corner of lot 3; thence easterly and southerly along the northern and eastern boundaries of the said lot 3 to the south-eastern corner of lot 3; thence easterly by a line parallel to and distant 145 ft. 2½ in. northerly of the northern building line of Kent-road to its intersection with the eastern building line of Kerr-street, being a point on the boundary of Sewerage Area No. 7; thence southerly, westerly, southerly, easterly and southerly along the western boundary of Sewerage Area No. 7 to the northern building line of Hector-street; thence westerly along the northern building line of Hector-street to a point on the eastern boundary of Crown allotment 30, section C, Parish of North Hamilton; thence southerly along the eastern boundary of the said Crown allotment 30 to a point on the northern boundary of lot 28 of lodged plan of subdivision 14329; thence easterly and southerly along the northern boundaries of lots 28 and 29 and the eastern boundary of lot 29 of the said lodged plan to the south-eastern corner of lot 29, being the north-eastern corner of Wright-street; thence southerly along the eastern building line of Wright-street to a point distant 140 feet north of the northern building line of King-street, being a point on the boundary of Sewerage Area No. 7; thence westerly,

southerly, westerly, southerly, south-easterly, south-westerly, northerly, westerly, north-westerly, southerly, north-westerly, westerly, northerly and westerly along the boundaries of Sewerage Areas Nos. 7, 5 and 4 to a point distant 160 feet west of the western building line of Lindsay-street; thence northerly by a line parallel to and distant 160 feet westerly of the western building line of Lindsay-street to a point distant 160 feet south of the southern building line of King-street; thence westerly by a line parallel to and distant 160 feet southerly of the southern building line of King-street to a point on the north-eastern building line of Coleraine-road; thence south-easterly along the north-eastern building line of Coleraine-road to a point on the southern boundary of Crown allotment 57, section A, Parish of North Hamilton, distant approximately 150 feet westerly from its eastern boundary, being a point on the western boundary of Sewerage Area No. 4; thence westerly, southerly, south-easterly, southerly, easterly and southerly along the boundary of Sewerage Area No. 4 to the point of commencement.

S. R. HARRIS, Chairman.  
J. E. RILEY, Member.  
H. F. DONALD, Secretary.

3509

## SHEPPARTON SEWERAGE AUTHORITY.

## GENERAL NOTICE.

*Defining Sewered Area No. 25.*

THE above-mentioned Sewerage Authority, having made provision for carrying the sewage from each and every property which, or any part of which, is within the sewered area hereinafter described, doth hereby declare that on and after the first day of December, 1962, each and every property which, or any part of which, is within the said sewered area, shall be deemed to be a sewered property within the meaning of the *Sewerage Districts Act 1958*.

## SCHEDULE.

The boundaries of the sewered area hereinafter referred to are as follows:—

*Sewered Area No. 25.*

Commencing at a point being the intersection of the western prolongation of the northern building line of Gilchrist-street with the western building line of Archer-street; thence northerly by part of that western building line of Archer-street across Sobraon-street to its intersection with the northern building line of Ashenden-street being the south-east corner of allotment 9, lodged plan No. 33434; thence easterly across Archer-street to the north-west corner of allotment 1, lodged plan No. 20523; thence easterly by the northern boundaries of allotments 1, 3, 4, 6, 7, 9, 10 and 12, lodged plan No. 20523 being also the southern boundaries of Sewered Areas Nos. 18 and 19 to the western building line of Callister-street; thence southerly by part of the western building line of Callister-street across Keppel-street and Maxwell-street to its intersection with the northern building line of Gilchrist-street being the south-east corner of allotment 58, lodged plan No. 20523; thence easterly by part of the northern building line of Gilchrist-street across Archer-street to the point of commencement.

V. E. VIBERT, Chairman.  
R. O'BRIEN, Secretary.

3502

## WARRAGUL WATERWORKS TRUST.

## PROPOSED DARNUM URBAN DISTRICT.

NOTICE is hereby given that the Warragul Waterworks Trust has made application to the Honorable the Minister of Water Supply for the proclamation of an Urban District at Darnum, and the construction, maintenance, and continuance of water supply works within that district under the provisions of the Water Acts.

A general plan and description of the proposed works have been submitted with the application, and copies of the same may be seen at the Trust's office at Warragul.

Dated at Warragul the 29th day of October, 1962.

3294

R. W. LEASK, Secretary.

NOTICE is hereby given that the Harrow Golf Club has applied for a lease of allotment 71A, Parish of Harrow, containing 180 acres 0 roods 30 perches, pursuant to section 134 of the *Land Act 1958*, for the purpose of amusement and recreation for a term of 21 years.

3235

**NOTICE** is hereby given that San Remo Fishermen's Co-operative Society Limited of San Remo has applied for a lease under section 134 of the *Land Act 1958*, for a term of 20 years, of allotment 1F, section A, Township of San Remo, Parish of Woolamai, as a site for Fish Freezing Works. 3224

**NOTICE** is hereby given that the Yackandandah and District Bowling Club has applied for a lease for a term of 21 years, under section 134 of the *Land Act 1958*, of 1 acre and 25 perches being allotment 6, section 10, Township of Yackandandah, for purposes of Amusement and Recreation (bowling green). 3297

**NOTICE OF INTENTION TO APPLY FOR A LICENCE TO DIVERT WATER AND CUT RACE FROM THE RIVER MURRAY, AT ROBINVALE.**

**I** HEREBY give notice that I intend to apply for a licence empowering me to divert water for a term of seven and a half years to the extent of 9 acre-feet per annum at a maximum rate of 2½ acre-feet per day of 24 hours for the market garden and pasture, being part of allotments 72 and 73, Parish of Bumbang, and to occupy certain Crown lands for works of diversion, and to cut a race thereon.

Any objection to such application must be forwarded, in writing, to reach the State Rivers and Water Supply Commission, Melbourne, before 9th December, 1962, being thirty days from the first publication of this notice.

ROBERT EDWARD KNIGHT.  
JEAN KNIGHT.

Box 407, Robinvale, Victoria. 3505

**NOTICE OF INTENTION TO APPLY FOR A LICENCE TO DIVERT WATER AND CUT RACE FROM THE RIVER MURRAY, AT KARADOC.**

**I** HEREBY give notice that I intend to apply for a licence empowering me to divert water for a term of eight years to the extent of 50 acre-feet per annum at a maximum rate of 5 acre-feet per day of 24 hours for the irrigation of 17 acres of pasture, being part of allotment 12, section B1, Parish of Mildura, and to occupy certain Crown lands for works of diversion, and to cut a race thereon.

Any objection to such application must be forwarded, in writing, to reach the State Rivers and Water Supply Commission, Melbourne, before 7th December, 1962, being 30 days from the first publication of this notice.

REINHOLD EDWIN ROHDE.

Box 206, Mildura. 3518

**NOTICE OF INTENTION TO APPLY FOR A LICENCE TO DIVERT WATER AND CUT RACE (RE-ISSUE) FROM THE RIVER MURRAY, AT NICHOLS POINT.**

**I** HEREBY give notice that I intend to apply for a licence empowering me to divert water for a term of eight years to the extent of 8½ acre-feet per annum at a maximum rate of 1½ acre-feet per day of 24 hours for the irrigation of 2½ acres of vines and market garden, being part of allotment 7, section 6, Parish of Mildura, and to occupy certain Crown lands for works of diversion, and to cut a race thereon.

Any objection to such application must be forwarded, in writing, to reach the State Rivers and Water Supply Commission, Melbourne, before 21st December, 1962, being 30 days from the first publication of this notice.

HOWARD FISHER.

Nichols Point, Post Office. 3506

**NOTICE OF INTENTION TO APPLY FOR A LICENCE TO DIVERT WATER AND CUT RACE FROM THE RIVER MURRAY, AT PIANGIL.**

**I** HEREBY give notice that I intend to apply for a licence empowering me to divert water for a term of eight years to the extent of 60 acre-feet per annum at a maximum rate of 5 acre-feet per day of 24 hours for the irrigation of 20 acres, being part of allotment 150, Parish of Piangil, and to occupy certain Crown lands for works of diversion, and to cut a race thereon.

Any objection to such application must be forwarded, in writing, to reach the State Rivers and Water Supply Commission, Melbourne, before 20th December, 1962, being 30 days from the first publication of this notice.

HAROLD HANKINSON.

Box 15, Piangil. 3499

**NOTICE OF INTENTION TO APPLY FOR A LICENCE TO DIVERT WATER AND CUT RACE FROM THE RIVER MURRAY, AT ROBINVALE.**

**I** HEREBY give notice that I intend to apply for a licence empowering me to divert water for a term of seven years to the extent of 9 acre-feet per annum at a maximum rate of 1 acre-foot per day of 24 hours for the growing of 3 acres of vegetables, being part of allotment 8, Parish of Bumbang, and to occupy certain Crown lands for works of diversion, and to cut a race thereon.

Any objection to such application must be forwarded, in writing, to reach the State Rivers and Water Supply Commission, Melbourne, before 21st December, 1962, being 30 days from the first publication of this notice.

ROBERT HAMILTON OLIVER.

Robinvale Post Office, Victoria. 3498

**NOTICE OF INTENTION TO APPLY FOR A LICENCE TO DIVERT WATER AND CUT RACE FROM THE RIVER MURRAY AT MERBEIN.**

**I** HEREBY give notice that I intend to apply for a licence empowering me to divert water for a term of eight years to the extent of 9 acre-feet per annum at a maximum rate of 1 acre-foot per day of 24 hours for the irrigation of 3 acres, being part of allotment 4J, section G, Parish of Merbein, and to occupy certain Crown lands for works of diversion, and to cut a race thereon.

Any objection to such application must be forwarded, in writing, to reach the State Rivers and Water Supply Commission, Melbourne, before 13th December, 1962, being 30 days from the first publication of this notice.

MERBEIN BRICKWORKS PTY. LTD.

P.O. Box 141, Merbein, Victoria. 3493

**NOTICE OF INTENTION TO APPLY FOR A LICENCE TO DIVERT WATER AND CUT RACE FROM THE RIVER MURRAY, AT ROBINVALE.**

**I** HEREBY give notice that I intend to apply for a licence empowering me to divert water for a term of seven and a half years to the extent of 9 acre-feet per annum at a maximum rate of ½ acre-foot per day of 24 hours for the irrigation of 3 acres of vines, being part of allotment 9, Parish of Bumbang, and to occupy certain Crown lands for works of diversion, and to cut a race thereon.

Any objection to such application must be forwarded, in writing, to reach the State Rivers and Water Supply Commission, Melbourne, before 8th December, 1962, being 30 days from the first publication of this notice.

WILLIAM FRANCIS LUCAS.

Box 172, Robinvale. 3492

**NOTICE OF INTENTION TO APPLY FOR A LICENCE TO DIVERT WATER AND CUT RACE FROM THE RIVER MURRAY, AT ROBINVALE.**

**I** HEREBY give notice that I intend to apply for a licence empowering me to divert water for a term of seven and a half years to the extent of 9 acre-feet per annum at a maximum rate of ½ acre-foot per day of 24 hours for the irrigation of 3 acres of pasture and fruit trees, being part of allotment 2, Parish of Bumbang, and to occupy certain Crown lands for works of diversion, and to cut a race thereon.

Any objection to such application must be forwarded, in writing, to reach the State Rivers and Water Supply Commission, Melbourne, before 16th December, 1962, being 30 days from the first publication of this notice.

ARTHUR HENRY DIXON.

Box 297, Robinvale. 3491

**NOTICE OF INTENTION TO APPLY FOR A LICENCE TO DIVERT WATER AND CUT RACE FROM THE RIVER MURRAY, AT ROBINVALE.**

**I** HEREBY give notice that I intend to apply for a licence empowering me to divert water for a term of seven and a half years to the extent of 12 acre-feet per annum at a maximum rate of 2 acre-feet per day of 24 hours for the irrigation of 4 acres of fruit trees and vines, being part of allotment part 2A, section C, Parish of Bumbang, and to occupy certain Crown lands for works of diversion, and to cut a race thereon.

Any objection to such application must be forwarded, in writing, to reach the State Rivers and Water Supply Commission, Melbourne, before 16th December, 1962, being 30 days from the first publication of this notice.

HOWARD LINDSAY WELSH.

Lock-road, Robinvale. 3490

**NOTICE OF INTENTION TO APPLY FOR A LICENCE TO DIVERT WATER AND CUT RACE FROM THE RIVER MURRAY AT PIANGIL.**

WE hereby give notice that we intend to apply for a licence empowering us to divert water for a term of seven years to the extent of 60 acre-feet per annum at a maximum rate of 24 acre-feet per day of 24 hours for the irrigation of 20 acres, being part of allotments 111 and 112, Parish of Piangil, and to occupy certain Crown lands for works of diversion, and to cut a race thereon.

Any objection to such application must be forwarded, in writing, to reach the State Rivers and Water Supply Commission, Melbourne, before 31st December, 1962, being 30 days from the first publication of this notice.

JOHN HENRY LUKE.  
A. BREE.

Piangil.  
Garden and Green, solicitors, 4 McCallum-street, Swan Hill. 3571

**NOTICE OF INTENTION TO APPLY FOR A LICENCE TO DIVERT WATER AND CUT RACE FROM THE RIVER MURRAY AT ROBINVALE.**

I HEREBY give notice that I intend to apply for a licence empowering me to divert water for a term of eight years to the extent of 9 acre-feet per annum at a maximum rate of 5 acre-feet per day of 24 hours for the irrigation of 3 acres, being allotment 63, Parish of Bumbang, County of Karkaroc, and to occupy certain Crown lands for works of diversion, and to cut a race thereon.

Any objection to such application must be forwarded, in writing, to reach the State Rivers and Water Supply Commission, Melbourne, before 15th December, 1962, being 30 days from the first publication of this notice.

WILLIAM NOEL CHIRGWIN,

Robinvale. 3565

**NOTICE OF INTENTION TO APPLY FOR A LICENCE TO DIVERT WATER AND CUT RACE (RE-ISSUE) FROM THE RIVER MURRAY AT OLD MILDURA.**

I HEREBY give notice that I intend to apply for a licence empowering me to divert water for a term of eight years to the extent of 9 acre-feet per annum at a maximum rate of 60,000 gallons per day of 24 hours for the irrigation of a market garden, being part of allotment 16A, section 12, block E, Parish of Mildura, and to occupy certain Crown lands for works of diversion, and to cut a race thereon.

Any objection to such application must be forwarded, in writing, to reach the State Rivers and Water Supply Commission, Melbourne, before 19th December, 1962, being 30 days from the first publication of this notice.

PASQUALE VARTULI.

P.O. Box 684, Mildura. 3564

**NOTICE OF INTENTION TO APPLY FOR A LICENCE TO DIVERT WATER AND CUT RACE FROM THE RIVER MURRAY AT ROBINVALE.**

I HEREBY give notice that I intend to apply for a licence empowering me to divert water for a term of seven and a half years to the extent of 12 acre-feet per annum at a maximum rate of  $\frac{1}{2}$  acre-foot per day of 24 hours for the irrigation of lucerne and fruit trees, being part of allotment 4, section —, Parish of Bumbang, and to occupy certain Crown lands for works of diversion, and to cut a race thereon.

Any objection to such application must be forwarded, in writing, to reach the State Rivers and Water Supply Commission, Melbourne, before 6th January, 1963, being 30 days from the first publication of this notice.

THOMAS EDWARD LAWRENCE.

P.O., Robinvale. 3563

**NOTICE OF INTENTION TO APPLY FOR A LICENCE TO DIVERT WATER AND CUT RACE FROM THE GOULBURN RIVER AT WHANREGARWEN.**

I HEREBY give notice that I intend to apply for a licence empowering me to divert water for a term of twenty years to the extent of 20 acre-feet per annum at a maximum rate of  $\frac{1}{4}$  acre-foot per day of 24 hours for the establishment of pastures, being part of allotment 67, section —, Parish of Whanregarwen, and to occupy certain Crown lands for works of diversion, and to cut a race thereon.

Any objection to such application must be forwarded, in writing, to reach the State Rivers and Water Supply Commission, Melbourne, before 12th December, 1962, being 30 days from the first publication of this notice.

WILLIAM COOPER.

"River View", Molesworth. 3562

**NOTICE OF INTENTION TO APPLY FOR A LICENCE TO DIVERT WATER AND CUT RACE FROM THE RIVER MURRAY AT NED'S CORNER (LAKE CALLALLERAINNE).**

I HEREBY give notice that I intend to apply for a licence empowering me to divert water for a term of eight years to the extent of 9 acre-feet per annum at a maximum rate of 1 acre-foot per day of 24 hours for the irrigating of 3 acres, being part of allotment 11b, section —, Parish of Mallroo, and to occupy certain Crown lands for works of diversion, and to cut a race thereon.

Any objection to such application must be forwarded, in writing, to reach the State Rivers and Water Supply Commission, Melbourne, before 14th December, 1962, being 30 days from the first publication of this notice.

E. CHIRNSIDE.

Lake Callalleraine, via Mildura. 3561  
CALLALLERAINNE).

**NOTICE OF INTENTION TO APPLY FOR A LICENCE TO DIVERT WATER AND CUT RACE FROM THE RIVER MURRAY AT ROBINVALE.**

I HEREBY give notice that I intend to apply for a licence empowering me to divert water for a term of eight years to the extent of 75 acre-feet per annum at a maximum rate of 5 acre-feet per day of 24 hours for the irrigation of 25 acres, being part of allotment A, Parish of Bumbang, County of Karkaroc, and to occupy certain Crown lands for works of diversion, and to cut a race thereon.

Any objection to such application must be forwarded, in writing, to reach the State Rivers and Water Supply Commission, Melbourne, before 19th December, 1962, being 30 days from the first publication of this notice.

ROCCO CAMINITI.

Robinvale. 3560

NOTICE is hereby given that the partnership heretofore subsisting between us the undersigned Kathleen Imelda Walters, Maurice Edmond Byrne, Frances Mary Brook and William Edmond Byrne, carrying on business as spirit merchants and grocers, at 207 Balaclava-road, Caulfield, under the style or firm of Mason and Byrne, has been dissolved as from the 8th day of November, 1962, so far as concerns the said William Edmond Byrne, who retires from the said firm.

Dated the 8th day of November, 1962.

K. I. WALTERS.  
F. M. BROOK.  
M. E. BYRNE.  
W. E. BYRNE.

3609

NOTICE is hereby given that the partnership heretofore subsisting between the undersigned Ronald Raitman and Bert Wickens, carrying on business as clothing manufacturers at 22 Patrick-street, Melbourne, under the business name of "Myrobe Productions", has been dissolved by mutual consent as from the 30th day of June, 1962. All debts owing by the said firm will be paid by Ronald Raitman, who will continue to carry on business under the business name of "Myrobe Productions" at the same place.

Dated the 12th day of November, 1962.

RONALD RAITMAN.  
BERT WICKENS.

Witness to both signatures—NORMAN RAITMAN.

3607

**NOTICE OF DISSOLUTION OF PARTNERSHIP.**

NOTICE is hereby given that the partnership heretofore subsisting between Lyle Garfield Ritchie, of 52 Cummings-road, East Brighton, and Daryl Garfield Ritchie, of 15 Madden-street, Balwyn, and Robert Lachlan Piesse, of 43 Sackville-street, Kew, in the manufacture and sale of wire strainers, crimpers and fencing equipment, and carried on under the name of "R. and R. Tool Co.", has been dissolved by L. G. Ritchie and D. G. Ritchie, under section 36 (c) of the *Partnership Act 1958*, as at and from the 25th September, 1962. 3606

**NOTICE** is hereby given that the partnership heretofore subsisting between Norman John Shankly, Norman Stephen Shankly and Walter James Archer, carrying on business as solicitors at 406 Lonsdale-street, Melbourne, under the style or firm of Norman Shankly and Archer, has been dissolved by mutual consent, as from the 19th day of November, 1962. Messrs. Norman J. Shankly and Norman S. Shankly will continue to practice at 12th Floor, 406 Lonsdale-street, Melbourne, under the name Norman J. Shankly and Shankly. Telephone numbers will be unchanged, MY 1276. W. J. Archer will practice in partnership with Messrs. P. Z. Shulman and B. R. Oddy, at 5th Floor, 406 Lonsdale-street, Melbourne, under the name Archer, Shulman and Oddy, telephone number will be 67-7121. All debts due and owing by the said firm shall be received and paid by either Norman J. Shankly and Shankly, or Archer, Schulman and Oddy. 3600

**NOTICE OF DISSOLUTION OF PARTNERSHIP.**

**NOTICE** is hereby given that the partnership heretofore subsisting between the undersigned Ng Yip, Charles Hong Chun Lew, Mei Lum Lew and Henry June Hee Lew, carrying on business as Chinese restaurant keepers at 167 Exhibition-street, Melbourne, under the name of Wing Loong Cafe, has been dissolved by mutual consent. All debts due and owing by the said late firm will be received and paid by Charles Hong Chun Lew and Mei Lum Lew, who will continue to carry on the business at the same place.

Dated the 11th day of October, 1962.

NG YIP.

Signed by the said Ng Yip in Victoria in the presence of—L. J. CALDWELL.

CHARLES H. C. LEW.

Signed by the said Charles Hong Chun Lew in the presence of—COLIN KEON-COHEEN.

MEI LUM LEW.

Signed by the said Mei Lum Lew in the presence of—COLIN KEON-COHEEN.

HENRY J. H. LEW.

Signed by the said Henry June Hee Lew in the presence of—P. KIRBY. 3580

**BLACKBURN REAL ESTATE AGENCY PTY. LIMITED**  
(IN VOLUNTARY LIQUIDATION).

**NOTICE** is hereby given that a General Meeting of the above company will be held at 1 Ringwood-street, Ringwood, on 24th day of December, at Two p.m. for the purpose of laying before the meeting an account showing how the winding up has been conducted and the property of the company has been disposed of.

3612 R. W. HOLT, Liquidator.

**The Companies Act 1938.—In the matter of NATIONAL MARKET RESEARCH COMPANY PTY. LTD.**

**NOTICE** is hereby given that pursuant to section 210 of the Companies Act, a Final Meeting of the Creditors of the above company will be held at the offices of Kennedy, Smail and Middlemiss, 31 Queen-street, Melbourne, on Wednesday, the 19th December, 1962, at Ten a.m.

*Business.*—To receive the liquidator's accounts.

Dated this 16th day of November, 1962.

E. R. SMAIL, Liquidator.

Kennedy, Smail and Middlemiss, 31 Queen-street, Melbourne. 3605

**In the matter of the Companies Act 1961.—And in the Matter of NORTHERN BAKERIES (COBURG) PROPRIETARY LIMITED.**

**NOTICE** is hereby given that at an Extraordinary General Meeting of Northern Bakeries (Coburg) Proprietary Limited, held at the registered office of the company, 170 Edward-street, East Brunswick, on the 13th November, 1962, it was resolved by Special Resolution that the company be wound up voluntarily.

3601 B. T. PARKER, Secretary.

**Notice of Winding Up Order.—In the matter of RIVIERA TRADING COMPANY PROPRIETARY LIMITED.**

**WINDING UP** Order made 20th November, 1962.

Name and address of Official Liquidator: Harold Keith Cartledge, 1 Palmerston-crescent, South Melbourne.

3615 D. L. CANAVAN, Petitioner.

**The Companies Act 1961.**

**OCEAN ENTERPRISES PROPRIETARY LIMITED**  
(IN LIQUIDATION).

*Notice of Final Meeting of Members and Creditors, Pursuant to Section 272.*

**NOTICE** is hereby given that a meeting of the members and of the creditors of the above-named company will be held on the 21st day of December, 1962, at the offices of D. S. and R. M. Martin, chartered accountants, 5th Floor, 224 Queen-street, Melbourne, at Eleven o'clock a.m., for the purpose of laying before them an account showing the manner in which the winding up has been conducted and the property of the company disposed of, and of hearing any explanations that may be given.

Dated this 16th day of November, 1962.

R. M. MARTIN, Liquidator.

D. S. and R. M. Martin, chartered accountants, 224 Queen-street, Melbourne. 3542

**IN THE MATTER OF DALREY DAIRYING AND GRAZING PROPRIETARY LIMITED.**

**AT** an Extraordinary General Meeting of the above-named company held at Dalry-road, Launching Place, on the 6th day of November, 1962, the following Special Resolution was duly passed:—

“That the company be wound up voluntarily.”

And at such last-mentioned meeting R. C. D. Warne-Smith, of 1189 High-street, Glen Iris, was appointed liquidator for the purpose of the winding up.

S. ISMAIL, Chairman.

Davies, Campbell and Piesse, solicitors, 401 Collins-street, Melbourne. 3589

**GROUP TYRE SERVICE PROPRIETARY.**

8 VICTORIA-STREET, WARRAGUL.

24th November, 1962.

**IT** is resolved that the company be wound up in accordance with the provisions of the Companies Act 1961, dealing with members voluntary winding up, and that Lindsay Ernest Charles Patison be appointed liquidator for this purpose.

24th November, 1962. 3568

**Companies Act 1961.—In the matter of SEQUENCE BUTTONS PROPRIETARY LIMITED (in Liquidation).**

**NOTICE** is hereby given, pursuant to section 247, that it is intended to declare a First and Final Dividend in the above matter. Creditors who have not proved their debts by the 21st December, 1962, will be excluded therefrom.

Dated this 19th day of November, 1962.

G. R. ORR, Liquidator.

266 Swan-street, Richmond, E.1. 3566

**The Companies Act 1961.**

**MELBOURNE INVESTMENT CORPORATION PROPRIETARY LIMITED.**

**AT** an Extraordinary General Meeting of members of the above company duly convened and held at 222 Queen-street, Melbourne, on Friday, 16th November, 1962, the following Special Resolution was duly passed:—

“That the company be wound up voluntarily and that the secretary take the necessary steps for this purpose in accordance with the Companies Act 1961.”

Dated this 19th day of November, 1962.

G. D. BLACK, Liquidator.

John Rezak and Co., public accountants, First Floor, 222 Queen-street, Melbourne. 3556

**The Companies Act 1961.**

**FOLLCO (AUST.) PTY. LTD. (IN LIQUIDATION).**

**NOTICE OF FINAL MEETING, PURSUANT TO SECTION 272.**

**A** General Meeting of members of the above company will be held at the office of Danby, Bland and Co., chartered accountants, 33 Queen's-road, Melbourne, at Ten-thirty a.m. on 17th January, 1963, for the purpose of receiving the liquidator's account and his report on the conduct of the liquidation.

3541 J. W. DANBY, Liquidator.

## ALCASTON HOUSE PTY. LTD.

(IN VOLUNTARY LIQUIDATION).

NOTICE is hereby given that the Final Meeting of the above company will be held at the office of M. V. Anderson and Co., chartered accountants, 277 William-street, Melbourne, on Thursday, 20th December, 1962, at Twelve noon, for the purpose of receiving the final accounts of the liquidation.

3598 M. V. ANDERSON & J. KENNEDY, Liquidators.

CREDITORS, next of kin and others having claims in respect of the estate of Bridget Mary Ryan, formerly of 38 McKillop-street, Geelong, but late of Grace McKellar House, Bell Park, Geelong, spinster, deceased (who died on the 12th day of August, 1962), are to send particulars of their claims to the executor, National Trustees, Executors and Agency Company of Australasia Limited, of 95 Queen-street, Melbourne, by the 23rd January, 1963, after which date the said executor will distribute the assets, having regard only to the claims of which it then has notice.

CRAWCOUR & HOLLYHOKE, solicitors, 39 Yarra-street, Geelong. 3511

CREDITORS, next of kin and others having claims in respect of the estate of Caroline Maud Andrews, late of 30 Newstead-street, Caulfield, widow, deceased (who died on the 4th day of June, 1962), are requested to send particulars of their claims to the National Trustees, Executors and Agency Company of Australasia Limited, of 95 Queen-street, Melbourne, the duly authorized administrator of the estate of the said deceased, care of the said company by the 31st day of January, 1963, after which date the administrator will distribute the assets, having regard only to the claims of which it has notice.

KENNETH J. CLEMENTS, 269 Glenhuntingly-road, Elsternwick, solicitor for the administrator. 3519

CREDITORS, next of kin and others having claims in respect of the estate of Alma Jane Dunster, late of Ararat, spinster, deceased (who died on the 11th day of September, 1962), are to send particulars of their claims to the executor, The Fidelity Trustee Company Limited, of 101 Lydiard-street north, Ballarat, by the 29th day of January, 1963, after which date it will distribute the assets, having regard only to the claims of which it then has notice.

BRIGGS & O'DRISCOLL, solicitors, Ararat. 3516

CREDITORS, next of kin and others having claims in respect of the estate of Percy Albert Waters, formerly of Ararat, postal employee and retired public servant, and late of 1 Breed-street, Traralgon, retired public servant, deceased (who died on 25th June, 1962), are required to send particulars of their claims to the Fidelity Trustee Company Limited, of 101 Lydiard-street north, Ballarat, the administrator with the will annexed by the 29th day of January, 1963, after which date it will distribute the assets of the said deceased, having regard only to the claims of which it shall then have had notice.

BRIGGS & O'DRISCOLL, solicitors, Ararat. 3517

EDITH EMILY COOMBE, late of 60 Leila-road, Carnegie, spinster, DECEASED, intestate.

CREDITORS, next of kin and others having claims against the estate of the deceased (who died on 11th June, 1962), are required by the administrator, Alfred Ernest Coombe, to send particulars to him, care of 120 William-street, Melbourne, by the 24th January, 1963, after which date he may convey and distribute the assets, having regard only to the claims of which he then has notice.

BLAKE & RIGGALL, 120 William-street, Melbourne, solicitors. 3594

CREDITORS, next of kin and others having claims in respect of the estate of Mary Josephine Edwards, late of 15 Walker-street, Prahran, married woman, deceased, intestate (who died on the 12th September, 1962), are to send particulars to The Fidelity Trustee Company Limited, of 50 Market-street, Melbourne, by the 26th January, 1963, after which date the assets will be distributed by the said company, having regard only to claims of which it then has notice.

THE FIDELITY TRUSTEE CO. LTD., 50 Market-street, Melbourne. 3593

## Trustee Act 1958.

## NOTICE TO CLAIMANTS.

PURSUANT to the Trustee Act 1958, creditors, next of kin and all other persons having claims in respect of the estate of any deceased person named below are required to send particulars to the legal personal representative or representatives, at the address stated, after which date the representative or representatives will distribute the assets, having regard only to the claims of which notice has been received:—

Harold Chapman, late of 64 Cox-street, Port Fairy, retired boot repairer, deceased, died 26th June, 1962.—Claims to the executrix, Hazel Annie Broadley, of 5 Grant-street, Port Fairy, married woman, care of Conlan and Leishman, solicitors, 38 Bank-street, Port Fairy, by 28th January, 1963. 3489

CREDITORS, next of kin and others having claims in respect of the estate of William Aiken, late of 29 Second-avenue, East Kew, engineer, deceased (who died on the 23rd May, 1962), are to send particulars of their claims to The Perpetual Executors and Trustees Association of Australia Limited, of 100-104 Queen-street, Melbourne, by the 29th day of January, 1963, after which date it will distribute the assets, having regard only to the claims of which it then has notice.

HENDERSON & BALL, solicitors, 430 Little Collins-street, Melbourne. 3591

CREDITORS, next of kin and others having claims in respect of the estate of Lillian Gertrude Henshall, late of 35 Grey-street, St. Kilda, widow, deceased (who died on the 22nd July, 1962), are hereby required to send particulars of such claims, in writing, to The Equity Trustees, Executors and Agency Company Limited, of 472 Bourke-street, Melbourne, on or before the 29th day of January, 1963, after which date the said company will proceed to distribute the assets of the said deceased among the persons entitled thereto, having regard only to the claims of which it then shall have had notice.

DUGDALE, DIMMICK & STEVENS, "Peacock House", 486 Bourke-street, Melbourne, solicitors for the said company. 3590

CREDITORS, next of kin and others having claims in respect of the estate of Gertrude Anneke Wallace, formerly of Narrandera, but late of 142 Park-street, West Brunswick, widow, deceased (who died on 4th July, 1962), are hereby required to send particulars of such claims, in writing, to The Equity Trustees, Executors and Agency Company Limited, 472 Bourke-street, Melbourne, on or before the 22nd day of January, 1963, after which date the said company will proceed to distribute the assets of the said deceased among the persons entitled thereto, having regard only to the claims of which it then shall have had notice.

DUGDALE, DIMMICK & STEVENS, "Peacock House", 486 Bourke-street, Melbourne, solicitors for the said company. 3588

CREDITORS, next of kin and others having claims in respect of the estate of Mabel Lillian Chambers, formerly of 7 Birdwood-avenue, Elwood, late of 58 Cochrane-street, Brighton, widow, deceased (who died on the 10th August, 1962), are hereby required to send particulars of such claims, in writing, to Charles Richard Stevens and Arnold William Dugdale, both of 486 Bourke-street, Melbourne, solicitors, on or before the 22nd day of January, 1963, after which date they will proceed to distribute the assets of the said deceased among the persons entitled thereto, having regard only to the claims of which they then shall have had notice.

DUGDALE, DIMMICK & STEVENS, "Peacock House", 486 Bourke-street, Melbourne, solicitors. 3587

CREDITORS, next of kin and others having claims in respect of the estate of Roger Francis Welsh, late of Barnawartha South, in the State of Victoria, farmer and grazier, deceased (who died on the 11th day of November, 1961), are to send particulars of their claims to the executors, Ruth Welsh, widow, and Richard Alan Welsh, farmer, both of Barnawartha South, addressed to the care of Frank B. Lethbridge, solicitor, Main-street, Rutherglen, by the 23rd day of January, 1963, after which date the said executors will distribute the assets, having regard only to the claims of which they shall then have had notice.

Dated the 16th day of November, 1962.

FRANK B. LETHBRIDGE, solicitor, Main-street, Rutherglen, solicitor for the executors. 3549

**CREDITORS**, next of kin and others having claims in respect of the estate of Patrick Tovey, late of Chiltern South, in the State of Victoria, farmer, deceased, intestate (who died on the 28th day of January, 1961), are to send particulars of their claims to the administratrix, Ann Pinnell Tovey, of Chiltern South, aforesaid widow, addressed to the care of Frank B. Lethbridge, solicitor, Main-street, Rutherglen, by the 23rd day of January, 1963, after which date the said administratrix will distribute the assets, having regard only to the claims of which she shall then have had notice.

Dated the 16th day of November, 1962.

FRANK B. LETHBRIDGE, solicitor, Main-street, Rutherglen, solicitor for the administratrix. 3548

**CREDITORS**, next of kin and others having claims in respect of the estate of John Goulburn Lockwood, late of Kiamal, farmer, deceased (who died on the 9th day of January, 1961), are required by Doris May Jacobs of 124 Kellett-street, Northcote, widow, to send particulars of their claims, care of her solicitor at the address set out below by the 21st January, 1963, after which date she will distribute the assets, having regard only to the claims of which she then shall have had notice.

A NEWTON SUPER, M.A., LL.B., barrister and solicitor, 366 Bourke-street, Melbourne. 3535

FLORENCE SARAH ANN THOMPSON, late of 807 Pleasant-street south, Ballarat, widow, DECEASED (who died on 20th August, 1962).

**CREDITORS**, next of kin and all persons having claims against the estate of the deceased are required to send particulars to the executor The Fidelity Trustee Company Limited (formerly The Ballarat Trustees Executors and Agency Company Limited), of 101 Lydiard-street north, Ballarat, care of its address above given on or before the 23rd January, 1963, after which date it will distribute the assets, having regard only to the claims of which it shall then have notice.

HEINZ & GORDON, solicitors, 209A Dana-street, Ballarat. 3537

THOMAS JOHNSTON BUCHAN, senior, late of White Lodge, Virginia-street, Newtown, Geelong, architect, DECEASED.

**CREDITORS**, next of kin and others having claims in respect of the estate of the deceased (who died on the 29th day of June, 1962), are required by the personal representatives The Fidelity Trustee Company Limited, of 101 Lydiard-street north, Ballarat, Thomas Johnston Buchan, junior, of 11 Fairlie-court, South Yarra, architect, and Loree Virginia Hancox, of 15 Balmoral-crescent, North Geelong, married woman, to send particulars thereof to them, care of the under-mentioned solicitors, by the 31st day of January, 1963, after which date the personal representatives may convey or distribute the assets, having regard only to the claims of which they then have notice.

WHYTE JUST & MOORE, solicitors, 27 Malop-street, Geelong. 3538

LUCY ROSE LANNIN, late of Farnsworth-street, Castlemaine, spinster, DECEASED.

**CREDITORS**, next of kin and others having claims in respect of the estate of the above-named deceased (who died on the 13th day of June, 1962), are required by the personal representative John Horwood Wightman Lawson, of Castlemaine, solicitor, to send particulars to him, in care of the undersigned solicitors, by the 31st day of January, 1963, after which date the personal representative may convey and distribute the assets, having regard only to the claims of which he then has notice.

Dated 15th November, 1962.

H. S. W. LAWSON & CO., solicitors, Castlemaine. 3521

ETHEL FLORENCE HANNAH LANNIN, late of Farnsworth-street, Castlemaine, spinster, DECEASED.

**CREDITORS**, next of kin and others having claims in respect of the estate of the above-named deceased (who died on the 25th day of January, 1962), are required by the personal representative John Horwood Wightman Lawson, of Castlemaine, solicitor, to send particulars to him, in care of the undersigned solicitors, by the 31st day of January, 1963, after which date the personal representative may convey and distribute the assets, having regard only to the claims of which he then has notice.

Dated 15th November, 1962.

H. S. W. LAWSON & CO., solicitors, Castlemaine. 3520

**CREDITORS**, next of kin and others having claims in respect of the estate of Doris Ursula Davidson, late of 4 Belmont-street, Preston, in the State of Victoria, Femme Sole, deceased (who died on the 4th day of April, 1962), are to send particulars of their claims to Allan Graham Davidson, the executor of the said deceased, care of the undersigned, by the 31st day of January, 1963, after which date he will distribute the assets, having regard only to the claims of which he has notice.

ERIC S. VANCE, solicitor, 357 Little Collins-street, Melbourne. 3614

**CREDITORS**, next of kin and others having claims in respect of the estate of Olive Doreen Morris, formerly of Flat 5, 25 The Esplanade, St. Kilda, but late of Flat 8, 44 Eildon-road, St. Kilda, in the State of Victoria, married woman, deceased (who died on the 30th day of July, 1962), are to send particulars of their claims to The Trustee, Executors and Agency Company Limited, of 401 Collins-street, Melbourne, in the said State by the 22nd day of January, 1963, after which date it will distribute the assets of the deceased, having regard only to the claims of which it then has notice.

HOME, WILKINSON & LOWRY, solicitors, 401 Collins-street, Melbourne. 3613

**CREDITORS**, next of kin and others having claims in respect of the will of Ruby Irene Gascoyne, late of 5 Adeline-street, Preston, in the State of Victoria, pensioner, deceased, (who died on the 13th day of June, 1962), are to send particulars of their claims to Lester Pearn and Fielden, of 443 Little Collins-street, Melbourne, by the 14th day of January, 1963, after which date it will distribute the assets, having regard only to the claims of which it then has notice.

LESTER PEARN & FIELDEN, solicitors, 443 Little Collins-street, Melbourne. 3611

**CREDITORS**, next of kin and others having claims in respect to the estate of Ernest Gabriel Zoukra, late of 96 Elgin-street, Hawthorn, retired company director, deceased, (who died on the 25th day of March, 1961), are required by the administratrix Mounira Daulaty Hallal, of 226 Melbourne road, North Williamstown, to send particulars thereof, by the 21st day of January, 1962, after which date the administratrix will convey or distribute the assets of the estate, having regard only to the claims of which she then has notice.

FAIRLIE GOLDENBERG & SULLIVAN, barristers and solicitors, 317 Collins-street, Melbourne. C.1. 3610

**CREDITORS**, next of kin and others having claims in respect of estate of William James Broadbent, late of 15 Richardson-street, Essendon, retired herbalist, deceased (who died on 19th July, 1962), are to send particulars of their claims to Norman Sydney Broadbent, Horace William Broadbent and The Equity Trustees, Executors and Agency Company Limited, care of The Equity, Trustees Executors and Agency Company Limited, at its registered office, situate at 472 Bourke-street, Melbourne, by the 23rd day of January, 1963, after which date they will distribute the assets, having regard only to the claims of which they then have notice.

COOK & McCALLUM, solicitors, 422 Collins-street, Melbourne. 3608

**CREDITORS**, next of kin and others having claims in respect of the estate of George Alfred Were, late of 17 Harry-street, Northcote, in the State of Victoria, electro-typer, deceased, intestate (who died on the 16th September, 1962), are required to send particulars of their claims to the administratrix, care of the under-mentioned solicitor, by the 31st day of January, 1963, after which date the administratrix will distribute the assets, having regard only to the claims of which she then has notice.

K. P. REES, B.A., LL.B., solicitor, 89 Queen-street, Melbourne. 3604

**CREDITORS**, next of kin and others having claims in respect of the estate of Florence Jean Moller (also known as Florence Jean Miller) late of 40 Geelong-road, Footscray, deceased (who died on the 22nd day of August, 1962), are to send particulars of their claims to the executor, Stanley Fryer, care of the under-mentioned solicitors, on or before the 22nd day of January, 1963, after which date the said executor will distribute the assets, having regard only to the claims of which notice has been received.

MARTIN & MARTIN, solicitors, 37 Queen-street, Melbourne. 3595



**CREDITORS**, next of kin and all others having claims against the estate of Rowland Astley Sutton, late of 6 Wilmoth-avenue, Murrumbidgee, in the State of Victoria, retired clerk, deceased, (who died on the 17th day of September, 1962), and probate of whose will was granted by the Supreme Court of Victoria, in its probate jurisdiction to the Sandhurst and Northern District Trustees Executors and Agency Company Limited, of View-street, Bendigo, in the said State are required to send particulars in writing of such claim or claims to the said company at its address, as aforesaid on or before the 22nd day of January, 1963, after which date the said company will proceed to distribute the assets of the said deceased, amongst the persons entitled thereto, having regard only to the claim or claims of which the said company shall then have had notice.

GAIR & BRAHE, 243 Collins-street, Melbourne. 3603

**CREDITORS**, next of kin and all others having claims against the estate of Emma Leah Hudspeth, formerly of 1 Whitehorse-road, Blackburn, in the State of Victoria, and of Flat 7, Whitehorse Lodge, 420 Whitehorse-road, Balwyn, in the said State, late of Flat 1, 402 Whitehorse-road, Balwyn, aforesaid widow, deceased (who died on the 7th day of September, 1962, and probate of whose will was granted by the Supreme Court of Victoria, in its probate jurisdiction, to Arthur Alexander Brahe, of 243 Collins-street, Melbourne, in the said State, solicitor, one of the executors appointed by the will of the said deceased), are required to send particulars, in writing, of such claim or claims to the said executor, care of the under-mentioned solicitor, on or before the 22nd day of January, 1963, after which date the said executor will proceed to distribute the assets of the said deceased amongst the persons entitled thereto, having regard only to the claim or claims of which the said executor shall then have had notice.

GAIR & BRAHE, 243 Collins-street, Melbourne. 3602

**CREDITORS**, next of kin and all others having claims against the estate of Olive Helen Parks-Smith, late of 60 Brunel-street, East Malvern, widow, deceased (who died on 29th December, 1961), are to send particulars of their claims to Perpetual Trustee Company Limited, of 33-39 Hunter-street, Sydney, in the State of New South Wales, the executor of the will of the said deceased, by the 31st day of January, 1963, after which date the said executor will distribute the assets, having regard only to the claims of which it then has notice.

J. COLIN STEDMAN & CAMERON, solicitors, 339 Collins-street, Melbourne. 3599

**CREDITORS**, next of kin and all others having claims in respect of the estate of Mabel Daranda Merritt, late of 7 Wales-street, West Footscray, deceased (who died on the 5th day of September, 1962), are to send particulars of their claims to the executors, Roderick Merritt and Maude Daranda Douglas, care of the under-mentioned solicitors, on or before the 22nd day of January, 1963, after which date the said executors will distribute the assets, having regard only to the claims of which notice has been received.

MARTIN & MARTIN, solicitors, 37 Queen-street, Melbourne. 3597

**CREDITORS**, next of kin and others having claims in respect of the estate of Robert Lorner Ballantyne, late of 6 Belson-street, East Malvern, deceased (who died on the 30th day of July, 1962), are to send particulars of their claims to the executor, John McDonald Martin, care of the under-mentioned solicitors, on or before the 22nd day of January, 1963, after which date the said executors will distribute the assets, having regard only to the claims of which notice has been received.

MARTIN & MARTIN, solicitors, 37 Queen-street, Melbourne. 3596

**CREDITORS**, next of kin and others having claims in respect of the estate of Margaret Emily Bennett, late of 37 Darling-street, South Yarra, in the State of Victoria, widow, deceased (who died on the 4th day of May, 1962), and probate of whose will and codicil has been granted to Arthur Dean Pearce, of 430 Little Collins-street, Melbourne, solicitor, are to send in particulars of their claims to the said executor, care of the under-mentioned solicitors, by the 24th January, 1963, after which date he will distribute the assets, having regard only to the claims of which he then has notice.

PEARCE & WEBSTER, solicitors, 430 Little Collins-street, Melbourne. 3579

**CREDITORS**, next of kin and others having claims in respect of the estate of Elizabeth Paisley, late of Camperdown, widow, deceased (who died on the 8th of May, 1962, and probate of whose will and codicil has been granted to James Aubrey Barby, of Corio, school employee, Gordon James Ironside, of Camperdown, engineer, and Hector Henry Allen, of 262 Packington-street, Newtown, yardman), are to send particulars, in writing, of their claims to the said executors, care of the under-mentioned solicitors, by the 31st day of January, 1963, after which date the executors will distribute the assets, having regard only to the claims of which they then have notice.

BUCKLAND & NEVETT, solicitors, Camperdown. 3494

**CREDITORS**, next of kin and others having claims against the estate of William McLagan Crerar, late of Hay, in the State of New South Wales, retired grazier, deceased (who died on the 18th day of June, 1962), are to send particulars of their claims to John Chitty Rose and The Equity Trustees, Executors and Agency Company Limited, of the care of the said The Equity Trustees, Executors and Agency Company Limited, at 472 Bourke-street, Melbourne, in the State of Victoria, by the 29th day of January, 1963, after which date the executors will distribute the assets of the deceased, having regard only to the claims of which they have notice.

ABBOTT, STILLMAN & WILSON, solicitors, 422 Little Collins-street, Melbourne. 3495

WILLIAM JAMES RUNTING, formerly of Barrybank, in the State of Victoria, but late of "Bringalbit", Kyneton, in the said State, farmer, DECEASED.

**CREDITORS**, next of kin and others having claims in respect of the estate of the said deceased (who died on the 6th day of June, 1962), are required by the personal representative, The Equity Trustees, Executors and Agency Company Limited, of 472 Bourke-street, Melbourne, to send particulars to it by the 31st day of January, 1963, after which date the personal representative may convey or distribute the assets, having regard only to the claims of which it then has notice.

H. HURRY & SON, solicitors, Kyneton, and at Woodend and Gisborne. 3487

CHARLES MICHAEL MAGINESS, late of Baring, in the State of Victoria, farmer, DECEASED (who died on the 6th day of August, 1962).

**CREDITORS**, next of kin and all persons having claims against the estate of the deceased are required to send particulars to the executor, The Fidelity Trustee Company Limited, of 101 Lydiard-street north, Ballarat, care of its address above given, on or before the 21st day of January, 1963, after which date it will distribute the assets, having regard only to the claims of which it shall then have notice.

E. M. TOBIN, LL.B., solicitor, Ouyen. 3496

**CREDITORS**, next of kin and others having claims in respect of the estate of Stuart Mackenzie Stedman, formerly of Rutherglen, in the State of Victoria, but late of Cobram, in the said State, orchard inspector, deceased (who died on the 26th day of July, 1962), are to send particulars of their claims to the executrix, Edna Beatrice Stedman, of Cobden, in the said State, widow, addressed to the care of Frank B. Lethbridge, solicitor, Main-street, Rutherglen, by the 23rd day of January, 1963, after which date the said executrix will distribute the assets, having regard only to the claims of which she shall then have had notice.

Dated the 16th day of November, 1962.

FRANK B. LETHBRIDGE, solicitor, Main-street, Rutherglen, solicitor for the executrix. 3547

**ALL** persons having claims against the estate of John Robert Gardner, late of Snake Valley, labourer, deceased, probate of whose will has been applied for by The Fidelity Trustee Company Limited, of 101 Lydiard-street north, Ballarat, the executor appointed by the said will, are hereby required to send particulars thereof, in writing, to the said company, on or before the 24th day of January, 1963, after which date the said company will proceed to distribute the assets of the said deceased, having regard only to the claims of which it shall then have had notice, and the said company will not be liable for the assets so distributed or any part thereof to any person of whose claim it shall not then have had notice.

R. G. DOBSON & CO., of 52 Lydiard-street, Ballarat, solicitors for the said company. 3486

**CREDITORS**, next of kin and others having claims against the estate of Eric Winton Jack, late of 15 Hampden-road, Armadale, retired, deceased (who died on the 10th day of March, 1962), are to send particulars of their claims to The Trustees, Executors and Agency Company Limited, at its registered office, 401 Collins-street, Melbourne, by the 23rd day of January, 1963, after which date the said company will distribute the assets, having regard only to the claims of which it then has notice.

EUSTACE L. J. MURPHY, solicitor, 40 Queen-street, Melbourne, 3592

EDMUND ARNOLD SCHUBERT, late of Sea Lake, retired farmer, DECEASED.

**CREDITORS**, next of kin and others having claims against the estate of the said deceased are required to send particulars of same to the executor, William George Johnston, in care of the undersigned, on or before the 22nd January, 1963, after which date he will distribute the assets, having regard only to the claims of which he then has notice.

DELANY & DELANY, solicitors, 270 Campbell-street, Swan Hill, 3586

**CREDITORS**, next of kin and others having claims in respect of James Davies Beer, late of 24 William-avenue, Dandenong, fitter, deceased (who died on the 28th August, 1962), are to send particulars of their claims to National Trustees, Executors and Agency Company of Australasia Limited, of 95 Queen-street, Melbourne, Victoria, by the 21st day of January, 1963, after which date it will distribute the assets, having regard only to the claims of which it then has notice.

FIELD, MORRISSEY & CO., 25 Langhorne-street, Dandenong, 3488

SYDNEY BELLAMY, late of 47 Bedford-street, Collingwood, labourer, DECEASED.

**CREDITORS**, next of kin and others having claims in respect of the estate of the deceased (who died on the 23rd January, 1962), are required by the administrator, Percival Bellamy, of 69 Albion-street, South Yarra, engineer, to send particulars to him by the 31st day of January, 1963, after which date the administrator may convey or distribute the assets, having regard only to the claims of which he then has notice.

Dated the 15th day of November, 1962.

F. E. O'BRIEN & CO., solicitors, 317 Collins-street, Melbourne, 3584

**CREDITORS**, next of kin or others having claims in respect of the estate of Gladys Ilma Olley, late of 123 Park-road, Cheltenham, in the State of Victoria, married woman, deceased (who died on the 1st September, 1962), are to send particulars of their claims to The Perpetual Executors and Trustees Association of Australia Limited, of 100-104 Queen-street, Melbourne, by the 24th January, 1963, after which date it will distribute the assets, having regard only to the claims of which it then has notice.

CORR & CORR, solicitors, 290 Latrobe-street, Melbourne, 3583

**CREDITORS**, next of kin and others having claims in respect of the estate of Janet Forrester Read, late of 34 Dudley-parade, Canterbury, widow, deceased (who died on the 30th day of June, 1962), are to send the particulars of their claims to The Trustees, Executors and Agency Company Limited, of 401 Collins-street, Melbourne, by the 31st day of January, 1963, after which date it will then distribute the assets, having regard only to the claims of which it then has notice.

Dated the 14th day of November, 1962.

W. B. & O. McCUTCHEON, solicitors, 150 Queen-street, Melbourne, 3582

**CREDITORS**, next of kin and others having claims in respect of the estate of Winifred Mary Sinclair, late of "High Clair", Healesville, married woman, deceased (who died on the 31st day of May, 1962), are to send the particulars of their claims to The Trustees, Executors and Agency Company Limited, of 401 Collins-street, Melbourne, by the 31st day of January, 1963, after which date it will distribute the assets, having regard only to the claims of which it then has notice.

Dated the 14th day of November, 1962.

W. B. & O. McCUTCHEON, solicitors, 150 Queen-street, Melbourne, 3581

**ALL** persons having claims against the estate of Charles Edward Gartly, formerly of 114 Summerhill-road, Glen Iris, but late of 24 Baker-parade, Ashburton, retired clerk, deceased, probate of whose will has been applied for by The Trustees, Executors and Agency Company Limited, of 401 Collins-street, Melbourne, the executor appointed by the said will, are hereby required to send particulars thereof, in writing, to the said company on or before the 17th day of January, 1963, after which date the said company will proceed to distribute the assets of the said deceased, having regard only to the claims of which it shall then have had notice, and the said company will not be liable for the assets so distributed or any part thereof to any person of whose claim it shall not then have had notice.

WM. MURRAY & SON, solicitors, 422 Collins-street, Melbourne, 3585

LOUISA MARGARET WESTERGAARD, late of 2 Gourlay-street, St. Kilda, widow, DECEASED.

**CREDITORS**, next of kin and others having claims in respect of the estate of the deceased (who died on the 28th day of July, 1962), are required by National Trustees, Executors and Agency Company of Australasia Limited, of 95 Queen-street, Melbourne, to send particulars to them by the 31st day of January, 1963, after which date the trustees may convey or distribute the assets, having regard only to the claims of which they then have notice.

ARTHUR SECOMB & CO., solicitors, 128 William-street, Melbourne, 3576

**CREDITORS**, next of kin and others having claims in respect of the estate of Walter William Hobson, late of 27 Melville-road, Pascoe Vale South, retired butcher, deceased (who died on the 9th day of August, 1962, and probate of whose will has been granted to Walter Talbot Hobson, of 1 Sybil-street, Moorabbin, clerk, and Eileen May Jennings, of 9 Wroxham-court, Fawkner, married woman), are to send in particulars of their claims to the said executors, care of the under-mentioned solicitors by the 24th January, 1963, after which date they will distribute the assets, having regard only to the claims of which they then have notice.

PEARCE & WEBSTER, solicitors, 430 Little Collins-street, Melbourne, 3578

**CREDITORS**, next of kin and others having claims in respect of the estate of Margaret Ffie Looker, late of 18 Grant-street, East Malvern, in the State of Victoria, spinster (who died on the 23rd day of July, 1962), are to send the particulars of their claims to The Trustees, Executors and Agency Company Limited, whose registered office is at No. 401 Collins-street, Melbourne, in the said State, by the 31st day of January, 1963, after which date it will distribute the assets, having regard only to the claims of which it then has notice.

Dated the 16th day of November, 1962.

BOOTHBY & BOOTHBY, solicitors, 883 Dandenong-road, Caulfield East, and at Korumburra, 3574

**CREDITORS**, next of kin and others having claims in respect of the estate of Reuben Tom Patton, late of 10 Testar-grove, Caulfield, university lecturer, deceased (who died on the 24th June, 1962), are requested to send particulars of their claims to the executors, Arthur Leslie Park and Donald Ledingham Cooper, care of the under-mentioned solicitors, on or before the 23rd day of January, 1963, after which date they will distribute the assets, having regard only to the claims of which they then have notice.

McKEAN & PARK, solicitors, 84 William-street, Melbourne, 3575

**CREDITORS**, next of kin and others having claims in respect of the estate of Charles David Martin, late of Chiltern, in the State of Victoria, retired grazier, deceased (who died on the 29th day of July, 1962), are to send particulars of their claims to the executor, Cecil Charles Dolphin Martin, of Glen Iris, in the State of Victoria, bank manager, Basil David Gordon Martin, of Warragul, in the said State, bank manager, and Alwyn Davies, of Brighton East, in the said State, bank officer, addressed to the care of Frank B. Lethbridge, solicitor, Main-street, Rutherglen, by the 23rd day of January, 1963, after which date the said executors will distribute the assets, having regard only to the claims of which they shall then have had notice.

Dated the 16th day of November, 1962.

FRANK B. LETHBRIDGE, solicitor, Main-street, Rutherglen, solicitor for the executors, 3550

**CREDITORS**, next of kin and others having claims in respect of the estate of Donald Norman Nicolson, late of Toongabbie in Victoria, retired farmer, deceased, (who died on 22nd February, 1962), are to send particulars of their claims to The Fidelity Trustee Company Limited, of 101 Lydiard-street north, Ballarat, at its branch office, 84 Hotham-street, Traralgon, by 31st January, 1963, after which date it will distribute the assets, having regard only to the claims of which it then has notice.

C. H. FORD, LL.M., solicitor, Traralgon. 3572

**CREDITORS**, next of kin and others having claims in respect of the estate of John Richard Fry, late of Kerang in the State of Victoria, retired farmer (who died on the 4th day of January, 1962), are required to send particulars of their claims to the executors, Horatio Smitheram and John Thompson Gerrand, in care of the under-mentioned solicitor, by the 31st day of January, 1963, after which date the executors will distribute the assets, having regard only to the claims of which they then have notice.

FRANCIS LYNCH, 54 Wellington-street, Kerang. 3567

**CREDITORS**, next of kin and others having claims in respect of the estate of Eliza Jane Carroll, late of 429 (formerly 180) Brunswick-road, West Brunswick, spinster, deceased (who died on the 8th day of December, 1961), are to send particulars of their claims to the Trustees Executors and Agency Company Limited, of 401 Collins-street, Melbourne, by the 30th day of January, 1963, after which date it will distribute the assets, having regard only to the claims of which it then has notice.

LEACH & THOMSON, solicitors, 472 Bourke-street, Melbourne. 3557

**CREDITORS**, next of kin and others having claims in respect of the estate of Amy Agnes Rohan, late of 33 Martin-street, Elwood, widow, deceased (who died on the 14th day of August, 1962), are to send particulars of their claims to the executors, Edward William Rohan and Ronald Stewart, addressed to them, care of Ronald Stewart, McIntosh and Co., of 422 Collins-street, Melbourne, on or before the 18th day of January, 1963, after which date the assets will be distributed, having regard only to the claims of which the executors then have notice.

RONALD STEWART, MCINTOSH & CO., solicitors, 422 Collins-street, Melbourne. 3555

ROBERT THOMSON, late of 17 Denbigh-road, Armadale, gentleman, DECEASED.

**CREDITORS**, next of kin and others having claims in respect of the estate of deceased (who died on 17th April, 1962), are required by the trustees, Myrtle Annie Thomson, of 17 Denbigh-road, Armadale, widow, Gwenda Meryl Mould, of 29 Denbigh-road, Armadale and Ethel Margaret Shaw, of 21 Denbigh-road, Armadale, married woman, to send particulars to them, care of the undersigned solicitor, by 25th January, 1963, after which date they may convey or distribute the assets, having regard only to the claims of which they then have notice.

R. C. H. BEATTIE, solicitor, 509 Collins-street, Melbourne. 3554

FRANCIS GEORGE WASHBROOK (usually known as Francis George Wright), late of 383 Neerim-road, Murrumbena, grocer, DECEASED.

**CREDITORS**, next of kin and others having claims in respect of the estate of deceased (who died on 8th July, 1962), are required by the trustee Edna Victoria Wright, of 383 Neerim-road, Murrumbena, widow, to send particulars to her, care of the undersigned solicitor, by 25th January, 1963, after which date she may convey or distribute the assets, having regard only to the claims of which she then has notice.

R. C. H. BEATTIE, solicitor, 509 Collins-street, Melbourne. 3553

LILIAN JANE TULLOCH, late of 102 Ascot-street south, Ballarat, widow, DECEASED.

**CREDITORS**, next of kin and others having claims in respect of the estate of the deceased (who died on 13th July, 1962), are required by the trustee, Roy Clive Hopetoun Beattie, of 61 Union-street, Armadale, solicitor, to send particulars to him, by 25th January, 1963, after which date he may convey or distribute the assets, having regard only to the claims of which he then has notice.

R. C. H. BEATTIE, solicitor, 509 Collins-street, Melbourne. 3552

RONALD JOSEPH GRAY, late of 296 Springvale-road, Glen Waverley, builder, DECEASED.

**CREDITORS**, next of kin and others having claims in respect of the estate of deceased (who died on 14th July, 1962), are required by the trustee, Roy Clive Hopetoun Beattie, of 61 Union-street, Armadale, solicitor, to send particulars to him, by 25th January, 1963, after which date he may convey or distribute the assets, having regard only to the claims of which he then has notice.

R. C. H. BEATTIE, solicitor, 509 Collins-street, Melbourne. 3551

JOHN MARTIN TOWK, late of Walpeup, in the State of Victoria, farmer, DECEASED (who died on the 25th day of July, 1962).

**CREDITORS**, next of kin and all persons having claims against the estate of the deceased are required to send particulars to the executor, The Fidelity Trustee Company Limited, of 101 Lydiard-street north, Ballarat, care of its address above given, on or before the 21st day of January, 1963, after which date it will distribute the assets, having regard only to the claims of which it shall then have notice.

E. M. TOBIN, LL.B., solicitor, Ouyen. 3497

FRANCIS LANSDOWNE KENNEDY, late of 22 Fulton-street, East St. Kilda, retired trustee company officer, DECEASED (who died on the 7th August, 1962).

**CREDITORS**, next of kin and all others having claims in respect of the estate of the said deceased are required by the executor, The Trustees, Executors and Agency Company Limited, of 401 Collins-street, Melbourne, to send particulars of such claims to the said company by the 25th January, 1963, after which date the said company will distribute the assets, having regard only to the claims of which it then has notice.

DAVIES, CAMPBELL & PIESE, 401 Collins-street, Melbourne, solicitors. 3577

In the Supreme Court of the State of Victoria.

SALE BY THE SHERIFF.

**ON** Friday, the eighteenth of January, 1963, at Eleven a.m., at the Police Station, Reservoir (unless process be stayed or satisfied):—All the estate and interest (if any) of High Crest Homes Pty. Ltd., of 562 St. Kilda-road, Melbourne, as proprietor of an estate in fee-simple in land described in certificate of title, volume 6097, folio 296, upon which is erected a brick veneer dwelling house known as No. 42, Dundee-street, Keon Park.

Registered mortgage No. B389432 affects the said estate and interest.

Terms: Cash only.

N. FROGLEY, Sheriff's Officer.

16th November, 1962. 3573

## IMPOUNDINGS

**BOX HILL**.—Impounded in Box Hill Pound, by Ranger.

1 roan mare, hack, black points, chain, no visible brand  
If not claimed and expenses paid, to be sold on 6th December, 1962.

3523—9/  
R. KENNEDY,  
Poundkeeper.

**HEALESVILLE**.—Impounded in Healesville Pound.

1 white female goat, no visible brand  
If not claimed and expenses paid, to be sold on 3rd December, 1962.

3503—9/  
E. PULLEN,  
Poundkeeper.

**HEYWOOD**.—Impounded in Heywood Pound, by Shire Ranger.

8 Hereford Cross heifer calves, piece out of each ear, no visible brand  
1 Shorthorn heifer calf, piece out of each ear, no visible brand  
1 light brindle heifer, piece out of each ear, no visible brand

If not claimed and expenses paid, to be sold on 6th December, 1962.

3522—18/  
C. H. SKIPWORTH,  
Poundkeeper.

**OxLEY.**—Impounded in Oxley Pound, from Bobinawarra.

1 Red Poll Shorthorn Cross steer, eighteen months old, two notches under off ear, no visible brand  
If not claimed and expenses paid, to be sold on 29th November, 1962.

M. PERKINS,  
Poundkeeper.

3534—12/

**PORTLAND.**—Impounded in Portland Pound, from Bridgewater-road, Portland, on 8th November, 1962.

5 Black Poll Hereford Cross steers, two to three years old, no visible brand  
1 Hereford steer, two to three years old, no visible brand  
If not claimed and expenses paid, to be sold on 6th December, 1962.

P. A. LOOKER,  
Poundkeeper.

3530—13/6

**SHEPPARTON.**—Impounded in Shepparton Pound.

10 sheep, four with mark on top of right ear, five with mark on top of left ear, one with no visible brand  
If not claimed and expenses paid, to be sold on 6th December, 1962.

C. L. MANSELL,  
Poundkeeper.

3559—10/6

**TRARALGON.**—Impounded in Traralgon Stock Pound, from private property on 20th November, 1962.

2 Merino crossbred wethers, tip out of both ears, horns, ½ wool, no visible brand  
If not claimed and expenses paid, to be sold on 7th December, 1962.

J. LINDSAY,  
Poundkeeper.

3616—12/

**STATE ACTS, 1960**

COPIES of the following Acts of Parliament of Victoria may be obtained at the Government Printing Office, or from any bookseller, at the price set opposite to each:—

No.	Price. s. d.
6607. Anzac Day .. .. .	1 0
6608. Agricultural Lime (Amendment) .. .. .	0 6
6609. Motor Car (Commencement) .. .. .	0 6
6610. Fisheries (Change of Title) .. .. .	0 6
6611. Stamps (Amendment) .. .. .	0 6
6612. Land (Public Authorities) .. .. .	0 6
6613. Coal Canal Bridge .. .. .	0 6
6614. Metropolitan Fire Brigades (Borrowing Powers) .. .. .	0 6
6615. Wodonga Lands Exchange .. .. .	0 6
6616. Licensing (Fees) .. .. .	0 6
6617. Home Finance (Loans to Minors) .. .. .	0 6
6618. Co-operative Housing Societies (Amendment) .. .. .	0 6
6619. Racing (Totalizators Extension) .. .. .	1 0
6620. Companies .. .. .	0 6
6621. Judges Salaries and Allowances .. .. .	0 6
6622. Coal Mines (Pensions Contributions) .. .. .	0 6
6623. Landlord and Tenant (Further Amendment) .. .. .	0 6
6624. Public Officers Salaries and Allowances .. .. .	0 9
6625. Legal Profession Practice (Amendment) .. .. .	0 6
6626. Church of England in Australia Constitution .. .. .	1 9
6627. Companies (Fees) .. .. .	0 6
6628. Motor Car (Amendment) .. .. .	1 0
6629. Geelong Waterworks and Sewerage (Amendment) .. .. .	0 6
6630. Latrobe Valley (Financial) .. .. .	0 6
6631. Labour and Industry (Amendment) .. .. .	0 6
6632. Acts Interpretation .. .. .	0 6
6633. Children's Court (Enforcement of Awards) .. .. .	0 6
6634. Supreme Court (Proceedings before Master) .. .. .	0 6
6635. Melbourne and Metropolitan Board of Works (Borrowing Powers) .. .. .	0 6
6636. Electoral Provinces .. .. .	0 9
6637. Town and Country Planning (Amendment) .. .. .	0 6
6638. Racing (Dog Races) .. .. .	0 6
6639. Industrial Safety Advisory Council .. .. .	0 6
6640. Administration and Probate (Offices) .. .. .	0 6
6641. Justices (Bail) .. .. .	0 6
6642. National Parks (Amendment) .. .. .	0 9
6643. Medical (Amendment) .. .. .	0 6
6644. Melbourne Harbor Trust Lands .. .. .	1 0
6645. Weights and Measures (Penalties) .. .. .	0 6
6646. Transfer of Land (Stratum Estates) .. .. .	0 6
6647. Local Government (Preston Streets Agreement) .. .. .	0 9
6648. John Storey Memorial Fund .. .. .	0 6

STATE ACTS, 1960—continued.

No.	Price. s. d.
6649. Police Offences (Amendment) .. .. .	0 6
6650. Motor Car (Third-Party Insurance) .. .. .	0 6
6651. Social Welfare .. .. .	2 9
6652. City of Melbourne Underground Railway Construction .. .. .	1 0
6653. Valuation of Land .. .. .	1 3
6654. Milk Board (Amendment) .. .. .	0 6
6655. Victoria Racing Club (Amendment) .. .. .	0 6
6656. Consolidated Revenue .. .. .	0 6
6657. Consolidated Revenue .. .. .	0 6
6658. Motor Car (Driving) .. .. .	0 6
6659. Licensing (Amendment) .. .. .	1 0
6660. Consolidated Revenue .. .. .	0 6
6661. Consolidated Revenue .. .. .	0 6
6662. Friendly Societies (Dental Clinics) .. .. .	0 6
6663. Cancer (Amendment) .. .. .	0 6
6664. Dried Fruits (Amendment) .. .. .	0 6
6665. Barwon Heads Lands Exchange .. .. .	0 6
6666. Revocation of Crown Reservations .. .. .	0 6
6667. The Constitution Act Amendment (Expenses) .. .. .	0 6
6668. Supreme Court (Orders) .. .. .	0 6
6669. Gippsland Railway Deviation .. .. .	0 9
6670. Hamilton Stockyards Railway Construction .. .. .	0 6
6671. Nurses (Amendment) .. .. .	0 6
6672. Ministry of Transport (Railway Officers) .. .. .	0 6
6673. Fruit and Vegetables (Road Barriers) .. .. .	0 6
6674. Transport Regulation (Qualifications of Chairman) .. .. .	0 6
6675. Motor Car (Insurance Surcharge Continuance) .. .. .	0 6
6676. Geelong Harbor Trust (Freezing Works Agreement) .. .. .	0 9
6677. Western Metropolitan Market (Amendment) .. .. .	0 6
6678. Racing (Trotting Races) .. .. .	0 6
6679. Wattle Park Land .. .. .	0 6
6680. Surplus Revenue .. .. .	0 6
6681. Milk and Dairy Supervision (Research Contributions) .. .. .	0 6
6682. Tourist (Amendment) .. .. .	0 6
6683. Fisheries (Crayfish) .. .. .	0 6
6684. Audit (Amendment) .. .. .	0 6
6685. Sale of Allotments of Land (Amendment) .. .. .	0 6
6686. Cattle Compensation (Amendment) .. .. .	0 6
6687. Co-operative Housing Societies (Guarantees) .. .. .	0 6
6688. State Library National Gallery National Museum and Institute of Applied Science .. .. .	1 3
6689. Medical (Blood Transfusion) .. .. .	0 6
6690. The Constitution Act Amendment (Treating) .. .. .	0 6
6691. State Forests Loan Application .. .. .	0 6
6692. Local Authorities Superannuation (Amendment) .. .. .	0 9
6693. Local Government (Disqualification) .. .. .	1 0
6694. Superannuation (Additions to Pensions) .. .. .	0 6
6695. Police Regulation (Pensions) .. .. .	0 6
6696. Trustee Companies (Amalgamation) .. .. .	0 6
6697. Geelong and Colac Railway (Deviation) .. .. .	0 6
6698. University Colleges Lands .. .. .	0 6
6699. Local Government (Private Street) .. .. .	0 6
6700. Northcote School .. .. .	0 6
6701. Public Works Loan Application .. .. .	0 9
6702. Tower Hill and Malmesbury Lands .. .. .	0 6
6703. Coal Mines (Pensions) .. .. .	0 6
6704. Vermin and Noxious Weeds (Financial) .. .. .	0 6
6705. Navigable Waters (Oil Pollution) .. .. .	1 0
6706. Business Names (Public Borrowings) .. .. .	0 6
6707. Health (Tuberculosis Arrangement) .. .. .	0 6
6708. Water Supply Loan Application .. .. .	1 3
6709. Railway Loan Application .. .. .	1 0
6710. Land Tax (Relief) .. .. .	0 6
6711. Land Tax (Rates) .. .. .	0 6
6712. Monash University (Amendment) .. .. .	0 6
6713. National Fitness Council of Victoria .. .. .	1 0
6714. Local Government (Keilor, Waverley and Springvale) .. .. .	0 6
6715. Explosives .. .. .	2 3
6716. Statute Law Revision .. .. .	0 9
6717. Motor Car (Abolition of Owners' Certificates) .. .. .	0 6
6718. Road Traffic (Amendment) .. .. .	0 6
6719. Milk Board (Powers) .. .. .	0 6
6720. Marketing of Primary Products (Members) .. .. .	0 6
6721. Melbourne and Geelong Mortgages .. .. .	0 9
6722. Building Societies (Amendment) .. .. .	0 9
6723. Local Government (Scaffolding Inspection) .. .. .	0 9
6724. State Electricity Commission (Borrowing) .. .. .	0 6
6725. Labour and Industry (Butchers' Shops) .. .. .	0 6
6726. Country Fire Authority (Sawmill Burners) .. .. .	0 6
6727. Sewerage Districts (Amendment) .. .. .	1 0
6728. Water (Amendment) .. .. .	1 3
6729. Housing (Powers) .. .. .	0 6
6730. Entertainments Tax (Amendment) .. .. .	0 6
6731. Crimes (Kidnapping) .. .. .	0 6
6732. Health (Amendment) .. .. .	0 6

STATE ACTS, 1960—continued.

No.	Price. s. d.
6733. Game (Licences) .. .. .	0 6
6734. Estate Agents (Amendment) .. .. .	0 6
6735. Appropriation of Revenue .. .. .	8 6

A. C. BROOKS,  
Government Printer.

STATE ACTS, 1961

COPIES of the following Acts of Parliament of Victoria may be obtained at the Government Printing Office, or from any bookseller, at the price set opposite to each:—

No.	Price. s. d.
6736. Public Works Committee (Special Exemption) .. .. .	0 6
6737. Railways (Permanent Service) .. .. .	0 6
6738. Superannuation (Railway Service) .. .. .	0 6
6739. Stamps (Amendment) .. .. .	0 6
6740. Employers and Employés (Attachment of Wages) .. .. .	0 6
6741. St. Kilda (Goldsmith and Shelley Streets) Land .. .. .	0 6
6742. Municipal Association (Amendment) .. .. .	0 6
6743. Wormbete Land .. .. .	0 6
6744. Grain Elevators (Borrowing) .. .. .	0 6
6745. Housing (Amendment) .. .. .	0 6
6746. Land (North-West Mallee Settlement Areas) .. .. .	0 9
6747. Ripon Peace Memorial Hospital Trust .. .. .	0 6
6748. Road Traffic (Parking on Railway and Municipal Property) .. .. .	0 6
6749. Co-operation (Amendment) .. .. .	0 6
6750. Heidelberg and Toolamba Lands Exchange .. .. .	0 6
6751. Town and Country Planning (Amendment) .. .. .	0 6
6752. Janet Clarke Hall .. .. .	0 6
6753. Transport Regulation (Compensation) .. .. .	0 6
6754. Bread Industry (Legal Proceedings) .. .. .	0 6
6755. Milk Pasteurization (Licences) .. .. .	0 6
6756. Health (Proprietary Medicines) .. .. .	0 6
6757. Police Offences (False Reports to Police) .. .. .	0 6
6758. Evidence (Children) .. .. .	0 6
6759. Statute Law Revision .. .. .	0 6
6760. Transport Regulation (Term of Office) .. .. .	0 6
6761. Prostitution .. .. .	0 6
6762. Motor Car (Amendment) .. .. .	1 0
6763. Game (Amendment) .. .. .	0 6
6764. The Constitution Act Amendment (Electoral) .. .. .	0 9
6765. Building Societies (Amendment) .. .. .	1 3
6766. Juries (Amendment) .. .. .	0 6
6767. Gas and Fuel Corporation (Borrowing) .. .. .	0 6
6768. Clean Air (Sub-committees) .. .. .	0 6
6769. Housing (Home Builders' Account) .. .. .	0 6
6770. Public Offences (Pinball Machines) .. .. .	0 6
6771. Fisheries (Commercial Council) .. .. .	0 6
6772. Consolidated Revenue .. .. .	0 6
6773. Consolidated Revenue .. .. .	0 6
6774. Consolidated Revenue .. .. .	0 6
6775. Game (Black Swans) .. .. .	0 6
6776. Distribution of Population (Joint Committee) .. .. .	0 9
6777. Public Works Interim Loan Application .. .. .	0 6
6778. Legal Profession Practice (Amendment) .. .. .	0 6
6779. Home Finance (Amendment) .. .. .	0 6
6780. Cancer (Amendment) .. .. .	0 6
6781. Tourist (Amendment) .. .. .	0 6
6782. Water (Ballarat Water Commissioners) .. .. .	0 6
6783. Commercial Goods Vehicles (Tow Trucks) .. .. .	0 6
6784. Consolidated Revenue .. .. .	0 6
6785. Local Government (Municipal Assistance Fund) .. .. .	0 6
6786. Agricultural Colleges (Leases) .. .. .	0 6
6787. United Lutheran Church Incorporation .. .. .	1 3
6788. West Melbourne Market Land (Amendment) .. .. .	0 6
6789. Portland Harbor Trust (Quarrying) .. .. .	0 6
6790. Racing (Bookmakers' Course Agents) .. .. .	0 9
6791. Stamps (Further Amendment) .. .. .	1 0
6792. North Geelong to Fyansford Railway Deviation .. .. .	0 6
6793. Apprenticeship (Amendment) .. .. .	0 6
6794. Land (Unused Roads and Water Frontages) .. .. .	0 9
6795. Motor Car (Insurance Surcharge) .. .. .	0 6
6796. Forests (Wood Pulp Agreement) .. .. .	2 0
6797. Dandenong Lands .. .. .	0 9
6798. Local Authorities Superannuation (Amendment) .. .. .	0 6
6799. R.S.L. Welfare Trust Fund .. .. .	0 9
6800. The Zinc Corporation Limited .. .. .	0 9
6801. Mines (Explosives) .. .. .	0 6
6802. University (Officers) .. .. .	0 6
6803. State Accident Insurance Office .. .. .	0 6
6804. Melbourne and Metropolitan Board of Works (Yarra River) .. .. .	0 6
6805. Legal Aid .. .. .	0 9
6806. Crimes (Breath Test Evidence) .. .. .	0 6

STATE ACTS, 1961.—continued.

No.	Price. s. d.
6807. Consolidated Revenue .. .. .	0 6
6808. Civil Aviation (Carriers' Liability) .. .. .	0 6
6809. Sheep Owners Protection .. .. .	1 0
6810. Entertainments Tax (Amendment) .. .. .	0 6
6811. Exhibition (Borrowing Powers) .. .. .	0 6
6812. Children's Welfare (Appeals) .. .. .	0 6
6813. Pawnbrokers (Amendment) .. .. .	0 6
6814. Property Law (Loans to Minors) .. .. .	0 6
6815. Disposal of Uncollected Goods .. .. .	1 0
6816. Milk and Dairy Supervision (Amendment) .. .. .	0 6
6817. State Forests Loan Application .. .. .	0 6
6818. Health (Dangerous Substances) .. .. .	0 6
6819. Money Lenders (Amendment) .. .. .	0 6
6820. Water Supply Loan Application .. .. .	1 0
6821. Co-operative Housing Societies (Amendment) .. .. .	0 6
6822. Legal Profession Practice (Further Amendment) .. .. .	0 6
6823. Labour and Industry (Women's Hairdressing) .. .. .	0 6
6824. Co-operation (Amendment) .. .. .	0 6
6825. Valuation of Land (Amendment) .. .. .	1 0
6826. Public Works Loan Application .. .. .	0 6
6827. Land Tax (Exemptions and Rates) .. .. .	0 9
6828. Landlord and Tenant (Amendment) .. .. .	0 9
6829. Mines (Aluminium Agreement) .. .. .	1 3
6830. Railway Loan Application .. .. .	1 0
6831. Railways (Funds) .. .. .	0 6
6832. Motor Boating .. .. .	1 3
6833. Police Regulation (Amendment) .. .. .	0 6
6834. Housing (Commonwealth and State Agreement) .. .. .	0 9
6835. Education (Amendment) .. .. .	0 6
6836. Racing (Off-course Doubles Totalizators) .. .. .	1 0
6837. Medical (Amendment) .. .. .	0 6
6838. Water and Sewerage Authorities (Proceedings and Finances) .. .. .	1 3
6839. Companies .. .. .	21 0
6840. The Constitution Act Amendment .. .. .	0 6
6841. Local Government (Streets and Abattoirs) .. .. .	0 6
6842. Crown Leases .. .. .	0 6
6843. Church of England (Greensborough Land) .. .. .	0 6
6844. Juries (Fees) .. .. .	0 6
6845. Limitation of Actions (Recovery of Imposts) .. .. .	0 6
6846. Rural Finance and Settlement Commission .. .. .	1 3
6847. Marine (Amendment) .. .. .	1 6
6848. Dog .. .. .	0 9
6849. Town and Country Planning .. .. .	3 3
6850. Appropriation of Revenue, 1960-61 .. .. .	8 9

A. C. BROOKS,  
Government Printer.

STATE ACTS, 1962

COPIES of the following Acts of Parliament of Victoria may be obtained at the Government Printing Office, or from any bookseller, at the price set opposite to each:—

No.	Price. s. d.
6851. Racing (Anzac Day) .. .. .	0 6
6852. Railways (Thomson River Bridge) .. .. .	0 6
6853. Business Names .. .. .	1 9
6854. Melbourne Cricket Ground .. .. .	0 6
6855. Evidence (Amendment) .. .. .	0 6
6856. Railways (Industrial Awards) .. .. .	0 6
6857. Children's Welfare (Assistance) .. .. .	0 6
6858. National Parks .. .. .	0 6
6859. Consolidated Revenue .. .. .	0 6
6860. Land (Industrial Grants) .. .. .	0 6
6861. Revocation and Excision of Crown Reservations .. .. .	1 0
6862. Standard Insurance Company Limited .. .. .	0 6
6863. The Constitution Act Amendment (Statute Law Revision Committee) .. .. .	0 6
6864. Dog (Registration Discs) .. .. .	0 6
6865. Game (Black Swans) Amendment .. .. .	0 6
6866. Administration and Probate (Amendment) .. .. .	0 6
6867. Statute Law Revision .. .. .	0 9
6868. Tottenham to Brooklyn Railway Construction .. .. .	0 6
6869. Kerang (Alexandra Park) Land .. .. .	0 6
6870. Forests (Amendment) .. .. .	0 6
6871. Melbourne Harbor Trust Lands .. .. .	1 6
6872. Dried Fruits (Expenses and Finances) .. .. .	0 6
6873. Housing (Home Builders' Account) .. .. .	0 6
6874. Supreme Court (Interest on Judgments) .. .. .	0 6
6875. The Constitution Act Amendment (Postal Voting) .. .. .	0 6
6876. Melbourne and Metropolitan Board of Works (Government Guarantee) .. .. .	0 6
6877. Stock (Artificial Breeding) .. .. .	0 9

STATE ACTS, 1962—continued.

No.	Price. s. d.
6878. Tattooing .. .. .	0 6
6879. Unclaimed Moneys .. .. .	1 0
6880. Cancer (Facilities) .. .. .	0 6
6881. Road Traffic (Traffic Control Items) .. .. .	0 6
6882. Consolidated Revenue .. .. .	0 6
6883. Health (Sampling of Foods) .. .. .	0 6
6884. Crimes (Detention) .. .. .	0 6
6885. Fisheries (Noxious Fish) .. .. .	0 9
6886. Subordinate Legislation .. .. .	1 3
6887. Country Fire Authority (Amendment) .. .. .	0 6
6888. Local Government (Amendment) .. .. .	1 3
6889. Poisons .. .. .	3 3
6890. Probate Duty .. .. .	3 6
Table of Acts and Enactments passed, date of operation, &c. .. .. .	0 3

A. C. BROOKS,  
Government Printer.

ACTS REPRINTED IN ACCORDANCE WITH THE AMENDMENTS INCORPORATION ACT 1958 (No. 6422).

No.	Price. s. d.
6191. Administration and Probate Act .. .. .	4 9
6219. Children's Welfare Act .. .. .	2 6
6225. Co-operation Act .. .. .	4 0
6246. Evidence Act .. .. .	3 6
6249. Fences Act .. .. .	1 3
6251. Firearms Act .. .. .	2 3
6274. Hospitals and Charities Act .. .. .	3 6
6283. Labour and Industry Act .. .. .	7 3
6285. Landlord and Tenant Act .. .. .	4 6
6293. Licensing Act .. .. .	9 3
6299. Local Government Act .. .. .	25 0
6325. Motor Car Act .. .. .	6 6
6328. Nurses Act .. .. .	2 0
6330. Partnership Act .. .. .	1 3
6363. Second-hand Dealers Act .. .. .	1 3
6367. Settled Land Act .. .. .	4 0
6375. Stamps Act .. .. .	6 0
6399. Transfer of Land Act .. .. .	5 0
6401. Trustee Act .. .. .	4 0
6419. Workers Compensation Act .. .. .	4 9
6455. Companies Act (2nd reprint) .. .. .	15 0

A. C. BROOKS,  
Government Printer.

Subordinate Legislation Act 1962.

NOTICE OF MAKING OF STATUTORY RULES.

IN pursuance of the provisions of the *Subordinate Legislation Act 1962* and the Regulations made thereunder, notice is given of the making of the following statutory rules:—

No.	Soldier Settlement Act 1958.	Price. s. d.
37/1962.	Amendment to Regulations—Sixty-Second Schedule .. .. .	0 3
	<i>County Court Act 1958.</i>	
38/1962.	New Scale of Fees—County Court .. .. .	0 6

Copies of these statutory rules may be purchased at the Sale of Publications Office, Government Printing Office, Macarthur-street, Melbourne.

A. C. BROOKS,  
Government Printer.

AGENTS FOR THE "VICTORIA GOVERNMENT GAZETTE".

THE following have been appointed agents to receive Advertisements and Subscriptions for the *Victoria Government Gazette*:—

- ANGUS & ROBERTSON LTD., 66-68 Elizabeth-street, Melbourne.
- ARMSTRONG BROS. PTY. LTD., Mollison-street, Kyneton.
- ARMSTRONG'S AGENCY, 205 Queen-street, Melbourne.
- ARNALL & JACKSON, 390 Barkly-street, Brunswick, N.10.
- BAIRNSDALE AUTHORIZED NEWSAGENCY, 132 Main-street, Bairnsdale.

- COOKE, F. R. & E. M., & SONS, 69 Bridge-street, Benalla.
  - DAVIS, WM. (MILDURA) PTY. LTD., 126 Eighth-street, Mildura.
  - DIXON'S NEWSAGENCY, 89 Firebrace-street, Horsham.
  - EDGAR'S NEWSAGENCY PTY. LTD., 293 Hargreaves-street, Bendigo.
  - FRANKS, H., & CO., 184 Ryrie-street, Geelong.
  - GORDON & GOTCH AUSTRALASIA LTD., 511 Little Collins-street, Melbourne.
  - GULLAN'S NEWSAGENCY, 88 Bridge-street, Ballarat.
  - HALES, D. & N., Henty-street, Casterton.
  - HAMPTON, A. C., 243 Mitchell-street, Bendigo.
  - HARSTON, PARTRIDGE & CO. PTY. LTD., 455 Little Collins-street, Melbourne.
  - THE MERCANTILE EXCHANGE, 90 Queen-street, Melbourne.
  - McGILL'S AUTHORIZED NEWSAGENCY, 183-5 Elizabeth-street, Melbourne.
  - PETTY, R. H. & W. M., 83 Murphy-street, Wangaratta.
  - PURDIE, J., & CO., 138 Moorabool-street, Geelong.
  - SALE AUTHORIZED NEWSAGENCY, 142 Raymond-street, Sale.
  - SKINNER'S AUTHORIZED NEWSAGENCY, 49-51 Franklin-street, Traralgon.
  - SMITH & DUNNON, 112-114 Gray-street, Hamilton.
  - TUFF'S SHEPPARTON NEWSAGENCY, 246 Wyndham-street, Shepparton.
  - VERNON, C. F. & H. J., 162 Bridge-road, Richmond.
  - VIEW POINT AUTHORIZED NEWSAGENCY, 4 View Point, Bendigo.
- A copy of the *Gazette* filed at each place for public reference.

CONTENTS

	PAGE
Acts of Parliament on sale at the Government Printing Office .. .. .	3862
Appointments .. .. .	3823
Companies Act 1961—Notice .. .. .	3818
Contracts .. .. .	3821
Estates of Deceased Persons .. .. .	3819
Government Notices .. .. .	3805
Impoundings .. .. .	3861
Lands .. .. .	3832
Melbourne and Metropolitan Board of Works—Notice .. .. .	3818
Mining .. .. .	3820
Notice of Making of Statutory Rules .. .. .	3864
Notice to Mariners .. .. .	3820
Orders in Council—	
Acts—Mental Health; Land; Country Roads; Sewerage Districts; Geelong Water-Works and Sewerage; Water; River Improvement; Landlord and Tenant; Stamps.	3825 et seq
Private Advertisements .. .. .	3844
Proclamations .. .. .	3805
Public Service Notices .. .. .	3840
Regulations—	
Acts—Police Regulation .. .. .	3817
Teaching Service .. .. .	3844
Resignation .. .. .	3824
State Rivers and Water Supply Commission .. .. .	3816
Tenders .. .. .	3837
Transport Regulation Board—Public Hearings .. .. .	3806
Waterworks Trusts .. .. .	3810