



# VICTORIA GOVERNMENT GAZETTE

Published by Authority

[Registered at the General Post Office, Melbourne, for transmission by post as a newspaper.]

No. 271

WEDNESDAY, MARCH 14

[1962

*Land Act 1958.*

UNALIENATED CROWN LAND AVAILABLE FOR SETTLEMENT UNDER IMPROVEMENT PURCHASE LEASES.

## PROCLAMATION

By His Excellency the Governor of the State of Victoria and its Dependencies in the Commonwealth of Australia,  
&c., &c., &c.

IN pursuance of the provisions of section 153 of the *Land Act 1958*, I, the Governor of the State of Victoria, in the Commonwealth of Australia, by and with the advice of the Executive Council of the said State, do by this Proclamation declare the unalienated Crown lands mentioned in the subjoined Schedule, to be available for settlement under improvement purchase leases.

## SCHEDULE.

County.	Parish.	Allotment.	Section.	Area.			Land Valuation.
				A.	R.	P.	
Lowan .. .. .	Charam .. .. .	88 and 93	..	260	0	0±	£2 per acre
Lowan .. .. .	Tallageira .. .. .	33	..	92	0	0±	£2 per acre
Lowan .. .. .	Tallageira .. .. .	33B	..	166	0	0±	£1 15s. per acre.

Given under my Hand and the Seal of the State of Victoria aforesaid, at Melbourne, this sixth day of March, in the year of our Lord One thousand nine hundred and sixty-two, and in the eleventh year of the reign of Her Majesty Queen Elizabeth II.

(L.S.)

By His Excellency's Command,

KEITH TURNBULL,  
Commissioner of Crown Lands and Survey.

DALLAS BROOKS.

GOD SAVE THE QUEEN!

Soldier Settlement Act 1958 (No. 6373).

ROADS CLOSED.

PROCLAMATION

By His Excellency the Governor of the State of Victoria and its Dependencies in the Commonwealth of Australia, &c., &c., &c.

WHEREAS section 40 (1) of the Soldier Settlement Act 1958 (No. 6373) prescribes that where any road (whether used or unused and whether formed or unformed) forms part of or intersects any estate and the Soldier Settlement Commission, after consultation with the council or councils of the municipality or municipalities concerned, certifies that the said road is unsuited to the proper subdivision of the estate:

And whereas the Soldier Settlement Commission, after consultation with the councils of the municipalities concerned, has so certified:

Now therefore, I, the Governor of the State of Victoria, in the Commonwealth of Australia, by and with the advice of the Executive Council of the said State, and in pursuance of section 40 of the Soldier Settlement Act 1958 (No. 6373), do by this my Proclamation direct that the roads, as described hereunder, be closed, that is to say:—

Parish of Ballangeich, County of Villiers, being the road indicated by hachure on plan hereunder.—(B.585(2) (D.33173).

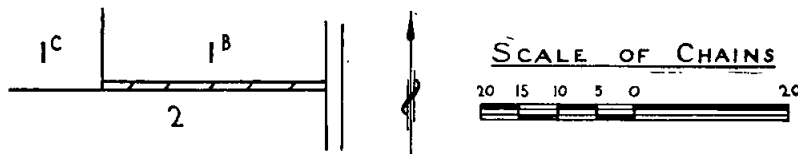

Parish of Woolsthorpe, County of Villiers, being the road indicated by hachure on plan hereunder.—(W.244(6) (Q.21(4) (D.33173).

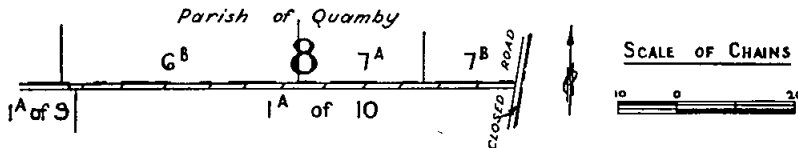

Parish of Drumdlemara, County of Buln Buln, being the road indicated by hachure on plan hereunder.—(D.197(E) (D.30974).

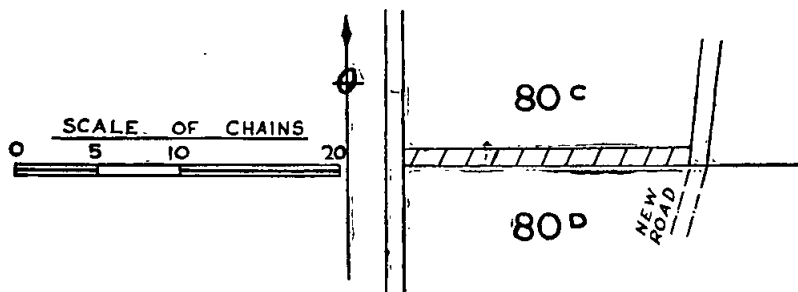

Parish of Kadnook, County of Lowan, being the road indicated by hachure on plan hereunder.—(K.128(4) (D.35758).

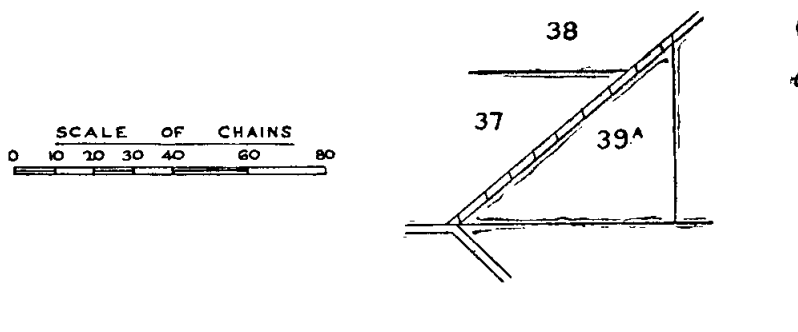

Parish of Kadnook, County of Lowan, being the road between allotments 34A, 41 and allotments 42, 42A.—(K.128<sup>(4)</sup>) (D.35758).

Parish of Kadnook, County of Lowan, being the road between allotments 40, 41, 42A, 43A, 43 and allotments 36, 38.—(K.128<sup>(4)</sup>) (D.35758).

Parish of Kadnook, County of Lowan, being the road between allotments 4, 5 and allotment 17.—(K.128<sup>(4)</sup>) (D.35758).

Parish of Kadnook, County of Lowan, being the road between section A (known as Kadnook Pre-emptive Section), allotments 5, 17 and allotments 9, 10, 11, 18.—(K.128<sup>(3)</sup>) (K.128<sup>(4)</sup>) (D.35758).

Parish of Kadnook, County of Lowan, being the roads indicated by hachure on plans hereunder.—(K.128<sup>(3)</sup>) (K.128<sup>(4)</sup>) (D.35758).

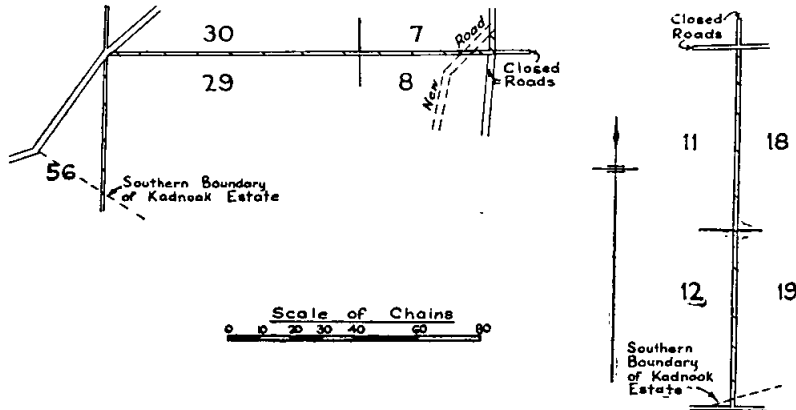

Parish of Yalimba East, County of Villiers, being the road between allotments 1B, 4B, section 5, and allotments 2A, 2B, 3A, 3B, section 5.—(Y.76<sup>(4)</sup>) (D.33714).

Parish of Yalimba East, County of Villiers, being the road between allotments 7B, 6B, section 6, and allotments 1A, 1B, 5A, section 6.—(Y.76<sup>(4)</sup>) (D.33714).

Parish of Yalimba East, County of Villiers, being the road between allotments 2A, 2B, 3A, 4B, section 6, and allotments 1A, 1B, 5B, section 6.—(Y.76<sup>(4)</sup>) (D.33714).

Parish of Yalimba, County of Villiers, being the road indicated by hachure on plan hereunder.—(Y.76<sup>(3)</sup>) (D.33714).

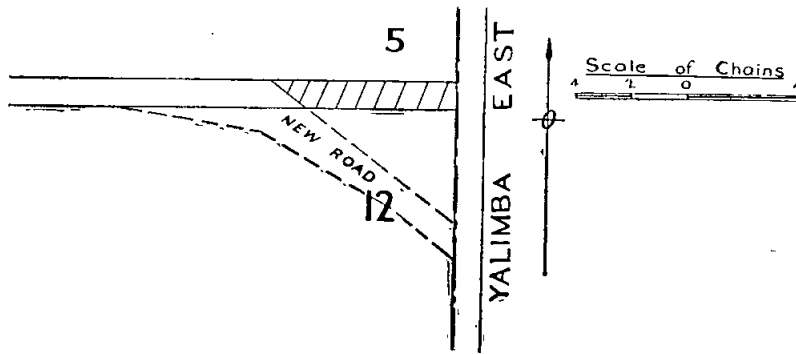

Parish of Yalimba East, County of Villiers, being the road indicated by hachure on plan hereunder.—(Y.76<sup>(4)</sup>) (D.33714).

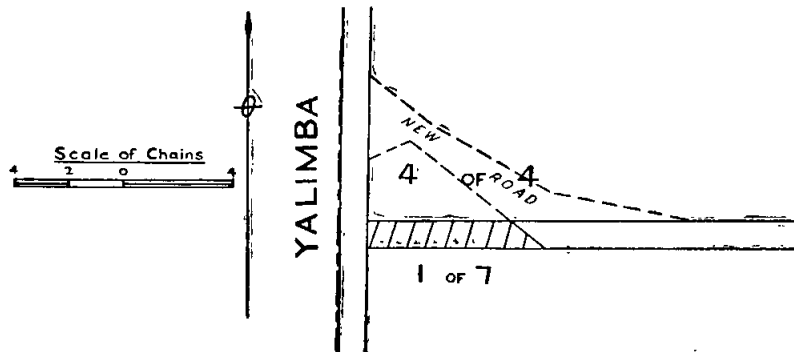

Parishes of Kay and Yalimba East, County of Villiers, being the roads indicated by hachure on plan hereunder.—(K.12<sup>(2)</sup>) (Y.76<sup>(4)</sup>) (C.359(A)) (D.33714).

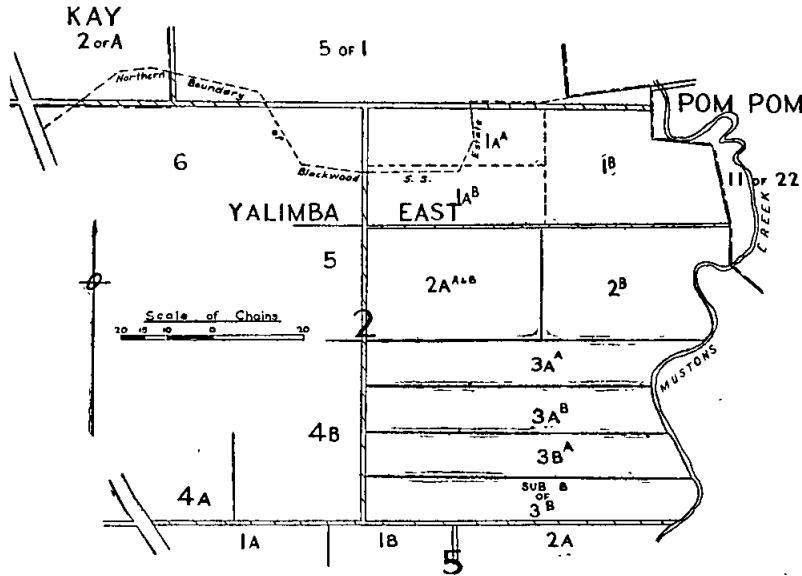

Parish of Lexton, County of Talbot, being the road indicated by hachure on plan hereunder.—(L.49(K)) (L.49<sup>(5)</sup>) (D.27333).

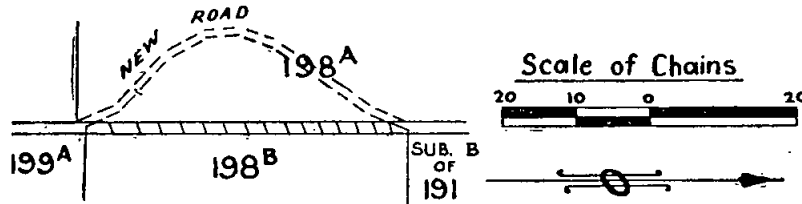

Parish of Murrandarra, County of Lowan, being the road between allotments 25, 24A, 24B, 24C and allotments 18, 17, 16, section A.—(M.461<sup>(2)</sup>) (M.461(D)) (D.34998).

Given under my Hand and the Seal of the State of Victoria aforesaid, at Melbourne, the fourteenth day of March, in the year of our Lord One thousand nine hundred and sixty-two, and in the eleventh year of the reign of Her Majesty Queen Elizabeth II.

(L.S.)

DALLAS BROOKS.

By His Excellency's Command,

KEITH TURNBULL,  
Minister of Soldier Settlement.

GOD SAVE THE QUEEN!

*Land Settlement Act 1959 (No. 6534).*

ROADS CLOSED.

PROCLAMATION

By His Excellency the Governor of the State of Victoria and its Dependencies in the Commonwealth of Australia, &c., &c., &c.

WHEREAS section 5 (1) of the *Land Settlement Act 1959*, No. 6534 (so far as the said section 5 extends and applies section 40 (1) of the *Soldier Settlement Act 1958*, No. 6373) prescribes that where any road (whether used or unused and whether formed or unformed) forms part of or intersects any estate and the Soldier Settlement Commission, after consultation with the council or councils of the municipality or municipalities concerned, certifies that the said road is unsuited to the proper subdivision of the estate:

And whereas the Soldier Settlement Commission, after consultation with the councils of the municipalities concerned, has so certified:

Now therefore, I, the Governor of the State of Victoria, in the Commonwealth of Australia, by and with the advice of the Executive Council of the said State, and in pursuance of the said section 5 of the *Land Settlement Act* 1959, No. 6534, do by this my Proclamation direct that the roads, as described hereunder, be closed, that is to say:—

Parish of La Trobe, County of Heytesbury, being the roads indicated by hachure on plans hereunder.—(L.143<sup>(3)</sup>) L.143<sup>(1)</sup> (D.26942).

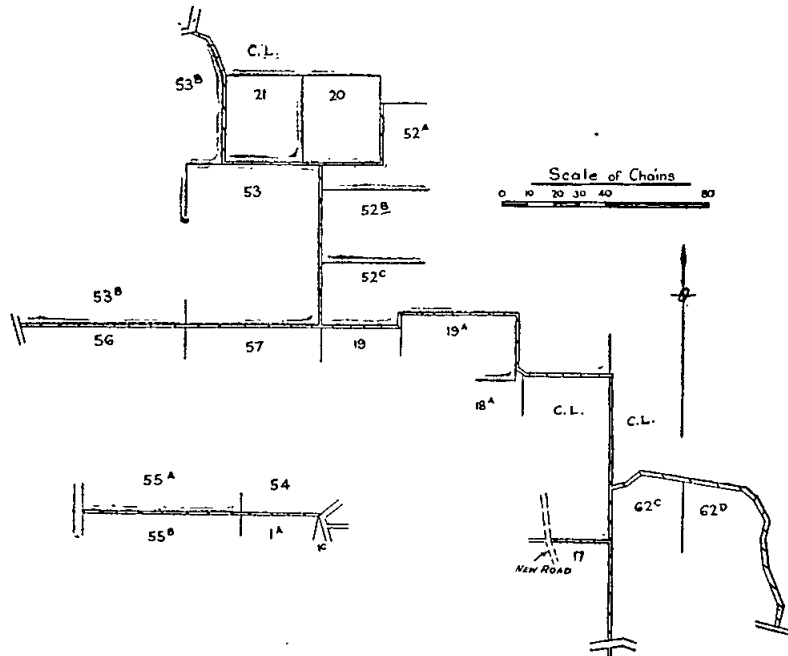

Given under my Hand and the Seal of the State of Victoria aforesaid, at Melbourne, the fourteenth day of March, in the year of our Lord One thousand nine hundred and sixty-two, and in the eleventh year of the reign of Her Majesty Queen Elizabeth II.

(L.S.)

DALLAS BROOKS.

By His Excellency's Command,

KEITH TURNBULL,  
Minister of Soldier Settlement.

GOD SAVE THE QUEEN!

BALLAARAT WEST TOWN COMMON DIMINISHED.

PROCLAMATION

By His Excellency the Governor of the State of Victoria and its Dependencies in the Commonwealth of Australia, &c., &c., &c.

WHEREAS by Division 12 of Part I. of the *Land Act* 1958 it is amongst other things enacted that the Governor in Council may from time to time increase, and, after one month's notice in the *Government Gazette*, diminish, alter, or abolish any common, and may from time to time re-proclaim the whole or any part of any such common for any of the purposes and subject to the provisions of the said Part of the said Act, and that nothing therein contained shall prevent the exercise of the powers conferred by the said Part of the said Act with respect to the leasing or licensing of any land comprised in any common: And whereas notice of the intention to diminish the Ballaarat West Town Common has been duly published in the *Government Gazette* for one month:

Now therefore I, the Governor of the State of Victoria in the Commonwealth of Australia, by and with the advice of the Executive Council of the said State, do hereby diminish the Ballaarat West Town Common by deducting therefrom 84 acres 1 rood 20 perches of land in the Parish of Dowling Forest comprised within the boundaries as defined by description published in the *Government Gazette* of 17th January, 1962.

Given under my Hand and the Seal of the State of Victoria aforesaid, at Melbourne, this sixth day of March, in the year of our Lord One thousand nine hundred and sixty-two, and in the eleventh year of the reign of Her Majesty Queen Elizabeth II.

(L.S.)

DALLAS BROOKS.

By His Excellency's Command,

KEITH TURNBULL,  
Commissioner of Crown Lands and Survey.

GOD SAVE THE QUEEN!

BALLAARAT WEST TOWN COMMON DIMINISHED.

PROCLAMATION

By His Excellency the Governor of the State of Victoria and its Dependencies in the Commonwealth of Australia, &c., &c., &c.

WHEREAS by Division 12 of Part I. of the *Land Act* 1958 it is amongst other things enacted that the Governor in Council may from time to time increase, and, after one month's notice in the *Government Gazette*, diminish, alter, or abolish any common, and may from time to time re-proclaim the whole or any part of any such common for any of the purposes and subject to the provisions of the said Part of the said Act, and that

nothing therein contained shall prevent the exercise of the powers conferred by the said Part of the said Act with respect to the leasing or licensing of any land comprised in any common: And whereas notice of the intention to diminish the Ballaarat West Town Common has been duly published in the *Government Gazette* for one month:

Now therefore I, the Governor of the State of Victoria in the Commonwealth of Australia, by and with the advice of the Executive Council of the said State, do hereby diminish the Ballaarat West Town Common by deducting therefrom 47 acres 2 roods 23 perches of land in the Parish of Dowling Forest comprised within the boundaries as defined by description published in the *Government Gazette* of 24th January, 1962.

Given under my Hand and the Seal of the State of Victoria aforesaid, at Melbourne, this sixth day of March, in the year of our Lord One thousand nine hundred and sixty-two, and in the eleventh year of the reign of Her Majesty Queen Elizabeth II.

(L.S.)

DALLAS BROOKS.

By His Excellency's Command,

KEITH TURNBULL,  
Commissioner of Crown Lands and Survey.

GOD SAVE THE QUEEN!

*Country Fire Authority Act 1958.*

## VARIATION OF SUMMER PERIOD IN RESPECT OF SPECIFIED PARTS OF THE COUNTRY AREA OF VICTORIA.

WHEREAS by section 4 of the *Country Fire Authority Act 1958* it is enacted that the Chief Secretary of Victoria, after consultation with the Minister of Forests, may from time to time by declaration published in the *Government Gazette* declare any period to be the summer period in respect of the country area of Victoria, or any specified part or parts thereof and, without affecting the generality of the foregoing, may declare different periods to be the summer period in respect of different parts of the said country area:

And whereas by the said sub-section it is further enacted that any declaration so published may be revoked, amended, or varied by a subsequent declaration so published:

And whereas by declarations issued on the tenth day of November, 1961, the seventeenth day of November, 1961, the twenty-eighth day of November, 1961, the fourth day of December, 1961, and the twelfth day of December, 1961, and published in the *Government Gazette* of the fifteenth day of November, 1961, the twenty-second day of November, 1961, the twenty-ninth day of November, 1961, the eighth day of December, 1961, and the thirteenth day of December, 1961, respectively, different summer periods expiring on the fifteenth day of April, 1962, were declared in respect of different parts of the country area of Victoria, including the parts of the said country area specified in the Schedule hereto:

And whereas it is deemed expedient that the aforesaid declarations should be varied in the manner hereinafter described:

And whereas the Chief Secretary and the Minister of Forests have consulted accordingly:

Now therefore I, Arthur Gordon Rylah, Chief Secretary of Victoria, do by this my declaration vary the aforesaid declarations by declaring that the summer period in respect of the parts of the country area of Victoria specified in the Schedule hereto shall end at midnight on the sixteenth day of March, 1962.

## SCHEDULE.

The Second Fire Control Region, comprising the municipal districts of the City of Bendigo, the Borough of Eaglehawk, and those portions of the Shires of Marong and Strathfieldsaye not included in the Twenty-first Fire Control Region;

the Ninth Fire Control Region, comprising the municipal districts of the Borough of Moe, the Shires of Buln Buln, Korumburra, Mirboo, Narracan, South Gippsland, Warragul, and Woorayl, and the Yallourn Works Area, as defined pursuant to the *State Electricity Commission Act 1958*;

the Tenth Fire Control Region, comprising the municipal districts of the City of Sale, the Borough of Traralgon, and the Shires of Alberton, Avon, Maffra, Morwell, Rosedale and Traralgon;

those portions of the Eleventh Fire Control Region, comprised by the municipal districts of the Shires of Bairnsdale, Orbost and Tambo;

those portions of the Seventeenth Fire Control Region, comprised by the municipal districts of the City of Horsham, the Shires of Dimboola, Dunmunkle, Kaniva, Lowan and Warracknabeal, and those portions of the Shires of Arapiles and Wimmera respectively which lie in a northerly direction from the under-mentioned boundaries, that is to say:—

(a) *Shire of Arapiles*.—Commencing at the intersection of the Riffe Butts-road with the McKenzie River; thence generally westerly and north-westerly along the aforementioned road and the Clear Lake—Tooen—Duffholme road to its intersection with the western boundary of the municipal district.

(b) *Shire of Wimmera*.—Commencing at the intersection of the Wimmera River with the Rocklands—Lubeck Channel on the eastern boundary of the municipal district; thence generally in a westerly and south-westerly direction along the aforementioned channel to its intersection with the McKenzie River on the western boundary of the municipal district;

those portions of the Nineteenth Fire Control Region, comprised by the municipal district of the Shire of Bet Bet;

those portions of the Twenty-first Fire Control Region, comprised by the municipal districts of the Town of Castlemaine, the Shires of Maldon and Metcalfe, and those portions of the Shire of Strathfieldsaye not included in the Second Fire Control Region;

and those portions of the Twenty-third Fire Control Region, comprised by the Shires of Rutherglen and Yarrowonga, and those portions of the Shire of Wangaratta defined in the First Schedule to this declaration.

*First Schedule.*

Commencing at a point on the eastern or right-hand bank of the Ovens River at its junction with the south side of the Murray Valley Highway on frontage abutting allotment Nos. 1 and A1, Parish of Boorhaman; thence easterly bounded by the southern side of Murray Valley Highway to the north-east corner of allotment 5 of said parish; thence southerly along eastern boundary of allotments 5 and 5A to the south-east corner of allotment 5A; thence crossing Government-road easterly; thence bearing easterly along northern boundary of allotments 8a, 8b, 9a and 9 to north-east corner of allotment 9; thence easterly across Government-road to the eastern boundary of Parish of Boorhaman; thence southerly along eastern side of Boundary-road with Rutherglen Shire to the south-west corner of allotment 32 of said Parish of Boorhaman; thence easterly along northern side of Boundary-road with Rutherglen Shire to the south-eastern corner of allotment No. 47, Parish of Boorhaman; thence easterly across Government-road to south-west corner of allotment 2a, Parish of Bontherambo; thence easterly along the northern side of Boundary-road to south-east corner of allotment 26A of said Parish of Bontherambo at its junction with Parish of Chiltern West at the western boundary of allotment B6, section XI. of said Parish of Chiltern West; thence easterly to a point on the northern side of Boundary-road situated 999 links south of west from the eastern corner of allotment E, section XI., Parish of Chiltern West; thence following the north-western boundary of the north-eastern Railway Reserve in a south-westerly direction through the Parish of Chiltern West, Bontherambo, Carraragarmunjee, and Wangaratta North to its junction with the north-eastern or right-hand bank of the Reidy Creek in the Shire of Wangaratta; thence following the said right-hand or eastern bank of Reidy Creek to its junction with the right-hand or eastern bank of the Ovens River; thence following the eastern bank of the Ovens River to the point of commencement.

A. G. RYLAH,  
Chief Secretary.

13th March, 1962.

CONTRACTS ACCEPTED.—(Series 1962-63.)

Contract No.	Particulars.	Amount.	Name of Contractor.	Charge against Vote or Fund.
2722	GENERAL STORES— Supply of Motor Spirit, Kerosene, &c., in such quantities as may be ordered from 1st April, 1962 to 31st March, 1963	Rates as per annex	The Shell Co. of Australia Ltd.	General Expenses, 1961-62 1962-63
2723	" " " " " " " "	"	Vacuum Oil Co. Pty. Ltd.	
2724	" " " " " " " "	"	B.P. Australia Ltd.	
2725	" " " " " " " "	"	Ampol Petroleum Vic. Pty. Ltd.	
2726	" " " " " " " "	"	Caltex Oil (Australia) Pty. Ltd.	
2727	" " " " " " " "	"	Atlantic Union Oil Co. Pty. Ltd.	
2728	" " " " " " " "	"	H. C. Sleigh Ltd.	
2729	" " " " " " " "	"	Neptune Oil Co. Pty. Ltd.	
2730	" " " " " " " "	"	Kangaroo Petroleum Co. Pty. Ltd.	

Approved—H. E. BOLTE, Treasurer.—27.2.62.

ANNEX TO CONTRACTS Nos. 1962/2722 TO 1962/2730.

Schedule No. 56.

MOTOR SPIRIT, KEROSENE, Etc.

CONTRACT FROM 1ST APRIL, 1962, TO 31ST MARCH, 1963.

- 1962/2722.—The Shell Co. of Australia Ltd. Security, £200.
- 1962/2723.—Vacuum Oil Co. Pty. Ltd. Security, £200.
- 1962/2724.—B.P. Australia Ltd. Security, £200.
- 1962/2725.—Ampol Petroleum Vic. Pty. Ltd. Security, £200.
- 1962/2726.—Caltex Oil (Australia) Pty. Ltd. Security, £200.
- 1962/2727.—Atlantic Union Oil Co. Pty. Ltd. Security, £200.
- 1962/2728.—H. C. Sleigh Ltd. Security, £200.
- 1962/2729.—Neptune Oil Co. Pty. Ltd. Security, £200.
- 1962/2730.—Kangaroo Petroleum Co. Pty. Ltd. Security, £200.

DISTRIBUTION OF ORDERS.

Orders for supplies of Item 2 are to be issued on the respective contractors as follows:—  
B.P. Australia Ltd.—All Departments.

Orders for supplies of Item 3 are to be issued on the respective contractors as follows:—  
Atlantic Union Oil Pty. Ltd.—Public Works Department.  
The Shell Co. of Australia Ltd.—Police Department as to one-half of requirements.  
Vacuum Oil Co. Pty. Ltd.—Police Department as to one-half of requirements.  
Neptune Oil Co. Pty. Ltd.—All other Departments.  
Ampol Petroleum Vic. Pty. Ltd.—Forests Commission as to two-thirds of requirements.  
Caltex Oil (Australia) Pty. Ltd.—Education Department.  
Kangaroo Petroleum Co. Pty. Ltd.—Forests Commission as to one-third of requirements.

Orders for supplies of Item 10 are to be issued on the respective contractors as follows:—  
Ampol Petroleum Vic. Pty. Ltd.—Health Department.  
Vacuum Oil Co. Pty. Ltd.—All other Departments.

Orders for supplies of Item 13 are to be issued on the respective contractors as follows:—  
The Shell Co. of Australia Ltd.—Mental Hygiene Department except Ballarat Mental Hospital.  
Caltex Oil (Aust.) Pty. Ltd.—Health Department.  
Neptune Oil Co. Pty. Ltd.—Government Printer.  
B.P. Australia Ltd.—All other Departments, and Ballarat Mental Hospital.

The rates shown are F.O.R. Melbourne, and cover delivery within the Metropolitan Free Delivery Area; for supplies outside that area, other than those forwarded on Storos and Transport Consignment Notes, freight differentials in accordance with the Contractors' differential lists are to be added. Contractors to supply copies of current differential lists to Departments requiring same.

Drums (4-gallon) become the property of the Government. Drums (44-gallon) will be charged at £2 each. This charge will be debited against Departments and credit will be allowed in full on return of drums in good order and condition.

Officers are required to return drums to the point of delivery within a reasonable time.

Rates for Items Nos. 9, 10, 11, and 12 exclude 1s. per gallon Duty, and Exemption Certificate number is to be quoted on each order for these items.

Item No. 14.—Rate to be increased by ten shillings (10s.) per ton (with £6 minimum charge) if delivered by road.

Item No.	Description of Articles.	Rate.	Name of Contractor.
1	Motor Spirit, Standard Grade—in 4-gallon drums .. per drum	£ s. d. 0 16 4	Neptune Oil Co. Pty. Ltd. B.P. Australia Ltd.
2	" " " " in 44-gallon drums .. per gal.	0 2 8	
3	" " " " in bulk into bowsers .. per gal.	0 2 7	Kangaroo Petroleum Co. Pty. Ltd. The Shell Co. of Australia Ltd. Vacuum Oil Co. Pty. Ltd. Neptune Oil Co. Pty. Ltd. Ampol Petroleum Vic. Pty. Ltd. Caltex Oil (Australia) Pty. Ltd. Atlantic Union Oil Co. Pty. Ltd.
4	Kerosene, 150 test—in 4-gallon drums .. per drum	0 13 9	
5	" " " " in 44-gallon drums .. per gal.	0 2 0½	Kangaroo Petroleum Co. Pty. Ltd.
6	" Power—in 4-gallon drums .. per drum	0 14 0	
7	" " " " in 44-gallon drums .. per gal.	0 2 1	Atlantic Union Oil Co. Pty. Ltd.
8	" " " " in bulk into bowsers .. per gal.	0 2 1	
9	Diesel Oil—in 44-gallon drums .. per ton	20 9 6	Neptune Oil Co. Pty. Ltd. Vacuum Oil Co. Pty. Ltd. Ampol Petroleum Vic. Pty. Ltd.
10	" " " in bulk into bowsers .. per ton	19 17 6	
11	Distillate—in 44-gallon drums .. per gal.	0 1 11½	H. C. Sleigh Ltd.
12	" in bulk into bowsers .. per gal.	0 1 11½	
13	Furnace Oil—in bulk .. per ton	12 4 6	Neptune Oil Co. Pty. Ltd. Caltex Oil (Aust.) Pty. Ltd. B.P. Australia Ltd. The Shell Co. of Australia Ltd.
14	Bunker Fuel .. per ton	10 1 6	

CONTRACTS ACCEPTED.—(Series 1961-62.)  
PROVISIONS.—MEAT.

No. of Contract.	Particulars of Each Tender Accepted.	Amount.	Name of Contractor.	Charge Against Vote or Fund.	
PROVISIONS—					
Supply of Meat, in such quantities as may be ordered, from 1st April, 1962, to 30th June, 1962					
Schedule No. 1.—Melbourne District—					
2693	Kew Mental Hospital .. .. .	Rates as per annex	F. Watkins Pty. Ltd. ..	General Expenses 1961-62	
2694	Pentridge Penal Establishment and "Fairlea" Female Prison, Fairfield	" "	Oscar Mayer Pty. Ltd. ..		
2695	Children's Welfare Depot, Royal Park, and Travancore Developmental Centre, Flemington	" "	J. H. Cooke Pty. Ltd. ..		
2696	"Winlaton" Juvenile School, 186 Springvale-road, Nunawading and "Allambie", 70 Elgar-road, Burwood	" "	J. H. Cooke, Pty. Ltd.		
2697	Royal Park Mental Hospital and Receiving House ..	" "	J. H. Cooke Pty. Ltd. ..		
Schedule No. 2.—Mont Park, Bundoora, Larundel, Janefield, Gresswell, and Pleasant View, Wood-street, Preston—					
2698	Mont Park District .. .. .	" "	W. Angliss and Co. (Aust.) Pty. Ltd.		
2699	Preston .. .. .	" "			
2700	Gresswell Sanatorium .. .. .	" "			
2701	Schedule No. 3.—SS. Rip and Dredges .. .. .	" "	Oscar Mayer Pty. Ltd. ..		
2702	Schedule No. 4.—Teachers' College and Hostels at Grattan-street, 93 Drummond-street, Carlton; 470 and 481 St. Kilda-road, Melbourne; 19 Queens-road, Melbourne; 152 Toorak-road west, South Yarra; Frank Tate House, 373 Dandenong-road, Armadale; "Redcourt" 6 and "Larnook," 13 Orrong-road Armadale; 11 Patterson-street, Hawthorn; 174 Punt-road, Prahran; 221 Burwood-road, Burwood; John Cannon House, 32 Belmont-avenue, Kew; 17 Moule-avenue, Brighton; Police Hospital, St. Kilda-road, Melbourne; and Mental Hygiene Clinic, 321 Glenferrie-road, Malvern; also 10A Orrong-road, Armadale, 572 St. Kilda-road, Melbourne, and Hastings-road, Frankston ..	" "	J. H. Cooke Pty. Ltd. ..		
2703	Schedule No. 5.—Heatherton Sanatorium, Cheltenham ..	" "	W. Angliss and Co. (Aust.) Pty. Ltd.		
2704	Schedule No. 6.—Ararat District .. .. .	" "	Thomas Borthwick and Sons (A/Asia) Ltd.		
Schedule No. 7.—Ballarat District—					
2705	Gaol and Mental Hospital .. .. .	" "	H. A. Morris		
2706	Teachers' Hostels .. .. .	" "	Victorian Inland Meat Authority		
2707	Schedule No. 8.—Beechworth District .. .. .	" "	E. Spencer .. .. .		
Schedule No. 9.—Bendigo District—					
2708	Gaol .. .. .	" "	Alan H. Gittins .. .. .		
2709	Sandhurst Boys' Centre .. .. .	" "	Alan H. Gittins .. .. .		
2710	Teachers' Hostels .. .. .	" "	Frank Wade .. .. .		
2711	Schedule No. 10.—Castlemaine District .. .. .	" "	McQueen Bros. .. .. .		
2712	Schedule No. 11.—School of Forestry, Creswick .. .. .	" "	H. J. Symons Pty. Ltd.		
2713	Schedule No. 13.—McLeod Settlement, French Island ..	" "	George Hayman .. .. .		
Schedule No. 14.—Geelong District—					
2714	Gaol .. .. .	" "	A. Bubb .. .. .		
2715	Teachers' Hostels .. .. .	" "	A. C. Knight .. .. .		
2716	Schedule No. 15.—Coorimungle Prison Camp, Hoytesbury Forest	" "	Heytesbury Butchery ..		
2717	Schedule No. 17.—Langi Kal Kal Training Centre ..	" "	F. P. Haintz and Son ..		
2718	Schedule No. 20.—Sale Gaol .. .. .	" "	T. L. Webster Pty. Ltd.		
2719	Schedule No. 21.—Pleasant Creek Special School, Stawell ..	" "	Thomas Borthwick and Sons (A/Asia) Ltd.		
2720	Schedule No. 22.—Sunbury District .. .. .	" "	F. Watkins Pty. Ltd. ..		
2721	Schedule No. 23.—Warrnambool District .. .. .	" "	Thomas Borthwick and Sons (A/Asia) Ltd.		

Approved H. E. BOLTE, Treasurer.—27.2.1962.

SCHEDULE NO. 1.—MELBOURNE DISTRICT.

ANNEX TO CONTRACT NO. 1962/2693.

F. Watkins Pty. Ltd., 184 Bourke-street, Melbourne.

Sub-schedule No. 9.

MEAT FOR MENTAL HOSPITAL, KEW.

Security, £35.

	£	s.	d.
Fresh Beef—			
1. Rolled Roast boneless (Brisket excluded)	per lb.	0	2 4
2. Buttocks .. .. .	do.	0	2 3
3. Shin and Gravy Beef (boneless) .. .. .	do.	0	2 3
4. Corned Beef—Rolled or Round, as ordered, without bone or cartilage	do.	0	2 6
5. Fresh Mutton—(Whole Sheep) (Kidney fat to be removed)	do.	0	0 10½
6. Veal—boned .. .. .	do.	0	2 4
7. Sausages—Mixed .. .. .	do.	0	1 9

SCHEDULE No. 1.—MELBOURNE DISTRICT—continued.

	£	s.	d.
8. Livers—Sheep .. .. .	per lb.	0	2 0
9. " Ox .. .. .	do.	0	1 8
10. Kidneys, Ox .. .. .	do.	0	2 9
11. " Sheep .. .. .	do.	0	2 2
12. Tripe, Fresh .. .. .	do.	0	1 0
13. Tongues—Ox .. .. .	do.	0	1 10
" Sheep .. .. .	each	0	0 8
14. Sausage—Belgium .. .. .	per lb.	0	2 4
15. Beef Loaf .. .. .	do.	0	2 6
16. Ham Loaf .. .. .	do.	0	3 3
17. Veal Loaf .. .. .	do.	0	3 3
18. Saveloys .. .. .	per doz.	0	3 6
19. Brains, Sheep .. .. .	per set	0	0 7
20. Fowls, First quality .. .. .	per lb.	0	5 6
21. Bacon Sides .. .. .	do.	0	4 6
22. Rabbit Fillets .. .. .	do.	0	4 9
23. Sausage Meat .. .. .	do.	0	1 4



SCHEDULE No. 1.—MELBOURNE DISTRICT—continued.

ANNEX TO CONTRACT No. 1962/2694.

Oscar Mayer Pty. Ltd., P.O. Box 163, Footscray.

Sub-schedule No. 10.

MEAT FOR PENTRIDGE PENAL ESTABLISHMENT, COBURG; AND "FAIRLEA" FEMALE PRISON, FAIRFIELD.

Security, £35.		£	s.	d.
Fresh Beef—				
1.	Fore-quarters	per lb.	0	1 4
2.	Minced	do.	0	2 0
3.	Corned Beef—Rolled or Round, as ordered, without bone or cartilage	do.	0	2 6
4.	Fresh Mutton (whole sheep)	do.	0	0 10½
5.	Sausages—Mixed—thin	do.	0	1 6
6.	Fresh Suet—Kidney	do.	0	0 7
7.	Saveloys	do.	0	1 10
8.	Sausage—Beef German	do.	0	2 2
9.	Sausage Mince	do.	0	1 1
10.	Dripping, Beef	do.	0	1 2
11.	Frankfurts	do.	0	2 0
12.	Livers—Sheep	do.	0	1 6
13.	Ham Loaf	do.	0	3 0

ANNEX TO CONTRACT No. 1962/2695.

J. H. Cooke Pty. Ltd., 378 Queen's-parade, Clifton Hill.

Sub-schedule No. 11.

MEAT FOR CHILDREN'S WELFARE DEPOT, ROYAL PARK, AND TRAVANCOBE DEVELOPMENTAL CENTRE, FLEMINGTON.

Security, £8.		£	s.	d.
1.	Fresh Beef—Rolled Roast Sirloin—Boneless	per lb.	0	2 7
2.	Beef—Corned—Silverside	do.	0	3 2
Fresh Mutton—				
3.	Legs	do.	0	1 5
4.	Legs (Two tooth)	do.	0	1 7
5.	Chops—Mid Loin (Two tooth)	do.	0	1 3
6.	Rib Chops as Cutlets (Two tooth)	do.	0	1 4
Steak—				
7.	Rump	do.	0	3 6
8.	Blade	do.	0	2 9
9.	Minced	do.	0	1 9
10.	Veal—Fillet, boneless	do.	0	3 3
11.	Pickled Pork	do.	0	2 0
12.	Sausages—Mixed	do.	0	1 8
13.	Sausage—Strasburg, Pork	do.	0	3 3
14.	Tripe—Fresh	do.	0	0 9
15.	Frys—Lamb	do.	0	1 9
16.	Ox Tongue	do.	0	1 6
17.	Frankfurts	do.	0	2 6
18.	Rabbits—Fresh	do.	0	3 3
19.	Sausage, Beef German	do.	0	2 7
20.	Kidney, Ox	do.	0	2 6
21.	Shanks, Sheep	each	0	0 3

ANNEX TO CONTRACT No. 1962/2696.

J. H. Cooke Pty. Ltd., 378 Queen's-parade, Clifton Hill.

Sub-schedule No. 12.

FOR "WINLATON" JUVENILE SCHOOL, 186 SPRINGVALE-ROAD, NUNAWADING, AND "ALLAMBIE", 70 ELGAR-ROAD, BURWOOD.

Security, £5.		£	s.	d.
Fresh Beef—				
1.	Rolled Roast Sirloin, Boneless	per lb.	0	2 6
2.	Corned—Silverside	do.	0	3 3
3.	Mutton Fresh—Fore-quarters	do.	0	0 11
4.	" " Legs (Two tooth)	do.	0	1 7
5.	" " Chops—Mid Loin (Two tooth)	do.	0	1 6
6.	" " Forequarter	do.	0	1 0
7.	Steak—Topside	do.	0	3 3
8.	Steak—Rump	do.	0	3 8
9.	" Stewing	do.	0	2 8
10.	" Minced	do.	0	2 2
11.	" Blade	do.	0	2 8
12.	Sausages—Mixed	do.	0	1 8
13.	Sausage Meat	do.	0	0 10
14.	Frys—Lamb	do.	0	1 9
15.	Veal—Fillet—Boneless	do.	0	3 3
16.	Veal—T bone	do.	0	3 3
17.	" Leg, boned	do.	0	2 11
18.	Pork—Pickled	do.	0	2 0
19.	Pressed Ham Loaf	do.	0	3 0
20.	Tongues—Ox	do.	0	1 6
21.	Dripping beef	do.	0	1 0
22.	Brains—Sheep	per set	0	0 5
23.	Sausage—Strasburg—Pork	per lb.	0	3 2
24.	Frankfurts	do.	0	2 5
25.	Rabbits—Fresh	do.	0	3 3
26.	Veal Cutlets	do.	0	3 3

ANNEX TO CONTRACT No. 1962/2697.

J. H. Cooke Pty. Ltd., 378 Queen's-parade, Clifton Hill.

Sub-schedule No. 13.

MEAT FOR RECEIVING HOUSE AND MENTAL HOSPITAL, ROYAL PARK.

Security, £10.		£	s.	d.
Fresh Beef—				
1.	Rolled Roast, boneless (Brisket excluded)	per lb.	0	2 6
2.	Thick Flank	do.	0	2 6
3.	Fresh Mutton (Legs)	do.	0	1 7
4.	Chops—Fore-quarter	do.	0	0 11
5.	Sausages—Thin	do.	0	1 8
6.	Sausage—Mince	do.	0	0 9
7.	Rabbits—Fresh	do.	0	3 3
8.	Fowls—First quality	do.	0	5 3
9.	Sausage, beef german	do.	0	2 6
10.	Beef, Corned—Rolled or round, as ordered, without bone or cartilage	do.	0	1 0

SCHEDULE No. 2.—MONT PARK AND SANATORIUM GRESSWELL, ETC.

ANNEX TO CONTRACT No. 1962/2698.

W. Angliss and Co. (Aust.) Pty. Ltd., 42 Bourke-street, Melbourne.

Sub-schedule No. 4.

MEAT.

(For Mont Park Mental Hospital, &c.)

Security, £35.		£	s.	d.
Fresh Beef—				
1.	Buttonks	per lb.	0	2 0
2.	Topside, pieces	do.	0	3 1
3.	Rolled Roast—Boneless (Brisket excluded)	do.	0	2 6
Beef, Corned—				
4.	Rolled or Round, as ordered, without bone or cartilage	do.	0	2 2
5.	Corned—Silverside	do.	0	3 2
Mutton, Fresh—				
6.	Carcass or Sides (Kidney fat to be removed)	do.	0	0 9½
7.	Legs	do.	0	1 5
Chops—				
8.	Loin	do.	0	1 4
9.	Forequarter	do.	0	1 0
Steak—				
10.	Rump	do.	0	3 9
11.	Minced	do.	0	2 3
12.	Sausage—Meat	do.	0	1 2
13.	Sausages—Mixed	do.	0	1 9
14.	Shanks—Sheep	each	0	0 6
15.	Tripe—Fresh	per lb.	0	0 8½
16.	Brains—Sheep	per set	0	0 6
17.	Kidneys—Ox	per lb.	0	2 6
18.	Livers—Sheep	do.	0	1 9
19.	Livers—Calves	do.	0	2 3
20.	Sausage—Beef German	do.	0	2 3
21.	Rabbits—Fresh	do.	0	3 0
22.	Ham Loaf	per lb.	0	3 3
23.	Fillet Veal	do.	0	2 6
24.	Fowls—First quality	do.	0	4 6
25.	Lamb Chops	do.	0	2 9
26.	Bones—Beef	do.	0	0 0½
27.	Bacon—Sides	do.	0	4 2
28.	Sweetbreads	per box	0	3 9
29.	Saveloys	per doz.	0	2 1
30.	Lamb, Sides	per lb.	0	1 10
31.	" Legs	do.	0	2 8
32.	Veal, minced	do.	0	2 3
33.	Beef—Shin	do.	0	1 3
34.	Pork—Chops	do.	0	3 6

ANNEX TO CONTRACT No. 1962/2699.

W. Angliss & Co. (Aust.) Pty. Ltd., 42 Bourke-street, Melbourne.

Sub-schedule No. 5.

MEAT.

(For Pleasant View Receiving House, Wood-street, Preston.)

Security, £5.		£	s.	d.
1.	Fresh Beef—Sirloin—Boneless (Brisket excluded)	per lb.	0	3 6
2.	Corned Beef—Silverside	do.	0	3 2
3.	Fresh Lamb—Legs	do.	0	2 8
Chops—				
4.	Loin—Lamb	do.	0	3 3
5.	Fore-quarter—Lamb	do.	0	1 3
6.	Livers—Lamb	do.	0	2 0
7.	Sausages—Pork	do.	0	1 9
8.	Dripping—Beef	do.	0	1 0
9.	Tongues—Sheep	do.	0	1 0

SCHEDULE No. 2.—MONT PARK AND SANATORIUM GRESSWELL, ETC.—*continued.*

	£	s.	d.
10. Brains—Sheep .. .. .	0	0	7
11. Frankfurts .. .. .	0	5	0
12. Sausage—Strasburg—Pork .. .. .	0	3	0
13. Rabbits—Fresh .. .. .	0	3	0
14. Capons .. .. .	0	5	0
15. Tripe .. .. .	0	0	9
16. Ham, tinned, 2lb. tin .. .. .	0	10	0
17. Pork—Fresh—Legs .. .. .	0	3	6
18. Steak—Buttock .. .. .	0	2	9
19. " Fillet .. .. .	0	5	0
20. " Minced .. .. .	0	2	3
21. Mutton—Legs (boiling) .. .. .	0	1	5

ANNEX TO CONTRACT No. 1962/2700.

W. Angliss and Co. (Aust.) Pty. Ltd. 42 Bourke-street, Melbourne.

Sub-schedule No. 6.

MEAT.

(For Gresswell Sanatorium.)

Security £15.

	£	s.	d.
1. Fresh Beef—Rolled Roast Sirloin (Boneless) per lb.	0	3	6
2. Beef—Corned Silverside .. .. .	0	3	3
3. Lamb—Fresh Legs .. .. .	0	2	8
4. " Chops—Mid-loin .. .. .	0	3	0
5. " " Chump .. .. .	0	2	6
6. " " Fore-quarter .. .. .	0	1	3
7. " " Cutlets .. .. .	0	3	0
8. " " Rolled .. .. .	0	1	6
9. Pork—Fresh Legs .. .. .	0	3	9
10. " Chops .. .. .	0	3	6
11. " " Pickled .. .. .	0	2	9
12. Mutton—Leg Chops .. .. .	0	1	6
13. Veal—Fresh, Shoulder .. .. .	0	1	3
14. " " Cutlets .. .. .	0	3	6
15. " " Fillet .. .. .	0	2	6
16. Steak—Rump .. .. .	0	3	9
17. " " Topside .. .. .	0	3	3
18. " " Blade .. .. .	0	2	6
19. " " Porterhouse .. .. .	0	3	9
20. " " Fillet .. .. .	0	5	0
21. " " Minced .. .. .	0	2	3
22. Brains—Sheep .. .. .	0	0	6
23. Fowls—First quality .. .. .	0	4	6
24. Frankfurts .. .. .	0	2	6
25. Ham Loaf .. .. .	0	3	3
26. " " Pressed Log .. .. .	0	7	9
27. " " Pressed Shoulder .. .. .	0	6	3
28. Kidneys—Ox .. .. .	0	2	9
29. " " Sheep .. .. .	0	2	6
30. Livers—Sheep .. .. .	0	1	9
31. " " Lamb .. .. .	0	1	9
32. " " Calves .. .. .	0	2	3
33. Rabbits—Fresh .. .. .	0	3	0
34. Sausages—Mixed .. .. .	0	1	9
35. " " Pork .. .. .	0	1	9
36. Sausage Meat .. .. .	0	1	2
37. " " Strasburg—Pork .. .. .	0	3	0
38. Shanks—Sheep .. .. .	0	0	6
39. Tripe—Fresh .. .. .	0	0	8½
40. Tongues—Ox .. .. .	0	1	9
41. " " Sheep .. .. .	0	1	0
42. Veal and Pork Loaf—Pressed .. .. .	0	3	3
43. Savoury Loaf—Pressed .. .. .	0	3	5
44. Ham—Leg—Raw .. .. .	0	5	0

SCHEDULE No. 4.—TEACHERS' COLLEGES, HOSTELS, POLICE HOSPITAL, ETC.

(Delivery at Institutions.)

TEACHERS' COLLEGES AND HOSTELS AT GRATTAN-STREET, 93 DRUMMOND-STREET, CARLTON; 470 AND 481 ST. KILDA ROAD, MELBOURNE; 19 QUEENS-ROAD, MELBOURNE; 152 TOORAK-ROAD WEST, SOUTH YARRA; TATE HOUSE, 373 DANDENONG-ROAD, ARMADALE; "REDCOURT" NO. 6, AND "LABNOOK," 13 ORRONG-ROAD, ARMADALE; 11 PATTERSON-STREET, HAWTHORN; 174 PUNT-ROAD, PRAHRAN, 221 BURWOOD-ROAD, BURWOOD; JOHN CANNON HOUSE, 32 BELMONT-AVENUE, KEW; 17 MOULE-AVENUE, BRIGHTON; POLICE HOSPITAL, ST. 321 GLENFERRIE-ROAD, MALVERN, ALSO 10A ORRONG-ROAD, ARMADALE, 572 ST. KILDA-ROAD, MELBOURNE, AND RASTINGS-ROAD, FRANKSTON.

ANNEX TO CONTRACT No. 1962/2702.

J. H. Cooke Pty. Ltd., 378 Queen's-parade, Clifton Hill.

Sub-schedule No. 2.

MEAT.

Security, £15.

	£	s.	d.
1. Fresh Beef—			
Rolled Prime Ribs, boneless .. .. .	0	2	6
Topside .. .. .	0	3	3
Sirloin, boneless .. .. .	0	2	8
Fresh Mutton—			
Legs .. .. .	0	1	7
Legs, pickled .. .. .	0	1	5
Sides, Two-tooth .. .. .	0	1	2
Legs, Two-tooth .. .. .	0	1	8
Cutlets .. .. .	0	1	6
Chops, Middle Loins .. .. .	0	1	3
Chops, Forequarter .. .. .	0	1	0
Chops, Chump .. .. .	0	1	3
12. Beef—Corned, Silverside .. .. .	0	3	0
Veal—			
Shoulder, boned .. .. .	0	1	9
Fillet, boneless .. .. .	0	3	6
Steak—			
Blade .. .. .	0	3	0
Minced Blade .. .. .	0	2	0
Stewing .. .. .	0	2	11
Rump .. .. .	0	3	10
Fillet .. .. .	0	5	0
20. Sausages—Mixed .. .. .	0	1	8
21. Sausage—Meat .. .. .	0	0	11
22. " " Beef, German .. .. .	0	2	9
23. " " Strasburg .. .. .	0	3	0
24. Livers—Sheep .. .. .	0	1	9
25. Kidneys—Sheep .. .. .	0	1	6
26. " " Ox .. .. .	0	2	6
27. Tongues—Ox .. .. .	0	1	3
28. Ox Tails .. .. .	0	1	3
29. Brains—Sheep .. .. .	0	0	5
30. Tripe—Fresh .. .. .	0	0	9
31. Frankfurts .. .. .	0	0	27
32. Bones—Soup .. .. .	no	charge	
33. Suet—Kidney .. .. .	0	0	5
34. Rabbits—Fresh .. .. .	0	3	3
35. Fowls—First quality .. .. .	0	5	3
36. Pork—Legs .. .. .	0	3	11
37. " " Loin .. .. .	0	3	9
38. Lamb, Legs .. .. .	0	3	0
39. Ham—Pressed .. .. .	0	7	0
40. Dripping—Beef .. .. .	0	1	0

SCHEDULE No. 3.—S.S. "Rip" AND DREDGES.

ANNEX TO CONTRACT No. 1962/2701.

Oscar Mayer Pty. Ltd., P.O. Box 163, Footscray.

Sub-schedule No. 3.

MEAT.

(Delivery at Yarra River Wharves.)

Security, £5.

	£	s.	d.
1. Fresh Beef—Roast .. .. .	0	2	0
Beef—Corned—			
Silverside .. .. .	0	3	2
Rolled .. .. .	0	2	1
Fresh Mutton—			
Fore-quarter .. .. .	0	0	8
Legs .. .. .	0	1	5
Chops—			
Forequarter .. .. .	0	0	10
Loin .. .. .	0	1	5
Steak—			
Rump .. .. .	0	4	6
Stewing .. .. .	0	2	1
Topside .. .. .	0	3	2
11. Sausages—Mixed .. .. .	0	1	8
12. Tripe—Fresh .. .. .	0	1	0
13. Livers—Sheep .. .. .	0	1	6
14. Suet—Kidney .. .. .	0	0	6
15. Rabbits—Fresh .. .. .	0	2	1
16. Ice .. .. .	0	2	6

SCHEDULE No. 5.—HEATHERTON SANATORIUM.

ANNEX TO CONTRACT No. 1962/2703.

W. Angliss and Co. (Aust.) Pty. Ltd., 42 Bourke-street, Melbourne, C.I.

Sub-schedule No. 3.

MEAT.

Security, £5.

	£	s.	d.
1. Beef, Fresh Roast—Rump .. .. .	0	3	9
2. " " Corned—Silverside .. .. .	0	3	2
3. Lamb, Fresh—Legs .. .. .	0	2	8
4. " " " Shoulder—Rolled .. .. .	0	1	3
5. " " " Chops Mid. Loins .. .. .	0	3	3
6. " " " Chops, Chump .. .. .	0	2	6
7. " " " Chops, Forequarter .. .. .	0	1	4
8. " " " Cutlets .. .. .	0	3	3
9. Pork, Fresh—Legs .. .. .	0	3	9
10. " " " Chops .. .. .	0	3	9
11. " " " Minced .. .. .	0	2	3
12. Veal—Shoulder—Boned .. .. .	0	1	3
13. " " " Cutlets .. .. .	0	3	3
14. Steak—Rump .. .. .	0	4	0
15. " " " Blade .. .. .	0	2	9
16. " " " Topside .. .. .	0	3	0
17. " " " Minced .. .. .	0	2	3
18. " " " Porterhouse .. .. .	0	3	0
19. " " " Fillet .. .. .	0	5	0

SCHEDULE No. 5.—HEATHERTON SANATORIUM—*continued.*

		£	s.	d.
20. Mutton, Pumped Leg .. .. .	per lb.	0	1	5
21. Tripe—Fresh .. .. .	do.	0	0	10
22. Brains—Sheep .. .. .	per set	0	0	7
23. Lambs Fry .. .. .	per lb.	0	2	0
24. Tongues—Sheep .. .. .	do.	0	1	0
25. Kidneys—Ox .. .. .	do.	0	2	9
26. " Sheep .. .. .	do.	0	2	6
27. Tails—Ox .. .. .	do.	0	1	9
28. Sausages—Pork .. .. .	do.	0	1	9
29. Frankfurts—Vienna .. .. .	do.	0	3	5
30. Beef German—Sausage .. .. .	do.	0	2	3
31. Ham—Loaf .. .. .	do.	0	3	3
32. " Pressed Shoulder .. .. .	do.	0	6	3
33. Rabbits, Fresh .. .. .	do.	0	3	0
34. Capons, First quality .. .. .	do.	0	5	0
35. Dripping, Beef .. .. .	do.	0	1	0

## SCHEDULE No. 6.—ARARAT DISTRICT.

## ANNEX TO CONTRACT No. 1962/2704.

Thomas Borthwick and Sons (A/Asia), P.O. Box 150,  
Portland.

## Sub-schedule No. 4.

## MEAT.

Security, £30.

		£	s.	d.
1. Fresh Beef—				
1. Rolled Roast (Boneless, brisket excluded)	per lb.	0	2	1
2. Buttocks .. .. .	do.	0	2	0
3. Fresh Mutton—Kidney fat to be removed	do.	0	0	10
4. " Middle Loin Chops .. .. .	do.	0	1	0
5. Corned Beef—Rolled or Round, as ordered, without bone or cartilage	do.	0	2	1
6. Kidney—Ox .. .. .	do.	0	2	0
7. Veal—Fillet .. .. .	do.	0	1	8
8. Sausages—Mixed .. .. .	do.	0	1	10
9. Steak—Topside .. .. .	do.	0	2	10
10. Beef Luncheon Loaf .. .. .	do.	0	1	10
11. Sausage Meat .. .. .	do.	0	1	2
12. Saveloys .. .. .	do.	0	1	11
13. Tripe—Fresh .. .. .	do.	0	1	0
Steak—				
14. Rump .. .. .	do.	0	4	3
15. Porterhouse .. .. .	do.	0	4	3

## SCHEDULE No. 7.—BALLARAT DISTRICT.

## ANNEX TO CONTRACT No. 1962/2705.

H. A. Morris, 107 Victoria-street, Ballarat.

## Sub-schedule No. 4.

## MEAT.

(For Gaol and Mental Hospital.)

Security, £35.

		£	s.	d.
Fresh Beef—				
1. Buttocks .. .. .	per lb.	0	2	4
2. Roast—Rolled (Brisket excluded) .. .. .	do.	0	2	2
3. Beef, Corned, Rolled or Round, as ordered, without bone or cartilage	do.	0	2	2
Mutton—Fresh—				
4. Kidney fat removed (Mental Hospital)	do.	0	0	11
5. Minced .. .. .	do.	0	2	9
6. Sausages .. .. .	do.	0	1	11
7. Sausage, Beef, German .. .. .	do.	0	1	11
8. Tripe .. .. .	do.	0	0	10
9. Veal, boned .. .. .	do.	0	3	3
10. Sausage Meat .. .. .	do.	0	1	3
11. Saveloys .. .. .	do.	0	1	11
12. Kidney—Ox .. .. .	do.	0	1	9

## ANNEX TO CONTRACT No. 1962/2706.

Victorian Inland Meat Authority, 522 Little Collins-street, Melbourne.

## Sub-schedule No. 5.

## MEAT.

For delivery to Teachers' Hostels as under:—

Gillies-street, Ballarat  
Beaufort House, Beaufort-avenue, Ballarat  
1415 Sturt-street, Ballarat  
130 Victoria-street, Ballarat  
126 Webster-street, Ballarat

Security, £5.

		£	s.	d.
1. Fresh Beef—Sirloin .. .. .	per lb.	0	3	9
2. Beef—Corned—Silverside .. .. .	do.	0	4	6
Fresh Mutton—				
3. Legs .. .. .	do.	0	2	2
4. Forquarter Chops .. .. .	do.	0	1	6
5. Legs Pickled .. .. .	do.	0	2	2
Two Tooth—				
6. Chump Chops .. .. .	do.	0	2	6

SCHEDULE No. 7.—BALLARAT DISTRICT—*continued.*

		£	s.	d.
7. Mid Loin Chops .. .. .	per lb.	0	2	6
Veal—				
8. Shoulder, Boned .. .. .	do.	0	3	3
9. Fillet, Boneless .. .. .	do.	0	3	9
Steak—				
10. Blade .. .. .	do.	0	4	0
11. Rump .. .. .	do.	0	5	0
12. Minced .. .. .	do.	0	2	6
13. Sausages—Mixed .. .. .	do.	0	1	9
14. Sausage Meat .. .. .	do.	0	1	5
15. Livers—Calves .. .. .	do.	0	1	3
16. Kidneys—Ox .. .. .	do.	0	1	6
17. Frankfurts .. .. .	do.	0	1	11
18. Ham Loaf .. .. .	do.	0	3	0
19. Dripping—Beef .. .. .	do.	0	1	0
20. Shanks—sheep .. .. .	each	0	0	5
21. Beef Luncheon .. .. .	per lb.	0	2	2

## SCHEDULE No. 8.—BEECHWORTH DISTRICT.

## ANNEX TO CONTRACT No. 1962/2707.

E. Spencer, Camp-street, Beechworth.

## Sub-schedule No. 4

## MEAT.

Security, £30.

		£	s.	d.
1. Fresh Beef (Gaol) .. .. .	per lb.	0	2	5
2. Fresh Beef—Rolled Roast, boneless, brisket excluded	do.	0	2	7
3. Corned Beef, Rolled or Round as ordered, without bone or cartilage	do.	0	2	7
4. Mutton—Fresh (kidney fat to be removed for Mental Hospitals)	do.	0	1	0
5. Beef Steak, minced .. .. .	do.	0	2	6
6. Sausage Meat .. .. .	do.	0	1	4
7. Sausages—Mixed .. .. .	do.	0	1	10
8. Sausage—German .. .. .	do.	0	2	7
9. Tripe—Fresh .. .. .	do.	0	1	4
10. Veal—Boned .. .. .	do.	0	2	6
11. Kidneys—Ox .. .. .	do.	0	1	9

## SCHEDULE No. 9.—BENDIGO DISTRICT.

## ANNEX TO CONTRACT No. 1962/2708.

Alan H. Gittins, 350 Hargreaves-street, Bendigo.

## Sub-schedule No. 7.

## MEAT.

For Gaol.

Security, £5.

		£	s.	d.
1. Fresh Beef .. .. .	per lb.	0	2	0
2. Corned Beef—Rolled, without bone or cartilage	do.	0	1	10
3. Fresh Mutton .. .. .	do.	0	1	0
4. Sausages—Mixed .. .. .	do.	0	1	9
5. Minced .. .. .	do.	0	1	2

## ANNEX TO CONTRACT No. 1962/2709.

Alan H. Gittins, 350 Hargreaves-street, Bendigo.

## Sub-schedule No. 8.

## MEAT.

For Sandhurst Boys' Centre, Bendigo.

Security, £5.

		£	s.	d.
1. Fresh Beef—Rolled Roast, boneless, brisket excluded	per lb.	0	3	3
2. Fresh Beef—Buttocks .. .. .	do.	0	2	8
3. Corned Beef—Rolled or round, as ordered, without bone or cartilage	per lb.	0	2	6
4. Corned Silverside .. .. .	do.	0	3	3
5. Fresh Mutton—Legs .. .. .	do.	0	1	10
6. " " Chops, Mid-Loin .. .. .	do.	0	1	10
7. Steak—Rump .. .. .	do.	0	5	0
8. " Stewing .. .. .	do.	0	3	6
9. Sausage Meat .. .. .	do.	0	1	2
10. Sausages—Mixed .. .. .	do.	0	1	9
11. Sausage—Beef German .. .. .	do.	0	2	6
12. Bacon, Rashers, Shoulder .. .. .	do.	0	6	0
13. Dripping—Beef .. .. .	do.	0	0	8
14. Shin—Beef .. .. .	do.	0	2	0
15. Lamb Chops .. .. .	do.	0	3	11
16. " Legs .. .. .	do.	0	3	2

SCHEDULE No. 9.—BENDIGO DISTRICT—*continued.*

ANNEX TO CONTRACT No. 1962/2710.

Frank Wade, 193 Williamson-street, Bendigo.

Sub-schedule No. 9.

MEAT.

For Teachers' College Hostels as under—

Osborne-street, Pleasant Vale, Bendigo.  
"Lancewood," McLaren-street, Bendigo.  
"Comersdale," Pantton-street, Golden Square, Bendigo.

	Security, £5.	£	s.	d.
Fresh Beef—				
1. Topside .. .. .	per lb.	0	3	6
2. Corned Beef—Rolled or Round, as ordered, without bone or cartilage .. .. .	do.	0	2	2
3. Corned Silverside .. .. .	do.	0	3	6
4. Fresh Mutton—Carcase .. .. .	do.	0	1	0
Steak—				
5. Blade (Minced) .. .. .	do.	0	2	9
6. Chuck .. .. .	do.	0	2	8
7. Rump .. .. .	do.	0	5	6
8. Sausages—Mixed .. .. .	do.	0	1	8
9. Sausage Meat .. .. .	do.	0	1	2
10. Livers—Sheep .. .. .	do.	0	0	6
11. Veal, Fillet—boneless .. .. .	do.	0	4	6
12. Brains—Sheep .. .. .	per set	0	0	6
13. Kidneys—Ox .. .. .	per lb.	0	1	3
14. Ox Tails .. .. .	do.	0	1	6
15. Sausage, Strasburg .. .. .	do.	0	3	7
16. Salad Loaf .. .. .	do.	0	3	5
17. Bacon, Middle Rashers .. .. .	do.	0	5	9

SCHEDULE No. 10.—CASTLEMAINE GAOL.

ANNEX TO CONTRACT No. 1962/2711.

McQueen Brothers, Hargreaves-street, Castlemaine.

Sub-schedule No. 2.

MEAT.

	Security, £5.	£	s.	d.
1. Fresh Beef .. .. .	per lb.	0	1	11
2. Fresh Mutton .. .. .	do.	0	1	3
3. Corned Beef—Rolled or Round, as ordered, without bone or cartilage .. .. .	do.	0	2	2
4. Minced Meat—Beef .. .. .	do.	0	2	3
5. Sausage Meat .. .. .	do.	0	1	3
6. Sausages—Mixed .. .. .	do.	0	1	6
7. Saveloys .. .. .	per doz.	0	4	6

SCHEDULE No. 11.—SCHOOL OF FORESTRY, CRESWICK

ANNEX TO CONTRACT No. 1962/2712.

H. J. Symons, Pty. Ltd., 1015 Macarthur-street, Ballarat.

Sub-schedule No. 4.

MEAT.

	Security, £3.	£	s.	d.
1. Fresh Beef—Topside .. .. .	per lb.	0	4	3
2. " " Sirloin, boneless .. .. .	do.	0	4	3
3. Corned, Silverside .. .. .	do.	0	4	3
4. Mutton—Fresh, sides .. .. .	do.	0	1	0
5. Pork—Fresh, leg .. .. .	do.	0	4	6
6. Steak—Stewing .. .. .	do.	0	3	8
7. " Minced .. .. .	do.	0	2	6
8. Sausages—Mixed .. .. .	do.	0	2	0
9. Sausage—Beef German .. .. .	do.	0	3	0
10. Kidney—Ox .. .. .	do.	0	2	0
11. Liver—Sheep .. .. .	do.	0	1	0
12. Saveloys .. .. .	per doz.	0	4	0

SCHEDULE No. 13.—McLEOD SETTLEMENT,

FRENCH ISLAND.

ANNEX TO CONTRACT No. 1962/2713.

George Hayman, Lang Lang.

Sub-schedule No. 3.

MEAT.

	Security, £5.	£	s.	d.
1. Fresh Beef .. .. .	per lb.	0	2	4
2. Mutton .. .. .	do.	0	1	2
3. Sausages—Mixed .. .. .	do.	0	2	3

SCHEDULE NO. 14.—GEEELONG DISTRICT.

ANNEX TO CONTRACT No. 1962/2714.

A. Bubb, 147 Moorabool-street, Geelong.

Sub-schedule No. 3.

MEAT.

For Gaol.

	Security, £5.	£	s.	d.
1. Fresh Beef .. .. .	per lb.	0	1	11
2. Corned Beef—Rolled or Round, without bone or cartilage .. .. .	do.	0	2	2
3. Fresh Mutton—Forequarters .. .. .	do.	0	0	10
4. " " —Legs .. .. .	do.	0	1	2
5. Beef—Minced .. .. .	do.	0	2	0
6. Sausages—Mixed .. .. .	do.	0	1	6
7. Sausage Meat .. .. .	do.	0	0	10
8. " Beef German .. .. .	do.	0	2	1
9. Dripping, Beef .. .. .	do.	0	0	10

ANNEX TO CONTRACT No. 1962/2715.

A. C. Knight, 27 Melbourne-road, North Geelong.

Sub-schedule No. 4.

MEAT.

For delivery to Teachers' Hostels as under—

"Lauriston," 23 Aberdeen-street, Geelong.  
"Forty-Five," The Esplanade, Western Beach, Geelong.  
"Hawthorn," Aberdeen-street, Geelong  
"Ariston," Packington-street, Geelong.  
"Warrain," 56 Western Beach, Geelong.

	Security, £5.	£	s.	d.
Fresh Beef—				
1. Sirloin, boneless .. .. .	per lb.	0	3	3
2. Topside Roast .. .. .	do.	0	3	3
3. Corned Beef—Rolled or Round, as ordered, without bone or cartilage .. .. .	do.	0	3	3
Mutton—				
4. Legs, Two-tooth .. .. .	do.	0	1	6
5. Forequarters, boned, rolled, and pickled .. .. .	do.	0	1	0
6. Chops, Forequarter .. .. .	do.	0	1	1
7. Chops, Cutlets .. .. .	do.	0	1	8
Steak—				
8. Chuck .. .. .	do.	0	2	11
9. Bladebone .. .. .	do.	0	3	0
10. Minced .. .. .	do.	0	2	2
11. Fillet—Veal .. .. .	do.	0	1	0
12. Tongues—Ox .. .. .	do.	0	1	0
13. Kidneys—Ox .. .. .	do.	0	1	8
Sausages—				
14. Mixed, thin .. .. .	do.	0	1	7
15. Pork, thick .. .. .	do.	0	1	7
16. Sausage—Pork, German .. .. .	do.	0	3	3
17. Sausage Mince .. .. .	do.	0	0	11
18. Bacon—Shoulder .. .. .	do.	0	4	0

SCHEDULE No. 15.—COORIEMUNGLE PRISON CAMP, HEYTESBURY FOREST.

ANNEX TO CONTRACT No. 1962/2716.

Heytesbury Butchery, Timboon.

Sub-schedule No. 3.

MEAT.

	Security, £4.	£	s.	d.
1. Fresh Beef .. .. .	per lb.	0	4	0
2. Corned Beef—Rolled or Round, as ordered, without bone or cartilage .. .. .	do.	0	3	6
3. Sausages—Mixed .. .. .	do.	0	2	6
4. Sausage Mince .. .. .	do.	0	1	9
5. Dripping—Beef .. .. .	do.	0	1	0

SCHEDULE No. 17.—LANGI KAL KAL TRAINING CENTRE

ANNEX TO CONTRACT No. 1962/2717.

F. P. Haintz and Son, Havelock-street, Beaufort.

Sub-schedule No. 2.

MEAT.

	Security, £5.	£	s.	d.
1. Fresh Beef—Boneless .. .. .	per lb.	0	4	0
2. Sausages—Mixed .. .. .	do.	0	2	0
3. Mince Meat .. .. .	do.	0	1	6

SCHEDULE No. 20.—SALE GAOL.

ANNEX TO CONTRACT No. 1962/2718.

T. J. Webster Pty. Ltd., 80 Raymond-street, Sale.

Sub-schedule No. 2.

MEAT.  
Security, £3.

		£	s.	d.
1. Fresh Beef	per lb.	0	2	7
2. Fresh Mutton, Chops—Forequarter	do.	0	1	3
3. " " Legs	do.	0	1	5
4. Corned Beef—Rolled or Round, as ordered, without bone or cartilage	do.	0	2	7
5. Sausage—Meat	do.	0	1	6

SCHEDULE No. 21.—PLEASANT CREEK SPECIAL SCHOOL, STAWELL.

ANNEX TO CONTRACT No. 1962/2719.

Thomas Borthwick and Sons (A/Asia) Ltd., P.O. Box 150, Portland.

Sub-schedule No. 3.

MEAT.

		£	s.	d.
Steak—	Security, £3.			
1. Rump	per lb.	0	4	6
2. Stewing (Minced when required)	do.	0	2	3
3. Fresh Mutton—Leg	do.	0	1	4
4. Chops—Middle Loin	do.	0	1	0
5. Sausages—Pork	do.	0	1	10
6. Livers—Sheep	do.	0	0	6
7. Sausage—Meat	do.	0	1	1
8. " —Pork German	do.	0	3	4
9. Bacon	do.	0	6	6
10. Beef—Rolled Roast	do.	0	2	6
11. Tripe—Fresh	do.	0	1	0
12. Kidney—Ox	do.	0	2	0
13. Saveloys	do.	0	2	0

SCHEDULE No. 22.—SUNBURY DISTRICT.

ANNEX TO CONTRACT No. 1962/2720.

F. Watkins Pty. Ltd., 150 Lonsdale-street, Melbourne.

Sub-schedule No. 5.

MEAT.

		£	s.	d.
Fresh Beef—	Security, £40.			
1. Rolled Roast, boneless (brisket excluded)	per lb.	0	2	6
2. Buttocks	do.	0	2	3
3. Fresh Mutton—Kidney fat to be removed	do.	6	0	11
4. Corned Beef—Rolled or Round, as ordered, without bone or cartilage	do.	0	2	6
5. Sausages—Mixed	do.	0	1	9
6. Sausage Meat	do.	0	1	4
7. Sausage—Beef—German	do.	0	2	4
8. Veal—Boneless	do.	0	2	3
9. Tripe—Fresh	do.	0	1	2
10. Ox Kidney	do.	0	3	0
11. Ox Liver	do.	0	1	8
12. Saveloys	per doz.	0	3	6

SCHEDULE No. 23.—WARRNAMBOOL DISTRICT.

ANNEX TO CONTRACT No. 1962/2721.

Thomas Borthwick and Sons (A/Asia) Ltd., P.O. Box 150, Portland.

Sub-schedule No. 4.

MEAT.

		£	s.	d.
	Security, £15.			
1. Fresh Beef—Rolled Roast (brisket excluded)	per lb.	0	2	2
2. Corned Beef—Rolled or Round, as ordered	do.	0	2	2
Fresh Mutton—				
3. Forequarters	do.	0	0	9
4. Legs	do.	0	1	2
5. Chops—Middle Loin	do.	0	1	1
Steak—				
6. Stewing	do.	0	2	2
7. Sausage—Beef German	do.	0	2	6
8. Livers—Sheep	do.	0	1	0
9. Sausage Meat	do.	0	1	4
10. Sausages—Beef	do.	0	2	0
11. " Pork	do.	0	2	2
12. Beef—Minced	do.	0	2	4
13. Kidneys—Ox	do.	0	2	6
14. Tripe—Fresh	do.	0	1	0
15. Saveloys	per doz.	0	4	0

CONTRACTS ACCEPTED.—(Series 1961-62.)

VICTORIAN RAILWAYS.

162. Erection, &c., of car-cleaning equipment and running repair shed at South Dynon, for £278,424 6s. (Contract 62053).—D.R.D. Constructions Pty. Ltd. 163. Electric lamps, at rates (Contract 62044).—Australian Incandescent Co. 164. Electric lamps, at rates (Contract 62141).—A. J. Ferguson and Co. Pty. Ltd. 165. Electric lamps, at rates (Contract 62142).—Elektran Pty. Ltd. 166. Electric lamps, at rates (Contract 62143).—Edmunds Bros. Pty. Ltd. 167. Electric lamps, at rates (Contract 62144).—Lighting Engineers Pty. Ltd. 168. Electric lamps, at rates (Contract 62145).—Phillips Electrical Industries Pty. Ltd. 169. Electric lamps, at rates (Contract 62146).—Condor Lamps A'asia Pty. Ltd. 170. Electric lamps, at rates (Contract 62147).—Australian Electrical Industries Pty. Ltd. 171. Electric lamps, at rates (Contract 62149).—Siemens Henley Pty. Ltd. 172. Electric lamps, at rates (Contract 62150).—Noyes Bros. Pty. Ltd. 173. Electric lamps, at rates (Contract 62148).—British General Electric Co. Pty. Ltd.

By order of the Victorian Railways Commissioners,  
W. WALKER, Secretary for Railways. 9.3.62.

GENERAL STORES.

Gazette No. 71, 2nd August, 1961, Schedule No. 20, Brushware, Painters'.—For Items Nos. 4 and 7 substitute £1 15s. 1d. each as from 21st August, 1961.

PRISONERS' MEALS IN LOCK-UPS.

CONTRACT ACCEPTED.

2692. For the supply of Prisoners' Meals at Warracknabeal from 22nd February, 1962, to 30th June, 1962.—Breakfast and Tea, 2s. 6d.; Hot Dinner, 4s. 6d.—Peter Tantanis.

H. COUTTS, Secretary to the Tender Board. 8.3.62.

ORDERS IN COUNCIL.—(Series 1961-62.)

EDUCATION DEPARTMENT.

2684. One only experimental hydraulic set, comprising one only electro-dynamometer-driven pump set, £1,340; one only No. 15 Gilkes Pelton wheel, £602; one only 6-in. Series VIII Gilkes "Francis" turbine, £767; one only 4-in. diameter Venturi meter with manometer, £148, for Ballarat School of Mines.—Coates and Co. Ltd., 252 Swanston-street, Melbourne.

2685. Four only electric sewing machines (£38 15s. each), for Blackburn Technical School, £155.—Singer Sewing Machine Co., 119 Glenferrie-road, Malvern.

2686. One only set of six interchangeable motors, for Footscray Technical College, £377.—F. W. Davey Co. Pty. Ltd., 288 Huntingdale-road, Huntingdale.

2687. One only cathode ray oscilloscope, 5-in. screen, £144; one only cathode ray oscilloscope, 3-in. screen, £71, for Castlemaine Technical College.—B. W. D. Electronics Pty. Ltd., 67-69 Burwood-road, Hawthorn.

2688. One only scintillation probe unit and collimator, £280 15s.; one only lead castle with accessories, £119 5s., for Swinburne Technical College.—Philips Electrical Industries Pty. Ltd., 590 Bourke-street, Melbourne.

2689. One only Progress No. 3a drilling machine, for Swinburne Technical College, £378.—McPherson's Ltd., 546 Collins-street, Melbourne.

2690. One only chassis dynamometer, for Royal Melbourne Institute of Technology, £2,020.—Weststeels (Vic.) Pty. Ltd., 1056 Dandenong-road, Carnegie, S.E.9.

2691. Four only calculating machines, for Swinburne Technical College, £308 15s.—Business Equipment Pty. Ltd., 408 Latrobe-street, Melbourne, C.1.

Approved by the Governor in Council, 6th March, 1962.—N. G. WISHART, Acting Clerk of the Executive Council.

STATE ELECTRICITY COMMISSION.

2731. For the demolition and removal of timber columns and supply, erection and sheeting of structural steel work, Box Hill Briquette Depot, to Specification No. 61-62/235, £6,491.—W. C. Burne and Sons Pty. Ltd.

2732. For the construction of steel and timber-framed control building, fire service and septic tanks at Terang Terminal Station, to Specification No. 61-62/233, £7,922.—Cliff Ford and Son.

2733. For loading, transporting and unloading poles from Bairnsdale Pole Depot to sites in the Gippsland area, for a period of twelve months, to Quotation No. 2879, at Schedule rates.—J. W. Hollingsworth and Co.

2734. For the supply of one international crawler tractor and revolving crane attachment for coal winning,

Yallourn, to Quotation No. 3530, £9,456.—Victorian Industrial Sales and Service Pty. Ltd.

2735. For the supply of screws and nails for a period of two years, to Specification No. 61-62/196, at Schedule rates.—Hardware Co. of Aust. Pty. Ltd.

2736. For the supply of screws for a period of two years, to specification No. 61-62/196, at Schedule rates.—Nicholls and Read Pty. Ltd.

Approved by the Governor in Council, 27th February, 1962.—N. G. WISHART, Acting Clerk of the Executive Council.

**PUBLIC TRUSTEE ACT 1958 (No. 6350).—SECTION 17.**

**I** HEREBY give notice that on the 26th February, 1962, the Public Trustee filed elections to administer the following deceased persons' estates, in accordance with section 17 of the *Public Trustee Act 1958*:—

ARDEN, ANDREW TIMOTHY CHARLES, late of 102 Rose-street, Fitzroy, pensioner, died 3rd October, 1961.

BAGSHAW, FRANK, formerly of Cato-street, Auburn, and 58 Davis-street, Kew, but late of 116 Barkers-road, Hawthorn, clerk, died 6th December, 1961.

DAVIS, JESSIE BERTHA, late of 294 Kooyong-road, Caulfield, spinster, died 3rd December, 1961.

FERGUSON, THOMAS MURRAY, late of 37 Freeman-street, North Fitzroy, pensioner, died 2nd December, 1961.

FRASER, ALLAN, late of Bundoora, war pensioner, died 21st October, 1961.

FREEMAN, ADA, late of Beechworth, widow, died 21st August, 1958.

HAMILTON, RACHEL, formerly of 7 Goodman-street, Brunswick, and Ward 6, Fairfield Hospital, late of 23 William-street, Fawkner, widow, died 8th September, 1961.

MCNAUGHTON, JOHN EDWARD, late of 61 Argyle-street, Fawkner, pensioner, died 28th November, 1952.

REID, JESSIE WILSON HADDEN, late of 118 Argyle-street, St. Kilda, widow, died 29th September, 1960.

WITHERS, WILLIAM THOMAS, late of 382 Victoria-street, North Richmond, pensioner, died 5th December, 1961.

**I** HEREBY give notice that on the 27th February, 1962, the Public Trustee filed elections to administer the following deceased persons' estates, in accordance with section 17 of the *Public Trustee Act 1958*:—

BROWN, ALICE, late of 3 Rennie-street, Coburg, married woman, died 5th July, 1959.

BUTTERWORTH, ADA AGNES, late of 1 Corsair-street, Richmond, widow, died 2nd January, 1962.

COMLEY, JAMES, late of 104 Inkerman-street, St. Kilda, retired carpet layer, died 11th July, 1961.

FOGARTY, MARGARET, late of 112 Powlett-street, East Melbourne, pensioner, died 18th November, 1961.

**I** HEREBY give notice that on the 2nd March, 1962, the Public Trustee filed elections to administer the following deceased persons' estates, in accordance with section 17 of the *Public Trustee Act 1958*:—

WHITE, ALICE, late of 70 Rutherglen-road, Rutherglen, spinster, died 19th October, 1961.

WHYTE, HELEN, late of Barnard-street, Bendigo, widow, died 26th April, 1961.

WOOD, MARGARET MAY, late of 6 Bastings-street, Northcote, widow, died 31st December, 1960.

A. D. DUNCAN,  
Public Trustee.

601 Little Collins-street, Melbourne, 7th March, 1962.

**NOTICE.**

**C**REDITORS, next of kin, and others having claims against the estate of any of the under-mentioned deceased persons are required to send particulars of their claims to the Public Trustee, 7th Floor, 601 Little Collins-street, Melbourne, the personal representative, on or before the 17th May, 1962, after which date the Public Trustee may convey or distribute the assets, having regard only to the claims of which the Public Trustee then has notice:—

ALEXANDER, HECTOR McDONALD, in the will called Hector Alexander, late of Melbourne Home and Hospital for the Aged, Cheltenham, pensioner, died 14th September, 1961.

ANGUS, CAMEAL, in the will called Cameal Ludge, late of 4 Denver-crescent, Elsternwick, gentlelady, died 2nd December, 1961.

ARDEN, ANDREW TIMOTHY CHARLES, late of 102 Rose-street, Fitzroy, pensioner, died 3rd October, 1961.

BAGSHAW, FRANK, formerly of Cato-street, Auburn, and 58 Davis-street, Kew, but late of 116 Barkers-road, Hawthorn, clerk, died 6th December, 1961.

BELL, WINIFRED, formerly of 6 Ruabon-road, Toorak, but late of 51 Canterbury-road, Toorak, widow, died 30th November, 1961.

BIRT, ROBERT, late of 14 Fuller-avenue, Glen Iris, clerk, died 30th December, 1961.

BOJARSKI, HENRYK IZYDOR, late of 322 Church-street, Richmond, labourer, died 6th December, 1961.

BRENCHLEY, GEORGE SAMUEL, late of 389 Upper Heidelberg-road, Ivanhoe, retired salesman, died 3rd January, 1962.

BRETHERTON, FRANCIS BARTHOLOMEW, late of Drung, farmer, died 2nd April, 1961.

BROWN, ALICE, late of 3 Rennie-street, Coburg, married woman, died 5th July, 1959.

BROWNLIE, EDGAR OSWALD, late of 83 McKinnon-road, McKinnon, confectioner, died 9th December, 1961.

BUTTERWORTH, ADA AGNES, late of 1 Corsair-street, Richmond, widow, died 2nd January, 1962.

COMLEY, JAMES, late of 104 Inkerman-street, St. Kilda, retired carpet layer, died 11th July, 1961.

DAVIS, JESSIE BERTHA, late of 294 Kooyong-road, Caulfield, spinster, died 3rd December, 1961.

DEVLIN, THOMAS JOSEPH, formerly of Heywood, late of 2 Mary-street, Hawthorn, military pensioner, died 20th September, 1961.

DRISCOLL, ALBERT JOHN, late of 51 Karma-avenue, East Malvern, retired teacher, died 8th December, 1961.

EUSTACE, CLAIRE MADELINE, late of 90 Canterbury-road, Middle Park, home duties, died 20th August, 1960.

GRANT, EVA MARGARET, late of "Myora", Irving-road, Toorak, domestic, died 22nd January, 1961.

FERGUSON, THOMAS MURRAY, late of 37 Freeman-street, North Fitzroy, pensioner, died 2nd December, 1961.

FOGARTY, MARGARET, late of 112 Powlett-street, East Melbourne, pensioner, died 18th November, 1961.

FRASER, ALLAN, late of Bundoora, war pensioner, died 21st October, 1961.

FREEMAN, ADA, late of Beechworth, widow, died 21st August, 1958.

HAMILTON, RACHEL, formerly of 7 Goodman-street, Brunswick, and Ward 6, Fairfield Hospital, late of 23 William-street, Fawkner, widow, died 8th September, 1961.

LARKINS, TIMOTHY, late of 1 Newman-street, West Brunswick, retired railway employee, died 27th November, 1961.

MCNAUGHTON, JOHN EDWARD, late of 61 Argyle-street, Fawkner, pensioner, died 28th November, 1952.

NORMAN, LESLIE EDWARD GEORGE, late of 17 Highbury-grove, East Prahran, truck driver, died 12th January, 1962.

REID, JESSIE WILSON HADDEN, late of 118 Argyle-street, St. Kilda, widow, died 29th September, 1960.

RYDER, ABY RAYMOND, late of Devonport, New Zealand, retired schoolmaster, died 23rd March, 1961.

STOCK, ALAN ERNEST, late of 9 Redhill-road, Springvale South, commercial traveller, died 27th October, 1961.

TINDALE, WILLIAM, formerly of 108 Collier-crescent, West Brunswick, late of Plenty-road, Bundoora, retired wharf labourer, died 5th July, 1961.

TOONE, JOHN FREDERICK, late of Balgowlah, N.S.W., school teacher, died 12th July, 1961.

WALSH, MARGARET LOUISE, late of 7 Yanakie-crescent, Caulfield, married woman, died 28th October, 1961.

WHITE, ALICE, late of 70 Rutherglen-road, Rutherglen, spinster, died 19th October, 1961.

WHYTE, HELEN, late of Barnard-street, Bendigo, widow, died 26th April, 1961.

WITHERS, WILLIAM THOMAS, late of 382 Victoria-street, North Richmond, pensioner, died 5th December, 1961.

WOOD, MARGARET MAY, late of 6 Bastings-street, Northcote, widow, died 31st December, 1960.

WYATT, MARY ISABELLA, formerly of 89 Croydon-road, Surrey Hills, late of Cheltenham, spinster, died 31st October, 1961.

A. D. DUNCAN,  
Public Trustee.

Melbourne, 7th March, 1962.

*State Savings Bank Act 1958, Section 30.*

THE STATE SAVINGS BANK OF VICTORIA.

ESTABLISHMENT OF BRANCHES.

**T**HE Commissioners of The State Savings Bank of Victoria hereby give notice of their intention to establish branches of the bank as under:—

Somerville, on 20th March, 1962.  
Templestowe, on 20th March, 1962.  
Birregurra, on 27th March, 1962.

T. E. HALL,  
General Manager.

**RULES AND REGULATIONS FOR THE CARE,  
PROTECTION AND MANAGEMENT OF THE  
"MOUNT BAW BAW ALPINE RESORT".**

WHEREAS by sub-section (2) of section 50 of the *Forests Act 1958* (No. 6254), the Governor in Council is enabled to make Rules and Regulations in regard to the care, protection and management of any land forming part of any reserved forest such land being a place of natural beauty or interest, or a health resort, and for the preservation of good order and decency therein, and also for the collection and receipt of tolls, entrance fees, or other charges for entering in or upon such land, or any specified part or parts thereof, and by such Rules and Regulations to extend and apply for the purpose of such section, and the Rules and Regulations thereunder, the provisions of sub-sections (2), (3), (4) and (5) of section 219 and section 222 of the *Land Act 1958* (No. 6284), with such alterations, substitutions, additions, omissions and modifications as are necessary or expedient for the purposes of carrying out the objects of this section: Now therefore His Excellency the Governor of the State of Victoria, in the Commonwealth of Australia, by and with the advice of the Executive Council of the said State, and in pursuance of the powers conferred as aforesaid, doth hereby make the following Rules and Regulations in respect of the land forming portion of the Reserved Forest in the Parishes of Telbit West and Fumina North, Counties of Tanjil and Buln Buln, comprising 2,450 acres more or less as shown by red border on plan A over 60/8 on file of correspondence No. 60/1244 in the Forests Department:—

**RULES AND REGULATIONS FOR THE CARE, PROTECTION AND  
MANAGEMENT OF THE "MOUNT BAW BAW ALPINE RESORT".  
HEREINAFTER REFERRED TO AS "THE RESORT".**

1. For the purpose of these Regulations—

"Commission" means the Forests Commission of Victoria.

"Committee" means the Committee of Management duly appointed under the *Forests Act* to control and manage the Resort.

"Duly authorized person" means any person specially authorized, in writing, by the Committee to enforce any or all of these Regulations.

"Licensee" means any person, club or organization to whom a permissive occupancy licence has been issued by the Commission.

2. No person who, in the opinion of any forest officer or member of the Committee or duly authorized person, has offender against decency as regards dress, language, or conduct shall remain on the Resort after having been requested or ordered by such officer or member or duly authorized person to leave.

3. No person shall light or maintain any fire within the Resort, except in accordance with the provisions of the *Forests Acts* and Regulations.

4. No person shall within the Resort carry or use firearms of any description.

5. No person shall—

(a) set any trap, or snare, or shoot, poison, hook or otherwise destroy or interfere with or take away any bird or animal (excepting hares, rabbits, wild dogs or wombats) or any skin, egg, feathers or nest;

(b) bring into the Resort any dog without the permission, in writing, of a duly authorized person;

(c) deposit or cause to be deposited waste paper, bottles, broken glass or any other litter on any part of the Resort, except in receptacles provided for that purpose by the Committee;

(d) intentionally break any glass bottle or other container within the Resort;

(e) commit a nuisance in any part of the Resort or in any building in the Resort.

6. No person shall—

(a) without being the holder of a licence for the purpose, remove, cut or in any way damage any trees (whether dead or alive) or any shrubs, ferns, plants, leaves or flowers within the Resort;

(b) bring into the Resort any seed or portion of any plant or plant any tree without the permission, in writing, of the Committee.

7. No person (other than an officer or employee of the Commission or a duly authorized person) shall enter any plot enclosed for plantation of young trees, shrubs or flowers, or for the protection of the young native species naturally grown, or remove therefrom any plant, bark, fruit, seed, leaves or flowers.

8. No building, booth or other structure shall be erected by any body or person unless—

(a) application in due form has been made, plans and specifications of the proposed structure submitted and the appropriate fees paid to the Committee;

(b) written approval of the Committee has been obtained for such plans and specifications;

(c) such body or person is a licensee within the meaning of these Regulations; and

(d) subject to the foregoing, construction is strictly in accordance with such approved plans and specifications and is restricted to the terms and conditions of the licence.

9. Any requirements of the Committee relating to water supply, drainage, sanitation, garbage or other condition of occupation of the site and directed, in writing, either generally or specifically to any licensee, shall be fulfilled by such licensee within the period if any stated in such direction.

10. (a) No garbage shall be deposited anywhere on the Resort, except in the garbage pits provided.

(b) All tins shall be flattened.

(c) All empty bottles shall be removed from lodge sites and placed at collection points as defined by the Committee.

11. No person shall—

(a) mark, write on, deface or in any way damage any buildings, posts, fences, railings, pillars or other structure or property or natural objects within the Resort;

(b) affix any bill or sign to any tree or structure within or around the Resort without the permission, in writing, of the Committee being first obtained.

12. No licensee shall create or permit any nuisance within the building erected on any land the subject of his licence or permit such building to be used in a disorderly manner through the consumption of liquor or otherwise.

13. No person shall offer for sale in the Resort any article without the permission to do so being first obtained from the Committee. Such written permission shall be produced at any time on demand to a duly authorized person.

14. (a) No person shall reside or camp within the Resort unless such person is properly accommodated in a building erected in accordance with the provisions of these Regulations except in an area that may be set aside for the purpose by the Committee and for such period that the Committee may determine.

(b) Whenever the officer in charge of the forest district considers it desirable for fire protection purposes

or for the safety of any person, he may direct any person to leave the Resort and any person so directed shall thereupon promptly leave the Resort.

15. No person shall park any motor car within the Resort, excepting at such places as are set apart by the Committee for that purpose and subject to payment of the prescribed fees.

16. (a) When so directed by notice, in writing, from the Committee or a forest officer, any licensee shall provide and maintain hard standings within his licenced area and means of access thereto for motor vehicles and such hard standings and means of access shall be of the nature specified and be provided within the time required by such notice.

(b) At any time when so directed by the Committee or a forest officer, no person shall drive or operate any self-propelled vehicle within the Resort, except on a surfaced road or on hard standings, but this Regulation shall not refer to tracked vehicles operating on a snow-covered surface.

17. The Commission may fix and collect from licensees, such annual fees or other charges for the purpose of improvement, development and maintenance of the Resort as may be deemed necessary upon recommendation of the Committee from time to time.

18. The maximum fees payable to the Committee shall be—

For plans—	£	s.	d.
(i) total floor area of building and appurtenances not exceeding 500 square feet .. .. .	5	5	0
(ii) for every additional 400 square feet, or part thereof .. .. .	2	2	0
<b>For parking motor cars and trailers—</b>			
(i) for each car or trailer—			
per day .. .. .	0	2	0
per week .. .. .	0	10	0
(ii) for each car with seating accommodation in excess of six persons and for each trailer with an overall length exceeding 12 feet—			
per day .. .. .	0	4	0
per week .. .. .	1	0	0

19. For the purpose of these Regulations the provision of sub-sections (4) and (5) of section 219 and the paragraphs (a), (b), (c), (e) and (f) of sub-section (1) of section 222 of the *Land Act 1958*, are extended and applied with such alterations, substitutions, additions, omissions and modifications that the said sub-sections (4) and (5) of section 219 and the said paragraphs (a), (b), (c) and (e) and (f) of sub-section (1) of section 222 shall read as follows:—

Section 219—

(4) Every person offending against these Regulations shall for each offence be liable to a penalty of not more than Five pounds, and every person who so offends and who after he has been warned by any forest officer, duly authorized person or by any member of the Police Force does not desist from so offending, may be forthwith apprehended by such forest officer, duly authorized person or member of the Police Force and taken before some justice to be dealt with according to law, and shall be liable to a penalty of not more than Ten pounds.

(5) The Governor in Council may at any time disallow and annul these Regulations and thereupon such Regulations shall have no force or effect.

Section 222—

(1) The Committee of Management or a majority of its members—

(a) may exercise all such powers, functions any authorities and shall carry out all such duties as are conferred or imposed upon such Committee by any Regulations made by the Governor in Council in respect of such land and shall have exclusive authority to do all such acts, matters and things as are necessary for or incidental to the carrying into effect or enforcement of all such regulations;

(b) may either in the name of any one or more of its members or in the name of some other person appointed in that behalf by the Committee or a majority of its members take any legal proceedings for the purpose aforesaid;

(c) may manage, improve and maintain such land for the purposes for which it is reserved;

(e) may expend any tolls, fees, charges or any other moneys received by the Committee in the management, improvement and maintenance of such land as aforesaid and with the approval of the Commission may employ officers, servants and workmen for such purposes; and

(f) shall keep a full and particular account of all sums of moneys received and expended by the Committee and shall furnish annually to the Commission a statement of such receipts and expenditure and of the balances in hand and (if so requested by the Commission) full particulars of any or all of such receipts and expenditure.

And the Honorable Lindsay Hamilton Simpson Thompson, Her Majesty's Minister of Forests for the State of Victoria, shall give the necessary directions herein accordingly.

N. G. WISHART,  
Acting Clerk of the Executive Council.

NOTICE TO MARINERS.

[No. 6 of 1962.]

AUSTRALIA.—VICTORIA.

PORT PHILLIP.

*Date.*—On or about 14th March, 1962.  
*Position.*—Timeball Tower Light (Williamstown Light-house). Lat. 37 deg. 52 min. S., Long. 144 deg. 55 min. E. (approximately).

*Position of Light Buoy.*—188 deg. distant 5.97 miles from the above position.

*Depth at Buoy.*—54 feet, mud.

*Details.*—Spherical light buoy, with yellow and black horizontal stripes now showing a flashing white light every 5 seconds, Flash 0.5 seconds. Elevation 12 feet. Visibility 7 miles.

*Caution.*—Spoil must not be dumped anywhere northward or within 2 cables of the buoy.

*Charts Affected.*—B.A. 1171.

*Publications.*—*Sailing Directions, Victoria*, 1959, pages 327 and 714.

C. O'MALLEY,  
Port Officer.

Ports and Harbors Branch,  
Department of Public Works,  
Melbourne, C.2, 9th March, 1962.

*Stock Diseases Act 1958.*

APPOINTMENT OF INSPECTOR OF STOCK.

THE Public Service Board, by certificate dated the 23rd February, 1962, has appointed ROBERT DOUGLAS CRAWFORD, to be an Inspector of Stock, under the provisions of Part I. of the *Stock Diseases Act 1958*, without additional salary.

F. M. READ,  
Director of Agriculture.

Melbourne, 6th March, 1962.



Transport Regulation Act.  
TRANSPORT REGULATION BOARD.

## NOTICES OF PUBLIC HEARINGS.

NOTICE is hereby given that the applications made by the persons named below for licences to operate commercial passenger vehicles on the route or routes, or in the manner set out opposite their names, will be heard at a time and place to be communicated to the parties:—

*Name and Address; Nature of Application.*

REED, R. V. & C., Box 165 Post Office, Bairnsdale; 1 commercial passenger vehicle, with seating capacity for 33 persons, to operate as follows:—(a) for the carriage of school children only from Bengworden to Bairnsdale under contract to the Bengworden school bus committee, (b) as a country special service omnibus from Bairnsdale.

WILLIS, R. J., 16 Devon-drive, East Doncaster; 1 commercial passenger vehicle to be purchased, with seating capacity for five persons, to operate as a country taxi-cab at Narre Warren.

KRAHE, R. W., Box 247, Horsham; 1 commercial passenger vehicle, with seating capacity for 25 persons, to operate under the same terms and conditions as licence No. C.O.168, held by the applicant.

HURST, R. R., 6 Queen-street, Korumburra; 1 commercial passenger vehicle, with seating capacity for 35 persons, to operate under the same terms and conditions as licence Nos. T.S.238, T.S.239, T.S.240, T.S.202, T.S.292 and T.S.673, in the name of the applicant.

WILSON, W. J., 35 Union-street, Kyabram; 1 commercial passenger vehicle, with seating capacity for 33 persons, to operate as follows:—(1) for the carriage of school children only between Gigarre and Kyabram, under contract to the Education Department, (2) as a country special service omnibus from Gigarre.

GOODACRE, E. R., Gray-street, Lismore; 1 commercial passenger vehicle, with seating capacity for 33 persons, to operate for the carriage of school children only, between Blakeville and Bacchus Marsh, under contract to the Education Department.

GRAY, R. W. & H. A. (trading as Taxi Cab Tours), 22 Kennedy-street, Keilor; 2 luxury limousines, to be purchased, each with seating capacity for five persons, to operate the following tours:—

1. *Half Day Tours, City Sights.*—Commencing from the Government Tourist Bureau in Collins-street, Melbourne; thence via Collins-street, Swanston-street, Victoria-street, Russell-street, Lonsdale-street, King-street, Collins-street, William-street, Peel-street, Flemington-road, Gatehouse-street, Royal-parade and Grattan-street to the University; thence via Rathdown-street and Victoria-parade to Fitzroy Gardens; thence via M.C.C., Olympic Pool, Myer Music Bowl and Shrine of Remembrance; thence via Anderson-street, Alexandra-avenue, Bruce-street, Grange-road, Hill-street, Orrong-road, St. George's-road, Toorak-road, Orrong-road, Dandenong-road, Wellington-street, Fitzroy-street, Lower Esplanade, Upper Esplanade and Fitzroy-street, returning to City via St. Kilda-road. 22s.

2. *Dandenong Ranges.*—From Melbourne to Dandenong Ranges via Kew, Ringwood, Croydon, Montrose, Mt. Dandenong, Olinda, Monbulk and Kallista, returning via either Ferny Creek or Belgrave; thence Upper Fern Tree Gully and Burwood to City. 32s.

3. *Day Tours, City Sights and Dandenong Ranges.*—Commencing from the Government Tourist Bureau in Collins-street, Melbourne, and proceeding via the route as specified in Tour No. 1 above to St. Kilda; thence via Dandenong-road and Warrigal-road to Box Hill; thence via Ringwood and Montrose to Mt. Dandenong, returning via Fern Tree Gully and Burwood to City. 52s.

4. *Healesville, Acheron Way and Dandenong Ranges.*—Commencing from Melbourne via Kew, Ringwood and Lilydale to Healesville; thence via Maroondah Highway and Acheron Way to Warburton; thence via Yarra Junction, Woori Yallock, Cockatoo, Monbulk, Sherbrooke Forest and Fern Tree Gully, returning via Burwood to City. 52s.

MELBOURNE & METROPOLITAN TRAMWAYS BOARD, 616 Little Collins-street, Melbourne; application for authority, pursuant to section 33 (1) of the *Transport Regulation Act 1958*, No. 6400, to operate the following deviations of routes for the carriage of school children only—

*Warrandyte-Melbourne.*—(a) from the corner of Doncaster-road and Ellsa-street, via Ellsa-street, Harrington-avenue and Greythorn-road to the Grey-

thorn High School; thence via Greythorn-road and Doncaster-road to Doncaster Park State School. Commencing February, 1962, (b) from the corner of Doncaster-road and Buchanan-avenue, via Buchanan-avenue, Maud-street and Marwal-avenue to St. Bede's School. Commenced July, 1961.

*Box Hill-Heidelberg.*—(a) from the corner of Manningham-road and Ayr-street, via Ayr-street, High-street, Doncaster-road, Ellsa-street and Harrington-avenue to the Greythorn High School; thence via Greythorn-road and Sweyn-street to St. Bridget's School, returning via Sweyn-street, Greythorn-road and Doncaster-road to Doncaster Park State School. (On trips to and from St. Bridget's School, no scholars to be picked up south of Harrington-avenue.) Commenced February, 1962, (b) from the corner of Burgundy and Cape streets, via Cape-street to St. John's School; thence via Cape and Banksia streets, Bulleen-road, Manningham-road, Thompsons-road, Union and Parker streets to Templestowe. Commenced July, 1961.

*Templestowe-Box Hill (via Serpells-road).*—From the corner of Blackburn-road and King-street, via Blackburn-road to Warrandyte-road; thence via Warrandyte-Melbourne (via Templestowe) and Box Hill-Heidelberg routes to the Templestowe High School in Manningham-road. Commenced July, 1961.

*Nunawading North-Box Hill.*—From the corner of Whitehorse and Middleborough roads, via Middleborough and Springfield roads to the Blackburn High School. Commenced July, 1961.

*East Doncaster Junction-Mitcham.*—From the corner of East Doncaster-road and Harrison-street, via Harrison-street, Mitcham-road and Victoria-avenue to the Mitcham Junior State School; thence via Victoria-avenue, Britannia-street and Whitehorse-road to St. John's School. Commenced July, 1961.

*Warrandyte-Ringwood (via Wonga and Oban roads).*—From the corner of Wonga-road and Byron-street, via Byron-street to the Norwood High School; thence via Byron-street and Mullum Mullum-road to normal route. Commenced July, 1961.

*Special Church Trips to St. Thomas's Church, Central-road, Blackburn.*—(a) from the corner of Middleborough and Ely roads, via Middleborough, Canterbury, Blackburn and Central roads, (b) from the corner of Springfield and Springvale roads, via Springvale and Central roads. Commenced July, 1961.

BRIGHTON GRAMMAR SCHOOL, 232 New-street, Brighton; 1 commercial passenger vehicle, with seating capacity for twelve passengers, to be purchased, to operate for the carriage of school sporting teams and school excursion parties to and from school and various sporting venues and excursion locations, free of charge, for the carriage of school pupils only.

BLUE & SILVER BUS LINES, 250 Balcombe-road, Mentone; application for variation of Route 204A (Mentone-Mordialloc-Cheltenham) to delete that portion of the route between Nepean Highway and the corner of Ward and Wallingford streets, and also that portion of Mena-avenue between Devon-street and Follett-street and instead to operate from Nepean Highway via Cobham and Ward streets to Follett-street; thence via Follett-road, Ivy-street and Devon-street to prescribed route.

QUINCE, C. W., 64 Ardyne-street, Murrumbeena; application for variation of permit authority to delete operations from the existing stand in Atherton-road, Oakleigh, north side, 40 feet west from Drummond-street to—(a) Moonee Valley Racecourse, (b) R.A.S. Showgrounds for night trotting meetings, and instead to operate from a stand in Portman-street, Oakleigh, south side, adjacent to the taxi loading stand to—(a) Moonee Valley Racecourse, (b) R.A.S. Showgrounds for night trotting meetings.

BRIDGES, O. J., 29 Florence-street, Mentone; application for variation of Route 211A (Mordialloc-Mentone-Springvale) to extend service from the Springvale Railway Station (north side) to Sandown Park Racecourse via Sandown and Springvale roads, Virginia-street, Frazer and Sandown roads to Springvale Railway Station. Service to be operated as and when required on occasions when horse or motor races are held at the course. (Fares to be determined.)

ST. MARY'S CO-OPERATIVE SOCIETY LTD., Maryknoll, via Nar-Nar-Goon; application for renewal of licence No. T.P.62, expiring 26th May, 1962, authorizing operations under the same terms and conditions.

NIMMO, W. A., 88 Brown-street, Heidelberg; application for renewal of metropolitan private hire car licence No. M.H.2404, expiring 24th April, 1962, authorizing operations from the depot of Luxury Cars Ltd., 18-20 Swan-street, Richmond.

HOUGH, H. W., 8 Sunnyside-grove, Bentleigh; application for renewal of metropolitan private hire car licence No. M.H.2400, expiring 25th April, 1962, authorizing operations from the depot of Luxury Cars Ltd., 18-20 Swan-street, Richmond.

KAYNE, V. A., Flat 5, 124 Alma-road, East St. Kilda; application for renewal of metropolitan private hire car licence No. M.H.2403, expiring 25th April, 1962, authorizing operations from the depot of Luxury Cars Ltd., 18-20 Swan-street, Richmond.

LEHMANN, A. R., 6 Peacock-street, West Brunswick; application for renewal of metropolitan private hire car licence No. M.H.2402, expiring 25th April, 1962, authorizing operations from the depot of Luxury Cars Ltd., 18-20 Swan-street, Richmond.

NUTTAL, S. A., 34 Cain-avenue, Northcote; application for renewal of metropolitan private hire car licence No. M.H.2401, expiring 25th April, 1962, authorizing operations from the depot of Luxury Cars Ltd., 18-20 Swan-street, Richmond.

DE ROSS, F. C., 22 Birdwood-street, Balwyn; application for one commercial passenger vehicle, with seating capacity for five persons, to operate as a metropolitan taxi-cab.

NOTICE is hereby given that the applications made by the persons named below for licences to operate the commercial goods vehicles on the route or routes, or in the manner set out opposite their names, will be held at a time and place to be communicated to the persons concerned:—

*Name and Address; Nature of Application.*

ADAMS, WILLIAM, & Co. LTD., 691 Geelong-road, Footscray; 1 commercial goods vehicle (17 cwt.) to operate throughout the State of Victoria, in the course of business as "general engineers" for the purpose of servicing machine tools and filtration plants—tools of trade, spare parts and materials incidental thereto.

BESSELL'S PTY. LTD., 275 Buckley-street, Essendon; 1 commercial goods vehicle (31 cwt.) to operate within a radius of 100 miles of own premises at Essendon, in the course of business as a "bread manufacturer"—own bread and bread products.

BRYAN BROS. & BORCH PTY. LTD., Corangamite-street, Colac; 1 commercial goods vehicle (7 cwt.) to operate throughout the State of Victoria, in the course of business as "windmill manufacturers" for the purpose of servicing and demonstrating windmills and associated equipment—tools of trade, spare parts, partly dismantled windmills and associated equipment for servicing and demonstration and materials incidental thereto.

CAMPBELL, M. S., 8 Neville-street, Traralgon; application to vary the conditions of existing licence No. T.T.D.444 by adding "within a radius of 20 miles of post office at Traralgon—logs on behalf of the Forestry Commission".

CASSIN, G. M., 15 Mile-lane, Yuroke; 1 commercial goods vehicle (11 cwt. and trailer) to operate throughout the State of Victoria for the purpose of collecting damaged motor vehicles on specially constructed trailer—second-hand damaged motor vehicles.

CLOW, V. W., 46 Denis-street, Mitcham; 1 commercial goods vehicle (8 cwt.) to operate within a radius of 50 miles of premises of Turner Industries Ltd. at Nunawading for the purpose of servicing and maintaining washing machines and motor mowers on behalf of the said company—tools of trade, spare parts and materials incidental to such servicing and maintenance.

CONROY, D. J., Ballan; 1 commercial goods vehicle (113 cwt.) to operate—(a) within a radius of 20 miles of post office at Ballan—general goods, (b) from and to places within a radius of 50 miles of post office at Ballan and from places situated within paragraph (a)—livestock.

COOKE, K. A., & K. G. DUNCAN (trading as Cooke and Duncan), 4 Sara-court, Traralgon; application to vary the conditions of existing licence No. T.D.5745 by adding—"From forest landings in Gynyah area to sawmill at Foster—logs".

COSTIN, R. B., Harris-road, Elliminyt; 1 commercial goods vehicle (128 cwt.) to operate—(a) within a radius of 50 miles from the post office at Colac—plant the property of a contractor and required by him for use in connexion with the construction or maintenance of some specific, existing or proposed road, street, footpath, bridge, pier, wharf, weir or channel, and

also the following materials, viz., metal, stones, screenings, ashes, gravel, sand and earth, (b) within a radius of 20 miles from the site of any construction or maintenance work performed pursuant to paragraph (a) above, or from the railway station nearest thereto—any other materials required for such work, (c) within a radius of 20 miles from the post office at Elliminyt—general goods excluding any plant or materials carried or to be carried pursuant to paragraphs (a) and (b) above.

CRABBE, R., Private Bag 11, Colac; 1 commercial goods vehicle (270 cwt.) to operate from forest landings in Aire Valley and Beech Forest district and Lower Gellibrand areas to Barangaroo—logs.

CUMMINGS, J. F., 46 Cooper-street, Alexandra; application to vary the conditions of existing licence No. T.T.D.598 by adding as paragraphs (c) and (d): "(c) from forest landings and bush sites in the Mt. Margaret, Marysville and Big River areas to timber mills within a radius of 25 miles of Melbourne—log flitches, (d) from Bowman's mill at Marysville to timber yards and direct to building sites within a radius of 25 miles of Melbourne—sawn timber".

FAIRWAY-HOWE-SCALES PTY. LTD., 9 Evans-street, Braybrook; 2 commercial goods vehicles (9 and 11 cwt.) to operate—(a) within a radius of 50 miles from own premises at Braybrook—own goods, (b) throughout the State of Victoria—scales for repair or having been repaired, test weights, tools of trade and spare parts incidental to servicing and installing scales and weighing machines.

FOSTER CLARKE (AUST.) LTD., 119-123 Cromwell-street, Collingwood; application to vary the conditions of existing licence No. T.D.5784 by adding as paragraph (b)—"within an area bounded by the Towns of Echuca, Nyah West, Sea Lake, Birchip and Charlton—own goods with replacement stocks being consigned to Kerang by rail".

GRUNDY, J. A., 14 Kinross-street, Bendigo; 1 commercial goods vehicle (8 cwt.) to operate in the course of business as a "building contractor" for the purpose of maintaining Housing Commission dwellings and school buildings under contract to the Public Works Department, within an area bounded by the Towns of Echuca, Kerang, Charlton, St. Arnaud, Maryborough, Kyneton, Seymour and Shepparton—tools of trade, and equipment incidental to such maintenance.

HARGREAVES, H., Gavan-street, Bright; 1 commercial goods vehicle (78 cwt.) to operate from Bright Pine Mills at Bright to consignees within a radius of 50 miles of Bright and to Benalla—sawn timber.

HUME BOTTLERS PTY. LTD., Tone-road, Wangaratta, Vic.; application to vary the conditions of existing licence No. D.A.33474/1 by deleting present conditions and adding in lieu: "Within a radius of 50 miles from own premises at Wangaratta and to and from Tallangatta and Corryong, in the course of business as 'aerated water and cordial manufacturers'—own aerated waters, cordials and empty return containers, subject to the condition that all goods so carried shall be for *en route* delivery only".

HUTTON, T., 513 Hargreaves-street, Bendigo; 1 commercial goods vehicle (7 cwt.) to operate within a radius of 100 miles of chief post office at Bendigo, in the course of business as "painter"—tools of trade, equipment, scaffolding and small quantities of material incidental to the completion of own contracts. Excluding the carriage of goods from Melbourne to Bendigo.

JOSEPH, K. M., Co. PTY. LTD., Post Office Box 36, Prahran; 1 commercial goods vehicle (10 cwt.) to operate in the course of business as "electrical engineers"—(a) within a radius of 50 miles from the post office situated at the corner of Bourke and Elizabeth streets, in the City of Melbourne—own goods, (b) throughout the State of Victoria—tools of trade and equipment only, (c) within a radius of 20 miles from any project currently under construction and engaged upon by the applicant—materials for use on such project.

KOCH, D. K., 20 Bayne-street, Bendigo; application to vary the conditions of existing licence No. D.A.45012 by deleting present conditions and adding in lieu: "To operate within an area bounded by the Townships of Kerang, Wycheproof, St. Arnaud, Avoca, Maryborough, Castlemaine, Heathcote, Murchison, Kyabram and Echuca, in the course of business as a 'building contractor'—tools of trade and own building materials incidental to the completion of own contracts."

MANGER & O'NEILL PTY. LTD., 83 Annesley-street, Echuca; 1 commercial goods vehicle (133 cwt.) to operate within a radius of 50 miles from own premises at Echuca and to and from the City of Wangaratta,

- the Townships of Wodonga, Benalla, Swan Hill, Lake Boga, Kerang, Murrabit and Seymour—own fruit, tomatoes, aerated waters, tomato sauce and canned goods, in the course of business as "food processors, beverage manufacturers and general wholesalers".
- MATHISKE, J. E.**, 3 Mitchell-street, Swan Hill; 1 commercial goods vehicle (140 cwt.) to operate—(a) within a radius of 95 miles of the post office at Cohuna and/or within a radius of 100 miles of the post office at Merbein (Bendigo Division of the Country Roads Board)—plant the property of a contractor and required for use in connexion with the construction or maintenance of some specific, existing or proposed road, street, footpath, bridge, wharf, pier, weir or channel, (b) within a radius of 20 miles from site of construction or maintenance work performed pursuant to paragraph (a) above, or from the railway station nearest thereto—metal, stones, screenings, ashes, gravel, sand, earth, and any other materials required for such work, (c) within a radius of 20 miles of the post office at Swan Hill—general goods.
- MATTHEWS, H. E.**, 41 Avondale-crescent, Morwell; 1 commercial goods vehicle (142 cwt.) to operate—(a) within a radius of 50 miles from the post office at Morwell—plant the property of a contractor and required by him for use in connexion with the construction or maintenance of some specific, existing or proposed road, street, footpath, bridge, pier, wharf, weir or channel and also the following materials, viz., metal, stones, screenings, ashes, gravel, sand, and earth, (b) within a radius of 20 miles from the site of any construction or maintenance work performed pursuant to paragraph (a) above, or from the railway station nearest thereto—any other materials required for such work, (c) within a radius of 20 miles from the post office at Morwell—general goods excluding any plant or materials carried or to be carried pursuant to paragraph (a) and (b) above.
- MILLAY, A. J.**, 44 Etzel-street, Airport West; 1 commercial goods vehicle (188 cwt.) to operate—(a) within a radius of 35 miles of Bayview Quarries Pty. Ltd. quarries at Berwick—screenings and stone dust, (b) from sand pits within a radius of 35 miles of Bayview Quarries Pty. Ltd.'s quarries at Berwick to the aforementioned quarries—sand.
- MORSE, MCG. W. (Jnr.)**, 40 Curtin-street, Flora Hill, Bendigo; 1 commercial goods vehicle (5 cwt.) to operate within a radius of 100 miles of chief post office at Bendigo, in the course of business as an "electrical fitter" for the purpose of servicing and installing electrical equipment—tools of trade, spare parts and materials incidental to servicing and installation, electrical equipment for specialized installation, and trade in appliances for return.
- MCPHERSON, I. A.**, 6 Park-lane, Traralgon; application to vary the conditions of existing licence No. T.T.D.300 by adding: "pulpwood chips from Dargo to A.P.M. Maryvale".
- OVEREND, B. C.**, care of M. Varney, Anderson-street, Bairnsdale; 1 commercial goods vehicle (292 cwt.) to operate—(a) from Bulumwaal and Mount Taylor forest areas to Lowe's sawmill at Mount Taylor—logs, (b) from sawmill at Mount Taylor to Bairnsdale Railway Station—sawn timber.
- PARKER, W. R.**, 13 Thorpe-street, California Gully, Eaglehawk; 1 commercial goods vehicle (8 cwt.) to operate throughout the State of Victoria, in the course of business as "electrical contractor"—tools of trade and materials incidental to own contracts. *Note.*—No goods are to be carried from Melbourne to Eaglehawk.
- RICHARDSON, JAMES, PTY. LTD.**, 14 Corrs-lane, Melbourne; 1 commercial goods vehicle (19 cwt.) to operate within a radius of 60 miles of own depot at Warrnambool, in course of business as "cigarette and tobacco distributors"—cigarettes, tobacco and hair-dressers supplies. *Note.*—All goods to be consigned by rail from Melbourne to Warrnambool.
- SANDHURST BRICK CO. LTD.**, Broadcasting House, View Point, Bendigo; 1 commercial goods vehicle (107 cwt.) to operate—(a) within a radius of 25 miles from the chief post office in the City of Bendigo—general goods, (b) within a radius of 70 miles from the chief post office in the City of Bendigo in the course of business as "brick manufacturers"—own bricks.
- SCHERGER, N. J.**, 20 Tobin-street, Ararat; 1 commercial goods vehicle (11 cwt.) to operate—(a) within the area west of a north/south line drawn through Melbourne, in course of business as "marine dealer"—marine goods, (b) within a radius of 50 miles of own premises at Ararat, in course of business as a "primary producer"—own goods.
- SIDES, W. L., & SONS PTY. LTD.**, 422 Collins-street, Melbourne; 1 commercial goods vehicle (153 cwt.) to operate throughout the State of Victoria in the course of business as "boring contractors"—tools of trade, boring equipment and materials incidental to own contracts.
- SINCLAIR, N.**, Munro; application to vary the conditions of existing licence No. D.A.38449 by adding: "within 50 miles of Munro Railway Station, in the course of business as 'Commonwealth Fertilizers agent'—bagged superphosphate".
- VICKERY, L. J. H. & A. M.**, 5 Leckie-street, Bentleigh; 1 commercial goods vehicle (8 cwt.) to operate within a radius of 50 miles of Turner Industries Ltd., at Nunawading as a "service mechanic" on behalf of said company for the purpose of servicing washing machines and motor mowers—tools of trade, spare parts, washing machines, motor mowers and appliances for repair or having been repaired and materials incidental thereto.

NOTICE is hereby given that the applications made by the persons named below for renewal of licences to operate the commercial goods vehicles, on the route or routes, or in the manner set out opposite their names, will be heard at a time and place to be communicated to the persons concerned:—

*Name and Address; Present Franchise; Licence No.; Date of Expiry.*

- BATTY, A.**, 2 Addis-street, Geelong West; 2 commercial goods vehicles (60 and 55 cwt.) to operate within a radius of 50 miles from the chief post office in the City of Geelong—(a) to operate as a mobile crane, (b) to carry septic tanks and small quantities of pipe on behalf of the Geelong Water Works and Sewerage Trust, (c) to carry in the course of business as "marine collector"—marine goods as designated in the *Marine Stores and Old Metals Act 1958*, No. 6303; D.A.622/3, D.A.622/5; 19th May, 1962.
- DALGETY & NEW ZEALAND LOAN LIMITED**, 1 Malop-street, Geelong; 1 commercial goods vehicle (11 cwt.) to operate within a radius of 75 miles from the place of business of the holders of this licence, in the City of Geelong—samples of stock and station commodities with the right to make an urgent incidental delivery of such items, in the course of licensees' business as "stock and station agents"; D.A.22627/4; 19th May, 1962.
- HELEYS PTY. LTD.**, Thirteenth-street, Mildura; 1 commercial goods vehicle (80 cwt.) to operate, in the course of licensees' business as "aerated water and cordial manufacturers"—own aerated waters, cordials and empty return bottles and containers—(a) within a radius of 50 miles from the post office at Mildura, (b) from and to the City of Mildura, to and from the Victorian-South Australian border, via the Sturt Highway *en route* to and from the Township of Berri (S.A.), (c) from and to the City of Mildura, to and from the Township of Robinvale and to and from the Township of Ouyen; D.A.8999; 18th May, 1962.
- HILL, F. C.**, 276 High-street, Belmont; 1 commercial goods vehicle (76 cwt.) to operate throughout the State of Victoria, for the purpose of towing or repairing wrecked and disabled vehicles—tools of trade, spare parts and materials incidental thereto; D.A.30446; 22nd July, 1961.
- JUDD, G. E., B. E. & H. C.** (trading as G. Judd and Sons), 34 Coghill-street, Yarrowonga; 1 commercial goods vehicle (215 cwt.) to operate within a radius of 50 miles from the post office at Yarrowonga—road-contracting plant and materials; D.A.1403/3; 19th May, 1962.
- PHELAN, W., & SONS PTY. LTD.**, 157 High-street, Maryborough; 2 commercial goods vehicles (128 and 72 cwt.) to operate throughout the State of Victoria—tools of trade and materials incidental to the erection and completion of prefabricated houses by the holder of this licence, in the course of business as "suppliers and contractors"; D.A.3633/5; D.A.3633/6; 26th May, 1962.
- PHELAN, W., & SONS PTY. LTD.**, 157 High-street, Maryborough; 1 commercial goods vehicle (13 cwt.) to operate throughout the State of Victoria—tools of trade and small quantities of materials incidental to or required for the purpose of making minor adjustments and repairs to finished contracts, in the course of business of the holders of this licence as "builders and contractors"; D.A.3633/7; 7th May, 1962.

**PUNTON'S SHOES PTY. LTD.**, 240 Wellington-street, Collingwood; 1 commercial goods vehicle (7 cwt.) to operate—(a) within a radius of 50 miles from the post office situate at the corner of Bourke and Elizabeth streets in the City of Melbourne, in the course of business as “manufacturers of shoes”—town goods, (b) from and to the City of Melbourne to and from own branch stores situated in the Cities of Ballarat, Hamilton, Bendigo, Horsham and Geelong; in the course of business as “manufacturers of shoes”—own samples of footwear, display signs and advertising material with the ability to carry special shoe sizes for urgent delivery and on return journeys from own stores damaged and obsolete stock.

*Special Condition.*—It is a special condition of this licence that a maximum number of twelve pairs of shoes only be carried on any one journey from the City of Melbourne; D.A.13518; 15th June, 1962.

**SEMENIC, A.**, 9 Tanner-street, Breakwater, Geelong; 1 commercial goods vehicle (105 cwt.) to operate—(a) within a radius of 90 miles of the post office at Wangaratta (Benalla Division of the Country Roads Board)—plant the property of a contractor and required for use in connexion with the construction or maintenance of some specific, existing or proposed road, street, footpath, bridge, wharf, pier, weir or channel, (b) within a radius of 20 miles from the site of construction or maintenance work performed pursuant to paragraph (a) above, or from the railway station nearest thereto—metal, stones, screenings, ashes, gravel, sand, earth and any other materials required for such work; D.A.25619/1; 19th May, 1962.

**SINGER SEWING MACHINE CO.**, 41A Langtree-avenue, Mildura; 1 commercial goods vehicle (7 cwt.) to operate within a radius of 100 miles from the post office at Mildura, for the purpose of delivering and servicing own sewing machines, and to carry sewing machine accessories, materials, tools of trade and sewing machine spare parts; D.A.13912; 3rd May, 1962.

**THOMPSON, JOHN, & Co. (HAMILTON) LTD.**, 138 Gray-street, Hamilton; 1 commercial goods vehicle (12 cwt.) to operate within a radius of 50 miles from the post office at Hamilton, in the course of business as “radio and electrical engineers” for the purpose of servicing and repair of radio sets and electrical appliances—tools of trade, spare parts, new electrical appliances for installation, second-hand electrical appliances for repair or having been repaired and materials incidental to trade; D.A.13913; 3rd May, 1962.

**WREN, T. & I. R.**, Tungamah; 1 commercial goods vehicle (125 cwt.) to operate—(a) (i) within a radius of 95 miles of the post office at Cohuna and/or within a radius of 100 miles of the post office at Merbein (Bendigo Division of the Country Roads Board), (ii) within a radius of 90 miles of the post office at Wangaratta (Benalla Division of the Country Roads Board)—plant the property of a contractor and required for use in connexion with the construction or maintenance of some specific, existing or proposed road, street, footpath, bridge, wharf, pier, weir or channel, (b) within a radius of 20 miles from site of construction or maintenance work performed, pursuant to paragraph (a) above, or from the railway station nearest thereto—metal, stones, screenings, ashes, gravel, sand, earth and any other materials required for such work; D.A.30096/1; 26th May, 1962.

Notice of any objection should be forwarded to reach the Secretary of the Board not later than Wednesday, 28th March, 1962.

B. P. KAY,  
Secretary.

Exhibition Buildings, Rathdowne-street, Carlton, N.3, 14th March, 1962.

*Marriage Act 1958.*

MINISTERS OF RELIGION REGISTERED TO CELEBRATE MARRIAGES IN VICTORIA.

It is hereby notified that in pursuance of the provisions of the *Marriage Act 1958*, No. 6306, Sec. 11, the undermentioned Officiating Ministers of Religion have been registered at this Office for the celebration of marriages in Victoria:—

Number in Register.	Name.	Designation.	Denomination.	Residence.	Date of Registration.
12600	French, David John ..	Priest ..	Church of England ..	All Saints Vicarage, East St. Kilda ..	13.2.62
12601	Pannach, Gordon Howard ..	Pastor ..	Evangelical Lutheran ..	235 Scott-street, Warracknabeal ..	15.2.62
12602	Davis, Percival William Frederick	High Priest	Church of Jesus Christ of Latter Day Saints	60 South-crescent, Northcote ..	15.2.62
12603	Brown, Donald ..	Priest ..	Roman Catholic ..	85 Studley Park-road, Kew ..	15.2.62
12604	Dawson, Bernard Marius ..	Priest ..	Roman Catholic ..	85 Stokes-street, Port Melbourne ..	15.2.62
12605	Kierce, Noel Pius ..	Priest ..	Roman Catholic ..	75 Wright-street, Middle Park ..	15.2.62
12606	Sharkey, Francis William John	Priest ..	Roman Catholic ..	57 Central-road, Blackburn ..	15.2.62
12607	Chapman, Henry Rowland ..	Major ..	Salvation Army ..	418 Clarke-street, Northcote ..	16.2.62
12608	Botsford, Harold William ..	Captain ..	Salvation Army ..	24 Outer-crescent, North Brighton ..	16.2.62
12609	Dyster, Kenneth ..	Minister ..	Presbyterian ..	Saxton-street, Numurkah ..	20.2.62
12610	Heaton, Oswald Richard Alwyn	Minister ..	Seventh-Day Adventists	1 Albion-road, Box Hill ..	20.2.62
12611	Hearn, George Arthur ..	Minister ..	Churches of Christ ..	Sinclair-street, Warragul ..	20.2.62
12612	Cook, John Wilbur ..	Minister ..	Baptist ..	55 Fitzroy-street, Kerang ..	20.2.62
12613	Goodman, Richard George ..	Priest ..	Church of England ..	24 Sternberg-street, Bendigo ..	22.2.62
12614	Rasmus, John Golden ..	Captain ..	Salvation Army ..	36 Henty-street, Portland ..	22.2.62
12615	Fletcher, Gilbert Roy ..	Ordained Elder	Wesleyan Methodist ..	22 Jesson-crescent, Dandenong ..	2.3.62
12616	Finn, Alan Joseph ..	Priest ..	Roman Catholic ..	47 Stanhope-street, Malvern ..	2.3.62
12617	Plunkett, Wilfred Edward ..	Priest ..	Roman Catholic ..	47 Stanhope-street, Malvern ..	2.3.62
12618	Ramjam, Martin ..	Priest ..	Roman Catholic ..	182 Power-street, Hawthorn ..	2.3.62

Office of the Government Statist,  
Melbourne, 2nd March, 1962.

F. W. CORRIE,  
Assistant Government Statist.

*Co-operation Act 1958.*

NOTICE OF REGISTRATION AND INCORPORATION OF A SOCIETY.

NOTICE is hereby given that Lombard House Co-operative Society Limited, which was registered under the *Companies Act 1958*, under the name of 157 a Beckett Street Proprietary Limited, was on the sixth day of March, 1962, registered under the *Co-operation Act 1958*, by virtue of which registration the society became incorporated thereunder.

Dated at Melbourne this sixth day of March, 1962.

E. T. EBBELS,  
Registrar of Co-operative Societies.

EDUCATION DEPARTMENT.

SUMMONING OFFICERS.

UNDER section 5 of the *Education Act 1958*, I hereby appoint—

Senior Constable JOHN OTTO TAPPE and  
First Constable STANLEY GORDON WRIGHT  
to summon parents within the State of Victoria.

JOHN S. BLOOMFIELD,  
Minister of Education.

Melbourne, 2nd March, 1962.

## COMPANIES ACT 1958.

NOTICE is hereby given, in pursuance of section 241 (2) of the Companies Act 1958, that at the expiration of three months from the date hereof, the names of the following companies will, unless cause is shown to the contrary, be struck off the Register.

Dated this 7th day of March, 1962.

T. S. WELSH,  
Registrar of Companies.  
Companies Registration Office,  
Melbourne.

## COMPANIES ABOVE REFERRED TO.

Name of Company.	No. of Registration.
Permarost (Sales) Pty. Limited	F 3130
Melbourne-Sydney Parcel Express Co. Pty. Limited	F 3309
Rapid Air Freight Pty. Limited	F 3315

## COMPANIES ACT 1958.

NOTICE is hereby given, in pursuance of sections 241 (2), 241 (3) (a) (b) and (c) of the Companies Act 1958, that at the expiration of three months from the date hereof, the names of the following companies will, unless cause is shown to the contrary, be struck off the Register, and the said companies will be dissolved.

Dated this 7th day of March, 1962.

T. S. WELSH,  
Registrar of Companies.  
Companies Registration Office,  
Melbourne.

## COMPANIES ABOVE REFERRED TO.

Name of Company.	No. of Registration.
Perpetual Forests (Mount Gambier) Proprietary Limited	11945
Karrah Metal Alloys (Victoria) Proprietary Limited	17291
Brewster Lee Motors Proprietary Limited	22751
Master Distributors Proprietary Limited	23416
Sydney C. Nielsen Pty. Limited	23957
Consumer Products International Proprietary Limited	24387
M. Olorenshaw and Co. Proprietary Limited	25416
Toorak Delicatessen Proprietary Limited	25550
Golf House, Mount Macedon Proprietary Limited	25587
Rolar Import-Export Company Proprietary Limited	26601
Melmore Biscuit Co. Proprietary Limited	26870
Creta Manufacturing Co. Proprietary Limited	27244
G. W. Fawaz Proprietary Limited	28271
Radio Physics Manufacturing Company Proprietary Limited	28603
Power Products (Australia) Proprietary Limited	29117
Bradon Textiles Proprietary Limited	32469
Wilson and McLean Proprietary Limited	34035
Hampshire Radio and Electrical Proprietary Limited	35312
Griffin Products (Australia) Proprietary Limited	35338
A. G. Home Decorators Proprietary Limited	37057
Eastern Car Imports Proprietary Limited	37494
J. M. B. Trading Co. Proprietary Limited	39205
Cahill and McMahon Motors (Wholesale) Proprietary Limited	40655
Baglins Radio and Television Proprietary Limited	41844
Indo Malay (Australia) Proprietary Limited	45264
The Viking Publishing Co. Pty. Limited	47177

## Fisheries Act 1958.

NOTICE OF INTENTION TO REVOKE THE PROCLAMATION PROHIBITING NETTING AT THE "PERCH GROUND", IN ANDERSON'S INLET.

IT is hereby notified for general information that it is intended, after the expiration of one month from the date of publication of this notice in the *Government Gazette*, to move His Excellency the Governor in Council to make a Proclamation revoking the Proclamation made the sixth day of June, 1912, and published in the *Government Gazette* of the nineteenth day of June, 1912, respecting the prohibition of netting at the "Perch Ground" in Anderson's Inlet.

E. R. MEAGHER,  
for Chief Secretary.

A. DUNBAVIN BUTCHER,  
Director of Fisheries and Wildlife.

## Melbourne and Metropolitan

## BOARD OF WORKS.

NOTICE TO THE OWNERS OF TENEMENTS IN THE UNDERMENTIONED STREETS, AND THE PRIVATE STREETS, LANES, COURTS AND ALLEYS OPENING THERETO.

THE main pipe in the said streets being laid down, the owners of all tenements situated as under are hereby required on or before the 16th April, 1962, to cause a proper pipe and stop cocks to be laid so as to supply water within such tenements from the main pipe.

W. K. Y. BROMLEY,  
Acting Secretary.  
6th March, 1962.

## STREET AND POSITION.

## Altona.

Millers-road, from Edward-street to McArthurs-road.  
McArthurs-road, from Millers-road to Cedula-road.  
Right-of-way 7½ chains west of Millers-road, from Duke-street to McArthurs-road.  
Millers-road, from Duke-street northwards 6 chains.

## Doncaster.

Bayley-grove, from Doncaster-road northwards 12 chains.  
Angus-grove, from Bayley-grove westwards 4½ chains.  
Arnold-grove, from Mount View-road northwards 4 chains.  
Wood-street, from 1½ chains west of Lankester-street westwards 7½ chains.

## Essendon.

Newsom-street, from Pentland-street south-westwards 5½ chains.  
Woods-street, from Newsom-street north-westwards 8 chains.  
Lawson-street, from Salisbury-street to Montague-street.

## Hawthorn.

Sellwood-street, from 8 chains east of Garden-street eastwards 5½ chains.

## Keilor.

Hampton-road, from Emerald-street south-eastwards 3½ chains.

## Ringwood.

Kenbry-road, from Barnic-road eastwards 4½ chains.  
Holland-road, from Old Lillydale-road westwards 11½ chains.  
Sunbeam-avenue, from Holland-road southwards 6½ chains.

## Waverley.

Blackburn-road, from Ricketts-road southwards 2½ chains.  
McLochlan-street, from Huntingdale-road to Hansen-street.  
Howard-avenue, from McLochlan-street to Grenfell-road.  
Grenfell-road, from Howard-avenue north-westwards 1½ chains.  
Grenfell-road, from Howard-avenue to Billing-street.  
Billing-street, from Grenfell-road to Jack-street.  
Jack-street, from Billing-street to Virginia-street.  
Virginia-street, from Jack-street eastwards ½ chain.  
Hillview-street, from McLochlan-street southwards ½ chain.  
Halliday-street, from McLochlan-street southwards 2½ chains.  
French-street, from 2 chains east of Howell-street eastwards 7½ chains.

## Town and Country Planning Act 1961.

MOE-NEWBOROUGH PLANNING SCHEME 1951.—  
AMENDMENT No. 4, 1961.

## NOTICE OF APPROVAL.

IN pursuance of the powers conferred by the *Town and Country Planning Act 1961*, the Governor in Council, by and with the advice of the Executive Council thereof on the 14th March, 1962, approved a Planning Scheme entitled the Moe-Newborough Planning Scheme 1951, Amendment No. 4, 1961, in respect of part of the municipal district of the Borough of Moe.

A copy of the Planning Scheme as approved may be inspected, during office hours, at the office of the Town and Country Planning Board, 61 Spring-street, Melbourne; at the office of the Council of the Borough of Moe; and when available, at the Office of Titles, Melbourne, and at the Central Plan Office of the Department of Crown Lands and Survey, Melbourne.

W. H. CRAIG, Secretary,  
Town and Country Planning Board.

*Town and Country Planning Act 1961.*  
**FRENCH ISLAND PLANNING SCHEME.**  
 INTERIM DEVELOPMENT ORDER.

BY virtue of the powers conferred by the *Town and Country Planning Act 1961* and of every other power enabling it in that behalf, the Town and Country Planning Board (hereinafter referred to as the responsible authority) having commenced the preparation of a Planning Scheme in accordance with the Town and Country Planning Acts then in force on the 14th day of September, 1960, hereby makes this Interim Development Order for the purpose of regulating, restricting, restraining and prohibiting the use or development of land and the erection, construction or carrying out of any buildings or works, that is to say:—

1. Except in accordance with the provisions of a permit issued by the responsible authority, no person shall use, subdivide or otherwise develop any land or erect, construct or carry out any buildings or works on any land within the area described in the Schedule hereto.

2. Notwithstanding the provisions of clause 1 hereof, this Interim Development Order shall not prohibit the erection, construction or carrying out of any buildings or works on any allotment having an area of not less than 10 acres which was separately owned at the date of coming into operation of this Order.

3. Nothing in this Interim Development Order shall prevent the continuance of the use of any land or of any existing building or works for the purposes for which the land or building or works was or were being lawfully used immediately before the coming into operation of this Order.

4. Nothing in this Interim Development Order shall prevent any dealing or the registration of any dealing with any land in a subdivision in the area described in the Schedule hereto which land as an allotment in that subdivision has been sold or agreed to be sold before the coming into operation of this Order.

5. Every application for a permit under the provisions of this Order shall be made on the prescribed form, copies of which may be obtained from the office of the responsible authority at 61 Spring-street, Melbourne.

SCHEDULE.

The whole of the Parish of French Island within the County of Mornington.

The common seal of the Town and Country Planning Board was hereto affixed, at Melbourne, this 7th day of March, 1962, in the presence of—

(SEAL) FRED. C. COOK, Chairman.  
 A. N. KEMSLEY, Member.  
 W. H. CRAIG, Secretary.

Approved by the Governor in Council, pursuant to section 17 of the *Town and Country Planning Act 1961*, on the 14th day of March, 1962.

N. G. WISHART,  
 Acting Clerk of the Executive Council.

STAMPS ACT.

IN pursuance of the powers contained in the Stamps Act, I hereby certify that, until further notice, Planet Oil Company N.L., is a company engaged solely or principally in the search or mining for petroleum.

Dated the 14th day of March, 1962.

D. G. RICHARDS,  
 Comptroller of Stamps.

APPOINTMENTS.

HIS Excellency the Governor of the State of Victoria, by and with the advice of the Executive Council thereof, has, by Orders made on the 6th day of May, 1962, been pleased to make the under-mentioned appointments, viz:—

CHIEF SECRETARY'S DEPARTMENT.

*Members of the National Art Gallery and Cultural Centre Building Committee.*

KENNETH GOWAN BEGG,  
 KENNETH BAILLIEU MYER, D.S.C., and  
 WILLIAM IAN POTTER,  
 pursuant to the provisions of the *National Art Gallery and Cultural Centre Act 1956*, to be members of the National Art Gallery and Cultural Centre Building Committee, for a term of five years from the 5th March, 1962.

*Trustees of the National Museum of Victoria.*

EDWIN SHERBON HILLS (Professor), D.Sc., Ph.D., D.I.C., F.G.S., and  
 SYDNEY SUNDERLAND (Professor), D.Sc., M.D., B.S., F.R.A.C.S. (Hon.), F.R.A.C.P.,  
 pursuant to the provisions of the *State Library National Gallery National Museum and Institute of Applied Science Act 1960*, to be Trustees of the National Museum of Victoria, for a term of three years from the 16th March, 1962.

*Trustees of the National Gallery of Victoria.*

WILLIAM RITCHIE, and  
 LEONARD BELL COX, M.D., B.S., F.R.A.C.P., M.R.C.P.,  
 pursuant to the provisions of the *State Library National Gallery National Museum and Institute of Applied Science Act 1960*, to be Trustees of the National Gallery of Victoria, for a term of three years from the 16th March, 1962.

*Trustees of the State Library.*

WILLIAM HENRY ELLWOOD, M.A., M.Ed.,  
 PATRICK KEITH SUTTON, M.L.A., and  
 ALFRED ERNEST McMICKEN, F.L.A.,  
 pursuant to the provisions of the *State Library National Gallery National Museum and Institute of Applied Science Act 1960*, to be Trustees of the State Library of Victoria, for a term of three years from the 16th March, 1962.

*Trustees of the Institute of Applied Science of Victoria.*

LAURENCE JOHN HARTNETT, C.B.E., F.R.S.A., M.I.E. Aust.,  
 OLIVER EMANUEL NILSSON, B.Sc., A.M.I.E. Aust., F.R.S.A., F.A.I.M., and  
 FRANK MORRES READ, M.Agr.Sc.,  
 pursuant to the provisions of the *State Library National Gallery National Museum and Institute of Applied Science Act 1960*, to be Trustees of the Institute of Applied Science of Victoria, for a term of three years from the 16th March, 1962.

*Totalizator Inspector.*

JOHN PERCIVAL DEMPSTER  
 to be an Inspector, pursuant to the provisions of section 113 of the *Racing Act 1958*, vice R. C. Willich, resigned.

HEALTH DEPARTMENT.

*Chief Executive Officer of National Fitness Council.*

BELINDA UTASSY  
 to be Chief Executive Officer of the National Fitness Council of Victoria, pursuant to the provisions of section 11 of the *National Fitness Council of Victoria Act 1960*, for the period ending the 31st May, 1962, vice Edward George Bailey, resigned.

LAW DEPARTMENT.

*Justices of the Peace.*

ARTHUR EDWARD HOUSTON, 337 Edwards-street, Reservoir,  
 to Keep the Peace in the Central Balliwick of the State of Victoria.

*Commissioners for Taking Declarations, &c.*

PATRICK HAMILTON MOLLER, 27 Harbury-street, Reservoir, N.19,  
 FRANCIS WILLIAM AMY, 6 Lytton-street, Glenroy,  
 MAISIE LORNA CAMERON, care of Post Office, Selby,  
 LAWRENCE JOHN CALDER, 49 Eastgate-street, Pascoe Vale South, and  
 ANTHONY STAUNTON, 193 Brunswick-road, Brunswick,  
 to be Commissioners for taking Declarations and Affidavits, pursuant to the provisions of the *Evidence Act 1958*, to resign upon removing from the neighbourhood of the addresses stated; and

PETER ABBOTSMITH, Manager, Carr Fowler Constructions Pty. Ltd., 464 Collins-street, Melbourne, and  
 MAURICE WILLIAM JOHNSON, President, Monbulk Sub-branch, The Returned Sailors, Soldiers and Airmen's Imperial League of Australia,  
 to be Commissioners for taking Declarations and Affidavits, pursuant to the provisions of the *Evidence Act 1958*, to resign upon ceasing to occupy their present positions.

*Deputy Clerk of the Peace and Registrar of the County Court.*

PHILIP JOHN RODDA,  
 to be Deputy Clerk of the Peace and Registrar of the County Court at Morwell, and Clerk of Petty Sessions and Clerk of the Children's Court at Morwell and Traralgon during the absence of G. R. Kevill on annual leave, to take effect from the date of commencement of duty.

*Clerks of Petty Sessions, &c.*

ALFRED ERNEST THOMPSON  
to be Clerk of Petty Sessions and Clerk of the Children's Court at Mooropna during the absence of G. J. Findlay on annual leave, to take effect from the date of commencement of duty;

ROBERT RATCLIFFE WILSON  
to be Clerk of Petty Sessions and Clerk of the Children's Court at Glenroy during the absence of E. Bonell on annual leave, to take effect from the date of commencement of duty;

FRANCIS LEO FITZPATRICK  
to be Clerk of Petty Sessions and Clerk of the Children's Court at Warracknabeal, Hopetoun and Minyip during the absence of E. N. Drayton on annual leave, to take effect from the date of commencement of duty; and

HUGH FRANCIS PATRICK ADAMS  
to be Clerk of Petty Sessions and Clerk of the Children's Court at Nhill, Dimboola, Jeparit, Kaniva and Rainbow during the absence of P. J. Menkhorst on annual leave, to take effect from the date of commencement of duty.

*Assistant Registrars of County Court.*

FRANCIS LEO FITZPATRICK  
to be an Assistant Registrar, pursuant to the provisions of sections 20 and 21 of the *County Court Act 1958*, for the County Court at Horsham during the absence of E. N. Drayton on annual leave, to take effect from the date of commencement of duty; and

HUGH FRANCIS PATRICK ADAMS  
to be an Assistant Registrar, pursuant to the provisions of sections 20 and 21 of the *County Court Act 1958*, for the County Court at Horsham during the absence of P. J. Menkhorst on annual leave, to take effect from the date of commencement of duty.

*Clerk of the Peace.*

BRYAN JOHN COSGRIFF  
to be Clerk of the Peace for the Eastern Bailiwick, Registrar of the County Court, Clerk of the Court of Mines and Clerk of the Petty Sessions and Clerk of the Children's Court at Bairnsdale, and Clerk of Petty Sessions and Clerk of the Children's Court at Bendoc, Bruthen, Cann River, Lakes Entrance, Lake Tyers, Omeo and Orbost during the absence of D. H. Ward on annual leave, to take effect from the date of commencement of duty.

*Deputy Clerk of the Peace, &c.*

FREDERICK JOHN DUTHIE  
to be Deputy Clerk of the Peace, Registrar of the County Court, Clerk of the Children's Court and Clerk of Petty Sessions at Warragul, and Clerk of the Children's Court and Clerk of the Petty Sessions at Bunyip, Drouin and Neerim South during the absence of G. F. Miller on annual leave, to take effect from the date of commencement of duty:

*Special Children's Court Magistrates.*

EDWARD WILLIAM SLATTERY, and  
ALEXANDER KNOX BROWN  
to be Special Children's Court Magistrates, pursuant to the provisions of section 5 of the *Children's Court Act 1958*, for all places within the State of Victoria where a Court of Petty Sessions is appointed or shall be appointed to be held under the provisions of the *Justices Act 1958*, to take effect from the 19th March, 1962.

## DEPARTMENT OF THE TREASURER.

*Collector of Imposts.*

GERARD FRANCIS O'BRIEN  
to be Collector of Imposts, Sheriff's Office, Department of Law, *vice* H. N. Bride.

*Receiver of Revenue (Acting).*

BRYAN JOHN COSGRIFF  
to act temporarily as Receiver of Revenue, Bairnsdale, during the absence of D. H. Ward on leave.

N. G. WISHART,  
Acting Clerk of the Executive Council.

At Government House,  
Melbourne, 6th March, 1962.

## RESIGNATION.

HIS Excellency the Governor of the State of Victoria, by and with the advice of the Executive Council thereof, has by Order made on the 6th day of March,

1962, accepted the resignation of the person named hereunder of the offices mentioned, *viz.*:—

## CHIEF SECRETARY'S DEPARTMENT.

KEVIN PHILLIPS, as a Probation Officer, pursuant to the provisions of the *Children's Court Act 1958*, for the Children's Court at Heidelberg.

N. G. WISHART,  
Acting Clerk of the Executive Council.

At Government House,  
Melbourne, 6th March, 1962.

## HEALTH ACT 1958 (No. 6270).—SECTION 16.

At Government House, Melbourne, the  
sixth day of March, 1962.

## PRESENT:

His Excellency the Governor of Victoria.  
Mr. Porter | Mr. Thompson.

## APPOINTMENT OF MEMBERS OF THE COMMISSION OF PUBLIC HEALTH.

PURSUANT to the provisions of section 16 of the *Health Act 1958*, His Excellency the Governor of the State of Victoria, by and with the advice of the Executive Council thereof, doth hereby appoint the following persons to be members of the Commission of Public Health for a term of three years as from and inclusive of the 24th March, 1962:—

WALTER ERNEST SUMMONS, O.B.E., M.D., D.P.H.,  
Medical Practitioner,  
HENRY McLORINAN, C.B.E., M.B., et Ch.B., Medical  
Practitioner,  
Councillor ALBERT KEITH LINES, O.B.E., J.P., representing metropolitan municipalities,  
Councillor THOMAS RICHARD FLOOD, J.P., representing cities, towns and boroughs other than metropolitan municipalities,  
Councillor ARTHUR SYDNEY THOMSON, representing shires other than metropolitan municipalities.  
FRANCIS JOHN CUTTS, J.P.

And the Honorable Ronald William Mack, Her Majesty's Minister of Health for the State of Victoria, shall give the necessary directions herein accordingly.

N. G. WISHART,  
Acting Clerk of the Executive Council.

## RURAL FINANCE AND SETTLEMENT COMMISSION ACT 1961.

At Government House, Melbourne, the sixth  
day of March, 1962.

## PRESENT:

His Excellency the Governor of Victoria.  
Mr. Porter | Mr. Thompson.

IN pursuance of the powers conferred by the *Rural Finance and Settlement Commission Act 1961*, His Excellency the Governor of the State of Victoria, by and with the advice of the Executive Council thereof, doth by this Order—

- (a) Appoint a Commission to be called the "Rural Finance and Settlement Commission" with effect from and inclusive of 16th March, 1962;
- (b) appoint Hugh Leslie Simpson, Ian Kenneth Morton and Leslie Lara Beardsell, to be members of the said Commission;
- (c) determine that the term of appointment of each of such members shall be a period of one year from and inclusive of 16th March, 1962;
- (d) appoint the said Hugh Leslie Simpson and Ian Kenneth Morton to be respectively Chairman and Deputy Chairman of the said Commission; and
- (e) fix the salaries to be paid to the said members as follows:—
 

Chairman	..	£4,400 per annum.
Deputy Chairman	..	£3,800 per annum.
The other member	..	£3,800 per annum.

And the Honorable Keith Hector Turnbull, Her Majesty's Commissioner of Crown Lands and Survey, shall give the necessary directions herein accordingly.

N. G. WISHART,  
Acting Clerk of the Executive Council.

WEIGHTS AND MEASURES ACT 1958.

At Government House, Melbourne, the sixth day of March, 1962.

PRESENT:

His Excellency the Governor of Victoria.

Mr. Porter

Mr. Thompson.

REGULATIONS.

IN pursuance of the powers conferred by the *Weights and Measures Act 1958* and all other powers him thereunto enabling, His Excellency the Governor of the State of Victoria in the Commonwealth of Australia, by and with the advice of the Executive Council of the said State, doth hereby further amend the *Weights and Measures Regulations 1959* as follows (that is to say):—

1. In Regulation 2, the expression "Registration of Repairers and Adjusters of Weighing and Measuring Instruments" is hereby revoked and the expression "Repair, Alteration and Adjustment of Weights, Measures and Instruments" is substituted therefor.

2. In paragraph (a) of Regulation 3, the following definition is hereby inserted after the definition of "Self-indicating pitbank weighing machine", "self-indicating platform weighing machine" and "self-indicating weighbridge":—

" 'Sell' includes barter or exchange; and also includes deal in, agree to sell, offer or expose for sale, keep or have in possession for sale, send forward or receive for sale or on sale, or authorize direct cause suffer permit or attempt any of such acts; and the derivatives of 'Sell' have a corresponding interpretation."

3. Sub-paragraphs (xii) and (xiii) of paragraph (a) of Regulation 64 as amended are hereby revoked and the following sub-paragraphs are substituted therefor:—

(xii) if denominated in terms of the Imperial system and marked with the letter 'S' or the word 'SQUAT', have its lowest graduation mark corresponding to a capacity of not less than 2 fluid drachms;

(xiii) if denominated in terms of the Imperial system and not marked with the letter 'S' or the word 'SQUAT', have its lowest graduation mark in accordance with the following Table:—

Capacity Corresponding to Highest Graduation Mark.	Capacity Corresponding to Lowest Graduation Mark.
Not over 2 fluid drachms .. .. .	Not less than 10 minims
Over 2 fluid drachms but not over 4 fluid drachms .. .. .	Not less than 20 minims
Over 4 fluid drachms but not over 2 fluid ounces .. .. .	Not less than 60 minims
Over 2 fluid ounces but not over 4 fluid ounces .. .. .	Not less than 4 fluid drachms
Over 4 fluid ounces but not over 8 fluid ounces .. .. .	Not less than 1 fluid ounce
Over 8 fluid ounces but not over 10 fluid ounces .. .. .	Not less than 4 fluid ounces
Over 10 fluid ounces but not over 20 fluid ounces .. .. .	Not less than 6 fluid ounces
Over 20 fluid ounces .. .. .	Not less than 10 fluid ounces

and

(xiv) if denominated in terms of the metric system, have its lowest graduation mark in accordance with the following Table:—

Capacity Corresponding to Highest Graduation Mark.	Capacity Corresponding to Lowest Graduation Mark.
Not over 5 millilitres .. .. .	Not less than 1 millilitre
Over 5 millilitres but not over 10 millilitres .. .. .	Not less than 2 millilitres
Over 10 millilitres but not over 20 millilitres .. .. .	Not less than 5 millilitres
Over 20 millilitres but not over 100 millilitres .. .. .	Not less than 10 millilitres
Over 100 millilitres but not over 200 millilitres .. .. .	Not less than 50 millilitres
Over 200 millilitres but not over 500 millilitres .. .. .	Not less than 100 millilitres
Over 500 millilitres .. .. .	Not less than 200 millilitres."

4. In Regulation 68, the following proviso is hereby inserted after paragraph (a):—

"Provided that this paragraph shall be subject to the issue of temporary permits (for stated periods not exceeding six months) which the Superintendent may issue if he thinks fit, in cases where he has



received applications (together with the prescribed fees) for the examination and testing of the patterns of farm milk tanks but where such examination and testing have not been completed."

5. The following Regulation is hereby inserted after Regulation 68:—

"68A. (a) Any person desiring to be authorized to issue permits for the temporary use (pending verification and stamping) of farm milk tanks which have been repaired may apply to the Superintendent for such authority on the appropriate Form A, Form B or Form C (as the case may be) as follows:—

FORM A.

STATE OF VICTORIA.

Weights and Measures Act.

APPLICATION BY A PRINCIPAL FOR AUTHORITY TO ISSUE PERMITS (THROUGH EMPLOYEES) FOR THE TEMPORARY USE (PENDING VERIFICATION AND STAMPING) OF FARM MILK TANKS WHICH HAVE BEEN REPAIRED.

Full name of person, company or firm (as the case may be)

Address

I hereby declare that—

- 1. The above-mentioned applicant employs at least one person who is competent to repair farm milk tanks and who is applying or has applied for authority to issue permits for temporary use (pending verification and stamping) of farm milk tanks which have been repaired.
2. All repairs in respect of which such permits will be issued will be effected by or under the personal supervision of a person so authorized.
3. The applicant has the necessary equipment to effect the said repairs.
4. In the event of the applicant ceasing to have in his employment a person so authorized such applicant shall cease forthwith to issue such permits.
5. The following is the name(s) of the person(s) who is applying or has applied to be so authorized:—

Declared at this day of 19 Signature

This declaration shall be signed by the Secretary of the applicant company, by a member of the applicant firm or by an individual acting as a principal (as the case may be).

FORM B.

(For use in any case where the principal will personally effect or personally supervise repairs of farm milk tanks or where such repairs or supervision are effected by the partner of a firm.)

STATE OF VICTORIA.

Weights and Measures Act.

APPLICATION BY A PRINCIPAL FOR AUTHORITY TO ISSUE PERMITS FOR THE TEMPORARY USE (PENDING VERIFICATION AND STAMPING) OF FARM MILK TANKS WHICH HAVE BEEN REPAIRED.

Full name of person or firm (as the case may be)

Address

I hereby declare that—

- 1. I am well acquainted with those provisions of the Weights and Measures Act and the Regulations made thereunder which relate to farm milk tanks.
2. All repairs in respect of which permits for the temporary use (pending verification and stamping) of farm milk tanks are to be issued will be effected by myself or under my personal supervision.
3. I have the necessary equipment to effect the said repairs.

Signature Date

I of declare that I have known the above-mentioned applicant for years and believe him to be a fit person to be authorized to issue permits in accordance with this application.

Signature Date

I of declare that I have known the above-mentioned applicant for years and believe him to be a fit person to be authorized to issue permits in accordance with this application.

Signature Date

FORM C.

STATE OF VICTORIA.

Weights and Measures Act.

APPLICATION BY A PERSON EMPLOYED BY A PRINCIPAL, FOR AUTHORITY TO ISSUE PERMITS FOR THE TEMPORARY USE (PENDING VERIFICATION AND STAMPING) OF FARM MILK TANKS WHICH HAVE BEEN REPAIRED.

Full name
Place of residence
Name and business address of employer

I hereby declare that—

- 1. I am well acquainted with those provisions of the Weights and Measures Act and the Regulations made thereunder which relate to farm milk tanks.
2. I have the necessary training and experience to enable me to carry out repairs on farm milk tanks in accordance with such provisions.

Signature
Date

I of declare that I have known the above-mentioned applicant for years and believe him to be a fit person to be authorized to issue permits in accordance with this application.

Signature
Date

I of declare that I have known the above-mentioned applicant for years and believe him to be a fit person to be authorized to issue permits in accordance with this application.

Signature
Date

(b) The Superintendent may—

- (i) make such inquiries as he deems necessary in connexion with any application made in accordance with paragraph (a) of this Regulation;
(ii) give written authority to any person who has submitted such an application and whom the Superintendent considers to be competent and otherwise satisfactory, to issue permits for the temporary use (pending verification and stamping) of farm milk tanks which have been repaired;
(iii) by endorsement on any authority issued pursuant to sub-paragraph (ii) of this paragraph, limit the classes of work to which such authority applies; and
(iv) cancel or suspend any authority granted by him pursuant to this Regulation if the grantee has been convicted of any offence under the Act or the Regulations or if in the opinion of the Superintendent there has been—
(a) a failure to effect any repair in a satisfactory manner; or
(b) any improper practice committed with respect to any matter relating to such repairs.

(c) Upon the application of any person to whom the issue of authority under paragraph (b) of this Regulation has been refused by the Superintendent or whose authority has been suspended or cancelled the Minister may review such refusal, suspension or cancellation and may make such order as he sees fit.

(d) Any authority granted pursuant to paragraph (b) of this Regulation shall be on such of the following forms as is appropriate:—

(For use where the application has been made on Form A as prescribed in paragraph (a) of this Regulation.)

STATE OF VICTORIA.
Weights and Measures Act.

AUTHORITY GRANTED TO A PRINCIPAL TO ISSUE (THROUGH EMPLOYEES) PERMITS FOR THE TEMPORARY USE (PENDING VERIFICATION AND STAMPING) OF FARM MILK TANKS WHICH HAVE BEEN REPAIRED.

This is to certify that of (while employing one or more persons similarly registered as "persons employed by a Principal") is authorized to issue such permits in respect of repairs made to farm milk tanks.

Superintendent of Weights and Measures.
Date

This authority is valid for five years from the date hereof and remains the property of the Government of Victoria.

(For use where the application has been made on Form B as prescribed in paragraph (a) of this Regulation.)

## STATE OF VICTORIA.

## Weights and Measures Act.

AUTHORITY GRANTED TO A PRINCIPAL, TO ISSUE PERMITS FOR THE TEMPORARY USE (PENDING VERIFICATION AND STAMPING) OF FARM MILK TANKS WHICH HAVE BEEN REPAIRED.

This is to certify that \_\_\_\_\_ of \_\_\_\_\_ is authorized to issue such permits, in respect of repairs made to farm milk tanks, by himself or under his personal supervision.

*Superintendent of Weights and Measures.*

Date

Signature of Person Authorized to Issue Permits

This certificate is valid for five years from the date hereof and remains the property of the Government of Victoria.

(For use where the application has been made on Form C as prescribed in paragraph (a) of this Regulation.)

## STATE OF VICTORIA.

## Weights and Measures Act.

AUTHORITY GRANTED TO A PERSON EMPLOYED BY A PRINCIPAL, TO ISSUE PERMITS FOR THE TEMPORARY USE (PENDING VERIFICATION AND STAMPING) OF A FARM MILK TANK WHICH HAS BEEN REPAIRED.

This is to certify that \_\_\_\_\_ of \_\_\_\_\_ is authorized, as a person employed by a Principal, to issue such permits, in respect of repairs made to farm milk tanks by himself or under his personal supervision.

*Superintendent of Weights and Measures.*

Date

Signature of Person Authorized to Issue Permits

This certificate is valid for five years from the date hereof and remains the property of the Government of Victoria.

(e) A farm milk tank which has been repaired by a person authorized pursuant to paragraph (d) of this Regulation may be used for trade prior to verification and stamping subject to the following conditions:—

- (i) the person by whom the repair has been effected shall hand to the owner of such farm milk tank a duly completed permit in the following form:—

PERMIT TO USE FARM MILK TANK, AFTER REPAIR,  
PENDING VERIFICATION AND STAMPING

1. The following farm milk tank has this day been repaired by myself or under my personal supervision:—

Maker's name  
Serial No.  
Property of  
Address

2. The said farm milk tank now complies with the provisions of the Weights and Measures Act and the Regulations made thereunder.

3. I am authorized to issue permits for the temporary use (pending verification and stamping) of farm milk tanks which have been repaired by myself.

\*4. I am employed by \_\_\_\_\_ who <sup>is</sup> <sub>are</sub> authorized as a principal to issue permits for the temporary use of farm milk tanks which have been repaired.

Or,

5. The said farm milk tank may be used for trade pending verification and stamping by an Inspector of Weights and Measures for a period which shall not exceed twenty-eight days from the date of this permit unless with the written consent of the Superintendent of Weights and Measures.

Signature

Date

\* The words "employed by" and "who <sup>is</sup> <sub>are</sub>" are to be struck out where the person issuing the permit has been authorized to do so as a principal.

- (ii) the person issuing such a permit shall within three days of making such repair deliver or cause to be delivered to the Superintendent an exact copy (made by means of carbon paper or other approved method) of the permit prescribed in sub-paragraph (i) of this paragraph; and

(iii) the owner of the farm milk tank shall on demand by an inspector produce the permit referred to in sub-paragraph (i) of this paragraph and such permit shall be cancelled forthwith should the inspector find that the farm milk tank does not comply with the requirements of the Act or the Regulations.

(f) No person shall issue a permit under paragraph (e) of this Regulation unless all the statements contained therein are true and correct in every particular.

6. Paragraph (ii) of the proviso to paragraph (b) of Regulation 183 is hereby revoked and the following paragraph is substituted therefor:—

“(ii) within seven days from the time of installation of such scale, notify the inspector operating in such area or (in the case of a scale subject to verification by the central administration) the Superintendent, of such installation.”

7. Regulation 200 shall be amended, as follows:—

(a) for the expression “twelve ounces,” there shall be substituted the expression “ten ounces, twelve ounces, fourteen ounces,”; and

(b) in sub-paragraph (10) of paragraph (vi) of the proviso, after the words “potato crisps” there shall be inserted the words “and other approved foods”.

8. In paragraph (u) of Regulation 203, after the words “potato crisps” there shall be inserted the words “and other approved foods”.

9. For Regulation 207A there shall be substituted the following Regulation:—

“207A. (a) No person shall sell meat by retail otherwise than by net weight except as provided in paragraph (b) of Regulation 201 of these Regulations.

(b) No person shall expose any piece of meat for sale by retail with the price of such piece displayed thereon unless the net weight or the price per pound of such meat is clearly and prominently displayed so as to be easily read by the purchaser or prospective purchaser, in letters and figures not less than three-eighths of one inch high.

(c) Meat sold following exposure for sale in conformity with paragraph (b) of this Regulation shall be exempted from the provisions of sub-sections (1) and (2) of section 73 of the *Weights and Measures Act 1958*.”

10. For the heading to Part XIX. there shall be substituted the following heading:—

“PART XIX.—REPAIR, ALTERATION AND ADJUSTMENT OF WEIGHTS, MEASURES AND INSTRUMENTS.”

11. Regulation 252 shall be amended as follows:—

(a) for the expression “252” there shall be substituted the expression “252 (a)”;

(b) after paragraph (a) there shall be inserted the following paragraph:—

“(b) The shifting of a fixed instrument from the position in which it was last verified shall be deemed to be an alteration of such instrument.”

12. After Regulation 253 there shall be inserted the following Regulation:—

“253A. In any case where a person registered under Regulation 249 or 250 of these Regulations, repairs, alters or adjusts a weighing or measuring instrument but does not issue a Certificate pursuant to Regulation 253 of these Regulations such person shall—

(a) on the completion of the repair, alteration or adjustment forthwith hand to the owner of such instrument a notice in the following form:—

NOTICE OF REPAIR, ALTERATION OR ADJUSTMENT OF WEIGHING OR MEASURING INSTRUMENT.

1. The following weighing or measuring instrument has this day been repaired, altered or adjusted by myself or under my personal supervision:—

Description of Instrument

Property of

Address

2. I am registered as a repairer and adjuster of weighing or measuring instruments of the type to which this Notice relates and am employed by

3. I have not issued a Certificate pursuant to Regulation 253 of the Weights and Measures Regulations in respect of such instrument which therefore cannot legally be used for trade until verified and stamped by an inspector of Weights and Measures.

4. I am sending a copy of this Notice to the appropriate Weights and Measures authority;  
and

- (b) within three days of making such repair, alteration or adjustment deliver or cause to be delivered to the inspector concerned or (in the case of an instrument which is to be verified by the central administration) the Superintendent, an exact copy (made by means of carbon paper or other approved method) of the Notice prescribed in paragraph (a) of this Regulation."

And the Honorable Arthur Gordon Rylah, Her Majesty's Chief Secretary for the State of Victoria, shall give the necessary directions herein accordingly.

N. G. WISHART,  
Acting Clerk of the Executive Council.

#### COMMERCIAL GOODS VEHICLES ACT 1958.

*At the Executive Council Chamber, Melbourne, the  
sixth day of March, 1962.*

PRESENT:

His Excellency the Governor of Victoria.  
Mr. Porter | Mr. Thompson.

#### TRANSPORT CONSOLIDATED REGULATIONS 1960.—AMENDMENTS TO REGULATIONS.

IN pursuance of the powers conferred by the *Commercial Goods Vehicles Act* 1958 (Part I.) and all other powers in that behalf him enabling, His Excellency the Governor of Victoria, by and with the advice of the Executive Council thereof, doth hereby amend the Transport Consolidated Regulations 1960, by adding additional provisions to take effect on and from the first day of June, 1962, viz.:—

- (1) In Regulation 4 of Part I. there shall be inserted the following definition after the definition of "Touring Omnibus":—

" 'Tow Truck' in Parts IV. and VI. means a licensed tow truck unless the contrary meaning is expressed."

- (2) The following additional Regulations shall be added to Part IV.:—

*Drivers' Certificates—Possession and Production.*

(9) (a) A tow truck shall not be driven by any person while not in possession of a certificate issued by the Board authorizing such person to drive such a vehicle.

(b) The holder of a driver's certificate to drive a tow truck shall produce such certificate for examination forthwith if requested by an Inspector to do so and, whether or not so requested, to the owner, driver or person in charge of any motor car to whom an offer to lift and carry or tow such motor car is made.

*Conditions of Operation of Tow Trucks.*

(10) (a) At all times while a tow truck is on a public highway there shall be carried therein a securely bound book of "Authority to Tow" forms numbered consecutively in duplicate in the form or to the effect of Form 5 of Part VIII. of these Regulations.

(b) "Authority to Tow" forms shall be used consecutively in order of serial number for the purposes prescribed in this Regulation.

(11) Subject to the provisions of Regulation 12 of this Part no driver of a tow truck shall, except where the owner of a motor car has given prior authority for the removal of that motor car and that driver while in transit to the location from which such operation is to commence is in possession of a completed "Authority to Tow" form signed by that owner in respect of that motor car, commence to lift and carry or tow any motor car unless he has entered on an "Authority to Tow" form—

- (i) the name and address of the owner of the tow truck where such name and address is not reprinted on the form;

- (ii) his own name as driver of the tow truck and the number of his driver's certificate to drive a tow truck;
  - (iii) the registered number of the tow truck;
  - (iv) the name and address of the owner of the motor car to be lifted and carried or towed and the make and registered number of that motor car;
  - (v) the date and the time at which the "Authority to Tow" form is entered and the places from and to which he intends to remove that motor car
- and thereafter has obtained on that form from the owner or driver or from an adult person claiming to be in charge of that motor car his signature as authority to remove that vehicle together with a description of his interest in that vehicle, and has delivered the duplicate of the completed form to that signatory.

(12) (a) Where through the absence or incapacity of the owner or driver or any adult person claiming to be in charge of such motor car, authority to move that vehicle cannot be obtained pursuant to Regulation 11 of this Part the driver of a tow truck may remove that vehicle to the nearest place of safe custody available to him after he has—

- (i) entered on an "Authority to Tow" form the information required thereon including the name and address of the owner of the motor car, if ascertainable; and
- (ii) obtained in writing on that form the authority of a member of the Police Force to remove that vehicle together with the name, number and rank and Station to which that member is attached and the reason for giving such authorization.

(b) Where on any public highway a motor car has been so damaged as to be incapable of being driven and because of its location is a traffic hazard the driver of a tow truck may where it is impossible for him to obtain authority for removal pursuant to Regulation 11 of this Part and Sub-regulation (a) of this regulation, and after he has entered on an "Authority to Tow" form all the information required thereon including the name and address of the owner of that motor car if ascertainable, move that motor car from the location of the hazard, but shall not remove it from the scene of the accident until he has obtained such authority pursuant to that regulation and sub-regulation.

(c) Where the driver of any tow truck has moved any motor car pursuant to an authority given under sub-regulations (a) or (b) of this regulation, the duplicate copy of the "Authority to Tow" form shall be delivered to the Board at its head office in Melbourne within 72 hours of the time of removal of such motor car.

(d) The original of each "Authority to Tow" form shall be retained by the owner of such tow truck for a period of twelve months at the address recorded on the licence applicable to such tow truck and shall be produced on request to an Inspector of the Board.

(13) The owner and the driver of any tow truck—

- (a) which is on any public highway without a book of "Authority to Tow" forms as prescribed being carried therein;
- (b) in respect of which "Authority to Tow" forms are used other than as prescribed herein or the duplicates of which are not delivered as prescribed;
- (c) in respect of which all the information required has not been entered on "Authority to Tow" form before the commencement of lifting and carrying or towing any motor car; or
- (d) which has been used to lift and carry or tow any motor car under the authority of paragraph (b) of Regulation 12 of this Part before the driver thereof has satisfied himself of the necessity for immediate removal and recorded such necessity on the relevant "Authority to Tow" form

shall severally be guilty of an offence against these Regulations.

*Special Provisions.*

(14) Any person who—

- (a) coerces or attempts to coerce, or induces or attempts to induce by trick or pretence, any person to sign an "Authority to Tow" form,
- (b) intimidates or attempts to intimidate by threat or force, prevents or attempts to prevent or obstructs the owner or the driver of any tow truck or any other person from complying with the provisions of these Regulations

shall be guilty of an offence against these Regulations.

(15) It shall be deemed to be a breach of the conditions of a licence issued with respect to a tow truck if the owner of such tow truck or any person employed by him or acting on his behalf fails to comply with the provisions of the Wireless Telegraphy Act of the Commonwealth of Australia or Regulations made thereunder.

(16) No owner or driver of a tow truck or person other than the driver employed by the owner of a tow truck in connexion with the operating of that tow truck shall—

- (a) move or attempt to move any motor car otherwise than in accordance with the Regulations contained in this Part;
- (b) commit any misconduct or misbehaviour whereby a breach of the peace may be occasioned or provoked;
- (c) create undue noise or disturbance; or
- (d) use any abusive, obscene or blasphemous language, or utter or make any threatening or insulting word or gesture.

(17) No driver of a tow truck which is fitted with any flashing warning light pursuant to these Regulations shall, except when that tow truck is stationary at the scene of an accident, cause or permit that light to be alight or operative.

(18) No driver of a tow truck shall lift and carry or tow any motor car so damaged as to be incapable of being towed on any two wheels otherwise than on a car ambulance of the type generally or specifically approved by the Board.

(3) The following additional Regulations shall be added in Part VI. of Division III.:-

**DIVISION III.—VEHICLES LICENSED TO OPERATE AS TOW TRUCKS.**

*Cranes—Specification, Location, &c.*

(47) Every tow truck shall be fitted with a crane with a maximum safe working load of not less than 3 tons which is located and mounted on such vehicle in the manner generally or specifically directed by the Board and which complies with and is maintained in accordance with the provisions of Part III. of the Lifts and Cranes Act and any Regulations made thereunder. Provided that the Board may for such period as it may deem necessary or expedient permit the continued use of a crane with a safe working load of less than 3 tons in cases where such crane was fitted to a vehicle licensed before the first day of April 1962.

*Vehicle Capacity and Wheel Equipment.*

(48) Every tow truck shall—

- (a) have a load capacity of not less than 25 hundredweights, and,
- (b) be fitted with dual wheels on the rear axle on both the near-side and the off-side.

Provided that the Board may for such period as it may deem necessary or expedient permit the use of any vehicle with a lesser load capacity and/or not so fitted with dual wheels.

*Driver's Seat.*

(49) The driver's seat shall be so constructed that no person may occupy any portion of the seat on the right-hand or off-side of the driver.

*Spacer Bars and Chains.*

(50) Every tow truck shall be equipped with suitable spacer bars and safety chains to enable the towing of any motor car on a public highway in a safe manner.

*Lights—Working and Warning.*

(51) Every tow truck shall be—

- (i) equipped with suitable fully adjustable lights so mounted that during the hours of darkness the coupling of the tow truck to any motor car to be lifted and carried or towed may be safely effected, and,
- (ii) fitted with a flashing warning light of a type required under the provisions of the Motor Car Act or any Regulation made thereunder or approved by the Chief Commissioner of Police for use at the scene of any accident.

*Portable Warning Devices.*

(52) Every tow truck shall be equipped with not less than three portable warning devices of the type prescribed in the Motor Car Regulations.

*Provision of Brooms, &c.*

(53) Every tow truck shall be equipped with a broom and such other equipment as is necessary for the driver thereof to comply with the provisions of the Road Traffic Regulations.

*Fire Extinguisher.*

(54) Every tow truck shall be fitted with a fire extinguisher, with a capacity of not less than 1 gallon of a type approved by and maintained to the satisfaction of the Board.

(4) Form 5 shall be added to Part VIII.

## FORM 5.

## REGULATION 10 (PART IV.).

Commercial Goods Vehicles Act 1958.

TRANSPORT REGULATION BOARD.

## AUTHORITY TO TOW.

Name of owner of tow truck  
Address of such owner  
Registration No.  
Transport Regulation Board Licence No.  
Name of driver of tow truck  
Driver's Certificate No.  
Name of owner of motor car to be towed  
Address of such owner  
Make and Registration No. of motor car to be towed  
Place from which motor car is to be moved  
Place to which motor car is to be moved  
Date Time

\* Being  
\* Due to the absence or incapacity of } the owner, driver or adult person  
in charge of the above described motor car I authorize it to be moved to the  
stated place.

† Signature.

\* Address if not owner.

\* Number, rank and Station of  
member of the Police Force.

\* Cross out inapplicable words.

† To be signed by the owner, the driver, an adult person apparently in charge, or, in their absence or incapacity, a member of the Police Force who shall record his rank, number, and Station.

And the Honorable Alexander John Fraser, Her Majesty's Acting Minister for Transport for the State of Victoria, shall give the necessary directions herein accordingly.

N. G. WISHART,

Acting Clerk of the Executive Council.

## DEPARTMENT OF CROWN LANDS AND SURVEY.

At Government House, Melbourne, the sixth  
day of March, 1962.

PRESENT:

His Excellency the Governor of Victoria.  
Mr. Porter | Mr. Thompson.

PINES.—Order in Council of 17th August, 1925, of 2 acres 2 roods of land in the Parish of Pines, as a site for a Public Hall.—(Rs.3164.)

And the Honorable Keith Hector Turnbull, Her Majesty's Commissioner of Crown Lands and Survey for the State of Victoria, shall give the necessary directions herein accordingly.

N. G. WISHART,  
Acting Clerk of the Executive Council.

## REVOCATIONS OF TEMPORARY RESERVATIONS OF LANDS BY ORDERS IN COUNCIL.

HIS Excellency the Governor of the State of Victoria, by and with the advice of the Executive Council thereof, doth hereby, in pursuance of the provisions of the *Land Act 1958*, revoke the temporary reservations of lands by Orders in Council hereinafter referred to, viz.:—

KINGOWER.—Order in Council of 31st August, 1874, of 2 acres of land in the Township of Kingower, as a site for State School purposes.—(W.83099.)

LANDSBOROUGH.—Order in Council of 28th June, 1904, of 3 acres 0 roods 30 perches of land in the Parish of Landsborough, as a site for Camping and Watering purposes.—(Rs.5306.)

LORNE.—Order in Council of 29th October, 1888, of 49 acres 2 roods 21 perches of land in the Parish of Lorne, as a site for Watering purposes.—(Rs.5118.)

MERRINEE.—Order in Council of 30th October, 1933, of 298 acres 2 roods 27 perches of land in the Parish of Merrinee, as a site for Public purposes.—(Rs.4338.)

## DEPARTMENT OF CROWN LANDS AND SURVEY.

At Government House, Melbourne, the sixth  
day of March, 1962.

PRESENT:

His Excellency the Governor of Victoria.  
Mr. Porter | Mr. Thompson.

## LANDS TEMPORARILY RESERVED AS SITES.

HIS Excellency the Governor of the State of Victoria, by and with the advice of the Executive Council thereof, doth hereby, in pursuance of the provisions of the *Land Act 1958*, reserve, temporarily, and also except from occupation for mining purposes under any miner's right, the land hereinafter described:—

ANGLESEA.—Site for Police purposes, 2 roods, Township of Anglesea, Parish of Jan Juc, County of Grant, as indicated by hachure on plan hereunder.—(A.183(c<sup>2</sup>)) (Rs.8120).



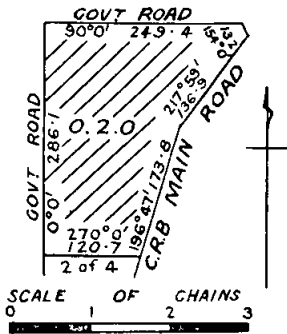

BYADUK.—Site for Public purposes, 3 roods 31 perches, Township of Byaduk, Parish of Byaduk, County of Normanby, as indicated by hachure on plan hereunder.—(B.569(4) (Rs.8121).

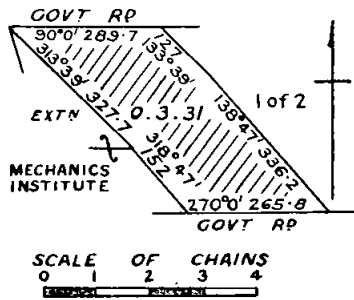

MORTLAKE.—Site for Public purposes, 1 acre 2 roods 20 perches, more or less, Township of Mortlake, Parish of Mortlake, County of Hampden, as indicated by hachure on plan hereunder.—(M.210(2) (Rs.8112).

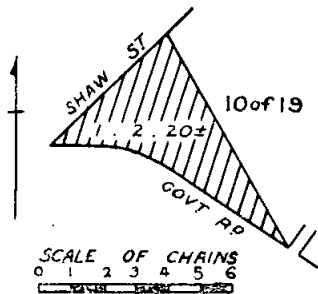

DARLINGTON.—Site for Public Recreation, in addition to and adjoining the site temporarily reserved therefor, by Order in Council of the 7th April, 1870, 1 acre 2 roods, more or less, Township of Darlington, Parish of Darlington, County of Hampden, as indicated by hachure on plan hereunder.—(D.5(4) (Rs.487).

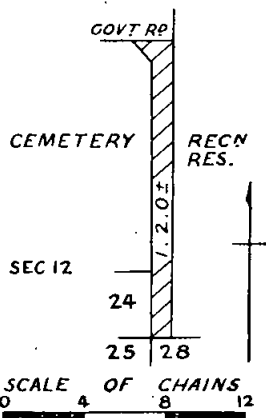

CANABORE.—Site for the purposes of the Forests Act, 7 acres 3 roods 33 perches, Parish of Canabore, County of Benambra, as indicated by hachure on plan hereunder.—(C.452(4) (Rs.8118).

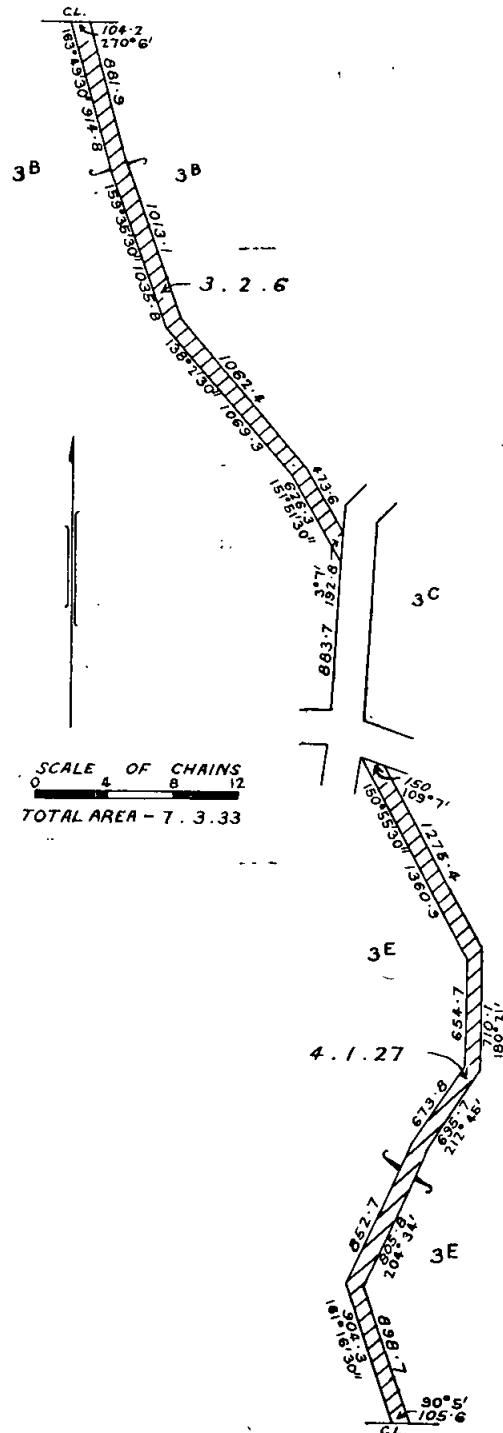

BUNYIP (TYNONG).—Site for a Public Hall, 2 roods, Parish of Bunyip, County of Mornington, as indicated by hachure on plan hereunder.—(B.606(4) (Rs.8113).

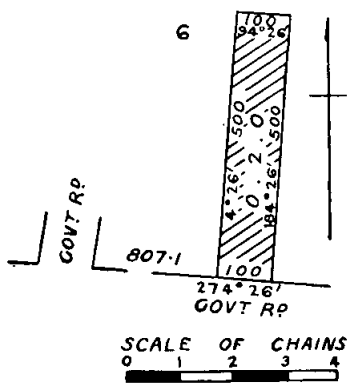

And the Honorable Keith Hector Turnbull, Her Majesty's Commissioner of Crown Lands and Survey for the State of Victoria, shall give the necessary directions herein accordingly.

N. G. WISHART,  
Acting Clerk of the Executive Council.

DEPARTMENT OF CROWN LANDS AND SURVEY.

At Government House, Melbourne, the sixth day of March, 1962.

PRESENT:  
His Excellency the Governor of Victoria.  
Mr. Porter | Mr. Thompson.

REVOCATION OF ORDER IN COUNCIL WITHHOLDING CERTAIN LAND FROM SALE, LEASING, AND LICENSING.

HIS Excellency the Governor of the State of Victoria, by and with the advice of the Executive Council thereof, doth hereby, in pursuance of the provisions of the *Land Act* 1958, revoke the withholding from sale, leasing and licensing of the land mentioned hereunder:—

LORNE.—Order in Council of 30th January, 1884, of 5 acres of land in the Parish of Lorne, as a site for Public purposes (State School).—(Rs.5118.)

And the Honorable Keith Hector Turnbull, Her Majesty's Commissioner of Crown Lands and Survey for the State of Victoria, shall give the necessary directions herein accordingly.

N. G. WISHART,  
Acting Clerk of the Executive Council.

DEPARTMENT OF CROWN LANDS AND SURVEY.

At Government House, Melbourne, the sixth day of March, 1962.

PRESENT:  
His Excellency the Governor of Victoria.  
Mr. Porter | Mr. Thompson.

UNUSED ROADS CLOSED.

HIS Excellency the Governor of the State of Victoria, by and with the advice of the Executive Council thereof, doth hereby direct that, in pursuance of the provisions of section 349 of the *Land Act* 1958, the unused roads referred to hereunder be closed, viz.:—

Parish of Boort, County of Gladstone, being the road between allotment 23A and allotments 25, 27C, 27, section D.—(B.654(?) (W.69706).

Parish of Koonda, County of Weeah, being the road between allotment 23 and allotments 28, 27.—(K.203(?) (O.10026/29).

Township of Neerim, Parish of Neerim, County of Buln Buln, being the road indicated by hachure on plan hereunder.—(N.121(?) (G.62711).

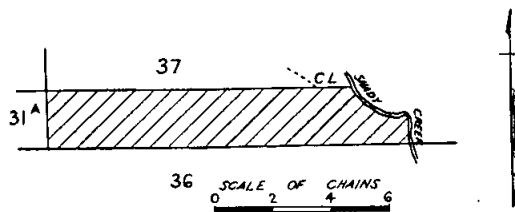

And the Honorable Keith Hector Turnbull, Her Majesty's Commissioner of Crown Lands and Survey for the State of Victoria, shall give the necessary directions herein accordingly.

N. G. WISHART,  
Acting Clerk of the Executive Council.

COUNTRY ROADS BOARD.

At Government House, Melbourne, the sixth day of March, 1962.

PRESENT:  
His Excellency the Governor of Victoria.  
Mr. Porter | Mr. Thompson.

ORDER APPROVING OF WIDENING AN EXISTING MAIN ROAD IN THE SHIRE OF WARRAGUL.

WHEREAS the Country Roads Board constituted under the *Country Roads Act* 1958 (No. 6229) has represented to His Excellency the Governor in Council that it appears to it desirable that the existing Warragul-Korumburra road in the Shire of Warragul (declared to be a main road under the said Act which declaration was confirmed by the Order in Council published in the *Government Gazette* of the 3rd December, 1913, on page 5155) should be widened by the said Board: And whereas the said Board in accordance with the requirements of section 19 of the said cited Act has caused to be prepared a map plan and estimate showing the points between which and on and through what land the said widening is proposed to be made and the cost of acquiring the land: And whereas on an inspection of the said map and plan and a consideration of the said estimate His Excellency the Governor in Council is satisfied that there are funds legally available for acquiring the land: Now therefore be it known by this present Order that His Excellency the Governor of the State of Victoria with the advice of the Executive Council thereof doth hereby approve of the said road being widened, that is to say:—

All those pieces of land in the Parish of Warragul, the boundaries of which are as follow:—

- (a) Commencing at an angle in the eastern boundary of the existing Warragul-Korumburra road, through allotment 62 of the said parish, formed by the intersection of lines bearing 227 deg. 8 min. and 186 deg. 15 min.; thence by lines bearing respectively 47 deg. 8 min. 445.4 links, 219 deg. 5 min. 538.6 links and 6 deg. 15 min. 115.8 links to the point of commencement.
- (b) Commencing at an angle in the western boundary of the existing Warragul-Korumburra road, through allotment 62 of the said parish, formed by the intersection of lines bearing 45 deg. 4 min. and 6 deg. 15 min.; thence by lines bearing respectively 225 deg. 4 min. 114 links, 256 deg. 19 min. 199 links, 277 deg. 38 min. 162.2 links, 61 deg. 43 min. 161.1 links, 55 deg. 25 min. 184.6 links, 51 deg. 23 min. 209 links and 186 deg. 15 min. 207 links to the point of commencement.
- (c) Commencing at the south-western angle of allotment 62 of the said parish; thence by lines bearing respectively 8 deg. 4 min. 169.2 links, 77 deg. 57 min. 64.5 links, 97 deg. 38 min. 179.3 links and 239 deg. 21 min. 307.6 links to the point of commencement.
- (d) Commencing at the northern angle of allotment 61B of the said parish; thence by lines bearing respectively 128 deg. 49 min. 139 links, 259 deg. 1 min. 147.8 links and 17 deg. 41 min. 121 links to the point of commencement.
- (e) Commencing at the south-eastern angle of allotment 61A of the said parish; thence by lines bearing respectively 249 deg. 19 min. 168 links, 278 deg. 4 min. 128 links, 27 deg. 34 min. 80.7 links, 61 deg. 26 min. 353 links and 17 deg. 41 min. 209 links to the point of commencement.

- (f) Commencing at a point on the western boundary of allotment 65A of the said parish, distant 278 deg. 7 min. 9 links and 217 deg. 51 min. 200 links from the north-eastern angle of the said allotment; thence by lines bearing respectively 202 deg. 45 min. 358.6 links, 233 deg. 54 min. 211.7 links, 31 deg. 3 min. 294.8 links and 37 deg. 51 min. 257 links to the point of commencement.
- (g) Commencing at an angle in the southern boundary of allotment 65A of the said parish, distant 52 deg. 5 min. 291 links, 78 deg. 31 min. 463 links and 89 deg. 40 min. 449.4 links from the south-western angle of the said allotment; thence by lines bearing respectively 80 deg. 14 min. 290.4 links, 62 deg. 23 min. 214.6 links, 50 deg. 38 min. 293.5 links, 211 deg. 3 min. 215 links, 240 deg. 15 min. 300 links and 269 deg. 40 min. 331.6 links to the point of commencement.
- (h) Commencing at the south-western angle of allotment 65A of the said parish; thence by lines bearing respectively 232 deg. 44 min. 52.7 links, 37 deg. 14 min. 211.5 links, 60 deg. 11 min. 263.7 links, 89 deg. 30 min. 369.5 links, 258 deg. 31 min. 463 links and 232 deg. 5 min. 291 links to the point of commencement.
- (i) Commencing at an angle in the western boundary of the existing Warragul-Korumburra road through allotment 64 of the said parish, formed by the intersection of lines bearing 51 deg. 10 min. and 9 deg. 5 min.; thence by lines bearing respectively 231 deg. 10 min. 294.4 links, 28 deg. 57 min. 581 links and 189 deg. 5 min. 328 links to the point of commencement.
- (j) Commencing at an angle in the western boundary of the existing Warragul-Korumburra road through allotment 64 of the said parish, formed by the intersection of lines bearing 351 deg. 11 min. and 51 deg. 10 min.; thence by lines bearing respectively 171 deg. 11 min. 578.4 links, 330 deg. 56 min. 144 links, 350 deg. 50 min. 280.3 links and 8 deg. 42 min. 171 links to the point of commencement.
- (k) Commencing at an angle in the eastern boundary of the existing Warragul-Korumburra road through allotment 64 of the said parish, formed by the intersection of lines bearing 231 deg. 10 min. and 171 deg. 11 min.; thence by lines bearing respectively 51 deg. 10 min. 230.7 links, 206 deg. 52 min. 210 links, 197 deg. 16 min. 176 links and 351 deg. 11 min. 213.3 links to the point of commencement.
- (l) Commencing at the intersection of the western boundary of the existing Warragul-Korumburra road with the northern boundary of allotment 68 of the said parish; thence by lines bearing respectively 165 deg. 16 min. 631 links, 338 deg. 13 min. 271 links and 350 deg. 31 min. 363.5 links to the point of commencement—
- which said pieces of land are particularly delineated and shown coloured red, yellow and blue on survey plans numbered 8224, 8225 and 8226, lodged in the office of the Country Roads Board.

And the Honorable Horace Rostill Petty, Her Majesty's Commissioner of Public Works for the State of Victoria, shall give the necessary directions herein accordingly.

N. G. WISHART,  
Acting Clerk of the Executive Council.

#### COUNTRY ROADS BOARD.

At Government House, Melbourne, the sixth day of March, 1962.

PRESENT:

His Excellency the Governor of Victoria.  
Mr. Porter | Mr. Thompson.

#### ORDER APPROVING OF WIDENING AN EXISTING MAIN ROAD IN THE SHIRE OF KORUMBURRA.

WHEREAS the Country Roads Board constituted under the *Country Roads Act 1958* (No. 6229) has represented to His Excellency the Governor in Council that it appears to be desirable that the existing Korumburra-Wonthaggi road in the Shire of Korumburra (declared to be a main road under the said Act which declaration was confirmed by the Order in Council published in the *Government Gazette* of the 13th May, 1914, on page 2049) should be widened by the said Board: And whereas the said Board in accordance with the require-

ments of section 19 of the said cited Act has caused to be prepared a map plan and estimate showing the points between which and on and through what land the said widening is proposed to be made and the cost of acquiring the land: And whereas on an inspection of the said map and plan and a consideration of the said estimate His Excellency the Governor in Council is satisfied that there are funds legally available for acquiring the land: Now therefore be it known by this present Order that His Excellency the Governor of the State of Victoria with the advice of the Executive Council thereof doth hereby approve of the said road being widened, that is to say:—

All that piece of land in the Parish of Korumburra, the boundaries of which are as follow:—Commencing at a point on the western boundary of lot 4 on plan of subdivision numbered 4693, lodged in the Office of Titles, and being part of allotment 90 of the said parish, distant 228 deg. 39 min. 365 links and 220 deg. 341 min. 122.9 links from the north-western angle thereof; thence by lines bearing respectively 196 deg. 30 min. 167 links, 243 deg. 34 min. 174 links and 40 deg. 344 min. 312.7 links to the point of commencement—which said piece of land is particularly delineated and shown coloured red on survey plan numbered 8204, lodged in the office of the Country Roads Board.

And the Honorable Horace Rostill Petty, Her Majesty's Commissioner of Public Works for the State of Victoria, shall give the necessary directions herein accordingly.

N. G. WISHART,  
Acting Clerk of the Executive Council.

#### COUNTRY ROADS BOARD.

At Government House, Melbourne, the sixth day of March, 1962.

PRESENT:

His Excellency the Governor of Victoria.  
Mr. Porter | Mr. Thompson.

#### DECLARATION OF A DEVIATION FROM THE WARBURTON HIGHWAY IN THE SHIRE OF LILLYDALE.

WHEREAS by sections 74 and 58 of the *Country Roads Act 1958* (No. 6229) it is amongst other things enacted that when the Country Roads Board under the provisions of the *Country Roads Act* has by Resolution declared a deviation to be a State highway the said Board may also declare that such deviation shall be in lieu of any existing highway or part thereof named in such Resolution and that on publication in the *Government Gazette* of the Order confirming such Resolution the existing highway or part thereof shall cease to be a State highway or be discontinued as provided in the Resolution: And whereas the said Board has by Resolution declared the deviation on the land described in the First Schedule to such Resolution to be a State highway and has also declared that such deviation shall be in lieu of the part of the existing highway being the land described in the Second Schedule to the said Resolution and that such part of the said existing highway as is described in the Third Schedule shall be discontinued: Now therefore His Excellency the Governor of the State of Victoria by and with the advice of the Executive Council thereof doth hereby confirm the said Resolution.

#### Resolution for Declaration of a Deviation of a State Highway under the *Country Roads Act*.

Whereas the land the site of the highway the course of which is below set out was taken by the Board under the provisions of the *Country Roads Act 1958* for the purpose of constructing such highway deviation which highway deviation has now been laid out and formed on the same: And whereas the said Board (being the Country Roads Board incorporated under the said Act) thinks that the highway aforesaid is fit to be used as a public highway such Board at a meeting now holden acting under the authority conferred upon it by sections 74 and 58 of the said Act doth by this present Resolution hereby declare the said highway deviation the course of which is described in the First Schedule hereto with the commencing and terminating points thereof respectively specified to be part of a State highway within the meaning and for the purposes of the *Country Roads Act 1958*: And the said Board doth also declare that such deviation shall be in lieu of the existing highway or part thereof described in the Second Schedule hereto and that such part of the said existing highway as is described in the Third Schedule shall be discontinued.

## FIRST SCHEDULE.

*Shire of Lillydale.*

30. *Warburton Highway*.—All those pieces of land in the Parish of Yering, the boundaries of which are as follow:—

- (a) Commencing at the eastern angle of allotment 4, section 28 of the said parish; thence by lines bearing respectively 244 deg. 33 min. 279 links, 281 deg. 36 min. 373 links, 342 deg. 37 min. 248 links, 102 deg. 25 min. 652.1 links and 133 deg. 22 min. 75.1 links to the point of commencement.
- (b) Commencing at a point on the northern boundary of allotment 3A, section 28 of the said parish, distant 114 deg. 59 min. 232 links from the north-western angle of the said allotment; thence by lines bearing respectively 114 deg. 59 min. 300 links, 162 deg. 37 min. 30 links and 298 deg. 56 min. 321 links to the point of commencement.
- (c) Commencing at the north-eastern angle of allotment 1, section 27 of the said parish; thence by lines bearing respectively 135 deg. 46 min. 90 links, 301 deg. 9½ min. 174.2 links and 106 deg. 33 min. 90 links to the point of commencement.
- (d) Commencing at a point on the eastern boundary of allotment 4B, section 28 of the said parish, distant 187 deg. 48 min. 64 ft. 3 in. from the north-eastern angle of the said allotment; thence by lines bearing respectively 187 deg. 48 min. 10 feet, 306 deg. 4 min. 278 ft. 6½ in., 111 deg. 1 min. 130 feet and 135 deg. 37 min. 150 ft. 4 in. to the point of commencement.
- (e) Commencing at a point on the northern boundary of allotment 3, section 28 of the said parish, distant 120 deg. 39 min. 295 ft. 7½ in. from the north-western angle of the said allotment; thence by lines bearing respectively 120 deg. 39 min. 650 feet, 298 deg. 29 min. 399 ft. 8 in. and 304 deg. 6 min. 251 ft. 1 in. to the point of commencement.
- (f) Commencing at a point on the northern boundary of allotment 3, section 28 of the said parish, distant 120 deg. 39 min. 1,035 ft. 7 in. and 89 deg. 15 min. 72 ft. 2 in. from the north-western angle of the said allotment; thence by lines bearing respectively 89 deg. 15 min. 146 ft. 3½ in., 125 deg. 31 min. 136 ft. 3 in. and 286 deg. 43 min. 268 ft. 6½ in. to the point of commencement.
- (g) Commencing at a point on the southern boundary of allotment 4A, section 28 of the said parish, distant 305 deg. 25 min. 338 ft. 7 in. and 269 deg. 10 min. 156 ft. 0½ in. from the south-eastern angle of the said allotment; thence by lines bearing respectively 269 deg. 10 min. 69 feet, 300 deg. 40 min. 77 ft. 3½ in. and 105 deg. 50 min. 140 ft. 10 in. to the point of commencement—

which said pieces of land are particularly delineated and shown coloured red and yellow on survey plans numbered 7688 and 7689, lodged in the office of the Country Roads Board.

## SECOND SCHEDULE.

*Shire of Lillydale.*

30. *Warburton Highway*.—All that piece of land in the Parish of Yering, being portion of a roadway of varying width and commencing at a point on the northern boundary of allotment 1, section 27 of the said parish, distant 64 deg. 33 min. 600 links from the north-western angle of the said allotment; thence south-westerly, westerly and north-westerly to a point on the northern boundary of allotment 3A, section 28 of the said parish, distant 114 deg. 59 min. 532 links and 162 deg. 37 min. 30 links from the north-western angle of the allotment last-named—which said piece of land is more particularly delineated and shown coloured blue on survey plan numbered 7689, lodged in the office of the Country Roads Board.

## THIRD SCHEDULE.

*Shire of Lillydale.*

30. *Warburton Highway*.—All those pieces of land in the Parish of Yering, the boundaries of which are as follow:—

- (a) Commencing at the south-eastern angle of allotment 4A, section 28 of the said parish; thence by lines bearing respectively 301 deg. 35 min. 253 ft. 2½ in., 285 deg. 50 min. 224 ft. 9½ in.,

89 deg. 10 min. 156 ft. 0½ in. and 125 deg. 25 min. 338 ft. 7 in. to the point of commencement.

- (b) Commencing at a point on the northern boundary of allotment 3, section 28 of the said parish, distant 120 deg. 39 min. 945 ft. 7½ in. from the north-western angle of the said allotment; thence by lines bearing respectively 106 deg. 43 min. 156 ft. 1½ in., 269 deg. 15 min. 72 ft. 2 in. and 300 deg. 39 min. 89 ft. 11½ in. to the point of commencement—

which said pieces of land are particularly delineated and shown coloured blue on survey plan numbered 7688, lodged in the office of the Country Roads Board.

The common seal of the Country Roads Board was hereto affixed, at Kew, this twenty-sixth day of February, One thousand nine hundred and sixty-two, in the presence of—

(SEAL) D. V. DARWIN, Chairman.  
W. H. NEVILLE, Member.  
R. E. V. DONALDSON, Secretary.

And the Honorable Horace Rostill Petty, Her Majesty's Commissioner of Public Works for the State of Victoria, shall give the necessary directions herein accordingly.

N. G. WISHART,  
Acting Clerk of the Executive Council.

## COUNTRY ROADS BOARD.

At Government House, Melbourne, the sixth day of March, 1962.

## PRESENT:

His Excellency the Governor of Victoria.  
Mr. Porter | Mr. Thompson.

## ORDER APPROVING OF WIDENING AN EXISTING MAIN ROAD IN THE SHIRE OF CROYDON.

WHEREAS the Country Roads Board constituted under the *Country Roads Act* 1958 (No. 6229) has represented to His Excellency the Governor in Council that it appears to it desirable that the existing Canterbury-road in the Shire of Croydon (declared to be a main road under the said Act which declaration was confirmed by the Order in Council published in the *Government Gazette* of the 23rd July, 1947, on pages 3984-5) should be widened by the said Board: And whereas the said Board in accordance with the requirements of section 19 of the said cited Act has caused to be prepared a map plan and estimate showing the points between which and on and through what land the said widening is proposed to be made and the cost of acquiring the land: And whereas on an inspection of the said map and plan and a consideration of the said estimate His Excellency the Governor in Council is satisfied that there are funds legally available for acquiring the land: Now therefore be it known by this present Order that His Excellency the Governor of the State of Victoria with the advice of the Executive Council thereof doth hereby approve of the said road being widened, that is to say:—

All those pieces of land in the Parish of Ringwood, the boundaries of which are as follow:—

- (a) Commencing at the south-eastern angle of lot 24 on plan of subdivision numbered 7088, lodged in the Office of Titles and being part of allotment 33 of the said parish; thence by lines bearing respectively 292 deg. 33½ min. 176 feet, 105 deg. 25½ min. 80 ft. 7½ in., 95 deg. 21 min. 90 ft. 9½ in., 82 deg. 36 min. 90 ft. 11 in., 74 deg. 22½ min. 61 ft. 1½ in. and 246 deg. 57½ min. 168 feet to the point of commencement.
- (b) Commencing at the western angle of lot 5 on plan of subdivision numbered 7088, lodged in the Office of Titles and being part of allotment 33 of the said parish; thence by lines bearing respectively 324 deg. 56 min. 152 ft. 6½ in., 133 deg. 4½ min. 155 ft. 8½ in., 119 deg. 58½ min. 209 ft. 8½ in. and 292 deg. 33½ min. 225 feet to the point of commencement—

which said pieces of land are particularly delineated and shown coloured red and blue on survey plan numbered 8465, lodged in the office of the Country Roads Board.

And the Honorable Horace Rostill Petty, Her Majesty's Commissioner of Public Works for the State of Victoria, shall give the necessary directions herein accordingly.

N. G. WISHART,  
Acting Clerk of the Executive Council.

## COUNTRY ROADS BOARD.

At Government House, Melbourne, the sixth day of March, 1962.

## PRESENT:

His Excellency the Governor of Victoria.  
Mr. Porter | Mr. Thompson.

## ORDER APPROVING OF WIDENING AN EXISTING MAIN ROAD IN THE SHIRE OF FLINDERS.

WHEREAS the Country Roads Board constituted under the *Country Roads Act 1958* (No. 6229) has represented to His Excellency the Governor in Council that it appears to it desirable that the existing Rosebud-Flinders road in the Shire of Flinders (declared to be a main road under the said Act which declaration was confirmed by the Order in Council published in the *Government Gazette* of the 5th October, 1932, on page 2256) should be widened by the said Board: And whereas the said Board in accordance with the requirements of section 19 of the said cited Act has caused to be prepared a map plan and estimate showing the points between which and on and through what land the said widening is proposed to be made and the cost of acquiring the land: And whereas on an inspection of the said map and plan and a consideration of the said estimate His Excellency the Governor in Council is satisfied that there are funds legally available for acquiring the land: Now therefore be it known by this present Order that His Excellency the Governor of the State of Victoria with the advice of the Executive Council thereof doth hereby approve of the said road being widened, that is to say:—

All those pieces of land in the Parish of Flinders, the boundaries of which are as follow:—

- (a) Commencing at the western angle of portion 52A of the said parish; thence by lines bearing respectively 64 deg. 7 min. 85 ft. 0½ in., 233 deg. 6 min. 513 ft. 7½ in., 42 deg. 5 min. 261 ft. 8 in. and 64 deg. 7 min. 176 ft. 7 in. to the point of commencement.
- (b) Commencing at a point on the northern boundary of portion 52A of the said parish, distant 64 deg. 7 min. 398 ft. 3½ in. from the western angle of the said portion; thence by lines bearing respectively 64 deg. 7 min. 109 ft. 11 in., 101 deg. 15 min. 109 ft. 11 in. and 262 deg. 41 min. 208 ft. 5 in. to the point of commencement—

which said pieces of land are particularly delineated and shown coloured red on survey plan numbered 8288, lodged in the office of the Country Roads Board.

And the Honorable Horace Rostill Petty, Her Majesty's Commissioner of Public Works for the State of Victoria, shall give the necessary directions herein accordingly.

N. G. WISHART,  
Acting Clerk of the Executive Council.

## COUNTRY ROADS BOARD.

At Government House, Melbourne, the sixth day of March, 1962.

## PRESENT:

His Excellency the Governor of Victoria.  
Mr. Porter | Mr. Thompson.

## ORDER APPROVING OF A DEVIATION FROM A MAIN ROAD IN THE SHIRE OF BANNOCKBURN.

WHEREAS the Country Roads Board constituted under the *Country Roads Act 1958* (No. 6229) has represented to His Excellency the Governor in Council that it appears to it desirable that the deviation hereinafter referred to from the existing Meredith-Mt. Mercer road in the Shire of Bannockburn (declared to be a main road under the said Act which declaration was confirmed by the Order in Council published in the *Government Gazette* of the 4th June, 1947, on page 2820) should be made by the said Board: And whereas the said Board in accordance with the requirements of section 19 of the said cited Act has caused to be prepared a map plan and estimate showing the points between which and on and through what land the said deviation is proposed to be made and the cost of acquiring

the land: And whereas on an inspection of the said map and plan and a consideration of the said estimate His Excellency the Governor in Council is satisfied that there are funds legally available for acquiring the land: Now therefore be it known by this present Order that His Excellency the Governor of the State of Victoria with the advice of the Executive Council thereof doth hereby approve of the said road being made, that is to say:—

All those pieces of land in the Parish of Meredith, the boundaries of which are as follow:—

- (a) Commencing at a point on the western boundary of allotment 180H of the said parish, distant 167 deg. 9 min. 93.5 links from the north-western angle of the said allotment; thence by lines bearing respectively 115 deg. 53 min. 790.2 links, 121 deg. 48 min. 423.6 links, 118 deg. 14 min. 215.4 links and 165 deg. 39 min. 40 links to Woodbourne Creek; thence westerly by the said creek; thence by lines bearing respectively 324 deg. 5 min. 190 links, 268 deg. 6 min. 251.2 links, 305 deg. 59 min. 213.3 links, 297 deg. 7 min. 692.4 links and 347 deg. 9 min. 139.1 links to the point of commencement.
- (b) Commencing at the north-eastern angle of allotment 156A of the said parish; thence by lines bearing respectively 166 deg. 3 min. 85.9 links, 285 deg. 34 min. 381.4 links and 93 deg. 8 min. 347.2 links to the point of commencement—

which said pieces of land are particularly delineated and shown coloured red on survey plan numbered 8427, lodged in the office of the Country Roads Board.

And the Honorable Horace Rostill Petty, Her Majesty's Commissioner of Public Works for the State of Victoria, shall give the necessary directions herein accordingly.

N. G. WISHART,  
Acting Clerk of the Executive Council.

## LANDLORD AND TENANT ACT 1958.

At Government House, Melbourne, the fourteenth day of March, 1962.

## PRESENT:

His Excellency the Governor of Victoria.  
Mr. Turnbull | Mr. Bloomfield.

## ORDER EXTENDING APPLICATION OF PART V. OF THE LANDLORD AND TENANT ACT 1958 TO CERTAIN PREMISES.

IN pursuance of the powers conferred by section 44 of the *Landlord and Tenant Act 1958*, His Excellency the Governor of Victoria, by and with the advice of the Executive Council thereof, doth hereby declare that the application of Part V. of the *Landlord and Tenant Act 1958* shall extend to each of the following premises:—

1. The premises known as No. 186 Beaconsfield-parade, Northcote.
2. The premises known as Flat No. 5 at No. 1 Elm-street, Hawthorn.
3. The premises known as Flat No. 8 at No. 1 Elm-street, Hawthorn.
4. The premises known as No. 8 Hickford-street, Reservoir.
5. The premises known as No. 196 Gladstone-street, South Melbourne.
6. The premises known as No. 14 Jersey-parade, Carnegie.
7. The premises known as No. 30 Albion-road, Box Hill.
8. The premises known as No. 4 Opie-street, Lower Fern Tree Gully, and all premises forming part of such premises.
9. The premises known as No. 17 Octavia-street, St. Kilda, and all premises forming part of such premises.
10. That part of the premises known as No. 64 Shoobra-road, Elsternwick, which on the 6th day of March, 1962, was let to one Phillip Townsend.

And the Honorable Arthur Gordon Rylah, Her Majesty's Attorney-General in and for the State of Victoria, shall give the necessary directions accordingly.

N. G. WISHART,  
Acting Clerk of the Executive Council.

LANDLORD AND TENANT ACT 1958.

At Government House, Melbourne, the fourteenth day of March, 1962.

PRESENT:

His Excellency the Governor of Victoria.  
Mr. Turnbull | Mr. Bloomfield.

ORDER EXTENDING APPLICATION OF PART V. OF THE LANDLORD AND TENANT ACT 1958 TO CERTAIN PREMISES AND DECLARING CERTAIN PREMISES TO BE "SPECIAL PREMISES" FOR THE PURPOSES OF THAT PART.

IN pursuance of the powers conferred by the *Landlord and Tenant Act 1958*, His Excellency the Governor of Victoria, by and with the advice of the Executive Council thereof, doth hereby declare—

1. That the application of Part V. of that Act shall extend to the premises known as No. 96 Brunswick-road, Brunswick, and to all premises forming part of such premises; and
2. The premises known as No. 1 Henry-street, Auburn, to be "special premises" for the purposes of Part V. of that Act.

And the Honorable Arthur Gordon Rylah, Her Majesty's Attorney-General, in and for the State of Victoria, shall give the necessary directions herein accordingly.

N. G. WISHART,  
Acting Clerk of the Executive Council.

APPROACHING LAND SALES.

SALES of Crown lands, in fee-simple, will be held at the under-mentioned places and dates, viz.:—

Bright.—Friday, 23rd March, 1962 ..	No. of Gazette. .. 16
-------------------------------------	-----------------------

SALE OF FREEHOLD LAND BY AUCTION.	
Branxholme.—Thursday, 29th March, 1962 ..	20

AUCTION OF RIGHT TO LEASE CROWN LAND.	
Melbourne.—Wednesday, 28th March, 1962 ..	16

PROPOSED REVOCATIONS OF TEMPORARY RESERVATIONS OF LANDS BY ORDERS IN COUNCIL.

IN pursuance of the provisions of the *Land Act 1958*, notice is hereby given that it is the intention of the Governor in Council to revoke the temporary reservations of lands by Orders in Council hereunder referred to, viz.:—

The following Notices were published 1° on the 28th February, 1962, pursuant to Orders of the 20th February, 1962.

GINQUAM.—The temporary reservation, by Order in Council of the 17th June, 1924, of 12 acres 19 perches of land in the Parish of Ginquam, as a site for Water Supply purposes.—(G.244<sup>(2)</sup>) (Rs.2939).

PURRUMBETE NORTH.—The temporary reservation, by Order in Council of the 15th May, 1923, of 2 acres of land in the Parish of Purrumbete North; as a site for State School purposes, so far only as the portion containing 9 perches, more or less, indicated by hachure on plan hereunder, is concerned.—P.100<sup>(2)</sup> (Rs.2728).

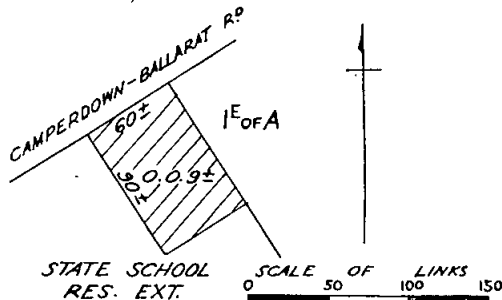

KEITH TURNBULL,  
Commissioner of Crown Lands and Survey.

PROPOSED REVOCATION OF TEMPORARY RESERVATION OF LAND BY ORDER IN COUNCIL.

IN pursuance of the provisions of the *Land Act 1958*, notice is hereby given that it is the intention of the Governor in Council to revoke the temporary reservation of land by Order in Council hereunder referred to, viz.:—

The following Notice was published 1° on the 21st February, 1962, pursuant to Order of the 13th February, 1962.

MIRBOO SOUTH.—The temporary reservation, by Order in Council of the 29th July, 1947, of 128 acres 2 roods 4 perches of land in the Parish of Mirboo South as a site for a Timber Reserve, so far only as the portion containing 56 acres more or less, indicated by hachure on plan hereunder, is concerned.—(M.517<sup>(10)</sup>) (Rs.5997).

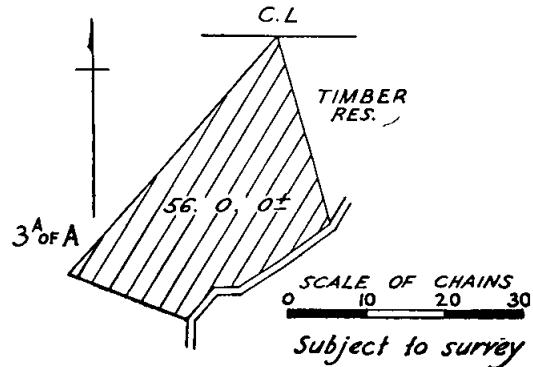

KEITH TURNBULL,  
Commissioner of Crown Lands and Survey.

PROPOSED REVOCATION OF TEMPORARY RESERVATION OF LAND BY ORDER IN COUNCIL.

IN pursuance of the provisions of the *Land Act 1958*, notice is hereby given that it is the intention of the Governor in Council to revoke the temporary reservation of land by Order in Council hereunder referred to, viz.:—

The following Notice was published 1° on the 14th March, 1962, pursuant to Order of the 6th March, 1962.

PIAMBIE.—The temporary reservation by Order in Council of the 27th February, 1924, of 1 acre of land in the Parish of Piambie, as a site for a Hall.—(P.184<sup>(3)</sup>) (Rs.2896).

KEITH TURNBULL,  
Commissioner of Crown Lands and Survey.

LOCAL LAND BOARDS.

IN pursuance of the provisions of section 34 of the *Land Act 1958*, notice is hereby given that public hearings at the following places and times, will be conducted by the persons respectively mentioned, being duly appointed in that behalf.

KEITH TURNBULL,  
Commissioner of Crown Lands and Survey.  
Department of Crown Lands and Survey,  
Melbourne.

SCHEDULE.

MYRTLEFORD LAND INSPECTOR'S OFFICE, Tuesday, 27th March, 1962, at 9.30 p.m.—W. M. Walsh and L. Gibney.  
WANGARATTA LAND OFFICE, Wednesday, 28th March, 1962, at 9 a.m.—W. M. Walsh and L. Gibney.

LOCAL LAND BOARDS.

IN pursuance of the provisions of section 34 of the *Land Act 1958*, notice is hereby given that public hearings at the following places and times, will be conducted by the persons respectively mentioned, being duly appointed in that behalf.

KEITH TURNBULL,  
Commissioner of Crown Lands and Survey.  
Department of Crown Lands and Survey,  
Melbourne.

SCHEDULE.

ALEXANDRA LAND INSPECTOR'S OFFICE, Monday, 9th April, 1962, at 11 a.m. and Tuesday, 10th April, 1962, at 9 a.m.—W. M. Walsh and K. C. Gittins.

*Land Act 1958.*  
PERMITS CANCELLED.

NOTICE is hereby given that the permit mentioned in the Schedule hereunder has been cancelled.

District.	Corr. No.	Name of Permit Holder.	Parish.	Allotment.	Section.	Area.
Hamilton .. ..	596/155	Hennig, A. D. ..	Kadnook .. ..	111	..	580 acres.

Department of Crown Lands and Survey,  
Melbourne, 13th March, 1962.

KEITH TURNBULL,  
Commissioner of Crown Lands and Survey.

*Land Act 1928.*

LICENCES UNDER THE LAND ACTS 1915, 1928 AND 1958, DECLARED VOID.

NOTICE is hereby given that the Licence in the Schedule hereunder has been Declared Void for the reason specified in each case.

District.	Corr. No.	Name of Licensee.	Section of Land Act under which Licensed.	Township.	Allotment.	Section.	Area.	Annual Rental.	Reasons for Voiding.
Horsham ..	094/138	L. K. M. Joyce	138	Warrackna-beal	4	19	A. B. P. 0 0 33	£ s. d. 2 0 0	On request of Licensee

Department of Crown Lands and Survey,  
Melbourne, 13th March, 1962.

KEITH TURNBULL,  
Commissioner of Crown Lands and Survey.

COMMITTEES OF MANAGEMENT OF RESERVES.  
APPOINTMENTS.

WHEREAS by section 221 of the *Land Act 1958* it is provided that it shall be lawful for the Governor in Council or the Board of Land and Works to appoint and remove any number of persons, not less than three, or any municipal council, or the governing body of any corporation, to be a Committee of Management of any specified Crown land reserved either temporarily or permanently for any of the purposes set out in section 14 of the *Land Act 1958*, and not conveyed to or vested in trustees: Now therefore the Board of Land and Works doth hereby appoint the under-mentioned persons to be members of the Committee of Management of the Reserves named:—

"LAKE WALLACE RESERVES."

Colin Napier Forster, Lindsay Gordon Dixon, John Daniel West, Errol Walter Thornton, Leon Blake Harris, Vernon Robertson Burns, John Duncan McFarlane, Alexander Pahl, Jack James Pahl, Ian Ellis Burns, Clement Mervyn Hausler, Robert John Caldwell, Cedric Ernest Thomas, Maurice Reginald Rushton and Allan John Goldsworthy as a Committee of Management for a period of three (3) years of the land in the Township of Edenhope, temporarily reserved for Public Park and Gardens by Order in Council dated 8th November, 1949, the land reserved for such purposes indicated by red colour on plan marked A/9.10.46, attached to Lands Department correspondence Rs.2468 (both of such areas being reserved for the additional purpose of Public Recreation by Order in Council dated 23rd September, 1952) and the land in the Parish of Edenhope reserved for Water Supply and Public Purposes and indicated by green and red colours respectively on plan marked E/9.10.46 attached to Lands Department correspondence Rs.2365. The said lands are known as the "Lake Wallace Foreshore Reserve" and "Lake Wallace Reserve".—(Corres. Rs.2468, 2365.)

"WHITTLESEA PUBLIC PARK."

Gordon Albert Goding (for so long only as he continues to be a Councillor and the elect of the Council of the Shire of Whittlesea), in the place of James Anderson Balharrie, (who has ceased to be a Councillor), as a member of the Committee of Management of the portion of the land reserved as a site for a Public Park in the Parish of Toorourrong at Whittlesea and that portion of the permanent reservation along the Plenty River, both of which are indicated by yellow and blue colours respectively on plan marked W.A./3.8.39 attached to Lands Department correspondence Rs.2111 and known as the "Whittlesea Public Park".—(Corres. Rs.2111.)

"BERRINGAMA RECREATION RESERVE."

Frederick Smedley in the place of Frederick Smeney as a member of the Committee of Management for the period ending 29th January, 1965, of the remaining portion of the lands temporarily reserved by Orders in Council dated 9th February, 1892 and 31st May, 1910, as sites for Public Recreation in the Township and Parish of Berringama, and known as the "Berringama Recreation Reserve".—(Corres. Rs.2592.)

"LYONS PUBLIC HALL AND RECREATION RESERVE."

Alfred Thomas Hiscock, Kevin Francis Davis, Allan Robert Wettenhall, Earnest James Hall, Richard Beal Davis, Gordon Forbes Barclay, Francis James Chenoweth, Harold Frederick Brian and John Ronald Brisbane as a Committee of Management for a period of three (3) years of the land in the Township of Lyons, Parish of Glenaulin temporarily reserved as a site for Public Hall and Public Recreation by Order in Council dated the 22nd April, 1952, and known as the "Lyons Public Hall and Recreation Reserve".—(Corres. Rs.6906.)

"DANYO RECREATION RESERVE."

Albert Alexander McKee, William Henry Harley, Alec G. Pritchard, Harold Friedrich Heintze, Jock Etherton, Ronald E. Beer, Clarence W. Crane, Albert E. Kalms and Brian A. Etherton as a Committee of Management for a period of three (3) years of the lands in the Parish of Danyo reserved by Orders in Council dated 27th September, 1922 and 5th August, 1929, as sites for Recreation purposes and Public Recreation respectively and known as the "Danyo Recreation Reserve".—(Corres. Rs.2578, 3886.)

"THE HILL END MECHANICS' INSTITUTE RESERVE."

John James Ralph, Clement John Paul, Raymond Gordon Colbert, Vernon Duncan Williams, George Edward Lee and James Luke Rees as a Committee of Management for a period of three years of the land temporarily reserved by Order in Council dated the 21st February, 1911, as a site for a Mechanics' Institute in the Parish of Neerim East and known as the "Hill End Mechanics' Institute Reserve".—(Corres. Rs.721.)

"HAWKESDALE RACECOURSE AND RECREATION RESERVE."

James Joseph Fitzgerald, Robert Williams, James Robert Grey, Francis Joseph Carlin and John Anthony O'Brien as a Committee of Management for a period of three (3) years of the land in the Township of Hawkesdale

temporarily reserved by Order in Council dated 20th December, 1887, as a site for a Racecourse and by Order in Council dated 26th February, 1957, for the additional purpose of Public Recreation and known as the "Hawkesdale Racecourse and Recreation Reserve".—(Corres. Rs.1634.)

"WILLANGIE EAST PUBLIC HALL AND RECREATION RESERVE."

William James Bailey, Keith Ernest Blythman, Keith Cyril Bailey, Roderick McSwain, Flora Nixon, John David Donnan and John Emonson as a Committee of Management for a period of three (3) years of the lands in the Parish of Willangie temporarily reserved by Order in Council dated 11th December, 1951, as a site for a Public Hall and by Order in Council dated 22nd March, 1922, as a site for Public Recreation.—(Corres. Rs.6772, Rs.6773.)

"DURHAM OX MECHANICS' INSTITUTE RESERVE."

Murray Kelvin Graham, Bernard John Byrne, Edgar Stanley Broad, Neil Albert Sinclair and Francis Henry Haw as a Committee of Management for a period of three (3) years of the land in the Town of Towangurr (Durham Ox) temporarily reserved by Order in Council dated the 13th May, 1908, as a site for a Mechanics' Institute and Free Library and known as the "Durham Ox Mechanics' Institute Reserve".—(Corres. Rs.1722.)

"QUAMBATOOK RECREATION RESERVE."

Francis George Holt, Robert Patrick Morgan, John Anthony Dunstan, Loughlin Patrick Curran and Keith Williamson as a Committee of Management for a period of three (3) years of the land in the Township of Quambatook temporarily reserved by Orders in Council of the 31st July, 1899 and 14th September, 1954, as a site for Public Recreation, known as the "Quambatook Recreation Reserve".—(Corres. Rs.729.)

"BUXTON MEMORIAL HALL RESERVE."

John Alexander Baxter, Roland David Fiske, William Henry Jones, Francis Sylvester Keppel, Margaret Ellen Keppel, Eric Robert Leslie and William Thomas Robert Scott as a Committee of Management for a period of three (3) years of the land temporarily reserved by Order in Council dated the 26th February, 1952, as a site for a Public Hall in the Parish of Buxton and known as the "Buxton Memorial Hall Reserve".—(Corres. Rs.5725.)

In witness whereof the common seal of the Board of Land and Works was hereunto affixed this twenty-eighth day of February, One thousand nine hundred and sixty-two in the presence of—

(SEAL) KEITH TURNBULL, President.  
L. B. MERCER, Member.

CLUNES UNITED BOROUGH AND GOLDFIELD COMMON.

AMENDED REGULATION.

IN pursuance of the Regulations relating to commons, made by the Governor in Council on 5th August, 1930, the Managers of the Clunes United Borough and Goldfield Common, having drafted the following amendment to clause 7 of the Regulations for the management thereof, submit the same for the approval of the Board of Land and Works.

Amendment.

Delete from clause 7 the words "Fifteen shillings (15s.);" and substitute therefor the words "Twenty shillings (20s.)."

The amendment as set out above is hereby approved by the Board of Land and Works.—(Rs.398.)

The common seal of the Board of Land and Works, affixed this 19th day of December, 1961, in the presence of—

(SEAL) KEITH TURNBULL, President.  
F. KLENNER, Member.

**PUBLIC SERVICE NOTICES**

PUBLIC SERVICE (PUBLIC SERVICE BOARD) REGULATION 52.—VACANCY.

THE Permanent Head of the Department shown has recommended the officer named hereunder for appointment to the under-mentioned vacancy.

Office and Classification.	Duties.	Qualifications.	Officer Recommended for Appointment.		
			Name.	Classification.	Date of Classification.
PROFESSIONAL DIVISION.					
WATER SUPPLY DEPARTMENT.					
Superintendent of Engineering Laboratories, Class "A1" (E2,175)	Under the Chief Designing Engineer, to control hydraulic research and the testing of materials used in construction of engineering works; the inspection of materials and components purchased by the Commission	A degree in Engineering or Science and experience in testing and use of materials used in the construction of water supply works; a knowledge of the methods used for the analysis and examination of water supplies and for testing of hydraulic models	Hirth, G	Executive Engineer, Class "A"	20.1.60

Appeals against such recommendation should be lodged with the Secretary to the Public Service Board not later than Saturday, the 24th March, 1962.

By order,

Office of the Public Service Board,  
Melbourne, 13th March, 1962.

V. P. SCULLY,  
Secretary.



## PUBLIC SERVICE OF VICTORIA.—VACANCIES.

APPLICATIONS will be received by the Public Service Board up to Wednesday, the 28th March, 1962, from persons employed in the Public Service of Victoria, who are eligible and qualified for appointment to the under-mentioned positions.

## ADMINISTRATIVE DIVISION.

## Chief Clerk, Class "A1", Education Department.

*Yearly Salary.*—£2,300.

*Duties.*—To be responsible under the Secretary for the organization and supervision of the office staff; to maintain close liaison with all heads of branches and with the training officer; to carry out other duties as required.

*Qualifications.*—A good knowledge of the Education, Public Service and Teaching Service Acts and of the Regulations thereunder; to be familiar with departmental organization and procedure; ability to control staff and the necessary initiative and ability to organize new work.

## Accountant, Class "A", Mental Hygiene Branch, Department of Health.

*Yearly Salary.*—£1,920, minimum; £2,060, maximum.

*Duties.*—To be Accountant of the Branch, to prepare estimates of and to exercise control over the revenue and expenditure of the Branch, and to direct the work of the Accounts section.

*Qualifications.*—A qualified Accountant preferably with a good knowledge of the appropriate legislation.

## Secretary, Classes "C2"—"B", Hobsons Park Mental Hospital, Trairagon, Mental Hygiene Branch, Department of Health.

*Yearly Salary.*—£1,170, minimum; £1,500, maximum.

*Duties.*—To be Secretary of the Hospital.

*Qualifications.*—Experience in organization of a Mental Hospital, including control of stores, clothing, provisions, &c., a good knowledge of the Mental Hygiene Act and Regulations; ability to control staff.

## Class "C2", State Motor Car Insurance Office, Chief Secretary's Department.

*Yearly Salary.*—£1,170, minimum; £1,280, maximum.

*Duties.*—To act as Claims Officer (Comprehensive Sub-section).

*Qualifications.*—A good knowledge of Comprehensive and Compulsory Third Party Motor Vehicle Insurance; practical experience in assessing and settling Comprehensive claims; a knowledge of the law relating to Motor Claims.

## Class "C", Office of the Public Service Board, Premier's Department.

*Yearly Salary.*—£710, minimum; £860, maximum.

*Duties.*—The preparation and maintenance of officers' record cards.

*Qualifications.*—A knowledge of the Public Service Act and Regulations and the salary schedules thereto; preferably to be familiar with the structure of Government Departments.

## Class "C", Office of the Housing Commission, Treasury.

*Yearly Salary.*—£710, minimum; £860, maximum.

*Duties.*—To carry out investigations and conduct correspondence in connexion with the formal cancellation of redundant subdivisional roads and easements and to compile reports from personal inspections made of premises affected.

*Qualifications.*—Ability to conduct correspondence and some knowledge of the principles governing land tenure. An understanding of the relevant sections of the Housing Act and ability to undertake searching in the Office of Titles are desirable.

## Class "C", Water Supply Department.

*Yearly Salary.*—£710, minimum; £860, maximum.

*Duties.*—To continuously reconcile the Commission's cost and financial ledgers and payroll postings. To check actual expenditure against the amounts authorized by Expenditure Authorities; to check the work of accounting machine operators and compile statements and returns as required.

*Qualifications.*—A good knowledge of Public Accounts and Stores Regulations, 1958.

## PROFESSIONAL DIVISION.

## Chemist, Classes "C1"—"B", Coroner's Court, Law Department.

*Yearly Salary.*—£960, minimum; £1,500, maximum—  
Male. £903, minimum; £1,443, maximum—  
Female.

*Duties.*—To analyse samples submitted by Coroners and Police, and, where necessary, to give evidence in Court proceedings.

*Qualifications.*—University Degree in Science, or Technical School Diploma with Chemistry or Biochemistry as a major subject. Applicants should be qualified for admission as Associate of Royal Australian Chemical Institute.

## Training Officer (Male), Physical Education, Classes "C1"—"C2", Social Welfare Branch, Chief Secretary's Department.

*Yearly Salary.*—£960, minimum; £1,280, maximum.

*Duties.*—To carry out a programme of physical training for personnel engaged in social welfare activities and to supervise physical education programmes in institutions throughout the Branch.

*Qualifications.*—A Diploma of Physical Education and experience in organizing physical education programmes.

## Clerk of Courts, Grade II., Classes "C1"—"C2", City Court, Courts Branch, Law Department.

*Yearly Salary.*—£960, minimum; £1,280, maximum.

*Qualifications.*—As prescribed by Public Service (Public Service Board) Regulation 58.

## Chemist (Male), Classes "C"—"C2", Explosives and Gas Examining Branch, Chief Secretary's Department.

*Yearly Salary.*—£860, minimum; £1,280, maximum. (Commencing salary according to experience.)

*Duties.*—To analyse and test explosives and materials connected with their manufacture; to assist in the inspection of explosives factories; to test town's gas in accordance with the provisions of the Gas Regulation Act; as required to sample and test liquified petroleum gas; to perform inspectional and other duties as directed.

*Qualifications.*—A degree in Science or an approved diploma, with chemistry as a major subject, or equivalent qualifications. Applicants should either hold a current licence to drive a motor car or be prepared to become so qualified.

## Assistant Engineer, Classes "C"—"C2", Shepparton Centre, Water Supply Department.

*Yearly Salary.*—£1,049, minimum; £1,709, maximum—  
Graduate. £909, minimum; £1,709, maximum—  
Diplomate. (Commencing salary according to experience.)

*Duties.*—To prepare designs and estimates for hydraulic and other structures, dams and channels, and, where necessary, to supervise construction work of this nature.

*Qualifications.*—A degree or diploma in Civil Engineering or other recognized engineering qualifications, preferably with some experience in design and construction of water supply work.

## Draughtsman, Classes "C"—"C1", Office of Titles, Law Department. (Four vacancies.)

*Yearly Salary.*—£710, minimum; £1,060, maximum.

*Duties.*—To assist in the examination of Transfer Dealings or Survey Plans.

*Qualifications.*—Experience in Transfer dealings and office procedure under the Transfer of Land and cognate Acts; a sound knowledge of the practical application of Survey; to have passed the examinations prescribed by Public Service (Public Service Board) Regulations 23 (a) or (b) and 95 (1) for survey draughtsman.

## TECHNICAL AND GENERAL DIVISION.

## Storekeeper, Dookie Agricultural College, Department of Agriculture.

*Yearly Salary.*—£526, minimum; £558, maximum.

*Duties.*—Under supervision to have charge of College bulk and detailed issue stores; to be responsible for the receipt, checking, and issue of stores and items of equipment and the keeping of relevant records; to be responsible for the safe custody of stores; to assist in the preparation of requisitions for stores and to supervise the work of the Storeman; other duties as required.

**Qualifications.**—Experience in the handling of bulk stores, hardware items; a good knowledge of storehouse procedure and stores accounting.

**Note.**—A residence is available for the successful applicant, if married, for which rental of 10 per cent. of standard salary, plus £16 per annum, will be charged. Particulars available from the Department of Agriculture.

**Attendant, Office of Titles, Law Department.** (Sixteen vacancies.)

**Yearly Salary.**—£398, minimum; £510, maximum. (Plus an allowance of £48 a year for searching duties.)

**Duties.**—To attend searches by the public and Government Departments of documents registered under the Transfer of Land Act; to advise as to the nature of various dealings on Titles and to sort and replace documents required for searches and dealings.

**Qualifications.**—To be active and tactful in dealing with the public, to have the capacity to assess search fees and to acquire the requisite knowledge of Titles and the various documents evidencing land transactions.

**Attendant (Female), Senior, Social Welfare Branch (Youth Welfare Division), Chief Secretary's Department.**

**Yearly Salary.**—£364, minimum; £396, maximum.

**Duties.**—To assist in the conduct of a girls' hostel at Nunawading, and, when required, to relieve the hostel supervisor.

**Qualifications.**—Ability to organize and supervise leisure time activities of girls, to supervise staff, and to assist generally with a planned rehabilitation programme. Experience in a girls' hostel or institution is desirable.

**Note.**—The successful applicant will be required to live in quarters. A deduction of £166 a year will be made from salary, representing the charge for quarters and rations.

**Note.**—The salary rates quoted above do not include the additional amount which is payable under Regulation 74 of the Board's Regulations.

By order,  
V. P. SCULLY,  
Secretary.

Office of the Public Service Board,  
Melbourne, 13th March, 1962.

**PUBLIC SERVICE OF VICTORIA.—VACANCY.  
DEPARTMENT OF HEALTH,  
MENTAL HYGIENE BRANCH,  
TECHNICAL AND GENERAL DIVISION.**

**A**PPPLICATIONS will be received by the Public Service Board up to Wednesday, the 4th April, 1962, from persons employed in the Public Service of Victoria, who are eligible and qualified for appointment to the under-mentioned position:—

**Head Nurse (Male), Ballarat Mental Hospital.**

**Yearly Salary.**—£798, minimum; £846, maximum.

**Duties.**—To assist Principal Nurse in management of male division, and to prepare leave sheets and other records as directed by the Principal Nurse; to give lectures to Student Nurses.

**Qualifications.**—A current practising certificate for Mental Nursing. Ability to direct and control staff and patients and to keep records.

**Note.**—The salary rates quoted above do not include the additional amount which is payable under Regulation 74 of the Board's Regulations.

By order,  
V. P. SCULLY,  
Secretary.

Office of the Public Service Board,  
Melbourne, 13th March, 1962.

**PUBLIC SERVICE OF VICTORIA.—VACANCIES.  
(TEMPORARY APPOINTMENT.)**

**A**PPPLICATIONS will be received by the Public Service Board up to Wednesday, the 28th March, 1962, from persons who are qualified for appointment to the under-mentioned positions:—

**Drill Assistant, Leading Hand, Mines Department.** (Two vacancies.)

**Yearly Salary.**—£462.

**Duties.**—To act as derrick man up to 100 feet above the ground; under the direction of the sub-foreman to be responsible for the ancillary equipment.

**Qualifications.**—To have had working experience on a Rotary Drilling Rig; to be capable of directing the work of the floor crew.

The salary rates quoted above do not include the additional amount which is payable under Regulation 74 of the Board's Regulations.

By order,  
V. P. SCULLY,  
Secretary.

Office of the Public Service Board,  
Melbourne, 13th March, 1962.

No. 1184. *Public Service Act 1958, Section 50.*

**REGULATIONS.—PART IV.—SALARIES AND INCREMENTS.**

**T**HE Public Service Board, in pursuance of the powers conferred by the *Public Service Act 1958*, hereby amends its Regulations as shown below:—

**SIXTH SCHEDULE.**

**TEMPORARY EMPLOYEES.**

*Designations of Positions and Rates of Salaries.*

Department and Designation of Position.	Yearly Rate of Salary.		Increments (Annual).
	Minimum.	Maximum.	
	£	£	
<b>DEPARTMENT OF CROWN LANDS AND SURVEY.</b>			
<i>Delete—</i> Engineer Mechanic, Buchan Caves	510	558	1 of £32 and 1 of £16
Guide, Buchan Caves ..	..	366	..
<i>Add—</i> Engineer Mechanic, Buchan Caves	558	590	1 of £32
Guide, Buchan Caves ..	414	446	1 of £32

A. GARRAN, Chairman,  
V. P. SCULLY, Secretary.

Office of the Public Service Board,  
Melbourne, 26th February, 1962.

No. 1183. *Public Service Act 1958.*

**REGULATIONS.—PART IV.—SALARIES AND INCREMENTS.**

**T**HE Public Service Board, in pursuance of the powers conferred by the *Public Service Act 1958*, hereby amends its Regulations as shown below:—

**FOURTH SCHEDULE.**

**ADMINISTRATIVE DIVISION.**

*Amount of Salary Assigned to Offices in Class "A1".*

Office.	Yearly Rate of Salary.
	£
<b>DEPARTMENT OF TREASURER.</b>	
<i>Delete—</i> Chief Clerk, Treasury .. ..	3,075
<i>Add—</i> Executive Officer, Treasury .. ..	3,075

A. GARRAN, Chairman,  
V. P. SCULLY, Secretary.

Office of the Public Service Board,  
Melbourne, 26th February, 1962.

### TENDERS—PUBLIC WORKS DEPARTMENT

TENDERS will be received at this Department until TEN a.m. on the days, and for the purposes, under mentioned.

Particulars may be learnt at the Department and also at places shown in parenthesis.

W.O. means Inspector of Works Office; P.S.—Police Station; T.S.—Technical School; H.E.S.—Higher Elementary School; S.S.—State School; H.S.—High School; C.S.—Consolidated School.

Tenders should be submitted on the Department's printed Tender Form. All tenders must be on a "Firm Tender" basis. The Board of Land and Works will not necessarily accept the lowest or any tender.

Tenders to be addressed to the Hon. the Commissioner of Public Works, and envelope containing tender to be marked "Tender for \_\_\_\_\_, closing \_\_\_\_\_".

NOTE.—No preliminary deposit is to be lodged with any tender, but a deposit in accordance with the prescribed Schedule may be required from each successful tenderer.

#### Tuesday, 20th March, 1962.

Altona North.—Supply of two 9-in. swing lathes, Technical School.

Ararat.—Supply of plastic mattress covers, Mental Hospital.

Ballarat.—Sanding and polishing floors, Senior Nurses' Home, Mental Hospital. (W.O., Ballarat.)

Ballarat.—New laundry and toilet at Chief Penal Officer's Quarters, Gaol. (W.O., Ballarat.)

Ballarat.—Connect residence, 12 Beaufort-avenue, to sewerage system, Teachers' Training College. (W.O., Ballarat.)

Beaufort.—Erection of second section, High School. (W.O., Ballarat; H.S., Beaufort.)

Beaufort.—Electrical installation in standard Domestic Arts Wing, High School. (W.O., Ballarat and Ararat.)

Beaufort.—Mechanical services for Domestic Arts Wing, High School.

Beaumaris North.—Boundary fencing, S.S. 4803. (S.S., Beaumaris North.)

Beechworth.—Supply and installation of fire service, S.S. 1560. (W.O., Wangaratta; P.S., Beechworth.)

Birchip.—Repairs and painting, S.S. 2602. (W.O., Warracknabeal; S.S. Birchip.)

Brunswick.—Supply of tables and chairs, Police Station, Dawson-street.

Clunes.—Repairs and renovations, Court House. (W.O. Maryborough.)

Clyde.—Septic tank, new boys out-office &c., and bore water supply, S.S. 3664. (S.S., Clyde.)

Cobrico.—New out-office block and septic tank installation, S.S. 1174. (W.O. Warrnambool; S.S., Cobrico.)

Coburg.—Maintenance of private automatic telephone system from 1st April, 1962, to 30th June, 1963, Pentridge Gaol.

Deepdene.—Repairs and painting, S.S. 3680

Echuca.—Renewal of flooring and painting, S.S. 208. (W.O., Shepparton.)

Echuca.—Supply of various timber furniture, Technical School.

Flemington.—Supply of rubber mattresses and pillows, Travancore Developmental Centre.

Frankston.—Provision of bicycle storage shed, Police Station. (P.S., Frankston.)

French Island.—Electrical installation in new Dormitory Block, McLeod Prison Farm. (W.O. Korumburra.)

Hampton.—Provision of fire escape stairs and storage space, High School. (H.S., Hampton.)

Hawkesdale.—Supply, delivery and installation of three pumps, High School. (W.O., Warrnambool.)

Kew.—Supply of rubber mattresses, "The Gables", Social Welfare Department.

Kew.—Supply of timber furniture, "The Gables", Social Welfare Department.

Kyvalley.—Repairs and painting externally to school and residence, S.S. 2823. (W.O. Shepparton; S.S., Kyvalley.)

Lal Lal.—Erect out-office, install septic closets, &c., S.S. 863 and residence. (W.O., Ballarat; S.S., Lal Lal.)

Learmonth.—Erect out-office, woodshed block, install septic tanks, S.S. 386 and residence. (W.O., Ballarat; S.S., Learmonth.)

Mallacoota.—Supply of and delivery of stone spalls weighing 20 lb. to 60 lb. (1 man) for foreshore protection, Ports and Harbors. (W.O., Bairnsdale and Forests Commission, Orbost.)

Melbourne.—Supply of beds, wardrobes, and chest of drawers, Teachers' College Hostel.

Melbourne.—Supply of bedspreads, eiderdowns and blankets, Teachers' College Hostel.

Melbourne.—Supply and delivery of one (1) only 19-ft. fibre-glass cabin type boat, together with tandem trailer, Ports and Harbors, Public Works Department.

Mont Park.—Supply, delivery, installation and testing of refrigeration plant for Cool-room in the General Stores Block, Mental Hospital.

Myrtleford.—New office accommodation, Police Station. (W.O., Wangaratta; P.S., Myrtleford.)

Narracan.—Construction of new out-office block, septic tanks and water supply installations, S.S. 2295. (W.O., Warragul; S.S., Narracan.)

Nullawarre North.—New out-office block and septic closets installation, S.S. 3206. (W.O., Warrnambool; S.S., Nullawarre North.)

Osborne's Flat.—Erection of one timber shelter-pavilion, S.S. 1463. (W.O., Wangaratta; S.S., Osborne's Flat.)

Port Fairy.—Septic tank installation, Consolidated School. (W.O., Warrnambool.)

Preston East.—Supply of various timber furniture, Technical School.

Preston East.—Supply and delivery of five 9-in. swing model "C" lathes, one 6-in. power hacksaw, four drill vices, Technical School.

Princes Hill.—Renewal of boundary fencing in pipe and chain mesh, S.S. 2955.

Richmond.—Repairs and painting to residence, 2 Burgess-street, S.S. 1396.

Sebastopol.—Supply of sewing machines, Technical School.

Shepparton.—New out-office and connexion to sewerage system, Lands and Survey Department residence, 47 Leithen-street. (W.O., Shepparton.)

Spotswood.—Erection of one shelter-pavilion, S.S. 3659.

Stawell.—Installation of cleaner's sink, alteration to sewer drains, Pleasant Creek Special School. (W.O., Ararat.)

Strathlea.—Repairs and painting, S.S. 4201. (W.O., Kyneton; S.S., Strathlea.)

Trafalgar South.—Installation of septic closets to existing out-offices for boys and girls and residence, S.S. 2527. (W.O., Warragul.)

Wairewa.—Repairs and painting, S.S. 3739. (W.O., Bairnsdale; S.S., Wairewa.)

Warracknabeal.—Repairs and painting, Court House. (W.O., Warracknabeal.)

Williamstown.—Repairs to roof, High School. (H.S., Williamstown.)

Woodend.—Internal repairs and renovations, Court House. (W.O., Kyneton.)

#### Tuesday, 27th March, 1962.

Alvie.—Connexion to town water supply, Consolidated School. (W.O., Camperdown; C.S., Alvie.)

Ballarat.—Roof repairs, Gaol. (W.O., Ballarat.)

Bendigo.—Renewal of fencing, former Boys' Training Farm. (W.O., Bendigo.)

Beveridge.—Shelter pavilion, S.S. 1476. (W.O., Alexandra.)

Cardross.—Installation of septic tanks &c., S.S. 4263. (W.O., Mildura.)

Droun.—Repairs and painting, Police Station. (W.O., Warragul; P.S., Droun.)

Eastville.—Erection of one timber shelter pavilion, S.S. 1245. (W.O., Bendigo.)

Frankston.—Supply various items of furniture, Teachers' College Hostel.

Frankston.—Supply of settees, Teachers' College Hostel.

Frankston.—Supply and fix mirrors to existing ward-ropes, Teachers' College Hostel.

Hamilton.—Erection of steel framed implement shed, Research Station. (W.O., Hamilton.)

Harrow.—Installation of septic tank and bore water supply, S.S. 2049. (W.O., Horsham and Hamilton.)

Highbett.—Fencing, High School. (H.S., Highbett.)

Melbourne.—Steel card cabinets, Companies Registration Branch, Crown Law Department, 453 Latrobe-street.

Melbourne.—Supply of court-room furniture, City Court.

Merbein West.—Additional out-offices and septic tank installations &c., school and residence, S.S. 3996. (W.O., Mildura.)

Mont Park.—Supply, delivery and fixing on site of new vapour curtains in main kitchen at Larundel Mental Hospital.

Moorabbin.—Additional lavatory accommodation, S.S. 4687. (S.S., Moorabbin.)

Mooroopna.—General repairs and painting, S.S. 1432. (W.O., Shepparton; S.S., Mooroopna.)

Noble Park.—Additional toilets and washing facilities, S.S. 3675. (S.S., Noble Park.)

Rosebud.—Roof repairs, High School. (Amended Specification.) (H.S., Rosebud.)

Stawell.—Alterations, new sanitary accommodation, connect to town sewerage, Technical School. (W.O., Ararat.)

Sunny Cliffs.—New out-office block and septic tanks at school and residence, S.S. 4416. (W.O., Mildura.)

Taggerty.—New sanitary accommodation, S.S. 2544. (W.O., Alexandra.)

Talbot.—New office and garage, Police Station. (W.O., Maryborough.)

Underbool.—Repairs to boundary fencing and provision of driveway gates, S.S. 3819. (W.O., Mildura.)

Vermont.—Supply and installation of an effluent pump for septic tank, High School.

Walpeup.—Septic tank installation and re-siting of existing closets at school and residence, S.S. 3747. (W.O., Mildura.)

West Melbourne.—Supply and delivery of 4 in. x 1 in. and 4 in. x 2 in. O.B. Hardwood, Government Cool Stores.

West Melbourne.—Supply and delivery of 6 in. x 1 in. dress O.B. Hardwood, Government Cool Stores.

Yalca South.—Septic tank and water installation at S.S. 2198. (W.O., Shepparton.)

Yallourn.—Aluminium windows—new Diploma Block, Technical School.

### Tuesday, 3rd April, 1962.

Areegra.—Purchase and removal of old school building, S.S. 2314. (W.O., Warracknabeal; S.S., Areegra.)

Broadmeadows.—Supply of 24-in. saw-bench and 12-in. hand-planing machine, Technical School.

Dudley.—Installation of septic tank, water supply, fire service and new timber out-offices block, S.S. 3674 and residence. (W.O., Korumburra; S.S., Dudley.)

Kalkee.—Installation of septic toilets and new out-office block, S.S. 1840. (W.O., Horsham; S.S., Kalkee.)

Kew.—Supply and delivery of one (1) portable ultra-short wave therapy apparatus, Mental Hospital.

Officer.—Septic tank installation, S.S. 2742 and residence. (S.S., Officer.)

Poowong.—Installation of septic tank, erection of new out-offices and bore water supply, Consolidated School. (W.O., Korumburra; C.S., Poowong.)

H. R. PETTY,  
Commissioner of Public Works.

Public Works Department,  
Melbourne, 13th March, 1962.

## PRIVATE ADVERTISEMENTS

### CITY OF GEELONG WEST.

#### ALTERED NAME OF STREET.

NOTICE is hereby given that the City of Geelong West has altered the name of Fyansford-road, between Minerva-road and McCurdy-road, to Autumn-street.

In future the full length of this street from Latrobe-terrace to McCurdy-road will be known as Autumn-street.  
136 R. J. HAMMETT, Town Clerk.

### CITY OF GEELONG WEST.

NOTICE is hereby given that the Council of the City of Geelong West has, under the provisions of the *Local Government Act 1958*, altered the name of the street within the municipality as set forth in the following Schedule:—

#### SCHEDULE.

*New Name; Old Name; Situation.*

Shannon-avenue; West Melbourne-road; between Aberdeen and Church streets.

143 R. J. HAMMETT, Town Clerk.

### CITY OF HEIDELBERG.

#### BY-LAW No. 225.

*Complementary to the Uniform Building Regulations—Erection of Apartments.*

A By-law of the City of Heidelberg, made under the provisions of the *Local Government Act 1958*, and amendments and clause 815 of the *Uniform Building Regulations of Victoria, 1961*, and numbered 225, for limiting the number of stories for buildings of Class III. occupancy (apartments).

IN pursuance of the powers conferred by the *Local Government Act 1958* and any and every other power thereunto enabling, the Mayor, Councillors and Citizens of

the City of Heidelberg with the approval of the Governor in Council order as follows:—

That By-law 219 be amended by inserting the words "and Class III. occupancy" after the word "occupancy" appearing in the second, fifth and seventh lines of clauses 3 and 4, also the second, fifth and sixth lines of clause 5.

The Resolution for passing this By-law was agreed to by the Council on the 11th December, 1961, and confirmed on the 5th February, 1962.

(SEAL) CHARLES A. MARTIN, Mayor.  
FRANK T. ROJO, Councillor.  
E. C. JACK, Acting Town Clerk.

Approved by the Governor in Council, on the 20th day of February, 1962.—N. G. WISHART, Acting Clerk of the Executive Council. 190

### CITY OF MOORABBIN.

NOTICE OF MAKING BY-LAWS NUMBERED 252, 253 AND 254.

NOTICE is hereby given that the Council of the City of Moorabbin has made the following By-laws, under the *Local Government Act 1958*:—

(1) A By-law, under the provisions of section 197 of the *Local Government Act 1958*, and numbered 252, for prohibiting or regulating the soliciting or collection in any road or street or from house to house adjacent thereto of gifts of money or of subscriptions for any purpose.

(2) A By-law, under the provisions of sections 197 and 799 of the *Local Government Act 1958*, and numbered 253, for the purposes of—

- (a) providing for the protection and control of tree reserves and gardens, garden plots, lawns, and ornamental plantations in or upon any street or road;
- (b) controlling and managing and preserving commons and public reserves of which the management is vested in the Council;
- (c) regulating the use and employment of pleasure grounds, gardens, and places of public resort or recreation;
- (d) repealing By-laws numbered 55, 70, 74, 139, 149, 173 and 178 of the City of Moorabbin.

(3) A By-law, under the provisions of section 197 of the *Local Government Act 1958*, and numbered 254, for—

- (a) preventing and extinguishing fires;
- (b) suppressing nuisances;
- (c) repealing By-law numbered 223 of the City of Moorabbin.

The Resolutions for passing such By-laws were agreed to by the Council on the 5th day of February, 1962, and confirmed on the 5th day of March, 1962.

True copies of the aforementioned By-laws numbered 252, 253 and 254 are open for inspection, free of charge, during office hours, at the offices of the Council, Nepean Highway, Moorabbin.

139 V. A. SMITH, Town Clerk.

### CITY OF PRAHRAN.

#### BY-LAW No. 237.

A By-law of the City of Prahran, made under the provisions of the *Dog Act 1958*, and numbered 237, for the purpose of altering By-law No. 224.

IN pursuance of the powers conferred by the Dog Acts and of any and every other power it thereunto enabling, the Mayor, Councillors and Citizens of the City of Prahran order as follows:—

1. From and after the coming into operation of this By-law, By-law No. 224, made and passed by the Council on the 18th day of November, 1957, and confirmed on the 16th day of December, 1957, is hereby altered as follows and to the extent that any part or parts thereof respectively which is or are inconsistent with or repugnant to this By-law are hereby expressly repealed:—

In clause 1 (a) the words "Five shillings" shall be deleted, and "Seven shillings and six pence" shall be substituted therefor.

Resolution for making and passing this By-law agreed to by the Council of the City of Prahran this 5th day of February, 1962. Confirmed this 5th day of March, 1962.

The common seal of the Mayor, Councillors and Citizens of the City of Prahran was hereunto affixed, in the presence of—

(SEAL) E. L. JONES, Mayor.  
SPENCER HARPER, Councillor.  
HENRY JONES, Town Clerk.

142

## BOROUGH OF SWAN HILL.

## LOAN No. 29.

*Notice of Intention to Borrow the Sum of £15,000.*

NOTICE is hereby given that it is the intention of the Council of the Borough of Swan Hill to borrow the sum of £15,000, on the credit of the municipal revenues of the Mayor, Councillors and Burgesses of the said Borough by the grant of a mortgage in accordance with the provisions of the *Local Government Act 1958*.

(a) The maximum rate of interest that may be paid is 5½ per cent. per annum.

(b) The period of the loan shall be fifteen years.

(c) The purpose for which the loan is to be applied is—

Capital works in the Electric Supply Department .. .. .	£5,000
Construction of roads and drains .. .. .	10,000
	£15,000

(d) The moneys borrowed shall be repayable by providing out of the municipal fund 30 half-yearly instalments of £740 15s. 4d. each, including principal and interest, on the 1st days of December and June during the currency of the loan. The first instalment shall be payable on the 1st day of December, 1962.

(e) Such moneys shall be repayable at the Commercial Bank of Australia Limited, Melbourne.

The plans and specifications and estimates of the costs of the proposed works, and a statement showing the proposed expenditure of the moneys to be borrowed, are open for inspection at the Municipal Offices, Swan Hill.

R. J. PUGSLEY, Town Clerk.

8th March, 1962. 141

## Town and Country Planning Acts.

## SHIRE OF COBRAM.

## EIGHTH SCHEDULE.

*Notice that a Planning Scheme has been Prepared and is Available for Inspection.*

## COBRAM PLANNING SCHEME.—AMENDMENT No. 2.

NOTICE is hereby given that the Shire of Cobram, in pursuance of its powers under the Town and Country Planning Acts has prepared a planning scheme for the Township of Cobram for the purpose of amending the Cobram Planning Scheme 1949.

All maps, plans, descriptions and other data fully setting out and explaining the planning scheme have been deposited at the Shire Office, Station-street, Cobram, and at the office of the Town and Country Planning Board, Melbourne, and will be open for inspection without payment of any fee by all persons affected, between the hours of 10 a.m. and 4.30 p.m. on all days of the week except Saturdays, Sundays and public holidays, until and including the 14th day of June, 1962.

Any persons affected by the planning scheme are required to set forth in writing all objections they may have, addressed to the Municipal Clerk, Shire Office, Cobram, on or before the 14th day of June, 1962.

191 R. T. CUTTS, Municipal Clerk.

## SHIRE OF CORIO.

## NOTICE OF CHANGE OF ROAD NAME.

NOTICE is hereby given that in pursuance of the powers conferred by the *Local Government Act 1958*, the Council of the Shire of Corio at a meeting held on the 24th January, 1962, carried a Resolution changing the name of the following road:—

*Old Name; New Name.*

Elgin-street; Shannon-avenue.

127 W. H. MYERS, Shire Secretary.

## SHIRE OF FRANKSTON.

## BY-LAW No. 104.

NOTICE is hereby given that the Council of the Shire of Frankston has enacted under the provisions of the Dog Act and any and every power thereunto enabling it. By-law numbered 104 for repealing By-law No. 95 and fixing registration and other fees under the Dog Act.

A copy of this By-law is open for inspection free of charge, during office hours at the office of the Council, Davey-street, Frankston.

A resolution for making and fixing this By-law was agreed to by the Council of the Shire of Frankston, on the 12th day of February, 1962, and confirmed on the 13th day of March, 1962.

G. C. PENTLAND, Shire Secretary.

Shire Office, Frankston. 125

## SHIRE OF LILLYDALE.

## BY-LAWS Nos. 146, 147 &amp; 148.

NOTICE is hereby given that the Council of the Shire of Lillydale has made By-laws under the *Local Government Act 1958* numbered 146, 147 and 148. The numbers, titles and summaries of the By-laws are:—

*By-law No. 146.*—To correct a typographical error in Clause 77 (a) (iii) of the Meeting Procedure By-law No. 108, and for other purposes.

*By-law No. 147.*—To extend all of the provisions of Part 1 of the *Police Offences Act 1958* (other than Section 6) to the whole of the Municipal District of the Shire of Lillydale and for other purposes.

*By-law No. 148.*—For the purpose of prohibiting the deposit or leaving of refuse or rubbish on streets, roads, lanes and passages and on land (excepting duly appointed Council tips) throughout the whole of the Municipal District of the Shire of Lillydale, providing penalties for offences against the By-law, and for other purposes.

A copy of each of these By-laws is open for inspection free of charge, during office hours, at the office of the Council.

124 T. H. COWLEY, Shire Secretary.

## SHIRE OF WHITTLESEA.

## LOAN No. G.8.

*Notice of Intention to Borrow the Sum of £5,000 for Permanent Works and Undertakings.*

NOTICE is hereby given that the Council of the Shire of Whittlesea proposes to borrow the sum of Five thousand pounds on the credit of the municipal revenues of the President, Councillors, and Ratepayers of the said Shire, such sum to be raised by the grant of a mortgage, in accordance with the provisions of the *Local Government Act 1958*.

1. The maximum rate of interest that may be paid is £5 10s. per cent. per annum.

2. The purpose for which the loan is to be applied is—

Thomastown Infant Welfare Centre ..	£1,000
Council Depot, Epping .. .. .	3,000
Main Drainage, Thomastown/Lalor ..	1,000
	£5,000

3. The period of the loan shall be ten years.

4. The moneys borrowed shall be repayable by providing out of the municipal fund twenty approximately equal half-yearly instalments, each including principal and interest, on the 1st day of December and the 1st day of June, during the currency of the loan. The first instalment shall be payable on the 1st day of December, 1962.

5. Such moneys shall be repayable at the State Savings Bank of Victoria, Melbourne.

The plans and specifications and the estimate of the cost of the proposed works, and a statement showing the proposed expenditure of the moneys to be borrowed, are open for inspection at the Shire Office, Epping.

118 R. G. C. COOK, Shire Secretary.

## SHIRE OF UPPER YARRA.

## LOAN No. 23.

*Notice of Intention to Borrow the Sum of £4,050 for Permanent Works and Undertakings.*

NOTICE is hereby given that the Council of the Shire of Upper Yarra proposes to borrow the sum of Four thousand and fifty pounds, on the credit of the municipal revenues of the President, Councillors and Ratepayers of the said Shire, such sum to be raised by the grant of a mortgage in accordance with the provisions of the *Local Government Act 1958*.

1. The maximum rate of interest that may be paid is £5 10s. per cent. per annum.

2. The purposes for which the loan is to be applied are:—

Drainage reconstruction at Warburton	
Recreation Reserve .. .. .	£1,380
Purchase of multi-wheel roller .. .. .	730
Purchase of water pump .. .. .	220
Purchase of office machinery .. .. .	170
Construction of footpaths at Warburton and Yarra Junction .. .. .	1,550
	£4,050

3. The period of the loan shall be ten years.

4. The moneys borrowed shall be repayable by providing out of the municipal fund twenty approximately equal half-yearly instalments, including principal and interest,

on the 1st day of May and the 1st day of November during the currency of the loan. The first instalment shall be payable on the 1st day of November, 1962.

5. Such moneys shall be repayable at the State Savings Bank of Victoria, Melbourne.

The plans and specifications and the estimate of the cost of the proposed works, and a statement showing the proposed expenditure of the moneys to be borrowed, are open for inspection at the Shire Hall, Yarra Junction.

Dated 23rd February, 1962.

137

J. N. EDDY, Shire Secretary.

#### Water Acts.

#### WARRANTYTE WATERWORKS TRUST.

NOTICE to owners of tenements in the under-mentioned streets in the Warrantyte Waterworks Area and the private streets, lanes, courts and alleys opening thereto:—

Pound-road.  
 Naughton-avenue.  
 Hutchinson-avenue.  
 Everard-drive.  
 Third-street.  
 Second-avenue.  
 West End-road, between Taroona-avenue and Second-avenue.  
 Taroona-avenue.  
 Heidelberg-Warrantyte road (McDougall's deviation) 8 chains north-west of Naughton-road.  
 Lorraine-avenue.  
 Heidelberg-Warrantyte road (Melbourne Hill) from Lorraine-avenue to lot 6 on plan of subdivision No. 19143, and from Yarra-street to lot 56 on plan of subdivision No. 19143.  
 Leber-street.  
 Colin-avenue.  
 Keen-avenue (Kent-street).  
 Harris Gully-road.  
 Hodgsons-road.  
 Gold Memorial-road.  
 Yarra-street.  
 Blair-street.  
 Cemetery-road.  
 Trezise-street, between Yarra-street and Brackenbury-street.  
 Brackenbury-street, between Forbes-street and Blair-street.  
 Brackenbury-street, between Whipstick Gully and Mullens-road.  
 Forbes-street, between Yarra-street and Brackenbury-street.  
 Stiggant-street.  
 Webb-street.  
 Mitchell-street.  
 David-street.  
 Magpie-street.  
 Tunnel-street.  
 Mullens-road.  
 Russell-road.  
 Masonic-avenue.  
 Wattleblossom-road.  
 Warrantyte-Ringwood road.  
 Godfrey-avenue.  
 Jumping Creek-road.  
 Warrantyte-Kangaroo Grounds-road.  
 Research-road.  
 Bradleys-lane, from Research-road, 31 chains south-westerly.  
 Castle-road, from Kangaroo Grounds-road to 7 chains east of Lewis-road.  
 Lewis-road.  
 Dingley Dell-road, from Kangaroo Ground-road to 7 chains north-west of that road.  
 Orborne-road, from Kangaroo Ground-road to the north-western corner of Crown allotment 25f, Parish of Nillumbik.

The main pipe in the said streets being laid down, the owners of all tenements situated as above, are hereby required, on or before the 19th day of April next, to cause proper pipes and stop cocks to be laid, so as to supply water within such tenements from the main pipe.

148

J. W. THOMSON, Secretary.

NOTICE is hereby given that Charlesworth Rubber Proprietary Limited has applied for a lease under section 134, *Land Act 1958*, for a term of 23 years from 6th May, 1962, of allotment 13, section 59, City of Port Melbourne, Parish of Melbourne South, containing 1 acre 0 roods 17 perches, as a site for rubber and hardware manufacture.

39

NOTICE is hereby given that the Northern District Ambulance Service has applied for a lease for a term of twenty-one (21) years under section 134 of the *Land Act 1958*, in respect of an area of Crown land containing approximately 34 perches, being portion of the Police Reserve, Parish of Rochester West, Township of Rochester, as a site for purposes of erection of an Ambulance Station.

17259

#### GEELONG WATERWORKS AND SEWERAGE TRUST.

PURSUANT to section 60 (2) of the *Geelong Waterworks and Sewerage Act 1958* (No. 6263), notice is hereby given of the intention of the Trust to construct sewers to provide for properties in and adjacent to—

*Shire of Bellarine*.—Hickey-street, Whittington, and Glover-street, Newcomb.

*Shire of Corio*.—Thorburn, Yaraan and Elsie streets, Elsie and Banfield streets, Drysdale-avenue, Hamlyn Heights.

*Shire of South Barwon*.—Nagle-drive, Belmont, Short-street, Belmont.

And more particularly as shown on maps which are open for inspection at the Trust's offices, between the hours of 9 a.m. and 4 p.m. daily, from Monday to Friday, inclusive.

Dated this 7th day of March, 1962.

146

B. C. HENSHAW, Secretary.

#### NOTICE OF INTENTION TO APPLY FOR A LICENCE TO DIVERT WATER AND CUT RACE (RE-ISSUE) FROM THE LITTLE RIVER, AT LITTLE RIVER.

I HEREBY give notice that I intend to apply for a licence empowering me to divert water for a term of eight years to the extent of 24 acre-feet per annum at a maximum rate of 5 acre-feet per day of 24 hours for the irrigating for market garden purposes of 12 acres, being part of allotment E, section 26, Parish of Murteaim, and to occupy certain Crown lands for works of diversion, and to cut a race thereon.

Any objection to such application must be forwarded, in writing, to reach the State Rivers and Water Supply Commission, Melbourne, before 14th April, 1962, being 30 days from the first publication of this notice.

FILIPPO ZANGHI.

Mile-road, Little River.

138

NOTICE is hereby given that the partnership heretofore subsisting between Robert Preston Storey and William Penman, both of Corryong, butchers, carrying on business as butchers, at Hansen-street, Corryong, under the style or firm name of R. P. Storey and W. Penman, has been dissolved as from the date hereof.

Dated the 5th day of March, 1962.

189

R. P. STOREY.

W. PENMAN.

NOTICE is hereby given that the partnership heretofore subsisting between the undersigned Ross Cecil Brown and Graham George Davis, carrying on business as R. and G. Panels, at Newham-street, Ringwood, has been dissolved by mutual consent as from the 21st day of February, 1962. All debts due and owing by the said late firm will be received and paid by the said Ross Cecil Brown, who will continue to carry on the business under the same name and style and at the same place.

130

The Companies Act 1958.—In the matter of BYLCO HOLDINGS PTY. LTD. (in Liquidation).

NOTICE is hereby given that at an Extraordinary Meeting of the members of the above-named company held on Tuesday, 27th February, 1962, it was resolved that the company be wound up voluntarily and at a meeting of creditors held on the same day, pursuant to section 201, it was resolved that for such purposes, Guy Newton Moore, of 34 Queens-road, Melbourne, S.C.2, chartered accountant, be appointed liquidator.

Notice is also given that, after 21 days from this date, I shall proceed to distribute the assets. All creditors having any claim against the company should furnish particulars of same by that date, otherwise I shall proceed to distribute the assets without regard to their claims.

Dated this 7th day of March, 1962.

GUY N. MOORE, Liquidator.

A Capper, Moore and Sons, 34 Queens-road, Melbourne.

183

## DUNLOP RUBBER AUSTRALIA LIMITED.

## REGISTER of Unclaimed Moneys held by Dunlop Rubber Australia Limited.

Name and Address of Owner on Books.	Total Amount Due to Owner.	Description of Unclaimed Money.	Date of Last Claim.
	£ s. d.		
Amanitidis, Nikolaos, 217 Russell-street, Melbourne .. .. .	2 7 4	Wages for Year ended 29th February, 1956	No Claim
Antic, Ratimir, 157 Spring-street, Melbourne .. .. .	2 7 9	" "	"
Bisarello, Bruno, 61 Palmerston-street, Carlton .. .. .	2 6 3	" "	"
Brassar, Peter, 38 Glenhuntly-road, Elsternwick .. .. .	2 10 11	" "	"
Bugalla, Christin, 240 Albert-road, South Melbourne .. .. .	2 13 0	" "	"
Brazzini, Emmio, 36 Beaconsfield-parade, Northcote .. .. .	1 4 9	" "	"
Benussi, Nives, 3 Mitchell-street, St. Kilda .. .. .	1 15 10	" "	"
Balletschoffer, Elizabeth, 15 Royal-crescent, Camberwell .. .. .	1 16 10	" "	"
Camilleria, Alexander, 82 Grady-street, Clifton Hill .. .. .	2 1 1	" "	"
Cureno, Silvio, 64 Waverley-parade, Pascoe Vale .. .. .	2 7 5	" "	"
Campbell, Elizabeth, 246 Albert-street, East Melbourne .. .. .	1 1 11	" "	"
Costa, Francesco, 68 O'Shannassy-street, North Melbourne .. .. .	2 19 5	" "	"
Einloon, Johann, 212 Canterbury-road, St. Kilda .. .. .	2 6 11	" "	"
Fulton, Robert Graham, 14 Elaroo-avenue, Camberwell .. .. .	0 6 8	" "	"
Grech, George, 2 Darling-street, Moonee Ponds .. .. .	0 10 7	" "	"
Grocholakis, Vera, 3 Grover-street, Pascoe Vale .. .. .	0 4 7	" "	"
Haertel, Halmu Georg, 206 Canterbury-road, St. Kilda .. .. .	1 5 6	" "	"
Judd, Arthur Spencer, 625 St. Kilda-road, Melbourne .. .. .	1 5 8	" "	"
Kodigal, Otto, 23 Meredith-street, Elwood .. .. .	0 10 3	" "	"
McCabe, Terance, 141 Victoria-parade, Melbourne .. .. .	2 5 7	" "	"
Nolan, Ugo, 61 Palmerston-street, Carlton .. .. .	2 10 2	" "	"
Piananto, Domenico, 19 Lytton-street, Carlton .. .. .	2 9 5	" "	"
Pilipovic, Dusan, 61 Wheatsheaf-road, Glenroy .. .. .	0 12 5	" "	"
Psaila, Gerard, 64 Westgarth-street, Fitzroy .. .. .	2 6 3	" "	"
Purvis, Lesley Jean, 31 Dalgetty-street, St. Kilda .. .. .	1 1 11	" "	"
Rosenthal, Peter Walter, 16 Avoca-street, South Yarra .. .. .	2 7 4	" "	"
Rolfo, Guisepppe, 210 Leicester-street, Carlton .. .. .	2 0 3	" "	"
Staltari, Francesco, 64 Westgarth-street, Fitzroy .. .. .	3 1 2	" "	"
Sourer, Valentine, 85 Albert-street, East Melbourne .. .. .	2 6 3	" "	"
Schembri, Charles, 163 Alexander-parade, North Fitzroy .. .. .	0 15 11	" "	"
Staffieri, Domenico, 317 Park-street, South Melbourne .. .. .	2 10 6	" "	"
Schneider, Anneliese, Lot 1, Main-road, East St. Albans .. .. .	0 12 10	" "	"
Tillinh, Willi, 61 Wheatsheaf-road, Glenroy .. .. .	0 12 5	" "	"
Taylor, Garth, 207 Canterbury-road, St. Kilda .. .. .	0 14 5	" "	"
Terzopoulos, Christos, 98 Curtain-street, North Carlton .. .. .	0 18 7	" "	"
Taschounidis, Theo, 132 Young-street, Fitzroy .. .. .	3 16 8	" "	"
Valencic, Milly, 505 Rathdown-street, Carlton .. .. .	1 1 10	" "	"
	64 6 7		

120

## Tenth Schedule.

## GORMANDALE CO-OP. CREAMERY AND BUTTER FACTORY CO. LTD.

## REGISTER of Unclaimed Moneys held by the Gormandale Co-op. Creamery and Butter Factory Co. Ltd.

Name and Address of Owner on Books.	Total Amount Due to Owner.	Description of Unclaimed Money.	Date of Last Claim.
	£ s. d.		
H. Green, (address not known) .. .. .	0 12 5	Payment for Cream ..	May, 1955
W. J. O'Meara, Koornalla .. .. .	0 15 8	" " " " ..	"
Exors of D. Aubrey, Cowwarr .. .. .	2 12 6	Dividend on 35 shares ..	Dec., 1955
A. B. Bell, Traralgon .. .. .	0 7 6	" " 5 " " ..	"
Exors. of G. Berryman, c/o Fidelity Trustee, Hotham-street, Traralgon .. .. .	0 16 6	" " 6 " " ..	"
Exors. of T. S. Campbell, 73 Breed-street, Traralgon .. .. .	0 7 6	" " 5 " " ..	"
Jas. Caldwell, 105 Stewart-street, Brunswick .. .. .	1 2 6	" " 15 " " ..	"
W. J. Hiam, Officer .. .. .	0 15 0	" " 10 " " ..	"
C. G. Harrup, Nyands-street, Burwood .. .. .	0 7 6	" " 5 " " ..	"
A. Layton (address not known) .. .. .	0 15 0	" " 10 " " ..	"
J. T. O'Connor, Yannathan .. .. .	1 2 6	" " 15 " " ..	"
E. Peel, Kincaid-street, Wagga, N.S.W. .. .. .	0 7 6	" " 5 " " ..	"
F. Sheills, 236 Bay-street, North Brighton .. .. .	0 7 6	" " 5 " " ..	"
G. Summerfield, Gainsborough, via Darnum .. .. .	0 7 6	" " 5 " " ..	"
O. Brill, 103 Argyle-street, Traralgon .. .. .	0 7 6	" " 5 " " ..	"
Les. Caldwell, Traralgon South .. .. .	0 7 6	" " 5 " " ..	"
Joseph Caldwell, Gormandale .. .. .	1 2 6	" " 15 " " ..	"
K. M. Lane, Gormandale .. .. .	0 7 6	" " 5 " " ..	"
V. T. Morley, Gormandale .. .. .	1 10 0	" " 20 " " ..	"
Verna Morley, Gormandale .. .. .	0 7 6	" " 5 " " ..	"
R. T. Jeffs, Carrarung Lower .. .. .	0 15 0	" " 10 " " ..	"
E. R. Lane (address not known) .. .. .	0 15 0	" " 10 " " ..	"
	16 9 7		

128

D. YOUNG, Secretary.

Companies Act 1958—Tenth Schedule.  
C.I.G. (VICTORIA) PTY. LTD.

**R**EGISTER of Unclaimed Moneys held by C.I.G. (Victoria) Pty. Ltd.

Name of Owner in Books.	Last Known Address.	Total Amount Due to Owner.	Description of Unclaimed Money.	Date of Last Claim.
		£ s. d.		
G. Griel .. .. .	Roseberry, N.S.W. .. .. .	30 0 0	Unclaimed cheque	No Claim
T. L. Rogers and Sons .. .. .	Hume Highway, Springhurst .. .. .	21 0 0	" "	" "
T. A. Wynne .. .. .	593 Toorak-road, Toorak .. .. .	7 10 0	" "	" "
J. Chapman .. .. .	c/o Leyson Publicity Service, Temple Court, 422 Collins-street, Melbourne	3 0 0	" "	" "
Stuart Thomas .. .. .	Third Floor, Temple Court, 422 Collins- street, Melbourne	3 0 0	" "	" "
G. and F. Motors .. .. .	1424 High-street, Malvern .. .. .	10 0 0	" "	" "
Classic Pictures .. .. .	25 Coquette-street, West Geelong .. .. .	3 0 0	" "	" "
N. Bridges .. .. .	Room 55, 306 Little Collins-street, Melbourne	7 10 0	" "	" "

126

A. D. LITCHFIELD, Secretary in Victoria.

Companies Act 1958.—Tenth Schedule.  
DOWELL AUSTRALIA LIMITED.

**R**EGISTER of Unclaimed Moneys held by the Dowell Australia Limited, on the first day of March, 1962.

Name of Owner on Books.	Total Amount due to Owner.	Description of Unclaimed Money.	Date of last Claim.
	£ s. d.		
Massey Green, Margaret, 82 Eastern-road, Turamurra .. .. .	1 7 6	Final dividend for year ending 30th June, 1960, on 100 shares Final dividend for year ending 30th June, 1961, on— 800 shares .. .. . 100 shares .. .. . 200 .. .. . 100 .. .. . 100 .. .. . 400 .. .. .	No Claim " " " " " "
Dagg, Florence, 16 Chatsworth-avenue, Brighton .. .. .	11 0 0	800 shares .. .. .	"
Moore, Dorothea, 18 Richardson-avenue Dynrme .. .. .	1 7 6	100 shares .. .. .	"
Round, Bertram, 61 St. Helens-road, Hawthorn .. .. .	2 15 0	200 .. .. .	"
Saunders, Cyril, 114 Canterbury-road, Middle Park .. .. .	1 7 6	100 .. .. .	"
Smith, Florence, 72A Withers-street, Albert Park .. .. .	1 7 6	100 .. .. .	"
Estate of Caspani .. .. .	5 10 0	400 .. .. .	"

134

AUSTRALIAN PROVINCIAL ASSURANCE ASSOCIATION LIMITED.

**R**EGISTER of Unclaimed Moneys held by the Australian Provincial Assurance Association Limited.

Name of Owner on Books.	Total Amount Due to Owner.	Description of Unclaimed Money.	Date of Last Claim.
	£ s. d.		
Fraatz, E. P. .. .. .	1 17 9	Accident claim .. .. .	7.4.55
Schaaf, K. .. .. .	0 5 0	Accident Insurance Premium .. .. .	27.9.55
Nikich, S. .. .. .	10 5 0	Commission .. .. .	28.7.55
Hamilton, J. S. .. .. .	2 2 0	Medical Fee .. .. .	4.4.55
Smith and Moore .. .. .	2 2 0	Medical Fee .. .. .	4.4.55
Green, M. B. .. .. .	0 19 5	Medical Fee .. .. .	4.4.55

178

THE KAURI TIMBER COMPANY LIMITED.

**R**EGISTER of Unclaimed Moneys held by the Kauri Timber Company Ltd., in the form of the Tenth Schedule as at 1st March, 1962:

Name and Address of Owner on Books.	Total Amount Due to Owner.	Description of Unclaimed Money.	Date of Last Claim.
	£ s. d.		
F. P. Ryland, Bathurst-street, Ringwood, New South Wales .. .. .	0 3 2	Dividend .. .. .	Dec., 1940
R. Joughin, Unknown .. .. .	0 4 9	" .. .. .	June, 1953
W. Robinson, 214 Litchfield-street, Christchurch .. .. .	0 9 7	" .. .. .	Dec., 1951
A. Cornille, Unknown .. .. .	20 0 0	" .. .. .	" "
J. Littler, Unknown .. .. .	1 2 2	" .. .. .	" "
I. Mercer, Unknown .. .. .	2 10 0	" .. .. .	June, 1957
M. A. Mitchell, Unknown .. .. .	7 8 0	" .. .. .	" "
L. M. Bumby, Unknown .. .. .	20 0 0	" .. .. .	" "
B. M. Morris, 26 Glenbrook-avenue, East Malvern .. .. .	4 0 0	Debenture Interest .. .. .	Aug., 1950

119



Companies Act 1958.

THE CUDGEWA DAIRY CO. LTD., CORRYONG.

**R**EGISTER of Unclaimed Moneys held by the Cudgewa Dairy Co. Ltd., Corryong, as at 1st March, 1962.

Name and Address of Owner on Books.	Total Amount Due to Owner.	Description of Unclaimed Money.	Date of Last Claim.
	£ s. d.		
Behrens, Dittner (address unknown)	0 5 0	1954 Dividend	No Claim
Bennette, E. A., Cudgewa	0 5 0	" " "	"
Betson, W., Beetoomba	0 1 0	" " "	"
Brooks, Thelma A., c/o Post Office, Corryong	0 7 0	" " "	"
Crook, Benjamin (address unknown)	1 11 0	" " "	"
Davis, Thomas C., Corryong	1 0 0	" " "	"
Forrest, Leonie, Newtown, Beechworth	0 5 0	" " "	"
Jarvis, Ernie C., c/o Union Bank, Wangaratta	0 2 0	" " "	"
Klippel, Thelma D., Corryong	0 1 0	" " "	"
Lowden, Lawrence, Tintalra	0 2 0	" " "	"
Matassi, L. D., (address unknown)	0 5 0	" " "	"
Menere, Ina M., 287 Burwood-road, Hawthorn	0 5 0	" " "	"
McDonald, Arthur J., Cudgewa	0 1 0	" " "	"
Seaton, Ian C., c/o Mrs. B. H. Menere, 287 Burwood-road, Hawthorn	0 5 0	" " "	"
Seaton, Isabel M., c/o H. T. Webb, Walbundrie	0 5 0	" " "	"
Sheather, J. S. (Estate of), J. Sheather, Corryong	2 13 0	" " "	"
Surridge, John (address unknown)	0 1 0	" " "	"
Swingler, Benjamin T., (Address unknown)	0 2 0	" " "	"
Vogel, E. and Paul, 550 Smollett-street, Albury	0 5 0	" " "	"
Vogel, Paul, 550 Smollett-street, Albury	0 2 0	" " "	"
Webb, Herbert T., Walbundrie	0 5 0	" " "	"
	8 8 0		

140

Company No. 3165/30063.

ROBERT HARPER AND COMPANY LIMITED.

**R**EGISTER of Unclaimed Moneys held by Robert Harper and Company Limited as at 1st March, 1962.

Name of Owner on Books.	Total Amount Due to Owner.	Description of Unclaimed Money.	Date of Last Claim.
	£ s. d.		
Sundry Shareholders—names unknown	29 4 4	Dividend	
E. McColl (deceased), address unknown	10 10 0	Wages	24.3.52

149

No. 27.—2189/62.—4

Companies Act 1958.—No. 6455.—Section 153.

CHEETHAM SALT LIMITED.

**R**EGISTER of Unclaimed Moneys held by Cheetham Salt Limited, as at 1st March, 1962.

Name of Owner on Books.	Total Amount Due to Owner.	Description of Unclaimed Money.	Date of Last Claim.
	£ s. d.		
P. Phipps	10 12 8	Wages	17.6.55
E. Brzdak	10 0 10	"	27.1.56

135

The Companies Act 1958.—In the matter of SEVEN SEAS SHIPPING AGENCY PTY. LTD. (in Liquidation).

**N**OTICE is hereby given that at an Extraordinary Meeting of the members of the above-named company held on Tuesday, 27th February, 1962, it was resolved that the company be wound up voluntarily and at a meeting of creditors held on the same day, pursuant to section 201, it was resolved that for such purposes, Guy Newton Moore, of 34 Queens-road, Melbourne, S.C.2, chartered accountant, be appointed liquidator.

Notice is also given that, after 21 days from this date, I shall proceed to distribute the assets. All creditors having any claim against the company should furnish particulars of same by that date, otherwise I shall proceed to distribute the assets without regard to their claims.

Dated this 7th day of March, 1962.

GUY N. MOORE, Liquidator.

A. Capper, Moore and Sons, 34 Queens-road, Melbourne.  
184

The Companies Act 1958.—In the matter of TASKER SPORTING GOODS PROPRIETARY LIMITED (in Liquidation).

**N**OTICE is hereby given that a First Dividend is intended to be declared in this matter. Creditors who have not proved their debts by the 29th day of March, 1962, will be excluded from the dividend.

Dated this 8th day of March, 1962.

N. E. STRETTON, Liquidator.  
G. R. THOMPSON, Liquidator.

Kennedy, Smail and Middlemiss, solicitors, 31 Queen-street, Melbourne, C.1.  
177

Companies Act 1958.—In the matter of SEDDON ELECTRICS PTY. LTD. (in Voluntary Liquidation).—Creditors' Voluntary Winding Up; and in the matter of the Companies Act 1958.

**N**OTICE is hereby given that, in pursuance of section 245, the Final Meeting of the shareholders of the above-named company will be held at the office of A. J. Irwin, 4th Floor, 366 Bourke-street, Melbourne, on Friday, the 13th day of April, 1962, at a quarter to Four o'clock in the afternoon, for the purpose of laying before the meeting an account showing how the winding up of the above-named company has been conducted and the property of the company disposed of, and of giving any explanation thereof.

Dated this 7th day of March, 1962.

A. J. IRWIN, Liquidator, 366 Bourke-street, Melbourne.  
170

Companies Act 1958.—In the matter of SEDDON ELECTRICS PTY. LTD. (in Voluntary Liquidation).—Creditors' Voluntary Winding Up; and in the matter of the Companies Act 1958.

**N**OTICE is hereby given that, in pursuance of section 245, the Final Meeting of the creditors of the above-named company will be held at the office of A. J. Irwin, 4th Floor, 366 Bourke-street, Melbourne, on Friday, the 13th day of April, 1962, at Four o'clock in the afternoon, for the purpose of laying before the meeting an account showing how the winding up of the above-named company has been conducted and the property of the company disposed of, and of giving any explanation thereof.

Dated this 7th day of March, 1962.

A. J. IRWIN, Liquidator, 366 Bourke-street, Melbourne.  
171

Section 153 (4)—Companies Act 1958—Tenth Schedule.  
MCEWAN'S LIMITED.**R**EGISTER of Unclaimed Moneys held by McEwan's Limited.

Name and Address of Owner on Books.	Total Amount Due to Owner.	Description of Unclaimed Money.	Date of Last Claim.
	£ s. d.		
Estate of C. E. Moore (deceased), 82 The Grove, East Coburg .. .. .	13 15 0	Dividends on 50 shares for years 1955-60	No claim
Bruce M. Henderson, 185 Foster-street, Dandenong .. .. .	2 10 0	Dividends on 50 shares for year 1955	"
George Jones, 27 Shakespeare-grove, Hawthorn .. .. .	1 5 0	Dividend on 50 shares for year 1955	"

164

## THE MERRIGUM BAKERY COMPANY LIMITED (IN LIQUIDATION).

NOTICE is hereby given that it is intended to make a first and final distribution of the assets of the above company.

Creditors who have not lodged their proof of debt on or before 2nd April, 1962, will be excluded.

ARTHUR T. B. GOYEN, Liquidator. 147  
15 First-street, Black Rock.

## YALLOURN NORTH THEATRE PROPRIETARY LIMITED.

AT a General Meeting of the members of Yallourn North Theatre Proprietary Limited duly convened and held at 8a Church-street, Morwell, on 19th day of February, 1962, the following Special Resolution was passed:—

"That the company be wound up voluntarily."

And at such last-mentioned meeting, James Charles Bush, of 9 Ann-street, Morwell, was appointed liquidator, for the purposes of the winding up.

Dated the 24th day of February, 1962.

144 ERNEST PINCINI, Chairman.

## Companies Act 1958.—In the matter of RETROLL CONSTRUCTIONS PTY. LTD.

NOTICE is hereby given that at an Extraordinary General Meeting of the above-named company, duly convened and held at 366 Bourke-street, Melbourne, at a quarter-past Three o'clock in the afternoon, on the 6th day of March, 1962, the following Special Resolution was duly passed:—

"That it has been proved to the satisfaction of this meeting that the company cannot by reason of its liabilities continue in business, and that it is advisable to wind up and accordingly that the company be wound up voluntarily, and that Allan John Irwin, of 366 Bourke-street, Melbourne, be appointed Liquidator for the purpose of the winding up."

Dated this 7th day of March, 1962.

A. J. IRWIN, Liquidator, 366 Bourke-street, Melbourne. 169

## THE WARRACKNABEAL ELECTRIC LIGHT COMPANY LIMITED (IN VOLUNTARY LIQUIDATION).

NOTICE PURSUANT TO SECTION 195 (3) OF THE COMPANIES ACT 1958 IN THE STATE OF VICTORIA.

NOTICE is hereby given that at a General Meeting of Members of Warracknabeal Electric Light Company Limited held on the 27th February, 1962, the following Special Resolution was passed:—

"That the company be wound up voluntarily and that Francis Raymond Pomeroy, of 123 Scott-street, Warracknabeal, be appointed liquidator for the purposes of such winding up."

Dated this 1st day of March, 1962.

129 F. R. POMEROY, Liquidator.

## THE GLENORMISTON BUTTER AND CHEESE FACTORY COMPANY LTD. (IN VOLUNTARY LIQUIDATION).

NOTICE is hereby given that the Final Meeting of the members of The Glenormiston Butter and Cheese Factory Company Limited (in Voluntary Liquidation) will be held at the office of Spry, Clark, Tootell and Co., Fifth Floor, 339 Collins-street, Melbourne, on Tuesday, 17th April, 1962, at 10 a.m. in the morning, for the purpose of section 210 (i) of the Companies Act.

Dated this 14th day of March, 1962.

161 R. MOORE, Liquidator.  
L. GARNSWORTHY, Liquidator.

## The Companies Act 1958.

## ALLBUILT CONSTRUCTION SUPPLIES PTY. LTD.

NOTICE is hereby given that a First Dividend is intended to be declared in the above matter.

Creditors who have not proved their debts by the 26th day of March, 1962, may be excluded from this dividend.

J. K. HALL, Liquidator.

Dated this 8th day of March, 1962.

Hall and Rose, chartered accountants, 163 William-street, Melbourne. 154

## The Companies Act 1958.

## SUNSTYLE VENETIANS &amp; AWNINGS PTY. LTD. (IN LIQUIDATION).

NOTICE is hereby given that a First and Final Dividend is intended to be declared in the above matter.

Creditors who have not proved their debts by the 23rd day of March, 1962, may be excluded from this dividend.

J. K. HALL, Liquidator.

Dated this 7th day of March, 1962.

Hall and Rose, chartered accountants, 163 William-street, Melbourne. 155

**CREDITORS, next of kin, and others having claims** in respect of the estate of Harold Gesling Hayden, late of 7 Howard-street, Kew, retired (who died on 29th November, 1961), are to send particulars of their claims to Winifred Hayden and John Hamilton Wilson, care of the undersigned, by the 17th day of May, 1962, after which date they will distribute the assets, having regard only to the claims of which they then have notice.

COOK & MCCALLUM, solicitors, 422 Collins-street, Melbourne. 162

**CREDITORS, next of kin, and others having claims** in respect of the estate of Florence Hermandiene Bates, late of "Lovell House", 389 Alma-road, Caulfield, spinster (who died on the 2nd January, 1962), are to send particulars of their claims to Emily Irene Robertson and Stacey David Amherst Martin, care of the undersigned, by the 17th day of May, 1962, after which date they will distribute the assets, having regard only to the claims of which they then have notice.

COOK & MCCALLUM, solicitors, 422 Collins-street, Melbourne. 163

MARTIN HOWMAN, late of 5 Howard-street, Glen Iris, retired farmer, DECEASED.

CREDITORS, next of kin and others having claims in respect of the estate of the above-named deceased (who died on the 7th day of November, 1961) are required by the trustees of the estate, Elfreda Wills and Dennison Howman Charter, to send particulars to them, care of the under-mentioned solicitors, by the 11th day of May, 1962, after which date the trustees may convey or distribute the assets, having regard only to the claims of which they then have notice.

MORGAN, FYFFE & MULKEARNS, 108 Queen-street, Melbourne, solicitors. 152

CREDITORS, next of kin and others having claims in respect of the estate of Ivy Tyler, late of 15 Cooraminta-street, Brunswick, in the State of Victoria, married woman, deceased (who died on the 4th day of November, 1961), are to send the particulars of their claims to the executor, The Equity Trustees, Executors and Agency Company Limited, 472 Bourke-street, Melbourne, by the 18th day of May, 1962, after which date it will distribute the assets, having regard only to the claims of which it then has notice.

Dated the 7th day of March, 1962.

COLIN KEON-COHEN, solicitor, of 472 Bourke-street, Melbourne. 153

CREDITORS, next of kin and others having claims against the estate of Millie Moore, late of 37 Illawarra-road, Hawthorn, in the State of Victoria, widow, deceased (who died on the 5th day of February, 1962), are required to send particulars of their claims to John Francis Carroll, of 118 Queen-street, Melbourne, solicitor, the executor of the said will, before the 31st day of May, 1962, after which date he will distribute the assets, having regard only to the claims of which he then has notice.

JOHN F. CARROLL, solicitor, 118 Queen-street, Melbourne. 156

CREDITORS, next of kin or others having claims in respect of the estate of Henry Thomlinson, late of 51 Evans-street, Brunswick, in the State of Victoria, retired builder and traveller (who died on the 14th June, 1959), are to send particulars of their claims to The Perpetual Executors and Trustees Association of Australia Limited, of 100-104 Queen-street, Melbourne, by the 18th May, 1962, after which date it will distribute the assets, having regard only to the claims of which it then has notice.

CORR & CORR, solicitors, 290 Latrobe-street, Melbourne. 157

CREDITORS, next of kin and others having claims in respect of the estate of Doris Jean Paton, late of 63 Willis-street, Hampton, spinster and stenographer (who died on the 27th day of April, 1961), are to send particulars of their claims to Middleton, McEacharn, Shaw and Birch, solicitors, of 224 Queen-street, Melbourne, by the 17th day of May, 1962, after which date they will distribute the assets, having regard only to the claims of which they then have notice.

MIDDLETON, MCEACHARN, SHAW & BIRCH, solicitors, 224 Queen-street, Melbourne. 151

CREDITORS, next of kin and others having claims in respect of Marie Elizabeth McConchie, late of 3 Bernard-street, Cheltenham, widow, deceased (who died on the 31st day of July, 1961), are to send particulars of their claims to Equity Trustees, Executors and Agency Company Limited, of 472 Bourke-street, Melbourne, Victoria, by the 8th day of June, 1962, after which date it will distribute the assets, having regard only to the claims of which it then has notice.

FIELD, MORRISSEY & CO., solicitors, 25 Langhorne-street, Dandenong. 145

HAROLD FYFE MILNER, late of 44 Ulupna-road, Ormond, electrician, DECEASED.

CREDITORS, next of kin, and others having claims in respect of the estate of the deceased (who died on the 9th August, 1961), are required by the trustees, Amy Ambrose and Mervyn Clyde Boutcher, whose address is care of W. E. Pearcey and Ivey, solicitors, 226 High-street, Ashburton, to send particulars to the trustees by the 15th day of May, 1962, after which date the trustees may convey or distribute the assets, in regard only to the claims of which they then have notice. 121

CREDITORS, next of kin, and others having claims in respect of the estate of Lily Keane, late of 441 Wellington-street, Clifton Hill, widow, deceased (who died on the 24th day of May, 1961), are required to send particulars of their claims to Francis Patrick Byrne, of 169 Queen's-parade, Clifton Hill, dentist, the executor of the will of the said deceased, care of the undersigned, by the 22nd day of May, 1962, after which date the executor may convey or distribute the assets, having regard only to the claims of which he then has notice.

Dated this 8th day of March, 1962.

H. P. R. MORGANTI, of 191 McKean-street, North Fitzroy, solicitor for the executor. 117

NOTICE OF CLAIM.—CARL RUPERT TEPPER, late of Caravan Park, Horsham, in the State of Victoria, first constable of police, DECEASED, intestate.

CREDITORS, next of kin and others having claims in respect of the estate of the deceased (who died on the 19th day of September, 1961) are required by the administrator, Max Amos Tepper, of Pryors-lane, Horsham, labourer, to send particulars to the undersigned, by the 31st day of May, 1962, after which date the administrator may convey or distribute the assets, having regard only to the claims of which he then has notice.

STEWART F. BROWN & PROUDFOOT, solicitors, 74 Wilson-street, Horsham, solicitors for the administrator. 122

OLIVE TEMPE BAGOT, late of No. 107 Caroline-street, South Yarra, spinster (who died on the 29th December, 1961).

CREDITORS, next of kin and all others having claims in respect of the estate of the said deceased are required by the executor, The Trustees, Executors and Agency Company Limited, of No. 401 Collins-street, Melbourne, to send particulars of such claims to the said company, by the 16th May, 1962, after which date the said company will distribute the assets, having regard only to the claims of which it then has notice.

DAVIES, CAMPBELL & PIESSE, 401 Collins-street, Melbourne, solicitors. 150

MARIA KIRKPATRICK, formerly of Houston-street, Donald, but late of Ballarat-road, Deer Park, widow, DECEASED.

CREDITORS, next of kin and others having claims in respect of the estate of the deceased (who died on the 7th day of October, 1961) are required by the executors, Robert Roland Kirkpatrick, of Ballarat-road, Deer Park, farmer, and Aquilla William Kirkpatrick, of Newham, via Kyneton, farmer, to send particulars to them, care of the under-mentioned solicitor, by the 24th day of May, 1962, after which date the executors may convey or distribute the assets, having regard only to the claims of which they then have notice.

J. E. SIEVERS, solicitor, 17 Sun-crescent, Sunshine. 132

GEORGE PALMER, late of 6 Hewlett-street, Albion, quarry worker, DECEASED.

CREDITORS, next of kin and others having claims in respect of the estate of the deceased (who died on the 14th day of June, 1961) are required by the executors, Sarah Jane Robb, of 6 Hewlett-street, Albion, married woman, and Jack McManus, of 54 Station-street, Deer Park, electrician, to send particulars to them, care of the under-mentioned solicitor, by the 24th day of May, 1962, after which date the executors may convey or distribute the assets, having regard only to the claims of which they then have notice.

J. E. SIEVERS, solicitor, 17 Sun-crescent, Sunshine. 133

CREDITORS, next of kin and all other persons having claims against the estate of Patrick Cummins, late of 20 Leahy-street, Shepparton, retired farmer, deceased (who died on 23rd July, 1961), are required by the executors of the will, Vincent Cummins, of Pine-road, Shepparton aforesaid, butcher, and Michael Thomas Kennedy, of Caniambo West, farmer, to send particulars of such claims to them, care of the undersigned, on or before the 31st May, 1962, after which date the executors will distribute the assets, having regard only to the claims of which they then have notice.

Dated the 6th day of March, 1962.

JOHN F. RIORDAN, solicitor, 26 Fryers-street, Shepparton. 193

**CREDITORS**, next of kin, and others having claims in respect of the estate of William John Gates, formerly of Leongatha South, but late of Tarwin, retired farmer, deceased (who died on the 29th October, 1961), are required to send particulars of their claims to Anthony Noel Lee Atkinson, formerly of Leongatha, now of Hamilton, in the State of Queensland, solicitor, the executor appointed by the deceased's will, care of the under-mentioned solicitors, by the 31st day of May, 1962, after which date the executor may convey or distribute the assets, having regard only to the claims of which he then has notice.

MARSHALL, MACKENZIE & WELSHMAN, solicitors,  
Leongatha. 158

**CREDITORS**, next of kin, and others having claims in respect of the estate of John Garfield Bird, late of Mirboo North, farmer, deceased (who died on the 3rd day of September, 1960), are requested to send particulars of their claims to Elsie Louise Agnes Bird, of Mirboo North, widow, the administratrix, care of the under-mentioned solicitors, by the 31st day of May, 1962, after which date the administratrix may convey or distribute the assets, having regard only to the claims of which she then has notice.

MARSHALL, MACKENZIE & WELSHMAN, solicitors,  
Leongatha. 159

PHYLLIS MAY WILSON, late of 22 Bloomfield-road, Ascot Vale, married woman, DECEASED, intestate.

**CREDITORS**, next of kin, and others having claims in respect of the estate of the deceased (who died on the 11th November, 1961), are required by William Gordon Wilson, of 22 Bloomfield-road, Ascot Vale, boiler-maker (the administrator to whom letters of administration were granted on 8th March, 1962), to send particulars to him, care of the undersigned solicitor, by the 15th day of May, 1962, after which date the administrator may convey or distribute the assets, having regard only to the claims of which he then has notice.

DUDLEY A. TREGENT, B.A., LL.M., solicitor, of 422  
Collins-street, Melbourne. 165

**CREDITORS**, next of kin, and others having claims in respect of the estate of Jeanne Athol Renton, late of 6 Ormsby-grove, Toorak, married woman, deceased (who died on the 19th day of October, 1961), are required to send particulars of their claims to The Trustees, Executors, and Agency Company Limited and Francis Ronald Hector MacDonald at the address of the said company, 401 Collins-street, Melbourne, by the 25th day of May, 1962, after which date they will distribute the assets, having regard only to the claims of which they then have notice.

LYNCH & MACDONALD, 360 Collins-street, Melbourne,  
solicitors for the executors. 166

**CREDITORS**, next of kin, and all others having claims in respect of the estate of Violet Walker Park, late of 151 Fitzroy-street, St. Kilda, in the State of Victoria, widow, deceased (who died on the 25th day of July, 1961), are to send the particulars of their claims to her administrator, The Trustees, Executors and Agency Company Limited, of 401 Collins-street, Melbourne, in the said State, by the 16th day of May, 1962, after which date the said administrator will distribute the assets, having regard only to the claims of which it then has notice.

HADEN SMITH & FITCHETT, solicitors, 405 Collins-  
street, Melbourne. 160

**CREDITORS**, next of kin, and others having claims in respect of the estate of Frederick Albert Browne, late of Auckland, in the Dominion of New Zealand, architect, deceased (who died on the 21st day of May, 1961), are to send particulars of their claims to The Trustees, Executors, and Agency Company Limited, of 401 Collins-street, Melbourne, by the 18th day of May, 1962, after which date the said company will distribute the estate of the said deceased, having regard only to the claims of which it then has notice.

GILLOTT, MOIR & AHERN, solicitors, of 95 Queen-  
street, Melbourne. 167

ANNIE RAMSDALE, late of 7 Robinson-street, Sunshine,  
spinster, DECEASED.

**CREDITORS**, next of kin and others having claims in respect of the estate of the deceased (who died on the 13th day of January, 1961) are required by the executor, William Charles Ramsdale, of 86 Mountain View-road, Montmorency, clerk, to send particulars to him, care of the under-mentioned solicitor, by the 24th day of May, 1962,

after which date the executor may convey or distribute the assets, having regard only to the claims of which he then has notice.

J. E. SIEVERS, solicitor, 17 Sun-crescent, Sunshine.  
131

**CREDITORS**, next of kin and others having claims in respect of the estate of Frederick Thomas Henry Goucher, late of 6 Relowe-crescent, Box Hill North, retired horticulturalist, deceased (who died on the 10th day of November, 1960), are required by the executor, Frederick Alan Goucher, of 6 Relowe-crescent, Box Hill North, trustee officer, to send particulars of their claims to him, care of his solicitors, at their address below, by the 16th day of May, 1962, after which date he may convey or distribute the assets, having regard only to the claims of which he then has notice.

UPTON & ETTIELSON, solicitors, 100 Queen-street,  
Melbourne. 173

**CREDITORS**, next of kin and others having claims in respect of the estate of Reginald George Monson, late of 38 Batman-street, Eltham, carpenter, deceased (who died on the 1st day of January, 1961), are to send particulars of their claims to Herbert Battye, care of Best, Hooper, Rintoul and Shallard, 100 Queen-street, Melbourne, on or before the 15th day of May, 1962, after which date the said Herbert Battye will distribute the assets of the said deceased, having regard only to the claims of which he then has notice.

BEST, HOOPER, RINTOUL & SHALLARD, solicitors,  
100 Queen-street, Melbourne. 176

CHARLES EDWARD RIGBY, late of 2 Venice-street,  
Mentone, retired, DECEASED.

**CREDITORS**, next of kin and others having claims in respect of the estate of the deceased (who died on the 24th day of September, 1961), are required by his personal representative, Vere Raymond Johnstone, of 90 William-street, Melbourne, solicitor, to send particulars to him, care of the undersigned, at their address mentioned hereunder, by the 15th day of May, 1962, after which date the personal representative may convey or distribute the assets, having regard only to the claims of which he then has notice.

RIGBY & FIELDING, solicitors, 90 William-street, Mel-  
bourne. 179

EDWIN BRITTON, late of 76 Spring-street, Preston,  
nurseryman, DECEASED.

**CREDITORS**, next of kin and others having claims in respect of the estate of the deceased (who died on the 28th day of August, 1961), are required by his personal representative, Vere Raymond Johnstone, of 90 William-street, Melbourne, solicitor, to send particulars to him, care of the undersigned, at their address mentioned hereunder, by the 15th day of May, 1962, after which date the personal representative may convey or distribute the assets, having regard only to the claims of which he then has notice.

RIGBY & FIELDING, solicitors, 90 William-street, Mel-  
bourne. 180

JOSEPH FRANCIS CAVAGNA, late of 28 Rodney-street,  
Bendigo, retired machinery merchant, DECEASED (who died on the 23rd day of March, 1961).

**CREDITORS**, next of kin and all other persons having claims against his estate are required by the executor, Sandhurst and Northern District Trustees, Executors and Agency Company Limited, of View-street, Bendigo, to send particulars thereof to it, on or before the 14th day of May, 1962, after which date it will distribute the estate, having regard only to the claims of which it then has notice.

Dated the 9th day of March, 1962.

HYETT, WILLIS & HYETT, 51 Bull-street, Bendigo,  
solicitors for the executor. 192

**CREDITORS**, next of kin and others having claims in respect of the estate of Emily Alice Noel, late of 2A Bent-street, Moonee Ponds, gentlewoman, deceased (who died on the 7th day of June, 1961), are required by the executors, William Albert Goghlan, of 411 Collins-street, Melbourne, chartered accountant, and Ralph Noel Thompson, of 28 Charteris-drive, East Ivanhoe, public servant, to send particulars of their claims to them, care of their solicitors, at their address below, by the 16th day of May, 1962, after which date it will distribute the assets, having regard only to the claims of which it then has notice.

UPTON & ETTIELSON, solicitors, 100 Queen-street,  
Melbourne. 172

**IMPOUNDINGS**

**KEILOR.**—Impounded in Keilor City Pound.  
 1 white female goat (milking), no visible brand  
 . If not claimed and expenses paid, to be sold on 29th  
 March, 1962.  
 L. S. ANDERSON,  
 195—9/  
 Poundkeeper.

**KERANG.**—Impounded in Kerang Pound.  
 2 Dorset Horn rams, two-tooth, no visible brand  
 1 Merino ewe, split on top of right ear, branded like T  
 on rump  
 . If not claimed and expenses paid, to be sold on 30th  
 March, 1962.  
 F. NANCARROW,  
 194—12/  
 Poundkeeper.

**LARA.**—Impounded in Lara Pound from Corio.  
 1 ram, no visible brand  
 2 ewes, green raddle mark down back, no visible brand  
 1 ram, red dot on back, Eddington 4 on right ear tag  
 1 ram, red dot on back, no visible brand  
 . If not claimed and expenses paid, to be sold on 31st  
 March, 1962.  
 RONALD W. ELLIS,  
 197—13/6  
 Poundkeeper.

**TRARALGON.**—Impounded in Traralgon Pound on 27th  
 February, 1962.  
 1 brown Jersey heifer, about six months, full ears, horns,  
 no visible brand  
 . Impounded on 3rd March, 1962.  
 1 fawn Jersey steer, wad hole off ear, no visible brand  
 . If not claimed and expenses paid, to be sold on 23rd  
 March, 1962.  
 J. LINDSAY,  
 123—15/  
 Poundkeeper.

**WARRNAMBOOL.**—Impounded in Warrnambool Pound.  
 1 brown and white Jersey cow, no visible brand  
 1 yellow heifer, no visible brand  
 . If not claimed and expenses paid, to be sold on 28th  
 March, 1962.  
 M. STONEHOUSE,  
 198—10/6  
 Poundkeeper.

**STATE ACTS, 1958.**

COPIES of the following Acts of Parliament of Victoria  
 may be obtained at the Government Printing Office,  
 or from any bookseller, at the price set opposite to each:—

No.	Price. s. d.
6171. Milk Board (Members) .. .. .	0 6
6172. Consolidated Revenue .. .. .	0 6
6173. Footscray (Lawson-street) Land .. .. .	0 6
6174. Railways (Contracts) .. .. .	0 6
6175. Game (Destruction) .. .. .	0 6
6176. Western Metropolitan Market (Amendment) .. .. .	0 6
6177. Local Government (Portland) .. .. .	0 6
6178. Melbourne (Flinders-street) Land .. .. .	0 6
6179. Public Account Advances (Home Builders' Account) .. .. .	0 6
6180. Snowy Mountains Hydro-electric Agreements .. .. .	2 6
6181. Gas and Fuel Corporation (Bendigo Undertaking) .. .. .	1 0
6182. Acts Interpretation .. .. .	0 6
6183. Railways (Employés) .. .. .	0 6
6184. Monash University .. .. .	1 9
6185. University (Council) .. .. .	0 6
6186. Marriage (Amendment) .. .. .	0 6
6187. Consolidated Revenue .. .. .	0 6
6188 } to } Consolidated Acts 1958.	
6421. } 6422. Amendments Incorporation .. .. .	0 6
6423. Police Offences (Trespass to Farms) .. .. .	0 6
6424. Fern Tree Gully and Gembrook Railway (Reconstruction) Amendment .. .. .	0 6
6425. Kew and Heidelberg Lands .. .. .	0 6
6426. Gas and Fuel Corporation (Maryborough Undertaking) .. .. .	0 6
6427. Local Government (Dandenong) .. .. .	0 6
6428. Responsible Ministers .. .. .	0 6
6429. Supreme Court and County Court (Judges) .. .. .	0 6

STATE ACTS, 1958—continued.

No.	Price. s. d.
6430. Melbourne and Metropolitan Board of Works (Borrowing Powers and Debentures) .. .. .	0 6
6431. Consolidated Revenue .. .. .	0 6
6432. Fences (Amendment) .. .. .	0 6
6433. Contracts of Sale (Payments) .. .. .	0 6
6434. Metropolitan Fire Brigades (Board) .. .. .	0 6
6435. Process Servers and Inquiry Agents (Repossession) .. .. .	0 6
6436. Housing (Broadmeadows Land) .. .. .	0 6
6437. Consolidated Revenue .. .. .	0 6
6438. Instruments (Bills of Sale) .. .. .	0 6
6439. Churches of Christ, Scientist Incorporation .. .. .	0 9
6440. Wheat Industry Stabilization .. .. .	1 0
6441. Dog (Guides for the Blind) .. .. .	0 6
6442. Monash University (Acquisition of Land) .. .. .	0 6
6443. Soldier Settlement (Loan) .. .. .	0 6
6444. Home Finance (Amendment) .. .. .	0 6
6445. Friendly Societies (Amendment) .. .. .	0 6
6446. Co-operative Housing Societies (Guarantees) .. .. .	0 6
6447. Land Tax (Exemptions and Rates) .. .. .	0 6
6448. River Murray Waters .. .. .	0 9
6449. Victorian Inland Meat Authority (Advances) .. .. .	0 6
6450. Stamps (Amendment) .. .. .	1 3
6451. Superannuation (Amendment) .. .. .	0 6
6452. Grain Elevators (Amendment) .. .. .	0 6
6453. Geelong Harbor Trust Lands .. .. .	1 0
6454. Melbourne Cricket Club (Guarantee) .. .. .	0 6
6455. Companies .. .. .	15 0
6456. Local Government (City of Oakleigh) .. .. .	0 6
6457. Co-operative Housing Societies (Residential Flats) .. .. .	0 6
6458. Transport Regulation (Fund) .. .. .	0 6
6459. Railways (Standardization Agreement) .. .. .	1 0
6460. Water Supply Loan Application .. .. .	1 3
6461. Co-operative Housing Societies (Insurance) .. .. .	0 6
6462. Racing (Amendment) .. .. .	0 6
6463. Motor Car (Third-party Insurance) .. .. .	0 6
6464. Firearms (Amendment) .. .. .	0 6
6465. Hawthorn and Kew Railway (Dismantling) .. .. .	0 6
6466. Juries (Amendment) .. .. .	0 9
6467. Tourist (Amendment) .. .. .	0 6
6468. Filled Milk .. .. .	0 9
6469. St. Kilda and Brighton Electric Street Railway (Dismantling) .. .. .	0 6
6470. Judges Salaries .. .. .	0 6
6471. Public Officers Salaries and Allowances .. .. .	0 6
6472. Ballarat Railway Land .. .. .	0 6
6473. Game (Licences) .. .. .	0 6
6474. Geelong Waterworks and Sewerage (Amendment) .. .. .	0 6
6475. Coal Mine Workers Pensions (Early Retirement) .. .. .	0 6
6476. Revenue Deficit Funding .. .. .	0 6
6477. Railway Loan Application .. .. .	1 3
6478. Administration and Probate (Amendment) .. .. .	0 9
6479. Local Government Department .. .. .	0 6
6480. Police Offences (Gaming) .. .. .	0 6
6481. Marine (Amendment) .. .. .	0 6
6482. Public Works Loan Application .. .. .	0 9
6483. Motor Car (Amendment) .. .. .	0 6
6484. Appropriation of Revenue, 1957-58 .. .. .	6 9
6485. Water (Valuations) .. .. .	0 6
6486. Police Regulation (Amendment) .. .. .	0 6
6487. State Forests Loan Application .. .. .	0 6
6488. Police Offences (Trap Shooting) .. .. .	0 6
6489. Sessional Acts Revision .. .. .	1 3

A. C. BROOKS,  
 Government Printer.

**STATE ACTS, 1959.**

COPIES of the following Acts of Parliament of Victoria  
 may be obtained at the Government Printing Office,  
 or from any bookseller, at the price set opposite to each:—

No.	Price. s. d.
6490. Water (Contracts) .. .. .	0 6
6491. Property Law (Amendment) .. .. .	0 6
6492. Agricultural Education (Amendment) .. .. .	0 6
6493. Swan Hill Railway Land .. .. .	0 6
6494. Stamps (Amendment) .. .. .	0 6
6495. Justices (Amendment) .. .. .	0 6
6496. Consolidated Revenue .. .. .	0 6
6497. State Electricity Commission (Tourist Areas) .. .. .	0 6
6498. Aborigines (Houses) .. .. .	0 6
6499. Superannuation (Amendment) .. .. .	0 6
6500. Country Roads (Amendment) .. .. .	0 6
6501. Bendigo Land .. .. .	0 6
6502. University (Honorary Degrees) .. .. .	0 6

STATE ACTS, 1959—continued.

No.	Price. s. d.
6503. Melbourne and Metropolitan Board of Works (Reconstitution) .. .. .	0 9
6504. Land (Charges) .. .. .	0 6
6505. Statute Law Revision .. .. .	1 0
6506. Legal Profession Practice (Amendment) .. .. .	0 6
6507. Health .. .. .	0 9
6508. Fisheries (Amendment) .. .. .	0 6
6509. Water (Irrigation Districts) .. .. .	0 6
6510. Broadmeadows (Rating on Unimproved Values) .. .. .	0 6
6511. Trustee (Amendment) .. .. .	0 6
6512. Nurses .. .. .	0 6
6513. Hairdressers Registration (Amendment) .. .. .	0 6
6514. Labour and Industry (Retail Trading Hours) .. .. .	0 6
6515. Milk Board (Amendment) .. .. .	0 6
6516. Stock Diseases (Amendment) .. .. .	0 9
6517. Hepburn Springs Land .. .. .	0 9
6518. Vermin and Noxious Weeds .. .. .	1 0
6519. The Constitution Act Amendment (Parliamentary Salaries) .. .. .	0 9
6520. Public Works Committee (Amendment) .. .. .	0 6
6521. Land (Plantation Areas) .. .. .	0 6
6522. National Art Gallery and Cultural Centre (Amendment) .. .. .	0 6
6523. Portland Harbor Trust (Amendment) .. .. .	0 6
6524. Revocation and Excision of Crown Reservations .. .. .	1 9
6525. Tourist (Amendment) .. .. .	0 6
6526. Town and Country Planning (Amendment) .. .. .	0 6
6527. Vegetation and Vine Diseases (Amendment) .. .. .	0 6
6528. Medical .. .. .	0 9
6529. Bread Industry .. .. .	1 0
6530. Cemeteries .. .. .	0 9
6531. Hire-Purchase .. .. .	2 3
6532. Motor Car (Amendment) .. .. .	0 9
6533. Motor Car (Hours of Driving) .. .. .	0 6
6534. Land Settlement .. .. .	1 9
6535. Local Government (Amendment) .. .. .	1 6
6536. Melbourne and Metropolitan Board of Works (Amendment) .. .. .	1 3
6537. Consolidated Revenue .. .. .	0 6
6538. War Veterans' Homes Trust .. .. .	1 3
6539. Frustrated Contracts .. .. .	0 6
6540. Evidence (Amendment) .. .. .	0 6
6541. Amendments Incorporation (Extension) .. .. .	0 6
6542. Melbourne and Richmond Lands .. .. .	0 9
6543. Local Government (Councillors' Declarations) .. .. .	0 6
6544. Transfer of Land (Amendment) .. .. .	0 6
6545. State Savings Bank (Amendment) .. .. .	0 6
6546. Country Roads (Offices and Buildings) .. .. .	0 6
6547. Statute Law Revision .. .. .	0 6
6548. Marriage (Fees) .. .. .	0 6
6549. State Electricity Commission (Hazelwood Power Station) .. .. .	0 6
6550. Fences (Amendment) .. .. .	0 6
6551. Coroners (Amendment) .. .. .	0 6
6552. Stamps .. .. .	0 6
6553. Motor Car (Insurance Surcharge) .. .. .	0 6
6554. Entertainments Tax (Reduction) .. .. .	0 6
6555. Melbourne and Metropolitan Tramways (Amendment) .. .. .	0 9
6556. Local Government (Municipalities Assistance Fund) .. .. .	0 6
6557. Police Offences (Penalties) .. .. .	0 6
6558. Consolidated Revenue .. .. .	0 6
6559. Road Traffic (Infringements) .. .. .	0 9
6560. Superannuation .. .. .	0 6
6561. Crimes (Penalties) .. .. .	0 6
6562. Alphington to East Preston Railway Construction (Housing) .. .. .	0 6
6563. Motor Car .. .. .	1 0
6564. Registration of Births, Deaths and Marriages .. .. .	2 3
6565. Coal Mines (Pensions) .. .. .	0 6
6566. Water Supply Loan Application .. .. .	1 3
6567. Game (Amendment) .. .. .	0 6
6568. Metropolitan Fire Brigades (Borrowing Powers) .. .. .	0 6
6569. Health (Amendment) .. .. .	0 6
6570. Police Regulation (Delegation of Powers) .. .. .	0 6
6571. Imprisonment of Fraudulent Debtors (Depositions) .. .. .	0 6
6572. Crimes (Sentences and Parole) .. .. .	0 6
6573. Gas and Fuel Corporation (Colonial Gas Association Undertakings) .. .. .	1 3
6574. Racing (Meetings) .. .. .	0 6
6575. Landlord and Tenant (Amendment) .. .. .	0 6
6576. Distribution of Population (Joint Committee) .. .. .	0 6
6577. Lifts and Cranes .. .. .	1 0
6578. Cemeteries (Investment of Funds) .. .. .	0 6
6579. Public Service (Amendment) .. .. .	0 6
6580. Trustee (Mortgages) .. .. .	0 6

STATE ACTS, 1959—continued.

No.	Price. s. d.
6581. Justices (Amendment) .. .. .	0 6
6582. Water (Irrigation) .. .. .	1 9
6583. Country Fire Authority (Amendment) .. .. .	0 6
6584. Milk Board (Milk Shops) .. .. .	0 6
6585. Forests (Pulpwood Agreement) .. .. .	1 3
6586. Police Offences (Betting) .. .. .	0 6
6587. Revenue Deficit Funding .. .. .	0 6
6588. Geelong Trades Hall Council (Trustees) .. .. .	0 6
6589. Melbourne Harbor Trust (Commissioners) .. .. .	0 6
6590. Railway Loan Application .. .. .	1 3
6591. State Forests Loan Application .. .. .	0 6
6592. Land Tax (Rates) .. .. .	0 6
6593. Teaching Service (Amendment) .. .. .	0 6
6594. Land (Special Grants) .. .. .	0 9
6595. Labour and Industry (Motor Car Shops) .. .. .	0 6
6596. Home Finance (Financial) .. .. .	0 6
6597. Dromana Land (Arthur's Seat Public Park) .. .. .	0 6
6598. Money Lenders (Amendment) .. .. .	0 6
6599. Landlord and Tenant (Fair Rents) .. .. .	0 6
6600. Labour and Industry (Amendment) .. .. .	0 6
6601. Local Government .. .. .	0 9
6602. Public Works Loan Application .. .. .	0 6
6603. Soldier Settlement (Amendment) .. .. .	0 6
6604. Water (Land Reclamation) .. .. .	0 6
6605. Mental Health .. .. .	4 3
6606. Appropriation of Revenue .. .. .	7 0

Table of Acts and Enactments passed date of operation, &c. .. .. . 0 6

A. C. BROOKS,  
Government Printer.

STATE ACTS, 1960.

COPIES of the following Acts of Parliament of Victoria may be obtained at the Government Printing Office, or from any bookseller, at the price set opposite to each:—

No.	Price. s. d.
6607. Anzac Day .. .. .	1 0
6608. Agricultural Lime (Amendment) .. .. .	0 6
6609. Motor Car (Commencement) .. .. .	0 6
6610. Fisheries (Change of Title) .. .. .	0 6
6611. Stamps (Amendment) .. .. .	0 6
6612. Land (Public Authorities) .. .. .	0 6
6613. Coal Canal Bridge .. .. .	0 6
6614. Metropolitan Fire Brigades (Borrowing Powers) .. .. .	0 6
6615. Wodonga Lands Exchange .. .. .	0 6
6616. Licensing (Fees) .. .. .	0 6
6617. Home Finance (Loans to Minors) .. .. .	0 6
6618. Co-operative Housing Societies (Amendment) .. .. .	0 6
6619. Racing (Totalizators Extension) .. .. .	1 0
6620. Companies .. .. .	0 6
6621. Judges Salaries and Allowances .. .. .	0 6
6622. Coal Mines (Pensions Contributions) .. .. .	0 6
6623. Landlord and Tenant (Further Amendment) .. .. .	0 6
6624. Public Officers Salaries and Allowances .. .. .	0 9
6625. Legal Profession Practice (Amendment) .. .. .	0 6
6626. Church of England in Australia Constitution .. .. .	1 9
6627. Companies (Fees) .. .. .	0 6
6628. Motor Car (Amendment) .. .. .	1 0
6629. Geelong Waterworks and Sewerage (Amendment) .. .. .	0 6
6630. Latrobe Valley (Financial) .. .. .	0 6
6631. Labour and Industry (Amendment) .. .. .	0 6
6632. Acts Interpretation .. .. .	0 6
6633. Children's Court (Enforcement of Awards) .. .. .	0 6
6634. Supreme Court (Proceedings before Master) .. .. .	0 6
6635. Melbourne and Metropolitan Board of Works (Borrowing Powers) .. .. .	0 6
6636. Electoral Provinces .. .. .	0 9
6637. Town and Country Planning (Amendment) .. .. .	0 6
6638. Racing (Dog Races) .. .. .	0 6
6639. Industrial Safety Advisory Council .. .. .	0 6
6640. Administration and Probate (Offices) .. .. .	0 6
6641. Justices (Bail) .. .. .	0 6
6642. National Parks (Amendment) .. .. .	0 9
6643. Medical (Amendment) .. .. .	0 6
6644. Melbourne Harbor Trust Lands .. .. .	1 0
6645. Weights and Measures (Penalties) .. .. .	0 6
6646. Transfer of Land (Stratum Estates) .. .. .	0 6
6647. Local Government (Preston Streets Agreement) .. .. .	0 9
6648. John Storey Memorial Fund .. .. .	0 6
6649. Police Offences (Amendment) .. .. .	0 6
6650. Motor Car (Third-Party Insurance) .. .. .	0 6
6651. Social Welfare .. .. .	2 9
6652. City of Melbourne Underground Railway Construction .. .. .	1 0

## STATE ACTS, 1960—continued.

No.	Price.	
	s.	d.
6653. Valuation of Land .. .. .	1	3
6654. Milk Board (Amendment) .. .. .	0	6
6655. Victoria Racing Club (Amendment) .. .. .	0	6
6656. Consolidated Revenue .. .. .	0	6
6657. Consolidated Revenue .. .. .	0	6
6658. Motor Car (Driving) .. .. .	0	6
6659. Licensing (Amendment) .. .. .	1	0
6660. Consolidated Revenue .. .. .	0	6
6661. Consolidated Revenue .. .. .	0	6
6662. Friendly Societies (Dental Clinics) .. .. .	0	6
6663. Cancer (Amendment) .. .. .	0	6
6664. Dried Fruits (Amendment) .. .. .	0	6
6665. Barwon Heads Lands Exchange .. .. .	0	6
6666. Revocation of Crown Reservations .. .. .	0	6
6667. The Constitution Act Amendment (Expenses) .. .. .	0	6
6668. Supreme Court (Orders) .. .. .	0	6
6669. Gippsland Railway Deviation .. .. .	0	9
6670. Hamilton Stockyards Railway Construction .. .. .	0	6
6671. Nurses (Amendment) .. .. .	0	6
6672. Ministry of Transport (Railway Officers) .. .. .	0	6
6673. Fruit and Vegetables (Road Barriers) .. .. .	0	6
6674. Transport Regulation (Qualifications of Chairman) .. .. .	0	6
6675. Motor Car (Insurance Surcharge Continuance) .. .. .	0	6
6676. Geelong Harbor Trust (Freezing Works Agreement) .. .. .	0	9
6677. Western Metropolitan Market (Amendment) .. .. .	0	6
6678. Racing (Trotting Races) .. .. .	0	6
6679. Wattle Park Land .. .. .	0	6
6680. Surplus Revenue .. .. .	0	6
6681. Milk and Dairy Supervision (Research Contributions) .. .. .	0	6
6682. Tourist (Amendment) .. .. .	0	6
6683. Fisheries (Crayfish) .. .. .	0	6
6684. Audit (Amendment) .. .. .	0	6
6685. Sale of Allotments of Land (Amendment) .. .. .	0	6
6686. Cattle Compensation (Amendment) .. .. .	0	6
6687. Co-operative Housing Societies (Guarantees) .. .. .	0	6
6688. State Library National Gallery National Museum and Institute of Applied Science .. .. .	1	3
6689. Medical (Blood Transfusion) .. .. .	0	6
6690. The Constitution Act Amendment (Treating) .. .. .	0	6
6691. State Forests Loan Application .. .. .	0	6
6692. Local Authorities Superannuation (Amendment) .. .. .	0	9
6693. Local Government (Disqualification) .. .. .	1	0
6694. Superannuation (Additions to Pensions) .. .. .	0	6
6695. Police Regulation (Pensions) .. .. .	0	6
6696. Trustee Companies (Amalgamation) .. .. .	0	6
6697. Geelong and Colac Railway (Deviation) .. .. .	0	6
6698. University Colleges Lands .. .. .	0	6
6699. Local Government (Private Street) .. .. .	0	6
6700. Northcote School .. .. .	0	6
6701. Public Works Loan Application .. .. .	0	9
6702. Tower Hill and Malmsbury Lands .. .. .	0	6
6703. Coal Mines (Pensions) .. .. .	0	6
6704. Vermin and Noxious Weeds (Financial) .. .. .	0	6
6705. Navigable Waters (Oil Pollution) .. .. .	1	0
6706. Business Names (Public Borrowings) .. .. .	0	6
6707. Health (Tuberculosis Arrangement) .. .. .	0	6
6708. Water Supply Loan Application .. .. .	1	3
6709. Railway Loan Application .. .. .	1	0
6710. Land Tax (Relief) .. .. .	0	6
6711. Land Tax (Rates) .. .. .	0	6
6712. Monash University (Amendment) .. .. .	0	6
6713. National Fitness Council of Victoria .. .. .	1	0
6714. Local Government (Keilor Waverley and Springvale) .. .. .	0	6
6715. Explosives .. .. .	2	3
6716. Statute Law Revision .. .. .	0	9
6717. Motor Car (Abolition of Owners' Certificates) .. .. .	0	6
6718. Road Traffic (Amendment) .. .. .	0	6
6719. Milk Board (Powers) .. .. .	0	6
6720. Marketing of Primary Products (Members) .. .. .	0	6
6721. Melbourne and Geelong Mortgages .. .. .	0	9
6722. Building Societies (Amendment) .. .. .	0	9
6723. Local Government (Scaffolding Inspection) .. .. .	0	9
6724. State Electricity Commission (Borrowing) .. .. .	0	6
6725. Labour and Industry (Butchers' Shops) .. .. .	0	6
6726. Country Fire Authority (Sawmill Burners) .. .. .	0	6
6727. Sewerage Districts (Amendment) .. .. .	1	0
6728. Water (Amendment) .. .. .	1	3
6729. Housing (Powers) .. .. .	0	6
6730. Entertainment Tax (Amendment) .. .. .	0	6
6731. Crimes (Kidnapping) .. .. .	0	6
6732. Health (Amendment) .. .. .	0	6
6733. Game (Licences) .. .. .	0	6
6734. Estate Agents (Amendment) .. .. .	0	6
6735. Appropriation of Revenue .. .. .	8	6

A. C. BROOKS,  
Government Printer.

## STATE ACTS, 1961.

COPIES of the following Acts of Parliament of Victoria may be obtained at the Government Printing Office, or from any bookseller, at the price set opposite to each:—

No.	Price.	
	s.	d.
6736. Public Works Committee (Special Exemption) .. .. .	0	6
6737. Railways (Permanent Service) .. .. .	0	6
6738. Superannuation (Railway Service) .. .. .	0	6
6739. Stamps (Amendment) .. .. .	0	6
6740. Employers and Employés (Attachment of Wages) .. .. .	0	6
6741. St. Kilda (Goldsmith and Shelley Streets) Land .. .. .	0	6
6742. Municipal Association (Amendment) .. .. .	0	6
6743. Wormbete Land .. .. .	0	6
6744. Grain Elevators (Borrowing) .. .. .	0	6
6745. Housing (Amendment) .. .. .	0	6
6746. Land (North-West Mallee Settlement Areas) .. .. .	0	9
6747. Ripon Peace Memorial Hospital Trust .. .. .	0	6
6748. Road Traffic (Parking on Railway and Municipal Property) .. .. .	0	6
6749. Co-operation (Amendment) .. .. .	0	6
6750. Heidelberg and Toolamba Lands Exchange .. .. .	0	6
6751. Town and Country Planning (Amendment) .. .. .	0	6
6752. Janet Clarke Hall .. .. .	0	6
6753. Transport Regulation (Compensation) .. .. .	0	6
6754. Bread Industry (Legal Proceedings) .. .. .	0	6
6755. Milk Pasteurization (Licences) .. .. .	0	6
6756. Health (Proprietary Medicines) .. .. .	0	6
6757. Police Offences (False Reports to Police) .. .. .	0	6
6758. Evidence (Children) .. .. .	0	6
6759. Statute Law Revision .. .. .	0	6
6760. Transport Regulation (Term of Office) .. .. .	0	6
6761. Prostitution .. .. .	0	6
6762. Motor Car (Amendment) .. .. .	1	0
6763. Game (Amendment) .. .. .	0	6
6764. The Constitution Act Amendment (Electoral) .. .. .	0	9
6765. Building Societies (Amendment) .. .. .	1	3
6766. Juries (Amendment) .. .. .	0	6
6767. Gas and Fuel Corporation (Borrowing) .. .. .	0	6
6768. Clean Air (Sub-committees) .. .. .	0	6
6769. Housing (Home Builders' Account) .. .. .	0	6
6770. Police Offences (Pinball Machines) .. .. .	0	6
6771. Fisheries (Commercial Council) .. .. .	0	6
6772. Consolidated Revenue .. .. .	0	6
6773. Consolidated Revenue .. .. .	0	6

A. C. BROOKS,  
Government Printer.

## ACTS REPRINTED IN ACCORDANCE WITH THE AMENDMENTS INCORPORATION ACT 1958 (No. 6422).

No.	Price.	
	s.	d.
6191. Administration and Probate Act .. .. .	4	9
6225. Co-operation Act .. .. .	4	0
6246. Evidence Act .. .. .	3	6
6251. Firearms Act .. .. .	2	3
6274. Hospitals and Charities Act .. .. .	3	6
6283. Labour and Industry Act .. .. .	7	3
6285. Landlord and Tenant Act .. .. .	4	6
6293. Licensing Act .. .. .	9	3
6299. Local Government Act .. .. .	25	0
6328. Nurses Act .. .. .	2	0
6363. Second-hand Dealers Act .. .. .	1	3
6375. Stamps Act .. .. .	6	0
6399. Transfer of Land Act .. .. .	5	0
6401. Trustee Act .. .. .	4	0
6419. Workers Compensation Act .. .. .	4	9
6455. Companies Act (2nd reprint) .. .. .	15	0

A. C. BROOKS,  
Government Printer.

## THE "VICTORIA GOVERNMENT GAZETTE".

SUBSCRIPTIONS.—The subscription, including postage, is £2 15s. per annum, £1 7s. 6d. half-yearly, or 13s. 9d. per quarter, payable in advance.

Subscriptions are required to commence and terminate with a month.

A lesser period than three months cannot be subscribed for.

Subscribers do not receive the Acts of Parliament with the GAZETTE.

ADVERTISEMENTS are charged at the rate of 1s. 6d. per line single column, and 3s. per line double column.

The title (£5 Reward, Dissolution of Partnerships, &c.) forms one or more lines as a heading.

*On an average, ten words make a line.*

*Every signature must likewise be counted as a line.*

*The final words of a paragraph, though only portion of a line, must be counted as one line.*

*SIGNATURES (in particular) and proper names must be written very plainly in the text; ONE SIDE ONLY of each slip of paper should be WRITTEN UPON.*

*ALL COMMUNICATIONS should be addressed to "The Government Printer, Melbourne".*

*ALL DOCUMENTS illegibly written will be returned unpublished, and where brands occur unprovided for by the ordinary letters of the alphabet, a worded explanatory description must be furnished.*

*THE VICTORIA GOVERNMENT GAZETTE is published on WEDNESDAY EVENING in each week, and Notices for insertion will be received by the Government Printer at or before ONE p.m. at ordinary rates, and late advertisements between ONE p.m. and FOUR p.m. at double rates on the day preceding the day of publication.*

*Single copies of the VICTORIA GOVERNMENT GAZETTE are One shilling, posted One shilling and five pence.*

*No GAZETTES prior to January, 1950, in stock.*

*\*\*\*ALL PAYMENTS ARE REQUIRED IN ADVANCE.—Remittances should be made by postal note, money order, or draft in favour of the Government Printer. Advertisements unaccompanied by a remittance sufficient to cover the cost of insertion will be returned unpublished.*

#### PUBLICATION OF OFFICIAL MATTER.

**A**TENTION is invited to the following procedure in relation to the publication of official matter in the *Government Gazette*:—

##### 1. Matter submitted to the Executive Council:

Matter submitted to the Executive Council which requires gazettal will normally be published in the issue of the following week.

Where urgent gazettal is required, special arrangements should be made with the *Gazette* Officer.

Publication will be facilitated by the submission of carbon copies for the use of the *Gazette* Officer.

##### 2. Other matter.

(a) All other matter duly certified by a responsible officer for publication should be lodged with the *Gazette* Officer not later than half-past Ten a.m. on Tuesday.

(b) Lengthy or involved notices should be forwarded several days before publication.

(c) Proofs, which will be supplied only when specifically requested, or at the direction of the *Gazette* Officer, should be returned promptly to avoid delay in publication.

(d) No additions or amendments to matter for publication will be accepted by telephone.

#### AGENTS FOR THE "VICTORIA GOVERNMENT GAZETTE".

**T**HE following have been appointed agents to receive Advertisements and Subscriptions for the *Victoria Government Gazette*:—

ARMSTRONG'S AGENCY, 205 Queen-street, Melbourne, C.I.

ARMSTRONG BROS., Kyneton.

ARNALL & JACKSON, 115 Barkly-street, West Brunswick.

BAIRNSDALE AUTHORIZED NEWSAGENCY, Main-street, Bairnsdale.

COOKE, F. R. & E. M., 69 Bridge-street, Benalla.

DAVIS, WM. (MILDURA) PTY. LTD., 126 Eighth-street, Mildura.

DIXON'S NEWSAGENCY, 89 Firebrace-street, Horsham.

EDGAR'S NEWSAGENCY, 293 Hargreaves-street, Bendigo.

FRANKS, HENRY, & CO., Booksellers and Stationers, 184 Ryrie-street, Geelong.

CORDON & GOTCH, News Agents, 511 Little Collins-street, Melbourne, C.I.; and corner of Barrack and Clarence streets, Sydney.

GULLAN'S NEWSAGENCY, 88 Bridge-street, Ballarat.

HALES, D. & N., Henty-street, Casterton.

HAMPTON, A. C., 243 Mitchell-street, Bendigo.

HARSTON, PARTRIDGE & CO. PTY. LTD., 455 Little Collins-street, Melbourne, C.I.

MERCANTILE EXCHANGE, 380 Collins-street, Melbourne, C.I.

PETTY, R. H. & W. M., 83 Murphy-street, Wangaratta.

PURDIE, J., & CO., 138 Moorabool-street, Geelong

SALE AUTHORIZED NEWSAGENCY, 142 Raymond-street, Sale.

SKINNER'S AUTHORIZED NEWSAGENCY, 49-51 Franklin-street, Traralgon.

SMITH & DUNNON, 112 Gray-street, Hamilton.

TUFF'S SHEPPARTON NEWSAGENCY, 246 Wyndham-street, Shepparton.

VERNON, C. F. & H. J., 162 Bridge-road, Richmond.

VIEW POINT NEWSAGENCY, 4 View Point, Bendigo.

A copy of the *Gazette* filed at each place for public reference.

#### CONTENTS

	PAGE
Acts of Parliament on sale at the Government Printing Office .. .. .	771
Appointments .. .. .	740
Companies Act 1958—Notices .. .. .	739
Contracts .. .. .	725
Estates of Deceased Persons .. .. .	732
Government Notices .. .. .	724
Impoundings .. .. .	771
Lands .. .. .	756
Melbourne and Metropolitan Board of Works—Notice .. .. .	739
Ministers of Religion Registered to Celebrate Marriages in Victoria .. .. .	738
Notice to Mariners .. .. .	734
Orders in Council—	
Acts—Health; Rural Finance and Settlement Commission .. .. .	741
Crown Lands; Country Roads; Landlord and Tenant .. .. .	750 et seq
Private Advertisements .. .. .	762
Proclamations .. .. .	719
Public Service Notices .. .. .	758
Regulations—	
Acts—Weights and Measures; Commercial Goods Vehicles .. .. .	742 et seq
Resignation .. .. .	741
Tenders .. .. .	761
Transport Regulation Board—Public Hearings .. .. .	735