



# VICTORIA

# GOVERNMENT GAZETTE

Published by Authority

*[Registered at the General Post Office, Melbourne, for transmission by post as a newspaper.]*

No. 68]

WEDNESDAY, JULY 29

[1964

*Land Act 1958.*

UNALIENATED CROWN LANDS AVAILABLE FOR SETTLEMENT UNDER IMPROVEMENT PURCHASE LEASES.

PROCLAMATION

By His Excellency the Governor of the State of Victoria and its Dependencies in the Commonwealth of Australia, &c., &c., &c.  
**I**N pursuance of the provisions of section 153 of the *Land Act 1958*, I, the Governor of the State of Victoria in the Commonwealth of Australia, by and with the advice of the Executive Council of the said State, do by this Proclamation declare the unalienated Crown lands mentioned in the subjoined Schedule, to be available for settlement under improvement purchase leases.

SCHEDULE.

County.	Parish.	Allotment.	Section.	Area.	Land Valuation.
				A. R. P.	
Delatite .. .. .	Edi .. .. .	3, 3A and 3B	19	70 0 0±	£5 per acre
Delatite .. .. .	Edi .. .. .	3C	16	50 0 0±	£4 per acre
Ripon .. .. .	Beaufort .. .. .	31	E1	61 1 1	£5 per acre
Ripon .. .. .	Beaufort .. .. .	33	E1	55 2 28	£8 per acre
Ripon .. .. .	Beaufort .. .. .	35	E1	53 1 28	£10 per acre
Ripon .. .. .	Beaufort .. .. .	36	E1	36 3 17	£10 per acre

Given under my Hand and the Seal of the State of Victoria aforesaid, at Melbourne, this twenty-first day of July, in the year of our Lord One thousand nine hundred and sixty-four, and in the thirteenth year of the reign of Her Majesty Queen Elizabeth II.

(L.S.)

ROHAN DELACOMBE.

By His Excellency's Command,

JIM BALFOUR,  
 Commissioner of Crown Lands and Survey.

GOD SAVE THE QUEEN !

PUBLIC HIGHWAY.—SHIRE OF SOUTH GIPPSLAND.

ACT OF PARLIAMENT.

PROCLAMATION

By His Excellency the Governor of the State of Victoria and its Dependencies in the Commonwealth of Australia, &c., &c., &c.

WHEREAS by the *Local Government Act 1958*, as amended, section 519, it is amongst other thing enacted that it shall be lawful for the Governor in Council at any time, and from time to time, upon request of the Council of any municipality, by notice in the *Government Gazette*, to proclaim any land reserved, used or by purchase or exchange acquired for a street, road, highway, thoroughfare, bridge, square, court, alley or right-of-way or any street, road, lane or passage made or laid out or proposed to be made or laid out on land of which a plan delineating that street, road, lane or passage has been lodged with the Registrar of Titles, to be a public highway and that such land shall thereupon and thenceforth from the date of such Proclamation become and be absolutely dedicated to the public as a public highway within the meaning of any law then or thereafter in force:

And whereas the Council of the Shire of South Gippsland has requested that the land hereinafter mentioned, used for a street, be so declared to be a public highway.

Now, therefore, I, the Governor of the State of Victoria in the Commonwealth of Australia, by and with the advice of the Executive Council of the said State, do by this Proclamation declare that all that piece of land shown hatched on the plan hereunder shall be a public highway within the meaning of the said Act.

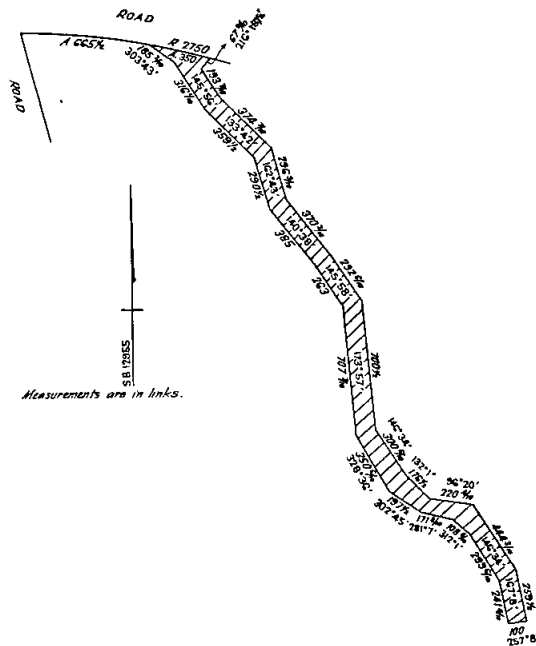

Given under my Hand and the Seal of the State of Victoria aforesaid, at Melbourne, this twenty-first day of July, in the year of our Lord One thousand nine hundred and sixty-four and in the thirteenth year of the reign of Her Majesty Queen Elizabeth II.

(L.S.) ROHAN DELACOMBE.

By His Excellency's Command,  
R. J. HAMER,  
Minister for Local Government.  
GOD SAVE THE QUEEN!

PROCLAMATION

By His Excellency the Governor of the State of Victoria and its Dependencies in the Commonwealth of Australia, &c., &c., &c.

I THE Governor of the State of Victoria, in the Commonwealth of Australia, do hereby declare that I have this day assented, in Her Majesty's name, to the Bill passed by the Parliament of the said State, the title whereof is hereunder set forth, that is to say:—

No. 7150. "An Act to apply out of the Consolidated Revenue the sum of Forty million eight hundred and sixty thousand nine hundred and ten pounds to the service of the year One thousand nine hundred and sixty-four and One thousand nine hundred and sixty-five."

Given under my Hand and the Seal of the State of Victoria aforesaid, at Melbourne, this twenty-first day of July, in the year of our Lord One thousand nine hundred and sixty-four and in the thirteenth year of the reign of Her Majesty Queen Elizabeth II.

(L.S.) ROHAN DELACOMBE.

By His Excellency's Command,  
A. G. RYLAH,  
Acting Premier,  
GOD SAVE THE QUEEN!

PUBLIC HOLIDAYS.

PROCLAMATION

By His Excellency the Governor of the State of Victoria and its Dependencies in the Commonwealth of Australia, &c., &c., &c.

IN pursuance of the provisions contained in Part III. of the *Public Service Act 1958*, I, the Governor of the State of Victoria, in the Commonwealth of Australia, by and with the advice of the Executive Council of the said State, do by this my Proclamation appoint the days and dates hereunder mentioned to be observed as Public Holidays or Public Half-Holidays (as the case may be) at the places respectively specified, viz.:—

Public Holidays:—

- MONDAY, THE 1ST MARCH, 1965, throughout the Borough of Echuca.
- \* MONDAY, THE 21ST SEPTEMBER, 1964, throughout the Shire of Phillip Island.
- SATURDAY, THE 7TH NOVEMBER, 1964, throughout the Central Riding of the Shire of Kerang.

Public Half-Holidays from the Hour of Twelve o'clock noon:—

- \* THURSDAY, THE 20TH AUGUST, 1964, throughout the Balmoral Riding of the Shire of Wannon.
- \* THURSDAY, THE 1ST OCTOBER, 1964, throughout the Shire of Wimmera.

\* Agricultural Show.

Given under my Hand and the Seal of the State of Victoria aforesaid, at Melbourne, this twenty-eighth day of July, in the year of our Lord One thousand nine hundred and sixty-four, and in the thirteenth year of the reign of Her Majesty Queen Elizabeth II.

(L.S.) ROHAN DELACOMBE.

By His Excellency's Command,  
V. F. WILCOX,  
Acting Chief Secretary.  
GOD SAVE THE QUEEN!

BANK HOLIDAYS.

PROCLAMATION

By His Excellency the Governor of the State of Victoria and its Dependencies in the Commonwealth of Australia, &c., &c., &c.

IN pursuance of the provisions of the *Bank Holidays Act 1958*, I, the Governor of the State of Victoria, in the Commonwealth of Australia, do by this my

Proclamation appoint the days and dates named hereunder special days to be observed as Bank Holidays or Bank Half-Holidays (as the case may be) at the places respectively mentioned, that is to say:—

*Bank Holidays:—*

WEDNESDAY, THE 12TH AUGUST, 1964, at St. James and Tungamah.

*Bank Half-Holidays from the Hour of 11 a.m.*

TUESDAY, 6TH OCTOBER, 1964, at Cobram, Katamatite and Strathmerton.

Given under my Hand and the Seal of the State of Victoria aforesaid, at Melbourne, this twenty-eighth day of July, in the year of our Lord One thousand nine hundred and sixty-four, and in the thirteenth year of the reign of Her Majesty Queen Elizabeth II.

(L.S.) ROHAN DELACOMBE.

By His Excellency's Command,

V. F. WILCOX,  
Acting Chief Secretary.

GOD SAVE THE QUEEN!

Melbourne and Metropolitan  
BOARD OF WORKS.

NOTICE TO THE OWNERS OF TENEMENTS IN THE UNDERMENTIONED STREETS, AND THE PRIVATE STREETS, LANES, COURTS AND ALLEYS OPENING THERETO.

THE main pipe in the said streets being laid down, the owners of all tenements situated as under are hereby required on or before the 31st August, 1964, to cause a proper pipe and stop cocks to be laid so as to supply water within such tenements from the main pipe.

H. J. SNADDEN,  
Secretary.

21st July, 1964.

STREET AND POSITION.

*Camberwell.*

Renown-street, from Kenny-street to Reading-avenue.

*Coburg.*

Gaffney-street, from Elizabeth-street to Connolly-avenue.

*Dandenong.*

Railway-parade, from Leige-avenue to Pamela-street.  
Pamela-street, from Railway-parade north-eastwards 4½ chains.

*Doncaster and Templestowe.*

Winston-drive, from 2 chains east of Leonard-court eastwards 12 chains.  
Kelly-street, from Winston-drive southwards 4½ chains.  
Hill-court, from Winston-drive southwards 5½ chains.

*Nunawading.*

Eckersley-court, from Rosslyn-street southwards 7½ chains.  
Royton-street, from Davis-street to Sartori-street.  
Sartori-street, from Royton-street eastwards 10 chains.  
Koonung-road, from Fithie-street to Douglas-street.  
Fithie-street, from Koonung-road eastwards 4½ chains.  
Douglas-street, from Koonung-road eastwards 5 chains.  
Henry-street, from Koonung-road westwards 14½ chains.  
Rodleigh-street, from Glebe-street westwards 4½ chains.  
Faulkner-street, from Glebe-street to Bennett-street.  
Eden-court, from Faulkner-street northwards 2½ chains.  
Primula-street, from Middleborough-road eastwards 18½ chains.  
Majtils-street, from Primula-street southwards 8½ chains.  
Hibiscus-road, from Primula-street southwards and eastwards 16½ chains.  
Caldwell-road, from Canterbury-road southwards and westwards 15½ chains.  
Tweed-street, from Caldwell-road westwards 4 chains.  
Rowan-street, from Caldwell-road southwards 5 chains.  
Osprey-street, from Rowan-street eastwards 4 chains.  
Taylor-avenue, from Middleborough-road eastwards 12 chains.  
Hilltop-crescent, from Middleborough-road eastwards 12 chains.  
Chasta-crescent, from Hodgson-street northwards and north-westwards 9½ chains.  
Fuller-avenue, from Chasta-crescent westwards 3½ chains.  
Proposed road 2½ chains south of Queen-street, from Rooks-road westwards 2½ chains.

*Oakleigh.*

Leagh-street, from Springs-road to Wandoo-avenue.  
Stafford-street, from Shafton-street westwards 5½ chains.

*Springvale.*

Karan-court, from Budge-street southwards and westwards 10½ chains.  
Elisabeth-avenue, from Springvale-road eastwards 9½ chains.  
Kilberry-avenue, from Elisabeth-avenue southwards 2½ chains.  
Prior-road, from Sandra-avenue westwards 4½ chains.  
Green-street, from Sandra-avenue westwards 4½ chains.  
Green-street, from Sandra-avenue eastwards 2½ chains.  
Sandra-avenue, from Green-street southwards 7 chains.

*Waverley.*

Leonie-avenue, from Waverley-road to Bernard-street.  
Oakern-street, from Leonie-avenue westwards 2½ chains.  
Bernard-street, from Leonie-avenue westwards 2½ chains.  
Sadie-street, from Pamela-street eastwards 7 chains.  
Sadie-street, from Pamela-street westwards 3 chains.  
Cora-court, from Sadie-street northwards 7 chains.  
Westerfield-drive, from Pamberley-drive south-westwards 20½ chains.  
Erawan-avenue, from Westerfield-drive southwards 5 chains.  
Dianne-court, from Erawan-avenue eastwards 5½ chains.  
Risdon-drive, from Westerfield-drive to Pamberley-drive.  
Hunsford-avenue, from Risdon-drive to Pamberley-avenue.  
Merlin-court, from Risdon-drive south-westwards 3 chains.  
Tulip-court, from Hunsford-avenue westwards 2½ chains.  
Berrydale-court, from Hunsford-avenue south-eastwards 3½ chains.  
Marina-court, from Risdon-drive south-eastwards 3½ chains.

PUBLIC TRUSTEE ACT 1958 (No. 6350), SECTION 17.

I HEREBY give notice that on the 10th July, 1964, the Public Trustee filed elections to administer the following deceased persons' estates, in accordance with section 17 of the Public Trustee Act 1958:—

FASUN, STANKO, late of Portland, labourer, died 17th January, 1964.

GUZIERSKI, FRANCISZEK, also known as Frank Guzaerska and Frank Guzaerski, late of 47 Flinders-street, Mentone, labourer, died 2nd January, 1964.

HAZELL, MAGNHILD KATHRINE, also known as Magnhild Kathrine Berkeley Hazell, formerly of Flat 3, Viewbank-road, Glen Iris, but late of Flat 2, 1435 High-street, Malvern, married woman, died 7th February, 1964.

WARNER, JOHN DUNBAR, formerly of "Broompark", Olinda, but late of 8 Black-street, Mont Albert, retired wool classer, died 6th October, 1963.

A. D. DUNCAN,  
Public Trustee.

256 Flinders-street, Melbourne, C.1, 22nd July, 1964.

NOTICE.

CREDITORS, next of kin and others having claims against the estate of any of the under-mentioned deceased persons are required to send particulars of their claims to the Public Trustee, 3rd Floor, 256 Flinders-street, Melbourne, the personal representative, on or before the 29th September, 1964, after which date the Public Trustee may convey or distribute the assets, having regard only to the claims of which the Public Trustee then has notice:—

FASUN, STANKO, late of Portland, labourer, died 17th January, 1964.

GUZIERSKI, FRANCISZEK, also known as Frank Guzaerska and Frank Guzaerski, late of 47 Flinders-street, Mentone, labourer, died 2nd January, 1964.

HAZELL, MAGNHILD KATHRINE, also known as Magnhild Kathrine Berkeley Hazell, formerly of Flat 3, Viewbank-road, Glen Iris, but late of Flat 2, 1435 High-street, Malvern, married woman, died 7th February, 1964.

WARNER, JOHN DUNBAR, formerly of "Broompark", Olinda, but late of 8 Black-street, Mont Albert, retired wool classer, died 6th October, 1963.

A. D. DUNCAN,  
Public Trustee.

Melbourne, 22nd July, 1964.

Transport Regulation Act.  
TRANSPORT REGULATION BOARD.

## HEARING OF APPLICATIONS.

NOTICE is hereby given that the following applications will be considered by the Transport Regulation Board at its offices at Rathdown-street, Carlton, at 10.15 a.m. on Wednesday, 19th August, 1964.

CONNELLY, M. M. (Mrs.), 6 Dorothy-avenue, Thomastown. One commercial passenger vehicle (S/C. 6) to operate for the carriage of pre-school children free of charge between the child minding centre situated at 6 Dorothy-avenue, Thomastown and the children's home addresses.

RICHARDS, S., 14 Wolverhampton-street, Footscray. Application for permit authority to operate vehicles holding licence No.'s M.C.423, M.C.424 and M.C.425 for the carriage of school children only from the Maribyrnong Migrant Hostel to the Maribyrnong State School, Warrs-road, Maribyrnong and return.

## TIME-TABLE.

## School Days Only.

Dep. Hostel	..	..	8.45 p.m.
Dep. School	..	..	3.45 p.m.

APPLICATIONS for renewal of licences as shown, by persons listed hereunder to operate under the same terms and conditions:—

BOX HILL & DISTRICT RETARDED & SPASTIC CHILDREN'S ASSOCIATION, 37 Thurston-street, Box Hill; T.P.55.

DAWSON, L. A., 11 Huntingdon-road, East Bentleigh; T.P.17.

DOWSON, R., 196 Eleventh-street, Mildura; C.T.662.

HAM, K. E., 130 Mt. Dandenong-road, Ringwood; C.T.82.

HERBERT, E. G. & W. G., 1 Elizabeth-street, Warragul; C.T.794.

HUNTINGTOWER SCHOOL ASSOCIATION, Waimarie-drive, Mount Waverley; T.P.100.

KINGSTON, F. C., 19 Wimmera-street, Stawell; C.O.109.

KRICAK, R., 157 Ballarat-road, Hamilton; C.O.237.

LAMBERT, A. H., 2 Second-avenue, Ascendale; C.T.230.

LANES TAXI SERVICE PTY. LTD., 159 Raglan-parade, Warrnambool; C.T.683.

MEMBREY, W. & M., 71 Broadway, Chelsea; T.P.131.

MOLLOY, J. W., 30 Worrell-street, Nunawading; C.T.791.

MCCOMBS TAXI SERVICE PTY. LTD., 51 Davey-street, Frankston; C.T.764, C.T.766.

McPHERSON, W. A., 43 Royal-avenue, Springvale; C.T.89.

OAKLEY, L. H. & M. J., 711 Humfray-street, Ballarat; C.O.192, C.O.175.

PATTERSON, E. G., Main-road, Hurstbridge; C.T.762.

PINCINI, E. J. & L., PTY. LTD., Baths-road, Mirboo North; C.O.72.

SEYMOUR PASSENGER SERVICES PTY. LTD., 7 Wallis-street, Seymour; C.O.31, C.O.32, C.O.35, C.O.36, C.O.37.

SMITH, L. K. (Mrs.), 9 Ryder-street, Noble Park; T.P.64.

STEWART, H. W. R., Woods Point; C.O.698.

WARRAGUL BUS LINES PTY. LTD., Queen-street, Warragul; C.O.92, C.O.114.

WAYGARA SAWMILLING CO. PTY. LTD., Box 225, Orbost; T.P.23.

Notice of any objection should be forwarded to reach the Secretary of the Board not later than Wednesday, 12th August, 1964.

Applicants are advised that it will not be necessary to appear on the hearing date specified above, unless advised in writing by the Board.

B. P. KAY,  
Secretary.

Exhibition Buildings, Rathdown-street, Carlton, N.3,  
Wednesday, 29th July, 1964.

Commercial Goods Vehicles Act.  
TRANSPORT REGULATION BOARD.

## HEARING OF APPLICATIONS.

NOTICE is hereby given that the following applications will be considered by the Transport Regulation Board at its offices at Rathdown-street, Carlton, at 10.15 a.m. on Wednesday, 19th August, 1964.

ACQUISTAPACE, L., 155 Clarke-street, Northcote. One commercial goods vehicle (139 cwt.) to operate within a 50-mile radius of the premises of Albion Quarrying Co. Pty. Ltd. at North Melbourne—road-making materials solely on behalf of the said company excluding the carriage of materials ex Geelong.

AUSTRALIAN PAPER MANUFACTURERS LTD., 2 South Gate, South Melbourne. One commercial goods vehicle (10 cwt.) to operate throughout the State of Victoria—engineering supplies, logging and forestry equipment and incidental supplies for use in connexion with own forestry and paper-making projects.

BAYVIEW QUARRIES PTY. LTD., 602 St. Kilda-road, Melbourne. Three commercial goods vehicles (approximately 200 cwt. each) to operate: (a) From sand pits within a 35-mile radius of Melbourne to own plants at Narre Warren, Berwick, Clayton, Springvale, Montrose, St. Helena, Tullamarine, Lysterfield, Dandenong and Bulla—sand. (b) From each of the plants referred to in paragraph (a) to consignees within a 35-mile radius thereof—screenings, stone-dust, hot asphalt and premix. (c) Within a 35-mile radius of each of the plants referred to in paragraph (a)—road-making plant and equipment.

BEAUREPAIRE TYRE SERVICE PTY. LTD., 102 Victoria-street, Carlton. One commercial goods vehicle (28 cwt.) to operate within a 50-mile radius of own branch premises at Kerang in the course of business as "Tire Retreaders and Distributors"—tires and tubes for sale and delivery, used tires for repair or having been retreaded or repaired, batteries, oil and motor car accessories.

BEAUREPAIRE TYRE SERVICE PTY. LTD., 102 Victoria-street, Carlton. One commercial goods vehicle (11 cwt.) to operate within a 50-mile radius of G.P.O., Melbourne in the course of business as "Tire Retreaders and Distributors"—tires and tubes for sale and delivery, used tires for repair and retreading, or having been repaired or retreaded, batteries, oil and motor car accessories.

BENNETT, M. C., Cambridge-street, Creswick. One commercial goods vehicle (5 cwt.) to operate from Creswick to Newstead—mail, newspapers and parcels on behalf of the P.M.G. Department.

JONES, T. A. & B. G. KELLY (trading as Bittern Plaster Works), Flinders-road, Bittern. One commercial goods vehicle (105 cwt.) to operate within a 40-mile radius of own premises at Bittern in the course of business as "Fibrous Plaster Manufacturers"—own goods.

BOLTE, M. H. & B. R., Elgin-street, Berwick. One commercial goods vehicle (141 cwt.) to operate within a 70-mile radius of the premises of Evans Bros. Pty. Ltd. at Scoresby—bricks solely on behalf of the said company.

BROWN, H. S. & SONS PTY. LTD., 55 Oliver-street, Ringwood. One commercial goods vehicle (136 cwt.) to operate: (a) Within a 20-mile radius of Ringwood—general goods. (b) From pits situate at Rockbank to places situate within paragraph (a) above—own honeycomb rock.

CARUSO, D., 23 White-street, North Fitzroy. One commercial goods vehicle (101 cwt.) to operate within a 70-mile radius of post office at Healesville (Dandenong Division of C.R.B.) as a "Road Contractor"—road-making plant and materials.

CHAMBERS, B. M., 73 Main-street, Bairnsdale. One commercial goods vehicle (20 cwt.) to operate in course of trade as "Produce Merchant, General Hardware Dealer and Reseller of Petroleum Products": (a) Between Bairnsdale and Swift's Creek—bran, pollard, wheat, maize, oats, general hardware, paints, pumps, piping, bottled gas, coke, sheep dips, weedicides, veterinary supplies, petroleum products and empty containers on behalf of B.P. Aust. Ltd. (b) Pumps and piping from Bairnsdale Railway Station to own premises at Bairnsdale.

DEMARCO BROS., 118 Ferrars-street, South Melbourne: One commercial goods vehicle (107 cwt.) to operate: (a) Throughout the State of Victoria in the course of business as "Paving and Terrazzo Contractors" for the carriage of tools of trade, equipment and concrete mixer incidental to own contracts, with the ability to carry sufficient quantity of facing stones and marble chippings for the completion of contracts currently engaged upon. (b) Within a 25-mile radius of the G.P.O., Melbourne, in the course of business as "Paving and Terrazzo Contractors"—own goods.

DIXON, R. H., 22 Roslyn-road, Belmont, Geelong. One commercial goods vehicle (10 cwt.) to operate throughout the State of Victoria in the course of business as "Marine Collector" marine stores as designated in the *Marine Stores and Old Metals Act* 1958 (No. 6303), but excluding the carriage of any such goods to wharves, docks, or ships for shipment or export purposes.

ELIAS, G., 36 Phillip-street, Bentleigh. Application to vary the conditions of licence No. D.A.47676 (L/C. 218 cwt.) by deleting from the existing conditions "agitator" and adding in lieu "bulk".

- McILROY, K. J. C.** (trading as Fernleigh Trading Co.), Sander-road, Bunyip. One commercial goods vehicle (74 cwt.) to operate: (a) From own property at Bunyip or from places within a 15-mile radius thereof to the City of Melbourne—own and neighbour's farm and orchard produce, own tea-tree sticks, firewood, posts and poles. (b) From Melbourne to places within a 15-mile radius of own premises at Bunyip. (i) Empty fruit cases and bins. (ii) Growers' seed in bags. (iii) Petroleum products in drums. (iv) Barbed wire, galvanized iron and other farm building materials.
- FIAT OF AUSTRALIA PTY. LTD.** (trading as Fiat Tractors (Vic.)), Warrigal-road, Moorabbin. One commercial goods vehicle (200 cwt.) to operate: (a) Within a 20-mile radius of own premises at Moorabbin in the course of business as "Tractor Manufacturers"—own goods. (b) Throughout the State of Victoria for the purpose of demonstrating own tractors and ancillary equipment—own tractors for demonstration, ancillary equipment incidental thereto for demonstration purposes only.
- FORBES-WILSON, D.**, care of post office at Cabarita, via Mildura. One commercial goods vehicle (30 cwt.) to operate: (a) Throughout the State of Victoria in the course of business as "Engineering Contractors"—own machinery. (b) Throughout the State of Victoria in the course of business as "Scrap Metal Dealer"—scrap metals.
- FORD-SWINTON INDUSTRIES PTY. LTD.**, 8-10 James-street, Clayton. One commercial goods vehicle (11 cwt.) to operate throughout the State of Victoria, in the course of business as "Heating Engineers" for the purpose of installing and servicing heating and air-conditioning units and systems—tools of trade, spare parts and equipment incidental to the completion of own contracts.
- R.M.S. PTY. LTD.**, (trading as T. S. Gill), 296 Darebin-road, Thornbury. One commercial goods vehicle (30 cwt.) to operate within a 50-mile radius of own branch premises at Morwell and in the area east of Morwell as far as Lakes Entrance, in course of business as "Glass Merchants and Glazing Contractors"—tools of trade, glass, shop fronts, shop fittings and small quantities of materials incidental to glazing, shop-fittings and glass tinting, all goods to be carried in connexion with own contracts only.
- ANDERSON, D. N., & B. W. ORCHARD** (trading as Gippsland Melbourne Freight Lines), 19-21 Louis-street, Airport West. Five commercial goods vehicles (283, 274, 298, 292 and 292 cwt.) to operate from sawmill owned and operated by H. Sumberg, at Cann River to Orbost Railway Station—sawn timber.
- GOULD, J. L., PTY. LTD.**, Falls-road, Marysville. Application to vary the conditions of licence No. T.T.D.213/3 (L/C. 259) by adding to the existing conditions "From Melbourne to Marysville, in course of business as 'Sawmillers & Primary Producers'—own goods only".
- HICKS, G.**, 10 Campbell-crescent, Ballarat. One commercial goods vehicle (9 cwt.) to operate: (a) Within a 25-mile radius of the post office at Ballarat—general goods. (b) Throughout the State of Victoria on behalf of the Victorian Railways, pursuant to a contract entered into between the Victorian State Government and the holders of this licence—gear and equipment incidental to railway breakdown repairs with the ability also to carry passengers not exceeding two at any one time.
- HULLAND, D. A. O.**, Box 1, Hopetoun. One commercial goods vehicle (95 cwt.) to operate: (a) Within a 50-mile radius of the post office at Hopetoun, in the course of business as "Machinery Agents"—farm tractors and machinery. (b) Within a 50-mile radius of the post office at Hopetoun—drummed petroleum products and empty return drums on behalf of Mobil Oil (Aust.) Pty. Ltd. (c) Within a 20-mile radius of the post office at Hopetoun—general goods.
- ROBERT HUTCHINSON LTD.**, Hartington-street, Glenroy. One commercial goods vehicle (124 cwt.) to operate within a 50-mile radius of own premises at Glenroy, in the course of business as "Flour Millers and Stock Feed Manufacturers"—own goods.
- JACKSON, G. J. E.**, 14 Beach-road, Beaumaris. One commercial goods vehicle (5 cwt.) to operate throughout the State of Victoria in the course of business as "Religious Goods Wholesaler"—religious goods.
- KENT, J. P.**, 59 Shiels-terrace, Casterton. Two commercial goods vehicles (243 cwt. each) to operate: (a) within a 20-mile radius of the post office at Casterton—general goods. (b) Within a 100-mile radius of the post office at Casterton—bulk superphosphate which has been picked up at railway stations within 50 miles of Casterton. (c) From places within a 50-mile radius of Casterton to Portland—bulk grain.
- JACK LEGGE PTY. LTD.**, 43 Thomson-street, Sale. One commercial goods vehicle (40 cwt.) to operate throughout the State of Victoria in the course of business as "Earthmoving Contractor" for the purpose of supervising own contracts and servicing own equipment—tools of trade, spare parts and materials incidental to the repair or completion of own contracts.
- FLOOR TREATMENTS PTY. LTD.** (trading as Magikist Carpet Cleaners), 367 High-street, Kew. One commercial goods vehicle (11 cwt.) to operate in the course of business as "Cleaning Contractors": (a) Within a 50-mile radius of own premises at Kew—goods connected with own business. (b) Throughout the State of Victoria. (i) Tools of trade, cleaning gear, equipment and materials incidental to own contracts. (ii) Carpets, suites and furnishings for cleaning at own premises and for subsequent return to customers.
- MILLS, F. N.**, Tucks-road, Shoreham. One commercial goods vehicle (74 cwt.) to operate: (a) Within a 20-mile radius of Shoreham—general goods. (b) From and to places defined in paragraph (a) above to and from places within a 50-mile radius of Shoreham—livestock.
- McGEE, P. J.**, 3 Bourke-street, Brunswick. One commercial goods vehicle (7 cwt.) to operate throughout the State of Victoria in the course of business as "Lampshade Manufacturer"—lampshades and lamp bases for display purposes with the ability to leave a sample or any incidental order of fragile plaster lamp bases.
- McGRATH, F. W.**, 40 Kars-street, Frankston. One commercial goods vehicle (69 cwt.) to operate: (a) Within a 25-mile radius of the G.P.O. Melbourne—general goods. (b) Within a 50-mile radius of the G.P.O. at Frankston—household furniture being the property or personal effects of a householder or of a member of his family when such goods are being moved. (i) From residence to residence. (ii) From residence for storage or sale. (iii) From storage to residence. (iv) From vendor to the residence of a purchaser.
- PITTS, J. W.** (trading as Narbethong Service Station), Maroondah Highway, Narbethong. One commercial goods vehicle (20 cwt.) to operate: (a) Within a 50-mile radius of own premises at Narbethong, in course of business as "Garage Proprietor"—own goods. (b) Within a 50-mile radius of the Mobil Oil Aust. Ltd. depot at Newport—petroleum products in prescribed containers and empty return containers.
- PALMER, H. G., PTY. LTD.**, 84 Flinders-lane, Melbourne. One commercial goods vehicle (19 cwt.) to operate within a 50-mile radius of own branch premises at Shepparton, in course of business as "Electrical Retailers and Repairers" for the purposes of installing and repairing of electrical appliances and/or motor mowers—tools of trade, installation equipment, spare parts, electrical appliances for motor mowers for repair or having been repaired and materials incidental thereto.
- PALMER, H. G., PTY. LTD.**, 84 Flinders-lane, Melbourne. One commercial goods vehicle (18 cwt.) to operate within a 50-mile radius of own branch premises at Wangaratta for the purpose of installing and repairing electrical appliances and/or motor mowers—electrical appliances and/or motor mowers for installation and repair or having been repaired, spare parts, tools of trade and materials incidental thereto.
- PALMER, H. G., PTY. LTD.**, 84 Flinders-lane, Melbourne. One commercial goods vehicle (18 cwt.) to operate within a 50-mile radius of own branch premises at Ballarat for the purpose of installing and repairing electrical appliances and/or motor mowers—electrical appliances and/or motor mowers for installation and repair or having been repaired, spare parts, tools of trade and materials incidental thereto.
- PALMER, H. G., PTY. LTD.**, 84 Flinders-lane, Melbourne. One commercial goods vehicle (18 cwt.) to operate within a 50-mile radius of own branch premises at Geelong, excluding operations to or from the City of Melbourne, for the purpose of installing or repairing electrical appliances and/or motor mowers—electrical appliances and/or motor mowers for installation and repair or having been repaired, spare parts, tools of trade and materials incidental thereto.
- PERMEWAN WRIGHT LTD.**, 31 King-street, Melbourne. Application to vary the conditions of licence No. D.A.1809/22 (L/C. 79 cwt.) by increasing the area of operations in paragraph (a) from 20 miles to 50 miles.

- PETERSVILLE AUSTRALIA LTD., "Petersville", Wellington-road, Clayton. One commercial goods vehicle (209 cwt.) to operate throughout the State of Victoria as a specially constructed insulated and refrigerated van for the purpose of supplying own distributors with ice-cream and frozen foods at a temperature not exceeding 10°F.
- PHOENIX BISCUIT PTY. LTD., Grosvenor-street, Abbotsford. One commercial goods vehicle (66 cwt.) to operate within the area bounded by Edenhope, Serviceton, Hopetoun, Birchip, St. Arnaud and Ararat—own biscuits, cake and sponge, with the proviso that all goods so carried shall have been initially consigned to Horsham by rail.
- PROPOSCH, V. A. & A. C. (trading as Proposch Bros.), Longwarry. One commercial goods vehicle (376 cwt.) to operate: (a) From forest landings within a 20-mile radius of the post office at Longwarry and from the Morwell area of own mill at Longwarry—logs. (b) From own mill at Longwarry to timber yards and building sites at Wonthaggi, Archie's Creek, Oakleigh, Springvale, Ringwood, Mitcham, Dandenong and to places within a 25-mile radius of the G.P.O., Melbourne—own sawn timber.
- PUTRA, M., 23 Goulburn-street, Yarraville. Application to vary the conditions of licence No. D.A.44863 (L/C.130 cwt.) by deleting the existing conditions and adding in lieu:—"To operate within a 50-mile radius of the premises of Albion Quarrying Co. Pty. Ltd., at North Melbourne—road-making materials solely on behalf of the said company excluding the carriage of materials from Geelong."
- READY MIXED CONCRETE (MELB.) PTY. LTD., 501 Swanston-street, Melbourne. One commercial goods vehicle (18 cwt.) to operate throughout the State of Victoria in the course of business as "Concrete Manufacturers"—tools of trade necessary for the maintenance of own equipment.
- REGENT MOTORS PTY. LTD., 86 Sturt-street, South Melbourne. One commercial goods vehicle (30 cwt.) to operate throughout the State of Victoria in course of business as "Automobile Manufacturers" for the purpose of servicing Land Rovers and supplying special servicing data—tools of trade, spare parts and special instructional equipment and materials.
- RICHARDSON, R. W. A., Bakewell-street, Tooradin. Application to vary the conditions of licences No. D.A.7372 and D.A.7372/1 (L/C.124 and 140 cwt.) by adding to the existing conditions as an additional paragraph "Within a 25-mile radius of G.P.O., Melbourne—general goods."
- RIGHETTI, L. & M. C., 77 Pynsent-street, Horsham. Application to vary the conditions of licence Nos. T.D.A.47723, T.D.A.47723/1 and T.D.A.47723/2 (L/C. 22, 16 and 8 cwt.) by adding to the existing conditions "As a distributor on behalf of Arnott Motteran Ltd., of Adelaide."
- ROBBINS, A. H., Gellibrand River. One commercial goods vehicle (325 cwt.) to operate: (a) From forest landings in the Heytesbury area to Terang Sawmilling and Timber Company's sawmill at Terang—logs. (b) From Terang Sawmilling and Timber Company's sawmill at Terang to consignees within a 50-mile radius of Terang Post Office—sawn timber.
- RYAN, J. B., 25 Collins-street, Morwell. One commercial goods vehicle (230 cwt.) to operate within a 50-mile radius of Morwell on behalf of W. L. Young Pty. Ltd., of Morwell—sawn timber.
- SANDERS, J. W., 39 Maddon-street, Kaniva. One commercial goods vehicle (11 cwt.) to operate: (a) Within a 20-mile radius of Kaniva Post Office—general goods. (b) Within a 50-mile radius of Kaniva Post Office—tools of trade, spare parts and small quantities of materials for the repair and servicing of own plant and vehicles with the proviso that all parts and materials are carried from Horsham.
- SHERRIFF, L., 220 Mansfield-street, Thornbury. One commercial goods vehicle (8 cwt.) to operate: (a) Within a 50-mile radius from the post office at Thornbury—own goods in the course of business as "Plumber". (b) Throughout the State of Victoria—tools of trade and equipment incidental to the completion of plumbing contracts on behalf of the Commonwealth Department of Works.
- SHORT, D. & E., 7 Welwyn-parade, Deer Park. One commercial goods vehicle (143 cwt.) to operate: (a) Within a 50-mile radius of G.P.O., Melbourne, on behalf of Reid Bros. and Carr Pty. Ltd.—hot asphalt. (b) Within a 25-mile radius of G.P.O., Melbourne—general goods.
- SMAILA, C. & A., 8 Kingsville-street, West Footscray. One commercial goods vehicle (199 cwt.) to operate within a 50-mile radius of the premises of Albion Quarrying Co. Pty. Ltd., at North Melbourne—premixed concrete in a specially constructed agitator vehicle solely on behalf of the said company.
- SMALIORIUS, B., 21 Haldane-street, Niddrie. One commercial goods vehicle (234 cwt.) to operate within a 50-mile radius of the premises of Reid Bros. and Carr Pty. Ltd., at Sunshine—hot asphalt, screenings and cold mix on behalf of the said company.
- SMITH, G. D., 18 Lewis-street, Frankston. One commercial goods vehicle (153 cwt.) to operate within a 50-mile radius of the premises of Tarax Drinks (Huntingdale) Pty. Ltd., at Huntingdale, but excluding any operations to or from the City of Geelong—aerated waters solely on behalf of the said company.
- STARES, R. E., Post Office, Yarragon. Application to vary the conditions of licence No. D.A.51471 (L/C. 110 cwt.) by deleting from the existing conditions "Longford" and adding in lieu "Yarragon."
- STEVENSON, G. R. & J., Licola-road, Heyfield. Application to vary the conditions of licence No. T.T.D.423/4 (L/C. 222 cwt.) by adding to the existing conditions "From Heyfield and Licola to the A.P.M. Ltd., at Maryvale—wood chips".
- SUNBEAM CORPORATION LTD., Sloan-street, Maribyrnong. One commercial goods vehicle (6 cwt.) to operate throughout the State of Victoria in the course of business as "Manufacturer of Electrical Appliances and Farm Machinery"—electrical appliances for demonstration purposes, machinery for installation, tools of trade, spare parts and materials incidental to servicing and maintaining such appliances and machinery.
- SUPER SPREAD AVIATION AUST. PTY. LTD., P.O. Box 7, Cheltenham. Four commercial goods vehicles (mobile cranes) to operate throughout the State of Victoria in the course of business as "Aerial Crop Dusters" for the purpose of operating the vehicles as mobile cranes incidental to loading superphosphate into aircraft for dusting purposes with the ability also to carry excess aviation fuel from farm to farm after flying operations.
- TONGALA MILK PRODUCTS PTY. LTD., 644 Victoria-street, North Melbourne. Two commercial goods vehicles (316 and 317 cwt.) to operate: (a) Throughout the State of Victoria in the course of business as "Milk Products Manufacturers"—goods and materials to and manufactured articles or products from own factory at Tongala (Approved decentralized secondary industry). (b) Between Tongala and Melbourne—goods and materials to and manufactured products from wholly owned subsidiary companies, The Northern Dairy Co. Ltd. factory at Tongala.
- WARREN, A. A., Barjarg, via Mansfield. Application to vary the conditions of licence No. D.A.50444 (L/C. 9 cwt.) by increasing the number of passengers allowed in paragraph (ii) from "two (2)" to "four (4)".
- WEINREB, I., Flat 6, 3 Seymour-road, Elsternwick. One commercial goods vehicle (15 cwt.) to operate throughout the State of Victoria in the course of business as "Wool and Skin Buyer" for the purpose of buying and carrying wool pieces and skins from farming properties for sale to Melbourne agents.
- WELCH PERRIN & CO. PTY. LTD., 48 Queen's Bridge-street, South Melbourne. One commercial goods vehicle (17 cwt.) to operate throughout the State of Victoria in the course of business as "Farm Machinery Distributors"—own agricultural and potato machinery for demonstration purposes only.
- WILLIAMS, I. M., 284 Wickham-road, Moorabbin. Two commercial goods vehicles (8 cwt. each) to operate throughout the State of Victoria in the course of business as "Electrical Contractor"—tools of trade, spare parts and small quantities of materials incidental to the completion of own contracts.
- WOOSTER, R., 15 Murray-street, Warrnambool. One commercial goods vehicle (135 cwt.) to operate within a 75-mile radius of post office at Peshurst (Warrnambool Division of C.R.B.) as a "Road Contractor"—road-making plant and materials.
- YORK, HENRY H., & CO. PTY. LTD., 376-394 Whitehorse-road, Nunawading. One commercial goods vehicle (9 cwt.) to operate throughout the State of Victoria in the course of business as "Manufacturers' Representatives"—sprays equipment and sprays both for experimental purposes and sufficient quantities of materials only necessary for completion of experiments.

## TOW TRUCKS

- HUSSEY, J. H. (trading as Allied Towing Service), 493 Spencer-street, West Melbourne. One commercial goods vehicle (79 cwt.) to operate throughout the State of Victoria as a "Tow Truck" for the purpose of lifting and carrying or towing and/or repairing wrecked or disabled vehicles—tools of trade, spare parts and materials incidental thereto.
- BARTON, J., 208 Main-street, Bacchus Marsh. One commercial goods vehicle (52 cwt.) to operate within a 50-mile radius of post office at Bacchus Marsh as a "Tow Truck" for the purpose of lifting and carrying or towing and/or repairing wrecked or disabled vehicles—tools of trade, spare parts and materials incidental thereto.
- GOLDSWORTHY, J. L. & C. W., & N. S. AUSTIN (trading as Kaniva Motors), Commercial-street, Kaniva. One commercial goods vehicle (63 cwt.) to operate throughout the State of Victoria as a "Tow Truck" for the purpose of lifting and carrying or towing and/or repairing wrecked or disabled vehicles—tools of trade, spare parts and materials incidental thereto.
- LLOYD, C. J. & J. M. (trading as C. J. Lloyd Motors), Belmore-street, Yarrowonga. One commercial goods vehicle (70 cwt.) to operate throughout the State of Victoria as a "Tow Truck" for the purpose of lifting and carrying or towing and/or repairing wrecked or disabled vehicles—tools of trade, spare parts and materials incidental thereto.
- STANWELD AUTO REPAIR SERVICE PTY. LTD., 602 South-road, Moorabbin. One commercial goods vehicle (39 cwt.) to operate throughout the State of Victoria for the purpose of lifting and carrying or towing and/or repairing wrecked or disabled vehicles—tools of trade, spare parts and materials incidental thereto.
- STATION MOTORS BODYWORKS PTY. LTD., 102 Dandenong-road, Frankston. One commercial goods vehicle (26 cwt.) to operate within a 50-mile radius of Frankston as a "Tow Truck" for the purpose of lifting and carrying or towing and/or repairing wrecked or disabled vehicles—tools of trade, spare parts and materials incidental thereto.
- BRINSMEAD, R. H. (trading as Agricultural and Domestic Sprays), 36 Menin-road, Nunawading; D.A.10588/3; 8th October, 1964; 56 cwt.
- BAULCH, L. J., Pascoe-street, Apollo Bay; D.A.28606; 8th October, 1964; 132 cwt.
- BENNETT, N. W., 12 Dally-street, Northcote; D.A.28559; 1st October, 1964; 96 cwt.
- BLACK, K. E., 18 Jennings-street, Colac; D.A.680; 1st October, 1964; 314 cwt.
- BROWN, F. S., 17 James-avenue, Aspendale; D.A.28750; 8th October, 1964; 51 cwt.
- BUSHHELLS PTY. LTD., 452 Flinders-street, Melbourne; D.A.773/2; 24th October, 1964; 7 cwt.
- DOYLE, J. & R. L., Day-street, Bendigo; D.A.998/4; 24th October, 1964; 111 cwt.
- EVANS, H. J., 13 Chausser-avenue, East Malvern; D.A.27602; 29th October, 1964; 13 cwt.
- FINCHETT, E. W., 127 French-street, Hamilton; D.A.28883; 22nd October, 1964; 29 cwt.
- FLEUREN, J. P., 25 High-street, Kangaroo Flat; D.A.40603; 10th October, 1964; 5 cwt.
- GOLDSWORTHY, E. J., A., R. E. & L. E. (trading as J. Goldsworthy & Sons), Dunlop-street, Mortlake; D.A.1169/1; 22nd October, 1964; 165 cwt.
- GREEN, F. H. & W. H. (trading as Green Bros.), Avenel; D.A.1196/1; 6th September, 1964; 244 cwt.
- HADDOCK, J. A., Ellery-street, Hastings; D.A.26908; 8th October, 1964; 103 cwt.
- HANNAFORD, ALF. & CO. LTD., 932-942 Port-road, Woodville, South Australia; D.A.1232/21; 19th April, 1964; 78 cwt.; D.A.1232/29; 19th April, 1964; 78 cwt.
- HARRIS, E. S., & CO. PTY. LTD., 43 Kepler-street, Warmambool; T.D.A.21645; 8th October, 1964; 250 cwt.
- HARRISON, E. H. & L. G., 33 Wellman-street, Box Hill; D.A.42027/5; 10th October, 1964; 29 cwt.
- HILDER, T. W., 305 Gillies-street, Thornbury; D.A.27448; 1st October, 1964; 106 cwt.
- INGLETON, V. H., Dunsford-street, Lancefield; D.A.27608; 29th October, 1964; 112 cwt.
- KILNER, F., & SONS PTY. LTD., 799 Burke-road, Camberwell; D.A.28569; 1st October, 1964; 58 cwt.
- KRUGER, P. E., 56 Allansford-road, Warmambool; D.A.1458/1; 29th October, 1964; 220 cwt.
- MAW, T. W., & SONS PTY. LTD., "Devon", Nepean Highway, Rosebud; D.A.39874/2; 11th July, 1964; 53 cwt.

- MC CRAITH REFRIGERATION SERVICE PTY. LTD., 491 Keilor-road, Niddrie; D.A.42638/1; 17th October, 1964; 10 cwt.; D.A.42638/2; 17th October, 1964; 9 cwt.
- MCPHERSON FIBROUS PLASTER CO. PTY. LTD., 38 Nepean Highway, Mentone; D.A.40593; 10th October, 1964; 107 cwt.
- O'BREE, R. H. P., 105 Victoria-street, Cobden; D.A.40599; 10th October, 1964; 136 cwt.
- PARKER, W. R., 702 Pleasant-street, Ballarat; D.A.28524/2; 1st October, 1964; 353 cwt.; D.A.28524/1; 1st October, 1964; 142 cwt.
- RIDSDALE, G., 501 Leith-street, Ballarat; D.A.39051; 1st August, 1964; 8 cwt.
- SIEMENS HENLEY PTY. LTD., 116-130 Leicester-street, Carlton; D.A.21711/1; 11th July, 1963; 42 cwt.
- SLEEP, C., Post Office, Clear Lake; D.A.35815; 24th October, 1964; 8 cwt.
- STANDARD FIBROUS PLASTER PTY. LTD., corner Commercial and Driffield roads, Morwell; D.A.2093/2; 22nd October, 1964; 103 cwt.
- WATKIN, S. F., 112 Patty-street, Mentone; D.A.2250; 12th July, 1964; 12 cwt.
- WHITTLE, G. T., 12 Wireless-street, Kangaroo Flat; D.A.16597; 10th October, 1964; 134 cwt.
- WIGGS, W. T., PTY. LTD., 116 French-street, Hamilton; D.A.40407/2; 17th October, 1964; 35 cwt.

**A**PPPLICATION by persons listed hereunder for renewal of licence as listed with variation of conditions in the manner set out opposite their names.

- FOODGUARD PTY. LTD., corner Stewart and Ryan streets, East Brunswick; D.A.48195/1; 24th October, 1964; 19 cwt.; with variation by deleting "Ice-cream Manufacturers" and adding in lieu "Refrigeration Manufacturers and Shop Fitters".
- MCPHERSON & TURNER (trading as Valley Potatoes), Carrier-street, Benalla; T.D.A.49738/1; 3rd September, 1964; 10 cwt.; with variation by adding to the existing conditions "and onions".
- MCPHERSON & TURNER (trading as Valley Potatoes), Carrier-street, Benalla; T.D.A.49738; 3rd September, 1964; 78 cwt.; with variation by adding to the existing conditions "and onions" and by adding as paragraph (b) "From growers in the Kinglake, Koroit, Winchelsea, Colac and Thorpdale areas to Sorting and Packing depot at Benalla—potatoes and onions".
- WILLIS, R. R., Main-street, Strathmerton; D.A.40646; 10th October, 1964; 134 cwt.; with variation by adding to the existing conditions in paragraph (b) "on behalf of Mobil Oil Aust. Ltd.".

Notice of any objection should be forwarded to reach the Secretary of the Board not later than 12th August, 1964.

Applicants are advised that it will not be necessary to appear on the hearing date specified above, unless advised in writing by the Board.

B. P. KAY,  
Secretary.

Exhibition Buildings, Rathdown-street, Carlton, N.3,  
29th July, 1964.

## DEPARTMENT OF MINES.

**S**UBJECT to any necessary excisions, &c., it is proposed to grant the following mining lease:—

8238, Mineral; Ivan John Harrington Walscott; 10a. 1r., Parish of Kinabulla.

## APPLICATION FOR LEASE REFUSED.

8272, Mineral; Frank Ian Daunt and Robert John Fraser; 50 acres, Parish of Walwa.

## CONSENT GRANTED TO TRANSFER OF TAILINGS LICENCE.

3174, Tailings Licence; from Frank Edward Evans to Arthur William Pulfer and George McLeod Holt.

## PETROLEUM EXPLORATION PERMIT GRANTED.

49, Petroleum Exploration Permit; Haematite Explorations Proprietary Limited; 1,690 square miles, being an area off-shore, adjoining Petroleum Exploration Permit No. 40.

## PETROLEUM EXPLORATION PERMIT EXPIRED.

17, Petroleum Exploration Permit; Tallageria No Liability; 2,186 square miles, County of Lowan.

T. A. DARCY,  
Minister of Mines.

## CONTRACTS ACCEPTED.—(Series 1963-64.)

## PUBLIC WORKS.

5174. Ararat, State School No. 800, fencing, £595 10s.—Cyclone Co. of Aust. Ltd.
5175. Apollo Bay, Consolidated School, heavy and light duty asphalt and resealing works, £4,134 5s.—Associated Bitumen Pty. Ltd.
5176. Ballarat, Dana-street, State School No. 33, conversion of Bristol class-rooms to Speech Therapy Centre, £872.—J. H. Brown & Son Pty. Ltd.
5177. Ballarat Mental Hospital, renewal of ceiling to Psychiatric Hospital "Dana House", £1,230.—Sebastopol Fibro Plaster Works.
5178. Ballarat, Paper Mills, rendering of reservoir for sprinkler system, £460.—J. & E. Jamieson.
5179. Beaufort, High School Residence, internal painting residence, Livingstone-street, £268.—M. G. Flynn.
5180. Bendigo, Law Court, improved lighting, &c., £562.—R. L. Campbell Pty. Ltd.
5181. Boorolite, State School No. 2157, installation of new out-houses and septic tank, £1,120.—Mansfield Plumbing & Hardware Supply.
5182. Burwood, Elgar-road, "Allambie", Social Welfare Department, supply and fixing of fibrous plaster and mineral wool in Matron's Flat, £529 10s.—G. N. Hendy Pty. Ltd.
5183. Carlton, Police Station, replacement of slate roof with galvanized iron, £532 2s.—A.B.C.A. Roofing.
5184. Chillingollah, State School No. 3997, new shelter pavilion and new tank stand for 800-gallon tank, £488.—R. B. McDonald.
5185. Dartmoor, State School No. 1035, removal of five (5) trees, £380.—H. McP. Pratt.
5186. Dookie, Agricultural College, supply and erection of prefabricated "Seymour" residence, £4,327 18s.—W. Phelan & Sons Pty. Ltd.
5187. Dookie, Agricultural College, internal repairs to domestic staff quarters, £894 12s.—N. L. Pinder.
5188. Drouin, State School No. 1924, erection of fencing, £670.—Cyclone Co. of Aust. Ltd.
5189. Fyans Park, State School No. 4919, electrical installation in new four (4) class-room school, £1,035 10s.—J. K. Carbines.
5190. Geelong, Teachers' College, erection of No. 2 bicycle shelters, £853.—N. A. Gillanders.
5191. Glenferrie, State School No. 1508, renovations and alterations to school and residence, £9,900.—A. La Rovere.
5192. Gunbower, Agriculture Department, Tobacco Research Station, supply and erection of prefabricated residence, £5,596 8s.—W. Phelan & Sons Pty. Ltd.
5193. Horsham, Clerk of Court's Residence, repairs and painting residence, 3 Dimboola-road, £850 11s. 6d.—H. G. Gregor.
5194. Janefield, Training Centre, electrical installation for new girls' ward, £2,650.—Laurel Electric Pty. Ltd.
5195. Koo-Wee-Rup, High School, electrical installation in L.T.C. extensions, &c., £5,450.—A.T.L. Electrical Co. Pty. Ltd.
5196. Kyneton, High School, attention to toilet facilities, £545 6s.—J. R. Baeck.
5197. Lake Boga, Lands Department Residence, provision of toilets to residence and depot, £405 11s.—A. C. Dawes.
5198. Landsborough West, State School No. 4005, erection of class-room, store-room, &c., £2,223.—A. V. Jennings Industries (Aust.) Ltd.
5199. Loch, State School No. 2912, non-party fencing, £350.—R. G. & V. J. Smith.
5200. Lyndhurst South, State School No. 1222, erection of fencing, £453.—Cyclone Company of Australia Ltd.
5201. Melbourne, Police Headquarters, Russell-street, supply and fix acoustic plaster ceilings, £548.—Olympic General Products Pty. Ltd.
5202. Melbourne, Russell-street, Police Headquarters, installation of additional electrical kitchen equipment, £735 16s.—H. Bruggink.
5203. Melbourne, Royal Melbourne Institute of Technology, supply and installation of plenum and exhaust air systems in Heat Engines Laboratory, £1,116.—Belsair Pty. Ltd.
5204. Melbourne, Royal Melbourne Institute of Technology, electrical installation in Food Technology Department in Building No. 3, £1,175 14s.—J. Lawrence Electrical Engineering Pty. Ltd.
5205. Mockinya, State School No. 2395, erect toilet block, install septic tank, £1,282 10s.—Cockroft & Haby.
5206. Mont Albert, State School No. 3943, supply and installation of gas heating to two (2) new class-rooms, £379 4s. 8d.—Colonial Gas Holdings Ltd.
5207. Mount Macedon, Memorial Cross Reserve, internal painting of residence and kiosk, £266.—J. E. Acott & G. A. McFarlane.
5208. Moyston, State School No. 1263 and residence, completion of septic tanks and installation of water service, £1,738 5s. 9d.—P. C. Nicholson.
5209. Murtoa, High School, installation of fire service, £1,203 6s.—Chas. Dawson & Son.
5210. Norlane North, State School No. 4927, electrical installation in new school of eight (8) L.T.C. class-rooms, £1,380.—J. K. Carbines.
5211. Pyramid Hill, State School No. 1712, erection of new chain mesh fence to front of school and residence, £306 10s.—Cyclone Co. of Aust. Ltd.
5212. Ruskin Park, State School No. 4916, non-party fencing, £429 10s.—Cyclone Co. of Aust. Ltd.
5213. Rutherglen, Agriculture Department, Research Station, external and internal renovations to residences Nos. 7, 8, 9 and 10, £3,350.—N. G. Stephens.
5214. Rye, Police Department, Office and Residence, supply and installation of hot water service, liquid petroleum gas service, sink heater and re-installation of S.C. stove, £380.—C. A. Hansen.
5215. Shepparton, High School, alterations to clerestory windows, £395 18s.—N. L. Pinder.
5216. Spring Gully, State School No. 3505, erection of front fencing, non-party, £273.—F. D. Connellan.
5217. Swan Hill, High School, Girls' Hostel, electrical installation, £504.—G. & J. M. Elliott.
5218. Swan Hill, Girls' Hostel, High School, new laundry and store—renovations and painting, £5,318 15s.—F. McMahon & Co.
5219. Warragul, Technical School, electrical installation for new cafeteria, £985.—Traralgon Electrical Service Pty. Ltd.
5220. Warrnambool East, State School No. 4773, two additional class-rooms, £4,265.—R. F. Bishop.
5221. Wendouree, State School No. 1813, provision of stainless steel troughs, &c., £419 9s.—Fargher & Roff.
5222. Werribee, Agriculture Department, Research Farm, erection of steel and galvanized iron shed, £1,080 12s.—Cyclone Co. of Australia Ltd.
5223. Yarram, Court House, general repairs, £545.—H. Wilson.
5224. Altona North, State School No. 4931, erection of a ten (10) class-room concrete veneer timber-framed Primary School, £45,951.—A. V. Jennings Industries (Aust.) Ltd.
5225. Geelong, High School, erection of Domestic Arts Block, £108,117.—D. A. Constructions Pty. Ltd.
5226. Kingsbury, State School No. 4845, four additional class-rooms, £20,692.—A. V. Jennings Industries (Australia) Limited.
5227. Melbourne, Police Department, Offices, 193 Spring-street, electrical installation in converted Dental Hospital, £11,350.—Laurel Electric Pty. Ltd.
5228. Melbourne, 304-328 Swanston-street, Institute of Applied Science of Victoria, erection of building to house a Planetarium, £10,750.—A. R. P. Crow & Sons Pty. Ltd.
5229. Ringwood, Technical School, extensions to second and third sections, £39,300.—P. M. Versteegen & Sons Pty. Ltd.
5230. Robinvale, High School, erection of modified Manual Arts Wing in concrete veneer, £25,325.—A. V. Jennings Industries (Aust.) Ltd.
5231. Altona North, State School No. 4931, plenum heating in new ten class-room school, £3,847.—Gray & Wood.
5232. Ballarat, Education Department, School of Mines, alterations, Physical Chemistry Laboratory, &c., £1,737.—A. & B. Oswald Pty. Ltd.
5233. Beechworth, High School, surface and underground drainage, road and pedestrian pavements and associated work, £7,180 15s.—A. P. Delaney & Co. Pty. Ltd.
5234. Bell Vue, State School No. 4733, renewal of corridor roof, £634.—Egeberg Building & Plumbing Service.
5235. Benalla, Police Station Residence, erection of brick veneer residence and brick garage, £7,213.—Euroa Building Co.
5236. Beveridge, State School No. 1476, renovations and painting, £793.—L. J. Jessop.
5237. Box Hill, Technical School, re-roofing of all flat roof areas with new aluminium decking, £3,083.—Aluminium Roofing Pty. Ltd.
5238. Brunswick West, Boys' State School No. 2890, rewiring of electrical installation and improved lighting, £1,580 12s.—H. N. Butcher.
5239. Burwood, 70 Elgar-road, Social Welfare Department, "Allambie", Reception Centre, erection of security fences, front and side boundaries, £1,970.—Diamond Fence & Gate Co. Pty. Ltd.
5240. Burwood East, State School No. 454, supply and installation of town gas heating, £1,072.—BH Thermal-Air Engineering.



5241. Burnley, Agriculture Department, Horticultural College, supply and installation of evaporative cooling equipment in the Sheep Facial Eczema and Wheat Root Rot Glasshouses, £4,100.—Crockford & Robertson Pty. Ltd.
5242. Casterton, 5 Sylvester-street, High School Residence, provision of internal toilet and connexion to sewer, £400.—H. Youlden & Son.
5243. Cheltenham Heights, State School No. 4930, plenum heating in new ten (10) class-room school, £3,648.—Bruce Sheet Metal Service.
5244. Clayton, State School No. 4747, external and internal repairs and painting, £1,991 12s.—J. H. Foster & Sons.
5245. Comet Hill, State School No. 4929, electrical installation in new school of eight (8) L.T.C. class-rooms, &c., £1,200.—W. R. Parker.
5246. Comet Hill, State School No. 4929, plenum heating to new eight class-room school, £2,267.—D. Smyth & Son Pty. Ltd.
5247. Dargo, State School No. 1081 and residence, supply and installation of an electric pump, £258 10s. 7d.—J. T. Shine (Shine Engineering Services).
5248. Dooen, Longerenong Agricultural College, fabrication of pressurized 4,000-gallon water tank, £776.—Cowley's Eureka Ironworks Pty. Ltd.
5249. Essendon, State School No. 483, electrical installation for alterations and improved lighting, £524.—J. F. Veall.
5250. Essendon, Technical School, asphalt repairs and paving construction, £2,900.—W. N. Kirkpatrick.
5251. Fairfield, State School No. 2711, additional ablu-tion troughs, £385 12s.—J. M. Coon.
5252. Footscray West, State School No. 3890, internal renovations, Cleaner's Residence, £888.—V. Laizans & Son.
5253. Goroke, Consolidated School, repairs and painting, residence, Station-street, £1,000.—K. H. Helstrup.
5254. Heidelberg, "Lentara", Family Group Home, 247 Banksia-street, erection of garage, paths, &c., £376 17s.—James Brown.
5255. Heywood, Consolidated School, asphalt repairs and resealing, £1,789 18s.—J. Keen.
5256. Kaniva, High School, erection of concrete post and wire fencing, £472 10s.—A.R.C. Engineering Co. Pty. Ltd.
5257. Kerang, High School, provision of new asphalt areas, concrete paving, drainage, fencing, beautification and associated works, £9,540 9s. 8d.—E. B. Mawson & Sons Pty. Ltd.
5258. Melbourne, Macarthur-street, State Laboratories, supply and installation and testing of a reverse cycle room air-conditioning unit in room 209, —268 9s. 5d.—Astor Electronics Pty. Ltd.
5259. Melbourne, Government Printing Office, Macarthur-street, supply and fix fibrous plaster to walls, ceilings and plaster acoustic tiling, £1,151.—Picton Hopkins and Son Pty. Ltd.
5260. Melbourne, Police Headquarters, Russell-street, supply and fix lead-ply partitions, £1,281.—V.I.A. Limited.
5261. Mont Park, Mental Hospital, provision of fly-wire doors and screens to Wards M.1 to M.6, and F.1 to F.6, at Mont Park and Wards C and R at Plenty, £2,767 10s.—A.R.C. Insect Screens Pty. Ltd.
5262. Mont Park, Janefield Mental Hospital, supply and installation of storage tank and electrically operated petrol pump, £440 10s.—Gibbert and Barker Manufacturing Company (Aust.) Pty. Ltd.
5263. Murchison, State School No. 1126, non-party fencing, £576.—A.R.C. Engineering Co. Pty. Ltd.
5264. Norwood, High School, non-party fencing and retaining wall, £1,853 18s. 6d.—A.R.C. Engineering Co. Pty. Ltd.
5265. Parkmore, State School No. 4881, asphaltting, concreting, drainage and associated works, £4,600 7s. 7d.—Wm. Loud Pty. Ltd.
5266. Port Melbourne, Salmon-street, Public Works Department, storeyard, brick and steel frame extension to Amenities Block, £8,600.—R. G. Dew.
5267. Richmond, Technical School, supply, delivery and installation of a panel storage rack in the Panel Beating Shop, £395.—J. T. Shine (Shine Engineering Services).
5268. Sebastian, State School No. 1510, fencing to school and residence, £660.—F. D. Connellan.
5269. Shepparton, Teachers' Flats, State School No. 4666, roof repairs, £377 2s.—A. & H. E. McDougall.
5270. Sunbury, Mental Hospital, gravel car parks, £1,070 2s. 6d.—B. Richards.
5271. Wantima, State School No. 3709, residence, external and internal renovations, £536.—Gleeson & Grigg.
5272. Warrenbayne, State School No. 1498, external painting to school and residence, £458.—H. Matthes.
5273. West Melbourne, Agriculture Department, Government Cool Stores, electrical installation for conversion of Cooling Chambers Nos. 4b and 6b, £686.—Beaumont Electrical Service.
5274. Bulleen, State School No. 4869, asphaltting, concreting, drainage, retaining walls and associated works, £10,339 5s.—L. J. Towers.
5275. Janefield, Mental Hospital, supply and installation of briquette fired steam generators and associated equipment in new Boiler House for Female Wards, £14,128.—Belsair Pty. Ltd.
5276. Koo-Wee-Rup, High School, new class-room wing, £39,660.—S. L. Cochrane
5277. Melbourne, Police Department, Old Dental Hospital, 193 Spring-street, demolition, alterations and renovations, £47,742.—W. J. Cody Pty. Ltd.
5278. Mont Park, Mental Hospital, supply and installation of steam, condensate, hot water and heating services for two (2) Geriatric Wards, £18,694.—Supertherm Industries Pty. Ltd.
5279. Red Hill, Consolidated School, new roofing, renovations and paintings, Police Station, £10,159.—D. B. Tincknell Pty. Ltd.
5280. Rye, Police Station, erection of residence, office and garage, &c., £13,445.—M. Gallagher.
5281. Sunshine West, High School, erection of third section, £63,671.—G. & A. Power Pty. Ltd.
5282. Auburn South, State School No. 4183, renewal and resiting of troughs, drainage, &c., £494.—H. & A. Tinsley Pty. Ltd.
5283. Bacchus Marsh, High School and Residences, connexion to town sewerage, £3,429 5s.—F. A. & E. M. Tickell.
5284. Burnley, Horticultural College, pipe and chain mesh fencing, (Orchard and Nursery area.) £604.—Diamond Fence & Gate Co. Pty. Ltd.
5285. Carlton, Motor Registration Branch, erection of Administration Office Buildings and associated site works, £2,115,000.
5286. Ararat, Mental Hospital, supply and installation of exhaust ventilation steam, condensate and hot water services in main kitchen, £12,617.—George Stone & Sons.
5287. Comet Hill, State School No. 4929, eight class-room concrete veneer timber framed school, £33,700.—E. Mills & Sons Pty. Ltd.
5288. Cheltenham Heights, State School No. 4930, erection of new Primary School, £43,130.—R. F. Hosie.
5289. Irymple, Research Station, construction of new brick insectary, £10,358.—S. Sandor.
5290. Stony Point, Westernport Bay, dredging, at rates.—Australian Dredging & General Works Pty. Ltd.
5291. Allansford, State School No. 3, internal and external renovations, £1,396.—Hose & Schultz.
5292. Ararat, Mental Hospital, electrical installation at Concert Hall, south end, £537 15s.—R. Gemmola.
5293. Apollo Bay, Lands and Survey Department Depot, provision of septic tank, £417 15s.—P. D. Cardilini.
5294. Ballarat, Mental Hospital, install fire services to serve residences for the Secretary and Medical Officer, £368 15s.—Fargher & Roff.
5295. Ballarat, Mental Hospital, conversion of four (4) toilets to storerooms, £333 9s.—B. W. Garnham.
5296. Bell Park, High School Residence, sewerage connexion to residence, £298 10s.—Tubular Products, Geelong.
5297. Benalla, Police Station, Sergeant's Residence, internal and external repairs and painting, £315.—J. T. Hale.
5298. Bendigo, High School Residence, external and internal painting and repairs to residence and out-buildings, 49 Russell-street, £1,426 12s.—N. C. Thirlwell.
5299. Big Hill, State School No. 1551 and residence, installation of new out-offices and septic tank, £1,118 5s.—R. House.
5300. Carag Carag, State School No. 2034, erection of out-office and installation of septic tank, £1,199 14s.—R. House.
5301. Charlton, Higher Elementary School No. 1480, replacement of flooring to Grade IV. and Infants' Rooms, £507 10s.—R. House.
5302. Cooramook, State School No. 1226, installation of septic tank and toilets, £782 13s.—F. Bos.
5303. Derrinallum, State School No. 2050, erection of concrete post, wire, paling and chain mesh fencing, £560.—G. J. Bonner.
5304. Dixie, State School No. 891, new laundry and bathroom, renovations to school and residence, £2,176 10s. 6d.—Kennedy & McPherson.
5305. Dunrobin, State School No. 3777, external painting to school and residence, £757 10s.—F. W. Jeffreys.
5306. Echuca West, State School No. 3916; new shelter pavilion 20 ft. x 16 ft., £394 19s. 6d.—K. Vredenburg.
5307. Ellerslie, State School No. 1461, residence, erection of garage, £255.—E. J. Hawkins.
5308. Essendon, State School No. 483, renovations and alterations, £1,994.—A. Dugina.
5309. Glengarry, State School No. 2888, repairs and painting to residence, £795.—Shrimpton & McNeilly.
5310. Gravel Hill, State School No. 1566, provision and installation of stainless steel urinal, £298 15s.—J. G. Hibberd Pty. Ltd.

5311. Horsham North, State School No. 4926, electrical installation in new school of eight (8) L.T.C. class-rooms, &c.—£1,715 15s.—J. W. McDowell.
5312. Kangaroo Flat, Police Station Residence, repairs and painting and provision of new toilet and laundry.—£1,148 5s.—J. G. Hibberd Pty. Ltd.
5313. Kerang, Fisheries and Wildlife Residence, external and internal repairs and painting, £616.—R. B. McDonald.
5314. Lockwood South, State School No. 385, erection of out-offices and installation of septic tank, £889 7s.—J. G. Hibberd Pty. Ltd.
5315. Mallacoota, Fisheries and Wildlife Department, Residence, renovations to residence, £1,176.—K. D. Sewell.
5316. Nalangil, State School No. 3189, Residence, chain mesh and paling fencing, £373 16s.—J. A. & K. A. Reid.
5317. Nathalia, State School No. 2060, renewal of water supply, £873 10s.—Roe & Cook.
5318. Numurkah, High School Residence, 172 Melville-street, provision of indoor toilet and septic installation, £360.—W. B. Roe & T. J. G. Cook.
5319. Omeo, Lands and Survey Residence, repairs and renovations, £1,012.—C. G. Sheean.
5320. Orbost, High School, general repairs, internal and external painting, £2,560.—K. D. Sewell.
5321. Panmure, State School No. 1079, Residence, drainage concrete paving and gravelling, £252 2s.—A. E. Mapleback.
5322. Portland North, State School No. 1194, drainage and asphalt works, £323 14s. 6d.—A. E. Mapleback.
5323. Redan, State School No. 1289, supply and installation of gas space heating system, £443 17s. 6d.—The Ballarat Gas Company.
5324. Ross Bridge, State School No. 1069, erect 16 ft. x 10 ft. shelter pavilion, £472.—H. A. Mannington.
5325. Sea Lake, State School No. 3273, new flooring, chalkboards with cupboards under, supply and installation of slow combustion heater in Infants' Room, £501 15s.—F. McMahon & Co.
5326. Shepparton, Department of Labour and Industry, Residence, 13 Esson-street, external renovations, £259 10s.—N. L. Pinder.
5327. Snob's Creek, Fisheries and Wildlife Hatchery, Chief Secretary's Department, construction of mould and fabrication of fibre glass hatching boxes, £1,320.—Savage Fibreglass Industries Pty. Ltd.
5328. Sunbury, Mental Hospital, supply and erection of No. 2 hay sheds, one—75 ft. x 30 ft. x 14 ft.; one—75 ft. x 40 ft. x 14 ft., £1,688 10s.—Holdsworth Constructions Pty. Ltd.
5329. Tatura, Research Station, internal renovations to foreman's residence, £447 15s.—F. van der Schoot.
5330. Tower Hill, State Game Reserve, forming, grading, draining and preparation for sealing roadway, total length 1,937 feet, £2,899.—J. R. Brown.
5331. Weerite, State School No. 3383, erection of 20 ft. x 10 ft. shelter pavilion, repairs and painting, £1,049 12s.—N. A. Wooding.
5332. Wendouree, State School No. 1813, internal and external painting, £1,100.—J. C. Thomas.
5333. Wendouree West, State School No. 4701, external painting, £528.—J. C. Thomas.
5334. Yea, Police Station Residence, internal and external renovations and painting, £979.—J. Heerink.
5335. Burwood, Social Welfare Department, "Allambie", Reception Centre, Elgar-road, electrical installation in two (2) flats, £641 10s.—W. J. Curry.
5336. Burwood, Allambie, Children's Home, Elgar-road, supply and installation of central heating and hot-water service equipment in Matron's and Sub-Matron's Flats, £807 15s.—L. F. Murray Pty. Ltd.
5337. Carlton, Mental Health Authority, St. Nicholas Hospital, electrical reticulation to various buildings, (stage two), £3,395.—R. A. Waldron Trading Co.
5338. Caulfield, Technical College, additional toilet blocks, £6,200.—M. A. Schiller.
5339. Caulfield, Technical School, supply and installation of an air conditioning unit in the Computer Room, £1,164 5s.—Unit Air Conditioners.
5340. Caulfield North, State School No. 3820, new shelter pavilions and renovations to school buildings (Main and Infants), £4,700.—A. La Rovere.
5341. Dalyston, State School No. 3376, installation of septic tank at residence, £304.—A. J. Avage & Son Pty. Ltd.
5342. Ellinbank, Research Station, supply and installation of a new 3 H.P. boiler with accessories and modification and re-installation of existing boiler, £1,206 15s.—Bruce Furneaux.
5343. Ferndale, State School No. 3571, installation of septic tank, £997.—A. J. Avage & Son Pty. Ltd.
5344. Fitzroy, State School No. 450, drinking and washing facilities, £978.—Egeberg Building and Plumbing Service.
5345. Geelong, Public Offices, repairs and painting, £6,311 7s.—C. P. Hornsey & Son.
5346. Hamilton, Agriculture Department, Research Farm, supply and installation of fire pump, and fresh water pump, £1,420.—C. A. Hansen.
5347. Horsham North, State School No. 4926, supply and installation of plenum heating in new eight class-room school, £2,425.—Gray & Wood.
5348. Keon Park, Technical School, external and internal renovations to caretaker's residence, £535.—J. Mazzetti.
5349. Kew, Mental Hospital, erection of standard brick veneer residence for Tutor, £6,100.—A. La Rovere.
5350. Korong Vale, Police Station, new concrete path, repairs and external painting at residence, £476 10s.—W. Chalmers.
5351. Langi Kal Kal, Training Centre, external renovations to two staff residences, £589.—R. H. Hibbins.
5352. Melbourne, State Immigration, 436 Queen-street, maintenance cleaning from 1st March, 1964 to 28th February, 1965, £296.—Linglow Cleaning Service.
5353. Melbourne, National Gallery, new mezzanine floor, &c., McAllan Store, £1,808.—C. Stringer & Co. Pty. Ltd.
5354. Melbourne, Public Works Department, Accounts Branch, Treasury-place, electric light and power installation, £1,835.—M. T. Carroll & Co. Pty. Ltd.
5355. Melbourne, Chief Secretary's, Old Treasury Building, supply and installation of air conditioning unit, &c., £392 2s.—Unit Air Conditioners.
5356. Melbourne, Public Works Department, Ports and Harbours Branch, electrical installation, rewiring, additions and alterations, £1,043.—R. A. Waldron Trading Co.
5357. Mont Park, Mental Hospital, electrical installation for two (2) new Geriatric Wards, £2,548.—Ross Bros. Electrical Engineers & Contractors Pty. Ltd.
5358. Mont Park, Mental Hospital, supply and installation of steam services and exhaust ventilation system to Meal Service Unit in Isolation Block, £510.—W. S. Atherton & Co.
5359. Niddrie, State School No. 4849, external painting and repairs, £450.—C. B. Bramich.
5360. Northcote, State School No. 1401, drainage works and asphalt repairs, £3,966 14s. 2d.—Roy Senior & Son Pty. Ltd.
5361. Reservoir, Police Station, repairs and painting of office buildings and out-buildings, £530.—Godfrey L. Ryan & Co.
5362. Rosebud, State School No. 2627, chain mesh fence and gates, £327.—Diamond Fence & Gate Co. Pty. Ltd.
5363. Royal Park, Mental Hospital, installation of hot-water boiler, hot-water service, alterations, ventilation and heating, stage one at Park Wards, £5,077 5s.—L. F. Murray Pty. Ltd.
5364. St. Albans, High School, earthworks, drainage and construction of Tennis Courts, £1,087 10s.—J. H. Nichols.
5365. St. Albans East, State School No. 4741, repairs and painting, £763.—J. Mazzetti.
5366. Scoresby, Horticultural Research Station, supply and installation of irrigation pump, £900.—George H. Curtis & Sons Pty. Ltd.
5367. Shepparton, State School No. 4666, renovations to Teachers' Flats, £908 10s.—P. R. Pinder.
5368. South Melbourne, State School No. 1852, replacement of chalkboards, £524.—A. La Rovere.
5369. Sunbury, Mental Hospital, repairs, widening and resurfacing of existing asphalt roads, £4,373.—B. Richards.
5370. Warragul, Technical School, erection of cafeteria, £9,475.—K. N. Warne.
5371. West Melbourne, Government Cool Stores, supply and delivery of sixteen (16) forced draught air cooling batteries for the North Raft, £4,736.—Muller's (Brunswick) Pty. Ltd.
5372. Williamstown North, State School No. 1409, repairs to toilets, £258.—G. C. Homewood.
5373. Wunghnu, State School No. 1938, non-party fencing, £660.—R. W. Lee.

MURRAY PORTER, Commissioner of Public Works.  
21.7.64.

#### CONTRACTS ACCEPTED.—(Series 1964-65.)

##### SOIL CONSERVATION AUTHORITY.

##### EPPALOCK CATCHMENT PROJECT.

460. Supply of fencing materials—600 fence posts, 500 strainers, and 550 stays, £631.—C. W. Spence, Maldon.

##### VICTORIAN RAILWAYS.

6. Horse shunting at Ballarat during the period from 1st July, 1964, to 30th June, 1965, at rates per hour (Contract 62659).—N. J. Purcell. 7. Railway Stores Suspense Account Act 6355, Division 4, Subdivision 111-112. Supply and Delivery of General Stores, at rates as may be ordered during the period 1st July, 1964, to 30th June, 1966. Items 6000-7780, inclusive. Details as per Book

No. 4 on display at Comptroller of Stores, Room 109, Spencer-street and Comptroller of Accounts, Room 177, Spencer-street. 8. Manufacture, supply and delivery of cast steel freight bogie parts (50-ton ride control bogies), for £418 per wagon set (Contract 62575).—Bradford Kendall Ltd. 9. Construction of reinforced concrete access roadway to leaseholds of Australian Cement Co. Ltd. and Victoria Portland Cement Co. Pty. Ltd., Arden-street, North Melbourne, for £9,011 15s. (Contract 62603). Ararat Concrete Paving Co. Pty. Ltd. 10. Dismantling &c., of advertising sign and associated equipment above Princes Bridge Railway Station, for £3,194 8s. (Contract 62609).—Walter H. Wright Pty. Ltd.

By order of the Victorian Railways Commissioners.  
W. WALKER, Secretary for Railways. 24.7.64.

#### ORDERS IN COUNCIL.—(Series 1963-64.)

##### STATE ELECTRICITY COMMISSION.

5374. For the supply of 74,500 22 kV and 5,900 11 kV pin type insulators, to Specification No. 63-64/255, £74,669.—Australian Porcelain Sales & Trading Pty. Ltd.

5375. For the supply of 22 kV and 11 kV pin type insulators for a period of two years, to Specification No. 63-64/255, at Schedule rates.—R. M. Hall Pty. Ltd.

5376. For the supply of 30,000 10-in. disc insulators for use on Commission's transmission and distribution system, to Specification No. 63-64/188, £38,025.—Australian Porcelain Sales & Trading Pty. Ltd.

5377. For the supply of 57,000 10-in. disc insulators for use on the Commission's transmission and distribution system, to Specification No. 63-64/188, £54,257.—A.C.I. Glass Insulators Co.

5378. For the supply of 10-in. disc insulators for use on the Commission's transmission and distribution system for a period of one year, to Specification No. 63-64/188, at Schedule rates.—Nilsen Porcelains (Aust.) Pty. Ltd.

Approved by the Governor in Council, 17th June, 1964.—J. COLQUHOUN, Clerk of the Executive Council.

5379. For the erection, maintenance and subsequent dismantling of a temporary acid cleaning plant for cleaning of boiler and ancillary equipment at Hazelwood Power Station, Stage 1, to Specification No. 58-59/73, at Schedule rates.—Babcock & Wilcox of Australia Pty. Ltd.

5380. For the design, supply, installation and maintenance of a heating and ventilating system for the Commission's Communication Centre, Kavanagh-street, South Melbourne, to Specification No. 63-64/301, £5,540.—Belsair Pty. Ltd.

5381. For the supply of general replacement parts for Chrysler vehicles for a period of one year, to Specification No. 63-64/373, at Schedule rates.—Lapco Pty. Ltd.

5382. For the supply and delivery of two 50-cwt. capacity tractor mounted pole erector borers for general construction work, to Specification No. 63-64/275, £9,700.—Tutt Bryant (Vic.) Pty. Ltd.

5383.—For the purchase of land and buildings remaining untransferred in certificate of title, volume 5165, folio 931, being the property known at 439 Flinders-lane, to form part of site for new Administrative Building, £33,495.—The Victorian Stevedoring & General Contracting Co. Pty. Ltd.

5384. For the sale of land and buildings being lot 1 on plan of subdivision No. 62081, and being part of the land described in certificate of title, volume 6765, folio 854, being known as 446-450 Flinders-street, Melbourne, £33,000.—The Victorian Stevedoring & General Contracting Co.

5385. For the purchase of land having a frontage of approximately 72 feet in Charles-street, Prahran, for extensions to District Depot, £5,525.—L. E. G. Gamble.

5386. For the acquisition of easement rights over part of Crown allotment 2, section 6, Parish of Mordialloc, for erection of the Heatherthon-Springvale transmission line, £5,500.—Clayton Industrial Estates Pty. Ltd.

5387. For the purchase of land having a frontage of 340 feet in Greens-lane, Dandenong, and being part of portion 94, Parish of Eumemmerring for a main sub-station site, £6,732.—A. R. Williams.

5388. For the acquisition of easement rights over land being part of Crown allotment 16, section 7, Parish of Mordialloc, for erection of the Heatherthon-Springvale transmission line, £6,436.—Amalgamated Developments Pty. Ltd.

Approved by the Governor in Council, 8th July, 1964.—J. COLQUHOUN, Clerk of the Executive Council.

#### ORDERS IN COUNCIL.—(Series 1964-65.)

##### PUBLIC WORKS.

461. Altona East, State School No. 4805, transfer of portable class-room No. 163, from High School, Essendon, and re-erection at State School No. 4805, Altona East, £309 18s. 3d.—A. V. Jennings Industries (Australia) Limited.—(V.308529.)

462. Ararat, Mental Hospital, Ward FX dormitory, supply and installation of steam heating, £574.—Ford-Swinton Industries Pty. Ltd.—(W.304187.)

463. Ballarat, Mental Hospital, supply of three washing machines, £264 6s.—Lighburn & Co. Ltd.—(W.46501.)

464. Gowrie Park, State School No. 4806, special grant authorized by the Education Department towards the cost of erection of a canteen at the school, £750.—Gowrie Park State School No. 4806 Committee.—(N.W.19672.)

465. Heatherthon, Sanatorium, supply and installation of X-ray film developing unit and alterations to dark room, £1,111.—Plastic Installations Pty. Ltd.—(S.E.181956.)

466. Melbourne, Parliament House, provision of telephone wiring in Hansard and press rooms, £252 5s. 2d.—Postmaster-General's Department.—(M.278797 "A")

467. Mooroolbark, Technical School, transfer of portable class-room No. 153, from Swinburne Technical College, Glenferrie, and re-erection at Technical School, Mooroolbark, £310 4s.—A. V. Jennings Industries (Australia) Limited.—(N.E.308519.)

468. Orbst, High School, additional special grant authorized by the Education Department towards cost of supply of top soil for the oval, and payment of professional fees in connexion with construction of oval and hockey field at the school, £470.—Orbst High School Advisory Council (S.E.275095.)

469. Sandringham, Technical School, replacement of sub-main cables (electrical) £331 5s.—J. Sweeney.—(S.E.48788.)

470. Traralgon, Hobson Park Hospital, modifications to boiler house equipment, £825.—Ekon Industries Pty. Ltd.—(S.E.185550 "B")

Approved by the Governor in Council, 21st July, 1964.—J. COLQUHOUN, Clerk of the Executive Council.

##### EDUCATION DEPARTMENT.

471. One only enamelling kiln for Caulfield Technical College, £224.—Watson Victor Ltd.

472. One only display oscilloscope for Caulfield Technical College, £405.—B.W.D. Electronics Pty. Ltd.

473. One only planing and jointing machine for Sunshine Technical School, (£390 less trade-in £60), £330.—Charles Wolfenden & Co.

474. One only power supply for Swinburne Technical College, £198.—B.W.D. Electronics Pty. Ltd.

475. One only impedance bridge for Caulfield Technical College, £107 10s.—Jacoby, Mitchell & Company Pty. Ltd.

Approved by the Governor in Council, 21st July, 1964.—J. COLQUHOUN, Clerk of the Executive Council.

##### State Electricity Commission Acts.

AGREEMENT RELATING TO THE ACQUISITION BY THE STATE ELECTRICITY COMMISSION OF VICTORIA OF AN ELECTRICITY SUPPLY UNDERTAKING AT KANIVA AND SERVICETON OPERATED BY THE SHIRE OF KANIVA.

HIS Excellency the Governor of the State of Victoria, by and with the advice of the Executive Council thereof, doth by Order made on the 28th day of July, 1964, approve the terms of an agreement between the State Electricity Commission of Victoria and the Shire of Kaniva relating to the acquisition by the Commission of the electricity supply undertaking at Kaniva and Serviceton operated by the said Shire Council as authorized by the Shire of Lawloit Electric Lighting Order No. 182-1924, the Serviceton Electric Lighting Order No. 299-1956 and the Shire of Kaniva (Outer Area) Electric Lighting Order No. 337-1963.

J. COLQUHOUN,

Clerk of the Executive Council.

At the Executive Council Chamber,  
Melbourne, 28th July, 1964.

##### BUILDING SOCIETIES ACT 1958.

NOTICE is hereby given that Australian Natives Association Permanent Building Society is registered under the provisions of the above Act.

Given under my hand this 20th day of July, 1964.

A. DOUGLAS,  
Registrar of Building Societies.

Health Act 1958.

VICTORIA—DEPARTMENT OF HEALTH.

NOTICE TO ATTEND FOR RADIOLOGICAL EXAMINATION.

To all persons aged twenty-one years and over enrolled or resident in the Subdivision specified hereunder in the State Electoral District of Ballaarat South.

TAKE notice that you are required to attend at a Department of Health X-ray unit sited in the public street at or as near as possible to the main entrance to the premises specified in this notice, at any time between the hours specified on one of the days specified and during the period specified in respect of those premises; and thereat to submit yourself to radiological examination of the chest for the purpose of ascertaining whether you may be suffering from pulmonary tuberculosis. If you have had a chest X-ray within the last twelve months and for that reason do not wish to be examined now, you should attend the unit as directed and submit particulars of the previous examination.

SPECIFIED SUBDIVISIONS, PREMISES, PERIODS, DAYS AND HOURS

Subdivision.	Premises.	Period.	Days.	Hours.
Ballaarat West	Dickins Store, cr. Grenville and Bridge streets, Ballaarat	Monday, 24th August, 1964, to Wednesday, 2nd September, 1964 (inclusive)	Monday, 24th August, 1964	From 2 p.m. to 5.30 p.m. and from 7 p.m. to 9 p.m.
	C.A.G.A. House, cr. Sturt and Doveton streets, Ballaarat		All other days during the period except Saturday, Sunday and Public Holidays	From 10 a.m. to 5.30 p.m. and from 7 p.m. to 9 p.m.
	Kings Marine Store, cr. Skipton and South streets, Ballaarat	Monday, 24th August, 1964, to Wednesday, 26th August, 1964 (inclusive)	Monday, 24th August, 1964	From 2 p.m. to 5.30 p.m. and from 7 p.m. to 9 p.m.
			All other days during the period except Public Holidays	From 10 a.m. to 5.30 p.m. and from 7 p.m. to 9 p.m.
	Harink's Store, 3 Jessie-street, Ballaarat	Thursday, 27th August, 1964, to Monday, 31st August, 1964 (inclusive)	Thursday, 27th August, 1964	From 2 p.m. to 5.30 p.m. and from 7 p.m. to 9 p.m.
			All other days during the period except Saturday, Sunday and Public Holidays	From 10 a.m. to 5.30 p.m. and from 7 p.m. to 9 p.m.
	State School, Gillies-street, Alfredton	Thursday, 3rd September, 1964, and Friday, 4th September, 1964	Thursday, 3rd September, 1964	From 2 p.m. to 5.30 p.m. and from 7 p.m. to 9 p.m.
			Friday, 4th September, 1964	From 10 a.m. to 5.30 p.m. and from 7 p.m. to 9 p.m.
Ballaarat East	McRobinson's Store, cr. Eureka and Queen streets, Ballaarat	Thursday, 3rd September, 1964, to Wednesday, 9th September, 1964 (inclusive)	Thursday, 3rd September, 1964	From 2 p.m. to 5.30 p.m. and from 7 p.m. to 9 p.m.
			All other days during the period except Saturday, Sunday and Public Holidays	From 10 a.m. to 5.30 p.m. and from 7 p.m. to 9 p.m.
	Caltex Service Station, cr. Barkly and Gladstone streets, Mt. Pleasant	Monday, 7th September, 1964, and Tuesday, 8th September, 1964	Monday, 7th September, 1964	From 2 p.m. to 5.30 p.m. and from 7 p.m. to 9 p.m.
		Tuesday, 8th September, 1964	From 10 a.m. to 5.30 p.m. and from 7 p.m. to 9 p.m.	
	Handy Car Sales, 84 Main-street, Ballaarat	Wednesday, 9th September, 1964, to Friday, 11th September, 1964 (inclusive)	Wednesday, 9th September, 1964	From 2 p.m. to 5.30 p.m. and from 7 p.m. to 9 p.m.
			All other days during the period except Public Holidays	From 10 a.m. to 5.30 p.m. and from 7 p.m. to 9 p.m.
Sebastopol	Town Hall, Sebastopol	Tuesday, 1st September, 1964, to Thursday, 3rd September, 1964 (inclusive)	Tuesday, 1st September, 1964	From 2 p.m. to 5.30 p.m. and from 7 p.m. to 9 p.m.
			All other days during the period except Public Holidays	From 10 a.m. to 5.30 p.m. and from 7 p.m. to 9 p.m.
	Dickins' Store, Albert-street, Sebastopol	Friday, 4th September, 1964, and Monday, 7th September, 1964	Friday, 4th September, 1964	From 2 p.m. to 5.30 p.m. and from 7 p.m. to 9 p.m.
			Monday, 7th September, 1964	From 10 a.m. to 5.30 p.m. and from 7 p.m. to 9 p.m.
	Shire Hall, Buninyong	Tuesday, 8th September, 1964, and Wednesday, 9th September, 1964	Tuesday, 8th September, 1964	From 2 p.m. to 5.30 p.m. and from 7 p.m. to 9 p.m.
		Wednesday, 9th September, 1964	From 10 a.m. to 5.30 p.m. and from 7 p.m. to 9 p.m.	
	Post Office, Mt. Clear	Thursday, 10th September, 1964, and Friday, 11th September, 1964	Thursday, 10th September, 1964	From 2 p.m. to 5.30 p.m. and from 7 p.m. to 9 p.m.
			Friday, 11th September, 1964	From 10 a.m. to 5.30 p.m. and from 7 p.m. to 9 p.m.
Warrenheip	State School, Warrenheip	Thursday, 10th September, 1964, and Friday, 11th September, 1964	Thursday, 10th September, 1964	From 2 p.m. to 5.30 p.m. and from 7 p.m. to 9 p.m.
			Friday, 11th September, 1964	From 10 a.m. to 5.30 p.m. and from 7 p.m. to 9 p.m.
	Post Office, Elaine	Monday, 14th September, 1964, to Wednesday, 16th September, 1964 (inclusive)	Monday, 14th September, 1964	From 2 p.m. to 5.30 p.m. and from 7 p.m. to 9 p.m.
			All other days during the period except Public Holidays	From 10 a.m. to 5.30 p.m. and from 7 p.m. to 9 p.m.
	Public Hall, Bungaree	Thursday, 17th September, 1964, and Friday, 18th September, 1964	Thursday, 17th September, 1964	From 2 p.m. to 5.30 p.m. and from 7 p.m. to 9 p.m.
			Friday, 18th September, 1964	From 10 a.m. to 5.30 p.m. and from 7 p.m. to 9 p.m.
Bacchus Marsh	R.S.L. Hall, Bacchus Marsh	Monday, 14th September, 1964, to Friday, 18th September, 1964 (inclusive)	Monday, 14th September, 1964	From 2 p.m. to 5.30 p.m. and from 7 p.m. to 9 p.m.
			All other days during the period except Public Holidays	From 10 a.m. to 5.30 p.m. and from 7 p.m. to 9 p.m.

## SPECIFIED SUBDIVISIONS, PREMISES, PERIODS, DAYS AND HOURS—continued.

Subdivision.	Premises.	Period.	Days.	Hours.
Ballan	Gordon Roadhouse, Gordon  Mechanic's Hall, Ballan	Monday, 14th September, 1964, and Tuesday, 15th September, 1964  Wednesday, 16th September, 1964, to Friday, 18th Sep- tember, 1964 (inclusive)	Monday, 14th September, 1964 Tuesday, 15th September, 1964 Wednesday, 16th Septem- ber, 1964 All other days during the period except Public Holidays	From 2 p.m. to 5.30 p.m. and from 7 p.m. to 9 p.m. From 10 a.m. to 5.30 p.m. and from 7 p.m. to 9 p.m. From 2 p.m. to 5.30 p.m. and from 7 p.m. to 9 p.m. From 10 a.m. to 5.30 p.m. and from 7 p.m. to 9 p.m.

NOTE.—Any person to whom this notice applies and who without reasonable excuse fails to comply with the requirements of the notice shall be guilty of an offence, and shall be liable to a penalty of not more than Twenty pounds.

Dated this 23rd day of July, One thousand nine hundred and sixty-four.

KEVIN BRENNAN,  
Chief Health Officer.

Country Roads Act 1958.  
COUNTRY ROADS BOARD.

NOTICE OF FIXING NEW ALIGNMENTS OF GOULBURN VALLEY  
HIGHWAY IN THE SHIRE OF NUMURKAH.

NOTICE is hereby given that the Country Roads Board under the powers conferred upon it by the *Country Roads Act 1958* (No. 6229) has fixed new alignments for the east side of Goulburn Valley Highway in the Shire of Numurkah as described hereunder, that is to say:—

- (a) Commencing at a point on the southern boundary of allotment 10, section 37, Township of Numurkah, Parish of Katunga, distant 90 deg. 2 min. 31 ft. 2½ in. from the south-western angle of the said allotment; thence by lines bearing 315 deg. 0 min. 21 ft. 2½ in. and 360 deg. 0 min. 1,930 ft. 11½ in. to a point on the northern boundary of a Water Supply Reserve in the said township distant 90 deg. 0 min. 14 feet from the north-western angle of the said reserve.
- (b) Commencing at a point on the southern boundary of a Public Recreation Reserve, Township of Numurkah, Parish of Katunga, distant 270 deg. 3 min. 40 feet from the south-eastern angle thereof; thence by a line bearing 45 deg. 2 min. 56 ft. 6½ in. to a point on the eastern boundary of the said Reserve distant 360 deg. 0 min. 40 feet from the said south-eastern angle.
- (c) Commencing at a point on the southern boundary of allotment 17c, Township of Numurkah, Parish of Katunga, distant 90 deg. 2 min. 35 ft. 1 in. from the south-western angle of the said allotment; thence by lines bearing respectively 324 deg. 33 min. 23 ft. 2¾ in., 19 deg. 4¼ min. 1,152 ft. 10 in., 53 deg. 36 min. 32 ft. 11½ in., 268 deg. 8½ min. 20 feet, 19 deg. 4¼ min. 70 ft. 9½ in., 88 deg. 8½ min. 5 feet, 323 deg. 36 min. 5 ft. 8 in., 19 deg. 4¼ min. 635 ft. 0¼ in., 53 deg. 36 min. 32 ft. 11½ in., 268 deg. 8½ min. 20 feet, 19 deg. 4¼ min. 53 ft. 6½ in., 88 deg. 8½ min. 5 feet, 323 deg. 36 min. 5 ft. 8 in., 19 deg. 4¼ min. 1,054 ft. 9¼ in., 54 deg. 30 min. 32 ft. 7¼ in., 269 deg. 57 min. 20 feet, 19 deg. 4¼ min. 69 ft. 10¼ in., 89 deg. 57 min. 20 feet, 324 deg. 30 min. 23 ft. 2½ in. and 19 deg. 4¼ min. 504 ft. 4¼ in. to a point in allotment 17A, section C, of the said parish, distant 19 deg. 47 min. 21 ft. 10 in., 19 deg. 5½ min. 781 ft. 1 in. and 89 deg. 57 min. 15 feet from the north-western angle of allotment 17b of the said section—

which said new alignments are shown on survey plans numbered 9577 and 9579, lodged in the office of the Country Roads Board.

Copies of the said Survey Plans are lodged in the offices of the Country Roads Board, the municipality of the Shire of Numurkah, the Registrar of Titles and the Registrar-General respectively and may be inspected by any person without a fee at any time at which such offices are open for business.

Dated the 17th day of July, 1964.

N. L. ALLANSON, Secretary.  
Country Roads Board, 60 Denmark-street, Kew, E.4.

ELECTION OF A MEMBER OF THE COMMITTEE OF  
CLASSIFIERS FOR THE PRIMARY SCHOOLS  
DIVISION, EDUCATION DEPARTMENT.

I HEREBY give notice, pursuant to clause 7 of Regulation 2 of the Teaching Service (Teachers Tribunal) Regulations, that it is my intention to proceed to the election of a teacher to the Committee of Classifiers for the Primary Schools Division.

Nominations for the said election must be lodged with or delivered by post to me at the Teachers Tribunal, Observatory House, Birdwood-avenue, South Yarra, S.E.1, before Noon of Monday, the 24th August, 1964.

In the event of more candidates than one being duly nominated, the poll for the said election will close at Four o'clock p.m. on Monday, the 26th October, 1964.

G. FENNELL, Returning Officer.

Office of the Teachers Tribunal, Melbourne.  
22nd July, 1964.

REGISTRATION OF BIRTHS DEATHS AND MARRIAGES  
ACT 1959, SECTION 7 (2).

IN accordance with the provisions of sub-section (2) of section 7 of the *Registration of Births Deaths and Marriages Act 1959*, I, the Chief Secretary of the State of Victoria, hereby appoint Mary Barbara Broom to be a Collecting Agent, at Nathalia, from the 18th January, 1964, during the absence on leave of John Pennington Davis.

V. F. WILCOX,  
Acting Chief Secretary.

Chief Secretary's Office,  
Melbourne, 21st July, 1964.

Vermin and Noxious Weeds Acts Nos. 6409 and 6518.  
APPOINTMENT.

IT is hereby notified that the Public Service Board, in exercise of its powers, has appointed—

ALFRED ALLAN GEBERT, an officer of the Department of Crown Lands and Survey,  
as Secretary to the Vermin and Noxious Weeds Destruction Board, without additional salary.

L. W. BIRCH,  
Secretary for Lands.

Melbourne, 22nd July, 1964.

UNCLAIMED MONEYS ACT 1962 (No. 6879).

PURSUANT to the powers conferred on me by section 10 of the *Unclaimed Moneys Act 1962*, I, Arthur Gordon Rylah, Acting Treasurer of the State of Victoria, do hereby from and inclusive of 31st July, 1964:—

(a) Cancel the assignment made on 31st July, 1962, of Charles Shorland Cole to the position of Registrar of Unclaimed Moneys; and

(b) Assign William Henry Breen, an officer in the Treasury, to the position of Registrar of Unclaimed Moneys.

A. G. RYLAH,  
Acting Treasurer.

The Treasury, Melbourne, 28th July, 1964.

LOCAL GOVERNMENT ACT 1958.

IN pursuance of the powers conferred by sub-section 3A of section 575 of the Local Government Act 1958, I, James Charles Murray Balfour, Her Majesty's Commissioner of Crown Lands and Survey in the State of Victoria, hereby declare that the roads set out on Crown land at Cape Paterson, Parish of Wonthaggi, County of Mornington, as delineated and indicated by hachure on the plan hereunder, be private streets within the meaning of and for the purposes of Division 10, Part XIX. of the said Act.—(Corres. No. G.61243.)

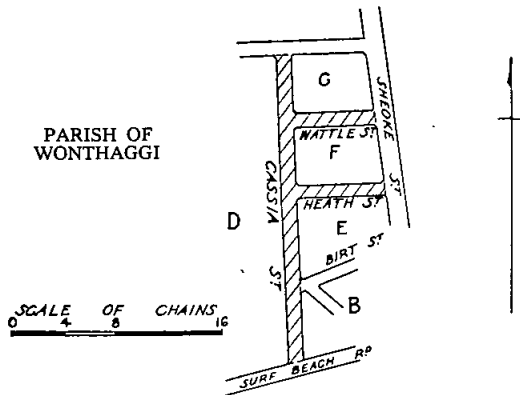

Dated at Melbourne, this 8th day of July, 1964.

JIM BALFOUR,  
Commissioner of Crown Lands and Survey.

LOCAL GOVERNMENT ACT 1958.

IN pursuance of the powers conferred by sub-section 3A of section 575 of the Local Government Act 1958, I, James Charles Murray Balfour, Her Majesty's Commissioner of Crown Lands and Survey in the State of Victoria, hereby declare that the roads set out on Crown land in the Township of Warneet, Parish of Sherwood, County of Mornington, as delineated and indicated by hachure on the plan hereunder, be a private street within the meaning of and for the purposes of Division 10, Part XIX. of the said Act.—(Corres. No. G.67190.)

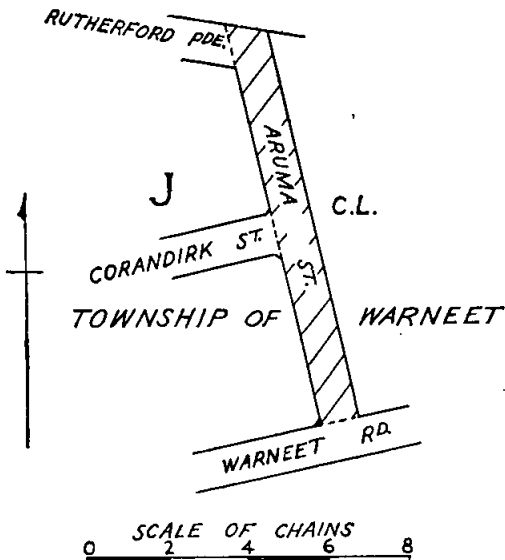

Dated at Melbourne, this 9th day of July, 1964.

JIM BALFOUR,  
Commissioner of Crown Lands and Survey.

SHIRE OF KORUMBURRA.

ROAD DEVIATION ORDER.

PURSUANT to the provisions of sections 522 and 526 of the Local Government Act 1958, the Council of the Shire of Korumburra hereby directs that the land in the Parish of Korumburra indicated by hatching on the plan hereunder which has been purchased, taken or acquired by it shall be a public highway on and from the date of the publication of this Order in the Government Gazette, and declares that such land shall be a public highway in lieu of the land indicated by cross hatching on the said plan.

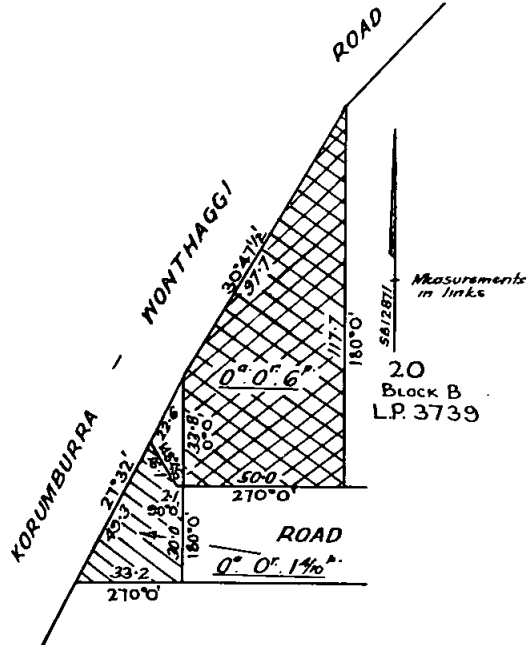

In witness whereof the common seal of the Shire President, Councillors and Ratepayers of the Shire of Korumburra was hereunto affixed this 20th day of November, 1963.

(SEAL) R. W. RITCHIE, President.  
H. C. GOAD, Councillor.  
W. O. CLARK, Secretary.

Approved by the Governor in Council, 21st July, 1964.—  
J. COLQUHOUN, Clerk of the Executive Council.

FRUIT AND VEGETABLES ACT 1958 (No. 6256).

HIS Excellency the Governor of the State of Victoria, by and with the advice of the Executive Council thereof, doth by Order made on the 21st day of July, 1964, in accordance with section 48 of the Fruit and Vegetables Act 1958 (No. 6256), authorize the person named hereunder who is an Inspector under the said Act, to take proceedings in respect of offences against Part II. of the said Act or Regulations thereunder—

BAILEY, BRIAN HERBERT.  
J. COLQUHOUN,  
Clerk of the Executive Council.

At the Executive Council Chamber,  
Melbourne, 21st July, 1964.

Co-operation Act 1958.

CROYDON OPEN YOUTH CLUB CO-OPERATIVE LIMITED.

NOTICE OF DISSOLUTION OF SOCIETY.

NOTICE is hereby given that I have this day registered the dissolution of the above-named society and have cancelled its registration under the above-named Act.

Dated at Melbourne this 15th day of July, 1964.

W. J. BRODIE,  
Registrar of Co-operative Societies.

## AUCTION SALES ACT 1958.

## LIST of Persons to whom Auctioneers' Licences have been issued during the month of June, 1964.

Name.	Address.	Date of Issue.
Brown, Allan Maxwell .. .. .	Yarra-road, Wonga Park .. .. .	9.6.64
Carter, Alan Thomas .. .. .	20 Ward-avenue, Oakleigh South .. .. .	30.6.64
Clingan, Geoffrey Ernest .. .. .	74 Marne-street, Kerang .. .. .	24.6.64
Davis, William Weston .. .. .	48 Jones-crescent, Rosanna .. .. .	30.6.64
Dobson, Ian .. .. .	Thelma-avenue, Boronia .. .. .	19.6.64
Drake, James N. K. .. .. .	Barr-street, Tungamah .. .. .	5.6.64
*Driscoll, Jack William Arthur .. .. .	16 Alward-avenue, Clayton .. .. .	2.6.64
†Egan, Graham James .. .. .	18 Moore-street, Melbourne .. .. .	9.6.64
Ford, Bryan .. .. .	5 Bowmans-parade, Oakleigh .. .. .	23.6.64
Goodwin, Sydney Thomas A. .. .. .	82 Splatt-street, Swan Hill .. .. .	1.6.64
Goudie, William Richard .. .. .	435 Graham-street, Garden City .. .. .	9.6.64
Hales, Eric Wm. .. .. .	178 Francis-street, Yarraville .. .. .	17.6.64
Hilderbrand, Roy Kenneth .. .. .	Labuan Square, Norlane .. .. .	2.6.64
Lette, Laurence McIntyre .. .. .	35 Gray-street, Swan Hill .. .. .	1.6.64
Macnaughtan, Malcolm James .. .. .	44 Heyington-place, Toorak .. .. .	22.6.64
Martin, Keith Lloyd .. .. .	"Wybalena", Beleura Hill-road, Mornington .. .. .	23.6.64
Morris, Leslie Harry .. .. .	13 Folkestone-crescent, Beaumaris .. .. .	24.6.64
Porter, Keith .. .. .	3 Teague-avenue, West Brunswick .. .. .	2.6.64
Seigel, Abe .. .. .	30 Ontario-street, Caulfield .. .. .	23.6.64
Sheridan, Allen Frederick .. .. .	1 Williams-parade, Bairnsdale .. .. .	18.6.64
Slee, Murray Wilfred .. .. .	72 Corio-street, Shepparton .. .. .	18.6.64
Stafford, Harry .. .. .	575 Inkerman-road, Caulfield .. .. .	23.6.64
Van Ekeris, Antoon Matthys .. .. .	111 Manningham-street, Parkville .. .. .	2.6.64
White, Raymond Derek .. .. .	270 William-street, Toorak .. .. .	16.6.64
Young, Donald Alfred .. .. .	5 Kathryn-street, Benalla .. .. .	8.6.64

\* By Transfer from G. H. Driscoll (Deceased).

† By Transfer from M. C. Stewart.

The Treasury,  
Melbourne, C.2, 27th July, 1964.

E. W. COATES,  
Director of Finance.

## CHILTERN WATERWORKS TRUST.

## RATING BY-LAW FOR THE YEAR 1964.

THE Chiltern Waterworks Trust, in pursuance and exercise of the powers conferred by the Water Acts, doth hereby make a rate for the supply of water for domestic purposes of Four shillings and six pence (4s. 6d.) in the pound on the annual municipal valuation of lands and tenements liable to be rated within the Chiltern Urban District.

Provided that in no case shall the amount of rate payable per annum in respect of any tenement (other than land on which there is not a building), be less than Six pounds fifteen shillings (£6 15s.), and in respect of land on which there is no building less than Forty shillings (£4).

Such rates are made and shall be levied upon the occupiers or owners of the said lands and tenements for the year commencing 1st January, 1964, and ending 31st December, 1964, and shall be payable in one amount on the 28th August, 1964, at the office of the said Trust.

The maximum quantity of water to be supplied for the year without further charge to any property rated by the Trust is hereby fixed at the quantity which, at a charge of Two shillings and nine pence (2s. 9d.) per 1,000 gallons, would produce an amount equal to the amount of the rate levied on such property for the said year.

The charge for water supplied by measure to any property rated by the Trust in excess of such maximum quantity, computed as in the last preceding clause, is hereby fixed at Two shillings and nine pence (2s. 9d.) per 1,000 gallons.

The charge for water supplied by measure shall be payable, on demand, at the office of the Trust, in Chiltern.

Passed this 16th day of July, 1964.

The common seal of the Chiltern Waterworks Trust was hereto affixed this 16th day of July, 1964, in the presence of—

(SEAL) J. R. DOW, Chairman.  
R. J. ROBERTS, Commissioner.  
M. J. OWENS, Secretary.

Approved, 21st July, 1964.—T. A. DARCY, Minister of Water Supply.

## SKIPTON WATERWORKS TRUST.

## RATING BY-LAW FOR THE PERIOD BEGINNING 1ST JANUARY, 1964, TO 31ST DECEMBER, 1964.

THE Skipton Waterworks Trust, in pursuance and exercise of the powers conferred by the Water Acts, doth hereby make a rate for the supply of water for domestic purposes of Two shillings and eight pence in the pound of the annual municipal valuation of lands and tenements liable to be rated within the Skipton Urban District.

Provided that in no case shall the amount of rate payable per annum in respect of any tenement (other than land on which there is no building) be less than Five pounds, and in respect of any land on which there is no building less than One pound.

Such rates are made and shall be levied upon the occupiers or the owners of the said lands and tenements for the period commencing the 1st day of January, 1964, and ending the 31st day of December, 1964, and shall be payable on the 29th day of July, 1964, at the office of the said Trust.

The maximum quantity of water to be supplied in the period without further charge to any property rated by the Trust is hereby fixed at the quantity which, at a charge of Two shillings and six pence per 1,000 gallons, would produce an amount equal to the amount of the rate levied on such property for the said period.

The charge for water supplied by measure to any property rated by the Trust in excess of such maximum quantity, computed as in the last preceding clause, is hereby fixed at Two shillings and six pence per 1,000 gallons.

The charge for water supplied by measure, shall be payable, on demand, at the office of the said Trust.

Passed this 3rd day of July, 1964.

(SEAL) S. WALDRON, Chairman.  
W. G. DOWLING, Commissioner.  
A. A. SINCLAIR, Secretary.

Approved, 21st July, 1964.—T. A. DARCY, Minister of Water Supply.

UNDERBOOL WATERWORKS TRUST.

RATING BY-LAW FOR THE YEAR ENDING 31ST DECEMBER, 1964.

THE Underbool Waterworks Trust, in pursuance and exercise of the powers conferred by the Water Acts, doth hereby make a rate for the supply of water for domestic purposes of Three shillings and six pence in the pound of the annual municipal valuation of lands and tenements liable to be rated in the Underbool Urban District.

Provided that in no case shall the amount payable per annum in respect of any tenement (other than land on which there is no building), be less than Six pounds fifteen shillings, and in respect of any land on which there is no building, Fifty shillings.

Such rates are made and shall be levied upon the occupiers or owners of the said lands and tenements for the year commencing on the 1st day of January, 1964, and shall be payable on the 29th day of July, 1964, at the office of the Trust, Ouyen.

The maximum quantity of water supplied in any one year without further charge to any property rated by the Trust, is hereby fixed at the quantity which, at a charge of Two shillings and six pence per 1,000 gallons, would produce an amount equal to the amount of the rate levied upon such property for the said year.

The charge for water supplied by measure to any property rated by the Trust in excess of such maximum quantity, computed as in the last preceding clause, is hereby fixed at Two shillings and six pence per 1,000 gallons.

The charge for water supplied by measure shall be payable, on demand, at the office of the Trust, Ouyen.

Passed this 17th day of June, 1964.

(SEAL) E. W. CROTHERS, Chairman.  
A. B. ELLIOTT, Commissioner.  
J. W. BALES, Secretary.

Approved, 21st July, 1964.—T. A. DARCY, Minister of Water Supply.

Victoria.

ACT 391.—SECOND SCHEDULE.

A STATEMENT of trusts having been submitted by the head or authorized representative of the denomination of Church of England, Diocese of St. Arnaud, under the provisions of the "Act to provide for the Abolition of State Aid to Religion," for allowance by the Governor, the same was allowed by him on the twenty-first day of July, 1964, and the following is the form in which such statement of trusts has been allowed:—

STATEMENT OF TRUSTS.

*Description of Land.*—2 acres, Township of Carisbrook, Parish of Carisbrook, County of Talbot, being allotment 6, section 8; Commencing at the northern angle of allotment 18, section 8; bounded thence by Green-street bearing 45 deg. 0 min. 400 links; by Urquhart-street bearing 135 deg. 0 min. 500 links; by Simson-street bearing 225 deg. 0 min. 400 links; and thence by allotments 7 and 18, bearing 315 deg. 0 min. 500 links to the commencing point.

*Name of Trustees.*—The St. Arnaud Diocesan Trustees, of Napier-street, St. Arnaud.

*Powers of Disposition.*—Power to lease (whether on building lease or otherwise), sell, create easements over, make, reserve, and close roads upon or over, mortgage, or exchange the said lands or any part thereof, and to erect buildings thereon, such powers to be exercised with the consent of the Bishop or Administrator of the Diocese of St. Arnaud for the time being acting under the advice of the Council of the Diocese, and subject to such powers and the exercise thereof to hold the said lands or so much thereof as may from time to time remain vested in the said Corporation for such purposes of the Church of England within the Diocese of St. Arnaud as the said Bishop or Administrator for the time being acting under the advice of the said Council of the Diocese, may direct.

*Purposes to which Proceeds of Disposition are to be Applied.*—To such purposes of the Church of England within the Diocese of St. Arnaud as the said Bishop or Administrator for the time being, acting under the advice of the said Council, may direct.

As witness the hand of the Governor of the State of Victoria, this twenty-first day of July, 1964.

ROHAN DELACOMBE,  
Governor of the State of Victoria.

Victoria.

ACT 391.—SECOND SCHEDULE.

A STATEMENT of trusts having been submitted by the head or authorized representative of the denomination of The Presbyterian Church of Victoria, under the provisions of the "Act to provide for the Abolition of State Aid to Religion," for allowance by the Governor, the same was allowed by him on the twenty-first day of July, 1964, and the following is the form in which such statement of trusts has been allowed:—

STATEMENT OF TRUSTS.

*Description of Land.*—1 acre 2 roods, Township of Trentham, Parish of Trentham, County of Dalhousie, being allotment 1, section 4B; Commencing at the north-western angle of allotment 2, section 4B; bounded thence by that allotment bearing 180 deg. 35 min. 500 links; by allotment 3 bearing 270 deg. 35 min. 300 links; by Market-street bearing 0 deg. 35 min. 500 links; and thence by Camp-street bearing 90 deg. 35 min. 300 links to the commencing point.

*Names of Trustees.*—The Presbyterian Church of Victoria Trusts Corporation.

*Powers of Disposition.*—With the consent of the General Assembly of "The Presbyterian Church of Victoria," to mortgage, sell, lease, exchange and transfer, and grant easements over the said land, or any part or parts thereof and, subject to such powers and the exercise thereof, to hold the said land, or so much thereof as may from time to time remain vested in the said trustees, upon such trusts for the said Presbyterian Church of Victoria, and for such purposes, and with and subject to such powers, and provisions as are contained in the document enrolled by the Registrar-General of the State of Victoria, pursuant to the provisions of the *Presbyterian Trusts Act 1890*, and styled "The Presbyterian Church of Victoria Model Trust Deed for . . . . . Site".

*Purposes to which Proceeds of Disposition are to be Applied.*—To pay the money coming to the hands of such trustees by virtue of any such power of disposition to the Treasurer for the time being of the Presbyterian Church of Victoria, to be by him applied first in payment of all incidental costs, next in payment to the said Presbyterian Church of Victoria, of all deductions heretofore or hereafter to be authorized, by the General Assembly of the said Church and as to the residue, for such purposes as the said Assembly has heretofore authorized or may hereafter authorize.

As witness the hand of the Governor of the State of Victoria, this twenty-first day of July, 1964.

ROHAN DELACOMBE,  
Governor of the State of Victoria.

Cemeteries Act 1958.

SCALE OF FEES OF THE HAZELWOOD PUBLIC CEMETERY.

IN pursuance of the powers conferred upon them by the Cemeteries Act, the Trustees of the Hazelwood Public Cemetery hereby make the following scale of fees, which shall come into operation upon publication in the *Government Gazette*, and from and after such publication every scale of fees heretofore made by the said Trustees shall be and is hereby rescinded to the extent to which it conflicts with this scale.

	£	s.	d.
Land, 8 ft. x 4 ft. . . . .	7	0	0
Sinking grave up to 4 ft. 6 in. (Child) . . . . .	5	0	0
Sinking grave up to 6 feet . . . . .	7	0	0
Sinking each additional foot . . . . .	1	0	0
Sinking grave for American type casket . . . . .	5	0	0 extra
Sinking on Saturdays— $1\frac{1}{2}$ times usual rate.			
Sinking on Sundays—double usual rate.			
Single interment of stillborn child . . . . .	1	5	0
Interment fee (except for stillborn child) . . . . .	1	10	0
Reopening fee for any grave . . . . .	1	10	0
Permit fee to erect any fence, vault, tomb, headstone or other monument—			
In concrete or brick . . . . .	1	0	0 plus
In stone work . . . . .	1	0	0 plus
			2½% of cost.

F. D. KELLY, Trustee.  
A. L. HARE, Trustee.  
A. W. WEBSTER, Trustee.

Approved by the Governor in Council, 21st July, 1964.—  
J. COLQUHOUN, Clerk of the Executive Council.



*Cemeteries Act 1958.*

**SCALE OF FEES OF THE BOWMANS FOREST PUBLIC CEMETERY.**

IN pursuance of the powers conferred upon them by the Cemeteries Act, the Trustees of the Bowmans Forest Public Cemetery hereby make the following scale of fees, which shall come into operation upon publication in the *Government Gazette*, and from and after such publication every scale of fees heretofore made by the said Trustees shall be and is hereby rescinded to the extent to which it conflicts with this scale.

<i>Public Graves.</i>		£	s.	d.
Interment in grave without exclusive right—Stillborn child ..	..	1	10	0
Interment in grave without exclusive right—Others ..	..	3	0	0
Number peg or label ..	..	0	10	0
<i>Private Graves.</i>				
Land, 8 ft. x 4 ft. ..	..	6	0	0
Own selection of land ..	..	2	0	0 extra
<i>Sinking Charges for Private Graves.</i>				
Sinking graves 6 feet deep ..	..	10	0	0
Each additional foot ..	..	1	0	0
Sinking oversize grave ..	..	2	0	0 extra
Cancellation of order to sink (if commenced) ..	..	1	0	0
<i>Reopening Charges.</i>				
Reopening grave (no cover) ..	..	8	0	0
Reopening grave (with cover or curb) ..	..	10	0	0
<i>Extra Charges.</i>				
Interment outside prescribed hours, or on Saturdays, Sundays, or Public Holidays ..	..	3	0	0
Interment in a private grave without due notice ..	..	3	0	0
<i>Miscellaneous Charges.</i>				
Certificate of right of burial ..	..	0	10	0
Number plate or brick ..	..	0	10	0
T. C. SPINK, Trustee. J. O'CONNOR, Trustee. J. NEARY, Trustee. R. P. O'CONNOR, Trustee.				

Approved by the Governor in Council, 21st July, 1964.—  
J. COLQUHOUN, Clerk of the Executive Council.

*Cemeteries Act 1958.*

**SCALE OF FEES OF THE BLUE MOUNTAIN PUBLIC CEMETERY.**

IN pursuance of the powers conferred upon them by the Cemeteries Act, the Trustees of the Blue Mountain Public Cemetery hereby make the following scale of fees, which shall come into operation upon publication in the *Government Gazette*, and from and after such publication every scale of fees heretofore made by the said Trustees shall be and is hereby rescinded to the extent to which it conflicts with this scale.

<i>Private Graves.</i>		£	s.	d.
Land, 8 ft. x 4 ft. ..	..	6	0	0
Own selection of land ..	..	2	0	0 extra
<i>Sinking Charges for Private Graves.</i>				
Sinking grave 6 feet deep ..	..	10	0	0
Each additional foot ..	..	1	0	0
Sinking oversize grave ..	..	2	0	0 extra
Cancellation of order to sink (if commenced) ..	..	1	0	0
<i>Reopening Charges.</i>				
Reopening grave (no cover) ..	..	8	0	0
Reopening grave (with cover or curb) ..	..	10	0	0
<i>Extra Charges.</i>				
Interment outside prescribed hours, or on Saturdays, Sundays or Public Holidays ..	..	3	0	0
Interment in a private grave without due notice ..	..	3	0	0

*Miscellaneous Charges.* £ s. d.

Certificate of right of burial ..	..	0	10	0
Number plate or brick ..	..	0	10	0
Permission to erect a headstone or monument ..	..	2½	% of cost, with a minimum of £2.	
Permission to construct a brick grave or to erect any stone kerb, brick tile-work or concrete ..	..	1	0	0
Exhuming the remains of a body (when authorized) ..	..	10	0	0
Interment of ashes in a private grave ..	..	2	0	0

STANLEY J. H. WOOD, Trustee.  
NORMAN J. ROBSON, Trustee.  
C. DONALD, Trustee.  
M. STEVENS, Trustee.

Approved by the Governor in Council, 21st July, 1964.—  
J. COLQUHOUN, Clerk of the Executive Council.

*Cemeteries Act 1958.*

**SCALE OF FEES OF THE WARRAGUL PUBLIC CEMETERY.**

IN pursuance of the powers conferred upon them by the Cemeteries Act, the trustees of the Warragul Public Cemetery hereby make the following scale of fees, which shall come into operation upon publication in the *Government Gazette*, and from and after such publication every scale of fees heretofore made by the said trustees shall be and is hereby rescinded to the extent to which it conflicts with this scale.

	£	s.	d.	
Land for private grave 8 ft. x 4 ft. ..	..	12	0	0
Sinking grave 5 ft. 6 in. ..	..	8	0	0
Sinking grave 7 ft. 6 in. ..	..	10	0	0
Sinking grave 9 ft. 6 in. ..	..	13	0	0
Sinking grave for child under 12 years ..	..	6	10	0
Re-opening adult grave ..	..	8	0	0
Public grave (Stillborn) ..	..	3	0	0
Public grave (Other than Stillborn) ..	..	8	0	0
Interment in public grave without due notice (extra) ..	..	3	3	0
Interment in private grave without due notice (extra) ..	..	4	4	0
Interment on Saturdays and Holidays (extra) ..	..	6	0	0
Interment on Sundays (if allowed), or not in usual hours—Double rate.	..			
Removing ledger or slab (at owner's risk) ..	..	2	10	0
Number Plate ..	..	0	12	0
Upkeep of grave, yearly ..	..	3	10	0
Burial of ashes, plus land (if required) ..	..	3	0	0
Permission to erect a monument—5 per cent. of cost plus £1 supervision fee and £2 deposit.	..			
Exhuming the remains of a body (when authorized) ..	..	10	0	0

JOSEPH WILLIAMS, Chairman.  
J. KEATING, Trustee.  
J. F. ALLCORN, Trustee.  
C. W. PEDERSEN, J.P., Secretary.

Approved by the Governor in Council, 21st July, 1964.—  
J. COLQUHOUN, Clerk of the Executive Council.

*Cemeteries Act 1958.*

**SCALE OF FEES OF THE WONTHAGGI PUBLIC CEMETERY.**

IN pursuance of the powers conferred upon them by the Cemeteries Act 1958 the trustees of the Wonthaggi Public Cemetery hereby make the following scale of fees, which shall come into operation upon publication in the *Government Gazette*, and from and after such publication every scale of fees heretofore made by the said trustees shall be and is hereby rescinded to the extent to which it conflicts with this scale.

<i>Sinking.</i>	£	s.	d.	
Adult's grave, 6 feet deep ..	..	10	0	0
Each additional foot ..	..	1	0	0
Child's grave, under 14 years ..	..	5	10	0
Child's grave, under 7 years ..	..	4	10	0

Dated this 16th day of April, 1964.

J. A. QUILFORD, Trustee.  
R. GRIEVE, Trustee.  
A. G. HOWLETT, Trustee.  
N. M. SIMMONS, Secretary.

Approved by the Governor in Council, 21st July, 1964.—  
J. COLQUHOUN, Clerk of the Executive Council.

*Cemeteries Act 1958.*

**SCALE OF FEES OF THE LEARMONTH PUBLIC CEMETERY.**

IN pursuance of the powers conferred upon them by the Cemeteries Act the trustees of the Learmonth Public Cemetery hereby make the following scale of fees, which shall come into operation upon publication in the *Government Gazette*, and from and after such publication every scale of fees heretofore made by the said trustees shall be and is hereby rescinded.

	£	s.	d.
Private Grave 8 ft. x 4 ft. . . . .	6	0	0
Own selection of land (extra) . . . . .	2	0	0
Public Grave . . . . .	3	10	0
Sinking grave 6 feet deep . . . . .	10	0	0
Sinking each additional foot . . . . .	1	0	0
Sinking oversize grave (extra) . . . . .	2	0	0
Interment on Saturdays, Sundays or Public Holidays (extra) . . . . .	3	0	0
Removal of slab . . . . .	2	0	0
Number plate . . . . .	0	10	0
Interment of ashes in a private grave . . . . .	2	0	0
Permission to erect a headstone or monument— 2½ per cent. of cost with a minimum of £2.	5	0	0
Re-opening fee . . . . .	5	0	0

M. DEAN, Trustee.  
P. DONOVAN, Trustee.  
K. WALKER, Trustee.

Approved by the Governor in Council, 21st July, 1964.—  
J. COLQUHOUN, Clerk of the Executive Council.

*Cemeteries Act 1958.*

**SCALE OF FEES OF THE LEXTON PUBLIC CEMETERY.**

IN pursuance of the powers conferred upon them by the Cemeteries Act, the trustees of the Lexton Public Cemetery hereby make the following scale of fees, which shall come into operation upon publication in the *Government Gazette*, and from and after such publication every scale of fees heretofore made by the said trustees shall be and is hereby rescinded to the extent to which it conflicts with this scale.

	£	s.	d.
Grave 8 ft. x 4 ft. . . . .	6	0	0
Re-opening fee . . . . .	4	0	0
For permission to erect a headstone or monument—2½ per cent. of cost with a minimum of £2.			
Interment outside prescribed hours, or on Saturdays, Sundays or Public Holidays . . . . .	3	0	0
Permission to construct a brick grave or to erect any stone kerb, brick tilework or concrete . . . . .	1	0	0
Interment of ashes in a private grave . . . . .	2	0	0

ROBERT CHARLES GILES, Trustee.  
IVIE CAMPBELL McERVALE, Trustee.  
JOHN LEXTON PALMBY, Trustee.

Approved by the Governor in Council, 21st July, 1964.—  
J. COLQUHOUN, Clerk of the Executive Council.

*Cemeteries Act 1958.*

**SCALE OF FEES OF THE LILYDALE PUBLIC CEMETERY.**

IN pursuance of the powers conferred upon them by the Cemeteries Act the trustees of the Lilydale Public Cemetery hereby make the following scale of fees, which shall come into operation upon publication in the *Government Gazette*, and from and after such publication every scale of fees heretofore made by the said trustees shall be and is hereby rescinded to the extent to which it conflicts with this scale.

<i>Private Graves.</i>			
	£	s.	d.
Land 8 ft. x 4 ft. . . . .	15	0	0
Own selection of land (extra) . . . . .	5	0	0
<i>Public Graves.</i>			
Interment in grave without exclusive right— Stillborn Child . . . . .	4	0	0
Interment in grave without exclusive right— Others . . . . .	8	0	0
Number Peg or Label . . . . .	0	10	0

*Sinking Charges for Private Graves.*

	£	s.	d.
Sinking grave 6 feet deep . . . . .	10	0	0
Each additional foot . . . . .	1	0	0
Sinking oversize grave (extra) . . . . .	2	0	0
Sinking oversize grave for American type casket (extra) . . . . .	4	0	0
Cancellation of order to sink (if commenced) . . . . .	2	0	0

*Re-opening Charges.*

Re-opening grave (no cover) . . . . .	10	0	0
Re-opening grave (with cover or curb) . . . . .	12	0	0

*Extra Charges.*

Interment not in the prescribed hours or on Saturdays, Sundays or Public Holidays . . . . .	6	0	0
Interment in private grave without due notice . . . . .	3	0	0
Late fee (per half-hour or part thereof in excess of first fifteen minutes) . . . . .	1	0	0

*Miscellaneous Charges.*

Certificate of Right of Burial . . . . .	0	10	0
Number plate or brick . . . . .	0	10	0
Inspection of plan or register . . . . .	0	10	0
Annual maintenance (single grave) . . . . .	2	0	0
Permission to erect a headstone or monument— 5 per cent. of cost, with a minimum of £2.			
Permission to construct a brick grave or to erect any stone kerb, brick tilework or concrete . . . . .	1	0	0
Grave renovations or additional inscription . . . . .	2	0	0
Exhuming the remains of a body (when authorized) . . . . .	10	0	0
Interment of ashes in a private grave . . . . .	3	0	0

A. E. TRENKNER, Trustee.  
A. J. BROWN, Trustee.  
F. O. CLARKE, Trustee.  
W. A. HAILES, Secretary.

Approved by the Governor in Council, 21st July, 1964.—  
J. COLQUHOUN, Clerk of the Executive Council.

*Cemeteries Act 1958.*

**SCALE OF FEES OF THE REDBANK PUBLIC CEMETERY.**

IN pursuance of the powers conferred upon them by the Cemeteries Act, the trustees of the Redbank Public Cemetery hereby make the following scale of fees, which shall come into operation upon publication in the *Government Gazette*, and from and after such publication every scale of fees heretofore made by the said trustees shall be and is hereby rescinded to the extent to which it conflicts with this scale.

<i>Public Graves.</i>			
	£	s.	d.
Interment in grave without exclusive right— Stillborn Child . . . . .	3	0	0
Interment in grave without exclusive right— Others . . . . .	6	0	0
Number Peg or Label . . . . .	0	10	0

*Private Graves.*

Land 8 ft. x 4 ft. . . . .	6	0	0
Own selection of land (extra) . . . . .	2	10	0

*Sinking Charges for Private Graves.*

Sinking graves . . . . .	12	0	0
Sinking oversize grave (extra) . . . . .	2	0	0
Cancellation of order to sink (if commenced) . . . . .	1	0	0
Removal of grave cover . . . . .	2	0	0

*Extra Charges.*

Interment outside prescribed hours, or on Saturdays, Sundays or Public Holidays . . . . .	3	0	0
Interment in a private grave without due notice . . . . .	3	0	0

*Miscellaneous Charges.*

Certificate of Right of Burial . . . . .	0	10	0
Number plate or brick . . . . .	0	10	0
Permission to erect a headstone or monument— 2½ per cent. of cost with a minimum of £2.			
Permission to construct a brick grave or to erect any stone kerb, brick tilework or concrete . . . . .	1	0	0
Exhuming the remains of a body (when authorized) . . . . .	10	0	0
Interment of ashes in a private grave . . . . .	2	0	0

DONALD GRANT, Trustee.  
R. E. BANDT, Trustee.  
B. J. SMITH, Trustee.

Approved by the Governor in Council, 21st July, 1964.—  
J. COLQUHOUN, Clerk of the Executive Council.

*Cemeteries Act 1958.*

SCALE OF FEES OF THE DONALD PUBLIC CEMETERY.

IN pursuance of the powers conferred upon them by the Cemeteries Act, the Trustees of the Donald Public Cemetery hereby make the following scale of fees, which shall come into operation upon publication in the *Government Gazette*, and from and after such publication every scale of fees heretofore made by the said Trustees shall be and is hereby rescinded to the extent to which it conflicts with this scale.

	£	s.	d.
Land, 8 ft. x 4 ft. . . . .	5	0	0
Land for baby's grave . . . . .	2	0	0
Sinking grave 6 feet . . . . .	8	0	0
Sinking each additional foot . . . . .	1	0	0
Removing slab . . . . .	2	0	0
Permission to erect headstone or monument— —2½% of cost with a minimum of £2. Interments on Saturdays, Sundays or Public Holidays to be charged— For sinking grave—1½ times the ordinary rate and an additional fee of £2.			

B. M. BASSET, Trustee.  
F. H. H. OAKLEY, Trustee.  
H. C. CUMMING, Trustee.

Approved by the Governor in Council, 21st July, 1964.—  
J. COLQUHOUN, Clerk of the Executive Council.

*Cemeteries Act 1958.*

SCALE OF FEES OF THE MINYIP PUBLIC CEMETERY.

IN pursuance of the powers conferred upon them by the Cemeteries Act, the trustees of the Minyip Public Cemetery hereby make the following scale of fees, which shall come into operation upon publication in the *Government Gazette*, and from and after such publication every scale of fees heretofore made by the said trustees shall be and is hereby rescinded to the extent to which it conflicts with this scale.

	£	s.	d.
Land 8 ft. x 4 ft. . . . .	6	0	0
Sinking grave 6 feet deep . . . . .	10	0	0
Each additional foot . . . . .	1	0	0
Sinking oversize grave (extra) . . . . .	2	0	0
Re-opening grave (with cover or curb) . . . . .	2	0	0
Interment outside prescribed hours, or on Saturdays, Sundays or Public Holidays . . . . .	3	0	0
Permission to erect a headstone or monument— 2½ per cent. of cost with a minimum of £2. Permission to construct a brick grave or to erect any stone kerb, brick tilework or concrete . . . . .	1	0	0
Interment of ashes in a private grave . . . . .	2	0	0

J. L. KING, Trustee.  
F. J. MAHER, Trustee.  
A. D. KELM, Trustee.

Approved by the Governor in Council, 21st July, 1964.—  
J. COLQUHOUN, Clerk of the Executive Council.

*Cemeteries Act 1958.*

SCALE OF FEES OF THE GROVEDALE PUBLIC CEMETERY.

IN pursuance of the powers conferred upon them by the Cemeteries Act, the trustees of the Grovedale Public Cemetery hereby make the following scale of fees, which shall come into operation upon publication in the *Government Gazette*, and from and after such publication every scale of fees heretofore made by the said trustees shall be and is hereby rescinded to the extent to which it conflicts with this scale.

	£	s.	d.
For permission to erect headstone, slab, fence, kerb or other monument—5 per cent. of cost with a minimum of £2 10s.			
Interment outside prescribed hours, or on Saturdays, Sundays or Public Holidays (extra) . . . . .	3	0	0

L. H. SCHULZE, Trustee.  
P. A. JASPER, Trustee.  
W. H. ROSSACK, Trustee.  
R. W. SCHNEIDER, Trustee.  
G. R. SCHNEIDER, Trustee.

Approved by the Governor in Council, 21st July, 1964.—  
J. COLQUHOUN, Clerk of the Executive Council.

*Cemeteries Act 1958.*

SCALE OF FEES OF THE PORT FAIRY GENERAL CEMETERY.

IN pursuance of the powers conferred upon them by the Cemeteries Act the trustees of the Port Fairy General Cemetery hereby make the following scale of fees which shall come into operation upon publication in the *Government Gazette*, and from and after such publication every scale of fees heretofore made by the said trustees shall be and is hereby rescinded to the extent to which it conflicts with this scale.

	£	s.	d.
<i>General Cemetery.</i>			
Land 8 ft. x 4 ft. . . . .	8	0	0
Sinking up to 9 feet . . . . .	10	0	0
Interment Fee . . . . .	3	10	0
Ordinary sinkings and re-openings . . . . .	7	10	0
Interment on week-ends and holidays, includ- ing grave-digging on these days (extra) . . . . .	3	0	0
Path maintenance charge on each interment . . . . .	5	0	0
Permission to erect monument—(8 ft. x 4 ft. grave) . . . . .	3	0	0
Permission to erect monument—(8 ft. x 8 ft. grave) . . . . .	6	0	0
Permission to inscribe headstone . . . . .	0	15	0
Permission to alter existing monument or to replace slab 8 ft. x 4 ft. . . . .	1	10	0

*Lawn Cemetery.*

Purchase of land 8 ft. x 4 ft. . . . .	11	10	0
Purchase of land in Stillborn Section . . . . .	2	10	0
Certificate . . . . .	0	15	0
Charge for each interment . . . . .	3	10	0
Sinking and Re-opening standard grave . . . . .	7	10	0
Sinking and Re-opening for American casket . . . . .	9	10	0
Sinking to 9 feet for standard casket . . . . .	10	0	0
Sinking to 9 feet for American casket . . . . .	12	0	0
Sinking on short notice (additional) . . . . .	2	10	0
Interment or grave digging on week-ends or holidays . . . . .	3	3	0
Sinking for stillborn caskets . . . . .	3	10	0
Lawn maintenance charge on each interment . . . . .	5	0	0
Monumental fees in advance on purchase of ground 8 ft. x 4 ft. . . . .	3	0	0
Permission to inscribe or alter headstone . . . . .	1	0	0

T. A. CROWE, Trustee.  
ALEX. G. HILL, Trustee.  
F. D. PEVITT, Trustee.

Approved by the Governor in Council, 21st July, 1964.—  
J. COLQUHOUN, Clerk of the Executive Council.

*Cemeteries Act 1958.*

SCALE OF FEES OF THE PYALONG PUBLIC CEMETERY.

IN pursuance of the powers conferred upon them by the Cemeteries Act the trustees of the Pyalong Public Cemetery hereby make the following scale of fees, which shall come into operation upon publication in the *Government Gazette*, and from and after such publication every scale of fees heretofore made by the said trustees shall be and is hereby rescinded to the extent to which it conflicts with this scale.

	£	s.	d.
Grave 8 ft. x 4 ft. . . . .	6	0	0
Own Selection of Land (extra) . . . . .	2	0	0
Re-opening Fee . . . . .	5	0	0
Sinking grave up to 7 feet . . . . .	20	0	0
Interment on Saturdays, Sundays, or Public Holidays (extra) . . . . .	3	0	0
Permission to erect a headstone or monument— 2½ per cent. of cost with a minimum of £2.			
Interment of ashes in a private grave . . . . .	2	0	0

J. K. EADES, Trustee.  
JOHN COOKE, Trustee.  
R. WALTER, Trustee.

Approved by the Governor in Council, 21st July, 1964.—  
J. COLQUHOUN, Clerk of the Executive Council.

Cemeteries Act 1958.

SCALE OF FEES OF THE CORACK PUBLIC CEMETERY.

IN pursuance of the powers conferred upon them by the Cemeteries Act, the Trustees of the Corack Public Cemetery hereby make the following scale of fees, which shall come into operation upon publication in the Government Gazette, and from and after such publication every scale of fees heretofore made by the said Trustees shall be and is hereby rescinded.

Table with 3 columns: Description, £, s. d.
Grave, 8 ft. x 4 ft. ... 6 0 0
Permission to erect a headstone or monument -2 1/2% of cost with a minimum of £2.
Interment of ashes in a private grave ... 2 0 0

DENIS J. HARTY, Trustee.
W. E. McCALLUM, Trustee.
N. K. MADDER, Trustee.

Approved by the Governor in Council, 21st July, 1964.—
J. COLQUHOUN, Clerk of the Executive Council.

Cemeteries Act 1958.

SCALE OF FEES OF THE BERRIWILLOCK PUBLIC CEMETERY.

IN pursuance of the powers conferred upon them by the Cemeteries Act, the Trustees of the Berrwillock Public Cemetery hereby make the following scale of fees, which shall come into operation upon publication in the Government Gazette, and from and after such publication every scale of fees heretofore made by the said Trustees shall be and is hereby rescinded to the extent to which it conflicts with this scale.

Table with 3 columns: Description, £, s. d.
Grave site 8 ft. x 4 ft. ... 4 0 0
Sinking grave 6 feet ... 8 0 0
Sinking grave 7 ft. 6 in. ... 10 0 0
Reopening grave ... 4 0 0

R. McNALLY, Trustee.
DANIEL ROGERS, Trustee.
KEITH F. WARNE, Trustee.

Approved by the Governor in Council, 21st July, 1964.—
J. COLQUHOUN, Clerk of the Executive Council.

Cemeteries Act 1958.

RULES AND REGULATIONS OF THE YALLOURN PUBLIC CEMETERY.

IN pursuance of the powers conferred upon them in the Cemeteries Act the Trustees of the Yallourn Public Cemetery hereby make the following Regulations (Schedules A and B) as required under Rules 3 and 5 of the Trust, which were gazetted on the 5th January, 1962.

SCHEDULE A—RULE 5.

YALLOURN PUBLIC CEMETERY.

No. of Order..... Date of Order.....19

PARTICULARS.

- 1. Name of Deceased.....
2. Age.....
3. Next of Kin.....
4. Late Residence.....
5. Denomination.....
6. No. of Grave..... Section.....
7. Depth..... Single, Double.....
8. Sinker or Re-opener.....
9. Date and Hour of Burial.....
10. Funeral Director.....
11. Sexton/Secretary.....

SCHEDULE B—RULE 3.

YALLOURN PUBLIC CEMETERY.

Burial Right.

No.....
On the application of ..... and upon the payment of the sum of ..... pounds ..... shillings, as per Order No. .... issued The Trustees of the Yallourn Public Cemetery do hereby grant and sell unto the said ..... the exclusive right of burial in that piece of ground ..... feet long by ..... feet broad, lying within the portion of the Cemetery appropriated for ..... burials, and marked No. .... compartment on

the map or plan of the Cemetery kept by the Trustees, as a family or private burial place, for the sole and separate use of the said ..... and h ..... representatives. Provided always and it is hereby declared that this grant is made subject to the terms and conditions following, viz.:—First, that the said piece of ground shall be kept and used by the said ..... or h ..... representatives solely as a burial place. Second that the said ..... and h ..... representatives shall in the use of the said piece of ground and access thereto be subject in every respect to such rules and regulations as the Trustees of the said Cemetery may from time to time make, and shall not be entitled to exercise the right to bury or inter therein except on payment of such fees as may from time to time be legally demanded, according to the scale of fees published as the Cemeteries Act directs.

Signed for and on behalf of the Trustees this ..... day of ..... 19 ..... (Secretary).

JAMES C. CULLEN, Trustee.
J. J. LAFFERTY, Trustee.
W. T. WALLACE, Trustee.

Approved by the Governor in Council, 21st July, 1964.—
J. COLQUHOUN, Clerk of the Executive Council.

RULES AND REGULATIONS OF THE GROVEDALE PUBLIC CEMETERY.

IN pursuance of the powers conferred by the Cemeteries Act 1958 (No. 6217), the Trustees of the Grovedale Public Cemetery make the following Rules and Regulations (that is to say):—

- 1. These Rules and Regulations shall come into force immediately after their publication in the Government Gazette.
2. All fees and charges shall be paid when applications are made or orders are given.
3. Any person desiring ground for a private grave shall apply to the Trustees therefor, who, if the application is approved and the prescribed fees are paid, will issue a burial right (Schedule B) which shall give the holder and his representatives the exclusive right of burial or interment in the portion of ground allotted thereby as a family or private burial place, and the right on obtaining the permission of the Trustees, as hereafter mentioned, to erect and maintain any monument, cenotaph, tablet, or other erection therein.
4. Any person desiring to construct a vault, tombstone, or other erection shall apply to the Trustees for permission to do so, and submit a plan or drawing with a copy of any proposed inscription or epitaph, and no such erection shall be made without the written approval of the Trustees, and upon payment of the prescribed fee.
5. No interment shall be permitted until an application has been made, the particulars required in the form Schedule A given, an order obtained, and a certificate from a Coroner, Justice of the Peace, or Registrar of Deaths has been delivered to the Secretary.
6. Application for an order for interment shall be made at least eight working hours before the time fixed for the burial.
7. No coffin shall be buried within 4 feet of the ordinary level of the ground unless it contains the body of a child under twelve years, when it shall be not less than 3 feet below the ordinary level of the ground, and a layer of earth at least six inches thick shall be left undisturbed above and around any coffin previously buried in the same grave.
8. The hours of burial shall be: On week-days, September to April inclusive, 10 a.m. to 6 p.m.; May to August inclusive, 10 a.m. to 4 p.m. No interment shall be allowed on Sunday except when it is certified, in writing, by the Officer of Health of the district, or by a Police Magistrate, or Justice of the Peace that for sanitary reasons it is necessary that the burial take place on that day; and on payment of a special fee as provided.
9. No re-interment or removal from another cemetery or another grave will be permitted until there can be submitted a certified copy of the original certificate of the Coroner, Justice of the Peace, or Registrar of Death, and the licence for disinterment of the Minister of the Crown authorized in that behalf.
10. No private grave shall be reopened or any interment permitted therein without the consent, in writing, of the person entitled to give the same.



*Honorary Probation Officers.*

DANIEL ARUNDELL (the Reverend), Catholic Presbytery, 11th-street, Mildura,  
 JOHN SARFIELD BROPHY, Villiers-street, Port Fairy, and  
 JOHN RUSSELL ROSE (the Reverend), Baptist Manse, 4 Yaldwin-street, Kyneton,  
 pursuant to the provisions of section 10 (1) of the *Children's Court Act 1958*, to be Honorary Probation Officers for all Children's Courts in Victoria; and  
 DANIEL ARUNDELL (the Reverend), Catholic Presbytery, 11th-street, Mildura,  
 THOMAS KEVIN LYTHGO, 98 Princess-street, Traralgon, and  
 PATRICK JOSEPH MAYE (the Reverend), Catholic Presbytery, Duke-street, Daylesford,  
 pursuant to the provisions of section 507 (2) of the *Crimes Act 1958*, to be Honorary Probation Officers for all Adult Courts in Victoria.

*Member of Aborigines Welfare Board.*

ROBERT PEN McLELLAN, B.A., E.D.,  
 pursuant to the provisions of the *Aborigines Act 1958*, to be a Member of the Aborigines Welfare Board, for the period ending the 22nd July, 1966, vice John Arthur Cole, resigned.

## DEPARTMENT OF CROWN LANDS AND SURVEY.

*Bailiff of Crown Lands.*

RONALD RALPH WAKELING, Caretaker, Public Offices, Ballarat,  
 to be a Bailiff of Crown lands without additional salary.

*Managers of Common.*

RALPH W. ALDERSON,  
 WILLIAM C. BATH,  
 A. N. CAMPBELL, and  
 LEIGH CRAIG EARL,  
 to be Managers of the Inverleigh Common for the period ending the 31st December, 1966.

*Members of Vermin and Noxious Weeds Destruction Board.*

GEOFFREY WILLIAM DOUGLAS, and  
 REGINALD THOMAS BORRIDGE,  
 pursuant to the provisions of the *Vermin and Noxious Weeds Act 1959* (No. 6518), to be members of the Vermin and Noxious Weeds Destruction Board for a period of five (5) years from the 29th July, 1964, and Geoffrey William Douglas to be Deputy Chairman of such Board.

## MINISTRY OF HEALTH.

*Deputy Secretary of Mental Hospital.*

DESMOND FRANCIS PURCELL  
 to be Deputy Secretary of Repatriation Mental Hospital, Bundoora and of Training Centre, Janefield, pursuant to the provisions of section 26 of the *Mental Health Act 1959*, as from and inclusive of 10th May, 1964, vice P. J. Belleville, transferred.

*Trustees of Cemeteries.*

DONALD MITCHELL  
 to be a Trustee of the Templestowe Public Cemetery, vice J. Beale, deceased;  
 FREDERICK ERNEST ONSLEY  
 to be a Trustee of the Maffra Public Cemetery, additional Trustee;  
 PATRICK EDWARD McCURRY  
 to be a Trustee of the Rochester Public Cemetery, additional Trustee;  
 JAMES IRVIN WALDER, and  
 RICHARD VINCENT TREBILCOCK,  
 to be Trustees of the Kerang Public Cemetery, additional Trustees;  
 THOMAS JOHN HICKS  
 to be a Trustee of the Goroke Public Cemetery, vice A. G. Brooks, resigned;  
 FRANCIS MOOR  
 to be a Trustee of the Nathalia Public Cemetery, vice A. Limbrick, resigned;  
 EDWARD WILSON  
 to be a Trustee of the Nathalia Public Cemetery, vice F. W. Bourke, resigned;  
 JOHN PENNINGTON DAVIS  
 to be a Trustee of the Nathalia Public Cemetery, vice R. J. Fairman, resigned;

COLIN WILFRED GARDNER  
 to be a Trustee of the Milawa Public Cemetery, vice J. C. Marks, deceased;

ALEX HILLAS  
 to be a Trustee of the Kiewa Public Cemetery, vice K. N. Waite, deceased;

EDWIN JAMES GAY  
 to be a Trustee of the Buninyong Public Cemetery, vice N. Coxall, resigned;

WILLIAM EDMUND GODDARD  
 to be a Trustee of the Wycheproof Public Cemetery, vice W. M. Farquhar, resigned;

ALAN JAMES CURNOW  
 to be a Trustee of the Wycheproof Public Cemetery, vice W. J. Harrison, resigned;

FRANCIS JAMES MANNIX  
 to be a Trustee of the Wycheproof Public Cemetery, vice C. H. White, resigned;

JOHN WILLIAM MACDONALD  
 to be a Trustee of the Wycheproof Public Cemetery, vice D. McLennan, resigned;

THOMAS HENRY WOOD  
 to be a Trustee of the Minyip Public Cemetery, vice J. Beilby, resigned;

ERNEST THEODORE LANDWEHR  
 to be a Trustee of the Minyip Public Cemetery, vice L. E. Nuske, resigned;

JAMES HAW  
 to be a Trustee of the Leongatha Public Cemetery, vice E. E. Bailey, deceased;

ROBERT GORDON HEYWOOD  
 to be a Trustee of the Bowmans Forest Public Cemetery, vice G. Heywood, resigned;

JOSEPH O'CONNOR  
 to be a Trustee of the Bowmans Forest Public Cemetery, vice J. Morrison, resigned;

KENNETH ORMOND KNEEBONE  
 to be a Trustee of the Bowmans Forest Public Cemetery, vice M. Connor, resigned;

RONALD PATRICK O'CONNOR  
 to be a Trustee of the Bowmans Forest Public Cemetery, vice W. Kneebone, resigned;

IVAN BRUCE YARD  
 to be a Trustee of the Murrayville Public Cemetery, vice F. W. Southwell, resigned;

HEDLEY JOHN LONG  
 to be a Trustee of the Myrtleford Public Cemetery, vice K. A. Weller, resigned;

ROBERT BRUCE MACPADDEN  
 to be a Trustee of the Lismore Public Cemetery, vice A. E. Murdoch, resigned;

FRANK THORNTON  
 to be a Trustee of the Lismore Public Cemetery, vice W. P. Oman, resigned;

JOHN ROBERTON ELKIN  
 to be a Trustee of the Wonthaggi Public Cemetery, vice J. G. McKenzie, resigned;

JOHN BUTCHER  
 to be a Trustee of the Muckleford Public Cemetery, vice W. Hatton, deceased;

NORMAN FORD  
 to be a Trustee of the Muckleford Public Cemetery, vice L. T. Pietsch, deceased;

REGINALD BASSETT  
 to be a Trustee of the Muckleford Public Cemetery, vice W. Farrell, deceased;

RAY EATON  
 to be a Trustee of the Cobram Public Cemetery, vice J. Martindale, resigned;

HUGH DICK  
 to be a Trustee of the Cobram Public Cemetery, vice J. Millerick, deceased; and

PAT CORBETT  
 to be a Trustee of the Cobram Public Cemetery, vice D. O'Dwyer, deceased.

*Public Vaccinators.*

JAMES CAMERON STEEN, M.B., Ch.B., and  
 TERENCE MARK HARDIKER, M.B., Ch.B.,  
 to be Public Vaccinators, Municipality of Walpeup;  
 THOMAS OWEN BEATTY, M.B., B.S.,  
 to be a Public Vaccinator, Municipality of Bairnsdale;  
 MERVYN NOEL ORTON, M.B., B.S.,  
 to be a Public Vaccinator, Municipality of Oakleigh; and  
 AUBREY SWEET, M.B., B.S.,  
 to be a Public Vaccinator, Municipality of Brunswick.

LAW DEPARTMENT.  
Assistant Registrar.

ALFRED RUSSELL ISON  
to be an Assistant Registrar, pursuant to the provisions of sections 20 and 21 of the County Court Act 1958, for the County Court at Sale and Korumburra, in the place of P. J. Rodda, relieved, to take effect from the date of commencement of duty.

Clerks of Petty Sessions, &c.

ALFRED RUSSELL ISON  
to be Clerk of Petty Sessions and Clerk of the Children's Court at Yarram, Foster and Toora, in the place of P. J. Rodda, relieved, to take effect from the date of commencement of duty;

GRAHAM PETER BALE  
to be Clerk of Petty Sessions and Clerk of the Children's Court at Melton, in the place of R. A. Ison, transferred, to take effect from the date of commencement of duty; and

MICHAEL AUGUSTUS RYAN  
to be Clerk of Petty Sessions and Clerk of the Children's Court at Heywood, during the absence of W. G. Meehan, on approved leave, to take effect from the date of commencement of duty.

Commissioners for Taking Declarations, &c.

FRANCIS XAVIER LYNCH, 9 El Ramleh-avenue, Wendouree, and

HENRY JOHN THOMAS, 94 Blackshaws-road, Newport, to be Commissioners for taking Declarations and Affidavits, pursuant to the provisions of the Evidence Act 1958, to resign upon removing from the neighbourhood of the addresses stated; and

RAYMOND FREDERICK PARKER, care of Tecray Pty. Ltd., 182 York-street, South Melbourne,

RAYMOND GEORGE PATTON, care of Corartie Pty. Limited, 490 Elizabeth-street, Melbourne,

ALAN BRUCE McMULLIN, care of McMullin, Heale & Co., chartered accountants, 39 Little Collins-street, Melbourne, and

REGINALD BRUCE CHURCH, care of R. J. Oehr and Church, chartered accountants, 486 Bourke-street, Melbourne,

to be Commissioners for taking Declarations and Affidavits, pursuant to the provisions of the Evidence Act 1958, to resign upon ceasing to occupy their present positions.

Justices of the Peace.

BERTRAM JAMES GARDNER, care of Railways Administrative Offices, Spencer-street, Melbourne,

ALFRED THORNAL BEWRY, care of Railways Administrative Offices, Spencer-street, Melbourne,

ROBERT GEORGE MCINTOSH, care of Railways Administrative Offices, Spencer-street, Melbourne,

CHARIS META ALEXANDER PELLING, Woodlands, Kangaroo Ground,

ALEXANDER WILLIAM BOND, 43 Clematis-avenue, North Altona, and

NOEL NORMAN JOSEPH PEPPARD, 4 Barr-street, Moorabbin,

to Keep the Peace in the Central Bailiwick of the State of Victoria.

DEPARTMENT OF THE TREASURER.

Receiver of Revenue.

ALFRED RUSSELL ISON  
to be Receiver of Revenue, Yarram, vice P. J. Rodda.

J. COLQUHOUN,  
Clerk of the Executive Council.

At the Executive Council Chamber,  
Melbourne, 21st July, 1964.

APPOINTMENTS.

HIS Excellency the Governor of the State of Victoria, by and with the advice of the Executive Council thereof, has, by Orders made on the 28th day of July, 1964, been pleased to make the under-mentioned appointments, viz.:-

DEPARTMENT OF WATER SUPPLY.  
Waterworks Trusts Commissioners.

JAMES GIBSON GREENHILL, and  
MAXWELL WARD HUTTON,  
to be Commissioners of the Corryong Waterworks Trust, each for a period of four years from the date hereof, subject to the provisions of the Water Acts; and

JAMES THOMAS PARKIN, and  
ARTHUR MALONE,  
to be Commissioners of the Rutherglen Waterworks Trust, each for a period of four years from the date hereof, subject to the provisions of the Water Acts.

J. COLQUHOUN,  
Clerk of the Executive Council.

At the Executive Council Chamber,  
Melbourne, 28th July, 1964.

RESIGNATIONS.

HIS Excellency the Governor of the State of Victoria, by and with the advice of the Executive Council thereof, has, by Orders made on the 21st day of July, 1964, accepted the resignations of the persons named hereunder of the offices mentioned, viz.:-

LAW DEPARTMENT.

PHILLIP ABSON, and PAUL JOSEPH COSAITIS, as Commissioners for taking Declarations and Affidavits, pursuant to the provisions of the Evidence Act 1958.

WILLIAM IGNATIUS COSTIGAN, from the Commission of the Peace for the Northern Bailiwick of the State of Victoria.

EDWARD KERR, from the Commission of the Peace for the Central Bailiwick of the State of Victoria.

HORACE CLEAL BLAKE, from the Commission of the Peace for all Bailiwicks of the State of Victoria.

J. COLQUHOUN,  
Clerk of the Executive Council.

At the Executive Council Chamber,  
Melbourne, 21st July, 1964.

DEPARTMENT OF CROWN LANDS AND SURVEY.

At the Executive Council Chamber, Melbourne, the  
twenty-first day of July, 1964.

PRESENT:

His Excellency the Governor of Victoria.  
Mr. Reid | Mr. Porter  
Mr. Rossiter | Mr. Dickie.

UNUSED ROADS CLOSED.

HIS Excellency the Governor of the State of Victoria, by and with the advice of the Executive Council thereof, doth hereby direct that, in pursuance of the provisions of section 349 of the Land Act 1958, the unused roads referred to hereunder be closed, viz.:-

Parish of Argyle, County of Grenville, being the portions of the road indicated by hachure on plan hereunder.—(A.152<sup>(b)</sup>) (J.31412).

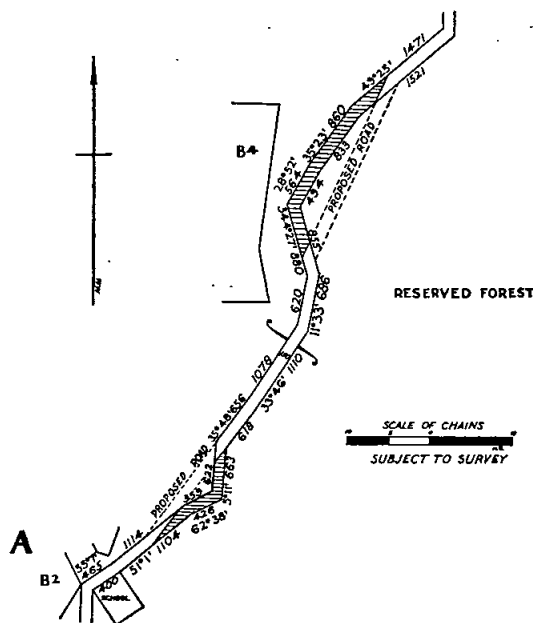

Parish of Axedale, County of Bendigo, being the road indicated by hachure on plan hereunder.—(A.98<sup>(4)</sup>) (W.85164).

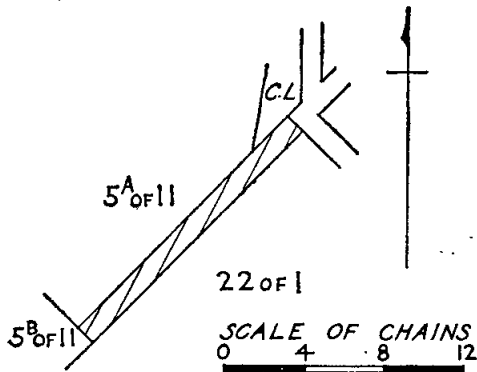

Parish of Bellellen, County of Borung, being the roads indicated by hachure on plan hereunder.—(B.571<sup>(4)</sup>) (C.99126).

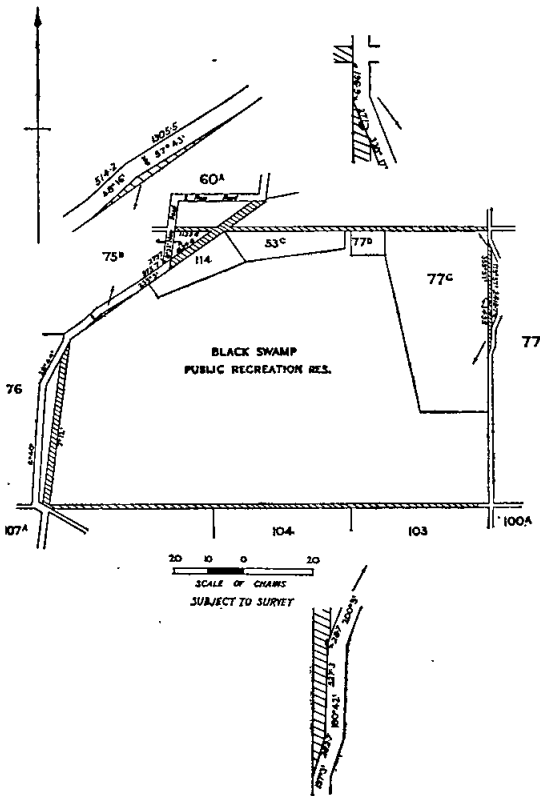

Parish of Tarrawarra, County of Evelyn, being the road between allotments 27A, 28A and allotment 22A.—(T.17<sup>(10)</sup>) (G.66170).

Parish of Tawanga, County of Bogong, being—(1) the road between allotment 1, section 12, and allotment 4, section 6; (2) the road between allotment 1A and allotment 2A, section 12.—(T.233<sup>(6)</sup>) (H.027845).

And the Honorable James Charles Murray Balfour, Her Majesty's Commissioner of Crown Lands and Survey for the State of Victoria, shall give the necessary directions herein accordingly.

J. COLQUHOUN, Clerk of the Executive Council.

DEPARTMENT OF CROWN LANDS AND SURVEY.

At the Executive Council Chamber, Melbourne, the twenty-first day of July, 1964.

PRESENT:

His Excellency the Governor of Victoria.

Mr. Reid | Mr. Porter  
Mr. Rossiter | Mr. Dickie.

VESTING OF LAND IN THE COUNTRY ROADS BOARD.

HIS Excellency the Governor of the State of Victoria, by and with the advice of the Executive Council thereof, doth by this Order made pursuant to section 22A (2) of the Land Act 1958, vest in the Country Roads Board the land in the Parish of Witchipool, County of Borung, as shown by hachure on the plan hereunder.

PARISH OF WITCHIPOOL

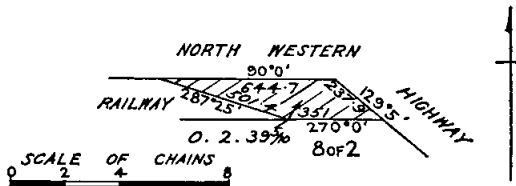

And the Honorable James Charles Murray Balfour, Her Majesty's Commissioner of Crown Lands and Survey for the State of Victoria, shall give the necessary directions herein accordingly.

J. COLQUHOUN, Clerk of the Executive Council.

DEPARTMENT OF CROWN LANDS AND SURVEY.

At the Executive Council Chamber, Melbourne, the twenty-first day of July, 1964.

PRESENT:

His Excellency the Governor of Victoria.

Mr. Reid | Mr. Porter  
Mr. Rossiter | Mr. Dickie.

LANDS TEMPORARILY RESERVED AS SITES.

HIS Excellency the Governor of the State of Victoria, by and with the advice of the Executive Council thereof, doth hereby, in pursuance of the provisions of the Land Act 1958, reserve, temporarily, and also except from occupation for mining purposes under any miner's right, the lands hereinafter described:—

MYSTIC PARK.—Site for a Rubbish Depot, 2 acres 1 rood 24 perches, more or less, Township of Mystic Park, Parish of Boga, County of Tatchera, as indicated by hachure on plan hereunder.—(M.551<sup>(2)</sup>) (Rs.8258).

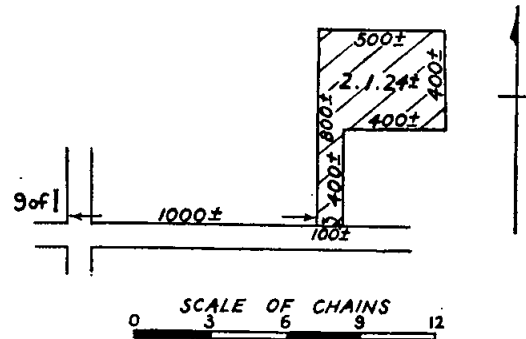



ORBOST EAST AND TABBARA.—Site for Wildlife purposes, 1,950 acres, more or less, Township of Tabbara and Parish of Orbost East, County of Croajingolong, as indicated by hachure on plan hereunder.—(O.23<sup>(1)</sup>) (T.261<sup>(4)</sup>), (Rs.8344).

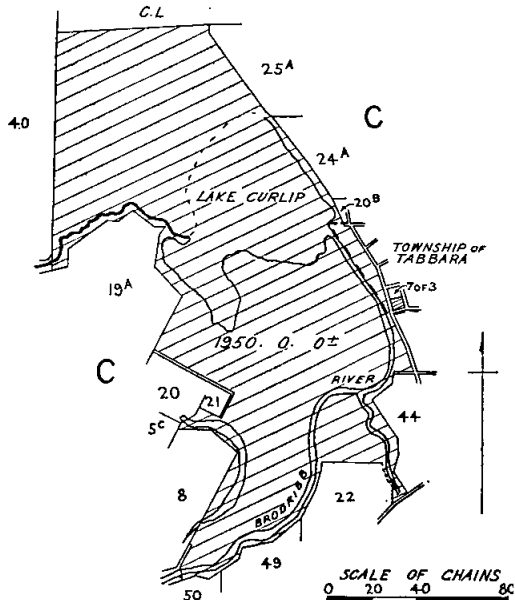

SHEPPARTON.—Site for Public purposes, 14 acres, more or less, Parish of Shepparton, County of Moira, as indicated by hachure on plan hereunder.—(S.283<sup>(9)</sup>) (Rs.8354).

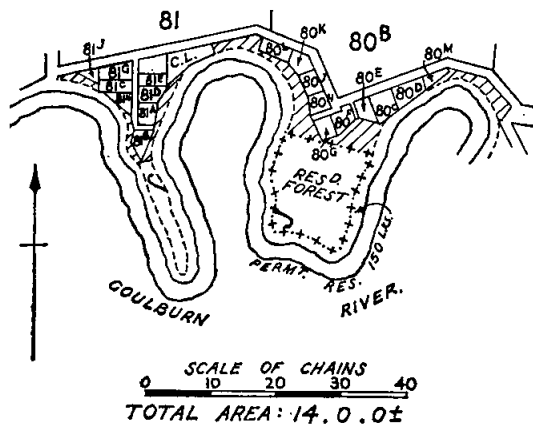

And the Honorable James Charles Murray Balfour, Her Majesty's Commissioner of Crown Lands and Survey for the State of Victoria, shall give the necessary directions herein accordingly.

J. COLQUHOUN,  
Clerk of the Executive Council.

DEPARTMENT OF CROWN LANDS AND SURVEY.

At the Executive Council Chamber, Melbourne, the twenty-first day of July, 1964.

PRESENT:  
His Excellency the Governor of Victoria.  
Mr. Reid | Mr. Porter  
Mr. Rossiter | Mr. Dickie.

REVOCATION OF TEMPORARY RESERVATION AND WITHHOLDING FROM SALE, LEASING, AND LICENSING OF LAND BY ORDER IN COUNCIL.

HIS Excellency the Governor of the State of Victoria, by and with the advice of the Executive Council thereof, doth hereby, in pursuance of the provisions of

the Land Act 1958, revoke the temporary reservation and the withholding from sale, leasing and licensing of the land by Order in Council hereinafter referred to, viz.:

TARRENGOWER.—Order in Council of the 7th January, 1878, of 1 acre 2 roods of land in the Parish of Tarrengower as a site for Public purposes (State School), and the temporary reservation by Order in Council of the 19th August, 1912, of 3 roods of land as an extension thereto.—(Rs.5826.)

And the Honorable James Charles Murray Balfour, Her Majesty's Commissioner of Crown Lands and Survey for the State of Victoria, shall give the necessary directions herein accordingly.

J. COLQUHOUN,  
Clerk of the Executive Council.

DEPARTMENT OF CROWN LANDS AND SURVEY.

At the Executive Council Chamber, Melbourne, the twenty-first day of July, 1964.

PRESENT:  
His Excellency the Governor of Victoria.  
Mr. Reid | Mr. Porter  
Mr. Rossiter | Mr. Dickie.

REVOCATIONS OF TEMPORARY RESERVATIONS OF LAND BY ORDERS IN COUNCIL.

HIS Excellency the Governor of the State of Victoria, by and with the advice of the Executive Council thereof, doth hereby, in pursuance of the provisions of the Land Act 1958, revoke the temporary reservations of land by Orders in Council hereinafter referred to, viz.:

BENDIGO.—Order in Council of 3rd October, 1950, of 50 acres 2 roods 24 perches of land at Bendigo, in the Parish of Sandhurst, as a site for Agricultural Showgrounds and Public Recreation, so far only as regards the portion thereof comprised within the boundaries published in the Government Gazette of 17th June, 1964, and containing 2 acres 1 rood 1 perch.—(Rs.6589.)

SNAKE ISLAND.—Order in Council of the 22nd September, 1908, of 11,500 acres, more or less, of land in the Parish of Snake Island as a site for a Public Park, and the temporary reservation by Order in Council of the 9th December, 1913, of 1,240 acres of land as an extension thereto.—(Rs.5945.)

And the Honorable James Charles Murray Balfour, Her Majesty's Commissioner of Crown Lands and Survey for the State of Victoria, shall give the necessary directions herein accordingly.

J. COLQUHOUN,  
Clerk of the Executive Council.

FRUIT AND VEGETABLES ACT 1958 (No. 6256).—VEGETATION AND VINE DISEASES ACT 1958 (No. 6407).

At the Executive Council Chamber, Melbourne, the twenty-first day of July, 1964.

PRESENT:  
His Excellency the Governor of Victoria.  
Mr. Reid | Mr. Porter  
Mr. Rossiter | Mr. Dickie.

IN pursuance of the powers conferred by the Fruit and Vegetables Act 1958 (No. 6256) and the Vegetation and Vine Diseases Act 1958 (No. 6407) and all other powers thereunto enabling him, His Excellency the Governor of the State of Victoria, by and with the advice of the Executive Council thereof, doth hereby appoint the under-mentioned persons as Inspectors:—

- GEYER, ADRIAN,
- GOODSELL, LESLIE,
- EATHER, LEONARD,
- BLIIM, AUBREY,
- MASON, WILLIAM CHARLES,
- RUTLEDGE, GEORGE JAMES, and
- GUPPY, GEORGE WILLIAM.

And the Honorable Gilbert Lawrence Chandler, Her Majesty's Minister of Agriculture for the State of Victoria, shall give the necessary directions herein accordingly.

J. COLQUHOUN,  
Clerk of the Executive Council.

## COUNTRY ROADS BOARD.

At the Executive Council Chamber, Melbourne, the twenty-first day of July, 1964.

## PRESENT:

His Excellency the Governor of Victoria.	
Mr. Reid	Mr. Porter
Mr. Rossiter	Mr. Dickie.

## ORDER APPROVING OF WIDENING AN EXISTING MAIN ROAD IN THE SHIRE OF WARRNAMBOOL.

WHEREAS the Country Roads Board constituted under the Country Roads Act 1958 (No. 6229) has represented to His Excellency the Governor in Council that it appears to it desirable that the existing Warrnambool-Caramut road in the Shire of Warrnambool (declared to be a main road under the said Act which declaration was confirmed by the Order in Council published in the Government Gazette of the 19th October, 1938, on page 3184) should be widened by the said Board: And whereas the said Board in accordance with the requirements of section 19 of the said cited Act has caused to be prepared a map plan and estimate showing the points between which and on and through what land the said widening is proposed to be made and the cost of acquiring the land: And whereas on an inspection of the said map and plan and a consideration of the said estimate His Excellency the Governor in Council is satisfied that there are funds legally available for acquiring the land: Now therefore be it known by this present Order that His Excellency the Governor of the State of Victoria with the advice of the Executive Council thereof doth hereby approve of the said road being widened, that is to say:—

All that piece of land in the Parish of Yangery, the boundaries of which are as follow:—Commencing at a point on the eastern boundary of allotment 20, of the said parish, distant 180 deg. 0 min. 125 links from the north-eastern angle of the said allotment; thence by lines bearing respectively 180 deg. 0 min. 60 links, 320 deg. 58 min. 238.2 links and 129 deg. 48 min. 195.2 links to the point of commencement.

Also, all that piece of land in the Parishes of Meerai and Yangery, the boundaries of which are as follow:—Commencing at the south-western angle of allotment 20, Parish of Meerai; thence by lines bearing respectively 0 deg. 0 min. 39 links, 20 deg. 50 min. 202 links, 191 deg. 37 min. 232.6 links, 184 deg. 24 min. 326 links and 360 deg. 0 min. 325 links to the point of commencement— which said pieces of land are particularly delineated and shown coloured red on survey plan numbered 9521, lodged in the office of the Country Roads Board.

And the Honorable Murray Victor Porter, Her Majesty's Commissioner of Public Works for the State of Victoria, shall give the necessary directions herein accordingly.

J. COLQUHOUN,  
Clerk of the Executive Council.

## COUNTRY ROADS BOARD.

At the Executive Council Chamber, Melbourne, the twenty-first day of July, 1964.

## PRESENT:

His Excellency the Governor of Victoria.	
Mr. Reid	Mr. Porter
Mr. Rossiter	Mr. Dickie.

## ORDER APPROVING OF WIDENING AN EXISTING STATE HIGHWAY IN THE SHIRE OF SEYMOUR.

WHEREAS the Country Roads Board constituted under the Country Roads Act 1958 (No. 6229) has represented to His Excellency the Governor in Council that it appears to it desirable that the existing Goulburn Valley Highway in the Shire of Seymour (declared to be a State highway under the said Act which declaration was confirmed by the Order in Council published in the Government Gazette of the 27th December, 1940, on page 4453) should be widened by the said Board: And whereas the said Board in accordance with the requirements of section 19 of the said cited Act has caused to be prepared a map plan and estimate showing the points between which and on and through what land the said widening is proposed to be made and the cost of acquiring the land: And whereas on an inspection of the said map and plan and a consideration of the said estimate His

Excellency the Governor in Council is satisfied that there are funds legally available for acquiring the land: Now therefore be it known by this present Order that His Excellency the Governor of the State of Victoria with the advice of the Executive Council thereof doth hereby approve of the said highway being widened, that is to say:—

All that piece of land in the Parishes of Traawool and Windham, the boundaries of which are as follow:—

Commencing at the southern angle of allotment 13 of the parish first named; thence by lines bearing respectively 311 deg. 33 min. 337 links, 318 deg. 11 min. 174.9 links, 129 deg. 1 min. 455.9 links, 142 deg. 50 min. 689.4 links, 175 deg. 52 min. 861 links, 347 deg. 46 min. 555.4 links, 334 deg. 5 min. 859 links and 48 deg. 11 min. 39 links to the point of commencement.

Also all those pieces of land in the Parish of Windham, the boundaries of which are as follow:—

(a) Commencing at the north-western angle of allotment 121 of the said parish; thence by lines bearing respectively 310 deg. 29 min. 126 links, 347 deg. 46 min. 368.1 links, 150 deg. 4 min. 480.9 links, 143 deg. 34 min. 272.9 links, 124 deg. 55 min. 331.5 links, 138 deg. 21 min. 234.9 links and 310 deg. 29 min. 862.7 links to the point of commencement.

(b) Commencing at the south-eastern angle of allotment 120 of the said parish; thence by lines bearing 284 deg. 47 min. 324 links and 298 deg. 11 min. 757 links; thence by the arc of a circle of radius of 5,850 links, a distance of 944.5 links; thence by lines bearing respectively 310 deg. 29 min. 1,123.1 links, 117 deg. 7 min. 254.2 links, 123 deg. 51 min. 442.8 links, 138 deg. 28 min. 535.4 links, 130 deg. 21 min. 315.4 links, 118 deg. 1 min. 1,049.8 links, 111 deg. 14 min. 385.7 links, 92 deg. 53 min. 109.3 links and 150 deg. 7 min. 86.1 links to the point of commencement—

which said pieces of land are particularly delineated and shown coloured red and blue on survey plans numbered 9666 and 9667, lodged in the office of the Country Roads Board.

And the Honorable Murray Victor Porter, Her Majesty's Commissioner of Public Works for the State of Victoria, shall give the necessary directions herein accordingly.

J. COLQUHOUN,  
Clerk of the Executive Council.

## COUNTRY ROADS BOARD.

At the Executive Council Chamber, Melbourne, the twenty-first day of July, 1964.

## PRESENT:

His Excellency the Governor of Victoria.	
Mr. Reid	Mr. Porter
Mr. Rossiter	Mr. Dickie.

## ORDER APPROVING OF WIDENING AN EXISTING STATE HIGHWAY IN THE SHIRE OF FRANKSTON.

WHEREAS the Country Roads Board constituted under the Country Roads Act 1958 (No. 6229) has represented to His Excellency the Governor in Council that it appears to it desirable that the existing Nepean Highway in the Shire of Frankston (declared to be a State highway under the said Act which declaration was confirmed by the Order in Council published in the Government Gazette of the 29th October, 1947, on pages 5573-5) should be widened by the said Board: And whereas the said Board in accordance with the requirements of section 19 of the said cited Act has caused to be prepared a map plan and estimate showing the points between which and on and through what land the said widening is proposed to be made and the cost of acquiring the land: And whereas on an inspection of the said map and plan and a consideration of the said estimate His Excellency the Governor in Council is satisfied that there are funds legally available for acquiring the land: Now therefore be it known by this present Order that His Excellency the Governor of the State of Victoria with the advice of the Executive Council thereof doth hereby approve of the said highway being widened, that is to say:—

All that piece of land in the Parish of Frankston, the boundaries of which are as follow:—Commencing at the south-eastern angle of lot 18, on plan of subdivision numbered 4780, lodged in the Office of Titles, and being part of allotment 13, section 4, of the said parish; thence

by lines bearing respectively 18 deg. 36 min. 165 ft. 8½ in., 194 deg. 20 min. 66 feet and 201 deg. 25 min. 100 feet to the point of commencement—which said piece of land is particularly delineated and shown coloured red and blue on survey plan numbered 9704, lodged in the office of the Country Roads Board.

And the Honorable Murray Victor Porter, Her Majesty's Commissioner of Public Works for the State of Victoria, shall give the necessary directions herein accordingly.

J. COLQUHOUN,  
Clerk of the Executive Council.

#### COUNTRY ROADS BOARD.

At the Executive Council Chamber, Melbourne, the  
twenty-first day of July, 1964.

PRESENT:

His Excellency the Governor of Victoria.  
Mr. Reid | Mr. Porter  
Mr. Rossiter | Mr. Dickie.

#### ORDER APPROVING OF A DEVIATION FROM A MAIN ROAD IN THE SHIRE OF AVON.

WHEREAS the Country Roads Board constituted under the Country Roads Act 1958 (No. 6229) has represented to His Excellency the Governor in Council that it appears to it desirable that the deviation hereinafter referred to from the existing Bengworden-road in the Shire of Avon (declared to be a main road under the said Act which declaration was confirmed by the Order in Council published in the Government Gazette of the 18th May, 1938, on page 1501) should be made by the said Board: And whereas the said Board in accordance with the requirements of section 19 of the said cited Act has caused to be prepared a map plan and estimate showing the points between which and on and through what land the said deviation is proposed to be made and the cost of acquiring the land: And whereas on an inspection of the said map and plan and a consideration of the said estimate His Excellency the Governor in Council is satisfied that there are funds legally available for acquiring the land: Now therefore be it known by this present Order that His Excellency the Governor of the State of Victoria with the advice of the Executive Council thereof doth hereby approve of the said road being made, that is to say:—

All those pieces of land in the Parish of Bengworden South, the boundaries of which are as follow:—

- (a) Commencing at the north-eastern angle of allotment 2, section 7, of the said parish; thence by lines bearing respectively 159 deg. 46 min. 257.5 links, 296 deg. 27 min. 545.4 links and 90 deg. 11 min. 399.3 links to the point of commencement.
- (b) Commencing at the south-eastern angle of allotment 1B, section 18, of the said parish; thence by lines bearing respectively 270 deg. 11 min. 724.7 links, 75 deg. 50 min. 405.3 links, 45 deg. 31 min. 253.4 links, 26 deg. 25 min. 62 links and 159 deg. 46 min. 356.6 links to the point of commencement.
- (c) Commencing at a point on the western boundary of allotment 2A, section 18, of the said parish, distant 339 deg. 46 min. 451.5 links from the south-western angle of the said allotment; thence by lines bearing respectively 339 deg. 46 min. 109.5 links, 28 deg. 59 min. 133 links and 186 deg. 55 min. 220.7 links to the point of commencement.
- (d) Commencing at a point on the eastern boundary of allotment 1B, section 18, of the said parish, distant 150 deg. 57 min. 870.7 links from the north-eastern angle of the said allotment; thence by lines bearing respectively 150 deg. 57 min. 265.3 links, 208 deg. 59 min. 279.5 links, 4 deg. 50 min. 334.1 links and 351 deg. 27 min. 145.1 links to the point of commencement—

which said pieces of land are particularly delineated and shown coloured red on survey plan numbered 9618, lodged in the office of the Country Roads Board.

And the Honorable Murray Victor Porter, Her Majesty's Commissioner of Public Works for the State of Victoria, shall give the necessary directions herein accordingly.

J. COLQUHOUN,  
Clerk of the Executive Council.

#### COUNTRY ROADS BOARD.

At the Executive Council Chamber, Melbourne, the  
twenty-first day of July, 1964.

PRESENT:

His Excellency the Governor of Victoria.  
Mr. Reid | Mr. Porter  
Mr. Rossiter | Mr. Dickie.

#### DECLARATION OF A DEVIATION FROM THE SOUTH GIPPSLAND HIGHWAY IN THE SHIRE OF KORUMBURRA.

WHEREAS by sections 74 and 58 of the Country Roads Act 1958 (No. 6229) it is amongst other things enacted that when the Country Roads Board under the provisions of the Country Roads Act has by Resolution declared a deviation to be a State highway the said Board may also declare that such deviation shall be in lieu of any existing highway or part thereof named in such Resolution and that on publication in the Government Gazette of the Order confirming such Resolution the existing highway or part thereof shall cease to be a State highway or be discontinued as provided in the Resolution: And whereas the said Board has by Resolution declared the deviation on the land described in the First Schedule to such Resolution to be a State highway and has also declared that such deviation shall be in lieu of the part of the existing highway being the land described in the Second Schedule to the said Resolution and that such part of the said existing highway shall be discontinued: Now therefore His Excellency the Governor of the State of Victoria doth hereby confirm the said Resolution.

#### Resolution for Declaration of a Deviation of a State Highway under the Country Roads Act.

Whereas the land the site of the highway the course of which is below set out was taken by the Board under the provisions of the Country Roads Act 1958 for the purpose of constructing such highway deviation which highway deviation has now been laid out and formed on the same: And whereas the said Board (being the Country Roads Board incorporated under the said Act) thinks that the highway aforesaid is fit to be used as a public highway such Board as a meeting now holden acting under the authority conferred upon it by sections 74 and 58 of the said Act doth by this present Resolution hereby declare the said highway deviation the course of which is described in the First Schedule hereto with the commencing and terminating points thereof respectively specified to be part of a State highway within the meaning and for the purposes of the Country Roads Act 1958: And the said Board doth also declare that such deviation shall be in lieu of the existing highway or part thereof described in the Second Schedule hereto and that such part of the said existing highway shall be discontinued.

#### FIRST SCHEDULE.

##### Shire of Korumburra.

8. South Gippsland Highway.—All those pieces of land in the Parish of Korumburra, the boundaries of which are as follow:—

- (a) Commencing at the south-western angle of allotment 7, section K, Township of Korumburra in the said parish; thence by lines bearing respectively 355 deg. 9 min. 12 links, 73 deg. 31 min. 280.7 links, 65 deg. 17 min. 327.6 links, 44 deg. 24½ min. 287.8 links, 27 deg. 11 min. 1,682.9 links, 36 deg. 57 min. 431.3 links, 59 deg. 16 min. 708 links, 87 deg. 23 min. 822.1 links, 90 deg. 26 min. 445 links, 88 deg. 36 min. 1,238 links, 80 deg. 30 min. 715.4 links, 49 deg. 3 min. 158.5 links, 81 deg. 51 min. 276 links, 103 deg. 41 min. 443.3 links, 95 deg. 32 min. 1,425.4 links, 81 deg. 54½ min. 612.3 links, 72 deg. 1 min. 649.4 links, 83 deg. 42 min. 725.7 links, 86 deg. 55 min. 378.5 links, 97 deg. 35½ min. 621.3 links, 90 deg. 51 min. 350 links, 146 deg. 29 min. 269.6 links, 277 deg. 26½ min. 707.1 links, 275 deg. 51½ min. 473.2 links, 265 deg. 6 min. 590.1 links, 253 deg. 25½ min. 727.3 links, 256 deg. 37 min. 652.5 links, 275 deg. 32 min. 930.8 links, 271 deg. 26 min. 302.4 links, 283 deg. 42 min. 159.7 links, 274 deg. 27 min. 431 links, 273 deg. 32 min. 163.6 links, 262 deg. 1 min. 377.4 links, 260 deg. 16 min. 527.4 links, 268 deg. 36 min. 1,914.2 links, 261 deg. 15 min. 407.7 links, 283 deg. 18 min. 150 links, 256 deg. 2 min. 465.4 links, 246 deg. 53 min. 209.2

links, 239 deg. 33 min. 355.4 links, 217 deg. 8 min. 566.6 links, 205 deg. 5 min. 1,149.6 links, 211 deg. 11 min. 603.4 links and 262 deg. 14 min. 784 links to the point of commencement; excepting such portions of the above described land as are already included in the declaration of the South Gippsland Highway.

- (b) Commencing at the north-western angle of allotment 94 of the said parish; thence by lines bearing respectively 88 deg. 31 min. 216 links, 82 deg. 14 min. 260 links, 256 deg. 39 min. 432 links, 214 deg. 27 min. 66.6 links and 352 deg. 14 min. 115 links to the point of commencement—

which said pieces of land are particularly delineated and shown coloured red, yellow and green on survey plans numbered 8498 and 8499, lodged in the office of the Country Roads Board.

SECOND SCHEDULE.  
Shire of Korumburra.

8. *South Gippsland Highway*.—All those pieces of land in the Parish of Korumburra, the boundaries of which are as follow:—

- (a) Commencing at a point on the northern boundary of allotment 7, section 4, of the said parish, distant 91 deg. 26 min. 1,035 links and 101 deg. 41 min. 269.9 links from the north-western angle of the said allotment; thence by lines bearing respectively 76 deg. 37 min. 580.3 links, 73 deg. 25½ min. 253.8 links, 221 deg. 22 min. 53.6 links, 203 deg. 47 min. 176 links, 221 deg. 34 min. 170 links and 281 deg. 41 min. 601.1 links to the point of commencement.
- (b) Commencing at an angle in the northern boundary of allotment 2, section J, of the said parish, formed by the intersection of lines bearing 109 deg. 39 min. and 14 deg. 12 min.; thence by lines bearing respectively 289 deg. 39 min. 58.2 links, 37 deg. 8 min. 148.6 links and 194 deg. 12 min. 142.4 links to the point of commencement—

which said pieces of land are particularly delineated and shown coloured blue on survey plans numbered 8498 and 8499, lodged in the office of the Country Roads Board.

Also, three pieces of land adjoining Crown land on the south-eastern boundary of the Township of Korumburra which are more particularly delineated and shown coloured blue on survey plan numbered 8499, lodged in the office of the Country Roads Board.

The common seal of Country Roads Board was hereto affixed, at Kew, this thirteenth day of July, One thousand nine hundred and sixty-four, in the presence of—

(SEAL) I. J. O'DONNELL, Chairman.  
H. S. GIBBS, Acting Member.  
N. L. ALLANSON, Secretary.

And the Honorable Murray Victor Porter, Her Majesty's Commissioner of Public Works for the State of Victoria, shall give the necessary directions herein accordingly.

J. COLQUHOUN,  
Clerk of the Executive Council.

COUNTRY ROADS BOARD.

At the Executive Council Chamber, Melbourne, the twenty-first day of July, 1964.

PRESENT:

His Excellency the Governor of Victoria.  
Mr. Reid | Mr. Porter  
Mr. Rossiter | Mr. Dickie.

ORDER APPROVING OF A DEVIATION FROM A MAIN ROAD IN THE SHIRE OF HEALESVILLE.

WHEREAS the Country Roads Board constituted under the *Country Roads Act 1958* (No. 6229) has represented to His Excellency the Governor in Council that it appears to be desirable that the deviation hereinafter referred to from the existing Eltham-Yarra Glen road in the Shire of Healesville (declared to be a main road under the said Act which declaration was confirmed by the Order in Council published in the *Government Gazette* of the 7th October, 1914, on page 4536) should be made by the Board: And whereas the said Board in accordance with the requirements of section 19 of the said cited Act has caused to be prepared a map plan and estimate showing the points between

which and on and through what land the said deviation is proposed to be made and the cost of acquiring the land: And whereas on an inspection of the said map and plan and a consideration of the said estimate His Excellency the Governor in Council is satisfied that there are funds legally available for acquiring the land: Now therefore be it known by this present Order that His Excellency the Governor of the State of Victoria with the advice of the Executive Council thereof doth hereby approve of the said road being made, that is to say:—

All those pieces of land in the Parish of Burgoyne, the boundaries of which are as follow:—

- (a) Commencing at the southern angle of lot 1 on plan of subdivision numbered 24500, lodged in the Office of Titles and being part of portion 5 of the said parish; thence by lines bearing respectively 6 deg. 6 min. 30 links, 31 deg. 54 min. 318.8 links, 201 deg. 58 min. 185 links, 208 deg. 23 min. 105 links and 235 deg. 11 min. 64 links to the point of commencement.
- (b) Commencing at the north-western angle of lot 1 on plan of subdivision numbered 3207, lodged in the Office of Titles and being part of portion 5 of the said parish; thence by lines bearing respectively 111 deg. 4½ min. 166.2 links, 216 deg. 31½ min. 990 links, 23 deg. 12½ min. 716 links and 37 deg. 35½ min. 249 links to the point of commencement.
- (c) Commencing at the southern angle of lot 3 on plan of subdivision numbered 24500, lodged in the Office of Titles and being part of portion 5 of the said parish: thence by lines bearing respectively 293 deg. 1 min. 283.3 links, 60 deg. 54 min. 699.2 links, 215 deg. 45 min. 78 links, 192 deg. 20 min. 216.6 links and 235 deg. 45 min. 312.5 links to the point of commencement.
- (d) Commencing at the north-eastern angle of lot 1 on plan of subdivision numbered 3207, lodged in the Office of Titles and being part of portion 5 of the said parish; thence by lines bearing respectively 43 deg. 49 min. 341 links, 45 deg. 11 min. 471 links, 61 deg. 49 min. 223 links, 62 deg. 40 min. 315 links, 67 deg. 37 min. 244 links, 45 deg. 25 min. 229 links, 79 deg. 37 min. 395 links, 106 deg. 52 min. 56.6 links, 248 deg. 44½ min. 682.6 links, 246 deg. 34 min. 244 links, 227 deg. 34½ min. 1,162.6 links, 235 deg. 45 min. 235.5 links, 11 deg. 17½ min. 115.1 links and 42 deg. 42½ min. 16 links to the point of commencement.
- (e) Commencing at the eastern angle of lot 3 on plan of subdivision numbered 15780, lodged in the Office of Titles and being part of portion 5 of the said parish; thence by lines bearing respectively 245 deg. 17 min. 290 links, 57 deg. 37½ min. 529.3 links and 228 deg. 33 min. 245 links to the point of commencement.
- (f) Commencing at the southern angle of lot 5 on plan of subdivision numbered 15780, lodged in the Office of Titles and being part of portion 5 of the said parish; thence by lines bearing respectively 289 deg. 14 min. 258.7 links, 95 deg. 45½ min. 372.4 links and 249 deg. 14 min. 135 links to the point of commencement—

which said pieces of land are particularly delineated and shown coloured red on survey plans numbered 9556, 9557 and 9558, lodged in the office of the Country Roads Board.

And the Honorable Murray Victor Porter, Her Majesty's Commissioner of Public Works for the State of Victoria, shall give the necessary directions herein accordingly.

J. COLQUHOUN,  
Clerk of the Executive Council.

COUNTRY ROADS BOARD.

At the Executive Council Chamber, Melbourne, the twenty-first day of July, 1964.

PRESENT:

His Excellency the Governor of Victoria.  
Mr. Reid | Mr. Porter  
Mr. Rossiter | Mr. Dickie.

ORDER APPROVING OF A DEVIATION FROM A MAIN ROAD IN THE SHIRE OF MINHAMITE.

WHEREAS the Country Roads Board constituted under the *Country Roads Act 1958* (No. 6229) has represented to His Excellency the Governor in Council that it

appears to it desirable that the existing Warrnambool-Hawkesdale-Penshurst road in the Shire of Minhamite (declared to a main road under the said Act which declaration was confirmed by the Order in Council published in the *Government Gazette* of the 9th December, 1914, on page 5528) should be widened by the said Board: And whereas the said Board in accordance with the requirements of section 19 of the said cited Act has caused to be prepared a map plan and estimate showing the points between which and on and through what land the said widening is proposed to be made and the cost of acquiring the land: And whereas on an inspection of the said map and plan and a consideration of the said estimate His Excellency the Governor in Council is satisfied that there are funds legally available for acquiring the land: Now therefore be it known by this present Order that His Excellency the Governor of the State of Victoria with the advice of the Executive Council thereof doth hereby approve of the said road being widened, that is to say:—

All that piece of land in the Parish of Kangertong, the boundaries of which are as follow:—Commencing at the north-eastern angle of allotment 3B, section 19, of the said parish; thence by lines bearing respectively 180 deg. 0 min. 790 links, 340 deg. 12 min. 450 links, 329 deg. 56 min. 501.4 links, 320 deg. 29 min. 450 links and 120 deg. 59 min. 805 links to the point of commencement—which said piece of land is particularly delineated and shown coloured red on survey plan numbered 9586, lodged in the office of the Country Roads Board.

And the Honorable Murray Victor Porter, Her Majesty's Commissioner of Public Works for the State of Victoria, shall give the necessary directions herein accordingly.

J. COLQUHOUN,  
Clerk of the Executive Council.

#### TOWN AND COUNTRY PLANNING ACT 1961.

At the Executive Council Chamber, Melbourne, the twenty-first day of July, 1964.

PRESENT:

His Excellency the Governor of Victoria.	
Mr. Reid	Mr. Porter
Mr. Rossiter	Mr. Dickie.

#### CITY OF CAMBERWELL PLANNING SCHEME 1954, AMENDMENT No. 13, 1964.

WHEREAS it is provided by section 32 of the *Town and Country Planning Act 1961* that the Governor in Council on the application of the responsible authority and after consideration by the Minister of a report thereon by the Town and Country Planning Board may amend a planning scheme where he is satisfied that the circumstances do not warrant the preparation of an amending planning scheme:

And whereas an application has been made by the Council of the City of Camberwell and a report of the Town and Country Planning Board on the said application has been considered by the Minister:

And whereas the City of Camberwell Planning Scheme 1954 (hereinafter referred to as the Principal Scheme) was approved by the Governor in Council on the 8th day of October, 1957:

Now therefore His Excellency the Governor of the State of Victoria by and with the advice of the Executive Council doth hereby amend the Principal Scheme by an amendment to be known as the City of Camberwell Planning Scheme 1954, Amendment No. 13, 1964, in the manner and to the extent shown as follows and the Principal Scheme and the variations herein shall be read and construed as one, that is to say:—

1. In clause 10, paragraphs (c) to (g) of sub-clause (1) shall be re-lettered (d) to (h) respectively.
2. In clause 10, after paragraph (b) of sub-clause (1) there shall be added the following new paragraph: " (c) Bank."

And the Honorable Rupert James Hamer, Her Majesty's Minister for Local Government for the State of Victoria, shall give the necessary directions herein accordingly.

J. COLQUHOUN,  
Clerk of the Executive Council.

#### LOCAL GOVERNMENT DEPARTMENT.

At the Executive Council Chamber, Melbourne, the twenty-first day of July, 1964.

PRESENT:

His Excellency the Governor of Victoria.	
Mr. Reid	Mr. Porter
Mr. Rossiter	Mr. Dickie.

#### ADVISORY COMMITTEE FOR NULLAWARRE DRAINAGE AREA.—SHIRE OF WARRNAMBOOL.

PURSUANT to the provisions of section 7 of the *Drainage Areas Act 1958*, His Excellency the Governor of the State of Victoria, by and with the advice of the Executive Council thereof, hereby orders that the advisory committee to be appointed for the Nullawarre Drainage Area in the Shire of Warrnambool shall consist of three members representing the Council of the said Shire and seven members representing the owners of land in the drainage area.

And the Honorable Rupert James Hamer, Her Majesty's Minister for Local Government for the State of Victoria, shall give the necessary directions herein accordingly.

J. COLQUHOUN,  
Clerk of the Executive Council.

#### LOCAL GOVERNMENT DEPARTMENT.

At the Executive Council Chamber, Melbourne, the twenty-first day of July, 1964.

PRESENT:

His Excellency the Governor of Victoria.	
Mr. Reid	Mr. Porter
Mr. Rossiter	Mr. Dickie.

#### APPLICATION TO ELECTIONS OF COUNCILLORS FOR THE SHIRE OF KNOX OF REGULATIONS RELATING TO COMPULSORY VOTING.

WHEREAS it is provided in section 149 of the *Local Government Act 1958*, as amended, that the Governor in Council, on the petition of the Council of any municipality, may, by Order published in the *Government Gazette*, apply to elections of councillors for such municipality, with any modifications provided for in such Order, all or any of the Regulations relating to compulsory voting made under the said section 149:

Now, therefore, His Excellency the Governor of the State of Victoria, by and with the advice of the Executive Council thereof, and in pursuance of a petition of the Council of the Shire of Knox, doth hereby order that the Regulations relating to compulsory voting at municipal elections made pursuant to the provisions of the said section 149, shall apply to elections of councillors for the municipality of the Shire of Knox.

And the Honorable Rupert James Hamer, Her Majesty's Minister for Local Government for the State of Victoria, shall give the necessary directions herein accordingly.

J. COLQUHOUN,  
Clerk of the Executive Council.

#### MILDURA URBAN WATER TRUST.

At the Executive Council Chamber, Melbourne, the twenty-eighth day of July, 1964.

PRESENT:

His Excellency the Governor of Victoria.	
Mr. Darcy	Mr. Rossiter.
Mr. Dickie	

#### SALE OF LAND.

HIS Excellency the Governor of the State of Victoria, by and with the advice of the Executive Council thereof, doth hereby, under the provisions of the *Mildura Irrigation and Water Trusts Act 1958*, approve of the sale by the Mildura Urban Water Trust of the land, on which is situated a reinforced concrete water tower, comprised within the boundaries described in the Schedule hereto.

## SCHEDULE.

Commencing at a point on the south-western boundary of lot 34, section 23, Block D, on plan of subdivision No. 2144, lodged in the Office of Titles, and being part of Crown portion I, Parish of Mildura, County of Karkaroc, such point being distant 19 feet north-westerly from the southernmost angle of the said lot 34; thence north-westerly along the said south-western boundary of lot 34 for a distance of 63 feet; thence through the said lot 34 and lot 33 by lines bearing north 45 deg. 16 min. east a distance of 61 feet, south 44 deg. 44 min. east a distance of 63 feet and south 45 deg. 16 min. west a distance of 61 feet to a point on the said south-western boundary of lot 34, being the point of commencement.

All of which land is shown on a plan approved by the Governor in Council and deposited in the office of the State Rivers and Water Supply Commission, Melbourne.—(Corres. No. 63/4747/19.)

And the Honorable Thomas Anthony Darcy, Her Majesty's Minister of Water Supply for the State of Victoria, shall give the necessary directions herein accordingly.

J. COLQUHOUN,  
Clerk of the Executive Council.

## MOUNT ELIZA SEWERAGE AUTHORITY.

At the Executive Council Chamber, Melbourne, the  
twenty-eighth day of July, 1964.

PRESENT:

His Excellency the Governor of Victoria.  
Mr. Darcy | Mr. Rossiter.  
Mr. Dickie

## CONSENT TO BORROWING £100,000.

UNDER the powers conferred by the Sewerage Districts Act and all other powers enabling him in that behalf, His Excellency the Governor of the State of Victoria, by and with the advice of the Executive Council of the said State, doth hereby consent to the Mount Eliza Sewerage Authority borrowing by the assignment of the General Fund, the sum of One hundred thousand pounds (£100,000) to meet the cost of sewerage works, as set forth in the detailed statement bearing date the 24th July, 1964.

And the Honorable Thomas Anthony Darcy, Her Majesty's Minister of Water Supply for the State of Victoria, shall give the necessary directions herein accordingly.

J. COLQUHOUN,  
Clerk of the Executive Council.

## HOUSING ACT 1958.

At the Executive Council Chamber, Melbourne, the  
twenty-eighth day of July, 1964.

PRESENT:

His Excellency the Governor of Victoria.  
Mr. Darcy | Mr. Rossiter.  
Mr. Dickie

## CLOSING OF ROADS AND EXTINGUISHMENT OF EASEMENTS AND RESTRICTIVE COVENANTS—CITY OF BROADMEADOWS.

WHEREAS by virtue and in exercise of the powers contained in the *Housing Act 1958* (No. 6275), Housing Commission has recommended to the Governor in Council that the roads, easements and restrictive covenants described in the Schedule hereto be closed and extinguished.

Now therefore His Excellency the Governor of the State of Victoria in the Commonwealth of Australia, by and with the advice of the Executive Council of the said State, doth in pursuance of the powers conferred by the said Act and upon such recommendation, consent and by this Order hereby close and extinguish such roads, easements and restrictive covenants.

## SCHEDULE.

*First*.—All of the roads shown coloured brown on plan of subdivision number 10689, lodged in the Office of Titles.

*Secondly*.—All of the road known as Creedon-street shown coloured brown on plan of subdivision number 6405, lodged in the Office of Titles.

*Thirdly*.—All of the road lying between lot 20 and lots 43 to 50 (both inclusive), on plan of subdivision number 10333, lodged in the Office of Titles and bounded by the southern prolongation of the eastern and western boundaries of lot 20 on the plan of subdivision aforesaid.

*Fourthly*.—Any easements affecting:

- (i) Lots number 2, 5, 8 and 11 on plan of subdivision number 6405, lodged in the Office of Titles.
- (ii) Lots numbered 2 to 7 (both inclusive), and 14 to 19 (both inclusive), on plan of subdivision number 10333, lodged in the Office of Titles.
- (iii) Lots numbered 1 to 5 (both inclusive), and 19 to 25 (both inclusive), on plan of subdivision number 10689, lodged in the Office of Titles.
- (iv) Lots numbered 1 to 10 (both inclusive), on plan of subdivision number 12946, lodged in the Office of Titles.
- (v) The land contained in certificate of title, volume 8316, folio 734.

*Fifthly*.—Any restrictive covenants affecting lots numbered 2, 3, 6 to 9 (both inclusive), 14 to 18 (both inclusive), 20 to 23 (both inclusive), 43, 44 and 46 to 50 (both inclusive), on plan of subdivision number 10333, lodged in the Office of Titles.

And the Honorable Lindsay Hamilton Simpson Thompson, Her Majesty's Minister of Housing for the State of Victoria, shall give the necessary directions herein accordingly.

J. COLQUHOUN,  
Clerk of the Executive Council.

## HOUSING ACT 1958.

At the Executive Council Chamber, Melbourne, the  
twenty-eighth day of July, 1964.

PRESENT:

His Excellency the Governor of Victoria.  
Mr. Darcy | Mr. Rossiter.  
Mr. Dickie

## EXTINGUISHMENT OF EASEMENTS—SHIRE OF KERANG.

WHEREAS by virtue and in exercise of the powers contained in the *Housing Act 1958* (No. 6275), Housing Commission has recommended to the Governor in Council that the easements described in the Schedule hereto be extinguished:

Now therefore His Excellency the Governor of the State of Victoria in the Commonwealth of Australia, by and with the advice of the Executive Council of the said State, doth in pursuance of the powers conferred by the said Act and upon such recommendation, consent and by this Order hereby extinguish such easements.

## SCHEDULE.

Any easements affecting the land shown coloured green on the map in the margin of certificate of title, volume 8086, folio 925.

And the Honorable Lindsay Hamilton Simpson Thompson, Her Majesty's Minister of Housing for the State of Victoria, shall give the necessary directions herein accordingly.

J. COLQUHOUN,  
Clerk of the Executive Council.

APPROACHING LAND SALES.

SALES of Crown lands, in fee-simple, will be held at the under-mentioned places and dates, viz.:-

	No. of Gazette.
Beechworth.—Monday, 10th August, 1964 ..	52
Goroke.—Wednesday, 12th August, 1964 ..	59
Mallacoota.—Wednesday, 2nd September, 1964 ..	66
Meenyan.—Tuesday, 18th August, 1964 ..	60
Orbost.—Tuesday, 1st September, 1964 ..	66
Ouyen.—Monday, 31st August, 1964 ..	66
Stawell.—Friday, 31st July, 1964 ..	52

AUCTION OF RIGHT TO LEASE CROWN LAND.

Queenscliff.—Friday, 7th August, 1964 ..	59
Wonthaggi.—Tuesday, 18th August, 1964 ..	60

PROPOSED REVOCATION OF TEMPORARY RESERVATION, AND THE WITHHOLDING FROM SALE, LEASING, AND LICENSING OF LAND BY ORDER IN COUNCIL.

IN pursuance of the provisions of the Land Act 1958, notice is hereby given that it is the intention of the Governor in Council to revoke the temporary reservation, and the withholding from sale, leasing and licensing of land by Order in Council hereunder referred to, viz.:-

The following Notice was published 1° on the 29th July, 1964, pursuant to Order of the 21st July, 1964.

MOREEP.—The temporary reservation as a site for Victorian Water Supply purposes, and the withholding from sale, leasing and licensing by Order in Council of the 18th October, 1875 (see Government Gazette of the 22nd October, 1875, page 1995) of 3,073 acres more or less, of land in the Parishes of Moreep, Beremboke and Anakie, are about to be revoked, so far only as the portions in the Parish of Moreep, containing 1 acre 2 roods 34 perches, indicated by hachure on plan hereunder are concerned.—(M.468<sup>(3)</sup>) (Rs.6566).

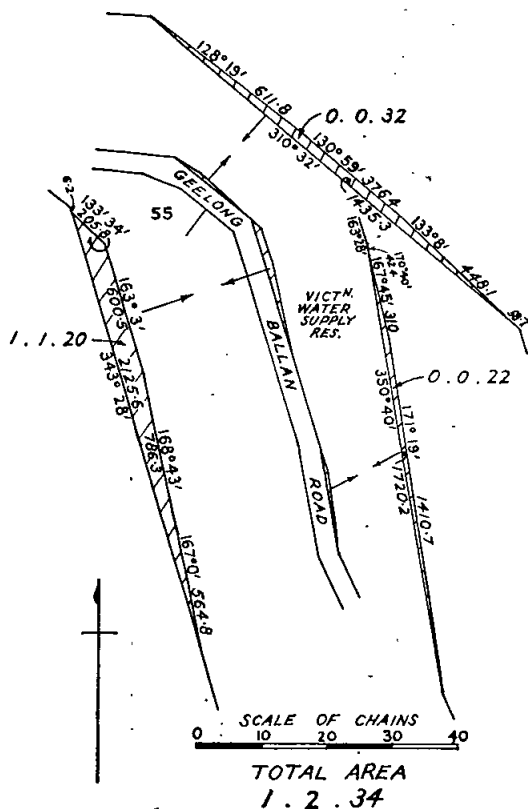

J. C. M. BALFOUR,  
Commissioner of Crown Lands and Survey.

PROPOSED REVOCATIONS OF TEMPORARY RESERVATIONS OF LANDS BY ORDERS IN COUNCIL.

IN pursuance of the provisions of the Land Act 1958, notice is hereby given that it is the intention of the Governor in Council to revoke the temporary reservations of lands by Orders in Council hereunder referred to, viz.:-  
The following Notices were published 1° on the 8th July, 1964, pursuant to Orders of the 30th June, 1964.

BITTERN (CRIB POINT).—The temporary reservation, by Order in Council of the 23rd September, 1958, of 16 acres more or less of land in the Parish of Bittern as a site for Public purposes so far only as the portion containing 1 rood more or less, indicated by hachure on plan hereunder, is concerned.—(B.397<sup>(10)</sup>) (Rs.3572).

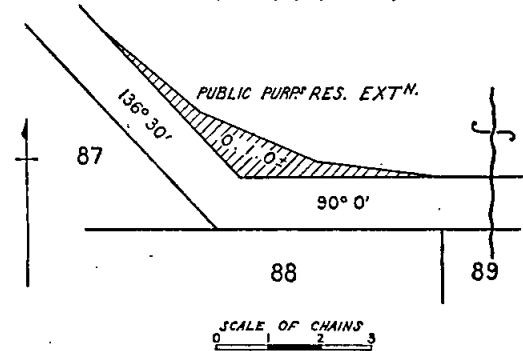

CRIB POINT.—The temporary reservation, by Order in Council of the 10th November, 1927, of 240 acres more or less of land in the Parish of Bittern and the Township of Crib Point (formerly Morradoo), as a site for Public purposes so far only as the portion in the Township of Crib Point containing 4 acres 3 roods more or less, indicated by hachure on plan hereunder, is concerned.—(M.531<sup>(2)</sup>) (Rs.3572).

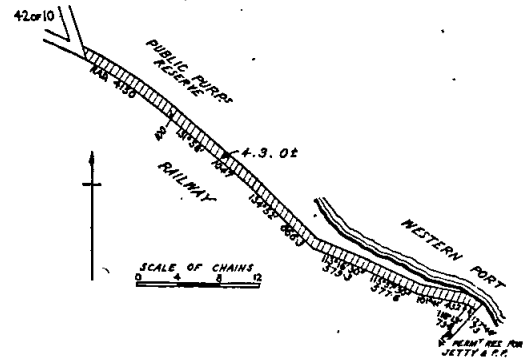

ECHUCA NORTH.—The temporary reservation, by Order in Council of the 2nd May, 1961, of 28 acres 2 roods 6 perches of land in the Parish of Echuca North as a site for Public Park and Recreation purposes so far only as the portion containing 3 acres, indicated by hachure on plan hereunder, is concerned.—(E.96<sup>(8)</sup>) (Rs.3944).

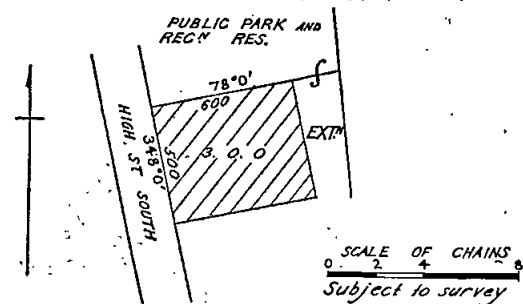

WAL WAL.—The temporary reservation, by Order in Council of the 13th September, 1886, of 35½ perches of land in the Parish of Warranook (now in the Township of Wal Wal) as a site for a Mechanics' Institute.—(W.428<sup>(2)</sup>) (Rs.5753).

KEITH TURNBULL,  
Commissioner of Crown Lands and Survey.

**PROPOSED REVOCATION OF TEMPORARY RESERVATION OF LAND BY ORDER IN COUNCIL.**

IN pursuance of the provisions of the *Land Act 1958*, notice is hereby given that it is the intention of the Governor in Council to revoke the temporary reservation of land by Order in Council hereunder referred to viz.:-

The following Notice was published 1° on the 15th July, 1964, pursuant to Order of the 8th July, 1964.

**SANDHURST (BENDIGO AND EAGLEHAWK).**—The temporary reservation, by Order in Council of the 16th October, 1894, of 5 acres of land at Bendigo and at Eaglehawk in the Parish of Sandhurst as a site for a Hospital or place for isolating persons suffering from Smallpox, Cholera, or other dangerous infectious or contagious disease, revoked as to part by Order of the 26th August, 1913, is about to be revoked so far as the balance thereof containing 4 acres 2 roods 7 perches, is concerned.—(S.371<sup>(2)</sup>) (C.56171).

**JIM BALFOUR,**  
Commissioner of Crown Lands and Survey.

**PROPOSED PERMANENT RESERVATIONS OF LANDS AS SITES.**

IN pursuance of the provisions of the *Land Act 1958*, notice is hereby given that it is the intention of the Governor in Council to permanently reserve as sites the lands hereunder referred to:-

The following Notices were published 1° on the 22nd July, 1964, pursuant to Orders of the 15th July, 1964.

**DANDENONG (SPRINGVALE).**—Land proposed to be permanently reserved as a site for a Cemetery also excepted from occupation for mining purposes under any miner's right, 21 acres 3 roods 7 perches, Parish of Dandenong, County of Bourke, as indicated by hachure on plan hereunder.—(D.19<sup>(6)</sup>) (Rs.8355).

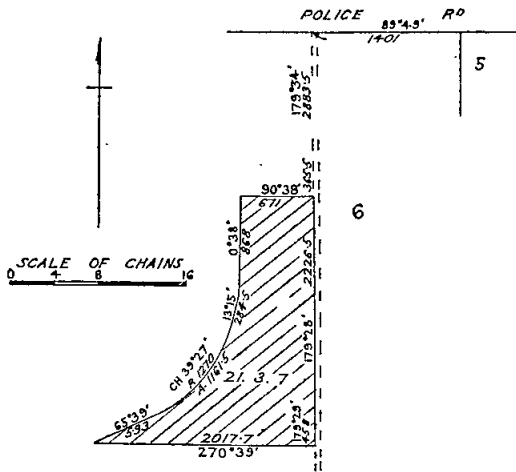

**FRANKSTON.**—Land proposed to be permanently reserved as a site for Public purposes, also excepted from occupation for mining purposes under any miner's right, 4 acres more or less, Parish of Frankston, County of Mornington, as indicated by hachure on plan hereunder.—(F.87<sup>(5)</sup>) (Rs.3203).

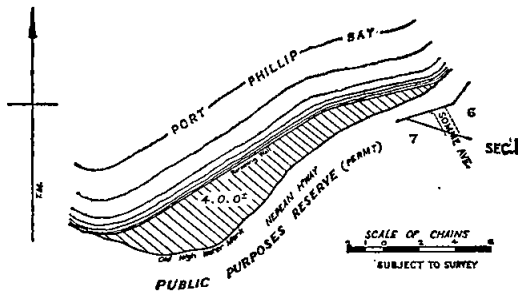

**PRAHRAN (AT CAULFIELD).**—Land proposed to be permanently reserved as a site for Public Recreation, also excepted from occupation for mining purposes under any miner's right, 4 acres, at Caulfield, Parish of Prahran, County of Bourke, as indicated by hachure on plan hereunder.—(P.79<sup>(1)</sup>) (Rs.140).

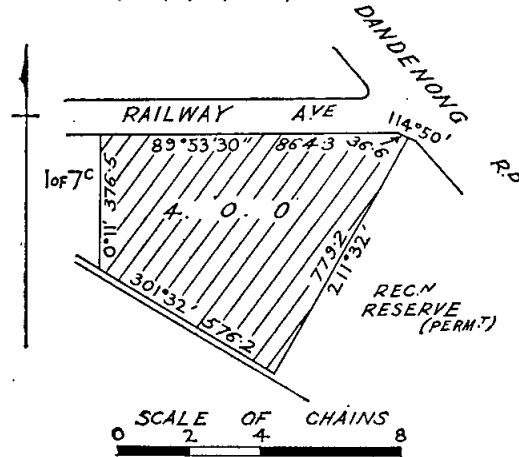

**J. C. M. BALFOUR,**  
Commissioner of Crown Lands and Survey.

**PROPOSED PERMANENT RESERVATIONS OF LANDS AS SITES.**

IN pursuance of the provisions of the *Land Act 1958*, notice is hereby given that it is the intention of the Governor in Council to permanently reserve as sites the lands hereunder referred to:-

The following Notices were published 1° on the 29th July, 1964, pursuant to Orders of the 21st July, 1964.

**WHITTLESEA.**—Land proposed to be permanently reserved as a site for Public purposes, also excepted from occupation for mining purposes under any miner's right, 1 acre 1 rood 20 perches, more or less, Township of Whittlesea, Parish of Toorourrong, County of Bourke, as indicated by hachure on plan hereunder.—(W.133<sup>(2)</sup>) (Rs.8345).

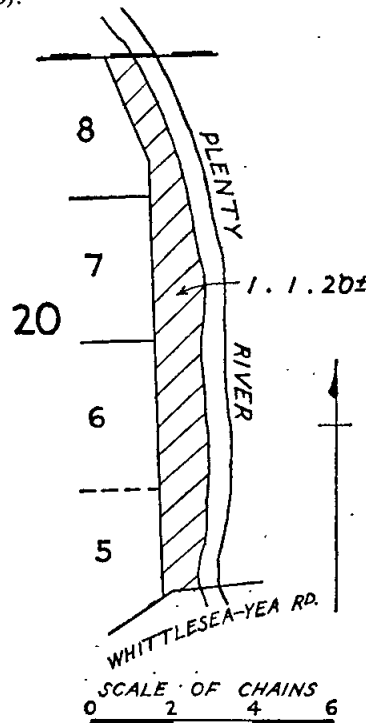



YAN YEAN (MERNDA).—Land proposed to be permanently reserved as a site for Public purposes, also excepted from occupation for mining purposes under any miner's right, 13 acres 3 roods 20 perches more or less, Parish of Yan Yeau, County of Bourke, as indicated by hachure on plan hereunder.—(Y.19<sup>(3)</sup>) (Rs.8345).

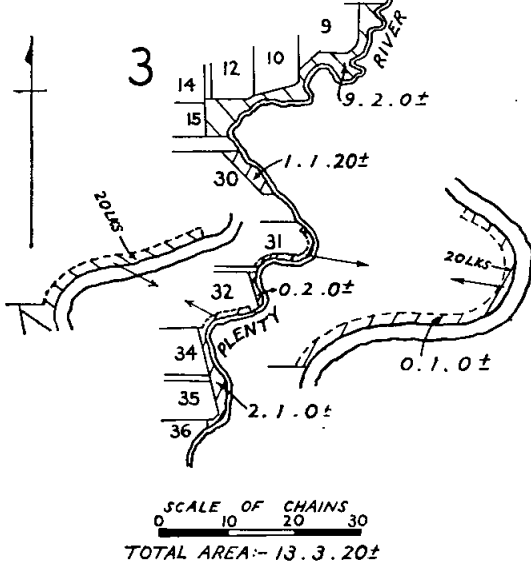

J. C. M. BALFOUR,  
Commissioner of Crown Lands and Survey.

PROPOSED REVOCATIONS OF TEMPORARY RESERVATIONS OF LANDS BY ORDERS IN COUNCIL.

IN pursuance of the provisions of the Land Act 1958, notice is hereby given that it is the intention of the Governor in Council to revoke the temporary reservations of lands by Orders in Council hereunder referred to, viz.:—

The following Notices were published 1° on the 22nd July, 1964, pursuant to Orders of the 15th July, 1964.

DROMANA.—The temporary reservation, by Orders in Council of the 28th December, 1864, and the 18th February, 1890, of 2 acres 3 roods 37½ perches of land in the Township of Dromana, as a site for Public Recreation and Public Garden is about to be revoked so far only as the portion containing 1 rood 18 perches, indicated by hachure on plan hereunder, is concerned.—(D.98<sup>(2)</sup>) (Rs.3081).

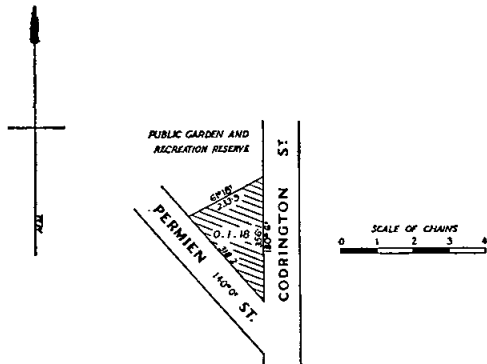

KARWEEN.—The temporary reservation, by Order in Council of the 10th December, 1928, of 4 acres of land in the Parish of Karween, as a site for a State School.—(K.214<sup>(6)</sup>) (Rs.3792).

WOORRAGEE.—The temporary reservation, by Order in Council of the 8th February, 1864 (see Government Gazette of the 23rd February, 1864, page 443), of 1 acre of land in the Parish of Woorragee, as a site for Wesleyan

Church purposes, is about to be revoked, so far only as the portion containing 25 perches, indicated by hachure on plan hereunder, is concerned.—(W.209<sup>(4)</sup>) (C.98900).

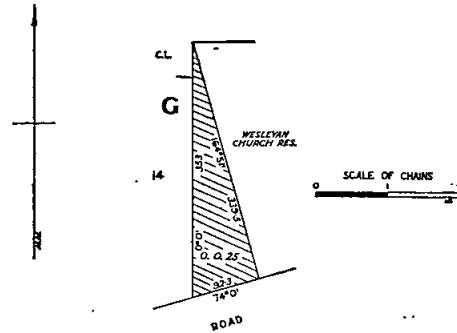

J. C. M. BALFOUR,  
Commissioner of Crown Lands and Survey.

PROPOSED REVOCATION OF TEMPORARY RESERVATION, AND THE WITHHOLDING FROM SALE, LEASING, AND LICENSING OF LAND BY ORDER IN COUNCIL.

IN pursuance of the provisions of the Land Act 1958, notice is hereby given that it is the intention of the Governor in Council to revoke the temporary reservation, and the withholding from sale, leasing and licensing of land by Order in Council hereunder referred to, viz.:—

The following Notice was published 1° on the 22nd July, 1964, pursuant to Order of the 15th July, 1964.

BRIGHT.—The temporary reservation as a site for Water Supply purposes and the withholding from sale, leasing and licensing by Order in Council of the 19th April, 1875, of 1920 acres more or less of land in the Parish of Bright are about to be revoked so far only as the portion containing 2 acres more or less, indicated by hachure on plan hereunder, is concerned.—(B.574<sup>(11)</sup>) (Rs.2196).

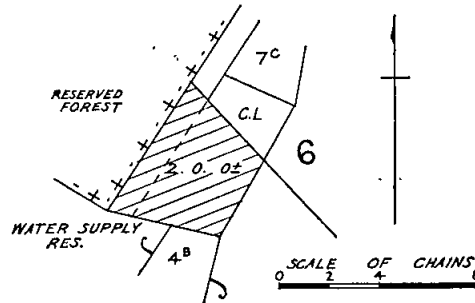

J. C. M. BALFOUR,  
Commissioner of Crown Lands and Survey.

LOCAL LAND BOARDS.

IN pursuance of the provisions of section 34 of the Land Act 1958, notice is hereby given that a public hearing at the following place and time, will be conducted by the persons respectively mentioned, being duly appointed in that behalf.

J. C. M. BALFOUR,  
Commissioner of Crown Lands and Survey.

Department of Crown Lands and Survey,  
Melbourne.

SCHEDULE.

MELBOURNE, BOARD ROOM, 2ND FLOOR, STATE PUBLIC OFFICES, TREASURY-PLACE, Wednesday, 12th August, 1964, at 11 a.m.—J. A. Murphy, and J. R. Wilding.

Land Act 1958.

LEASES SURRENDERED.

NOTICE is hereby given that the Governor in Council has accepted the surrender of the Leases mentioned in the Schedule hereunder for the reason specified in each case.

District.	Corr. No.	Name.	Section of Land Act under which Leased.	Parish.	Allotment.	Section.	Area.	Class.	Reason.
Mallee ..	140/8	James Patrick Foley	Section 8, Land (North-West Mallee Settlement Areas) Act 1948-49	Nenandie	23 and 24	..	A. R. P. 4,561 0 0	..	Purchase lease to issue
Mallee ..	9/8	Charles Raymond Nickolai	Section 8, Land (North-West Mallee Settlement Areas) Act 1948-49	Karween	49 and 52	..	3,389 0 0	..	Purchase lease to issue

Department of Crown Lands and Survey,  
Melbourne, 21st July, 1964.

J. C. M. BALFOUR,  
Commissioner of Crown Lands and Survey.

PROPOSED REVOCATION OF TEMPORARY RESERVATION OF LAND BY ORDER IN COUNCIL.

IN pursuance of the provisions of the Land Act 1958, notice is hereby given that it is the intention of the Governor in Council to revoke the temporary reservation of land by Order in Council hereunder referred to, viz.:

The following Notice was published 1° on the 29th July, 1964, pursuant to Order of the 21st July, 1964.

MOREEP.—The temporary reservation, by Order in Council of the 19th February, 1866 (see Government Gazette of the 2nd March, 1866, page 510) of 3,900 acres more or less of land in the Parishes of Moreep and Ballark, as a site for Water Supply purposes, revoked as to part by Order of the 31st May, 1955, is about to be revoked so far only as the portions in the Parish of Moreep containing 5 acres 0 roods 39 perches, indicated by hachure on plan hereunder are concerned.—(M.468<sup>(2)</sup>) (Rs.6566).

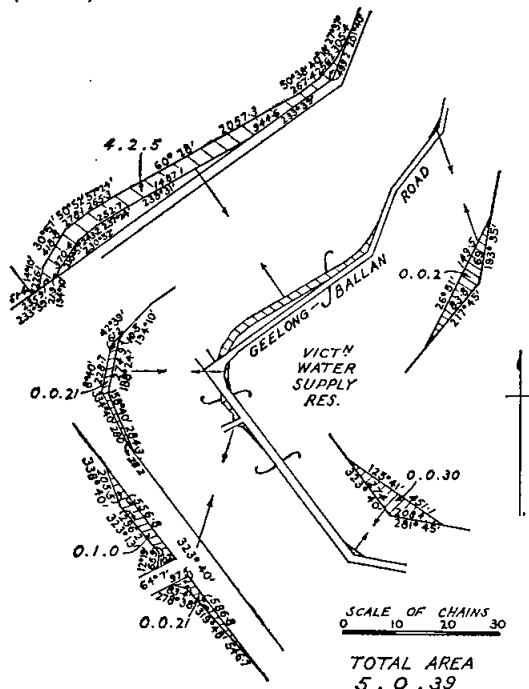

J. C. M. BALFOUR,  
Commissioner of Crown Lands and Survey.

TENDERS—PUBLIC WORKS DEPARTMENT

TENDERS will be received at this Department's Head Office, Treasury-place, Melbourne, until TEN a.m. on the dates, and for the purposes under mentioned.

Particulars may be learnt at the Department and also at places shown in parentheses.

W.O. means Inspector of Works Office; P.S.—Police Station; T.S.—Technical School; H.E.S.—Higher Elementary School; S.S.—State School; H.S.—High School; C.S.—Consolidated School.

Tenders should be submitted on the Department's printed Tender Form and will not be received by telephone. All tenders must be on a "Firm Tender" basis. The Board of Land and Works will not necessarily accept the lowest or any tender.

Tenders to be addressed to the Hon. the Commissioner of Public Works, and envelope containing tender to be marked "Tender for , closing Tuesday, ,".

NOTE.—No preliminary deposit is to be lodged with any tender, but a deposit in accordance with the prescribed Schedule may be required from each successful tenderer.

Tuesday, 4th August, 1964.

Building, Electrical and Mechanical Works.

- Agnes.—Septic tank installation, S.S. 3043. (W.O., Korumburra; S.S., Agnes.)
- Bacchus Marsh.—Connexion to town sewerage, Police Station. (W.O., Ballarat; P.S., Bacchus Marsh.)
- Ballarat.—Repairs and painting to residence, 1128 Eyre-street, Department of Labour and Industry. (W.O., Ballarat.)
- Bayswater.—Erection of extended third section of High School in concrete veneer, L.T.C.
- Beaumaris.—Installation of staff toilet, sewer drains, &c., S.S. 3899.
- Castlemaine.—Erection of brick internal toilet for Women Teachers, S.S. 119. (W.O., Kyneton.)
- Clayton North.—New display boards, repairs and painting, S.S. 734.
- Corio.—Repairs and painting, S.S. 124 and residence. (W.O., Geelong.)
- Dandenong.—Chain mesh fence around Tennis Courts, High School.
- Dandenong West.—Renewal of water supply and additional out-offices, S.S. 4217. (S.S., Dandenong West.)
- Dean's Marsh.—Erection of porch, cloakroom and partitions, S.S. 1642. (W.O., Camperdown and Geelong; S.S., Dean's Marsh.)
- Drouin South.—Repairs and painting, school and residence, S.S. 2313. (W.O., Warragul; S.S., Drouin South.)
- Geelong.—Renovations to staff quarters, Training Prison. (W.O., Geelong.)

- Greythorn.—Supply and installation of central heating extension, S.S. 4694.
- Heatherton.—Repairs to bathrooms, Sanatorium.
- Koondrook.—External repairs and painting, erection of new shelter shed, S.S. 2265. (W.O., Swan Hill; S.S., Koondrook.)
- Melbourne.—Alterations to Policewomen's office, Police Headquarters, Russell-street.
- Melbourne.—Supply and installation of ventilation in Rex Building, Royal Melbourne Institute of Technology.
- Melbourne.—Roof timber replacements and various repairs, painting and decorating school, Royal Melbourne Institute of Technology.
- Melbourne.—Design and construction of a Swimming Pool, Government House.
- Mount Eliza.—Erection of shelter pavilion, S.S. 1368. (S.S., Mount Eliza.)
- Mt. Waverley.—Connexion to main sewer, Police Station residence.
- Murrumbena.—Fireproofing and enclosing balcony, S.S. 3449.
- Orbost.—New roof, renovations and painting, S.S. 2744. (W.O., Bairnsdale; S.S., Orbost.)
- Ormond East.—Additional bedroom and alterations, Caretaker's residence, S.S. 4366.
- Preston South.—Re-flooring to Infants school section and provision of a new Fuel Shed, S.S. 824.
- Sale.—Internal toilets and renovations to residences 8A, 8B, Barkly-street, Technical School. (W.O., Traralgon; T.S., Sale.)
- Southmoor.—Erection of chain mesh fence and gates, S.S. 4910.
- St. Arnaud.—Replacement of all slate roofs and re-flooring in school library, High School. (W.O., Maryborough; H.S., St. Arnaud.)
- Sunvale.—External repairs and painting, S.S. 4818.
- Talindert.—Internal and external repairs and painting, S.S. 3644. (W.O., Camperdown; S.S., Talindert.)
- Trawalla.—Remove residence at Tourello and re-site at Trawalla, with renovations, S.S. 1150. (W.O., Ballarat.)
- Wangaratta.—Provision of office, District School Inspector's residence. (W.O., Wangaratta.)
- Williamstown North.—Chain mesh fencing, S.S. 1409.
- Yarrowonga.—Renovations and additions, Lands Department residence. (W.O., Wangaratta.)
- Furniture and Furnishings.**
- Boort.—Supply of tube steel tables and tube steel chairs, High School.
- Melbourne.—Supply of filing cabinets, Motor Registration Branch, Exhibition Buildings.
- Moorabbin.—Supply and install steel library shelving, Technical School.
- Stawell.—Supply of tubular steel beds, Pleasant Creek Special School.
- Stawell.—Supply of rubber mattresses, Pleasant Creek Special School.
- Stawell.—Supply of waterproof mattress covers, Pleasant Creek Special School.
- Various.—Supply of specimen cases, High Schools.
- Yallourn.—Supply and install steel library shelving, Technical College. (W.O., Traralgon.)
- Site Works.**
- Croydon.—Retaining wall, concreting, drainage and associated works, S.S. 4219.
- Miscellaneous.**
- Goulburn Weir.—Purchase and removal of old school building, S.S. 3358. (P.S., Nagambie.)
- Melbourne.—Supply and installation of beverage cooling equipment for the refreshment room, Parliament House.
- Melbourne.—Supply of two electric ovens, William Angliss Food Trades School.

## Tuesday, 11th August, 1964.

### Building, Electrical and Mechanical Works.

- Carlton.—Renewal of roof with terra cotta tiles, S.S. 2605.
- Casterton.—Additional room, renovations and painting, Lands and Survey Department residence, Widdicombe-street. (W.O., Hamilton; P.S., Casterton.)
- Coatesville.—Re-siting residence on school site, S.S. 4712. (Amended specification.)
- Collingwood.—Extension of retaining walls and erection of new store, Technical School.
- Dederang.—External and internal repairs and painting to residence, S.S. 1772. (W.O., Wangaratta.)
- Dimboola.—Toilet facilities, High School. (W.O., Warracknabeal; H.S., Dimboola.)
- Doveton.—Connexion to sewerage main, High School. (H.S., Doveton.)

- Elwood.—Additions to boys' and girls' toilets, High School.
- Footscray.—Installation and supply of Chemistry Laboratory benches, Technical School.
- Frankston.—Supply and installation of Rabbit Refuse Disposal Units, Keith Turnbull Research Station.
- Geelong.—Supply and installation of intercommunication system, Chest Clinic, Ryrie-street. (W.O., Geelong.)
- Goroke.—Erection of timber residence, garage, &c., Lands and Survey Department. (W.O., Horsham; P.S., Goroke.)
- Hamilton.—Supply and erection of glazed aluminium porch screen, Public Works Department Offices. (W.O., Hamilton.)
- Hamilton South-West.—Electrical installation in new school of eight (8) L.T.C. class-rooms, &c., S.S. 4847. (W.O., Hamilton.)
- Hamilton South-west.—Plenum heating to eight class-room school, S.S. 4847. (W.O., Hamilton.)
- Hawksburn.—New timber fire escape stairway, S.S. 1467.
- Irymple.—Electrical installation, New Insectary, Agriculture Department. (W.O., Mildura.)
- Kangaroo Flat.—Second and third sections of timber-framed concrete veneer school buildings, Technical School. (W.O., Bendigo.)
- Kerang.—Erection of brick veneer residence, brick garage and generator room, Korangie Wildlife Reserve. (W.O., Swan Hill.)
- Langkoop.—Repairs and painting, S.S. 2633. (W.O., Horsham.)
- Melbourne.—Supply and installation of air conditioning equipment in Rooms 209 and 210, Agriculture Department, Public Offices, Treasury-place.
- Mont Park.—Conversion of existing hot-water system to 105°F. system and supply of 180°F. system in Ward "M", Plenty Mental Hospital.
- Moorabbin West.—Internal repairs and painting, S.S. 4643.
- Mooroolbark.—Electrical installation in Stages 2 and 3, Technical School.
- Mornington.—Staff toilet and basin, S.S. 2033. (S.S., Mornington.)
- Moyston.—Internal repairs and painting to residence, S.S. 1263. (W.O., Ararat; S.S., Moyston.)
- Northcote.—Supply and installation of gas heating, S.S. 1401, Visual Education Centre.
- Northcote.—Electrical installation in Visual Education Centre, S.S. 1401.
- Patchewollock.—Renovations and painting, S.S. 3973. (W.O., Warracknabeal; S.S., Patchewollock.)
- Prahran.—Installation of electrical heating for main building and dormitory block, Secondary Teachers' College Hostel, 174 Punt-road.
- Royal Park.—Supply, delivery and installation of additional hot-water equipment and kitchen exhaust equipment at "Quamby", Youth Reception Centre.
- Royal Park.—Labour and scaffolding to lay approximately 100,000 bricks, Mental Hospital. (W.O., Royal Park Mental Hospital.)
- Somerville.—Additional toilets for S.S. 2656, and septic tank for residence. (S.S., Somerville.)
- Stawell.—Erect chain mesh fencing and repairs, S.S. 502. (W.O., Ararat; S.S., Stawell.)
- Traralgon.—Addition of two entrance porches, Technical School. (W.O., Traralgon.)
- Turriff West.—New out-office, repairs and painting, S.S. 3946. (W.O., Warracknabeal; S.S., Turriff West.) (Amended specification.)
- Various.—Disconnexion, transportation and re-erection of prefabricated portable class-rooms from various school sites to various other school sites in Victoria.
- Wangaratta West.—Non-party fencing, S.S. 4642. (W.O., Wangaratta.)
- White Hills.—Supply and installation of sawdust extraction system, Technical School. (W.O., Bendigo.)
- Yarra Glen.—New fence and gate, S.S. 956.
- Furniture and Furnishings.**
- Geelong.—Supply of Examination Tables, Gordon Institute of Technology. (W.O., Geelong.)
- Kingsbury.—Supply of modelling room furniture, Technical School.
- Melbourne.—Supply of hand operated steel mobile shelving units, Examining Branch, Lands and Survey Department.
- Site Works.**
- Ballarat.—Asphalting, concreting, gravelling and drainage, S.S. 4762. (W.O., Ballarat.)
- Waverley North.—Asphalt paving, concreting, gravelling, retaining walls, drainage and ancillary works, S.S. 4884.

**Miscellaneous.**

Carlton.—Maintenance cleaning, 1st September, 1964, to 31st August, 1965, Exhibition Buildings, Rathdown-street.  
 Glenroy.—Supply of machine tools, Technical School.  
 Melbourne.—Maintenance cleaning, 1st September, 1964, to 31st August, 1965, Agriculture Department, Treasury-place.  
 Port Melbourne.—Supply of fire hose, Public Works Department Storeyard.  
 Port Melbourne.—Supply of pile shoes, Public Works Department Storeyard.

**Tuesday, 18th August, 1964.****Building, Electrical and Mechanical Works.**

Ballarat.—Extension of verandah to form Office, Junior Technical School, School of Mines. (W.O., Ballarat.)  
 Bayswater.—Electrical installation in extended Stage 3, High School.  
 Bayswater.—Supply and installation of extensions to central heating and hot water systems for Stage 3, High School.  
 Boorhaman East.—Septic tank installation and site works, S.S. 3317. (W.O., Wangaratta; S.S., Boorhaman East.)  
 Burwood East.—Electrical installation in additional class-rooms, &c., S.S. 454.  
 Crossover.—Erection of out-offices and installation of septic tank, S.S. 3131. (W.O., Warragul; S.S., Crossover.)  
 Footscray.—Provision of male staff toilet and general repairs, Girls' Secondary School.  
 Frankston.—Erection of rabbit proof boundary fence and internal stock fence, Vegetable Research Station.  
 Kangaroo Flat.—Electrical installation in Stages 2 and 3, Technical School. (W.O., Bendigo.)  
 Kangaroo Flat.—Mechanical services for Stage 3, Technical School. (W.O., Bendigo.)  
 Keon Park.—Additional washing facilities, S.S. 4739. (S.S., Keon Park.)  
 Kew.—Erection of standard brick veneer residence for Principal Female Nurse, Mental Hospital.  
 Lake Boga.—Renovations and painting to school and residence, S.S. 3278. (W.O., Swan Hill; S.S., Lake Boga.)  
 Laverton.—Erection of brick two-storey Police Office, residence, store, boiler room, Police Station. (W.O., Geelong.)  
 Moorabbin West.—Supply and installation of central heating in two additional staff rooms and alteration of Boiler House, S.S. 4643.  
 Pascoe Vale.—Erection of chain mesh fencing, School of Textiles.  
 Preston.—Supply and installation of a steam turbine and condenser Plant Cooling Tower and pipework reticulation, Technical School.  
 Seymour.—Supply and installation of town gas heating, S.S. 547. (W.O., Shepparton.)  
 St. Kilda Park.—External and internal repairs and painting, S.S. 2460.  
 Studfield.—New Primary School building of eight class-rooms, &c., S.S. 4920.  
 Studfield.—Electrical installation in new school of eight L.T.C. class-rooms, &c., S.S. 4920.  
 Studfield.—Plenum heating in new eight class-rooms, S.S. 4920.  
 Truganina.—External and internal repairs and painting, Explosive Reserve.  
 Walpeup.—Erection of Research Laboratory, Research Station. (W.O., Mildura.)

**Furniture and Furnishings.**

Melbourne.—Supply of furniture and furnishings for period 1st September, 1964 to 31st August, 1965, Various State Government Departments.

**Site Works.**

Winters Flat.—Provision of new asphalt areas, drainage, concrete retaining walls, fencing, beautification and associated works, S.S. 652. (W.O., Bendigo, Kyneton and Maryborough.)

**Miscellaneous.**

Trafalgar East.—Purchase and removal of old school building, &c., S.S. 3499. (W.O., Warragul; S.S., Trafalgar East.)

Williamstown.—Supply and delivery of a marine diesel engine for a 20 foot Work Boat, Ports & Harbors.

Williamstown.—Supply and delivery of one (1) diesel driven compressor, Ports and Harbors.

M. V. PORTER,  
 Commissioner of Public Works.

Public Works Department,  
 Melbourne, 27th July, 1964.

**TENDERS FOR THE SERVICE, 1964-65.****REQUISITES FOR EDUCATION DEPARTMENT.**

TENDERS will be received until Eleven o'clock a.m. on Friday, 21st August, 1964, from persons willing to supply the under-mentioned articles, in such quantities as may be ordered by the Victorian Government, from the 1st September, 1964, to the 31st August, 1965:—  
*Schedule No.*

1. Requisites (Junior School).
2. Exercise Books and Requisites.

The prices tendered must not include sales tax.

Security.—Five per cent. of total amount of tender accepted, but in no case will security of less than £3 be received.

Schedules as above, with full particulars, may be obtained from the Secretary to the Tender Board, by whom also the samples will be shown and any information afforded to persons tendering.

*Should the tenderer be in a position to supply a suitable substitute of Commonwealth production or manufacture in place of any sample exhibited that may be of imported origin, he may tender for such substitute, but must submit with his tender a sample of the article offered.*

In all cases the country of origin of the articles tendered must be stated, and the total cost of each item extended in the columns provided.

Security will be required either in Commonwealth Treasury Bonds, or approved bank guarantee, fixed deposit receipt, Savings Bank deposit book, or non-negotiable cheque in favour of the Secretary to the Tender Board, as the tenderer may elect.

The security must be completed and the contract signed within five days of acceptance of the tender, failing which the contract may be again advertised, or another tender accepted.

The lowest or any tender will not necessarily be accepted.

In the event of tenderers withdrawing or attempting to withdraw their tenders before notification of acceptance of same, or failing to take up their accepted tenders within the prescribed period after notification of acceptance, they may be disqualified from tendering or holding any future contracts for Government supplies for a period of one year, such disqualification to date from the notification of acceptance of tender. It is also stipulated that, if a tenderer be a member of a firm and such firm be interested in the contract, the tender shall be in the name of the firm and not in that of the individual and that, for a breach of this condition the tender will be declared informal.

Tenders enclosed in a separate envelope, and having the words "Tender for———" (as the case may be) written thereon, must be deposited in the Tender-box at the Tender Board Offices, 107 Russell-street, Melbourne, or if sent by post, postage must be prepaid, and the tenders addressed to the Chairman of the Tender Board, Tender Board Offices, 107 Russell-street, Melbourne, C.I., which office they must reach not later than by first post on the date of closing of tenders.

**CONDITIONS OF CONTRACT.**

1. Except where definite quantities are specified the Government will not be bound to order from the contractor all the articles enumerated in the schedule, but only those articles, and such quantities of those articles, as it may be found necessary to order. Should the Government, however, require a larger supply of any article than the estimated quantity stated in the schedules, the contractor will nevertheless be bound to supply the same at contract rates.

The Government reserves the right to purchase otherwise than from the contractor articles of any of the several kinds enumerated in the schedules the purchase of which is, in the opinion of the Tender Board, necessary in order to meet special circumstances or special requirements.

2. The supplies are to be the same as sample where so stated, and of the particular manufacture indicated in the schedule of tenders. In the case of different makers' goods, the contractor will be required to supply the kind ordered. *The supplies are to be the best quality of their several kinds or manufacture.* In the event of the tender having been accepted for goods manufactured within the Commonwealth or manufactured within any other part of the British Empire (as the case may be), all such goods supplied shall, if required by the Government, bear evidence that they are of the particular manufacture tendered for.

and, in addition, the contractor may at any time during the currency of the contract be called on to furnish a statutory declaration as to the country of origin of the goods supplied.

3. Except where otherwise stated in the schedule, the value of all packages, cases, casks, &c., whether bulk be broken or not, must be included in the prices stated in the contractor's tender; all such packages, &c., to be considered the property of the Government, and no charges or expenses whatsoever beyond the price tendered and set out in the schedule will be allowed to the contractor for any articles or packages, cases, casks, &c. The net weight or quantity only will be paid for. Contractors must provide, without extra charge, whatever labour may be required in the packing of stores, and the stores shall be packed in such a manner as shall secure them from injury during transit, and until delivery such stores shall be at the risk of the contractor.

4. All orders for supplies will emanate from the Education Department. The goods shall be delivered as may be directed by the officer ordering the supply.

5. Supplies ordered for delivery in the Melbourne District are to be delivered free of all charges (whether cartage, freight, &c.), and, for the purposes of these contracts, Melbourne District will include a radius of 12 miles from the Elizabeth-street Post Office. For supplies outside that radius the goods must be delivered free on rails at Flinders-street or Spencer-street Railway Stations as required.

6. Arrangements as to time of delivery and inspection of goods will be made by the Secretary, Education Department, or such other officer whom he may appoint.

7. Orders must receive prompt execution; and in the event of the goods not being delivered within forty-eight hours after the contractor shall have received the order, or within such other time as the order may specify for delivery, it will be competent for the officer named in clause 6, or the head of the department to whom the goods are to be supplied, on giving the contractor twenty-four hours' notice to purchase the supplies, or any like supplies that are suitable for the service, at the contractor's risk, and the extra expense incurred over and above the contract price (if any) will be deducted from the contractor's account or from the security money.

8. Delivery will not be deemed to have been made until the goods have been approved. In case of the rejection or return of any supplies, the contractor shall bear the whole cost of replacing the supplies rejected or returned, otherwise purchases will be effected at the contractor's risk and the extra expense deducted as in clause 7.

9. The official order issued by the Education Department shall be forwarded by the contractor to the officer authorized to accept delivery, who shall acknowledge thereon the receipt of the goods accepted and return the order to the contractor, who will attach same to his claim for payment.

10. All orders, duly receipted, shall be returned to the Education Department at the end of each month, accompanied by an account in the prescribed form for the articles supplied during the month, and, on receipt of same, the contractor shall be entitled to payment, due time to be allowed for the examination and verification of the claim.

11. The acceptance of the supplies shall be subject to the approval of the officer authorized to take delivery of the stores, or such other officer as shall be named in the schedules. Delivery of the articles will not be deemed to have been made until they have been handed in good order and condition to the head teacher of the school or such other person as may be authorized to accept delivery, &c. The contractor may, however, claim a survey on any goods objected to; but in that case he must, within twenty-four hours after objection is made give notice thereof, in writing, to the officer rejecting the goods. If, after the delivery of the supplies has been taken, any deficiency or defect is discovered therein, such deficient or defective stores may be returned to the contractor.

12. The members of Boards of survey will be appointed by the Treasurer of the State for the time being, and the decision of the Board is to be considered as final. If the Board shall decide that the article is not of proper quality it must be immediately replaced by the contractor, failing which it, or any like supply that is suitable for the service, will be procured elsewhere, and the survey fees and extra expense (if any) will be deducted as in clause 7.

13. All goods forwarded under these contracts shall, where practicable, be forwarded by rail, and all consignments shall bear the number of the consignment notes

under which they are forwarded, and also the name of the contractor by whom consigned, on a legibly-written business label.

14. When the contractor is required to make delivery of goods at a railway station for transmission by rail, he shall obtain a receipt for the goods in duplicate on the Stores and Transport consignment note, at the same time handing in a triplicate and quadruplicate of the form as an authority for the Railways to act as agent for, and charge the freight to, the Stores and Transport Office or such other Department as shall be named therein. He shall as soon as possible, and not later than twenty-four hours thereafter, deliver the original at the Tender Board Offices, the duplicate to be forwarded to consignee in accordance with clause 15, and the quintuplicate to be retained by himself. Should the goods thus forwarded be rejected, the contractor must bear the cost of replacing such goods, for which service the departmental consignment note is not to be used. Any infringement of this condition will subject the contractor to such mulct as the Tender Board may recommend under clause 17 of these conditions. Such mulct may be deducted as in clause 7.

15. *Immediately after the consignment of the goods, the officer to whom they are forwarded shall be notified by the contractor, on the duplicate consignment note provided for the purpose, that the goods have been sent. On receipt of this document, the officer to whom it has been forwarded shall acknowledge thereon the receipt of the goods without delay to the Stores and Transport Office. In the event of loss through failure on the part of the contractor to comply with this condition he will be held responsible, and the amount of the loss incurred for same will be deducted as in clause 7.*

16. Should the order on the contractor specially provide that goods of a fragile character, or such as are liable to suffer loss by leakage, shall be consigned at the risk of the Railways Commissioners under special freight conditions, the contractor shall in such instance provide, in writing, on the consignment note an intimation to that effect, failing which, in the event of loss, he shall bear the whole cost of replacing the goods, the amount being deducted from the contractor's account or the security money.

17. A refusal to execute orders, irregularity in the quantity or quality of the supplies, delay in delivering or replacing them when required, or non-compliance with the terms of clauses 14 and 15 of these conditions respecting the forwarding of consignment notes, &c., will subject the contractor, upon report from the Tender Board, to such mulct not exceeding Fifty pounds as the said Treasurer may direct and the amount may be deducted as in clause 7. It will also be in the power of the said Treasurer upon such refusal, irregularity, or delay, to terminate the contract forthwith, and declare forfeit the whole or any portion of the security money; and, in addition, the contractor will be disqualified from tendering or holding any future contract or contracts for a period of one year from the date of such disqualification.

18. Contractors are not at liberty to transfer their contracts under cover of power of attorney, coupled with an interest or otherwise; and no such transfer will be recognized by the Government. If it is found during the currency of the contract that the contractor has not conformed to the condition of advertisement—which stipulates that if a tenderer be a member of a firm, and such firm be interested in the contract, the tender shall be in the name of the firm, and not in that of the individual—then the said Treasurer may, on the recommendation of the Tender Board, determine the contract, and forfeit the security money.

19. The contracts entered into under these conditions are not to be considered as being broken, infringed, or vitiated by the importation of stores for the Government service, or by any contracts or purchases made by the Agent-General for Victoria, or by any contracts or agreements made for supplies to Technical Schools, or by any article being made at any Government establishment and supplied for the use of the Education Department, or by the consumption of the surplus stock of any Government establishment.

20. Notwithstanding anything contained to the contrary in section 152 of the Customs Act 1901-36, it is hereby expressly provided that upon any alteration of the duty collected affecting the goods included in this contract, the contract price shall not be altered, and the contract may be terminated at the opinion of either party by two months' notice in writing from the first day of the calendar month next ensuing, and within the period for which the contract is made. The contract for the unaffected items shall remain in full force and effect. Any notice to be served under this condition shall be deemed to have been duly served if sent to the contractor in a registered letter to his last known place of business or abode.

21. Under no circumstances, other than those mentioned in clause 20, will a contractor be permitted to abandon his contract. In the event of the contractor failing to carry on the contract, the contract security money will in that case be absolutely forfeited; and, in addition, the contractor will be held liable for any loss which the Government may sustain in consequence of such failure.

22. Should the Minister of Education for the time being decide to discontinue the use of any book, map, or any other article in the schedule, or to direct that any book, map, or any other article other than those enumerated therein be taken into use he shall at any time give six months' notice of such intention or decision to the contractor, and after the expiration of the period of such notice the Education Department shall not be bound to take any further supply of such book, map, or any other article, nor shall the contractor be bound to supply the same, and all books or maps not in the schedule, but which it may be decided to introduce, shall be supplied by the contractor after expiration of such notice at a price to be agreed on between the Minister of Education for the time being and the contractor.

H. E. BOLTE,  
Treasurer.

The Treasury,  
Melbourne, 27th July, 1964.

TENDERS FOR THE SERVICE, 1964-65.  
GENERAL STORES.

TENDERS will be received until Eleven o'clock a.m. on Friday, 21st August, 1964, from persons willing to supply the under-mentioned articles in such quantities as may be ordered by the Victorian Government, from the 1st September, 1964, to the 31st August, 1965:—

Schedules, as above, with full particulars, may be obtained from the Secretary to the Tender Board, by whom also the samples will be shown and any information afforded to persons tendering.

In all cases the total cost of each item must be extended in the columns provided.

Schedule No.

- 68. Stamps, Rubber.
- 69. Stationery (General) and Typewriters, Carbon Papers, Typewriter Ribbons, &c., Typograph Material.

The prices tendered must not include sales tax.

Security.—Five per cent. of total amount of tender accepted, but in no case will security of less than £3 be received.

Security will be required either in Commonwealth Treasury Bonds, or approved bank guarantee, fixed deposit receipt, Savings Bank deposit book, or non-negotiable cheque in favour of the Secretary to the Tender Board, as the tenderer may elect.

The security must be completed and the contract signed within five days of acceptance of the tender, failing which the contract may be again advertised, or another tender accepted.

The lowest or any tender will not necessarily be accepted.

In the event of tenderers withdrawing or attempting to withdraw their tenders before notification of acceptance of same or failing to take up their accepted tenders within the prescribed period after notification of acceptance, they may be disqualified from tendering or holding any future contracts for Government supplies for a period of twelve months, such disqualification to date from the notification of acceptance of tender. It is also stipulated that, if a tenderer be a member of a firm and such firm be interested in the contract, the tender shall be in the name of the firm and not in that of the individual and that, for a breach of this condition, the tender will be declared informal.

Tenders enclosed in a separate envelope, and having the words "Tender for———" (as the case may be) written thereon, must be deposited in the Tender-box at the Tender Board Offices, 107 Russell-street, Melbourne, or if sent by post, postage must be prepaid, and the tenders addressed to the Chairman of the Tender Board, Tender Board Offices, 107 Russell-street, Melbourne, C.1, which office they must reach not later than by first post on the date of closing of tenders.

The conditions of contract are those published in the Victoria Government Gazette, No. 18, dated 18th April, 1964, pages 604 to 605.

H. E. BOLTE,  
Treasurer.

The Treasury,  
Melbourne, 27th July, 1964.

**PUBLIC SERVICE NOTICES**

PUBLIC SERVICE OF VICTORIA.—RECLASSIFICATION.

THE Public Service Board has raised the classification of the under-mentioned office as shown, and appointed thereto the officer named hereunder.

Office and Former Classification.	Revised Classification.	Duties.	Qualifications.	Officer Appointed.
-----------------------------------	-------------------------	---------	-----------------	--------------------

PROFESSIONAL DIVISION.

WATER SUPPLY DEPARTMENT.

Boort Centre.

District Engineer, Class 2	Class 3	To supervise and control rural and urban water supplies, works and expenditure within the Districts controlled from the Centre	A Degree or Diploma in Civil Engineering and qualification as an Engineer of Water Supply; experience in the administration of irrigation districts or on other water supply works; versed in modern engineering practice and in design, construction and maintenance	Kermode, W. D.
-------------------------------	---------	--	---	-------------------

Office of the Public Service Board,  
Melbourne, 28th July, 1964.

By order,  
V. P. SCULLY,  
Secretary.

## PUBLIC SERVICE OF VICTORIA.—VACANCIES.

APPLICATIONS will be received by the Public Service Board up to Wednesday, the 12th August, 1964, from persons employed in the Public Service of Victoria, who are eligible and qualified for appointment to the under-mentioned positions.

## ADMINISTRATIVE DIVISION.

**Class "B", Office of the Chief Commissioner of Police, Chief Secretary's Department.**

*Yearly Salary.*—£2,028, minimum; £2,148, maximum.

*Duties.*—To be in charge of the Research and Relieving Branch; special duties as required.

*Qualifications.*—Organizing and administrative ability. Secretarial experience would be an advantage.

**Class "B", Office of the Housing Commission, Treasury.**

*Yearly Salary.*—£2,028, minimum; £2,148, maximum.

*Duties.*—To be in charge of the Powers-Samas Punch Card Accounting for rental revenue of the Commission.

*Qualifications.*—A qualified accountant, with experience of Powers-Samas Punch Card accounting; preferably conversant with the Commission's operations under the Housing Acts, especially in relation to rental revenue and rental rebates; capable of controlling staff.

**Class "C2", Office of the Government Statist, Chief Secretary's Department.**

*Yearly Salary.*—£1,788, minimum; £1,908, maximum.

*Duties.*—To act as Accountant and Staff Clerk to the Branch.

*Qualifications.*—A qualified Accountant with a good knowledge of the Public Service Act and Regulations, the Superannuation Acts and Regulations respecting Public Accounts.

**Class "C2", Office of the Housing Commission, Treasury.**

*Yearly Salary.*—£1,788, minimum; £1,908, maximum.

*Duties.*—To act as deputy to the Accountant, House Sales; to be responsible for processing quarterly sales under Act 6275; to prepare journal entries incorporating sales in the general ledger; to maintain progressive figures of sales for preparation of annual trading accounts; to pass for payment commissions payable to agents, and conduct correspondence in connexion therewith.

*Qualifications.*—Preferably a knowledge of Act 6275 relating to House Sales, the provisions for sale of houses under the Commonwealth and State Housing Agreements, and the Regulations governing the Death Benefit Scheme.

**Class "C1", Division of State Development, Premier's Department.**

*Yearly Salary.*—£1,558, minimum; £1,668, maximum.

*Duties.*—To control the correspondence systems of the Division; to assist in the drafting of general correspondence; to act as Secretary to the Committee of Management of the Former Explosives Factory Area at Ballarat; to deal with the accounts of the Division including certain of those chargeable to the Decentralization Fund; and to maintain financial records relating to the Decentralization Fund and prepare statements therefrom.

*Qualifications.*—A good knowledge of correspondence, registration and filing systems; practical experience in general office routine; ability to prepare reports and draft correspondence; a good knowledge of the Public Accounts and Stores Regulations.

**Class "C1", Office of the Housing Commission, Treasury. (Three vacancies.)**

*Yearly Salary.*—£1,558, minimum; £1,668, maximum.

## POSITION No. 1.

*Duties.*—Under the officer in Charge, Arrears Section, to be responsible for the collection of arrears of rent in country districts.

*Qualifications.*—Ability to conduct correspondence and interviews. A knowledge of the policies and procedures of the Commission in respect of arrears, and a knowledge of the Commission's mechanized accounting system would be an advantage.

## POSITION No. 2.

*Duties.*—To be responsible to the House Sales Accountant for effecting adjustments between estimated and actual costs of units, and preparing the necessary Commonwealth schedules; compiling or checking financial statements in connexion with settlements, assignments, death benefit transfers and mortgages and cancellations.

*Qualifications.*—Preferably to be conversant with financial sections of the Housing Act and application of Death Benefit Regulations.

## POSITION No. 3.

*Duties.*—Responsible for the supervision, training and output of the Powers Bureau Ledgerkeepers; to prepare master controls and data and balance weekly cash receipts; to establish estate balances from master controls for balancing of ledgers, and to assist the Officer in Charge.

*Qualifications.*—Preferably a knowledge of Powers-Samas accounting procedures, machine ledger posting and balancing. To have made substantial progress in accounting studies.

NOTE.—Separate applications must be submitted for these positions.

**Class "C1", Water Supply Department.**

*Yearly Salary.*—£1,558, minimum; £1,668, maximum.

*Duties.*—To be responsible for the Water Supply Plant and Machinery Accounts. To prepare reports on and to analyse operational costs of hired plant, including motor vehicles; to prepare directions to centres and works concerning hire rates for plant and the charging of funds.

*Qualifications.*—A knowledge of the Public Accounts and Stores Regulations and accounting procedure. A knowledge of mechanized accounting systems is desirable.

**Class "C", Public Works Department.**

*Yearly Salary.*—£1,283, minimum; £1,448, maximum.

*Duties.*—To undertake work in connexion with updating of staff records and to assist in organizing and controlling the activities and personnel of the Staff Records Section.

*Qualifications.*—A good knowledge of the Public Service Act and Regulations; ability to draft correspondence; training in registry work would be desirable.

## PROFESSIONAL DIVISION.

**Senior Valuer, Class "B1", Office of the Housing Commission, Treasury.**

*Yearly Salary.*—£2,293, minimum; £2,443, maximum.

*Duties.*—To be responsible for all valuations made by the Valuation Section of the Commission; to supervise and make valuations in connexion with the acquisition or purchase by the Commission of real estate; to maintain current valuations involved in the sale of houses and land by the Commission; to negotiate, as required, with owners regarding the acquisition of land by private negotiation or compulsory process.

*Qualifications.*—To be entitled to an unrestricted certificate of qualification from the Valuers Qualification Board. Experience in negotiating the purchase of land would be an advantage.

**Superintending Surveyor, Class "B1", Water Supply Department.**

*Yearly Salary.*—£2,293, minimum; £2,443, maximum.

*Duties.*—To direct field survey parties engaged on investigations of proposed dam sites, reservoir siltation measurements and other special projects.

*Qualifications.*—Appropriate experience as a Licensed Surveyor with experience in engineering and topographical surveys including the use of echosounder, tellurometer and photogrammetric equipment.

**Professional Assistant, Class "C2", Crown Solicitor's Office, Law Department.**

*Yearly Salary.*—£1,788, minimum; £1,908, maximum.

*Duties.*—To assist in the work of the Crown Solicitor's Office.

*Qualifications.*—To have completed the subjects prescribed for the course of LL.B.

**Chemist, Classes "C"—"C2", Coroner's Court, Law Department.**

*Yearly Emolument.*—£1,448, minimum; £2,293, maximum—Science Graduate.  
£1,393, minimum; £2,293, maximum—Chemistry Diplomat.

(Commencing salary will be determined according to qualifications and experience.)

*Duties.*—To analyse samples submitted by Coroners and Police and, where necessary, to give evidence in Court proceedings.

*Qualifications.*—University Degree in Science or Technical School Diploma with Chemistry or Biochemistry as a major subject. Applicants should be qualified for admission as Associate of the Royal Australian Chemical Institute.

**Draughtsman, Class "C", Department of Crown Lands and Survey.**

*Yearly Salary.*—£1,283, minimum; £1,448, maximum.

*Duties.*—To compile maps and plans for reproduction; to draw plans from Surveyors' field notes; to prepare Certified Plans and Certificates of Adjustment; general draughting work.

*Qualifications.*—A competent survey draughtsman with a good knowledge of compiling cadastral maps and plans and of survey computations. To possess the pre-requisite qualifications prescribed in paragraphs (a) or (b) of Public Service (Public Service Board) Regulation 23.

**TECHNICAL AND GENERAL DIVISION.****Dairy Projects Officer, Department of Agriculture.**

*Yearly Salary.*—£1,643, minimum; £1,747, maximum.

*Duties.*—Under the direction of the Chief Dairy Research Officer, to supervise the manufacture of butter, cheese and other dairy products; to record data relating to experiments; to carry out tests relating to experiments; to give lectures and demonstrations; to assist, generally, the dairy research officers with dairy manufacturing projects which are being carried out at the School of Dairy Technology, Werribee, under the Research Programme of the Australian Dairy Produce Board.

*Qualifications.*—A Certificate of Competency in Dairy Manufacture (Werribee) or a Dairy Diploma or equivalent or higher qualifications. Experience in dairy manufacturing work is essential and good knowledge of chemical, physical and bacteriological tests on dairy products is required.

**Inspector, Milk Board, Warragul, Department of Agriculture.**

*Yearly Salary.*—£1,331, minimum; £1,435, maximum.

*Duties.*—To examine and check records kept by dairy farmers, Authorized Agents of the Board, dairymen and milk carriers and to examine consignments of milk purchased by the Board; to inspect and report on milk shop premises; other duties of an inspectorial nature.

*Qualifications.*—A qualified dairy supervisor, with a knowledge of the Milk Board Acts and Regulations and the Regulations under the Health Act relative to food premises and food cleanliness.

**Officer in Charge, San Remo Depot, Ports and Harbours Branch, Public Works Department.**

*Yearly Salary.*—£1,241, minimum; £1,331, maximum.

*Duties.*—To be Officer in Charge of the departmental depot at San Remo and to supervise dredging, boat slipping and launching operations. To exhibit tide and depth signals as required and supervise maintenance, repairs and replacements to wharves and jetties, &c.

*Qualifications.*—A general knowledge of Westernport; a competent wharf carpenter with experience in supervising the construction and maintenance of harbour structures; to be conversant with installations and mechanism of automatic and fixed lights and dredging.

**Youth Officer (Male), Senior, Youth Welfare Division, Social Welfare Branch, Chief Secretary's Department. (Three vacancies.)**

*Yearly Salary.*—£1,205, minimum; £1,241, maximum.

*Duties.*—Under direction to control a section of the Youth Training Centre at "Turana", Parkville.

*Qualifications.*—A good knowledge of modern methods in youth care; ability to conduct training programmes and group activities for trainees; ability to apply instructions relating to care and treatment of trainees. Ability to supervise staff.

**Fitter, Leading Hand, State Forests Department.**

*Yearly Salary.*—£1,169.

(Plus an allowance of £35 a year for all work actually performed within the central and field workshops and repair centres.)

*Duties.*—To assemble and repair diesel-powered and other equipment in country areas as required, and supervise the work of other field fitters.

*Qualifications.*—A qualified or recognized motor mechanic or fitter with extensive experience in repair of diesel-powered equipment; to be a licensed motor truck driver and capable of supervising the work of other tradesmen.

**Water Bailiff, Water Supply Department.**

1 Vacancy—Cohuna.

1 Vacancy—Rochester.

*Yearly Salary.*—£972, minimum; £1,079, maximum.

*Qualifications.*—Ability to control and regulate the supply of water to irrigators and to keep the necessary records and make reports and arithmetical computations; a knowledge of water requirements for crops and grasses grown under irrigation, the methods of preparation of land for irrigation and methods of channel and drain construction and maintenance.

NOTE.—The successful applicants will be required to occupy the official residences provided and vacation of the residences will not be permitted without the express approval of the Water Supply Department. A rental of 10 per cent. of total emolument inclusive of the amount payable under Regulation 74, less £36 6s. a year will be charged. Occupancy will be subject to a formal tenancy agreement being entered into. Particulars are available from the Water Supply Department.

Separate applications must be submitted for these positions.

**Chief Prison Officer (Female), "Fairlea", Prisons Division, Social Welfare Branch, Chief Secretary's Department.**

*Yearly Salary.*—£1,025.

*Duties.*—To relieve the Deputy Governor as required; under the direction of the Governor to be responsible for the control of the clothing store; other duties as directed.

*Qualifications.*—Experience in institutional and staff management and ability to control delinquent females.

**Motor Truck Driver, Gresswell Sanatorium, Tuberculosis Branch, Department of Health.**

*Yearly Salary.*—£989, minimum; £1,007, maximum.

*Qualifications.*—A licensed motor driver with ability to effect running repairs.

**Machinist (Female), Grade III., Milk Board, Department of Agriculture.**

*Yearly Salary.*—£917, minimum; £953, maximum.

*Duties.*—To enter receipt and payment journals; to post entries to dairymen and control accounts; to prepare periodical summaries and daily bankings; to draw cheques for payment of contract suppliers and carriers; other duties as required.

*Qualifications.*—A competent Remington Accounting Machine operator.

**Storeman, Grade I., Youth Welfare Division, Social Welfare, Chief Secretary's Department.**

*Yearly Salary.*—£921, minimum; £938, maximum.

*Duties.*—To assist in the store at "Turana" Youth Training Centre, Parkville.

*Qualifications.*—A knowledge of general stores, clothing and provisions, and experience in the control handling, custody and issue of stores. A knowledge of the Public Accounts and Stores Regulations 1958 is desirable.

NOTE.—The salary rates quoted above do not include the additional amount which is payable under Regulation 74 of the Board's Regulations.

By order.

V. P. SCULLY,  
Secretary.

Office of the Public Service Board,  
Melbourne, 28th July, 1964.



## PUBLIC SERVICE OF VICTORIA.—VACANCY.

## DEPARTMENT OF HEALTH.

## MENTAL HYGIENE BRANCH.

## TECHNICAL AND GENERAL DIVISION.

APPLICATIONS will be received by the Public Service Board up to Wednesday, 19th August, 1964, from persons employed in the Public Service of Victoria, who are eligible and qualified for appointment to the under-mentioned position.

**Deputy Charge Nurse (Female), Psychiatric Centre, Dandenong. (Four vacancies.)**

*Yearly Salary.*—£881, minimum; £917, maximum.

*Duties.*—To be second in charge of a ward.

*Qualifications.*—A current practising certificate for Mental Nursing and approved experience.

NOTE.—Successful applicants will be required to work an eight hour roster.

The salary rates quoted above do not include the additional amount which is payable under Regulation 74 of the Board's Regulations.

By order,

V. P. SCULLY,  
Secretary.

Office of the Public Service Board,  
Melbourne, 28th July, 1964.

## PUBLIC SERVICE OF VICTORIA.—VACANCY.

(TEMPORARY APPOINTMENT.)

APPLICATIONS will be received by the Public Service Board up to Wednesday, the 12th August, 1964, from persons who are qualified for appointment to the under-mentioned position:—

**Field Officer, Department of Agriculture.**

*Yearly Salary.*—

Junior—At 18 years of age—£803;  
at 19 years of age—£900;  
at 20 years of age—£1,010.

Adult—£1,259, minimum; £1,383, maximum.

*Duties.*—To assist in horticultural experiments and other work as directed.

*Qualifications.*—Diploma of an approved Agricultural College or equivalent.

NOTE.—Field Officers are eligible for appointment to the position of Field Officer, Senior, salary range £1,539–£1,695, and on passing a qualifying examination, for appointment to the Professional Division as Experimental Officer, salary range £1,393–£1,908.

NOTE.—The salary rates quoted above do not include the additional amount which is payable under Regulation 74 of the Board's Regulations.

By order,

V. P. SCULLY,  
Secretary.

Office of the Public Service Board,  
Melbourne, 28th July, 1964.

## PUBLIC SERVICE OF VICTORIA.

## SPEED TEST FOR TYPISTS (FEMALE).

*Public Service (Public Service Board) Regulations.*

A TYPING test at the rate of not less than 42 words a minute for a period of 10 minutes will be held on Saturday, 19th September, 1964.

Successful candidates will be entitled to the increased rates set out in regulation 98 of the Public Service (Public Service Board) Regulations.

*Applications to sit for the test should be lodged with the Secretary, Public Service Board, not later than Saturday, 29th August, 1964. Applicants should specify the type of machine preferred.*

*Candidates will be notified of the time and place of the test.*

By order,

V. P. SCULLY,  
Secretary.

Office of the Public Service Board,  
Melbourne, 28th July, 1964.

## PUBLIC SERVICE OF VICTORIA.

EXAMINATION TO QUALIFY FOR REGISTRATION FOR APPOINTMENT AS ASSISTANT (MALE), GRADE I, TECHNICAL AND GENERAL DIVISION.

*Date of Examination.*—12th September, 1964.

*Eligibility to Enter.*—Officers of the Technical and General Division or employees who have completed three months' satisfactory service are eligible to sit for examination.

*Subjects of Examination.*—The subjects of the examination, at Proficiency Certificate standard, are—

English (an Essay and Précis Writing).  
Arithmetic.

*Applications.*—Forms of application, which must be submitted through the Permanent Head of the candidate's Department are available at the Office of the Public Service Board.

*Closing Date.*—Applications must reach the Secretary, Public Service Board, not later than Saturday, the 22nd August, 1964.

Reasonable facilities will be provided for candidates residing in country districts to sit for examination in local centres.

By order,

V. P. SCULLY,  
Secretary.

Office of the Public Service Board,  
Melbourne, 28th July, 1964.

## FREE PLACES AT UNIVERSITY.

APPLICATIONS are invited from persons (other than teachers) in the employment of the Government of Victoria for Free Places at the University of Melbourne, or Monash University, to be awarded from the beginning of 1965.

*Who Can Apply?*

Applicants must satisfy the following requirements:—

- (a) They must be in the permanent service of the Government of Victoria, or be temporary employees of the Victorian Railways.
- (b) They must have matriculated. (Candidates for the Matriculation examination this year may, however, apply).

Consideration will be given to age, suitability, qualifications, period of service of the applicant, and a report and recommendation of his permanent departmental head and a personal interview with the Selection Committee.  
*Benefits.*

Free Places are tenable for the full length of an approved course for any degree, diploma or licence. A successful applicant will be granted such leave of absence on full pay as may be prescribed to enable him to attend essential lectures, practical and other work, and examinations. He will be admitted, without fees, to all lectures and examinations of his course.  
*Bond.*

The holder of a Free Place will be required to enter into an agreement that he will remain in the service of the Government of Victoria for five years after the termination of his Free Place.

*Applications due 1st November.*

Applications must be submitted to the Permanent Head of the Department in which the applicant is employed, by the 1st November, 1964. Permanent Heads of departments should ensure that such applications are forwarded to reach the Secretary, Education Department, Melbourne, C.2, not later than the 25th November, 1964.

**PRIVATE ADVERTISEMENTS****CITY OF BENDIGO.**

BY-LAW No. 109.

A By-law of the City of Bendigo made under section 197 of the *Local Government Act 1958*, and numbered 109 to amend By-law No. 40 for regulating traffic and processions.

IN pursuance of the powers conferred by the *Local Government Act 1958* and every other power therein enabling, the Mayor, Councillors and Citizens of the City of Bendigo order as follows:—

That after clause 16 (e) of By-law No. 40 the following clause be inserted:—

16. (f) No procession of vehicles, motor cars or persons for funeral purposes shall pass or proceed along—

- (a) Mitchell-street, between Charing-cross and Lyttleton-terrace;
- (b) Hargreaves-street, between Bull-street and Edward-street;
- (c) Williamson-street, between Pall Mall and Myers-street;
- (d) Lyttleton-terrace, between Mundy-street and Mitchell-street;

between the hours of 8 a.m. and 6 p.m. on any day Monday to Friday inclusive, and on any Saturday between the hours of 8 a.m. and 1 p.m. except with the prior consent, in writing, of the Council in consideration of the granting or refusal of which the Council shall have due regard to the volume of traffic likely to be experienced at the time and on the route of the proposed procession, together with the question of public safety and the like circumstances.

Resolution for passing this By-law agreed to by the Council of the City of Bendigo on the 16th day of June, 1964, and confirmed on the 20th day of July, 1964.

The common seal of the Mayor, Councillors and Citizens of the City of Bendigo was hereunto affixed in the presence of—

(SEAL) A. S. CRAIG, Mayor.  
T. R. FLOOD, Councillor.  
1882 A. J. WATTS, Town Clerk.

*Local Government Act 1958.***CITY OF CAMBERWELL.**

WHEREAS in pursuance of the powers conferred by the above Act the Council of the City of Camberwell deems it expedient to extend and increase the area of open space in the City of Camberwell for the purpose whereof it is necessary to compulsorily acquire all that piece of land commencing at a point on the south-western boundary of allotment 132a, Parish of Boroondara, such boundary being on the north-eastern alignment of Camberwell-road on a bearing of 309 deg. 27 min. distance 502 ft. 8 in. from the southern alignment of Tyrone-street; thence by lines bearing respectively 45 deg. 18 min. 150 feet, 309 deg. 27 min. 120 feet, 1 deg. 25 min. 25 ft. 4 in., 126 deg. 57 min. 62 ft. 7 in., 90 deg. 0 min. 162 feet, 0 deg. 0 min. 150 feet, 90 deg. 0 min. 28 ft. 2 in., 134 deg. 39 min. 27 ft. 11 in., 130 deg. 56 min. 37 ft. 10 in., 148 deg. 20 min. 33 ft. 8½ in., 169 deg. 3 min. 33 ft. 0½ in., 173 deg. 41 min. 33 ft. 11½ in., 189 deg. 53 min. 40 feet, 182 deg. 35 min. 5 ft. 8 in., 195 deg. 32 min. 33 ft. 1 in., 205 deg. 36 min. 33 ft. 11 in., 178 deg. 4 min. 34 feet, 158 deg. 7 min. 40 ft. 6 in., 150 deg. 7 min. 33 feet, 160 deg. 47 min. 42 ft. 5 in., 173 deg. 2 min. 16 ft. 5 in., 172 deg. 48 min. 9 ft. 1 in., 181 deg. 23 min. 19 ft. 10 in., 223 deg. 6 min. 137 ft. 3½ in., to the north-eastern alignment of Camberwell-road and thence 309 deg. 27 min. 334 ft. 6½ in. along the said alignment to the point of commencement. Then commencing at a point on the southern alignment of Tyrone-street, being east of the north-eastern corner of the land described above by lines bearing respectively 90 deg. 0 min. 24 ft. 11½ in. and 168 deg. 32 min. 1 ft. 6 in.; and thence by lines bearing respectively 89 deg. 34 min. 84 ft. 0½ in., 173 deg. 18 min. 370 ft. 3 in., 269 deg. 21 min. 37 ft. 8 in., 329 deg. 59 min. 55 ft. 2 in., 349 deg. 4 min. 67 ft. 11 in., 22 deg. 43 min. 40 ft. 4 in., 42 deg. 9 min. 22 ft. 4½ in., 1 deg. 33 min. 41 ft. 3 in., 7 deg. 4 min. 51 ft. 3 in., 326 deg. 28 min. 69 ft. 3½ in., 314 deg. 17 min. 54 ft. 8½ in. and 319 deg. 48 min. 14 ft. 10½ in. to the point of commencement and the Council has instructed its Engineer to prepare such maps and other papers in compliance

with the provisions of Division 4, Part XVIII. of the above Act; notice is hereby given that the maps and other papers showing (a) the general description of the work or undertaking for which the land proposed to be taken is to be used, (b) the description of the lands proposed to be taken, and (c) the names of the owners or reputed owners, lessees or reputed lessees, mortgagees and occupiers of those lands so far as these can be ascertained by the Council are deposited at the office of the Council, Camberwell-road, Camberwell, and are open for inspection between the hours of Ten o'clock in the forenoon and Four o'clock in the afternoon on all weekdays except Saturday. All persons affected by the proposed work or undertaking are hereby required within 40 clear days from the publication of this notice in the *Government Gazette* to set forth in writing addressed to the said Council or the Chief Administrator all objections which they may have to the work or undertaking.

Dated this 21st day of July, 1964.

By order,

1910 L. F. CHEFFERS, Chief Administrator.

**CITY OF CAMBERWELL.**

BY-LAW No. 133.

*Buildings.*

A BY-LAW of the City of Camberwell, made under section 926 of the *Local Government Act 1958*, and the *Uniform Building Regulations*.

1. By-law 115 of the City of Camberwell is amended by prescribing that the land described hereunder shall be a site on which eight flats can be erected.

*Description of Land.*

On the east side of Burke-road, commencing 370 feet south of Maylands-avenue and having a frontage of 128 ft. 3 in. by a depth of 163 feet and being the land more particularly described in certificate of title, volume 8392, folio 592 and volume 8155, folio 967.

2. The By-law shall come into operation upon publication of the Notice of the making thereof in the *Government Gazette*.

3. The Resolution for the passing of this By-law was passed by the Council at its meeting on 20th day of April, 1964, and confirmed at a meeting on the 18th day of May, 1964. The By-law was approved by the Governor in Council on the 21st day of July, 1964.

4. A copy of this By-law may be inspected, free of charge, at the Municipal Offices, Camberwell-road, Camberwell.

1895 L. F. CHEFFERS, Chief Administrator.

**CITY OF CAMBERWELL.**

BY-LAW No. 134.

*Buildings.*

A BY-LAW of the City of Camberwell made under section 926 of the *Local Government Act 1958*, and the *Uniform Building Regulations*.

1. By-Law 115 of the City of Camberwell is amended by prescribing that the land described hereunder shall be a site on which eight flats can be erected:—

*Description of Land.*

On the east side of Power-street, commencing 110 feet north of John-street and having a frontage of 109 ft. 4½ in. by a depth of 201 ft. 8½ in. and being the land more particularly described in certificate of title, volume 6799, folio 1359741.

2. The By-law shall come into operation upon publication of the Notice of the making thereof in the *Government Gazette*.

3. The Resolution for the passing of this By-law was passed by the Council at its meeting on 18th day of May, 1964, and confirmed at a meeting on the 22nd day of June, 1964. The By-law was approved by the Governor in Council on the 21st day of July, 1964.

4. A copy of this By-law may be inspected, free of charge, at the Municipal Offices, Camberwell-road, Camberwell.

1893 L. F. CHEFFERS, Chief Administrator.

## CITY OF SPRINGVALE.

## BY-LAW No. 167.

A By-law of the City of Springvale made under the provisions of sections 197 and 799 of the *Local Government Act 1958*, and numbered 167 for the purpose of regulating the use and enjoyment of pleasure grounds, gardens and places of public resort or recreation.

IN pursuance of the powers conferred by the *Local Government Act 1958* and every other power thereunto enabling, the Mayor, Councillors and Citizens of the City of Springvale order as follows:—

1. In this By-law unless inconsistent with the context or subject matter—

“Area” means the Municipal Offices of the Council and the City Hall and the open spaces surrounding the same and being—

All that piece of land containing 5a. 3r. 12.2p., being part of Crown allotment C, section 12, Parish of Dandenong, and being more particularly described as—

Commencing at a point on the eastern boundary of Springvale-road, being 2,043 ft. 4 in. north of the northern boundary of Heatherton-road, thence by a line 265 ft. 4 in. in length bearing 359 deg. 29 min., being part of the eastern boundary of Springvale-road; thence by a line 86 ft. 0½ in. in length bearing 90 deg. 01 min.; thence by a line 53 ft. 5 in. in length bearing 359 deg. 38 min.; thence by a line 43 ft. 2 in. in a north-westerly direction; thence by a line 291 ft. 8 in. in length bearing 90 deg. 01 min.; thence by a line 93 ft. 5 in. in length bearing 179 deg. 38 min.; thence by a line 496 ft. 10 in. in length bearing 90 deg. 01 min.; thence by a line 265 ft. 4 in. in length bearing 179 deg. 38 min.; thence by a line 858 feet in length bearing 270 deg. 01 min. to the point of commencement.

“Council” means the Council of the City of Springvale.

“Proper Officer” means any person appointed or employed by the Council to supervise and regulate the parking of vehicles in the area or to carry out the provisions of this by-law.

“Vehicle” means any conveyance, designed to be propelled or drawn by any means and includes an articulated vehicle, a bicycle and an animal driven or ridden but does not include a tram or train.

2. Subject to compliance with the provisions of this by-law every person shall be entitled to have the use and enjoyment of the open spaces within the area whilst within such area to transact business with the Council or to attend any function being held therein.

3. No person shall—

- climb or jump over any gate or fence in or around the area;
- stick bills on any such gate or fence or on any seat, building or tree within the area;
- damage, deface or injure in any way any building, gate, seat, fence, appliance or other improvement or any lawn, garden, shrub or tree in the area;
- leave or deposit any bottle, can, glass, paper, rubbish or refuse within the area;
- throw or discharge any missile likely to cause danger or annoyance to any person in the area, or damage to any building, gate, fence, seat, tree, shrub or other improvement therein;
- play or practice any game, throw any ball, or let off fireworks within the area.

4. Within the area no person shall—

- park any vehicle except on a road or parking bay set aside for that purpose;
- park any vehicle in any place whatsoever where the proper officer has directed such person not to park such vehicle;
- park any vehicle on any lawn, garden or pathway;
- drive any vehicle over or along any lawn, garden or pathway.

5. Every person who damages or defaces any building, gate, fence, seat, lawn, tree, shrub, pathway, appliance or other improvement within the area shall be liable for the cost of replacing or repairing the same as the case may require, which cost shall be a civil debt recoverable summarily.

6. Every person guilty of a wilful act or default contrary to the provisions of this by-law shall be liable to a penalty of not less than £5 nor more than £20, and to a further penalty of not more than £5 for each day on which such offence is continued after a conviction or order by any court.

7. This by-law shall apply to and have operation throughout that part of the municipal district of the City of Springvale defined as the area herein.

Resolution for passing this by-law agreed to by the Council, the sixteenth day of June, 1964, and confirmed on the twentieth day of July, 1964.

The common seal of the Mayor, Councillors and Citizens of the City of Springvale was hereunto affixed in the presence of—

(SEAL) D. A. JEANES, Councillor.  
K. C. MARRIOTT, Councillor.  
H. L. WILLIAMS, Town Clerk.

1881

## CITY OF SUNSHINE.

POUND ABOLISHED AND POUND ESTABLISHED.

NOTICE is hereby given that the Sunshine Pound which was located in Ballarat-road, Deer Park, has been abolished.

Notice is further given that a pound has been established and located at Forrest-street, Sunshine, in the vicinity of the Kororoit Creek bridge.

1897 T. W. DEUTSCHMANN, Town Clerk.

## SHIRE OF ALTONA

## LOAN No. 45.

Notice of Intention to Borrow the Sum of £20,000 for Permanent Works and Undertakings.

NOTICE is hereby given—

- That the Council of the Shire of Altona proposes to borrow the sum of Twenty thousand pounds, on the credit of the municipal revenues of the President, Councillors and Ratepayers of the said Shire, by the grant of a mortgage under the provisions of the *Local Government Act*.
- The maximum rate of interest to be paid is Five pounds two shillings and sixpence per centum per annum.
- The period of the loan shall be 40 years, and such moneys shall be repayable at the Office of the State Superannuation Board, Treasury Buildings, Melbourne, or at such other place or places as the Board may from time to time require.
- The purpose for which the loan is to be applied is:—

Part cost of construction of Altona  
Public Library . . . . . £20,000

- The moneys borrowed shall be repayable by providing out of the Municipal Fund approximately £210 9s. 5d. annually for 40 years, to be invested in accordance with the said Act to form a sinking fund, and interest to be paid half-yearly during the currency of the loan. The first payment shall be on the 1st day of May, 1965.

The plans and specifications and the estimate of the cost of the proposed work and a statement showing the proposed expenditure of the moneys to be borrowed, are open for inspection at the Civic Offices, 115 Civic-parade, Altona, during office hours.

Dated this 28th day of July, 1964.

1957 JAMES W. WATERS, Shire Secretary.

## SHIRE OF ALTONA.

## LOAN No. 46.

Notice of Intention to Borrow the Sum of £25,000 for Permanent Works and Undertakings.

NOTICE is hereby given—

- That the Council of the Shire of Altona proposes to borrow the sum of Twenty five thousand pounds, on the credit of the municipal revenues of the President, Councillors and Ratepayers of the said Shire, by the grant of mortgage under the provisions of the *Local Government Act*.
- The maximum rate of interest to be paid is Five pounds two shillings and sixpence per centum per annum.
- The period of the loan shall be ten years and such moneys shall be repayable at the office of the State Savings Bank of Victoria.
- The purpose for which the loan is to be applied is:—

Land Acquisition—Mason-street  
Widening . . . . . £25,000

- The moneys borrowed shall be repayable by providing out of the Municipal Fund, twenty half-

yearly payments of approximately £1,613 3s. 3d. including principal and interest on the 1st day of May and the 1st day of November during the currency of the loan. The first payment shall be payable on the 1st day of May, 1965.

The plans and specifications and the estimate of the cost of the proposed work and a statement showing the proposed expenditure of the moneys to be borrowed are open for inspection at the Civic Offices, Altona, during office hours.

Dated this 28th day of July, 1964.

1958 JAMES W. WATERS, Shire Secretary.

SHIRE OF ARARAT.

WEIGHBRIDGE-KEEPER, MAROONA.

NOTICE is hereby given that the Council of the Shire of Ararat has appointed Elizabeth Doris Kelly weighbridge-keeper of the Maroona weighbridge with effect from 1st July, 1964, in place of Arthur Emerson Peart, who has resigned.

1875 K. N. BISHOP, Shire Secretary.

SHIRE OF BELLARINE.

LOAN No. 27.

Notice of Intention to Borrow the Sum of £25,000 for Permanent Works and Undertakings.

NOTICE is hereby given that the Council of the Shire of Bellarine proposes to borrow the principal sum of Twenty-five thousand pounds on the credit of the municipal revenues of the President, Councillors and Ratepayers of the said Shire, such sum to be raised by the grant of a mortgage in accordance with the provisions of the Local Government Act 1958.

1. The maximum rate of interest that may be paid is 5 per cent. per annum.
2. The purpose for which the loan is to be applied is as follows:—

Newcomb and Whittington—

	£	£
(a) Wilson-road drain extension ..	2,000	
(b) Purchase of land for recreation reserve ..	4,000	
(c) Construction of kerb and channel on south side of Portarlington-road between Boundary-road and Wilsons-road ..	1,500	
	7,500	

Ocean Grove—

Construction of concrete kerbing and channelling:		
Presidents-avenue, between Orton-street and The Terrace (including underground drain) ..	1,675	
Draper-street, between Presidents-avenue and Field-street, and Field-street between Draper-street and Powell-street ..	1,450	
The Parade, south side only between Bramwell-street to Tuckfield-street ..	450	
Orton-street, between Lookout-road and Field-street ..	2,200	
Construction of footpath:		
Orton-street, north side only, Lookout-road to Field-street ..	800	
Draper-street, north side only, Field-street to Presidents-avenue ..	675	
Construction of stairway at corner of The Parade and Field-street: ..	250	
	7,500	

Portarlington—

Construction of concrete kerbing and channelling, and culverts:		
Stevens-street—Fisher to Gellibrand streets; Gellibrand-street—Stevens to Fenwick streets; Fenwick-street—Gellibrand to Batman streets; Batman-street—Fenwick to Newcombe streets; Newcombe-street—Batman-street to gully near Mercer-street ..	6,400	
Fenwick-street—north side between Brown and Harding streets; south side from Harding to High streets; south side two lots west of High-street ..	1,100	
	7,500	

Drysdale—

	£	£
Construction of concrete kerbing and channelling:		
Victory-avenue, north side west of Palmerston-street; High-street—east side between Granville and Newcombe streets; High-street—west side, two lots west of Fairview-street; Murradoc-road—one lot (Mullers) ..	700	
Construction of footpath:		
Murradoc-road—south side High-street easterly 300 feet; Princess-street—east side fire brigade southerly 500 feet ..	800	
	1,500	

St. Leonards—

Construction of footpath, kerbing and channelling:		
Hotel to Blanche-street;		
Construction of concrete kerbing and channelling:		
First-avenue northerly 500 feet ..	1,000	
	1,000	
		£25,000

3. The period of the loan shall be ten years.

4. The moneys borrowed shall be repayable by providing out of the Municipal Fund twenty half-yearly instalments of approximately £1,603 13s. 6d. each, including principal and interest, on the 1st day of March and the 1st day of September, during the currency of the loan.

The first instalment shall be payable on the 1st day of March, 1965.

5. Such moneys shall be repayable to the Commissioners of the State Savings Bank of Victoria, at the office of the said Commissioners, 139-165 Elizabeth-street, Melbourne.

The plans and specifications and the estimate of the cost of the proposed works and a statement showing the proposed expenditure of the moneys to be borrowed, are open for inspection at the office of the Council of the Shire of Bellarine, Drysdale.

Dated 23rd July, 1964.

1878 H. A. WILLIAMS, Shire Secretary.

SHIRE OF HASTINGS.

LOAN No. 9.

Notice of Intention to Borrow the Sum of £6,000 for Permanent Works and Undertakings.

NOTICE is hereby given that the Council of the Shire of Hastings, in pursuance of powers conferred by the Local Government Acts, intends to borrow the sum of £6,000 on the credit of the municipal revenues of the President, Councillors and Ratepayers of the said Shire, such sum to be raised by the grant of mortgage, in accordance with the said Acts and states:—

(a) The amount of principal moneys it is proposed to borrow is £6,000.

(b) The maximum rate of interest that may be paid is £5 2s. 6d. per cent. per annum.

(c) The period of the loan will be ten (10) years and the time or times at which the moneys borrowed are to be repayable are the 29th day of March, and the 29th day of September in each year during the currency of the loan commencing on the 29th day of March, 1965. The place of repayment shall be at the English, Scottish and Australia Savings Bank Ltd., Melbourne.

(d) The purpose for which the loan is to be applied is for permanent works and undertakings, viz:—

Provision of furniture and fittings for Municipal Offices and Council Chamber.

(e) The loan is to be liquidated by half-yearly payments of £387 3s. 2d. including interest, payable out of the Municipal Fund.

Plans and specifications and an estimate of the cost of such works and undertakings, and a statement showing the proposed expenditure of the money to be borrowed, are open for inspection by ratepayers, during office hours, at the Shire Offices, Hastings, for one (1) month after the publication of this notice.

Dated at Hastings this 21st day of July, 1964.

1860 L. A. WALKER, Shire Secretary.

## SHIRE OF HASTINGS.

## LOAN No. 10.

*Notice of Intention to Borrow the Sum of £5,000 for Permanent Works and Undertakings.*

NOTICE is hereby given that the Council of the Shire of Hastings, in pursuance of powers conferred by the Local Government Acts, intends to borrow the sum of £5,000 on the credit of the municipal revenues of the President, Councillors and Ratepayers of the said Shire, such sum to be raised by the grant of mortgage, in accordance with the said Acts and states:—

(a) The amount of principal moneys it is proposed to borrow is £5,000.

(b) The maximum rate of interest that may be paid is £5 2s. 6d. per cent. per annum.

(c) The period of the loan will be fifteen (15) years, and the time or times at which the moneys borrowed are to be repayable are the 29th day of March, and the 29th day of September in each year during the currency of the loan commencing on the 29th day of March, 1965. The place of repayment shall be at the English, Scottish and Australia Savings Bank Ltd., Melbourne.

(d) The purpose for which the loan is to be applied is for permanent works and undertakings, viz:—

Construction of Grant-road, Baxter—£2,000.  
Construction of Marine-parade, Hastings—£2,400.  
Construction of dog and cattle pound, Hastings—£600.

(e) The loan is to be liquidated by half-yearly payments of £240 17s. 8d. including interest, payable out of the Municipal Fund.

Plans and specifications and an estimate of the cost of such works and undertakings, and a statement showing the proposed expenditure of the money to be borrowed, are open for inspection by ratepayers, during office hours, at the Shire Offices, Hastings, for one (1) month after the publication of this notice.

Dated at Hastings this 21st day of July, 1964.

1861 L. A. WALKER, Shire Secretary.

## SHIRE OF HASTINGS.

## BY-LAW No. 10.

A BY-LAW of the Shire of Hastings, made under sections 197, 212, 213 and 222 of the *Local Government Act 1958*, for the purpose of regulating the proceedings of Council Meetings, Committee Meetings and other Meetings conducted by the Shire of Hastings and for other purposes.

Notice is hereby given that this By-law was agreed to by the Council of the Shire of Hastings on the 16th day of June, 1964, and confirmed on the 21st day of July, 1964.

A copy of the By-law is open for inspection, free of charge, during office hours at the Municipal Offices, Hastings.

1898 L. A. WALKER, Shire Secretary.

## SHIRE OF KERANG.

## NOTICE OF INTENTION TO ACQUIRE LAND COMPULSORILY.

WHEREAS the Council of the Shire of Kerang deems it expedient to exercise its powers of taking land compulsorily for the work or undertaking mentioned hereunder, notice is hereby given as follows:—

1. The Council intends to acquire all that piece of land being part of Crown allotment 3, section 2, Town and Parish of Kerang, having a frontage of 33 feet to Fitzroy-street, Kerang, by a depth of 120 feet to be used as a site for the erection of a Comfort Station.

2. A plan of such land and a schedule of the owners thereof are deposited at the Memorial Municipal Chambers, Kerang, and are available for inspection by all interested parties during office hours free of charge for a period of 40 clear days from the date of publication of this notice in the *Government Gazette*.

3. The Council hereby requires all persons affected by the said proposal to set forth, in writing, addressed to the Shire Secretary, Kerang, within 40 clear days from the date of publication aforesaid all objections they may have to the taking of the said land.

4. At the ordinary meeting of the Council next after the expiration of the said 40 clear days the Council will consider any such objections and any person so objecting as aforesaid may appear before the Council in support of such objection.

Dated the 22nd day of July, 1964.

By order of the Council,

1879 L. R. RUNDLE, Shire Secretary.

## SHIRE OF MORNINGTON.

## BY-LAW No. 84.

*Meeting Procedure Amendment By-law.*

NOTICE is hereby given that the Council of the Shire of Mornington has made a By-law under the *Local Government Act 1958*, as amended and all other powers it thereunto enabling for the purposes of:—

(a) amending By-law number 79,

(b) regulating the proceedings of Council meetings relating to the date of ordinary meetings of the Council,

and for other purposes.

Notice is also hereby given that a copy of the above-mentioned By-law is open for inspection, free of charge, during office hours, at the office of the said Council, Queen-street, Mornington.

Dated this 22nd day of July, 1964.

1863 D. G. COLLINGS, Shire Secretary.

*Town and Country Planning Act 1961.*

## SHIRE OF NARRACAN.—YALLOURN NORTH PLANNING SCHEME 1951.

NOTICE THAT A PLANNING SCHEME TO AMEND THE YALLOURN NORTH PLANNING SCHEME 1951 HAS BEEN PREPARED AND IS AVAILABLE FOR INSPECTION.

*Amendment No. 1, 1964.*

NOTICE is hereby given that the Council of the Shire of Narracan in pursuance of its powers under the Town and Country Planning Acts has prepared a planning scheme for the purpose of amending the Yalourn North Planning Scheme 1951 as follows:—

(a) Land abutting Fourth and Reserve streets; from Public Open Space Reserve to Commercial Zone.

(b) Roadway between Rossmore-avenue and Baillie-street; from projected roadway to Residential "A" Zone.

(c) Marshall-street; re-alignment of Southern Portion.

A copy of the scheme has been deposited at the Shire Office, Trafalgar, and at the office of the Town and Country Planning Board, 179 Queen-street, Melbourne, and will be open for inspection during office hours by any person, free of charge.

Any persons affected by the Planning Scheme are required to set forth, in writing, all objections they may have, addressed to the Shire Secretary, Shire Office, Trafalgar, on or before the 4th day of November, 1964, and to state whether they wish to be heard in respect of their objections.

Dated this 24th day of July, 1964.

1892 W. F. NELSON, Shire Secretary.

## SHIRE OF OTWAY.

## LOAN No. 14.

*Notice of Intention to Borrow.*

NOTICE is hereby given that the Council of the Shire of Otway intends to borrow the sum of £6,000 (Six thousand pounds) on the credit of the President, Councillors and Ratepayers of the said Shire, by grant of mortgage, and in accordance with the provisions of the *Local Government Act*.

1. The maximum rate of interest that may be paid is 5½ per cent. per annum.

2. The loan to be applied for financing a drainage scheme for a section of the Apollo Bay Township.

3. The loan to be repaid over a period of fifteen years.

4. The moneys borrowed shall be repayable by providing out of the Municipal Fund from revenue of the Apollo Bay Riding, 30 equal half-yearly instalments of approximately £289 4s. on the 1st day of May and the 1st day of November during the currency of the loan. The first instalment shall be repayable on the 1st day of May, 1965.

5. Such moneys shall be repayable to the Commercial Bank of Australia Limited, Melbourne.

The plans and specifications and estimates of the cost of the works, and statement showing the proposed expenditure of the moneys to be borrowed, are open for inspection at the Shire Office, Beech Forest.

Dated the 19th July, 1964.

1902 T. J. FRY, Shire Secretary.

## SHIRE OF OXLEY.

NOTICE OF INTENTION TO BORROW THE SUM OF £10,000 FOR PERMANENT WORKS AND UNDERTAKINGS.

NOTICE is hereby given that the Council of the Shire of Oxley proposes to borrow the sum of Ten thousand pounds on the credit of the municipal revenues of the President, Councillors and Ratepayers of the said Shire, such sum to be raised by grant of a mortgage in accordance with the provisions of the *Local Government Act 1958*.

1. The maximum rate of interest that may be paid is £5 2s. 6d. per centum per annum.
2. The purpose for which the loan is to be applied is:—

The Purchase of Road-making Plant and Equipment.

3. The period of the loan shall be ten years.

4. The money borrowed shall be repayable by providing out of the Municipal Fund twenty half-yearly instalments of approximately £645 5s. 4d. each, including principal and interest on the 30th day of March and the 30th day of September during the currency of the loan, first instalment shall be payable on the 30th day of March, 1965.

5. Such money shall be repayable at the Commonwealth Savings Bank, Melbourne.

Plans and specifications and estimates of the cost of the proposed works and a statement showing the proposed expenditure of the money to be borrowed, are open for inspection at the Shire of Oxley Office, Reid-street, Wangaratta.

1981

D. REID, Shire Secretary.

*Town and Country Planning Act 1961.*

## SHIRE OF SOUTH BARWON.—GEELOG PLANNING SCHEME 1959.

NOTICE THAT A PLANNING SCHEME HAS BEEN PREPARED AND IS AVAILABLE FOR INSPECTION.

*Amendment No. 3, 1964.*

NOTICE is hereby given that the Shire of South Barwon, in pursuance of its powers under the *Town and Country Planning Act 1961*, has prepared a Planning Scheme for the following area—

All that area covering properties known as 21, 23 and 25 Church-street, Belmont,

for the purpose of varying the zoning of the area from Residential "A" to Commercial "B".

A copy of the scheme has been deposited at the Shire Office, Mt. Pleasant-road, Belmont, and at the office of the Town and Country Planning Board, 179 Queen-street, Melbourne, and will be open for inspection during office hours by any person free of charge.

Any persons affected by the Planning Scheme are required to set forth in writing, all objections they may have, addressed to the Shire Secretary, Shire Office, Mt. Pleasant-road, Belmont, on or before the 31st day of August, 1964, and to state whether they wish to be heard in respect of their objections.

1876

E. T. CORNISH, Shire Secretary.

## SHIRE OF TAMBO.

PLEASE take notice that the Council of the Shire of Tambo has by an Order, made on the 14th day of July, 1964, directed that the land described hereunder shall be a public highway.

## LAND REFERRED TO

Lot 2, on plan of subdivision No. 19029.  
1931

G. W. RIDSDALE, Shire Secretary.

*Sewerage Districts Act (Sixth Schedule).*

## THE BACCHUS MARSH SEWERAGE AUTHORITY.

## GENERAL NOTICE.

THE above-mentioned Sewerage Authority having made provision for carrying off the sewage from each and every property which or any part of which is within the sewerage area hereinafter described doth hereby declare that on and after the 20th day of July, 1964, each and every property which or any part of which is within the said sewerage area shall be deemed to be a seweraged property within the meaning of the *Sewerage Districts Act 1958*.

*Sewerage Area No. 3.*

The boundaries of the sewerage area hereinafter referred to are all that part of Bacchus Marsh Sewerage

Districts lying south of the Werribee river, together with all other parts of the said Sewerage District which have not already been declared a sewerage area.

By order of the said Sewerage Authority.

1872

T. J. SHEA, Chairman.  
A. W. BOND, Secretary.

*Town and Country Planning Act 1961 (Twelfth Schedule).*

## PORTLAND PLANNING SCHEME 1957.

NOTICE THAT A PLANNING SCHEME HAS BEEN PREPARED AND IS AVAILABLE FOR INSPECTION.

*Amendment No. 4, 1964.*

NOTICE is hereby given that the Council of the Town of Portland in pursuance of its powers under the *Town and Country Planning Act 1961* has prepared a Planning Scheme for amending the original scheme as it applies to the Town of Portland for the purpose of:—

1. Re-zoning land to provide site for Aerodrome and amendment of road locations necessitated by the same.

A copy of the scheme has been deposited at the Town Hall, Portland, and at the office of the Town and Country Planning Board, 179 Queen-street, Melbourne, and will be open for inspection during office hours by any person, free of charge.

Any persons affected by the Planning Scheme are required to set forth, in writing, all objections they may have, addressed to the Town Clerk at the Town Hall, Portland, on or before the 30th day of October, 1964, and to state whether they wish to be heard in respect of their objections.

E. NOEL T. HENRY, Town Clerk.

27th July, 1964.

1896

## THE BALLARAT SEWERAGE AUTHORITY.

## GENERAL NOTICE.

THE above-mentioned Sewerage Authority having made provision for carrying off the sewage from each and every property which or any part of which is within the Sewerage Areas hereinafter described doth hereby declare that on and after the 1st day of September, 1964, each and every property which or any part of which is within the said Sewerage Areas shall be deemed to be a seweraged property within the meaning of the *Sewerage Districts Act 1958*.

The boundaries of the Sewerage Areas hereinbefore referred to are:—

*Sewerage Area No. 244.*

*City of Ballarat.*—Commencing at the north-east corner of No. 18 Hillside-drive being a point on the boundary of Sewerage Area No. 201; thence southerly to the south-east corner of vacant allotment No. 12 Hillside-drive, southerly about 199 feet to the north-east corner of No. 10 Hillside-drive, southerly about 272 feet to a point on the eastern boundary of No. 10A Landsborough-street, about 120 feet from Landsborough-street, being a point on the boundary of Sewerage Area No. 149; thence westerly, northerly, westerly, northerly, north-easterly, northerly and easterly along the boundaries of Sewerage Areas Nos. 149 and 201 to the point of commencement.

*Sewerage Area No. 245.*

*Shire of Ballarat.*—Commencing at the south-west corner of No. 1018 Howitt-street, being a point on the boundaries of Sewerage Areas Nos. 225 and 241; thence south-westerly, southerly, westerly, northerly, north-westerly, westerly, northerly, north-westerly, northerly, easterly, southerly, north-easterly, easterly, southerly, easterly, north-easterly, easterly, southerly and easterly along the boundaries of Sewerage Areas Nos. 225, 120, 132, 136 and 241 to the point of commencement.

Further particulars regarding the streets or parts of streets in which sewers have been laid may be ascertained on inquiry at the Authority's office.

By order of the said Sewerage Authority,

1891

A. W. NICHOLSON, Chairman.  
CHAS. H. CLAMP, Secretary.

## GEELOG WATERWORKS AND SEWERAGE TRUST.

## GENERAL NOTICE.

THE above-mentioned Trust having made provision for carrying off the sewage from each and every property which or any part of which is within the sewerage area hereinafter described doth hereby declare that on and after the 1st day of August, 1964, each and every property which or any part of which is within the said sewerage

area shall be deemed and taken to be deemed property within the meaning of the *Geelong Waterworks and Sewerage Act 1958*.

## SEWERAGE AREA No. 302.

*Shire of South Barwon, Parish of Barrabool,  
County of Grant.*

Commencing at a point being the south-west corner of the intersection of Mount Pleasant-road and Murray-street, North Highton, which is also a point on the boundary of Sewerage Area No. 233; thence northerly across Mount Pleasant-road to a point being the south-west corner of lot No. 89 Mount Pleasant-road; thence northerly along the west side of the said lot No. 89 to a point being the north-west corner of lot No. 89; thence westerly along the southern boundary of lot No. 92 Merino-court and lot No. 85 Lambhill-crescent to a point being on the east side of Lambhill-crescent; thence north-easterly along the east side of Lambhill-crescent to a point being on the prolongation of the west boundary of lot No. 68 Lambhill-crescent; thence north-westerly across Lambhill-crescent and continue north-westerly along the western boundary of the said lot No. 68 to a point being the south-west corner of lot No. 45 Reigate-road; thence south-westerly along the southern boundary of lot No. 46 to a point being the south-west corner of lot No. 46 Reigate-road; thence north-westerly along the western boundary of the said lot No. 46 and crossing Reigate-road to a point being on the north side of Reigate-road; thence north-easterly along the north side of Reigate-road for a distance of 164 feet approximately; thence north-westerly by a line bearing 340 deg. 7 min. for a distance of 142 feet; thence north-westerly by a line bearing 70 deg. 7 min. for a distance of 460 feet; thence by a line bearing 89 deg. 46 min. and crossing Montpellier-drive to a point being on the east side of Montpellier-drive; thence southerly along the east side of Montpellier-drive and crossing Reigate-road and Lambhill-crescent to a point being the north-west corner of lot No. 53 Mount Pleasant-road; thence easterly along the northern boundaries of lots No. 53 to 51 inclusive Mount Pleasant-road to a point being the north-east corner of the said lot No. 51, which is also a point on the western boundary of Education Department's property; thence northerly along the western boundary of the Education Department's property to a point being on the south side of Lambhill-crescent; thence easterly along the south side of Lambhill-crescent to a point being the south-east corner of the intersection of Lambhill-crescent and Cheam-walk; thence northerly along the east side of Cheam-walk to a point being the north-west corner of lot No. 130 Cheam-walk; thence north-easterly along the northern boundary of the said lot No. 130 to a point being the north-east corner of lot No. 130; thence southerly along the eastern boundaries of lots No. 130 to 135 inclusive Cheam-walk, which also follows boundaries of Sewerage Areas Nos. 256 and 246, and continuing southerly along the eastern boundary of the Education Department property and crossing Mount Pleasant-road, to a point being the south-west corner of the intersection of Mount Pleasant-road and Arkana-avenue, which is also a point on the boundaries of Sewerage Areas Nos. 223 and 246; thence westerly along the south side of Mount Pleasant-road and crossing Marcus and Murray streets to the point of commencement.

## SEWERAGE AREA No. 304.

*City of Geelong West, Parish of Moorpanyal,  
County of Grant.*

Commencing at a point being the south-east corner of the intersection of Knight-avenue and Norwood-street, Herne Hill, which is also a point on the boundaries of Sewerage Areas Nos. 98 and 100; thence northerly across Knight-avenue and continuing northerly along the east side of Norwood-street and crossing Finchaven-street to a point being the south-west corner of the Western Cemetery, which is also a point on the boundary of Sewerage Area No. 234; thence easterly along the southern boundary of the Western Cemetery and crossing Edinburgh-street to a point being on the east side of Edinburgh-street, which is also a point on the boundary of Sewerage Area No. 185; thence southerly along the east side of Edinburgh-street and crossing Hilltop-street to a point being the north-east corner of the intersection of Edinburgh-street and Finchaven-street, which is also a point on the boundaries of Sewerage Areas Nos. 185 and 105; thence westerly across Edinburgh-street and continuing westerly along the north side of Finchaven-street to a point being 412 feet approximately east from the north-east corner of the intersection of Norwood and Finchaven streets, which is also a point on the boundary of Sewerage Area No. 105; thence southerly on a straight line across Finchaven-street and continuing southerly following the western boundary of Sewerage Area No. 105 and crossing Knight-avenue to a

point being on the south side of Knight-avenue, which is also a point on the boundaries of Sewerage Areas Nos. 105 and 98; thence westerly along the south side of Knight-avenue to the point of commencement.

By order of the Commissioners,

(SEAL)

J. CARR, Chairman.

B. C. HENSHAW, Secretary.

1901

NOTICE is hereby given that the Evangelical Lutheran Church of Australia (Victorian District) Inc. has applied for a lease under section 134, *Land Act 1958*, of portion of Quarry Reserve in Township of Anglesea for a term of 21 years as a site for Amusement and Recreation (Camp Site). 1526

NOTICE OF INTENTION TO APPLY FOR A LICENCE TO DIVERT WATER AND CUT RACE (RE-ISSUE) FROM THE RIVER MURRAY, AT PIANGIL.

I HEREBY give notice that I intend to apply for a licence empowering me to divert water for a term of six years to the extent of 21 acre-feet per annum at a maximum rate of 4 acre-feet per day of 24 hours for the purpose of irrigating 7 acres of vegetables, being part of allotment 149, Parish of Piangil, and to occupy certain Crown lands for works of diversion, and to cut a race thereon.

Any objection to such application must be forwarded, in writing, to reach the State Rivers and Water Supply Commission, Melbourne, before 28th August, 1964, being 30 days from the first publication of this notice.

C. CACCAVIELLO.

Box 10, Piangil, Victoria.

1885

NOTICE OF INTENTION TO APPLY FOR A LICENCE TO DIVERT WATER AND CUT RACE FROM THE RIVER MURRAY (LAGOON), AT BONEGILLA.

I HEREBY give notice that I intend to apply for a licence empowering me to divert water for a term of six years to the extent of 20 acre-feet per annum at a maximum rate of 1 acre-foot per day of 24 hours for the irrigating of 10 acres of pasture on part of allotment 15, section 5, Parish of Bonegilla, and to occupy certain Crown lands for works of diversion, and to cut a race thereon.

Any objection to such application must be forwarded, in writing, to reach the State Rivers and Water Supply Commission, Melbourne, before 24th August, 1964, being 30 days from the first publication of this notice.

RONALD ALBERT RAPSEY.

Rockgilla, Private Bag, Wodonga.

1858

NOTICE OF INTENTION TO APPLY FOR A LICENCE TO DIVERT WATER AND CUT RACE (RE-ISSUE) FROM THE GOULBURN RIVER, AT WHANREGARWAN.

I HEREBY give notice that I intend to apply for a licence empowering me to divert water for a term of seven years to the extent of 80 acre-feet per annum at a maximum rate of 2 acre-feet per day of 24 hours for the purpose of irrigating 40 acres, being part of allotment 53, Parish of Acheron, and to occupy certain Crown lands for works of diversion, and to cut a race thereon.

Any objection to such application must be forwarded, in writing, to reach the State Rivers and Water Supply Commission, Melbourne, before 2nd August, 1964, being 30 days from the first publication of this notice.

GEOFFREY NEVILLE COOKSON.

Box 47, Alexandra.

1859

NOTICE OF INTENTION TO APPLY FOR A LICENCE TO DIVERT WATER AND CUT RACE FROM THE RIVER MURRAY, AT BOUNDARY BEND.

I HEREBY give notice that I intend to apply for a licence empowering me to divert water for a term of six years to the extent of 9 acre-feet per annum at a maximum rate of  $\frac{1}{2}$  acre-foot per day of 24 hours for the irrigation of 3 acres of citrus, being part of allotment 1E, Parish of Narrung, and to occupy certain Crown lands for works of diversion and to cut a race thereon.

Any objection to such application must be forwarded in writing to reach the State Rivers and Water Supply Commission, Melbourne, before 24th August, 1964, being 30 days from the first publication of this notice.

JOSEPH EDWIN RENNEY.

Boundary Bend.

1934

## NOTICE OF DISSOLUTION OF PARTNERSHIP.

NOTICE is hereby given that the partnership heretofore subsisting between the undersigned Jeffrey Maxwell Stanley and Lester William Stanley, at Springvale-road, Springvale, under the name of Calcare Service Station, shall be dissolved by mutual consent as from the 24th day of July, 1964.

Dated the 17th day of July, 1964.

J. STANLEY.  
L. W. STANLEY.  
1927

Witness—W. V. DEEKER.

NOTICE is hereby given that the partnership heretofore subsisting between Francis Joseph Prowse, manufacturer, and Marion Lois Prowse, married woman, both of 18 Service-road, Blackburn, in the State of Victoria, carrying on business at 18 Service-road, Blackburn, under the name of "K.F.M. Industries", has been dissolved as from the 30th day of June, 1964.

Dated this 18th day of July, 1964.

FRANCIS JOSEPH PROWSE.

Signed by the said Francis Joseph Prowse, in the presence of—

P. HAMBLIN, Accountant.

MARION LOIS PROWSE.

Signed by the said Marion Lois Prowse, in the presence of—

1937

P. HAMBLIN, Accountant.

NOTICE is hereby given that the partnership heretofore subsisting between Geoffrey Gordon Hicks and Ena May Hicks, carrying on business as hardware retailers, at Main-street, Belgrave, under the style or firm of Belgrave Hardware Store, has been dissolved by mutual consent as from the 30th day of June, 1964.

1942

E. M. HICKS.

NOTICE is hereby given that the partnership heretofore subsisting between us, the undersigned Maurice Iskowicz, Sonia Iskowicz, Zane Mason and Lorna Mason, carrying on business as shopkeepers at 81 Ludstone-street, Hampton, under the style or firm of Issko and Mason, has been dissolved by mutual consent as from the 13th day of July, 1964.

MAURICE ISKOWICZ.  
SONIA ISKOWICZ.  
Z. MASON.  
L. MASON.

Dated at Melbourne the 17th day of July, 1964.

J. Okno, Papas and Co., solicitors, 390 Lonsdale-street, Melbourne. 1907

THE partnership between Ronald Patrick Stewart and John Andrew McIntosh, carrying on business as solicitors, under the firm name of Ronald Stewart McIntosh & Co., at 422 Collins-street, Melbourne, was dissolved by mutual consent on the 30th day of June, 1964. The practice has been acquired by Morven Bond, who will carry on the business under the firm name of Ronald Stewart McIntosh & Co. at the same address, and he will receive all payments and pay all debts of the former partnership.

Dated 22nd July, 1964.

RONALD STEWART.  
JOHN A. MCINTOSH.  
MORVEN BOND.

1951

NOTICE is hereby given that the partnership heretofore subsisting between the undersigned Malcolm John McClelland and Arthur Lionel Lyster, carrying on business as estate agents at Mt. Eliza under the name of "Lyster, McClelland & Co." has been dissolved by mutual consent as from the 1st day of July, 1964.

All debts due to and owing by the said late firm will be received and paid by Malcolm John McClelland who will continue to carry on the business at the same address.

Dated this 23rd day of July, 1964.

A. L. LYSTER.  
M. J. MCCLELLAND.

1979

VLANDIS PTY. LTD. (IN VOLUNTARY LIQUIDATION).

NOTICE is hereby given that a General Meeting of the above company will be held at the registered office of the company on Thursday, 3rd September, 1964, at 2 p.m., for the purpose of laying before the meeting an account showing how the winding up of the company has been conducted and the property of the company disposed of, and giving any explanations thereof.

1936

R. C. MACKENZIE, F.A.S.A., Liquidator.

The Companies Act 1961.—In the matter of ROBUS PTY. LTD. (in Liquidation).

NOTICE is hereby given that a First Dividend is intended to be declared in this matter. Creditors who have not proved their debt by the 13th August, 1964, will be excluded from the dividend.

Dated this 23rd day of July, 1964.

E. R. SMAIL, Liquidator.

Kennedy, Smail & Middlemiss, 296 Little Lonsdale-street, Melbourne. 1930

Companies Act 1961.—Re A. J. BUSINESSES PTY. LTD.—Notice of Meeting of Creditors, Pursuant to Section 260.

NOTICE is hereby given that a Meeting of Creditors of the above company will be held at the Honorary Justices Board Room, 6th Floor, 34 Queen-street, Melbourne, at 10.30 a.m., on Friday, July 31st, 1964, a meeting of the members of the company having been convened on the same day at 10 a.m. for the purpose of considering and if thought fit passing a Special Resolution that the company be wound up voluntarily, pursuant to section 254 of the Act.

Dated this 22nd day of July, 1964.

A. J. THOMPSON, Director.

John P. Hyman & Co., public accountants, 792 Elizabeth-street, Melbourne. 1926

Companies Act 1961.—Re OCEAN ROAD MOTELS PTY. LTD. (in Voluntary Liquidation).—Notice Pursuant to Section 272.

NOTICE is hereby given that a Final Meeting of shareholders and creditors of the above company will be held in the offices of the liquidator, on Monday, 3rd August, at 10.30 a.m., pursuant to the above section, for the purpose of laying before them an account and giving an explanation thereof as prescribed by the Act.

Dated this 24th day of July, 1964.

JOHN P. HYMAN, Liquidator.

John P. Hyman & Co., public accountants, 792 Elizabeth-street, Melbourne. 1913

GRIFFITHS AND WEST PROPRIETARY LIMITED  
(IN VOLUNTARY LIQUIDATION.)

Notice Convening Final Meeting, Pursuant to Section 272 of the Companies Act 1961.

PURSUANT to section 272 of the Companies Act 1961, a General Meeting of members of the above-named company will be held at the office of the liquidator, 2nd floor, 339 Collins-street, Melbourne, on Monday, 31st August, 1964, at 10 a.m. for the purpose of having an account laid before them showing the manner in which the winding up has been conducted and the property of the company disposed of, and of hearing any explanations that may be given by the liquidator.

Dated this 27th day of July, 1964.

1929

P. S. HESELTINE, Liquidator.

The Companies Act 1961.—In the matter of BERRY & BARSTOW PTY. LTD. (in Voluntary Liquidation).

NOTICE is hereby given that pursuant to section 272 of the Companies Act a Final Meeting of the members and creditors of the above company will be held at the office of H. McIntosh Joss and Co., 6 Albany-road, Toorak, on Tuesday, the 1st of September, 1964, at 10.30 a.m.

Business.—To receive the liquidator's accounts.

Dated this 29th day of July, 1964.

1883

H. MCINTOSH JOSS, Liquidator.

Companies Act 1961.

SPARROW HARDWICK (AUSTRALIA) PTY. LIMITED  
(IN VOLUNTARY LIQUIDATION).

PURSUANT to section 254 (2) (b) of the Companies Act 1961, notice is hereby given that, at an Extraordinary General Meeting of the company, duly convened and held on July 24, 1964, the following Resolution was passed as a Special Resolution:—

"That the company be wound up voluntarily."

And at such meeting William Reynolds Pearson, chartered accountant, of 90 Queen-street, Melbourne, was appointed liquidator for the purposes of the winding up.

Dated this 24th day of July, 1964.

W. R. PEARSON, Liquidator.

Pearson and Tatnall, public accountants, 90 Queen-street, Melbourne. 1899



Unclaimed Moneys Act 1962.

REGISTER of Unclaimed Moneys held by the—

Name of Owner on Books and Last Known Address.	Total Amount Due to Owner.	Description of Unclaimed Moneys.	Date when Amount first became Payable.
	£ s. d.		
<b>THE "TRIBUNE" PUBLISHING CO. LTD.</b>			
Barrett, Patrick, 203 Brunswick-road, East Brunswick .. .. .	5 4 0	Dividends .. .. .	26.12.44
Britt, Michael, 40 Gladstone-street, Kew .. .. .	5 4 0	" .. .. .	" .. .. .
Brazil, Thomas (Rev.) (estate of), Williamstown .. .. .	6 10 0	" .. .. .	31.3.54
Considine, Thomas (Rev.) (estate of), Seymour .. .. .	13 0 0	" .. .. .	26.12.44
Curran, John, Highfield-road, Quaker Hill, N.S.W. .. .. .	5 4 0	" .. .. .	" .. .. .
Curtain, Andrew A., 134 Albert-street, East Malvern .. .. .	23 12 0	" .. .. .	4.1.46
Collins, Thomas (Rev.) (estate of), Mentone .. .. .	12 8 0	" .. .. .	7.3.51
Dunne, William, Johnston-street, Fitzroy .. .. .	5 4 0	" .. .. .	26.12.44
Dwyer, Athanasius, 186 Swanston-street, Melbourne .. .. .	9 5 0	" .. .. .	29.5.63
Dynon, Mary Ellen (Mrs.), Victoria-street, Camberwell .. .. .	13 0 0	" .. .. .	" .. .. .
Dunphy, William (Rev.), St. Mary's Presbytery, Paeroa, N.Z. .. .. .	26 0 0	" .. .. .	" .. .. .
Flynn, Michael James, South Wangaratta .. .. .	5 4 0	" .. .. .	" .. .. .
Fitzpatrick, Christopher, 348 Lygon-street, Carlton .. .. .	5 4 0	" .. .. .	" .. .. .
Fitzgerald, Patrick T. (Rev.), St. Mary's, Geelong .. .. .	5 4 0	" .. .. .	" .. .. .
Grogan, John Joseph (estate of), 147 Canterbury-road, Middle Park .. .. .	6 12 0	" .. .. .	29.3.55
Hennessy, Frank, 186 Faraday-street, Carlton .. .. .	7 16 0	" .. .. .	26.12.44
Hade, Nora (Miss), Park-street, Brunswick .. .. .	5 4 0	" .. .. .	" .. .. .
Hoyne, Maurice (Rev.), St. Mary's, Gympie, Queensland .. .. .	5 4 0	" .. .. .	" .. .. .
Hickey, Cornelius, 11 Mary-street, Hawthorn .. .. .	5 4 0	" .. .. .	" .. .. .
Kavanagh, Patrick (Rev.), Nagambie .. .. .	13 0 0	" .. .. .	" .. .. .
Luby, Edmund Joseph (Rev.), St. Ambrose's, Brunswick .. .. .	13 0 0	" .. .. .	" .. .. .
Lacy, Peter, 23 Guildford-street, Melbourne .. .. .	13 0 0	" .. .. .	" .. .. .
Lennon, Patrick (Rev.), Koroit .. .. .	13 0 0	" .. .. .	" .. .. .
Maher, Thomas, 9 Derby-street, Kew .. .. .	5 4 0	" .. .. .	" .. .. .
Merner, Francis (Rev.) (estate of), Mansfield .. .. .	6 10 0	" .. .. .	" .. .. .
McBreen, Mary E. (Mrs.) 576 Canning-street, North Carlton .. .. .	5 4 0	" .. .. .	" .. .. .
McGuire, James, Fenwick-street, Carlton .. .. .	5 4 0	" .. .. .	" .. .. .
McInerney, John T., Faraday-street, Carlton .. .. .	13 0 0	" .. .. .	" .. .. .
McNamara, Elizabeth (Mrs.), 142 Fenwick-street, North Carlton .. .. .	5 4 0	" .. .. .	" .. .. .
McCarthy, Catherine (Miss), Crossley P.O. .. .. .	7 4 0	" .. .. .	7.1.46
Neenan, Stephen, 82 Parker-street, Williamstown .. .. .	5 4 0	" .. .. .	26.12.44
O'Meara, Joseph T. P., 180 Park-street, West Brunswick .. .. .	13 0 0	" .. .. .	" .. .. .
O'Hanlon, Edward, Burnt Creek, Mansfield .. .. .	5 4 0	" .. .. .	" .. .. .
O'Sullivan, T. J. (Rev.), Cayuga, N.D., U.S.A. .. .. .	26 0 0	" .. .. .	" .. .. .
O'Malley, John Joseph, Victoria Hotel, Warrnambool .. .. .	13 0 0	" .. .. .	" .. .. .
Rafferty, Patrick (Rev.) (estate of), The Presbytery, Kew .. .. .	15 10 0	" .. .. .	7.3.51
Smith, Annie (Miss), 100 Pakington-street, Kew .. .. .	13 0 0	" .. .. .	26.12.44
Sheedy, John T., 272 Station-street, North Carlton .. .. .	13 0 0	" .. .. .	" .. .. .
Sheedy, Michael, 272 Station-street, Carlton .. .. .	13 0 0	" .. .. .	" .. .. .
Synott, James (Rev.) (estate of), Sale .. .. .	5 4 0	" .. .. .	" .. .. .
Stormont, J. C. (Mrs.), 218 Lennox-street, Richmond .. .. .	7 16 0	" .. .. .	" .. .. .
Tydemans, Wishart, V. Semmler, c/o C.Y.M.S. P.O., Horsham .. .. .	5 4 0	" .. .. .	" .. .. .
1862			
<b>LINCOLN STUART AND COMPANY PROPRIETARY LIMITED.</b>			
Willder, Derebin, Collins-street, Melbourne .. .. .	7 5 0	Dividend .. .. .	12.9.63
1890			

**Companies Act 1961.**  
**BYSEL PROPRIETARY LIMITED**  
 (IN VOLUNTARY LIQUIDATION).  
 NOTICE is hereby given, pursuant to section 254 (3) (b) of the Companies Act 1961, that at an Extraordinary General Meeting of members of Bysel Proprietary Limited, duly convened and held at 578 St. Kilda-road, Melbourne, on the 23rd day of July, 1964, the following Special Resolution was duly passed:—  
**SPECIAL RESOLUTION.**  
 "That the company be wound up voluntarily and that Thomas Henry King, of 578 St. Kilda-road, Melbourne, be hereby appointed liquidator for the purposes of such winding up."  
 Dated at Melbourne the 23rd day of July, 1964.  
 1972 T. H. KING, Liquidator.

**The Companies Act 1961.—In the matter of KONGWAK ASSOCIATE CO. LTD. (in Voluntary Liquidation).**  
 NOTICE is hereby given that pursuant to section 272 of the Companies Act a Final Meeting of members of the above company will be held at the office of H. McIntosh Joss and Co., 6 Albany-road, Toorak, on Tuesday, the 1st of September, 1964, at 1 p.m.  
**Business.—**To receive the liquidator's accounts.  
 Dated this 29th day of July, 1964.  
 1884 H. MCINTOSH JOSS, Liquidator.

**The Companies Act 1958.—In the matter of K.C. ACCESSORIES PTY. LIMITED (IN LIQUIDATION).**  
 NOTICE is hereby given that pursuant to section 210 of the Companies Act a Final Meeting of the creditors of the above company will be held at the offices of Kennedy, Smail and Middlemiss, 296-300 Little Lonsdale-street, Melbourne, on Wednesday, the 26th day of August, 1964, at 10.30 a.m.  
**Business.—**To receive the liquidator's accounts.  
 Dated this 27th day of July, 1964.  
 ALLAN MURRAY HORSBURGH, Liquidator.  
 Kennedy, Smail and Middlemiss, 296-300 Little Lonsdale-street, Melbourne. 1968

**The Companies Act 1961.—In the matter of VICTOR INDUSTRIES PROPRIETARY LIMITED.—Notice re Meeting of Creditors Pursuant to Section 260.**  
 NOTICE is hereby given that a Meeting of creditors of the above-named company will be held at the offices of Kennedy, Smail and Middlemiss, 296 Little Lonsdale-street, Melbourne, on Tuesday, the 4th day of August, 1964, at 11.00 a.m., the company having convened a meeting of its members for the same day for the purpose of considering a Resolution that the company be wound up voluntarily.  
 Dated this 23rd day of July, 1964.  
 1967 M. J. QUIRK, Director.

The Companies Act 1961.—In the matter of W.Z. MANUFACTURING COMPANY PTY. LTD. (IN LIQUIDATION).

NOTICE is hereby given that pursuant to section 272 of the Companies Act a Final Meeting of the creditors of the above company will be held at the offices of Kennedy, Smail and Middlemiss, 296-300 Little Lonsdale-street, Melbourne, on Wednesday, the 26th day of August, 1964, at 10.00 a.m.

Business:—To receive the liquidator's accounts.

Dated this 27th day of July, 1964.

ALLAN MURRAY HORSBURGH, Liquidator.

Kennedy, Smail and Middlemiss, 296-300 Little Lonsdale-street, Melbourne. 1969

The Companies Act 1961.—In the matter of L. A. NEALE PTY. LIMITED.

NOTICE is hereby given that at an Extraordinary General Meeting of the members of the above-mentioned company held on the 23rd day of July, 1964, it was resolved that the company be wound up voluntarily and that Ronald Dennis Widdows, of 125 William-street, Melbourne, be appointed liquidator for the purpose of such winding up.

Notice is also hereby given that after 21 days from this date the above-named liquidator shall proceed to distribute the assets. All creditors having any claim against the company should furnish particulars of the same by that date otherwise the liquidator shall proceed to distribute the assets without regard to their claim.

Dated this 23rd day of July, 1964.

R. D. WIDDOWS, Room 49, 2nd Floor, 125 William-street, Melbourne. 1959

The Companies Act 1961.—In the matter of NEILSON WELDING PTY. LIMITED.

NOTICE is hereby given that at an Extraordinary General Meeting of the members of the above-mentioned company held on the 23rd day of July, 1964, it was resolved that the company be wound up voluntarily and that Ronald Dennis Widdows, of 125 William-street, Melbourne, be appointed liquidator for the purpose of such winding up.

Notice is also hereby given that after 21 days from this date the above-named liquidator shall proceed to distribute the assets. All creditors having any claim against the company should furnish particulars of the same by that date otherwise the liquidator shall proceed to distribute the assets without regard to their claim.

Dated this 23rd day of July, 1964.

R. D. WIDDOWS, Room 49, 2nd Floor, 125 William-street, Melbourne. 1960

Companies Act 1961.

ALLEY BROS. PROPRIETARY LIMITED.

AT an Extraordinary General Meeting of Alley Bros. Proprietary Limited, duly convened and held at office of Taylor and Rees, 234 Collins-street, Melbourne, on Monday, the 27th day of July, 1964, at 10.30 a.m., the following Resolution was duly passed as a Special Resolution:—

“That the company be wound up voluntarily.”

And at such meeting, Barbara Luree Rees, of 234 Collins-street, Melbourne, chartered accountant, was appointed liquidator for the purpose of the winding up.

Dated this 27th day of July, 1964.

1894 B. L. REES, Liquidator.

GOROKE FREEZING & TRADING COMPANY PROPRIETARY LIMITED.

SPECIAL RESOLUTION TO WIND UP, PURSUANT TO SECTION 254 OF THE COMPANIES ACT, 1961.

AT an Extraordinary General Meeting of the above-named company, duly convened and held at 343 Little Collins-street, Melbourne, on the 17th day of July, 1964, the following Resolution was duly passed as a Special Resolution:—

“That the company wind up voluntarily.”

And at such last-mentioned meeting Richard James Burman, 343 Little Collins-street, Melbourne, was appointed liquidator for the purpose of the winding up.

Dated this 20th day of July, 1964.

1865 R. J. BURMAN, Liquidator.

In the matter of The Companies Act 1961.—And in the matter of MAVAL MEAT COMPANY PROPRIETARY LIMITED.

NOTICE is hereby given that a Petition for the winding up of the above-named company by the Supreme Court was on the 24th day of July, 1964, presented to the said court by A. F. G. Watkins Proprietary Limited, and the said petition is directed to be heard before the court sitting at Melbourne on the 31st day of August, 1964, and any creditor or contributory of the said company desirous to support or oppose the making of an Order on the said petition may appear at the time of hearing by himself or his counsel for that purpose; and a copy of the petition will be furnished to any creditor or contributory of the said company requiring the same by the undersigned on payment of the regulated charge for the same.

The petitioner's address is Somerville-road, Brooklyn.

The petitioner's solicitors are Evans, Masters and Gilbert, of 34 Queen-street, Melbourne.

NOTE.—Any person who intends to appear on the hearing of the said petition must serve on or send by post to the above-named solicitor for the petitioner, notice, in writing, of his intention so to do. The notice must state the name and address of person, or, if a firm the name and address of the firm, and must be signed by the person or firm, or his or their solicitor (if any), and must be served, or, if posted, must be sent by post in sufficient time to reach the above named not later than 12 o'clock on the 28th day of August, 1964. 1887

METRAB PROPRIETARY LIMITED.

SPECIAL RESOLUTION TO WIND UP, PURSUANT TO SECTION 254 OF THE COMPANIES ACT, 1961.

AT an Extraordinary General Meeting of the above-named company, duly convened and held at 343 Little Collins-street, Melbourne, on the 17th day of July, 1964, the following Resolution was duly passed as a Special Resolution:—

“That the company wind up voluntarily.”

And at such last-mentioned meeting Richard James Burman, 343 Little Collins-street, Melbourne, was appointed liquidator for the purpose of the winding up.

Dated this 20th day of July, 1964.

1864 R. J. BURMAN, Liquidator.

In the Supreme Court of Victoria.—1964, Co.6905.—In the matter of the Companies Act 1961; and in the matter of HARULIN PROPRIETARY LIMITED.

NOTICE is hereby given that a petition for the winding up of the above-named company by the Supreme Court was on the 28th day of July, 1964, presented by Leo Thomas FitzGerald, Deputy Commissioner of Taxation of the Commonwealth of Australia. And that the said petition is directed to be heard before the court sitting at the Fourteenth Court, Law Courts, William-street, Melbourne, at the hour of 10.30 o'clock in the forenoon on the 1st day of September, 1964; and any creditor or contributory of the said company desiring to support or oppose the making of an Order on the said petition may appear at the time of hearing by himself or his counsel for that purpose; and a copy of the said petition will be furnished to any creditor or contributory of the said company requiring the same by the undersigned on payment of the regulated charge for the same.

The petitioner's official address is 152 Elizabeth-street, Melbourne.

The Petitioner's solicitor is Robert Burns Hutchison, Acting Crown Solicitor for the Commonwealth, 440 Little Collins-street, Melbourne.

R. B. HUTCHISON.

NOTE.—Any person who intends to appear on the hearing of the said petition must serve on or send by post to the above-mentioned R. B. Hutchison, notice, in writing, of his intention so to do. The notice must state the name and address of the person, or, if a firm, the name and address of the firm and must be signed by the person or firm, or his or their solicitor (if any), and must be served or, if posted, must be sent by post in sufficient time to reach the above named not later than Four o'clock in the afternoon of the 31st day of August, 1964. 1980

The Companies Act 1961.  
DALTON ESTATES PTY. LTD.  
(IN VOLUNTARY LIQUIDATION).

NOTICE CONVENING FINAL MEETING OF MEMBERS PURSUANT TO SECTION 272.

NOTICE is hereby given in pursuance of section 272 of the Companies Act 1961, that the Final Meeting of the members of the above-named company will be held at the offices of A. H. G. Clarke and Co., 1st Floor, 470 Bourke-street, Melbourne, on the 27th day of August, 1964, at 3.00 p.m., to consider the liquidator's final accounts of the voluntary winding up.

Dated this 21st day of July, 1964.  
1866 A. M. LOCKE, Liquidator.

THE Perpetual Executors and Trustees Association of Australia Limited, whose registered office is situate at Nos. 100-104 Queen-street, Melbourne, in the State of Victoria, and Ivan Edward Byam Wight, chartered accountant, of 20 Catherine-street, Canterbury, in the said State, the executors of the will of Reuben Wight (sometimes known as James Rueben Wight), (who died on the 7th day of November, 1963), require all creditors, next of kin and others having claims against the property or estate of the said deceased to send to the said executors, in the care of the said Association, on or before the 1st day of October, 1964, particulars in writing of such claims, after which date the said executors intend to convey or distribute such property or estate to or among the persons entitled thereto, having regard only to the claims of which they shall have had notice.

PARKINSON & HART, solicitors, 406 Lonsdale-street, Melbourne. 1962

WESBLE KENNETH PERRY, of 87 South-road, Brighton Beach, bursar, the executor of the will of Winifred Annie Grigg, late of 6 Hume-street, Armadale, widow deceased (who died on the 12th December, 1963), requires all creditors, next of kin and others having claims against the property or estate of the said deceased, to send to the executor, in care of the under-mentioned solicitors, on or before the 30th September, 1964, particulars, in writing, of such claims, after which date the said executor intends to convey or distribute such property or estate to or amongst the persons entitled thereto, having regard only to the claims of which he shall have had notice.

Dated the 24th day of July, 1964.  
FREDERICK W. COX & SON, solicitors, 452 Lonsdale-street, Melbourne. 1925

Trustee Act 1958.  
NOTICE TO CLAIMANTS.

PURSUANT to the Trustee Act 1958, creditors, next of kin and all other persons having claims in respect of the estate of the deceased persons named below are required to send particulars to the legal personal representative or representatives at the addresses stated, after which date the representative or representatives will distribute the assets, having regard only to the claims of which notice has been received:—

William John Dooley, late of 104 The Esplanade, Williamstown, retired bookmaker, deceased, died on the 19th day of August, 1963.—Claims to the executrix, Muriel Dooley, of 104 The Esplanade, Williamstown, widow, care of John F. Carroll, of 4 Paisley-street, Footscray, solicitor, by the 30th day of September, 1964. John F. Carroll, LL.B., solicitor, 4 Paisley-street, Footscray. 1950

Ada Josephine Meyer, late of 65 Park-street, St. Kilda, Victoria, spinster, deceased, who died on 30th March, 1964.—Claims to National Trustees, Executors and Agency Company of Australasia Limited, the executor appointed by the will of the said deceased, by the 8th of October, 1964. T. A. Kennedy, LL.B., solicitor, 509 Collins-street, Melbourne. 1956

Arthur William Heath, late of Cornella, via Toolleen, farmer, who died on the 20th day of November, 1963.—Claims to the executors, National Trustees, Executors and Agency Company of Australasia Limited, (Farmers and Citizens Division), of 46 Queen-street, Bendigo, and Arthur William Heath and Victor Samuel Barlow, both of Wanalta, farmers, in care of the said company, not later than the 30th day of September, 1964. Schleiger & Smalley, solicitors, 290 Williamson-street, Bendigo. 1877

GARNET WOLSELEY EGAN, late of 94 Queens-avenue, Carnegie, in the State of Victoria, gentleman, DECEASED (who died on the 23rd day of February, 1964).

CREDITORS and next of kin having claim against the estate of the deceased are requested by the executors, Gerald Edward Delaney and Ronald Ashmore, to send particulars of their claims to the under-mentioned solicitors on or before the 30th day of September, 1964, after which date they will distribute the assets, having regard only to the claims of which they then have notice.

GERALD E. DELANEY & CO., solicitors, of 452 Lonsdale-street, Melbourne. 1944

CREDITORS, next of kin and others having claims against the estate of Robert Thomas Parry, late of 9 Fallon-street, Brunswick, in the State of Victoria, retired motor engineer, deceased (who died on the 16th day of October, 1963), are to send particulars of their claims to Philip Henry Pippey, of 1 Watts-street, Box Hill, in the said State, solicitor, the executor to whom probate of the will of the said deceased has been granted on or before the 10th day of October, 1964, after which date the executor intends to convey or distribute the assets of the said deceased among the persons entitled thereto, having regard only to the claims of which he shall then have had notice. 1945

CREDITORS, next of kin and others having claims in respect of the estate of Ethel Maude Mary Phair, late of 6 Mathoura-road, Toorak, widow, deceased (who died on the 15th day of March, 1964), are to send particulars of their claims to The Trustees, Executors and Agency Company Limited, of 401 Collins-street, Melbourne, by the 12th of October, 1964, after which date it will distribute the assets, having regard only to the claims of which it then has notice.

W. CAREW & CO., solicitors, of 224 Queen-street, Melbourne. 1943

CREDITORS, next of kin and others having claims in respect of the estate of Lewis Augustus Denia, late of Mills-street, Heyfield, carpenter, deceased, intestate (who died on the 24th day of June, 1964), are required by the administratrix, Elizabeth Mamie Jennings, of Riverview-road, Heyfield, married woman, to send particulars of their claims to her, care of the under-mentioned solicitors, by the 6th day of October, 1964, after which date she will distribute the assets, having regard only to the claims of which she then has notice.

C. P. SEMMENS & HATCH, solicitors, Maffra. 1935

CREDITORS, next of kin and others having claims in respect of the estate of Emil Thorson, late of Mount Best, via Foster, farmer, deceased (who died on the 10th day of April, 1964), are to send the particulars of their claims to National Trustees, Executors and Agency Company of Australasia Limited, of 95 Queen-street, Melbourne, by the 30th day of September, 1964, after which date it will distribute the assets, having regard only to the claims of which it then has notice.

SKINNER & HART, solicitors, of Commercial-road, Yarram. 1932

CREDITORS, next of kin and others having claims in respect of the estate of Florence Harrison, late of 20 Galeka-street, Merlynston, spinster, deceased (who died on the 11th day of December, 1960), are to send particulars of their claims to the administrator, The Equity Trustees, Executors and Agency Company Limited, at the under-mentioned address, by the 30th day of September, 1964, after which date it will distribute the assets, having regard only to the claims of which it then has notice.

STRUGNELL & STRUGNELL, solicitors, 455 Sydney-road, Coburg. 1933

CHARLES PALMER WANE, formerly of 5 Glen-street, Hawthorn, but late of 42 St. Albans-road, East Geelong, gentleman, DECEASED.

CREDITORS, next of kin and others having claims in respect of the estate of the said deceased (who died 24th December, 1963), are required by the applicants for grant of probate of the will of David Charles Wane, of 25 Wattle-tree-road, Drumcondra, North Geelong, sales representative, and Lillian May Wane, of 30 Logan-street, North Geelong, widow, to send particulars to them, care of the undersigned solicitors, by 30th September, 1964, after which date the said applicants may convey or distribute the assets, having regard only to the claims of which they then have notice.

WIGHTON & McDONALD, solicitors, 189-191 Moorabool-street, Geelong. 1880

ROSINA FANNY EVISON, formerly of Nilma, but late of Bairnsdale, widow, DECEASED.

CREDITORS, next of kin and others having claims in respect of the estate of the deceased (who died on 2nd day of December, 1963), are required by the executor, William Mole, of 5 Penny-avenue, Warragul, to send particulars to him, care of the undersigned solicitors, by the 5th day of October, 1964, after which date the executor may convey or distribute the assets, having regard only to the claims of which he then has notice.

GRAY, FRIEND & LONG, solicitors, Warragul. 1868

CREDITORS, next of kin and others having claims in respect of the estate of Margaret Alkemade, late of Coimadai, widow, deceased (who died on the 26th day of May, 1964, and probate of whose will has been granted to Ian William Alkemade and Royston Petrus Alkemade, both of Coimadai, farmers), are required to send particulars of their claims to the said executors, care of the under-mentioned solicitors, by the 1st day of October, 1964, after which date they will distribute the assets, having regard only to the claims of which they then have notice.

PEARCE & WEBSTER, solicitors, 430 Little Collins-street, Melbourne. 1908

CREDITORS, next of kin and others having claims in respect of the estate of Frederick Roy Lee, late of 198 Kooyong-road, Toorak, in the State of Victoria, director, deceased (who died on the 7th day of May, 1964), are required to send particulars of their claims to Maxwell Harry Joseph, the executor of the estate of the said deceased, care of Strongman and Crouch, solicitors, of 118 Queen-street, Melbourne, by the 7th day of October, 1964, after which date the said Maxwell Harry Joseph will distribute the assets, having regard only to the claims of which he then has notice.

STRONGMAN & CROUCH, solicitors, 118 Queen-street, Melbourne. 1904

CREDITORS, next of kin and others having claims in respect of the estate of Florence Eliza Bower, late of 72 Victoria-road, Auburn, in the State of Victoria, spinster, deceased (who died on the 15th May, 1964), are requested by The Equity Trustees, Executors and Agency Company Limited, of 472 Bourke-street, Melbourne, in the said State, the executor of the will of the said deceased, to send particulars of their claims to the said company by the 10th of October, 1964, after which date the said company will distribute the assets, having regard only to the claims of which it then has notice.

EGGLESTON, CLIFTON-JONES & CO., solicitors, 578 Bourke-street, Melbourne. 1905

CREDITORS, next of kin and others having claims in respect of the estate of Andrew James Tynan, late of 15 Cohuna-street, West Brunswick, retired gasman, deceased (who died on the 2nd day of June, 1964), are to send particulars of their claims to the executrix, Jessie Christina Thomas, at the under-mentioned address, by the 30th day of September, 1964, after which date she will distribute the assets, having regard only to the claims of which she then has notice.

STRUGNELL & STRUGNELL, solicitors, 455 Sydney-road, Coburg. 1982

CREDITORS, next of kin and others having claims in respect of the estate of Daisy Winifred Turner, late of 54 Bindy-street, Forest Hill, widow, deceased (who died on the 26th January, 1964), are to send particulars of their claims to the executors, Bernard William Gaynor and Desmond Russell Gleisner, care of the undersigned, by the 6th day of October, 1964, after which date they will distribute the assets, having regard only to the claims of which they then have notice.

RENNICK & GAYNOR, solicitors, 473 Bourke-street, Melbourne. 1966

CREDITORS, next of kin and others having claims in respect of the estate of Leslie Edward Ball, late of 17 Albion-road, Glen Iris, retired, deceased (who died on 27th April, 1964), are to send particulars of their claims to The Trustees, Executors and Agency Company Limited, of 401 Collins-street, Melbourne, by 2nd October, 1964, after which date it will distribute the assets, having regard only to the claims of which it then has notice.

MOULE, HAMILTON & DERHAM, 224 Queen-street, Melbourne. 1970

JOHN MARQUIS, late of 17 Mount Pleasant-drive, Mount Waverley, in the State of Victoria, retired bootmaker, DECEASED.

CREDITORS, next of kin and others having claims in respect of the estate of the deceased (who died on the 7th day of December, 1963), are required by the personal representative, Norman James Gibbs, of 17 Mount Pleasant-drive, Mount Waverley, to send particulars to him, care of the undersigned solicitors, by the 18th day of August, 1964, after which date the personal representative may convey or distribute the assets, having regard only to the claims of which the said Norman James Gibbs then has notice.

Dated the 21st day of July, 1964.

CORR & CORR, solicitors, 290 Latrobe-street, Melbourne. 1906

CREDITORS, next of kin and others having claims in respect of the estate of Lillia Camelia Cardwell (also known as Lily Camelia Cardwell), late of Flat 4, 27 Range-street, Camberwell, in the State of Victoria, widow, deceased (who died on the 13th day of April, 1964), are to send particulars of their claims to The Trustees, Executors and Agency Company Limited, of 401 Collins-street, Melbourne, the executor of the said estate, by 30th day of September, 1964, after which date it will distribute the assets, having regard only to the claims of which it then has notice.

AKEHURST, FRIEND & HAACK, solicitors, of 405 Collins-street, Melbourne. 1912

JOHN ANDREW BRODY, late of 1 Peers-street, East Brunswick, in the State of Victoria, gentleman, DECEASED.

CREDITORS, next of kin and others having claims in respect of the estate of the deceased (who died on the 5th day of April, 1964), are required by the personal representative, Noel Patrick Brody, of 35 St. Andrews-avenue, Rosanna, to send particulars to him by the 4th September, 1964, after which date the personal representative may convey or distribute the assets, having regard only to the claims of which he then has notice.

Dated the 29th day of July, 1964. 1946

CREDITORS, next of kin and others having claims in respect of the estate of Elizabeth Harriet Couchman, late of 60 Hanover-street, Brunswick, widow (who died on the 31st July, 1963), are to send particulars of their claims to The Equity Trustees, Executors and Agency Company Limited, of 472 Bourke-street, Melbourne, by the 29th day of October, 1964, after which date it will distribute the assets, having regard only to the claims of which it then has notice.

R. H. DUNN, solicitor, 178 Queen-street, Melbourne. 1947

CREDITORS, next of kin and others having claims in respect of the estate of Alfred Joseph Veness, late of 67 Green-street, Ivanhoe, in the State of Victoria, retired, deceased (who died on the 23rd day of May, 1964), are to send particulars of their claims to the Equity Trustees, Executors and Agency Company Limited, of 472 Bourke-street, Melbourne, by the 8th day of October, 1964.

H. B. V. DIMELow, solicitor, 422 Collins-street, Melbourne. 1948

CREDITORS, next of kin and others having claims against the estate of Christopher George McRae, formerly of 8 Stanley-street, Carrum, but late of 42 Mentone-parade, Mentone, retired farmer, deceased (who died on the 13th day of June, 1964), are to send particulars of their claims to The Trustees, Executors and Agency Company Limited at its registered office, 401 Collins-street, Melbourne, by the 1st day of October, 1964, after which date the said company will distribute the assets, having regard only to the claims of which it then has notice.

EUSTACE L. J. MURPHY, solicitor, 40 Queen-street, Melbourne. 1971

CREDITORS, next of kin and others having claims in respect of the estate of Isabella Georgina Everett, late of 63 O'Grady-street, Albert Park, married woman, deceased (who died on the 8th day of February, 1964), are required to send particulars of their claims to the executor, The Union Fidelity Trustee Company of Australia Limited, of 333 Collins-street, Melbourne, by the 27th day of September, 1964, after which date the said executor will distribute the assets, having regard only to the claims to which they then have notice.

M. F. HUGHES, LL.B., barrister and solicitor, 300 Barkly-street, Brunswick, N.10. 1952

LILLIAN RUTH PITHER, late of Riversdale-court, Hawthorn, in the State of Victoria, married woman.

CREDITORS, next of kin and others having claims in respect of the estate of the deceased (who died on the 21st day of February, 1964), are requested by the trustee, The Equity Trustees, Executors and Agency Company Limited, of 472 Bourke-street, Melbourne, to send particulars to it by the 30th day of September, 1964, after which date the trustee may convey or distribute the assets, having regard only to the claims of which it then has notice.

W. E. PEARCEY & IVEY, 90 William-street, Melbourne, solicitors for The Equity Trustees, Executors & Agency Co. Ltd. 1949

CREDITORS, next of kin and others having claims in respect of the estate of Maggie Fairbairn McIntyre, formerly of "Mountside", Winchelsea, in Victoria, but late of "Varna", Lorne, in Victoria, widow, deceased (who died on the 6th day of April, 1964), are required by the executors, Hector Charles McIntyre, of "Wargoona", Winchelsea, aforesaid, and Donald Armytage McIntyre, of "Mountside", Winchelsea, aforesaid, graziers, to send particulars to them, care of the under-mentioned solicitors, by the 30th day of September, 1964, after which date they may convey or distribute the assets, having regard only to the claims of which they then have notice.

AITKEN, WALKER & STRACHAN, solicitors, 123 William-street, Melbourne. 1955

CREDITORS, next of kin and others having claims in respect of the estate of George Hayes, late of Tooborac, grazier, deceased (who died on the 12th day of January, 1964, and probate of whose will was granted by the Supreme Court of Victoria, on the 17th day of July, 1964, to Charles Henry Hayes of Nulla Vale, via Lancefield, grazier, and Walter John McLay, of Harpin-street, Bendigo, accountant, the executors named in the said will), are to send particulars of their claims to the solicitors for the said executors, at the address hereunder mentioned, by the 18th day of November, 1964, after which date the executors will distribute the assets, having regard only to the claims of which they then have notice.

COHEN KIRBY & CO., solicitors, cnr. Pall Mall and Bull-street, Bendigo, solicitors for the said executors. 1940

CREDITORS, next of kin and others having claims in respect of the estate of Margery Elizabeth Read, late of 7 Brook-street, Hawthorn, married woman, deceased (who died on 11th December, 1963), are required by the executors Donald Davies Read of Warramong, Tarcutta, in the State of New South Wales, grazier, and Kenneth Michael Abbott Smith of 217 Highfield-road, Camberwell, in the State of Victoria, gentleman, to send particulars of their claims to them, care of Rogers & Gaylard, solicitors, of 281 Collins-street, Melbourne, by the 7th day of October, 1964, after which date the said executors will distribute the assets of the deceased, having regard only to the claims of which they then shall have had notice.

ROGERS & GAYLARD, solicitors, 281 Collins-street, Melbourne. 1964

CREDITORS, next of kin and others having claims in respect of the estate of Harold Ernest Wigney Nicklen, late of Bunyip, farmer, deceased (who died on the 22nd day of June, 1964), are required to send particulars of their claims to The Union-Fidelity Trustee Company of Australia Limited (in the will called the Fidelity Trustee Company Limited), at its registered office, situate at 333 Collins-street, Melbourne, by the 7th day of October, 1964, after which date it will distribute the assets, having regard only to the claims of which it then shall have had notice.

ROGERS & GAYLARD, solicitors, 281 Collins-street, Melbourne. 1965

MARGARET AMELIA WALLACE, late of 31 George-street, Fitzroy, widow, DECEASED.

CREDITORS, next of kin and others having claims against the estate of the above-named deceased (who died on the 29th day of March, 1964), are to send particulars of their claims to National Trustees, Executors and Agency Company of Australasia Limited, addressed to the registered office of the said company, at 95 Queen-street, Melbourne, by the 30th day of September, 1964, after which date the said company will distribute the assets, having regard only to the claims of which it then has notice.

H. H. HOARE, solicitor, 118 Queen-street, Melbourne. 1909

CREDITORS and others having claims against the estate of Philip John Crowley, formerly of 134 Toorak-road, South Yarra, but late of 201 Burnley-street Richmond, retired railway employee, deceased (who died on the 28th day of May, 1964), are required to send particulars, in writing, of their claims to John Cooke, of 383 Collins-street, Melbourne, solicitor, the executor of the will of the said deceased, on or before the 30th day of September, 1964, after which date he will distribute the assets, having regard only to the claims of which he shall have had notice.

COOKE & CUSSEN, solicitors, 383 Collins-street, Melbourne. 1924

CREDITORS, next of kin and others having claims in respect of the estate of William Sydney Robinson, late of "Kilmarie", Portsea, farmer, deceased (who died on 13th September, 1963), are to send the particulars of their claims to the executor, Eugene Gorman, of 13 Otrira-road, Caulfield, Queen's Counsel, by the 7th day of October, 1964, after which date it will distribute the assets, having regard only to the claims of which it then has notice.

ARTHUR ROBINSON & CO., solicitors, 360 Collins-street, Melbourne. 1919

CREDITORS, next of kin and others having claims in respect of the estate of Eric Cottrell, late of 21 Rochester-road, Canterbury, mining engineer, deceased (who died on 29th October, 1963), are to send particulars of their claims to the executrix, Maxine Betty Cottrell, of 21 Rochester-road, Canterbury, widow, by the 7th day of October, 1964, after which date it will distribute the assets, having regard only to the claims of which it then has notice.

ARTHUR ROBINSON & CO., solicitors, 360 Collins-street, Melbourne. 1918

JOHANNES PETSCHER, late of Hopetoun, farmer, DECEASED.

CREDITORS, next of kin and others having claims in respect of the estate of the deceased (who died on the 19th day of February, 1964), are required by the executors of the will, Leonard Reginald Petschel, of Rainbow, farmer, and George Grant Edelsten, of Portland, retired farmer, to send particulars of their claims to the said executors, care of the under-mentioned solicitors, by the 7th day of October, 1964, after which date they may distribute the assets, having regard only to the claims of which they then have notice.

HIGGS, PETERSEN & DUNNE, solicitors, Rainbow. 1917

CARL JOHANNES LUDWIG ANDERSON, late of Tarran-yurk, farmer, DECEASED.

CREDITORS, next of kin and others having claims in respect of the estate of the deceased (who died on the 19th September, 1963), are required by the executors of the will, Charles Alfred Anderson, of Woomelang, first constable of police, and Allen Leslie Anderson, of Tarran-yurk, farmer, to send particulars to them, care of the under-mentioned solicitors, by the 1st day of October, 1964, after which date the executors may distribute the assets, having regard only to the claims of which they then have notice.

HIGGS, PETERSEN & DUNNE, solicitors, Rainbow. 1916

JANE CHRISTIAN TURNBULL, formerly of "Myoora", Irving-road, Toorak, but late of Cliveden Mansions, Wellington-parade, Melbourne, spinster, DECEASED.

CREDITORS, next of kin and others having claims against the estate of the deceased (who died on 25th June, 1963), are required by the executors, John Ralph Burt and Hubert Silvers Black, to send particulars to them, care of 120 William-street, Melbourne, by the 1st October, 1964, after which date they may convey and distribute the assets, having regard only to the claims of which they then have notice.

BLAKE & RIGGALL, solicitors, 120 William-street, Melbourne. 1915

CREDITORS, next of kin and others having claims in respect of the estate of Charles Donoghue, late of Bairnsdale, grazier, deceased (who died on the 13th September, 1963), are to send particulars of their claims to The Union-Fidelity Trustee Company of Australia Limited, of 333 Collins-street, Melbourne, by the 15th day of October, 1964, after which date it will distribute the assets, having regard only to the claim of which it then has notice.

J. I. LANFRANCHI, solicitor, Bairnsdale. 1889

KARL KLEIN, late of Clyde, in the State of Victoria, service station proprietor, DECEASED.

CREDITORS, next of kin and others having claims in respect of the estate of the deceased (who died on the 23rd day of October, 1962), are required by Elizabeth Klein, of Clyde, widow, and William Brunt Campbell, of Clyde North, farmer, to send particulars to them; care of John Patrick Rhoden, of 376 Collins-street, Melbourne, by the 2nd day of October, 1964, after which date the trustees may convey or distribute the assets, having regard only to the claims of which they then have notice.

Dated the 27th day of July, 1964.

JOHN P. RHODEN, solicitor, 376 Collins-street, Melbourne. 1914

HERMINE ELISE LAIRD-SMITH, late of 47-49 Ormond Esplanade, Elwood, in Victoria, widow, DECEASED.

CREDITORS, next of kin and others having claims in respect of the estate of the above-named deceased (who died on 26th December, 1962), are required by the executors, Geoffrey John Laird-Smith, of Mooreville-road, Burnie, in Tasmania, farmer, and Edward August Kayser, of Rembrandt Strasse, 29 Dusseldorf 4, in West Germany, gentleman, to send particulars to them, care of the under-mentioned solicitors, by the 30th September, 1964, after which date the executors may convey or distribute the assets, having regard only to the claims of which they then have notice.

MCCRACKEN & MCCRACKEN, solicitors, 317 Collins-street, Melbourne. 1974

FLORENCE ELIZABETH WICKLIFFE HODGES, late of 61 Vanberg-road, Essendon, widow, DECEASED.

CREDITORS, next of kin and others having claims in respect of the estate of the above-named deceased (who died on 10th June, 1964), are required by the executrix, Mariamne Helene Speer, of 61 Vanberg-road, Essendon, married woman, to send particulars to her, care of the under-mentioned solicitors, by the 30th September, 1964, after which date the executrix may convey or distribute the assets, having regard only to the claims of which she then has notice.

MCCRACKEN & MCCRACKEN, solicitors, 317 Collins-street, Melbourne. 1973

ELLA MURIEL FARAGHER, late of 8 Church-street, Drouin, spinster, DECEASED.

CREDITORS, next of kin and others having claims in respect of the estate of the above-named deceased (who died on 20th May, 1964), are required by the executor and executrix, Raymond Sydney Schmidt, student, and Elvie Margaret Schmidt, married woman, both of 15 Selwyn-street, Canterbury, to send particulars to them, care of the under-mentioned solicitors, by the 30th September, 1964, after which date the executor and executrix may convey or distribute the assets, having regard only to the claims of which they then have notice.

MCCRACKEN & MCCRACKEN, solicitors, 317 Collins-street, Melbourne. 1975

JOHN EDWARD LAZARUS, late of 136 Nicholson-street, East Brunswick, milk bar proprietor, DECEASED.

CREDITORS, next of kin and others having claims in respect of the estate of the above-named deceased (who died on 31st May, 1964), are required by the executors, John Edward Lazarus, of 2 O'Connor-street, Reservoir, textile mechanic, and Leslie Kenneth Lazarus, of 9 Kelsby-street, Reservoir, electrical engineer, to send particulars to them, care of the under-mentioned solicitors, by the 30th September, 1964, after which date the executors may convey or distribute the assets, having regard only to the claims of which they then have notice.

MCCRACKEN & MCCRACKEN, solicitors, 317 Collins-street, Melbourne. 1976

HENRY WOODS, late of Repatriation Hospital, Heidelberg, pensioner, DECEASED.

CREDITORS, next of kin and others having claims in respect of the estate of the above-named deceased (who died on 23rd May, 1964), are required by the applicant for probate, Mavis Quick, of 61 Inkerman-street, St. Kilda, assistant examiner, to send particulars to her, care of the under-mentioned solicitors, by the 30th September, 1964, after which date the applicant for probate may convey or distribute the assets, having regard only to the claims of which she then has notice.

MCCRACKEN & MCCRACKEN, solicitors, 317 Collins-street, Melbourne. 1977

HAROLD HUNT, late of 11 Trevethic-road, Springvale, in Victoria, retired market gardener, DECEASED.

CREDITORS, next of kin and others having claims in respect of the estate of the above-named deceased (who died on 13th May, 1964), are required by the executors, Richard George Hunt, of Tullimbar, Albion Park, in New South Wales, school teacher, and Ian George Hunt, of 139 Rowan-street, Wangaratta, in Victoria, representative, to send particulars to them, care of the under-mentioned solicitors, by the 30th September, 1964, after which date the executors may convey or distribute the assets, having regard only to the claims of which they then have notice.

MCCRACKEN & MCCRACKEN, solicitors, 317 Collins-street, Melbourne. 1978

CREDITORS, next of kin and others having claims in respect of the estate of Cecil Norris, formerly of Lower Hutt, New Zealand, but latterly of 434 St. Kilda-road, Melbourne, director of sales, deceased (who died on 25th December, 1962), are to send the particulars of their claims to the personal representative, Henry Francis Howden Selleck, of 360 Collins-street, Melbourne, solicitor, by the 7th day of October, 1964, after which date it will distribute the assets, having regard only to the claims of which it then has notice.

ARTHUR ROBINSON & CO., solicitors, 360 Collins-street, Melbourne. 1922

CREDITORS, next of kin and others having claims in respect of the estate of Arthur Marks Coulson, late of 16 Kirkwood-avenue, Sandringham, managing director, deceased (who died on the 11th day of August, 1963), are to send the particulars of their claims to the executrix, Lydia Coulson, of 16 Kirkwood-avenue, Sandringham, widow, by the 7th day of October, 1964, after which date it will distribute the assets, having regard only to the claims of which it then has notice.

ARTHUR ROBINSON & CO., solicitors, 360 Collins-street, Melbourne. 1923

CREDITORS, next of kin and others having claims in respect of the estate of Samuel Childs, late of Mount View-road, Upper Fern Tree Gully, in the State of Victoria, retired railway employee, deceased (who died on the 17th day of November, 1963), are required by the executor, John Thomas Winters, of Dawson-street, Upper Fern Tree Gully, in the said State, garage proprietor, to send particulars of their claims to him, care of Winifred McCook, solicitor, 173 Whitehorse-road, Ringwood, by the 30th day of September, 1964, after which date the said executor will distribute the assets of the deceased, having regard only to the claims of which he then shall have had notice.

WINIFRED MCCOOK, LL.B., 173 Whitehorse-road, Ringwood. 1886

CREDITORS, next of kin and others having claims in respect of the estate of Donald James McDonnell, late of Bairnsdale, retired, deceased (who died on the 27th October, 1963), are to send particulars of their claims to the Union-Fidelity Trustee Company of Australia Limited, of 333 Collins-street, Melbourne, by the 15th day of October, 1964, after which date it will distribute the assets, having regard only to the claim of which it then has notice.

J. I. LANFRANCHI, solicitor, Bairnsdale. 1888

CREDITORS, next of kin and others having claims in respect of the estate of Walter Solomon Joseph, late of 386 Orrong-road, Caulfield, manufacturer, deceased (who died on 14th July, 1962), are to send the particulars of their claims to the executors, Elsie Antionette Heugle, of 53 Munro-street, North Kew, married woman, and Frank Wilson Bett, of 360 Collins-street, Melbourne, solicitor, by the 7th day of October, 1964, after which date it will distribute the assets, having regard only to the claims of which it then has notice.

ARTHUR ROBINSON & CO., solicitors, 360 Collins-street, Melbourne. 1921

CREDITORS, next of kin and others having claims in respect of the estate of Ethel Mary Robertson, late of "Englefield", Illabo, New South Wales, married woman, deceased (who died on the 21st day of February, 1964) are to send the particulars of their claims to The Union-Fidelity Trustee Company of Australia Limited, of 333 Collins-street, Melbourne, by the 1st day of October, 1964, after which date it will distribute the assets, having regard only to the claims of which it then has notice.

HULL, NEWNS & LORD, solicitors, 58 Gray-street, Hamilton. 1871

PATRICK BALFE, late of 2 Capel-street, West Melbourne, retired, DECEASED.

**CREDITORS**, next of kin and others having claims in respect of the estate of the deceased (who died on the 15th day of January, 1963), are required by the executor, Hubert George Gabriel Mercovich, to send particulars to the undersigned solicitors, by the 6th day of October, 1964, after which date the executor may convey or distribute the assets, having regard only to the claims of which he then has had notice.

WILFRID J. OSBORNE & OSBORNE, solicitors, Seymour.  
1939

**CREDITORS**, next of kin and others having claims in respect of the estate of Anthony Arthur Robinson, late of 36 Walsh-street, South Yarra, solicitor, deceased (who died on 21st March, 1964), are to send the particulars of their claims to the executors, Beverley Nelson Robinson of 36 Walsh-street, South Yarra, widow, and Hugh Matheson Morgan of 16 Millicent-avenue, Toorak, solicitor, care of the under-mentioned solicitors, by 7th October, 1964, after which date the executors may convey or distribute the assets, having regard only to the claims of which they then have notice.

ARTHUR ROBINSON & CO., solicitors, 360 Collins-street, Melbourne.  
1928

**CREDITORS**, next of kin and others having claims in respect of the estate of Frances Mary Mellow, late of 5129 Washington Boulevard, St. Louis 8, Missouri, in the United States of America, widow, deceased (who died on 15th October, 1962), are to send the particulars of their claims to the personal representative Henry Francis Howden Selleck, of 360 Collins-street, Melbourne, solicitor, by the 7th day of October, 1964, after which date it will distribute the assets, having regard only to the claims of which it then has notice.

ARTHUR ROBINSON & CO., solicitors, 360 Collins-street, Melbourne.  
1920

RE LILLIAN SARAH MEAD, late of Kilgour-street, Geelong, spinster, DECEASED.

**CREDITORS**, next of kin and all persons having claims against the estate of the above-named are required by the executrix of the will, Harriet Ethel Lee, of Waterdale-road, Ivanhoe, widow, to send particulars to her, care of the under-mentioned solicitors, on or before 30th September, 1964, after which date she will distribute the assets, having regard only to the claims of which she then has notice.

BIRDSEY & BARTLETT, solicitors, 166A Ryrie-street, Geelong.  
1873

**CREDITORS**, next of kin and others having claims against the under-mentioned person are required to send particulars thereto to May Elva Marsh, care of R. P. Barrett & Son, solicitors, 473 Bourke-street, Melbourne, on or before the 30th day of September, 1964, otherwise they may be excluded when the assets are being distributed. Name: Sarah Coop, late of 150 Hotham-street, St. Kilda, widow, deceased. Date of death: 15th day of May, 1964.

R. P. BARRETT & SON, solicitors, 473 Bourke-street, Melbourne.  
1903

**CREDITORS**, next of kin and others having claims in respect of the estate of Alice Jessie Jamieson, late of 80 Emo-road, East Malvern, retired teacher, deceased (who died on the 1st April, 1964), are required to send particulars of their claims to the executor The Union Fidelity Trustee Company of Australia Limited of 333 Collins-street, Melbourne, by the 30th September, 1964, after which date the said executor will distribute the assets, having regard only to the claims to which they then have notice.

WATERS & STEWART, solicitors, 422 Collins-street, Melbourne.  
1963

MARGARET MARY SULLIVAN, late of 31 Edsall-street, Malvern, widow, DECEASED.

**CREDITORS**, next of kin and others having claims in respect of the estate of the deceased (who died on the 30th day of April, 1964), are required by the personal representative, National Trustees, Executors and Agency Company of Australasia Limited, of 95 Queen-street, Melbourne, to send particulars to it, by the 5th day of October, 1964, after which date the said Company may convey or distribute the assets, having regard to claims of which it then has notice.

THOMAS BURKE, LL.B., B.COMM., barrister & solicitor, 152 Wattle-tree-road, Malvern.  
1938

**CREDITORS**, next of kin and all others having claims in respect of the estate of Isabel Ruth Fitzpatrick, late of 33 High-street, Mont Albert, married woman, deceased (who died on the 2nd day of March, 1964), are required by her executors The Trustees Executors and Agency Company Limited, of 401 Collins-street, Melbourne, and Bertram Charles Fitzpatrick of 33 High-street, Mont Albert, patent attorney, to send particulars of their claims, to the said Company, at its said address, by the 1st day of October, 1964, after which date the said executors will distribute the assets, having regard only to the claims of which they then have notice.

HADEN SMITH & FITCHETT, solicitors, 450 Collins-street, Melbourne.  
1961

In the Supreme Court of the State of Victoria.

SALE BY THE SHERIFF.

**ON** Wednesday, the 9th of September, 1964, at Two p.m., at Post Office, St. Leonards (unless process be stayed or satisfied):—

All the estate and interest (if any) of Edward John Twomey, of 39 Howard-street, Reservoir, as proprietor of an estate in fee simple in the land described in certificate of title, volume 8310, folio 370.

The land which is vacant is situated on the south side of Fairview-street, St. Leonards, 46 ft. 6 in. from the corner of Cliff-street, and has a frontage of 54 feet, and a depth of 119 ft. 4 in. on the east side, and a depth of 127 ft. ½ in. on the west side, and has a width of 54 ft. 6½ in. on the south side.

Terms—Cash only.

JOHN SHIRLEY, Sheriff's Officer.

22nd July, 1964.  
1941

In the Supreme Court of the State of Victoria.

SALE BY THE SHERIFF.

**ON** Tuesday, the 8th of September, 1964, at Ten-thirty a.m., at the Police Station, Clayton (unless process be stayed or satisfied):—

All the estate and interest (if any) of Gabor Pongracz, of 412 Warrigal-road, South Oakleigh, builder, as proprietor of an estate in fee simple in the land described in certificate of title, volume 5658, folio 590, upon which are erected brick flats and known as 412 Warrigal-road, South Oakleigh. The said land which is lot 30 on plan of subdivision No. 13185, has been re-subdivided into lots 1 to 5 (both inclusive) on plan of subdivision No. 64646.

Registered mortgages No. B.646537 and B.708508, affect the said estate and interest.

Terms—Cash only.

DAVID J. JOHNSTON, Sheriff's Officer.

21st July, 1964.  
1911

In the Supreme Court of the State of Victoria.

SALE BY THE SHERIFF.

**ON** Tuesday, the 8th of September, 1964, at 10 a.m., at the Police Station, Prahran (unless process be stayed or satisfied):—

All the estate and interest (if any) of Charles Henry Appleton, of 36 York-street, Prahran, tram driver, as proprietor of an estate in fee simple in the land described in certificate of title, volume 2741, folio 044, upon which is erected a single-fronted weatherboard dwelling-house known as No. 36 York-street, Prahran.

Registered mortgage No. B.920021 affects the said estate and interest.

Terms—Cash only.

DAVID J. JOHNSTON, Sheriff's Officer.

27th July, 1964.  
1953

In the Supreme Court of the State of Victoria.

SALE BY THE SHERIFF.

**ON** Tuesday, the 8th of September, 1964, at 10 a.m., at the Police Station, Coburg (unless process be stayed or satisfied):—

All the estate and interest (if any) of Francesco Lumbica (also known as Francesco Lumbaco), waterside worker, of 5 Harriet-street, Coburg, as proprietor of an estate in fee simple in the land described in certificate of title, volume 4285, folio 822, upon which is erected a weatherboard dwelling-house known as No. 5 Harriet-street, Coburg.

Registered mortgage No. B.410931 affects the said estate and interest.

Terms—Cash only.

N. FROGLEY, Sheriff's Officer.

27th July, 1964.  
1954

**IMPOUNDINGS**

**COHUNA.**—Impounded in Cohuna Pound.  
 1 Hereford steer, moon notch left ear, no visible brand  
 If not claimed and expenses paid, to be sold on 13th August, 1964.  
 R. E. KNOWLES,  
 1867—12/ Municipal Clerk.

**DONALD.**—Impounded in Donald Pound by Shire Ranger G. L. Burton, from Swanwater North-road, Cope Cope.  
 2 Shorthorn cows with heifers at foot, no visible brand  
 If not claimed and expenses paid, to be sold on 14th August, 1964.  
 W. A. CAMERON,  
 1983—16/ Poundkeeper.

**HEIDELBERG.**—Impounded in Diamond Creek Pound.  
 1 red Hereford bull calf, no visible brand  
 1 black Hereford heifer calf, no visible brand  
 1 Jersey calf, no visible brand  
 If not claimed and expenses paid, to be sold on 13th August, 1964.  
 F. PHILLIPS,  
 1900—16/ Town Clerk.

**HUNTLY.**—Impounded in the Huntly Pound, from the Midland Highway at Huntly, by the Country Roads Board Inspector, on 21st July, 1964.  
 1 red or brown vealer heifer, white star, no visible brand  
 4 red or brown steers, no visible brands  
 1 red or brown steer, white star, white on belly and tail, no visible brand  
 1 Jersey type steer, no visible brand  
 1 red Shorthorn type steer, no visible brand  
 1 red Shorthorn type bullock, no visible brand  
 1 white Shorthorn type bullock, no visible brand  
 1 Jersey type steer, no visible brand  
 1 brindle and white steer, no visible brand  
 1 roan Shorthorn type steer, no visible brand  
 If not claimed and expenses paid, to be sold on 11th August, 1964.  
 G. SLOAN,  
 1870—36/ Poundkeeper.

**WARRAGUL.**—Impounded in Warragul Pound, from Warragul Showgrounds, on 17th July, 1964.  
 1 brown Jersey heifer (poley), approximately two years old, no visible brand  
 If not claimed and expenses paid, to be sold on 6th August, 1964.  
 E. McGRATH,  
 1869—16/ Poundkeeper.

*Subordinate Legislation Act 1962.*

**NOTICE OF MAKING OF STATUTORY RULES.**

IN pursuance of the provisions of the *Subordinate Legislation Act 1962* and the Regulations made thereunder, notice is given of the making of the following statutory rules:—

No.	Motor Car Act 1958.	Price. s. d.
89/1964.	Motor Car (General Amendment No. 2) Regulations 1964 .. .. .	0 6
	Mental Health Act 1959 (No. 6605), Section 113.	
90/1964.	Mental Health (Car Mileage Rates) Amendment Regulations 1964 .. .. .	0 6

No.	Seeds Act 1958 (No. 6364).	Price. s. d.
91/1964.	Seed Certification (Currie Cocksfoot) Regulations 1964 .. .. .	0 6
	Health Act 1958 (No. 6270).	
92/1964.	Meat Transport Vehicles (Amendment) Regulations 1964 .. .. .	0 6
	Fisheries Act 1958.	
93/1964.	Commercial Fisheries Council (Mileage Rates) Regulations 1964 .. .. .	0 6
	Motor Car Act 1958.	
94/1964.	Premiums Committee (Mileage Rates) Regulations 1964 .. .. .	0 6
	Racing Act 1958.	
95/1964.	Dog Racing Control Board (Mileage Rates) Regulations 1964 .. .. .	0 6
	Police Offences Act 1958.	
96/1964.	Police Offences (Animals) Regulations 1964 .. .. .	0 9

Copies of these statutory rules may be purchased at the Sale of Publications Section of the Government Printing Office, located at Macarthur-street, Melbourne, C.2. If ordered by mail, remittance should be addressed to "The Government Printer, Box 203, P.O., North Melbourne, N.1.", and should include 5d. extra for postage.

A. C. BROOKS,  
 Government Printer.

**CONTENTS**

	PAGE
Act of Parliament .. .. .	2456
Appointments .. .. .	2475
Auction Sales Act .. .. .	2469
Bank Holidays .. .. .	2456
Cemeteries—Scale of Fees .. .. .	2470
Contracts .. .. .	2462
Country Roads Board .. .. .	2467
Estates of Deceased Persons .. .. .	2457
Government Notices .. .. .	2457
Impoundings .. .. .	2510
Lands .. .. .	2485
Melbourne and Metropolitan Board of Works— Notice .. .. .	2457
Mining .. .. .	2461
Notice of Making of Statutory Rules .. .. .	2510
Orders in Council—	
Acts—Land; Fruit and Vegetables; Country Roads; Town and Country Planning; Local Government; Mildura Irrigation and Water Trusts; Sewerage Districts; Housing.	2477 et seq
Private Advertisements .. .. .	2496
Proclamations .. .. .	2455
Public Holidays .. .. .	2456
Public Service Notices .. .. .	2492
Resignations .. .. .	2477
Tenders .. .. .	2488
Transport Regulation Board—Public Hearings .. .. .	2458
Waterworks Trusts .. .. .	2469