



VICTORIA
GOVERNMENT GAZETTE

Published by Authority

[Registered at the General Post Office, Melbourne, for transmission by post as a newspaper.]

No. 70]

WEDNESDAY, AUGUST 5

[1964

PUBLIC HALF-HOLIDAYS.

PROCLAMATION

By the Lieutenant-Governor as Deputy for His Excellency the Governor of the State of Victoria and its Dependencies in the Commonwealth of Australia, &c., &c., &c.

IN pursuance of the provisions contained in Part III. of the *Public Service Act 1958*, I, the Lieutenant-Governor as Deputy for the Governor of the State of Victoria, in the Commonwealth of Australia, by and with the advice of the Executive Council of the said State, do by this my Proclamation appoint the days and dates hereunder mentioned to be observed as Public Half-Holidays at the places respectively specified, viz.:—

Public Half-Holidays from the Hour of Twelve o'clock noon:—

WEDNESDAY, THE 14TH OCTOBER, 1964, throughout the Shire of Charlton.

FRIDAY, THE 4TH SEPTEMBER, 1964, throughout the Shire of Korong.

WEDNESDAY, THE 16TH SEPTEMBER, 1964, throughout the Shire of Seymour.

*WEDNESDAY, THE 14TH OCTOBER, 1964, throughout the North and Tyrrell Ridings and the Township of Culgoa, in the Shire of Wycheproof.

*WEDNESDAY, THE 21ST OCTOBER, 1964, throughout the South and Central Ridings, excluding the Township of Culgoa, in the Shire of Wycheproof.

* Agricultural Show.

Given under my Hand and the Seal of the State of Victoria aforesaid, at Melbourne, this fourth day of August, in the year of our Lord One thousand nine hundred and sixty-four, and in the thirteenth year of the reign of Her Majesty Queen Elizabeth II.

(L.S.)

E. F. HERRING.

By His Excellency's Command,

V. F. WILCOX,
Acting Chief Secretary.

GOD SAVE THE QUEEN!

BROADFORD COMMON DIMINISHED.

PROCLAMATION

By His Excellency the Governor of the State of Victoria and its Dependencies in the Commonwealth of Australia, &c., &c., &c.

WHEREAS by Division 12 of Part I. of the *Land Act 1958* it is amongst other things enacted that the Governor in Council may from time to time increase, and, after one month's notice in the *Government Gazette*, diminish, alter, or abolish any common, and may from time to time re-proclaim the whole or any part of any such common for any of the purposes and subject to the provisions of the said Part of the said Act, and that nothing therein contained shall prevent the exercise of the powers conferred by the said Part of the said Act with respect to the leasing or licensing of any land comprised in any common: And whereas notice of the intention to diminish the Broadford Common has been duly published in the *Government Gazette* for one month:

Now therefore I, the Governor of the State of Victoria, in the Commonwealth of Australia, by and with the advice of the Executive Council of the said State, do hereby diminish the Broadford Common proclaimed as such on the 30th August, 1886, by deducting therefrom 1 rood 20 perches comprised within boundaries as defined by description published in the *Government Gazette* of the 17th June, 1964.—(C.70447).

Given under my Hand and the Seal of the State of Victoria aforesaid, at Melbourne, this twenty-eighth day of July, in the year of our Lord One thousand nine hundred and sixty-four, and in the thirteenth year of the reign of Her Majesty Queen Elizabeth II.

(L.S.)

ROHAN DELACOMBE.

By His Excellency's Command,

JIM BALFOUR,
Commissioner of Crown Lands and Survey.

GOD SAVE THE QUEEN!

MONASH UNIVERSITY (AMENDMENT) ACT 1964.

DATE OF COMING INTO OPERATION.

PROCLAMATION

By the Lieutenant-Governor as deputy for His Excellency the Governor of the State of Victoria and its Dependencies in the Commonwealth of Australia, &c., &c., &c.

WHEREAS by an Act of the Parliament of the State of Victoria passed in the thirteenth year of the reign of Her Majesty Queen Elizabeth II. intitled the *Monash University (Amendment) Act 1964* it is amongst other things enacted that the Act shall come into operation on a day to be fixed by Proclamation of the Governor in Council published in the *Government Gazette*: Now therefore I, the Lieutenant-Governor as Deputy for the Governor of the State of Victoria acting by and with the advice of the Executive Council thereof do by this my Proclamation fix Friday the seventh day of August, One thousand nine hundred and sixty-four, as the date upon which the said *Monash University (Amendment) Act 1964* shall come into operation in the said State of Victoria.

Given under my Hand and the Seal of the State of Victoria aforesaid, at Melbourne, this fourth day of August, in the year of our Lord One thousand nine hundred and sixty-four, and in the thirteenth year of the reign of Her Majesty Queen Elizabeth II.

(L.S.)

E. F. HERRING.

By His Excellency's Command,

JOHN BLOOMFIELD,

Minister of Education.

GOD SAVE THE QUEEN!

Land Act 1958, section 25.

THE TOWNSHIP DESIGNATION OF LYNDHURST SOUTH ALTERED TO SKYE.

PROCLAMATION

By His Excellency the Governor of the State of Victoria and its Dependencies in the Commonwealth of Australia, &c., &c., &c.

I, THE Governor of the State of Victoria in the Commonwealth of Australia, by and with the advice of the Executive Council of the said State and in pursuance of the provisions contained in section 25 of the *Land Act 1958* do hereby proclaim that the designation of the Township proclaimed on the 15th July, 1952, is hereby altered from Lyndhurst South to Skye.—(L.101^(r)) (C.93720).

Given under my Hand and the Seal of the State of Victoria aforesaid, at Melbourne, this twenty-eighth day of July, in the year of our Lord One thousand nine hundred and sixty-four, and in the thirteenth year of the reign of Her Majesty Queen Elizabeth II.

(L.S.)

ROHAN DELACOMBE.

By His Excellency's Command,

JIM BALFOUR,

Commissioner of Crown Lands and Survey.

GOD SAVE THE QUEEN!

Motor Car Act 1958, Section 51.

EFFECTIVE DATE OF WITHDRAWAL BY AUTHORIZED INSURER.

WHEREAS by notice in writing dated the twenty-eighth day of July, 1964, the following authorized insurer under Part V. of the *Motor Car Act 1958*, namely:—

ATLAS ASSURANCE COMPANY LIMITED

has withdrawn from insurance business in terms of the aforesaid Part:

Now therefore, I, Her Majesty's Acting Chief Secretary for the State of Victoria, in pursuance of the provisions of section 41 of the said Act, do hereby specify the 1st day of November, 1964, as the date upon which such notice of withdrawal shall have effect.

V. F. WILCOX,

Acting Chief Secretary.

Chief Secretary's Office,
Melbourne, 30th July, 1964.

Melbourne and Metropolitan

BOARD OF WORKS.

GENERAL NOTICE.

THE Melbourne and Metropolitan Board of Works, having made sewers for carrying off the sewage from each and every property which, or any part of which, abuts on the streets or parts of streets in which such sewers are laid, and which are included within the sewerage areas hereinafter described, doth hereby declare that on and after the 5th September, 1964, each and every property which, or any part of which, abuts on the said streets or parts of streets, shall be deemed to be a sewered property within the meaning of the *Melbourne and Metropolitan Board of Works Act 1958*.

The Sewerage Areas hereinbefore referred to are:—

Sewerage Area No. 1891.

City of Waverley.—Commencing at the intersection of Huntingdale-road and High Street-road; thence easterly along High Street-road, southerly along the eastern boundary of a reserve and the eastern boundaries of lots 8 and 11 Broilga-street and lot 16 Cheviot-road, further southerly along the western boundaries of lots 28 to 25 Farquarson-street, easterly along the southern boundary of the said lot 25, southerly along Farquarson-street, easterly along Holskamp-street, southerly along Stephenson's-road to the boundary of Sewerage Area No. 1844, generally south-westerly, northerly, westerly, northerly and westerly along the boundary of Sewerage Area No. 1844 to the boundary of Sewerage Area No. 1676, northerly, westerly and north-westerly along the boundary of Sewerage Area No. 1676 to the boundary of Sewerage Area No. 1647, northerly along the boundary of Sewerage Area No. 1647 to the boundary of Sewerage Area No. 1681, northerly along the boundary of Sewerage Area No. 1681 to the commencing point.

Sewerage Area No. 1892.

City of Sunshine.—Commencing at the intersection of Berkshire-road and Busch-street; thence easterly along Berkshire-road to the boundary of Sewerage Area No. 1884, southerly and westerly along the boundary of Sewerage Area No. 1884 to the boundary of Sewerage Area No. 1804, further westerly along the boundary of Sewerage Area No. 1804 to the boundary of Sewerage Area No. 1635, further westerly along the boundary of Sewerage Area No. 1635 to the boundary of Sewerage Area No. 1699, northerly along the boundary of Sewerage Area No. 1699 to the commencing point.

Further particulars regarding the streets or parts of streets in which sewers have been laid may be ascertained on inquiry at the Board's office.

By order of the Board,

H. J. SNADDEN, Secretary.

110 Spencer-street, Melbourne, C.I, 4th August, 1964.

LAW DEPARTMENT.

APPOINTMENT AMENDED.

HIS Excellency the Governor of the State of Victoria, by and with the advice of the Executive Council thereof, doth, by Order made on the 28th day of July, 1964, amend the Order in Council approved on the 14th July, 1964, appointing Douglas McLean Lindsay to Keep the Peace in the Central Bailiwick of the State of Victoria by the substitution of the words "Southern Bailiwick" for the words "Central Bailiwick".

J. COLQUHOUN,

Clerk of the Executive Council.

At the Executive Council Chamber,
Melbourne, 28th July, 1964.

LAW DEPARTMENT.

CURATOR OF CONVICT'S PROPERTY.

HIS Excellency the Governor of the State of Victoria, by and with the advice of the Executive Council thereof, doth, by Order made on the 28th day of July, 1964, pursuant to the provisions of section 550 of the *Crimes Act 1958*, direct that the custody and management of the property of the convict Alexander Morrison be committed to Valwynne Clare Morrison, of 136 Shannon-avenue, Geelong West, as a curator hereby appointed in that behalf.

J. COLQUHOUN,

Clerk of the Executive Council.

At the Executive Council Chamber,
Melbourne, 28th July, 1964.

Transport Regulation Act.
TRANSPORT REGULATION BOARD.

HEARING OF APPLICATIONS.

NOTICE is hereby given that the following applications will be considered by the Transport Regulation Board at its offices at Rathdown-street, Carlton, at 10.15 a.m. on Thursday, 27th August, 1964.

Applications for a Metropolitan Private Hire Car licence by persons listed hereunder to operate one commercial passenger vehicle with seating capacity for five persons from the depot of Luxury Cars Ltd.
BELL, K. C., 9 Sutton-parade, Box Hill.
BRYGEL, M., 7 Oulton-street, North Caulfield.
BURNS, K. W., 49 Exhibition-street, McKinnon.
BYRNE, J. R., Flat 16, 2 Redan-street, St. Kilda.
COALL, P. J., 257 Rathmines-street, Fairfield.
GEORGE, C., 7 Lennox-street, Moonee Ponds.
GRAY, R. W., 17 Payne-street, Caulfield.
HEANEY, R. H., 487 Elgar-road, Box Hill.
ITALIANO, N., 150 Eley-road, South Blackburn.
JONES, R. G., 131 Peel-street, Kew.
MICALLEF, P., 67 Winifred-street, Oak Park.
MOLNAR, G., Flat 15, 119 Brighton-road, Elsternwick.
NICHOLS, G. S., 96 Eskdale-road, Caulfield.
OLSEN, O., 13 Kingston-street, Hampton.
PARKER, A. E., 31 Morton-street, Clayton.
PARKER, C. E., 1 Molden-street, Bentleigh.
PETERSON, B. M., 68 Clarke-street, Prahran.
POLLOCK, M. Mc., Flat 2, 1 Manningtree-road, Hawthorn.
PUGLIESE, R., 92 Gardenvale-road, Gardenvale.
ROBERTSON, R. M., 15 Almay-grove, Heidelberg.
ROGERS, W. J., "Dawn", Gleghorn-road, Kallista.
SODING, J. R., 103 Gordon-street, Balwyn.
STEER, D. E., 8 Bournville-avenue, East Brighton.
GIBBS, E., 4 Highland-avenue, Clayton.
WHISTON, E. V., 858 Drummond-street, North Carlton.
BOUNDY, J. J., 42 Alwyn-street, Mitcham.

Notice of any objection should be forwarded to reach the Secretary of the Board not later than Wednesday, 19th August, 1964.

B. P. KAY,
Secretary.

Exhibition Buildings, Rathdown-street, Carlton, N.3,
Wednesday, 5th August, 1964.

Transport Regulation Act.
TRANSPORT REGULATION BOARD.

HEARING OF APPLICATIONS.

NOTICE is hereby given that the following applications will be considered by the Transport Regulation Board at its offices at Rathdown-street, Carlton, at 10.15 a.m. on Wednesday, 26th August, 1964.

CURREN, R. W., 528 Barkers-road, Hawthorn. Application to operate metropolitan passenger service Route 78A (Camberwell-Canterbury-East Kew) as at presently operated under licences held by the applicant with the following amendment to present service:—To extend service from the corner of Doncaster and Balwyn roads via Balwyn-road, Larbert-avenue, Stroma-avenue and Balwyn-road to normal route. (Sections, fares and time-table to be determined).
GRAY, K. G., 142 Pine-avenue, Mildura. One commercial passenger vehicle (S/C. 5) to operate under the same terms and conditions as existing taxi-cabs licensed at Mildura.
HURLE, M. J., 275 Campbell-street, Swan Hill. One commercial passenger vehicle (S/C. 11) to operate as a country special service omnibus within a 50-mile radius of Swan Hill.
KING, V. F., 5 Main-street, Mornington. One commercial passenger vehicle (S/C. 5) to operate under the same terms and conditions as existing taxi-cabs licensed at Mornington, subject to the cancellation of licence C.H.92 in the name of the applicant.
MANLEY, L. G., Serpentine.—One commercial passenger vehicle (S/C. 30) to operate for the carriage of school children only between Pickles corner to East Loddon Consolidated School under contract to the Education Department.
NORTH SUNSHINE BUS SERVICE PTY. LTD., 7 Hall-street, Yarraville. One commercial passenger vehicle (S/C. 35) to be purchased, to operate as an additional metropolitan stage omnibus on Route 131A (Sunshine-North Sunshine) under the same terms and conditions as licences already held by the applicant company.
RENNIE, F. H., & SON PTY. LTD., 285 Station-street, Box Hill. Application to operate Route 67A (Box Hill-Burwood-Jordanville) deviation A as at present operated under M.O. licences held by the applicant with the following amendments to present service.

To amend existing route to operate from the Box Hill Railway Station via Station-street, Canterbury-road, Haig, Foch, and Station streets, Riversdale-road, Station-street, Burwood-road, Parer, Puerta and Somers streets, Waratah-avenue, Warrigal-road to Burwood Tram Terminus, return trips to be operated via Burwood-road, Central-avenue, Louden-road and Warrigal-road to route.

RICHARDS, S., 14 Wolverhampton-street, Footscray. Application for permit authority to operate vehicle licence No. M.C.424 at separate and distinct fares for the carriage of munitions workers between Sunshine and the Maribyrnong Commonwealth Munitions Factories via Hampshire-road, Station and Monash streets, South-road, Ashley-road, Alma-street, Elphinstone-street, Barkly-street and Gordon-street.

TIME-TABLE.

Depart Sunshine	.. 6.55 a.m.
Depart Factory	.. 4.15 p.m.

RICHARDS, S., 14 Wolverhampton-street, Footscray. Application for permit authority to operate vehicle licence M.C.425 at separate and distinct fares for the carriage of munitions workers between Newport West and the Maribyrnong Commonwealth Munitions Factories via Champion, Melbourne, Williamstown and Geelong roads, Gordon and Mitchell streets, Rosamond-road and Williamson-road.

TIME-TABLE.

Depart Newport West	.. 6.40 a.m.
Depart Factories	.. 4.15 p.m.

RUSSELL, V. E. (Mrs.), 656 Bell-street, Pascoe Vale. One commercial passenger vehicle (S/C. 6) to operate free of charge for the carriage of infant children to and from the suburbs of Coburg, Pascoe Vale, Broadmeadows, Brunswick, and Preston to and from the applicant's day nursery situated at 97 Bell-street, Coburg.

RYAN BROS. BUS SERVICE PTY. LTD., 42 Brunel-street, Essendon. One commercial passenger vehicle (S/C. 32) to operate as an additional metropolitan stage omnibus on Route 15A (Moonee Ponds-Aberfeldie) under the same terms and conditions as licences already held in the applicant's name.

CURRER, R. W. (trading as Sandringham-Mentone Bus Lines), 379 Beach-road, Mentone. One commercial passenger vehicle to be purchased with a large seating capacity to operate as an additional country stage omnibus on Route 216A (Mentone-Black Rock-Sandringham) under the same terms and conditions as licences already held by the applicant.

TRANS OTWAY LTD., corner Ryrie and Fenwick streets, Geelong. One commercial passenger vehicle with (S/C. 33) to operate as follows:—(a) Under the same terms and conditions as existing C.O. licences in the name of the applicant company. (b) For the carriage of school children only between Bellbrea and Geelong under contract to the Education Department. Subject to cancellation of licence U.O.447 in the name of the applicant company.

TURNBULL, A. A., Commercial-road, Yarram. One commercial passenger vehicle (S/C. 35) to operate as follows:—(1) For the carriage of school children only between Yarram and Tooloonook via Lord's-lane thence to North Devon State School thence to Yarram High School under contract to the Education Department. (2) As a country special service omnibus from Yarram.

UREN, R. H., South Gippsland Highway, Lang Lang. One commercial passenger vehicle (S/C. 5) to operate under private hire conditions from Lang Lang.

VENTURA MOTORS PTY. LTD., 1037 Centre-road, South Oakleigh. One commercial passenger vehicle with large seating capacity to operate as a Country stage omnibus on the following route:—

Mount Waverley-Monash University.—Commencing at Mount Waverley Railway Station via Stephenson's-road, Waverley-road, Forster-road, Gardiners-road, into University grounds and through to Wellington-road.

Sections and Fares.—1. Mt. Waverley-corner Waverley and Stephenson's roads, 6d. 2. Corner Waverley and Stephenson's roads-corner Wilca and Forester roads, 9d. 3. Corner Wilca and Forester roads-corner Fern Tree Gully and Forster roads, 1s. 4. Corner Fern Tree Gully and Forster roads-corner Gardiners-road and West Gate, 1s. 1d. 5. Corner Gardiners-road and West Gate-Wellington-road (University) 1s. 2d.

Time-table (to be operated on days when University is open for student tuition only, Mondays—Fridays.—Depart Mount Waverley 8.40 a.m.. Depart University 5.50 p.m.

NOTE.—This application replaces that previously gazetted wherein permit rights only were sought.

NOTE.—No pick up or set down of intermediate traffic between Mt. Waverley Station and corner Waverley-road and Forster-road.

WILLIS BUS SERVICE PTY. LTD., 518 Canterbury-road, Vermont. Application for a required number of commercial passenger vehicles to operate on the following route:—*Nunawading-East Burwood.*—Commencing from the Nunawading Railway Station via Station-street, Mt. Pleasant-road, Eugenia-street, Lasiandra-avenue, Canterbury-road, Mahoneys-road, Barter-crescent, Norma-road and Springvale-road to Channel O, returning via the same route to the corner of Mt. Pleasant-road and East India-avenue thence via East India-avenue and Springvale-road to Nunawading Railway Station. (Sections, fares and time-table to be determined.)

APPLICATIONS for renewal of licences as shown, by persons listed hereunder to operate under the same terms and conditions:—

BROADBENT, B., 17 June-street, Morwell, C.T.770.

BRYCE, D. L. F., and the estate of the late G. L. Bryce, Beulah; T.P.116.

CLARKE, L. T., 31 High-street, Terang; T.S.222.

CURREN, R. W., 528 Barkers-road, Hawthorn; T.P.188.

HERITAGE, F. S., Maroondah Highway, Healesville; C.H.445.

HURREN, M. G., Taroona-avenue, Warrandyte; C.T.356.

JOHNSON, A. C. & A. J., 117 Edgar-street, Portland; C.T.85.

KILLEAN, P. V. & G. M., 36 Ocean-grove, Warrnambool; C.T.91.

MOLESWORTH, E. M., 529 St. George's-road, Thornbury; T.P.141.

MORWELL TAXIS, 14 Denise-street, Morwell; C.T.84.

MCQUADE, J. A., & B. T. LOWRY, Nullawil; T.P.120.

PARKINSON, A., 5 Corio-street, Moonee Ponds; T.P.132.

PARRETT, A. W., 5 Dodds-street, Camperdown; C.T.81.

ROBERTS, J. H., Tallangatta; T.P.53.

NORMAN SMORGAN & SONS PTY. LTD., Somerville-road, Brooklyn; T.P.63.

SONNTAG, E. R., Box 136, Jeparit; T.P.48.

THOMAS BORTHWICK & SONS PTY. LTD., 543 Little Collins-street, Melbourne; T.P.67.

TREZISE, A. R., "Kinder-Gaye" Private Kindergarten, 350 Hightt-street, Richmond; T.P.140.

WARRNAMBOOL BUS LINES PTY. LTD., 273 Raglan-parade, Warrnambool; C.O.299.

WOOLNOUGH, A. S. & G. F., Fenwick-street, Portarlington; C.O.43.

Notice of any objection should be forwarded to reach the Secretary of the Board not later than Wednesday, 19th August, 1964.

Applicants are advised that it will not be necessary to appear on the hearing date specified above, unless advised, in writing, by the Board.

B. P. KAY,

Secretary.

Exhibition Buildings, Rathdown-street, Carlton, N.3, Wednesday, 5th August, 1964.

Commercial Goods Vehicles Act.

TRANSPORT REGULATION BOARD.

HEARING OF APPLICATIONS.

NOTICE is hereby given that the following applications will be considered by the Transport Regulation Board at its offices at Rathdown-street, Carlton, at 10.15 a.m. on Wednesday, 26th August, 1964.

BARKLA, G. J., 24 Veronica-street, East Bentleigh. One commercial goods vehicle (126 cwt.) to operate within a 50-mile radius of the premises of Tarax Drinks (Huntingdale) Pty. Ltd., at Huntingdale—aerated waters in glass containers, empty return containers and up to 20 cartons of canned aerated water on behalf of the said company.

BENTLEY, J. N. & R. M., Snells-road, Nar-Nar-Goon. One commercial goods vehicle (135 cwt.) to operate: (a) Within a 35-mile radius of the premises of Bayview Quarries Pty. Ltd., at Narre Warren—screenings and stone dust solely on behalf of the said company. (b) From pits situate within the radius as defined in paragraph (a) above to the said premises—sand.

BODINNAR, S. C., PTY. LTD., Nyah West. Application to vary the conditions of licence No. D.A.696 (L/C. 117 cwt.) by adding to the existing conditions as paragraph (c) "Within a 20-mile radius of Nyah West—general goods".

BROWN, C. J., 17 James-street, Aspendale. One commercial goods vehicle (80 cwt.) to operate throughout the State of Victoria as a "Marine Dealer"—marine goods as designated in the *Marine Stores and Old Metals Act 1958* (No. 6303).

BURT, R. G., 9 Sayle-street, Sebastopol. One commercial goods vehicle (30 cwt.) to operate throughout the State of Victoria in the course of business as "Scrap Metal Dealer"—scrap metals excluding the carriage of any such goods to wharves, docks or ships for shipment or export purposes.

BUTTERWORTH, G. M. & V. F., Buchan South. Application to vary the conditions of licence No. D.A.48613 (L/C. 159 cwt.) by adding to the existing conditions:—(a) "Within a 50-mile radius of Buchan Post Office—firewood. (b) From forest areas situated within a 20-mile radius of Buchan Post Office to Bruthen Railway Station—railway sleepers".

CANT, F. W., & I. R. JONES, 88 Waterloo-road, Trafalgar. One commercial goods vehicle (150 cwt.) to operate within a 50-mile radius of own depot at Trafalgar and to Seaspray and Stratford—aerated waters having been purchased from Marchants and Co. Ltd., all goods so carried having been initially consigned by rail to Trafalgar.

COLEMAN, C. O., Post Office, Toongabbie. One commercial goods vehicle (40 cwt.) to operate: (a) Within a 20-mile radius of Toongabbie—general goods. (b) Within a 50-mile radius of Toongabbie—own goods solely in course of business as a "Primary Producer". (c) In an area bounded by the Townships of Bairnsdale, Yarram and Warragul—own stud stock to shows and stud stock sales.

COLGATE PALMOLIVE PTY. LTD., 660 Footscray-road, West Melbourne. Two commercial goods vehicles (9 and 10 cwt.) to operate in the course of business as "Soap and Cosmetic Manufacturers": (a) Within a 50-mile radius from own premises at West Melbourne own goods. (b) Throughout the State of Victoria for the purpose of sales promotion—display materials, tools of trade and equipment incidental thereto and samples of own goods.

COOMBS, A. G., PTY. LTD., 20 Cochranes-road, Moorabbin. One commercial goods vehicle (11 cwt.) to operate throughout the State of Victoria in the course of business as "Heating Engineers"—tools of trade, spare parts and equipment incidental to the installation, servicing and maintenance of air conditioning units and heating systems.

CORNTHWAITE, R. I., 36 Armstrong-street, Charlton. One commercial goods vehicle (101 cwt.) to operate within a 100-mile radius of Charlton in the course of business as "Builder"—tools of trade, scaffolding, and small quantities of materials incidental to completion of own contracts.

DAVIS, C. E., 9 Foley-street, Euroa. One commercial goods vehicle (80 cwt.) to operate throughout the State of Victoria in the course of business as "Marine Collector"—marine goods as designated in the *Marine Stores and Old Metals Act 1958* (No. 6303) but excluding the carriage of any such goods to wharves, docks or ships for shipment or export purposes.

DUNKLEY, D., 7 Gardiner-street, Berwick. One commercial goods vehicle (145 cwt.) to operate: (a) Within a 35-mile radius of the premises of Bayview Quarries Pty. Ltd., at Berwick—screenings and stone dust on behalf of the said company. (b) From pits situate within the above radius to the said premises—sand.

FITHALL, W. E., 13 Victoria-street, Hamilton. Application to vary the conditions of licence No. D.A.50996 (L/C. 5 cwt.) by deleting the existing conditions and adding in lieu:—"Within a 50-mile radius from post office at Hamilton in the course of business as 'Electrical Salesman'—electrical goods for repair or having been repaired, tools of trade, spare parts or any other goods being the property of W. McDonald, Goldsmith-street, Hamilton—electrical agent for Healings Pty. Ltd."

GENERAL MOTORS—HOLDEN'S PTY. LTD., Princes Highway, Dandenong. Two commercial goods vehicles (10 cwt. each) to operate within a 50-mile radius of own premises at Dandenong in the course of business as "Motor Vehicle Distributors"—own motor parts and chassis members.

GREAT EASTERN BRICK CO. LTD., Janette-street, Traralgon. One commercial goods vehicle (121 cwt.) to operate within a 70-mile radius of own premises at Traralgon and to the Township of Lakes Entrance—own bricks.

- MALE, H. E.** (trading as H. P. M. Water Carriers), Fisheries-road, Devon Meadows. One commercial goods vehicle (77 cwt.) to operate within a 50-mile radius of post office at Cranbourne as a water tanker unit.
- JACKSON, K. W.**, 24 Willoughby-street, Reservoir. One commercial goods vehicle (97 cwt.) to operate: (a) Within a 25-mile radius of the G.P.O., Melbourne—general goods. (b) Within a 70-mile radius of the premises of Hoffman Brick and Potteries Pty. Ltd., at Brunswick—bricks solely on behalf of the said company.
- JEFFREY, J., & SONS PTY. LTD.**, Wegner-street, Morwell. Two commercial goods vehicles (7 and 10 cwt.) to operate within a 70-mile radius from the post office at Yarram for the purpose of supervising own contracts in the course of business as "Civil and Construction Engineers"—tools of trade, spare parts and materials incidental to the repair of own equipment or the completion of own contracts.
- JOHNSON, R. S. & S. J.**, The Esplanade, Lakes Entrance. One commercial goods vehicle (8 cwt.) to operate throughout that part of Victoria east of a north/south line drawn through Traralgon in the course of business as "Tire Distributors"—new tires and tubes, tires and tubes for repair or having been repaired, and batteries.
- JOSEPH, K. M., & Co. PTY. LTD.**, Box 36, P.O., Prahran. One commercial goods vehicle (65 cwt.) to operate in the course of business as "Electrical Engineers":—(a) Within a 50-mile radius from the post office at the corner of Bourke-street and Elizabeth-street, in the City of Melbourne—own goods. (b) Throughout the State of Victoria—tools of trade and equipment only. (c) Within a 20-mile radius from any project currently under construction and engaged upon—materials for use on such project.
- LITTLEHALES, R. M.**, 340 Humffray-street, Ballarat. One commercial goods vehicle (212 cwt.) to operate: (a) Within a 20-mile radius from the Township of Beech Forest—railway sleepers and rails, plant and equipment. (b) From any section of the closed railway line between the Township of Weeaproun and the City of Colac only to the Colac railway yards—railway sleepers, rails and associated materials on behalf of the Victorian Railways Commissioners.
- LIVINGSTONE, L. V.**, Buchan. One commercial goods vehicle (255 cwt.) to operate within a 50-mile radius of post office at Buchan and that part of the State of Victoria east of a north/south line drawn through Buchan in the course of business as "Contractors"—own bulldozers, tractors and associated equipment.
- LOBB, E. G.**, 7 Hall-road, Hernes Oak, via Yallourn. One commercial goods vehicle (174 cwt.) to operate from forest and private landings in the Noojee, Licola and Yarram areas and within a 25-mile radius of A.P.M. Maryvale to the said premises—pulpwood.
- LUCAS, K. J., & W. F. VAN DAMME**, 135 Murdock-road, Wangaratta. One commercial goods vehicle (approximately 500 cwt.) to operate: (a) Within a 100-mile radius of post office at Wangaratta—own earth-moving equipment. (b) From contract site to contract site within a 50-mile radius of Wangaratta—earth-moving equipment on behalf of other contractors.
- MACLEOD, J. K.**, George's-road, The Patch. One commercial goods vehicle (11 cwt.) to operate throughout the State of Victoria in the course of business as "Builder"—tools of trade and small quantities of materials for the completion and supervision of own contracts.
- MAURI BROS. & THOMSON (ENGINEERS) PTY. LTD.**, 509 Williamstown-road, Port Melbourne. Three commercial goods vehicles (18, 7 and 7 cwt.) to operate throughout the State of Victoria in the course of business as "Engineers" for the purpose of servicing own manufactured food processing machines—tools of trade, spare parts and materials incidental thereto, also machinery parts for repair or having been repaired.
- MOTOR SPARES LTD.**, 28 Faithful-street, Wangaratta. One commercial goods vehicle (7 cwt.) to operate within a 50-mile radius of Wangaratta in course of business as "Automobile Accessories Distributors"—motor parts and accessories, electrical goods and marine motors.
- MURRAY, W. A.**, 51 Watson-street, Wodonga. One commercial goods vehicle (150 cwt.) to operate within a 50-mile radius of the premises of Border Ready Mixed Pty. Ltd., at Wodonga in a specially constructed agitator vehicle—ready mixed concrete solely on behalf of the said company.
- MCCARTHY, K. T.**, 7 Dunlop-street, Yarrowonga. One commercial goods vehicle (220 cwt.) to operate within a 50-mile radius of the Victoria/New South Wales border at Yarrowonga as a "Road Contractor"—road-making plant and materials.
- MCGUINNESS, L. A.**, "Avonlea", Rollins-road, Lovely Banks. One commercial goods vehicle (200 cwt.) to operate within a 50-mile radius from the chief post office in the City of Geelong as a water tanker unit.
- NITSCHKE, M. G.**, Noradjuha. One commercial goods vehicle (10 cwt.) to operate: (a) Within a 50-mile radius of own premises at Noradjuha in the course of business as "General Storekeeper and Grazier"—own goods. (b) Within a 50-mile radius of Noradjuha—drummed petroleum products and empty return drums on behalf of Esso Standard Oil (Aust.) Pty. Ltd.
- NORTH-EAST LOGGING CO. PTY. LTD.**, Booth-street, Rutherglen. Two commercial goods vehicles (146 and 258 cwt.) to operate: (a) From Forest Commission landings in the House Creek, Mt. Ben and Gypsey Creek areas to the Glen Creek sawmills at Glen Creek—logs. (b) From Forest Commission forest landings in the Whitlands and Myrrhee areas to the Rutherglen Timber Co. sawmills at Rutherglen—logs. (c) From Rutherglen Timber Co. yards at Rutherglen and Glen Creek sawmills at Glen Creek to consignees within a 50-mile radius of the afore-mentioned sawmills at Rutherglen and Glen Creek—sawn timber. (d) From Forest Commission forest at Mt. Bogong to Mt. Beauty Timber Pty. Ltd. at Tawonga—logs. (e) Within a 50-mile radius from Tawonga mill of Mt. Beauty Timber Pty. Ltd.—sawn timber.
- PETERS, I. B.**, Jumbunna-road, Korumburra. One commercial goods vehicle (116 cwt.) to operate: (a) Within a 20-mile radius of Korumburra—general goods. (b) Within a 50-mile radius of the Caltex Oil Co. Pty. Ltd. depot at Korumburra—petroleum products in prescribed types of containers and empty returns.
- READER, G. E.**, Springvale-road, Springvale South. Application to vary the conditions of licence No. D.A.44551 (L/C. 79 cwt.) by adding to the existing conditions "Within a 50-mile radius of Springvale in the course of business as 'Shell-grit Distributor'—shell grit."
- RINGWOOD TIMBER & TRADING CO. PTY. LTD.**, Maroondah Highway, Ringwood. One commercial goods vehicle (259 cwt.) to operate from Geelong to own premises at Ringwood in the course of business as "Timber and Hardware Merchants"—own bagged cement.
- THERMAL TRADERS (VIC.) PTY. LTD.**, 55 Flemington-road, North Melbourne. One commercial goods vehicle (11 cwt.) to operate throughout the State of Victoria in the course of business as "Liquid Gas Suppliers" for the purposes of servicing and maintaining liquid gas cylinders—tools of trade and materials incidental to such work.
- TURNBULL, J. M. (Mrs.)**, care of Private Bag 241, Horsham. One commercial goods vehicle (11 cwt.) to operate within a 50-mile radius of post office at Horsham as a "Herd Tester"—herd testing equipment on behalf of Horsham and District Herd Testing Association.
- WEAVER, R. E. & H. M.** (trading as T.W. Transport), Box 12, Peshurst. One commercial goods vehicle (213 cwt.) to operate: (a) Within a 50-mile radius of post office at Peshurst as a "Road Contractor"—road-making plant and materials. (b) Within a 20-mile radius of post office at Peshurst—general goods.
- VAN GAAL, W. H.**, Commercial-road, Yarram. One commercial goods vehicle (144 cwt.) to operate within a 30-mile radius of Yarram in course of business as "Builder and Joiner"—tools of trade, equipment and materials incidental to the completion of own contracts.
- VICTORIAN MASTER BUTCHERS LTD.**, 86 Stubbs-street, Kensington. One commercial goods vehicle (19 cwt.) to operate throughout the State of Victoria in the course of business as "Butchers Supplies Distributors"—own goods.
- WARTON, E. S.**, 26 Sturt-street, Mulwala, N.S.W. One commercial goods vehicle (234 cwt.) to operate within a 50-mile radius of the Victoria/New South Wales border at Yarrowonga as a "Road Contractor"—road-making plant and materials.
- WENTWORTH, S. B. & W. A.**, 26 Loch-terrace, East Geelong. One commercial goods vehicle (149 cwt.) to operate within a 50-mile radius of the premises of Hawaiian Australian Concrete Pty. Ltd. at Corio—concrete masonry.

WHEELDON, J. D., 67 McLeod-street, Bairnsdale. Application to vary the conditions of licence No. D.A.47216/1 (L/C. 130 cwt.) by deleting the existing conditions and adding in lieu "(a) Within an 85-mile radius of post office at Orbost (Bairnsdale Division of C.R.B.) as a 'Road Contractor'—road-making plant and materials. (b) Within a 20-mile radius of post office at Bairnsdale—general goods."

WOPENKA, J. & O., 11 Calder Highway, East Keilor. One commercial goods vehicle (121 cwt.) to operate throughout the State of Victoria in the course of business as "Travelling Showman"—own generating plant and equipment.

TOW TRUCKS.

WESTON, G., & V. AHYEE (trading as A.W. Panels), 104 Dandenong-road, Frankston. One commercial goods vehicle (70 cwt.) to operate throughout the State of Victoria as a "Tow Truck" for the purpose of lifting and carrying or towing and/or repairing wrecked or disabled vehicles—tools of trade, spare parts and materials incidental thereto.

CARROLL, J. P., Mountjoy-parade, Lorne. One commercial goods vehicle (60 cwt.) to operate within a 100-mile radius of post office at Lorne as a "Tow Truck" for the purpose of lifting and carrying or towing and/or repairing wrecked or disabled vehicles—tools of trade, spare parts and materials incidental thereto.

APPPLICATION for renewal of licence as shown, by persons listed hereunder to operate under the same terms and conditions from the date of expiry shown in each case.

ALT, S. H., 31 Edward-street, Horsham; D.A.38857; 11th April, 1964; 150 cwt.

DALTON, D. P., Whorouly, via Wangaratta; D.A.40639; 24th October, 1964; 76 cwt.; D.A.40639/1; 24th October, 1964; 119 cwt.

MURPHY, J. F., 1 Wondah-street, Tallangatta; D.A.40348/1; 24th October, 1964; 116 cwt.

PROCESSED FISH DISTRIBUTORS PTY. LTD., 8 Fishmarket, New Footscray-road, West Melbourne; T.D.A.34729/5; 3rd September, 1964; 21 cwt.

TRANS OTWAY LTD., cnr. Ryrle and Fenwick streets, Geelong; D.A.2179/15; 22nd October, 1964; 66 cwt.; D.A.2179/16; 22nd October, 1964; 68 cwt.

TOW TRUCK.

PETTS, W. F., Albert-road, Creswick; T.D.A.37081; 7th September, 1964; 17 cwt.

Notice of any objection should be forwarded to reach the Secretary of the Board not later than 19th August, 1964.

Applicants are advised that it will not be necessary to appear on the hearing date specified above, unless advised, in writing, by the Board.

B. P. KAY,
Secretary.

Exhibition Buildings, Rathdown-street, Carlton, N.3, 5th August, 1964.

DEPARTMENT OF MINES.

SUBJECT to any necessary excision, &c., it is proposed to grant the following mining leases:—

8153, Mineral; Walter Brown and Kenneth Blackmore; 19a. Or. 29p., Parish of Korumburra.

8225, Mineral; Wilhelm Johann Kruger; 10 acres, Parish of Banu Boniyit.

MINING LEASE GRANTED.

8238, Mineral; Ivan John Harrington Walscott; 10a. 1r. Op., Parish of Kinabulla.

CONSENTS GRANTED TO TRANSFER WATER RIGHT LICENCES.

1230, Water Right; from Kenneth Wright to Glen Wills Goldfields No Liability.

1234, Water Right; from Kenneth Wright to Glen Wills Goldfields No Liability.

T. A. DARCY,
Minister of Mines.

LOCAL GOVERNMENT DEPARTMENT.

ORDER CONFIRMED.—SHIRE OF PHILLIP ISLAND.

THE Minister of the Crown administering the *Local Government Act 1958*, as amended, on the 14th day of July, 1964, confirmed the Order hereinafter referred to in pursuance of section 514 of the said Act, namely:—

An Order of the Council of the Shire of Phillip Island made on the 18th March, 1964, directing the compulsory taking of the land described hereunder for the purpose of extending and increasing the recreation reserve at Cowes:—

Those parts of lots 8, 9, 10, 11 and 12 on plan of subdivision No. 9412, lodged in the Office of Titles, bounded by the eastern boundaries of the said lots and a line parallel to and distant 66 feet westerly therefrom.

R. J. HAMER,

Minister for Local Government.

Local Government Department,
Melbourne.

LOCAL GOVERNMENT DEPARTMENT.

ORDER CONFIRMED.—SHIRE OF CRANBOURNE.

THE Minister of the Crown administering the *Local Government Act 1958*, as amended, on the 25th day of June, 1964, confirmed the Order hereinafter referred to in pursuance of section 514 of the said Act, namely:—

An Order of the Council of the Shire of Cranbourne made on the 8th May, 1964, directing the compulsory taking of the land described hereunder for the purpose of providing a Public Purposes Reserve:—

All that piece or parcel of land commencing at a point reached by lines bearing respectively north 400 links, west 248.5 links from the south-east corner of Crown allotment 5, Township and Parish of Cranbourne; and thence bounded by lines bearing west 151.5 links, north 100 links, east 151.5 links and south 100 links to the commencing point.

M. V. PORTER,

Minister for Local Government.

Local Government Department,
Melbourne.

LOCAL GOVERNMENT DEPARTMENT.

SHIRE OF BERWICK.—ORDER CONFIRMED.

THE Minister of the Crown administering the *Local Government Act 1958*, as amended, on the 29th day of June, 1964, confirmed the Order hereinafter referred to in pursuance of section 514 of the said Act, namely:—

An order of the Council of the Shire of Berwick made on the 17th February, 1964, directing the compulsory taking of all that piece of land being lot 4 on plan of subdivision No. 2788, lodged at the Office of Titles, for the purpose of re-aligning Railway-avenue.

M. V. PORTER,

Minister for Local Government.

Local Government Department,
Melbourne.

Teaching Service Act 1958 (No. 6391).

TEACHERS TRIBUNAL ELECTION.

PURSUANT to the provisions of the Teachers Tribunal Regulations, I hereby declare that the election conducted by me on the 27th of July, 1964, has resulted in—

DOUGLAS RANKING BROWN, being elected as member of the Teachers Tribunal, and

JOHN HARRIS (State School No. 824, Preston South), being elected as the deputy of such member.

R. H. BIGGS,

Returning Officer.

POLICE OFFENCES ACT 1958.

IN pursuance of the powers conferred upon the Chief Secretary by sub-section (3) of section 184 of the *Police Offences Act 1958*, I, the Acting Chief Secretary of the State of Victoria, do by this notice grant exemption from compliance with sub-sections (1) and (2) of section 184 of the said Act with respect to the publication of "The Lovely Sergeant" distributed by Colorgrature Publications, 26-30 Flinders-street, Melbourne.

V. F. WILCOX,

Acting Chief Secretary.

Chief Secretary's Office,
Melbourne, 30th July, 1964.

COMPANIES ACT 1961.

NOTICE is hereby given that in pursuance of section 308 (5) of the Companies Act 1961 the names of the companies referred to below have been struck off the Register, and on publication of this Notice in the Government Gazette the said companies will be dissolved.

Dated this 28th day of July, 1964.

T. S. WELSH,
Registrar of Companies.

Companies Registration Office,
Melbourne.

COMPANIES ABOVE REFERRED TO.		Number of Registration.	
Name of Company.			
Devon and Cornwall Gold Mining Company Limited	M1	Southern Cross Consols Quartz Mining Company No Liability	M44
Bright Star Quartz Mining Company Limited	M2	The Coopers Creek Sluicing Company Limited	M45
The Argus United No. 1 Tribute Quartz Mining Company Limited	M3	South Johnson's Tribute Company Limited	M46
The Wonderful Reef Quartz Mining Company Limited	M4	Princess Alexandra Tribute Company St. Mungo Line Eaglehawk Limited	M47
The Cerberus Quartz Gold Mining Company Limited	M5	The Band of Hope Quartz Mining Company Limited	M48
Oriental Quartz Mining Company Sandhurst Limited	M6	The New Moon Tribute Quartz Mining Company No Liability	M49
The South Golden Fleece Gold Mining Company No. 2 Limited	M7	Essex Gold Mining Company Limited	M50
Myrtle Reef Freehold Gold Mining Company Limited	M8	The Specimen Gully Extended Quartz Gold Mining Company Limited	M51
Extended South Myrtle Creek Mining Company Limited	M9	The Southern Cross Consols Quartz Mining Company No Liability	M52
New Myrtle Creek Quartz Mining Company Limited	M10	Union Gold Mining Company Limited	M53
The New Fear Not Tribute Company No. 2 Limited	M11	Golden Dream Gold Mining Company Limited	M54
Extended Chewton United Gold Mining Company Limited	M12	The Welcome Gold Mining Company Limited	M55
Echo Tribute Quartz Mining Company Limited	M13	Newington and Pleasant Creek Quartz Mining Company Registered	M56
Australian United Tribute No. 1 Company Limited	M14	The Mountain Rose Gold Mining Company Limited	M57
South Richard Heales Quartz Mining Company Registered	M15	Wheal Friendship Gold Mining Company Limited	M58
South Ramrod Quartz Mining Company Registered Limited	M16	The Mackintosh's Vineyard Reef Gold Mining Company No Liability	M59
Duke & Duchess of Cornwall Extended Gold Mining Company Limited	M17	North Band of Hope Gold Mining Company Limited	M60
Redan Tribute Company Limited	M18	Charleston Quartz Mining Company Limited	M61
The Jennie Wilton Gold and Quartz Mining Company Limited	M19	Railway Gold Mining Company Limited	M62
Duke of Edinburgh Quartz Mining Company Limited	M20	Pioneer Deep Sinking Mining Company No Liability	M63
The South Prince of Wales Tribute Company Limited	M21	The Royal South Extended Hustlers Quartz Mining Company Limited	M64
Vulcan Quartz Mining Company Limited	M22	The Marquis of Lorne Quartz Mining Company Limited	M65
Purdett Coutts Quartz Mining Company Limited	M23	The Great Golden Fleece Gold Mining Company Limited	M66
The Golden Elephant Tribute Company Limited	M24	Britannia Gold and Antimony Mining Company Limited	M67
Great Extended South Dead Cat Quartz Gold Mining Company Limited	M25	The Young Franklin Company Limited	M68
Ponte Quartz Mining Company Limited	M26	Argus Company No. 2 Limited	M69
The Pearl Gold Mining Company Limited	M27	Albion Quartz Mining Company Limited	M70
The Labrador Gold Mining Company Limited	M28	North Catherine Extended Quartz Mining Company No Liability	M71
North Canadian Gold Mining Company Limited	M29	The North Specimen Hill Tribute Company No. 1 Limited	M72
Mount Tarrangower Gold Mining Company Maldon Limited	M30	United Star Quartz Mining Company No Liability	M73
North Park Mining Company No Liability	M31	Albert Gold Mining Company Registered	M74
The Haddon Great Extended Gold Mining Company No Liability	M32	The Christmas and Possum United Tribute Company Limited	M75
Locomotive Gold Mining Company Limited	M33	Caledonian Quartz and Alluvial Gold Mining Company Limited	M76
North Cumberland Gold Mining Company Limited	M34	The North Easter Quartz Mining Company Limited	M77
Princess Louise Gold Mining Company Limited	M35	The United Working Miners Gold Mining Company Limited	M78
The Extended Chewton United Gold Mining Company Limited	M36	South Imperial Garden Gully Quartz Mining Company Limited	M79
The Wheal Terrill Quartz Mining Company No Liability	M37	The Lewis's Amalgamated Sebastopol Reef Quartz Mining Company No Liability	M80
The City of Salford Quartz Mining Company Limited	M38	The Hit or Miss Gold Mining Company Limited	M81
South Extended Hustlers Tribute Company Limited	M39	Roselle Tribute Gold Mining Company Limited	M82
Welcome Gold Mining Company Limited	M40	New Dominion Gold Mining Company Limited	M83
The Excelsior Mining and Crushing Company Registered	M40	North Dividend Quartz Company No Liability	M84
The Golden Dream Gold Mining Company Limited	M41	The Newbery Indefatigable Quartz Mining Company Limited	M85
The Castlemaine North Devonshire Gold Mining Company Registered	M41	Creswick Quartz Mining Company Limited	M86
The South Extended Burra Tribute Company Registered	M41	Warrens Road Reserve Quartz Gold Mining Company Limited	M87
The Ancient Briton Quartz Mining Company Registered	M41	British Empire Gold Mining Company Limited	M88
The Union Gold Mining Company Limited	M42	Anglo African Gold Mining Company Limited	M89
The Agnes Gold Mining Company Registered	M42	South Extended Englishman Gold Mining Company No Liability	M90
The Braidwoods Tribute Company Registered	M42	The Thomson Gold Mining Company Limited	M91
The McMillens Tribute Company Registered	M42	Murindal Silver and Lead Mining and Smelting Company Limited	M92
The Railway Tribute Company Registered	M42	Duchess of Devonshire Gold Quartz Mining Company No Liability	M93
The Whites Freehold Tribute Company No. 2 Registered	M42	The Malmesbury Reservoir Quartz Mining Company Limited	M94
The Collman and Tacchis Extended G.M. Tribute Co. Registered	M42	Homeward Bound Gold Mining Company Limited	M95
Llanberris Quartz Mining Company Registered	M42	Kampfs Gully Quartz Mining Company No Liability	M96
Haddon Grand Junction Gold Mining Company No Liability	M43	The Royal Prince Gold Mining Company Fryers No Liability	M97
		Evening Star Gold Mining Company Limited	M98
		The Christmas Reef Tribute Quartz Mining Company Limited	M99
		The Australian Pyrites Company Limited	M100
		The Gavan Duffy Gold Mining Company Limited	M101
		The United Moon Quartz Mining Company Limited	M102
		Brandenberg Quartz Mining Company Limited	M103
		The Manchester Gold Mining Tribute Company Limited	M104
		Lothair Gold Mining Company Registered	M105
		Loyal Liberal Quartz Mining Company Registered	M106
		Crown Cross Reef Company Registered	M107
		North Flora Gold Mining Company Limited	M108

Name of Company.	Number of Registration.	Name of Company.	Number of Registration.
Goldsborough Quartz Mining Company Registered	M109	Red Jacket Quartz Mining Company Registered	M170
Kneebone Gold and Tin Mining Company Registered	M110	Great Southern Reefs Company Limited ..	M171
Inkermann Mining Company Registered ..	M111	The Express Mining Company Registered ..	M172
Little Joe Quartz Mining Company Registered ..	M112	Oriental Gold Mining Company Registered ..	M173
The Sir John Franklin Quartz Gold Mining Company Registered	M112	Moore's Golden Fleece Tribute Company Limited ..	M174
Perseverance Quartz Mining Company Registered	M113	Bendigo Mac No. 1 Gold Mining Company Limited	M175
The Welcome Quartz Mining Company Limited ..	M114	North Carshalton Railway Reserve Gold Mining Company Limited	M176
East Scotchmans Quartz Mining Company	M115	Providence Extended Gold Mining Registered ..	M177
Lothair Extended Gold Mining Company No Liability	M116	Apsley Gold Mining Company Registered ..	M178
Leichardt United Company Limited ..	M117	Mclvor Quartz Mining Company Registered ..	M179
The Conservative Tribute Gold Mining Company Limited	M118	Evelyn Tunnel Gold Mining Company Warrantdye Registered	M180
Lawrison Prince of Wales Gold Mining Company Registered	M119	The Ellenborough Gold Mining Company Limited	M181
Great Extended Hustlers Reef Quartz Mining Tribute Company No. 2 Limited ..	M120	Hartmanns Gold Mining Company Limited ..	M182
Gippslander Gold Mining Company Limited ..	M121	The Niagara Gold Mining Company Registered ..	M183
The Planet Gold Mining Company Limited ..	M122	South Sandstone Tribute Company No Liability ..	M184
G. G. Consols Tribute Company Limited ..	M123	White Hills Quartz Mining Company Limited ..	M185
Darlington Gold Mining Company Registered ..	M124	The Hope and Anchor Quartz Mining Company Limited	M186
Golden Point Reefing Company Registered ..	M125	The Revival Quartz Mining Company Registered ..	M187
The Garden Gully Old Chum Tribute Company Registered	M125	The Melbourne and Avoca Gold Mining Company Registered	M188
The Great Eagle Tribute Company Registered ..	M125	The United Mint Gold Mining Company Registered	M189
The Prince Alfred Tribute Company Registered ..	M125	The A1 Gold Mining Company Castle Reef Raspberry Creek Registered	M190
Stewarts Ellesmere Black Lead Tribute Company Registered	M125	The Hope Mining Company Registered ..	M191
Southern Star Gold Mining Company Registered	M125	The Strap and Buckle Gold Mining and Crushing Company Registered	M192
New Great Extended Eagle Tribute Company Limited	M126	McKenzie Street Gold Mining Company Registered	M192
Old Hampshire Quartz Mining Company	M127	The Ajax Gold Mining Company Registered ..	M193
Pleasant Creek Cross Reef Quartz Mining Company Registered	M128	The Specimen Hill Quartz Mining Company Registered	M194
The Wonder of the East Gold Mining Company Limited	M129	Baltic Gold Mining Company Limited ..	M195
G. V. Brooke Gold Mining Company Limited ..	M130	The Locomotive Tribute Company No. 2 North Limited	M196
Bendigo and Melbourne Quartz Mining and Drainage Company Registered	M131	The North Easter Gold Mining Company Limited ..	M197
Central Golden City Gold Mining Company Limited	M132	Victoria Quartz Mining Company Registered ..	M198
The Cornish Quartz Mining Company Registered	M133	The Marquis of Lorne Gold Mining Company Limited	M199
The Raywood Mint Quartz and Gold Mining Company Limited	M134	The North Welcome Home Gold Mining Company Limited	M200
The Magnet Quartz Mining Company Limited ..	M135	The Pass By Gold Mining Company Limited ..	M201
Canterbury Quartz Mining Company Limited ..	M136	North Extended Golden Fleece Tribute Company Registered	M202
The Vineyard Tribute Quartz Mining Company Limited	M137	The G. G. Brilliant Tribute Company Limited ..	M203
Cambrian Gold Mining Company Limited ..	M138	The Golden Freehold Quartz Mining Company No Liability	M204
Wellington Gold & Tin Mining Company Registered	M139	Wonnongalla Gold Mining Company No Liability	M205
South Dead Cat Quartz Mining Company No Liability	M140	Rose of the Big Hill Company Limited ..	M206
New Hampshire Quartz Mining Company Registered	M141	Malabar Gold Mining Company Limited ..	M207
Golden Age Quartz Mining Company Registered	M142	Golden Cross Quartz Mining Company No Liability	M208
Clunes No. 1 Quartz and Alluvial Gold Mining Company Limited	M143	The Uncle Tom Gold Mining Company Limited ..	M209
Hope of Australia Gold Mining Company Limited	M144	Sons and Doma Consols Company Registered ..	M210
South Belle Vue Tribute Company Limited ..	M145	Denmark Consols Tribute Company Limited ..	M211
Lightning Gold Mining Company No Liability ..	M146	Central Birds Tribute Company Limited ..	M212
Walhalla Consols Company Registered ..	M147	Sir Walter Scott Quartz Mining Company Limited	M213
North Gippsland Gold Mining Company Registered	M148	The Great Lawrence & Belle Vue Gold Mining Company Limited	M214
Albion Quartz Mining Company Registered ..	M149	The Sovereign Mining Company No Liability	M215
Long Tunnel Extended Gold Mining Company Registered	M150	Morey Freehold Gold Mining Company No Liability	M216
Great Tunnelling Gold Mining Company Registered	M151	Sandhurst and Saint Arnaud Chrysolite Tribute Company Limited	M217
Breadalbane Quartz Mining Company Registered	M152	South Welcome Home Tribute Company Limited	M218
All England Gold Mining Company ..	M153	North Royal Standard Tribute Quartz Mining Company Limited	M219
North Cornish Quartz Mining Company Registered	M154	The Hustlers Queen Freehold Tribute Gold Mining Company Limited	M220
South Temperance Quartz Mining Company No Liability	M155	The Don Hustlers Gold Mining Company Limited	M221
Waterloo Reefing Company Registered ..	M156	South Cohens Quartz Mining Company No Liability	M222
Empress Gold Mining Company No Liability ..	M157	Anchor of Hope Mining Company Registered ..	M223
The Liverpool Reef Gold Mining Company Limited	M158	The North Costerfield Gold and Antimony Mining Company No Liability	M224
Belfast Tribute Company Limited ..	M159	North Green Valley Gold Mining Company Limited	M225
Speculation Gold Mining Company Registered ..	M160	The Concordia Gold Mining Company Limited ..	M226
Enterprise Gold Mining Company Registered ..	M161	Hustlers Main Reef Gold Mining Company No Liability	M227
Eaglehawk Union Quartz Mining Company Registered	M162	Harrison Redan Tribute Company Limited ..	M228
Tarengower Nuggetty Alliance Quartz Mining Company Registered	M163	The Johnson's Reef Gold Mines Tribute Company Limited	M229
Catherine and St. Mungo Gold Mining Company Limited	M164	The Eagle Gold Mining Company Limited ..	M230
Harbinger Gold Mining Company Registered ..	M165	Middleton's Reef Quartz Mining Company Limited	M231
Sloanes and Scotchmans Reef Quartz Mining Company Registered	M166	Feeleys North Prospect Company Limited ..	M232
The Happy Go Lucky Gold and Quartz Mining Company Registered	M167	G. V. Brooke Gold Mining Tribute Company Limited	M233
Mysterious Quartz Gold Mining Company Registered	M168	Melbourne and Sandhurst United Gold Mining Company Limited	M234
The South Extended Englishman Gold Mining Company Limited	M169	Opossum Reef Mining Company Registered ..	M235
		The Rothschild Mining Company No Liability ..	M236
		United Golden Age Mining Company Registered ..	M237
		Cherry Tree Flat Mining Company Registered ..	M238
		Little Cornish Tribute Company No Liability ..	M239
		North Eagle Hawk Quartz Mining Company Limited	M240

Name of Company.	Number of Registration.	Name of Company.	Number of Registration.
The Great Extended North Dead Cat Quartz Gold Mining Company Limited ..	M241	Ellesmere New Chum and Belle Vue Tribute Company Limited ..	M303
The Buchan Lead and Silver Mining Company No Liability ..	M242	The Great Comet and North Albert Tribute Company Limited ..	M304
South Lancashire Gold Mining Company Limited ..	M243	Valancourt Tribute Number Two Company Limited ..	M305
The Woodside Gold Mining Company Limited ..	M244	The Druids Company Limited ..	M306
The Stafford and Ramrod Gold Mining Company Limited ..	M245	Monk Gold Mining Company Limited ..	M307
Market Gold Mining Company No Liability ..	M246	Black Prince Extended Gold Mining Company Limited ..	M308
The Cornish United Quartz Mining Company No Liability ..	M247	North Golden Fleece & Glasgow United Tribute Company No. 4 Limited ..	M309
The McLellan Gold Mining Company No Liability ..	M248	Eureka and Vineyard Quartz Mining Company Limited ..	M310
Cosmopolitan Quartz Mining Company Limited ..	M249	Scotsons Gold Mining Company Limited ..	M311
Extended Fruehling Gold Mining Company Limited ..	M250	Great Extended South Welcome Home Tribute Company Limited ..	M312
Powerful Gold Mining Company Limited ..	M251	The Eglinton Gold and Quartz Mining Company Limited ..	M313
Dayspring Quartz Mining Company Limited ..	M252	The Cora Gold Mining Company Limited ..	M314
Great Corfu Quartz Mining Company Limited ..	M253	The Royal Myrtle Creek Quartz Gold Mining Company Limited ..	M315
Concordia Tribute Gold Mining Company Limited ..	M254	The North Pigeon Tribute Company Limited ..	M316
United Drovers Reef Gold Mining Company Limited ..	M255	The Bishops Tribute Quartz Mining Company No. 1 ..	M317
Stafford and Diamond Hill United Quartz Mining Company Limited ..	M256	North New Homeward Bound Buninyong Estate No Liability ..	M318
Royal Sceptre Quartz Mining Company No. 1 Limited ..	M257	Queen Victoria Hustlers Tribute Company Limited ..	M319
South Britannia Gold Mining Company Limited ..	M258	North Star Quartz Mining Company Limited ..	M320
The New North Crown Nimrod Gold Mining Company Limited ..	M259	Mopoke Tribute No. 1 Gold Mining Company No Liability ..	M321
Lake Como Extended Gold Mining Company Limited ..	M260	Dairy Hill Company Limited ..	M322
Q. C. E. Gold Mining Company Limited ..	M261	The North Caledonia Quartz Gold Mining Company Limited ..	M323
The South Golden Sovereign Quartz Mining Company Limited ..	M262	Stones Windmill Hill Tribute Company Registered ..	M324
The Victoria Tribute Gold Mining Company Limited ..	M263	Sawer's and Walker's Freehold Tribute Company Limited ..	M325
Northumberland Gold Mining Company Limited ..	M264	The Royal William Hustlers Gold Mining Company Limited ..	M326
G. V. Brooke Gold Mining Tribute Company No. 2 Limited ..	M265	Golden Eagle Quartz Mining Company Limited ..	M327
Little Comet Company Limited ..	M266	The North Poverty Gold Mining Company Limited ..	M328
South Eureka Consols Quartz Mining Company No Liability ..	M267	The Metropolitan Quartz Mining and Crushing Company Limited ..	M329
The Old England Gold Mining Company Limited ..	M268	Central Moonta Tribute No. 1 Company Limited ..	M330
Sandhurst and Eaglehawk Pyrites Gold Extraction Company Limited ..	M269	Planet Tribute Gold Mining Company Limited ..	M331
Hunts Gold Mining Tribute Company Limited ..	M270	Englishman's Reef Gold Mining Company Limited ..	M332
South Welcome Home Tribute Company No. 1 Limited ..	M271	Anderson's Freehold Gold Mining Company No Liability ..	M333
Ferrons No. 2 Tribute Company Limited ..	M272	The United Poverty Havelock Tribute Company Tarnagulla Limited ..	M334
South Golden Fleece Consols Tribute Quartz Mining Company Limited ..	M273	Investigator Gold Mining Company Limited ..	M335
Central Comet Tribute Company Limited ..	M274	Stafford Consols Gold Mining Company Registered ..	M336
The Myrtle Creek Freehold Gold Mining Company Limited ..	M275	Sir William Don Gold Mining Tribute Company Limited ..	M337
Surprise Gold Mining Company No Liability ..	M276	Royal Albert United Tribute Company Limited ..	M338
The South Imperial Garden Gully Quartz Mining Company Limited ..	M277	The Eureka Tribute Company Number 2 Limited ..	M339
The Great Hope Tribute Company Limited ..	M278	The United Brothers Gold Mining Company Limited ..	M340
No Name Gold Mining Company Limited ..	M279	Hall & Cos. Tribute Company Limited ..	M341
Great Extended Catherine Gold Mining Company No Liability ..	M280	Helen Mar Gold Mining Company Limited ..	M342
St. Leger Quartz Mining Company Registered ..	M281	The New Bendigo Quartz Mining Company Limited ..	M343
The Warrantye Sailors Reef Gold Mining Company Limited ..	M282	The Peabody Quartz Mining Company Limited ..	M344
The Imperial Frenchmans Gold and Quartz Mining Company Limited ..	M283	The South Barkly Reef Gold Mining Company Limited ..	M345
The Great Extended Gold Mining Company Registered ..	M284	Foundry Tribute Gold Mining Company Limited ..	M346
Lady Mary Tribute Gold Mining Company Limited ..	M285	The Gentle Annie Gold Mining Company Limited ..	M347
Grand Trunk and Golden Sovereign United Tribute Gold Mining Company Limited ..	M286	Sandhurst Tribute No. 2 Gold Mining Company Limited ..	M348
Golden Sovereign Extended Tribute Gold Mining Company Limited ..	M287	The Poverty and Havelock United Quartz Mining Company Limited ..	M349
Nebraska Gold Mining Company Limited ..	M288	Golden Point and Wexford Mining Company Limited ..	M350
Gladstone Gold Mining Company Limited ..	M289	The Golden Chest Quartz Mining Company Limited ..	M351
North Devonshire Amalgamated Gold Mining Company Limited ..	M290	The South Cambrian Gold Mining Company Limited ..	M352
The New Caledonia Company Limited ..	M291	The Newcastle on Tyne Gold Mining Company Limited ..	M353
Meteor Quartz and Alluvial Gold Mining Company Limited ..	M292	Black Hill South Quartz Mining Company No Liability ..	M354
The Golden South Gold Mining Company Limited ..	M293	Ballanee Quartz Mining Company No Liability ..	M355
Canterbury Copper Silver and Lead Mining Company Limited ..	M294	The North Belle Vue and Old Chum Company Limited ..	M356
Alison Gold and Antimony Mining Company Registered ..	M295	The Defiance Gold Mining Company No Liability ..	M357
Big Stafford Tribute Gold Mining Company Limited ..	M296	The Great Caledonia Quartz and Alluvial Mining Company Registered ..	M358
The South Cross Reef Quartz Mining Company Limited ..	M297	East Whip Gold Mining Tribute Company Limited ..	M359
Adventure G.Q.M. Co. Registered ..	M298	The Royal Meath Gold Mining Company Limited ..	M360
The Blink Bonny Quartz Mining Company Limited ..	M299	The Buninyong Estate No. 1 South Quartz and Alluvial Gold Mining Company No Liability ..	M361
North Prince Alfred Gold Mining Company No Liability ..	M300	Beaumonts Company Limited ..	M362
South Britannia Freehold Tribute Gold Mining Company Limited ..	M301	The View Hill Gold Mining Company Limited ..	M363
South Nelson Tribute G.M. Co. Registered ..	M302	Old Colonist Gold Mining Company Limited ..	M364
Napier Quartz & Alluvial Gold Mining Company Registered ..	M302	The No Surrender Gold Mining Company Registered ..	M365
		Harneys Freehold Tribute Company Limited ..	M366
		J. B. Watsons Freehold Tribute Company Limited ..	M367
		South Argus Quartz Mining Company Registered ..	M368

Name of Company.	Number of Registration.	Name of Company.	Number of Registration.
The North Specimen Hill Extended Tribute Company Limited	M369	Kent South Stafford Reef Quartz Mining Company Limited	M427
The A.I. Perthshire Mining Company Limited	M370	The Hustlers and Paulina Gold Mining Company Limited	M428
The Rose and Shamrock Gold Mining Company Limited	M371	West Poverty Reef Quartz Gold Mining Company Tarnagulla Limited	M429
The Gippsland Consols Quartz Mining Company No Liability	M372	The Extended St. Mungo Gold Mining Company Limited	M430
The Extended All Friends Gold Mining Company Limited	M373	The South West Garden Gully Gold Mining Company Limited	M431
The Latham and Watsons Tribute Company No. 2 Limited	M374	The Belle Vue Shenandoah Tribute Company Limited	M432
The Verlin Amalgamated Quartz Mining Company No Liability	M375	The North Belle Vue Shenandoah Tribute Company Limited	M433
The South Poverty and Havelock United Quartz Mining Company Limited	M376	The North Shenandoah Black Lead Tribute Company Limited	M434
The Bismark United Quartz Mining Company Limited	M377	The South Band of Hope Gold Mining Company Registered	M435
The Old Flora Gold Mining Company Limited	M378	The St. George and United Poverty Tribute Gold Mining Company Number One Limited	M436
The Marquis of Lorne Gold Mining Company Limited	M379	The Watsons Freehold Gold and Quartz Mining Company Limited	M437
The Richard Heales Gold Mining Company Registered	M380	The Pioneer Quartz Mining Company Limited	M438
The New Chum Consolidated Gold Mining Company Limited	M381	The Buninyong Estate Gold Mining Company No Liability	M439
The African Gold Mining Company Limited	M382	South New Moon Tribute No. 2 Gold Mining Company Limited	M440
The Golden Hope Tribute Company Sandstone Reef Llanelly Limited	M383	North United Miners Gold Mining Company Limited	M441
The North Golden Rock Quartz Mining Company Limited	M384	South United Miners Gold Mining Company Limited	M442
California Company East Tribute Gold Mining Company Limited	M385	The Victoria Gold Mining Company Limited	M443
John O'Shanassy Gold Mining Company Limited	M386	The South Monument Hill Tribute Company Registered	M444
The South New Moon Tribute Company No. 1 Limited	M387	The Central Windmill Hill Mining Company Limited	M445
New Caledonia Tribute Company No. 1 North Limited	M388	The Rich Hill Tribute Gold Mining Company No Liability	M446
Hartmann's Concord Mining Company Limited	M389	South Band of Hope Tribute Company No. 1 Limited	M447
The Hustlers Pride Tribute Company Limited	M390	Lothair Freehold Company No Liability	M448
The London & Lancashire Gold Mining Company Limited	M391	The South Lothair Gold Mining Company No Liability	M449
The Acadia Tribute Company Registered	M392	Golden Fleece Gold Mining Company Limited	M450
The Arternus Quartz Mining Company Registered	M393	West Poverty Reef Quartz Gold Mining Company Limited	M451
The New South Cornish Quartz Mining Company Registered	M394	The Grand Trunk Tribute Company No. 2 Limited	M452
The Band and Lake Gold Mining Company No Liability	M395	South New Moon Tribute-No. 3 Gold Mining Company Limited	M453
The Hampton Court Quartz Mining Company Limited	M396	The Albion Quartz Mining Company Limited	M454
The Englishman Reef Gold Mining Company No Liability	M397	The Great Northern Poverty Gold Mining Company No Liability	M455
Saints Company Registered	M398	No. 1 North Clunes Alluvial and Quartz Gold Mining Company No Liability	M456
The North Abe Lincoln Quartz Mining Company Lauriston No Liability	M399	The Defiance Quartz Mining Company No Liability	M457
The Young Frederick the Great Tribute Company Limited	M400	The South Costerfield Gold and Antimony Mining Company No Liability	M458
The Union Gold Mining Company Limited	M401	The North Lothair Quartz Mining Company No Liability	M459
The South Empire Tribute Gold Mining Company Limited	M402	The North Ajax Gold Mining Company Registered	M460
Turner & Sinclair's Prince of Wales Tribute Gold Mining Company Limited	M403	Morning Star Quartz Company No Liability	M461
The Caroline Gold Mining Company Registered	M404	The United Fear Not Quartz Mining Company Limited	M462
The Friedmans Reef Tribute Company Registered	M405	Criterion Gold Mining Company No Liability	M463
The Sunset Quartz Mining Company Registered	M406	The London and Oriental United Mining Company No Liability	M464
The Morning Light Tribute Company Registered	M407	The Red Jacket Quartz Mining Company Limited	M465
The South Golden Fleece Quartz Mining Company No. 2 Limited	M408	Black Horse Quartz Mining Company Registered	M466
The Rose and Shamrock Tribute Company Limited	M409	Harts Moon Reef Tribute Gold Mining Company Limited	M467
The Royal South Frenchman's Reef Gold Mining Company Limited	M410	The North Golden Fleece and Glasgow United Tribute Company No. 3 Limited	M468
The Montebello Gold Mining Company Limited	M411	The Great Carshalton Tribute Company Limited	M469
The Golden Era Gold Mining Company Tarnagulla Limited	M412	The Florence Gold Mining Tribute Company Limited	M470
The German Gully Quartz Mining Company Limited	M413	The Golden Line Gold Mining Company Limited	M471
South Burra Tribute Company Limited	M414	The Orient Gold Mines Company Limited	M472
The Great South Welcome Home Tribute Company Limited	M415	West Grand Trunk Quartz Mining Company Limited	M473
Byronic Tribute Gold Mining Company Sandhurst Limited	M416	The West Poverty Tribute No. 1 Gold Mining Company Limited	M474
The Sandhurst & Bell Rock Quartz Mining Tribute Company Limited	M417	The North Warrens Gold Mining Company No Liability	M475
The Golden Age Gold Mining Company Limited	M418	The Extended Specimen Reef Quartz Mining Company Limited	M476
The South Temperance Quartz Mining Company No Liability	M419	The No. 1, 2, 3 and 4 South Specimen Reef Quartz Mining Company Limited	M477
The Golden Fleece Gold Mining Company No Liability	M420	The No. 1 and 2 North Specimen Reef Quartz Mining Company Limited	M478
The Golden Gate Gold Mining Company No Liability	M421	The Adelong Gold Mining Company Limited	M479
The Advance Quartz Mining Company Limited	M422	The Duke of Devonshire Gold Mining Company Limited	M480
The Crystal Reef Quartz Mining Company Limited	M423	The Neptune Quartz Mining Company Limited	M481
The X. L. Gold Mining Company Limited	M424	The Hero Quartz Mining Company No Liability	M482
The Constellation Gold Mining Company Limited	M425	The Devonshire Gold Mining Company No Liability	M483
The Duke of Kent Gold Mining Company Limited	M426	The Union Quartz Mining Company Limited	M484
		The Clifton Rock Quartz Mining Company Limited	M485
		The Fryers Quartz Mining Company Registered	M486
		The Queens Reef Gold Mining Company Limited	M487

Name of Company.	Number of Registration.	Name of Company.	Number of Registration.
Commercial Tribute Company Limited ..	M488	The Venture Gold Mining Company Limited ..	M554
Central Moon Tribute Gold Mining Company Limited ..	M489	The Ellesmere Quartz Mining Company No. 1 No Liability ..	M555
The Hustlers Consols United Tribute Quartz Mining Company No Liability ..	M490	The Armagh Quartz Mining Company No Liability ..	M556
The Neptune Gold Mining Tribute Company Limited ..	M491	New Dimocks Reef Quartz Mining Company No Liability ..	M557
The North G.G. Golden Gully Company Limited ..	M492	The Jupiter Gold Mining Company Limited ..	M558
The Watsons Freehold Gold Mining Company Limited ..	M493	The Queen of the Alps Quartz Mining Company Limited ..	M559
Carters Extended Gold Mining Company No Liability ..	M494	The North Eastern Quartz Mining Company No Liability ..	M560
The All Nations Gold Mining Company Limited ..	M495	The Great Northern Junction Company Registered ..	M561
The Collmann and Tacchis Pups Gold Mining Company Limited ..	M496	The Kingtons Freehold Estate Mining Company Registered ..	M562
The May Day Freehold Gold Mining Company No Liability ..	M497	The Inkermann and Durham Junction Gold Mining Company Registered ..	M563
The Macks Creek Gold Mining Company Limited ..	M498	The West Scotchmans Quartz Mining Company Limited ..	M564
Star of Victoria Gold Mining Company Limited ..	M499	The Darling Quartz Mining Company Limited ..	M565
Old Moon Tribute Gold Mining Company Limited Franklin St. Mungo ..	M500	The New-Guinea Gold Mining Company No Liability ..	M566
Nelson Gold Mining Company No Liability ..	M501	The Rourke and Henderson Quartz Mining Company Limited ..	M567
The Young Extended Gold Mining Company Limited ..	M502	The Kildare Gold Mining Company Limited ..	M568
The Mark Antony Gold Mining Company No Liability ..	M503	The Alta and Nelson Quartz Mining Company Registered ..	M569
Great Hustlers Mining Company Limited ..	M504	The Countess Mining Company No Liability ..	M570
The South Saxon Gold Mining Company No Liability ..	M505	The Hills Tribute Quartz Gold Mining Company Caledonia Reef Limited ..	M571
Mia Mia. Company Limited ..	M506	The Nuggetty & Trafalgar Quartz Mining Company Limited ..	M573
Carshalton Monarch Company Limited ..	M507	The Alabama Quartz Mining Company Limited ..	M574
Robbins Tribute Gold Mining Company Limited ..	M508	The Golden Crown Quartz Mining Company No Liability ..	M575
C. & I. New Moon Tribute Gold Mining Company Limited ..	M509	The Potosi Silver Lead and Copper Mining Company No Liability ..	M576
White Horse Gold Mining Company No Liability ..	M510	The Band of Hope Gold Mining Company Limited ..	M577
The Burra Burra Quartz and Alluvial Gold Mining Company Limited ..	M511	The London and Melbourne Gold Mining Company Registered ..	M578
The Great Victoria Stafford Tribute Quartz Mining Company Limited ..	M512	Nos. 14, 15 and 16 South Cross Reef Quartz Mining Company Limited ..	M579
The Gladstone Quartz Mining Company Limited ..	M513	The Warrior Tribute Quartz Gold Mining Company No Liability ..	M580
The Moon Reef Tribute Company Limited ..	M514	The Mount Tarrangower Gold Mining Company Maldon No Liability ..	M581
The North Ajax Gold Mining Company No Liability ..	M515	The New Cornhill Gold Mining Company Gaffney's Creek No Liability ..	M582
The Golden Eagle Gold Mining Company Limited ..	M516	The South New Caledonia Gold Mining Company Limited ..	M583
The No. 1 North Cornish Quartz Mining Co. Registered ..	M517	Arcadian Quartz Mining Company Limited ..	M584
The South Glengonner Quartz and Alluvial Gold Mining Company Limited ..	M518	The Great Specimen Quartz Mining Company Limited ..	M585
The Never Can Tell Gold Mining Company Limited ..	M519	Malmsbury Reserve Gold Mining Company Registered ..	M586
The W.T. Creek Alluvial Gold Mining Company Registered ..	M520	The Parade Gold Mining Company No Liability ..	M587
The Specimen Reef Quartz Mining Company Limited ..	M521	The Specimen Hill Quartz Mining Company No Liability ..	M588
The Pioneer Tribute Quartz Mining Company Limited ..	M522	Main Lead Consols Gold Mining Company No Liability ..	M589
The Sheet Anchor Gold Mining Company Limited ..	M523	The Waradgery Gold Mining Company No Liability ..	M590
New Julius Caesar Gold Mining Company No Liability ..	M524	The Melbourne and Lauriston Gold Mining Company Registered ..	M591
The New North Caledonia Quartz Mining Company Limited ..	M525	The Little Newington Quartz Mining Company Limited ..	M592
The Melbourne and Frankfort Quartz Mining Company Limited ..	M526	The Tylden Rising Sun Gold Mining Company Limited ..	M593
The United Kingdom Extended Quartz Gold Mining Company Limited ..	M527	The Iron Stone Hill Lead Gold Mining Company Limited ..	M594
The Kong Meng and Columbia Tribute Gold Mining Company Limited ..	M528	Hattie Shepparde Tribute Quartz Mining Company Limited ..	M595
The Abe Lincoln Tribute Company No Liability ..	M529	The Bon Accord Quartz Mining Company Limited ..	M596
Nelson Gold Mining Company Limited ..	M530	The Great Central Gold Mining Company No Liability ..	M597
Britannia Gold Mining Company No Liability ..	M531	Phoenix Aladdin Gold Mining Company Limited ..	M598
New Italian Hill Quartz Mining Company Limited ..	M532	The Percydale Gold & Silver Lead Mining Company No Liability ..	M599
The Excelsior Tin Mining Company Limited ..	M533	The Pheasant Creek Cross Reef Gold Mining Company Limited ..	M600
The Dives Gold Mining Company No Liability ..	M534	The Try Again Gold Mining Company No Liability ..	M601
New Greeds Reef Quartz Mining Company No Liability ..	M535	The Frosty Morning Quartz and Alluvial Mining Company Limited ..	M602
The Ajax Tunnel Company Limited ..	M536	New Caledonia Tribute Company No. 3 North Limited ..	M603
The Cumberland Quartz Gold Mining Tribute Company Registered ..	M537	The Well in the Desert Quartz Mining Company Limited ..	M604
White Eagle Gold Mining Company Limited ..	M538	The Eastern Gold Mining Company No Liability ..	M605
The Best Chance Gold Mining Company No Liability ..	M539	Nos. 17, 13 and 17A South Cross Reef Quartz Mining Company Limited ..	M606
The North Gleasons Quartz Mining Company Limited ..	M540	Original Golden Fleece No. 1 Tribute Gold Mining Company Limited ..	M607
Theadora Gold Mining Company Limited ..	M541	The Duke of Cornwall Gold Mining Company Limited ..	M608
The Naylors Tribute Company Registered ..	M542	The Golden Gate Quartz Mining Company Limited ..	M609
The Black Prince Gold Mining Company Registered ..	M543		
The Great Berlin Golden Quartz Mining Company No Liability ..	M544		
The New Caledonia Tribute Company No. 2 North Limited ..	M545		
The Just In Time Quartz Mining Company Limited ..	M546		
The North Middlesex Quartz Gold Mining Company Registered ..	M547		
The Queen Victoria Gold Mining Company Limited ..	M548		
The Victoria Reef Quartz Mining Company Limited ..	M549		
The Frenchmans Reef Gold Mining Company Registered ..	M550		
The Ferrons Reef Gold Mining Company Registered ..	M551		
The Cattles Reef Gold Mining Company Registered ..	M552		
	M553		

Name of Company.	Number of Registration.	Name of Company.	Number of Registration.
The Harbinger Extended Gold Mining Company Limited	M610	The Tambaroora Gold Mining Company Limited	M674
The Morning Star Quartz Mining Company Limited	M611	The Gold Mines Quartz and Alluvial Gold Mining Company Limited	M675
The Longfellows Gold Mining Company Registered	M612	The Lauriston Junction Gold Mining Company Limited	M676
The My Dream Gold Mining Company Registered	M613	The Albion Gold Mining Company Limited	M677
The Fern Tree Gold Mining Company Registered	M614	The New Golden Freehold Quartz Mining Company No Liability	M678
The Last Chance Gold Mining Company No Liability	M615	The Lily of the Valley Quartz Mining Company No Liability	M679
The United Central Eaglehawk Quartz Mining Company Maldon Limited	M616	The Palmerston Gold Mining Company Limited	M680
The Stafford Mint Gold Mines Company Registered	M617	The New Magnum Bonum Gold Mining Company Limited	M681
The Morning Star Quartz Mining Company Limited	M618	The Great Extended Quartz Gold Mining Company No Liability	M682
The North Devonshire Tribute Company Registered	M619	South True Briton Tribute Quartz Mining Company Limited	M683
The South Eaglehawk Quartz Mining Company Registered	M620	The North Prince Alfred Quartz Mining Company Limited	M684
The Schlemmes Tribute Company Registered	M621	The United Endeavour Gold and Tin Mining Company No Liability	M685
The Tom Thumb Gold Mining Company Registered	M622	The Australian Gold Mining Company Limited	M686
The West Feely Gold Mining Company Registered	M623	The Mak Siccar Gold Mining Company Limited	M687
Central Carshalton Company Limited	M624	The Last Chance Extended Gold Mining Company No Liability	M688
Poverty and Havelock Gold Mining Company Limited	M625	Moores Hustlers Freehold Company Limited	M689
The Adventure Gold Mining Company Limited	M626	The Black Prince Gold Mining and Crushing Company Swifts Creek Registered	M690
The Grand United Deep Lead Gold Mining Company Limited	M627	The Emerald Gold Mining Company Limited	M691
McGirrs Main Royal Tribute Gold Mining Company Limited	M628	The Ballarat Gold Mining Company Limited	M692
The Sir William Roger Quartz Mining Company Limited	M629	The Alma Company Limited	M693
The Buninyong Tribute Company No Liability	M630	The Lord Malmsbury Gold Mining Company Limited	M694
The Great Extended Hermit Gold Mining Company Limited	M631	The United No. 2 Barnes Reef Gold Mining and Crushing Company Limited	M695
The Comet & United Tribute Company Limited	M632	The Lady Barkly Gold Mining Tribute Company Limited	M696
The Canary Tribute Company Registered	M633	The North Hustlers Comet Gold Mining Company No Liability	M697
The Reserve Quartz Mining Company Registered	M634	The "Star of Hope" United Gold Mining Company Limited	M698
The Simpsons Tribute Gold Mining Company Limited	M635	The South Learmonth and Egerton Amalgamated Quartz Mining Company No Liability	M699
The Fear Not Extended Quartz Mining Company Limited	M636	Try Again Quartz Mining Company Limited	M700
The Sloanes and Scotchman Extended Quartz Mining Company Limited	M637	The Magdala Quartz Company No Liability	M701
Richard Heales Gold Mining Company No Liability	M638	Malcolms Tribute Quartz Mining Company Limited	M702
The New Reefers Hope Quartz Gold Mining Company No Liability	M639	The New Gobur Gold Mining Company Limited	M703
The Victorian Mint Quartz Mining Company No Liability	M640	The Central Burra Tribute Company Limited	M704
The Dan O'Connell Gold Mining Company Limited	M641	Betts and Walkers Gold Mining Company Limited	M705
The Bluchers Reef Tribute Quartz Gold Mining Company Limited	M642	Bendigo and Redesdale Gold Mining Company Limited	M706
The Darlington Extended Quartz Mining Company Limited	M643	The General Havelock Gold Mining Company Registered	M707
The Defiance Extended Gold Mining Company No Liability	M644	Sailor Bills Creek Gold Mining Company Registered	M708
The Homeward Bound Gold Mining Company Guildford Limited	M646	The Foundry Quartz Mining Company Limited	M709
The Bruce Tribute Company Limited	M647	The Glencoe Junction Gold Mining Company Registered	M710
Whites Freehold Tribute Company No. 1 Registered	M648	The Mountaineer Gold Mining Company Limited	M711
The Linscotts Reef Tribute Quartz Mining Company Limited	M649	The A1 Gold Mining Company Limited	M712
Cornish and Crown Quartz Mining Company Registered	M650	The Golden Bar Quartz Mining Company Limited	M713
Johnsons Reef Consols Company Limited	M651	The Tommy Dodd Q. & A. G.M. Co. Registered	M714
The Band of Hope Gold Mining Company No Liability	M652	Glengonner Quartz & Alluvial Gold Mining Company Registered	M715
The Lone Star Extended Quartz Mining Company Limited	M653	Hermit Gold Mining Company Limited	M716
The North Perseverance Gold Mining Company Caledonia Registered	M654	The Great Extended Last Chance Quartz Mining Company No Liability	M717
The Nelson Quartz Gold Mining Company No Liability	M655	The South Devonshire Reef Gold Mining Company No Liability	M718
The St. Mungo Hill Tribute Gold Mining Company Limited	M656	The Cadmus Gold Mining Company No Liability	M719
The Easter Enterprise Tribute Company Limited	M657	The North Hustlers Reef Gold Mining Company No Liability	M720
The Easter Prospecting Gold Mining Company Limited	M658	Four Leaved Shamrock Company Limited	M721
The Tea Tree Gold Mining Company No Liability	M659	The Lindsay Quartz Mining Company No Liability	M722
The Nelson United Quartz Mining Company Maldon Limited	M660	The Stafford Fleece Tribute Company Limited	M723
The Magnet Quartz Gold Mining Company No Liability	M661	The North Empire Tribute Company Limited	M724
The Williams Freehold Gold Mining Company Limited	M662	The Racecourse Gold Mining Company Registered	M725
La Creole Quartz Mining Company Limited	M663	South New Moon United Tribute Company Limited	M726
The North Aberfeldy Gold Mining Company Limited	M664	The Northampton Gold Mining Company Limited	M727
The Eagle Mining Company Registered	M665	The Central Windmill Gold Mining Tribute Company No Liability	M728
The Havilah Tribute Company Limited	M666	South Frasers Reef Gold Mining Company Registered	M729
The New Southern Star Quartz Mining Company Limited	M667	Frasers Reef Gold Mining Company Registered	M730
The Premier Quartz Mining Company No Liability	M668	Progressive Gold Mining Company Registered	M731
The Prospectors Gold Mining Company Stockyard Creek Limited	M669	The Crown Cross No. 2 Quartz Mining Company Limited	M732
The Foster Gold Mining Company No Liability	M670	The Undaunted Quartz Mining Company Limited	M733
The Fenton Quartz Mining Company Limited	M671	The Ophir Gold Mining Company Limited	M734
The Old Beehive Mining Company Limited	M672	The Lone Star Extended Gold Mining Company Limited	M735
Stafford Fleece Gold Mining Company Limited	M673	The No Surrender Quartz Mining Company Limited	M736
		The Hanover Cross Reef Company Limited	M737
		The Extended South Johnsons Tribute Company Limited	M738

Name of Company.	Number of Registration.	Name of Company.	Number of Registration.
The Britannia Quartz Mining Company Limited ..	M739	The Richmond Quartz Mining Company Waterloo	M804
The Nicholson River Sluicing Company Limited ..	M740	No Liability ..	M805
The Prince of Wales Quartz Mining Company Limited ..	M741	The Central Costerfield Antimony Company Limited	M806
The Black Hill South Extended Quartz Mining Company No Liability ..	M742	The Keotong Stream Tin Mining Company No Liability ..	M807
Hustlers Royal Reserve Company No. 1 Limited ..	M743	The Native Youths Quartz Mining Company No Liability ..	M808
Hustlers Royal Reserve Company No. 2 Limited ..	M744	Albion United Gold Mining Company Limited ..	M809
Cora Linn United Tribute Company Limited ..	M745	The North Vicksburg Quartz Mining Company No Liability ..	M810
The Sea Queen Quartz Mining Company Limited ..	M746	The Nil Desperandum Gold Mining Company No Liability ..	M811
The Gladstone Quartz Mining Company Limited ..	M747	The Opies Gold Mining Company Limited ..	M812
The Avoca Tribute Gold Mining Company No Liability ..	M748	The Great Northern Cross Reef Gold Mining Company Limited ..	M813
The Golden Reef Gold Mining Company Registered	M749	Glencoe Tribute Company No. 3 Limited ..	M814
The Equity Freehold Company Limited ..	M750	The Castlemaine, Sandhurst and Melbourne Paving and Slate Mining Company Limited ..	M815
The Duke of Devonshire Tribute Company Limited	M751	The Nil Desperandum United Quartz Mining Company No Liability ..	M816
Newcombes Gold Mining Tribute Company Limited	M752	Stafford Fleece North Tribute Company Limited	M817
The New Koh-I-Noor Gold Mining Company No Liability ..	M753	The New Golden Reef Gold Mining Company No Liability ..	M818
The North Sea Tribute Company Limited ..	M754	The Ferrons No. 1 Tribute Company Limited ..	M819
The Welcome Quartz Mining Company No Liability	M755	The Columbian Quartz Mining Coy. Limited ..	M820
The Glengonner Gold Mining Company Limited ..	M756	The Sovereign Consols Mining Company No Liability ..	M821
The North Britannia Tribute Company Limited ..	M757	The Gold Mines Gold Mining Company Limited ..	M822
The North Bendigo and Melbourne and Railway Reserve Gold Mining Company Limited ..	M758	The Galatea Quartz and Alluvial Gold Mining Company Limited ..	M823
Eclipse Quartz Mining Company No Liability ..	M759	The Great Malvern Gold Mining Company No Liability ..	M824
Nos. 3, 4 & 5 Scotchmans Reef Quartz Mining Company Limited ..	M760	Golden Hope Mining Company No Liability ..	M825
The Richmond Gold Mining Company No Liability	M761	The Isabella Gold Mining Company Registered ..	M826
The Murrindindie Quartz Mining Company No Liability ..	M762	The North Scotchmans Quartz Mining Company No Liability ..	M827
The Undaunted Quartz Mining Company No Liability ..	M763	The Albion Quartz Mining Company No Liability	M828
The Comet Quartz Mining Company Registered ..	M764	No. 2 Clifton Rock Quartz Mining Company Limited	M829
The Last Chance Gold Mining Company Limited	M765	The Stanley Quartz Mining Company Limited ..	M830
The New Eureka Gold Mining Company No Liability	M766	The Cosmopolitan Gold Mining Company No Liability ..	M831
The Elliotts Freehold Gold Mining Company No Liability ..	M767	The Albion Quartz Mining Company Limited ..	M832
The United North Park Gold Mining Company No Liability ..	M768	The North Undaunted Quartz Mining Company Limited ..	M833
The Crown Sloanes Quartz Mining Company Limited ..	M769	Bullion Consols Quartz Mining Company Limited	M834
The New Discovery Tribute Company No. 2 South Limited ..	M770	The Ocean Wave Quartz Mining Company Limited	M835
Good Hope Tunnelling and Quartz Mining Company Registered ..	M771	The Royal Gold Mining Company No Liability ..	M836
The Grand Junction Gold Mining Company Limited	M772	The New Flying Scud Quartz Mining Company No Liability ..	M837
Snobs Hill Gold Mining Company Limited ..	M773	The Dominion Gold Mining Company No Liability	M838
Bismarck Tribute Gold Mining Company Limited	M774	New Kohinoor Tribute Company No Liability ..	M839
Perseverance Quartz Mining Company No Liability	M775	New Mariners and Sloanes Quartz Mining Company Registered ..	M840
South Welcome Mining Company No Liability ..	M776	The Golden Reef Extended Gold Mining Company No Liability ..	M841
Great Britannia Quartz Mining Company Limited ..	M777	The Buln Buln Extended Gold Mining Company Limited ..	M842
North Extended Old Chum Tribute Company Limited ..	M778	The Northern Freehold Gold Mining Company Limited ..	M843
The Wattle Gully United No. 1 Tribute Gold Mining Company Limited ..	M779	The Argus United Quartz Mining Company Limited	M844
The Finchs Reef Tribute Quartz Mining Company Limited ..	M780	Diamond Creek Gold Mining Company Limited ..	M845
The 8 & 9 South Cross Reef Quartz Mining Company No Liability ..	M781	The United Kingdom Quartz Mining Company No Liability ..	M846
The South Murindal Silver and Lead Mining Company No Liability ..	M782	The North Havilah Gold Mining Company Limited	M847
The Lord Napier Quartz Mining Company Limited	M783	The King of Prussia Tribute Company Limited ..	M848
The South Comet Gold Mining Company Limited	M784	Young Sultan Mining Company No Liability ..	M849
The New Discovery Tribute Company No. 1 Limited	M785	The Sunday Creek Gold and Antimony Company Limited ..	M850
Ferrons No. 3 Tribute Company Limited ..	M786	The Britannia Gold Mining Company Limited ..	M851
The South Triumph Quartz Mining Company No Liability ..	M787	The Maryborough Pyrites and Gold Extracting Company No Liability ..	M852
The Eureka Quartz Mining Company No Liability	M788	Johnsons Reef Extended Tribute Company Limited	M853
The New Hustlers Mining Company Limited ..	M789	The Extended North Cross Reef Quartz Mining Company Limited ..	M854
The Heales and Fleece Consols Company Limited	M790	The Mackay Copper Mining Company Limited ..	M855
The Forest Queen Quartz Mining Company No Liability ..	M791	The Defiance Gold Mining Company Limited ..	M856
Eight and Nine South Cross Reef Quartz Mining Company Limited ..	M792	The Jupiter Quartz Mining Company No Liability	M857
The Energetic Quartz Mining Company Limited ..	M793	The Young Duke Quartz Mining Company Limited	M858
The Ben Nevis Gold Mining Company Limited ..	M794	The Crown Cross No. 3 Quartz Mining Company Limited ..	M859
The Sir George Bowen Quartz & Alluvial Gold Mining Company No Liability ..	M795	The Eaglehawk Mining Company Limited ..	M860
Prince Albert Quartz Mining Tribute Company Limited ..	M796	The No. 1 Scotchmans Quartz Mining Company Limited ..	M861
The Pygmalion Quartz Mining Company Limited	M797	The Prince of Wales Gold Mining Company Limited	M862
The British Lion Quartz Mining Company No Liability ..	M798	Muir's South St. Mungo Tribute Company Limited	M863
The Comet and Hermit Consols Gold Mining Company Limited ..	M799	North Parkers Quartz Mining Company No Liability	M864
The New Caledonia Quartz Mining Company No Liability ..	M800	The St. George Company Limited ..	M865
The Central Flora Tribute Company Limited ..	M801	The Cornish Extended Quartz and Alluvial Gold Mining Company Registered ..	M866
The Alexandra Quartz Mining Company Limited ..	M802	Stafford Antimony and Gold Tribute Company Limited ..	M867
Coles Alliance Tribute Company Limited ..	M803	The Clarkes Freehold Gold Mining Company No Liability ..	M868

Name of Company.	Number of Registration.	Name of Company.	Number of Registration.
The Rosedale and Ferry Hill Gold Mining Company Limited	M868	The Extended Stirlingshire & Nuggety Reef Quartz Mining Company Limited	M926
The West Golden Fleece Gold Mining Company Limited	M869	The Carolina No. 2 Quartz Mining Company Limited	M927
The London Reefing Company Limited	M870	New Kangaroo Bob Quartz Mining Company No Liability	M928
The Eureka Quartz Mining Company Limited	M871	Robinsons Freehold Gold Mining Company No Liability	M929
New Golden Fleece Quartz Mining Company Limited	M872	The Band of Hope Quartz Mining Company Limited	M930
South Parkers Mining Company No Liability	M873	12, 13 & 12A South Cross Reef Quartz Mining Company Limited	M931
The Dividend Quartz Mining Company Registered	M874	2 and 6 Cross Reef Quartz Mining Company Limited	M932
The Prince of Wales Gold Mining Company No Liability	M875	Frees Tribute Quartz Mining Company Limited	M933
The Cambrian Reef Gold Mining Company Limited	M876	The Main Stay Quartz Mining Company Limited	M934
The United Devonshire Company Limited	M877	The Keatchs Freehold Gold Mining Company No Liability	M935
The Northern Grand Junction Quartz Mining Company Limited	M878	The Kerrit Bareet Gold Mining Company No Liability	M936
Jacks Venture Quartz Mining Company Limited	M879	Gostelows Freehold Gold Mining Company No. 2 Liability	M937
The South Prince Patrick Quartz Mining Company Limited	M880	The Goldfinch Quartz Mining Company Limited	M938
The Maryborough Consols Gold Mining Company Limited	M881	The Ulster Quartz Mining Company Limited	M939
The Great Southern Gold Mining Company Limited	M882	The Wonga and Birmingham Junction Quartz Mining Company Limited	M940
South Great Britannia Quartz Mining Company Limited	M883	2 and 6 Cross Reef Quartz Mining Company No Liability	M941
The East Golden Reef Gold Mining Company No Liability	M884	The Taras Hall Extended Gold Mining Company Limited	M942
The Rensison Flat Gold Mining Company Limited	M885	Richardsons Homestead Freehold Gold Mining Company No Liability	M943
The Ram Gold Mining Company Limited	M886	7, 8 and 9 North Scotchmans Quartz Mining Company Limited	M944
The West Scotchmans No. 2 Quartz Mining Company Limited	M887	The Hit or Miss Gold Mining Company No Liability	M945
The G. V. Brooke United Tribute Company Limited	M888	The Western Lewers Freehold Gold Mining Company No Liability	M946
The Extended Stirlingshire & Nuggety Reef Quartz Mining Company Limited	M889	The Cunnings Freehold Gold Mining Company No Liability	M947
The Extended Crown Cross Reef Quartz Mining Company Limited	M890	The Lewers Central Freehold Gold Mining Company No Liability	M948
East Kohinoor Gold Mining Company No Liability	M891	The Prince of Wales Gold Mining Company No Liability	M949
The Princess Olga Reefing Company Limited	M892	The Prince Alfred Quartz Mining Company Limited	M950
The East Scotchmans Gold Mining Company Limited	M893	Youngs St. Mungo Tribute Company Limited	M951
Don Extended Quartz Mining Company No Liability	M894	The Lewers No. 2 Freehold Gold Mining Company No Liability	M953
The Rhydney Quartz Mining Company No Liability	M895	The Ryans Freehold Junction Gold Mining Company No Liability	M954
The Lily of the Valley Gold Quartz Mining Company Registered	M896	Columbian No. 2 Quartz Mining Company Limited	M955
The North Darlington Gold Mining Company Limited	M897	Bullion Consols Tribute Quartz Mining Company Limited	M956
Central Cookmans Reef Quartz Mining Company Maldon Limited	M898	The Sir George Bowen Quartz Mining Company No Liability	M957
Eureka Tunnel Mining Company No Liability	M899	Camerons Freehold Gold Mining Company No Liability	M958
The Mysterious Tribute Quartz Mining Company Limited	M900	The Telegraph Quartz Mining Company Limited	M959
Kershaws Tribute Company Limited	M901	Hard Hill Quartz Gold Mining Company Registered	M960
The Atlantic Quartz and Alluvial Gold Mining Company No Liability	M902	Golden Crown Quartz Mining Company Registered	M961
The Wonga Wonga Quartz Mining Company Limited	M903	Browns Quartz Mining Company Limited	M962
The Germania Quartz Gold Mining Company Limited	M904	St. Mungo Hill No. 1 Gold Mining Company Limited	M963
The Lady Bowen Tribute Company Limited	M905	The Extended Napier Gold Mining Company Limited	M964
The Golden Gate Gold Mining Company Limited	M906	The South Prince Patrick No. 2 Quartz Mining Company Limited	M965
Richardsons Freehold Junction Gold Mining Company No Liability	M907	The Percydale Pioneer Gold Mining and Quartz Crushing Company Limited	M966
The Emerald Isle and Rose of Denmark Mining Company Limited	M908	North Elliotts Tribute Gold Mining Company Limited	M967
The Alma Extended Gold Mining Company No Liability	M909	The West Germania Quartz Mining Company Limited	M968
Western Heales Gold Mining Company Limited	M910	The North New Hustlers Tribute Company Limited	M969
Waterloo Gold Mining Company No Liability	M911	Specimen Hill United Company Limited	M970
The Triumph Tribute Company Limited	M912	Victoria Tower Company Limited	M971
The Golden Wedge Quartz Mining Company Limited	M913	The New Brilliant Tribute Company Limited	M972
The Morning Star Quartz Mining Company Limited	M914	The 10 & 11 Perthshire Quartz Mining Company No Liability	M973
No. 3 Crown Wonga Wonga Quartz Mining Company Limited	M915	The Charters Towers Gold Mining Company No Liability	M974
The Gleasons Lease Gold Mining Company Limited	M916	The New Fear Not Quartz Mining Company Limited	M975
The Superb Quartz Mining Company Limited	M917	The New Ringwood Antimony Mining Company Limited	M976
The Union Gold Mining Company Limited	M918	The True Blue Company Limited	M977
The Lewers Sovereign Gold Mining Company No Liability	M919	The Remarkable Quartz Mining Company Limited	M978
The South Cross Reef Gold Mining Company Limited	M920	Garden Gully Junction Gold Mining Company Limited	M979
The Little Newington and All England United Quartz Mining Company Limited	M921	The Old Sir William Don Quartz and Alluvial Mining Company No Liability	M980
The Belfast Gold Mining Company Limited	M922		
The No. 2 South Clifton Rock Quartz Mining Company Limited	M923		
Lewers Golden Lead Gold Mining Company No Liability	M924		
North Scotchmans Reef United Company No Liability	M925		

ERRATUM.

In the list of Contracts Accepted—(Series 1963-64) Public Works, which appeared on pages 2462-2464 of Victoria Government Gazette No. 68, dated 29th July, 1964, for item number 5285 appearing therein substitute the following:—

5285. Carlton, Motor Registration Branch, erection of Administration Office Building and associated site works, £2,115,000.—Keith G. Hooker Pty. Ltd.

CONTRACTS ACCEPTED.—(Series 1963-64.)

GENERAL STORES.

Gazette No. 64, 7th August, 1963, Schedule No. 1, Printing Papers, &c.—For Item No. 263, substitute £168 per ton as from 23rd April, 1964.

CONTRACTS ACCEPTED.—(Series 1964-65.)

GENERAL STORES.

Gazette No. 31, 22nd April, 1964, Schedule No. 52, Tools (General). For the rates shown opposite the following items, substitute the rates as set out hereunder:—Item No. 27, £1 13s. each as from 15th July, 1964. Item No. 29, £2 4s. 11d. each as from 22nd July, 1964.

Gazette No. 62, 9th July, 1964. Please note the alterations in respect of the under-mentioned Schedules:—

Schedule No. 25, Chemicals, &c. Items Nos. 13, 14 and 25. For Blyth Chemicals Ltd., substitute Amalgamated Chemicals (Victoria) Pty. Ltd.

Schedule No. 26, Clothing, Uniform. Item No. 2, substitute white for grey; Item No. 3, £2 6s. 6d. each; Item No. 4, £2 6s. 6d. each; Item No. 5, £2 8s. 6d. each as from 20th July, 1964.

Schedule No. 27, Cocks and Fittings, &c. Item No. 33, 14s. 7d. each; Item No. 34, 19s. each; Item No. 35, £1 2s. 5d. each; Item No. 36, £1 10s. 1d. each; Item No. 37, £1 19s. 9d. each; Item No. 38, £2 6s. 5d. each as from 1st July, 1964.

Schedule No. 29, Cordage, Lines, &c. Item No. 10, 10s. 3d. per lb.; Item No. 11, £1 14s. 6d. per gross yards; Item No. 13, 14s. 9d. per dozen as from 9th July, 1964.

Schedule No. 36, Earthenware and Glassware. Item No. 3, Sub-schedule C, £3 1s. 6d. per dozen; Item No. 4, Sub-schedule C, 11s. 9d. per dozen as from 1st July, 1964.

Schedule No. 37, Electric Lamps, Accessories, &c. Item No. 36, 16s. 8d. each; Item No. 40, £4 3s. per dozen; Item No. 41, Batteries, Leakproof, 11s. 8d. per dozen as from 1st July, 1964.

Schedule No. 39, Furniture, &c. Item No. 11, four-seat, £14 12s. each; five-seat, £17 9s. each; six-seat, £19 5s. each; Item No. 49, £27 17s. 6d. each as from 1st July, 1964.

Schedule No. 46, India-rubber Goods. Item No. 1, 1s. 11½d. per foot; Item No. 2, 2s. 6d. per foot; Item No. 3, 3s. 2½d. per foot; Item No. 5, 2s. 8½d. per foot; Item No. 6, 4s. 4d. per foot, all less 25 per cent. as from 1st July, 1964.

Schedule No. 54, Metals. Item No. 10, £166 per ton as from 6th July, 1964.

Schedule No. 63, Piping, Ridging, &c. Item No. 1, 6s. 10d.; Item No. 2, 9s. 2d.; Item No. 3, 7s. 7d.; Item No. 4, 10s.; Item No. 5, 8s. 8d.; Item No. 6, 11s. 3d.; Item No. 7, 9s. 9d.; Item No. 8, 12s. 10d.; Item No. 9, 10s. 6d.; Item No. 10, 13s. 11d.; Item No. 11, 12s. 11d.; Item No. 12, 17s. 6d.; Item No. 13, 14s.; Item No. 14, 19s. 7d.; Item No. 15, 11s.; Item No. 16, 14s. 8d.; Item No. 17, 12s. 4d.; Item No. 18, 16s. 6d.; Item No. 19, 14s. 2d.; Item No. 20, 19s. 2d.; Item No. 21, 7s. 4d.; Item No. 22, 9s. 5d.; Item No. 23, 7s. 11d.; Item No. 24, 10s. 3d.; Item No. 25, 8s. 8d.; Item No. 26, 11s. 3d.; Item No. 27, 11s. 10d.; Item No. 28, 15s. 3d. (per 6-foot length); Item No. 29, up to 5 inch, 26 gauge, 16s. 10d. each; 24 gauge, 17s. 10d. each; up to 6 inch, 26 gauge, 17s. 7d. each; 24 gauge, 19s. 2d. each; Item No. 30, up to 3 inch, 26 gauge, 8s. 11d. each; 24 gauge, 11s. each; up to 3½ inch and 4 inch, 26 gauge, 9s. 2d. each; 24 gauge, 11s. 7d. each; Item No. 31, 11s. per dozen. All prices less 25 per cent., less 2½ per cent. 30 days, as from 1st July, 1964.

Schedule No. 77, White Lead, &c. Item No. 4, £9 4s. per cwt.; Item No. 5, £9 6s. per cwt.; Item No. 6, £9 9s. per cwt.; 14-lb. tin, £10 4s. per cwt.; 7-lb. tin, £10 10s. per cwt., as from 8th July, 1964.

H. COUTTS, Secretary to the Tender Board. 3.8.64.

ORDERS IN COUNCIL.—(Series 1963-64.)

STATE ELECTRICITY COMMISSION.

5389. For the erection of Stage 2 of the Central Maintenance Depot and Electrical Testing Laboratory, Fishermen's Bend, to Specification No. 63-64/132, £72,117.—T. W. Morris & Son Pty. Ltd.

5390. For the supply of H.V. testing equipment for testing of electrical plant in the laboratory or field, to Specification No. 63-64/200, £4,060.—A.S.E.A. Electric (Aust.) Pty. Ltd.

5391. For the supply of 35 50 kVA transformers and accessories for Metropolitan substations, to Specification No. 63-64/324, £11,055.—Power & Distribution Transformers Pty. Ltd.

5392. For the construction of a reinforced concrete deck for the 220 kV switchyard Richmond Terminal Station, to Specification No. 63-64/351, £29,524 6s.—Prentice Bros. & Minson Pty. Ltd.

5393. For the construction of additions and alterations to amenities block, Fishermen's Bend, to Specification No. 63-64/384, £20,273.—S. Vegsund.

5394. For the supply and delivery of approximately 120,000 tons of small black coal for the Newport Power Station over a period of 9 months, to Specification No. 63-64/338, £5 5s. 6d. a ton.—R. W. Miller & Co. Pty. Ltd.

Approved by the Governor in Council, 15th July, 1964.—J. COLQUHOUN, Clerk of the Executive Council.

ORDERS IN COUNCIL.—(Series 1964-65.)

PUBLIC WORKS.

476. Ballarat, Base Hospital, reimbursement for alterations to Ward 6, Tuberculosis Chalet under the Commonwealth State Tuberculosis Agreement, £1,942 13s. 4d.—Ballarat and District Base Hospital.—(W.47527.)

477. Beechworth, Mental Hospital, mechanical maintenance, £871.—Ross's Pty. Ltd.—(N.E.308252.)

478. Brunswick, sinking six test bores at site of proposed new High School, £484.—Southern States Drilling Co. Pty. Ltd.—(N.W.43328.)

479. Golden Point, State School No. 1493, supply and installation of gas heating units, £266 8s.—The Ballarat Gas Company.—(W.21423 "D").

480. Ilwaco, State School No. 690, provision of bore, as specified, for water supply to toilets, £494 17s. 10d.—C. T. Brookes and E. S. Leach.—(S.W.43834.)

481. Melbourne, Mines Department, 107 Russell-street, electrical installation, first and second floors, £3,347 14s.—J. Newall Pty. Ltd.—(M.21170 "A").

482. Melbourne, Public Library and National Gallery, electrical work, £1,162 14s. 9d.—Smith and Osborne (Contractors).—(M.22511.)

483. Melbourne, Public Offices, Parliament Place, supply and fixing baffle wall and acoustic ceiling, Furnace and Plant Rooms, £545.—Insulwool Products Pty. Ltd.—(M.45206.)

484. Melbourne, Public Works Department, Ports and Harbours Branch, cutting and supplying twenty-one (21) mild steel shackles and swivel pieces, for buoys to be used in Westernport Bay, £588.—Buchanan and Brock Pty. Ltd.—(P. & H. 32801.)

485. Mont Park, Gresswell Sanatorium, supply of bed pan sterilizer, £288.—K. G. Luke Australia Pty. Ltd.—(N.E.304007.)

486. Port Melbourne, Public Works Department, new furniture store, sheeting walls and roof with galvanized iron and fixing timber girts (labour only), £469 10s.—R. G. Dew.—(M.21924.)

487. Sunbury, Mental Hospital, maintenance of P.A.X. telephone system for the period 1st July, 1964, to 30th June, 1965, £384 12s.—Communication Systems of Australia Pty. Ltd.—(N.W.255194.)

Approved by the Governor in Council, 28th July, 1964.—J. COLQUHOUN, Clerk of the Executive Council.

EDUCATION DEPARTMENT.

488. One (1) only Automatic Calculating Machine for Caulfield Technical College, £369.—MacDougalls Ltd.

489. One (1) only Semi-Self Indicating Scale Avery Model for Preston Technical School, £121.—W. & T. Avery (Aust.) Pty. Ltd.

490. One (1) only Electric Calculating Machine for Royal Melbourne Institute of Technology, £490.—Data Control.

491. One (1) only Vernier Theodolite for Yallourn Technical College, £248.—A. E. Parsons.

492. One (1) only Framed Structures Apparatus for Yallourn Technical College, £219 2s.—Townson & Mercer (Vic.)

493. One (1) only Laboratory Sieve Shaker for Yallourn Technical College, £119 10s.—Watson Victor Ltd.

494. One (1) only Filter Unit with Slurry and Priming Tank for Collingwood Technical School, £322.—Robert Bryce & Co. Ltd.

495. One (1) only Electric Pottery Kiln and Pyrometer for Swan Hill Technical School, £203 10s.—Haigh Resistances Pty. Ltd.

496. One (1) only Engine Indicating Equipment for Yallourn Technical College, £451.—Electronic Industries Imports Pty. Ltd.

497. One (1) only Specimen Mounting Press (£155); and one (1) only Specimen Polisher (£145) for Yallourn Technical College, £300.—Watson Victor Ltd.

Approved by the Governor in Council, 28th July, 1964.—J. COLQUHOUN, Clerk of the Executive Council.

NOTICE TO MARINERS.

[No. 9 OF 1964.]

AUSTRALIA.—VICTORIA.

CORNER INLET APPROACH.

1. Light-buoy missing from station.
2. Temporarily replaced by unlit buoy.

Position.—Front Light on Lighthouse Point, Lat. 38 deg. 51 min. S., Long. 146 deg. 28 min. E. (Approx.).

1. Details.—The Red light-buoy, No. 1, showing a Red flashing light every 4 seconds, stationed 092 deg. 20 min. distant 4.0 miles from the above position, is missing from station and has been washed ashore.

2. Date.—On or about 28th July, 1964.

Details.—The light-buoy will be temporarily replaced by a first class steel unlit can buoy painted Red and numbered 1.

Charts Affected.—Aust. 145, 199 B.A., 1703.

Publication.—Sailing Directions, Victoria, 1959, page 503.

A. J. WAGGLEN,
Port Officer.

Ports and Harbors Branch,
Department of Public Works,
Melbourne, C.2, 28th July, 1964.

NOTICE TO MARINERS.

[No. 10 OF 1964.]

AUSTRALIA.—VICTORIA.

THE following Notice to Mariners, which has been received from the Harbor Master, Portland, is published for general information.

A. J. WAGGLEN,
Port Officer.

Ports and Harbors Branch,
Department of Public Works,
Melbourne, C.2, 27th July, 1964.

PORTLAND HARBOR TRUST COMMISSIONERS, PORT OF PORTLAND.

Information About Lights.

1. Position.—Whaler Point Lighthouse, Lat. 38 deg. 20 min. 24 sec. S., Long. 141 deg. 36 min. 45 sec. E. (Approx.).

Details.—This light, triple flashing every 30 seconds, has developed a mechanical fault and the normal sequence flash 1.0 sec., eclipse 3.5 secs., flash 1.0 sec., eclipse 3.5 secs., flash 1.0 sec., eclipse 20 secs., is followed by flash 1.0 sec., eclipse 3.5 secs., flash 1.0 sec., eclipse 3.5 secs., flash 20 secs., eclipse 1.0 sec. These two sequences follow alternately. Other details remain unaltered, and further notice will issue on light being restored to normal.

2. Former Notice.—(No. 8 of 1964) T. hereby cancelled.

Position of Breakwater Light.—8½ cables 120 deg. from position (1) above.

Details.—A Flashing Red light, with a half-second flash every second, shows from a spiral concrete and glass tower at an elevation of 60 feet (18 m 3) on the end of the main breakwater. Visibility 5 miles (minimum).

Chart Affected.—B.A. 1062 and inset.

Publications.—Sailing Directions, Victoria, 1959, page 77. List of Lights, Vol. 10, 1960, page 171.

PUBLIC TRUSTEE ACT 1958 (No. 6350), SECTION 17.

I HEREBY give notice that on the 16th July, 1964, the Public Trustee filed elections to administer the following deceased persons' estates, in accordance with section 17 of the Public Trustee Act 1958:—

BLACK, WILLIAM, late of Werribee Vale-road, Bacchus Marsh, quarry worker, died 19th May, 1964.

WEATHERALL, BEATRICE VICTORIA, late of Old Eltham-road, Lower Plenty, spinster, died 18th March, 1964.

WHELAN, IRENE ANNIE, late of 32 Jolimont-terrace, Jolimont, widow, died 2nd April, 1964.

WILSON, EMMA CECILIA, late of Echuca, spinster, died 1st March, 1964.

A. D. DUNCAN,
Public Trustee.

256 Flinders-street, Melbourne, C.1, 29th July, 1964.

NOTICE.

CREDITORS, next of kin and others having claims against the estate of any of the under-mentioned deceased persons are required to send particulars of their claims to the Public Trustee, 256 Flinders-street, Melbourne, the personal representative, on or before the 6th October, 1964, after which date the Public Trustee may convey or distribute the assets, having regard only to the claims of which the Public Trustee then has notice:—

ACKLAND, VERA EUNICE MARIE, formerly of 26 Agett-road, Claremont, Western Australia, and of 7 Avalon Flats, 247 Adelaide-terrace, Perth, and of Bethesda Hospital, 25 Queenslea-drive, Claremont, but late of 36A Victoria-avenue, Claremont, married woman, died 4th May, 1963.

APPLETON, ROSE, formerly of 99 Oban-drive, Glasgow, Scotland, but late of Flat 7, 22 Kingsley-street, Elwood, married woman, died 25th May, 1964.

AROSSA, TERESA, late of Viale, Indipendenza, Canelli, Asti, Italy, widow, died 14th April, 1963.

BIRCH, BERYL MILDRED, also known as Beryl Birch, formerly Beryl Mildred Scammell, formerly of 7 Jellicoe-street, Cheltenham, but late of 12 Red Bluff-street, Black Rock, married woman, died 6th May, 1964.

BLACK, WILLIAM, late of Werribee Vale-road, Bacchus Marsh, quarry worker, died 19th May, 1964.

BLAND, WERNER BATTAMS ZAHNLER, also known as Werner Battans Bland, late of 31 Cain-avenue, Northcote, retired machinist, died 10th May, 1964.

BROWN, GLADYS, late of 9A Charlotte-place, East St. Kilda, widow, died 20th May, 1964.

BURNLEY, LEONARD ALFRED GLEDHILL, late of Wellington, New Zealand, retired insurance official, died 2nd December, 1963.

GILCHRIST, THOMAS, late of Blackhill-road, Selby, retired labourer, died 21st March, 1964.

HARTLEY, RONALD, late of Flat 3, 11 Park-street, St. Kilda, maintenance fitter, died 18th April, 1964.

HARVEY, JOHN FRANCIS, late of 35 Hardwick-street, East Coburg, municipal employee, died 30th March, 1964.

KLEIN, MAX, late of 73 Amess-street, North Carlton, leather finisher, died 19th April, 1963.

MATHIESON, THOMAS BLUE, formerly of State Savings Bank, Murrumbidgee, but late of 44 Albany-crescent, Surrey Hills, retired bank manager, died 3rd March, 1964.

MEYER, AUGUST HERBERT, late of Whitlands, farmer, died 9th April, 1962.

MILLER, JOHN, formerly of 7 West-street, Surrey Hills, but late of Bundoora, war pensioner, died 31st March, 1964.

MCADAM, JOHN LACHLAND NOBLE, also known as John McAdam, late of 65 Cadonna-street, Box Hill South, laboratory assistant, died 6th May, 1964.

McSWEENEY, JOHN FRANCIS, formerly of Aberdeen Hotel, St. Georges-road, North Fitzroy, but late of Little Sisters of the Poor, St. Georges-road, Northcote, retired teacher, died 23rd May, 1964.

PARKHILL, HONOR LAVINIA, formerly of 141 Grange-road, Glenhuntly, but late of 49 Florizel-street, Burwood, widow, died 30th April, 1964.

PAYNE, EDWARD THOMAS, formerly of 130 Stawell-street, Burnley, but late of 23 Spruce-street, Lambton, New South Wales, retired cutter, died 2nd March, 1964.

PEARSON, GEOFFREY FRANK, late of 26 Albion-street, South Yarra, clerk, died 17th April, 1964.

PYLYPIW, PETRO, also known as Peter Pylypiw, formerly of 29 Seabeach-parade, North Geelong, but late of 243 Shannon-avenue, West Geelong, labourer, died 16th February, 1964.

SCARLETT, DOROTHY, late of 38 Lorne-parade, Mont Albert, clerk, died 24th February, 1964.

SQUIRE, FRANCIS LINDSAY, late of Christchurch, New Zealand, clerk, died 27th January, 1964.

UHR-HENRY, AGGELIKE, late of 2 Mallum-avenue, Frankston, dressmaker, died 25th January, 1964.

WEATHERALL, BEATRICE VICTORIA, late of Old Eltham-road, Lower Plenty, spinster, died 18th March, 1964.

WENTMAN, LESLIE FRANCIS JAMES, late of 8 Norfolk-road, Surrey Hills, linotype mechanic, died 21st November, 1963.

WHELAN, IRENE ANNIE, late of 32 Jolimont-terrace, Jolimont, widow, died 2nd April, 1964.

WILSON, EMMA CECILIA, late of Echuca, spinster, died 1st March, 1964.

WOOD, FREDERICK ALBERT, late of 71 Willsmere-road, Kew, retired public servant, died 10th March, 1964.

WREGG, KATE ELLEN, formerly of Campbell's Creek, via Castlemaine, but late of 30 First-avenue, Rosebud, widow, died 1st May, 1964.

A. D. DUNCAN,
Public Trustee.

Melbourne, 29th July, 1964.

LONGWOOD WATERWORKS TRUST.

RATING BY-LAW FOR THE YEAR 1964.

THE Longwood Waterworks Trust, in pursuance and exercise of the powers conferred by the Water Acts, doth hereby make the following rates for the supply of water for domestic purposes, on lands and tenements liable to be rated within the district of the Trust.

On such lands and tenements a rate of Two shillings and nine pence in the pound on the Annual Municipal Valuation.

Provided that in no case shall the amount of rate payable per annum in respect of any tenement (other than land on which there is no building) be less than One hundred shillings, and in respect of any land on which there is no building be less than Forty-five shillings.

Such rates are made and shall be levied upon the occupiers or owners of the said lands or tenements, for the year commencing on the 1st day of January, 1964, and shall be payable on the 6th day of August, 1964, at the office of the said Trust.

Passed this 26th day of June, 1964.

(SEAL) E. MACFARLANE, Secretary.
T. BRODIE, Acting Chairman.

Approved, 31st July, 1964.—T. A. DARCY, Minister of Water Supply.

WESTERNPORT WATERWORKS TRUST.

RATING BY-LAW FOR THE YEAR 1964.

By-law No. 4.

THE Westernport Waterworks Trust, in pursuance and exercise of its powers conferred by the Water Acts, doth hereby make a rate for the supply of water for domestic purposes of Twenty-four pence in the pound on the net annual value of land and tenements liable to be rated within the Bass, Cowes, Newhaven and San Remo Urban Districts.

Such rate is made and shall be levied upon the occupiers or owners of lands and tenements for the year commencing on the 1st day of January, 1964, and shall be due and payable on the 1st day of September, 1964, at the office of the Trust, Thompson-avenue, Cowes.

Passed this 27th day of May, 1964.

(SEAL) E. H. SHAW, Chairman.
J. VORWERG, Commissioner.
STAN A. HARRIS, Secretary.

Approved, 31st July, 1964.—T. A. DARCY.—Minister of Water Supply.

DEPARTMENT OF CROWN LANDS AND SURVEY.

ORDER AMENDED.

HIS Excellency the Governor of the State of Victoria, by and with the advice of the Executive Council thereof doth, by Order made on the 28th day of July, 1964, amend the Order in Council approved on the 17th June, 1964, relating to the revocation of the Reserve for Watering purposes at Bendigo in the Parish of Sandhurst, by the substitution of the area of "1 acre 0 rods 17 4/10 perches" for the area of "1 acre 6 rods 17 4/10 perches" appearing therein.

J. COLQUHOUN,
Clerk of the Executive Council.

At the Executive Council Chamber,
Melbourne, 28th July, 1964.

No. 70.—6953/64.—2

Children's Welfare Act 1958.

DECLARATION OF INSTITUTION AS AN APPROVED CHILDREN'S HOME.

IN accordance with the provisions of Regulation 42 of Division 1 of the Social Welfare Regulations 1962, notice is hereby given that on the twenty-seventh day of July, 1964, acting in pursuance of the powers conferred by sub-section (1) of section 14 of the *Children's Welfare Act 1958*, I declared "Overton", 243 View-street, Bendigo, to be an approved Children's Home for the purposes of the said Act.

V. F. WILCOX,
Acting Chief Secretary.

Chief Secretary's Office,
Melbourne, 27th July, 1964.

Children's Welfare Act 1958.

DECLARATION OF INSTITUTION AS AN APPROVED CHILDREN'S HOME.

IN accordance with the provisions of Regulation 42 of Division 1 of the Social Welfare Regulations 1962, notice is hereby given that on the twenty-eighth day of July, 1964, acting in pursuance of the powers conferred by sub-section (1) of section 14 of the *Children's Welfare Act 1958*, I declared "Providence" Children's Home, 12 Pilmer-street, Bacchus Marsh, to be an approved Children's Home for the purposes of the said Act.

V. F. WILCOX,
Acting Chief Secretary.

Chief Secretary's Office,
Melbourne, 28th July, 1964.

APPOINTMENTS.

HIS Excellency the Governor of the State of Victoria, by and with the advice of the Executive Council thereof, has, by Orders made on the 28th day of July, 1964, been pleased to make the under-mentioned appointments, viz.:—

CHIEF SECRETARY'S DEPARTMENT.

Electoral Registrar (Acting).

CLOUS STEFFEN

to be Electoral Registrar (Acting) for the Avoca, Carisbrook, Charlton, Donald, Dunolly, Inglewood, Landsborough, Maryborough, Minyip, Murtoa, St. Arnaud and Wedderburn Subdivisions of the Electoral District of Kara Kara; and for the Dimboola, Goroce, Horsham, Horsham South, Kaniva, Nhill, Stawell and Warracknabeal Subdivisions of the Electoral District of Lowan, to take effect on and from the 13th July, 1964, during the absence on leave of Daniel James Walsh.

DEPARTMENT OF CROWN LANDS AND SURVEY.

Bailiff of Crown Lands.

CLARENCE WALTER GEBERT

to be a Bailiff of Crown lands, without additional salary.

Trustees of Site.

ROBERT JOSEPH CLARKE, JOHN RICHARD PENRHYN SMITH, and JOHN WILLIAM WHINNEY,

to be Trustees of the land permanently reserved on the 20th September, 1886, as a site for a Mechanics Institute at Footscray, in the place of Daniel Warren, Alexander McDonald, Edward Johnstone, Charles William Cox, and William Charles Hosken, all deceased.

LAW DEPARTMENT.

Assistant Registrar of County Court.

BRYAN JOHN COSGRIFF

to be Assistant Registrar pursuant to the provisions of sections 20 and 21 of the *County Court Act 1958*, for the County Court at Morwell and Warragul, during the absence of K. T. Ryan, on annual leave, to take effect from the date of commencement of duty.

Clerks of Petty Sessions, &c.

BRYAN JOHN COSGRIFF

to be Clerk of Petty Sessions and Clerk of the Children's Court at Moe, Erica, Trafalgar and Yallourn, during the absence of K. T. Ryan, on annual leave, to take effect from the date of commencement of duty; and

JAMES PATRICK HANRAHAN

to be Clerk of Petty Sessions and Clerk of the Children's Court at Melton in the place of G. P. Bale, relieved, to take effect from the date of commencement of duty.

Clerk of Children's Court.

PETER GRAEME CHESTERFIELD to be Clerk of the Children's Court at Box Hill, Broadmeadows, Camberwell, Carlton, Chelsea, Collingwood, Fern Tree Gully, Footscray, Hawthorn, Kew, Moonee Ponds, Northcote, North Melbourne, Oakleigh, Port Melbourne, Preston, Richmond, Ringwood, South Melbourne, Springvale and Williamstown, during the absence of R. P. White, on recreation leave, to take effect from the date of commencement of duty.

Commissioners for Taking Declarations, &c.

PHILLIP DAVID MACARTNEY CONDELL, care of The Broken Hill Proprietary Coy. Ltd., Essington Lewis House, 500 Bourke-street, Melbourne; and
DONALD JOHN MCNEILL, care of Commonwealth Trading Bank of Australia, Oakleigh, to be Commissioners for taking Declarations and Affidavits pursuant to the provisions of the Evidence Act 1958, to resign upon ceasing to occupy their present positions; and
GEOFFREY ARTHUR COX, care of Department of Agriculture, Victoria, Treasury Gardens, Melbourne; and
CLARENCE WALTER GEBERT, care of Department of Crown Lands and Survey, Treasury-place, Melbourne, to be Commissioners for taking Declarations and Affidavits pursuant to the provisions of the Evidence Act 1958, to refrain from charging fees and to resign upon ceasing to occupy their present positions.

Deputy Clerk of the Peace, &c.

GEOFFREY STEPHEN HOARE to be Deputy Clerk of the Peace, Registrar of the County Court, Clerk of Petty Sessions and Clerk of the Children's Court at Colac and Clerk of Petty Sessions and Clerk of the Children's Court at Apollo Bay, Lorne and Winchelsea, during the absence of A. R. Penfold, on annual leave, to take effect from the date of commencement of duty.

Justices of the Peace.

LESLIE ROBERT MACHIN, 427 Glen Eira-road, Caulfield, to Keep the Peace in the Central Bailiwick of the State of Victoria;
CLIFFORD HENRY HANCOCK, Laen, via Donald, to Keep the Peace in the Western Bailiwick of the State of Victoria; and
JOSEPH JOHN EDWARD MCENTEE, 16 High-street, Traralgon; and
WILLIAM CHARLES WELSH, Midland Highway, Yinnar, to Keep the Peace in the Eastern Bailiwick of the State of Victoria.

DEPARTMENT OF PUBLIC WORKS.

Wharf Manager.

Sergeant FREDERICK GORDON JONES, V.B. No. 9955, to be Wharf Manager, at Brighton, as from 17th June, 1964, to carry out that portion of Part II. of the Marine Act 1958, which relates to the Management of Public Wharves, and to be an officer under section 19 of such Act to levy and collect wharfage rates thereat, at a remuneration of £20 per annum, vice Sergeant Darrell Keith Downie, No. 9447, transferred.

DEPARTMENT OF THE TREASURER.

Collector of Imposts.

PETER LAURENCE JULIFF to be Collector of Imposts, Office of the Government Statist, Chief Secretary's Department, vice F. M. Hurst.

Receiver of Revenue (Acting).

GEOFFREY STEPHEN HOARE to act temporarily as Receiver of Revenue, Colac, during the absence of A. R. Penfold, on leave.

J. COLQUHOUN,
Clerk of the Executive Council.

At the Executive Council Chamber,
Melbourne, 28th July, 1964.

APPOINTMENTS.

THE Lieutenant-Governor, as Deputy for His Excellency the Governor of the State of Victoria, by and with the advice of the Executive Council thereof, has, by Orders made on the 4th day of August, 1964, been pleased to make the under-mentioned appointments, viz.:—

DEPARTMENT OF WATER SUPPLY.

Waterworks Trusts Commissioners.

WILLIAM MALCOLM McTAGGART to be a Commissioner of the Colbinabbin Waterworks Trust for a period of three years from the date hereof, subject to the provisions of the Water Acts;
FREDERICK WILLIAM BENJAMIN RAYNER to be a Commissioner of the Myrtleford Waterworks Trust for a period of four years from the date hereof, subject to the provisions of the Water Acts;
REGINALD ARTHUR COOK to be a Commissioner of the Walwa Waterworks Trust for a period of four years from the date hereof, subject to the provisions of the Water Acts; and
FREDERICK WILLIAM WARD to be a Commissioner of the Yarrowonga Urban Waterworks Trust for a period of two years from the date hereof, subject to the provisions of the Water Acts.

J. COLQUHOUN,
Clerk of the Executive Council.

At the Executive Council Chamber,
Melbourne, 4th August, 1964.

RESIGNATIONS.

HIS Excellency the Governor of the State of Victoria, by and with the advice of the Executive Council thereof, has, by Orders made on the 28th day of July, 1964, accepted the resignations of the persons named hereunder of the offices mentioned, viz.:—

DEPARTMENT OF LABOUR AND INDUSTRY.

MARY NORTHCOTT, as a member of the State Relief Committee.

LAW DEPARTMENT.

EDWARD SEYMOUR TRIM, from the Commission of the Peace for the Northern Bailiwick of the State of Victoria.

J. COLQUHOUN,
Clerk of the Executive Council.

At the Executive Council Chamber,
Melbourne, 28th July, 1964.

STAMPS ACT 1958 (No. 6375).

At the Executive Council Chamber, Melbourne,
the twenty-eighth day of July, 1964.

PRESENT:

His Excellency the Governor of Victoria.
Mr. Darcy | Mr. Rossiter.
Mr. Dickie |

REVOCATION OF DECLARATION OF APPROVED VENDOR.

HIS Excellency the Governor of the State of Victoria, by and with the advice of the Executive Council thereof doth by this Order made pursuant to section 131C of the Stamps Act 1958 (No. 6375) revoke the declaration made on the 16th August, 1960, and published in the Government Gazette of 17th August, 1960, declaring the person named hereunder to be an "approved vendor" for the purposes of subdivision (14) of Division three of Part II. of the Stamps Act 1958.

167. GLEN ACCEPTANCE COMPANY.

And the Honorable Arthur Gordon Rylah, Her Majesty's Acting Treasurer for the State of Victoria, shall give the necessary directions herein accordingly.

J. COLQUHOUN,
Clerk of the Executive Council.

DEPARTMENT OF CROWN LANDS AND SURVEY.

At the Executive Council Chamber, Melbourne, the twenty-eighth day of July, 1964.

PRESENT:

His Excellency the Governor of Victoria. Mr. Darcy Mr. Dickie Mr. Rossiter.

VESTING OF LAND IN THE COUNTRY ROADS BOARD.

HIS Excellency the Governor of the State of Victoria, by and with the advice of the Executive Council thereof, doth by this Order made pursuant to section 22A (2) of the Land Act 1958, vest in the Country Roads Board the land in the Township of Boort as shown by hachure on the plan hereunder.

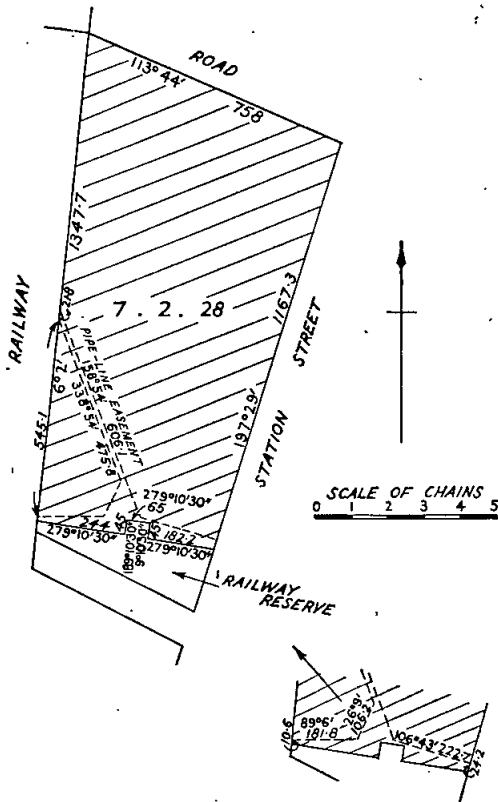

provisions of section 349 of the Land Act 1958, the unused roads referred to hereunder be closed, viz.:-

Parish of Beechworth, County of Bogong, being the roads indicated by hachure on plan hereunder.—(B.349(28) (H.028202).

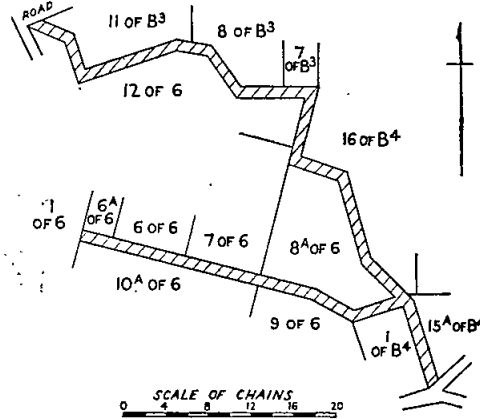

Township of Chiltern, Parish of Chiltern, County of Bogong, being the road between allotment 1 and allotment 15, section M2.—(C.225(*) (H.028050).

Parish of Enfield, County of Grenville, being the road indicated by hachure on plan hereunder.—(E.52(*) (J.30432).

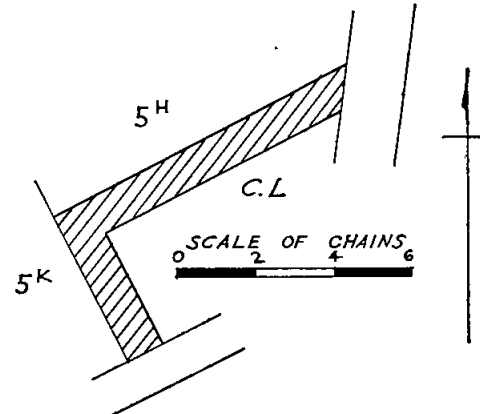

Township of Inglewood, Parish of Inglewood, County of Gladstone, being the road between allotments 17, 18, section D and allotments 22, 21, 20, 15, section A.—(L.4(*) (W.82698).

Parish of Norong, County of Bogong, being the road indicated by hachure on plan hereunder.—(N.74(*) (H.027972).

And the Honorable James Charles Murray Balfour, Her Majesty's Commissioner of Crown Lands and Survey for the State of Victoria, shall give the necessary directions herein accordingly.

J. COLQUHOUN, Clerk of the Executive Council.

DEPARTMENT OF CROWN LANDS AND SURVEY.

At the Executive Council Chamber, Melbourne, the twenty-eighth day of July, 1964.

PRESENT:

His Excellency the Governor of Victoria. Mr. Darcy Mr. Dickie Mr. Rossiter.

UNUSED ROADS CLOSED.

HIS Excellency the Governor of the State of Victoria, by and with the advice of the Executive Council thereof, doth hereby direct that, in pursuance of the

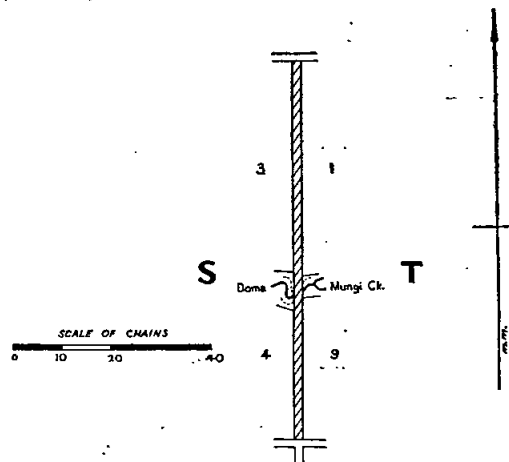

Parishes of Narrawaturk and Paaratte, County of Heytesbury, being the roads indicated by hachure on plan hereunder.—(N.94⁽⁴⁾), P.160(A¹¹) (C.98121).

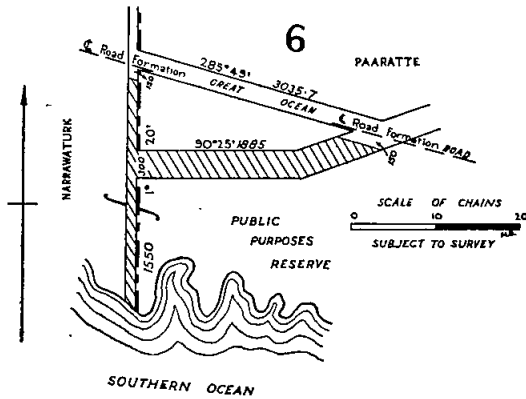

Parish of Waarre, County of Heytesbury, being the road indicated by hachure on plan hereunder.—(W.360⁽⁸⁾) (C.98121).

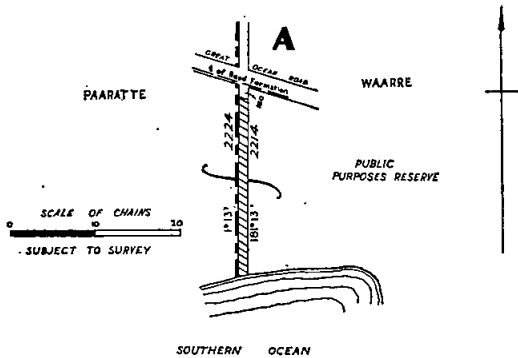

Parish of Wedderburne, County of Gladstone, being the road between allotments 15, 16, 17, 19 and allotments 14A, 14, 2A, 12, 17A, 20, section 12.—(W.116⁽¹⁸⁾) (W.61448).

Parish of Woorinen, County of Tatchera, being the road between allotments 55, 62 and allotments 58, 60.—(W.391⁽¹⁾) (M.40948).

Township of Wycheproof, Parish of Bunguluke, County of Kara Kara, being the road indicated by hachure on plan hereunder.—(W.287⁽⁷⁾) (C.98233).

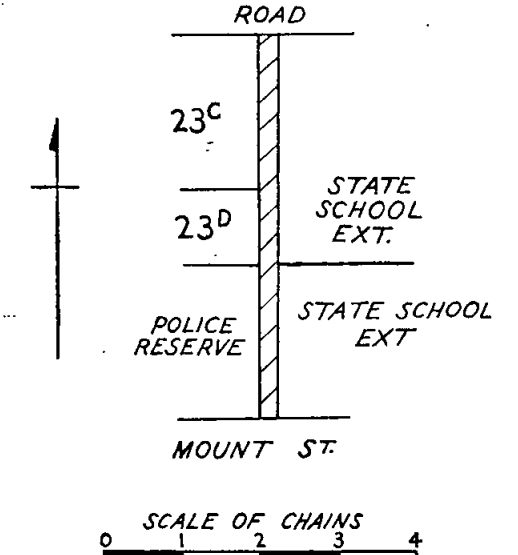

And the Honorable James Charles Murray Balfour, Her Majesty's Commissioner of Crown Lands and Survey for the State of Victoria, shall give the necessary directions herein accordingly.

J. COLQUHOUN,
Clerk of the Executive Council.

DEPARTMENT OF CROWN LANDS AND SURVEY.

At the Executive Council Chamber, Melbourne, the twenty-eighth day of July, 1964.

PRESENT:

His Excellency the Governor of Victoria.
Mr. Darcy | Mr. Rossiter.
Mr. Dickie

LANDS TEMPORARILY RESERVED AS SITES.

HIS Excellency the Governor of the State of Victoria, by and with the advice of the Executive Council thereof, doth hereby, in pursuance of the provisions of the Land Act 1958, reserve, temporarily, and also except from occupation for mining purposes under any miner's right, the lands hereinafter described:—

ARARAT.—Site for Social Welfare purposes 99 acres 3 roods 16 perches, Parish of Ararat, County of Ripon, as indicated by hachure on plan hereunder.—(A.149⁽²⁸⁾) (Rs.8350).

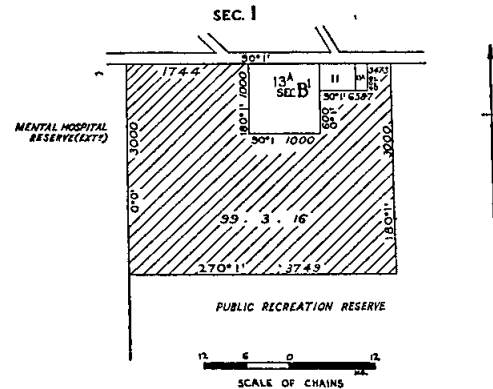

DOOLAN.—Site for the Supply of Gravel, in addition to and adjoining the site temporarily reserved therefore, by Order in Council of the 19th July, 1949, 23 acres 1 rood 24 perches, more or less, Parish of Doolan, County of Delatite, as indicated by hachure on plan hereunder.—(D.154⁽⁸⁾) (Rs.6394).

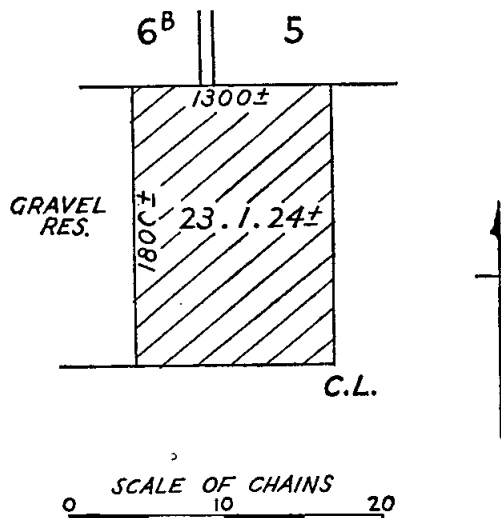

KALKEE.—Site for Plantation purposes, 28 acres 2 roods 12 perches, Parish of Kalkee, County of Borung, as indicated by hachure on plan hereunder.—(K.143^(*)) (Rs.7698).

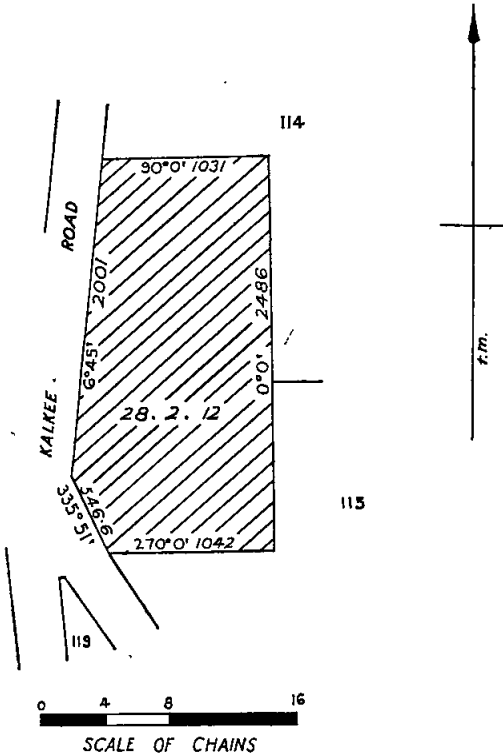

MEPUNGA (NARINGAL).—Site for the Preservation of Native Fauna and Flora, 6 acres 3 roods 36 perches, Parish of Mepunga, County of Heytesbury, as indicated by hachure on plan hereunder.—(M.252^(*)) (Rs.8353).

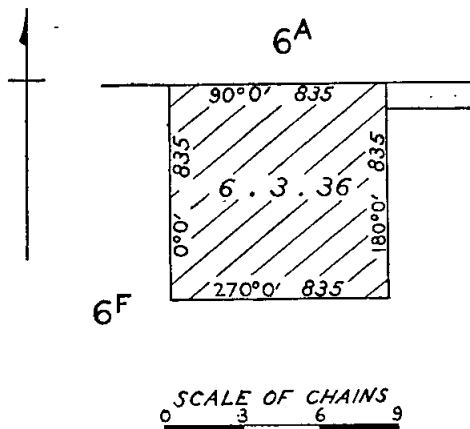

And the Honorable James Charles Murray Balfour, Her Majesty's Commissioner of Crown Lands and Survey for the State of Victoria, shall give the necessary directions herein accordingly.

J. COLQUHOUN,
Clerk of the Executive Council.

DEPARTMENT OF CROWN LANDS AND SURVEY.

At the Executive Council Chamber, Melbourne, the twenty-eighth day of July, 1964.

PRESENT:

His Excellency the Governor of Victoria.
Mr. Darcy | Mr. Rossiter.
Mr. Dickie

VESTING OF LAND IN THE COUNTRY ROADS BOARD.

HIS Excellency the Governor of the State of Victoria, by and with the advice of the Executive Council thereof, doth by this Order made pursuant to section 22A (2) of the Land Act 1958, vest in the Country Roads Board the land in the Township of Bunyip as shown by hachure on the plan hereunder.

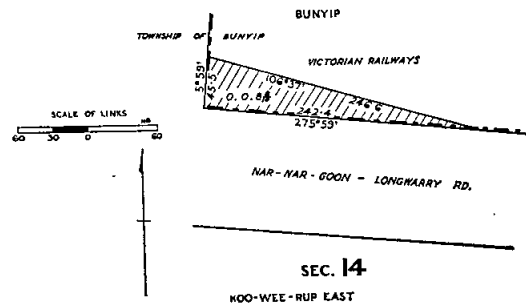

And the Honorable James Charles Murray Balfour, Her Majesty's Commissioner of Crown Lands and Survey for the State of Victoria, shall give the necessary directions herein accordingly.

J. COLQUHOUN,
Clerk of the Executive Council.

DEPARTMENT OF CROWN LANDS AND SURVEY.

At the Executive Council Chamber, Melbourne, the twenty-eighth day of July, 1964.

PRESENT:

His Excellency the Governor of Victoria.
Mr. Darcy | Mr. Rossiter.
Mr. Dickie

REVOCATION OF TEMPORARY RESERVATION AND WITHHOLDING FROM SALE, LEASING, AND LICENSING OF LAND BY ORDER IN COUNCIL.

HIS Excellency the Governor of the State of Victoria, by and with the advice of the Executive Council thereof, doth hereby, in pursuance of the provisions of the Land Act 1958, revoke the temporary reservation and the withholding from sale, leasing and licensing of the land by Order in Council hereinafter referred to, viz.:—

SALE.—Order in Council of 3rd April, 1876, of 84 acres, more or less, of land in the Parish of Sale, as a site for Public purposes.—(C.99184.)

And the Honorable James Charles Murray Balfour, Her Majesty's Commissioner of Crown Lands and Survey for the State of Victoria, shall give the necessary directions herein accordingly.

J. COLQUHOUN,
Clerk of the Executive Council.

COUNTRY ROADS BOARD.

At the Executive Council Chamber, Melbourne,
the twenty-eighth day of July, 1964.

PRESENT:

His Excellency the Governor of Victoria.	
Mr. Darcy	Mr. Rossiter.
Mr. Dickie	

ORDER APPROVING OF WIDENING AN EXISTING MAIN ROAD IN THE CITY OF BROADMEADOWS.

WHEREAS the Country Roads Board constituted under the *Country Roads Act 1958* (No. 6229) has represented to His Excellency the Governor in Council that it appears to it desirable that the existing Mickleham-road in the City of Broadmeadows (declared to be a main road under the said Act which declaration was confirmed by the Order in Council published in the *Government Gazette* of the 19th February, 1941, on page 911) should be widened by the said Board: And whereas the said Board in accordance with the requirements of section 19 of the said cited Act has caused to be prepared a map plan and estimate showing the points between which and on and through what land the said widening is proposed to be made and the cost of acquiring the land: And whereas on an inspection of the said map and plan and a consideration of the said estimate His Excellency the Governor in Council is satisfied that there are funds legally available for acquiring the land: Now therefore be it known by this present Order that His Excellency the Governor of the State of Victoria with the advice of the Executive Council thereof doth hereby approve of the said road being widened, that is to say:—

All those pieces of land in the Parish of Tullamarine, the boundaries of which are as follow:—

(a) Commencing at the north-eastern angle of portion 3 of the said parish; thence by lines bearing respectively 178 deg. 28 min. 1,310 ft. 8 in., 179 deg. 13 min. 792 feet, 315 deg. 18 min. 172 ft. 9½ in., 67 deg. 3 min. 59 ft. 3¼ in., 358 deg. 48½ min. 1,137 ft. 0½ in., 1 deg. 17 min. 1,442 ft. 2½ in. and 178 deg. 56 min. 622 ft. 7¼ in. to the point of commencement.

(b) Commencing at a point on the northern boundary of allotment 1, portion 4, of the said parish, distant 88 deg. 22 min. 70 ft. 3¼ in. from the south-eastern angle of portion 6; thence by lines bearing respectively 89 deg. 37 min. 35 ft. 6½ in., 181 deg. 17 min. 822 feet and 358 deg. 48½ min. 821 ft. 8¾ in. to the point of commencement—

which said pieces of land are particularly delineated and shown coloured red on survey plan numbered 9573, lodged in the office of the Country Roads Board.

And the Honorable Murray Victor Porter, Her Majesty's Commissioner of Public Works for the State of Victoria, shall give the necessary directions herein accordingly.

J. COLQUHOUN,
Clerk of the Executive Council.

COUNTRY ROADS BOARD.

At the Executive Council Chamber, Melbourne,
the twenty-eighth day of July, 1964.

PRESENT:

His Excellency the Governor of Victoria.	
Mr. Darcy	Mr. Rossiter.
Mr. Dickie	

ORDER APPROVING OF WIDENING AN EXISTING MAIN ROAD IN THE SHIRE OF BARRABOOL.

WHEREAS the Country Roads Board constituted under the *Country Roads Act 1958* (No. 6229) has represented to His Excellency the Governor in Council that it appears to it desirable that the existing Torquay-road in the Shire of Barrabool (declared to be a main road under the said Act which declaration was confirmed by the Order in Council published in the *Government Gazette* of the 6th August, 1930, on page 2061) should be widened by the said Board: And whereas

the said Board in accordance with the requirements of section 19 of the said cited Act has caused to be prepared a map plan and estimate showing the points between which and on and through what land the said widening is proposed to be made and the cost of acquiring the land: And whereas on an inspection of the said map and plan and a consideration of the said estimate His Excellency the Governor in Council is satisfied that there are funds legally available for acquiring the land: Now therefore be it known by this present Order that His Excellency the Governor of the State of Victoria with the advice of the Executive Council thereof doth hereby approve of the said road being widened, that is to say:—

All that piece of land in the Parish of Puebla, the boundaries of which are as follow:—Commencing at the intersection of the western boundary of the existing Torquay-road with the northern boundary of allotment 71 of the said parish; thence by lines bearing respectively 156 deg. 3 min. 1,228 links, 166 deg. 20 min. 368.9 links, 180 deg. 0 min. 395.5 links, 283 deg. 23 min. 181 links, 360 deg. 0 min. 500.7 links, 344 deg. 38 min. 349 links, 338 deg. 21½ min. 373.3 links, 336 deg. 3 min. 688.5 links, 303 deg. 2 min. 38.6 links and 90 deg. 1 min. 132.4 links to the point of commencement—which said piece of land is particularly delineated and shown coloured red on survey plan numbered 9622, lodged in the office of the Country Roads Board.

And the Honorable Murray Victor Porter, Her Majesty's Commissioner of Public Works for the State of Victoria, shall give the necessary directions herein accordingly.

J. COLQUHOUN,
Clerk of the Executive Council.

COUNTRY ROADS BOARD.

At the Executive Council Chamber, Melbourne,
the twenty-eighth day of July, 1964.

PRESENT:

His Excellency the Governor of Victoria.	
Mr. Darcy	Mr. Rossiter.
Mr. Dickie	

ORDER APPROVING OF WIDENING AN EXISTING MAIN ROAD IN THE SHIRE OF ROMSEY.

WHEREAS the Country Roads Board constituted under the *Country Roads Act 1958* (No. 6229) has represented to His Excellency the Governor in Council that it appears to it desirable that the existing Gisborne-Kilmore road in the Shire of Romsey (declared to be a main road under the said Act which declaration was confirmed by the Order in Council published in the *Government Gazette* of the 4th June, 1947, on page 2818) should be widened by the said Board: And whereas the said Board in accordance with the requirements of section 19 of the said cited Act has caused to be prepared a map plan and estimate showing the points between which and on and through what land the said widening is proposed to be made and the cost of acquiring the land: And whereas on an inspection of the said map and plan and a consideration of the said estimate His Excellency the Governor in Council is satisfied that there are funds legally available for acquiring the land: Now therefore be it known by this present Order that His Excellency the Governor of the State of Victoria with the advice of the Executive Council thereof doth hereby approve of the said road being widened, that is to say:—

All that piece of land in the Parish of Kerrie, the boundaries of which are as follow:—Commencing at the north-western angle of allotment 21, section A, of the said parish; thence by lines bearing respectively 73 deg. 22 min. 783.7 links, 237 deg. 0 min. 724.4 links, 208 deg. 29 min. 51 links, 198 deg. 25 min. 788.1 links and 7 deg. 41 min. 971.5 links to the point of commencement—which said piece of land is particularly delineated and shown coloured red on survey plan numbered 9654, lodged in the office of the Country Roads Board.

And the Honorable Murray Victor Porter, Her Majesty's Commissioner of Public Works for the State of Victoria, shall give the necessary directions herein accordingly.

J. COLQUHOUN,
Clerk of the Executive Council.

COUNTRY ROADS BOARD.

At the Executive Council Chamber, Melbourne,
the twenty-eighth day of July, 1964.

PRESENT:

His Excellency the Governor of Victoria.
Mr. Darcy | Mr. Rossiter.
Mr. Dickie

ORDER APPROVING THE WIDENING OF AN EXISTING STATE HIGHWAY IN THE SHIRE OF NUMURKAH.

WHEREAS:

I. Section 114 of the *Country Roads Act 1958* (herein called "the Act") provides (*inter alia*) in—

- (a) Sub-section (1) thereof that the powers conferred upon municipal councils by Division fourteen of Part XIX. of the *Local Government Act 1958* shall so far as applicable be conferred upon the Country Roads Board (herein called "the Board") so far as relates to the declaration of the alignment, the widening and opening up of State highways and that the provisions of the said Division shall, with certain modifications, extend and apply accordingly;
- (b) sub-section (2) thereof that no State highway shall be widened or opened up pursuant to the said section unless the Governor in Council has by Order published in the *Government Gazette* approved such widening or opening up.

II. The Board has—

- (a) in exercise of the powers conferred upon it by the said section 114 and for the purpose of widening the Goulburn Valley Highway in the Shire of Numurkah (declared by the Board pursuant to the Act or some corresponding previous enactment to be a State highway which declaration was confirmed by an Order of the Governor in Council published in the *Government Gazette* of the 27th December, 1940, at page 4453 thereof) by Resolution dated the eleventh day of May, 1964, fixed new alignments for the east side of the said highway;
- (b) in accordance with the provisions of section 19 of the Act caused to be prepared a map plan and estimate showing—
- the points between which and the lands on and through which the said widening is proposed to be made; and
 - the cost of acquiring the land.

III. The Governor in Council is satisfied that there are funds legally available for acquiring the said land.

Now therefore His Excellency the Governor of the State of Victoria with the advice of the Executive Council thereof by this Order approves for the purposes of sections 20, 74 and 114 of the Act—

- (a) the widening of the said Goulburn Valley Highway so as to include therein the land described in the Schedule hereto; and
- (b) the acquisition of the land so described.

SCHEDULE.

All those pieces of land in the Parish of Katunga, the boundaries of which are as follow:—

- (a) Commencing at the south-eastern angle of a Public Recreation Reserve, Township of Numurkah, in the said parish; thence by lines bearing respectively 270 deg. 3 min. 40 feet, 45 deg. 2 min. 56 ft. 6½ in. and 180 deg. 0 min. 40 feet to the point of commencement.
- (b) Commencing at the south-western angle of allotment 10, section 37, Township of Numurkah, in the said parish; thence by lines bearing respectively 0 deg. 2 min. 660 feet, 1 deg. 36 min. 66 feet, 360 deg. 0 min. 1,219 ft. 11½ in., 90 deg. 0 min. 14 feet, 180 deg. 0 min. 1,930 ft. 11½ in., 135 deg. 0 min. 21 ft. 2½ in. and 270 deg. 2 min. 31 ft. 2½ in. to the point of commencement.
- (c) Commencing at the south-western angle of allotment 7c, section C, Township of Numurkah, in the said parish; thence by lines bearing

respectively 18 deg. 57 min. 139 ft. 11 in., 19 deg. 4 min. 1,052 ft. 3½ in., 19 deg. 1½ min. 730 ft. 9½ in., 19 deg. 6½ min. 925 ft. 3 in., 19 deg. 47 min. 21 ft. 10 in., 19 deg. 5½ min. 781 ft. 1 in., 89 deg. 57 min. 15 feet, 199 deg. 4½ min. 504 ft. 4½ in., 144 deg. 30 min. 23 ft. 2½ in., 269 deg. 57 min. 20 feet, 199 deg. 4½ min. 69 ft. 10½ in., 89 deg. 57 min. 20 feet, 234 deg. 30 min. 32 ft. 7½ in., 199 deg. 4½ min. 1,054 ft. 9½ in., 143 deg. 36 min. 5 ft. 8 in., 268 deg. 8½ min. 5 feet, 199 deg. 4½ min. 53 ft. 6½ in., 88 deg. 8½ min. 20 feet, 233 deg. 36 min. 32 ft. 11½ in., 199 deg. 4½ min. 635 ft. 0½ in., 143 deg. 36 min. 5 ft. 8 in., 268 deg. 8½ min. 5 feet, 199 deg. 4½ min. 70 ft. 9½ in., 88 deg. 8½ min. 20 feet, 233 deg. 36 min. 32 ft. 11½ in., 199 deg. 4½ min. 1,152 ft. 10 in., 144 deg. 33 min. 23 ft. 2½ in. and 270 deg. 2 min. 35 ft. 1 in. to the point of commencement—

which said pieces of land are particularly delineated and shown coloured red and yellow on survey plans numbered 9577 and 9579, lodged in the office of the Country Roads Board.

And the Honorable Murray Victor Porter, Her Majesty's Commissioner of Public Works for the State of Victoria, shall give the necessary directions herein accordingly.

J. COLQUHOUN,
Clerk of the Executive Council.

COUNTRY ROADS BOARD.

At the Executive Council Chamber, Melbourne,
the twenty-eighth day of July, 1964.

PRESENT:

His Excellency the Governor of Victoria.
Mr. Darcy | Mr. Rossiter.
Mr. Dickie

ORDER APPROVING OF A DEVIATION FROM A STATE HIGHWAY IN THE SHIRE OF PORTLAND.

WHEREAS the Country Roads Board constituted under the *Country Roads Act 1958* (No. 6229) has represented to His Excellency the Governor in Council that it appears to it desirable that the deviation hereinafter referred to from the existing Princes Highway in the Shire of Portland (declared to be a State highway under the said Act which declaration was confirmed by the Order in Council published in the *Government Gazette* of the 8th July, 1925, on pages 2371-3) should be made by the said Board: And whereas the said Board in accordance with the requirements of section 19 of the said cited Act has caused to be prepared a map plan and estimate showing the points between which and on and through what land the said deviation is proposed to be made and the cost of acquiring the land: And whereas on an inspection of the said map and plan and a consideration of the said estimate His Excellency the Governor in Council is satisfied that there are funds legally available for acquiring the land: Now therefore be it known by this present Order that His Excellency the Governor of the State of Victoria with the advice of the Executive Council thereof doth hereby approve of the said highway being made, that is to say:—

All that piece of land in the Parish of Narrawong, the boundaries of which are as follow:—Commencing at a point on the eastern boundary of allotment 46 of the said parish, distant 360 deg. 0 min. 1,309.2 links from the south-eastern angle of the said allotment; thence by lines bearing respectively 214 deg. 24 min. 732.6 links, 223 deg. 59 min. 653 links, 241 deg. 7 min. 764.5 links, 265 deg. 0 min. 1,353.6 links, 82 deg. 2 min. 604.3 links, 72 deg. 9 min. 592.1 links, 58 deg. 3 min. 897.7 links, 40 deg. 36 min. 745.7 links, 25 deg. 47 min. 741.9 links, 11 deg. 14 min. 787.7 links and 180 deg. 0 min. 1,185.4 links to the point of commencement—which said piece of land is particularly delineated and shown coloured red on survey plan numbered 9659, lodged in the office of the Country Roads Board.

And the Honorable Murray Victor Porter, Her Majesty's Commissioner of Public Works for the State of Victoria, shall give the necessary directions herein accordingly.

J. COLQUHOUN,
Clerk of the Executive Council.

COUNTRY ROADS BOARD.

At the Executive Council Chamber, Melbourne,
the twenty-eighth day of July, 1964.

PRESENT:

His Excellency the Governor of Victoria.
Mr. Darcy | Mr. Rossiter.
Mr. Dickie

ORDER APPROVING OF A NEW ROAD IN THE
SHIRE OF KNOX.

WHEREAS the Country Roads Board constituted under the *Country Roads Act 1958* (No. 6229) has represented to His Excellency the Governor in Council that it appears to it desirable that the Bergin Army-road in the Shire of Knox should be made by the said Board; And whereas the said Board in accordance with the requirements of section 19 of the said cited Act has caused to be prepared a map plan and estimate showing the points between which and on and through what land the said new road is proposed to be made and the cost of acquiring the land; And whereas on an inspection of the said map and plan and a consideration of the said estimate His Excellency the Governor in Council is satisfied that there are funds legally available for acquiring the land: Now therefore be it known by this present Order that His Excellency the Governor of the State of Victoria with the advice of the Executive Council thereof doth hereby approve of the said road being made, that is to say:—

All that piece of land in the Parish of Narree Worrان, the boundaries of which are as follow:—Commencing at a point on the southern boundary of portion 6 of the said parish, distant 278 deg. 33 min. 1,136.1 links from the south-eastern angle of the said portion; thence by lines bearing respectively 278 deg. 33 min. 163 links, 64 deg. 55 min. 36.9 links, 28 deg. 10 min. 574.1 links, 14 deg. 35 min. 142.2 links, 350 deg. 53 min. 163.5 links, 331 deg. 32 min. 177.3 links, 137 deg. 57 min. 429.4 links, 261 deg. 45 min. 29.5 links, 208 deg. 10 min. 667.5 links, 201 deg. 2 min. 71.8 links and 147 deg. 54 min. 26.3 links to the point of commencement—which said piece of land is particularly delineated and shown coloured red and blue on survey plan numbered 9598, lodged in the office of the Country Roads Board.

And the Honorable Murray Victor Porter, Her Majesty's Commissioner of Public Works for the State of Victoria, shall give the necessary directions herein accordingly.

J. COLQUHOUN,
Clerk of the Executive Council.

COUNTRY ROADS BOARD.

At the Executive Council Chamber, Melbourne,
the twenty-eighth day of July, 1964.

PRESENT:

His Excellency the Governor of Victoria.
Mr. Darcy | Mr. Rossiter.
Mr. Dickie

ORDER APPROVING OF WIDENING AN EXISTING
FOREST ROAD IN THE SHIRE OF BET BET.

WHEREAS the Country Roads Board constituted under the *Country Roads Act 1958* (No. 6229) has represented to His Excellency the Governor in Council that it appears to it desirable that the existing Bealiba-Moliagul road in the Shire of Bet Bet (declared to be a forest road under the said Act which declaration was confirmed by the Order in Council published in the *Government Gazette* of the 6th June, 1945, on pages 1411-2) should be widened by the said Board: And whereas the said Board in accordance with the requirements of sections 19 and 94 of the said cited Act has caused to be prepared a map plan and estimate showing the points between which and on and through what land the said widening is proposed to be made and the cost of acquiring the land: And whereas on an inspection of the said map and plan and a consideration of the said estimate His Excellency the Governor in Council is satisfied that there are funds legally available for acquiring the land: Now therefore be it known by this present Order that His Excellency the Governor of the

State of Victoria with the advice of the Executive Council thereof doth hereby approve of the said road being widened, that is to say:—

All that piece of land in the Parish of Bealiba, the boundaries of which are as follow:—Commencing at the north-western angle of allotment 16, section F, of the said parish; thence by lines bearing respectively 100 deg. 51 min. 196 feet, 259 deg. 43 min. 164 ft. 5 in., 244 deg. 44 min. 109 ft. 8 in., 228 deg. 0 min. 142 ft. 2 in. and 39 deg. 55 min. 271 ft. 5 in. to the point of commencement—which said piece of land is particularly delineated and shown coloured red on survey plan numbered 9620, lodged in the office of the Country Roads Board.

And the Honorable Murray Victor Porter, Her Majesty's Commissioner of Public Works for the State of Victoria, shall give the necessary directions herein accordingly.

J. COLQUHOUN,
Clerk of the Executive Council.

COUNTRY ROADS BOARD.

At the Executive Council Chamber, Melbourne,
the twenty-eighth day of July, 1964.

PRESENT:

His Excellency the Governor of Victoria.
Mr. Darcy | Mr. Rossiter.
Mr. Dickie

ORDER APPROVING OF A NEW ROAD IN THE
CITY OF NEWTOWN AND CHILWELL.

WHEREAS the Country Roads Board constituted under the *Country Roads Act 1958* (No. 6229) has represented to His Excellency the Governor in Council that it appears to it desirable that the Princes Bridge Approach-road in the City of Newtown and Chilwell should be made by the said Board: And whereas the said Board in accordance with the requirements of section 19 of the said cited Act has caused to be prepared a map plan and estimate showing the points between which and on and through what land the said new road is proposed to be made and the cost of acquiring the land: And whereas on an inspection of the said map and plan and a consideration of the said estimate His Excellency the Governor in Council is satisfied that there are funds legally available for acquiring the land: Now therefore be it known by this present Order that His Excellency the Governor of the State of Victoria with the advice of the Executive Council thereof doth hereby approve of the said road being made, that is to say:—

All those pieces of land in the Parish of Moorpanyal, the boundaries of which are as follow:—

- (a) Commencing at the south-eastern angle of portion 1, section 12, of the said parish; thence south-westerly by the bank of the Barwon River; thence by lines bearing respectively 328 deg. 30½ min. 63 ft. 4 in., 55 deg. 35 min. 150 feet, 33 deg. 46 min. 197 ft. 3½ in. and 180 deg. 0 min. 42 ft. 9 in. to the point of commencement.
- (b) Commencing at a point in portion 1, section 12, of the said parish, distant 360 deg. 0 min. 42 ft. 9 in., 213 deg. 46 min. 197 ft. 3½ in., 235 deg. 35 min. 150 links and 248 deg. 25½ min. 201 feet from the south-eastern angle of the said portion; thence by a line bearing 148 deg. 30½ min. 296 ft. 1 in. to the northern bank of the Barwon River; thence westerly and north-westerly by the said bank; thence by lines bearing respectively 125 deg. 8 min. 150 feet, 114 deg. 10 min. 150 feet, 103 deg. 12 min. 150 feet, 92 deg. 14 min. 150 feet and 81 deg. 16 min. 150 feet to the point of commencement—

which said pieces of land are particularly delineated and shown coloured red and blue on survey plan numbered 9484, lodged in the office of the Country Roads Board.

And the Honorable Murray Victor Porter, Her Majesty's Commissioner of Public Works for the State of Victoria, shall give the necessary directions herein accordingly.

J. COLQUHOUN,
Clerk of the Executive Council.

COUNTRY ROADS BOARD.

At the Executive Council Chamber, Melbourne,
the twenty-eighth day of July, 1964.

PRESENT:

His Excellency the Governor of Victoria.	
Mr. Darcy	Mr. Rossiter.
Mr. Dickie	

ORDER APPROVING OF WIDENING AN EXISTING MAIN ROAD IN THE SHIRE OF SEYMOUR.

WHEREAS the Country Roads Board constituted under the *Country Roads Act 1958* (No. 6229) has represented to His Excellency the Governor in Council that it appears to it desirable that the existing Highlands-road in the Shire of Seymour (declared to be a main road under the said Act which declaration was confirmed by the Order in Council published in the *Government Gazette* of the 19th October, 1932, on page 2387) should be widened by the said Board: And whereas the said Board in accordance with the requirements of section 19 of the said cited Act has caused to be prepared a map plan and estimate showing the points between which and on and through what land the said widening is proposed to be made and the cost of acquiring the land: And whereas on an inspection of the said map and plan and a consideration of the said estimate His Excellency the Governor in Council is satisfied that there are funds legally available for acquiring the land: Now therefore be it known by this present Order that His Excellency the Governor of the State of Victoria with the advice of the Executive Council thereof doth hereby approve of the said road being widened, that is to say:—

All those pieces of land in the Parish of Worrhough, the boundaries of which are as follow:—

- (a) Commencing at the southern angle of allotment 6, section A, of the said parish; thence by lines bearing respectively 309 deg. 7 min. 300 links, 115 deg. 55 min. 441.4 links and 271 deg. 17 min. 164.3 links to the point of commencement.
- (b) Commencing at a point on the southern boundary of allotment 11A, section A, of the said parish, distant 91 deg. 17 min. 550 links from the south-western angle of the said allotment; thence by lines bearing respectively 109 deg. 21 min. 613.3 links, 119 deg. 45 min. 309 links and 292 deg. 50 min. 919 links to the point of commencement—

which said pieces of land are particularly delineated and shown coloured red and yellow on survey plan numbered 9681, lodged in the office of the Country Roads Board.

And the Honorable Murray Victor Porter, Her Majesty's Commissioner of Public Works for the State of Victoria, shall give the necessary directions herein accordingly.

J. COLQUHOUN,
Clerk of the Executive Council.

WESTERNPORT (OIL REFINERY) ACT 1963.

At the Executive Council Chamber, Melbourne,
the twenty-eighth day of July, 1964.

PRESENT:

His Excellency the Governor of Victoria.	
Mr. Darcy	Mr. Rossiter.
Mr. Dickie	

APPROVAL OF A PIPE-LINE ROUTE.

WHEREAS it is provided by the *Westernport (Oil Refinery) Act 1963*, that B.P. Refinery (Westernport) Pty. Limited, subject to the Act and the agreement set out in the Schedule thereto, may construct and operate pipe-lines by such routes as are approved by Order of the Governor in Council published in the *Government Gazette*:

And whereas it is further provided that when the route of a pipe-line has been so approved such pipe-line shall be an authorized pipe-line within the meaning of the Act and that any such authorized pipe-line may deviate from the approved route within such limits of lateral deviation as are specified in the Order:

Now, therefore, His Excellency the Governor of the State of Victoria, by and with the advice of the Executive Council thereof and in pursuance of the provisions of section 6 of the said Act, hereby approves the route defined hereunder and specifies distances of three hundred feet (300') on each side of such route as the limits of lateral deviation of the authorized pipe-line:—

Commencing in the Parish of Bittern, at a point on the north side of Wooley's-road, 104.6 links west of the south-east corner of Crown allotment 85B; thence in a north-westerly direction through Crown allotment 85B to a point 104.1 links west of the south-east corner of Crown allotment 85A; thence in a north-westerly direction through Crown allotment 85A to a point which is 76.4 links on a bearing of 233 deg. 34 min. from the south-east corner of Crown allotment 84B; thence through Crown allotment 85A to a point on the boundary of Crown allotment 85A and Crown allotment 84B distance 52.1 links; thence in a north-westerly direction through Crown allotment 84B to a point 86.8 links west of the south-east corner of Crown allotment 84A; thence north-westerly through Crown allotment 84A to a point which is 78.7 links on a bearing of 224 deg. 56 min. from the south-east corner of Crown allotment 83B; thence on a bearing of 299 deg. 01 min. for a distance of 115.1 links to a point on the boundary of Crown allotments 84A and 83B; thence through Crown allotment 83B and Crown allotment 83A on a bearing of 299 deg. 01 min. for a distance of 2,893.8 links; thence on a bearing of 359 deg. 22½ min. to a point 319 links east of the north-west corner of Crown allotment 83B; thence through Crown land for 1,450 links in a northerly direction to a point which is 1,314 links west of the most south-easterly corner of Crown allotment 83A; thence through Crown allotment 83A on a bearing of 359 deg. 05 min. to the south bank of the Warringine Creek; thence in the Parish of Tyabb from a point which is 168 deg. 39 min. and 354 links and 197.9 links and 138 deg. 34 min. from the north-west corner of Crown allotment 100 through Crown allotment 100 to a point on the south side of Salmon-street which is 193.6 links easterly of the north-west corner of Crown allotment 100; thence northerly across Salmon-street; thence from a point which is 74 ft. 5½ in. easterly of the north-east corner of the intersection of Railway-crescent and Salmon-street through lots 257-262 inclusive and Railway-crescent on plan of subdivision No. 2933 lodged in the Office of Titles on a bearing of 359 deg. 05 min. for a distance of 354 ft. 7½ in. to the east side of the Railway property on which is located the Frankston and Stony Point Railway; thence by a line generally 30 feet west of the eastern boundary of the Railway property northerly to a point on the eastern boundary 1,403 ft. 3 in. south of the southern building line of Mornington-road, Tyabb; thence across Flinders-Frankston road to a point 1,341 ft. 4 in. south of the southern building line of Mornington-road, and 36 ft. 0 in. west of the east building line of Flinders-Frankston road; thence in a northerly direction parallel to this east building line to a point 1,363 ft. 3 in. north of the north building line of Central-avenue; thence to a point on the east building line 75.8 links north of the north-west corner of Crown allotment 51, Parish of Tyabb; thence through Bunguan Pre-emptive Right on a bearing of 99 deg. 12½ min. for a distance of 530.8 links; thence on a bearing of 17 deg. 42½ min. to the south side of O'Neill's-road to a point which is 911.9 links easterly of the north-west corner of Bunguan Pre-emptive Right; thence northerly across O'Neill's-road to the north side of O'Neill's-road to a point which is 926.4 links easterly of the south-west corner of Crown allotment 40B; thence through Crown allotment 40B to a point which is 398.6 links easterly of a bend in the southern boundary of Crown allotment 40A; thence through Crown allotment 40A on a bearing of 17 deg. 39½ min. for a distance of 18.2 links and then on a bearing of 28 deg. 04 min. for a distance of 1,007.5 links to the eastern boundary of Crown allotment 40A; thence through Crown allotment 40 on a bearing of 28 deg. 04 min. for a distance of 161.9 links then on a bearing of 18 deg. 10½ min. to the north boundary of Crown allotment 40 to a point which is 329.5 links westerly of the north-east corner of Crown allotment 40; thence through Crown allotment 41 to the west side of Government road to a point which is 1,001.4 links north of south-east corner of Crown allotment 41; thence north-easterly across a Government road to the east side, to a point which is 2,741.8 links south of the north-west corner of Crown allotment 38A; thence northerly through Crown allotment 38 to the south side of Bungower-road to a point 900.5 links east of the north-west corner of Crown allotment 38A; thence northerly across Bungower-road to the north side to a point which is 928 links east of the south-west corner of Crown allotment 24A; thence northerly through Crown allotment 24A to the eastern boundary of Crown allotment 24A to a point 973.4 links south of the north-west corner of Crown allotment 24B; thence northerly through Crown allotment

24B to the north side of Crown allotment 24B to a point 268.2 links east of the north-west corner of Crown allotment 24B; thence northerly through Crown allotment 15 to the eastern boundary of Crown allotment 15 to a point 791.2 links south of the north-west corner of Crown allotment 14A; thence northerly through Crown allotment 14A to the south side of Eramosa-road to a point 218.1 links east of the north-west corner of Crown allotment 14A; thence northerly across Eramosa-road to the north side to a point which is 239.6 links east of the south-west corner of Crown allotment 11; thence northerly through Crown allotment 11 to the north boundary of Crown allotment 11 to a point 77.4 links east of the south-east corner of a Water Reserve; thence through Crown allotment 3B on a bearing of 12 deg. 00 min. for a distance of 3,414.6 links; thence on a bearing of 0 deg. 18 min. to the south side of South Boundary-road to a point 983.3 links north-westerly from the north-west corner of Crown allotment 3A; thence northerly across South Boundary-road to the north side to a point which is in the Parish of Langwarrin and 399.4 links south-easterly from the south-west corner of lot 122 on plan of subdivision No. 1740, lodged in the Office of Titles; thence northerly through Crown allotment 90 on a bearing of 7 deg. 18½ min. to the south side of Larnach-road to a point which is 135 ft. 6 in. easterly of a bend on the north boundary of lot 125 on plan of subdivision No. 1740 lodged in the Office of Titles; thence northerly across Larnach-road to the north side to a point which is 75.8 links easterly of the south-west corner of lot 163 on plan of subdivision No. 2064, lodged in the Office of Titles; thence through Crown allotments 79 and 78 on a bearing of 359 deg. 58 min. for a distance of 3,881.6 links; thence on a bearing of 315 deg. 00 min. to the south side of Victoria-road to a point which is 42.9 links west of the north-east corner of lot 178 on plan of subdivision No. 2064 lodged in the Office of Titles; thence north-westerly to the north side of Victoria-road to a point which is 107.2 links east of the south-west corner of lot 231 on plan of subdivision No. 2064 lodged in the Office of Titles; thence on a bearing of 315 deg. 00 min. for a distance of 44.4 links; thence due north through Crown allotments 78 and 77 to the south side of Camp-road to a point which is 79 links south-easterly of the north-west corner of lot 233 on plan of subdivision No. 2064 lodged in the Office of Titles; thence northerly to the north side of Camp-road to a point which is 6.4 links east of a bend on the south side of lot 239 on plan of subdivision No. 2064 lodged in the Office of Titles; thence on a bearing of 359 deg. 59 min. for 994 links; thence on a bearing of 44 deg. 59 min. for 337.6 links; thence on a bearing of 359 deg. 57 min. to the south side of Robinsons-road to a point which is 156.3 links west of the north-east corner of lot 239 on plan of subdivision No. 2064 lodged in the Office of Titles; thence northerly to the north side of Robinsons-road to a point which is 75.8 links west of the south-east corner of lot 14 on plan of subdivision No. 13105 lodged in the Office of Titles; thence northerly through Crown allotment 65 to the north side of Donald-road to a point which is 2,430.8 links west of the north-east corner of Crown allotment 65; thence northerly through Crown allotment 64 to the north boundary of Crown allotment 64 to a point which is 2,683.3 links west of the north-east corner of Crown allotment 64; thence through Crown allotment 55 on a bearing of 354 deg. 56 min. for 1,060 links; thence on a bearing of 359 deg. 58 min. to the south side of North-road to a point which is 2,776.5 links west of the north-east corner of Crown allotment 55; thence northerly to the north side of North-road to a point which is 2,775.8 links west of the south-east corner of Crown allotment 15; thence through Crown allotment 15, on a bearing of 359 deg. 58 min. for 1,852 links and then a bearing of 357 deg. 34 min. to the north boundary of Crown allotment 15 to a point which is 2,810.8 links west of the south-east corner of Crown allotment 16; thence through Crown allotments 16, 17, 22 and 23 to the south side of McKays-road to a point which is 3,231.7 links west of the north-east corner of Crown allotment 22; thence northerly to the north side of McKays-road to a point which is 576.1 links west of the south-east corner of Crown allotment 24A; thence through Crown allotment 24A on a bearing of 6 deg. 08 min. for 714.4 links then on a bearing of 20 deg. 53½ min. for 1,389.5 links, then on a bearing of 2 deg. 45 min. for 395.0 links; thence on a bearing of 340 deg. 32 min. for 1,086.6 links to the south side of Frankston-Cranbourne road to a point 625.9 links south-westerly from the north-east corner of Crown allotment 24A; thence northerly to the north side of Frankston-Cranbourne road to a point which is 87 links north-easterly of the south-west corner of Crown allotment 30A; thence north-westerly through Crown allotment 30A to the western boundary of Crown allotment 30A to a point which is 181.5 links north of the south-western corner of Crown allotment 30A; thence through Crown allotment 31 on a bearing of 340 deg. 30 min. for 161.4 links; thence on a bearing of 8 deg. 33

min. through Crown allotment 31 and Crown allotment 31A to the northern boundary of Crown allotment 31A to a point which is 75.8 links west of the north-eastern corner of Crown allotment 31A; thence through Crown allotment 32 on a bearing of 9 deg. 00 min. for 1,077.8 links; thence on a bearing of 53 deg. 33 min. for 100.9 links; thence on a bearing of 9 deg. 28 min. for 1,153.5 links; thence on a bearing of 8 deg. 33 min. for 755 links to the south side of Bullarto-road to a point which is 1,324.2 links east of the north-western corner of Crown allotment 32; thence northerly to the north side of Bullarto-road to a point which is in the Parish of Lyndhurst and 3,694.8 links west of the south-eastern corner of Crown allotment 31; thence through Crown allotment 31 for a bearing of 359 deg. 49½ min. for 2,801 links and 359 deg. 47 min. for 1,322.4 links to the northern boundary of Crown allotment 31 to a point which is 3,714 links west of the north-east corner of Crown allotment 31; thence northerly through Crown allotment 30A to the northern boundary of Crown allotment 30A to a point which is 3,715 links west of the north-eastern corner of Crown allotment 30A; thence northerly through Crown allotment 30 to the south side of Hall-road to a point which is 1,019 links east of the north-west corner of Crown allotment 30; thence northerly to the north side of Hall-road to a point which is 113.4 links west of the south-eastern corner of Crown allotment 33; thence through Crown allotment 33 on a bearing of 0 deg. 16 min. for 3,092.1 links, then on a bearing of 0 deg. 14 min. through Crown allotment 33 and Crown allotment 40 to the south side of Wedge-road to a point which is 3,923.5 links east of the north-western corner of Crown allotment 40; thence northerly to the north side of Wedge-road to a point which is 75.8 links west of the south-eastern corner of Crown allotment 43; thence through Crown allotment 43 on a bearing of 359 deg. 59½ min. for 4,018.2 links and a bearing of 359 deg. 55½ min. to the south side of Thompsons-road to a point which is 75.8 links west of the north-eastern corner of Crown allotment 43; thence northerly to the north side of Thompsons-road to a point 75.8 links west of the south-eastern corner of Crown allotment 44; thence northerly through Crown allotment 44 to a point 75.8 links west of the north-western corner of Crown allotment 25 and then northerly through Crown allotment 44 to the south side of Glasscocks-road to a point which is 105.8 links west of the north-eastern corner of Crown allotment 44; thence northerly to the north side of Glasscocks-road to a point which is in the Parish of Eumemmerring and 75.8 links west of the south-eastern corner of Crown allotment 48; thence through Crown allotment 48 for a bearing of 359 deg. 19½ min. for 11 chains; thence northerly to the northern boundary of Crown allotment 48 to a point 75.8 links west of the north-eastern corner of Crown allotment 48; thence northerly through Crown allotment 47 to the south side of Bassetts-road to a point which is 4,027.2 links east of the north-western corner of Crown allotment 47; thence northerly to the north side of Bassetts-road to a point 4,028.3 links east of the south-western corner of Crown allotment 66; thence northerly through Crown allotment 66 to the northern boundary of Crown allotment 66 to a point which is 75.8 links west of the south-eastern corner of Crown allotment 69; thence through Crown allotment 69 on a bearing of 359 deg. 54 min. for 1,622.5 links then due north for 1,602 links; thence on a bearing of 331 deg. 49 min. to the south side of Abbotts-road to a point which is 3,895 links east of the north-west corner of Crown allotment 69; thence north-westerly to the north side of Abbotts-road to a point which is 3,941 links east of the south-western corner of Crown allotment 80; thence north-westerly through Crown allotment 80 to the north boundary of Crown allotment 80 to a point which is 2,149.5 links east of the north-west corner of Crown allotment 80; thence through Crown allotment 82 on a bearing of 331 deg. 53 min. for 626.8 links to a Gas and Fuel Corporation easement on certificate of title, volume 6768, folio 421; thence by a line 32 feet to the east of and parallel with the eastern boundary of that easement to the northern boundary of Crown allotment 82, Parish of Eumemmerring.

And the Honorable Rupert James Hamer, Her Majesty's Minister for Local Government for the State of Victoria, shall give the necessary directions herein accordingly.

J. COLQUHOUN,
Clerk of the Executive Council.

STATE RELIEF COMMITTEE ACT 1958.

At the Executive Council Chamber, Melbourne,
the twenty-eighth day of July, 1964.

PRESENT:

His Excellency the Governor of Victoria.
Mr. Darcy | Mr. Rossiter.
Mr. Dickie |

APPOINTMENT OF A MEMBER OF THE STATE RELIEF COMMITTEE.

IN pursuance of the powers conferred by the *State Relief Committee Act 1958*, His Excellency the Governor of the State of Victoria, by and with the advice of the Executive Council thereof, doth by this Order appoint the following person to be a member of the State Relief Committee from the 28th day of July, 1964, until the 10th day of December, 1964:—

PHYLIS IRENE FROST, C.B.E., J.P., vice Mary Northcott, resigned.

And the Honorable George Oswald Reid, Her Majesty's Minister of Labour and Industry for the State of Victoria, shall give the necessary directions herein accordingly.

J. COLQUHOUN,
Clerk of the Executive Council.

LANDLORD AND TENANT ACT 1958.

At the Executive Council Chamber, Melbourne,
the twenty-eighth day of July, 1964.

PRESENT:

His Excellency the Governor of Victoria.
Mr. Darcy | Mr. Rossiter.
Mr. Dickie |

ORDER EXTENDING APPLICATION OF PART V. OF THE LANDLORD AND TENANT ACT 1958 TO CERTAIN PREMISES.

IN pursuance of the powers conferred by section 44 of the *Landlord and Tenant Act 1958*, His Excellency the Governor of Victoria, by and with the advice of the Executive Council thereof, doth hereby declare that the application of Part V. of the *Landlord and Tenant Act 1958* shall extend to the following premises:—

1. The premises known as No. 82 Alexandra-parade, Fitzroy.
2. The premises known as No. 154 Donald-street, East Brunswick.
3. The rear part of the premises known as No. 221 Beach-road, Mordialloc, leased to Francesco Marino Re on 16th July, 1964.
4. The premises known as No. 10 Barry-street, South Yarra.
5. The premises known as No. 373 Fitzroy-street, Fitzroy.
6. The premises known as No. 3 Coleman-street, North Fitzroy.
7. The premises known as No. 28 Alexandra-avenue, East Geelong, and all premises forming part of such premises.

And the Honorable Arthur Gordon Rylah, Her Majesty's Attorney-General for the State of Victoria, shall give the necessary directions herein accordingly.

J. COLQUHOUN,
Clerk of the Executive Council.

MOTOR CAR ACT 1958.

At the Executive Council Chamber, Melbourne, the
fourth day of August, 1964.

PRESENT:

The Lieutenant-Governor as Deputy for His Excellency
the Governor of Victoria.
Mr. Thompson | Mr. Porter.
Mr. Darcy |

MOTOR CAR TRIALS OF SPEED AT EASTERN BEACH, GEELONG.

WHEREAS it is enacted by sub-section (2) of section eight-three of the *Motor Car Act 1958* that, if a motor car is used on a highway for purposes of racing or of trial of speed, the driver or the person in charge thereof shall be liable to a penalty of not more than Fifty pounds, provided that the said sub-section (2) shall not apply to a motor car used as aforesaid on any highway or portion thereof specified by Order in Council published in the *Government Gazette* and on such days and during such hours as are specified in the Order:

And whereas the Western District Car Club (Inc.) has requested that such an Order be made so as to enable motor car trials of speed to be conducted by the said Club on Ritchie Boulevard on Sunday, the twenty-third day of August, 1964:

Now therefore the Lieutenant-Governor as Deputy for His Excellency the Governor of the State of Victoria, by and with the advice of the Executive Council thereof, and in pursuance of the powers conferred by the *Motor Car Act 1958*, doth by this Order specify Ritchie Boulevard within the municipal district of the City of Geelong, as a highway in respect of which any motor car may, without being subject to the application of the said sub-section (2) of section eighty-three of the *Motor Car Act 1958* be used for purposes of trials of speed under the control and supervision of the said Western District Car Club (Inc.) on Sunday, the twenty-third day of August, 1964, between the hours of thirty minutes past Twelve o'clock and thirty minutes past Four o'clock in the afternoon, provided:

- (1) That onlookers and other unauthorized persons are refused admittance to the "pits" and the area behind the starting line;
- (2) that admittance to the "pit area" be restricted to those persons possessing "pit passes";
- (3) that the issue of "pit passes" be restricted to adult persons;
- (4) that onlookers be confined to the lawns above the wall on the south side of the footpath on the south side of the boulevard and that where the wall terminates at the intersection of Bellerine-street the line of the wall be continued with barricades across Bellerine-street to Transvaal Square;
- (5) that an adequate number of bales of straw be placed in front of the barricades at the intersection of Bellerine-street and also along the roadway at the eastern boundary of Transvaal Square where Ritchie Boulevard joins Victoria-terrace;
- (6) that officials be placed at frequent intervals on the north side of Ritchie Boulevard at the "pits" at the intersection of Bellerine-street and at the "run-off" in Victoria-terrace;
- (7) that the western limit of the "run-off" be protected with bales of straw;
- (8) that the officer in charge of police in attendance is satisfied that such highway is in a satisfactory condition for racing purposes and that adequate arrangements have been made for the safety of the public.

And the Honorable Vernon Francis Wilcox, Her Majesty's Acting Chief Secretary, shall give the necessary directions herein accordingly.

J. COLQUHOUN,
Clerk of the Executive Council.

MARYBOROUGH SEWERAGE AUTHORITY.

At the Executive Council Chamber, Melbourne, the fourth day of August, 1964.

PRESENT:

The Lieutenant-Governor, as Deputy for His Excellency the Governor of Victoria.

Mr. Thompson | Mr. Porter.
Mr. Darcy

CONSENT TO BORROWING £75,000.

UNDER the powers conferred by the Sewerage Districts Act and all other powers enabling him in that behalf, the Lieutenant-Governor, as Deputy for His Excellency the Governor of the State of Victoria, by and with the advice of the Executive Council of the said State, doth hereby consent to the Maryborough Sewerage Authority borrowing by the assignment of the General Fund the sum of Seventy-five thousand pounds (£75,000) for the conversion of Loans Nos. 1 and 17.

And the Honorable Thomas Anthony Darcy, Her Majesty's Minister of Water Supply for the State of Victoria, shall give the necessary directions herein accordingly.

J. COLQUHOUN,
Clerk of the Executive Council.

HOUSING ACT 1958.

At the Executive Council Chamber, Melbourne, the fourth day of August, 1964.

PRESENT:

The Lieutenant-Governor as Deputy for His Excellency the Governor of Victoria.

Mr. Thompson | Mr. Porter.
Mr. Darcy

EXTINGUISHMENT OF EASEMENTS—SHIRE OF MYRTLEFORD.

WHEREAS by virtue and in exercise of the powers contained in the Housing Act 1958 (No. 6275) Housing Commission has recommended to the Governor in Council that the easements described in the Schedule hereto be extinguished.

Now therefore the Lieutenant-Governor as Deputy for His Excellency the Governor of the State of Victoria in the Commonwealth of Australia by and with the advice of the Executive Council of the said State, doth in pursuance of the powers conferred by the said Act and upon such recommendation, consent and by this Order hereby extinguish such easements.

SCHEDULE.

Any easements affecting the land contained in certificate of title, volume 8150, folio 771.

And the Honorable Lindsay Hamilton Simpson Thompson, Her Majesty's Minister of Housing for the State of Victoria, shall give the necessary directions herein accordingly.

J. COLQUHOUN,
Clerk of the Executive Council.

APPROACHING LAND SALES.

SALES of Crown lands, in fee-simple, will be held at the under-mentioned places and dates, viz.:

	No. of Gazette.
Beechworth.—Monday, 10th August, 1964 ..	52
Bright.—Thursday, 10th September, 1964 ..	70
Chiltern.—Wednesday, 9th September, 1964 ..	70
Foster.—Friday, 11th September, 1964 ..	70
Goroke.—Wednesday, 12th August, 1964 ..	59
Mallacoota.—Wednesday, 2nd September, 1964 ..	66
Meeniyian.—Tuesday, 18th August, 1964 ..	60
Orbost.—Tuesday, 1st September, 1964 ..	66
Ouyen.—Monday, 31st August, 1964 ..	66
Wangaratta.—Friday, 11th September, 1964 ..	70

AUCTION OF RIGHT TO LEASE CROWN LAND.

Queenscliff.—Friday, 7th August, 1964 .. 59
Wonthaggi.—Tuesday, 18th August, 1964 .. 60

SALE OF CLOSER SETTLEMENT LAND BY AUCTION

Berwick.—Friday, 11th September, 1964 .. 70

SALES OF CROWN LAND BY AUCTION.

The land will be offered for sale in fee-simple, and subject to the provisions of the Land Act and Regulations thereunder.

The upset price is the sum at which bidding will start, and no bid below that sum can be accepted. The highest bidder at or above that sum shall be the purchaser, subject to signature of contract and any necessary payment.

TERMS:

A deposit of at least 12½% of the purchase price must be paid at the sale, either in cash or by cheque.

The residue is payable in half-yearly instalments, in accordance with the following scale, or may be paid off at any earlier time.

£20 and under, 6 instalments.
Over £20, and not exceeding £50, 8 instalments.
Over £50, and not exceeding £100, 10 instalments.
Over £100, and not exceeding £200, 12 instalments.
Over £200, and not exceeding £300, 14 instalments.
Over £300, and not exceeding £400, 16 instalments.
Over £400, and not exceeding £500, 18 instalments.
Over £500, 20 instalments.

Interest at the rate of 5% per annum is payable with all payments of residue, and is computed for each instalment from the date of sale to the date of such payment. Additional interest is charged if any instalment is not paid on or before the due date.

If paid off within 30 days of sale, no interest is payable.

FEES, ETC.:

Also payable at the sale, in addition to the deposit, are the survey fee and, if applicable, the valuation of improvements (if purchaser be not the owner thereof).

Payable with balance of purchase money—

Crown Grant fee—50 acres and under ..	£1 10s.
Over 50 acres ..	£2
Purchase money £5 or under	£1

Assurance Fund contribution—One halfpenny for each £1 of purchase price. (This is a fund established to guarantee the validity of freehold titles.)

Transfer of interest prior to completion of payment may be allowed on payment of £1 fee and subject to stamp duty.

If unable to attend personally, a prospective purchaser may arrange for another person to bid as his agent.

Attention is drawn to section 95, Land Act 1958, which provides that the purchaser shall be deemed to be the owner for the purposes of other Acts; also to an amendment to the Local Government Act providing for Government roads, in certain circumstances, to be declared "private streets", thus making the purchaser liable to contribute to the cost of street construction.

J. C. M. BALFOUR,
Commissioner of Crown Lands and Survey.

Office of Crown Lands and Survey,
Melbourne, 5th August, 1964.

FOSTER.—Sale (No. 11747) of Crown land in fee-simple, by auction, will be held at the LAND INSPECTOR'S OFFICE, FOSTER, ON FRIDAY, the 11th SEPTEMBER, 1964, at ONE o'clock p.m. To be conducted by J. R. WILDING, Land Officer, Melbourne.

Lot 1.

TOWNSHIP OF FOSTER, PARISH OF WONGA WONGA SOUTH. Fronting the east side of Pioneer-street about 12 chains south of Bridge-street.

Upset price £100 the lot. Survey fee £6.

Area 33 perches, subject to survey, allotment 2B of section 23. One month allowed for removal of improvements.

NOTE.—This land is within the area covered by an Interim Development Order administered by the South Gippsland Shire Council.—(G.65604.)

CHILTERN.—Sale (No. 11750) of Crown land in fee-simple, by auction, will be held at the LAND INSPECTOR'S OFFICE, CHILTERN, on WEDNESDAY, the 9th SEPTEMBER, 1964, at half-past NINE o'clock a.m. To be conducted by D. M. O'CONNOR, Land Officer, Beechworth.

Lot 1.

PARISH OF CHILTERN WEST, COUNTY OF BOGONG.
About 4 miles east of Rutherglen and about $\frac{1}{4}$ mile south of the Murray Valley Highway.

Upset price £60 the lot. Survey fee £12 5s.
Area 18a. 3r. 34p., allotment 26B of section 7A. One month allowed for removal of improvements.—(H.024579.)

Lot 2.

TOWNSHIP OF CHILTERN, PARISH OF CHILTERN, COUNTY OF BOGONG.
Fronting the west side of Scott-street about 3 chains north-west of Skerry-street.

Upset price £12 the lot. Survey fee £6 12s. 6d.
Area 2r. 21p., allotment 4A of section 16. One month allowed for removal of improvements.—(H.011488.)

WANGARATTA.—Sale (No. 11749) of Crown land in fee-simple, by auction, will be held at the LAND OFFICE, MURPHY-STREET, WANGARATTA, on FRIDAY, the 11th SEPTEMBER, 1964, at TEN o'clock a.m. To be conducted by D. M. O'CONNOR, Land Officer, Wangaratta.

Lot 1.

TOWNSHIP OF WANGARATTA, PARISH OF WANGARATTA NORTH, COUNTY OF DELATITE.
At the eastern corner of the intersection of Fraser and Wilson streets.

Upset price £30 the lot. Survey fee £7 10s.
Area 3r 17p., subject to survey, allotment 10 of section 42.—(H.027155.)

PARISH OF WANGARATTA SOUTH, COUNTY OF DELATITE.
Fronting the east side of a Government road about 20 chains south of Newman-street and about 7 chains west of the Wangaratta-Geta road.

Lot 2.

Upset price £330 the lot. Survey fee £7.
Area 1a. 1r. 5p., allotment 8d of section 31A.

Lot 3.

Upset price £330 the lot. Survey fee £7.
Area 1a. 1r. 5p., allotment 8L of section 31A.—(H.029768.)

Lot 4.

Fronting the western side of a Government road about 6 chains south of Newman-street and 5 chains west of the Wangaratta-Geta road.

Upset price £400 the lot. Survey fee £8.
Area 1a. 0r. 2p., allotment 34 of section 31A. One month allowed for removal of improvements.—(H.029870.)

NOTE.—Lots 1 to 4 inclusive are within the area covered by an Interim Development Order administered by the Wangaratta Sub-Regional Planning Committee.

BRIGHT.—Sale (No. 11748) of Crown land in fee-simple, by auction, will be held in the LAND INSPECTOR'S OFFICE, BRIGHT, on THURSDAY, the 10th SEPTEMBER, 1964, at TEN o'clock a.m. To be conducted by D. M. O'CONNOR, Land Officer, Beechworth.

PARISH OF BRIGHT, COUNTY OF DELATITE.
Fronting the southern side of the Bright-Harrietville road about 1 mile east of the Morse's Creek bridge.

Lot 1.

Upset price £75 the lot. Survey fee £6.
Area 1 rood, allotment 15u of section C. One month allowed for removal of improvements.

Lot 2.

Upset price £75 the lot. Survey fee £6.
Area 1 rood, allotment 15v of section C. One month allowed for removal of improvements.

Lot 3.

Upset price £75 the lot. Survey fee £6.
Area 1 rood, allotment 15w of section C. One month allowed for removal of improvements.—(H.019641.)

Lot 4.

Fronting the east side of a Government road about 2 chains north of Bright-Harrietville road and about 1 mile east of the Morse's Creek Bridge.

Upset price £25 the lot. Survey fee £6 10s.
Area 1r. 19p., allotment 15x of section C. One month allowed for removal of improvements.—(H.023517.)

Lot 5.

TOWNSHIP OF WANDLIGONG, PARISH OF BRIGHT, COUNTY OF DELATITE.

In the south-east of the Township between the north-eastern side of a Government road and the reservation to Growler's Creek.

Upset price £30 the lot. Survey fee £8 17s. 6d.
Area 4a. 3r. 29p., allotment 60A of section U.—(H.023881.)

Lot 6.

PARISH OF POREPUNKAH, COUNTY OF DELATITE.
About 1 mile north-west of Bright abutting the reservation to the southern side of the Ovens River.

Upset price £20 the lot. Survey fee £8.
Area 1a. 1r. 39p., allotment 17D of section 7. Subject to State Electricity Commission easement 30 links wide. One month allowed for removal of improvements.—(H.025930.)

SALE OF CLOSER SETTLEMENT LAND BY AUCTION.

The land will be offered for sale in fee-simple, and subject to the provisions of the Closer Settlement Act and Regulations thereunder.

The upset price is the sum at which bidding will start, and no bid below that sum can be accepted. The highest bidder at or above that sum shall be the purchaser, subject to signature of contract and any necessary payment.

TERMS:

A deposit of at least 20% of the purchase price must be paid at the sale, either in cash or by cheque.

The residue is payable in twenty equal half-yearly instalments.

Interest at the rate of 5% per annum is payable with all payments of residue, and is computed on the unpaid balance.

If paid off within 30 days of sale, no interest is payable.

FEES, ETC.:

Also payable at the sale, in addition to the deposit, are the survey fee and, if applicable, the valuation of improvements (if purchaser be not the owner thereof).

Payable with balance of purchase money—

Crown Grant fee—50 acres and under	..	£1 10s.
Over 50 acres	..	£2
Purchase money £5 or under	£1	

Assurance Fund contribution.—One halfpenny for each £1 of purchase price. (This is a fund established to guarantee the validity of freehold titles.)

Transfer of interest prior to completion of payment may be allowed on payment of £1 fee and subject to stamp duty, and to payment of such additional deposit as may be required.

If unable to attend personally, a prospective purchaser may arrange for another person to bid as his agent.

J. C. M. BALFOUR,
Commissioner of Crown Lands and Survey.
Office of Crown Lands and Survey,
Melbourne, 5th August, 1964.

BERWICK.—Sale of Closer Settlement land in fee-simple, by auction, will be held at the COURT HOUSE, BERWICK, on FRIDAY, the 11th SEPTEMBER, 1964, at half-past NINE o'clock a.m. To be conducted by J. R. WILDING, Land Officer, Melbourne.

PARISH OF BERWICK, COUNTY OF MORNINGTON.
Having a frontage of about 11 chains to the southern side of Golf Links-road about 45 chains west of the Clyde-Berwick road.

Upset price £5,000 the lot. Survey fee £12 5s.
Area 16 a. 3r. 1p., allotment 33 of section 4. Subject to drainage easement 20 links wide and pipe-line easement 15 links wide. Valuation of improvements £155.—L. H. Eyckens.)

NOTES.—1. Purchase price includes Crown improvements comprising five-roomed weatherboard dwelling, out-buildings, fencing, &c., but does not include improvements effected by former lessee. The valuation of the former lessee's improvements (£155) is payable in addition to the purchase price.

2. Water is laid on to the property for stock and domestic use but is understood to be not available for market gardening.

3. The house will be open for inspection from 2 p.m. to 4 p.m. on Saturday, 29th August, Wednesday, 2nd, and Saturday, 5th September, 1964.—(G.61987.)

PROPOSED REVOCATION OF TEMPORARY RESERVATION OF LAND BY ORDER IN COUNCIL.

IN pursuance of the provisions of the *Land Act 1958*, notice is hereby given that it is the intention of the Governor in Council to revoke the temporary reservation of land by Order in Council hereunder referred to viz.:

The following Notice was published 1° on the 15th July, 1964, pursuant to Order of the 8th July, 1964.

SANDHURST (BENDIGO AND EAGLEHAWK).—The temporary reservation, by Order in Council of the 16th October, 1894, of 5 acres of land at Bendigo and at Eaglehawk in the Parish of Sandhurst as a site for a Hospital or place for isolating persons suffering from Smallpox, Cholera, or other dangerous infectious or contagious disease, revoked as to part by Order of the 26th August, 1913, is about to be revoked so far as the balance thereof containing 4 acres 2 roods 7 perches, is concerned.—(S.371⁽²⁰⁾) (C.56171).

JIM BALFOUR,
Commissioner of Crown Lands and Survey.

PROPOSED REVOCATION OF TEMPORARY RESERVATION, AND THE WITHHOLDING FROM SALE, LEASING, AND LICENSING OF LAND BY ORDER IN COUNCIL.

IN pursuance of the provisions of the *Land Act 1958*, notice is hereby given that it is the intention of the Governor in Council to revoke the temporary reservation, and the withholding from sale, leasing and licensing of land by Order in Council hereunder referred to, viz.:

The following Notice was published 1° on the 22nd July, 1964, pursuant to Order of the 15th July, 1964.

BRIGHT.—The temporary reservation as a site for Water Supply purposes and the withholding from sale, leasing and licensing by Order in Council of the 19th April, 1875, of 1920 acres more or less of land in the Parish of Bright are about to be revoked so far only as the portion containing 2 acres more or less, indicated by hachure on plan hereunder, is concerned.—(B.574⁽¹¹⁾) (Rs.2196).

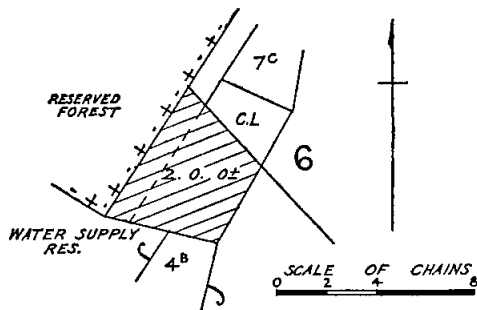

J. C. M. BALFOUR,
Commissioner of Crown Lands and Survey.

PROPOSED REVOCATION OF TEMPORARY RESERVATION OF LAND BY ORDER IN COUNCIL.

IN pursuance of the provisions of the *Land Act 1958*, notice is hereby given that it is the intention of the Governor in Council to revoke the temporary reservation of land by Order in Council hereunder referred to, viz.:

The following Notice was published 1° on the 29th July, 1964, pursuant to Order of the 21st July, 1964.

MOREEP.—The temporary reservation, by Order in Council of the 19th February, 1866 (see *Government Gazette* of the 2nd March, 1866, page 510) of 3,900 acres more or less of land in the Parishes of Moreep and Ballark, as a site for Water Supply purposes, revoked as to part by Order of the 31st May, 1955, is about to be

revoked so far only as the portions in the Parish of Moreep containing 5 acres 0 roods 39 perches, indicated by hachure on plan hereunder are concerned.—(M.468⁽²⁾) (Rs.6566).

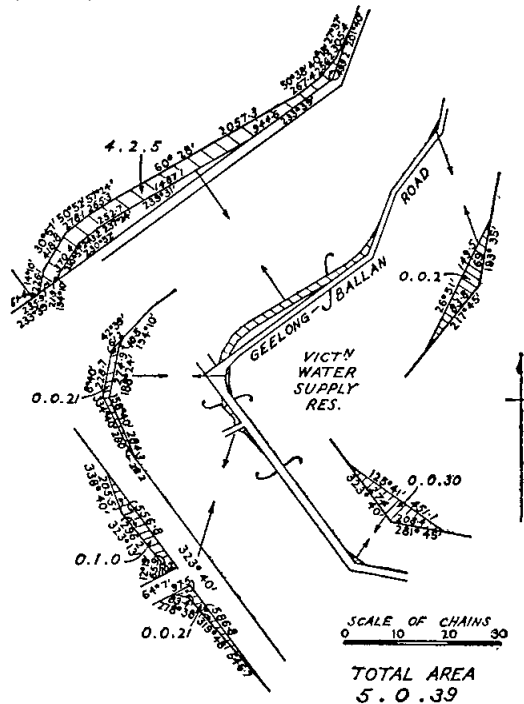

J. C. M. BALFOUR,
Commissioner of Crown Lands and Survey.

PROPOSED REVOCATIONS OF TEMPORARY RESERVATIONS OF LANDS BY ORDERS IN COUNCIL.

IN pursuance of the provisions of the *Land Act 1958*, notice is hereby given that it is the intention of the Governor in Council to revoke the temporary reservations of lands by Orders in Council hereunder referred to, viz.:

The following Notices were published 1° on the 22nd July, 1964, pursuant to Orders of the 15th July, 1964.

DROMANA.—The temporary reservation, by Orders in Council of the 28th December, 1864, and the 18th February, 1890, of 2 acres 3 roods 37½ perches of land in the Township of Dromana, as a site for Public Recreation and Public Garden is about to be revoked so far only as the portion containing 1 rood 18 perches, indicated by hachure on plan hereunder, is concerned.—(D.98⁽²⁾) (Rs.3081).

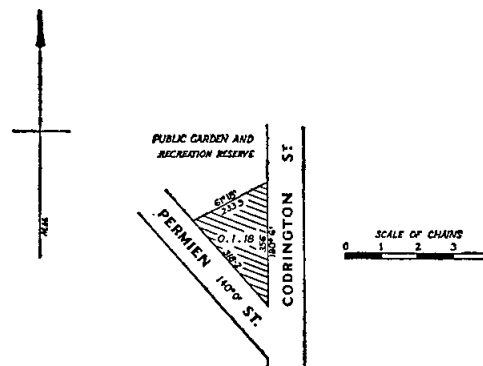

KARWEEN.—The temporary reservation, by Order in Council of the 10th December, 1928, of 4 acres of land in the Parish of Karween, as a site for a State School.—(K.214⁽²⁾) (Rs.3792).

WOORRAGEE.—The temporary reservation, by Order in Council of the 8th February, 1864 (see *Government Gazette* of the 23rd February, 1864, page 443), of 1 acre

of land in the Parish of Woorragee, as a site for Wesleyan Church purposes, is about to be revoked, so far only as the portion containing 25 perches, indicated by hachure on plan hereunder, is concerned.—(W.209(4) (C.98900).

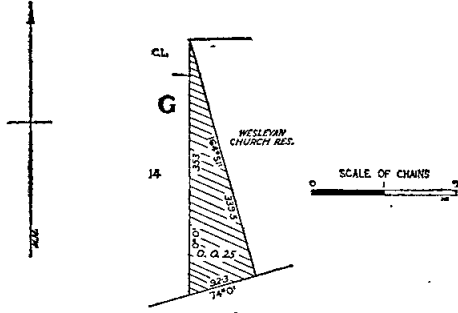

J. C. M. BALFOUR,
Commissioner of Crown Lands and Survey.

PRARRAN (AT CAULFIELD).—Land proposed to be permanently reserved as a site for Public Recreation, also excepted from occupation for mining purposes under any miner's right, 4 acres, at Caulfield, Parish of Prahran, County of Bourke, as indicated by hachure on plan hereunder.—(P.79(T1) (Rs.140).

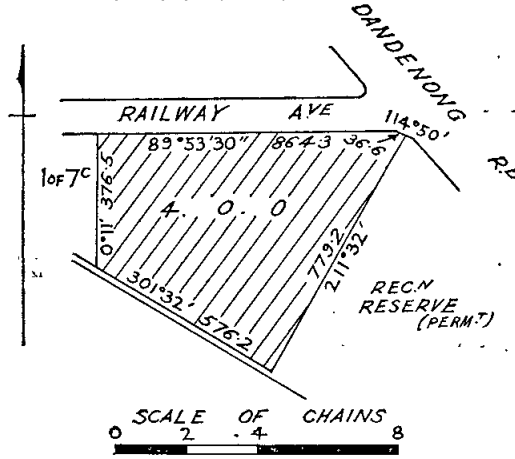

J. C. M. BALFOUR,
Commissioner of Crown Lands and Survey.

PROPOSED PERMANENT RESERVATIONS OF LANDS AS SITES.

IN pursuance of the provisions of the Land Act 1958, notice is hereby given that it is the intention of the Governor in Council to permanently reserve as sites the lands hereunder referred to:—

The following Notices were published 1° on the 22nd July, 1964, pursuant to Orders of the 15th July, 1964.

DANDENONG (SPRINGVALE).—Land proposed to be permanently reserved as a site for a Cemetery also excepted from occupation for mining purposes under any miner's right, 21 acres 3 roods 7 perches, Parish of Dandenong, County of Bourke, as indicated by hachure on plan hereunder.—(D.19(5) (Rs.8355).

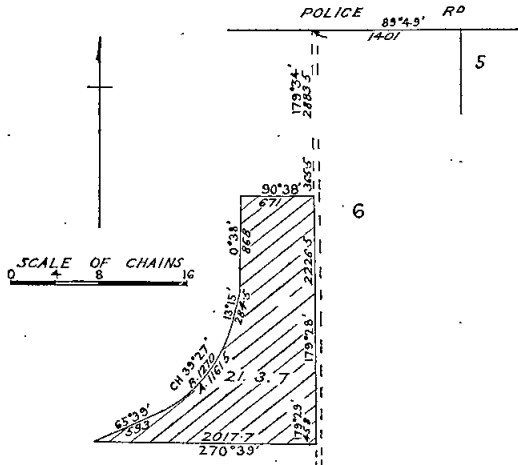

FRANKSTON.—Land proposed to be permanently reserved as a site for Public purposes, also excepted from occupation for mining purposes under any miner's right, 4 acres more or less, Parish of Frankston, County of Mornington, as indicated by hachure on plan hereunder.—(F.87(5) (Rs.3203).

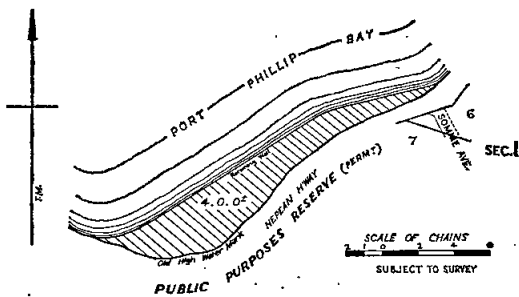

PROPOSED PERMANENT RESERVATIONS OF LANDS AS SITES.

IN pursuance of the provisions of the Land Act 1958, notice is hereby given that it is the intention of the Governor in Council to permanently reserve as sites the lands hereunder referred to:—

The following Notices were published 1° on the 29th July, 1964, pursuant to Orders of the 21st July, 1964.

WHITTLESEA.—Land proposed to be permanently reserved as a site for Public purposes, also excepted from occupation for mining purposes under any miner's right, 1 acre 1 rood 20 perches, more or less, Township of Whittlesea, Parish of Toorourrong, County of Bourke, as indicated by hachure on plan hereunder.—(W.133(2) (Rs.8345).

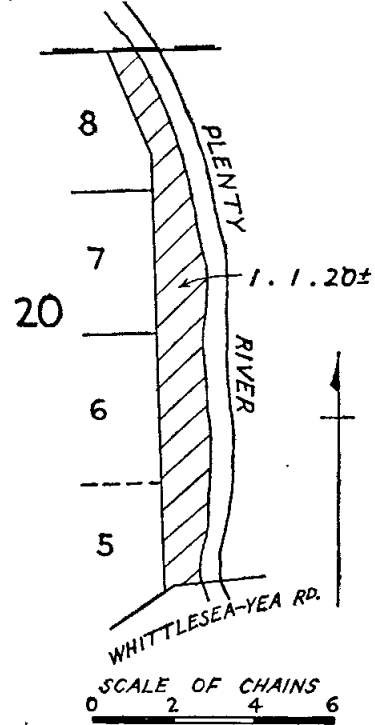

YAN YEAN (MERNDA).—Land proposed to be permanently reserved as a site for Public purposes, also excepted from occupation for mining purposes under any miner's right, 13 acres 3 roods 20 perches more or less, Parish of Yan Yean, County of Bourke, as indicated by hachure on plan hereunder.—(Y.19⁽³⁾) (Rs.8345).

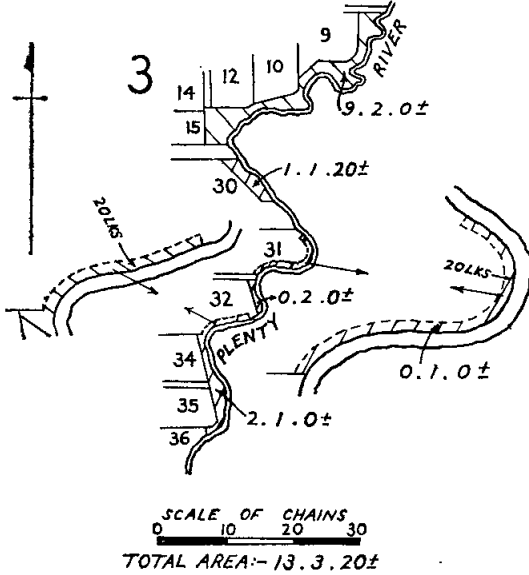

J. C. M. BALFOUR,
Commissioner of Crown Lands and Survey.

SOUTH MELBOURNE.—Land proposed to be permanently reserved as a site for Public Gardens, 1 acre 0 roods 29 perches, City of South Melbourne, Parish of Melbourne South, County of Bourke, being the site temporarily reserved therefor by Order in Council of the 9th October, 1962.—(M.333⁽³²⁾) (Rs.1179).

J. C. M. BALFOUR,
Commissioner of Crown Lands and Survey.

PROPOSED REVOCATIONS OF TEMPORARY RESERVATIONS OF LANDS BY ORDERS IN COUNCIL.

IN pursuance of the provisions of the Land Act 1958, notice is hereby given that it is the intention of the Governor in Council to revoke the temporary reservations of lands by Orders in Council hereunder referred to, viz.:

The following Notices were published 1^o on the 5th August, 1964, pursuant to Orders of the 28th July, 1964.

—ONDIR (LAKE CUNDARE).—The temporary reservation, by Order in Council of the 14th June, 1910, of 3 roods 25 perches of land in the Parish of Ondit, as a site for a State School.—(O.6⁽⁴⁾) (C.47729).

SCARSDALE.—The temporary reservation, by Order in Council of the 20th March, 1899, of 2 roods 8 8/10 perches of land in the Parish of Scarsdale, as a site for Police purposes.—(S.249⁽¹²⁾) (C.7207).

SHEPPARTON.—The temporary reservation, by Order in Council of the 6th March, 1896, of 3 acres 0 roods 4 1/2 perches of land in the Parish of Shepparton, as a site for a State School.—(S.283⁽¹⁰⁾) (C.95116).

STRATFORD.—The temporary reservation, by Order in Council of the 24th November, 1959, of 7 acres more or less of land in the Township of Stratford, as a site for Caravan and Tourist Camping Park, is about to be revoked so far only as the portion containing 3 roods 30 perches more or less, indicated by hachure on plan hereunder is concerned.—(S.346⁽⁸⁾) (Rs.7862).

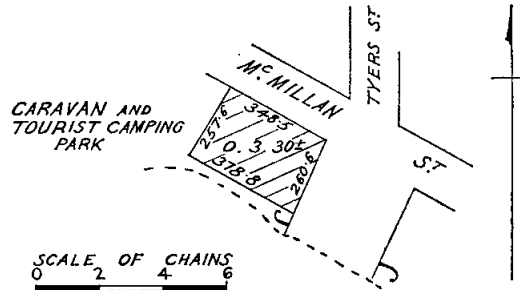

J. C. M. BALFOUR,
Commissioner of Crown Lands and Survey.

PROPOSED PERMANENT RESERVATIONS OF LANDS AS SITES.

IN pursuance of the provisions of the Land Act 1958, notice is hereby given that it is the intention of the Governor in Council to permanently reserve as sites the lands hereunder referred to:—

The following Notices were published 1^o on the 5th August, 1964, pursuant to Orders of the 28th July, 1964.

DOUTTA GALLA (ESSENDON).—Land proposed to be permanently reserved as a site for Public Park and Public Recreation, 19 acres 3 roods, at Essendon, Parish of Douтта Galla, County of Bourke, being the site temporarily reserved therefor by Order in Council of the 4th September, 1963.—(D.85⁽⁶⁾) (Rs.1009).

DOUTTA GALLA (STRATHMORE).—Land proposed to be permanently reserved as a site for Public Park and Playground, 8 acres 3 roods 9 perches, at Hawstead, Parish of Douтта Galla, County of Bourke, being the sites temporarily reserved therefor by Orders in Council of the 27th May, 1921, and 12th April, 1928.—(E.68^(b)) (Rs.2310).

Land Act 1958.

LEASES SURRENDERED.

NOTICE is hereby given that the Governor in Council has accepted the surrender of the Leases mentioned in the Schedule hereunder for the reason specified in each case.

District.	Corr. No.	Name.	Section of Land Act under which Leased.	Parish.	Allotment.	Section.	Area.	Class.	Reason.
Melbourne	0562/134	The Commonwealth of Australia	134	City of South Melbourne	82A	..	A. R. P. 0 0 34 1/16	..	New lease to issue
Melbourne	0420/134	Miller and Co. (Machinery) Proprietary Limited	134	City of South Melbourne	53	..	0 0 25 1/16	..	Expired

Department of Crown Lands and Survey,
Melbourne, 28th July, 1964.

J. C. M. BALFOUR,
Commissioner of Crown Lands and Survey.

PROPOSED REVOCATION OF TEMPORARY RESERVATION, AND THE WITHHOLDING FROM SALE, LEASING, AND LICENSING OF LAND BY ORDER IN COUNCIL.

IN pursuance of the provisions of the *Land Act* 1958, notice is hereby given that it is the intention of the Governor in Council to revoke the temporary reservation, and the withholding from sale, leasing and licensing of land by Order in Council hereunder referred to, viz.:-

The following Notice was published 1° on the 29th July, 1964, pursuant to Order of the 21st July, 1964.

MOREEP.—The temporary reservation as a site for Victorian Water Supply purposes, and the withholding from sale, leasing and licensing by Order in Council of the 18th October, 1875 (see *Government Gazette* of the 22nd October, 1875, page 1995) of 3,073 acres more or less, of land in the Parishes of Moreep, Beremboke and Anakie, are about to be revoked, so far only as the portions in the Parish of Moreep, containing 1 acre 2 roods 34 perches, indicated by hachure on plan hereunder are concerned.—(M.468⁽²⁾) (Rs.6566).

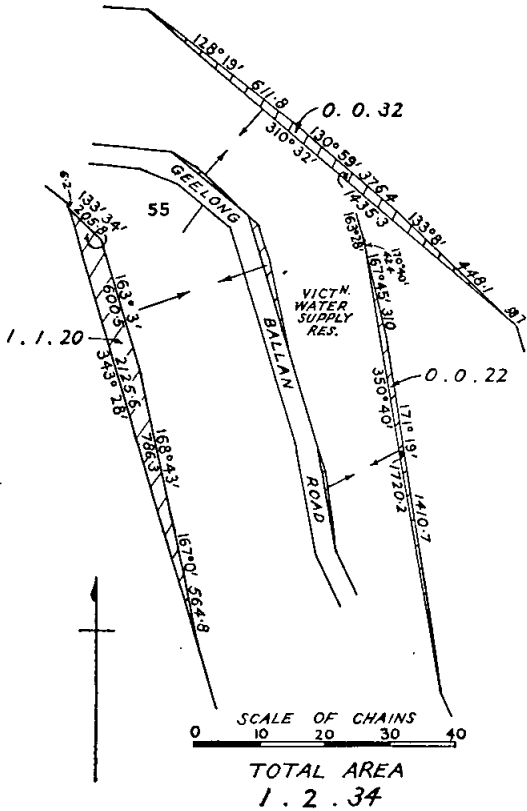

J. C. M. BALFOUR,
Commissioner of Crown Lands and Survey.

LOCAL LAND BOARDS.

IN pursuance of the provisions of section 34 of the *Land Act* 1958, notice is hereby given that public hearings at the following places and times, will be conducted by the persons respectively mentioned, being duly appointed in that behalf.

J. C. M. BALFOUR,
Commissioner of Crown Lands and Survey.

Department of Crown Lands and Survey,
Melbourne.

SCHEDULE.

CANN RIVER PUBLIC HALL, Tuesday, 18th August, 1964, at 1.30 p.m.—W. C. Harry, H. J. Macdonald.
No. 70.—6953/64.—3

COMMON ABOUT TO BE DIMINISHED.

IN pursuance of the provisions contained in the *Land Act* 1958, notice is hereby given that it is the intention of the Governor in Council to diminish the common hereinafter mentioned, viz.:-

The following Notice was published 1° on the 5th August, 1964, pursuant to Order of the 28th July, 1964.

The Rokewood Goldfield Common, proclaimed on the 28th January, 1861, and extended by Proclamations of the 25th April, 1864, and the 24th December, 1866, is about to be diminished by the excision therefrom of the portion in the Parish of Commeralghip containing 9 acres 2 roods 38 perches, indicated by hachure on plan hereunder.—(Rs.435).

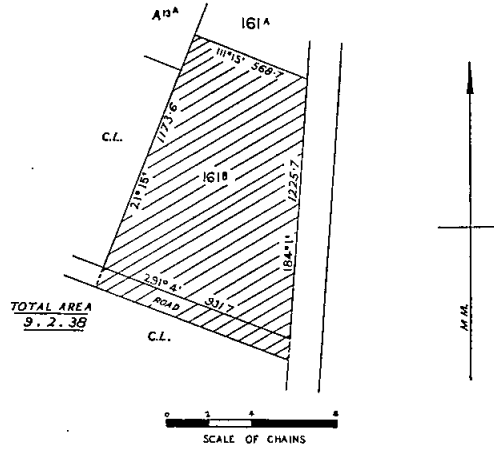

J. C. M. BALFOUR,
Commissioner of Crown Lands and Survey.

TENDERS—PUBLIC WORKS DEPARTMENT

TENDERS will be received at this Department's Head Office, Treasury-place, Melbourne, until TEN a.m. on the dates, and for the purposes under mentioned.

Particulars may be learnt at the Department and also at places shown in parentheses.

W.O. means Inspector of Works Office; P.S.—Police Station; T.S.—Technical School; H.E.S.—Higher Elementary School; S.S.—State School; H.S.—High School; C.S.—Consolidated School.

Tenders should be submitted on the Department's printed Tender Form and will not be received by telephone. All tenders must be on a "Firm Tender" basis. The Board of Land and Works will not necessarily accept the lowest or any tender.

Tenders to be addressed to the Hon. the Commissioner of Public Works, and envelope containing tender to be marked "Tender for , closing Tuesday, ,".

NOTE.—No preliminary deposit is to be lodged with any tender, but a deposit in accordance with the prescribed Schedule may be required from each successful tenderer.

Tuesday, 11th August, 1964.

Building, Electrical and Mechanical Works.

- Carlton.—Renewal of roof with terra cotta tiles, S.S. 2605.
- Casterton.—Additional room, renovations and painting, Lands and Survey Department residence, Widdicombe-street. (W.O., Hamilton; P.S., Casterton.)
- Coatesville.—Re-siting residence on school site, S.S. 4712. (Amended specification.)
- Collingwood.—Extension of retaining walls and erection of new store, Technical School.
- Dederang.—External and internal repairs and painting to residence, S.S. 1772. (W.O., Wangaratta.)
- Dimboola.—Toilet facilities, High School. (W.O., Warracknabeal; H.S., Dimboola.)
- Doveyton.—Connexion to sewerage main, High School. (H.S., Doveyton.)
- Elwood.—Additions to boys' and girls' toilets, High School.

Footscray.—Installation and supply of Chemistry Laboratory benches, Technical School.

Frankston.—Supply and installation of Rabbit Refuse Disposal Units, Keith Turnbull Research Station.

Geelong.—Supply and installation of intercommunication system, Chest Clinic, Ryrie-street. (W.O., Geelong.)

Goroke.—Erection of timber residence, garage, &c., Lands and Survey Department. (W.O., Horsham; P.S., Goroke.)

Hamilton.—Supply and erection of glazed aluminium porch screen, Public Works Department Offices. (W.O., Hamilton.)

Hamilton South-West.—Electrical installation in new school of eight (8) L.T.C. class-rooms, &c., S.S. 4847. (W.O., Hamilton.)

Hamilton South-west.—Plenum heating to eight classroom school, S.S. 4847. (W.O., Hamilton.)

Hawksburn.—New timber fire escape stairway, S.S. 1467.

Irymple.—Electrical installation, New Insectary, Agriculture Department. (W.O., Mildura.)

Kangaroo Flat.—Second and third sections of timber-framed concrete veneer school buildings, Technical School. (W.O., Bendigo.)

Kerang.—Erection of brick veneer residence, brick garage and generator room, Korangie Wildlife Reserve. (W.O., Swan Hill.)

Langkoop.—Repairs and painting, S.S. 2633. (W.O., Horsham.)

Melbourne.—Supply and installation of air conditioning equipment in Rooms 209 and 210, Agriculture Department, Public Offices, Treasury-place.

Mont Park.—Conversion of existing hot-water system to 105°F. system and supply of 180°F. system in Ward "M", Plenty Mental Hospital.

Moorabbin West.—Internal repairs and painting, S.S. 4643.

Mooroolbark.—Electrical installation in Stages 2 and 3, Technical School.

Mornington.—Staff toilet and basin, S.S. 2033. (S.S., Mornington.)

Moyston.—Internal repairs and painting to residence, S.S. 1263. (W.O., Ararat; S.S., Moyston.)

Northcote.—Supply and installation of gas heating, S.S. 1401, Visual Education Centre.

Northcote.—Electrical installation in Visual Education Centre, S.S. 1401.

Patchewollock.—Renovations and painting, S.S. 3973. (W.O., Warracknabeal; S.S., Patchewollock.)

Prahran.—Installation of electrical heating for main building and dormitory block, Secondary Teachers' College Hostel, 174 Punt-road.

Royal Park.—Supply, delivery and installation of additional hot-water equipment and kitchen exhaust equipment at "Quamby", Youth Reception Centre.

Royal Park.—Labour and scaffolding to lay approximately 100,000 bricks, Mental Hospital. (W.O., Royal Park Mental Hospital.)

Somerville.—Additional toilets for S.S. 2656, and septic tank for residence. (S.S., Somerville.)

Stawell.—Erect chain mesh fencing and repairs, S.S. 502. (W.O., Ararat; S.S., Stawell.)

Traralgon.—Addition of two entrance porches, Technical School. (W.O., Traralgon.)

Turriff West.—New out-office, repairs and painting, S.S. 3946. (W.O., Warracknabeal; S.S., Turriff West.) (Amended specification.)

Various.—Disconnexion, transportation and re-erection of prefabricated portable class-rooms from various school sites to various other school sites in Victoria.

Wangaratta West.—Non-party fencing, S.S. 4642. (W.O., Wangaratta.)

White Hills.—Supply and installation of sawdust extraction system, Technical School. (W.O., Bendigo.)

Yarra Glen.—New fence and gate, S.S. 956.

Furniture and Furnishings.

Geelong.—Supply of Examination Tables, Gordon Institute of Technology. (W.O., Geelong.)

Kingsbury.—Supply of modelling room furniture, Technical School.

Melbourne.—Supply of hand operated steel mobile shelving units, Examining Branch, Lands and Survey Department.

Site Works.

Ballarat.—Asphalting, concreting, gravelling and drainage, S.S. 4762. (W.O., Ballarat.)

Waverley North.—Asphalt paving, concreting, gravelling, retaining walls, drainage and ancillary works, S.S. 4884.

Miscellaneous.

Carlton.—Maintenance cleaning, 1st September, 1964, to 31st August, 1965, Exhibition Buildings, Rathdown-street.

Glenroy.—Supply of machine tools, Technical School.

Melbourne.—Maintenance cleaning, 1st September, 1964, to 31st August, 1965, Agriculture Department, Treasury-place.

Port Melbourne.—Supply of fire hose, Public Works Department Storeyard.

Port Melbourne.—Supply of pile shoes, Public Works Department Storeyard.

West Melbourne.—Supply and delivery of approximately 8,000 cubic yards of good quality earth or rock filling, Government Printing Office Bulk Store site, Footscray-road.

Tuesday, 18th August, 1964.

Building, Electrical and Mechanical Works.

Ballarat.—Extension of verandah to form Office, Junior Technical School, School of Mines. (W.O., Ballarat.)

Ballarat.—Electrical installation—re-organization of Engineering Machine Shop and improved lighting, School of Mines. (Amended Specification). (W.O., Ballarat.)

Bayswater.—Electrical installation in extended Stage 3, High School.

Bayswater.—Supply and installation of extensions to central heating and hot water systems for Stage 3, High School.

Boorhaman East.—Septic tank installation and site works, S.S. 3317. (W.O., Wangaratta; S.S., Boorhaman East.)

Broadmeadows.—Second and third sections of timber framed concrete veneer school buildings, Technical School.

Broadmeadows.—Supply and installation of extensions to central heating and hot water service—Stage 3, Technical School.

Burbank.—Erection of six class-room Primary School, S.S. 4917.

Burbank.—Plenum heating in new six class-rooms, S.S. 4917. (W.O., Maryborough.)

Burwood East.—Electrical installation in additional class-rooms, &c., S.S. 454.

Crossover.—Erection of out-offices and installation of septic tank, S.S. 3131. (W.O., Warragul; S.S., Crossover.)

Footscray.—Provision of male staff toilet and general repairs, Girls' Secondary School.

Frankston.—Erection of rabbit proof boundary fence and internal stock fence, Vegetable Research Station.

Highett.—Provision of sink to staffroom, S.S. 4677.

Kangaroo Flat.—Electrical installation in Stages 2 and 3, Technical School. (W.O., Bendigo.)

Kangaroo Flat.—Mechanical services for Stage 3, Technical School. (W.O., Bendigo.)

Keon Park.—Additional washing facilities, S.S. 4739. (S.S., Keon Park.)

Kew.—Erection of standard brick veneer residence for Principal Female Nurse, Mental Hospital.

Lake Boga.—Renovations and painting to school and residence, S.S. 3278. (W.O., Swan Hill; S.S., Lake Boga.)

Laverton.—Erection of brick two-storey Police Office, residence, store, boiler room, Police Station. (W.O., Geelong.)

Moorabbin West.—Supply and installation of central heating in two additional staff rooms and alteration of Boiler House, S.S. 4643.

Nunawading.—Erection of brick Dressing Rooms, Plant room and store, "Winlaton" Girls' Home.

Pascoe Vale.—Erection of chain mesh fencing, School of Textiles.

Preston.—Supply and installation of a steam turbine and condenser Plant Cooling Tower and pipework reticulation, Technical School.

Seymour.—Supply and installation of town gas heating, S.S. 547. (W.O., Shepparton.)

St. Kilda Park.—External and internal repairs and painting, S.S. 2460.

Studfield.—New Primary School building of eight class-rooms, &c., S.S. 4920.

Studfield.—Electrical installation in new school of eight L.T.C. class-rooms, &c., S.S. 4920.

Studfield.—Plenum heating in new eight class-rooms, S.S. 4920.

Truganina.—External and internal repairs and painting, Explosive Reserve.

Walpeup.—Erection of Research Laboratory, Research Station. (W.O., Mildura.)

Furniture and Furnishings.

Coburg.—Supply of Workshop furniture, Technical School.

Melbourne.—Supply of furniture and furnishings for period 1st September, 1964 to 31st August, 1965, Various State Government Departments.

Site Works.

Winters Flat.—Provision of new asphalt areas, drainage, concrete retaining walls, fencing, beautification and associated works, S.S. 652. (W.O., Bendigo, Kyneton and Maryborough.)

Miscellaneous.

Trafalgar East.—Purchase and removal of old school building, &c., S.S. 3499. (W.O., Warragul; S.S., Trafalgar East.)

Melbourne.—Supply of materials for Spirit Duplicators, Public Works Department, Head Office, Treasury-place.

Melbourne.—Supply of bricks, Public Works Department. Williamstown.—Supply and delivery of a marine diesel engine for a 20 foot Work Boat, Ports & Harbors.

Williamstown.—Supply and delivery of one (1) diesel driven compressor, Ports and Harbors.

Tuesday, 25th August, 1964.

Building, Electrical and Mechanical Works.

Airey's Inlet.—Erection of one shelter pavilion, S.S. 3195. (W.O., Geelong.)

Ararat.—Roof repairs, renew spouting, &c., to Nurses' Home, Mental Hospital. (W.O., Ararat.)

Ballarat.—Supply and installation of condensate return from main kitchen to Boiler House, Mental Hospital. (W.O., Ballarat.)

Ballarat.—Renovations to residence, 1018 Ligar-street, Public Works Department. (W.O., Ballarat.)

Baringhup.—New laundry, renovations and painting, S.S. 1687, residence. (W.O., Bendigo; S.S. Baringhup.)

Beaumaris North.—Replacement of existing warm air furnace and associated modifications to plenum system, S.S. 4803.

Beechworth.—New vinyl finished concrete floors to dining room and passages, Ward 10, Mental Hospital. (W.O., Wangaratta.)

Beechworth.—External repairs and painting, nurses' quarters, Mental Hospital. (W.O., Wangaratta.)

Belmont.—Improvement of natural lighting in three (3) class-rooms S.S. 26. (W.O., Geelong.)

Benalla.—Renovations, new toilet, &c., to Police Station residence, 2 Egmont-street. (W.O., Benalla.)

Bentleigh West.—Repairs and painting to Caretaker's residence, S.S. 4318.

Camberwell South.—Extensions to heating, S.S. 4170.

Camp Hill.—New internal female toilet and alterations, S.S. 1976. (W.O., Bendigo.)

Casterton.—Interior and exterior painting, High School residence, 24 Russell-street. (W.O., Hamilton; H.S., Casterton.)

Cranbourne.—Rewiring of electrical installation, S.S. 2068. (Amended Specification). (P.S., Cranbourne.)

Dandenong.—Erection of concrete masonry fence, Psychiatric Unit.

Dartmoor.—Erection of timber residence and timber garage and fuel store, Lands and Survey Department. (W.O., Warrambool.)

Forrest.—Erection of chain mesh and concrete post and wire non-party fencing, S.S. 2708. (W.O., Camperdown; S.S., Forrest.)

Glenthompson.—Erection of a timber office, Lands and Survey Department. (W.O., Hamilton.)

Heathcote.—Renovations to residence, Police Station. (W.O., Bendigo; P.S., Heathcote.)

Neerim South.—Removal of office from Morwell Police Station and re-site, &c., at Neerim South Police Station. (W.O., Warragul and Traralgon.)

Netherby.—Renovations and painting, S.S. 2651 residence. (W.O., Horsham; S.S., Netherby.)

Newhaven.—Installation of septic tanks, &c., S.S. 3053. (W.O., Korumburra; S.S., Newhaven.)

Newport.—Additional drinking and toilet facilities, S.S. 113.

Ross Creek.—External repairs and painting, S.S. 803. (W.O., Ballarat.)

Sunbury.—Provision of covered way, Mental Hospital.

Swan Hill.—New store, renovations and painting, S.S. 1142. (W.O., Swan Hill and Mildura; S.S., Swan Hill.)

Sydenham.—Renewal of party fencing, S.S. 3559.

Traralgon.—Supply and installation of one instrument and dressing sterilizer and exhaust ventilation in Industrial Workers Block, Hodson Park Hospital. (W.O., Traralgon.)

Warragul.—New fire and general water supply, Technical and High Schools. (W.O., Warragul.)

Yarrowonga.—Various repairs, external and internal painting, renewal of garage, S.S. 1819 residence. (W.O., Benalla; S.S., Yarrowonga.)

Yeodene.—Erection of shelter pavilion, S.S. 1114. (W.O., Camperdown; S.S., Yeodene.)

Site Works.

Boronia.—Surface and underground drainage, road and pedestrian pavements, S.S. 4081.

Braybrook.—Paving, drainage and associated works, High School.

Middlefield.—Asphalting, concreting, retaining walls, drainage and associated works, S.S. 4878.

Rushworth.—Grading and gravelling Playing Area, High School. (W.O., Shepparton.)

M. V. PORTER,
Commissioner of Public Works.

Public Works Department,
Melbourne, 3rd August, 1964.

PUBLIC SERVICE NOTICES

No. 1421.

Public Service Act 1958, Section 39.

REGULATIONS.—PART IV.—SALARIES AND INCREMENTS.

THE Public Service Board in pursuance of the powers conferred by the *Public Service Act 1958*, hereby amends its Regulations as shown below :—

FOURTH SCHEDULE.

ADMINISTRATIVE DIVISION.

Amount of Salaries Assigned to Offices in Class " A1 ".

Office.	Yearly Rate of Salary.
	£
TREASURY.	
<i>Delete—</i> Accountant to the Treasury	3,885
<i>Add—</i> Accountant to the Treasury	3,495

This Regulation shall have effect as on and from the 31st July, 1964.

A. GARRAN, Chairman.
V. P. SCULLY, Secretary.

Office of the Public Service Board,
Melbourne, 24th July, 1964.

No. 1424.

Public Service Act 1958, Section 50.

REGULATIONS.—PART IV.—SALARIES AND INCREMENTS.

THE Public Service Board, in pursuance of the powers conferred by the *Public Service Act 1958*, hereby amends its Regulations as shown below :—

SIXTH SCHEDULE.

TEMPORARY EMPLOYEES.

Designations of Positions and Rates of Salaries.

Department and Designation of Position.	Yearly Rate of Salary.		Increments (Annual).
	Minimum.	Maximum.	
	£	£	
CHIEF SECRETARY'S DEPARTMENT.			
<i>Add—</i> Research Assistant (Female), Traffic Commission ..	1,096	1,261	3 of £55

A. GARRAN, Chairman.
V. P. SCULLY, Secretary.

Office of the Public Service Board,
Melbourne, 28th July, 1964.

No. 1422.

Public Service Act 1958, Section 50.

REGULATIONS.—PART IV.—SALARIES AND INCREMENTS.

THE Public Service Board, in pursuance of the powers conferred by the *Public Service Act 1958*, hereby amends its Regulations as shown below :—

SIXTH SCHEDULE.

TEMPORARY EMPLOYEES.

Designations of Positions and Rates of Salaries.

Department and Designation of Position.	Yearly Rate of Salary.		Increments (Annual).
	Minimum.	Maximum.	
EDUCATION DEPARTMENT.	£	£	
TEACHERS' COLLEGES AND SCHOOLS.*			
<i>Add—</i>			
Clerical Assistant (Female), Grade III.	971	1,025	1 of £36 and 1 of £18
Clerical Assistant (Female), Grade II.	917	935	1 of £18
Clerical Assistant (Female), Grade I.	863	899	1 of £36

* Excluding Colleges and Schools approved by the Board.

A. GARRAN, Chairman.
V. P. SCULLY, Secretary.

Office of the Public Service Board,
Melbourne, 21st July, 1964.

No. 1423.

PUBLIC SERVICE ACT 1958.

THE Public Service Board, in pursuance of the powers conferred by the *Public Service Act 1958*, hereby amends the Public Service (Public Service Board) Regulations as follows:—

PART X.—LEAVE OF ABSENCE.

DIVISION I.—GENERAL.

Regulation 163.

Clause (b) of sub-regulation (1) is revoked and the following clause is inserted in lieu thereof—

“(b) any continuous period of sick leave without pay to the extent that it exceeds three months or the sum of any periods of sick leave without pay to the extent that it exceeds three months in such calendar year.”

A. GARRAN, Chairman.
V. P. SCULLY, Secretary.

Office of the Public Service Board,
Melbourne, 20th July, 1964.

PUBLIC SERVICE OF VICTORIA.—VACANCIES.

APPLICATIONS will be received by the Public Service Board up to Wednesday, the 19th August, 1964, from persons employed in the Public Service of Victoria, who are eligible and qualified for appointment to the under-mentioned positions:—

ADMINISTRATIVE DIVISION.

Assistant Accountant to the Treasury, Class “A1”, Treasury.

Yearly Salary.—£3,035.
Duties.—To assist the Accountant to the Treasury in the control and administration of the Accounts Branch.
Qualifications.—A qualified Accountant with a good knowledge of all aspects of Treasury accounting and procedures.

Class “B1”, Crown Solicitor’s Office, Law Department.

Yearly Salary.—£2,293, minimum; £2,443, maximum.
Duties.—To be Deputy Officer in Charge of the Criminal Law Branch and as such to assist the Officer in Charge in the general supervision of the Branch and in all matters which fall within his purview.
Qualifications.—Extensive experience in the criminal jurisdiction, ability to organize, and adequate knowledge of criminal law and the law of criminal Procedure and Evidence.

Class “C”, Office of the Chief Commissioner of Police, Chief Secretary’s Department.

Yearly Salary.—£1,283, minimum; £1,448, maximum.
Duties.—To assist in the Research and Relieving Branch, and to perform other duties as required.
Qualifications.—Ability to conduct correspondence. A knowledge of the organization and procedure of the Police Department would be an advantage.

Class “C”, Family Welfare Division, Social Welfare Branch, Chief Secretary’s Department.

Yearly Salary.—£1,283, minimum; £1,448, maximum.
Duties.—To assist the Officer in Charge of the Child Care Section in dealing with miscellaneous correspondence and enquiries; to compile ward history sheets and cards; to relieve within the Foster Care and Adoption, Child Migration and Infant Life Protection Sub-sections as required.
Qualifications.—A competent correspondence clerk preferably with experience in the keeping of records. Capable of interviewing and dealing with the public. A knowledge of the Children’s Welfare and Social Welfare Acts and the Regulations is desirable.

Class “E”, Tatura Centre, Water Supply Department.

Applications are invited from Class “E”, Administrative Division officers, who are desirous of transferring to the above position.

PROFESSIONAL DIVISION.

Director of Child Health (Medical), Class “A1”, Maternal and Child Welfare Branch, Department of Health.

Yearly Salary.—£4,125.
Duties.—To co-ordinate and supervise the work of school medical officers, school nurses and consultants, and the in-service training of professional and nursing staff of the School Medical Services; to investigate and report on the health of school children and teachers, and perform special examinations as required; other cognate work as required.
Qualifications.—A legally qualified medical practitioner of Victoria, and preferably a recognized specialist in paediatrics, holding a post-graduate medical qualification (M.D., M.R.A.C.P., or equivalent qualification).

Engineer, Class 1, Ports and Harbours Branch, Public Works Department.

Yearly Salary.—£1,461, minimum; £2,293, maximum. (Commencing salary will be determined within this initial range according to experience and qualifications.)
Duties.—To assist in the design of proposed harbour engineering works and in the supervision and construction and maintenance works.
Qualifications.—Degree or Diploma in Civil Engineering or equivalent qualifications.

Valuer, Classes “C1”–“C2”, Office of the Housing Commission, Treasury.

Yearly Salary.—£1,558, minimum; £1,908, maximum.
Duties.—Under the direction of the Senior Valuer, to carry out valuations of all classes of real estate.
Qualifications.—To be a member of or qualified for admission to the Commonwealth Institute of Valuers or to possess an unrestricted certificate of qualification under the Valuation of Land Act.

TECHNICAL AND GENERAL DIVISION.

Estimating Officer, Assistant, Office of the Housing Commission, Treasury.

Yearly Salary.—£1,331, minimum; £1,435, maximum.
Duties.—To be responsible to the Chief Architect for assisting with preparation of estimates, schedules, cost analyses, valuations for interim certificates, measuring and pricing variations, settling final accounts and operating schedule of rates contracts.

Qualifications.—Experience in similar duties, and capable of determining costs through measurement and pricing.

Field Officer, Office of the Housing Commission, Treasury.

Yearly Salary.—£1,223, minimum; £1,331, maximum.
Duties.—To assist in co-ordinating the provision of utility services with building construction on Commission Estates.

Qualifications.—Initiative and ability to conduct interviews, prepare reports and keep records; a good knowledge of the miscellaneous engineering work connected with development of large-scale housing projects.

Sister, Infant Welfare, Maternal and Child Welfare Branch, Department of Health.

Yearly Salary.—£1,133.

Duties.—To assist in the conduct and supervision of Infant Welfare and Ante Natal activities.

Qualifications.—A current Annual Practising Certificate issued by the Victorian Nursing Council in General Nursing, Midwifery and Infant Welfare; a driver's licence and experience in management of Victorian Infant Welfare Services are desirable.

Inspector (Rochester Centre), Water Supply Department.

Yearly Salary.—£1,079, minimum; £1,133, maximum.

Duties.—Under supervision to control the maintenance of works on, and water distribution through, the Waranga Major Outlet, the Waranga Deakin Offtake, and the Waranga Western Main Channel to the Wanalta Creek Floodway.

Qualifications.—Experience in the maintenance of large irrigation channels and channel structures and able to supervise and direct the work of repair gangs. Ability and experience in the control, measurement, regulation and distribution of large volumes of water and experience in keeping records and making computations.

NOTE.—The successful applicant will be required to occupy the official residence provided and vacation of the residence will not be permitted without the express approval of the Water Supply Department. A rental of 10 per cent. of total emolument inclusive of the amount payable under Regulation 74, less £36 6s. a year will be charged. Occupancy will be subject to a formal tenancy agreement being entered into. Particulars are available from the Water Supply Department.

Water Bailiff (Robinvale Centre), Water Supply Department.

Yearly Salary.—£972, minimum; £1,079, maximum.

Qualifications.—Ability to control and regulate the supply of water to irrigators and to keep the necessary records and make reports and arithmetical computations; a knowledge of water requirements for crops and grasses grown under irrigation, the methods of preparation of land for irrigation and methods of channel and drain construction and maintenance.

NOTE.—The successful applicant will be required to occupy the official residence provided and vacation of the residence will not be permitted without the express approval of the Water Supply Department. A rental of 10 per cent. of total emolument inclusive of the amount payable under Regulation 74, less £36 6s. a year will be charged. Occupancy will be subject to a formal tenancy agreement being entered into. Particulars are available from the Water Supply Department.

Storekeeper, Fisheries and Wildlife Branch, Chief Secretary's Department.

Yearly Salary.—£1,061.

Duties.—Under direction, to have charge of all stores and stationery; to be responsible for the receipt, issue and accounting of all stores and stationery and the keeping of stores records; to maintain a continuous stock check of stores and stationery.

Qualifications.—Experience in the keeping and issue of stores; a knowledge of Part V. of the Public Accounts and Stores Regulations.

NOTE.—The salary rates quoted above do not include the additional amount which is payable under Regulation 74 of the Board's Regulations.

By order,
V. P. SCULLY,
Secretary.

Office of the Public Service Board,
Melbourne, 4th August, 1964.

PUBLIC SERVICE OF VICTORIA.—VACANCIES.

(TEMPORARY APPOINTMENTS.)

A PPLICATIONS will be received by the Public Service Board up to Wednesday, the 19th August, 1964, from persons who are qualified for appointment to the under-mentioned positions:—

Draughtsman, Grade III, Department of Crown Lands and Survey.

Yearly Salary.—£1,259, minimum; £1,331, maximum.

Duties.—To note on departmental plans, permanent marks placed under the Survey Co-ordination Act. To maintain indices on plans and cards and to perform general draughting work as required.

Qualifications.—To be a neat draughtsman. Some survey draughting experience is desirable.

Survey Assistant, Grade I, Department of Crown Lands and Survey. (Two vacancies.)

Yearly Salary.—£1,115, minimum; £1,187, maximum.

Duties.—Under the direction of a Licensed Surveyor to carry out survey duties in the field.

Qualifications.—Experience in obtaining Geodetic and Topographic field survey information and capable of directing Field Assistants (Survey).

Water Bailiff, Relieving, (Bendigo Centre), Water Supply Department.

Yearly Salary.—£972, minimum; £1,043, maximum.

Duties.—To assist in distribution of water to irrigators and to keep necessary records. To assist in maintenance of irrigation and drainage channels and structures. To relieve water bailiffs as required.

Qualifications.—To be physically capable of manual work, with ability to carry out clerical work involving keeping of records and preparation of reports. Of good personality and preferably some knowledge of irrigation.

NOTE.—The salary rates quoted above do not include the additional amount which is payable under Regulation 74 of the Board's Regulations.

By order,
V. P. SCULLY,
Secretary.

Office of the Public Service Board,
Melbourne, 4th August, 1964.

PUBLIC SERVICE OF VICTORIA.—VACANCIES.

DEPARTMENT OF HEALTH.

MENTAL HYGIENE BRANCH.

TECHNICAL AND GENERAL DIVISION.

A PPLICATIONS will be received by the Public Service Board up to Wednesday, 26th August, 1964, from persons employed in the Public Service of Victoria, who are eligible and qualified for appointment to the under-mentioned positions:—

Assistant Head Nurse (Female), Beechworth.

Yearly Salary.—£1,115, minimum; £1,187, maximum.

Duties.—To assist Principal Female Nurse in management of Female Division, and to prepare leave sheets and other records as directed; to relieve senior officers as required and give lectures to Student Nurses and others.

Qualifications.—A current practising certificate for Mental Nursing. Ability to direct and control staff and patients and keep records.

Deputy Charge Nurse (Male).

Two vacancies—Psychiatric Centre, Dandenong.

Five vacancies—Mont Park.

Yearly Salary.—£1,097, minimum; £1,133, maximum.

Duties.—To be second in charge of a ward.

Qualifications.—A current practising certificate for Mental Nursing and approved experience.

Separate applications must be submitted for these positions.

Deputy Charge Nurse (Male), Kew Cottages.

Yearly Salary.—£1,097, minimum; £1,133, maximum.

Duties.—To be second in charge of a ward.

Qualifications.—A current practising certificate for Mental Deficiency Nursing and approved experience.

Cook (Male), Grade II, Receiving House, Royal Park.
Yearly Salary.—£1,079, minimum; £1,115, maximum.
Duties.—To be in charge of the kitchen and staff therein.
Qualifications.—A competent cook with experience in large quantity preparation and cooking of food-stuffs and ability to control a staff of cooks.

Shoemaker, Grade II, Sunbury.
Yearly Salary.—£1,061, minimum; £1,115, maximum.
Duties.—Manufacture and repair of boots and shoes.
Qualifications.—A fully qualified shoemaker and repairer; and able to make footwear for patients with abnormal feet.

Motor Truck Driver, Larundel.
Yearly Salary.—£989, minimum; £1,007, maximum.
Duties.—To distribute laundry, provisions, heavy and light goods, &c., throughout Larundel and adjoining hospitals.
Qualifications.—A licensed motor truck driver.
 The salary rates quoted above do not include the additional amount which is payable under Regulation 74 of the Board's Regulations.

By order,
 V. P. SCULLY,
 Secretary.
 Office of the Public Service Board,
 Melbourne, 4th August, 1964.

PUBLIC SERVICE OF VICTORIA.—RECLASSIFICATIONS.

THE Public Service Board has raised the classification of the under-mentioned offices as shown, and appointed thereto the respective officers named hereunder.

Office and Former Classification.	Revised Classification.	Duties.	Qualifications.	Officer Appointed.
ADMINISTRATIVE DIVISION.				
PREMIER'S DEPARTMENT.				
<i>Audit Office.</i>				
Auditor, Grade I, Class "B"	Class "B1"	To perform the duties appropriate to an Auditor, Grade I., including the audit of a Government Department or State Authority and, if required, to be the Deputy to a Senior Auditor responsible for all audits within a district	A qualified Accountant with wide experience in the practice of auditing	Ramsden, I. C.
TREASURY.				
<i>Office of the Housing Commission.</i>				
Class "C2"	Class "B"	To administer the Central District Office, controlling rental, tenancy and maintenance matters affecting Commission property	Ability to administer a District Office; a knowledge of the policy and procedure of the Housing Commission; a current car driver's licence	O'Donohue, G. N.
PROFESSIONAL DIVISION.				
CHIEF SECRETARY'S DEPARTMENT.				
<i>National Gallery.</i>				
Deputy Director, National Gallery, Class "B1"	Classes "B1"—"A"	To assist the Director of the National Gallery of Victoria in general administrative matters; to initiate exhibitions and lecture; to be responsible for the formulation of policy and supervision of the work of the Office of Education	A knowledge of the history and techniques of the Fine and Applied Arts; organizing ability and a practical knowledge of Art Gallery and Museum Administration. Preferably an appropriate university Degree	Thomson, G. A.
DEPARTMENT OF HEALTH.				
<i>Mental Hygiene Branch.</i>				
Psychologist, Class "B1"	Senior Psychologist, Class "A"	To undertake diagnostic testing, to conduct psychological surveys and to assist in the direction of training courses for intellectually defective children, to formulate and conduct research programmes in Psychology	A Degree in Psychology and qualifications for Associateship of the British Psychological Society; approved experience in psychological testing of children, and in vocational guidance, and ability to formulate and conduct research programming in Psychology	Macmillan, M. B.
TECHNICAL AND GENERAL DIVISION.				
LAW DEPARTMENT.				
<i>Titles Office (Survey).</i>				
Assistant (Female), Draughting, Grades F10-F13 inclusive	Assistant Draughtswoman, Grade I., Grades F14-F18 inclusive	To prepare detailed sketches of Transfer of Land, Creations and Surrenders of Easements, Surrenders of Leasehold and Consolidation of Land in different Titles; to prepare, when required, complex diagrams on new Certificates of Titles	A good penwoman with a good knowledge of Titles Office practice and procedure	Perkins, Yvonne M.

Office of the Public Service Board,
 Melbourne, 4th August, 1964.

By order,
 V. P. SCULLY,
 Secretary.

PUBLIC SERVICE (PUBLIC SERVICE BOARD) REGULATION 52.—VACANCIES.

THE Permanent Heads of the Departments shown have recommended the officers named hereunder for appointment to the under-mentioned vacancies.

Office and Classification.	Duties.	Qualifications.	Officer Recommended for Appointment.		
			Name.	Classification.	Date of Classification.

PROFESSIONAL DIVISION.

DEPARTMENT OF LAW.

Crown Solicitor's Office.

Legal Assistant, (Labour), Class "B1"	To act as the Crown Solicitor's representative with the Department of Labour and Industry; to advise on evidence required in relation to prosecutions and Acts administered by that Department; to conduct such prosecutions and to appear in proceedings before the Industrial Appeal Court	A barrister and solicitor of the Supreme Court of Victoria with adequate experience for the discharge of the duties of the office	Lyons, A. X. ..	Professional Assistant, Class "C2"	1.1.63
---------------------------------------	--	---	-----------------	------------------------------------	--------

TECHNICAL AND GENERAL DIVISION.

DEPARTMENT OF CROWN LANDS AND SURVEY.

Gardener, Senior, Grade 24	To be responsible for the care and maintenance of any section of the Royal Botanic Gardens, and to instruct, when required, less experienced gardeners in their specialized problems	A good knowledge of the various methods of gardening as practised at the Royal Botanic Gardens, preferably with a specialized knowledge of certain plants and their cultural treatment; experience as a Gardener, Grade III. or equivalent, for at least five years; ability to instruct other gardeners in their specialized problems	Wood, F. ...	Gardener, Grade III., Grade 21	28.8.50
----------------------------	--	--	--------------	--------------------------------	---------

Appeals against such recommendations should be lodged with the Secretary to the Public Service Board not later than Saturday, the 15th August, 1964.

Office of the Public Service Board,
Melbourne, 4th August, 1964.

By order,
V. P. SCULLY,
Secretary.

*Teaching Service Act 1958.*TEACHING SERVICE (TEACHERS TRIBUNAL)
REGULATIONS.

AMENDMENT No. 65.

THE Teachers Tribunal, in pursuance of the powers conferred by the *Teaching Service Act 1958*, hereby amends Regulation 9 of the Teaching Service (Teachers Tribunal) Regulations in the manner following, that is to say:—

REGULATION 9.

In clauses 2 (g) (ii), 2 (g) (iii), 2 (h) (ii) and 2 (h) (iii), for the expression "Physics Grade II." substitute the expression "either Physics Grades IIA. and IIB. or Physics Grades III. and IV."

LOUIS F. C. GARLICK Chairman.

G. FENNELL, Secretary.

Office of the Teachers Tribunal,
Melbourne, 27th July, 1964.

PRIVATE ADVERTISEMENTS**CITY OF BRIGHTON.**

NOTICE is hereby given that in pursuance of the powers conferred by the *Local Government Act 1958* the Council of the City of Brighton has made By-law No. 181 for the purpose of repealing By-law No. 179 and amending By-law No. 167 to permit the erection of three-storey buildings in specified parts of the Municipality.

A copy of the said By-law is open for inspection free of charge during office hours at the Municipal Offices, Boxshall-street, Brighton.

A. C. G. DEGARIS, Town Clerk.
Municipal Offices, Brighton, 30th July, 1964. 2010

CITY OF BRIGHTON.**BY-LAW No. 180.**

NOTICE is hereby given that in pursuance of the powers conferred by the *Health Act 1958* and the *Local Government Act 1958* the Council of the City of Brighton has made By-law No. 180 for the following purposes:—

- (a) Regulating the keeping of animals and limiting the number of animals kept on any property (viz., dogs).
- (b) Controlling and regulating the use of premises with a view to preventing objectionable noises at unreasonable times.
- (c) Suppressing nuisances.
- (d) Repealing By-law No. 117 of the City of Brighton.

A copy of the said By-law is open for inspection free of charge during office hours at the Municipal Offices, Boxshall-street, Brighton.

A. C. G. DEGARIS, Town Clerk.
Municipal Offices, Brighton, 29th July, 1964. 2009

CITY OF BRUNSWICK.**BY-LAW No. 171.**

A By-law of the City of Brunswick made under the provisions of the *Health Act 1958* for the provision, use and control of receptacles for the deposit and collection of refuse and rubbish and describing the types of suitable receptacles.

RESOLUTION for passing this By-law was agreed to by the Council on the 4th May, 1964, and was confirmed on the 1st June, 1964.

In witness whereof the common seal of the Mayor, Councillors and Citizens of the City of Brunswick was hereto affixed, in the presence of—

(SEAL) G. H. WENDEL, Mayor.
L. J. HENKEL, Councillor.
H. W. FOLETTA, Town Clerk.

Submitted to the Commission of Public Health on the 9th day of June, 1964.—A. T. GARDNER, Secretary to the Commission.

Approved by the Governor in Council, 21st July, 1964.—
J. COLQUHOUN, Clerk of the Executive Council. 2003

CITY OF COLLINGWOOD.**BY-LAWS.**

NOTICE is hereby given that the Council of the City of Collingwood has made the following By-laws:—

No. 98. Vermin and Noxious Weeds.

- For (a) Requiring the destruction of rats and other vermin or pests.
- (b) Requiring the destruction on the property or premises of any owner or occupier and the adjacent half width of any street or road on which the property or premises abuts of any weeds declared by this By-law to be noxious weeds; and
- (c) Authorizing the Council in certain events to cause measures to be taken to destroy vermin pests or weeds at the expense of the owner or occupier.

No. 100. Tree and Fence Height.

- For (a) Prohibiting or regulating the use of private property situate at the junction of streets or roads for the growing of trees, shrubs or hedges within certain limits.
- (b) Requiring the removal or lopping of such trees, shrubs or hedges.

- (c) Requiring the reduction in height of any portion of a fence within 30 feet of the junction of any streets or roads.

- (d) Authorizing the Council at the expense of the owner to remove or lop certain trees, shrubs or hedges and to reduce in height certain fences.

No. 101. Fencing of Land.

For (a) Requiring that vacant land shall be enclosed with a substantial fence.

- (b) Requiring that land which the Council has declared to be unsightly or destructive of the amenity of the neighbourhood shall be enclosed with a sufficient fence.

No. 107. Mobile Crane.

For prohibiting or regulating the use as a crane on any road of any mobile crane.

No. 108. Proceedings of Council.

For adopting certain provisions of the 15th Schedule of the *Local Government Act 1958* and carrying out certain purposes provided for in the said Schedule.

No. 109. Adoption of the 15th Schedule.

For adopting certain provisions of the 15th Schedule to the *Local Government Act 1958* and carrying out certain purposes provided for in the said Schedule.

No. 110. Street Reserves Protection.

For providing for the protection and control of—

- (a) Tree reserves and gardens, garden plots, lawns and ornamental plantations in or upon any street or road.
- (b) Trees, shrubs and plants and three guards, statues, monuments, fountains and seats erected in or upon any street or road.
- (c) Posts, fences, raised pavings and places of refuge in or upon any street or road.

Regulation No. 16.

For appointing the times and hours during or at which respectively any registered building or ground or any public building registered with the Commission of Public Health shall be used for the purpose for which it is registered or shall be closed.

Copies of the By-laws are open for inspection free of charge during office hours.

Resolution for passing these By-laws was agreed to by the Council of the City of Collingwood on the 8th day of June, 1964, and confirmed on the 6th day of July, 1964.

2011 L. D. COOK, Town Clerk.

CITY OF DANDENONG.**BY-LAW No. 30.**

A By-law of the City of Dandenong, numbered 30, made under the provisions of the *Health Act 1958*, for fixing the fees and dues payable to the Council of the City of Dandenong, under Part XV. of the *Health Act 1958*, for examining and branding carcasses of animals or meat reared and slaughtered by any person on his own premises, which premises are situated outside the "Dandenong Meat Area", and also for the examining and branding of carcasses of animals or meat slaughtered at any abattoir within the "Dandenong Meat Area" as at present constituted and as may be constituted within the City of Dandenong.

IN pursuance of the powers conferred by the *Health Act 1958*, the Mayor Councillors and Citizens of the City of Dandenong hereby orders as follows:—

1. By-law No. 11 of the City of Dandenong is hereby repealed.
2. The fees and dues payable for examining and branding by or under the direction of the Meat Inspector—
 - (a) any carcass or side of—
 - (i) bull, cow, calf (other than a bobby-calf), heifer, ox or steer, shall be Three shillings and six pence;
 - (ii) bobby-calf, goat, kid, lamb or sheep shall be Nine pence;
 - (iii) swine shall be One shilling and three pence;
 - (b) any portion of the carcass less than one side of any swine derived from any place other than an abattoir situated within the "Dandenong Meat Area" shall be Three pence.

3. The fee for any certificate as to an examination made by a Meat Inspector shall be Five shillings.

4. All fees payable under this By-law shall be paid monthly to the City Treasurer, Dandenong, or at such other period as may be directed by the Council.

5. For the purposes of this By-law a "bobby-calf" shall mean a calf not more than six weeks old.

Resolution for passing this By-law agreed to by the Council on the 13th day of April, 1964, and confirmed on the 11th day of May, 1964.

The common seal of the Mayor, Councillors and Citizens of the City of Dandenong was hereto affixed, in the presence of—

(SEAL) A. C. DOWNARD, Mayor.
ERIC R. HILL, Councillor.
C. A. ELLIOTT, Town Clerk.

Submitted to the Commission of Public Health on the 2nd day of June, 1964.—A. T. GARDNER, Secretary to the Commission.

Approved by the Governor in Council on the 21st day of July, 1964.—J. COLQUHOUN, Clerk of the Executive Council, 1988

CITY OF ESSENDON.

BY-LAW NO. 164.

Nuisances By-law.

A By-law of the City of Essendon made under section 197 of the Local Government Act 1958, and numbered 164 for—

- (a) Suppressing nuisances.
- (b) Prohibiting or minimizing noises in public highways.
- (c) Prohibiting spitting or expectorating on footpaths.
- (d) Prohibiting the throwing placing or leaving upon any public highway of orange peel banana peel or other vegetable matter.
- (e) Controlling the use of footways or roadways by children using skates, trucks, scooters or other like toy vehicles.
- (f) Prohibiting or regulating cattle being allowed to graze or wander upon any land not enclosed by a substantial fence.
- (g) Prescribing the distance from any adjoining land or from any street or public place or from any building within which it shall not be lawful to deposit such combustible materials as are specified herein.
- (h) Generally for maintaining the good rule and government of the Municipality.

IN pursuance of the powers conferred by the Local Government Act 1958 and of any and every other power it thereunto enabling the Mayor, Councillors and Citizens of the City of Essendon order as follows:—

(1) This By-law shall be known as the Nuisances By-law.

(2) Division 6 of By-law No. 87 of the City of Essendon relating to the prevention of nuisances and accidents, By-law No. 124 of the said City relating to noises, and By-law No. 141 of the said City relating to preventing obstruction of the carriage and footways, and By-law No. 147 of the said City relating to the deposit of combustible materials are hereby repealed.

(3) In this By-law unless the context otherwise requires "Instrument" means any instrument, device or thing whatsoever capable of making or being used for making sound or noise and without affecting the generality of the foregoing includes any loud-speaker amplifier broadcasting set wireless receiving set television set gramophone piano player piano or other instrument or device.

(4) No person shall in any public highway cause or permit or suffer to be cause any noise:

- (a) by shouting calling out haranguing or singing; or
- (b) by using operating controlling sounding or playing any instrument.

(5) No person shall in or upon any land house building or place make or cause or permit or suffer to be made or caused such a volume or amount of sound or noise as to be an annoyance or nuisance to any other person being in or upon any other land house building or place or in or upon any public highway—

- (a) by shouting calling out haranguing or singing; or
- (b) by using operating controlling sounding or playing any instrument.

(6) No person shall in or upon any premises use or operate any instrument or any machinery or plant in such manner as to cause any objectionable noise at any unreasonable time.

(7) No person shall spit or expectorate on any foot-path.

(8) No person shall use any street or road for the purpose of washing painting or (save in case of emergency) repairing dismantling or assembling any vehicle.

(9) No person shall at any time between the hours of eight o'clock in the morning and six o'clock in the afternoon of any day obstruct or annoy passengers along any street or road by raising or discharging dust or causing water to flow upon or across such street or road.

(10) No person shall permit to run from any land or premises into or upon any street or road any offensive liquid or matter.

(11) No person shall drive any cattle in or along any of the streets specified in the Schedule hereto.

(12) Subject as hereinafter provided no person shall drive any cattle in or along any street between the hours of eight o'clock in the morning and twelve noon, provided always that this clause shall not apply to the following streets, namely—

Ascot Vale-road from Flemington Racecourse railway south to junction with Epsom-road and Racecourse-road, and Epsom-road from the Flemington Racecourse railway south-easterly to its junction with Ascot Vale-road and Racecourse-road.

(13) No person shall throw place or leave upon any public highway any orange peel banana peel or other vegetable matter.

(14) No child shall on any footway use any skates truck scooter or other like toy vehicle in such manner as to interfere with the passage of or cause annoyance to persons being lawfully upon such footway.

(15) No person shall permit or suffer any cattle to graze or wander upon any land not enclosed by a substantial fence.

(16) The distance from any adjoining land or from any building within which it shall not be lawful to deposit any timber or any wooden or cardboard boxes or cases or any paper hay or straw is hereby prescribed as six feet.

(17) No person shall deposit any timber or any wooden or cardboard boxes or cases or any paper hay or straw contrary to the provisions of the last preceding clause.

(18) Save as is herein otherwise provided this By-law shall apply to and have operation throughout the whole of the Municipal District.

THE SCHEDULE HEREINBEFORE REFERRED TO.

All streets in the Municipality excepting those specified in clause 12.

Resolution for passing this By-law agreed to by the Council of the City of Essendon on the 25th day of November, 1963, and confirmed on the 23rd day of December, 1963.

The corporate seal of the Mayor, Councillors and Citizens of the City of Essendon was hereunto affixed, in the presence of—

(SEAL) H. W. COUSINS, Mayor.
J. J. BASTICK, Councillor.
K. LISTER, Town Clerk.

Approved by the Governor in Council on the 22nd day of April, 1964.—J. COLQUHOUN, Clerk of the Executive Council, 1997

Town and Country Planning Act 1961.

CITY OF GEELONG.—GEELONG PLANNING SCHEME 1959.

NOTICE THAT A PLANNING SCHEME HAS BEEN PREPARED AND IS AVAILABLE FOR INSPECTION.

Amendment No. 2.

NOTICE is hereby given that the City of Geelong in pursuance of its powers under the Town and Country Planning Act 1961 has prepared a Planning Scheme for the following areas:—

(a) Land situated between Park-crescent and Fyans-street with a frontage of approximately 135 feet, located 135 feet, more or less, west of Moorabool-street, for the purpose of varying the zoning of the land from Industrial "A" to Residential "B".

(b) Land situated in Myers-street, south side, 133 feet more or less westerly from Moorabool-street, with a frontage of 33 feet by a depth of 75 feet for the purpose of varying the zoning of the land from Commercial "B" to Residential "B".

(c) Land situated in Martin-street between McDonald-street and Lane No. 68 for the purpose of varying the zoning of the land from Commercial "B" to Residential "A".

(d) Land situated between Weddell-road and Melbourne-road to the north of Coxon-parade for the purpose of amending the plan to conform with the plan of subdivision of the Housing Commission area and to provide for the deletion of Minor Road R38.

(e) Land abutting Liverpool-street at the eastern extremity and on the southern boundary for the purpose of varying the zoning of the land from P6, Geelong Harbour Trust purposes, to O2, Recreation Ground.

(f) Land situated in McKillop-street, between Bourke-crescent and Fitzroy-street and being known as Hopetoun Park for the purpose of amending the zoning from Residential "A" to O2, Recreation Ground.

(g) Land situated in Boundary-road, between Queens-cliffe railway and Winstanley-road for the purpose of varying the zoning of the land from Residential "A" to Commercial "C".

(h) Land situated between Myers-street and Little Myers-street, and being known as Hay Market Reserve for the purpose of varying the zoning of the land from P9, Municipal Purposes, to Commercial "B".

A copy of the scheme has been deposited at the City Hall, Gheringhap-street, Geelong, and at the office of the Town and Country Planning Board, 179 Queen-street, Melbourne, and will be open for inspection during office hours by any person free of charge.

Any persons affected by the Planning Scheme are required to set forth, in writing, all objections they may have, addressed to the Town Clerk, City of Geelong, City Hall, Geelong, on or before the 5th day of November, 1964, and to state whether they wish to be heard in respect of their objections.

L. L. WALTER, Town Clerk.

29th July, 1964.

2019

CITY OF MELBOURNE.

CONDITIONS GOVERNING THE SUPPLY OF ELECTRICAL ENERGY.

NOTICE is hereby given that the Council of the City of Melbourne at a meeting held on 6th July, 1964, adopted the under-mentioned revised conditions as those governing the supply of electrical energy by the Corporation's Electric Supply Department to all consumers within the municipality other than those supplied by the State Electricity Commission of Victoria, and that the said conditions are now in operation.

CONDITIONS.

Application.

Application for supply of electrical energy must be made on the printed form attached to this sheet. This form properly filled in is to be detached and forwarded to the Electric Supply Office not less than four days before the supply is required.

Security.

The Council may, either before or after a supply is given, demand a security for payments. If such security be not paid within the time specified, the supply may be disconnected. Application can be made for a refund of amount twelve months from date of payment.

Installation.

A supply will not be given to any installation until the latter complies with the requirements specified in the Wiring Regulations of the State Electricity Commission.

No charge will be made for the testing and connexion of such installation, but in the event of failure to pass the tests specified in such rules a charge may be made for every subsequent test.

Should any defect or any departure from the above wiring regulations be thereafter discovered, the Council may forthwith cut off and discontinue the supply until such defect or departure is remedied to its satisfaction.

Re-connexion.

Any supply that has been disconnected for non-payment of accounts due, or for security demanded, shall not be renewed until all arrears due, together with a re-connexion fee, shall have been paid.

Charges.

The consumer shall be charged at one or more of the tariffs at which the Council supplies electricity and according to the Council's classification of the supplies and the purposes for which the electricity is required, including prescribed minimum charges, if any. On application, the consumer will be supplied with details of the tariffs applicable to the nature and classification of his supply.

Removal and Re-installation.

Where the supply shall have been disconnected because of any breach of these conditions and the meters subsequently removed, then an additional fee shall be charged to cover the cost of removal and installation of meters. The fee shall apply to any application for re-connexion of the same installation at the same premises within a period of twelve months and for those cases where the disconnection was applied for merely as a means of avoiding the payment of any of the authority's legitimate charges.

Voltage.

The standard pressures of supply available in the Council's area are as follows:—

Alternating current, 240 and 415 volts.

Consumers are advised to apply to the Electric Supply Office for further information regarding supply to any portion of the area served by the Council.

Motors, &c.

The Council shall not be held responsible for any expense that may be incurred by the consumer in altering or replacing his motors or other apparatus to suit any change in voltage, phase, &c., of the supply system which may be introduced by the Council hereafter.

Sub-stations.

When in the opinion of the Council the supply of electricity to a consumer's premises can best be effected by placing a transformer sub-station on such premises the consumer shall until the agreement for such supply shall be terminated provide free of cost to the Council the space necessary for and suitable to the erection of such sub-station, the position of which shall be fixed by mutual agreement, but so as to allow free passage to and from the sub-station at any time of the Council's representatives and apparatus. The transformer instruments and other apparatus erected by the Council in connexion with such sub-stations shall be under its sole control and may be removed by it on the termination of such agreement.

Separate Occupancies.

The Council will not supply electrical energy to any consumer for consumption on premises comprising more than one occupancy unless each such occupancy is separately metered and the Council may discontinue any supply serving more than one occupancy until a separate application has been received for each occupancy and each such occupancy is separately metered. The applicant for supply to any separately occupied premises may be the owner or occupier but if both apply the Council may designate which is to be the consumer in respect of such premises.

Termination of Service.

Except as otherwise provided, three clear days notice shall be given, in writing, by either party to the other before discontinuing the supply.

Availability.

The Council will make supply available at the consumer's terminals which shall be the point of attachment of the service lines of the Council to the consumer's wires on the consumer's premises and the Council shall decide the location of the said point of attachment; provided that—

(a) If the service lines need be longer than 60 feet (plus where the distributing mains are not on the near side of the thoroughfare, the distance across the thoroughfare) overhead or ten feet underground the Council may require the consumer to pay the cost of supplying the wire and fittings for the extra distance. The consumer shall bear the cost of providing and erecting all poles which are required on his premises for supporting service wires.

(b) The consumer shall not make or replace or allow any person other than the Council's officers to make or replace final connexions between the service lines and the consumer's installation.

- (c) The Council shall provide and may fix on any part of the consumer's premises any necessary meters, time switches and service fuses. These shall remain the Council's property. In the case of private houses and flats, meters and time switches shall be placed outside and the consumer shall provide any necessary housing or protection.
- (d) The consumer shall be responsible for the safe keeping of and for any loss of or damage to equipment provided on the consumer's premises by the Council.
- (e) The cost of the maintenance of any equipment erected on the consumer's premises at the consumer's cost shall be borne by the consumer, who shall repay to the Council any sums it may expend in such maintenance.
- (f) The consumer shall not in any way interfere with any apparatus provided and owned by the Council, but shall at all times be obliged to report to the Council any apparent defects therein. The Council may at any time remove any tree, limb or other thing on the consumer's premises which may endanger the the safety or efficiency of any service lines or apparatus.
- (b) If the consumer should refuse to allow any officer or agent of the Council who produces his official badge to enter the consumer's premises at a reasonable time and inspect and/or assess the premises, test, remove, fix, read, or inspect any meter or inspect or test the consumer's installation and consuming devices; or
- (c) If the consumer should make default in paying any sum due to the Council whether for electricity supply, meter rental or otherwise; or
- (d) If the consumer should commit or allow any breach or offence under the *Electric Light and Power Act 1958* or any applicable regulations; or
- (e) If the consumer's service lines, installation or consuming devices fail in any way to comply with the requirements of any relevant regulations for the time being in force or are in any way in the opinion of the Council's responsible officer unsafe or defective; or
- (f) If the consumer commits a breach of these conditions.

2015

GEO. SMITH, Acting Town Clerk.

CITY OF NORTHCOTE.

LOAN No. 71.

Notice of Intention to Borrow the Sum of £25,000 for Permanent Works and Undertakings.

NOTICE is hereby given that the Council of the City of Northcote proposes to borrow the principal sum of £25,000 on the credit of the municipal revenues of the Mayor, Councillors and Citizens of the said City, such sum to be raised by the grant of a mortgage in accordance with the provisions of the *Local Government Act 1958*.

1. The maximum rate of interest that may be paid is £5 2s. 6d. per cent. per annum.
2. The purpose for which the loan is to be applied is—
Capital Extensions in the Electricity Supply Undertaking.
3. The period of the loan shall be ten years.
4. The moneys borrowed shall be repayable by providing out of the Municipal Fund twenty half-yearly instalments of approximately £1,613 3s. each, including principal and interest on the 1st day of May and the 1st day of November during the currency of the loan. The first instalment shall be payable on the 1st day of May, 1965.
5. Such moneys shall be repayable to the Commissioners of the State Savings Bank of Victoria at the office of the said Commissioners, 139-165 Elizabeth-street, Melbourne.

The plans and specifications and the estimate of the cost of the proposed works, and a statement showing the proposed expenditure of the moneys to be borrowed, are open for inspection at the office of the Council of the City of Northcote at the Town Hall, Northcote.

E. MASON, Town Clerk and City Manager.

Dated the 5th August, 1964.

2023

CITY OF PRAHRAN.

LOAN No. 36.

NOTICE is hereby given that the Council of the City of Prahran proposes to borrow the principal sum of Sixty thousand pounds on the credit of the municipal revenues of the Mayor, Councillors and Citizens of the said City, such sum to be raised by the grant of a mortgage in accordance with the provisions of the *Local Government Act 1958*.

1. The maximum rate of interest that may be paid is 5½ per cent. per annum.
2. The purpose for which the loan is to be applied is construction of Refuse Destructor, Surrey-road, South Yarra, part cost.
3. The period of the loan shall be ten years.
4. The moneys borrowed shall be repayable by providing out of the Municipal Fund twenty half-yearly instalments of approximately £3,871 10s. each, including principal and interest on the 1st day of May and the 1st day of November during the currency of the loan. The first instalment shall be payable on the 1st day of May, 1965.
5. Such moneys shall be repayable to the Commissioners of the State Savings Bank of Victoria, at the office of the said Commissioners, 139-165 Elizabeth-street, Melbourne.

The plans and specifications and the estimate of the cost of the proposed works and a statement showing the proposed expenditure of the moneys to be borrowed are open for inspection at the office of the Council of the City of Prahran, at the Town Hall, Prahran.

1992

HENRY T. JONES, Town Clerk.

Alterations.

The consumer shall notify the Council—

- (a) At least three days before he makes any additions or alterations to the installation or outlets, or consuming devices such as lamps, motors, &c.
- (b) Forthwith upon making any structural addition to or erecting partitions in his premises if he is supplied at a tariff which includes a charge per room or on any area basis.
- (c) Forthwith if he substitutes any consuming device for other or adds any such device if in either case it is of a kind to be charged for in accordance with its rating or capacity or another tariff.

All notices shall be given on the proper official form.

Illegal Use.

- (a) The consumer shall not use the supply nor permit it to be used for any purpose, or at any premises other than those referred to in his application.
- (b) The consumer shall not use for lighting purposes electricity supplied through a meter which is used to measure the supply for power purposes, or for any purpose or during any hours electricity supplied through a meter which is used to measure the supply used for another purpose or during other hours for which the charge is lower.

Access to Premises.

The Council's duly authorized officers shall have access to a consumer's premises at all reasonable hours for the purpose of testing or inspecting the service lines, poles, consuming devices, and/or installation, assessing premises and for testing or reading the meter or meters, provided always that the consumer may refuse admittance to any officer or agent of the Council unless his official badge is produced on request.

Accounts Rendered.

Subject to the Council's usual practice (the terms whereof shall be communicated upon request) as to the testing of and the rectifying of the record of meters used to measure supplies given for no fixed period, the register of the meter or meters supplied and fixed by the Council shall be prima facie evidence of the electricity consumed, and money owing to the Council (whether for electricity consumed, for meter rental or for other charge) shall be due without further demand on the rendering of the account, and shall be payable by the consumer at the Electric Supply Office, Town Hall, Melbourne. Any account will be taken to have been duly rendered if left at the premises where the supply is given, or if given to any officer or servant of the consumer, or if posted to the consumer, and to have been rendered at the time when it is so left or given or posted.

Disconnexion.

The Council, if it thinks fit, may refuse to give or may discontinue the supply of electricity.

- (a) If the consumer should use or deal with the electricity supplied to him in such manner as might interfere with the efficient supply of electricity to other consumers supplied by the Council; or

CITY OF SANDRINGHAM.

LOAN No. 89.

Notice of Intention to Borrow the Sum of £25,000 for Permanent Works and Undertakings.

NOTICE is hereby given that the Council of the City of Sandringham proposes to borrow the principal sum of Twenty-five thousand pounds on the credit of the municipal revenues of the Mayor, Councillors and Citizens of the said City, such sum to be raised by the grant of a mortgage in accordance with the provisions of the Local Government Act 1958.

1. The maximum rate of interest that may be paid is £5 2s. 6d. per cent. per annum.

2. The purpose for which the loan is to be applied is:—

Road reconstruction—Thomas-street (Hampton to Kerferd-street) ..	£9,000
Holyrood-street—Council proportion ..	16,000
	£25,000

3. The period of the loan shall be ten years.

4. The moneys borrowed shall be repayable by providing out of the Municipal Fund twenty half-yearly instalments of approximately £1,613 3s. each, including principal and interest on the 1st day of May and the 1st day of November, during the currency of the loan. The first instalment shall be payable on the 1st day of May, 1965.

5. Such moneys shall be repayable to the Commissioners of the State Savings Bank of Victoria, at the office of the said Commissioners, 139-165 Elizabeth-street, Melbourne.

The plans and specifications and the estimate of the cost of the proposed works and a statement showing the proposed expenditure of the moneys to be borrowed are open for inspection at the office of the Council of the City of Sandringham, at Town Hall, Abbott-street, Sandringham, S.8.

2005

F. G. TRICKS, Town Clerk.

CITY OF SOUTH MELBOURNE.

BY-LAW No. 420.

A By-law of the City of South Melbourne made under the Health Act 1958 and numbered 420 for the purpose of prescribing the fees to be charged for the registration of premises and food vending machines and for the renewal and transfer of registration thereof pursuant to such Act.

THE Mayor, Councillors and Citizens of the City of South Melbourne in pursuance of the powers conferred by the Health Act 1958 and every other Act or power enabling it in that behalf doth hereby make the By-law and order as follows:—

1. That By-law No. 413 made by the Council of the City of South Melbourne be and the same is hereby repealed, provided that such repeal shall not prejudice or affect any right accrued or liability incurred or prosecution for any act or omission prior to the commencement of this By-law.

2. The fees to be charged received and taken by the Council of the City of South Melbourne for the registration or the renewal or transfer of the registration of premises or food vending machines pursuant to the provisions of the Health Act 1958 shall be as follows:

(a) For the granting or annual renewal of registration of premises—

Nature of Premises	Fees payable.	
	£	s. d.
Offensive trades premises (other than those referred to below) ..	5	0 0
Offensive trades premises (being fat extracting or melting or rendering works which are conducted at premises occupied principally as a butcher's shop and at which fat is extracted melted or rendered only from materials derived from such shop) ..	1	0 0
Cattle sale-yards ..	1	0 0
Boarding-houses ..	2	0 0
Common lodging-houses ..	2	0 0
Eating-houses ..	2	0 0
Apartment-houses—		
containing not more than one apartment ..	1	0 0
containing more than one apartment ..	2	0 0
Camping areas ..	2	0 0

Food Premises—

(i) Where not more than five persons (including the proprietor and his family) are employed ..

..	2	0 0
----	---	-----

Nature of Premises.

Fees Payable.

£ s. d.

(ii) where more than five such persons are employed—additional for each person in excess of five ..	0	2	6
Provided that the maximum fee payable shall be ..	25	0	0
Premises at or in any part of which eggs for sale are received or stored for the purpose of being chilled ..	2	0	0
Premises in which are conducted hairdressers' shops, beauty parlours or other like establishments, or chiropodists' establishments, or establishments where tattooing or like processes are performed ..	1	0	0
(b) For the granting or annual renewal of registration of any food vending machine ..	2	0	0
(c) For any transfer of registration ..	0	2	6

Provided however that—

(i) in respect to any registration granted after the 31st day of March in any year the fee shall be calculated at the rate of one-quarter of the fee prescribed by this By-law for each full three months or part thereof between the date of such registration and the 31st day of December following;

(ii) where application for the renewal of registration is not lodged with the Council until after the last day fixed for the lodging thereof an additional fee of one-half of the relevant prescribed fee otherwise payable for the renewal of registration shall be paid.

3. Such fees shall be paid to the Town Clerk of the City of South Melbourne by any person making application for such registration renewal or transfer respectively.

4. This By-law shall apply to and have operation throughout the whole of the Municipal District of the City of South Melbourne.

Resolution adopting this By-law agreed to by the Council of the City of South Melbourne on the 25th day of March, 1964, and confirmed at a meeting of the said Council on the 29th day of April, 1964.

(SEAL) C. B. COLLETT, Mayor.
D. McK. PATRICK, Councillor.
H. ALEXANDER, Town Clerk.

Submitted to the Commission of Public Health on the 12th day of May, 1964.—A. T. GARDNER, Secretary, Commission of Public Health.

Approved by the Governor in Council, 21st July, 1964.—J. COLQUHOUN, Clerk of the Executive Council. 1989

CITY OF TRARALGON.

AT a meeting of the Council of the City of Traralgon held at the Municipal Offices, Traralgon, on the 27th day of July, 1964, the Council confirmed the following Resolution.

That the Council of the City of Traralgon borrow the sum of £30,000 (Thirty thousand pounds) on the credit of the Mayor, Councillors and Citizens of the City of Traralgon, such is to be raised by the grant of a mortgage in accordance with the provisions of the Local Government Act 1958.

1. The maximum rate of interest that may be paid is £5 5s. per centum per annum.

2. The purposes for which the loan is to be applied are:—

(a) Street construction, drainage works, kerbing, channelling and paving in the City of Traralgon ..	£27,500
(b) Purchase of office equipment ..	1,750
(c) Alteration of offices and provision for shelving ..	750
	£30,000

3. The period of the loan shall be 40 years.

4. The moneys borrowed shall be repayable by providing out of the Municipal Fund 80 half-yearly instalments of approximately £961, including principal and interest on the currency of the loan. The first of such instalments shall be payable on 1st February, 1965.

5. Such moneys shall be repayable at the State Superannuation Board Offices, Melbourne.

2012 LESLIE M. HICKMAN, Acting Town Clerk.

TOWN OF CASTLEMAINE.

BY-LAW No. 119.

A By-law of the Town of Castlemaine, made under the Health Act 1958, and numbered 119, for the prescribing of fees to be charged for the registration of premises, and food vending machines, and for the renewal or transfer of such registrations, pursuant to the provisions of the said Act.

IN pursuance of the powers contained in the Health Act 1958 and of all other powers enabling it in that behalf, the Mayor, Councillors and Burgesses of the Town of Castlemaine order as follows:—

1. This By-law shall come into operation on the day after the publication thereof in the *Government Gazette*.
2. By-law No. 104 is hereby repealed.
3. The fees for granting or annual renewal of registration of premises shall be as follows:—

Nature of Premises.	Fees.
	£ s. d.
Offensive trade premises (other than those referred to below)	5 0 0
Offensive trade premises (being fat extracting or melting or rendering works which are conducted at premises occupied principally as a butchers shop and at which fat is extracted, melted or rendered only from materials derived from such shop)	1 0 0
Cattle sale-yards	1 0 0
Boarding houses	1 10 0
Common lodging houses	1 10 0
Eating houses	1 10 0
Apartment houses—	
containing not more than 1 apartment	0 15 0
containing more than 1 apartment	1 10 0
Camping areas	1 10 0
Food premises—	
(i) where not more than five persons (including the proprietor and his family) are employed	1 10 0
(ii) where more than five such persons are employed additional for each person in excess of five	0 2 0
Provided that the maximum fee payable shall be	25 0 0
Premises at or in any part of which eggs for sale are received or stored for the purpose of being chilled	1 10 0
Hairdressers' shops, beauty parlours or other like establishments and chiropodists' establishments	1 0 0

4. The fee for the granting or annual renewal of registration of any food vending machine shall be One pound ten shillings.

5. The fee for any transfer of registration shall be Two shillings and six pence.

6. Where application for the renewal of registration is not lodged with the Council until after the last day fixed for the lodging thereof, an additional fee of one-quarter of the relative prescribed fee shall be paid to the Council.

7. This By-law shall apply to and have effect throughout the whole of the Town of Castlemaine.

Resolution for passing this By-law No. 119 was agreed to by the Council on the 5th day of March, 1964, and confirmed on the 9th day of April, 1964.

In witness whereof the common seal of the Town of Castlemaine was hereunto affixed this 28th day of May, 1964, in the presence of—

KEITH LEWIS, Mayor.
JOHN S. VERLIN, Councillor.
I. C. SMITH, Town Clerk.

Submitted to the Commission of Public Health on the 9th day of May, 1964.—A. T. GARDNER, Secretary to the Commission.

Approved by the Governor in Council, the 21st day of July, 1964.—J. COLQUHOUN, Clerk of the Executive Council.
2002

TOWN OF STAWELL.

By-law No. 55, made pursuant to the Health Act 1958, and the Local Government Act 1958, for the purpose of regulating the keeping of animals (including birds) within the municipality of the Town of Stawell.

NOTICE is given that this By-law has been made and a copy is available for inspection free of charge during office hours at the Municipal Offices.

L. L. SMITH, Town Clerk.
30th July, 1964. 2029

SHIRE OF ALTONA.

LOAN No. 46.

Notice of Intention to Borrow the Sum of £25,000 for Permanent Works and Undertakings.

MASON-STREET WIDENING—LAND ACQUISITION.

NOTICE is hereby given that the Council of the Shire of Altona proposes to borrow the principal sum of Twenty-five thousand pounds on the credit of the municipal revenues of the President, Councillors and Ratepayers of the said Shire, such sum to be raised by the grant of a mortgage in accordance with the provisions of the Local Government Act 1958.

1. The maximum rate of interest that may be paid is £5 2s. 6d. per cent. per annum.
2. The purpose for which the loan is to be applied is Mason-street widening—Land Acquisition, £25,000.
3. The period of the loan shall be ten (10) years.
4. The moneys borrowed shall be repayable by providing out of the Municipal Fund twenty half-yearly instalments of approximately £1,613 3s. each, including principal and interest on the 1st day of May and the 1st day of November during the currency of the loan. The first instalment shall be payable on the 1st day of May, 1965.

5. Such moneys shall be repayable to the Commissioners of the State Savings Bank of Victoria at the office of the said Commissioners, 139-165 Elizabeth-street, Melbourne.

The plans and specifications and the estimate of the cost of the proposed works and a statement showing the proposed expenditure of the moneys to be borrowed, are open for inspection at the office of the Council of the Shire of Altona, at the Civic Offices, at 115 Civic-parade, Altona, W.18.

JAMES W. WATERS, Shire Secretary.
29th July, 1964. 2017

SHIRE OF ALTONA.

LOAN No. 47.

Notice of Intention to Borrow the Sum of £10,000 for Permanent Works and Undertakings.

NOTICE is hereby given that the Council of the Shire of Altona proposes to borrow the sum of Ten thousand pounds on the credit of the municipal revenues of the President, Councillors and Ratepayers of the said Shire, such sum to be raised by the grant of a mortgage in accordance with the provisions of the Local Government Act 1958.

1. The maximum rate of interest that may be paid is £5 2s. 6d. per cent. per annum.
2. The purposes for which the loan is to be applied is—
 - (a) Portion of cost of excavator loader —Plant Purchase £6,835
 - (b) Reimbursement of Municipal Fund for Plant Purchase £3,165
3. The period of the loan shall be ten years.

4. The moneys borrowed shall be repayable by providing out of the Municipal Fund twenty half-yearly instalments of approximately £645 5s. 4d. each, including principal and interest on the first day of May and the first day of November during the currency of the loan. The first instalment shall be payable on the first day of May, 1965.

5. Such moneys shall be repayable at the Australia and New Zealand Savings Bank Limited, Melbourne.

The plans and specifications and the estimate of the cost of the proposed works and a statement showing the proposed expenditure of the moneys to be borrowed, are open for inspection at the Civic Offices, 115 Civic-parade, Altona.

JAMES W. WATERS, Shire Secretary.
2018

SHIRE OF BASS.

BY-LAW No. 41.

Road Openings, &c.

NOTICE is hereby given that in pursuance of the powers conferred by the Local Government Acts, and every other power thereunto enabling, the Council of the Shire of Bass have made By-law No. 41, for the following purposes:—

1. Providing for the issue of permits for the opening and breaking up any street or road under the management of the Council, or replacing any of the materials thereof.

2. Prescribing the fees to be paid for the issue of road opening permits, &c.

Resolution for making this By-law was passed on the 4th day of June, 1964, and confirmed on 2nd day of July, 1964.

A copy of the By-law is open for inspection, free of charge, during office hours at the Shire Office, Dalyston.

H. R. BUTTERWORTH, Shire Secretary.

Shire Hall, Dalyston, 29th July, 1964. 2027

SHIRE OF BEECHWORTH.

LOAN No. 10.

Notice of Intention to Borrow the Sum of £3,700 for Permanent Works and Undertakings.

NOTICE is hereby given that the Council of the Shire of Beechworth intends to borrow the sum of Three thousand seven hundred pounds (£3,700) on the credit of the President, Councillors and Ratepayers of the said Shire, by the grant of a mortgage, in accordance with the provisions of the Local Government Acts.

In connexion therewith the following information is stated:—

- (a) The amount of the principal moneys which it is proposed to borrow is Three thousand seven hundred pounds (£3,700).
- (b) The maximum rate of interest that may be paid is £4 17s. 6d. per centum per annum.
- (c) The period of the loan will be six years and the times at which the moneys borrowed are to be repayable are the 6th day of May and November during the currency of the loan commencing on the 6th May, 1965. The place of repayment will be the Bank of New South Wales, Beechworth.
- (d) The purpose for which the loan is to be applied is the purchase of plant, viz., a tractor and a steel roller.
- (e) The manner in which the loan is to be liquidated is by provision out of the Municipal Fund in each half-year during the currency of the loan of the sum of £359 6s. 9d. which includes principal and interest.

The plans and specifications and estimate of the cost of the works and a statement showing the proposed expenditure of the moneys to be borrowed are open for inspection at the Shire Office.

Dated this 3rd day of August, 1964.

2068 G. T. GRAY, Shire Secretary.

SHIRE OF ELTHAM.

LOAN No. 53.

Notice of Intention to Borrow the Sum of £30,000 for Permanent Works and Undertakings.

NOTICE is hereby given that the Council of the Shire of Eltham proposes to borrow the sum of Thirty thousand pounds by the grant of a mortgage over a separate rate made by Resolution of the Council on the 18th May, 1964, and confirmed by order of the Governor in Council published in the *Government Gazette* the 17th June, 1964.

1. The maximum rate of interest that may be paid is £5 2s. 6d. per cent. per annum.
2. The purpose for which the loan is to be applied is the provision of off-street parking facilities for use in connexion with the Main-road, Eltham, Shopping Centre.
3. The moneys borrowed shall be repayable by providing out of the income from the separate rate 32 half-yearly instalments of approximately £1,385 3s. each, including principal and interest on the 1st day of October and the 1st day of April, during the currency of the loan. The first instalment shall be payable on the 1st day of April, 1965.

4. Such moneys shall be repayable at The Commercial Savings Bank of Australia Limited, Melbourne, or at the Council's bankers for the time being in Melbourne.

The plans and specifications and the estimate of the cost of the proposed works and a statement showing the proposed expenditure of the money to be borrowed are open for inspection at the Shire Offices, Eltham.

M. B. WATSON, Shire Secretary.

4th August, 1964. 1995

SHIRE OF GLENELG.

BY-LAW No. 56.

A BY-LAW of the Shire of Glenelg made under the provisions of the Health Acts and the Local Government Acts and every other power enabling it in that behalf, and numbered 56 for regulating the controlling, the collection and disposal of trade and household refuse and rubbish within the boundaries of the Garbage Area of the Township of Casterton.

1. By-laws Nos. 42 and 43 of the Shire of Glenelg are hereby repealed.

2. In this By-law unless inconsistent with the context or subject-matter—

- (a) "Council" means the municipal council of the Shire of Glenelg.
- (b) "Tip" means an area defined and approved by the Council and the Commission of Public Health as a site for the disposal of rubbish and refuse.
- (c) "Garbage Area" means the area referred to in the Schedule hereto from the premises of which refuse and rubbish is collected by the Council by means of a regular weekly service.
- (d) "Authorized Officer" means the Engineer or Health Inspector or By-laws Inspector of the Council for the time being.

3. Every occupier of premises within the garbage area of the Township of Casterton (save and except those premises expressly exempted and excluded by any Resolution or order of the Council) shall for the temporary storage of refuse and rubbish, provide or cause to be provided and kept thereat a ratproof, flyproof and waterproof receptacle made of durable non-absorbent material fitted with a cover of like material. Such receptacle shall be cylindrical in shape and present smooth surfaces free from projections and sharp edges and shall be not less than 5 nor more than 10 gallons in capacity.

4. Every occupier as aforesaid shall—

- (a) Cause such refuse or rubbish receptacle in use at his premises and the cover thereof to be kept in a clean and sanitary condition at all times.
- (b) Cause such receptacle to be disinfected with some efficient disinfectant and deodorant when necessary.
- (c) Cause such receptacle to be maintained in good order and condition.
- (d) Cause all household or trade refuse arising from or upon such premises from time to time to be deposited in such receptacle after such refuse or rubbish has been wrapped in newspaper or like material.
- (e) Cause such receptacle to be continuously covered save when refuse or rubbish is being deposited therein or discharged therefrom.

5. No person shall deposit or cause to be deposited any wet refuse or rubbish, ashes, flowers or garden clippings in any receptacle unless the same is properly wrapped in paper or some other suitable wrapping.

6. Every occupier of premises shall on the morning of the day appointed by the Council for the collection of refuse or rubbish, place the covered receptacle at or near the entrance to the premises where the same may be easily picked up and emptied by the contractor.

7. The occupier of any premises desirous of disposing of any indestructible rubbish or waste material not suitable to be placed in refuse or rubbish receptacle may cause the same to be carted to a tip approved of and defined by the Council from time to time and disposed of thereat in the manner required by notice exhibited at such tip or by such other means as the Council or its authorized officer may direct.

8. Before any motor car body or chassis or other bulky article having a volume of more than 2 cubic feet is disposed of at the tip, such article shall be reduced to a reasonable size by cutting or flattening so that it will pack firmly and take up a minimum of space.

9. No person except the Council's garbage contractor shall, unless with the permission of the Council or its authorized officer deposit or cause to be deposited at the tip any waste foodstuff, trade waste or other putrescible matter and where such permission has been so obtained such person upon depositing such matter shall immediately cause the same to be covered with sufficient soil to prevent any nuisance arising therefrom as the Council's authorized officer shall direct.

10. No person shall without the consent of the Council or its authorized officer enter upon a site enclosed as a tip except for the purpose of depositing rubbish therein.

11. Every person lawfully entering any tip site shall, upon leaving see that the gates are effectively closed.

12. No person shall deposit or leave any refuse or rubbish on any land, road, street, lane or passage.

13. No person shall permit any cattle to enter or graze upon the site of any tip.

14. Any person committing a breach of this By-law shall for every such breach be liable to a penalty not exceeding Five pounds, and in the case of a continuing offence, to a further daily penalty not exceeding Two pounds.

15. This By-law shall come into operation upon its publication in the *Victoria Government Gazette*:

SCHEDULE.

Garbage area as referred to in this By-law shall be deemed to mean and include that land within the Parish of Casterton more particularly described as allotment 7 of section 18, allotments 3, 4 and 5 of section 6, allotments 7, 8 and 9, section 17, allotments 45 and 46, together with all the land within the Township of Casterton, Parish of Casterton excepting the following allotments 1, 2, 3, 4, 4B, 4C, 4D, 5, 6, 7, 8, 9, 10, 11, 12, 13, 14, 15, 16, 17, 18, 19, 20, 21, 22, 23, 24, 25, 31, 32, 44, 45, 46, 47, 48, allotments 6, 7, 8, 9, 10 of section 23A, allotments 1, 2 and 3 of section 31A, all allotments contained within sections 21, 24, 24A, 25, 27, 31, 35, 40, allotments 13, 14, 15 of section 23, allotments 7, 8, 9, 10, 11, 12 of section 29, allotments 3, 6, 7, 8, 9, 10, 11, 12, 13, 14, 15, 16, 17 of section 26, allotments 13A, 14A, 15A, 16A, 17A, 18A, 19A of section 39, and any such additional land as may be declared to be part of the Garbage Area by Resolution of the Council from time to time.

Resolution for passing this By-law was agreed to by the Council the 16th day of December, 1963, and confirmed by the Council on the 20th day of January, 1964.

The common seal of the President, Councillors and ratepayers of the Shire of Glenelg was hereunto affixed, in the presence of—

(SEAL) H. D. MITCHELL, President.
T. J. HOWLETT, Councillor.
J. B. HANSEN, Secretary.

Submitted to the Commission of Public Health on the 12th day of May, 1964.—A. T. GARDNER, Secretary, Commission of Public Health.

Approved by the Governor in Council, 21st July, 1964.—J. COLQUHOUN, Clerk of the Executive Council. 2001

SHIRE OF KILMORE.
KILMORE POUND.
Abolition of Pound.

NOTICE is hereby given that in accordance with the provision of section 4 of the Pounds Act 1958, that Pound situated in Patrick-street, Kilmore, shall as from midnight on Friday, 7th August, 1964, cease to be an appointed place for the impounding of cattle.

Appointment of Pound.

Notice is hereby given that, in accordance with section 4 of the Pounds Act 1958, Council has appointed that area of land described as commencing at a point on the northern boundary of Crown allotment 13Y in the Parish of Glenburnie, County of Dalhousie, being 293 links from the north-western corner of the said Crown allotment 13Y; thence by a line bearing north 66 deg. 25 min., east 484 links; thence by a line bearing south 560 links; thence by a line bearing west 444 links; thence by a line bearing north 366 links to the point of commencement and containing an area of 2 acres and 9 perches or thereabouts as a place to be a Pound as from midnight on Friday, 7th August, 1964.

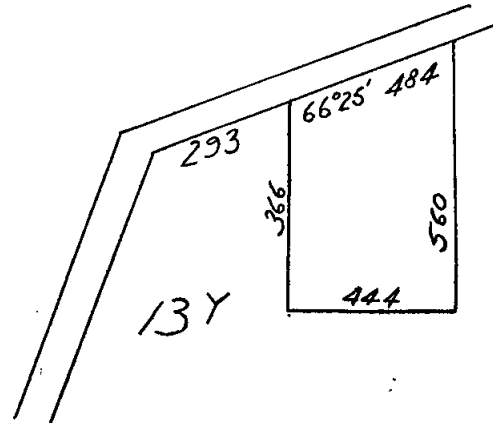

This Pound to be known as the Kilmore Pound.
2016 BRIAN J. HOBAN, Shire Secretary.

SHIRE OF LILLYDALE.

NOTICE is hereby given that Senior Constable Russell McDonagh Bennett, No. 9122, has been appointed as Prosecuting Officer to the Shire of Lillydale, in lieu of Senior Constable Sydney James Hutchins.

2028 T. H. COWLEY, Shire Secretary.

SHIRE OF ORBOST.

BY-LAW No. 55.

A By-law of the Shire of Orbost made under the provisions of the Health Act 1958 (and numbered 55) for the purposes of prescribing the fees to be charged for the registration of certain premises and for the renewal and transfer of such registrations for prescribing additional fees in certain cases and for the repeal of By-law No. 46.

IN pursuance of the powers conferred by the Health Act 1958 and of any other power thereunto enabling them in that behalf the President, Councillors and Ratepayers of the Shire of Orbost order as follows:—

1. By-law No. 46 of the Shire of Orbost shall be and is hereby repealed.

2. In respect of the under-mentioned classes of premises the following fees are hereby prescribed for the granting or annual renewal of registration:—

Nature of Premises.	Fees.	
	£	s. d.
Offensive trades premises (other than those referred to below)	5	0 0
Offensive trades premises (being fat extracting or melting or rendering works which are conducted at premises occupied principally as a butcher's shop and at which fat is extracted melted or rendered only from materials derived from such shop)	1	0 0
Cattle sale-yards	1	0 0
Boarding-houses	2	0 0
Common lodging-houses	2	0 0
Eating-houses	2	0 0
Apartment-houses—		
Containing not more than one apartment	1	0 0
Containing more than one apartment	2	0 0
Camping areas	2	0 0
Food premises—		
(i) Where not more than five persons (including the proprietor and his family) are employed	2	0 0
(ii) Where more than five persons are employed additional for each person in excess of five	0	2 6
Provided that the maximum fee payable shall be	25	0 0
Premises at or in any part of which eggs for sale are received or stored for the purpose of being chilled	2	0 0

3. The fee for the transfer of any registration is hereby prescribed as 2s. 6d.

4. Where application for the renewal of registration is not lodged until after the last date fixed for the lodging thereof an additional fee amounting to one-half of the relevant prescribed fee otherwise payable for renewal of registration shall be paid.

The Resolution for making and passing this By-law was agreed to by the Council at its ordinary meeting held on Friday, 14th day of February, 1964, and confirmed on Friday, 13th day of March, 1964.

The common seal of the President, Councillors and Ratepayers of the Shire of Orbst was hereunto affixed in the presence of—

C. T. TRUSCOTT, Councillor.
(SEAL) GEORGE E. CAMERON, Councillor.
M. H. GARDNER, Shire Secretary.

Submitted to the Commission of Public Health on the 2nd June, 1964.—A. T. GARDNER, Secretary, Commission of Public Health.

Approved by the Governor in Council, 21st July, 1964.—J. COLQUHOUN, Clerk of the Executive Council. 2021

SHIRE OF TRARALGON.

LOAN No. 52.

Notice of Intention to Borrow.

NOTICE is hereby given that the Council of the Shire of Traralgon proposes to borrow the sum of £1,500 on the credit of the municipal revenues of the President, Councillors and Ratepayers of the said Shire, such sum to be raised by the grant of a mortgage, in accordance with the provisions of the *Local Government Act 1958*.

1. The maximum rate of interest that may be paid is £5 2s. 6d.

2. The purpose for which the loan is to be applied is for the installation of septic tank systems.

3. The period of loan shall be ten years.

4. The moneys shall be repayable by providing out of the Municipal Fund twenty half-yearly instalments of £96 15s. 10d. each, including principal and interest, on the 1st day of November and the 1st day of May, during the currency of the loan.

5. Such moneys shall be repayable at the Australia and New Zealand Savings Bank Limited, Melbourne.

The plans and specifications and the estimate of the cost, and a statement showing the proposed expenditure of the moneys to be borrowed, are open for inspection at the Shire Offices, Kay-street, Traralgon.

28th July, 1964.

1993 W. TEASDALE, Shire Secretary.

SHIRE OF UPPER YARRA.

NOTICE is hereby given that the Council of the Shire of Upper Yarra by Resolution dated the 7th July, 1964, has directed that henceforth the land comprised in the certificate of titles, volume 7670, folio 088 and volume 8332, folio 327, shall be known as and deemed to be part of the Yarra Junction Recreation Reserve.

The description of the land referred to is lots 1, 2 and part of lot 3 of section 7 on plan of subdivision 4348, being part of Crown allotment 52F, Parish of Woorti Yallock, County of Evelyn, and having an area of 7½ acres or thereabouts.

2008 J. N. EDDY, Shire Secretary.

GEELONG WATERWORKS AND SEWERAGE TRUST.

PURSUANT to section 60 (2) of the *Geelong Waterworks and Sewerage Act 1958* (No. 6263), notice is hereby given of the intention of the Trust to construct sewers to provide for properties in and adjacent to—

Shire of South Barwon—

Cara-road and Dyson-avenue, Highton.
Lambhill-crescent, Highton.

City of Geelong—

Tanner-street, Breakwater.

Shire of Corio—

Anakie-road.

and more particularly as shown on maps which are open for public inspection at the Trust's Offices, Rylie-street, Geelong, between the hours of 9 a.m. and 4 p.m. daily, from Monday to Friday.

Dated this 3rd day of August, 1964.

2066 B. C. HENSHAW, Secretary.

GEELONG WATERWORKS AND SEWERAGE TRUST.

NOTICE to owners of tenements in the under-mentioned streets and private streets, lanes, courts and alleys opening thereto:—

City of Geelong.

St. Albans-road, 1,329 feet between Carr-street and Campaspe-street.

Campaspe-street, 1,692 feet.

Winstanley-road, 1,615 feet between Campaspe-street and Boundary-road.

Olney-avenue, 1,648 feet between Winstanley-road and Boundary-road.

Medding-court, 358 feet north from Winstanley-road.

Herring-court, 493 feet south from Winstanley-road.

Jamieson-street, 563 feet between Winstanley-road and Olney-avenue.

Kahle-court, 438 feet south from Winstanley-road.

Holman-street, 168 feet south from Hardiman-street to lot 8.

R.O.W. north off Winstanley-road, 135 feet.

Geelong West.

Roscommon-place, 170 feet west from Minerva-road to lot 2.

Gordon-avenue, 1,565 feet from Latrobe-terrace to Pakington-street (north side).

Roxby-street, 129 feet west from Bostock-avenue.

Shire of Bellarine.

Richard-road, 537 feet west from Helms-road. (Private.)

Anthony-street, 1,586 feet south from Richards-road to lot 95. (Private.)

Gail-street, 411 feet between Anthony-street and Helms-road. (Private.)

R.O.W. rear of Helms-road, 62 feet north from Gail-street. (Private.)

Dorward-avenue, 746 feet west from lot 26 to Mimosa-street.

Herbert-court, 285 feet north from Pitman-street.

Charles-street, 316 feet west from Breadalbane-street to lot 109.

Raeburn-court, 406 feet south off Dorward-avenue.

Newtown and Chilwell.

Gairloch-grove, 550 feet south from Craigie-road to lot 34.

Craigie-road, 64 feet west from lot 51 to lot 50.

Shire of South Barwon.

Nott-street, 594 feet east from Learmouth-street to lot 36. (Private.)

Kidman-avenue, 1,122 feet east from Colac-road to lot 76. (Private.)

Learmouth-street, 885 feet south from Yvonne-street to lot 14. (Private.)

Henry-street, 567 feet between Stephen-street and Colac-grove west.

Nagle-drive, 128 feet west from lot 32 to Colac-grove west.

Torulosa-court, 465 feet east from Valley-road south. (Private.)

Cambra-road, 140 feet west from Mernda-parade.

Montpellier-drive, 733 feet north from Culzean-crescent. (Private.)

Lambhill-crescent, 559 feet between Montpellier-drive and Cheam-walk. (Private.)

Highton-court, 160 feet north of Lambhill-crescent. (Private.)

Cheam-walk, 570 feet between Riegate-road and Lambhill-crescent. (Private.)

Thornbury-lane, 143 feet east from Riegate-road. (Private.)

Lemins-road, 2,461 feet.

Marandaz-road, 1,025 feet north from Lemins-road.

Digby-avenue, 582 feet south from Roslyn-road to lot 8.

East View-parade, 308 feet from existing main to lot 1.

McKenzie-street, 65 feet north from existing main.

Nagle-drive, 43 feet from lot 34 to 18 inches Colac-grove west.

Marjorie-avenue, 129 feet from lot 65 to 18 inches Colac-grove west.

Henry-street, 154 feet from lot 251 to 18 inches Colac-grove west.

Davis-street, 117 feet from lot 174 to 18 inches Colac-grove west.

Summit-avenue, 72 feet from lot 90 to 18 inches Colac-grove west.

Bracken-court, 260 feet west off Valley-road north.

Hutt-street, 594 feet west off Adelaide-street.

Crows-road, 367 feet east from Bailey-street.

Reserve-road, 1,180 feet between Barwon Heads-road and Sparrowvale-road.

Shire of Corio.

Watson-street, 303 feet between Separation-street and Deakin-street.

Railway-terrace, 345 feet between Edol-street and Holmes-street.

Holmes-street, 119 feet north from Railway-terrace.

Vermont-avenue, 1,440 feet between Bacchus Marsh-road and Nevada-avenue.

Nevada-avenue, 585 feet between Vermont-avenue and Cox-road.

Georgia-grove, 1,585 feet.
 Central-avenue, 320 feet between Neil-street and Corin-
 ella-street.
 Ruhamah-avenue, 108 feet west from existing main to lot
 128.
 Kinlock-street, 76 feet west from existing main to lot 88.
 Anakie-road, 185 feet south from Cox-road.
 Elmore-street, 524 feet west from Thompson-street to lot
 118.
 Coleman-avenue, 441 feet north from Donnybrook-road to
 lot 251.
 Graham-street, 337 feet south from existing main to Lily-
 street.
 Kirriemuir-street, 331 feet south from lot 35.
 Peter-street, 711 feet between Anakie-road and Eagleview-
 crescent. (Private.)
 Eagleview-crescent, 721 feet between Peter-street and
 Wolsely-grove. (Private.)
 Chanel-avenue, 610 feet between Peter-street and Wolsely-
 grove. (Private.)
 Hill-street, 258 feet north of McKay-street.
 Synnot-street, 262 feet south from existing main to Lily-
 street.
 Almana-street, 155 feet south from lot 69 to lot 72.
 Neil-street, 537 feet west from lot 409 to Ward-street.
 Royal-crescent, 157 feet west from Murray-street to lot 76.
 Murray-street, 70 feet north from existing main to Royal-
 crescent.
 Teak-street, 407 feet between Chaucer-street and Downie-
 street.
 Rodbrough-crescent, 160 feet south from Plantation-road to
 lot 24.
 May-street, 71 feet west from lot 178 to lot 179.
 Libau-avenue, 78 feet from lot 101 to lot 99.
 Milan-street, 373 feet west from existing main to Tallin-
 street.
 Lincoln-street, 1,193 feet south from Plantation-road to
 Merlin-crescent. (Private.)
 Merlin-crescent, 1,597 feet. (Private.)
 Ingleburn-crescent, 289 feet between Bacchus Marsh-road
 and Merlin-crescent. (Private.)
 Kansas-avenue, 1,223 feet west from Anakie-road to lot
 228.
 Hennessy-avenue, 155 feet south from Church-street to
 lot 26.
 Church-street, 700 feet between McCurdy-road and Graylea-
 avenue.
 Graylea-avenue, 670 feet between Church-street and Azile-
 mont-avenue.
 Graylea-avenue, 780 feet between Bealamajn and Bon View-
 avenue.
 Bon View-avenue, 150 feet east from Graylea-avenue to lot
 25.
 Hennessy-avenue, 430 feet north from Bealamajn to lot 44.
 Chaucer-street, 335 feet between Teak-street and Acacia-
 street.
 Wyoming-avenue, 1,275 feet between Oregon-avenue and
 Princess-street.
 Vermont-avenue, 1,275 feet between Oregon-avenue and
 Princess-street.
 Princess-street, 290 feet between Cox-road and Vermont-
 avenue.
 Korrumburra-avenue, 493 feet between Cox-road and lot
 45.
 Seaside-parade, 404 feet from Seabreeze-parade to lot 118.
 Acacia-street, 169 feet from Chaucer-street to lot 127.
 Avonlea-road, 1,576 feet west from Rollins-road to lot 6.
 (Private.)
 Bayview-road, 760 feet between lot 206 to lot 191.
 Barton-street, 1,290 feet east from existing dead end to
 Acacia-street.
 Edol-street, 280 feet south from Cowie-street.
 Caroline-street, 660 feet west from lot 37 to lot 49.
 Donnybrook-road, 869 feet west from dead end to lot 171.
 Jemma-street, 410 feet west from lot 313 to existing F.P.
 at main.
 Stonehaven-road, 508 feet from Darebin-street to lot 112.
 Ernest-street, 1,673 feet from lot 158 to Rollins-road.
 Evans-road, 2,340 feet north from Anakie-road.
 Hinton-avenue, 430 feet from Cox-road to lot 114.
 Gordon-avenue, 457 feet from lot 12 to lot 165.
 Kaunas-street, 84 feet from lot 260 to lot 262.
 Acacia-street, 154 feet from lot 127 to lot 124.
 Royal-crescent, 115 feet from lot 176 to lot 178.
 Liston-street, 622 feet from lot 322 to Rollins-road.
 Oregon-avenue, 100 feet south from Vermont-avenue.
 Corio Quay-road, 3,030 feet south from existing main to
 Langdon-street.

The main pipe in the said streets being laid down the
 owners of all tenements situated as above are hereby
 required on or before the 1st day of September, 1964,

to cause a proper pipe and stop cocks to be laid so as
 to supply water within such tenements from the main pipe.

The common seal of the Geelong Waterworks and
 Sewerage Trust was hereunto affixed this 31st
 day of July, 1964, in the presence of—

(SEAL) J. CARR, Chairman.
 L. W. SPRAGUE, Commissioner.
 B. C. HENSHAW, Secretary.

2020
 NOTICE OF INTENTION TO APPLY FOR A LICENCE TO
 DIVERT WATER AND CUT RACE, FROM THE
 NARCOOYIA CREEK, AT LAKE POWELL JUNCTION.

I HEREBY give notice that I intend to apply for a
 licence empowering me to divert water for a term
 of six years to the extent of 87 acre-feet per annum at a
 maximum rate of 3 acre-feet per day of 24 hours for the
 irrigation of 29 acres of trees, vines, vegetables and
 pasture, being part of allotment 4A, Parish of Nenandie,
 and to occupy certain Crown lands for works of diversion,
 and to cut a race thereon.

Any objection to such application must be forwarded,
 in writing, to reach the State Rivers and Water Supply
 Commission, Melbourne, before 30th August, 1964, being
 30 days from the first publication of this notice.

ANTONIO ZARA.

Robinvale. 1998

NOTICE OF INTENTION TO APPLY FOR A LICENCE TO
 DIVERT WATER AND CUT RACE, FROM THE
 NARCOOYIA CREEK, AT LAKE POWELL JUNCTION.

I HEREBY give notice that I intend to apply for a
 licence empowering me to divert water for a term of
 six years to the extent of 108 acre-feet per annum at a
 maximum rate of 3 acre-feet per day of 24 hours for the
 irrigation of 36 acres of trees, vines, vegetables and
 pasture, being part of allotment 4A, Parish of Nenandie,
 and to occupy certain Crown lands for works of diversion,
 and to cut a race thereon.

Any objection to such application must be forwarded,
 in writing, to reach the State Rivers and Water Supply
 Commission, Melbourne, before 30th August, 1964, being
 30 days from the first publication of this notice.

CARMELO ZARA.

Robinvale. 1999

NOTICE OF INTENTION TO APPLY FOR A LICENCE TO
 DIVERT WATER AND CUT RACE (RE-ISSUE) FROM
 THE RIVER MURRAY AT YELTA.

I HEREBY give notice that I intend to apply for a licence
 empowering me to divert water for a term of six
 years to the extent of 15 acre-feet per annum at a
 maximum rate of 3 acre-feet per day of 24 hours for the
 irrigation of 5 acres, being part of allotments 4U and 4T,
 section G, Parish of Merbein, and to occupy certain
 Crown lands for works of diversion, and to cut a race
 thereon.

Any objection to such application must be forwarded,
 in writing, to reach the State Rivers and Water Supply
 Commission, Melbourne, before 28th August, 1964, being
 30 days from the first publication of this notice.

RONALD HOCKING.

Box 105, Merbein, Victoria. 1994

NOTICE OF INTENTION TO APPLY FOR A LICENCE TO
 DIVERT WATER AND CUT RACE (RE-ISSUE) FROM
 THE RIVER MURRAY AT BONEGILLA.

I HEREBY give notice that I intend to apply for a licence
 empowering me to divert water for a term of four
 years to the extent of 100 acre-feet per annum at a maxi-
 mum rate of 2 acre-feet per day of 24 hours for the
 irrigation of 50 acres, being part of allotment 7 (LP4456),
 part allotment 1 and 2, section 7, lots 10 and 11, LP4456,
 Parish of Bonegilla, and to occupy certain Crown lands
 for works of diversion, and to cut a race thereon.

Any objection to such application must be forwarded,
 in writing, to reach the State Rivers and Water Supply
 Commission, Melbourne, before 28th August, 1964, being
 30 days from the first publication of this notice.

RONALD REID.

Talgarno Roadside, via Wodonga, Victoria. 1985

NOTICE is hereby given that E. L. Yencken and Company
 Proprietary Limited has applied for a lease, under
 section 134 of the Land Act 1958, for a term of 45 years
 from 1st October, 1964, of allotment 5, section A, City of
 South Melbourne, Parish of Melbourne South, containing
 1a. 3r. 32p., as a site for showrooms, offices and ware-
 house. 2013

NOTICE is hereby given that Templestowe Bowling Club has applied for a lease under section 134, *Land Act 1958*, of Crown land fronting Parker-street, Township of Templestowe, for a term of 21 years as a site for Amusement and Recreation (Bowling Club). 1990

NOTICE is hereby given that Lang Lang Golf Club has applied for a lease under section 143 of the *Land Act 1958*, of allotment 90A, Parish of Lang Lang, for a term of 21 years as a site for Amusement and Recreation (Golf Club). 2073

I, KARL WAGNER (formerly Karoly Szabo), male nurse, of 3 Woodlands-avenue, East Kew, in the State of Victoria, do hereby give notice that the name of Karoly Szabo is absolutely renounced and abandoned by me and in lieu thereof the name of Karl Wagner is assumed and adopted by me and it is intended henceforth upon all occasions at all times to use and that I be called and known by the full name of Karl Wagner in lieu of Karoly Szabo and that such intended change is declared and evidenced by a deed poll dated the 23rd day of July, 1964, and deposited in the office of the Registrar-General of the said State on the 23rd day of July, 1964.

Dated the 23rd day of July, 1964.

KARL WAGNER.

Peter D. Garretty, solicitor, 151 Queen-street, Melbourne, C.1. 2014

I, GRAHAM GEORGE COBURN, of 50 Narracan-avenue, Yallourn, in the State of Victoria, assistant greenkeeper, heretofore called and known by the name of Graham George Cockburn, hereby give public notice that by a Deed Poll dated the 20th day of July, 1964, duly executed and attested and deposited with the Registrar General of the said State on the 28th day of July, 1964, I formally and absolutely renounced and abandoned the said surname of Cockburn and declared that I had assumed and adopted and intended thenceforth upon all occasions to use and subscribe the surname of Coburn instead of the said surname of Cockburn and so as to be at all times thereafter called, known and described by the said surname of Coburn.

Dated the 28th day of July, 1964.

G. G. COBURN.

Witness—W. A. Cook.

1986

NOTICE is hereby given that the partnership heretofore subsisting between Beverley Blanch Freestone, Reginald Butterworth, Harold William Wainer and Jean Irene Wainer, carrying on the business as "Private Hospital Proprietors", at Sunset House Private Hospital, Mount Dandenong-road, Montrose, under the style or firm name of Sunset House Private Hospital, has been dissolved as from the 21st day of July, 1964, so far as concerns the said Harold William Wainer and Jean Irene Wainer who retire from the said firm.

Dated the 23rd day of July, 1964.

BEVERLEY B. FREESTONE.

Signed by the said Beverley Blanch Freestone, in the presence of—J. A. PATTERSON.

R. BUTTERWORTH.

Signed by the said Reginald Butterworth, in the presence of—J. A. PATTERSON.

H. W. WAINER.

Signed by the said Harold William Wainer, in the presence of—J. A. PATTERSON.

JEAN I. WAINER.

Signed by the said Jean Irene Wainer, in the presence of—J. A. PATTERSON. 2067

NOTICE is hereby given that the partnership heretofore subsisting between Henry George Judkins, of Berry-street, Box Hill, Christopher Lancaster, of Court-street, Box Hill, Leonard Arthur Elmslie Dixon, of Arnold-street, Box Hill, Leonard Langmore of Marlborough-street, Mont Albert, and Robert Bruce Baldock, of 30 Severn-street, Box Hill, all medical practitioners, under the firm name of The Whitehorse-road Clinic, at 925 Whitehorse-road, Box Hill, has been dissolved as from the 30th day of June, 1964, so far as concerns the said Robert Bruce Baldock who has retired from the said partnership. Dr. Robert Bruce Baldock has been acting as a part-time assistant as from the 1st day of July, 1964.

Dated the 28th day of July, 1964.

1987

NOTICE is hereby given that the partnership heretofore subsisting between us the undersigned Kevan John Standen, Betty Standen, Maurice John Gilmore and Angela Catherine Gilmore, carrying on business as "Commission Agents", at the corner of Naretha and Hastings streets, Swan Hill, under the style or firm of Standen and Gilmore, has been dissolved as from the 12th day of June, 1964. All accounts due to or owing by the firm of Standen and Gilmore will be received and paid by A. J. Brown and Associates, accountants, McCrae-street, Swan Hill, to whom such accounts and payments should be made.

Dated the 30th day of July, 1964.

K. J. STANDEN.
B. STANDEN.
M. J. GILMORE.
A. C. GILMORE.

Delany and Delany, solicitors for Kevan John Standen and Betty Standen.

Garden and Green, solicitors for Maurice John Gilmore and Angela Catherine Gilmore. 2054

NOTICE is hereby given that the partnership hitherto subsisting between Seymour Rodda Roe and John Stewart Roe and carried on under the firm name of S. R. Roe & Son, has been disbanded by mutual consent and all accounts owing to the firm and particulars of accounts owing by the firm must be forwarded to Hamilton, Clarke and Clarke, solicitors, Benalla. The business will in future be carried on under the same name by John Stewart Roe.

Dated the 1st day of July, 1964.

S. R. ROE.
JOHN S. ROE.

2022

ATOM HOLDINGS PROPRIETARY LIMITED.

NOTICE is hereby given that the following Special Resolution was passed on 28th July, 1964:—

"Resolved as a Special Resolution that the company be wound up voluntarily and that Harry Wason McCutcheon be appointed liquidator."

2036

B. A. TAYLOR, Secretary.

WICK INVESTMENTS PROPRIETARY LIMITED.

NOTICE is hereby given that the following Special Resolution was passed on 28th July, 1964:—

"Resolved as a Special Resolution that the company be wound up voluntarily and that Harry Wason McCutcheon be appointed liquidator."

2037

D. G. CULLEY, Secretary.

LEVANSWELL CONTRACTING PROPRIETARY LIMITED.

NOTICE is hereby given that the following Special Resolution was passed on 28th July, 1964:—

"Resolved as a Special Resolution that the company be wound up voluntarily and that Harry Wason McCutcheon be appointed liquidator."

2038

D. G. CULLEY, Secretary.

FRIG AIR CONDITIONING SERVICE PROPRIETARY LIMITED.

NOTICE is hereby given that the following Special Resolution was passed on 28th July, 1964:—

"Resolved as a Special Resolution that the company be wound up voluntarily and that Harry Wason McCutcheon be appointed liquidator."

2039

L. T. CHISHOLM, Secretary.

SURE USED REFRIGERATORS PTY. LIMITED.

NOTICE is hereby given that the following Special Resolution was passed on 28th July, 1964:—

"Resolved as a Special Resolution that the company be wound up voluntarily and that Harry Wason McCutcheon be appointed liquidator."

2040

L. T. CHISHOLM, Secretary.

Companies Act 1961.—In the matter of HERMES REAL ESTATE CO. PTY. LTD. (in Voluntary Liquidation).

NOTICE is hereby given, pursuant to section 254 of the *Companies Act 1961*, that at an Extraordinary General Meeting of the above-named company, held on 28th July, 1964, it was resolved that the company be wound up voluntarily, and that Lefkios Papadopoulos, of 1 Pavo-street, North Balwyn, be appointed liquidator of the company.

Dated this 28th day of July, 1964.

2042.

L. PAPADOPOULOS, Liquidator.

KERSWIC HOLDING PROPRIETARY LIMITED.

NOTICE is hereby given that the following Special Resolution was passed on 28th July, 1964:—

“Resolved as a Special Resolution that the company be wound up voluntarily and that Harry Wason McCutcheon be appointed liquidator.”

2041

L. T. CHISHOLM, Secretary.

The Companies Act 1961.

TELRAY AERIALS PTY. LTD. (IN LIQUIDATION).

NOTICE CONVENING FINAL MEETING OF MEMBERS AND CREDITORS, PURSUANT TO SECTION 272.

NOTICE is hereby given in pursuance of section 272 of the Companies Act 1961 that a meeting of the members and creditors of the above-named company will be held on the 2nd day of September, 1964, at the offices of Hall & Rose, chartered accountants, 163 William-street, Melbourne, at half-past Ten o'clock in the forenoon, for the purpose of having an account laid before them, showing the manner in which the winding up has been conducted and the property of the company disposed of, and of hearing any explanations that may be given by the liquidator.

Dated this 3rd day of August, 1964.

J. K. HALL, Liquidator.

Hall & Rose, chartered accountants, 163 William-street, Melbourne, C.1. 2053

Companies Act 1961.

NINETEEN KIREEP PROPRIETARY LIMITED.

NOTICE OF MEETING OF COMPANY PURSUANT TO SECTION 272 (1).

NOTICE is hereby given pursuant to section 272 of the Companies Act 1961 that a General Meeting of the above-named company will be held at 2nd Floor, 99 Queen-street, Melbourne, on Monday, the 7th day of September, 1964, at 9.30 o'clock in the forenoon for the purpose of laying before the meeting the account referred to in section 272 (1) of the said Act and giving any necessary explanation thereof.

Dated this 29th day of July, 1964.

2083

FRANK SMITH, Liquidator.

Companies Act 1961.

TOORAK CARAVANS PROPRIETARY LIMITED (IN VOLUNTARY LIQUIDATION).

NOTICE CONVENING FINAL MEETING, PURSUANT TO SECTION 272 (1).

NOTICE is hereby given, in pursuance of section 272 (1) of the Companies Act 1961, that a General Meeting of the members and creditors of the above-named company will be held at my office, 112 Patterson-road, Moorabbin, on the 7th day of September, 1964, at 10 o'clock in the forenoon, for the purpose of having an account laid before them showing the manner in which the winding up has been conducted and the property of the company disposed of and of hearing any explanation that may be given by the liquidator.

Dated the 31st day of July, 1964.

2059

R. W. FOX, Liquidator.

In the matter of the Companies Act 1961; and in the matter of BRAEMORE INVESTMENT TRUST PROPRIETARY LIMITED.—Members' Voluntary Winding Up.—Notice of Special Resolution, Pursuant to Section 254 (2) (b).

AT an Extraordinary General Meeting of the members of Braemore Investment Trust Proprietary Limited, convened and held on Friday, the 31st day of July, 1964, the following Special Resolution was passed:—

“That the company be wound up voluntarily as a Members Voluntary Winding Up.”

At the said meeting, the members appointed John David Spence, care of Edwin V. Nixon and Partners, 401 Collins-street, Melbourne, to act as liquidator for the purpose of winding up the affairs and distributing the assets of the company.

In order that the liquidator may proceed promptly with payments to the shareholders, the liquidator requests that should there be any person who has a claim against the company, such person will lodge proof thereof with the liquidator within fourteen days from the date hereof at the said address. Any such claim established to the satisfaction of the liquidator will be paid promptly. If no proofs of debt are received by that date, the liquidator will proceed with the distribution to the shareholders.

WEIGALL & CROWTHER, solicitors for the company. 2032

The Companies Act 1961.—In the matter of MITCHAM ELECTRIC MOTOR REWINDING COMPANY PROPRIETARY LIMITED (in Voluntary Liquidation).

NOTICE is hereby given that a Meeting of Shareholders of the above-named company will be held at 179 Burwood-road, Auburn, on the 1st day of September, 1964, at Ten in the forenoon, for the purpose of receiving an account of the liquidator's acts and dealings and the conduct of the winding up since the date of liquidation.

Dated this 27th day of July, 1964.

1984

W. G. SUTER, Liquidator.

Companies Act 1961.

R. McNAUGHTON & SON PTY. LTD.

NOTICE OF MEETING OF CREDITORS.

NOTICE is hereby given that a Meeting of Creditors of R. McNaughton & Son Pty. Ltd. will be held at Room 516, 342 Flinders-street, Melbourne, on the 14th day of August, 1964, at 11 o'clock in the forenoon, for the purpose of placing the company under official management and appointing an official manager as provided in Part IX. of the Companies Act 1961.

Dated this 3rd day of August, 1964.

R. McNAUGHTON, Director.

Bastian, Bent and Cogle, Suite 18, 545 St. Kilda-road, Melbourne, S.C.3. 2065

In the Supreme Court.—In the matter of the Companies Act 1961; and in the matter of MENTONE TEN-PIN BOWLING CO. LIMITED.

NOTICE is hereby given that by order of the Supreme Court of Victoria dated the 22nd day of July, 1964, the reduction of capital of Mentone Ten-pin Bowling Co. Limited resolved upon by the Special Resolution of company passed on the 3rd day of June, 1964, whereby the share capital of the company was resolved to be reduced to £150,000 divided into 600,000 ordinary shares of 5s. each of which 260,000 ordinary shares of 5s. have been issued and are deemed to have been fully paid up (making a total of £65,000 paid up) and of which the balance of 340,000 ordinary shares of 5s. each have not yet been issued, was confirmed by the said Supreme Court of Victoria in accordance with section 64 of the Companies Act 1961.

LLOYD P. GOODE & CO., solicitors, 388 Bourke-street, Melbourne. 2033

In the Supreme Court of Victoria (1964, CO6902).—In the matter of the Companies Act 1961; and in the matter of AJAX REFRIGERATION PROPRIETARY LIMITED (Under Official Management).

NOTICE is hereby given that a petition for the winding up of the above-named company by the Supreme Court was on the 23rd day of July, 1964, presented by John Arthur Coakley, public accountant, the Official Manager of the above-named company. And that the said petition is directed to be heard before the court sitting at the Fourteenth Court, Law Courts, William-street, Melbourne, at the hour of 10.30 o'clock in the forenoon, on the 21st day of August, 1964, and any creditor or contributory of the said company desiring to support or oppose the making of an Order on the said petition may appear at the time of hearing by himself or his counsel for that purpose; and a copy of the said petition will be furnished to any creditor or contributory of the said company requiring the same by the undersigned on payment of the regulated charge for the same.

The petitioner's address is Second Floor, 125 William-street, Melbourne.

The petitioner's solicitor is Imants Dizgalvis, of the firm of I. Dizgalvis & Co., of 390 Lonsdale-street, Melbourne.

I. DIZGALVIS.

NOTE.—Any person who intends to appear on the hearing of the said petition must serve on or send by post to the above-mentioned petitioner or his above-named solicitor, notice, in writing, of his intention to do so. The notice must state the name and address of the person, or, if a firm, the name and address of the firm, and must be signed by the person or firm, or his or their solicitor (if any), and must be served or, if posted, must be sent by post in sufficient time to reach the above named not later than Four o'clock in the afternoon of the 20th day of August, 1964. 2049

L. G. AXTON PROPRIETARY LIMITED (IN VOLUNTARY LIQUIDATION).

PURSUANT TO SECTION 254 (2) OF THE COMPANIES ACT 1961.

AT an Extraordinary General Meeting of the members of the said company duly convened and held at 277A Toorak-road, Burwood, on Friday, 31st July, at 8.30 p.m., the following Special Resolution was passed:—

"That the company be wound up voluntarily and that George Emery Thomas Christian, public accountant, of 277A Toorak-road, Burwood, be and is hereby appointed liquidator for the purposes of such winding up."

Dated this 3rd day of August, 1964.

2079

G. E. T. CHRISTIAN, Liquidator.

PURSUANT to the *Trustee Act 1928*, notice is hereby given that all persons having claims against the estate of Herbert Robert Woodley, formerly of Wellington, company manager, but late of Christchurch, New Zealand, retired hotelkeeper, deceased (who died on the 10th day of May, 1963, and probate of whose will was granted to The Guardian Trust and Executors Company of New Zealand Limited, by the Supreme Court of the said State in its Probate Jurisdiction on the 16th day of July, 1963), are hereby required to send particulars, in writing, of such claims to The Trustees, Executors and Agency Company Limited, of 401 Collins-street, Melbourne, the duly constituted attorney of The Guardian Trust and Executors Company of New Zealand Limited, on or before the 14th day of October, 1964, after which date the said The Trustees, Executors and Agency Company Limited will proceed to distribute the assets of the said Herbert Robert Woodley, deceased, which shall have come to its hands amongst the persons entitled thereto, having regard only to the claims of which it shall then have had notice. And notice is hereby further given that the said The Trustees, Executors and Agency Company Limited will not be liable for the assets so distributed or any part thereof to any person of whose claim it shall not have had notice as aforesaid.

ALEXR. GRANT, DICKSON & KING, solicitors, 119 William-street, Melbourne. 2031

RONALD GEORGE SMITH, formerly of 14 Nottingham-street, Kensington, and of 7 Angus-avenue, Newport, but late of 26 The Esplanade, Maribyrnong, in the State of Victoria, labourer, DECEASED.

PURSUANT to the *Trustee Act 1923*, creditors, next of kin and all other persons having claims against the estate of the above-named deceased (who died on the 8th day of December, 1962), are required by the executors, Katherine Alice Smith, of 82 Stawell-road, Horsham, in the State of Victoria, widow, and Thomas Frederick Smith, of 8 Leicester-square, Seaholme, in the said State, labourer, to whom probate of deceased's will has been granted to send particulars of such claims to the executor, care of the undersigned Lawson & Jardine, on or before the 7th day of October, 1964, after which date the executors will distribute the assets of the deceased, having regard only to the claims of which they have then had notice.

LAWSON & JARDINE, solicitors, 123 William-street, Melbourne. 62 6397. 2045

CREDITORS, next of kin and others having claims in respect of the estate of Samuel Gordon Hayles, late of 35 Warley-road, East Malvern, retired bricklayer, deceased (who died on the 16th day of June, 1964), are to send particulars of their claims to the executrix, Catherine Gladys Innes, of 29 Beech-street, East Malvern, married woman, at her said address by the 16th day of October, 1964, after which date the said executrix will distribute the estate of the said deceased, having regard only to the claims of which she then has notice.

W. ROSS RICHARDS, solicitor, 9 Beech-street, East Malvern. 2070

CREDITORS, next of kin and others having claims against the estate of John Sutton, late of 15 Hillside-terrace, Ascot Vale, retired inspector of police, deceased (who died on the 24th April, 1964), are required to send particulars thereof to National Trustees, Executors and Agency Company of Australasia Limited, the administrator of the estate of the said deceased, addressed to the care of the said company at its registered office, 95 Queen-street, Melbourne, by the 21st October, 1964, after which date the said company will distribute the assets of the deceased, having regard only to the claims of which the said company shall then have notice.

GAVAN, DUFFY & KING, solicitors, 95 Queen-street, Melbourne. 2074

CREDITORS, next of kin and others having claims in respect of the estate of Alfred Joseph Veness, late of 67 Green-street, Ivanhoe, in the State of Victoria, retired, deceased (who died on the 23rd day of May, 1964), are to send particulars of their claims to the Equity Trustees, Executors and Agency Company Limited, of 472 Bourke-street, Melbourne, by the 15th day of October, 1964, after which date it will distribute the assets, having regard only to the claims of which it then has notice.

H. B. V. DIMELow, solicitor, 422 Collins-street, Melbourne. 2069

CREDITORS, next of kin and others having claims in respect of the estate of Anne Dashwood Hooper, late of 91 Gold-street, Collingwood, in the State of Victoria, widow, deceased (who died on the 3rd day of May, 1964), are to send particulars of their claims to The Perpetual Executors and Trustees Association of Australia Limited, of 100-104 Queen-street, Melbourne, in the State of Victoria, by the 7th day of October, 1964, after which date it will distribute the assets, having regard only to the claims of which it then has notice.

HENDERSON & BALL, solicitors, 430 Little Collins-street, Melbourne. 2050

CREDITORS, next of kin and others having claims in respect of the estate of Violet Dugard, late of 10 William-street, Essendon (who died on the 12th day of March, 1964), are to send particulars of their claims to The Perpetual Executors and Trustees Association of Australia Limited, of 100-104 Queen-street, Melbourne, by the 19th October, 1964, after which date it will distribute the estate, having regard only to the claims to which it then has notice.

HENDERSON & BALL, solicitors, 430 Little Collins-street, Melbourne. 2052

MARGARET ANN MCFARLANE, late of Masterton, in New Zealand, widow, DECEASED.

CREDITORS, next of kin and others having claims in respect of the estate of the above-named deceased (who died on or about the 22nd day of December, 1963), are required to send particulars of their claims to The Trustees, Executors and Agency Company Limited, of 401 Collins-street, Melbourne, by the 12th day of October, 1964, after which date the company may convey or distribute the assets, having regard only to the claims of which it then has notice.

DAVID THOMAS & FRENKEL, of 104 Queen-street, Melbourne, solicitors for the said company. 2051

DORA MAY ADENEY, late of 7 Scenic-drive, Ringwood East, married woman, DECEASED.

CREDITORS, next of kin and others having claims in respect of the estate of the deceased (who died on the 28th March, 1964), are required by The Trustees, Executors and Agency Company Limited, of 401 Collins-street, Melbourne, to send particulars of their claims to the said company by the 7th day of October, 1964, after which date the company may convey or distribute the assets, having regard only to the claims of which it shall then have had notice.

DUGDALE, DIMMICK & STEVENS, solicitors, "Peacock House", 486 Bourke-street, Melbourne. 2055

THOMAS FREDERICK FLETCHER, late of Smeaton, farmer, DECEASED (who died on the 11th May, 1964).

CREDITORS, next of kin and all persons having claims against the estate of the deceased, are required to send particulars to the executor, The Union-Fidelity Trustee Company of Australia Limited, of 333 Collins-street, Melbourne, care of its address above given, on or before the 6th October, 1964, after which date it will distribute the assets, having regard only to the claims of which it shall then have notice.

HEINZ & GORDON, solicitors, 209 Dana-street, Ballarat. 2025

CREDITORS and others having claims against the estate of Roderick Duncan McLean, late of 136 Park-street, St. Kilda, storeman-clerk, deceased (who died on the 11th day of February, 1964), are required to send particulars, in writing, of their claims to William John McLean, in care of Cooke and Cussen, of 383 Collins-street, Melbourne, solicitors, the administrator of the estate of the said deceased, on or before the 13th day of September, 1964, after which date he will distribute the assets, having regard only to the claims of which he shall have had notice.

COOKE & CUSSEN, solicitors, 383 Collins-street, Melbourne. 2044

EMILY MAY HAWKESWORTH, late of 2 Clarendon-street, Ballarat, widow, DECEASED (who died on the 7th May, 1964).

CREDITORS, next of kin and all persons having claims against the estate of the deceased, are required to send particulars to the executors, The Union-Fidelity Trustee Company of Australia Limited, of 333 Collins-street, Melbourne (formerly The Fidelity Trustee Company Limited, of 101 Lydiard-street north, Ballarat, and formerly The Ballarat Trustees, Executors and Agency Company Limited, of 101 Lydiard-street north, Ballarat), and Barbara Flora Gunn, of 2 Clarendon-street, Ballarat, married woman, care of the said company at its address above given, on or before the 6th October, 1964, after which date it and she will distribute the assets, having regard only to the claims of which it and she shall then have notice.

HEINZ & GORDON, solicitors, 209 Dana-street, Ballarat. 2026

CREDITORS, next of kin and others having claims in respect of the estate of the late Charles Francis Derham, late of Morwell North, farmer, deceased (who died on the 1st June, 1964), are to send particulars of their claims to the executors, Louisa Selina Derham, Thomas George Derham and Frank Stanley Budge, care of the undersigned, by the 31st of October, 1964, after which date they will distribute the assets, having regard only for the claims which they then have notice.

TRUCANO, RYAN & CO., solicitors, cnr. Gude's Arcade and Buckley-street, Morwell. 1991

CREDITORS, next of kin and others having claims in respect of the estate of William Newling, late of Dundas-road, Maryborough, retired farmer, deceased (who died on the 19th day of June, 1964), are to send the particulars of their claims to The Union-Fidelity Trustee Company of Australia Limited, of 101 Lydiard-street north, Ballarat, on or before the 30th day of October, 1964, after which date it will distribute the assets, having regard only to the claims of which it has notice.

HERRING, BATHURST & BRUCE, solicitors, Maryborough. 2004

LEO THOMAS SCANLON, late of Lethbridge, formerly council employee, lately railway employee, DECEASED.

CREDITORS, next of kin and others having claims in respect of the estate of the deceased (who died on the 9th day of April, 1964), are required by the personal representative, Vincent Scanlon, of Lethbridge, farmer, to send particulars of their claims to the said Vincent Scanlon at the office of F. G. Gargan, solicitor, at 51 Malop-street, Geelong, by the 15th day of October, 1964, after which date the said Vincent Scanlon will distribute the assets, having regard only to the claims of which he then has notice.

Dated the 30th day of July, 1964.

F. G. GARGAN, solicitor, National Bank Buildings, 51 Malop-street, Geelong. 2006

CREDITORS, next of kin and others having claims in respect of the estate of Annie Marie Frances Pryor, late of 72 Hawthorn-grove, Hawthorn, widow, deceased (who died on the 20th day of March, 1964), and probate of whose will has been granted to Herbert Mervyn Pryor, of Grandview-grove, Inverloch, gentleman, and Una Frances Myers, of 20 Glebe-street, Randwick, in the State of New South Wales, married woman, are to send in particulars of their claims to the said executors, care of the under-mentioned solicitors, by the 8th day of October, 1964, after which date they will distribute the assets, having regard only to the claims of which they then have notice.

PEARCE & WEBSTER, solicitors, 430 Little Collins-street, Melbourne. 2047

CREDITORS, next of kin and others having claims in respect of the estate of Catherine Noble, late of 1 Sefton-place, East Camberwell, spinster, deceased (who died on the 25th day of May, 1964), are required by the executor and executrix of the will of the deceased, Geoffrey Urie Nathan, of 380 Bourke-street, Melbourne, solicitor, and Anna Chalmers McLennan, of 33 Aroona-road, Caulfield, retired law clerk, to send particulars of their claims to them, care of the under-mentioned solicitors, by the 12th day of October, 1964, after which date they will distribute the assets, having regard only to the claims of which they then have notice.

JOHN W. McCOMAS & CO., solicitors, 380 Bourke-street, Melbourne. 2035

CREDITORS, next of kin and others having claims in respect of the estate of Charles George Joseph Borrett, late of 8 Fairlie-court, South Yarra, investor, deceased (who died on 12th May, 1964) are to send particulars of their claims to National Trustees, Executors and Agency Company of Australasia Limited at its registered office, situate at 95 Queen-street, Melbourne, by the 7th day of October, 1964, after which date it will distribute the assets, having regard only to the claims of which it then has notice.

COOK & McCALLUM, solicitors, 422 Collins-street, Melbourne. 2034

CREDITORS, next of kin and others having claims in respect of the estate of George Edward Gayther, late of 11 McDonald-street, Preston, spring manufacturer, deceased (who died on the 7th day of March, 1964), are to send the particulars of their claims to The Union-Fidelity Trustee Company of Australia Limited, of 333 Collins-street, Melbourne, by the 16th day of October, 1964, after which date it will distribute the assets, having regard only to the claims of which it then has notice.

FRANK GREY SMITH & SON, solicitors, Collins House, Melbourne. 2043

CREDITORS, next of kin and others having claims in respect of the estate of Alice Seath, late of 354 Cardigan-street, Carlton, spinster, deceased, intestate (who died on the 4th January, 1964) are to send particulars of their claims to Gladys Ivy Kenny, the administratrix of the estate of the said deceased, care of the solicitors hereunder mentioned, on or before the 7th October, 1964, after which date it is the intention of the said Gladys Ivy Kenny to distribute the assets of the said deceased, having regard only to the claims of which she then has notice.

R. WADHAM & DOIG, solicitors, of 383 Flinders-lane, Melbourne. 2046

CREDITORS, next of kin and others having claims in respect of the estate of Amos Akers, late of Main-street, Bacchus Marsh, retired labourer, deceased (who died on the 24th day of February, 1964), and probate of whose will has been granted to Pansy Prudence Cook, of 16 Dalveen-road, West Ivanhoe, widow, are required to send particulars of their claims to the said executrix, care of the under-mentioned solicitors, by the 8th day of October, 1964, after which date she will distribute the assets, having regard only to the claims of which she then has notice.

PEARCE & WEBSTER, solicitors, 430 Little Collins-street, Melbourne. 2048

CREDITORS, next of kin and others having claims in respect of the estate of the late Charles Francis Derham, late of Morwell North, farmer, deceased (who died on the 1st June, 1964), are to send particulars of their claims to the executors, Louisa Selina Derham, Frank Stanley Derham and Leslie Budge, care of the undersigned, by the 31st of October, 1964, after which date they will distribute the assets, having regard only for the claims which they then have notice.

TRUCANO, RYAN & CO., solicitors, corner Gude's Arcade and Buckley-street, Morwell. 2064

PATRICIA MAUREEN TURNER, formerly of 23 Carlisle-avenue, East St. Kilda, but late of 54 Wilgah-street, East St. Kilda, in the State of Victoria, married woman, DECEASED.

CREDITORS, next of kin and others having claims in respect of the estate of the deceased (who died on the 11th day of September, 1963), are required by the trustee, National Trustees, Executors and Agency Company of Australasia Limited, to send particulars thereof to it at 95 Queen-street, Melbourne, by the 7th day of October, 1964, after which date it may convey or distribute the assets, having regard only to the claims of which it has notice.

DAVID FOGARTY, LL.B., solicitor, 84 Chapel-street, St. Kilda. 2056

MABEL FLORENCE CAROL TOZER, late of Wilson-street, Healesville, married woman, DECEASED.

CREDITORS, next of kin and others having claims in respect of the estate of the deceased (who died on the 11th day of February, 1964), are required by the executor, James Cyril Tozer, of Wilson-street, Healesville, draper, to send particulars to him care of the undersigned on or before the 18th day of October, 1964, after which date he will distribute the assets, having regard only to the claims of which he then has notice.

R. P. BAYLOR & CO., solicitors, Healesville. 2062

FLORENCE MAY RANKINS, late of 27 Elm-grove, Ripponlea, in the State of Victoria, widow, DECEASED.

CREDITORS, next of kin and others having claims in respect of the estate of the deceased (who died on the 2nd day of November, 1963), are required by the trustee, Elsie Young, to send particulars thereof to her, in care of the undersigned solicitor, by the 7th day of October, 1964, after which date she may convey or distribute the assets, having regard only to the claims of which she then has notice.

DAVID FOGARTY, LL.B., solicitor, 84 Chapel-street, St. Kilda. 2057

RONALD ADAMS, late of Steele's Creek, timber worker, DECEASED.

CREDITORS, next of kin and others having claims in respect of the estate of the deceased (who died on the 25th day of April, 1963), are required by the executor, Richard Patrick Baylor, of 124 Nicholson-street, Healesville, solicitor, to send particulars to him, care of the undersigned on or before the 18th day of October, 1964, after which date he will distribute the assets, having regard only to the claims of which he then has notice.

R. P. BAYLOR & CO., solicitors, Healesville. 2061

CREDITORS, next of kin and others having claims in respect of the estate of George Lucas, late of 7 Baxter-street, Frankston, retired naval officer (who died on the 2nd August, 1963), are requested to send particulars of their claims to the executor, Arthur Leslie Park, care of the under-mentioned solicitors, on or before the 7th October, 1964, after which date he will distribute the assets, having regard only to the claims of which he then has notice.

MCKEAN, PARK & COOPER, solicitors, 84 William-street, Melbourne. 2076

WILLIAM LEWIS, late of Maroondah-parade, Healesville, gentleman, DECEASED.

CREDITORS, next of kin and others having claims in respect of the estate of the deceased (who died on the 31st day of May, 1964), are required by the executor, Frederick Morris Burroughs, of Camerons-road, Healesville, gentleman, to send particulars to him, care of the undersigned, on or before the 18th day of October, 1964, after which date he will distribute the assets having regard only to the claims of which he then has notice.

R. P. BAYLOR & CO., solicitors, Healesville. 2060

CREDITORS, next of kin and others having claims against the estate of Ada Margaret O'Connor, late of 12 Deakin-street, Yarraville, in the State of Victoria, widow, deceased (who died on the 22nd day of May, 1964), are required to send particulars of their claims to The Union-Fidelity Trustee Company of Australia Limited, of 333 Collins-street, Melbourne, by the 10th day of October, 1964, after which date the said company will distribute the assets, having regard only to the claims of which it then has notice.

EALLES & MILLER, solicitors, 443 Little Collins-street, Melbourne, C.I. 2077

GEORGE HURSE, late of Wangaratta, in the State of Victoria, retired farmer, DECEASED.

CREDITORS, next of kin and others having claims in respect of the estate of the above-named deceased (who died on 15th August, 1963), are required by the executors, Edward George Hurse, of Yackandandah, farmer, and Gordon Murray McCracken, of Wangaratta, solicitor, to send particulars to them, care of Murdoch, Living and McCracken, of Reid-street, Wangaratta, by the 6th October, 1964, after which date the executors may convey or distribute the assets, having regard only to the claims of which they then have notice.

MCCRACKEN & MCCRACKEN, 317 Collins-street, Melbourne, solicitors. 2080

CREDITORS and others having claims against the estate of Gertrude May Smith, late of 95 Mortimore-street, Moorabbin, widow, deceased (who died on the 25th day of May, 1964), are required to send particulars, in writing, of their claims to John Arthur Potter and Mary Frances Potter, in care of Cooke and Cussen, of 383 Collins-street, Melbourne, solicitors, the executors of the will of the said deceased, on or before the 14th day of October, 1964, after which date they will distribute the assets, having regard only to the claims of which they shall have had notice.

COOKE & CUSSEN, solicitors, 383 Collins-street, Melbourne. 2081

EVANGELINE LOUISA EDQUIST, late of 157 Highfield-road, Camberwell, widow, DECEASED.

CREDITORS, next of kin and others having claims in respect of the estate of the deceased (who died on 18th June, 1963), are required by the executor, Richard Courtney Edquist, of 5 Grange-road, Kew, to send particulars to him by the 13th day of October, 1964, after which date the said executor may convey or distribute the assets, having regard only to the claims of which he then has notice.

Dated this 3rd day of August, 1964.

ARTHUR ROBINSON & CO., solicitors, 360 Collins-street, Melbourne. 2082

MARION JEAN BLATCHFORD, late of "Downderry", Somerville, in the State of Victoria, married woman, DECEASED.

CREDITORS, next of kin and others having claims in respect of the estate of the deceased (who died on the 19th day of September, 1963), are required by the executor, Sidney Bond Seymour, of 129 William-street, Melbourne, in the said State, solicitor, to send particulars to him on or before the 19th day of October, 1964, after which date the said executor may convey or distribute the assets, having regard only to the claims of which he shall then have had notice.

WILLIAMS & MATTHEWS, solicitors, 129 William-street, Melbourne. 2075

EMMELINE IRVINE, late of Kew Mental Hospital, Kew, Victoria, widow, DECEASED.

CREDITORS, next of kin and others having claims in respect of the estate of the deceased (who died on 24th July, 1963), are required by her executor, The Equity Trustees, Executors and Agency Company Limited, of 472 Bourke-street, Melbourne, Victoria, to send particulars to it by the 8th day of October, 1964, after which date the executor may convey or distribute the assets, having regard only to the claims of which it then has notice.

J. ROBERTSON MACMILLAN & CO., solicitors, South Melbourne. 2078

CREDITORS, next of kin and others having claims in respect of the estate of Floreon Maud Kelsey, late of 4 Dickson-crescent, Ringwood, in the State of Victoria, married woman, deceased (who died on the 24th April, 1964), are required to send particulars of their claims to the executors, the National Trustees, Executors and Agency Company Limited, of 95 Queen-street, Melbourne, within two months of the date hereof, after which time they will distribute the assets, having regard only to the claims of which they then have notice.

R. W. HOLT AND CLEMINSON, solicitors, 1 Ringwood-street, Ringwood. 2071

JEAN MARTIN PAGE (also known as Jeanie Martin Page), formerly of No. 7 Rowe-street, Warrington, in the State of Victoria, but late of No. 91 Warrigal-road, Oakleigh, in the said State, widow, DECEASED.

CREDITORS, next of kin and others having claims in respect of the estate of the deceased are required by the National Trustees, Executors and Agency Company of Australasia Limited, of No. 95 Queen-street, Melbourne, in the said State, the executor of the will of the said deceased, to send particulars to it (the said executor), by the 7th day of October, 1964, after which date the said executor may convey or distribute the assets, having regard only to the claims of which it then has notice.

Dated this 5th day of August, 1964.

MAURICE GOLDBERG & CO., of No. 305 Bridge-road, Richmond, solicitors for the executor. 2058

In the Supreme Court of the State of Victoria.

SALE BY THE SHERIFF.

ON Tuesday, the 15th of September, 1964, at Ten o'clock a.m., at the Police Station, Fairfield (unless process be stayed or satisfied):—

All the estate and interest (if any) of Albert Victor Bottomley and Nancy Lila Bottomley, caterer and married woman, respectively, both of 8 St. Gothards-road, Alphington, as joint proprietors of an estate in fee simple in the land described in certificate of title, volume 8222, folio 337, upon which is erected a weatherboard dwelling-house known as No. 8 St. Gothards-road, Alphington.

Registered mortgage No. B.488698, affects the said estate and interest.

Terms: Cash only.

N. FROGLEY, Sheriff's Officer.

30th July, 1964.

2030

IMPOUNDINGS

BALLARAT.—Impounded in Ballarat City Pound.
 1 white polled wether goat, no visible brand
 If not claimed and expenses paid, to be sold on 18th August, 1964.
 2024—12/ R. A. GILES, Poundkeeper.

EPPING.—Impounded in Epping Pound, by K. Taylor.
 1 cream coloured horse, no visible brand
 1 skewbald horse, no visible brand
 1 bay horse, no visible brand
 1 bay horse, white blaze and two white socks on back legs, no visible brand
 1 bay horse, white blaze, no visible brand
 1 bay horse, no visible brand
 If not claimed and expenses paid, to be sold on 21st August, 1964.
 2072—24/ W. HERD, Poundkeeper.

KERANG.—Impounded in Kerang Pound, on 31st July, 1964.
 1 white store pig, no marks or brands
 If not claimed and expenses paid, to be sold on 19th August, 1964.
 2063—14/ G. S. COOK, Poundkeeper.

MORTLAKE.—Impounded in Mortlake Pound, on 23rd July, 1964.
 1 Black Poll yearling bull, no visible brand or ear marks
 1 brindle and white yearling bull, no visible brand, no ear marks
 1 Black Poll yearling steer, with white face, W in near ear, no visible brand
 1 Hereford yearling heifer, no visible brand or ear mark
 If not claimed and expenses paid, to be sold on 20th August, 1964.
 2007—24/ H. M. ROBERTSON, Poundkeeper.

MORWELL.—Impounded in Morwell Pound.
 1 ram, no visible brand
 If not claimed, and expenses paid, to be sold on 18th August, 1964.
 2000—12/ S. HUGUENIN, Poundkeeper.

OXLEY.—Impounded in Oxley Pound, from J. G. Rickards, Everton.
 1 five-year-old poll Hereford bullock, mottled face, notch out of left ear, hole in right ear, fire brand C.R. near rump
 If not claimed and expenses paid, to be sold on 20th August, 1964.
 1996—18/ M. PERKINS, Poundkeeper.

Subordinate Legislation Act 1962.

NOTICE OF MAKING OF STATUTORY RULES.

IN pursuance of the provisions of the *Subordinate Legislation Act 1962* and the Regulations made thereunder, notice is given of the making of the following statutory rules:—

No.		Price.
		s. d.
97/1964.	The Pilot (Pilottage Exemption) Regulations 1964	1 0
98/1964.	Stock (Artificial Breeding) Act 1962 (No. 6877). Stock (Artificial Breeding of Cattle) Amendment Regulations 1964	0 6
99/1964.	National Parks Act 1958. National Park (Mileage Allowances Amendment) Regulations 1964	0 6

No.	State Electricity Commission Acts.	Price.
		s. d.
100/1964.	State Electricity Commission Inspection of Electrical Installations (Amendment) Regulations 1964	0 6

Copies of these statutory rules may be purchased at the Sale of Publications Section of the Government Printing Office, located at Macarthur-street, Melbourne, C.2. If ordered by mail, remittance should be addressed to "The Government Printer, Box 203, P.O., North Melbourne, N.1.", and should include 5d. extra for postage.

A. C. BROOKS,
Government Printer.

ACTS REPRINTED IN ACCORDANCE WITH THE AMENDMENTS INCORPORATION ACT 1958 (No. 6422), AND ON SALE AT THE GOVERNMENT PRINTING OFFICE.

No.		Price.
		s. d.
6189.	Acts Interpretation Act 1958	1 6
6191.	Administration and Probate Act 1958	3 6
6219.	Children's Welfare Act	2 6
6222.	Commercial Goods Vehicles Act 1958	1 9
6225.	Co-operation Act	4 0
6226.	Co-operative Housing Societies Act 1958	4 0
6228.	Country Fire Authority Act	4 0
6229.	Country Roads Act	4 0
6231.	Crimes Act 1958	13 3
6236.	Dog Act 1958	1 6
6246.	Evidence Act	3 6
6249.	Fences Act	1 3
6251.	Firearms Act	2 3
6259.	Gaols Act	1 6
6265.	Goods Act 1958 (Second Reprint)	2 6
6270.	Health Act 1958	14 6
6274.	Hospitals and Charities Act	3 6
6279.	Instruments Act	3 6
6282.	Justices Act 1958	11 3
6283.	Labour and Industry Act 1958	7 6
6293.	Licensing Act	9 3
6295.	Limitation of Actions Act 1958	1 6
6299.	The Local Government Act 1958	35 0
6309.	Medical Act	3 9
6315.	Metropolitan Fire Brigades Act 1958	2 9
6324.	Money Lenders Act 1958	2 6
6325.	Motor Car Act	6 6
6328.	Nurses Act	2 0
6330.	Partnership Act	1 3
6338.	Police Regulation Act 1958	4 6
6344.	Property Law Act	9 0
6349.	Public Service Act 1958	2 9
6350.	Public Trustee Act 1958	3 6
6363.	Second-hand Dealers Act	1 3
6367.	Settled Land Act	4 0
6375.	Stamps Act 1958	7 0
6377.	State Electricity Commission Act 1958	5 0
6379.	State Savings Bank Act 1958	4 3
6401.	Trustee Act	4 0
6419.	Workers Compensation Act 1958	5 0
6651.	Social Welfare Act 1960	3 6
6653.	Valuation of Land Act 1960	1 6
6832.	Motor Boating Act 1961	1 6
6839.	Companies Act 1961	22 6
6879.	Unclaimed Moneys Act 1962	1 3
6886.	Subordinate Legislation Act 1962	1 6
6889.	Poisons Act 1962	3 6
6890.	Probate Duty Act 1962	3 9

A. C. BROOKS,
Government Printer.

PUBLICATION OF OFFICIAL MATTER.

ATENTION is invited to the following procedure in relation to the publication of official matter in the *Government Gazette*:—

- Matter submitted to the Executive Council.*
 Matters submitted to the Executive Council which requires gazettal will normally be published in the issue of the following week.
 Where urgent gazettal is required, special arrangements should be made with the *Gazette Officer*.
 Publication will be facilitated by the submission of carbon copies for the use of the *Gazette Officer*.
- Other matter.*
 (a) All other matter duly certified by a responsible officer for publication should be lodged with the *Gazette Officer* not later than half-past Ten a.m. on Tuesday.

(b) Lengthy or involved notices should be forwarded several days before publication.

(c) Proofs, which will be supplied only when specifically requested or, at the direction of the Gazette Officer, should be returned promptly to avoid delay in publication.

(d) No additions or amendments to matter for publication will be accepted by telephone.

THE "VICTORIA GOVERNMENT GAZETTE".

SUBSCRIPTIONS.—The subscription, including postage, is £2 15s. per annum, £1 7s. 6d. half-yearly, or 13s. 9d. per quarter, payable in advance.

Subscriptions are required for whole months, and must cover at least a quarter.

Single copies are One shilling, posted One shilling and five pence. Subscribers do not receive the Acts of Parliament with the GAZETTE.

GAZETTES are held in stock for five years only.

PRIVATE ADVERTISEMENTS.—The charge for insertion is 2s. per line single column, and 4s. per line double column. The title forms one or more lines as a heading. On an average ten words make a line of single column. Every signature must likewise be counted as a line. The final words of a paragraph, though only portion of a line, must be counted as one line. Signatures (in particular) and proper names must be written very plainly in the text; ONE SIDE ONLY of each sheet of paper should be WRITTEN UPON.

All documents illegibly written will be returned unpublished, and where brands occur unprovided for by the ordinary letters of the alphabet, a worded explanatory description must be furnished.

Advertisements unaccompanied by a remittance sufficient to cover the cost of the insertion will be returned unpublished.

THE VICTORIA GOVERNMENT GAZETTE is published on WEDNESDAY EVENING in each week, and Notices for insertion will be received by the Government Printer at or before ONE p.m. at ordinary rates, and late advertisements between ONE p.m. and FOUR p.m. at double rates on the day preceding the day of publication.

PAYMENTS.—All payments are required in advance and remittances should be made by cheque, postal note, or money order payable to "GOVERNMENT PRINTER".

ADDRESS.—All communications should be addressed to "The Government Printer, Box 203, P.O., North Melbourne".

AGENTS FOR THE "VICTORIA GOVERNMENT GAZETTE".

THE following have been appointed agents to receive Advertisements and Subscriptions for the Victoria Government Gazette:—

ARMSTRONG BROS. PTY. LTD., Mollison-street, Kyneton.

ARMSTRONG'S AGENCY, 205 Queen-street, Melbourne.

ARNALL & JACKSON, 390 Barkly-street, Brunswick, N.10.

BAIRNSDALE AUTHORIZED NEWSAGENCY, 132 Main-street, Bairnsdale.

COOKE, F. R. & E. M., & SONS, 69 Bridge-street, Benalla.

DAVIES, G. & M. V., 112 Gray-street, Hamilton.

DAVIS, WM. (MILDURA) PTY. LTD., 126 Eighth-street, Mildura.

DIXON'S NEWSAGENCY, 89 Firebrace-street, Horsham.

EDGAR'S NEWSAGENCY PTY. LTD., 293 Hargreaves-street, Bendigo.

FRANKS, H., & CO., 184 Ryrie-street, Geelong.

GORDON & GOTCH AUSTRALASIA LTD., 511 Little Collins-street, Melbourne.

GULLAN'S NEWSAGENCY, 88 Bridge-street, Ballarat.

HALES, D. & N., Henty-street, Casterton.

HAMPTON, A. C., 243 Mitchell-street, Bendigo.

HARSTON, PARTRIDGE & CO. PTY. LTD., 455 Little Collins-street, Melbourne.

THE MERCANTILE EXCHANGE, 90 Queen-street, Melbourne.

MCGILL'S AUTHORIZED NEWSAGENCY, 183-5 Elizabeth-street, Melbourne.

PETTY, R. H. & W. M., 83 Murphy-street, Wangaratta.

PURDIE, J., & CO., 138 Moorabool-street, Geelong.

SAJF AUTHORIZED NEWSAGENCY, 142 Raymond-street, Sale.

SKINNER'S AUTHORIZED NEWSAGENCY, 49-51 Franklin-street, Traralgon.

TUFF'S SHEPPARTON NEWSAGENCY, 246 Wyndham-street, Shepparton.

VERNON, C. F. & H. J., 162 Bridge-road, Richmond.

VIEW POINT AUTHORIZED NEWSAGENCY, 4 View Point, Bendigo.

A copy of the Gazette filed at each place for public reference.

CONTENTS

	PAGE
Acts of Parliament on sale at the Government Printing Office	2601
Appointments	2563
Companies Act 1961—Notice	2553
Contracts	2561
Estates of Deceased Persons	2562
Government Notices	2548
Impoundings	2601
Lands	2574
Melbourne and Metropolitan Board of Works—Notice	2548
Mining	2552
Notice to Mariners	2562
Notice of Making of Statutory Rules	2601
Orders in Council—	
Acts—Stamps; Land; Country Roads; Westernport (Oil Refinery); State Relief Committee; Landlord and Tenant; Motor Car; Sewerage Districts; Housing.	2564 et seq
Private Advertisements	2586
Proclamations	2547
Public Half-Holidays	2547
Public Service Notices	2581
Regulations—	
Acts—Teaching Service	2552
Teaching Service	2585
Resignations	2564
Tenders	2579
Transport Regulation Board—Public Hearings	2549
Waterworks Trusts	2563