



VICTORIA
GOVERNMENT GAZETTE

Published by Authority

[Registered at the General Post Office, Melbourne, for transmission by post as a newspaper.]

No. 71]

WEDNESDAY, AUGUST 12

[1964

Land Act 1958.

UNALIENATED CROWN LANDS AVAILABLE FOR SETTLEMENT UNDER IMPROVEMENT PURCHASE LEASES.

PROCLAMATION

By the Lieutenant-Governor as Deputy for His Excellency the Governor of the State of Victoria and its Dependencies
in the Commonwealth of Australia, &c., &c., &c.

IN pursuance of the provisions of section 153 of the *Land Act 1958*, I, the Lieutenant-Governor as Deputy for the Governor of the State of Victoria in the Commonwealth of Australia, by and with the advice of the Executive Council of the said State, do by this Proclamation declare the unalienated Crown lands mentioned in the subjoined Schedule, to be available for settlement under improvement purchase leases.

SCHEDULE.

County.	Parish.	Allotment.	Section.	Area.			Land Valuation.
				A.	R.	P.	
Follett	Byjuke	21	..	200	0	0±	£1 10s. per acre
Follett	Byjuke	23	..	280	0	0±	£1 10s. per acre
Gladstone	Wyचितella	61	..	70	0	0	£12 per acre
Tambo	Tildesley West	7	C.	670	0	0±	£1 10s. per acre
Tambo	Tildesley West	4	C.	350	0	0±	£1 10s. per acre
Tambo	Tildesley West	5	C.	300	0	0±	£1 10s. per acre
Tambo	Tildesley West	6	C.	300	0	0±	£1 10s. per acre
Tambo	Tildesley West	8	C.	325	0	0±	£1 10s. per acre
Tambo	Tildesley West	8A	C.	325	0	0±	£1 10s. per acre

Given under my Hand and the Seal of the State of Victoria aforesaid, at Melbourne, this fourth day of August, in the year of our Lord One thousand nine hundred and sixty-four, and in the thirteenth year of the reign of Her Majesty Queen Elizabeth II.

(L.S.)

E. F. HERRING.

By His Excellency's Command,

JIM BALFOUR,
Commissioner of Crown Lands and Survey.

GOD SAVE THE QUEEN !

Land Act 1958.

AREA OF LAND COMPRISED IN CERTAIN CLASSES DIMINISHED OR INCREASED.

PROCLAMATION

By the Lieutenant-Governor as Deputy for His Excellency the Governor of the State of Victoria and its Dependencies in the Commonwealth of Australia, &c., &c., &c.

WHEREAS by the *Land Act 1958* it is amongst other things enacted that the Governor in Council may, by Proclamation to be published in the *Government Gazette*, at any time diminish or increase the area of land comprised in any of the classes mentioned in Part I, Division 1, section 5, of the said *Land Act 1958*, but that the area of lands which may be sold by auction (Class 6), shall not be increased except as in certain cases in the said Act provided: Now therefore I, the Lieutenant-Governor as Deputy for the Governor of the State of Victoria, in the Commonwealth of Australia, by and with the advice of the Executive Council of the said State, and in accordance with the provisions of sections 94 and 117 of the *Land Act 1958* aforesaid, do hereby diminish or increase (as the case may be) the areas of Crown lands comprised in Classes 7 and 6 of the classes mentioned in section 5 of the *Land Act 1958* aforesaid, to the extent set forth in the subjoined Schedule (that is to say) :—

Schedule referred to.

CLASSES DIMINISHED OR INCREASED.

County.	Parish.	Allotment.	Section.	Area.	Diminished.	Increased.	Description.
					Class.	Class.	
Grenville	Smythesdale	D13	..	A. R. P. 3 2 0±	7	6	About 1 mile north-west of Smythesdale R.S.

Given under my Hand and the Seal of the State of Victoria, aforesaid, at Melbourne, this fourth day of August, in the year of our Lord One thousand nine hundred and sixty-four, and in the thirteenth year of the reign of Her Majesty Queen Elizabeth II.

(L.S.)

E. F. HERRING.

By His Excellency's Command,

JIM BALFOUR,

Commissioner of Crown Lands and Survey.

GOD SAVE THE QUEEN!

PUBLIC HIGHWAY.—SHIRE OF FRANKSTON.

PUBLIC HIGHWAYS.—CITY OF BRIGHTON.

PROCLAMATION

By the Lieutenant-Governor as Deputy for His Excellency the Governor of the State of Victoria and its Dependencies in the Commonwealth of Australia, &c., &c., &c.

WHEREAS by the *Local Government Act 1958*, as amended, section 519, it is amongst other things enacted that it shall be lawful for the Governor in Council at any time, and from time to time, upon request of the Council of any municipality, by notice in the *Government Gazette*, to proclaim any land reserved, used or by purchase or exchange acquired for a street, road, highway, thoroughfare, bridge, square, court, alley or right-of-way or any street, road, lane or passage made or laid out or proposed to be made or laid out on any land of which a plan delineating that street, road, lane or passage has been lodged with the Registrar of Titles, to be a public highway and that such land shall thereupon and thenceforth from the date of such Proclamation become and be absolutely dedicated to the public as a public highway within the meaning of any law then or thereafter in force:

And whereas the Council of the Shire of Frankston has requested that the land hereinafter mentioned, being a street, road, lane or passage made or laid out or proposed to be made or laid out on land of which a plan delineating that street, road, lane or passage has been lodged with the Registrar of Titles, be so declared to be a public highway:

Now, therefore, I, the Lieutenant-Governor as Deputy for the Governor of the State of Victoria, by and with the advice of the Executive Council of the said State, do by this Proclamation declare that Coleman's-road, coloured brown on plan of subdivision No. 4911, lodged in the Office of Titles, shall be a public highway within the meaning of the said Act.

Given under my Hand and the Seal of the State of Victoria aforesaid, at Melbourne, this fourth day of August in the year of our Lord One thousand nine hundred and sixty-four and in the thirteenth year of the reign of Her Majesty Queen Elizabeth II.

(L.S.)

E. F. HERRING.

By His Excellency's Command,

R. J. HAMER,

Minister for Local Government.

GOD SAVE THE QUEEN!

PROCLAMATION

By the Lieutenant-Governor as Deputy for His Excellency the Governor of the State of Victoria and its Dependencies in the Commonwealth of Australia, &c., &c., &c.

WHEREAS by the *Local Government Act 1958*, as amended, section 519, it is amongst other things enacted that it shall be lawful for the Governor in Council at any time, and from time to time, upon the request of the Council of any municipality, by notice in the *Government Gazette*, to proclaim any land reserved, used or by purchase or exchange acquired for a street, road, highway, thoroughfare, bridge, square, court, alley or right-of-way or any street, road, lane or passage made or laid out or proposed to be made or laid out on any land of which a plan delineating that street, road, lane or passage has been lodged with the Registrar of Titles to be a public highway, and that such land shall thereupon and thenceforth from the date of such Proclamation become and be absolutely dedicated to the public as a public highway within the meaning of any law then or thereafter in force:

And whereas, the Council of the City of Brighton has requested that the land hereinafter mentioned, used for streets be so declared to be public highways:

Now therefore, I, the Lieutenant-Governor as Deputy for the Governor of the State of Victoria in the Commonwealth of Australia, by and with the advice of the Executive Council of the said State, do by this Proclamation declare that Kent-avenue and the road 15 feet wide, both coloured brown on plan of subdivision No. 14707, lodged in the Office of Titles, shall be public highways within the meaning of the said Act.

Given under my Hand and the Seal of the State of Victoria aforesaid, at Melbourne, this fourth day of August in the year of our Lord One thousand nine hundred and sixty-four and in the thirteenth year of the reign of Her Majesty Queen Elizabeth II.

(L.S.)

E. F. HERRING.

By His Excellency's Command,

R. J. HAMER,

Minister for Local Government.

GOD SAVE THE QUEEN!

PUBLIC HIGHWAY.—CITY OF MOORABBIN.

PROCLAMATION

By the Lieutenant-Governor as Deputy for His Excellency the Governor of the State of Victoria and its Dependencies in the Commonwealth of Australia, &c., &c., &c.

WHEREAS by the Local Government Act 1958, as amended, section 519, it is amongst other things enacted that it shall be lawful for the Governor in Council at any time, and from time to time, upon request of the Council of any municipality, by notice in the *Government Gazette*, to proclaim any land reserved, used or by purchase or exchange acquired for a street, road, highway, thoroughfare, bridge, square, court, alley or right-of-way or any street, road, lane or passage made or laid out or proposed to be made or laid out on any land of which a plan delineating that street, road, lane or passage has been lodged with the Registrar of Titles to be a public highway, and that such land shall thereupon and thenceforth from the date of such Proclamation become and be absolutely dedicated to the public as a public highway within the meaning of any law then or thereafter in force:

And whereas, the Council of the City of Moorabbin has requested that the land hereinafter mentioned, used for a street, be so declared to be a public highway:

Now, therefore, I, the Lieutenant-Governor as Deputy for the Governor of the State of Victoria in the Commonwealth of Australia, by and with the advice of the Executive Council of the said State, do by this Proclamation declare that all that piece of land, being Tuck-street, shown hatched on the plan hereunder, shall be a public highway within the meaning of the said Act.

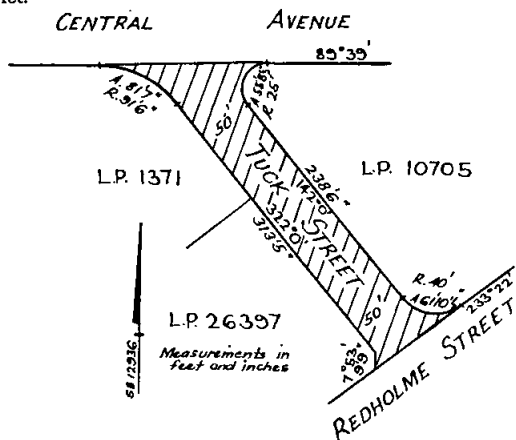

Given under my Hand and the Seal of the State of Victoria aforesaid, at Melbourne, this fourth day of August in the year of our Lord One thousand nine hundred and sixty-four and in the thirteenth year of the reign of Her Majesty Queen Elizabeth II.

(L.S.) E. F. HERRING.

By His Excellency's Command,
R. J. HAMER,
Minister for Local Government.
GOD SAVE THE QUEEN!

Public Service Act 1958.
ALTERATION OF DAY APPOINTED PUBLIC HOLIDAY IN SHIRE OF ROMSEY.

PROCLAMATION

By His Excellency the Governor of the State of Victoria and its Dependencies in the Commonwealth of Australia, &c., &c., &c.

WHEREAS by sub-section (1) of section 67 of the Public Service Act 1958, Thursday, the twenty-fourth day of September, 1964, shall be observed as a public holiday throughout the municipalities mentioned in the Fourth Schedule to the said Act, including the Shire of Romsey:

And whereas it is made to appear to me expedient that the said day should not be a public holiday throughout the Shire of Romsey:

Now therefore I, the Governor of the State of Victoria, in the Commonwealth of Australia, by and with the advice of the Executive Council of the said State, and in pursuance of the provisions of sub-section (3) of section 67 of the Public Service Act 1958, do by this my Proclamation declare that the said day shall not be a public holiday throughout the Shire of Romsey and appoint—

MONDAY, THE 21ST DAY OF SEPTEMBER, 1964,
to be a public holiday throughout the Shire of Romsey.

Given under my Hand and the Seal of the State of Victoria aforesaid, at Melbourne, this eleventh day of August, in the year of our Lord One thousand nine hundred and sixty-four, and in the thirteenth year of the reign of Her Majesty Queen Elizabeth II.

(L.S.) ROHAN DELACOMBE.

By His Excellency's Command,
V. F. WILCOX,
Acting Chief Secretary.
GOD SAVE THE QUEEN!

MILK PASTEURIZATION ACT 1958.

PROCLAMATION

By His Excellency the Governor of the State of Victoria and its Dependencies in the Commonwealth of Australia, &c., &c., &c.

WHEREAS by section 4 of the Milk Pasteurization Act 1958 (No. 6319) it is provided that a day be fixed by Proclamation of the Governor in Council published in the *Government Gazette* in relation to a prescribed district:

And whereas the Municipality of the City of Colac has been prescribed as a District for the purposes of the said Act:

Now, therefore, I, the Governor of the State of Victoria, by and with the advice of the Executive Council thereof, do by this my Proclamation fix Monday, the 24th August, 1964, as the day after which no person shall in the prescribed district set out above—

- (a) sell or deliver milk except milk pasteurized at licensed pasteurizing premises and bottled and sealed as prescribed; or
- (b) (in the case where the milk is sold and delivered at a shop for immediate consumption by a customer at the shop) sell or deliver milk except milk pasteurized at licensed pasteurizing premises.

Given under my Hand and the Seal of the State of Victoria aforesaid, at Melbourne, this eleventh day of August, in the year of our Lord One thousand nine hundred and sixty-four, and in the thirteenth year of the reign of Her Majesty Queen Elizabeth II.

(L.S.) ROHAN DELACOMBE.

By His Excellency's Command,
VANCE DICKIE,
Acting Minister of Agriculture.
GOD SAVE THE QUEEN!

BANK HALF-HOLIDAYS.

PROCLAMATION

By His Excellency the Governor of the State of Victoria and its Dependencies in the Commonwealth of Australia, &c., &c., &c.

IN pursuance of the provisions of the *Bank Holidays Act* 1958, I, the Governor of the State of Victoria, in the Commonwealth of Australia, do by this my Proclamation appoint the days and dates named hereunder special days to be observed as Bank Half-Holidays at the places respectively mentioned, that is to say:—

Bank Half-Holidays from the Hour of Eleven a.m.:—

- TUESDAY, THE 1ST SEPTEMBER, 1964, at Natimuk.
- WEDNESDAY, THE 14TH OCTOBER, 1964, at Charlton.
- WEDNESDAY, THE 21ST OCTOBER, 1964, at Geelong, Geelong West, North Geelong, Norlane and Shire of South Barwon.

Given under my Hand and the Seal of the State of Victoria aforesaid, at Melbourne, this eleventh day of August, in the year of our Lord One thousand

nine hundred and sixty-four, and in the thirteenth year of the reign of Her Majesty Queen Elizabeth II.

(L.S.) ROHAN DELACOMBE.

By His Excellency's Command,
V. F. WILCOX,
Acting Chief Secretary.

GOD SAVE THE QUEEN!

LOCAL GOVERNMENT DEPARTMENT.

ORDER CONFIRMED.—SHIRE OF BELLARINE.

THE Minister of the Crown administering the *Local Government Act 1958*, as amended, on the 16th day of July, 1964, confirmed the Order hereinafter referred to in pursuance of section 514 of the said Act, namely:—

An Order of the Council of the Shire of Bellarine made on the 1st July, 1964, directing the compulsory taking of the land described in certificate of title, volume 2281, folio 103, for the purpose of a site for a Pre-School Centre.

R. J. HAMER,
Minister for Local Government.

Local Government Department,
Melbourne.

LOCAL GOVERNMENT ACT 1958.

IN pursuance of the powers conferred by sub-section 3A of section 575 of the *Local Government Act 1958*, I, the Honorable James Charles Murray Balfour, Her Majesty's Commissioner of Crown Lands and Survey in the State of Victoria hereby declare that the road set out on Crown land in the Township of Marlo, Parish of Orbost East, County of Croajingolong, as delineated and indicated by hachure on the plan hereunder, be a private street within the meaning of and for the purposes of Division 10, Part XIX. of the said Act.—(Corres. No. H.027071A.)

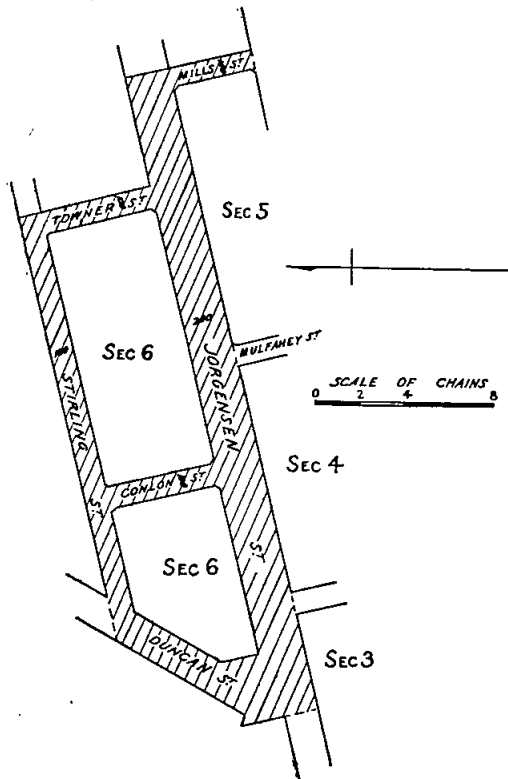

Dated at Melbourne this twenty-seventh day of July, 1964.

JIM BALFOUR,
Commissioner of Crown Lands and Survey.

LOCAL GOVERNMENT DEPARTMENT.

SHIRE OF MORNINGTON.—ORDER CONFIRMED.

THE Minister of the Crown administering the *Local Government Act 1958*, as amended, on the 27th day of July, 1964, confirmed the Order hereinafter referred to in pursuance of section 514 of the said Act, namely:—

An Order of the Council of the Shire of Mornington made on the 10th January, 1964, directing the compulsory taking of the land described hereunder for the purpose of widening Webb-street, Mornington:—

All those pieces of land being parts of Crown allotment 41, section 22, Parish of Moorooduc:—

- (a) Commencing at a point being the easternmost corner of the intersection of Webb-street and Esplanade, Mornington; thence by lines bearing respectively 40 deg. 29 min. 18 ft. 6 in., 177 deg. 32 min. 21 ft. 11½ in., 134 deg. 35 min. 286 ft. 5½ in., 140 deg. 1 min. 36 ft. 11½ in., 314 deg. 35 min. 337 ft. 11 in. home to the commencing point.
- (b) Commencing at a point being the westernmost corner of the intersection of Webb-street and Esplanade, Mornington; thence by lines bearing respectively 134 deg. 35 min. 15 feet, 279 deg. 28 min. 24 ft. 6½ in., 64 deg. 21 min. 15 feet home to the commencing point.
- (c) Commencing at a point distant 134 deg. 35 min. 152 feet from the westernmost corner of the intersection of Webb-street and Esplanade, Mornington; thence by lines bearing respectively 134 deg. 35 min. 10 feet, 225 deg. 49 min. 10 feet, 0 deg. 12 min. 14 feet home to the commencing point.
- (d) Commencing at a point distant 134 deg. 35 min. 172 feet from the westernmost corner of the intersection of Webb-street and Esplanade; thence by lines bearing respectively 134 deg. 35 min. 10 feet, 270 deg. 12 min. 14 ft. 3½ in., 45 deg. 49 min. 10 feet home to the commencing point.
- (e) Commencing at a point distant 134 deg. 35 min. 282 feet from the westernmost corner of the intersection of Webb-street and Esplanade, Mornington; thence by lines bearing respectively 134 deg. 35 min. 15 feet, 225 deg. 49 min. 15 feet, 0 deg. 12 min. 21 feet home to the commencing point.

R. J. HAMER,
Minister for Local Government.

Local Government Department,
Melbourne.

APPOINTMENT OF COMMITTEE OF MANAGEMENT,
PARISH OF MOOROOPNA.

IN pursuance of the provisions of section 50 of the *Forests Act 1958* (No. 6254), I, Lindsay Hamilton Simpson Thompson, Her Majesty's Minister of Forests in the State of Victoria, on the recommendation of the Forests Commission, do hereby appoint the Commissioners of the Shepparton Urban Waterworks Trust as Members of the Committee of Management under the thirtieth day of September, 1967, of the land forming part of the Reserved Forest, in the Parish of Mooroopna, shown by pink colour on plan marked B.39/2671/1.10.40, in correspondence file 58/939 of the Forests Commission.

Dated at Melbourne the 7th day of August, 1964.

L. H. S. THOMPSON,
Minister of Forests.

Drainage Areas Act.

SPECIAL MAINTENANCE CHARGE MADE BY THE COUNCIL OF THE SHIRE OF SOUTH GIPPSLAND IN RESPECT OF THE BLACK SWAMP DRAINAGE AREA.

NOTICE is hereby given that on the fourth day of August, 1964, in accordance with the provisions of section 36 of the *Drainage Areas Act 1958*, the Governor in Council approved of the estimate of the cost of proposed maintenance works in the Black Swamp Drainage Area submitted by the Council of the Shire of South Gippsland, and of the making by the Council of a Special Maintenance Charge on properties within the said Drainage Area, for the year ending 30th June, 1965.

J. COLQUHOUN,
Clerk of the Executive Council.

Melbourne.

Transport Regulation Act.
TRANSPORT REGULATION BOARD.
HEARING OF APPLICATIONS.

NOTICE is hereby given that the following applications will be considered by the Transport Regulation Board at its offices at Rathdown-street, Carlton, at 10.15 a.m. on Wednesday, 2nd September, 1964.

GRIFFITH, J. W., 17 Roper-street, Mt. Beauty. Application to vary C.O. licences to include the ability to operate in addition to the rights provided by Part 3 of document dated 9th May, 1963, and headed "Conditions as to Extension of Route", the right to operate as and when required at separate and distinct fares from and to Mt. Beauty to and from Falls Creek, Howmans Gap, Bogong and to Omeo.

GRIFFITH, J. W., 17 Roper-street, Mount Beauty. One commercial passenger vehicle (S/C. 37) to operate under the same terms and conditions as existing C.O. licences in the name of the applicant.

PEELER, M. C., 516 Bluff-road, Hampton. One commercial passenger vehicle with large seating capacity (to be purchased) to operate as a metropolitan special service omnibus within a 50-mile radius of the G.P.O., Melbourne.

POINT COOK-WERRIBEE PASSENGER SERVICE PTY. LTD., Railway-avenue, Laverton. Application for permit authority to operate one "M.C." licensed vehicle (under contract to Drug Houses of Australia Ltd.) for the carriage of employees only between Werribee and the factory premises situated at Cherry-lane, Brooklyn.

Time-table (Weekdays Only).

Depart Werribee 7.30 a.m. Depart Factory 4.20 p.m.

PYLE, T. J., Tawonga South. One commercial passenger vehicle (S/C. 5) to operate as follows:—(a) Under the same terms and conditions as licence No. C.O.433, i.e., route Mt. Beauty to Bright, also tours as prescribed. (b) As and when required at separate and distinct fares between Mt. Beauty and Falls Creek, Howmans Gap and Bogong. (c) To operate at otherwise than at separate and distinct fares (private hire) from Tawonga South to places within a 50-mile radius of Tawonga South Post Office. (d) Additional tours from Mt. Beauty to—(1) Trappers Gap via Tawonga. (2) Simmonds Creek-road via Tawonga South.

PYLE, T. J., Tawonga South. Application to vary licences T.S.776, T.S.191, C.O.443 and C.T.262 to include the ability to operate as and when required at separate and distinct fares from and to, and from Mt. Beauty and Falls Creek, Howmans Gap and Bogong.

Bus Fares:

Mt. Beauty to Falls Creek, 15s. single; 20s. return.
Mt. Beauty to Howmans Gap, 15s. single; 20s. return.
Mt. Beauty to Bogong, 7s. 6d. single; 10s. return.

PYLE, T. J., Tawonga South. Application to vary licences T.S.776 and T.S.191 to include the ability to operate tours as follows:—(a) Tours as prescribed in licence C.O.433. (b) Between Mt. Beauty and Trappers Creek via Tawonga. (c) Between Mt. Beauty and Simmonds Creek-road via Tawonga.

APPPLICATIONS for renewal of licences as shown, by persons listed hereunder, to operate under the same terms and conditions:—

ARMSTRONG, I. R. & P. M., Cape Otway-road, Moriac; T.P.3.
BENNETT, M. E., & D. M. RUTTLEDGE, "Mulloka", Alexander-road, Warrandyte; T.P.196.

COOK, I. J., A. A. & R. H. J., 321 Autumn-street, Herne Hill, Geelong; U.O.446.

CORIO BUS LINES PTY. LTD., Catherine-street, Geelong West; U.O.476.

CRACKNELL, R. B., 119 High-street, Seymour; C.T.312.

JASPER, W. & S. W. (trading as Jasper Bros.), Main-street, Rutherglen; T.S.526.

SOUTER, R. J. W., 4 Lehem-avenue, South Oakleigh; C.O.22, C.O.150, C.O.207.

U.S. MOTORS (TAXIS) PTY. LTD., Monbulk-road, Belgrave; C.T.357.

Notice of any objection should be forwarded to reach the Secretary of the Board not later than Wednesday, 26th August, 1964.

Applicants are advised that it will not be necessary to appear on the hearing date specified above, unless advised in writing by the Board.

B. P. KAY,
Secretary.

Exhibition Buildings, Rathdown-street, Carlton, N.3,
Wednesday, 12th August, 1964.

Transport Regulation Act.
TRANSPORT REGULATION BOARD.
HEARING OF APPLICATION.

NOTICE is hereby given that the following application will be considered by the Transport Regulation Board at its offices at Rathdown-street, Carlton, at 10.15 a.m. on Wednesday, 26th August, 1964.

PLUMMER, K. D. & W. S., 11 Whyte-grove, Mont Albert. Application for a passenger permit to operate one metropolitan special service omnibus under contract to the Monash University for the carriage of students on the following route:—Commencing Kew Junction, thence via Hawthorn, Glenferrie, Auburn, Camberwell, East Camberwell, Ashburton, Burwood, East Malvern, East Oakleigh.

Time-table:

To arrive at Monash University at 8.55 a.m.
To depart from Monash University at 5.40 p.m.

Notice of any objection should be forwarded to reach the Secretary of the Board not later than Monday, 24th August, 1964.

B. P. KAY,
Secretary.

Exhibition Buildings, Rathdown-street, Carlton, N.3,
Wednesday, 12th August, 1964.

Commercial Goods Vehicles Act.
TRANSPORT REGULATION BOARD.
HEARING OF APPLICATION.

NOTICE is hereby given that the following applications will be considered by the Transport Regulation Board at its offices at Rathdown-street, Carlton, at 10.15 a.m. on Wednesday, 2nd September, 1964.

ARMSTRONGS (BENDIGO) MOTOR TYRE SERVICE PTY. LTD., View Point, Bendigo. One commercial goods vehicle (9 cwt.) to operate within a 50-mile radius from the chief post office in the City of Bendigo and to and from the Town of St. Arnaud, the Townships of Quambatook, Gisborne, Boort, Charlton and Wyche-proof—new tires and tubes, tires and tubes for repair or having been repaired, such tires and tubes so carried being only for fitting on site by own serviceman, tools of trade and equipment incidental to such fittings and servicing, batteries and motor car accessories with the ability also to carry or tow an air compressor.

ARTANO, M., 9 Brown-street, Traralgon. One commercial goods vehicle (160 cwt.) to operate from forest landings within a 25-mile radius of the A.P.M. at Maryvale to the said premises—pulpwood.

BARKER, N. C., 11 Eastmead-road, Croydon. One commercial goods vehicle (212 cwt.) to operate: (a) Within a 35-mile radius of the premises of Bayview Quarries Pty. Ltd. at Montrose—screenings and stone dust solely on behalf of the said company. (b) From pits situate within the above radius of the said premises—sand.

BARTEL, N. A. & F. M., Post Office Rutherglen. One commercial goods vehicle (270 cwt.) to operate within a 50-mile radius of the post office at Stanley to Alstergrens Mill at Stanley—logs.

BEAMENT, R., 13 Peel-street, Bendigo. One commercial goods vehicle (8 cwt.) to operate within the area bounded by Castlemaine, Maryborough, St. Arnaud, Donald, Birchip, Sea Lake, Piangal, the N.S.W. border, Wyuna, Kyabram, Stanhope and Heathcote in the course of business as "Pest and Weed Exterminators"—tools of trade, spray equipment and materials incidental to the completion of own contracts.

BEAUREPAIRE TYRE SERVICE PTY. LTD., 102 Victoria-street, Carlton. Application to vary the conditions of licence No. D.A.629/84 (L/C. 11 cwt.) by adding to the existing conditions "Alexandra, Eildon and Yarck".

BIDWELL, V. T., Tamboon-road, Cann River. One commercial goods vehicle (40 cwt.) to operate: (a) Within a 50-mile radius of Cann River in the course of business as "General Storekeeper and Greengrocer"—own goods. (b) To and from the City of Melbourne in the course of business as "General Storekeeper and Greengrocer"—fresh fruit and vegetables.

BLAY, J. A., 13 Brown-street, Stawell. One commercial goods vehicle (66 cwt.) to operate: (a) Within a 100-mile radius from the post office at Stawell in the course of business as "Marine Collector"—marine goods as designated in the *Marine Stores and Old Metals Act 1958* (No. 6303). (b) From own premises at Stawell to the City of Melbourne—marine stores having been collected pursuant to paragraph (a) above.

- BODINNAR, S. R.** (trading as Bodinnar's Rural Supplies), Sea Lake. One commercial goods vehicle (15 cwt.) to operate: (a) Within a 50-mile radius of own premises at Sea Lake in the course of business as "Garage Proprietor"—agricultural and automotive spare parts and tools of trade for the purpose of servicing such machinery. (b) North of a straight line drawn from Portland to Wodonga—tools of trade and spare parts necessary for the maintenance of second-hand farm machinery having previously been sold by the licensee.
- BOYD, K. J.**, Great Western. One commercial goods vehicle (79 cwt.) to operate: (a) Within a 20-mile radius of post office at Great Western—general goods. (b) Within a 50-mile radius of Great Western in course of business as "Firewood Merchant"—firewood.
- BURKE, F. E. & N. A.**, Neerim Junction. One commercial goods vehicle (332 cwt.) to operate from forest and private landings in the Federal and Icy Creek areas to the A.P.M. at Maryvale—pulpwood.
- CANT, G., & SONS**, 37 Bayliss-street, West Preston. Two commercial goods vehicles (147 and 189 cwt.) to operate within a 25-mile radius of Melbourne—bagged cement from manufacturers at Geelong and Waurin Ponds.
- CECIL, G. L.**, Drouin-road, Poowong. One commercial goods vehicle (102 cwt.) to operate: (a) From the S.E.C. at Morwell to the Poowong Butter Factory—bagged briquettes. (b) Within a 20-mile radius of Poowong—general goods.
- CECIL, G. L.**, Drouin-road, Poowong. One commercial goods vehicle (144 cwt.) to operate: (a) From the S.E.C. at Morwell to the Poowong Butter Factory—bulk briquettes. (b) Within a 20-mile radius of Poowong—general goods.
- CLARKE, C. L.**, 25 Armstrong-court, Traralgon. One commercial goods vehicle (140 cwt.) to operate: (a) Within a 50-mile radius of Traralgon as a "Road Contractor"—road-making plant and materials. (b) Within a 20-mile radius of Traralgon—loam, sand, screenings and gravel.
- COHNS (BENDIGO) PTY. LTD.**, Bridge-street, Bendigo. Application to vary the conditions of licence Nos. D.A.47789, D.A.47789/1, D.A.47789/2, D.A.47789/3, D.A.47789/4, D.A.47789/5 and D.A.47789/6 (L/C. 100, 207, 146, 142, 143, 180 and 64 cwt.) by deleting from the existing conditions "(a) From licences as above delete all reference to the carriage of the company's own raw materials and manufactured goods and related empty returns. (b) Special conditions paragraphs (a) and (b)." and adding in lieu:—"Throughout the State of Victoria other than the Gippsland area for the carriage of goods and materials for use in the Company's own manufacturing activities to, and articles and products manufactured from—(a) Own decentralized industry at Bendigo; (b) the decentralized industries of:—Cohns (Ballarat) Pty. Ltd.—Ararat, Cohns (Swan Hill) Pty. Ltd.—Swan Hill, Cohns (Wangaratta) Pty. Ltd.—Wangaratta."
- COHNS (SWAN HILL) PTY. LTD.**, Wills-street, Swan Hill. Application to vary the conditions of licence Nos. D.A.47813, D.A.47813/1, D.A.47813/2, D.A.47813/3, D.A.47813/4 and D.A.47813/5 (L/C. 145, 258, 218, 261, 261 and 120 cwt.), by deleting from the existing conditions "From licences as above delete all reference to the carriage of the Company's own raw materials and manufactured goods and related empty returns" and adding in lieu:—"Throughout the State of Victoria other than the Gippsland area—for the carriage of goods and materials for use in the Company's own manufacturing activities to, and articles and products manufactured from—(a) Own decentralized industry at Swan Hill; (b) the decentralized industries of:—Cohns (Ballarat) Pty. Ltd.—Ararat, Cohns (Bendigo) Pty. Ltd.—Bendigo, Cohns (Wangaratta) Pty. Ltd.—Wangaratta."
- COHNS (WANGARATTA) PTY. LTD.**, Phillipson-street, Wangaratta. Application to vary the conditions of licence Nos. D.A.47825, D.A.47825/1, D.A.47825/2, D.A.47825/3 and D.A.47825/4 (L/C. 80, 194, 84, 106 and 45 cwt.) by deleting from the existing conditions "From the licences as above delete all reference to the carriage of the Company's own raw materials and manufactured goods and related empty returns" and by adding in lieu:—"Throughout the State of Victoria other than the Gippsland area for the carriage of goods and materials for use in the company's own manufacturing activities to and articles and products manufactured from—
(a) Own decentralized industry at Wangaratta;
(b) the decentralized industries of:—
Cohns (Bendigo) Pty. Ltd.—Bendigo,
Cohns (Ballarat) Pty. Ltd.—Ararat,
Cohns (Swan Hill) Pty. Ltd.—Swan Hill."
- COHNS (BENDIGO) PTY. LTD. (YEA DIVISION)**, North-street, Yea. Application to vary the conditions of licence Nos. D.A.47837, D.A.47837/1 (L/C. 78 and 149 cwt.) by deleting from the existing conditions "From licences as above all reference to the carriage of the company's own raw materials and manufactured goods and related empty returns" and adding in lieu: "Throughout the State of Victoria other than the Gippsland Area—for the carriage of goods and materials for use in the company's own manufacturing to and articles and products manufactured from—
The decentralized industries of:—
Cohns (Bendigo) Pty. Ltd.,
Cohns (Ballarat) Pty. Ltd.,
Cohns (Wangaratta) Pty. Ltd.,
Cohns (Swan Hill) Pty. Ltd."
- COHNS (BALLARAT) PTY. LTD.**, Barkly-street, Ararat. Application to vary the conditions of licence Nos. D.A.47780, D.A.47780/1, D.A.47780/2, D.A.47780/3, D.A.47780/4 and D.A.47780/5 (L/C. 79, 9, 9, 152, 106 and 112 cwt.) by deleting from the existing conditions "From licences as above all reference to the carriage of the company's own raw materials and manufactured goods and related returns" and adding in lieu: "Throughout the State of Victoria other than the Gippsland area for the carriage of goods and materials for use in the company's own manufacturing activities to and articles and products manufactured from—
(a) Own decentralized industry at Ararat;
(b) the decentralized industries of:—
Cohns (Bendigo) Pty. Ltd.—Bendigo,
Cohns (Swan Hill) Pty. Ltd.—Swan Hill,
Cohns (Wangaratta) Pty. Ltd.—Wangaratta."
- WILLIAM CROSBY (MERCHANDISE) PTY. LTD.**, 266 King-street, Melbourne. One commercial goods vehicle (37 cwt.) to operate throughout the State of Victoria for the purpose of laying and servicing bituminous roofs and floors—tools of trade and materials incidental to the completion of own contracts.
- DAVIES, G. A.** (trading as Davies Motor Wreckers), 18 Elsworth-street, Ballarat. One commercial goods vehicle (10 cwt.) to operate throughout the State of Victoria in the course of business as "Motor Wrecker"—tools of trade, second-hand spare parts and materials incidental thereto.
- DEVANNEY BROS. PTY. LTD.**, 108 Panton-street, Golden Square. One commercial goods vehicle (228 cwt.) to operate: (a) Within a 50-mile radius of the post office at Bendigo as a "Road Contractor"—road-making plant and materials. (b) Within a 25-mile radius of the post office at Bendigo—general goods.
- DOWEL, A. L. & B.**, Old Eltham-road, Lower Plenty. One commercial goods vehicle (150 cwt.) to operate: (a) Within a 25-mile radius of the G.P.O., Melbourne—general goods. (b) Within a 70-mile radius of the premises of Monier-Besser Pty. Ltd. at Broadmeadows—concrete masonry bricks on behalf of the said company.
- DOWLE, R. G.**, 8 Hales-crescent, Jacana. One commercial goods vehicle (6 cwt.) to operate throughout the State of Victoria in the course of business as "Carpet Layer"—tools of trade and floor coverings in house lots for laying purposes only.
- ELIAS, G.**, 36 Phillip-street, Bentleigh. Application to vary the conditions of licence No. D.A.47676 (L/C. 218 cwt.) by deleting the existing conditions and adding in lieu:—" (a) To operate within a 25-mile radius of the premises of Ready Mixed Concrete (Vic.) Pty. Ltd. at North Melbourne in a specially constructed bulk vehicle—bulk cement. (b) To operate within a 15-mile radius of the premises of Ready Mixed Concrete (Vic.) Pty. Ltd. at North Geelong in a specially constructed bulk vehicle—bulk cement. (c) To operate from the North Melbourne and Oakleigh plants of Ready Mixed Concrete (Vic.) Pty. Ltd. to the Ready Mixed Concrete (Vic.) Pty. Ltd. depot at Bittern in a specially constructed bulk vehicle—bulk cement." *Special Conditions.*—Excluding the carriage of any materials between Melbourne and Geelong.
- FITZPATRICK, W. M.**, Post Office Box 63, Charlton. One commercial goods vehicle (247 cwt.) to operate: (a) Within the Shire of Wycheproof as a "Road Contractor"—road-making plant and materials. (b) Within a 20-mile radius of the post office at Charlton—general goods.
- FOLEY EXCAVATIONS PTY. LTD.**, Post Office Box 96, Traralgon. One commercial goods vehicle (10 cwt.) to operate: (a) Throughout the State of Victoria in the course of business as "Earth-moving Contractors"—tools of trade and spare parts incidental to the servicing and repair of own machinery. (b) Within a

- 20-mile radius from site of any project currently engaged upon or from the railway station nearest thereto—materials for use on such project.
- GAMBLE, I. W.**, Lot 50, Florence-street, Clayton North. One commercial goods vehicle (9 cwt.) to operate within a 100-mile radius from the premises of Stegbar Windows Pty. Ltd. at Springvale—windows and window components for fitting purposes only, tools of trade and materials incidental thereto on behalf of the said company.
- GAUCI, J.**, Lot 420, Bent-street, St. Albans. One commercial goods vehicle (126 cwt.) to operate within a 50-mile radius of the premises of Albion Quarrying Co. Pty. Ltd. at North Melbourne, excluding operations from Geelong—road-making plant, hot asphalt, premix and road-making materials.
- GRANT, J. E. & D. S.**, 32 Albert-street, Daylesford. One commercial goods vehicle (6 cwt.) to operate: (a) Within a 50-mile radius of Daylesford in the course of business as "Florists and Nurserymen"—seedlings, shrubs, cut flowers, ornamental tubs and pots. (b) From Dandenong and Melbourne to Daylesford—seedlings, shrubs, cut flowers, ornamental tubs and pots.
- HANNAH, P. A.**, 196 Warrigal-road, Oakleigh. One commercial goods vehicle (18 cwt.) to operate from Melbourne to Beaufort, Ararat, Stawell, Horsham, Dimboola, Nhill, Warracknabeal, Murtoa, Minyip, Rupanyup, St. Arnaud and Avoca—block cakes, short-cakes, meringues, pavlova shells, jam tarts, snowballs and potato chips.
- HEALY, F. A.** (trading as Peninsular Spring Works), Ross Smith-avenue, Frankston. One commercial goods vehicle (7 cwt. and trailer 14 cwt.) to operate: (a) Within a 50-mile radius of own premises at Frankston in course of business as "Spring Manufacturers"—own goods. (b) From own factory at Frankston to the premises of Franklin Caravan Co. at Learmonth-road, Ballarat—caravan springs.
- HEMPHILL, J. F.**, Beveridge. One commercial goods vehicle (117 cwt.) to operate: (a) Within a 20-mile radius of post office at Beveridge—general goods. (b) Within a 50-mile radius of the depot of Mobil Oil Aust. Ltd. at Yarraville—petroleum products in prescribed types of containers and empty containers. (c) Within a 20-mile radius of post office at Beveridge and to and from the City of Melbourne—superphosphate.
- HOWE-RICHARDSON SCALE CO. PTY. LTD.**, 9 Evans-street, Braybrook. Application to vary the conditions of licence Nos. D.A.52340, D.A.52340/1, D.A.52340/2, D.A.52340/3, D.A.52340/4, D.A.52340/5 and D.A.52340/6 (L/C. 11, 11, 11, 11, 11, 11 and 59 cwt.) by adding to the existing conditions in paragraph (b) "dial cabinets and scale units".
- JAY-CEE POTATO CHIPS PTY. LTD.**, 21 Cottage-street, Blackburn. One commercial goods vehicle (12 cwt.) to operate within a 50-mile radius of own premises at Traralgon and to Phillip Island and places *en route* in the West and to Lakes Entrance and places *en route* in the East in the course of business as "Potato Chip Manufacturers"—own potato chips. NOTE.—All chips to be initially consigned from Melbourne to Traralgon or Sale Railway Stations.
- KENNEDY, K. T.**, 53 Wawunna-road, Horsham. One commercial goods vehicle (100 cwt.) to operate: (a) Within a 20-mile radius of Horsham—general goods. (b) Within a 50-mile radius of the Neptune Oil Co. Pty. Ltd. depot at Horsham—petroleum products in bulk and in prescribed types of containers and empty return containers.
- KOCAY, N.**, 137 Blackburn-road, Syndal. One commercial goods vehicle (148 cwt.) to operate: (a) Within a 35-mile radius of the premises of Bayview Quarries Pty. Ltd. at Berwick—screenings and stone-dust on behalf of the said company. (b) From pits situate within the above radius of the said premises—sand.
- MALLEYS LTD.**, 91 Leveson-street, North Melbourne. One commercial goods vehicle (10 cwt.) to operate throughout the State of Victoria as a "Serviceman" for the purpose of servicing electrical refrigerators, washing machines and cookers—tools of trade, spare parts and materials incidental thereto.
- MASKELL, E. P. & T. H. GRIBBEN** (trading as Maskell and Gribben), 201 Corio-street, Shepparton. One commercial goods vehicle (155 cwt.) to operate: (a) Within a 95-mile radius of post office at Cohuna and/or 100-mile radius of post office at Merbein (Bendigo Division of C.R.B.) as a "Road Contractor"—road-making plant and materials. (b) Within a 50-mile radius of post office at Shepparton—own screenings, sand, stone and gravel.
- MIRTSCHIN, W. B.**, Woolsthorpe, via Warrnambool. Application to vary the conditions of licence No. D.A.15269 (L/C. 100 cwt.) by adding to the existing conditions:—(c) From properties within a 20-mile radius of Woolsthorpe to Portland—wool. (d) From wool sales at Portland to railway stations at Port Fairy and Warrnambool—wool.
- MOBILE INDUSTRIAL EQUIPMENT LTD.**, 410 Whitehorse-road, Mitcham. One commercial goods vehicle (19 cwt.) to operate in the course of business of the licensee as "Manufacturer and Distributor of Agricultural Equipment". (a) Within a 50-mile radius from own premises at Mitcham—own goods. (b) Throughout the State of Victoria for the purposes of demonstrating and servicing agricultural appliances, tools of trade, spare parts and materials incidental thereto, also agricultural appliances for demonstration, for repair or having been repaired.
- MORGAN, G. H.**, Stead-street, Sale. One commercial goods vehicle (69 cwt.) to operate: (a) Within a 20-mile radius of post office at Sale—fertilizers, fencing materials, firewood, timber and hay. (b) From and to places within a 20-mile radius of Sale to and from places within a 50-mile radius of Sale—livestock. (c) Within a 50-mile radius of post office at Sale—furniture or personal effects of a householder or member of his family when being moved—(i) From residence to residence; (ii) from residence for storage or sale; (iii) from storage to residence; (iv) from a vendor to the residence of a purchaser.
- MCLAREN, W. J.**, 24 Baynes-street, Terang. One commercial goods vehicle (10 cwt.) to operate from places within a 50-mile radius of Terang to dealers in Geelong in the course of business as "Buyer"—wool dags, dead wool, tallow, sheep skins, second-hand bags and own goods.
- PALMER, H. G., PTY. LTD.**, 84 Flinders-lane, Melbourne. One commercial goods vehicle (18 cwt.) to operate within a 50-mile radius from the chief post office in the City of Geelong in the course of business as "Electrical Goods Retailers" but excluding operations to or from the City of Melbourne—own electrical goods and home appliances, electrical appliances for installation, tools of trade, spare parts and materials incidental to the installation, servicing and maintenance of such appliances.
- PALMER, H. G., PTY. LTD.**, 84 Flinders-lane, Melbourne. One commercial goods vehicle (19 cwt.) to operate within a 50-mile radius of own branch premises at Traralgon in course of business as "Electrical Retailers and Repairers" for the purposes of installing and repairing electrical appliances and/or motor mowers—tools of trade, installation equipment, spare parts, electrical appliances and/or motor mowers for repair or having been repaired and materials incidental thereto.
- PALMER, I. S.**, King George-street, Cohuna. One commercial goods vehicle (136 cwt.) to operate within a 50-mile radius of post office at Cohuna as a "Road Contractor" on behalf of E. B. Mawson and Sons Pty. Ltd.—road-making plant and materials.
- PAYNTER, F. L. & E. M.** (trading as Paynter's Tyre and Battery Service), 94 Moore-street, Moe. One commercial goods vehicle (15 cwt.) to operate within a 50-mile radius of Moe in the course of business as "Tyre and Battery Service"—new tires and tubes, second-hand tires, tires for recapping or repair, new batteries, batteries for repair or reconditioning and second-hand batteries.
- PEARSON, I. E.**, 107 Duke-street, Sunshine. One commercial goods vehicle (141 cwt.) to operate within a 50-mile radius of the premises of Albion Quarrying Co. Pty. Ltd. at Sunshine, excluding operations from Geelong—road-making plant, hot asphalt, pre-mix and road-making materials.
- PULLEN, P.**, Box 157, Casterton. One commercial goods vehicle (75 cwt.) to operate: (a) Within a 20-mile radius of post office at Casterton—general goods. (b) From and to Shell Co. of Australia Depot at Portland, to and from own depot at Casterton and to and from places situated within a 20-mile radius thereof—petroleum products in prescribed types of containers and empty return containers.
- RAND, D. A.**, Lot 1, Skye-road, Frankston. One commercial goods vehicle (150 cwt. and trailer 248 cwt.) to operate from Geelong to Melbourne—bagged cement.
- ROBERTS, D. J. & A. N.** (trading as D. A. Roberts (Bendigo)), 11 Forest-street, Bendigo. One commercial goods vehicle (8 cwt.) to operate in course of business as "Automotive and Industrial Electrical Engineers" within that part of Victoria bounded by the Towns of Swan Hill, Birchip, Donald, Maryborough, Daylesford, Kyneton, Kilmore, Seymour, Murchison, Rochester, Echuca and Swan Hill—Exide batteries and changeover automotive electrical equipment and electrical equipment for repair or having been repaired.
- ROCHE BROS. PTY. LTD.**, 22 Dynon-road, South Kensington. One commercial goods vehicle (252 cwt.) to operate: (a) Throughout the State of Victoria—earth-moving

- equipment (power excavators, tractors, road rollers, graders, &c.), owned and operated by the holders of this licence and on behalf of the Forests Commission and the Country Roads Board. (b) Within a 25-mile radius of G.P.O., Melbourne—general goods.
- PEDDLE, R. M., Boolarra. One commercial goods vehicle (256 cwt.) to operate from forestry landings in the Waygara area to the railway station at Nowa Nowa—S.E.C. poles.
- RIEMSLAG-BAAS, R., 106 Otway-street, Portland. One commercial goods vehicle (116 cwt.) to operate: (a) Within a 20-mile radius of Portland—general goods. (b) Within a 50-mile radius of Portland—own goods in the course of business as "Primary Producer".
- ROSS, J. A. G., R. A. & A. (trading as A. Ross & Sons), 2 Oriental-street, Stawell. Two commercial goods vehicles (78 cwt. and 100 cwt.) to operate: (a) Within a 20-mile radius of the post office at Stawell—general goods. (b) Within a 50-mile radius of own Esso Standard Oil Aust. Pty. Ltd. depot at Stawell—petroleum products in prescribed types of containers and empty return containers.
- RUGYS, A., Niddrie. Application to vary the conditions of licence No. D.A.52528 (L/C. 170 cwt.) by deleting "Essendon" and adding in lieu "Broadmeadows".
- SADDINGTON, K. G., 22 Highview-road, East Bentleigh. One commercial goods vehicle (8 cwt.) to operate within a 100-mile radius of the premises of Stegbar Windowalls Pty. Ltd. at Springvale—windows and window components for fitting purposes only on behalf of the said company.
- SILVESTER, D. P., 130 Grey-street, Traralgon. Application to vary the conditions of licence No. T.T.D.549 (L/C. 266 cwt.) by adding to the existing conditions "From forest and private areas in the Matlock and Licola areas to the A.P.M. at Maryvale—pulpwood and pulp-logs".
- SKIDMORE, E. G., 21 Fenacre-street, Strathmore. One commercial goods vehicle (133 cwt.) to operate: (a) From own property at Woodend to consignees in the metropolitan area of Melbourne—logs and firewood. (b) From own property at Woodend to the C.S.R. factory at Bacchus Marsh—pulpwood. (c) From own property at Woodend to consignees at Bacchus Marsh—firewood.
- SLOAN, W. E., 100 San Mateo-avenue, Mildura. One commercial goods vehicle (10 cwt.) to operate within a 95-mile radius of the post office at Cohuna and/or a 100-mile radius of the post office at Merbein (Bendigo Division of the C.R.B.), in the course of business as "Contractor"—tools of trade, spare parts and small quantities of fuels and greases incidental only to the operation of own vehicles.
- SUPER SPREAD AVIATION AUST. PTY. LTD., Post Office, Box 7, Cheltenham. One commercial goods vehicle (65 cwt.) to operate: (a) Throughout the State of Victoria in the course of business as "Aerial Agriculturists" as an emergency breakdown vehicle—tools of trade, spare parts, replacement aircraft engines and equipment incidental to the repair of own aircraft. (b) From spraying site to spraying site—excess aircraft fuel and chemicals.
- TARAXALE BREWING CO. PTY. LTD., 3 Douro-street, North Geelong. Two commercial goods vehicles (10 cwt. each) to operate within a 70-mile radius from own premises at Geelong and to and from the Townships of Warrnambool and Port Fairy and places en route in the course of business as "Aerated Water Manufacturers" as travellers units—advertising materials, samples of own goods, drinking straws and can openers for advertising purposes, and small quantities of own goods to replace imperfect or damaged stock (not to exceed five cases of aerated waters).
- TOWNLEY, R. G., Rossiter-road, Koo-Wee-Rup. Applications of licence No. D.A.43295/4 (L/C. 234 cwt.) by deleting the existing conditions and adding in lieu "Within a 50-mile radius of Koo-Wee-Rup, in the course of business as 'Produce Merchant'—own goods".
- TRANS-WEST HAULAGE PTY. LTD., 45 Ryrrie-street, Geelong. One commercial goods vehicle (260 cwt.) to operate: (a) From Yallourn to the premises of Australian Paper Manufacturers Ltd. at Maryvale—brown coal. (b) From Yallourn North Extension to the S.E.C. area at Yallourn North Open Cut—brown coal.
- WHEELDON, J. D., 67 McLeod-street, Bairnsdale. One commercial goods vehicle (140 cwt.) to operate: (a) Within an 85-mile radius of the post office at Orbost (Bairnsdale Division of C.R.B.) as a "Road Contractor"—road-making plant and materials. (b) Within a 20-mile radius of the post office at Bairnsdale—general goods.
- WILSON, W. D. & L. M., PTY. LTD., 3 Fairview-street, Traralgon. Two commercial goods vehicles (240 cwt. and 230 cwt.) to operate: (a) Within a 50-mile radius of Jacobs Creek at Erica, on behalf of Latrobe Quarries Pty. Ltd.—screenings and crushed rock. (b) From the Yallourn North Open Cut to the Gas and Fuel Corporation at Morwell—brown coal. (c) From S.E.C. at Morwell to various industries in Traralgon—bulk briquettes. (d) From Dutson, via Longford, to Primary Producers at Yallourn North—bulk agricultural lime.
- WILSON, W. D. & L. M., PTY. LTD., 3 Fairview-street, Traralgon. Application to vary the conditions of licence No. T.D.10870 (L/C. 220 cwt.) by adding to the existing conditions "From S.E.C. at Yallourn North to Gas and Fuel Corporation at Morwell—brown coal, from S.E.C. at Morwell to various industries at Traralgon—bulk briquettes, from Dutson via Longford to Primary Producers at Yallourn North—bulk agricultural lime".
- WITHAY, I. G., 128 Maryvale-road, Morwell. One commercial goods vehicle (141 cwt.) to operate: (a) Within a 20-mile radius of Morwell—general goods, (b) within a 50-mile radius of the Ampol Petroleum (Vic.) Pty. Ltd. depot at Morwell—petroleum products in prescribed types of containers and empty return containers.

TOW TRUCKS.

WHITE, R. F., 6 Learmonth-street, Queenscliff. One commercial goods vehicle (41 cwt.) to operate within a 50-mile radius of the post office at Queenscliff as a "Tow Truck" for the purpose of lifting and carrying or towing and/or repairing wrecked or disabled vehicles—tools of trade, spare parts and materials incidental thereto.

APPLICATION for renewal of licence as shown, by persons listed hereunder to operate under the same terms and conditions from the date of expiry shown in each case.

- ANDREWS, F. L., 15 Mark-street, Wodonga; D.A.27609; 29th October, 1964; 100 cwt.
- FARMER, GEORGE, PTY. LTD., Eureka-street, Ballarat; T.D.A.44430/9; 14th October, 1964; 81 cwt.
- GIPPSLAND FUEL INJECTION SERVICES PTY. LTD., 8 Holmes-road, Morwell; D.A.40642; 24th October, 1964; 8 cwt.
- HAMSTEAD, J. P., 98 Drummond-street, Oakleigh; D.A.1228; 8th September, 1964; 111 cwt.
- HUMPHREY, CHRIS & CO. PTY. LTD., 76 Hotham-street, Traralgon; D.A. 40426; 17th October, 1964; 15 cwt.; D.A.40426/1; 17th October, 1964; 8 cwt.
- LENEN, F., Hobson-street, Stratford; D.A.1488; 24th September, 1964; 131 cwt.
- MAKOWSKI, S. (trading as S. Makov Sports-swear), Flat 6, 93 Hotham-street, East St. Kilda; D.A.28838; 12th November, 1964; 8 cwt.
- PATERSON, S., Lot 96, Grimshaw-street, Bundoora; D.A.27326; 10th September, 1964; 101 cwt.
- SUNBEAM FROZEN FOODS PTY. LTD., 865 Nepean Highway, Moorabbin; T.D.A.44991; 27th November, 1964; 35 cwt; T.D.A. 44991/1; 27th November, 1964; 35 cwt.

TOW TRUCKS.

- MITCHELL, GREG PTY. LTD., 50 Little Ryrrie-street, Geelong; T.D.A.49571/1; 7th October, 1964; 30 cwt.
- VANDERWIEL MOTORS PTY. LTD., 189 Waverley-road, East Malvern; D.A.35983/2; 29th August, 1964; 14 cwt.
- WILSON, R. S., Bristol-road, Torquay; T.D.A.45724/2, 28th October, 1964; 30 cwt.

APPLICATION by persons listed hereunder for renewal of licence as listed with variation of conditions in the manner set out opposite the name.

- BRAUND, W. P., 13 Russell-street, Camperdown; D.A.28525; 1st October, 1964; 174 cwt; with variation by deleting from paragraph (b) of the existing conditions "Childers Cove" and adding in lieu "Ellerslie".
- SHANAHAN, J. F. & C. P. (trading as P. T. Shanahan and Sons), Princes Highway, Bairnsdale; D.A.19269/1; 1st October, 1964; 127 cwt.; with variation by deleting the existing conditions and adding in lieu "(a) within an 85-mile radius of the post office at Orbost (Bairnsdale Division of the C.R.B.) as a 'Road Contractor'—road-making plant and materials, (b) within a 20-mile radius of the post office at Bairnsdale—general goods".

Notice of any objection should be forwarded to reach the Secretary of the Board not later than 26th August, 1964.

Applicants are advised that it will not be necessary to appear on the hearing date specified above, unless advised, in writing, by the Board.

B. P. KAY,
Secretary.

Exhibition Buildings, Rathdown-street, Carlton, N.3, 12th August, 1964.

COMPANIES ACT 1961.

NOTICE is hereby given that in pursuance of section 308 (5) of the Companies Act 1961 the names of the companies referred to below have been struck off the Register, and on publication of this notice in the Government Gazette the said companies will be dissolved.

Dated this 6th day of August, 1964.

B. MITCHAM,
Assistant Registrar of Companies.

Companies Registration Office,
Melbourne.

COMPANIES ABOVE REFERRED TO.		Name of Company.		Number of Registration.
	Name of Company.			
	Roberts Tribute Company Limited		New Nelson Tribute No. 1 Company Limited	M1030
	The United Kingdom Quartz Mining Company Limited		South Golden Lion Company Limited	M1031
	The Lewers Freehold Gold Mining Company No Liability		The North Birmingham Quartz Mining Company Limited	M1032
	Jersey Tribute Gold Mining Company Limited		The Murchison Gold and Antimony Mining Company No Liability	M1033
	Clough & Hurells North Devonshire Tribute Company Limited		Kangaroo Hills Gold Mining Company No Liability	M1034
	The Homeward Bound Quartz Mining Company No Liability		Victory Mining Company No Liability	M1035
	The Perseverance Quartz Mining Company Limited		The Star of the East Quartz Mining Company Limited	M1036
	The Reliance Tribute Company Limited		The Garry Castle and Republic Quartz Mining Company Limited	M1037
	The South Newcombe Gold Mining Company Limited		North Don & Danish United Gold Mining Company No Liability	M1038
	The New Hustlers and Redan Quartz Mining Company Limited		The Hustlers Premier Gold Mining Company Limited	M1039
	The Mount Erip Quartz Gold Mining Company No Liability		The Carolina Quartz Mining Company Limited	M1040
	The Spring Hill Reserve Gold Mining Company No Liability		The Doma Mungi Tribute Company Limited	M1041
	Leishmans Reserve Gold Mining Company No Liability		The Birds Reef Tribute Company No. 1 Limited	M1042
	The Little Wonder Quartz Mining Company Limited		South Hartmanns Company Limited	M1043
	The North Sebastopol Reef Quartz Mining Company Registered		The Mariners and Sloanes Quartz Mining Company Limited	M1044
	The Railway Tribute Company Limited		The North Arcadian Tribute Company Limited	M1045
	The Eldorado Quartz Mining Company No Liability		The South Britannia Gold Mining Company Limited	M1046
	Coulthards Freehold Gold Mining Company No Liability		The United Devonshire Tribute Company No. 4 Limited	M1047
	The Maidstone Company Limited		St. Arnaud Quartz Crushing Company No Liability	M1048
	The Menai Gold Mining Company Limited		The Perseverance Gold Mining Company Limited	M1049
	The Prince Arthur Quartz Mining Company Limited		The Monte Christo Quartz Gold Mining and Crushing Company Limited	M1050
	The Golden Lion Tribute Company No. 2 Limited		The New Bonnie Dundee Quartz Mining and Crushing Company Limited	M1050
	The Stawell Quartz Mining Company Limited		Clann Colla Tribute Company Limited	M1052
	The O.Q.X. Gold Mining Company Limited		The Wellington Gold Mining Company No Liability	M1053
	Camerons North West Freehold Gold Mining Company No Liability		Post Office Reef Consols Quartz Mining Company No Liability	M1054
	The North Sultan Quartz Mining Company No Liability		The New Nelson Tribute No. 2 North Company Limited	M1055
	The Germania Junction Quartz Mining Company Limited		The Waterloo and Argyle Quartz Mining Company Limited	M1056
	Whites Freehold United Tribute Company Limited		The Golden Crown No. 1 Quartz Mining Company Limited	M1057
	Stewarts Freehold Tribute Company Limited		Nos. 2, 3, 4 and 5 Scotchmans Reef Quartz Mining Company Limited	M1058
	The Invincible Quartz Mining Company Registered		Golden Era Tribute Company Limited	M1059
	The Maid of Screene Quartz Mining Company Limited		The Great Extended Hartmanns Company Limited	M1060
	Mount Doran Quartz Crushing and Gold Mining Company No Liability		The Southern Cross Reefing Company Limited	M1061
	The Homebush Mining Company Limited		Grand Duke Gold Mining Company No Liability	M1062
	The Triumph Alluvial Gold Mining Company No Liability		The Royal Surrey Freehold Tribute Quartz Mining Company Limited	M1063
	The South True Briton Gold Mining Company Limited		The Hopewell Quartz Mining Company No Liability	M1064
	The Nicholson River Sluicing Company Extended Limited		Energetic Tribute Company Limited	M1065
	The Rising City Tribute Company Limited		All Nations Company Limited	M1066
	London and Clunes Company No Liability		The Victoria Hill Quartz Mining Company Limited	M1067
	Hero Extended Company No Liability		No. 3 South Prince Patrick Quartz Mining Company Limited	M1068
	The New Longfellows Gold Mining Company No Liability		Tay Quartz Mining Company No Liability	M1069
	The Great Gordon Quartz Mining Company Limited		The New Charlton Gold Mining Company Beaufort No Liability	M1070
	The Rising Sun Quartz Mining Company Limited		The Crown Cross Reef United Mining Company Limited	M1071
	The Triumph Quartz Mining Company No Liability		The New North Cohens Gold Mining Company Limited	M1072
	The Bendigo and Melbourne Tribute Company Limited		The New Nelson Tribute Company No. 2 South Limited	M1073
	Wyatt and Wallis's Tribute Company Limited		The March Reef United Gold Mining Company Limited	M1074
	The Golden Crown Quartz Mining Company Limited		South Bruce Tribute Company Limited	M1075
	The Little Wimmera Gold Mining Company Limited		Belgrave Gold Mining Company No Liability	M1076
	The Duchess Quartz Mining Company No Liability		Imperial Hartmanns Gold Mining Company Limited	M1077
	The North Hansel Monday Tribute Company Limited		Gerardines No. 1 North Tribute Company Limited	M1078
			The Diana Garden Gully Gold Mining Company Limited	M1079
			The Clyde Gold Mining Company Limited	M1080
			The Maryborough Quartz Gold Mining Company Limited	M1081
			The Gerardine and Moores Tribute Company Limited	M1082
			The Roxburgh Gold Mining Company Limited	M1083
			The Max Quartz Mining Company No Liability	M1084
			The Great Extended North Hustlers Company Limited	M1085
			The Reality Gold Mining Company Limited	M1086
			The Surrey Quartz Mining Company Limited	M1087
			Juno Quartz Mining Company No Liability	M1088
			The Golden Gate Alluvial Gold Mining Company No Liability	M1089
			North Britain Tribute Company Limited	M1090
			The Monument Hill Tribute Company Registered	M1091
			Danish Gold Mining Company No Liability	M1092
			North Morning Light Tribute Company Limited	M1093
			The Royal Gladstone Tribute Company Limited	M1094

Name of Company.	Number of Registration.	Name of Company.	Number of Registration.
The Glendinnings Freehold Gold Mining Company No Liability	M1095	Horwoods Freehold Gold Mining Company Limited	M1141
The St. Pauls Tribute Company No Liability	M1096	The King of the Rangers Gold Mining Company Limited	M1142
Rhine Tribute Company No. 1 Limited	M1097	The Royal Standard Gold Mining Company Limited	M1143
The Darling Flat Quartz Mining and Crushing Company Limited	M1098	United Ovens Gold and Tin Mining Company Registered	M1143
The No. 1 South Tribute Quartz Mining Company Limited	M1099	Colorado Gold Mining Company Registered	M1143
Royal St. Mungo Hill Tribute Company Limited	M1100	The South Extended Black Forest Gold Mining Company No Liability	M1144
Crown Garden Gully Company Limited	M1101	The United Darlington Mining Company Limited	M1145
The Central Hansel Monday Tribute Company Limited	M1102	The Wimmera Gold Mining Company Limited	M1146
The South New Chum Tribute Company Limited	M1103	The Young Sultana Quartz Mining Company Limited	M1147
The Royal Standard Gold Mining Company Limited	M1104	The Lewers Royal Mint Gold Mining Company No Liability	M1148
Clough & Hurells South Wellington Tribute Company Limited	M1105	The New Black Horse Company No Liability	M1149
South Browns Quartz Mining Company Limited	M1106	The Eureka Quartz Mining Company Limited	M1150
The Blenheim Gold Mining Tribute Company Limited	M1107	The North Albion Quartz Mining Company Limited	M1151
The Duke of Edinburgh Gold Mining Company Limited	M1108	The Corsair Quartz Mining Company No Liability	M1152
The Hawkins Freehold Gold Mining Company No Liability	M1109	The Gostelows Freehold Gold Mining Company No Liability	M1153
The All Nations Quartz Mining Company Limited	M1110	Premier Garden Gully Company No. 2 Limited	M1154
The Third Hill Quartz Mining Company No Liability	M1111	The New Moon Gold Mining Company Limited	M1155
The New Hustlers Mining Company No. 1 Limited	M1112	The Greys Freehold Gold Mining Company No Liability	M1156
The Victorian Gold Mining Company No Liability	M1113	The Diana Garden Gully Tribute No. 1 Company Limited	M1157
The North Britannia Gold Mining Company No Liability	M1114	The Lal Lal Iron Company Limited	M1158
The Friendship Gold Mining Company Limited	M1115	Eldorado Quartz Mining Company No Liability	M1159
The New Victoria Queen Tribute Company Limited	M1116	The Cleveland Reefs Gold Mining Company Limited	M1160
The North Champion Gold Mining Company Limited	M1117	The Westcotts Freehold Gold Mining Company No Liability	M1161
The Phoenix Gold Mining Company No Liability	M1118	The Chambers Antimony and Gold Mining Company Limited	M1162
The Original Lawrence and New Chum Tribute Company Limited	M1119	The Croesus Quartz Mining Company No Liability	M1163
The Rising Star Tribute Company No Liability	M1120	The Nos. 1 and 2 North Scotchmans Quartz Mining Company Limited	M1164
The Britannia Tribute Company Registered	M1121	North Cornish Company No Liability	M1165
Ryes Union Jack Freehold Tribute Company Registered	M1121	The Royal Standard Tribute Company Limited	M1166
The Caledonian Tribute Company Registered	M1121	The Black Hill South Quartz Mining Company No Liability	M1167
The Carolina Tribute Company Registered	M1121	The Don Extended No. 1 Tribute Quartz Mining Company No Liability	M1168
The Crown Tribute Quartz Mining Company Registered	M1121	The Great Extended Western Gold Mining Company Limited	M1169
The Empress Gold Mining Company Registered	M1121	The New St. Mungo Tribute Company Limited	M1170
The Extended North Hustlers Tribute Company Registered	M1121	The First Chance Gold Mining Company No Liability	M1171
The Kent Tribute Company Registered	M1121	Parade Extended Gold Mining Company No Liability	M1172
The Locomotive Tribute No. 2 Company Registered	M1121	The Golden Valley Quartz Mining Company Limited	M1173
The Narong Gold Mining Company Registered	M1121	The Defiance Tribute Quartz Mining Company Limited	M1174
Dunns Reef Gold Mining Company Registered	M1121	The Albion Quartz Mining Company Limited	M1175
The Pascoes No. 2 Tribute Company Barretts Registered	M1122	The Hopes Tribute Quartz Mining Company Limited	M1176
The South Denmark Tribute Company Registered	M1122	The Tommy Dodd United Gold Mining Company Limited	M1177
The Unicorn Tribute Company Registered	M1122	Arch Duke Quartz Company No Liability	M1178
The Boompje Tribute Company Registered	M1122	Cullens Railways Hustlers Gold Mining Company Registered	M1179
The Burmese Gold Mining Tribute Company Registered	M1122	Golden Lion Tribute Company No. 1 Registered	M1179
The Great Extended Nelson Reef Quartz Mining Company Registered	M1122	Grand Trunk Hustlers Company Registered	M1179
The South Sandhurst Tribute Company Registered	M1122	Great Republic Gold Mining Company Registered	M1179
The South Union Jack Gold Mining Company Registered	M1122	Lawrence & Larnia United Gold Mining Company Registered	M1179
Clinkers Hill Mining Company Registered	M1122	Never Can Tell Gold Mining Company Registered	M1179
Devonshire Reef Gold Mining Company Registered	M1122	North Golden Fleece & Glasgow United Tribute Company No. 1 Registered	M1179
The Napier Tribute Company Registered	M1122	South Extended Hustlers Company Registered	M1179
The National Alluvial and Quartz Mining Company Limited	M1123	United South Garden Gully Gold Mining Company Registered	M1179
Kneebone and Jeffreys Tribute Company Limited	M1124	Vital Company Registered	M1179
The Risks Mining Company No Liability	M1125	Victoria Consols Mining Company Registered	M1180
The Deep Lead and Welshmans Flat Junction Gold Mining Company Limited	M1126	The Duke and Duchess United Company Limited	M1180
The Dannebrog Gold Mining Company Limited	M1127	The Kara Kara Gold Mining Company Limited	M1181
The Golden Rose Tribute Company No Liability	M1128	The Volunteer Company No Liability	M1182
The Tamar Quartz Gold Mining Company No Liability	M1129	The Great North Sultan Quartz Mining Company No Liability	M1183
The Black Hawk Gold Mining Company Limited	M1130	The Mitchells Golden Freehold Company No Liability	M1184
The New Red Jacket Gold Mining Company Limited	M1131	The Surprise Tribute Company Limited	M1185
Black Hill Extended Quartz Mining Company No Liability	M1132	The Crystal Reef Quartz Mining Company No Liability	M1186
The Jacksons Quartz Mining Company No Liability	M1133	Mitchells Golden Freehold Gold Mining Company No Liability	M1187
The Friedmans Tribute No. 1 Gold Mining Company Limited	M1134	The Queen Quartz Mining Company No Liability	M1188
The Lewers Nor-West Freehold Gold Mining Company No Liability	M1135	The Nell Gwynne Quartz Mining Company Limited	M1189
The Tambo River Sluicing Company No Liability	M1136	The West Germania Quartz Mining Company Limited	M1190
The Stratford and Avon United Gold Mining Company No Liability	M1137	The Viceroy Mining Company No Liability	M1191
The Souter Johnny Quartz Mining Company No Liability	M1138	The Montrose Quartz Mining Company No Liability	M1192
Alliance Tribute Company Limited	M1139		
The Stirling Gold Mining Company Limited	M1140		

Name of Company.	Number of Registration.	Name of Company.	Number of Registration.
The Lady Bowen Quartz Mining Company No Liability ..	M1193	The Comet Company No Liability ..	M1256
The Rose of Denmark Mining Company Limited ..	M1194	Excelsior Quartz Mining Company Limited ..	M1257
The Victory Gold Mining Company No Liability ..	M1195	The Devonshire Reef Gold Mining Company No Liability ..	M1258
The Countess Tribute Company No Liability ..	M1196	The Poverty Gold Mining Company Limited ..	M1259
The Rothschild Quartz Mining Company Limited ..	M1197	Union Quartz Mining and Crushing Company Limited ..	M1260
The South Extended Sultan Gold Mining Company Limited ..	M1198	Rose D'Armour Mining Company No Liability ..	M1261
Orams Reef Mining Company No Liability ..	M1199	The South Albion Quartz Mining Company Limited ..	M1262
The Revival Alluvial Gold Mining Company No Liability ..	M1200	The Maiden Hill Gold Mining Company Limited ..	M1263
The North Hero Extended Mining Company No Liability ..	M1201	The Egerton Company Limited ..	M1264
Creswick Consols Gold Mining Company Limited ..	M1202	The Rose Mining Company No Liability ..	M1265
The Premier Tribute Quartz Mining Company Limited ..	M1203	The Lorne Quartz Mining Company Limited ..	M1266
The Great Extended Gold Mining Company No Liability ..	M1204	The Chiltern Sons of Freedom Mining Company Limited ..	M1268
The Pioneer Gold Mining Company Limited ..	M1205	The Long Tunnel Freehold Gold Mining Company Limited ..	M1269
The Just In Time Gold Mining Company Limited ..	M1206	The Southern Freehold Gold Mining Company No Liability ..	M1270
Blue Peter Gold Mining Company No Liability ..	M1207	The New Welcome Quartz Mining Company No Liability ..	M1271
The Tarwin Tin Mining Company Limited ..	M1208	The New Bristol Gold Mining Company No Liability ..	M1272
The Coomassie Quartz Mining Company No Liability ..	M1209	Homeward Bound Company No Liability ..	M1273
The West Parade Quartz Mining Company No Liability ..	M1210	The Lady Franklin Gold Mining Company No Liability ..	M1274
The Bertha Gold Mining Company Limited ..	M1211	The Murchison Gold Mining Company No Liability ..	M1275
Junction Gold Mining Company No Liability ..	M1212	Royal Crown Quartz Mining Company Registered ..	M1276
The Ophir Gold Mining Company Limited ..	M1213	The Just in Time Quartz Mining Company Limited ..	M1277
The Band of Hope Tribute Quartz Mining Company Limited ..	M1214	The Alpine Gold Mining Company Registered ..	M1278
The Albert Gold Mining and Crushing Company No Liability ..	M1215	The Passbye Tribute Company Registered ..	M1278
The Freestone Creek Deep Lead Gold Mining Company No Liability ..	M1216	The Wallaby Reef Tribute Quartz Mining Company Registered ..	M1278
The Walhalla Cooper Mining Company Limited ..	M1217	Pioneer Mining Coy. Registered ..	M1278
Derwent Jacks Quartz Gold Mining Company Limited ..	M1218	Wattle Gully United Gold Mining Company Registered ..	M1278
The Bertha Gold Mining Company Chewton Limited ..	M1219	The Eldorado Gold Mining Company Registered ..	M1278
South Whip Tribute Company Limited ..	M1220	The Argus Freehold Gold Mining Company Registered ..	M1278
The Warrior Extended Quartz Gold Mining Company Limited ..	M1221	The Rising Star Quartz Mining Company Registered ..	M1278
The Albion Gold Mining Company Limited ..	M1222	The New Perseverance Quartz Mining Company No Liability ..	M1279
Richardsons Western Freehold Gold Mining Company No Liability ..	M1223	The New Wellington Quartz Mining Company Limited ..	M1280
The Speedwell Mining Company No Liability ..	M1224	Jingellic Tin Lodes Mining Company Limited ..	M1281
The United Pioneer Gold Mining Company Limited ..	M1225	New Lothair Gold Mining Company No Liability ..	M1282
The Aberfeldie Gold Mining Company No Liability ..	M1226	The A.I. United Company No Liability ..	M1283
The Pleasant Creek and Moyston Extended Quartz Mining Company Limited ..	M1227	The Helvetia Gold Mining Company Limited ..	M1284
The Fonthill Gold Mining Company Limited ..	M1228	The Sir John Franklin Mining Company No Liability ..	M1285
The New Grand Junction Mining Company Limited ..	M1229	The Duchess of Edinburgh Gold Mining Company No Liability ..	M1286
The Baron Rothschild Freehold Gold Mining Company No Liability ..	M1230	The Nichols Freehold Gold Mining Company No Liability ..	M1287
The Nelson Gold Mining Company Limited ..	M1232	The Sydenham Quartz Gold Mining Company Limited ..	M1288
The Alliance Miners Gold Mining Company No Liability ..	M1233	The Wilsons Hill Tribute Company No Liability ..	M1289
The Kingston Park Freehold Company No Liability ..	M1234	The Italian Hill Long Tunnel Gold Mining Company Limited ..	M1290
The Dan Ryans Freehold Gold Mining Company No Liability ..	M1235	Moonta Quartz Mining Company No Liability ..	M1291
Venus Quartz Mining Company No Liability ..	M1236	The Great Northern Gold Mining Company Limited ..	M1292
The North Dead Cat Gold Mining Company Registered ..	M1237	The Prince of Wales Quartz Mining Tribute Company No Liability ..	M1293
The Ajax Mining Company Registered ..	M1237	New Golden Lake Gold Mining Company Limited ..	M1294
The Golden Fleece Old Chum Company Registered ..	M1237	The Goldsborough Gold Mining Company Limited ..	M1295
North Volunteer Tribute Company Limited ..	M1238	The Bald Hills Gold Mining Company No Liability ..	M1296
The United Hand and Band Company No Liability ..	M1239	St. Osyth Gold Mining Company Limited ..	M1297
The Bunyans Freehold Gold Mining Company No Liability ..	M1240	The North Steiglitz Quartz Mining Company Limited ..	M1298
The Houston Quartz Mining Company Limited ..	M1241	Abergavenny Quartz Mining Company No Liability ..	M1299
The Perserverance Gold Mining Company Limited ..	M1242	Parkers United Company No Liability ..	M1300
The Auriferous Sluicing Company Seymour No Liability ..	M1243	The White Horse Reef Quartz Gold Mining Company Limited ..	M1301
The Armagh Alluvial Gold Mining Company No Liability ..	M1244	The Waterloo Gold Mining Company Limited ..	M1302
The Bendigo Marble Lime and Cement Mining and Manufacturing Company Limited ..	M1245	The Benalla Hope Gold Mining Company No Liability ..	M1303
The Mountaineer Black River Gold Mining Company Limited ..	M1246	The Great Extended Quartz Mining Company Limited ..	M1304
The South Golden Lion Tribute Company Limited ..	M1247	Acadia Catherine Gold Mining Company No Liability ..	M1305
The Old Happy Tribute Gold Mining Company Limited ..	M1248	The Florence Gold Mining Company No Liability ..	M1306
St. George Tribute Company Limited ..	M1249	The Prussian Gold Mining Company Limited ..	M1307
The Aurora Borealis Gold Mining Company Limited ..	M1250	The New Albion Quartz Mining Company Registered ..	M1308
The Jonadab Gold Mining Company Registered ..	M1251	Bennison Flat Tribute Company No Liability ..	M1309
The Carters Freehold Gold Mining Company No Liability ..	M1252	Williams Pig Hill Quartz Mining Company No Liability ..	M1310
The New North Park Mining Company No Liability ..	M1253	The New Magnet Quartz Gold Mining Company No Liability ..	M1311
Cerberus Company Limited ..	M1254	The Cathcart Gold Mining Company No Liability ..	M1312
The Star of the East Gold Mining Company No Liability ..	M1255	The Eureka Extended Company No Liability ..	M1313

Name of Company.	Number of Registration.	Name of Company.	Number of Registration.
The Preston Hill Gold Mining Company No Liability ..	M1314	The Extended Energetic Gold Mining Company No Liability ..	M1380
The Central Waterworks Freehold Gold Mining Company Limited ..	M1315	The Union Quartz Mining Company Limited ..	M1381
New Victoria Gold Mining Company No Liability ..	M1316	North Dimock's Reef Company No Liability ..	M1382
The New Chum Quartz Mining Company Limited With Prepayment ..	M1317	Stawell Big Hill Quartz Mining Company Limited ..	M1383
Central New Chum Tribute Company No Liability ..	M1318	The Loughlin Gold Mining Company No Liability ..	M1384
The Crown Quartz Mining Company No Liability ..	M1319	Ovens Gold and Tin Mining Company No Liability ..	M1385
Pennycooks Freehold Gold Mining Company No Liability ..	M1320	Mitchells Bank of England Gold Mining Company No Liability ..	M1386
The Iactolus Gold Mining Company Limited ..	M1321	Argyle Quartz Company No Liability ..	M1387
The Ryrries Freehold Gold Mining Company No Liability ..	M1322	St. Arnaud Cross Reef Tribute Company Limited ..	M1388
Rushworth United Gold Mining Company Limited ..	M1323	Sterling Quartz Mining Company Limited ..	M1389
The Beechworth Prospecting Company Limited ..	M1324	The South Creswick Quartz Mining Company No Liability ..	M1390
The Working Miners' Quartz Mining and Crushing Company No Liability ..	M1325	The Hope Quartz Gold Mining Company No Liability ..	M1391
Smiths Freehold Mining Company No Liability ..	M1326	The Scotchmans United Mining Company Limited ..	M1392
The Nuggetty Alliance Quartz Mining Company No Liability ..	M1327	Victoria Mining Company No Liability ..	M1393
Richardsons Freehold Gold Mining Company No Liability ..	M1328	The Ringwood Antimony Mining Company Limited ..	M1394
The Associated Claims Company Limited ..	M1329	The Aurora Gold Mining Company Limited ..	M1395
Glenroy Tribute Company Limited ..	M1330	South Devonshire Tribute Company Limited ..	M1396
Glencoe Gold Mining Company Limited ..	M1331	The South Welshman's Reef Quartz Mining Company No Liability ..	M1397
City of Ballarat Company Limited ..	M1332	The New Chum Consolidated Company No Liability ..	M1398
The Golden Lion Tribute Company No Liability ..	M1333	Central Mining Company Limited ..	M1399
Energetic Quartz Mining Company No Liability ..	M1334	Reefton Quartz Mining Company Limited ..	M1400
The Barrys Reef Mining Company No Liability ..	M1335	The West Wilsons Hill Quartz Mining Company Limited ..	M1401
The Johnsons and Websters United Mining Company No Liability ..	M1336	The Cloughs Tribute Company No Liability ..	M1402
The New North Gippsland Gold Mining Company No Liability ..	M1337	Energetic Quartz Mining Company Limited ..	M1403
The East Lothair Gold Mining Company No Liability ..	M1338	The New Rhymney Quartz Mining Company No Liability ..	M1404
The Shaws Great Extended Quartz Mining Company No Liability ..	M1340	The New St. George Gold Mining Company No Liability ..	M1405
Eclipse Mining Company Limited ..	M1341	The South Cohens Tribute Quartz Mining Company Limited ..	M1406
The Providence Mining Company No Liability ..	M1342	The Linton Quartz Mining Company No Liability ..	M1407
Eureka Consols Tribute Company Limited ..	M1343	The New Chum Quartz Mining Company Limited ..	M1408
The Arcadian Tribute Company Limited ..	M1344	The Sultana Gold Mining Company Registered ..	M1409
The Cambrian Company Limited ..	M1345	The St. Osyth Gold Mining Company Limited ..	M1410
The Defiance Gold Mining Company No Liability ..	M1346	Prince of Wales and Pegleg Gold Mining Company No Liability ..	M1411
The United Wellington Gold and Tin Mining Company Limited ..	M1347	The King of Prussia Gold Mining Company Limited ..	M1412
The Dykes Freehold Gold Mining Company No Liability ..	M1348	The New Argus Gold Finding Company No Liability ..	M1413
Duke of Devonshire Tribute Company Limited ..	M1349	The Smythesdale Consols Quartz Mining Company No Liability ..	M1414
Bells Tribute Company Limited ..	M1350	The Creswick Gold Mining Company No Liability ..	M1415
South Go-Ahead Tribute Company Limited ..	M1351	The Contest Gold Mining Company No Liability ..	M1416
The Phoenix Tribute Company Limited ..	M1352	The North Juno Company No Liability ..	M1417
The New North Briton Gold Mining Company Limited ..	M1353	The Merton Gold and Antimony Mining Company Limited ..	M1418
The South Todds Mining Company Limited ..	M1354	The New Diadem Quartz Mining Company Limited ..	M1419
South Kitto's Tribute Company Limited ..	M1355	The Malmsbury Confluence Gold Mining Company Limited ..	M1420
The Todds New Discovery Tribute Company Limited ..	M1356	The Grand Junction Gold and Antimony Mining Company Limited ..	M1421
The Baroness Rothschild Gold Mining Company No Liability ..	M1357	The Great Southern Garden Gully Company No Liability ..	M1422
The Railway Tribute No. 2 Company Registered ..	M1358	The Rourke and Henderson Extended Company No Liability ..	M1424
The United Black Hill Company No Liability ..	M1359	The South Alabama Quartz Mining Company Limited ..	M1425
The Fear Not Gold Mining Company Limited ..	M1360	Hunters Tribute Company Limited ..	M1426
The Prince of Wales Amalgamated Company Limited ..	M1361	Bowens Homestead Gold Mining Company No Liability ..	M1427
The De Murska Company No Liability ..	M1362	Lal Lal Iron Company No Liability ..	M1428
The Spelling Bee Quartz Mining Company Limited ..	M1363	Simmonds Lighting Reef Gold Mining Company Limited ..	M1429
The Albert Tribute Company Limited ..	M1364	New Durham Company No Liability ..	M1430
The Royal Mail Gold Mines Company No Liability ..	M1365	The Pyrenees Lead and Gold Mining Company Limited ..	M1431
The North Bells Tribute Company Limited ..	M1366	The Franklinford Gold Mining Company Limited ..	M1432
Davies's Freehold Gold Mining Company No Liability ..	M1367	Royal Harry Quartz Mining Company No Liability ..	M1433
The Creswick and Clunes Grand Junction Mining Company No Liability ..	M1368	The Tulip Gold Mining Company Limited ..	M1434
The Elaine Company No Liability ..	M1369	The Working Miners Gold Mining Company Limited ..	M1435
The Welshmans Reef Quartz Mining Company No Liability ..	M1370	The Pig Tail Quartz Mining Company No Liability ..	M1436
The New Chum and Belle Vue Reef Railway Company Limited ..	M1371	Rourke and Hendersons Extended Tribute Company Limited ..	M1438
The Princess Royal Quartz Gold Mining Company Limited ..	M1372	Magdala Company No Liability ..	M1439
The New Chum United Gold Mining Company No Liability ..	M1373	The Royal Catherine Quartz Mining Company Limited ..	M1440
The Ristori Freehold Gold Mining Company No Liability ..	M1374	Union Gold Mining Company Registered ..	M1441
The New Kangaroo Quartz Mining Company No Liability ..	M1375	Panton Hill Quartz Mining Company Limited ..	M1442
The North Long Tunnel Gold Mining Company Limited ..	M1376	The Devonshire Tribute Company Limited ..	M1443
The Emperor Gold Mining Company Limited ..	M1377	The Great Northern Quartz Mining Company No Liability ..	M1444
Crocodile Company No Liability ..	M1378	The Township Reef Quartz Mining Company No Liability ..	M1445
The Thistlewaite Estate Gold Mining Company No Liability ..	M1379	The Josephine Tin Mining Company No Liability ..	M1446
		The Australasian Gold Mining Company Registered ..	M1447
		The Lord Raglan and St. Arnaud Quartz Gold Mining Company No Liability ..	M1448

Name of Company.	Number of Registration.	Name of Company.	Number of Registration.
The Royal Exchange Gold Mining Company No Liability	M1449	The Beaufort United Gold Mining Company No Liability	M1516
The Clunes Consols Gold Mining Company Limited	M1450	The Phillips Reef Gold Mining Company Registered	M1517
The Tommy Dodd Gold Mining Company Limited	M1451	The North Catherine Gold Mining Amalgamated Company Limited	M1518
The Extended North Birds Mining Company Limited	M1452	The United Miners Company No Liability	M1519
The Eureka Extended Tribute Company Limited	M1453	The Browns Consols Company No Liability	M1520
Pinchgut Junction Mining Company No Liability	M1454	Devils Point Tribute Company No Liability	M1521
The Victoria and Queensland Copper Mining Company No Liability	M1455	The Victoria United Tribute Company No Liability	M1522
The Princess Royal Quartz Gold Mining Company Limited	M1457	The Empire Amalgamated Company No Liability	M1523
Magnetic Quartz Mining Tribute Company Limited	M1458	Empress Mining Company No Liability	M1524
Great Southern Tribute Company Limited	M1459	The Pride of the East Quartz Mining Company No Liability	M1525
The Warrandyte Freehold Gold Mining Company No Liability	M1460	The New Piggoreet Quartz Mining Company No Liability	M1526
The Black Horse United Company No Liability	M1461	The Ko-i-Noor Tribute Company No Liability	M1527
Moon Reef Tribute Gold Mining Company Limited	M1462	Alabama and Butlers Reef Company No Liability	M1528
The South Garden Gully Railway Tribute Company Limited	M1463	The Leviathan Company Registered	M1529
The All Nations Gold Mining Company Limited	M1464	The Band of Hope and Albion Consols No. 4 Tribute Company No Liability	M1530
Try Again Extended No. 1 South Quartz Mining Company No Liability	M1466	The Bendigo and Williamstown Gold Mining Company Limited	M1531
The Duke and Timor Tribute Gold Mining Company Limited	M1467	Prince of Wales Company No Liability	M1532
The Victoria Reef Quartz Mining Company No Liability	M1468	Grays Mining Tribute Company Limited	M1533
New Empress Gold Mining Company No Liability	M1469	North Black Horse Company No Liability	M1534
Royal Garden Gully Company Limited	M1470	The United Bodies Tribute Quartz Mining Company Limited	M1535
The Chiltern Valley Gold Mines Company Limited	M1471	The Old Germania Quartz Mining Company Limited	M1536
The United Miner Company No Liability	M1472	The Telegraph United Quartz Mining Company Limited	M1537
North Stafford Tribute Company Limited	M1473	The Mariners Reef Mining Company Limited	M1538
The North Star and Red Jacket United Quartz Mining Company Limited	M1474	The New Enterprise Company No Liability	M1539
The North Pandora Gold Mining Company Limited	M1475	The Mary Gladstone Quartz Mining Company Limited	M1540
The New Australasian Gold Mining Company No Liability	M1476	The Shamrock Quartz Mining Company Limited	M1541
The North Sultan Mining Company No Liability	M1477	Albion Mining and Drainage Co. Registered	M1542
The Camerons Quartz Mining Company No Liability	M1478	Ranzau Tribute Company Registered	M1542
The Band of Hope and Albion Consols No. 2 Tribute Company No Liability	M1479	The Collmann and Tacchis Reef Amalgamated Gold Mining Company Registered	M1542
The Serapis Mining Company No Liability	M1480	The Hibernia Reef Tribute Company Registered	M1542
Grand Secret Gold Mining Company No Liability	M1481	The Hustlers Reef Railway Company Registered	M1542
The New Enterprise Quartz Gold Mining Company Chewton Limited	M1482	The Hustlers Reef Railway Tribute Company Registered	M1542
Mars Gold Mining Company No Liability	M1483	The Lily of the Valley Gold Mining Company No Liability	M1544
The Empress Gold Mining Company No Liability	M1484	The Alabama and Champion United Gold Mining Company Limited	M1545
The Victoria United Mining Company No Liability	M1485	The First Hill United Gold Mining Company Limited	M1546
The Perseverance Quartz Crushing and Gold Mining Tribute Company No Liability	M1486	The Try Again Tribute Company Limited	M1547
The Empress of India Tribute Company No Liability	M1487	The Extended Cross Reef Quartz Mining Company Registered	M1547
The Phoenix Quartz Mining Company Limited	M1488	The Nil Desperandum Gold Mining Company No Liability	M1548
The Golden Spring Tribute Company Limited	M1489	The Buckland Quartz Mining Company Limited	M1549
The No. 1 South Alabama Quartz Mining Company Limited	M1490	The Try Again Tribute Gold Mining Company Limited	M1550
The Royal Crown Quartz Mining Company Limited	M1491	Kings Birthday Quartz Gold Mining Company Limited	M1551
The Junction Tribute Gold Mining Company No Liability	M1492	The South Birthday Quartz Company No Liability	M1552
Central Garden Gully Quartz Mining Company Limited	M1493	Confidence Extended Company No Liability	M1553
The Great Central Victoria Company No Liability	M1494	The United Hustlers and Redan Company No Liability	M1554
The Enterprise Mining Company Ringwood Limited	M1495	The Homebush Gold Mining Company No Liability	M1555
The Perseverance Tribute Gold Mining Company Limited	M1496	Morsehead Gold Mining Company No Liability	M1556
The New Wellington Gold and Tin Mining Company No Liability	M1497	The Woolbrook Gold Mining Company Limited	M1557
South Simpsons Tribute Company Limited	M1498	The Band of Hope Company No Liability	M1558
The Duchess of Timor Tribute Gold Mining Company Limited	M1499	The Cohens Great Northern Gold Mining Company Limited	M1559
New City Company Limited	M1500	The Caledonia Tribute Gold Mining Company Limited	M1560
The Wheal Terrill Quartz Company Limited	M1501	Dykes North West Gold Mining Company No Liability	M1561
The Daly Lead Tribute Gold Mining Company Limited	M1502	The Cosmopolitan Quartz Mining Company Limited	M1562
The Duke of Cornwall Quartz Mining Company No Liability	M1503	The Union Lead Hydraulic Gold Mining Company No Liability	M1564
The Golden Stream Tribute Company No Liability	M1504	The Nerrina Quartz Mining Company No Liability	M1565
Perseverance United Quartz Mining Company Limited	M1505	The Long Tunnel Extended Gold Mining Company No Liability	M1566
The Ronshaw Freehold Gold Mining Company Registered	M1506	The Eagle Hawk Union Quartz Mining Company No Liability	M1567
Pearl Company Limited	M1507	The Black Hill Deep Shaft Tribute Company No Liability	M1568
The Coleraine Coal Mining Company Limited	M1508	The Ararat Quartz Gold Mining Company No Liability	M1569
The New Eureka Gold Mining Company No Liability	M1509	The Union Quartz Mining Company No Liability	M1570
The Phoenix Gold Mining Company No Liability	M1510	The New Era Mining Company Limited	M1571
The New Band of Hope Company No Liability	M1511	The Sulieman Pasha Quartz and Alluvial Gold Mining Company No Liability	M1572
The Try Again Company No Liability	M1512	The Llewellyn Gold Mining Company No Liability	M1573
The New Sovereign Mining Company No Liability	M1513	The Amalgamated Quartz Mining Company of Alexandra Limited	M1574
New Hit or Miss Quartz Mining Company No Liability	M1514		
The Bell Rock Quartz Mining Company Limited	M1515		

Name of Company.	Number of Registration.	Name of Company.	Number of Registration.
The North Birthday Freehold Quartz Company Limited	M1575	The Novelty Tribute Company Registered	M1644
The New Years Gift Quartz Mining Company Limited	M1576	The Perseverance Quartz Gold Mining Company Registered	M1644
The No. 2 Indicator Mining Company No Liability	M1577	The Pall Mall Gold Mining Company Registered	M1644
The Duke Company No Liability	M1578	The Royal Britannia Tribute Company Registered	M1644
Fidlers Quartz Mining Company No Liability	M1579	The North King of Prussia Gold Mining Company Limited	M1645
Victory Quartz Mining Company No Liability	M1580	The Duke Tribute Company Limited	M1646
The Guiding Star Tribute Company No Liability	M1581	The Energetic Antimony and Gold Mining Company Limited	M1647
The Golden Fleece Tribute Company No. 2 Registered	M1582	The United Quartz Mining Company No Liability	M1648
The South Cross United Gold Mining Company Limited	M1583	The Seven Hills Extended Freehold and Leasehold Company No Liability	M1649
The North Waihalla Gold Mining Company Limited	M1584	The Spring Hill Leads Gold Mining Company No Liability	M1650
The South Belle Vue United Company No Liability	M1585	The Spring Hill Grand Junction Gold Mining Company No Liability	M1651
Spread Eagle Quartz Mining and Dunolly Public Crushing Company Limited	M1586	The Easter Prospecting Tribute Company Limited	M1652
The Telephone Quartz Mining Company No Liability	M1587	The Hope Quartz Mining Company No Liability	M1653
The Pyrenees Tunnel Quartz Mining Company No Liability	M1588	The Chilwell Gold Mining Company No Liability	M1654
The Brawns Freehold Gold Mining Company No Liability	M1589	The Forbes Union Gold Mining Company No Liability	M1655
All Fours Quartz Mining Company No Liability	M1590	The New Clarence Gold Mining Company Limited	M1656
The Koh-i-Noor Tribute Company No Liability	M1591	The Renaissance Mining Company Limited	M1657
Poverty Company No Liability	M1592	The Progress Quartz Mining Company No Liability	M1658
The Golden Gale Tribute Company Limited	M1593	The New Briseis Quartz Mining Company No Liability	M1659
Victoria Gold and Antimony Mining Company Limited	M1594	The James Service Tribute Company Limited	M1660
The Birds Reef Tribute Company No. 1 Limited	M1595	The Enterprise Quartz Mining Company Limited	M1661
Goldbrook Company No Liability	M1596	Bristol Quartz Mining Company No Liability	M1662
The Rescue Gold Mining Company Limited	M1597	Clarke Freehold Mining Company No Liability	M1663
Belgium Quartz Mining Company No Liability	M1598	Beaconsfield Quartz Mining Company Limited	M1664
Great Southern Consols Gold Mining Company No Liability	M1599	The Central Lightning Reef Gold Mining Company Limited	M1665
The Rising Star Quartz Mining Company Limited	M1600	The North New Moon Gold Mining Company No Liability	M1666
The Dalmazia Quartz Mining Company Limited	M1601	The Earl of Beaconsfield Gold Mining Company No Liability	M1667
Dalmatia Gold Mining Company No Liability	M1602	The Baron and Richardsons Western United Gold Mining Companies No Liability	M1668
Golden Belt Gold Mining Company No Liability	M1603	The New Tubal Cain Quartz Mining Company Limited	M1669
Hibernia Freehold Tribute Company Limited	M1604	The Kummerlos Gold Mining Company No Liability	M1670
Serjeants Freehold Quartz Mining Company No Liability	M1605	The Baw Baw Sluicing Company Limited	M1671
Yorkshire Gold Mining Company Limited	M1606	South Yorkshire Gold Mining Company No Liability	M1672
The Great Wonder Company No Liability	M1607	The South German Reef Tribute Company Limited	M1673
Hobart Pasha Gold Mining Company No Liability	M1608	Welcome Reef Quartz Mining Company Limited	M1674
The New Phoenix Gold Mining Company No Liability	M1609	The North United Hustlers and Redan Company Limited	M1675
New Darlington Quartz Mining Company Limited	M1610	The Victory Quartz Mining Company No Liability	M1676
The Forbes Freehold Gold Mining Company Limited	M1611	The Number One North United Quartz Mining Company No Liability	M1677
The Lone Hand Company No Liability	M1612	The Waterloo Gold Mining Company No Liability	M1678
Eagle Hawk Tribute Company Limited	M1613	The Doyles Reef Quartz Mining Company No Liability	M1679
New Pig Tail Quartz Mining Company No Liability	M1614	The South Progress Quartz Mining Company No Liability	M1680
New Junction Gold Mining Company Limited	M1615	The Beaufort Gold Mining Company No Liability	M1681
Queen Victoria Gold Mining Company No Liability	M1616	The St. Mungo Gold Mining Company No Liability	M1682
Royal Birthday Quartz Mining Company Limited	M1617	The South Victoria Gold Mining Company No Liability	M1683
Aurora Quartz Mining Company Limited	M1618	The Band of Hope Quartz Mining Company No Liability	M1684
Maximilian Gold Mining Company Limited	M1619	The Daniel Ryans Speculation Gold Mining Company No Liability	M1685
The Carisbrook Consols Gold Mining Company Limited	M1620	The Great Extended Progress Gold Mining Company No Liability	M1686
The North Gippsland Prospecting Company Limited	M1621	New Perseverance Gold Mining Company No Liability	M1687
Hard Hill Mining Company Limited	M1622	The Patersons Process Pyrites and Mining Company No Liability	M1688
Victoria Gold Mining Company No Liability	M1623	Kilmore Quartz and Alluvial Gold Mining Company Limited	M1689
South Virginia Gold Mining Company Limited	M1624	The New Happy Go Lucky Gold Mining Company Limited	M1690
Homeward Bound Gold Mining Company No Liability	M1625	The Davies Freehold Junction Gold Mining Company No Liability	M1691
Rising Sun Tribute Company No Liability	M1626	The Prince of Wales Mining Company Limited	M1692
Lady Barkly Gold Mining Company Registered	M1626	The Parade Tribute Company No Liability	M1693
Rising Sun Company No Liability	M1627	Havilah Gold Mining Company No Liability	M1694
Morgans Birthday Quartz Company No Liability	M1628	The Kyneton United Gold Mining Company No Liability	M1695
The Madame Berry Gold Mining Company No Liability	M1629	The Hepburn Home Paddock Gold Mining Company No Liability	M1696
The Black Cloud Gold and Antimony Mining Company Limited	M1630	North Doyles Gold Mining Company Limited	M1697
The Major Gold Mining Company No Liability	M1631	Victoria No. 2 Gold Mining Company No Liability	M1698
The North Cohens Reef Mining Company No Liability	M1632	The You Know Quartz Mining Company Limited	M1699
The Rose Gold Mining Company No Liability	M1633	The New St. George Quartz Company No Liability	M1700
Graham Berry Gold Mining Company No Liability	M1634	Nuggetty Birthday Quartz Mining Company Limited	M1701
The Melrose Mining Company Limited	M1635		
The Jersey Reef Quartz Mining Company Limited	M1636		
The Prince of Wales Tribute Company No Liability	M1637		
The Rose and Shamrock Quartz Mining Company No Liability	M1638		
The Aberfeldy Sluicing Company Limited	M1639		
The British Queen Quartz Mining Company Limited	M1640		
Lord Beaconsfield Reefing Company Limited	M1641		
Smalls Tribute Company Limited	M1642		
Currans Freehold Quartz Mining Company No Liability	M1643		

Name of Company.	Number of Registration.	Name of Company.	Number of Registration.
The Queen Mining Company No Liability	M1702	Wilsons Freehold Gold Mining Company No Liability	M1759
The New Band of Hope and Albion Consols Gold Mining Company No Liability	M1703	The Sir Garnet Wolseley Quartz and Alluvial Gold Mining Company No Liability	M1760
The South Defiance Gold Mining Company No Liability	M1704	The Victoria Regina Gold Mining Company No Liability	M1761
Saint George and Band Quartz Company No Liability	M1705	Washington Freehold Gold Mining Company No Liability	M1762
The United Specimen Hill and Phenix Extended Gold Mining Company Limited	M1706	St. Anns Quartz Mining Company Limited	M1763
North Band and Albion Freehold Quartz Mining Company No Liability	M1707	The Lord Harry Company No Liability	M1764
North Yorkshire Quartz Mining Company No Liability	M1708	The Hobart Pasha No. 2 Gold Mining Company No Liability	M1765
Clarks Freehold Quartz and Alluvial Gold Mining Company No Liability	M1709	The Alpine Gold Mining Company No Liability	M1766
The South United Quartz Mining Company No Liability	M1710	The Shepherds Reef Gold Mining Company No Liability	M1767
The Victoria Hydraulic Gold Mining Company No Liability	M1711	The Colac Prospecting Coal Mining Company Limited	M1768
The Colac Prospecting Coal Company Number 3 Limited	M1712	No. 2 Band of Hope Quartz Mining Company No Liability	M1769
The Marchioness of Normanby Gold Mining Company No Liability	M1713	The New Morning Light Mining Company No Liability	M1770
Hockings United Quartz Company No Liability	M1714	Haddon Extended Gold Mining Company No Liability	M1771
The Crescent Freehold Gold Mining Company No Liability	M1715	Royal Saxon Gold Mining Company No Liability	M1772
The Young Band and Albion Freehold Quartz Mining Company No Liability	M1716	The Band of Hope Company No Liability	M1773
The Beaconsfield Gold Mining Company No Liability	M1717	Corn Exchange Quartz Gold Mining Company No Liability	M1774
The Hillsborough Quartz Mining Company Limited	M1718	South New Moon Gold Mining Company Registered	M1775
The Waterloo Consols Gold Mining Company No Liability	M1719	The East Waterloo Gold Mining Company No Liability	M1776
The Briagolong Gold Mining Company Limited	M1720	The Hope of Richmond Gold Mining Company Limited	M1777
The Panton Gold Mining Company Limited	M1721	The Wilkins Freehold Gold Mining Company No Liability	M1778
North Lord Warden Gold Mining Company Limited	M1722	The Ryan & Harringtons Freehold Gold Mining Coy. No Liability	M1779
The Good Hope Gold Mining Company Limited	M1723	Mount Greenock Freehold Estate Gold Mining Company No Liability	M1780
The Bendigo Working Miners Company Limited	M1724	The Duke of Edinburgh Gold Mining Company Limited	M1781
Star of the East Company No Liability	M1725	The Little Wonder Gold Mining Company No Liability	M1782
The All Nations Tribute Company Limited	M1726	The Langridge Great Extended Gold Mining Company No Liability	M1783
The North Star Gold Mining Company Limited	M1727	South Band of Hope Freehold Gold Mining Company No Liability	M1784
The Colac Coal and Mineral Prospecting Company No. 2 Limited	M1728	New Kong Meng Company No Liability	M1785
The Hermann Freehold Quartz Mining Company No Liability	M1729	The Mount Budgee Quartz Gold Mining Company No Liability	M1786
The Albion Quartz Mining Company No Liability	M1730	The Norths German Reef Company Limited	M1787
The Parkins Reef Tribute Company Limited	M1731	The Champion Quartz and Alluvial Gold Mining Company No Liability	M1788
The Kentish Reef Gold Mining Company No Liability	M1732	The Baker Pasha Gold Mining Company No Liability	M1789
The Williams Freehold Mining Company No Liability	M1733	New Chum Railway Company No Liability	M1790
The No. 1 North Hustlers and Redan Company Limited	M1734	The South New Moon Gold Mining Company No Liability	M1791
The Hustlers and Redan Company Limited	M1735	New St. Mungo Gold Mining Company No Liability	M1792
The Sheoak Gold Mining Company Limited	M1736	The Reward Coal Mining Company No Liability	M1793
Serjeants Freehold Quartz Mining Company No Liability	M1737	Crunes Quartz Mining Company Registered	M1793
The Leviathan Reef Company No Liability	M1738	Napoleon United Company No Liability	M1794
The Star and Thomson Gold Mining Company No Liability	M1739	The Old Welshmans Reef Gold Mining Company No Liability	M1795
The Kilmore United Quartz and Alluvial Gold Mining Company Limited	M1740	The Burnt Creek Gold Mining Company No Liability	M1796
The Onward Gold Mining Company Limited	M1741	Dunns Reef Company Limited	M1797
The Extended Cosmopolitan Quartz Mining Company No Liability	M1742	Russell Square Gold Mining Company No Liability	M1798
The Charlesons Freehold Gold Mining Company No Liability	M1743	The Golden Crown Quartz Mining Company No Liability	M1799
Ophelia Gold Mining Company No Liability	M1744	The All Nations Gold Mining Company Limited	M1800
The Lummas Freehold Quartz Mining Company No Liability	M1745	Burkes Flat Quartz Mining Company Limited	M1801
United Black Hill Tribute Company No Liability	M1746	The Homeward Bound Gold Mining Company No Liability	M1802
The North Homebush Gold Mining Company No Liability	M1747	Mount Clear Gold Mining Company No Liability	M1803
The King Charlie Gold Mining Company No Liability	M1748	The Rip Van Winkle Gold Mining Company No Liability	M1804
The St. Anns Gold Mining Company Limited	M1749	The Bombay Gold and Antimony Mining Company Limited	M1805
The Sovereign Hill Mining Company No Liability	M1750	The Clarkes Freehold Gold Mining Company No Liability	M1806
The Red Jacket Quartz Mining Company No Liability	M1751	The Home Bush Consols Gold Mining Company No Liability	M1807
The Ballarat and Beaufort Consols Gold Mining Company No Liability	M1752	The East Kohinoor Mining Company No Liability	M1808
The Frushers Freehold Company No Liability	M1753	The Ararat Deep Leads Gold Mining Company No Liability	M1809
The Gippsland Coal Mining Company Limited	M1754	The Australasian and Eaglehawk Gold Mining Company No Liability	M1810
The Union Extended Gold Mining Company No Liability	M1755	The Stawell Tribute Company No Liability	M1811
The Moores Reef Quartz Mining Company Limited	M1756	The South United Hustlers and Redan Gold Mining Company No Liability	M1812
The Fiery Creek Gold Mining Company No Liability	M1757	The New Good Hope Quartz Mining and Tunneling Company No Liability	M1813
The Smiths Freehold United Quartz Company No Liability	M1758		

Name of Company.	Number of Registration.	Name of Company.	Number of Registration.
The North Kohinoor Gold Mining Company No Liability	M1814	The Working Miners Extended Gold Mining Company No Liability	M1873
The Eureka Phoenix Quartz Company Limited	M1815	North Shamrock Amalgamated Quartz Mining Company No Liability	M1874
Lauries Freehold Quartz Mining Company No Liability	M1816	The New Washington Quartz Mining Company No Liability	M1875
The Normanby Quartz Mining Company Limited	M1817	The Marshalls Freehold Quartz Company No Liability	M1876
The Phoenix Gold Mining Company Limited	M1818	Cosmopolitan Freehold Company No Liability	M1877
The Normanby Quartz Mining Company No Liability	M1819	Mazeppa Gold Mining Company No Liability	M1878
The Enterprise Gold Mining Company No Liability	M1820	Sackville Mining Company No Liability	M1879
The Count Bismarck Tribute Company No Liability	M1821	Gibbings Freehold Gold Mining Company No Liability	M1880
The Australasian Extended Gold Mining Company No Liability	M1822	The Lord Chelmsford Gold Mining Company No Liability	M1881
Wellington Company No Liability	M1823	Bruuns' United Freehold Gold Mining Company No Liability	M1882
Wilson's Freehold Company No Liability	M1824	The Young Band Extended Quartz Mining Company No Liability	M1883
The Morning Star Gold Mining Company No Liability	M1825	The No. 4 New Kohinoor Gold Mining Company No Liability	M1884
Esperanza Quartz Company No Liability	M1826	New Comet Company No Liability	M1885
Eaglehawk Alliance Quartz Mining Company No Liability	M1827	Warehams Freehold Gold Mining Company No Liability	M1886
The Bamganie Gold Mining Company No Liability	M1828	The New Crescent Freehold Gold Mining Company No Liability	M1887
South G.G. Gold Mining Company No Liability	M1829	The Eureka Gold Mining Company No Liability	M1888
The Brownes Freehold Gold Mining Company No Liability	M1830	The Lyons Street Freehold Quartz Mining Company No Liability	M1889
The West Pemberley Estate Gold Mining Company No Liability	M1831	Morning Star Company No Liability	M1890
The Sebastopol Quartz Alluvial and Waterwheel Company No Liability	M1832	The Finns Reef Mining Company No Liability	M1891
The Bonanza Freehold Quartz Mining Company No Liability	M1833	The Young Phoenix Tribute Gold Mining Company No Liability	M1892
South Band and Albion Freehold Company No Liability	M1834	Goldbrook Junction Company No Liability	M1893
The New Burra Burra Q.M. Co. No Liability	M1835	The Morning Star Gold and Antimony Mining Company Limited	M1894
The No. 2 Corn Exchange Gold Mining Company No Liability	M1836	The South Star Quartz Mining Company Limited	M1895
The Nos. 3 and 4 New Grand Junction Tribute Company Limited	M1837	The Telegraph Extended Quartz Mining Company No Liability	M1896
The Overland Quartz Mining Company No Liability	M1838	The Multistriate Gold Mining Company Limited	M1897
The Davies Stonebarn Gold Mining Company No Liability	M1839	The Venture Quartz Mining Company Limited	M1898
The De Murksa No. 2 Freehold Gold Mining Company No Liability	M1840	The Revival Tribute Company No Liability	M1899
Benns Freehold Company No Liability	M1841	The A1 and Inkermann Quartz and Alluvial Gold Mining Company No Liability	M1900
Homebush United Company No Liability	M1842	Lady Mary Quartz Mining Company No Liability	M1901
The New Kohinoor Extended Gold Mining Company No Liability	M1843	The Wilsons Township Reef Freehold Quartz Mining Company No Liability	M1902
The Sadowa Junction Gold Mining Company No Liability	M1844	The Sailor Jack Gold Mining Company No Liability	M1903
Hawthorne's Freehold Company No Liability	M1845	The No. 2 New Burra Burra Quartz Mining Company No Liability	M1904
The Stockyard Gold Mining Company Limited	M1846	The Golden Star Gold Mining Company No Liability	M1905
The Harvest Home Quartz Gold Mining Company No Liability	M1847	The Great Britain Gold Mining Company No Liability	M1906
New Sir William Don Gold Mining Company No Liability	M1848	The Frederick the Great Tribute Company No Liability	M1907
The New Britannia Gold Mining Company No Liability	M1849	Great Nelson United Quartz Mining Company No Liability	M1908
The No. 3 New Kohinoor Gold Mining Company No Liability	M1850	Butlers United Freehold Company No Liability	M1909
The No. 2 New Kohinoor Gold Mining Company No Liability	M1851	The Band and Bartons Consols No Liability	M1910
Jones' Freehold Quartz Mining Company No Liability	M1852	The Great Central Gold Mining Company No Liability	M1911
The Ballarat Quartz Mining Company No Liability	M1853	The Reporter Quartz and Alluvial Gold Mining Company No Liability	M1912
The Gays Freehold Quartz Mining Co. No Liability	M1854	The Try Again Gold Mining Company Limited	M1913
The Ballarat Gold Mining Company No Liability	M1855	North Hurdsville Freehold United Company No Liability	M1914
The Band of Hope Quartz Company No Liability	M1857	South Hurdsville Freehold Company No Liability	M1915
Hicks Freehold Company No Liability	M1858	The A One Quartz Mining Company No Liability	M1916
Young Washington Freehold Coy. No Liability	M1859	South Scotchmans and Albion United Company No Liability	M1917
The Great Extended Hustlers Gold Mining Tribute Company No Liability	M1860	Prince of Wales Quartz Mining Company No Liability	M1918
No. 3 Band of Hope Quartz Mining Company No Liability	M1861	The Lake Wendouree Mining Company No Liability	M1919
The Happy Land Quartz and Alluvial Gold Mining Company No Liability	M1862	The East Hurdsville Freehold Company No Liability	M1920
The Carisbrook Gold Mining Company No Liability	M1863	Pratts Freehold Quartz Mining Company No Liability	M1921
The Collis Washington Quartz Mining Company No Liability	M1864	Bairds Freehold Gold Mining Company No Liability	M1922
The Hurdsville Freehold Quartz Company No Liability	M1865	The No. 5 New Kohinoor Gold Mining Company No Liability	M1923
The South G.G. Tribute Company No. 1 No Liability	M1866	The Wellington Freehold Quartz Company No Liability	M1924
Ballarat Consols Gold Mining Company No Liability	M1867	North Washington Freehold Gold Mining Company No Liability	M1925
South Kohinoor Freehold Company No Liability	M1868	The North G.G. Consolidated Company No Liability	M1926
Kaiser Wilhelm Alluvial Gold Mining Company No Liability	M1869	New Mair Street Freehold Quartz Mining Company No Liability	M1927
The Clunes and Cockatoo Gold Mining Company No Liability	M1870	North Welcome Quartz Mining Company No Liability	M1928
Kohinoor Consols Gold Mining Company No Liability	M1871	The South Homebush Gold Mining Company No Liability	M1929
Hoffnung Gold Mining Company No Liability	M1872		

Name of Company.	Number of Registration.	Name of Company.	Number of Registration.
Mount Glasgow Freehold Gold Mining Company No Liability	M1930	The New Independent Gold Mining Company No Liability	M1985
Bond and Irvings Freehold Quartz Mining Company No Liability	M1931	New Discovery Gold Mining Company No Liability	M1986
The No. 4 Band of Hope Mining Company No Liability	M1932	The Spring Hill Freehold Gold Mining Company No Liability	M1987
Brennans United Company No Liability	M1933	The New Lauries Freehold Quartz Mining Company No Liability	M1988
North Kohinoor Extended Quartz Company No Liability	M1934	The Eureka Quartz Mining Company No Liability	M1990
Princess United Mining Company No Liability	M1935	The Queen of the Ranges Quartz Mining Company No Liability	M1991
Kohinoor Consolidated Quartz and Alluvial Gold Mining Company No Liability	M1936	The Robin Hood Gold Mining Company No Liability	M1992
Finlaysons Freehold Quartz Mining Company No Liability	M1937	The Young Hurdsfield United Gold Mining Company No Liability	M1993
Central Hurdsfield Freehold United Company No Liability	M1938	The Vance and Fewtrell United Gold Mining Company No Liability	M1994
Johnsons Freehold Gold Mining Company No Liability	M1939	Oldfields Gold Mining Company Limited	M1995
Morey Freehold Quartz Mining Company No Liability	M1940	The Extended G.G. Gold Mining Company No Liability	M1996
The Kaiser Gold Mining Company No Liability	M1941	Hurdsfield Consol Mining Company No Liability	M1997
The United Morning Star Hill Gold Mining Company No Liability	M1942	The United Kohinoor Gold Mining Company No Liability	M1998
Nichols Freehold Gold Mining Company No Liability	M1943	New Homebush Consols Gold Mining Company No Liability	M1999
Smiths Freehold Company No Liability	M1944	The South Brockfield Gold Mining Company Limited	M2000
Prince of Wales Quartz and Alluvial Company No Liability	M1945		
The Royal George Quartz Gold Mining Company No Liability	M1946		
The Sandridge and Welcome United Gold Mining Company No Liability	M1947		
The North Frederick The Great Gold Mining Company No Liability	M1948		
Excelsior Quartz Mining Company No Liability	M1949		
The Cornish Quartz Mining Company No Liability	M1950		
The Royal South Garden Gully Company Limited	M1951		
The Greenock and Sadowa Extended Company No Liability	M1952		
North Harvest Home Quartz Mining Company No Liability	M1953		
Prince of Wales Birthday Quartz Mining Company No Liability	M1954		
The Happier Land Quartz Mining Company No Liability	M1955		
The Orient Gold Mining Company No Liability	M1956		
Hurdsfield Extended Mining Company No Liability	M1957		
The Lady Elizabeth Quartz Mining Company No Liability	M1958		
The King of the Ranges Quartz Mining Company No Liability	M1959		
The Scandinavian Gold Mining Company No Liability	M1960		
The British Gold Mining Company No Liability	M1961		
Gates Freehold Gold Mining Company No Liability	M1962		
Central Hustlers and Redan Tribute Company No Liability	M1963		
United Ajax Gold Mining Company No Liability	M1964		
The Great Hurdsfield Mining Company No Liability	M1965		
Pride of the Ranges Quartz Mining Company No Liability	M1966		
The Stonewall Jackson Quartz Mining Company No Liability	M1967		
Rose of the Hills Quartz Mining Company No Liability	M1968		
No. 2 East Hurdsfield Gold Mining Company No Liability	M1969		
Comet Quartz Mining Company No Liability	M1970		
New North Homebush Company No Liability	M1971		
United Albion and Kohinoor Consols Quartz Mining Company No Liability	M1972		
The Pattersons Reef Quartz Mining Company No Liability	M1973		
The Bucks Head Gold Mining Company No Liability	M1974		
City of York Quartz Mining Company No Liability	M1975		
The Magpie & Frenchmans United Quartz Mining Company No Liability	M1976		
Bald Hills Company No Liability	M1977		
The Extended G.G. Gold Mining Company No Liability	M1978		
L.B.B. Consols Gold Mining Company No Liability	M1979		
The South Harvest Home Quartz Mining Company No Liability	M1980		
Consolidated East Hurdsfield Gold Mining Company No Liability	M1981		
Ferrons Reef Company No Liability	M1982		
Hadden Valley Gold Mining Company No Liability	M1983		
The Frederick The Great Freehold Tribute Company Limited	M1984		

DEPARTMENT OF MINES.

APPLICATION FOR LEASE DECLARED VOID.

8246, Mineral; Australian Paper Manufacturers Limited; 24a. 2r. 20p., Parish of Buchan.

TAILINGS LICENCES GRANTED.

3334, Tailings Licence; Alfred George Leech; Parishes of Maryborough and Bet Bet (in lieu of Tailings Licence No. 3263, expired).
 3335, Tailings Licence; Thomas Stephen Taylor and John Oswald Krause; Parish of Stawell (in lieu of Tailings Licence No. 3236, expired).
 3337, Tailings Licence; The Country Roads Board; Parish of Korumburra (in lieu of Tailings Licence No. 3109, expired).

CONSENT GRANTED TO TRANSFER MINING LEASE.

5600, Gippsland; from Robert George Johnston and Charlie Klingzot to Charlie Klingzot.

MINERAL SEARCH LICENCES GRANTED.

557, Mineral Search Licence; Roland Walton; 480 acres, Parish of Dorchap.
 558, Mineral Search Licence; Roland Walton; 480 acres, Parish of Dorchap.
 559, Mineral Search Licence; Roland Walton; 478 acres, Parish of Dorchap.
 561, Mineral Search Licence; Roland Walton; 480 acres, Parish of Dorchap.
 567, Mineral Search Licence; Gordon Lewis, Thomas Francis Schubert and Hans John Veit; 50 acres, Parish of Canabore.
 573, Mineral Search Licence; Joseph Barca; 50 acres, Parish of Beremboke (in lieu of Mineral Search Licence No. 431, expired).
 578, Mineral Search Licence; Lindsay Gordon McRae; 50 acres, Parish of Buchan.
 584, Mineral Search Licence; James Say; 200 acres (in lieu of Mineral Search Licences Nos. 460, 461, 462 and 463, expired).
 586, Mineral Search Licence; Edward Arthur Knox; 28 acres, Parish of Enoch's Point (in lieu of Mineral Search Licence No. 465, expired).

MINERAL SEARCH LICENCE EXPIRED.

446, Mineral Search Licence; Barry Russell Hayes; 50 acres, Parish of Granton.

T. A. DARCY,
Minister of Mines.

MINING LEASES DECLARED VOID.

9193, Castlemaine; Paul Edward Clarke; 18a. 0r. 10p., Parish of Chewton.
 9201, Ballarat; North Deborah Mining Company No Liability; 285a. 1r. 20p., Parish of Moorarbool West.

E. CONDON,
Secretary for Mines.

STATE RIVERS AND WATER SUPPLY COMMISSION.

LICENCES TO DIVERT WATER AND CUT RACES, PURSUANT TO THE PROVISIONS OF THE WATER ACT 1958.

LICENCES as detailed hereunder to divert water and cut races have been revoked by the Governor in Council as from the dates shown :—

Licence No.	Name of Licensee.	Source of Supply.	Term of Licence and Commencing Date.	Date of Revocation.
43	Thomas William Spittal and Nancy Jean Spittal	Gunbower Creek ..	Fifteen years from 1.7.57 ..	30.6.64
45	Agnes Catherine Hewlett	Gunbower Creek ..	Fourteen and one half years from 1.1.58	30.6.64
61	Lawrence Herbert Fehring	Gunbower Creek ..	Fifteen years from 1.7.57 ..	30.6.64
72	Stella R. Poxon	Gunbower Creek (Turners Lagoon)	Fifteen years from 1.7.57 ..	30.6.64
99	Horace Daniel Paull and Edith Marjorie Paull (formerly Joseph Clarence Stanley and Edith Marjorie Paull)	Gunbower Creek ..	Fifteen years from 1.7.57 ..	30.6.64
103	Albert Thomas Easton	Gunbower Creek ..	Fifteen years from 1.7.57 ..	30.6.64
107	John H. Saville	Gunbower Creek ..	Fifteen years from 1.7.57 ..	30.6.64
110	Ernest David Garner	Gunbower Creek ..	Fifteen years from 1.7.57 ..	30.6.64
114	W. Phyland and Sons	Gunbower Creek ..	Fifteen years from 1.7.57 ..	30.6.64
124	Patrick Lancelot Keely (formerly K. Miller) ..	Gunbower Creek ..	Fourteen and one half years from 1.1.58	30.6.64
136	Ronald George Hancock	Gunbower Creek ..	Fifteen years from 1.7.57 ..	30.6.64
145	Ernest Wilson and Norman Wilson ..	Gunbower Creek ..	Fourteen and one half years from 1.1.58	30.6.64
146	Ernest Wilson and Norman Wilson ..	Gunbower Creek ..	Fourteen and one half years from 1.1.58	30.6.64
153	David Ernest Hipwell	Gunbower Creek ..	Fifteen years from 1.7.57 ..	30.6.64
154	George Arthur Hipwell	Gunbower Creek ..	Fifteen years from 1.7.57 ..	30.6.64
165	Ruby Emma Gallaway (formerly the Executors of the Estate of E. H. North)	Gunbower Creek ..	Fifteen years from 1.7.58 ..	30.6.64
167	Edward Bernard Mawson	Gunbower Creek ..	Fifteen years from 1.7.58 ..	30.6.64
174	Herbert William Richardson	Gunbower Creek ..	Fifteen years from 1.7.58 ..	30.6.64
182	Alexander Bruce Whitehead	Gunbower Creek ..	Fifteen years from 1.7.58 ..	30.6.64
197	Lawrence Herbert Fehring (formerly John Treacy Burke)	Gunbower Creek ..	Five years from 1.7.60 ..	30.6.64
198	John Raymond Bruns	Gunbower Creek ..	Fifteen years from 1.7.58 ..	30.6.64
203	Leslie Oliver Munzel	Gunbower Creek (Deep Creek)	Fifteen years from 1.7.58 ..	30.6.64
207	David Ernest Hipwell	Gunbower Creek ..	Fifteen years from 1.7.58 ..	30.6.64
216	Catherine Grey Leo	Gunbower Creek ..	Fifteen years from 1.7.58 ..	30.6.64
217	Catherine Grey Leo	Gunbower Creek (National Channel)	Fifteen years from 1.7.58 ..	30.6.64
224	Leslie Gordon Peace and Ethel Florence Peace (formerly Executors of Estate of Mary Jane Elizabeth Phyland)	Gunbower Creek ..	Fifteen years from 1.7.58 ..	30.6.64
310	Eric William Fenn	Gunbower Creek ..	Fifteen years from 1.7.59 ..	30.6.64
372	Arthur William Magee and Winifred May Magee	Gunbower Creek ..	Fifteen years from 1.7.57 ..	30.6.64
396	Douglas McDonald Russell	Gunbower Creek ..	Fifteen years from 1.7.57 ..	30.6.64
535/171	Thomas Dun Spittal	Gunbower Creek ..	Fifteen years from 1.7.58 ..	30.6.64
809/208	Leslie John Taylor	Gunbower Creek ..	Fifteen years from 1.7.58 ..	30.6.64
1221/154	Winifred May Magee	Gunbower Creek ..	Thirteen and one half years from 1.1.59	30.6.64
1245/154	Frederick James Hipwell	Gunbower Creek ..	Thirteen and one half years from 1.1.59	30.6.64
1257/172	James Geoffrey Russell	Gunbower Creek ..	Fifteen years from 1.7.59 ..	30.6.64
1444/339	Guisepe Di Bella and Rosa Di Bella ..	Gunbower Creek ..	Four years from 1.7.61 ..	30.6.64
1587/375	George Henry Hipwell	Gunbower Creek ..	Four years from 1.7.61 ..	30.6.64

Office of the State Rivers and Water Supply Commission,
Melbourne, 11th August, 1964.G. W. LEWIS, Acting Secretary,
State Rivers and Water Supply Commission.

STATE RIVERS AND WATER SUPPLY COMMISSION.

LICENCE TO DIVERT WATER, PURSUANT TO THE PROVISIONS OF THE WATER ACT 1958.

THE Licence as detailed hereunder to divert water has been revoked by the Governor in Council as from the date shown :—

Licence No.	Name of Licensee.	Source of Supply.	Term of Licence and Commencing Date.	Date of Revocation.
690	William Michael Shelley	Gunbower Creek ..	Four years from 1.7.61 ..	30.6.64

Office of the State Rivers and Water Supply Commission,
Melbourne, 11th August, 1964.G. W. LEWIS, Acting Secretary,
State Rivers and Water Supply Commission.

STATE RIVERS AND WATER SUPPLY COMMISSION.

LICENCES TO DIVERT WATER AND CUT RACES, PURSUANT TO THE PROVISIONS OF THE WATER ACT 1958.

THE Governor in Council has approved of the granting by the State Rivers and Water Supply Commission of licences as detailed hereunder for the term of years from the date specified in each case to the persons named in the following Schedule :—

SCHEDULE.

Licence No.	Term of Licence and Commencing Date.	Name and Address of Person to Whom Licence is to be Granted.	Source of Supply.	Area Authorized to be Irrigated Per Annum.	Volume of Water Authorized to be Diverted Per Annum.
				acres.	ac. ft.
291	One year from 1.7.64 ..	William John Campbell and Fanny Alison Campbell, Gunbower	Mount Hope Creek	..	1000
426	Six years from 1.7.64 ..	Vincenzo Di Mase, Mildura ..	River Murray ..	20	60
446	Six years from 1.7.64 ..	Eileen Mary Murrell, Colignan ..	River Murray ..	8	24
1888	Six years from 1.7.64 ..	Michael Patrick Breen, Shepparton ..	Goulburn River ..	100	200
1889	Six years from 1.7.64 ..	Malcolm Ritchie Macrae and Eileen Nellie Macrae, Caulfield	Goulburn River ..	50	100
1890	Fifteen years from 1.7.64..	Alfred Ernest Jarvis, Kergunyah ..	Kiewa River ..	25	50
1891	Fifteen years from 1.7.64 ..	Albert Gay Seymour, Tawonga Road-side	Kiewa River ..	25	50
1892	Seven years from 1.7.63 ..	Apex Park Committee, Mildura ..	River Murray	3
1893	Seven years from 1.7.63 ..	Ronald Henry Ferguson, Nichols Point	River Murray ..	8	24
1894	Seven years from 1.7.63 ..	Neil Smith Macfarlane, Wemen ..	River Murray ..	100	300
1895	Seven years from 1.7.63 ..	Reinhold Edwin Rohde, Mildura ..	River Murray ..	16½	50
1896	Six years from 1.7.64 ..	Jack Melbourne Taylor, Barnawartha	River Murray (Ana-Branch)	30	60
1897	Six years from 1.7.64 ..	Roy Vernon Wilson, Cobram ..	River Murray ..	25	50

Office of the State Rivers and Water Supply Commission,
Melbourne, 11th August, 1964.

G. W. LEWIS, Acting Secretary,
State Rivers and Water Supply Commission.

MITCHELL RIVER IMPROVEMENT TRUST.

RATING BY-LAW No. 7.

THE Mitchell River Improvement Trust, in pursuance and exercise of the powers conferred by the River Improvement Act 1958, doth hereby make the By-law following:—

1. The following rate, to be called the "Mitchell River Improvement District River Improvement Rate" is hereby made and shall be levied upon the occupiers or owners of all properties within the Mitchell River Improvement District which are rateable to any municipality:—

A rate of Seven pence in the pound on the net annual municipal value of all those properties within the First Division as determined by Order in Council made on the 14th January, 1964, and published in the *Government Gazette* of the 15th January, 1964, being those lands shown coloured green on the plan titled "Mitchell River Improvement Trust Proposed Rating Divisions", approved by the Governor in Council and deposited at the Office of the State Rivers and Water Supply Commission, at Melbourne. (Corres. No. 60/263/25). Provided that the sum of One shilling shall be the minimum amount payable in respect of any property liable to be rated in the said Division.

A rate of Five pence in the pound on the net annual municipal value of all those properties within the Second Division, being those lands shown coloured brown on the said plan. Provided the sum of One shilling shall be the minimum amount payable in respect of any property liable to be rated in the said Division.

A rate of Four pence in the pound on the net annual municipal value of all those properties within the Third Division, being those lands shown coloured yellow on the said plan. Provided that the sum of One shilling shall be the minimum amount payable in respect of any property liable to be rated in the said Division.

2. Such rates are made and shall be levied for the period beginning on the 1st day of January, 1964, and ending with the 31st day of December, 1964, and shall be payable on the 12th day of August, 1964, at the office of the Mitchell River Improvement Trust, Nicholson-street, Bairnsdale.

3. Such person or persons as the Mitchell River Improvement Trust may from time to time appoint for the purpose shall be and is or are hereby authorized to demand, receive, collect and recover the said rate.

The foregoing By-law was made by the Mitchell River Improvement Trust on the 8th day of June, 1964, and the

Common Seal of the said Trust was hereunto affixed, this 8th day of June, 1964.

(SEAL) W. H. DUMARESQ, Chairman.
T. H. DAVISON, Commissioner.
J. B. NEALE, Secretary.

Approved by the Governor in Council, 11th August, 1964.—J. COLQUHOUN, Clerk of the Executive Council.

Water Acts.

STATE RIVERS AND WATER SUPPLY COMMISSION.
DANDENONG—SPRINGVALE, CARRUM DOWNS, PAKENHAM,
WESTERNPORT AND CRANBOURNE URBAN DISTRICTS.

NOTICE to owners of tenements in the under-mentioned streets in the above-mentioned Urban Districts and the private streets, lanes, courts and alleys opening thereto:—

DANDENONG—SPRINGVALE URBAN DISTRICT.

Dandenong.

Cullimore-court, lots 4, 3, 2, 1 9, 10, 11 and 12.

CARRUM DOWNS URBAN DISTRICT.

Clifton-grove, from end of existing main (opposite lot 6 on lodged plan of subdivision No. 4911) to a point opposite lot 7 and about 7 chains northerly from Pagett-road.

PAKENHAM URBAN DISTRICT.

King-street, from end of existing main (8½ chains north of Henry-street) to the Princes Highway.

WESTERNPORT URBAN DISTRICT.

Hastings.

Pinewood-drive, from end to existing main opposite lot 52 to a point opposite lot 56 about 3 chains westerly from Penshurst-avenue.

CRANBOURNE URBAN DISTRICT.

Binding-avenue, from Carol-avenue to Campbell-parade.
Campbell-parade, from Binding-avenue to a point opposite lot 337, about 4½ chains westerly.
Carol-avenue.

The main pipe in the said streets being laid down, the owners of all tenements situated as above are hereby required, on or before the 12th day of September next, to cause proper pipes and stop cocks to be laid, so as to supply water within such tenements from the main pipe.

G. W. LEWIS, Acting Secretary,
State Rivers and Water Supply Commission.

Melbourne, 7th August, 1964.

State Electricity Commission Acts.

ELECTRICAL APPROVALS BOARD.

PURSUANT to Regulation 16 of the Electrical Approvals Regulations—Approval of Equipment, 1953, the State Electricity Commission of Victoria hereby gives notice that it has withdrawn approval of the under-mentioned articles as from 24th July, 1964 :—

Name of Applicant.	Article and Reference No.	Date of Certificate of Approval.	Approvals Marking.
Philips Electrical Industries Pty. Ltd.	Razor, Trade Name "Philishave", Cat. No. SC7800, 200/250 volts, 8 watts, AW/KG/05	7.9.56	S/24
Philips Electrical Industries Pty. Ltd.	Razor, Trade Name "Philips", Cat. No. SC7780, 220 volts, 6 watts, AW/KG/06	6.12.57	S/24
Philips Electrical Industries Pty. Ltd.	Razor, Trade Name "Philishave", Cat. No. SC7800, 200/250 volts, 8 watts, AW/KG/07	10.7.59	S/24
Philips Electrical Industries Pty. Ltd.	Razor, Trade Name "Philips", Cat. No. SC7860, 200/250 volts, 6 watts, AW/KG/08	9.9.60	S/24
Philips Electrical Industries Pty. Ltd.	Razor, Trade Name "Philips", Cat. No. SC7911G, 200/250 volts, 6 watts, AW/KG/09	9.9.60	S/24
Philips Electrical Industries Pty. Ltd.	Razor, Trade Name "Philishave Speedshaver", Cat. No. SC7950, 200/250 volts, 8 watts, AW/KG/10	6.2.61	S/24
F. B. Lippman and Son Pty. Ltd. . .	Table Lamp, Trade Name "Beecher", Cat. No. 220A, 230 volts, BK/SO/01	21.11.57	S/34
F. B. Lippman and Son Pty. Ltd. . .	Spotlight, Trade Name "Beecher", Cat. No. 94, 230 volts, BK/SO/02	21.11.57	S/34
F. B. Lippman and Son Pty. Ltd. . .	Table Lamp, Trade Name "Beecher", Cat. No. 281, 230 volts, BK/SO/06	21.11.57	S/34
D. G. Lockwood and Co. Pty. Ltd.	Table Lamp, Trade Name "Daydream", Cat. No. SD42, 240 volts, BK/TA/01	30.12.57	S/6
D. G. Lockwood and Co. Pty. Ltd.	Table Lamp, Trade Name "Daydream", Cat. No. SD41, 240 volts, BK/TA/02	30.12.57	S/6
D. G. Lockwood and Co. Pty. Ltd.	Table Lamp, Trade Name "Daydream", Cat. No. SD35, 240 volts, BK/TA/03	30.12.57	S/6
D. G. Lockwood and Co. Pty. Ltd.	Table Lamp, Trade Name "Daydream", Cat. No. SD33, 240 volts, BK/TA/04	30.12.57	S/6
D. G. Lockwood and Co. Pty. Ltd.	Bed Lamp, Trade Name "Daydream", Cat. No. SD29, 240 volts, BK/TA/05	30.12.57	S/6
D. G. Lockwood and Co. Pty. Ltd.	Bed Lamp, Trade Name "Daydream", Cat. No. SD23, 240 volts, BK/TA/06	30.12.57	S/6
D. G. Lockwood and Co. Pty. Ltd.	Table Lamp, Trade Name "Daydream", Cat. No. SD21, 240 volts, BK/TA/07	30.12.57	S/6
D. G. Lockwood and Co. Pty. Ltd.	Table Lamp, Trade Name "Daydream", Cat. No. SD16, 240 volts, BK/TA/08	30.12.57	S/6
D. G. Lockwood and Co. Pty. Ltd.	Desk Lamp, Trade Name "Daydream", Cat. No. SD7, 240 volts, BK/TA/10	30.12.57	S/6
D. G. Lockwood and Co. Pty. Ltd.	Bed Lamp, Trade Name "Daydream", Cat. No. SD2, 240 volts, BK/TA/11	30.12.57	S/6
D. G. Lockwood and Co. Pty. Ltd.	Table Lamp, Trade Name "Daydream", Cat. No. SD12, 240 volts, BK/TA/12	30.12.57	S/6
D. G. Lockwood and Co. Pty. Ltd.	Bed Lamp, Trade Name "Daydream", Cat. No. SD4, 240 volts, BK/TA/13	30.12.57	S/6
D. G. Lockwood and Co. Pty. Ltd.	Bed Lamp, Trade Name "Daydream", Cat. No. SD69/2, 240 volts, BK/TA/14	30.12.57	S/6
D. G. Lockwood and Co. Pty. Ltd.	Table Lamp, Trade Name "Daydream", Cat. No. SD62, 240 volts, BK/TA/15	5.9.58	S/6
D. G. Lockwood and Co. Pty. Ltd.	Bed Lamp, Trade Name "Daydream", Cat. No. SD69/1, 240 volts, BK/TA/16	5.9.58	S/6
D. G. Lockwood and Co. Pty. Ltd.	Bed Lamp, Trade Name "Daydream", Cat. No. SD74/1, 240 volts, BK/TA/19	11.2.59	S/6
D. G. Lockwood and Co. Pty. Ltd.	Bed Lamp, Trade Name "Daydream", Cat. No. SD67/1, 240 volts, BK/TA/29	8.8.60	S/6

Dated the tenth day of August, 1964.

L. G. MORRISON, Secretary.

PUBLIC TRUSTEE ACT 1958 (No. 6350).—SECTION 17.

I HEREBY give notice that on the 23rd July, 1964, the Public Trustee filed elections to administer the following deceased persons' estates, in accordance with section 17 of the Public Trustee Act 1958:—

ALFORD, JOSEPH WILLIAM, formerly of Ward 4 North, Royal Melbourne Hospital, Melbourne, but late of Mount Royal, Parkville, pensioner, died 18th May, 1964.

BALL, FRANK BRADBROOK, late of 9 Gray-court, Beaumaris, in the will referred to as 9 Grey's-court, Beaumaris, retired gardener, died 6th June, 1964.

BELL, EMMA, formerly of 21 Anderson-street, Thornbury, late of Daysdale, via Corowa, N.S.W., widow, died 14th March, 1964.

BENNIE, WILLIAM MURCHISON, formerly of 5A Sunbry-crescent, Surrey Hills, but late of 74 Bendigo-street, Richmond, retired cabinet maker, died 19th November, 1963.

BLAIM, ALFRED, late of 51 Union-street, Brunswick, painter, died 3rd June, 1964.

FERRIS, ALEXANDER, formerly of Flat 20, Judge Book Village, Eltham, but late of 17 Neptune-street, Mornington, retired technician, died 30th March, 1964.

GLEESON, EDITH, late of Bendigo Home and Hospital for the Aged, Bendigo, widow, died 24th December, 1962.

PITTOCK, KENNETH NEIL, formerly of 18 Dixon-street, Mentone, but late of 8 Rochester-street, Kew, wood machinist with the R.A.A.F., died 18th December, 1963.

SMITH, HARRY GRENFELL, late of 9 Burnell-street, West Brunswick, motor mechanic, died 28th May, 1964.

WELLS, GRACE GRIMMOND, late of 47 Wilgah-street, East St. Kilda, married woman, died 27th April, 1964.

A. D. DUNCAN,
Public Trustee.

256 Flinders-street, Melbourne, C.1, 5th August, 1964.

NOTICE.

CREDITORS, next of kin and others having claims against the estate of any of the under-mentioned deceased persons are required to send particulars of their claims to the Public Trustee, 256 Flinders-street, Melbourne, the personal representative, on or before the 13th October, 1964, after which date the Public Trustee may convey or distribute the assets, having regard only to the claims of which the Public Trustee then has notice:—

ALFORD, JOSEPH WILLIAM, formerly of Ward 4 North, Royal Melbourne Hospital, Melbourne, but late of Mount Royal, Parkville, pensioner, died 18th May, 1964.

BALL, FRANK BRADBROOK, late of 9 Gray-court, Beaumaris, in the will referred to as 9 Grey's-court, Beaumaris, retired gardener, died 6th June, 1964.

BELL, EMMA, formerly of 21 Anderson-street, Thornbury, late of Daysdale, via Corowa, N.S.W., widow, died 14th March, 1964.

BENNIE, WILLIAM MURCHISON, formerly of 5A Sunbury-crescent, Surrey Hills, but late of 74 Bendigo-street, Richmond; retired cabinet maker, died 19th November, 1963.

BLAIM, ALFRED, late of 51 Union-street, Brunswick, painter, died 3rd June, 1964.

FERRIS, ALEXANDER, formerly of Flat 20, Judge Book Village, Eltham, but late of 17 Neptune-street, Mornington, retired technician, died 30th March, 1964.

FRIE, ALBERT CHARLES, late of 26 Dean-street, East Preston, retired salesman, died 17th April, 1964.

GLEESON, EDITH, late of Bendigo Home and Hospital for the Aged, Bendigo, widow, died 24th December, 1962.

HANRAHAN, MARGARET, formerly of Yea, but late of 24 Chelsea-road, Chelsea, school teacher, died 17th January, 1963.

HOGAN, ADA MARY, formerly of 34 Bishop-street, East Oakleigh, late of 23 Gadd-street, Oakleigh, widow, died 16th February, 1964.

IAEGER, LOUIS EDMOND, late of 10 Manning-road, East Malvern, retired chief clerk, died 26th December, 1963.

KING, GEORGE, late of 4 York-street, St. Kilda, costs clerk, died 13th April, 1964.

MALONEY, STEPHEN JAMES, late of 63 Oakbank-street, Newport, retired railway employee, died 10th May, 1964.

NORRIS, EDWARD, late of Westport, New Zealand, retired sawmiller, died 4th October, 1963.

PITTOCK, KENNETH NEIL, formerly of 18 Dixon-street, Mentone, but late of 8 Rochester-street, Kew, wood machinist with the R.A.A.F., died 18th December, 1963.

REID or ALLEN, EMMA IMRAY, late of 23 Brebner-crescent, Aberdeen, Scotland, married woman, died 21st November, 1963.

RIPPER, ROWLAND VIVIAN, late of 6 Shepreth-street, Surrey Hills, retired superintendent of police, died 1st May, 1964.

SMITH, HARRY GRENPELL, late of 9 Burnell-street, West Brunswick, motor mechanic, died 28th May, 1964.

STELLIN, JAMES, late of Wellington, New Zealand, estate agent, died 4th April, 1964.

STEWART, HERBERT VICTOR JAMES, sometimes known as Herbert Victor Stewart, late of Mount Royal Home for the Aged, Parkville, retired public servant, died 28th April, 1964.

UHR-HENRY, HARRY BRUCE, late of 2 Mallum-avenue, Frankston, paymaster, died 25th January, 1964.

VOUTIER, GEORGE EDWARD, late of 385 Elgar-road, Box Hill, pensioner, died 5th October, 1963.

WELLS, GRACE GRIMMOND, late of 47 Wilgah-street, East St. Kilda, married woman, died 27th April, 1964.

WHITCHELL, JESSIE DORIS IRENE, formerly of 22 Hutcheson-street, Moonee Ponds, but late of Perpetua Private Hospital, 673 Lygon-street, North Carlton, widow, died 20th May, 1964.

WILLIAMS, HELENA, late of 32 Castlemaine-street, Yarra-ville, widow, died 26th May, 1964.

A. D. DUNCAN,
Public Trustee.

Melbourne, 5th August, 1964.

Melbourne and Metropolitan
BOARD OF WORKS.

NOTICE TO THE OWNERS OF TENEMENTS IN THE UNDER-MENTIONED STREETS, AND THE PRIVATE STREETS, LANES, COURTS AND ALLEYS OPENING THERETO.

THE main pipe in the said streets being laid down, the owners of all tenements situated as under are hereby required, on or before the 14th September, 1964, to cause a proper pipe and stop cocks to be laid so as to supply water within such tenements from the main pipe.

H. J. SNADDEN,
Secretary.

4th August, 1964.

STREET AND POSITION.

Broadmeadows.

Bates-court, from Sunset Boulevard southwards 8 chains.

Camberwell.

Wattle Valley-road, from Kalang-street to Nevis-street.

Coburg.

Hocking-street, from Pallett-street eastwards 4½ chains.

Lily-avenue, from Guilfoyle-avenue to Audrey-avenue.

Doncaster and Templestowe.

Atkinson-street, from Mahoney-street westwards 11 chains.
Mahoney-street, from Atkinson-street southwards 11 chains.

Eltham.

Henry-street, from Bible-street to Grey-street.
Grey-street, from Henry-street to York-street.
Leslie-court, from Longs-road north-eastwards 5½ chains.

Melbourne.

Barry-lane, from Little Bourke-street northwards 2½ chains.

Moorabbin.

Jennifer-street, from Cavanagh-street eastwards 13½ chains.
Shadwell-street, from Silver-street to Jennifer-street.
Fordyce-street, from Silver-street to Jennifer-street.

Nunawading.

Fulton-road, from Blackburn-road to Adrian-street.
Adrian-street, from Fulton-road northwards 4½ chains.
Adrian-street, from Fulton-road southwards 5½ chains.
Mahoneys-road, from 1½ chains south of Flora-street southwards 30½ chains.

Bindy-street, from Mahoneys-road westwards 3 chains.
Lee-Ann street, from Mahoneys-road westwards 3 chains.

Paul-road, from Mahoneys-road to Barter-crescent.

Barter-crescent, from Paul-road southwards 14½ chains.

Barter-crescent, from Paul-road northwards 15½ chains.

Norma-road, from Barter-crescent eastwards 2 chains.

Lenna-street, from Crow-street to Hilltop-crescent.

Hilltop-crescent, from Lenna-street southwards and westwards 8½ chains.

Hilltop-crescent, from Lenna-street northwards 9 chains.

Taylor-street, from Hilltop-crescent westwards 3½ chains.

Reedwood-avenue, from Hilltop-crescent westwards 3½ chains.

Right-of-way, from 2 chains west of Brentford-square, from Canterbury-road to Sherman-street.

Sherman-street, from Brentford-square westwards 3 chains.

Brentford-square, from Sherman-street northwards 1½ chains.

Quentin-street, from 3 chains south of Parkmore-road southwards 1½ chains.

Olympic-court, from Glebe-street westwards 4½ chains.

Sherman-street, from Leddy-street eastwards 5½ chains.

Leddy-street, from Sherman-street southwards 3½ chains.

Jocelyn-court, from end of existing main opposite lot 25, westwards ½ chain.

Preston.

Eileen-street, from Tyler-street southwards 1½ chains.

Springvale.

Kerrison-avenue, from Comber-street to Heatherton-road.
Douglas-street, from Shepreth-avenue south-eastwards 6½ chains.

Simpson-street, from Heatherton-road to Walsh-street.

Waverley.

Garrison-drive, from Gallaghers-road westwards 15 chains.
Sunvalley-avenue, from Gallaghers-road to Driftwood-drive.

Driftwood-drive, from Sunvalley-avenue to Garrison drive.

Wattle-tree-court, from Garrison-drive southwards 4½ chains.

Ricketts-road, from Foster-road to Gilby-road.

Gilby-road, from Ricketts-road southwards 8½ chains.

Watsons-road, from Waverley-road southwards 16½ chains.

Joyce-avenue, from Waverley-road southwards 16½ chains.

Roberts-road, from Joyce-avenue westwards 9 chains.

Dion-road, from Roberts-road southwards 5 chains.

Roland-street, from Darbyshire-road northwards 5½ chains.

Caledonia-crescent, from Wattle-grove eastwards, southwards and westwards to Wattle-grove.

Lewis-street, from Purse-street to Jubilee-street.

Jubilee-street, from Essex-road northwards 10½ chains.

Cratloe-road, from Bengal-crescent northwards 9½ chains.

Bengal-crescent, from Jubilee-street eastwards, northwards and westwards to Cratloe-road.

Whittlesea.

Mahoneys-road, from Hughes-parade to Industrial-avenue.

MOTOR CAR ACT 1958, SECTION 19.

NOTICE is hereby given that, for the purpose of section 19 of the Motor Car Act 1958, the Veteran Car Club of Victoria and the Vintage Drivers' Club Limited are approved as associations to organize and conduct official rallies of veteran motor cars and vintage motor cars, respectively.

R. H. ARNOLD,
Chief Commissioner of Police.

CONTRACTS ACCEPTED.—(Series 1963-64.)

PUBLIC WORKS.

5395. Glen Waverley, High School, asphaltting, concreting, drainage and associated works, £17,463 3s. 5d.—Wm. Loud Pty. Ltd.
5396. Yallourn, Technical School, new road, asphalt paving, drainage, retaining walls, &c., diploma block, £13,070.—Kennedy Haulage Pty. Ltd.
5397. Ararat, Mental Hospital, supply and installation of exhaust ventilation and sink heaters in toilets, concert hall, £381.—D. M. Beaumont.
5398. Ballarat, Mental Hospital, supply and installation of heating to south side room of former laundry, £726.—J. L. Wilson.
5399. Bellfield, State School No. 4656, provision of internal female staff toilet and store-room, £540 14s. 10d.—J. Brown.
5400. Brighton, High School, additional girls' toilets, £2,150 10s.—Egeberg Building & Plumbing Service.
5401. Camberwell, State School No. 888, renewal of timber floors, class-rooms 1 and 2, £525.—L. F. Hillyear.
5402. Casterton, High School, supply, installation of extensions to the central heating and hot water service, £7,551.—Ford-Swinton Industries Pty. Ltd.
5403. Cheltenham Heights, State School No. 4930, electrical installation in new school of ten (10) L.T.C. class-rooms, &c., £1,550.—Chadstone Electrical Services.
5404. Coburg, High School, supply and installation of extension of heating system, £851.—J. Wilson.
5405. Coburg, Bell-street, Health Department, T.B. Clinic, supply, installation, testing and maintenance of heating and hot water services, £7,790.—Frederick W. Nielsen Pty. Ltd.
5406. Cocoroc, State School No. 3230, renovations and repairs to school and residence, £1,292.—N. Peshut.
5407. Croydon West, State School No. 4879, asphaltting, concreting, drainage and associated works, £6,343 13s.—J. H. Nichols.
5408. Eltham, Police Station Residence, new fencing, renovations and painting, £891.—L. J. Jessop.
5409. Frankston Forest, State School No. 4872, construction of surface and underground drains, pedestrian pavements in asphalt, concrete and gravel and associated works, £8,800 9s. 6d.—J. H. Nichols.
5410. Fyans Park, State School No. 4919, supply and installation of plenum heating in new four class-room school, £1,875.—D. M. Beaumont.
5411. Healesville, State School No. 849, repairs and painting to school and residence, £695.—K. Helstrup.
5412. Heidelberg West, State School No. 4267, internal toilet (Infant Section), £360 10s.—C. McCarthy.
5413. Inverloch, Police Station, electrical installation, £275.—D. R. Ross.
5414. Larundel, Mental Hospital, electrical reticulation to Wards M.8, 9, 10 and 11, £1,268.—H. C. Marshall & Co. Pty. Ltd.
5415. Kew, Mental Hospital, supply and erection of pipe and chain mesh fencing, Special School, Children's Cottages, £445.—Diamond Fence & Gate Co. Pty. Ltd.
5416. Kingsbury, State School No. 4845, plenum heating for four class-rooms, £1,818.—Bruce Sheet Metal Service.
5417. Koo-Wee-Rup, High School, supply and installation of heating and hot water systems and L.P. gas, £9,920.—Thermic Heating & Ventilation.
5418. Melbourne, Crown Law Department, Offices, 459 Lonsdale-street, renewal of fire service, £630.—Victory Plumbing Services Pty. Ltd.
5419. Melbourne, 605 Flinders-street Extension, Fisheries and Wildlife Department, provision of new covered way to staircases and external and internal repairs and painting, £799.—Goldspink Bros. & Jones.
5420. Melbourne, Russell-street Police Headquarters, electrical installation in Deputy and Assistant Commissioners' Offices, £565 15s.—A. E. Stone.
5421. Melbourne, Police Depot, St. Kilda-road, attention to roof and external painting, £3,086.—S. Jokic.
5422. Melbourne, Secondary Teachers' Hostel, 572 St. Kilda-road, new spouting and miscellaneous repairs, £488 13s.—W. K. Murphy.
5423. Melton, State School No. 430 and Residence, renovations to school and residence, £1,122 10s.—J. A. Macpherson.
5424. Mont Park, Mental Hospital, renewal of electrical installation for Ward F.15, £1,770.—R. A. Waldron Trading Co.
5425. Rosebrook, State School No. 526 Residence, internal and external painting and repairs, £323 6s.—R. E. D. Smith.
5426. Rosebud, State School No. 2627, electrical installation for five (5) L.T.C. additional class-rooms, £641 13s.—D. A. Christie.
5427. Royal Park, Mental Hospital, supply, delivery and fixing on site of new stainless steel benchwork for new kitchen, £1,758 7s. 6d.—E.G.A. (S. Cunningham) Pty. Ltd.
5428. Royal Park, Mental Hospital, supply and erection of Directional Signs, £280 4s. 6d.—Plastic Price Ticket Co. (Aust.) Pty. Ltd.
5429. Rye, Police Office and Residence, electrical installation, £345.—D. R. Ross.
5430. Shepparton, Girls' Secondary School, chain mesh fence and gates, £1,461.—Diamond Fence & Gate Co. Pty. Ltd.
5431. Sunbury, Mental Hospital, replacement of ceilings in Ward F.6, £257.—L. W. Friezer.
5432. Sunbury, Mental Hospital, renewal of sewer line at Ward F.3, £645.—L. W. Friezer.
5433. Sunshine West, High School, electrical installation in extended Stage 3, £3,300.—R. W. Hodgson & Co.
5434. Sunshine West, High School, supply and installation of extensions to the central heating and hot water systems, £5,294.—Sandilux Pty. Ltd.
5435. Tamleugh North, State School No. 2453, fencing, £514.—W. G. Blake.
5436. Traragon, Technical School, site works including concrete paving, asphalt paving, drainage, &c., £7,212.—P. McNulty & J. W. Rumble.
5437. Warragul, Technical School, extension of hot water services to new cafeteria, £421.—J. L. Wilson.
5438. Watsonia, Technical School, provision of store-room, £250.—C. McCarthy.
5439. Waverley, High School, internal and external repairs and renovations, £7,500.—North Essendon Painting Service.
5440. Werribee, State School No. 649, Residence, 25 Jellicoe-street, connexion to sewerage, £255 12s.—R. & H. Rivett.
5441. Wheeler's Hill, Social Welfare Department, Family Division, Jells-road, provision of additional storage space under building, £463 10s.—K. L. Ward.
5442. Williamstown, Technical School, electrical installation in extensions to second and third sections, £3,526 10s.—K. J. Dupuy.
5443. Williamstown, Technical School, supply and installation of heating, hot water service, exhaust fans and fume cupboard exhaust systems, £2,770.—Bruce Sheet Metal Service.
5444. Willenabrina, State School No. 2632, new out-offices, install septic tank, £1,330.—C. L. Hobson.
5445. Westall, High School and State School No. 4851, asphaltting, concreting, drainage and associated works, £19,177.—G. Pelletier Pty. Ltd.
5446. Bairnsdale, Technical School, repairs and painting to residence, 38 Wallace-street, £545.—T. Lambert.
5447. Ballarat North, State School No. 4690, site works, £350.—R. Coffield.
5448. Ballarat, School of Mines, external painting to plumbing shop, £369.—Ballarat Colour Centre.
5449. Ballarat, Mental Hospital, removal and renovations to shelter sheds, £375.—A. & B. Oswald Pty. Ltd.
5450. Bethanga, Police Station, provision of a new toilet, £323.—Stone Bros. Pty. Ltd.
5451. Boort, High School, erection of timber-framed residence and garage, £6,342 10s.—Pope & Derby.
5452. Casterton, State School No. 2058, concrete paving, asphalt repairs and drainage, £948 0s. 6d.—A. E. Mapleback.
5453. Cavendish, State School No. 116 and residence, site works, asphalt, concrete, gravel paving, asphalt repairs, &c., £1,696 8s. 9d.—A. E. Mapleback.
5454. Cheshunt South, State School No. 3076, installation of septic tank and new toilets, £998 10s.—B. B. & O. E. Walker.
5455. Darraweit Guim, State School No. 878, electric hot water service to residence, £258.—J. Phillipson.
5456. Edenhope, High School, erection of timber residence and garage, £4,600.—G. Lenneth.
5457. Euroa, High School, connexion to sewer &c., £2,520.—Stone Bros. Pty. Ltd.
5458. Footscray West, State School No. 3890, erection of fencing and fencing repairs, £442.—A.A.A. Fencing Contractors.
5459. Foster, Consolidated School, removal and re-erection of shelter shed and equipment, £265.—P. J. O'Brien.
5460. Hamilton, State School No. 295, Residence, 83 Stephen-street, internal repairs and painting, £330 2s. 6d.—J. & M. Wilkinson (Ham.) Pty. Ltd.
5461. Hastings, State School No. 1098 and Residence, renovations and painting, £2,124.—D. B. Tincknell Pty. Ltd.
5462. Hawthorn West, State School No. 293, earthworks, drainage, asphaltting, concreting and associated works, £2,351 7s. 11d.—Wm. Loud Pty. Ltd.
5463. Horsham, State School No. 298, general renovations, £2,599 4s.—Geo. Lange & Sons Pty. Ltd.
5464. Horsham, Police Station, repairs and painting, £2,215 12s.—Geo. Lange & Sons Pty. Ltd.
5465. Janeffield, Mental Hospital, electrical installation in new boiler house, £686.—R.Y.M. Electrical Contractors & Engineering Co. Pty. Ltd.

5466. Kingsbury, State School No. 4845, electrical installation in new block of four (4) class-rooms, &c., £849 16s.—K. J. Dupuy.

5467. Kingsville, State School No. 3988, renewal of pans, cisterns, seats and part of water service, £646.—D. W. & M. W. McAuslan Pty. Ltd.

5468. Koo-Wee-Rup, State School No. 2629, erection of timber-framed residence and garage, £4,790.—G. Rossetti.

5469. Melbourne, various Public Offices, clearing of refuse and collection of garbage, 1st July, 1964 to 30th June, 1965, £2,804.—Industrial Waste Collection (Vic.) Pty. Ltd.

5470. Melbourne, Head Office, Department of Labour and Industry, 100 Exhibition-street, maintenance cleaning, 1st June, 1964 to 31st May, 1965, £3,408.—Utility Office Cleaning Services Pty. Ltd.

5471. Melbourne, Fisheries and Wildlife Department, 605 Flinders-street Extension, maintenance cleaning, 1st June, 1964 to 31st May 1965, £2,292.—Utility Office Cleaning Services Pty. Ltd.

5472. Melbourne, Childrens Court and Clinic, Batman-avenue, maintenance cleaning, 1st June, 1964 to 31st May, 1965, £1,000.—Utility Office Cleaning Services Pty. Ltd.

5473. Melbourne & Suburbs, various Government buildings, chimney sweeping, 1st July, 1964 to 30th June, 1965 inclusive, at rates.—R. M. Evans.

5474. Molesworth, State School No. 2233, internal and external repairs to school, residence and out-buildings, £1,654.—H. E. Prett.

5475. Nhill, High School, roof repairs, "Bristol" building, £1,398.—D. B. Tincknell Pty. Ltd.

5476. Parkdale, State School No. 4171, new staff-room, toilet and store, £2,155.—D. B. Tincknell Pty. Ltd.

5477. Preston, Mental Health Authority, Pleasant View Receiving Home, renovations to kitchen, £280.—A. La Rovere.

5478. Royal Park, Mental Hospital, supply and fix new terra cotta tile roof at Male Wards, Park Wards, £303.—Wunderlich Limited.

5479. Royal Park, Mental Hospital, supply and installation of modifications to steam, condensate heating and hot water services to Administration Building, main kitchen and female Convalescent Ward "A", £3,675.—B. H. Thermal-Air Engineering.

5480. Russells Bridge, State School No. 530, septic tank and bore water supply, £1,560 10s.—R. Dragt.

5481. Rutherglen, Court House, fencing, party and non-party, £348.—L. F. Dalton.

5482. Shepparton, Lands and Survey Department, residence, repairs and repainting, £1,289.—N. L. Pinder.

5483. Shepparton, Technical School, residence, provision of timber garage with brick front, £397 12s.—N. L. Pinder.

5484. South Melbourne, J. H. Boyd Girls' School Domestic College, provision of stainless steel drinking troughs, £275 3s. 6d.—Meginess and Sons.

5485. South Yarra, Royal Botanic Gardens, supply and erection of a Waldor Greenhouse, £1,602 19s. 9d.—Banyule Australia Pty. Ltd.

5486. South Yarra, Mental Health Authority, Observatory Buildings, Domain-road, maintenance cleaning, 1st June, 1964 to 31st May, 1965, £884.—Utility Office Cleaning Services Pty. Ltd.

5487. Terang, High School, residence, internal renovations, £297.—Thomas Aitken.

5488. Truganina, Chief Secretary's Office, Explosives Reserve, erection of fencing, £4,070.—A.A.A. Fencing Contractors.

5489. Yea, High School, conversion of store to servery, £525.—W. J. Clay.

5490. Yea, Land and Survey Department, residence, septic installation, £271 18s.—H. G. Clements.

MURRAY PORTER, Commissioner of Public Works, 4.8.64.

CONTRACTS ACCEPTED.—(Series 1964-65.)

VICTORIAN RAILWAYS.

11. Manufacture, supply and delivery of disc wheels, at £35 15s. each, F.O.R. South Brisbane (Contract 62600).—Bradford Kendall Ltd. 12. Manufacture, supply and delivery of Rigid Urethane Foam, at rates (Contract 62594).—Korthane Pty. Ltd. 13. Construction and erection of mild steel verandah extensions (for use over platforms No. 1 Spencer-street Station), for £977 15s. 10d. (Contract 62611).—Viac Products Pty. Ltd.

By order of the Victorian Railways Commissioners.

W. WALKER,
Secretary for Railways.

Melbourne, 7th August, 1964.

GENERAL STORES.

Gazette No. 62, 9th July, 1964. For the rates shown opposite the items in the respective schedules, substitute the rates as set out hereunder:—

Schedule No. 37, Electric Lamps, Accessories, &c. Item No. 80, £1 17s.; Item No. 83, £2 19s. 7d.; Item No. 84, £2 14s. 2d.; Item No. 85, £2 10s. 7d.; Item No. 86, £4 0s. 5d.; Item No. 87, £5 15s. 9d.; Item No. 88, £7 0s. 9d.; Item No. 89, £9 2s. 11d.; Item No. 90, 17s. 3d.; Item No. 91, £1 10s. 11d.; Item No. 92, £1 4s. 10d.; Item No. 93, £1 14s. 1d.; Item No. 94, £2 5s. 11d.; Item No. 95, £3 4s. 7d.; Item No. 99, £12 18s. 2d.; Item No. 100, £25 15s. 4d.; Item No. 101, £1 17s.; Item No. 102, £2 14s. 2d.; Item No. 103, £2 8s.; Item No. 104, £2 19s. 7d.; Item No. 105, £2 14s. 2d.; Item No. 108, £5 15s. 9d.; Item No. 110, £9 2s. 11d.; Item No. 122, £5 5s. 3d.; Item No. 123, £6 17s. 4d.; Item No. 124, £6 1s. 10d.; Item No. 125, £8 1s. 4d. per coil of 100 yards, as from 27th July, 1964.

Schedule No. 48, Iron (galvanized). Item No. 1, £102 17s. 9d.; Item No. 2, £102 17s. 9d.; Item No. 3, £104 8s. 5d.; Item No. 4, £107 9s. 10d.; Item No. 5, £112 9s. 1d.; Item No. 6, £108 1s. 8d.; Item No. 7, £108 1s. 8d.; Item No. 8, £108 1s. 8d.; Item No. 9, £109 5s. 4d.; Item No. 10, £109 5s. 4d.; Item No. 11, £109 5s. 4d., as from 1st August, 1964. Rates are per ton for lots of 1 to under 10 tons. Rates for lots under 1 ton; Item Nos. 1 and 2, £105 4s. 11d.; Item No. 3, £106 16s. 4d.; Item No. 4, £109 19s. 2d.; Item No. 5, £115 0s. 8d.; Item Nos. 6, 7 and 8, £110 11s. 3d.; Item Nos. 9, 10 and 11, £111 15s. 5d. Discount and cartage rates still apply.

Schedule No. 53, Leather. Item No. 13, 10s. 4d. each, as from 1st July, 1964.

Schedule No. 54, Metals. Item No. 10, £175 1s. per ton, as from 30th July, 1964.

H. COUTTS, Secretary to the Tender Board. 10.8.64.

PUBLIC WORKS.

506. Balmarring, Foreshore, supply, stone, spalls and rubble, £3,155.—R. J. & K. D. Brown.

507. Warrambool, Foreshore, supply spalls, £2,437.—Des. B. Barker.

508. Myrtleford, High School, Supply soup urn and refrigerator, £320 5s. 6d.—Ahearn, Main & Stott Pty. Ltd.

509. Sunbury, Mental Hospital, supply and deliver curtain material, £609 7s. 6d.—Hoad Manufacturing Pty. Ltd.

510. Carlton, St. Nicholas Hospital, supply floor polishers, £356 7s.—H. Rossitor & Sons.

511. Carlton, St. Nicholas Hospital, supply radios and sterilizers, £248 3s. 8d.—Australian Electrical Industries Pty. Ltd.

512. Ballarat Mental Hospital, supply timber, £562 10s.—Mordialloc Timber Co. Pty. Ltd.

513. Ballarat, Mental Hospital, supply pinewood, £374 17s.—Charles Rouch Pty. Ltd.

514. Kingsbury, Technical School, supply tables and benches, £563 9s. 6d.—Kennett Bros. & Rayner Pty. Ltd.

515. Lalor, High School, supply electric soup urn, £315 5s. 6d.—Ahearn, Main & Stott Pty. Ltd.

516. Stawell, Pleasant Creek, Special School, supply planing machine, £438 10s.—Charles Wolfenden & Co.

517. Stawell, Pleasant Creek, Special School, supply planing and thickening machine, woodcutting band-saw, £1,017 5s.—McPherson's Ltd.

518. Swan Hill, Technical School, supply workshop equipment, £3,277.—Demco Machinery Co. (Vic.) Pty. Ltd.

519. Swan Hill, Technical School, supply workshop equipment, £483 11s. 6d.—E. A. Machin & Co. Ltd.

520. West Melbourne, Government Cool Stores, supply and deliver steel roof trusses, £1,590.—Associated Iron Industries.

521. Burwood, "Allambie" Children's Home, supply curtains, £900.—Hoad Manufacturing Pty. Ltd.

522. Melbourne, Titles Office, re-surface counters, £469 9s. 6d.—F. G. Hayes.

523. Collingwood, Technical School, supply and fix timber shelving, £552 8s.—F. G. Hayes.

524. Mont Park, Mental Hospital, supply tractor mower, £444 13s. 9d.—Scott Bonnar Australia Pty. Ltd.

525. Carlton, Motor Registration Branch, supply special mobiles and desk tops, £471.—Brownbuilt Ltd.

526. Bundoora, Mental Hospital, supply food trolleys, £1,385.—K. G. Luke Aust. Pty. Ltd.

527. Bundoora, Mental Hospital, supply vegetable mill, £267 10s.—Henry Berry & Co. (Aust.) Ltd.

528. Melbourne, Town and Country Planning Board, supply and install steel storage units, £605 15s. 6d.—Brownbuilt Ltd.

529. Werribee, State Research Farm, supply timber, £728 7s. 2d.—J. Wright & Sons Pty. Ltd.

530. West Parkville, "Turana", supply durialiam beds, £361 10s.—Namco Furniture.

531. Williamstown, P.W.D. Dredging Depot, supply mild-steel pipe, £748.—Toorong Steel Construction Pty. Ltd.
532. Mont Park, Mental Hospital, supply hot presses, £465.—Ahearn, Main & Stott Pty. Ltd.
533. Melbourne, Royal Botanic Gardens, supply gas range, £510.—Waldorf Appliance Distributors.
534. Bundoora, Janefield Training Colony, supply hot presses, £690.—Ahearn, Main & Stott Pty. Ltd.
535. Melbourne, Motor Registration Branch, supply steel cabinets, £687 7s. 6d.—Brownbuilt Ltd.
536. Dookie, Agricultural College, supply fencing wire, £282 3s.—(A. A.) Lords Ltd.
537. Stawell, Technical School, supply soup urn and refrigerator, £311 5s. 6d.—Ahearn, Main & Stott Pty. Ltd.
538. Coburg, H.M. Pentridge Prison, supply bricks, £291 15s.—Brick Industries Ltd.
539. Royal Park, Mental Hospital, supply planing and thickening machine, £714 10s.—McPherson's Ltd.
540. Longerenong, Agricultural College, supply and install curtains, £332.—Hoad Manufacturing Pty. Ltd.
541. Hawthorn, Swinburne Technical School, supply tables, drawing, £294.—D. F. Cowan Sales Pty. Ltd.
542. Geelong North, Bell Park High School, supply chairs, £350 8s.—Aristoc Industries Pty. Ltd.
543. Sunbury, Psychiatric Hospital, supply and fix bed screens, £1,161.—J. D. Fagan Pty. Ltd.
544. Kyabram, High School, supply racks and benches, £269 7s. 10d.—Traralgon Furniture Pty. Ltd.
545. Hawthorn, Swinburne Technical School, supply and install work tables, £413 1s. 4d.—Traralgon Furniture Pty. Ltd.

MURRAY PORTER, Commissioner of Public Works.
5.8.64.

ORDERS IN COUNCIL.—(Series 1963-64.)

STATE ELECTRICITY COMMISSION.

5491. For the supply of 40 watt fluorescent lanterns for public lighting for a period of one year, to Specification No. 63-64/152, at schedule rates.—Daylite Industries Ltd.

Approved by the Governor in Council, 30th June, 1964.
—J. COLQUHOUN, Clerk of the Executive Council.

5492. For the construction of high and/or low voltage lines and substations in the Eastern Metropolitan Branch, for a period of two years, to Specification No. 63-64/286, at schedule rates.—F. & M. Barker.

5493. For the construction of high and/or low voltage lines and substations in the South-Western Branch for a period of two years, to Specification No. 63-64/286, at schedule rates.—J. J. Cairns.

5494. For the construction of high and/or low voltage lines and substations in the Eastern Metropolitan Branch, for a period of two years, to Specification No. 63-64/286, at schedule rates.—G. M. & P. A. Duncan.

5495. For the construction of high and/or low voltage lines and substations in the Eastern Metropolitan Branch for a period of two years, to Specification No. 63-64/286, at schedule rates.—Eastern Power Lines Pty. Ltd.

5496. For the construction of high and/or low voltage lines and substations in the Eastern Metropolitan Branch for a period of two years, to Specification No. 63-64/286, at schedule rates.—Eddie Bros. Pty. Ltd.

5497. For the construction of high and/or low voltage lines and substations in the Eastern Metropolitan Branch for a period of two years, to Specification No. 63-64/286, at schedule rates.—Ian Taylor Constructions Pty. Ltd.

5498. For the construction of high and/or low voltage lines and substations in the Metropolitan Branch for a period of two years, to Specification No. 63-64/286, at schedule rates.—K. M. Joseph Co. Pty. Ltd.

5499. For the construction of high and/or low voltage lines and substations in the Northern Branch for a period of two years, to Specification No. 63-64/286, at schedule rates.—Northern Constructions.

5500. For the construction of high and/or low voltage lines and substations in the North-Eastern Branch for a period of two years, to Specification No. 63-64/286, at schedule rates.—M. J. O'Neill.

5501. For the construction of high and/or low voltage lines and substations in the Northern Branch for a period of two years, to Specification No. 63-64/286, at schedule rates.—M. A. Saunders & Son.

5502. For the construction of high and/or low voltage lines and substations in the Wimmera Branch for a period of two years, to Specification No. 63-64/286, at schedule rates.—J. E. Spooner.

5503. For the construction of high and/or low voltage lines and substations in the Eastern Metropolitan Branch for a period of two years, to Specification No. 63-64/286, at schedule rates.—Waratah Electrical Connections Pty. Ltd.

5504. For the manufacture and supply of polythene insulated and sheathed, self-supporting aerial control cable for a period of two years, to Specification No. 63-64/322, at schedule rates.—Cablemakers (A.C.T.) Pty. Ltd.

5505. For the supply of brooms and brushware for a period of two years, to Specification No. 63-64/191, at schedule rates.—John Zevenboom & Co.

Approved by the Governor in Council, 15th July, 1964.
—J. COLQUHOUN, Clerk of the Executive Council.

5506. For the supply of two synchronous condensers and associated plant for Fishermen's Bend and Templestowe Terminal Stations, to Specification No. 63-64/72, £802,898, plus items at schedule rates.—A.S.E.A. Electric (Aust.) Pty. Ltd.

5507. For the supply of two 6.6 kV current limiting reactors for substation "NR" (North Richmond) to Specification No. 63-64/377, £8,940.—Australian General Electric Pty. Ltd.

5508. For the supply and erection of two 1,650,000 lb. per hour boilers and associated plant for stage 3, Hazelwood Power Station, to Specification No. 63-64/220, £13,790,890.—Babcock & Wilcox of Aust. Pty. Ltd.

5509. For the supply of galvanized spouting, rigging, downpiping, &c., for a period of two years, to Specification No. 63-64/280, at schedule rates.—H. W. Creek & Sons Pty. Ltd.

5510. For the supply of high vacuum oil treatment plant for preparation of transformer oil, to Specification No. 63-64/228, £8,474 1s. 3d.—Marweight Equipment Pty. Ltd.

5511. For the supply and erection of two 200 M.W. turbogenerators and associated plant for stage 3, Hazelwood Power Station, to Specification No. 63-64/221, £4,411,479.—C. A. Parsons & Co. Ltd.

5512. For the supply of four 500-h.p. bevel helical reduction gear boxes for moveable conveyors, Morwell Iron Cut, to Specification No. 63-64/376, £17,860.—Sonnerdale Richardson David Brown (Vic.) Pty. Ltd.

5513. For the supply of 66 kV disconnecting switches for metropolitan and country terminal stations and substations for a period of one year, to Specification No. 63-64/350, at schedule rates.—Switchgear Pty. Ltd.

Approved by the Governor in Council, 21st July, 1964.
—J. COLQUHOUN, Clerk of the Executive Council.

ORDERS IN COUNCIL.—(Series 1964-65.)

PUBLIC WORKS.

498. Glen Waverley, High School, special grant authorized by the Education Department towards cost of construction of basketball/tennis courts at the school, £1,213 10s.—Glen Waverley High School Advisory Council. (N.E.10010.)

499. Dallas, State School No. 4900, transfer of portable class-room No. 85 from High School, Korumburra, and re-erection at State School No. 4900, Dallas, £539 19s.—A. V. Jennings Industries (Australia) Limited. (V.301980.)

500. Melbourne, Law Courts, sculpture and casting of a new Statue of Justice, £8,385.—Ray Ewers (M.10575.)

501. Melbourne, Public Service Board, Board Room, supply and erection of seven (7) off double-hung windows, &c., £566 10s.—A. J. Brooks (Vic.) Pty. Ltd. (M.28342.)

502. Melbourne, Royal Botanic Gardens, supply of 1,400 feet of 4-in. Belltite joint cast iron pressure pipe, £572 6s. 6d.—Mettters-Clow Pty. Ltd. (M.35454.)

503. Melbourne, Royal Melbourne Institute of Technology, Administration and Accountancy Building, supply and installation of ventilation to dining rooms, £953.—Bruce Sheet Metal Service. (M.26679.)

504. Melbourne, Withalitt House, 453 Latrobe-street, security services for the period 27th July, 1964, to 31st May, 1965, at rates, estimated to cost £450.—Metropolitan Night Patrol Service Pty. Ltd. (M.48104.)

505. Research, State School No. 2959, transfer of portable class-room No. 71 from State School No. 4727, Koonung Heights, and re-erection at State School No. 2959, Research, £309 2s. 3d.—A. V. Jennings Industries (Australia) Limited. (V.301966.)

Approved by the Governor in Council, 4th August, 1964.
—J. COLQUHOUN, Clerk of the Executive Council.

Town and Country Planning Act 1961.

SHIRE OF FERN TREE GULLY.

INTERIM DEVELOPMENT ORDER.

WHEREAS by the *Town and Country Planning Act 1961* it is provided that a responsible authority may, with the approval of the Governor in Council, make an Interim Development Order regulating, restricting, restraining or prohibiting the use or development of any land or the erection, construction or carrying out of any buildings or works on any land within any area to which the scheme relates:

And whereas the Council of the Shire of Fern Tree Gully, on the 7th day of June, 1954, commenced the preparation of a planning scheme for the whole of the Shire of Fern Tree Gully as then constituted:

And whereas, pursuant to section 16 of the *Local Government Act 1958*, the Shire of Knox was constituted on the 16th November, 1963, by the severance of portion of the Shire of Fern Tree Gully:

And whereas by an Order made pursuant to section 51 of the *Town and Country Planning Act 1961*, the Governor in Council, on the 17th day of December, 1963, ordered that the said scheme be divided into two parts and that the Council of the Shire of Knox and the Council of the Shire of Fern Tree Gully be separately authorized to continue the preparation of the said scheme as divided and that each be deemed always to have been the responsible authority in relation to that part of the scheme within their respective municipal districts:

Now therefore, by virtue of the powers conferred by the *Town and Country Planning Act 1961*, and of every other power enabling it in that behalf, the Council of the Shire of Fern Tree Gully (hereinafter referred to as the Responsible Authority) hereby, with the approval of the Governor in Council given pursuant to section 17 of the said Act, makes the following Interim Development Order for the purpose or regulating, restricting, restraining or prohibiting the use or development of any land or the erection, construction or carrying out of any buildings or works, that is to say:—

1. Except in accordance with the provisions of a permit issued by the Responsible Authority, no person shall—

- (a) use, subdivide or otherwise develop any land or erect, construct or carry out any buildings or works on any land within the area described in the First Schedule hereto; or
- (b) fell, destroy or uproot any living indigenous species of trees on any land described in the Second Schedule hereto.

2. Nothing in this Interim Development Order shall prevent—

- (a) the continuance of the use of any land or of any existing building or works for the purposes for which the land or building or works was or were being lawfully used immediately before the coming into operation of this Order;
- (b) any dealing, or the registration of any dealing with any land in any subdivision of which a plan has been sealed by the Council of the Shire of Fern Tree Gully, and lodged with the Registrar of Titles, pursuant to section 569 of the *Local Government Act 1958*, before the coming into operation of this Order; or
- (c) the destruction and removal of any plant proclaimed by the Governor in Council as a noxious weed by virtue of the provisions of sub-section (2) of section 3 of Act No. 6409.

3. Every application for a permit under the provisions of this Order shall be made on the prescribed form, copies of which may be obtained from the office of the Responsible Authority at the municipal offices of the Shire of Fern Tree Gully.

FIRST SCHEDULE.

The whole of the municipal district of the Shire of Fern Tree Gully.

SECOND SCHEDULE.

- (a) All land comprising any road or street or within 20 feet of any road or street in the Shire of Fern Tree Gully.
- (b) All land in the Shire of Fern Tree Gully which is within 2 chains of any creek, stream or defined natural watercourse.

(c) All land in the Shire of Fern Tree Gully comprising the Crown allotments listed hereunder:—

Parish of Gembrook.

Crown allotments 43, 43A, 44, 51, 52, 56A, 60B, 60C and 65A.

Crown allotments 1 to 20 (inclusive), section F.

Parish of Monbulk.

Crown allotments 5, 8 and 10, section C.

Crown allotments 23, 26, 27, 30, 31, 34, 35 and 36, section G.

Crown allotments 38 to 44 (inclusive), section J.

Crown allotments 23, 26, 27, 30 to 34 (inclusive), section K.

Crown allotments 15, 17 to 23 (inclusive), section L.

Parish of Nangana.

Crown allotments 10, 20, 21, 26, 26A, 27, 42D, 42F, 43A, 43B, 43E, 43J, 43K, 46A, 46D to 46H (inclusive), 46J, 47B, 47C, 55, 55D, 56A, 56H, 57, 60A, 60C, 73C, 73D, 74C, 74E, 76, 76A, 91, 91A, 91C, 91D, 94 to 97 (inclusive), 102, 103A, 104A, 105A, 106 and 107.

Parish of Narree Worrana.

Monbulk pre-emptive right.

Crown allotments K3, K4, K5 and K6.

Crown allotments 31B, 31E, 32, 33, 33B, 33C, 33D, 33F, 34A to 34E (inclusive), 35C, 35E, 43K, 43L, 45A, 49, 70A, 70B, 70C, 70F, 70M, 70P, 71A, 71B, 101, 102A to 102G (inclusive), 104A, 104B, 105B, 105C, 105D, 105E, 106B, 106D, 106E, 106G, 108C, 108D, 108E, 108G, 108H, 108K, 108M, 109C to 109G (inclusive), 111, 111A and 111B.

Crown allotments 1, 2, 3C, 3D, 3E, 34, 35, 37, 37A, 38C, 39 to 42 (inclusive), 45 and 46A, section A.

Crown allotments 36 to 40 (inclusive), 42 to 45 (inclusive), section B.

Parish of Scoresby.

Crown allotments 77, 77A, part 78, 83 to 90 (inclusive), 42 to 45 (inclusive), section B.

Parish of Scoresby.

Crown allotments 77, 77A, part 78, 83 to 90 (inclusive), part 126, 127 and 128.

Crown allotments 34 to 42 (inclusive), 42A, 43, 50 to 56 (inclusive), 56A, 57 to 61 (inclusive), section A.

In witness whereof the common seal of the President, Councillors and Ratepayers of the Shire of Fern Tree Gully was hereunto affixed this sixth day of July, 1964.

BASIL W. H. BOTTOMLEY, Shire President.

(SEAL) G. G. GILMOUR, Councillor.

R. B. WEBB, Shire Secretary.

Report by the Town and Country Planning Board on the 23rd day of July, 1964.—Recommended for approval.—FRED. C. COOK, Chairman.

Approved by the Governor in Council on the 11th day of August, 1964.—J. COLQUHOUN, Clerk of the Executive Council.

*Town and Country Planning Act 1961.*CITY OF MOORABBIN PLANNING SCHEME.—
SECTION 1.

AMENDMENT No. 10, 1964.

Notice of Approval.

IN pursuance of the powers conferred by the *Town and Country Planning Act 1961*, the Governor in Council on the 11th August, 1964, approved a planning scheme entitled the City of Moorabbin Planning Scheme, Section 1, Amendment No. 10, 1964, in respect of part of the municipal district of the City of Moorabbin.

A copy of the planning scheme as approved may be inspected during office hours at the offices of the Town and Country Planning Board, 179 Queen-street, Melbourne; at the office of the Council of the City of Moorabbin; and when available, at the Office of Titles, Melbourne, and at the Central Plan Office of the Department of Crown Lands and Survey, Melbourne.

W. H. CRAIG,

Secretary, Town and Country Planning Board.

Town and Country Planning Act 1961.

CITY OF CAMBERWELL PLANNING SCHEME 1954.

AMENDMENT No. 12, 1963.

Notice of Approval.

IN pursuance of the powers conferred by the *Town and Country Planning Act 1961*, the Governor in Council on the 11th August, 1964, approved a planning scheme entitled the City of Camberwell Planning Scheme 1954, Amendment No. 12, 1963, in respect of part of the municipal district of the City of Camberwell.

A copy of the planning scheme as approved may be inspected during office hours at the offices of the Town and Country Planning Board, 179 Queen-street, Melbourne; at the office of the Council of the City of Camberwell; and when available, at the Office of Titles, Melbourne, and at the Central Plan Office of the Department of Crown Lands and Survey, Melbourne.

W. H. CRAIG,
Secretary, Town and Country Planning Board.

Police Regulation Act 1958.

POLICE SERVICE BOARD ELECTIONS.

PURSUANT to the provisions of the *Police Regulations 1957*, I hereby declare that the elections conducted by me on 30th July, 1964, have resulted in—

WILLIAM JAMES MCLAREN,
being elected as a Member of the Police Service Board for the term of office commencing on 19th August, 1964; and

ANTHONY WILLIAM MELBOURNE SNELL,
being elected as the Deputy of such Member.

A. F. WANKE,
Returning Officer.

WORKERS COMPENSATION ACT 1958, SECTION 72.

THE Lieutenant-Governor as Deputy for His Excellency the Governor of the State of Victoria, by and with the advice of the Executive Council thereof, doth, by Order made on the 4th day of August, 1964, pursuant to the provisions of the *Workers Compensation Act 1958*, approve the Fire and All Risks Insurance Co. Ltd. as an "Insurer" for the period from the first day of August, 1964, to the thirtieth day of September, 1964.

J. COLQUHOUN,
Clerk of the Executive Council.

At the Executive Council Chamber,
Melbourne, 4th August, 1964.

DEPARTMENT OF LABOUR AND INDUSTRY.

DETERMINATION OF THE HOSPITAL AND BENEVOLENT HOMES BOARD.

ATTENTION is drawn to the fact that a notice of appeal to the Industrial Appeals Court has been lodged against paragraph D of clause 14A (Annual Holiday) of the Determination of the Hospital and Benevolent Homes Board made on the 22nd July, 1964.

Section 45 (1) (b) of Act No. 6283, provides that when an appeal is made in accordance with that Act, the parts of the Determination appealed against shall not come into operation until the appeal has been dealt with by the Court.

M. WALSH,
Secretary.

APPOINTMENTS.

THE Lieutenant-Governor as Deputy for His Excellency the Governor of the State of Victoria, by and with the advice of the Executive Council thereof, has, by Orders made on the 4th day of August, 1964, been pleased to make the under-mentioned appointments, viz.:—

CHIEF SECRETARY'S DEPARTMENT.

Assistants to Inspector of Fisheries.

ROBERT WILLIAM EAMES, and
PETER FRANCIS O'RILEY,
pursuant to the provisions of the *Fisheries Act 1958*, to be Assistants to the Inspector of Fisheries.

Chairman of Police Service Board.

BENJAMIN JAMES DUNN, O.B.E., a Judge of County Courts,
pursuant to the provisions of the *Police Regulation Act 1958*, to be Chairman of the Police Service Board, for the term of three years from the 19th August, 1964.

Member of Police Service Board.

DUNCAN STORMONT RAMAGE, O.B.E.,
pursuant to the provisions of the *Police Regulation Act 1958*, to be the Member representing the Government of Victoria on the Police Service Board, for the term of three years from the 19th August, 1964.

Chairman of Workers Compensation Board.

GEORGE LEO DETHRIDGE, a Judge of County Courts,
pursuant to the provisions of the *Workers Compensation Act 1958*, to be Chairman of the Workers Compensation Board, for the period from the 8th August, 1964, to the 10th October, 1965, vice Leonard E. B. Stretton, resigned.

Chairman of Supplementary Workers Compensation Board.

HUBERT THEODORE FREDERICO, a Judge of County Courts,
pursuant to the provisions of the *Workers Compensation Act 1958*, to be Chairman of the Supplementary Workers Compensation Board, for the period from the 8th August, 1964, to the 31st December, 1964, vice George Leo Dethridge, appointed Chairman of the Workers Compensation Board.

Electoral Registrars (Acting).

GEORGE LEO CHAMBERLAIN
to be Electoral Registrar (Acting) for the Brighton and Hampton Subdivisions of the Electoral District of Brighton; and for the Brighton East and Elsternwick Subdivisions of the Electoral District of Elsternwick, to take effect on and from the 22nd July, 1964, during the absence, on leave, of Frederick Macaulay;

ATHOL HERBERT THOMPSON
to be Electoral Registrar (Acting) for the Box Hill, Doncaster, Lilydale, Surrey Hills and Warrandyte Subdivisions of the Electoral District of Box Hill; and for the Diamond Creek, Eltham, Healesville, Heidelberg and Warburton Subdivisions of the Electoral District of Evelyn, to take effect on and from the 3rd August, 1964, during the absence, on leave, of Herbert William Hodgson; and

LAURIE THOMAS WILLIAMS
to be Electoral Registrar (Acting) for the Heidelberg West and Preston Subdivisions of the Electoral District of Preston; and for the Reservoir East and Reservoir West Subdivisions of the Electoral District of Reservoir, to take effect on and from the 27th July, 1964, during the absence, on leave, of Samuel Mitchelmore.

Licensing Inspectors.

LINDSEY GEORGE BENT, Superintendent, Grade II,
to be a Licensing Inspector for the purposes of the *Licensing Act 1958*, vice Ian Alistair McNiven, Superintendent, Grade II., resigned; and

FREDERICK TAYLOR KENNEDY, Inspector, Grade I,
to be a Licensing Inspector for the purposes of the *Licensing Act 1958*, vice Roy Henry Warne, Inspector, Grade I., resigned.

Public Auditor.

GORDON GRAHAM MASON,
pursuant to the provisions of section 41 of the *Friendly Societies Act 1958*, to be a Public Auditor for the purposes of the said Act.

LAW DEPARTMENT.

Clerks of Children's Courts.

LINDSAY THOMAS GOULD
to be Clerk of the Children's Court at Fern Tree Gully and Oakleigh in the place of R. T. White, transferred, to take effect from the date of commencement of duty; and

RAYMOND PERCIVAL WHITE
to be Clerk of the Children's Court at Brunswick and Sunshine in the place of L. T. Gould, transferred, to take effect from the date of commencement of duty.

Commissioners for Taking Declarations, &c.

KONSTANDIS KYRATZIS, care of State Motor Car Insurance Office, 412 Collins-street, Melbourne,
to be a Commissioner for taking Declarations and Affidavits, pursuant to the provisions of the *Evidence Act 1958*, to refrain from charging fees and to resign upon ceasing to occupy his present position;

BRUCE FARQUHARSON MCLAREN, care of Canine Catering Co. Pty. Ltd., 107 Whitehorse-road, Blackburn,
to be a Commissioner for taking Declarations and Affidavits, pursuant to the provisions of the *Evidence Act 1958*, to resign upon ceasing to occupy his present position; and

CHRISTOPHER JOHN MARTIN, Nepean Highway, Rosebud,
and

THOMAS JAMES GREER, 36 Pilgrim-street, Footscray,
to be Commissioners for taking Declarations and Affidavits, pursuant to the provisions of the *Evidence Act 1958*, to resign upon removing from the neighbourhood of the addresses stated.

Judge of the County Court.

ERIC EDGAR HEWITT, Q.C., B.A., LL.B., a Barrister at Law who has practised as a Barrister in Victoria for a period of seven years, to be a Judge of the County Court and a Judge of Courts of Mines, under the provisions of the County Court Acts, to take effect from the date of commencement of duty.

Chairman of General Sessions.

ERIC EDGAR HEWITT, Q.C., B.A., LL.B., a Barrister at Law of Victoria who has practised for a period of five years, to be a Chairman of General Sessions under the provisions of the Justices Act 1958, to take effect from the date of commencement of duty.

Justices of the Peace.

EDGAR LLOYD ROBINSON, 150 Buckley-street, Morwell, to Keep the Peace in the Eastern Bailiwick of the State of Victoria; and

IAN ALEX ATKYNS, 48 Woods-street, Donald, to Keep the Peace in the Western Bailiwick of the State of Victoria.

DEPARTMENT OF MINES.

Member of Sludge Abatement Board.

PAUL EDWARD CLARKE, B.M.E., M.Aust.I.M.M., State Mining Engineer, to be a Member of the Sludge Abatement Board, vice Gilbert Hadden, M.Aust.I.M.M., retired Chief Mining Inspector, during such time as he holds the said office of State Mining Engineer for the Department of Mines.

DEPARTMENT OF THE TREASURER.

Collector of Imposts (Acting).

LINDSAY THOMAS GOULD to act temporarily as Collector of Imposts, Children's Court, Law Department, vice D. B. Scully, for the period 22nd June, 1964, to 26th June, 1964, both dates inclusive.

J. COLQUHOUN,
Clerk of the Executive Council.

At the Executive Council Chamber,
Melbourne, 4th August, 1964.

APPOINTMENTS.

HIS Excellency the Governor of the State of Victoria, by and with the advice of the Executive Council thereof, has by Orders made on the 11th day of August, 1964, been pleased to make the under-mentioned appointments, viz.:—

DEPARTMENT OF WATER SUPPLY.

Members of Sewerage Authority.

SAMUEL ALLENBY CLARKE, WALLACE FREDERICK HUGHES, and COLIN RAYMOND MOORE, to be Members of the Mount Beauty Sewerage Authority each for a period of four years from the date hereof, subject to the provisions of the Sewerage Districts Acts.

J. COLQUHOUN,
Clerk of the Executive Council.

At the Executive Council Chamber,
Melbourne, 11th August, 1964.

RESIGNATIONS.

THE Lieutenant-Governor as Deputy for His Excellency the Governor of the State of Victoria, by and with the advice of the Executive Council thereof, has, by Orders made on the 4th day of August, 1964, accepted the resignations of the persons named hereunder of the offices mentioned, viz.:—

CHIEF SECRETARY'S DEPARTMENT.

ROY HENRY WARNE, Inspector, Grade I, as a Licensing Inspector for the purposes of the Licensing Act 1958, to date from and inclusive of 13th July, 1964.

LAW DEPARTMENT.

REGINALD JOHN SOUTER, and ALFRED ALLAN GEBERT, as Commissioners for taking Declarations and Affidavits, pursuant to the provisions of the Evidence Act 1958.

J. COLQUHOUN,
Clerk of the Executive Council.

At the Executive Council Chamber,
Melbourne, 4th August, 1964.

DEPARTMENT OF CROWN LANDS AND SURVEY.

At the Executive Council Chamber, Melbourne, the fourth day of August, 1964.

PRESENT:

The Lieutenant-Governor as Deputy for His Excellency the Governor of Victoria.

Mr. Thompson | Mr. Porter.
Mr. Darcy

UNUSED ROADS CLOSED.

THE Lieutenant-Governor as Deputy for His Excellency the Governor of the State of Victoria, by and with the advice of the Executive Council thereof, doth hereby direct that, in pursuance of the provisions of section 349 of the Land Act 1958, the unused roads referred to hereunder be closed, viz.:—

Parish of Barwongemoong, County of Polwarth, being the road indicated by hachure on plan hereunder.—(B.742^(s)) (Misc.3567).

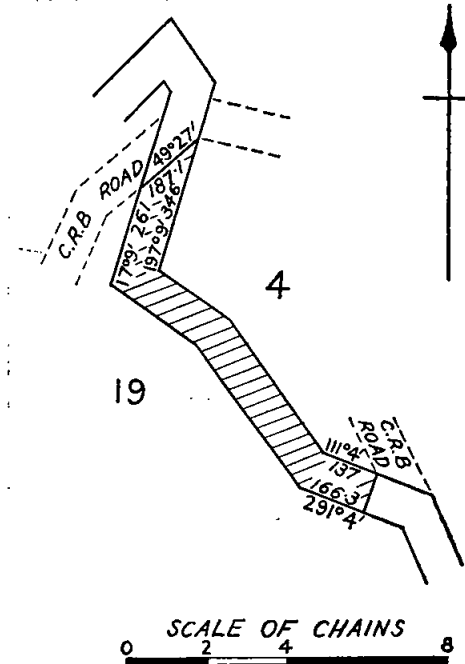

Parishes of Karabeal and Mokanger, County of Dundas, being the roads indicated by hachure on plan hereunder.—(K.144^(s)), M.419^(s)) (Z.30796).

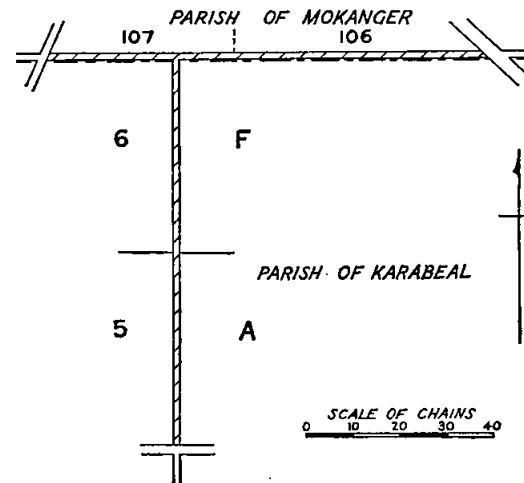

Parish of Mirboo South, County of Buln Buln, being the portion of the width of the road indicated by hachure on plan hereunder.—(M.517⁽¹⁾) (G.55972).

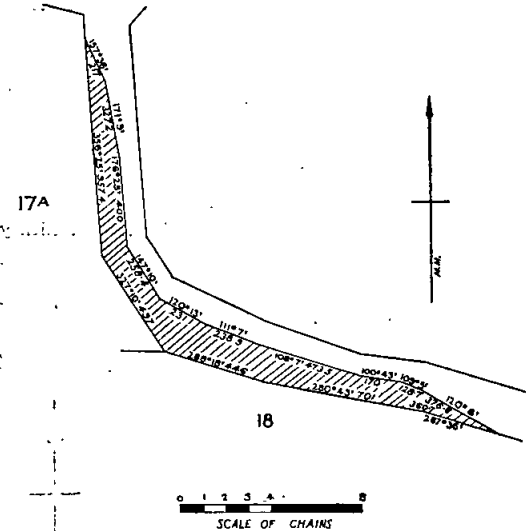

Parish of Orbost, County of Croajingolong, being the road indicated by hachure on plan hereunder.—(O.23⁽²⁾) (H.023926).

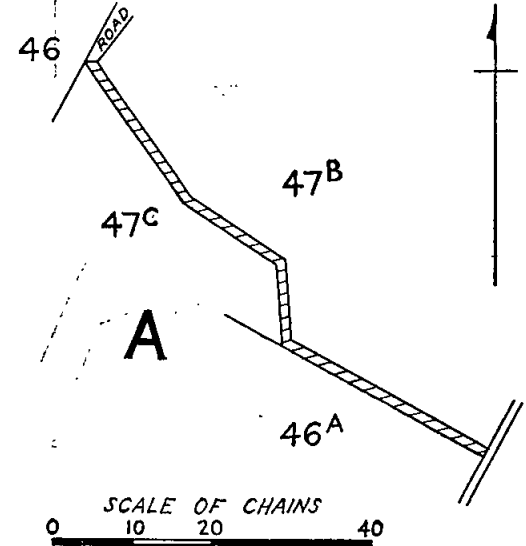

Township of Tongio West, Parish of Tongio-Munjie West, County of Dargo, being the road indicated by hachure on plan hereunder.—(T.159(A²)) (H.028930).

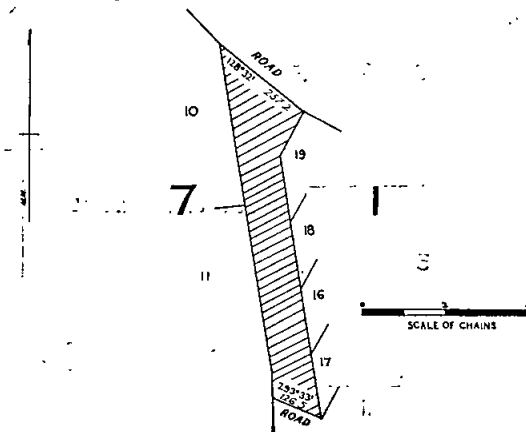

And the Honorable James Charles Murray Balfour, Her Majesty's Commissioner of Crown Lands and Survey for the State of Victoria, shall give the necessary directions herein accordingly.

J. COLQUHOUN,
Clerk of the Executive Council.

DEPARTMENT OF CROWN LANDS AND SURVEY.

At the Executive Council Chamber, Melbourne, the fourth day of August, 1964.

PRESENT:

The Lieutenant-Governor as Deputy for His Excellency the Governor of Victoria.

Mr. Thompson | Mr. Porter.
Mr. Darcy

REVOCATION OF ORDER IN COUNCIL WITHHOLDING CERTAIN LAND FROM SALE, LEASING, AND LICENSING.

THE Lieutenant-Governor as Deputy for His Excellency the Governor of the State of Victoria, by and with the advice of the Executive Council thereof, doth hereby, in pursuance of the provisions of the Land Act 1958, revoke the withholding from sale, leasing, and licensing of the land mentioned hereunder:—

BUNGEET.—The withholding from sale, leasing and licensing, by Order in Council of the 22nd March, 1875 (see *Government Gazette* of the 9th April, 1875, page 691) of 20 acres of land in the Parish of Bungeet, is hereby revoked.—(B.618⁽³⁾) (Rs.8357).

And the Honorable James Charles Murray Balfour, Her Majesty's Commissioner of Crown Lands and Survey for the State of Victoria, shall give the necessary directions herein accordingly.

J. COLQUHOUN,
Clerk of the Executive Council.

DEPARTMENT OF CROWN LANDS AND SURVEY.

At the Executive Council Chamber, Melbourne, the fourth day of August, 1964.

PRESENT:

The Lieutenant-Governor as Deputy for His Excellency the Governor of Victoria.

Mr. Thompson | Mr. Porter.
Mr. Darcy

LANDS TEMPORARILY RESERVED AS SITES.

THE Lieutenant-Governor as Deputy for His Excellency the Governor of the State of Victoria, by and with the advice of the Executive Council thereof, doth hereby, in pursuance of the provisions of the Land Act 1958, reserve, temporarily, and also except from occupation for mining purposes under any miner's right, the lands hereinafter described:—

MOORPANYAL.—Site for Railway purposes, 2 roods, Parish of Moorpanyal, County of Grant, as indicated by hachure on plan hereunder.—(M.199⁽⁶⁾) (Rs.8347).

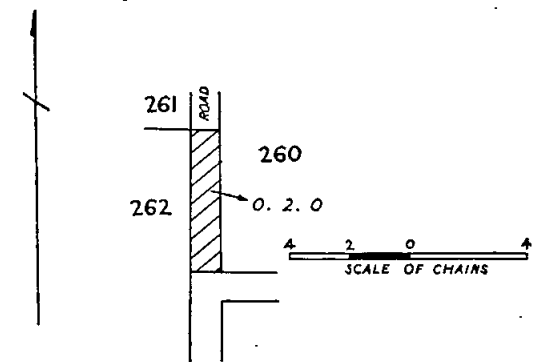

TAMINICK.—Site for the Preservation of Native Flora, 13 acres 3 roods 1 perch, Parish of Taminick, County of Moira, as indicated by hachure on plan hereunder.—(T.155(*) (Rs.7423).

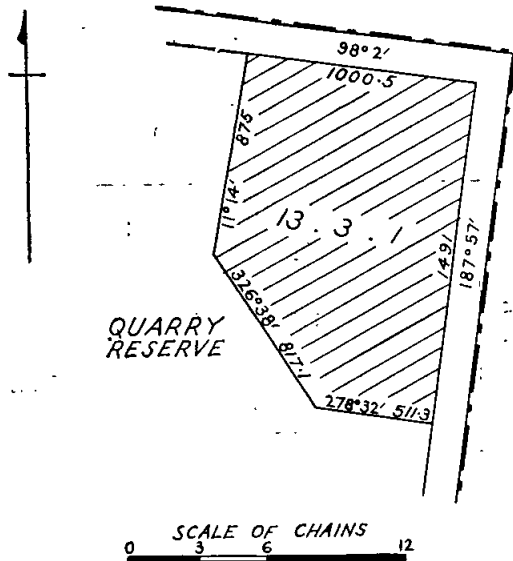

And the Honorable James Charles Murray Balfour, Her Majesty's Commissioner of Crown Lands and Survey for the State of Victoria, shall give the necessary directions herein accordingly.

J. COLQUHOUN,
Clerk of the Executive Council.

DEPARTMENT OF CROWN LANDS AND SURVEY.

At the Executive Council Chamber, Melbourne, the fourth day of August, 1964.

PRESENT:

The Lieutenant-Governor as Deputy for His Excellency the Governor of Victoria.

Mr. Thompson | Mr. Porter.
Mr. Darcy

REVOCATIONS OF TEMPORARY RESERVATIONS OF LAND BY ORDERS IN COUNCIL.

THE Lieutenant-Governor as Deputy for His Excellency the Governor of the State of Victoria, by and with the advice of the Executive Council thereof, doth hereby, in pursuance of the provisions of the Land Act 1958, revoke the temporary reservations of land by Orders in Council hereinafter referred to, viz.:—

DOUTTA GALLA.—Order in Council of 10th February, 1915, of 3 roods 31 8/10 perches of land at Essendon, in the Parish of Doutta Galla, as a site for Public Baths and Municipal Storage Yards.—(Rs.36.)

SALE.—Order in Council of the 20th April, 1911, of 30 acres, more or less, of land in the Township of Sale and the Parish of Sale, as a site for Public purposes, revoked as to part by various Orders, so far only as regards the portion thereof comprised within the boundaries published in the Government Gazette of the 1st July, 1964, and containing 11 acres, more or less.—(Rs.1505.)

TULILLAH.—Order in Council of 10th December, 1929, of 21 acres 3 roods 30 perches of land in the Parish of Tulillah as a site for Public Recreation.—(Rs.3942.)

And the Honorable James Charles Murray Balfour, Her Majesty's Commissioner of Crown Lands and Survey for the State of Victoria, shall give the necessary directions herein accordingly.

J. COLQUHOUN,
Clerk of the Executive Council.

LOCAL GOVERNMENT DEPARTMENT.

At the Executive Council Chamber, Melbourne, the fourth day of August, 1964.

PRESENT:

The Lieutenant-Governor as Deputy for His Excellency the Governor of Victoria.

Mr. Thompson | Mr. Porter.
Mr. Darcy

ROADS DISCONTINUED.—SHIRE OF WOORAYL.

WHEREAS it is provided in section 528 (2) of the Local Government Act 1958, as amended, that where a road (whether or not a public highway but not being a road set out on land of the Crown) or any part thereof is not required for public use, the Governor in Council, on request of the Council of the municipality in which such road is situated, made not less than one month after publishing in a newspaper generally circulating in the district and posting to the registered proprietor (if any) of the land and any person known to have an interest in the land notice of intention to make such a request, may, by Order published in the Government Gazette, direct that such road or part shall be discontinued and thereupon such road or part shall be discontinued accordingly:

And whereas the Council of the Shire of Woorayl has requested that the Governor in Council direct that part of Millicent-street and another road in the Township of Leongatha be discontinued, and, not less than one month previously, has published in a newspaper generally circulating in the district and posted to the registered proprietor of the land in the roads and to all persons known to have an interest in the said roads notice of intention to make such request:

Now therefore the Lieutenant-Governor as Deputy for His Excellency the Governor of the State of Victoria, by and with the advice of the Executive Council thereof, hereby directs that the said roads, which are shown hatched on the plan hereunder, shall be discontinued and that the land may be sold by the Council of the Shire of Woorayl by agreement.

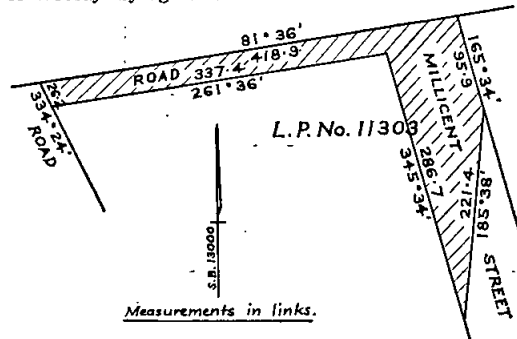

And the Honorable Rupert James Hamer, Her Majesty's Minister for Local Government for the State of Victoria, shall give the necessary directions herein accordingly.

J. COLQUHOUN,
Clerk of the Executive Council.

LOCAL GOVERNMENT DEPARTMENT.

At the Executive Council Chamber, Melbourne, the fourth day of August, 1964.

PRESENT:

The Lieutenant-Governor as Deputy for His Excellency the Governor of Victoria.

Mr. Thompson | Mr. Porter.
Mr. Darcy

ROAD DISCONTINUED.—CITY OF CAMBERWELL.

WHEREAS it is provided in section 528 (2) of the Local Government Act 1958, as amended, that where a road (whether or not a public highway but not being a road set out on land of the Crown) or any part thereof is not required for public use, the Governor in Council, on request of the Council of the municipality in which such road is situated, made not less than one month after

publishing in a newspaper generally circulating in the district and posting to the registered proprietor (if any) of the land and any person known to have an interest in the land notice of intention to make such a request, may, by Order published in the *Government Gazette*, direct that such road or part shall be discontinued and thereupon such road or part shall be discontinued accordingly:

And whereas the Council of the City of Camberwell has requested that the Governor in Council direct that part of Short-road, Camberwell, be discontinued, and, not less than one month previously, has published in a newspaper generally circulating in the district and posted to the registered proprietor of the land in the road and to all persons known to have an interest in the said road notice of intention to make such request:

Now therefore the Lieutenant-Governor as Deputy for His Excellency the Governor of the State of Victoria, by and with the advice of the Executive Council thereof, hereby directs that the portion of Short-road, north of Crown-avenue, which is delineated on the plan hereunder, shall be discontinued and that the land may be sold by the Council of the City of Camberwell by agreement.

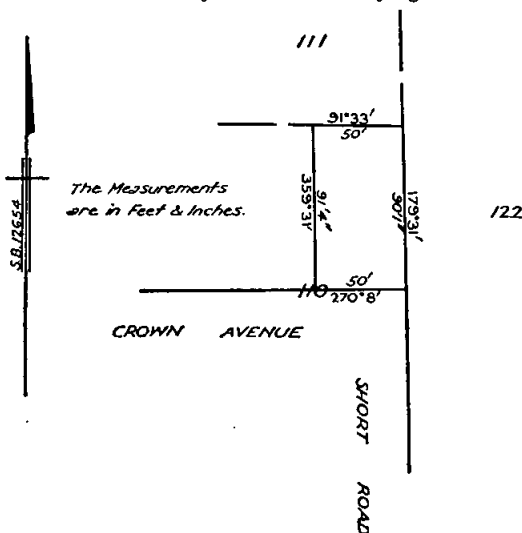

And the Honorable Rupert James Hamer, Her Majesty's Minister for Local Government for the State of Victoria, shall give the necessary directions herein accordingly.

J. COLQUHOUN,
Clerk of the Executive Council.

LOCAL GOVERNMENT DEPARTMENT.

At the Executive Council Chamber, Melbourne, the fourth day of August, 1964.

PRESENT:

The Lieutenant-Governor as Deputy for His Excellency the Governor of Victoria.

Mr. Thompson | Mr. Porter.
Mr. Darcy

ROAD DISCONTINUED.—CITY OF CAMBERWELL.

WHEREAS it is provided in section 523 (2) of the *Local Government Act 1958*, that where a road (whether or not a public highway but not being a road set out on land of the Crown) or any part thereof is not required for public use, the Governor in Council, on request of the Council of the municipality in which such road is situated, made not less than one month after publishing in a newspaper generally circulating in the district and posting to the registered proprietor (if any) of the land and any person known to have an interest in the land notice of intention to make such a request, may, by Order published in the *Government Gazette*, direct that such road or part shall be discontinued and thereupon such road or part shall be discontinued accordingly:

And whereas the Council of the City of Camberwell has requested that the Governor in Council direct that a right-of-way, off Vauxhall-road, be discontinued, and, not less than one month previously, has published in a newspaper generally circulating in the district and posted to

the registered proprietor of the land in the road and to all persons known to have an interest in the said land notice of intention to make such request:

Now therefore the Lieutenant-Governor as Deputy for His Excellency the Governor of the State of Victoria, by and with the advice of the Executive Council thereof, hereby directs that the said road, which is shown by hachure on the plan hereunder, shall be discontinued and that the land may be sold by the Council of the City of Camberwell by agreement.

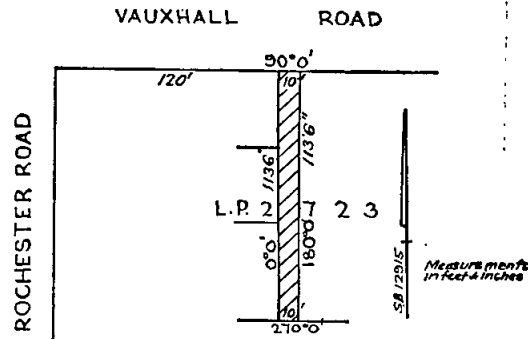

And the Honorable Rupert James Hamer, Her Majesty's Minister for Local Government for the State of Victoria, shall give the necessary directions herein accordingly.

J. COLQUHOUN,
Clerk of the Executive Council.

LOCAL GOVERNMENT DEPARTMENT.

At the Executive Council Chamber, Melbourne, the fourth day of August, 1964.

PRESENT:

The Lieutenant-Governor as Deputy for His Excellency the Governor of Victoria.

Mr. Thompson | Mr. Porter.
Mr. Darcy

APPOINTMENT OF MEMBER AND CHAIRMAN OF THE BUILDING REGULATIONS COMMITTEE.

WHEREAS for the purpose of Part XLIX., Division 2, of the *Local Government Act 1958*, as amended, it is enacted by section 920 (1) of the said Act that there shall be a committee to be known as the Building Regulations Committee, consisting of eight members, of whom one, who shall be the Chairman, shall be appointed by the Governor in Council.

Now, therefore, the Lieutenant-Governor as Deputy for His Excellency the Governor of the State of Victoria, by and with the advice of the Executive Council thereof, doth by this Order appoint Albert Keith Lines to be a member and Chairman of the said Committee for a period of three years ending on the 22nd August, 1967.

And the Honorable Rupert James Hamer, Her Majesty's Minister for Local Government for the State of Victoria, shall give the necessary directions herein accordingly.

J. COLQUHOUN,
Clerk of the Executive Council.

LOCAL GOVERNMENT DEPARTMENT.

At the Executive Council Chamber, Melbourne, the fourth day of August, 1964.

PRESENT:

The Lieutenant-Governor as Deputy for His Excellency the Governor of Victoria.

Mr. Thompson | Mr. Porter.
Mr. Darcy

ALTERATION OF TIME FOR CLOSING POLL AT MUNICIPAL ELECTIONS.—SHIRE OF KORUMBURRA.

THE Lieutenant-Governor as Deputy for His Excellency the Governor of the State of Victoria, by and with the advice of the Executive Council thereof, in pursuance of the powers conferred by section 134 of the

Local Government Act 1958, as amended, and in compliance with the prayer of a petition presented by the Council of the Shire of Korumburra hereby declares that the hour for closing the poll at municipal elections for the said Shire shall be Eight o'clock in the afternoon.

And the Honorable Rupert James Hamer, Her Majesty's Minister for Local Government for the State of Victoria, shall give the necessary directions herein accordingly.

J. COLQUHOUN,
Clerk of the Executive Council.

LOCAL GOVERNMENT DEPARTMENT.

At the Executive Council Chamber, Melbourne, the fourth day of August, 1964.

PRESENT:

The Lieutenant-Governor as Deputy for His Excellency the Governor of Victoria.

Mr. Thompson | Mr. Porter.
Mr. Darcy

ALTERATION OF TIME FOR CLOSING POLL AT MUNICIPAL ELECTIONS.—SHIRE OF KNOX.

THE Lieutenant-Governor as Deputy for His Excellency the Governor of the State of Victoria, by and with the advice of the Executive Council thereof, in pursuance of the powers conferred by section 134 of the *Local Government Act 1958*, as amended, and in compliance with the prayer of a petition presented by the Council of the Shire of Knox hereby declares that the hour for closing the poll at municipal elections for the said Shire shall be Six o'clock in the afternoon.

And the Honorable Rupert James Hamer, Her Majesty's Minister for Local Government for the State of Victoria, shall give the necessary directions herein accordingly.

J. COLQUHOUN,
Clerk of the Executive Council.

LOCAL GOVERNMENT DEPARTMENT.

At the Executive Council Chamber, Melbourne, the fourth day of August, 1964.

PRESENT:

The Lieutenant-Governor as Deputy for His Excellency the Governor of Victoria.

Mr. Thompson | Mr. Porter.
Mr. Darcy

CONFIRMATION OF SEPARATE RATE.—CITY OF CAMBERWELL.

IN pursuance of the provisions of section 287 of the *Local Government Act 1958*, as amended, the Lieutenant-Governor as Deputy for His Excellency the Governor of the State of Victoria, by and with the advice of the Executive Council thereof, hereby confirms a separate rate of Four pence in the pound on the unimproved capital value of certain properties described hereunder, which rate was made by the Council of the City of Camberwell on the 22nd June, 1964, for the purpose of providing off-street parking facilities for use in connexion with the Canterbury-road, Canterbury, Shopping Centre:—

Properties to be Rated—

- (a) The rateable properties fronting the north side of Canterbury-road from Balwyn-road eastward to and including No. 247 Canterbury-road.
- (b) The rateable properties fronting the west side of Rochester-road being No. 1 and No. 3 Rochester-road.
- (c) The rateable properties fronting the south side of Canterbury-road from the eastern extremity of the Canterbury Gardens to and including No. 202 Canterbury-road.
- (d) The rateable property fronting Railway-place.

And the Honorable Rupert James Hamer, Her Majesty's Minister for Local Government for the State of Victoria, shall give the necessary directions herein accordingly.

J. COLQUHOUN,
Clerk of the Executive Council.

LOCAL GOVERNMENT DEPARTMENT.

At the Executive Council Chamber, Melbourne, the fourth day of August, 1964.

PRESENT:

The Lieutenant-Governor as Deputy for His Excellency the Governor of Victoria.

Mr. Thompson | Mr. Porter.
Mr. Darcy

APPLICATION TO ELECTIONS OF COUNCILLORS FOR THE SHIRE OF KNOX OF REGULATIONS RELATING TO VOTING BY POST.

WHEREAS it is provided in section 149 of the *Local Government Act 1958*, as amended, that the Governor in Council, on the petition of the council of any municipality, may, by Order published in the *Government Gazette*, apply to elections of councillors for such municipality, with any modifications provided for in such Order, all or any of the regulations relating to voting by post made under section 149:

Now, therefore, the Lieutenant-Governor as Deputy for His Excellency the Governor of the State of Victoria, by and with the advice of the Executive Council thereof, and in pursuance of a petition of the Council of the Shire of Knox, doth hereby order that the regulations relating to voting by post at municipal elections, made by the Governor in Council under the said section, shall apply to elections of councillors for the municipality of the Shire of Knox.

And the Honorable Rupert James Hamer, Her Majesty's Minister for Local Government for the State of Victoria, shall give the necessary directions herein accordingly.

J. COLQUHOUN,
Clerk of the Executive Council.

COUNTRY ROADS BOARD.

At the Executive Council Chamber, Melbourne, the fourth day of August, 1964.

PRESENT:

The Lieutenant-Governor as Deputy for His Excellency the Governor of Victoria.

Mr. Thompson | Mr. Porter.
Mr. Darcy

DECLARATION OF A DEVIATION FROM THE LEXTON-TALBOT ROAD IN THE SHIRE OF LEXTON.

WHEREAS by sections 21 and 58 of the *Country Roads Act 1958* (No. 6229) it is amongst other things enacted that when the Country Roads Board under the provisions of the *Country Roads Act* has by Resolution declared a deviation to be a main road the said Board may also declare that such deviation shall be in lieu of any existing road or part thereof named in such Resolution and that on publication in the *Government Gazette* of the Order confirming such Resolution the existing road or part thereof shall cease to be a main road or be discontinued as provided in the Resolution: And whereas the said Board has by Resolution declared the deviation on the land described in the First Schedule to such Resolution to be a main road and has also declared that such deviation shall be in lieu of the part of the existing road being the land described in the Second Schedule to the said Resolution and that such part of the said existing road shall be discontinued: Now therefore the Lieutenant-Governor as Deputy for His Excellency the Governor of the State of Victoria by and with the advice of the Executive Council thereof doth hereby confirm the said Resolution.

Resolution for Declaration of a Deviation of a Main Road under the Country Roads Act.

Whereas the land the site of the road the course of which is below set out was taken by the Board under the provisions of the *Country Roads Act 1958* for the purpose of constructing such road deviation which road deviation has now been laid out and formed on the same: And whereas the said Board (being the Country Roads Board incorporated under the said Act) thinks that the road aforesaid is fit to be used as a public highway such Board at a meeting now holden acting under the authority

conferred upon it by sections 21 and 58 of the said Act doth by this present Resolution hereby declare the said road deviation the course of which is described in the First Schedule hereto with the commencing and terminating points thereof respectively specified to be part of a main road within the meaning and for the purposes of the *Country Roads Act 1958*. And the said Board doth also declare that such deviation shall be in lieu of the existing road or part thereof described in the Second Schedule hereto and that such part of the said existing road as is described in the Third Schedule shall be discontinued.

FIRST SCHEDULE.
Shire of Lexton.

5. *Lexton-Talbot road (9305)*.—All those pieces of land in the Parish of Caralulup, the boundaries of which are as follow:—

- (a) Commencing at a point on the southern boundary of allotment 1, Parish of Caralulup, distant 272 deg. 0 min. 952.3 links from the south-eastern angle of the said allotment; thence by lines bearing respectively 272 deg. 0 min. 717.8 links, 71 deg. 39 min. 838.1 links, 45 deg. 13 min. 864.5 links, 18 deg. 48 min. 783.8 links, 180 deg. 0 min. 459.6 links, 198 deg. 48 min. 384.4 links and 225 deg. 13 min. 1,158.8 links to the point of commencement.
- (b) Commencing at a point on the western boundary of allotment 4A of the said parish, distant 179 deg. 45 min. 1,263.3 links from the north-western angle of the said allotment; thence by lines bearing respectively 18 deg. 53 min. 491.6 links, 45 deg. 40 min. 936.9 links, 71 deg. 42 min. 457 links, 90 deg. 0 min. 6,128.2 links, 263 deg. 26 min. 437.2 links, 270 deg. 0 min. 5,367.4 links, 251 deg. 42 min. 716.7 links, 225 deg. 40 min. 866.5 links, 198 deg. 53 min. 888.2 links and 359 deg. 45 min. 457.6 links to the point of commencement.
- (c) Commencing at the south-eastern angle of allotment 54B of the said parish; thence by lines bearing respectively 270 deg. 0 min. 1,064 links, 83 deg. 26 min. 584.7 links, 70 deg. 21 min. 513 links, 57 deg. 11 min. 481 links, 214 deg. 0 min. 454.5 links and 230 deg. 33 min. 194.2 links to the point of commencement—

which said pieces of land are particularly delineated and shown coloured red and yellow on survey plans numbered 7139 and 7853, lodged in the office of the Country Roads Board.

SECOND SCHEDULE.
Shire of Lexton.

5. *Lexton-Talbot road (9305)*.—All those pieces of land in the Parish of Caralulup, the boundaries of which are as follow:—

- (a) Commencing at a point on the southern boundary of allotment 1 of the said parish, distant 272 deg. 0 min. 952.3 links from the south-eastern angle of the said allotment; thence easterly to the said angle and northerly to a point on the eastern boundary of allotment 1, distant 359 deg. 45 min. 1,213.5 links from the said angle.
- (b) Commencing at the north-eastern angle of allotment 4A of the said parish; thence by lines bearing respectively 179 deg. 45 min. 1,263.3 links, 198 deg. 53 min. 457.6 links, 359 deg. 45 min. 1,796.2 links, 90 deg. 0 min. 1,721.3 links, 251 deg. 42 min. 318.5 links and 270 deg. 0 min. 1,268.5 links to the point of commencement—

which said pieces of land are particularly delineated and shown coloured light and dark-blue on survey plan numbered 7139, lodged in the office of the Country Roads Board.

THIRD SCHEDULE.
Shire of Lexton.

5. *Lexton-Talbot road (9305)*.—All those pieces of land in the Parish of Caralulup, the boundaries of which are as follow:—

- (a) Commencing at the south-eastern angle of allotment 1 of the said parish; thence by lines bearing respectively 359 deg. 45 min. 1,213.5 links, 18 deg. 48 min. 459.6 links, 179 deg. 45 min. 1,653.8 links and 272 deg. 0 min. 150.1 links to the point of commencement.

- (b) Commencing at the north-western angle of allotment 4A of the said parish; thence by lines bearing respectively 359 deg. 45 min. 100 links, 90 deg. 0 min. 1,571.3 links, 251 deg. 42 min. 318.5 links and 270 deg. 0 min. 1,268.5 links to the point of commencement—

which said pieces of land are particularly delineated and shown coloured dark-blue on survey plan numbered 7139, lodged in the office of the Country Roads Board.

The common seal of Country Roads Board was hereto affixed, at Kew, this twenty-seventh day of July, One thousand nine hundred and sixty-four, in the presence of—

(SEAL) I. J. O'DONNELL, Chairman.
H. S. GIBBS, Acting Member.
N. L. ALLANSON, Secretary.

And the Honorable Murray Victor Porter, Her Majesty's Commissioner of Public Works for the State of Victoria, shall give the necessary directions herein accordingly.

J. COLQUHOUN,
Clerk of the Executive Council.

COUNTRY ROADS BOARD.

At the Executive Council Chamber, Melbourne, the fourth day of August, 1964.

PRESENT:

The Lieutenant-Governor as Deputy for His Excellency the Governor of Victoria.

Mr. Thompson | Mr. Porter.
Mr. Darcy

DECLARATION OF A DEVIATION FROM THE COLAC-FORREST ROAD IN THE SHIRE OF COLAC.

WHEREAS by sections 21 and 58 of the *Country Roads Act 1958* (No. 6229) it is amongst other things enacted that when the Country Roads Board under the provisions of the *Country Roads Act* has by Resolution declared a deviation to be a main road the said Board may also declare that such deviation shall be in lieu of any existing road or part thereof named in such Resolution and that on publication in the *Government Gazette* of the Order confirming such Resolution the existing road or part thereof shall cease to be a main road or be discontinued as provided in the Resolution: And whereas the said Board has by Resolution declared the deviation on the land described in the First Schedule to such Resolution to be a main road and has also declared that such deviation shall be in lieu of the part of the existing road being the land described in the Second Schedule to the said Resolution and that such part of the said existing road shall be discontinued: Now therefore the Lieutenant-Governor as Deputy for His Excellency the Governor of the State of Victoria by and with the advice of the Executive Council thereof doth hereby confirm the said Resolution.

Resolution for Declaration of a Deviation of a Main Road under the Country Roads Act.

Whereas the land the site of the road the course of which is below set out was taken by the Board under the provisions of the *Country Roads Act 1958* for the purpose of constructing such road deviation which road deviation has now been laid out and formed on the same: And whereas the said Board (being the Country Roads Board incorporated under the said Act) thinks that the road aforesaid is fit to be used as a public highway such Board at a meeting now holden acting under the authority conferred upon it by sections 21 and 58 of the said Act doth by this present Resolution hereby declare the said road deviation the course of which is described in the First Schedule hereto with the commencing and terminating points thereof respectively specified to be part of a main road within the meaning and for the purposes of the *Country Roads Act 1958*: And the said Board doth also declare that such deviation shall be in lieu of the existing road or part thereof described in the Second Schedule hereto and that such part of the said existing road shall be discontinued.

FIRST SCHEDULE.

Shire of Colac.

12. Colac-Forrest road (3712).—All those pieces of land in the Parish of Gerangamete, the boundaries of which are as follow:—

- (a) Commencing at a point on the southern boundary of allotment 56 of the said parish, distant 90 deg. 1½ min. 4,163.6 links from the south-western angle of the said allotment; thence by lines bearing respectively 11 deg. 14 min. 911 links, 182 deg. 1 min. 674 links, 209 deg. 46 min. 253.3 links and 270 deg. 1½ min. 28 links to the point of commencement.
- (b) Commencing at a point in allotment 54c of the said parish, distant 90 deg. 1½ min. 4,191.6 links, 29 deg. 46 min. 253.3 links and 2 deg. 1 min. 3,061.1 links from the south-western angle of allotment 56; thence by lines bearing respectively 352 deg. 41 min. 374.2 links, 346 deg. 19 min. 523.4 links, 121 deg. 1 min. 140.7 links, 166 deg. 19 min. 292.6 links and 182 deg. 1 min. 523.2 links to the point of commencement.
- (c) Commencing at an angle in the eastern boundary of the existing Colac-Forrest road through allotment 54b of the said parish formed by the intersection of lines bearing 188 deg. 46 min. and 168 deg. 17 min.; thence by lines bearing respectively 8 deg. 46 min. 223.5 links, 166 deg. 19 min. 474 links, 300 deg. 56 min. 128.5 links and 348 deg. 17 min. 177.3 links to the point of commencement.
- (d) Commencing at an angle in the eastern boundary of the existing Colac-Forrest road, through allotment 54A of the said parish, formed by the intersection of lines bearing 322 deg. 40 min. and 11 deg. 11 min.; thence by lines bearing respectively 11 deg. 11 min. 400 links, 186 deg. 15 min. 434.8 links and 322 deg. 40 min. 50 links to the point of commencement.
- (e) Commencing at an angle in the western boundary of the existing Colac-Forrest road through allotment 54A of the said parish, formed by the intersection of lines bearing 323 deg. 24 min. and 11 deg. 11 min.; thence by lines bearing respectively 143 deg. 24 min. 269.1 links, 173 deg. 26 min. 337 links, 166 deg. 19 min. 201.7 links, 188 deg. 55 min. 260.2 links, 346 deg. 19 min. 642 links and 351 deg. 51½ min. 384 links to the point of commencement.
- (f) Commencing at a point on the southern boundary of allotment 48 of the said parish, distant 90 deg. 0 min. 6,158.7 links from the south-western angle of the said allotment; thence by lines bearing respectively 11 deg. 17 min. 1,484 links, 4 deg. 22 min. 318 links, 180 deg. 0 min. 605 links, 199 deg. 39 min. 447.3 links, 191 deg. 8 min. 761 links and 270 deg. 0 min. 17.3 links to the point of commencement.
- (g) Commencing at a point on the eastern boundary of allotment 48 of the said parish, distant 180 deg. 0 min. 3,582.7 links from the north-eastern angle of the said allotment; thence by lines bearing respectively 21 deg. 2 min. 287 links, 180 deg. 0 min. 1,384.2 links, 324 deg. 56 min. 179.3 links and 360 deg. 0 min. 969.6 links to the point of commencement—

which said pieces of land are particularly delineated and shown coloured red on survey plans numbered 8571 and 8572, lodged in the office of the Country Roads Board.

SECOND SCHEDULE.

Shire of Colac.

12. Colac-Forrest road (3712).—All those pieces of land in the Parish of Gerangamete, the boundaries of which are as follow:—

- (a) Commencing at an angle in the eastern boundary of the existing Colac-Forrest road through allotment 54b of the said parish, formed by the intersection of lines bearing 2 deg. 2½ min. and 300 deg. 56 min.; thence by lines bearing respectively 182 deg. 2½ min. 661.5 links, 346 deg. 19 min. 379.5 links, 2 deg. 1 min. 167.9 links, 331 deg. 13 min. 121.6 links, 301 deg. 1 min. 19.3 links, 346 deg. 19 min. 141.5 links and 120 deg. 56 min. 251.9 links to the point of commencement.

- (b) Commencing at an angle in the western boundary of the existing Colac-Forrest road through allotment 54b of the said parish, formed by the intersection of lines bearing 188 deg. 55 min. and 169 deg. 3 min.; thence by lines bearing respectively 8 deg. 55 min. 212.7 links, 166 deg. 19 min. 541 links, 301 deg. 1 min. 131.8 links and 349 deg. 3 min. 252.1 links to the point of commencement.
- (c) Commencing at an angle in the eastern boundary of the existing Colac-Forrest road through allotment 54A of the said parish, formed by the intersection of lines bearing 357 deg. 19 min. and 322 deg. 40 min.; thence by lines bearing respectively 177 deg. 19 min. 409.9 links, 188 deg. 46 min. 319.4 links, 346 deg. 19 min. 264.7 links, 8 deg. 55 min. 65.9 links, 355 deg. 31 min. 376.4 links, 143 deg. 24 min. 112.6 links, 353 deg. 26 min. 202.8 links and 142 deg. 40 min. 332.3 links to the point of commencement.
- (d) Commencing at a point on the eastern boundary of allotment 48 of the said parish, distant 180 deg. 0 min. 3,304 links from the north-eastern angle of the said allotment; thence by lines bearing respectively 180 deg. 0 min. 278.7 links, 201 deg. 2 min. 576.4 links, 173 deg. 32 min. 164 links, 144 deg. 56 min. 328 links, 180 deg. 0 min. 174 links, 324 deg. 56 min. 496 links, 353 deg. 32 min. 214 links and 21 deg. 2 min. 861 links to the point of commencement—

which said pieces of land are particularly delineated and shown coloured blue on survey plans numbered 8571 and 8572, lodged in the office of the Country Roads Board.

The common seal of Country Roads Board was hereto affixed, at Kew, this twenty-seventh day of July, One thousand nine hundred and sixty-four, in the presence of—

I. J. O'DONNELL, Chairman.
H. S. GIBBS, Acting Member.
N. L. ALLANSON, Secretary.

(SEAL)

And the Honorable Murray Victor Porter, Her Majesty's Commissioner of Public Works for the State of Victoria, shall give the necessary directions herein accordingly.

J. COLQUHOUN,
Clerk of the Executive Council.

COUNTRY ROADS BOARD.

At the Executive Council Chamber, Melbourne, the fourth day of August, 1964.

PRESENT:

The Lieutenant-Governor as Deputy for His Excellency the Governor of Victoria.

Mr. Thompson | Mr. Porter.
Mr. Darcy

ORDER APPROVING OF A DEVIATION FROM A MAIN ROAD IN THE SHIRE OF HEYTESBURY.

WHEREAS the Country Roads Board constituted under the *Country Roads Act 1958* (No. 6229) has represented to His Excellency the Governor in Council that it appears to it desirable that the deviation hereinafter referred to from the existing Cobden-Terang road in the Shire of Heytesbury (declared to be a main road under the said Act which declaration was confirmed by the Order in Council published in the *Government Gazette* of the 19th October, 1932, on page 2387) should be made by the said Board: And whereas the said Board in accordance with the requirements of section 19 of the said cited Act has caused to be prepared a map plan and estimate showing the points between which and on and through what land the said deviation is proposed to be made and the cost of acquiring the land: And whereas on an inspection of the said map and plan and a consideration of the said estimate His Excellency the Governor in Council is satisfied that there are funds legally available for acquiring the land: Now therefore be it known by this present Order that the Lieutenant-Governor as Deputy for His Excellency the Governor of the State of Victoria with the advice of the Executive Council thereof doth hereby approve of the said road being made, that is to say:—

All those pieces of land in the Parish of Elingamite, the boundaries of which are as follow:—

- (a) Commencing at a point on the eastern boundary of allotment 3B, section 1, of the said parish, distant 170 deg. 6 min. 3,158 links from the

north-eastern angle of the said allotment; thence by lines bearing respectively 170 deg. 6 min. 753 links, 337 deg. 35 min. 407 links, 320 deg. 56 min. 264 links, 304 deg. 10 min. 330.2 links, and 93 deg. 3 min. 466 links to the point of commencement.

(b) Commencing at a point on the southern boundary of allotment 1A, section 7, of the said parish, distant 90 deg. 0 min. 425.1 links from the south-western angle of the said allotment; thence by lines bearing respectively 303 deg. 40 min. 317.3 links, 315 deg. 18 min. 331.9 links, 350 deg. 0 min. 451 links, 155 deg. 14 min. 460 links, 135 deg. 18 min. 260 links, 123 deg. 40 min. 233 links, 104 deg. 49 min. 486 links and 270 deg. 0 min. 463.5 links to the point of commencement.

(c) Commencing at a point on the eastern boundary of allotment 7, section 3, of the said parish, distant 189 deg. 40 min. 236.2 links from the north-eastern angle of the said allotment; thence by lines bearing respectively 189 deg. 40 min. 802.2 links, 338 deg. 54 min. 700 links, 301 deg. 22 min. 630.5 links, 277 deg. 23 min. 330 links, 90 deg. 0 min. 999.4 links, 187 deg. 45 min. 236.2 links and 89 deg. 46 min. 284.8 links to the point of commencement—

which said pieces of land are particularly delineated and shown coloured red on survey plans numbered 9487 and 9488, lodged in the office of the Country Roads Board.

And the Honorable Murray Victor Porter, Her Majesty's Commissioner of Public Works for the State of Victoria, shall give the necessary directions herein accordingly.

J. COLQUHOUN,
Clerk of the Executive Council.

COUNTRY ROADS BOARD.

At the Executive Council Chamber, Melbourne, the fourth day of August, 1964.

PRESENT:

The Lieutenant-Governor as Deputy for His Excellency the Governor of Victoria.

Mr. Thompson | Mr. Porter.
Mr. Darcy

ORDER APPROVING OF WIDENING AN EXISTING ROAD IN THE CITY OF FOOTSCRAY.

WHEREAS the Country Roads Board constituted under the Country Roads Act 1958 (No. 6229) has represented to His Excellency the Governor in Council that it appears to it desirable that the existing Somerville-road in the City of Footscray should be widened by the said Board: And whereas the said Board in accordance with the requirements of section 19 of the said cited Act has caused to be prepared a map plan and estimate showing the points between which and on and through what land the said widening is proposed to be made and the cost of acquiring the land: And whereas on an inspection of the said map and plan and a consideration of the said estimate His Excellency the Governor in Council is satisfied that there are funds legally available for acquiring the land: Now therefore be it known by this present Order that the Lieutenant-Governor as Deputy for His Excellency the Governor of the State of Victoria with the advice of the Executive Council thereof doth hereby approve of the said road being widened, that is to say:—

All that piece of land in the Parish of Cut-Paw-Paw, the boundaries of which are as follow:—Commencing at the south-western angle of land comprised in certificate of title, volume 2805, folio 997, entered in the register book, and being part of portion D, section 14, of the said parish; thence by lines bearing respectively 0 deg. 25½ min. 43 feet, 139 deg. 19 min. 22 ft. 7½ in., 98 deg. 13½ min. 186 ft. 0½ in. and 270 deg. 13½ min. 199 ft. 2 in. to the point of commencement—which said piece of land is particularly delineated and shown coloured red on survey plan numbered 9596, lodged in the office of the Country Roads Board.

And the Honorable Murray Victor Porter, Her Majesty's Commissioner of Public Works for the State of Victoria, shall give the necessary directions herein accordingly.

J. COLQUHOUN,
Clerk of the Executive Council.

COUNTRY ROADS BOARD.

At the Executive Council Chamber, Melbourne, the fourth day of August, 1964.

PRESENT:

The Lieutenant-Governor as Deputy for His Excellency the Governor of Victoria.

Mr. Thompson | Mr. Porter.
Mr. Darcy

ORDER APPROVING OF A DEVIATION FROM A MAIN ROAD IN THE SHIRE OF WARRAGUL.

WHEREAS the Country Roads Board constituted under the Country Roads Act 1958 (No. 6229) has represented to His Excellency the Governor in Council that it appears to it desirable that the deviation hereinafter referred to from the existing Hazeldean-road in the Shire of Warragul (declared to be a main road under the said Act which declaration was confirmed by the Order in Council published in the Government Gazette of the 9th April, 1941, on page 1520) should be made by the said Board: And whereas the said Board in accordance with the requirements of section 19 of the said cited Act has caused to be prepared a map plan and estimate showing the points between which and on and through what land the said deviation is proposed to be made and the cost of acquiring the land: And whereas on an inspection of the said map and plan and a consideration of the said estimate His Excellency the Governor in Council is satisfied that there are funds legally available for acquiring the land: Now therefore be it known by this present Order that the Lieutenant-Governor as Deputy for His Excellency the Governor of the State of Victoria with the advice of the Executive Council thereof doth hereby approve of the said road being made, that is to say:—

All that piece of land in the Parish of Warragul, the boundaries of which are as follow:—Commencing at a point on the southern boundary of allotment 55 of the said parish, distant 279 deg. 10 min. 336.4 links from the south-eastern angle of the said allotment; thence by lines bearing respectively 189 deg. 10 min. 100 links, 279 deg. 10 min. 1932 links, 321 deg. 9 min. 309.5 links, 317 deg. 37 min. 405 links, 123 deg. 39 min. 328.3 links, 118 deg. 57 min. 530 links, 103 deg. 52 min. 530 links and 99 deg. 10 min. 1,153.5 links to the point of commencement—which said piece of land is particularly delineated and shown coloured red and green on survey plan numbered 9545, lodged in the office of the Country Roads Board.

And the Honorable Murray Victor Porter, Her Majesty's Commissioner of Public Works for the State of Victoria, shall give the necessary directions herein accordingly.

J. COLQUHOUN,
Clerk of the Executive Council.

COUNTRY ROADS BOARD.

At the Executive Council Chamber, Melbourne, the fourth day of August, 1964.

PRESENT:

The Lieutenant-Governor as Deputy for His Excellency the Governor of Victoria.

Mr. Thompson | Mr. Porter.
Mr. Darcy

ORDER APPROVING OF WIDENING AN EXISTING STATE HIGHWAY IN THE CITY OF KEILOR.

WHEREAS the Country Roads Board constituted under the Country Roads Act 1958 (No. 6229) has represented to His Excellency the Governor in Council that it appears to it desirable that the existing Calder Highway in the City of Keilor (declared to be a State highway under the said Act which declaration was confirmed by the Order in Council published in the Government Gazette of the 8th July, 1925, on page 2371) should be widened by the said Board: And whereas the said Board in accordance with the requirements of section 19 of the said cited Act has caused to be prepared a map plan and estimate showing the points between which and on and through what land the said widening is proposed to be made and the cost of acquiring the land: And whereas on an inspection of the said map and plan and a consideration of the said estimate His Excellency the Governor in Council is satisfied

that there are funds legally available for acquiring the land: Now therefore be it known by this present Order that the Lieutenant-Governor as Deputy for His Excellency the Governor of the State of Victoria with the advice of the Executive Council thereof doth hereby approve of the said highway being widened, that is to say:—

All that piece of land in the Parish of Dousta Galla, the boundaries of which are as follow:—Commencing at a point in allotment D, section 18, of the said parish, distant 96 deg. 20 min. 53 ft. 11 in. from the north-eastern angle of lot 25 on plan of subdivision numbered 13021, lodged in the Office of Titles, and being part of the said allotment; thence by lines bearing respectively 28 deg. 17 min. 142 ft. 3½ in., 96 deg. 20 min. 73 ft. 3½ in., 208 deg. 16 min. 203 ft. 6½ in., 298 deg. 13 min. 68 ft. 0½ in. and 28 deg. 17 min. 33 ft. 11 in. to the point of commencement—which said piece of land is particularly delineated and shown coloured red on survey plan numbered 9451, lodged in the office of the Country Roads Board.

And the Honorable Murray Victor Porter, Her Majesty's Commissioner of Public Works for the State of Victoria, shall give the necessary directions herein accordingly.

J. COLQUHOUN,
Clerk of the Executive Council.

COUNTRY ROADS BOARD.

At the Executive Council Chamber, Melbourne, the fourth day of August, 1964.

PRESENT:

The Lieutenant-Governor as Deputy for His Excellency the Governor of Victoria.

Mr. Thompson	Mr. Porter.
Mr. Darcy	

DECLARATION OF A DEVIATION FROM THE MIDLAND HIGHWAY IN THE SHIRES OF MANSFIELD AND BENALLA.

WHEREAS by sections 74 and 58 of the *Country Roads Act 1958* (No. 6229) it is amongst other things enacted that when the Country Roads Board under the provisions of the *Country Roads Act* has by Resolution declared a deviation to be a State highway the said Board may also declare that such deviation shall be in lieu of any existing highway or part thereof named in such Resolution and that on publication in the *Government Gazette* of the Order confirming such Resolution the existing highway or part thereof shall cease to be a State highway or be discontinued as provided in the Resolution: And whereas the said Board has by Resolution declared the deviation on the land described in the First Schedule to such Resolution to be a State highway and has also declared that such deviation shall be in lieu of the part of the existing highway being the land described in the Second Schedule to the said Resolution and that such part of the said existing highway shall be discontinued: Now therefore the Lieutenant-Governor as Deputy for His Excellency the Governor of the State of Victoria by and with the advice of the Executive Council thereof doth hereby confirm the said Resolution.

Resolution for Declaration of a Deviation of a State Highway under the Country Roads Act.

Whereas the land the site of the highway the course of which is below set out was taken by the Board under the provisions of the *Country Roads Act 1958* for the purpose of constructing such highway deviation which highway deviation has now been laid out and formed on the same: And whereas the said Board (being the Country Roads Board incorporated under the said Act) thinks that the highway aforesaid is fit to be used as a public highway such Board at a meeting now holden acting under the authority conferred upon it by sections 74 and 58 of the said Act doth by this present Resolution hereby declare the said highway deviation the course of which is described in the First Schedule hereto with the commencing and terminating points thereof respectively specified to be part of a State highway within the meaning and for the purposes of the *Country Roads Act 1958*: And the said Board doth also declare that such deviation shall be in lieu of the existing highway or part thereof described in the Second Schedule hereto and that such part of the said existing highway shall be discontinued.

FIRST SCHEDULE.

Shires of Mansfield and Benalla.

9. *Midland Highway*.—All those pieces of land in the Parish of Nillahcootie, the boundaries of which are as follow:—

- (a) Commencing at an angle in the eastern boundary of the existing Midland Highway through allotment 3B of the said parish formed by the intersection of lines bearing 203 deg. 42 min. and 213 deg. 28 min.; thence by lines bearing respectively 23 deg. 42 min. 32 links, 203 deg. 39 min. 463.8 links, 217 deg. 42½ min. 1,019.2 links, 214 deg. 38½ min. 676.8 links, 32 deg. 43 min. 431.5 links, 28 deg. 13 min. 547.9 links, 63 deg. 3 min. 144.5 links and 33 deg. 28 min. 1,015.8 links to the point of commencement.
- (b) Commencing at an angle in the western boundary of the existing Midland Highway through allotment 4A of the said parish, formed by the intersection of lines bearing 44 deg. 44 min. and 32 deg. 43 min.; thence by lines bearing respectively 224 deg. 44 min. 250.2 links, 34 deg. 30 min. 1,034.9 links, 208 deg. 13 min. 253.4 links and 212 deg. 43 min. 537 links to the point of commencement.
- (c) Commencing at an angle in the eastern boundary of the existing Midland Highway through allotment 4A of the said parish formed by the intersection of lines bearing 224 deg. 44 min. and 208 deg. 31 min.; thence by lines bearing respectively 44 deg. 44 min. 362.4 links, 212 deg. 15½ min. 600.1 links, 196 deg. 26 min. 415.1 links, 344 deg. 56 min. 83.7 links, 10 deg. 42 min. 298.1 links and 28 deg. 31 min. 312.3 links to the point of commencement.
- (d) Commencing at an angle in the western boundary of the existing Midland Highway through allotment 4A of the said parish formed by the intersection of lines bearing 10 deg. 42 min. and 28 deg. 31 min.; thence by lines bearing respectively 190 deg. 42 min. 248 links, 4 deg. 29 min. 225.8 links, 34 deg. 30 min. 154.7 links and 208 deg. 31 min. 123.9 links to the point of commencement.
- (e) Commencing at an angle in the western boundary of the existing Midland Highway through allotment 5 of the said parish formed by the intersection of lines bearing 357 deg. 37 min. and 344 deg. 56 min.; thence by lines bearing respectively 177 deg. 37 min. 250 links, 183 deg. 8 min. 653 links, 352 deg. 40 min. 907.6 links, 4 deg. 29 min. 408.6 links and 164 deg. 56 min. 420.1 links to the point of commencement.
- (f) Commencing at an angle in the eastern boundary of the existing Midland Highway through allotment 4A of the said parish, formed by the intersection of lines bearing 178 deg. 27 min. and 153 deg. 0 min.; thence by lines bearing respectively 358 deg. 27 min. 515.2 links, 172 deg. 33 min. 661.6 links and 333 deg. 0 min. 158.3 links to the point of commencement.
- (g) Commencing at a point on the northern boundary of allotment 46 of the said parish, distant 279 deg. 51 min. 21.4 links from the north-eastern angle of the said allotment; thence by lines bearing respectively 158 deg. 13 min. 157.5 links, 165 deg. 19 min. 224.6 links, 181 deg. 4 min. 971 links, 209 deg. 29 min. 401 links, 164 deg. 26 min. 1,116 links, 342 deg. 2½ min. 1,094.8 links, 9 deg. 7 min. 669 links, 348 deg. 27 min. 1,123.9 links, 353 deg. 51 min. 749 links, 159 deg. 40 min. 555.1 links, 181 deg. 5 min. 120.6 links, 154 deg. 39 min. 148 links and 99 deg. 51 min. 84.6 links to the point of commencement.
- (h) Commencing at the northern angle of allotment 46A of the said parish; thence by lines bearing respectively 122 deg. 16 min. 172.6 links, 176 deg. 55 min. 479.9 links, 337 deg. 50 min. 521.3 links and 15 deg. 42 min. 92 links to the point of commencement—

which said pieces of land are particularly delineated and shown coloured red and green on survey plans numbered 8594 and 8595, lodged in the office of the Country Roads Board.

SECOND SCHEDULE.
Shire of Mansfield.

9. *Midland Highway*.—All those pieces of land in the Parish of Nillahcootie, the boundaries of which are as follow:—

- (a) Commencing at an angle in the eastern boundary of the existing Midland Highway through allotment 4A of the said parish, formed by the intersection of lines bearing 44 deg. 44 min. and 32 deg. 43 min.; thence by lines bearing respectively 224 deg. 44 min. 19.1 links, 32 deg. 15½ min. 22.2 links, 34 deg. 38½ min. 123.8 links and 212 deg. 43 min. 127.2 links to the point of commencement.
- (b) Commencing at an angle in the western boundary of the existing Midland Highway through allotment 4A of the said parish, formed by the intersection of lines bearing 224 deg. 44 min. and 208 deg. 31 min.; thence by lines bearing respectively 44 deg. 44 min. 136.8 links, 214 deg. 30 min. 366.4 links and 28 deg. 31 min. 233.1 links to the point of commencement.
- (c) Commencing at an angle in the western boundary of the existing Midland Highway through allotment 5 of the said parish, formed by the intersection of lines bearing 190 deg. 42 min. and 164 deg. 56 min.; thence by lines bearing respectively 10 deg. 42 min. 108 links, 184 deg. 29 min. 140.2 links and 344 deg. 56 min. 34.9 links to the point of commencement.
- (d) Commencing at an angle in the eastern boundary of the existing Midland Highway through allotment 5 of the said parish, formed by the intersection of lines bearing 357 deg. 37 min. and 344 deg. 56 min.; thence by lines bearing respectively 177 deg. 37 min. 273.9 links, 183 deg. 8 min. 442.3 links, 344 deg. 58 min. 222.1 links, 358 deg. 32 min. 842.6 links and 164 deg. 56 min. 353.7 links to the point of commencement.
- (e) Commencing at the north-eastern angle of allotment 46 of the said parish; thence by lines bearing respectively 279 deg. 51 min. 21.4 links, 337 deg. 37 min. 129 links, 353 deg. 46 min. 335.1 links, 352 deg. 33 min. 235.7 links, 153 deg. 0 min. 275.3 links, 181 deg. 5 min. 260.3 links, 154 deg. 39 min. 218.6 links, 99 deg. 51 min. 31.8 links, 164 deg. 1 min. 493.8 links, 179 deg. 56 min. 623.4 links, 275 deg. 22 min. 41.1 links, 355 deg. 4 min. 577 links, 351 deg. 22 min. 169.1 links, 338 deg. 13 min. 245.9 links and 345 deg. 19 min. 147.4 links to the point of commencement—

which said pieces of land are particularly delineated and shown coloured blue on survey plans numbered 8594 and 8595, lodged in the office of the Country Roads Board.

The common seal of Country Roads Board was hereto affixed, at Kew, this twenty-seventh day of July, One thousand nine hundred and sixty-four, in the presence of—

(SEAL) I. J. O'DONNELL, Chairman.
H. S. GIBBS, Acting Member.
N. L. ALLANSON, Secretary.

And the Honorable Murray Victor Porter, Her Majesty's Commissioner of Public Works for the State of Victoria, shall give the necessary directions herein accordingly.

J. COLQUHOUN,
Clerk of the Executive Council.

MINES ACT 1958.

At the Executive Council Chamber, Melbourne, the fourth day of August, 1964.

PRESENT:

The Lieutenant-Governor as Deputy for His Excellency the Governor of Victoria.

Mr. Thompson | Mr. Porter.
Mr. Darcy

LAND EXCEPTED FROM OCCUPATION FOR MINING PURPOSES.

THE Lieutenant-Governor as Deputy for His Excellency the Governor of the State of Victoria, by and with the advice of the Executive Council thereof, doth hereby, in pursuance of the provisions of the *Mines Act 1958*, except from occupation for mining purposes under any

miner's right or from being leased under a mining lease the land on which is situated the mining dam hereinafter described:—

Phoenix Dam, situated on an area of Crown land adjoining and south of Heywood-street in the City of Bendigo.

And the Honorable Thomas Anthony Darcy, Her Majesty's Minister of Mines for the State of Victoria, shall give the necessary directions herein accordingly.

J. COLQUHOUN,
Clerk of the Executive Council.

LANDLORD AND TENANT ACT 1958.

At the Executive Council Chamber, Melbourne, the fourth day of August, 1964.

PRESENT:

The Lieutenant-Governor as Deputy for His Excellency the Governor of Victoria.

Mr. Thompson | Mr. Porter.
Mr. Darcy

ORDER EXTENDING APPLICATION OF PART V. OF THE LANDLORD AND TENANT ACT 1958 TO CERTAIN PREMISES.

IN pursuance of the powers conferred by section 44 of the *Landlord and Tenant Act 1958*, the Lieutenant-Governor as Deputy for His Excellency the Governor of Victoria, by and with the advice of the Executive Council thereof, doth hereby declare that the application of Part V. of the *Landlord and Tenant Act 1958* shall extend to the following premises:—

1. The premises known as No. 152 Roden-street, West Melbourne.
2. The premises known as No. 372 Lygon-street, East Brunswick.
3. The premises known as No. 26 Victoria-road, Northcote.
4. The premises known as No. 48 Whitehall-street, Footscray.
5. The premises known as No. 32 Clarence-street, Elsternwick, and to all premises forming part of such premises.

And the Honorable Arthur Gordon Rylah, Her Majesty's Attorney-General for the State of Victoria, shall give the necessary directions herein accordingly.

J. COLQUHOUN,
Clerk of the Executive Council.

LANDLORD AND TENANT ACT 1958.

At the Executive Council Chamber, Melbourne, the eleventh day of August, 1964.

PRESENT:

His Excellency the Governor of Victoria.
Mr. Bloomfield | Mr. Dickie.

ORDER EXTENDING APPLICATION OF PART V. OF THE LANDLORD AND TENANT ACT 1958 TO CERTAIN PREMISES.

IN pursuance of the powers conferred by section 44 of the *Landlord and Tenant Act 1958*, His Excellency the Governor of Victoria, by and with the advice of the Executive Council thereof, doth hereby declare that the application of Part V. of the *Landlord and Tenant Act 1958* shall extend to the following premises:

1. The premises known as No. 5 Oxford-street Collingwood.
2. The premises known as No. 21 Hotham-street, Collingwood.
3. The premises known as No. 14 Kennedy-street, Fairfield.

And the Honorable Vernon Francis Wilcox, acting for and on behalf of Her Majesty's Attorney-General for the State of Victoria, shall give the necessary directions herein accordingly.

J. COLQUHOUN,
Clerk of the Executive Council.

Water Act 1958.

STATE RIVERS AND WATER SUPPLY COMMISSION.

At the Executive Council Chamber, Melbourne, the
eleventh day of August, 1964.

PRESENT:

His Excellency the Governor of Victoria.
Mr. Bloomfield | Mr. Dickie.

CAMPERDOWN, COBDEN AND TERANG URBAN DISTRICTS UNITED TO FORM OTWAY URBAN DISTRICT.

UNDER the powers conferred by the Water Act 1958, and all other powers enabling him in that behalf, His Excellency the Governor of the State of Victoria, with the advice of the Executive Council of the said State, on the recommendation of the State Rivers and Water Supply Commission, doth hereby declare, order, and direct as follows:—

That the Camperdown Urban District, the Cobden Urban District, and the Terang Urban District be united as from the 15th day of August, 1964, so as to form one district to be known as Otway Urban District and that the lands comprising the said Otway Urban District shall be those which at the 14th day of August, 1964, were included within the boundaries of the said Camperdown, Cobden and Terang Urban Districts.—(Corr. No. 60/5458.)

And the Honorable Thomas Anthony Darcy, Her Majesty's Minister of Water Supply for the State of Victoria, shall give the necessary directions herein accordingly.

J. COLQUHOUN,
Clerk of the Executive Council.

WARRANTYTE WATERWORKS TRUST.

At the Executive Council Chamber, Melbourne, the
eleventh day of August, 1964.

PRESENT:

His Excellency the Governor of Victoria.
Mr. Bloomfield | Mr. Dickie.

APPROVAL OF PLAN SHOWING SITE OF A PIPE-LINE.

HIS Excellency the Governor of the State of Victoria, by and with the advice of the Executive Council thereof, doth hereby approve in accordance with the provisions of the Water Acts, a plan showing the site for a pipe-line to be constructed by the Warrandyte Waterworks Trust within its Waterworks District on the lands as described in the Schedule hereto.

SCHEDULE.

The site of the pipe-line shall be a strip of land 50 links in width being 25 links on each side of the centre-line of the said pipe-line commencing at a point in a road reserve known as Harris Gully-road, near the north-western angle of Crown allotment 27⁴, Parish of Warrandyte, County of Evelyn, being a point on the boundary of the Warrandyte Waterworks District; thence southerly along the said road reserve to its intersection with a road reserve known as Beauty Gully-road; thence generally south-easterly along the said Beauty Gully-road a distance of approximately 850 links.

All of which lands are shown on a plan approved by the Governor in Council and deposited in the office of the State Rivers and Water Supply Commission, Melbourne.—(Corr. 59/8034/137.)

And the Honorable Thomas Anthony Darcy, Her Majesty's Minister of Water Supply for the State of Victoria, shall give the necessary directions herein accordingly.

J. COLQUHOUN,
Clerk of the Executive Council.

MORNINGTON SEWERAGE AUTHORITY.

At the Executive Council Chamber, Melbourne, the
eleventh day of August, 1964.

PRESENT:

His Excellency the Governor of Victoria.
Mr. Bloomfield | Mr. Dickie.

EXTENT OF SEWERAGE DISTRICT INCREASED.

UNDER the powers conferred by the Sewerage Districts Act and all other powers enabling him in that behalf, His Excellency the Governor of the State of Victoria, by and with the advice of the Executive Council of the said State, doth hereby declare, order and direct as follows:—

That the extent of the Sewerage District of the Mornington Sewerage Authority be increased by adding to the same the lands comprised within the boundaries described in the Schedule hereto, and as on and from the date hereof, the extent of such District shall be deemed to be increased accordingly.

SCHEDULE.

Commencing at the south-eastern angle of lot 33 on lodged plan of subdivision No. 54437, Crown allotment 33, section 25, Parish of Moorooduc, County of Mornington, being a point on the boundary of the existing Sewerage District also being a point on the western boundary of Prince-street; thence southerly along the western boundary of the road known as Prince-street to a point in line with the northern boundary of lot 9 on lodged plan of subdivision No. 19635, Crown allotment 32; thence westerly along a line being the continuation of the northern boundary of the said lot 9 and along its northern boundary to its north-western angle; thence southerly along the western boundaries of the said lot 9 and of lot 10 to its south-western angle; thence westerly along the southern boundary of a road known as Johns-road and by a line being the continuation thereof across a road to the eastern boundary of a Permanent Foreshore Reserve; thence northerly along the said eastern boundary of the Permanent Foreshore Reserve to a point on the boundary of the existing Sewerage District; thence easterly, northerly and easterly along the boundary of the existing Sewerage District to the point of commencement.

All of which lands are shown on a plan approved by the Governor in Council and deposited in the office of the State Rivers and Water Supply Commission, Melbourne.—(Corres. 63/935/67.)

And the Honorable Thomas Anthony Darcy, Her Majesty's Minister of Water Supply for the State of Victoria, shall give the necessary directions herein accordingly.

J. COLQUHOUN,
Clerk of the Executive Council.

LOCAL GOVERNMENT DEPARTMENT.

At the Executive Council Chamber, Melbourne, the
eleventh day of August, 1964.

PRESENT:

His Excellency the Governor of Victoria.
Mr. Bloomfield | Mr. Dickie.

RE-SUBDIVISION OF THE SHIRE OF TUNGAMAH.

PURSUANT to the provisions of section 47 of the Local Government Act 1958, as amended, His Excellency the Governor of the State of Victoria by and with the advice of the Executive Council thereof, and in compliance with an application of the Council of the Shire of Tungamah under the said section, hereby re-subdivides the municipal district of the said municipality in the manner described hereunder, such re-subdivision to take effect on and from the 1st October, 1964:—

SHIRE OF TUNGAMAH.

North-West Riding (Constituted).

Commencing at the north-western angle of the Parish of Katandra being a point on the western boundary of the Shire; thence easterly by the northern boundaries of the Parishes of Katandra and Yabba Yabba to the south-eastern angle of the Parish of Youanmite; thence northerly by the eastern boundary of that parish to the Shire boundary and thence westerly and southerly by the Shire boundary to the point of commencement.

South-West Riding (Reduced and Redefined).

Commencing at the north-western angle of the Parish of Katandra being a point on the western boundary of the Shire; thence easterly by the northern boundaries of the Parishes of Katandra and Yabba Yabba to the north-eastern angle of the latter parish; thence southerly, easterly, southerly, westerly and southerly by the eastern boundary of the said parish to the Shire boundary and thence westerly and northerly by the Shire boundary to the point of commencement.

Previous Gazettal 1953/1325.

Central Riding (Unaltered).

Previous Gazettal 1953/1325.

Southern Riding (Unaltered).

Previous Gazettal 1953/1325.

And the Honorable Rupert James Hamer, Her Majesty's Minister for Local Government for the State of Victoria, shall give the necessary directions herein accordingly.

J. COLQUHOUN,
Clerk of the Executive Council.

POLICE REGULATION ACT 1958.

At the Executive Council Chamber, Melbourne,
the eleventh day of August, 1964.

PRESENT:

His Excellency the Governor of Victoria.
Mr. Bloomfield | Mr. Dickie.

APPOINTMENT OF A SUPERINTENDENT OF POLICE AS A DEPUTY MEMBER OF THE POLICE DISCIPLINE BOARD.

WHEREAS William Richard Renton, a Superintendent of Police, who is a member of the Police Discipline Board, is unavailable to carry out his duties as a member of the said Board:

And whereas the Chief Commissioner of Police has nominated Raymond Walter Carlile, a Superintendent of Police, to act as the Deputy of the said member of the said Board:

Now therefore His Excellency the Governor of the State of Victoria, in the Commonwealth of Australia, by and with the advice of the Executive Council of the said State, and in pursuance of the powers conferred by the *Police Regulation Act 1958*, doth by this Order appoint the said Raymond Walter Carlile to act as the Deputy of the said William Richard Renton, during the period from the eleventh day of August, 1964, until the said William Richard Renton is available to carry out his duties as a member of the said Board.

And the Honorable Arthur Gordon Rylah, Her Majesty's Chief Secretary for the State of Victoria, shall give the necessary directions herein accordingly.

J. COLQUHOUN,
Clerk of the Executive Council.

TOWN AND COUNTRY PLANNING ACT 1961.

At the Executive Council Chamber, Melbourne,
the eleventh day of August, 1964.

PRESENT:

His Excellency the Governor of Victoria.
Mr. Bloomfield | Mr. Dickie.

REVOCATION OF INTERIM DEVELOPMENT ORDER.—SHIRE OF FERN TREE GULLY PLANNING SCHEME.

WHEREAS by virtue of the *Town and Country Planning Act 1961* it is provided that the Governor in Council may at any time after consultation by the Minister with the responsible authority and the Town and Country Planning Board revoke amend or vary any Interim Development Order in whole or in part and such revocation amendment or variation shall come into operation upon publication of notice thereof in the *Government Gazette*;

And whereas an Interim Development Order was made by the Town and Country Planning Board and approved by the Governor in Council on the 20th March, 1962, and published in the *Government Gazette* No. 30, dated the 21st March, 1962:

And whereas the Governor in Council on the 17th December, 1963, ordered that the responsible authority for the purpose of the subsequent operation and effect of the hereinbefore recited Interim Development Order shall be the Council of the Shire of Fern Tree Gully and the Council of the Shire of Knox in so far as the said Interim Development Order applies to their respective municipal districts:

Now therefore the Governor in Council, after consultation by the Minister with the Council of the Shire of Fern Tree Gully and the Town and Country Planning Board doth hereby revoke the said Interim Development Order in so far as it relates to any land within the municipal district of the Shire of Fern Tree Gully.

And the Honorable Rupert James Hamer, Her Majesty's Minister for Local Government for the State of Victoria, shall give the necessary directions herein accordingly.

J. COLQUHOUN,
Clerk of the Executive Council.

HOUSING ACT 1958.

At the Executive Council Chamber, Melbourne,
the eleventh day of August, 1964.

PRESENT:

His Excellency the Governor of Victoria.
Mr. Bloomfield | Mr. Dickie.

EXTINGUISHMENT OF RESTRICTIVE COVENANTS.—CITY OF PRESTON.

WHEREAS by virtue and in exercise of the powers contained in the *Housing Act 1958* (No. 6275) Housing Commission has recommended to the Governor in Council that the restrictive covenants described in the Schedule hereto be extinguished.

Now therefore His Excellency the Governor of the State of Victoria in the Commonwealth of Australia by and with the advice of the Executive Council of the said State, doth in pursuance of the powers conferred by the said Act and upon such recommendation, consent and by this Order hereby extinguish such restrictive covenants.

SCHEDULE.

Any restrictive covenants affecting lots numbered 134 and 135 on plan of subdivision No. 12498 lodged in the Office of Titles.

And the Honorable Lindsay Hamilton Simpson Thompson, Her Majesty's Minister of Housing for the State of Victoria, shall give the necessary directions herein accordingly.

J. COLQUHOUN,
Clerk of the Executive Council.

APPROACHING LAND SALES.

SALES of Crown lands, in fee-simple, will be held at the under-mentioned places and dates, viz.:

	No. of Gazette.
Bright.—Thursday, 10th September, 1964 ..	70
Chiltern.—Wednesday, 9th September, 1964 ..	70
Foster.—Friday, 11th September, 1964 ..	70
Heathcote.—Friday, 18th September, 1964 ..	71
Mallacoota.—Wednesday, 2nd September, 1964 ..	66
Mansfield.—Friday, 18th September, 1964 ..	71
Meenyan.—Tuesday, 18th August, 1964 ..	60
Orbost.—Tuesday, 1st September, 1964 ..	66
Ouyen.—Monday, 31st August, 1964 ..	66
Wangaratta.—Friday, 11th September, 1964 ..	70

AUCTION OF RIGHT TO LEASE CROWN LAND.

Wonthaggi.—Tuesday, 18th August, 1964 .. 60

SALE OF CLOSER SETTLEMENT LAND BY AUCTION

Berwick.—Friday, 11th September, 1964 .. 70

SALE OF FREEHOLD LAND BY AUCTION.

Rupanyup.—Friday, 18th September, 1964 .. 71

SALES OF CROWN LAND BY AUCTION.

The land will be offered for sale in fee-simple, and subject to the provisions of the Land Act and Regulations thereunder.

The **upset price** is the sum at which bidding will start, and no bid below that sum can be accepted. The highest bidder at or above that sum shall be the purchaser, subject to signature of contract and any necessary payment.

TERMS:

A deposit of at least 12½% of the purchase price must be paid at the sale, either in cash or by cheque.

The residue is payable in half-yearly instalments, in accordance with the following scale, or may be paid off at any earlier time.

£20 and under, 6 instalments.
Over £20, and not exceeding £50, 8 instalments.
Over £50, and not exceeding £100, 10 instalments.
Over £100, and not exceeding £200, 12 instalments.
Over £200, and not exceeding £300, 14 instalments.
Over £300, and not exceeding £400, 16 instalments.
Over £400, and not exceeding £500, 18 instalments.
Over £500, 20 instalments.

Interest at the rate of 5% per annum is payable with all payments of residue, and is computed for each instalment from the date of sale to the date of such payment. Additional interest is charged if any instalment is not paid on or before the due date.

If paid off within 30 days of sale, no interest is payable

FEES, ETC.:

Also payable at the sale, in addition to the deposit, are the survey fee and, if applicable, the valuation of improvements (if purchaser be not the owner thereof).

Payable with balance of purchase money—

Crown Grant fee—50 acres and under	£1 10s.
Over 50 acres	£2
Purchase money £5 or under	£1

Assurance Fund contribution—One halfpenny for each £1 of purchase price. (This is a fund established to guarantee the validity of freehold titles.)

Transfer of interest prior to completion of payment may be allowed on payment of £1 fee and subject to stamp duty.

If unable to attend personally, a prospective purchaser may arrange for another person to bid as his agent.

Attention is drawn to section 95, *Land Act 1958*, which provides that the purchaser shall be deemed to be the owner for the purposes of other Acts; also to an amendment to the Local Government Act providing for Government roads in certain circumstances, to be declared "private streets" thus making the purchaser liable to contribute to the cost of street construction.

J. C. M. BALFOUR,
Commissioner of Crown Lands and Survey.

Office of Crown Lands and Survey,
Melbourne, 12th August, 1964.

MANSFIELD.—Sale (No. 11752) of Crown land in fee-simple, by auction, will be held at the LAND INSPECTOR'S OFFICE, MANSFIELD, on FRIDAY, the 18th SEPTEMBER, 1964, at half-past TWO o'clock p.m. To be conducted by G. H. WILSON, Land Officer, Seymour.

Lot 1.

PARISH OF DUERAN, COUNTY OF DELATITE.

At the Junction of the Mansfield-Whitfield and Toombullup-Benalla roads.

Upset price £50 the lot. Survey fee £9 12s. 6d.

Area 6a. 3r. 37p., allotment 2A of section B. Valuation of improvements £675 (Forests Commission) (Residence, outbuilding, fencing and pine trees).—(H.029567.)

HEATHCOTE.—Sale (No. 11753) of Crown land in fee-simple, by auction, will be held at the LAND INSPECTOR'S OFFICE, HEATHCOTE, on FRIDAY, the 18th SEPTEMBER, 1964, at half-past TEN o'clock a.m. To be conducted by G. H. WILSON, Land Officer, Seymour.

PARISH OF HEATHCOTE, COUNTY OF DALHOUSIE.

Lot 1.

Fronting the east side of a bitumen road about ½ mile south of the Argyle Railway Station.

Upset price £80 the lot. Survey fee £7.

Area 1a. 2r. 9p., allotment 13x. Valuation of improvements £1,212 (Residence and fencing) (P. Case).—(H.028138A.)

Lot 2.

About ½ mile north-west of the Argyle Railway Station and east of the McIvor Creek.

Upset price £12 the lot. Survey fee £8 17s. 6d.

Area 4 acres, allotment 6c.—(H.029529.)

SALE OF FREEHOLD LAND BY AUCTION.

RUPANYUP.—A sale of freehold land, by auction, for and on behalf of the Minister of Education, will be held at the PUBLIC HALL, CROMIE-STREET, RUPANYUP, on FRIDAY, the 18th SEPTEMBER, 1964, at THREE o'clock p.m. To be conducted by E. M. FLOYD, Land Officer, Seymour.

Lot 1.

PARISH OF LALLAT, COUNTY OF BORUNG.

Being the site and buildings of the former Dalcross State School.

Upset price £193 the lot.

Area 5 acres, being allotment 34c and being the land described in Crown Grant, volume 5462, folio 251, together with all improvements thereon.

CONDITIONS.

Deposit of at least 12½ per cent. of purchase price payable at sale and balance within 60 days. Purchaser to arrange for, and bear costs of, registration of transfer of titles.—(M.43138.)

PROPOSED REVOCATIONS OF TEMPORARY RESERVATIONS OF LANDS BY ORDERS IN COUNCIL.

IN pursuance of the provisions of the *Land Act 1958*, notice is hereby given that it is the intention of the Governor in Council to revoke the temporary reservations of lands by Orders in Council hereunder referred to, viz.:

The following Notices were published 1^o on the 5th August, 1964, pursuant to Orders of the 28th July, 1964.

ONDIT (LAKE CUNDARE).—The temporary reservation, by Order in Council of the 14th June, 1910, of 3 roods 25 perches of land in the Parish of Ondit, as a site for a State School.—(O.6⁽⁴⁾) (C.47729).

SCARSDALE.—The temporary reservation, by Order in Council of the 20th March, 1899, of 2 roods 8 8/10 perches of land in the Parish of Scarsdale, as a site for Police purposes.—(S.249⁽¹²⁾) (C.7207).

SHEPPARTON.—The temporary reservation, by Order in Council of the 6th March, 1896, of 3 acres 0 roods 4½ perches of land in the Parish of Shepparton, as a site for a State School.—(S.283⁽¹⁰⁾) (C.95116).

STRATFORD.—The temporary reservation, by Order in Council of the 24th November, 1959, of 7 acres more or less of land in the Township of Stratford, as a site for Caravan and Tourist Camping Park, is about to be revoked so far only as the portion containing 3 roods 30 perches more or less, indicated by hachure on plan hereunder is concerned.—(S.346⁽⁸⁾) (Rs.7862).

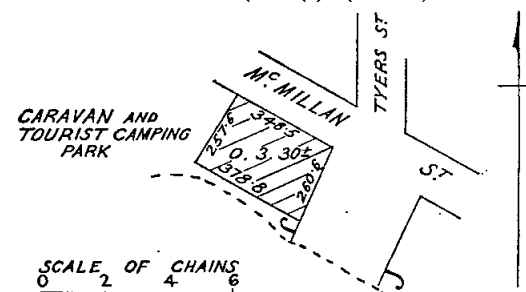

J. C. M. BALFOUR,
Commissioner of Crown Lands and Survey.

PROPOSED REVOCATION OF TEMPORARY RESERVATION, AND THE WITHHOLDING FROM SALE, LEASING, AND LICENSING OF LAND BY ORDER IN COUNCIL.

IN pursuance of the provisions of the *Land Act 1958*, notice is hereby given that it is the intention of the Governor in Council to revoke the temporary reservation, and the withholding from sale, leasing and licensing of land by Order in Council hereunder referred to, viz.:—

The following Notice was published 1° on the 29th July, 1964, pursuant to Order of the 21st July, 1964.

MOREEP.—The temporary reservation as a site for Victorian Water Supply purposes, and the withholding from sale, leasing and licensing by Order in Council of the 18th October, 1875 (see *Government Gazette* of the 22nd October, 1875, page 1995) of 3,073 acres more or less, of land in the Parishes of Moreep, Beremboke and Anakie, are about to be revoked, so far only as the portions in the Parish of Moreep, containing 1 acre 2 roods 34 perches, indicated by hachure on plan hereunder are concerned.—(M.468^(*)) (Rs.6566).

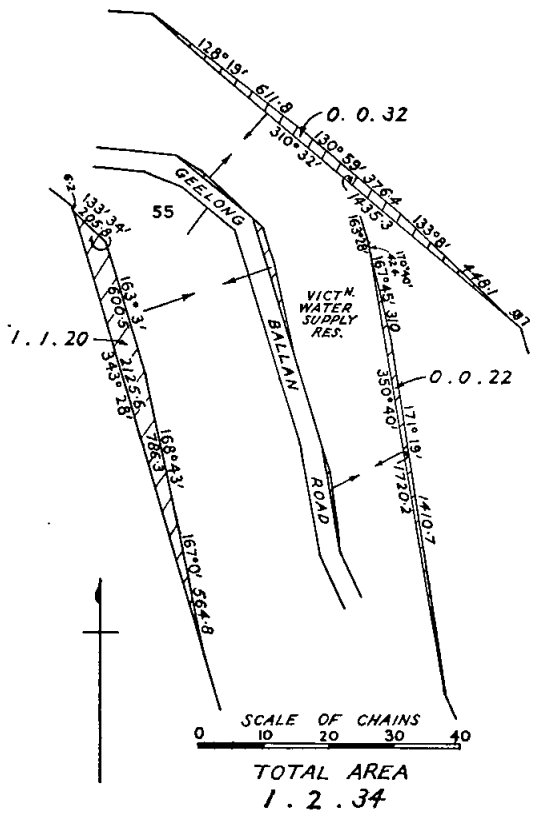

J. C. M. BALFOUR,
Commissioner of Crown Lands and Survey.

PROPOSED PERMANENT RESERVATIONS OF LANDS AS SITES.

IN pursuance of the provisions of the *Land Act 1958*, notice is hereby given that it is the intention of the Governor in Council to permanently reserve as sites the lands hereunder referred to:—

The following Notices were published 1° on the 5th August, 1964, pursuant to Orders of the 28th July, 1964.

DOUTTA GALLA (ESSENDON).—Land proposed to be permanently reserved as a site for Public Park and Public Recreation, 19 acres 3 roods, at Essendon, Parish of Doutta Galla, County of Bourke, being the site temporarily reserved therefor by Order in Council of the 4th September, 1963.—(D.85^(*)) (Rs.1009).

DOUTTA GALLA (STRATHMORE).—Land proposed to be permanently reserved as a site for Public Park and Playground, 8 acres 3 roods 9 perches, at Hawstead, Parish

of Doutta Galla, County of Bourke, being the sites temporarily reserved therefor by Orders in Council of the 27th May, 1921, and 12th April, 1928.—(E.68^(p)) (Rs.2310).

SOUTH MELBOURNE.—Land proposed to be permanently reserved as a site for Public Gardens, 1 acre 0 roods 29 perches, City of South Melbourne, Parish of Melbourne South, County of Bourke, being the site temporarily reserved therefor by Order in Council of the 9th October, 1962.—(M.333⁽³²⁾) (Rs.1179).

J. C. M. BALFOUR,
Commissioner of Crown Lands and Survey.

PROPOSED REVOCATIONS OF TEMPORARY RESERVATIONS OF LANDS BY ORDERS IN COUNCIL.

IN pursuance of the provisions of the *Land Act 1958*, notice is hereby given that it is the intention of the Governor in Council to revoke the temporary reservations of lands by Orders in Council hereunder referred to, viz.:—

The following Notices were published 1° on the 22nd July, 1964, pursuant to Orders of the 15th July, 1964.

DROMANA.—The temporary reservation, by Orders in Council of the 28th December, 1864, and the 18th February, 1890, of 2 acres 3 roods 37½ perches of land in the Township of Dromana, as a site for Public Recreation and Public Garden is about to be revoked so far only as the portion containing 1 rood 18 perches, indicated by hachure on plan hereunder, is concerned.—(D.98⁽²⁾) (Rs.3081).

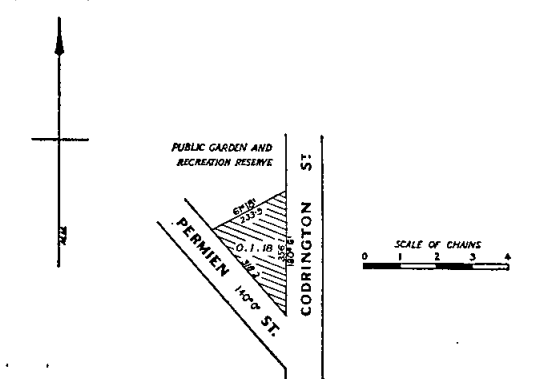

KARWEEN.—The temporary reservation, by Order in Council of the 10th December, 1928, of 4 acres of land in the Parish of Karween, as a site for a State School.—(K.214^(*)) (Rs.3792).

WOORRAGEE.—The temporary reservation, by Order in Council of the 8th February, 1864 (see *Government Gazette* of the 23rd February, 1864, page 443), of 1 acre of land in the Parish of Wooragee, as a site for Wesleyan Church purposes, is about to be revoked, so far only as the portion containing 25 perches, indicated by hachure on plan hereunder, is concerned.—(W.209^(*)) (C.98900).

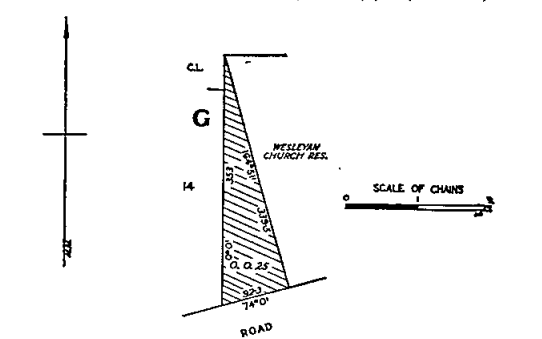

J. C. M. BALFOUR,
Commissioner of Crown Lands and Survey.

PROPOSED REVOCATIONS OF TEMPORARY RESERVATIONS OF LANDS BY ORDERS IN COUNCIL.

IN pursuance of the provisions of the Land Act 1958, notice is hereby given that it is the intention of the Governor in Council to revoke the temporary reservations of lands by Orders in Council hereunder referred to, viz.:—

The following Notices were published 1° on the 12th August, 1964, pursuant to Orders of the 4th August, 1964.

FRANKSTON.—The temporary reservation, by Order in Council of the 14th November, 1961, of 1 acre 2 roods 20 perches of land in the Township of Frankston as a site for Public purposes.—(F.86(+)) (Rs.3396).

JINDIVICK.—The temporary reservation, by Order in Council of the 3rd August, 1954, of 13 acres 2 roods, more or less, of land in the Parish of Jindivick as a site for Water Supply purposes.—(J.34(v)) (Rs.7286).

J. C. M. BALFOUR,
Commissioner of Crown Lands and Survey.

PROPOSED PERMANENT RESERVATIONS OF LANDS AS SITES.

IN pursuance of the provisions of the Land Act 1958, notice is hereby given that it is the intention of the Governor in Council to permanently reserve as sites the lands hereunder referred to:—

The following Notices were published 1° on the 22nd July, 1964, pursuant to Orders of the 15th July, 1964.

DANDENONG (SPRINGVALE).—Land proposed to be permanently reserved as a site for a Cemetery also excepted from occupation for mining purposes under any miner's right, 21 acres 3 roods 7 perches, Parish of Dandenong, County of Bourke, as indicated by hachure on plan hereunder.—(D.19(6)) (Rs.8355).

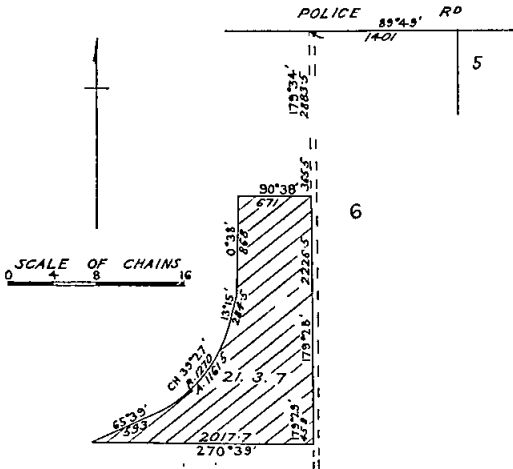

FRANKSTON.—Land proposed to be permanently reserved as a site for Public purposes, also excepted from occupation for mining purposes under any miner's right, 4 acres more or less, Parish of Frankston, County of Mornington, as indicated by hachure on plan hereunder.—(F.87(5)) (Rs.3203).

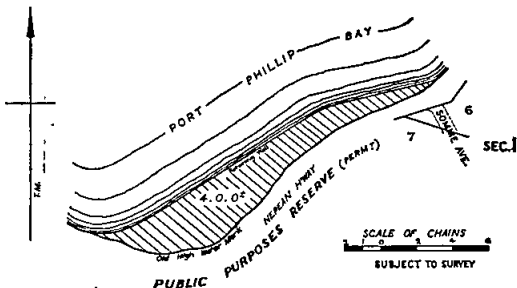

PRAHRAN (AT CAULFIELD).—Land proposed to be permanently reserved as a site for Public Recreation, also excepted from occupation for mining purposes under any miner's right, 4 acres, at Caulfield, Parish of Prahran, County of Bourke, as indicated by hachure on plan hereunder.—(P.79(T1)) (Rs.140).

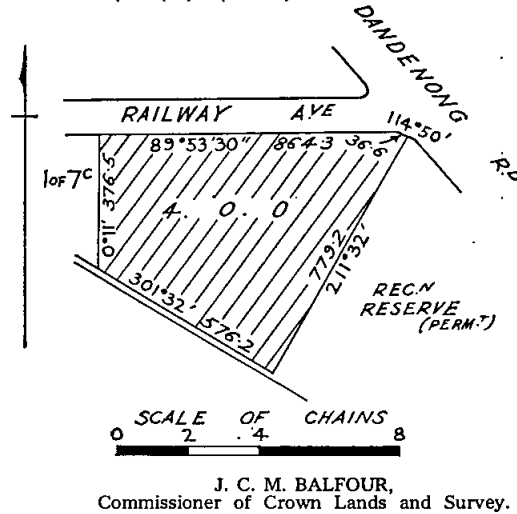

PROPOSED PERMANENT RESERVATIONS OF LANDS AS SITES.

IN pursuance of the provisions of the Land Act 1958, notice is hereby given that it is the intention of the Governor in Council to permanently reserve as sites the lands hereunder referred to:—

The following Notices were published 1° on the 29th July, 1964, pursuant to Orders of the 21st July, 1964.

WHITTLESEA.—Land proposed to be permanently reserved as a site for Public purposes, also excepted from occupation for mining purposes under any miner's right, 1 acre 1 rood 20 perches, more or less, Township of Whittlesea, Parish of Toorourrong, County of Bourke, as indicated by hachure on plan hereunder.—(W.133(2)) (Rs.8345).

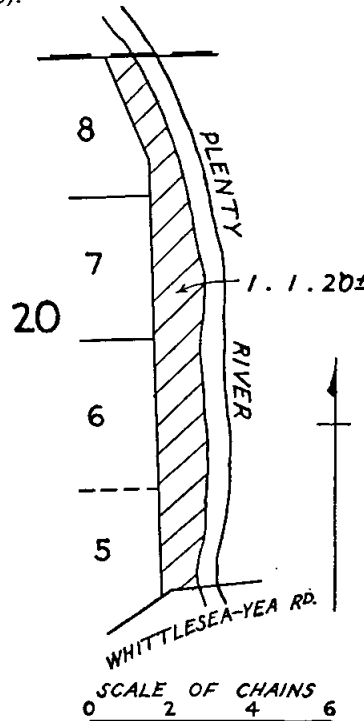

YAN YEAN (MERINDA).—Land proposed to be permanently reserved as a site for Public purposes, also excepted from occupation for mining purposes under any miner's right, 13 acres 3 roods 20 perches more or less, Parish of Yan Yean, County of Bourke, as indicated by hachure on plan hereunder.—(Y.19⁽³⁾) (Rs.8345).

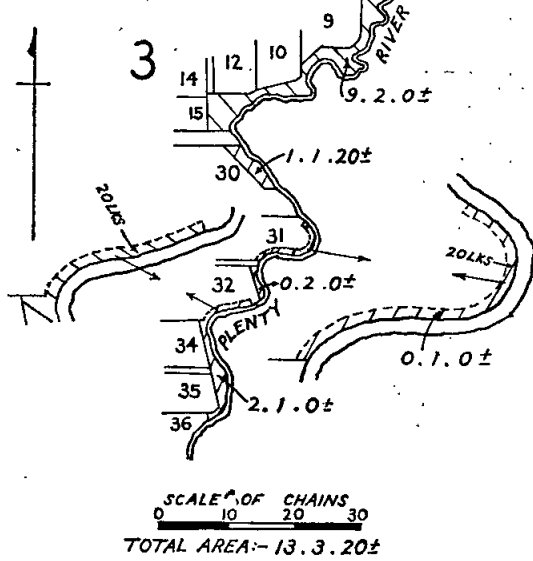

J. C. M. BALFOUR,
Commissioner of Crown Lands and Survey.

PROPOSED REVOCATION OF TEMPORARY RESERVATION, AND THE WITHHOLDING FROM SALE, LEASING, AND LICENSING OF LAND BY ORDER IN COUNCIL.

IN pursuance of the provisions of the Land Act 1958, notice is hereby given that it is the intention of the Governor in Council to revoke the temporary reservation, and the withholding from sale, leasing and licensing of land by Order in Council hereunder referred to, viz.:

The following Notice was published 1^o on the 22nd July, 1964, pursuant to Order of the 15th July, 1964.

BRIGHT.—The temporary reservation as a site for Water Supply purposes and the withholding from sale, leasing and licensing by Order in Council of the 19th April, 1875, of 1920 acres more or less of land in the Parish of Bright are about to be revoked so far only as the portion containing 2 acres more or less, indicated by hachure on plan hereunder, is concerned.—(B.574⁽¹¹⁾) (Rs.2196).

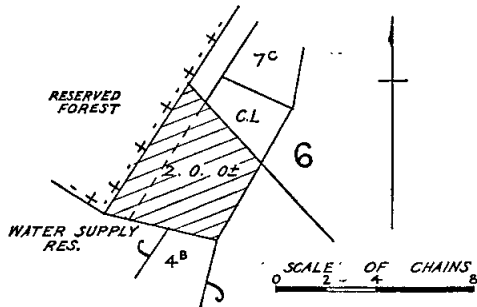

J. C. M. BALFOUR,
Commissioner of Crown Lands and Survey.

PROPOSED REVOCATION OF TEMPORARY RESERVATION OF LAND BY ORDER IN COUNCIL.

IN pursuance of the provisions of the Land Act 1958, notice is hereby given that it is the intention of the Governor in Council to revoke the temporary reservation of land by Order in Council hereunder referred to, viz.:

The following Notice was published 1^o on the 29th July, 1964, pursuant to Order of the 21st July, 1964.

MOREEP.—The temporary reservation, by Order in Council of the 19th February, 1866 (see Government Gazette of the 2nd March, 1866, page 510) of 3,900 acres

more or less of land in the Parishes of Moreep and Ballark, as a site for Water Supply purposes, revoked as to part by Order of the 31st May, 1955, is about to be revoked so far only as the portions in the Parish of Moreep containing 5 acres 0 roods 39 perches, indicated by hachure on plan hereunder are concerned.—(M.468⁽⁸⁾) (Rs.6566).

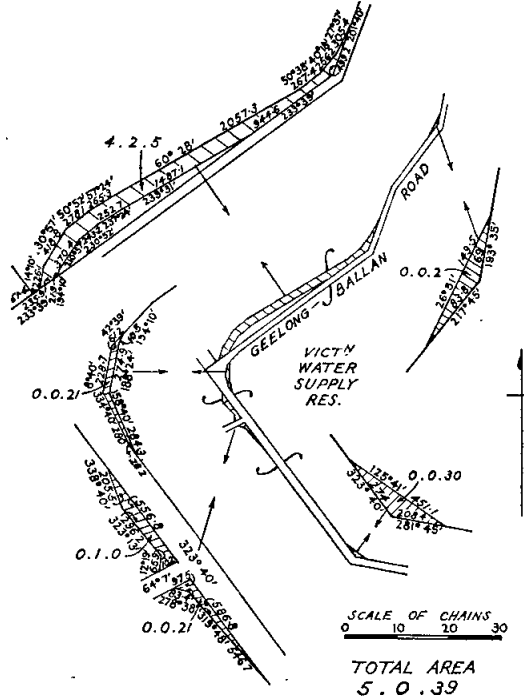

J. C. M. BALFOUR,
Commissioner of Crown Lands and Survey.

COMMON ABOUT TO BE DIMINISHED.

IN pursuance of the provisions contained in the Land Act 1958, notice is hereby given that it is the intention of the Governor in Council to diminish the common hereinafter mentioned, viz.:

The following Notice was published 1^o on the 5th August, 1964, pursuant to Order of the 28th July, 1964.

The Rokewood Goldfield Common, proclaimed on the 28th January, 1861, and extended by Proclamations of the 25th April, 1864, and the 24th December, 1866, is about to be diminished by the excision therefrom of the portion in the Parish of Commeralghip containing 9 acres 2 roods 38 perches, indicated by hachure on plan hereunder.—(Rs.435).

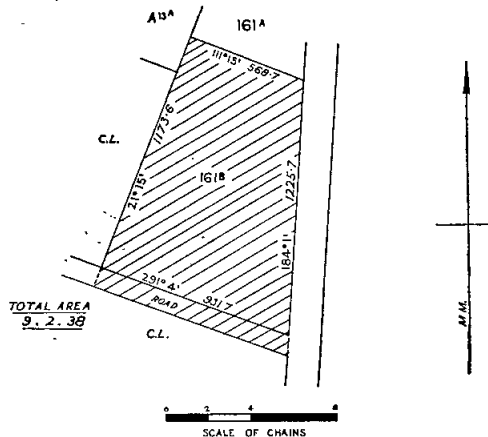

J. C. M. BALFOUR,
Commissioner of Crown Lands and Survey.

Land Act 1958.

LICENCES UNDER THE LAND ACTS 1928 AND 1958 DECLARED VOID.

NOTICE is hereby given that the Licence in the Schedule hereunder has been Declared Void for the reason specified.

District.	Corr. No.	Name of Licensee.	Section of Land Act under which Licensed.	Parish.	Allotment.	Section.	Area.	Annual Rental.	Reason for Voiding.
Mallee	010709/138	Edward Smith	138	Tyntynder North	17F	1	A. R. P. 1 1 36	£ s. d. 3 10 0	Non-compliance with conditions

Department of Crown Lands and Survey,
Melbourne, 10th August, 1964.

J. C. M. BALFOUR,
Commissioner of Crown Lands and Survey.

Land Act 1958.

LEASES SURRENDERED.

NOTICE is hereby given that the Governor in Council has accepted the surrender of the Leases mentioned in the Schedule hereunder for the reason specified in each case.

District.	Corr. No.	Name.	Section of Land Act under which Leased.	Parish.	Allotment.	Section.	Area.	Class.	Reason.
Melbourne	0420/134	Miller and Co. (Machinery) Proprietary Ltd.	134	City of South Melbourne	53	..	A. R. P. 0 0 25 $\frac{1}{10}$..	Expired
Melbourne	0464/134	L. J., S., and W. Fink	134	City of South Melbourne	1 and 2	D	1 0 6	..	New lease to issue

Department of Crown Lands and Survey,
Melbourne, 4th August, 1964.

J. C. M. BALFOUR,
Commissioner of Crown Lands and Survey.

LOCAL LAND BOARDS.

IN pursuance of the provisions of section 34 of the Land Act 1958, notice is hereby given that a public hearing at the following place and time, will be conducted by the persons respectively mentioned, being duly appointed in that behalf.

J. C. M. BALFOUR,
Commissioner of Crown Lands and Survey.
Department of Crown Lands and Survey,
Melbourne.

and binding on the parties thereto. In any event an agreement for a term of occupancy for a period longer than 21 years shall not be approved.—(Corres. Rs.7292.)

The common seal of the Board of Land and Works was hereto affixed this third day of August, 1964, in the presence of—

(SEAL) JIM BALFOUR, President.
L. W. BIRCH, Member.

COMMITTEES OF MANAGEMENT OF RESERVES.

APPOINTMENTS.

WHEREAS by section 221 of the Land Act 1958 it is provided that it shall be lawful for the Governor in Council or the Board of Land and Works to appoint and remove any number of persons, not less than three, or any municipal council, or the governing body of any corporation, to be a Committee of Management of any specified Crown land reserved either temporarily or permanently for any of the purposes set out in section 14 of the Land Act 1958, and not conveyed to or vested in trustees: Now therefore the Board of Land and Works doth hereby appoint the under-mentioned persons to be members of the Committee of Management of the Reserves named:—

"ARARAT RACECOURSE AND RECREATION RESERVE."

George Alfred Turner for so long as he continues to be a Councillor and the elect of the City of Ararat, in the place of Kevin Bayliss Murphy, who ceased to be a Councillor of the City of Ararat, as a member of the Committee of Management of the land temporarily reserved by Order in Council dated the 11th December, 1865, as a site for Racecourse and Recreation Ground at Ararat, and known as the "Ararat Racecourse and Recreation Reserve".—(Corres. Rs.2494.)

RESERVE FOR PUBLIC RECREATION AT BETHANGA.

Alfred Leonard Costello, Malcolm Hugh Harris, Thomas Norman Martin, John William Mitchell, Mervyn George Packer, Claude John Rowley and Ian Goldsworthy Sirl as a Committee of Management for a period of three (3) years of the land in the Township of Bethanga, Parish of

SCHEDULE.

GEELONG LAND OFFICE, Wednesday, 26th August, 1964,
at 10 a.m.—J. A. Murphy and C. G. Knight.

AMENDMENT OF REGULATIONS FOR THE CARE, PROTECTION AND MANAGEMENT OF THE "KARDINIA OVAL", GEELONG.

THE Board of Land and Works, in pursuance of the powers conferred on it, doth hereby amend the Regulations made by it on the 26th September, 1930, and amended by it on the 14th day of May, 1958, and the 8th day of April, 1964, for the care, protection and management of the land in the City of Geelong permanently reserved as a site for Public Recreation, pursuant to the provisions of the Geelong (Kardinia Park) Land Act 1950, and the Land Acts, and known as "Kardinia Oval", by adding after Regulation No. 21 the following Regulation:—

22. The Committee may enter into a contract or agreement with any person or association of persons, corporate or unincorporate, for the occupation by such person or the members of such association by way of licence only on such terms and conditions as the Committee thinks proper of any portion of the Reserve but so as not to create a tenancy or any other tenure in the land so occupied. If the Committee should agree to a period of occupancy for a term longer than twelve months, then the approval, in writing, of the Board of Land and Works must be first had and obtained before such agreement is valid

Berringa, temporarily reserved by Orders in Council of the 22nd May, 1882, the 11th April, 1932, and the 3rd May, 1932, as a site for Public Recreation.—(Corres. Rs.4010.)

This appointment is in lieu of all previous appointments in respect of the said land, which are hereby revoked.

RESERVE FOR PRESERVATION OF NATIVE FLORA AND FAUNA,
PARISH OF BOLWARRA.

Alexander Clifford Beaglehole, Noel Fulford Learmonth, Oswald Hector Lightbody, Eugene William Finck, Bertram Edwin Carthew, Stanley Edward Finck, Christian John Finck and Norman Neil Wade as a Committee of Management for a period of three (3) years of the land in the Parish of Bolwarra temporarily reserved by Order in Council of the 15th January, 1957, as a site for the Preservation of Native Flora and Fauna, and known as the "Nine Mile Wild Flower Sanctuary".—(Corres. Rs.7349.)

"CORACK MECHANICS' INSTITUTE RESERVE."

Denis Joseph Harty, Clifford Arthur Madder, Eric Joseph McCallum, Fredrick Harold Goldsmith, Athol John Raymond Madder, Patrick Joseph Brennan and Alan John Sands as a Committee of Management for a period of three (3) years of the land permanently reserved by Order in Council dated 6th July, 1891, as a site for a Mechanics' Institute and Free Library in the Township of Corack, and known as the "Corack Mechanics' Institute Reserve".—(Corres. Rs.4070.)

"EVERTON PUBLIC PARK."

Francis Vincent Keogh, John Victor Diffey, Raymond Thomas Chamberlain, Archibald Gordon Douglas and Wilfred George Bennett as a Committee of Management for a period of three (3) years of the land temporarily reserved by Order in Council dated 27th December, 1901, as a site for a Public Park in the Township of Everton, and known as the "Everton Public Park".—(Corres. Rs.2682.)

"FORREST (YAUGHER) RECREATION RESERVE."

Francis Leo Whitehead, Cyril Irvine Lidgerwood, Alan Maxwell Whelan, Norman Charles Rourke, Bruce Neale and Allan Francis Frizon as a Committee of Management for a period of three (3) years of the remaining portion of the land reserved by Order in Council dated the 17th August, 1927, as a site for Public Recreation in the Parish of Yaugher, and known as the "Forrest Recreation Reserve".—(Corres. Rs.3543.)

"GORMANDALE MECHANICS' INSTITUTE RESERVE."

James Charles Thexton, William Alan Bissett, John Barrie Coney, Donald James Younger, Sydney James Lay, Lindsay Alfred Onley and Noel William Schroeter as a Committee of Management for a period of three (3) years of the land permanently reserved by Order in Council dated 3rd October, 1932, as a site for a Mechanics' Institute in the Parish of Willung, and known as the "Gormandale Mechanics' Institute Reserve".—(Corres. Rs.4229.)

"HADDON RECREATION RESERVE."

Colin Edward Brown, William Edric Martin, Robert Walter Taylor, Percival Learmonth Smith, Robert Arthur Allison, Neil Shaw Mitchell, Arnold William Bayley and Gordon Stanley Wilson as a Committee of Management for a period ending the 29th September, 1966, of the land in the Township of Haddon, temporarily reserved by Orders in Council dated the 30th August, 1910, and the 17th June, 1964, as a site for Public Recreation, and known as the "Haddon Recreation Reserve".—(Corres. Rs.8278.)

This appointment is in lieu of all previous appointments in respect of the said land, which are hereby revoked.

"HEYFIELD PARK RESERVE."

Francis Merlin Zacher, Victor Frederick Fawaz and Allan George Trew (for so long only as they continue to be Councillors and the elect of the Council of the Shire of Maffra) and John Andrew Gannon, Laurence Edward John Nolan, Ralph Lay, James Henry Anderson, Vincent Edward Cummins, David Thomas Ware, Edward Warren Howell, John Eric Graves, John Joseph Mahoney and Thomas Abel Reid (for a period of three (3) years), as a Committee of Management of the land in the Township of Heyfield, Parish of Tinambra, temporarily reserved by Orders in Council dated 2nd September, 1878, and 18th September, 1928, as a site for Public Purposes, and known as the "Heyfield Park Reserve".—(Corres. Rs.2764.)

"HEYFIELD RECREATION RESERVE."

Francis Merlin Zacher, Victor Frederick Fawaz and Allan George Trew (for so long only as they continue to be Councillors and the elect of the Council of the Shire of Maffra), and James Henry Anderson, Ralph Lay, Carl Vernon Graham, Vincent Edward Cummins, Ronald James Kerr, David Thomas Ware, Edwind Ormond Riseley, John Francis Boucher, John Eric Graves, Brian Leonard Rodaughan, Charles Henry Lincoln and John Joseph Mahoney (for a period of three (3) years), as a Committee of Management of the land in the Township of Heyfield, Parish of Tinambra, temporarily reserved by Order in Council dated the 23rd November, 1885, as a site for Public Recreation, and known as the "Heyfield Recreation Reserve".—(Corres. Rs.3531.)

"HEYFIELD SWIMMING POOL RESERVE."

Francis Merlin Zacher, Victor Frederick Fawaz and Allan George Trew (for so long only as they continue to be Councillors and the elect of the Council of the Shire of Maffra) and John Andrew Gannon, Laurence Edward John Nolan, Carl Vernon Graham, Vincent Edward Cummins, John Eric Graves and John Joseph Mahoney (for a period of three (3) years), as a Committee of Management of the land in the Township of Heyfield, Parish of Tinambra, temporarily reserved by Order in Council dated 18th September, 1939, as a site for Public purposes, together with portion of the Permanent Reservation along the Thomson River, both of which areas are coloured red on plan marked T over 6.9.1939, attached to Lands Department correspondence Rs.4985, and known as the "Heyfield Swimming Pool Reserve".—(Corres. Rs.4985.)

"HEYWOOD RECREATION RESERVE."

Norman Avenel Beavis, Bertram Charles Price, James Samuel Porter, Leslie Keith Rundell and Lawrence William Porter as a Committee of Management for a period of three (3) years of the land in the Town of Heywood, temporarily reserved by Order in Council dated the 23rd November, 1891, as a site for Public Recreation, and known as the "Heywood Recreation Reserve".—(Corres. Rs.76.)

"KIAMAL PUBLIC HALL RESERVE."

V. J. Pearson, K. P. Lonergan, F. A. Hickmott, W. C. Dixon, R. L. Hickmott, A. M. Munro, A. M. Jardine, L. G. McDougall, N. S. Vallance and H. E. Dean as a Committee of Management for a period of three (3) years of the land temporarily reserved by Order in Council dated the 10th February, 1920, as a site for Public Hall in the Township of Kiamal, and known as the "Kiamal Public Hall Reserve".—(Corres. Rs.2093.)

"KOO-WEE-RUP NORTH (FIVE MILE) RECREATION AND MECHANICS' INSTITUTE RESERVES."

Percy Bazil Fechner, Allan George Wason, Andrew Herbert Garbellini, Kenneth Murray Price, Roy McKane, Duncan Denis Sandy and David McQualter as a Committee of Management for a period of three (3) years of the remaining portion of the land temporarily reserved by Order in Council dated 22nd July, 1908, as a site for Public Recreation in the Parish of Koo-Wee-Rup, and of the land temporarily reserved by Order in Council dated 6th November, 1947, as a site for Public Recreation, in addition to and adjoining the first-mentioned site, both of which sites are together known as the "Koo-Wee-Rup North (Five Mile) Recreation Reserve", and also of the land temporarily reserved by Order in Council dated 4th April, 1911, as a site for a Mechanics' Institute in the Parish of Koo-Wee-Rup, and known as the "Koo-Wee-Rup North (Five Mile) Mechanics' Institute Reserve".—(Corres. Rs.6052, Rs.3604.)

"KURRACA WEST RECREATION RESERVE."

Ellis Stephenson, Eric Shelton, L. W. Shelton, Kenneth Stewart Hargreaves, Herbert Hugh Hargreaves, William Norman Doggett and Clifford Huntley Hannah as a Committee of Management for a period of three (3) years of the land temporarily reserved by Order in Council dated 27th July, 1936, as a site for Public Recreation in the Parish of Kurraca, and known as the "Kurraca West Recreation Reserve".—(Corres. Rs.4568.)

"LAKE BOLAC RACECOURSE AND RECREATION RESERVE."

James Wills, James Clifford Murray, Arthur George Veale, Lindsay Buckley Robertson, Hillary Alexander McInnes, Albert Noel Gale, Donald Graham, George Weston Hucker and Stanley Gordon Davis as a Committee of Management for a period of three (3) years of the lands temporarily reserved by Orders in Council dated 29th September, 1873, and 22nd February, 1955, as sites

for Racing and other Recreation purposes in the Township of Lake Bolac, Parish of Parupa, and together known as the "Lake Bolac Racecourse and Recreation Reserve".—(Corres. Rs.3912.)

"LAKE TCHUM RESERVE" IN THE PARISH OF KARYRIE.

Kenneth Reginald Barlow (the nominee of the State Rivers and Water Supply Commission), Herbert George Taylor, Edward Roy Lee, Charles Desmond O'Donnell, Robert Charles Young, Richard Lee Bales, William Edwin Lee, Edwin John Beacham, Arthur Duncan Hillgrove, Matthias Vincent O'Keefe, James Joseph Ryan and Francis John Thomas King as a Committee of Management for a period of three (3) years of the land in the Parish of Karyrie, reserved by Order in Council of the 21st January, 1937, as a site for Conservation of Water and Public Recreation, and known as the "Lake Tchum Reserve".—(Corres. Rs.4636.)

"HOWITT PARK", LUCKNOW.

Eric Laurence Gascoigne, Arthur Wood, John Hansen Nielson, Frances Hilda Reid, Mavis Una McKimmie, Leslie William Cousins, Roderick McRae Woodhouse, and Thomas Owen Stephenson for a period of three (3) years, and G. H. Davison and William Henry Dumaresq for as long as they continue to be Councillors and the elect of the Shire of Bairnsdale as a Committee of Management of the land in the Township of Lucknow, Parish of Wy-Yung, temporarily reserved by Orders in Council dated the 26th November, 1928, 4th March, 1958, and the 18th April, 1961, as a site for Public Park, Recreation and Public purposes, and known as "Howitt Park", at Lucknow.—(Corres. Rs.3789.)

"MANDURANG RECREATION RESERVE."

Clarence Joseph Abbott, Graeme Stephen Pearce, Kenneth Davey Pearce, Ronald Charles Allott, Henry Edward Kofeod, Francis Poole and John Knox Adams as a Committee of Management for a period of three (3) years, of land in the Parish of Mandurang, temporarily reserved by Order in Council dated 27th March, 1956, as a site for Public Recreation, and known as the "Mandurang Recreation Reserve".—(Corres. Rs.5690.)

"MOE RECREATION RESERVE No. 1."

James Henry Goldsmith, Richard Gerald Gray, Tom Weeks, Colin Charles Jackson, Lindsay Norman George, Kenneth Charles Wagner, Douglas Lindsay Forbes, Roy Campbell Latta, Norman Henry Meadows, Stanley Walter Mills, Thomas Bezer Drew, Claude Stanley Staff, Albert Edward Jones, Neil John Long and Robert Bennet Dunkley as a Committee of Management for a period of three (3) years of the land in the Parish of Yarragon, temporarily reserved as a site for Racecourse and other purposes of Public Recreation, and known as the "Moe Recreation Reserve No. 1".—(Corres. Rs.684.)

"NARRAPORT COMMUNITY PLANTATION RESERVE."

William Thomas Hunt, Alan Colin Currie, Edwin Roy Lee, John Synan Sheahan, Harold Robert John Botheras and Allan Douglas Matheson as a Committee of Management for a period of three (3) years of the land in the Parish of Karyrie, temporarily reserved by Order in Council of 21st February, 1961, as a site for Plantation purposes, and known as the "Narraport Community Plantation Reserve".—(Corres. Rs.8014.)

"NHILL RACECOURSE AND RECREATION RESERVE."

William Joseph Lynch, Vincent John Dart, William James Rintoule, Arthur Samuel Alexander and Charles Leonard Handley as a Committee of Management for a period of three (3) years of the remaining portion of the land temporarily reserved by Order in Council dated 10th November, 1885, as a site for a Racecourse and for other purposes of Public Recreation in the Parish of Balrootan, and known as the "Nhill Racecourse and Recreation Reserve".—(Corres. Rs.6337.)

"NOWA NOWA PUBLIC HALL RESERVE."

Michael Velden, Ethel Lambourn, Gladys Kingston, Sylvia Velden, Lois Bzoooy, Colin Collings, Keith Dennison, Peter Velden, Mary Sinclair and Nona Collings as a Committee of Management for a period ending the 2nd May, 1966, of the land in the Township of Nowa Nowa, Parish of Ninnie, temporarily reserved by Order in Council dated the 23rd October, 1962, as a site for a Public Hall, and known as the "Nowa Nowa Public Hall Reserve".—(Corres. Rs.8172.)

This appointment is in lieu of all previous appointments in respect of the said land, which are hereby revoked.

"NULLAWIL RECREATION RESERVE."

Jack Donald Cobham McLean, Vincent Joseph Lowry, James Michael Brennan, Leonard James Hogan, Ralph Bartram, Ken E. Townrow, Martin Mervyn Ryan, Patrick James Hogan, John Ryan, Edwin Clive Townrow, Ian J. Poyner, Herbert Adrian Clarke, Stanley Watson, William J. Watts, Keith D. Bartram, Robert Lawrence Kelly, Ian Poyner, James McDonald Cooper, Matthew Milton Bennett, T. S. Shanley, Donald Francis Marquis and John Goddard Prentice as a Committee of Management for a period of three (3) years of the land temporarily reserved by Order in Council of 1st November, 1948, as a site for Public Recreation in the Parish of Nullawil, and known as the "Nullawil Recreation Reserve".—(Corres. Rs.6276.)

"MUNICIPAL OFFICES RESERVE", TOWNSHIP OF NUMURKAH.

The Council of the Shire of Numurkah as a Committee of Management of the land in the Township of Numurkah, temporarily reserved by Order in Council dated the 5th May, 1964, as a site for Municipal Offices.—(Corres. Rs.8299.)

"OCEAN GROVE FORESHORE RESERVE."

Claude Scipio Williams, Elliott Scott Inglis, Alfred Trevor Smith, Allan Claude Ray, William Frederick McDermott, Reginald Guyett and Percy Charles Hugh as a Committee of Management for a period of three (3) years of such portions of the Reserve for Public purposes in the Parishes of Bellarine and Paywit as are indicated by red colour on plan marked B/25.9.29, attached to Lands Department correspondence Rs.3922, and known as the "Ocean Grove Foreshore Reserve".—(Corres. Rs.3922.)

"PORTARLINGTON PUBLIC RECREATION AND PUBLIC PURPOSES RESERVE."

James Henderson, Percy John Adanis, Stanley Samuel Nash, Valentine Harry Ibbotson, Roy Francis Johnston, Bertram Canning and William Lindsay Good as a Committee of Management for a period ending the 26th May, 1967, of the land in the Township of Portarlington, temporarily reserved by Order in Council dated the 28th April, 1964, as a site for Public Recreation and Public purposes, and known as the "Portarlington Public Recreation and Public Purposes Reserve".—(Corres. Rs.8322.)

"RIPPLEBROOK RECREATION RESERVE."

Lawrence Folliot Cawcutt, Robert Samuel Henwood, Henry Charles Axford, Keith Hamilton Parker and Joseph Preston as a Committee of Management for a period of three (3) years of the land in the Parish of Yannathan, temporarily reserved by Order in Council of the 31st May, 1955, as a site for Public Recreation, and known as the "Ripplebrook Recreation Reserve".—(Corres. Rs.7353.)

"ROCHESTER PUBLIC PARK AND RECREATION RESERVE AND CAMPASPE RIVER FRONTAGE RESERVE."

Alan Gordon Moon, William Matson Taylor, Clarence Ferguson Rowarth, Maurice Amadee Dupuy, Alan Percival Goodall, Allan Carl Meyenn, Ernest Henry Vine, Alec Franklin Acocks, Sydney Leigh Johnston, John Morgan Jenkins and William John Moore as a Committee of Management for a period of three (3) years of the land in the Township of Rochester, temporarily reserved by Orders in Council dated the 26th September, 1892, 19th December, 1932, and 24th June, 1952, as a site for Public Park and Public Recreation and of the reserved Crown lands in the said Township indicated by red colour on plan marked R/11.12.34 with Lands Department correspondence Rs.4413.—(Corres. Rs.4280, Rs.4413.)

"STRATHBOGIE NORTH RECREATION RESERVE."

Lindsay Douglas Simpson, John Frederick Anker, John Samuel Hindle, Marsden Arthur Gardiner, Norman John Watkins, Bruce Robertson Armstrong, G. M. Sebire and Samuel Hodges as a Committee of Management for a period of three (3) years of the land temporarily reserved by Order in Council dated 22nd November, 1921, as a site for Recreation purposes in the Parish of Strathbogie, and known as "Strathbogie North Recreation Reserve".—(Corres. Rs.2432.)

"VITE VITE NORTH PUBLIC HALL RESERVE."

William Ronald Stevens, Ronald James Goodwin May, Sydney Desmond Brain, Alan John Brunton, Henry George Waldron as a Committee of Management for a period of three (3) years of the land in the Parish of Vite Vite, temporarily reserved as a site for a Public Hall by Order in Council dated the 22nd April, 1952, and known as the "Vite Vite North Public Hall Reserve".—(Corres. Rs.6898.)

"WARRACKNABEAL SHOW YARDS RESERVE."

Frederick George Hewitt, John Quentin King, Ambrose Robert Arnold, William Robert Reynolds, William George Powell, Robert Roy King and Wilfred Arthur Hewitt as a Committee of Management for a period of three (3) years of the lands reserved by Orders in Council dated 26th February, 1889, 2nd April, 1889, 8th September, 1892, and 2nd May, 1922, as sites for Show Yards in the Township of Warracknabeal, and known as the "Warracknabeal Show Yards Reserve".—(Corres. Rs.11.)

"WILLOW GROVE PUBLIC HALL RESERVE."

James Charles Murray Balfour, William Mervyn Erbs, James Harold Wisewould, Francis Richard Needham, William Henry Hunt, James William Marslen, Frank Donald Douglas Lamont, Cyril Harcourt Williams and Leonard Rowsell as a Committee of Management for a period of three (3) years of the land permanently reserved by Order in Council dated 8th November, 1904, as a site for a Public Hall in the Township of Willow Grove, and known as the "Willow Grove Public Hall Reserve".—(Corres. Rs.5365.)

"WOMBELANO RECREATION RESERVE."

Albert John Adams, Oliver Leslie Shrive, William Russell Anson, Charles Powell Smith, Reginald Hobbs, Ian Anson, Bertie Henry Anderson, Thomas Heenan and Kevin Ough as a Committee of Management for a period of three (3) years of the land in the Township of Konnepra, temporarily reserved as a site for Public Recreation by Order in Council dated the 20th May, 1952, and known as the "Wombelano Recreation Reserve".—(Corres. Rs.6915.)

In witness whereof the common seal of the Board of Land and Works was hereunto affixed this third day of August, One thousand nine hundred and sixty-four, in the presence of—

(SEAL) JIM BALFOUR, President.
L. W. BIRCH, Member.

TENDERS—PUBLIC WORKS DEPARTMENT

TENDERS will be received at this Department's Head Office, Treasury-place, Melbourne, until **TEN** a.m. on the dates, and for the purposes under mentioned.

Particulars may be learnt at the Department and also at places shown in parentheses.

W.O. means Inspector of Works Office; P.S.—Police Station; T.S.—Technical School; H.E.S.—Higher Elementary School; S.S.—State School; H.S.—High School; C.S.—Consolidated School.

Tenders should be submitted on the Department's printed Tender Form and will not be received by telephone. All tenders must be on a "Firm Tender" basis. The Board of Land and Works will not necessarily accept the lowest or any tender.

Tenders to be addressed to the Hon. the Commissioner of Public Works, and envelope containing tender to be marked "Tender for , closing Tuesday, ".

NOTE.—No preliminary deposit is to be lodged with any tender, but a deposit in accordance with the prescribed Schedule may be required from each successful tenderer.

Tuesday, 18th August, 1964.

Building, Electrical and Mechanical Works.

Ballarat.—Extension of verandah to form Office, Junior Technical School, School of Mines. (W.O., Ballarat.)

Ballarat.—Electrical installation—re-organization of Engineering Machine Shop and improved lighting, School of Mines. (Amended Specification). (W.O., Ballarat.)

Bayswater.—Electrical installation in extended Stage 3, High School.

Bayswater.—Supply and installation of extensions to central heating and hot water systems for Stage 3, High School.

Boorhaman East.—Septic tank installation and site works, S.S. 3317. (W.O., Wangaratta; S.S., Boorhaman East.)

Broadmeadows.—Second and third sections of timber framed concrete veneer school buildings, Technical School.

Broadmeadows.—Supply and installation of extensions to central heating and hot water service—Stage 3, Technical School.

Burbank.—Erection of six class-room Primary School, S.S. 4917.

Burbank.—Plenum heating in new six class-rooms, S.S. 4917. (W.O., Maryborough.)

Burwood East.—Electrical installation in additional class-rooms, &c., S.S. 454.

Crossover.—Erection of out-offices and installation of septic tank, S.S. 3131. (W.O., Warragul; S.S., Crossover.)

Footscray.—Provision of male staff toilet and general repairs, Girls' Secondary School.

Frankston.—Erection of rabbit proof boundary fence and internal stock fence, Vegetable Research Station.

Highett.—Provision of sink to staffroom, S.S. 4677.

Kangaroo Flat.—Electrical installation in Stages 2 and 3, Technical School. (W.O., Bendigo.)

Kangaroo Flat.—Mechanical services for Stage 3, Technical School. (W.O., Bendigo.)

Keon Park.—Additional washing facilities, S.S. 4739. (S.S., Keon Park.)

Kew.—Erection of standard brick veneer residence for Principal Female Nurse, Mental Hospital.

Lake Boga.—Renovations and painting to school and residence, S.S. 3278. (W.O., Swan Hill; S.S., Lake Boga.)

Laverton.—Erection of brick two-storey Police Office, residence, store, boiler room, Police Station. (W.O., Geelong.)

Melbourne.—Supplying and fixing of vinyl tiles, Sales Section, Government Printing Office, Macarthur-street.

Moorabbin West.—Supply and installation of central heating in two additional staff rooms and alteration of Boiler House, S.S. 4643.

Nunawading.—Erection of brick Dressing Rooms, Plant room and store, "Winlaton" Girls' Home.

Pascoe Vale.—Erection of chain mesh fencing, School of Textiles.

Preston.—Supply and installation of a steam turbine and condenser Plant Cooling Tower and pipework reticulation, Technical School.

Seymour.—Supply and installation of town gas heating, S.S. 547. (W.O., Shepparton.)

St. Kilda Park.—External and internal repairs and painting, S.S. 2460.

Studfield.—New Primary School building of eight class-rooms, &c., S.S. 4920.

Studfield.—Electrical installation in new school of eight L.T.C. class-rooms, &c., S.S. 4920.

Studfield.—Plenum heating in new eight class-rooms, S.S. 4920.

Truganina.—External and internal repairs and painting, Explosive Reserve.

Walpeup.—Erection of Research Laboratory, Research Station. (W.O., Mildura.)

Furniture and Furnishings.

Coburg.—Supply of Workshop furniture, Technical School.

Melbourne.—Supply of furniture and furnishings for period 1st September, 1964 to 31st August, 1965, Various State Government Departments.

Site Works.

Winters Flat.—Provision of new asphalt areas, drainage, concrete retaining walls, fencing, beautification and associated works, S.S. 652. (W.O., Bendigo, Kyneton and Maryborough.)

Miscellaneous.

Trafalgar East.—Purchase and removal of old school building, &c., S.S. 3499. (W.O., Warragul; S.S., Trafalgar East.)

Melbourne.—Supply of materials for Spirit Duplicators, Public Works Department, Head Office, Treasury-place.

Melbourne.—Supply of bricks, Public Works Department.

Williamstown.—Supply and delivery of a marine diesel engine for a 20 foot Work Boat, Ports & Harbors.

Williamstown.—Supply and delivery of one (1) diesel driven compressor, Ports and Harbors.

Tuesday, 25th August, 1964.

Building, Electrical and Mechanical Works.

Airey's Inlet.—Erection of one shelter pavilion, S.S. 3195. (W.O., Geelong.)

Ararat.—Roof repairs, renew spouting, &c., to Nurses' Home, Mental Hospital. (W.O., Ararat.)

Ardeer.—Repairs and painting, S.S. 4848.

Ballarat.—Supply and installation of condensate return from main kitchen to Boiler House, Mental Hospital. (W.O., Ballarat.)

Ballarat.—Renovations to residence, 1018 Ligar-street, Public Works Department. (W.O., Ballarat.)

Ballarat.—Restoration of Ward M.11 to Social and Training Unit, Mental Hospital. (W.O., Ballarat.) (Quantities available.)

Baringhup.—New laundry, renovations and painting, S.S. 1687, residence. (W.O., Bendigo; S.S. Baringhup.)

Beaumaris North.—Replacement of existing warm air furnace and associated modifications to plenum system, S.S. 4803.

Beechworth.—New vinyl finished concrete floors to dining room and passages, Ward 10, Mental Hospital. (W.O., Wangaratta.)

Beechworth.—External repairs and painting, nurses' quarters, Mental Hospital. (W.O., Wangaratta.)

Belmont.—Improvement of natural lighting in three (3) class-rooms S.S. 26. (W.O., Geelong.)

Benalla.—Renovations, new toilet, &c., to Police Station residence, 2 Egmont-street. (W.O., Benalla.)

Bentleigh West.—Repairs and painting to Caretaker's residence, S.S. 4318.

Blackburn.—External repairs and painting, Technical School.

Burbank.—Electrical installation in new school of six (6) class-rooms, &c., S.S. 4917.

Camberwell South.—Extensions to heating, S.S. 4170.

Camp Hill.—New internal female toilet and alterations, S.S. 1976. (W.O., Bendigo.)

Casterton.—Interior and exterior painting, High School residence, 24 Russell-street. (W.O., Hamilton; H.S., Casterton.)

Cranbourne.—Rewiring of electrical installation, S.S. 2068. (Amended Specification). (P.S., Cranbourne.)

Dandenong.—Erection of concrete masonry fence, Psychiatric Unit.

Dartmoor.—Erection of timber residence and timber garage and fuel store, Lands and Survey Department. (W.O., Warrnambool.)

Forrest.—Erection of chain mesh and concrete post and wire non-party fencing, S.S. 2708. (W.O., Camperdown; S.S., Forrest.)

Glenthompson.—Erection of a timber office, Lands and Survey Department. (W.O., Hamilton.)

Heathcote.—Renovations to residence, Police Station. (W.O., Bendigo; P.S., Heathcote.)

Melbourne.—Hot water and exhaust connexions to Film Processor, Health Department, Milton House, 25 Flinders-lane.

Neerim South.—Removal of office from Morwell Police Station and re-site, &c., at Neerim South Police Station. (W.O., Warragul and Traralgon.)

Netherby.—Renovations and painting, S.S. 2651 residence. (W.O., Horsham; S.S., Netherby.)

Newhaven.—Installation of septic tanks, &c., S.S. 3053. (W.O., Korumburra; S.S., Newhaven.)

Newport.—Additional drinking and toilet facilities, S.S. 113.

Port Melbourne.—Design, supply, fabrication and erection of structural steel framework, Mines Department Store.

Ross Creek.—External repairs and painting, S.S. 803. (W.O., Ballarat.)

Sunbury.—Provision of covered way, Mental Hospital.

Swan Hill.—New store, renovations and painting, S.S. 1142. (W.O., Swan Hill and Mildura; S.S., Swan Hill.)

Sydenham.—Renewal of party fencing, S.S. 3559.

Traralgon.—Supply and installation of one instrument and dressing sterilizer and exhaust ventilation in Industrial Workers Block, Hodson Park Hospital. (W.O., Traralgon.)

Various.—Extended third sections to four (4) timber-framed High Schools at Wattle Park, Watsonia, Thornbury and Banyule.

Warragul.—New fire and general water supply, Technical and High Schools. (W.O., Warragul.)

Yarrowonga.—Various repairs, external and internal painting, renewal of garage, S.S. 1819 residence. (W.O., Benalla; S.S., Yarrowonga.)

Yeodene.—Erection of shelter pavilion, S.S. 1114. (W.O., Camperdown; S.S., Yeodene.)

Furniture and Furnishings.

Beechworth.—Supply of curtain material, Mental Hospital.

Mont Park.—Supply of wheel chairs, Mental Hospital.

Site Works.

Boronia.—Surface and underground drainage, road and pedestrian pavements, S.S. 4081.

Box Hill North.—Drainage and earthworks, S.S. 4717. (Amended specification.)

Braybrook.—Paving, drainage and associated works, High School.

Middlefield.—Asphalting, concreting, retaining walls, drainage and associated works, S.S. 4878.

Rushworth.—Grading and gravelling Playing Area, High School. (W.O., Shepparton.)

Sunbury.—Concrete paving, Mental Hospital.

Miscellaneous.

Melbourne.—Maintenance cleaning, 1st September, 1964, to 31st August, 1965, Licensing Court, 632 Bourke-street.

Tuesday, 1st September, 1964.

Building, Electrical and Mechanical Works.

Bacchus Marsh.—External painting, S.S. 28. (W.O. Ballarat; S.S., Bacchus Marsh.)

Broadmeadows.—Electrical installation in stages two and three, Technical School.

Burnley.—Supply and installation of air conditioning unit in Insectary Glasshouse, Plant Research Laboratory.

Camperdown.—Connexion to town sewer, High School. (W.O., Camperdown.)

Castlemaine.—Erection of brick internal toilet for Women Teachers, S.S. 119. (W.O., Kyneton.)

Geelong.—Supply and installation of ventilation, first floor, Gordon Institute of Technology. (W.O., Geelong.)

Glenormiston.—Erection of machinery shed, Agriculture Department Estate. (W.O., Camperdown.)

Kerang.—New bicycle shed, High School. (W.O., Swan Hill; High School, Kerang.)

Lyndale.—External renovations, residence, High School. (H.S. Lyndale.)

Macarthur.—Roof renewal and external painting, S.S. 1317. (W.O., Warrnambool and Hamilton; S.S. Macarthur.)

Melbourne.—Supply, installation and testing of mechanical ventilation of Conference Room and male and female toilets, Council of Adult Education Theatre, 19 Russell-street.

Melbourne.—Roof timber replacements and various repairs, &c., painting and decorating school, Royal Melbourne Institute of Technology.

Merino.—Renovations to school buildings, Consolidated School. (W.O., Hamilton; C.S., Merino.) (Amended specification.)

Mont Park.—Electrical reticulation to Geriatric Wards, Mental Hospital.

Mysia.—Internal renovations to residence, S.S. 1899. (W.O., Bendigo.)

Royal Park.—Supply and installation of heating boiler, plenum heating and hot water reticulation in Male Ward (stage two) at Park Wards, Mental Hospital.

Snob's Creek.—Erection of brick veneer residence, brick garage and fuel room, Fish Hatchery. (W.O., Alexandra.) (Amended Specification.)

Vinifera.—Fencing, S.S. 4150. (W.O., Swan Hill, Mildura; S.S. Vinifera.)

Yarrowonga.—Renovations and additions, Lands Department Residence. (W.O., Wangaratta.)

Furniture and Furnishings.

Carlton.—Supply of tube steel chairs and tables, St. Nicholas Hospital.

Geelong.—Three-drawer steel filing cabinets, Teachers' College.

Melbourne.—Supply, make and fix curtains, Latrobe Library.

Melbourne.—Supply and installation of steel library and general purpose shelving, Latrobe Library.

Site Works.

Jordanville.—Asphalt works, earthworks, retaining walls and drainage, Technical School.

Miscellaneous.

Goulburn Weir.—Purchase and removal of old school building, S.S. 3358. (P.S., Nagambie.)

Port Melbourne.—Supply and delivery of three (3) only seven-ton capacity petrol engine prime mover chassis and cabins, Public Works Department Plant Depot, Salmon-street.

M. V. PORTER,

Commissioner of Public Works.

Public Works Department,
Melbourne, 10th August, 1964.

PUBLIC SERVICE NOTICES**PUBLIC SERVICE OF VICTORIA.—VACANCIES.**

APPPLICATIONS will be received by the Public Service Board up to Wednesday, 26th August, 1964, from persons employed in the Public Service of Victoria, who are eligible and qualified for appointment to the under-mentioned positions.

ADMINISTRATIVE DIVISION.**Class "B1", Accounts Branch, Treasury.**

Yearly Salary.—£2,293, minimum; £2,443, maximum.
Duties.—To keep the Public Ledger; to prepare and supervise the preparation of Statements for inclusion in the Treasurer's Annual Finance Statement, and for submission to the Auditor-General; under the direction of the Accountant, to supervise and control the staff engaged in the posting of subsidiary Revenue and Expenditure Ledgers.
Qualifications.—A qualified accountant with a knowledge of the fundamental principles governing the Treasury accounting system, the Public Accounts and Stores Regulations and Statutes relating to finance.

Class "B", Office of the Housing Commission, Treasury.

Yearly Salary.—£2,028, minimum; £2,148, maximum.
Duties.—To act as Accountant in Charge of Revenue; to be responsible for the Powers-Samas Punch Card accounting for rental revenue of the Commission, assessment and revision of rental rebates, and accounting for rentals of sundry tenants and vacated tenants arrears.
Qualifications.—A qualified Accountant. Preferably experience of Powers-Samas Punch Card accounting, conversant with the Commission's operations under the Housing Acts, especially in relation to rental revenue and rental rebates. Capable of controlling a large staff.

NOTE.—This advertisement is in lieu of that for a Class "B", Office of the Housing Commission, Treasury, which appeared on page 2493 of the *Government Gazette* dated the 29th July, 1964.

Class "C2", Office of the Housing Commission, Treasury.

Yearly Salary.—£1,788, minimum; £1,908, maximum.
Duties.—Under the direction of the Internal Auditor to be in charge of the Internal Audit Section at the Concrete House Project, Holmsglen, to make special investigations and reports and to act as Secretary of the Surplus Materials Disposals Committee.
Qualifications.—Substantial progress in the study of Accountancy, capable of conducting audits and investigations into accounts. Preference will be given to a qualified accountant with the necessary qualifications.

Class "C2", Taxation (Land Tax) Office, Treasury.

Yearly Salary.—£1,788, minimum; £1,908, maximum.
Duties.—To have charge of General and Divisional Ledgers, and keep Land Tax and Probate Duty accounts; to be responsible for the certification of accounts affecting assessments and amendments, and for demands issued in respect of overdue accounts; to be responsible for the prosecution work of the Branch.
Qualifications.—A competent ledger keeper with a knowledge of assessing and of the Land Tax Act and Regulations.

Class "C", Ballarat Teacher's College, Education Department.

Yearly Salary.—£1,283, minimum; £1,448, maximum.
Duties.—Under the Principal to have charge of the office at the Ballarat Teachers' College, and to keep the college account books and records.
Qualifications.—A knowledge of the Public Accounts and Stores Regulations, and of the relevant portions of the Teaching Service and Education Acts and Regulations.

Class "C", State Accident Insurance Office, Chief Secretary's Department.

Yearly Salary.—£1,283, minimum; £1,448, maximum.
Duties.—To relieve and assist the Expenditure Officer and the Credit Control Officer; to reconcile the Trust Account, Claims Recoveries Accounts and Agents' Accounts; to follow up outstanding items; special duties as required.

Qualifications.—A good knowledge of the Public Accounts and Stores Regulations and the Regulations under the Public Service Act. Preferably conversant with the activities of the State Accident and Motor Car Insurance Offices.

Class "C", Mont Park Mental Hospital, Mental Hygiene Branch, Department of Health.

Yearly Salary.—£1,283, minimum; £1,448, maximum.
Duties.—To assist with staff work, salary and pay sheets, and records, overtime and penalty rates and staff ration accounts.

Qualifications.—A knowledge of the Mental Health Act, the Public Service Acts and Regulations, and staff matters.

Class "C", Office of the Housing Commission, Treasury.

Yearly Salary.—£1,283, minimum; £1,448, maximum.
Duties.—To be responsible to the Chief Architect for assisting the Contracts Officer in assembly of plans and contract documents, checking and comparing tenders and standing of contractors, and preparation and signing of contracts.

Qualifications.—General administrative experience; preferably experience in administrative aspects of contract letting, particularly in relation to building contracts.

Class "C", Water Supply Department.

Yearly Salary.—£1,283, minimum; £1,448, maximum.
Duties.—To process requisitions and prepare orders for supplies, especially building materials, iron, steel, rubber goods and irrigation equipment.

Qualifications.—A good knowledge of the stores requirements and procedure. A knowledge of the Public Accounts and Stores Regulations 1958.

PROFESSIONAL DIVISION.**Assistant Agricultural Extension Officer, Classes "C"—"C2", Department of Agriculture. (Three vacancies.)**

Yearly Emolument.—£1,613, minimum; £2,293, maximum. (Commencing salary will be within this initial range according to experience but advancement is not limited to the maximum quoted.)

Duties.—After a period of training, to undertake agricultural extension work.

Qualifications.—A degree in Agricultural Science of the University of Melbourne, or its equivalent.

Draughtsman, Class "C", Office of Titles, Law Department.

Yearly Salary.—£1,283, minimum; £1,448, maximum.
Duties.—To assist in the examination of Transfer Dealings and Survey Plans.

Qualifications.—Three years' experience in dealing with Transfer or Survey Plans; a knowledge of office procedure under the Transfer of Land Act and cognate Acts and of the practical application of survey; to have passed the examinations prescribed by Public Service (Public Service Board) Regulation 23 (a) or (b).

TECHNICAL AND GENERAL DIVISION.**Maintenance Supervisor Assistant, Office of the Housing Commission, Treasury. (Three vacancies.)**

Yearly Salary.—£1,383.

Positions Nos. 1, 2 and 3.

Duties.—To prepare reports, estimates and specifications regarding painting, renovations and general maintenance of Commission houses, to assist in supervising the work of maintenance contractors, and day labour painters, and in issuing work orders and verifying contractors' accounts.

Positions Nos. 1 and 2.

Qualifications.—A qualified painting tradesman with experience in general house maintenance including external and internal painting renovations; ability to assess and report on house painting and maintenance, and to prepare specifications and estimates. A current driver's licence.

Position No. 3.

Qualifications.—Qualified carpenter with experience in general house maintenance including external and internal painting renovations; ability to assess and report on house painting and maintenance, and to prepare specifications and estimates. A current driver's licence.

NOTE.—Separate applications must be submitted for the above positions.

Cash Register Operator, Taxation (Land Tax) Office, Treasury.

Yearly Salary.—£1,223, minimum; £1,331, maximum.
Duties.—To operate a multiple cash register, and general accounts duties as required.
Qualifications.—Ability to handle moneys and preferably experience in the operation of a multiple cash register. A knowledge of the Land Tax Act is desirable.

Assistant Overseer of Works and Buildings, Prisons Division, Social Welfare Branch, Chief Secretary's Department.

Yearly Salary.—£1,187, minimum; £1,331, maximum.
Duties.—To assist the Overseer of Works and Buildings in the carpenters' and other shops; to instruct prisoners employed therein in the various trades; other duties as directed.
Qualifications.—A skilled carpenter, with a knowledge of building construction in all branches, and competent to prepare plans and specifications.

Estate Officer, Grade I, Office of the Housing Commission, Treasury. (Two vacancies.)

Yearly Salary.—£1,151, minimum; £1,223, maximum.
Duties.—To perform Housing Estate duties in respect of a section of a district including revenue collection, interviewing tenants regarding rental arrears, advising tenants on matters affecting their tenancy, and inspecting and reporting on dwellings and various phases of estate management.
Qualifications.—To be educated to Intermediate Certificate standard and able to make investigations and prepare reports. Experience in dealing with the public and capable of handling public moneys; a car driver's licence.

NOTE.—After completing three years' satisfactory service as Estate Officer, Grade I, will be eligible for progression to Estate Officer, Grade II. (£1,259-£1,295).

Photographer, Grade I, Department of Agriculture.

Yearly Salary.—£1,115, minimum; £1,223, maximum.
Duties.—To undertake all phases of still photographic work and to assist in the photographing of motion pictures.
Qualifications.—Experience in outdoor and indoor photography, in dark-room work and in cine photography. A knowledge of colour photography is essential.

Laundryman, Youth Welfare Division, Social Welfare Branch, Chief Secretary's Department.

Yearly Salary.—£955, minimum; £989, maximum.
Duties.—To assist in the laundry at "Turana", Parkville; to relieve the laundry Foreman as required.
Qualifications.—Experience with steam and electrical laundry equipment and general laundry routine.

Farm Assistant, Dookie Agricultural College, Department of Agriculture.

Yearly Salary.—£938, minimum; £972, maximum.
Duties.—To assist in the practical work of the farm and instruction and control of students; other duties as required.
Qualifications.—A sound practical knowledge of farm machinery, including tractors, and of farming.

NOTE.—Accommodation is available for a single man at a charge of £166 a year. Particulars available from the Department of Agriculture.

The salary rates quoted above do not include the additional amount which is payable under Regulation 74 of the Board's Regulations.

By order,
 V. P. SCULLY,
 Secretary.

Office of the Public Service Board,
 Melbourne, 11th August, 1964.

PUBLIC SERVICE OF VICTORIA.—VACANCIES.
 (TEMPORARY APPOINTMENT.)

APPLICATIONS will be received by the Public Service Board up to Wednesday, the 26th August, 1964, from persons who are qualified for appointment to the under-mentioned position:—

Draughtsman, Grades III.-V., Public Works Department.

Yearly Salary.—£1,259, minimum; £1,643, maximum.
 (Commencing salary will be determined within this initial range according to experience.)

No. 71.—7256/64.—4

Duties.—To plan water supply and sewerage installations for public buildings and institutions and to prepare details, specifications and estimates.

Qualifications.—Experience in sewerage draughting and capable of preparing working drawings and specifications for water supply installations, &c.; a good knowledge of the By-laws of the Melbourne and Metropolitan Board of Works and Country Sewerage Authorities.

NOTE.—The salary rates quoted above do not include the additional amount which is payable under Regulation 74 of the Board's Regulations.

By order,
 V. P. SCULLY,
 Secretary.

Office of the Public Service Board,
 Melbourne, 11th August, 1964.

PUBLIC SERVICE OF VICTORIA.—VACANCIES.
DEPARTMENT OF HEALTH.
MENTAL HYGIENE BRANCH.
TECHNICAL AND GENERAL DIVISION.

APPLICATIONS will be received by the Public Service Board up to Wednesday, 2nd September, 1964, from persons employed in the Public Service of Victoria, who are eligible and qualified for appointment to the under-mentioned positions.

Principal Nurse (Female), Mont Park.

Yearly Salary.—£1,431, minimum; £1,483, maximum.
Duties.—Under direction of the Psychiatrist Superintendent to have charge of Female Division, staff and patients.

Qualifications.—A current practising Certificate for mental nursing. Experience in a senior position in a Mental Hospital, tact and ability to control patients and staff, compile reports and records relating thereto and to give lectures to Student Nurses.

Assistant Head Nurse (Male), Royal Park.

Yearly Salary.—£1,331, minimum; £1,383, maximum.
Duties.—To assist Principal Male Nurse or Head Nurse (Male), in management of male division, and to prepare leave sheets and other records as directed; to relieve senior officers as required, and to give lectures to Student Nurses and other staff.

Qualifications.—A current practising certificate for Mental Nursing, ability to direct and control staff and patients, and to keep records.

Deputy Charge Nurse (Male).

Two vacancies—Psychiatric Centre, Dandenong.
 One vacancy—Mont Park.

Yearly Salary.—£1,097, minimum; £1,133, maximum.
Duties.—To be Second in Charge of a ward.
Qualifications.—A current practising certificate for Mental Nursing and approved experience.

NOTE.—Separate applications must be submitted for these positions. Successful applicants will be required to work an eight-hour roster at Dandenong.

Deputy Charge Nurse (Male), Sandhurst Boys' Centre, Bendigo.

Yearly Salary.—£1,097, minimum; £1,133, maximum.
Duties.—To be Second in Charge of a ward.
Qualifications.—A current practising certificate for mental defectives or mental nursing and approved experience.

Cook (Male), Grade II., Sandhurst Boys' Centre, Bendigo.

Yearly Salary.—£1,079, minimum; £1,115, maximum.
Duties.—To be in charge of the Kitchen and staff therein.

Qualifications.—A competent Cook, with experience in large quantity preparation and cooking of food-stuffs, and ability to control staff.

The salary rates quoted above do not include the additional amount which is payable under Regulation 74 of the Board's Regulations.

By order,
 V. P. SCULLY,
 Secretary.

Office of the Public Service Board,
 Melbourne, 11th August, 1964.

PUBLIC SERVICE OF VICTORIA.—RECLASSIFICATIONS.

THE Public Service Board has raised the classification of the under-mentioned offices as shown, and appointed thereto the respective officers named hereunder.

Office and Former Classification.	Revised Classification.	Duties.	Qualifications.	Officer Appointed.
ADMINISTRATIVE DIVISION.				
PREMIER'S DEPARTMENT.				
<i>Tourist Development Authority.</i>				
Class "C2"	Class "B"	To be Manager of the Victorian Government Tourist Bureau, Adelaide	A sound knowledge of the tourist resorts of Victoria and a good working knowledge of the tourist resorts and geography of other Australian States; to be conversant with time-tables, fares and conditions of travel by rail, road, sea and air throughout Australia, to have a basic knowledge of world travel	Schroder, F. R.
TREASURY.				
<i>Superannuation Board.</i>				
Class "C"	Class "C1"	To examine and check returns of contributions and make the necessary records; to assist generally in the administration of the Superannuation Act and to advise departmental staff and accounting officers on superannuation requirements and procedures	A good knowledge of and preferably experience in administering the provisions of the Superannuation Act	Rose, D. C.
PROFESSIONAL DIVISION.				
WATER SUPPLY DEPARTMENT.				
Superintending Draughtsman, (Design), Class "A"	Class "A1" (£2,895)	Under the direction of the Senior Designing Engineer, to supervise and organize the work of draughtsmen and tracers engaged on the preparation of engineering drawings and the assembly of engineering data in connexion with the planning of irrigation and water supply systems	To be skilled in cartographic and engineering draughting, with specialized experience in the planning and design of irrigation and water supply works, and in the supervision of a draughting office	Cahir, G. A.
TECHNICAL AND GENERAL DIVISION.				
DEPARTMENT OF AGRICULTURE.				
Assistant (Female), Grade II., Grades F14-F15 inclusive	Grade III., Grades F17-F19 inclusive	To maintain the mailing list and to attend to the various routine matters in connexion with the publication of the <i>Dairy Farming Digest</i> , to prepare accounts for Digests supplied, to record and file correspondence and library references in the Dairy Husbandry Branch, to keep records of field projects and to draft letters	Experience in general office work, the recording and filing of correspondence and the drafting of letters; preferably a knowledge of the office routine and the activities of the Dairying Division	Bayliss, Catherine D.

Office of the Public Service Board,
Melbourne, 11th August, 1964.

By order,
V. P. SCULLY,
Secretary.

PRIVATE ADVERTISEMENTS**CITY OF BOX HILL.**

BY-LAW NO. 117.

Camping and Caravan By-law.

A By-law of the City of Box Hill made under sections 97 and 198 of the *Local Government Act 1958* and numbered 117 for prohibiting or regulating camping on roads, prohibiting or regulating the leaving, standing of caravans on streets or roads and the placing of caravans on private property, prohibiting, regulating and restricting the use of caravan or camping parks or sites and regulating, restricting, restraining or prohibiting the erection of buildings or erections.

IN pursuance of the powers conferred by the *Local Government Act 1958* and of any and every other

power it thereunto enabling the Mayor, Councillors and Citizens of the City of Box Hill order as follows:—

1. This By-law may be known as the Camping and Caravan By-law.
2. No person shall camp on any road.
3. No person shall leave standing any caravan on any street or road for any period exceeding 24 hours.
4. Subject as is hereinafter provided no person shall without the prior consent, in writing, of the Council, place any caravan on any private property which is not a camping area in respect of which a current permit issued by the Council under the *Camping Regulations 1958* or

any amendment or alteration thereof is in existence provided always that nothing in this clause shall prevent—

- (a) The placing by the owner of any land of not more than one caravan belonging to him on such land where such caravan is not without the prior consent, in writing, of the Council used by any person for the purpose of sleeping or living therein.
- (b) The placing of caravans for sale or hire on any land the use of which for the purposes of the business of selling or hiring caravans is not prohibited by any Planning Scheme made under the *Town and Country Planning Act 1961* or any statutory amendment, modification, or re-enactment thereof, By-law or Regulation or in respect of which a permit for such use has been granted under any Interim Development Order made under the *Town and Country Planning Act 1961* or any statutory amendment, modification or re-enactment thereof.

5. No person shall, without the prior consent, in writing, of the Council, erect or construct on any land any tent or similar structure.

6. This By-law shall apply to and have operation throughout the whole of the municipal district.

7. Any person guilty of a continuing offence contrary to this By-law shall be liable to a penalty of Five pounds for each day on which an offence against this By-law shall be continued after a conviction or order by any court.

Resolution for passing this By-law agreed to by the Council of the City of Box Hill on the 23rd day of March, 1964, and confirmed on the 20th day of April, 1964.

The corporate seal of the Mayor, Councillors and Citizens of the City of Box Hill was hereunto affixed in the presence of—

(SEAL) E. O. LUNDGREN, Mayor.
W. G. HOSIE, Councillor.
A. N. WALLS, Town Clerk.

Approved by the Governor in Council the 15th day of July, 1964.—J. COLQUHOUN, Clerk of the Executive Council. 2091

CITY OF BROADMEADOWS.
BY-LAW No. 43.

A By-law of the City of Broadmeadows made under the provisions of sections 197 (1) (ii), 197 (1) (xlv), 212, 213 and 222 of the *Local Government Act 1958* as amended and all other powers it enabling thereto and numbered 43 for and with respect to—

- (a) carrying out the purposes provided for in Division (4) of Part 1 of the Fifteenth Schedule to the *Local Government Act 1958* as amended, and
- (b) prescribing penalties for breaches of this By-law.

IN pursuance of the powers conferred upon by the *Local Government Act 1958* as amended and in pursuance of all other powers it thereunto enabling the Mayor, Councillors and Citizens of the City of Broadmeadows hereby order as follows:—

1. This By-law shall come into operation on the day after its publication in the *Government Gazette* of the State of Victoria.

2. This By-law shall apply to and have operation throughout the whole of the municipal district of the City of Broadmeadows.

3. In this By-law unless inconsistent with the context or subject matter—

- (a) "City Engineer" means the person for the time being holding the office of City Engineer of the City of Broadmeadows and includes any person from time to time acting as City Engineer.
- (b) "Council" means the Council of the City of Broadmeadows.
- (c) "Crossing" means a crossing for the passage of animals and vehicles over any footway or channel of any street or road from land adjoining or abutting on such footway to such street or road.
- (d) "Surveyor" means the Building Surveyor or any competent person appointed by the Council to carry out the duties of Building Surveyor under the *Uniform Building Regulations, Victoria*.

4. Notwithstanding the provisions of Division (4) of Part 1 of the Fifteenth Schedule to the *Local Government Act 1958* as amended no person shall make or commence

to make a crossing pursuant to paragraph 16 of the said Division (4) unless he is the holder of a written permit from the Council authorizing the making of such crossing or without first having paid the fee payable in respect thereof as hereinafter provided.

5. Before any person makes or commences to make such crossing he shall submit to the Surveyor or the City Engineer together with the notice and specification referred to in paragraph 16 of the said Division (4) an application, in writing, signed by such person for a permit authorizing the making of such crossing.

6. (1) The Surveyor or City Engineer shall examine such application, notice and specification submitted and if—

- (a) The crossing will if constructed in accordance with such notice and specification comply with the provisions of all Acts, By-laws and Regulations administered by the Council and applying on the date of submission thereof, and
- (b) the fee hereinafter prescribed as payable in respect of the permit for which application is made has been paid to the Council

the Council or its proper officer shall within seven clear days from the giving of such notice grant to the applicant a written permit for the making of such crossing.

(2) If the application for a permit is not granted the Council shall state, in writing, its reasons for refusal and may in its discretion refund the whole or portion of the fee paid therefor.

7. With every application for a permit in respect of the making of a crossing there shall be paid to the Council a fee of One pound ten shillings.

8. Any person doing or causing to be done an act forbidden to be done or failing to do an act directed to be done by this By-law and any person who in the execution of any work for which a permit is required fails to comply with the standards prescribed under the said Division (4) shall be guilty of an offence against this By-law.

9. Any person who is guilty of an offence against this By-law shall be liable, on conviction, to a penalty of not more than Twenty pounds.

Resolution for passing this By-law agreed to by the Council of the City of Broadmeadows on the 6th day July, 1964, and confirmed on the 3rd day of August, 1964.

The common seal of the Mayor, Councillors and Citizens of the City of Broadmeadows was hereunto affixed in our presence by order of the Council.

(SEAL) R. K. EVANS, Mayor.
COLIN B. SMITH, Councillor.
E. F. SMILEY, Town Clerk.

2100

CITY OF CAULFIELD.

BY-LAW No. 131.

A By-law of the City of Caulfield, No. 131, and made, pursuant to the powers conferred on the Council of the Municipality by clause 403 and table 401 of the *Uniform Building Regulations Victoria*, made under the *Local Government Act 1958*, for fixing fees and deposits and for repealing the whole of a certain By-law.

IN pursuance of the powers conferred by the *Local Government Act 1958*, and the *Uniform Building Regulations Victoria*, and of any and every power it thereunto enabling the Mayor, Councillors and Citizens of the City of Caulfield, order as follows:—

1. By-law No. 94, the Resolution for the making of which was passed by the Council on the 16th day of November, 1954, confirmed on the 20th day of December, 1954, and approved by the Governor in Council on the 16th day of March, 1955, is hereby repealed.

2. With every application for a permit in respect of any of the matters set out in paragraphs (a), (b) and (c) hereof, there shall be paid to the Council the respective fee and deposit prescribed therein, that is to say:—

- (a) Construction of temporary crossing: Fee 5s.; Deposit £24 15s.
- (b) Street opening: Fee £2 10s.
- (c) Use of footpath or roadway during building operations: Fee 5s.; Deposit £5.

3. This By-law shall apply to and have operation throughout the whole of the municipal district.

Resolution for passing this By-law agreed to by the Council on the 21st day of April, 1964, and confirmed on the 19th day of May, 1964.

The corporate seal of the Mayor, Councillors and Citizens of the City of Caulfield was hereunto affixed, in the presence of—

(SEAL) D. C. BRICKER, Mayor.
H. G. NELSON, Town Clerk.

Approved by the Governor in Council, 30th June, 1964.
—J. COLQUHOUN, Clerk of the Executive Council. 2093

CITY OF FOOTSCRAY.

BY-LAW No. 274.

A By-law of the City of Footscray, numbered 274, made under section 197 of the Local Government Acts, for prescribing areas within the municipal district as business areas and prohibiting or regulating within the whole or any part of such business areas the use of any land or the erection (including adaptation for use) or the use of any building or portion of a building for the purposes of a dwelling or for the purposes of certain classes of trades, industries, manufactures, businesses or public amusements.

IN pursuance of the powers conferred by the Local Government Acts and of every power it thereunto enabling the Mayor, Councillors and Citizens of the City of Footscray with the approval of the Governor in Council order as follows:—

1. The areas within the municipal district specified in the First Schedule hereto shall be and are hereby prescribed as business areas within which is prohibited the erection (including adaptation for use) or the use of any building or portion of a building for the purposes of a dwelling or for the purposes of any trade, industry, manufacture, business or public amusement other than any trade or business prescribed in the Second Schedule hereto.

2. That Schedule A of By-law No. 74 be amended by excising therefrom the said land described in the First Schedule hereto.

THE FIRST SCHEDULE.

1. All that piece of land being Crown allotment 1 and part of Crown allotment 2, Crown portion 8, section XVI, Parish of Cut-paw-paw, County of Bourke, and bounded by a line commencing at a point on the southern building line of Barkly-street and the western boundary of the said Crown allotment 2; and thence by this said western boundary of Crown allotment 2 bearing south 0 deg. 36 min. east distance 992 ft. 7½ in. to the northern building line of Cross-street; thence by the said building line of Cross-street bearing north 89 deg. 08 min. east distance 539 ft. 10½ in.; thence by the north-western building line of Geelong-road, bearing north 48 deg. 06 min. east distance 162 ft. 4½ in.; thence by the western building line of Gordon-street bearing north 0 deg. 44 min. west distance 678 ft. 1½ in.; thence by a line bearing south 89 deg. 24 min. west distance 305 ft. 6 in.; thence by a line bearing north 0 deg. 44 min. west distance 201 feet; and thence by the southern building line of Barkly-street bearing south 89 deg. 24 min. west distant 354 ft. 6 in. to the point of commencement.

2. All that piece of land being part of Crown portion 3, section 8, City of Footscray, Parish of Cut-paw-paw, County of Bourke and bounded by a line commencing at a point being the intersection of the eastern building line of Williamstown-road and northern building line of Anderson-street; thence by the northern building line of Anderson-street bearing south 89 deg. 39 min. east distance 375 feet; thence by a line bearing north 0 deg. 35 min. east distance 75 feet; thence by a line bearing north 43 degrees east distance 185 feet; thence by a line bearing north 0 deg. 35 min. east distance 426 feet; thence by a line bearing north 89 deg. 39 min. west distance 500 feet; thence by the eastern building line of Williamstown-road bearing south 0 deg. 35 min. west distance 636 ft. 8½ in. to the point of commencement.

THE SECOND SCHEDULE.

1. Recreational and sporting activities, entertainments and public amusements and amenities and catering facilities connected therewith, erection and use of clubrooms, parking of motor vehicles and display of advertisements.

Resolution for passing this By-law agreed to by the Council of the City of Footscray on the 3rd day of February, 1964, and confirmed on the 23rd day of March, 1964.

The common seal of the Mayor, Councillors and Citizens of the City of Footscray was affixed hereto, in our presence by order of the Council—

(SEAL) W. FOGARTY, Mayor.
R. BASSETT, Councillor.
E. J. SMITH, Town Clerk.

Approved by the Governor in Council, 30th June, 1964.
—J. COLQUHOUN, Clerk of the Executive Council. 2099

CITY OF HORSHAM.

BY-LAW No. 53.

PURSUANT to the powers conferred by the Local Government Act 1958, the Mayor, Councillors and Citizens of the City of Horsham have made By-law No. 53, the general purpose of the By-law being as follows:—

1. To repeal By-law No. 33.

2. To prohibit or regulate the use of private property situate at the junction of streets or roads for the growing of trees, shrubs or hedges abutting on any such street or road or within 10 feet therefrom, or within a distance of 30 feet from the junction of any streets or roads.

3. To require the removal or lopping of trees, shrubs or hedges (whether planted before or after the commencement of the Local Government Act 1958) from or on any private property so situate where such trees, shrubs or hedges abut on or are within 10 feet of such street or road or within a distance of 30 feet from the junction of any streets or roads.

4. To require the reduction to a height not exceeding 3 ft. 6 in. of any portion of a fence within 30 feet of the junction of any streets or roads.

5. To authorize the Council, at the expense of the owner (the amount of which expenses may be recovered by the Council in a Court of Petty Sessions as a civil debt recoverable summarily):—

(a) To remove or lop trees, shrubs or hedges growing or being on private property so situate which are not removed or lopped as required by or under this By-law.

(b) To reduce in height any portion of a fence which is not reduced in height as required by or under this By-law.

A copy of the By-law is open for inspection, free of charge, during office hours, at the Town Hall, Horsham.

2113

A. R. CONN, Town Clerk.

CITY OF MILDURA.

LOAN No. 60.

Notice of Intention to Borrow the Sum of £15,000 for Permanent Works and Undertakings.

NOTICE is hereby given that the Council of the City of Mildura proposes to borrow the principal sum of Fifteen thousand pounds on the credit of the municipal revenues of the Mayor, Councillors and Citizens of the said City, such sum to be raised by the grant of a mortgage in accordance with the provisions of the Local Government Act 1958.

1. The maximum rate of interest that may be paid is £5 2s. 6d. per cent. per annum.

2. The purpose for which the loan is to be applied is Council's proportion of C.A.R. works programme in the construction of portion of Ontario-avenue, Cherry-avenue, Seventh-street and Eighth-street.

3. The period of the loan shall be ten years.

4. The moneys borrowed shall be repayable by providing out of the Municipal Fund twenty half-yearly instalments of approximately £967 18s. each, including principal and interest, on the 1st day of May and the 1st day of November, during the currency of the loan. The first instalment shall be payable on the 1st day of May, 1965.

5. Such moneys shall be repayable to the Commissioners of the State Savings Bank of Victoria at the office of the said Commissioners, 139-165 Elizabeth-street, Melbourne.

The plans and specifications and the estimate of the cost of the proposed works and a statement showing the proposed expenditure of the moneys to be borrowed are open for inspection at the office of the Council of the City of Mildura at Civic Buildings, Deakin-avenue, Mildura.

4th August, 1964.

2084

W. J. DOWNIE, Town Clerk.

CITY OF MOORABBIN.

LOAN No. 139.

Notice of Intention to Borrow the Sum of £25,000
for Permanent Works and Undertakings.

NOTICE is hereby given that the Council of the City of Moorabbin proposes to borrow the principal sum of Twenty-five thousand pounds on the credit of the municipal revenues of the Mayor, Councillors and Citizens of the said City, such sum to be raised by the grant of a mortgage in accordance with the provisions of the Local Government Act 1958.

1. The maximum rate of interest that may be paid is £5 2s. 6d. per cent. per annum.

2. The purpose for which the loan is to be applied is the part cost of the construction of swimming pools.

3. The period of the loan shall be ten years.

4. The moneys borrowed shall be repayable by providing out of the Municipal Fund twenty half-yearly instalments of approximately £1,613 3s. each, including principal and interest, on the 1st day of May and the 1st day of November during the currency of the loan. The first instalment shall be payable on the 1st day of May, 1965.

5. Such moneys shall be repayable to the Commissioners of the State Savings Bank of Victoria at the office of the said Commissioners, 139-165 Elizabeth-street, Melbourne.

The plans and specifications and the estimate of the cost of the proposed works and a statement showing the proposed expenditure of the moneys to be borrowed are open for inspection at the office of the Council of the City of Moorabbin, Nepean Highway, Moorabbin.

Dated this 7th day of August, 1964.

2092

V. A. SMITH, Town Clerk.

CITY OF SUNSHINE.

BY-LAW No. 99.

Derelict and Unregistered Cars By-law.

A By-law of the City of Sunshine made under the provisions of the Local Government Act and all other powers it thereunto enabling, passed by a special order of the Council of the City of Sunshine, sealed with the common seal of the City of Sunshine, advertised in accordance with the provisions of the Local Government Acts, approved by the Governor in Council and numbered 99 for the purposes of:

- (a) prohibiting the leaving standing of derelict or unregistered motor cars on streets or roads;
- (b) providing for the removal and disposal of such motor cars;
- (c) imposing charges for such removal and disposal;
- (d) requiring the payment of expenses by persons committing breaches of this By-law;
- (e) requiring the payment of expenses by persons failing to execute work directed by this By-law to be executed;
- (f) suppressing nuisances;
- (g) imposing penalties for breaches of this By-law; and for other purposes.

IN pursuance of the powers conferred upon it by the Local Government Acts and in pursuance of all other powers it thereunto enabling, the Mayor, Councillors and Citizens of the City of Sunshine hereby orders as follows:—

Short Title.

1. This By-law is the Derelict and Unregistered Cars By-law.

Commencement of By-law and Area of its Operation.

2. This By-law operates:
 - (a) from the day after—
 - (i) this By-law; or
 - (ii) notice of its making,
 is published in the *Government Gazette*;
 - (b) throughout the City.

3. In this By-law unless the contrary appears:

- (a) the under-mentioned words and phrases bear the following meaning:—
 - (i) "City" means the municipal district of the City of Sunshine;
 - (ii) "Clause" means a clause of this By-law;
 - (iii) "Council" means Council of the City;
 - (iv) "Offence" means any wilful act or default contrary to this By-law;

(v) "Proper Officer" means an officer appointed by the Council or by its Town Clerk or City Engineer to do the relevant act matter or thing under this By-law;

(b) words of:

- (i) singular meaning include the plural;
- (ii) masculine gender include the feminine, and vice versa.

Prohibition.

4. No person shall leave a derelict or unregistered motor car standing on any highway, street, road, lane, pathway, right-of-way or any other place.

Car Removal.

5. (a) The owner of any motor car left contrary to clause 4 shall remove it within 72 hours after it is so left.

(b) If a motor car is left contrary to clause 4 the Proper Officer or any agent appointed by the Council may remove it to the Council depot.

Redemption.

6. (a) If a motor car is removed under clause 5 (b) the Proper Officer shall by written notice to its owner give him 21 days within which to redeem it.

(b) If the owner is not located by reasonable efforts within 28 days after the motor car is removed to the Council depot the Proper Officer shall publish a newspaper advertisement giving the owner 21 days from the date the advertisement is published within which to redeem the motor car.

7. (a) A motor car shall be redeemed by payment to the Council of an amount of 2s. 6d. for each mile the motor car was towed or driven from and between the place it was left to the Council depot, together with the payment of any other expenses incurred by the Council in connexion with the motor car.

(b) The sum payable under clause 7 (a) is additional to any penalty for an offence.

Sale.

8. (a) If a motor car removed to the Council depot is not redeemed within 21 days after the notice is served or the advertisement is published under clause 6 it may be sold by the Council by public auction or by tender.

(b) The proceeds of a sale under this clause shall be applied in satisfaction or reduction of:

- (i) The sum or sums payable under clauses 6 (b) or 7 (a);
- (ii) any other sum or sums disbursed by the Council in connexion with the motor car or sale thereof;
- (iii) a further sum of £10.

(c) Any balance of the proceeds of sale shall be held by the Council in trust for a period of twelve months and if not claimed by the former owner of the motor car within that time may be paid into the Municipal Fund.

Penalties.

9. The penalties for offences are:—

Offence.	Penalty.
First offence	Maximum £20.
Second (or more) similar offence	Maximum £20. Minimum £5.

Continuing offence—for each day on which the offence is continued after a conviction or order by any court Maximum £5 a day.

Notice of motion for the making of this By-law given by Cr. Grundy on 30th April, 1964, and recorded as No. 789 in the notice of motion book.

Resolution for passing this By-law agreed to by the Council on 4th May, 1964.

Special order advertisement published in the *Sunshine Advocate* newspaper on 21st and 28th May, 1964.

Copy of this By-law deposited at the Council office for inspection on 4th May, 1964.

Resolution confirmed on 1st June, 1964.

The common seal of the Mayor, Councillors and Citizens of the City of Sunshine was hereunto affixed in the presence of—

(SEAL) F. J. GRUNDY, Mayor.
J. MOORE, Councillor.
T. W. DEUTSCHMANN, Town Clerk.

Approved by the Governor in Council on 21st July, 1964.
—J. COLQUHOUN, Clerk of the Executive Council. 2111

CITY OF ST. KILDA.

BY-LAW No. 182.

A By-law of the City of St. Kilda made under the provisions of the *Health Act 1958*, and every other power it thereunto enabling and numbered 182 for altering By-law No. 151 of the said City and for the provision, use and control of receptacles for the deposit and collection of refuse and rubbish.

IN pursuance of the powers contained in the *Health Act 1958*, and of all other powers it thereunto enabling the Council of the City of St. Kilda, in the name and on behalf of the Mayor, Councillors and Citizens of the City of St. Kilda, orders as follows:—

1. By-law No. 151 of the City of St. Kilda shall be altered as follows:—

(a) By adding to clause 4, the following additional definition:—

“House” includes any building or portion of a building used or intended, adapted or designed as a separate dwelling and includes a flat.

(b) By inserting after clause 8 thereof the following additional clause:—

8A. The proprietor shall mark such receptacle with the number of the house, shop, factory or building of which he is the proprietor or within which he resides and, where he is the occupant of a flat, shall also mark such receptacle with the number or distinguishing name of such flat. The proprietor shall renew the number, numbers or name marked on such receptacle as often as they are obliterated or defaced; and if any proprietor neglects for one week after notice to him from the Council to mark such receptacle with its number or numbers or distinguishing name or to renew the number, numbers or name thereof as aforesaid, he shall commit an offence against this By-law.

Resolution for passing this By-law agreed to by the Council the 11th day of May, 1964, and confirmed the 8th day of June, 1964.

The common seal of the Mayor, Councillors and Citizens of the City of St. Kilda, was hereunto affixed the 8th day of June, 1964, in the presence of—

(SEAL) S. ALDOUS, Mayor.
J. TALBOT, Councillor.
W. H. GREAVES, Town Clerk.

Submitted to the Commission of Public Health on the 23rd day of June, 1964.—A. T. GARDNER, Secretary to the Commission. 2095

BOROUGH OF KYABRAM.

LOAN No. 10.

Notice of Intention to Borrow the Sum of £7,000 for Permanent Works and Undertakings.

NOTICE is hereby given that the Council of the Borough of Kyabram proposes to borrow the sum of Seven thousand pounds on the credit of the municipal revenues of the Mayor, Councillors and Burgesses of the said Borough, such sum to be raised by the grant of a mortgage in accordance with the provisions of the *Local Government Acts*.

1. The maximum rate of interest that may be paid is £5 2s. 6d. per cent. per annum.

2. The purpose for which the loan is to be applied is—
Purchase of Property for future Recreational Purposes.

3. The period of the loan shall be fifteen years.

4. The moneys borrowed shall be repayable by providing out of the Municipal Fund, thirty half-yearly instalments of £337 4s. 9d. each, including principal and interest, on the 1st day of May and the 1st day of November during the currency of the loan. The first instalment shall be repayable on the 1st day of May, 1965.

5. Such moneys shall be repayable at the E. S. & A. Savings Bank Limited in Melbourne.

2103 J. A. CLAREY, F.I.M.A., Town Clerk.

Local Government Act 1958.

SHIRE OF BAIRNSDALE.

DECLARATION OF PRIVATE STREETS AS PUBLIC HIGHWAYS.

IN pursuance of the powers conferred by section 587 (3) of the *Local Government Act 1958*, the Council of the Shire of Bairnsdale on the application of the Housing Commission of Victoria, hereby declares the following private streets which have been constructed to the satisfaction of the Council to be dedicated to the public as public highways.

Streets Referred to.

Davies-street, James-court, Macleod-street and Stavely-street as set out in lodged plan No. 40775, and Cemetery-road (widening) as set out in lodged plan No. 56387.

In witness whereof the common seal of the President, Councillors and Ratepayers of the Shire of Bairnsdale was hereunto affixed this 3rd day of August, 1964—

(SEAL) ARTHUR J. FREEMAN, President.
J. T. HANSEN, Councillor.
E. LLOYD BRINDLEY, Secretary.

2089

SHIRE OF BROADFORD.

NOTICE is hereby given that Senior Constable William Macrae, No. 10679, has been appointed Prosecuting Officer for the Shire of Broadford in place of Senior Constable Allan Fenton.

2154 M. D. WADE, Shire Secretary.

SHIRE OF CROYDON.

BY-LAW No. 9.

Hoardings By-law.

A By-law of the Shire of Croydon made under the provision of section 198 of the *Local Government Act 1958*, and numbered 9, for—

(a) regulating restraining or prohibiting the erection or construction of hoardings;

(b) regulating restricting or preventing the exhibition of advertisements in such places and in such manner or by such means as to affect injuriously the amenities of a public park or pleasure promenade or to disfigure the natural beauty of the landscape;

(c) regulating and controlling all advertisements attached or fixed or painted on any hoardings or on any buildings or any fence rock cliff or tree and regulating and controlling the erection or use of coloured lights and signs in the vicinity of traffic control lights or signs or of street intersections;

(d) authorizing the Council to pull down demolish and remove hoardings or any part thereof erected or constructed contrary to this By-law or not pulled down demolished or removed as required by or under this By-law and to sell the materials and apply the proceeds in reimbursing the expenses for pulling down demolishing and removing such hoardings or such part thereof and in paying into the Municipal Fund any fees or penalties due by the owner thereof; and

(e) appointing fees which may be charged and received by the Council for any act done or to be done by any of its officers under this By-law and for any permit or licence to be issued by the Council.

IN pursuance of the powers conferred by the *Local Government Act 1958* and of any and every other power it thereunto enabling, the President, Councillors and Ratepayers of the Shire of Croydon orders as follows:—

1. In this By-law unless inconsistent with the context or subject-matter—

“Council” means the Council of the Shire of Croydon.

“Proper Officer” means the Building Surveyor to the Council or his deputy or any other person authorized, in writing, by the Council to carry out the provisions of this By-law.

2. No person shall erect or construct any hoarding unless—

(a) a written permit has been issued by the Council or its Proper Officer authorizing such erection or construction; and

(b) the fees in respect thereof specified in the First Schedule hereto have first been paid to the Council.

3. Every application for a permit to erect or construct a hoarding shall be accompanied by—
- (a) the written consent of the owner of the land on which the hoarding is to be erected or constructed to the lodging of such application;
 - (b) properly prepared plans and specifications for the erection or construction thereof; and
 - (c) a block plan drawn in ink to a scale of not less than one inch to forty feet showing the boundaries and dimensions of the allotment of land on which the hoarding is to be erected or constructed, whether such allotment is at the intersection of two streets and if not the position of the allotment in relation to the nearest street corner and the position and dimensions of the proposed hoarding in relation to the boundaries of the allotment, and in the case of a hoarding consisting of an illuminated sign a sketch showing the wording of the sign, the colours of the proposed illuminations and whether the illuminations will be constant or intermittent.
4. No person shall erect any hoarding not attached to a building within a distance from the building line of any street or road equal to the greatest height of such hoarding or with the lowest part of any such hoarding other than the main supports thereof less than three feet from the level of the land on which it is erected.
5. No person shall erect any hoarding—
- (a) covering any window or architectural projection in any building;
 - (b) over or in front of any dwelling-house;
 - (c) so that any part of the same is less than eight feet over the level of any footpath over which it may be erected; or
 - (d) exceeding twenty feet in height or having a face area exceeding 30 square feet without the written permission of the Council.
6. No hoarding consisting of an illuminated sign shall be erected or constructed attached to the wall of any building unless—
- (a) it is attached so as not to cover any portion of any window or architectural projection in such wall;
 - (b) it does not overhang or extend over any footpath at a less height than twelve feet unless it is also attached to a veranda;
 - (c) it is attached to a metal frame or box secured firmly to such wall;
 - (d) it or any part thereof does not project over any footpath if the face area exceeds 30 square feet; and
 - (e) it is terminated at least two feet six inches from the edge of any kerblin in front of such building.
7. No hoarding consisting of an illuminated sign shall be erected or constructed attached to any veranda without the written permission of the proper officer and unless—
- (a) any part of the same is not less than eight feet above the level of any footpath over which it may be erected;
 - (b) it is rigidly supported from the frame work of any such veranda by steel supports; and
 - (c) it is terminated at least two feet six inches from the edge of the kerblin in front of the building to which such veranda is attached.
8. (1) Nothing in this By-law shall preclude the erection of a hoarding consisting of an illuminated sign or sky sign erected on or supported by a pole, steel tower or similar structure.
- (2) Any such sign may be erected subject to its location and design being approved in writing by the Council.
9. No person shall erect any hoarding exceeding five square feet in any area within the municipal district, zoned from time to time under any Interim Development Order or Planning Scheme of the Council, as Residential, without the consent in writing of the Council.
- (a) Notwithstanding the previous clause, any estate agent may erect a sign not exceeding 30 square feet, advertising the property on which it is erected, for sale or auction, such sign to be removed fourteen days after exchange of contracts of sale.
10. No person shall erect or use on any public highway any matter or thing which purports to be or is an imitation of or is similar to any major or minor traffic control item or interferes with the effectiveness of or prevents any person from clearly distinguishing any major or minor traffic control item.
11. (1) Every permit to erect or construct a hoarding issued by the Council shall be issued on the express condition that any such hoarding shall be maintained at all times in good order and condition.
- (2) If the Council or the Proper Officer is of the opinion that any hoarding erected pursuant to a permit issued under this By-law is in a ruinous dilapidated or dangerous condition the Council may cause the Proper Officer to serve or the Proper Officer may serve a notice in writing on the owner or occupier of the premises on which the hoarding is erected or to which the hoarding is attached requiring such owner or occupier to bring the same into conformity with the requirements of this By-law or demolish the same.
- (3) Any person failing to comply with the requirements of any such notice within the time specified therein shall be guilty of an offence against this By-law.
12. (1) No person shall attach affix or paint on any hoarding or on any building or on any fence rock cliff or tree any advertisement which is unsightly or which is obscene indecent or defamatory.
- (2) The Council may remove or obliterate or delete any advertisement attached or fixed or painted on any hoarding or on any building or any fence rock cliff or tree contrary to sub-clause (1) hereof and recover from the person responsible therefor the cost of so doing as a civil debt recoverable in any Court or competent jurisdiction.
13. No person shall exhibit an advertisement in such place or in such manner or by such means as to affect injuriously the amenities of a public park or pleasure promenade or to disfigure the natural beauty of the landscape.
14. (1) Where any hoarding is erected or constructed contrary to this By-law and the owner fails to comply with a written notice by the Council signed by the Proper Officer to make any such hoarding comply with the provisions of this By-law within the time specified in such notice then the Council is hereby authorized to—
- (a) enter upon the subject land or premises and pull down demolish or remove any such hoarding;
 - (b) sell the material therefrom and apply the proceeds in reimbursing the expenses of such pulling down demolishing and removing; and
 - (c) pay into the Municipal Fund any fees or penalties due by such owner.
- (2) If the proceeds of any such sale are insufficient to meet the costs of the Council of such pulling down and removal then the amount of such costs still outstanding may be recoverable by the Council from such owner as a civil debt recoverable in any Court of competent jurisdiction.
15. (1) In the event of any owner of premises being prevented by the occupier thereof from complying with any notice served on such owner under the provisions of this By-law such owner shall notify the Proper Officer accordingly.
- (2) The Proper Officer may then serve a notice on the occupier of such premises requiring the occupier to allow the owner to comply with the provisions of the notice served on such owner within a time specified therein.
- (3) If the occupier fails to allow the owner to comply with the requirements of the first-mentioned notice within the time stipulated in the notice referred to in sub-clause (2) hereof then he shall be guilty of an offence against this By-law.
16. Every person guilty of a wilful act of default contrary to provisions of this By-law shall be liable to a penalty of not less than Five pounds nor more than Twenty pounds and to a further penalty of not more than Five pounds for each day on which an offence is continued after a conviction or order of any court.
17. This By-law (except clause 9 hereof which shall apply to and have operation throughout the said residential areas only) shall apply to and have operation throughout the whole of the municipal district of the Shire of Croydon.

FIRST SCHEDULE.

	£ s. d.
Permit to erect or construct a hoarding not exceeding an area of 20 square feet	0 15 0
Permit to erect or construct a hoarding exceeding an area of 20 square feet	1 0 0
For each 100 square feet or portion thereof exceeding 20 square feet	0 5 0

Resolution for the passing of this By-law agreed to by the Council on the 2nd day of March, 1964, and confirmed on the 6th day of April, 1964.

The common seal of the President, Councillors and Ratepayers of the Shire of Croydon was hereto affixed on the 6th day of April, 1964, in the presence of—

2112 (SEAL) G. N. FROST, Councillor.
E. L. SMITH, Councillor.
K. A. MCKAY, Shire Secretary.

SHIRE OF DIMBOOLA.

POUND ABOLISHED AND POUND ESTABLISHED.

NOTICE is hereby given that the Dimboola Pound, which was located over the bridge in Lochiel-street, Dimboola, has been abolished.

Notice is further given that a Pound has been established and located on allotments 2 and 3, section 22, Town and Parish of Dimboola. 2108

SHIRE OF KNOX.

LOAN NO. 1.

Notice of Intention to Borrow the Sum of £15,000 for Permanent Works and Undertakings.

NOTICE is hereby given that the Council of the Shire of Knox in pursuance of powers conferred by the *Local Government Act 1958*, and amendments thereto, intends to borrow the sum of £15,000 on the credit of the municipal revenue of the President, Councillors and Ratepayers of the said Shire, such sum to be raised by a grant of mortgage, in accordance with the said Act, and states:—

(a) The amount of principal moneys it is proposed to borrow is £15,000.

(b) The maximum rate of interest that may be paid is £5 2s. 6d. per cent. per annum.

(c) The period of the loan will be 40 years and the time at which the moneys borrowed are to be repayable is 1st November, 2004. The place of repayment will be State Superannuation Board, Treasury-place, Melbourne, C.2.

(d) The purpose for which the loan is to be applied is for permanent works and undertakings, viz.,

Knoxfield area drainage works.

(e) The loan is to be liquidated by the creation of a Sinking Fund pursuant to section 428A of the *Local Government Act 1958* or any amendment thereto.

Plans and specifications and an estimate of the cost of such works and undertakings, and statement showing the proposed expenditure of the moneys to be borrowed are open for inspection by Ratepayers, during office hours, at the Shire Offices, Fern Tree Gully, for one month after the publication of this notice.

Dated at Fern Tree Gully this 6th day of August, 1964.

N. G. HAYNES, Shire Secretary.

Shire Hall, Fern Tree Gully. 2155

SHIRE OF MANSFIELD.

LOAN NO. 45.

Notice of Intention to Borrow the Sum of £14,730 for Permanent Works and Undertakings.

NOTICE is hereby given that the Council of the Shire of Mansfield proposes to borrow the principal sum of Fourteen thousand, seven hundred and thirty pounds on the credit of the municipal revenues of the President, Councillors and Ratepayers of the said Shire, such sum to be raised by the grant of a mortgage in accordance with the provisions of the *Local Government Act 1958*.

1. The maximum rate of interest that may be paid is five per cent. per annum.

2. The purpose for which the loan is to be applied is—
Purchase of two power graders.

3. The period of the loan shall be five years.

4. The moneys borrowed shall be repayable by providing out of the Municipal Fund ten half-yearly instalments of approximately £1,683 each, including principal

and interest, on the 1st day of May and the 1st day of November during the currency of the loan. The first instalment shall be payable on the 1st day of May, 1965.

5. Such moneys shall be repayable to the Commissioners of the State Savings Bank of Victoria at the office of the said Commissioners, 139-165 Elizabeth-street, Melbourne.

The plans and specifications and the estimate of the cost of the proposed works and a statement showing the proposed expenditure of the moneys to be borrowed are open for inspection at the office of the Council of the Shire of Mansfield at Highett-street, Mansfield.

Dated the 3rd of August, 1964.

2088 R. WOMERSLEY, Shire Secretary.

SHIRE OF WOORAYL.

NOTICE OF INTENTION TO BORROW THE SUM OF £13,000 FOR PERMANENT WORKS AND UNDERTAKINGS.

NOTICE is hereby given that the Council of the Shire of Woorayl proposes to borrow the sum of £13,000 on the credit of the municipal revenues of the President, Councillors and Ratepayers, such sum to be raised by grant of a mortgage, in accordance with the provisions of the *Local Government Act 1958*, as amended.

1. The maximum rate of interest to be paid is £5 2s. 6d. per centum per annum.

2. The purposes for which the loan is to be applied is—

Construction of Lyon-street, Hyland-place and Michael-place	£6,600
Plant and office equipment	1,750
Office alterations	2,500
Playground	600
Depot improvements	1,550
	£13,000

3. The period of the loan shall be ten years.

4. The money borrowed shall be repayable by providing out of the Municipal Fund twenty half-yearly instalments of approximately £838 16s. 11d. each, including principal and interest, on the 1st day of November and the 1st day of May of each year during the currency of the loan. The first instalment being payable on the 1st day of May, 1965.

5. Such money shall be repayable to the Australia and New Zealand Savings Bank Ltd., Melbourne.

Plans and specifications and estimates of the cost of the proposed works and a statement showing the proposed expenditure of the money to be borrowed may be inspected at the office of the Council.

K. G. BRYDON, Shire Secretary.

10th August, 1964. 2153

DIOCESE OF WANGARATTA.

DIOCESAN SYNOD.

NOTICE is hereby given that the Bishop of Wangaratta has convened the Diocesan Synod for Monday, 31st August, 1964, at 10 a.m. at the Lower Town Hall, Wangaratta.

2087 J. J. WHEATLEY, Registrar.

NOTICE OF INTENTION TO APPLY FOR A LICENCE TO DIVERT WATER AND CUT RACE (RE-ISSUE) FROM THE PYRAMID CREEK, AT MILNE'S BRIDGE.

I HEREBY give notice that I intend to apply for a licence empowering me to divert water for a term of one year to the extent of 6 acre-feet per annum at a maximum rate of 10 acre-feet per day of 24 hours for the purpose of irrigating 3 acres, being part of allotment 24A, Parish of Gannawarra, and to occupy certain Crown lands for works of diversion, and to cut a race thereon.

Any objection to such application must be forwarded, in writing, to reach the State Rivers and Water Supply Commission, Melbourne, before 11th September, 1964, being 30 days from the first publication of this notice.

HENRY JAMES NEWSTEAD.

Milne's Bridge, via Kerang. 2145

NOTICE is hereby given that E. L. Yencken and Company Proprietary Limited has applied for a lease, under section 134 of the *Land Act 1958*, for a term of 45 years from 1st October, 1964, of allotment 5, section A, City of South Melbourne, Parish of Melbourne South, containing 1a. 3r. 32p., as a site for showrooms, offices and warehouse. 2013

NOTICE is hereby given that Templestowe Bowling Club has applied for a lease under section 134, *Land Act 1958*, of Crown land fronting Parker-street, Township of Templestowe, for a term of 21 years as a site for Amusement and Recreation (Bowling Club). 1990

NOTICE is hereby given that Lang Lang Golf Club has applied for a lease under section 143 of the *Land Act 1958*, of allotment 90A, Parish of Lang Lang, for a term of 21 years as a site for Amusement and Recreation (Golf Club). 2073

YARRAM WATERWORKS TRUST.

BY-LAW NO. 4.

NOTICE is hereby given that By-law No. 4 covering water services to houses at Yarram, was adopted by the Yarram Waterworks Trust on the 14th day of May, 1964, and approved by the Governor in Council on the 8th day of July, 1964.

The By-Law provides for the following matters:—

1. Repeal of By-law No. 3.
2. Licensing of Plumbers.
3. Construction and Arrangement of Works.
4. Materials.
5. Connexions to Mains.
6. Repairs and Meters.
7. Misuse and Waste.
8. Private Fire Services.
9. Inspections.
10. Penalties.

A copy of the said By-law is open for inspection, free of charge, during office hours only, at the offices of the Trust, Commercial-road, Yarram.

2090

S. PONSFORD, Secretary.

WARRNAMBOOL SEWERAGE AUTHORITY.

GENERAL NOTICE.

THE above-mentioned Sewerage Authority, having made sewers for carrying off the sewage from each and every property which, or any part of which abuts on the streets or parts of streets, in which such sewers are laid, and which are included within the sewerage areas hereinafter described, doth hereby declare that, on and after the 1st day of October, 1964, each and every property which, or any part of which abuts on the said streets or part of streets shall be deemed to be sewerage property within the meaning of the *Sewerage Districts Act 1958*.

The boundaries of the sewerage areas hereinafter referred to are:—

Sewer Area No. 47.

That portion of the Warrnambool Sewerage District known as No. 79 Hider-street, which is surrounded on all sides by proclaimed sewer area No. 32, and consists of that part of Crown allotment 15, section 64, City of Warrnambool, and has its north-east corner 86 ft. 1 in. south along the west side of Hider-street from the south-west corner of Raglan-parade and Hider-street, and has a frontage to Hider-street of 79 feet and a depth of 66 feet.

Sewer Area No. 48.

That part of the Warrnambool Sewerage District commencing at the north-east corner of the Princes Highway and Morriss-road, which is the south-west corner of proclaimed sewer area No. 36, and bounded by a line running in a clockwise direction along the north side of the Princes Highway, the east side of Parker-street and the south side of Fairfax-avenue and its production to the east side of Morriss-road; thence south along the east side of Morriss-road to the starting point. The line as described contains therein lots 1 to 60 of C.A. 69 and part C.A.'s. 68 to 70, Parish of Wangoom, County of Villiers, but excluded from this proclaimed sewer area are lots 44 to 49 inclusive.

2098

(SEAL) E. P. GIBBONS, Chairman.
K. L. ARNEL, Secretary.

NOTICE pursuant to the *Partnership Act 1958* is hereby given that the partnership carried on by Ernest William Webb, Kathleen Webb and David Gilbert Webb, all of Yackandandah, in the State of Victoria, under the business name of E. W. K. and D. G. Webb, has been dissolved by mutual consent as from the 30th June, 1964. And further take notice that particulars of any debts due by E. W. K. and D. G. Webb should be addressed to the said David Gilbert Webb, at Yackandandah, who will accept responsibility therefor and who will henceforth carry on the business on his own behalf.

Dated the 30th day of July, 1964.

E. W. WEBB.
K. WEBB
D. G. WEBB.McKenzie, McHarg and Wray, solicitors, Yackandandah.
2142

NOTICE is hereby given that the partnership heretofore subsisting between Michael Nicholas Lolagis, of 40 Queens-avenue, Caulfield, medical practitioner, and Samuel Shub, of 15 Percy-street, Black Rock, medical practitioner, carrying on medical practices at 232 Koornang-road, Carnegie, and 149 Centre Dandenong-road, Cheltenham, under the firm name of Carnegie Medical Centre, has been dissolved as from the date hereof.

Dated this 31st day of July, 1964.

2129

MICHAEL N. LOLAGIS.
S. SHUB.

SHELLEY CONSTRUCTIONS.

20 BROWNING-STREET, KINGSBURY.

NOTICE is hereby given that the partnership heretofore subsisting between Gordon Shelley, Joyce Shelley and Phipps Gay, carrying on the business of steel erection under the firm name of Shelley Constructions, has been dissolved as from the 21st July, 1964.

Dated 31st July, 1964.

GORDON SHELLEY.
JOYCE SHELLEY.
PHIPPS GAY.

Witness—B. E. VINCENT.

2165

Companies Act 1961.—In the matter of a Scheme of Arrangement, Pursuant to Section 182 (1) (a) of the *Companies Act*, between GLENELG MANUFACTURING COMPANY PTY. LTD., its Members and Creditors.—Notice of Dividend.

NOTICE is hereby given that the First Dividend is intended to be declared in the above matter. Creditors should lodge proof of debts within 21 days of this date, otherwise I shall distribute the dividend without regard to their claims.

Dated this 7th day of August, 1964.

GLENELG MANUFACTURING COMPANY PROPRIETARY LIMITED (GLYN JENKINS, Trustee appointed under the scheme).

Day, Neilson, Jenkins & Johns, chartered accountants, 199-203 Moorabool-street, Geelong. 2104

The Companies Act 1961.—In the matter of A. T. POWER (PYALONG) PTY. LIMITED (in Voluntary Liquidation).

NOTICE is hereby given that at a Meeting of Creditors held on the 29th day of July, 1964, it was resolved that J. K. Hall, chartered accountant, of 163 William-street, Melbourne, be appointed liquidator. Notice is also given that after 21 days from this date I shall proceed to distribute the assets. All creditors having any claims against the company should furnish particulars of same by that date, otherwise I shall proceed to distribute the assets without regard to their claim.

Dated this 4th day of August, 1964.

J. K. HALL, Liquidator.

Hall & Rose, chartered accountants, 164 William-street, Melbourne. 2116

The Companies Act 1961.

HOMATECTS PTY. LTD. (IN LIQUIDATION).

NOTICE CONVENING FINAL MEETING OF CREDITORS, PURSUANT TO SECTION 272.

NOTICE is hereby given in pursuance of section 272 of the *Companies Act 1961*, that a Meeting of the creditors of the above-named company will be held on the 9th day of September, 1964, at the offices of Hall & Rose, chartered accountants, 163 William-street, Melbourne, at half-past Ten a.m. for the purpose of having an account laid before them showing the manner in which the winding up has been conducted and the property of the company disposed of, and of hearing any explanations that may be given by the liquidator.

Dated this 10th day of August, 1964.

J. K. HALL, Liquidator.

Hall & Rose, chartered accountants, 163 William-street, Melbourne, C.1. 2124

The Companies Act 1961.—In the matter of YALLOURN & DISTRICT CO-OPERATIVE SOCIETY PTY. LTD. (in Liquidation).

NOTICE is hereby given that a First and Final Dividend is intended to be declared in this matter. Creditors who have not proved their debts by the 31st day of August, 1964, will be excluded from the dividend.

Dated this 10th day of August, 1964.

G. R. THOMPSON & N. E. STRETTON, Liquidators.

Kennedy, Smail & Middlemiss, 296 Little Lonsdale-street, Melbourne. 2130

The Companies Act 1961.—In the matter of SOCIETE FRANCAISE DES TEXTILES PTY. LIMITED (in Voluntary Liquidation).—Members Winding Up.

NOTICE is hereby given that at an Extraordinary General Meeting of the above-named company duly convened and held at 166 Queen-street, Melbourne, on the 4th day of August, 1964, the following Resolution was passed as a Special Resolution:—

“That the company be wound up voluntarily and that Brian Wolfe Boase, of 50 Cardigan-street, Carlton, be appointed the liquidator for the purpose of such winding up.”

Dated the 4th day of August, 1964.

2127

B. W. BOASE, Liquidator.

Companies Act 1961.

JOHN BRAY HOMES PTY. LTD.

NOTICE PURSUANT TO SECTION 254 (2) (b) OF THE COMPANIES ACT 1961.

NOTICE is hereby given that at an Extraordinary Meeting of the members of the above-named company held on Friday, the 31st July, 1964, it was resolved that the company be wound up voluntarily and at a Meeting of Creditors held on the same day, pursuant to section 260, it was resolved that for such purposes, Bruce Edward Fordham, of 50 Toorak-road, South Yarra, chartered accountant, be appointed liquidator. Notice is also given that after 21 days from this date, I shall proceed to distribute the assets. All creditors having any claims against the company should furnish particulars of same by that date, otherwise I shall proceed to distribute the assets without regard to their claim.

Dated this 7th day of August, 1964.

BRUCE FORDHAM, Liquidator.

Bruce Fordham, chartered accountant, 50 Toorak-road, South Yarra. 2128

RUSSO BROS. INVESTMENTS PTY. LIMITED.

AT an Extraordinary General Meeting of the above-named company duly convened and held at Starling-road, Officer, on the 6th day of August, 1964, the following Resolution was duly passed as a Special Resolution:—

“That the company be wound up voluntarily.”

Dated the 6th day of August, 1964.

2133

N. RUSSO, Chairman.

Companies Act 1961, Section 254 (2).

AIRLANE HOMES PROPRIETARY LIMITED.

NOTICE OF RESOLUTION.

AT an Extraordinary Meeting of the members of Airlane Homes Proprietary Limited, duly convened and held at 8 Earl-street, Airport West, on the 31st day of July, 1964, the Special Resolution set out below was duly passed:—

“That it has been proved to the satisfaction of this meeting that the company cannot by reason of its liabilities continue its business, and that it is advisable to wind up the same and accordingly that the company be wound up voluntarily, and that Andrew Ian Sinclair be appointed liquidator of the company.”

2134

J. S. WISHART, Director.

MABRO FABRICS PROPRIETARY LIMITED.

SPECIAL RESOLUTION TO WIND UP, PURSUANT TO SECTION 254 (2).

AT an Extraordinary General Meeting of the above-named company, duly convened and held at the Australia Hotel, 266 Collins-street, Melbourne, on Wednesday, the 22nd day of July, 1964, at Two p.m., the following Resolution was duly passed as a Special Resolution:—

“Resolved unanimously as a Special Resolution that the company be wound up voluntarily.”

And at such meeting, Arthur Henry Etherington, of 3rd Floor, 419 Lonsdale-street, Melbourne, was appointed liquidator for the purposes of the winding up.

Dated this 29th day of July, 1964.

2141

ARTHUR H. MATEAR, Chairman.

Notice of Winding Up Order.—In the matter of G.N.L. CONSTRUCTIONS PTY. LIMITED.

WINDING Up Order made 4th August, 1964.

Name and address of official liquidator: Robert Charles David Warne-Smith, 456 Collins-street, Melbourne.

2177

ROBERT BURNS HUTCHISON, Petitioner.

In the Supreme Court of Victoria.—1964, No. 6908.—In the matter of the Companies Act 1961; and in the matter of WEBB'S GUARANTEE COMPANY PROPRIETARY LIMITED.

NOTICE is hereby given that a petition for the winding up of the above-named company by the Supreme Court was on the 31st day of July, 1964, presented to the said Court by Webb's Radio and Electrical Proprietary Limited (receiver and manager appointed). And that the said petition is directed to be heard before the Court sitting at Melbourne, at the hour of half-past Ten in the forenoon on the 31st day of August, 1964; and any creditor or contributory of the said company desiring to support or oppose the making of an Order on the said petition may appear at the time of hearing by himself or his counsel for that purpose; and a copy of the petition will be furnished to any creditor or contributory of the said company requiring the same by the undersigned on payment of the regulated charge for the same.

The petitioner's address is 525 North-road, Ormond.

The petitioner's solicitors are Blake and Riggall, of 120 William-street, Melbourne.

NOTE.—Any person who intends to appear on the hearing of the said petition must serve on or send by post to the above-named Blake and Riggall notice, in writing, of his intention so to do. The notice must state the name and address of the person, or if a firm, the name and address of the firm, and must be signed by the person or firm, or his or their solicitor (if any), and must be served or, if posted, must be sent by post in sufficient time to reach the above named not later than Four o'clock in the afternoon of the 28th day of August, 1964.

2136

Notice of Winding Up Order.—In the matter of ADOX INVESTMENTS PTY. LIMITED.

WINDING Up Order made 4th August, 1964.

Name and address of official liquidator: Guy Newton Moore, 34 Queens-road, Melbourne.

JAMES CANNY, Deputy Commissioner of Taxation of the Commonwealth of Australia, Petitioner. 2170

Notice of Winding Up Order.—In the matter of HI-MARK BLINDS PROPRIETARY LIMITED.

WINDING Up Order made 7th August, 1964.

Name and address of official liquidator: Edwin Samuel Parkinson, 343 Little Collins-street, Melbourne.

JAMES CANNY, Deputy Commissioner of Taxation of the Commonwealth of Australia, Petitioner. 2171

Notice of Winding Up Order.—In the matter of BASALL INVESTMENTS PROPRIETARY LIMITED (formerly U.S. Constructions (Vic.) Proprietary Limited).

WINDING Up Order made 4th August, 1964.

Name and address of official liquidator: Reginald Wilfrid Ellis, of 360 Collins-street, Melbourne.

2176

JAMES CANNY, Petitioner.

Companies Act 1961.—Re A. J. BUSINESSES PTY. LTD. (IN VOLUNTARY LIQUIDATION).

AT a Meeting of the company held at the Board Room, Honorary Justices Association, 34 Queen-street, Melbourne, on Friday, 31st July, 1964, at Ten a.m., it was resolved that the company, being unable to pay its debts, be wound up voluntarily and that for that purpose John Phillip Hyman, public accountant, of 792 Elizabeth-street, Melbourne, be and is hereby appointed liquidator.

Dated this 31st day of July, 1964.

A. J. THOMPSON, Director.

John P. Hyman & Co., 792 Elizabeth-street, Melbourne. 2139

Companies Act 1961.—Notice of Final Meeting of the Company and the Creditors.—In the matter of STANTON WEARNE PTY. LTD. (in Liquidation).—And in the matter of the Companies Act 1961.

NOTICE is hereby given that pursuant to section 272 of the Companies Act 1961 a Final Meeting of the company and the creditors will be held at the Institute of Chartered Accountants, 23 McKillop-street, Melbourne, on Friday, 18th September, 1964, at Three o'clock in the afternoon, for the purpose of laying before it an account showing how the winding up has been conducted and the property of the company has been disposed of, and giving any explanations required.

Dated this 10th day of August, 1964.

2174

JOHN A. COAKLEY, Liquidator.

The Companies Act 1961.—In the matter of VICTOR INDUSTRIES PROPRIETARY LIMITED.

NOTICE is hereby given that at an Extraordinary Meeting of the members of the above-named company held on the 4th day of August, 1964, it was resolved that the company be wound up voluntarily, and at a meeting of creditors held on the same day pursuant to section 260, it was resolved that for such purpose Norman Eric Stretton, of 296 Little Lonsdale-street, Melbourne, accountant, be appointed liquidator.

Notice is also given that after twenty-one days from this date I shall proceed to distribute the assets. All creditors having any claims against the company should furnish particulars of same by that date, otherwise I shall proceed to distribute the assets without regard to their claim.

Dated this 5th day of August, 1964.

N. E. STRETTON, Liquidator.

Kennedy, Smail and Middlemiss, 296 Little Lonsdale-street, Melbourne. 2138

RE DAVID JENNINGS & SON PTY. LTD.

NOTICE is hereby given in accordance with section 260 of the Companies Act 1961, that a Meeting of Creditors of David Jennings & Son Pty. Ltd. will be held in the Meeting Room of the Honorary Justices Association Building, 34 Queen-street, Melbourne, on Friday, the 21st August, 1964, at Ten a.m.

By order of the Board,

2156 B. H. WHITAKER, Secretary.

In the Supreme Court of Victoria.—1964, C.O.6889.—In the matter of the Companies Act 1961.—And in the matter of MIRROR NEWSPAPERS PROPRIETARY LIMITED.

NOTICE is hereby given that a petition for the winding up of the above-named company by the Supreme Court was on the 26th day of June, 1964, presented by James Canny, Deputy Commissioner of Taxation of the Commonwealth of Australia. And that the said petition is directed to be heard before the court sitting at the Fourteenth Court, Law Courts, William-street, Melbourne, at the hour of half-past Ten o'clock in the forenoon on the 28th day of August, 1964; and any creditor or contributory of the said company desiring to support or oppose the making of an order on the said petition may appear at the time of hearing by himself or his counsel for that purpose; and a copy of the said petition will be furnished to any creditor or contributory of the said company requiring the same by the undersigned, on payment of the regulated charge for the same.

The petitioner's official address is 436 Lonsdale-street, Melbourne.

The petitioner's solicitor is Robert Burns Hutchison, Acting Crown Solicitor for the Commonwealth, 440 Little Collins-street, Melbourne.

R. B. HUTCHISON.

NOTE.—Any person who intends to appear on the hearing of the said petition must serve on or send by post to the above-mentioned R. B. Hutchison, notice in writing of his intention so to do. The notice must state the name and address of the person, or, if a firm, the name and address of the firm, and must be signed by the person or firm, or his or their solicitor (if any), and must be served or, if posted, must be sent by post in sufficient time to reach the above named not later than Four o'clock in the afternoon of the 27th day of August, 1964. 2169

Companies Act 1961.—In the matter of HOLLAND SERVICES PROPRIETARY LIMITED (in Voluntary Liquidation).

NOTICE is hereby given that at an Extraordinary Meeting of the members of the above-named company held on Monday the 3rd day of August, 1964, it was resolved that the company be wound up voluntarily, and that Sydney Lionel Holland, of 1 Adrian-street, Burwood, secretary, whose address for service is 65 Palmerston-crescent, South Melbourne, be appointed liquidator for the purpose of such winding up. Notice is also hereby given that after 21 days from this date the above-named liquidator shall proceed to distribute the assets. All creditors having any claim against the company should furnish particulars of the same by that date, otherwise the liquidator shall proceed to distribute the assets without regard to their claim.

Dated this 5th day of August, 1964.

S. L. HOLLAND, Liquidator.

Norman, Cartledge and Browne, 1 Palmerston-crescent, South Melbourne. 2179

The Companies Act 1961.—In the matter of ROBERT CRAIG PROPRIETARY LIMITED (in Voluntary Liquidation).

NOTICE is hereby given that a First Dividend is intended to be declared in this matter. Creditors who have not proved their debts by the 20th day of August, 1964, will be excluded from the dividend.

Dated the 7th day of August, 1964.

2144 J. D. CULLEN, Liquidator.

UNCLAIMED MONEYS ACT 1962.

REGISTER of unclaimed money held by Verdun Horace Bickham and Henry Daniel Bickham (as executors of the will and unadministered estate of Susan Fitzpatrick, late of 28 Barrett-street, Albert Park, spinster, deceased).

The legal personal representative of Arthur Henry Gilmore, late of 80 Acland-street, St. Kilda, deceased, intestate; £36 3s. 6d.; proportion of the unadministered estate of Susan Fitzpatrick, deceased, was entitled under her will (£43 10s. 6d.), less costs incurred by the executors in attempting to identify the person entitled thereto; 10th May, 1962.

H. D. BICKHAM.

V. H. BICKHAM.

J. T. Brock, solicitor, 161-173 Sturt-street, South Melbourne. 2096

THE TRUSTEES, EXECUTORS AND AGENCY Company Limited, whose registered office is situate at 401 Collins-street, Melbourne, executor of the will of Ethel May Laurie Page, late of 43 High-street, Northcote, spinster, deceased (who died on the 10th May, 1964), require all creditors, next of kin and others having claims against the property or estate of the said deceased to send particulars to the said company, on or before the 15th day of October, 1964, after which date the said company may convey or distribute the assets, having regard only to the claims of which it then has notice.

TOLHURST, DRUCE & EMMERSON, 357 Little Collins-street, Melbourne, solicitors. 2178

NOTICE TO CLAIMANTS.

PURSUANT to the Trustee Act 1958, creditors, next of kin and all other persons having claims in respect of the estate of the deceased persons named below are required to send particulars to the legal personal representative or representatives at the addresses stated, after which date the representative or representatives will distribute the assets, having regard only to the claims of which notice has been received:—

John Hamilton Colquhoun, late of 34 Forster-street, Williamstown, retired blacksmith, deceased, died on the 25th day of May, 1964.—Claims to the executors, Dudley John George Colquhoun, of 117 Berkshire-road, North Sunshine, gentleman, and Elsie Annie Cobbin, of 17 Federal-street, Williamstown, married woman, care of John F. Carroll, of 4 Paisley-street, Footscray, solicitor, by the 14th day of October, 1964. John F. Carroll, LL.B., solicitor, 4 Paisley-street, Footscray. 2157

Margaret Victoria Parkin, late of 63 Fraser-street, Airport West, widow, deceased, intestate, died on the 14th day of May, 1964.—Claims to the administrator, John Wilson Parkin, of 12 Outlook-drive, Doncaster, engineer, care of John F. Carroll, of 4 Paisley-street, Footscray, solicitor, by the 14th day of October, 1964. John F. Carroll, LL.B., solicitor, 4 Paisley-street, Footscray. 2158

Marie Helena Bye, late of 26 Rowe-street, Maidstone, married woman, deceased, died on the 23rd day of March, 1964.—Claims to the executors, William Frederick Bye, of 26 Rowe-street, Maidstone, retired railway employee, and Gwendoline Elizabeth Henderson, of 2 Delacy-street, Maidstone, married woman, care of John F. Carroll, of 4 Paisley-street, Footscray, solicitor, by the 14th day of October, 1964. John F. Carroll, LL.B., solicitor, 4 Paisley-street, Footscray. 2159

PURSUANT to the provisions of the Trustee Act 1958, creditors, next of kin and all other persons having claims in respect of the estate of Jeanie McMurtrie Chadwick, late of 29 Kooyong-road, Armadale, spinster (who died on the 23rd May, 1964), are required to send particulars of their claims to the executor, Lyston Arthur Chisholm, of 339 Collins-street, Melbourne, solicitor, by the 21st October, 1964, after which date the executor will distribute the assets, having regard only to the claims of which he shall then have had notice.

MADDOCK, LONIE & CHISHOLM, solicitors, 339 Collins-street, Melbourne. 2120

PURSUANT to the provisions of the *Trustee Act 1958*, creditors, next of kin and all other persons having claims in respect of the estate of Martha MacDonald, late of 216 Woodland-street, North Essendon, widow (who died on the 18th March, 1964), are required to send particulars of their claims to the executors, Patricia Roberts Anyon, of McKenzie-street, Stawell, married woman, and Donald Lyston Chisholm, of 339 Collins-street, Melbourne, solicitor, by the 21st October, 1964, after which date the executors will distribute the assets, having regard only to the claims of which they shall then have had notice.

MADDOCK, LONIE & CHISHOLM, solicitors, 339 Collins-street, Melbourne. 2121

PURSUANT to the provisions of the *Trustee Act 1958*, creditors, next of kin and all other persons having claims in respect of the estate of Olive Gertrude Whitehead, formerly of 36 Goldsmith-street, Elwood, but late of Wilglen Private Hospital, 3 Moule-avenue, Brighton, widow (who died on the 8th March, 1964), are required to send particulars of their claims to the executors, Laurence William Whitehead, of 29 Raymond-street, Mount Pleasant, Perth, in the State of Western Australia, manager, and Lyston Arthur Chisholm, of 339 Collins-street, Melbourne, in the State of Victoria, solicitor, by the 21st October, 1964, after which date the executors will distribute the assets, having regard only to the claims of which they shall then have had notice.

MADDOCK, LONIE & CHISHOLM, solicitors, 339 Collins-street, Melbourne. 2122

TRUSTEE ACT 1958.

CREDITORS, next of kin and others having claims against any of the estates specified below, are required to send particulars, in writing, of such claims to the personal representatives of such estate in care of Morrison and Teare, solicitors, Numurkah, on or before 6th November, 1964, after which date the assets of the estate will be conveyed or distributed among the persons entitled thereto, having regard only to the claims to which the representatives shall then have had notice:—

Sarah Irvin, late of Cobram, gentlewoman, deceased (died 24th May, 1964).

Margaret Ann McIntyre, late of Cobram, widow, deceased (died 15th February, 1964). 2097

NORMAN EDWARD KENT, late of 21 Woodland-avenue, Croydon, gentleman, DECEASED.

CREDITORS, next of kin and others having claims against the estate of the deceased (who died on the 7th day of May, 1964), are required by the executors, The Trustees, Executors and Agency Company Limited, of 401 Collins-street, Melbourne, and Robert Henry Vaughan Kent, of 68 New-street, Brighton, to send particulars to them to the care of the above company by the 31st day of October, 1964, after which date the executors may convey or distribute the assets, having regard only to the claims of which they then have notice.

Dated the 5th day of August, 1964.

MADDEN, BUTLER, ELDER & GRAHAM, solicitors, 99 Queen-street, Melbourne. 2137

ROSINA WILLIAMS, late of 239 Lydiard-street north, Ballarat, spinster, DECEASED (who died on 9th March, 1964).

CREDITORS, next of kin and all persons having claims against the estate of the deceased are required to send particulars to the executor, Phillip Allen Tonkin, of 3 Devonshire-road, East Malvern, company representative, care of his address above given, on or before the 13th October, 1964, after which date he will distribute the assets, having regard only to the claims of which he shall then have notice.

HEINZ & GORDON, solicitors, 209 Dana-street, Ballarat. 2106

DANIEL SNEDDON, late of 2 Boyle-street, Ballarat, retired builder, DECEASED (who died on 22nd May, 1964).

CREDITORS, next of kin and all persons having claims against the estate of the deceased, are required to send particulars to the executor, The Union-Fidelity Trustee Company of Australia Limited, of 333 Collins-street, Melbourne (formerly The Fidelity Trustee Company Limited, of 101 Lydiard-street north, Ballarat), care of its address above given on or before the 13th October, 1964, after which date it will distribute the assets, having regard only to the claims of which it shall then have notice.

HEINZ & GORDON, solicitors, 209 Dana-street, Ballarat. 2107

CREDITORS, next of kin and all persons having claims in respect of the estate of Janet Turnbull McLeod, late of Flat 4, 47 Yerrin-street, Balwyn, in the State of Victoria, spinster, deceased (who died on the 9th day of June, 1964, and probate of whose will was ordered by the Supreme Court of Victoria in its probate jurisdiction, to be granted to Arthur Augustus Brahe, of 7 Dorrington-avenue, East Malvern in the said State, retired solicitor), are required to send particulars, in writing, of such claims to the said executor in care of the undersigned solicitors on or before the 15th day of October, 1964, after which date the said executor will proceed to distribute the assets of the said deceased amongst the persons entitled thereto, having regard only to the claim or claims of which the said executor shall then have had notice.

GAIR & BRAHE, solicitors, of 243 Collins-street, Melbourne. 2086

CREDITORS, next of kin or others having claims in respect of the estate of Alice Rita Joyce Taylor, late of 179 Warrigal-road, Oakleigh, in the State of Victoria, home duties, deceased (who died on the 27th May, 1964), are to send particulars of their claims to the Perpetual Executors and Trustees Association of Australia Limited, of 100-104 Queen-street, Melbourne, by the 14th October, 1964, after which date it will distribute the assets, having regard only to the claims of which it then has notice.

CORR & CORR, solicitors, 290 Latrobe-street, Melbourne. 2119

CREDITORS, next of kin and others having claims in respect of the estate of Edmond Thomas Toucher, late of 104 Studley Park-road, Kew, in the State of Victoria, gentleman, deceased (who died on the 2nd day of October, 1962), are to send particulars of their claims to the National Trustees, Executors and Agency Company of Australasia Limited, of 95 Queen-street, Melbourne, by the 14th day of October, 1964, after which date the said company will distribute the assets of the said estate, having regard only to claims of which it then has notice.

ROYSTON T. CAHIR, barrister and solicitor, 475 Collins-street, Melbourne. 2166

EDITH MARY WARREN, formerly of 4, but late of 10 Hornby-street, Windsor, widow, DECEASED.

CREDITORS, next of kin and others having claims against the estate of the deceased (who died on the 19th day of May, 1963), are required to send particulars thereof to George Thomson Miller, of 26 Downes-avenue, Brighton, agent, care of the undersigned solicitor, by the 13th day of October, 1964, after which date he will distribute the assets of the deceased, having regard only to the claims of which he then has notice.

E. K. O'DONNELL, solicitor, 173 Greville-street, Prahran. 2167

CREDITORS, next of kin and others having claims in respect of the estate of Cecil Robert Bruce Douglas, late of 59 Amaroo-street, Chadstone, public servant, deceased (who died on the 23rd day of February, 1961), are to send the particulars of their claims to The Trustees, Executors and Agency Company Limited, of 401 Collins-street, Melbourne, by 14th day of October, 1964, after which date it will distribute the assets, having regard only to the claims of which it then has notice.

MCNAB & MCNAB, solicitors, 17 Queen-street, Melbourne. 2168

CREDITORS, next of kin and others having claims in respect of the estate of Norman Hedley Leggo, late of 4 Joy-street, Newborough, cleaner, deceased (who died on the 20th April, 1964), are to send particulars of their claims to The Perpetual Executors and Trustees Association of Australia Limited, of 100-104 Queen-street, Melbourne, by the 19th October, 1964, after which date it will distribute the assets, having regard only to the claims of which it then has notice.

RENNICK & GAYNOR, solicitors, 473 Bourke-street, Melbourne. 2175

SAMUEL JOHN THOMAS GREENWOOD, late of Morwell West, grazier, DECEASED.

CREDITORS, next of kin and others having claims in respect of the estate of the deceased (who died on the 26th day of April, 1964), are required by the trustee, August Henry Godridge, to send particulars to him, care of Bruce, Watt, Ambrose & Co., solicitors, of Morwell, by the 14th day of October, 1964, after which date the trustee may distribute the assets, having regard only to the claims of which he then has notice.

BRUCE, WATT, AMBROSE & CO., solicitors, Morwell. 2173

SAMUEL EDWARD LIONEL LEGGETT, late of 9 McArthur-street, Malvern, taxi driver, DECEASED.

CREDITORS, next of kin and others having claims in respect of the estate of the deceased (who died on the 8th day of November, 1963), are required by the trustee, Blanche Leggett, of 1387 Malvern-road, Malvern, widow, to send particulars to her, care of the under-mentioned solicitor, by the 21st day of October, 1964, after which date the trustee may convey or distribute the assets, having regard only to the claims of which she then has notice.

Dated this 5th day of August, 1964.

THOMAS BURKE, LL.B., B.Comm., barrister and solicitor, 152 Wattletree-road, Malvern. 2180

OLIVE BLUCHER, late of 286 Commercial-road, Morwell, married woman, DECEASED.

CREDITORS, next of kin and others having claims in respect of the estate of the deceased (who died on the 12th day of June, 1964), are required by the trustees, Donald Dunbar and Alfred Charles Harvey, to send particulars to them, care of Bruce, Watt, Ambrose & Co., solicitors, of Morwell, by the 14th day of October, 1964, after which date the trustees may distribute the assets, having regard only to the claims of which they then have notice.

BRUCE, WATT, AMBROSE & CO., solicitors, Morwell. 2172

LEWIS EDWIN LOGAN, late of 50 Trevelyan-street, Elsternwick, engineer, DECEASED.

CREDITORS, next of kin and others having claims in respect of the estate of the deceased (who died on the 22nd day of April, 1964), are required by the trustee, Derek Edwin Logan, of 4 Princes-avenue, Longwarry, teacher, to send particulars to him, care of the under-mentioned solicitor, by the 21st day of October, 1964, after which date the trustee may convey or distribute the assets, having regard only to the claims of which he then has notice.

Dated this 5th day of August, 1964.

THOMAS BURKE, LL.B., B.Comm., barrister and solicitor, 152 Wattletree-road, Malvern. 2181

CREDITORS, next of kin and others having claims in respect of the estate of Isaac Louis Lewis, late of 166 Gordon-street, Coburg, grocer, deceased, intestate (who died on the 15th day of August, 1961), are to send particulars of their claims to the executrix, Miriam Lewis, at the under-mentioned address, by the 15th day of October, 1964, after which date she will distribute the assets, having regard only to the claims of which she then has notice.

JULIAN MERCER & KIVEN, solicitors, 224 Queen-street, Melbourne. 2143

CREDITORS, next of kin and others having claims in respect of the estate of Florence Victoria Marshall, formerly of 906 Swanston-street, Carlton, in the State of Victoria, married woman, but late of 35 McCracken-street, Kensington, in the said State, widow, deceased (who died on the 28th day of September, 1963), are requested to send particulars of their claims to the executors, William John McLennan and John Eudes Stewart, care of the under-mentioned solicitor, by the 31st October, 1964, after which date they will distribute the assets, having regard only as to the claims of which they then have notice.

JOHN STEWART, solicitor, 290 Racecourse-road, Newmarket. 2150

KATHLEEN McGRATH, late of 106 Mont Albert-road, Canterbury, in the State of Victoria, married woman, DECEASED (who died on 3rd July, 1963).

CREDITORS, next of kin and all other persons having claims against the estate of the deceased, are required by the executors of her will, Kathleen Helen Peppard, of 13 Oakdale-avenue, Balwyn, in the State of Victoria, married woman, and John Kevin McGrath, of 4 Mansion-road, Bellevue Hill, in the State of New South Wales, company director, and Frances Mary McCarthy, of 1505 High-street, Glen Iris, in the State of Victoria, married woman, to send particulars thereof to them, care of the under-mentioned solicitors, before 21st October, 1964, after which date they may distribute the assets of the deceased, having regard only to the claims of which they then have notice.

COLTMAN, WYATT & ANDERSON, solicitors, of 578 Bourke-street, Melbourne. 2114

CREDITORS, next of kin and others having claims in respect of the estate of Laurel Millicent Hendra Brown (also known as Laurel Millicent Brown), late of 57 Westbourne-road, Kensington, in the State of Victoria, widow (formerly home duties), deceased (who died on the 29th day of February, 1964), are requested to send particulars of their claims to the administratrix, Iris Ellen Brown, care of the under-mentioned solicitor, by the 31st October, 1964, after which date she will distribute the assets, having regard only to the claims of which she then has notice.

JOHN STEWART, solicitor, 290 Racecourse-road, Newmarket. 2151

ANNIE ELIZABETH EIME, late of Minyip, widow, DECEASED.

CREDITORS, next of kin and others having claims in respect of the estate of the deceased (who died on the 11th day of September, 1963), are required to send particulars of same to the executors, John Alexander MacLeod Noall and Doris Leslie Bull, care of Noall and Barlee, solicitors, Warracknabeal, by the 16th day of October, 1964, after which date the executors may convey or distribute the assets, having regard only to the claims of which they have notice.

NOALL & BARLEE, solicitors, Warracknabeal. 2101

CREDITORS, next of kin and others having claims in respect of the estate of Francis Rowe, late of 1 James-street, Surrey Hills, salesman, deceased (who died on the 10th day of March, 1964), are to send particulars of their claims to the executor, Cornelius John Durack, of 20 Beresford-street, Mont Albert, by the 31st day of October, 1964, after which date he will distribute the assets, having regard only to the claims of which he then has notice.

CLEARY, ROSS & DOHERTY, solicitors, 40 Queen-street, Melbourne. 2162

CREDITORS, next of kin and others having claims in respect of the estate of Ethel May Pearce Stewart, late of 29 Kinkora-road, Blackburn, in the State of Victoria, widow, deceased (who died on the 7th day of April, 1964), are to send particulars of their claims to Joyce Elaine Stewart, care of H. L. Yuncken and Yuncken, solicitors, of 443 Little Collins-street, Melbourne, in the said State, the executrix of the will of the said deceased, by the 14th day of October, 1964, after which date the executrix will distribute the assets, having regard only to the claims of which she shall then have had notice.

H. L. YUNCKEN & YUNCKEN, solicitors, of 443 Little Collins-street, Melbourne, C.I. 2163

CREDITORS, next of kin and others having claims in respect of the estate of Elizabeth Galbraith Mackay Struthers Lothian Beckett, formerly of Yarra Junction, but late of 56 Coonans-road, South Pascoe Vale, widow, deceased (who died on the 21st day of February, 1964), are to send particulars of their claims to Elizabeth Boase, care of H. L. Yuncken and Yuncken, solicitors, of 443 Little Collins-street, Melbourne, in the said State, the executrix of the will of the said deceased, by the 14th day of October, 1964, after which date the executrix will distribute the assets, having regard only to the claims of which she shall then have had notice.

H. L. YUNCKEN & YUNCKEN, solicitors, of 443 Little Collins-street, Melbourne, C.I. 2164

CREDITORS, next of kin and others having claims in respect of the estate of Helen Ruth Cobb, late of 33 Suffolk-road, Surrey Hills, widow, formerly married woman, deceased (who died on the 21st day of April, 1964), are to send particulars of their claims to The Equity Trustees, Executors and Agency Company Limited, of 472 Bourke-street, Melbourne, by the 14th day of October, 1964, after which date it will distribute the assets, having regard only to the claims of which it then has notice.

GILBERT, FIELD & WARNE, 406 Collins-street, Melbourne, solicitors for the applicant. 2131

CREDITORS, next of kin and others having claims in respect of the estate of George Cleland, late of 61 Edgar-street, Footscray, retired motor garage proprietor, deceased (who died on the 18th day of February, 1964), are to send particulars of their claims to the executrix, Ruby Jean Malbon, care of the under-mentioned solicitors, by the 16th day of October, 1964, after which date she will distribute the assets, having regard only to the claims of which she then has notice.

MAHONY, O'BRIEN & DUGGAN, solicitors, 37 Queen-street, Melbourne. 2132

HARRIS DUNMAN HIRST, late of 106 Finch-street, East Malvern, dentist, DECEASED (who died on 16th April, 1964).

CREDITORS, next of kin and all other persons having claims against the estate of the deceased are required by the executors of his will, The Equity Trustees, Executors and Agency Company Limited, of 472 Bourke-street, Melbourne, and Sarah Elizabeth Hirst, of 106 Finch-street, East Malvern, widow, to send particulars thereof to them, care of the under-mentioned solicitors, before 28th October, 1964, after which date they may distribute the assets of the deceased, having regard only to the claims of which they then have notice.

COLTMAN, WYATT & ANDERSON, solicitors, 578 Bourke-street, Melbourne. 2161

THOMAS JAMES LOFTS, late of 2 Gaffney-street, Coburg, in the State of Victoria, retired spinner, DECEASED (who died on the 20th day of June, 1964).

CREDITORS, next of kin and others having claims against the estate of the said deceased are required by the executors, Alberta Loraine Bacon and Roy Bacon, both of 2 Gaffney-street, Coburg, to send particulars of their claims to the under-mentioned solicitors on or before the 30th day of September, 1964, after which date the executors will distribute the assets of the deceased amongst the persons entitled thereto, having regard only to the claims of which they shall then have notice.

H. K. McCLEERY & CO., solicitors, 158 Bell-street, Coburg. 2146

HAROLD JOHN WILKIN, late of 12 Newton-street, Surrey Hills, in the State of Victoria, retired shipping clerk, DECEASED (who died on the 5th day of May, 1964).

CREDITORS, next of kin and others having claims against the estate of the said deceased are required by the executor, Ralph Spencer, of 12 Newton-street, Surrey Hills, teacher, to send particulars of their claims to the under-mentioned solicitors on or before the 30th day of September, 1964, after which date the executor will distribute the assets of the deceased amongst the persons entitled thereto, having regard only to the claims of which he shall then have notice.

H. K. McCLEERY & CO., solicitors, 158 Bell-street, Coburg. 2147

CREDITORS, next of kin and others having claims against the estate of Ethel Louisa Grayland, late of 93 Victoria-street, Cobden, in the State of Victoria, widow, deceased, intestate (who died on the 12th day of February, 1963), are to send particulars of their claims to The Union-Fidelity Trustee Company of Australia Limited, at 8 Malop-street, Geelong, by the 26th day of October, 1964, after which date it will distribute the assets, having regard only to the claims of which it then has notice.

ARTHUR E. GEORGE & SONS, Cobden, solicitors for the executor. 2149

CREDITORS, next of kin and others having claims against the estate of Clarence William Dreher, late of 4 Hodgson-street, Eaglehawk, in the State of Victoria, pensioner, deceased (who died on the 21st day of March, 1964), are required to send particulars of their claims to National Trustees, Executors and Agency Company of Australasia Limited, of 46 Queen-street, Bendigo, in the said State, by the 21st day of October, 1964, after which date the said company will distribute the assets of the said deceased, having regard only to the claims of which it then has notice.

WATSON JAMES & ROGERS, R.A.C.V. Building, View Point, Bendigo, solicitors for the administrator. 2152

CREDITORS, next of kin and others having claims in respect of the estate of John Daniel Fitzgerald, formerly of Lower Bebington, near Birkenhead, Cheshire, England, soldier, but late of Yallourn, labourer, deceased (who died on 14th May, 1963, and letters of administration of whose estate with the will annexed were granted on 18th May, 1964, to John Graham Bolton, of Kyneton, solicitor, the attorney under power of Eleanor Fitzgerald, of 101 Thornleigh-avenue, Mill Park Estate, Eastham, Cheshire, England, widow, the executrix and sole beneficiary named in the said will) are required to send particulars of their claims to the said administrator, in care of the undersigned solicitors, before the 13th October, 1964, after which date he will distribute the assets, having regard only to the claims of which he shall then have had notice.

PALMER, STEVENS & RENNICK, solicitors, Kyneton. 2110

CREDITORS, next of kin and others having claims in respect of the estate of John Charles Nicholson, formerly of Phoenix Hotel, Sydney-road, Brunswick, licensed victualler, but late of 14 Avondale-avenue, Chelsea, gentleman, deceased (who died on the 27th day of March, 1964), are to send particulars of their claims to the executor, National Trustees, Executors and Agency Company of Australasia Limited, 95 Queen-street, Melbourne, by the 31st day of October, 1964, after which date it will distribute the assets, having regard only to the claims of which it then has notice.

IVAN L. McDONALD, solicitor, 114 Balcombe-road, Mentone. 2160

WILLIAM JAMES FERGUSON, late of 53 Mitchell-street, Bairnsdale, retired, DECEASED.

CREDITORS, next of kin and others having claims in respect of the estate of the deceased (who died on the 23rd April, 1964), are required by the trustee, The Union-Fidelity Trustee Company of Australia Limited (formerly The Fidelity Trustee Company Limited) of 333 Collins-street, Melbourne, to send particulars to it by the 15th day of October, 1964, after which date the trustee may convey or distribute the assets, having regard only to the claims of which it then has notice.

Dated the 23rd day of July, 1964.

A. J. B. WELSHMAN, Leongatha, solicitor for the trustee. 2102

CHARLES MILLER, late of Nagambie, retired farmer and grazier, DECEASED.

CREDITORS, next of kin and others having claims in respect of the estate of the deceased (who died on the 21st day of August, 1963), are required by the executor, Charles Gordon Stanley Miller, to send particulars to the undersigned solicitors, by the 19th day of October, 1964, after which date the executor may convey or distribute the assets, having regard only to the claims of which he then has had notice.

WILFRID J. OSBORNE & OSBORNE, solicitors, Seymour. 2109

CREDITORS, next of kin and others having claims in respect of the estate of James Burdon, late of 24 McKillop-street, Geelong, in the State of Victoria, pensioner, deceased (who died on the 10th day of April, 1964), are to send the particulars of their claims to the Union-Fidelity Trustee Company of Australia Limited, at its office at 8 Malop-street, Geelong, aforesaid, by the 15th day of October, 1964, after which date it will distribute the assets, having regard only to the claims of which it then has notice.

FREEMAN & FALLAW, solicitors, 41 Yarra-street, Geelong. 2085

CREDITORS, next of kin and others having claims in respect of the estate of Ernest Heinrich Marschner, formerly of Caulfield, manager, but late of Carisbrook-street, Bannaring Beach, gentleman, deceased (who died on the 3rd day of June, 1964), are required by the administratrix, Etheline Connor, to send particulars to her, care of the under-mentioned proctors, by the 16th October, 1964, after which date the administratrix may convey or distribute the assets, having regard only to the claims of which she then has notice.

DOYLE & KERR, solicitors, 108 Queen-street, Melbourne. 2117

CREDITORS, next of kin and others having claims in respect of the estate of Gladys Hetty Wilson (also known as Gladys Hetty Beck), late of 67 Oak-avenue, Mentone, in the State of Victoria, married woman, deceased (who died on the 13th day of December, 1963), are to send particulars of their claims to Leo Browne, solicitor, of 180 Elgin-street, Carlton, in the said State, by the 20th day of October, 1964, after which date he will distribute the assets, having regard only to the claims of which he then has notice.

LEO BROWNE, solicitor, 180 Elgin-street, Carlton. 2123

CREDITORS, next of kin and others having claims in respect of the estate of Pola Rosenblatt, late of 77 Lumeah-street, Caulfield, deceased (who died on 20th day of May, 1960), are requested to send particulars of their claims to the executor, care of the undersigned solicitors, by the 17th day of October, 1964, after which date he will distribute the assets, having regard only to the claims of which he then has notice.

FREDERICK OWEN & ASSOCIATES, solicitors, 84 William-street, Melbourne. 2140

CREDITORS, next of kin and others having claims in respect of the estate of Pauline Murphy (also known as Pauline Elizabeth Murphy) formerly of 276 Glen Eira-road, Elsternwick, in the State of Victoria, but late of 155 Glen Eira-road, Elsternwick aforesaid, widow (who died on the 26th May, 1964) are to send particulars of their claims to the executor, the National Trustees, Executors, and Agency Company of Australasia Limited, of 95 Queen-street, Melbourne, on or before the 12th day of October, 1964, after which date it will proceed to distribute the said estate, having regard only to the claims of which it then has notice.

BRENDAN, McGUINNESS & CO., solicitors, 118 Queen-street, Melbourne. 2115

CREDITORS, next of kin and others having claims in respect of the estate of Thomas William Flower, late of 44 Bayview-street, Williamstown, in the State of Victoria, retired head teacher, deceased (who died on the 18th day of May, 1964), are to send particulars of their claims to the Trustees, Executors and Agency Company Limited, of 401 Collins-street, Melbourne, in the said State, the executors of the will of the said deceased, by the 15th day of October, 1964, after which date the said executors will distribute the assets, having regard only to the claims of which they shall then have had notice.

H. L. YUNCKEN & YUNCKEN, solicitors, 443 Little Collins-street, Melbourne. 2118

CHARLES LEONARD GILES, late of 18 Glyndon-road, Camberwell, in the State of Victoria, nurseryman, DECEASED.

CREDITORS, next of kin and others having claims in respect of the estate of the deceased (who died on the 10th day of December, 1963), are required by the trustees, Joyce Westcott, married woman, and Trevor George Westcott, manager, both of 3 Hender-court, Balwyn, to send particulars to them, care of the undersigned solicitors, by the 19th day of October, 1964, after which date they may convey or distribute the assets, having regard only to the claims of which they then have notice.

Dated the 5th August, 1964.

R. E. LEWIS ORR & GIBSON, solicitors, 825 Burke-road Camberwell. 2126

CREDITORS, next of kin and others having claims in respect of the estate of Leslie Francis Freemantle, late of 3 Denmark-street, Kew, in the State of Victoria, medical practitioner, deceased (who died on the 6th day of June, 1963), are to send the particulars of their claims to the executors, Roy Malcolm Freemantle, of 7 Lansell-crescent, Camberwell, and John Avon Crow, of 458 Dandenong-road, Caulfield, care of Kiddle, Briggs and Willox, by the 18th day of November, 1964, after which date the said executors will distribute the assets of the said deceased, having regard only to the claims of which they shall then have had notice.

KIDDLE, BRIGGS & WILLOX, solicitors, 400 Collins-street, Melbourne. 2135

EILEEN PARKER, late of Flat 8, No. 150 Power-street, Hawthorn, and also of Grant-street, Colac, in the State of Victoria, married woman, DECEASED.

CREDITORS, next of kin and others having claims in respect of the estate of the deceased (who died on the 4th day of November, 1963), are required by the executors, the Union-Fidelity Trustee Company of Australia Limited, of 333 Collins-street, Melbourne, and Colin Crichton Begg, of 28 Gellibrand-street, Colac, solicitor, to send particulars of their claims to the executors by the 1st day of November, 1964, after which date the executors may convey or distribute the assets, having regard only to the claims of which they then have notice.

Dated this 6th day of August, 1964.

SEWELL & SEWELL, Murray-street, Colac, solicitors for the executors. 2125

In the Supreme Court of the State of Victoria.

SALE BY THE SHERIFF.

ON Saturday, the 12th of September, 1964, at 10 a.m., at the Police Station, Orbost (unless process be stayed or satisfied):—

All the estate and interest (if any) of Philip Graham Harris and Jean Beryl Harris, both of Greenacres Caravan Park, Dandenong, as joint proprietors of an estate in fee simple in the land described in certificate of title volume 8189, folio 657, upon which is erected a seven-roomed

weatherboard house with corrugated iron roof, known as lots 3 and 4, Reed-street, Orbost. The property is situate 73 ft. 5 in. from the south corner of Arnold-street and Reed-street, Orbost.

Registered mortgage No. B588524 affects the said estate and interest.

Terms: Cash only.

2094

J. R. HALL, Sheriff's Officer.

IMPOUNDINGS

CAMPBELLFIELD.—Impounded in Campbellfield Pound.

2 Jersey heifer calves, four weeks old, no visible brands
If not claimed and expenses paid, to be sold on 27th August, 1964.

G. A. BRIDGES,
Town Clerk.

2182—12/

ELTHAM.—Impounded in Eltham Shire Pound by Ranger.

1 black bull, fully grown, no visible brand
If not claimed and expenses paid, to be sold on 29th August, 1964.

G. MATHEWS,
Poundkeeper.

2105—12/

HEYWOOD.—Impounded in Heywood Pound.

1 small Hereford cross cow, notch out of tip off side ear, no visible brand.
1 small Hereford cross cow, no ear marks or visible brand.
If not claimed and expenses paid, to be sold on 28th August, 1964.

C. SHIPWORTH,
Poundkeeper.

2148—16/

Subordinate Legislation Act 1962.

NOTICE OF MAKING OF STATUTORY RULES.

IN pursuance of the provisions of the *Subordinate Legislation Act 1962* and the Regulations made thereunder, notice is given of the making of the following statutory rules:—

No.	Rural Finance and Settlement Commission Act 1961.	Price. s. d.
101/1964.	Rural Finance and Settlement (Insurance Policy and Land Settlement Purchase Lease) Regulations 1964 ..	1 3
	<i>Labour and Industry Act 1958.</i>	
102/1964.	Labour and Industry (Shop Trading Hours) Regulations 1964 ..	1 0

Copies of these statutory rules may be purchased at the Sale of Publications Section of the Government Printing Office, located at Macarthur-street, Melbourne, C.2. If ordered by mail, remittance should be addressed to "The Government Printer, Box 203, P.O., North Melbourne, N.I.", and should include 5d. extra for postage.

A. C. BROOKS,
Government Printer.

PUBLICATION OF OFFICIAL MATTER.

ATTENTION is invited to the following procedure in relation to the publication of official matter in the *Government Gazette*:—

1. *Matter submitted to the Executive Council.*

Matters submitted to the Executive Council which requires gazettal will normally be published in the issue of the following week.

Where urgent gazettal is required, special arrangements should be made with the *Gazette Officer*.

Publication will be facilitated by the submission of carbon copies for the use of the *Gazette Officer*.

2. *Other matter.*

(a) All other matter duly certified by a responsible officer for publication should be lodged with the *Gazette Officer* not later than half-past Ten a.m. on Tuesday.

(b) Lengthy or involved notices should be forwarded several days before publication.

(c) Proofs, which will be supplied only when specifically requested or, at the direction of the Gazette Officer, should be returned promptly to avoid delay in publication.

(d) No additions or amendments to matter for publication will be accepted by telephone.

THE "VICTORIA GOVERNMENT GAZETTE".

SUBSCRIPTIONS.—The subscription, including postage, is £2 15s. per annum, £1 7s. 6d. half-yearly, or 13s. 9d. per quarter, payable in advance.

Subscriptions are required for whole months, and must cover at least a quarter.

Single copies are One shilling, posted One shilling and five pence. Subscribers do not receive the Acts of Parliament with the GAZETTE.

GAZETTES are held in stock for five years only.

PRIVATE ADVERTISEMENTS.—The charge for insertion is 2s. per line single column, and 4s. per line double column. The title forms one or more lines as a heading. On an average ten words make a line of single column. Every signature must likewise be counted as a line. The final words of a paragraph, though only portion of a line, must be counted as one line. Signatures (in particular) and proper names must be written very plainly in the text; ONE SIDE ONLY of each sheet of paper should be WRITTEN UPON.

All documents illegibly written will be returned unpublished, and where brands occur unprovided for by the ordinary letters of the alphabet, a worded explanatory description must be furnished.

Advertisements unaccompanied by a remittance sufficient to cover the cost of the insertion will be returned unpublished.

THE VICTORIA GOVERNMENT GAZETTE is published on WEDNESDAY EVENING in each week, and Notices for insertion will be received by the Government Printer at or before ONE p.m. at ordinary rates, and late advertisements between ONE p.m. and FOUR p.m. at double rates on the day preceding the day of publication.

PAYMENTS.—All payments are required in advance and remittances should be made by cheque, postal note, or money order payable to "GOVERNMENT PRINTER".

ADDRESS.—All communications should be addressed to "The Government Printer, Box 203, P.O., North Melbourne".

AGENTS FOR THE "VICTORIA GOVERNMENT GAZETTE".

THE following have been appointed agents to receive Advertisements and Subscriptions for the Victoria Government Gazette:—

ARMSTRONG BROS. PTY. LTD., Mollison-street, Kyneton.

ARMSTRONG'S AGENCY, 205 Queen-street, Melbourne.

ARNALL & JACKSON, 390 Barkly-street, Brunswick, N.10.

BAIRNSDALE AUTHORIZED NEWSAGENCY, 132 Main-street, Bairnsdale.

COOKE, F. R. & E. M., & SONS, 69 Bridge-street, Benalla.

DAVIES, G. & M. V., 112 Gray-street, Hamilton.

DAVIS, WM. (MILDURA) PTY. LTD., 126 Eighth-street, Mildura.

DIXON'S NEWSAGENCY, 89 Firebrace-street, Horsham.

EDGAR'S NEWSAGENCY PTY. LTD., 293 Hargreaves-street, Bendigo.

HALES, D. & N., Henty-street, Casterton.

FRANKS, H., & CO., 184 Ryrie-street, Geelong.

GORDON & GOTCH AUSTRALASIA LTD., 511 Little Collins-street, Melbourne.

GULLAN'S NEWSAGENCY, 88 Bridge-street, Ballarat.

HAMPTON, A. C., 243 Mitchell-street, Bendigo.

HARSTON, PARTRIDGE & CO. PTY. LTD., 455 Little Collins-street, Melbourne.

THE MERCANTILE EXCHANGE, 90 Queen-street, Melbourne.

MCGILL'S AUTHORIZED NEWSAGENCY, 183-5 Elizabeth-street, Melbourne.

PETTY, R. H. & W. M., 83 Murphy-street, Wangaratta.

PURDIE, J., & CO., 138 Moorabool-street, Geelong.

SALE AUTHORIZED NEWSAGENCY, 142 Raymond-street, Sale.

SKINNER'S AUTHORIZED NEWSAGENCY, 49-51 Franklin-street, Traralgon.

TUFF'S SHEPPARTON NEWSAGENCY, 246 Wyndham-street, Shepparton.

VERNON, C. F. & H. J., 162 Bridge-road, Richmond.

VIEW POINT AUTHORIZED NEWSAGENCY, 4 View Point, Bendigo.

A copy of the Gazette filed at each place for public reference.

CONTENTS

	PAGE
Appointments	2628
Bank Half-Holidays	2605
Companies Act 1961—Notice	2611
Contracts	2624
Estates of Deceased Persons	2622
Government Notices	2606
Impoundings	2665
Lands	2640
Melbourne and Metropolitan Board of Works—	
Notice	2623
Mining	2619
Notice of Making of Statutory Rules	2665
Orders in Council—	
Acts—Land; Local Government; Country Roads; Mines; Landlord and Tenant; Water; Sewerage Districts; Local Government; Police Regulation; Town and Country Planning; Housing.	2629 et seq
Private Advertisements	2652
Proclamations	2603
Public Service Notices	2650
Regulations—	
Acts—Police Regulation	2628
Resignations	2629
State Rivers and Water Supply Commission	2620
Tenders	2648
Transport Regulation Board—Public Hearings	2607