

[3377]



# VICTORIA GOVERNMENT GAZETTE

Published by Authority

[Registered at the General Post Office, Melbourne, for transmission by post as a newspaper.]

No. 89]

WEDNESDAY, NOVEMBER 4

[1964

*Land Act 1958.*

UNALIENATED CROWN LANDS AVAILABLE FOR SETTLEMENT UNDER IMPROVEMENT PURCHASE LEASES.

### PROCLAMATION

By His Excellency the Governor of the State of Victoria and its Dependencies in the Commonwealth of Australia, &c., &c., &c.

IN pursuance of the provisions of section 153 of the *Land Act 1958*, I, the Governor of the State of Victoria in the Commonwealth of Australia, by and with the advice of the Executive Council of the said State, do by this Proclamation declare the unalienated Crown lands mentioned in the subjoined Schedule, to be available for settlement under improvement purchase leases.

### SCHEDULE.

Country.	Parish.	Allotment.	Section.	Area.	Land Valuation.
				A. R. P.	
Delatite .. .. .	Edi .. .. .	10	10	125 0 0	£4 per acre
Delatite .. .. .	Edi .. .. .	11	10	115 0 0	£5 per acre

Given under my Hand and the Seal of the State of Victoria aforesaid, at Melbourne, this twenty-seventh day of October, in the year of our Lord One thousand nine hundred and sixty-four, and in the thirteenth year of the reign of Her Majesty Queen Elizabeth II.

(L.S.)

ROHAN DELACOMBE.

By His Excellency's Command,

JIM BALFOUR,

Commissioner of Crown Lands and Survey.

GOD SAVE THE QUEEN !

Land Act 1958, Section 25.  
TOWNSHIP OF BALLAARAT ALTERED.

PROCLAMATION

By His Excellency the Governor of the State of Victoria and its Dependencies in the Commonwealth of Australia, &c., &c., &c.

I, THE Governor of the State of Victoria, in the Commonwealth of Australia, by and with the advice of the Executive Council of the said State, and in pursuance of the provisions contained in section 25 of the Land Act 1958, do by this Proclamation alter the Township of Ballarat, proclaimed as such on the 11th August, 1953, by:—

- (a) The excision therefrom of the portion indicated by hachure on plan A hereunder,
- (b) the addition thereto of the portion indicated by hachure on plan B hereunder.—(B.128(14) (C.95336).

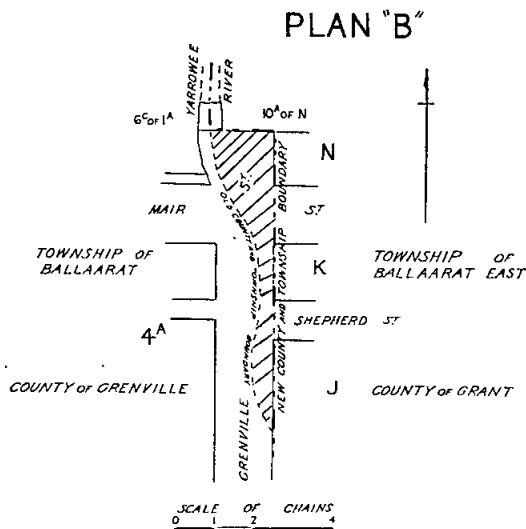
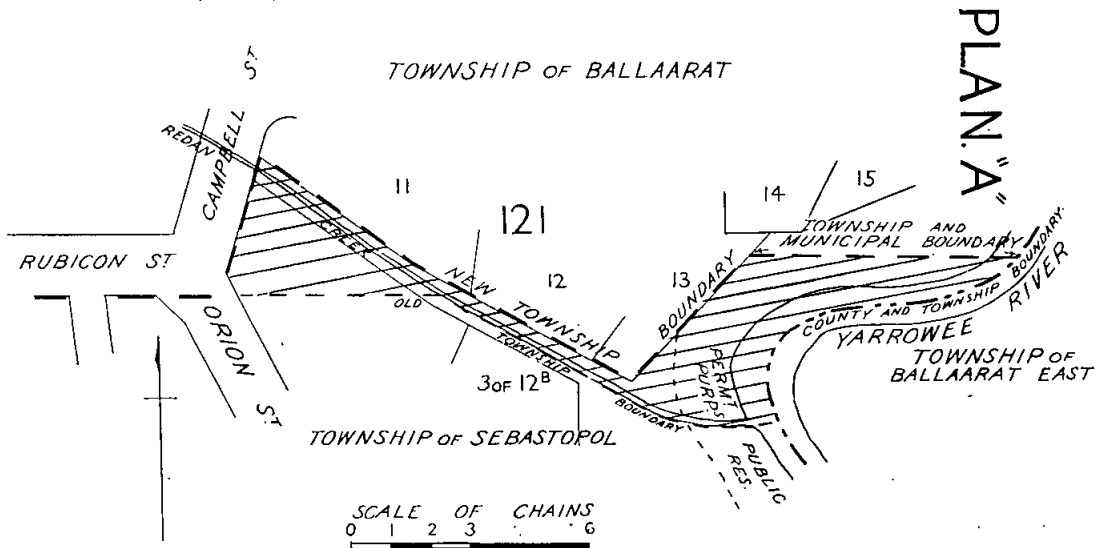

Given under my Hand and the Seal of the State of Victoria aforesaid, at Melbourne, this twenty-seventh day of October, in the year of our Lord One thousand nine hundred and sixty-four, and in the thirteenth year of the reign of Her Majesty Queen Elizabeth II.

(L.S.)

ROHAN DELACOMBE.

By His Excellency's Command,

JIM BALFOUR,  
Commissioner of Crown Lands and Survey.

GOD SAVE THE QUEEN!

Land Act 1958, Section 25.  
TOWNSHIP OF SEBASTOPOL EXTENDED.

PROCLAMATION

By His Excellency the Governor of the State of Victoria and its Dependencies in the Commonwealth of Australia, &c., &c., &c.

I, THE Governor of the State of Victoria, in the Commonwealth of Australia, by and with the advice of the Executive Council of the said State, and in pursuance of the provisions contained in section 25 of the Land Act 1958, do by this Proclamation extend the Township of Sebastopol, proclaimed as such on the 17th December, 1952, by the addition thereto of the portion indicated by hachure on plan hereunder.—(S.353<sup>(5)</sup>) (C.94050).

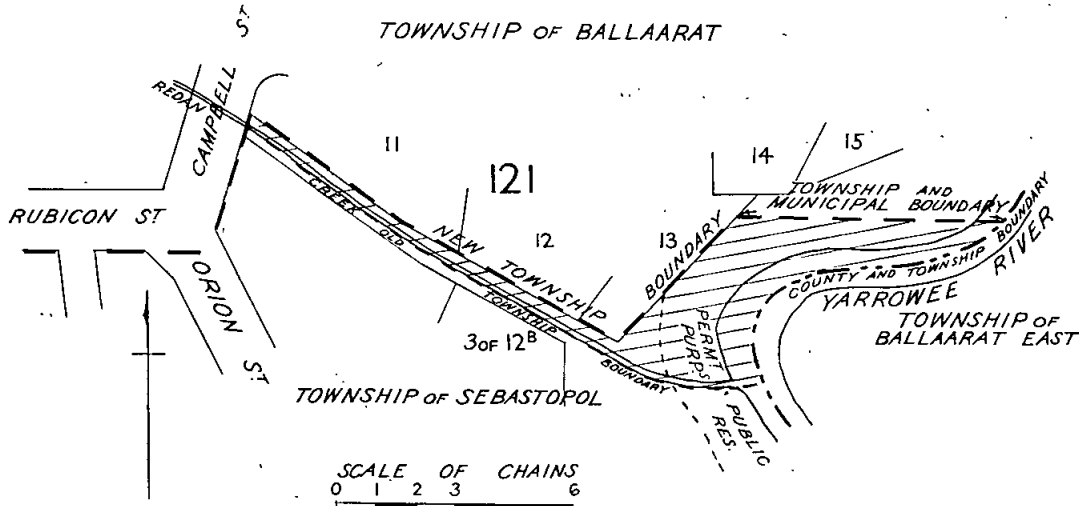

Given under my Hand and the Seal of the State of Victoria aforesaid, at Melbourne, this twenty-seventh day of October, in the year of our Lord One thousand nine hundred and sixty-four, and in the thirteenth year of the reign of Her Majesty Queen Elizabeth II.

(L.S.)

ROHAN DELACOMBE.

By His Excellency's Command,  
JIM BALFOUR,  
Commissioner of Crown Lands and Survey.

GOD SAVE THE QUEEN!

Land Act 1958, Section 25.  
TOWNSHIP OF CULLULLERAINE DIMINISHED.

PROCLAMATION

By His Excellency the Governor of the State of Victoria and its Dependencies in the Commonwealth of Australia, &c., &c., &c.

I, THE Governor of the State of Victoria, in the Commonwealth of Australia, by and with the advice of the Executive Council of the said State, and in pursuance of the provisions contained in section 25 of the Land Act 1958, do by this Proclamation diminish the Township of Cullulleraine, proclaimed as such on the 23rd December, 1936, by the excision therefrom of the portion indicated by hachure on plan hereunder.—(M.499<sup>(1)</sup>) (C) (C.84253).

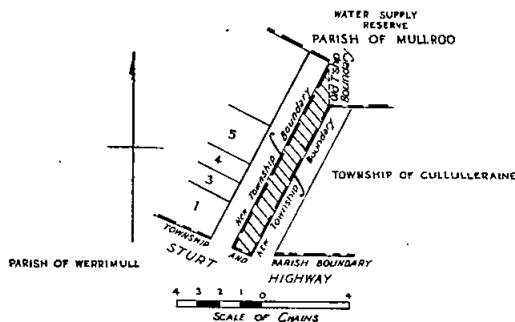

Given under my Hand and the Seal of the State of Victoria aforesaid, at Melbourne, this twenty-seventh day of October, in the year of our Lord One thousand nine hundred and sixty-four, and in the thirteenth year of the reign of Her Majesty Queen Elizabeth II.

(L.S.)

ROHAN DELACOMBE.

By His Excellency's Command,  
JIM BALFOUR,  
Commissioner of Crown Lands and Survey.  
GOD SAVE THE QUEEN!

Land Act 1958, Section 25.  
COUNTY BOUNDARY ALTERED.

PROCLAMATION

By His Excellency the Governor of the State of Victoria and its Dependencies in the Commonwealth of Australia, &c., &c., &c.

I, THE Governor of the State of Victoria, in the Commonwealth of Australia, by and with the advice of the Executive Council of the said State, and in pursuance of the provisions contained in section 25 of the Land Act 1958, do, by this my Proclamation, alter the common boundary between the County of Grant (proclaimed as such on the 2nd June, 1853) and the County of Grenville (proclaimed as such on the 29th December, 1848, and the 21st February, 1881) to the extent that the portion indicated by hachure on plan hereunder is hereby excised from the County of Grant and added to the County of Grenville and the portion indicated by cross hachure is hereby excised from the County of Grenville and added to the County of Grant.—(B.128<sup>(40)</sup>) (C.93051).

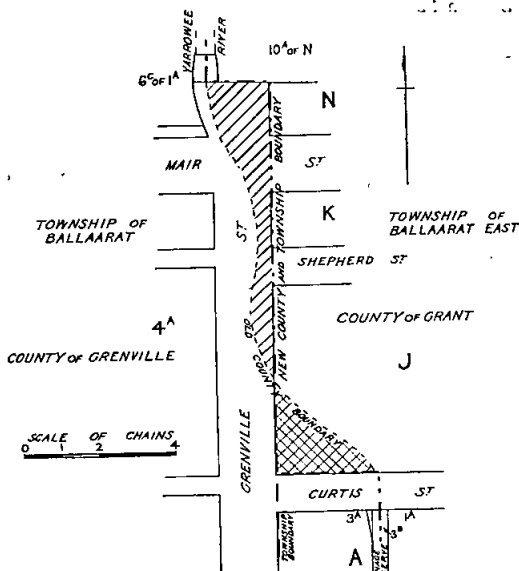

Given under my Hand and the Seal of the State of Victoria aforesaid, at Melbourne, this twenty-seventh day of October, in the year of our Lord One thousand nine hundred and sixty-four, and in the thirteenth year of the reign of Her Majesty Queen Elizabeth II.

(L.S.) ROHAN DELACOMBE.

By His Excellency's Command,  
JIM BALFOUR,  
Commissioner of Crown Lands and Survey.  
GOD SAVE THE QUEEN!

Land Act 1958, Section 25.  
TOWNSHIP OF KULWIN DIMINISHED.

PROCLAMATION

By His Excellency the Governor of the State of Victoria and its Dependencies in the Commonwealth of Australia, &c., &c., &c.

I, THE Governor of the State of Victoria, in the Commonwealth of Australia, by and with the advice of the Executive Council of the said State, and in pursuance of the provisions contained in section 25 of the Land Act 1958, do by this Proclamation diminish the Township of Kulwin, proclaimed as such on the 8th November, 1937, and amended by Proclamation of the 4th September, 1939, by the excision therefrom of the portion indicated by hachure on plan hereunder.—(K.207(t) (C.90592).

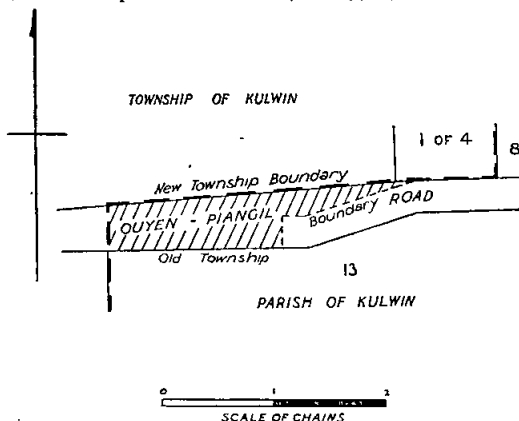

Given under my Hand and the Seal of the State of Victoria aforesaid, at Melbourne, this twenty-seventh day of October, in the year of our Lord

One thousand nine hundred and sixty-four, and in the thirteenth year of the reign of Her Majesty Queen Elizabeth II.

(L.S.) ROHAN DELACOMBE.

By His Excellency's Command,  
JIM BALFOUR,  
Commissioner of Crown Lands and Survey.  
GOD SAVE THE QUEEN!

Land Act 1958, Section 25.  
TOWNSHIP OF BALLAARAT EAST DIMINISHED.

PROCLAMATION

By His Excellency the Governor of the State of Victoria and its Dependencies in the Commonwealth of Australia, &c., &c., &c.

I, THE Governor of the State of Victoria, in the Commonwealth of Australia, by and with the advice of the Executive Council of the said State, and in pursuance of the provisions contained in section 25 of the Land Act 1958, do, by this Proclamation diminish the Township of Ballaarat East, proclaimed as such on the 11th August, 1953, by the excision therefrom of the portion indicated by hachure on plan hereunder.—(B.128(46) (C.93051).

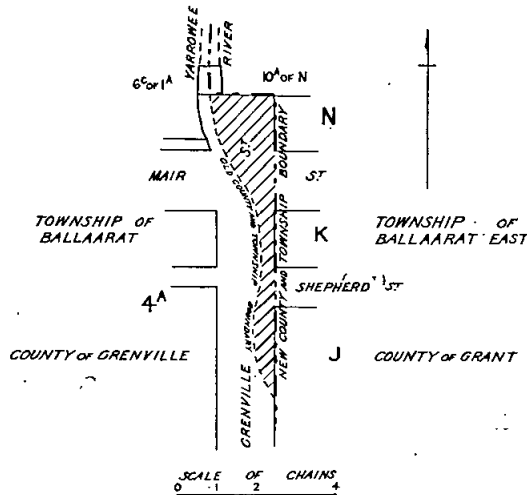

Given under my Hand and the Seal of the State of Victoria aforesaid, at Melbourne, this twenty-seventh day of October, in the year of our Lord One thousand nine hundred and sixty-four, and in the thirteenth year of the reign of Her Majesty Queen Elizabeth II.

(L.S.) ROHAN DELACOMBE.

By His Excellency's Command,  
JIM BALFOUR,  
Commissioner of Crown Lands and Survey.  
GOD SAVE THE QUEEN!

ACT OF PARLIAMENT.

PROCLAMATION

By His Excellency the Governor of the State of Victoria and its Dependencies in the Commonwealth of Australia, &c., &c., &c.

I, THE Governor of the State of Victoria, in the Commonwealth of Australia, do hereby declare that I have this day assented, in Her Majesty's name, to the Bill passed by the Parliament of the said State, the title whereof is hereunder set forth, that is to say:—

No. 7167. "An Act to apply out of the Consolidated Revenue the sum of Twenty-nine million three hundred and forty thousand six hundred and eighty pounds to the service of the year One thousand nine hundred and sixty-four and One thousand nine hundred and sixty-five."

Given under my Hand and the Seal of the State of Victoria aforesaid, at Melbourne, this twentieth day of October, in the year of our Lord One thousand nine hundred and sixty-four, and in the thirteenth year of the reign of Her Majesty Queen Elizabeth II.

(L.S.) ROHAN DELACOMBE.

By His Excellency's Command,  
HENRY E. BOLTE,  
Premier.

GOD SAVE THE QUEEN!

#### LOCAL GOVERNMENT DEPARTMENT.

##### PROCLAMATION EXTENDING THE OPERATION OF THE UNIFORM BUILDING REGULATIONS

By His Excellency the Governor of the State of Victoria and its Dependencies in the Commonwealth of Australia, &c., &c., &c.

WHEREAS section 916a of the *Local Government Act* 1958, as amended, provides, *inter alia*, that the Governor in Council may, by Proclamation published in the *Government Gazette*, at the request of the Council of any municipality (not being a city or town) extend the operation of the Regulations made under Part XLIX. of the Act to the municipal district of such municipality or any part thereof:

And whereas the Council of the Shire of Diamond Valley has requested that the operation of the Uniform Building Regulations be extended to the whole of the municipal district of the said municipality:

Now therefore, I, the Governor of the State of Victoria, by and with the advice of the Executive Council thereof, by this my Proclamation, extend the operation of the Regulations made under Part XLIX. of the *Local Government Act* 1958, as amended, to the whole of the municipal district of the Shire of Diamond Valley and Order that the said Regulations shall come into operation in the said municipal district on publication of this Proclamation in the *Government Gazette*, provided that Parts I. and II. of Chapter 8 thereof shall not be deemed to come into operation till the 30th January, 1965, except in so far as may be necessary to enable the Council of the said municipality to make By-laws, pursuant to the powers conferred by Part III. of the said Chapter, and provided further that no such By-law shall come into operation before the 30th January, 1965.

Given under my Hand and the Seal of the State of Victoria aforesaid, at Melbourne, this twenty-seventh day of October, in the year of our Lord One thousand nine hundred and sixty-four, and in the thirteenth year of the reign of Her Majesty Queen Elizabeth II.

(L.S.) ROHAN DELACOMBE.

By His Excellency's Command,  
R. J. HAMER,  
Minister for Local Government.

GOD SAVE THE QUEEN!

#### PUBLIC HIGHWAY.—SHIRE OF BELLARINE.

##### PROCLAMATION

By His Excellency the Governor of the State of Victoria and its Dependencies in the Commonwealth of Australia, &c., &c., &c.

WHEREAS by the *Local Government Act* 1958, as amended, section 519, it is amongst other things enacted that it shall be lawful for the Governor in Council at any time and from time to time upon request of the Council of any municipality by notice in the *Government Gazette* to proclaim any land reserved used or by purchase or exchange acquired for a street road highway thoroughfare bridge square court alley or right-of-way or any street road lane or passage made or laid out or proposed to be made or laid out on any land of which a plan delineating that street road lane or passage has been lodged with the Registrar of Titles to be a public highway and that such land shall thereupon and thenceforth from the date of such Proclamation become and be absolutely dedicated to the public as a public highway within the meaning of any law then or thereafter in force:

And whereas the Council of the Shire of Bellarine has requested that the land hereinafter mentioned, being a street made or laid out or proposed to be made or laid

out on land of which a plan delineating that street has been lodged with the Registrar of Titles, be so declared to be a public highway.

Now therefore I, the Governor of the State of Victoria in the Commonwealth of Australia, by and with the advice of the Executive Council of the said State, do by this Proclamation declare that Reaby-street, coloured brown on plan of subdivision No. 2560, lodged in the Office of Titles, shall be a public highway within the meaning of the said Act.

Given under my Hand and the Seal of the State of Victoria aforesaid, at Melbourne, this twenty-seventh day of October, in the year of our Lord One thousand nine hundred and sixty-four, and in the thirteenth year of the reign of Her Majesty Queen Elizabeth II.

(L.S.) ROHAN DELACOMBE.

By His Excellency's Command,  
R. J. HAMER,  
Minister for Local Government.

GOD SAVE THE QUEEN!

#### Milk Board Act 1958 (No. 6318).

##### MILK DISTRICTS.

##### PROCLAMATION

By His Excellency the Governor of the State of Victoria and its Dependencies in the Commonwealth of Australia, &c., &c., &c.

I, THE Governor of the State of Victoria, in the Commonwealth of Australia, by and with the advice of the Executive Council of the said State, and in pursuance of the provision of the *Milk Board Act* 1958 and all other powers enabling me in that behalf, do by this my Proclamation amend the declarations of the Milk Districts specified hereunder as follows:—

##### *The West Gippsland Milk District and the Dandenong Ranges Milk District.*

That part of the municipal district of Berwick described hereunder shall be excised from the areas previously proclaimed as comprising the West Gippsland Milk District and shall be added to the areas previously proclaimed as comprising the Dandenong Ranges Milk District—

All that area within and inside the following boundary, namely, commencing at the junction of the municipal boundary with the Beenak East-road; thence south-westerly and westerly along that road to its junction with the Belgrave-Gembrook road; thence westerly along that road to its junction with Mt. Burnett-road; thence southerly and westerly along that road to its junction with Paternoster-road; thence north-westerly along that road to its junction with the municipal boundary; thence easterly north-easterly and south-easterly along the municipal boundary to the commencing point.

Given under my Hand and the Seal of the State of Victoria aforesaid, at Melbourne, this twenty-seventh day of October, in the year of our Lord One thousand nine hundred and sixty-four, and in the thirteenth year of the reign of Her Majesty Queen Elizabeth II.

(L.S.) ROHAN DELACOMBE.

By His Excellency's Command,  
VANCE DICKIE,  
Acting Minister of Agriculture.

GOD SAVE THE QUEEN!

#### PUBLIC HIGHWAY.—CITY OF HAWTHORN.

##### PROCLAMATION

By His Excellency the Governor of the State of Victoria and its Dependencies in the Commonwealth of Australia, &c., &c., &c.

WHEREAS by the *Local Government Act* 1958, as amended, section 519, it is amongst other things enacted that it shall be lawful for the Governor in Council at any time and from time to time upon request of the Council of any municipality by notice in the *Government Gazette* to proclaim any land reserved used or by purchase or exchange acquired for a street road highway thoroughfare bridge square court alley or right-of-way or any street road lane or passage made or laid out or proposed

to be made or laid out on any land of which a plan delineating that street road lane or passage has been lodged with the Registrar of Titles to be a public highway and that such land shall thereupon and thenceforth from the date of such Proclamation become and be absolutely dedicated to the public as a public highway within the meaning of any law then or thereafter in force:

And whereas the Council of the City of Hawthorn has requested that the land hereinafter mentioned, used for a street, be so declared to be a public highway:

Now therefore I, the Governor of the State of Victoria in the Commonwealth of Australia, by and with the advice of the Executive Council of the said State, do by this Proclamation declare that all that piece of land, off Montrose-street, Hawthorn, indicated by hatching on the plan hereunder, shall be a public highway within the meaning of the said Act.

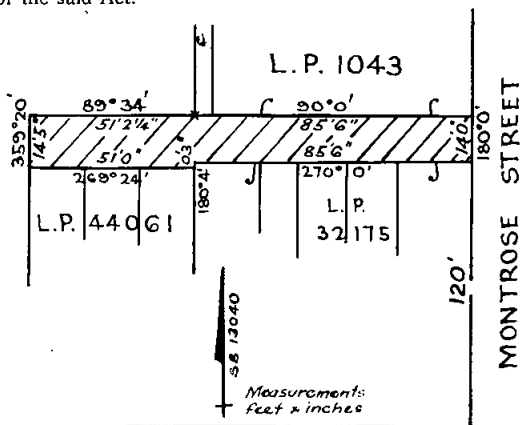

**BURWOOD ROAD**

Given under my Hand and the Seal of the State of Victoria aforesaid, at Melbourne, this twenty-seventh day of October, in the year of our Lord One thousand nine hundred and sixty-four, and in the thirteenth year of the reign of Her Majesty Queen Elizabeth II.

(L.S.) **ROHAN DELACOMBE.**

By His Excellency's Command,  
**R. J. HAMER,**  
Minister for Local Government.  
GOD SAVE THE QUEEN!

**Forests Act 1958 (No. 6254).  
DECLARATION OF LAND NOT TO BE A FIRE  
PROTECTED AREA.**

IN pursuance of the powers conferred by section 3 of the *Forests Act 1958*, I, Lindsay Hamilton Simpson Thompson, Her Majesty's Minister of Forests in the State of Victoria, hereby declare that any land which is within 1 mile of any reserved forest or of any area of unoccupied Crown land proclaimed as a protected forest pursuant to this Act or any corresponding previous enactment or of any national park, and which is situated within the parishes and part parishes specified in the Schedule hereto, shall not be a fire protected area.

**SCHEDULE.**

The Parishes of Avenel, Balmattum, Benalla, Brankett, Bungeet, Currawa, Devenish, Dookie, Doolam, Garratanbunell, Glenrowen, Goomalibee, Goorambat, Gooram Gooram Gong, Greta, Kelfeera, Killawarra, Longwood, Lurg, Merton, Mokoan, Monea South, Peechelba, Rothesay, Ruffv, Stewarton, St. James, Tarcombe, Upotipotpon, Wangaratta South, Wills, Winton.

**Euroa**—the whole of the parish except that portion which is east of Forlong's-road and south of the Euroa-Strathbogie road.

**Marraveeny**—the whole of the parish except allotments 22, 23, 41, 41A, 42, 42A and 42B in section B.

**Wondoomarook**—that portion of the parish which is south of Seven Creeks.

**L. H. S. THOMPSON,**  
Minister of Forests.

28th October, 1964.

**NOTICE TO MARINERS.**

[No. 17 of 1964.] T.

**AUSTRALIA.—VICTORIA.**

**PORT PHILLIP.**

**Buoys Established.**

**Position.**—St. Kilda Outer Breakwater Head Light, Lat. 37 deg. 51 min. 46 sec. S., Long. 144 deg. 57 min. 35 sec. E. (approx.).

**Details.**—Buoys have been established in the following positions from the above light:—

- (a) 14.5 cables 182 deg.
- (b) 10 cables 232 deg.
- (c) 2 cables 343 deg.

**Character.**—The buoys are two stainless steel 18-gallon drums welded together, carrying a wooden staff 11 feet above water level, surmounted by round metal discs painted yellow.

The buoys will be withdrawn at the end of April, 1965.

**Charts Affected.**—B.A. Nos. 624, 1171, Aust. 144, 153.

**A. J. WAGGLEN,**  
Port Officer for Victoria.

Ports and Harbors Branch,  
Department of Public Works,  
Melbourne, C.2, 30th October, 1964.

**NOTICE TO MARINERS.**

[No. 16 of 1964.]

**AUSTRALIA.—VICTORIA.**

THE following Notice to Mariners, which has been received from the Harbor Master, Geelong, is published for general information.

**A. J. WAGGLEN,**  
Port Officer.

Ports and Harbors Branch,  
Department of Public Works,  
Melbourne, C.2, 27th October, 1964.

**GEELONG HARBOR TRUST COMMISSIONERS.**

**PORT OF GEELONG.**

**(A) New Pier Under Construction.**

**Position.**—Point Henry Signal Station. Lat. 38 deg. 07 min. 51 sec. S. Long. 144 deg. 25 min. 28 sec. E. (approximately).

**Details.**—A new pier is under construction commencing at a point 140 deg. 45 min. 10.7 sec., distant 1,181 feet from the above position. The pier will proceed in a 066 deg. 20 min. direction for a distance of 4,331 feet to the seaward extremity of the main berthing head.

**Remarks.**—Anchor lights will be exhibited by floating plant moored in the vicinity during the period of construction and white lights will be exhibited from the extremity of the pier as it proceeds seaward.

Further details of pier will be promulgated on completion of construction.

**Caution.**—Masters and persons in charge of small craft are advised to navigate with caution in the area.

**(B) Pier Extension Completed—Light Established.**

- (1) Former Notice No. 1 of 1964.
- (2) Light established.

**Details.**—(1) Construction of the extension to the Bulk Wheat Pier has been completed.

**Details.**—(2) A fixed red light has been established at the seaward extremity of the pier, on the centre line, and immediately below the deck level of the pier.

**Arc of Visibility.**—From 047 deg. through West to 227 deg.

**Height Above Sea Level.**—14 feet.

**CONTRACTS ACCEPTED.—(Series 1964-65.)**

**SOIL CONSERVATION AUTHORITY.**

1594. Erection of 231 feet of fencing at the Soil Conservation Authority residence, Wright-street, Heathcote, £188.—P. Frylink, Lawson-street, Bendigo.

**SUGARLOAF GROUP CONSERVATION AREA.**

1595. Hire of tractor and operator on works, £1 10s. an hour.—Mr. Barker, Corryong; H. Sheather, Corryong; J. Lebner, Corryong.

## VICTORIAN RAILWAYS.

48. Supply and delivery of broken metal, screenings, toppings, crushed rock and dust as may be ordered, in writing, during the period from 1st July, 1964, to 30th June, 1966, at rates (Contract 62638).—Rowlands Quarries Ltd. 49. Supply and delivery of broken metal, screenings, toppings, crushed rock and dust as may be ordered, in writing, during the period from 1st July, 1964, to 30th June, 1966, at rates (Contract 62639).—Mobile Quarries (Vic.) Pty. Ltd. 50. Supply and delivery of broken metal, screenings, toppings, crushed rock and dust as may be ordered, in writing, during the period from 1st July, 1964, to 30th June, 1966, at rates (Contract 62640).—Geelong Quarries Pty. Ltd. 51. Manufacture, supply and laying of bituminous concrete for pavement at Flexivan Loading Area Extension on South Dynon and roadway in North Dynon area in connexion with sidings for Unilever Australia Pty. Ltd., for £9,365 7s. 11d. (Contract 626/68.—Albion Quarrying Co. Pty. Ltd. 52. Supply and delivery of battery cell replating elements for train lighting batteries, at £440 per set, delivered Shelter Shed Store, North Melbourne (Contract 62685).—J. Stone & Co. (A'asia) Pty. Ltd.

By order of the Victorian Railways Commissioners,  
W. WALKER, Secretary. 30.10.64.

## ORDERS IN COUNCIL.—(Series 1964-65.)

## PUBLIC WORKS.

1596. Ballarat, Mental Hospital, repairs to concrete floors and laying of welded sheet vinyl, toilet areas, Wards 25 and 26, £1,228 8s. 6d.—Laminex Industries.—(W.279157.)

1597. Carlton, St. Nicholas Hospital, supply and fixing of curtains, £592 18s.—Hoad Manufacturing Pty. Ltd.—(M.57951.)

1598. Hamilton, Technical School, special grant authorized by the Education Department towards the cost of construction of canteen and shower rooms at the school, £1,500.—Hamilton Technical School Council.—(S.W.003871.)

1599. Melbourne, High School, supply and fixing of special lecture room seating, £1,164.—Aristoc Industries Pty. Ltd.—(M.302047 "A".)

1600. Melbourne, Ports and Harbors Branch, general repairs to dredge "Matthew Flinders", £7,406 3s. 1d.—Buchanan & Brock Pty. Ltd.—(P. & H. 206374.)

1601. Oakleigh, State School No. 1601, supply and installation of gas heating, £1,724 13s. 4d.—Colonial Gas Holdings Ltd.—(S.E.46998.)

1602. Sale, special grant authorized by the Education Department towards the cost of developing McMillan Park, Sale, and Sale Friendly Societies Reserve for school recreational purposes, £1,900.—Sale City Council, £1,500, and Sale Friendly Societies Recreation Reserve Committee, £400.—(S.E. 300957.)

Approved by the Governor in Council, 27th October, 1964.—J. COLQUHOUN, Clerk of the Executive Council.

## FORESTS COMMISSION.

Loan Fund Act No. 7028, Item 6.—

1603. To the purchase of lot 6 on the plan of subdivision 63395 and being part of allotment 58, Parish of Mooroolbark, containing 7 acres 1 rood 6 perches, for forest purposes, £510.—C. F. Angelo.

Approved by the Governor in Council, 11th August, 1964.—J. COLQUHOUN, Clerk of the Executive Council.

## STATE ELECTRICITY COMMISSION.

1604. For the supply of 45 amp. indoor fuse boxes for size 1 cartridges for a period of two years, to Specification No. 64-65/20, at Schedule rates.—Gordon Faine & Sons Pty. Ltd.

Approved by the Governor in Council, 22nd September, 1964.—J. COLQUHOUN, Clerk of the Executive Council.

1605. For the supply of 10,024 feet of 48-in. rubber conveyor belting for conveyors at Yallourn, Morwell and Hazelwood, to Specification No. 63-64/364, £66,850.—Apex Belting Pty. Ltd.

1606. For the supply of 205 tons of steel plate for general maintenance, to Quotation No. 1570, at Schedule rates.—Australian Iron & Steel Pty. Ltd.

1607. For the supply of 124 tons of flat steel bar, to Quotation No. 1525, at Schedule rates.—The Broken Hill Pty. Co. Ltd.

1608. For the supply of 5,000 feet of rubber insulated 6.6 kV trailing cable for coal winning operations at Morwell, to Specification No. 64-65/22, £6,340.—Cable-makers (A.C.T.) Pty. Ltd.

1609. For the supply of electrical appliances and spare parts for merchandising for a period of twelve months, to Quotation No. 1553, at Schedule rates.—Email Ltd.

1610. For the supply of safety helmets, caps and head harnesses for a period of two years, to Specification No. 64-65/12, at Schedule rates.—Industrial Protective Co. Pty. Ltd.

1611. For the supply and erection of one 110/20 ton electrically operated overhead travelling crane and modifications to existing crane for turbine house, Hazelwood Power Station, to Specification No. 64-65/106, £48,465.—Moore Crane & Engineering Co. Pty. Ltd.

Approved by the Governor in Council, 13th October, 1964.—J. COLQUHOUN, Clerk of the Executive Council.

## TEACHING SERVICE (TEACHERS TRIBUNAL) REGULATIONS.

ELECTION OF A MEMBER OF THE COMMITTEE OF CLASSIFIERS FOR THE PRIMARY SCHOOLS DIVISION, EDUCATION DEPARTMENT.

I HEREBY give notice, pursuant to clause 20 of Regulation 2 of the Teaching Service (Teachers Tribunal) Regulations, that the election which closed with me on the 26th October, 1964, has resulted in

PHILLIP THURLBY DWYER

being elected to the office of Member of the Committee of Classifiers for the Primary Schools Division for the period commencing on the 17th November, 1964.

G. FENNELL,  
Returning Officer.

Office of the Teachers Tribunal,  
Melbourne, 27th October, 1964.

## COMPANIES ACT 1961.

NOTICE is hereby given that in pursuance of section 308 (5) of the Companies Act 1961 the names of the companies referred to below have been struck off the Register, and on publication of this notice in the Government Gazette the said companies will be dissolved

Dated this 29th day of October, 1964.

B. MITCHAM,  
Assistant Registrar of Companies.

Companies Registration Office,  
Melbourne.

## COMPANIES ABOVE REFERRED TO.

Name of Company.	Number of Registration.
Burdett Coutts Quartz Mining Company Limited	M23
Goldsbrough Quartz Mining Company Registered	M109
Lauriston Prince of Wales Gold Mining Company Registered	M119
The Berlin Amalgamated Quartz Mining Company No Liability	M375
The Walhalla Copper Mining Company Limited	M1217
The Perseverance Gold Mining Company Limited	M1242
The Goldsbrough Mining Company Limited	M1295
The Emperor Gold Mining Company Limited	M1377
The Thistlethwaite Estate Gold Mining Company No Liability	M1379
The New United Miners Company No Liability	M1519
The Bairds Hurdsfield Freehold Mining Company No Liability	M2051
Hurdsfield United Freehold Gold Mining Company No Liability	M2064
The North Water Wheel Company No Liability	M2065
North Homeward Bound Company No Liability	M2779
The General Wyndham United Estate Gold Mining Company No Liability	M3043
The Wildboar Mining Company No Liability	M3181
The Eldorado Quartz Mining Company No Liability	M3284
The Loch Tyne and B B Gold Mining Company No Liability	M5564
Fawcett Gold Mining Company No Liability	M5825
Morans Luck Gold Mining Company No Liability	M6055
Racecourse Bucket Dredging Company No Liability	M8229

## Commercial Goods Vehicles Act.

## TRANSPORT REGULATION BOARD.

## HEARING OF APPLICATIONS.

**NOTICE** is hereby given that the following applications will be considered by the Transport Regulation Board at its offices at Rathdown-street, Carlton, at 10.15 a.m. on Wednesday, 25th November, 1964.

- ANGWIN, G. M.**, Post Office Box 110, Wodonga. One commercial goods vehicle (146 cwt.) to operate:—(a) Within a 20-mile radius of Wodonga—general goods. (b) Within a 70-mile radius of Wodonga—masonry bricks solely on behalf of Weatherall masonry.
- BAILLIE, L.**, Lot 50, Hillview-avenue, Kilsyth. One commercial goods vehicle (129 cwt.) to operate:—(a) Within a 25-mile radius of the G.P.O., Melbourne—general goods. (b) From sand pits at Cranbourne to places as defined in paragraph (a) above—sand and overburden soil.
- BALLARAT DEEP FREEZE FOOD CO. PTY. LTD.**, 21 Grenville-street north, Ballarat. One commercial goods vehicle (44 cwt.) to operate as a specially constructed insulated and refrigerated vehicle in the course of business as "Frozen Food Distributors" within that part of the State of Victoria west of the north/south line drawn through the City of Melbourne—frozen fish, poultry, processed fruit and vegetables.
- BAYVIEW QUARRIES PTY. LTD.**, 602 St. Kilda-road, Melbourne. One commercial goods vehicle (200 cwt.) to operate within a 50-mile radius from own premises at Montrose in the course of business as "Premixed Concrete Manufacturers" in a specially constructed vehicle—premixed concrete.
- BEAUREPAIRE TYRE SERVICE PTY. LTD.**, 102 Victoria-street, Carlton. One commercial goods vehicle (11 cwt.) to operate within a 50-mile radius from own Mitcham branch premises in the course of business of the licensee as "Tire Retreaders and Distributors"—tires and tubes for sale and delivery, used tires for repair or retreading or having been repaired or retreaded, batteries, oil and motor car accessories.
- BENTLEY, A. G.** (trading as A. Bentley Engineering Sales), 15 McCulloch-street, Donald. Two commercial goods vehicles (39 and 6 cwt.) to operate:—(a) Within a 50-mile radius of own premises at Horsham in course of business as "garage and general engineers"—own goods, (b) in that part of the State of Victoria west of a line drawn north and south through the City of Melbourne—tools of trade and small quantities of materials incidental to the repair and servicing of tractors and farm machinery.
- BETHUNE, F. N., PTY. LTD.**, 51 Camberwell-road, Hawthorn East. Two commercial goods vehicles (6 cwt. each) to operate throughout the State of Victoria in the course of business as "Pump Manufacturers"—pumping plants for installation, for repair or having been repaired, tools of trade, spare parts and materials incidental to the installation and servicing of pumping equipment.
- BOWD, R. A.**, 43 Leonard-street, Robinvale. One commercial goods vehicle (4 cwt.) to operate within a 100-mile radius of Robinvale in the course of business as Plumber—tools of trade, equipment and materials incidental to the completion of own contract.
- BRANDSEN, L. A.**, 1 Swan-street, Bairnsdale. One commercial goods vehicle (15 cwt.) to operate between own premises at Bairnsdale and places situate within a 20-mile radius of Licola—own tools of trade and equipment in the course of business as "Timber Contractor".
- BRENNAN, P. A. & W. F.**, 7A Wilson-street, Horsham. One commercial goods vehicle (211 cwt.) to operate within a 50-mile radius of post office at Horsham. (a) Tools of trade, materials and equipment incidental to contracts in course of business as "Builders". (b) Own goods in the course of business as "Primary Producers". (c) In the course of business as "Agricultural Contractors"—materials and equipment incidental thereto.
- BUNTINE, R.**, 18 Calthorpe-street, Gisborne. Two commercial goods vehicles (234 and 226 cwt.) to operate: (a) From Melbourne to Gisborne—basic steel for the use in manufacturing processes solely on behalf of Gisborne Manufacturing Co. Pty. Ltd., at Gisborne (approved decentralized secondary industry). (b) Throughout the State of Victoria—manufactured articles and products from the said company's factory at Gisborne solely on behalf of that company.
- CLARK, C.** (trading as Calder General Agency), 133 High-street, Charlton. One commercial goods vehicle (97 cwt.) to operate: (a) Within a 20-mile radius of Charlton—general goods. (b) Within a 50-mile radius of Charlton in course of business as "Firewood and Fence Post Contractor and Supplier"—own firewood and fencing posts.
- CERAMIC TRANSPORT PTY. LTD.**, 125 Springvale-road, Springvale. One commercial goods vehicle (125 cwt.) to operate: (a) Within a 20-mile radius of post office at Springvale—general goods. (b) Within a 70-mile radius of Brick Industries Ltd. premises at East Burwood—bricks on behalf of the said company.
- CHALK, A. B.**, 103 Mary-street, Morwell. One commercial goods vehicle (126 cwt.) to operate: (a) Within a 50-mile radius of post office at Morwell—(i) In the course of business as "Road Making and Bridge Building Contractor"—own equipment, tools of trade, and road-making materials. (ii) Own equipment, tools of trade and materials incidental to own pipe laying and structural steel contracts. (b) Within a 20-mile radius of post office at Morwell—general goods.
- COLLINS, W. & L.**, King-street, Pakenham East. One commercial goods vehicle (91 cwt.) to operate within a 50-mile radius of Pakenham East in course of business as a "Scrap Metal Dealer"—scrap metal and marine stores as defined in the *Marine Stores and Old Metals Act 1958* (No. 6303).
- CUARNEKCI, F.**, 462 Queensberry-street, North Melbourne. One commercial goods vehicle (41 cwt.) to operate throughout the State of Victoria as a "Travelling Showman"—own sideshow equipment and novelty prizes.
- DALE, W. H.**, Cranbourne-road, Cranbourne. One commercial goods vehicle (139 cwt.) to operate: (a) Within a 25-mile radius of the G.P.O., Melbourne—general goods. (b) From pits at Cranbourne to places as defined in paragraph (a)—sand.
- DALGETY & NEW ZEALAND LOAN LTD.**, 538 Collins-street, Melbourne. One commercial goods vehicle (11 cwt.) to operate within a 50-mile radius of own branch premises at Bendigo in the course of business as "Stock and Station Agents"—own goods.
- DALGETY & NEW ZEALAND LOAN LTD.**, 538 Collins-street, Melbourne. One commercial goods vehicle (11 cwt.) to operate within a 50-mile radius of own branch premises at Kyneton in the course of business as "Stock and Station Agents"—own goods.
- ELLIS, A. W. & N. A.**, Box 29, Pimpinio. One commercial goods vehicle (114 cwt.) to operate: (a) Within a 80-mile radius of post office at Dimboola (Horsham Division of C.R.B.) as a "Road Contractor"—road-making plant and materials. (b) Within a 20-mile radius of post office at Pimpinio—general goods.
- ELLSTED CONTRACTING CO. PTY. LTD.**, 23 Anderson-road, Thornbury. One commercial goods vehicle (29 cwt.) to operate: (a) Within a 50-mile radius of own premises at Thornbury in course of business as "Civil Engineers"—own goods. (b) Throughout the State of Victoria—tools of trade and equipment. (c) Within a 20-mile radius of any contract currently engaged upon or from the nearest railway station thereto—materials for use on such contract.
- ETA FOODS (VIC.) PTY. LTD.**, corner Ballarat-road and Lacey-street, Braybrook. One commercial goods vehicle (9 cwt.) to operate: (a) Within a 50-mile radius of own premises at Braybrook in course of business as "Nut Foods Manufacturers"—own goods. (b) Throughout the State of Victoria as a sales supervisor for the purpose of advertising and sales promotion—samples, advertising, display materials, small quantity of stock for replacement of damaged or unsaleable stock with the ability to return with damaged or unsaleable stock.
- FITZPATRICK, P. J.**, 1108 Etiwanda-avenue, Mildura. One commercial goods vehicle (18 cwt.) to operate: (a) Mails may be carried on the vehicle along the routes subject to the mail contract entered into between the Postmaster Generals Department and the holder of this licence, i.e. Red Cliffs to Meringur. (b) Newspapers and parcels may be carried on the vehicle along the routes but so that the weight of any one parcel shall not exceed the weight of twenty-eight (28 lb.) and so also that the total weight of such newspapers and parcels carried at any one time shall not exceed three and one half hundredweight for the carriage of newspapers. (c) The only rates to be charged for the carriage of newspapers and parcels pursuant to the conditions of this licence shall be set out in the schedule attached hereto entitled "Goods Rates Schedule".
- GERRISH, A. D.**, Warburton East. One commercial goods vehicle (240 cwt.) to operate: (a) From forestry allocation in the Matlock area to G. N. Raymonds sawmill at Matlock—logs. (b) From forest areas in the Matlock area to G. N. Raymonds sawmill at Warburton—logs.



**GIPPSLAND TYRE SERVICE & RUBBER CO. PTY. LTD.**, 239 Princes Highway, Morwell. One commercial goods vehicle (11 cwt.) to operate within a 50-mile radius of own premises at Morwell in the course of business as "Tyre Service"—new tires, second-hand tires for retreading or having been repaired and new and second-hand batteries.

**HARDIE RUBBER CO. PTY. LTD.**, 239 Princes Highway, Morwell. One commercial goods vehicle (9 cwt.) to operate within a 50-mile radius of Morwell in the course of business as "Tyre Service"—new tires, second-hand tires for retreading or having been retreaded and new and second-hand batteries.

**HEALY, A. & E. M.**, Curia-street, Mansfield. Application to vary the conditions of licence No. T.T.D.772 (L/C. 400 cwt.) approximately by adding as an additional paragraph (d) "Within a 50-mile radius of Mansfield as a low-loader—own logging, road-making and earth-moving equipment and on behalf of Country Roads Board and other contractors."

**HEATH'S MOTORS PTY. LTD.**, 160 Little Malop-street, Geelong. One commercial goods vehicle (10 cwt. and a specially constructed car carrying trailer 40 cwt.) to operate throughout the State of Victoria for the purpose of repairing or towing disabled or wrecked vehicles—tools, spare parts and materials incidental to trade.

**HERNAN, T. W.**, Hume Highway, Winton. One commercial goods vehicle (143 cwt.) to operate: (a) Within a 20-mile radius of post office at Winton—general goods. (b) From and to places situate within a 20-mile radius of Winton to and from places situate within 50 miles of Winton—livestock.

**HUTTON, J. C., PTY. LTD.**, 65 High-street, Preston. One commercial goods vehicle (84 cwt.) to operate throughout the State of Victoria in the course of business as "Bacon and Smallgoods Manufacturers" in a specially constructed and refrigerated vehicle—fresh meat, cooked meals, sausages and smallgoods, with the ability to carry up to 3 cwt. of lard, dripping, cheese, canned hams and margarine.

**JENSEN, T. H.**, McGregor-avenue, Healesville. One commercial goods vehicle (275 cwt.) to operate from forest landings in the Molesworth area to mills at Healesville—logs.

**LIPMAN, W.**, Lyons-street, Rosedale. One commercial goods vehicle (220 cwt.) to operate from forestry landings in the Tamboritha and Licola areas to Australia Paper Mill at Maryvale—pulpwood.

**LITTLE, J. R.**, 20 Coghill-street, Yarrowonga. One commercial goods vehicle (111 cwt.) to operate: (a) Within a 90-mile radius of post office at Wangaratta (Benalla Division of Country Roads Board) as a "Road Contractor"—road-making plant and materials. (b) Within a 20-mile radius of post office at Yarrowonga—general goods.

**MACKAY, K. R.**, Numurkah. One commercial goods vehicle (80 cwt.) to operate: (a) Within a 20-mile radius of post office at Numurkah—general goods. (b) Throughout the State of Victoria in the course of business as "Fencing and Hay Baling Contractor"—own tools of trade and equipment, including own tractor. (c) Within a 20-mile radius of site of fencing contract currently engaged upon, or from the railway station nearest thereto—materials for use on such contract. (d) Within a 20-mile radius of site of current hay baling contract or to the nearest railway station—baled hay.

**MILLER, A.**, 9 Brown-street, Traralgon. One commercial goods vehicle (151 cwt.) to operate from the Erica area to the A.P.M. Ltd., at Maryvale—pulpwood.

**NEVILL, J. L.**, Hepburn Springs. One commercial goods vehicle (131 cwt.) to operate: (a) From forest areas at Daylesford and Trentham to C.S.R. factory at Bacchus Marsh—pulpwood. (b) Within the areas described in paragraph (a) above in the course of business as "Logging Contractor"—own tools of trade and equipment.

**PETERSVILLE AUSTRALIA LTD.**, Wellington-road, Clayton. One commercial goods vehicle (75 cwt.) to operate throughout the State of Victoria as a specially constructed insulated and refrigerated van for the purpose of supplying own distributors with ice cream and frozen foods at a temperature not exceeding 10°F.

**PYLE, T. J.**, Tawonga South. One commercial goods vehicle (150 cwt.) to operate: (a) Within a 50-mile radius of Tawonga South as a "Road Contractor"—road-making plant and materials. (b) Within a 20-mile radius of Tawonga South—General goods.

**REMBISZ, B. & P.**, 62 Domain-street, Glenroy. One commercial goods vehicle (184 cwt.) to operate within a 50-mile radius of Victorian Quarries Limited premises at Dromana solely on behalf of the said company in a specially constructed transit mixer—premixed concrete.

**ROBERTS, V. A. A.**, 83 Chapman-street, Swan Hill. One commercial goods vehicle (8 cwt.) to operate within a 100-mile radius of own premises at Swan Hill in the course of business as "Painter and Signwriter"—tools of trade, equipment and materials incidental to the completion of own contracts.

**ROUGHAN HAULAGE PTY. LTD.**, 47 Surrey-road, Blackburn. One commercial goods vehicle (285 cwt.) to operate: (a) Within a 25-mile radius of G.P.O., Melbourne—general goods. (b) From quarries and pits within paragraph (a) and from Cranbourne to Bittern on behalf of Ready Mixed Concrete (Victoria) Pty. Ltd.—sand and screenings.

**RUSSELL, C. R.**, 4 Railway-avenue, Horsham. One commercial goods vehicle (246 cwt.) to operate: (a) From Horsham to places in the Melbourne and metropolitan area and to Portland Freezing Works at Portland—butter on behalf of the Horsham Butter Factory (approved decentralized secondary industry). (b) From Melbourne to Horsham and to places situate within a 50-mile radius thereof and to Rainbow and Edenhope on behalf of Carines Fibrous Plaster of Horsham (approved decentralized secondary industry)—plaster, hemp, and battens. (c) Conditions as permitted under "E.H." rights.

NOTE.—This application replaces application, in the same name, published in the *Victoria Government Gazette* No. 73, dated 26th August, 1964.

**SMART, G. V. & L. M.**, 36 High-street, Beechworth. One commercial goods vehicle (80 cwt.) to operate: (a) Within a 20-mile radius of post office at Beechworth—general goods. (b) Within a 50-mile radius of own depot at Beechworth—petroleum products in bulk, in prescribed types of containers and empty return containers solely on behalf of Amoco (Aust.) Pty. Ltd.

**TREVOR BOILER & ENGINEERING CO. PTY. LTD.**, Steel-street, North Melbourne. One commercial goods vehicle (18 cwt.) to operate in the course of business as "Boiler-makers and Engineers": (a) Within a 50-mile radius of G.P.O., Melbourne—own goods. (b) Throughout the State of Victoria for the purpose of installing and servicing own manufactured boilers—own boilers, tools of trade and equipment incidental thereto.

**TAINTON, R. E.**, 12 Malvern-street, Vermont. One commercial goods vehicle (139 cwt.) to operate within a 50-mile radius of Albion Quarrying Co. Pty. Ltd., at North Melbourne—road-making plant, hot asphalt, premix and road-making materials solely on behalf of the said company, but excluding the carriage of materials from Geelong.

**UNITED TYRE SERVICE (VIC.) PTY. LTD.**, 239 Princes Highway, Morwell. One commercial goods vehicle (10 cwt.) to operate within a 50-mile radius of own branch premises of Morwell in the course of business as "Tyre Service"—new tires, second-hand tires for retreading or having been retreaded and new and second-hand batteries.

**WIGNALL, A. G.**, 13 View-street, Clayton. One commercial goods vehicle (77 cwt.) to operate within a 50-mile radius of the premises of Tarax Drinks (Huntingdale) Pty. Ltd., at Huntingdale—aerated waters solely on behalf of the said company excluding any operations to the City of Geelong.

**WORSELDINE, R. L.**, Myers-street, Lakes Entrance. One commercial goods vehicle (111 cwt.) to operate: (a) Within a 85-mile radius of Orbost (Bairnsdale Division of Country Roads Board) as a "Road Contractor"—road-making plant and materials. (b) Within a 20-mile radius of post office at Lakes Entrance—general goods.

#### TOW TRUCK.

**BOEMO MOTORS PTY. LTD.**, 286 Johnston-street, Abbotsford. One commercial goods vehicle (58 cwt.) to operate within a 50-mile radius of own premises at Abbotsford as a "Tow Truck" for the purpose of lifting and carrying or towing and/or repairing wrecked or disabled vehicles—tools of trade, spare parts and materials incidental thereto.

APPLICATION for renewal of licence as shown, by persons listed hereunder to operate under the same terms and conditions from the date of expiry shown in each case.

**AGENCIES, A. H., & SALES PTY. LTD.**, 519 High-street, Prahran; T.D.A.45101; 8th January, 1965; 17 cwt.; T.D.A.45101/1; 8th January, 1965; 17 cwt.

**ALBION QUARRYING CO. PTY. LTD.**, Benmore-street, North Geelong; D.A.520/52; 12th December, 1964; 142 cwt.

**BERRY, HENRY, & CO. (A'ASIA) LTD.**, 1 Fennell-street, Port Melbourne; D.A.661/6; 17th January, 1965; 86 cwt.

BRIDGES, W. J., Barnard-street, Lakes Entrance; D.A.28184; 21st January, 1965; 66 cwt.

CARR FOWLER CONSTRUCTIONS PTY. LTD., 141A Arden-street, North Melbourne; D.A.45797/17; 16th January, 1965; 50 cwt.

COCA COLA BOTTLERS (GEELONG) PTY. LTD., Corio Quay-road, North Geelong; D.A.27356/1; 29th January, 1965; 90 cwt.

DALGETY & NEW ZEALAND LOAN LTD., 1-7 Malop-street, Geelong; D.A.46176/11; 16th January, 1965; 11 cwt.

DENNERT, R. C., Box 254, Hamilton; D.A.41610; 16th January, 1965; 12 cwt.

HUMPHRIES, E. S., & F. N. SIMPSON, Box 39, Nullawill; D.A.1339/1; 16th January, 1965; 259 cwt.

LANGLEY, H. E., 17 Baxter-street, Bendigo; D.A.6343; 21st January, 1965; 10 cwt.

LEECH, A. G., PTY. LTD., 62 Nolan-street, Maryborough; D.A.1482/7; 16th January, 1965; 152 cwt.

MARFLEET & WEIGHT LTD., Flockhart-street, Abbotsford; D.A.1552/3; 29th January, 1965; 9 cwt.

MARTIN, B. E., Moyhu; D.A.40383/1; 23rd January, 1965; 122 cwt.

MATHRICK, H. & C., PTY. LTD., 64 Princes Highway, Warrambool; D.A.41216; 16th January, 1965; 19 cwt.; D.A.41216/1; 16th January, 1965; 19 cwt.

MATTHEWS, F. C., 60 Emu-street, North Maidstone; D.A.1576; 12th November, 1964; 7 cwt.

MITCHELL, R., 6 Claude-street, Shepparton; D.A.1614/2; 16th January, 1965; 50 cwt.

MCGREGOR, J. A., 141-143 Ashenden-street, Shepparton; D.A.27266; 21st January, 1965; 108 cwt.

MCWILLIAMS WINES PTY. LTD., 27 Munster-terrace, North Melbourne; D.A.41537/2; 16th January, 1965; 7 cwt.; D.A.41537/3; 16th January, 1965; 7 cwt. D.A.41537/4; 16th January, 1965; 7 cwt.

MCWILLIAMS WINES PTY. LTD., 27 Munster-terrace, North Melbourne; D.A.41537; 16th January, 1965; 17 cwt.; D.A.41537/1; 16th January, 1965; 17 cwt.

NELSON, L. (trading as Nelson Lampshade Co.), 67 Liston-street, Burwood; D.A.41484; 16th January, 1965; 18 cwt.

PATERSONS PTY. LTD., 152 Bourke-street, Melbourne; D.A.1782/18; 29th January, 1965; 11 cwt; D.A.1782/19; 29th January, 1965; 59 cwt.

HOWARD, M., E. TYRRELL & D. J. REDDAN (trading as D. W. Reddan), 285-287 Little Lonsdale-street, Melbourne; D.A.40601/4; 7th November, 1964; 21 cwt.

HOWARD, M., E. TYRRELL & D. J. REDDAN (trading as D. W. Reddan), 285-287 Little Lonsdale-street, Melbourne; D.A.40601/5; 21st November, 1964; 10 cwt.; D.A.40601/3; 7th November, 1964; 21 cwt.

ROGERS, L. C. S. (estate of the late), 115 Lime-avenue, Mildura; D.A.38309/1; 5th December, 1964; 100 cwt.

RYAN, B. W., 15 Ritchie-street, Leongatha; D.A.7003/1; 17th December, 1964; 303 cwt.

SVANOSIO, N. & J., 83 Neale-street, Bendigo; D.A.36437/3; 5th December, 1964; 134 cwt.

THOMPSONS (CASTLEMAINE) LTD., Parker-street, Castle-maine; D.A.2156/1; 21st January, 1965; 11 cwt.

TREZISE, H. F. A., Duke-street, Myrtleford; D.A.42998/1; 5th December, 1964; 61 cwt.

TRICKEY, S., 16 Laidman-street, Maryborough; D.A.41698; 23rd January, 1965; 120 cwt.

WALKER, K. D., Walkers-road, Lara; D.A.41475; 16th January, 1965; 80 cwt.

WALLACE, D. F., Teesdale; D.A.16643; 29th January, 1965; 269 cwt.

WALLACE, D. F., Teesdale; D.A.16643/1; 29th January, 1965; 247 cwt.

WALLACE, E. D., Kergunyah; D.A.28192; 29th January, 1965; 282 cwt.

WEINERT, P. M., Meringur; D.A.2262; 17th December, 1964; 106 cwt.

WILLIAMSON, J. C., 127 East Boundary-road, East Bentleigh; D.A.13198; 23rd January, 1965; 137 cwt.

## TOW TRUCKS.

DAWE, H. T., Main-street, Chewton; D.A.41487; 16th January, 1965; 20 cwt.

DONOVAN BRUSH MOTORS PTY. LTD., 37-39 Rowan-street, Wangaratta; T.D.A.46867; 27th January, 1965; 8 cwt.

WILLIAMS, M. O., A. D. ROHDE & S. R. HICKS (trading as Red Cliffs Central Motors), 13-15 Jacaranda-street, Red Cliffs; T.D.A.46280; 10th December, 1964; 40 cwt.

GILLIES, C. R. & P. S. FLETCHER (trading as Rye Service Station), 1124 Nepean Highway, Rye; T.D.A.46370; 14th January, 1965; 35 cwt.

TRELLER, J. F., Main-street, Poowong; T.D.A.37991; 14th January, 1965; 30 cwt.

WANGARATTA MOTORS PTY. LTD., 15 Reid-street, Wangaratta; T.D.A. 46958; 27th January, 1965; 15 cwt.

APPLICATION by persons listed hereunder for renewal of the licences listed with variation of conditions in the manner set out opposite the names.

PICKETT, TAS. PTY. LTD., 153 Palmer-street, Richmond; D.A.40922/4; 14th November, 1964; 22 cwt; with variation by deleting the existing conditions and adding in lieu:—"Within a 50-mile radius of own depot in the Town of Alexandra, in the course of business as 'Tobacco and Cigarette Merchants'—own goods. NOTE.—All goods to be initially consigned by rail to Alexandra".

WALLACE, D. F., Teesdale; D.A.16643/2; 29th January, 1965; 265 cwt.; with variation by adding to the existing conditions as paragraph (c) "From and to Newport to and from licencees' premises at Teesdale petroleum products in prescribed containers and empty containers on behalf of Ampol Petroleum Co. Ltd".

Notice of any objection should be forwarded to reach the Secretary of the Board not later than Wednesday, 18th November, 1964.

Applicants are advised that it will not be necessary to appear on the hearing date specified above, unless advised, in writing, by the Board.

B. P. KAY,  
Secretary.

Exhibition Buildings, Rathdown-street, Carlton, N.3, 4th November, 1964.

Transport Regulation Act.  
TRANSPORT REGULATION BOARD.  
HEARING OF APPLICATIONS.

NOTICE is hereby given that the following applications will be considered by the Transport Regulation Board at its offices at Rathdown-street, Carlton, at 10.15 a.m., on Wednesday, 25th November, 1964.

BARNES BUS LINES (ESSENDON) PTY. LTD., corner Station-road and Ballarat-road, Deer Park. Application for variation of all "M.O." licences Route 39 (Keilor-Essendon-Moonee Ponds) to include the ability to deviate certain trips only from the corner of Keilor-road and Woorite-place (on trips from Niddrie) via Woorite-place, Nyah-street, Clark-road, Quinn-grove, Ash-grove, Rachel-road, Dinah-parade to Milleera-road, thence via normal route. Section: Corner Quinn-grove and Ash-grove. Through fare to remain the same.

CONWAY, A. F. & L. M., 71 McLean-street, Maffra. One commercial passenger vehicle with seating capacity for 37 persons to operate as follows:—(a) For the carriage of school children only between Heyfield via Denison to Sale under contract to the Education Department. (b) As a country special service omnibus from Maffra.

EAST PRESTON & EPPING BUS SERVICES HOLDINGS PTY. LTD., 922 High-street, Reservoir. Application to operate metropolitan Route 122A (Preston-Epping) as at present operated under licences held by the applicant with the following amendment to present service:—With extension from the corner of Plenty-road and Frier-avenue via Plenty-road, Wood-street to northern entrance of Northland Shopping Centre to bus terminal returning via Jensen-road, Albert-street, Wood-street, Plenty-road to normal route. Or alternatively: With extension from the corner of Plenty-road and Frier-avenue via Plenty-road, Wood-street to northern entrance of Northland Shopping Centre to bus terminal returning by the Wood-street entrance, via Wood-street and Plenty-road to normal route. (This application replaces that previously gazetted.)

EAST PRESTON & EPPING BUS SERVICES HOLDINGS PTY. LTD., 922 High-street, Reservoir. Application to operate metropolitan Route 1A (Thornbury-Edwardes Park-West Reservoir-East Reservoir) as at present operated under licences held by the applicant with the following amendments to present service:—With extension (a) on the Boldrewood-parade-East Reservoir service to operate from the corner of High-street and Wood-street via Wood-street to northern entrance of Northland Shopping Centre to bus terminal returning via Jensen-road, Albert-street and Wood-street to normal route. An alternative to the use of Jensen-road on return journeys to be via Wood-street and over the same route as the forward journey. With extension (b) on the West Reservoir-Edwardes Park service to operate from the corner of Spring-street and Regent-street via Spring-street, Murray-road, Bond-street, Cramer-street, Gower-street, Albert-street, Murray-road to the Northland Shopping

Centre bus terminal returning via Jensen-road, Albert-street, Gower-street, Cramer-street, Bond-street, Murray-road, Spring-street to normal route. An alternative to the use of Jensen-road on return journeys to be via the Murray-road entrance and same route as forward journey. *Alternatively:* To operate extension (b) from the corner of Wood-street and High-street via Wood-street to the northern entrance of Northland Shopping Centre to bus terminal returning via Jensen-road, Albert-street and Wood-street to normal route. An alternative to the use of Jensen-road on return journeys to be via the Wood-street entrance then same route as forward journey. With extension (c) on the Thornbury service to operate from the corner of Dundas-street and Albert-street via Albert-street, Murray-road to the bus terminal in the Northland Shopping Centre, returning via Jensen-road and Albert-street to Dundas-street. An alternative to the use of Jensen-road on return journeys to be via the Murray-road entrance then by same route as forward journey. (This application replaces that application previously gazetted.)

**EAST PRESTON & EPPING BUS SERVICES HOLDINGS PTY. LTD.**, 922 High-street, Reservoir. Application to operate metropolitan Route No. 138A (North Reservoir-Reservoir) as at present operated under licences held by the applicant with the following amendment to present service:—With extension from Reservoir Railway Station via High-street, Wood-street, to the northern entrance of Northland Shopping Centre to the bus terminal, returning via Jensen-road, Albert-street, Wood-street, High-street to normal route or *alternatively*—With extension from Reservoir Railway Station via High-street, Wood-street to the northern entrance of Northland Shopping Centre to bus terminal, returning by the Wood-street entrance via Wood-street and High-street to normal route. (This application replaces that previously gazetted.)

**GLEESON, C. Z.**, 61 McCrae-road, Rosanna. One commercial passenger vehicle with seating capacity for five passengers, to operate for the carriage of kindergarten children free of charge between the child minding centre situated at 61 McCrae-road, Rosanna, and the children's homes situated in the Watsonia, Greensborough, Eltham and Kew districts.

**HOAD, R. C.**, Kardini-crescent, Warronwood, via South Warrandyte. One commercial passenger vehicle with seating capacity for five persons to operate under the same terms and conditions as existing taxi-cabs licensed at Croydon.

**NUGENT, E. M. & J. H.** (trading as Kiddville Day Nursery), 25 Fallon-street, South Caulfield. One commercial passenger vehicle with seating capacity for six passengers, to operate for the carriage of kindergarten children between the child minding centre, situated at 25 Fallon-street, South Caulfield, and the children's home addresses.

**PIONEER TOURIST COACHES PTY. LTD.**, 489 Swanston-street, Melbourne. Application for permit authority to operate week-end tours, for surfing enthusiasts and others, from Melbourne to Torquay on the following dates:—21st November, 1964, 28th November, 1964; 5th December, 1964, 12th December, 1964, and 19th December, 1964.

## ITINERARY.

Sat. Dep. Swanston-street 8.00 a.m., via Geelong and overnight at Torquay.

Sun. Dep. Torquay 6.00 p.m. Arr. Melbourne approximately 8.00 p.m.

Fares, which will include accommodation, to be determined later.

**PLUMMER, K. D. & W. S.**, 25 Keystone-crescent, North Kew. Application for authority to operate vehicle licence No. M.C.430 at separate and distinct fares from the loading stand appointed for the use of metropolitan special service omnibuses in Harp-road, Kew, south side, east from High-street to Flemington racecourse on days when horse racing events are being held. (Fare to be determined.)

**RICHARDSON, H. I.**, Church-street, Lakes Entrance. Application for variation of licence No. T.S.201 to delete the existing charter rights from Orbost and to include operation as a country special service omnibus from Lakes Entrance.

**SCHNEIDER, L. & V. WESTENDORF**, 16 Barkly-street, South Portland. One commercial passenger vehicle with seating capacity for five persons, to operate under the same terms and conditions as existing taxi-cabs licensed at Portland, subject to the cancellation of licence No. C.H.2.

**TATRA DEVELOPMENT PTY. LTD.**, 160 Queen-street, Melbourne. Two commercial passenger vehicles each with seating capacity for ten persons, to operate for the carriage of passengers between Mt. Buffalo Chalet and Tatra Inn, Mt. Buffalo. Fares 5s. single.

**U.S. MOTORS (TAXIS) PTY. LTD.**, Monbulk-road, Belgrave. Application for variation of all C.T. licences held in the company name to operate at separate and distinct fares between Belgrave, Monbulk, Olinda, Upwey and Upper Fern Tree Gully to Sandown racecourse on race days only, via Belgrave, Upper Fern Tree Gully, Fern Tree Gully-road, Stud-road, Wellington-road, Springvale-road, Dandenong-road (with pick-up rights over bus routes operated by U.S. Motors (Belgrave) Pty. Ltd., as far as the Stamford Hotel, Rowville. Fares to be determined.)

**U.S. MOTORS (BELGRAVE) PTY. LTD.**, Monbulk-road, Belgrave. Application for variation of all C.O. licences held in the company name to operate at separate and distinct fares between Belgrave and Sandown racecourse from Main-street, Belgrave, via Upper Fern Tree Gully, Burwood-road, Fern Tree Gully-road to Scoresby and then via Stud-road to Wellington-road, Springvale-road and Dandenong-road (with pick-up rights over routes at present operated by the company as far as Stamford Hotel, Rowville)—on race days only. Fare 5s. single, 8s. return.

**VENTURA MOTORS PTY. LTD.**, 1037 Centre-road, South Oakleigh. Application for variation of Route No. 26A (Glen Iris—Glen Waverley) to delete the existing turning procedure west of Glen Iris Railway Station, via High-street, Wandee-road, Lower Malvern-road and High-street to a stand situated close to the railway gates and instead to operate the following turning procedure:—via High-street and Wills-street to Glen Iris Railway Station (east side), and to special turning arrangement at the corner of Kerford-road, Glen Iris, returning via the same route.

Notice of any objection should be forwarded to reach the Secretary of the Board not later than Wednesday, 18th November, 1964.

Applicants are advised that it will not be necessary to appear on the hearing date specified above unless advised, in writing by the Board.

B. P. KÁY,  
Secretary.

Exhibition Buildings, Rathdown-street, Carlton, N.3,  
Wednesday, 4th November, 1964.

Melbourne and Metropolitan  
BOARD OF WORKS.

NOTICE TO THE OWNERS OF TENEMENTS IN THE UNDERMENTIONED STREETS, AND THE PRIVATE STREETS, LANES, COURTS AND ALLEYS OPENING THERE TO.

THE main pipe in the said streets being laid down, the owners of all tenements situated as under are hereby required, on or before the 7th December, 1964, to cause a proper pipe and stop cocks to be laid so as to supply water within such tenements from the main pipe.

H. J. SNADDEN,  
Secretary.

27th October, 1964.

## STREET AND POSITION.

## Doncaster and Templestowe.

Kiewa-street, from 1½ chains west of Rubicon-crescent westwards 7¾ chains.

Kiewa-street, from Wetherby-road westwards 14½ chains.

Darcy-street, from Kiewa-street northwards 3¼ chains.

Rubicon-crescent, from Kiewa-street southwards 16½ chains.

Burilla-avenue, from Rubicon-crescent westwards 3 chains.

Tandara-avenue, from Rubicon-crescent westwards 3 chains.

Riddell-street, from Clauscen-street northwards 2¾ chains.

Clauscen-street, from Horsfall-street westwards 14½ chains.

Horsfall-street, from Clauscen-street southwards 4½ chains.

Bedford-court, from Clauscen-street southwards 4 chains.

Essex-court, from Clauscen-street southwards 4 chains.

William-street, from Manningham-road northwards 10½ chains.

Collins-street, from William-street eastwards 4 chains.

Collins-street, from Rose-street westwards 5½ chains.

Flinders-street, from William-street to Rose-street.

Rose-street, from Manningham-road northwards 3¾ chains.

Rose-street, from Sylvia-street southwards 2½ chains.

## Hawthorn.

Right-of-way 2 chains north of Burwood-road, from Montrose-street westwards 2 chains.

*Heidelberg.*

Lees-court, from McCrae-road eastwards 3½ chains.  
 Nepean-street, from Longmuir-road eastwards 25¼ chains.  
 Elder-street, from Longmuir-road to Delta-road.  
 Manfred-street, from Elder-street southwards 3 chains.  
 Kardinia-street, from Nepean-street to Orana-drive.  
 Orana-drive, from Elder-street to Delta-road.  
 Delta-road, from Elder-street to Orana-drive.  
 Yerrawa-drive, from Elder-street to Kardinia-street.  
 Cooinda-crescent, from Orana-drive to Elder-street.

*Keilor.*

Arbor-terrace, from Medfield-avenue northwards 9 chains.  
 Doyle-street, from Ridley-avenue to Somerset-street.

*Moorabbin.*

Samuel-court, from Florence-street southwards 6½ chains.  
 Opal-court, from Florence-street southwards 6½ chains.

*Springvale.*

Sharon-road, from 5½ chains west of Hosken-street westwards 11 chains.

*St. Kilda.*

Marlborough-street, from 12½ chains east of Chapel-street eastwards ½ chain.  
 Pollington-crescent, from 2½ chains north-west of Victoria-street north-westwards 1½ chains.

*Sunshine.*

Percy-street, from Sydenham-road to Wills-street.  
 Harris-street, from Percy-street westwards and southwards to Wills-street.  
 Kirby-court, from Harris-street southwards 5½ chains.  
 Wills-street, from Harris-street to Percy-street.  
 Buckley-avenue, from Ford-avenue to Godfrey-avenue.  
 Buckley-avenue, from Heron-avenue to McIntyre-road.  
 Byrne-street, from Poole-street southwards 13½ chains.

*Waverley.*

Madeline-street, from The Ridge to Mulgrave-street.  
 Mulgrave-street, from Madeline-street to Martin-place.  
 Angus-drive, from Madeline-street to Martin-place.  
 Aurisch-avenue, from Walter-street westwards and northwards 9½ chains.  
 Rangoon-court, from Wattle-grove eastwards 5½ chains.  
 Noumea-court, from Wattle-grove eastwards 5½ chains.  
 Carson-street, from Wattle-grove eastwards 10 chains.  
 Suva-street, from Carson-street northwards 11½ chains.  
 Tahiti-crescent, from Carson-street southwards 3 chains.  
 Fiji-court, from Carson-street southwards 4 chains.

Melbourne and Metropolitan  
 BOARD OF WORKS.

NOTICE is hereby given that after the publication of this advertisement in the *Government Gazette*, and once in not less than two daily newspapers published in the metropolis, the Melbourne and Metropolitan Board of Works will proceed to compulsorily take (unless the same is in the meantime acquired by the Board from the owner or owners or other persons interested by mutual agreement) the land mentioned and described in the Schedule hereto.

The nature of the works in respect of which the land is proposed to be taken is for the purposes in connexion with a proposed water supply main and a pumping station.

A plan of the proposed works will be open for inspection at the offices of the Board, 110 Spencer-street, Melbourne, from the date hereof until the 23rd November, 1964, during office hours.

The quantity of land which the Board requires for the purpose of such works and other particulars are set forth below.

The consent of the Governor in Council was duly obtained in terms of the Board's principal Act (No. 6310), on the 6th October, 1964.

## SCHEDULE.

All that piece of land being parts of Crown portion 15 and Crown section 16, Parish of Yuroke, commencing at the intersection of the northern boundary of Patullo-lane and the western boundary of the North-Eastern Railway; thence westerly along the first-mentioned boundary for 100 links; thence northerly by a line west of and parallel to the North-Eastern Railway for 379 links; thence easterly by a line for 50 links; thence northerly by lines 50 links west of and parallel to the western boundary of the North-Eastern Railway to the northern boundary of the land in certificate of title, volume 2807, folio 378; thence easterly

by the last-mentioned boundary for 50 links to the western boundary of the North-Eastern Railway; thence southerly by the last-mentioned boundary to the commencing point.  
 Dated the 26th day of October, 1964.

H. J. SNADDEN,  
 Secretary.

## DEPARTMENT OF MINES.

## MINERAL SEARCH LICENCES GRANTED.

- 574, Mineral Search Licence; Roland Walton; 440 acres, Parishes of Wollonaby and Ludrik-Munjie.  
 575, Mineral Search Licence; Roland Walton; 330 acres, Parishes of Wollonaby and Ludrik-Munjie.  
 576, Mineral Search Licence; Roland Walton; 200 acres; Parishes of Wollonaby and Ludrik-Munjie.  
 577, Mineral Search Licence; Roland Walton; 425 acres; Parishes of Wollonaby and Ludrik-Munjie.  
 585, Mineral Search Licence; Roland Walton; 180 acres; Parish of Tongaro.  
 591, Mineral Search Licence; Maxwell Robert Fielding; 60 acres; Parishes of Wollonaby and Ludrik-Munjie.  
 592, Mineral Search Licence; Maxwell Robert Fielding; 238 acres; Parishes of Wollonaby and Ludrik-Munjie.  
 593, Mineral Search Licence; Maxwell Robert Fielding; 242 acres; Parishes of Wollonaby and Ludrik-Munjie.  
 594, Mineral Search Licence; Maxwell Robert Fielding; 244 acres; Parishes of Wollonaby and Ludrik-Munjie.  
 595, Mineral Search Licence; Maxwell Robert Fielding; 246 acres; Parishes of Wollonaby and Ludrik-Munjie.  
 596, Mineral Search Licence; Maxwell Robert Fielding; 250 acres; Parishes of Wollonaby and Ludrik-Munjie.  
 597, Mineral Search Licence; Harry Arthur Hill; 250 acres; Parishes of Tongaro and Bogong.  
 598, Mineral Search Licence; Harry Arthur Hill; 250 acres; Parishes of Tongaro and Bogong.  
 599, Mineral Search Licence; Harry Arthur Hill; 246 acres; Parishes of Tongaro and Bogong.  
 600, Mineral Search Licence; Harry Arthur Hill; 250 acres; Parishes of Tongaro and Bogong.  
 601, Mineral Search Licence; Harry Arthur Hill; 250 acres; Parishes of Tongaro and Bogong.  
 602, Mineral Search Licence; Harry Arthur Hill; 250 acres; Parishes of Tongaro and Bogong.  
 603, Mineral Search Licence; Harry Arthur Hill; 250 acres; Parishes of Tongaro and Bogong.  
 609, Mineral Search Licence; James Say; 600 acres; Parish of Deddick.  
 610, Mineral Search Licence; James Say; 200 acres; Parish of Deddick.

T. A. DARCY, Minister of Mines.

## CANN RIVER IMPROVEMENT TRUST.

## BY-LAW NO. 1.

THE Cann River Improvement Trust, in pursuance and exercise of the powers conferred by the *River Improvement Act 1958*, doth hereby make the By-law following:—

1. The following rate, to be called the "Cann River Improvement District River Improvement Rate", is hereby made and shall be levied upon the occupiers or owners of all the properties within the Cann River Improvement District which are rateable to any municipality, a rate of Nine pence in the £1 on the net annual municipal value of such properties. Provided that the sum of One shilling shall be the minimum amount of rate in respect of any property liable to be rated in the said district.

2. Such rate is made and shall be levied for the year beginning with the 1st day of January, 1964, and ending with the 31st day of December, 1964, and shall be payable on the 15th day of November, 1964, at the office of the Cann River Improvement Trust, Noorinbee.

3. Such person or persons as the Cann River Improvement Trust may from time to time appoint for that purpose shall be or is or are hereby authorized to demand, receive, collect, and recover the said rate.

The foregoing By-law was made by the Cann River Improvement Trust on the 14th day of September, 1964, and the common seal of the said Trust was hereunto affixed on the 14th day of September, 1964.

(SEAL) GEORGE E. CAMERON, Chairman.  
 A. S. NEILSON, Commissioner.  
 D. S. BROOME, Secretary.

Approved by the Governor in Council, 27th October, 1964.—J. COLQUHOUN, Clerk of the Executive Council.

## REGISTER OF DISTRIBUTORS OF PRINTED MATTER.

The following is a copy of the Register corrected to the end of October, 1964, and is published in accordance with the requirements of sub-section (3) of section 182 of *Police Offences Act 1958*.

Name.	Address.	Date of Registration.
Hyde Distributing Company Pty. Ltd.	247 Collins-street, Melbourne, C.1	18.8.54
Victorian Magazine Distributors Pty. Ltd.	247 Collins-street, Melbourne, C.1	18.8.54
Australian Musical Productions Pty. Ltd.	Princess Theatre, Spring-street, Melbourne, C.1	2.9.54
Consolidated Press Limited	247 Collins-street, Melbourne, C.1	2.9.54
Shakespeare Head Press Pty. Ltd.	247 Collins-street, Melbourne, C.1	2.9.54
Robertson and Mullens Limited	107-113 Elizabeth-street, Melbourne, C.1	7.9.54
J. Ewins and Sons Pty. Ltd.	111 Sturt-street, Ballarat	7.9.54
Moe Books and Stationery Pty. Ltd.	46A George-street, Moe	7.9.54
Burns, Oates and Washbourne (Australia) Pty. Ltd.	72-74 Bourke-street, Melbourne, C.1	7.9.54
The Argus and Australasian Ltd.	26 Flinders-street, Melbourne, C.1	8.9.54
Gordon and Gotch (Australasia) Ltd.	511 Little Collins-street, Melbourne, C.1	13.9.54
Larry Cleland Pty. Ltd.	125 Swanston-street, Melbourne, C.1	13.9.54
The Book Depot	c/o The Methodist Conference of Victoria and Tasmania, 288 Little Collins-street, Melbourne, C.1	15.9.54
L. J. M. Hodder and Company	328 Flinders-street, Melbourne, C.1	21.9.54
Strautins, Janis Arturs	573 Flinders-lane, Melbourne, C.1	21.9.54
B. H. Walshe and Son	34 Queen-street, Melbourne, C.1	23.9.54
Stanley Young Pty. Ltd.	244 Swanston-street, Melbourne, C.1	23.9.54
Associated Newspapers Limited	392-396 Little Collins-street, Melbourne, C.1	23.9.54
Hicks Smith and Sons Pty. Ltd.	23 McKillop-street, Melbourne, C.1	27.9.54
Lothian Publishing Co. Pty. Ltd.	1 Fleming-place, Melbourne, C.1	27.9.54
Whitcombe and Tombs Pty. Ltd.	322 Collins-street, Melbourne, C.1	4.10.54
W. Ramsay (Surgical) Limited	340 Swanston-street, Melbourne, C.1	7.10.54
William Heinemann Limited	317 Collins-street, Melbourne, C.1	12.10.54
Edwards Dunlop and Co. Ltd.	382 Lonsdale-street, Melbourne, C.1	13.10.54
Alex. Cowan (Australia) Pty. Ltd.	500 Collins-street, Melbourne, C.1	14.10.54
F. W. Cheshire Pty. Ltd.	338 Little Collins-street, Melbourne, C.1	20.10.54
Longmans Green and Co. Ltd.	531 Little Collins-street, Melbourne, C.1	22.10.54
Angus and Robertson Ltd.	66-68 Elizabeth-street, Melbourne, C.1	25.10.54
Shepson and Company	109 Swanston-street, Melbourne, C.1	29.10.54
Southdown Press Pty. Ltd.	51 Queen-street, Melbourne, C.1	29.10.54
G. J. Coles and Company Ltd.	282 Little Collins-street, Melbourne, C.1	1.11.54
Technical Book and Magazine Co.	297-299 Swanston-street, Melbourne, C.1	3.11.54
Cassell and Company Ltd.	210 Queen-street, Melbourne, C.1	4.11.54
Harding Publicity	5 Davey-street, Mordialloc	5.11.54
The Herald and Weekly Times	44-74 Flinders-street, Melbourne, C.1	5.11.54
H. and S. Publications	Bringelly-road, Austral, New South Wales	10.11.54
Davies, Cyril Victor	66 McBride-avenue, Wonthaggi	10.11.54
Berry, Anderson and Company	207 Sturt-street, Ballarat	16.11.54
William Collins (Overseas) Ltd.	527-531 Little Collins-street, Melbourne, C.1	16.11.54
MacMillan and Company Limited	32 Flinders-street, Melbourne, C.1	25.11.54
Thompson, James Walter	137 Gloucester-street, Sydney, New South Wales	2.12.54
Oxford University Press Australian Branch	346 Little Collins-street, Melbourne, C.1	2.12.54
De Dion Publishing Company	Sassafras, Victoria	11.1.55
B. J. Ball Limited	401 Post Office-place, Melbourne, C.1	21.2.55
N.S.W. Bookstall Co. Pty. Ltd.	112 Castlereagh-street, Sydney, New South Wales	22.2.55
Robert Burns Book Club	17 Railway-avenue, Caulfield	1.3.55
Georgian House Pty. Ltd.	296 Beaconsfield-parade, Middle Park	9.3.55
Cologravure Publications	44-74 Flinders-street, Melbourne, C.1	24.3.55
United Press Book Division	44-74 Flinders-street, Melbourne, C.1	24.3.55
Herald-Sun Readers Book Club	44-74 Flinders-street, Melbourne, C.1	24.3.55
"Truth" and "Sportsman" Limited	Hosking House, Hosking-place, 84A Pitt-street, Sydney, New South Wales	29.3.55
The Legend Press Pty. Ltd.	31 Macquarie-place, Sydney, New South Wales	27.4.55
Commercial Publications Pty. Ltd.	262 Queen's-parade, Clifton Hill	28.5.55
Spicers (Australia) Pty. Ltd.	377 Lonsdale-street, Melbourne, C.1	17.7.57
Unification Pty. Ltd.	497 Collins-street, Melbourne, C.1	27.9.57
Horwitz Publications Inc. Pty. Ltd.	406 Lonsdale-street, Melbourne, C.1	9.5.58
Brian Vincent Casey—Distribution in Victoria on behalf of Adult Education Publications, Pelican-street, Surry Hills, New South Wales	572 Lonsdale-street, Melbourne, C.1	1.9.58
Goldray Publications	P.O. Box 2, Austral, New South Wales ; Lot 4A Bringelly- road, Austral, New South Wales	25.9.59
Herald Gravure Printers	26 Flinders-street, Melbourne, C.1	14.11.61
Baringhup Enterprises	P.O. Box 72, Mt. Waverley	18.11.63
Melbourne Lifeline Publications	335 Beaconsfield-parade, St. Kilda	8.6.64

## LOCAL GOVERNMENT DEPARTMENT.

## ORDER CONFIRMED.—SHIRE OF FRANKSTON.

THE Minister of the Crown administering the *Local Government Act 1958*, as amended, on the 16th day of October, 1964, confirmed the Order hereinafter referred to, in pursuance of section 514 of the said Act, namely:—

An Order of the Council of the Shire of Frankston, made on the 14th September, 1964, directing the compulsory taking of the land described hereunder for the extension of Montague Park as a place of public resort and recreation:—All that piece of land commencing at a point in Crown allotment 7, section 11, Parish of Frankston, such point

being connected with the south-western corner of the said Crown allotment by lines bearing north 71 deg. 2 min. west 412 ft. 6 in.; thence south 18 deg. 58 min. west for 105 feet respectively to the said Crown allotment corner; thence from the point of commencement by lines bearing north 18 deg. 58 min. east for 105 feet, south 71 deg. 2 min. east for 412 ft. 6 in.; thence south 18 deg. 58 min. west for 105 feet; thence north 71 deg. 2 min. west for 412 ft. 6 in. to the point of commencement.

R. J. HAMER,

Minister for Local Government.

Local Government Department,  
Melbourne.

## LOCAL GOVERNMENT DEPARTMENT.

## CITY OF CAMBERWELL.—ORDER CONFIRMED.

THE Minister of the Crown administering the *Local Government Act 1958*, as amended, on the 27th day of October, 1964, confirmed the Order hereinafter referred to, in pursuance of section 514 of the said Act, namely:—

An Order of the Council of the City of Camberwell directing the compulsory taking of land for the purpose of extending and increasing the area of open space in the said City, such land being those portions of Crown allotment 132B, Parish of Boroondara, described hereunder:—

- (1) Commencing at a point on the south-western boundary of allotment 132B, Parish of Boroondara, such boundary being on the north-eastern alignment of Camberwell-road on a bearing of 309 deg. 27 min. a distance of 502 ft. 8 in. from the southern alignment of Tyrone-street; thence by lines bearing respectively 45 deg. 18 min. 150 feet, 309 deg. 27 min. 120 feet, 1 deg. 25 min. 25 ft. 4 in., 126 deg. 57 min. 62 ft. 7 in., 90 deg. 0 min. 162 feet, 0 deg. 0 min. 150 feet, 90 deg. 0 min. 28 ft. 2 in., 134 deg. 39 min. 27 ft. 11 in., 130 deg. 56 min. 37 ft. 10 in., 148 deg. 20 min. 33 ft. 8½ in., 169 deg. 3 min. 33 ft. 0½ in., 173 deg. 41 min. 33 ft. 11½ in., 189 deg. 53 min. 40 feet, 182 deg. 35 min. 5 ft. 8 in., 195 deg. 32 min. 33 ft. 1 in., 205 deg. 36 min. 33 ft. 11 in., 178 deg. 4 min. 34 feet, 158 deg. 7 min. 40 ft. 6 in., 150 deg. 7 min. 33 feet, 160 deg. 47 min. 42 ft. 5 in., 173 deg. 2 min. 16 ft. 5 in., 172 deg. 48 min. 9 ft. 1 in., 181 deg. 23 min. 19 ft. 10 in., 223 deg. 6 min. 137 ft. 3½ in. to the north-eastern alignment of Camberwell-road and thence 309 deg. 27 min. 334 ft. 6½ in. along the said alignment to the point of commencement.
- (2) Commencing at a point on the southern alignment of Tyrone-street, being east of the north-eastern corner of the land described above, by lines bearing respectively 90 deg. 0 min. 24 ft. 11½ in. and 168 deg. 32 min. 1 ft. 6 in. and thence by lines bearing respectively 89 deg. 34 min. 84 ft. 0½ in., 173 deg. 18 min. 370 ft. 3 in., 269 deg. 21 min. 37 ft. 8 in., 329 deg. 59 min. 55 ft. 2 in., 349 deg. 4 min. 67 ft. 11 in., 22 deg. 43 min., 40 ft. 4 in., 42 deg. 9 min. 22 ft. 4½ in., 1 deg. 33 min. 41 ft. 3 in., 7 deg. 4 min. 51 ft. 3 in., 326 deg. 28 min. 69 ft. 3½ in., 314 deg. 17 min. 54 ft. 8½ in. and 319 deg. 48 min. 14 ft. 10½ in. to the point of commencement.

R. J. HAMER,

Minister for Local Government.

Local Government Department,  
Melbourne.

## LOCAL GOVERNMENT ACT.

## PETITION FOR ALTERATION OF THE NAME OF THE SHIRE OF FERN TREE GULLY TO THE SHIRE OF SHERBROOKE.

IN pursuance of the provisions of the *Local Government Act 1958*, as amended, section 43, the substance and prayer of a petition presented to His Excellency the Governor in Council, in accordance with section 38 of the said Act, are published, viz.:—

The President, Councillors and Ratepayers of the municipality of the Shire of Fern Tree Gully pray that His Excellency the Governor in Council, in exercise of the powers and authorities contained in section 16, sub-section (13) of the *Local Government Act 1958*, as amended, will alter the name of the municipal district of the Shire of Fern Tree Gully and of the corporation thereof to the Shire of Sherbrooke.

The reasons given by the petitioners are:—

1. The severance of the municipal district, on 16th November, 1963, has resulted in—
  - (a) The Township of Fern Tree Gully being situated outside the municipal district of the Shire of Fern Tree Gully, a position causing a great deal of confusion in the minds of ratepayers. This confusion will be even greater in the near future, when the office of the Council is re-established within the new municipal boundary.
  - (b) The character of the municipality changing. It is considered that a name associated with tourist attractions existing within the municipal district, such as Sherbrooke Forest, would be more appropriate.

2. That the interests of Local Government would be better served by changing the name of the municipality.

R. J. HAMER,  
Minister for Local Government.

## PUBLIC TRUSTEE ACT 1958 (No. 6350).—SECTION 17.

I HEREBY give notice that on the 16th October, 1964, the Public Trustee filed elections to administer the following deceased persons' estates, in accordance with section 17 of the *Public Trustee Act 1958*:—

BARBER, BERNICE OLIVIA, also known as Bernice Olivia Hunter, late of 2A Salisbury-street, Caulfield, clerk, died 3rd August, 1964.

BREWSTER, MARY, late of 179 Power-street, Hawthorn, pensioner, died 26th July, 1964.

I HEREBY give notice that on the 19th October, 1964, the Public Trustee filed elections to administer the following deceased persons' estates, in accordance with section 17 of the *Public Trustee Act 1958*:—

CAMPBELL, CLARE, late of Flat 5, 13 Myrmiong-street, Burwood, clerk, died 6th July, 1964.

DAVIES, LILY, also known as Lillie Davies, late of Gillies-street, Ballarat, spinster, died 15th February, 1964.

DOWLING, ROY MILTON, late of Red Cliffs, chemist, died 4th July, 1964.

GALE, FREDERICK GEORGE, late of 53 Young-street, Fitzroy, retired salesman, died 24th July, 1964.

GREENE, CHARLES FREDERICK, late of Sturt-street, Echuca, pensioner, died 1st August, 1964.

HALL, RAYMOND LESLIE WILLIAM, also known as Raymond Leslie, late of 16 Wharton-street, Surrey Hills, garage proprietor, died 26th June, 1964.

HORSTED, HERBERT CHARLES, late of South-road, Hamilton, retired horse trainer, died 23rd July, 1963.

LANSDOWN, CONSTANCE ANNIE, late of 42 McLachlan-street, Northcote, pensioner, died 18th March, 1964.

MEYERDIERKS, HANS DIETER, late of 61 Fitzroy-street, St. Kilda, general hand, died 12th December, 1963.

MCLEAN, ROBERT, late of Main-road, Kinglake, pensioner, died 16th July, 1964.

A. D. DUNCAN,  
Public Trustee.

256 Flinders-street, Melbourne, C.1, 28th October, 1964.

## NOTICE.

CREDITORS, next of kin, and others having claims against the estate of any of the under-mentioned deceased persons are required to send particulars of their claims to the Public Trustee, 256 Flinders-street, Melbourne, the personal representative, on or before the 5th January, 1965, after which date the Public Trustee may convey or distribute the assets, having regard only to the claims of which the Public Trustee then has notice:—

BARBER, BERNICE OLIVIA, also known as Bernice Olivia Hunter, late of 2A Salisbury-street, Caulfield, clerk, died 3rd August, 1964.

BREWSTER, MARY, late of 179 Power-street, Hawthorn, pensioner, died 26th July, 1964.

CAMPBELL, CLARE, late of Flat 5, 13 Myrmiong-street, Burwood, clerk, died 6th July, 1964.

DAVIES, LILY, also known as Lillie Davies, late of Gillies-street, Ballarat, spinster, died 15th February, 1964.

DOWLING, ROY MILTON, late of Red Cliffs, chemist, died 4th July, 1964.

GALE, FREDERICK GEORGE, late of 53 Young-street, Fitzroy, retired salesman, died 24th July, 1964.

GREENE, CHARLES FREDERICK, late of Sturt-street, Echuca, pensioner, died 1st August, 1964.

HALL, RAYMOND LESLIE WILLIAM, also known as Raymond Leslie, late of 16 Wharton-street, Surrey Hills, garage proprietor, died 26th June, 1964.

HORSTED, HERBERT CHARLES, late of South-road, Hamilton, retired horse trainer, died 23rd July, 1963.

LANSDOWN, CONSTANCE ANNIE, late of 42 McLachlan-street, Northcote, pensioner, died 18th March, 1964.

MEYERDIERKS, HANS DIETER, late of 61 Fitzroy-street, St. Kilda, general hand, died 12th December, 1963.

MCLEAN, ROBERT, late of Main-road, Kinglake, pensioner, died 16th July, 1964.

ROULSTON, WILLIAM HENRY, late of 30 Bliburg-street, Jacana, stone polisher, died 15th July, 1964.

A. D. DUNCAN,  
Public Trustee.

Melbourne, 28th October, 1964.

## REVOCATION OF APPOINTMENT.

**HIS** Excellency the Governor of the State of Victoria, by and with the advice of the Executive Council thereof, has, by Order made on the 27th day of October, 1964, revoked the following appointment, viz.:—

DEPARTMENT OF CROWN LANDS AND SURVEY.

FRANK SAMUEL WEBB  
as a Bailiff of Crown lands.

J. COLQUHOUN,  
Clerk of the Executive Council.

At the Executive Council Chamber,  
Melbourne, 27th October, 1964.

## APPOINTMENTS.

**HIS** Excellency the Governor of the State of Victoria, by and with the advice of the Executive Council thereof, has, by Orders made on the 27th day of October, 1964, been pleased to make the under-mentioned appointments, viz.:—

CHIEF SECRETARY'S DEPARTMENT.

*Electoral Registrar (Acting).*

VICTOR LAURENCE MANNIX

to be Electoral Registrar (Acting) for the Mildura, Ouyen, Rainbow, Red Cliffs and Robinvale Subdivisions of the Electoral District of Mildura; and for the Birchip, Boort, Hopetoun, Jeparit, Kerang, Nyah West, Quambatook, Sea Lake, Swan Hill and Wycheproof Subdivisions of the Electoral District of Swan Hill, to take effect on and from the 21st October, 1964, during the absence, on leave, of Henry Alfred Harmer.

*Special Magistrates.*

ARTHUR WALLACH, and

BARRY JOSEPH O'TOOLE,

pursuant to the provisions of section 39 of the *Children's Welfare Act 1958*, to be Special Magistrates for the purposes of the said Act.

DEPARTMENT OF CROWN LANDS AND SURVEY.

*Bailiff of Crown Lands.*

FRANK WALLACE WEBB  
to be a Bailiff of Crown lands.

MINISTRY OF HEALTH.

*Government Representatives on Hospitals Committees.*

(Pursuant to Hospitals and Charities Act.)

PETER PAUL CONLAN

to be Government Representative on Committee of Management of Port Fairy Hospital, pursuant to the provisions of section 48 of the *Hospitals and Charities Act 1958* for a further period of three years expiring on the 7th November, 1967; and

KEITH HAROLD LOVETT

to be Government Representative on Committee of Management of Wimmera Base Hospital, pursuant to the provisions of section 48 of the *Hospitals and Charities Act 1958* for a further period of three years expiring on the 14th November, 1967.

*Member of Clean Air Committee.*

Professor PETER WILLIAM WHITTON, Ph.D., B.Sc., (Eng.), D.I.C., M.I.Mech.E.,

to be a Member of the Clean Air Committee, pursuant to section 10 (2) (b) (v) of the provisions of the *Clean Air Act 1958* for the period ending the 28th February, 1966, vice P. L. Henderson, deceased.

LAW DEPARTMENT.

*Commissioners for Taking Declarations, &c.*

ALBERT WILLIAM JOHN SPACKMAN, care of State Electricity Commission, Yallourn, and

JOHN MICHAEL McMAHON, care of Animal Health Research Laboratory, Commonwealth Scientific and Industrial Research Organization, Parkville,

to be Commissioners for taking Declarations and Affidavits, pursuant to the provisions of the *Evidence Act 1958*, to resign upon ceasing to occupy their present positions; and

FREDERICK ALAN RITCHIE, 514 Barkly-street, Ballarat, KEVIN WILLIAM BACON, 6 Marnoo-street, Braybrook, BRIAN WILLIAM MIER, Lot 12, Genoa-court, Mt. Waverley,

NOEL ANTHONY RODBARD-BEAN, 12 Crown-road, Bonbeach,

JOHN RICHARD IRWIN KNIGHT, 19 Robb-street, Spotswood, and

DONALD KENNETH MCKENZIE, 57 Nicholson-street, Orbst,

to be Commissioners for taking Declarations and Affidavits, pursuant to the provisions of the *Evidence Act 1958*, to resign upon removing from the neighbourhood of the addresses stated.

*Deputy Coroner.*

JOHN VAN HERPEN, J.P., Coleraine,

to be a Deputy Coroner, pursuant to the provisions of the *Coroner's Act 1958*, to act and have jurisdiction for and during the absence of the Coroner at and in the vicinity of Coleraine.

*Justices of the Peace.*

JOHN CONINGSBY GARDINER, 69 Riviera-street, Mentone, and

JOHN BUCKLEY, 728 High-street, Armadale,

to Keep the Peace in the Central Bailiwick of the State of Victoria;

ALAN OSWALD OPIE, Leitchville, and

GRACE MARY BROOKS, Holly-street, Golden Square, to Keep the Peace in the Midland Bailiwick of the State of Victoria; and

JOHN ERIC McCLELLAND, 17 William-street, Newtown, to Keep the Peace in the Southern Bailiwick of the State of Victoria.

DEPARTMENT OF THE TREASURER.

*Receivers of Revenue (Acting).*

JOHN HENRY WILKINSON

to act temporarily as Receiver of Revenue, Camperdown, during the absence of G. G. Moon, on leave; and

ALAN JOHN MATFIN

to act temporarily as Receiver of Revenue, Echuca, during the absence of M. M. Saunder, on leave.

J. COLQUHOUN,

Clerk of the Executive Council.

At the Executive Council Chamber,  
Melbourne, 27th October, 1964.

## RESIGNATIONS.

**HIS** Excellency the Governor of the State of Victoria, by and with the advice of the Executive Council thereof, has, by Orders made on the 27th day of October, 1964, accepted the resignations of the persons named hereunder of the offices mentioned, viz.:—

LAW DEPARTMENT.

THOMAS GOODALL, as a Commissioner for taking Declarations and Affidavits, pursuant to the provisions of the *Evidence Act 1958*.

JOHN ERIC McCLELLAND from the Commission of the Peace for the Midland Bailiwick of the State of Victoria.

J. COLQUHOUN,

Clerk of the Executive Council.

At the Executive Council Chamber,  
Melbourne, 27th October, 1964.

## LOCAL GOVERNMENT DEPARTMENT.

At the Executive Council Chamber, Melbourne, the twenty-seventh day of October, 1964.

PRESENT:

His Excellency the Governor of Victoria.

Mr. Porter  
Mr. Dickie

Mr. Mack.

## REFUSAL OF REQUEST, SHIRE OF MORNINGTON.

**HIS** Excellency the Governor of the State of Victoria, by and with the advice of the Executive Council thereof, and in pursuance of powers conferred by Part II. of the *Local Government Act 1958*, as amended, hereby refuses to grant a request submitted by certain ratepayers for the severance of portion of the Shire of Mornington and constitution of such portion as a new municipality.

And the Honorable Rupert James Hamer, Her Majesty's Minister for Local Government for the State of Victoria, shall give the necessary directions herein accordingly.

J. COLQUHOUN,  
Clerk of the Executive Council.

## LOCAL GOVERNMENT DEPARTMENT.

At the Executive Council Chamber, Melbourne, the  
twenty-seventh day of October, 1964.

PRESENT:

His Excellency the Governor of Victoria.	
Mr. Porter	Mr. Mack.
Mr. Dickie	

## REFUSAL OF REQUEST FOR SEVERANCE OF PART OF THE MUNICIPAL DISTRICT OF THE SHIRE OF RODNEY AND FOR ANNEXATION OF SUCH PART TO THE MUNICIPAL DISTRICT OF THE CITY OF SHEPPARTON.

HIS Excellency the Governor of the State of Victoria, by and with the advice of the Executive Council thereof and in pursuance of the powers conferred by section 35 (2) of the *Local Government Act 1958*, hereby refuses to grant a Request made by certain ratepayers of the Shire of Rodney that a certain area be severed from the municipal district of the said Shire and annexed to the municipal district of the City of Shepparton.

And the Honorable Rupert James Hamer, Her Majesty's Minister for Local Government for the State of Victoria, shall give the necessary directions herein accordingly.

J. COLQUHOUN,  
Clerk of the Executive Council.

## LOCAL GOVERNMENT DEPARTMENT.

At the Executive Council Chamber, Melbourne, the  
twenty-seventh day of October, 1964.

PRESENT:

His Excellency the Governor of Victoria.	
Mr. Porter	Mr. Mack.
Mr. Dickie	

## REFUSAL OF REQUEST FOR SEVERANCE OF PART OF THE MUNICIPAL DISTRICT OF THE SHIRE OF WERRIBEE AND FOR THE CONSTITUTION THEREOF AS A BOROUGH.

HIS Excellency the Governor of the State of Victoria, by and with the advice of the Executive Council thereof and in pursuance of the powers conferred by section 35 (2) of the *Local Government Act 1958*, as amended, hereby refuses to grant a Request made by certain ratepayers of the Shire of Werribee for the severance of portion of the municipal district of the said Shire and for the constitution thereof as a Borough.

And the Honorable Rupert James Hamer, Her Majesty's Minister for Local Government for the State of Victoria, shall give the necessary directions herein accordingly.

J. COLQUHOUN,  
Clerk of the Executive Council.

## LOCAL GOVERNMENT DEPARTMENT.

At the Executive Council Chamber, Melbourne, the  
twenty-seventh day of October, 1964.

PRESENT:

His Excellency the Governor of Victoria.	
Mr. Porter	Mr. Mack.
Mr. Dickie	

## REFUSAL OF REQUEST FOR SEVERANCE OF PART OF THE MUNICIPAL DISTRICT OF THE SHIRE OF FRANKSTON AND FOR THE CONSTITUTION THEREOF AS A SEPARATE MUNICIPALITY.

HIS Excellency the Governor of the State of Victoria, by and with the advice of the Executive Council thereof and in pursuance of the powers conferred by section 35 (2) of the *Local Government Act 1958*, as amended, hereby refuses to grant a Request made by certain ratepayers of the Shire of Frankston for the severance of portion of the municipal district of the Shire of Frankston and for the constitution thereof as a separate municipality.

And the Honorable Rupert James Hamer, Her Majesty's Minister for Local Government for the State of Victoria, shall give the necessary directions herein accordingly.

J. COLQUHOUN,  
Clerk of the Executive Council.

## LOCAL GOVERNMENT DEPARTMENT.

At the Executive Council Chamber, Melbourne, the  
twenty-seventh day of October, 1964.

PRESENT:

His Excellency the Governor of Victoria.	
Mr. Porter	Mr. Mack.
Mr. Dickie	

## REFUSAL OF REQUEST FOR RE-SUBDIVISION OF THE MUNICIPAL DISTRICT OF THE SHIRE OF ORBOST.

HIS Excellency the Governor of the State of Victoria, by and with the advice of the Executive Council thereof and in pursuance of the powers conferred by section 35 (2) of the *Local Government Act 1958*, as amended, hereby refuses to grant a Request made by certain ratepayers of the Shire of Orbost for re-subdivision of the municipal district of the said Shire.

And the Honorable Rupert James Hamer, Her Majesty's Minister for Local Government for the State of Victoria, shall give the necessary directions herein accordingly.

J. COLQUHOUN,  
Clerk of the Executive Council.

## DEPARTMENT OF CROWN LANDS AND SURVEY.

At the Executive Council Chamber, Melbourne, the  
twenty-seventh day of October, 1964.

PRESENT:

His Excellency the Governor of Victoria.	
Mr. Porter	Mr. Mack.
Mr. Dickie	

## REVOCATION OF TEMPORARY RESERVATION AND WITHHOLDING FROM SALE, LEASING, AND LICENSING OF LAND BY ORDER IN COUNCIL.

HIS Excellency the Governor of the State of Victoria, by and with the advice of the Executive Council thereof, doth hereby, in pursuance of the provisions of the *Land Act 1958*, revoke the temporary reservation and the withholding from sale, leasing and licensing of the land by Order in Council hereinafter referred to, viz.:

MAFFRA.—Order in Council of 25th November, 1879, of 1 acre of land in the Township of Maffra as a site for a Pound.—(Rs.5757.)

And the Honorable James Charles Murray Balfour, Her Majesty's Commissioner of Crown Lands and Survey for the State of Victoria, shall give the necessary directions herein accordingly.

J. COLQUHOUN,  
Clerk of the Executive Council.

## DEPARTMENT OF CROWN LANDS AND SURVEY.

At the Executive Council Chamber, Melbourne, the  
twenty-seventh day of October, 1964.

PRESENT:

His Excellency the Governor of Victoria.	
Mr. Porter	Mr. Mack.
Mr. Dickie	

## REVOCATIONS OF TEMPORARY RESERVATIONS OF LAND BY ORDERS IN COUNCIL.

HIS Excellency the Governor of the State of Victoria, by and with the advice of the Executive Council thereof, doth hereby, in pursuance of the provisions of the *Land Act 1958*, revoke the temporary reservations of land by Orders in Council hereinafter referred to, viz.:

BULN BULN.—Order in Council of the 11th August, 1879, of certain Crown lands on the shores of Bass Strait and the Southern Ocean as sites for Public purposes, revoked as to part by various Orders, so far only as the



portions in the County of Buln Buln indicated by blue colour on plan H with Lands Department correspondence Rs. 2362.—(Rs.2362.)

**ECHUCA.**—Order in Council of 29th December, 1868, of 1 acre 2 roods of land in the Township of Echuca as a site for Police purposes, so far only as regards the portion thereof comprised within the boundaries published in the *Government Gazette* of 23rd September, 1964, and containing 1 acre.—(Rs.4886.)

**FRYERS.**—Order in Council of the 23rd August, 1927, of 99 acres of land in the Parish of Fryers as a site for a Public Park and Recreation, so far only as regards the portion thereof comprised within the boundaries published in the *Government Gazette* of 23rd September, 1964, and containing 1 rood 6 1/10 perches.—(Rs.3188.)

**GUNYAH GUNYAH.**—Order in Council of 20th October, 1908, of 2,000 acres, more or less, of land in the Parish of Gunyah Gunyah as a site for the Growth and Preservation of Timber, so far only as regards the portion thereof comprised within the boundaries published in the *Government Gazette* of 19th August, 1964, and containing 1,748 acres, more or less.—(Rs.7035.)

**WARRENHEIP.**—Order in Council of the 14th August, 1871, of 7 acres 3 roods 9 perches of land in the Parish of Warrenheip as a site for Watering purposes, and whence stone may be procured, revoked as to part by Order of the 14th September, 1954, so far only as regards the balance thereof containing 5 acres 2 roods 23 perches.—(C.92175.)

And the Honorable James Charles Murray Balfour, Her Majesty's Commissioner of Crown Lands and Survey for the State of Victoria, shall give the necessary directions herein accordingly.

J. COLQUHOUN,  
Clerk of the Executive Council.

DEPARTMENT OF CROWN LANDS AND SURVEY.

At the Executive Council Chamber, Melbourne, the twenty-seventh day of October, 1964.

PRESENT:

His Excellency the Governor of Victoria.  
Mr. Porter | Mr. Mack.  
Mr. Dickie

UNUSED ROADS CLOSED.

HIS Excellency the Governor of the State of Victoria, by and with the advice of the Executive Council thereof, doth hereby direct that, in pursuance of the provisions of section 349 of the *Land Act 1958*, the unused roads referred to hereunder be closed, viz.:—

Township of Fyansford, Parish of Moorpanyal, County of Grant, being: (1) the road between allotments 4, 5, 6 and 7, section 1, and allotments 1, 2 and 3, section 2, (2) the road between allotment 11, section 1, Township of Fyansford and allotment 1, section 14, Parish of Moorpanyal.—(F.93<sup>(2)</sup>) (Misc. 3586).

And the Honorable James Charles Murray Balfour, Her Majesty's Commissioner of Crown Lands and Survey for the State of Victoria, shall give the necessary directions herein accordingly.

J. COLQUHOUN,  
Clerk of the Executive Council.

DEPARTMENT OF CROWN LANDS AND SURVEY.

At the Executive Council Chamber, Melbourne, the twenty-seventh day of October, 1964.

PRESENT:

His Excellency the Governor of Victoria.  
Mr. Porter | Mr. Mack.  
Mr. Dickie

LANDS TEMPORARILY RESERVED AS SITES.

HIS Excellency the Governor of the State of Victoria, by and with the advice of the Executive Council thereof, doth hereby, in pursuance of the provisions of the *Land Act 1958*, reserve, temporarily, and also except from occupation for mining purposes under any miner's right, the lands hereinafter described:—

**DROMANA.**—Site for a Court House, 1 rood 18 perches, Township of Dromana, Parish of Kangerong, County of Mornington, as indicated by hachure on plan hereunder.—(D.98<sup>(2)</sup>) (Rs.8381).

No. 89.—9917/64.—2

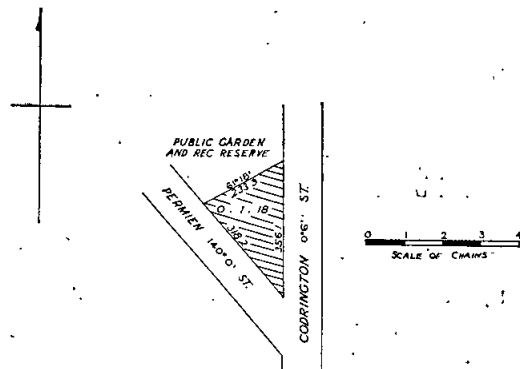

**DROUIN.**—Site for Water Supply and Sewerage purposes, 1 rood 6 perches, Township of Drouin West, County of Buln Buln, as indicated by hachure on plan hereunder.—(D.173<sup>(2)</sup>) (Rs.8383).

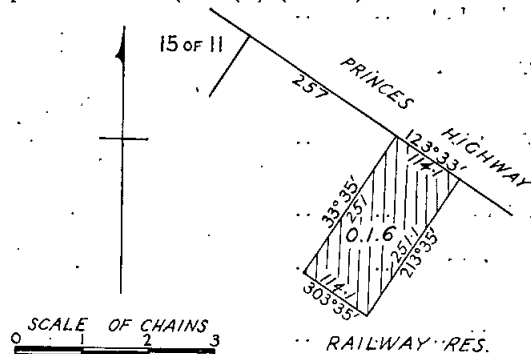

And the Honorable James Charles Murray Balfour, Her Majesty's Commissioner of Crown Lands and Survey for the State of Victoria, shall give the necessary directions herein accordingly.

J. COLQUHOUN,  
Clerk of the Executive Council.

RAILWAYS ACT 1958.

At the Executive Council Chamber, Melbourne, the twenty-seventh day of October, 1964.

PRESENT:

His Excellency the Governor of Victoria.  
Mr. Porter | Mr. Mack.  
Mr. Dickie

ORDER CLOSING RAILWAY LEVEL CROSSING AT 113M. 33C., SITUATED AT BYASS-STREET, SHEPPARTON.

WHEREAS, pursuant to the provisions of the *Railways Act 1958* (No. 6355), the Victorian Railways Commissioners recommended to the Governor in Council that the railway level crossing at 113M. 33C., situated at Byass-street, Shepparton, should be closed and gave the several notices required under that Act and having considered the objections to the said recommendation, His Excellency the Governor of the State of Victoria, with the advice of the Executive Council thereof, and being satisfied—

- (a) that the requisite notices have been given,
- (b) that not less than two months have expired since the last of such notices was given,
- (c) that satisfactory alternative means of crossing the railway line are available for the public,

doth hereby order that the said level crossing shall be closed on and after 1st November, 1964.

And the Honorable Edward Raymond Meagher, Her Majesty's Minister of Transport for the State of Victoria, shall give the necessary directions herein accordingly.

J. COLQUHOUN,  
Clerk of the Executive Council.

## JUSTICES ACT 1958.

At the Executive Council Chamber, Melbourne, the  
twenty-seventh day of October, 1964.

## PRESENT:

His Excellency the Governor of Victoria.  
Mr. Porter | Mr. Mack.  
Mr. Dickie

COURTS OF GENERAL SESSIONS OF THE PEACE FOR  
THE YEAR 1965.

IN pursuance of the provisions of the *Justices Act 1958*, His Excellency the Governor of the State of Victoria, by and with the advice of the Executive Council thereof, doth by this present Order direct that the dates for holding Courts of General Sessions of the Peace during the year 1965 be appointed as specified in the subjoined Schedule, viz.:—

ARARAT .. ..	Thursday, 22nd April, Tuesday, 10th August.
BAIRNSDALE .. ..	Tuesday, 2nd March. Wednesday, 16th June. Tuesday, 19th October.
BALLARAT .. ..	Wednesday, 3rd February. Tuesday, 4th May. Tuesday, 3rd August. Wednesday, 3rd November.
BENDIGO .. ..	Wednesday, 3rd February. Tuesday, 4th May. Tuesday, 3rd August. Wednesday, 1st December.
COLAC .. ..	Thursday, 22nd April. Tuesday, 14th September. Wednesday, 3rd November.
GEELONG .. ..	Tuesday, 2nd March. Tuesday, 1st June. Wednesday, 1st September. Wednesday, 1st December.
HAMILTON .. ..	Tuesday, 16th February. Tuesday, 1st June. Tuesday, 19th October.
HORSHAM .. ..	Tuesday, 2nd March. Tuesday, 20th July. Tuesday, 16th November.
KERANG .. ..	Tuesday, 6th April. Tuesday, 20th July. Tuesday, 5th October.
KORUMBURRA .. ..	Tuesday, 23rd February. Tuesday, 24th August. Wednesday, 3rd November. Wednesday, 10th March.
MARYBOROUGH .. ..	Tuesday, 14th September. Monday, 18th January. Tuesday, 2nd February. Monday, 1st March. Thursday, 1st April. Monday, 3rd May. Tuesday, 1st June. Thursday, 1st July. Monday, 2nd August. Wednesday, 1st September. Friday, 1st October. Monday, 1st November. Wednesday, 1st December.
MILDURA .. ..	Monday, 22nd March. Tuesday, 20th July. Monday, 20th September. Monday, 15th November.
MORWELL .. ..	Wednesday, 10th March. Tuesday, 22nd June. Wednesday, 1st September. Tuesday, 14th December.
SALE .. ..	Tuesday, 6th April. Tuesday, 3rd August. Tuesday, 23rd November.
SHEPPARTON .. ..	Wednesday, 3rd February. Tuesday, 4th May. Tuesday, 17th August. Wednesday, 3rd November.
WANGARATTA .. ..	Wednesday, 3rd February. Tuesday, 1st June. Wednesday, 1st September. Wednesday, 1st December.
WARRAGUL .. ..	Tuesday, 16th March. Tuesday, 18th May.
WARRNAMBOOL .. ..	Tuesday, 5th October. Tuesday, 23rd March. Tuesday, 20th July. Tuesday, 21st September. Wednesday, 1st December.

And the Honorable Arthur Gordon Rylah, Her Majesty's Attorney-General for the State of Victoria, shall give the necessary directions herein accordingly.

J. COLQUHOUN,  
Clerk of the Executive Council.

SOIL CONSERVATION AND LAND UTILIZATION  
ACT 1958.

At the Executive Council Chamber, Melbourne, the  
twenty-ninth day of October, 1964.

## PRESENT:

His Excellency the Governor of Victoria.  
Mr. Mack | Mr. Dickie.

DISTRICT ADVISORY COMMITTEE.—AVON SOIL  
CONSERVATION DISTRICT.

IN pursuance of the powers conferred by section 15 of the *Soil Conservation and Land Utilization Act*, His Excellency the Governor of the State of Victoria by and with the advice of the Executive Council thereof doth hereby appoint the following persons to be members of the District Advisory Committee of the Avon Soil Conservation District for a term of three years from 21st November, 1964.

COLIN LATHROP MURRAY—being a person elected to represent grazing, agricultural and other relevant interests in the District.

RONALD BLANDFORD—being a person elected to represent grazing, agricultural and other relevant interests in the District.

ERIC EDWARD CUMMING—being a person elected to represent grazing, agricultural and other relevant interests in the District.

NORMAN FULLARTON CHESTER—being a person elected to represent grazing, agricultural and other relevant interests in the District.

FRANCIS ROBERTS DRAKE—being the person representing the Department of Agriculture.

STANLEY CHARLES BUTLER—being the person representing the Forests Commission.

BRUCE MALCOLM NICHOLSON—being the person representing the Soil Conservation Authority.

And the Honorable James Charles Murray Balfour, Her Majesty's Minister for Conservation for the State of Victoria, shall give the necessary directions herein accordingly.

J. COLQUHOUN,  
Clerk of the Executive Council.

## TRANSPORT REGULATION BOARD.

At the Executive Council Chamber, Melbourne, the  
twenty-seventh day of October, 1964.

## PRESENT:

His Excellency the Governor of Victoria.  
Mr. Porter | Mr. Mack.  
Mr. Dickie

IN pursuance of the powers in that behalf, conferred by the *Transport Regulation Act 1958*, and amended by the *Transport Regulation (Term of Office) Act 1961*, His Excellency the Governor of the State of Victoria, by and with the advice of the Executive Council thereof, doth by this Order hereby re-appoint the under-mentioned person to be Member of the Transport Regulation Board as from the third day of November, 1964, to the thirty-first day of July, 1965.

BERTRAM JAMES BINGER, being a person engaged in commercial pursuits outside an area within a radius of 25 miles from the post office situated at the corner of Bourke-street and Elizabeth-street in the City of Melbourne after consultation with and with the approval of the governing body of the body known as the Melbourne Chamber of Commerce.

And the Honorable Edward Raymond Meagher, Her Majesty's Minister of Transport for the State of Victoria, shall give the necessary directions herein accordingly.

J. COLQUHOUN,  
Clerk of the Executive Council.

LAND ACT 1958.

At the Executive Council Chamber, Melbourne, the twenty-seventh day of October, 1964.

PRESENT:

His Excellency the Governor of Victoria.  
Mr. Porter | Mr. Mack.  
Mr. Dickie

LAND ACCEPTED BY THE CROWN FOR ROAD PURPOSES IN EXCHANGE FOR CROWN LAND IN THE PARISH OF CUT-PAW-PAW.

IN pursuance of the powers conferred by section 208 of the Land Act 1958, His Excellency the Governor of the State of Victoria, by and with the advice of the Executive Council thereof, doth by Order made on the 27th day of October, 1964, accept the new road in the Parish of Cut-paw-paw, as defined by technical description hereunder, in exchange for the land traversed by the old road, as defined by Technical description hereunder, on terms mutually agreed upon:—

Land accepted by the Crown for road purposes, 2 roods 21 perches, Parish of Cut-paw-paw, County of Bourke, as indicated by hachure on plan hereunder.

Crown land given in exchange, 1 acre 2 roods 21 perches, Parish of Cut-paw-paw, County of Bourke, as indicated by cross hachure on plan hereunder.—(C.345(18) (02521/138).

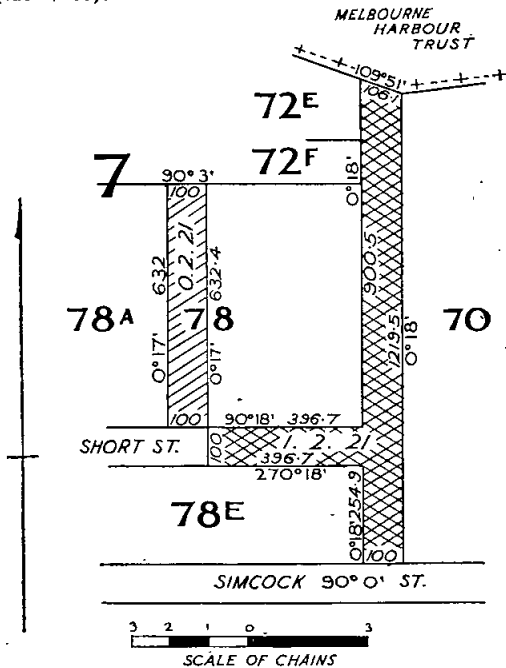

And the Honorable James Charles Murray Balfour, Her Majesty's Commissioner of Crown Lands and Survey for the State of Victoria, shall give the necessary directions herein accordingly.

J. COLQUHOUN,  
Clerk of the Executive Council.

AGRICULTURAL COLLEGES ACT 1958 (No. 6194).

At the Executive Council Chamber, Melbourne, the twenty-seventh day of October, 1964.

PRESENT:

His Excellency the Governor of Victoria.  
Mr. Porter | Mr. Mack.  
Mr. Dickie

APPOINTMENT OF MEMBERS OF ADVISORY COMMITTEE.

IN pursuance of the powers conferred by the Agricultural Colleges Act 1958 (No. 6194), and all other powers him thereunto enabling, His Excellency the Governor of

the State of Victoria, by and with the advice of the Executive Council thereof, doth by this Order hereby appoint the under-mentioned persons as members of the Advisory Committee constituted for the purposes of the said Act for a period of three (3) years:—

The person holding the position of Superintendent of Agricultural Education in the Department of Agriculture, who is hereby appointed also, in accordance with sub-section (1) of section 8 of the said Act, as Chairman of the said Committee.  
Professor HOWARD CARLYLE FORSTER, appointed in accordance with sub-section (2) of section 8 of the said Act, as representing the Faculty of Agriculture at the University of Melbourne.  
RICHARD HORACE ROE and FREDERICK JOHN LEETE, appointed in accordance with sub-section (2) of section 8 of the said Act.  
HENRY WALTER WILLIAMS, appointed in accordance with sub-section (3) of section 8 of the said Act.  
JOHN ALLEN RUSSELL.

And the Honorable Vance Oakley Dickie, Her Majesty's Acting Minister of Agriculture for the State of Victoria, shall give the necessary directions herein accordingly.

J. COLQUHOUN,  
Clerk of the Executive Council.

PATRIOTIC FUNDS ACT 1958.

At the Executive Council Chamber, Melbourne, the twenty-seventh day of October, 1964.

PRESENT:

His Excellency the Governor of Victoria.  
Mr. Porter | Mr. Mack.  
Mr. Dickie

APPOINTMENT OF TRUSTEES.

WHEREAS the New Zealand Sub-branch R.S.S. & A.I.L.A. Welfare Patriotic Fund B379 (hereinafter called "the said fund") is a patriotic fund within the meaning of the Patriotic Funds Act 1958: And whereas the original Trustees of the said fund cannot be found: And whereas it is provided by sub-section (1) of section 13 of the said Act that where there are no trustees of any patriotic fund or where in the opinion of the Governor in Council the trustees of any patriotic fund cannot be ascertained or found the Governor in Council may by Order in Council published in the Government Gazette appoint a person to be trustee of such fund: Now therefore in pursuance of the hereinbefore recited powers His Excellency the Governor of Victoria by and with the advice of the Executive Council thereof doth hereby appoint the under-mentioned persons to be trustees of the said fund:—

LYNDSAY JOHN FAHEY, 18 Holroyd-street, Kew, bank manager.  
CHRISTIAN STEWART LANGE, 65 Millewa-avenue, Chadstone, sales engineer.  
DAVID HENRY GILROY HAWKINS, Flat 2, Stanhope-street, Malvern, wool company representative.

And the Honorable Arthur Gordon Rylah, Her Majesty's Attorney-General for the State of Victoria, shall give the necessary directions herein accordingly.

J. COLQUHOUN,  
Clerk of the Executive Council.

PUBLIC SERVICE ACT 1958.

At the Executive Council Chamber, Melbourne, the twenty-seventh day of October, 1964.

PRESENT:

His Excellency the Governor of Victoria.  
Mr. Porter | Mr. Mack.  
Mr. Dickie

APPOINTMENT OF A DEPUTY TO THE GOVERNMENT REPRESENTATIVE MEMBER OF THE PUBLIC SERVICE BOARD.

IN pursuance of the provisions of section 15, sub-section (1) of the Public Service Act 1958, His Excellency the Governor of the State of Victoria, by and with the

advice of the Executive Council thereof, doth by this Order appoint Alwyn Harper Rigg, Deputy of William Thomas Place, the Government Representative Member of the Public Service Board, during the illness of the said William Thomas Place from and inclusive of 27th October, 1964, and until such date as the said Member first resumes duty following such illness.

And the Honorable Henry Edward Bolte, Her Majesty's Premier for the State of Victoria, shall give the necessary directions herein accordingly.

J. COLQUHOUN,  
Clerk of the Executive Council.

#### COUNTRY FIRE AUTHORITY ACT 1958.

At the Executive Council Chamber, Melbourne, the twenty-seventh day of October, 1964.

PRESENT:

His Excellency the Governor of Victoria.  
Mr. Porter | Mr. Mack.  
Mr. Dickie |

#### CONSENT TO BORROWING OF THIRTY THOUSAND POUNDS BY THE COUNTRY FIRE AUTHORITY.

WHEREAS by section 82 of the *Country Fire Authority Act 1958*, it is enacted that the Country Fire Authority, with the consent of the Governor in Council may from time to time, borrow such moneys as it deems necessary in order to enable it to carry out and perform the powers, authorities and duties vested in or conferred or imposed upon it by the said Act:

And whereas the Country Fire Authority deems it necessary to borrow the sum of Thirty thousand pounds for the purposes aforesaid:

Now therefore, His Excellency the Governor of the State of Victoria, in the Commonwealth of Australia, by and with the advice of the Executive Council of the said State and in pursuance of the powers conferred by the said section 82 of the *Country Fire Authority Act 1958* and all other powers him thereunto enabling, doth by this order consent to the borrowing by the Country Fire Authority of the sum of £30,000 (Thirty thousand pounds) for a period of ten (10) years, to be liquidated by half-yearly repayments on the principal sum, with interest at the rate of Five pounds two shillings and six pence (£5 2s. 6d. per centum per annum.

And the Honorable Arthur Gordon Rylah, Her Majesty's Chief Secretary for the State of Victoria, shall give the necessary directions herein accordingly.

J. COLQUHOUN,  
Clerk of the Executive Council.

#### HOSPITALS AND CHARITIES ACT 1958, SECTION 52.

At the Executive Council Chamber, Melbourne, the twenty-seventh day of October, 1964.

PRESENT:

His Excellency the Governor of Victoria.  
Mr. Porter | Mr. Mack.  
Mr. Dickie |

#### EXTENSION OF THE OBJECTS OR PURPOSES OF THE COLAC DISTRICT HOSPITAL.

WHEREAS the Colac District Hospital is an incorporated institution within the meaning of the *Hospitals and Charities Act 1958*:

And whereas the Committee of the said institution has agreed that the objects or purposes of the institution should be extended:

And whereas the Hospitals and Charities Commission after enquiry and report has recommended that the objects or purposes of the institution should be so extended:

Now therefore His Excellency the Governor of the State of Victoria, by and with the advice of the Executive Council thereof, doth hereby extend the objects or purposes of the Colac District Hospital so that such objects or purposes shall be as follows:—

- (a) To afford relief, including maintenance and the treatment or cure of, or attention to, any disease or ailment, or any injury consequent on any accident, medical and surgical attendance, medicine, nursing assistance, support or aid of any kind or in any form to such persons as are entitled thereto under the Act;
- (b) to provide facilities for carrying out investigation into all ailments, diseases, injuries, or other matters affecting the human body;
- (c) to provide facilities for the treatment of intermediate and private patients or either of them.

And the Honorable Ronald William Mack, Her Majesty's Minister of Health for the State of Victoria, shall give the necessary directions herein accordingly.

J. COLQUHOUN,  
Clerk of the Executive Council.

#### HOUSING ACT 1958.

At the Executive Council Chamber, Melbourne, the twenty-seventh day of October, 1964.

PRESENT:

His Excellency the Governor of Victoria.  
Mr. Porter | Mr. Mack.  
Mr. Dickie |

#### EXTINGUISHMENT OF EASEMENTS AND RESTRICTIVE COVENANTS.—CITY OF BROADMEADOWS.

WHEREAS by virtue of and in exercise of the powers contained in the *Housing Act 1958* (No. 6275) Housing Commission has recommended to the Governor in Council that the easements and restrictive covenants described in the Schedule hereto be extinguished.

Now therefore His Excellency the Governor of the State of Victoria in the Commonwealth of Australia by and with the advice of the Executive Council of the said State, doth in pursuance of the powers conferred by the said Act and upon such recommendation, consent and by this Order hereby extinguish such easements and restrictive covenants.

#### SCHEDULE.

First.—Any easements affecting:—

- (i) Lots numbered 172 to 178 (both inclusive), 353 to 356 (both inclusive), 359 to 362 (both inclusive), 364, 366 to 397 (both inclusive), all on plan of subdivision No. 9838, lodged in the Office of Titles.
- (ii) Lots numbered 438 to 450 (both inclusive), 505 to 514 (both inclusive), 516, 520 to 523 (both inclusive), 525 to 562 (both inclusive), 617 to 621 (both inclusive), 623, 626 to 628 (both inclusive), 635, 638 to 670 (both inclusive), all on plan of subdivision No. 11346, lodged in the Office of Titles.

Secondly.—Any restrictive covenants affecting:—

- (i) Lots numbered 147 to 153 (both inclusive), 172 to 178 (both inclusive), 353 to 356 (both inclusive), 359 to 362 (both inclusive), 364, 366 to 397 (both inclusive), all on plan of subdivision No. 9838, lodged in the Office of Titles.
- (ii) Lots numbered 509 to 514 (both inclusive), 516, 520 to 523 (both inclusive), 525 to 570 (both inclusive), 574 to 600 (both inclusive), 602 to 603 (both inclusive), 606, 609 to 613 (both inclusive), 617 to 621 (both inclusive), 623, 626 to 628 (both inclusive), 635, 638 to 684 (both inclusive), 686 to 722 (both inclusive), all on plan of subdivision No. 11346, lodged in the Office of Titles.

And the Honorable Lindsay Hamilton Simpson Thompson, Her Majesty's Minister of Housing for the State of Victoria, shall give the necessary directions herein accordingly.

J. COLQUHOUN,  
Clerk of the Executive Council.

COUNTRY ROADS BOARD.

At the Executive Council Chamber, Melbourne, the twenty-seventh day of October, 1964.

PRESENT:

His Excellency the Governor of Victoria.  
 Mr. Porter | Mr. Mack.  
 Mr. Dickie

DECLARATION OF A DEVIATION FROM THE KILFEERA-ROAD IN THE SHIRE OF BENALLA.

WHEREAS by sections 21 and 58 of the *Country Roads Act 1958* (No. 6229) it is amongst other things enacted that when the Country Roads Board under the provisions of the Country Roads Act has by Resolution declared a deviation to be a main road the said Board may also declare that such deviation shall be in lieu of any existing road or part thereof named in such Resolution and that on publication in the *Government Gazette* of the Order confirming such Resolution the existing road or part thereof shall cease to be a main road or be discontinued as provided in the Resolution: And whereas the said Board has by Resolution declared the deviation on the land described in the First Schedule to such Resolution to be a main road and has also declared that such deviation shall be in lieu of the part of the existing road being the land described in the Second Schedule to the said Resolution and that such part of the said existing road shall be discontinued: Now therefore His Excellency the Governor of the State of Victoria by and with the advice of the Executive Council thereof doth hereby confirm the said Resolution.

Resolution for Declaration of a Deviation of a Main Road under the Country Roads Act.

Whereas the land the site of the road the course of which is below set out was taken by the Board under the provisions of the *Country Roads Act 1958* for the purpose of constructing such road deviation which road deviation has now been laid out and formed on the same: And whereas the said Board (being the Country Roads Board incorporated under the Act) thinks that the road aforesaid is fit to be used as a public highway such Board at a meeting now holden acting under the authority conferred upon it by sections 21 and 58 of the said Act doth by this present Resolution hereby declare the said road deviation the course of which is described in the First Schedule hereto with the commencing and terminating points thereof respectively specified to be part of a main road within the meaning and for the purposes of the *Country Roads Act 1958*: And the said Board doth also declare that such deviation shall be in lieu of the existing road or part thereof described in the Second Schedule hereto and that such part of the said existing road shall be discontinued.

FIRST SCHEDULE.  
 Shire of Benalla.

9. *Kilfeera-road* (1809).—All those pieces of land in the Parish of Tatong, the boundaries of which are as follow:—

- (a) Commencing at the north-eastern angle of allotment 10, section B, of the said parish; thence by lines bearing respectively 161 deg. 0 min. 111.4 links, 261 deg. 25 min. 234 links and 54 deg. 17 min. 240.3 links to the point of commencement.
- (b) Commencing at the north-western angle of allotment 9A, section B, of the said parish; thence by lines bearing respectively 103 deg. 34 min. 188.2 links, 263 deg. 2 min. 162.2 links and 341 deg. 0 min. 67.5 links to the point of commencement.
- (c) Commencing at an angle in the southern boundary of allotment 12, section B, of the said parish, formed by the intersection of lines bearing 136 deg. 0 min. and 71 deg. 8 min.; thence by lines bearing respectively 316 deg. 0 min. 199.5 links, 103 deg. 33 min. 337.1 links and 251 deg. 8 min. 200 links to the point of commencement.
- (d) Commencing at a point on the northern boundary of allotment 9, section B, of the said parish, distant 303 deg. 42 min. 316.5 links from the north-eastern angle of the said allotment; thence by lines bearing respectively 261 deg. 56 min. 685 links, 24 deg. 40 min. 237.8 links, 81 deg. 56 min. 332.5 links and 123 deg. 42 min. 300.3 links to the point of commencement.

- (e) Commencing at the south-eastern angle of allotment 2, section B, of the said parish; thence by lines bearing respectively 309 deg. 20 min. 659 links, 113 deg. 56 min. 522.3 links, 107 deg. 0 min. 518.9 links and 263 deg. 21 min. 467 links to the point of commencement—

which said pieces of land are particularly delineated and shown coloured red on survey plans numbered 8383, 8384 and 8385, lodged in the office of the Country Roads Board.

SECOND SCHEDULE.

Shire of Benalla.

9. *Kilfeera-road* (1809).—All those pieces of land in the Parish of Tatong, the boundaries of which are as follow:—

- (a) Commencing at an angle in the southern boundary of allotment 12, section B, of the said parish, formed by the intersection of lines bearing 24 deg. 40 min. and 123 deg. 42 min.; thence by lines bearing respectively 123 deg. 42 min. 743.4 links, 261 deg. 56 min. 300.3 links, 303 deg. 42 min. 283.2 links, 204 deg. 40 min. 224.2 links, 261 deg. 56 min. 149.7 links, 251 deg. 8 min. 104.8 links and 24 deg. 40 min. 612 links to the point of commencement.
- (b) Commencing at the north-eastern angle of allotment 3, section B<sup>1</sup>, of the said parish; thence by lines bearing respectively 309 deg. 26 min. 482 links, 113 deg. 56 min. 411 links and 181 deg. 24 min. 139.5 links to the point of commencement.
- (c) Commencing at the north-western angle of allotment 5A, section B<sup>1</sup>, of the said parish; thence by lines bearing respectively 1 deg. 24 min. 212 links, 107 deg. 0 min. 551.4 links, 263 deg. 21 min. 275 links and 265 deg. 48 min. 260 links to the point of commencement—

which said pieces of land are particularly delineated and shown coloured blue on survey plans numbered 8384 and 8385, lodged in the office of the Country Roads Board.

The common seal of Country Roads Board was hereto affixed, at Kew, this nineteenth day of October, One thousand nine hundred and sixty-four, in the presence of—

(SEAL) I. J. O'DONNELL, Chairman.  
 F. WEST, Member.  
 C. C. LIDDELL, Acting Secretary.

And the Honorable Murray Victor Porter, Her Majesty's Commissioner of Public Works for the State of Victoria, shall give the necessary directions herein accordingly.

J. COLQUHOUN,  
 Clerk of the Executive Council.

COUNTRY ROADS BOARD.

At the Executive Council Chamber, Melbourne, the twenty-seventh day of October, 1964.

PRESENT:

His Excellency the Governor of Victoria.  
 Mr. Porter | Mr. Mack.  
 Mr. Dickie

DECLARATION OF A DEVIATION FROM THE LISMORE-ROAD IN THE SHIRE OF GRENVILLE.

WHEREAS by sections 21 and 58 of the *Country Roads Act 1958* (No. 6229) it is amongst other things enacted that when the Country Roads Board under the provisions of the Country Roads Act has by Resolution declared a deviation to be a main road the said Board may also declare that such deviation shall be in lieu of any existing road or part thereof named in such Resolution and that on publication in the *Government Gazette* of the Order confirming such Resolution the existing road or part thereof shall cease to be a main road or be discontinued as provided in the Resolution: And whereas the said Board has by Resolution declared the deviation on the land described in the First Schedule to such Resolution to be a main road and has also declared that such deviation shall be in lieu of the part of the existing road being the land described in the Second Schedule to the said Resolution and that such part of the said existing road shall be discontinued: Now therefore His Excellency the Governor of the State of Victoria by and with the advice of the Executive Council thereof doth hereby confirm the said Resolution.

*Resolution for Declaration of a Deviation of a Main Road under the Country Roads Act.*

Whereas the land the site of the road the course of which is below set out was taken by the Board under the provisions of the *Country Roads Act 1958* for the purpose of constructing such road deviation which road deviation has now been laid out and formed on the same: And whereas the said Board (being the *Country Roads Board* incorporated under the said Act) thinks that the road aforesaid is fit to be used as a public highway such Board at a meeting now holden acting under the authority conferred upon it by sections 21 and 58 of the said Act doth by this present Resolution hereby declare the said road deviation the course of which is described in the First Schedule hereto with the commencing and terminating points thereof respectively specified to be part of a main road within the meaning and for the purposes of the *Country Roads Act 1958*: And the said Board doth also declare that such deviation shall be in lieu of the existing road or part thereof described in the Second Schedule hereto and that such part of the said existing road shall be discontinued.

FIRST SCHEDULE.  
*Shire of Grenville.*

3. *Lismore-road* (6903).—All that piece of land in the Parishes of Mindai and Mannibadar, the boundaries of which are as follow:—

Commencing at the south-western angle of allotment 136A, Parish of Mannibadar; thence by lines bearing respectively 253 deg. 0 min. 261.7 links, 48 deg. 37 min. 873.1 links and 218 deg. 58 min. 643.8 links to the point of commencement.

Also, all those pieces of land in the Parish of Mannibadar, the boundaries of which are as follow:—

(a) Commencing at a point on the southern boundary of the existing *Lismore-road* through allotment 144 of the said parish, distant 73 deg. 0 min. 769 links from an angle in the said boundary formed by the intersection of lines bearing 31 deg. 27 min. and 73 deg. 0 min.; thence by lines bearing respectively 73 deg. 0 min. 798.2 links, 242 deg. 10 min. 2,035.8 links, 31 deg. 27 min. 293.7 links and 62 deg. 10 min. 999.3 links to the point of commencement.

(b) Commencing at an angle in the northern boundary of the existing *Lismore-road* through allotment 144 of the said parish, formed by the intersection of lines bearing 39 deg. 43 min. and 86 deg. 22 min.; thence by lines bearing respectively 53 deg. 8 min. 814.2 links, 62 deg. 10 min. 637 links, 211 deg. 27 min. 293.7 links, 242 deg. 10 min. 384.5 links, 229 deg. 47 min. 519.3 links and 266 deg. 22 min. 325.7 links to the point of commencement.

(c) Commencing at an angle in the eastern boundary of the existing *Lismore-road* through allotment 144 of the said parish, formed by the intersection of lines bearing 219 deg. 43 min. and 193 deg. 34 min.; thence by lines bearing respectively 39 deg. 43 min. 560 links, 86 deg. 22 min. 58.9 links, 216 deg. 13 min. 455.8 links, 208 deg. 14 min. 501.5 links and 13 deg. 34 min. 385.6 links to the point of commencement.

Also, all that piece of land in the Parish of Wallinduc, the boundaries of which are as follow:—

Commencing at the eastern angle of lot 17 on plan of subdivision numbered 5090, lodged in the Office of Titles, and being part of allotment K of the said parish; thence by lines bearing respectively 219 deg. 0 min. 605 links, 29 deg. 16 min. 959.9 links and 193 deg. 34 min. 377.7 links to the point of commencement—

which said pieces of land are particularly delineated and shown coloured red on survey plan numbered 8701, lodged in the office of the *Country Roads Board*.

SECOND SCHEDULE.  
*Shire of Grenville.*

3. *Lismore-road* (6903).—All those pieces of land in the Parish of Mannibadar, the boundaries of which are as follow:—

(a) Commencing at an angle in the northern boundary of the existing *Lismore-road* through allotment 144 of the said parish, formed by the intersection of lines bearing 253 deg. 0 min. and 211 deg. 27 min.; thence by lines bearing respectively 73 deg. 0 min. 1,627.3 links, 242 deg. 24 min. 815.1 links, 253 deg. 0 min. 769 links, 211 deg. 27 min. 283.8 links, 242 deg. 10 min. 293.7 links and 31 deg. 27 min. 593.1 links to the point of commencement.

(b) Commencing at an angle in the eastern boundary of the existing *Lismore-road* through allotment 44 of the said parish, formed by the intersection of lines bearing 53 deg. 13 min. and 31 deg. 27 min.; thence by lines bearing respectively 233 deg. 13 min. 715 links, 266 deg. 22 min. 295.6 links, 49 deg. 47 min. 251.7 links, 86 deg. 22 min. 148.8 links, 53 deg. 13 min. 641 links, 31 deg. 27 min. 142.2 links, 62 deg. 10 min. 293.7 links and 211 deg. 27 min. 423.5 links to the point of commencement—

which said pieces of land are particularly delineated and shown coloured blue on survey plan numbered 8701, lodged in the office of the *Country Roads Board*.

The common seal of *Country Roads Board* was hereto affixed, at Kew, this nineteenth day of October, One thousand nine hundred and sixty-four, in the presence of—

(SEAL) I. J. O'DONNELL, Chairman.  
F. WEST, Member.  
C. C. LIDDELL, Acting Secretary.

And the Honorable Murray Victor Porter, Her Majesty's Commissioner of Public Works for the State of Victoria, shall give the necessary directions herein accordingly.

J. COLQUHOUN,  
Clerk of the Executive Council.

COUNTRY ROADS BOARD.

At the Executive Council Chamber, Melbourne, the twenty-seventh day of October, 1964.

PRESENT:

His Excellency the Governor of Victoria.  
Mr. Porter | Mr. Mack.  
Mr. Dickie

ORDER APPROVING OF WIDENING AN EXISTING MAIN ROAD IN THE SHIRE OF TRARALGON.

WHEREAS the *Country Roads Board* constituted under the *Country Roads Act 1958* (No. 6229) has represented to His Excellency the Governor in Council that it appears to it desirable that the existing *Flynn's Creek-road* in the *Shire of Traralgon* (declared to be a main road under the said Act which declaration was confirmed by the Order in Council published in the *Government Gazette* of the 28th May, 1947, on pages 2732-3) should be widened by the said Board: And whereas the said Board in accordance with the requirements of section 19 of the said cited Act has caused to be prepared a map plan and estimate showing the points between which and on and through what land the said widening is proposed to be made and the cost of acquiring the land: And whereas on an inspection of the said map and plan and a consideration of the said estimate His Excellency the Governor in Council is satisfied that there are funds legally available for acquiring the land: Now therefore be it known by this present Order that His Excellency the Governor of the State of Victoria with the advice of the Executive Council thereof doth hereby approve of the said road being widened, that is to say:—

All those pieces of land in the Parish of Loy Yang, the boundaries of which are as follow:—

(a) Commencing at an angle in the eastern boundary of the existing *Flynn's Creek-road*, through allotment 13N of the said parish, formed by the intersection of lines bearing 34 deg. 25 min. and 74 deg. 12 min.; thence by lines bearing respectively 74 deg. 12 min. 194.1 links, 234 deg. 34 min. 369.5 links and 34 deg. 25 min. 198.8 links to the point of commencement.

(b) Commencing at an angle in the western boundary of the existing *Flynn's Creek-road*, through allotment 13N of the said parish, formed by the intersection of lines bearing 74 deg. 12 min. and 42 deg. 22 min.; thence by lines bearing respectively 254 deg. 12 min. 142.1 links, 58 deg. 13 min. 274.1 links and 222 deg. 22 min. 143 links to the point of commencement.

(c) Commencing at a point on the eastern boundary of allotment 13N of the said parish, distant 180 deg. 3 min. 222.6 links from the north-eastern angle of the said allotment; thence by lines bearing respectively 180 deg. 3 min. 218.4

links, 222 deg. 22 min. 215.7 links and 21 deg. 4 min. 404.8 links to the point of commencement—

which said pieces of land are particularly delineated and shown coloured red on survey plan numbered 9808, lodged in the office of the Country Roads Board.

And the Honorable Murray Victor Porter, Her Majesty's Commissioner of Public Works for the State of Victoria, shall give the necessary directions herein accordingly.

J. COLQUHOUN,  
Clerk of the Executive Council.

COUNTRY ROADS BOARD.

At the Executive Council Chamber, Melbourne, the twenty-seventh day of October, 1964.

PRESENT:

His Excellency the Governor of Victoria.	
Mr. Porter	Mr. Mack.
Mr. Dickie	

ORDER IN COUNCIL CONFIRMING RESOLUTION OF THE COUNTRY ROADS BOARD RESCINDING RESOLUTION DECLARING A CERTAIN HIGHWAY IN THE BOROUGH OF DAYLESFORD TO BE A MAIN ROAD.

WHEREAS by the Resolution set out below and dated the nineteenth day of October, 1964, the Country Roads Board incorporated under the *Country Roads Act 1958* (No. 6229) being of opinion that the road set out or described in the Schedule to the same is no longer of sufficient importance to be considered a main road resolved that the Resolutions passed by the Board on the twenty-eighth day of July, 1915, and the eighteenth day of September, 1929, and confirmed by the Governor in Council by Orders published in the *Government Gazettes* of the twelfth day of July, 1915, on page 2759 and the second day of September, 1929, on page 351 declaring the highway particulars of which are therein set out or described a main road be rescinded so far as the same covers the said highway between the points referred to in the Resolution hereby confirmed: And whereas the said Act amongst other things provides that the Governor in Council may by Order published in the *Government Gazette* confirm such Resolution whereupon any road or part thereof mentioned in such Resolution shall cease to be a main road: And whereas it is deemed desirable to confirm the Resolution so made and passed by the Country Roads Board: Now therefore His Excellency the Governor of the State of Victoria by and with the advice of the Executive Council thereof doth hereby confirm such Resolution and declare that upon the publication of this Order in the *Government Gazette* the road mentioned in the Schedule to such Resolution shall cease to be a main road within the meaning of the *Country Roads Act*.

*Resolution of the Country Roads Board to Rescind a Main Road.*

The Country Roads Board constituted under the *Country Roads Act 1958* (No. 6229) at a meeting now holden being of opinion that the main road hereinafter referred to and more particularly described in the Schedule hereto is no longer of sufficient importance to be considered a main road hereby resolves that the Resolutions passed by the Board on the twenty-eighth day of July, 1915, and the eighteenth day of September, 1929, and confirmed by the Governor in Council by an Order published in the *Government Gazettes* of the twelfth day of July, 1915, on page 2759 and the second day of September, 1929, on page 351 declaring the highway particulars of which are therein set out or described a main road be rescinded.

SCHEDULE.

*Borough of Daylesford.*

*Ballarat-road.*—Commencing at a point on the western boundary of the Borough near the south-eastern angle of allotment 23B, section A, Parish of Wombat; thence south-easterly, easterly and north-easterly to the eastern angle of allotment A, section 25, in the said parish; thence south-easterly, north-easterly and northerly to the north-western angle of section 40, Township of Daylesford; thence northerly and north-easterly to its junction with the Ballan-road near the north-eastern angle of allotment 1A, section 28, of the said township.

The common seal of Country Roads Board was hereto affixed, at Kew, this nineteenth day of October, One thousand nine hundred and sixty-four, in the presence of—

(SEAL) I. J. O'DONNELL, Chairman.  
F. WEST, Member.  
C. C. LIDDELL, Acting Secretary.

And the Honorable Murray Victor Porter, Her Majesty's Commissioner of Public Works for the State of Victoria, shall give the necessary directions herein accordingly.

J. COLQUHOUN,  
Clerk of the Executive Council.

COUNTRY ROADS BOARD.

At the Executive Council Chamber, Melbourne, the twenty-seventh day of October, 1964.

PRESENT:

His Excellency the Governor of Victoria.	
Mr. Porter	Mr. Mack.
Mr. Dickie	

ORDER APPROVING OF WIDENING AN EXISTING MAIN ROAD IN THE SHIRE OF CORIO.

WHEREAS the Country Roads Board constituted under the *Country Roads Act 1958* (No. 6229) has represented to His Excellency the Governor in Council that it appears to it desirable that the existing Geelong-Ballan road in the Shire of Corio (declared to be a main road under the said Act which declaration was confirmed by the Order in Council published in the *Government Gazette* of the 4th June, 1947, on page 2817) should be widened by the said Board: And whereas the said Board in accordance with the requirements of section 19 of the said cited Act has caused to be prepared a map plan and estimate showing the points between which and on and through what land the said widening is proposed to be made and the cost of acquiring the land: And whereas on an inspection of the said map and plan and a consideration of the said estimate His Excellency the Governor in Council is satisfied that there are funds legally available for acquiring the land: Now therefore be it known by this present Order that His Excellency the Governor of the State of Victoria with the advice of the Executive Council thereof doth hereby approve of the said road being widened, that is to say:—

All that piece of land in the Parish of Anakie, the boundaries of which are as follow:—Commencing at the south-western angle of portion 54 of the said parish; thence by lines bearing respectively 7 deg. 32 min. 419.5 links, 183 deg. 31 min. 416.7 links, 176 deg. 48½ min. 245.6 links and 350 deg. 1¼ min. 249 links to the point of commencement—which said piece of land is particularly delineated and shown coloured red on survey plan numbered 9761, lodged in the office of the Country Roads Board.

And the Honorable Murray Victor Porter, Her Majesty's Commissioner of Public Works for the State of Victoria, shall give the necessary directions herein accordingly.

J. COLQUHOUN,  
Clerk of the Executive Council.

COUNTRY ROADS BOARD.

At the Executive Council Chamber, Melbourne, the twenty-seventh day of October, 1964.

PRESENT:

His Excellency the Governor of Victoria.	
Mr. Porter	Mr. Mack.
Mr. Dickie	

ORDER APPROVING OF WIDENING AN EXISTING MAIN ROAD IN THE SHIRE OF CORIO.

WHEREAS the Country Roads Board constituted under the *Country Roads Act 1958* (No. 6229) has represented to His Excellency the Governor in Council that it appears to it desirable that the existing Geelong-Ballan road in the Shire of Corio (declared to be a main road under the said Act which declaration was confirmed by the Order in Council published in the *Government Gazette*

of the 4th June, 1947, on page 2817) should be widened by the said Board: And whereas the said Board in accordance with the requirements of section 19 of the said cited Act has caused to be prepared a map plan and estimate showing the points between which and on and through what land the said widening is proposed to be made and the cost of acquiring the land: And whereas on an inspection of the said map and plan and a consideration of the said estimate His Excellency the Governor in Council is satisfied that there are funds legally available for acquiring the land: Now therefore be it known by this present Order that His Excellency the Governor of the State of Victoria with the advice of the Executive Council thereof doth hereby approve of the said road being widened, that is to say:—

All those pieces of land in the Parish of Anakie, the boundaries of which are as follow:—

- (a) Commencing at the north-western angle of lot 2 on plan of subdivision numbered 17225, lodged in the Office of Titles, and being part of portion 42 of the said parish; thence by lines bearing respectively 161 deg. 19 min. 190.2 links, 160 deg. 12½ min. 229.5 links, 151 deg. 58 min. 517.9 links, 323 deg. 32 min. 512.3 links and 350 deg. 1½ min. 448 links to the point of commencement.
- (b) Commencing at the south-eastern angle of portion 44 of the said parish; thence by lines bearing respectively 139 deg. 18 min. 132.2 links, 159 deg. 3 min. 340.9 links, 332 deg. 57 min. 338 links, 301 deg. 45 min. 33.2 links, 308 deg. 27 min. 161.1 links, 26 deg. 49 min. 90 links and 143 deg. 32 min. 100 links to the point of commencement—

which said pieces of land are particularly delineated and shown coloured red and yellow on survey plan numbered 9762, lodged in the office of the Country Roads Board.

And the Honorable Murray Victor Porter, Her Majesty's Commissioner of Public Works for the State of Victoria, shall give the necessary directions herein accordingly.

J. COLQUHOUN,  
Clerk of the Executive Council.

#### COUNTRY ROADS BOARD.

At the Executive Council Chamber, Melbourne, the twenty-seventh day of October, 1964.

##### PRESENT:

His Excellency the Governor of Victoria.  
Mr. Porter | Mr. Mack.  
Mr. Dickie

#### ORDER APPROVING OF WIDENING AN EXISTING MAIN ROAD IN THE SHIRE OF MOUNT ROUSE.

WHEREAS the Country Roads Board constituted under the Country Roads Act 1958 (No. 6229) has represented to His Excellency the Governor in Council that it appears to it desirable that the existing Penshurst-Warmambool road in the Shire of Mount Rouse (declared to be a main road under the said Act which declaration was confirmed by the Order in Council published in the *Government Gazette* of the 12th November, 1941, on page 3762) should be widened by the said Board: And whereas the said Board in accordance with the requirements of section 19 of the said cited Act has caused to be prepared a map plan and estimate showing the points between which and on and through what land the said widening is proposed to be made and the cost of acquiring the land: And whereas on an inspection of the said map and plan and a consideration of the said estimate His Excellency the Governor in Council is satisfied that there are funds legally available for acquiring the land: Now therefore be it known by this present Order that His Excellency the Governor of the State of Victoria with the advice of the Executive Council thereof doth hereby approve of the said road being widened, that is to say:—

All that piece of land in the Parish of Yatmerone, the boundaries of which are as follow:—Commencing at an angle in the western boundary of allotment 4, section 11, of the said parish, formed by the intersection of lines bearing 141 deg. 14 min. and 185 deg. 46 min.; thence by lines bearing respectively 185 deg. 46 min. 837.3 links, 353 deg. 26½ min. 794.4 links, 337 deg. 50 min. 573.7 links and 141 deg. 14 min. 625.1 links to the point of commencement—which said piece of land is particularly delineated and shown coloured red of survey plan numbered 9728, lodged in the office of the Country Roads Board.

And the Honorable Murray Victor Porter, Her Majesty's Commissioner of Public Works for the State of Victoria, shall give the necessary directions herein accordingly.

J. COLQUHOUN,  
Clerk of the Executive Council.

#### COUNTRY ROADS BOARD.

At the Executive Council Chamber, Melbourne, the twenty-seventh day of October, 1964.

##### PRESENT:

His Excellency the Governor of Victoria.  
Mr. Porter | Mr. Mack.  
Mr. Dickie

#### ORDER APPROVING OF WIDENING AN EXISTING STATE HIGHWAY IN THE SHIRE OF GLENELG.

WHEREAS the Country Roads Board constituted under the Country Roads Act 1958 (No. 6229) has represented to His Excellency the Governor in Council that it appears to it desirable that the existing Glenelg Highway in the Shire of Glenelg (declared to be a State highway under the said Act which declaration was confirmed by the Order in Council published in the *Government Gazette* of the 10th August, 1960, on pages 2743-8) should be widened by the said Board: And whereas the said Board in accordance with the requirements of section 19 of the said cited Act has caused to be prepared a map plan and estimate showing the points between which and on and through what land the said widening is proposed to be made and the cost of acquiring the land: And whereas on an inspection of the said map and plan and a consideration of the said estimate His Excellency the Governor in Council is satisfied that there are funds legally available for acquiring the land: Now therefore be it known by this present Order that His Excellency the Governor of the State of Victoria with the advice of the Executive Council thereof doth hereby approve of the said highway being widened, that is to say:—

All those pieces of land in the Parish of Ardno, the boundaries of which are as follow:—

- (a) Commencing at the western angle of allotment 7 of the said parish; thence by lines bearing respectively 65 deg. 41 min. 424.4 links, 229 deg. 41 min. 990.5 links, 32 deg. 31 min. 499 links and 65 deg. 41 min. 110 links to the point of commencement.
- (b) Commencing at a point on the north-western boundary of allotment 7 of the said parish, distant 65 deg. 41 min. 1,934.8 links from the western angle of the said allotment; thence by lines bearing respectively 65 deg. 41 min. 289.2 links, 89 deg. 1 min. 240 links and 256 deg. 15 min. 518.4 links to the point of commencement—

which said pieces of land are particularly delineated and shown coloured red on survey plan numbered 9727, lodged in the office of the Country Roads Board.

And the Honorable Murray Victor Porter, Her Majesty's Commissioner of Public Works for the State of Victoria, shall give the necessary directions herein accordingly.

J. COLQUHOUN,  
Clerk of the Executive Council.

#### COUNTRY ROADS BOARD.

At the Executive Council Chamber, Melbourne, the twenty-seventh day of October, 1964.

##### PRESENT:

His Excellency the Governor of Victoria.  
Mr. Porter | Mr. Mack.  
Mr. Dickie

#### ORDER IN COUNCIL CONFIRMING RESOLUTION OF THE COUNTRY ROADS BOARD RESCINDING RESOLUTION DECLARING A CERTAIN HIGHWAY IN THE SHIRE OF GLENLYON TO BE A MAIN ROAD.

WHEREAS by the Resolution set out below and dated the nineteenth day of October, 1964, the Country Roads Board incorporated under the Country Roads Act 1958 (No. 6229) being of opinion that the road set out or described in the Schedule to the same is no longer of



sufficient importance to be considered a main road resolved that the Resolution passed by the Board on the twenty-seventh day of August, 1915, and confirmed by the Governor in Council by an Order published in the *Government Gazette* of the sixteenth day of August, 1915, on page 3124 declaring the highway particulars of which are therein set out or described a main road be rescinded so far as the same covers the said highway between the points referred to in the Resolution hereby confirmed: And whereas the said Act amongst other things provides that the Governor in Council may by Order published in the *Government Gazette* confirm such Resolution whereupon any road or part thereof mentioned in such Resolution shall cease to be a main road: And whereas it is deemed desirable to confirm the Resolution so made and passed by the Country Roads Board: Now therefore His Excellency the Governor of the State of Victoria by and with the advice of the Executive Council thereof doth hereby confirm such Resolution and declare that upon the publication of this Order in the *Government Gazette* the road mentioned in the Schedule to such Resolution shall cease to be a main road within the meaning of the Country Roads Act.

*Resolution of the Country Roads Board to Rescind a Main Road.*

The Country Roads Board constituted under the Country Roads Act 1958 (No. 6229) at a meeting now holden being of opinion that the main road hereinafter referred to and more particularly described in the Schedule hereto is no longer of sufficient importance to be considered a main road hereby resolves that the Resolution passed by the Board on the twenty-seventh day of August, 1915, and confirmed by the Governor in Council by an Order published in the *Government Gazette* of the sixteenth day of August, 1915, on page 3124 declaring the highway particulars of which are therein set out or described a main road be rescinded.

SCHEDULE.  
*Shire of Glenlyon.*

*Ballarat-road.*—Commencing at its junction with the Midland Highway at a culvert over Sailors Creek in the Parish of Wombat distant south-westerly about 24 chains from the junction of the said creek with Wombat Creek (survey plan 9118); thence generally easterly to the north-western angle of allotment 29c, section A, of the said parish, and further easterly and south-easterly to a point on the western boundary of the Borough of Daylesford, near the south-eastern angle of allotment 23b of the said section.

The common seal of Country Roads Board was hereto affixed, at Kew, this nineteenth day of October, One thousand nine hundred and sixty-four, in the presence of—

I. J. O'DONNELL, Chairman.  
F. WEST, Member.  
C. C. LIDDELL, Acting Secretary.

And the Honorable Murray Victor Porter, Her Majesty's Commissioner of Public Works for the State of Victoria, shall give the necessary directions herein accordingly.

J. COLQUHOUN,  
Clerk of the Executive Council.

APPROACHING LAND SALES.

SALES of Crown lands, in fee-simple, will be held at the under-mentioned places and dates, viz.:

	No. of Gazette.
Ararat.—Thursday, 19th November, 1964 ..	84
Ballarat.—Tuesday, 17th November, 1964 ..	84
Bendigo.—Thursday, 10th December, 1964 ..	88
Casterton.—Thursday, 3rd December, 1964 ..	88
Dartmoor.—Tuesday, 1st December, 1964 ..	88
Dimboola.—Tuesday, 1st December, 1964 ..	88
Kaniva.—Tuesday, 1st December, 1964 ..	88
Melbourne.—Thursday, 10th December, 1964 ..	82
Orbost.—Monday, 7th December, 1964 ..	88
Ouyen.—Monday, 23rd November, 1964 ..	84
Red Cliffs.—Friday, 27th November, 1964 ..	86

AUCTION OF RIGHT TO LEASE CROWN LAND.

Melbourne.—Wednesday, 11th November, 1964	81
Queenscliff.—Wednesday, 9th December, 1964	88

COMMON ABOUT TO BE ABOLISHED.

IN pursuance of the provisions contained in the Land Act 1958, notice is hereby given that it is the intention of the Governor in Council to abolish the common hereinafter mentioned, viz.:

The following Notice was published 1° on the 21st October, 1964, pursuant to Order of the 13th October, 1964.

The Rokewood Goldfield Common proclaimed on the 28th January, 1861, and extended by proclamations of the 25th April, 1864, and the 24th December, 1866, is about to be abolished.—(Rs.435.)

J. C. M. BALFOUR,  
Commissioner of Crown Lands and Survey.

PROPOSED PERMANENT RESERVATION OF LAND AS A SITE.

IN pursuance of the provisions of the Land Act 1958, notice is hereby given that it is the intention of the Governor in Council to permanently reserve as a site the land hereunder referred to:—

The following Notice was published 1° on the 14th October, 1964, pursuant to Order of the 6th October, 1964.

JIKA JIKA (CLIFTON HILL).—Land proposed to be permanently reserved as a site for a Public Park and other purposes of Public Recreation, 23 acres, more or less, at Clifton Hill, City of Collingwood, Parish of Jika Jika, County of Bourke, being the site temporarily reserved therefor by Order in Council of the 1st December, 1908.—(C.366(\*) (Rs.602).

J. C. M. BALFOUR,  
Commissioner of Crown Lands and Survey.

PROPOSED REVOCATION OF TEMPORARY RESERVATION OF LAND BY ORDER IN COUNCIL.

IN pursuance of the provisions of the Land Act 1958, notice is hereby given that it is the intention of the Governor in Council to revoke the temporary reservation of land by Order in Council hereunder referred to, viz.:

The following Notice was published 1° on the 28th October, 1964, pursuant to Order of the 20th October, 1964.

BARRARBOOL (GEELONG).—The temporary reservation, by Order in Council of the 17th February, 1862, of 105 acres of land in the Parish of Barrarbool, as a site for a Public Park and Gardens, as a place of resort for inhabitants of the municipal districts of South Barwon and Newtown and Chilwell, is about to be revoked, so far only as the portion containing 2 acres 2 roods 20 perches, indicated by hachure on plan hereunder, is concerned.—(B.34(\*) (Rs.2131).

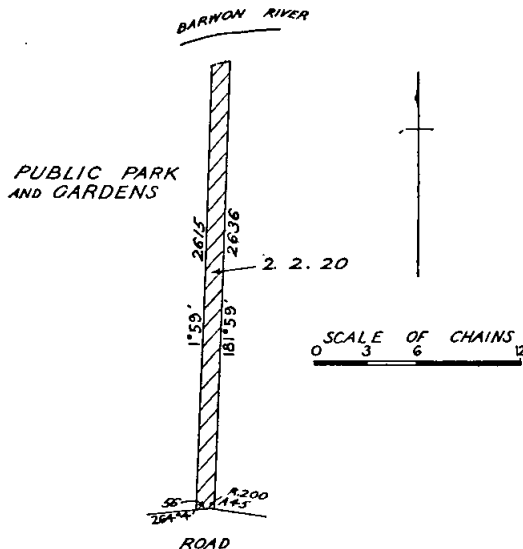

J. C. M. BALFOUR,  
Commissioner of Crown Lands and Survey.

**PROPOSED REVOCATION OF TEMPORARY RESERVATION OF LAND BY ORDER IN COUNCIL.**

IN pursuance of the provisions of the Land Act 1958, notice is hereby given that it is the intention of the Governor in Council to revoke the temporary reservation of land by Order in Council hereunder referred to, viz.:-

The following Notice was published 1° on the 14th October, 1964, pursuant to Order of the 6th October, 1964.

**DONDANGADALE.**—The temporary reservation by Order in Council of the 21st February, 1928, of 4 acres, more or less, of land in the Parish of Dondangadale as a site for Water and Camping.—(D.196(?) (Rs.3623).

J. C. M. BALFOUR,  
Commissioner of Crown Lands and Survey.

**PROPOSED REVOCATION OF TEMPORARY RESERVATION OF LAND BY ORDER IN COUNCIL.**

IN pursuance of the provisions of the Land Act 1958, notice is hereby given that it is the intention of the Governor in Council to revoke the temporary reservation of land by Order in Council hereunder referred to, viz.:-

The following Notice was published 1° on the 4th November, 1964, pursuant to Order of the 27th October, 1964.

**CONEWARRE (BARWON HEADS).**—The temporary reservation, by Order in Council of the 17th July, 1962, of 58 acres 1 rood 25 perches of land in the Parish of Conewarre as a site for Public purposes and Recreation is about to be revoked so far only as the portion containing 1 acre 2 roods 19 perches, indicated by hachure on plan hereunder, is concerned.—(C.261(4) (Rs.8149).

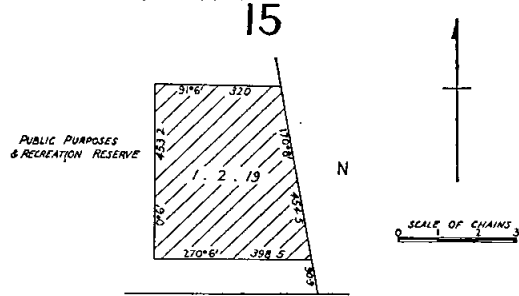

J. C. M. BALFOUR,  
Commissioner of Crown Lands and Survey.

**COMMITTEES OF MANAGEMENT OF RESERVES.  
APPOINTMENTS.**

WHEREAS by section 221 of the Land Act 1958 it is provided that it shall be lawful for the Governor in Council or the Board of Land and Works to appoint and remove any number of persons, not less than three, or any municipal council, or the governing body of any corporation, to be a Committee of Management of any specified Crown land reserved either temporarily or permanently for any of the purposes set out in section 14 of the Land Act 1958, and not conveyed to or vested in trustees: Now therefore the Board of Land and Works doth hereby appoint the under-mentioned persons to be members of the Committee of Management of the Reserves named:—

**“CUDGEWA NORTH PUBLIC RECREATION RESERVE.”**

Gordon Reynolds, Annie Phillips, Selby Jeffries, Ruben Hamilton, William Barber, Ray Campbell, Ruben Schlenker, Noelene Reynolds, Harold Star and Max Hamilton as a Committee of Management for a period ending the 15th August, 1965, of the land in the Parish of Cudgewa temporarily reserved by Orders in Council dated the 15th May, 1962, and the 27th April, 1964, as a site for Public Recreation, and known as the “Cudgewa North Public Recreation Reserve”.

This appointment is in lieu of the appointment made on the 16th August, 1962, which is hereby revoked.—(Corres. Rs.5189.)

**“NELSON PUBLIC PURPOSES AND RECREATION RESERVES.”**

Henry Geo Surman, Francis Henry Moore, Albert Stevens, Frederick John Nash, Ian McPherson, Charles Frederick Johnson and E. M. Campbell as the Committee

of Management for a period of three (3) years of the land in the Parish of Glenelg indicated by red colour on the plans marked “G” over 17.3.49 and “G” over 14.4.54 with Lands Department correspondence files Nos. Rs.4859 and Rs.4731 respectively, and known as the “Nelson Public Purposes and Recreation Reserves”.—(Corres. Rs.4859, Rs.4730, Rs.4731 and Rs.4725.)

**“ROSEBUD FORESHORE AND RECREATION RESERVE.”**

Albert Ernest Short in the place of John Maxwell Fox resigned, as a member of the Committee of Management for a period ending the 30th September, 1966, of such portion of the land reserved as a site for Public purposes in the Parish of Wannaeue as is indicated by red colour on plan marked A/11.12.1937, attached to Lands Department correspondence Rs.3351, and known as the “Rosebud Foreshore and Recreation Reserve”.—(Corres. Rs.3351.)

**“RUSHWORTH PUBLIC PARK RESERVE.”**

Leonard Charles Coyle, James Edgar Gleeson, Ronald Stewart Risstrom, John Gordon Raglus, Hubert John Priston Elms, Jeffrey Leonard Perry, George Tasman Locke, Archer Bertram Crawford, Walter Albert Locke, Alfred William Raglus and John Ellis Risstrom as a Committee of Management for a period of three (3) years of the land temporarily reserved as a site for a Public Park in the Township of Rushworth, and known as the “Rushworth Public Park Reserve”.—(Corres. Rs.767.)

**“WOODEND SWIMMING POOL AND CHILDREN’S PLAYGROUND RESERVE.”**

Gerald Keating, Alan Cameron Andison and Gilbert Gordon (for so long only as they continue to be Councillors and the elect of the Council of the Shire of Newham and Woodend) and Marjorie Ray Cranney, M. Gertrude Kellett, Russell Davies, John William Winstanley, Alan William Holmes, Harold Edward Howe and Ruby McKenzie for a period of three (3) years of the land in the Township of Woodend temporarily reserved by Order in Council dated 18th January, 1949, as a site for a Swimming Pool and Children’s Playground, and known as the “Woodend Swimming Pool and Children’s Playground Reserve”.—(Corres. Rs.6309.)

In witness whereof the common seal of the Board of Land and Works was hereunto affixed this twenty-sixth day of October, One thousand nine hundred and sixty-four, in the presence of—

(SEAL) JIM BALFOUR, President.  
L. W. BIRCH, Member.

**LOCAL LAND BOARDS.**

IN pursuance of the provisions of section 34 of the Land Act 1958, notice is hereby given that public hearings at the following places and times, will be conducted by the persons respectively mentioned, being duly appointed in that behalf.

J. C. M. BALFOUR,  
Commissioner of Crown Lands and Survey.

Department of Crown Lands and Survey,  
Melbourne.

**SCHEDULE.**

DAYLESFORD LAND INSPECTOR’S OFFICE, Thursday 19th November, 1964, at 11.30 a.m.—N. J. Cahill, G. E. Harpin.

MELBOURNE, BOARD ROOM, ROOM 206A, 2ND FLOOR, PUBLIC OFFICES, TREASURY-PLACE, Friday, 20th November, 1964, at 10 a.m.—N. J. Cahill, G. E. Harpin.

MELBOURNE, BOARD ROOM, ROOM 206A, 2ND FLOOR, PUBLIC OFFICES, TREASURY PLACE, Monday, 30th November, 1964, at 9.30 a.m.—N. J. Cahill, C. G. Knight.

COLAC LAND INSPECTOR’S OFFICE, Tuesday, 1st December, 1964, at 11.30 a.m. and Wednesday, 2nd December, 1964, at 9.30 a.m.—N. J. Cahill, C. G. Knight.

GEE LONG LAND OFFICE, Thursday, 3rd and Friday, 4th December, 1964, at 10 a.m. each day.—N. J. Cahill, C. G. Knight.

ARARAT LAND INSPECTOR’S OFFICE, COURT HOUSE, Thursday, 19th November, 1964, at 1.15 p.m.—L. Gibney.

BALLARAT LAND OFFICE, STATE OFFICES, CAMP-STREET, Friday, 20th November, 1964, at 9.15 a.m.—L. Gibney.

## Land Act 1958.

## LICENCES UNDER THE LAND ACTS 1928 AND 1958 DECLARED VOID.

NOTICE is hereby given that the Licence in the Schedule hereunder has been Declared Void for the reason specified.

District.	Corr. No.	Name of Licensee.	Section of Land Act under which Licensed.	Parish.	Allotment.	Section.	Area.	Annual Rental.	Reason for Voiding.
Melbourne	02510/129	Petroleum Refineries (Aust.) Proprietary Limited	129	Cut-Paw-Paw	Pipe-line routes through Crown lands between Railway-terrace and Breakwater Pier at Williamstown		A. R. P.	£ s. d. 25 0 0	Within area now vested in Melbourne Harbor Trust

Department of Crown Lands and Survey,  
Melbourne, 2nd November, 1964.

J. C. M. BALFOUR,  
Commissioner of Crown Lands and Survey.

## LAND SETTLEMENT ACT 1959.

IN pursuance of section 46 of the *Land Settlement Act 1959*, in so far as it extends and applies the provisions of section 125 of the *Soldier Settlement Act 1958*, I, James Charles Murray Balfour, Her Majesty's Commissioner of Crown Lands and Survey, hereby declare that the farming land specified in the Schedule hereunder to be land suitable for settlement under the *Land Settlement Act 1959*.

## SCHEDULE.

Firstly, 4,417 acres more or less, and being allotments E1, E2, 18B, 19B, 23, 24, 25, 26, 29B, 30A, 31A, 36, 37, 42A, 42B, 43, 44, 45, 73A, 73B, 74A, 74B, 76A, 78B, 79A and 79B, Parish of Rochester West and such portions of allotments 20B and 22, Parish of Rochester West as lie within the Campaspe Irrigation District.

Secondly, 2,850 acres more or less, and being allotments 73A, 73B, 73C, 74, 74A, 75A, 75B, 76, 77A, 77B, 78, 79, 82A, 82B, 83, 84, 85 and 86, Parish of Diggera.

Signed at Melbourne this 2nd day of November, 1964.

JIM BALFOUR,  
Commissioner of Crown Lands and Survey.

## TENDERS—PUBLIC WORKS DEPARTMENT

TENDERS will be received at this Department's Head Office, Treasury-place, Melbourne, until TEN a.m. on the dates, and for the purposes under mentioned.

Particulars may be learnt at the Department and also at places shown in parentheses.

W.O. means Inspector of Works Office; P.S.—Police Station; T.S.—Technical School; H.E.S.—Higher Elementary School; S.S.—State School; H.S.—High School; C.S.—Consolidated School.

Tenders should be submitted on the Department's printed Tender Form and will not be received by telephone. All tenders must be on a "Firm Tender" basis. The Board of Land and Works will not necessarily accept the lowest or any tender.

Tenders to be addressed to the Hon. the Commissioner of Public Works, and envelope containing tender to be marked "Tender for \_\_\_\_\_, closing Tuesday."

NOTE.—No preliminary deposit is to be lodged with any tender, but a deposit in accordance with the prescribed Schedule may be required from each successful tenderer.

Tuesday, 10th November, 1964.

## Building, Electrical and Mechanical Works.

Bacchus Marsh.—External painting, S.S. 28. (Amended Specification.) (W.O., Ballarat; S.S. Bacchus Marsh.)  
Bairnsdale.—Electrical installation in second and part third sections, High School. (W.O., Bairnsdale.)  
Ballarat.—Repairs and painting, S.S. 695. (W.O., Ballarat.)

Beechworth.—Provision of staff and patients toilet, &c., Mental Hospital. (W.O., Wangaratta.)

Bessiebelle.—External painting to school and residence, S.S. 2147. (W.O., Warrnambool; S.S., Bessiebelle.)

Braeside.—Repairs and painting residence—Kershaw-street, Mordialloc, S.S. 3910.

Carlton.—Additional storage space to cafeteria and new benches, &c., to kitchen, Melbourne Teachers' College.

Derrinallum.—Repairs and painting, S.S. 2050 and residence. (W.O., Camperdown; S.S., Derrinallum.)

Dimboola.—Attention to flooring, installation of slow-combustion heater, S.S. 1372. (W.O., Warracknabeal; S.S., Dimboola.)

Echuca.—Re-blocking, new toilet and bedroom, repairs and painting, High School residence—3 Minor-street. (W.O., Shepparton; H.S., Echuca.)

Fairfield.—Supply, installation and testing of paging system, Infectious Diseases Hospital.

Fern Tree Gully North.—Installation of filter plant and chlorination unit, S.S. 4718. (S.S., Fern Tree Gully North.)

Frankston.—Replacement of cisterns and wire mesh covers, S.S. 1464.

Goroke.—Erection of timber residence, garage, &c., Lands and Survey Department. (W.O., Horsham; P.S., Goroke.)

Gunbower.—Water supply installation, Research Station. (W.O., Bendigo; Research Station, Gunbower.)

Hampton.—Provision of bench—Physics Room, High School.

Horsham West.—Repairs and painting, residence—79 Wawunna-road, S.S. 4697. (W.O., Horsham.)

Iona.—Provision of storeroom and laundry, S.S. 3201. (S.S., Iona.)

Kaniva.—Supply and installation of an electric pump and pressure cylinder, High School. (W.O., Ballarat, Horsham, and H.S., Kaniva.)

Kerang.—New bicycle shed, High School. (W.O., Swan Hill; H.S., Kerang.)

Melbourne.—Electrical installation, Stage 1, Ancillary Medical School (Therapy), 625-629 Swanston-street, Health Department.

Melbourne.—Reconstruction and remodelling—Stage 1, Ancillary Medical School (Therapy), Health Department, 625-629 Swanston-street. (Specified Bills of Quantities Available.)

Melbourne.—Supply and installation of three electric passenger lifts, Ancillary Medical School (Therapy), Health Department, 629 Swanston-street.

Melbourne.—Supply, delivery, installation and testing of mechanical services, Ancillary Medical School (Therapy), Health Department, 629 Swanston-street.

Monterey.—Electrical installation in new school of fourteen L.T.C. class-rooms, &c., S.S. 4939.

Monterey.—Supply and installation of plenum heating in new fourteen class-rooms, S.S. 4939.

Mont Park.—Supply, delivery and installation of three 100-lb. drying tumblers and one 100-lb. hydro-extractor in laundry, Larundel Mental Hospital.

Mornington.—Fencing, S.S. 2033. (S.S., Mornington.)

Mount Macedon.—Erection of a Radio Repeater Station, Police Department. (W.O., Kyneton.)

Pembroke.—New Primary School of ten class-rooms, &c., with ancillary buildings, S.S. 4937.

Pembroke.—Electrical installation in new school of ten L.T.C. class-rooms, &c., S.S. 4937.

Pembroke.—Supply and installation of plenum heating in new ten class-rooms, S.S. 4937.

Reedy Flat.—Repairs and painting, S.S. 2844. (W.O., Bairnsdale; S.S., Reedy Flat.)

Robinvale.—Fencing, residences Nos. 1, 2 and 3, and Teachers' Flats, Consolidated School. (W.O., Swan Hill and Mildura; C.S., Robinvale.)

Sale.—Erection of brick Boiler House, Technical School. (W.O., Traralgon; T.S., Sale.)

Sunbury.—Erection of brick veneer residence, Mental Hospital.

Traralgon.—Erection of brick veneer residence and garage, Hobson Park Hospital. (W.O., Traralgon.)

Werribee.—Erection of brick kitchen, dining room, toilets and stores, Research Farm. (W.O., Geelong.)

Werribee.—Electrical installation for new kitchen and dining room, Research Farm.

Williamstown.—Repairs to roof, High School.

#### Furniture and Furnishings.

Carlton.—Supply of steel filing cabinets, Motor Registration Branch, Exhibition Buildings.

Essendon.—Supply and fix curtains, Technical School.

#### Site Works.

Ailsa.—Provision of concrete paving and gravel access road, S.S. 1536. (W.O., Warracknabeal.)

Bendigo.—Excavation, filling and grading of site, Psychiatric Hospital. (W.O., Bendigo.)

Colac.—Concrete paving and drainage, S.S. 117. (W.O., Camperdown and Geelong; S.S., Colac.)

Dunkeld.—Asphalt, concrete and gravel pavements, asphalt repairs and concrete kerbing, Consolidated School. (W.O., Hamilton and Warrnambool; C.S., Dunkeld.)

Eltham East.—Provision of asphalt and concrete paving and associated works, S.S., 4897.

Golden Square.—Excavation, filling, grassing and water supply to Playing Field, High School. (W.O., Bendigo.)

Grasmere.—Removal of 26 pine trees, S.S. 1817. (W.O., Camperdown and Warrnambool; S.S., Grasmere.)

Neerim South.—Earthworks, concreting, drainage, asphalt, and associated works, High School. (W.O., Traralgon and Warragul; P.S., Moe and Morwell.)

Warncoort.—Asphalt repairs, concrete and gravel paving and drainage, S.S. 2218. (W.O., Camperdown and Geelong; S.S., Warncoort.)

#### Miscellaneous.

Cornish Town.—Purchase and removal of old timber residence, S.S. 802. (W.O., Wangaratta; S.S., Cornish Town.)

Rame Head.—Salvage of light buoy and associated equipment, Ports and Harbours. (P.W.D. Depots at Lakes Entrance and Port Welshpool; Fisheries and Wildlife Department at Mallacoota.)

### Tuesday, 17th November, 1964.

#### Building, Electrical and Mechanical Works.

Altona West.—Electrical installation in four additional L.T.C. class-rooms, &c., S.S. 4862.

Altona West.—Supply and installation of plenum heating to four additional class-rooms, S.S. 4862.

Bentleigh East.—Erection of new shelter pavilion, S.S. 2083.

Bunyip.—Internal and external renovations, residence, S.S. 2229. (S.S., Bunyip.)

Clifton Hill.—Replacement of urinal and cisterns in stainless steel and various repairs to toilets, S.S. 3146.

Croydon.—Interior and exterior repairs and painting, High School.

Dromana.—Internal and external renovations, S.S. 184 and residence. (S.S., Dromana.)

Edenhope.—Replace sliding doors, provision of new concrete steps, High School. (W.O., Horsham; H.S., Edenhope.)

Forrest.—Renovations, out-offices, septic tank installation, S.S. 2708, and residence. (W.O., Camperdown; S.S., Forrest.)

Geelong.—Repairs to steel windows, Technical School. (W.O., Geelong.)

Gerang.—Boundary fencing in concrete post and wire, S.S. 2618. (W.O., Warracknabeal; S.S., Gerang.)

Gorae.—Septic tank installation and new out-office block, S.S. 2532. (W.O., Warrnambool; S.S., Gorae.)

Hampton.—External and internal repairs and painting, residence, S.S. 3754.

Harrisfield.—Renovations and additional drinking facilities, S.S. 4730.

Highbett.—Installation of troughs, sewer drain, &c., S.S. 4677.

Highton.—Connexion to sewer and fire service, S.S. 304. (W.O., Geelong; S.S., Highton.)

Mardan South.—Internal repairs and painting to residence, S.S. 3166. (W.O., Korumburra; S.S., Mardan South.)

Mordialloc.—Wire mesh fence and gates, S.S. 846.

Mt. Buffalo.—Toilet and picnic shelter block, Dingo Dell, National Park. (W.O., Benalla and Wangaratta; Ranger's Office, National Park, Mt. Buffalo.)

Oak Park.—Additional toilets, &c., S.S. 4721.

Ormond East.—Internal and external painting and repairs to cleaner's residence, S.S. 4366.

Overport.—Renovations, S.S. 4780. (S.S., Overport.)

Preston.—Electrical installation in new Trades Block, Technical School.

Richmond.—Alterations and renovations to Assembly Hall, Technical School.

South Yarra.—Timber partitions in Locker Room, Melbourne High School.

St. Albans North.—Electrical installation in two additional L.T.C. class-rooms, &c., S.S. 4811.

St. Albans North.—Supply and installation of plenum heating to two additional class-rooms, S.S. 4811.

Sunbury.—Alterations and additions to Kiosk, Mental Hospital.

Sunshine North.—Electrical installation in four additional L.T.C. class-rooms, &c., S.S. 4745.

Sunshine North.—Supply and installation of plenum heating to four additional class-rooms, S.S. 4745.

Tecoma.—New roof to Bristol unit, repairs and painting, S.S. 3356.

Terang.—Erection of out-office block, sewerage connexion and water supply installation, S.S. 617. (W.O., Camperdown; S.S., Terang.)

Tongala.—Erection of Domestic and Manual Arts Wing and additional class-rooms in cement rendered, timber-framed construction, Consolidated School. (W.O., Shepparton; C.S., Tongala.)

Tongala.—Electrical installation in new Domestic and Manual Arts Wing, Consolidated School. (W.O., Bendigo and Shepparton.)

Tongala.—Supply and installation of heating and hot-water service to Domestic and Manual Arts Wing and extension of heating in Infants Wing, Consolidated School. (W.O., Shepparton, Bendigo and Wangaratta; C.S., Tongala.)

Upper Fern Tree Gully.—Repairs and painting, new toilet and garage, S.S. 3926, residence—4 Hilltop-road.

Various.—Supply and installation of liquid petroleum gas-heating system in 23 portable class-rooms, Schools, North-Western area.

Various.—Supply and installation of liquid petroleum gas-heating system in eighteen portable class-rooms, Schools, Eastern area.

Various.—Supply and installation of liquid petroleum gas-heating system in eight portable class-rooms, Schools, Metropolitan and Western areas.

Wodonga.—Temporary connexion to sewer, Technical School and residence. (W.O., Wangaratta; T.S., Wodonga.)

#### Furniture and Furnishings.

Sebastopol.—Supply of various timber items of furniture, Technical School.

St. Albans.—Supply of various timber items of furniture, Technical School.

#### Site Works.

Clayton West.—Asphalting, concreting, drainage and associated works, S.S. 4840.

Malmsbury.—Drainage works, Stage 3, Youth Training Centre. (W.O., Bendigo and Kyneton.)

Mt. Buffalo.—Construction of concrete pondage weir at Dingo Dell, National Park. (W.O., Benalla and Wangaratta; Ranger's Office, National Park, Mt. Buffalo.)

Mt. Buffalo.—Reconstruction and construction of drains, Dingo Dell, National Park. (W.O., Benalla and Wangaratta; Ranger's Office, National Park, Mt. Buffalo.)

Warrnambool.—Asphalt and concrete paving, kerbing, channelling, retaining walls, drainage, beautification and associated works, Technical School. (W.O., Warrnambool.)

#### Miscellaneous.

Ballarat.—Supply of furniture timber, plywood and veneered corestock, Mental Hospital.

Buchan.—Supply and fabrication of five road signs, Caves Reserve, Lands Department. (W.O., Bairnsdale; P.S., Orbost.)

Coburg.—Supply of food containers, Pentridge Gaol.

Kotupna.—Purchase and removal of windmill, S.S. 1999. (W.O., Benalla; S.S., Kotupna.)

Melbourne.—Maintenance cleaning, 1st December, 1964, to 30th November, 1965, Agriculture Department, Treasury-place.

North Melbourne.—Window cleaning, period 1st November, 1964, to 31st October, 1965, Government Printing Office, Macaulay-road.

Warburton.—Purchase and removal of old timber residence, Police Station. (P.S., Warburton.)

### Tuesday, 24th November, 1964.

#### Building, Electrical and Mechanical Works.

Apollo Bay.—Renovations to Consolidated School residence, 3 Noel-street. (W.O., Camperdown; C.S., Apollo Bay.)

Box Hill.—Internal and external repairs and painting, S.S. 2383. (Amended Specification.)

Broadmeadows.—Repairs and painting, S.S. 4875.

Footscray.—Alterations to Diploma Section, Technical College.

Glen Valley.—External and internal repairs and painting, S.S. 3558. (W.O., Bairnsdale; S.S., Glen Valley.)

Hamilton.—Renewal of roof, S.S. 295. (Amended Specification.) (W.O., Hamilton.)

Irrewarra.—Internal and external painting, S.S. 4099. (W.O., Camperdown; S.S., Irrewarra.)

Irymple.—Mechanical services in new Insectary, including air conditioning and refrigeration, Research Station. (W.O., Mildura and Swan Hill.)

Merlynston.—New steel fire escape stairway, S.S. 4328.

Murrayville.—Repairs and painting, Consolidated School and residences. (W.O., Mildura; C.S., Murrayville.)

Noble Park.—Erection of chain mesh and rails to fencing, Technical School.

Sale.—Electrical installation for heating equipment, Technical School. (W.O., Traralgon and Bairnsdale; T.S., Sale.)

Sale.—Supply and installation of central heating system, Technical School. (Amended Specification.) (W.O., Bairnsdale and Warragul; T.S., Sale.)

Various.—Erection of 99 timber class-rooms, staff-rooms and stores in 34 Sub-district Contracts, comprising from one to ten class-rooms, Schools. The tenderer may tender for all or any of the Sub-District Contracts. (W.O., Alexandra, Ballarat, Geelong, Hamilton, Bairnsdale, Benalla, Bendigo, Camperdown, Horsham, Korumburra, Mildura, Traralgon, Shepparton, Swan Hill, Warracknabeal, Warragul, Wangaratta and Warrnambool.)

Warragul.—New fire and general water supply, Technical and High Schools. (W.O., Warragul.)

Werribee.—Connexion to main sewer, Police Station and residence. (W.O., Geelong; P.S., Werribee.)

Yallourn.—New toilet facilities, S.S. 4085. (W.O., Traralgon; S.S., Yallourn.)

#### Site Works.

Briar Hill.—Earthworks, asphaltting, rock beaching, concreting, drainage and associated works, S.S. 4341.

Brighton.—Asphaltting, concreting, drainage and maintenance work, Technical School.

Mansfield.—Earthworks, road construction, asphaltting, concreting, drainage and associated works, High School. (W.O., Wangaratta; H.S., Mansfield.)

Seaford.—Asphaltting, concreting, drainage and maintenance work, S.S. 3835.

#### Miscellaneous.

Royal Park.—Supply and delivery to site of steel security windows, "Turana", Social Welfare Department.

### Tuesday, 1st December, 1964.

#### Furniture and Furnishings.

Various.—Laying, sealing and polishing linoleum in various State buildings in the State of Victoria, from 1st January, 1965, to 31st December, 1965. (W.O., Geelong, Ballarat, Warrnambool, Bendigo, Shepparton and Mildura.)

#### Miscellaneous.

Melbourne.—Supply and delivery of 36-ft. pilot launch, Ports and Harbors Branch, Public Works Department. (W.O., Geelong.)

M. V. PORTER,  
Commissioner of Public Works.

Public Works Department,  
Melbourne, C.2, 2nd November, 1964.

## PUBLIC SERVICE NOTICES

Public Service Act 1958.

### PUBLIC SERVICE (PUBLIC SERVICE BOARD) REGULATION 58.

EXAMINATION—CLERK OF COURTS.

NOTICE is hereby given that the candidates named hereunder qualified for promotion to Class "C", Professional Division as Clerks of Courts at the examination held on the 6th and 7th August, 1964.

#### Name.

Crotty, Kevin Edward.  
Devlin, Desmond John.  
Hodgens, Francis.  
Lewis, Keith William.  
Murphy, John Martin.  
Ryan, Christopher John.  
Turnbull, Howard Wilson.  
Von Einem, Ian Maxwell.

The following candidates passed in the subjects shown:—

#### Statute Law No. 1.

Lewis, Keith William.  
Crotty, Kevin Edward.  
Byrne, Lewis Phillip.  
Bruckner, Robert Alan.  
Smith, Roger Thomas.  
Slattery, John Francis.  
Saker, Rodney Gerald.  
Philpott, Geoffrey Melville.  
O'Connor, Michael Hayden.  
Munro, Ronald William.

#### Statute Law No. 2.

Hodgens, Francis.  
Devlin, Desmond John.  
Crotty, Kevin Edward.  
Von Einem, Ian Maxwell.  
Turnbull, Howard Wilson.  
Ryan, Christopher John.  
Round, Murray Burton.  
McHugh, Robert John.  
Murphy, John Martin.

#### Introduction to Law and Practice.

Lewis, Keith William.  
Handley, Leonard Frederick.  
Halpin, Brian John.  
Corbo, Lawrence James  
Bolster, John Douglas.  
Smith, Roger Thomas.  
Ryan, Christopher John.  
Richardson, Malcolm John.

By order,

V. P. SCULLY,  
Secretary.

Office of the Public Service Board,  
Melbourne, 2nd November, 1964.

### APPOINTMENT OF A DEPUTY TO A MEMBER OF THE PUBLIC SERVICE BOARD.

WHEREAS in the manner prescribed by the Regulations and at an election held in conjunction with the election of Frederick Charles McArdle as the public service representative on the Public Service Board, Kevin John Tutty was elected to be his deputy in the case of his suspension, illness or absence:

And whereas the said Frederick Charles McArdle is unable by reason of illness to attend the meeting of the Board on the 28th October, 1964:

Now therefore, at the request of the said Frederick Charles McArdle and in pursuance of the powers conferred by section 15 (2A) of the *Public Service Act 1958*, I do hereby appoint the said Kevin John Tutty to be the deputy of Frederick Charles McArdle on the above-mentioned date.

Given under my hand at Melbourne this twenty-eighth day of October, 1964.

A. GARRAN,  
Chairman.

## PUBLIC SERVICE OF VICTORIA.—RECLASSIFICATIONS.

THE Public Service Board has raised the classification of the under-mentioned offices as shown, and appointed thereto the respective officers named hereunder.

Office and Former Classification.	Revised Classification.	Duties.	Qualifications.	Officer Appointed.
<b>ADMINISTRATIVE DIVISION.</b>				
<b>DEPARTMENT OF LABOUR AND INDUSTRY.</b>				
<i>Apprenticeship Commission.</i>				
Class "C1"	Class "C2"	To be officer in charge of the Schooling Section	A good knowledge of the Apprenticeship Act and Regulations and of the requirements for technical training of apprentices; experience in correspondence and controlling staff	Schmidli, J.
<b>PROFESSIONAL DIVISION.</b>				
<b>DEPARTMENT OF AGRICULTURE.</b>				
Senior Plant Pathologist, Class "B1"	Class "A"	Under the Chief Biologist to conduct research and investigation work into the cause and control of Victorian plant disease problems particularly Tobacco diseases; to survey plant disease outbreaks and deliver lectures, conduct field experiments, and other work in plant pathology as required	Bachelor of Agricultural Science or Science with a sound post graduate training in plant pathology; experience in the conduct of research and advisory work in plant disease problems and their control; experience in the investigation of Tobacco diseases; capacity to lecture, conduct laboratory and field experiments and prepare suitable scientific reports	Paddick, R. G.
<b>TECHNICAL AND GENERAL DIVISION.</b>				
<b>DEPARTMENT OF AGRICULTURE.</b>				
Orchard Inspector, Grades 32-34 inclusive (four offices)	Orchard Inspector, Senior, Grade 35	To accept supervisory responsibilities in the work of fruit fly control and eradication; to inspect fruit in shops, markets and orchards for the presence of pests and diseases; other duties as required	A good knowledge of the principles and practice of fruit fly control and eradication and relevant legislation; to have passed the prescribed examination for appointment to the position of Orchard Inspector in the Technical and General Division and to have had at least twelve months experience in that position; ability to supervise staff	Pump, W. H. Bloom, A. A. Hicks, L. J. McLauchlan, W. A.
Motor Mechanic, Grades 21-24 inclusive	Motor Mechanic Instructor, Grade 26	To maintain and repair trucks, tractors and engines on the College property and to instruct students in driving and mechanical repairs and maintenance; to assist generally in the Mechanized Section; other duties as required	A competent and qualified motor mechanic with experience in the maintenance and repair of motor vehicles and tractors; ability to instruct students	Gillard, G. W.

Office of the Public Service Board,  
Melbourne, 2nd November, 1964.

By order,  
V. P. SCULLY,  
Secretary.

## PUBLIC SERVICE OF VICTORIA.—VACANCIES.

APPLICATIONS will be received by the Public Service Board up to Wednesday, the 18th November, 1964, from persons employed in the Public Service of Victoria, who are eligible and qualified for appointment to the under-mentioned positions:—

## ADMINISTRATIVE DIVISION.

**Manager, Melbourne Branch, Victorian Government Tourist Bureau, Class "A", Tourist Development Authority, Premier's Department.**

*Yearly Salary.*—£2,613, minimum; £2,763, maximum.

*Duties.*—To be Manager of the Victorian Government Tourist Bureau, Melbourne.

*Qualifications.*—To be conversant with all forms of travel, inside and outside Australia, and with the operations, booking, accounting and rostering procedures of Victorian Government Tourist Bureaux. Capable of controlling staff.

**NOTE.**—The Officer appointed to this position will be required to work a regular five-and-a-half day week—Monday to Saturday morning, inclusive.

## Class "C1", Department of Crown Lands and Survey.

*Yearly Salary.*—£1,558, minimum; £1,668, maximum.

*Duties.*—To keep the Expenditure Appropriation Ledger and to be responsible for the Department Advance Account, Cash-book and Journal of Expenditure; to control and reimburse accounts in country centres.

*Qualifications.*—A good knowledge of the appropriate sections of the Acts authorizing departmental expenditure and of the Public Accounts and Stores Regulations 1958.

## Class "C1", National Parks Authority, Premier's Department.

*Yearly Salary.*—£1,558, minimum; £1,668, maximum.

*Duties.*—To assist the Secretary of the Authority; to prepare reports on meetings of technical sub-committees; to have charge of the preparation of leases and permits; to prepare draft works and maintenance budgets; to handle liaison with constructing authorities, Committees of Management and municipal councils regarding the Authority's works programme; other duties as required.

**Qualifications.**—Ability to conduct interviews and prepare reports; preferably a knowledge of legislation affecting national parks and the organization of the Authority and park committees; a current motor driver's licence is desirable.

**Classes "C"—"C1", Office of the Public Trustee, Law Department.**

**Yearly Salary.**—£1,283, minimum; £1,668, maximum.

**Duties.**—To act as Assistant Trust Officer and to relieve Trust Officers (Protected Persons' Section).

**Qualifications.**—A general knowledge of the provisions of the Public Trustee Act relating to and preferably experience in the administration of estates of Protected Persons and of the Mental Health Act.

**Class "E", Tongala Centre, Water Supply Department.**

Applications are invited from Class "E". Administrative Division officers, who are desirous of transferring to the above position.

**PROFESSIONAL DIVISION.**

**Assistant Agricultural Extension Officer, Classes "C"—"C2", Department of Agriculture.**

**Yearly Emolument.**—£1,613, minimum; £2,293, maximum.

(Commencing salary will be determined according to experience.)

**Duties.**—After a period of training to undertake district agricultural extension work.

**Qualifications.**—A Degree in Agricultural Science.

**Chemist, Classes "C"—"C2", Explosives and Gas Examining Branch, Chief Secretary's Department.**

**Yearly Emolument.**—£1,448, minimum; £2,293, maximum (Degree in Science).

£1,393, minimum; £2,293, maximum (Diploma in Chemistry.)

(Commencing salary will be determined according to qualifications and experience.)

**Duties.**—To examine and test explosives and other hazardous materials; to test gas in accordance with provisions of the Gas Regulation Act and the Liquefied Petroleum Gas Act; to test inflammable liquids in accordance with the Inflammable Liquids Act; to perform inspectional duties as directed and to conduct investigations in connexion with explosions and into matters related to explosives, liquefied petroleum gas, inflammable liquids and other dangerous substances.

**Qualifications.**—A Degree in Science with Chemistry as a major subject or a Diploma of Applied Chemistry from an approved technical college and to be an Associate of the Royal Australian Chemical Institute; special training and experience in the examination and testing and the physical and chemical properties of explosives and other dangerous substances; a good general knowledge of explosives factory procedure and of safety principles applicable to the petroleum and liquefied petroleum gas industries, a good knowledge of the Explosives Act, the Gas Regulation Act, the Inflammable Liquids Act and the Liquefied Petroleum Gas Act and Regulations would be an advantage.

**NOTE.**—Applications will be accepted from persons expecting to qualify at the end of the current academic year.

**TECHNICAL AND GENERAL DIVISION.**

**Ticket Printer, Foreman, Government Printing Office, Treasury.**

**Yearly Salary.**—£1,591.

**Duties.**—To take charge of the Daily Ticket Branch of the Government Printing Office; to maintain records; other duties as required.

**Qualifications.**—A sound knowledge of the organization and operation of the Daily Ticket Branch; experience in the running of railway ticket printing machines; ability to control staff.

**Chief Prison Officer, Prisons Division, Social Welfare Branch, Chief Secretary's Department. (Two vacancies.)**

**Yearly Salary.**—£1,487, minimum; £1,539, maximum.

**Position No. 1.**

**Duties.**—Under the direction of the Superintendent Langi Kal Training Centre to control staff and assist in the management of the institution; or

to fill any position of equivalent rank in the Prisons Division as directed, to live in quarters provided.

**Position No. 2.**

**Duties.**—Under the direction of the Governor Beechworth Training Prison to control staff and assist in the management of the institution; or to fill any position of equivalent rank in the Prisons Division as directed. To live in quarters provided.

**Positions Nos. 1 and 2.**

**Qualifications.**—To be a Senior Prison Officer who has passed the examinations under Regulation 63 of the Public Service (Public Service Board) Regulations for promotion to Chief Prison Officer; a good knowledge of prison problems and modern development, and able to control staff and prisoners.

**NOTE.**—Rent for the quarters is 7½ per cent. of total emolument inclusive of the allowance payable under Regulation 74 less £27 4s. 6d. a year.

Separate applications must be submitted for these positions.

**Draughting Assistant, Grade III., Department of Crown Lands and Survey.**

**Yearly Salary.**—£1,259, minimum; £1,331, maximum.

**Duties.**—To assist in the preparation of topographic maps from aerial photographs using second order stereo-plotting equipment.

**Qualifications.**—A good knowledge of the use of aerial photographs for topographic mapping, and conversant with the principles of A.G. Stereo-Plotting and Multiplex equipment.

**Works Inspector, Tongala Centre, Water Supply Department.**

**Yearly Salary.**—£1,259, minimum; £1,331, maximum.

**Duties.**—To supervise water distribution within his section of the district, and, under direction, to supervise the construction, maintenance and repair of works and gangs and workmen engaged on these works; to be responsible for material and equipment in his charge and to keep records of work done and render reports as required.

**Qualifications.**—Capable of setting out work from plans; extensive experience in the construction, maintenance and repair of supply channels and drainage systems in Irrigation Districts, and in the distribution and disposal of water; capacity for handling men and supervising gangs; capable of keeping records.

**NOTE.**—The successful applicant will be required to occupy the official residence provided and vacation of the residence will not be permitted without the express approval of the Water Supply Department. A rental of 10 per cent. of total emolument inclusive of the amount payable under Regulation 74, less £36 6s. a year will be charged. Occupancy will be subject to a formal tenancy agreement being entered into. Particulars are available from the Water Supply Department.

**Plumber, Public Works Department.**

**Yearly Salary.**—£1,061, minimum; £1,115, maximum.

**Duties.**—To perform general plumbing work and to attend to roofs, gutters and stormwater drains, gas, water and sewerage services and to assist with hot water and heating systems and to generally assist the Senior Engineer Plumber.

**Qualifications.**—A qualified plumber with the Certificate of the Melbourne and Metropolitan Board of Works; able to prepare reports; a good knowledge of the gas, water, sewerage, hot water and heating installations in the public buildings in the Melbourne city area is desirable.

**Youth Officers (Male), Youth Welfare Division, Social Welfare Branch, Chief Secretary's Department. (Six vacancies).**

**Yearly Salary.**—£972, minimum; £1,115, maximum.

**Duties.**—To assist in the care, supervision and treatment of youth trainees.

**Qualifications.**—Ability to acquire and apply a knowledge of modern methods of care and treatment, and of the instructions and procedures of a Youth Training Centre, preferably, experience in youth

work. To have passed the examinations prescribed under Regulation 34 (4) of the Public Service (Public Service Board) Regulations and be between the ages of 21 and 47 years.

**Shorthand Writer and Typist (Female), Senior, Probation and Parole Division, Social Welfare Branch, Chief Secretary's Department.**

*Yearly Salary.*—£1,007, minimum; £1,043, maximum.

*Duties.*—As Secretary to the Chief Probation and Parole Officer, to be responsible for the supervision of the work of the Shorthand Writer and Typists staff of the Division.

*Qualifications.*—A competent typist with ability to write shorthand at the rate of 100 words a minute.

**Storeman, Grade II., Office of the Chief Commissioner of Police, Chief Secretary's Department. (Two vacancies.)**

*Yearly Salary.*—£972, minimum; £1,025, maximum.

*Duties.*—To serve at the counter, assist generally in the store, and undertake clerical work.

*Qualifications.*—Familiar with the different types of motor vehicle parts and accessories and capable of keeping records.

*NOTE.*—As a skeleton staff must always be maintained in the Store, the successful applicants will be rostered for duty on week-ends and public holidays, and paid additional rates under Regulation 110 of the Public Service (Public Service Board) Regulations. They will normally work on day shift but may be rostered, at regular intervals, to work a shift from 2 p.m. to 10.30 p.m.

**Chauffeur, Departmental, Local Government Department.**

*Yearly Salary.*—£972, minimum; £989, maximum.

*Duties.*—To drive departmental motor vehicle as required; to be responsible for its regular maintenance; to keep records; other duties as required.

*Qualifications.*—To be capable, reliable and experienced driver and able to effect minor repairs to a motor vehicle.

**Storeman, Grade I., Office of the Chief Commissioner of Police, Chief Secretary's Department. (Two vacancies.)**

*Yearly Salary.*—£921, minimum; £938, maximum.

*Position No. 1.*

*Duties.*—To drive the delivery truck operated by the General Store, deliver and collect goods, and assist generally in the Store.

*Qualifications.*—A current driver's licence and prepared to qualify as an approved driver of Police Vehicles. To be energetic and capable of handling heavy parcels.

*Position No. 2.*

*Duties.*—To assemble and pack stores for distribution to Police Stations and assist generally.

*Qualifications.*—Energetic and capable of handling heavy parcels. Some previous experience in the handling of stores, the possession of a current motor car driver's licence and willingness to qualify as an approved driver of Police vehicles would be an advantage.

*NOTE.*—Separate applications must be submitted for these positions.

**Assistant (Female), Grade III., Motor Registration Branch, Office of the Chief Commissioner of Police, Chief Secretary's Department.**

*Yearly Salary.*—£881, minimum; £917, maximum.

*Duties.*—To complete refund claim forms and prepare Treasury Schedules and reimbursements.

*Qualifications.*—A good knowledge of the various classifications and fees under the Motor Car Acts and the Motor Car (Third Party Insurance) Regulations; a competent typist.

The salary rates quoted above do not include the additional amount which is payable under Regulation 74 of the Board's Regulations.

By order,  
V. P. SCULLY,  
Secretary.

Office of the Public Service Board,  
Melbourne, 2nd November, 1964.

**PUBLIC SERVICE OF VICTORIA.—VACANCY.**

(TEMPORARY APPOINTMENT.)

APPLICATIONS will be received by the Public Service Board up to Wednesday, the 18th November, 1964, from persons who are qualified for appointment to the under-mentioned position:—

**Caretaker (Resident), State Accident Insurance Office Chief Secretary's Department.**

*Yearly Salary.*—£921.

*Duties.*—To act as Caretaker and be responsible for maintaining building services including the boiler for central heating; to effect minor repairs; to control and direct cleaning staff and assist with cleaning when necessary.

*Qualifications.*—To be physically capable of performing the duties, reliable and able to undertake minor repairs. Ability to control staff and experience in cleaning duties.

*NOTE.*—The salary rates quoted above do not include the additional amount which is payable under Regulation 74 of the Board's Regulations.

By order,  
V. P. SCULLY,  
Secretary.

Office of the Public Service Board,  
Melbourne, 2nd November, 1964.

**PUBLIC SERVICE OF VICTORIA.—VACANCIES.**

**DEPARTMENT OF HEALTH.**

**MENTAL HYGIENE BRANCH.**

**TECHNICAL AND GENERAL DIVISION.**

APPLICATIONS will be received by the Public Service Board up to Wednesday, 25th November, 1964, from persons employed in the Public Service of Victoria, who are eligible and qualified for appointment to the under-mentioned positions:—

**Assistant Head Nurse (Female), St. Nicholas Hospital, Carlton.**

*Yearly Salary.*—£1,115, minimum; £1,187, maximum.

*Duties.*—To assist Head Nurse (Female) in management of the Hospital, and to prepare leave sheets and other records as directed.

*Qualifications.*—A current practising certificate for Mental Defectives. Ability to direct and control staff and patients and keep records.

*NOTE.*—Successful applicant may be required to work an eight-hour roster.

(This advertisement is in lieu of that for an Assistant Head Nurse (Female), St. Nicholas Hospital, Carlton, which appeared on page 3235 of the *Government Gazette* dated 14th October, 1964.)

**Painter, Grade II., Sunbury.**

*Yearly Salary.*—£1,061, minimum; £1,115, maximum.

*Duties.*—To carry out general painting and glazing.

*Qualifications.*—A competent and qualified painter (conversant with mixing and using of paints) and glazier.

**Cook (Male), Grade I., Larundel.**

*Yearly Salary.*—£1,025, minimum; £1,043, maximum.

*Duties.*—To assist in preparation, cooking and serving of meals for patients and staff, and cleanliness of kitchen.

*Qualifications.*—A knowledge of and experience in large quantity cooking.

**Charge Nurse (Female), Beechworth.**

*Yearly Salary.*—£953, minimum; £1,025, maximum.

*Duties.*—To take charge or sub-charge of a ward in a Mental Hospital and to assist in the training of Student Nurses and Ward Assistants.

*Qualifications.*—A current practising Certificate for Mental Nursing.

**Charge Nurse (Female), St. Nicholas Hospital, Carlton. (Four Vacancies.)**

*Yearly Salary.*—£953, minimum; £1,025, maximum.

*Duties.*—To take charge or sub-charge of a ward in a Mental Hospital.



**Qualifications.**—A current practising Certificate for Mental Defectives and experience as a Deputy Charge Nurse in a Mental Hospital.

**NOTE.**—Successful applicants may be required to work an eight-hour roster.

(This advertisement is in lieu of that for a Charge Nurse (Female), St. Nicholas Hospital, Carlton (Four Vacancies), which appeared on page 3236 of the *Government Gazette*, dated 14th October, 1964.)

**Fireman, Bendigo.**

**Yearly Salary.**—£972, minimum; £1,007, maximum.

**Duties.**—To fire boilers and to assist Engineer Mechanic.

**Qualifications.**—Boiler Attendant's Certificate or higher qualifications.

**Deputy Charge Nurse (Female), All Institutions.**

**Yearly Salary.**—£881, minimum; £917, maximum.

**Duties.**—To be second in charge of a ward.

**Qualifications.**—A current practising certificate for Mental Defectives and approved experience or a current practising Certificate for Mental Nursing and approved experience.

**Deputy Charge Nurse (Female), St. Nicholas Hospital, Carlton. (Ten vacancies.)**

**Yearly Salary.**—£881, minimum; £917, maximum.

**Duties.**—To be second in charge of a ward.

**Qualifications.**—A current practising Certificate for Mental Defectives and approved experience.

**NOTE.**—Successful applicants may be required to work an eight-hour roster.

(This advertisement is in lieu of that for a Deputy Charge Nurse (Female), St. Nicholas Hospital, Carlton (Ten Vacancies), which appeared on page 3236 of the *Government Gazette*, dated 14th October, 1964.)

The salary rates quoted above do not include the additional amount which is payable under Regulation 74 of the Board's Regulations.

By order,  
V. P. SCULLY,  
Secretary.

Office of the Public Service Board,  
Melbourne, 2nd November, 1964.

**PRIVATE ADVERTISEMENTS**

(Published in lieu of advertisement appearing on pp. 2652 and 2653, *Victoria Government Gazette*, No. 71, 12th August, 1964.)

**CITY OF BOX HILL**

**BY-LAW No. 117**

*Camping and Caravan By-law*

A by-law of the City of Box Hill made under Sections 97 and 198 of the *Local Government Act 1958* and Numbered 117 for prohibiting or regulating camping on roads, prohibiting or regulating the leaving standing of caravans on streets or roads and the placing of caravans on private property, prohibiting regulating and restricting the use of caravan or camping parks or sites and regulating restricting restraining or prohibiting the erection of buildings or erections.

**IN** pursuance of the powers conferred by the *Local Government Act 1958* and of any and every other power it thereunto enabling the Mayor Councillors and Citizens of the City of Box Hill orders as follows:—

- (1) This By-law may be known as the Camping and Caravan By-law.
- (2) No person shall camp on any road.
- (3) No person shall leave standing any caravan on any street or road for any period exceeding twenty-four hours.
- (4) Subject as is hereinafter provided no person shall without the prior consent in writing of the Council place any caravan on any private property which is not a camping area in respect of which a current permit issued by the Council under the *Camping Regulations 1958* or any amendment or alteration thereof is in existence Provided Always that nothing in this clause shall prevent:
  - (a) The placing by the owner of any land of not more than one caravan belonging to him on such land where such caravan is not without the prior consent in writing of the Council used by any person for the purpose of sleeping or living therein.
  - (b) The placing of caravans for sale or hire on any land the use of which for the purposes of the business of selling or hiring caravans is not prohibited by any Planning Scheme made under the *Town and Country Planning Act 1961* or any statutory amendment modification or re-enactment thereof By-law or Regulation or in respect of which a permit for such use has been granted under any Interim Development Order made under the *Town and Country Planning Act 1961* or any statutory amendment modification or re-enactment thereof.
- (5) No person shall without the prior consent in writing of the Council erect or construct on any land any tent or similar structure.
- (6) This By-law shall apply to and have operation throughout the whole of the municipal district.
- (7) Any person guilty of a continuing offence contrary to this By-law shall be liable to a penalty of Five pounds for each day on which an offence against this By-law shall be continued after a conviction or order by any Court.

Resolution for passing the By-law agreed to by the Council of the City of Box Hill on the twenty-third day of March 1964 and confirmed on the twentieth day of April 1964.

THE CORPORATE SEAL OF THE MAYOR)  
COUNCILLOR AND CITIZENS OF THE)  
CITY OF BOX HILL was hereunto affixed)  
in the presence of:

E. O. LUNDGREN      MAYOR  
W. G. HOSIE          COUNCILLOR  
A. N. WALLS          TOWN CLERK

Approved by the Governor-in-Council the fifteenth day of July 1964.

3202

J. COLQUHOUN  
Clerk of the Executive Council.

No. 1441.

*Public Service Act 1958, Section 50.*

**REGULATIONS.—PART IV.—SALARIES AND INCREMENTS.**

**T**HE Public Service Board, in pursuance of the powers conferred by the *Public Service Act 1958*, hereby amends its Regulations as shown below:—

**SIXTH SCHEDULE.**  
**TEMPORARY EMPLOYEES.**

*Designations of Positions and Rates of Salaries.*

Department and Designation of Position.	Yearly Rate of Salary.		Increments (Annual).
	Minimum.	Maximum.	
GENERAL.	£	£	
Add—Scientific Officer (Female)..	1,151	1,721	2 of £55, 1 of £110, 2 of £55, 1 of £120 and 2 of £60

A. GARRAN, Chairman.  
V. P. SCULLY, Secretary.

Office of the Public Service Board,  
Melbourne, 19th October, 1964.

CITY OF CHELSEA.

LOAN No. 36.

*Notice of Intention to Borrow.*

NOTICE is hereby given that the Council of the City of Chelsea intends to borrow Thirty-five thousand pounds (£35,000) on the credit of the Mayor, Councillors and Citizens of the said City by the grant of a mortgage in accordance with the provisions of the *Local Government Acts*.

In connexion therewith the following information is stated:—

- (a) The amount of the principal moneys which it is proposed to borrow is £35,000.
- (b) The maximum rate of interest that may be paid is Five pounds ten shillings (£5 10s.) per centum per annum.
- (c) The times at which the moneys borrowed are to be repayable are on the 1st day of March and the 1st day of September in each year, the loan to have a currency of fifteen (15 years), the first payment to be made on the 1st day of September, 1965.
- (d) The manner in which the loan is to be liquidated is by provision out of the municipal fund in each half-year during the currency of the Loan of the sum of £1,728 9s. 2d. which includes principal and interest.
- (e) Such moneys shall be repayable at the Commonwealth Banking Corporation Melbourne.
- (f) The purposes for which the Loan is to be applied are:—

	£
1. Purchase of Land .. .. .	20,000
2. Provision of Radio Control for Vehicles .. .. .	1,000
3. Road Crossings .. .. .	5,000
4. Construction of Concrete Foot-paths .. .. .	4,000
5. Development of Reserves .. .. .	5,000
	£35,000

The plans and specifications and the estimate of the cost of the proposed works and a statement showing the proposed expenditure of the moneys to be borrowed are open for inspection at the Municipal Offices, Chelsea, during office hours.

Dated this 4th day of November, 1964.

3243 F. J. WALSHE, Town Clerk.

CITY OF KEW.

LOAN No. 51.

*Notice of Intention to Borrow the Sum of £50,000 for Permanent Works and Undertakings.*

NOTICE is hereby given that the Council of the City of Kew proposes to borrow the sum of £50,000 on the credit of the municipal revenues of the Mayor, Councillors and Citizens of the said City, such sum to be raised by the sale of debentures, in accordance with the provisions of the *Local Government Acts*.

1. The maximum rate of interest that may be paid is Five pounds ten shillings (£5 10s.) per cent. per annum.
2. The period of the loan shall be 20 years.
3. The moneys borrowed shall be repayable by providing out of the municipal fund 40 half-yearly instalments of £2,076 11s. 6d. each, including principal and interest, on the 30th day of April and the 30th day of October during the currency of the loan. The first instalment shall be payable on the 30th day of October, 1965.
4. Such moneys shall be repayable at the National Bank of Australasia Limited, Melbourne, or at the Council's bankers for the time being in Melbourne.
5. The purposes for which the loan is to be applied are—

Traffic Improvements—	
Traffic Light Control Signals .. .. .	£4,000
Construction of Burke-road Bridge and Approaches .. .. .	10,000
Reconstruction of Streets—	
Willsmere-road, aBeckett-street, Charles-street, St. John's-parade, Stirling-street, Foley-street, Park-crescent, Loch-street, Ridgeway-avenue, Dean-street, Scott-street, Wills-street, Eglinton-street, Barry-street .. .. .	35,300
Underground Drain—Malin-street .. .. .	700
	£50,000

The plans and specifications and the estimate of the cost of the proposed works, and a statement showing the proposed expenditure of the moneys to be borrowed, are open for inspection at the Town Hall, Walpole-street, Kew.

Dated this 28th day of October, 1964.

3222 W. D. BIRRELL, Town Clerk.

CITY OF KEW.

LOAN No. 52.

*Notice of Intention to Borrow the Sum of £50,000 for Permanent Works and Undertakings.*

NOTICE is hereby given that the Council of the City of Kew proposes to borrow the sum of £50,000 on the credit of the municipal revenues of the Mayor, Councillors and Citizens of the said City, such sum to be raised by the grant of a mortgage, in accordance with the provisions of the *Local Government Acts*.

1. The maximum rate of interest that may be paid is Five pounds ten shillings (£5 10s.) per cent. per annum.
2. The period of the loan shall be 20 years.
3. The moneys borrowed shall be repayable by providing out of the municipal fund 40 half-yearly instalments of £2,076 11s. 6d. each, including principal and interest, on the 30th day of April and the 30th day of October during the currency of the loan. The first instalment shall be payable on the 30th day of October, 1965.
4. Such moneys shall be repayable at the National Bank of Australasia Limited, Melbourne, or at the Council's bankers for the time being in Melbourne.
5. The purposes for which the loan is to be applied are—

Municipal Depot—	
Buildings to house plant .. .. .	£5,000
Places of Public Resort and Recreation—	
Swimming Pool Improvements .. .. .	£14,000
Willsmere Park — Dressing Pavilion .. .. .	8,500
Victoria Park — Fencing and Parking Area .. .. .	1,000
	23,500
Construction of Roads—	
Studley Park-road, Princess-street, Harp-road, Burke-road, Wellington-street .. .. .	19,000
Reconstruction of Walmer-street Bridge Approaches .. .. .	2,500
	£50,000

The plans and specifications and the estimate of the cost of the proposed works, and a statement showing the proposed expenditure of the moneys to be borrowed, are open for inspection at the Town Hall, Walpole-street, Kew.

Dated this 28th day of October, 1964.

3221 W. D. BIRRELL, Town Clerk.

CITY OF NORTHCOTE.

LOAN No. 73.

*Notice of Intention to Borrow.*

NOTICE is hereby given that the Council of the City of Northcote intends to borrow £20,000 (Twenty thousand pounds) on the credit of the Mayor, Councillors, and Citizens of the said City by the grant of a mortgage in accordance with the provisions of the *Local Government Acts*.

In connexion therewith the following information is stated:—

- (a) The amount of the principal moneys which it is proposed to borrow is £20,000 (Twenty thousand pounds).
- (b) The maximum rate of interest that may be paid is £5 10s. per centum per annum.
- (c) The times which the moneys borrowed are to be repayable are the 1st day of September, 1965, and the 1st days of March and September during the years, 1966-1980 inclusive, and that the place such moneys shall be repayable is at the Bank of New South Wales, Northcote.
- (d) The purpose for which the loan is to be applied is:—

1. Development of Garbage Depots, including purchase of new machinery for use therein.
2. Replacement of Traffic Control Signals.
3. Development of Reserves.
4. Road Reconstruction.

- (e) The manner in which the loan is to be liquidated is by provision out of the municipal fund in each half-year during the currency of the loan of the sum of £987 13s. 9d. which includes principal and interest.

The plans and specifications and estimate of the cost of the works and a statement showing the proposed expenditure of the moneys to be borrowed are open for inspection at the Town Hall.

Dated this 2nd day of November, 1964.

3245

E. MASON, Town Clerk.

## CITY OF OAKLEIGH.

LOAN No. 93.

*Notice of Intention to Borrow the Sum of £50,000 for Permanent Works and Undertakings.*

NOTICE is hereby given that the Council of the City of Oakleigh proposes to borrow the sum of Fifty thousand pounds on the credit of the municipal revenues of the Mayor, Councillors and Citizens of the said City, such sum to be raised by the grant of a mortgage, in accordance with the provisions of the *Local Government Act 1958*.

1. The maximum rate of interest that may be paid is 5s. 10s. per cent. per annum.

2. The purpose for which the loan is to be applied is—

(a) Road reconstruction .. ..	£42,950
(b) Footway construction .. ..	3,050
(c) Drainage work .. ..	4,000
	£50,000

3. The currency of the loan shall be fifteen years.

4. The moneys borrowed shall be liquidated by the payment of 30 half-yearly instalments of approximately £2,469 4s. 5d. each, including principal and interest, on the 1st day of September and the 1st day of March during the years 1965/80 inclusive. The first instalments shall be payable on the 1st day of September, 1965.

5. The place that the moneys shall be repayable is at the C.B.C. Savings Bank Limited, Oakleigh.

The plans and specifications and the estimate of the cost of the proposed works, and a statement showing the proposed expenditure of the moneys to be borrowed, are open for inspection at the Municipal Offices, Atherton-road, Oakleigh.

3214

A. E. RAVEN, Town Clerk.

## BOROUGH OF KYABRAM.

BY-LAW No. 12.

A By-law of the Borough of Kyabram, made under the *Local Government Act 1958*, and the Uniform Building Regulations of Victoria, and numbered 12, for determining, applying, dispensing with or regulating such matter or things as are left to be determined, applied, dispensed with or regulated by the Council of the said Borough of Kyabram, under the Uniform Building Regulations of Victoria.

PURSUANT to the powers conferred by the *Local Government Act 1958*, the Uniform Building Regulations of Victoria and all other powers thereunto enabling the Mayor, Councillors and Burgesses of the Borough of Kyabram order as follows:—

1. By-law No. 2 of the Borough of Kyabram is hereby repealed.

2. This By-law shall come into operation on the day after publication in the *Government Gazette* of—

- (a) This By-law; or  
(b) notice of its making,

as the case may be.

3. The areas set out as described in the First Schedule hereto are hereby prescribed as Brick areas and no person shall in any such area construct or cause to be constructed any building the external walls of which are of material other than masonry or concrete save and except an outbuilding having a floor area of less than 100 square feet.

4. The minimum area, depth and width of frontage specified in column 3 of Table 804, of Uniform Building Regulations, Victoria (hereinafter called the Regulations) as amended by Uniform Building Regulations Amending Regulations No. 2, 16th December, 1959, are hereby adopted as the minimum area, depth, width and frontage of land on which a building of Class I. or II. shall be constructed throughout the municipal district of the said Borough of Kyabram.

5. (a) The minimum distance of the outer wall of any building of Class I. or II. occupancy from the frontage of any land is hereby specified as 15 feet.

(b) No person shall construct any building of Class I. and II. occupancy closer to the frontage of any land than 15 feet.

6. In the case of a building or any land forming part of a subdivision approved by the Council and lodged with the Office of Titles prior to the date of commencement of the Regulations the requirements of clause 813 of the Regulations are hereby dispensed with.

## FIRST SCHEDULE.

(a) That portion of Allan-street to a depth of 100 feet from the Building line lying between the eastern building lines of Dawes-road and Saunders-street, and the point where the Echuca-Toolamba railway line crosses Allan-street at the eastern end thereof.

(b) That portion of Albion-street to a depth of 100 feet from the building line from the northern building line of Allan-street to the southern building line of Station-street.

(c) That portion of Union-street to a depth of 100 feet from the building line from the southern building line of the intersection of Tulloh and Drum-streets to the northern building line of Fenaughty-street.

(d) That portion of Lake-road to a depth of 100 feet from the building line from the southern building line of Allan-street to the northern building line of Fenaughty-street.

(e) That portion of Church-street to a depth of 100 feet from the building line from the northern building line of Allan-street to the southern building line of Tulloh-street.

(f) The whole of Bradley-street to a depth of 100 feet from the building line.

(g) That portion of Fenaughty-street to a depth of 100 feet from the building line lying between the eastern building line of Bishop-street and the eastern building line of Goddard-street.

(h) The whole of Unitt-street to a depth of 100 feet from the building line.

(i) That portion of the south side of Tulloh-street to a depth of 100 feet from the building line lying between the western building line of Union-street and the eastern building line of Church-street.

(j) The whole of the south side of Drum-street to a depth of 100 feet from the building line.

Resolution for passing this By-law agreed to by the Council on the 23rd March, 1960, and confirmed on the 27th April, 1960.

The common seal of the Mayor, Councillors and Burgesses of the Council of the Borough of Kyabram was hereto affixed this 27th day of April, 1960, in the presence of—

(SEAL) ARTHUR E. CROW, Mayor.  
THEO. HOWARD, Councillor.  
JACK A. CLAREY, Town Clerk.

Approved by the Governor in Council, 13th October, 1964.—J. COLQUHOUN, Clerk of the Executive Council.

3233

## Local Government Act 1958, Section 512.

SHIRE OF ALTONA.

NOTICE OF INTENTION TO TAKE LAND COMPULSORILY.

*Library Site—The Circle—Altona East.*

WHEREAS the Council of the Shire of Altona deems it expedient to execute the works or undertakings of providing the land described as:

Lots 706 and 707 of lodged plan 12843 at The Circle, Altona East,

for a site for a municipal library:

And whereas for the purpose thereof the exercise of the compulsory power of taking the said land will in the Council's opinion be necessary and desirable:

And whereas the Council has caused to be prepared a plan setting out and describing such work or undertaking and the exact site and measurements thereof and the names of the owners or reputed owners, lessees or reputed lessees and the occupiers thereof as far as such names can be ascertained by the Council:

And whereas such plan is deposited at the office of the said Council at 115 Civic-parade, Altona, and is and shall be open for inspection by all persons interested at all reasonable hours for the space of 40 clear days after publication in the *Government Gazette*:

Now notice is hereby given to all persons affected by the proposed work or undertaking to the said Council or the Shire Secretary of the Shire of Altona within 40 clear days from the publication of this notice in the *Government Gazette* all objections which they may have to the said works or undertaking.

Dated at Altona this 27th day of October, 1964.

3206 JAMES W. WATERS, Shire Secretary.

*Local Government Act 1958, Section 512.*

SHIRE OF ALTONA.

NOTICE OF INTENTION TO TAKE LAND COMPULSORILY.

*Pedestrian Underpass—Altona North.*

WHEREAS the Council of the Shire of Altona deems it expedient to execute the works or undertakings of providing the land described as:

Lots 46, 47 and 48 of lodged plan 12103 in Millers-road, Altona North,

for the provision of land for the laying down of a trackway or pavement in connexion with the provision of a pedestrian underpass across Millers-road adjacent thereto:

And whereas for the purpose thereof the exercise of the compulsory power of taking the said land will in the Council's opinion be necessary and desirable:

And whereas the Council has caused to be prepared a plan setting out and describing such work or undertaking and the exact site and measurements thereof and the names of the owners or reputed owners, lessees or reputed lessees and the occupiers thereof as far as such names can be ascertained by the Council:

And whereas such plan is deposited at the office of the said Council at 115 Civic-parade, Altona, and is and shall be open for inspection by all persons interested at all reasonable hours for the space of 40 clear days after publication in the *Government Gazette*:

Now notice is hereby given to all persons affected by the proposed work or undertaking to the said Council or the Shire Secretary of the Shire of Altona within 40 clear days from the publication of this notice in the *Government Gazette* all objections which they may have to the said works or undertaking.

Dated at Altona this 27th day of October, 1964.

3207 JAMES W. WATERS, Shire Secretary.

SHIRE OF BARRABOOL.

NOTICE is given that Mr. J. L. Vagg, of Moriac, has been appointed as Poundkeeper for the Shire of Barrabool, in lieu of Mr. H. Collins.

3232 G. L. PEARCE, Shire Secretary.

*Town and Country Planning Act 1961 (Twelfth Schedule).*

NOTICE THAT A PLANNING SCHEME HAS BEEN PREPARED AND IS AVAILABLE FOR INSPECTION.

OCEAN ROAD PLANNING SCHEME.—AMENDMENT NO. 4.

NOTICE is hereby given that the Shire of Barrabool in pursuance of its powers under the *Town and Country Planning Act 1961* has prepared a Planning Scheme for part of Crown allotment 67, Parish of Puebla, containing 1.4 acres for the purpose of re-zoning land from Agricultural to Residential.

A copy of the scheme has been deposited at the Shire Office, 441 Moorabool-street, South Geelong, and at the office of the Town and Country Planning Board, 61 Spring-street, Melbourne, and will be open for inspection during office hours by any person free of charge.

Any persons affected by the Planning Scheme are required to set forth, in writing, all objections they may have, addressed to the Shire Secretary, Shire of Barrabool, 441 Moorabool-street, South Geelong, on or before the 4th day of December, 1964, and to state whether they wish to be heard in respect of their objections.

Date: 30th October, 1964.

3231 G. L. PEARCE, Shire Secretary.

SHIRE OF BELLARINE.

LOAN NO. 28.

*Notice of Intention to Borrow the Sum of £25,000 for Permanent Works and Undertakings.*

NOTICE is hereby given that the Council of the Shire of Bellarine proposes to borrow the principal sum of Twenty-five thousand pounds on the credit of the municipal revenues of the President, Councillors and Rate-payers of the said Shire, such sum to be raised by the grant of a mortgage in accordance with the provisions of the *Local Government Act 1958*,

1. The maximum rate of interest that may be paid is £5 7s. 6d. per cent. per annum.

2. The purpose for which the loan is to be applied is:—

	£
Acquisition of land for Recreation Reserve at Newcomb .. .. .	6,250
Construction of street adjacent to Newcomb recreation reserve .. .. .	2,000
Construction of Regent-street, Newcomb .. .. .	4,000
Purchase of land for Recreation Reserve at Wallington .. .. .	2,000
Underground Drainage north of Ocean Grove State School .. .. .	4,000
Construction of Concrete Kerbing and Channelling in Bramwell-street, Ocean Grove, between The Avenue and The Terrace .. .. .	1,250
Construction of Kerbing and Channelling at Portarlinton in Clarke-street, Geelong-road and Drysdale-street, Smythe-street, and High-street .. .. .	5,000
Underground Drainage, Sproat-street, Portarlinton .. .. .	500
	£25,000

3. The period of the loan shall be ten years.

4. The moneys borrowed shall be repayable by providing out of the municipal fund twenty half-yearly instalments of approximately £1,632 4s. 6d. each including principal and interest, on the 1st day of January, and the 1st day of July during the currency of the loan. The first instalment shall be payable on the 1st day of July, 1965.

5. Such moneys shall be repayable to the Commissioners of the State Savings Bank of Victoria at the office of the said Commissioners, 139-165 Elizabeth-street, Melbourne.

The plans and specifications and the estimate of the cost of the proposed works and a statement showing the proposed expenditure of the moneys to be borrowed are open for inspection at the office of the Council of the Shire of Bellarine at Drysdale.

Date: 23rd October, 1964.

3213 H. A. WILLIAMS, Shire Secretary.

*Town and Country Planning Act 1961 (Twelfth Schedule).*  
SHIRE OF CORIO.—GEE LONG PLANNING SCHEME, 1959.

NOTICE THAT A PLANNING SCHEME HAS BEEN PREPARED AND IS AVAILABLE FOR INSPECTION.

*Amendment No. 6, 1964.*

NOTICE is hereby given that the Council of the Shire of Corio, in pursuance of its powers under the *Town and Country Planning Act 1961*, has prepared a Planning Scheme for the following:—

(1) Land—Fordtown Estate, Norlane, with frontages to The Boulevard, Birdwood-avenue, and Surrey-street.

(2) Land—North Geelong Tram Estate, with frontages to Donga-road, Holmes-street and the Victorian Railways land.

(3) Land on the south-west corner of Donnybrook-street and Peacock-avenue.

(4) Land, part Crown allotment 31, Parish of Moorpanyal, fronting Braund-avenue.

(5) Land, on the south-west corner of Cox-road and the Melbourne-road, for the purposes of:—

1. Altering the zoning of:—

(1) above, from Industrial "D" to Industrial "A".

(2) above, from Industrial "D" to Industrial "A".

(3) above, from Agricultural "C" to P2 (hospital purposes) and P8 (municipal purposes).

(4) above, from Agricultural "E" to Industrial "B".

(5) above, from P2 (hospital purposes) to P8 (municipal purposes).

A copy of the scheme has been deposited at the Shire Office, "Osborne House", North Geelong, and at the office of the Town and Country Planning Board, 61 Spring-street, Melbourne, and will be open for inspection during office hours by any person free of charge.

Any person affected by the Planning Scheme are required to set forth, in writing, all objections they may have, addressed to the Shire Secretary, Shire of Corio, "Osborne House", North Geelong, on or before the 4th day of February, 1965, and state whether they wish to be heard in respect of their objections.

Dated this 28th day of October, 1964.

3235 W. H. MYERS, Shire Secretary.

## SHIRE OF GLENELG.

SPECIAL ORDER RELATING TO THE FIXING OF DUES FOR THE USE OF THE CORPORATION SALE-YARDS ON THE FOURTH FRIDAY OF EVERY MONTH PURSUANT TO SECTION 762 OF THE LOCAL GOVERNMENT ACT 1958.

THE fees for the use of the Corporation Sale-yards for sales of sheep on the fourth Friday of every month:—

- (a) Where the number of agents or auctioneers selling, is less than three—for each agent or auctioneer selling, the sum of £ s. d. 2 2 0
- (b) Where the number of agents or auctioneers selling is three or more—for each agent or auctioneer selling, the sum of 1 1 0

Resolution for passing this Order was agreed to by the Council of the Shire of Glenelg on the 21st day of September, 1964.

Confirmed on the 26th day of October, 1964.

The common seal of the President, Councillors and Ratepayers of the Shire of Glenelg was hereunto affixed in the presence of—

(SEAL) C. MCK. EMERSON, President.  
D. P. MULLANE, Councillor.  
J. B. HANSEN, Secretary.

3239

## SHIRE OF GLENELG.

## ORDER CHANGING NAME OF STREET.

NOTICE is hereby given that at a Meeting of the Council of the Shire of Glenelg held on the 26th day of October, 1964, the said Council in pursuance of the provisions of the Local Government Act 1958, did make an Order:—

That the name of the street heretofore variously known as Mount Gambier-road, Henty-street and Gillespie-street, situated between Miller-street and Russell-street, Casterton, be now known for its full width as Henty-street.

3240 J. B. HANSEN, Shire Secretary.

## SHIRE OF GLENELG.

## BY-LAW No. 58.

A By-law of the Shire of Glenelg under Part XXX of the Local Government Act 1958 and numbered 58 for amending By-law Number 37 and By-law number 47 for fixing the days and hours on each day on which the Market shall be held.

IN pursuance of the powers conferred by the Local Government Act 1958 and all other powers thereunto enabling the President Councillors and Ratepayers of the Shire of Glenelg Order as follows:

This By-law shall be read and construed as one with By-law Number 37 and By-law No. 47 and shall come into operation upon its publication in the Victorian Government Gazette.

(i) After Clause 3 of By-law Number 37 as amended by By-law No. 47 the following Clause shall be inserted:—

4A. The Market shall be open from sunrise to sunset on the Fourth Friday in every month for the sale of sheep. Sheep shall not be received at the market after the hour of twelve noon on any market day provided that if any sheep shall arrive at Casterton by train or transport on a Market Day they may be admitted to the Market after Twelve o'clock noon if notice of their arrival shall be given to the Inspector immediately after the train or transport carrying the sheep shall have arrived.

(ii) Clause 3A of By-law Number 47 shall be amended by inserting after the words "Shire of Glenelg is held" appearing in the fifth line, the words "or on the Fourth Friday in any month"

RESOLUTION for passing this By-law was agreed to by the Council of the Shire of Glenelg on the 23rd day of June One thousand nine hundred and sixty-four.

CONFIRMED on the 20th day of July One thousand nine hundred and sixty-four.

THE COMMON SEAL OF THE PRESIDENT  
COUNCILLORS AND RATEPAYERS OF  
THE SHIRE OF GLENELG WAS HERE-  
UNTO AFFIXED IN THE PRESENCE OF

H. D. MITCHELL PRESIDENT  
J. R. HARGREAVES COUNCILLOR  
J. B. HANSEN SECRETARY

3238

## SHIRE OF KNOX.

## LOAN No. 2.

Notice of Intention to Borrow the Sum of £15,000 for Permanent Works and Undertakings.

NOTICE is hereby given that the Council of the Shire of Knox in pursuance of powers conferred by the Local Government Acts, intends to borrow the sum of £15,000 on the credit of the municipal revenues of the President, Councillors, and Ratepayers of the said Shire, such sum to be raised by the grant of mortgage, in accordance with the said Acts and states:—

- (a) The amount of principal moneys it is proposed to borrow is £15,000.
- (b) The maximum rate of interest that may be paid is £5 6s. 3d. per cent. per annum.
- (c) The period of the loan will be seven (7) years and the time or times at which the moneys borrowed are to be repayable on the 1st day of February and the 1st day of August in each year during the currency of the loan, commencing on the 1st day of August, 1965. The place of repayment will be the English, Scottish and Australian Bank Ltd., Boronia.
- (d) The purpose for which the loan is to be applied is for permanent works and undertakings, viz.:—

Purchase of Plant and Equipment,  
Power Grader, Utility Trucks,  
Motor Trucks, Emulsion Sprayer,  
Vibrating Roller . . . . . £15,000

- (e) The loan is to be liquidated by half-yearly payments of approximately £1,297 including principal and interest, payable out of the municipal fund.

Plans and specifications and an estimate of the cost of such works and undertakings, and a statement showing the proposed expenditure of the money to be borrowed, are open for inspection by ratepayers, during office hours, at the Shire Offices, Fern Tree Gully, for one month after the publication of this notice.

Dated at Fern Tree Gully this 28th day of October, 1964.

3220 N. G. HAYNES, Shire Secretary.

## SHIRE OF KNOX.

## BY-LAW No. 3.

A By-law of the Shire of Knox made under the Local Government Acts and numbered 3, for the requiring that land declared to be unsightly or destructive of the amenity of the neighbourhood shall be enclosed with a sufficient fence.

IN pursuance of the powers conferred by the Local Government Act and of any and every other power it thereunto enabling The President Councillors and Ratepayers of the Shire of Knox order as follows:

- In this By-law unless the context otherwise requires "Land" means any interest legal or equitable in any realty situate in the Shire of Knox.  
"Council" means the Council of the Shire of Knox.
- Where the Council is of the opinion that any property is unsightly or destructive of the amenity of the neighbourhood it may cause to be served upon the owner or occupier of the said land a Notice declaring the said property to be unsightly or destructive of the amenity of the neighbourhood indicating the nature of the unsightliness or the destruction of the amenity or both and requiring the owner or occupier to remedy the unsightliness or destruction of the amenity by enclosing the property with a sufficient fence to be constructed within 28 days in such a manner as specified by the Council in the said Notice.
- Any person who fails to comply with the said Notice or other written instructions of the Council made pursuant to this By-law shall be guilty of an offence under this By-law and may be liable to a penalty of not more than £20 and to a further penalty of £5 for each day on which the offence against the By-law is continued after the service of the Notice or written instruction.
- Should the owner or occupier fail to comply with the Notice issued and served upon him pursuant to Clause 1 hereof the Building Surveyor of the Shire of Knox may forthwith and without Notice prepare plans and specifications and cause to be erected a sufficient fence.

5. The owner and occupier shall each be jointly and severally liable for any reasonable cost incurred by the Shire of Knox in the preparation of the plans and specifications and in the erection of the said sufficient fence.

The Resolution for passing this By-law was agreed to by the Council of the Shire of Knox on the 2nd day of September, 1964 and confirmed on the 21st day of October, 1964

THE COMMON SEAL of the PRESIDENT  
COUNCILLORS AND RATEPAYERS of the  
Shire of Knox was hereto affixed in the  
presence of:

	D. G. KEITH	PRESIDENT
(SEAL)	N. P. CARROLL	COUNCILLOR
3209	N. G. HAYNES	SHIRE SECRETARY

## SHIRE OF NEWSTEAD.

LOAN No. 6.

*Notice of Intention to Borrow the Sum of £5,000  
for Permanent Works and Undertakings.*

NOTICE is hereby given that the Council of the Shire of Newstead proposes to borrow the sum of Five thousand pounds on the credit of the municipal revenues of the President, Councillors and Ratepayers of the said Shire of Newstead, such sum to be secured by the grant of a mortgage in accordance with the provisions of the *Local Government Act 1958*.

1. The maximum rate of interest that may be paid is £5 5s. per cent. per annum.

2. The purpose for which the loan is to be applied is the purchase of road-making plant.

3. The period of the loan shall be five years.

4. The moneys borrowed shall be repayable by providing out of the municipal fund ten half-yearly instalments of approximately £648 each including principal and interest, on the 1st day of February and the 1st day of August during the currency of the loan. The first instalment shall be payable on the 1st day of August, 1965.

5. Such moneys shall be payable at the National Bank Savings Bank Limited, Melbourne.

Specifications and an estimate of the proposed expenditure of the moneys to be borrowed is open for inspection at the Shire Office, Newstead.

Date: 3rd November, 1964.

3230 D. J. R. DUNTON, Shire Secretary.

## SHIRE OF WYCHEPROOF.

LOAN No. 39.

*Notice of Intention to Borrow the Sum of £15,000  
for Permanent Works and Undertakings.*

NOTICE is hereby given that the Council of the Shire of Wycheproof proposes to borrow the principal sum of Fifteen thousand pounds on the credit of the municipal revenues of the President, Councillors and Ratepayers of the said Shire, such sum to be raised by the grant of a mortgage in accordance with the provisions of the *Local Government Act 1958*.

1. The maximum rate of interest that may be paid is £5 7s. 6d. per cent. per annum.

2. The purpose for which the loan is to be applied is purchase of road-making plant.

3. The period of the loan shall be ten years.

4. The moneys borrowed shall be repayable by providing out of the municipal fund twenty half-yearly instalments of approximately £979 6s. 8d. each, including principal and interest, on the 1st day of January and the 1st day of July during the currency of the loan. The first instalment shall be payable on the 1st day of July, 1965.

5. Such moneys shall be repayable to the Commissioners of the State Savings Bank of Victoria at the office of the said Commissioners, 139-165 Elizabeth-street, Melbourne.

The plans and specifications and the estimate of the cost of the proposed works and a statement showing the proposed expenditure of the moneys to be borrowed, are open for inspection at the office of the Council of the Shire of Wycheproof, at Wycheproof.

3219 ADRIAN SAYERS, Shire Secretary.

I, ROBERT THOMAS MCPHERSON, of 24 Teck-street, Jordanville, will not be responsible for any debts incurred by others in my name, without my written authority, as from this date, 4th November, 1964.

3201A R. MCPHERSON.

NOTICE is hereby given that Fleetways Properties Pty. Limited has applied for a lease, under section 134 of the *Land Act 1958*, for a term of 46 years from 6th December, 1964, of allotment 21, section 59, City of Port Melbourne, containing 1 acre 1 rood 13 perches, as a site for transport and storage. 3001

NOTICE is hereby given that John Sharp & Sons Pty. Limited has applied for a lease, under section 134 of the *Land Act 1958*, for a term of 45 years from 1st January, 1965, in respect of allotment 7, section A, City of South Melbourne, containing 0a. 3r. 15 and 9/10p., as a site for Offices, Stores and/or Showrooms, Workshops and Factories. 3217

I, FRANCES COLLINS, of Nowa Nowa, in the State of Victoria, heretofore called by the name of Fredrika Frances Heasley hereby give public notice that by a Deed Poll dated the 22nd day of October, 1964, duly executed, attested and deposited with the Registrar General of the said State, on the 23rd day of October, 1964, I formally and absolutely renounced and abandoned the said name of Fredrika Frances Heasley and declared that I had assumed and adopted and intended thenceforth upon all occasions whatsoever to use and subscribe in lieu thereof the name of Frances Collins so as to be at all times thereafter called known and described by the said name of Frances Collins.

Dated the 4th day of November, 1964.

FRANCES COLLINS.

A. P. Agg & Engel, Bairnsdale, solicitors for the said Frances Collins. 3215

I, ANNIE LESLEY PARKER, of 30 Minerva-road, Geelong West, in the State of Victoria, home duties, heretofore called and known by the name of Annie Lesley Moloney, hereby give public notice that by a deed poll dated the 23rd day of September, 1964, duly executed, attested and deposited with the Registrar-General of the said State on the 21st day of October, 1964, I formally and absolutely renounced and abandoned the surname of Moloney, and declared that I had assumed and adopted and intended thenceforth upon all occasions whatsoever to use and subscribe the surname of Parker instead of the said surname of Moloney, and so as to be at all times thereafter called, known and described by the said surname of Parker.

Dated the 28th day of October, 1964.

ANNIE LESLEY PARKER.

Witness—J. A. CRAWLEY, solicitor, 39 Yarra-street, Geelong. 3229

NOTICE OF INTENTION TO APPLY FOR A LICENCE TO DIVERT WATER AND CUT RACE FROM THE RIVER MURRAY AT YARRAWONGA.

WE hereby give notice that we intend to apply for a licence empowering us to divert water for a term of six years to the extent of 200 acre-feet per annum at a maximum rate of 8 acre-feet per day of 24 hours for the irrigation of 100 acres of pasture, being part of allotments 11A and 12A, Parish of Yarrowonga, and to occupy certain Crown lands for works of diversion, and to cut a race thereon.

Any objection to such application must be forwarded, in writing to reach the State Rivers and Water Supply Commission, Melbourne, before 4th December, 1964, being 30 days from the first publication of this notice.

LEONARD WILLIAM HICKS.

DENISE HICKS.

50 Houell-street, Yarrowonga.

G. M. Castles and Middleton, solicitors, Yarrowonga. 3237

NOTICE OF INTENTION TO APPLY FOR A LICENCE TO DIVERT WATER FROM THE TOOMUC CREEK AT PAKENHAM.

I HEREBY give notice that I intend to apply for a licence empowering me to divert water for a term of fifteen years to the extent of 40 acre-feet per annum at a maximum rate of 1 acre-feet per day of 24 hours for the irrigation of 20 acres of orchard, being part of allotment 77c, Parish of Nar-Nar-Goon.

Any objection to such application must be forwarded, in writing to reach the State Rivers and Water Supply Commission, Melbourne, before November 30th, 1964, being 30 days from the first publication of this notice.

KEITH RAMAGE.

"Brierfield Orchards", Toomuc-road, Pakenham. 3241

**NOTICE OF INTENTION TO APPLY FOR A LICENCE TO DIVERT WATER FROM THE TOOMUC CREEK AT PAKENHAM.**

I HEREBY give notice that I intend to apply for a licence empowering me to divert water for a term of fifteen years to the extent of 40 acre-feet per annum at a maximum rate of 1 acre-feet per day of 24 hours for the irrigation of 20 acres of orchard, being part of allotment 77b, Parish of Nar-Nar-Goon.

Any objection to such application must be forwarded, in writing to reach the State Rivers and Water Supply Commission, Melbourne, before November 30th, 1964, being 30 days from the first publication of this notice.

KEITH RAMAGE.

"Brierfield Orchards", Toomuc-road, Pakenham. 3242

**NOTICE OF INTENTION TO APPLY FOR A LICENCE TO DIVERT WATER AND CUT RACE (RE-ISSUE) FROM THE RIVER MURRAY, AT BANNERTON.**

I HEREBY give notice that I intend to apply for a licence empowering me to divert water for a term of seven years to the extent of 9 acre-feet per annum at a maximum rate of 1 acre-feet per day of 24 hours for the irrigation of 3 acres for trees, vines, pastures or vegetables, being part of allotment 6, Parish of Bumbang, and to occupy certain Crown lands for works of diversion, and to cut a race thereon.

Any objection to such application must be forwarded, in writing to reach the State Rivers and Water Supply Commission, Melbourne, before 3rd December, 1964, being 30 days from the first publication of this notice.

DOUGLAS WALTER NOURSE.

Robinvale. 3244

**GEELONG WATERWORKS AND SEWERAGE TRUST.**

PURSUANT to section 60 (2) of the *Geelong Waterworks and Sewerage Act 1958* (No. 6263), notice is hereby given of the intention of the Trust to construct sewers to provide for properties in and adjacent to:—

*Shire of South Barwon:*

Apex-avenue west from Colac-grove west,  
Highton-court, Lambhill-crescent,  
Princes Highway (Greenfields Estate),  
Corner South Valley-road and Bonse-y-road,  
Kidman-avenue—

and more particularly as shown on maps which are open for public inspection at the Trust's Offices, Ryrie-street, Geelong, between the hours of 9 a.m. and 4 p.m. daily, from Monday to Friday.

Dated this 28th day of October, 1964.

3216 B. C. HENSHAW, Secretary.

**WODONGA SEWERAGE AUTHORITY.**

**GENERAL NOTICE.**

THE above-mentioned Sewerage Authority having made provision for carrying off the sewage from each and every property which, or any part of which, is within the sewerage area hereinafter described, doth hereby declare that on and after the 1st day of November, 1964, each and every property which, or any part of which, is within the said sewerage area shall be deemed to be a seweraged property within the meaning of the *Sewerage Districts Act 1958*.

The boundaries of the Sewerage Area hereinbefore referred to are:—

Commencing from a point being the intersection between the southern boundary of Wilson-street and the western boundary of Vermont-street on the northern boundary of Crown allotment 2, section H, Parish of Wodonga, County of Bogong; thence in a southerly direction along the western boundary of Vermont-street for a distance of approximately 1,056 feet to the northern boundary of Crown allotment 3, section H, Parish of Wodonga, County of Bogong; thence in a westerly direction along the northern boundary of the said Crown allotment 3, section H, a distance of approximately 340 feet to the north-western corner of the said Crown allotment 3, section H; thence in a southerly direction along the western boundary of the said Crown allotment 3, section H, a distance of approximately 287 ft. 1½ in. to a point being its intersection with House Creek; thence in a general westerly and northerly direction following the line of House Creek around Crown allotment 1, section H, and Crown allotment 1, section G, Parish of Wodonga, County of Bogong, to the most westerly intersection of House Creek with the southern boundary of Brockley-street as shown on parish plan of Wodonga sheet 2; thence in an easterly direction along the northern boundary of the

said Crown allotment 1, section G, being also the southern boundary of Brockley-street to a point being the intersection of the western boundary of Hereford-street with the south boundary of Brockley-street on the northern boundary of the said Crown allotment 1, section G; thence southerly along the western boundary of Hereford-street a distance of approximately 700 feet to a point being the projection of the southern boundary of James-street on the western boundary of Hereford-street; thence easterly across Hereford-street a distance of approximately 50 feet to a point being the intersection of the southern boundary of James-street with the eastern boundary of Hereford-street; thence easterly along the southern boundary of James-street a distance of 717 ft. 6¼ in. to its intersection with the western boundary of Lindsay-street; thence southerly for a distance of approximately 356 ft. 1 in. along the western boundary of Lindsay-street across to the southern boundary of Wilson-street being also the northern boundary of the said Crown allotment 1, section H; thence easterly a distance of approximately 680 feet along the southern boundary of Wilson-street being also the northern boundaries of Crown allotment 1 and 2, section H, to the point of commencement.

By order of the Wodonga Sewerage Authority,

J. S. HORE, Chairman.  
3218 G. J. MORTON, Secretary.

*Companies Act 1958.*

**CASUALS BY HEATHER PROPRIETARY LIMITED (IN LIQUIDATION).**

NOTICE CONVENING FINAL MEETING OF MEMBERS AND CREDITORS PURSUANT TO SECTION 210.

NOTICE is hereby given in pursuance of section 210 of the *Companies Act 1958*, that a General Meeting of the members of the above-named company will be held on the 8th day of December, 1964, at the office of R. D. Widdows, Room 49, Second Floor, 125 William-street, Melbourne, at 11 a.m. in the forenoon and that a Meeting of Creditors will be held at 11.15 a.m. in the forenoon at the same place and on the same day for the purpose of having an account laid before them showing the manner in which the winding up has been conducted and the property of the company disposed of, and of hearing any explanations that may be given by the liquidator.

Dated this 28th day of October, 1964.

R. D. WIDDOWS, Room 49, 2nd Floor, 125 William-street,  
Melbourne. 3256

*Companies Act 1958.*

**RON CHARLTON WHOLESALE PROPRIETARY LIMITED (IN LIQUIDATION).**

NOTICE CONVENING FINAL MEETING OF MEMBERS AND CREDITORS PURSUANT TO SECTION 210.

NOTICE is hereby given in pursuance of section 210 of the *Companies Act 1958*, that a General Meeting of the members of the above-named company will be held on the 7th day of December, 1964, at the office of R. D. Widdows, Room 49, Second Floor, 125 William-street, Melbourne, at 11 a.m. in the forenoon and that a Meeting of Creditors will be held at 11.15 a.m. in the forenoon at the same place and on the same day for the purpose of having an account laid before them showing the manner in which the winding up has been conducted and the property of the company disposed of, and of hearing any explanations that may be given by the liquidator.

Dated this 28th day of October, 1964.

R. D. WIDDOWS, Room 49, 2nd Floor, 125 William-street,  
Melbourne. 3257

*Companies Act 1961.*

**JOWIL CONSTRUCTION CO. PTY. LTD.**

PURSUANT TO SECTION 260 OF THE COMPANIES ACT 1961.

NOTICE is hereby given that a Meeting of Creditors of Jowil Construction Co. Pty. Limited will be held at the Institute of Chartered Accountants, 23 McKillop-street, Melbourne, on Tuesday, 24th November, 1964, at 11 a.m. for the purpose of considering the company's affairs, the company having convened an Extraordinary General Meeting of its members to be held on the same day and for the purpose of considering and if thought fit passing a Special Resolution that the company be wound up voluntarily.

Dated this 3rd day of November, 1964.

J. W. VAN STEKELENBURGH, Director.  
Hall & Rose, chartered accountants, 163 William-street,  
Melbourne. 3246

In the matter of the *Companies Act 1961*.—And in the matter of C. A. CLARKE PROPRIETARY LIMITED.

NOTICE is hereby given that at an Extraordinary General Meeting of the above-named company duly convened and held at 17 Karma-avenue, East Malvern, on the 26th day of October, 1964, the following Resolution was duly passed as a Special Resolution:—

“That the company be wound up voluntarily and that John Newton Morey of E. N. Morey and Son, public accountants, is hereby appointed liquidator at a remuneration in accordance with the scale of fees laid down by the Australian Society of Accountants.”

Dated this 2nd day of November, 1964.

3271 L. O. LANGTON, Chairman.

*Companies Act 1961*, Section 254 (2).

KORNIE FOOD CO. PTY. LTD.

AT an Extraordinary General Meeting of the members of Kornie Food Co. Pty. Ltd., convened and held at 277 William-street, Melbourne, on the 26th day of October, 1964, the Special Resolution set out below was passed:—

“That the company be wound up voluntarily and that Howard Joseph Foster, of 277 William-street, Melbourne, be and is hereby appointed liquidator of the company for the purposes of such winding up.”

Dated this 26th day of October, 1964.

3251 H. J. FOSTER, Liquidator.

FOOD FAIR PROPRIETARY LIMITED (IN VOLUNTARY LIQUIDATION).

NOTICE is hereby given, in pursuance of section 272 of the *Companies Act 1961*, that a General Meeting of the members of the above-named company will be held at 287 Bourke-street, Melbourne, on Tuesday, 8th December, 1964, at 9.30 a.m., for the purpose of receiving the liquidator's account showing how the winding up has been conducted and the property of the company has been disposed of and of hearing any explanation that may be given by the liquidator.

Dated this 2nd day of November, 1964.

3253 H. A. B. McWILLIAM, Liquidator.

*Companies Act 1958*.

FOUNDATION PUBLICITY PROPRIETARY LIMITED (IN LIQUIDATION).

NOTICE CONVENING FINAL MEETING OF MEMBERS AND CREDITORS PURSUANT TO SECTION 210.

NOTICE is hereby given in pursuance of section 210 of the *Companies Act 1958*, that a General Meeting of the members of the above-named company will be held on the 7th day of December, 1964, at the office of R. D. Widdows, Room 49, Second Floor, 125 William-street, Melbourne, at 2 p.m. in the afternoon and that a Meeting of Creditors will be held at 2.15 p.m. in the afternoon at the same place and on the same day for the purpose of having an account laid before them showing the manner in which the winding up has been conducted and the property of the company disposed of, and of hearing any explanations that may be given by the liquidator.

Dated this 28th day of October, 1964.

R. D. WIDDOWS, Liquidator.

R. D. Widdows, Room 49, 2nd Floor, 125 William-street, Melbourne. 3254

*Companies Act 1958*.

NEWIT MANUFACTURING CO. PROPRIETARY LIMITED (IN LIQUIDATION).

NOTICE CONVENING FINAL MEETING OF MEMBERS AND CREDITORS PURSUANT TO SECTION 210.

NOTICE is hereby given in pursuance of section 210 of the *Companies Act 1958*, that a General Meeting of the members of the above-named company will be held on the 8th day of December, 1964, at the office of J. A. Coakley, Room 48, Second Floor, 125 William-street, Melbourne, at 3.30 p.m. in the afternoon, and that a Meeting of Creditors will be held at 3.45 p.m. in the afternoon at the same place and on the same day for the purpose of having an account laid before them showing the manner in which the winding up has been conducted and the property of the company disposed of, and of hearing any explanations that may be given by the liquidator.

Dated this 28th day of October, 1964.

J. A. COAKLEY, Liquidator.

J. A. Coakley, Room 48, 2nd Floor, 125 William-street, Melbourne. 3255

*Companies Act 1961*.—In the matter of MIRROR NEWSPAPERS PTY. LTD. (IN LIQUIDATION).

NOTICE is hereby given that a First and Final Dividend of 20s. in the £1 is intended to be declared in this matter. Creditors who have not proved their debts by the 18th day of November, 1964, will be excluded from the Dividend.

Dated this 30th day of October, 1964.

3262 JOHN C. COUZENS, Liquidator.

*Companies Act 1961*, Section 254 (2).

JOHN R. BELL & CO. PTY. LTD. (WHOLLY OWNED SUBSIDIARY OF SIDNEY COOKE LIMITED).

NOTICE is hereby given, following on the formation by Sidney Cooke Limited of a new subsidiary, Sidney Cooke Fasteners Pty. Ltd., for the purpose as announced last year of merging the activities of their several wire and metal products subsidiaries, that at an Extraordinary General Meeting of the members of John R. Bell & Co. Pty. Ltd., duly convened and held at 225 Queen-street, Melbourne, on the 28th day of October, 1964, the following Special Resolution was duly passed:—

“That the company forthwith go into voluntary liquidation pursuant to section 254 (2) of the *Companies Act 1961*, a Declaration of Solvency having been made by the directors in accordance with section 257, and filed with the Registrar of Companies.”

And at such meeting Sidney Bertram Wills Cooke, of 343 Little Collins-street, Melbourne, chartered accountant, was appointed liquidator for the purposes of the winding up.

Dated this 30th day of October, 1964.

3210 S. T. HIGGS, Secretary.

*Companies Act 1961*, Section 254 (2).

F. GOLDS NAIL PTY. LTD. (WHOLLY OWNED SUBSIDIARY OF SIDNEY COOKE LIMITED).

NOTICE is hereby given, following on the formation by Sidney Cooke Limited of a new subsidiary, Sidney Cooke Fasteners Pty. Ltd., for the purpose as announced last year of merging the activities of their several wire and metal products subsidiaries, that at an Extraordinary General Meeting of the members of F. Golds Nail Pty. Ltd., duly convened and held at 225 Queen-street, Melbourne, on the 28th day of October, 1964, the following Special Resolution was duly passed:—

“That the company forthwith go into voluntary liquidation pursuant to section 254 (2) of the *Companies Act 1961*, a Declaration of Solvency having been made by the directors in accordance with section 257, and filed with the Registrar of Companies.”

And at such meeting Sidney Bertram Wills Cooke, of 343 Little Collins-street, Melbourne, chartered accountant, was appointed liquidator for the purposes of winding up.

Dated this 30th day of October, 1964.

3211 R. F. McCracken, Secretary.

The *Companies Act 1961*.—In the matter of MOON TILES PROPRIETARY LIMITED.—Notice of Meeting of Creditors, Pursuant to section 260.

NOTICE is hereby given that a Meeting of Creditors of the above-named company will be held at the Institute of Chartered Accountants in Australia, 23 McKillop-street, Melbourne, in the State of Victoria, at 11 o'clock in the forenoon on Friday, the 13th November, 1964, the company having convened a meeting of its members for the same day for the purpose of considering a Resolution that the company be wound up voluntarily.

Dated the 30th day of October, 1964.

R. MAZOLETTI, Director.

Home, Wilkinson & Lowry, solicitors, 401 Collins-street, Melbourne. 3212

The *Companies Act 1961*.

HIGHETT MOTORS SALES & FINANCE CO. PTY. LTD. (IN LIQUIDATION).

NOTICE is hereby given that a First and Final Dividend is intended to be declared in the above matter. Creditors who have not proved their debts by the 22nd day of November, 1964, may be excluded from this Dividend.

Dated this 2nd day of November, 1964.

J. K. HALL, Liquidator.

Hall & Rose, chartered accountants, 163 William-street, Melbourne. 3227



Companies Act 1961.—In the matter of SLADE BETTS PTY. LTD.

NOTICE is hereby given that at an Extraordinary Meeting of the members of the above-named company held on the 29th day of October, 1964, it was resolved that the company be wound up voluntarily, and at a meeting of creditors held on the same day pursuant to section 260, it was resolved that for such purpose Harold Keith Cartledge, of 130 Commercial-road, Morwell, chartered accountant, be appointed liquidator.

Notice is also given that after 21 days from this date I shall proceed to distribute the assets. All creditors having any claim against the company should furnish particulars of same by that date, otherwise I shall proceed to distribute the assets without regard to their claim.

Dated this 30th day of October, 1964.

H. K. CARTLEDGE, Liquidator.

Norman, Cartledge & Holden, 130 Commercial-road, Morwell. 3228

Trustee Act 1958.

NOTICE TO CLAIMANTS.

PURSUANT to the Trustee Act 1958, creditors, next of kin and all other persons having claims in respect of the estate of any deceased person named below are required to send particulars to the legal personal representative or representatives at the addresses stated, after which date the representative or representatives will distribute the assets, having regard only to the claims of which notice has been received:—

Ada Caroline Trotman, late of "Weerona", 402 Waverley-road, East Malvern, widow, deceased (who died on the 25th of August, 1964).—Claims to the executor, Reverend Robert Fisher, care of Gray & Gray, solicitors, 18 High-street, Northcote, by the 15th of January, 1965. 3260

CREDITORS, next of kin and others having claims in respect of the estate of Francis James Doran, late of Station-street, Foster, in the State of Victoria, retired farmer, deceased (who died on 19th April, 1964, and probate of whose will was granted by the Supreme Court of Victoria on 21st October, 1964, to John William Doorty, of Peterkin-street, Traralgon, in said State, foreman, and Murray George Rudd, of Murray-road, Preston, in said State, baker), are to send particulars of their claims to the said executors, care of the below-mentioned solicitors by 15th January, 1965, after which date they will distribute the assets of the deceased, having regard only to the claims of which they then have notice.

Dated this 26th day of October, 1964.

BRUCE & LITTLETON, solicitors, Traralgon. 3208

CREDITORS, next of kin and others having claims against the estate of Eileen Dorothy Hannan, late of Flat 7, 100 Hotham-street, East Melbourne, retired public servant, deceased (who died on the 9th day of June, 1964), are requested to send particulars of their claims, in writing, to National Trustees, Executors and Agency Company of Australasia Limited, at its registered office, 95 Queen-street, Melbourne, the executor appointed by the will of the deceased on or before the 5th day of January, 1965, after which date the said company will distribute the assets of the said deceased, having regard only to the claims of which it then has notice as aforesaid.

JOHN D. BARRON, solicitor, 20 Queen-street, Melbourne. 3266

CREDITORS, next of kin and others having claims in respect of the estate of William Smith, late of 7 Sturrock-street, East Brunswick, engineer, deceased (who died on the 10th day of May, 1964), are required by National Trustees, Executors and Agency Company of Australasia Limited, of 95 Queen-street, Melbourne, and Harold Evelyn Smith, of 24 Scotia-street, Moonee Ponds, engineer (the proving executors of the will of the said deceased) to send particulars of their claims to the said company, at its address aforesaid, by the 15th day of January, 1965, after which date the said executors will distribute the assets of the estate of the said deceased, having regard only to the claims of which it then has notice.

Dated this 30th day of October, 1964.

JOHN, MORAN & HAYES, solicitors, 422 Collins-street, Melbourne. 3226

No. 89.—9917/64.—4

WILLIAM LINDSAY HILL, late of 36 St. Vincent's-street, Albert Park, retired shipwright, DECEASED, intestate.

CREDITORS, next of kin and others having claims against the estate of the said deceased (who died on 3rd February, 1964), are to send particulars of their claims to The Union-Fidelity Trustee Company of Australia Limited, the registered office of which is situate at 333 Collins-street, Melbourne, by the 6th day of January, 1965, after which date it will distribute the assets, having regard only to the claims of which it then has notice.

BLAKE & RIGGALL, solicitors, 120 William-street, Melbourne. 3265

CREDITORS, next of kin and others having claims against the estate of Luigi Bassi, late of Woori Yallock, farmer, deceased, intestate (who died on the 18th day of December, 1963), are required to send particulars of such claims to the administrator, National Trustees, Executors and Agency Company of Australasia Limited, at 95 Queen-street, Melbourne, before the 15th day of January, 1965, after which date the said company will proceed to distribute the assets of the said estate, having regard only to claims of which it then has notice.

EALES & MILLER, solicitors, 443 Little Collins-street, Melbourne. 3259

EILEEN ELIZABETH STAPLETON, late of 45 Havelock-road, Hawthorn East, widow, DECEASED.

CREDITORS, next of kin and others having claims against the estate of the above-named deceased (who died on 3rd August, 1964), are to send particulars of their claims to National Trustees, Executors and Agency Company of Australasia Limited, addressed to the office of the said company, at 95 Queen-street, Melbourne, by the 9th day of January, 1965, after which date the said company will distribute the assets, having regard only to the claims of which it then has notice.

H. H. HOARE, solicitor, 118 Queen-street, Melbourne. 3225

CREDITORS, next of kin and others having claims against the estate of Lillian Mary Kerley Bennett, late of 423 Lygon-street, Carlton, canteen worker, deceased (who died on 6th June, 1964), are required by Patrick Francis Toohey, the surviving executor of the will of the deceased, to send to him care of the undersigned solicitors, particulars thereof on or before the 10th day of January, 1965, after which date he will distribute the assets, having regard only to the claims of which he shall then have notice.

GAVAN, DUFFY & KING, solicitors, 95 Queen-street, Melbourne. 3224

THE TRUSTEES, EXECUTORS AND AGENCY COMPANY LIMITED, whose registered office is situate at 401 Collins-street, Melbourne, in the State of Victoria, the executor appointed by the will of John Ernest Morris, late of "Chislehurst", Sassafra, in the said State, retired bank manager, deceased (who died on the 21st June, 1964), requires all creditors, next of kin and others having claims against the property or estate of the said deceased, to send to the said company on or before the 15th day of January, 1965, particulars, in writing, of such claims, after which date the said company intends to convey or distribute such property or estate to or among the persons entitled thereto, having regard only to the claims of which it shall have had notice.

Dated the 29th day of October, 1964.

LANDER & ROGERS, solicitors, 118 Queen-street, Melbourne. 3249

GIOVANNI VENEROSA, formerly of 31 Gold-street, Collingwood, in the State of Victoria, but late of 81 Hodgkinson-street, Clifton Hill, in the said State, retired, DECEASED.

NATIONAL TRUSTEES, EXECUTORS AND AGENCY COMPANY OF AUSTRALASIA LIMITED (in the will called The National Trustees, Executors and Agency Company Limited), of 95 Queen-street, Melbourne, in the said State, the executor of the will of the above-named deceased (who died on the 21st day of June, 1964), requires all creditors, next of kin and others having claims against the property or estate of the said deceased to send to the company, at its registered address, before the 7th day of January, 1965, particulars, in writing, of such claims, after which date the said company intends to convey or distribute such property or estate to or among the persons entitled thereto, having regard to the claims of which they shall have had notice.

J. PERILLO, ADAMI & CO., solicitors, 209 Nicholson-street, Footscray. 3250

DONALD, DUNCAN, McDONALD, late of Seal Lake, (in respect of the estate of the deceased (who died on the 29th day of August, 1964), are required by the trustee, The Union-Fidelity Trustee Company of Australia Limited, of 101, Lydiard-street north, Ballarat, to send particulars to it by the 24th day of January, 1965, after which date the trustee may convey or distribute the assets, having regard only to the claims of which it then has notice.

Dated 23rd October, 1964.  
K. W. ENTWISLE, Hopetoun, estate solicitor. 3248

CREDITORS, next of kin and others having claims in respect of the estate of the late William Evans, late of 81 Alliss-street, Morwell West, pensioner, deceased (who died on the 5th November, 1963), are to send particulars of their claims to the executor, The Union-Fidelity Trustee Company of Australia Limited, care of the undersigned, by the 31st day of January, 1965, after which date it will distribute the assets, having regard only for the claims of which it then has notice.

TRUCANO, RYAN and CO., solicitors, corner Gude's Arcade and Buckley-street, Morwell. 3252

CREDITORS, next of kin and others having claims in respect of the estate of Herman Segal, late of 55 Goldsmith-street, Elwood, tobacconist, deceased (who died on the 31st day of July, 1962), are requested to send particulars of their claims to Nathan Segal, of 78 Broadway, Elwood, Jack Segal, Flat 2, 487 St. Kilda-road, Melbourne, and Alexander Reuben Sacks, of 3 Grant-avenue, Toorak, the executors of the will of the said deceased, by the 4th day of January, 1965, after which date the executors will distribute the assets, having regard only to the claims of which they have notice.

ALECK SACKS & SON, 341-3 Drummond-street, Carlton, solicitors for the executors. 3258

CREDITORS, next of kin and others having claims in respect of the estate of Elsie Alice Watson, formerly of "Corrabert", 210 Orrong-road, Toorak, but late of 7 Cheel-street, Armadale, spinster, deceased (who died on the 24th day of March, 1964), are required to send particulars of their claims to her trustees, George James Watson, of 46 Coronation-street, West Footscray, retired, and Joseph Condon, of 50 Dickson-street, Bacchus Marsh, foreman, care of the office of the solicitors mentioned below, by the 18th day of January, 1965, after which date the trustees may convey or distribute the deceased's assets, having regard only to claims of which they then have notice.

LYNCH & MACDONALD, solicitors, 360 Collins-street, Melbourne. 3270

CREDITORS, next of kin and others having claims in respect of the intestate estate of Elizabeth Margaret Lyons, late of 24 Nottingham-street, Prahran, in the State of Victoria, widow, deceased (who died on the 10th day of August, 1964), are to send particulars of their claims to The Perpetual Executors and Trustees Association of Australia Limited, of 100 Queen-street, Melbourne, by the 15th day of January, 1965, after which date the company will distribute the assets, having regard only to the claims of which it then has notice.

Dated the 30th day of October, 1964.  
HOLT, NEWMAN & HOLT, 178 Collins-street, Melbourne, solicitors for the executor. 3267

THE PERPETUAL EXECUTORS AND TRUSTEES ASSOCIATION OF AUSTRALIA LIMITED, whose registered office is situate at Nos. 100-104 Queen-street, Melbourne, in the State of Victoria, the executor of the will of Isabelle Irene Annie Lilly, late of Alma Private Hospital, 150 Alma-road, St. Kilda, in the said State, spinster (who died on the 5th June, 1964), requires all creditors, next of kin and others having claims against the property or estate of the said deceased, to send to the said company, on or before the 7th January, 1965, particulars, in writing, of such claims, after which date the said company intends to convey or distribute such property or estate to or among the persons entitled thereto, having regard only to the claims of which it shall have had notice.

Dated the 29th day of October, 1964.  
TOLHURST, DRUCE & EMMERSON, solicitors, 357 Little Collins-street, Melbourne. 3261

CREDITORS, next of kin and others having claims in respect of the estate of Ernest Ransford Albert Blume, late of Sunnyside-avenue, Kallista, retired, electrical engineer, deceased, intestate (who died on the 19th December, 1963), are required by the administratrix, Beryl, Alice, Cecilia Blume, of Sunnyside-avenue, Kallista, widow, to send particulars of their claims to her, care of Rogers & Gaylard, solicitors, of 281 Collins-street, Melbourne, by the 13th January, 1965, after which date the said administratrix will distribute the assets of the deceased, having regard only to the claims of which she then shall have had notice.

ROGERS & GAYLARD, solicitors, 281 Collins-street, Melbourne. 3268

CREDITORS, next of kin and others having claims in respect of the estate of Lucy May Foster, formerly of 247 Beach-road, Black Rock, and of 75 Curtain-street, North Carlton, but late of 100 Hickford-street, East Brunswick, spinster, deceased (who died on the 16th day of May, 1964), are required to send particulars of their claims to her trustee, Dorothy Gladys Kirk, of 8 Mena-avenue, Cheltenham, widow, care of the office of the solicitors mentioned below, by the 18th day of January, 1965, after which date the trustee may convey or distribute the deceased's assets, having regard only to the claims of which she then has notice.

LYNCH & MACDONALD, solicitors, 360 Collins-street, Melbourne. 3269

CREDITORS, next of kin and all others having claims against the estate of Elsie Elizabeth Goode, late of 254 Booran-road, Ormond, in the State of Victoria, widow, deceased (who died on 16th July, 1964), are requested to send particulars of such claims to the executrix and executor of the estate, Lola Mary Margaret Clarke and Lloyd Pym Goode, at the address shown hereunder on or before the expiration of two months from the date of publication hereof after which date the executors will distribute the assets, having regard only to the claims of which they shall then have had notice.

LLOYD P. GOODE & CO., solicitors, 388 Bourke-street, Melbourne. 3264

SARAH JANE ARMSTRONG, late of "The Breen", Romsey, in the State of Victoria, widow, DECEASED.

CREDITORS, next of kin and others having claims in respect of the estate of the deceased (who died on the 15th day of April, 1964), are required by the trustee, John Alfred Collins, of Kyneton, in the said State, solicitor, to send particulars to him by the 15th day of January, 1965, after which date the trustee may convey or distribute the assets, having regard only to the claims of which he then has notice.

Dated the 27th day of October, 1964.  
ARMSTRONG & COLLINS, solicitors, 2 Jennings-street, Kyneton. 3205

MARION IRVING KIDDLE, late of "Killara", Stawell, grazier, deceased (who died on the 15th May, 1964.)

CREDITORS, next of kin and all others having claims in respect of the estate of the said deceased are required by the executors, Richard Noel Darling, of 401 Collins-street, Melbourne, solicitor, and James Herbert Webb, of Alfred-street, Stawell, solicitor, to send particulars of such claims, care of Davies, Campbell & Piesse, solicitors, of 401 Collins-street, Melbourne, by the 7th January, 1965, after which date the said executors will distribute the assets, having regard only to the claims of which they then have notice.

DAVIES, CAMPBELL & PIESSE, 401 Collins-street, Melbourne, solicitors. 3223

CREDITORS, next of kin and others having claims in respect of the estate of Annie Florence Hamilton, late of 37 Henrietta-street, Hawthorn, widow, deceased (who died on the 2nd day of June, 1964), are requested to send particulars of their claims to the National Trustees, Executors and Agency Company of Australasia Limited, of 95 Queen-street, Melbourne, and Kenneth John Clements, of 255 Glenhantly-road, Elsternwick, the executors of the will of the said deceased, in care of the said company, by the 15th day of January, 1965, after which date the executors will distribute the assets, having regard only to the claims of which they have notice.

KENNETH J. CLEMENTS, solicitor, 255 Glenhantly-road, Elsternwick. 3236

**CREDITORS**, next of kin and others having claims in respect of the estate of Harold Thomas Lawrence, late of Queens-road, Somerville (who died on the 26th day of August, 1964), are to send particulars of their claims to the National Trustees, Executors & Agency Company of Australasia Limited, the registered office of which is situate at 95 Queen-street, Melbourne; by the 11th day of January, 1965, after which date it will distribute the assets, having regard only to the claims of which it then has notice.

R. P. BARRETT & SON, solicitors, 473 Bourke-street, Melbourne. 3247

**CREDITORS**, next of kin and others having claims in respect of the estate of Florence Adelaide Harris, late of Menin-road, Monbulk, widow, deceased (who died on the 26th day of July, 1964), are requested to send particulars of their claims to The Trustees, Executors and Agency Company Limited, of 401 Collins-street, Melbourne, the executor of the will of the said deceased, in care of the said company, by the 15th day of January, 1965, after which date the executor will distribute the assets, having regard only to the claims of which it then has notice.

KENNETH J. CLEMENTS, solicitor, 255 Glenhuntingly-road, Elsternwick. 3234

GEORGE ARTHUR HOLMES, late of 83 Walsh-street, South Yarra, in the State of Victoria, retired, DECEASED.

**CREDITORS**, next of kin and others having claims in respect of the estate of the deceased (who died on the 18th day of June, 1964), are required by the executor, Hugh Percival Hall, of 339 Collins-street, Melbourne, solicitor, to send particulars to him, by the 7th day of January, 1965, after which date the executor may convey or distribute the assets, having regard only to the claims of which he then has notice.

MEARES, DUIGAN & HALL, solicitors, 339 Collins-street, Melbourne. 3263

AGNES ORWELL CLEMENTS, late of Silvester-street, Cobden, married woman, DECEASED.

**CREDITORS**, next of kin and others having claims in respect of the estate of the deceased (who died on the 11th of December, 1962), are required by the executors, Bernard Leslie Vagg and Roy Leslie Clements to send particulars to them, care of the under-mentioned solicitors, by the 14th day of January, 1965, after which date they may convey or distribute the assets, having regard only to the claims of which they then have notice.

BUCKLAND & NEVETT, solicitors, Camperdown. 3202A

JOHN AMBROSE MCGINNESS, late of Camperdown, farmer, DECEASED.

**CREDITORS**, next of kin and others having claims in respect of the estate of the deceased (who died on the 7th of August, 1963), are required by the executors, John McGinness, Keith Anthony McGinness and Ellen Clare McGinness, to send particulars to them, care of the under-mentioned solicitors, by the 14th day of January, 1965, after which date they may convey or distribute the assets, having regard only to the claims of which they then have notice.

BUCKLAND & NEVETT, solicitors, Camperdown. 3203

ANDREW JOHN WHYTCROSS, late of Camperdown, farmer, DECEASED.

**CREDITORS**, next of kin and others having claims in respect of the estate of the deceased (who died on the 11th of July, 1963), are required by the executors, John Maxwell Whytcross and Robert Harvey O'Neill, to send particulars to them, care of the under-mentioned solicitors, by the 14th day of January, 1965, after which date they may convey or distribute the assets, having regard only to the claims of which they then have notice.

BUCKLAND & NEVETT, solicitors, Camperdown. 3204

*Subordinate Legislation Act 1962.*

NOTICE OF MAKING OF STATUTORY RULES.

IN pursuance of the provisions of the *Subordinate Legislation Act 1962* and the Regulations made thereunder, notice is given of the making of the following statutory rules:—

No.	Country Fire Authority Act 1958.	Price.
142/1964.	Country Fire Authority (Loan No. 46) Regulations 1964	s. d. 0 9

Copies of these statutory rules may be purchased at the Sale of Publications Section of the Government Printing Office, located at Macarthur-street, Melbourne, P.2. If

ordered by mail, remittance should be addressed to "The Government Printer, Box 203, P.O., North Melbourne, N.1.", and should include 5d. extra for postage.

AGENTS FOR THE "VICTORIA GOVERNMENT GAZETTE"  
ARMSTRONG BROS. PTY. LTD., Mollison-street, Kyneton.

THE "VICTORIA GOVERNMENT GAZETTE"

SUBSCRIPTIONS.—The subscription, including postage, is £2 15s. per annum, £1 7s. 6d. half-yearly, or 13s. 9d. per quarter, payable in advance.

Subscriptions are required for whole months, and must cover at least a quarter.

Single copies are One shilling, posted One shilling and five pence. Subscribers do not receive the Acts of Parliament with the GAZETTE.

GAZETTES are held in stock for five years only.

PRIVATE ADVERTISEMENTS.—The charge for insertion is 2s. per line single column, and 4s. per line double column. The title forms one or more lines as a heading. On an average ten words make a line of single column. Every signature must likewise be counted as a line. The final words of a paragraph, though only portion of a line, must be counted as one line. Signatures (in particular) and proper names must be written very plainly in the text; ONE SIDE ONLY of each sheet of paper should be WRITTEN UPON.

All documents illegibly written will be returned unpublished, and where brands occur unprovided for by the ordinary letters of the alphabet, a worded explanatory description must be furnished.

Advertisements unaccompanied by a remittance sufficient to cover the cost of the insertion will be returned unpublished.

THE VICTORIA GOVERNMENT GAZETTE is published on WEDNESDAY EVENING in each week, and Notices for insertion will be received by the Government Printer at or before ONE p.m. at ordinary rates, and late advertisements between ONE p.m. and FOUR p.m. at double rates on the day preceding the day of publication.

PAYMENTS.—All payments are required in advance and remittances should be made by cheque, postal note, or money order payable to "GOVERNMENT PRINTER".

ADDRESS.—All communications should be addressed to "The Government Printer, Box 203, P.O., North Melbourne".

AGENTS FOR THE "VICTORIA GOVERNMENT GAZETTE".

THE following have been appointed agents to receive Advertisements and Subscriptions for the Victoria Government Gazette:—

ARMSTRONG BROS. PTY. LTD., Mollison-street, Kyneton.

ARMSTRONG'S AGENCY, 205 Queen-street, Melbourne.

ARNALL & JACKSON, 390 Barkly-street, Brunswick, N.10.

BARNSDALE AUTHORIZED NEWSAGENCY, 132 Main-street, Bairnsdale.

COOKE, F. R. & E. M., & SONS, 69 Bridge-street, Benalla.

DAVIES, G. & M. V., 112 Gray-street, Hamilton.

DAVIS, WM. (MILDURA) PTY. LTD., 126 Eighth-street, Mildura.

DIXON'S NEWSAGENCY, 89 Firebrace-street, Horsham.

EDGAR'S NEWSAGENCY PTY. LTD., 293 Hargreaves-street, Bendigo.

FRANKS, H., & CO., 184 Ryrrie-street, Geelong.

GORDON & GOTCH AUSTRALASIA LTD., 511 Little Collins-street, Melbourne.

GULLAN'S NEWSAGENCY, 88 Bridge-street, Ballarat.

HALES, D. & N., Henty-street, Casterton.

HAMPTON, A. C., 243 Mitchell-street, Bendigo.

HARSTON, PARTRIDGE & CO. PTY. LTD., 455 Little Collins-street, Melbourne.

THE MERCANTILE EXCHANGE, 90 Queen-street, Melbourne.

MCGILL'S AUTHORIZED NEWSAGENCY, 183-5 Elizabeth-street, Melbourne.

PETTY, R. H. & W. M., 83 Murphy-street, Wangaratta.

PURDIE, J., & CO., 138 Moorabool-street, Geelong.  
 SALE AUTHORIZED NEWSAGENCY, 142 Raymond-street, Sale.  
 SKINNER'S AUTHORIZED NEWSAGENCY, 49-51 Franklin-street, Traralgon.  
 TUFF'S SHEPPARTON NEWSAGENCY, 246 Wyndham-street, Shepparton.  
 VERNON, C. F. & H. J., 162 Bridge-road, Richmond.  
 VIEW POINT AUTHORIZED NEWSAGENCY, 4 View-Point, Bendigo.

A copy of the Gazette filed at each place for public reference.

**CONTENTS**

	PAGE
Act of Parliament .. .. .	3380
Appointments .. .. .	3391
Companies Act 1961—Notice .. .. .	3383
Contracts .. .. .	3382
Estates of Deceased Persons .. .. .	3390
Government Notices .. .. .	3382
Lands .. .. .	3401
Melbourne and Metropolitan Board of Works— Notices .. .. .	3387
Mining .. .. .	3388
Notices to Mariners .. .. .	3382
Notice of Making of Statutory Rules .. .. .	3419
Orders in Council— Acts—Local Government; Land; Railways; Justices; Soil Conservation and Land Utilization; Transport Regulation; Land; Agricultural Colleges; Patriotic Funds; Public Service; Country Fire Authority; Hospitals and Charities; Housing; Country Roads.	3391 et seq
Private Advertisements .. .. .	3409
Proclamations .. .. .	3377
Public Service Notices .. .. .	3405
Resignations .. .. .	3391
Tenders .. .. .	3403
Transport Regulation Board—Public Hearings .. .. .	3384

**PUBLICATION OF OFFICIAL MATTER.**

ATTENTION is invited to the following procedure in relation to the publication of official matter in the *Government Gazette*:—

**1. Matter submitted to the Executive Council.**

Matters submitted to the Executive Council which requires gazettal will normally be published in the issue of the following week.

Where urgent gazettal is required, special arrangements should be made with the *Gazette Officer*.

Publication will be facilitated by the submission of carbon copies for the use of the *Gazette Officer*.

**2. Other matter.**

(a) All other matter duly certified by a responsible officer for publication should be lodged with the *Gazette Officer* not later than half-past Ten a.m. on Tuesday.

(b) Lengthy or involved notices should be forwarded several days before publication.

(c) Proofs, which will be supplied only when specifically requested or, at the direction of the *Gazette Officer*, should be returned promptly to avoid delay in publication.

(d) No additions or amendments to matter for publication will be accepted by telephone.