



VICTORIA
GOVERNMENT GAZETTE

Published by Authority

[Registered at the General Post Office, Melbourne, for transmission by post as a newspaper.]

No. 53]

WEDNESDAY, JULY 7

[1965

Land Act 1958.

AREA OF LAND COMPRISED IN CERTAIN CLASSES DIMINISHED OR INCREASED.

PROCLAMATION

By His Excellency the Governor of the State of Victoria and its Dependencies in the Commonwealth of Australia, &c., &c., &c.

WHEREAS by the *Land Act 1958* it is amongst other things enacted that the Governor in Council may, by Proclamation to be published in the *Government Gazette*, at any time diminish or increase the area of land comprised in any of the classes mentioned in Part I., Division 1, section 5, of the said *Land Act 1958*, but that the area of lands which may be sold by auction (Class 6), shall not be increased except as in certain cases in the said Act provided: Now therefore I, the Governor of the State of Victoria, in the Commonwealth of Australia, by and with the advice of the Executive Council of the said State, and in accordance with the provisions of sections 94 and 117 of the *Land Act 1958* aforesaid, do hereby diminish or increase (as the case may be) the areas of Crown lands comprised in Class 6 of the classes mentioned in section 5 of the *Land Act 1958* aforesaid, to the extent set forth in the subjoined Schedule (that is to say):—

Schedule referred to.

CLASSES DIMINISHED OR INCREASED.

County.	Parish.	Allotment.	Section.	Area.	Diminished.	Increased.	Description.
					Class.	Class.	
Bogong	Lilliput	4F	3	A. R. P. 0 1 24	..	6	In the North-east of the Parish

Given under my Hand and the Seal of the State of Victoria aforesaid, at Melbourne, this twenty-ninth day of June, in the year of our Lord One thousand nine hundred and sixty-five, and in the fourteenth year of the reign of Her Majesty Queen Elizabeth II.

(L.S.)

ROHAN DELACOMBE.

By His Excellency's Command,

JIM BALFOUR,

Minister of Lands.

GOD SAVE THE QUEEN !

Land Act 1958.

UNALIENATED CROWN LAND AVAILABLE FOR SETTLEMENT UNDER IMPROVEMENT PURCHASE LEASES.

PROCLAMATION

By His Excellency the Governor of the State of Victoria and its Dependencies in the Commonwealth of Australia, &c., &c., &c.

IN pursuance of the provisions of section 153 of the *Land Act 1958*, I, the Governor of the State of Victoria in the Commonwealth of Australia, by and with the advice of the Executive Council of the said State, do by this Proclamation declare the unalienated Crown lands mentioned in the subjoined Schedule, to be available for settlement under improvement purchase leases.

SCHEDULE.

County.	Parish.	Allotment.	Section.	Area.	Land Valuation.
				A. R. P.	
Tambo	Tildesley West	7A	C	450 0 0±	£1 10s. per acre

Given under my Hand and the Seal of the State of Victoria aforesaid, at Melbourne, this twenty-ninth day of June, in the year of our Lord One thousand nine hundred and sixty-five, and in the fourteenth year of the reign of Her Majesty Queen Elizabeth II.

ROHAN DELACOMBE.

(L.S.)

By His Excellency's Command,

JIM BALFOUR,
Minister of Lands.

GOD SAVE THE QUEEN !

PUBLIC HIGHWAYS.—SHIRE OF KNOX.

PROCLAMATION

By His Excellency the Governor of the State of Victoria and its Dependencies in the Commonwealth of Australia, &c., &c., &c.

WHEREAS by the *Local Government Act 1958*, as amended, section 519, it is amongst other things enacted that it shall be lawful for the Governor in Council at any time and from time to time upon request of the Council of any municipality by notice in the *Government Gazette* to proclaim any land reserved used or by purchase or exchange acquired for a street road highway thoroughfare bridge square court alley or right-of-way or any street road lane or passage made or laid out or proposed to be made or laid out on any land of which a plan delineating that street road lane or passage has been lodged with the Registrar of Titles to be a public highway and that such land shall thereupon and thenceforth from the date of such proclamation become and be absolutely dedicated to the public as a public highway within the meaning of any law then or thereafter in force.

And whereas the Council of the Shire of Knox has requested that the streets hereinafter mentioned, being streets roads lanes or passages made or laid out or proposed to be made or laid out on land of which a plan delineating those streets has been lodged with the Registrar of Titles, be so declared to be public highways.

Now therefore, I, the Governor of the State of Victoria in the Commonwealth of Australia, by and with the advice of the Executive Council of the said State, do by this Proclamation declare that Norwich-street and Penrith-street coloured brown on plan of subdivision No. 53713, lodged in the Office of Titles shall be public highways within the meaning of the said Act.

Given under my Hand and the Seal of the State of Victoria aforesaid, at Melbourne, this twenty-ninth day of June, in the year of our Lord One thousand, nine hundred and sixty-five and in the fourteenth year of the reign of Her Majesty Queen Elizabeth II.

(L.S.) ROHAN DELACOMBE.

By His Excellency's Command,

R. J. HAMER,
Minister for Local Government.

GOD SAVE THE QUEEN !

Victoria Institute of Colleges Act 1965.

DATE OF INCORPORATION OF THE VICTORIA INSTITUTE OF COLLEGES AS A BODY POLITIC AND CORPORATE.

PROCLAMATION

By His Excellency the Governor of the State of Victoria and its Dependencies in the Commonwealth of Australia, &c., &c., &c.

WHEREAS by an Act of Parliament of the State of Victoria passed in the thirteenth year of the reign of Her present Majesty Queen Elizabeth II. intitled the *Victoria Institute of Colleges Act 1965* it is amongst other things enacted that the said Institute shall be incorporated as a body politic and corporate upon a day to be fixed by Proclamation of the Governor in Council published in the *Government Gazette*:

Now therefore I, the Governor of the State of Victoria, acting by and with the advice of the Executive Council thereof, do by this my Proclamation fix the seventh day of July, One thousand nine hundred and sixty-five, as the date on which the Institute shall be incorporated as a body politic and corporate.

Given under my Hand and the Seal of the State of Victoria aforesaid, at Melbourne, this sixth day of July, in the year of our Lord One thousand nine hundred and sixty-five, and in the fourteenth year of the reign of Her Majesty Queen Elizabeth II.

(L.S.) ROHAN DELACOMBE.

By His Excellency's Command,

J. S. BLOOMFIELD,
Minister of Education.

GOD SAVE THE QUEEN !

PUBLIC HALF-HOLIDAYS.

PROCLAMATION

By His Excellency the Governor of the State of Victoria and its Dependencies in the Commonwealth of Australia, &c., &c., &c.

IN pursuance of the provisions contained in Part III. of the *Public Service Act 1958*, I, the Governor of the State of Victoria, in the Commonwealth of Australia, by and with the advice of the Executive Council of the said

State, do by this my Proclamation appoint the days and dates hereunder mentioned to be observed as Public Half-Holidays at the places respectively specified, viz.:—

Public Half-Holidays from the Hour of Twelve o'clock noon:—

- *THURSDAY, THE 30TH SEPTEMBER, 1965, throughout the Shire of Wimmera.
- *TUESDAY, THE 12TH OCTOBER, 1965, throughout the Shire of Birchip.
- *WEDNESDAY, THE 13TH OCTOBER, 1965, throughout the North and Tyrrell Ridings and Township of Culgoa, in the Shire of Wycheproof.
- *WEDNESDAY, THE 20TH OCTOBER, 1965, throughout the South and Central Ridings, excluding the Township of Culgoa, in the Shire of Wycheproof.

* Agricultural Show.

Given under my Hand and the Seal of the State of Victoria aforesaid, at Melbourne, this sixth day of July, in the year of our Lord One thousand nine hundred and sixty-five, and in the fourteenth year of the reign of Her Majesty Queen Elizabeth II.

(L.S.) ROHAN DELACOMBE.

By His Excellency's Command,

V. F. WILCOX,
Acting Chief Secretary.

GOD SAVE THE QUEEN!

PUBLIC TRUSTEE ACT 1958 (No. 6350), SECTION 17.

I HEREBY give notice that on the 16th June, 1965, the Public Trustee filed elections to administer the following deceased persons' estates, in accordance with section 17 of the *Public Trustee Act 1958*:—

CHAPMAN, JAMES PATRICK, late of 11 Little Ingle-street, Port Melbourne, slaughterman, died 16th February, 1962.

PORTER, JOSIAH WHITFIELD, formerly of Scarsdale, but late of 34 Chadstone-road, Chadstone, retired public servant, died 6th April, 1965.

A. D. DUNCAN,
Public Trustee.

256 Flinders-street, Melbourne, C.1, 1st July, 1965.

NOTICE.

CREDITORS, next of kin and others having claims against the estate of any of the under-mentioned deceased persons are required to send particulars of their claims to the Public Trustee, 256 Flinders-street, Melbourne, the personal representative, on or before the 7th September, 1965, after which date the Public Trustee may convey or distribute the assets, having regard only to the claims of which the Public Trustee then has notice:—

BAIRD, MARY, late of 3 Fawkner-street, South Yarra, widow, died 2nd May, 1965.

BLOCK, ALICE EDITH, late of 12 Allambee-avenue, Camberwell, married woman, died 30th November, 1964.

CARTER, HORACE EDWIN, also known as Horace Edward Carter, late of 24 Chaley-street, Burwood, retired carpenter, died 8th April, 1965.

CHAPMAN, JAMES PATRICK, late of 11 Little Ingle-street, Port Melbourne, slaughterman, died 16th February, 1965.

CRUMPTON, THOMAS BLAIR, late of 1 Davis-avenue, Camberwell, retired clerk, died between 28th April, 1965, and 2nd May, 1965.

DAVIES, RUBY VIOLETTE, late of 45 Molden-street, East Ormond, widow, died 27th March, 1965.

FORBES, EVA, late of Minifie-avenue, Anglesea, widow, died 7th March, 1965.

NELSON, JOHN THOMAS, late of "The Rest", Blackwood, Victoria, retired store clerk, died 5th November, 1964.

PARKIN, EDWIN APPELBY, formerly of 13 Bayview-street, Northcote, but late of 65 Nolan-street, Niddrie, retired public servant, died 16th March, 1965.

PEMBERTON, ETHEL RUTH DIXON, late of 41 Narroon-road, Alphington, spinster, died 11th April, 1965.

PORTER, JOSIAH WHITFIELD, formerly of Scarsdale, but late of 34 Chadstone-road, Chadstone, retired public servant, died 6th April, 1965.

RYAN, JOHN WILLIAM, late of 4 Swan-street, West Footscray, P.M.G. linesman, died 28th March, 1965.

WALKER, EILEEN MAY, late of Flat 26, 47 Yerrin-street, Balwyn, gentlewoman, died 16th January, 1965.

WATKINS, ALICE, late of 2 Manningham-street, Parkville, widow, died 6th March, 1965.

A. D. DUNCAN,
Public Trustee.

Melbourne, 1st July, 1965.

Housing Act 1958 (Section 99 of Act No. 6275).
GENERAL NOTICE TO PARTIES EMPOWERED BY THE "LANDS COMPENSATION ACT 1958" TO SELL AND CONVEY OR GRANT AND RELEASE, PURSUANT TO SECTION 99 OF ACT 6275.

GENERAL NOTICE TO TREAT FOR LAND IN A RECLAMATION AREA AT KENSINGTON.

IN pursuance of the provisions contained in the *Housing Act 1958* and of the *Lands Compensation Act 1958* Housing Commission (hereinafter referred to as the Commission) hereby doth give notice that the lands, tenements and hereditaments described in the Schedule hereto are required for the purpose of the *Housing Act 1958*, and that the Commission is authorized by the provisions of section 68 of the *Housing Act 1958*, to purchase or take compulsorily the said lands.

And the Commission accordingly hereby gives notice to all the parties interested in such lands and to all persons empowered by the *Lands Compensation Act 1958*, to sell and convey or grant and release the lands so required that it requires to take and purchase the lands referred to in the said Schedule hereto and that it is willing to treat with such parties or persons for the purchase thereof and as to the compensation to be made and for the damage that may be sustained by reason of the execution of the works.

And further the Commission hereby requires such parties or persons on or before the expiration of 21 days from the seventeenth day of July, 1965, to deliver to the offices of the Commission, at 179 Queen-street, Melbourne, a statement, in writing, of the particulars of the estate and interest in the said lands, tenements and hereditaments and of the claims made in respect thereof.

Dated the twenty-ninth day of June, 1965.

By order of the Commission,

A. L. BOHN,
Secretary.

SCHEDULE.

All that piece of land situate within the municipality of the City of Melbourne, being part of Crown allotment 19, section 2, Parish of Doutta Galla, and being the land bounded on the north-west by the boundary between Crown allotments 19 and 20, section 2, Parish of Doutta Galla on the north-east by the south-western alignment of Derby-street on the south-east by the north-western alignment of Ormond-street on the south-west by the north-eastern alignment of Altona-street excepting thereout—

First, the land comprised in certificates of title, volume 4645, folio 917 and volume 6086, folio 161.

Secondly, lots numbered 28, 29 and 60 on plan of subdivision No. 2438, lodged in the Office of Titles, being part of the land comprised in certificate of title, volume 6062, folio 346.

Thirdly, so much of the road shown coloured yellow on the map in the margin of certificate of title, volume 6086, folio 161 as lies to the south-west of the north-westerly prolongation of the north-eastern boundary of the land in the said certificate of title.

Fourthly, so much of the road shown 11 feet wide on plan of subdivision No. 2438, lodged in the Office of Titles and adjoining lot No. 28 on the said plan of subdivision, and so much of the reserve, 1 foot wide adjoining such road, as lie to the south-west of the north-westerly prolongation of the north-eastern boundary of the said lot 28.

Plans are available for inspection at the Estates Branch of the Housing Commission situated on the seventh floor, at 179 Queen-street, Melbourne, and forms for the making of claims will also be available on application to the Commission.

Housing Act 1958.

NOTICE OF RESOLUTION UNDER SECTION 99 (4) OF ACT No. 6275.

NOTICE is hereby given that Housing Commission on the twenty-eighth day of June, 1965, resolved as follows:—

"Whereas Housing Commission in respect of the lands described in the Schedule hereto has given notice to the parties interested under section 9 of the *Lands Compensation Act 1958*, as incorporated with the *Housing Act 1958*, Housing Commission hereby resolves that the lands described in the Schedule hereto are finally appropriated for the purposes of the *Housing Act 1958*."

SCHEDULE.

The whole of Crown allotment 4, Parish of Paywit.

A. L. BOHN,
Secretary.

Police Regulation Act 1958.
POLICE FORCE OF VICTORIA.

DETERMINATION No. 116 OF THE POLICE SERVICE BOARD.

THE Police Service Board, in pursuance of the powers in that behalf conferred by the *Police Regulation Act 1958*, hereby makes the following Determination, that is to say:—

1. The Determination No. 107 of the Police Service Board of the 15th November, 1963, and published in the *Government Gazette* of the 4th February, 1964, as amended is further amended as follows:—

By deleting paragraphs 72 and 73 and substituting therefor the following paragraphs:—

“72. Members who use their own motor cars, motor cycles with side-cars, motor cycles or bicycles on police duty, shall be paid for such use in accordance with the following scale:—

(a) For members who are issued with the “B” Pass by the Victorian Government Motor Transport Committee authorizing the holder to obtain supplies of petrol and oil at Government rates:—

	For the first 5,000 miles in a financial year. A mile d.	Mileage over 5,000 miles in a financial year. A mile d.
Motor cars—		
17 h.p. and over ..	10.5	5.8
Under 17 h.p. ..	8.9	4.9
Motor cycles with side-cars ..	4.5	2.5
Motor cycles ..	3.8	2.2

(b) For members who are not issued with the “B” Pass referred to in sub-paragraph (a):—

	For the first 5,000 miles in a financial year. A mile d.	Mileage over 5,000 miles in a financial year. A mile d.
Motor cars—		
17 h.p. and over ..	11.6	7.9
Under 17 h.p. ..	9.7	6.5
Motor cycles with side-cars ..	4.9	3.3
Motor cycles ..	4.2	2.8

(c) For bicycles—at the rate of 1.3d. per mile, irrespective of mileage.

73. Unless the Police Service Board otherwise determines, the above-mentioned rates shall be varied from time to time to comply with any scale of rates determined by the Mileage Rates Conference established by the Government.”

2. This Determination shall come into operation on the 1st July, 1965.

Dated at Melbourne this twenty-ninth day of June, 1965.

BEN J. DUNN,
A Judge of the County Court of Victoria,
Chairman and Member of the Police
Service Board.

D. S. RAMAGE,
Member of the Police Service Board.

W. J. McLAREN,
Member of the Police Service Board.

Police Regulation Act 1958.
POLICE FORCE OF VICTORIA.

DETERMINATION No. 117 OF THE POLICE SERVICE BOARD.

THE Police Service Board, in pursuance of the powers in that behalf conferred by the *Police Regulation Act 1958*, hereby makes the following Determination, that is to say:—

1. The Determination No. 107 of the Police Service Board of the 15th November, 1963, and published in the *Government Gazette* of the 4th February, 1964, as amended is further amended as follows:—

(a) Paragraph 15 is amended—

(i) by deleting the words “Station Officer” and substituting therefor the word “Officer”;

(ii) by deleting the words “Town Hall” and substituting therefor the words “City Traffic Station”.

(b) Sub-paragraph (a) of paragraph 25 is amended by deleting the words "Town Hall" and substituting therefor the words "City Traffic Station".

(c) By deleting paragraph 34 and substituting the following paragraph—

"34. (a) Whenever a member is authorized by the Chief Commissioner or the Officer in Charge of the District to perform temporarily the duties of a rank or position higher than his own for a period or periods exceeding in the aggregate 28 days in any year, he shall be paid, for the period or periods during which he was performing such higher duties, at a rate not less than the minimum salary and appropriate allowances (if any, but excluding any higher or additional uniform allowance appropriate to the higher rank or position), attached to the higher rank or position.

(b) If the Chief Commissioner or the Officer in Charge of the District, in any particular case, is satisfied that it was not practicable to obtain such authority before the higher duties were performed and that those higher duties were in fact reasonably performed by a member he may authorize payment for the performance of those higher duties.

(c) The Chief Commissioner may prescribe the form on which applications for such authority may be made, and issue any orders necessary to implement the provisions of this paragraph."

2. This Determination shall come into operation on the 1st July, 1965.

Dated at Melbourne this twenty-ninth day of June, 1965.

BEN. J. DUNN,
A Judge of the County Court of Victoria,
Chairman and Member of the Police
Service Board.

D. S. RAMAGE,
Member of the Police Service Board.

W. J. McLAREN,
Member of the Police Service Board.

WORKERS COMPENSATION ACT 1958, SECTION 72.

HIS Excellency the Governor of the State of Victoria, by and with the advice of the Executive Council thereof, doth, by Order made on the 6th day of July, 1965, pursuant to the provisions of the *Workers Compensation Act 1958*, approve the companies named hereunder as "Insurers" for the period ending the 30th day of June, 1966:—

A.M.P. Fire and General Insurance Company Limited.
Associated National Insurance Company Limited.
Guild Insurance Co. Limited.
Perpetual General Insurance and Guarantee Company Limited.
Provincial Insurance Company Limited.
United Insurance Company Limited.
Victoria Insurance Company Limited.

J. COLQUHOUN,
Clerk of the Executive Council.

At the Executive Council Chamber,
Melbourne, 6th July, 1965.

Labour and Industry Act 1958.

LABOUR AND INDUSTRY (EXPLOSIVE-POWERED TOOLS) REGULATIONS 1965.

PURSUANT to the provisions of the *Labour and Industry (Explosive-Powered Tools) Regulations 1965*, I give notice that, having determined that it would be unnecessary, because of the characteristics of a sample of a tool submitted for approval by Hilti (Aust.) Pty. Ltd., bearing the serial number 0000842, to require the owner or any other person to comply with the provisions of Regulation 5(c); 9; 10; and 12 (1) and (2) of the aforesaid Regulations in respect of any tool made in accordance with such sample, I did on the 2nd July, 1965, grant my approval to such tool in accordance with such determination.

I specify the manner in which the tool is to be described for the purposes of the Regulations shall be "Hilti DX300".

P. F. PRIOR,
Chief Inspector of Factories and Shops.
2nd July, 1965.

POLICE OFFENCES ACT 1958.

IN pursuance of the powers conferred upon the Chief Secretary by sub-section (3) of section 184 of the *Police Offences Act 1958*, I, the Acting Chief Secretary of the State of Victoria, do by this notice grant exemption from compliance with sub-sections (1) and (2) of section 184 of the said Act with respect to the publication "Z-Car Detective" distributed by Colorgravure Publications, 26-30 Flinders-street, Melbourne.

V. F. WILCOX,
Acting Chief Secretary.
Chief Secretary's Office,
Melbourne, 29th June, 1965.

MINES DEPARTMENT.

APPLICATION FOR LEASE DECLARED ABANDONED.

8252; Mineral; John Lamerand; 640 acres, Parish of Dorchapp.

TERM OF PETROLEUM EXPLORATION PERMIT EXTENDED.

22, Petroleum Exploration Permit; Frome Broken Hill Pty. Ltd.; 4,000 square miles, off shore in Bass Strait.

APPLICATION FOR EXPLORATION LICENCE REFUSED.

9, Exploration Licence; Quality Earths Pty. Limited; 5 square miles, Parish of Ballarat.

T. A. DARCY,
Minister of Mines.

MINING LEASE DECLARED VOID.

8347, Beechworth; Ronald Brian Bell; 37a. 2r. 7p., Parish of Burrungabugge.

E. CONDON,
Secretary for Mines.

MINES DEPARTMENT.

TRANSFER OF OFFICERS, EXPLOSIVES AND GAS EXAMINING BRANCH, CHIEF SECRETARY'S DEPARTMENT, TO THE MINES DEPARTMENT.

HIS Excellency the Governor of the State of Victoria, by and with the advice of the Executive Council thereof, has by Order made on the 29th day of June, 1965, on the recommendation of the Public Service Board, transferred the under-mentioned officers, Explosives and Gas Examining Branch, Chief Secretary's Department, to the Mines Department, at their present salaries or total emoluments, as from and inclusive of the 1st July, 1965.

Name.	Office.	Classification.
<i>Professional Division.</i>		
Cobbett, Arthur Matthew	Chief Inspector of Explosives, Gas Examiner and Chief Inspector of Inflammable Liquids	Class "A1"
Buckley, Ronald Francis	Assistant Chief Inspector of Explosives and Assistant Gas Examiner	Class "A1"
Kilmartin, John Patrick	Senior Chemist	Class "A"
Hammer, Robert Leonard	Chemist	Class "B1"
Sietzema, Piet Bart	Chemical Engineer	Class 2
Eustace, Ian Graham	Chemist	Class "B1"
McKendrick, Norman Ernest	Chemist	Class "B1"
Dambrosi, Duilio	Chemist	Class "C"
Wallace, Andrew Finnigan Johnston	Chemist	Class "C1"
Sinnott, Patrick John James	Chemist	Class "C"
Gurr, Alan Maxwell	Chemist	Class "C"
Pritchard, Alfred Alan	Chemist	Class "C"
<i>Administrative Division.</i>		
Campion, William Jeremiah	Class "B"
Sikorski, George	Class "C1"
Kiefer, Ernst	Class "D"
Makings, Alan Leigh	Class "E" (2nd sub-division)
Telfer, Ian James (on probation)	Class "E" (1st sub-division)
Hicks, Raymond Bruce (on probation)..	Class "E" (1st sub-division)
<i>Technical and General Division.</i>		
Simmonds, Leslie Samuel	Inspector of Explosives, Grade II.	Grades 37-38
Paxton, John Eric	Inspector of Explosives, Grade I.	Grades 30-34
Hyde, Leslie George	Inspector of Explosives, Grade I.	Grades 30-34
Bristow, William Richard	Inspector of Explosives, Grade I.	Grades 30-34
Aitken, Alexander Ernest	Inspector of Explosives, Grade I.	Grades 30-34
Hamilton, Gordon	Inspector of Gas Meters, Supervising	Grade 35
Geddes, Charles Bernard	Inspector of Gas Meters, Senior	Grades 30-31
Griffiths, Albert	Inspector of Gas Meters	Grades 20-24
Upward, Percy Frederick	Inspector of Gas Meters	Grades 20-24
Shirrefs, George Everard	Inspector of Gas Meters	Grades 20-24
Levi, Keith Joseph	Inspector of Gas Meters	Grades 20-24
Trott, Walter Alexander Cedric	Inspector of Gas Meters	Grades 20-24
Collison, Ronald	Inspector of Gas Meters	Grades 20-24
Vacant <i>Vice</i> —Frank Szczepaniak	Inspector of Gas Meters	Grades 20-24

At the Executive Council Chamber,
Melbourne, 29th June, 1965.

J. COLQUHOUN,
Clerk of the Executive Council.

Medical Board of Victoria.

RECORD OF TEMPORARY MEDICAL REGISTRATION AS AT THE 30TH JUNE, 1965.

PRINTED and published under the direction of the Medical Board of Victoria pursuant to the provisions of Section 11. of the *Medical Act 1958.*

Number of Certificate.	Date of Issue.	To Whom Issued.	Address.	Qualifications.	Limitations and Restrictions.
T. 55	1.4.65	Hubble, Bryan Douglas	c/o Preston and Northcote Hospital	M.D., Manitoba, 1959	Issued for a period not exceeding one (1) year and entitling the holder to work as a medical practitioner only whilst engaged in the project of research set out in the letter referred to the Secretary of the Medical Board by the Manager of the Preston and Northcote Hospital, dated 25th February, 1965 and signed by the Secretary, Medical Staff Committee, Victorian Plastic Surgery Unit
T. 56	6.5.65	De Boer, Willem Gysbert	c/o Dept. of Pathology, Medical School, Alfred Hospital	M.B., B.S., Groningen 1952 ; D.T.M., Leyden, 1952	Issued for a period not exceeding one (1) year and entitling the holder to work as a medical practitioner only whilst he holds a teaching post with the Monash University, Clayton and whilst engaged on teaching and research duties under the direction of the Medical School of that University

C. H. C. SEARBY, Chairman.
P. DUNCAN, Secretary.

Transport Regulation Act.
TRANSPORT REGULATION BOARD.
 HEARING OF APPLICATIONS.

NOTICE is hereby given that the following applications will be considered by the Transport Regulation Board at its offices at Rathdown-street, Carlton, at 10.15 a.m., on Wednesday, 28th July, 1965.

BONO, F., & G. SITA, Station-road, Deer Park. One commercial passenger vehicle, to be purchased, with large seating capacity, to operate as an additional metropolitan stage omnibus on Route 142A (Footscray-Maribyrnong-Avondale Heights) under the same terms and conditions as licences already held in the applicant's name.

CUNNINGHAM, A. W., PTY. LTD., 100 Bromfield-street, Colac. One commercial passenger vehicle (S/C. 41) to operate under the same terms and conditions as existing C.O. licences in the name of the applicant company.

GLENROY BUS SERVICE CO. PTY. LTD., 492 Pascoe Vale-road, Pascoe Vale. Five commercial passenger vehicles, with large seating capacities, to operate Route 48A (Moonee Ponds-Glenroy-Broadmeadows) as at present prescribed, with the ability to extend part (b) of route from the corner of Mascoma-street and Amar-street, via Mascoma-street, Peck-avenue, Pascoe Vale-road, Stewart-street, McCracken-avenue, to a bus stop in Gaffney-street thirty (30) feet west of Parker-street at the Pascoe Vale Railway Station. Return journey to operate via Gaffney-street and Park-street to Stewart-street. (Sections, fares and time-table to be determined.)

KASTORIA BUS LINES PTY. LTD., 132 Marshall-road, Airport West. Application for permit authority to operate vehicle licensed No. M.C.528 for the carriage of employees only of L. M. Ericssons Pty. Ltd., Broadmeadows, from Moonee Ponds, via Mt. Alexander-road, Buckley-street, Russell-street, Mt. Alexander-road, Keilor-road, Mathews-avenue, Bulla-road, Broadmeadows-road, Camp-road, to the company premises situated in Blair-street, Broadmeadows.

TIME-TABLE (Week-days only).

Depart Moonee Ponds 6.45 a.m.
 Depart L. M. Ericssons 5.30 p.m.

KASTORIA BUS LINES PTY. LTD., 132 Marshall-road, Airport West. Application for variation of all C.O. licences on Route 209A (Sunbury-Moonee Ponds) and Route 210A (Broadmeadows-Moonee Ponds) to delete Parer-road on deviation (c) and (a) of respective routes, which authorizes deviation of service from the corner of Parer-road and Lancefield-road, via Parer-road, McNamara-avenue, Keilor-road and Hoffmans-road to St. Christopher's School, Niddrie High School and St. John Bosco's, returning to normal route via Keilor-road, and instead to operate via King-street.

QUENNEL, G. R., and G. LEINKAUF, 5 White-avenue, North Kew. One commercial passenger vehicle (S/C. 8) to operate for the carriage of skiers and ski equipment between the car park on the Lake Mountain-road and the summit of Lake Mountain as and when required. Fares.—10s. single per person and ski equipment.

APPLICATIONS for renewal of licences as shown, by persons listed hereunder, to operate under the same terms and conditions:—

CARTER, A. J. W., K. A., & J. M., Edgar-street, Heywood; C.H.56.

COSTAR, R. G. & G. O., 40 Royal-road, Bonbeach; C.T.806.
CUTHBERTSON & RICHARDS SAWMILLS PTY. LTD., Payne-street, Bairnsdale; T.P.235.

FISHER, A. V. (Mrs.), (trading as Hawthorn Minding Centre), 332 Barkers-road, Hawthorn; T.P.130.

MONSON, A. J., 284 Mount-street, Albury, New South Wales; T.P.127.

MOONEY, L., 121 Avoca-street, Maryborough; C.T.554.

RAND, R. A., Melbourne-road, Hastings; T.S.564.

RICKERT, H. E., Melbourne-road, Hastings; T.S.565.

ROBERTS, J. H., Main-street, Tallangatta; T.P.53.

Notice of any objection should be forwarded to reach the Secretary of the Board not later than Wednesday, 21st July, 1965.

Applicants are advised that it will not be necessary to appear on the hearing date specified above, unless advised in writing by the Board.

B. P. KAY,
 Secretary.

Exhibition Buildings, Rathdown-street, Carlton, N.3,
 Wednesday, 7th July, 1965.

Commercial Goods Vehicles Act.
TRANSPORT REGULATION BOARD.
 HEARING OF APPLICATIONS.

NOTICE is hereby given that the following applications will be considered by the Transport Regulation Board at its offices at Rathdown-street, Carlton, at 10.15 a.m. on Wednesday, 28th July, 1965.

A.E.I. ENGINEERING PTY. LTD., Post Office Box 85, Port Melbourne. One commercial goods vehicle (L/C. 10 cwt.) to operate throughout the State of Victoria in the course of business as "Electrical Engineers and Contractors"—tools of trade, equipment and materials incidental to the repair or completion of own contracts.

ASCOM PTY. LTD., 63 Queensbridge-street, South Melbourne. One commercial goods vehicle (L/C. 87 cwt.) to operate in the course of business as "Civil Engineers":—(a) Within a 25-mile radius from the post office situated at the corner of Bourke and Elizabeth streets in the City of Melbourne—own goods. (b) Throughout the State of Victoria—tools of trade and equipment only incidental to own contracts. (c) Within a 20-mile radius from the site of any project currently engaged upon or from the railway station nearest thereto—own materials for use on such project.

ASSOCIATED KILN DRIERS LTD., Post Office Box 100, corner Gellibrand and Dennis streets, Colac. One commercial goods vehicle (L/C. 200 cwt. approximately) to operate from Colac to the Melbourne metropolitan area and to Ballarat and Warrnambool serving places en route in the course of business as "Timber Kiln Driers"—kiln dried and dressed radiata pine from the Otway Plantation. (Vehicle to be purchased.)

BARTLETT, R. H. & R. I. (trading as R. H. Bartlett & Sons), Mortlake-road, Terang. One commercial goods vehicle (L/C. 137 cwt.) to operate: (a) Within a 50-mile radius from the post office at Terang as a "Road Contractor"—road-making plant and materials. (b) Within a 20-mile radius from the post office at Terang—general goods.

BELL, I. J., 42 Benga-avenue, Dandenong West. One commercial goods vehicle (L/C. 88 cwt.) to operate: (a) Within a 25-mile radius of the G.P.O., Melbourne, in the course of business as "Cartage Contractor"—sand, screenings, soil, stone dust. (b) To and from pits situated at Cranbourne for delivery within the radius described in paragraph (a) above—sand.

BLOOM, S. R., 972 Burke-road, Deepdene. Application to vary the conditions of licence No. D.A.45274 (L/C. 131 cwt.) by adding to the existing conditions as paragraphs: "(c) From Bacchus Marsh to places situated within the radius described in paragraph (a) above—river stones and rockery stone. (d) From Toolangi to places situated within the radius described in paragraph (a) above—soil".

BRAY, A., Lot 91, Newton-street, Seaford. One commercial goods vehicle (L/C. 244 cwt.) to operate within a 50-mile radius of the premises of Albion Quarrying Co. Pty. Ltd. at North Melbourne excluding any operations from Geelong—road-making plant, hot asphalt, premix and road-making materials solely on behalf of the said company.

BRETHERTON, E. A., 27 McMillan-street, Traralgon. Application to vary the conditions of licence No. T.T.D.871 (L/C. 142 cwt.) by adding to the existing conditions "from forest landings in the Glenmaggie area to the A.P.M. at Maryvale—pulpwood."

BURGESS, B. & A., PTY. LTD., Post Office Box 120, Horsham. Three commercial goods vehicles (L/C. 249 cwt. each) to operate: (a) Within an 80-mile radius of post office at Dimboola (Horsham Division of the Country Roads Board) as a "Road Contractor"—road-making plant and materials. (b) Within a 20-mile radius of post office at Horsham—general goods.

BURKE, G. W. & E. A., Nayook. Application to vary the conditions of licence No. T.T.D.1030 (L/C. 163 cwt.) by deleting "the existing conditions" and adding in lieu "from forest landings within a 15-mile radius of Neerim South to the A.P.M. at Maryvale—pulpwood."

CHRISTOPHER, R. N., 37 Moore-street, Traralgon. Application to vary the conditions of licence No. T.T.D.848 (L/C. 172 cwt.) by adding to the existing conditions "From forest landings in the Seaview area and within a 25-mile radius of the A.P.M. and to the A.P.M. at Maryvale—pulpwood."

CLARKE MOBILE CRANES PTY. LTD., 167 Normanby-road, South Melbourne. Two commercial goods vehicles (L/C. 219 and 261 cwt.) to operate: (a) Throughout the State of Victoria in the course of business as "Crane Hirers and Erection Engineers and Contractors"—tools of trade, crane jibs and parts and erection equipment incidental to own contracts.

- (b) Within a 25-mile radius from the post office situated at the corner of Bourke and Elizabeth streets. in the City of Melbourne—general goods.
- COHNS (BENDIGO) PTY. LTD.**, Bridge-street, Bendigo. One commercial goods vehicle (L/C. 156 cwt.) to operate: (a) Goods as follows in the course of business of "Soft Drink, Cordial, Sauce and Food Manufacturers" being an approved decentralized secondary industry carried on at Bendigo and similarly carried on by the same Company at Yea and also by its associated Companies—Cohns (Ballarat) Pty. Ltd. at Ararat; Cohns (Wangaratta) Pty. Ltd. at Wangaratta, and Cohns (Swan Hill) Pty. Ltd. at Swan Hill, namely:—(i) From points within the State of Victoria (but excluding the Gippsland area) to own approved decentralized secondary industry factory at Bendigo or any of its aforesaid associated Companies at Ararat, Wangaratta and Swan Hill—raw materials and goods associated with or required solely for use in the manufacturing or processing of such approved decentralized industry, but subject to the condition that the majority of raw sugar for use in the aforesaid industry at the said factories in each case shall be forwarded to the railway station at Ararat, Yea, Bendigo, Swan Hill or Wangaratta as the case may be. (ii) From own factory premises and each of the aforesaid associated Companies to points within the State of Victoria (but excluding the Gippsland area)—manufactured and/or processed products of such approved decentralized industry. (b) Goods as follows in the course of business as "Soft Drink, Cordial, Sauce and Food Suppliers" in the following area only, namely, within that part of the State of Victoria bounded on the east by a line drawn from the Township of Wallan; thence north through the Township of Numurkah; thence north-west to the Township of Nathalia and from; thence north to the River Murray; on the south by a line drawn west from the Township of Wallan through the Townships of Clarkefield and Gisborne to the City of Ballarat; on the west by a line drawn from the City of Ballarat and extending north through the Townships of Lexton, Buangor, Avoca and Rupanyup to Wycheproof; on the north by a line drawn extending east from Wycheproof through Gunbower and, thence by the River Murray—soft drink, cordial, sauce and food lines (not being own manufactured products of the approved decentralized secondary industry or of its associate Companies as specified in paragraph (a) of this document) together with empty return containers and subject to the following special conditions:—
- Special Conditions:* (i) Goods shall not be carried pursuant to paragraph (b) above, for delivery within the City of Ballarat or the Ballarat Urban District nor shall goods be carried from the City or Urban District of Ballarat for delivery within the area defined in paragraph (b) above. (ii) Goods shall not be carried pursuant to paragraph (b) above, for transfer or transshipment to any other vehicle for carriage to any destination outside the area specified in the said paragraph (b).
- COSTIN, R. G., Noojee.** One commercial goods vehicle (L/C. 318 cwt.) to operate: 1. From bush landings in Noojee area to Kennedy's mill at Pakenham, Andrew's mill and Longwarry Timber Co. at Longwarry, Pearce's mill at Bunyip, mills at Garfield, Suckling's mill at Noojee, the Noojee Sawmilling Co. and Limberlost mill at Nayook—logs. 2. Within a 40-mile radius of Noojee—own agricultural machinery and bulldozer and sufficient fuel for operation of own machinery.
- COWLAND, R. B.,** Post Office Box 67, Macarthur. One commercial goods vehicle (L/C. 144 cwt.) to operate: (a) Within a 20-mile radius of post office at Macarthur—general goods. (b) Within a 50-mile radius of post office at Macarthur as an "Earth-moving Contractor" own earth-moving plant and equipment and tools of trade. (c) Within a 50-mile radius of post office at Macarthur as a "Road Contractor"—road-making materials.
- DEIPENAU, H. E., PTY. LTD.,** 75 Victoria-street, East Brunswick. One commercial goods vehicle (L/C. 219 cwt.) to operate from the rail siding at Arden-street, North Melbourne to consignees within a 25-mile radius of Melbourne and to the plant of Victorian Quarries Ltd. at Dromana in a specially constructed bulk tanker—bulk cement.
- DOLMAN, J.,** 8 Alexander-avenue, Moe. One commercial goods vehicle (L/C. 265 cwt.) to operate: (a) From forest landings in Erica area to the State mill at Erica—logs. (b) From forest landings in the Moe, Erica, and Moondarra areas towards mill at Drouin, Pearce mill at Bunyip and Boards mill at Pakenham—logs. (c) Within a 20-mile radius of Moe—logs and timber.
- DRIDAN, J. L. & A. L.,** Elmhurst. One commercial goods vehicle (L/C. 227 cwt.) to operate: (a) Within a 25-mile radius from the post office at Elmhurst—general goods. (b) From and to places situated within the radius as defined in paragraph (a) above, to and from places situated within a 50-mile radius from the post office at Elmhurst—livestock. (c) From and to the B.P. Australia Ltd. depot at Ballarat to and from Elmhurst—petroleum products in prescribed types of containers and empty return containers.
- DUNLOP RUBBER AUST. LTD.,** 69 Shadforth-street, Kerang. One commercial goods vehicle (L/C. 8 cwt.) to operate within a 50-mile radius from own branch premises at Kerang in the course of business as "Tyre Retreaders and Distributors"—new tires and tubes, tires and tubes for repair or having been repaired, batteries, oil, motor car accessories and polythene piping.
- EVERY, F. J. PTY. LTD.,** 14 King-street, Bendigo. One commercial goods vehicle (L/C. 9 cwt.) to operate: (a) Within a 20-mile radius of the post office in Bendigo—goods in course of business as "Booksellers and Stationers". (b) Throughout the State of Victoria in the course of business as "Commercial Traveller"—samples of own goods.
- FARMAIR PTY. LTD.,** Tinamba. Two commercial goods vehicles (L/C. 8 and 113 cwt.) to operate in the course of business as "Aerial Spraying Contractor". (a) Throughout the State of Victoria—own tools of trade, equipment and spare parts. (b) Within a 20-mile radius from the site of any contract currently engaged upon or from the railway station or fuel depot nearest thereto—superphosphate and chemicals for aerial spraying, aviation fuel and lubricants.
- BROWNE, R. D. & J. M.** (trading as Helicopter Agricultural Spraying Co.), 6 Chapman-street, Swan Hill. One commercial goods vehicle (L/C. 15 cwt.) to operate throughout the State of Victoria in the course of business as "Helicopter Operators"—tools of trade and spare parts incidental to the servicing of own aircraft, spraying materials and equipment required for own aerial spraying contracts together with sufficient fuel to operate own helicopters on site but limiting the amount of chemicals that can be carried to 10 cwt. on any one trip.
- HERMAN, R.,** Post Office Box 174, Traralgon. Application to vary the conditions of licence No. T.T.D.1034 (L/C. 148 cwt.) by adding to the existing conditions "From landings in the Yarra Junction and Millgrove areas to the A.P.M. at Maryvale—pulpwood".
- HILLGROVE, A. D.,** Post Office Box 27, Birchip. One commercial goods vehicle (L/C. 8 cwt.) to operate throughout the State of Victoria for the purpose of servicing and maintaining earth-moving equipment in the course of business as "Earth-moving contractor"—tools of trade, spare parts and materials incidental thereto.
- JAMES CHOCOLATES (WHOLESALE) PTY. LTD.,** 294 Hoddle-street, Abbotsford. One commercial goods vehicle (L/C. 10 cwt.) to operate: (a) Within a 50-mile radius of own premises at Abbotsford in course of business as "Chocolate Wholesalers"—own goods. (b) Throughout the State of Victoria for the purpose of booking orders—samples and display materials for advertising.
- JANS, A. & V.,** 141 Liddiards-road, Traralgon. Application to vary the conditions of licence No. T.T.D.851 (L/C. 155 cwt.) by adding to the existing conditions as an additional paragraph:—"From forest landings in the Seaview area to the A.P.M. at Maryvale—pulpwood."
- JORY, W. B.,** Deakin-avenue, Mildura. One commercial goods vehicle (L/C. 30 cwt.) to operate west of a north/south line drawn through Mildura and north of the Sturt Highway—mail and parcels under contract to the P.M.G.'s Department.
- KEATH, ROBIN, PTY. LTD.,** Post Office Box 128, Horsham. One commercial goods vehicle (L/C. 11 cwt.) to operate within a 70-mile radius from own premises at Horsham in course of business as "Tire Dealers"—new tires and tubes, tires and tubes for repair or having been repaired, automotive batteries and also tools of trade incidental to the fitting of tires and tubes.
- MASFIELD, R. H.,** 36 Windsor-avenue, Strathmore. One commercial goods vehicle (L/C. 140 cwt.) to operate: (a) Throughout the State of Victoria in the course of business as "Site Contractor"—own tools of trade, equipment and machinery. (b) Within a 20-mile radius from the site of a current contract—materials for use on such contract. (c) From construction site to construction site—small quantity of unused materials.

MILLIGAN, W. D., 143 Fern Tree Gully-road, Oakleigh. One commercial goods vehicle (L/C. 126 cwt.) to operate within a 70-mile radius from the premises of the New Gamble Brick & Quarrying Co. Pty. Ltd. at Oakleigh—bricks on behalf of the said company.

MCCUSKEY, B. A., 117 Hargreaves-street, Bendigo. One commercial goods vehicle (L/C. 11 cwt.) to operate in the course of business as "Tire Retreaders and Distributors of Motor Car Accessories"; (a) Within a 50-mile radius from the chief post office in the City of Bendigo—tires, tubes, batteries, petrol, oil and greases. (b) Within that part of the State of Victoria bounded by and including the Cities of Echuca and Shepparton and the Townships of Kilmore, Daylesford, Avoca, St. Arnaud, Charlton, Wycheproof and Kerang—truck and tractor tires for recapping or retreading or having been recapped or retreaded subject to the condition that such goods collected for consignment to Bendigo shall be forwarded by rail from the nearest or most convenient railway station with the exception that upon returning to Bendigo at completion of each trading period one pay-load of tires may be carried.

PERMEWAN WRIGHT LTD., 31 King-street, Melbourne. One commercial goods vehicle (L/C. 7 cwt.) to operate within a 50-mile radius of own branch premises at Rochester in the course of business as "General and Produce Merchants"—own goods.

PESTCO PTY. LTD., 1008 Sturt-street, Ballarat. One commercial goods vehicle (L/C. 10 cwt.) to operate within that part of the State of Victoria north of a line drawn east and west through the Township of Bacchus Marsh in the course of business as "Pest Controllers"—tools of trade, spraying equipment and small quantities of materials incidental to own contracts subject to the condition that all initial supplies of concentrated chemicals used in connexion therewith shall be forwarded by rail to railway stations at Ballarat, Horsham, Wedderburn or Shepparton.

PICTON HOPKINS & SON PTY. LTD., 130 Church-street, Richmond. One commercial goods vehicle (L/C. 82 cwt.) to operate: (a) Within a 25-mile radius of Richmond in the course of business as "Plaster Craftsman"—own goods. (b) (i) Throughout the State of Victoria in the course of business as "Plaster Craftsman"—fibrous plaster sheeting, mouldings, sisal and plaster sufficient only for the fixing of the aforementioned sheets and mouldings, battens, nails, insulating materials, viz.: Fibreglass, insulwool and rockwool, suspended ceilings, component parts, associated acoustic tiles and sprayed finishes. (ii) Terrazzo slabs and/or materials incidental to fixing of same and materials necessary for laying concrete floors, expanded metal, sand, cement plaster in small quantities for setting and associated materials necessary to carry out solid plastering contracts, vinyl and lino tiles and adhesives, scaffolding, plant, tools of trade for use in connexion with own building contracts. (c) Within a 20-mile radius of own branch premises at Herne's Oak—own goods.

PROHOROFF, F., 21 Mathoura-street, Horsham. One commercial goods vehicle (L/C. 200 cwt. approximately) to operate: (a) Within a 20-mile radius of Horsham Post Office—general goods. (b) Within a 50-mile radius of the Horsham Post Office—gypsum.

REPLACEMENT PARTS PTY. LTD., 618 Elizabeth-street, Melbourne. One commercial goods vehicle (L/C. 11 cwt.) to operate within a 50-mile radius from own premises at Coburg and to and from the Townships of Avenel and Seymour in the course of business as "Distributors of Automotive Parts and Accessories as a Travellers Vehicle" for the purpose of booking orders—samples and spare parts and automotive accessories, display and advertising materials, with the ability to leave a spare part in an emergency and pick up an engine or parts for reconditioning or having been reconditioned.

RYAN, M. A., 34A Roslyn-street, Middle Brighton. Application to vary the conditions of licence No. DA.47288 (L/C. 16 cwt.) by adding to the existing conditions as an additional paragraph—"To operate within a 50-mile radius from the post office at Wangaratta—own goods, such goods having been initially forwarded to Wangaratta by rail."

SCOTTS WROUGHT IRON, 3 Mafeking-street, Bendigo. One commercial goods vehicle (L/C. 70 cwt.) to operate in the course of business as "Welders"—(a) Within a 50-mile radius from the chief post office in the City of Bendigo and to and from the City of Shepparton—welding plant, tools of trade, and spare parts incidental only to own contracts. (b) Within a 25-mile radius from the chief post office in the City of Bendigo—own welded products for delivery direct to clients.

SHELLEY, P. E., PTY. LTD., Labilliere-street, Bacchus Marsh. One commercial goods vehicle (L/C. 300 cwt.) to operate: (a) From and to the premises of C.S.R. Firbeboard Group at Bacchus Marsh to and from consignees situated within a 50-mile radius from such premises—finished fibreboard products, empty pallets and damaged products returned to Bacchus Marsh for claim. (b) From and to the City of Melbourne to and from the Township of Bacchus Marsh—general goods.

SHORT, O., 17 Urquhart-street, Horsham. One commercial goods vehicle (L/C. 7 cwt.) to operate: (a) Within a 50-mile radius of post office at Horsham in the course of business as "Electrical Retailers and Engineer"—own goods. (b) Within a 100-mile radius of post office at Horsham—tools of trade, spare parts and materials incidental to the servicing and maintenance of electrical appliances and equipment.

SNAITH, L. & M. F., Private Bag, Ballan. One commercial goods vehicle (L/C. 143 cwt.) to operate: (a) Within a 20-mile radius from the post office at Mt. Wallace—general goods. (b) From and to places situated within a 10-mile radius from the post office aforesaid to and from places situated within the limits of the City of Geelong—general goods. (c) From and to places situated within a 10-mile radius from the post office at Mt. Wallace to and from the City of Melbourne via the Townships of Bacchus Marsh or Lara—general goods. (d) From and to places situated within a 50-mile radius from the post office at Mt. Wallace to and from places within the radius as defined in paragraph (a) above—livestock.

STONE BROS. PTY. LTD., 49 Rowan-street, Wangaratta. One commercial goods vehicle (L/C. 60 cwt.) to operate within a 75-mile radius of own premises at Wangaratta and to Corryong and towns en route in course of business as "Plumber"—tools of trade, equipment, materials required for completion of own contracts, sewerage pipes, fittings, tanks, piping and plumbing fixtures in connexion with own contracts only.

VIC OAK SAWMILLS PTY. LTD., Goulburn Valley Highway, Thornton. Application to vary the conditions of licence No. T.T.D.832 (L/C. 240 cwt.) by adding to the existing conditions as additional paragraphs:— (i) Within a 20-mile radius of Marysville—general goods. (ii) Within a 50-mile radius of own sawmill at Marysville—own logging equipment."

WHITE, D., 88 Bendigo-road, Kerang. One commercial goods vehicle (L/C. 206 cwt.) to operate: (i) Within a 50-mile radius of the post office at Kerang—road-making and bridge materials in the course of business as a "Road Contractor". (ii) Within a 20-mile radius of the post office at Kerang—general goods.

WHITFORD, W., Cypress-road, Brown Hill, Ballarat. One commercial goods vehicle (L/C. 142 cwt.) to operate: (a) Within a 25-mile radius of the chief post office at Ballarat—general goods. (b) Within a 70-mile radius of the chief post office at Ballarat to operate on behalf of Martin Stoneware Pipe Pty. Ltd. at Ballarat—earthenware pipes and fittings and associated materials solely on behalf of the said Company.

WOOD, D. R., 15 Kimberly-avenue, Swan Hill. One commercial goods vehicle (L/C. 335 cwt.) to operate within a 100-mile radius of post office at Swan Hill in the course of business as "Earth-moving Contractors"—own earth-moving equipment.

ZANKER, A. D., Williams-road, Horsham. One commercial goods vehicle (L/C. 147 cwt.) to operate within that part of Victoria west of a line drawn north/south through Melbourne as a "Marine Dealer"—marine goods as defined in the *Marine Stores and Old Metals Act 1958* (No. 6303), but excluding the carriage of any such goods to wharves, docks or ships for shipment or export purposes.

TOW TRUCK.

CENTRAL TOWING SERVICE, 245 Johnston-street, Abbotsford. One commercial goods vehicle (L/C. 34 cwt.) to operate as a "Tow Truck" throughout the State of Victoria for the purpose of lifting and carrying or towing and/or repairing wrecked or disabled vehicles—tools of trade, spare parts and materials incidental thereto.

APPLICATION for renewal of licence as shown, by persons listed hereunder to operate under the same terms and conditions from the date of expiry shown in each case.

ALLEN, V. G., 575 Hargreaves-street, Bendigo; D.A.42343; 1st August, 1965; 28 cwt.

BALLARAT DEEP FREEZE FOOD CO. PTY. LTD., 21 Grenville-street north, Ballarat; T.D.A.39041/3; 31st August, 1965; 35 cwt.

BERRY, J., 12 Smith-street, Ballarat; D.A.30717; 9th September, 1965; 16 cwt.
 BLENCOWE, R., Frankston-road, Dandenong; D.A.44490; 17th September, 1965; 145 cwt.
 COUTTS, T. J., PTY. LTD., 54 Lydiard-street north, Ballarat; D.A.7611/3; 21st September, 1965; 8 cwt.
 DEVILEE, J. J. & H. D. (trading as John Devilee Refrigeration), Post Office Box 599, 7 Sunnyside-avenue, Mildura; D.A.44290; 28th August, 1965; 32 cwt.
 FARMAIR PTY. LTD., Tinamba; D.A.43786; 10th July, 1965; 19 cwt.; D.A.43786/3; 10th July, 1965; 15 cwt.
 HARBOUR, R. & L. M., Yendon; D.A.30462; 16th September, 1965; 114 cwt.
 INSULATION MATERIALS & SERVICES PTY. LTD., 428 Burwood-road, Hawthorn; D.A.25296/1; 23rd September, 1965; 17 cwt.
 KENT, GEORGE (AUSTRALIA) PTY. LTD., 563 Victoria-street, Abbotsford; D.A.1426/3; 9th September, 1965; 11 cwt.
 MORAN, A. & D., PTY. LTD., 8 Buchanan-street, Ivanhoe; D.A.44467; 17th September, 1965; 8 cwt.
 NATIONAL TYRE SERVICE (WANGARATTA) PTY. LTD., 4-10 Handley-street, Wangaratta; D.A.2374/34; 9th September, 1965; 17 cwt.
 SHELLY, P. E., Labilliere-street, Bacchus Marsh; D.A.2022/8; 17th September, 1965; 240 cwt.
 SHELLY, P. E., Labilliere-street, Bacchus Marsh; D.A.2022/5; 17th July, 1965; 271 cwt.; D.A.2022/6; 17th July, 1965; 257 cwt.
 SHELLY, P. E., Labilliere-street, Bacchus Marsh; D.A.2022/7 17th July, 1965; 242 cwt.
 SIDES, W. L., & SON PTY. LTD., 422 Collins-street, Melbourne; D.A.28601/11; 17th September, 1965; 74 cwt.; D.A.28601/12; 17th September, 1965; 52 cwt.
 VICTORIAN BACON PTY. LTD., Post Office Box 42, Cheltenham-road, Dandenong; D.A.44144; 4th September, 1965; 71 cwt.; D.A.44144/2; 4th September, 1965; 22 cwt.; D.A.44144/3; 4th September, 1965; 64 cwt.; D.A.44144/4; 4th September, 1965; 107 cwt.; D.A.44144/5; 4th September, 1965; 61 cwt.; D.A.44144/6; 4th September, 1965; 60 cwt.; D.A.44144/7; 4th September, 1965; 52 cwt.; D.A.44144/8; 4th September, 1965; 22 cwt.; D.A.44144/9; 4th September, 1965; 23 cwt.; D.A.44144/10; 4th September, 1965; 68 cwt.

TOW TRUCKS.

MELBOURNE TOWING SERVICE PTY. LTD., 169 City-road, South Melbourne; D.A.28169/13; 21st August, 1965; 74 cwt.; D.A.28169/14; 21st August, 1965; 61 cwt.; D.A.28169/15; 21st August, 1965; 79 cwt.; D.A.28169/16; 28th August, 1965; 68 cwt.
 M.R.W. PTY. LTD. (trading as Rising Sun Towing Service), 2 Williamstown-road, West Footscray; D.A.44494; 17th September, 1965; 43 cwt.

APPPLICATION by persons listed hereunder for renewal of the licence listed with variation of conditions in the manner set out opposite the name.

CUTHBERTSON & RICHARDS PTY. LTD., Payne-street, Bairnsdale; D.A.43930/1; 7th August, 1965; application to renew and vary the conditions of licence No. D.A.43930/1 (L/C. 101 cwt.) by adding to the existing conditions as an additional paragraph:—"Within a 20-mile radius of the post office at Bairnsdale—sawdust, sawmill off-cuts or firewood."

Notice of any objection should be forwarded to reach the Secretary of the Board not later than Wednesday, 21st July, 1965.

Applicants are advised that it will not be necessary to appear on the hearing date specified above unless advised in writing by the Board.

B. P. KAY,
Secretary.

Exhibition Buildings, Rathdown-street, Carlton, N.3, 7th July, 1965.

DEPARTMENT OF CROWN LANDS AND SURVEY.
DRAWING OF TOPOGRAPHIC MAPS.

QUOTATIONS will be received until noon 26th July, 1965, for the drawing of topographic and base maps from compiled information. The lowest or any tender will not necessarily be accepted.

Full particulars may be obtained from:—

The Surveyor General, Department of Crown Lands and Survey, Treasury-place, Melbourne.

ALAN J. HOLT,
Secretary for Lands.

DEPARTMENT OF CROWN LANDS AND SURVEY.
AMENDMENT OF ORDER IN COUNCIL TEMPORARILY
RESERVING LAND.

HIS Excellency the Governor of the State of Victoria, by and with the advice of the Executive Council thereof, doth, by Order made on the 29th day of June, 1965, amend the Order in Council approved on the 9th June, 1965, which reserved a certain area of land in the Township of Sale as a site for Public Park and Public Recreation, by substituting the area of 2 roods 26 perches for the area of 26 perches.—(Rs.1321).

J. COLQUHOUN,

Clerk of the Executive Council.

At the Executive Council Chamber,
Melbourne, 29th June, 1965.

NOTICE.

LABOUR AND INDUSTRY ACT 1958, SECTION 45B—REFERENCE OF A MATTER TO THE INDUSTRIAL APPEALS COURT.

NOTICE is hereby given that, pursuant to the provisions of section 45b of the *Labour and Industry Act 1958*, the Minister of Labour and Industry has referred to the Industrial Appeals Court for determination by it the following matter, viz.:—the effect of the judgment delivered by the Commonwealth Conciliation and Arbitration Commission on the 29th day of June, 1965, in the Metal Trades Cases (C. Nos. 4 and 834 of 1965) on the rates of wages fixed by the determinations of the Wages Boards mentioned in the Schedule hereto.

Notice is also given that the Industrial Appeals Court will deal with the aforesaid matter on Thursday, the twenty-second day of July, 1965, at No. 1 Boardroom, Workers' Compensation Board offices, 160 Queen-street, Melbourne.

... Dated at Melbourne this sixth day of July, 1965.

C. R. DEDMAN,
Registrar, Industrial Appeals Court.

SCHEDULE.

Agricultural and Pastoral Workers; Ambulance Services; Animal Manure; Asbestos Cement; Biscuit; Boiler-makers; Boot Trade; Bread Carters; Bread Trade; Brick Trade; Brush Makers; Building Sheets (Compressed Straw); Bulk Grain Workers; Butter Factories; Caretakers; Carpenters; Cement; Cement Articles; Cemetery Employees; Cleaners; Commercial Clerks; Commercial Travellers; Condenseries; Confectioners; Cork Trade; Dairy Farm Workers; Dental Mechanics; Dispensaries; Draughtsmen; Electroplaters; Engineers and Brassworkers (Skilled); Engineers and Brassworkers (Unskilled); Entertainment Employees (Performers); Excavation or Road Work; Factory Engine-Drivers; Fibrous Plasterers; File-makers; Fire Brick and Refractories; Fire Brigade Officers; Fire Fighters; Flock; Frozen Goods; Fruit Packing; Garden Employees; Grocers (Wholesale); Hairdressers, Horsehair; Hospital and Benevolent Homes; Hospital Pharmacists; Ice; Ice Cream; Industrial Gases; Iron and Steel Rolling; Ironmoulders; Journalists; Knitting Trade; Laundry Workers; Lift; Limeburners; Manufacturing Chemists; Meat Preservers; Millet Broom; Mineral Earths; Mining Engine-Drivers; Mothercraft Nurses; Musicians; Nail-makers; Non-Ferrous Metals; Nurserymen; Paint and Colour; Painters; Pastrycooks; Photographers; Photographic Goods; Plasterers; Plaster of Paris; Posterhangers; Pottery; Poultry Farm Workers; Production Planning; Quarry; Rabbit Processing; Radio Announcers; Retail Dairy; Road Patrolmen; Roofing Tiles; Saltworkers; Sand Pit; Sausage Casings; Scientific and Technical Workers; Sewage Distribution; Sewer Builders; Shearing Industry; Shops Board No. 2 (Boot Repairers); Shops Board No. 3 (Butchers); Shops Board No. 6 (Chemists); Shops Board No. 10 (Fish and Poultry); Slaughtering for Export; Special Service Firemen; Sportsground Maintenance; Storemen; Packers and Sorters; Sugar Refiners; Synthetic Filament Yarn; Tar and Bitumen; Tennis Strings; Tile-layers; Underground Clay Mining; Undertakers; Vegetable Growers; Watchmen; Waterfront Watchmen; Wharfs and Jetties; Wire Fence and Tubular Gate; Woollen and Cotton Trade; Clerks (Meat Works); Law Clerks; Plumbers; Shops Board No. 1 (Boot Dealers); Shops Board No. 7 (Country Shop Assistants); Shops Board No. 8 (Delicatessens); Shops Board No. 9 (Drapers and Men's Clothing); Shops Board No. 14 (Furniture Dealers); Shops Board No. 15 (Grocers); Shops Board No. 16 (Hardware); Shops Board No. 17 (Tobacconists); Shops Board No. 18 (Miscellaneous Shops); Shops Board No. 19 (Confectionery, Pastry, Fruit and Vegetable); Shops Board No. 22 (Motor Requisites); Shops Board No. 23 (Electrical and Radio Goods); Shops Board No. 21 (Booksellers and Newsagents).

FARM PRODUCE AGENTS ACT (No. 6248).

LIST of persons to whom Farm Produce Agents' Licences have been issued for the year ending December, 1965, and each of whom has lodged a fidelity bond, in accordance with the requirements of the Act:—

<i>Name; Principal Place of Business.</i>	<i>Name; Principal Place of Business.</i>
Abidin, Besim, 48 Evans-street, Brunswick.	Bourke, F. W., Pty. Ltd., 34-36 Doveton-street north, Ballarat.
Acme Seed Store, Newham, via Woodend.	Bove, Antoine, 65 Capel-street, North Melbourne.
Adgemis, Peter John, 8 Rae-street, Hawthorn.	Brabazon, Stanley Percival, Burwood-road, Fern Tree Gully.
Agosta, Frank, and Sons, 74 Clarendon-street, Thornbury.	Bradbury, J. C., and Sons Pty. Ltd., 122 King-street, Melbourne.
Aidone, Sam., 122 Peel-street, North Melbourne.	Briggs, Neil John, 5 Allawarre-avenue, Croydon.
Aitken, D. S., Pty. Ltd., 24 Walsh-street, Coburg.	Brophy, Foley and Co., 204 Mair-street, Ballarat.
Albioli, Vincenzo, 200 Pascoe Vale-road, Moonee Ponds.	Brown and Dureau Ltd., cnr. Kavanah and Ireland streets, South Melbourne.
Alderuccio, Guiseppe, 62 Chapman-street, North Melbourne.	Brown, G., 20 Queen-street, Bendigo.
Alexander, E., and Sons, Heathmere, Victoria.	Brunt, Arthur, Pty. Ltd., 385 Lygon-street, Brunswick.
Alexander, J. M., 39 Liverpool-street, West Coburg.	Bryant and Gourley, 22 Peel-street north, Ballarat.
Alexander, G. N., 299 Plenty-road, Preston.	Buck, R. J. E., Anderson's Creek-road, Doncaster East.
Alicastro, Nicola, 21 Ferris-place, South Melbourne.	Bungaree Potato Distributing Co., 42-44 Nicholson-street, Abbotsford.
Allen, C. J., Station-street, Somerville.	Bunge (Aust.) Pty. Ltd., 224 Queen-street, Melbourne.
Aloi, Pasquale, 67 Bruce-street, Colac.	Burgi, B. and E., Victoria-road, Wandin North.
Amalfi, Frank, 30 Elizabeth-street, Fawkner.	Butler, T. E., and Co. Pty. Ltd., 64 Railway-road, Blackburn.
Amalfi, Jim, 28 Elizabeth-street, Fawkner.	Callanders Pty. Ltd., 25 Murphy-street, Wangaratta.
Amalfi, Louis, 762 Burke-road, Camberwell.	Cammaroto, Francesco, 33 Robertson-street, Kensington.
Amato Bros., 31 Lorne-street, Moonee Ponds.	Cambridge, A. B., Pty. Ltd., 77 Whitehall-street, Footscray.
Anderson, David, and Co., 76 Wilson-street, Horsham.	Captain Distributing Co. Ltd., 481 Flinders-lane, Melbourne.
Andrews, Fruit and Vegetable Market, Lyttleton-terrace, Bendigo.	Careri, Rocco, 148 Cooper-street, Essendon.
Angliss, W., and Co. (Aust.) Pty. Ltd., 42 Bourke-street, Melbourne.	Carrazza and Co., 1042 Drummond-street, North Carlton.
Anguey, Robert Osborne, 51 Nungerner-street, Balwyn.	Carrozza, Diego, 15 Birch-street, West Preston.
Ansell, Vernon, and Co. Pty. Ltd., 524 Collins-street, Melbourne.	Caveny, William, Dennington.
Archibald Honey Co., Spring-road, Dingley.	Chambers, G. E., Red Hill.
Arena, Luigi, 191 Errol-street, North Melbourne.	Chapman, Leslie Ernest, Charteris-road, Wandin East.
Ashworth, K. P., Hay's-place, Geelong.	Chen, W. D., Fruit Co. Pty. Ltd., 9 Wholesale Fruit Market, Melbourne.
Augello, Matteo, 71 The Grove, Coburg.	Chin, S. H., Bros. Pty. Ltd., 33 Wholesale Fruit Market, Melbourne.
Aumann, Edward Graham, 11 Yarra-road, Croydon.	Chinn, F. A., and Co., 40 Wholesale Fruit Market, Melbourne.
Austral Fruit Agency, 147 Therry-street, Melbourne.	Chivers, Craig, & Co., Porter-street, Templestowe.
Austral Grain and Ambler Pty. Ltd., 46-52 King-street, Melbourne.	Christie, W. J., 30 Madden-avenue, Mildura.
Australian Beeswax and Beeline Products of Daylesford (B. W. McCahon), Lake-road, Daylesford.	Ciccone, V., 285 George-street, Fitzroy.
Australian Estates Co. Ltd., 114 William-street, Melbourne.	Cimino, Sebastiano, 68 Hammond-street, Thornbury.
Australian Estates Company (Agencies) Pty. Ltd., 114 William-street, Melbourne.	Clarke, G. S., Station-street, Somerville.
Australian Mercantile Land and Finance Co. Ltd., 122 William-street, Melbourne.	Clements, C. E., and Co. Pty. Ltd., 34 Queen-street, Melbourne.
Baker, Harold, Wandin East.	Collins, C. and S., 36 Thames-promenade, Chelsea.
Baker, L. F., Burwood-road, Wantirna.	Conaughton, J. P., and Co., corner of Doveton and Mair streets, Ballarat.
Ballantyne, K. L., Pty. Ltd., 295 Grant-street, South Melbourne.	Cook, G. J., 91 Peel-street, North Melbourne.
Bandias, A., Falconer-road, Warrandyte South.	Cooney, R. M., and Co., McLeod-street, Orbst.
Banson, George, and Son Pty. Ltd., 20 Wholesale Fruit Market, Melbourne.	Cooper, G. W., Main-road, Silvan.
Barbaro, A., 4 Murray-street, Brunswick West.	Co-operated Dried Fruit Sales Pty. Ltd., 16-24 Jeffcott-street, Melbourne.
Barker and Staff Pty. Ltd., 294 Victoria-street, North Melbourne.	Corlass, Ian, Katunga.
Barker, Green and Parke Pty. Ltd., 298 Victoria-street, North Melbourne.	Cornish, R., and Sons Pty. Ltd., 184 Franklin-street, Melbourne.
Barker Produce (Vic.) Pty. Ltd., 298 Victoria-street, North Melbourne.	Corstorphan, James Francis, Morack-road, Vermont.
Barratt, W. H., Beenak-road, Seville.	Courtney, Michael Edward, Daylesford.
Barrow, Alfred, Pty. Ltd., 47 King-street, Melbourne.	Cousin, Ian, F. T., Meyers-road, Merricks North.
Barrow Bros. Commission Agency Pty. Ltd., 460-466 Flinders-lane, Melbourne.	Cowin, W., 200 Brighton-street, Richmond.
Beckoff, T., 55 Brougham-street, North Melbourne.	Cowling, W., Market-square, Bendigo.
Bellfair Poultry Supply Pty. Ltd., 225 Dundas-street, Preston.	Cramer, E., and Sons Pty. Ltd., 54 Tuaggara-street, Maryborough.
Bellofiore and Son, 3 Cobden-street, North Melbourne.	Crema and Co., 31 Alice-street, Coburg.
Bellofiore, Michael, 173 Melville-road, West Brunswick.	Crickard, F. B., and Co., 443 Little Collins-street, Melbourne.
Bendigo Quick Frozen Foods Pty. Ltd., Aspinall-street, Golden Square.	Cristofaro and Sons Pty. Ltd., 249 Franklin-street, Melbourne.
Bennett, J. F., and Co. Pty. Ltd., 1 Curtis-street, Ballarat.	Croker, Arthur Edwin, 17 Palmerston-grove, Oakleigh.
Bentleigh Poultry Auctions, Keys-road, Moorabbin.	Crossland, Alexander Cecil, Warburton-road, Wandin North.
Bertucci, Guiseppe, 7 Gunnedah-street, Sunshine.	Crowley, Thomas George, Kinglake West.
Black, H. R., Pty. Ltd., 395 Queen-street, Melbourne.	Croydon Market Auction and Real Estate Pty. Ltd., 13 Kent-avenue, Croydon.
Black, Malcolm David, 14 Jellicoe-street, Noble Park.	Crystal Ice and Cool Stores Co., 123 Garsed-street, Bendigo.
Blackham, W. H., Pty. Ltd., 59-61 King-street, Melbourne.	Cullen, Jack, 176 Lyttleton-terrace, Bendigo.
Blooms Fruit Shop, 314 Wyndham-street, Shepparton.	Cunningham, D. and B., 7 Mile-road, Nar-Nar-Goon.
Blue Moon Fruit Co-op. Ltd., 60 Railway-road, Blackburn.	Curnow's (Bendigo), Queen-street, Bendigo.
B. and M. Fruit Agency, 149 Therry-street, Melbourne.	Cutbush, G. E., and Co., Dean (Victoria).
Bodley, H. H., and Son Pty. Ltd., Riverside-avenue, South Melbourne.	Cutrale, Tony, 39 Mirams-street, Ascot Vale.
Bonney, Stan., 267 Punt-road, Richmond.	Daffy, Michael Joseph, Beeac, Victoria.
Booth, Frank, and Sons Pty. Ltd., 16 Wholesale Fruit Market, Melbourne.	D'Agostino and Son, 60 North-road, East Reservoir.
Border Grain Pty. Ltd., 6 Chapman-street, Swan Hill.	Dalgety and New Zealand Loan Ltd., 461 Bourke-street, Melbourne, C.I.
Borgia Bros., 77 McKillop-street, Geelong.	D'Aloisio, V. and D., Chapman-road, Silvan.
Borthwick, Thos., and Sons (Aust.) Ltd., 543 Little Collins-street, Melbourne.	D'Aloisio, Panfilo, 7 Clyde-street, Lilydale.
Borwick, P. B. and R. W., 47 Bromfield-street, Colac.	Davis, J. L., Pty. Ltd., 7 Curdie-street, Camperdown.
Bourgazas, Nicholas, Pomona, via Wentworth, N.S.W.	Davis, J., Pty. Ltd., 8 Wholesale Fruit Market, Melbourne.
	Davis, Lancaster, and Co., 601-611 Little Lonsdale-street, Melbourne.
	De Bernardi, J. A. and E. L., Station-street, Somerville.
	De Cicco, Carmine Pasquale, 110 O'Shannassy-street, North Melbourne.

Name; Principal Place of Business.

De Iulio, A., and Son, The Eyrie, Lilydale.
 Demaria, Giovanni, 9 Shuter-street, Moonee Ponds.
 Demaria, Domenico, 136 Reynards-road, Coburg.
 Demarte, D., 80 Chapman-street, North Melbourne.
 Dennys, Lascelles Ltd., Moorabool-street, Geelong.
 D'Esposito, Gaspare, Moxham-road, Monbulk.
 De Vincentiis, Domenico, Main-street, Lilydale.
 Di Battista, A. and N., Beenak-road, Wandin.
 Di Benedetto, L. and F., 5 Montgomery-street, Richmond.
 Dickson, D. S., Wonga-road, Ringwood North.
 Di Labio, F. and M., 58 Barrow-street, East Coburg.
 Dimattina, F., and Co. Pty. Ltd., 50 Wholesale Fruit Market, Melbourne.
 Di Pietrantonio, Joseph, Queens-road, Silvan.
 Divola, D., and Sons, 122 Eighth-street, Mildura.
 Dobbie Bros., 114 Creswick-road, Ballarat.
 Donoghue, J. E., Pty. Ltd., 527 Collins-street, Melbourne.
 Douglas, Harold, Pty. Ltd., 32 Peel-street, West Melbourne.
 Doyle, L. J., Pty. Ltd., 51 Queen-street, Melbourne.
 Dreyfus, Louis, and Co. Ltd., 505 St. Kilda-road, Melbourne.
 Drouin Co-operative Butter Factory Co. Ltd., Lardner-road, Drouin.
 Dunn, Neville Frederick, 12 Fleming-street, West Brunswick.
 Dyer, W. and A., 601 Little Lonsdale-street, Melbourne.
 Dykes, Mark, Pty. Ltd., 8 Oakhill-avenue, Regent.
 Edgar, C. R., and Co. Pty. Ltd., 528 Lonsdale-street, Melbourne.
 Edwards, M. T., Red Hill South.
 Elder Smith Goldsbrough Mort Ltd., 499-501 Bourke-street, Melbourne.
 Enbom, P. W., 56 Radovick-street, Korumburra.
 Evans, C. W., 4 Gordon-street, Korumburra.
 Everard, Jim (Wallace), Wallace, Victoria.
 Faba, Silvino, Lot 29b, off McBride-street, Fawkner.
 Fairbairn, L. A., and Co., incorporating Younghusband Ltd., Main-street, Bacchus Marsh.
 Fallow Products, 90 William-street, Melbourne.
 Fankhauser, Ernest L. R., Stevens-road, Vermont.
 Farquhar, Stan, Pty. Ltd., 610 Talbot-street, Ballarat.
 Farquhar, J. T., and Sons, 19 Mair-street, Ballarat East.
 Feiglin, M., and Sons, Pty. Ltd., Station-street, Nunawading.
 Ferlazzo, G., and Co. Pty. Ltd., 49 Wholesale Fruit Market, Melbourne.
 Ferris, H., Pty. Ltd., Mollison-street, Kyneton.
 Festival Packers Pty. Ltd., 723B Centre-road, East Bentleigh.
 Fiesta, Fare Pty. Ltd., Main-road, Research.
 Foley Bros. (London) Pty. Ltd., 213 King-street, Melbourne.
 Forbes and Snell Pty. Ltd., 530 Collins-street, Melbourne.
 Frankel, H. and S., 44 Wholesale Fruit Market, Melbourne.
 Frazer, R. J. and A. M., 43 Fortuna-avenue, North Balwyn.
 French, E. G., Victoria-street, Hastings.
 Friedman, M., 286-288 Victoria-street, North Melbourne.
 Gabriel, Kimon, 452 Albion-street, West Brunswick.
 Gallo, G., 41 Miller-street, West Melbourne.
 Gammaldi G. and V., 115 Peel-street, North Melbourne.
 Gangemi, Rosario, 27 Byron-street, Moonee Ponds.
 Gaspari, Gabriele, 14 Sumner-avenue, Northcote.
 Gatto, Antonio, 209 Cecil-street, South Melbourne.
 Gaud, H. M. (Melbourne), 452 Queen-street, Melbourne.
 Gavin, C. P. and L. M., Crossley.
 Gaudion, P. G. and L. B., Beenak-road, Wandin.
 Geelong and Cressy Trading Co. Ltd., 138 Malop-street, Geelong.
 Gells Gippsland Honey Supply, McClure-street, Maryborough.
 "Gem" Fruit and Produce (Stephen John Adgemis), 260 Victoria-street, North Melbourne.
 Geraldton Fruit Co., 57 Wholesale Fruit Market, Melbourne.
 Gippsland and Northern Co-op. Co. Ltd., 492 Flinders-lane, Melbourne.
 Glasshouse Tomato Growers of South Australia Co-operative Ltd., 11 Anders-avenue, Oaklands Park, South Australia.
 Godfrey, Dan, and Co. Pty. Ltd., Dandenong.
 Golden Poultry Farm Pty. Ltd., 51 Playne-street, Frankston.
 Golden Valley Fruit Co. Pty. Ltd., 15 Wholesale Fruit Market, Melbourne.
 Goodrich, Francis G., Shoreham-road, Red Hill South.
 Goodwin, N. F., 40 High-street, Coburg.
 Gormann, W. J., Pty. Ltd., 31 King-street, Melbourne.
 Gould, R., Warrantye-road, Baxter.
 (The) Grain Handling Corporation Pty. Ltd., 528 Lonsdale-street, Melbourne.
 Green, N., and Son Pty. Ltd., 113A Therry-street, Melbourne.
 Grindal, E. H., 23 Wales-street, West Brunswick.
 Groves, McVitty and Co. Pty. Ltd., Blackburn-road, Clayton.

Name; Principal Place of Business.

Gugger, N. A., Hyland-street, Fyansford.
 Guys Fruit Service Pty. Ltd., 228 Pascoe Vale-road, Essendon.
 Haag, O. and S. G., Victoria-road, Seville.
 Hancock, A. W., and Co. Pty. Ltd., 104 Armstrong-street north, Ballarat.
 Hanger, H., Pty. Ltd., 1248 Burke-road, North Balwyn.
 Hardidge, Herbert John, King-street, East Doncaster.
 Harris, H. R., corner of Flinders-lane and Knight's-place, Melbourne.
 Harrison, Neil J., 1125 Doncaster-road, Donvale.
 Harvey, Dann, and Co. Pty. Ltd., 118 Fyans-street, Geelong.
 Harwood and Ahern Pty. Ltd., 1-3 Cobden-street, North Melbourne.
 Haughton, William, and Co. Pty. Ltd., 545 Little Collins-street, Melbourne.
 Hedditch, N. S. F., and Son Pty. Ltd., 85 Percy-street, Portland.
 Hester Bros. Poultry Service, Powells-avenue, East Bendigo.
 Hibbins, W. R., and Sons, 40 Talbot-avenue, East St. Kilda.
 Hill, Frank A., and Co., Charing Cross, Bendigo.
 Holden, W. M., Hogan-street, Tatura.
 Holland and Holland, Station-street, Cobram.
 Holland, D. and G., Modella-road, Iona, via Bunyip.
 Hoopell's Hardware, Timber and Fodder Store, Mollison-street, Malmsbury.
 Horsfield, L., "Dalkeith", R.S.D., Thorpdale.
 How, Keith Clifton, 16 Westminster-drive, Avondale Heights.
 Howell, James (Jnr.), Victoria-road, Wandin North.
 Huile Trading Co., 119 Therry-street, Melbourne.
 Hunscha, A. R. and J. G., P.O. Box 10, Jeparit.
 Hunter, W. B., Corio-street, Shepparton.
 Hurst and Green, 11 Cobden-street, North Melbourne.
 Hutchinson, Robert, Ltd., Hartington-street, Glenroy.
 Hyland, David, and Sons Pty. Ltd., Salmon-street, Port Melbourne.
 Hyman, J., and Sons Pty. Ltd., 51 Wholesale Fruit Market, Melbourne.
 Ierianni, Antonio, 54 Fischer-street, Coburg.
 Interlandi, G., 173 Cumberland-road, Pascoe Vale.
 International Fruit and Mercantile Co. Pty. Ltd., 60 Railway-road, Blackburn.
 Inverno, S., and Co., Koo-Wee-Rup.
 Italia, Salvatore, 40 Linda-street, Coburg.
 Iuele, M. and G., 396 Albert-street, West Brunswick.
 Jackel, G. O., and Sons, Williams-road, Wangaratta.
 Jackson, Shands, Pty. Ltd., 540 Little Collins-street, Melbourne.
 James, H. K., 12-18 Northumberland-street, South Melbourne.
 Johnston, H. and L., Birregurra, Victoria.
 Johnston, Harold Vincent, Blackburn-road, Doncaster East.
 Jonas Wholesale Pty. Ltd., 146 Dudley-street, Melbourne.
 Kalafatis Bros., P.O. Box 13, Lemnos.
 Kapisris Bros., 290 Victoria-street, North Melbourne.
 Kardos, J. I., 44 Anakie-road, Bell Park, Geelong.
 Kelly, A. C. and I., 149 Therry-street, Melbourne.
 Kelly, Maurice Thomas, Bungaree P.O.
 Kilmore-Broadford Dairy Co., Sutherland-street, Kilmore.
 Kimpton, W. S. and Sons, 143 Queen-street, Melbourne.
 King, E. G. Pty. Ltd., 2 Wholesale Fruit Market, Melbourne.
 King, J. L., and Co., Queen-street, Bendigo.
 Kirks Bazaar, 1144 Mt. Alexander-road, Essendon.
 Knee, F. J., Dudley-road, Wonga Park.
 Kolmanic, Mirko, P.O., Kinglake.
 Kondopidis, Michael, 250 Victoria-street, North Melbourne.
 Koroit and Tower Hill Farmers Co-op. Society Ltd., Koroit.
 Lambie, D. A. and Co., P.O. Box 139, Merbein.
 Lanera, P. G., 15 Spicer-street, Beaumaris.
 Lanteri, M., and Son, 113 Wellington-street, Flemington.
 Lanteri, Santi, 48 Wholesale Fruit Market, Melbourne.
 Launceston Market Supplies Pty. Ltd., 7 William-street, Launceston, Tasmania.
 Lauritz, W. G. and Sons, 21 Viaduct Buildings, Queens Bridge, Melbourne.
 Lawless, T. J., and Co., 107-109 Lydiard-street, Ballarat.
 Lee, Graeme Walter, 31 Pendle-street, Box Hill.
 Legg, F. J., and Son, 300 Burwood-road, Burwood.
 Leong Hoong Cheong and Co. Pty. Ltd., 16 Barnes-avenue, Burwood.
 Lepre, Gerald, 80 Rose-street, Coburg West.
 Lincinti, Lorenzo, 1 Montgomery-street, Moonee Ponds.
 Lindsay and Charteris, Wandin.
 Long, James, T. G., Kerang, Victoria.
 Louey Pang, H., and Co. Pty. Ltd., 186 Franklin-street, Melbourne.
 Lovett, H. L. E., and Co., 23 Wholesale Fruit Market, Melbourne.
 Lowan, H. W., 206 Edward-street, East Brunswick.
 Lunt, G. and M., Rear 228 Dorcas-street, South Melbourne.
 Lyndon and Jones Pty. Ltd., 40 Princess-street, Traralgon.

Name; Principal Place of Business.

Mace, E. H., Pty. Ltd., 95 Cecil-street, South Melbourne.
 Mackaness and Avery Pty. Ltd., 11 Cobden-street, North Melbourne.
 Mackaness Produce, 11 Cobden-street, North Melbourne.
 Madafferi, F., and Co., 36 Chapman-street, North Melbourne.
 Madden, P. F., "Sea View", Tower Hill.
 Maffra Packing Co. Pty. Ltd., Rose-street, Heyfield.
 Mamnone, Filippo, 130A Eighth-street, Mildura.
 Mandica, Domenico, 1 Ailsa-street, Ascot Vale, W.2.
 Marazita, G. and M., and Co., 298 Union-street, West Brunswick.
 Marsh, E. G., Pty. Ltd., 522 Flinders-lane, Melbourne.
 Marshall, R. and K. F., Neerim, Victoria.
 Martakis, G., and Son Pty. Ltd., 390 Clarendon-street, South Melbourne.
 Martinello and Pistrutto, 1 Chapman-street, North Melbourne.
 Marvelli, Pasquale, 20 Dene-avenue, East Malvern.
 Maryborough Flour Mills Pty. Ltd., 38 Albert-street, Maryborough.
 Mason, G. F., 21 Leura-grove, Hawthorn.
 Massaro, Guiseppe, 273 Mt. Alexander-road, Ascot Vale.
 Mastromauro, A., 89 Suffolk-street, West Footscray.
 Matthews, F. E., and Son, Korong Vale.
 Maxwell, C. S., and Co., 8 Kathryn-street, Benalla.
 Mazzetto and Valentine, 305 Cumberland-road, West Breen.
 Mellor, F. R., and Son, 452 Queen-street, Melbourne.
 Menta, Michelangelo, 36 Ascot Vale-road, Flemington.
 Mentiplay, D., and Co. Pty. Ltd., 27 Wholesale Fruit Market, Melbourne.
 Mentiplay, D., and Co. (Vegetables) Pty. Ltd., 27 Wholesale Fruit Market, Melbourne.
 Metro Vegetable and Fruit Merchants Pty. Ltd., 11 Gillies-street, Hampton.
 M. G. C. Pty. Ltd., 5 Moss-place, North Melbourne.
 Micheli, J. and V., 70 Christmas-street, Northcote. N.16.
 Michell and Son, Newlyn.
 Midland Fruit Supply, 163 Hargreaves-street, Bendigo.
 Mildura Leading Fruit Shop, 138 Eighth-street, Mildura.
 Miller, A. F. and R. P., Church-street, Doncaster.
 Millis, Alfred, and Sons Pty. Ltd., 438 Queen-street, Melbourne.
 Mimmo, Guiseppe, 265 Albion-street, Brunswick.
 Mirarchi, Nicodemo, 28 Leveson-street, North Melbourne.
 Mobbs, N. and J., Knox-street, Daylesford.
 Montague, W. F., Pty. Ltd., Horswood-road, Narre Warren North.
 Morriss, G. N., and Co., Central Mart, Colac.
 Mortimer, David Alexander, High-street, Drysdale.
 Moss, J., and Sons Pty. Ltd., 11 Wholesale Fruit Market, Melbourne.
 Motta, John, P.O., Koo-Wee-Rup.
 Moulden, E. T., and Sons Pty. Ltd., 561 Bell-street, Preston.
 Mulholland, D. J., and Co. Pty. Ltd., 24 Arthurton-road, Northcote.
 Mumford, J. G., Pty. Ltd., 35 Wholesale Fruit Market, Melbourne.
 Muratore, Filomena, 15 Avondale-street, Hampton.
 Murphy, W. T., Bros. Pty. Ltd., 594 Burwood-road, Auburn.
 Murray's Wholesale Fruit Supply, 187 Adderley-street, West Melbourne.
 Murray Valley By-Products Pty. Ltd., Osboldstone-road, Wangaratta.
 McBeth, J. P., 207 Neerim-road, Carnegie.
 McCarthy, H. A., and Son, Mount Clear, via Ballarat.
 McCraith, John A., and G., Pty. Ltd., 284 City-road, South Melbourne.
 McCulloch Carrying Co. Pty. Ltd., 468 Collins-street, Melbourne.
 McKeddie Orchards, Main Ridge, Victoria.
 McKenzie, M. J., and Sons, Woorarra-avenue, East Doncaster.
 McKinnon, C., Post Office, Box 3, St. Arnaud.
 McKirdy, I. J. Queens-road, Wandin.
 McPhail, Anderson, and Co. Pty. Ltd., 224 Queen-street, Melbourne.
 McPhee, B. P., 31 Delaware-street, Reservoir.
 McRae, John, and Son Pty. Ltd., Jung.
 Nash, S., and Sons, Drysdale.
 Natalizio, Emanuele, 201 Raleigh-street, Thornbury.
 Neim, Petrit, 4 McLean-street, West Brunswick.
 Nelson, P. N. and F. R., Haley's Gully-road, Hurstbridge.
 Newport Poultry Supply, 131 Johnston-street, Newport.
 Nichol, A., and Sons Pty. Ltd., 31 Wholesale Fruit Market, Melbourne.
 Nicholas, Pat, 38 Lincoln-road, Essendon, W.5.
 Nichols, John Frederick, Lalor's-road, Healesville.
 Nolan, H. C., Pty. Ltd., 618 Queensberry-street, North Melbourne.
 Nolan, T. J., Binney-street, Euroa.

Name; Principal Place of Business.

Noonan, J. F., Pty. Ltd., 623 Collins-street, Melbourne.
 North Eastern Co-op. Society Ltd., Reid-street, Wangaratta.
 Nunn, G. P. and M. G., 10 Sturt-street, Ballarat.
 Orlando, T., and Co. (Fruit) Pty. Ltd., 13 Wholesale Fruit Market, Melbourne.
 Orlando, T., and Co. (Vegetables) Pty. Ltd., 13 Wholesale Fruit Market, Melbourne.
 O'Toole, H., Illowa.
 Pack Kee, 55 Wholesale Fruit Market, Melbourne.
 Pakenham Fruit Growers' and Producers' Co-operative Ltd., 38 James-street, Pakenham East.
 Panton, M. J., 114 Chapel-street, Windsor.
 Patchett Produce Distributors Pty. Ltd., 103 Victoria-street, West Melbourne.
 Pays (Kerang) Pty. Ltd., 31 King-street, Melbourne.
 Peachey, R. A., and Son Pty. Ltd., 623 Collins-street, Melbourne.
 Pearce, George Arthur, 9 Winston-drive, South Caulfield.
 Pellegrino, A., 146 Brunswick-street, Fitzroy.
 Pellegrino, C., and Co. Pty. Ltd., 280 Victoria-street, North Melbourne.
 Penna, A. W., Pty. Ltd., 1 Canning-street, West Maribyrnong.
 Permewans (Colac) Pty. Ltd., 31 King-street, Melbourne.
 Permewans (Horsham) Pty. Ltd., 31 King-street, Melbourne.
 Permewans (Wangaratta) Pty. Ltd., 31 King-street, Melbourne.
 Permewans (Warragul) Pty. Ltd., 31 King-street, Melbourne.
 Permewan Wright Ltd., 31 King-street, Melbourne.
 Perry, William Anderson, Sunnyclyffs P.O., Red Cliffs.
 Petracca, Noe, Albert-road, Lilydale.
 Pette, V. 20 Brougham-street, North Melbourne.
 Pettolina, Angelo, 314 Gillies-street, Thornbury.
 Petty, J. W., and Co., Myers-road, Balnarring.
 Piccolo, Carmelo, 46 Moyangul-drive, East Keilor.
 Piccolo, Francesco, P.O. Box 470, Swan Hill.
 Pignataro, Guiseppe, Monbulk-Seville road, Silvan.
 Pignataro, Rocco, Seville-Monbulk road, Silvan.
 Pirrie Bros., 136 Exhibition-street, Melbourne.
 Pitt, A. E., 14 Wholesale Fruit Market, Melbourne.
 Pizaro, Ronald J., 60 Catherine-street, West Coburg.
 Plant, C. S. and D. E., 22 Breed-street, Traralgon.
 Ponte, Charles, 96 Weston-street, Brunswick.
 Ponte, Frank, 24 Mitchell-street, Brunswick.
 Ponte, V. and S., 450 Queensberry-street, North Melbourne.
 Portelli, E. (Kyneton Ice and Freezing Works), 176 Mollison-street, Kyneton.
 Porter, L. M., Pty. Ltd. (Bendigo and District Grocers' Association), Stanley-street, Bendigo.
 Potato Producers' Co-operative Ltd., 475 Collins-street, Melbourne.
 Potter Bros. Pty. Ltd., 219 Williamson-street, Bendigo.
 Potter (Melb.) Pty. Ltd., 49 Wholesale Fruit Market, Melbourne.
 Poultrymen and Farmers Trading Co. Pty. Ltd., 696 Queensberry-street, North Melbourne.
 Poultrymen and Farmers Trading Co. (Frankston) Pty. Ltd., 696 Queensberry-street, North Melbourne.
 Poultrymen and Farmers Trading Co. (Somerville) Pty. Ltd., 696 Queensberry-street, North Melbourne.
 Pratt, David and Sons, 215-221 Mair-street, Ballarat.
 Presti, Lorenzo, 92 Paisley-street, Footscray.
 Prestia, Antonio, 16 James-street, Fawkner.
 Producers Co-op. Distributing Society Ltd., 7 Wholesale Fruit Market, Melbourne.
 Pullar, P., and Nephew, 59 Wholesale Fruit Market, Melbourne.
 Pump, John William, Burwood-road, Wantirna South.
 Pump, L. G., Manningham-road, Lower Templestowe.
 P.W. Proprietary Limited, 31 King-street, Melbourne.
 Quattrocchi, Antonio, 5 Nolan-street, North Essendon.
 Quayle and Hutton, 23-25 Mair-street, Ballarat.
 Quick, P. R., and Sons, 458 Queen-street, Melbourne.
 Quong, Hi Shing, Pty. Ltd., 407 Queen-street, Melbourne.
 Quong, Hoong Wah, Pty. Ltd., 41 Wholesale Fruit Market, Melbourne.
 Radatti, Saverio, 14 Thomson-street, Northcote.
 Radeff, Sava, 57 Peel-street, West Melbourne.
 Raffaele, Joseph, Main-street, Bairnsdale.
 Ralphs and Bravo Pty. Ltd., 24 Wholesale Fruit Market, Melbourne.
 Ramsay's Orange House Pty. Ltd., Red Cliffs.
 Rangeview Orchards, Lum-road, Glen Waverley.
 Rawson, Henry Claude, Moore-street, Erica.
 Reid, Don, 81 Wyndham-street, Shepparton.
 Richardson, H. F., and Co., Lonsdale-street, South Geelong.
 Rigando, R. and D., 782 Centre-road, East Bentleigh.
 River Farms Produce, Wallace, Victoria.
 Riverina Voluntary Barley Pool Pty. Ltd., 528 Lonsdale-street, Melbourne.
 Rizza, S. and P., 101 Raymond-street, Sale.

Name; Principal Place of Business.

Robertson, H. A. and H. D., 46 John-street, East Brunswick.

Robinvale Citrus Groves Pty. Ltd., 10-14 Leicester-street, Carlton.

Roderick, W., Hosie-street, Bairnsdale.

Rodriguez Bros., 156 Donald-street, Brunswick.

Rohr, George, Pty. Ltd., 9 Queen-street, Melbourne.

Rose, Arthur Thomas, 30 Lambeth-avenue, Armadale.

Rosenfield, R. J. and L. N., Pty. Ltd., 52 Wholesale Fruit Market, Melbourne.

Ross, J. W., Pty. Ltd., 13 Wholesale Fruit Market, Melbourne.

Rossin, G. and Sons, 75 Moreland-road, East Coburg.

Royle, William, and Son, 483 Flinders-lane, Melbourne.

Rullo, Pasquale, 9 Byron-street, Moonee Ponds.

Rural Distributing Co. Pty. Ltd., 20 Wholesale Fruit Market, Melbourne.

Rushan, Selim, 100 Union-street, Brunswick.

Russell, Frank, Box 150, P.O., Warrnambool.

Russo, Bros., 23 Evelyn-street, Frankston.

Sabatino, R., and Co., 14 Wyuna-street, West Brunswick.

Sallmann, Jack, and Co., 123 Lloyd-street, Dimboola.

Salpietro Bros., 264 Victoria-street, North Melbourne.

Samargis, George, 131 Gertrude-street, Fitzroy.

Sang Goon and Co., 56 Wholesale Fruit Market, Melbourne.

Sanitarium Health Food Co., 118 Union-street, Windsor.

Santalucia, A., and Sons Pty. Ltd., 47 Capel-street, North Melbourne.

Santarosa, Giacinto, 118 Peel-street, North Melbourne.

Saunders Malt Extract Pty. Ltd., Trenerry-crescent, Abbotsford, N.9.

Scarff Bros. Pty. Ltd., 317 Collins-street, Melbourne.

Schultz, A. J., 20 Edgevale-road, Kew.

Schutt and Barrie Pty. Ltd., Geelong-road, West Footscray.

Schuyt, Johannes, Main-road, Silvan.

Sciarrone, Giuseppe, 10 Menzies-court, West Brunswick.

Scollo, Joe, 520 Heatherton-road, Dandenong.

Scollo, Samuel, 520 Heatherton-road, Dandenong.

Scott, Alex and Co. Pty. Ltd., 147 Lonsdale-street, Dandenong.

Scown, L. H., and Standen, D. I., 15 Rutherford-street, Swan Hill.

Sesto, Geo., 104 Capel-street, North Melbourne.

Sesto, John, 27 Argyle-avenue, Chelsea.

Sirro, L., 392A Brunswick-road, Brunswick.

Shaw, F. C. and J. L., Wiseman-road, Burleigh.

Shea, Hood and Co. Pty. Ltd., 535 Flinders-lane, Melbourne.

Shue, D. Louey Bros. Pty. Ltd., 186 Franklin-street, Melbourne.

Sicura, Paola, 420 Brunswick-road, West Brunswick.

Sicura, Paola Giuseppe, 355 Brunswick-road, West Brunswick.

Silbert, Sharp and Davies Pty. Ltd., 17 Wholesale Fruit Market, Melbourne.

Silk, Kevin Mark, 24 Wholesale Fruit Market, Melbourne.

Silks Vegetables Pty. Ltd., 24 Wholesale Fruit Market, Melbourne.

Simmons, S. F., Pty. Ltd., 9 Blackwood-street, North Melbourne.

Smith, David, Pty. Ltd., 3 Wholesale Fruit Market, Melbourne.

Smith, Gilbert E., Army-road, Pakenham East.

Smith, L. A., and Sons (Ballarat), 25 Doveton-street, Ballarat.

Smith, L. D. and L. M., Mangan's-road, Lilydale.

Smith and Milne, 1114 Howitt-street, Wendouree.

Smith, Robert, 21 Moorhouse-street, East Camberwell.

Smith, W. C., and Son, 90 Wilcox-street, Preston.

Smith, W. D., Main-road, Seville.

Smith, William John, 1116 Howitt-street, Ballarat.

Smorgons Rabbit and Poultry Packing Co. Pty. Ltd., Somerville-road, Brooklyn.

Smyth and Murphy, Gillies-street, Benalla.

Snowcap Products, 16 Charlton-avenue, Cheltenham.

Soccio, Matteo, 42 McColl-street, Brunswick.

Soccio, S., 450 Albion-street, West Brunswick.

Sortino, Mario, 45 Murray-street, West Brunswick.

Spence, J. G. and A. J., Stanley-road, Red Hill South.

Stabb, A. E., 10 Payne-street, West Caulfield.

Star Fruit Co. Pty. Ltd., 460 Queen-street, Melbourne.

Starr, R. K., 18 Orr-street, Yarrowonga.

Stellato, Louis, Pty. Ltd., 741 Nepean Highway, East Brighton.

Stott, T., and Sons, Pty. Ltd., 26 Wholesale Fruit Market, Melbourne.

Strachan and Co. Ltd, 25-43 Moorabool-street, Geelong.

Strangio, Frank, Chapmans-road, Silvan.

Street, Ronald J., 27 Salmon-street, Hastings.

Stuart, Ralph A., and Co. Pty. Ltd., 357-367 King-street, Melbourne.

Stubley, P., and Son Pty. Ltd., 45 Main-road, Greensborough.

Sun Loong, 46 Wholesale Fruit Market, Melbourne.

Name; Principal Place of Business.

Sun Sui Wah Pty. Ltd., 58 Wholesale Fruit Market, Melbourne.

Sympag Pty. Ltd., Camp-street, Kangaroo Flat.

Tainton, K. and M., Burwood-road, East Burwood.

Taralaikov, Petar, Settlement-road, Childers.

Taranto, Bartolomeo, Settlement-road, Bundoora.

Tartaglia, Giuseppe, 207 Reynards-street, South Pascoe Vale.

Tassone, Pasquale, 40 South-street, Ascot Vale.

Taverna, Bruno, 2 Garden-court, Chadstone.

Taverna, Charles, Lake Boga.

Taverna, V., 27 St. James-street, Moonee Ponds.

Taylor, E. J., and Son, "Somerset", Moorooduc.

Tesoriero and Natoli, 11 Station-street, Frankston.

Testarotta, Agostino, 22 Johnson-street, Sunshine.

T. F. S. Distributors (Melbourne), 87A Ballarat-road, Footscray.

T. F. S. Potatoes Ltd., East-street, Daylesford.

The Committee of Direction of Fruit Marketing, 168 Franklin-street, Melbourne.

Thiele, S. H. and P. M., Kennedy's-road Pakenham East.

Thomas, I. H., 942 Canterbury-road, Box Hill.

Thompson Bros., Chaff and Produce, Cherry-street, Werribee.

Thompson, Geoffrey (Markets) Pty. Ltd., 40 Queen-street, Melbourne.

Till, H., and Son Pty. Ltd., 35 Peel-street, North Melbourne.

Tinker, W. and W., 183 Fairy-street, Warrnambool.

Tocumwal Trading Co. Pty. Ltd., Meninya-street, Moama, New South Wales.

Tonkin Bros., Midland Apiaries, Talbot-road, Maryborough.

Torre, Charles, 440 Victoria-street, North Melbourne.

Torresi, U., and Sons, 30 Rathmines-street, Fairfield.

Townley, Ronald George, Rossiter-road, Koo-Wee-Rup.

Trellis, John George, 41 Peel-street, West Melbourne.

Trethowan, J. V., and Sons, Brooklyn-road, Melton South.

Trew's Poultry Supplies, 126 Wilson-street, Colac.

Tricarico, Michael, 158 Mt. Dandenong-road, Ringwood East.

Triplett, L. J., 20 Bolinda-road, North Balwyn.

Tripodi, Serafino, 12 Combermere-street, Essendon.

Tripodi, Vincent, 12 Combermere-street, Essendon.

Tulloch, A., and Co., 114 King-street, Melbourne.

Tulloch, Jenkin, Pty. Ltd., 33 Desailly-street, Sale.

Tully, L. J. and B. L., Victoria-street, Doncaster.

Tyabb Co-operative Trading & Cool Stores Ltd., The, Peacock-road, Tyabb.

Tyner, J. and R., 465 Collins-street, Melbourne.

Unthank, V. R., Cool Stores-road, Hastings.

Valley Potatoes, Warrenbayne, Victoria.

Valos Bros., 16 Fanny-street, Moonee Ponds.

Varapodio, Amato, 303 Barkers-road, Kew.

Varapodio, R., and Sons, 303 Barkers-road, Kew.

Vear, F. W. (Fruit) Pty. Ltd., 28 Wholesale Fruit Market, Melbourne.

Vear, F. W., Overseas Pty. Ltd., 28 Wholesale Fruit Market, Melbourne.

Vear, F. W., Pty. Ltd., 28 Wholesale Fruit Market, Melbourne.

Vear, F. W. (Vegetables) Pty. Ltd., 28 Wholesale Fruit Market, Melbourne.

Vear, Kenneth F., Coolart-road, Hastings.

Venuto, A., 256 Victoria-street, North Melbourne.

Victorian Butter Factories Co-op. Ltd., 54-60 King-street, Melbourne.

Victorian Oat Growers' Pool and Marketing Co. Ltd., 528 Lonsdale-street, Melbourne.

Victorian Producers' Co-operative Co. Ltd., 578-584 Flinders-lane, Melbourne.

Victorian Wheatgrowers' Corporation Ltd., 296 Macaulay-road, North Melbourne.

Villani, Antonio, 39 Dundas-street, Preston.

Villani, Leonardo, 46-48 Erskine-street, North Melbourne.

Visalli, G., 261 Maribyrnong-road, Ascot Vale.

Wadeson Bros., Grassy Flat-road, Diamond Creek.

Wake, H. J., 101 Pearson-street, Brunswick West.

Ward, H. S. K., Pty. Ltd., 24-38 Spencer-street, Melbourne.

Watkins Fruit Co. Pty. Ltd., 5 Wholesale Fruit Market, Melbourne.

Watson, J., and Co. Pty. Ltd., Brougham-street, Geelong.

Webber Bros. Pty. Ltd., 4 Courtney-street, North Melbourne.

Weddel and Co. (Aust.) Pty. Ltd., 43 King-street, Melbourne.

Westaway, H. J., Station-street, Somerville.

Westaway, William Oscar, Harcourt, Victoria.

Western District Co-op. Co. Ltd., 14-20 King-street, Melbourne.

Western District Fruit Supply, The, 281 Timor-street, Warrnambool.

Western Murray Fruit Supply Pty. Ltd., 147 Ninth-street, Mildura.

Name; Principal Place of Business.

Westmore, F. W., and Son, 275 Canterbury-road, Heathmont.
 Whaley Geo., and Sons, 9 Fitzgibbon-avenue, West Brunswick.
 White, A. G., Queens-road, Silvan.
 Wiffen, W. S., and Sons, Willis-street, Portarlington.
 Wilco Honey Pty. Ltd., 13 Calder Highway, East Keilor.
 Willey, Gilbert Thomas, Stevens-street, Portarlington.
 Williams, A. E. and K. E., Queens-road, Silvan.
 Williams, G. A., and Son, 53 Koonung-road, Blackburn.
 Williams, G. R., 49 Welfare-parade, Burwood.
 Williams, Henry, E., and Sons Pty. Ltd., 3 High-street, Maryborough.
 Willis, Bros. Pty. Ltd., Piper-street, Kyneton.
 Wills, Ian Russell, 33 Hopetoun-street, Bendigo.
 Wilson, Herbert, Pty. Ltd., 10 Wholesale Fruit Market, Melbourne.
 Wilson and Sons, Produce Merchants, Pty. Ltd., 407 Royal-parade, Parkville.
 Wing, Hie, and Co. (Bananas) Pty. Ltd., 409 Queen-street, Melbourne.
 Wing, Hie, and Co. Pty. Ltd., 53 Wholesale Fruit Market, Melbourne.
 Wing, R. A., and Co. Pty. Ltd., 37 Wholesale Fruit Market, Melbourne.
 Wing, Young, and Co. Pty. Ltd., 38 Wholesale Fruit Market, Melbourne.
 Wodonga Poultry Suppliers, Athol-street, Wodonga.
 Woodend Produce Store and Real Estate Agency, Woodend.
 Woodward, K. and V. F., Koo-Wee-Rup North.
 Woolf, G., and Sons Pty. Ltd., 29-30 Wholesale Fruit Market, Melbourne.
 Wright Stephenson and Co. Ltd., 330 St. Kilda-road, Melbourne.
 Yandell, John Richard, 47 Campbell-street, Castlemaine.
 Yee Hop Loong Pty. Ltd., 32 Wholesale Fruit Market, Melbourne.
 Yee Tong and Co. Pty. Ltd., 43 Wholesale Fruit Market, Melbourne.
 Yick, Sam, and Co., 39 Wholesale Fruit Market, Melbourne.
 Young, Kenneth Frederick, 1 St. Andrews-avenue, Bendigo.
 Young, Sang, 45 Wholesale Fruit Market, Melbourne.
 Young, Tim, and Co. Pty. Ltd., 18 Wholesale Fruit Market, Melbourne.
 Younghusband Ltd., 94 King-street, Melbourne.
 Young's Market (Horsham), 34 Pynsent-street, Horsham.
 Zammicheli, Umberto, 18 Moore-street, Coburg.
 Zerbe, Leslie Herman, Anderson's Creek-road, East Doncaster.
 Zissis, Nick, Box 482, P.O., Mildura.
 Zorro Produce, 53 Weston-street, Brunswick.

LIST of persons to whom Farm Produce Agents' Licences have been issued for the year ending December, 1965, all of whom are exempt from the provisions of paragraphs (a) and (b) of sub-section (1) of section 10 of Act 6248 in regard to lodging a fidelity bond:—

Name; Principal Place of Business.

Alexandra, George Robert, 109 Therry-street, Melbourne.
 Anthony Bros., 34 Adelaide-street, Malvern.
 Argentino, Aghito (Mrs.), 29 Sheddon-street, Pascoe Vale.
 Australian Wholesale Grocery Pty. Ltd., 103 Victoria-street, Fitzroy.
 Ben's Fruit Emporium, 37 Langford-street, Moe.
 British United Dairies Pty. Ltd., 141 Osborne-street, South Yarra.
 Bunning, William Henry, 7 Block Arcade, Ballarat.
 Bynon, John Arthur, Myrtle-street, Myrtleford.
 Captain House Pty. Ltd., 479 Flinders-lane, Melbourne.
 Casamento, J., 63 Japan-street, Warrnambool.
 Cations and Garfield, 18 Church-street, Werribee.
 Cleary, Michael, 33 Dudley-street, North Essendon.
 Cole, A. H. and D. M., 93 Liebig-street, Warrnambool.
 Collyvas Bros., 88 Main-street, Stawell.
 Cooper, Neil Vinton, Commercial-road, Yarram.
 Copolov, Myer, 38 Westbury-street, East St. Kilda.
 Country Fruit Distributors, 34 Teague-street, Niddrie.
 Crosby, Frank, 8 Beauford-street, Huntingdale.
 Davies, N., 1 Odin-street, Strathmore.
 Dickson, Leslie George, Second-street, Hepburn Springs.
 Diggers' Fruit Stall, Little Malop-street, Geelong.
 Ferguson, Archibald Thomas, Flat 7, 42 Burnett-street, St. Kilda.
 Fratantaro, J. and M., Diggers-road, Werribee South.
 Frederick Poly Products, 6 Laluma-street, Essendon.
 Gandolfo, G., 31 Sheddon-street, Pascoe Vale.
 Gazis, Zois, 11 Nolan-street, Maryborough.
 Graves, Arthur, 81 Capel-street, North Melbourne.
 Greene, Owen, and Son, 36 Henty-street, Casterton.
 Grigg, James, and Son, 14-16 South-street, Ascot Vale.
 Grinham, Reginald Bruce, Whyte-street, Coleraine.

Name; Principal Place of Business.

Hadwen, J. T., Pty. Ltd., 153 Princes-street, Port Melbourne.
 Hall's Fruit Supply, 21 Victoria-street, Nhill.
 Hamilton Fruit Company, 122 Gray-street, Hamilton.
 Holloway, F. J., 62 Radovick-street, Korumburra.
 Jochinke, O. W., Pty. Ltd., 30 Wimmera-street, Dimboola.
 Joosen, M. C. and A. M., 121 Edgar-street, Portland.
 Kleeman, P. E., 26 Head-street, Elwood.
 Lavery, David, and Son Pty. Ltd., 406 Lonsdale-street, Melbourne.
 Layne, J. J., 69 Clausen-street, North Fitzroy.
 Lazzaro Bros., 66 Raymond-street, Sale.
 McCarty, H., 67 Heidelberg-road, Ivanhoe.
 McKay, Macleod Pty. Ltd., 63 Mair-street east, Ballarat.
 Marriott, A., 1161 Centre-road, South Oakleigh.
 Martiniello, L. and A., 52 Bridge-street, Benalla.
 Maryvale Fruit Supply, 97 Argyle-street, Traralgon.
 Matera Bros., 37 Bear-street, Leongatha.
 Misuraca, M., and Co., 29 Smith-street, Warragul.
 Mugavin, A. L., Pty. Ltd., 225 Dundas-street, Preston.
 Myrtleford Fruit Palace, Myrtleford, Victoria.
 Ogden's Poultry Supply, 131 Carlisle-street, Balaclava.
 O'Hara, T., 315 Coventry-street, South Melbourne.
 Paxinos, J., 161 Clarendon-street, South Melbourne.
 Portogallo, V., and Sons, Kay-road, Werribee.
 Priestley, E. M. and F. R., 18 Melville-street, Nurmukah.
 Primrose Fruit Supply, Deniliquin (New South Wales).
 Producers Packing Co. Pty. Ltd., 539 Flinders-lane, Melbourne.
 Rankin, Edwin Douglas, 75 Preston-street, Geelong West.
 Restuccia, Rosario, 43 Alkman-crescent, Chadstone.
 Sau, Ignacij, 54 Lambie-street, Cooma, New South Wales.
 Sciarone, Francesco, 35 Tyler-street, North Fitzroy.
 Soumilas, H. and I., 170 Barker-street, Castlemaine.
 South Western Fruit Supply, 43 Horner-street, Hamilton.
 Stoneman, Mary Ellen, 10 Charles-street, Brunswick.
 Thomas, E. W., 119 Victoria-street, Melbourne.
 Tripodi, Rocco, 148 Cooper-street, Essendon.
 Wade, H. M., and Co. Pty. Ltd., 21 Wholesale Fruit Market, Melbourne.
 Walker, Fred, 1167 Dandenong-road, East Malvern.
 Walsh, E. J., Bros., 331 Latrobe-street, Melbourne.
 Wangaratta Fruit Palace, 37 Reid-street, Wangaratta.
 Webb, L. G. and M. M., Commercial-road, Yarram.
 Websters Dairy Produce Supply Pty. Ltd., 2 Arthurton-road, Northcote, N.16.
 Westaway, N. E., 121 Waverley-street, Moonee Ponds.
 Williams Bros., 8 Buckingham-avenue, Bentleigh.
 Wilson, Donald Rex, 91 Valentine-street, Ivanhoe.
 Wimmera and Mallee Fruit and Vegetable Distributors, 87 Firebrace-street, Horsham.
 Young's Wholesale Supply, 39 Railway-street, Seymour.
 Zagami, B., and Sons, 172 Main-street, Bairnsdale.

LIST of brokers to whom Farm Produce Agents' Licences have been issued for the year ending December, 1965, and each of whom is exempt from lodging a fidelity bond (in accordance with the provisions of section 10, sub-section (6) of Act 6248):—

Name; Principal Place of Business.

Box, A. D., 528 Collins-street, Melbourne.
 Coutts, R. W., 422 Collins-street, Melbourne.
 Fox, E. J., 120 King-street, Melbourne.
 Gidley, John, 483 Collins-street, Melbourne.
 Jackett, Herbert, Pty. Ltd., 43 Elizabeth-street, Melbourne.
 Kilgour, Douglas D., 465 Collins-street, Melbourne.
 Leaver, C. H., (Aust.) Pty. Ltd., 431 Bourke-street, Melbourne.
 Moore, Robert, S. M., 90-92 William-street, Melbourne.
 See, John, 1136 Malvern-road, Malvern.
 Smith, E., and Son, 528 Collins-street, Melbourne.
 Stephens, G. K., 538 Flinders-street, Melbourne.
 Wood, C. H., and Co., 75 Queens-road, Melbourne.

FRANK M. READ,
 Director of Agriculture.

*Co-operation Act 1958.***THE WHITEHORSE CLUB CO-OPERATIVE LIMITED.****NOTICE OF DISSOLUTION OF SOCIETY.**

NOTICE is hereby given that I have this day registered the dissolution of the above-named society and have cancelled its registration under the above-named Act.
 Dated at Melbourne, this fifth day of July, 1965.

J. W. JUNGWIRTH,
 Acting Registrar of Co-operative Societies.

CONTRACTS ACCEPTED.—(Series 1965-66.)
 SUPPLY OF PRISONERS' MEALS IN LOCK-UPS.
 FROM 1ST JULY, 1965, TO 30TH JUNE, 1966.

Number of Contract.	Locality.	Particulars of Each Tender Accepted.		Name of Contractor.	Charge against Vote or Fund.
		At per Meal, Breakfast and Tea.	At per Meal, Hot Dinner.		
		<i>s. d.</i>	<i>s. d.</i>		
263	Melbourne District—				
	Carlton	3 6	4 6	J. Hall	
264	Fitzroy	3 6	4 6	D. N. Slattery	
265	Russell-street	4 0	5 0	Russell-street Police Dining Room	
266	North Melbourne	3 0	4 0	M. Henderson	
267	Richmond	4 0	5 6	D. Quilici	
268	South Melbourne	3 6	5 0	P. E. Vickers	
269	Collingwood	3 0	5 6	J. W. Black	
270	Bourke-street West	3 6	4 6	M. H. Mulla	
	Bourke District—				
271	Brunswick	4 6	5 0	J. W. Collins	
272	Flemington	3 0	4 0	Ellen M. Benson	
273	Footscray	4 0	6 0	G. E. A. Kay	
274	Moonee Ponds	3 6	4 6	Leon Marmine	
275	Ascot Vale	3 0	5 0	E. G. Gibbs	
276	Bacchus Marsh	3 0	4 6	M. I. Griffiths	
277	Pascoe Vale	4 6	5 0	F. M. Findlay	
278	Sunbury	4 6	4 6	L. Bridges	
279	Central Highlands District— Ballarat	4 0	5 6	A. B. Boshier	
280	Mallee District— Mildura Lock-up and Gaol	4 0	5 0	M. Zolis	
	Upper Goulburn District—				
281	Eildon	4 6	6 6	H. Renz	
282	Mansfield	3 6	4 0	E. M. Meneghini	
283	Pyalong	3 6	4 6	J. M. Thompson	
284	Seymour	4 6	5 0	Seymour De Luxe Services Pty. Ltd.	
	Gippsland District—				
285	Yallourn	5 0	6 0	R. Sadler	
286	Loch	4 0	5 6	J. Muir	
287	Trafalgar	4 0	5 0	C. V. Lucas	
288	Warragul	3 0	4 0	A. Xenos	
	Goulburn District—				
289	Echuca	3 6	4 6	J. Waters	
290	Shepparton	3 0	3 6	Reid and Kelson	
	Loddon District—				
291	Bendigo	5 0	6 0	S. M. Manning	
292	Kerang	3 6	5 6	C. Klidas	
	Barwon District—				
293	Geelong	5 0	7 6	I. Hasegawa	
294	Birregurra	3 6	4 6	A. M. Kelly	
295	Drysdale	2 6	3 6	D. Shirley	
296	Inverloch	2 6	3 6	H. J. Crowe	
297	Meredith	2 6	3 6	H. W. Powles	

General Expenses. 1965-66.

CONTRACTS ACCEPTED—continued.
SUPPLY OF PRISONERS' MEALS IN LOCK-UPS—continued.

Number of Contract	Locality.	Particulars of Each Tender Accepted.		Name of Contractor.	Charge against Vote or Fund.
		At per Meal, Breakfast and tea.	At per Meal, Hot Dinner.		
Corangamite District—					
298	Apollo Bay	4 0	5 6	J. Fitzgerald	}
299	Camperdown	5 0	7 6	W. J. Pollock	
300	Warrnambool	5 0	6 0	Commodore Provincial Motel Pty. Ltd...	
301	Warrnambool Gaol	15s. per day			
Yarra District—					
302	Box Hill	3 6	5 0	J. S. Clarke	}
303	Ivanhoe	3 6	4 6	M. F. Bourke	
304	Kew	3 6	4 6	R. G. Lowe	
305	Mount Evelyn	3 0	3 6	B. D. Watts	
306	Northcote	4 0	5 0	N. Grieves	
307	Ringwood	4 0	5 0	F. S. Martin	
308	Warburton	4 6	5 6	G. W. Platt	
309	Yarra Junction	5 0	6 0	I. M. Paul	
310	Whittlesea	4 0	5 0	G. L. Smith	
East Gippsland District—					
311	Buchan	3 6	5 0	George F. Coleman	}
312	Sale	3 6	4 6	S. Gerowdaras	
313	Orbost	3 6	5 0	M. T. Hall	
Glenelg District—					
314	Ararat	3 6	4 6	W. J. Lloyd	}
315	Hamilton	4 0	5 0	F. Bowman	
316	Portland	4 6	5 6	R. Nuske	
317	Casterton	5 0	6 6	B. Johnson	
Wimmera District—					
318	Stawell	4 0	5 0	H. Hampson	}
319	Warracknabeal	2 6	4 6	P. Tantanis	
320	Jeparit	3 0	4 0	F. Music	
Flinders District—					
321	Dandenong	3 0.	4 0	J. L. Jones	}
322	Emerald	5 0	6 0	J. M. Sweeney	
323	Frankston	3 6	4 0	H. J. Bedson	
324	Mornington	3 6	5 0	J. W. Pepper	
325	Oakleigh	3 6	5 6	T. Pakula	
Upper Murray District—					
326	Wangaratta	4 6	5 6	F. T. Brown	}
327	Wodonga	3 0	4 6	M. Veliotis	
Henty District—					
328	Brighton	3 6	4 6	M. E. Bower	}
329	Camberwell	4 6	5 6	L. Nicholas	
330	Hawthorn	4 6	5 0	A. Bonnar	
331	Malvern	3 6	4 6	V. Xanthopoulos	
332	Prahran	3 0	4 0	P. Antalfy	
333	St. Kilda	3 3	5 0	E. Kantor	

General Expenses 1965-66.

Approved—H. E. BOLTE, Treasurer,—6.7.65

CONTRACTS ACCEPTED.—(Series 1965-66.)

PROVISIONS.—MEAT.

No. of Contract.	Particulars of Each Tender Accepted.	Amount.	Name of Contractor.	Charge Against Vote or Fund.
	PROVISIONS— Supply of Meat, in such quantities as may be ordered, from 1st August, 1965 to 31st October, 1965 Schedule No. 1.—Melbourne District—			
232	Kew Mental Hospital	Rates as per annex	F. Watkins Pty. Ltd. ..	General Expenses 1965-66
233	Children's Cottages, Kew	" "	Swift Australian Co. Pty. Ltd.	
234	Pentridge Penal Establishment and "Fairlea" Female Prison, Fairfield	" "		
235	"Turana" Youth Training Centre, Royal Park, and Travancore Developmental Centre, Flemington	" "	W. Angliss and Co. (Aust.) Pty. Ltd.	
236	"Winlaton" Girls' Training Centre, 186 Springvale-road, Nunawading, and "Allambie", 70 Elgar-road, Burwood	" "		
237	Royal Park Psychiatric Hospital	" "	J. H. Cooke Pty. Ltd. ..	
	Schedule No. 2.—Mont Park, Bundoora, Larundel, Janefeld, Gresswell, and Pleasant View, Wood-street, Preston—			
238	Mont Park District	" "	G. K. and M. Reynolds Bros. Pty. Ltd.	
239	Preston	" "		
240	Gresswell Sanatorium	" "	W. Angliss and Co. (Aust.) Pty. Ltd.	
241	Schedule No. 3.—SS. Rip and Dredges	" "		
242	Schedule No. 4.—Teachers' College and Hostels at Grattan-street, 93 Drummond-street, Carlton; 470, 481 and 572 St. Kilda-road, Melbourne; 19 Queen's-road, Melbourne; 152 Toorak-road West, South Yarra; Frank Tate House, 373 Dandenong-road Armadale; "Redcourt", No. 6, "Larnook", 13, and No. 10A Orrong-road, Armadale; 11 Patterson-street, Hawthorn; 174 Punt-road, Prahran; 221 Burwood-road, Burwood; John Cannon House, 32 Belmont-avenue, Kew, 17 Moule-avenue, Brighton, and Hastings-road, Frankston; and Police Hospital, St. Kilda-road, Melbourne; Mental Hygiene Clinic, 321 Glenferrie-road, Malvern	" "	E. Spencer	
243	Schedule No. 5.—Heatherton Sanatorium, Cheltenham	" "		
244	Schedule No. 6.—Ararat District	" "	Alan H. Gittins	
245	Schedule No. 7.—Ballarat District— Gaol and Mental Hospital	" "		
246	Teachers' Hostels	" "	McQueen Bros.	
247	Schedule No. 8.—Beechworth District	" "		
248	Schedule No. 9.—Bendigo District— Gaol	" "	L. Thompson	
249	Sandhurst Boys' Centre	" "		
250	Teachers' Hostels	" "	Heytesbury Butchery	
251	Schedule No. 10.—Castlemaine District	" "		
252	Schedule No. 11.—School of Forestry, Creswick	" "	R. Schuback	
253	Schedule No. 13.—McLeod Settlement, French Island	" "		
254	Schedule No. 14.—Geelong District— Gaol	" "	F. Watkins Pty. Ltd. ..	
255	Teachers' Hostels	" "		Thomas Borthwick and Sons (A/asia) Ltd.
256	Schedule No. 15.—Coorimungle Prison Camp, Heytesbury Forest	" "	Stoddart Bros.	
257	Schedule No. 17.—Langi Kal Kal Training Centre	" "		
258	Schedule No. 20.—Sale Gaol	" "		
259	Schedule No. 21.—Pleasant Creek Special School, Stawell	" "		
260	Schedule No. 22.—Sunbury District	" "		
261	Schedule No. 23.—Warrnambool District	" "		
262	Schedule No. 24.—Hobson Park Hospital, Traralgon	" "		

Approved H. E. BOLTE, Treasurer—6.7.65.

SCHEDULE No. 1.—MELBOURNE DISTRICT.

ANNEX TO CONTRACT NO. 1965/232.
F. Watkins Pty. Ltd., 256 Russell-street, Melbourne.

Sub-schedule No. 1.
MEAT FOR MENTAL HOSPITAL, KEW.
Security, £20.

	£	s.	d.
Fresh Beef—			
1. Rolled Roast, boneless (Brisket per lb. excluded)	0	2	10
2. Buttocks	0	2	5
3. Shin and Gravy Beef (boneless)	0	2	6
4. Corned Beef—Rolled or Round, as ordered, without bone or cartilage	0	2	8

SCHEDULE No. 1.—MELBOURNE DISTRICT—continued.

	£	s.	d.
5. Fresh Mutton—(whole sheep) (Kidney fat to be removed) per lb.	0	1	3½
6. Veal—boned	0	2	6
7. Sausages—Mixed	0	2	0
8. Sausage Meat	0	1	5
9. Kidneys, Ox	0	3	3
10. Tripe, Fresh	0	0	11
11. Saveloys	0	3	3
12. Fowls, First quality	0	4	4
13. Bacon Sides	0	5	4
14. Steak, Stewing	0	2	6
15. Livers—Ox	0	1	6
16. Tongues—Ox	0	1	8

SCHEDULE No. 1.—MELBOURNE DISTRICT—*continued.*

ANNEX TO CONTRACT No. 1965/233.

F. Watkins Pty. Ltd., 256 Russell-street, Melbourne.
Sub-schedule No. 2.

MEAT FOR CHILDREN'S COTTAGES, KEW.
Security, £15.

		£	s.	d.
Fresh Beef—				
1. Buttocks	per lb.	0	2	5
2. Fresh Mutton, (whole sheep) (Kidney fat to be removed)	do.	0	1	3½
3. Fresh Mutton, Pumped Leg	do.	0	1	11
4. Sausages, mixed	do.	0	2	0
5. Sausage Meat	do.	0	1	5
6. Fresh Veal, boned	do.	0	2	6
7. Brains, Sheep	per set	0	0	11
8. Bacon, Sides	do.	0	5	4
9. Fowls, First quality	do.	0	4	4
10. Fresh Beef, Shin, Gravy and Stewing	do.	0	2	6
11. Saveloys	do.	0	1	10
12. Fresh Beef, Corned, Rolled, without bone or cartilage	do.	0	2	8
13. Kidneys, Sheep	do.	0	3	0

ANNEX TO CONTRACT No. 1965/234.

Swift Australian Co. Pty. Ltd., Champion-road, Newport.

Sub-schedule No. 3.

MEAT FOR PENTRIDGE PENAL ESTABLISHMENT, COBURG; AND "FAIRLEA" FEMALE PRISON, FAIRFIELD.

		£	s.	d.
Fresh Beef—				
1. Forequarters	per lb.	0	1	7½
2. Minced	do.	0	2	6
3. Corned Beef—Rolled or Round, as ordered, without bone or cartilage	do.	0	2	9
4. Fresh Mutton (whole sheep)	do.	0	1	3½
5. Sausages—Mixed—Thin	do.	0	2	1
6. Fresh Suet—Kidney	do.	0	0	11
7. Sausage—Beef, German	do.	0	2	8
8. Sausage, Mince	do.	0	1	6
9. Dripping, Beef	do.	0	1	3
10. Frankfurts	do.	0	2	8
11. Ham Loaf	do.	0	3	3
12. Fresh Mutton Legs	Fairlea do.	0	2	0
13. Fresh Beef Rolled Roast Boneless } only	Fairlea do.	0	3	3

ANNEX TO CONTRACT No. 1965/235.

J. H. Cooke Pty. Ltd., 378 Queen's-parade, Clifton Hill.

Sub-schedule No. 4.

MEAT FOR "TURANA" YOUTH TRAINING CENTRE, ROYAL PARK, AND TRAVANCORE DEVELOPMENTAL CENTRE, FLEMINGTON.

		£	s.	d.
Fresh Beef—Rolled Roast (Sirloin, Boneless)	per lb.	0	3	3
2. Beef—Corned—Silverside	do.	0	3	9
Fresh Mutton—				
3. Rib Chops as Cutlets	do.	0	1	6
4. Legs	do.	0	2	0
5. Legs (Two-tooth)	do.	0	2	1
6. Chops—Mid. Loin (Two-tooth)	do.	0	1	9
7. Chump Chops	do.	0	2	0
8. Veal, Legs	do.	0	0	0
Steak—				
9. Rump	do.	0	4	0
10. Blade	do.	0	3	3
11. Minced	do.	0	2	5
12. Topside	do.	0	3	9
13. Rissole	do.	0	2	5
14. Veal—Fillet, boneless	do.	0	2	6
15. Pork—Chops	do.	0	4	0
16. Sausages—Mixed	do.	0	2	0
17. Sausage—Strasburg, Pork	do.	0	3	9
18. Frys—Lamb	do.	0	2	6
19. Ox Kidney	do.	0	2	6
20. Frankfurts	do.	0	2	9
21. Rabbits—Fresh	do.	0	2	9
22. Shanks—Sheep	each	0	0	4
23. Sausage—Beef—German	per lb.	0	0	0

ANNEX TO CONTRACT No. 1965/236.

J. H. Cooke Pty. Ltd., 378 Queen's-parade, Clifton Hill.

Sub-schedule No. 5.

MEAT FOR "WINLTON" GIRLS' TRAINING CENTRE, 186 SPRINGVALE-ROAD, NUNAWADING, AND "ALLAMBIE", 70 ELGAR-ROAD, BURWOOD.

		£	s.	d.
Fresh Beef—				
1. Rolled Roast Sirloin, Boneless	per lb.	0	3	5
2. Beef—Corned—Silverside	do.	0	3	9
Mutton, Fresh—				
3. Chump Chops (Two-tooth)	do.	0	1	11
4. Legs	do.	0	2	0
5. Chops—Mid. Loin	do.	0	1	9
6. Chops—Forequarter	do.	0	1	6

SCHEDULE No. 1.—MELBOURNE DISTRICT—*continued.*

		£	s.	d.
Steak—				
7. Topside	per lb.	0	3	9
8. Rump	do.	0	4	9
9. Stewing	do.	0	3	0
10. Minced	do.	0	2	6
11. Blade	do.	0	3	1
12. Sausages—Mixed	do.	0	2	0
13. Sausage Meat	do.	0	1	3
14. Frys—Lamb	do.	0	2	3
Veal—				
15. Fillet, Boneless	do.	0	4	0
16. T-bone	do.	0	4	3
17. Veal—Leg, Boned	do.	0	3	5
18. Pork—Pickled (excluding legs)	do.	0	2	6
19. Pressed Ham Loaf	do.	0	3	3
20. Tongues—Ox	do.	0	1	6
21. Dripping—Beef	do.	0	1	3
22. Brains—Sheep	per set	0	0	8
23. Sausage—Strasburg, Pork	per lb.	0	3	9
24. Frankfurts	do.	0	2	9
25. Rabbits—Fresh	do.	0	3	0
26. Kidneys—Sheep	do.	0	1	6
27. " Ox	do.	0	2	9
28. Sheep Shanks	each	0	0	8

ANNEX TO CONTRACT No. 1965/237.

J. H. Cooke Pty. Ltd., 378 Queen's-parade, Clifton Hill.

Sub-schedule No. 6.

MEAT FOR PSYCHIATRIC HOSPITAL, ROYAL PARK.

		£	s.	d.
Fresh Beef—				
1. Rolled Roast, boneless (Brisket excluded)	per lb.	0	3	3
2. Thick Flank	do.	0	3	4
3. Fresh Mutton (legs)	do.	0	2	0
4. Chops—Forequarter	do.	0	1	6
5. Sausages—Mixed	do.	0	2	0
6. Sausage—Meat	do.	0	1	3
7. Saveloys	do.	0	2	6
8. Corned Silverside	do.	0	3	7
9. Fowls—First quality	do.	0	4	9
10. Rabbits—Fresh	do.	0	3	0

SCHEDULE No. 2.—MONT PARK AND SANATORIUM GRESSWELL, ETC.

ANNEX TO CONTRACT No. 1965/238.

W. Angliss and Co. (Aust.) Pty. Ltd., 42 Bourke-street, Melbourne.

Sub-schedule No. 1.

MEAT FOR MONT PARK MENTAL HOSPITAL, ETC.

		£	s.	d.
Fresh Beef—				
1. Buttocks	per lb.	0	2	5
2. Topside Pieces	do.	0	0	0
3. Roast	do.	0	0	0
Beef, Corned—				
4. Rolled or Round, as ordered, without bone or cartilage	do.	0	2	5
5. Silverside	do.	0	3	6
Mutton, Fresh—				
6. Carcass or Sides (Kidney fat to be removed)	do.	0	1	2½
7. Legs	do.	0	2	0
Chops—				
8. Forequarter	do.	0	1	6
9. Loin	do.	0	1	10
10. Lamb, Loin	do.	0	3	3
11. Lamb—Carcass	do.	0	2	2
Steak—				
12. Topside	do.	0	3	3
13. Stewing	do.	0	2	9
14. Minced	do.	0	2	6
15. Buttock, sliced	do.	0	3	3
16. Saveloys	per doz.	0	4	6
17. Sausages—Mixed	per lb.	0	2	1
18. Shanks—Sheep	each	0	0	6
19. Tripe, Fresh	per lb.	0	0	11
20. Brains—Sheep	per set	0	0	8
21. Kidneys, Ox	per lb.	0	3	0
22. Lambs Fry	do.	0	0	0
23. Beef, German	do.	0	2	4
24. Rabbits—Fresh	do.	0	3	0
25. Ham Loaf	do.	0	3	0
26. Fillet—Veal	do.	0	2	6
27. Fowls—First quality	do.	0	4	2
28. Sausage, Strasburg, Pork	do.	0	3	2
29. Bones Beef	do.	0	0	0½

**SCHEDULE No. 2.—MONT PARK AND SANATORIUM
GRESSWELL, ETC.—continued.**

	£	s.	d.
30. Veal Minced per lb.	0	0	0
31. Beef, Rolled Roast—boneless, (Brisket excluded)	0	2	11
32. Sausage—Pork-German do.	0	0	0
33. Frankfurts per doz.	0	5	8

ANNEX TO CONTRACT No. 1965/239.

W. Angliss and Co. (Aust.) Pty. Ltd., 42 Bourke-street, Melbourne.

Sub-schedule No. 2.

MEAT FOR PLEASANT VIEW RECEIVING HOUSE, WOOD-STREET
PRESTON.

	£	s.	d.
1. Fresh Beef—Sirloin, boneless (Brisket excluded)	0	3	4
2. Corned Beef—Silverside do.	0	3	6
3. Fresh Lamb—Legs do.	0	3	2
Chops—			
4. Lamb—Forequarter do.	0	1	9
5. Lamb, Loin do.	0	3	3
6. Sausages—Pork do.	0	2	2
7. Dripping—Beef do.	0	1	2½
8. Suet do.	0	0	8
9. Mutton, Legs, boiling do.	0	2	0
10. Tripe do.	0	0	11
11. Ham, tinned, 2-lb. tin do.	0	11	3
12. Pork—Fresh, Legs do.	0	4	3
Steak—			
13. Buttock do.	0	3	3
14. Minced do.	0	2	6
15. Sausage—Strasbourg, Pork do.	0	3	2
16. Tongues—Sheep do.	0	1	3
17. Brains—Sheep per set	0	0	8
18. Frankfurts per doz.	0	5	8
19. Rabbits—Fresh per lb.	0	3	0
20. Capons do.	0	5	0
21. Lambs Fry do.	0	2	3

ANNEX TO CONTRACT No. 1965/240.

W. Angliss and Co. (Aust.) Pty. Ltd., 42 Bourke-street, Melbourne.

Sub-schedule No. 3.

MEAT FOR GRESSWELL SANATORIUM.

	£	s.	d.
1. Fresh Beef—Rolled Roast Sirloin (boneless)	0	3	3
2. Beef—Corned, Silverside do.	0	3	6
Lamb—			
3. Fresh, Legs do.	0	3	2
4. Chops—Mid. Loin do.	0	3	3
5. " Chump do.	0	2	0
6. Cutlets do.	0	3	3
Pork—			
7. Fresh, Legs do.	0	4	1
8. Chops do.	0	4	6
9. Pickled do.	0	2	9
10. Mutton—Leg Chops do.	0	1	11
Veal—			
11. Fresh, Shoulder do.	0	1	3
12. Cutlets do.	0	3	9
13. Fillet do.	0	3	9
Steak—			
14. Rump do.	0	4	3
15. Topside do.	0	3	3
16. Fillet do.	0	6	6
17. Minced do.	0	2	6
18. Brains—Sheep per set	0	0	8
19. Fowls—First quality per lb.	0	4	2
20. Frankfurts do.	0	2	10
21. Ham Loaf do.	0	3	0
22. " Pressed Leg do.	0	9	3
23. Kidneys—Ox do.	0	3	0
24. " Sheep do.	0	2	9
25. Livers—Lamb do.	0	2	3
26. Rabbits—Fresh do.	0	3	0
27. Sausages—Mixed do.	0	2	1
28. " Pork do.	0	2	2
29. Sausage Meat do.	0	1	0
30. " Strasbourg, Pork do.	0	3	2
31. Tripe—Fresh do.	0	0	11
32. Tongues—Ox do.	0	1	3
33. " Sheep do.	0	1	3
34. Veal and Pork Loaf—Pressed do.	0	3	0
35. Savoury Loaf—Pressed do.	0	3	0
36. Ham—Leg, Raw do.	0	7	6

SCHEDULE No. 3.—S.S. "Rip" AND DREDGES.

ANNEX TO CONTRACT No. 1965/241.

G. K. and M. Reynolds Bros. Pty. Ltd., 4 Blackwood-street, North Melbourne.

Sub-schedule No. 1.

MEAT FOR DELIVERY AT YARRA RIVER WHARVES.

	Security, £5.	£	s.	d.
1. Fresh Beef—Roast per lb.	0	1	9	
Beef, Corned—				
2. Silverside do.	0	3	6	
3. Rolled do.	0	1	5	
Fresh Mutton—				
4. Forequarter do.	0	0	5	
5. Legs do.	0	1	11	
Chops—				
6. Forequarter do.	0	0	6	
7. Loin do.	0	0	10	
Steak—				
8. Rump do.	0	4	3	
9. Stewing do.	0	2	6	
10. Topside do.	0	3	5	
11. Sausages—Mixed do.	0	2	2	
12. Tripe—Fresh do.	0	1	0	
13. Livers—Sheep do.	0	2	3	
14. Suet—Kidney do.	0	0	6	
15. Rabbits—Fresh do.	0	2	9	
16. Ice per cwt.	0	0	9	

**SCHEDULE No. 4.—TEACHERS' COLLEGES, HOSTELS,
POLICE HOSPITAL, ETC.**

(Delivery at Institutions.)

TEACHERS' COLLEGE AND HOSTELS AT GRATTAN-STREET, 93 DRUMMOND-STREET, CARLTON; 470, 481 AND 572 ST. KILDAROAD, MELBOURNE; 19 QUEEN'S-ROAD, MELBOURNE; 152 TOORAK-ROAD WEST, SOUTH YARRA; FRANK TATE HOUSE, 373 DANDENONG-ROAD, ARMADALE; "REDCOURT" NO. 6, "LARNOOK", 13 AND NO. 10A ORRONG-ROAD, ARMADALE; 11 PATTERSON-STREET, HAWTHORN; 174 PUNT-ROAD, PRAHRAN; 221 BURWOOD-ROAD, BURWOOD; JOHN CANNON HOUSE, 32 BELMONT-AVENUE, KEW; 17 MOULE-AVENUE, BRIGHTON; AND HASTINGS-ROAD, FRANKSTON; POLICE HOSPITAL, ST. KILDAROAD, MELBOURNE; AND MENTAL HYGIENE CLINIC, GLENFERRIE-ROAD, MALVERN.

ANNEX TO CONTRACT No. 1965/242.

J. H. Cooke Pty. Ltd., 378 Queen's-parade, Clifton Hill.

Sub-schedule No. 1.

	Security, £15.	£	s.	d.
Fresh Beef—				
1. Rolled Prime Ribs, boneless per lb.	0	3	6	
2. Topside do.	0	3	9	
3. Sirloin, boneless do.	0	3	9	
Fresh Mutton—				
4. Legs do.	0	2	0	
5. Legs, pickled do.	0	2	0	
6. Sides, Two-tooth do.	0	1	0	
7. Legs, Two-tooth do.	0	2	1	
8. Cutlets do.	0	2	4	
9. Chops, Mid. Loin do.	0	1	11	
10. Chops, Forequarter do.	0	1	6	
11. Chops, Chump do.	0	2	0	
12. Beef—Corned, Silverside do.	0	3	9	
Veal—				
13. Shoulder, boned do.	0	1	6	
14. Fillet, boneless do.	0	4	4	
Steak—				
15. Blade do.	0	3	5	
16. Minced do.	0	2	8	
17. Stewing do.	0	3	6	
18. Rump do.	0	4	9	
19. Fillet do.	0	7	0	
20. Sausages—Mixed do.	0	2	2	
21. Sausage—Meat do.	0	1	4	
22. " Beef, German do.	0	2	9	
23. " Strasbourg do.	0	3	9	
24. Livers—Sheep do.	0	2	7	
25. Kidneys—Sheep do.	0	1	6	
26. " Ox do.	0	2	9	
27. Tongues—Ox do.	0	1	9	
28. Ox Tails do.	0	1	6	
29. Brains—Sheep per set	0	0	8	
30. Tripe—Fresh per lb.	0	0	9	
31. Frankfurts do.	0	2	9	
32. Bones—Soup do.	0	0	3	
33. Suet—Kidney do.	0	0	3	
34. Rabbits—Fresh do.	0	2	10	
35. Fowls—First quality do.	0	4	9	
36. Pork—Legs do.	0	4	6	
37. " Loin do.	0	4	0	
38. Lamb, legs do.	0	3	9	
39. Ham, pressed do.	0	8	4	
40. Dripping do.	0	1	3	

SCHEDULE No. 5.—HEATHERTON SANATORIUM.

ANNEX TO CONTRACT No. 1965/243.

W. Angliss and Co. (Aust.) Pty. Ltd., 42 Bourke-street, Melbourne.

Sub-schedule No. 1.

MEAT. Security, £5. Table listing items like Beef, Fresh Roast—Sirloin, Rolled Roast, Corned—Silverside, Lamb, Fresh—Legs, etc. with columns for description, unit, and price in £ s. d.

SCHEDULE No. 6.—ARARAT DISTRICT.

ANNEX TO CONTRACT No. 1965/244.

H. A. Morris, 107 Victoria-street, Ballarat.

Sub-schedule No. 1.

MEAT. Security, £30. Table listing items like Fresh Beef—Rolled Roast (Boneless, brisket excluded), Buttocks, Fresh Mutton—Kidney fat to be removed, etc. with columns for description, unit, and price in £ s. d.

SCHEDULE No. 7.—BALLARAT DISTRICT.

ANNEX TO CONTRACT No. 1965/245.

H. A. Morris, 107 Victoria-street, Ballarat.

Sub-schedule No. 1.

MEAT FOR GAOL AND MENTAL HOSPITAL. Security, £35. Table listing items like Fresh Beef—Buttocks, Roast—Rolled (Brisket excluded), Beef, Corned, Rolled or Round, as ordered, without bone or cartilage, etc. with columns for description, unit, and price in £ s. d.

SCHEDULE No. 7.—BALLARAT DISTRICT—continued.

ANNEX TO CONTRACT No. 1965/246.

H. A. Morris, 107 Victoria-street, Ballarat.

Sub-schedule No. 2.

MEAT.

For delivery to Teachers' Hostels as under :—

Gillies-street, Ballarat. Beaufort House, Beaufort-avenue, Ballarat. 1415 Sturt-street, Ballarat. 130 Victoria-street, Ballarat. 126 Webster-street, Ballarat.

Security, £5. Table listing items like Fresh Beef—Sirloin, Beef—Corned, Silverside, Fresh Mutton—Legs, etc. with columns for description, unit, and price in £ s. d.

SCHEDULE No. 8.—BEECHWORTH DISTRICT.

ANNEX TO CONTRACT No. 1965/247.

E. Spencer, Camp-street, Beechworth.

Sub-schedule No. 1.

MEAT.

Security, £30. Table listing items like Fresh Beef (Gaol), Corned Beef, Rolled or Round as ordered, without bone or cartilage, Mutton—Fresh (Kidney fat to be removed for Mental Hospitals), etc. with columns for description, unit, and price in £ s. d.

SCHEDULE No. 9.—BENDIGO DISTRICT.

ANNEX TO CONTRACT No. 1965/248.

Alan H. Gittins, 350 Hargreaves-street, Bendigo.

Sub-schedule No. 1.

MEAT FOR GAOL.

Security, £5. Table listing items like Fresh Beef, Fresh Mutton, Sausages—Mixed, Minced meat, Saveloys, etc. with columns for description, unit, and price in £ s. d.

ANNEX TO CONTRACT No. 1965/249.

Alan H. Gittins, 350 Hargreaves-street, Bendigo.

Sub-schedule No. 2.

MEAT FOR SANDHURST BOYS' CENTRE, BENDIGO.

Security, £5. Table listing items like Fresh Beef—Rolled Roast, boneless, brisket excluded, Fresh Beef—Rib Roast, Corned Beef—Rolled or Round, as ordered, without bone or cartilage, etc. with columns for description, unit, and price in £ s. d.

SCHEDULE No. 9.—BENDIGO DISTRICT—continued.

	£	s.	d.
13. Sausage—Beef, German per lb.	0	0	0
14. Bacon, Rashers, Shoulder do.	0	7	6
15. Lamb—Legs do.	0	3	0
16. Lamb Chops—Middle Loin do.	0	4	0
17. Ham Loaf do.	0	3	10
18. Kidney—Ox do.	0	1	6
19. Pork Leg do.	0	4	6
20. Pork, Pickled Rolled Shoulder do.	0	0	0
21. Saveloys per doz.	0	4	0
22. Lambs Fry per lb.	0	1	6
23. Sausage Meat do.	0	1	2

ANNEX TO CONTRACT No. 1965/250.

Frank Wade, 193 Williamson-street, Bendigo.

Sub-schedule No. 3.

MEAT.

For Teachers' College Hostels as under—
Osborne-street, Pleasant Vale, Bendigo.
"Lancewood," McLaren-street, Bendigo.
"Comersdale," Panton-street, Golden Square, Bendigo.

	£	s.	d.
1. Fresh Beef—Topside per lb.	0	5	6
2. Corned Beef—Rolled or Round, as ordered, without bone or cartilage do.	0	2	0
3. Corned Silverside do.	0	4	9
4. Fresh Mutton—Carcass do.	0	0	11
Steak—			
5. Blade—Minced do.	0	3	6
6. Chuck do.	0	3	9
7. Rump do.	0	6	6
8. Sausages—Mixed do.	0	2	6
9. Sausage Meat do.	0	1	9
10. Livers—Sheep do.	0	1	6
11. Veal—Fillet, boneless do.	0	5	6
12. Brains—Sheep per set	0	0	3
13. Kidneys—Ox per lb.	0	1	0
14. Pork—Fresh, Loin do.	0	5	0
15. Sausage—Strasbourg do.	0	2	9
16. Salad Loaf do.	0	3	3
17. Bacon, Middle Rashers do.	0	7	6

SCHEDULE No. 10.—CASTLEMAINE GAOL.

ANNEX TO CONTRACT No. 1965/251.

McQueen Brothers, Hargraves-street, Castlemaine.

Sub-schedule No. 1.

MEAT.

	£	s.	d.
1. Fresh Beef per lb.	0	2	6
2. Fresh Mutton do.	0	1	8
3. Corned Beef—Rolled or Round, as ordered, without bone or cartilage do.	0	2	9
4. Minced Meat—Beef do.	0	2	9
5. Sausage Meat do.	0	1	6
6. Saveloys per doz.	0	4	9

SCHEDULE No. 11.—SCHOOL OF FORESTRY, CRESWICK.

ANNEX TO CONTRACT No. 1965/252.

H. J. Symons Pty. Ltd., 1015 Macarthur-street, Ballarat.

Sub-schedule No. 1.

MEAT.

	£	s.	d.
Fresh Beef—			
1. Topside per lb.	0	5	0
2. Sirloin, boneless do.	0	5	0
3. Corned, Silverside do.	0	5	0
4. Mutton—Fresh, sides do.	0	1	4
5. Pork—Fresh, leg do.	0	5	0
Steak—			
6. Stewing do.	0	4	6
7. Minced do.	0	3	3
8. Sausages—Mixed do.	0	2	3
9. Sausage—Beef, German do.	0	3	9
10. Kidney—Ox do.	0	2	0
11. Liver—Sheep do.	0	1	0
12. Saveloys per doz.	0	4	0

SCHEDULE No. 13.—MCLEOD SETTLEMENT, FRENCH ISLAND.

ANNEX TO CONTRACT No. 1965/253.

L. Thompson, Lang Lang.

Sub-schedule No. 1.

MEAT.

	£	s.	d.
1. Fresh Beef per lb.	0	2	6
2. Mutton do.	0	1	6
3. Sausages—Mixed do.	0	2	4

SCHEDULE No. 14.—GEELONG DISTRICT.

ANNEX TO CONTRACT No. 1965/254.

W. Angliss and Co. (Aust.) Pty. Ltd., 42 Bourke-street, Melbourne.

Sub-schedule No. 1.

MEAT FOR GAOL.

	£	s.	d.
Security, £5.			
1. Fresh Beef per lb.	0	1	9
2. Corned Beef—Rolled or Round, without bone or cartilage do.	0	1	11
Fresh Mutton—			
3. Forequarters do.	0	1	0
4. Legs do.	0	1	11
5. Beef—Minced do.	0	1	11
6. Sausages—Mixed do.	0	2	0
7. Sausage Meat do.	0	1	0

ANNEX TO CONTRACT No. 1965/255.

W. Angliss and Co. (Aust.) Pty. Ltd., 42 Bourke-street, Melbourne.

Sub-schedule No. 2.

MEAT.

For delivery to Teachers' Hostels as under—
"Lauriston", 23 Aberdeen-street, Geelong.
"Forty-Five", The Esplanade, Western Beach, Geelong.
"Hawthorn", Aberdeen-street, Geelong.
"Ariston", Packington-street, Geelong.
"Warrain", 56 Western Beach, Geelong.

	£	s.	d.
Security, £5.			
1. Fresh Beef—Sirloin, boneless per lb.	0	3	0
2. Corned Beef—Rolled or Round, as ordered, without bone or cartilage do.	0	3	0
Mutton—			
3. Legs, Two-tooth do.	0	1	11
4. Forequarters, boned, rolled, and pickled do.	0	1	0
5. Chops, Forequarter do.	0	1	2
6. Chops, Cutlets do.	0	1	11
Steak—			
7. Chuck do.	0	2	7
8. Bladebone do.	0	2	10
9. Minced do.	0	1	11
10. Fillet—Veal do.	0	1	0
11. Tongues—Ox do.	0	1	0
12. Kidneys—Ox do.	0	1	0
Sausages—			
13. Mixed, thin do.	0	2	0
14. Pork, thick do.	0	2	0
Sausage—			
15. Pork, German do.	0	2	10
16. Mince do.	0	1	0
17. Bacon—Shoulder do.	0	4	11

SCHEDULE No. 15.—COORIEMUNGLE PRISON CAMP, HEYTESBURY FOREST.

ANNEX TO CONTRACT No. 1965/256.

Heytesbury Butchery, Timboon.

Sub-schedule No. 1.

MEAT.

	£	s.	d.
Security, £4.			
1. Fresh Beef per lb.	0	4	7
2. Corned Beef—Rolled or Round, as ordered, without bone or cartilage do.	0	3	8
3. Sausages—Mixed do.	0	2	8
4. Sausage Mince do.	0	1	11

SCHEDULE No. 17.—LANGI KAL KAL TRAINING CENTRE.

ANNEX TO CONTRACT No. 1965/257.

H. A. Morris, 105 Victoria-street, Ballarat.

Sub-schedule No. 1.

MEAT.

	£	s.	d.
Security, £5.			
1. Sausages—Mixed per lb.	0	2	0
2. Fresh Beef—Boneless do.	0	3	5

SCHEDULE No. 20.—SALE GAOL.

ANNEX TO CONTRACT No. 1965/258.

R. Schuback, 99B Simpson-street, Sale.

Sub-schedule No. 1.

MEAT.

	£	s.	d.
Security, £3.			
1. Fresh Beef per lb.	0	2	11
Fresh Mutton—			
2. Chops, Forequarter do.	0	1	11
3. Corned Beef—Rolled or Round, as ordered, without bone or cartilage do.	0	2	9
4. Sausage Meat do.	0	1	8

SCHEDULE No. 21.—PLEASANT CREEK SPECIAL SCHOOL, STAWELL.

ANNEX TO CONTRACT No. 1965/259.

Thomas Borthwick and Sons (Asia) Ltd., Box 150, Portland.

Sub-schedule No. 1.

MEAT.			
Steak—	Security, £3.	£	s. d.
1. Rump	per lb.	0	5 6
2. Stewing (minced when required) ..	do.	0	2 10
3. Fresh Mutton—	do.	0	2 0
4. Chops—Leg	do.	0	2 2
5. Sausages—Pork	do.	0	2 0
6. Bacon Rashers, Shoulder	do.	0	7 6
7. Beef—Corned, Silverside	do.	0	3 10
8. Kidney—Ox	do.	0	2 6
9. Saveloys	do.	0	2 3
10. Sausage, Mince	do.	0	1 6
11. Livers—Sheep	do.	0	1 3
12. Tripe, Fresh	do.	0	1 3
13. Mutton, Forequarter Chops	do.	0	1 6
14. Beef, Rolled Roast, Brisket excluded ..	do.	0	3 4

SCHEDULE No. 22.—SUNBURY DISTRICT.

ANNEX TO CONTRACT No. 1965/260.

F. Watkins Pty. Ltd., 256 Russell-street, Melbourne.

Sub-schedule No. 1.

MEAT.			
Fresh Beef—	Security, £40.	£	s. d.
1. Rolled Roast, boneless (brisket per lb. 0 3 0 excluded)			
2. Buttocks	do.	0	2 6
3. Fresh Mutton—Kidney fat to be do. 0 1 4½ removed			
4. Corned Beef—Rolled or Round, as do. 0 2 9 ordered, without bone or cartilage			
5. Sausages—Mixed	do.	0	2 0
6. Sausage Meat	do.	0	1 6
7. Veal—Boneless	do.	0	2 6
8. Lambs Fry	do.	0	0 0
9. Ox—Kidney	do.	0	3 3
10. Steak—Rump	do.	0	4 4
11. " —Topside	do.	0	3 7
12. Saveloys	per doz.	0	3 0

SCHEDULE No. 23.—WARRNAMBOOL DISTRICT.

ANNEX TO CONTRACT No. 1965/261.

Thomas Borthwick and Sons (Asia) Ltd., P.O. Box 150, Portland.

Sub-schedule No. 1.

MEAT.			
Fresh Beef—	Security, £15.	£	s. d.
1. Fresh Beef—Rolled Roast (brisket per lb. 0 3 4 excluded)			
2. Corned Beef—Rolled or Round, as do. 0 2 10 ordered			
Fresh Mutton—			
3. Forequarters	do.	0	1 4
4. Legs	do.	0	2 2
5. Chops—Middle Loin	do.	0	2 3
Steak—			
6. Stewing	do.	0	3 2
7. Minced	do.	0	2 10
8. Sausage Meat	do.	0	1 7
Sausages—			
9. Beef	do.	0	2 1
10. Pork	do.	0	2 4
11. Kidneys—Ox	do.	0	2 6
12. Tripe, Fresh	do.	0	0 0
13. Livers, Sheep	do.	0	0 0
14. Saveloys	per doz.	0	4 6

SCHEDULE No. 24.—HOBSON PARK HOSPITAL, TRARALGON.

ANNEX TO CONTRACT No. 1965/269.

Stoddart Bros., 77 Franklin-street, Traralgon.

Sub-schedule No. 1.

MEAT.			
	Security, £5.	£	s. d.
1. Rolled Prime Ribs, boneless	per lb.	0	4 0
2. Thick Flank (Minced when required) ..	do.	0	4 6
3. Steak, Topside	do.	0	4 6
4. Corned Silverside	do.	0	4 6
5. Fresh Mutton, Legs (pickled, boned, and do. 0 0 0 rolled)			
6. Chops, forequarter, Lamb	do.	0	3 4
7. Lambs Fry	do.	0	1 0
8. Steak, Blade	do.	0	4 6
9. Fresh Mutton, Legs, Two-tooth	do.	0	2 10
10. Ham Loaf	do.	0	0 0
11. Tails—Ox	do.	0	1 9
12. Sausages, Mixed	do.	0	2 4
13. Sausage, Strasburg	do.	0	0 0
14. Bacon, Middles	do.	0	7 3
15. Pigs' Cheeks	do.	0	1 0
16. Fowls, First quality	do.	0	5 6
17. Tripe, Fresh	do.	0	0 0

CONTRACTS ACCEPTED.—(Series 1965-66.)

PROVISIONS.

Gazette No. 40, 8th June, 1965, Schedule No. 24, Sub-schedule No. 1, Breadstuffs.—For Item No. 2 substitute £3 2s. 6d. per bag as from 1st July, 1965.

H. COUTTS, Secretary to the Tender Board. 5.7.65.

SOIL CONSERVATION AUTHORITY.

EPPALOCK CATCHMENT.—CONTRACT EARTHWORKS.

Hire of tractors for construction of diversion banks and associated earthworks:

230. G. A. Lewis, Bendigo, £2 5s. an hour.

231. A. C. J. Boyer, Taradale, £2 2s. 6d. an hour.

R. D. HALL, Secretary.

ORDERS IN COUNCIL.—(Series 1964-65.)

PUBLIC WORKS.

4287. Ballarat, Mental Hospital, electrical maintenance to kitchen and therapy centre, £789 6s. 6d.—J. R. Blight & Son.—(W.308227.)

4288. Coburg, Chest Clinic, Bell-street, supply of three (3) Surgeons' Desks—twin pedestal with matching side tables and eighty-nine (89) special chairs, £830 5s.—Myer Teale Pty. Ltd.—(N.W.67612.)

4289. Glenferrie, Swinburne Technical College, supply and installation of service lift in cafeteria, £1,181.—Gwillim & Charlton Pty. Ltd.—(M.232241.)

4290. Melbourne, Main Warehouse, Government Printing Office, Macarthur-street, supply and installation of "Compactus" steel shelving unit, £3,902.—Brownbuilt Ltd.—(M.265042.)

4291. Melbourne, School of Hairdressing, supply of ten (10) fibreglass backward shampoo troughs, £972.—Hillcastle Pty. Ltd.—(M.161700.)

4292. Melbourne, State Public Offices, Car Park, preliminary works for estimated sum of £40,000.—John R. & E. Seccull Pty. Ltd.—(M.39735.)

4293. Royal Park, Receiving House, supply and fixing of plaster to wards, cafeteria and corridors, &c., £1,046.—Pascoe Plaster Products Pty. Ltd.—(M.246777.)

4294. St. Kilda, State School No. 1479, special grant authorized by the Education Department towards the cost of ground improvements at the school, £1,144.—St. Kilda State School No. 1479 Committee.—(M.307731.)

4295. Toolern Vale, State School No. 946, new L.T.C. class-room, &c.—£2,584 10s.—A. V. Jennings Industries (Aust.) Ltd.—(W.70090.)

Approved by the Governor in Council, 29th June, 1965.—J. COLQUHOUN, Clerk of the Executive Council.

FORESTS COMMISSION.

Loan Fund Act No. 7172, Item 6, Project PX—

4296. To the purchase of that allotment 57M, Parish of Binginwarri, County of Buln Buln, comprising 63 acres 18 perches for forest purposes, £200.—N. Lithgow.

Approved by the Governor in Council, 16th June, 1965.—J. COLQUHOUN, Clerk of the Executive Council.

Loan Fund Act No. 7172, Item 6, Project PX—

4297. To the purchase of that Allotment 33, Parish of Gunyah Gunyah, County of Buln Buln, containing 179 acres 2 roods 33 perches, for forest purposes, £808 13s. 7d.—Estate of the late T. R. Tucker.

Approved by the Governor in Council, 30th March, 1965.—J. COLQUHOUN, Clerk of the Executive Council.

STATE ELECTRICITY COMMISSION.

4298. For the supply of boiler suits, overalls, and dust coats for a period of two years, to Specification No. 64-65/287, at Schedule rates.—Sterling Clothing Co. Pty. Ltd.

4299. For the supply of boiler suits, overalls, and dust coats for a period of two years, to Specification No. 64-65/287, at Schedule rates.—Cushen Clothing Co. Pty. Ltd.

Approved by the Governor in Council, 18th May, 1965.—J. COLQUHOUN, Clerk of the Executive Council.

4300. For the supply of leather gloves for a period of two years, to Specification No. 64-65/221, at Schedule rates.—N.B. & L. Trading Co. (Vic.) Pty. Ltd.

4301. For the supply of leather gloves for a period of two years, to Specification No. 64-65/221, at Schedule rates.—Simpson's Gloves Pty. Ltd.

4302. For the erection of a 220 kV switchyard for Hazelwood Power Station, stage 3, to Specification No. 64-65/127, £203,493, plus items at Schedule rates.—A.E.I. Engineering Pty. Ltd.

4303. For the supply of soft solder for a period of two years, to Specification No. 64-65/321, at Schedule rates.—W. H. Billings & Sons Pty. Ltd.

Approved by the Governor in Council, 1st June, 1965.—J. COLQUHOUN, Clerk of the Executive Council.

4304. For the supply of stationary lead acid batteries for terminal stations and sub-stations for a period of two years, to Specification No. 64-65/262, at Schedule rates.—Dunlop Rubber Australia Ltd.

4305. For the supply of diesel fuel oil for stationary engines for a period of one year, to Specification No. 64-65/109A, at Schedule rates.—Mobil Oil Australia Ltd.

4306. For the construction of reinforced concrete sedimentation tanks for Yalloom town water treatment plant, to Specification No. 64-65/102, £5,558 14s. 8d.—Coast Contractors (Gippsland) Pty. Ltd.

4307. For the supply of 11/6.6 kV auto-transformers for metropolitan sub-stations, to Specification No. 64-65/253, £57,276 6s. 8d.—Wilson Electric Transformer Co. Pty. Ltd.

4308. For the supply of 400 reels of light-weight reinforced bitumen-laminated paper for briquette packaging, to Specification No. 64-65/317, £15,343.—Australian Sisalkraft Pty. Ltd.

4309. For the supply of two hydraulically-operated 50-cwt. capacity pole/erector borers for construction work, to Specification No. 64-65/358, £13,704 15s. 6d.—Queen's Bridge Motor and Engineering Co. Pty. Ltd.

4310. For the supply of 24,500 insulator pins and nuts for distribution line hardware, to Quotation No. 4819, £5,542.—S. G. Sewell Pty. Ltd.

4311. For the modification of nine 10 MVA transformers for metropolitan sub-station conversion to 11 kV, to Quotation No. 4059, £38,253.—A.E.I. Engineering Pty. Ltd.

4312. For the supply of 37 International vehicles for the change-over of high-mileage vehicles, to Quotation No. 4731, £53,987 13s. 6d.—International Harvester Co. of Australia Pty. Ltd.

4313. For the purchase by the Commission of land at Mildura for District Depot site, such land being part of lot 2 on plan of subdivision No. 18584, Parish of Mildura, and being the whole of the land described in certificate of title, volume 8468, folio 565, £24,000.—J. Cantor.

Approved by the Governor in Council, 9th June, 1965.—J. COLQUHOUN, Clerk of the Executive Council.

PUBLIC NOTICE.

AN auction of unclaimed and confiscated liquor in the possession of Police will be held at the premises at 43 Little Bourke-street, Melbourne, at 10 a.m., on Tuesday, the 27th July, 1965.

R. H. ARNOLD,
Chief Commissioner of Police.

Melbourne and Metropolitan

BOARD OF WORKS.

GENERAL NOTICE.

THE Melbourne and Metropolitan Board of Works, having made sewers for carrying off the sewage from each and every property which, or any part of which, abuts on the streets or parts of streets in which such sewers are laid, and which are included within the Sewerage Areas hereinafter described, doth hereby declare that on and after the 7th August, 1965, each and every property which, or any part of which, abuts on the said streets or parts of streets, shall be deemed to be a seweraged property within the meaning of the Melbourne and Metropolitan Board of Works Act 1958.

The Sewerage Areas hereinbefore referred to are:—

Sewerage Area No. 1,946.

City of Nunawading.—Commencing at the junction of Springfield-road and Southey-street; thence northerly along Southey-street, westerly along the southern boundaries of lots 80 Southey-street, 56 and 55 Harris-street and 13 Koonung-road, northerly along Koonung-road to Koonung Creek, generally easterly along the said creek to Surrey-road, southerly along Surrey-road to a point about 297 feet north of the northern boundary of Springfield-road, westerly along the southern boundaries of lots 1 Surrey-road and 2 Gay-street, southerly along Gay-street, westerly along Springfield-road to a point about 265 feet west of the western boundary of Gay-street, southerly along the eastern boundary of lot 1 Springfield-road, westerly along the southern boundaries of lots 1 to 3 Springfield-road, northerly along the western boundary of the said lot 3, westerly along Springfield-road to the commencing point.

Sewerage Area No. 1,947.

City of Waverley.—Commencing at the junction of Chandler-grove and Webb-street on the boundary of Sewerage Area No. 1,394; thence generally easterly following the said boundary and the boundary of Sewerage Area No. 1,609 to Montpellier-road, southerly along Montpellier-road, westerly along the southern boundaries of lots 112 Montpellier-road and 101 and 100 Hazel-court, southerly along the eastern boundaries of lots 88 to 81 Silver Ash-avenue, westerly along the southern boundary of the said lot 81, south-westerly along Silver Ash-avenue, north-westerly along the south-western boundary of lot 150 Silver Ash-avenue, northerly along the western boundary of the said lot 150, westerly along the southern boundaries of lots 43 to 38 Kanooka-avenue and 35 and 34 Ashwood-drive, further westerly by a line in continuation to Gardiners Creek, generally northerly and easterly along Gardiners Creek to Chandler-grove, southerly along Chandler-grove to the commencing point.

Sewerage Area No. 1,948.

City of Northcote.—Commencing at the junction of Perry-street and Montefiore-street on the boundary of Sewerage Area No. 788; thence generally westerly and southerly following the said boundary to McGregor-street, westerly along McGregor-street, northerly along Arthur-street, easterly along Darebin-road to the boundary of Sewerage Area No. 1,569, southerly, westerly, and southerly following the boundaries of Sewerage Areas Nos. 1,569 and 788 to the commencing point.

Sewerage Area No. 1,949.

City of Preston.—Commencing at the junction of Wagga-road and Lloyd-avenue; thence easterly along Lloyd-avenue, northerly along the western boundaries of lots 517 Lloyd-avenue and 422 Liston-avenue, easterly along Liston-avenue, northerly along Ranleigh-avenue, easterly along Arundel-avenue, northerly along the western boundaries of lots 218 Arundel-avenue and 194 Keon-parade, easterly along Keon-parade, south-westerly along Cheddar-road west, south-easterly along the north-eastern boundary of lot 574 Cheddar-road west, south-westerly along the south-eastern boundaries of lots 574 to 585 Cheddar-road west, north-westerly along Daleglen-street, south-westerly along Cheddar-road west, westerly and northerly along the southern and portion of the western boundaries of lot 544 Cheddar-road west, westerly along the southern boundaries of lots 559 and 448 Lambassa-grove, 440 and 414 Enderly-avenue and 406 Wagga-road, northerly along Wagga-road to the commencing point.

Sewerage Area No. 1,950.

City of Preston.—Commencing at the junction of Banbury-road and Colthur-street; thence easterly along Colthur-street, southerly along the eastern boundaries of lots 4 Colthur-street, 3 and 38 Luke-street and 5 Leamington-street, further southerly along Seaver-street, easterly along the northern boundary of lot 40 Seaver-street, southerly along the eastern boundaries of lots 40 to 42 Seaver-street, south-westerly by a line to and along the south-eastern boundary of a park reserve, further south-westerly along the south-eastern boundary of Glenburne-street, south-easterly along Edwardes-street, south-westerly and generally westerly along the boundaries of the property of Reservoir Hotel Pty. Ltd. to the eastern boundary of lot 7 Pitt-street, northerly by a line to the north-eastern angle of lot 3 Pitt-street, westerly along the southern boundaries of properties on the southern side of Edwardes-street to the north-western angle of lot 10 Pitt-street, southerly by a line to the south-western angle of lot 8 Pitt-street, westerly by a line to the north-eastern angle of lot 1 Newlands-road, southerly and westerly along the eastern and southern boundaries of the said lot 1, further westerly along the southern boundaries of lots 22 Newlands-road and 23 to 33 Zinnia-street, northerly along the western boundaries of lots 33 and 34 Zinnia-street and 55 Kelverne-street, easterly along Kelverne-street, northerly along the western boundaries of lots 56 Kelverne-street and 1 Edwardes-street, westerly by a line being the production of the southern boundary of Edwardes-street to a point 700 feet west of the western boundary of Radford-street, northerly by a line parallel to Radford-street a distance of 444 feet, easterly by a line to a point in Radford-street 378 feet north of the northern boundary of Edwardes-street, northerly along Radford-street, easterly along the northern boundaries of lot 1 Radford-street and lots 2 to 4 Edwardes-street, northerly by a line to a point on the southern boundary of lot 48 Plateau-road 330 feet west of the western boundary of Plateau-road, westerly along the southern boundary of the said lot 48 to its south-western angle, northerly by a line to the north-western angle of lot 56 Plateau-road, easterly along the northern boundary of the said lot 56 to a point 327 feet west of the western boundary of Plateau-road, northerly by a line parallel to Plateau-road a distance of 100 feet, easterly by a line to a point on the western boundary of Plateau-road 1,992 feet north of the northern boundary of Edwardes-street, south-easterly by a line to a point on the eastern boundary of Plateau-road 1,000 feet north of the northern boundary of Thrower-street, easterly by a line at right angles to Plateau-road a distance of 150 feet, southerly by a line parallel to Plateau-road a distance of 100 feet, easterly along portion of the northern boundary of lot 1 Plateau-road, southerly along the eastern boundaries of the said lot 1 and lot 2 Plateau-road, easterly by a line to a point in Lakeside-avenue 800 feet north of the northern boundary of Thrower-street, northerly along Lakeside-avenue

a distance of 200 feet, easterly along the northern boundary of lot 7 Lakeside-avenue, northerly along the western boundaries of lots 3 and 4 Banbury-road, easterly along the northern boundary of the said lot 4, southerly along Banbury-road to the commencing point.

Sewerage Area No. 1,951.

City of Waverley.—Commencing at the junction of View-bank-road and Highton-road; thence easterly along Highton-road, southerly along the eastern boundary of lot 42 Highton-road, westerly along the southern boundary of the said lot 42, south-easterly along the north-eastern boundary of lot 32 Eagle-court, south-westerly along the south-eastern boundary of lot 31 Eagle-court, south-easterly along the north-eastern boundary of lot 22 Como-court, south-westerly along the south-eastern boundary of lot 21 Como-court, south-easterly along the north-eastern boundary of lot 12 Amstel-court, south-westerly along the south-eastern boundary of lot 11 Amstel-court, easterly along the northern boundary of lot 1 Fern Tree Gully-road, southerly along the eastern boundary of the said lot 1, westerly along Fern Tree Gully-road, northerly along the western boundaries of lots 35 to 50 and 71 to 79 Briggs-street, north-easterly along the north-western boundaries of lots 79 to 81 Briggs-street, easterly along the northern boundaries of lots 82 and 83 Briggs-street and 85 Stanley-avenue, southerly along Stanley-avenue, easterly along the northern boundaries of lots 1 to 6 Therese-avenue, north-easterly along the north-western boundaries of lots 7 to 15 Therese-avenue, southerly along the eastern boundaries of lots 15 and 17 Therese-avenue, 18 to 22 Acton-street and 23 Catherine-avenue, easterly by a line from the south-eastern angle of the said lot 23 to the north-western angle of lot 62 Highton-road, further easterly along the northern boundaries of lots 62 to 59 Highton-road, southerly along the eastern boundary of the said lot 59, easterly along Highton-road to the commencing point.

Sewerage Area No. 1,952.

City of Waverley.—Commencing at the junction of Coolabah-road and Antoinette-court; thence westerly along Antoinette-court, north-westerly along the north-eastern boundary of lot 184 Antoinette-court, southerly along the western boundaries of lots 184 and 183 Antoinette-court and 167 and 166 Melba-street, easterly along the southern boundaries of lots 166 to 159 Melba-street, northerly along the eastern boundary of the said lot 159, easterly along Melba-street, northerly along Coolabah-road to the commencing point.

Further particulars regarding the streets or parts of streets in which sewers have been laid may be ascertained on inquiry at the Board's office.

By order of the Board,

H. J. SNADDEN,
Secretary.

110 Spencer-street, Melbourne, C.1, 6th July, 1965.

Process Servers and Inquiry Agents Act 1958.

APPLICATION FOR LICENCES LODGED WITH CLERKS OF COURTS.

BY direction of the Chief Secretary, the subjoined lists of "new" applications for process servers and inquiry agents licences are published for general information.

Applicant.	Address.	Court.	Tentative Date of Hearing of Application.
<i>Inquiry Agents Licence.</i>			
Renfree, Phillip Raymond	25 Patty-street, Mentone	Cheltenham .. .	21.7.65
<i>Process Servers Licences.</i>			
Abbott, Stuart Keith	c/o R. A. Marsden and Co., 414 Lonsdale-street, Melbourne	Camberwell .. .	22.7.65
Blake, John Warwick	Flat 3, 14 Sinclair-street, Drouin	Drouin	19.7.65
McArthur, Donald Malcolm	2 Harding-street, Hightett	Cheltenham	8.7.65
O'Sullivan, Dennis Patrick	27 Wadeson-street, Cobram	Cobram	28.7.65

Attention is directed to the provisions of the above Act and regulations thereunder relating to the lodgement of objections to applications.

Chief Secretary's Office,
Melbourne, 5th July, 1965.

C. W. PHILLIPS, Registrar,
Process Servers and Inquiry Agents.

SPRINGHURST WATERWORKS TRUST.

RATING BY-LAW FOR THE YEAR 1965.

THE Springhurst Waterworks Trust, in pursuance and exercise of the power conferred by Section 250 (2) of the Water Act 1958 doth hereby make a rate of Three shillings and Six pence in the pound on the annual municipal valuation of lands and tenements liable to be rated within the Springhurst Urban District.

Provided that in no case shall the amount of rate payable per annum in respect of any tenement (other than land in which there is not a building) be less than Six pounds fifteen shillings, and in respect of land on which there is no building less than Two pounds.

Such rate is made and shall be levied upon the occupiers or owners of the said lands and tenements for the year commencing 1st January and ending 31st December 1965, and shall be payable in one amount on 1st August 1965 at the Office of the said Trust.

The maximum quantity of water to be supplied in the said period without further charge to any property rated by the Trust is hereby fixed at the quantity which at a charge of Two shillings and Six pence per 1,000 gallons would produce an amount equal to the amount of the rate levied on such property for the said period.

The charge for water supplied by measure to any property rated by the Trust in excess of such maximum quantity computed as in the last preceding clause is hereby fixed at Two shillings and Six pence per 1,000 gallons.

The charge for water supplied by measure to any property not rated by the Trust is hereby fixed at Two shillings and Six pence per 1,000 gallons and the minimum quantity of water to be charged for in cases where water is so supplied is hereby fixed at 2,000 gallons.

The seal of the Springhurst Waterworks Trust was hereby affixed, this 7th day of June, 1965, in the presence of—

D. J. DUNNE, Chairman.

(SEAL) R. HARBINSON, Commissioner.

V. KENTMANN, Secretary.

Approved, 29th June, 1965.—T. A. DARCY, Minister of Water Supply.

TOORA WATERWORKS TRUST.

RATING BY-LAW FOR THE YEAR 1965.

THE Toora Waterworks Trust, in pursuance and exercise of the powers conferred by the Water Acts, hereby makes the following rates for the supply of water for domestic and ordinary purposes on lands and tenements liable to be rated within the Toora Urban District:—

On such lands and tenements a rate of Two shillings in the pound on the amount of the annual municipal valuation.

Provided that in no case shall the amount payable in respect of any tenements (other than land on which there is no building) be less than Two pounds, and in respect of any land on which there is no building be less than One pound.

Such rates are made and shall be the amount levied upon the occupiers or owners of such lands and tenements for the year commencing on the 1st day of January 1965, and ending on the 31st day of December, 1965 and shall be payable on the 29th of July 1965, at the Trust Office.

The maximum quantity of water to be supplied in any one year without any further charge to any property rated by the Trust is hereby fixed at the quantity which, at the charge of One shilling and sixpence per 1,000 gallons, would produce an amount equal to the amount of the rate levied on such property for the said year.

The charge for water supplied by measure to any property rated by the Trust in excess of such maximum quantity, computed as in the last preceding clause, is hereby fixed at One shilling and sixpence per 1,000 gallons.

The charge for water supplied by measure shall be payable, on demand, at the Trust Office.

Passed this 23rd day of April, 1965.

(SEAL) W. E. COOK, Chairman.

A. W. SMITH, Secretary.

Approved, 29th June, 1965.—T. A. DARCY, Minister of Water Supply.

BARNAWARTHA WATERWORKS TRUST.

RATING BY-LAW FOR THE YEAR 1965.

THE Barnawartha Waterworks Trust, in pursuance and exercise of the powers conferred by the Water Acts, doth hereby make a rate for the supply of water for domestic purposes of Three shillings and six pence in the pound on the annual municipal valuation of lands and tenements liable to be rated within the Barnawartha Urban District.

Provided that in no case shall the amount of rate payable per annum in respect of any tenement (other than land on which there is not a building) be less than Seven pounds, ten shillings, and in respect of land on which there is no building less than Two pounds.

Such rates are made and shall be levied upon the occupiers or owners of the said lands and tenements for the year commencing 1st January, 1965, and ending 31st December, 1965, and shall be payable in one amount on 15th July, 1965, at the office of the said Trust in Chiltern.

The maximum quantity of water to be supplied for the year without further charge to any property rated by the Trust is hereby fixed at the quantity which, at a charge of Three shillings per 1,000 gallons, would produce an amount equal to the amount of the rate levied on such property for the said year.

The charge for water supplied by measure to any property rated by the Trust in excess of such maximum quantity, computed as in the last preceding clause, is hereby fixed at Three shillings per 1,000 gallons.

The charge for water supplied to any property not rated by the Trust is hereby fixed at Three shillings per 1,000 gallons, and the minimum quantity of water to be charged for in cases where water is so supplied is hereby fixed at 1,000 gallons.

The charge for water supplied by measure shall be payable on demand at the office of the Trust in Chiltern.

Passed this 10th day of June, 1965.

The common seal of the Barnawartha Waterworks Trust was hereto affixed this 10th day of June, 1965, in the presence of—

R. D. OATES, Chairman.

(SEAL) S. R. PENNINGTON, Commissioner.

M. J. OWENS, Secretary.

Approved, 29th June, 1965.—T. A. DARCY, Minister of Water Supply.

RUTHERGLEN WATERWORKS TRUST.

RATING BY-LAW FOR THE YEAR 1965.

THE Rutherglen Waterworks Trust, in pursuance and exercise of the powers conferred by the Water Acts, doth hereby make a rate for the supply of water for domestic purposes of Twenty pence in the pound on the annual municipal valuation of lands and tenements liable to be rated within the Rutherglen Urban District.

Provided that in no case shall the amount of rate payable per annum in respect of any tenement (other than land on which there is no building) be less than Ninety shillings, and in respect of any land on which there is no building less than Fifty shillings.

Such rates are made and shall be levied upon the occupiers or owners of the said lands and tenements for the year commencing on the 1st day of January, 1965, and shall be payable on the 16th day of July, 1965, at the office of the said Trust, Shire Hall, Rutherglen.

The maximum quantity of water to be supplied in any one year, without further charge to any property rated by the Trust, is hereby fixed at the quantity which, at a charge of One shilling and six pence per 1,000 gallons, would produce an amount equal to the amount of the rate levied on such property for the said year.

The charge for water supplied by measure to any property rated by the Trust in excess of such maximum quantity, computed as in the last preceding clause, is hereby fixed at One shilling per 1,000 gallons.

The charge for water supplied by measure to any property not rated by the Trust is hereby fixed at One shilling and six pence per 1,000 gallons, and the minimum quantity of water to be charged for in cases where water is so supplied is hereby fixed at 73,000 gallons.

The charge for water supplied by measure shall be payable, on demand, at the office of the Trust, Shire Hall, Rutherglen.

Passed this 16th day of June, 1965.

(SEAL) W. JASPER, Chairman.
S. T. DOWNS, Commissioner.
C. A. RICKETTS, Secretary.

Approved, 29th June, 1965.—T. A. DARCY, Minister of Water Supply.

TOORA WATERWORKS TRUST.

RATING BY-LAW FOR THE YEAR 1965.

THE Toora Waterworks Trust, in pursuance and exercise of the powers conferred by the Water Acts, hereby makes the following rates for the supply of water for domestic and ordinary purposes on lands and tenements liable to be rated within the WELSHPOOL Urban District:—

On such lands and tenements a rate of Three shillings in the pound on the amount of municipal valuation.

Provided that in no case shall the amount of rate payable in respect of any tenement (other than land on which there is no building) be less than Five pounds, and in respect of any land on which there is no building, be less than One pound.

Such rates are made and shall be levied upon the occupiers or owners of such lands and tenements for the year commencing on the 1st day of January, 1965 and ending on the 31st day of December, 1965 and shall be payable on the 29th day of July, 1965 at the Trust Office.

The maximum quantity of water to be supplied in any one year, without any further charge to any property rated by the Trust, is hereby fixed at the quantity which, at a charge of Two shillings per 1,000 gallons, would produce an amount equal to the amount of the rate levied on such property for the said year.

The charge for water supplied by measure to any property rated by the Trust in excess of such maximum quantity, computed as in the last preceding clause, is hereby fixed at Two shillings per 1,000 gallons.

The charge for water supplied by measure to any property not rated by the Trust is hereby fixed at Two shillings per 1,000 gallons, and the minimum quantity of water to be charged is fixed at 5,000 gallons.

The charge for water supplied by the Trust by measure shall be payable on demand at the Trust Office.

Passed this 23rd day of April, 1965.

(SEAL) W. E. COOK, Chairman.
A. W. SMITH, Secretary.

Approved, 29th June, 1965.—T. A. DARCY, Minister of Water Supply.

TOORA WATERWORKS TRUST.

RATING BY-LAW FOR THE YEAR 1965.

THE Toora Waterworks Trust, in pursuance and exercise of the powers conferred by the Water Acts, hereby makes the following rates for the supply of water for domestic and ordinary purposes on the land and tenements liable to be rated within the PORT WELSHPOOL Urban District:—

On such lands and tenements a rate of Three shillings in the pound on the amount of annual municipal valuation.

Provided that in no case shall the amount of rate payable in respect of any tenement (other than land on which there is no building) be less than Five pounds, and in respect of any land on which there is no building, less than One pound.

Such rates are made and shall be levied upon the occupiers or owners of such lands and tenements for the year commencing on the 1st day of January, 1965 and ending on the 31st day of December, 1965 and shall be payable on the 29th day of July, 1965, at the Trust Office.

The maximum quantity of water to be supplied in any one year, without any further charge to any property rated by the Trust, is hereby fixed at the quantity which, at a charge of Two shillings per 1,000 gallons, would produce an amount equal to the amount of rate levied on such property for said year.

The charge for water supplied by measure to any property rated by the Trust in excess of such maximum quantity, computed as in the last preceding clause, is hereby fixed at Two shillings per 1,000 gallons.

The charge for water supplied by measure to any property not rated by the Trust is hereby fixed at Two shillings per 1,000 gallons, and the minimum quantity of water to be charged is fixed at 5,000 gallons.

The charge for water supplied by the Trust by measure shall be payable on demand at the Trust Office.

Passed this 23rd day of April, 1965.

(SEAL) W. E. COOK, Chairman.
A. W. SMITH, Secretary.

Approved, 29th June, 1965.—T. A. DARCY, Minister of Water Supply.

CASTERTON SEWERAGE AUTHORITY.

BY-LAW No. 4.

Minimum Sewerage Rate.

THE Casterton Sewerage Authority, in pursuance and exercise of powers conferred by the Sewerage Districts Acts, doth hereby make the following By-law:—

1. In no case shall the amount of sewerage rate payable annually be less than Ten pounds (£10) in respect of any rateable sewerer property on which there is a building and Seven pounds (£7) in respect of any rateable sewerer property on which there is no building.

2. This By-law will have effect from the 1st day of October, 1965.

By-law No. 2 is hereby repealed.

Passed by the Casterton Sewerage Authority at the Ordinary Bi-monthly Meeting held on the 14th April, 1965, and confirmed at the Ordinary Bi-monthly Meeting of the Authority held on the 9th day of June, 1965.

In witness whereof the common seal of the said Authority was affixed hereto, in the presence of—

(SEAL) H. D. MITCHELL, Chairman.
T. J. HOWLETT, Member.
R. D. WATSON, Secretary.

Approved by the Governor in Council, 29th June, 1965.—J. COLQUHOUN, Clerk of the Executive Council.

FIRST MILDURA IRRIGATION TRUST.

AMENDMENT TO REGULATION No. 1.

THE Commissioners of the First Mildura Irrigation Trust, in pursuance of the powers conferred upon them by the *Mildura Irrigation and Water Trusts Act 1958* do hereby make the following Regulation:—

Clause No. 67 of Regulation No. 1 as amended by the Regulation made on the 10th day of February, 1961, shall be further amended by substituting for the words "Seven hundred and fifty" where appearing therein the words "Eight hundred and fifty."

This amendment shall have effect from the 1st day of January, 1965.

The foregoing Regulation was made by the Commissioners of the First Mildura Irrigation Trust this 23rd day of April, 1965.

(SEAL) W. B. HAWSON, Commissioner.
F. R. MESSENGER, Commissioner.
F. G. LLOYD, Commissioner.
A. W. BLOMQUIST, Commissioner.
H. F. MCKENZIE, Commissioner.
SYDNEY V. NICE, Secretary.

Approved by the Governor in Council, 29th June, 1965.—J. COLQUHOUN, Clerk of the Executive Council.

Town and Country Planning Act 1961.

GEELONG PLANNING SCHEME.

AMENDMENT No. 6, 1964.

Notice of Approval.

IN pursuance of the powers conferred by the *Town and Country Planning Act 1961*, the Governor in Council on the 6th July, 1965, approved a Planning Scheme entitled the Geelong Planning Scheme 1959, Amendment No. 6, 1964, in respect of part of the municipal district of the City of Geelong West.

A copy of the Planning Scheme as approved may be inspected during office hours at the office of the Town and Country Planning Board, 179 Queen-street, Melbourne; at the office of the City of Geelong West, 153 Pakington-street, Geelong West; and when available, at the Office of Titles, Melbourne, and at the Central Plan Office of the Department of Crown Lands and Survey, Melbourne.

W. H. CRAIG, Secretary,
Town and Country Planning Board.

Melbourne Harbor Trust Act 1958.

TO THE OWNERS OF THE MOTOR BOAT "MYONI".
WHEREAS the Motor Boat "Myoni" has sunk within the Port of Melbourne: And whereas the Melbourne Harbor Trust Commissioners consider that such vessel is likely to become an obstruction to the safe and convenient navigation of the said port: Now therefore the said Melbourne Harbor Trust Commissioners pursuant to the powers conferred upon them by the provisions of section 87 of the *Melbourne Harbor Trust Act 1958* hereby require you—

to raise the vessel from the bed of the waters of the port and to make the hull seaworthy within a period of 30 days from the published date of this notice;

or

to remove such vessel from the said port within a period of 30 days from the published date of this notice.

M. W. CLIFTON,
 Secretary.

Fruit and Vegetables Act 1958 (No. 6256).

PERSONS AUTHORIZED TO TAKE PROCEEDINGS.

HIS Excellency the Governor of the State of Victoria, by and with the advice of the Executive Council thereof, has, by Orders made on the 29th day of June, 1965, pursuant to section 48 of the *Fruit and Vegetables Act 1958* (No. 6256), authorized the persons named hereunder, who are Inspectors under the said Act, to take proceedings in respect of offences against Part II. of the said Act or the Regulations thereunder—

ARTHUR LAWRENCE ADCOCK.
 WILLIAM EDWIN BIRKENHEAD.
 DONALD LENNOX CHRISTISON.
 WILLIAM LLOYD CREMER.
 PATRICK LAWRENCE CROZIER.
 WILLIAM ALFRED GERRETT.
 BRIAN KEITH KELLY.
 DOUGLAS RAILTON MATTHEWS.
 KENNETH ROGER PLUMMER.
 SAMUEL CHARLES TAYLOR.
 RICHARD CHARLES WALLACE.
 ROBERT ALLAN WELLER.
 BRIAN CLIFTON WORSLEY.

J. COLQUHOUN,
 Clerk of the Executive Council.

At the Executive Council Chamber,
 Melbourne, 29th June, 1965.

APPOINTMENTS.

HIS Excellency the Governor of the State of Victoria, by and with the advice of the Executive Council thereof, has, by Orders made on the 29th day of June, 1965, been pleased to make the under-mentioned appointments, viz.:—

DEPARTMENT OF AGRICULTURE.

Inspector.

DONALD LENNOX CHRISTISON
 to be an Inspector, pursuant to the *Fruit and Vegetables Act 1958* (No. 6256) and the *Vegetation and Vine Diseases Act 1958* (No. 6407).

CHIEF SECRETARY'S DEPARTMENT.

Electoral Registrar (Acting).

JOHN WEBB
 to be Electoral Registrar (Acting) for the Oakleigh and Oakleigh East Subdivisions of the Electoral District of Oakleigh; and for the Bentleigh North, Carnegie and Glenhuntly Subdivisions of the Electoral District of Ormond, to take effect on and from the 17th June, 1965, during the absence on leave of William John Champion Furlonger.

Governor of Prison.

RONALD BONE,
 pursuant to the provisions of the *Gaols Act 1958*, to be Governor of Wron Wron Reforestation Prison, from the 21st June, 1965.

Governor (Acting) of Training Prison.

ROY SEAMER VODDEN,
 pursuant to the provisions of the *Gaols Act 1958*, to be Governor (Acting) of Her Majesty's Training Prison, Bendigo, from the 5th July, 1965, to the 18th July, 1965, both dates inclusive, during the absence on leave of Daniel Martin Kearney.

Licensing Inspector.

ALBERT VERDUN THOMSON, Inspector of Police, Grade I., to be a Licensing Inspector for the purposes of the *Licensing Act 1958*, vice Michael Francis Sharkey, resigned.

Prison Chaplain.

THOMAS O'CONNELL (the Reverend Father), to be Roman Catholic Chaplain (part-time) to Morwell River Reforestation Prison, from the 10th May, 1965, vice Peter Harris (the Reverend Father), resigned.

Special Magistrate.

DONALD PERCIVAL WATKINS,
 pursuant to the provisions of section 39 of the *Children's Welfare Act 1958*, to be a Special Magistrate for the purposes of the said Act.

DEPARTMENT OF CROWN LANDS AND SURVEY.

Bailiffs of Crown Lands.

ALBERT LOUIS LE MESCAM,
 FREDERICK RAYMOND REDENBACH, and
 PETER THOMAS STRAW
 to be Bailiffs of Crown lands, without additional salary.

MINISTRY OF HEALTH.

Members of Committees of Management.

GORDON ROSSLYN COULTHARD
 to be a Member of the Committee of Management of Tallangatta Hospital, pursuant to proviso (a) of section 48 (1) of the *Hospitals and Charities Act 1958*, for a period of three years, vice E. A. Ried, J.P., resigned;

ARTHUR EDWARD NELSON
 to be a Member of the Committee of Management of Woorayl District Memorial Hospital, pursuant to proviso (a) of section 48 (1) of the *Hospitals and Charities Act 1958*, for a further term of three years, expiring on the 22nd June, 1968;

Sir ARTHUR SMITHERS, C.B.E.;
 to be a Member of the Committee of Management of The Royal Melbourne Hospital, pursuant to proviso (a) of section 48 (1) of the *Hospitals and Charities Act 1958*, for a further term of three years, expiring on the 29th June, 1968;

HENRY GEORGE BORRODELL FISHER
 to be a Member of the Committee of Management of Maryborough and District Hospital, pursuant to proviso (a) of section 48 (1) of the *Hospitals and Charities Act 1958*, for a further term of three years, expiring on the 29th June, 1968; and

JOHN VALENTINE WILLIAMSON
 to be a Member of the Committee of Management of Ararat and District Hospital, pursuant to proviso (a) of section 48 (1) of the *Hospitals and Charities Act 1958*, for a period of three years, vice P. K. Burge, resigned.

LAW DEPARTMENT.

Arbitrator.

LOUIS VOUMARD, Q.C., a Barrister at Law, who has practised as a barrister in Victoria for a period of seven years,
 to be an Arbitrator under the provisions of the *Sale of Land Act 1962*, to take effect from the 1st July, 1965, until 30th June, 1966, both dates inclusive.

Assistant Collector for Interstate Maintenance.

JOHN BARRY RIES
 to be an Assistant Collector for Interstate Maintenance, pursuant to the provisions of section 53 of the *Maintenance Act 1958*, in the place of H. P. B. King, transferred, to take effect from the date of commencement of duty.

Assistant Registrar.

MICHAEL FRANCIS MALONEY
 to be an Assistant Registrar, pursuant to the provisions of the *County Court Act 1958*, for the County Court at Ballarat, in the place of M. W. Gerkens, transferred, to take effect from the date of commencement of duty.

Clerks of Petty Sessions, &c.

MICHAEL FRANCIS MALONEY
 to be Clerk of Petty Sessions and Clerk of the Children's Courts at Daylesford, Creswick, Clunes and Trentham, in the place of M. W. Gerkens, transferred, to take effect from the date of commencement of duty;

KEVIN JOHN BURGESS
to be Clerk of Petty Sessions and Clerk of the Children's Court, at Whittlesea, in the place of D. B. Scully, transferred, to take effect from the date of commencement of duty;

BERNARD JAMES STOCKS
to be Clerk of Petty Sessions and Clerk of the Children's Court at Melton, in the place of J. P. Hanrahan, transferred, to take effect from the date of commencement of duty; and

IAN MAXWELL VON EINEM
to be Clerk of Petty Sessions and Clerk of the Children's Court at Queenscliff, in the place of B. J. Stocks, transferred, to take effect from the date of commencement of duty.

Clerk of Children's Court.

KEVIN JOHN BURGESS
to be Clerk of the Children's Court at Melbourne, in the place of D. B. Scully, transferred, to take effect from the date of commencement of duty.

Commissioners for Taking Declarations, &c.

RONALD NARINE DAVIES, 51 Hodder-street, East Brighton; and

DAVID JAMES NOLAN, 1 Dunure-court, Balwyn,
to be Commissioners for taking Declarations and Affidavits, pursuant to the provisions of the *Evidence Act 1958*, to resign upon removing from the neighbourhood of the addresses stated; and

GEORGE KEITH TRUMAN, 2A Maysbury-avenue, Brighton Beach,
to be a Commissioner for taking Declarations and Affidavits, pursuant to the provisions of the *Evidence Act 1958*, to resign upon ceasing to occupy his present position.

Deputy Clerk of the Peace, &c.

GREGORY JAMES FINDLAY
to be Deputy Clerk of the Peace, Registrar of the County Court, Clerk of Petty Sessions and Clerk of the Children's Court at Korumburra and Clerk of Petty Sessions and Clerk of the Children's Court at Leongatha and Meeniyan, in the place of G. T. Wheelhouse, transferred, to take effect from the date of commencement of duty.

Deputy Coroner.

JOHN OWEN WOOD, J.P., Perrin-street, Robinvale,
to be a Deputy Coroner, pursuant to the provisions of the *Coroner's Act 1958*, to act and have jurisdiction for and during the absence of the Coroner at and in the vicinity of Robinvale.

Justices of the Peace.

KURT EDWARD BERNHARD LIPPMANN, 13 Lygon-street, South Caulfield,
EDWARD CECIL LUCAS, 16 Ivan-avenue, Edithvale,
KEITH RONALD FARFOR, 8 Irving-street, Malvern, and
FRANK PAGE CHIPPERFIELD, care of State Electricity Commission of Victoria, 22 William-street, Melbourne,
to Keep the Peace in the Central Bailiwick of the State of Victoria;

LESLIE ARNOLD MILLER, Bullioh, via Tallangatta, and
REGINALD ARROWSMITH DOUGLAS, Barnawartha,
to Keep the Peace in the Northern Bailiwick of the State of Victoria; and

CLEMENT NORMAN PESKETT, Post Office, Forrest,
to Keep the Peace in the Southern Bailiwick of the State of Victoria.

DEPARTMENT OF PUBLIC WORKS.

Wharf Manager.

Senior Constable JOSEPH ANTHONY BRENNAN, No. 10983,
to be Wharf Manager at Werribee, as from 4th May, 1965, to carry out that portion of Part II. of the *Marine Act 1958*, which relates to the management of Public Wharves, and to be an officer under section 19 of such Act to levy and collect wharfage rates thereat, at a remuneration of £12 10s. per annum, vice Senior Constable Bruce Daniel Noel O'Sullivan, No. 10645, transferred.

DEPARTMENT OF THE TREASURER.

Chairman of Aborigines Welfare Board.

JAMES HENRY DAVEY
to be Chairman of the Aborigines Welfare Board, pursuant to section 4 (1) (a) of the *Aborigines Act 1958*, for the period from the 1st July, 1965, to the 22nd July, 1966, both dates inclusive.

Members of Aborigines Welfare Board.

ALBERT GEORGE BOOTH (nominated by the Chief Secretary),
to be a Member of the Aborigines Welfare Board, pursuant to section 4 (1) (b) of the *Aborigines Act 1958*, for the period from the 1st July, 1965, to the 22nd July, 1966, both dates inclusive;

JACK PERCIVAL GASKIN (nominated by the Minister of Housing)

to be a Member of the Aborigines Welfare Board, pursuant to section 4 (1) (d) of the *Aborigines Act 1958*, for the period from the 1st July, 1965, to the 22nd July, 1966, both dates inclusive; and

Dr. COLIN MARTIN TATZ (selected from a panel of three names submitted by the President for the time being of the Aborigines Advancement League)

to be a Member of the Aborigines Welfare Board, pursuant to section 4 (1) (f) of the *Aborigines Act 1958*, for the period from the 1st July, 1965, to the 22nd July, 1966, both dates inclusive.

Member of Co-operative Societies Advisory Council.

IAN FRANCIS McLAREN, F.C.A. (Aust.),
to be a Member of the Co-operative Societies Advisory Council, pursuant to the provisions of section 93 of the *Co-operation Act 1958* (No. 6225), for the period from 1st July, 1965, to 18th July, 1967, both dates inclusive.

Member of Home Finance Trust.

IAN CLIVE HOWARD
to be a Member of the Home Finance Trust, pursuant to the provisions of section 4 (c) of the *Home Finance Act 1962* (No. 6933), for the period from 1st July, 1965, to 23rd May, 1966, both dates inclusive.

Collector of Imposts (Acting).

DENNIS GRANT
to act temporarily as Collector of Imposts, Weights and Measures Office, Chief Secretary's Department, vice C. A. Walsh.

J. COLQUHOUN,

Clerk of the Executive Council.
At the Executive Council Chamber,
Melbourne, 29th June, 1965.

APPOINTMENTS.

HIS Excellency the Governor of the State of Victoria, by and with the advice of the Executive Council thereof, has, by Orders made on the 6th day of July, 1965, been pleased to make the under-mentioned appointments, viz.:—

DEPARTMENT OF WATER SUPPLY.

Commissioners of River Improvement Trust.

JEFFREY LEONARD BALDWIN,
CLIVE OLAF HILL,
ALLAN LEWIS MARRIOTT,
JAMES ANDREW SAWYER, and
BIGO ERIC STONEY,
to be Commissioners of the Yarra River Improvement Trust, each to hold office as such from the date hereof until the second Thursday in the month of July in the year 1967, subject to the provisions of the River Improvement Act.

Waterworks Trust Commissioner.

WILLIAM JOHN CHARLES PEACOCK
to be a Commissioner of the Yallourn North Waterworks Trust for a period of four years from the date hereof, subject to the provisions of the Water Act.

J. COLQUHOUN,

Clerk of the Executive Council.
At the Executive Council Chamber,
Melbourne, 6th July, 1965.

RESIGNATIONS.

HIS Excellency the Governor of the State of Victoria, by and with the advice of the Executive Council thereof, has, by Orders made on the 29th day of June, 1965, accepted the resignations of the persons named hereunder of the offices mentioned, viz.:—

LAW DEPARTMENT.

HARRY PEARSON, as a Commissioner for taking Declarations and Affidavits, pursuant to the provisions of the *Evidence Act 1958*.

JAMES WILLIAM BARKER, from the Commission of the Peace for the Central Bailiwick of the State of Victoria.

JOHN JAMES TOMLINSON, from the Commission of the Peace for the Central Bailiwick of the State of Victoria.

DEPARTMENT OF THE TREASURER.

LESLIE GEORGE NORMAN, as a member of the Co-operative Societies Advisory Council, to date from and inclusive of 1st July, 1965.

LESLIE GEORGE NORMAN, as a member of the Home Finance Trust, to date from and inclusive of 1st July, 1965.

J. COLQUHOUN,
Clerk of the Executive Council.

At the Executive Council Chamber,
Melbourne, 29th June, 1965.

COUNTRY ROADS BOARD.

At the Executive Council Chamber, Melbourne, the
twenty-ninth day of June, 1965.

PRESENT:

His Excellency the Governor of Victoria.
Mr. Hamer | Mr. Darcy.
Mr. Rossiter

COUNTRY ROADS BOARD.

At the Executive Council Chamber, Melbourne, the
twenty-ninth day of June, 1965.

PRESENT:

His Excellency the Governor of Victoria.
Mr. Hamer | Mr. Darcy.
Mr. Rossiter

ORDER APPROVING OF A DEVIATION FROM A MAIN ROAD IN THE SHIRE OF METCALFE.

WHEREAS the Country Roads Board constituted under the *Country Roads Act 1958* (No. 6229) has represented to His Excellency the Governor in Council that it appears to it desirable that the deviation hereinafter referred to from the existing Bendigo-Sutton Grange road in the Shire of Metcalfe (declared to be a main road under the said Act which declaration was confirmed by the Order in Council published in the *Government Gazette* of the 16th July, 1947, on pages 3851-55) should be made by the said Board: And whereas the said Board in accordance with the requirements of section 19 of the said cited Act has caused to be prepared a map, plan and estimate showing the points between which and on and through what land the said deviation is proposed to be made and the cost of acquiring the land: And whereas on an inspection of the said map and plan and a consideration of the said estimate His Excellency the Governor in Council is satisfied that there are funds legally available for acquiring the land: Now therefore be it known by this present Order that His Excellency the Governor of the State of Victoria with the advice of the Executive Council thereof doth hereby approve of the said road being made, that is to say:—

All those pieces of land in the Parish of Sutton Grange, the boundaries of which are as follow:—

- (a) Commencing at a point on the eastern boundary of portion 1, Parish of Sutton Grange, distant 168 deg. 13 min. 153 links from the northern angle of the said portion; thence by lines bearing respectively 168 deg. 13 min. 386.2 links, 195 deg. 30 min. 391.8 links, 139 deg. 40 min. 330 links, 201 deg. 30 min. 215 links, 163 deg. 20 min. 200 links, 215 deg. 22 min. 115.1 links, 151 deg. 29 min. 719.8 links, 168 deg. 13 min. 1,002 links, 339 deg. 1 min. 1,056.5 links, 331 deg. 29 min. 878.1 links, 340 deg. 34 min. 307.5 links, 345 deg. 9 min. 513.9 links, 312 deg. 50 min. 258.5 links, 45 deg. 21 min. 419.8 links and 71 deg. 44½ min. 289.1 links to the point of commencement.
- (b) Commencing at the southern angle of a State School Reserve, Township of Sutton Grange in the said parish; thence by lines bearing respectively 28 deg. 35 min. 91.5 links, 7 deg. 52 min. 74.6 links, 2 deg. 4 min. 59.9 links, 354 deg. 48 min. 404.5 links, 338 deg. 38 min. 121 links, 312 deg. 2 min. 267.9 links, 333 deg. 28½ min. 570.3 links, 334 deg. 16 min. 1,271.9 links, 144 deg. 45 min. 1,629.5 links and 158 deg. 55 min. 540.4 links; thence by the arc of a circle of radius 762 links a distance of 773 links the chord of which arc bears 188 deg. 7 min. to the point of commencement—

which said pieces of land are particularly delineated and shown coloured red and yellow on survey plans numbered 10051 and 10052, lodged in the office of the Country Roads Board.

And the Honorable James Charles Murray Balfour, Her Majesty's Acting Minister of Public Works for the State of Victoria, shall give the necessary directions herein accordingly.

J. COLQUHOUN,
Clerk of the Executive Council.

DECLARATION OF A DEVIATION FROM THE KERANG-QUAMBATOOK ROAD IN THE SHIRE OF KERANG.

WHEREAS by sections 21 and 58 of the *Country Roads Act 1958* (No. 6229) it is amongst other things enacted that when the Country Roads Board under the provisions of the *Country Roads Act* has by Resolution declared a deviation to be a main road the said Board may also declare that such deviation shall be in lieu of any existing road or part thereof named in such Resolution and that on publication in the *Government Gazette* of the Order confirming such Resolution the existing road or part thereof shall cease to be a main road or be discontinued as provided in the Resolution: And whereas the said Board has by Resolution declared the deviation on the land described in the First Schedule to such Resolution to be a main road and has also declared that such deviation shall be in lieu of the part of the existing road being the land described in the Second Schedule to the said Resolution and that such part of the said existing road as is described in the Third Schedule shall be discontinued: Now therefore His Excellency the Governor of the State of Victoria by and with the advice of the Executive Council thereof doth hereby confirm the said Resolution.

Resolution for Declaration of a Deviation of a Main Road under the Country Roads Act.

Whereas the land the site of the road the course of which is below set out was taken by the Board under the provisions of the *Country Roads Act 1958* for the purpose of constructing such road deviation which road deviation has now been laid out and formed on the same: And whereas the said Board (being the Country Roads Board incorporated under the said Act) thinks that the road aforesaid is fit to be used as a public highway such Board at a meeting now holden acting under the authority conferred upon it by sections 21 and 58 of the said Act doth by this present Resolution hereby declare the said road deviation the course of which is described in the First Schedule hereto with the commencing and terminating points thereof respectively specified to be part of a main road within the meaning and for the purposes of the *Country Roads Act 1958*: And the said Board doth also declare that such deviation shall be in lieu of the existing road or part thereof described in the Second Schedule hereto and that such part of the said existing road as is described in the Third Schedule shall be discontinued.

FIRST SCHEDULE.

Shire of Kerang.

5. Kerang-Quambatook road (8405).—All those pieces of land in the Parish of Budgerum West, the boundaries of which are as follow:—

- (a) Commencing at the north-western angle of allotment 3A, section E, of the said parish; thence by lines bearing respectively 16 deg. 46 min. 101.8 links, 62 deg. 16 min. 1,644 links, 232 deg. 36 min. 1,304.5 links, 234 deg. 36 min. 666.5 links and 16 deg. 46 min. 330 links to the point of commencement.
- (b) Commencing at a point on the eastern boundary of allotment 3, section E, of the said parish, distant 196 deg. 46 min. 1,225 links and 234 deg. 36 min. 1,802 links from the north-eastern angle of the said allotment; thence by lines bearing respectively 214 deg. 36 min. 810 links, 266 deg. 34 min. 523.3 links and 54 deg. 36 min. 1,205.1 links to the point of commencement.
- (c) Commencing at the south-eastern angle of allotment 3, section E, of the said parish; thence by lines bearing respectively 255 deg. 31 min. 288 links, 270 deg. 0 min. 42.9 links, 54 deg. 36 min. 750 links and 218 deg. 37 min. 463.9 links to the point of commencement.

- (d) Commencing at an angle in the western boundary of a Public Purposes Reserve opposite allotment 3, section E, in the said parish, formed by the intersection of lines bearing 266 deg. 34 min. and 218 deg. 37 min.; thence by lines bearing respectively 86 deg. 34 min. 88.8 links, 234 deg. 36 min. 239.4 links and 38 deg. 37 min. 170.7 links to the point of commencement.
- (e) Commencing at an angle in the western boundary of a Public Purposes Reserve opposite allotment 9, section E of the said parish, formed by the intersection of lines bearing 255 deg. 31 min. and 223 deg. 5 min.; thence by lines bearing respectively 75 deg. 31 min. 677.8 links, 234 deg. 36 min. 1,820.8 links and 43 deg. 5 min. 1,212.1 links to the point of commencement.
- (f) Commencing at an angle in the western boundary of a Public Purposes Reserve opposite allotment 10, section E, of the said parish, formed by the intersection of lines bearing 235 deg. 28 min. and 205 deg. 20 min.; thence by lines bearing respectively 55 deg. 28 min. 679 links, 222 deg. 57 min. 1,126.3 links and 25 deg. 20 min. 486.2 links to the point of commencement.
- (g) Commencing at the southern angle of allotment 10A of the said parish; thence by lines bearing respectively 243 deg. 52 min. 1,307.9 links, 43 deg. 5½ min. 2,675 links and 205 deg. 20 min. 1,524.9 links to the point of commencement.
- (h) Commencing at a point on the western boundary of a Public Purposes Reserve opposite allotment 11A, section E, of the said parish, distant 243 deg. 52 min. 1,307.9 links and 223 deg. 5½ min. 845.8 links from the north-eastern angle of the said allotment; thence by lines bearing respectively 63 deg. 52 min. 422.9 links, 223 deg. 5½ min. 1,051.7 links, 26 deg. 46 min. 533.6 links and 43 deg. 5½ min. 144.2 links to the point of commencement.
- (b) Commencing at an angle in the eastern boundary of allotment 3, section E, of the said parish formed by the intersection of lines bearing 266 deg. 34 min. and 218 deg. 37 min.; thence by lines bearing respectively 86 deg. 34 min. 416.7 links, 234 deg. 36 min. 1,123.6 links and 38 deg. 37 min. 801.1 links to the point of commencement.
- (c) Commencing at a point on the eastern boundary of allotment 10, section E, of the said parish, distant 223 deg. 5 min. 404 links from the north-eastern angle of the said allotment; thence by lines bearing respectively 222 deg. 57 min. 2,353.7 links, 25 deg. 20 min. 1,016.1 links and 55 deg. 28 min. 1,419 links to the point of commencement.
- (d) Commencing at the south-western angle of allotment 11A, section E, of the said parish; thence by lines bearing respectively 63 deg. 52 min. 958.6 links, 223 deg. 5½ min. 845.8 links, 243 deg. 52 min. 672 links, 206 deg. 46 min. 84.8 links, 223 deg. 5½ min. 1,067.3 links and 26 deg. 46 min. 1,209.7 links to the point of commencement—

which said pieces of land are particularly delineated and shown coloured blue on survey plans numbered 7787 and 7787A, lodged in the office of the Country Roads Board.

The common seal of the Country Roads Board was hereto affixed at Kew, this twenty-first day of June, One thousand nine hundred and sixty-five, in the presence of—

(SEAL) I. J. O'DONNELL, Chairman.
F. WEST, Member.
N. L. ALLANSON, Secretary.

And the Honorable James Charles Murray Balfour, Her Majesty's Acting Minister of Public Works for the State of Victoria, shall give the necessary directions herein accordingly.

J. COLQUHOUN,
Clerk of the Executive Council.

Also all that piece of land in the Parishes of Budgerum East and Budgerum West, the boundaries of which are as follow:—

Commencing at a point on the northern boundary of allotment 4, section 1, Parish of Budgerum East, distant 236 deg. 1 min. 811.7 links from the north-eastern angle of the said allotment; thence by lines bearing respectively 93 deg. 52 min. 561 links, 149 deg. 7 min. 210.9 links, 275 deg. 53 min. 865.6 links, 266 deg. 51 min. 467.5 links, 273 deg. 52 min. 2,150 links, 71 deg. 58 min. 536.2 links and 93 deg. 52 min. 2,300 links to the point of commencement—

which said pieces of land are particularly delineated and shown coloured red and yellow on survey plans numbered 7787, 7787A, 7788 and 7788A, lodged in the office of the Country Roads Board.

SECOND SCHEDULE.

Shire of Kerang.

5. *Kerang-Quambatook road* (8405).—All that piece of land in the Parishes of Budgerum East and Budgerum West, being a roadway of varying width, and commencing at a point on the western boundary of allotment 11, section 1, Parish of Budgerum East, distant 360 deg. 0 min. 100 links from the south-western angle of the said allotment; thence northerly to and across the Avoca River to the southern angle of allotment 1B, section E, Parish of Budgerum West; thence south-westerly by a roadway 2 chains wide, a distance of 3,500 links approximately, to its junction with the new road—which said piece of land is more particularly delineated and shown coloured blue on survey plan numbered 7788A, lodged in the office of the Country Roads Board.

THIRD SCHEDULE.

Shire of Kerang.

4. *Kerang-Quambatook road* (8405).—All those pieces of land in the Parish of Budgerum West, the boundaries of which are as follow:—

- (a) Commencing at the eastern angle of Crown land, distant 90 deg. 0 min. 450 links from the north-eastern angle of allotment 9, section E, of the said parish; thence by lines bearing respectively 90 deg. 0 min. 337.5 links, 162 deg. 18 min. 121.6 links, 234 deg. 36 min. 1,766.4 links and 43 deg. 5 min. 1,559.6 links to the point of commencement.

COUNTRY ROADS BOARD.

At the Executive Council Chamber, Melbourne, the twenty-ninth day of June, 1965.

PRESENT:

His Excellency the Governor of Victoria.
Mr. Hamer | Mr. Darcy.
Mr. Rossiter

DECLARATION OF A DEVIATION FROM THE TYERS-ROAD IN THE SHIRE OF MORWELL.

WHEREAS by sections 21 and 58 of the *Country Roads Act* 1958 (No. 6229) it is amongst other things enacted that when the Country Roads Board under the provisions of the *Country Roads Act* has by Resolution declared a deviation to be a main road the said Board may also declare that such deviation shall be in lieu of any existing road or part thereof named in such Resolution and that on publication in the *Government Gazette* of the Order confirming such Resolution the existing road or part thereof shall cease to be a main road or be discontinued as provided in the Resolution: And whereas the said Board has by Resolution declared the deviation on the land described in the First Schedule to such Resolution to be a main road and has also declared that such deviation shall be in lieu of the part of the existing road being the land described in the Second Schedule to the said Resolution and that such part of the said existing road shall be discontinued: Now therefore His Excellency the Governor of the State of Victoria by and with the advice of the Executive Council thereof doth hereby confirm the said Resolution.

Resolution for Declaration of a Deviation of a Main Road under the Country Roads Act.

Whereas the land the site of the road the course of which is below set out was taken by the Board under the provisions of the *Country Roads Act* 1958 for the purpose of constructing such road deviation which road deviation has now been laid out and formed on the same: And whereas the said Board (being the Country Roads Board

incorporated under the said Act) thinks that the road aforesaid is fit to be used as a public highway such Board at a meeting now holden acting under the authority conferred upon it by sections 21 and 58 of the said Act doth by this present Resolution hereby declare the said road deviation the course of which is described in the First Schedule hereto with the commencing and terminating points thereof respectively specified to be part of a main road within the meaning and for the purposes of the Country Roads Act 1958: And the said Board doth also declare that such deviation shall be in lieu of the existing road or part thereof described in the Second Schedule hereto and that such part of the said existing road shall be discontinued.

FIRST SCHEDULE.

Shire of Morwell.

Tyers-road.—All that piece of land in the Parish of Tanjil East, the boundaries of which are as follow:—Commencing at a point on the western boundary of allotment 14E of the said parish, distant 359 deg. 50 min. 179.6 links from the south-western angle of the said allotment; thence by lines bearing respectively 243 deg. 54 min. 111.2 links, 243 deg. 53 min. 806.3 links, 252 deg. 21½ min. 1,047.8 links, 238 deg. 18½ min. 1,321.8 links, 271 deg. 59 min. 202.5 links, 238 deg. 35 min. 721.5 links, 18 deg. 33 min. 56.2 links, 58 deg. 17½ min. 2,170.7 links, 72 deg. 28 min. 876 links, 69 deg. 31 min. 285.7 links, 63 deg. 39 min. 401.5 links, 63 deg. 30 min. 488.7 links, 63 deg. 17½ min. 1,704.2 links, 58 deg. 1 min. 274.2 links, 228 deg. 35 min. 679.4 links and 243 deg. 7 min. 1,395.7 links to the point of commencement—which said piece of land is particularly delineated and shown coloured red, yellow and green on survey plan numbered 8972, lodged in the office of the Country Roads Board.

SECOND SCHEDULE.

Shire of Morwell.

Tyers-road.—All those pieces of land in the Parish of Tanjil East, the boundaries of which are as follow:—

- (a) Commencing at the north-eastern angle of allotment 30b, section A, of the said parish; thence by lines bearing respectively 245 deg. 38 min. 313.5 links, 271 deg. 59 min. 933 links, 61 deg. 53 min. 199.4 links, 91 deg. 59 min. 737.1 links, 65 deg. 38 min. 362.7 links and 195 deg. 11 min. 129.7 links to the point of commencement.
- (b) Commencing at the north-eastern angle of allotment 30b, section A, of the said parish; thence easterly by a 1-chain reserve along the southern boundary of allotment 30b of the said section to the western angle of allotment 30c thereof.
- (c) Commencing at the western angle of allotment 30c, section A, of the said parish; thence by lines bearing respectively 266 deg. 46 min. 121.8 links, 31 deg. 34 min. 689.3 links, 60 deg. 0 min. 328.4 links, 159 deg. 46 min. 101.5 links, 240 deg. 0 min. 285.9 links and 211 deg. 34 min. 594.5 links to the point of commencement.
- (d) Commencing at the northern angle of allotment 30c, section A, of the said parish; thence north-easterly along a river reserve adjoining allotments 30b and 14E of the said section; thence north-easterly by a 1-chain reserve through the allotment last named to a point therein distant 359 deg. 50 min. 179.6 links and 63 deg. 7 min. 1,395.7 links from the south-western angle of the said allotment 14E—

which said pieces of land are particularly delineated and shown coloured blue on survey plan numbered 8972, lodged in the office of the Country Roads Board.

The common seal of the Country Roads Board was hereto affixed at Kew, this fifteenth day of June, One thousand nine hundred and sixty-five, in the presence of—

R. E. DONALDSON, Deputy Chairman.

(SEAL) F. WEST, Member.

N. L. ALLANSON, Secretary.

And the Honorable James Charles Murray Balfour, Her Majesty's Acting Minister of Public Works for the State of Victoria, shall give the necessary directions herein accordingly.

J. COLQUHOUN,
Clerk of the Executive Council.

COUNTRY ROADS BOARD.

At the Executive Council Chamber, Melbourne, the
twenty-ninth day of June, 1965.

PRESENT:

His Excellency the Governor of Victoria.

Mr. Hamer
Mr. Rossiter

Mr. Darcy:

DECLARATION OF A DEVIATION FROM THE
MANSFIELD-WOODS POINT ROAD IN THE SHIRE
OF MANSFIELD.

WHEREAS by sections 21 and 58 of the Country Roads Act 1958 (No. 6229) it is amongst other things enacted that when the Country Roads Board under the provisions of the Country Roads Act has by Resolution declared a deviation to be a main road the said Board may also declare that such deviation shall be in lieu of any existing road or part thereof named in such Resolution and that on publication in the Government Gazette of the Order confirming such Resolution the existing road or part thereof shall cease to be a main road or be discontinued as provided in the Resolution: And whereas the said Board has by Resolution declared the deviation on the land described in the First Schedule to such Resolution to be a main road and has also declared that such deviation shall be in lieu of the part of the existing road being the land described in the Second Schedule to the said Resolution: Now therefore His Excellency the Governor of the State of Victoria by and with the advice of the Executive Council thereof doth hereby confirm the said resolution.

Resolution for Declaration of a Deviation of a Main Road
under the Country Roads Act.

Whereas the land the site of the road the course of which is below set out was taken by the Board under the provisions of the Country Roads Act 1958 for the purpose of constructing such road deviation which road deviation has now been laid out and formed on the same: And whereas the said Board (being the Country Roads Board incorporated under the said Act) thinks that the road aforesaid is fit to be used as a public highway such Board at a meeting now holden acting under the authority conferred upon it by sections 21 and 58 of the said Act doth by this present Resolution hereby declare the said road deviation the course of which is described in the First Schedule hereto with the commencing and terminating points thereof respectively specified to be part of a main road within the meaning and for the purposes of the Country Roads Act 1958: And the said Board doth also declare that such deviation shall be in lieu of the existing road or part thereof described in the Second Schedule hereto.

FIRST SCHEDULE.

Shire of Mansfield.

3. *Mansfield-Woods Point road (9903).*—All that piece of land in the Parishes of Howqua and Jamieson, the boundaries of which are as follow:—Commencing at the north-western angle of allotment 109c, Parish of Howqua; thence by lines bearing respectively 324 deg. 12½ min. 298 links, 323 deg. 30 min. 1,619 links, 40 deg. 26 min. 57.6 links, 138 deg. 35 min. 19.7 links, 143 deg. 40 min. 801.9 links, 143 deg. 8 min. 797.2 links, 114 deg. 7 min. 649 links, 102 deg. 34 min. 241.9 links, 113 deg. 11 min. 1,089.4 links, 173 deg. 23 min. 474.6 links, 185 deg. 47 min. 230.3 links, 198 deg. 14½ min. 503.2 links, 136 deg. 51 min. 287.7 links, 169 deg. 53 min. 519.5 links, 144 deg. 29 min. 254.8 links, 158 deg. 56 min. 2,010.1 links, 156 deg. 57 min. 451.3 links, 319 deg. 45 min. 657 links, 338 deg. 56 min. 1,816 links, 324 deg. 29 min. 212.9 links, 307 deg. 8 min. 229.4 links, 344 deg. 23½ min. 552 links, 319 deg. 45 min. 100 links, 10 deg. 54 min. 702.8 links, 341 deg. 59 min. 502.6 links, 291 deg. 42 min. 1,346 links and 334 deg. 21 min. 82.8 links to the point of commencement—which said piece of land is particularly delineated and shown coloured red and red-hatched on survey plan numbered 8259, lodged in the office of the Country Roads Board.

SECOND SCHEDULE.

Shire of Mansfield.

3. *Mansfield-Woods Point road (9903).*—All that piece of land in the Parishes of Howqua and Jamieson, the boundaries of which are as follow:—Commencing at the

southern angle of allotment 109c, Parish of Howqua; thence by lines bearing respectively 139 deg. 45 min. 2,927.3 links, 158 deg. 56 min. 913 links, 319 deg. 45 min. 3,859.9 links, 346 deg. 8 min. 1,928.4 links, 334 deg. 21 min. 281 links, 323 deg. 30 min. 320 links, 111 deg. 42 min. 531.7 links, 154 deg. 21 min. 235.2 links and 166 deg. 8 min. 1,889 links to the point of commencement—which said piece of land is particularly delineated and shown coloured blue on survey plan numbered 8259, lodged in the office of the Country Roads Board.

The common seal of the Country Roads Board was hereto affixed at Kew, this twenty-first day of June, One thousand nine hundred and sixty-five, in the presence of—

(SEAL) I. J. O'DONNELL, Chairman.
F. WEST, Member.
N. L. ALLANSON, Secretary.

And the Honorable James Charles Murray Balfour, Her Majesty's Acting Minister of Public Works for the State of Victoria, shall give the necessary directions herein accordingly.

J. COLQUHOUN,
Clerk of the Executive Council.

COUNTRY ROADS BOARD.

At the Executive Council Chamber, Melbourne, the twenty-ninth day of June, 1965.

PRESENT:

His Excellency the Governor of Victoria.
Mr. Hamer | Mr. Darcy.
Mr. Rossiter

ORDER APPROVING OF WIDENING AN EXISTING STATE HIGHWAY IN THE SHIRE OF HAMPDEN.

WHEREAS the Country Roads Board constituted under the *Country Roads Act 1958* (No. 6229) has represented to His Excellency the Governor in Council that it appears to it desirable that the existing Hamilton Highway in the Shire of Hampden (declared to be a State highway under the said Act which declaration was confirmed by the Order in Council published in the *Government Gazette* of the 10th August, 1960, on pages 2743-8) should be widened by the said Board: And whereas the said Board in accordance with the requirements of section 19 of the said cited Act has caused to be prepared a map, plan and estimate showing the points between which and on and through what land the said widening is proposed to be made and the cost of acquiring the land: And whereas on an inspection of the said map and plan and a consideration of the said estimate His Excellency the Governor in Council is satisfied that there are funds legally available for acquiring the land: Now therefore be it known by this present Order that His Excellency the Governor of the State of Victoria with the advice of the Executive Council thereof doth hereby approve of the said highway being widened, that is to say:—

All that piece of land in the Parish of Darlington, the boundaries of which are as follow:—

Commencing at the north-eastern angle of allotment 3A, section 14, of the said parish; thence by lines bearing respectively 104 deg. 30 min. 328.8 links, 277 deg. 43 min. 559.4 links and 88 deg. 16 min. 236.2 links, to the point of commencement.

Also, all that piece of land in the Parish of Jellalabad the boundaries of which are as follow:—

Commencing at the south-eastern angle of allotment 11, section 11, of the said parish; thence by lines bearing respectively 274 deg. 47 min. 229.6 links, 75 deg. 5 min. 403.2 links and 232 deg. 36 min. 202.4 links to the point of commencement—

which said piece of land is particularly delineated and shown coloured red on survey plans numbered 9931 and 9932 lodged in the office of the Country Roads Board.

And the Honorable James Charles Murray Balfour, Her Majesty's Acting Minister of Public Works for the State of Victoria, shall give the necessary directions herein accordingly.

J. COLQUHOUN,
Clerk of the Executive Council.

COUNTRY ROADS BOARD.

At the Executive Council Chamber, Melbourne, the twenty-ninth day of June, 1965.

PRESENT:

His Excellency the Governor of Victoria.
Mr. Hamer | Mr. Darcy.
Mr. Rossiter

ORDER APPROVING OF WIDENING AN EXISTING MAIN ROAD IN THE SHIRE OF KORUMBURRA.

WHEREAS the Country Roads Board constituted under the *Country Roads Act 1958* (No. 6229) has represented to His Excellency the Governor in Council that it appears to it desirable that the existing Korumburra-Wonthaggi road in the Shire of Korumburra (declared to be a main road under the said Act which declaration was confirmed by the Order in Council published in the *Government Gazette* of the 13th May, 1914, on page 2049) should be widened by the said Board: And whereas the said Board in accordance with the requirements of section 19 of the said cited Act has caused to be prepared a map, plan and estimate showing the points between which and on and through what land the said widening is proposed to be made and the cost of acquiring the land: And whereas on an inspection of the said map and plan and a consideration of the said estimate His Excellency the Governor in Council is satisfied that there are funds legally available for acquiring the land: Now therefore be it known by this present Order that His Excellency the Governor of the State of Victoria with the advice of the Executive Council thereof doth hereby approve of the said road being widened, that is to say:—

All that piece of land in the Parish of Korumburra, the boundaries of which are as follow:—Commencing at the north-eastern angle of lot 3 on plan of subdivision numbered 50580, lodged in the Office of Titles and being part of allotment 90 of the said parish; thence by lines bearing respectively 207 deg. 32 min. 65 ft. 7½ in., 228 deg. 39 min. 19 ft. 2¼ in., 269 deg. 57 min. 12 feet and 38 deg. 41 min. 90 ft. 9½ in. to the point of commencement—which said piece of land is particularly delineated and shown coloured red on survey plan numbered 10099, lodged in the office of the Country Roads Board.

And the Honorable James Charles Murray Balfour, Her Majesty's Acting Minister of Public Works for the State of Victoria, shall give the necessary directions herein accordingly.

J. COLQUHOUN,
Clerk of the Executive Council.

COUNTRY ROADS BOARD.

At the Executive Council Chamber, Melbourne, the twenty-ninth day of June, 1965.

PRESENT:

His Excellency the Governor of Victoria.
Mr. Hamer | Mr. Darcy.
Mr. Rossiter

DECLARATION OF A DEVIATION FROM WARROWITUE-ROAD IN THE SHIRE OF McIVOR.

WHEREAS by sections 58 and 94 of the *Country Roads Act 1958* (No. 6229) it is amongst other things enacted that when the Country Roads Board under the provisions of the *Country Roads Act* has by Resolution declared a deviation to be a forest road the said Board may also declare that such deviation shall be in lieu of any existing road or part thereof named in such Resolution and that on publication in the *Government Gazette* of the Order confirming such Resolution the existing road or part thereof shall cease to be a forest road or be discontinued as provided in the Resolution: And whereas the said Board has by Resolution declared the deviation on the land described in the First Schedule to such Resolution to be a forest road and has also declared that such deviation shall be in lieu of the part of the existing road being the land described in the Second Schedule to the said Resolution: Now therefore His Excellency the Governor of the State of Victoria by and with the advice of the Executive Council thereof doth hereby confirm the said Resolution.

Resolution for Declaration of a Deviation of a Forest Road under the Country Roads Act.

Whereas the land the site of the road the course of which is below set out was taken by the Board under the provisions of the Country Roads Act 1958 for the purpose of constructing such road deviation which road deviation has now been laid out and formed on the same: And whereas the said Board (being the Country Roads Board incorporated under the said Act) thinks that the road aforesaid is fit to be used as a public highway such Board at a meeting now holden acting under the authority conferred upon it by sections 58 and 94 of the said Act doth by this present Resolution hereby declare the said road deviation the course of which is described in the First Schedule hereto with the commencing and terminating points thereof respectively specified to be part of a forest road within the meaning and for the purposes of the said Act: And the said Board doth also declare that such deviation shall be in lieu of the existing road or part thereof described in the Second Schedule hereto.

FIRST SCHEDULE.
Shire of McIvor.

Warrowitue-road.—All that piece of land in the Parish of Heathcote, being a roadway of varying width, and commencing at its junction with the Northern Highway at the western angle of allotment 18E of the said parish; thence north-easterly to and across McIvor Creek to the northern angle of allotment 19B of the said parish—which said piece of land is more particularly delineated and shown coloured red on survey plan numbered 10123, lodged in the office of the Country Roads Board.

SECOND SCHEDULE.
Shire of McIvor.

Warrowitue-road.—All that piece of land in the Parish of Heathcote, being a roadway of varying width, and commencing at its junction with the Northern Highway at the western angle of allotment 18A of the said parish; thence north-easterly to and across McIvor Creek to the northern angle of allotment 19A of the said parish; thence south-easterly to the eastern angle of the allotment last named—which said piece of land is more particularly delineated and shown coloured blue on survey plan numbered 10123, lodged in the office of the Country Roads Board.

The common seal of the Country Roads Board was hereto affixed at Kew, this twenty-first day of June, One thousand nine hundred and sixty-five, in the presence of—

(SEAL) I. J. O'DONNELL, Chairman.
F. WEST, Member.
N. L. ALLANSON, Secretary.

And the Honorable James Charles Murray Balfour, Her Majesty's Acting Minister of Public Works for the State of Victoria, shall give the necessary directions herein accordingly.

J. COLQUHOUN,
Clerk of the Executive Council.

DEPARTMENT OF CROWN LANDS AND SURVEY.

At the Executive Council Chamber, Melbourne, the twenty-ninth day of June, 1965.

PRESENT:
His Excellency the Governor of Victoria.
Mr. Hamer | Mr. Darcy.
Mr. Rossiter

REVOCATIONS OF TEMPORARY RESERVATIONS OF LAND BY ORDERS IN COUNCIL.

HIS Excellency the Governor of the State of Victoria, by and with the advice of the Executive Council thereof, doth hereby, in pursuance of the provisions of the Land Act 1958, revoke the temporary reservations of land by Orders in Council hereinafter referred to, viz.:—

BALLARAT EAST.—Order in Council of 27th June, 1870, of 18½ perches of land in the Township of Ballarat East as a site for a Place of Public Worship in connexion with the Presbyterian Denomination.—(C.91802.)

CARWARP.—Order in Council of 6th November, 1947, of 15 acres of land in the Parish of Carwarp, as a site for Public Recreation.—(Rs.3288.)

COLVINSBY AND WARRAK.—Order in Council of 7th May, 1877, of 148 acres 2 roods 28 perches of land in the Parishes of Colvinsey and Warrak, as a site for Victorian Water Supply purposes.—(C.99359.)

MOHICAN.—Order in Council of 13th April, 1965, of 148 acres 2 roods, more or less, of land in the Parish of Mohican, as a site for Public purposes (Social Welfare Branch Adventure Camp) so far only as regards the portion thereof comprised within the boundaries published in the Government Gazette of 26th May, 1965, and containing 1 acre 3 roods, more or less.—(Rs.8436.)

SANDHURST.—Order in Council of the 24th September, 1912, of 5 acres 1 rood 9 perches of land in the Parish of Sandhurst as a site for Public Gardens, revoked as to part by Order of the 12th March, 1918, so far only as the portion containing 1 rood 13 perches, more or less, indicated by hachure on plan published in the Government Gazette of the 26th May, 1965.—(Rs.782.)

STUARTMILL.—Order in Council of 29th April, 1921, of 1 acre 2 roods 33 perches of land in the Township of Stuartmill, as a site for State School purposes.—(Rs.2126.)

WERRAP.—Order in Council of 27th January, 1920, of 4 acres 0 roods 0 perches of land in the Parish of Werrap, as a site for State School purposes.—(Rs.2097.)

And the Honorable James Charles Murray Balfour, Her Majesty's Minister of Lands for the State of Victoria, shall give the necessary directions herein accordingly.

J. COLQUHOUN,
Clerk of the Executive Council.

DEPARTMENT OF CROWN LANDS AND SURVEY.

At the Executive Council Chamber, Melbourne, the twenty-ninth day of June, 1965.

PRESENT:
His Excellency the Governor of Victoria.
Mr. Hamer | Mr. Darcy.
Mr. Rossiter

VESTING OF LAND IN THE COUNTRY ROADS BOARD.

HIS Excellency the Governor of the State of Victoria, by and with the advice of the Executive Council thereof, doth by this Order made pursuant to section 22A (2) of the Land Act 1958, vest in the Country Roads Board the land in the Parish of Congongella South, County of Borung as shown by hachure on the plan hereunder.

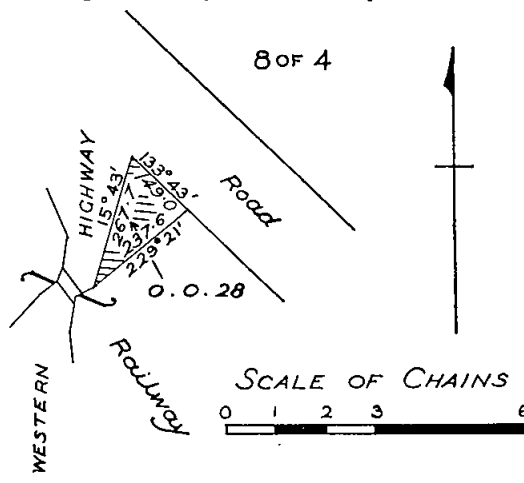

And the Honorable James Charles Murray Balfour, Her Majesty's Minister of Lands for the State of Victoria, shall give the necessary directions herein accordingly.

J. COLQUHOUN,
Clerk of the Executive Council.

DEPARTMENT OF CROWN LANDS AND SURVEY.

At the Executive Council Chamber, Melbourne, the twenty-ninth day of June, 1965.

PRESENT:

His Excellency the Governor of Victoria.
Mr. Hamer | Mr. Darcy.
Mr. Rossiter

UNUSED ROADS CLOSED.

HIS Excellency the Governor of the State of Victoria, by and with the advice of the Executive Council thereof, doth hereby direct that, in pursuance of the provisions of section 349 of the Land Act 1958, the unused roads referred to hereunder be closed, viz:—

Parish of Jeetho, County of Mornington, being the roads indicated by hachure on plan hereunder.—(J.41(?) (Misc.3644.)

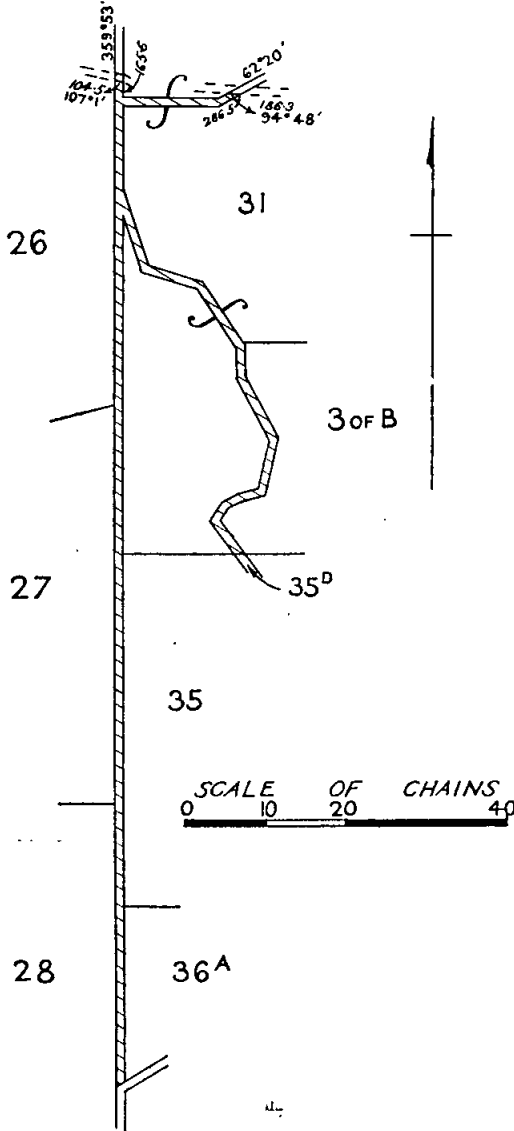

Parish of Trentham, County of Dalhousie, being the portion of the width of the road indicated by hachure on plan hereunder.—(T.171(*) (W.82056.)

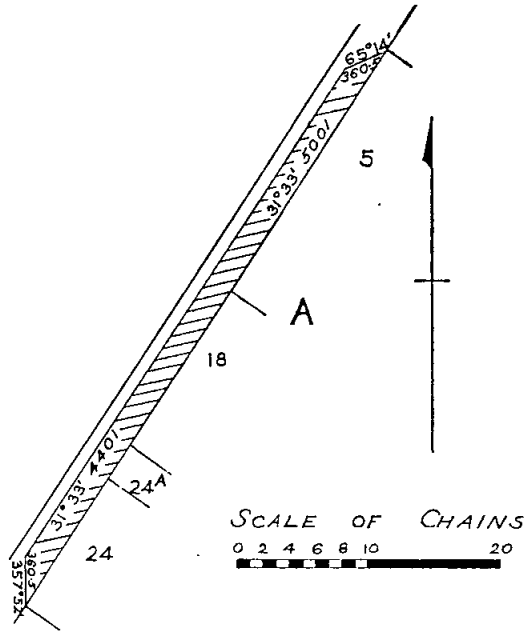

And the Honorable James Charles Murray Balfour, Her Majesty's Minister of Lands for the State of Victoria, shall give the necessary directions herein accordingly.

J. COLQUHOUN,
Clerk of the Executive Council.

DEPARTMENT OF CROWN LANDS AND SURVEY.

At the Executive Council Chamber, Melbourne, the twenty-ninth day of June, 1965.

PRESENT:

His Excellency the Governor of Victoria.
Mr. Hamer | Mr. Darcy.
Mr. Rossiter

THE SETTING APART OF LAND BY ORDER IN COUNCIL REVOKED.

HIS Excellency the Governor of the State of Victoria, by and with the advice of the Executive Council thereof, doth hereby, in pursuance of the provisions of the Land Act 1958, revoke the setting apart of the land mentioned hereunder:—

MOORPANYAL.—The setting apart, by Order in Council of the 6th September, 1858, of 1 acre 2 roods 15 perches of land in the Parish of Moorpanyal as a site for a Quarry.—(M.199(*) (C.83268.)

And the Honorable James Charles Murray Balfour, Her Majesty's Minister of Lands for the State of Victoria, shall give the necessary directions herein accordingly.

J. COLQUHOUN,
Clerk of the Executive Council.

DEPARTMENT OF CROWN LANDS AND SURVEY.

At the Executive Council Chamber, Melbourne, the twenty-ninth day of June, 1965.

PRESENT:

His Excellency the Governor of Victoria.
Mr. Hamer | Mr. Darcy.
Mr. Rossiter

LANDS PERMANENTLY RESERVED AS SITES.

HIS Excellency the Governor of the State of Victoria, by and with the advice of the Executive Council thereof, doth hereby, in pursuance of the provisions of the

Land Act 1958, permanently reserve as sites the lands hereinafter described:—

ELTHAM.—As a site for Public Recreation, 57 acres 3 roods 32 perches of land in the Township of Eltham, being the site temporarily reserved therefor by Order in Council of the 28th May, 1913, and known as the Eltham Park Reserve.—(Rs.932.)

HAWKESDALE.—As a site for a Racecourse and Public Recreation, 146 acres 0 roods 21 perches of land in the Township of Hawkesdale being the site temporarily reserved therefor by Orders in Council of the 20th December, 1887, and the 26th February, 1957, and known as the Hawkesdale Racecourse and Recreation Reserve.—(Rs.1634.)

And the Honorable James Charles Murray Balfour, Her Majesty's Minister of Lands for the State of Victoria, shall give the necessary directions herein accordingly.

J. COLQUHOUN,
Clerk of the Executive Council.

DEPARTMENT OF CROWN LANDS AND SURVEY.

At the Executive Council Chamber, Melbourne, the twenty-ninth day of June, 1965.

PRESENT:

His Excellency the Governor of Victoria.
Mr. Hamer | Mr. Darcy.
Mr. Rossiter

REVOCATION OF TEMPORARY RESERVATION AND THE WITHHOLDING FROM SALE, LEASING AND LICENSING, OF LAND BY ORDER IN COUNCIL.

HIS Excellency the Governor of the State of Victoria, by and with the advice of the Executive Council thereof, doth hereby, in pursuance of the provisions of the Land Act 1958, revoke the temporary reservation and the withholding from sale, leasing and licensing of land by Order in Council hereinafter referred to, viz.:—

GLENROWEN.—Order in Council of 18th December, 1883, of 1 rood 24 perches of land in the Township of Glenrowen, as a site for Mechanics' Institute.—(Rs.7044.)

And the Honorable James Charles Murray Balfour, Her Majesty's Minister of Lands for the State of Victoria, shall give the necessary directions herein accordingly.

J. COLQUHOUN,
Clerk of the Executive Council.

VICTORIA INSTITUTE OF COLLEGES ACT 1965.

At the Executive Council Chamber, Melbourne, the twenty-ninth day of June, 1965.

PRESENT:

His Excellency the Governor of Victoria.
Mr. Hamer | Mr. Darcy.
Mr. Rossiter

APPOINTMENT OF INTERIM COUNCIL.

WHEREAS by sections 42 and 43 of the Victoria Institute of Colleges Act 1965 (No. 7291) it is provided *inter alia* that until the appointed day for the constitution of the Council of the Institute the affairs concerns and property of the Institute shall be governed and administered by an Interim Council appointed by His Excellency the Governor in Council by Order published in the Government Gazette:

Now therefore His Excellency the Governor of the State of Victoria by and with the advice of the Executive Council thereof doth by this Order appoint the following person to be a member of the said Interim Council for a period not more than one year after the commencement of this Act:

EDNA LILY GORDON.

And the Honorable John Stoughton Bloomfield, Her Majesty's Minister of Education for the State of Victoria, shall give the necessary directions herein accordingly.

J. COLQUHOUN,
Clerk of the Executive Council.

HOUSING ACT 1958.

At the Executive Council Chamber, Melbourne, the twenty-ninth day of June, 1965.

PRESENT:

His Excellency the Governor of Victoria.
Mr. Hamer | Mr. Darcy.
Mr. Rossiter

DECLARATION OF PRIVATE STREETS AS PUBLIC HIGHWAYS WITHIN THE CITIES OF GEELONG AND GEELONG WEST.

WHEREAS pursuant to section 107 of the Housing Act 1958 it is among other things enacted that where works have been carried out in accordance with an agreement for the full construction of any roads, pavements, culverts or drains made pursuant to the provisions of the said section 107 such roads, pavements, culverts or drains shall be under the care and management of the Municipality which shall be liable for the cost of any maintenance, repair, alteration or re-construction thereof and the Governor in Council may by order published in the Government Gazette declare any road so constructed to be a public highway.

And whereas by Orders dated the twenty-eighth day of January, 1964, the Governor in Council consented to agreements between the Housing Commission and the Cities of Geelong and Geelong West regarding street and drainage construction in Coxon-parade and Cooma-court, situated in the municipality of the Cities of Geelong and Geelong West and the carrying out of the works enumerated in the said agreements.

And whereas the works of road pavements, culvert and drainage construction have now been carried out in accordance with the said agreements, between the Housing Commission and the Cities of Geelong and Geelong West.

Now therefore His Excellency the Governor of the State of Victoria by and with the advice of the Executive Council of the said State and in pursuance of the powers conferred by section 107 of the Housing Act and upon recommendation of the Housing Commission, doth by this order declare the streets more particularly delineated and shown hachured on the plan hereunder to be absolutely dedicated to the public as Public Highways within the meaning of any law now or hereafter in force, and that the Council of the Municipality in which the streets are situate shall hereafter be liable for all cost of any maintenance, repair, alteration or re-construction thereof.

PART OF CROWN ALLOTMENTS 72 & 73F
PARISH OF MOORPANYAL

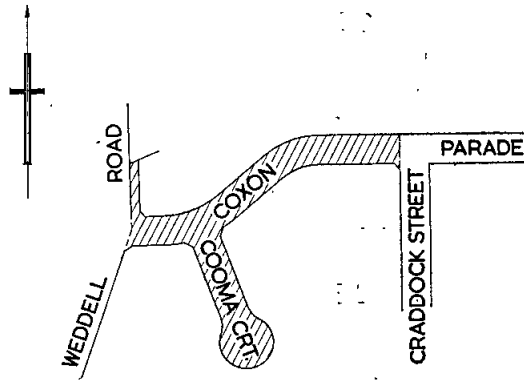

And the Honorable Lindsay Hamilton Simpson Thompson, Her Majesty's Minister of Housing for the State of Victoria, shall give the necessary directions herein accordingly.

J. COLQUHOUN,
Clerk of the Executive Council.

LOCAL GOVERNMENT DEPARTMENT.

At the Executive Council Chamber, Melbourne, the twenty-ninth day of June, 1965.

PRESENT:

His Excellency the Governor of Victoria.
Mr. Hamer | Mr. Darcy.
Mr. Rossiter

ROAD DISCONTINUED—CITY OF DANDENONG.

WHEREAS it is provided in section 528 (2) of the Local Government Act, as amended, that where a road (whether or not a public highway but not being a road set out on land of the Crown) or any part thereof is not required for public use the Governor in Council on the request of the Council of the municipality in which such road is situated made not less than one month after publishing in a newspaper generally circulating in the district and posting to the registered proprietor (if any) of the land and any person known to have an interest in the land notice of intention to make such a request may by Order published in the *Government Gazette* direct that such road or part shall be discontinued and thereupon such road or part shall be discontinued accordingly.

And whereas the Council of the City of Dandenong has requested that the Governor in Council direct that portion of Carmen-street, Dandenong, be discontinued and not less than one month previously has published in a newspaper generally circulating in the district and posted to the registered proprietor of the land in the road and to all persons known to have an interest in the said road notice of intention to make such request.

Now therefore His Excellency the Governor of the State of Victoria, by and with the advice of the Executive Council thereof, hereby directs:

- (a) that the portion of the said road, which is shown by hachure and cross-hachure on the plan hereunder, shall be discontinued;
- (b) that notwithstanding such discontinuance the Dandenong Sewerage Authority shall continue to have and possess the same right title power authority or interest in or in relation to the whole of the land shown by cross-hachure on the said plan as it had or possessed prior to such discontinuance with respect to or in connexion with any sewers or drains laid or erected in on or over such land for the purpose of sewerage or drainage;
- (c) that, subject to any such right title power authority or interest, the land in the portion of the said road may be sold by the Council of the City of Dandenong by agreement.

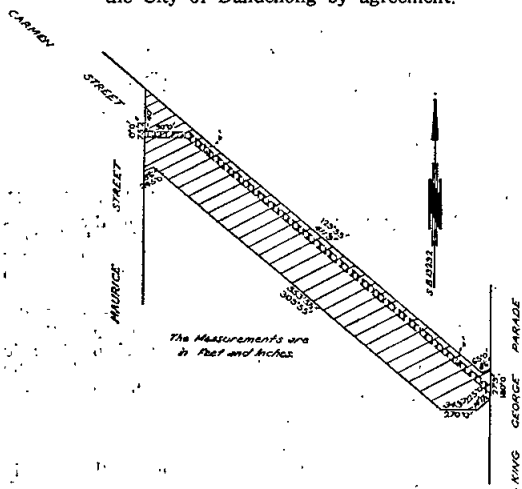

And the Honorable Rupert James Hamer, Her Majesty's Minister for Local Government for the State of Victoria, shall give the necessary directions herein accordingly.

J. COLQUHOUN,
Clerk of the Executive Council.

LOCAL GOVERNMENT DEPARTMENT.

At the Executive Council Chamber, Melbourne, the twenty-ninth day of June, 1965.

PRESENT:

His Excellency the Governor of Victoria.
Mr. Hamer | Mr. Darcy.
Mr. Rossiter

VESTING OF A RESERVE IN THE OAKLEIGH CITY COUNCIL.

WHEREAS it is provided by section 569BA of the *Local Government Act 1958*, as amended, that where any map or plan has been lodged or deposited with the Registrar of Titles pursuant to section 97 of the *Transfer of Land Act 1958* or any corresponding previous enactment (whether before or after the commencement of the *Local Government Act 1963*) and any allotment on that map or plan has been transferred the Governor in Council on the request of the council of the municipality may by Order published in the *Government Gazette* direct that the whole or any part of the land comprised in any reserve shown on that map or plan shall vest in the council whereupon such land shall so vest freed and discharged from any mortgage charge lease or sub-lease:

And whereas the Council of the City of Oakleigh has requested that a reserve shown on a plan of subdivision be vested in the Council and an allotment on that plan has been transferred:

Now therefore, I, the Governor of the State of Victoria, by and with the advice of the Executive Council thereof, do by this Order vest in the Council of the City of Oakleigh certain land being the Garden and Recreation Reserve coloured green on plan of subdivision No. 19037, lodged in the Office of Titles.

And the Honorable Rupert James Hamer, Her Majesty's Minister for Local Government for the State of Victoria, shall give the necessary directions herein accordingly.

J. COLQUHOUN,
Clerk of the Executive Council.

HOSPITALS AND CHARITIES ACT 1958, SECTION 52.

At the Executive Council Chamber, Melbourne, the twenty-ninth day of June, 1965.

PRESENT:

His Excellency the Governor of Victoria.
Mr. Hamer | Mr. Darcy.
Mr. Rossiter

EXTENSION OF THE OBJECTS OR PURPOSES OF PORT FAIRY HOSPITAL.

WHEREAS the Port Fairy Hospital is an incorporated institution within the meaning of the *Hospitals and Charities Act 1958*:

And whereas the Committee of Management of the said institution has agreed that the objects or purposes of the institution should be extended:

And whereas the Hospitals and Charities Commission after enquiry has recommended that the objects or purposes of the institution should be so extended:

Now therefore His Excellency the Governor of the State of Victoria by and with the advice of the Executive Council of the said State hereby extends the objects or purposes of the Port Fairy Hospital so that such objects or purposes shall be as follows:—

- (a) To afford relief, including maintenance and the treatment or cure of, or attention to, any disease or ailment, or any injury consequent on any accident, medical and/or surgical attendance, medicine, nursing assistance, support or aid of any kind or in any form to such persons as are entitled thereto under the Act;
- (b) to provide for the carrying out of investigations into ailments, diseases, injuries or other matters affecting the human body;
- (c) to provide facilities for the treatment of intermediate and private patients or either of them.

And the Honorable John Frederick Rossiter, Her Majesty's Acting Minister of Health for the State of Victoria, shall give the necessary directions herein accordingly.

J. COLQUHOUN,
Clerk of the Executive Council.

DEPARTMENT OF CROWN LANDS AND SURVEY.

At the Executive Council Chamber, Melbourne, the sixth day of July, 1965.

PRESENT:
 His Excellency the Governor of Victoria.
 Mr. Bolte | Mr. Chandler
 Mr. Bloomfield | Mr. Reid
 Mr. Hamer | Mr. Balfour
 Mr. Darcy | Mr. Rossiter.
 Mr. Wilcox

LAND TEMPORARILY RESERVED AS A SITE.

HIS Excellency the Governor of the State of Victoria, by and with the advice of the Executive Council thereof, doth hereby, in pursuance of the provisions of the Land Act 1958, reserve, temporarily, and also except from occupation for mining purposes under any miner's right, the land hereinafter described:—

ST. KILDA.—Site for Public Recreation in addition to and adjoining the site temporarily reserved therefor by Order in Council of the 5th May, 1964, at St. Kilda, Parish of Melbourne South, County of Bourke, as indicated by hachure on plan hereunder.—(M.333(25) (Rs.8333.))

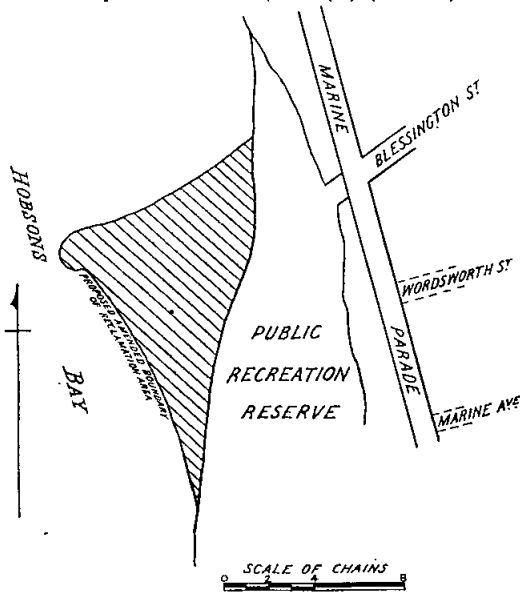

And the Honorable James Charles Murray Balfour, Her Majesty's Minister of Lands for the State of Victoria, shall give the necessary directions herein accordingly.

J. COLQUHOUN,
 Clerk of the Executive Council.

LANDLORD AND TENANT ACT 1958.

At the Executive Council Chamber, Melbourne, the sixth day of July, 1965.

PRESENT:
 His Excellency the Governor of Victoria.
 Mr. Bolte | Mr. Chandler
 Mr. Bloomfield | Mr. Reid
 Mr. Hamer | Mr. Balfour
 Mr. Darcy | Mr. Rossiter.
 Mr. Wilcox

ORDER EXTENDING APPLICATION OF PART V. OF THE LANDLORD AND TENANT ACT 1958 TO CERTAIN PREMISES.

IN pursuance of the powers conferred by section 44 of the Landlord and Tenant Act 1958, His Excellency the Governor of Victoria, by and with the advice of the

Executive Council thereof, doth hereby declare that the application of Part V. of the Landlord and Tenant Act 1958 shall extend to the following premises:—

1. The premises known as Number 4 Tyrone-street, South Yarra.
2. The premises known as Number 3 Garnet-street, Sunshine.
3. The premises known as Number 10 Charlotte-street, Collingwood.
4. The premises known as Number 21 Carlisle-avenue, East St. Kilda, and to all premises forming part of such premises.

And the Honorable Vernon Francis Wilcox, Her Majesty's Acting Attorney-General for the State of Victoria, shall give the necessary directions herein accordingly.

J. COLQUHOUN,
 Clerk of the Executive Council.

STATE SAVINGS BANK ACT 1958, No. 6379.

At the Executive Council Chamber, Melbourne, the sixth day of July, 1965.

PRESENT:
 His Excellency the Governor of Victoria.
 Mr. Bolte | Mr. Chandler
 Mr. Bloomfield | Mr. Reid
 Mr. Hamer | Mr. Balfour
 Mr. Darcy | Mr. Rossiter.
 Mr. Wilcox

IN accordance with the provisions of sub-section (6) of section 8 of the State Savings Bank Act 1958, His Excellency the Governor of the State of Victoria, by and with the advice of the Executive Council thereof, doth by this Order re-appoint—

WILLIAM LIONEL MOSS
 a Commissioner of the State Savings Bank of Victoria for a period of seven years from and inclusive of the eleventh day of July, 1965.

And the Honorable Henry Edward Bolte, Her Majesty's Treasurer for the State of Victoria, shall give the necessary directions herein accordingly.

J. COLQUHOUN,
 Clerk of the Executive Council.

HOUSING ACT 1958.

At the Executive Council Chamber, Melbourne, the sixth day of July, 1965.

PRESENT:
 His Excellency the Governor of Victoria.
 Mr. Bolte | Mr. Chandler
 Mr. Bloomfield | Mr. Reid
 Mr. Hamer | Mr. Balfour
 Mr. Darcy | Mr. Rossiter.
 Mr. Wilcox

CLOSING OF A ROAD.—CITY OF WILLIAMSTOWN.

WHEREAS by virtue and in exercise of the powers contained in the Housing Act 1958 (No. 6275) Housing Commission has recommended to the Governor in Council that the road described in the Schedule hereto be closed.

Now therefore His Excellency the Governor of the State of Victoria in the Commonwealth of Australia by and with the advice of the Executive Council of the said State, doth in pursuance of the powers conferred by the said Act and upon such recommendation, consent and by this Order hereby close such road.

SCHEDULE:

The land delineated and coloured blue on the map in the margin of certificate of title, volume 8458, folio 685.

And the Honorable Lindsay Hamilton Simpson Thompson, Her Majesty's Minister of Housing for the State of Victoria, shall give the necessary directions herein accordingly.

J. COLQUHOUN,
 Clerk of the Executive Council.

Water Act 1958.

STATE RIVERS AND WATER SUPPLY COMMISSION.

At the Executive Council Chamber, Melbourne, the sixth day of July, 1965.

PRESENT:

His Excellency the Governor of Victoria.	
Mr. Bolte	Mr. Chandler
Mr. Bloomfield	Mr. Reid
Mr. Hamer	Mr. Balfour
Mr. Darcy	Mr. Rossiter.
Mr. Wilcox	

GOULBURN-MURRAY IRRIGATION DISTRICT—PORTIONS EXCISED.—RODNEY IRRIGATION AREA—BOUNDARIES VARIED.

UNDER the powers conferred by the *Water Act 1958* and all other powers enabling him in that behalf, His Excellency the Governor of the State of Victoria, with the advice of the Executive Council of the said State, on the recommendation of the State Rivers and Water Supply Commission, doth hereby declare, order, and direct as follows:—

That there shall be excised from the Goulburn-Murray Irrigation District those portions of the same set out and described in the Schedule hereto and that the boundaries of the Rodney Irrigation Area be varied to excise from the said area the aforesaid portions, which portions shall be deemed to be excised from the said irrigation district and irrigation area as from the 30th day of June, 1965.

SCHEDULE.

Portion 1.—The whole of lot 1 on lodged plan of subdivision No. 64543 and the whole of lot 1 on lodged plan of subdivision No. 66149, Parish of Kyabram East, County of Rodney, together with that portion of McCormick-road adjoining the southern boundaries of those lots.

Portion 2.—Commencing at the north-western angle of lot 9 on lodged plan of subdivision No. 62395, Parish of Kyabram East, County of Rodney; thence easterly by the northern boundaries of said lot 9, the land described in certificate of title, volume 6240, folio 973, and a line in continuation thereof to the eastern boundary of Webb-street; thence southerly by that street boundary to a point in line with the northern boundary of Saleyards road; thence westerly by a line and the last-mentioned road boundary to the south-western angle of the land described in certificate of title, volume 8245, folio 643; thence northerly by the western boundaries of that land and of lot 9 on lodged plan of subdivision No. 62395 aforesaid to the point of commencement.

Portion 3.—Commencing at the south-eastern angle of lot 8 on lodged plan of subdivision No. 62458, Parish of Kyabram East, County of Rodney; thence westerly by the southern boundaries of said lot 8 and lots 7, 6, 5, 4, 3, 2 and 1 to the eastern boundary of the land described in certificate of title, volume 8191, folio 931; thence southerly and westerly by the eastern and southern boundaries of that land to the eastern boundary of Webb-street; thence northerly by that street boundary to the northern boundary of Tisdall-road; thence easterly by that road boundary to a point in line with the eastern boundary of lot 8 aforesaid; thence southerly by a line across Tisdall-road and the eastern boundary of lot 8 to the point of commencement.

Portion 4.—The whole of lots 9, 10 and 12 on lodged plan of subdivision No. 62458, Parish of Kyabram East, County of Rodney.

Portion 5.—Commencing at the south-western angle of lot 19 on lodged plan of subdivision No. 58384, Parish of Kyabram East, county of Rodney; thence northerly by the eastern boundary of Julia-street, to a point distant 9 chains southerly from the southern boundary of Allan-street; thence easterly by a line parallel to Allan-street to the eastern boundary of lot 9; thence southerly by the eastern boundaries of said lot 9 and lots 10 to 19 inclusive and westerly by the southern boundary of said lot 19 to the point of commencement.

Portion 6.—Commencing at a point in the western boundary of lot 40 on lodged plan of subdivision No. 67046 distant 9 chains southerly from and at right angles to the southern boundary of Allan-street, Kyabram all in the Parish of Kyabram East, County of Rodney; thence easterly by a line parallel to Allan-street a distance of about 4 chains to the eastern boundary of the Rodney Irrigation Area prior to this Order; thence southerly by

the last-mentioned boundary a distance of 632 links; thence westerly by a line parallel to Fenaughty-street to a point in line with the western boundary of lot 43 on aforesaid lodged plan of subdivision No. 67046; thence northerly by a line and the western boundaries of said lot 43 and lots 42, 41 and 40 to the point of commencement.

The lands set out and described in the foregoing Schedule are shown on a plan approved by the Governor in Council, and deposited in the office of the State Rivers and Water Supply Commission, Melbourne.—(Corres. Nos. 59/6172, 63/4185, 64/323, 64/379, 64/3978, 62/4570.)

And the Honorable Thomas Anthony Darcy, Her Majesty's Minister of Water Supply for the State of Victoria, shall give the necessary directions herein accordingly.

J. COLQUHOUN,
Clerk of the Executive Council.

Water Act 1958.

STATE RIVERS AND WATER SUPPLY COMMISSION.

At the Executive Council Chamber, Melbourne, the sixth day of July, 1965.

PRESENT:

His Excellency the Governor of Victoria.	
Mr. Bolte	Mr. Chandler
Mr. Bloomfield	Mr. Reid
Mr. Hamer	Mr. Balfour
Mr. Darcy	Mr. Rossiter.
Mr. Wilcox	

CRANBOURNE URBAN DISTRICT—AREA OF DISTRICT INCREASED.

UNDER the powers conferred by the *Water Act 1958* and all other powers enabling him in that behalf, His Excellency the Governor of the State of Victoria, with the advice of the Executive Council of the said State, on the recommendation of the State Rivers and Water Supply Commission, doth hereby declare, order, and direct as follows:—

That the area of the Cranbourne Urban District be increased by adding thereto the lands set out and described in the Schedule hereto and as on and from the 15th day of July, 1965, the area of such District shall be deemed to be so increased.

SCHEDULE.

Commencing at the south-western angle of lot 1 on lodged plan of subdivision No. 41870, Parish of Cranbourne, County of Mornington; thence northerly by the western boundaries of said lot 1 and lots 3 to 16 inclusive and by a line in continuation thereof across the South Gippsland Railway Reserve to the north-eastern boundary of that reserve; thence north-westerly by that railway reserve to a point in line with the northern boundary of lot 179 on lodged plan of subdivision No. 43290; thence easterly by a line and the northern boundaries of said lot 179 and lots 177, 176, 175, 174, 173, 172, 171 and 170 to the north-eastern angle of the last-mentioned lot; thence northerly by the western boundary of lot 169 and easterly by the northern boundaries of said lot 169 and lots 53, 52, 51, 48, 47, 46, 45, 44, 43, 42, 41, 40 and 39 and a line connecting those boundaries to the south-western boundary of Averno-street; thence north-westerly and north-easterly by the south-western and north-western boundaries of Averno-street and a line in continuation of the last mentioned boundary to the north-eastern boundary of the Dandenong to Cranbourne road; thence south-easterly by that road boundary to the northern boundary of Camms-road; thence westerly by the last mentioned road boundary to the point of commencement.

The lands set out and described in the foregoing Schedule are shown on a plan approved by the Governor in Council, and deposited in the office of the State Rivers and Water Supply Commission, Melbourne.—(Corres. 60/3810.)

And the Honorable Thomas Anthony Darcy, Her Majesty's Minister of Water Supply for the State of Victoria, shall give the necessary directions herein accordingly.

J. COLQUHOUN,
Clerk of the Executive Council.

Water Act 1958.

STATE RIVERS AND WATER SUPPLY COMMISSION.

At the Executive Council Chamber, Melbourne, the sixth day of July, 1965.

PRESENT:

His Excellency the Governor of Victoria.	
Mr. Bolte	Mr. Chandler
Mr. Bloomfield	Mr. Reid
Mr. Hamer	Mr. Balfour
Mr. Darcy	Mr. Rossiter.
Mr. Wilcox	

GOULBURN—MURRAY IRRIGATION DISTRICT—DISTRICT EXTENDED.—CAMPASPE IRRIGATION AREA—BOUNDARIES VARIED.

UNDER the powers conferred by the *Water Act 1958* and all other powers enabling him in that behalf, His Excellency the Governor of the State of Victoria, with the advice of the Executive Council of the said State on the recommendation of the State Rivers and Water Supply Commission, doth hereby declare, order, and direct as follows:—

That the Goulburn—Murray Irrigation District be extended and the boundaries of the Campaspe Irrigation Area be varied by adding to the said district and area the lands set out and described in the schedule hereto, and as on and from the 15th day of July, 1965, such district shall be deemed to be so extended and the boundaries of such area shall be so varied.

SCHEDULE.

The whole of allotments 39A, 40A, and 41A, Parish of Ellesmere, County of Bendigo.

The lands set out and described in the foregoing Schedule are shown on a plan approved by the Governor in Council, and deposited in the office of the State Rivers and Water Supply Commission, Melbourne.—(Corres. No. 60/3816.)

And the Honorable Thomas Anthony Darcy, Her Majesty's Minister of Water Supply for the State of Victoria, shall give the necessary directions herein accordingly.

J. COLQUHOUN,
Clerk of the Executive Council.

WATER ACT 1958.

At the Executive Council Chamber, Melbourne, the sixth day of July, 1965.

PRESENT:

His Excellency the Governor of Victoria.	
Mr. Bolte	Mr. Chandler
Mr. Bloomfield	Mr. Reid
Mr. Hamer	Mr. Balfour
Mr. Darcy	Mr. Rossiter.
Mr. Wilcox	

KYABRAM WATER SUPPLY DISTRICT—LOCAL GOVERNING BODY, KYABRAM BOROUGH COUNCIL.—AREA OF DISTRICT INCREASED.

UNDER the powers conferred by the *Water Act 1958* and all other powers enabling him in that behalf, His Excellency the Governor of the State of Victoria, with the advice of the Executive Council of the said State, doth hereby declare, order and direct as follows:—

That the area of the Kyabram Water Supply District, under the control of the Kyabram Borough Council, as a local governing body, be increased by adding thereto the lands set out and described in the Schedule hereto, and as on and from the 15th day of July, 1965, the area of such District shall be deemed to be so increased.

SCHEDULE.

1. The whole of lot 1 on lodged plan of subdivision No. 64543 and the whole of lot 1 on lodged plan of subdivision No. 66149, Parish of Kyabram East, County of Rodney, together with that portion of McCormick-road adjoining the southern boundaries of those lots.

2. Commencing at the north-western angle of lot 9 on lodged plan of subdivision No. 62395, Parish of Kyabram East, County of Rodney; thence easterly by the northern boundaries of said lot 9, the land described in certificate

of title, volume 6240, folio 973, and a line in continuation thereof to the eastern boundary of Webb-street; thence southerly by that street boundary to a point in line with the northern boundary of Saleyards-road; thence westerly by a line and the last-mentioned road boundary to the south-western angle of the land described in certificate of title, volume 8245, folio 643; thence northerly by the western boundaries of that land and of lot 9 on lodged plan of subdivision No. 62395 aforesaid to the point of commencement.

3. Commencing at the south-eastern angle of lot 8 on lodged plan of subdivision No. 62458, Parish of Kyabram East, County of Rodney; thence westerly by the southern boundaries of said lot 8 and lots 7, 6, 5, 4, 3, 2 and 1 to the eastern boundary of the land described in certificate of title, volume 8191, folio 931; thence southerly and westerly by the eastern and southern boundaries of that land to the eastern boundary of Webb-street; thence northerly by that street boundary to the northern boundary of Tisdall-road; thence easterly by that road boundary to a point in line with the eastern boundary of lot 8 aforesaid; thence southerly by a line across Tisdall-road and the eastern boundary of lot 8 to the point of commencement.

4. The whole of lots 9, 10 and 12 on lodged plan of subdivision No. 62458, Parish of Kyabram East, County of Rodney.

5. Commencing at the south-western angle of lot 19 on lodged plan of subdivision No. 58384, Parish of Kyabram East, County of Rodney; thence northerly by the eastern boundary of Julia-street to a point distant 9 chains southerly from the southern boundary of Allan-street; thence easterly by a line parallel to Allan-street to the eastern boundary of lot 9; thence southerly by the eastern boundaries of said lot 9 and lots 10 to 19 inclusive and westerly by the southern boundary of said lot 19 to the point of commencement.

6. Commencing at a point in the western boundary of lot 40 on lodged plan of subdivision No. 67046 distant 9 chains southerly from and at right angles to the southern boundary of Allan-street, Kyabram, all in the Parish of Kyabram East, County of Rodney; thence easterly by a line parallel to Allan-street a distance of about 4 chains to the western boundary of the Kyabram Water Supply District prior to this Order; thence southerly by the last-mentioned boundary a distance of 632 links; thence westerly by a line parallel to Fenaughty-street to a point in line with the western boundary of lot 43 on aforesaid lodged plan of subdivision No. 67046; thence northerly by a line and the western boundaries of said lot 43 and lots 42, 41 and 40 to the point of commencement.

The lands set out and described in the foregoing Schedule are shown on a plan approved by the Governor in Council, and deposited in the Office of the State Rivers and Water Supply Commission, Melbourne.—(Corr. Nos. 59/6172, 63/4185, 64/323, 64/379, 64/3978, 62/4570.)

And the Honorable Thomas Anthony Darcy, Her Majesty's Minister of Water Supply for the State of Victoria, shall give the necessary directions herein accordingly.

J. COLQUHOUN,
Clerk of the Executive Council.

WARRAGUL WATERWORKS TRUST.

At the Executive Council Chamber, Melbourne, the sixth day of July, 1965.

PRESENT:

His Excellency the Governor of Victoria.	
Mr. Bolte	Mr. Chandler
Mr. Bloomfield	Mr. Reid
Mr. Hamer	Mr. Balfour
Mr. Darcy	Mr. Rossiter.
Mr. Wilcox	

EXTENT OF WATERWORKS DISTRICT DIMINISHED.

UNDER the powers conferred by the *Water Acts* and all other powers enabling him in that behalf, His Excellency the Governor of the State of Victoria, by and with the advice of the Executive Council of the said State, doth hereby declare, order and direct as follows:—

That the extent of the Waterworks District of the Warragul Waterworks Trust be diminished by excising therefrom the land within the boundaries described in the Schedule hereto and as on and from the 1st August, 1965, the extent of such District shall be deemed to be diminished accordingly.

SCHEDULE.

Commencing at a point on the southern boundary of Crown allotment 77, Parish of Drouin East, County of Buln Buln being distant 4,136 1/10th links westerly from its eastern boundary; thence northerly by a line bearing north 9 deg. 21 min. east to a point on a line parallel to and distant 7 chains northerly from the said southern boundary of Crown allotment 77 being also a point on the Waterworks District Boundary; thence westerly along the said line parallel to and distant 7 chains northerly from the said southern boundary of Crown allotment 77 to a point in line with the eastern boundary of section X, Township of Warragul; thence southerly by a line through the said Crown allotment 77 being also along the Waterworks District boundary to a point on the said southern boundary of Crown allotment 77 being also the continuation of the said eastern boundary of section X; thence easterly along the southern boundary of the said Crown allotment 77 to the point of commencement.

All of which boundaries are shown on a plan approved by the Governor in Council and deposited in the office of the State Rivers and Water Supply Commission, Melbourne.—(Corr. 63/118/167.)

And the Honorable Thomas Anthony Darcy, Her Majesty's Minister of Water Supply for the State of Victoria, shall give the necessary directions herein accordingly.

J. COLQUHOUN,
Clerk of the Executive Council.

BOROUGH ECHUCA WATER TRUST.

At the Executive Council Chamber, Melbourne, the sixth day of July, 1965.

PRESENT:

His Excellency the Governor of Victoria.	
Mr. Bolte	Mr. Chandler
Mr. Bloomfield	Mr. Reid
Mr. Hamer	Mr. Balfour
Mr. Darcy	Mr. Rossiter.
Mr. Wilcox	

AMENDMENT OF ORDER.

UNDER the powers conferred by the Water Act and all other powers enabling him in that behalf, His Excellency the Governor of the State of Victoria, by and with the advice of the Executive Council of the said State, doth hereby declare, order and direct that the corporate name of the Borough Echuca Water Trust shall be altered to the Echuca Waterworks Trust, such alteration to take effect as on and from the first day of October, 1965.

And the Honorable Thomas Anthony Darcy, Her Majesty's Minister of Water Supply for the State of Victoria, shall give the necessary directions herein accordingly.

J. COLQUHOUN,
Clerk of the Executive Council.

BOROUGH ECHUCA WATER TRUST.

At the Executive Council Chamber, Melbourne, the sixth day of July, 1965.

PRESENT:

His Excellency the Governor of Victoria.	
Mr. Bolte	Mr. Chandler
Mr. Bloomfield	Mr. Reid
Mr. Hamer	Mr. Balfour
Mr. Darcy	Mr. Rossiter.
Mr. Wilcox	

UNDER the powers conferred by the Water Act and all other powers enabling him in that behalf, His Excellency the Governor of the State of Victoria, by and with the advice of the Executive Council of the said State, doth hereby consent to the Borough Echuca Water Trust damasking its common seal and adopting and using a new common seal in lieu thereof as on and from the first day of October, 1965.

And the Honorable Thomas Anthony Darcy, Her Majesty's Minister of Water Supply for the State of Victoria, shall give the necessary directions herein accordingly.

J. COLQUHOUN,
Clerk of the Executive Council.

CHILDREN'S WELFARE ACT 1958.

At the Executive Council Chamber, Melbourne, the sixth day of July, 1965.

PRESENT:

His Excellency the Governor of Victoria.	
Mr. Bolte	Mr. Chandler
Mr. Bloomfield	Mr. Reid
Mr. Hamer	Mr. Balfour
Mr. Darcy	Mr. Rossiter.
Mr. Wilcox	

IN pursuance of the powers contained in the Children's Welfare Act 1958 and all other powers him thereunto enabling, His Excellency the Governor of the State of Victoria, in the Commonwealth of Australia, by and with the advice of the Executive Council of the said State, doth by this Order for the purposes of the said Act, establish as a children's home for the care and welfare of children or young persons admitted to the care of the Social Welfare Branch of the Chief Secretary's Department, the Institution known as "Iloura" Girls' Home, situated at 23 Maleela-avenue, Balwyn.

And the Honorable Vernon Francis Wilcox, Her Majesty's Acting Chief Secretary for the State of Victoria, shall give the necessary directions herein accordingly.

J. COLQUHOUN,
Clerk of the Executive Council.

APPROACHING LAND SALES.

SALES of Crown lands, in fee-simple, will be held at the under-mentioned places and dates, viz.:—

	No. of Gazette.
Beechworth.—Wednesday, 11th August, 1965	53
Bendigo.—Thursday, 22nd July, 1965	45
Bright.—Thursday, 12th August, 1965	53
Myrtleford.—Thursday, 12th August, 1965	53
Orbost.—Monday, 12th July, 1965	41
Wodonga.—Wednesday, 11th August, 1965	53

SALES OF CROWN LAND BY AUCTION.

The land will be offered for sale in fee-simple, and subject to the provisions of the Land Act and Regulations thereunder.

The upset price is the sum at which bidding will start, and no bid below that sum can be accepted. The highest bidder at or above that sum shall be the purchaser, subject to signature of contract and any necessary payment.

TERMS:

A deposit of at least 12½% of the purchase price must be paid at the sale, either in cash or by cheque.

The residue is payable in half-yearly instalments, in accordance with the following scale, or may be paid off at any earlier time.

£20 and under, 6 instalments.
Over £20, and not exceeding £50, 8 instalments.
Over £50, and not exceeding £100, 10 instalments.
Over £100, and not exceeding £200, 12 instalments.
Over £200, and not exceeding £300, 14 instalments.
Over £300, and not exceeding £400, 16 instalments.
Over £400, and not exceeding £500, 18 instalments.
Over £500, 20 instalments.

Interest at the rate of 5% per annum is payable with all payments of residue, and is computed for each instalment from the date of sale to the date of such payment. Additional interest is charged if any instalment is not paid on or before the due date.

If paid off within 30 days of sale, no interest is payable.

FEES, ETC.:

Also payable at the sale, in addition to the deposit, are the survey fee and, if applicable, the valuation of improvements (if purchaser be not the owner thereof).

Payable with balance of purchase money—

Crown Grant fee—50 acres and under	£1 10s.
Over 50 acres	£2
Purchase money £5 or under	£1

Assurance Fund contribution—One halfpenny for each £1 of purchase price. (This is a fund established to guarantee the validity of freehold titles.)

Transfer of interest prior to completion of payment may be allowed on payment of £1 fee and subject to stamp duty.

If unable to attend personally, a prospective purchaser may arrange for another person to bid as his agent.

Attention is drawn to section 95, *Land Act 1958*, which provides that the purchaser shall be deemed to be the owner for the purposes of other Acts; also to an amendment to the Local Government Act providing for Government roads, in certain circumstances, to be declared "private streets", thus making the purchaser liable to contribute to the cost of street construction.

J. C. M. BALFOUR,
Minister of Lands.

Office of Crown Lands and Survey,
Melbourne, 7th July, 1965.

BEECHWORTH.—Sale (No. 11783) of Crown land, in fee-simple, by auction, will be held at the LAND OFFICE, BEECHWORTH, on WEDNESDAY, the 11th AUGUST, 1965, at TEN o'clock a.m. To be conducted by D. M. O'CONNOR, Land Officer, Beechworth.

Lot 1.

PARISH OF STANLEY, COUNTY OF BOGONG.

About 2 miles south of the Township of Stanley.

Upset price £300 the lot. Survey fee £16 2s. 6d.

Area 41 a. 1r. 34p., allotment 6 of section 12A.—(H.025952.)

Lot 2.

PARISH OF WOORAGEE NORTH, COUNTY OF BOGONG.

About 4 miles south-east of the Chiltern railway station.

Upset price £50 the lot. Survey fee £7 12s. 6d.

Area 4a. 2r. 26p., allotment 2d of section J¹. Subject to drainage easement 1 chain wide.—(H.013319.)

WODONGA.—Sale (No. 11784) of Crown land, in fee-simple, by auction, will be held at the LAND INSPECTOR'S OFFICE, WODONGA, on WEDNESDAY, the 11th AUGUST, 1965, at ONE o'clock p.m. To be conducted by D. M. O'CONNOR, Land Officer, Beechworth.

Lot 1.

TOWNSHIP OF BETHANGA, PARISH OF BERRINGA, COUNTY OF BENAMBRA.

Fronting the northern side of Paton-street about 6 chains west of Broome-street.

Upset price £20 the lot. Survey fee £8.

Area 1a. 1r. 30p., allotment 27 of section M.—(H.025110.)

BRIGHT.—Sale (No. 11785) of Crown land, in fee-simple, by auction, will be held at the COURT HOUSE, BRIGHT, on THURSDAY, the 12th AUGUST, 1965, at 1 o'clock p.m. To be conducted by D. M. O'CONNOR, Land Officer, Beechworth.

TOWNSHIP OF WANDILIGONG, PARISH OF BRIGHT, COUNTY OF DELATTE.

Fronting the east side of a government road about 4 chains north of the State School reserves.

Lot 1.

Upset price £180 the lot. Survey fee £7 17s. 6d.

Area 3a. 0r. 31p., allotment 35B. Valuation of improvements £9 (E. J. Goldsworthy) (Trees). One month allowed for removal of garage and fencing.—(H.011926.)

Lot 2.

In the north-west of the Township about 2 chains east of Morses creek.

Upset price £50 the lot. Survey fee £6.

Area 35 perches, allotment 84A. One month allowed for removal of improvements.—(H.026296.)

MYRTLEFORD.—Sale (No. 11786) of Crown land, in fee-simple, by auction, will be held at the LAND INSPECTOR'S OFFICE, MYRTLEFORD, on THURSDAY, the 12th AUGUST, 1965, at ELEVEN o'clock a.m. To be conducted by D. M. O'CONNOR, Land Officer, Beechworth.

Lot 1.

TOWNSHIP OF MYRTLEFORD, PARISH OF MYRTLEFORD, COUNTY OF BOGONG.

Fronting the north side of Elgin-street about 13 chains east of Albert-street.

Upset price £75 the lot. Survey fee £5 5s.

Area 27 perches, allotment 5B of section 13.—(H.026822.)

PARISH OF BRIGHT, COUNTY OF DELATTE.

Abutting the western side of the reservation to Bakers-creek and about $\frac{1}{2}$ mile south of Bright.

Upset price £75 per lot. Survey fee £6 10s. per lot.

One month allowed for removal of improvements.

Lot 3.

Area 1r. 7p., allotment 17 of section 6.

Lot 4.

Area 1r. 7p., allotment 18 of section 6.—(H.027772.)

Lot 5.

About $\frac{1}{2}$ mile north of the Township of Wandiligong and about 3 chains east of the Country Roads Board main road.

Upset price £50 the lot. Survey fee £5 5s.

Area 34 perches, allotment 33B of section W. One month allowed for removal of improvements.—(H.029935.)

Abutting the eastern side of the reservation to the Morses creek and about 3 miles south of Wandiligong.

Upset price £45 per lot. Survey fee £9 12s. 6d. per lot.

Lot 4.

Area 9a. 3r. 14p., allotment S.13A.

Lot 5.

Area 8a. 2r. 22p., allotment S.13C.—(H.027326.)

PROPOSED PERMANENT RESERVATIONS OF LANDS AS SITES.

IN pursuance of the provisions of the *Land Act 1958*, notice is hereby given that it is the intention of the Governor in Council to permanently reserve as sites the lands hereunder referred to:—

The following Notices were published 1^o on the 23rd June, 1965, pursuant to Orders of the 16th June, 1965.

BRIDGEWATER.—Land proposed to be permanently reserved as a site for Public Recreation, also excepted from occupation for mining purposes under any miner's right, 12 acres 3 roods 28 perches, Township of Bridgewater, Parish of Bridgewater, County of Bendigo, being the sites temporarily reserved therefor by Orders in Council of the 26th March, 1889, 24th February, 1926, and the 15th March, 1949, and known as the Bridgewater Recreation Reserve.—(B.437^(*)) (Rs.1932).

MIRBOO NORTH.—Land proposed to be permanently reserved as a site for Racecourse, Showground and General Recreation purposes, also excepted from occupation for mining purposes under any miner's right, 49 acres 1 rood 27 perches, Township of Mirboo North, Parish of Mirboo, County of Buln Buln, being the site temporarily reserved therefor by Order in Council of the 19th October, 1910, and known as the Mirboo North Recreation Reserve.—(M.517⁽¹²⁾) (Rs.3667).

J. C. M. BALFOUR,
Minister of Lands.

PROPOSED PERMANENT RESERVATIONS OF LANDS AS SITES.

IN pursuance of the provisions of the *Land Act 1958*, notice is hereby given that it is the intention of the Governor in Council to permanently reserve as sites the lands hereunder referred to:—

The following Notices were published 1^o on the 30th June, 1965, pursuant to Orders of the 22nd June, 1965.

MIRBOO NORTH.—Land proposed to be permanently reserved as a site for Tourist Camping purposes, also excepted from occupation for mining purposes under any miner's right, 8 acres 1 rood 10 perches more or less, Township of Mirboo North, Parish of Mirboo, County of Buln Buln, being the remaining portion of the site temporarily reserved therefor by Order in Council of the 22nd November, 1955.—(M.517⁽¹²⁾) (Rs.7399).

MIRBOO NORTH.—Land proposed to be permanently reserved as a site for Public Baths, also excepted from occupation for mining purposes under any miner's right, 15 acres 3 roods 13 perches, more or less, Township of Mirboo North, Parish of Mirboo, County of Buln Buln, being the remaining portion of the site temporarily reserved therefor by Order in Council of the 13th August, 1907, and the whole of the sites temporarily reserved therefor by Orders in Council of the 18th August, 1908, 14th October, 1929, 25th February, 1941, 20th January, 1948, 22nd November, 1955, and the 7th April, 1959, and known as the Mirboo North Public Baths Reserve.—(M.517⁽¹²⁾) (Rs.3430).

J. C. M. BALFOUR,
Minister of Lands.

PROPOSED REVOCATIONS OF TEMPORARY RESERVATIONS OF LANDS BY ORDERS IN COUNCIL.

IN pursuance of the provisions of the *Land Act 1958*, notice is hereby given that it is the intention of the Governor in Council to revoke the temporary reservations of lands by Orders in Council hereunder referred to, viz.:-

The following Notices were published 1^o on the 16th June, 1965, pursuant to Orders of the 9th June, 1965.

DRUMDLEMARA.—The temporary reservation, by Order in Council of the 4th July, 1922, of 2 roods 23 perches of land in the Parish of Drumdlemara as a site for Mechanics' Institute is about to be revoked so far only as the portion containing 11 perches, indicated by hachure on plan hereunder, is concerned.—(D.197^(*)) (Rs.2522.)

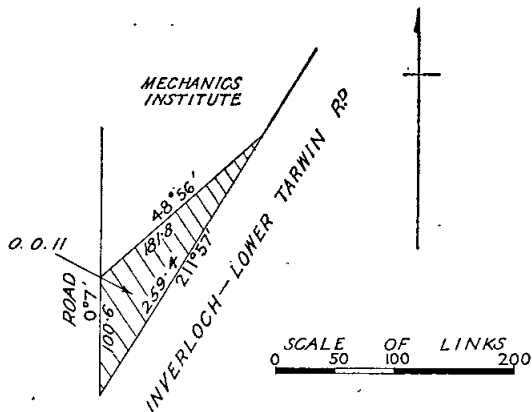

KERANG.—The temporary reservation, by Order in Council of the 8th May, 1951, of 24 acres more or less of land in the Township of Kerang as a site for Public Recreation is about to be revoked so far only as the portion containing 1 acre 1 rood 5 perches, indicated by hachure on plan hereunder, is concerned.—(K.19⁽¹¹⁾) (Rs.6663).

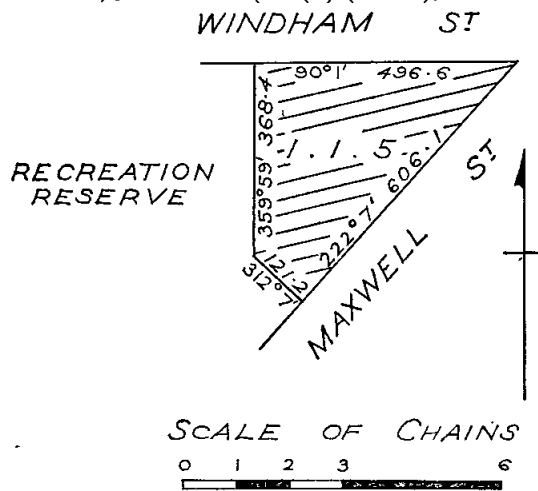

J. C. M. BALFOUR,
Minister of Lands.

PROPOSED REVOCATIONS OF TEMPORARY RESERVATIONS OF LANDS BY ORDERS IN COUNCIL.

IN pursuance of the provisions of the *Land Act 1958*, notice is hereby given that it is the intention of the Governor in Council to revoke the temporary reservations of lands by Orders in Council hereunder referred to, viz.:-

The following Notices were published 1^o on the 30th June, 1965, pursuant to Orders of the 22nd June, 1965.

APSLEY.—The temporary reservation by Order in Council of the 8th December, 1873, of 1 acre of land in the Township of Apsley, as a site for State School purposes.—(A.32^(*)) (Rs.6753.)

BOROONDARA (KEW).—The temporary reservation, by Order in Council of the 2nd January, 1945, of 8 acres 0 roods 15 perches of land in the Parish of Boroondara, as a site for Public purposes.—(B.415^(*)) (Rs.5538.)

HOMERTON (HEYWOOD).—The temporary reservation by Order in Council of the 17th November, 1873, of 99 acres 3 roods 37 perches of land in the Parish of Homerton, as a site for Racecourse and General Recreation purposes, and the temporary reservation by Order in Council of the 18th October, 1886, of 49 acres 0 roods 5 perches of land as an extension thereto, are about to be revoked.—(H.109^(*)) (Rs.383.)

WAIL.—The temporary reservation by Order in Council of the 9th July, 1912 (see *Government Gazette* of the 17th July, 1912, page 2870) of 5 acres 1 rood 38 perches of land in the Parish of Wail as a site for Water Supply purposes is about to be revoked, so far only as the portion containing 3 acres 1 rood 32 perches, indicated by hachure on plan hereunder is concerned.—(W.306^(*)) (M.40949.)

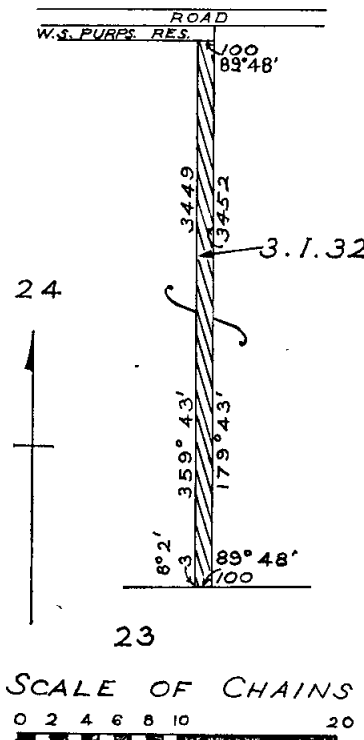

J. C. M. BALFOUR,
Minister of Lands.

PROPOSED REVOCATIONS OF TEMPORARY RESERVATIONS OF LANDS BY ORDERS IN COUNCIL.

IN pursuance of the provisions of the *Land Act 1958*, notice is hereby given that it is the intention of the Governor in Council to revoke the temporary reservations of lands by Orders in Council hereunder referred to, viz.:-

The following Notices were published 1^o on the 7th July, 1965, pursuant to Orders of the 29th June, 1965.

HORSHAM.—The temporary reservation, by Order in Council of the 4th May, 1886, of 8 acres 0 roods 28 perches of land in the Township of Horsham as a site for Municipal purposes, revoked as to part by Order of the 30th March, 1931, is about to be revoked so far as the balance thereof containing 6 acres 3 roods 11½ perches, is concerned.—(H.91^(*)) (Rs.4204.)

MANSFIELD.—The temporary reservation, by Order in Council of the 24th July, 1917, of 1 acre 1 rood 3 perches, more or less, of land in the Township of Mansfield as a site for Swimming purposes.—(M.35^(*)) (Rs.1647.)

MOORPANYAL.—The temporary reservation, by Order in Council of the 30th June, 1866 (see *Government Gazette* of the 10th August, 1866, page 1721) of 2 acres of land in the Parish of Moorpanyal as a site for the purpose of Affording a Supply of Stone for Road Metal.—(M.199^(*)) (C.83268.)

PARWAN.—The temporary reservation, by Order in Council of the 12th August, 1901, of 2 acres of land in the Parish of Parwan as a site for a State School.—(P.8⁽³⁾) (O.1681/130).

PROOINGA.—The temporary reservation, by Order in Council of the 27th March, 1917, of 4 acres 2 roods 24 perches of land in the Parish of Prooinga as a site for a State School is about to be revoked so far only as the portion containing 30 perches, indicated by hachure on plan hereunder, is concerned.—(P.179⁽³⁾) (Rs.1442).

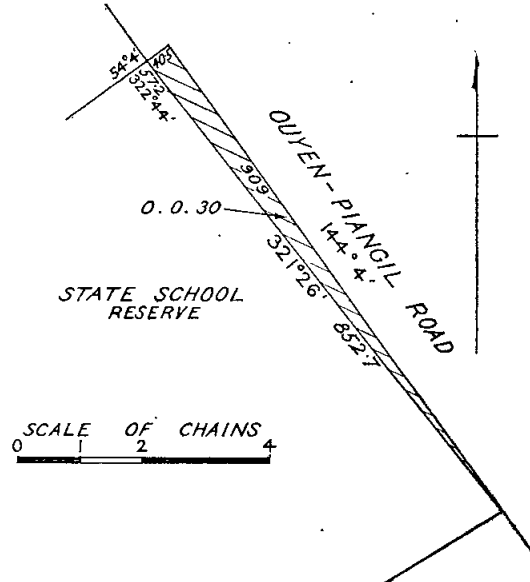

J. C. M. BALFOUR,
Minister of Lands.

LEONGATHA.—The temporary reservation, by Order in Council of the 10th March, 1903, of 2 acres 2 roods of land in the Parish of Leongatha, as a site for Watering purposes, is about to be revoked, so far only as the portion containing 13 perches, indicated by hachure on plan hereunder, is concerned.—(L.167⁽⁸⁾) (Rs.8174).

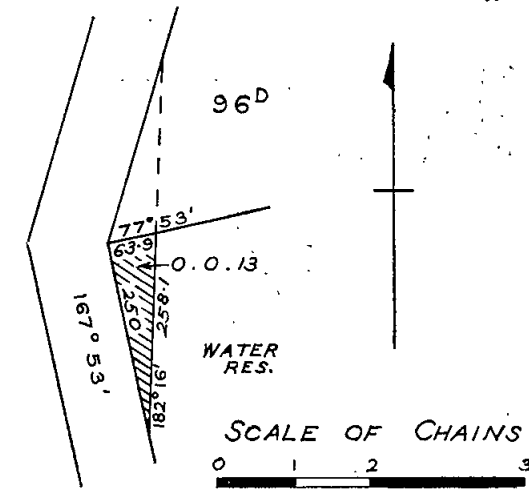

NATIMUK.—The temporary reservation, by Order in Council of the 16th April, 1889, of 1 rood 6 5/10 perches of land in the Township of Natimuk (formerly Parish of Natimuk), as a site for a Post and Telegraph Office.—(N.117⁽⁹⁾) (C.99635).

STAWELL.—The temporary reservation, by Order in Council of the 20th April, 1874, of 5 acres of land in the Parish of Stawell, as a site for a Manure Depot.—(S.329⁽¹⁰⁾) (C.86065).

STAWELL.—The temporary reservation, by Order in Council of the 31st July, 1899, of 32 acres 1 rood 31 perches of land in the Parish of Stawell, as a site for a Manure Depot is about to be revoked so far only as the portion containing 8 acres 3 roods more or less, indicated by hachure on plan hereunder, is concerned.—(S.329⁽¹⁰⁾) (C.86065).

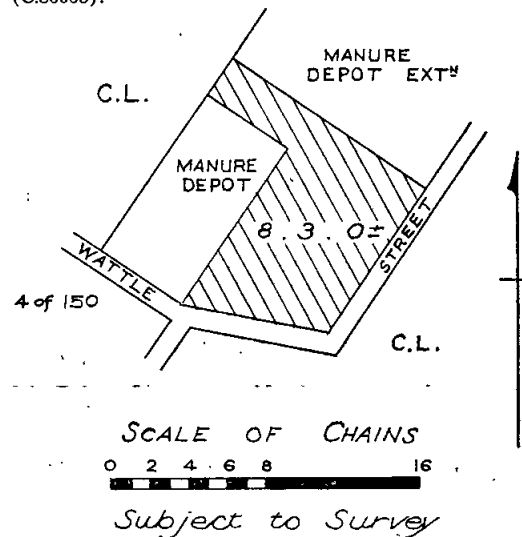

TANJIL.—The temporary reservation, by Order in Council of the 28th April, 1964, of 5 acres 1 rood 8 perches of land in the Parish of Tanjil, as a site for Public Recreation.—(T.189⁽¹⁰⁾) (Rs.8317).

J. C. M. BALFOUR,
Minister of Lands.

PROPOSED REVOCATIONS OF TEMPORARY RESERVATIONS OF LANDS BY ORDERS IN COUNCIL.

IN pursuance of the provisions of the *Land Act 1958*, notice is hereby given that it is the intention of the Governor in Council to revoke the temporary reservations of lands by Orders in Council hereunder referred to, viz.:

The following Notices were published 1^o on the 23rd June, 1965, pursuant to Orders of the 16th June, 1965.

DIMBOOLA.—The temporary reservation, by Order in Council of the 20th May 1890 (see *Government Gazette* of the 23rd May, 1890, page 1944), of 173 acres 3 roods 21 perches of land in the Parish of Dimboola, as a site for the Growth and Preservation of Timber, revoked as to part by Order of the 8th July, 1964, is about to be revoked so far only as the portions containing 55 acres more or less, indicated by hachure on plan hereunder, are concerned.—(D.150⁽¹⁰⁾) (Rs.5962).

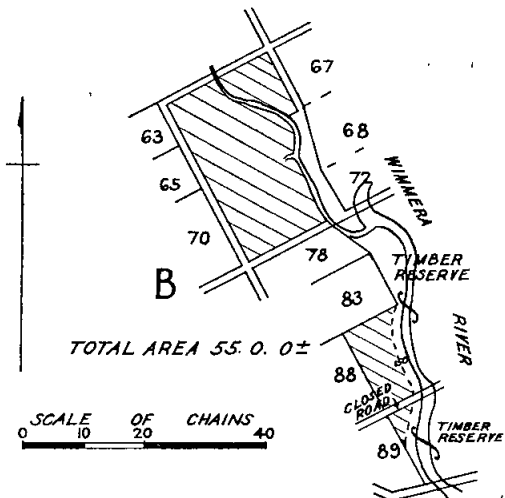

PROPOSED REVOCATION OF TEMPORARY RESERVATION, AND THE WITHHOLDING FROM SALE, LEASING, AND LICENSING OF LAND BY ORDER IN COUNCIL.

IN pursuance of the provisions of the *Land Act 1958*, notice is hereby given that it is the intention of the Governor in Council to revoke the temporary reservation, and the withholding from sale, leasing and licensing of land by Order in Council hereunder referred to, viz.:—

The following Notice was published 1° on the 16th June, 1965, pursuant to Order of the 9th June, 1965.

JIKA JIKA (NORTH MELBOURNE).—The temporary reservation as a site for Ornamental Plantation and the withholding from sale, leasing and licensing by Order in Council of the 17th July, 1882, of 3 roods 11 perches of land in the Parish of Jika Jika (formerly Town of Hotham).—(M.314⁽¹³⁾) (Rs.8379.)

J. C. M. BALFOUR,
Minister of Lands.

PROPOSED PERMANENT RESERVATIONS OF LANDS AS SITES.

IN pursuance of the provisions of the *Land Act 1958*, notice is hereby given that it is the intention of the Governor in Council to permanently reserve as sites the lands hereunder referred to:—

The following Notices were published 1° on the 7th July, 1965, pursuant to Orders of the 29th June, 1965.

BUNYIP (TYNONG).—Land proposed to be permanently reserved as a site for Public Recreation also excepted from occupation for mining purposes under any miner's right, 20 acres 0 roods 35 perches, Parish of Bunyip, County of Mornington, being the site temporarily reserved therefor by Order in Council of the 8th November, 1961, and known as the Tynong Recreation Reserve.—(B.606⁽⁶⁾) (Rs.8074.)

YACKANDANDAH.—Land proposed to be permanently reserved as a site for a Racecourse and other purposes of Public Recreation, also excepted from occupation for mining purposes under any miner's right, 64 acres 3 roods 3¼ perches, Parish of Yackandandah, County of Bogong, being the remaining portion of the site temporarily reserved therefor by Order in Council of the 13th February, 1895, and the whole of the site temporarily reserved therefor by Order in Council of the 18th April, 1905, and known as the Yackandandah Racecourse and Recreation Reserve.—(Y.45⁽¹⁴⁾) (Rs.2746.)

J. C. M. BALFOUR,
Minister of Lands.

LOCAL LAND BOARDS.

IN pursuance of the provisions of section 34 of the *Land Act 1958*, notice is hereby given that public hearings at the following places and times will be conducted by the persons respectively mentioned, being duly appointed in that behalf.

J. C. M. BALFOUR,
Minister of Lands.

Department of Crown Lands and Survey,
Melbourne.

SCHEDULE.

TRARALGON LAND INSPECTOR'S OFFICE, Wednesday, 21st July, 1965, at 9 a.m.—H. J. Macdonald and W. C. Harry.

CAMPERDOWN STATE PUBLIC OFFICE, ASSEMBLY ROOM, Wednesday 4th August, 1965, at 1 p.m., and Thursday, 5th August, 1965, at 9 a.m.—C. G. Knight and W. J. Mackintosh.

REGULATIONS FOR THE CARE, PROTECTION AND MANAGEMENT OF THE CAMPING AND PUBLIC RECREATION RESERVE, PARISH OF CANABORE.

WHEREAS by section 218 of the *Land Act 1958* the Minister of Lands is empowered to make regulations as to any land which under the provisions of that Act or of any other Act relating to Crown lands has been reserved for any public purpose whatsoever and which has not been conveyed to or vested in trustees: And whereas certain Crown lands in the Parish of Canabore and described in a notice published in the *Gazette* of the twenty-eighth day of November, 1962, were temporarily reserved as a site for Camping and Public Recreation: And whereas such lands (hereinafter called "the Reserve") have not been conveyed to or vested in trustees; And whereas it is expedient that regulations for the care, protection and management of the Reserve and for other purposes connected therewith should be made: Now therefore I, James Charles Murray Balfour,

Her Majesty's Minister of Lands in and for the State of Victoria, in pursuance of the powers aforesaid, do hereby make the following Regulations for or with respect to the Reserve:—

The Reserve has been placed under the control of a Committee of Management with power and authority to enforce the following Regulations:—

1. No person shall climb or jump over any fences or gates in or around the Reserve, post bills thereon, or engrave names on the fences, trees, seats or other improvements therein, or otherwise disfigure injure or destroy the said property or remove any soil therefrom.

2. No person shall deposit, or cause to be deposited any waste paper, bottles, cans, or any other litter on any part of the Reserve, except in the receptacles provided for the purpose.

3. No person shall erect any structure on the Reserve other than a tent or booth, and then only as hereinafter provided.

4. No person shall camp or erect any tent in or upon the Reserve, except in such places as shall from time to time be set apart for such purpose, and then only by obtaining a permit to do so upon such terms and conditions and payment of such fees, as the Committee of Management shall determine.

5. No persons shall erect a booth in the Reserve for the purpose of offering for sale any articles, nor shall any person offer for sale in the Reserve any articles without permission in writing and subject to such conditions or payment of such fees fixed by the Committee of Management.

6. No person shall light fires except in places set apart for that purpose by the Committee of Management and no refuse material shall be burned in the Reserve, except by a representative of the Committee of Management and then only in places set apart for that purpose.

7. No person shall break glass of any kind in the Reserve, or leave thereon anything which shall or may injure any person.

8. No person shall discharge any firearm in or upon the Reserve.

9. No person shall put in or on the Reserve any cattle, goats, pigs, horses, or other animals, or any vehicles without the permission of the Committee of Management first obtained.

10. Any stock camped in the Reserve is put there at the owner's risk and any damage to said property and improvements incurred by stock is said owner's responsibility.

11. No person shall bring into the Reserve any dog, unless controlled by a chain or cord, without the permission in writing of the Committee of Management first obtained.

12. Permission of the Committee of Management must be obtained beforehand for the holding of all organized sports, picnics or functions of any kind in the Reserve.—(Rs.8179.)

Given under my hand at Melbourne, on the 29th day of June, 1965.

JIM BALFOUR,
Minister of Lands.

Every person who contravenes or fails to comply with these Regulations shall, in accordance with the provisions of section 218 of the *Land Act 1958*, for each offence be liable to a penalty of not more than Five pounds, and every person who contravenes or fails to comply with any such Regulations, and who, after he has been warned by any bailiff of Crown lands or by any member of the Police Force, does not desist therefrom may be forthwith apprehended by such Bailiff or member of the Police Force and taken before some justice to be dealt with according to law and shall be liable to a penalty of not more than Ten pounds.

REGULATIONS FOR THE CARE, PROTECTION AND MANAGEMENT OF THE "WARRENBAYNE WEST RECREATION RESERVE".

WHEREAS by section 218 of the *Land Act 1958* the Minister of Lands is empowered to make Regulations as to any land which under the provisions of that Act or of any other Act relating to Crown lands has been reserved for any public purpose whatsoever and which has not been conveyed to or vested in trustees: And whereas certain Crown lands in the Parish of Warrenbayne and described in a notice published in the *Gazette* of the second day of October, 1963, were temporarily reserved

as a site for Public Recreation: And whereas such lands (hereinafter called "the Reserve") have not been conveyed to or vested in trustees: And whereas it is expedient that Regulations for the care, protection and management of the Reserve and for other purposes connected therewith should be made: Now therefore I, James Charles Murray Balfour, Her Majesty's Minister of Lands in and for the State of Victoria, in pursuance of the powers aforesaid, do hereby make the following Regulations for or with respect to the Reserve:—

The Reserve has been placed under the control of a Committee of Management with power and authority to enforce the following Regulations.

REGULATIONS.

1. The Reserve shall be opened to the public from sunrise to sunset, free of charge, except on such days, not exceeding 52 in any one year, as the Reserve may be set apart for cricket or football matches, fêtes, sports, or holiday amusements, on any of which occasions a sum not exceeding Five shillings may be charged and taken for admission of every adult to the Reserve.

2. No person shall—

- (a) Enter or remain in the Reserve who may offend against decency as regards dress, language, or conduct, or who may behave in a disorderly, unseemly, or offensive manner, or create or take part in any disturbance.
- (b) Enter or remain in the Reserve whilst in a state of intoxication.
- (c) Bring any intoxicating liquor on to the Reserve without the consent of the Committee first obtained.
- (d) Exercise or train any horse or pony on the Reserve, or any part thereof, without the consent of the Committee first obtained.

3. The Committee shall have power to hold entertainments, shows, or performances on the Reserve, and to make a charge for admission thereto as hereinbefore provided.

4. The Committee shall have power to let any portion of the Reserve to any club, association, person or society for the purpose of holding entertainments, performances, shows, or sports, subject to the payment of such fees and on such terms as it may deem to be reasonable and consistent with these Regulations, and to authorize any club, association, society, or person to make a charge for admission thereto as hereinbefore provided in these Regulations.

5. No persons, except the Committee or its officers or employees on duty shall enter any part of the Reserve, on an occasion when a charge is made for admission thereto without first paying the fees chargeable for such admission.

6. No person shall park a motor car, vehicle or motor cycle in the Reserve except at such places as are set apart for the purpose by the Committee who reserve the right to make a parking charge not exceeding Two shillings for each vehicle.

7. No person shall play or engage in any organized sport, game or competition within the Reserve on Sundays, Good Friday, or Anzac Day without the permission, in writing, of the Committee first obtained.

8. Persons renting or hiring any stand, building, erection, or enclosure on the occasion of any sports, fêtes, or holiday amusements may be required to deposit any sum which the Committee may at any time determine by way of guarantee that due care shall be taken of such stand, building, erection, or enclosure, and such Committee, in its absolute discretion, may make good any damage or injury sustained by such stand, building, erection, or enclosure, or anything contained therein during such occupancy or hiring, and deduct the cost of making good such damage, injury or loss from the sum of money deposited by way of guarantee, and all persons so renting or hiring shall abide by these Regulations, and by any order given by the Committee.

9. No person shall, in the Reserve, interfere with or break or damage any of the trees, plants or shrubs, or pluck any flowers, or climb, jump or get over or under any of the fences, gates, seats, or other structures therein, or roll or throw stones or other missiles, or leave any bottles, broken glass, paper, fruit peel, or any refuse or rubbish whatever therein or post bills or advertisements on any of the fences, gates, seats or other structures therein.

10. No person shall light a fire in the Reserve without the consent of the Committee.

11. No person shall bring into the Reserve any dog, unless controlled by a chain or cord, without permission, in writing, of the Committee first obtained.

12. No person shall put in the Reserve, any cattle, horses, sheep, goats, pigs, or other animals without the permission, in writing, of the Committee first obtained.

13. No person shall camp in the Reserve, nor erect therein any building or any booth for the purpose of offering for sale any article, without permission, in writing, of the Committee first obtained.

14. No person shall enter the Reserve, or pass over the playing area or oval with any vehicle, or on horseback, without the permission of the Committee first obtained, nor drive or ride amongst or to the danger or annoyance of persons assembled on any part of the Reserve.

15. No person shall bet publicly in any part of the Reserve, without permission, in writing, of the Committee first obtained.

16. No person, club or other body shall, without the consent of the Committee first obtained, grade or scrape the ground off or cut any grass growing on any part of the Reserve.

17. No person shall remove any earth, sand, stone, marl, or gravel from the Reserve.—(Rs.8265.)

Given under my hand at Melbourne on the 29th day of June, 1965.

JIM BALFOUR,
Minister of Lands.

Every person who contravenes or fails to comply with these Regulations shall, in accordance with the provisions of section 218 of the *Land Act 1958*, for each offence be liable to a penalty of not more than Five pounds, and every person who contravenes or fails to comply with any such Regulations, and who, after he has been warned by any bailiff of Crown lands or by any member of the Police Force, does not desist therefrom may be forthwith apprehended by such bailiff or member of the Police Force and taken before some justice to be dealt with according to law and shall be liable to a penalty of not more than Ten pounds.

REGULATIONS FOR THE CARE, PROTECTION AND MANAGEMENT OF THE BIRCHIP RECREATION AND SHOWGROUNDS RESERVE.

WHEREAS by section 218 of the *Land Act 1958*, the Minister of Lands is empowered to make Regulations as to any land which under the provisions of that Act or any other Act relating to Crown Lands has been reserved for any public purpose whatsoever and which has not been conveyed to or vested in trustees: Now therefore I, James Charles Murray Balfour, Her Majesty's Minister of Lands in and for the State of Victoria, in pursuance of the powers aforesaid, do hereby make the following Regulations for the reserved Crown land shown hachured red on plan marked B./10.6.65 attached to Lands Department correspondence Rs.1922, and known as the Birchip Recreation and Showgrounds Reserve.

The Reserve has been placed under the control of a Committee of Management with power and authority to enforce the following Regulations:—

REGULATIONS.

1. The Reserve shall be open to the public free of charge from sunrise to sunset, except on such days as the Reserve may be set apart for cricket, football or other matches, shows, sports, fêtes, musical performances, outdoor gatherings or holiday amusements, on any of which occasions an admission fee may be charged; but no person shall be permitted to enter any of the buildings on the Reserve on days on which fees for admission are not being charged without permission, in writing, of the Committee of Management first obtained.

2. No person shall—

- (a) Enter or remain in the Reserve who may offend against decency as regards dress, language or conduct, or who may behave in a disorderly, unseemly or offensive manner or create or take part in any disturbance.
- (b) Enter or remain in the Reserve whilst in a state of intoxication.
- (c) Use indecent or offensive language in the Reserve.
- (d) Offer any articles for sale, or bring any intoxicating liquor on to the Reserve, without in either case the consent, in writing, of the Committee of Management.
- (e) Obstruct, hinder or interfere with any person under authority from the Committee of Management or employed by them at the Reserve.
- (f) Exercise or train any horse or pony on the Reserve or any part thereof without the consent, in writing, of the Committee of Management.

3. The Committee of Management shall have power to hold entertainments, shows or performances in the Reserve, and to make a charge for admission thereto as hereinbefore provided.

4. The Committee of Management shall have power to let any portion of the Reserve to any club, association, person or society for the purpose of holding entertainment, performances, shows or sports, subject to the payment of such fees and on such terms as it may be deemed to be reasonable and consistent with these Regulations, and to authorize any club, association, society or person to make a charge for admission thereto, as provided hereinbefore in these Regulations.

5. No club, association, society or person shall hold any entertainment, performance, show or ceremony in any part of the Reserve without the written authority of the Committee of Management first obtained.

6. No person except the Committee of Management or its officers or employees on duty shall enter any part of the Reserve when a charge is made for admission without first paying the fees chargeable for admission.

7. No person shall park a motor car, vehicle or motor cycle within the Reserve except at such places as are set apart for that purpose by the Committee of Management.

8. No person shall play, practice or engage in any organized games, sports or entertainments of any sort in the Reserve at any time without the permission, in writing, of the Committee of Management first obtained.

9. No person shall bet publicly in any part of the Reserve without permission, in writing, of the Committee of Management first obtained.

10. No person, club or other bodies using the Reserve shall damage any buildings in any part of the Reserve or the fittings thereof, and in the event of such damage occurring during their occupancy thereof such person, club or others shall be responsible for such damage and pay the Committee of Management the cost of making good and repairing same.

11. No person shall in the Reserve interfere with or break or damage any of the trees, plants or shrubs, or pluck any flowers or walk on the beds or borders or climb, jump, get under or over any of the fences, gates, seats or other structures, nor roll or throw stones or other missiles, or leave any bottles, broken glass, paper, orange peel, banana skins or any refuse or rubbish whatever therein or post bills or advertisements on any of the fences, gates, seats or other structures therein.

12. No person shall light a fire in the Reserve except at such places as are set apart for that purpose by the Committee of Management.

13. No person shall put in the Reserve any cattle, horses, sheep, goats, pigs or any other animals without the permission, in writing, of the Committee of Management first obtained. The fees to be charged for any agistment shall be fixed by the Committee of Management.

14. No person shall camp in the Reserve or erect therein any building or any other structure, without the consent, in writing, of the Committee of Management first being obtained.

15. No person shall sell or offer for sale in the Reserve any article without the permission, in writing, of the Committee of Management first had and obtained, and then only subject to such conditions as such Committee may determine.

16. No person, club or other body shall, without the written consent of the Committee of Management first obtained, grade, cut, burn or scrape any part of the Reserve or any grass growing thereon.

17. No person shall practice, play or engage in any sports including tennis, quoits, hockey or any games or footracing except in the portion of the Reserve set apart for that purpose and then only with the permission of the Committee first obtained, and such permission may be granted subject to such terms and conditions as the Committee may determine.

18. No person shall enter the Reserve or pass over the playing area or oval, with any vehicle or on horseback, without the permission of the Committee first obtained, nor ride or drive amongst or to the danger or annoyance of persons assembled on any part of the Reserve.

19. No person shall remove any earth, sand, stones, marble or gravel from the Reserve.

20. The Committee shall accept no responsibility or liability for any injury or accident that may occur at any time within the Reserve.

21. No person shall erect or display any signs, advertising materials or notices within the Reserve without the permission of the Committee of Management, in writing.

22. No person shall on any portion of the Reserve cause or permit any outcry, sound or noise to be emitted from an amplifier, loud speaker, public address system or like instrument without first obtaining the written permission of the Committee and such permission may be granted subject to such terms, conditions and restrictions as may be imposed by the Committee of Management.

CARAVAN PARK REGULATIONS.

23. The Committee of Management may set apart a portion or portions of the Reserve as and for the purposes of a Caravan Park and may make, fix and collect fees or other charges for entering and use of any such area or the buildings thereon.

24. In the area set aside by the Committee as a Caravan Park, the following Regulations shall apply.

25. In these Regulations, unless inconsistent with the context or subject-matter—

“Camping” includes the parking of a vehicle on the camping site.

“Camping site” means an individual site set apart by the Committee for the parking of vehicles and for the erection of tents.

“Caretaker” shall mean the Manager or Deputy Caretaker appointed by the Committee.

“Occupier” includes each and every person in charge of a vehicle parked on a camping site and the person in charge of any tent thereon.

“Refuse” includes food and all discarded matter.

“Sanitary conveniences” includes urinals, water closets, showers, water taps, gully traps, wash troughs, washing machines, wash coppers, wash basins, refuse bins and receptacles provided by the Committee for depositing therein of refuse.

“Vehicle” includes—

(a) motor cars within the meaning of the *Motor Car Act 1958*; and

(b) caravans and trailers.

Parking of Vehicles.

26. The person in charge of a vehicle and who desires to park the same in the Caravan Park, shall park it on a camping site as directed by the Caretaker or, in his absence, on a vacant camping site in the said park and shall pay to the Caretaker the fees prescribed in accordance with these Regulations.

27. No occupier or other person shall park any vehicle and/or erect any tent or annexe so that any part thereof shall extend beyond the limits of the camping site occupied by him.

Time Limit on Camping.

28. No person other than a person desirous of holidaying in the Caravan Park shall bring a caravan therein and then only for a period of not more than three weeks at any one time save that under exceptional circumstances the Committee may extend the period of time upon receipt of a request, in writing, from the person or persons concerned.

Sub-Letting.

29. No person shall sub-let any vehicle within the Caravan Park without the permission, in writing, of the Committee first obtained.

Animals.

30. No animals other than dogs shall be permitted in the Caravan Park and then only if confined to camping sites occupied by their owners or persons in charge of such dogs, or on a leash, or within the enclosure set apart for dogs.

31. If, in the opinion of the Caretaker, any dog is causing annoyance or disturbance to persons within the Caravan Park the owner or person for the time being in charge of such animal shall forthwith remove it from the Caravan Park.

Conduct in the Caravan Park.

32. No occupier shall deposit or cause to be deposited refuse in or on any part of the Caravan Park other than in receptacles provided for that purpose by the Committee.

33. Each occupier shall keep the camping site allocated to him clean and tidy.

34. Waste water shall be placed in or directed into receptacles provided by the Committee and under no circumstances shall waste water be deposited on or allowed to overflow on to the grounds of the Caravan Park. Occupiers shall be responsible for the emptying of such receptacles as directed by the Caretaker and then only into gully traps provided for that purpose.

35. The digging of trenches around vehicles or tents is prohibited.

36. No fires shall be lighted in the Caravan Park, except in such places as may be appointed by the Committee.

37. No person shall erect any building or structure in the Caravan Park other than annexes made of canvas or similar material which shall be deemed to be part of a vehicle and any tent or similar structure approved by the Caretaker.

38. No person shall—

(a) mark, write on or deface or in any way damage any building, post, fence, railing, pillar or any other structure or property within the Caravan Park;

(b) affix any bill, sign or notice board to any tree or structure within the Caravan Park without permission, in writing, of the Committee first obtained.

39. No person shall without permission, in writing, of the Committee first obtained, operate or use any loud-speaker, amplifier or broadcasting equipment (mechanical or electrical) for broadcasting music, speech or other noises or sound within the Caravan Park.

40. No person shall without permission, in writing, of the Committee first obtained and subject to such conditions as the Committee thinks fit within the Caravan Park—

(a) sell or offer for sale any article or commodity whatsoever or distribute any bill or like thing or place any chair, seat or other item for hire;

(b) erect or place therein any building, booth, shed, stand, screen, post, rail, fence, swing or seat or other erection or obstruction of any kind whatsoever, or in any way enclose any part of the Caravan Park;

(c) preach, declaim, harangue or deliver any address of any kind to members of the public;

(d) carry, use or discharge any fireworks, firearms, air gun or other lethal weapons.

41. No person shall spit or expectorate on any path or in any building or erection on the Caravan Park.

42. No person shall remove or displace any board, plate or fitting for the exhibition of any Regulations, neither shall any person remove or displace any notice fixed or set up in the Caravan Park by the Committee.

43. No person shall wilfully obstruct, disturb, interrupt or annoy any officer or employee of the Committee in the proper execution of his work and duty.

44. No person shall wilfully obstruct, disturb or annoy any other person in the proper use of the Caravan Park.

45. No person shall play, practice or engage in any game or sport within the Caravan Park without the consent of the Committee.

46. No male over the age of six years shall enter or use any place, room, convenience or building set apart for the use of females, and no females shall enter or use any place, room, convenience or building set apart for the use of males.

47. No person shall offend against decency as regards dress, language or conduct, or the use of unnecessarily loud talking, or by any unnecessary noise disturbing or otherwise annoying persons in the Caravan Park.

48. No person over the age of fourteen years shall use playground equipment erected within the Caravan Park.

49. No person shall cut, saw, dig, move or displace any tree, bough, live or dead timber, wood or other material which may be in or around the Caravan Park without the consent, in writing, of the Committee.

50. No person shall remove any stone, soil, sand or loam from the Caravan Park without the consent, in writing, of the Committee.

51. No person shall drive any vehicle within the Caravan Park at a greater speed than 5 miles per hour.

Fees.

52. Every occupier shall pay to the Caretaker the respective fees prescribed from time to time by the Committee.

General.

53. Every person holding or purporting to hold any receipt or permission, in writing, issued by the Committee shall, on demand by any members of the Committee or any officer thereof or any member of the Police Force, produce such receipt or permission.

54. Any person who shall offend against any of these Regulations may be requested to leave the Caravan Park forthwith, and his refusal or failure to leave when so requested by the Caretaker or any duly authorized officer of the Committee or any member of the Police Force shall constitute a further offence against these Regulations.—(Rs.1922.)

These Regulations are made in lieu of the Regulations made by the Board of Land and Works on the 20th July, 1939, which are hereby revoked.

Given under my hand, at Melbourne, on the 29th day of June, 1965.

JIM BALFOUR,
Minister of Lands.

Every person who contravenes or fails to comply with these Regulations shall, in accordance with the provisions of section 218 of the *Land Act 1958*, for each offence be liable to a penalty of not more than Five pounds, and every person who contravenes or fails to comply with any such Regulations, and who, after he has been warned by any bailiff of Crown lands or by any member of the Police Force, does not desist therefrom may be forthwith apprehended by such bailiff or member of the Police Force and taken before some justice to be dealt with according to law and shall be liable to a penalty of not more than Ten pounds.

COMMITTEES OF MANAGEMENT OF RESERVES.

APPOINTMENTS.

NOTICE is hereby given that, in pursuance of section 221 of the *Land Act 1958*, the following appointments of Committees of Management of reserved Crown lands have been made by the Minister of Lands:—

“AXEDALE RACECOURSE AND RECREATION RESERVE.”

James George Mill, John Joseph O'Brien, William Nash Lienhop, Edmond Joseph O'Dwyer and James Christy Doak as a Committee of Management for a period of three (3) years of the remaining portions of the lands permanently reserved by Orders in Council dated the 10th March, 1873, and 4th May, 1914 (excluding the School Plantation area vide letter of the 8th May, 1961, on Lands Department correspondence Rs.19) as sites for Racecourse and General Recreation purposes in the Township of Axedale, and known as the “Axedale Racecourse and Recreation Reserve”.—(Corres. Rs. 19.)

“BENDIGO RACECOURSE RESERVE.”

Henry William Snell, in the place of Leonard Livingston Dungey (deceased) as a member of the Committee of Management of the land in the City of Bendigo, Parish of Sandhurst, permanently reserved by Order in Council dated the 11th August, 1873, as a site for a Racecourse and known as the “Bendigo Racecourse Reserve”.—(Corres. Rs.5552.)

“CALLIGNEE MECHANICS' INSTITUTE RESERVE.”

Bill Bishop, Leonard John Pump, Charles Richardson (Jnr.), Charles Richardson, Raymond Arthur Symons, Charles Victor Tovell, Sydney Lamper and Neville Gordon Summerfield as a Committee of management for a period of three (3) years of the land temporarily reserved by Order in Council dated 27th May, 1909, as a site for a Mechanics' Institute in the Township of Toomung, and known as the “Callignee Mechanics' Institute Reserve”.—(Corres. Rs.1399.)

“ELLMINYT MEMORIAL PARK AND RECREATION RESERVE.”

James Lewis Ballagh, Clarence William Ballagh, William Francis Benallack, Thomas Mervyn Gladman, Donald Keith McCoombe, Kevin Fulford and Robert James Gladman as a Committee of Management for a period of three (3) years of the land in the Parish of Elliminyt temporarily reserved by Order in Council of 17th August, 1925, as a site for Public Park and Recreation and known as the “Elliminyt Memorial Park and Recreation Reserve”.—(Corres. Rs.3142.)

“RESERVE FOR PUBLIC PURPOSES (SHOWGROUND)”, IN THE TOWNSHIP OF EUROA.

Denis McCormack, Norman R. Ralston, Ian W. Davidson, Herbert H. Mackrell and Thomas Ferguson as the Committee of Management for a period of three (3) years of the land in the Township of Euroa temporarily reserved by Order in Council dated the 25th May, 1965, as a site for Public purposes (Showground).—(Corres. Rs.8447.)

"FERNIHURST RECREATION RESERVE."

George Mahoney, Joseph Herbert Evans, Eric Huggins, Robert Austin Coutts, Graeme Faulkner, Kenneth Pattison and William Pattison as a Committee of Management for a period of three (3) years of the land temporarily reserved by Order in Council dated 8th April, 1929, as a site for Public Recreation in the Parish of Mysia, and known as the "Fernihurst Recreation Reserve".—(Corres. Rs.3844.)

"JINDIVICK MECHANICS' INSTITUTE."

Albert George Pretty, Clifford Arthur Howlett, Philip Martin Emery, Milton William Neal and Bernard Michael Condon as a Committee of Management for a period of three (3) years of the land in the Parish of Jindivick temporarily reserved by Order in Council of the 10th January, 1956, as a site for a Public Hall and known as the "Jindivick Mechanics' Institute".—(Corres. Rs.7407.)

"KAMAROOKA RECREATION RESERVE."

Neville John McKenzie, Donald James Aitken, Richard Matchett Ayres, Raymond Alexander Wilson, George Geoffrey Cail, William George Demeo, John Joseph Demeo, Arthur Charles Evans, Geoffrey Pedersen, John Frederick Cail, John Home Hay and Bruce Albert Cail as a Committee of Management for a period of three (3) years of the land temporarily reserved by Order in Council of 18th April, 1950, as a site for Public Recreation in the Parish of Kamarooka, and known as the "Kamarooka Recreation Reserve".—(Corres. Rs.6529.)

"MAJORCA PUBLIC HALL RESERVE."

Eric S. Bucknall, Frank J. Johnson, James N. Adams, George T. Johnson, G. W. Svensen and Bruce E. Buick as a Committee of Management for a period ending the 29th September, 1966, of the land in the Township of Majorca, temporarily reserved by Order in Council dated the 25th May, 1965, as a site for Public Purposes (Public Hall), and known as the "Majorca Public Hall Reserve".—(Corres. Rs.8423.)

"MEREDITH RACECOURSE RESERVE."

John Alfred Marchmont, William Lloyd Cooke, Norman Edward Lowne, Donald Murray Hughan, Christopher Daniel Mooney, Alfred Ernest Wells and Edwin John Tansley as a Committee of Management for a period of three (3) years of the land temporarily reserved for Racecourse and General Recreation purposes in the Parish of Meredith, and known as the "Meredith Racecourse Reserve".—(Corres. Rs.301.)

"BAYNES PARK", PUBLIC RECREATION RESERVE, PARISH OF MONBULK.

The Council of the Shire of Sherbrooke as a Committee of Management of the land in the Parish of Monbulk, temporarily reserved by Orders in Council dated the 8th May, 1962, and the 18th May, 1965, as sites for Public Recreation and known as "Baynes Park".

This appointment is in lieu of the appointment made on the 19th June, 1962, which is hereby revoked.—(Corres. Rs.8129.)

PUBLIC RECREATION AND DRAINAGE RESERVE, AT MORWELL, PARISH OF MARYVALE.

The Council of the Shire of Morwell as a Committee of Management of the land in the Parish of Maryvale, temporarily reserved by Order in Council dated the 18th May, 1965, as a site for Public Recreation and Drainage purpose.—(Corres. Rs.8418.)

"PENSHURST RACECOURSE RESERVE."

Daniel Maxwell Ewing, William Edwin Hinchcliff, Desmond John Kelly, Amos Benjamin Burrow, and Roy Schramm as a Committee of Management for a period of three (3) years of the land in the Parish of Yalimba, temporarily reserved by Orders in Council dated the 17th October, 1864, as a site for a Racecourse and other purposes of Public Recreation.—(Corres. Rs.974.)

SEWERAGE PURPOSES RESERVE, IN THE TOWNSHIP OF PORTLAND.

The Portland Sewerage Authority as a Committee of Management of the land in the Township of Portland temporarily reserved by Order in Council dated the 16th March, 1965, as a site for Public purposes (sewerage).—(Corres. Rs.8244.)

No. 53.—5592/65.—4

"SEYMOUR RACECOURSE AND PUBLIC RECREATION RESERVE."

Patrick Leahy and John William O'Connor in the places of Roy Hogarth Thompson and William Edgar Reddie (resigned) as members of the Committee of Management for a period ending the 7th April, 1967, of the remaining portion of the land permanently reserved by Order in Council dated the 8th February, 1887, as a site for Racecourse and other purposes of Public Recreation in the Parish of Tallarook, and known as the "Seymour Racecourse Reserve".—(Corres. Rs.1416.)

"TUNGAMAH MECHANICS' INSTITUTE AND FREE LIBRARY RESERVE."

Francis William Marks, John Peter Mulquaney, Maurice Cleary, Vernon Duncan Barnes, Walter Buerckner and Norman Jellicoe Skinner as a Committee of Management for a period of three (3) years of the land permanently reserved by Order in Council dated the 28th November, 1887, as a site for a Mechanics' Institute and Free Library at Tungamah, and known as the "Tungamah Mechanics' Institute and Free Library".—(Corres. Rs.5283.)

"WARRNAMBOOL KINDERGARTEN AND CHILDREN'S PLAYGROUND RESERVE."

Edward Patrick Gibbons and Florence Jane Collins for so long as they continue to be councillors and the elect of the Council of the City of Warrnambool and Horace Carson Verey, Harold William Grayson and Ralph Illidge for a period of three (3) years as the Committee of Management of the land in the Township of Warrnambool temporarily reserved by Order in Council of the 8th August, 1955, as a site for a Kindergarten and Children's Playground.—(Corres. Rs.7376.)

"WESBURN PUBLIC PARK AND RECREATION RESERVE."

The Council of the Shire of Upper Yarra as the Committee of Management of the lands in the Parish of Warburton temporarily reserved by Orders in Council dated the 30th August, 1886, 29th July, 1889, and the 25th May, 1965, as sites for Public Park and Recreation purposes.

This appointment is in lieu of all previous appointments in respect of the said lands, which are hereby revoked.—(Corres. Rs.2136.)

ALAN J. HOLT,
Secretary for Lands.

29th June, 1965.

TENDERS—PUBLIC WORKS DEPARTMENT

TENDERS will be received at the Head Office of the Public Works Department, Treasury-place, Melbourne, until TEN a.m. on the dates shown and for the purposes mentioned hereunder.

Particulars and tender forms may be obtained at the Contracts Office, Room 7, Building Division, Parliament-place, and at the places indicated in brackets after certain items.

The abbreviations shown in the brackets mean the following:—W.O.—Inspector of Works Office; P.S.—Police Station; C.S.—Consolidated School; H.E.S.—Higher Elementary School; H.S.—High School; S.S.—State School; T.S.—Technical School.

Tenders should be submitted on the Department's printed Tender Form and will not be received by telephone. All tenders must be on a "Firm Tender" basis. The lowest or any tender will not necessarily be accepted.

Tenders are to be addressed to the Minister of Public Works, and the envelopes containing the tender is to be clearly marked "Tender for _____, closing Tuesday, _____".

No preliminary deposit is to be lodged with any tender, but a successful tenderer will be required to pay a deposit for any accepted tender of the value of £1,500 or over.

Tuesday, 13th July, 1965.

Building, Electrical and Mechanical Works.

Bairnsdale.—Additional room, repairs and painting, Mines Department Residence. (W.O., Bairnsdale.)
Ballarat.—Supply and installation of steam heaters for Workshop Blocks, Mental Hospital. (W.O., Ballarat.)
Brunswick.—Erection of steel-framed multi-story High School. (Specified Bills of Quantities available.)

Castlemaine.—New toilet facilities, Gaol. (W.O., Bendigo; Gaol, Castlemaine.)

Cheltenham.—Sewer connexion, High School.

Chilwell.—Painting and repairs and alterations to toilets, S.S. 2061. (W.O., Geelong.)

Cobram.—Provision of additional room, new porch, repairs and painting, Police Station. (W.O., Benalla; Police Station, Cobram.)

Footscray.—Repairs and painting, Health Department, Dental Centre.

Jacana.—Connexion of sewerage, S.S. 4839.

Karingal.—Erection of an eight class-room brick veneer Primary School, S.S. 4922.

Karingal.—Electrical installation, new school of eight L.T.C. class-rooms, &c., S.S. 4922.

Karingal.—Plenum heating in new eight class-room school, S.S. 4922.

Mitcham.—New chain mesh fence and gates, High School.

Mont Park.—Supply and installation of plenum heating, hot-water system, steam and condensate reticulation for Recreation Block, Wards F.7, F.8, F.9 and F.10, Mental Hospital.

Pearcedale.—Septic tank installation, S.S. 2961 and residence. (S.S., Pearcedale.)

Somers.—Replacement of urinals, provision of showers, &c., School Camp, S.S. 4647. (S.S., Somers.)

Syndal.—Sewer connexion, Technical School.

Tottenham.—Supply and installation of extensions to heating and hot-water systems, Technical School.

Traralgon.—Erection of woodsheds, &c., residences, Hobson Park Hospital. (W.O., Traralgon.)

Willaura.—Repairs and painting, Court House. (W.O., Ararat; Police Station, Willaura.)

Furniture and Furnishings.

Frankston.—Supply of office furniture, Keith Turnbull Research Station.

Frankston.—Supply and fix pin-up boards, Keith Turnbull Research Station.

Melbourne.—Supply of executive furniture, Registry of Co-operative Housing, 191 Queen-street.

Mt. Eliza.—Supply of adjustable tables, Royal Children's Hospital, S.S. 4290.

Timboon.—Supply of blackout curtains, High School.

Toorak.—Supply of adjustable tables, Marathon Spastic Centre, S.S. 4676.

Site Works.

Ascot Vale West.—Earthworks, asphaltting, concreting, drainage and associated works, S.S. 4025.

Canterbury.—Asphaltting, concreting, drainage, road construction, retaining walls and associated works, Girls' High School.

Doveton.—Site works including asphalt paving, concrete paving, drainage, &c., Technical School. (Police Station, Morwell.)

Essendon.—Concrete and asphalt paving, &c., around Gymnasium, High School. (Amended Specification.)

Heatherdale.—Earthworks, asphaltting, drainage, retaining walls, concreting and associated works, S.S. 4904.

Miscellaneous.

Foster.—Purchase and removal of building, High School. (W.O., Korumburra; H.S., Foster.)

Tuesday, 20th July, 1965.

Building, Electrical and Mechanical Works.

Alberton.—Repairs, painting and additions, S.S. 1 and Residence. (W.O., Traralgon; S.S., Alberton.)

Ararat.—Repairs and painting, Police Station Residence, 3 Tobin-street. (W.O., Ararat; P.S., Stawell.)

Belmont.—Roof repairs, S.S. 26. (W.O., Geelong.)

Brunswick South-West.—Renewal of water supply and additional washing facilities, S.S. 4304.

Brunswick West.—Erection of brick toilet block, S.S. 2890.

Burwood.—Internal repairs and painting, Technical School.

Camperdown.—Erection of additional laundries and toilets and connexion to town sewerage, Teachers' Flats, 3 Hopetoun-street, High School. (W.O., Camperdown.)

Clayton.—Supply and installation of Packaged Sewage Treatment Plant, Monash Secondary Teachers' College.

Coburg.—External renovations, Teachers' College.

Doncaster.—Repair works to swimming pool, S.S. 197.

Dookie.—Electrical installation for new Biology and Chemistry Laboratories, Agricultural College. (W.O., Shepparton and Benalla; Agricultural College, Dookie.)

Echuca West.—Repairs, external painting and erection of fencing, residence, 69 Mitchell-street, S.S. 3916. (W.O., Shepparton; S.S., Echuca West.)

Euroa.—New toilets and renovations to bathroom, residence, S.S. 1706. (W.O., Alexandra; S.S., Euroa.)

Flemington.—New chain mesh fence and gates, &c., S.S. 250.

Glenthompson.—External and internal painting, S.S. 947. (W.O., Hamilton; S.S., Glenthompson.)

Gresswell.—Installation of heaters in residences and Nurses' Hostels, Sanatorium.

Harrietsville.—Renovations to school and residence, S.S. 843. (W.O., Wangaratta; S.S., Harrietsville.)

Hawksburn.—Gas heating, S.S. 1467.

Inverloch.—Repairs and painting, S.S. 2776. (W.O., Korumburra; S.S., Inverloch.)

Keysborough.—Repairs and painting, S.S. 1466.

Kingsville.—Repairs and painting, Police Station.

Leongatha.—Renovations and painting, High School. (W.O., Korumburra; Police Station, Leongatha.)

Maribyrnong.—Internal renovations, High School.

Middle Park.—Renewal of pans, cisterns, seats and urinals, &c., S.S. 2815.

Morwell.—Addition of concrete veneer Science Wing, High School. (W.O., Traralgon.)

Myrtleford.—Alterations and additions to Leaf Storage Barn, Tobacco Research Station. (W.O., Benalla; Research Station, Myrtleford.)

Newhaven.—Internal and external repairs, renovations and painting, S.S. 3053 and Residence. (W.O., Korumburra; S.S., Newhaven.)

Ormond.—Repairs and painting, Police Station and Residence.

Reservoir West.—Repairs and painting, S.S. 4711.

Seymour.—Repairs and painting to residence and out-buildings, Police Station. (W.O., Alexandra; P.S., Seymour.)

Thornbury.—Repairs, renovations and painting to Family Group Homes "Bunyarra" and "Benwerrin", Social Welfare Department, Clarendon-street.

Trafalgar.—Repairs to roof, external and internal painting, S.S. 2185. (W.O., Warragul; S.S., Trafalgar.)

Wallan Wallan.—Re-blocking, repairs and painting, Police Station and Residence. (W.O., Alexandra; Police Station, Wallan Wallan.)

Waurm Ponds.—Repairs and painting to school and residence, S.S. 1040. (W.O., Geelong; S.S., Waurm Ponds.)

West Melbourne.—Demolition and removal of concrete air raid shelters, William Angliss Food Trades School.

Whorouly East.—Installation of sewerage, S.S. 2478. (W.O., Benalla.)

Youanmite.—Conversion to septic tank, S.S. 3641. (W.O., Benalla; S.S., Youanmite.)

Site Works.

Amstel.—Asphaltting, concreting, drainage, graveling and associated works, S.S. 4801.

Ashwood.—Asphaltting, concreting, drainage, paving repairs and associated works, S.S. 4698.

Oakleigh.—Asphaltting, concreting, drainage and associated works, Technical School.

Various.—Asphalt and concrete paving, re-grading and drainage works at various schools in the Prahran-Caulfield-Ripponlea area.

Miscellaneous.

Port Melbourne.—Supply of three Class 6 Crawler Tractors (Australian Standard D4 1964), fitted with ancillary equipment, Public Works Department Depot.

Port Melbourne.—Supply of 3,000 garbage bins, Public Works Department Storeyard, 69 Salmon-street.

Tuesday, 27th July, 1965.

Building, Electrical and Mechanical Works.

Bannockburn.—Internal and external painting and repairs, S.S. 932. (W.O., Geelong.)

Belmont.—Addition of Science Wing, High School. (W.O., Geelong.)

Belmont.—Electrical installation in additional Science Wing, High School. (W.O., Geelong.)

Belmont.—Mechanical services in new Science Wing, High School. (W.O., Geelong.)
 Benalla.—Mechanical services to building extensions, Technical School. (W.O., Benalla.)
 Bendigo.—Septic tank installations, school and residence, School for the Deaf, S.S. 4726. (W.O., Bendigo.)
 Blackburn.—New roof, repairs and painting, S.S. 2923.
 Burnley Gardens.—Additions, repairs and renovations to Principal's Residence, Agricultural Department.
 Cloverlea.—Erection of out-offices, installation of septic tank and bore water supply, S.S. 3520. (W.O., Warragul; S.S., Cloverlea.)
 Coburg.—Renovations, Social Welfare Department, Family Group Home "Moonya", 27 Jackson-parade.
 Digby.—Renovations, S.S. 2047. (W.O., Warrnambool; S.S., Digby.)
 Dooen.—Electrical installation for Biology and Physics Laboratories, Longerehong Agricultural College. (W.O., Horsham.)
 Echuca.—Electrical installation, re-wiring and improved lighting, Technical School. (W.O., Shepparton; P.S., Echuca.)
 Eltham.—Repairs and painting, Court House.
 Frankston.—General repairs and painting to Aluminium Pre-fabricated Buildings; Technical School.
 Geelong East.—Renovations, S.S. 451. (W.O., Geelong.)
 Gnotuk.—New toilet block and septic tank installation, S.S. 3392. (W.O., Camperdown; S.S., Gnotuk.)
 Goulburn Weir.—Erection of out-offices and installation of septic tank, S.S. 3358. (W.O., Alexandra; S.S., Goulburn Weir.)
 Heathmont.—Repairs and painting, S.S. 4688.
 Jancourt East.—Repairs and external painting, provision of new out-offices and tanks and conversion to septic sewerage, S.S. 3783 and Residence. (W.O., Warrnambool; S.S., Jancourt East.)
 Jordanville.—Repairs and internal painting, Technical School.
 Melbourne.—Internal repairs and painting, Secondary Teachers' College Hostel, "Warwillah", 572 St. Kilda-road.
 Melbourne.—External and internal renovations, St. Kilda-road Police Station, Bowen-crescent.
 Melton South.—Repairs, painting and installation of septic tank, S.S. 3717, Residence.
 Mont Park.—Electrical reticulation and installation for Remodelled Wards F.7, F.8, F.9 and F.10, Mental Hospital.
 Morwell.—Electrical installation, Additional Science Wing, High School. (W.O., Traralgon.)
 Mount Waverley.—External repairs and painting—internal work to Residence only, Police Station and Residence.
 Nathalia.—Re-roofing Domestic Arts Wing, High School. (W.O., Shepparton.)
 Point Lonsdale.—Repairs and external painting, S.S. 3322. (W.O., Geelong.)
 Queenscliff.—Additions and alterations and brick garage, Police Station. (W.O., Geelong; P.S., Queenscliff.)

Seymour.—Repairs and re-painting to residence and out-buildings, Police Station Residence, 58 Tallarook-street. (W.O., Alexandra; P.S., Seymour.)
 Skipton.—New shelter pavilion, repairs and painting, S.S. 582 and Residence. (W.O., Camperdown; S.S., Skipton.)
 South Yarra.—Erection of residence for Caretaker, Melbourne High School. (Amended Specification.)
 St. Arnaud.—Renovations, S.S. 1646. (W.O., Maryborough; P.S., St. Arnaud; S.S., St. Arnaud.)
 Stawell.—Erection of two Dependent Patients Wards, Pleasant Creek Special School. (W.O., Ararat and Ballarat) (Bills of Quantities Available.)
 Strathmerton.—Repairs and painting, S.S. 2790. (W.O., Shepparton; S.S., Strathmerton.)
 Traralgon.—Plenum heating, new six additional classrooms, S.S. 4700. (W.O., Traralgon.)
 Wangaratta.—Addition of Science Wing in cement rendered timber framed construction, High School. (W.O., Wangaratta.)
 Wesburn.—New toilet, renovations and painting, S.S. 3466, Residence.
 Woodend.—Erection of laundry, W.C. and repairs, Police Station Residence. (W.O., Kyneton; P.S., Woodend.)
 Zeerust.—Conversion to septic tank, S.S. 4359. (W.O., Shepparton; S.S., Zeerust.)

Site Works.

Eastmont.—Asphalting, concreting, drainage, gravelling, retaining walls and associated works, S.S. 4789.
 Forest Hill.—Asphalt maintenance repairs and other associated works, S.S. 4251.
 Ringwood.—Asphalting, asphalt maintenance, drainage, concreting and associated works, S.S. 2997.
 Southmoor.—Asphalting, concreting, drainage, grassing and associated works, S.S. 4910.

Miscellaneous.

Various.—Supply and delivery of A.C.-D.C. Control Cubicles and Bench Type Switchboard Panels for Benalla, Echuca and Horsham Technical Schools.

NOTICE.

The Public Works Department gives notice that tenders based on Drawings, Specifications and Bills of Quantities will be invited in the next few weeks for Alterations and two-story additional wings to the Fitzroy High School.

Plans are available at Contracts Office, Room 7, Public Works Department, Parliament-place, Melbourne, for reference purposes.

A further notice will be issued informing tenderers of the date of closing of tenders.

J. C. M. BALFOUR,
 Acting Minister of Public Works.

Public Works Department,
 Melbourne, C.2, 5th July, 1965.

PUBLIC SERVICE NOTICES

PUBLIC SERVICE OF VICTORIA.—RECLASSIFICATION.

THE Public Service Board has raised the classification of the under-mentioned office as shown, and appointed thereto the officer named hereunder:

Office and Former Classification.	Revised Classification.	Duties.	Qualifications.	Officer Appointed.
-----------------------------------	-------------------------	---------	-----------------	--------------------

PROFESSIONAL DIVISION.

TREASURY.

Office of the Housing Commission.

Draughtsman, Class "E"	Class "D" (with right of progression to Class "C")	To prepare preliminary sketches and site plans for low-rental estates and preliminary overall layouts for villa estates	A competent architectural draftsman, preferably with some experience in the duties and a knowledge of the Uniform Building Regulations as these apply to the siting of buildings and the subdivision of land	Kenworthy, N. R.
------------------------	--	---	--	------------------

Office of the Public Service Board,
 Melbourne, 6th July, 1965.

By order,
 V. P. SCULLY,
 Secretary.

No. 1509.

Public Service Act 1958.

REGULATIONS.—PART IV.—SALARIES AND INCREMENTS.

THE Public Service Board, in pursuance of the powers conferred by the *Public Service Act 1958*, hereby amends its Regulations as shown below :—

FOURTH SCHEDULE.

ADMINISTRATIVE DIVISION.

Amount of Salary Assigned to Offices in Class "A1"

Office.	Yearly Rate of Salary.
	£
PREMIER'S DEPARTMENT.	
<i>Add—</i> Special Duties Officer, Office of the Public Service Board	4,048

A. GARRAN, Chairman.
N. J. SIMMANANCE, Acting Secretary.

Office of the Public Service Board,
Melbourne, 28th June, 1965.

No. 1508.

Public Service Act 1958, Section 50.

REGULATIONS.—PART IV.—SALARIES AND INCREMENTS.

THE Public Service Board, in pursuance of the powers conferred by the *Public Service Act 1958*, hereby amends its Regulations as shown below :—

SIXTH SCHEDULE.

TEMPORARY EMPLOYEES.

Designations of Positions and Rates of Salaries.

Department and Designation of Position.	Yearly Rate of Salary.		Increments (Annual).
	Minimum.	Maximum.	
	£	£	
DEPARTMENT OF HEALTH.			
MENTAL HYGIENE.			
<i>Delete—</i>			
Pharmaceutical Chemist (Male)	..	1,558	..
Pharmaceutical Chemist (Female)	..	1,371	..
<i>Add—</i>			
Pharmaceutical Chemist (Male)	..	1,668	..
Pharmaceutical Chemist (Female)	..	1,481	..
LAW DEPARTMENT.			
<i>Delete—</i>			
Pharmaceutical Chemist	1,558	..

A. GARRAN, Chairman.
N. J. SIMMANANCE, Acting Secretary.

Office of the Public Service Board,
Melbourne, 10th June, 1965.

No. 1510.

PUBLIC SERVICE ACT 1958.

THE Public Service Board, in pursuance of the powers conferred by the *Public Service Act 1958*, hereby amends the Public Service (Public Service Board) Regulations as follows:—

PART X.—LEAVE OF ABSENCE.

Division III.—Sick Leave.

After paragraph (e) of Regulation 166 (1), the following proviso is inserted:—

"Provided further that no period of absence from duty to render service under the Commonwealth National Service Act shall be regarded as service for sick leave purposes."

Division V.—Leave on Account of Pressing Necessity.
After Regulation 181 the following heading and Regulation are inserted:—

"Commonwealth National Service Act.

181A. Where any officer or employee is required to absent himself from duty to render service under the Commonwealth National Service Act he shall be deemed to have been granted leave of absence without pay from the date of call-up until the date of discharge under such conditions as are contained in any directions of the Board which may issue from time to time."

A. GARRAN, Chairman.
V. P. SCULLY, Secretary.

Office of the Public Service Board,
Melbourne, 21st June, 1965.

PUBLIC SERVICE OF VICTORIA.—VACANCIES.

APPLICATIONS will be received by the Public Service Board up to Wednesday, the 21st July, 1965, from persons employed in the Public Service of Victoria, who are eligible and qualified for appointment to the under-mentioned positions:—

ADMINISTRATIVE DIVISION.

Public Service Inspector (Electronic Data Processing), Class "B", Office of the Public Service Board, Premier's Department.

Yearly Salary.—£2,028, minimum; £2,148, maximum.

Duties.—In accordance with section 44 (2) of the *Public Service Act 1958*, to undertake, under direction, investigations in relation to the promotion of efficiency in the working of and oversight of the methods of conducting business in departments in the field of E.D.P. planning.

Qualifications.—A general knowledge of electronic data processing techniques; ability to conduct investigations into and report on procedures and work methods in the Public Service; a Diploma in Public Administration or other appropriate qualification will be an advantage.

Class "C2", Department of Agriculture.

Yearly Salary.—£1,788, minimum; £1,908, maximum.

Duties.—To act as Assistant Staff and Industrial Officer.

Qualifications.—A good knowledge of the Public Service Act and Regulations and conversant with Industrial Awards.

Class "C2", Office of the Government Statist, Chief Secretary's Department.

Yearly Salary.—£1,788, minimum; £1,908, maximum.

Duties.—To supervise staff engaged in searching records of births, deaths and marriages, fee assessment and index preparation. To assist in assessing fees payable on multiple applications and extended searches and to conduct correspondence in connexion with applications for information contained in records.

Qualifications.—Conversant with the procedures of the Registration Branch; a good knowledge of the *Registration of Births, Deaths and Marriages Act 1959* and Regulations, ability to conduct correspondence and supervise staff.

Assistant, Public Service Inspector (Electronic Data Processing), Class "C2", Office of the Public Service Board, Premier's Department.

Yearly Salary.—£1,788, minimum; £1,908, maximum.

Duties.—In accordance with section 44 (2) of the *Public Service Act 1958*, to undertake, under direction, investigations in relation to the promotion of efficiency in the working of and oversight of the methods of conducting business in departments in the field of E.D.P. planning.

Qualifications.—A general knowledge of electronic data processing techniques; ability to conduct investigations into and report on procedures and work methods in the Public Service; a Diploma in Public Administration or other appropriate qualification will be an advantage.

Class "C2", Office of the Chief Commissioner of Police, Chief Secretary's Department.

Yearly Salary.—£1,788, minimum; £1,908, maximum.

Duties.—To be responsible for the recording of and accounting for moneys collected on notices issued for road traffic infringements.

Qualifications.—Preferably to be conversant with the Road Traffic (Infringements) Act 1965; a knowledge of the Regulations relating to the collection of public moneys.

Assistant Audit Inspector, Class "C1", Audit Office, Premier's Department.

Yearly Salary.—£1,558, minimum; £1,668, maximum.
Duties.—To conduct audits throughout Victoria and to perform examination duties as directed by the Auditor-General.

Qualifications.—Substantial progress in the study of accountancy and experience in the practice of auditing.

Class "C1", Taxation (Land Tax) Office, Treasury.

Yearly Salary.—£1,558, minimum; £1,668, maximum.
Duties.—To have charge of a section of the Assessing Branch and to direct a staff of officers engaged in the preparation of assessments; to prepare involved assessments and to ascertain the liability for tax of lessees under section 43 of the Land Tax Act.

Qualifications.—Experience in assessing duties, with a good knowledge of the Land Tax Act and Regulations and principles relating to transactions in Land.

Class "C", Office of the Chief Commissioner of Police, Chief Secretary's Department. (Four vacancies.)

Yearly Salary.—£1,283, minimum; £1,448, maximum.
Position No. 1.

Duties.—To supervise the recording of notices issued for road traffic infringements.

Qualifications.—Experience in the keeping of records.
Position No. 2.

Duties.—To process moneys received in payment of penalties prescribed in notices issued for road traffic infringements.

Qualifications.—Experienced in the receipt of and accounting for public moneys.
Position No. 3.

Duties.—To attend to the opening of mail and to conduct correspondence associated with notices issued for road traffic infringements.

Qualifications.—Ability to conduct correspondence; a knowledge of the organization and procedures of the Police Department is desirable.
Position No. 4.

Duties.—To prepare staff requisitions, memoranda and returns relating to staff; to relieve the Staff Clerk as required.

Qualifications.—A knowledge of the Public Service Acts and Regulations and some practical experience of staff work. A knowledge of the organization and activities of the Police Department is desirable.

NOTE.—Separate applications must be submitted for these positions.

PROFESSIONAL DIVISION.

Assistant Senior Chemist, Class "A", Coroner's Court, Law Department.

Yearly Salary.—£2,613, minimum; £2,763, maximum.
Duties.—Under the general direction of the Senior Chemist, to carry out analysis of specimens submitted by Police and Coroners, to supervise laboratory work, to give evidence as required in Court proceedings and to act as deputy to the Senior Chemist when required.

Qualifications.—Degree or Diploma in Science (Chemistry); considerable experience in the analysis of tissue for drugs and poisons; to be familiar with modern instrumental methods and to have had considerable Court experience; to be familiar with the analysis of blood for alcohol.

Senior Inspecting Clerk of Courts, Class "A", Courts Branch, Law Department.

Yearly Salary.—£2,613, minimum; £2,763, maximum.
Qualifications.—To have passed the Stipendiary Magistrates examination; at least ten years' experience as a Clerk of Courts; a good knowledge of the duties of the office and the office of Receiver and Paymaster.

Second in Charge, Conveyancing Branch, Classes "B1"—"A", Crown Solicitor's Office, Law Department.

Yearly Salary.—£2,293, minimum; £2,763, maximum.
Duties.—To be Second in Charge of the Conveyancing Branch, Crown Solicitor's Office.

Qualifications.—A barrister and solicitor of the Supreme Court of Victoria with adequate experience in conveyancing matters.

Valuer, Classes "C1"—"C2", Taxation (Land Tax) Office, Treasury.

Total Emolument.—£1,668, minimum; £2,088, maximum—unrestricted certificate.
£1,613, minimum; £2,088, maximum—restricted certificate.

(Commencing salary will be determined within this range according to qualifications and experience.)

Duties.—To carry out inspections and make valuations of real estate for Land Tax, Probate Duty and Stamp Duty purposes.

Qualifications.—To be entitled to an unrestricted certificate of qualification from the Valuers' Qualification Board, or to be qualified for admission to the Commonwealth Institute of Valuers.

NOTE.—It is desirable that the appointee be the owner of a motor car and willing to use it on valuation work.

TECHNICAL AND GENERAL DIVISION.

Chief Prison Officer, Prisons Division, Social Welfare Branch, Chief Secretary's Department.

Yearly Salary.—£1,539, minimum; £1,591, maximum.
Duties.—Under the direction of the Governor, Her Majesty's Prison, Pentridge, to have charge of a Division or to fill any such position of equivalent rank in the Prisons Division as directed.

Qualifications.—A Senior Prison Officer, who has passed the required examination, under Regulation 63 (6) of the Public Service (Public Service Board) Regulations for promotion to the office of Chief Prison Officer, a good knowledge of prison problems and modern developments, to have tact and be able to control staff and prisoners.

Inspector of Land Settlement, Department of Crown Lands and Survey. (Three vacancies.)

Yearly Salary.—£1,187, minimum; £1,487, maximum.
Duties.—To administer the *Vermin and Noxious Weeds Act 1958*, to inspect and furnish reports and valuations on land and improvements as required under the provisions of the Land, Closer Settlement, Wire Netting and Agricultural Colleges Acts, and for other Departments and Government Instrumentalities.

Qualifications.—A knowledge of the relevant provisions of the above-mentioned Acts; ability to make land valuations and to advise on farming methods generally, including the correct utilization of land; to have passed the prescribed examination as set out in Regulation 36 of the Public Service (Public Service Board) Regulations.

Radiographer (Male or Female), Coburg Chest Clinic, Tuberculosis Branch, Department of Health.

Yearly Salary.—
Male: £1,295, minimum; £1,435, maximum.
Female: £1,061, minimum; £1,223, maximum.
Duties.—Under the direction of the Director of Tuberculosis to carry out radiography work with fixed and mobile X-ray machines and maintain records, filing and storage of X-rays as required.

Qualifications.—Experience in chest radiography; the certificate of competency in Radiography of the Conjoint Board of the College of Radiologists of Australasia and the Australasian Institute of Radiography or equivalent.

Senior Prison Officer, Prisons Division, Social Welfare Branch, Chief Secretary's Department.

Yearly Salary.—£1,295, minimum; £1,383, maximum.
Duties.—To assist in the control of a Division, to act as Chief Prison Officer in his absence; other duties as directed, including those of storekeeper where allotted to Country Prisons, and of Officer in Charge for night watches and for court escorts. Applicants should be prepared to take up duty in Country Prisons.

Qualifications.—To have passed the prescribed examination for promotion; to have a satisfactory record of service, the qualities of leadership required of a senior officer in the management of staff and prisoners and the experience and ability to assume responsibility. Ability to act as Storekeeper when required.

Matron, "Allambie", Burwood, Family Welfare Division, Social Welfare Branch, Chief Secretary's Department.

Yearly Salary.—£1,379 (plus an allowance of £46 a year for possessing the Infant Welfare Certificate).

Duties.—As Matron to be responsible for the general organization and control of the female staff and to undertake duties, as directed, relating to the proper care, treatment and welfare of children at "Allambie".

Qualifications.—A triple certificated nurse with a knowledge of child-care and institutional practice; ability to control and direct staff and capacity for organizing and management; the Pre-School Certificate of the Maternal and Child Welfare Branch would be an advantage.

NOTE.—Quarters and rations supplied at a charge of £166 a year. Additional payment at the rate of quarter time is made for rostered time of ordinary duty performed on a Saturday or a public holiday and additional payment at the rate of half-time for such duty performed on a Sunday. Payment at the rate of time and a half is made for overtime duty.

Herd Test Organiser, Department of Agriculture.

Yearly Salary.—£1,223, minimum; £1,331, maximum.

Duties.—To supervise and assist the work of Grade Herd Recording Associations in one of the major dairying districts; to assist in the preparation of dairy sire surveys and farm management surveys; to organize field days and deliver lectures for Herd Recording Associations; and to promote generally Grade Herd Recording work of the district.

Qualifications.—Certificate in Herd Testing and sound experience in Associations' herd recording work. A good knowledge of dairy stock and dairy farm management. Sound practical experience in dairy farming.

NOTE.—An officer shall not be paid a salary in excess of £1,259 a year standard unless he has passed the examination prescribed for Dairy Supervisors in Public Service (Public Service Board) Regulation 40 (1). It is essential that the successful applicant be in possession of a motor car or willing to procure one before appointment.

Cash Register Operator, Office of the Chief Commissioner of Police, Chief Secretary's Department.

Yearly Salary.—£1,223, minimum; £1,331, maximum.

Duties.—To operate a cash register.

Qualifications.—Experience in operating a multiple cash register and in the handling and accounting for public moneys.

Deputy Matron, "Allambie", Burwood, Family Welfare Division, Social Welfare Branch, Chief Secretary's Department.

Yearly Salary.—£1,187, minimum; £1,223, maximum (plus an allowance of £46 a year for possessing the Infant Welfare Certificate).

Duties.—To assist in the organization and control of female staff and to undertake duties as directed relating to the care, treatment and welfare of children.

Qualifications.—A triple-certificated Nurse with a knowledge of child care and institutional practice.

NOTE.—Quarters and rations supplied at a charge of £166 a year. Additional payment at the rate of quarter time is made for rostered time of ordinary duty performed on a Saturday or a public holiday and additional payment at the rate of half time for such duty performed on a Sunday. Payment at the rate of time and a half is made for overtime duty.

Engineer Mechanic, Buchan Caves, Department of Crown Lands and Survey.

Yearly Salary.—£1,115, minimum; £1,223, maximum.

Duties.—To be responsible for the operation of a diesel generating plant (D.C.) and the maintenance of electrical reticulation and wiring in the Caves; other duties as required.

Qualifications.—An "A" or "B" Grade Electrical Mechanics' Licence issued by the State Electricity Commission of Victoria; general experience in maintenance of electric light and power installation and the operation of diesel generating plant.

Technical Assistant (Male), Fisheries and Wildlife Branch, Chief Secretary's Department.

Yearly Salary.—At 18 years of age, £703; at 19 years of age, £800; at 20 years of age, £910.

Adult—£1,097, minimum; £1,205, maximum.

Duties.—To assist the Native Fish Research Officer in field and laboratory investigation on freshwater fish; other duties as directed.

Qualifications.—Able to perform field duties under all conditions; a good physique, a current driving licence, experience in the use of boats, and the ability to make reliable technical observations without supervision. Intermediate Certificate or equivalent. Some knowledge of freshwater fish and an ability to use laboratory equipment is desirable.

Foreman, Viticultural Station, Rutherglen, Department of Agriculture.

Yearly Salary.—£1,043, minimum; £1,133, maximum.

Duties.—Under the Manager, to arrange the duties of the vineyard and cellar hands employed at the Viticultural Station, Rutherglen, and the Viticultural Nursery, Wahgunyah, to maintain work records of exempt employees and to oversee their work, and to carry out vineyard grafting, propagation and cellar work as required.

Qualifications.—A good practical knowledge of vine growing and winemaking in the north-east of Victoria; a proved capacity to handle men; and a knowledge of the practical work required in viticultural experiments and the grafting and propagation of vines.

Water Bailiff, Tatura Centre, Water Supply Department.

Yearly Salary.—£972, minimum; £1,079, maximum.

Qualifications.—Ability to control and regulate the supply of water to irrigators and to keep the necessary records and make arithmetical computations; a knowledge of water requirements for crops and grasses grown under irrigation, the methods of preparation of land for irrigation and methods of channel and drain construction and maintenance.

NOTE.—The successful applicant will be required to occupy the official residence provided and vacation of the residence will not be permitted without the express approval of the Water Supply Department. A rental of 10 per cent. of total emolument, inclusive of the amount payable under Regulation 74, less £36 6s. a year will be charged. Occupancy will be subject to formal tenancy agreement being entered into. Particulars are available from the Water Supply Department.

Shorthand Writer and Typist (Female), Senior, Crown Solicitor's Office, Law Department.

Yearly Salary.—£1,007, minimum; £1,043, maximum.

Duties.—To be in charge of the Common Law (General) Typist Pool.

Qualifications.—To have passed the Shorthand Speed Test at 100 words a minute; ability to control and direct staff.

NOTE.—The salary rates quoted above do not include the additional amount which is payable under Regulation 74 of the Board's Regulations.

By order,

V. P. SCULLY,
Secretary,
Office of the Public Service Board,
Melbourne, 6th July, 1965.

PUBLIC SERVICE OF VICTORIA.—VACANCIES.

DEPARTMENT OF HEALTH.

MENTAL HYGIENE BRANCH.

TECHNICAL AND GENERAL DIVISION.

APPLICATIONS will be received by the Public Service Board up to Wednesday, the 28th July, 1965, from persons employed in the Public Service of Victoria, who are eligible and qualified for appointment to the under-mentioned positions:—

Engineer, Beechworth.

Yearly Salary.—£1,591, minimum; £1,695, maximum.

Duties.—To be responsible for the operation and maintenance of the various steam, mechanical and electrical plant also water supply and sewerage systems.

Qualifications.—A first-class Board of Trade Certificate or an appropriate equivalent qualification or to be eligible for membership of the Institute of Hospital Engineers; appropriate practical experience.

NOTE.—A residence is available for the successful applicant, if married, for which a rental of £170 a year will be charged. Particulars available from the Mental Health Authority.

Assistant Head Nurse (Male), Ararat.

Yearly Salary.—£1,383, minimum; £1,435, maximum.

Duties.—To assist Principal Male Nurse or Head Nurse (Male), in management of male division, and to prepare leave sheets and other records as directed; to relieve senior officers as required, and to give lectures to Student Nurses and others.

Qualifications.—A current practising certificate for Mental Nursing, ability to direct and control staff and patients, and to keep records.

Charge Nurse (Male), Ararat.

Yearly Salary.—£1,223, minimum; £1,295, maximum.

Duties.—To take charge or sub-charge of a ward in a Mental Hospital and to assist in the training of Student Nurses and others.

Qualifications.—A current practising certificate for Mental Nursing.

Electrical Mechanic, Senior, Mont Park.

Yearly Salary.—£1,151, minimum; £1,223, maximum.

Duties.—Under the direction of the Engineer to maintain wiring and electrical equipment, including motors, cookers, urns, radiators, toasters, &c., to undertake minor electrical installations, and to assist the Engineer generally.

Qualifications.—An "A" Grade Wiring Licence.

Painter, Grade II., Mont Park.

Yearly Salary.—£1,061, minimum; £1,187, maximum.

Duties.—To carry out general painting and glazing, and the training of patients to help in painting work.

Qualifications.—A competent and qualified painter (conversant with mixing and using of paints) and glazier, and experienced in the control of mental patients.

Kitchenman, Kew.

Yearly Salary.—£904, minimum; £1,007, maximum.

Duties.—To assist cooks generally in preparation of vegetables and other foodstuffs. Attending to cleanliness of kitchen.

Qualifications.—Some knowledge of cooking is desirable.

Deputy Charge Nurse (Female). (Eight vacancies.)

Yearly Salary.—£935, minimum; £971, maximum.

Seven vacancies—St. Nicholas Hospital, Carlton.

Duties.—To be second in charge of a ward.

Qualifications.—A current practising certificate for Mental Defectives and approved experience.

One vacancy—Dandenong.

Duties.—To be second in charge of a ward.

Qualifications.—A current practising certificate for Mental Nursing and approved experience.

NOTE.—Successful applicants may be required to work an 8-hour roster.

Separate applications must be submitted for these positions.

The salary rates quoted above do not include the additional amount which is payable under Regulation 74 of the Board's Regulations.

By order,
V. P. SCULLY,
Secretary.

Office of the Public Service Board,
Melbourne, 6th July, 1965.

PUBLIC SERVICE OF VICTORIA.—VACANCY.

(TEMPORARY APPOINTMENT.)

APPLICATIONS will be received by the Public Service Board up to Wednesday, the 21st July, 1965, from persons who are qualified for appointment to the under-mentioned position:—

Assistant (Male), Grade III., Office of the Housing Commission, Treasury.

Yearly Salary.—£1,025, minimum; £1,061, maximum.

Duties.—To be responsible for the operation of the Home Ownership Advisory Bureau.

Qualifications.—To be educated to Intermediate Certificate standard. To be tactful in dealing with the public, and to possess a good personality. Ability to conduct correspondence and to organize the collection and collation of financial data is essential. Some knowledge of finance in relation to home ownership and real estate transactions is desirable.

The salary rates quoted above do not include the additional amount which is payable under Regulation 74 of the Board's Regulations.

By order,

V. P. SCULLY,
Secretary.

Office of the Public Service Board,
Melbourne, 6th July, 1965.

AUSTRALIAN ADMINISTRATIVE STAFF COLLEGE.

NOMINATION FOR SESSION No. 24.

(29th September, 1965, to 9th December, 1965.)

APPLICATIONS are invited from officers of appropriate classification and responsibility in the Administrative and Professional Divisions for nomination to attend the above-mentioned Session of the Australian Administrative Staff College.

Information submitted should include details of age, classification, experience and qualifications, and a brief statement indicating the level of responsibility of the applicant and the extent to which he is engaged in managerial activity.

General Information.

The Aim of the Course.

The aim of the course is to prepare the experienced and able administrator to accept growing responsibility by providing an opportunity for critical study of the fundamentals of the process of management.

Age.

Experience indicates that suitable candidates for the course are normally between thirty-five and fifty years of age.

Candidates.

Lack of academic qualification does not debar a candidate but candidates must be men who have demonstrated their administrative capacity and are regarded as being capable of undertaking higher executive responsibility as their training and experience develop and opportunity offers.

Selection.

Selections for each course are made by the College after interviewing nominees (no nominee from the Victorian Public Service has failed to be accepted to date).

Charges.

The officer nominated will be regarded as being on official duty and his fees will be paid by the Board. In addition he will be eligible to receive an allowance for incidentals of 15s. a day.

If desired more detailed information may be obtained from the Staff Section of the various Departments.

Applications should be addressed to the Secretary to the Public Service Board and submitted through the Permanent Head of the Department. They must reach the Board's office not later than Friday, 23rd July, 1965.

V. P. SCULLY, Secretary.

Office of the Public Service Board,
Melbourne, 6th July, 1965.

Teaching Service Act 1958.

TEACHING SERVICE (CLASSIFICATION, SALARIES AND ALLOWANCES) REGULATIONS.

AMENDMENT No. 81.

HE Teachers Tribunal, in pursuance of the powers conferred by the *Teaching Service Act 1958*, hereby amends the Teaching Service (Classification, Salaries and Allowances) Regulations, published in *Government Gazette* No. 48, dated the 22nd June, 1965, in the manner following, that is to say:—

PART XII.—ALLOWANCES.

In the prescription of annual allowances for Class II., appearing after paragraph (e) of clause 31 (B) insert the figures "100" in the column headed "Technical.E" and the figures "200" in the column headed "Technical.\$".

(To take effect from and including the 4th July, 1965.)

LOUIS F. C. GARLICK Chairman.
G. FENNELL, Secretary.

Office of the Teachers Tribunal,
Melbourne, 1st July, 1965.

PRIVATE ADVERTISEMENTS

CITY OF ARARAT.

ORDER CHANGING NAME OF STREET.

NOTICE is hereby given that a Meeting of the Council of the City of Ararat held on the 7th June, 1965, the said Council, in pursuance of the powers conferred by the *Local Government Act 1958*, did make an Order changing the name of the following street:—

Old Name; New Name.

McLean-street; Maclean-street.

By order of the Council,

J. I. GRENFELL, Town Clerk.

6806

CITY OF BRIGHTON.

REGULATION FOR THE CARE, PROTECTION AND MANAGEMENT OF ELSTERNWICK PUBLIC PARK AND RECREATION RESERVE.

IN pursuance of the powers conferred by section 219 of the *Land Act 1958*, the Minister of Lands and the Mayor, Councillors and Citizens of the City of Brighton as trustees of the land known as Elsternwick Public Park and Recreation Reserve (hereinafter referred to as the "Reserve") do hereby rescind the Regulation in respect of the said land as approved by the Governor in Council on the 21st April, 1953, and in lieu thereof do hereby make the following Regulation:—

REGULATION.

No person shall play or practise at any game or sport or athletics or any organized competition in any part of the Reserve on Sundays with the following exceptions:—

All approved games, which may only be played with the permission of the Trustees and only at such times as the Trustees decide and on such areas as may from time to time be defined or set aside by the Trustees for the purpose of any such game.

Every person offending against this Regulation shall, in accordance with the provisions of section 219 of the *Land Act 1958*, for each offence be liable to a penalty of not more than Five pounds (£5), and every person who so offends, and who, after he has been warned by any bailiff of Crown lands or by any member of the Police Force, officer or servant of the Trustees or of the Committee of Management appointed, may be forthwith apprehended by such bailiff, officer, or servant, or member of the Police Force, and taken before some Justice to be dealt with according to law, and shall be liable to a penalty of not more than Ten pounds (£10).—(Rs. 3090).

Given under my hand at Melbourne, this 15th day of June, 1965.—JIM BALFOUR, Minister of Lands.

The common seal of the Mayor, Councillors, and Citizens of the City of Brighton was hereunto affixed, this 28th day of June, 1965.

(SEAL)

J. E. BOWN, Mayor.
W. B. LOVELL, Councillor.
C. DEGARIS, Town Clerk.

6805

Town and Country Planning Act 1961 (Twelfth Schedule).

CITY OF BRUNSWICK.—CITY OF BRUNSWICK PLANNING SCHEME 1956.

NOTICE THAT A PLANNING SCHEME HAS BEEN PREPARED AND IS AVAILABLE FOR INSPECTION.

Amendment No. 11, 1965.

NOTICE is hereby given that the Council of the City of Brunswick in pursuance of its powers under the *Town and Country Planning Act 1961* has prepared a planning Scheme for the City of Brunswick in respect of the provision for parking space and the use of land for parking purposes.

A copy of the scheme has been deposited at the Municipal Offices, Town Hall, Brunswick, and at the office of the Town and Country Planning Board, 179 Queen-street, Melbourne, and will be open for inspection during office hours, by any person, free of charge.

Any persons affected by the Planning Scheme are required to set forth, in writing, all objections they may have, addressed to the Town Clerk, Town Hall, Brunswick, on or before the 6th day of August, 1965, and to state whether they wish to be heard in respect of their objections.

6903

H. W. FOLETTA, Town Clerk.

CITY OF CAMBERWELL..

LOAN No. 64.

Notice of Intention to Borrow the Sum of £15,000 for Permanent Works and Undertakings.

NOTICE is hereby given that the Council of the City of Camberwell proposes to borrow the principal sum of Fifteen thousand pounds on the credit of the Mayor, Councillors and Citizens of the said City of Camberwell, such sum to be raised by the grant of a mortgage in accordance with the provisions of the *Local Government Act 1958*.

1. The maximum rate of interest that may be paid is £5 12s. 6d. per centum per annum.

2. The purposes for which the loan is to be applied are—

Erection of pavilion Highfield Park (part cost)	£5,750
Development of Burwood Reserve, Hartwell Reserve, Balwyn Park, South Camberwell Reserve and Beckett Park	9,250
	£15,000

3. The period of the loan shall be ten years.

4. The moneys borrowed shall be repayable by providing out of the municipal fund twenty half-yearly instalments of approximately £990 16s. 9d. each, including principal and interest on the 1st day of April and the 1st day of October during the currency of the loan. The first instalment shall be payable on the 1st day of April, 1966.

5. Such moneys shall be repayable to the Commissioners of the State Savings Bank of Victoria, 139-165 Elizabeth-street, Melbourne.

The plans and specifications and the estimate of the cost of the proposed works and a statement showing the proposed expenditure of the moneys to be borrowed are open for inspection at the Office of the Council of the City of Camberwell, at the Civic Centre, Camberwell-road, Camberwell.

Dated the 6th July, 1965.

L. F. CHEFFERS, Chief Administrator and Town Clerk. 6822

CITY OF CAMBERWELL.

LOAN No. 63.

Notice of Intention to Borrow the Sum of £25,000 for Permanent Works and Undertakings.

NOTICE is hereby given that the Council of the City of Camberwell intends to borrow the sum hereinafter mentioned on the credit of the municipal revenues of the Mayor, Councillors and Citizens of the City of Camberwell by the grant of a mortgage in accordance with the provisions of the Local Government Acts, and Notice is hereby further given:—

- (a) That the sum of the principal moneys which it is proposed to borrow is £25,000.
- (b) That the maximum rate of interest that may be paid is £5 12s. 6d. per centum per annum.
- (c) The sum borrowed and interest thereon are to be repayable by twenty half-yearly instalments each of approximately £1,651 8s. 0d. on the 1st day of April and the 1st day of October in each year, and the place at which moneys are to be repayable is the Commercial Bank of Australia Ltd., Melbourne. The first instalment shall be payable on the 1st April, 1966.
- (d) The purposes for which the loan is to be applied are:—

Roadworks	£2,500
Development of Parks and Gardens	22,500
	£25,000

(e) The loan is to be liquidated by appropriation out of the municipal fund.

(f) The plans, specifications and estimate for the cost of such works, and the statement showing the proposed expenditure of the money to be borrowed are open for inspection at the office of the Council, Municipal Chambers, Camberwell, during office hours.

Dated the 6th July, 1965.

L. F. CHEFFERS, Chief Administrator and Town Clerk. 6823

CITY OF ECHUCA.

LOAN No. 48.

Notice of Intention to Borrow.

NOTICE is hereby given that the Council of the City of Echuca intends to borrow Twenty thousand pounds (£20,000) on the credit of the Mayor, Councillors and Citizens of the said City of Echuca by the grant of a mortgage in accordance with the provisions of the Local Government Act.

In connexion therewith the following information is stated:—

- (a) The amount of principal moneys which it is proposed to borrow is £20,000 (Twenty thousand pounds).
- (b) The maximum rate of interest that may be paid is £5 15s. per centum per annum.
- (c) The purposes for which the loan is to be applied are kerb and channel construction, footpaths, drainage and toilet block and part cost of acquiring a rubbish disposal site.
- (d) The period of the loan shall be twenty years.
- (e) The moneys borrowed shall be repayable by providing out of the municipal fund 40 half-yearly instalments of approximately £847 17s. each, including principal and interest on the 1st day of February and the 1st day of August during the currency of the loan. The first instalment shall be payable on the 1st day of February, 1966.
- (f) Such moneys shall be repayable at the office of the Local Authorities Superannuation Board,

"Rigby House", 15 Queens-road, Melbourne, or such other place or places as the Board from time to time may require.

The plans and specifications and the estimate of cost of the proposed works and a statement showing the proposed expenditure of the moneys to be borrowed, are open for inspection at the Town Hall, Echuca.

K. F. McCARTNEY, Town Clerk.

Town Hall, Echuca, 5th July, 1965.

6878

CITY OF FOOTSCRAY.

BY-LAW No. 278.

A By-law of the City of Footscray numbered 278 made under the provisions of the *Local Government Act 1958* to prohibit on from and after a date specified herein the erection or placing against or in front of any house or building abutting upon any public footway in any specified street or part thereof any verandah not supported by cantilevers brackets or projecting supports and not otherwise and requiring the pulling down and removal of such verandahs before a date also specified herein.

IN pursuance of the powers conferred by section 198 of the *Local Government Act 1958* the Mayor, Councillors and Citizens of the City of Footscray with the approval of the Governor in Council order as follows:—

1. That on from and after the first day of August, 1965 the erection or placing against or in front of any house or building abutting upon any public footway in any street or part thereof within the Municipal boundaries of the City of Footscray of any verandah over or across such footway is prohibited unless such verandah is supported by cantilevers brackets or projecting supports and not otherwise.

2. The owner of any verandah erected or placed against or in front of any house or building abutting upon any public footway in any street or part thereof specified in the Schedule hereto before the first mentioned date which verandah is upon over or across such footway and is supported otherwise than by cantilevers, brackets or projecting supports, shall pull down and remove such verandah before the first day of October, 1975.

SCHEDULE HEREINBEFORE REFERRED TO

1. All portions of the streets set out in the Schedule to By-law No. 126 other than the portions specified in such Schedule.

2. Both sides of all streets and portions of streets within the Municipal boundaries of the City of Footscray which are not specified in the said Schedule to By-law No. 126.

Resolution for passing this By-law agreed to by the Council of the City of Footscray on the Third day of May 1965, and confirmed on the Thirty-first day of May, 1965.

The common seal of the Mayor, Councillors and Citizens of the City of Footscray was hereunto affixed in our presence by order of the Council—

ALLAN C. CURTIN, Mayor.

(SEAL) W. FOGARTY, Councillor.

E. J. SMITH, Town Clerk.

Approved by the Governor in Council, 22nd June, 1965.—J. COLQUHOUN, Clerk of the Executive Council. 6825

CITY OF PRESTON.

BY-LAW No. 78.

NOTICE is hereby given that the Council of the City of Preston has made a By-law under the provisions of the *Local Government Act 1958* and numbered 78 for repealing By-law No. 72 and for controlling and regulating the use of premises with a view to preventing objectionable noises at unreasonable times.

A copy of the By-law is open for inspection, free of charge, during office hours at the offices of the Council, Town Hall, High-street, Preston.

Resolution for passing this By-law was agreed to by the Council of the City of Preston on the 10th day of May, 1965, and confirmed on the 7th day of June, 1965.

Approved by the Governor in Council on the 22nd day of June, 1965. 6842

J. C. DONATH, Town Clerk.

CITY OF PRESTON.

BY-LAW No. 79.

NOTICE is hereby given that the Council of the City of Preston has made a By-law under the provisions of the *Local Government Act 1958* and numbered 79 for the purpose of suppressing nuisances.

A copy of the By-law is open for inspection, free of charge, during office hours at the offices of the Council, Town Hall, High-street, Preston.

Resolution for passing this By-law was agreed to by the Council of the City of Preston on the 10th day of May, 1965, and confirmed on the 7th day of June, 1965.

Approved by the Governor in Council on the 22nd day of June, 1965.
6843

J. C. DONATH, Town Clerk.

CITY OF RINGWOOD.

LOAN No. 64.

Notice of Intention to Borrow the Sum of £10,000 for Permanent Works and Undertakings.

NOTICE is hereby given that the Council of the City of Ringwood proposes to borrow the principal sum of £10,000 (Ten thousand pounds) on the credit of the municipal revenues of the Mayor, Councillors and Citizens of the said City, such sum to be raised by the grant of a mortgage in accordance with the provisions of the *Local Government Act 1958*.

1. The maximum rate of interest that may be paid is £5 7s. 6d. per centum per annum.
2. The purpose for which the loan is to be applied is—
Reconstruction of Maroondah Highway, (part cost) £10,000
3. The period of the loan shall be ten years.
4. The moneys borrowed shall be repayable by providing out of the municipal fund twenty half-yearly instalments of approximately £652 15s. each, including principal and interest on the 1st days of April and October in each year, during the currency of the loan. The first instalment shall be payable on the 1st day of April, 1966.
5. That such moneys shall be repayable to the E.S. & A. Savings Bank, of 287 Collins-street, Melbourne, at the office of the said bank.

The plans and specifications and the estimate of the cost of the proposed works and a statement showing the proposed expenditure of the moneys to be borrowed, are open for inspection at the office of the Council of the City of Ringwood, Maroondah Highway, Ringwood.

F. P. DWERRYHOUSE, Town Hall, Ringwood, 28th June, 1965. 6804

CITY OF TRARALGON.

LOAN No. 13.

NOTICE is hereby given that at a meeting held on 24th May, 1965, the Council approved the following Resolution:—

1. That the Council of the City of Traralgon do and does hereby resolve to borrow the sum of £5,000 (Five thousand pounds) on the credit of the Mayor, Councillors and Citizens of the City of Traralgon, such sum to be secured by the grant of a mortgage in accordance with the provisions of the *Local Government Act 1958*.
2. The maximum rate of interest to be paid shall be 5½ per centum per annum.
3. The moneys borrowed shall be repayable by twenty (20) half-yearly instalments of approximately £330 5s. 7d. (Three hundred and thirty pounds five shillings and seven pence) including principal and interest by providing out of the receipts of moneys payable under schemes of private street construction and advances from the municipal fund should such receipts be insufficient.
4. The period of the loan shall be ten (10) years.
5. Such moneys shall be repayable at the State Savings Bank of Victoria, Melbourne.
6. The purpose for which the loan is to be applied is the defraying of the cost of the execution of schemes of private street construction in accordance with Division 10, Part XIX. of the *Local Government Act 1958*.

Notice is further given that the above Resolution was confirmed at the meeting of the Council held in the Council Chambers, on Monday, 28th June, 1965.

6814

LESLIE M. HICKMAN, Town Clerk.

BOROUGH OF WONTHAGGI.

BY-LAW No. 37.

A By-law of the Borough of Wonthaggi made under the provisions of the *Local Government Act 1958* and numbered 37 for the purpose of prohibiting or regulating the soliciting or collection from house to house adjacent to any street or road of gifts of money or of subscriptions for any purpose.

IN pursuance of the powers conferred by the *Local Government Act 1958*, the Mayor, Councillors and Burgesses of the Borough of Wonthaggi order as follows—

1. No person shall solicit or collect from house to house adjacent to any road or street within the municipal district of the Borough of Wonthaggi gifts of money or subscriptions for any purpose, except for approved local charities the proceeds of whose collections will be spent within the Borough and then only with the written permission of the Council to do so.

The Resolution for making and passing this By-law was agreed to by the Council at a meeting held on the 17th day of May, 1965, and confirmed at a meeting held on the 21st day of June, 1965.

In witness whereof the common seal of the Mayor, Councillors and Burgesses of the Borough of Wonthaggi was hereunto affixed this 21st day of June, 1965, in the presence of—

(SEAL) FRANCIS V. TURNER, Mayor.
6807 G. A. ALLAN, Councillor.
N. M. SIMMONS, Town Clerk.

SHIRE OF BASS.

BY-LAW No. 42.

A BY-LAW of the SHIRE OF BASS, made under section 326 of the *Health Act 1958* and Numbered 42 for the regulation and management of the meat area within the municipal district of the said Shire as at present constituted, and for:—

- (a) prescribing the conditions on which animals may be received into or supplied or removed from the abattoirs therein situate;
- (b) fixing the rates of fees or dues payable to the Council of the said Shire under part XV. of the *Health Act 1958*;
- (c) prescribing the times for selling and for slaughtering animals, and for selling carcasses or meat at the said Abattoirs;
- (d) the feeding, watering and tending, and the preventing of cruelty to and overcrowding of, animals in the said abattoirs; and
- (e) stopping temporarily the manufacture of and the sale of small goods in circumstances in which danger to the consumer is apprehended owing to uncleanness or to the presence of infection on or about the premises where such manufacture or sale is carried on.

IN exercise of the powers conferred by the *Health Act 1958*, and of every and any other power it thereunto enabling, the President, Councillors and Ratepayers of the Shire of Bass hereby order as follows:—

1. That BY-LAW NO. 32 is hereby repealed.
 2. In this By-law—
“The Council” means the Council of the SHIRE OF BASS.
“The Meat Inspector” means the meat inspector appointed and/or provided by the Council for the inspection and supervision of any abattoir in the meat area.
“The meat area” means all that area comprised in the Woolamai and Powlett Ridings of the aforementioned Shire.
 3. This BY-LAW shall apply to the meat area as defined in Clause 2 hereof, and such area shall, as to the enforcement of the meat Supervision Regulations therein be under the direction of the Meat Inspector.
 4. This BY-LAW shall come into full force and operation on its approval by the Governor in Council, and immediately after its publication in the *Government Gazette*.
 5. The times for slaughtering animals in the meat area shall be between the hours of seven o'clock a.m. and four o'clock p.m. on Mondays, Tuesdays, Wednesdays, Thursdays, and Fridays in each week.
- No animal shall be slaughtered in the meat area on Saturdays, Sundays or gazetted holidays, unless with the consent in writing, of the Meat Inspector, to whom at

least twenty four (24) hours notice in writing of intention to slaughter on those days must be given. All expenses incurred by reason of such slaughtering on Saturdays, Sundays, or gazetted public holidays shall be paid by the person obtaining such consent.

6. No animal visibly or known to be affected by any contagious or infectious disease shall be received into any abattoir in the meat area except with the express permission of the Meat Inspector.

7. No person shall remove or permit to be removed from any abattoir in the meat area any carcass, or part of the carcass, of any animal slaughtered thereat until the same has been examined by the Meat Inspector and passed by him as fit for human food and branded by him with the regulation brand, or rendered unfit for human consumption in the manner prescribed by the Meat Supervision Regulations.

8. No sheep shall be removed from any abattoir in the meat area with the head attached.

9. The fees payable to the Council for examining and branding carcasses, parts of carcasses, or meat by or under the direction of the Meat Inspector shall be as follows:—

(a) For examining and branding any carcass of or meat derived from any:—

(a) Bull, Cow, Calf (other than bobby-calf), heifer, ox, or steer 4/6d.

(b) Bobby-calf, goat, kid, lamb, or sheep 6d.

(c) Swine 1/6d.

For any certificate as to an examination made by a Meat Inspector 4/-.

"Bobby Calf" means a calf not more than six (6) weeks old.

In addition to these fees and the expenses referred to in Clause 5 hereof, a fee of two pounds (£2.) shall be paid by any person slaughtering animals on any Saturday, Sunday, or gazetted public holiday with the consent of the Meat Inspector.

The said fees shall be paid by the proprietor of any abattoir carried on in the meat area to the Council, and shall be so paid by the proprietor thereof to the Shire Secretary of the Council at the Office of the Council at Dalyston once at least in every week, and the amount of each such payment shall correspond with and be accompanied by a voucher from the meat inspector.

10. The proprietor of any abattoir in the meat area shall not, nor shall any person having the management or control of any animals in the abattoir:—

(a) Suffer any cruelty to take place towards any animal at any time in the abattoir.

(b) Suffer animals to be overcrowded in the abattoir.

11. Any person who shall, by wilful act or default, contravene any of the provisions of this BY-LAW shall be guilty of an offence, and shall, on conviction be liable to a penalty not exceeding Twenty Pounds (£20.).

Resolution for passing this BY-LAW was adopted by the Council of the SHIRE OF BASS on the 3rd day of December, 1964, and confirmed on the 4th day of February, 1965.

In witness whereof the Common Seal of the President, Councillors and Ratepayers of the Shire of Bass was hereunto affixed, in the presence of—

(SEAL) G. L. GARRY, President.
A. THOM, Councillor.
K. F. McRAE, Councillor.
H. BUTTERWORTH, Shire Secretary.

Submitted to the Commission of Public Health on 25th May, 1965.—A. T. GARDNER, Secretary, Commission of Public Health.

Approved by the Governor in Council, 9th June, 1965.—J. COLQUHOUN, Clerk of the Executive Council. 6831

SHIRE OF DONCASTER AND TEMPLESTOWE.

WHEREAS the Council of the Shire of Doncaster and Templestowe deems it expedient to exercise its powers of taking compulsorily the land described in the Schedule hereto for the purpose of providing pleasure grounds and places of public resort, pursuant to section 799 of the *Local Government Act 1958*, and acquiring the said land for that purpose, and whereas the Council has caused to be prepared a map and other papers setting out the general description of the work or undertaking for which the land proposed to be taken is to be used, the description of the lands proposed to be taken and the names of the owners or reputed owners, lessees,

mortgagees and occupiers of that land so far as those names are known to or can be ascertained by the Council, and whereas the said plan and other papers are deposited at the office of the said Council at Doncaster, and are and shall be open for inspection by all persons interested at all reasonable hours for the space of 40 clear days after the publication of this notice in the *Government Gazette*.

Now notice is hereby given to all persons affected by the proposed taking of the said land to set forth, in writing, addressed to the Council or Shire Secretary within 40 clear days of the publication of this notice in the *Government Gazette* all objections which they may have to the taking of the said land.

THE SCHEDULE HEREINBEFORE REFERRED TO:

Lots 488 and 489 Park-road and lots 504 and 505 Aviemore-crescent, as shown on L.P. 11939.

By order,
J. W. THOMSON, Shire Secretary.

6900

SHIRE OF DONCASTER AND TEMPLESTOWE.

WHEREAS the Council of the Shire of Doncaster and Templestowe deems it expedient to exercise its power of taking compulsorily the land described in the Schedule hereto for the purposes of providing pleasure grounds and places of public resort and recreation on lands pursuant to section 799 of the *Local Government Act 1958* and for Maternity and Child Welfare Centres, pursuant to section 807 of the *Local Government Act 1958* and acquiring the said land for that purpose, and whereas the Council has caused to be prepared a map and other papers setting out the general description of the work or undertaking for which the land proposed to be taken is to be used, the description of the land proposed to be taken and the names of the owners or reputed owners, lessees, mortgagees and occupiers of that land so far as those names are known to or can be ascertained by the Council and whereas the said plan and other papers are deposited at the Office of the Council at Doncaster, and are and shall be open for inspection by all persons interested, at all reasonable hours for the space of 40 clear days after the publication of this notice in the *Government Gazette*.

Now notice is hereby given to all persons affected by the proposed taking of the said land to set forth, in writing, addressed to the Council or Shire Secretary within 40 clear days of the publication of this notice in the *Government Gazette* all objections which they may have to the taking of the said land.

THE SCHEDULE HEREINBEFORE REFERRED TO:

Lot 92 on the plan of subdivision lodged at the Office of Titles, Melbourne, and numbered 57683, and described in certificate of title, volume 8427, folio 956, having an area of 3 acres 2 roods 18 2/10ths perches.

By order,
J. W. THOMSON, Shire Secretary.

6901

SHIRE OF EAST LODDON.

LOAN No. 19.

Notice of Intention to Borrow the Sum of £15,000 for Permanent Works and Undertakings.

NOTICE is hereby given that the Council of the Shire of East Loddon proposes to borrow the principal sum of Fifteen thousand pounds on the credit of the municipal revenues of the President, Councillors and Ratepayers of the said Shire, such sum to be raised by the grant of a mortgage in accordance with the provisions of the *Local Government Act 1958*.

1. The maximum rate of interest that may be paid is 5½ per cent. per annum.

2. The purpose for which the loan is to be applied is kerb and channel, street construction and drainage in the following streets:—Glossop, Haig, Joffre, Patrick and Keeley streets, O'Brien-avenue, Francis-lane, and Bendigo-Pyramid road at Mitiamo, and Bendigo-Pyramid road at Dungee.

3. The period of the loan shall be fifteen years.

4. The moneys borrowed shall be repayable by providing out of the municipal fund 30 half-yearly instalments of approximately £753 each, including principal and interest, on the 1st day of April and the 1st day of October during the currency of the loan. The first instalment shall be payable on the 1st day of April, 1966.

5. Such moneys shall be repayable to the Commissioners of the State Savings Bank of Victoria at the office of the said Commissioners, 139-165 Elizabeth-street, Melbourne.

The plans and specifications and the estimate of the cost of the proposed works, and a statement showing the proposed expenditure of the moneys to be borrowed, are open for inspection at the office of the Council of the Shire of East Loddon, at Serpentine, Victoria.

Dated 3rd July, 1965.

6845 T. J. RUDKINS, Shire Secretary.

SHIRE OF GLENLYON.

BY-LAW No. 30.

NOTICE is hereby given that the Council of the Shire of Glenlyon has made a By-law under the provisions of the *Health Act 1958*, and *Local Government Act 1958*, and numbered 30, for repealing By-law No. 21, and for fixing the times for slaughtering animals and prescribing fees for examination and branding of carcasses or meat.

A copy of the By-law is open for inspection, free of charge, during office hours at the offices of the Council, at Town Hall, Daylesford.

Resolution for making this By-law was agreed to by the Council on the 9th March, 1965, and confirmed on the 12th April, 1965.

6851 A. A. N. DEED, Shire Secretary.

SHIRE OF HEALESVILLE.

NOTICE OF NAMING OF STREET.

THE Council of the Shire of Healesville did, on the 29th day of June, 1965, name the road in the Township of Marysville commencing at the south-east corner of section A in the said township and passing in a westerly and southerly direction through section A and allotment 9, section 1, locally known as Deviation-road and/or Old Melbourne-road, to be Barton-avenue.

6849 W. M. OLIVER, Shire Secretary.

SHIRE OF KOWREE.

LOAN No. 24.

NOTICE is hereby given that the Council of the Shire of Kowree proposes to borrow the sum of Fifteen thousand pounds (£15,000) on the credit of the municipal revenues of the President, Councillors and Ratepayers of the Shire of Kowree, such sum to be raised by the grant of the *Local Government Act 1958*, and subsequent enactments

1. The maximum rate of interest that may be paid is £5 15s. per centum per annum.

2. The purpose for which the loan is to be applied is for—Part payment of the construction of the New Municipal Offices and Council Chambers.

3. The period of the loan shall be twenty years.

4. The moneys borrowed shall be repayable by providing out of the municipal fund 40 equal half-yearly instalments, each including principal and interest on the 1st day of September and the 1st day of March, during the currency of the loan. The first instalment shall be payable on the 1st day of September, 1965.

5. Such moneys shall be repayable at the National Bank of Australasia Limited, Melbourne, or at the Council's bankers, for the time being in Melbourne.

The plans and specifications and the estimate of the cost of the proposed works, and a statement showing the proposed expenditure of the moneys to be borrowed, are open for inspection at the Shire Offices, Edenhope.

Dated at Edenhope this 28th day of June, 1965.

6815 H. ERNEST WALKER, Shire Secretary.

SHIRE OF KOWREE.

LOAN No. 23.

NOTICE is hereby given that the Council of the Shire of Kowree proposes to borrow the sum of Fifteen thousand pounds (£15,000) on the credit of the municipal revenues of the President, Councillors and Ratepayers of the Shire of Kowree, such sum to be raised by the grant of a mortgage, in accordance with the provisions of the *Local Government Act 1958*, and subsequent enactments.

1. The maximum rate of interest that may be paid is £5 15s. per centum per annum.

2. The purpose for which the loan is to be applied is for—Part payment of the construction of the New Municipal Offices and Council Chambers.

3. The period of the loan shall be twenty years.

4. The moneys borrowed shall be repayable by providing out of the municipal fund 40 equal half-yearly instalments, each including principal and interest on the 1st day of March and the 1st day of September, during the currency of the loan. The first instalment shall be payable on the 1st day of March, 1966.

5. Such moneys shall be repayable at the National Bank of Australasia Limited, Melbourne, or at the Council's bankers, for the time being in Melbourne.

The plans and specifications and the estimate of the cost of the proposed works, and a statement showing the proposed expenditure of the moneys to be borrowed, are open for inspection at the Shire Offices, Edenhope.

Dated at Edenhope this 28th day of June, 1965.

6816 H. ERNEST WALKER, Shire Secretary.

Town and Country Planning Act 1961 (Twelfth Schedule).

SHIRE OF MORWELL.—MORWELL PLANNING SCHEME 1954.

NOTICE THAT A PLANNING SCHEME HAS BEEN PREPARED AND IS AVAILABLE FOR INSPECTION.

Amendment No. 13, 1965.

NOTICE is hereby given that the Shire of Morwell, in pursuance of its powers under the *Town and Country Planning Act 1961*, has prepared a Planning Scheme for—

That part of the municipal district of the Shire of Morwell within the Parish of Maryvale shown on the map and described as follows:—

Lots 23 and 24, and parts lots 22 and 25 on lodged plan No. 1483 being part Crown allotment 11A, Parish of Maryvale.

The purpose of the scheme is to rezone residential land as a Special Commercial Area.

A copy of the scheme has been deposited at the Shire Office, Commercial-road, Morwell, and at the office of the Town and Country Planning Board, 179 Queen-street, Melbourne, and will be open for inspection during office hours, by any person, free of charge.

Any persons affected by the Planning Scheme are required to set forth, in writing, all objections they may have, addressed to the Shire Secretary, Shire Office, Commercial-road, Morwell, on or before the 9th day of August, 1965, and state whether they wish to be heard in respect of these objections.

1st July, 1965.

6834 R. J. LORD, Shire Secretary.

Town and Country Planning Act 1961 (Twelfth Schedule).

SHIRE OF MORWELL.—MORWELL PLANNING SCHEME 1954.

NOTICE THAT A PLANNING SCHEME HAS BEEN PREPARED AND IS AVAILABLE FOR INSPECTION.

Amendment No. 12, 1965.

NOTICE is hereby given that the Shire of Morwell, in pursuance of its powers under the *Town and Country Planning Act 1961*, has prepared a Planning Scheme for—

That part of the municipal district of the Shire of Morwell within the Parish of Maryvale shown on the map and described as follows:—

Part of Crown allotment 67, Parish of Maryvale.

The purpose of the scheme is to rezone agricultural land to Residential Zone 'B' (high density residential area).

A copy of the scheme has been deposited at the Shire Office, Commercial-road, Morwell, and at the office of the Town and Country Planning Board, 179 Queen-street, Melbourne, and will be open for inspection during office hours, by any person, free of charge.

Any persons affected by the Planning Scheme are required to set forth, in writing, all objections they may have, addressed to the Shire Secretary, Shire Office, Commercial-road, Morwell, on or before the 9th day of August, 1965, and state whether they wish to be heard in respect of these objections.

1st July, 1965.

6838 R. J. LORD, Shire Secretary.

Town and Country Planning Act 1961 (Twelfth Schedule).
**SHIRE OF MORWELL.—MORWELL PLANNING
 SCHEME 1954.**

NOTICE THAT A PLANNING SCHEME HAS BEEN PREPARED AND
 IS AVAILABLE FOR INSPECTION.

Amendment No. 14, 1965.

NOTICE is hereby given that the Shire of Morwell, in
 pursuance of its powers under the *Town and
 Country Planning Act 1961*, has prepared a Planning
 Scheme for—

That part of the municipal district of the Shire of
 Morwell within the Parish of Maryvale shown on the map
 and described as follows:—

Parts of Crown allotments 45 and 46, Parish of
 Maryvale.

The purpose of the scheme is to rezone land reserved
 for public buildings to a Special Industry Zone.

A copy of the scheme has been deposited at the Shire
 Office, Commercial-road, Morwell, and at the office of the
 Town and Country Planning Board, 179 Queen-street,
 Melbourne, and will be open for inspection during office
 hours, by any person, free of charge.

Any persons affected by the Planning Scheme are
 required to set forth, in writing, all objections they may
 have, addressed to the Shire Secretary, Shire Office,
 Commercial-road, Morwell, on or before the 8th day of
 October, 1965, and state whether they wish to be heard
 in respect to these objections.

1st July, 1965.

6840

R. J. LORD, Shire Secretary.

SHIRE OF SEYMOUR.

LOAN No. 22.

*Notice of Intention to Borrow the Sum of £23,000 for
 Permanent Works and Undertakings.*

NOTICE is hereby given that the Council of the Shire
 of Seymour proposes to borrow the principal sum of
 Twenty-three thousand pounds on the credit of the
 municipal revenues of the President, Councillors and
 Ratepayers of the said Shire of Seymour, such sum to be
 raised by the grant of a mortgage in accordance with the
 provisions of the *Local Government Act 1958*.

1. The maximum rate of interest that may be paid is
 £5 15s. 0d. per centum per annum.

2. The purpose for which the loan is to be applied
 is—

(a) Balance of expenditure on Seymour
 Olympic Swimming Pool .. £16,500
 (b) Construction of Shire Residence .. £6,500

3. The period of the loan shall be fifteen years.

4. The moneys borrowed shall be repayable by providing
 out of the municipal fund 30 half-yearly instalments of
 approximately £1,154 11s. each, including principal and
 interest, on the 1st day of October and the 1st day of
 April during the currency of the loan. The first instal-
 ment shall be payable on the 1st day of April, 1966.

5. Such moneys shall be repayable to the Commissioners
 of the State Savings Bank of Victoria at the office of the
 said Commissioners, 139-165 Elizabeth-street, Melbourne.

The plans and specifications and the estimate of the
 cost of the proposed works and a statement showing the
 proposed expenditure of the moneys to be borrowed are
 open for inspection at the office of the Council of the
 Shire of Seymour, at Council Offices, Station-street,
 Seymour.

28th June, 1965.

6818

E. F. VAN LEEUWEN, Shire Secretary.

SHIRE OF TAMBO.

*Notice of Intention to Borrow the Sum of £4,365 for
 Permanent Works and Undertakings.*

NOTICE is hereby given that the Council of the Shire
 of Tambo proposes to borrow the sum of Four
 thousand three hundred and sixty-five pounds on the
 credit of the municipal revenues of the President, Councillors
 and Ratepayers of the said Shire such sum to be
 raised by the grant of a mortgage in accordance with the
 provisions of the *Local Government Act 1958*.

1. The maximum rate of interest that may be paid is
 £5 17s. 6d. per centum per annum.

2. The purpose for which the loan is to be applied is
 for the part cost of constructing new Council Chambers,
 at Bruthen.

3. The period of the loan shall be fifteen years.

4. The moneys borrowed shall be repayable by providing
 out of the municipal fund 29 half-yearly instalments of
 £153 10s. 5d. each, including principal and interest, on the
 1st day of March and the 1st day of September during
 the currency of the loan and a final instalment of £3,211
 15s. 11d. The first instalment shall be payable on the
 1st day of March, 1966.

5. Such moneys shall be repayable at the C.B.C. Savings
 Bank Limited, Melbourne.

The plans and specifications and the estimate of the
 cost of the proposed works and a statement showing
 the proposed expenditure of the moneys to be borrowed
 are open for inspection at the Shire Office, Bruthen.

6812

G. W. RIDSDALE, Shire Secretary.

SHIRE OF VIOLET TOWN.

LOAN No. 17.

*Notice of Intention to Borrow the Sum of £2,500 for
 Permanent Works and Undertakings.*

NOTICE is hereby given that the Council of the Shire
 of Violet Town proposes to borrow the principal sum
 of Two thousand five hundred pounds on the credit of
 the municipal revenues of the President, Councillors and
 Ratepayers of the said Shire, such sum to be raised by
 the grant of a mortgage in accordance with the provisions
 of the *Local Government Act 1958*.

1. The maximum rate of interest that may be paid is
 5½ per cent. per annum.

2. The purpose for which the loan is to be applied is
 the purchase of one motor truck.

3. The period of the loan shall be five years.

4. The moneys borrowed shall be repayable by providing
 out of the municipal fund ten half-yearly instalments of
 approximately £289 7s. each, including principal and
 interest, on the 1st day of April and the 1st day of
 October during the currency of the loan. The first
 instalment shall be payable on the 1st day of April, 1966.

5. Such moneys shall be repayable to the Commissioners
 of The State Savings Bank of Victoria at the office of
 the said Commissioners, 139-165 Elizabeth-street, Mel-
 bourne.

The plans and specifications and the estimate of the
 cost of the proposed works and a statement showing the
 proposed expenditure of the moneys to be borrowed
 are open for inspection at the office of the Council of the
 Shire of Violet Town, at Violet Town.

6832.

B. C. REES, Shire Secretary.

SHIRE OF WERRIBEE.

PROSECUTING OFFICER.

NOTICE is hereby given that the Council of the Shire of
 Werribee did, at a Meeting held on the 10th June,
 1965, appoint Senior Constable Joseph Anthony Brennan,
 10983, as Prosecuting Officer for the Shire of Werribee.

N. G. MINNS, Shire Secretary.

Municipal Offices, Werribee, 2nd July, 1965. 6841

Town and Country Planning Act 1961

(Fourteenth Schedule).

COBRAM PLANNING SCHEME.

IN pursuance of the powers conferred by the *Town and
 Country Planning Act 1961*, the Governor in Council
 on the 9th June, 1965, approved a planning scheme,
 Amendment No. 5 in respect of the municipal district of
 the Shire of Cobram, and such planning scheme came
 into force on 16th June, 1965.

A copy of the planning scheme as approved, may be
 inspected, free of charge, during office hours, at the office
 of the Town and Country Planning Board, 179 Queen-
 street, Melbourne, and at the office of the Shire of
 Cobram; and when available, at the Office of Titles, Mel-
 bourne, and at the Central Plan Office, of the Department
 of Crown Lands and Survey, Melbourne.

Cobram, 30th June, 1965.

6821

R. T. CUTTS, Shire Secretary.

**AMENDMENT OF REGULATIONS FOR THE CARE,
 PROTECTION AND MANAGEMENT OF THE
 "CAULFIELD RACECOURSE RESERVE".**

WE, James David Macdonald, the Honorable Sir John
 Herman Lienhop, the Honorable Sir Herbert John
 Thornhill Hyland, the Honorable Sir Arthur George
 Warner, the Honorable Arthur Gordon Rylah, the Hon-
 orable Henry Edward Bolte, Edwin James Kennon, Norman
 de Winton Robinson, John Leslie Davis, Sir Rupert William

John Clarke, Robert Alexander Hunter, Thomas Symington Carlyon, Andrew John George Sinclair, Ernest Edwin Gunn and William Richardson Thomson, being the duly appointed Trustees of the land reserved for Racing, Recreation and Public Park purposes and premises, being allotment A, at Caulfield, in the Parish of Prahran, County of Bourke, the subject matter of a Crown grant, volume 7275, folio 1454814, and known as the "Caulfield Race-course Reserve", in the exercise of the powers conferred on us by the said Crown grant, and by the *Land Act 1958*, and of any and every other power enabling us so to do, and with the approval of the Governor in Council do hereby amend the Regulations made by the Trustees on the 7th July, 1931, and approved by the Governor in Council on the 13th October, 1931, and as were amended by the Trustees on the 22nd August, 1950, and 21st February, 1953, respectively and approved by the Governor in Council on the 31st October, 1950, and 31st March, 1953, respectively, by rescinding Regulation V. in its entirety and by amending Regulation IV. to read: "Horses shall be trained and exercised on such part or parts of the said land as the Trustees or some person duly authorized, in writing, by the Trustees may from time to time direct. No person shall train or exercise a horse upon any other part of the said land."

Dated this 30th day of June, 1965.

J. D. MACDONALD.	J. L. DAVIS.	
J. H. LIENHOP.	R. W. I. CLARKE.	
H. J. T. HYLAND.	R. A. HUNTER.	
A. G. WARNER.	T. S. CARLYON.	
A. G. RYLAH.	A. J. G. SINCLAIR.	
H. E. BOLTE.	E. E. GUNN.	
E. J. KENNON.	W. R. THOMSON.	
N. de W. ROBINSON.		6926

GEELONG WATERWORKS AND SEWERAGE TRUST.

PURSUANT to section 60 (2) of the *Geelong Waterworks and Sewerage Act 1958* (No. 6263), notice is hereby given of the intention of the Trust to construct sewers to provide for properties in and adjacent to:—

Cambra-road, East Belmont, Shire of South Barwon.
Ruhamah-street, Bell Post Hill, Shire of Corio.
Boronia-street, Newcomb, Shire of Bellarine.
Culzean-crescent, North Highton, Shire of South Barwon.
Hamlyn-avenue, Hamlyn Heights, Shire of Corio,
and more particularly as shown on maps which are open for public inspection at the Trust's Offices, Ryrie-street, Geelong, between the hours of 9 a.m. and 4 p.m., daily from Monday to Friday.

Dated this 2nd day of July, 1965.

6850 B. C. HENSHAW, Secretary.

Water Act.

PROPOSED SALE CITY WATER AUTHORITY.

NOTICE is hereby given that the Sale City Council has made application to the Honourable the Minister of Water Supply for the constitution of a Local Governing Body, and for the Proclamation of a Water Supply District at Sale for the purpose of taking over the municipality's waterworks supplying water to the City of Sale, for the construction of new works to augment supplies to the said City, and for the maintenance and continuance of water supply works within the said district under the provisions of the Water Acts.

A general plan and description of the proposal has been submitted with the application, and copies of same may be seen at the Council Chambers, Sale.

Dated at Sale, the 23rd day of June, 1965.

6692 J. R. RAY, Town Clerk.

NOTICE OF INTENTION TO APPLY FOR A LICENCE TO DIVERT WATER AND CUT RACE (RE-ISSUE) FROM THE EAST KIEWA RIVER, AT MT. BEAUTY.

WE hereby give notice that we intend to apply for a licence empowering us to divert water for a term of fifteen years to the extent of 100 acre-feet per annum at a maximum rate of 2 acre-feet per day of 24 hours for the irrigation of 50 acres of tobacco, being part of allotment 1, section 4, Parish of Werमतong, and to occupy certain Crown lands for works of diversion, and to cut a race thereon.

Any objection to such application must be forwarded, in writing, to reach the State Rivers and Water Supply Commission, Melbourne, before 20th July, 1965, being 30 days from the first publication of this notice.

J. R. SHARP.
P. J. SHARP.
Bright. 6809

NOTICE OF INTENTION TO APPLY FOR A LICENCE TO DIVERT WATER AND CUT RACE FROM THE WEST KIEWA RIVER, AT MT. BEAUTY.

WE hereby give notice that we intend to apply for a licence empowering us to divert water for a term of fifteen years to the extent of 100 acre-feet per annum at a maximum rate of 2 acre-feet per day of 24 hours for the irrigation of 50 acres of tobacco, being part of allotment 3, section 4, Parish of Freeburgh, and to occupy certain Crown lands for works of diversion, and to cut a race thereon.

Any objections to such application must be forwarded, in writing, to reach the State Rivers and Water Supply Commission, Melbourne, before 20th July, 1965, being 30 days from the first publication of this notice.

GEORGE SHARP.
RICHARD SHARP.

Bright. 6810

NOTICE OF INTENTION TO APPLY FOR A LICENCE TO DIVERT WATER FROM THE OVENS RIVER, AT WANGARATTA.

I HEREBY give notice that I intend to apply for a licence empowering me to divert water for a term of eight years to the extent of 24 acre-feet per annum at a maximum rate of 2 acre-feet per day of 24 hours for the irrigation of 12 acres of tobacco and tomatoes, being allotments 6, 7 and 8, section 10, Parish of Wangaratta North, and to occupy certain Crown lands for works of diversion.

Any objections to such application must be forwarded, in writing, to reach the State Rivers and Water Supply Commission, Melbourne, before 29th July, 1965, being 30 days from the first publication of this notice.

GUISEPPE PAOLA.

18 Langlands-street, Wangaratta. 6808

NOTICE OF INTENTION TO APPLY FOR A LICENCE TO DIVERT WATER AND CUT RACE FROM THE KIEWA RIVER, AT DEDERANG, VICTORIA.

I HEREBY give notice that I intend to apply for a licence empowering me to divert water for a term of fifteen years to the extent of 50 acre-feet per annum at a maximum rate of 2 acre-feet per day of 24 hours for the irrigation of 25 acres of pasture, being part of allotment 13, Parish of Dederang, and to occupy certain Crown lands for works of diversion, and to cut a race thereon.

Any objection to such application must be forwarded, in writing, to reach the State Rivers and Water Supply Commission, Melbourne, before 20th July, 1965, being 30 days from the first publication of this notice.

WALTER LESLIE BECK.

"Dederang Park", Box 86, Tawonga Roadside, via Wodonga, Victoria. 6828

NOTICE OF INTENTION TO APPLY FOR A LICENCE TO DIVERT WATER AND CUT RACE (RE-ISSUE) FROM THE OVENS RIVER, AT WANGARATTA.

I HEREBY give notice that I intend to apply for a licence empowering me to divert water for a term of eight years to the extent of 75 acre-feet per annum at a maximum rate of 2 acre-feet per day of 24 hours for the irrigation of hops, pasture and lucerne, being part of allotments 1, 1A, 1L and 1M, Parish of Wangaratta North, and to occupy certain Crown lands for works of diversion, and to cut a race thereon.

Any objection to such application must be forwarded, in writing, to reach the State Rivers and Water Supply Commission, Melbourne, before 20th July, 1965, being 30 days from the first publication of this notice.

CLEMENT ROBERTS WILLIAM FISHER.

East Wangaratta. 6829

NOTICE OF INTENTION TO APPLY FOR A LICENCE TO DIVERT WATER AND CUT RACE (RE-ISSUE) FROM THE OVENS RIVER, AT WHOROULY EAST.

WE hereby give notice that we intend to apply for a licence empowering us to divert water for a term of eight years to the extent of 9 acre-feet per annum at a maximum rate of 1½ acre-feet per day of 24 hours for the irrigation of 6 acres of tobacco, being part of allotment 8c, Parish of Murmungee, and to occupy certain Crown lands for works of diversion, and to cut a race thereon.

Any objection to such application must be forwarded, in writing, to reach the State Rivers and Water Supply Commission, Melbourne, before 28th July, 1965, being 30 days from the first publication of this notice.

V. & B. LYONS AND CO.

Whorouly East, Victoria. 6876

NOTICE OF INTENTION TO APPLY FOR A LICENCE TO DIVERT WATER AND CUT RACE FROM THE OVENS RIVER, AT WHOROULY.

I HEREBY give notice that I intend to apply for a licence empowering me to divert water for a term of eight years to the extent of 60 acre-feet per annum at a maximum rate of 2 acre-feet per day of 24 hours for the irrigation of 40 acres of tobacco and pastures, being part of allotments 21 and 21B, no section, Parish of Whorouly, and to occupy certain Crown lands for works of diversion, and to cut a race thereon.

Any objection to such application must be forwarded, in writing, to reach the State Rivers and Water Supply Commission, Melbourne, before 28th July, 1965, being 30 days from the first publication of this notice.

G. A. KNEEBONE.

2 Larkings-street, Wangaratta. 6884

NOTICE OF INTENTION TO APPLY FOR A LICENCE TO DIVERT WATER AND CUT RACE (RE-ISSUE) FROM THE OVENS RIVER, AT WHOROULY EAST.

WE hereby give notice that we intend to apply for a licence empowering us to divert water for a term of eight years to the extent of 52½ acre-feet per annum at a maximum rate of 1½ acre-feet per day of 24 hours for the irrigation of 35 acres of tobacco, being part of allotments 71 and 71o, Parish of Whorouly, and to occupy certain Crown lands for works of diversion, and to cut a race thereon.

Any objection to such application must be forwarded, in writing, to reach the State Rivers and Water Supply Commission, Melbourne, before 8th July, 1965, being 30 days from the first publication of this notice.

V. & B. LYONS AND CO.

Whorouly East, Victoria, 6877

NOTICE is hereby given that the Glenelg District Ambulance Service, of Hamilton, has applied for a lease under section 134, *Land Act 1958*, for a term of 21 years over portion of the State School reserve in section 4, Township of Edenhope, with frontages of 159 links and 152 links respectively to Wallace and Elizabeth streets, as a site for an ambulance station.

6852 F. WORTH, Superintendent and Secretary.

NOTICE is hereby given that the Wimmera District Ambulance Service has applied for a lease for a term of 21 years, pursuant to section 134 of the *Land Act 1958*, in respect of an area of Crown lands containing 3 roads 1 perch, being allotment 9, section 19, Township of Warracknabeal, Parish of Werrigar, as a site for an ambulance station.

6853 G. H. BRANSGROVE, Superintendent/Secretary.

PURSUANT of the provisions of the *Livery and Agistment Act 1958*, it is the intention of the Monomeith Agistment Farm to sell by public auction to be conducted by Wright Stephenson and Co. Ltd., on 9th July, 1965, the thoroughbred gelding "EXPERT" the property of the Estate of the late F. Hardiman for the unpaid account for agistment charges from 29th May, 1964, to 8th July, 1965, totalling £237 0s. 6d.

24th June, 1965. F. P. CURTIN, Secretary. 6720

PURSUANT of the provisions of the *Livery and Agistment Act 1958*, it is the intention of the Monomeith Agistment Farm to sell by public auction to be conducted by Wright Stephenson and Co. Ltd., on 9th July, 1965, the thoroughbred filly "COROCENT" the property of the Estate of the late F. Hardiman for the unpaid account for agistment fees from 18th February, 1964, to 8th July, 1965, totalling £273 0s. 6d.

24th June, 1965. F. P. CURTIN, Secretary. 6721

PURSUANT of the provisions of the *Livery and Agistment Act 1958*, it is the intention of the Monomeith Agistment Farm to sell by public auction to be conducted by Wright Stephenson and Co. Ltd., on 9th July, 1965, the thoroughbred filly by "Livorno" from "Late Arrival" the property of Mr. R. Higgins for the unpaid account for agistment charges from 28th July, 1963, to 8th July, 1965, totalling £111 14s. 3d.

24th June, 1965. F. P. CURTIN, Secretary. 6722

NOTICE OF DISSOLUTION OF PARTNERSHIP.

NOTICE is hereby given that the partnership heretofore subsisting between Mavis Isobella Erica Hart and Marguerite Myrtle Reid, carrying on business as florists at 183 Barkly-street, Ararat, under the business name of "The Floral Nook" has been dissolved by mutual consent.

All accounts and payments should be forwarded to H. J. Carruthers, public accountant, 164A Barkly-street, Ararat.

I. HART.
M. M. REID.

6880

NOTICE OF DISSOLUTION OF PARTNERSHIP.

NOTICE is hereby given that the partnership heretofore subsisting between us the undersigned, Alan Rex Miller, of 29 The Ridge, Blackburn, and Mavis Edna Lang, of 283A Toorak-road, Burwood, carrying on business as personal introductions, at 283 Toorak-road, Burwood, under style or firm for Your Harmony Service, has been dissolved by mutual consent as from the 1st day of June, 1965. So far as concerns the said Mavis Edna Lang, who retires from the firm. All debts due to and owing by the said late firm, as from 31st May, 1965, will be received and paid by the said Alan Rex Miller who will continue to carry on the said business under the same style or firm.

Dated the 17th day of June, 1965.

ALAN REX MILLER.
MAVIS EDNA LANG.

6899

NOTICE is hereby given that the partnership heretofore subsisting between Ralph Hadley Nelson, of 39 Collins-street, Thornbury, Ralph Walter Nelson, of 732 Plenty-road, Preston, and Henry Francis Nelson, of 35 Dobson-avenue, Rosanna, carrying on business as hardware merchants and general retail store, at 869-871 High-street, Thornbury, under the style of "R. H. Nelson and Sons", has been dissolved as from the 30th day of June, 1965, so far as concerns the said Ralph Hadley Nelson, who retires from the said firm.

Dated the 30th day of June, 1965.

R. H. NELSON.
R. W. NELSON.
H. F. NELSON.

6922

NOTICE is hereby given that the partnership heretofore subsisting between William David Peacock and Edward Byam Wight, carrying on business as engineers, at Normanby-road, Nottingham, under the style or firm of Wilby Engineering Company, has been dissolved as from the 28th day of February, 1965, so far as concerns the said Edward Byam Wight who retires from the said firm. All debts due to and owing by the said late firm will be received and paid respectively by the said William David Peacock, who will continue to carry on the said business under the said firm name.

E. B. WIGHT.
W. D. PEACOCK.

Keith Hercules, LL.B., solicitor, 443 Little Collins-street, Melbourne. 6890

NOTICE is hereby given that the partnership carried on between Herbert Damm, William Keith Damm and Robert Leonard Damm all of Mongans Bridge, farmers, under the name of H. Damm & Sons has been dissolved from the 30th June, 1965, and that particulars of all debts due by the said H. Damm & Sons should be sent to Herbert Damm, Yackandandah.

Dated the 1st day of July, 1965.

HERBERT DAMM.
WILLIAM K. DAMM.
ROBERT L. DAMM.

McKenzie-McHarg & Wray, solicitors, Yackandandah. 6881

NOTICE is hereby given that the partnership subsisting between Robert Henry Sloan and Arthur Pike Clarke, carrying on business as men's wear retailers, at No. 109 Murphy-street, Wangaratta, under the firm name of "R. M. Sloan & Co." has been dissolved as from the 30th day of June, 1965. Robert Henry Sloan will thereafter carry on the business of men's wear retailer at No. 109 Murphy-street, Wangaratta, under the firm name of R. M. Sloan & Co.

A. P. CLARKE.
R. H. SLOAN.

W. G. Just, B.A., LL.B., solicitor, 71 Reid-street Wangaratta. 6833

NOTICE OF DISSOLUTION OF PARTNERSHIP.

NOTICE is hereby given that the partnership heretofore subsisting between the undersigned Morris Ellis, Morris Maldwyn Richard Ellis and Thomas Albert Ernest Ellis, all of 809 Sturt-street, Ballarat, in the State of Victoria, Engineers and Machinery Agents, carrying on business as Engineers and Machinery Agents, at 809 Sturt-street, Ballarat, aforesaid, under the name of Morris Ellis & Sons, has been dissolved by mutual consent as from the 30th day of June, 1965. All debts due and owing by the said late firm will be received and paid by Morris Maldwyn Richard Ellis and Thomas Albert Ernest Ellis, who will continue to carry on the business at the same place.

Dated the 30th day of June, 1965.

MORRIS ELLIS.
THOMAS A. E. ELLIS.
MORRIS M. R. ELLIS.

6835

NOTICE is hereby given that the partnership heretofore subsisting between the undersigned Leslie Lawrence Wolfe, Clifford John Wolfe, Stanley Lawrence Wolfe, Leslie Alan Wolfe and Leon William Wolfe, carrying on business as Wodonga, under the name of "Wolfe Bros." has been dissolved by mutual consent as from the 30th day of June, 1959. All debts due to and owing by the said late firm will be received and paid at the office of J. S. N. Harris, 90 High-street, Wodonga.

Dated at Wodonga, the 30th day of June, 1965.

LESLIE LAWRENCE WOLFE.
CLIFFORD JOHN WOLFE.
STANLEY LAWRENCE WOLFE.
LESLIE ALAN WOLFE.
LEON WILLIAM WOLFE.

Witness—R. F. WILTSHIRE, J.P.

6836

NOTICE OF DISSOLUTION OF PARTNERSHIP.

NOTICE is hereby given that the partnership heretofore subsisting between James Angus Matthews, of High-street, Wodonga, General Storekeeper, and James Angus Matthews, aforesaid, and James Stewart Noel Harris, of Wodonga, Solicitor as trustees of William Williams' settlement in favour of Lynette Marie Matthews, carrying on business as "J. A. Matthews & Co.", at High-street, Wodonga, has been dissolved by mutual consent as from the 30th day of June, 1965. All debts due to and owing by the said late firm will be received and paid by James Angus Matthews, who will continue to carry on the business at the same place under the same name.

Dated at Wodonga, the 1st day of July, 1965.

J. A. MATTHEWS.
J. A. MATTHEWS.
J. S. N. HARRIS.

Witness—G. CAIRNCROSS.

6837

NOTICE is hereby given that the partnership heretofore subsisting between Elizabeth Violet Taylor and Bruce Ivan Horace Marshall, under the firm name "Pampered Pooches and People" has been dissolved as from the 12th day of February, 1965.

Dated this 5th day of July, 1965.

E. V. TAYLOR.
B. I. H. MARSHALL.

Corr & Corr, solicitors, 290 Latrobe-street, Melbourne.

6854

NOTICE is hereby given that the partnership heretofore subsisting between Alexander Edward Tims, late of 35 Stanley-street, Black Rock (who died on 29th January, 1964), and the said Alexander Edward Tims and Norman Charles Tims, of 27 Boyle-street, Ashburton, as trustees of the estate of Charles William Benjamin Tims, deceased, carrying on business as manufacturers, manufacturers' agents and importers, at 143 Franklin-street, Melbourne and 379 Somerville-road, West Footscray, under the style or firm of Chas. E. Tims & Son, has been dissolved as from the 1st day of July, 1965, the partnership undertaking having been acquired by Charles Tims Pty. Limited, which company will carry on business at the same addresses.

Dated the 1st day of July, 1965.

N. C. TIMS.
M. A. TIMS.

Executors and trustees of the will and estate of Alexander Edward Tims, deceased.

N. C. TIMS.

Trustee of estate of Charles William Benjamin Tims, deceased.

6875

J. & R. A. BEATY BROS.—DISSOLUTION OF PARTNERSHIP.

NOTICE is hereby given that the partnership heretofore subsisting between us the undersigned, John Beaty Robert Alexander Beaty, Robert Donald Beaty and Keith Herbert Watt, carrying on business as farmers and graziers at "Pinewood", Toolern Vale, under the style or firm of "J. & R. A. Beaty Bros.", has been dissolved as from the 30th day of June, 1965. Accounts for debts due by and payment of debts due to the partnership should be forwarded and made to J. & R. A. Beaty Bros. at the above address.

Dated the 1st day of July, 1965.

JOHN BEATY.
ROBERT A. BEATY.
ROBERT D. BEATY.
K. H. WATT.

6871

NOTICE is hereby given that the partnership heretofore subsisting between Alexander Norman Henderson, John Harding Butler and Stanley John Korvin, carrying on business as Architects, at 18 Queens-road, Melbourne, under the style or firm of Henderson, Butler & Korvin, has been dissolved as from the 1st day of July, 1965.

A. N. HENDERSON.
J. H. BUTLER.
S. J. KORVIN.

H. S. W. Lawson Hughes & Co. 357 Little Collins, street Melbourne. 6859

NOTICE is hereby given that the partnership heretofore subsisting between the undersigned Marie Elizabeth Fisher and Howard Berriman Fisher, carrying on business as Woollen Merchants, at 287 Flinders-lane, Melbourne, under the name or style of "W. Sparr Fisher & Co.", has been dissolved by mutual consent as from the 30th day of June, 1965. All debts due to and owing by the late firm will be received and paid by Howard Berriman Fisher, who will continue to carry on the business at the same place.

Dated this 30th day of June, 1965.

M. E. FISHER.
H. B. FISHER.

J. Allan Anderson & Son, solicitors, 472 Bourke-street, Melbourne. 6860

NOTICE is hereby given that as from the 1st July, 1965, Percy Wyton Briggs will retire from the law firm of Kiddle, Briggs and Willox, of 400 Collins-street, Melbourne. The firm's practice will be continued under the same name by the remaining partners, Allan Edward Willox, George Wilfred Munro, Victor Alexander Robinson Chapple and John Edward Byrne, who will collect all moneys due to the partnership. Percy Wyton Briggs will continue his association with the firm in the capacity of consultant.

Dated this 30th day of June, 1965.

PERCY W. BRIGGS.
ALLAN E. WILLOX.
GEORGE W. MUNRO.
V. A. R. CHAPPLE.
JOHN E. BYRNE.

6921

WOULD you kindly note that on 30th June, 1965, the partnership of Henry Austin Horne and Edgar Vernon Horne, trading as "Burbury Horne and Co.", garage proprietors, of 157-159 High-street, Echuca, terminated.

Since such date this business is to be carried on by Burbury Horne and Co. Proprietary Limited.

1st July, 1965.

6883

DRS. IAN DOUGLAS BUCHANAN SUTHERLAND and GRAEME RONALD PENINGTON both carrying on practice as medical practitioners in partnership, at 438 High-street, Golden Square, hereby advise that the partnership was dissolved by mutual consent on 30th June, 1965.

Dr. Graeme Ronald Penington will continue to carry on the practice at the same address. 6813

The Companies Act 1961.—In the matter of C. W. SHIPPING & TRANSPORT COMPANY PROPRIETARY LIMITED (in Voluntary Liquidation).

NOTICE is hereby given pursuant to section 272 of the Companies Act 1961, that the Final General Meeting of the members of the above-named company will be held at 44 Queen-street, Melbourne, on the 13th August, 1965, at 10.10 a.m., when I shall lay before the meeting an account showing how the winding-up has been conducted and the property of the company disposed of.

Dated this 29th day of June, 1965.

6872

C. J. WAUGH, Liquidator.

Unclaimed Moneys Act 1962.

REGISTER of Unclaimed Moneys held by—

Name of Owner on Books and Last Known Address.	Total Amount Due to Owner.	Description of Unclaimed Moneys.	Date when Amount first became Payable.
	£ s. d.		
MAC. ROBERTSON PTY. LTD.			
Magro, Joseph, 158 Fitzroy-street, Fitzroy	6 4 4	Wages	1.4.63
Hunter, Alan David, 37 Blair-street, Coburg	9 15 11	"	8.4.63
Dawson, Kaye Lesley, 166 Barkly-street, Brunswick	9 17 6	"	15.4.63
Portelli, Joseph, 321 Fitzroy-street, Fitzroy	6 6 3	"	6.5.63
Papadopoulos, Anastasia, 12 Darebin-road, Northcote	8 13 11	"	"
Makridis, Mary, 20 Alfred-street, Blackburn	8 6 3	"	15.7.63
Tamis, Lawrence, 278 Cotham-road, Kew	6 4 8	"	29.7.63
Newton, Barry, 46 Clyde-street, Thornbury	10 2 10	"	5.8.63
Ross, William, 36 Elizabeth-street, North Richmond	5 15 2	"	6.1.64
King, Alan James, 77 Rathmines-street, Caulfield	16 7 0	"	20.1.64
Adamopoulos, Steve, 62 Sackville-street, Collingwood	20 17 8	"	27.1.64
Joxsa, Alex, 2 Lindsay-avenue, Elwood	8 1 11	"	"
Neave, P. N. (estate of), c/o Allen, Allen and Hemsley, Box 50 G.P.O., Sydney, N.S.W.	21 12 0	Dividend	8.4.63

The Companies Act 1961.—In the matter of CORIO TRANSPORT COMPANY PROPRIETARY LIMITED (in Voluntary Liquidation).

NOTICE is hereby given pursuant to section 272 of the Companies Act 1961, that the Final General Meeting of the members of the above-named company will be held at 44 Queen-street, Melbourne, on the 13th August, 1965, at 10.5 a.m., when I shall lay before the meeting an account showing how the winding-up has been conducted and the property of the company disposed of.

Dated this 29th day of June, 1965.

6873 C. J. WAUGH, Liquidator.

The Companies Act 1961.—In the matter of PARCEL TAXI SERVICE PROPRIETARY LIMITED (in Voluntary Liquidation).

NOTICE is hereby given pursuant to section 272 of the Companies Act 1961, that the Final General Meeting of the members of the above-named company will be held at 44 Queen-street, Melbourne, on the 13th August, 1965, at 10 a.m., when I shall lay before the meeting an account showing how the winding-up has been conducted and the property of the company disposed of.

Dated this 29th day of June, 1965.

6874 C. J. WAUGH, Liquidator.

The Companies Act 1961.

J. & R. L. DOYLE PTY. LTD.

NOTICE OF MEETING OF CREDITORS.

NOTICE is hereby given that a meeting of the creditors of the above-named company in pursuance of section 260 of the Companies Act will be held at Temperance Hall, View-street, Bendigo, on the 16th day of July, 1965, at 2.30 o'clock in the afternoon, for the purposes set out in sections 260, 261 and 262 of the said Act.

AGENDA.

1. To consider a special Resolution for winding up passed by the above-named company. 2. To consider a statement of the position of the company's affairs together with a list of creditors and the estimated amount of their claims. 3. To nominate a person to be liquidator for the purpose of winding up the affairs and distributing the assets of the company. 4. If thought fit to appoint a committee of inspection. 5. To consider the persons and number thereof to be appointed as a committee of inspection. 6. If a committee of inspection is not to be appointed to fix the remuneration of the liquidator.

Dated the 5th day of July, 1965.

6811 N. McLAREN YOUNG, Secretary.

THE directors of Jaydee Joinery Pty. Ltd. hereby advise that the following Resolution was duly passed at a general meeting of the members of Jaydee Joinery Pty. Ltd. on the 21st June, 1965.

That Jaydee Joinery Pty. Ltd. be placed in Voluntary Liquidation immediately, and that John Barry Reid, of J. Barry Reid & Co., be and is hereby appointed liquidator of the company.

6882

J. B. REID.

LIDLAW AND WILSON PTY. LTD. (IN LIQUIDATION).
NOTICE OF MEETING.

NOTICE is hereby given that a general meeting of the above company will be held at 12 noon, on the 8th day of August, 1965, at the office of T. A. Rank and Robinson, solicitors, 388 Bourke-street, Melbourne, for the purpose of laying before the meeting an account showing how the winding up of the company has been conducted and the property of the company has been disposed of, and giving any explanation thereof.

W. A. WOODALL, Chartered Accountant, Liquidator.

626 Riversdale-road, Box Hill, Victoria, 5th July, 1965.
6827

THE NELLA ENAMELLING & ELECTROPLATING COMPANY PROPRIETARY LIMITED.

NOTICE OF MEETING OF CREDITORS.

NOTICE is hereby given of a meeting of creditors to be held pursuant to section 260 of the Companies Act 1961 at the Registered Office of the company, 306 Little Collins-street, Melbourne, on the 23rd day of July, 1965, at 11.15 in the forenoon, for the purpose of presenting to the creditors a statement of assets and liabilities of the company, and advising them of the shareholders' decision to pass a Resolution for the voluntary winding up of the company.

Creditors may, if they so desire, appoint a liquidator and a committee of inspection to act with the liquidator.

Dated this 29th day of June, 1965.

6817 T. D. McDERMOTT, Director.

The Companies Act 1958.

WHITEMAN'S GARAGES PROPRIETARY LIMITED
(IN VOLUNTARY LIQUIDATION).

NOTICE is hereby given that, pursuant to section 209 of the Companies Act 1958, the Annual Meeting of Contributors in the above matter will be held at the office of Ernest Fookes and Company, 339 Collins-street, Melbourne, on Friday, the 16th day of July, 1965, at 2.30 o'clock in the afternoon, and the Annual Meeting of Creditors will be held at the same place and on the same day at 3 o'clock in the afternoon.

6913 ALAN J. FOOKES, Liquidator.

The Companies Act 1961.

MARBE KNITTING MILLS PTY. LTD. (IN LIQUIDATION).

Notice to Creditors of Intention to Declare Dividend.

A FIRST Dividend is intended to be declared in the above matter. Creditors who have not proved their debt by the 19th day of July, 1965, will be excluded from this dividend. The date of liquidation was the 12th day of May, 1965.

Dated this 2nd day of July, 1965.

LEWIS LUCKINS, F.C.A., Liquidator.

Lewis Luckins & Co., chartered accountants, 397 Little Collins-street, Melbourne, C.1. 67 5215, 67 5216. 6918

*Companies Act 1961.***BIRMIL PROPRIETARY LIMITED.**
(IN VOLUNTARY LIQUIDATION).*Notice of Final Meeting.*

NOTICE is hereby given that, pursuant to section 272 of the *Companies Act 1961*, a General Meeting of the members of the above-named company will be held at the offices of Cleveland, Scott & Hislop, chartered accountants, 271 William-street, Melbourne, on Monday, 9th August, 1965, at 3 o'clock in the afternoon, for the purpose of having an account laid before them showing the manner in which the winding up has been conducted and the property of the company disposed of and of hearing any explanation that may be given by the liquidator.

6916

D. C. PETLEY, Liquidator.

*Companies Act 1961.***LACHLAN PROPRIETARY LIMITED.**
(IN VOLUNTARY LIQUIDATION).*Notice of Final Meeting.*

NOTICE is hereby given that, pursuant to section 272 of the *Companies Act 1961*, a General Meeting of the members of the above-named company will be held at the offices of Cleveland, Scott & Hislop, chartered accountants, 271 William-street, Melbourne, on Monday, 9th August, 1965, at 2.15 o'clock in the afternoon, for the purpose of having an account laid before them showing the manner in which the winding up has been conducted and the property of the company disposed of and of hearing any explanation that may be given by the liquidator.

6917

D. C. PETLEY, Liquidator.

Companies Act 1961.—In the matter of PERMAWEAR HOSIERY PROPRIETARY LIMITED.—Notice re Meeting of Creditors, pursuant to Section 260.

NOTICE is hereby given that a Meeting of Creditors of the above-named company will be held at the Board Room, Institute of Chartered Accountants, 23 McKillop-street, Melbourne, at 10.30 a.m., on Tuesday, the 13th July, 1965, the company having convened a meeting of its members for the same day for the purpose of considering a Resolution that the company be wound up voluntarily.

Dated this 2nd day of July, 1965.

G. PILE, Director.

A. Neville Bird & Co., public accountants, 397 Little Collins-street, Melbourne, C.1, 67 5215, 67 5216. 6919

The *Companies Act 1961.*—In the matter of HANWELL PROPRIETARY LIMITED.

NOTICE is hereby given that at a Meeting of Members of Hanwell Proprietary Limited, held at Melbourne on the 29th day of June, 1965, the following Resolution was passed as a Special Resolution:—

"That the company be wound up voluntarily."

L. P. SMART, Liquidator.
V. K. REYNOLDS, Liquidator.

G. Marquand & Son, chartered accountants, 51 Queen-street, Melbourne, C.1. 6920

The *Companies Act 1961.*—In the matter of LOWTHER COURT PROPRIETARY LIMITED.

NOTICE is hereby given that at a Meeting of Members of Lowther Court Proprietary Limited, held at Melbourne on the 29th June, 1965, the following Resolution was passed as a Special Resolution:—

"That the company be wound up voluntarily."

L. P. SMART, Liquidator.
V. K. REYNOLDS, Liquidator.

G. Marquand & Son, chartered accountants, 51 Queen-street, Melbourne, C.1. 6923

The *Companies Act 1961.*—In the matter of ANTHONY COURT PROPRIETARY LIMITED.

NOTICE is hereby given that at a Meeting of Members of Anthony Court Proprietary Limited, held at Melbourne on the 29th day of June, 1965, the following Resolution was passed as a Special Resolution:—

"That the company be wound up voluntarily."

L. P. SMART, Liquidator.
V. K. REYNOLDS, Liquidator.

G. Marquand & Son, chartered accountants, 51 Queen-street, Melbourne, C.1. 6924

S. & D. S. PROPRIETARY LIMITED.

IN accordance with section 254 (2) (b) of the *Companies Act 1961*, notice is hereby given that at an Extraordinary Meeting of the members of the above-named company, held on the 18th day of June, 1965, it was resolved as a Special Resolution that the company be wound up voluntarily.

Dated this 21st day of June, 1965.

6925

J. B. HUTCHINS, Liquidator.

CONCRETE CRAFTSMEN PTY. LTD. (In Liquidation).

NOTICE OF FINAL MEETING OF COMPANY AND CREDITORS.

TAKE notice that a meeting of creditors of Concrete Craftsmen Pty. Ltd. (In Liquidation) will be held at the office of Kennedy & Courtney, 1st Floor, Mitchell House, 358 Lonsdale-street, Melbourne, on Wednesday, 11th August, 1965, at 11.30 a.m.

The meeting will be to receive a report from the liquidator on the completion of the administration of the Liquidation of the Company.

6888

B. J. BRANAGAN, Liquidator.

In the matter of the *Companies Act 1961*, and in the matter of A. R. COMPANY PTY. LTD. (In Voluntary Liquidation).

AT an Extraordinary General Meeting of shareholders of A. R. Company Pty. Ltd., held in the registered office, 295-297 Elizabeth-street, Melbourne, on Wednesday, 30th June, 1965, the following Resolution was duly passed as a Special Resolution:

That it has been proved to the satisfaction of the Meeting that the Company cannot, by reason of its liabilities, continue its business and that it is advisable to wind up the same, and accordingly that the company be wound up voluntarily and that Mr. Keith Campbell Geary, of 133 Beaumont-street, Hamilton, New South Wales, chartered accountant, be and he is hereby, nominated as liquidator, for the purpose of winding up the company.

6889

R. W. CULPAN, Chairman.

The *Companies Act 1961.*

R.R.S. (VIC.) PTY. LIMITED.

PURSUANT TO SECTIONS 254 AND 258.

AT an Extraordinary General Meeting of the members of R.R.S. (Vic.) Pty. Limited, convened and held at 55 Kooyong Koot-road, Hawthorn, on Wednesday, 30th June, 1965, the following Special Resolution was duly passed:—

"That the company be wound up voluntarily and that Mervyn Stanley Hill, chartered accountant, be appointed liquidator of the company."

6892

I. C. SAUNDERS, Director.

*Companies Act 1961.*SHIRLEYS FERTILIZERS (VICTORIA) PTY. LIMITED.
MEMBERS VOLUNTARY WINDING UP.

AT an Extraordinary General Meeting of the members of Shirleys Fertilizers (Victoria) Pty. Limited, duly convened and held at Sydney, on the 2nd day of July, 1965, the Special Resolution set out below was duly passed.

"Resolved that the company be wound up voluntarily and that A. F. Campbell, of Cook, Tomlins and Mirams, chartered accountants, 447 Collins-street, Melbourne, having notified, in writing, his consent to act as liquidator of the company be and is hereby appointed liquidator for the purpose of such winding up."

Dated this 2nd day of July, 1965.

6902

P. N. PACKHAM, Director and Secretary.

FELTON GRIMWADE DENTAL COMPANY PTY.
LIMITED.

AT an Extraordinary General Meeting of the above-named company duly convened and held at 504 Bourke-street, Melbourne, on the 30th day of June, 1965, a Special Resolution was passed to the effect that the company be wound up voluntarily, and an ordinary Resolution was passed to the effect that Graham Ernest Rogers, of 2 Beatrice-street, Burwood, be appointed liquidator for the purposes of the winding up.

Dated the 2nd day of July, 1965.

6904

K. LANDY, Director.

D.H.A. (INVESTMENTS) PTY. LTD.

AT an Extraordinary General Meeting of the above-named company, duly convened and held at 504 Bourke-street, Melbourne, on the 30th day of June, 1965, a Special Resolution was passed to the effect that the company be wound up voluntarily, and an ordinary Resolution was passed to the effect that Graham Ernest Rogers, of 2 Beatrice-street, Burwood, be appointed liquidator for the purposes of the winding up.

Dated the 2nd day of July, 1965.

6905 J. B. STORRAR, Director.

Notice of Winding-up Order.—In the matter of
MINSAN PROPRIETARY LIMITED.

WINDING-UP Order made 2nd July, 1965.

Name and address of official liquidator, Bruce Edward Fordham, 50 Toorak-road, South Yarra.

JAMES CANNY, Deputy Commissioner of Taxation of the Commonwealth of Australia, Petitioner. 6909

Notice of Winding-up Order.—In the matter of
CREDITO ITALO-AUSTRALIANO PROPRIETARY LIMITED.

WINDING-UP Order made 2nd July, 1965.

Name and address of official liquidator, Peter William Harvey, 440 Collins-street, Melbourne.

JAMES CANNY, Deputy Commissioner of Taxation of the Commonwealth of Australia, Petitioner. 6910

Trustee Act 1958.

NOTICE TO CLAIMANTS.

PURSUANT to the Trustee Act 1958, creditors, next of kin and all other persons having claims in respect of the estate of any deceased person named below are required to send particulars to the legal personal representative or representatives at the addresses stated, after which date the representative or representatives will distribute the assets, having regard only to the claims of which notice has been received:—

John Michael O'Brien, late of 39 Newcastle-street, Newport, retired railwayman, deceased, died on the 22nd day of June, 1964.—Claims to the executors, Mary Margaret O'Brien, widow, and John Joseph O'Brien, fitter and turner, both of 39 Newcastle-street, Newport, care of John F. Carroll of 4 Paisley-street Footscray, solicitor, by the 10th day of September, 1965. John F. Carroll, LL.B., solicitor, 4 Paisley-street, Footscray. 6895

ALL persons having claims against the estate of William Coulson Dixon, late of 532 Grey-street, Hamilton, New Zealand, retired, deceased (who died on the 2nd November, 1964), and probate of whose will was on the 25th January, 1965, granted by the Supreme Court of New Zealand to the Guardian Trust and Executors Company of New Zealand Limited of Auckland, New Zealand, and application to the Supreme Court of Victoria (Probate Jurisdiction) by the Perpetual Executors and Trustees Association of Australia Limited to seal such probate (having been granted on the 1st July, 1965), are hereby required to send particulars of such claims to The Perpetual Executors and Trustees Association of Australia Limited at its registered office at 100-104 Queen-street, Melbourne, on or before the 15th September, 1965, after which date the said company will proceed to transfer, convey or distribute the said estate to or among the persons entitled thereto, having regard only to the claims of which it shall then have had notice and will not be liable for the assets so transferred, conveyed or distributed to any persons of whose claim it shall not then have had notice.

MULLETT & LANGFORD, solicitors, 470 Bourke-street, Melbourne. 6911

EDITH DORA STARKOFF DECEASED.—NOTICE TO CLAIMANTS AND OTHERS.

CREDITORS, next of kin and others having claims in respect of the estate of Edith Dora Starkoff, late of Flat 10, 510 Glenferrie-road, Hawthorn, married woman, deceased (who died on the 3rd day of November, 1964), are to send particulars of their claims to The Equity Trustees, Executors and Agency Company Limited, at its office No. 472 Bourke-street, Melbourne, by the 10th day of September, 1965, after which date it will distribute the assets, having regard only to the claims of which it then has notice.

J. M. SMITH & EMMERTON, 170 Queen-street, Melbourne, solicitors for the said company. 6870

NOTICE TO CLAIMANTS.

THE PERPETUAL EXECUTORS AND TRUSTEES ASSOCIATION OF AUSTRALIA LIMITED, whose registered office is situate at Nos. 100-104 Queen-street, Melbourne, in the State of Victoria, and Henry Wright Amos, of 65 Ringwood-street, Ringwood, in the said State, executors of the will of Louisa Amos (who died on the 10th day of February, 1965), require all creditors, next of kin and others having claims against the property or estate of the said deceased, to send to the said executors, in the care of the said association, on or before the 27th day of October, 1965, particulars in writing of such claims after which date the said executors intend to convey or distribute such property or estate to or among the persons entitled thereto, having regard only to the claims of which they shall have had notice.

Dated the 2nd day of July, 1965.

NORVAL H. DOOLEY & SON, solicitors, 31 Queen-street, Melbourne. 6857

CREDITORS, next of kin and all others having claims in respect of the estate of Edna May Middleton, late of 5 Stafford-street, West Preston, married woman, deceased (who died on the 16th November, 1964), are to send particulars of their claims to the executor, Vaughan Frederick Kiessling, care of his solicitors, whose name and address is set out below, by the 9th day of August, 1965, after which date the executor will distribute the assets, having regard only to the claims of which he then has notice.

H. S. W. LAWSON, HUGHES & CO., solicitors, 357 Little Collins-street, Melbourne. 6856

CREDITORS, next of kin and others having claims in respect of the estate of Kitty Stuart Wade, late of 70 Kay-street, Traralgon, in the State of Victoria, widow, deceased, intestate (who died on 15th March, 1965), and Letters of Administration of whose estate were granted by the Supreme Court of Victoria, on 11th June, 1965, to David Grant MacCubbin, of 15 Finlayson-crescent, Traralgon, aforesaid, retired, are to send particulars of their claims to the said administrator, care of the below-mentioned solicitors, by the 31st August, 1965, after which date he will distribute the assets of the deceased, having regard only to the claims of which he then has notice.

Dated the 17th day of June, 1965.

BRUCE & LITTLETON, solicitors, Traralgon. 6839

CREDITORS, next of kin and others having claims in respect of the estate of Eileen Hester Goss, late of 195 Wingrove-street, Fairfield, widow, deceased (who died on the 30th day of March, 1965), are to send particulars of their claims to Royston Thomas Cahir, solicitor of 475 Collins-street, Melbourne, by the 9th day of September, 1965, after which date the executors will distribute the assets of the said estate, having regard only to claims of which they then have notice.

ROYSTON T. CAHIR, barrister and solicitor, 475 Collins-street, Melbourne. 6868

CREDITORS, next of kin and others having claims in respect of the estate of Ernest Clyde Howard, formerly of 165 Gilbert-road, Preston, but late of corner of Hunter-street and Olinda-road, Monbulk, formerly grocer but late retired, deceased (who died on the 18th day of May, 1965), are to send particulars of their claims to Royston Thomas Cahir, solicitor, of 475 Collins-street, Melbourne, by the 9th day of September, 1965, after which date the executor will distribute the assets of the said estate, having regard only to claims of which he then has notice.

ROYSTON T. CAHIR, barrister and solicitor, 475 Collins-street, Melbourne. 6869

In the will of LEWIS GEORGE BAKER, late of Newstead, in the State of Victoria, poultry farmer, DECEASED.

CREDITORS, next of kin and all persons having claims against the estate of the above-named deceased are hereby requested to send particulars in writing of such claims to the executrix of the estate of the said Lewis George Baker, deceased, in the care of the under-named solicitor, on or before the 30th day of September, 1965, after which date the said executrix will proceed to distribute the assets of the said Lewis George Baker, deceased, having regard only to the claims of which she shall then have had notice, and notice is hereby given that the said executrix will not be liable for the assets so distributed or any part thereof to any person of whose claim she shall not have had notice as aforesaid.

PATRICIA M. COUTTS, Nolan-street, Maryborough, solicitor for the applicant. 6894

ARLINE AUGUSTA GAME, late of Pendell, Wynyard, Tasmania, married woman, DECEASED.

CREDITORS, next of kin and others having claims against the estate of the deceased (who died on the 3rd day of July, 1964), are required by the executors, Thomas Graham, of 31 Queen-street, Melbourne, Victoria, solicitor, and John Septimus Game, of Pendell, Wynyard, aforesaid, retired, to send particulars to them, care of the under-mentioned solicitors, by the 15th day of September, 1965, after which date the executors may convey or distribute the assets, having regard only to the claims of which they then have notice,

Dated the 2nd day of July, 1965.

MADDEN, BUTLER, ELDER & GRAHAM, solicitors,
31 Queen-street, Melbourne. 6915

CREDITORS, next of kin and others having claims against the estate of Vincenzo (known also as Vincent and James) Letizia, late of Kongwak, farmer, deceased (who died on the 6th day of May, 1965), are required by Beatrice Maud Letizia, the executrix of the will of deceased, to send to her, addressed to the care of the undersigned solicitors, particulars thereof, on or before the 17th day of September, 1965, after which date she will distribute the estate of deceased, having regard only to the claims of which she shall then have notice.

BIRCH, ROSS & BARLOW, solicitors, Wonthaggi. 6893

LEIF GORDON BANGSUND, late of 19 Gladstone-avenue, Northcote, maintenance worker, DECEASED (who died on 16th day of April, 1965).

CREDITORS, next of kin and all other persons having claims against the estate of the deceased are required by the executrix of his will, Ivy Pearl Bangsund, of 19 Gladstone-avenue, Northcote, widow, to send particulars thereof to her, care of the under-mentioned solicitors, before 10th September, 1965, after which date she may distribute the assets of the deceased, having regard only to the claims of which she then has notice.

COLTMAN, WYATT & ANDERSON, solicitors, 578 Bourke-street, Melbourne. 6885

CREDITORS, next of kin and all others having claims against the estate of Mabel Violet Suckling, late of 52 Edwards-avenue, Garden City, in the State of Victoria, widow, deceased, intestate (who died on the 6th August, 1964), are requested to send particulars of such claims to Hope Katherine Saville, of 66 Dunstan-parade, Garden City, the administratrix of the above estate at her address, on or before the expiration of two months from the date of publication hereof, after which date the said administratrix will distribute the assets, having regard only to the claims of which she shall then have had notice.

LLOYD P. GOODE & CO., solicitors, 388 Bourke-street, Melbourne. 6906

EVELYN EMMA WILSON, late of 50 Arthur-street, South Yarra, in the State of Victoria, spinster, DECEASED.

CREDITORS, next of kin and others having claims in respect of the estate of the above deceased (who died on the 25th day of December, 1964), are required by the trustees, Peter Balmford and Aubrey Galway Schrader, both of 166 Queen-street, Melbourne, in the said State, solicitors, to send particulars to them, care of the under-mentioned by the 2nd day of September, 1965, after which date the trustees may convey or distribute the assets, having regard only to the claims of which they then have notice.

WHITING & BYRNE, solicitors, 166 Queen-street, Melbourne. 6864

ANGUS McDONALD, formerly of Korumburra, in the State of Victoria, but late of "Hazeldeane", Corio, in the said State, retired farmer, DECEASED

CREDITORS, next of kin and others having claims in respect of the estate of the deceased (who died on the 18th day of January, 1965), are required by the executors, Simon James O'Halloran, of Lance Creek, via Wonthaggi, in the said State, and Joseph Hales, of Korrine, via Glen Alvie, in the said State, farmers, to send particulars to them, care of Boothby & Boothby, solicitors, 883 Dandenong-road, Caulfield East, in the said State, by the 23rd day of September, 1965, after which date the said executors may convey or distribute the assets, having regard only to the claims of which they then have notice.

Dated the 29th day of June, 1965.

BOOTHBY & BOOTHBY, solicitors, 883 Dandenong-road, Caulfield East. 6866

CREDITORS, next of kin and all others having claims against the estate of Ada Priest, late of Duke of Edinburgh Hotel, Sydney-road, Brunswick, in the State of Victoria, widow, deceased (who died on 24th October, 1964), are requested to send particulars of such claims to Joyce Constance Sheldon, of 430 Sydney-road, Brunswick, the executrix of the above estate at her address, on or before the expiration of two months from the date of publication hereof, after which date the said executrix will distribute the assets, having regard only to the claims of which she shall then have had notice.

LLOYD P. GOODE & CO., solicitors, 388 Bourke-street, Melbourne. 6908

CREDITORS, next of kin and others having claims in respect of the estate of Alma Georgina Waltham, late of Glengarry, in the State of Victoria, married woman, deceased, intestate (who died on 21st January, 1965, and letters of administration of whose estate were granted by the Supreme Court of Victoria on 10th June, 1965, to George Edward Waltham, of Glengarry, aforesaid, farmer), are to send particulars of their claims to the said administrator, care of the below-mentioned solicitors, by the 10th September, 1965, after which date he will distribute the assets of the deceased, having regard only to the claims of which he then has notice.

Dated the 29th day of June, 1965.

BRUCE & LITTLETON, solicitors, Traralgon. 6826

CREDITORS, next of kin and others having claims in respect of the estate of Clive Stuart Foster (also called Forster) Marsh, late of 6 Tuson-street, Ararat, in the State of Victoria, and also of 329 Waterworks-road, Ashgrove, in the State of Queensland, commission agent and bookmaker, deceased (who died on the 15th day of January, 1965), are to send particulars of their claims to the executor, John Edward Joseph Briggs, of Ararat, aforesaid, solicitor, by the 15th day of September, 1965, after which date he will distribute the assets, having regard only to the claims of which he then has notice.

BRIGGS & O'DRISCOLL, solicitors, 94 Barkly-street, Ararat. 6830

CREDITORS, next of kin and others having claims in respect of the estate of Ronald William Franklin, late of 35 Scotia-street, West Preston, in the State of Victoria, pensioner, deceased (who died on the 17th day of September, 1964), are to send the particulars of their claims to Louisa Isabel Franklin, of 35 Scotia-street, West Preston, by the 22nd day of September, 1965, after which date she will distribute the assets, having regard to the claims of which she then has notice.

READ & READ, solicitors, 422 Collins-street, Melbourne. 6887

AUGUST WILHELM STARICK, late of 431 Campbell-street, Swan Hill, in the State of Victoria, grader driver, DECEASED (who died on 7th May, 1964).

CREDITORS, next of kin and all other persons having claims against the estate of the deceased are required by the executors of the will, Lisle May Starick and Norman Scott, to send particulars to them, care of the undersigned, on or before the 1st day of October, 1965, after which date they will distribute the assets, having regard only to the claims of which they then have notice.

GARDEN & GREEN, solicitors, 4 McCallum-street, Swan Hill. 6848

CREDITORS, next of kin and others having claims in respect of the estate of Isabella Jane Lucas, late of 209 Barkly-avenue, Burnley, formerly married woman, but late widow, deceased (who died on the 21st February, 1965), are to send particulars of their claims to Royston Thomas Cahir, solicitor, of 475 Collins-street, Melbourne, by the 9th day of September, 1965, after which date the executrix will distribute the assets of the said estate, having regard only to claims of which she then has notice.

ROYSTON T. CAHIR, barrister & solicitor, 475 Collins-street, Melbourne. 6867

CREDITORS, next of kin and others having claims in respect of the estate of Elsie May Hogg, late of 140 Moreland-road, Brunswick, in the State of Victoria, spinster, deceased (who died on the 16th day of February, 1965), are to send particulars of their claims to Heffey & Butler, solicitors, 369 Lonsdale-street, Melbourne, by 21st September, 1965, after which date they will distribute the assets, having regard only to the claims of which they then have notice.

HEFFEY & BUTLER, solicitors, 369 Lonsdale-street, Melbourne. 6858

CREDITORS, next of kin and others having claims in respect of the estate of Frederick Kitchener Woods, late of 230 Camberwell-road, Camberwell, estate agent, deceased (who died on the 10th day of December, 1964), are to send particulars of their claims to the executors, William McKenzie Anderson and Kenneth William Hecht, of care of Oakley Thompson and Co., 443 Little Collins-street, Melbourne, by the 21st day of September, 1965, after which date the executors will distribute the assets, having regard only to the claims of which they then have notice.

OAKLEY THOMPSON & CO., solicitors, 443 Little Collins-street, Melbourne. 6897

Re **FRANCIS JOSEPH DUFFY**, late of 61 Queens-parade, Clifton Hill, caretaker, DECEASED.

CREDITORS, next of kin and others having claims in respect of the estate of the deceased (who died on the 1st day of March, 1964), are required by the executor, Maurice Gerard Fitzgerald, of "Tarcoola", Coleraine, grazier, to send particulars to him, in care of the undersigned, by the 15th day of September, 1965, after which date the executor may convey or distribute the assets, having regard only to the claims of which he has had notice.

FITZGERALD & NASH, solicitors, Whyte-street, Coleraine. 6896

CREDITORS, next of kin and others having claims in respect of the estate of Ellen Dwyer, late of 3 Robinson-street, Moonee Ponds, widow (who died on the 2nd day of March, 1965), are to send the particulars of their claims to National Trustees, Executors and Agency Company of Australasia Limited, of 95 Queen-street, Melbourne, by the 8th day of September, 1965, after which date it will distribute the assets, having regard only to the claims of which it then has notice.

RUSSELL, KENNEDY & COOK, solicitors, 401 Collins-street, Melbourne. 6912

CREDITORS, next of kin and others having claims in respect of the estate of Dorothy Dewar, late of Clegg-road, Wandin North, widow, deceased (who died on the 25th day of April, 1965), are to send particulars of their claims to the executor, William Powell, care of the under-mentioned solicitors, on or before the 9th day of September, 1965, after which date the executor will distribute the assets, having regard only to the claims of which he then has notice.

MARTIN & MARTIN, solicitors, 37 Queen-street, Melbourne. 6914

CREDITORS, next of kin and others having claims in respect of the estate of Irene Annie Johnston, late of 37 Alfred-road, Burwood, gentlewoman, deceased (who died on the 24th day of March, 1965), are to send particulars of their claims to Mr. Robert George Johnston and The Union Fidelity Trustee Company of Australia Limited, care of the said Union Fidelity Trustee Company of Australia Limited, at its registered office situate at 100 Exhibition-street, Melbourne, by the 8th day of September, 1965, after which date they will distribute the estate, having regard only to the claims of which they then have notice.

SLATER AND GORDON, solicitors, of 127 William-street, Melbourne. 6886

KENNETH LYLE GREENWOOD, late of 56 Station-street, Belgrave, retired maintenance fitter, DECEASED.

CREDITORS, next of kin and others having claims in respect of the estate of the said deceased (who died on the 29th January, 1965), are required by Margaret Alison Lewis, of 12 Baldwin-street, East Gordon, New South Wales, to send particulars to her care of the undersigned, on or before the 10th day of September, 1965, after which date they will distribute the assets, having regard only to the claims of which they then have notice.

WISEWOULD, DUNCAN & HANGER, solicitors, 11 Bank-place, Melbourne. 6855

CREDITORS, next of kin and others having claims in respect of the estate of Violet Alice Mary McDougall, formerly of Mosman, but late of 45 Spencer-road, Cremorne, in the State of New South Wales, spinster, deceased (who died on the 27th day of December, 1964), are to send particulars of their claims to The Equity Trustees, Executors and Agency Company Limited, of 472 Bourke-street, Melbourne, by the 9th day of August, 1965, after which date it will distribute the assets, having regard only to the claims of which it then has notice.

FENTON & DUNN, solicitors, 422 Collins-street, Melbourne. 6863

CREDITORS, next of kin and others having claims in respect of the estate of Eric Hilton Cox, formerly of Main-road, Lower Templestowe, in the State of Victoria, farmer, but late of 21 Glendale-road, Templestowe, in the said State, gentleman, deceased (who died on the 1st day of January, 1965), are required by the executors, Henrietta Cox, of 21 Glendale-road, aforesaid, and Alan John Robinson, of 388 Bourke-street, Melbourne, in the said State, to send particulars of their claims to them care of the under-mentioned solicitors by the 30th day of September, 1965, after which date the executors will distribute the assets, having regard only to the claims of which they then have notice.

T. A. RANK & ROBINSON, solicitors, 388 Bourke-street, Melbourne. 6846

CREDITORS, next of kin and others having claims in respect of the estate of Frank Raymond Burnham, formerly of "Vailima", Toolondo, in the State of Victoria, grazier, but late of "Villa Vailima", Augusta-street, Mt. Martha, in the said State, gentleman, deceased, (who died on the 14th day of June, 1964), are required by the executors, Elaine Brownbill, of 2 Highton-grove, Balwyn, in the said State, and George Leonard Lansell, of "Char Singh", Moulamein, in the State of New South Wales, to send particulars of their claims to them care of the under-mentioned solicitors, by the 30th day of September, 1965, after which date the executors will distribute the assets, having regard only to the claims of which they then have notice.

T. A. RANK & ROBINSON, solicitors, 388 Bourke-street, Melbourne. 6847

CREDITORS, next of kin and others having claims in respect of the estate of Marjorie Elizabeth Helsby, late of 35 Napier-street, Deniliquin, New South Wales, married woman, deceased, intestate (who died on 2nd March, 1965), are to send particulars of their claims to The Equity Trustees, Executors and Agency Company Limited, of 472 Bourke-street, Melbourne, by 13th September, 1965, after which date it will distribute the assets, having regard only to the claims of which it then has notice.

R. C. H. BEATTIE, solicitor, 509 Collins-street, Melbourne. 6898

CREDITORS, next of kin and all others having claims against the estate of Mary Lauretta Brown, late of 28 Bryant-street, Flemington, in the State of Victoria, widow, deceased (who died on the 25th of April, 1965), are requested to send particulars of such claims to Lottie Livingston Gleeson, of 16 De Chene-parade, North Coburg, the executrix of the above estate at her address, on or before the expiration of two months from the date of publication hereof, after which date the said executrix will distribute the assets, having regard only to the claims of which she shall then have had notice.

LOYD P. GOODE & CO., solicitors, 388 Bourke-street, Melbourne. 6907

CREDITORS, next of kin and others having claims in respect of the estate of Charles Desmond Costello, late of Hastings, Hawke's Bay, in New Zealand, medical practitioner (who died on or about the 3rd day of October, 1964), are to send particulars of their claims to The Trustees, Executors & Agency Company Limited, the duly appointed attorney, under power of the executor of the will, of the said Charles Desmond Costello, at its registered office, 401 Collins-street, Melbourne, by the 10th day of September, 1965, after which date it will distribute the assets, having regard only to the claims of which it then has notice.

PRICE & CHAMBERLIN, solicitors, 443 Little Collins-street, Melbourne. 6865

In the Supreme Court of the State of Victoria.

SALE BY THE SHERRIFF.

ON Friday, the 20th of August, 1965, at 10 a.m., at the Police Station, Sunshine (unless process be stayed or satisfied):—

All the estate and interest (if any) of Dugald James McDougall, coremaker, of 34 Chelsey-street, Deer Park, as joint proprietor, with Julia Isobel McDougall, married woman, of the same address, of an estate in fee simple in the land described in certificate of title, volume 7955, folio 177, upon which is erected a brick dwelling house known as No. 34 Chelsey-street, Deer Park.

Registered mortgage Nos. A706686 and B766676 affect the said estate and interest.

Terms: Cash only.

N. FROGLEY, Sheriff's Officer. 6861
5th July, 1965.

In the Supreme Court of the State of Victoria.

SALE BY THE SHERRIFF.

ON Friday, the 20th of August, 1965, 10.15 a.m., at the Police Station, Sunshine (unless process be stayed or satisfied):—

All the estate and interest (if any) of Domokas Kendi and Sevastita Kendi, labourer and married woman respectively, both of 24 Montasell-avenue, Deer Park, as joint proprietors of an estate in fee simple in the land described in certificate of title, volume 8273, folio 898 upon which is erected a weatherboard dwelling house known as No. 24 Montasell-avenue, Deer Park.

Registered mortgage No. B897956 affects the said estate and interest.

Terms: Cash only.

N. FROGLEY, Sheriff's Officer.

5th July, 1965. 6862

IMPOUNDINGS

BROADMEADOWS.—Impounded at Campbellfield.

1 chestnut pony (colt) 18 months old

If not claimed and expenses paid, to be sold at noon on Thursday, 22nd July, 1965.

A. OLIVER,
Poundkeeper.

LINTON.—Impounded in Linton Pound.

44 Merino wethers, notch in front of left ear, and some with a tip out of left ear, no visible brand

If not claimed and expenses paid, to be sold on 22nd July, 1965.

E. W. GRIGG,
Poundkeeper.

TATURA.—Impounded in Tatura Pound.

1 Polled Dorset Horn ram, no visible brand
1 Dorset Horn ram, tattoo mark F inside diamond 545

If not claimed, and expenses paid, to be sold on 22nd July, 1965.

J. H. MACTIER,
Poundkeeper.

WAVERLEY.—Impounded in Waverley Pound.

1 Taffy gelding pony, about 12 hands, saddle marks white, two white socks hind legs, long tail, mane, and coat, no visible brands or marks

If not claimed and expenses paid, will be sold at Dandenong Market, on Friday, 23rd July, 1965.

P. C. CONLEN,
Poundkeeper.

YARRA JUNCTION.—Impounded in Yarra Junction Pound.

1 black and white Friesian heifer, no visible brand
If not claimed and expenses paid, to be sold on 24th July, 1965.

M. BERUDE,
Poundkeeper.

Subordinate Legislation Act 1962.

NOTICE OF MAKING OF STATUTORY RULES.

IN pursuance of the provisions of the *Subordinate Legislation Act 1962* and the Regulations made thereunder, notice is given of the making of the following statutory rules:—

No.	Melbourne Harbor Trust Act 1958.	Price.
	s. d.	
97/1965.	Melbourne Harbor Trust (Miscellaneous Amendments) Regulations 1965, No. 55	4 3
	Melbourne Harbor Trust Act 1958.	
98/1965.	Melbourne Harbor Trust Regulations (Amendments) 1965, No. 62.	0 6

No.	Health Act 1958 (No. 6270).	Price.
	s. d.	
99/1965.	Registration (Health Acts) Amendment Regulations 1965	0 9
	Education Act 1958; Teaching Service Act 1958; University Act 1958.	
100/1965.	Education Department Regulations 1962 (Amendment No. 6)	2 9
	State Electricity Commission Acts.	
101/1965.	State Electricity Commission Wiring (Amendment) Regulations 1965	0 9
	Stamps Act 1958.	
102/1965.	Stamps (Cheques) Regulations 1965	1 0
	Explosives Act 1960.	
103/1965.	Order Relating to the Classification of Explosives	0 6
	Explosives Act 1960.	
104/1965.	Explosives (Amendment No. 1) Regulations 1965	0 6
	Apprenticeship Act 1958.	
105/1965.	Apprenticeship (Fibrous Plastering Trade) (Amendment) Regulations 1965	0 6
	Poisons Act 1962 (No. 6889).	
106/1965.	Special Poisons (Prohibition) Regulations 1965	0 6

Copies of these statutory rules may be purchased at the Sale of Publications Section of the Government Printing Office, located at Macarthur-street, Melbourne, C.2. If ordered by mail, remittance should be addressed to "The Government Printer, Box 203, P.O., North Melbourne, N.1.", and should include 6d. extra for postage.

A. C. BROOKS,
Government Printer.

STATE ACTS, 1965

COPIES of the following Acts of Parliament of Victoria may be obtained at the Government Printing Office, or from any accredited agents, at the price set opposite to each:—

No.		Price
		s. d.
7238.	Wills (Minors')	0 6
7239.	Cattle Compensation (Amendment)	0 6
7240.	Swine (Amendment)	0 6
7241.	Social Welfare (Cadetships)	0 6
7242.	Appeal Costs Fund (Amendment)	0 6
7243.	Altona Railway Extension	0 9
7244.	Transfer of Land (Removal of Caveats)	0 6
7245.	Water Authorities Accident Insurance	0 9
7246.	Portland Harbor Trusts (Amendment)	1 0
7247.	Melbourne and Metropolitan Board of Works (Borrowing Powers)	0 6
7248.	Justices (Registration)	1 0
7249.	Mildura Irrigation and Water Trusts (Amendment)	0 9
7250.	Health (Tuberculosis Arrangement)	0 9
7251.	Children's Court (Admission to Hearings)	0 6
7252.	Bendigo Land (Special Grant)	0 6
7253.	Werribee Waterworks District (Abolition)	0 6
7254.	Dandenong Valley Authority (Amendment)	0 6
7255.	Legal Aid (Costs)	0 6
7256.	Agricultural Education (Continuation)	0 6
7257.	Geelong (Kardinia Park) Land	0 6
7258.	Water (Amendment)	0 9
7259.	Victorian Inland Meat Authority (Amendment)	0 6
7260.	The Constitution Act Amendment (Subordinate Legislation Committee)	0 6
7261.	Country Fire Authority	0 9
7262.	Subordinate Legislation (Amendment)	0 6
7263.	Crimes (Illegal Use of Motor Cars)	0 9
7264.	Property Law (Loans to Minors)	0 9
7265.	Soil Conservation (Water Resources)	0 9
7266.	Grain Elevators (Borrowing Powers)	0 6
7267.	Aborigines (Amendment)	0 6
7268.	Stamps	1 0
7269.	Crimes (Parole)	0 6

A. C. BROOKS,
Government Printer.

ACTS REPRINTED IN ACCORDANCE WITH THE AMENDMENTS INCORPORATION ACT 1958 (No. 6422), AND FOR SALE AT THE SALE OF PUBLICATIONS BRANCH OF THE GOVERNMENT PRINTING OFFICE, MACARTHUR-STREET, MELBOURNE.

No.	Price. s. d.
6189. Acts Interpretation (Incorporating amendments up to No. 7146)	1 6
6191. Administration and Probate (<i>Second Reprint</i> —Incorporating amendments up to No. 6920)	3 6
6209. Boiler Inspection (Incorporating amendments up to No. 7072)	1 9
6218. Children's Court (Incorporating amendments up to No. 7084)	2 0
6219. Children's Welfare (Incorporating amendments up to No. 6812)	2 6
6220. Clean Air (Incorporating amendments up to No. 6886)	1 0
6222. Commercial Goods Vehicles (Incorporating amendments up to No. 6886)	1 9
6225. Co-operation (<i>Second Reprint</i> —Incorporating amendments up to No. 7083)	4 3
6226. Co-operative Housing Societies (Incorporating amendments up to No. 7097)	4 0
6228. Country Fire Authority (Incorporating amendments up to No. 7065)	4 0
6229. Country Roads (Incorporating amendments up to No. 6943)	4 0
6231. Crimes (Incorporating amendments up to No. 6958)	13 3
6236. Dog (<i>Second Reprint</i> —Incorporating amendments up to No. 7065)	1 6
6242. Employers and Employe's (Incorporating amendments up to No. 6740)	1 9
6245. Estate Agents (<i>Second Reprint</i> —Incorporating amendments up to No. 7134)	3 9
6246. Evidence (Incorporating amendments up to No. 6758)	3 6
6249. Fences (Incorporating amendments up to No. 6550)	1 3
6251. Firearms (Incorporating amendments up to No. 6716)	2 3
6259. Gaols (Incorporating amendments up to No. 6651)	1 6
6265. Goods (<i>Third Reprint</i> —Incorporating amendments up to No. 7131)	2 9
6270. Health (Incorporating amendments up to No. 6886)	14 6
6274. Hospitals and Charities (Incorporating amendments up to No. 6716)	3 6
6279. Instruments (<i>Second Reprint</i> —Incorporating amendments up to No. 6886)	3 9
6282. Justices (Incorporating amendments up to No. 6961)	11 3
6283. Labour and Industry (<i>Second Reprint</i> —Incorporating amendments up to No. 7143)	7 6
6285. Landlord and Tenant (<i>Second Reprint</i> —Incorporating amendments up to No. 6996)	5 0
6289. Land Tax (Incorporating amendments up to No. 7099)	3 3
6291. Legal Profession Practice (Incorporating amendments up to No. 7065)	4 6
6293. Licensing (Incorporating amendments up to No. 6659)	9 3
6295. Limitation of Actions (Incorporating amendments up to No. 6845)	1 6
6298. Local Authorities Superannuation (Incorporating amendments up to No. 6894)	2 6
6299. Local Government (Incorporating amendments up to No. 7052)	35 0
5309. Medical (Incorporating amendments up to No. 6837)	3 9
6310. Melbourne and Metropolitan Board of Works Act 1958 (Incorporating amendments up to No. 7054)	8 6
6315. Metropolitan Fire Brigades (Incorporating amendments up to No. 6886)	2 9
6317. Milk and Dairy Supervision (Incorporating amendments up to No. 6964)	4 0
6318. Milk Board Act (Incorporating amendments up to No. 7093)	2 3
6324. Money Lenders (Incorporating amendments up to No. 6886)	2 6
6325. Motor Car (Incorporating amendments up to No. 6867)	6 6
6328. Nurses (Incorporating amendments up to No. 6716)	2 0
6330. Partnership	1 6
6337. Police Offences (Incorporating amendments up to No. 7145)	8 3
6338. Police Regulation (Incorporating amendments up to No. 7081)	4 6

ACTS REPRINTED IN ACCORDANCE WITH THE AMENDMENTS INCORPORATION ACT 1958 (No. 6422)—*continued*.

No.	Price. s. d.
6343. Process Servers and Inquiry Agents (Incorporating amendments up to 7126)	1 3
6344. Property Law (Incorporating amendments up to No. 6867)	9 0
6349. Public Service (Incorporating amendments up to No. 6886)	2 9
6350. Public Trustee (Incorporating amendments up to No. 6961)	3 6
6359. Road Traffic (Incorporating amendments up to No. 6999)	1 6
6363. Second-Hand Dealers	1 3
6367. Settled Land (Incorporating amendments up to No. 6505)	4 0
6372. Soil Conservation and Land Utilization Act 1958 (Incorporating amendments up to No. 6961)	2 0
6375. Stamps (<i>Second Reprint</i> —Incorporating amendments up to No. 7142)	7 0
6377. State Electricity Commission (Incorporating amendments up to No. 7054)	5 0
6379. State Savings Bank (Incorporating amendments up to No. 6886)	4 3
6399. Transfer of Land (<i>Second Reprint</i> —Incorporating amendments up to No. 7130)	5 3
6401. Trustee (<i>Second Reprint</i> —Incorporating amendments up to No. 6963)	4 3
6413. Water (Incorporating amendments up to No. 7228)	14 3
6414. Weights and Measures (Including Amendments up to No. 6918)	3 3
6419. Workers Compensation (Incorporating amendments up to No. 7063)	5 0
6577. Lifts and Cranes (Incorporating amendments up to No. 6886)	1 3
6585. Forests (Pulpwood Agreement) (Incorporating amendments up to No. 6886)	1 6
6605. Mental Health (Incorporating amendments up to No. 7135)	4 6
6651. Social Welfare (<i>Second Reprint</i> —Incorporating amendments up to No. 7084)	3 6
6653. Valuation of Land (Incorporating amendments up to No. 7019)	1 6
6832. Motor Boating (Incorporating amendments up to No. 6961)	1 6
6839. Companies (Incorporating amendments up to No. 7142)	22 6
6879. Unclaimed Moneys (Incorporating amendments up to No. 6961)	1 3
6886. Subordinate Legislation (Incorporating amendments up to No. 6961)	1 6
6889. Poisons (Incorporating amendments up to No. 7065)	3 6
6890. Probate Duty (Incorporating amendments up to No. 6970)	3 9

A. C. BROOKS,
Government Printer.

PUBLICATION OF OFFICIAL MATTER.

ATTENTION is invited to the following procedure in relation to the publication of official matter in the *Government Gazette*:—

1. Matter submitted to the Executive Council.

Matters submitted to the Executive Council which requires gazettal will normally be published in the issue of the following week.

Where urgent gazettal is required, special arrangements should be made with the Gazette Officer, Room 9, first floor, Old Treasury Building.

Publication will be facilitated by the submission of carbon copies for the use of the Gazette Officer.

2. Other matter.

(a) All other matter duly certified by a responsible officer for publication should be lodged with the Gazette Officer not later than half-past Ten a.m. on Tuesday.

(b) Lengthy or involved notices should be forwarded several days before publication.

(c) Proofs, which will be supplied only when specifically requested or, at the direction of the Gazette Officer, should be returned promptly to avoid delay in publication.

(d) No additions or amendments to matter for publication will be accepted by telephone.

THE "VICTORIA GOVERNMENT GAZETTE".

SUBSCRIPTIONS.—The subscription, including postage, is £2 15s. per annum, or £1 7s. 6d. per half year, payable in advance.

Subscriptions are required for whole months, and must cover at least a half year.

Single copies are One shilling, posted One shilling and six pence. Subscribers do not receive the Acts of Parliament with the GAZETTE.

GAZETTES are held in stock for five years only.

PRIVATE ADVERTISEMENTS.—The charge for insertion is 2s. per line single column, and 4s. per line double column. The title forms one or more lines as a heading. On an average ten words make a line of single column. Every signature must likewise be counted as a line. The final words of a paragraph, though only portion of a line, must be counted as one line. Signatures (in particular) and proper names must be written very plainly in the text; ONE SIDE ONLY of each sheet of paper should be WRITTEN UPON.

All documents illegibly written will be returned unpublished, and where brands occur unprovided for by the ordinary letters of the alphabet, a worded explanatory description must be furnished.

Advertisements unaccompanied by a remittance sufficient to cover the cost of the insertion will be returned unpublished.

THE VICTORIA GOVERNMENT GAZETTE is published on WEDNESDAY EVENING in each week, and Notices for insertion will be received by the Government Printer at or before ONE p.m. at ordinary rates, and late advertisements between ONE p.m. and FOUR p.m. at double rates on the day preceding the day of publication.

PAYMENTS.—All payments are required in advance and remittances should be made by cheque, postal note, or money order payable to "GOVERNMENT PRINTER".

ADDRESS.—All communications should be addressed to "The Government Printer, Box 203, P.O., North Melbourne".

AGENTS FOR THE "VICTORIA GOVERNMENT GAZETTE".

THE following have been appointed agents to receive Advertisements and Subscriptions for the Victoria Government Gazette:—

- ARMSTRONG'S AGENCY, 205 Queen-street, Melbourne.
- ARNALL & JACKSON, 390 Barkly-street, Brunswick, N.10.
- BAIRNSDALE AUTHORIZED NEWSAGENCY, 132 Main-street, Bairnsdale.
- COOKE, F. R. & E. M., & SONS, 69 Bridge-street, Benalla.
- DAVIES, G. & M. V., 112 Gray-street, Hamilton.
- DAVIS, WM. (MILDURA) PTY. LTD., 126 Eighth-street, Mildura.
- DIXON'S NEWSAGENCY, 89 Firebrace-street, Horsham.
- EDGAR'S NEWSAGENCY PTY. LTD., 293 Hargreaves-street, Bendigo.
- FRANKS, H., & CO., 184 Ryrrie-street, Geelong.
- GORDON & GOTCH AUSTRALASIA LTD., 511 Little Collins-street, Melbourne.
- GULLAN'S NEWSAGENCY, 88 Bridge-street, Ballarat.

- HALES, D. & N., Henty-street, Casterton.
- HAMPTON, A. C., 243 Mitchell-street, Bendigo.
- HARSTON, PARTRIDGE & CO. PTY. LTD., 455 Little Collins-street, Melbourne.
- KYNETON GUARDIAN PTY. LTD., P.O. Box 18, Kyneton.
- THE MERCANTILE EXCHANGE, 90 Queen-street, Melbourne.
- MCGILL'S AUTHORIZED NEWSAGENCY, 183-5 Elizabeth-street, Melbourne.
- PETTY, R. H. & W. M., 83 Murphy-street, Wangaratta.
- PURDIE, J., & CO., 138 Moorabool-street, Geelong.
- SALE AUTHORIZED NEWSAGENCY, 142 Raymond-street, Sale.
- SKINNER'S AUTHORIZED NEWSAGENCY, 49-51 Franklin-street, Traralgon.
- TUFF'S SHEPPARTON NEWSAGENCY, 246 Wyndham-street, Shepparton.
- VERNON, C. F. & H. J., 162 Bridge-road, Richmond.
- VIEW POINT AUTHORIZED NEWSAGENCY, 4 View-Point, Bendigo.

A copy of the Gazette filed at each place for public reference.

CONTENTS

	PAGE
Acts of Parliament on sale at the Government Printing Office.	2220
Appointments	2178
Contracts	2166
Estates of Deceased Persons	2153
Government Notices	2153
Impoundings	2220
Lands	2191
Melbourne and Metropolitan Board of Works—	
Notice	2174
Mining	2155
Notice of Making of Statutory Rules	2220
Orders in Council—	
Acts—Country Roads; Land; Victoria Institute of Colleges; Housing; Local Government; Hospitals and Charities; Land; Landlord and Tenant; State Savings Bank; Housing; Water; Children's Welfare.	2180 et seq
Private Advertisements	2206
Proclamations	2151
Public Half-Holidays	2152
Public Service Notices	2201
Regulations—	
Acts—Police Regulation	2154
Resignations	2179
Tenders	2199
Transport Regulation Board—Public Hearings	2157
Waterworks Trusts	2176