



VICTORIA GOVERNMENT GAZETTE

Published by Authority

[Registered at the General Post Office, Melbourne, for transmission by post as a newspaper.]

No. 861

WEDNESDAY, OCTOBER 20

[1965

PROCLAMATIONS

Land Act 1958.

AREA OF LAND COMPRISED IN CERTAIN CLASSES DIMINISHED OR INCREASED.

PROCLAMATION

By His Excellency the Governor of the State of Victoria and its Dependencies in the Commonwealth of Australia, &c., &c., &c.

WHEREAS by the *Land Act 1958* it is amongst other things enacted that the Governor in Council may, by Proclamation to be published in the *Government Gazette*, at any time diminish or increase the area of land comprised in any of the classes mentioned in Part I., Division 1, section 5, of the said *Land Act 1958*, but that the area of lands which may be sold by auction (Class 6), shall not be increased except as in certain cases in the said Act provided: Now therefore I, the Governor of the State of Victoria, in the Commonwealth of Australia, by and with the advice of the Executive Council of the said State, and in accordance with the provisions of sections 94 and 117 of the *Land Act 1958* aforesaid, do hereby diminish or increase (as the case may be) the areas of Crown lands comprised in Classes 6 and 7 of the classes mentioned in section 5 of the *Land Act 1958* aforesaid, to the extent set forth in the subjoined Schedule (that is to say):—

Schedule referred to.

CLASSES DIMINISHED OR INCREASED.

County.	Parish.	Allotment.	Section.	Area.	Diminished.	Increased.	Description.
					Class.	Class.	
				A. R. P.			
Borong Illawarra ..	161E	..	8 3 30	..	6	About 1½ miles north west of Stawell Township
Grenville Clarksdale ..	21C	E	1 0 0	7	6	In the north of the Parish
Talbot Clunes ..	19	1	2 0 0	..	6	In the centre of the Parish

Given under my Hand and the Seal of the State of Victoria, aforesaid, at Melbourne, this twelfth day of October, in the year of Our Lord One thousand nine hundred and sixty-five, and in the fourteenth year of the reign of Her Majesty Queen Elizabeth II.

ROHAN DELACOMBE.

(L.S.)

By His Excellency's Command,

JIM BALFOUR,
Minister of Lands.

GOD SAVE THE QUEEN!

Land Act 1958.

UNALIENATED CROWN LAND AVAILABLE FOR SETTLEMENT UNDER IMPROVEMENT PURCHASE LEASES.

PROCLAMATION

By His Excellency the Governor of the State of Victoria and its Dependencies in the Commonwealth of Australia, &c., &c., &c.

IN pursuance of the provisions of section 153 of the *Land Act 1958*, I, the Governor of the State of Victoria in the Commonwealth of Australia, by and with the advice of the Executive Council of the said State, do by this Proclamation declare the unalienated Crown lands mentioned in the subjoined Schedule, to be available for settlement under improvement purchase leases.

SCHEDULE.

County.	Parish.	Allotment.	Section.	Area.	Land Valuation.
Normanby	Weecurra	17A & 17B	C	A. R. P. 295 0 0±	£1 per acre

Given under my hand and the Seal of the State of Victoria aforesaid, at Melbourne, this twelfth day of October, in the year of our Lord One thousand nine hundred and sixty-five, and in the fourteenth year of the reign of Her Majesty Queen Elizabeth II.

ROHAN DELACOMBE.

(L.S.) By His Excellency's Command,

JIM BALFOUR,

Minister of Lands.

GOD SAVE THE QUEEN!

*Apprenticeship Act 1958.*BRICKLAYING AND PLASTERING TRADES
PROCLAIMED APPRENTICESHIP TRADES
OUTSIDE THE METROPOLITAN DISTRICT.

PROCLAMATION

By His Excellency the Governor of the State of Victoria and its Dependencies in the Commonwealth of Australia, &c., &c., &c.

WHEREAS section 13 of the *Apprenticeship Act 1958* provides, *inter alia*, that after the Minister has taken into consideration any recommendation made by the Apprenticeship Commission the Governor in Council, for the purposes of the said Act, may from time to time by Proclamation proclaim any trades to be apprenticeship trades:

And whereas the Apprenticeship Commission, having notified in the manner prescribed by the said Act its intention to recommend that the trades of bricklaying and plastering, insofar as they are carried on in the whole of the State of Victoria outside and excepting the Metropolitan District, be proclaimed apprenticeship trades under the said Act, and having considered the representations made on behalf of the employers and employees in the said trades, has recommended to the Minister that the said trades be so proclaimed:

And whereas the Minister has taken the said recommendation into consideration:

Now therefore I, the Governor of the State of Victoria, in the Commonwealth of Australia, by and with the advice of the Executive Council of the said State, do by this my Proclamation proclaim the trades of bricklaying and plastering insofar as they are carried on in the whole of the State of Victoria outside and excepting the Metropolitan District, to be apprenticeship trades.

Given under my Hand and the Seal of the State of Victoria aforesaid, at Melbourne, this twelfth day of October, in the year of our Lord One thousand nine hundred and sixty-five, and in the fourteenth year of the reign of Her Majesty Queen Elizabeth II.

(L.S.) ROHAN DELACOMBE.

By His Excellency's Command,

G. O. REID,

Minister of Labour and Industry.

GOD SAVE THE QUEEN!

*Apprenticeship Act 1958.*COOKING TRADE PROCLAIMED AN APPRENTICESHIP
TRADE OUTSIDE THE METROPOLITAN DISTRICT.

PROCLAMATION

By His Excellency the Governor of the State of Victoria and its Dependencies in the Commonwealth of Australia, &c., &c., &c.

WHEREAS section 13 of the *Apprenticeship Act 1958* provides, *inter alia*, that after the Minister has taken into consideration any recommendation made by the Apprenticeship Commission the Governor in Council for the purposes of the said Act may from time to time by Proclamation proclaim any trades to be apprenticeship trades:

AND WHEREAS the Apprenticeship Commission having notified in the manner prescribed by the said Act its intention to recommend that the trade of cooking be proclaimed an apprenticeship trade under the said Act, insofar as it is carried on in any hotel, club, restaurant, eating house, coffee palace, boarding house, hospital or industrial canteen anywhere in the State of Victoria outside and excepting the Metropolitan District, in which three or more adult persons are permanently employed in the kitchen, and having considered the representations made on behalf of the employers and employees in the said trades, has recommended to the Minister that the said trade be so proclaimed:

AND WHEREAS the Minister has taken the said recommendation into consideration:

NOW, THEREFORE I, the Governor of the State of Victoria, in the Commonwealth of Australia, by and with the advice of the Executive Council of the said State, do by this Proclamation proclaim the trade of cooking to be an apprenticeship trade insofar as it is carried on in any hotel, club, restaurant, eating house, coffee palace, boarding house, hospital or industrial canteen anywhere in the State of Victoria outside and excepting the Metropolitan District, in which three or more adult persons are permanently employed in the kitchen.

Given under my Hand and the Seal of the State of Victoria aforesaid, at Melbourne, this twelfth day of October, in the year of our Lord One thousand nine hundred and sixty-five, and in the fourteenth year of the reign of Her Majesty Queen Elizabeth II.

(L.S.) ROHAN DELACOMBE.

By His Excellency's Command,

G. O. REID,

Minister of Labour and Industry.

GOD SAVE THE QUEEN!

PUBLIC HOLIDAYS.

PROCLAMATION

By His Excellency the Governor of the State of Victoria and its Dependencies in the Commonwealth of Australia, &c., &c., &c.

IN pursuance of the provisions contained in Part III. of the Public Service Act 1958, I, the Governor of the State of Victoria, in the Commonwealth of Australia, by and with the advice of the Executive Council of the said State, do by this my Proclamation appoint the days and dates hereunder mentioned to be observed as Public Holidays or Public Half-Holidays (as the case may be) at the places respectively specified, viz.:—

Public Holiday:—

TUESDAY, THE 2ND NOVEMBER, 1965, throughout the Borough of Eaglehawk.

Public Half-Holidays from the Hour of Twelve o'clock noon:—

WEDNESDAY, THE 10TH NOVEMBER, 1965, throughout the Borough of Eaglehawk.

WEDNESDAY, THE 17TH NOVEMBER, 1965, throughout the Shire of Buninyong.

Given under my Hand and the Seal of the State of Victoria aforesaid, at Melbourne, this nineteenth day of October, in the year of our Lord One thousand nine hundred and sixty-five, and in the fourteenth year of the reign of Her Majesty Queen Elizabeth II.

(L.S.) ROHAN DELACOMBE.

By His Excellency's Command,

A. G. RYLAH,
Chief Secretary.

GOD SAVE THE QUEEN!

ACTS OF PARLIAMENT.

PROCLAMATION

By His Excellency the Governor of the State of Victoria and its Dependencies in the Commonwealth of Australia, &c., &c., &c.

I THE Governor of the State of Victoria, in the Commonwealth of Australia, do hereby declare that I have this day assented, in Her Majesty's name, to the Bills passed by the Parliament of the said State, the titles whereof are hereunder set forth together with the short titles, that is to say:—

No. 7298. "An Act to make Provision with respect to the Supply of Electricity in Victoria by Local Government Authorities and other Corporate Bodies in New South Wales and South Australia." (*Electric Light and Power (Interstate Supplies) Act 1965.*)

Given under my Hand and the Seal of the State of Victoria aforesaid, at Melbourne, this nineteenth day of October, in the year of our Lord One thousand nine hundred and sixty-five and in the fourteenth year of the reign of Her Majesty Queen Elizabeth II.

(L.S.) ROHAN DELACOMBE.

By His Excellency's Command,

HENRY E. BOLTE,
Premier.

GOD SAVE THE QUEEN!

LOCAL GOVERNMENT DEPARTMENT.

PROCLAMATION EXTENDING THE OPERATION OF THE UNIFORM BUILDING REGULATIONS.

By His Excellency the Governor of the State of Victoria and its Dependencies in the Commonwealth of Australia, &c., &c., &c.

WHEREAS section 916A of the *Local Government Act 1958*, as amended, provides, *inter alia*, that the Governor in Council may, by proclamation published in the *Government Gazette*, at the request of the council of any municipality (not being a city or town) extend the operation of Part XLIX. of the said Act to the municipal district of such municipality or any part thereof:

AND WHEREAS by Proclamation published in the *Government Gazette* on the 27th August, 1948, the operation of the said Part was extended to part of the municipal district of the Shire of Mortlake.

AND WHEREAS the Council of the Shire of Mortlake has requested that the operation of the said Part be extended to a further part of the municipal district of the Shire of Mortlake.

NOW THEREFORE I, the Governor of the State of Victoria, by and with the advice of the Executive Council thereof, by this, my proclamation, do hereby extend the operation of the Regulations made under Part XLIX. of the *Local Government Act 1958*, as amended, to that part of the municipal district of the Shire of Mortlake defined hereunder:

All that portion of Crown Section A (Mt. Shadwell P.R.), Parish of Mortlake, County of Hampden, commencing at the road intersection at the north-eastern corner of Lot 19 on L.P. 4917 lodged at the Office of Titles and bounded on the East by the road shown on that plan, being the Eastern boundaries of Lots 19, 18, 17 on L.P. 4917 aforesaid and bounded on the South and West by the Terang-Mortlake Railway Line and bounded on the North by the Government-road being Northern boundary of Crown Section A to the point of commencement.

And order that the said Regulations shall come into operation in the above described part of the municipal district of the Shire of Mortlake on publication of this Proclamation in the *Government Gazette*, provided that Parts I. and II. of Chapter 8 thereof shall not be deemed to come into operation till the 20th January, 1966, except in so far as may be necessary to enable the Council of the said municipality to make by-laws pursuant to the powers conferred by Part III. of the said Chapter and provided further that no such by-law shall come into operation before the 20th January, 1966.

Given under my Hand and the Seal of the State of Victoria aforesaid, at Melbourne, this twelfth day of October, in the year of our Lord One thousand nine hundred and sixty-five, and in the fourteenth year of the reign of Her Majesty Queen Elizabeth II.

(L.S.) ROHAN DELACOMBE.

By His Excellency's Command,

R. J. HAMER,
Minister for Local Government.
GOD SAVE THE QUEEN!

GOVERNMENT NOTICES

HOLIDAY.—MELBOURNE CUP DAY.

NOTICE is hereby given that on—

TUESDAY, THE 2ND NOVEMBER, 1965,

the Public Offices in the municipalities mentioned hereunder will be closed, that day being appointed by the *Public Service Act 1958* to be observed as a holiday in the Public Offices:—

The Cities of Box Hill, Brighton, Broadmeadows, Brunswick, Camberwell, Caulfield, Chelsea, Coburg, Collingwood, Dandenong, Essendon, Fitzroy, Footscray, Hawthorn, Heidelberg, Kellor, Kew, Malvern, Melbourne, Moorabbin, Mordialloc, Northcote, Nunawading, Oakleigh, Port Melbourne, Prahran, Preston, Richmond, Ringwood, St. Kilda, Sandringham, South Melbourne, Springvale, Sunshine, Waverley and Williamstown; the Shires of Altona, Bacchus Marsh, Berwick, Bulla, Cranbourne, Croydon, Diamond Valley, Doncaster and Templestowe, Eltham, Frankston, Gisborne, Hastings, Knox, Lillydale, Melton, Mornington, Romsey, Sherbrooke, Werribee and Whittlesea.

This notice relates only to the closing of the State Public Offices. All inquiries regarding holidays in other offices and in shops and industry should be directed to the Department of Labour and Industry, 110 Exhibition-street, Melbourne. (Telephone 63-0321, Extension 6158 or 6721.)

A. G. RYLAH,
Chief Secretary.

Chief Secretary's Office,
Melbourne, 5th October, 1965.

CORRIGENDUM.

IN By-law No. 36 of the Shire of Portland which was published in *Victoria Government Gazette*, No. 80, dated 29th September, 1965 (pages 3083-4), for the final paragraph of such By-law commencing "Resolution for passing" and ending "18th day of September, 1965", substitute the following paragraph:—

"Resolution for passing this By-law agreed to by the Council of the Shire of Portland the 13th day of August, 1965, and confirmed at the meeting of the said Council held on the 10th day of September, 1965."

Transport Regulation Act.
TRANSPORT REGULATION BOARD.
 HEARING OF APPLICATIONS.

NOTICE is hereby given that the following applications will be considered by the Transport Regulation Board at its offices at Rathdown-street, Carlton, at 9.30 a.m. on Monday, 8th November, 1965.

D.A. CONSTRUCTIONS PTY. LTD., 55 Gheringhap-street, Geelong. One commercial passenger vehicle (S/C. 10) to operate for the carriage of the applicant company's employees only as follows:—(a) Between the Geelong Post Office and any point within a 25-mile radius of the Geelong Post Office as and when required. (b) Between the Geelong Post Office and Altona as and when required.

C.B.P. CONSTRUCTING CO. PTY. LTD., 31 Agnes-street, East Melbourne. Two commercial goods vehicles with seating capacity for 10 and 20 persons respectively, to operate free of charge for the carriage of employees engaged in sewerage construction works as authorized by the Melbourne and Metropolitan Board of Works from time to time and currently operated between Carlton, Brunswick and Fitzroy and the sewerage construction site at Mitcham.

Time-table.

Depart Brunswick 6 a.m.—6.30 a.m.
 Depart Mitcham 4 p.m.—4.30 p.m.

MARTYR, H., PTY. LTD., Main-street, Warburton. Two commercial passenger vehicles each with (S/C. 37) to operate under the same terms and conditions as existing "C.O." licences in the name of the applicant company.

REED, R. V. & C., P.O. Box 165, Bairnsdale. One commercial passenger vehicle (S/C. 5) to operate from Bairnsdale, via Forge Creek-road and Goon Nure, to Bengworden, returning to Bairnsdale via the Bengworden-road and Princes Highway, for the carriage of passengers, mails and freight, subject to the cancellation of the "E.C." licence.

Time-table (Monday to Friday).

Depart Bairnsdale 10.30 a.m.
 Depart Forge Creek 10.45 a.m.
 Depart Goon Nure 11.15 a.m.
 Depart Bengworden 11.40 a.m.
 Arrive Bairnsdale 12.15 p.m.

Fares.

Bairnsdale to Forge Creek 3s.
 Bairnsdale to Goon Nure 5s.
 Bairnsdale to Bengworden 5s.
 Bairnsdale to Bairnsdale 10s.

APPLICATION for renewal of licences as shown, by persons listed hereunder, to operate under the same terms and conditions:—

BULLER, A. E., 8 Strezleckie-road, Yallourn. C.T.353, C.T.39.
CRAMP, K. H., Main-street, Speed. T.P.157.

DASHWOOD, R. E., Box 87, Goroke. T.S.7.
DULLARD, P. J. (Monsignor), The Holy Rosary School, Eden-street, Heathcote. T.P.27.

FLOODS MOTOR SERVICE PTY. LTD., Arnold-street, Bendigo. C.O.265, C.O.274, C.O.294, C.O.448, C.O.449, C.O.450, C.O.453, C.O.455, C.O.456, C.O.457, C.O.459, C.O.460, C.O.736, C.O.862, T.S.784.

GRIEVE, T. R., 42 Little-avenue, Mooroopna. T.S.438.

HÖLMES, D. E. & H. J., Box 30, Numurkah. T.S.23.

JOYKEL PTY. LTD., 47 Baynton-street, Kyneton. T.S.227.

KENNY, J., A'Beckett-street, Rushworth. T.S.243.

KING, J. D., Church-street, Lakes Entrance. T.S.482.

LEYSHAM, F. C. (trading as Heyfield Bus Service), Box 15, Heyfield. T.S.270.

LIDDELL, J. C., Chandler-road, Dandenong. C.T.30.

MADSEN, A., Lavers Hill. T.S.277.

MANLEY, L., Serpentine. T.S.567.

NEWTON, J. & I. W., Fuller-avenue, Rochester. T.S.789, T.S.22.

O'CONNELL, P. D. & E. A., 10 Queen Elizabeth-drive, Tallangatta. T.S.835, T.S.581.

POVEY, M. J. & M. B. (trading as Povey's Bus Service), Campbell-street, Merino. T.S.154, T.S.445, T.S.446.

ROBERTS, A. T. A., 5 Tuck-street, Cheltenham. C.T.43.

SECULOVIC, M., 19 Roma-street, Bell Park, Geelong. T.P.68.

SLADE, P. G. & M. C., 87 Miller-street, Tongala. T.S.118.

STEPHENSON, D., Conness-street, Chiltern. T.S.123.

STONEHOUSE, B. C. (Mrs.), 37 Tocomwal-road, Numurkah. T.S.568.

VICTORIA HALL SUNDAY SCHOOL, 11 Coronation-street, West Footscray. T.P.22.

Notice of any objection should be forwarded to reach the Secretary of the Board not later than Wednesday, 3rd November, 1965.

Applicants are advised that it will not be necessary to appear on the hearing date specified above, unless advised in writing by the Board.

B. P. KAY,
 Secretary.

Exhibition Buildings, Rathdown-street, Carlton, N.3, Wednesday, 20th October, 1965.

Commercial Goods Vehicles Act.
TRANSPORT REGULATION BOARD.

HEARING OF APPLICATIONS.

NOTICE is hereby given that the following applications will be considered by the Transport Regulation Board at its offices at Rathdown-street, Carlton, at 9.30 a.m., on Monday, 8th November, 1965.

ADAMS, D. & W., & Co. PTY. LTD., 174 Chesterville-road, Moorabbin. Two commercial goods vehicles (L/C. 15 and 11 cwt.) to operate throughout the State of Victoria in the course of business as "Pest Control Contractors"—tools of trade, spraying equipment and small quantities of materials incidental to the completion of own contracts.

AGGREGATE CONTRACTING CO. PTY. LTD., 22 Park-street, Seymour. One commercial goods vehicle (L/C. 192 cwt.) to operate in the course of business as "Premixed Concrete Manufacturer"—(a) Within a 50-mile radius from own premises at Seymour—own premixed concrete. (b) Within a 50-mile radius from own branch premises at Colbinabbin—own premixed concrete.

ALBION-REID PTY. LTD., 141A Arden-street, North Melbourne. One commercial goods vehicle (L/C. 290 cwt.) to operate within a 50-mile radius from own premises at North Melbourne in the course of business as "Road Construction Contractors"—road-making materials and plant, hot asphalt and premix.

A.R.C. ENGINEERING PTY. LTD., 528 Ballarat-road, Sunshine. Four commercial goods vehicles (L/C. 106, 104, 232 and 239 cwt.) to operate within a 25-mile radius from the G.P.O., Melbourne and to places on the Mornington Peninsula—own goods.

ASCOM PTY. LTD., 63 Queen's Bridge-street, South Melbourne. One commercial goods vehicle (L/C. 180 cwt. approximately) to operate in the course of business as "Civil Engineers and Contractors"—(a) Within a 25-mile radius from the G.P.O., in the City of Melbourne—own goods. (b) Throughout the State of Victoria—tools of trade and equipment only. (c) Within a 20-mile radius from the site of any project currently engaged upon or from the railway station nearest thereto—materials for use on such project.

BENNETT, D. J., 30 Longbourne-avenue, North Clayton. One commercial goods vehicle (L/C. 111 cwt.) to operate within a 70-mile radius from the premises of Evans Bros. Pty. Ltd. at Scoresby and/or Oakleigh—bricks solely on behalf of the said company.

BERRY, J. W. & D. C. & C. A. & K. SPRAGUE (trading as Berry and Sprague), Gellibrand. One commercial goods vehicle (L/C. 260 cwt.) to operate: (a) Within a 20-mile radius from the post office at Gellibrand—logs and sawn timber. (b) From forest landings at Lower Gellibrand, Kennedy's Creek, Apollo Bay and Heytesbury Soldier Settlement areas to C. and K. Spragues sawmills at Barongarook—logs. This application replaces licence No. T.T.D.770 held by the applicant.

BUCKLEY, J., Chenery-street, Mansfield. One commercial goods vehicle (L/C. 271 cwt.) to operate: (a) From forest landings in the Howqua and King River areas to sawmills at Mansfield and Benalla—logs. (b) From forest landings in the Jamieson, Mt. Buller and Tolmie areas to sawmills at Mansfield and Benalla—logs. (c) From the premises of Markovitus sawmill at Mansfield to consignees within a 50-mile radius thereof—sawn timber. This application replaces licence No. T.T.D.152 held by the applicant.

CALCIMO PTY. LTD., Willung South. Application to vary the conditions of licence Nos. D.A.54373 and D.A.54373/1 (L/C. 139 cwt. each) by deleting the present conditions and adding in lieu: "(a) Within a 50-mile radius respectively of own pits at Merryman's Creek, Longford, Yanakie and Bairnsdale to consignees within a 50-mile radius thereof—own bulk lime. (b) Throughout the total area covered by the radii specified in paragraph (a) above in the course of business as a 'Lime Contractor'—own equipment".

COHNS (WANGARATTA) PTY. LTD., Phillipson-street, Wangaratta. One commercial goods vehicle (L/C. 15 cwt.) to operate: (a) Goods as follows in the course of business as "Soft Drink, Cordial, Sauce and Food Manufacturers" being an approved decentralized secondary industry carried on at Wangaratta and similarly carried on by its associated companies, Cohns (Ballarat) Pty. Ltd. at Ararat, Cohns (Bendigo) Pty. Ltd. at Bendigo and Yea and Cohns (Swan Hill) Pty. Ltd. at Swan Hill, namely— (i) From points within the State of Victoria (but excluding the Gippsland area) to own approved decentralized secondary industry factory at Wangaratta or of any of its aforesaid associated companies at Ararat, Bendigo and Swan Hill—raw materials and goods associated with or required solely for use in the manufacturing or processing of such approved decentralized industry but subject to the condition that the majority of raw sugar for use in the aforesaid industry at the said factories in each case shall be forwarded to the railway station nearest thereto namely the railway station at Ararat, Bendigo, Yea, Swan Hill or Wangaratta as the case may be. (ii) From own factory premises and each of the aforesaid associated companies to points within the State of Victoria (but excluding the Gippsland area)—manufactured and/or processed products of such approved decentralized industry. (b) In the course of business as "Soft Drink, Cordial, Sauce and Food Suppliers" in the following area only namely, within that part of the State of Victoria bounded on the east by a line drawn south from Khancoban (in the State of New South Wales) through the Township of Mt. Beauty to Mansfield, on the south by an angular line extending from Mansfield to Euroa and thence from Euroa to Nagambie, on the west by a line drawn north from Nagambie through the City of Shepparton to Numurkah and thence continuing west from Numurkah to Nathalia and thence due north to the River Murray—soft drink, cordial, sauce and food lines (not being own manufactured products of own approved decentralized secondary industry or of its associated companies as specified in paragraph (a) above together with empty return containers and subject to the condition that goods shall not be carried on the vehicle for transfer and/or transshipment to any other vehicle for carriage to any destination outside the boundaries specified herein.

CROSS, J. A., 8 Sharp-street, Chilwell. One commercial goods vehicle (L/C. 8 cwt.) to operate within a 50-mile radius of the chief post office in the City of Geelong in the course of business as a "Carpet and Linoleum Layer" on behalf of Myer (Geelong) Ltd.—carpets, linoleum, underfelts, tools of trade and materials incidental to the completion of contracts on behalf of the said company.

DALGETY & NEW ZEALAND LOAN LTD., 538 Collins-street, Melbourne. One commercial goods vehicle (L/C. 11 cwt.) to operate within a 60-mile radius of own branch premises at Dandenong in the course of business as "Stock and Station Agents"—own goods.

DAVIS, C. S. & A. J. (trading as Davis Bros.), 23 Hunter-street, Heywood. One commercial goods vehicle (L/C. 10 cwt.) to operate within a 50-mile radius of own premises at Heywood in the course of business as "Tire Retreaders and Distributors"—new tires and tubes, tires and tubes for repair or retreading or having been repaired or retreaded, batteries, oil and motor car accessories.

DENSLEY, A. N. (trading as A. Densley & Co.), 4 Patricia-street, Warrnambool. One commercial goods vehicle (L/C. 7 cwt.) to operate: (a) Within a 50-mile radius from the post office at Warrnambool—own goods in the course of business as "plumber". (b) Throughout the State of Victoria—tools of trade and spare parts incidental to the repair, maintenance and installation of furnace equipment on behalf of the Public Works Department.

DUNCAN, A. S. & J. M. D., 314 Manningham-road, Doncaster. One commercial goods vehicle (L/C. 189 cwt.) to operate within a 50-mile radius of the premises of Specified Concrete (Vic.) Pty. Ltd. at Northcote as an agitator vehicle—premixed concrete.

FONTANA, J., 23 Dickens-street, Lalor. One commercial goods vehicle (L/C. 141 cwt.) to operate: (a) Within a 35-mile radius of the premises of Bayview Quarries Pty. Ltd., at Tullamarine—screenings and stonedust. (b) From pits within a 35-mile radius of Tullamarine to the plant of Bayview Quarries Pty. Ltd.—sand.

FONTANA, M. & S., 141 Keon-parade, Keon Park. One commercial goods vehicle (L/C. 139 cwt.) to operate: (a) Within a 35-mile radius of the premises of Bayview Quarries Pty. Ltd. at Tullamarine—screenings,

stone dust and premix on behalf of the said company. (b) From pits within a 35-mile radius of Tullamarine to the plant of Bayview Quarries Pty. Ltd.—sand.

GLENMIX PTY. LTD., Glenrowan. One commercial goods vehicle (L/C. 171 cwt.) to operate as a specially constructed agitator vehicle, in the course of business as "Premixed Concrete Suppliers": (a) Within a 50-mile radius from own premises at Glenrowan—own premixed concrete. (b) Within a 50-mile radius from own branch premises at Benalla—own premixed concrete.

HARRISON, G. J., PTY. LTD., 928 Hampton-street, North Brighton. One commercial goods vehicle (L/C. 10 cwt.) to operate throughout the State of Victoria in the course of business as a "Shopfitting Contractor"—tools of trade and small quantities of materials incidental to the completion of own contracts.

HASSETT, J. & R., 43 Lardner-road, Drouin. One commercial goods vehicle (L/C. 310 cwt.) to operate from Longwarry to Springvale—sawn timber. This application replaces licence No. T.T.D.227, held by the applicant.

HILL, J. D., 9 Douglas-street, Kaniva. One commercial goods vehicle (L/C. 115 cwt.) to operate within a 50-mile radius from own premises at Kaniva in the course of business as "Concreting Contractor"—tools of trade, equipment and materials incidental to the completion of own contracts.

HILL, V. J., 55 Somerset-street, Richmond. Application to vary the conditions of licence No. D.A.53758 (L/C. 39 cwt.) by adding to the existing conditions "and within the area east of a north/south line, drawn through the City of Melbourne".

HOLDENSON & NEILSON FRESHFOOD PTY. LTD., 95 Cecil-street, South Melbourne. One commercial goods vehicle (L/C. 19 cwt.) to operate throughout the State of Victoria in the course of business as "Butter and Cheese Manufacturers" for the purpose of servicing and maintaining own factories and equipment—tools of trade, spare parts and materials incidental thereto, also equipment for repair or having been repaired.

KELLY, D. J., 12 Bath-street, Swan Hill. One commercial goods vehicle (L/C. 140 cwt.) to operate: (a) Within a 50-mile radius from the post office at Swan Hill as a "Road Contractor"—road-making plant and materials. (b) Within a 20-mile radius from the post office at Swan Hill—general goods.

KENDALL, A. W., Brodribb River via Orbost. One commercial goods vehicle (L/C. 61 cwt.) to operate: (a) Throughout the Shire of Orbost in the course of duties as "Ranger" for the said shire—own horse, own dog, camping equipment and impounded cattle. (b) In course of business as "Primary Producer" from and to own property at Brodribb to and from sale-yards at Orbost and Bairsdale—own livestock.

LEAHY'S ELECTRICAL INDUSTRIES LTD., 142 Koroit-street, Warrnambool. One commercial goods vehicle (L/C. 7 cwt.) to operate within a 50-mile radius from the post office at Warrnambool in the course of business as "Electrical Retailer, Plumbing and Building Contractor" for the purpose of installing, servicing and maintaining electrical appliances and completing plumbing and building contracts—electrical appliances for installation, for repair or having been repaired, tools of trade, plumbing and building materials incidental to the completion of own contracts.

LONG, K. J., Road Knight-street, Lakes Entrance. One commercial goods vehicle (L/C. 260 cwt.) to operate: 1. Within that part of the State of Victoria east of the Mitchell and Dargo Rivers and west of the Snowy River but excluding any operations north of an east/west line drawn through the settlement of Glen Wills and excluding any operations within a 20-mile radius of the post office at Omeo—logs. 2. From sawmills situated in the area defined in paragraph 1 above: (a) To the nearest railway station. (b) For delivery to customers and building sites within a 20-mile radius of the Lakes Entrance Post Office—sawn timber.

This application replaces licence, No. T.T.D.266 held by the applicant.

MAWSON, E. B., & SONS PTY. LTD., P.O. Box 66, Cohuna. One commercial goods vehicle (L/C. 11 cwt.) to operate throughout the State of Victoria in the course of business as "Contractors and Quarrymasters"—tools of trade, spare parts and materials incidental to the servicing and maintenance of own vehicles and earth-moving equipment.

MCMMASTER, D. L., 126 Yarrowee-street, Sebastopol. One commercial goods vehicle (L/C. 29 cwt.) to operate from Ballarat to forests in the Beech Forest area

- and for distribution within a 25-mile radius of the chief post office in the City of Ballarat—ti-tree sticks and ti-tree brush.
- NATIONAL TYRE SERVICE (SWAN HILL) PTY. LTD.**, 7 McCrae-street, Swan Hill. One commercial goods vehicle (L/C. 15 cwt.) to operate within a 70-mile radius from own business premises at Swan Hill—new and secondhand tires and tubes, also tires for retreading and return when retreaded, also batteries and polythene piping in the course of business as "Tire Retreaders and Distributors".
- O'CONNOR, J. P.**, Willung South. Application to vary the conditions of licence No. D.A.47783/2 (L/C. 130 cwt.) by deleting "the existing conditions" and adding in lieu: (a) Within a 50-mile radius respectively of own pits at Merryman's Creek, Longford, Yanakie and Bainsdale, to consignees within a 50-mile radius thereof—own bulk line. (b) throughout the total area covered by the radii specified in paragraph (a) above in the course of business as a "Lime Contractor"—own equipment.
- PELZ, F.**, 10 Angus-street, Morwell. One commercial goods vehicle (L/C. 220 cwt.) to operate: (a) Within a 25-mile radius of the A.P.M. at Maryvale—pulpwood. (b) From forest landings in the Gembrook, Powelltown, Mt. Margaret, Licola and Noojee areas to the A.P.M. at Maryvale—pulpwood.
- PLATER, W. J.**, 61 Crowley-street, Warrnambool. One commercial goods vehicle (L/C. 5 cwt. with 10 cwt. trailer) to operate: (a) Within a 20-mile radius from the Warrnambool Post Office—general goods. (b) Within a 75-mile radius from the Warrnambool Post Office as a "Marine Dealer"—marine stores and old metals as defined in the *Marine Stores and Old Metals Act 1958* (No. 6303), but excluding any operations to wharves, docks or ships for shipment or export purposes.
- PURCELL, P. J.**, 20 Gladstone-street, Orbost. Application to vary the conditions of licence No. T.T.D.578 (L/C. 261 cwt.) by deleting "the existing conditions" and adding in lieu:—(a) Within that part of the State of Victoria east of the Snowy River—logs. (b) From and to places situated within the area defined in paragraph (a) above to and from Newmerella and Waygara—logs. (c) From sawmills situated within the area defined in paragraph (a) above and from Newmerella to the railway station at Orbost—sawn timber. (d) To consignees and building sites situated within a 20-mile radius from the post office at Orbost—sawn timber."
- READY MIXED CONCRETE (VIC.) PTY. LTD.**, 501 Swanston-street, Melbourne. Two commercial goods vehicles (L/C. 199 and 197 cwt.) to operate within a 50-mile radius of the G.P.O. Melbourne in the course of business as "Ready Mixed Concrete Manufacturers"—ready mixed concrete in a specially constructed agitator vehicle.
- RICHARDS, H. F.**, 29 Crisp-street, Wangaratta. One commercial goods vehicle (L/C. 117 cwt.) to operate: (a) Within a 20-mile radius from own premises at Wangaratta in the course of business as "Sawmiller"—own goods. (b) To consignees within a 50-mile radius from own premises at Wangaratta in the course of business as "Sawmiller"—sawn timber.
- SCHWEPPE (AUST.) LTD.**, 137 Chesterville-road, Highett. Two commercial goods vehicles (L/C. 183 cwt. each) to operate within a 50-mile radius from own premises at Highett in the course of business as "Aerated Water Manufacturer" but excluding any operations to or from the City of Geelong—aerated waters and empty return containers.
- SERGAS, M. A.**, 30 Beech-street, Wodonga. One commercial goods vehicle (L/C. 148 cwt.) to operate: (a) Within a 50-mile radius of the Wodonga Post Office as a "Road Contractor"—road-making plant and materials. (b) Within a 20-mile radius of the Wodonga Post Office—general goods.
- SHERRIFF, R. A.**, 76 King-street, Dandenong. One commercial goods vehicle (L/C. 157 cwt.) to operate: (a) Within a 35-mile radius of the premises of Bayview Quarries Pty. Ltd. at Berwick—screenings, stonedust and premix on behalf of the said company. (b) From pits within a 35-mile radius of Berwick to the plant of Bayview Quarries Pty. Ltd.—sand.
- SHIELDS, G. A.**, Musk Vale P.O., via Daylesford. One commercial goods vehicle (L/C. 123 cwt.) to operate from forestry allocations at Daylesford and Trentham to the C.S.R. factory at Bacchus Marsh—pulpwood. This application replaces licence No. T.T.D.883 held by the applicant.
- STANBIL MOTORS, Charing Cross, Bendigo.** One commercial goods vehicle (L/C. 40 cwt.) to operate in the course of business as "Garage Proprietors and Farm Machinery Distributors":—(a) Within a 50-mile radius from own premises at Bendigo—own goods. (b) Within a 100-mile radius from own premises at Bendigo but excluding the carriage of any goods whatsoever from the City of Melbourne to the City of Bendigo—tools of trade, spare parts and materials incidental to the servicing and maintenance of farm implements and motor vehicles.
- SULLIVAN, R. J.**, 5 Delta-avenue, Ashwood. One commercial goods vehicle (L/C. 26 cwt.) to operate throughout the State of Victoria in the course of business as "Marine Collector"—special wares, marine stores and old metals as designated in the *Marine Stores and Old Metals Act 1958* (No. 6303) Part 1, Section (3) but excluding the use of any trailer in conjunction with the vehicle so licensed.
- SYKES, R. A.** (trading as Sykes Transport), 39 Bailey-street, Belmont. One commercial goods vehicle (L/C. 302 cwt.) to operate from the premises of Marchants Aerated Waters and Cordials Pty. Ltd. at Clayton to the store of Colledge Confectionery Co. at South Geelong—aerated waters and empty bottles.
- TOORONGA STEEL CONSTRUCTION PTY. LTD.**, 8-10 Weir-street, Glen Iris. One commercial goods vehicle (L/C. 50 cwt.) to operate: (a) Within a 50-mile radius of own premises at Glen Iris in course of business as "Engineers"—own goods. (b) From Melbourne to own decentralized secondary industry (engineering) works at Wangaratta—raw materials. (c) From own works at Wangaratta to Melbourne semi-finished and finished products. (d) Within a 50-mile radius of own branch premises at Wangaratta in course of business as "Engineers"—own goods.
- TOPPA ICE CREAM PTY. LTD.**, 99 Bell-street, Preston. One commercial goods vehicle (L/C. 11 cwt.) to operate in the course of business as "Ice Cream Manufacturers": (a) Within a 50-mile radius of own branch premises at Traralgon—own goods. (b) Throughout the State of Victoria for the purpose of servicing and maintaining own depots, refrigeration equipment and motor vehicles—tools of trade, spare parts and small quantities of materials incidental thereto.
- SETH TRENFIELD & SONS, Gaffney's Creek.** One commercial goods vehicle (L/C. 231 cwt.) to operate: (a) To and from the City of Melbourne from and to places on or adjacent to the Mansfield-Woods Point road including the Township of Woods Point but not nearer to Mansfield than a point along such road 3 miles south of the Mansfield Post Office via the road passing the Townships of Alexandra and Mansfield or via the road passing through the Townships of Tallarook and Mansfield or alternatively via the main Lilydale-Warburton road—general goods. (b) To and from Mansfield from and to places situate between and including the Townships of Jamieson and Woods Point. (c) To and from Warburton from and to places situate between and including the Townships of Jamieson and Woods Point.
- TWIGG, A. D., & SONS, P.O. Box 52, Berriwillock.** One commercial goods vehicle (L/C. 16 cwt.) to operate within a 150-mile radius of own premises at Berriwillock—spare parts, fuel and incidental equipment needed for maintenance and servicing of own equipment, in the course of business as "Earth-moving Contractors".
- TWIGG, A. D., & SONS, Berriwillock.** One commercial goods vehicle (L/C. 251 cwt.) to operate as a low loader within a 150-mile radius from own premises at Berriwillock, in the course of business as "Earth-moving Contractors"—own plant and equipment.
- WARDROP, GEORGE, LTD.**, 197 Elizabeth-street, Melbourne. One commercial goods vehicle (L/C. 10 cwt.) to operate: (a) Within a 50-mile radius from own premises in the City of Melbourne—own goods in the course of business as "Tailors and Mercers"; (b) From own premises in the City of Melbourne to own branch stores at Morwell, Geelong, Warrnambool, Portland and Hamilton, in the course of business as "Tailors and Mercers"—general drapery merchandise, men's suits, materials for suit manufacture and partly manufactured goods.
- WATSON, A.**, 71 Purdy-street, Tongala. One commercial goods vehicle (L/C. 100 cwt.) to operate: (a) From Forests Commission forest landings in the Barnah-Piccola area and from private forest areas in the Rochester-Elmore district to own sawmill at Tongala—red gum logs. (b) Within a 20-mile radius of own sawmill at Tongala—sawn timber, wood, posts, strainers and stays. (c) From and to own sawmill at Tongala to and from the areas as defined in paragraphs (a) and (b) above—tools of trade and equipment. This application replaces licence No. T.T.D.528 held by the applicant.
- WITTINGSLOW, TOM, PTY. LTD.**, 4 Austin-street, Fairfield. One commercial goods vehicle (L/C. 30 cwt.) to operate throughout the State of Victoria in the course of business as "Travelling Showman"—tools of trade, own equipment and novelty prizes.

YOUNG, J. W. & T. A. (trading as W. H. Young and Sons), 182 High-street, Shepparton. One commercial goods vehicle (L/C. 239 cwt.) to operate: (a) Within a 50-mile radius from the post office at Shepparton as a "Road Contractor"—road-making plant and materials. (b) Within a 20-mile radius from the post office at Shepparton—general goods.

TOW TRUCKS.

BALACLAVA BODY WORKS PTY. LTD., 116 Carlisle-street, St. Kilda. One commercial goods vehicle (L/C. 34 cwt.) to operate as a "Tow Truck" throughout the State of Victoria for the purpose of lifting and carrying or towing and/or repairing wrecked or disabled vehicles—tools of trade, spare parts and materials incidental thereto.

DAWE, HARRY & SON, Chewton. One commercial goods vehicle (L/C. 29 cwt.) to operate as a "Tow Truck" throughout the State of Victoria for the purpose of lifting and carrying or towing and/or repairing wrecked or disabled vehicles—tools of trade, spare parts and materials incidental thereto.

MARTIN, R. J. (trading as Wantirna Towing Service), Main-road, Fern Tree Gully. One commercial goods vehicle (L/C. 28 cwt.) to operate as a "Tow Truck" throughout the State of Victoria for the purpose of lifting and carrying or towing and/or repairing wrecked or disabled vehicles—tools of trade, spare parts and materials incidental thereto.

APPPLICATION for renewal of licence as shown by persons listed hereunder to operate under the same terms and conditions from the date of expiry shown in each case.

ADAMS, JAMES S., & Co. PTY. LTD., Nepean Highway, Mornington; D.A.509/3; 18th December, 1965; 9 cwt.

BEAUREPAIRE TYRE SERVICE PTY. LTD., 102 Victoria-street, Carlton; D.A.629/26; 20th December, 1965; 13 cwt.

BEAUREPAIRE TYRE SERVICE PTY. LTD., 102 Victoria-street, Carlton; D.A.629/61; 18th December, 1965; 18 cwt.; D.A.629/62; 18th December, 1965; 11 cwt.

BEAUREPAIRE TYRE SERVICE PTY. LTD., 102 Victoria-street, Carlton; D.A.629/63; 18th December, 1965; 16 cwt.

BEAUREPAIRE TYRE SERVICE PTY. LTD., 102 Victoria-street, Carlton; D.A.629/64; 11th December, 1965; 16 cwt.

BLACKWOOD, E. C., PTY. LTD., 21-45 Kavanagh-street, South Melbourne; D.A.9509/1; 30th November, 1965; 113 cwt.

CORIO TIMBER CO., Roseneath-street, North Geelong; D.A.44823; 20th November, 1965; 250 cwt.

ENVER, O., 26 Boston-street, Fawkner; D.A.44608; 16th October, 1965; 139 cwt.

GIRGARRE CHEESE CO. PTY. LTD., 177 Victoria-parade, Collingwood; D.A.14433/5; 18th December, 1965; 9 cwt.

GREEN, A. S., 8 Halpen-crescent, Shepparton; D.A.44695; 7th November, 1965; 16 cwt.

HALL, S. G., Maroondah Highway, Narbethong; T.D.A.31322; 17th December, 1965; 99 cwt.

HARDING, R. L., Bennett-street; Dandenong; D.A.1241/1; 19th November, 1965; 79 cwt.

HICKS, J. A. J., Princes Highway, Officer; D.A.1293/1; 19th November, 1965; 118 cwt.

HOSE, F. G., 13 Powell-street West, Ocean Grove; D.A.44921; 7th November, 1965; 173 cwt.; D.A.44921/1; 7th November, 1965; 160 cwt.

JOSEPH, K. M., & Co. PTY. LTD., P.O. Box 36, Prahran; D.A.38452/6; 27th November, 1965; 9 cwt.

MILLER, JAMES & Co. PTY. LTD., 29 Dawson-street, Brunswick; D.A.1604/2; 9th November, 1965; 7 cwt.

MOTOR TYRE SERVICE PTY. LTD., Baillie-street, Horsham; D.A.30929/1; 5th November, 1965; 12 cwt.; D.A.30929/4; 5th November, 1965; 11 cwt.

MCRAE, D. L., 48 Edith-street, Horsham; D.A.44958; 27th November, 1965; 106 cwt.

PETERS, H. R., 530 Small-street, Albury; D.A.28370; 27th November, 1965; 229 cwt.

PETERSVILLE AUSTRALIA LTD., Wellington-road, Clayton; T.D.A. 1813/19; 18th December, 1965; 74 cwt.;

T.D.A.1813/20; 11th December, 1965; 106 cwt.;

T.D.A.1813/80; 16th December, 1965; 77 cwt.;

T.D.A.1813/81; 16th December, 1965; 75 cwt.;

T.D.A.1813/108; 21st December, 1965; 232 cwt.;

T.D.A.1813/109; 21st December, 1965; 75 cwt.

ROUGHAN HAULAGE PTY. LTD., 47 Surrey-road, Blackburn; T.D.A.54237; 21st December, 1965; 285 cwt.

TYRE-LUG (AUST.) PTY. LTD., 55 Market-road, West Footscray; D.A.35245/2; 17th December, 1965; 11 cwt.

TYRE-LUG (AUST.) PTY. LTD., 55 Market-road, West Footscray; D.A.43268/9; 11th December, 1965; 40 cwt.

VAN AKKEREN, A. J., 9 King-street, Dandenong; D.A.44864; 7th November, 1965; 72 cwt.

WILLIAMS, B. H., Collis-road, (P.O. Box 45), Foster; D.A.16827/1; 27th November, 1965; 89 cwt.

SHARP, S. V. & E. M. (trading as Woodend Produce Store and Real Estate Agency), Woodend; D.A.30844; 9th December, 1965; 58 cwt.

TOW TRUCK RENEWAL.

BENSLEY, P. R. & B. E. (trading as Bensley Bros.), Alumatta-street, Wangaratta; D.A.20783; 7th November, 1965; (mobile crane).

RENEWALS WITH VARIATION.

APPPLICATION by the persons listed hereunder for renewal of the licences listed with variation of conditions in the manner set out opposite the names.

DICKSON, R. A., 7 William-street, Lorne; D.A.34316; 27th November, 1965. Application to renew and vary the conditions of licence No. D.A.34316 (L/C. 90 cwt.) by deleting from the existing conditions "paragraph (c)" and adding in lieu as paragraph (c): "Within a 20-mile radius of the post office at Lorne—general goods"

HOADLEY'S CHOCOLATES LTD., 99 Coventry-street, South Melbourne. D.A.1308/6; 9th December, 1965. Application to renew and vary the conditions of licence No. D.A.1308/6 (L/C. 65 cwt.) by deleting "paragraph (a)" from the existing conditions.

MELBOURNE WIRE WORKS PTY. LTD., Clayton-road, Clayton. D.A.45084; 11th December, 1965, D.A.45084/1; 11th December, 1965. Application to renew and vary the conditions of licences Nos. D.A.45084 and D.A.45084/1 (L/C. 11 cwt. each) by deleting from paragraph (a) "Richmond" and adding in lieu "Clayton".

WILLIAMS, B. H., Collis-road, (P.O. Box 45), Foster. D.A.16827; 7th November, 1965. Application to renew and vary the conditions of licence No. D.A.16827 (L/C. 128 cwt.) by deleting from paragraph (e) "Colac" and adding in lieu "Foster".

Notice of any objection should be forwarded to reach the Secretary of the Board not later than Wednesday, 3rd November, 1965.

Applicants are advised that it will not be necessary to appear on the hearing date specified above, unless advised, in writing, by the Board.

B. P. KAY,

Secretary.

Exhibition Buildings, Rathdown-street, Carlton, N.3, 20th October, 1965.

Transport Regulation Act.

TRANSPORT REGULATION BOARD.

NOTICE No. 68.

Hiring Rates and Fares Specified for Metropolitan Taxi-cabs and Private Hire Cars.

TAKE notice that, pursuant to powers conferred on the Board by the provisions of Regulation 45 of Part III. of the Transport Consolidated Regulations 1960, the Board hereby specifies, in accordance with the provisions of Regulations 5 of Part I. of the said Regulations, hiring rates and fares to be charged for the carriage of passengers in vehicles the licences issued in respect of which are classified as Metropolitan Taxi-cabs or Private Hire Cars as the case may be.

Hiring rates and fares specified herein shall apply to journeys commencing at or after midnight on Sunday, 31st October, 1965, from which date and time hiring rates and fares previously specified by the Board as related to vehicles of such licence classification are hereby repealed.

Hiring rates specified herein relate to journeys wholly within a 25-mile radius from the General Post Office situated at the corner of Bourke and Elizabeth streets in the City of Melbourne. The hiring rate applicable in respect of any journey to or from (where permitted by the conditions of licence) a destination outside the said radius shall be the rate agreed by the hirer prior to the commencement of such journey.

PART A.—HIRING RATES.

1. By distance from the place of picking up of the hirer to the place of setting down—

(a) On a journey which commences and finishes within the Metropolitan Area and the extensions thereof, including any journey which is not wholly within the said Area and the extensions thereof, the hiring rate shall be computed—

	£	s.	d.	\$.c.
For the first one-ninth of a mile or any part thereof	0	2	0	0.20
For each additional one-ninth of a mile or any part thereof	0	0	2.4	0.02

(b) On journeys partly within and partly outside or wholly outside the Metropolitan Area and the extensions thereof, where permitted by the conditions of licence, the hiring rate shall be computed at the rates specified in (a) above plus an additional 1 shilling (10 cents) for each complete mile over which the hirer is carried outside the said Area and extensions thereof.

	£	s.	d.	\$	c.
2. By time for detention on all journeys at the rate per hour of	1	0	0	2	00

3. If the vehicle is bespoken by the intending hirer through a depot to which the vehicle hired is attached an additional charge shall be made of

0	1	6	0	15	
---	---	---	---	----	--

4. Luggage: For each package carried outside of the passenger compartment of such vehicle

0	0	6	0	05	
---	---	---	---	----	--

(No charge shall be made for luggage carried inside the passenger compartment).

PART B.—WEDDINGS AND FUNERALS.

1. By time—on journeys which commence and finish within the Metropolitan Area and the extensions thereof, irrespective of distance travelled, the charge shall be computed from the ordered time of first picking up of the passengers to the final setting down thereof—

	£	s.	d.	\$	c.
(a) In respect of vehicles approved by the Board as large cars— For the first hour or any part thereof	4	15	0	9	50
For each additional half-hour or part thereof	1	0	0	2	00
(b) In respect of vehicles other than large cars— For the first hour or part thereof	3	10	0	7	00
For each additional half-hour or part thereof	0	15	0	1	50

2. By time—on journeys which commence within the Metropolitan Area and the extensions thereof but finish outside of such Area and extensions, or which commence outside such Area and extensions, where permitted by the conditions of the licence, the charge shall be computed as specified in Clause 1 of this Part plus an additional charge as under for each complete mile by the most direct route between the point where the journey commences or finishes, as the case may be, outside of such Area and extensions and the limits of the boundary of the said Area and extensions—

	£	s.	d.	\$	c.
(a) In respect of vehicles approved by the Board as large cars	0	2	0	0	20
(b) In respect of vehicles other than large cars	0	1	6	0	15

3. For the purposes of this Part—

- (a) a wedding hiring shall relate solely to hirings for the conveyance of the bridal party provided that the hiring has been pre-booked in advance and a deposit has been paid in respect thereof at the time of such pre-booking; and
- (b) a funeral hiring shall relate solely to hirings pre-booked by funeral directors as supplementary mourning coaches.

PART C.—REQUEST FOR LARGE CAR.

Where the hirer requests a special service with a large car and a vehicle approved as a large car is supplied, the hiring rate shall be computed on the basis of the charges specified in Part A hereof excluding those specified in Clause 3 of that Part plus an additional charge of Ten shillings (\$1.00) for each half hour or part thereof for the duration of the hiring.

PART D.—THE METROPOLITAN AREA AND EXTENSIONS THEREOF.

The extensions of the Metropolitan Area referred to in this Notice shall be:—

1. The area contiguous to the southern boundary of the Metropolitan area as prescribed and bounded by the Melbourne-Frankston railway line, Tulip-grove, Victor-avenue, Weatherall-road, Church-street, Cromer-road and the coast of Port Phillip Bay; and

2. The area contiguous to the eastern boundary of the Metropolitan Area as prescribed and bounded by Doncaster (Main) road, Mitcham-road, Springvale-road and Fern Tree Gully-road.

PART E.—APPROVAL OF LARGE CARS.

The Board hereby approves as a large car any vehicle with a registration assessment in excess of 54 power/weight units and licensed with the Board under the classification of a Metropolitan Taxi-cab or Private Hire Car as at 6th March, 1963, and vehicles licenced since that date of the following make and model:—

- Chevrolet—Belair.
- Dodge—Phoenix.
- Ford—Fairlane and Galaxie.
- Humber—Super Snipe.
- Mercedes—220, 230 and 300 (all Sedan types).
- Pontiac—Laurentian and Parisienne.
- Rambler—Classic and Ambassador.
- Studebaker—Lark.

PART F.—SPECIAL PROVISIONS.

Notwithstanding the provisions of Part A hereof, while carrying more than one hirer within the provisions of Regulation 21 of Part III. of the Transport Consolidated Regulations 1960, the driver of any vehicle to which this Notice relates may not charge each hirer an amount for hire exceeding 75 per centum of the amount recorded on the taximeter at the destination of each hirer.

PART G.—FARES.

1. Notwithstanding the provisions of Regulation 21 of Part III. of the Transport Consolidated Regulations 1960, passengers may be carried at separate and distinct fares for each passenger in vehicles the licences issued in respect of which are classified as Metropolitan Taxi-cabs solely between loading stands and destinations specified in this Part under the following conditions:—

- (a) Every journey shall—
 - (i) commence at a loading stand within a municipality as specified and finish at a destination related thereto or commence at a loading stand at a destination as specified and finish in the vicinity of the loading stand within a municipality related thereto,
 - (ii) subject to the direction of traffic control authorities, follow the most direct route between such loading stand and the destination related thereto or between such destination and the vicinity of the loading stand related thereto, and
 - (iii) with the exception of journeys to the Flemington Racecourse on Melbourne Cup Day, be made from such loading stands to destinations related thereto under a system known as "Odds and Evens" whereby vehicles where the last numeral appearing on the registration plate is an odd numeral, and vehicles where the last numeral is an even numeral, operate to such destinations in alternate weeks, the week related to such "Odd" vehicles being the week commencing on 1st November, 1965;
- (b) The fare to be charged for each passenger on each journey shall be the fare specified in this Part related to such journey;
- (c) Subject to the provisions of Regulation 36 (ix) of Part III. of the said Regulations, the driver of such a vehicle who has placed his vehicle on a loading stand specified in this Part shall carry any passenger desiring transport to a destination related to such loading stand at the fare specified in this Part; and
- (d) With the exception of Melbourne Cup Day, such vehicles shall not occupy loading stands specified in this Part before 9 a.m. on days on which sporting events are being held at the destinations related thereto.

2. Loading stands to be used, destinations related thereto, and fares related to journeys between such points, shall be as specified hereunder:—

	£	s.	d.	\$	c.
<i>Between Loading Stands in the City of Melbourne (Excluding Newmarket) and</i>					
Flemington Racecourse	0	4	0	0	40
Flemington Racecourse (Melbourne Cup Day)	0	5	0	0	50
Moonee Valley Racecourse	0	4	0	0	40
Caulfield Racecourse	0	5	0	0	50
West Melbourne Stadium (Festival Hall)	0	2	6	0	25
R.A.S. Showgrounds (Trotting Meetings only)	0	4	0	0	40

	£	s.	d.	\$	c.
Melbourne Cricket Ground	0	2	0	0.20	
Sandown Park Racecourse (Horse Race-meetings only)	0	12	0	1.20	
Between Loading Stand in Racecourse-road, Newmarket, City of Melbourne, and					
Flemington Racecourse	0	1	6	0.15	
Flemington Racecourse (Melbourne Cup Day)	0	2	6	0.25	
R.A.S. Showgrounds (Trotting Meetings only)	0	1	6	0.15	
Moonee Valley Racecourse	0	2	6	0.25	
Between Loading Stands in the City of Brunswick and					
Flemington Racecourse	0	4	0	0.40	
Flemington Racecourse (Melbourne Cup Day)	0	5	0	0.50	
Moonee Valley Racecourse	0	2	6	0.25	
R.A.S. Showgrounds (Trotting Meetings only)	0	4	0	0.40	
Between Loading Stands in the City of Camberwell and					
Caulfield Racecourse	0	4	0	0.40	
Sandown Park Racecourse (Horse Race-meetings only)	0	9	0	0.90	
Between Loading Stand in Gordon-street, Elsternwick, City of Caulfield and					
Caulfield Racecourse	0	2	6	0.25	
Sandown Park Racecourse (Horse Race-meetings only)	0	8	0	0.80	
Between Loading Stand in Railway-avenue, City of Caulfield and					
Flemington Racecourse	0	6	0	0.60	
Flemington Racecourse (Melbourne Cup Day)	0	7	0	0.70	
Moonee Valley Racecourse	0	6	0	0.60	
Between Loading Stands in the City of Essendon and					
Flemington Racecourse	0	2	6	0.25	
Flemington Racecourse (Melbourne Cup Day)	0	4	0	0.40	
Caulfield Racecourse	0	6	0	0.60	
R.A.S. Showgrounds (Trotting Meetings only)	0	2	6	0.25	
West Melbourne Stadium (Festival Hall)	0	4	0	0.40	
Between Loading Stands in the City of Footscray and					
Flemington Racecourse	0	2	0	0.20	
Flemington Racecourse (Melbourne Cup Day)	0	3	0	0.30	
Moonee Valley Racecourse	0	3	0	0.30	
Caulfield Racecourse	0	6	0	0.60	
R.A.S. Showgrounds (Trotting Meetings only)	0	2	6	0.25	
West Melbourne Stadium (Festival Hall)	0	2	6	0.25	
Between Loading Stands in the City of Northcote and					
Flemington Racecourse	0	4	0	0.40	
Flemington Racecourse (Melbourne Cup Day)	0	5	0	0.50	
Caulfield Racecourse	0	5	0	0.50	
Moonee Valley Racecourse	0	4	0	0.40	
R.A.S. Showgrounds (Trotting Meetings only)	0	4	0	0.40	
Between Loading Stands in the City of Preston and					
Flemington Racecourse	0	4	0	0.40	
Flemington Racecourse (Melbourne Cup Day)	0	5	0	0.50	
Moonee Valley Racecourse	0	4	0	0.40	
Caulfield Racecourse	0	6	0	0.60	
Between Loading Stands in the City of St. Kilda and					
Flemington Racecourse	0	5	0	0.50	
Flemington Racecourse (Melbourne Cup Day)	0	6	0	0.60	
Moonee Valley Racecourse	0	5	0	0.50	
Caulfield Racecourse	0	4	0	0.40	
R.A.S. Showgrounds (Trotting Meetings only)	0	5	0	0.50	
Sandown Park Racecourse (Horse Race-meetings only)	0	9	0	0.90	

By order of the Transport Regulation Board,
 B. P. KAY,
 Secretary.

Town and Country Planning Act 1961.

SHIRE OF ELTHAM.

INTERIM DEVELOPMENT ORDER.

Notice of Approval.

IN pursuance of the powers conferred by the Town and Country Planning Act 1961, the Governor in Council on the 19th day of October, 1965, approved an Interim Development Order made by the Council of the Shire of Eltham for that portion of the municipal district of the Shire of Eltham known as the Eltham Business Centre.

The Interim Development Order provides that the use, subdivision or development of any land within the area described or the erection, construction or carrying out of any buildings, roads or other works thereon is prohibited except that the responsible authority may permit such uses, subdivision, development, erection, constructions or other works as it thinks proper.

A copy of the Interim Development Order and the map showing the area affected may be inspected, free of charge, at the offices of the Council, Shire Offices, Main-road, Eltham, and at the offices of the Town and Country Planning Board, 61 Spring-street, Melbourne.

M. B. WATSON, Shire Secretary.

Town and Country Planning Act 1961.

CITY OF BROADMEADOWS PLANNING SCHEME 1949.

AMENDMENT No. 14, 1965.

Notice of Approval.

IN pursuance of the powers conferred by the Town and Country Planning Act 1961, the Governor in Council on the 19th October, 1965, approved a planning scheme entitled the City of Broadmeadows Planning Scheme 1949, Amendment No. 14, 1965, in respect of part of the municipal district of the City of Broadmeadows.

A copy of this planning scheme as approved may be inspected during office hours at the office of the Town and Country Planning Board, 179 Queen-street, Melbourne, at the office of the City of Broadmeadows, at Broadmeadows, and when available, at the Office of Titles, Melbourne, and at the Central Plan Office of the Department of Crown Lands and Survey, Melbourne.

W. H. CRAIG, Secretary,
 Town and Country Planning Board.

Town and Country Planning Act 1961.

MOE-NEWBOROUGH PLANNING SCHEME 1951.

AMENDMENT No. 10, 1965.

Notice of Amendment.

IN pursuance of the powers conferred by sub-section 6 of section 32 of the Town and Country Planning Act 1961, the Governor in Council, on the 19th October, 1965, amended the Moe-Newborough Planning Scheme 1951, in respect of land being lot 1, lodged plan 56459, on the south-west corner of the Moe-Yallourn Deviation and the Old Sale-road.

A copy of the amendment may be inspected during office hours at the office of the Town and Country Planning Board, 179 Queen-street, Melbourne, at the office of the Council of the City of Moe, at Moe, and when available at the Office of Titles, Melbourne, and at the Central Plan Office of the Department of Crown Lands and Survey, Melbourne.

W. H. CRAIG, Secretary,
 Town and Country Planning Board.

Dried Fruits Act 1958.

STATE OF VICTORIA.

NOTICE.

I GILBERT LAWRENCE CHANDLER, Minister of Agriculture, acting upon the recommendation of the Victorian Dried Fruits Board, hereby give notice that I have determined the maximum proportions of Dried Vine Fruits produced in Victoria in the year One thousand nine hundred and sixty-five, that may be marketed within Victoria, are as follows:—

Dried Currants	30 per cent.
Dried Sultanas	12½ per cent.
Lexias	25 per cent.

G. L. CHANDLER,
 Minister of Agriculture.

Department of Agriculture,
 Melbourne, 11th October, 1965.

Process Servers and Inquiry Agents Act 1958.

APPLICATIONS FOR LICENCES LODGED WITH CLERKS OF COURTS.

BY direction of the Chief Secretary, the subjoined lists of "new" applications for process servers and inquiry agents licences are published for general information.

Applicant.	Address.	Court.	Tentative Date of Hearing of Application.
<i>Inquiry Agents Licences.</i>			
Emery, Kenneth Stanley	42 Comber-street, Noble Park	Springvale	10.11.65
Tsempelis, Jim	MI-4 Investigation Service, 18 Collins-street, Melbourne	Melbourne	9.11.65
Vakakis, George	176 Victoria-avenue, Albert Park	Coburg	4.11.65
<i>Process Servers Licences.</i>			
Brennan, Brenda Rose	c/o I. R. von Sivers and Co., 128 Wills-street, Glen Iris	Camberwell	4.11.65
Emery, Kenneth Stanley	42 Comber-street, Noble Park	Springvale	10.11.65
Tasker, Norman	107 Kangaroo-road, Oakleigh	Oakleigh	5.11.65
Tsempelis, Jim	MI-4 Investigation Service, 18 Collins-street, Melbourne	Melbourne	9.11.65
Vakakis, George	176 Victoria-avenue, Albert Park	Coburg	4.11.65

Attention is directed to the provisions of the above Act and regulations thereunder relating to the lodgement of objections to applications.

Chief Secretary's Office,
Melbourne, 18th October, 1965.

C. W. PHILLIPS, Registrar,
Process Servers and Inquiry Agents.

CONTRACTS ACCEPTED.—(Series 1965-66.)

FIREWOOD.

Period—From 1st October, 1965, to 30th September, 1966.

Item No.	Security.	Particulars.	Kinds of Firewood.	Rate per Cord of 128 cubic feet.	Name of Contractor.	Charge against Vote or Fund.
	£	FIREWOOD—		£ s. d.		
		Supply of Firewood, in such quantities as may be ordered, from 1st October, 1965, to 30th September, 1966, at the under-mentioned places.				
1	20	Ararat— For the various Government Offices, including Mental Hospital— 2-ft. billets 1-ft. billets	Red Gum and Box " " " "	11 0 0 } 12 6 0 }	<i>A. Storti, Banfield-street, Ararat (A)</i>	General Expenses, 1965-66 and 1966-67.
1	25	Ballarat— For the Mental Hospital only, in 2-ft. billets	Gum, Peppermint, and Messmate	8 0 0	<i>H. O'Callaghan, 1119 Howitt-street, Ballarat (A)</i>	
2	25	For the Mental Hospital, in 5-ft. lengths	Stringybark, Gum, and Peppermint	4 4 0	<i>W. P. Tuddenham and Sons, Ross Creek (A)</i>	
1	3	Beechworth— For the Mental Hospital and Government Offices, in 2-ft. billets	Stringybark, Red Gum, Red Box, Messmate, and Apple Box	6 15 0 } 7 2 0 }	<i>F. C. Jensen, Beechworth (A)</i>	
2	25	For the Mental Hospital, in 1-ft. billets				
1	..	Sunbury— For Mental Hospital, in 2-ft. billets	Mixed Wood	Order from Forests Commission	

Where the name of the supplier is shown in italics, with the sign (A), no contract has been executed, and supplies are to be purchased from the persons named, under Tender Board Agreement.

5th October, 1965.

H. COUTTS,
Secretary to the Tender Board.

CONTRACTS ACCEPTED.—(Series 1965-66.)

PROVISIONS.—MEAT.

No. of Contract.	Particulars of Each Tender Accepted.	Amount.	Name of Contractor.	Charge Against Vote or Fund.	
PROVISIONS—					
Supply of Meat, in such quantities as may be ordered, from 1st November, 1965, to 31st January, 1966					
Schedule No. 1.—Melbourne District—					
1267	Kew Mental Hospital	Rates as per annex	F. Watkins Pty. Ltd. ..	General Expenses 1965-66	
1268	Children's Cottages, Kew ..	" "	Swift Australian Co. Pty. Ltd.		
1269	Pentridge Penal Establishment and "Fairlea" Female Prison, Fairfield ..	" "			J. H. Cooke Pty. Ltd. ..
1270	"Turana" Youth Training Centre, Royal Park, and Travancore Developmental Centre, Flemington ..	" "	W. Angliss and Co. (Aust.) Pty. Ltd.		
1271	"Winlton" Girls' Training Centre, 186 Springvale-road, Nunawading, and "Allambie", 70 Elgar-road, Burwood ..	" "			G. K. and M. Reynolds Bros. Pty. Ltd.
1272	Royal Park Psychiatric Hospital	" "	J. H. Cooke Pty. Ltd. ..		
Schedule No. 2.—Mont Park, Bundoora, Larundel, Janefield, Gresswell, and Pleasant View, Wood-street, Preston—					
1273	Mont Park District	" "	W. Angliss and Co. (Aust.) Pty. Ltd.		
1274	Preston	" "			G. K. and M. Reynolds Bros. Pty. Ltd.
1275	Gresswell Sanatorium	" "	J. H. Cooke Pty. Ltd. ..		
1276	Schedule No. 3.—SS. Rip and Dredges	" "			W. Angliss and Co. (Aust.) Pty. Ltd.
1277	Schedule No. 4.—Teachers' College and Hostels at Grattan-street, 93 Drummond-street, Carlton; 470, 481 and 572 St. Kilda-road, Melbourne; 19 Queen's-road, Melbourne; 152 Toorak-road West, South Yarra; Frank Tate House, 373 Dandenong-road, Armadale; "Redcourt", No. 6, "Larnook", 13, and No. 10A Orrong-road, Armadale; 11 Patterson-street, Hawthorn; 174 Punt-road, Prahran; 221 Burwood-road, Burwood; John Cannon House, 32 Belmont-avenue, Kew, 17 Moule-avenue, Brighton, and Hastings-road, Frankston; and Police Hospital, St. Kilda-road, Melbourne; Mental Hygiene Clinic, 321 Glenferrie-road, Malvern ..	" "	H. A. Morris		
1278	Schedule No. 5.—Heatherston Sanatorium, Cheltenham ..	" "			Victorian Inland Meat Authority
1279	Schedule No. 6.—Ararat District	" "	E. Spencer		
Schedule No. 7.—Ballarat District—					
1280	Gaol and Mental Hospital	" "	Alan H. Gittins		
1281	Teachers' Hostels	" "			Alan H. Gittins
Schedule No. 8.—Beechworth District					
Schedule No. 9.—Bendigo District—					
1282	Gaol	" "	Frank Wade		
1283	Sandhurst Boys' Centre	" "			McQueen Bros.
1284	Teachers' Hostels	" "	H. J. Symons Pty. Ltd. ..		
1285	Schedule No. 10.—Castlemaine District	" "			L. Thompson
1286	Schedule No. 11.—School of Forestry, Creswick	" "	W. Angliss and Co. (Aust.) Pty. Ltd.		
1287	Schedule No. 13.—McLeod Settlement, French Island ..	" "		Heytesbury Butchery ..	
1288	Schedule No. 14.—Geelong District—	" "	H. A. Morris		
1289	Gaol	" "		R. Schuback	
1290	Teachers' Hostels	" "	Thomas Borthwick and Sons (A/asia) Ltd. ..		
1291	Schedule No. 15.—Coorimungie Prison Camp, Heytesbury Forest	" "		F. Watkins Pty. Ltd. ..	
1292	Schedule No. 17.—Langi Kal Kal Training Centre	" "	Thomas Borthwick and Sons (A/asia) Ltd. ..		
1293	Schedule No. 20.—Sale Gaol	" "		Stoddart Bros.	
1294	Schedule No. 21.—Pleasant Creek Special School, Stawell ..	" "	Stoddart Bros.		
1295	Schedule No. 22.—Sunbury District	" "		Stoddart Bros.	
1296	Schedule No. 23.—Warrnambool District	" "	Stoddart Bros.		
1297	Schedule No. 24.—Hobson Park Hospital, Traralgon	" "		Stoddart Bros.	

Approved H. E. BOLTE, Treasurer—12.10.65

SCHEDULE No. 1.—MELBOURNE DISTRICT.

ANNEX TO CONTRACT NO. 1965/1267.

F. Watkins Pty. Ltd., 256 Russell-street, Melbourne.

Sub-schedule No. 1.

MEAT FOR MENTAL HOSPITAL, KEW.

Security, £20.

Fresh Beef—		£ s. d.
1. Rolled Roast, boneless (Brisket excluded)	per lb.	0 3 0
2. Buttocks	do.	0 2 6
3. Shin and Gravy Beef (boneless)	do.	0 2 6
4. Corned Beef—Rolled or Round, as ordered, without bone or cartilage	do.	0 2 10

SCHEDULE No. 1.—MELBOURNE DISTRICT—continued.

5. Fresh Mutton—(whole sheep) (Kidney fat to be removed)	per lb.	0 1 4½
6. Veal—boned	do.	0 2 6
7. Sausages—Mixed	do.	0 2 2
8. Sausage Meat	do.	0 1 5
9. Kidneys, Ox	do.	0 3 3
10. Tripe, Fresh	do.	0 0 11
11. Saveloys	per doz.	0 3 3
12. Fowls, First quality	per lb.	0 4 4
13. Bacon Sides	do.	0 5 4
14. Steak, Stewing	do.	0 2 6
15. Livers—Ox	do.	0 1 6
16. Tongues—Ox	do.	0 1 8
17. Sausage, Belgium	do.	0 3 0

SCHEDULE No. 1.—MELBOURNE DISTRICT—*continued.*

ANNEX TO CONTRACT No. 1965/1268.
F. Watkins Pty. Ltd., 256 Russell-street, Melbourne.
 Sub-schedule No. 2.
 MEAT FOR CHILDREN'S COTTAGES, KEW.

Security, £15.		£	s.	d.
Fresh Beef—				
1. Buttocks	per lb.	0	2	6
2. Fresh Mutton, (whole sheep) (Kidney fat to be removed)	do.	0	1	4½
3. Fresh Mutton, Pumped Leg	do.	0	2	0
4. Sausages, mixed	do.	0	2	2
5. Sausage Meat	do.	0	1	5
6. Fresh Veal, boned	do.	0	2	6
7. Brains, Sheep	per set	0	0	11
8. Bacon, Sides	per lb.	0	5	4
9. Fowls, First quality	do.	0	4	4
10. Fresh Beef, Shin, Gravy and Stewing	do.	0	2	6
11. Livers, Sheep	do.	0	2	6
12. Fresh Beef, Corned, Rolled, without bone or cartilage	do.	0	0	0
13. Kidneys, Sheep	do.	0	3	0
14. Beef Loaf	do.	0	3	0
15. Fresh Beef, Rolled Roast, Brisket excluded	do.	0	3	0

ANNEX TO CONTRACT No. 1965/1269.
Swift Australian Co. Pty. Ltd., Champion-road, Newport.
 Sub-schedule No. 3.

MEAT FOR PENRIDGE PENAL ESTABLISHMENT, COBURG; AND "FAIRLEA" FEMALE PRISON, FAIRFIELD.		£	s.	d.
Security, £35.				
1. Forequarters	per lb.	0	1	8
2. Minced	do.	0	2	6
3. Corned Beef—Rolled or Round, as ordered, without bone or cartilage	do.	0	3	0
4. Fresh Mutton (whole sheep)	do.	0	1	4
5. Sausages—Mixed—Thin	do.	0	2	2
6. Fresh Suet—Kidney	do.	0	1	0
7. Sausage—Beef, German	do.	0	3	0
8. Sausage, Mince	do.	0	1	6
9. Dripping, Beef	do.	0	1	4
10. Frankfurts	do.	0	2	6
11. Ham Loaf	do.	0	3	4
12. Fresh Mutton Legs	Fairlea do.	0	2	2
13. Fresh Beef Rolled Roast Boneless } only	Fairlea do.	0	3	5

ANNEX TO CONTRACT No. 1965/1270.
J. H. Cooke Pty. Ltd., 378 Queen's-parade, Clifton Hill.
 Sub-schedule No. 4.

MEAT FOR "TURANA" YOUTH TRAINING CENTRE, ROYAL PARK, AND TRAVANCORE DEVELOPMENTAL CENTRE, FLEMINGTON.		£	s.	d.
Security, £8.				
1. Fresh Beef—Rolled Roast (Sirloin, Boneless)	per lb.	0	3	6
2. Beef—Corned—Silverside	do.	0	4	6
Fresh Mutton—				
3. Rib Chops as Cutlets	do.	0	1	8
4. Legs	do.	0	2	2
5. Legs (Two-tooth)	do.	0	2	3
6. Chops—Mid. Loin (Two-tooth)	do.	0	2	0
7. Chump Chops	do.	0	2	1
8. Veal, Legs	do.	0	0	0
Steak—				
9. Rump	do.	0	4	0
10. Blade	do.	0	3	7
11. Minced	do.	0	2	9
12. Topside	do.	0	4	6
13. Rissole	do.	0	2	9
14. Veal—Fillet, boneless	do.	0	2	9
15. Pork—Chops	do.	0	4	0
16. Sausages—Mixed	do.	0	2	3
17. Sausage—Strasburg, Pork	do.	0	3	9
18. Frys—Lamb	do.	0	2	6
19. Ox Kidney	do.	0	3	0
20. Frankfurts	do.	0	2	9
21. Rabbits—Fresh	do.	0	2	9
22. Shanks—Sheep	each	0	0	6
23. Sausage—Beef-German	per lb.	0	0	0
24. Fowls, 1st Quality	do.	0	4	9

ANNEX TO CONTRACT No. 1965/1271.
J. H. Cooke Pty. Ltd., 378 Queen's-parade, Clifton Hill.
 Sub-schedule No. 5.

MEAT FOR "WINLATON" GIRLS' TRAINING CENTRE, 186 SPRINGVALE-ROAD, NUNAWADING, AND "ALLAMBIE", 70 ELGAR-ROAD, BURWOOD.		£	s.	d.
Security, £5.				
1. Rolled Roast Sirloin, Boneless	per lb.	0	3	7
2. Beef—Corned—Silverside	do.	0	4	6
Mutton, Fresh—				
3. Chump Chops (Two-tooth)	do.	0	2	3

SCHEDULE No. 1.—MELBOURNE DISTRICT—*continued.*

Mutton, Fresh— <i>continued.</i>		£	s.	d.
4. Legs	per lb.	0	2	3
5. Chops—Mid. Loin	do.	0	2	0
6. Chops—Forequarter	do.	0	1	7
Steak—				
7. Topside	do.	0	4	6
8. Rump	do.	0	4	11
9. Stewing	do.	0	3	6
10. Minced	do.	0	2	11
11. Blade	do.	0	3	6
12. Sausages—Mixed	do.	0	2	3
13. Sausage Meat	do.	0	1	3
14. Frys—Lamb	do.	0	2	6
Veal—				
15. Fillet, Boneless	do.	0	4	6
16. T-bone	do.	0	4	6
17. Veal—Leg, Boned	do.	0	3	9
18. Pork—Pickled (excluding legs)	do.	0	2	6
19. Pressed Ham Loaf	do.	0	3	6
20. Tongues—Ox	do.	0	1	3
21. Dripping—Beef	do.	0	1	3
22. Brains—Sheep	per set	0	0	9
23. Sausage—Strasburg, Pork	per lb.	0	3	9
24. Frankfurts	do.	0	2	9
25. Rabbits—Fresh	do.	0	3	0
26. Kidneys—Sheep	do.	0	1	6
27. " Ox	do.	0	3	0
28. Sheep Shanks	each	0	0	6

ANNEX TO CONTRACT No. 1965/1272.
J. H. Cooke Pty. Ltd., 378 Queen's-parade, Clifton Hill.
 Sub-schedule No. 6.

MEAT FOR PSYCHIATRIC HOSPITAL, ROYAL PARK.		£	s.	d.
Security, £10.				
1. Rolled Roast, boneless (Brisket excluded)	per lb.	0	3	6
2. Thick Flank	do.	0	3	6
3. Fresh Mutton (legs)	do.	0	2	1
4. Chops—Forequarter	do.	0	1	7
5. Sausages—Mixed	do.	0	2	2
6. Sausage—Meat	do.	0	1	3
7. Saveloys	do.	0	0	0
8. Corned Silverside	do.	0	4	6
9. Fowls—First quality	do.	0	4	9
10. Rabbits—Fresh	do.	0	3	0
11. Sausage, Beef German	do.	0	2	10
12. Kidneys—Ox	do.	0	3	0

SCHEDULE No. 2.—MONT PARK AND SANATORIUM GRESSWELL, ETC.

ANNEX TO CONTRACT No. 1965/1273.
W. Angliss and Co. (Aust.) Pty. Ltd., 42 Bourke-street, Melbourne.
 Sub-schedule No. 1.

MEAT FOR MONT PARK MENTAL HOSPITAL, ETC.		£	s.	d.
Security, £35.				
1. Buttocks	per lb.	0	2	5
2. Topside Pieces	do.	0	0	0
3. Roast	do.	0	0	0
Beef, Corned—				
4. Rolled or Round, as ordered, without bone or cartilage	do.	0	2	6
5. Silverside	do.	0	4	0
Mutton, Fresh—				
6. Carcass or Sides (Kidney fat to be removed)	do.	0	1	1½
7. Legs	do.	0	1	10
Chops—				
8. Forequarter	do.	0	0	0
9. Loin, Middle	do.	0	1	10
10. Lamb, Loin	do.	0	3	3
11. Lamb—Carcass	do.	0	2	2
Steak—				
12. Topside	do.	0	3	9
13. Stewing	do.	0	2	9
14. Minced	do.	0	2	6
15. Buttock, sliced	do.	0	3	9
16. Saveloys	per doz.	0	0	0
17. Sausages—Mixed	per lb.	0	2	2
18. Shanks—Sheep	each	0	0	6
19. Tripe, Fresh	per lb.	0	0	11
20. Brains—Sheep	per set	0	0	10
21. Kidneys, Ox	per lb.	0	3	0
22. Lambs Fry	do.	0	0	0
23. Beef, German	do.	0	2	4
24. Rabbits—Fresh	do.	0	3	3
25. Ham Loaf	do.	0	3	0
26. Fillet—Veal	do.	0	2	9
27. Fowls—First quality	do.	0	4	2
28. Sausage, Strasburg, Pork	do.	0	3	2
29. Bones Beef	do.	0	0	0½

SCHEDULE No. 2.—MONT PARK AND SANATORIUM GRESSWELL, ETC.—*continued.*

	£	s.	d.
30. Veal Minced per lb.	0	2	9
31. Beef, Rolled Roast—boneless, (Brisket excluded) do.	0	3	1
32. Sausage—Meat do.	0	1	4
33. Lamb, Legs do.	0	3	2
34. Lamb Cutlets do.	0	3	3

ANNEX TO CONTRACT No. 1965/1274.

W. Angliss and Co. (Aust.) Pty. Ltd., 42 Bourke-street, Melbourne.

Sub-schedule No. 2.

MEAT FOR PLEASANT VIEW RECEIVING HOUSE, WOOD-STREET PRESTON.

	Security, £5.	£	s.	d.
1. Fresh Beef—Sirloin, boneless (Brisket excluded) per lb.	0	3	6	
2. Corned Beef—Silverside do.	0	4	0	
3. Fresh Lamb—Legs do.	0	3	2	
Chops—				
4. Lamb—Forequarter do.	0	0	0	
5. Lamb, Loin do.	0	3	3	
6. Sausages—Pork do.	0	2	3	
7. Dripping—Beef do.	0	1	3½	
8. Suet do.	0	0	0	
9. Mutton, Legs, boiling do.	0	0	0	
10. Tripe do.	0	0	11	
11. Ham, tinned, 2-lb. tin do.	0	11	3	
12. Pork—Fresh, Legs do.	0	4	3	
Steak—				
13. Blade do.	0	3	0	
14. Minced do.	0	2	6	
15. Sausage—Strasburg, Pork do.	0	3	2	
16. Tongues—Sheep do.	0	0	0	
17. Brains—Sheep per set	0	0	0	
18. Frankfurts per doz.	0	6	0	
19. Rabbits—Fresh per lb.	0	0	0	
20. Capons do.	0	5	0	
21. Lambs Livers do.	0	2	6	

ANNEX TO CONTRACT No. 1965/1275.

W. Angliss and Co. (Aust.) Pty. Ltd., 42 Bourke-street, Melbourne.

Sub-schedule No. 3.

MEAT FOR GRESSWELL SANATORIUM.

	Security, £15.	£	s.	d.
1. Fresh Beef—Rolled Roast Sirloin (boneless) per lb.	0	3	3	
2. Beef—Corned, Silverside do.	0	4	0	
Lamb—				
3. Fresh, Legs do.	0	3	2	
4. Chops—Mid. Loin do.	0	3	3	
5. " Chump do.	0	2	0	
6. Cutlets do.	0	3	3	
Pork—				
7. Fresh, Legs do.	0	4	3	
8. Chops do.	0	4	6	
9. Pickled do.	0	2	9	
10. Mutton—Leg Chops do.	0	1	11	
Veal—				
11. Fresh, Shoulder do.	0	1	3	
12. Cutlets do.	0	4	0	
13. Fillet do.	0	4	0	
Steak—				
14. Rump do.	0	4	3	
15. Topside do.	0	3	9	
16. Fillet do.	0	6	6	
17. Minced do.	0	2	6	
18. Brains—Sheep per set	0	0	10	
19. Fowls—First quality per lb.	0	4	2	
20. Frankfurts do.	0	2	10	
21. Ham Loaf do.	0	3	0	
22. " Pressed Leg do.	0	9	3	
23. Kidneys—Ox do.	0	3	0	
24. " Sheep do.	0	2	9	
25. Livers—Lamb do.	0	2	3	
26. Rabbits—Fresh do.	0	3	3	
27. Sausages—Mixed do.	0	2	2	
28. " Pork do.	0	2	3	
29. Sausage Meat do.	0	1	4	
30. " Strasburg, Pork do.	0	3	2	
31. Tripe—Fresh do.	0	0	11	
32. Tongues—Ox do.	0	1	3	
33. " Sheep do.	0	1	3	
34. Veal and Pork Loaf—Pressed do.	0	3	0	
35. Savoury Loaf—Pressed do.	0	3	0	
36. Ham—Leg, Raw do.	0	7	6	

SCHEDULE No. 3.—S.S. "Rip" AND DREDGES.

ANNEX TO CONTRACT No. 1965/1276.

G. K. and M. Reynolds Bros. Pty. Ltd., 4 Blackwood-street, North Melbourne.

Sub-schedule No. 1.

MEAT FOR DELIVERY AT YARRA RIVER WHARVES.

	Security, £5.	£	s.	d.
1. Fresh Beef—Roast per lb.	0	1	9	
Beef, Corned—				
2. Silverside do.	0	3	9	
3. Rolled do.	0	1	5	
Fresh Mutton—				
4. Forequarter do.	0	0	6	
5. Legs do.	0	2	1	
Chops—				
6. Forequarter do.	0	0	6	
7. Loin do.	0	0	11	
Steak—				
8. Rump do.	0	4	6	
9. Stewing do.	0	2	9	
10. Topside do.	0	3	9	
11. Sausages—Mixed do.	0	2	2	
12. Tripe—Fresh do.	0	1	1	
13. Livers—Sheep do.	0	2	0	
14. Suet—Kidney do.	0	0	8	
15. Rabbits—Fresh do.	0	2	10	
16. Ice per cwt.	0	0	9	

SCHEDULE No. 4.—TEACHERS' COLLEGES, HOSTELS, POLICE HOSPITAL, ETC.

(Delivery at Institutions.)

TEACHERS' COLLEGE AND HOSTELS AT GRATTAN-STREET, 93 DRUMMOND-STREET, CARLTON; 470, 481 AND 572 ST. KILDA-ROAD, MELBOURNE; 19 QUEEN'S-ROAD, MELBOURNE; 152 TOORAK-ROAD WEST, SOUTH YARRA; FRANK TATE HOUSE, 373 DANDENONG-ROAD, ARMADALE; "REDCOURT" NO. 6, "LARNOOK", 13 AND NO. 10A ORRONG-ROAD, ARMADALE; 11 PATTERSON-STREET, HAWTHORN; 174 PUNT-ROAD, PRAHRAN; 221 BURWOOD-ROAD, BURWOOD; JOHN CANNON HOUSE, 32 BELMONT-AVENUE, KEW; 17 MOULE-AVENUE, BRIGHTON; AND HASTINGS-ROAD, FRANKSTON; POLICE HOSPITAL, ST. KILDA-ROAD, MELBOURNE; AND MENTAL HYGIENE CLINIC, GLENFERRIE-ROAD, MALVERN.

ANNEX TO CONTRACT No. 1965/1277.

J. H. Cooke Pty. Ltd., 378 Queen's-parade, Clifton Hill.

Sub-schedule No. 1.

	MEAT.	Security, £15.	£	s.	d.
1. Fresh Beef—					
2. Rolled Prime Ribs, boneless per lb.	0	3	6		
3. Topside do.	0	4	6		
4. Sirloin, boneless do.	0	3	9		
Fresh Mutton—					
5. Legs do.	0	2	1		
6. Legs, pickled do.	0	2	1		
7. Sides, Two-tooth do.	0	1	0		
8. Legs, Two-tooth do.	0	2	3		
9. Cutlets do.	0	2	6		
10. Chops, Mid. Loin do.	0	2	0		
11. Chops, Forequarter do.	0	1	6		
12. Chops, Chump do.	0	2	1		
13. Beef—Corned, Silverside do.	0	4	6		
Veal—					
14. Shoulder, boned do.	0	1	6		
15. Fillet, boneless do.	0	4	9		
Steak—					
16. Blade do.	0	3	10		
17. Minced do.	0	2	10		
18. Stewing do.	0	3	9		
19. Rump do.	0	4	11		
20. Fillet do.	0	7	3		
21. Sausages—Mixed do.	0	2	3		
22. " Sausage—Meat do.	0	1	4		
23. " Beef, German do.	0	2	10		
24. " Strasburg do.	0	3	9		
25. Livers—Sheep do.	0	2	7		
26. Kidneys—Sheep do.	0	1	6		
27. " Ox do.	0	3	0		
28. Tongues—Ox do.	0	1	9		
29. Ox Tails do.	0	1	6		
30. Brains—Sheep do.	0	1	6		
31. Tripe—Fresh per set	0	0	8		
32. Frankfurts per lb.	0	0	9		
33. Bones—Soup do.	0	2	10		
34. Suet—Kidney do.	0	0	3		
35. Rabbits—Fresh do.	0	2	10		
36. Fowls—First quality do.	0	4	9		
37. Pork—Legs do.	0	4	6		
38. " Loin do.	0	4	0		
39. Lamb, legs do.	0	3	5		
40. Ham, pressed do.	0	8	9		
Dripping do.	0	1	3		

SCHEDULE No. 9.—BENDIGO DISTRICT—continued.

	per lb.	£	s.	d.
13. Sausage—Beef, German	0 2 9			
14. Bacon, Rashers, Shoulder	0 7 9			
15. Lamb—Legs	0 3 6			
16. Lamb Chops—Middle Loin	0 0 0			
17. Ham Loaf	0 3 9			
18. Kidney—Ox	0 1 9			
19. Pork Leg	0 5 0			
20. Pork, Pickled Rolled Shoulder	0 4 6			
21. Saveloys	0 0 0			
22. Livers, Sheep	0 1 6			
23. Sausage Meat	0 0 0			

ANNEX TO CONTRACT No. 1965/1285.

Frank Wade, 193 Williamson-street, Bendigo.

Sub-schedule No. 3.

MEAT.

For Teachers' College Hostels as under—
Osborne-street, Pleasant Vale, Bendigo.
"Lancewood," McLaren-street, Bendigo.
"Comersdale," Pantom-street, Golden Square, Bendigo.

	per lb.	£	s.	d.
1. Fresh Beef—Topside	0 6 6			
2. Corned Beef—Rolled or Round, as ordered, without bone or cartilage	0 3 0			
3. Corned Silverside	0 5 6			
4. Fresh Mutton—Carcass	0 0 11			
Steak—				
5. Blade—Minced	0 4 6			
6. Chuck	0 4 6			
7. Rump	0 7 0			
8. Sausages—Mixed	0 2 6			
9. Sausage Meat	0 1 9			
10. Livers—Sheep	0 1 6			
11. Veal—Fillet, boneless	0 6 6			
12. Brains—Sheep	per set 0 0 3			
13. Kidneys—Ox	per lb. 0 1 6			
14. Pork—Fresh, Loin	0 5 6			
15. Sausage—Strasbourg	0 3 9			
16. Salad Loaf	0 3 3			
17. Bacon, Middle Rashers	0 7 6			

SCHEDULE No. 10.—CASTLEMAINE GAOL.

ANNEX TO CONTRACT No. 1965/1286.

McQueen Brothers, Hargraves-street, Castlemaine.

Sub-schedule No. 1.

MEAT.

	per lb.	£	s.	d.
1. Fresh Beef	0 2 6			
2. Fresh Mutton	0 1 9			
3. Corned Beef—Rolled or Round, as ordered, without bone or cartilage	0 2 9			
4. Minced Meat—Beef	0 2 9			
5. Sausage Meat	0 1 6			
6. Saveloys	per doz. 0 4 9			

SCHEDULE No. 11.—SCHOOL OF FORESTRY, CRESWICK.

ANNEX TO CONTRACT No. 1965/1287.

H. J. Symons Pty. Ltd, 1015 Macarthur-street, Ballarat.

Sub-schedule No. 1.

MEAT.

	per lb.	£	s.	d.
1. Fresh Beef—				
Topside	0 5 3			
2. Sirloin, boneless	0 5 0			
3. Corned, Silverside	0 5 0			
4. Mutton—Fresh, sides	0 1 6			
5. Pork—Fresh, leg	0 5 0			
Steak—				
6. Stewing	0 4 8			
7. Minced	0 3 6			
8. Sausages—Mixed	0 2 6			
9. Sausage—Beef, German	0 3 9			
10. Kidney—Ox	0 2 0			
11. Liver—Sheep	0 1 0			
12. Saveloys	per doz. 0 4 0			

SCHEDULE No. 13.—MCLEOD SETTLEMENT, FRENCH ISLAND.

ANNEX TO CONTRACT No. 1965/1288.

L. Thompson, Lang Lang.

Sub-schedule No. 1.

MEAT.

	per lb.	£	s.	d.
1. Fresh Beef	0 2 8			
2. Mutton	0 1 8			
3. Sausages—Mixed	0 2 8			

SCHEDULE No. 14.—GEELONG DISTRICT.

ANNEX TO CONTRACT No. 1965/1289.

W. Angliss and Co. (Aust.) Pty. Ltd., 42 Bourke-street, Melbourne.

Sub-schedule No. 1.

MEAT FOR GAOL.

	per lb.	£	s.	d.
Security, £5.				
1. Fresh Beef	0 1 11			
2. Corned Beef—Rolled or Round, without bone or cartilage	0 2 3			
Fresh Mutton—				
3. Forequarters	0 1 3			
4. Legs	0 2 3			
5. Beef—Minced	0 1 11			
6. Sausages—Mixed	0 2 0			
7. Sausage Meat	0 1 0			

ANNEX TO CONTRACT No. 1965/1290.

W. Angliss and Co. (Aust.) Pty. Ltd., 42 Bourke-street, Melbourne.

Sub-schedule No. 2.

MEAT.

For delivery to Teachers' Hostels as under—
"Lauriston", 23 Aberdeen-street, Geelong.
"Forty-Five", The Esplanade, Western Beach, Geelong.
"Hawthorn", Aberdeen-street, Geelong.
"Ariston", Packington-street, Geelong.
"Warrain", 56 Western Beach, Geelong.

	per lb.	£	s.	d.
Security, £5.				
1. Fresh Beef—Sirloin, boneless	0 3 3			
2. Corned Beef—Rolled or Round, as ordered, without bone or cartilage	0 3 3			
Mutton—				
3. Legs, Two-tooth	0 2 3			
4. Forequarters, boned, rolled, and pickled	0 1 3			
5. Chops, Forequarter	0 1 5			
6. Chops, Cutlets	0 2 3			
Steak—				
7. Chuck	0 2 9			
8. Bladebone	0 3 1			
9. Minced	0 1 11			
10. Fillet—Veal	0 1 0			
11. Tongues—Ox	0 1 0			
12. Kidneys—Ox	0 1 0			
Sausages—				
13. Mixed, thin	0 2 0			
14. Pork, thick	0 2 0			
Sausage—				
15. Pork, German	0 2 10			
16. Mince	0 1 0			
17. Bacon—Shoulder	0 4 11			

SCHEDULE No. 15.—COORIE MUNGLE PRISON CAMP, HEYTESBURY FOREST.

ANNEX TO CONTRACT No. 1965/1291.

Heytesbury Butchery, Timboon.

Sub-schedule No. 1.

MEAT.

	per lb.	£	s.	d.
Security, £4.				
1. Fresh Beef	0 5 1			
2. Corned Beef—Rolled or Round, as ordered, without bone or cartilage	0 4 2			
3. Sausages—Mixed	0 3 0			
4. Sausage Mince	0 2 3			

SCHEDULE No. 17.—LANGI KAL KAL TRAINING CENTRE.

ANNEX TO CONTRACT No. 1965/1292.

H. A. Morris, 105 Victoria-street, Ballarat.

Sub-schedule No. 1.

MEAT.

	per lb.	£	s.	d.
Security, £5.				
1. Sausages—Mixed	0 2 0			
2. Fresh Beef—Boneless	0 3 5			

SCHEDULE No. 20.—SALE GAOL.

ANNEX TO CONTRACT No. 1965/1293.

R. Schuback, 99B Simpson-street, Sale.

Sub-schedule No. 1.

MEAT.

	per lb.	£	s.	d.
Security, £3.				
1. Fresh Beef	0 3 0			
Fresh Mutton—				
2. Chops, Forequarter	0 1 11			
3. Corned Beef—Rolled or Round, as ordered, without bone or cartilage	0 2 9			
4. Sausage Meat	0 1 9			

SCHEDULE No. 21.—PLEASANT CREEK SPECIAL SCHOOL, STAWELL.

ANNEX TO CONTRACT No. 1965/1294.

Thomas Borthwick and Sons (Asia) Ltd., Box 150, Portland.

Sub-schedule No. 1.

MEAT.		Security, £3.	£	s.	d.
Steak—					
1. Rump	per lb.	0	6	0	
2. Minced	do.	0	3	4	
3. Fresh Mutton	do.	0	2	0	
4. Chops—Leg	do.	0	2	4	
5. Sausages—Pork	do.	0	2	4	
6. Bacon Rashers, Shoulder	do.	0	7	6	
7. Beef—Corned, Silverside	do.	0	4	4	
8. Kidney—Ox	do.	0	2	6	
9. Sausage, Pork German	do.	0	4	8	
10. Sausage Meat	do.	0	1	9	
11. Livers—Sheep	do.	0	1	4	
12. Meat Loaf	do.	0	3	8	
13. Mutton, Forequarter Chops	do.	0	1	6	
14. Beef, Rolled Roast, Brisket excluded	do.	0	3	10	
15. Tongues—Ox	do.	0	2	0	
16. Mutton Legs—Fresh	do.	0	2	2	

SCHEDULE No. 22.—SUNBURY DISTRICT.

ANNEX TO CONTRACT No. 1965/1295.

F. Watkins Pty. Ltd., 256 Russell-street, Melbourne.

Sub-schedule No. 1.

MEAT.		Security, £40.	£	s.	d.
Fresh Beef—					
1. Rolled Roast, boneless (brisket excluded)	per lb.	0	3	0	
2. Buttocks	do.	0	2	7	
3. Fresh Mutton—Kidney fat to be removed	fat to be	0	1	5½	
4. Corned Beef—Rolled or Round, as ordered, without bone or cartilage	do.	0	2	11	
5. Sausages—Mixed	do.	0	2	2	
6. Sausage Meat	do.	0	1	6	
7. Veal—Boneless	do.	0	2	6	
8. Tripe Fresh	do.	0	1	0	
9. Ox—Kidney	do.	0	3	3	
10. Steak—Rump	do.	0	4	6	
11. „ —Topside	do.	0	3	9	
12. Sausage, Beef German	do.	0	3	0	

SCHEDULE No. 23.—WARRNAMBOOL DISTRICT.

ANNEX TO CONTRACT No. 1965/1296.

Thomas Borthwick and Sons (Asia) Ltd., P.O. Box 150, Portland.

Sub-schedule No. 1.

MEAT.		Security, £15.	£	s.	d.
1. Fresh Beef—Rolled Roast (brisket excluded)	per lb.	0	3	10	
2. Corned Beef—Rolled or Round, as ordered	do.	0	3	4	
Fresh Mutton—					
3. Forequarters	do.	0	1	4	
4. Legs	do.	0	2	2	
5. Chops—Middle Loin	do.	0	2	4	
Steak—					
6. Stewing	do.	0	3	8	
7. Minced	do.	0	3	4	
8. Sausage Meat	do.	0	1	9	
Sausages—					
9. Beef	do.	0	2	4	
10. Pork	do.	0	2	6	
11. Kidneys—Ox	do.	0	2	8	
12. Sausage, Beef German	do.	0	3	8	
13. Livers, Sheep	do.	0	1	4	
14. Steak—Topside	do.	0	4	8	

SCHEDULE No. 24.—HOBSON PARK HOSPITAL, TRARALGON.

ANNEX TO CONTRACT No. 1965/1297.

Stoddart Bros., 77 Franklin-street, Traralgon.

Sub-schedule No. 1.

MEAT.		Security, £5.	£	s.	d.
1. Rolled Prime Ribs, boneless	per lb.	0	4	6	
2. Thick Flank (Minced when required)	do.	0	4	6	
3. Steak, Topside	do.	0	4	6	
4. Corned Silverside	do.	0	4	6	
5. Fresh Mutton, Legs (pickled, boned, and rolled)	do.	0	2	6	
6. Chops, forequarter, Lamb	do.	0	2	10	
7. Lambs Fry	do.	0	1	6	
8. Steak, Blade	do.	0	4	6	
9. Fresh Mutton, Legs, Two-tooth	do.	0	2	6	
10. Ham Loaf	do.	0	5	6	
11. Tails—Ox	do.	0	1	6	
12. Sausages, Mixed	do.	0	2	4	
13. Sausage, Pork German	do.	0	4	8	
14. Bacon, Middles	do.	0	7	3	
15. Pigs' Cheeks	do.	0	0	0	
16. Fowls, First quality	do.	0	0	0	
17. Tripe, Fresh	do.	0	0	0	

CONTRACTS ACCEPTED.—(Series 1965-66.)

PRISONERS' MEALS IN LOCK-UPS.

CONTRACT CANCELLED.

Gazette No. 53, 7th July, 1965, Prisoners' Meals, Collingwood.—Contract No. 269 is hereby cancelled.

CONTRACT ACCEPTED.

1308. For the supply of Prisoners' Meals at Collingwood, Breakfast and Tea, 3s.; Hot Dinner, 5s. 6d.—G. M. Porter, as from 8th October, 1965.

Gazette No. 53, 7th July, 1965, Prisoners' Meals, North Melbourne.—For rates shown opposite Contract No. 266, substitute Breakfast and Tea, 4s.; Hot Dinner, 5s.; as from 8th October, 1965.

H. COUTTS, Secretary to the Tender Board. 18.10.65.

SOIL CONSERVATION AUTHORITY.

SHEEP STATION CREEK GROUP CONSERVATION AREA.

1298. Construction of three reinforced concrete structures, £2,000.—S. Juhasz, 7 Capella-street, North Balwyn.

R. D. HALL, Secretary.

ORDERS IN COUNCIL.—(Series 1965-66.)

FORESTS COMMISSION.

Loan Fund Act No. 7172, Item 6—

1253. To the purchase of that lots 9, 10, 11, 12 and 13, on the plan of subdivision No. 21036, being part of allotment 6, section 2, Parish of Mooroolbark, County of

Evelyn for forest purposes, £660.—Mrs. Dorothy Clark Peters.

Approved by the Governor in Council, 5th October, 1965.—J. COLQUHOUN, Clerk of the Executive Council.

EDUCATION DEPARTMENT.

1254. One (1) only bench folder, for Doveton Technical School, £137 15s.—McPherson's Ltd.

1255. One (1) only plan printing and developing machine, for Glenroy Technical School, £235.—Ozapaper Ltd.

1256. Dictation equipment, for Gordon Institute of Technology, Geelong, £1,698.—The Audio-Typing Equipment Co. Pty. Ltd.

1257. Three (3) only cathode ray oscilloscopes, (£85 10s. each), for Gordon Institute of Technology, Geelong, £256 10s.—Warburton Franki Industries.

1258. One (1) only toolmakers' microscope, for Echuca Technical School, £250.—Qualos Sales Pty. Ltd.

1259. One (1) only photocopying machine, for Wonthaggi Technical and High School, £148.—J. W. Folk Pty. Ltd.

Approved by the Governor in Council, 12th October, 1965.—J. COLQUHOUN, Clerk of the Executive Council.

PUBLIC WORKS.

1260. Carlton, St. Nicholas Hospital, Mental Health Authority, conversion of observation block to sheltered workshop, £1,068.—McDougall-Ireland Pty. Ltd.—(M.40140.)

1261. Koonung High School, contribution towards the cost of drainage works, £19,542 5s. 6d.—Melbourne and Metropolitan Board of Works.—(N.E.22967 "G".)

1262. Manangatang, Consolidated school, supply and installation of air conditioning equipment in two class-rooms, £1,344.—D. Smyth & Son Pty. Ltd.—(N.W.85595.)

1263. Melbourne, Public Offices, Treasury Buildings, replacement of existing heating water pipework, £743 14s.—W. S. Atherton & Co. Pty. Ltd.—(M.78573.)

1264. Melbourne, State Government Offices, 61 Spring-street, Old Treasury Buildings, and State Laboratory, watching services from 1st July, 1965, to 30th June, 1966, £600 12s.—Australian Watching Co. Pty. Ltd.—(M.48112.)

1265. Mildura West, State School No. 3983, supply and installation of air conditioning equipment, one class-room, £645.—D. Smyth & Son Pty. Ltd.—(N.W.85594.)

1266. Plenty Mental Hospital, Mental Health Authority, supply of cell locks, £834 12s.—J. Hubball Pty. Ltd.—(N.E.38850.)

Approved by the Governor in Council, 12th October, 1965.—J. COLQUHOUN, Clerk of the Executive Council.

STATE ELECTRICITY COMMISSION.

1299. For the supply of black insulating tape for a period of two years, to Specification No. 64-65/296, at Schedule rates.—Mica & Insulating Supplies Co. Pty. Ltd.

1300. For the supply of underground cable terminal boxes for a period of two years, to Specification No. 64-65/355, at Schedule rates.—Switchgear Pty. Ltd.

Approved by the Governor in Council, 15th September, 1965.—J. COLQUHOUN, Clerk of the Executive Council.

1301. For the supply of public lighting standard brackets and accessories for street lighting for a period of one year, to Specification No. 64-65/315, at Schedule rates.—Gamma Welding Constructions.

1302. For the supply of replacement parts for various vehicles marketed by General Motors-Holdens Pty. Ltd. in Latrobe Valley area for a period of two years, to Specification 65-66/34, at Schedule rates.—R. Foster Yallourn Motors Pty. Ltd.

1303. For the supply of 33 International vehicles, to Quotation No. 4731, £51,649 8s. 5d.—International Harvester Co. of Aust. Pty. Ltd.

1304. For the construction of earthworks, concrete paving, water and sewerage reticulation, and associated work, Hazelwood Power Station, stage 4, to Specification No. 65-66/86, £64,392 10s.—J. Jeffrey & Sons Pty. Ltd.

1305. For the supply of electrical appliances and spare parts for merchandizing for a period of two years, to Quotation No. 1175, at Schedule rates.—Sunbeam Corporation.

1306. For earth wire cover strips for a period of two years, to Specification No. 65-66/26, at Schedule rates.—J. Wright & Sons Pty. Ltd.

1307. For the purchase of property in Saviges-road, Moe, being lot 2 on plan of subdivision 70191, lodged at Office of Titles, being part of Crown allotments 34 and 35, Township of Moe, and Parish of Yarragon, for a main sub-station site, £5,817 3s. 9d.—Moe Co-operative Dairying Co. Ltd.

Approved by the Governor in Council, 21st September, 1965.—J. COLQUHOUN, Clerk of the Executive Council.

Co-operation Act 1958.

SIXTH OAKLEIGH-MONASH BOY SCOUT GROUP CO-OPERATIVE LIMITED.

(FORMERLY SIXTH OAKLEIGH BOY SCOUT GROUP CO-OPERATIVE LIMITED.)

Notice of Change of Name of Society.

NOTICE is hereby given that I have this day registered a change of the name of Sixth Oakleigh Boy Scout Group Co-operative Limited, which was incorporated as a Community Advancement Society under the above-named Act, on the first day of October, 1963, and is now incorporated under the name of Sixth Oakleigh-Monash Boy Scout Group Co-operative Limited under the said Act.

Dated at Melbourne this sixth day of October, 1965.

J. W. JUNGWIRTH,

Deputy Registrar of Co-operative Societies.

No. 86.—9513/65.—2

WANGARATTA WATERWORKS TRUST.

AUTHORITY TO OBTAIN BANK OVERDRAFT.

HIS Excellency the Governor of the State of Victoria, by and with the advice of the Executive Council thereof, doth, by Order made on the 19th day of October, 1965, authorize the Wangaratta Waterworks Trust to obtain in pursuance of the provisions of section 286 of the Water Act 1958 (No. 6413) an advance or advances during the year ending 30th September, 1966, from the Bank of New South Wales, Wangaratta, by overdraft of the Trust's current account thereat, such overdraft not to exceed at any one time the sum of Ten thousand pounds (£10,000).

J. COLQUHOUN,

Clerk of the Executive Council.

At the Executive Council Chamber,
Melbourne, 19th October, 1965.

LOUGH CALVERT DRAINAGE TRUST.

RATING BY-LAW 1965.

THE Lough Calvert Drainage Trust, in pursuance and exercise of the powers conferred by the River Improvement Act 1958, doth hereby make the By-Law following:—

1. The following Rate to be called the "Lough Calvert Drainage District Drainage Rate" is hereby made and shall be levied upon the occupiers or owners of all properties in the Lough Calvert Drainage District which are rateable to any municipality:—

- (a) A rate of eleven pence in the pound on the net annual municipal value of all properties in the First Division of the Lough Calvert Drainage District shown coloured green on the plan titled "Lough Calvert Drainage District Rating Divisions 1958", approved by the Governor in Council, and deposited at the Office of the State Rivers and Water Supply Commission at Melbourne.
- (b) A rate of ten pence in the pound on the net annual municipal value of all properties in the Second Division of the Lough Calvert Drainage District shown coloured brown on the said plan.
- (c) A rate of nine pence in the pound on the net annual municipal value of all properties in the Third Division of the Lough Calvert Drainage District shown coloured yellow on the said plan.
- (d) A rate of five pence half penny in the pound on the net annual municipal value of all properties in the Fourth Division of the Lough Calvert Drainage District shown coloured grey on the said plan.
- (e) A rate of four pence in the pound on the net annual municipal value of all properties in the Fifth Division of the Lough Calvert Drainage District shown coloured violet on the said plan.
- (f) A rate of two pence in the pound on the net annual municipal value of all properties in the Sixth Division of the Lough Calvert Drainage District shown coloured pink on the said plan.
- (g) No rate is made or levied in respect of any property within the Seventh Division of the Lough Calvert Drainage District comprising all those lands not included in the First, Second, Third, Fourth, Fifth or Sixth Divisions.

Provided that in no case shall the amount of Rate payable in respect of any rateable property within the Lough Calvert Drainage District be less than one shilling.

2. Such rate is made and shall be levied for the period beginning the 1st day of January, 1965, and ending on the 31st day of December, 1965, and shall be payable on the 20th day of October, 1965, at the office of the Lough Calvert Drainage Trust at Colac.

3. Such person or persons as the Lough Calvert Drainage Trust may from time to time appoint for that purpose shall be and is or are hereby authorized to demand, receive, collect and recover the said Rate.

The foregoing By-Law was made by the Lough Calvert Drainage Trust on the 12th day of July, 1965, and the seal of the said Trust was hereby affixed, this 12th day of July, 1965, in the presence of—

(SEAL) T. A. BARNARD, Chairman.
H. J. HARBOUR, Commissioner.
A. C. THEODORE, Secretary.

Approved by the Governor in Council, 19th October, 1965.—J. COLQUHOUN, Clerk of the Executive Council.

THORPDALE WATERWORKS TRUST.

RATING BY-LAW 1965.

THE Thorpdale Waterworks Trust, in pursuance and exercise of the powers conferred by the Water Acts, doth hereby make a rate for the supply of water for domestic purposes of Three shillings in the pound on the annual municipal valuation of lands and tenements liable to be rated within the Thorpdale Urban District.

Provided that in no case shall the amount of rate payable in respect of any tenement (other than land on which there is no building) be less than Six pounds, and in respect of any land on which there is no building less than One pound ten shillings.

Such rates are made and shall be levied upon the occupiers or owners of the said lands and tenements for the year commencing the 1st day of January, 1965, and ending on the 31st day of December, 1965, and shall be payable on the 20th day of October, 1965, at the office of the said Trust.

The maximum quantity of water to be supplied in any one year without further charge to any property rated by the Trust is hereby fixed at the quantity which, at a charge of Three shillings per 1,000 gallons, would produce an amount equal to the amount of the rate levied on such property for the said year.

The charge for water supplied by measure to any property rated by the Trust in excess of such maximum quantity, computed as in the last preceding clause, is hereby fixed at Three shillings per 1,000 gallons.

The charge for water supplied by measure shall be payable, on demand, at the office of the Trust.

(SEAL) ALAN F. GUNN, Chairman.
HOWARD E. STEWART, Commissioner.
W. F. NELSON, Secretary.

Approved 13th October, 1965.—T. A. DARCY, Minister of Water Supply.

SHIRE OF WARRACKNABEAL.

ROAD DEVIATION ORDER.

IN pursuance of the powers conferred by sections 522 and 526 of the Local Government Act 1958, the Council of the Shire of Warracknabeal doth hereby direct that the land in the Parish of Cannum, shown hatched on the plan hereunder, which has been purchased or acquired by it, shall be a public highway from and after the date of publication of this Order in the Government Gazette, and doth declare that such land shall be a public highway in lieu of the land in the said parish shown cross-hatched on the said plan.

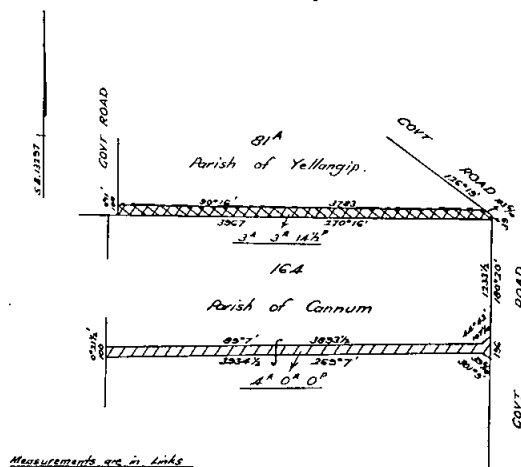

Measurements are in Links

The common seal of the President, Councillors and Ratepayers of the Shire of Warracknabeal was hereunto affixed this 17th day of December, 1964, in the presence of—

(SEAL) H. H. WOODS, President.
JOHN Q. KING, Councillor.
S. FELL, Secretary.

Confirmed by the Governor in Council, 12th October, 1965.—J. COLQUHOUN, Clerk of the Executive Council.

SHIRE OF WARRACKNABEAL.

ROAD DEVIATION ORDER.

IN pursuance of the powers conferred by sections 522 and 526 of the Local Government Act 1958, the Council of the Shire of Warracknabeal doth hereby direct that the land in the Parish of Willenabrana, shown hatched on the plan hereunder which has been purchased or acquired by it, shall be a public highway from and after the date of publication of this Order in the Government Gazette, and doth declare that such land shall be a public highway in lieu of the land in the said parish shown cross-hatched on the said plan.

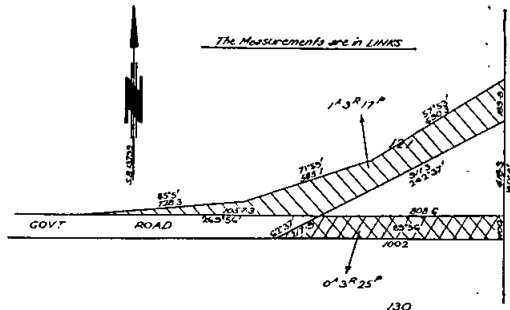

The common seal of the President, Councillors and Ratepayers of the Shire of Warracknabeal was hereunto affixed this 17th day of December, 1964, in the presence of—

(SEAL) H. H. WOODS, President.
JOHN Q. KING, Councillor.
S. FELL, Secretary.

Confirmed by the Governor in Council, 12th October, 1965.—J. COLQUHOUN, Clerk of the Executive Council.

SHIRE OF WARRACKNABEAL.

ROAD DEVIATION ORDER.

IN pursuance of the powers conferred by sections 522 and 526 of the Local Government Act 1958, the Council of the Shire of Warracknabeal doth hereby direct that the land in the Parish of Willenabrana, shown hatched on the plan hereunder which has been purchased or acquired by it, shall be a public highway from and after the date of publication of this Order in the Government Gazette, and doth declare that such land shall be a public highway in lieu of the land in the said parish shown cross-hatched on the said plan.

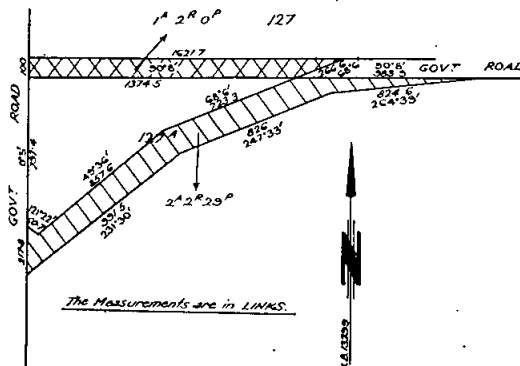

The Measurements are in Links.

The common seal of the President, Councillors and Ratepayers of the Shire of Warracknabeal was hereunto affixed this 17th day of December, 1964, in the presence of—

(SEAL) H. H. WOODS, President.
JOHN Q. KING, Councillor.
S. FELL, Secretary.

Confirmed by the Governor in Council, 12th October, 1965.—J. COLQUHOUN, Clerk of the Executive Council.

SHIRE OF KOWREE.
ROAD DEVIATION ORDER.

IN pursuance of the powers conferred by sections 522 and 526 of the Local Government Act 1958, the Council of the Shire of Kowree doth hereby direct that the land in the Parish of Jallakin shown hatched on the plan hereunder, which has been taken, purchased or acquired by it, shall be a public highway from and after the date of publication of this Order in the Government Gazette, and doth declare that such land shall be a public highway in lieu of the land in the said Parish shown cross-hatched on the said plan.

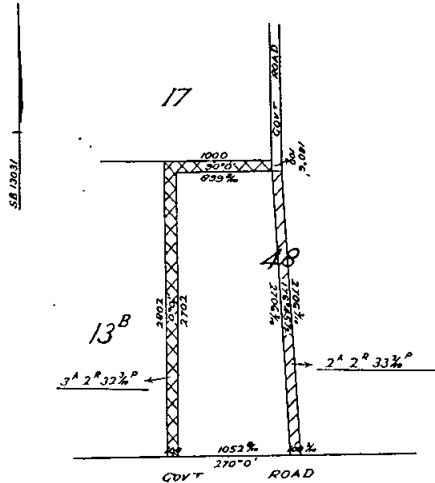

Measurements are in Links

The Common Seal of the President, Councillors and Ratepayers of the Shire of Kowree, was hereunto affixed this 7th day of June, 1965, in the presence of—

(SEAL) D. A. BULL, President.
RAYMOND L. AMPT, Councillor.
H. ERNEST WALKER, Secretary.

Approved by the Governor in Council, 12th October, 1965.—J. COLQUHOUN, Clerk of the Executive Council.

DEPARTMENT OF MINES.

SUBJECT to any necessary excisions, &c., it is proposed to grant the following mining lease:—

8335, Mineral; Sulphates Limited; 7a. 3r. 6p., Parish of Allambie East.

MINING LEASES GRANTED.

- 8415, Beechworth; R.R. Mining Proprietary Limited; 56a. Or. 14p., Parish of Hotham.
- 11371, Bendigo; Robert Noel Hird, Terrence Edward Hird and Harold Edward Hird; 17a. 2r. 5p., Parish of Heathcote.
- 9240, Castlemaine; Andrew Robert Soutar; 68a. Or., 30p., Parish of Faraday.
- 8321, Mineral; Harry Sydney Nottle; and Alice Agnes Nottle; 55a. Or. 0p., Parish of Warraquil.
- 8337, Mineral; Sulphates Limited; 81a. 2r. 5p., Parish of Allambie East.
- 8355, Mineral; Keith William Pohlner; 10a. Or. 0p., Parish of Gerang Gerung.
- 8357, Mineral; Herbert Henry Scholz; 66a. Or. 0p., Parish of Banu Bonyit.
- 8361, Mineral; John Lawson Barber; 32a. Or. 32p., Parish of Wail.
- 8370, Mineral; Bendigo Pottery Proprietary Limited; 10a. 3r., 26p., Parish of Huntly.

APPLICATION FOR LEASES DECLARED ABANDONED.

- 2762, Ararat; Gold Mines of Australia Limited transferred to Western Mining Corporation Limited; 440 acres, Parish of Stawell.
- 2763, Ararat; Gold Mines of Australia Limited transferred to Western Mining Corporation Limited; 900 acres, Parishes of Illawarra and Stawell.
- 2765, Ararat; Gold Mines of Australia Limited transferred to Western Mining Corporation Limited; 900 acres, Parish of Illawarra.
- 2766, Ararat; Gold Mines of Australia Limited transferred to Western Mining Corporation Limited; 88 acres, Parish of Stawell.

- 2768, Ararat; Gold Mines of Australia Limited transferred to Western Mining Corporation Limited; 1,000 acres, Parish of Illawarra.
- 2776, Ararat; Gold Mines of Australia Limited transferred to Western Mining Corporation Limited; 260 acres, Parish of Stawell.
- 2779, Ararat; Gold Mines of Australia Limited transferred to Western Mining Corporation Limited; 1,300 acres, Parish of Stawell.
- 2790, Ararat; Gold Mines of Australia Limited; transferred to Western Mining Corporation Limited; 1,300 acres, Parish of Illawarra.
- 2828, Ararat; Gold Mines of Australia Limited, transferred to Western Mining Corporation Limited; 10,000 acres, Parishes of Illawarra and Stawell.

TAILINGS LICENCES GRANTED.

- 3421, Tailings Licence; Cyril John Smith, at Long Gully.
- 3423, Tailings Licence; Albert William Trotter, Parish of Moreep.
- 3425, Tailings Licence; Bendigo Pottery Proprietary Limited; Parish of Sandhurst.
- 3426, Tailings Licence; Antonio Sis; Parish of Langi Kal Kal.
- 3427, Tailings Licence; State Rivers and Water Supply Commission; Parish of Drummond.

MINING LEASE EXPIRED.

8259, Beechworth; Alexander Clarence Smith; 9a. 2r. 1p., Parish of Goulburn.

TAILINGS LICENCE EXPIRED.

3183, Tailings Licence; County Roads Board, Parish of Moorabool West.

T. A. DARCY,
Minister of Mines.

Local Government Act.

PETITION FOR DECLARATION OF THE TOWN OF CASTLEMAINE AS A CITY.

IN pursuance of the provisions of the Local Government Act 1958, as amended, section 43, the substance and prayer of a petition presented to His Excellency the Governor in Council, in accordance with section 38 of the said Act, are published, viz.:—

The petition of the Mayor, Councillors and Burgesses of the municipality of the Town of Castlemaine sheweth that the gross revenue of the municipality of the Town of Castlemaine for the year ended 30th September, 1965, exceeded the sum of £30,000, as set out in the statement of accounts for that year.

The petitioners therefore pray that His Excellency the Governor in Council, in exercise of the powers and authorities contained in section 16, sub-section (12) of the Local Government Act 1958, as amended, will declare the municipality of the Town of Castlemaine to be a City.

R. J. HAMER,
Minister for Local Government.

Local Government Department,
Melbourne.

LOCAL GOVERNMENT DEPARTMENT.

ORDER CONFIRMED.—SHIRE OF WERRIBEE.

THE Minister of the Crown administering the Local Government Act 1965, confirmed the Order hereinafter referred to, in pursuance of section 514 of the said Act, namely:

An Order of the Council of the Shire of Werribee, made on the 30th August, 1965, directing the compulsory taking of the land described hereunder for the purpose of providing a site for a depot for the disposal of refuse and rubbish and the erection of an incinerator:

“All that piece of land, being part of Crown allotment 1, section 9, in the Parish of Mambourin, and being part of the land described as lot 62 on plan of subdivision No. 5410, lodged in the Office of Titles, Melbourne, the boundaries of which are as follows:—Commencing at a point on the south-east boundary of said lot 62, distant 2,342 links from the south-west corner of said lot 62; thence by lines bearing 338 deg. 33 min. 1,127.3 links, 359 deg. 29 min. 334.6 links, 50 deg. 3 min. 319.9 links, 136 deg. 0 min. 189.5 links, 187 deg. 45 min. 478.3 links, 59 deg. 56 min. 231.4 links, 338 deg. 33 min. 906.4 links and 235 deg. 32½ min. 34.2 links to the point of commencement.”

R. J. HAMER,
Minister for Local Government.

Local Government Department,
Melbourne.

Melbourne and Metropolitan Board of Works Act 1958.
MELBOURNE AND METROPOLITAN BOARD OF WORKS
BY-LAW No. 89 RELATING TO WATER SUPPLY.

MELBOURNE AND METROPOLITAN BOARD OF WORKS (hereinafter called "the Board") pursuant to and in exercise and execution of the powers and authorities conferred upon the Board by the *Melbourne and Metropolitan Board of Works Act 1958* (as amended) and in exercise and execution of any other powers and authorities in anywise enabling the Board in that behalf doth hereby make the By-law following, that is to say:—

1. This By-law shall be read and construed as one with By-law No. 81 duly made and passed by the Board on the 18th day of September, 1962, and published in the *Government Gazette* on the 3rd day of October, 1962.

2. The said By-law No. 81 is hereby amended as follows:—

(a) In clause 2 for the word "it" where first appearing in the definition of "Proper Officer" there shall be substituted the expression "the Engineer-in-Chief".

(b) For clause 38 (b) there shall be substituted the following:—

"38. (b) The size of a service pipe for the supply of water for domestic purposes to any tenement other than a building occupied as business premises or as flats or as a place of public recreation or entertainment or by an institution shall be permitted in accordance with the following, that is to say:—

(i) A $\frac{3}{4}$ -in. service pipe for a tenement rated on a valuation of not more than £400 and having an area of less than 1,000 square yards;

(ii) A 1-in. service pipe for a tenement rated on a valuation of more than £400 or having an area of more than 1,000 square yards;

(iii) A 1½-in. service pipe for a tenement rated on a valuation of more than £400 and having an area of more than 3,000 square yards or for a tenement rated on a valuation of more than £800;

(iv) A 1½-in. service pipe for a tenement rated on a valuation of more than £800 and having an area of more than 3,000 square yards or for a tenement rated on a valuation of more than £1,200.

Provided however that where the supply of water is in the opinion of the Engineer-in-Chief insufficient to meet the normal demands of the tenements in the vicinity the sizes of service pipes to be laid to connect such tenements to a water main or arterial main will be determined by the Engineer-in-Chief irrespective of the valuations or areas of such tenements".

3. The said By-law No. 81 as hereinbefore amended is hereby ratified and confirmed.

The foregoing By-law was made and passed by the Melbourne and Metropolitan Board of Works, and the common seal of the said Board was hereunto affixed the 14th day of September, 1965—

R. E. TRICKEY, Chairman.
 (SEAL) M. H. FENNELL, Member.
 H. SNADDEN, Secretary.

Melbourne and Metropolitan
 BOARD OF WORKS.

NOTICE is hereby given that, after the publication of this advertisement in the *Government Gazette* and once in not less than two daily newspapers published in the metropolis, the Melbourne and Metropolitan Board of Works will proceed to compulsorily take (unless the same is in the meantime acquired by the Board from the owner or owners or other persons interested by mutual agreement) the land mentioned and described in the Schedule hereto.

The nature of the works in respect of which the land is proposed to be taken is for the purposes of constructing a water supply reservoir.

A plan of the proposed works will be open for inspection at the offices of the Board, 110 Spencer-street, Melbourne, from the date hereof until the 7th day of November, 1965, during office hours.

The quantity of land which the Board requires for the purpose of such works and other particulars are set forth below.

The consent of the Governor in Council was duly obtained in terms of the Board's principal Act (No. 6310) on the 28th day of September, 1965.

SCHEDULE.

All that piece of land being part of Crown allotment E, section Z, Parish of Mooroolbark, commencing at a point in the eastern boundary of the said Crown allotment E, 4,400 links south of the northern boundary thereof; thence south-westerly by a line bearing 215 deg. 59½ min. for 1,855 and 2/10 links; thence easterly by a line bearing 95 deg. 35 min. for 939 links to the eastern boundary of the said Crown allotment E; thence northerly by the last-mentioned boundary for 1,600 links to the commencing point and containing 7 acres 2 roods and 1 and 9/10 perches.

Dated the 13th day of October 1965.

H. J. SNADDEN,
 Secretary.

Melbourne and Metropolitan
 BOARD OF WORKS.

NOTICE is hereby given that, after the publication of this advertisement in the *Government Gazette* and once in not less than two daily newspapers published in the metropolis, the Melbourne and Metropolitan Board of Works will proceed to compulsorily take (unless the same is in the meantime acquired by the Board from the owner or owners or other persons interested by mutual agreement) the land mentioned and described in the Schedule hereto.

The nature of the works in respect of which the land is proposed to be taken is for the purposes of main drainage and river improvement on land adjacent to Kororoit Creek.

A plan of the proposed works will be open for inspection at the offices of the Board, 110 Spencer-street, Melbourne, from the date hereof until the 30th day of October, 1965, during office hours.

The quantity of land which the Board requires for the purpose of such works and other particulars are set forth below.

The consent of the Governor in Council was duly obtained in terms of the Board's principal Act (No. 6310) on the 28th day of September, 1965.

SCHEDULE.

All that piece of land being part of Crown allotments B and C, section 9, Parish of Maribyrnong, commencing at a point being the intersection of left bank of Kororoit Creek and the southern boundary of Ballarat Railway Reserve; thence easterly by the last-mentioned boundary for 311 feet to the western boundary of Fraser-street; thence southerly by a line bearing 179 deg. 37 min. for 176 feet; thence easterly by a line bearing 89 deg. 37 min. for 55 feet; thence southerly by a line bearing 179 deg. 37 min. for 10 feet; thence easterly by a line bearing 89 deg. 47 min. for 50 feet; thence southerly by a line bearing 179 deg. 37 min. for 176 feet; thence generally easterly by lines bearing 116 deg. 22 min. for 279 ft. 11½ in. 89 deg. 37 min. for 300 feet, 104 deg. 12 min. for 51 ft. 8 in. and 89 deg. 37 min. for 406 feet; thence northerly by a line bearing 359 deg. 37 min. for 66 feet to the southern boundary of Ripon-street; thence easterly by the last-mentioned boundary for 38 feet; thence southerly by a line bearing 179 deg. 37 min. for 206 ft. 8 in. to the left bank of Kororoit Creek; thence generally westerly and northerly by the last-mentioned creek bank to the commencing point and containing 5 acres 3 roods and 28 perches.

Dated the 11th day of October, 1965.

H. J. SNADDEN,
 Secretary.

Melbourne and Metropolitan
BOARD OF WORKS.

NOTICE TO THE OWNERS OF TENEMENTS IN THE UNDER-MENTIONED STREETS, AND THE PRIVATE STREETS, LANES, COURTS AND ALLEYS OPENING THERETO.

THE main pipe in the said streets being laid down, the owners of all tenements situated as under are hereby required on or before the 22nd November, 1965, to cause a proper pipe and stop cocks to be laid so as to supply water within such tenements from the main pipe.

H. J. SNADDEN,
Secretary.

12th October, 1965.

STREET AND POSITION.

Box Hill.

Cole-court, from Woodhouse-grove eastwards 4 chains.

Broadmeadows.

Murray-street, from Harold-street to Apsley-street.
Apsley-street, from Murray-street eastwards 3 chains.

Caulfield.

Bella Vista-court, from Pental-road to Alma-road.

Chelsea.

Nirringa-avenue, from $\frac{1}{2}$ chains north-west of Barook-street north-westwards $6\frac{1}{2}$ chains.

Dandenong.

Brunet-street, from Heatherton-road to Gloria-avenue.
Gloria-avenue, from Brunet-street eastwards $4\frac{1}{2}$ chains.
Nicole-avenue, from Brunet-street eastwards $3\frac{1}{2}$ chains.

Kew.

Perry-court, from Rimington-avenue northwards $3\frac{1}{2}$ chains.

Moorabbin.

Kenjulie-drive, from Bellevue-road to Brady-road.
Elswill-street, from Bellevue-road to Kenjulie-drive.
Friendship-square, from Cavanagh-street eastwards and northwards $9\frac{1}{2}$ chains.
Warren-road, from Cavanagh-street eastwards 8 chains.
Genoa-street, from Matilda-road eastwards $1\frac{1}{2}$ chains.
Kelsall-court, from Spring-road westwards 13 chains.

Nunawading.

Bahama-court, from McClares-road westwards 4 chains.
Kett-street, from $1\frac{1}{2}$ chains south-east of Winifred-street south-eastwards $6\frac{1}{2}$ chains.
Busana-way, from Kett-street to Junction-road.
Kent-court, from Rialton-avenue northwards 7 chains.
Peacedale-grove, from 3 chains north of Koroit-street to Jubilee-street.
Sharrow-road, from Wattle Valley-road south-westwards 9 chains.
Russell-street, from Burnt-street to Jubilee-street.
Burnt-street, from Russell-street eastwards $8\frac{1}{2}$ chains.

Oakleigh.

Fairland-avenue, from Leumear-street to Tullius-avenue.
Marcella-court, from Fairland-avenue northwards $7\frac{1}{2}$ chains.
Berrima-street, from Clayton-road to Patrick-street.
Mountbatten-court, from Berrima-street southwards $6\frac{1}{2}$ chains.
Aitkinson-street, from Rae-street southwards $3\frac{1}{2}$ chains.
Milton-avenue, from Rosebank-avenue northwards 10 chains.
Haughton-road, from Milton-avenue to Wordsworth-avenue.
Wordsworth-avenue, from Haughton-road southwards $11\frac{1}{2}$ chains.
Oakes-avenue, from Wordsworth-avenue westwards $1\frac{1}{2}$ chains.

Preston.

Pallant-avenue, from Hughes-parade to Massey-avenue.
Massey-avenue, from Pallant-avenue to Broadhurst-avenue.
Broadhurst-avenue, from Massey-avenue to Radford-road.
Radford-road, from $26\frac{1}{2}$ chains north of Edwards-street to Broadhurst-avenue.

Springvale.

Furnew-street, from Woods-street to Orsino-street.
Orsino-street, from Furnew-street northwards 1 chain.
Amiel-street, from Furnew-street northwards $2\frac{1}{2}$ chains.
Woods-street, from Furnew-street southwards $4\frac{1}{2}$ chains.
Birmingham-street, from Woods-street to Davidson-street.
Deaney-street, from Birmingham-street southwards $4\frac{1}{2}$ chains.
Flynn-street, from Gove-street southwards 12 chains.

Waverley.

Harris-crescent, from Kalonga-court northwards and westwards 9 chains.

Smyth-street, from $2\frac{1}{2}$ chains south of Oakern-street southwards 11 chains.

Islay-court, from Smyth-street westwards 5 chains.

Rivoli-court, from Smyth-street westwards 5 chains.

Legana-street, from Wilga-street to Lemont-avenue.

Lemont-avenue, from Legana-street westwards 4 chains.

Lemont-avenue, from Legana-street eastwards 10 chains.

Apsley-street, from Lemont-avenue to Highclere-avenue.

Gretna-street, from Lemont-avenue to Highclere-avenue.

Highclere-avenue, from Gretna-street eastwards 2 chains.

Highclere-avenue, from Gretna-street westwards 17 chains.

Birrahlee-street, from Dallas-street to Elonara-court.

Elonara-court, from Birrahlee-street to William-street.

Antoinette-court, from Elonara-court westwards $8\frac{1}{2}$ chains.

Dean-avenue, from Lawrence-road to Vasey-street.

NOTICE TO MARINERS.

[No. 9 OF 1965.]

AUSTRALIA.—VICTORIA.

WESTERNPORT.

Alteration in Lights.

Date.—On or about 21st October, 1965.

(1) *Position*.—Flinders Breakwater Head Light, Lat. 38 deg. 28 min. 37 sec. S., Long. 145 deg. 01 min. 48 sec. E.

Remarks.—The existing light will be altered to accord with the details given hereunder.

Abridged Description.—Fl. W.R.G. 4 sec. 21 feet (6m4) 8M.

Description.—A flashing light with WHITE, RED and GREEN sectors will be shown from the top of a 16 feet post situated at the northern end of the breakwater jetty.

Characteristics.—Flash 3 seconds, eclipse 1 second.

Elevation.—21 feet (6m4).

Visibility.—8 miles.

Details.—The light will show RED from 212 deg. to 264 deg.; WHITE thence to 301 deg.; GREEN thence to 321 deg.; RED thence to 347 deg.; obscured elsewhere.

(2) *Position*.—Grant Point Light, Lat. 38 deg. 31 min. 09 sec. S., Long. 145 deg. 07 min. 06 sec. E.

Remarks.—The existing light will be altered to accord with the details given hereunder.

Abridged Description.—Gp. Fl. (2) W.R. 12 sec. 170 feet (51m8) 19, 14M.

Description.—A group-flashing light with WHITE and RED sectors will be shown from the top of a 62 feet framework tower situated on the headland at the western extremity of Phillip Island.

Characteristics.—Flash 3 seconds; eclipse 1 second; flash 1 second; eclipse 7 seconds.

If electric current fails the light will be group-flashing every nine (9) seconds, thus—flash 1 second; eclipse 1 second; flash 1 second; eclipse 6 seconds.

Elevation.—170 feet (51m8).

Visibility.—White, 19 miles.

Red, 14 miles.

Details.—The light will show WHITE from 290 deg. through north and east to 121 deg., RED elsewhere.

Charts Affected.—B.A. Nos. 1171, 1695b, 1707, 3169, Aus. 144, 156.

Publications.—*Sailing Directions, Victoria*, 1959, pages 389, 392, 732. *Australia Pilot*, Vol. 11, 1956, page 108. *List of Lights*, Volume 10, Nos. 2426, 2424.

A. J. WAGGLEN,

Port Officer.

Ports and Harbors Branch,

Public Works Department,

Melbourne, C.2, 15th October, 1965.

Health Act 1958.

VICTORIA—DEPARTMENT OF HEALTH.

NOTICE TO ATTEND FOR RADIOLOGICAL EXAMINATION.

To all persons aged twenty-one years and over enrolled or resident in the Subdivisions specified hereunder in the State Electoral District of Murray Valley.

TAKE notice that you are required to attend at a Department of Health X-ray unit sited in the public street at or as near as possible to the main entrance to the premises specified in this notice, at any time between the hours specified on one of the days specified and during the period specified in respect of those premises, and thereat to submit yourself to radiological examination of the chest for the purpose of ascertaining whether you may be suffering from pulmonary tuberculosis. If you have had a chest X-ray within the last twelve months and for that reason do not wish to be examined now, you should attend the unit as directed and submit particulars of the previous examination.

SPECIFIED SUBDIVISIONS, PREMISES, PERIODS, DAYS AND HOURS.

Subdivision.	Premises.	Period.	Days.	Hours.
Rutherglen ..	Public Hall, Springhurst	Friday, 29th October, 1965	Friday, 29th October, 1965	From 2 p.m. to 5.30 p.m. and from 7 p.m. to 9 p.m.
	Shire Office, Rutherglen	Monday, 1st November, 1965, to Wednesday, 3rd November, 1965 (inclusive)	Monday 1st November 1965 All other days during the Period except Public Holidays	From 7 p.m. to 9 p.m. From 10 a.m. to 5.30 p.m. and from 7 p.m. to 9 p.m.
	Post Office, Wahgunyah	Thursday, 4th November, 1965	Thursday, 4th November, 1965	From 11 a.m. to 5.30 p.m. and from 7 p.m. to 9 p.m.
Yarrowonga	Shire Hall, Yarrowonga	Friday, 5th November, 1965, to Wednesday 10th November, 1965 (inclusive)	Friday, 5th November, 1965 All other days during the period except Saturday, Sunday and Public Holi- days	From 2 p.m. to 5.30 p.m. and from 7 p.m. to 9 p.m. From 10 a.m. to 5.30 p.m. and from 7 p.m. to 9 p.m.
	Shire Office, Tungamah	Thursday, 11th November, 1965	Thursday, 11th November, 1965	From 11 a.m. to 5.30 p.m. and from 7 p.m. to 9 p.m.
Cobram ..	Memorial Hall, Yarroweyah	Monday, 8th November, 1965	Monday, 8th November, 1965	From 2 p.m. to 5.30 p.m. and from 7 p.m. to 9 p.m.
	Shire Hall, Cobram ..	Tuesday, 9th November, 1965, to Thursday, 11th November, 1965 (inclusive)	Tuesday, 9th November, 1965 All other days during the period except Public Holidays	From 11 a.m. to 5.30 p.m. and from 7 p.m. to 9 p.m. From 10 a.m. to 5.30 p.m. and from 7 p.m. to 9 p.m.
	Public Hall, Strathmerton	Friday, 12th November, 1965	Friday, 12th November, 1965	From 11 a.m. to 5.30 p.m. and from 7 p.m. to 9 p.m.
Numurkah ..	State School, Dunbalane	Monday, 8th November, 1965	Monday, 8th November, 1965	From 2 p.m. to 5.30 p.m. and from 7 p.m. to 9 p.m.
	Town Hall, Numurkah	Tuesday, 9th November, 1965, to Friday, 12th Novem- ber, 1965 (inclusive)	Tuesday, 9th November, 1965 All other days during the period except Public Holidays	From 2 p.m. to 5.30 p.m. and from 7 p.m. to 9 p.m. From 10 a.m. to 5.30 p.m. and from 7 p.m. to 9 p.m.
	Public Hall, Katamatite	Friday, 12th November, 1965	Friday, 12th November, 1965	From 11 a.m. to 5.30 p.m. and from 7 p.m. to 9 p.m.
	Public Hall, Katunga ..	Monday 15th November, 1965, and Tuesday, 16th November, 1965	Monday, 15th November, 1965 Tuesday, 16th November, 1965	From 10 a.m. to 5.30 p.m. and from 7 p.m. to 9 p.m.
Nathalia ..	Public Hall, Kantandra West	Monday, 15th November, 1965, and Tuesday, 16th November, 1965	Monday, 15th November, 1965 Tuesday, 16th November, 1965	From 10 a.m. to 5.30 p.m. and from 7 p.m. to 9 p.m.
	Public Hall, Nathalia ..	Monday, 15th November, 1965, to Wednesday, 17th November, 1965 (inclusive)	Monday, 15th November, 1965 All other days during the period except Public Holidays	From 10 a.m. to 5.30 p.m. and from 7 p.m. to 9 p.m. From 11 a.m. to 5.30 p.m. and from 7 p.m. to 9 p.m.
	Public Hall, Waaia ..	Wednesday, 17th November, 1965	Wednesday, 17th Novem- ber, 1965	From 11 a.m. to 5.30 p.m. and from 7 p.m. to 9 p.m.
Shepparton..	Post Office, Picola ..	Thursday, 18th November, 1965	Thursday, 18th November, 1965	From 11 a.m. to 5.30 p.m. and from 7 p.m. to 9 p.m.
	Memorial Hall, Tallygaroopna	Wednesday, 17th November, 1965	Wednesday, 17th Novem- ber, 1965	From 11 a.m. to 5.30 p.m. and from 7 p.m. to 9 p.m.
	Memorial Hall, Congupna-road	Thursday, 18th November, 1965	Thursday, 18th November, 1965	From 11 a.m. to 5.30 p.m. and from 7 p.m. to 9 p.m.
	Public Hall, Lemnos ..	Thursday, 18th November, 1965	Thursday, 18th November, 1965	From 11 a.m. to 5.30 p.m. and from 7 p.m. to 9 p.m.
	Shepparton (3 centres)— (1) Princes Park, Marungi-street (2) Health Centre, cr. Balaclava-road, and Wyndham-street (3) Cr. St. Andrews and St. Georges roads	Friday, 19th November, 1965, to Friday, 26th November, 1965 (inclusive)	Friday, 19th November, 1965 All other days during the period except Saturday, Sunday and Public Holi- days	From 2 p.m. to 5.30 p.m. and from 7 p.m. to 9 p.m. From 10 a.m. to 5.30 p.m. and from 7 p.m. to 9 p.m.
	R.S.L. Hall, Mooroopna	Monday, 29th November, 1965, to Thursday, 2nd December, 1965 (inclusive)	Monday, 29th November, 1965 All other days during the period except Public Holidays	From 7 p.m. to 9 p.m. From 10 a.m. to 5.30 p.m. and from 7 p.m. to 9 p.m.
	Public Hall, Ardmona ..	Friday, 3rd December, 1965	Friday, 3rd December, 1965	From 2 p.m. to 5.30 p.m. and from 7 p.m. to 9 p.m.

NOTE.—Any person to whom this notice applies and who without reasonable excuse fails to comply with the requirements of the notice shall be guilty of an offence, and shall be liable to a penalty of not more than twenty pounds.

Dated this eleventh day of October, One Thousand nine hundred and sixty-five.

KEVIN BRENNAN, Chief Health Officer.

State Electricity Commission Acts.

ELECTRICAL APPROVALS BOARD.

PURSUANT to Regulation 16 of the Electrical Approvals Regulations—Approval of Equipment, 1953, the State Electricity Commission of Victoria hereby gives notice that it has withdrawn approval of the under-mentioned articles :—

Name of Applicant.	Article and Reference No.	Date of Certificate of Approval	Date of Withdrawal of Approval.	Approvals Marking.
A. E. Ackland Pty. Ltd.	B.C. Lampholder, Trade Name "Reeves", Cat. No. 1204/3, 250 volts, Ref. No. BA/A1/07	28.5.58	7.9.65	S/48
Wunulla Electric Pty. Ltd.	Griller, Trade Name "Hot Dog", Cat. No. A1, 240 volts, 1 amp., Ref. No. BC/A5W/01	9.10.64	7.9.65	N/544
Aladdin Industries Pty. Ltd.	Floor Standard, Trade Name "Aladdin", Cat. No. 50, 240 volts, Ref. No. BK/BT/02	20.6.58	7.9.65	S/29
" " "	Lamp Standard, Trade Name "Aladdin", Cat. No. 19, 240 volts, Ref. No. BK/BT/10	5.6.59	7.9.65	N/258
" " "	Lamp Standard, Trade Name "Aladdin", Cat. No. 20, 240 volts, Ref. No. BK/BT/12	10.6.59	7.9.65	N/258
" " "	Table Lamp, Trade Name "Aladdin", Cat. No. L34, 240 volts, Ref. No. BK/BT/13	14.10.59	7.9.65	N/258
" " "	Lamp Standard, Trade Name "Aladdin", Cat. No. 24, 240 volts, Ref. No. BK/BT/14	14.10.59	7.9.65	N/258
Tallerman and Co. Pty. Ltd.	Table Lamp, Trade Name "Q.H.P.", Cat. No. Perfecto, 240 volts, Ref. No. BK/FC/01	25.2.58	7.9.65	S/52
Classic Paramount Productions Pty. Ltd.	Table Lamp, Trade Name "Abstract", Cat. No. W1, 240 volts, Ref. No. BK/TG/03	12.5.58	7.9.65	S/41
Nylex Products Pty. Ltd.	Bed Lamp, Trade Name "Duperite Consort", Cat. No. DP2599, 230 volts, Ref. No. BK/SI/04	24/10/57	21/9/65	S/5

Dated the 19th day of October, 1965.

L. G. MORRISON, Secretary.

AUCTION SALES ACT 1958.

BENALLA.—Notice is hereby given that the Annual Meeting of Justices for the Licensing of Auctioneers will be held at the Court House, Benalla, on Tuesday, the 23rd day of November, 1965, at the hour of Ten o'clock in the forenoon.—R. F. FREEMAN, Clerk of Petty Sessions.

BIRCHIP.—Notice is hereby given that the Annual Meeting of Justices for the Licensing of Auctioneers will be held at the Court of Petty Sessions, Birchip, on Tuesday, the 23rd day of November, 1965, at 2.30 o'clock in the afternoon. Dated at Birchip, this 29th day of September, 1965.—I. J. BENNETT, Clerk of Petty Sessions.

CASTERTON.—Notice is hereby given that the Annual Meeting of Justices for the Licensing of Auctioneers will be held at the Court House, Casterton, on Tuesday, the 23rd day of November, 1965, at the hour of Ten o'clock in the forenoon. Dated this 11th day of October, 1965.—R. J. MCALLISTER, Clerk of Petty Sessions.

CHARLTON.—Notice is hereby given that the Annual Meeting of Justices for the Licensing of Auctioneers will be held at the Court House, Charlton, on Tuesday, the 23rd day of November, 1965, at Ten o'clock in the forenoon. Dated at Charlton, the 11th day of October, 1965. R. N. COUTTS, Clerk of Courts.

DONALD.—Notice is hereby given that the Annual Meeting of Justices for the Licensing of Auctioneers will be held at the Court of Petty Sessions, Donald, on Tuesday, the 23rd day of November, 1965, at Ten o'clock in the forenoon. Dated at Donald, this 29th day of September, 1965.—I. J. BENNETT, Clerk of Petty Sessions.

EUROA.—Notice is hereby given that the Annual Meeting of Justices for the Licensing of Auctioneers will be held at the Court House, Euroa, on Tuesday, the 23rd day of November, 1965, at the hour of Ten o'clock in the forenoon.—R. F. FREEMAN, Clerk of Petty Sessions.

INGLEWOOD.—Notice is hereby given that the Annual Meeting of Justices for the Licensing of Auctioneers will be held at the Court House, Inglewood, on Tuesday, the 23rd day of November, 1965, at Ten o'clock in the forenoon. Dated the 14th day of October, 1965.—G. P. MURPHY, Clerk of Petty Sessions.

KILMORE.—Notice is hereby given that the Annual Meeting of Justices for the Licensing of Auctioneers will be held at the Court House, Kilmore, on Tuesday, the 23rd day of November, 1965, at the hour of 10.30 o'clock in the forenoon. Dated at Kilmore, this 18th day of October, 1965.—J. L. MCGAAN, Clerk of Petty Sessions.

MANSFIELD AND YEA.—Notice is hereby given that the Annual Meeting of Justices for the Licensing of Auctioneers will be held at the Court House, on Tuesday, the 23rd day of November, 1965.—A. R. ELLIS, Clerk of Courts.

MARYBOROUGH.—Notice is hereby given that the Annual Meeting of Justices for the Licensing of Auctioneers will be held at the Court House, Maryborough, on Tuesday, the 23rd November, 1965, at Ten a.m. Dated at Maryborough, this 14th October, 1965.—R. J. CANNING, Clerk of Petty Sessions.

MELBOURNE.—Notice is hereby given that the Annual Meeting of Justices for the Licensing of Auctioneers will be held at the Court of Petty Sessions, Melbourne, on Tuesday, the 23rd day of November, 1965, at Ten o'clock in the forenoon. Dated at Melbourne this 11th day of October, 1965.—G. L. WEBSTER, Clerk of Petty Sessions, Melbourne.

MILDURA.—Notice is hereby given that the Annual Meeting of Justices for the Licensing of Auctioneers will be held at the Law Courts, Mildura, on Tuesday, the 23rd day of November, 1965, at Ten o'clock in the forenoon. Dated at Mildura, this 15th day of October, 1965.—J. KEARNEY, Clerk of Petty Sessions.

MOE.—Notice is hereby given that the Annual Meeting of Justices for the Licensing of Auctioneers will be held at the Court House, Moe, on Tuesday, the 23rd day of November, 1965, at the hour of 10.30 o'clock in the forenoon. Dated this 11th day of October, 1965.—K. T. RYAN, Clerk of Petty Sessions.

SEYMOUR.—Notice is hereby given that the Annual Meeting of Justices for the Licensing of Auctioneers will be held at the Court House, Seymour, on Tuesday, the 23rd day of November, 1965, at the hour of Ten o'clock in the forenoon. Dated at Seymour, this 18th day of October, 1965.—J. L. MCGAAN, Clerk of Petty Sessions.

SHEPPARTON.—Notice is hereby given that the Annual Meeting of Justices for the Licensing of Auctioneers will be held at the Court House, Shepparton, on Tuesday, the 23rd day of November, 1965, at Ten o'clock in the forenoon.—J. F. O'HARA, Clerk of Petty Sessions.

ST. ARNAUD.—Notice is hereby given that the Annual Meeting of Justices for the Licensing of Auctioneers will be held at the Court of Petty Sessions, St. Arnaud, on Tuesday, the 23rd day of November, 1965, at Ten o'clock in the forenoon. Dated at St. Arnaud, this 29th day of September, 1965.—I. J. BENNETT, Clerk of Petty Sessions.

SWAN HILL.—Notice is hereby given that the Annual Meeting of Justices for the Licensing of Auctioneers will be held at the Court House, Swan Hill, on Tuesday, the 23rd day of November, 1965, at Ten o'clock in the forenoon. Dated at Swan Hill, this 15th day of October, 1965.—B. G. MEEHAN, Clerk of Petty Sessions, Swan Hill.

WANGARATTA.—Notice is hereby given that the Annual Meeting of Justices for the Licensing of Auctioneers will be held at the Law Courts, Wangaratta, on Tuesday, the 23rd day of November, 1965, at the hour of Ten o'clock in the forenoon.—A. VALE, Clerk of Petty Sessions.

WARRACKNABEAL.—Notice is hereby given that the Annual Meeting of Justices for the Licensing of Auctioneers will be held at the Court House, Warracknabeal, on Tuesday, the 23rd day of November, 1965, at the hour of Ten o'clock in the forenoon. Dated this 12th day of October, 1965.—E. N. DRAYTON, Clerk of Petty Sessions.

WARRNAMBOOL.—Notice is hereby given that the Annual Meeting of Justices for the Licensing of Auctioneers will be held at the Court House, Warrnambool, on Tuesday, the 23rd day of November, 1965, at the hour of Ten o'clock in the forenoon. Dated at Warrnambool this 14th day of October, 1965.—V. G. STAFFORD, Clerk of Petty Sessions.

WONTHAGGI.—Notice is hereby given that the Annual Meeting of Justices for the Licensing of Auctioneers will be held at the Court House, Wonthaggi, on Tuesday, the 23rd day of November, 1965, at the hour of Ten o'clock in the forenoon. Dated the 12th day of October, 1965.—M. J. SHELTON, Clerk of Petty Sessions.

YARRAM.—Notice is hereby given that the Annual Meeting of Justices for the Licensing of Auctioneers will be held at the Court House, Yarram, on Tuesday, the 23rd day of November, 1965, at the hour of Ten o'clock in the forenoon. Dated at Yarram this 8th day of October, 1965.—R. A. ISON, Clerk of Petty Sessions.

YARRAWONGA.—Notice is hereby given that the Annual Meeting of Justices for the Licensing of Auctioneers will be held at the Law Courts, Yarrowonga, on Tuesday, the 23rd day of November, 1965, at the hour of Ten o'clock in the forenoon.—A. VALE, Clerk of Petty Sessions.

WILSON'S PROMONTORY NATIONAL PARK.

NOTICE is hereby given that the National Parks Authority intends to seek, pursuant to section 9 (4) of the *National Parks Act 1958*, the consent of the Governor in Council to the granting by it of a lease, particulars of which are as under:—

Name of Park.—Wilson's Promontory National Park.

Location of Land.—In the Tidal River Township, on the northern side of the main road, approximately 900 feet westerly from the entrance office, being an area of 0.2 acres more or less (shown as an inset to the plan "Tidal River Camping Area" lodged with the Central Plan Office of the Lands Department and numbered National Parks No. 4A).

Purpose of Lease.—To provide tourist services incorporating eating facilities, butcher's shop and delicatessen, milk bar, confectionery shop, sale of motor fuels, and such other facilities as the Authority may from time to time approve in accordance with the Act.

Term of Lease.—For the period ending the 31st day of December, 1978.

L. H. SMITH, Director of National Parks.

WILSON'S PROMONTORY NATIONAL PARK.

NOTICE is hereby given that the National Parks Authority intends to seek, pursuant to Section 9 (4) of the *National Parks Act 1958*, the consent of the Governor in Council to the granting by it of a lease, particulars of which are as under:—

Name of Park.—Wilson's Promontory National Park.

Location of Land.—Approximately ten acres of the tongue of land lying between the Tidal River and the Promontory road and the summit of Pillar Point at its north-eastern extremity.

Purpose of Lease.—Providing overnight accommodation and other facilities for visitors to the said Park.

Term of Lease.—75 years.

L. H. SMITH,

Director of National Parks.

Melbourne,

24th September, 1965.

PUBLIC TRUSTEE ACT 1958 (No. 6350), SECTION 17.

I HEREBY give notice that on the 29th September, 1965, the Public Trustee filed elections to administer the following deceased persons' estates, in accordance with section 17 of the *Public Trustee Act 1958*.

CARTER, GRENDALINE, formerly of 2 Grimwade-street, Reservoir, but late of 42 St. Clems-road, East Doncaster, widow, died 10th August, 1965.

CREEVEY, ARTHUR, also known as Arthur John Creevey, late of 36 McArthur-place, Carlton, retired tailors presser, died 9th July, 1965.

KEOGH, ANNIE TERESA, late of 12 Berry-street, Coburg, spinster, died 5th August, 1965.

MORRISON, JAMES PATRICK MICHAEL, also known as James Morrison, late of Mount Royal, Parkville, pensioner, died 27th June, 1964.

SKILLMAN, CONSTANCE, late of 16 Elmie-street, Hawthorn, widow, died 3rd August, 1965.

I HEREBY give notice that on the 1st September, 1965, the Public Trustee filed elections to administer the following deceased persons' estates, in accordance with section 17 of the *Public Trustee Act 1958*:—

BARNES, MARY ANN, late of 9 Mackay-street, Essendon, widow, died 30th July, 1965.

BICKET, WILLIAM VAUGHAN, late of Mount Royal, Parkville, pensioner, died 28th July, 1965.

CHAMPION, MARY MAY, late of Ballarat, widow, died 30th May, 1965.

HAMILTON, IVER CLOW, also known as Iver Hamilton, late of 1064 Malvern-road, Malvern, retired station manager, died 6th August, 1965.

HUNNIFORD, MARY ELLEN, late of 35 Gipps-street, East Melbourne, widow, died 19th July, 1965.

JEZIL, MIROSLAV, also known as George Jezil, formerly of 38 Eades-street, North Melbourne, but late of 140 Palmer-street, Darlinghurst, New South Wales, labourer, died on or about 25th March, 1965.

KRAUSE, MARY, late of Sunbury, spinster, died 15th April, 1965.

RAMAGE, JOHN WALTER, late of 37 Ulupna-road, Ormond, retired stores supervisor, died 18th July, 1965.

WALLIS, HENRY JOHN, formerly of 117 Underwood-road, Lower Fern Tree Gully, but late of Old Government-road, Selby, retired P.M.G. employee, died 13th July, 1965.

A. D. DUNCAN,

Public Trustee.

256 Flinders-street, Melbourne, C.1, 11th October, 1965.

I HEREBY give notice that on the 1st September, 1965, the Public Trustee filed elections to administer the following deceased person's estate in accordance with section 17 of the *Public Trustee Act 1958*:—

HARTWIG, MAXWELL HERMANN, late of 213 Burnley-street, Richmond, engineer, died 12th May, 1965.

A. D. DUNCAN,

Public Trustee.

256 Flinders-street, Melbourne, C.1, 12th October, 1965.

NOTICE.

CREDITORS, next of kin and others having claims against the estate of any of the under-mentioned deceased persons are required to send particulars of their claims to the Public Trustee, 256 Flinders-street, Melbourne, the personal representative, on or before the 16th December, 1965, after which date the Public Trustee may convey or distribute the assets, having regard only to the claims of which the Public Trustee then has notice:—

BAKER, THOMAS HENRY, late of 173 Gooch-street, Thornbury, retired salesman, died 10th August, 1965.

BANBURY, ANNIE, formerly of 15 Clarke-street, Elwood, but late of 19 Kett-street, Nunawading, widow, died 25th July, 1965.

BARNES, MARY ANN, late of 9 Mackay-street, Essendon, widow, died 30th July, 1965.

BEADLE, FREDERICK CHARLES, late of 21 Blanche-street, North Brighton, retired carpenter, died 7th August, 1965.

BICKET, WILLIAM VAUGHAN, late of Mount Royal, Parkville, pensioner, died 28th July, 1965.

BRAY, MARJORIE LEAH, late of 102 Harold-street, Middle Park, sales woman, died 1st August, 1965.

BRUCE, LAURA, also known as Bruce, Laura Ann, formerly of 10 Queen-street, Nunawading, but late of 8 Tehan-street, Seymour, widow, died 17th June, 1965.

CARTER, GRENDALENE, formerly of 2 Grimwade-street, Reservoir, but late of 42 St. Clems-road, East Doncaster, widow, died 10th August, 1965.

CHAMPION, MARY MAY, late of Ballarat, widow, died 30th May, 1965.

COLEMAN, WILLIAM GEORGE, late of 566 Nepean Highway, East Brighton, retired cooper, died 26th July, 1965.

COSGROVE, BEATRICE, late of 8 Westminster-street, Oakleigh, widow, died 16th July, 1965.

CREEVEY, ARTHUR, also known as Arthur John Creevey, late of 36 McArthur-place, Carlton, retired tailors presser, died 9th July, 1965.

DAVIES, JOHN WILLIAM, late of 18 Finsbury-street, Flemington, furnaceman, died 11th January, 1957.

DEAN, CHARLES, late of 51 Paxton-street, South Kingsville, pensioner, died 26th August, 1964.

DEAN, SUSAN, late of 51 Paxton-street, South Kingsville, pensioner, died 25th June, 1964.

FOSTER, BEATRICE ETHEL, formerly of 26 Lambeth-avenue, Armadale, but late of 26 Lianeast-street, Malvern, spinster, died 16th July, 1965.

GIBSON, JOSEPH HENRY, late of Toolleen, Victoria, mechanic, died between 13th March, 1965 and 23rd March, 1965.

GUSTAFSSON, ERNEST, late of 485 Dryburgh-street, North Melbourne, painter and docker, died 4th June, 1965.

HAMILTON, IVER CLOW, also known as Iver Hamilton, late of 1064 Malvern-road, Malvern, retired station manager, died 6th August, 1965.

HARTWIG, MAXWELL HERMANN, late of 213 Burnley-street, Richmond, engineer, died 12th May, 1965.

HATTON, JOAN, late of 275 Richardson-street, Middle Park, widow, died 4th July, 1965.

HUGHES, JAMES PERCIVAL, late of 27 Fifth-avenue, Brunswick, retired clerk, died 24th July, 1965.

HUNNIFORD, MARY ELLEN, late of 35 Gipps-street, East Melbourne, widow, died 19th July, 1965.

JEZIL, MIROSLAV, also known as George Jezil, formerly of 38 Eades-street, North Melbourne, but late of 140 Palmer-street, Darlinghurst, New South Wales, labourer, died on or about 25th March, 1965.

KEOGH, ANNIE TERESA, late of 12 Berry-street, Coburg, spinster, died 5th August, 1965.

KRAUSE, MARY, late of Sunbury, spinster, died 15th April, 1965.

LOUCH, VERNON ESCOURT, late of 23 Bendigo-street, Prahran, furniture dealer, died 9th August, 1964.

LYSTER, JAMES EDWARD, late of 7 Gordon-street, Prahran, retired timber worker, died 24th June, 1965.

MASTERS, KIT CLAUDE, late of 35 Henry-street, St. Albans, spare parts examiner, died 8th March, 1965.

MAY, JOSEPH, late of 109 Dendy-street, Brighton, textile machinery erector, died 16th August, 1964.

MORRISON, JAMES PATRICK MICHAEL, also known as James Morrison, late of Mount Royal, Parkville, pensioner, died 27th June, 1964.

MULIC, DZEVAD, formerly of 153 Park-street, Parkville, but late of 445 Elizabeth-street, Melbourne, fitter, died 13th July, 1964.

MURRELLS, MARGUERITE EMILY, late of 34 Charles-street, Ascot Vale, retired clerk, died 9th June, 1965.

McHENRY, SYDNEY RAYMOND, late of 18 Garfield-street, Cheltenham, Commonwealth public servant, died 15th June, 1965.

McKEON, PATRICK JAMES, late of 48 Howell-street, Echuca, retired miller, died 19th July, 1964.

NICHOLLS, JAMES MICHAEL, formerly of 168 Bouverie-street, Carlton, but late of 49 Winmalee-road, Balwyn, retired engine driver, died 13th August, 1965.

O'DONNELL, JAMES JOSEPH, late of 133 North-road, Gardenvale, retired draper, died 15th July, 1965.

OLDHAM, GEORGE, formerly of 11 Alma-grove, St. Kilda, but late of 3 Sandford-street, Highett, retired public servant, died 29th June, 1965.

RAMAGE, JOHN WALTER, late of 37 Ulupna-road, Ormond, retired stores supervisor, died 18th July, 1965.

SIMMONS, SAMUEL HERBERT, late of 16 Federation-street, Ascot Vale, cleaner, died 22nd April, 1965.

SKILLMAN, CONSTANCE, late of 16 Elmie-street, Hawthorn, widow, died 3rd August, 1965.

SPEED, ALICE JOSEPHINE, late of 2 Ross-street, Northcote, married woman, died 26th July, 1965.

THOMAS, ROBERT EVAN, late of 57 Almond-street, South Caulfield, retired railway employee, died 15th June, 1965.

WALLIS, HENRY JOHN, formerly of 117 Underwood-road, Lower Fern Tree Gully, but late of Old Government-road, Selby, retired P.M.G. employee, died 13th July, 1965.

WYLIE, JOHN CONNELL, late of 3 Mardan-street, East Newborough, coppersmith, died 5th May, 1965.

A. D. DUNCAN,

Public Trustee.

Melbourne, 11th October, 1965.

NOTICE.

CREDITORS, next of kin and others having claims against the estate of any of the under-mentioned deceased persons are required to send particulars of their claims to the Public Trustee, 256 Flinders-street, Melbourne, the personal representative, on or before the 23rd December, 1965, after which date the Public Trustee may convey or distribute the assets, having regard only to the claims of which the Public Trustee then has notice:—

ADAMS, LOTTIE AUGUSTA, late of 2 Loch-street, Hawthorn, widow, died 10th August, 1965.

ABRAHAMSSON, Ada, late of 11 Pearson-street, West Brunswick, widow, died 22nd February, 1965.

ASPER, WILLIAM, late of 15 Lucas-street, Brighton East, retired labourer, died 4th June, 1965.

BRIEN, ELIZA ELSIE, also known as Elsie Brien, formerly of 21 Elm-street, Hawthorn, but late of Flat 11, 64 Stanhope-street, Malvern, spinster, died 18th August, 1965.

HOWARD, MOYA LYNETTE, late of Katandra West, married woman, died 27th January, 1963.

LUBLINIECKI, JAN, also known as John Lubliniecki, late of 59 Geelong-road, Footscray, storeman, died 6th December, 1964.

WADDLE, WALTER PERCY, late of 143 Rae-street, North Fitzroy, labourer, died 22nd May, 1965.

WALLER, AUGUSTUS CHARLES, late of 54 Acland-street, St. Kilda, retired insurance officer, died 25th August, 1965.

A. D. DUNCAN,

Public Trustee.

Melbourne, 13th October, 1965.

SUPERANNUATION ACT 1958.

ELECTION BY CONTRIBUTORS OF A MEMBER OF THE STATE SUPERANNUATION BOARD—NON RAILWAY REPRESENTATIVE.

NOTICE is hereby given that, in connexion with the election of a member (non Railway Representative) of the State Superannuation Board, in pursuance of the Superannuation Act 1958, the following candidates have been nominated, viz.:—

Name.	Department.	Branch.
Alfred Lawrence Gerrard	Education ..	Teaching
David John McDonald ..	Education ..	Teaching
Cecil Ewart Moran ..	Health ..	Mental Hygiene
David Claude Townsend	Country Roads ..	Secretary's
Robertson ..	Board	
John Charles Warwick ..	Education ..	Teaching

As the number of candidates nominated is greater than the number required to be elected, a vote shall be taken to decide the election. Ballot papers will be forwarded to all contributors entitled to vote, and these must be returned to reach the Returning Officer (F. C. Heath, State Treasury, Melbourne, C.2), not later than 4 p.m., on Monday, the 22nd November, 1965. The postage on ballot papers returned through the post must be prepaid.

The attention of voters is invited to the endorsement required on the front of the envelope.

F. C. HEATH,
Returning Officer.

SUPERANNUATION ACT 1958.

IT is hereby notified that the following contributor within the meaning of the *Superannuation Act 1958* has been elected, pursuant to the provisions of section 49 of the said Act, for appointment as a member of the State Superannuation Board for a term of five years from and inclusive of the 24th December, 1965:—

BERNARD FREDERICK FITZPATRICK (by contributors in the Railway Service).

HENRY E. BOLTE,
Treasurer.

The Treasury,
Melbourne, 18th October, 1965.

APPOINTMENTS AND RESIGNATIONS

APPOINTMENTS.

HIS Excellency the Governor of the State of Victoria, by and with the advice of the Executive Council thereof, has, by Orders made on the 12th day of October, 1965, been pleased to make the under-mentioned appointments, viz.:—

CHIEF SECRETARY'S DEPARTMENT.

Chief Probation Officer, &c.

JOHN DEAKIN KEATING

pursuant to the provisions of section 9 (1) of the *Children's Court Act 1958*, sections 507 (1) and 533 (3) of the *Crimes Act 1958*, and section 36 (1) of the *Social Welfare Act 1960*, to be Chief Probation Officer for Children's Courts, Chief Probation Officer, Chief Parole Officer and Chief Youth Parole Officer, respectively.

Electoral Registrar.

RAYMOND GEORGE RENFREE

to be Electoral Registrar for the Berwick, Cranbourne, Dandenong, Dandenong North, Keysborough and Mordialloc East Subdivisions of the Electoral District of Dandenong; and for the Box Hill South, Burwood South, Clayton, Mt. Waverley and Mulgrave Subdivisions of the Electoral District of Mulgrave, to take effect on and from the 1st October, 1965, *vice* Arthur Ross Croucher, resigned.

Electoral Registrars (Acting).

WILLIAM DOUGLAS ARCH

to be Electoral Registrar (Acting) for the Bendigo, Eaglehawk, Elmore, Raywood and Sandhurst East Subdivisions of the Electoral District of Bendigo; and for the Castlemaine, Golden Square, Heathcote, Kyneton, Maldon, Marong, Seymour and Strathfieldsaye Subdivisions of the Electoral District of Midlands, to take effect on and from the 11th October, 1965, during the absence on leave of William Frederick Bridger; and

THOMAS MICHAEL O'DEA

to be Electoral Registrar (Acting) for the Drouin, Koo-Wee-Rup, Korumburra, Loch, Pakenham, Warragul and Wonthaggi Subdivisions of the Electoral District of Gippsland West; and for the Morwell, Neerim South, Trafalgar, Warragul North and Yallourn Subdivisions of the Electoral District of Morwell, to take effect on and from the 29th October, 1965, during the absence on leave of John Ronald Geoffrey Hayes.

Honorary Probation Officers.

ALAN ERNEST BROWN, 224 Princes Highway, Drouin,
RONALD VINCENT CULLIN (the Reverend Father), St. Mary's Presbytery, Myrtleford.

ROBERT JOHN GINN, 36 Aitchison-avenue, Ashburton,
GRAHAM ALBERT HOLLEY (the Reverend), St. Luke's Vicarage, 192 Napier-street, Bendigo.

UNA GLORIA PASCOE (Mrs.), 30 Jennifer-street, Fawkner, and

KEVIN BARTON SMITH, 10 Hanover-street, Brunswick, pursuant to the provisions of section 10 (1) of the *Children's Court Act 1958*, to be Honorary Probation Officers for all Children's Courts in Victoria.

Licensing Inspectors.

DONALD STEWART RITCHIE, Inspector of Police, Grade I, to be a Licensing Inspector for the purposes of the *Licensing Act 1958*, *vice* Arnold Lyle Capuano, resigned; and

NORMAN SYDNEY SUMPTER, Inspector, Grade I, to be a Licensing Inspector for the purposes of the *Licensing Act 1958*, *vice* Campbell George Thomas Payne, resigned.

Member of Metropolitan Fire Brigades Appeal Tribunal.

WILLIAM ALEXANDER MCPHERSON, pursuant to the provisions of the *Metropolitan Fire Brigades Act 1958*, to be a member of the Metropolitan Fire Brigades Appeal Tribunal, for a period of two years from 22nd-October, 1965.

Stipendiary Probation Officers, &c.

MARK ANDRICH
NEIL THOMAS HEARN BEGGS,
ERIC BENJAMIN,
HELEN ISOBEL BESEMERES,
ARTHUR GORDON BLAIN,
BENNIE DAVID BODNA,
DAVID JOHN BRABET,
GEOFFREY THOMAS CUDDIHY,
LEOPOLD DOBES,
ROBERT RONALD FENTON,
FRANCES FREEMAN (Miss),
JENNIFER GRIERSON (Miss),
FRANK ELDON GRINLINTON,
IAN SYDNEY GEORGE HAWKER,
WILLIAM PAUL HEALY,
NEIL DUNSTAN HOWARD,
FRANCIS GREGORY HYLAND,
HELEN ISAACHSEN (Miss),
DAVID KAIGHAN IRONS,
KATHLEEN FRANCES KELLY,
DAVID EDWARD LORD,
MIKLOS LOVASS,
MARTIN CHARLES DAVID MERCHANT,
RUDOLF MIKLOSVARY,
BRIAN BENSON MITCHELL,
CATHERINE AGNES O'DWYER (Miss)
WILLIAM GERARD O'REILLY
JAMES MCCAMISH PEARCE,
NEVILLE JOHN PELL,
ZSOMBOR PETER PETERFFY,
MANOHRAN PONNUSAMY,
PETER JAMES ROBERT REDDING,
DARRAN HAMILTON ROOM,
ELIZABETH ELLEN ROWELL (Miss),
JOAN MARIE SCRATTON (Mrs.),
ROBERT GLEDHILL SETTLE,
STEPHEN SUPPAN,
LESLIE MICHAEL SZABO,
ANTHONY MURRAY WADSWORTH, and
FAY DOROTHY YULE (Mrs.),

pursuant to the provisions of section 9 (2) of the *Children's Court Act 1958*, sections 507 (1) and 533 (3) of the *Crimes Act 1958* and section 36 (1) of the *Social Welfare Act 1960*, to be Stipendiary Probation Officers for Children's Courts, Stipendiary Probation Officers, Stipendiary Parole Officers and Stipendiary Youth Parole Officers respectively.

MINISTRY OF HEALTH.

Members of Committees of Management of Hospitals.

Councillor THOMAS RICHARD FLOOD

to be a member of the Committee of Management of Bendigo Home and Hospital for the Aged, pursuant to proviso (b) to section 48 (1) of the *Hospitals and Charities Act 1958*, for a further period expiring the 30th September, 1968. (In lieu of appointment published in the *Government Gazette* of 29th September, 1965, on page 3053);

RUGBY WINTER LARMOUR

to be a member of the Committee of Management of The Wycheproof Hospital, pursuant to proviso (a) to section 48 (1) of the *Hospitals and Charities Act 1958*, for a further period of three years expiring the 26th October, 1968; and

BASIL CHRISTIE

to be a member of the Committee of Management of Heywood and District Memorial Hospital, pursuant to proviso (a) to section 48 (1) of the *Hospitals and Charities Act 1958* for a period of three years.

LAW DEPARTMENT.

Assistant Registrars.

JOHN ARTHUR GIDLEY

to be an Assistant Registrar, pursuant to the provisions of sections 20 and 21 of the *County Court Act 1958*, for the County Court at Warrnambool, during the absence of G. G. Moon, on annual leave, to take effect from the date of commencement of duty; and

GREGORY FRANCIS MEEHAN

to be an Assistant Registrar, pursuant to the provisions of sections 20 and 21 of the *County Court Act 1958*, for the County Court at Bendigo, during the absence of G. W. Thompson, on annual leave, to take effect from the date of commencement of duty.

Clerks of Petty Sessions, &c.

JOHN ARTHUR GIDLEY
to be Clerk of Petty Sessions and Clerk of the Children's Court at Camperdown, Cobden, Lismore, Mortlake and Terang, during the absence of G. G. Moon, on annual leave, to take effect from the date of commencement of duty;

GREGORY FRANCIS MEEHAN
to be Clerk of the Court of Mines at Kyneton and Clerk of the Children's Court and Clerk of Petty Sessions at Kyneton, Gisborne, Lancefield, Romsey, Sunbury and Woodend, during the absence of G. W. Thompson, on annual leave, to take effect from the date of commencement of duty; and

KEITH WILLIAM LEWIS
to be Clerk of Petty Sessions and Clerk of the Children's Court at Beech Forest, Birregurra, Cressy and Rokewood, during the absence of W. G. Meehan, on annual leave, to take effect from the date of commencement of duty.

Commissioner for Taking Declarations, &c.

LEONARD PETER MARCHESI, Office of the Public Service Board, Public Offices, Melbourne, C.2,
to be a Commissioner for taking Declarations and Affidavits, pursuant to the provisions of the Evidence Act 1958, to refrain from charging fees and to resign upon ceasing to occupy his present position.

Justices of the Peace.

JOHN ANDREW PETER FULLARTON, 74 Ardmillan-road, Moonree Ponds,
ROY GEORGE GEIER, 77 Rowena-parade, Richmond,
REGINALD LAWRENCE HARRIS, 1783 Dandenong-road, East Oakleigh, and
THOMAS LAWRENCE WILLIAMS, 500 Middleborough-road, Box Hill,
to Keep the Peace in the Central Bailiwick of the State of Victoria;

CHRISTIAN NOEL DUGGAN, Morgan's-road, Meeniyah, and
LEONARD MERVYN SMITH, 2 Gordon-street, Yallourn
to Keep the Peace in the Eastern Bailiwick of the State of Victoria;

ALAN RAYMOND WOOD, 103 Thurla-street, Swan Hill,
to Keep the Peace in the Midland Bailiwick of the State of Victoria;

FRANK WARREN RICHARDS, "Willodri", Oxley,
to Keep the Peace in the Northern Bailiwick of the State of Victoria; and

JOHN CALVERT, Weering, Private Bag, Geelong, and
STANLEY JOHN GRIMMER, 30 Walls-street, Camperdown,
to Keep the Peace in the Southern Bailiwick of the State of Victoria.

LOCAL GOVERNMENT DEPARTMENT.

Member of the Municipal Electrical Engineers Board.

PETER MITCHELL BUCHANAN, B.E.(Elec.),
to be a Member of the Municipal Electrical Engineers Board, pursuant to the provisions of section 177 of the Local Government Act 1958, vice Geoffrey Townley Cuthbert, retired.

J. COLQUHOUN,
Clerk of the Executive Council.

At the Executive Council Chamber,
Melbourne, 12th October, 1965.

APPOINTMENTS.

HIS Excellency the Governor of the State of Victoria, by and with the advice of the Executive Council thereof, has by Orders made on the 19th day of October, 1965, been pleased to make the under-mentioned appointments, viz.:—

DEPARTMENT OF WATER SUPPLY.
Members of Sewerage Authority.

DOUGLAS HAMILTON MURRELL,
MALCOLM HEASLOP STOTT; and
GEORGE MERVYN JOSEPH TIBBLES,
to be Members of the Casterton Sewerage Authority each to hold office for a period of four years commencing on the 25th October, 1965, their present terms of office expiring on the 24th October, 1965.

Waterworks Trust Commissioner.

IAN HENRY SCHROETER
to be a Commissioner of the Rosedale Waterworks Trust for a period of four years from the date hereof, subject to the provisions of the Water Act.

J. COLQUHOUN,
Clerk of the Executive Council.

At the Executive Council Chamber,
Melbourne, 19th October, 1965.

APPOINTMENTS REVOKED.

HIS Excellency the Governor of the State of Victoria, by and with the advice of the Executive Council thereof, doth, by Order made on the 12th day of October, 1965, revoke the following appointments, viz.:—

DEPARTMENT OF CROWN LANDS AND SURVEY.

FREDERICK GEORGE SWINDLEY, and
PETER DONALD FERRIS,
as Bailiffs of Crown Lands.
J. COLQUHOUN,
Clerk of the Executive Council.
At the Executive Council Chamber,
Melbourne, 12th October, 1965.

EDUCATION DEPARTMENT.

APPOINTMENT OF SUMMONING OFFICER.

UNDER section 5 of the Education Act 1958, I hereby appoint—
First Constable **VERNON EDWARD NUSKE**,
to summon parents within the State of Victoria.
11th October, 1965.

JOHN BLOOMFIELD,
Minister of Education.

Fertilizers Act 1958.

APPOINTMENT OF OFFICIAL ANALYST.

THE Public Service Board, in exercise of its powers, has by certificate dated 22nd September, 1965, appointed—

FRANCIS ROY PLUMMER, Chemist, Professional Division,
Department of Agriculture,
as an Official Analyst, Department of Agriculture, under the provisions of section 9 of the Fertilizers Act 1958, without additional salary.

FRANK M. READ,
Director of Agriculture.

PESTICIDES ACT 1958.

APPOINTMENT OF INSPECTOR AND ANALYST.

IN exercise of its powers, the Public Service Board, by certificate dated the 22nd September, 1965, has appointed **HENRY ERNEST MUNRO**, Chemist, Professional Division, Department of Agriculture, as an Inspector and Analyst, Department of Agriculture, under section 13 of the Pesticides Act 1958, without additional salary.

FRANK M. READ,
Director of Agriculture.

Fruit and Vegetables Act 1958 (No. 6256).

PERSONS AUTHORIZED TO TAKE PROCEEDINGS.

HIS Excellency the Governor of the State of Victoria, by and with the advice of the Executive Council thereof, doth by Order made on the 12th day of October, 1965, in accordance with the provisions of Section 48 of the Fruit and Vegetables Act 1958 (No. 6256), authorize the persons named hereunder, who are Inspectors under the said Act, to take proceedings in respect of offences against Part II. of the said Act or the Regulations thereunder:—

PIETER GEORGE SLOTEGRAAF,
HENRY MCKIE,
GEORGE EVERARD MORRISON.

J. COLQUHOUN,
Clerk of the Executive Council.

At the Executive Council Chamber,
Melbourne, 12th October, 1965.

RESIGNATIONS.

HIS Excellency the Governor of the State of Victoria, by and with the advice of the Executive Council thereof, has, by Orders made on the 12th day of October, 1965, accepted the resignations of the persons named hereunder of the offices mentioned, viz.:—

CHIEF SECRETARY'S DEPARTMENT

ARNOLD LYLE CAPUANO, Chief Inspector of Police, as a Licensing Inspector for the purposes of the Licensing Act 1958, from 16th September, 1965.

ARTHUR ROSS CROUCHER, as Electoral Registrar for the Berwick, Cranbourne, Dandenong, Dandenong North, Keysborough and Mordialloc East Subdivisions of the Electoral District of Dandenong; and for the Box Hill South, Burwood South, Clayton, Mt. Waverley and Mulgrave Subdivisions of the Electoral District of Mulgrave, to date from and inclusive of the 1st October, 1965.

LAW DEPARTMENT.

HENRY FRANCIS HAYWARD, from the Commission of the Peace for the Central Bailiwick of the State of Victoria.

HUBERT VICTOR MELLIS, from the Commission of the Peace for the Eastern Bailiwick of the State of Victoria.

BASIL LATHROP MURRAY, one of Her Majesty's Counsel, one of the inspectors appointed pursuant to section 173 of the Companies Act 1961—

(a) by Order in Council, dated 9th April, 1963, to investigate the affairs of Reid Murray Holdings Limited and 70 other companies specified therein, and

(b) by Order in Council, dated 28th May, 1963, to investigate the affairs of Lustre Hosiery Limited and four other companies specified therein,

from his office as such inspector, with effect from 22nd September, 1965.

J. COLQUHOUN,
Clerk of the Executive Council.

At the Executive Council Chamber,
Melbourne, 12th October, 1965.

ORDERS IN COUNCIL

DEPARTMENT OF CROWN LANDS AND SURVEY.

At the Executive Council Chamber, Melbourne, the twelfth day of October, 1965.

PRESENT:

His Excellency the Governor of Victoria.
Mr. Chandler | Mr. Darcy.
Mr. Rossiter

LANDS TEMPORARILY RESERVED AS SITES.

HIS Excellency the Governor of the State of Victoria, by and with the advice of the Executive Council thereof, doth hereby, in pursuance of the provisions of the Land Act 1958, reserve temporarily, and also except from occupation for mining purposes under any miner's right, the lands hereinafter described:—

MOOROODUC.—Site for a Public Park, 8 acres 2 roods 10 perches, more or less, Parish of Moorooduc, County of Mornington, as indicated by hachure on plan hereunder.—(M.161^(a)) (Rs.8543.)

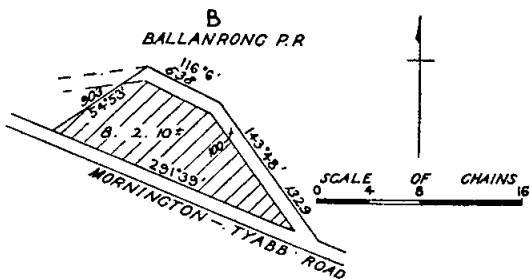

PORTLAND.—Site for Public purposes, 4 acres 2 roods 35 perches, Township of Portland, Parish of Portland, County of Normanby, as indicated by hachure on plan hereunder.—(P.69⁽⁷⁾) (Rs.8544.)

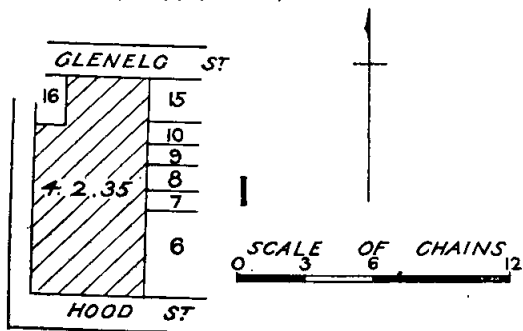

COHUNA.—Site for State School purposes, 1 acre 30 perches, more or less, Township of Cohuna, Parish of Cohuna, County of Gunbower, as indicated by hachure on plan hereunder.—(C.424⁽⁶⁾) (Rs.5164.)

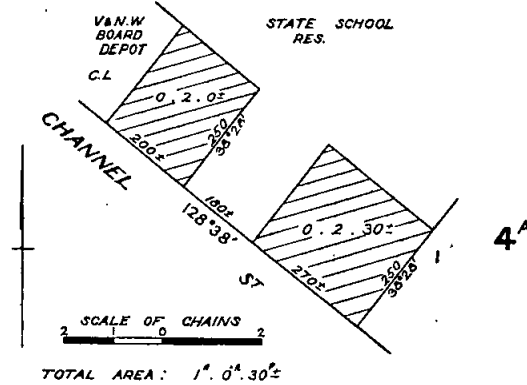

STRATFORD.—Site for Public purposes (Swimming Pool), 3 roods 30 perches, more or less, Township of Stratford, Parish of Stratford, County of Tanjil, as indicated by hachure on plan hereunder.—(S.346⁽⁸⁾) (Rs.8528.)

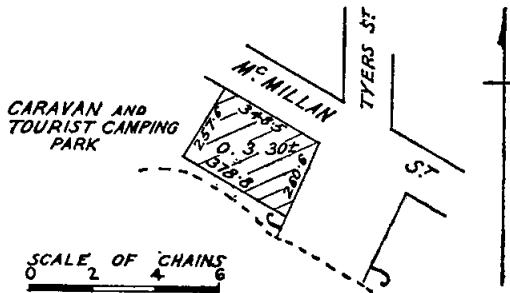

TONG BONG.—Site for Public purposes (Supply of Gravel), 68 acres, more or less, Parish of Tong Bong, County of Buln Buln, as indicated by hachure on plan hereunder.—(T.269⁽²⁾) (Rs.8537.)

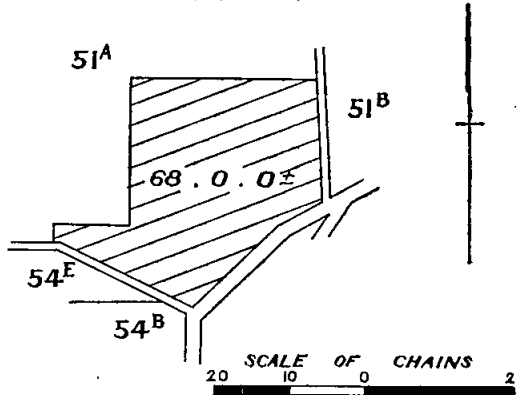

SUNBURY.—Site for Public purposes (Swimming Pool), 6 acres 12 perches, Township of Sunbury, Parish of Buttletjorkk, County of Bourke, as indicated by hachure on plan hereunder.—(S.351⁽⁶⁾) (Rs.8294.)

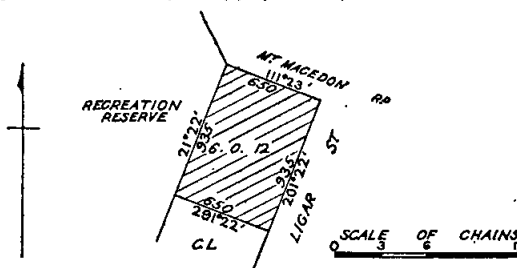

TOOLONDO.—Site for Public Recreation in addition to and adjoining the site temporarily reserved therefor by Order in Council of the 17th September, 1934, 1 rood 37 perches, Township of Toolondo, Parish of Toolondo, County of Lowan, as indicated by hachure on plan hereunder.—(T.187(*) (Rs.4402.)

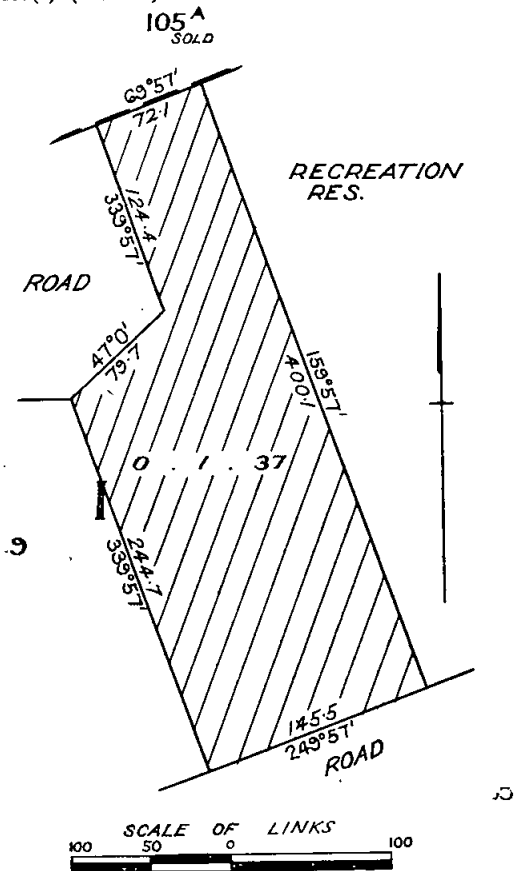

22A (2) of the Land Act 1958, vest in the Country Roads Board the land in the Township of Carwarp, Parish of Carwarp West, as shown by hachure on plan hereunder.

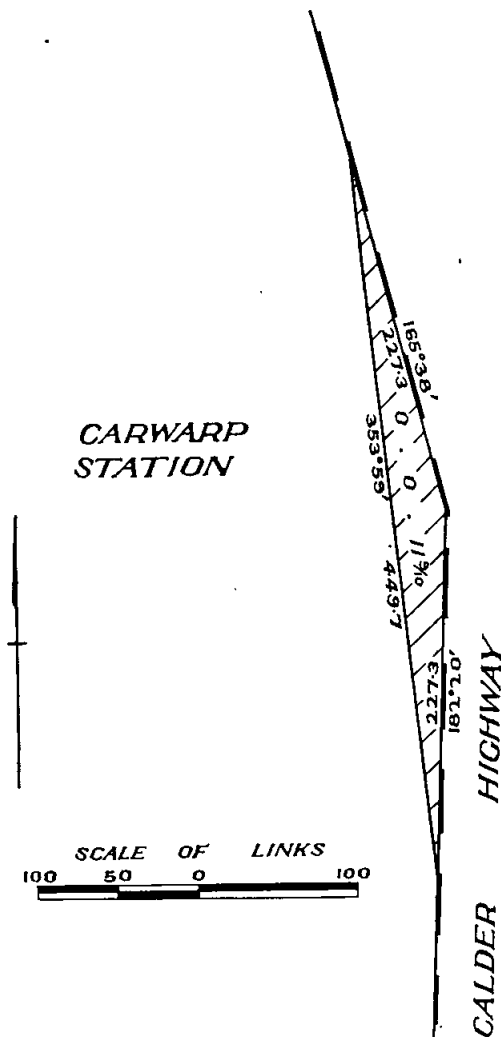

WERRIGAR (WARRACKNABEAL).—Site for Public purposes, 2 roods 10 perches, more or less, Parish of Werrigar, County of Borung, as indicated by hachure on plan hereunder.—(W.293(*) (Rs.8532.)

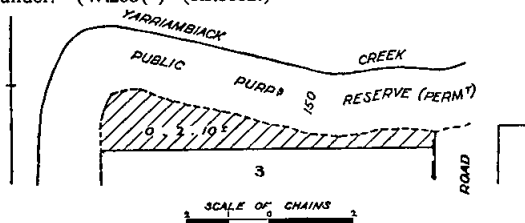

And the Honorable James Charles Murray Balfour, Her Majesty's Minister of Lands for the State of Victoria, shall give the necessary directions herein accordingly.

J. COLQUHOUN,
Clerk of the Executive Council.

And the Honorable James Charles Murray Balfour, Her Majesty's Minister of Lands for the State of Victoria, shall give the necessary directions herein accordingly.

J. COLQUHOUN,
Clerk of the Executive Council.

DEPARTMENT OF CROWN LANDS AND SURVEY.

DEPARTMENT OF CROWN LANDS AND SURVEY.

At the Executive Council Chamber, Melbourne, the twelfth day of October, 1965.

At the Executive Council Chamber, Melbourne, the twelfth day of October, 1965.

PRESENT:

His Excellency the Governor of Victoria.
Mr. Chandler | Mr. Darcy.
Mr. Rossiter

PRESENT:

His Excellency the Governor of Victoria.
Mr. Chandler | Mr. Darcy.
Mr. Rossiter

UNUSED ROADS CLOSED.

VESTING OF LAND IN THE COUNTRY ROADS BOARD.
HIS Excellency the Governor of the State of Victoria, by and with the advice of the Executive Council thereof, doth by this Order made pursuant to section

HIS Excellency the Governor of the State of Victoria, by and with the advice of the Executive Council thereof, doth hereby direct that, in pursuance of the

provisions of section 349 of the *Land Act 1958*, the unused roads referred to hereunder be closed, viz.:-

Township of Mallacoota, Parish of Mallacoota, County of Croajingolong, being the portion of the width of the road indicated by hachure on plan hereunder.—(M.550^(o)) (H.029716.)

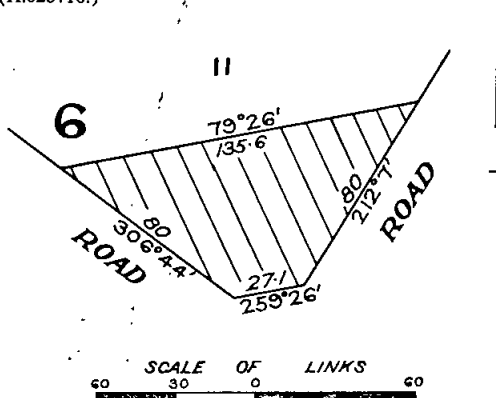

Parish of Terrick Terrick East, County of Gunbower, being the road between allotment 162 and allotments 163, 164.—(T.207^(o)) (W.84703.)

Parish of Trentham, County of Dalhousie, being the road between allotment 73b and allotment 50b.—(T.171⁽⁴⁾) (W.86786.)

And the Honorable James Charles Murray Balfour, Her Majesty's Minister of Lands for the State of Victoria, shall give the necessary directions herein accordingly.

J. COLQUHOUN,
Clerk of the Executive Council.

DEPARTMENT OF CROWN LANDS AND SURVEY.

At the Executive Council Chamber, Melbourne, the twelfth day of October, 1965.

PRESENT:
His Excellency the Governor of Victoria.
Mr. Chandler | Mr. Darcy.
Mr. Rossiter

REVOCATIONS OF TEMPORARY RESERVATIONS OF LANDS BY ORDERS IN COUNCIL.

HIS Excellency the Governor of the State of Victoria, by and with the advice of the Executive Council thereof, doth hereby, in pursuance of the provisions of the *Land Act 1958*, revoke the temporary reservations of lands by Orders in Council hereinafter referred to, viz.:-

BARMAH.—Order in Council of the 11th September, 1928, of 35 1/10 perches of land in the Township of Barmah, as a site for Public Recreation.—(Rs.3380.)

BARMAH.—Order in Council of 26th October, 1926, of 2 acres 1 rood 33 perches of land in the Township of Barmah, as a site for Public Recreation, so far only as regards the portion thereof comprised within the boundaries published in the *Government Gazette* of 8th September, 1955, and containing 1 acre 17 perches.—(Rs.3380.)

BARNAWARTHA.—Order in Council of 3rd May, 1898, of 1 acre of land in the Township of Barnawartha, as a site for Water Supply purposes.—(C.99235.)

BENDIGO.—Order in Council of the 9th February, 1892, of 26 3/10 perches of land at Bendigo (City of Bendigo), Parish of Sandhurst, as a site for Water Channel and Drainage purposes, so far only as the portion containing 11 4/10 perches and separately described as such in the *Government Gazette* of the 12th February, 1892.—(B.61445.)

BUMBANG.—Order in Council of the 22nd January, 1952, of 1 acre 30 perches of land in the Parish of Bumbang, as a site for a Public Hall.—(Rs.6815.)

DROUIN.—Order in Council of 10th April, 1899, of 1 acre of land in the Township of Drouin, as a site for a Rubbish Depot.—(Rs.8442.)

SALE.—Order in Council of 6th June, 1956, of 92 acres of land in the Township of Sale, as a site for Public Park and Public Recreation, revoked as to part by Order of the 30th June, 1959, so far only as regards the portion thereof comprised within the boundaries published in the *Government Gazette* of 8th September, 1965, and containing 1 rood and 37 perches.—(Rs.1321.)

And the Honorable James Charles Murray Balfour, Her Majesty's Minister of Lands for the State of Victoria, shall give the necessary directions herein accordingly.

J. COLQUHOUN,
Clerk of the Executive Council.

LANDLORD AND TENANT ACT 1958.

At the Executive Council Chamber, Melbourne, the twelfth day of October, 1965.

PRESENT:
His Excellency the Governor of Victoria.
Mr. Chandler | Mr. Darcy.
Mr. Rossiter

ORDER EXCLUDING CERTAIN PREMISES FROM THE OPERATION OF CERTAIN OF THE PROVISIONS CONTAINED IN PART V. OF THE LANDLORD AND TENANT ACT 1958.

IN pursuance of the powers conferred upon him by the *Landlord and Tenant Act 1958*, His Excellency the Governor of the State of Victoria, by and with the advice of the Executive Council thereof, doth hereby declare that the premises known as Number 244 Barkly-street, Brunswick, shall be excluded from the operation of the whole of the provisions contained in Divisions 2 and 3 of Part V. of the *Landlord and Tenant Act 1958*.

And the Honorable Arthur Gordon Rylah, Her Majesty's Attorney-General for the State of Victoria, shall give the necessary directions herein accordingly.

J. COLQUHOUN,
Clerk of the Executive Council.

LANDLORD AND TENANT ACT 1958.

At the Executive Council Chamber, Melbourne, the twelfth day of October, 1965.

PRESENT:
His Excellency the Governor of Victoria.
Mr. Chandler | Mr. Darcy.
Mr. Rossiter

ORDER EXTENDING APPLICATION OF PART V. OF THE LANDLORD AND TENANT ACT 1958 TO CERTAIN PREMISES.

IN pursuance of the powers conferred by section 44 of the *Landlord and Tenant Act 1958*, His Excellency the Governor of Victoria, by and with the advice of the Executive Council, doth hereby declare that the application of Part V. of the *Landlord and Tenant Act 1958* shall extend to the following premises:-

1. The premises known as No. 143 Faraday-street, Carlton.
2. The premises known as No. 56 Laity-street, Richmond.
3. The premises known as No. 127 Barkly-street, Carlton.
4. The premises known as No. 65 Graham-street, Sunshine.

And the Honorable Arthur Gordon Rylah, Her Majesty's Attorney-General for the State of Victoria, shall give the necessary directions herein accordingly.

J. COLQUHOUN,
Clerk of the Executive Council.

LOCAL GOVERNMENT DEPARTMENT.

At the Executive Council Chamber, Melbourne, the
twelfth day of October, 1965.

PRESENT:

His Excellency the Governor of Victoria.
Mr. Chandler | Mr. Darcy.
Mr. Rossiter

VESTING OF A RESERVE IN THE SUNSHINE CITY COUNCIL.

WHEREAS it is provided by section 569BA of the *Local Government Act 1958*, as amended, that where any map or plan has been lodged or deposited with the Registrar of Titles pursuant to section 97 of the *Transfer of Land Act* or any corresponding previous enactment (whether before or after the commencement of the *Local Government Act 1963*) and any allotment on that map or plan has been transferred the Governor in Council on the request of the council of the municipality may by Order published in the *Government Gazette* direct that the whole or any part of the land comprised in any reserve shown on that map or plan shall vest in the council whereupon such land shall so vest freed and discharged from any mortgage charge lease or sub-lease:

And whereas the Council of the City of Sunshine has requested that a reserve shown on a plan of subdivision be vested in the council and an allotment on that plan has been transferred:

Now therefore the Governor of the State of Victoria, by and with the advice of the Executive Council thereof, doth by this Order vest in the Council of the City of Sunshine certain land being the Reserve for Plantation Drainage and Sewerage coloured green on plan of subdivision No. 11263 lodged in the Office of Titles.

And the Honorable Rupert James Hamer, Her Majesty's Minister for Local Government for the State of Victoria, shall give the necessary directions herein accordingly.

J. COLQUHOUN,
Clerk of the Executive Council.

LOCAL GOVERNMENT DEPARTMENT.

At the Executive Council Chamber, Melbourne, the
twelfth day of October, 1965.

PRESENT:

His Excellency the Governor of Victoria.
Mr. Chandler | Mr. Darcy.
Mr. Rossiter

VESTING OF A RESERVE IN THE WARRACKNABEAL SHIRE COUNCIL.

WHEREAS it is provided by section 569BA of the *Local Government Act 1958*, as amended, that where any map or plan has been lodged or deposited with the Registrar of Titles pursuant to section 97 of the *Transfer of Land Act* or any corresponding previous enactment (whether before or after the commencement of the *Local Government Act 1963*) and any allotment on that map or plan has been transferred the Governor in Council on the request of the council of the municipality may by Order published in the *Government Gazette* direct that the whole or any part of the land comprised in any reserve shown on that map or plan shall vest in the council whereupon such land shall so vest freed and discharged from any mortgage charge lease or sub-lease:

And whereas the Council of the Shire of Warracknabeal has requested that a reserve shown on a plan of subdivision be vested in the council and an allotment on that plan has been transferred:

Now therefore the Governor of the State of Victoria, by and with the advice of the Executive Council thereof, doth by this Order vest in the Council of the Shire of Warracknabeal certain land being the reserve coloured green on plan of subdivision, No. 26886, lodged in the Office of Titles.

And the Honorable Rupert James Hamer, Her Majesty's Minister for Local Government for the State of Victoria, shall give the necessary directions herein accordingly.

J. COLQUHOUN,
Clerk of the Executive Council.

COUNTRY ROADS BOARD.

At the Executive Council Chamber, Melbourne, the
twelfth day of October, 1965.

PRESENT:

His Excellency the Governor of Victoria.
Mr. Chandler | Mr. Darcy.
Mr. Rossiter

DECLARATION OF A DEVIATION FROM THE MURRAY VALLEY HIGHWAY IN THE SHIRE OF SWAN HILL.

WHEREAS by sections 74 and 58 of the *Country Roads Act 1958* (No. 6229) it is amongst other things enacted that when the Country Roads Board under the provisions of the *Country Roads Act* has by Resolution declared a deviation to be a State highway the said Board may also declare that such deviation shall be in lieu of any existing highway or part thereof named in such Resolution and that on publication in the *Government Gazette* of the Order confirming such Resolution the existing highway or part thereof shall cease to be a State highway or be discontinued as provided in the Resolution: And whereas the said Board has by Resolution declared the deviation on the land described in the First Schedule to such Resolution to be a State highway and has also declared that such deviation shall be in lieu of the part of the existing highway being the land described in the Second Schedule to the said Resolution and that such part of the said existing highway shall be discontinued: Now therefore His Excellency the Governor of the State of Victoria by and with the advice of the Executive Council thereof doth hereby confirm the said Resolution.

Resolution for Declaration of a Deviation of a State Highway under the Country Roads Act.

Whereas the land the site of the highway the course of which is below set out was taken by the Board under the provisions of the *Country Roads Act 1958* for the purpose of constructing such highway deviation which highway deviation has now been laid out and formed on the same: And whereas the said Board (being the Country Roads Board incorporated under the said Act) thinks that the highway aforesaid is fit to be used as a public highway such Board at a meeting now holden acting under the authority conferred upon it by sections 74 and 58 of the said Act doth by this present Resolution hereby declare the said highway deviation the course of which is described in the First Schedule hereto with the commencing and terminating points thereof respectively specified to be part of a State highway within the meaning and for the purposes of the *Country Roads Act 1958*: And the said Board doth also declare that such deviation shall be in lieu of the existing highway or part thereof described in the Second Schedule hereto and that such part of the said existing highway shall be discontinued.

FIRST SCHEDULE.

Shire of Swan Hill.

Murray Valley Highway.—All those pieces of land in the Parish of Yungera, the boundaries of which are as follow:—

- (a) Commencing at the north-eastern angle of allotment 2 of the said parish; thence by lines bearing respectively 86 deg. 3 min. 303 links, 83 deg. 12 min. 4,019 links, 86 deg. 3 min. 2,042 links, 80 deg. 26 min. 1,139.4 links, 258 deg. 54½ min. 4,085 links, 264 deg. 14 min. 3,159 links, 283 deg. 21 min. 6,368.5 links, 90 deg. 24 min. 1,338.7 links, 103 deg. 21 min. 2,995.1 links, 140 deg. 12 min. 500.2 links and 94 deg. 42 min. 1,326 links to the point of commencement.
- (b) Commencing at the northern angle of allotment 4 of the said parish; thence by lines bearing respectively 125 deg. 11 min. 2,287 links, 294 deg. 34 min. 1,698.2 links, 282 deg. 21 min. 717.4 links, 284 deg. 27 min. 864.4 links, 271 deg. 55 min. 792.6 links and 83 deg. 51 min. 2,017 links to the point of commencement.
- (c) Commencing at the north-western angle of allotment 30 of the said parish; thence by lines bearing respectively 98 deg. 36 min. 1,319 links, 119 deg. 11 min. 1,227 links, 133 deg. 28 min. 1,066 links, 114 deg. 46 min. 2,429 links, 122 deg. 44 min. 1,973 links, 70 deg. 50 min.

2,598 links, 243 deg. 52 min. 1,283.5 links, 257 deg. 32½ min. 1,333.2 links, 296 deg. 36 min. 1,333.0 links, 297 deg. 17 min. 6,551.0 links and 358 deg. 28 min. 13.4 links to the point of commencement.

- (d) Commencing at an angle in the northern boundary of allotment 6 of the said parish formed by the intersection of lines bearing 263 deg. 5 min. and 210 deg. 19 min.; thence by lines bearing respectively 83 deg. 5 min. 901 links, 102 deg. 53 min. 1,975.9 links, 268 deg. 15½ min. 1,844.4 links, 252 deg. 55 min. 915.3 links, 233 deg. 49½ min. 748.8 links, 218 deg. 14½ min. 877.8 links and 30 deg. 19 min. 2,071.7 links to the point of commencement—

which said pieces of land are particularly delineated and shown coloured red and yellow on survey plans numbered 9657 and 9658, lodged in the office of the Country Roads Board.

SECOND SCHEDULE.

Shire of Swan Hill.

Murray Valley Highway.—All those pieces of land in the Parish of Yungera, the boundaries of which are as follow:—

- (a) Commencing at the south-western angle of allotment 3 of the said parish; thence by lines bearing respectively 86 deg. 3 min. 6,006.1 links, 257 deg. 38½ min. 2,049.2 links, 263 deg. 12 min. 3,519 links, 270 deg. 27 min. 496.4 links and 0 deg. 5 min. 437.6 links to the point of commencement.
- (b) Commencing at the south-eastern angle of allotment 2b of the said parish; thence by lines bearing respectively 180 deg. 5 min. 381.6 links, 282 deg. 50 min. 1,683.6 links, 320 deg. 12 min. 878.8 links, 270 deg. 24 min. 2,351.7 links, 283 deg. 21 min. 1,338.7 links, 90 deg. 24 min. 3,795.6 links, 140 deg. 12 min. 1,364.0 links and 86 deg. 3 min. 1,192.0 links to the point of commencement—

which said pieces of land are particularly delineated and shown coloured blue on survey plan numbered 9657, lodged in the office of the Country Roads Board.

The common seal of the Country Roads Board was hereto affixed, at Kew, this fourth day of October, One thousand nine hundred and sixty-five, in the presence of—

(SEAL) I. J. O'DONNELL, Chairman.
R. E. DONALDSON, Member.
N. L. ALLANSON, Secretary.

And the Honorable James Charles Murray Balfour Her Majesty's Acting Minister of Public Works for the State of Victoria, shall give the necessary directions herein accordingly.

J. COLQUHOUN,
Clerk of the Executive Council.

COUNTRY ROADS BOARD.

At the Executive Council Chamber, Melbourne, the twelfth day of October, 1965.

PRESENT:

His Excellency the Governor of Victoria.
Mr. Chandler | Mr. Darcy.
Mr. Rossiter

ORDER APPROVING OF WIDENING AN EXISTING MAIN ROAD IN THE SHIRE OF HEALESVILLE.

WHEREAS the Country Roads Board constituted under the Country Roads Act 1958 (No. 6229) has represented to His Excellency the Governor in Council that it appears to it desirable that the existing Healesville-Kinglake-road in the Shire of Healesville (declared to be a main road under the said Act which declaration was confirmed by the Order in Council published in the Government Gazette of the 5th October, 1932, on page 2256) should be widened by the said Board: And whereas the said Board in accordance with the requirements of section 19 of the said cited Act has caused to be prepared a map plan and estimate showing the points between which and on and through what land the said widening is proposed to be made and the cost of acquiring the land: And whereas on an inspection of the said map and

plan and a consideration of the said estimate His Excellency the Governor in Council is satisfied that there are funds legally available for acquiring the land: Now therefore be it known by this present Order that His Excellency the Governor of the State of Victoria with the advice of the Executive Council thereof doth hereby approve of the said road being widened, that is to say:—

All those pieces of land in the Parish of Tarrawarra, the boundaries of which are as follow:—

- (a) Commencing at the north-eastern angle of allotment 2 of the said parish; thence by lines bearing respectively 152 deg. 5 min. 617.1 links, 318 deg. 47 min. 298.6 links, 293 deg. 45 min. 1,041.7 links and 96 deg. 33 min. 867 links to the point of commencement.
- (b) Commencing at the south-eastern angle of allotment 31 of the said parish; thence by lines bearing respectively 276 deg. 44 min. 55 links, 58 deg. 28 min. 64.1 links and 180 deg. 4 min. 40 links to the point of commencement.
- (c) Commencing at the south-western angle of allotment 3A of the said parish; thence by lines bearing respectively 0 deg. 4 min. 121.8 links, 151 deg. 42 min. 147.6 links and 276 deg. 36 min. 70.6 links to the point of commencement—

which said pieces of land are particularly delineated and shown coloured red on survey plan numbered 10173, lodged in the office of the Country Roads Board.

And the Honorable James Charles Murray Balfour, Her Majesty's Acting Minister of Public Works for the State of Victoria, shall give the necessary directions herein accordingly.

J. COLQUHOUN,
Clerk of the Executive Council.

COUNTRY ROADS BOARD.

At the Executive Council Chamber, Melbourne, the twelfth day of October, 1965.

PRESENT:

His Excellency the Governor of Victoria.
Mr. Chandler | Mr. Darcy.
Mr. Rossiter

ORDER APPROVING OF WIDENING AN EXISTING MAIN ROAD IN THE SHIRE OF AVON.

WHEREAS the Country Roads Board constituted under the Country Roads Act 1958 (No. 6229) has represented to His Excellency the Governor in Council that it appears to it desirable that the existing Bengworden-road in the Shire of Avon (declared to be a main road under the said Act which declaration was confirmed by the Order in Council published in the Government Gazette of the 18th May, 1938, on page 1501) should be widened by the said Board: And whereas the said Board in accordance with the requirements of section 19 of the said cited Act has caused to be prepared a map plan and estimate showing the points between which and on and through what land the said widening is proposed to be made and the cost of acquiring the land: And whereas on an inspection of the said map and plan and a consideration of the said estimate His Excellency the Governor in Council is satisfied that there are funds legally available for acquiring the land: Now therefore be it known by this present Order that His Excellency the Governor of the State of Victoria with the advice of the Executive Council thereof doth hereby approve of the said road being widened, that is to say:—

All that piece of land in the Parish of Yeerung, the boundaries of which are as follow:—Commencing at the south-eastern angle of allotment 15c, section 4, of the said parish; thence by lines bearing respectively 235 deg. 59 min. 346.8 links, 34 deg. 48 min. 275.4 links, 18 deg. 55 min. 401.8 links and 180 deg. 0 min. 412.2 links to the point of commencement—which said piece of land is particularly delineated and shown coloured red on survey plan numbered 10196, lodged in the office of the Country Roads Board.

And the Honorable James Charles Murray Balfour, Her Majesty's Acting Minister of Public Works for the State of Victoria, shall give the necessary directions herein accordingly.

J. COLQUHOUN,
Clerk of the Executive Council.

COUNTRY ROADS BOARD.

At the Executive Council Chamber, Melbourne, the
twelfth day of October, 1965.

PRESENT:

His Excellency the Governor of Victoria.	
Mr. Chandler	Mr. Darcy.
Mr. Rossiter	

ORDER APPROVING OF A DEVIATION FROM A MAIN ROAD IN THE SHIRE OF BEECHWORTH.

WHEREAS the Country Roads Board constituted under the Country Roads Act 1958 (No. 6229) has represented to His Excellency the Governor in Council that it appears to it desirable that the deviation hereinafter referred to from the existing Myrtleford-Yackandandah road in the Shire of Beechworth (declared to be a main road under the said Act which declaration was confirmed by the Order in Council published in the Government Gazette of the 21st September, 1932, on page 2177) should be made by the said Board: And whereas the said Board in accordance with the requirements of section 19 of the said cited Act has caused to be prepared a map plan and estimate showing the points between which and on and through what land the said deviation is proposed to be made and the cost of acquiring the land: And whereas on an inspection of the said map and plan and a consideration of the said estimate His Excellency the Governor in Council is satisfied that there are funds legally available for acquiring the land: Now therefore be it known by this present Order that His Excellency the Governor of the State of Victoria with the advice of the Executive Council thereof doth hereby approve of the said road being made, that is to say:—

All those pieces of land in the Parish of Mudgegonga, the boundaries of which are as follow:—

- (a) Commencing at the south-eastern angle of allotment 11, section C, of the said parish; thence by lines bearing respectively 239 deg. 17 min. 84.9 links, 22 deg. 53 min. 312.5 links, 11 deg. 35 min. 182 links, 180 deg. 5 min. 184.4 links and 199 deg. 35 min. 253 links to the point of commencement.
- (b) Commencing at a point on the western boundary of allotment 9, section C, of the said parish, distant 3 deg. 23 min. 334.5 links from the south-western angle of the said allotment; thence by lines bearing respectively 3 deg. 23 min. 195.5 links, 22 deg. 12 min. 402.2 links and 196 deg. 4 min. 590.6 links to the point of commencement—

which said pieces of land are particularly delineated and shown coloured red on survey plan numbered 10119, lodged in the office of the Country Roads Board.

And the Honorable James Charles Murray Balfour, Her Majesty's Acting Minister of Public Works for the State of Victoria, shall give the necessary directions herein accordingly.

J. COLQUHOUN,
Clerk of the Executive Council.

COUNTRY ROADS BOARD.

At the Executive Council Chamber, Melbourne, the
twelfth day of October, 1965.

PRESENT:

His Excellency the Governor of Victoria.	
Mr. Chandler	Mr. Darcy.
Mr. Rossiter	

DECLARATION OF THE WIDENING OF THE NORTHERN HIGHWAY IN THE SHIRE OF PYALONG.

WHEREAS by sections 21 and 74 of the Country Roads Act 1958 (No. 6229) it is amongst other things enacted that when the Country Roads Board under the provisions of the Country Roads Act has taken the land necessary for constructing the highway or deviation or widening it shall as soon as it thinks such highway or deviation or widening is fit to be used as a public highway by Resolution declare the highway or deviation or widening to be a State highway or part thereof and that upon publication in the Government Gazette of the Order of the Governor

in Council confirming such Resolution such highway or deviation or widening shall thereupon be a State highway or a part thereof within the meaning of the said Act: And whereas the said Board has by Resolution declared the highway on the land described in the Schedule to such Resolution to be part of a State highway: Now therefore His Excellency the Governor of the State of Victoria by and with the advice of the Executive Council thereof doth hereby confirm the said Resolution.

Resolution for Declaration of the Widening of a State Highway under the Country Roads Act.

Whereas the land the site of the highway the course of which is below set out was taken by the Board under the provisions of the Country Roads Act for the purpose of widening the State highway aforesaid which widening has now been laid out and formed on the same: And whereas the said Board (being the Country Roads Board incorporated under the said Act) thinks that the widening aforesaid is fit to be used as part of a public highway such Board at a meeting now holden doth by this Resolution hereby declare the same as described in the Schedule hereto with the commencing and terminating points thereof respectively specified to be part of the State highway within the meaning and for the purposes of the Country Roads Act.

SCHEDULE.

Shire of Pyalong.

4. Northern Highway.—All that piece of land in the Township and Parish of Pyalong, the boundaries of which are as follow:—Commencing at the most northerly angle of allotment 10, section 9 of the said township; thence by lines bearing respectively 32 deg. 20 min. 133 ft. 11 in., 201 deg. 16 min. 133 ft., 157 deg. 9 min. 130 ft. 5½ in. and 330 deg. 31½ min. 150 ft. 5½ in. to the point of commencement—which said piece of land is particularly delineated and shown coloured red on survey plan numbered 6924, lodged in the office of the Country Roads Board.

The common seal of the Country Roads Board was hereto affixed, at Kew, this fourth day of October, One thousand nine hundred and sixty-five, in the presence of—

	I. J. O'DONNELL, Chairman.
(SEAL)	R. E. DONALDSON, Member.
	N. L. ALLANSON, Secretary.

And the Honorable James Charles Murray Balfour Her Majesty's Acting Minister of Public Works for the State of Victoria, shall give the necessary directions herein accordingly.

J. COLQUHOUN,
Clerk of the Executive Council.

COUNTRY ROADS BOARD.

At the Executive Council Chamber, Melbourne, the
twelfth day of October, 1965.

PRESENT:

His Excellency the Governor of Victoria.	
Mr. Chandler	Mr. Darcy.
Mr. Rossiter	

DECLARATION OF THE WIDENING OF WOOLSTHORPE-HEYWOOD ROAD IN THE SHIRE OF MINHAMITE.

WHEREAS by section 21 of the Country Roads Act 1958 (No. 6229) it is amongst other things enacted that when the Country Roads Board under the provisions of the Country Roads Act has taken the land necessary for constructing the road or deviation or widening it shall as soon as it thinks such road or deviation or widening is fit to be used as a public highway by Resolution declare the road or deviation or widening to be a main road or part thereof and that upon publication in the Government Gazette of the Order of the Governor in Council confirming such Resolution such road or deviation or widening shall thereupon be a main road or a part thereof within the meaning of the said Act: And whereas the said Board has by Resolution declared the road on the land described in the Schedule to such Resolution to be part of a main road: Now therefore His Excellency the Governor of the State of Victoria by and with the advice of the Executive Council thereof doth hereby confirm the said Resolution.

Resolution for Declaration of the Widening of a Main Road under the Country Roads Act.

Whereas the land the site of the road the course of which is below set out was taken by the Board under the provisions of the Country Roads Act for the purpose of widening the main road aforesaid which widening has now been laid out and formed on the same: And whereas the said Board (being the Country Roads Board incorporated under the said Act) thinks that the widening aforesaid is fit to be used as part of a public highway such Board at a meeting now holden doth by this Resolution hereby declare the same as described in the Schedule hereto with the commencing and terminating points thereof respectively specified to be part of the main road within the meaning and for the purposes of the Country Roads Act.

SCHEDULE.

Shire of Minnamite.

5. *Woolsthorpe—Heywood road (10705).*—All that piece of land in the Parish of Kapong, the boundaries of which are as follow:—Commencing at the north-eastern angle of allotment 1A, section 3, of the said parish; thence by lines bearing respectively 127 deg. 19 min. 317.4 links, 290 deg. 29 min. 635.7 links and 95 deg. 0 min. 344.4 links to the point of commencement—which said piece of land is particularly delineated and shown coloured red on survey plan numbered 7455, lodged in the office of the Country Roads Board.

The common seal of the Country Roads Board was hereto affixed, at Kew, this fourth day of October, One thousand nine hundred and sixty-five, in the presence of—

(SEAL) I. J. O'DONNELL, Chairman.
R. E. DONALDSON, Member.
N. L. ALLANSON, Secretary.

And the Honorable James Charles Murray Balfour Her Majesty's Acting Minister of Public Works for the State of Victoria, shall give the necessary directions herein accordingly.

J. COLQUHOUN,
Clerk of the Executive Council.

MILDURA URBAN WATER TRUST.

At the Executive Council Chamber, Melbourne, the nineteenth day of October, 1965.

PRESENT:

His Excellency the Governor of Victoria.
Mr. Meagher | Mr. Balfour.
Mr. Dickie

SALE OF LAND.

HIS Excellency the Governor of the State of Victoria, by and with the advice of the Executive Council thereof, doth hereby, under the provisions of the Mildura Irrigation and Water Trusts Act approve of the sale by the Mildura Urban Water Trust of the land comprised within the boundaries described in the Schedule hereto.

SCHEDULE.

Commencing at a point on the south-western boundary of allotment 45, on lodged plan of subdivision numbered 2641, being part of Crown portion 1, Parish of Mildura, County of Karkaroc, such point being distant 70 feet south-easterly from its westernmost angle; thence through the said allotments 45 and 44 by lines bearing north 45 deg. 16 min. east, a distance of 120 feet, south 44 deg. 44 min. east a distance of 95 feet, south 45 deg. 16 min. west a distance of 120 feet and north 44 deg. 44 min. west a distance of 95 feet to the point of commencement.

All of which lands are shown on a plan approved by the Governor in Council and deposited in the office of the State Rivers and Water Supply Commission, Melbourne.—(Corr. No. 63/4747/47).

And the Honorable Thomas Anthony Darcy, Her Majesty's Minister of Water Supply for the State of Victoria, shall give the necessary directions herein accordingly.

J. COLQUHOUN,
Clerk of the Executive Council.

BOOLARRA WATERWORKS TRUST.

At the Executive Council Chamber, Melbourne, the nineteenth day of October, 1965.

PRESENT:

His Excellency the Governor of Victoria.
Mr. Meagher | Mr. Balfour.
Mr. Dickie

EXTENT OF DISTRICTS INCREASED.

UNDER the powers conferred by the Water Act and all other powers enabling him in that behalf, His Excellency the Governor of the State of Victoria, by and with the advice of the Executive Council of the said State, doth hereby declare, order and direct as follows:—

That the extent of the Waterworks and Urban Districts of the Boolarra Waterworks Trust be increased by adding to the same the land comprised within the boundaries described in the Schedule hereto, and as on and from the date hereof, the extent of such Districts shall be deemed to be increased accordingly.

SCHEDULE.

Commencing at the north-western angle of a State Forest Reserve F.A. 1928—3685 near the easternmost angle of Crown allotment 140A, Parish of Mirboo, County of Buln Buln, being a point on the southern boundary of the existing Waterworks District; thence south-westerly along the north-western boundary of the said State Forest Reserve to a point in line with the south-western boundary of allotment 68 on lodged plan of subdivision numbered 56873; thence north-westerly by a line across a road and along the said south-western boundary of allotment 68 to its westernmost angle; thence north-westerly by a line through the said Crown allotment 140A to the southernmost angle of allotment 56; thence north-westerly along the south-western boundary of the said allotment 56 and by a line being a continuation thereof across a road (C.R.B. 1936—33A) to a point on the north-western boundary of the said road; thence north-easterly along the said north-western boundary of a road a distance of approximately 1,000 links to an angle on the said boundary; thence north-easterly by a line across a road to the westernmost angle of allotment 3 of lodged plan of subdivision No. 61954, Township of Boolarra; thence generally north-easterly and south-easterly along the northern boundary of the said allotment 3 to a point on the western boundary of Crown allotment 9, section 3 being a point on the boundary of the existing Waterworks District; thence southerly and easterly along the boundary of the existing Waterworks District to the point of commencement.

All of which boundaries are shown on a plan approved by the Governor in Council and deposited in the office of the State Rivers and Water Supply Commission, Melbourne.—(Corres. 60/2298/19).

And the Honorable Thomas Anthony Darcy, Her Majesty's Minister of Water Supply for the State of Victoria, shall give the necessary directions herein accordingly.

J. COLQUHOUN,
Clerk of the Executive Council.

BALLARAT SEWERAGE AUTHORITY.

At the Executive Council Chamber, Melbourne, the nineteenth day of October, 1965.

PRESENT:

His Excellency the Governor of Victoria.
Mr. Meagher | Mr. Balfour.
Mr. Dickie

APPROVAL TO EXTENSION OF SITE OF TREATMENT WORKS AND TO THE ACQUISITION OF LAND.

UNDER the powers conferred by the Sewerage Districts Acts and all other powers enabling him in that behalf, His Excellency the Governor of the State of Victoria, by and with the advice of the Executive Council of the said State, doth hereby consent to an extension of the site of sewage treatment works as described in the schedule hereto and to the compulsory acquisition of the land described in the said Schedule.

SCHEDULE.

All of that land comprising lot 1 of Crown section A, Wyndholm Pre-Emptive Right, Parish of Dowling Forest, County of Ripon.

All of which lands are shown on a plan approved by the Governor in Council and deposited in the office of the State Rivers and Water Supply Commission, Melbourne.—(Corr. 62/3613/60).

And the Honorable Thomas Anthony Darcy, Her Majesty's Minister of Water Supply for the State of Victoria, shall give the necessary directions herein accordingly.

J. COLQUHOUN,
Clerk of the Executive Council.

LANDLORD AND TENANT ACT 1958.

At the Executive Council Chamber, Melbourne, the nineteenth day of October, 1965.

PRESENT:

His Excellency the Governor of Victoria.
Mr. Meagher | Mr. Balfour.
Mr. Dickie

ORDER EXTENDING APPLICATION OF PART V. OF THE LANDLORD AND TENANT ACT 1958 TO CERTAIN PREMISES.

IN pursuance of the powers conferred by section 44 of the *Landlord and Tenant Act 1958*, His Excellency the Governor of Victoria, by and with the advice of the Executive Council, doth hereby declare that the application of Part V. of the *Landlord and Tenant Act 1958* shall extend to the following premises:—

1. The whole of the premises known as Number 8 Wilson-street, East Malvern.
2. The premises known as Number 27 Little Charles-street, Abbotsford.

And the Honorable Arthur Gordon Rylah, Her Majesty's Attorney-General for the State of Victoria, shall give the necessary directions herein accordingly.

J. COLQUHOUN,
Clerk of the Executive Council.

UNIVERSITY ACT 1958.

At the Executive Council Chamber, Melbourne, the nineteenth day of October, 1965.

PRESENT:

His Excellency the Governor of Victoria.
Mr. Meagher | Mr. Balfour.
Mr. Dickie

APPROVAL OF THE ALIENATION OR DISPOSAL OF PROPERTY—ESTATE OF DANIEL BRUMLEY, DECEASED.

IN pursuance of the powers conferred by section 4 of the *University Act 1958*, His Excellency the Governor of Victoria, by and with the advice of the Executive Council thereof, doth hereby approve of the alienation or disposal by the University of Melbourne of the real property described hereunder:—

All those pieces of land 2,124 acres 1 rood and 7 perches or thereabouts being the whole of the land more particularly described in certificates of title, volume 3834, folio 612, volume 1229, folio 704, volume 6406, folio 136 and Crown grants volume 3791, folio 149, volume 5995, folio 857, volume 4407, folio 256, volume 7951, folio 195, volume 5664, folio 640, volume 5856, folio 085, volume 6531, folio 036, volume 7720, folio 149, being the property known as "Leura", at Branhholme in the State of Victoria.

And the Honorable Arthur Gordon Rylah, Her Majesty's Attorney-General for the State of Victoria, shall give the necessary directions herein accordingly.

J. COLQUHOUN,
Clerk of the Executive Council.

MOTOR CAR ACT 1958.

At the Executive Council Chamber, Melbourne, the nineteenth day of October, 1965.

PRESENT:

His Excellency the Governor of Victoria.
Mr. Meagher | Mr. Balfour.
Mr. Dickie

MOTOR CAR TRIALS OF SPEED WITHIN THE TOWN OF CAMPERDOWN AND THE SHIRE OF HAMPDEN.

WHEREAS it is enacted by sub-section (2) of section eighty-three of the *Motor Car Act 1958* that, if a motor car is used on a highway for purposes of racing or of trial of speed, the driver or the person in charge thereof shall be liable to a penalty of not more than Fifty pounds, provided that the said sub-section (2) shall not apply to a motor car used as aforesaid on any highway or portion thereof specified by Order in Council published in the *Government Gazette* and on such days and during such hours as are specified in the Order:

And whereas the Camperdown Motor Sports Club has requested that such an Order be made to enable motor car trials of speed to be conducted by the said Club on Old Timboon-road on Sunday the fifth day of December, 1965, and Sunday the sixth day of March, 1966:

Now therefore His Excellency the Governor of the State of Victoria, by and with the advice of the Executive Council thereof, and in pursuance of the powers conferred by the *Motor Car Act 1958*, doth by this Order specify that portion of the Old Timboon-road within the Town of Camperdown and the Shire of Hampden lying between the rail crossing and the old Geelong-road as a highway in respect of which any motor car may, without being subject to the application of the said sub-section (2) of section 83 of the *Motor Car Act*, be used for purposes of trials of speed under the control of the said Camperdown Motor Sports Club on Sunday the fifth day of December, 1965, and Sunday the sixth day of March, 1966, between the hours of ten o'clock in the forenoon and five o'clock in the afternoon on each day provided that the Officer in Charge of Police in attendance is satisfied that the highway is in a satisfactory condition for racing purposes and that adequate arrangements have been made for the safety of the public.

And the Honorable Arthur Gordon Rylah, Her Majesty's Chief Secretary for the State of Victoria, shall give the necessary directions herein accordingly.

J. COLQUHOUN,
Clerk of the Executive Council.

LANDS DEPARTMENT NOTICES

APPROACHING LAND SALES.

SALES of Crown lands, in fee-simple, will be held at the under-mentioned places and dates, viz.:—

	No. of Gazette.
Ararat.—Thursday, 18th November, 1965	82
Ballarat.—Wednesday, 1st December, 1965	86
Balmoral.—Thursday, 21st October, 1965	74
Murrayville.—Tuesday, 23rd November, 1965	86
Underbool.—Tuesday, 23rd November, 1965	86

SALE OF CROWN LAND BY AUCTION.

The land will be offered for sale in fee-simple, and subject to the provisions of the Land Act and Regulations thereunder.

The upset price is the sum at which bidding will start, and no bid below that sum can be accepted. The highest bidder at or above that sum shall be the purchaser, subject to signature of contract and any necessary payment.

TERMS:

A deposit of at least 12½% of the purchase price must be paid at the sale, either in cash or by cheque.

The residue is payable in half-yearly instalments in accordance with the following scale, or may be paid off at any earlier time.

- £20 and under, 6 instalments.
- Over £20, and not exceeding £50, 8 instalments.
- Over £50, and not exceeding £100, 10 instalments.
- Over £100, and not exceeding £200, 12 instalments.
- Over £200, and not exceeding £300, 14 instalments.
- Over £300, and not exceeding £400, 16 instalments.
- Over £400, and not exceeding £500, 18 instalments.
- Over £500, 20 instalments.

Interest at the rate of 5% per annum is payable with all payments of residue, and is computed for each instalment from the date of sale to the date of such payment. Additional interest is charged if any instalment is not paid on or before the due date.

If paid off within 30 days of sale, no interest is payable.

FEES, ETC.:

Also payable at the sale, in addition to the deposit, are the survey fee and, if applicable, the valuation of improvements (if purchaser be not the owner thereof).

Payable with balance of purchase money—

Crown Grant fee—50 acres and under ..	£1 10s.
Over 50 acres ..	£2
Purchase money £5 or under	£1

Assurance Fund contribution.—One halfpenny for each £1 of purchase price. (This is a fund established to guarantee the validity of freehold titles.)

Transfer of interest prior to completion of payment may be allowed on payment of £1 fee and subject to stamp duty.

If unable to attend personally, a prospective purchaser may arrange for another person to bid as his agent.

Attention is drawn to section 95, *Land Act 1958*, which provides that the purchaser shall be deemed to be the owner for the purposes of other Acts; also to an amendment to the Local Government Act providing for Government roads, in certain circumstances, to be declared "private streets", thus making the purchaser liable to contribute to the cost of street construction.

J. C. M. BALFOUR,
Minister of Lands.

Office of Crown Lands and Survey,
Melbourne, 20th October, 1965.

MURRAYVILLE.—Sale (No. 11794) of Crown land in fee-simple, by auction, will be held at the LAND INSPECTOR'S OFFICE, MURRAYVILLE, on TUESDAY, the 23rd NOVEMBER, 1965, at TWO o'clock p.m. To be conducted by N. J. FITZGERALD, Land Officer, Ballarat.

TOWNSHIP OF MURRAYVILLE, PARISH OF DANYO, COUNTY OF WEEAH.

Fronting the northern side of Poole-street about 23 chains west of Reed-street.

Upset price £35 per lot. Survey fee £6 10s. per lot.

Lot 1.

Area 1r. 20p., allotment 20 of section 7.

Lot 2.

Area 1r. 20p., allotment 21 of section 7.—(M.60165.)

Fronting the southern side of Ouyen Highway about 15 chains east of Sharrock-street.

Upset price £35 per lot. Survey fee £7 10s. per lot.

Lot 3.

Area 3r. 31p., subject to survey, allotment 6 of section 19.

Lot 4.

Area 3r. 31p., subject to survey, allotment 7 of section 19.

Lot 5.

Area 3r. 31p., subject to survey, allotment 8 of section 19.—(M.51356.)

UNDERBOOL.—Sale (No. 11795) of Crown land in fee-simple, by auction, will be held at the LAND INSPECTOR'S OFFICE, UNDERBOOL, on TUESDAY, the 23rd NOVEMBER, 1965, at TWELVE noon. To be conducted by N. J. FITZGERALD, Land Officer, Ballarat.

Lot 1.

PARISH OF KATTYOONG, COUNTY OF WEEAH.

Fronting the eastern side of a Government road and about 4½ miles north of the Torrita Railway Station.

Upset price £150 the lot. Survey fee £16 2s. 6d.

Area 34a. 1r. 4p., subject to survey, allotment 8A. Subject to water channel easement.

NOTE.—The upset price includes a valuation of the dam situated on the allotment.—(M.35991.)

Lot 2.

TOWNSHIP OF TORRITA, PARISH OF NYANG, COUNTY OF WEEAH.

Fronting the south-western side of a Government road and east of the State School Reserve.

Upset price £15 the lot. Survey fee £10.

Area 2r. 26p., subject to survey, allotment 8 of section 1. One month allowed for removal of improvements.—(M.44581.)

BALLARAT.—Sale (No. 11796) of Crown land in fee-simple, by auction, will be held at the LAND OFFICE, CAMP-STREET, BALLARAT, on WEDNESDAY, the 1st DECEMBER, 1965, at TWO o'clock p.m. To be conducted by N. J. FITZGERALD, Land Officer, Ballarat.

TOWNSHIP OF CRESWICK, PARISH OF CRESWICK, COUNTY OF TALBOT.

Lot 1.

Fronting the northern side of Macs-street about 110 links south of Alfred-street.

Upset price £70 the lot. Survey fee £6.

Area 1r. 12p., allotment 2 of section 73H. One month allowed for removal of improvements.—(J.26727.)

Fronting the north side of Ascot-road about 7 chains west of Reed-street.

Lot 2.

Upset price £30 the lot. Survey fee £6.

Area 36 perches, allotment 14A of section 48A.

Lot 3.

Upset price £30 the lot. Survey fee £6 10s.

Area 1r. 2p., allotment 14B of section 48A.—(J.29980.)

Lot 4.

At the south-east corner of Orr and Gardiner streets.

Upset price £30 the lot. Survey fee £7 7s. 6d.

Area 2a. 1r. 20p., allotment 14 of section B. One month allowed for removal of improvements.—(J.25867.)

PARISH OF CRESWICK, COUNTY OF TALBOT.

At Springmount, fronting the southern side of the main Creswick—Castlemaine road.

Upset price £20 per lot. Survey fee £6 12s. 6d. per lot.

Lot 5.

Area 1 acre, allotment 23 of section Z.

Lot 6.

Area 1 acre, allotment 24 of section Z.

Lot 7.

Area 1 acre, allotment 25 of section Z.

Lot 8.

Area 1 acre, allotment 26 of section Z.—(J.31570.)

Abutting the southern boundary of the Township of Broomfield.

Lot 9.

Upset price £25 the lot. Survey fee £7 12s. 6d.

Area 3 acres, subject to survey, allotment 19 of section F.

Lot 10.

Upset price £8 the lot. Survey fee £6 12s. 6d.

Area 2r. 16p., subject to survey, allotment 21 of section F.—(J.31537.)

TOWNSHIP OF CLUNES, PARISH OF CLUNES, COUNTY OF TALBOT.

Lot 11.

Fronting the east side of Suburban-street about 4 chains north of Victoria-street.

Upset price £35 the lot. Survey fee £6 12s. 6d.

Area 2r. 4p., allotment 4 of section 36.—(J.29171.)

Lot 12.

At the southern corner of Cameron and Leslie streets.

Upset price £25 the lot. Survey fee £6 10s.

Area 1r. 32p., allotment 12 of section 21.

NOTE.—Allotment 12 as now offered comprises land hitherto shown on Departmental plans as allotments 12 and 13.—(J.30287.)

Lot 13.

TOWNSHIP OF LEXTON, PARISH OF LEXTON, COUNTY OF TALBOT.

Fronting the north-west side of Williamson-street about 2½ chains east of Thompson-street.

Upset price £63 the lot. Survey fee £5 5s.

Area 35 perches, subject to survey, allotment 9 of section 13. Valuation of improvements £600 (Lexton Shire Council) (House, outbuildings and fencing).—(J.29401.)

Lot 14.

PARISH OF RAGLAN, COUNTY OF RIPON.

At Waterloo, fronting the south side of a Government road, and being a former gravel reserve.

Upset price £5 the lot. Survey fee £8.

Area 5a. 0r. 10p., allotment 55B of section 3. One month allowed for removal of improvements. Grantee shall not be entitled to compensation for any damage to be done by mining. (Section 81 Land Act 1958).—(J.29731.)

PROPOSED REVOCATION OF TEMPORARY RESERVATION OF LAND BY ORDER IN COUNCIL.

IN pursuance of the provisions of the Land Act 1958, notice is hereby given that it is the intention of the Governor in Council to revoke the temporary reservation of land by Order in Council hereunder referred to, viz.:

The following Notice was published 1° on the 29th September, 1965, pursuant to Order of the 21st September, 1965.

BULLARTO.—The temporary reservation by Order in Council of the 21st August, 1951 of 2 acres, more or less, of land in the Parish of Bullarto, as a site for Water Supply purposes.—(B.645(*) (Rs.2547).

J. C. M. BALFOUR,
Commissioner of Crown Lands and Survey.

PROPOSED REVOCATIONS OF TEMPORARY RESERVATIONS OF LANDS BY ORDERS IN COUNCIL.

IN pursuance of the provisions of the Land Act 1958, notice is hereby given that it is the intention of the Governor in Council to revoke the temporary reservations of lands by Orders in Council hereunder referred to, viz.:

The following Notices were published 1° on the 20th October, 1965, pursuant to Orders of the 12th October, 1965.

MOORABBIN (SANDRINGHAM).—The temporary reservation, by Order in Council of the 6th October, 1953, of 5 acres 2 roods 4 perches of land in the Parish of Moorabbin, as a site for Hospital purposes, is about to be revoked so far

only as the portion containing 39 perches, indicated by hachure on plan hereunder, is concerned.—(M.164(*) (Rs.7153).

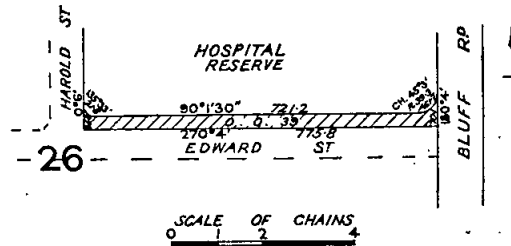

NEWBURY.—The temporary reservation, by Order in Council of the 10th October, 1892, of 1 rood 7 perches of land in the Township of Newbury (formerly Garlicks), as a site for a Mechanics' Institute.—(N.189(*) (Rs.6274).

PRAHRAN (CAULFIELD).—The temporary reservation, by Order in Council of the 24th April, 1956, of 62 acres 1 rood 2 perches more or less of land at Caulfield, in the Parish of Prahran, as a site for Public Park, Gardens and Public Recreation, is about to be revoked so far only as the portion containing 5 acres 0 roods 2 perches, indicated by hachure on plan hereunder, is concerned.—(P.81(*) (Rs.215).

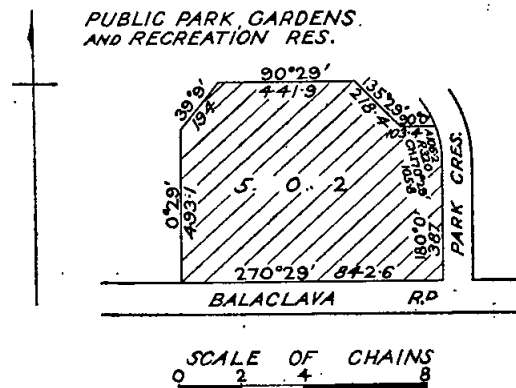

WARRACKNABEAL.—The temporary reservation, by Order in Council of the 26th February, 1889, of 5 acres 0 roods 35½ perches of land in the Township of Warracknabeal, as a site for Show Yards, is about to be revoked, so far only as the portion containing 1 rood, more or less, indicated by hachure on plan hereunder, is concerned.—(W.293(*) (Rs.11).

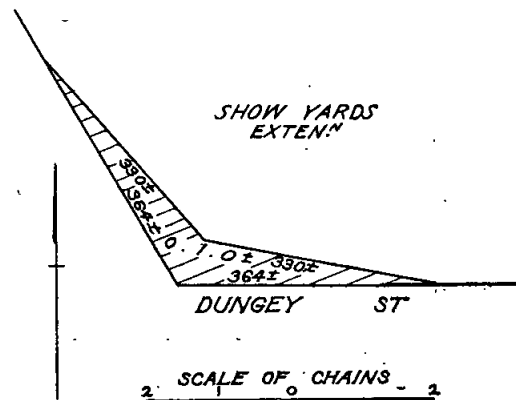

WARRENMANG.—The temporary reservation, by Order in Council of the 20th July, 1874 (see Government Gazette of the 24th July, 1874, page 1387), of 12 acres 0 roods 28 perches of land in the Parish of Warrenmang, as a site for Watering and Camping purposes, is about to be

revoked, so far only as the portion containing 1 acre 1 rood 33 perches, indicated by hachure on plan hereunder, is concerned.—(W.42^(*)) (C.98893).

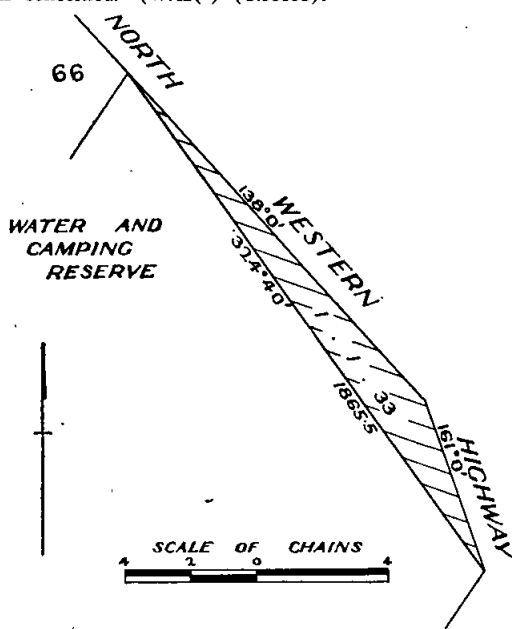

WOODEND.—The temporary reservation, by Order in Council of the 25th November, 1918, of 1 acre 3 roods 44/10 perches of land in the Township of Woodend, as a site for Public Park and Gardens, revoked as to part by Order of the 23rd November, 1948, and the temporary reservation by Order in Council of the 1st March, 1960, of the remaining portion for the additional purpose of Public Recreation, are about to be revoked, so far only as the portion containing 12 perches more or less, indicated by hachure on plan hereunder, is concerned.—(W.199^(*)) (Rs.112).

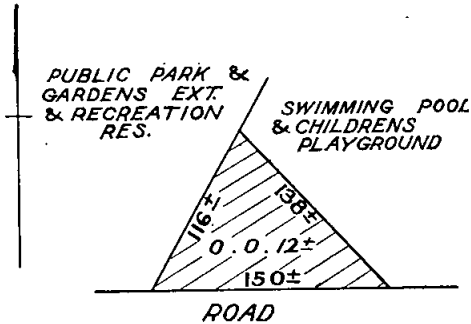

SCALE OF LINKS
100 50 0 100

SUBJECT TO SURVEY

J. C. M. BALFOUR,
Minister of Lands.

PROPOSED PERMANENT RESERVATIONS OF LANDS AS SITES.

IN pursuance of the provisions of the Land Act 1958, notice is hereby given that it is the intention of the Governor in Council to permanently reserve as sites, and also except from occupation for mining purposes under any miner's right, the lands hereunder referred to:—

The following Notices were published 1^o on the 20th October, 1965, pursuant to Orders of the 12th October, 1965.

JAMIESON.—Land proposed to be permanently reserved as a site for Public Recreation, 39 perches more or less, Township of Jamieson, Parish of Jamieson, County of

Wonnangatta, as indicated by hachure on plan hereunder.—(J.22^(*)) (Rs.8433).

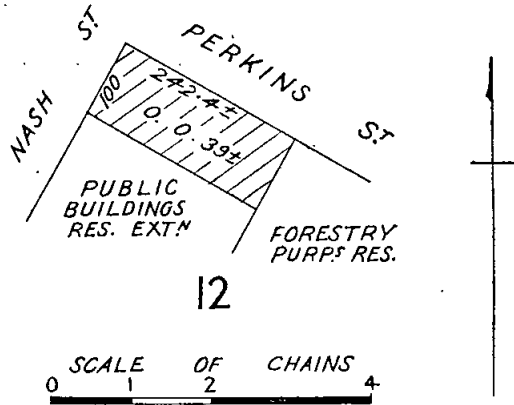

JIKA JIKA (NORTH MELBOURNE).—Land proposed to be permanently reserved as a site for a Public Park, 3 roods 11 perches, at North Melbourne, Parish of Jika Jika, County of Bourke, as indicated by hachure on plan hereunder.—(M314⁽¹³⁾) (Rs.8379).

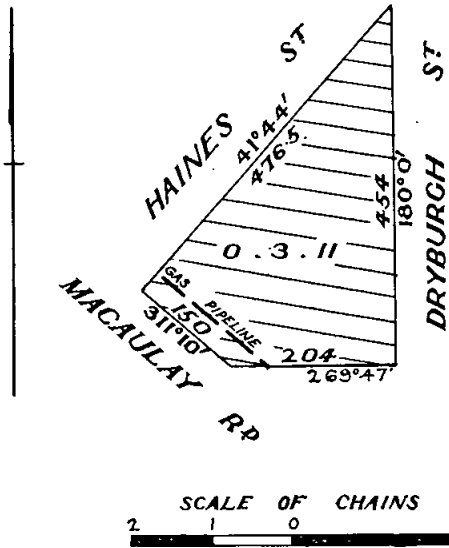

MYRRHEE.—Land proposed to be permanently reserved as a site for Public purposes, 30 perches more or less, Parish of Myrrhee, County of Delatite, as indicated by hachure on plan hereunder.—(M.297^(*)) (Rs.8526).

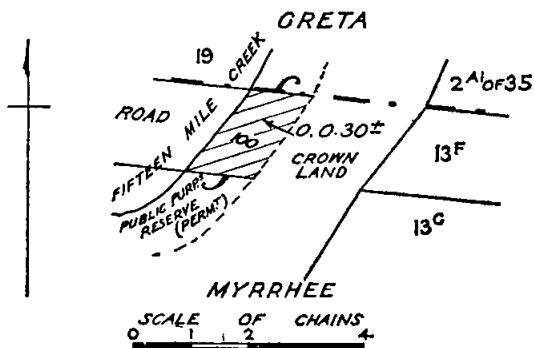

J. C. M. BALFOUR,
Minister of Lands.

LIST OF CROWN LANDS AVAILABLE.

THE under-mentioned areas are available for application as provided by various sections of the *Land Act* 1958, and all applications received on or before Thursday, 18th November, 1965, will be deemed to have been made simultaneously, but any application lodged after such date may be considered if received in time for inclusion in the advertisement of the cases to be heard at the Local Land Board.

Applications on proper form, accompanied by 5s. duty stamp uncanceled (registration fee), may be delivered or forwarded by post to the Local Land Officer or to any Crown Lands Office in Victoria.

Subject to the approval of the Secretary for Lands, when the survey fee exceeds £25 but does not exceed £50, a deposit of £25 may be paid, and when the fee exceeds £50, a deposit of 50 per cent. of the fee, the balance in either case being payable over six years in half-yearly instalments.

Marked plans of any particular area, application forms, and any further information may be obtained from the Crown Lands Department, Melbourne, and Land Office, St. Arnaud.

Department of Crown Lands and Survey,
Melbourne, 18th October, 1965.

J. C. M. BALFOUR,
Minister of Lands.

* Improvements may be subject to re-valuation after land has been granted to an applicant.

Local Land Office.	County.	Parish.	Allotment.	Area.	How Available.		Survey Fee.	Valuation of Improvements (if any).	Location of Land, &c.	Nearest Railway Station or Township and Distance in miles therefrom.	How Accessible.	Water Supply.	General Description of Land—Soil, Timber, Suitability (Grazing, &c.).
					Classification.	Value per Acre.							
					A. R. P.		£ s. d.		£ s. d.				
St. Arnaud	Kara Kara	St. Arnaud	12C	A ¹ 7 3 8± (Subject to Survey)	2nd	10 0 0	9 12 6	2,976 0 0	1½ miles south of St. Arnaud	St. Arnaud Railway Station—1½ miles	Fronts gravelled road (Lock-road)	Piped from nearby Reservoir	Gravelly, auriferous. Shade trees only. Suitable for cultivation and orchards. (W84693)

AVAILABLE UNDER SECTION 44 OF THE LAND ACT 1958.

COMMON ABOUT TO BE DIMINISHED.

IN pursuance of the provisions contained in the *Land Act 1958*, notice is hereby given that it is the intention of the Governor in Council to diminish the common hereinafter mentioned, viz.:—

The following Notice was published 1^o on the 13th October, 1965, pursuant to Order of the 5th October, 1965.

The Amherst United Town and Gold Field Common, now designated the Amherst United Borough and Gold Field Common, proclaimed as such on the 17th October, 1862, the 13th November, 1862, and the 10th November, 1863, is about to be diminished by the excision therefrom of all lands except the portions indicated by hachure on plan hereunder and containing 440 acres more or less.—(Rs.35.)

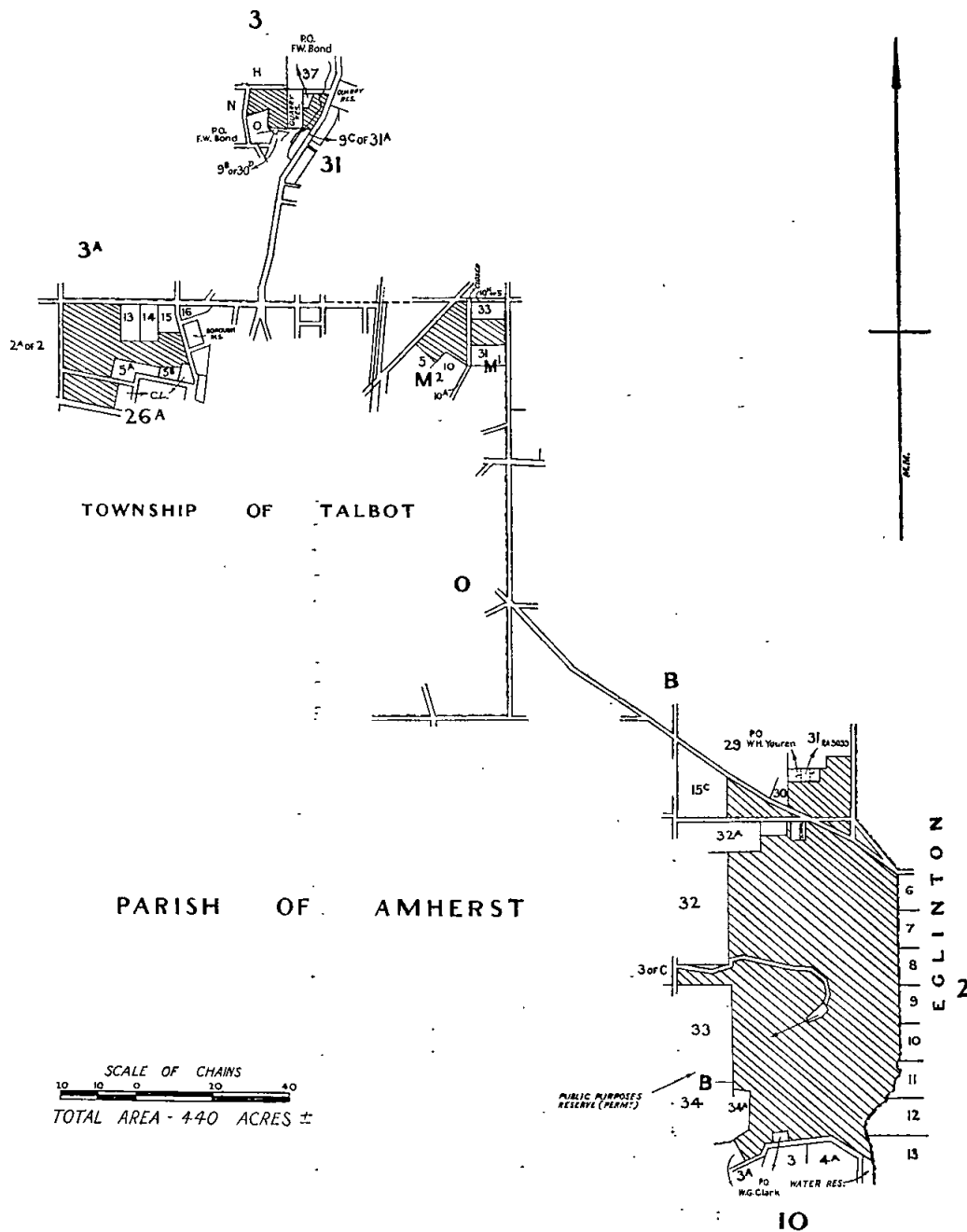

J. C. M. BALFOUR,
 Minister of Lands.

PROPOSED REVOCATION OF TEMPORARY RESERVATION OF LAND BY ORDER IN COUNCIL.

IN pursuance of the provisions of the Land Act 1958, notice is hereby given that it is the intention of the Governor in Council to revoke the temporary reservation of land by Order in Council hereunder referred to, viz.:—

The following Notice was published 1° on the 6th October, 1965, pursuant to Order of the 28th September, 1965.

WOORAGEE NORTH.—The temporary reservation by Order in Council of the 12th May, 1885, of 143 acres, more or less, of land in the Parish of Wooragee North, as a site for Camping and Watering purposes, is about to be revoked so far only as the portions containing 1 acre 0 roods 28 perches, more or less, indicated by hachure on plan hereunder are concerned.—(W.210(4) (C.73322.))

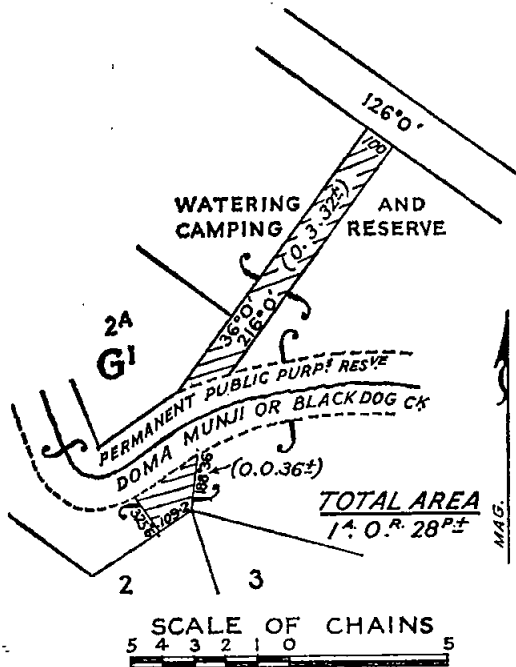

J. C. M. BALFOUR,
Minister of Lands.

PROPOSED PERMANENT RESERVATIONS OF LANDS AS SITES.

IN pursuance of the provisions of the Land Act 1958, notice is hereby given that it is the intention of the Governor in Council to permanently reserve as sites, and also except from occupation for mining purposes under any miner's right, the lands hereunder referred to:—

The following Notices were published 1° on the 13th October, 1965, pursuant to Orders of the 5th October, 1965.

BIRCHIP.—Land proposed to be permanently reserved as a site for a Public Park and other purposes of Public Recreation, 8 acres, 5/10 perches, Township of Birchip, Parish of Wirmbirchip, County of Karkaroc, being the remaining portion of the site temporarily reserved therefor by Order in Council of the 29th August, 1905, and the whole of the site temporarily reserved as an addition thereto by Order in Council of the 25th September, 1909.—(B.722(8) (Rs.1922.))

BIRCHIP.—Land proposed to be permanently reserved as a site for Public purposes (show-yards), 10 acres, Township of Birchip, Parish of Wirmbirchip, County of Karkaroc, being the sites temporarily reserved therefor by Orders in Council of the 25th August, 1890, and the 29th November, 1894.—(B.722(8) (Rs.1923.))

J. C. M. BALFOUR,
Minister of Lands.

PROPOSED REVOCATIONS OF TEMPORARY RESERVATIONS OF LANDS BY ORDERS IN COUNCIL.

IN pursuance of the provisions of the Land Act 1958, notice is hereby given that it is the intention of the Governor in Council to revoke the temporary reservations of lands by Orders in Council hereunder referred to, viz.:—

The following Notices were published 1° on the 13th October, 1965, pursuant to Orders of the 5th October, 1965.

BALLARAT.—The temporary reservation, by Order in Council, of the 8th January, 1889, of 37 9/10 perches of land in the Parish of Ballarat as a site for Railway purposes.—(B.126(12) (R.26910.))

BULLIOH.—The temporary reservation, by Order in Council, of the 14th November, 1961, of 1 rood 8 perches of land in the Parish of Bullioh, as a site for Water Supply purposes.—(B.608(8) (Rs.8073.))

MOORPANYAL.—The temporary reservation, by Order in Council, of the 4th October, 1949, of 10 acres 30 perches, more or less, of land in the Parish of Moorpanyal (at Geelong West) as a site for Public Park and Public Recreation, is about to be revoked so far only as the portion containing 1 rood 21 perches, indicated by hachure on plan hereunder is concerned.—(M.199(4) (Rs.5533.))

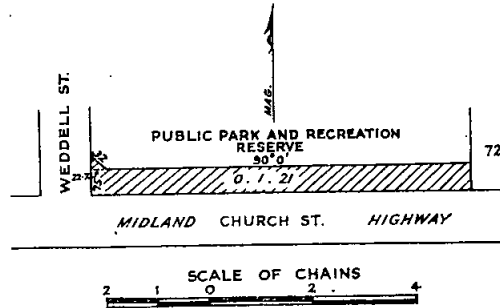

PIMPINIO.—The temporary reservation, by Order in Council, of the 4th July, 1938, of 7 acres, more or less, of land in the Township of Pimpinio, as a site for Public Recreation, revoked as to part by Order of the 9th October, 1956, is about to be revoked, so far as the balance thereof containing 2 acres 20 perches, more or less, is concerned.—(P.141(2) (Rs.4835.))

J. C. M. BALFOUR,
Minister of Lands.

PROPOSED REVOCATION OF TEMPORARY RESERVATION, AND THE WITHHOLDING FROM SALE, LEASING AND LICENSING OF LAND BY ORDER IN COUNCIL.

IN pursuance of the provisions of the Land Act 1958, notice is hereby given that it is the intention of the Governor in Council to revoke the temporary reservation, and the withholding from sale, leasing and licensing of land by Order in Council hereunder referred to, viz.:—

The following Notice was published 1° on the 20th October, 1965, pursuant to Order of the 12th October, 1965.

TINTALDRA.—The temporary reservation as a site for the use of Department of Trade and Customs and the withholding from sale, leasing and licensing by Order in Council of the 22nd May, 1883, of 35 acres 1 rood 4 perches of land in the Parish of Tintaldra.—(T.143(8) (C.77796.))

J. C. M. BALFOUR,
Minister of Lands.

PROPOSED REVOCATION OF TEMPORARY RESERVATION, AND THE WITHHOLDING FROM SALE, LEASING, AND LICENSING OF LAND BY ORDER IN COUNCIL.

IN pursuance of the provisions of the Land Act 1958, notice is hereby given that it is the intention of the Governor in Council to revoke the temporary reservation,

and the withholding from sale, leasing, and licensing, of land by Order in Council hereunder referred to, viz.:—

The following Notice was published 1° on the 13th October, 1965, pursuant to Order of the 5th October, 1965.

TERRICK TERRICK SOUTH.—The temporary reservation as a site for Police purposes and the withholding from sale, leasing and licensing, by Order in Council, of the 9th December, 1878 (see *Government Gazette*, of the 13th December, 1878, page 3313), of 2 acres of land in the Township of Terrick Terrick South (formerly Mitiamo).—(T.315⁽²⁾) (C.99710.)

J. C. M. BALFOUR,
Minister of Lands.

Land Settlement Act 1959.

LAND AVAILABLE FOR APPLICATION.

NOTIFICATION is hereby given in accordance with Section 7 of the *Land Settlement Act 1959*, that the under-mentioned holdings are available for settlement.

Any male person who is not less than 21 years of age and who is a British subject may apply on the prescribed form for settlement on any holding, indicating where he applies in respect of more than one holding his order of preference therefor.

Prescribed application forms, plans and further details may be obtained from the Acting Secretary, Rural Finance and Settlement Commission, State Public Offices, Melbourne, C.2.

Closing date for receipt of completed application forms for settlement on these holdings is the 15th November, 1965, such applications to be in the hands of the Acting Secretary, Rural Finance and Settlement Commission, on or before that date.

M. J. CRONIN,
Acting Secretary.

Rural Finance and Settlement Commission,
Melbourne, C.2. 13th October, 1965.

SCHEDULE OF ALLOTMENTS.

SUBDIVISION OF THIRTEENTH PORTION OF HETYESBURY PROJECT.

PARISHES OF JANCOURT, LATROBE AND WAARRE—COUNTY OF HETYESBURY.

Suitable for Dairying with Supplementary Production of Fat Stock.

Lot Number on Plan of Subdivision.	Approximate Area in Acres (Subject to Survey).
115	193
117	188
177	190
178	200
234	180
235	210
236	180
237	180
238	180
239	180
240	180
242	180
244	200
245	190
246	190
247	190

COMMON ABOUT TO BE DIMINISHED.

IN pursuance of the provisions contained in the *Land Act 1958*, notice is hereby given that it is the intention of the Governor in Council to diminish the common hereinafter mentioned, viz.:—

The following Notice was published 1° on the 13th October, 1965, pursuant to Order of the 5th October, 1965.

The Ballaarat West Town Common, proclaimed as such on the 28th January, 1861, is about to be diminished by the excision therefrom of the portions indicated by hachure on plan hereunder.—(C.91998.)

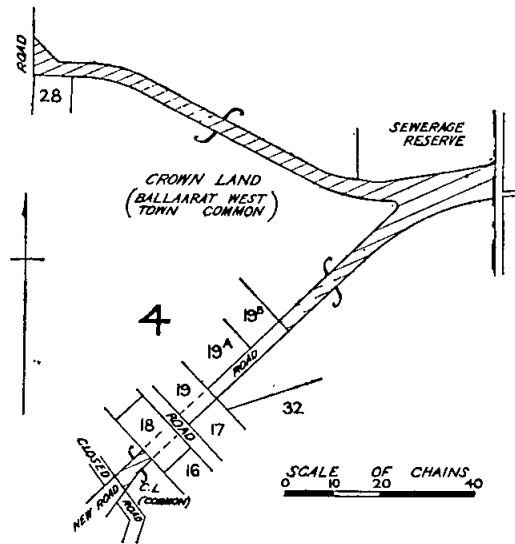

J. C. M. BALFOUR,
Minister of Lands.

COMMITTEES OF MANAGEMENT OF RESERVES.

APPOINTMENTS.

NOTICE is hereby given that, in pursuance of section 221 of the *Land Act 1958*, the following appointments of Committees of Management of reserved Crown lands have been made by the Minister of Lands:—

"HORDERN VALE—GLEN AIRE MEMORIAL HALL AND RECREATION RESERVE."

Robert William Box, John William Suares, Terrence Arthur Lowan, Geoffrey Raymond Barber, David John Denney, Ian Trevor Denney, John Samuel Swain, William John Sinclair and Cyril Robert Marriner as a Committee of Management for a period of three (3) years of land in the Parish of Otway temporarily reserved by Order in Council of the 15th May, 1956, as a site for a Public Hall and Recreation and of the land reserved by Order in Council dated the 6th July, 1965, as an extension thereto and together known as the "Hordern Vale—Glen Aire Memorial Hall and Recreation Reserve".—(Corres. Rs.1705.)

"LAKES ENTRANCE FORESHORE, NORTH ARM RESERVES."

Clem Jones (for so long as he continues to be a Councillor and the elect of Council the Shire of Tambo) in the place of Ian Rutherford Buimer (no longer a Councillor) as a member of the Committee of Management of the land in the Township of Lakes Entrance temporarily reserved by Order in Council dated the 29th June, 1953, as a site for Tourist Camping and Picnic Ground and known as the "North Arm Reserve", Lakes Entrance, and of the reserved Crown lands in the Parish of Colquhoun as is indicated by red colour on plan C/18-3-55 attached to Lands Department correspondence Rs.3353.—(Corres. Rs.7123, Rs. 3353.)

"WOODSTOCK WEST RECREATION RESERVE."

Ernest Kenneth Stone, Herbert William Freemantle, Raymond John Stone, Frank Tracey Johnson, Anthony John Comer, Ronald Marshall Moore, Raymond Clifford Johnson, Reginald Joseph Stone and Leslie David Stone as a Committee of Management for a period ending the 30th September, 1968, of the land temporarily reserved by Order in Council dated the 20th April, 1911, as a site for Public Recreation in the Parish of Woodstock and known as the "Woodstock West Recreation Reserve".—(Corres. Rs.1198.)

"WOOLSTHORPE MECHANICS' INSTITUTE RESERVE."

Peter Herbert Peterson, Thomas Maxwell Mathison, Francis William Murphy, Lawrence Doolan, William James Dennis, George Robert Davidson, Sidney Ian Strotten, Frederick Raymond Baulch and Allan Warburton as a Committee of Management for a period of three (3) years of the land in the Township of Woolsthorpe temporarily reserved by Order in Council dated the 26th November,

1888, as a site for a Mechanics' Institute and Free Library and known as the "Woolsthorpe Mechanics' Institute Reserve".—(Corres. Rs.4638.)

ALAN J. HOLT,
Secretary for Lands.

13th October, 1965.

AMENDMENT TO THE REGULATIONS FOR THE CARE, PROTECTION AND MANAGEMENT OF THE RESERVE FOR PUBLIC PURPOSES IN THE PARISH OF GEMBROOK.

WHEREAS in pursuance of section 218 of the *Land Act 1958* as then enacted the Board of Land and Works on the twenty-third day of July, 1929, made Regulations for the care, protection and management of certain Crown land in the Parish of Gembrook and described in a notice published in the *Government Gazette* of the twenty-third day of November, 1927, which reserved the said land as a site for Public Purposes: And whereas the said Board was dissolved by the *Public Lands and Works Act 1964* which provided *inter alia* that all Regulations made by the Board shall remain in force subject to the *Land Act 1958*: And whereas the Minister of Lands is now empowered to make Regulations for or with respect to the said land (hereinafter called "the Reserve") in pursuance of section 218 of the *Land Act 1958*: And whereas it is expedient that the Regulations made by the Board as aforesaid should be amended: Now therefore I, James Charles Murray Balfour, Her Majesty's Minister of Lands in and for the State of Victoria, do hereby make the following Regulation for and with respect to the Reserve:—

8. No person shall camp on the Reserve, except on such parts as may be specially set apart for that purpose by the Committee and then only after obtaining permission of the Committee in writing and subject to the payment of such fees and upon such conditions as the Committee may determine from time to time.

Such written permission, shall, if required, be produced at any time to any person duly authorized by the Committee to demand production thereof.—(Rs.3578.)

Given under my hand at Melbourne on the 13th day of October, 1965.

JIM BALFOUR,
Minister of Lands.

Every person who contravenes or fails to comply with these Regulations shall, in accordance with the provisions of section 218 of the *Land Act 1958*, for each offence be liable to a penalty of not more than Five pounds, and every person who contravenes or fails to comply with any such Regulations, and who, after he has been warned by any bailiff of Crown lands or by any member of the Police Force, does not desist therefrom may be forthwith apprehended by such bailiff or member of the Police Force and taken before some justice to be dealt with according to law and shall be liable to a penalty of not more than Ten pounds.

ADDITIONAL REGULATIONS FOR THE CARE, PROTECTION AND MANAGEMENT OF THE "BOTANICAL GARDENS RESERVE," CASTLEMAINE.

WHEREAS in pursuance of section 218 of the *Land Act 1958* as then enacted the Board of Land and Works on the second day of May, 1956, made Regulations for the

care, protection and management of certain Crown land in the Township of Castlemaine and described in a notice published in the *Government Gazette* of the thirty-first day of May, 1956, which reserved the said land as a site for Public Recreation, Tourist Camping and Public Park purposes: And whereas the said Board was dissolved by the *Public Lands and Works Act 1964*, which provided *inter alia* that all Regulations made by the Board shall remain in force subject to the *Land Act 1958*: And whereas the Minister of Lands is now empowered to make Regulations for or with respect to the said land (hereinafter called the Reserve): Now therefore I, James Charles Murray Balfour, Her Majesty's Minister of Lands, in pursuance of the power conferred aforesaid, do hereby make the following additional Regulation:—

10. (c) No person other than an employee of the Committee shall ride a bicycle or motor cycle or drive a motor car or any other vehicle within the Reserve other than on or upon the areas laid out as roadways except for the purpose of entering or leaving the place or places set apart for parking vehicles in accordance with clause (a) hereof and no person other than an employee of the Committee shall ride a bicycle or motor cycle or drive a motor car or any other vehicle between sunset and sunrise on or upon any part of the Reserve other than the areas laid out as roadways.—(Rs.177.)

Given under my hand at Melbourne on the 13th day of October, 1965.

JIM BALFOUR,
Minister of Lands.

Every person who contravenes or fails to comply with these Regulations shall, in accordance with the provisions of section 218 of the *Land Act 1958*, for each offence be liable to a penalty of not more than Five pounds, and every person who contravenes or fails to comply with any such Regulations, and who, after he has been warned by any bailiff of Crown lands or by any member of the Police Force, does not desist therefrom may be forthwith apprehended by such bailiff or member of the Police Force and taken before some justice to be dealt with according to law and shall be liable to a penalty of not more than Ten pounds.

LOCAL LAND BOARDS.

IN pursuance of the provisions of section 34 of the *Land Act 1958*, notice is hereby given that public hearings at the following places and times, will be conducted by the persons respectively mentioned, being duly appointed in that behalf.

J. C. M. BALFOUR,
Minister of Lands.

Department of Crown Lands and Survey,
Melbourne.

SCHEDULE.

BALLARAT LAND OFFICE, PUBLIC OFFICES, Wednesday, 10th November, 1965, at 9 a.m.—N. J. Fitzgerald and P. T. Ledger.

SALE BY AUCTION.

NOTICE is hereby given that the following Contract of Sale has been cancelled.

Lot.	Place of Sale.	Date of Sale.	Allotment.	Section.	Parish.	Area.	Purchaser.
6	Sale	6.10.1857	1	4	Longford	A. R. P. 0 2 0	G. T. Jones

Department of Lands and Survey,
Melbourne, C.2.

JIM BALFOUR,
Minister of Lands.

PUBLIC SERVICE NOTICES

PUBLIC SERVICE (PUBLIC SERVICE BOARD) REGULATION 52.—VACANCIES.

THE Permanent Heads of the Departments shown have recommended the officers named hereunder for appointment to the under-mentioned vacancies.

Office and Classification.	Duties.	Qualifications.	Officer Recommended for Appointment.		
			Name.	Classification.	Date of Classification.
ADMINISTRATIVE DIVISION.					
DEPARTMENT OF CROWN LANDS AND SURVEY.					
Class "C2" ..	To assist the Revenue Officer ; to supervise the Ledger-keepers ; to prepare information for the Annual Report and financial statements as required	A qualified Accountant ; to have had experience in the receipt and recording of public moneys and to be conversant with the provisions of the <i>Land Act</i> 1958 ; a knowledge of mechanized accounting by inbuilt register automatic machines is desirable	Lewenberg, H.	Class "C2" ..	27.7.62
Class "C" ..	To check and process the receipt of moneys paid into collection accounts throughout the State and to supervise the issue of clearance cheques drawn thereon ; to receive and check returns submitted by country collectors	A knowledge of banking procedure and the sections of the Public Accounts and Stores Regulations 1958 which deal with the collection of public moneys	Blackman, J. W.	Class "C" ..	8.4.63
EDUCATION DEPARTMENT.					
Class "C2" ..	To have charge of the section dealing with secondary and consolidated schools and teachers' colleges ; to deal with correspondence and with the larger requisitions and reports submitted by the Public Works Department, as well as with special problems relating to furniture and equipment	A knowledge of the organization and administration of the Buildings branch and of the practices followed particularly in regard to the larger school buildings is desirable	Folvig, J. G. ..	Class "C2" ..	24.10.62
TECHNICAL AND GENERAL DIVISION.					
DEPARTMENT OF HEALTH.					
<i>Mental Hygiene Branch—Mont Park Hospital.</i>					
Principal Nurse (Female), Grades F44-F45 inclusive	Under the direction of the Psychiatrist Superintendent to have charge of the Female Division, Staff and Patients	Current practising certificate for Mental Nursing ; experience in a senior position in a Mental Hospital, ability to control patients and staff, compile reports and records, and give lectures to Student Nurses and others	McMannis, Noreen M.	Principal Nurse (Female), Grades F44-F45 inclusive	29.6.64

Appeals against such recommendations should be lodged with the Secretary to the Public Service Board not later than Saturday, the 30th October, 1965.

Office of the Public Service Board,
Melbourne, 19th October, 1965.

By order,
V. P. SCULLY,
Secretary.

PUBLIC SERVICE OF VICTORIA.—RECLASSIFICATIONS.

THE Public Service Board has raised the classification of the under-mentioned offices as shown, and appointed thereto the respective officers named hereunder.

Office and Former Classification.	Revised Classification.	Duties.	Qualifications.	Officer Appointed.
ADMINISTRATIVE DIVISION.				
TREASURY.				
<i>Stamp Duties Office.</i>				
Class "C1" ..	Class "C2" ..	To be second in charge of the Inspections Branch ; to examine and check the records of insurers, bankers and printers ; to assist generally in the instruction and direction of the inspection staff	A knowledge of the relevant provisions of the Stamps Act and Regulations ; to be a qualified accountant or to have made substantial progress towards such qualification	Lachowicz, A.

PUBLIC SERVICE OF VICTORIA.—RECLASSIFICATIONS—*continued.*

Office and Former Classification.	Revised Classification.	Duties.	Qualifications.	Officer Appointed.
TECHNICAL AND GENERAL DIVISION.				
DEPARTMENT OF HEALTH.				
<i>General Health Branch.</i>				
Assistant (Analytical), Grade 35	Grade 37	Under general direction to carry out routine testing of foods, waters, effluents, &c.	To have completed part of a chemistry Diploma course; considerable experience in routine analyses	Almond, T. L. J.

Office of the Public Service Board,
Melbourne, 19th October, 1965.

By order,
V. P. SCULLY,
Secretary.

No. 1541.

Public Service Act 1958, Section 50.
REGULATIONS.—PART IV.—SALARIES AND INCREMENTS.

THE Public Service Board, in pursuance of the powers conferred by the *Public Service Act 1958*, hereby amends its Regulations as shown below :—

SIXTH SCHEDULE.
TEMPORARY EMPLOYEES.

Designations of Positions and Rates of Salaries.

Department and Designation of Position.	Yearly Rate of Salary.		Increments (Annual).
	Minimum.	Maximum.	
PUBLIC WORKS DEPARTMENT.			
<i>Delete—</i>			
Inspector (Civil Engineering Works)	1,509	1,614	1 of £52 and 1 of £53
Inspector of Works	1,509	1,614	1 of £52 and 1 of £53
<i>Add—</i>			
Inspector (Civil Engineering Works)	1,720	1,826	2 of £53
Inspector of Works	1,720	1,826	2 of £53

This Regulation shall have effect as on and from the 12th October, 1965.

A. GARRAN, Chairman.
V. P. SCULLY, Secretary.

Office of the Public Service Board,
Melbourne, 13th October, 1965.

No. 1542.

Public Service Act 1958, Section 50.
REGULATIONS.—PART IV.—SALARIES AND INCREMENTS.

THE Public Service Board, in pursuance of the powers conferred by the *Public Service Act 1958*, hereby amends its Regulations as shown below :—

SIXTH SCHEDULE.
TEMPORARY EMPLOYEES.

Designations of Positions and Rates of Salaries.

Department and Designation of Position.	Yearly Rate of Salary.		Increments (Annual).
	Minimum.	Maximum.	
WATER SUPPLY DEPARTMENT			
<i>Add—</i>			
Electrical Supervisor, Grade I.	1,331	1,457	2 of £37 and 1 of £52

A. GARRAN, Chairman.
V. P. SCULLY, Secretary.

Office of the Public Service Board,
Melbourne, 8th October, 1965.

PUBLIC SERVICE OF VICTORIA.—VACANCIES.

APPLICATIONS will be received by the Public Service Board up to Wednesday, the 3rd November, 1965, from persons employed in the Public Service of Victoria, who are eligible and qualified for appointment to the under-mentioned positions:—

ADMINISTRATIVE DIVISION.

Class "B", Motor Registration Branch, Office of the Chief Commissioner of Police, Chief Secretary's Department.

Yearly Salary.—£2,111, minimum; £2,233, maximum.
Duties.—To be Training and Methods Officer of the Motor Registration Branch; to undertake a continuing programme of staff training and methods review and special duties in the Department as required.

Qualifications.—Good general administrative experience and aptitude for training and methods work, and preferably to hold a Diploma of Public Administration or equivalent. A knowledge of the activities, organization and procedures of the Motor Registration Branch would be an advantage.

NOTE.—Prior to taking up duty the appointee may be attached to the Board's Office for an appropriate period to gain practical experience.

Class "B", Social Welfare Branch, Chief Secretary's Department.

Yearly Salary.—£2,111, minimum; £2,233, maximum.
Duties.—To be Staff Officer of the Social Welfare Branch.

Qualifications.—A good knowledge of the Public Service Acts and Regulations. Experience in staff work, preferably in relation to institutions. A knowledge of the staff requirements of the Branch would be an advantage.

Class "B", Department of Crown Lands and Survey.

Yearly Salary.—£2,111, minimum; £2,233, maximum.
Duties.—To be Training and Methods Officer of the Department; to undertake a continuing programme of Staff Training and methods review.

Qualifications.—Good general administrative experience and aptitude for training and methods work, and preferably to hold a Diploma of Public Administration or equivalent qualification. A knowledge of the activities, organization and procedures of the Department of Crown Lands and Survey is desirable.

NOTE.—Prior to taking up duty the appointee may be attached to the Board's Office for an appropriate period to gain practical experience.

Class "C2", Education Department.

Yearly Salary.—£1,867, minimum; £1,989, maximum.
Duties.—To supervise the sections dealing with primary schools; to deal with correspondence and reports relating to primary school buildings and grounds.
Qualifications.—A good knowledge of the organization and administration of the Buildings Branch and preferably, a knowledge of the organization of the Public Works Department.

Class "C2", Local Government Department.

Yearly Salary.—£1,867, minimum; £1,989, maximum.
Duties.—To act as Accountant and Staff Officer.
Qualifications.—To be a qualified accountant or to have made substantial progress in accounting studies; a good knowledge of the Public Accounts and Stores Regulations, Superannuation Act and Public Service Acts and Regulations.

Class "C2", Office of the Housing Commission, Treasury.

Yearly Salary.—£1,867, minimum; £1,989, maximum.

Duties.—Under the Officer in Charge, House Sales Accounts Department, to have charge of the Ledgers Section; the preparation of financial statements for settlements, assignments, &c., the raising of journal entries, and the quarterly reconciliation of house purchase general ledger accounts.

Qualifications.—A knowledge of the procedures for keeping house purchase accounts, preferably to be conversant with the financial provisions of the Housing Acts and the Commonwealth/State Housing Agreements relating to house sales and the Regulations governing the Death Benefit Scheme; ability to control staff.

Class "C1", Department of Crown Lands and Survey.

Yearly Salary.—£1,634, minimum; £1,746, maximum.

Duties.—To supervise and instruct personal ledger-keepers in the billing and receipt of rentals from Crown lands and to control the mechanized accounts which record this information; to be responsible for the issue of Crown Grant Facings.

Qualifications.—To have a sound knowledge of the various methods of selling, leasing and licensing Crown lands under the *Land Act 1958*; to be conversant with mechanized accounting; to be capable of training and controlling staff.

Class "C", Motor Registration Branch, Office of the Chief Commissioner of Police, Chief Secretary's Department.

Yearly Salary.—£1,355, minimum; £1,523, maximum.

Duties.—To supervise mail opening, and to organize the distribution of, and maintain security over, all mail received in the Inwards Mail Assessment Section.

Qualifications.—A knowledge of the Motor Car Acts and Regulations and the fees and premiums payable thereunder, and of the procedure in the Inwards Mail Assessment Section.

Class "C", Department of Crown Lands and Survey, (Two vacancies.)

Yearly Salary.—£1,355, minimum; £1,523, maximum.

Position No. 1.

Duties.—To keep the Departmental Trust Account and to be responsible for the disbursement of moneys collected; to be responsible for the payment of claims and the charging of premiums under the Closer Settlement Insurance Fund.

Qualifications.—A knowledge of the Public Accounts and Stores Regulations 1958 and of the financial provisions of the various Acts administered by the Department; a knowledge of mechanical accounting methods.

Position No. 2.

Duties.—To collate information for Treasury estimates; to assist in the preparation of accounting reports.

Qualifications.—To be familiar with the Treasury system of accounts and to have had experience in the preparation of financial statement. Some progress in an accountancy course desirable.

NOTE.—Separate applications must be submitted for these positions.

Class "C", State Forests Department.

Yearly Salary.—£1,355, minimum; £1,523, maximum.

Duties.—To supervise and perform clerical duties in the Sales and Marketing Branch, and to deal with inquiries from district officers and the public in regard to timber sales.

Qualifications.—Some knowledge of the Department's administration and its activities, and preferably a knowledge of the utilization of forest produce and the procedures adopted for its sale.

PROFESSIONAL DIVISION.**Agricultural Extension Officer, Classes "C" - "C2", Department of Agriculture.**

Yearly Salary.—£1,690, minimum; £2,380, maximum.

(Commencing salary will be determined according to experience.)

Duties.—Under the Senior Agronomist to undertake district advisory work on cereal agronomy; to make field investigations and surveys; to arrange demonstrations and lectures, and to prepare articles for publication.

Qualifications.—To possess the Degree of Agricultural Science; practical experience in agricultural problems; experience in agricultural problems; experience in the growing of farm crops; a knowledge of modern farm practice and literary ability.

NOTE.—In the first instance the appointee will be stationed at Sea Lake. A house is available for the successful applicant, if married.

Soils Officer, Classes "C" - "C2", Department of Agriculture.

Yearly Salary.—£1,690, minimum; £2,380, maximum—
Agricultural Science.

£1,523, minimum; £2,380, maximum—
Science.

£1,467, minimum; £2,380, maximum—
Diploma in Chemistry.

(Commencing salary will be determined according to qualifications and experience.)

Duties.—Under direction, to carry out soil surveying in the field and analysis of soils in the Laboratory.

Qualifications.—A University degree in Agricultural Science or in Science with Chemistry as a major subject, or other appropriate qualifications or an approved diploma in Chemistry.

Film Librarian (Female), Class "C", State Film Centre, Premier's Department.

Yearly Salary.—£1,135, minimum; £1,323, maximum.

Duties.—To assist in the cataloguing of films and the preparation of synopses of films. To assist in the preparation of printed catalogues, film lists and information sheets, and in the selection of programmes of films for public screenings by the State Film Centre and its borrowing groups. To maintain a small reference library on local and overseas films and film production.

Qualifications.—To possess a University Degree and to have passed the first three subjects for the Registration Certificate of the Library Association of Australia or the equivalent, or, as an alternative to the above qualifications, to have obtained the Registration Certificate of the Library Association. Experience in special library work would be an advantage.

TECHNICAL AND GENERAL DIVISION.**Fisheries and Wildlife Officer, Grade I, Fisheries and Wildlife Branch, Chief Secretary's Department.**

Yearly Salary.—

At 18 years of age, £679;

at 19 years of age, £784;

at 20 years of age, £892.

Adult—£1,093, minimum; £1,203, maximum.

Duties.—To enforce the provisions of the Fisheries and Game Acts and Regulations, to address public meetings and generally to assist in the outside work of the Branch.

Qualifications.—The Intermediate Certificate or equivalent qualification, good personality, physically strong and preferably under 30 years of age, interested in the conservation and management of fish and wildlife, able to manage a motor boat and to make running repairs to motor vehicles and marine engines; a current driving licence.

NOTE.—An allowance is payable at the rate of 30 per cent. of total salary, for work at week-ends and public holidays, plus an additional weeks leave. After completion of four years' satisfactory service as Fisheries and Wildlife Officer, Grade I, and on passing the prescribed examination will be eligible for progression to Fisheries and Wildlife Officer, Grade II. (£1,259-£1,405).

This advertisement is in lieu of the advertisement for Fisheries and Wildlife Officer, Grade I, Fisheries and Wildlife Branch, Chief Secretary's Department, appearing on page 3216 of *Gazette* No. 85, of the 13th October, 1965.

Truck Driver and Assistant, Weights and Measures Branch, Local Government Department.

Yearly Salary.—£1,129, minimum; £1,165, maximum.

Duties.—To drive a heavy motor vehicle and fork-lift truck; to assist in the testing and servicing of weightbridges in any part of the State and, as directed, in other work of the Branch.

Qualifications.—A licensed motor driver with experience in driving heavy motor vehicles and in mechanical work.

Clerical Assistant (Female), Grade II., Teachers' Colleges and Schools, Huntingdale High School, Education Department.

Yearly Salary.—£970, minimum; £988, maximum.

Duties.—To assist headmaster in keeping official account and other books of account; to receive, record and bank money collected by the school, to supervise the work of typist; to act as receptionist and to carry out other clerical duties as directed by headmaster.

Qualifications.—Office experience, preferably in one of the larger schools of the Education Department; knowledge of bookkeeping, particularly departmental requirements in connexion with keeping school accounts; ability to type, tact in dealing with the public.

Typist (Female), Supervising, Public Works Department.

Yearly Salary.—£952, minimum; £970, maximum.

Duties.—Under direction of the Officer-in-Charge, Accounts Payable Section, to supervise the typing pool.

Qualifications.—An experienced typist; ability to control, direct and train members of a typing pool.

Child Care Officer (Female), Senior, "Sutton Grange", Mornington, Family Welfare Division, Social Welfare Branch, Chief Secretary's Department.

Yearly Salary.—

Adult—£862, minimum; £898, maximum.

Duties.—To assist in the care of children, and in the supervision of a small staff; to relieve the Assistant Matron as required.

Qualifications.—Experience in the care of children, and competent to supervise and direct staff.

NOTE.—Quarters and rations are provided at a charge of £166 a year.

By order,
V. P. SCULLY,
Secretary.

Office of the Public Service Board,
Melbourne, 19th October, 1965.

PUBLIC SERVICE OF VICTORIA.—VACANCIES.**DEPARTMENT OF HEALTH.****MENTAL HYGIENE BRANCH.****TECHNICAL AND GENERAL DIVISION.**

APPPLICATIONS will be received by the Public Service Board up to Wednesday, the 10th November, 1965, from persons employed in the Public Service of Victoria, who are eligible and qualified for appointment to the under-mentioned positions:—

Head Nurse (Male), Mont Park.

Yearly Salary.—£1,879, minimum; £1,932, maximum.

Duties.—To assist Principal Nurse in management of the Male Division and to prepare leave sheets and other records as directed by the Principal Nurse, to give lectures to Student Nurses and others.

Qualifications.—A current practising Certificate of Mental Nursing, ability to direct and control staff and patients and to keep records.

Charge Nurse (Female). (Three vacancies.)

Yearly Salary.—£1,282, minimum; £1,386, maximum.

POSITIONS NO. 1 AND 2—ERNEST JONES CLINIC,
PRESTON.

Duties.—To supervise medical equipment and assist the medical staff in physical examinations and the administration of intravenous drugs, &c.

Qualifications.—A Mental Nursing and/or General Nursing Certificate.

POSITION NO. 3—HOBSON PARK, TRARALGON.

Duties.—To take charge or sub-charge of a ward in a Mental Hospital.

Qualifications.—A current practising Certificate for Mental Nursing.

NOTE.—Successful applicant will be required to work an eight-hour roster.

Separate applications must be submitted for these positions.

Carpenter, Grade I, Royal Park.

Yearly Salary.—£1,093, minimum; £1,147, maximum.

Duties.—To assist in all carpentering work.

Qualifications.—A competent and experienced carpenter.

Cook (Male), Grade I, Royal Park. (Two vacancies.)

Yearly Salary.—£1,093, minimum; £1,147, maximum.

Duties.—To assist in preparation, cooking and serving of meals for patients and staff, and in maintenance and cleanliness of kitchen.

Qualifications.—A knowledge of and experience in large quantity cooking.

Kitchenman, Royal Park. (Two vacancies.)

Yearly Salary.—£970, minimum; £1,075, maximum.

Duties.—To assist cooks generally, preparation of vegetables and other foodstuffs. Attending to cleanliness of kitchen.

Qualifications.—Some knowledge of cooking is desirable.

Dental Attendant (Female), Grade I, Ballarat.

Yearly Salary.—

Junior—at 20 years of age, £732.

Adult—£793, minimum; £844, maximum.

Duties.—To assist in dental surgery.

Qualifications.—Educated to Intermediate standard; experience as a dental attendant, minimum age twenty years.

By order,
V. P. SCULLY,
Secretary.

Office of the Public Service Board,
Melbourne, 19th October, 1965.

PUBLIC SERVICE OF VICTORIA.—VACANCIES.**(TEMPORARY APPOINTMENTS.)**

APPPLICATIONS will be received by the Public Service Board up to Wednesday, the 3rd November, 1965, from persons who are qualified for appointment to the under-mentioned positions:—

Field Officer, Department of Agriculture.

Yearly Salary.—

Junior—at 18 years of age, £852;

at 19 years of age, £956.

at 20 years of age, £1,073.

Adult—£1,331, minimum; £1,561, maximum.

(Commencing salary will be determined within this initial range according to experience, but advancement is not limited to the maximum quoted.)

Duties.—To assist the veterinary staff in the control of stock diseases, Strain 19 Brucella Abortus vaccination, the rapid field antigen test for Pullorum Disease, and other duties as directed.

Qualifications.—A Dookie or Longerenong Diploma of Agriculture or its equivalent, and a practical knowledge of live stock and their management.

NOTE.—Field Officers are eligible for appointment to the position of Field Officer, Senior, salary range, £1,614—£1,773, and on passing a qualifying examination for appointment to the Professional Division as Experimental Officer, £1,467—£1,987.

Photographer (Male), Department of Agriculture.

Yearly Salary.—

Junior—at 19 years of age, £797;

at 20 years of age, £919.

Adult—£1,184, minimum; £1,331, maximum.

Duties.—To undertake all phases of still photographic work and to assist in the photographing of motion pictures.

Qualifications.—Experience in outdoor and indoor photography, in darkroom work and in cine photography. A knowledge of colour photography is essential.

By order,
V. P. SCULLY,
Secretary.

Office of the Public Service Board,
Melbourne, 19th October, 1965.

EXAMINATION OF APPLICANTS FOR LICENCE AS SHORTHAND WRITER.

IT is hereby notified that an examination of applicants for licence as Shorthand Writer will be held at the Law Courts (No. 15 Court), Melbourne, on Saturday, the 27th November, 1965, at Ten o'clock a.m.

Applications for permission to attend the examination together with an entry fee of Twenty-one shillings (£1 1s.), must be forwarded to reach the Secretary, Public Service Board, Treasury-place, Melbourne, C.2 (where a copy of the Regulations may be obtained), not later than Saturday, the 13th November, 1965.

Satisfactory evidence of—

- (1) Name in full,
- (2) Having attained the age of twenty-one (21) years, and

(3) Good moral character, should be submitted with application.

By order,
V. P. SCULLY,
Secretary.

Office of the Public Service Board,
Melbourne, 19th October, 1965.

PUBLIC SERVICE OF VICTORIA.—SPEED TEST FOR TYPISTS (FEMALE).

PUBLIC SERVICE (PUBLIC SERVICE BOARD) REGULATIONS.
A TYPING test at the rate of not less than 42 words a minute for a period of ten minutes will be held on Saturday, 4th December, 1965.

Successful candidates will be entitled to the increased rates set out in Regulation 98 of the Public Service (Public Service Board) Regulations.

Applications to sit for the test should be lodged on the prescribed form with the Secretary, Public Service Board, not later than Saturday, 13th November, 1965. Applicants should specify the type of machine preferred.

Candidates will be notified of the time and place of the test.

By order,
V. P. SCULLY,
Secretary.

Office of the Public Service Board,
Melbourne, 26th October, 1965.

TENDERS

PUBLIC WORKS DEPARTMENT

TENDERS will be received at the Head Office of the Public Works Department, Treasury-place, Melbourne, until TEN a.m. on the dates shown and for the purposes mentioned hereunder.

Particulars and tender forms may be obtained at the Contracts Office, Room 7, Building Division, Parliament-place, and at the places indicated in brackets after certain items.

The abbreviations shown in the brackets mean the following:—W.O.—Inspector of Works Office; P.S.—Police Station; C.S.—Consolidated School; H.E.S.—Higher Elementary School; H.S.—High School; S.S.—State School; T.S.—Technical School.

Tenders should be submitted on the Department's printed Tender Form and will not be received by telephone. All tenders must be on a "Firm Tender" basis. The lowest or any tender will not necessarily be accepted.

Tenders are to be addressed to the Minister of Public Works, and the envelope containing the tender is to be clearly marked "Tender for _____, closing Tuesday, _____".

No preliminary deposit is to be lodged with any tender, but a successful tenderer will be required to pay a deposit for any accepted tender of the value of £2,500 or over.

Tuesday, 26th October, 1965.

Building, Electrical and Mechanical Works.

Ballarat.—Supply and installation of mechanical services in new Science Wing, High School. (W.O., Ballarat.)

Ballarat East.—Supply and installation of heating, hot-water and ventilation for new Science Wing, High School. (W.O., Ballarat.)

Bendoc.—Erection of Police Station and Court House, &c. (W.O., Bairnsdale; P.S., Orbost.)

Bendoc.—Electrical installation and diesel generating plant, Police Station and Court House. (W.O., Bairnsdale.)

Bendoc.—Supply and installation of hot-water service and L.P. gas heating in Court House and Residence and Police Station.

Birchip.—Erection of new cell, store and brick garage, Police Station. (W.O., Warracknabeal; P.S., Birchip.)

Burnley.—Erection of brick head house to twin glass-house, Horticultural College.

Castlemaine.—New toilet facilities, Gaol. (W.O., Kyneton and Bendigo.) (Amended Specification.)

Club Terrace.—Conversion to septic tanks, &c., S.S. 3343. (W.O., Bairnsdale; S.S., Club Terrace.)

Glenferrie.—Installation of stainless steel urinal and abutment and drinking troughs, S.S. 1508.

Mount Taylor.—Conversion to septic tanks, S.S. 3467. (W.O., Bairnsdale; S.S., Mount Taylor.)

Talindert.—Erection of out-offices and installation of septic tank, S.S. 3644. (W.O., Camperdown; S.S., Talindert.)

Various.—Electrical installation, additional science wings, High Schools, Karingal and Rosebud.

Wangaratta.—Repairs and painting to residence, 104 Swan-street, Technical School. (W.O., Wangaratta.)

Wantima.—Erection of a shelter pavilion and woodshed, S.S. 3709.

Wedderburn.—Supply and installation of five new slow-combustion heaters, S.S. 794. (W.O., Bendigo; S.S., Wedderburn.)

Yea.—Re-blocking, repairs, alterations and painting to residence in Oliver-street, S.S. 699. (W.O., Alexandra; S.S., Yea.)

Site Works.

Derrinallum.—Asphalt repairs, concrete paving, kerbing, channelling, drainage and associated works, S.S. 2050. (W.O., Camperdown.)

Fairhills.—Surface and underground drainage, asphalt, gravel and concrete pavements and associated work, S.S. 4906.

Karingal.—Surface drainage and paving (in concrete, gravel and asphalt construction), High School.

Mullum.—Asphalting, concreting, drainage, retaining walls and associated works, S.S. 4886.

Springvale.—Construction of new asphalt, asphalt repairs, concreting, drainage works and earthworks, High School.

Miscellaneous.

Nathalia.—Purchase and removal of detached classroom, S.S. 2060.

Wednesday, 3rd November, 1965.

Building, Electrical and Mechanical Works.

Altona North.—Supply and installation of extension of heating to four additional class-rooms, High School.

Braybrook.—Supply and installation of extension of heating to four additional class-rooms, High School.

Bundalong South.—Erection of toilet block and installation of septic sewerage to school and residence, S.S. 2109. (W.O., Benalla.)

Collingwood.—Renewal of water supply and repairs to boys' and girls' out-offices, Primary School 1895.

Croydon West.—Erection of first and second sections in brick veneer, High School.

Croydon West.—Supply and installation of mechanical services, stages 1 and 2, High School.

Dandenong.—Supply and installation of mechanical services in building extensions, Girls' Secondary School.

Dandenong.—Electrical installation, New Art and Music Wing, and alterations to existing buildings, Girls' Secondary School.

Doveton.—Supply and installation of extension of heating to four additional class-rooms, High School.

Edenhope.—Erection of brick veneer residence, office, &c., Police Station. (W.O., Horsham; P.S., Edenhope.)

Elwood.—Additional toilet facilities, S.S. 3942.

Footscray.—Soundproofing offices, Technical School, Ballarat road. (Amended Specification.)

Hawthorn.—Replacement of existing cast iron science wastes with P.V.C. pipe and fittings, Swinburne Technical College.

Jindivick.—Conversion to wet septic tanks, &c., S.S. 1951 and residence. (W.O., Warragul; S.S., Jindivick.)

Lakeside.—Supply and installation of extension of heating to four additional class-rooms, High School.

Licola.—Toilet block, septic tank and water supply, S.S. 3748. (W.O., Traralgon; S.S., Licola.)

Loch.—New toilet cubicles and septic tank installation, S.S. 2912 and residence. (W.O., Korumburra; S.S., Loch.)

Melbourne.—Demolition, alterations and renovations to Singer Building, Royal Melbourne Institute of Technology.

Melbourne.—Supply and installation of plenum heating, exhaust systems and air conditioning, Computer Room in Singer Building, Royal Melbourne Institute of Technology.

Melbourne.—Supply, installation and testing of central heating and addition of heating coils to ventilation system in the Planetarium, Institute of Applied Science, Swanston-street.

Mont Park.—Additions and alterations to Psychiatrist Superintendent's residence, 4 Adamson-street, Heidelberg, Mental Hospital.

Moorabbin.—Electrical installation, extended stage three, High School.

Noble Park.—Supply and installation of extension of heating to four additional class-rooms, High School.

Olinda.—Installation of rainwater tank and renewal of toilet suites, S.S. 3494. (S.S., Olinda.)

Ormond East.—Renewal of urinals, pans, cisterns and repairs to toilet blocks, S.S. 4366.

Preston.—Electrical installation, re-wiring and re-lighting, Technical College.

Strathbogie West.—Installation of sewerage, S.S. 2267. (W.O., Alexandra.)

Swan Hill.—Supply and installation of extensions to heating systems, High School. (W.O., Swan Hill and Bendigo.)

Various.—Additional class-rooms to five timber-framed High Schools at Altona North, Braybrook, Doveton, Lakeside, Noble Park. Tenderers are invited to tender for one or both of the above as follows:—Contract "A", Doveton-Noble Park; Contract "B", Braybrook, Lakeside, Altona North.

Various.—Contract "A", supply and erect 35 (30 24 ft. x 24 ft. and five 32 ft. x 24 ft.) timber-framed prefabricated portable class-rooms on various school sites in Victoria. Contract "B" as above. Tenderers may tender for either or both contracts.

Vermont.—Electrical installation, extended stage three, High School.

Westall.—Electrical installation, extended stage three, High School.

Williamstown.—Design, manufacture, delivery and installation of a sawdust extraction plant at Ports & Harbors Dredging Depot, Ann-street.

Furniture and Furnishings.

Carlton.—Supply of steel cabinets, Motor Registration Branch, Exhibition Buildings.

South Yarra.—Supply of 40 x 4 door timber storage cabinets and 20 timber bases as per drawings and specifications, Herbarium, Royal Botanic Gardens.

Site Works.

Maribymong.—Earthworks, drainage and concrete paving, Government Printing Office, Bulk Paper Store, Raleigh-road.

Markwood.—Drainage and pavement construction (concrete and gravel and asphalt construction), S.S. 1221. (W.O., Wangaratta.)

Mentone.—Gravelling, paving, maintenance and associated work, Girls' School.

Yea.—Drainage and pavement construction (in concrete and gravel with bituminous surface) and associated work, High School. (W.O., Alexandra.)

Tuesday, 9th November, 1965.

Building, Electrical and Mechanical Works.

Burwood East.—Demolition and removal of old brick residence and out-buildings, S.S. 454.

Bungador.—Erection of out-offices and installation of septic tank, S.S. 4255. (W.O., Warrnambool; S.S., Bungador.)

Coburg.—Supply and installation of hot-water service in New Young Offenders' Block, Pentridge Gaol.

Croydon West.—Electrical installation, stages one and two, High School.

Hamilton.—Erection of Administration and Laboratory Building Research Station. (W.O., Hamilton.)

Maffra.—Staff toilets and general alterations to Science Rooms, &c., High School. (W.O., Traralgon; H.S., Maffra.)

Middle Indigo.—Conversion to septic tank, S.S. 1115. (W.O., Wangaratta; S.S., Middle Indigo.)

Mitta Junction.—Erection of toilets, S.S. 4080. (W.O., Wangaratta.)

Shepparton.—Supply and installation of extensions to heating and hot-water services, High School. (W.O., Shepparton, Wangaratta and Bendigo.)

Sunbury.—Replacement of timber floors and steps to veranda with concrete, Wards M.4, 5 and 7, Wards F.4, 4A, 6 and 6A, Mental Hospital.

Upwey.—Supply and installation of mechanical services for Science Wing and Library Wing, High School.

Various.—Supply and installation of mechanical services in two Science Rooms, High Schools, Rosebud and Karingal.

Furniture and Furnishings.

Mont Park.—Supply and erection of 28 aluminium awning blinds with radial arms for Ward F.12, Mental Hospital.

Site Works.

Bendigo.—Installation of fire service together with necessary repairs to asphalt and other areas, Teachers Training College. (W.O., Bendigo.)

Broadmeadows.—General site works, Technical School.

Hawthorn.—Construction of asphalt paving, concrete footpaths, retaining walls and drainage, including landscape and repairs to existing paving for new Diploma Block, Swinburne Technical College.

Nhill.—Asphalt, concrete and gravel paving, asphalt repairs, kerbing, drainage and associated works at High School and Primary School 2411.

Royal Park.—Construction of heavy duty asphalt, asphalt repairs, drainage, concreting, earthworks and associated works, Psychiatric Hospital.

J. C. M. BALFOUR,
Acting Minister of Public Works.

Public Works Department,
Melbourne, 18th October, 1965.

No. 86.—9513/65.—4

TENDERS FOR GRAZING.

(Section 130, Land Act 1958.)

For the period 1st December, 1965, to 30th September, 1966, renewable annually for a further period where stated.

Tender forms and all particulars can be obtained on application to the Crown Lands Department, Melbourne, or any of the Land Offices in the country.

Tenders endorsed "Tender for Grazing" must reach the Secretary for Lands, Department of Crown Lands, Tender-box, State Treasury Buildings, Melbourne, C.2, at or before Noon on Wednesday, the 24th November, 1965.

TENDERS are invited and must be lodged at the Lands Department, Melbourne, at or before Noon on Wednesday, the 24th November, 1965, for the right to depasture stock on the following unappropriated portions of lands, subject to the Regulations approved by the Governor in Council and also the subjoined conditions.

CONDITIONS.

1. The period of occupation will be from 1st December, 1965, to 30th September, 1966, renewable annually for a further period where stated.

2. The rent for ten months—for which the licence will be issued, and the licence fee of 7s. 6d., must accompany the tender, otherwise the offer of the next highest tenderer who complies with this condition may be accepted.

3. The licensee shall pay shire rates and all other charges for the period of occupation.

4. Separate tenders must be lodged for each block.

5. Tenders to be addressed to the Secretary for Lands (Department of Crown Lands Tender-box), Melbourne, C.2, and endorsed Tender for Grazing.

6. The highest or any tender not necessarily accepted.

7. Tenderers must give their full name, occupation, and ordinary postal address.

8. Where permission to fence has been granted, the outgoing tenant has the option to remove any existing fencing owned by him within one month, or he may arrange with the incoming tenant to pay for it in accordance with the provisions of section 133, "Land Act 1958".

In all cases, the ingoing tenant will be held responsible for the care and maintenance of any improvements.

Licences issued will be for grazing only and will NOT authorize clearing or removal of timber or cultivation of the ground.

J. C. M. BALFOUR,
Minister of Lands.

Department of Crown Lands and Survey,
Melbourne, 20th October, 1965.

Lot 1 (B.2017). Area 40,000 acres—

Parishes of Wingan, Baawang, Wooyoot and Thurra, County of Croajingolong, being Grazing Block 65, Formerly held by G. H. Dowell. Period of occupation ten months, from 1st December, 1965, renewable annually for four years from 1st October, 1966.—(Bairnsdale 53/130.)

Lot 2 (B.2018.) Area 29,000 acres—

Parishes of Baawang, Karlo, Toonyarak and Wooyoot, being Grazing Block 64, County of Croajingolong. Formerly held by H. J. Stagg. Period of occupation, ten months from 1st December, 1965, renewable annually for four years from 1st October, 1966.—(Bairnsdale 4/130.)

Lot 3 (B.2019). Area 23,500 acres—

Parish of Wingan, County of Croajingolong, being Grazing Block 66. Formerly held by R. Goldie. Period of occupation, ten months from 1st December, 1965, renewable annually for four years from 1st October, 1966.—(Bairnsdale 3/130.)

Lot 4 (B.2020). Area 18,000 acres—

Parish of Brindat, County of Croajingolong, being Grazing Block 76. Formerly held by R. J. MacDonald. Period of occupation, ten months from 1st December, 1965, renewable annually for four years from 1st October, 1966.—(Bairnsdale 271/130.)

Lot 5 (B.2021). Area 5,250 acres—

Parishes of Budgee Budgee and Cobbanah, County of Wonnangatta, being Grazing Block 62. Formerly held by D. and H. Treasure. Period of occupation, ten months from 1st December, 1965, renewable annually for four years from 1st October, 1966.—(Sale 180/121.)

Lot 6 (B.2022). Area 22,000 acres—

Parish of Moroka, County of Wonnangatta, being Grazing Block 59. Formerly held by Dr. R. O. Wootton. Period of occupation, ten months from 1st December, 1965, renewable annually for four years from 1st October, 1966.—(Sale 216/130.)

Lot 7 (B.2023). Area 295 acres—

Parish of Derrimut, County of Bourke, being the site of the proposed abattoirs, Crown allotments 3 and 5 and parts of 1, 2, 4 and 6, section 7. Period of occupation, ten months from 1st December, 1965, renewable annually for two years from 1st October, 1966. Fencing of the eastern boundary of the area is allowed at licensees own risk.—(Melbourne 1625/130.)

Lot 8 (B.2024). Area 10 acres—

Parish of Kangernong, County of Mornington, being the Water Reserve at the north-west corner of allotment 27b. Formerly held by L. D. Mee. Period of occupation, ten months from 1st December, 1965, renewable annually for a period of four years from 1st October, 1966.—(Melbourne 01558/130.)

Lot 9 (B.2025). Area 1,000 acres—

Parishes of Bungeet and Karrabumet, County of Moira, being allotment 6 (Water Reserve) and the frontages to both sides of the adjoining part of the Back Creek in the Parish of Bungeet, and allotments 48 and 49 (Rowan's Swamp), allotment 55 (Water Reserve), the adjoining Water and Public Purposes Reserve, and allotment 56 in the Parish of Karrabumet. Formerly held by A. McDonald and D. McDonald. Period of occupation, ten months from 1st December, 1965, renewable annually for four years from 1st October, 1966.—(Benalla 153/130.)

Lot 10 (B.2026). Area 50 acres—

Township of Portarlinton, Parish of Bellarine, abutting on to the north, allotments 46, 47, 48 and 78. Formerly held by J. Muller. Period of occupation, ten months from 1st December, 1965, renewable annually for four years from 1st October, 1966.—(Geelong 319/130.)

Lot 11 (B.2027). Area 14,000 acres—

Parishes of Mallacoota and Betka, being Grazing Block 74, County of Croajingolong. Formerly held by G. J. Ventry. Period of occupation, ten months from 1st December, 1965, renewable annually for four years from 1st October, 1966.—(Bairnsdale 0619/130.)

Lot 12 (B.2028). Area 1,824 acres—

Parish of Berringama, County of Croajingolong, being allotments 34 and 36 and all that part of 44 north of the railway line, section 1. Formerly held by C. J. McMillan. Period of occupation, ten months from 1st December, 1965, renewable annually for four years from 1st October, 1966.—(Beechworth 453/130.)

PRIVATE ADVERTISEMENTS

CITY OF BRIGHTON.

BY-LAW No. 187.

A By-law of the City of Brighton made under the Health Act 1958 and numbered 187 and under and pursuant to all other powers in that behalf enabling for the purposes of prescribing fees to be paid to the Council for registration and renewal of registration of food vending machines.

IN pursuance of the powers aforesaid the Mayor, Councillors and Citizens of the City of Brighton order as follows:—

1. The fees to be paid to the Council for each registration or renewal of registration of the several classes of food vending machines hereunder specified shall be those set opposite to such classes respectively, namely:—

- (i) Machines operated by one to two pennies or cents a sale—5s. or 50 cents.
- (ii) Machines operated by a coin or coins to the value of three pennies or 3 cents a sale—10s. or 1 dollar.

(iii) Machines operated by coins in excess of three pennies or cents in value but not exceeding sixpence or five cents—20s. or 2 dollars.

(iv) Machines operated by coins in excess of sixpence or five cents in value—40s. or 4 dollars.

2. This By-law shall apply to and have operation throughout the whole of the municipal district of the City of Brighton.

Resolution for passing this By-law was agreed to by the Council on the 26th day of July, 1965, and confirmed on the 23rd day of August, 1965.

In witness whereof the common seal of the Mayor, Councillors and Citizens of the City of Brighton was hereto affixed this 23rd day of August, 1965.

J. E. BOWN, Mayor.

W. B. LOVELL, Councillor.

C. DeGARIS, Town Clerk.

(SEAL)

Submitted to the Commission of Public Health on the 14th day of September, 1965.—A. T. GARDNER, Secretary, Commission of Public Health.

Confirmed by the Governor in Council the fifth day of October, 1965.—J. COLQUHOUN, Clerk of the Executive Council. 8462

CITY OF BROADMEADOWS.

ORDER CHANGING NAME OF STREET.

NOTICE is hereby given that at a meeting of the Council of the City of Broadmeadows, held on Monday, 11th October, 1965, the said Council, in pursuance of the provisions of the Local Government Act 1958, did make an order changing the name of the street set out hereunder:—

Old Name; New Name; Location.

Railway-parade, Upfield; Garner-parade, Upfield; from Edmund to a point 170 feet south of Geach-street.

8465

E. F. SMILEY, Town Clerk.

Local Government Act 1958.

CITY OF CAMBERWELL.

WHEREAS in pursuance of the powers conferred by the above Act the Council of the City of Camberwell deems it expedient to give improved access to the rear of properties fronting Maling-road and for the purpose whereof it is necessary to compulsorily acquire all that piece of land commencing at the north-west corner of the land described in Certificate of Title volume 6067, folio 285 bounded by lines bearing 89 deg. 58 min. for 10 ft., 225 deg. for 14 ft 2 in. and 0 deg. for 10 ft. to the commencing point and the Council has instructed its engineer to prepare such maps and other papers in compliance with the provisions of division 4, part XVIII, of the above Act notice is hereby given that the maps and other papers showing (a) the general description of the work or undertaking for which the land proposed to be taken is to be used (b) the description of the lands proposed to be taken, and (c) the names of the owners or reputed owners lessees or reputed lessees mortgagees and occupiers of those lands so far as these can be ascertained by the Council are deposited at the office of the Council, Camberwell-road, Camberwell and are open for inspection between the hours of 10 o'clock in the forenoon and 4 o'clock in the afternoon on all week days except Saturday. All persons affected by the proposed work or undertaking are hereby required within 40 clear days from the publication of this Notice in the Government Gazette to set forth in writing addressed to the said Council or the Chief Administrator all objections which they may have to the work or undertaking.

8452

L. P. CHEFFERS, Chief Administrator.

CITY OF COBURG.

LOAN No. 97.

Notice of Intention to Borrow the Sum of £25,000 for Permanent Works and Undertakings.

NOTICE is hereby given that the Council of the City of Coburg proposes to borrow the principal sum of Twenty-five thousand pounds secured by a charge over the general rates of the municipality, such sum to be raised by the grant of a mortgage in accordance with the provisions of the Local Government Act 1958.

1. The maximum rate of interest that may be paid is 15s. per cent. per annum.

2. The purposes for which the loan is to be applied are:—

- Erection of pavilion at Cole Reserve.
- Erection of pavilion at De Chene Reserve.
- Erection of girl guide hall at Pascoe Vale.

Erection of bowling club room at City Oval.
Road and drainage works, Reynolds-parade.
Purchase of "reserve" land in the Dromana-avenue area.

3. The period of the loan shall be fifteen years.

4. The moneys borrowed shall be repayable by providing out of the municipal fund 30 half-yearly instalments of approximately £1,255 each, including principal and interest, on the 1st day of February and the 1st day of August, during the currency of the loan. The first instalment shall be payable on the 1st day of August, 1966.

5. Such moneys shall be repayable to the Commissioners of the State Savings Bank of Victoria at the office of the said Commissioners, corner Elizabeth and Bourke streets, Melbourne.

The plans and specifications and the estimate of the cost of the proposed works and a statement showing the proposed expenditure of the moneys to be borrowed, are open for inspection at the office of the Council of the City of Coburg, at Town Hall, Coburg.

Dated 8th October, 1965.

8382 G. A. BRIDGES, Town Clerk.

CITY OF COLLINGWOOD.
BY-LAWS 97, 99 AND 102.

NOTICE is hereby given that the Council of the City of Collingwood has made the following by-laws:—

By-law 97.—*Refuse and Rubbish.*

A By-law of the City of Collingwood made under section 197 of the *Local Government Act 1958* and section 93 of the *Health Act 1958* and numbered 97 for—

- (a) Prohibiting the depositing or leaving of refuse or rubbish on streets, roads, lanes or passages or on any land.
- (b) The provision, use and control of receptacles for the deposit and collection of refuse and rubbish and prescribing the size and shape of and the materials to be used in the construction of such receptacles.
- (c) Imposing upon the occupier of any premises the duties of the cleansing of footways and pavements adjoining such premises.

By-law 99.—*Health Registration Fees.*

A By-law of the City of Collingwood made under section 368 of the *Health Act 1958* and numbered 99 for prescribing fees for registration and renewal and transfer of registration of premises.

By-law 102.—*Animals.*

A By-law of the City of Collingwood made under sections 197 and 198 of the *Local Government Act 1958* and section 93 of the *Health Act 1958* for—

- (a) Regulating the keeping of animals or birds including poultry.
- (b) Regulating cleanliness in and adjacent to areas where animals and birds are kept.

Resolution for passing these By-laws was agreed to by the Council of the City of Collingwood on the 12th day of July, 1965, and confirmed on the 9th day of August, 1965.

Copies of the By-laws are open for inspection free of charge during office hours.

8468 L. D. COOK, Town Clerk.

CITY OF HEIDELBERG.
APPOINTMENT OF POUNDKEEPER.

NOTICE is hereby given that Mr. George Moot has been appointed Poundkeeper for the Macleod Pound, in lieu of Mr. George Anderson, resigned.

E. C. W. JACK, Town Clerk and Chief Administrator.
13th October, 1965.

8398

CITY OF MILDURA.
LOAN No. 64.

Notice of Intention to Borrow the Sum of £15,000 for Permanent Works and Undertakings.

NOTICE is hereby given that the Council of the City of Mildura intends to borrow the principal sum herein-after mentioned on the credit of the municipal revenues of the Mayor, Councillors and Citizens of the City of Mildura by the grant of a mortgage in accordance with the provisions of the *Local Government Acts*, and Notice is hereby further given—

- (a) That the amount of the principal sum which it is proposed to borrow is £15,000.

(b) The maximum rate of interest that may be paid is £5 12s. 6d. per centum per annum.

(c) The moneys borrowed and interest thereon are to be repayable by twenty half-yearly instalments each of approximately £990 16s. 9d. on the 1st day of January and the 1st day of July in each year, and the place at which such moneys are to be repayable is the National Bank Savings Bank Ltd., Collins-street, Melbourne.

The first instalment shall be payable on the 1st day of July, 1966.

(d) The purposes for which the loan is to be applied are:
Purchase of Plant £15,000.

(e) The loan is to be liquidated by appropriation out of the municipal fund.

(f) The plans, specifications and estimate for the cost of such works and the statement showing the proposed expenditure of the money to be borrowed, are open for inspection at the office of the Council, Civic Buildings, Deakin-avenue, Mildura, during office hours.

Dated the 20th day of October, 1965.

8415 W. J. DOWNIE, Town Clerk.

CITY OF MILDURA.
LOAN No. 63.

Notice of Intention to Borrow the Sum of £25,000 for Permanent Work and Undertakings.

NOTICE is hereby given that the Council of the City of Mildura proposes to borrow the principal sum of £25,000 secured by a charge over the general rates of the municipality, such sum to be raised by the grant of a mortgage in accordance with the provisions of the *Local Government Act 1958*.

1. The maximum rate of interest that may be paid is £5 15s. per cent. per annum.

2. The purposes for which the loan is to be applied are:

(1.) C.A.R. Programme—actual estimate	£20,520	
(2.) Drainage—		
(a) Cherry-avenue out-fall	£500	
(b) Eleventh-street, kerb and channel	200	
		700
(3.) Footpath Construction		
(a) Residential area—		
8th-street Pine-Walnut avenues	£400	
9th-street Pine-Walnut avenues	400	
10th-street Lime-Pine lane to Pine avenue	100	
11th-street Deakin-Orange avenues	400	
8th-street Orange-Lemon avenues	200	
		1,500
(b) City Area (Deakin-avenue, 8th-street, Langtree - avenue, 9th-street)	1,000	
		2,500
(4.) Apex Park Water Supply		1,280
		£25,000

3. The period of the loan shall be fifteen years.

4. The moneys borrowed shall be repayable by providing out of the municipal fund half-yearly instalments of approximately £1,254 19s. each including principal and interest on the 1st day of July and the 1st day of January during the currency of the loan. The first instalment shall be payable on the 1st day of July, 1966.

5. Such moneys shall be repayable to The Commissioners of The State Savings Bank of Victoria at the office of the said Commissioners, corner Elizabeth and Bourke streets, Melbourne.

The plans and specifications and the estimate of the cost of the proposed works and a statement showing the proposed expenditure of the moneys to be borrowed are open for inspection at the office of the Council of the City of Mildura, at Civic Buildings, Mildura.

20th October, 1965.

8414 W. J. DOWNIE, Town Clerk.

CITY OF MORDIALLOC.

BY-LAW No. 133.

Animal (Amendment) By-law.

A BY-LAW of the City of Mordialloc made under section 93 of the *Health Act 1958* and section 197 of the *Local Government Act 1958* and numbered 133 for:—

- (a) The regulating of the keeping of animals (including birds) and the regulating or prohibiting of the keeping of any place or the storage of anything which in the opinion of the Council may be offensive injurious to health or dangerous.

- (b) Suppressing nuisances.

1. This By-law shall be known as the Animal (Amendment) By-law.

2. By-law No. 48 of the City of Mordialloc relating to the keeping of stables and similar buildings is hereby repealed.

3. By-law No. 122 of the City of Mordialloc shall be amended as follows:—

In Clause 1 the following definition shall be added—“Cattle” has the same meaning as in the *Local Government Act 1958*. That Clause 14 in By-law No. 122 be deleted and the following Clause be inserted.

14. The owner or occupier of any land on which are kept any cattle shall:—

- (a) Cause such premises to be kept at all times in a clean wholesome and sanitary condition and shall cause all dung or other manure produced or accumulated therein to be each day placed in a manure pit constructed on such land in accordance with the provisions of paragraph (f) of Clause 3125 of the *Uniform Building Regulations, Victoria*.
- (b) Cause such manure pit to be emptied and thoroughly cleaned out and the contents thereof to be disposed of at least once during every period of four consecutive days in such a manner as shall not constitute any nuisance.

4. This By-law shall apply to and have operation throughout the whole of the municipal district of the City of Mordialloc.

Resolution for passing this By-law agreed to by the Council of the City of Mordialloc on the twenty-sixth day of July, 1965, and confirmed on the twenty-third day of August, 1965.

The common seal of the Mayor, Councillors and Citizens of the City of Mordialloc was hereunto affixed in the presence of—

(SEAL) HECTOR R. WARD, Mayor.
M. W. BUXTON, Councillor.
J. GRUT, Town Clerk.

Approved by the Commission of Public Health on the thirty-first day of August, 1965.—A. T. GARDNER, Secretary, Commission of Public Health.

Approved by the Governor in Council on the fifth day of October, 1965.—J. COLQUHOUN, Clerk of the Executive Council. 8410

CITY OF NORTHCOTE

BY-LAW No. 166

A By-Law of the City of Northcote made under the provisions of the *Health Act 1958* and numbered 166 for or with respect to:—

- (a) The provision, use and control of receptacles for the deposit and collection of refuse and rubbish (whether temporary or otherwise) and prescribing the size and shape of and the materials to be used in the construction of such receptacles; and

- (b) Preventing and regulating the deposit of refuse and rubbish upon streets and other lands and places under the control of the Council.

IN pursuance of the powers conferred by the *Health Act 1958* and all other powers it thereunto enabling, the Mayor, Councillors and Citizens of the City of Northcote order as follows:—

1. By-Law No. 25 of the City of Northcote is hereby repealed.

2. In this By-Law unless inconsistent with the context or subject matter—

“City Engineer” means the City Engineer for the time being of the City of Northcote.

“Council” means the Council of the City of Northcote.

“Dry refuse” means dry and hard refuse, dry and hard waste and garden refuse but does not include household refuse or garbage as herein-after defined.

“Household refuse” means household refuse and rubbish including food waste and discarded food ordinarily used for human consumption.

“Occupier” means and includes the occupier, owner, tenant, the person in charge or having the management or control of property.

“Property” means house, building or premises.

3. The occupier of every property within the City of Northcote shall provide or cause to be provided and kept a receptacle or receptacles as herein prescribed and shall cause all household refuse produced, collected or accumulated on such property to be from time to time deposited and kept in such receptacle or receptacles. Every such receptacle shall be kept in a clean and inoffensive state and shall be kept constantly covered by a lid described hereunder except when household refuse is being deposited therein or discharged therefrom.

4. Every receptacle for the keeping of household refuse shall be:—

- (a) strongly constructed of galvanised iron of not less than 24 gauge or approved plastic;
- (b) cylindrical in shape;
- (c) of a capacity not exceeding three cubic feet;
- (d) provided with a tight fitting lid and properly fixed side lifting handles;
- (e) constructed so as to be capable of being easily and conveniently carried by one man; and
- (f) watertight and flyproof.

5. No person shall place or cause or permit to be placed any slops or liquid waste in any such receptacle, nor shall deposit therein any refuse unless such refuse has been previously effectively wrapped in paper.

6. No person shall place any ashes in any such receptacle unless such ashes are securely wrapped in paper and were not sufficiently hot at the time of wrapping to ignite or scorch the paper in which they are wrapped.

7. The occupier shall cause such receptacle to be kept at all times in good order and condition.

8. At such hours and on such days as may be appointed by the City Engineer receptacles containing household refuse for collection and disposal may be placed on the footway adjoining the property used by the occupier near to the street channel or in such other location as may be approved by the City Engineer.

9. No person shall remove from any such receptacle any substance except for the disposal of the whole contents of such receptacle in a manner and at a place approved by the Council.

10. (a) The Council may from time to time place in streets throughout the said municipal district vehicles for the reception of dry refuse.

(b) No person shall deposit any dry refuse for removal by the Council in any place other than in any vehicle placed in any street for the collection of such dry refuse.

(c) No person shall deposit in such a vehicle any refuse rubbish or garbage other than dry refuse.

(d) No person other than a person duly authorized by the Council shall remove any dry refuse deposited for collection as hereinbefore provided.

11. Subject to clause 10 hereof no person shall deposit any refuse or rubbish upon any street in the municipal district of the City of Northcote or other land or place under the control of the Council except at an authorized garbage depot.

12. Any person who is guilty of a wilful act or default contrary to any of the provisions of this By-law shall on conviction be liable to a penalty not exceeding Twenty pounds and not less than Two pounds for every such offence, or in the case of a continuing offence, to a penalty not exceeding Five pounds for each and every day during which such offence is continued after a conviction or order by any court.

Resolution for passing this By-law agreed to by the Council of the City of Northcote on the 26th day of July, 1965, and confirmed on the 23rd day of August, 1965.

The common seal of the Mayor, Councillors and Citizens of the City of Northcote was hereunto affixed, in the presence of—

(SEAL) R. E. BRYAN, Mayor.
R. INMAN, Councillor.
E. MASON, Town Clerk.

Submitted to the Commission of Public Health on the 14th day of September, 1965.

Approved by the Governor in Council on the 5th day of October, 1965.—J. COLQUHOUN, Clerk of the Executive Council. 8413

CITY OF RINGWOOD.

LOAN No. 65.

Notice of Intention to Borrow the Sum of £16,920 (\$33,840) for Permanent Works and Undertakings.

NOTICE is hereby given that the Council of the City of Ringwood proposes to borrow the principal sum of £16,920 (Sixteen thousand nine hundred and twenty pounds) (\$33,840) on the credit of the municipal revenues of the Mayor, Councillors and Citizens of the said City, such sum to be raised by the grant of a mortgage in accordance with the provisions of the *Local Government Act 1958*.

1. The maximum rate of interest that may be paid is £5 12s. 6d. (5.625) per centum per annum.
2. The purpose for which the loan is to be applied is:—

Pipe Drainage Works—Council's portion of cost of—

(a) Reconstruction Warrandyte-road (Loughnan-road/Mullum Creek)	£750	\$1,500
(b) Reconstruction Bedford-road (Greenwood-avenue/Railway Line)	2,000	4,000
(c) Reconstruction Mullum-road (Byron-street to Jeffrey-drive)	500	1,000
(d) East side Heatherdale-road, Canterbury-road north	4,500	9,000
(e) Canterbury-road / Campbell-street Outlet Drain	900	1,800
(f) Outlet Main Drain Maidstone-street through— Southwood State School	£1,500 (\$3,000)	
Proclamation Park	3,000 (\$6,000)	
	4,500	9,000
(g) Main Drain, Great Ryrie-street south of Emerald-street, through Aquinas College to link with South Ringwood Drain (half cost Aquinas College)	2,000	4,000
(h) Outlet Drain, Possum-lane, through lot 29	700	1,400
(i) Main Drain, adjacent lots 26/27 Pleasant-drive	600	1,200
(j) Main Drain, adjacent lots 8/9 Pleasant-drive	470	940
	£16,920	\$33,840

3. The period of the loan shall be ten years.
4. The moneys borrowed shall be repayable by providing out of the municipal fund twenty half-yearly instalments of approximately £1,117 17s. 6d. (\$2,235.75) each, including principal and interest, on the 1st day of September and March in each year during the currency of the loan. The first instalment shall be payable on the 1st day of September, 1966.
5. That such moneys shall be repayable to the E.S. & A. Savings Bank, of 287 Collins-street, Melbourne, at the office of the said bank.

The plans and specifications and the estimate of the cost of the proposed works, and a statement showing the proposed expenditure of the moneys to be borrowed, are open for inspection at the office of the Council of the City of Ringwood, Maroondah Highway, Ringwood.

F. P. DWERRYHOUSE, Town Clerk.
Town Hall, Ringwood, 15th October, 1965. 8412

CITY OF RINGWOOD.

LOAN No. 66.

Notice of Intention to Borrow the Sum of £25,000 (\$50,000) for Permanent Works and Undertakings.

NOTICE is hereby given that the Council of the City of Ringwood proposes to borrow the principal sum of £25,000 (Twenty-five thousand pounds) (\$50,000) secured by a charge over the general rates of the municipality, such sum to be raised by the grant of a mortgage, in accordance with the provisions of the *Local Government Act 1958*.

1. The maximum rate of interest that may be paid is £5 12s. 6d. (5.625) per centum per annum.
2. The purpose for which the loan is to be applied is:—

Buildings—

Balance of construction, Stage 1, Nursery	£2,750	\$5,500
---	--------	---------

Roads—

Portion of cost—Bus terminal	2,400	4,800
------------------------------	-------	-------

Council contribution, Reconstruction of Bedford-road (Greenwood-avenue to railway line)	£18,000	\$36,000
Portion of Council contribution, Reconstruction of Wantirna-road (City-road to Maroondah Highway)	1,850	3,700
	£25,000	\$50,000

3. The period of the loan shall be ten years.
4. The moneys borrowed shall be repayable by providing out of the municipal fund twenty half-yearly instalments of approximately £1,651 7s. 11d. (\$3,302.8) each, including principal and interest, on the 1st day of September and March in each year during the currency of the loan. The first instalment shall be payable on the 1st day of September, 1966.
5. That such moneys shall be repayable to the Commissioners of the State Savings Bank of Victoria, at the office of the said Commissioners, corner Elizabeth and Bourke streets, Melbourne.

The plans and specifications and the estimate of the cost of the proposed works, and a statement showing the proposed expenditure of the moneys to be borrowed, are open for inspection at the office of the Council of the City of Ringwood, Maroondah Highway, Ringwood.

F. P. DWERRYHOUSE, Town Clerk.
Town Hall, Ringwood, 15th October, 1965. 8411

CITY OF WAVERLEY.

APPOINTMENT OF PROSECUTING OFFICER.

NOTICE is hereby given that Sergeant William Eric John Senior, No. 8891, has been appointed Prosecuting Officer to the Council of the City of Waverley.

8394 F. S. BALES, Town Clerk.

Local Government Act 1958.

SHIRE OF BACCHUS MARSH.

DECLARATION OF PRIVATE STREETS AS PUBLIC HIGHWAYS.

IN pursuance of the powers conferred by section 587 (3) of the *Local Government Act 1958*, the Council of the Shire of Bacchus Marsh, on the application of the Housing Commission of Victoria, hereby declares the following street which has been constructed to the satisfaction of the Council, to be dedicated to the public as a Public Highway.

Street Referred To.

Lidgett-street, as set out on lodged plan No. 58849.

The common seal of the President, Councillors and Ratepayers of the Shire of Bacchus Marsh was hereunto affixed this 11th day of October, 1965, in the presence of—

(SEAL) A. J. WIGNELL, Councillor.
THOS. J. DUFFY, Councillor.
8466 A. W. BOND, Shire Secretary.

SHIRE OF BALLARAT.

NOTICE is hereby given that Sergeant Ormond Buckingham Robinson, No. 9818, has been appointed Prosecuting Officer for the Shire of Ballarat, replacing Senior Constable E. J. Dillon, No. 9640, who has resigned.

8383 JAMES H. MITCHELL, Shire Secretary.

SHIRE OF BASS.

LOAN No. 27.

Notice of Intention to Borrow the Sum of £15,000 for Permanent Works and Undertakings.

NOTICE is hereby given that the Council of the Shire of Bass proposes to borrow the principal sum of Fifteen thousand pounds secured by a charge over the general rates of the municipality, such sum to be raised by the grant of a mortgage in accordance with the provisions of the *Local Government Act 1958*.

1. The maximum rate of interest that may be paid is £5 11s. 3d. per centum per annum.
2. The purpose for which the loan is to be applied is for the purchase of one road grader and miscellaneous plant.
3. The period of the loan shall be seven (7) years.

4. The moneys borrowed shall be repayable by providing out of the municipal fund half-yearly instalments of approximately £1,308 3s. 6d. each, including principal and interest, on the 1st day of July and the 1st day of January, during the currency of the loan. The first instalment shall be payable on the 1st day of July, 1966.

5. Such moneys shall be repayable to the Commissioners of the State Savings Bank of Victoria at the office of the said Commissioners, corner Elizabeth and Bourke streets, Melbourne.

The plans and specifications and the estimate of the cost of the proposed works and a statement showing the proposed expenditure of the moneys to be borrowed are open for inspection at the office of the Council of the Shire of Bass at the Shire Office, Dalyston, Victoria.

14th October, 1965.

8463

G. J. HARLAND, Shire Secretary.

SHIRE OR BERWICK.

BY-LAW No. 49.

Refuse and Rubbish By-Law.

A By-Law of the Shire of Berwick made under Section 197 of the *Local Government Act 1958* and Section 98 of the *Health Act 1958* and numbered 49 for:

- (a) Prohibiting the deposit or leaving of refuse or rubbish on streets roads lanes or passages or on any land.
- (b) The provision use and control of receptacles for the deposit and collection of refuse and rubbish and prescribing the size and shape of and the materials to be used in the construction of such receptacles.
- (c) Imposing upon the occupier of any premises the duties of the cleansing of footways and pavements adjoining such premises.

IN pursuance of the powers conferred by the *Local Government Act 1958* and the *Health Act 1958* and of any and every other power it thereunto enabling the President Councillors and Ratepayers of the Shire of Berwick orders as follows:—

(1) This By-Law shall be known as the Refuse and Rubbish By-Law.

(2) By-Law No. 25 of the Shire of Berwick relating to the leaving of refuse or rubbish on streets or land and By-Law No. 30 of the said Shire relating to rubbish receptacles are hereby repealed.

(3) No person shall deposit or leave any refuse or rubbish on any street road lane or passage.

(4) No person shall deposit or leave any refuse or rubbish on any land (other than land set apart for the purpose by the council) unless the same is deposited in such a receptacle and in such manner as it is hereinafter provided.

(5) (a) The Council may by notice in writing under the hand of the Shire Secretary or Health Inspector require the owner or occupier of any land to remove or destroy (within the time limited to such notice) all refuse on such land (other than refuse or rubbish the removal of which the Council has undertaken or contracted for under Section 48 of the *Health Act 1958*).

(b) Any owner or occupier to whom any such notice shall have been given shall comply with the terms thereof within the time therein limited.

(6) The occupier of every premises shall provide and at all times keep at such premises a receptacle constructed in accordance with the provisions of the next succeeding clause hereof for the deposit and collection of refuse and rubbish or so many of such receptacles as may be necessary to contain all refuse and rubbish from such premises and shall cause all such refuse and rubbish to be placed in such receptacle or receptacles with the least possible delay.

(7) No such receptacle shall exceed three cubic feet in volume and every such receptacle shall be constructed of galvanized iron properly riveted and soldered so as to be watertight or of strong and impervious plastic material and shall be fitted with handles for convenience in lifting or moving and emptying the same and shall be provided with a close fitting metal or plastic cover so constructed and fitted as to exclude the entry of rats mice flies and other vermin and insects.

(8) All refuse or rubbish likely to become offensive shall be wrapped in paper before being placed in any such receptacle.

(9) The occupier of every premises shall on the day of which the Council notifies him that refuse and rubbish shall be collected from such premises place the receptacle or receptacles provided by him immediately inside the gate of such premises leading to a street upon which such premises adjoin or abut.

(10) The occupier of every premises shall cause every such receptacle on his premises to be kept at all times clean and disinfected and properly covered with such close fitting cover provided as aforesaid.

(11) The occupier of every premises shall cleanse and at all times keep clean the footway and pavement adjoining such premises.

(12) Any person guilty of any wilful act or default contrary to clause 3 or clause 4 of this By-Law shall for a first offence be liable to a penalty of not more than £20 and for any second or subsequent offence contrary thereto be liable to a penalty of not less than £10 nor more than One hundred pounds.

(13) This By-Law shall apply to and have operation throughout the whole of the Municipal district.

Resolution for passing this By-Law agreed to by the Council of the Shire of Berwick on the 16th day of March, 1965, and confirmed on the 26th day of April, 1965.

The corporate seal of the President Councillors and Ratepayers of the Shire of Berwick was hereunto affixed in the presence of:

(SEAL) R. R. WAKENSHAW, President.
A. G. ROBINSON, Councillor.
BEATRICE THOMAS, Shire Secretary.

Submitted to the Commissioner of Public Health on the 17th day of August, 1965.

Approved by the Governor in Council 5th October, 1965.
—J. COLQUHOUN, Clerk of the Executive Council.

8408

SHIRE OF BIRCHIP.

LOAN No. 27.

Notice of Intention to Borrow the Sum of £11,000 for Permanent Works and Undertakings.

NOTICE is hereby given that the Council of the Shire of Birchip proposes to borrow the principal sum of £11,000 secured by a charge over the general rates of the municipality, such sum to be raised by the grant of a mortgage in accordance with the provisions of the *Local Government Act 1958*.

1. The maximum rate of interest that may be paid is 5½ per cent. per annum.

2. The purpose for which the loan is to be applied is:—

Purchase of road-making equipment.

3. The period of the loan shall be six years.

4. The moneys borrowed shall be repayable by providing out of the municipal fund half-yearly instalments of approximately £1,088 13s. each, including principal and interest, on the 1st day of January and the 1st day of July, during the currency of the loan. The first instalment shall be payable on the 1st day of July, 1966.

5. Such moneys shall be repayable to the Commissioners of the State Savings Bank of Victoria at the office of the said Commissioners, corner Elizabeth and Bourke streets, Melbourne.

The plans and specifications and the estimate of the cost of the proposed works and a statement showing the proposed expenditure of the moneys to be borrowed, are open for inspection at the office of the Council of the Shire of Birchip, at Cumming-avenue, Birchip.

8395 WALTER J. MCQUILLEN, Shire Secretary.

SHIRE OF BIRCHIP.

BY-LAW No. 26.

A By-Law of the Shire of Birchip, made under the provisions of Section 198 of the *Local Government Act 1958*, and numbered 26, for the purpose of:—

(a) Prohibiting on, from and after the date specified herein the erection or placing against or in front of any house or building abutting upon any public footway in any street or part thereof specified herein, of any verandah over or across such footway unless such verandah is supported by cantilevers brackets or projecting supports, and not otherwise.

(b) Requiring the pulling down and removal before the date specified herein of all verandahs erected or placed against or in front of any house or building abutting upon any such public footway which verandahs are upon, over or across such footway and are supported otherwise than by cantilevers, brackets or projecting supports.

IN pursuance of the powers conferred by the *Local Government Acts*, the President, Councillors and Ratepayers of the Shire of Birchip order as follows:—

1. On, from and after the 1st day of November, 1965, no person shall erect or place in front of any house or building abutting upon any public footway in any street

or part thereof within the Central Riding of the Shire of Birchip, any verandah over or across such footway unless such verandah is supported by cantilevers, brackets or projecting supports.

2. The owner of any verandah which is now, or before the first day of November, 1965, shall have been erected or placed against or in front of any house or building abutting upon any public footway of any street or part thereof within the Central Riding of the Shire of Birchip which verandah is upon, over or across such footway and is supported otherwise than by cantilevers, brackets or projecting supports, shall pull down and remove such verandah before the 1st day of November, 1980.

3. This By-Law shall apply to and have operation throughout the whole of the Central Riding of the Shire of Birchip.

Resolution for passing this By-Law agreed to by the Council of the Shire of Birchip on the 16th day of August, 1965, and confirmed on the 20th day of September, 1965.

The common seal of the President, Councillors and Ratepayers of the Shire of Birchip was hereunto affixed, in the presence of—

(SEAL) T. P. CONNELLAN, President.
ROBERT J. REID, Councillor.
WALTER J. McQUILLEN, Secretary.

Approved by the Governor in Council the 5th day of October, 1965.—J. COLQUHOUN, Clerk of the Executive Council. 8409

SHIRE OF DONCASTER AND TEMPLESTOWE.

WHEREAS the Council of the Shire of Doncaster and Templestowe deems it expedient to exercise its powers of taking compulsorily the land described in the Schedule hereto for the purpose of re-aligning the road at the corner of Kenneth-street and Thompsons-road, Bulleen, pursuant to the provisions of section 621 of the *Local Government Act 1958*, and acquiring the said land for that purpose: And whereas the Council has caused to be prepared a map and other papers setting out the general description of the work or undertaking for which the land proposed to be taken is to be used the description of the lands proposed to be taken and the names of the owners or reputed owners lessees or reputed lessees mortgagees and occupiers of that land so far as those names are known to or can be ascertained by the Council: And whereas the said map and other papers are deposited at the office of the said Council at Doncaster and are and shall be open for inspection by all persons interested at all reasonable hours for the space of forty clear days after the publication of this notice in the *Government Gazette*: Now it is hereby given to all persons affected by the proposed taking of the said land to set forth in writing addressed to the Council or the Shire Secretary within forty clear days of the publication of this notice in the *Government Gazette* all objections which they may have to the taking of the said land.

THE SCHEDULE HEREINBEFORE REFERRED TO.

The land shown as lot 1 on lodged plan 12331 part of Unwins Crown Special Survey, Parish of Bulleen, County of Bourke and described as follows:—Commencing at the south-east intersection of Thompsons-road and Kenneth-street and thence, bounded by lines bearing and distant respectively, 52 deg. 39 min. 10 feet, 206 deg. 16 min. 17 ft. 11 in. and 359 deg. 53 min. 10 feet back to the commencing point. 8467

SHIRE OF MARONG.

BY-LAW No. 34.

A By-Law of the Shire of Marong numbered 34 made under Section 368 of the *Health Act 1958* and the *Food Vending Machine Regulations* for fixing fees for the registration and transfer of registration of food vending machines.

IN pursuance of the powers conferred by the *Health Act 1958*, and of any and every other power thereto enabling it, the Council of the Shire of Marong orders as follows:—

(a) The following fees are hereby fixed:—

For the granting of annual renewal of Registration of Food Vending Machines—

	s. d.
(i) Machines operated by one to two pennies a sale	5 0
(ii) Machines operated by a coin or coins to the value of three pennies a sale	10 0

	s. d.
(iii) Machines operated by coins in excess of three pennies in value but not exceeding sixpence	20 0
(vi) Machines operated by coins in excess of sixpence in value	40 0
(v) For any transfer of registration	2 6

(b) That this By-Law shall apply to and have operation throughout the whole of the municipal district.

Resolution for passing this By-law was agreed to by the Council of the Shire of Marong this 3rd day of March, 1965 and confirmed by Special Order at a meeting of the said Council held on the 7th day of April, 1965.

The Corporate Seal of the President, Councillors and Ratepayers of the Shire of Marong was affixed hereto this 4th day of August 1965 in the presence of—

(SEAL) R. CAIN, President.
J. H. COLLINS, Councillor.
ROSS M. GRAHAM, Secretary.

Approved by the Governor in Council, 5th October, 1965.—J. COLQUHOUN, Clerk of the Executive Council. 8406

Town and Country Planning Act 1961 (Twelfth Schedule).
SHIRE OF SEYMOUR.—SEYMOUR PLANNING SCHEME.

NOTICE THAT A PLANNING SCHEME HAS BEEN PREPARED AND IS AVAILABLE FOR INSPECTION.

NOTICE is hereby given that the Council of the Shire of Seymour in pursuance of its powers under the *Town and Country Planning Act 1961*, has prepared a Planning Scheme for the area enclosed within the Township of Seymour and within Crown allotments 1, 2, 2A, 3, 3A, 4, 5A, 5B, 6, 6A, 7, 7A, 7B, 7C, 8, 8A, 9, of section W and Crown allotments 1, 2, 3, 4, 5, 6, 7, 8, 9 of section X all in Parish of Seymour and within Crown allotments 14, 14A, 14B, 15, 16, 17, 18, 19, 20, 21, 22, 23, 44A1, 44B, 45A1, 45A2, 45B, 45B1, 46, 47, 47A, 47B, 48A, 49, 50, 51, 52, 52A, 53, 54A, 54B of section L, Parish of Tallarook, for the purpose of regulating the future development of the described area into zones.

A copy of the scheme has been deposited at the Shire Offices, Seymour, and at the office of the Town and Country Planning Board, 61 Spring-street, Melbourne, and will be open for inspection during office hours by any person free of charge.

Any persons affected by the Planning Scheme are required to set forth in writing all objections they may have, addressed to Municipal Clerk, Shire of Seymour, Shire Office, Seymour, on or before the 20th day of January, 1966, and to state whether they wish to be heard in respect of their objections.

A. W. HALL, Shire Secretary.

12th October, 1965. 8397

G. BOGGI, Talbot-street, Lower Templestowe, announces, that since 1st August, 1965, he has no connexion with the business of Latrobe Panels, 11 Kirkdale-street, Brunswick. All creditors of that business are advised accordingly. 8391

I. WALTER STANLEY BAYLEY, 1 Westbrook-street, East Kew, trading as Hiah and Bayley, will not be responsible for any debts incurred in the name of Hiah and Bayley without my written authority.

Dated this 18th October, 1965.

8469 W. S. T. BAYLEY.

GEELONG WATERWORKS AND SEWERAGE TRUST.

PURSUANT to section 60 (2) of the *Geelong Waterworks and Sewerage Act 1958* (No. 6263), notice is hereby given of the intention of the Trust to construct sewers to provide for properties in and adjacent to—

Settlement and Torquay roads, East Belmont, Shire of South Barwon,
Mt. Pleasant and Scenic roads, North Highton, Shire of South Barwon,
Tegwen-street, East Belmont, Shire of South Barwon,
and more particularly as shown on maps which are open for public inspection at the Trust's Offices, Ryrie-street, Geelong, between the hours of 9 a.m. and 4 p.m. daily, from Monday to Friday.

Dated this 12th day of October, 1965.

8390 B. C. HENSHAW, Secretary.

NOTICE OF INTENTION TO APPLY FOR A LICENCE TO DIVERT WATER AND CUT RACE FROM THE YARRAWONGA WEIR POOL, AT BUNDALONG.

I HEREBY give notice that I intend to apply for a licence empowering me to divert water for a term of fifteen years to the extent of 70 acre-feet per annum at a maximum rate of 100,000 gallons per day of 24 hours for the irrigation of pastures on 35 acres, being part of allotments 7, 8, 10 and 12A, Parish of Bundalong, and to occupy certain Crown lands for works of diversion, and to cut a race thereon.

Any objection to such application must be forwarded, in writing, to reach the State Rivers and Water Supply Commission, Melbourne, before 13th November, 1965, being 30 days from the first publication of this notice.

WILLIAM ALBERT BOTT.

Moreland Private Bag, Yarrowonga. 8389

NOTICE OF INTENTION TO APPLY FOR A LICENCE TO DIVERT WATER AND CUT RACE FROM THE KIEWA RIVER AT DEDERANG.

I HEREBY give notice that I intend to apply for a licence empowering me to divert water for a term of fifteen years to the extent of 50 acre-feet per annum at a maximum rate of 2 acre-feet per day of 24 hours for the irrigation of 25 acres of pasture and crops, being part of allotment 15, section 6, Parish of Kergunyah, and to occupy certain Crown lands for works of diversion, and to cut a race thereon.

Any objection to such application must be forwarded in writing to reach the State Rivers and Water Supply Commission, Melbourne, before 20th November, 1965, being 30 days from the first publication of this notice.

ARNOLD JOSEPH ELLWOOD.

Private Bag 62, Wodonga, Victoria. 8399

NOTICE OF INTENTION TO APPLY FOR A LICENCE TO DIVERT WATER AND CUT RACE (RE-ISSUE) FROM THE RIVER MURRAY AT PIANGIL.

I HEREBY give notice that I intend to apply for a licence empowering me to divert water for a term of five years to the extent of 65 acre-feet per annum at a maximum rate of 12 acre-feet per day of 24 hours for the irrigation of 60 acres of citrus and stone fruits and vines, being part of allotment 153A, Parish of Piangil, and to occupy certain Crown lands for works of diversion, and to cut a race thereon.

Any objection to such application must be forwarded in writing to reach the State Rivers and Water Supply Commission, Melbourne, before 20th November, 1965, being 30 days from the first publication of this notice.

FRASER EDWARD JOHN NICHOLS.

Piangil. 8400

I, GRACE DUCA, of Woorinen, in the State of Victoria, domestic, heretofore called and known by the name of GRACE SFAMENI, give public notice that by deed poll dated the 27th day of September, 1965, duly executed and attested and deposited with the Registrar-General in the said State, on the 5th day of October, 1965, I formally absolutely renounced and abandoned the said name of Grace Sfameni and declared that I had assumed and adopted and intended thenceforth upon all occasions whatsoever to use and subscribe the name of Grace Duca so as to be, at all times thereafter called named and described by the said name of Grace Duca.

DELANY & DELANY, barristers & solicitors, 270 Campbell-street, Swan Hill. 8448

I, SANDRA ASTLEY-ROTHERAM (formerly Elka Sandra Sher), of 16 Maitland-avenue, East Kew, in the State of Victoria, widow, do hereby give notice that the name of Elka Sandra Sher, is absolutely renounced and abandoned by me and in lieu thereof the name of Sandra Astley-Rotheram is assumed and adopted by me and it is intended henceforth upon all occasions at all times to use and that I be called and known by the full name of Sandra Astley-Rotheram in lieu of Elka Sandra Sher, and that such intended change is declared and evidenced by a deed poll dated the 7th day of October, 1965, and deposited in the office of the Registrar-General of the said State on the 12th day of October, 1965.

Dated the 7th day of October, 1965.

SANDRA ASTLEY-ROTHERAM.

Peter D. Garretty, solicitor, 151 Queen-street, Melbourne. 8396

NOTICE is hereby given that the Penshurst Youth Club has applied for a lease of allotments 8, 9 and 10, section 6, Township of Penshurst, containing 1½ acres, pursuant to section 134 of the Land Act 1958, for the purpose of amusement and recreation for a term of 21 years. 8151

NOTICE is hereby given that John Bond Bennett has applied for a lease under section 134 of the Land Act 1958, for a term of 21 years from 1st December, 1965, of an area of Crown land in section K, Parish of Bright, containing 8 acres more or less, as a site for the purpose of providing accommodation and facilities for tourists. 8088

NOTICE is hereby given that the Boy Scouts Association, Victorian Branch, has applied for a lease under section 134 of the Land Act 1958, for a term of 21 years, of an area of Crown lands in section 20, Township of Kangaroo Flat, Parish of Sandhurst fronting Church-street, and containing about 0.28 acres, as a site for purposes of amusement and recreation (Scout Hall site). 8198

NOTICE is hereby given that the Moe Bowling Club has applied for a lease under section 134 of the Land Act 1958, for a term of 21 years over an area of approximately 1 acre, to be excised from the Racecourse and Recreation Reserve, Township of Moe, as a site for Amusement and Recreation (bowling club). 8295

NOTICE is hereby given that we, N. L. Scarlett, Erle Wood, and Keith Salter, trustees of the Balmoral Golf Club, have applied for a lease under section 134 of the Land Act 1958, for a term of twenty-one (21) years of an area of Crown land being allotment 5, Parish of Yat Nat, containing 159 acres 1 rood 10 perches for recreation purposes.

N. L. SCARLETT.
ERLE WOOD.
KEITH SALTER.

8356

NOTICE is hereby given that the partnership heretofore subsisting between the undersigned John William Chase, of 7 Wallace-street, Morwell, and George Henry Jordon, of 178 Commercial-road, Morwell, carrying on a fishmongery business at Morwell and Moe has been dissolved by mutual consent as from the 16th day of September, 1965. All debts due to and owing by the said John William Chase and George Henry Jordon will be paid by George Henry Jordon who will continue to carry on the business at the same places.

Dated at Morwell the 8th day of October, 1965.

J. W. CHASE.
G. H. JORDON.

Witness to both signatures—M. CALLAGHAN, 176 Commercial-road, Morwell, shop assistant. 8441

NOTICE is hereby given that the partnership heretofore subsisting between David Alan Hawker, of Nichols-road, Leongatha, garage proprietor, and Harold Ramsey, of Nichols-road, Leongatha, garage proprietor, carrying on business under the name of Mardan Motors at Nichols-road, Leongatha, has been dissolved by mutual consent as from the 30th September, 1965, and the said business shall be carried on by the said Harold Ramsey as and from that date. All debts due to and owing by the said partnership will be received and paid by the said Harold Ramsey, who will continue to carry on the business at the same place.

Dated this 14th day of October, 1965.

D. A. HAWKER.
H. RAMSEY.

8470

NOTICE is hereby given that the partnership heretofore subsisting between Leslie Thomas Bulger, and Edgar Ross Jones, at 185 Maple-street, Golden Square, under the firm name of "Golden City Pest Control", was dissolved by mutual consent on the 1st day of October, 1965. All Shepparton debts due by and moneys due to the late firm will be paid or received by the said, Edgar Ross Jones, at 12 Cornish-street, Shepparton, and all Bendigo debts due by and moneys due to the late firm will be paid or received by the said Leslie Thomas Bulger, at 185 Maple-street, Golden Square.

SCHLEIGER & SMALLEY, solicitors, 290 Williamson-street, Bendigo. 8384

Companies Act 1961.—In the matter of ASCOT ROAD CONSTRUCTING CO. PTY. LTD., 1 Macartney-street, Reservoir.
—Notice of meeting—Creditors Voluntary Winding Up, Pursuant to Section 260.

NOTICE is hereby given that a meeting of creditors of the above-named company will be held at Room 513, Fourth Floor, Federation Building, 342 Flinders-street, Melbourne, on Wednesday, 27th October, 1965, at 10.30 a.m.

The company having convened a meeting of its members for the same day for the purpose of considering a Resolution that the company be wound up voluntarily.

Dated this 12th day of October, 1965.

W. A. NELSON, Director.

Bastian, Bent and Cougle, public accountants, Suite 18, 545 St. Kilda-road, Melbourne, S.C.3., Victoria. 8402

Notice of Winding-up Order.—In the matter of MALCOLME COLLINS PTY. LTD.

WINDING-UP Order made 8th October, 1965.

Name and address of liquidator, Peter William Harvey; of 440 Collins-street, Melbourne.

HEDDERWICK, FOOKES & ALSTON, solicitors for the petitioner. 8436

Notice of Winding-up Order.—In the matter of SERENELLA SHOES PROPRIETARY LIMITED.

WINDING-UP Order made the 12th October, 1965.

Name and address of liquidator, John Kenneth Hall, of 163 William-street, Melbourne, C.1.

WEIGALL & CROWTHER, solicitors for the petitioner. 8458

Companies Act 1961.

NOTICE OF FINAL MEETING OF SHAREHOLDERS OF I. D. MATEAR PROPRIETARY LIMITED (IN LIQ.).

NOTICE is hereby given that, pursuant to section 272 of the *Companies Act 1961*, a General Meeting of the members of I. D. Matear Proprietary Limited (In Liquidation) will be held at 419 Lonsdale-street, Melbourne, on Thursday, the 25th day of November, 1965, at Three o'clock in the afternoon, for the purpose of laying before the meeting an account showing how the winding up has been conducted and the property of the company has been disposed of, and of giving any explanation of the account. 8428

A. H. ETHERINGTON, Liquidator.

HOWARD-DUNCAN PTY. LTD.

NOTICE is hereby given that, in pursuance of section 272 (2) of the *Companies Act 1961*, a Final Meeting of the shareholders of Howard-Duncan Pty. Ltd. will be held at the office of Hughes, Fincher & Rodda, 290 Latrobe-street, Melbourne, on the 22nd day of November, 1965, at Three p.m., for the purpose of laying before the shareholders a statement of account showing the manner in which the winding up of the company has been conducted and the property of the company disposed of.

Dated this 15th day of October, 1965.

8429 NORMAN HARRIS, Liquidator.

The *Companies Act 1958.*—In the matter of OSBORNE TIMBER & TRADING CO. PTY. LTD. (IN LIQUIDATION).

NOTICE is hereby given that pursuant to section 210 of the *Companies Act* a Final Meeting of the creditors of the above company will be held at the offices of Kennedy, Smail & Middlemiss, 296-300 Little Lonsdale-street, Melbourne, on Wednesday, the 17th day of November, 1965, at 10.30 a.m.

Business to receive liquidator's accounts.

Dated this 12th day of October, 1965.

EDWARD RONALD SMAIL, Liquidator.

Kennedy, Smail & Middlemiss, 296 Little Lonsdale-street, Melbourne. 8434

In the matter of section 254 of the *Companies Act 1961.*—And in the matter of NEWBURN PROPRIETARY LIMITED (IN LIQUIDATION).

NOTICE is hereby given that at an Extraordinary General Meeting of Newburn Proprietary Limited (in Liquidation) held on 15th October, 1965, a Special Resolution was passed that the company be wound up voluntarily.

Dated 15th day of October, 1965.

8435 V. M. ROMBERG, Secretary.

CONSOLIDATED TIN DREDGING COMPANY LIMITED (in Voluntary Liquidation).

NOTICE CONVENING FINAL MEETING.

NOTICE is hereby given, pursuant to section 272 of the *Companies Act 1961*, that a General Meeting of the members of the above-named company will be held at 181 Clarence-street, Sydney, New South Wales, on the 17th day of November, 1965, at Ten o'clock in the forenoon, for the purpose of having an account laid before them showing the manner in which the winding up has been conducted and the property of the company disposed of, and of hearing any explanation that may be given by the liquidator.

8424

R. F. STREET, Liquidator.

The *Companies Act 1934-1960.*

RED TERROR GOLD MINES NO LIABILITY (in Liquidation).

NOTICE OF FINAL GENERAL MEETING OF SHAREHOLDERS AND FINAL MEETING OF CREDITORS.

NOTICE is hereby given, pursuant to the *Companies Act 1934-1960*, that a General Meeting of shareholders of the company will be held at the offices of Milne, Stevens, Searcy & Co., Steamship Building, 17 Currie-street, Adelaide, on Friday, 19th November, 1965, at 11 a.m. for the purpose of receiving the liquidator's account, showing how the winding up has been conducted and the property of the company disposed of.

Notice is also given that a Meeting of the creditors of the company will be held at the offices of Milne, Stevens, Searcy & Co., Steamship Building, 17 Currie-street, Adelaide, on Friday, 19th November, 1965, at 11.30 a.m. for the purpose of receiving the liquidator's account, showing how the winding up has been conducted and the property of the company disposed of.

Dated this 21st day of October, 1965.

8454

K. L. MILNE, Liquidator.

The *Companies Act 1934-1960.*

BROCKS CREEK URANIUM NO LIABILITY (in Liquidation).

NOTICE OF FINAL GENERAL MEETING OF SHAREHOLDERS AND FINAL MEETING OF CREDITORS.

NOTICE is hereby given, pursuant to the *Companies Act 1934-1960*, that a General Meeting of shareholders of the company will be held at the offices of Milne, Stevens, Searcy & Co., Steamship Building, 17 Currie-street, Adelaide, on Friday, 19th November, 1965, at 12 noon for the purpose of receiving the liquidator's account, showing how the winding up has been conducted and the property of the company disposed of.

Notice is also given that a Meeting of creditors of the company will be held at the offices of Milne, Stevens, Searcy & Co., Steamship Building, 17 Currie street, Adelaide, on Friday, 19th November, 1965, at 12.30 p.m. for the purpose of receiving the liquidator's account, showing how the winding up has been conducted and the property of the company disposed of.

Dated this 21st day of October, 1965.

8455

K. L. MILNE, Liquidator.

The *Companies Act 1958.*—In the matter of EASTSIDE APPLIANCE CENTRE PTY. LTD. (in Liquidation).

NOTICE is hereby given that a Second and Final Dividend is intended to be declared in this matter. Creditors who have not proved their debts by the 11th day of November, 1965, will be excluded from the dividend.

Dated this 21st day of October, 1965.

E. R. SMAIL, Liquidator.

Kennedy, Smail & Middlemiss, 296-300 Little Lonsdale-street, Melbourne, C.1. 8484

The *Companies Act 1961.*—In the matter of NALPA INVESTMENT PROPRIETARY LIMITED ((in Liquidation).

NOTICE is hereby given that pursuant to section 272 of the *Companies Act* a Final Meeting of the Creditors of the above company will be held at the offices of Kennedy, Smail and Middlemiss, 296-300 Little Lonsdale-street, Melbourne, on Wednesday, the 17th day of November, 1965, at 11 a.m.

Business to receive the Liquidator's Accounts.

Dated this 15th day of October, 1965.

EDWARD RONALD SMAIL, Liquidator.

Kennedy, Smail & Middlemiss, 296-300 Little Lonsdale-street, Melbourne. 8485

In the Supreme Court of Victoria (1965 CO7107).—In the matter of the *Companies Act 1961*; and in the matter of THOMPSON AND ASSOCIATES PTY. LIMITED.

NOTICE is hereby given that a petition for the winding up of the above-named company by the Supreme Court was on the 15th day of October, 1965, presented by James Canny, Deputy Commissioner of Taxation for the Commonwealth of Australia. And that the said petition is directed to be heard before the court sitting at the Fourteenth Court, Law Courts, William-street, Melbourne, at the hour of 10.30 o'clock in the forenoon, on the 12th day of November, 1965, and any creditor or contributory of the said company desiring to support or oppose the making of an order on the said petition may appear at the time of hearing by himself or his counsel for that purpose; and a copy of the said petition will be furnished to any creditor or contributory of the said company requiring the same by the undersigned on payment of the regulated charge for same.

The petitioner's official address is 436 Lonsdale-street, Melbourne.

The petitioner's solicitor is Harold Edward Renfree, Crown Solicitor for the Commonwealth, of 440 Little Collins-street, Melbourne.

H. E. RENFREE.

NOTE.—Any person who intends to appear on the hearing of the said petition must serve on or send by post to the above-named H. E. Renfree, notice in writing of his intention so to do. The notice must state the name and address of the person, or, if a firm, the name and address of the firm, and must be signed by the person or firm, or his or their solicitor (if any), and must be served or if posted, must be sent by post in sufficient time to reach the above-named not later than 4 o'clock in the afternoon of the 11th day of November, 1965. 8481

In the Supreme Court of Victoria (1965 CO7106).—In the matter of the *Companies Act 1961*; and in the matter of GALLMODES PROPRIETARY LIMITED.

NOTICE is hereby given that a petition for the winding up of the above-named company by the Supreme Court was on the 13th day of October, 1965, presented by James Canny, Deputy Commissioner of Taxation, for the Commonwealth of Australia. And that the said petition is directed to be heard before the court sitting at the Fourteenth Court, Law Courts, William-street, Melbourne, at the hour of 10.30 o'clock in the forenoon, on the 12th day of November, 1965, and any creditor or contributory of the said company desiring to support or oppose the making of an order on the said petition may appear at the time of hearing by himself or his counsel for that purpose; and a copy of the said petition will be furnished to any creditor or contributory of the said company requiring the same by the under-signed on payment of the regulated charge for the same.

The petitioner's official address is, 436 Lonsdale-street, Melbourne.

The petitioner's solicitor is Harold Edward Renfree, Crown Solicitor for the Commonwealth, of 440 Little Collins-street, Melbourne.

H. E. RENFREE.

NOTE.—Any person who intends to appear on the hearing of the said petition must serve on or send by post to the above-named, H. E. Renfree, notice in writing, of his intention so to do. The notice must state the name and address of the person, or, if a firm, the name and address of the firm, and must be signed by the person or firm, or his or their solicitor (if any), and must be served or if posted, must be sent by post in sufficient time to reach the above named not later than 4 o'clock in the afternoon of the 11th day of November, 1965. 8482

R.B.S. HOLDINGS PTY. LIMITED.

NOTICE is hereby given that in pursuance of section 272 (2) of the *Companies Act 1961*, a Final Meeting of the shareholders of R.B.S. Holdings Pty. Limited will be held at 357 King-street, Melbourne, on the 22nd day of November, 1965, at 3 p.m., for the purpose of laying before the shareholders a statement of account showing the manner in which the winding up of the company has been conducted and the property of the company disposed of.

Dated this 18th day of October, 1965.

8483 ROLAND JAMES QUING, Liquidator.

The *Companies Act 1958*.—In the matter of O'SHANNASSY BROS. PROPRIETARY LIMITED (in Liquidation).

NOTICE is hereby given that pursuant to section 210 of the *Companies Act* a Final Meeting of the Creditors of the above company will be held at the offices of

Kennedy, Smail & Middlemiss, 296-300 Little Lonsdale-street, Melbourne, on Wednesday, the 17th day of November, 1965, at 11.30 a.m.

Business to receive the Liquidator's Accounts.

Dated this 15th day of October, 1965.

EDWARD RONALD SMAIL, Liquidator.

Kennedy, Smail & Middlemiss, 296-300 Little Lonsdale-street, Melbourne. 8486

The *Companies Act 1961*.—In the matter of G. H. REID AND SONS (PENINSULA QUARRIES) PROPRIETARY LIMITED (in Voluntary Liquidation).

NOTICE is hereby given that at an Extraordinary General Meeting of Shareholders of the above-named company held on the 15th day of October, 1965, it was resolved that the company be wound up voluntarily and that Douglas Orson Oldfield, chartered accountant, of 395 Collins-street, Melbourne, be and is hereby appointed liquidator for the purpose of such winding up.

Dated this 15th day of October, 1965.

D. O. OLDFIELD, Liquidator, 395 Collins-street, Melbourne, C.1. 8488

HAROLD FRANCIS GOULD, late of corner of Sailors Gully-road, and Raywood-road, Eaglehawk, retired painter, DECEASED.

CREDITORS, next of kin and others having claims in respect of the estate of the above-named deceased (who died on the 18th day of June, 1964), are required by the personal representative, Sandhurst and Northern District Trustees, Executors and Agency Company Limited, of 18 View-street, Bendigo, to send particulars to it by the 21st day of December, 1965, after which date the said company may convey or distribute the assets, having regard only to the claims of which it has notice.

HOGAN, HOGAN & PETERSEN, solicitors, of 68 Bull-street, Bendigo. 8385

FREDERICK GEORGE HOWE, late of "Roslyn," Coppin-grove, Sorrento, gentleman, DECEASED.

CREDITORS, next of kin and others having claims in respect of the estate of the deceased (who died on the 17th day of July, 1965), are required by the administrator, The Trustees, Executors and Agency Company Limited, of 401 Collins-street, Melbourne, to send particulars to it by the 24th day of December, 1965, after which date the administrator may convey or distribute the assets, having regard only to the claims of which it then has notice.

DUGDALE, DIMMICK & STEVENS, solicitors, 486 Bourke-street, Melbourne. 8444

CREDITORS, next of kin and all others having claims in respect of the estate of Stanley Joseph O'Brien, formerly of Warburton, but late of 226 Lawrence-street, Wodonga, gentleman, deceased (who died on 19th July, 1964), are to send the particulars of such claims to the executrix, Veronica Elizabeth O'Brien, care of the under-signed solicitors, by the 21st December, 1965, after which date the said executrix will distribute the assets, having regard to the claims of which she then has notice.

PROUDFOOT, HORTON & COOKE, solicitors, 452 Lonsdale-street, Melbourne. 8445

CREDITORS, next of kin and others having claims in respect of the estate of Joseph John Grant, late of 36 Gordon-avenue, North Clayton, in the State of Victoria, insurance representative, deceased (who died on the 29th day of May, 1965), are to send the particulars of their claims to The National Trustees, Executors and Agency Company of Australasia Limited, of 95 Queen-street, Melbourne, in the said State, by the 24th day of December, 1965, after which date it will distribute the assets, having regard only to the claims of which it then has notice.

J. McD. JONES & PURCELL, solicitors, 540 Lonsdale-street, Melbourne. 8450

RONALD JAMES MIRAMS, late of Old Sale-road, Trafalgar North, farmer, DECEASED.

CREDITORS, next of kin and others having claims in respect of the estate of the deceased (who died on the 15th May, 1965), are required by the trustee, Irene Patricia Mirams, to send particulars to her, care of the under-signed solicitors, by the 31st December, 1965, after which date the trustee may convey or distribute the assets, having regard only to the claims of which she then has notice.

GRAY, FRIEND & LONG, solicitors, Warragul. 8420

JOHN SMITH MACDONALD, late of Corona, Miga Lake, grazier, DECEASED.

CREDITORS, next of kin and others having claims in respect of the estate of the deceased (who died on the 24th day of April, 1965), are required by Arthur Williams Phillips and Victor Paul O'Brien, both of Horsham, solicitors, the executors of the deceased's will, to send particulars to them, care of the undersigned, by the 1st day of February, 1966, after which date they may convey or distribute the assets, having regard only to the claims of which they then have notice.

POWER & BENNETT, solicitors, Horsham. 8417

JOSEPH HERBERT ERIC LOVELAND, late of 28 Peace-avenue, Warragul, garage proprietor, DECEASED.

CREDITORS, next of kin and others having claims in respect of the estate of the deceased (who died on the 19th May, 1965), are required by the trustees, Mary Loveland and James Fowler, to send particulars to them, care of the undersigned solicitors, by the 31st December, 1965, after which date the trustees may convey or distribute the assets, having regard only to the claims of which they then have notice.

GRAY, FRIEND & LONG, solicitors, Warragul. 8418

EDMUND BURKE POLINESS, late of 14 Bowen-street, Warragul, auctioneer, DECEASED.

CREDITORS, next of kin and others having claims in respect of the estate of the deceased (who died on the 17th June, 1965), are required by the trustee, Kathleen Sophia Poliness, to send particulars to her, care of the undersigned solicitors, by the 31st December, 1965, after which date the trustee may convey or distribute the assets, having regard only to the claims of which she then has notice.

GRAY, FRIEND & LONG, solicitors, Warragul. 8419

WILLIAM ARTHUR JOHN BEST, late of Camperdown, retired manager, DECEASED.

CREDITORS, next of kin and others having claims in respect of the estate of the deceased (who died on the 6th day of August, 1965), are required by the executors, Brian William Best and Colin Lalene Best, both of Camperdown, to send particulars to them, care of the under-mentioned solicitors, by the 31st day of December, 1965, after which date they may convey or distribute the assets, having regard only to the claims of which they then had notice.

BUCKLAND & NEVETT, solicitors, Camperdown. 8464

JAMES WINTER DODDS, late of 9 Scotsburn-grove, Toorak, company director, DECEASED.

CREDITORS, next of kin and others having claims against the estate of the deceased (who died on 5th May, 1965), are required by the executors, Brenda Dodds, Patrick John Vance Ramsden and John Ralph Burt, to send particulars to them, care of 120 William-street, Melbourne, by the 22nd December, 1965, after which date they may convey and distribute the assets, having regard only to the claims of which they then have notice.

BLAKE & RIGGALL, solicitors, 120 William-street, Melbourne. 8425

IRENE ALTEA DELPRAT, late of 23 Ethel-street, Balgowlah, New South Wales, widow, DECEASED.

CREDITORS, next of kin and others having claims against the estate of the deceased (who died on 31st October, 1964), are required by the executors, Bernard Gore Brett, John Ralph Burt and Moyna Delprat, to send particulars to them, care of 120 William-street, Melbourne, by the 22nd December, 1965, after which date they may convey and distribute the assets, having regard only to the claims of which they then have notice.

BLAKE & RIGGALL, solicitors, 120 William-street, Melbourne. 8426

CREDITORS, next of kin and others having claims against the estate of Martha Ann Crabtree, late of Flat 1, 179 Koornang-road, Carnegie, in the State of Victoria, widow, deceased (who died on the 20th day of February, 1965), are to send particulars of their claims to The Equity Trustees, Executors and Agency Company Limited, of 472 Bourke-street, Melbourne, by the 30th day of December, 1965, after which date it will distribute the assets, having regard only to the claims of which it then has notice.

G. A. BURCHILL, solicitor, 34 Queen-street, Melbourne. 8447

MARY ELIZABETH WALLS, late of "St. Ninians", 65 Euston-road, Oakleigh, in the State of Victoria, gentlewoman, DECEASED.

CREDITORS, next of kin and others having claims against the estate of the said deceased (who died on the 11th August, 1965), are required by Vera Gladys Walls, of 65 Euston-road, Oakleigh, aforesaid, gentlewoman and Charles Victor Pinney, of 164 Atherton-road, Oakleigh, aforesaid, law clerk, the executrix and executor respectively, appointed by the will of the deceased, to send particulars of their claims to the said executrix and executor, in the care of the under-mentioned solicitor, by the 21st December, 1965, after which date the said executrix and executor may convey or distribute the assets of the said deceased, having regard only to the claims of which the said executrix and executor then has notice.

Dated the 14th day of October, 1965.

COLIN B. CAMPBELL, LL.B., solicitor, 65A Atherton-road, Oakleigh. 8453

CREDITORS, next of kin and others having claims against the estate of George Basil Panagopoulo, formerly of 221A Balaclava-road, Caulfield, but late of 12 Lynch-street, Hawthorn, manufacturer, deceased, intestate (who died on the 22nd day of December, 1963), and letters of administration of whose estate has been granted to Ekaterini Panagopoulo, the widow of the said deceased, are to send particulars of their claims to the said Ekaterini Panagopoulo, care of the under-mentioned solicitor, on or before the 28th day of December, 1965, after which date the administratrix will distribute the assets, having regard only for the claims of which she then has notice.

JOHN I. SULLIVAN, solicitor, corner Kooyong and Glenhuntly roads, Caulfield. 8459

CREDITORS, next of kin and others having claims in respect of the estate of George Dickson Brown, late of 33 Munro-street, Kew, Victoria, gentleman, deceased (who died on the 6th August, 1964, and probate of whose will and codicil was granted to The Equity Trustees, Executors and Agency Company Limited, of 472 Bourke-street, Melbourne), are hereby requested to send particulars to the said company at its said address on or before the 17th day of December, 1965, after which date the said company will proceed to distribute the assets of the said deceased amongst the persons entitled thereto, having regard only to the claims of which it shall then have had notice.

Dated this 20th day of October, 1965.

D. BRUCE TUNNOCK, CLARKE & CASEY, 452 Lonsdale-street, Melbourne, solicitors for the applicant. 8446

CREDITORS, next of kin and others having claims in respect of the estate of Harry Conrad Fahle, late of 19 Hedgeley-avenue, East Malvern, retired director, deceased (who died on the 20th day of April, 1965), are to send the particulars of their claims to The Equity Trustees, Executors and Agency Company Limited, of 472 Bourke-street, Melbourne, by the 29th day of December, 1965, after which date it will distribute the assets, having regard only to the claims of which it then has notice.

FENTON & DUNN, solicitors, 422 Collins-street, Melbourne. 8479

CREDITORS, next of kin and others having claims in respect of the estate of Esther Kurzman, late of 39 Albert-street, Geelong West, in the State of Victoria, widow, deceased (who died on the 29th day of April, 1965), are to send the particulars of their claims to The Union-Fidelity Trustee Company of Australia Limited, of 100 Exhibition-street, Melbourne, by the 20th day of December, 1965, after which date it will distribute the assets, having regard only to the claims of which it then has notice.

HODGES, HALL & CO., solicitors, 143 Little Malop-street, Geelong. 8480

CREDITORS, next of kin and others having claims in respect of the estate of Annie Cecilia Agnes Chenoweth, late of Leongatha, widow, deceased intestate (who died on the 19th day of July, 1964), are required by the administrator, Alan Richard Chenoweth, of Nerrena, railway employee, to send particulars of their claims to him, care of the under-mentioned solicitors, by the 31st day of December, 1965, after which date the administrator will distribute the assets, having regard only to the claims of which he then has notice.

MARSHALL & MACKENZIE, solicitors, Leongatha. 8401

KARLIS KEVIETIS, late of 27 Tennyson-street, Kew, formerly textile painter, but late pensioner, DECEASED.

LEONHARDS STILVE, of 27 Tennyson-street, Kew, surveyor assistant, and Evalds Karklins, of 396 Gaffney-street, Pascoe Vale, machine operator, the executors of the will of the deceased (who died on the 27th day of June, 1965), require all creditors, next of kin and others having claims against the property or estate of the said deceased to send to them, care of the under-mentioned solicitors, on or before the 3rd day of January, 1966, particulars, in writing, of such claims, after which date the said executors intend to convey or distribute such property or estate to or among the persons entitled thereto, having regard only to the claims of which they shall have had notice.

Dated this 18th day of October, 1965.

I. DIZGALVIS & CO., solicitors, of 390 Lonsdale-street, Melbourne. 8478

NOTICE TO CREDITORS.

THE UNION-FIDELITY TRUSTEE COMPANY OF AUSTRALIA LIMITED, of 100 Exhibition-street, Melbourne, the executor of the will of Francis James Hatfield, late of 145 Toorak-road, Camberwell, teacher, deceased (who died on the 13th July, 1965), requires all creditors, next of kin and others having claims against the property or estate of the said deceased, to send to it the said executor at its address afore-mentioned on or before the 20th day of December, 1965, particulars, in writing, of such claims, after which date the said executor intends to convey or distribute such property in estate to or among the persons entitled thereto, having regard only to the claims to which it shall have had notice.

DARVALL & HAMBLETON, solicitors, 7th Floor, T. & G. Building, 147 Collins-street, Melbourne. 8487

Trustee Act 1958.

NOTICE TO CLAIMANTS.

PURSUANT to the Trustee Act 1958, creditors, next of kin and all other persons having claims in respect of the estate of the deceased persons named below are required to send particulars to the legal personal representative or representatives at the addresses stated, after which date the representative or representatives will distribute the assets, having regard only to the claims of which notice has been received:—

Leslie John Reeves Brown, late of 84 Elphin-street, Newport, retired railway employee, deceased, who died on the 1st day of August, 1965.—Claims to the executrix, Yvonne Leslie Reeves Egan, of 84 Elphin-street, Newport, married woman, care of John F. Carroll, of 4 Paisley-street, Footscray, solicitor, by the 22nd day of December, 1965. John F. Carroll, LL.B., solicitor, 4 Paisley-street, Footscray. 8471

Alfred Edward Hobill, late of 76 Alma-terrace, Newport, retired munition worker, deceased, died on the 24th day of August, 1965.—Claims to the executrix, Jessie Elizabeth Hobill, of 76 Alma-terrace, Newport, widow, care of John F. Carroll, of 4 Paisley-street, Footscray, solicitor, by the 22nd day of December, 1965. John F. Carroll, LL.B., solicitor, 4 Paisley-street, Footscray. 8472

JOHN Allan Terrett and Francis Thomas Terrett, both of Benalla, merchants, executors of the will and codicil of Martha Kissack, late of Benalla, in the State of Victoria, trained nurse (who died on the 22nd day of June, 1964), requires all creditors, next of kin and others having claims against the property or estate of the said deceased, to send particulars of such claims in writing, care of Hamilton Clarke and Clarke, 55 Nunn-street, Benalla, on or before the 3rd day of January, 1966, after which day the said executors intend to convey or distribute such property or estate to or among the persons entitled thereto, having regard only to the claims of which they shall then have had notice.

Dated this 14th day of October, 1965.

HAMILTON CLARKE & CLARKE, 55 Nunn-street, Benalla, proctors for the said executors. 8403

CREDITORS, next of kin and others having claims in respect of the estate of Ernest Allan Cheslea Jenkin, late of 6 Gavan-street, Burwood, in the State of Victoria, retired, deceased (who died on the 20th December, 1964), are requested to send particulars of their claims to the administratrix, Elsie Walsh, of 68 Nepean Highway, Mentone, on or before the 20th day of December, 1965, after which date she will distribute the assets, having regard only to the claims of which she then has notice.

8387

ELLEN FANNY MCKENZIE BORBIDGE, late of 45 Webster-street, Ballarat, married woman, DECEASED.

CREDITORS, next of kin and others having claims in respect of the estate of the above-named deceased (who died on the 20th day of September, 1964), are required by the executrix, Edith Irene Ewart, of Camperdown, widow, to send particulars to her in care of Arthur E. George and Sons, solicitors, 132 Manifold-street, Camperdown, by the 3rd day of January, 1966, after which date the executrix may convey or distribute the assets, having regard only to the claims of which she then has notice.

Dated the 14th day of October, 1965.

ARTHUR E. GEORGE & SONS, solicitors, 132 Manifold-street, Camperdown. 8404

CREDITORS, next of kin and others having claims in respect of the estate of John Campbell Scott, late of 193 Carinish-street, Clayton, in the State of Victoria, labourer, deceased intestate (who died on the 15th May, 1965), and letters of administration of whose estate were granted by the Supreme Court of Victoria, on 17th October, 1965, to Eileen Scott, of 103 Breed-street, Traralgon, in said State, widow, are to send particulars of their claims to the said administratrix, care of the below-mentioned solicitors by the 25th November, 1965, after which date she will distribute the assets of the deceased, having regard only to the claims of which she then has notice.

Dated the 11th day of October, 1965.

BRUCE & LITTLETON, solicitors, Traralgon. 8386

ESTATE OF STANLEY WILLIAM NORMAN, DECEASED.

NOTICE is hereby given that creditors, beneficiaries and others having claims against the estate of Stanley William Norman, deceased, late of 96 Main-street, Greensborough, Victoria, formerly of 32 Eton-street, Redfern, South Australia, retired steriliser (who died at Melbourne, in the State of Victoria, on the 10th day of July, 1965), and probate of whose will was granted to Executor Trustee and Agency Company of South Australia Limited, of 22 Grenfell-street, Adelaide, in the State of South Australia, are directed to send full particulars of their claims to the said company on or before 20th day of November, 1965, otherwise they will be excluded from the distribution of the estate.

Dated this 14th day of October, 1965.

EXECUTOR TRUSTEE AND AGENCY COMPANY OF SOUTH AUSTRALIA LIMITED, 22 Grenfell-street, Adelaide. 8388

REGINALD JOSEPH WALL, late of 26 Railway-avenue, East Caulfield, retired, DECEASED.

CREDITORS, next of kin and others having claims in respect of the estate of the above-named deceased (who died on the 12th day of March, 1965), are required by Stanley Wilkinson Misson, of 19 Madeline-street, Burwood, solicitor, to send particulars to him, care of the undersigned by the 24th day of December, 1965, after which date the executor may convey or distribute the assets, having regard only to the claims of which he then has notice.

S. W. MISSON & BARTLEY, solicitors, 59 Waverley-road, East Malvern. 8392

GEORGE ROBERT GREGG, senior, late of Swan Hill, in the State of Victoria, retired orchardist, DECEASED (who died on 4th December, 1964).

CREDITORS, next of kin and all other persons having claims against the estate of the deceased are required by the executors of the will, Jessie Gregg and Henry John Gregg, to send particulars to them care of the undersigned, on or before the 12th day of January, 1966, after which date they will distribute the assets, having regard only to the claims of which they then have notice.

GARDEN & GREEN, solicitors, 4 McCallum-street, Swan Hill. 8393

CREDITORS, next of kin and others having claims against the estate of Irving Winter Hetherington, late of Avoca, in Victoria, retired bank manager, deceased (who died on the 26th day of August, 1965), are required by the executor of his will and first codicil thereto, the Union-Fidelity Trustee Company of Australia Limited, of 101 Lydiard-street north, Ballarat, to send particulars thereof to the said executor, care of the undersigned on or before the 20th day of December, 1965, after which date the said executor will distribute the assets, having regard only to the claims of which it then has notice.

J. K. SPARK, solicitor, St. Arnaud.

8460

CREDITORS, next of kin and others having claims in respect of the estate of Charles Fildas Langford, late of 16 Woodville-avenue, Glenhuntly, gentleman, deceased (who died on the 22nd August, 1965), are to send particulars of their claims to the Equity Trustees, Executors and Agency Company Limited, at 472 Bourke-street, Melbourne, by the 23rd December, 1965, after which date it will distribute the assets, having regard only to the claims of which it then has notice.

LEACH & THOMSON, solicitors, 472 Bourke-street, Melbourne. 8473

CREDITORS, next of kin and others having claims in respect of the estate of Fernie Alberta May Fletcher, late of 1 Eddy-street, Moonee Ponds, spinster, deceased (who died on the 3rd day of November, 1964), are to send the particulars of their claims to the executor, Leonard Clinton Shaw, in care of Middleton, McEacharn, Shaw & Birch, of 224 Queen-street, Melbourne, solicitors, by the 23rd day of December, 1965, after which date the executor will distribute the assets, having regard only to the claims of which he then has notice.

MIDDLETON, MCEACHARN, SHAW & BIRCH, solicitors, 224 Queen-street, Melbourne. 8474

ELLEN ELIZABETH MENZIES, late of 26 Kiama-road, Flemington, widow, DECEASED, intestate.

CREDITORS, next of kin and others having claims in respect of the estate of the above-named deceased (who died on the 26th day of July, 1965), are required by the administrator, National Trustees, Executors and Agency Company of Australasia Limited, of 95 Queen-street, Melbourne, to send particulars to it at its address aforesaid by the 22nd day of December, 1965, after which date the said administrator may convey or distribute the assets of the said deceased, having regard only to the claims of which it then has notice.

BERNARD NOLAN, solicitor, 595 Bourke-street, Melbourne. 8475

HERBERT CHARLES FERRIER, formerly of 24 Lillimuir-road, Ormond, but late of Repatriation Hospital, Bundoora, retired farmer, DECEASED (who died on the 16th day of May, 1965).

CREDITORS, next of kin and all other persons having claims against the estate of the deceased, are required by the executor of his will, John Charles Ferrier, of 24 Lillimuir-road, Ormond, formerly newsagent, but now postmaster, to send particulars thereof to him, care of the under-mentioned solicitors before the 22nd day of December, 1965, after which date he may distribute the assets of the deceased, having regard only to the claims of which he then has notice.

COLTMAN, WYATT & ANDERSON, solicitors, of 578 Bourke-street, Melbourne. 8476

CREDITORS, next of kin and others having claims in respect of the estate of Emma Margueretta Lyall, late of 88 Victoria-street, Coburg, in the State of Victoria, married woman, deceased (who died on the 19th May, 1965), are to send the particulars of their claims to the administratrix, Betty Lorraine Congleton, in care of Colin Keon-Cohen, 472 Bourke-street, Melbourne, by the 22nd December, 1965, after which date she will distribute the assets, having regard only to the claims of which she then has notice.

Dated the 19th October, 1965.

COLIN KEON-COHEN, solicitors, 472 Bourke-street, Melbourne. 8477

HELEN LOIS WALKER, formerly of 15 Orrong-grove, Caulfield North, but late of Mercer Court, 17 Mercer-road, Malvern, in the State of Victoria, married woman, DECEASED.

CREDITORS, next of kin and others having claims in respect of the estate of the above-named deceased (who died on the 1st day of August, 1964), are required by the Trustees, Executors and Agency Company Limited, of 401 Collins-street, Melbourne, in the State of Victoria to whom letters of administration of the estate of the said deceased with the will and codicil annexed were granted pursuant to the authority of Reginald James Forbes one of the executors named in and appointed by the said will, and the said executor, to send particulars to the Trustees, Executors and Agency Company Limited, by the 21st day of December, 1965, after which date the said company intends to convey or distribute the assets of the estate, having regard only to the claims of which it may then have notice.

KEITH A. NESS & SON, solicitors, 411 Collins-street, Melbourne. 8431

CREDITORS, next of kin and others having claims in respect of the estate of Ellen Irene Galt, late of 382-384 Nepean Highway, Frankston, spinster, deceased (who died on the 15th day of May, 1965), are to send particulars of their claims to Peter McCallum and John Watson McCallum, care of the undersigned, by the 22nd day of December, 1965, after which date they will distribute the assets, having regard only to the claims of which they then have notice.

COOK & MCCALLUM, solicitors, 422 Collins-street, Melbourne. 8427

CONSTANCE MYRA WALLACE-DUNLOP, late of Warragul, gentlewoman, DECEASED (who died on the 2nd April, 1965).

CREDITORS, next of kin and all persons having claims against the estate of the deceased, are required to send particulars to the executor, the Trustees, Executors and Agency Company Limited, of 401 Collins-street, Melbourne, on or before the 20th day of December, 1965, after which date it will distribute the assets, having regard only to the claims of which it shall then have notice.

R. W. SHELLARD & SON, solicitors, Albert-street, Daylesford. 8416

CREDITORS, next of kin and others having claims in respect of the estate of Beryl May Williamson, late of 45 Moselle-street, Box Hill, spinster, deceased (who died on the 1st June, 1965), are to send particulars of their claims to The Perpetual Executors and Trustees Association of Australia Limited, of 100-104 Queen-street, Melbourne, by the 28th December, after which date it will distribute the assets, having regard only to the claims of which it then has notice.

HENDERSON & BALL, solicitors, 430 Little Collins-street, Melbourne. 8440

CREDITORS, next of kin and others having claims in respect of the estate of Aladar David, late of 13 Macartney-avenue, Kew, laundry proprietor, deceased, intestate (who died on 1st February, 1965), are requested by the administratrix, Irene David, to send particulars of their claims to her, care of the undersigned solicitors, by the 23rd day of December, 1965, after which date she will distribute the estate, having regard only to the claims of which she then has notice.

FREDERICK OWEN & ASSOCIATES, solicitors, 84 William-street, Melbourne. 8432

EDMUND GOLLOP, late of 2 Hansen-road, Boronia, pensioner, DECEASED.

CREDITORS, next of kin and others having claims in respect of the estate of the deceased (who died on the 26th May, 1965), are required by Dudley Ackerley Tregent, of 422 Collins-street, Melbourne, solicitor, the executor to whom probate was granted on the 12th October, 1965, to send particulars to him by the 21st day of December, 1965, after which date the executor may convey or distribute the assets, having regard only to the claims of which he then has notice.

DUDLEY A. TREGENT, B.A., LL.M., solicitor, 422 Collins-street, Melbourne. 8433

HEATHER ADELAIDE JOHNSON, late of Milton Hill, 57 Hewish-road, Croydon, in the State of Victoria, married woman, DECEASED.

CREDITORS, next of kin and others having claims in respect of the estate of the deceased (who died on the 7th June, 1965) are required by the personal representatives, The Union Fidelity Trustee Company of Australia Limited, of 100 Exhibition-street, Melbourne, in the said State, to send particulars to them, by 22nd December, 1965, after which date the personal representatives may convey or distribute the assets having regard only to the claims of which they then have notice.

HEDDERWICK, FOOKES & ALSTON, 103 William-street, Melbourne. 8437

EDGAR CHARLES HOWES, formerly of 2 Robross-street, Cheltenham, but late of 3 Margaret-street, Mordialloc, retired R.A.F., DECEASED (who died on the 20th August, 1965).

CREDITORS and next of kin having claims against the estate of the deceased, are requested by the executors, Garry Roger Howes, and Gerald Edward Delany, to send particulars of their claims to the under-mentioned solicitors on or before the 24th day of December, 1965, after which date they will distribute the assets, having regard only to the claims of which they then have notice.

GERALD E. DELANY & CO., solicitors, 452 Lonsdale-street, Melbourne. 8449

MAISIE CLARICE HORE, late of Ryan's-road, Buln Buln, widow, DECEASED.

CREDITORS, next of kin and others having claims in respect of the estate of the deceased (who died on the 21st March, 1965), are required by the trustee, Robert George Robbins, to send particulars to him, care of the undersigned solicitors by the 31st December, 1965, after which date the trustee may convey or distribute the assets, having regard only to the claims of which he then has notice.

GRAY, FRIEND & LONG, solicitors, Warragul. 8422

CREDITORS, next of kin and others having claims in respect of the estate of Mary Buxton, formerly of "Sunnyside", Mount Macedon, but late of 40 Normanby-road, Middle Brighton, spinster, deceased (who died on the 24th April, 1965), are to send particulars of their claims to John Augustine Pitt, of 10 Milfay-avenue, Kew, public servant, and Richard Raymond Buxton, of 47 Bay-street, Brighton, estate agent, by the 24th December, 1965, after which date they will distribute the assets, having regard only to the claims of which they then have notice.

CORR & CORR, solicitors, 290 Latrobe-street, Melbourne. 8451

BERNARD JOSEPH RYAN, late of 36 Synott-street, Werribee, farmer (DECEASED).

CREDITORS, next of kin and others having claims in respect of the above-named deceased (who died on the 5th December, 1965), are required by the executor, National Trustees, Executors and Agency Company of Australasia Limited, of 95 Queen-street, Melbourne, to send particulars to the said company at its address aforesaid, by the 27th day of December, 1965, after which date the said executor may convey or distribute the assets, having regard only to the claims of which it then has notice.

BERNARD NOLAN, solicitor, 595 Bourke-street, Melbourne. 8439

CREDITORS, next of kin and others having claims in respect of the estate of Frances Skolar, late of 47 Beddoe-street, East Bentleigh, widow, deceased (who died on the 9th day of February, 1965), are required by the executor, James Noel Bird, of 118 Queen-street, Melbourne, solicitor, to send particulars of their claims to him, care of Strongman & Crouch, of 118 Queen-street, Melbourne, by the 26th day of December, 1965, after which date the executor will distribute the assets, having regard only to the claims of which he shall then have had notice.

STRONGMAN & CROUCH, solicitors, of 118 Queen-street, Melbourne. 8442

EVELYN HOWE, late of Roslyn, Coppin-grove, Sorrento, spinster, DECEASED.

CREDITORS, next of kin and others having claims in respect of the estate of the deceased (who died on the 16th day of July, 1965), are required by the administrator, The Trustees, Executors and Agency Company Limited, of 401 Collins-street, Melbourne, to send particulars to it, by the 24th day of December, 1965, after which date the administrator may convey or distribute the assets, having regard only to the claims of which it then has notice.

DUGDALE, DIMMICK & STEVENS, solicitors, 486 Bourke-street, Melbourne. 8443

JOHN MAXWELL COLTISH, late of Buln Buln-road, Drouin, farmer, DECEASED.

CREDITORS, next of kin and others having claims in respect of the estate of the deceased (who died on the 6th May, 1965), are required by the trustee, Brenda Joy Coltish, to send particulars to her care of the undersigned solicitors by the 31st December, 1965, after which date the trustee may convey or distribute the assets, having regard only to the claims of which she then has notice.

GRAY, FRIEND & LONG, solicitors, Warragul. 8421

ALBERT TWEED MANN, late of Ellenbank, retired farmer, DECEASED.

CREDITORS, next of kin and others having claims in respect of the estate of the deceased (who died on the 19th June, 1965), are required by the trustees, Keith Robert Farthing, and Elizabeth Hilda Fraser, to send particulars to them, care of the undersigned solicitors by the 31st December, 1965, after which date the trustees may convey or distribute the assets, having regard only to the claims of which they then have notice.

GRAY, FRIEND & LONG, solicitors, Warragul. 8423

PRESTON GUY REYNOLDS, late of 1043 Malvern-road, Toorak, in the State of Victoria, medical practitioner, DECEASED.

CREDITORS, next of kin and others having claims in respect of the estate of the above-named deceased (who died on the 8th day of June, 1965), are required by the executor, The Trustees, Executors and Agency Company Limited, of 401 Collins-street, Melbourne, to send particulars to it by the 23rd day of December, 1965, after which date the executor may convey or distribute the assets, having regard only to the claims of which it then has notice.

Dated the 20th day of October, 1965.

MEARES, DUGAN & HALL, solicitors, 339 Collins-street, Melbourne. 8430

JOHN ATHANASAKIS (usually known as John Athas), late of 161 Mansfield-street, Northcote, retired boot repairer, DECEASED.

CREDITORS, next of kin and others having claims in respect of the estate of the said deceased (who died on the 11th July, 1965), are required by The Equity Trustees, Executors and Agency Company Limited, of 472 Bourke-street, Melbourne, to send particulars to them care of the undersigned, on or before, the 20th December, 1965, after which date they will distribute the assets, having regard only to the claims of which they then have notice.

WISEWOULD, DUNCAN & HANGER, solicitors, 11 Bank-place, Melbourne. 8438

In the Supreme Court of the State of Victoria.

SALE BY THE SHERIFF.

ON Friday, the 3rd of December, 1965, at Ten a.m., at the Police Station, Pascoe Vale (unless process be stayed or satisfied):—

All the estate and interest (if any) of R. Casale, married woman, of 16 Camdon-street, Pascoe Vale, as joint proprietor with Alessandro Casale, labourer, of an estate in fee-simple in the land described in certificate of title, volume 6757, folio 236, upon which is erected a weather-board dwelling house, known as No. 16 Camdon-street, Pascoe Vale.

Registered mortgage Nos. C.223320 and C.232045 affect the said estate and interest.

Terms: Cash only.

8456 N. FROGLEY, Sheriff's Officer.

In the Supreme Court of the State of Victoria.

SALE BY THE SHERIFF.

ON Friday, the 3rd of December, 1965, at Ten a.m., at the Police Station, Bayswater (unless process be stayed or satisfied):—

All the estate and interest (if any) of G. W. Prentice and F. M. Prentice, individual and married woman respectively, both of 25 Somerset-street, Wantirna South, as joint proprietors of an estate in fee-simple in the land described in certificate of title, volume 8481, folio 085, upon which is erected a cream brick veneer dwelling house, known as No. 25 Somerset-street, Wantirna South.

Registered Mortgage No. B.822892 and Caveat No. C.12500 affect the said estate and interest.

Terms: Cash only.

DAVID J. JOHNSTON, Sheriff's Officer. 8457

IMPOUNDINGS

KERANG.—Impounded in Kerang Pound, on 11th October, 1965.

1 chestnut pony, no visible marks or brand

If not claimed and expenses paid, to be sold on 5th November, 1965.

8405—14/ F. F. HASTIE, Poundkeeper.

KERANG.—Impounded in Kerang Pound on 15th October, 1965.

2 Merino lambs, no visible brands

1 long tail ram lamb, red brand, blue raddle on back

1 ram lamb, red raddle, green brand on back

1 border ram, notch back left ear, tagged right ear

"Nardoo", no visible brand

2 border rams, tattooed right ear, tag 2436, no visible brand

If not claimed and expenses paid, to be sold on 5th November, 1965.

8489—26/ F. F. HASTIE, Poundkeeper.

Subordinate Legislation Act 1962.

NOTICE OF MAKING OF STATUTORY RULES.

IN pursuance of the provisions of the *Subordinate Legislation Act 1962* and the Regulations made thereunder notice is given of the making of the following statutory rules:—

No.	Marine Act 1958.	Price. s. d.
197/1965.	The Pilot (Pilotage Exemption) Regulations 1965	1 0
<i>Labour and Industry Act 1958.</i>		
198/1965.	Labour and Industry (General Safety) Regulations 1965	1 0
<i>Apprenticeship Act 1958.</i>		
199/1965.	Apprenticeship (Flat Glass Trades) Regulations 1965	1 0
<i>Apprenticeship Act 1958.</i>		
200/1965.	Apprenticeship (Vehicle Trades) Regulations 1965	1 3
<i>Justices Act 1958.</i>		
201/1965.	Justices Act Amending Rules 1965	0 6

Copies of these statutory rules may be purchased at the Sale of Publications Section of the Government Printing Office, located at Macarthur-street, Melbourne, C.2. If ordered by mail, remittance should be addressed to "The Government Printer, Box 203, P.O., North Melbourne, N.1.", and should include 6d. extra for postage.

A. C. BROOKS,
Government Printer.

ACTS REPRINTED IN ACCORDANCE WITH THE AMENDMENTS INCORPORATION ACT 1958 (No. 6422), AND FOR SALE AT THE SALE OF PUBLICATIONS BRANCH OF THE GOVERNMENT PRINTING OFFICE, MACARTHUR-STREET, MELBOURNE.

No.		Price. s. d.
6189.	Acts Interpretation (Incorporating amendments up to No. 7146)	1 6
6191.	Administration and Probate (<i>Second Reprint</i> —Incorporating amendments up to No. 6920)	3 6
6209.	Boiler Inspection (Incorporating amendments up to No. 7072)	1 9
6218.	Children's Court (Incorporating amendments up to No. 7084)	2 0
6219.	Children's Welfare (Incorporating amendments up to No. 6812)	2 6
6220.	Clean Air (Incorporating amendments up to No. 6886)	1 0
6222.	Commercial Goods Vehicles (Incorporating amendments up to No. 6886)	1 9
6839.	Companies (Incorporating amendments up to No. 7142)	22 6
6225.	Co-operation (<i>Second Reprint</i> —Incorporating amendments up to No. 7083)	4 3
6226.	Co-operative Housing Societies (Incorporating amendments up to No. 7097)	4 0
6228.	Country Fire Authority (Incorporating amendments up to No. 7065)	4 0
6229.	Country Roads (Incorporating amendments up to No. 6943)	4 0
6231.	Crimes (Incorporating amendments up to No. 6958)	13 3
6236.	Dog (<i>Second Reprint</i> —Incorporating amendments up to No. 7065)	1 6
6242.	Employers and Employe's (Incorporating amendments up to No. 6740)	1 9
6245.	Estate Agents (<i>Second Reprint</i> —Incorporating amendments up to No. 7134)	3 9
6246.	Evidence (Incorporating amendments up to No. 6758)	3 6
6249.	Fences (Incorporating amendments up to No. 6550)	1 3
6251.	Firearms (Incorporating amendments up to No. 6716)	2 3
6585.	Forests (Pulpwood Agreement) (Incorporating amendments up to No. 6886)	1 6
6259.	Gaols (Incorporating amendments up to No. 6651)	1 6
6265.	Goods (<i>Third Reprint</i> —Incorporating amendments up to No. 7131)	2 9
6270.	Health (Incorporating amendments up to No. 6886)	14 6

ACTS REPRINTED IN ACCORDANCE WITH THE AMENDMENTS INCORPORATION ACT 1958 (No. 6422)—continued.

No.		Price. s. d.
6274.	Hospitals and Charities (Incorporating amendments up to No. 6716)	3 6
6279.	Instruments (<i>Second Reprint</i> —Incorporating amendments up to No. 6886)	3 9
6282.	Justices (Incorporating amendments up to No. 6961)	11 3
6283.	Labour and Industry (<i>Second Reprint</i> —Incorporating amendments up to No. 7143)	7 6
6285.	Landlord and Tenant (<i>Second Reprint</i> —Incorporating amendments up to No. 6996)	5 0
6289.	Land Tax (Incorporating amendments up to No. 7099)	3 3
6291.	Legal Profession Practice (Incorporating amendments up to No. 7065)	4 6
6293.	Licensing Act (<i>Second Reprint</i> —Incorporating Amendments up to No. 7054)	9 6
6577.	Lifts and Cranes (Incorporating amendments up to No. 6886)	1 3
6295.	Limitation of Actions (Incorporating amendments up to No. 6845)	1 6
6298.	Local Authorities Superannuation (Incorporating amendments up to No. 6894)	2 6
6299.	Local Government (Incorporating amendments up to No. 7052)	35 0
5309.	Medical (Incorporating amendments up to No. 6837)	3 9
6310.	Melbourne and Metropolitan Board of Works Act 1958 (Incorporating amendments up to No. 7054)	8 6
6605.	Mental Health (Incorporating amendments up to No. 7135)	4 6
6315.	Metropolitan Fire Brigades (Incorporating amendments up to No. 6886)	2 9
6317.	Milk and Dairy Supervision (Incorporating amendments up to No. 6964)	4 0
6318.	Milk Board Act (Incorporating amendments up to No. 7093)	2 3
6324.	Money Lenders (Incorporating amendments up to No. 6886)	2 6
6832.	Motor Boating (Incorporating amendments up to No. 6961)	1 6
6325.	Motor Car (Incorporating amendments up to No. 6867)	6 6
6328.	Nurses (Incorporating amendments up to No. 6716)	2 0
6330.	Partnership	1 6
6889.	Poisons (Incorporating amendments up to No. 7065)	3 6
6337.	Police Offences (Incorporating amendments up to No. 7145)	8 3
6338.	Police Regulation (Incorporating amendments up to No. 7081)	4 6
6890.	Probate Duty (Incorporating amendments up to No. 6970)	3 9
6343.	Process Servers and Inquiry Agents (Incorporating amendments up to 7126)	1 3 0
6344.	Property Law (Incorporating amendments up to No. 6867)	9 0
6349.	Public Service (Incorporating amendments up to No. 6886)	2 9
6350.	Public Trustee (Incorporating amendments up to No. 6961)	3 6
6359.	Road Traffic (Incorporating amendments up to No. 6999)	1 6
6363.	Second-Hand Dealers	1 3
6367.	Settled Land (Incorporating amendments up to No. 6505)	4 0
6651.	Social Welfare (<i>Second Reprint</i> —Incorporating amendments up to No. 7084)	3 6
6372.	Soil Conservation and Land Utilization Act 1958 (Incorporating amendments up to No. 6961)	2 0
6375.	Stamps (<i>Second Reprint</i> —Incorporating amendments up to No. 7142)	7 0
6377.	State Electricity Commission (Incorporating amendments up to No. 7054)	5 0
6379.	State Savings Bank (Incorporating amendments up to No. 6886)	4 3
6886.	Subordinate Legislation (Incorporating amendments up to No. 6961)	1 6
6399.	Transfer of Land (<i>Second Reprint</i> —Incorporating amendments up to No. 7130)	5 3
6401.	Trustee (<i>Second Reprint</i> —Incorporating amendments up to No. 6963)	4 3
6879.	Unclaimed Moneys (Incorporating amendments up to No. 6961)	1 3
6653.	Valuation of Land (Incorporating amendments up to No. 7019)	1 6
6413.	Water (Incorporating amendments up to No. 7228)	14 3

ACTS REPRINTED IN ACCORDANCE WITH THE AMENDMENTS INCORPORATION ACT 1958 (No. 6422)—continued.

No.		Price.
		s. d.
6414.	Weights and Measures (Including amendments up to No. 6918) ..	3 3
6419.	Workers Compensation (Incorporating amendments up to No. 7063) ..	5 0

FIRST NOTIFICATION OF REPRINT—

6210.	Building Societies Act 1958 (Incorporating Amendments up to No. 7125) ..	2 6
-------	--	-----

A. C. BROOKS,
Government Printer.

AGENTS FOR THE "VICTORIA GOVERNMENT GAZETTE".

THE following have been appointed agents to receive Advertisements and Subscriptions for the Victoria Government Gazette:—

- ARMSTRONG'S AGENCY, 205 Queen-street, Melbourne.
- ARNALL & JACKSON, 390 Barkly-street, Brunswick, N.10.
- BAIRNSDALE AUTHORIZED NEWSAGENCY, 132 Main-street, Bairnsdale.
- COOKE, F. R. & E. M., & SONS, 69 Bridge-street, Benalla.
- DAVIES, G. & M. V., 112 Gray-street, Hamilton.
- DAVIS, WM. (MILDURA) PTY. LTD., 126 Eighth-street, Mildura.
- DIXON'S NEWSAGENCY, 89 Firebrace-street, Horsham.
- EDGAR'S NEWSAGENCY PTY. LTD., 293 Hargreaves-street, Bendigo.
- FRANKS, H., & CO., 184 Ryrrie-street, Geelong.
- GORDON & GOTCH AUSTRALASIA LTD., 511 Little Collins-street, Melbourne.
- GULLAN'S NEWSAGENCY, 88 Bridge-street, Ballarat.
- HALES, D. & N., Henty-street, Casterton.
- HAMPTON, A. C., 243 Mitchell-street, Bendigo.
- HARSTON, PARTRIDGE & CO. PTY. LTD., 455 Little Collins-street, Melbourne.
- KYNETON GUARDIAN PTY. LTD., P.O. Box 18, Kyneton.
- THE MERCANTILE EXCHANGE, 90 Queen-street, Melbourne.
- MCGILL'S AUTHORIZED NEWSAGENCY, 183-5 Elizabeth-street, Melbourne.
- PETTY, R. H. & W. M., 83 Murphy-street, Wangaratta.
- PURDIE, J., & CO., 138 Moorabool-street, Geelong.
- SALE AUTHORIZED NEWSAGENCY, 142 Raymond-street, Sale.
- SKINNER'S AUTHORIZED NEWSAGENCY, 49-51 Franklin-street, Traralgon.
- TUFF'S SHEPPARTON NEWSAGENCY, 246 Wyndham-street, Shepparton.
- VERNON, C. F. & H. J., 162 Bridge-road, Richmond.
- VIEW POINT AUTHORIZED NEWSAGENCY, 4 View-Point, Bendigo.

A copy of the Gazette filed at each place for public reference.

THE "VICTORIA GOVERNMENT GAZETTE".

SUBSCRIPTIONS.—The subscription, including postage, is £2 15s. per annum, or £1 7s. 6d. per half year, payable in advance.

Subscriptions are required for whole months, and must cover at least a half year.

Single copies are One shilling, posted One shilling and six pence. Subscribers do not receive the Acts of Parliament with the GAZETTE.

GAZETTES are held in stock for five years only.

PRIVATE ADVERTISEMENTS.—The charge for insertion is 2s. per line single column, and 4s. per line double column. The title forms one or more lines as a heading. On an average ten words make a line of single column. Every signature must likewise be counted as a line. The final words of a paragraph, though only portion of a line, must be counted as one line. Signatures (in particular) and proper names must be written very plainly in the text; ONE SIDE ONLY of each sheet of paper should be WRITTEN UPON.

All documents illegibly written will be returned unpublished, and where brands occur unprovided for by the ordinary letters of the alphabet, a worded explanatory description must be furnished.

Advertisements unaccompanied by a remittance sufficient to cover the cost of the insertion will be returned unpublished.

THE VICTORIA GOVERNMENT GAZETTE is published on WEDNESDAY EVENING in each week, and Notices for insertion will be received by the Government Printer at or before ONE p.m. at ordinary rates, and late advertisements between ONE p.m. and FOUR p.m. at double rates on the day preceding the day of publication.

PAYMENTS.—All payments are required in advance and remittances should be made by cheque, postal note, or money order payable to "GOVERNMENT PRINTER".

ADDRESS.—All communications should be addressed to "The Government Printer, Box 203, P.O., North Melbourne".

PUBLICATION OF OFFICIAL MATTER.

ATTENTION is invited to the following procedure in relation to the publication of official matter in the Government Gazette:—

1. Matter submitted to the Executive Council.

Matters submitted to the Executive Council which requires gazettal will normally be published in the issue of the following week.

Where urgent gazettal is required, special arrangements should be made with the Gazette Officer, Room 9, first floor, Old Treasury Building.

Publication will be facilitated by the submission of carbon copies for the use of the Gazette Officer.

2. Other matter.

(a) All other matter duly certified by a responsible officer for publication should be lodged with the Gazette Officer not later than half-past Ten a.m. on Tuesday.

(b) Lengthy or involved notices should be forwarded several days before publication.

(c) Proofs, which will be supplied only when specifically requested or, at the direction of the Gazette Officer, should be returned promptly to avoid delay in publication.

(d) No additions or amendments to matter for publication will be accepted by telephone.

CONTENTS

	PAGE
Acts of Parliament	3237
Acts of Parliament on sale at the Government Printing Office	3297
Appointments	3260
Auction Sales Act	3257
Contracts	3244
Estates of Deceased Persons	3258
Government Notices	3237
Holiday—Melbourne Cup Day	3237
Impoundings	3296
Lands	3269
Melbourne and Metropolitan Board of Works—Notices	3254
Mining	3253
Notice to Mariners	3255
Notice of Making of Statutory Rules	3297
Orders in Council—	
Acts—Land; Landlord and Tenant; Local Government; Country Roads; Water; Sewerage Districts; Landlord and Tenant; University; Motor Car.	3262 et seq
Private Advertisements	3284
Proclamations	3235
Public Holidays	3237
Public Service Notices	3278
Resignations	3261
Tenders	3282
Transport Regulation Board—Public Hearings	3238
Waterworks Trusts	3251