

[2045]



# VICTORIA GOVERNMENT GAZETTE

Published by Authority

[Registered at the General Post Office, Melbourne, for transmission by post as a newspaper.]

No. 40]

WEDNESDAY, JUNE 8

[1966

Government House,  
Melbourne.

## LEVEE AT PARLIAMENT HOUSE, MELBOURNE.

In honour of the Birthday of Her Majesty the Queen, His Excellency the Governor of Victoria, Major-General Sir Rohan Delacombe, K.C.M.G., K.B.E., C.B., D.S.O., K.St.J., will hold a Levee at Parliament House, Spring-street, Melbourne, at 9.45 a.m. on Saturday, 11th June, 1966.

On the occasion of the celebration of The Queen's Birthday, His Excellency is anxious to receive as many citizens as possible.

In accordance with previous custom, there will be no precedence in the order of presentation, but it is requested that members of services and all public bodies group themselves together for presentation, as far as possible.

It is requested that those entitled to wear uniform or official dress will do so on this occasion, but His Excellency will be pleased to receive those not entitled to wear uniform or official dress in morning suit or lounge suit.

For the guidance of those attending the Levee, it will be appropriate, for those who wish to do so, to wear Honours, Decorations and Awards.

Private Entree Cards will admit recipients to the South Door of the Spring-street Entrance at Parliament House at 9.30 a.m. All other citizens are requested to enter by the North Door of the Spring-street Entrance at 10.15 a.m.

It is particularly desired that gentlemen attending the Levee should provide themselves with a card on which should be printed or typed in capitals, or written in block letters, their styles of address for presentation, in order to facilitate announcement to His Excellency.

By His Excellency's Command,

M. V. FLETCHER, Brigadier,  
Private Secretary and Comptroller.

### PROCLAMATIONS

*Land Act 1958.*

#### AREA OF LAND COMPRISED IN CERTAIN CLASSES DIMINISHED OR INCREASED.

##### PROCLAMATION

By the Lieutenant-Governor as Deputy for His Excellency the Governor of the State of Victoria and its Dependencies in the Commonwealth of Australia, &c., &c., &c.

WHEREAS by the *Land Act 1958* it is amongst other things enacted that the Governor in Council may, by Proclamation to be published in the *Government Gazette*, at any time diminish or increase the area of land comprised in any of the classes mentioned in Part I., Division 1, section 5, of the said *Land Act 1958*, but that the area of lands which may be sold by auction (Class 6), shall not be increased except as in certain cases in the said Act provided: Now therefore I, the Lieutenant-Governor as Deputy for the Governor of the State of Victoria, in the Commonwealth of Australia, by and with the advice of the Executive Council of the said State, and in accordance with the provisions of sections 94 and 117 of the *Land Act 1958* aforesaid, do hereby diminish or increase (as the case may be) the areas of Crown lands comprised in Classes 3 and 6 of the classes mentioned in section 5 of the *Land Act 1958* aforesaid, to the extent set forth in the subjoined Schedule (that is to say) :—

Schedule referred to.

##### CLASSES DIMINISHED OR INCREASED.

County.	Parish.	Allotment.	Section.	Area.	Diminished.	Increased.	Description.
					Class.	Class.	
				A. R. P.			
Croajingolong ..	Orbost East ..	37A	C	4 0 21	..	6	In the north-east of the parish
		37B	..	4 0 14	..	..	
Bogong ..	Porepunkah ..	15D	7	0 2 9	3	6	In the east of the parish
Bogong ..	Porepunkah ..	5	5	1 0 34	..	6	North of Everton-Bright Railway and Ovens River
Wonnangatta ..	Jamieson ..	8	10	0 2 33	3	6	In the south of the parish
		9	10	0 2 14	3	6	

Given under my Hand and the Seal of the State of Victoria, aforesaid, at Melbourne, this thirty-first day of May, in the year of Our Lord One thousand nine hundred and sixty-six and in the fifteenth year of the reign of Her Majesty Queen Elizabeth II.

E. F. HERRING.

(L.S.)

By His Excellency's Command,

JIM BALFOUR,  
Minister of Lands.

GOD SAVE THE QUEEN!

*Land Act 1958.*

#### UNALIENATED CROWN LAND AVAILABLE FOR SETTLEMENT UNDER IMPROVEMENT PURCHASE LEASE.

##### PROCLAMATION

By the Lieutenant-Governor as Deputy for His Excellency the Governor of the State of Victoria and its Dependencies in the Commonwealth of Australia, &c., &c., &c.

IN pursuance of the provisions of section 153 of the *Land Act 1958*, I, the Lieutenant-Governor as Deputy for the Governor of the State of Victoria in the Commonwealth of Australia, by and with the advice of the Executive Council of the said State, do by this Proclamation declare the unalienated Crown lands mentioned in the subjoined Schedule, to be available for settlement under improvement purchase lease.

##### SCHEDULE.

County.	Parish.	Allotment.	Section.	Area.	Land Valuation.
				A. R. P.	
Tanjil ..	Wa-De-Lock ..	4A, 4B, 4C, 4D	8	500, 0 0±	\$2 per acre.

Given under my Hand and the Seal of the State of Victoria aforesaid, at Melbourne, this thirty-first day of May, in the year of Our Lord One thousand nine hundred and sixty-six, and in the fifteenth year of the reign of Her Majesty Queen Elizabeth II.

E. F. HERRING.

(L.S.)

By His Excellency's Command,

JIM BALFOUR,  
Minister of Lands.

GOD SAVE THE QUEEN!

**PUBLIC HIGHWAY—SHIRE OF DONCASTER AND TEMPLESTOWE.**

**PROCLAMATION**

By the Lieutenant-Governor as Deputy for His Excellency the Governor of the State of Victoria and its Dependencies in the Commonwealth of Australia, &c., &c., &c.

**WHEREAS** by the *Local Government Act 1958*, as amended, section 519, it is amongst other things enacted that it shall be lawful for the Governor in Council at any time and from time to time upon request of the Council of any municipality by notice in the *Government Gazette* to proclaim any land reserved used or by purchase or exchange acquired for a street road highway thoroughfare bridge square court alley or right of way or any street road lane or passage made or laid out or proposed to be made or laid out on land of which a plan of subdivision delineating that street road lane or passage has been sealed with the seal of the municipality under subdivision (3) of Division 9 of Part XIX. of the *Local Government Act 1958*, or a corresponding previous enactment to be a public highway and that such land shall thereupon and thenceforth from the date of such Proclamation become and be absolutely dedicated to the public as a public highway within the meaning of any law then or thereafter in force:

And whereas the Council of the Shire of Doncaster and Templestowe, has requested that the land hereinafter mentioned, being a street made or laid out or proposed to be made or laid out on land of which a plan of subdivision delineating that street has been sealed with the seal of the municipality under subdivision (3) of Division 9 of Part XIX. of the *Local Government Act 1958*, or a corresponding previous enactment, be so declared to be a public highway:

Now therefore I, the Lieutenant-Governor as Deputy for the Governor of the State of Victoria in the Commonwealth of Australia, by and with the advice of the Executive Council of the said State, do by this Proclamation declare that Alva-avenue, coloured brown on plan of subdivision No. 11940, lodged in the Office of Titles shall be a public highway within the meaning of the said Act.

Given under my Hand and the Seal of the State of Victoria aforesaid, at Melbourne, this thirty-first day of May, in the year of our Lord One thousand nine hundred and sixty-six and in the fifteenth year of the reign of Her Majesty Queen Elizabeth II.

(L.S.) E. F. HERRING.

By His Excellency's Command.

R. J. HAMER,  
Minister for Local Government.

GOD SAVE THE QUEEN!

**PUBLIC HIGHWAY—SHIRE OF MANSFIELD.**

**PROCLAMATION**

By the Lieutenant-Governor as Deputy for His Excellency the Governor of the State of Victoria and its Dependencies in the Commonwealth of Australia, &c., &c., &c.

**WHEREAS** by the *Local Government Act 1958*, as amended, section 519, it is amongst other things enacted that it shall be lawful for the Governor in Council at any time and from time to time upon request of the Council of any municipality by notice in the *Government Gazette* to proclaim any land reserved used or by purchase or exchange acquired for a street road highway thoroughfare bridge square court alley or right of way or any street road lane or passage made or laid out or proposed to be made or laid out on land of which a plan of subdivision delineating that street road lane or passage has been sealed with the seal of the municipality under subdivision (3) of Division 9 of Part XIX. of the *Local Government Act 1958*, or a corresponding previous enactment to be a public highway and that such land shall thereupon and thenceforth from the date of such Proclamation become and be absolutely dedicated to the public as a public highway within the meaning of any law then or thereafter in force:

And whereas the Council of the Shire of Mansfield has requested that the land hereinafter mentioned, used for a street, be so declared to be a public highway:

Now therefore I, the Lieutenant-Governor as Deputy for the Governor of the State of Victoria in the Commonwealth of Australia, by and with the advice of the Executive Council of the said State, do by this Proclamation declare that Clarke-street, Mansfield, shown hatched on the plan hereunder shall be a public highway within the meaning of the said Act.

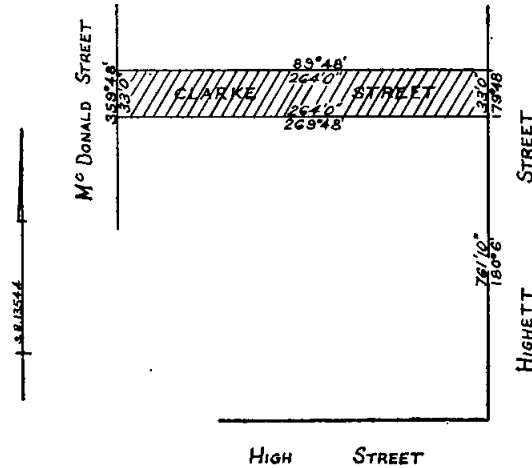

MEASUREMENTS ARE IN FEET AND INCHES

Given under my Hand and the Seal of the State of Victoria aforesaid, at Melbourne, this thirty-first day of May, in the year of our Lord One thousand nine hundred and sixty-six and in the fifteenth year of the reign of Her Majesty Queen Elizabeth II.

(L.S.) E. F. HERRING.

By His Excellency's Command.

R. J. HAMER,  
Minister for Local Government.

GOD SAVE THE QUEEN!

**Apprenticeship Act 1958.**

**WOOD MACHINING TRADE PROCLAIMED TO BE AN APPRENTICESHIP TRADE.**

**PROCLAMATION**

By the Lieutenant-Governor as Deputy for His Excellency the Governor of the State of Victoria and its Dependencies in the Commonwealth of Australia, &c., &c., &c.

**WHEREAS** section 13 of the *Apprenticeship Act 1958* provides, *inter alia*, that after the Minister has taken into consideration any recommendation made by the Apprenticeship Commission the Governor in Council, for the purposes of the said Act, may from time to time by Proclamation proclaim any trades to be apprenticeship trades and that the Governor in Council (whether with or without any recommendation of the said Commission) may by Proclamation at any time revoke, amend or vary any such Proclamation:

And whereas the trade of Machining (Furniture) was proclaimed to be an apprenticeship trade within the Metropolitan District on the 25th of March, 1952 and within the remainder of the State of Victoria on the 10th of June, 1965:

And whereas the Apprenticeship Commission, having notified in the manner prescribed by the said Act its intention to recommend that the trade of Wood Machining be proclaimed to be an apprenticeship trade within the whole of the State of Victoria, and having considered the representations made on behalf of employers and employees in the said trade, has recommended to the Minister that the said trade be so proclaimed and that the Proclamation of the trade of Machining (Furniture) as an apprenticeship trade in consequence be revoked:

And whereas the Minister has taken the said recommendation into consideration:

Now therefore I, the lieutenant-Governor as Deputy for the Governor of the State of Victoria in the Commonwealth of Australia, by and with the advice of the Executive Council of the said State, do by this my Proclamation:—

- (a) proclaim the trade of Wood Machining to be an apprenticeship trade within the whole of the State of Victoria;
- (b) revoke the Proclamations made on the 25th of March, 1952 and the 10th of June, 1965, in so far as they relate to the trade of Machining (Furniture).

Given under my Hand and the Seal of the State of Victoria aforesaid, at Melbourne, this thirty-first day of May, in the year of our Lord One thousand nine hundred and sixty-six and in the fifteenth year of the reign of Her Majesty Queen Elizabeth II.

(L.S.) E. F. HERRING.

By His Excellency's Command.

V. F. WILCOX,  
Minister of Labour and Industry.

GOD SAVE THE QUEEN !

*Apprenticeship Act 1958.*

GARDENING TRADE PROCLAIMED TO BE AN  
APPRENTICESHIP TRADE.

PROCLAMATION

By the Lieutenant-Governor as Deputy for His Excellency the Governor of the State of Victoria and its Dependencies in the Commonwealth of Australia, &c., &c.

WHEREAS section 13 of the *Apprenticeship Act 1958* provides, *inter alia*, that after the Minister has taken into consideration any recommendation made by the Apprenticeship Commission the Governor in Council, for the purposes of the said Act, may from time to time by Proclamation proclaim any trades to be apprenticeship trades:

And whereas the Apprenticeship Commission having notified in the manner prescribed by the said Act its intention to recommend that the gardening trade, in so far as it is carried on in municipal councils, racing clubs, foreshore trusts, golf clubs and cemetery trusts, in the Metropolitan District, be proclaimed an apprenticeship trade under the said Act, and having considered the representations made on behalf of the employers and employees in the said trade, has recommended to the Minister that the said trade be so proclaimed:

And whereas the Minister has taken the said recommendation into consideration:

Now therefore I, the Lieutenant-Governor as Deputy for the Governor of the State of Victoria in the Commonwealth of Australia, by and with the advice of the Executive Council of the said State, do by this my Proclamation proclaim the gardening trade, in so far as it is carried on in municipal councils, racing clubs, foreshore trusts and cemetery trusts, in the Metropolitan District, to be an apprenticeship trade.

Given under my Hand and the Seal of the State of Victoria aforesaid, at Melbourne, this thirty-first day of May, in the year of our Lord One thousand nine hundred and sixty-six and in the fifteenth year of the reign of Her Majesty Queen Elizabeth II.

(L.S.) E. F. HERRING.

By His Excellency's Command,

V. F. WILCOX,  
Minister of Labour and Industry.

GOD SAVE THE QUEEN !

LOCAL GOVERNMENT DEPARTMENT.

PROCLAMATION EXTENDING THE OPERATION OF  
THE UNIFORM BUILDING REGULATIONS.

By the Lieutenant-Governor as Deputy for His Excellency the Governor of the State of Victoria and its Dependencies in the Commonwealth of Australia, &c., &c.

WHEREAS section 916A of the *Local Government Act 1958*, as amended, provides—*inter alia*—that the Governor in Council may, by Proclamation published in the *Government Gazette*, at the request of the Council

of any municipality (not being a city or town) extend the operation of Part XLIX. of the said Act to the municipal district of such municipality or any part thereof:

And whereas by Proclamations published in the *Government Gazette* on the 25th May, 1947, 29th October, 1952 and 6th May, 1959, the operation of the said Part was extended to parts of the municipal district of the Shire of Buninyong:

And whereas the Council of the Shire of Buninyong has requested that the operation of the said Part be extended to the balance of the municipal district of the Shire of Buninyong:

Now therefore I, the Lieutenant-Governor as Deputy for the Governor of the State of Victoria, by and with the advice of the Executive Council thereof, by this, my Proclamation, do hereby extend the operation of the Regulations made under Part XLIX. of the *Local Government Act 1958*, as amended, to that part of the municipal district of the Shire of Buninyong to which they do not already apply, and order that the said Regulations shall come into operation in the above-mentioned part of the municipal district of the Shire of Buninyong on publication of this Proclamation in the *Government Gazette*, provided that Parts I. and II. of Chapter 8 thereof shall not be deemed to come into operation till the 8th September, 1966, except in so far as may be necessary to enable the Council of the said municipality to make by-laws pursuant to the powers conferred by Part III. of the said Chapter and provided further that no such by-laws shall come into operation before the 8th September, 1966.

Given under my Hand and the Seal of the State of Victoria aforesaid, at Melbourne, this thirty-first day of May, in the year of our Lord One thousand nine hundred and sixty-six and in the fifteenth year of the reign of Her Majesty Queen Elizabeth II.

(L.S.) E. F. HERRING.

By His Excellency's Command.

R. J. HAMER,  
Minister for Local Government.

GOD SAVE THE QUEEN !

MOTOR BOATING ACT 1961.—SECTION 4 (1).

PROCLAMATION

By the Lieutenant-Governor as Deputy for His Excellency the Governor of the State of Victoria and its Dependencies in the Commonwealth of Australia, &c., &c.

WHEREAS by section 2 of the *Motor Boating Act 1961* it is amongst other things enacted that the Governor in Council by Proclamation published in the *Government Gazette*, may from time to time appoint an Authority in control over any Victorian waters:

And whereas by section 4 of the *Motor Boating Act 1961* the Governor in Council, on the recommendation of an Authority having control over any Victorian waters, may by Proclamation published in the *Government Gazette* set aside or prohibit or restrict the use of any specified part or parts of any waters under the control of the Authority for any specified class or classes of boating or similar activity:

And whereas the Bridgewater Park Trust has been proclaimed the Authority over the waters of the River Loddon at Bridgewater in the Shire of Marong:

And whereas the Bridgewater Park Trust has recommended the prohibition of a certain part of the waters of the said river for all classes of boating and the setting aside of another part of the waters of the said river for water ski-ing:

Now therefore I, the Lieutenant-Governor as Deputy for the Governor of the State of Victoria, in the Commonwealth of Australia, by and with the advice of the Executive Council of the said State and in pursuance of the powers conferred by the *Motor Boating Act 1961*, do by this my Proclamation—

- (1) Prohibit the use of that part of the waters of the River Loddon at Bridgewater which lie between the railway bridge and the weir and bounded by the eastern bank of the said river and an imaginary line, parallel to the bank, from a point 150 feet westward along the bridge from the eastern bank, to the island adjacent to the weir, in midstream, for all classes of boating.
- (2) Set aside that part of the waters of the River Loddon from the road bridge over the said river for a distance of two miles in a southerly direction for water ski-ing.

The waters specified above are those delineated in the drawing No. L.R.A.1 in the Schedule hereto.

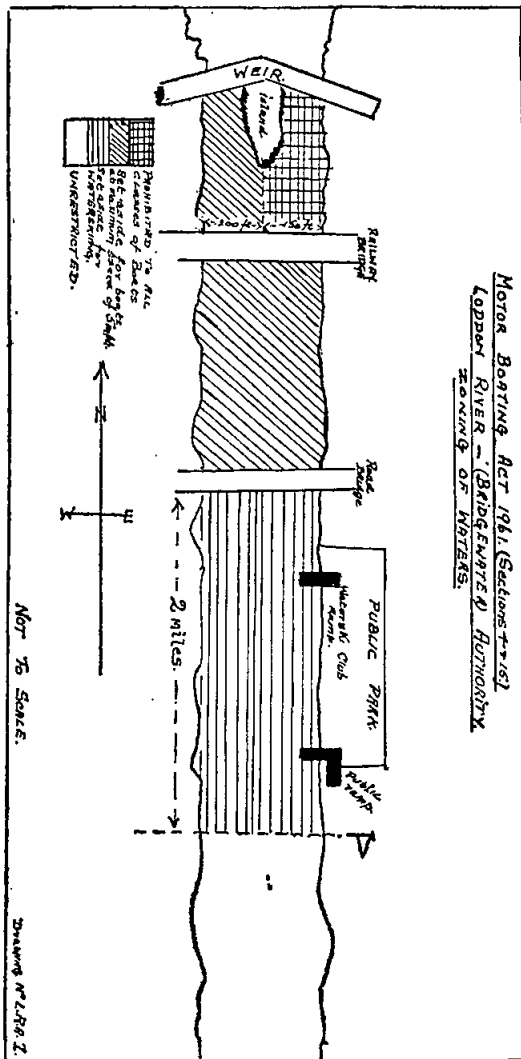

Given under my Hand and the Seal of the State of Victoria aforesaid, at Melbourne, this thirty-first day of May, in the year of our Lord One thousand nine hundred and sixty-six and in the fifteenth year of the reign of Her Majesty Queen Elizabeth II.

(L.S.) E. F. HERRING.

By His Excellency's Command,  
J. W. MANSON,  
Acting Chief Secretary.

GOD SAVE THE QUEEN!

METROPOLITAN TRANSPORTATION COMMITTEE (AMENDMENT) ACT 1965 (No. 7307).

PROCLAMATION

By the Lieutenant-Governor as Deputy for His Excellency the Governor of the State of Victoria and its Dependencies in the Commonwealth of Australia, &c., &c.

WHEREAS it is provided in sub-section (3) of section 1 of the Metropolitan Transportation Committee (Amendment) Act, 1965 (No. 7307), that the said Act shall come into operation on a day to be fixed by Proclamation of the Governor in Council published in the Government Gazette:

Now therefore, I, the Lieutenant-Governor as Deputy for the Governor of the State of Victoria, by and with the advice of the Executive Council thereof, do by this my Proclamation fix the 13th day of June, 1966, as the date on which the said Act shall come into operation.

Given under my Hand and the Seal of the State of Victoria aforesaid, at Melbourne, this thirty-first day of May, in the year of our Lord One thousand nine hundred and sixty-six and in the fifteenth year of the reign of Her Majesty Queen Elizabeth II.

(L.S.) E. F. HERRING.

By His Excellency's Command,  
R. J. HAMER,  
Acting Minister of Transport.  
GOD SAVE THE QUEEN!

WATER (RATING BY AREA) ACT 1966 (No. 7419).  
DATE OF COMING INTO OPERATION.

PROCLAMATION

By His Excellency the Governor of the State of Victoria and its Dependencies in the Commonwealth of Australia, &c., &c., &c.

WHEREAS it is provided by section 1 (3) of the WATER (RATING BY AREA) ACT (NO. 7419) that the said Act shall come into operation on a day to be fixed by Proclamation of the Governor in Council published in the Government Gazette: Now therefore I, the Governor of the State of Victoria, by and with the advice of the Executive Council thereof do by this my Proclamation fix the 15th day of June, 1966 as the date on which the said Act shall come into operation.

Given under my Hand and the Seal of the State of Victoria aforesaid, at Melbourne, this seventh day of June, in the year of our Lord One thousand nine hundred and sixty-six and in the fifteenth year of the reign of Her Majesty Queen Elizabeth II.

(L.S.) ROHAN DELACOMBE.

By His Excellency's Command,  
T. A. DARCY,  
Minister of Water Supply.  
GOD SAVE THE QUEEN!

Water Act 1958.

OTWAY WATERWORKS DISTRICT.  
PORTION OF DISTRICT PROCLAIMED AN "URBAN DISTRICT".

PROCLAMATION

By His Excellency the Governor of the State of Victoria and its Dependencies in the Commonwealth of Australia, &c., &c., &c.

UNDER the powers conferred by the Water Act 1958 and all other powers enabling me in that behalf, I, the Governor of the State of Victoria, with the advice of the Executive Council thereof, do hereby proclaim that as on and from the first day of July, 1966 that portion of the Otway Waterworks District, included within the boundaries set out and described in the Schedule hereto shall be and become an "Urban District" for the purposes of the said Act, and shall be known as Simpson Urban District.

SCHEDULE.

Boundaries of Simpson Urban District.

Commencing at the south-eastern angle of allotment 165, parish of Cooriejong, county of Heytesbury; thence by lines bearing South 16° 48' West 804 links, South 34° 47' East 2,535 4/10 links to the western boundary of a Government road; thence south-easterly by a line across that road to the most western angle of allotment 2A, parish of Corodjil; thence south-easterly and north-easterly by the south-western and south-eastern boundaries of that allotment to the most eastern angle thereof; thence south-easterly by the south-western boundary of the Simpson to Kennedy's Creek Road to the most northern angle of allotment 3A; thence south-westerly, south-easterly, and north-easterly by the north-western, south-western, and south-eastern boundaries of that allotment to the most eastern angle thereof; thence south-easterly by the south-western boundary of the Simpson to Kennedy's Creek Road to the most northern angle of allotment 5; thence by lines bearing

South 58° 25' West 225 3/10 links, South 31° 30' East 545 links and North 67° 59' East to the north-eastern boundary of the Simpson to Kennedy's Creek Road; thence north-westerly by that road boundary to the most southern angle of allotment 4A; thence north-easterly by the south-eastern boundary of that allotment and generally north-westerly by the north-eastern boundaries of said allotment 4A and allotment 1A and a line connecting those boundaries to the north-eastern angle of the last-mentioned allotment; thence westerly by the northern boundary of that allotment and northerly by the eastern boundary of Lavers Hill-road to the south-western angle of allotment 1B; thence easterly, northerly and westerly by the southern, eastern and northern boundaries of said allotment 1B, parish of Coradjil to the north-western angle thereof; thence northerly by the eastern boundary of Lavers Hill-road to a point in line with the northern boundary of allotment 95A, parish of Cooriejong; thence westerly by a line and the last-mentioned allotment boundary and southerly by the western boundary of said allotment 95A to the south-western angle of that allotment; thence generally north-westerly by the north-eastern boundaries of a Government road to a point in line with the western boundary of allotment 164; thence southerly by a line and the western boundaries of allotments 164 and 165 and easterly by the southern boundary of the last-mentioned allotment to the point of commencement.

Given under my Hand and the Seal of the State of Victoria aforesaid, at Melbourne, this seventh day of June, in the year of our Lord One thousand nine hundred and sixty-six, and in the fifteenth year of the reign of Her Majesty Queen Elizabeth II.

(L.S.) ROHAN DELACOMBE.

By His Excellency's Command,

T. A. DARCY,  
Minister of Water Supply.

GOD SAVE THE QUEEN!

Vermin and Noxious Weeds Acts.  
SIMULTANEOUS DESTRUCTION OF VERMIN.

PROCLAMATION

By the Lieutenant-Governor as Deputy for His Excellency the Governor of the State of Victoria and its Dependencies in the Commonwealth of Australia, &c., &c., &c.

WHEREAS by section 7 of the *Vermin and Noxious Weeds Act 1958* (No. 6409), as amended by section 7 of the *Vermin and Noxious Weeds Act 1959* (No. 6518), it is enacted that the Governor in Council may from time to time by Proclamation in relation to land in the whole of Victoria or to land in any part of Victoria described in the Proclamation require every owner or occupier of such land to destroy the vermin on such land by means of poisoning with a derivative of monofluoroacetic acid strychnine or arsenic or by fumigation of burrows and warrens and specify the method by which such poisoning or fumigation shall be undertaken and further direct the time within which it shall be undertaken and require such owners or occupiers to continue such poisoning or fumigation until the vermin are destroyed to the satisfaction of an Inspector:

Now therefore I, the Lieutenant-Governor as Deputy for the Governor of the State of Victoria in the Commonwealth of Australia, by and with the advice of the Executive Council of the said State, do hereby, in relation to land in the whole of Victoria, require every owner or occupier of such land to destroy certain vermin, to wit, rabbits, on such land by means of fumigation of burrows and warrens with calcium cyanide, chloropicrin, carbon tetrachloride or carbon monoxide and direct that such fumigation shall be undertaken within the period of four weeks commencing on Monday, the eighteenth day of July, One thousand nine hundred and sixty-six and require such owners or occupiers to continue such fumigation until the rabbits are destroyed to the satisfaction of an Inspector.

Given under my Hand and the Seal of the State of Victoria aforesaid, at Melbourne, this thirty-first day of May, in the year of our Lord One thousand nine hundred and sixty-six and in the fifteenth year of the reign of Her Majesty Queen Elizabeth II.

(L.S.) E. F. HERRING.

By His Excellency's Command.

J. C. M. BALFOUR,  
Minister of Lands.

GOD SAVE THE QUEEN!

GOVERNMENT NOTICES

PUBLIC HOLIDAY.—QUEEN'S BIRTHDAY.

IT is hereby notified that on—

MONDAY, THE 13TH JUNE, 1966,

the Public Offices will be closed, such day having been appointed by the *Public Service Act 1958* to be observed as a holiday in the Public Offices throughout the State of Victoria.

This notice relates only to the closing of the State Public Offices. All inquiries regarding the holiday in other offices and in shops and industry, should be directed to the Department of Labour and Industry, 110 Exhibition-street, Melbourne, C.1 (Telephone 63 0321, Extension 6158 or 6721).

JAMES W. MANSON,  
Acting Chief Secretary.

Chief Secretary's Office,  
Melbourne, C.1, 13th May, 1966.

(The Proclamation appears in the *Government Gazette* dated 31st March, 1965.)

*Stock Diseases Act 1958* (No. 6382).

QUARANTINE DISTRICT.

THE quarantine restrictions imposed on the following property have been removed:—

Name; Address.

Hassett, J. T.; Buffalo.

D. M. FLYNN,  
Chief Inspector of Stock.

*Hospitals Superannuation Act 1965*.

FUND OPENING DAY.

IT is hereby notified that the Hospitals Superannuation Board has fixed Friday, the first day of July, 1966, as the day on which the Hospitals Superannuation Fund will be opened.

W. BELLHOUSE, Manager,  
Hospitals Superannuation Board.

30th May, 1966.

*Labour and Industry Act 1958*.

LABOUR AND INDUSTRY (EXPLOSIVE-POWERED TOOLS) REGULATIONS 1965.

PURSUANT to the provisions of the *Labour and Industry (Explosive-powered Tools) Regulations 1965*, I give notice that, having determined that it would be unnecessary, because of the characteristics of a sample of a tool submitted for approval by Scan Trading Co. Pty. Ltd. bearing the serial number 11798, to require the owner or any other person to comply with the provisions of regulation 5 (c), 9, 10, and 12 (1) and (2) of the aforesaid Regulations in respect of any tool made in accordance with such sample, I did on the 31st May, 1966, grant my approval to such tool in accordance with such determination.

I specify the manner in which the tool is to be described for the purposes of the Regulations shall be "OBO SG. II".

P. F. PRIOR,  
Chief Inspector of Factories and Shops.

31st May, 1966.

*Town and Country Planning Act 1961*.  
GEELONG PLANNING SCHEME 1959.

AMENDMENT No. 3, 1965.

(CITY OF NEWTOWN AND CHILWELL.)

Notice of Approval.

IN pursuance of the powers conferred by the *Town and Country Planning Act 1961*, the Governor in Council on the 7th June, 1966, approved a planning scheme entitled the Geelong Planning Scheme 1959, Amendment No. 3, 1965 (City of Newtown and Chilwell), in respect of part of the municipal district of the City of Newtown and Chilwell.

A copy of the planning scheme as approved may be inspected during office hours at the office of the Town and Country Planning Board, 179 Queen-street, Melbourne; at the office of the Council of the City of Newtown and Chilwell, Newtown; and when available, at the Office of Titles, Melbourne, and at the Central Plan Office of the Department of Crown Lands and Survey, Melbourne.

W. H. CRAIG,  
Secretary, Town and Country Planning Board.

Commercial Goods Vehicles Act.  
TRANSPORT REGULATION BOARD.

## HEARING OF APPLICATIONS.

NOTICE is hereby given that the following applications will be considered by the Transport Regulation Board at its offices at Rathdown-street, Carlton, at 10.15 a.m. on Wednesday, 29th June, 1966.

BRINSMEAD, R. H., (trading as Agricultural & Domestic Sprays), 36 Menin-road, Nunawading. One commercial goods vehicle (L/C. 58 cwt.) to operate throughout the State of Victoria in the course of business as "Spraying Contractor" in a specially constructed tanker vehicle—tools of trade, spraying equipment and materials incidental to own contracts together with own camping gear.

ALBION REID PTY. LTD., 141A Arden-street, North Melbourne. One commercial goods vehicle (L/C. 77 cwt.) to operate throughout the State of Victoria in a specially constructed tanker in the course of business as "Road Construction Engineers" for the purpose of spraying road contracts—tar and bitumen emulsion in bulk.

ALLEN, B. A. & E., Deakin-avenue, Mildura. One commercial goods vehicle (L/C. 146 cwt.) to operate: (a) Within a 20-mile radius of the post office at Mildura—general goods. (b) From pits at Hattah to the premises of Murray Valley Plaster Works at Mildura—gypsum in bulk.

ANDERSON, D. N., F. P. & N. G., (trading as D. N. Anderson Pty. Ltd.), 145 Nicholson-street, Orbost. One commercial goods vehicle (L/C. 280 cwt.) to operate: (a) Within that part of the State of Victoria east of the Snowy River—logs. (b) From forest landings situated within the area specified to paragraph (a) above in Newmerella and Waygara—logs. (c) From sawmills situated within the area specified in paragraph (a) above and at Newmerella to the railway station at Orbost—sawn timber. (d) Within a 20-mile radius from the post office at Cann River—sawn timber. This application replaces licence No. T.T.D.1056/1 held by the applicant.

BAGGS, H. W., F. & H. F. J., cnr. Victoria & Day streets, Bairnsdale. Two commercial goods vehicles (L/C. both 10 cwt.) to operate throughout the State of Victoria as "Mortuary Vehicles" in the course of business as "Funeral Director".

BEAUREPAIRE TYRE SERVICE PTY LTD., 102 Victoria-street, Carlton. One commercial goods vehicle (L/C. 11 cwt.) to operate within a 50-mile radius of own branch premises at Frankston in the course of business as "Tire Distributors and Retreaders," tires and tubes for sale and delivery, used tires for repair or retread, or having been repaired or retreaded, and also oil and motor car accessories.

ATHANASIADIS, J., 25 Mason-street, Traralgon. One commercial goods vehicle (L/C. 135 cwt.) to operate within a 25-mile radius from the premises of Australian Paper Manufacturers Ltd. at Maryvale—pulpwood. This application replaces licence No. T.T.D.1058 held by the applicant.

BROWNFIELD, R. J., Lot 5, Hattam-road, Bendigo. One commercial goods vehicle (L/C. 10 cwt.) to operate within a 100-mile radius from the chief post office in the city of Bendigo in the course of business as "Electrical Contractor" but excluding any operations whatsoever between the City of Melbourne and the City of Bendigo—tools of trade, materials and equipment incidental to own contracts.

GERRISH, K. E., & P. H. BURGESS (trading as B. & G. Transport), 1 Tintern-avenue, Bayswater. One commercial goods vehicle (L/C. 215 cwt.) to operate: (a) From forest landings in the Matlock area to Warburton—logs. (b) From forest landings in the Jamieson area to Mansfield—logs. This application replaces licence No. T.T.D.481 held by the applicant.

BANTICK, D. V. & V. L. L. (trading as Bantick Bros. Pty. Ltd.), Marysville. One commercial goods vehicle (L/C. 185 cwt.) to operate: 1. From any forest landings in the Niagara and Upper Yarra forestry districts and the North Big River area—logs. (a) To the railway station at Healesville and to any mill or dump which is located within a 20-mile radius of such landing or of the railway station at Healesville. (b) To any mill or timber yard situated within a 25-mile radius of the G.P.O., Melbourne. 2. From McNeil & Radcliffe's sawmill at Marysville, Rowe, Webb and Anderson's sawmill at Thornton to consignees at Healesville and Melbourne—sawn timber. This application replaces licence No. T.T.D.116 held by the applicant.

BRUNT, M. L. & F. I., & F. M. & J. MORAN (trading as Brunt & Moran), 128 Wilson-street, Colac. One commercial goods vehicle (L/C. 276 cwt.) to operate: (a) Within a 20-mile radius from the post office at Colac—

logs and sawn timber. (b) From forest landings in the Aire Valley and Camperdown areas to Associated Kiln Driers Ltd., sawmills at Colac—logs. This application replaces licence No. T.T.D.835 held by the applicant.

BURGESS, J., & W. NOYES (trading as Burgess & Noyes Pty. Ltd.), Kepler-street, Warrnambool. Two commercial goods vehicles (L/C. 10 and 12 cwt.) to operate within a 70-mile radius from own premises at Warrnambool in the course of business as "Garage Proprietors" (Tractor, Agricultural Machinery and Chain Sawn Agents) for the purpose of demonstrating and servicing agricultural machinery—agricultural machinery for demonstration, for repair or having been repaired, tools of trade, spare parts and materials incidental thereto.

BURGOYNE, B. T., Lot 6, Actoal-drive, Montrose. One commercial goods vehicle (L/C. 7 cwt.) to operate within a 100-mile radius of the G.P.O., Melbourne, solely on behalf of Turner Manufacturing Co. Pty. Ltd.—lawn mowers, washing machines and appliances for servicing and installation, tools of trade and spare parts incidental only to the servicing and maintenance of any such machines and appliances.

CHEYNE, R., PTY. LTD., Coorimungie, via Timboon. One commercial goods vehicle (L/C. 200 cwt.) to operate: (a) Throughout the State of Victoria as an "Earth-moving and Road Making Contractor"—earth-moving equipment and tools of trade. (b) Within a 20-mile radius from any construction site situated within Warrnambool Division of Country Roads Board (75-mile radius of Peshurst) metal, stones, screenings, ashes, gravel, sand, earth and any other materials required for such work. (c) Within a 20-mile radius from post office at Timboon—general goods.

COLLIS, W. S., Foster. One commercial goods vehicle (L/C. 237 cwt.) to operate: (a) From private landings within a 50-mile radius of the post office at Foster to own sawmill at Foster—logs. (b) From own sawmill at Foster to consignees within a 50-mile radius of Foster Post Office—sawn timber. This application replaces licence No. T.T.D.471/1 held by the applicant.

ECKERSLEY, T. B. & V. M. (trading as Eckersley & Gates), 140 Mount Dandenong-road, Croйдon. One commercial goods vehicle (L/C. 252 cwt.) to operate: (1) From Reid Bros. sawmill at Yarra Junction—sawn timber—(a) To any customer if delivered within a 20-mile radius of the aforesaid sawmill at Yarra Junction. (b) To any merchant or builder if delivered to timber yards or direct on to building sites which are located within a 25-mile radius of the G.P.O., Melbourne. (2) From forest landings in the Hoddles Creek area to Leech's sawmill at Yarra Junction—logs. This application replaces licence No. T.T.D.187 held by the applicant.

EVANS, D. C. F., Roadside Delivery, via Broadford. One commercial goods vehicle (L/C. 440 cwt.) to operate from private landings in the Kinglake area to timber mills in the Metropolitan Area of Melbourne and to the S.E.C. depot at Brooklyn—logs and poles.

This application replaces licence No. T.T.D.749 held by the applicant.

EVANS, F. H., Roadside Delivery, via Broadford. One commercial goods vehicle (L/C. 270 cwt.) to operate: (a) From Flowerdale to Brooklyn—poles. (b) From Flowerdale to Preston and Thomastown—logs. (c) Within a 25-mile radius of the post office at Flowerdale—bulldozers.

This application replaces licence No. T.T.D.191 held by the applicant.

FICARRA, F., 1 Marlborough-street, Herne Hill, Geelong. One commercial goods vehicle (L/C. 202 cwt.) to operate within a 50-mile radius of the chief post office in the City of Geelong—premixed concrete in a specially constructed agitator vehicle solely on behalf of Rite-Mix Concrete Pty. Ltd.

FRIZON, A., & SONS, Forrest. One commercial goods vehicle (L/C. 276 cwt.) to operate from own sawmill at Forrest to Fagg Bros. Pty. Ltd. at Geelong—sawn timber.

GROUND SPRAY PTY. LTD., 112 Lava-street, Warrnambool. One commercial goods vehicle (L/C. 6 cwt.) to operate within a 50-mile radius of own premises in the City of Warrnambool in the course of business as "Agricultural Spray Contractors"—own goods, spraying equipment and tools of trade incidental to own contracts subject to the condition that all goods carried shall be those having been initially consigned by rail to the railway station at Warrnambool.

GROUND SPRAY PTY. LTD., 23 Murray-street, Colac. Two commercial goods vehicles (L/C. 20 and 30 cwt.) to operate within that part of the State of Victoria west of a north/south line drawn through the City of Melbourne in the course of business as "Agricultural Spray Contractors"—small quantities of agricultural

- chemicals, pesticides, insecticides and weedicides, not exceeding 4 cwt., tools of trade and spraying equipment incidental to own contracts subject to the conditions that all initial supplies of concentrated chemicals, pesticides, insecticides and weedicides used in connexion therewith shall be forwarded by rail to the railway station at Colac.
- HAMILTON, L. T.**, 42 Clarendon-street, West Coburg. One commercial goods vehicle (L/C. 141 cwt.) to operate from pits at Bacchus Marsh to the premises of the Northcote Brick Co. Pty. Ltd. at Northcote and at Burwood—white clay on behalf of the said company.
- HESZ, S.**, Mary-street, Heyfield. One commercial goods vehicle (L/C. 245 cwt.) to operate from forest landings in the Licola area to sawmills at Licola and Heyfield—logs.  
This application replaces licence No. T.T.D.235 held by the applicant.
- HUG, E. L.**, Firebrace-road, Heyfield. One commercial goods vehicle (L/C. 254 cwt.) to operate: (1) From forest landings in the McAlister area via Licola to sawmills at Heyfield—logs. (2) Within a 50-mile radius from the post office at Heyfield—plant and equipment, materials, fertilizers, seed, produce, feed, livestock and all other goods in connexion with own primary production and agricultural pursuits.
- INTERNATIONAL HARVESTER CO. OF AUST. PTY. LTD.**, 171-205 City-road, South Melbourne. One commercial goods vehicle (L/C. 16 cwt.) to operate throughout the State of Victoria in the course of business as "Tractor, Truck and Farm Machinery Manufacturers" for the purpose of maintaining and servicing such machines and machinery—tools of trade, spare parts and materials incidental thereto.
- INTRAC PTY. LTD.**, 256-264 Princes Highway, Dandenong. Four commercial goods vehicles (L/C. all 11 cwt.) to operate throughout the State of Victoria in the course of business as "Industrial Machinery Manufacturers and Distributors" for the purpose of servicing industrial machinery—tools of trade, spare parts and materials incidental to servicing in the field.
- KEAYS, R. G. & M. E.**, Strath Creek. Application to vary the conditions of licence No. D.A.56064 by adding as an additional paragraph (f) "from the area between Kerrisdale and the Dairy Creek-road within a 4-mile radius of Kerrisdale and Melbourne—wool."
- LEAHY'S ELECTRICAL INDUSTRIES LTD.**, 142 Koroit-street, Warrambool. Three commercial goods vehicles (L/C. 13, 17 and 17 cwt.) to operate within a 50-mile radius of Warrambool in the course of business as "Electrical Contractor, Retailer, Plumbing and Building Contractors" for the purpose of installing, servicing and maintaining electrical appliances and completing plumbing and building contracts—tools of trade, electrical goods for installation, repair or having been repaired and plumbing and building materials incidental to the completion of own contracts.
- MONSON, A. J.**, 284 Mount-street, Albury, New South Wales. One commercial goods vehicle (L/C. 7 cwt.) to operate: (a) From Albury, via Hume Weir, to Cudgewa and Corryong—newspapers, parcels, motor parts and tires. (b) From Corryong to places *en route*, via Koetong to Tallangatta—bread and newspapers (per roadside delivery).
- MORRIS, G. H.**, Britannia Creek-road, Wesburn. One commercial goods vehicle (L/C. 230 cwt.) to operate: (1) From Tuckman's sawmill at Warburton—sawn timber—(a) To any customer if delivered within a 20-mile radius of Warburton and/or Yarra Junction. (b) To any merchant or builder if delivered to a timber yard or direct on to building site which is located within a 25-mile radius of the G.P.O., Melbourne. (2) From the Reefton Timber Co.'s sawmill at Reefton to any merchant or builder within a 25-mile radius of the G.P.O., Melbourne—sawn timber.  
This application replaces licence No. T.T.D.279 held by the applicant.
- PARKER, R. A., K. N., & B. T.** (trading as Parker Bros. Earthmoving), 52 Wimple-street, Seymour. One commercial goods vehicle (L/C. 246 cwt.) to operate within a 50-mile radius of the post office at Seymour as an "Earth-moving contractor"—own earth-moving plant and equipment.
- PETERSVILLE AUSTRALIA LTD.**, Wellington-road, Clayton. Three commercial goods vehicles (L/C. 78 cwt. each) to operate throughout the State of Victoria as a specially constructed insulated and refrigerated van for the purpose of supplying own distributors with ice-cream, frozen vegetables, frozen fish and frozen poultry at a temperature not exceeding 10 degrees Fahrenheit.
- PHELAN, W., & SONS PTY. LTD.**, 157 High-street, Maryborough. Two commercial goods vehicles (L/C. 7 and 8 cwt.) to operate throughout the State of Victoria in the course of business as "Joinery Manufacturers and Building Contractors" but excluding the carriage of any goods whatsoever from the City of Melbourne to the City of Maryborough—tools of trade, timber and building materials incidental to the completion of own contracts.
- PHELAN, W., & SONS PTY. LTD.**, 157 High-street, Maryborough. One commercial goods vehicle (L/C. 64 cwt.) to operate throughout the State of Victoria in the course of business as "Prefabricated House Builders and Contractors, Joinery Manufacturers and House Removers" but excluding the carriage of any goods whatsoever from the City of Melbourne to the City of Maryborough—tools of trade, timber and building materials incidental to the completion of own contracts.
- PRESHA ENGINEERING PTY. LTD.**, Fern Tree Gully-road, Notting Hill. Three commercial goods vehicles (L/C. 11 cwt. each) to operate: (a) Within a 50-mile radius of the post office situate at the corner of Bourke and Elizabeth streets in the City of Melbourne in the course of business as "Manufacturers of Steam Generators"—own goods. (b) Throughout the State of Victoria for the purpose of servicing and repairing steam generators—tools of trade, spare parts and materials incidental to such servicing and repair.
- PYKE, N. A.**, Railway-avenue, Darnum. One commercial goods vehicle (L/C. 300 cwt.) to operate: (1) From forest landings within a 20-mile radius of the post office at Warragul to sawmills within a 20-mile radius of Warragul Post Office and at Pakenham and Springvale—logs. (2) From forest landings in the Erica area to sawmills within a 20-mile radius of the post office at Warragul and at Pakenham and Springvale—logs. (3) From landings in the Mirboo North and Turton Creek areas to sawmills within a 20-mile radius of the post office at Warragul and to sawmills at Pakenham and Springvale—logs.  
This application replaces licence No. T.T.D.322 held by the applicant.
- ROCHE BROS. PTY. LTD.**, 22 Dynon-road, South Kensington. One commercial goods vehicle (L/C. 187 cwt.) to operate: (a) Earth-moving equipment (power excavators, tractors, road rollers, grader, &c.) owned and operated by the applicant as follows: (i) Throughout the State of Victoria in connexion with own contracts. (ii) Within a 25-mile radius from the G.P.O., Melbourne on behalf of the Forests Commission of Victoria and the Country Roads Board. (b) Within a 25-mile radius of the G.P.O., Melbourne—general goods.
- SCHULZ, E. H. C.**, 33 Commercial-road, Benalla. One commercial goods vehicle (L/C. 253 cwt.) to operate: (1) From forest landings in the Samaria area to own sawmill at Benalla—logs. (2) From the said sawmill at Benalla to consignees at Kyabram—sawn timber. (3) From own sawmill at Benalla to consignees within a 50-mile radius of the post office at Benalla—sawn timber.  
This application replaces licence No. T.T.D.342 held by the applicant.
- SMEATH BROS. PTY. LTD.**, 173 Spring-street, Regent. One commercial goods vehicle (L/C. 143 cwt.) to operate within a 70-mile radius of the premises of Clifton Brick Holdings Ltd. at Preston—bricks.
- SUMMERHAYES, H. R.**, Brimpaen. One commercial goods vehicle (L/C. 60 cwt.) to operate: (1) Within a 20-mile radius from the property of Mr. R. Bell at West Brimpaen—general goods. (2) Within a 50-mile radius from the above property at West Brimpaen—firewood.
- WIGNALL, K. G.**, McIvor-road, Bendigo. One commercial goods vehicle (L/C. 78 cwt.) to operate within a 100-mile radius of the premises of Phillips Bricks and Pottery Pty. Ltd., at Bendigo, but excluding the Metropolitan Area of Melbourne—bricks.
- WRIGHT, E. A.**, MOTORS PTY. LTD., 137 Kepler-street, Warrambool. Application to vary the conditions of licence Nos. D.A.36424/9 and D.A.36424/8 by deleting "50 miles" and adding in lieu—"70 miles".
- WRIGHT, LUKE, INDUSTRIES PTY. LTD.**, 120 Clarendon-street, South Melbourne. One commercial goods vehicle (L/C. 7 cwt.) to operate throughout the State of Victoria in the course of business as "Frozen Food Distributors"—frozen fish, frozen poultry, fresh poultry and frozen processed vegetables.
- YALLOURN BAKERY PTY. LTD.**, John-street, Yallourn North. One commercial goods vehicle (L/C. 11 cwt.) to operate: (a) Within a 50-mile radius of own premises at Yallourn in the course of business as "Bakers"—own bread. (b) Within a 50-mile radius of own branch premises at Bairnsdale—own bread.
- WILKINSON, K. R.**, 436 Heidelberg-road, Fairfield. One commercial goods vehicle (L/C. 8 cwt. plus trailer 24 cwt.) to operate throughout the State of Victoria



in the course of business as "Marine Dealer"—marine goods as designated in the *Marine Stores and Old Metals Act 1958* (No. 6303), Part 1 (3).

*Special Proviso.*—That the combined load capacities of both prime mover and any trailer attached thereto shall not exceed 120 cwt.

OSBORNE, W. C. & J. E. (trading as William Charles Osborne & Son), Anakie, via Geelong. Three commercial goods vehicles (L/C. 255, 100 and 72 cwt.) to operate within a 20-mile radius of own place of business at Anakie for the carriage of general goods.

(This licence to replace existing E.C. licence of Anakie now limited under the provisions of the *Road Transport Act 1965.*)

#### TOW TRUCKS.

BURGER, B. (trading as Burger Motors), corner Waverley and Malvern roads, East Malvern. One commercial goods vehicle (L/C. 70 cwt.) to operate throughout the State of Victoria as a "Tow Truck" for the purpose of lifting and carrying or towing and/or repairing wrecked or disabled vehicles—tools of trade, spare parts and materials incidental thereto.

CARMODY MOTORS PTY. LTD., Parfitt-road, Wangaratta. One commercial goods vehicle (L/C. 68 cwt.) to operate within a 50-mile radius of Wangaratta as a "Tow Truck" for the purpose of lifting and carrying or towing and/or repairing wrecked or disabled vehicles—tools of trade, spare parts and materials incidental thereto.

CARROLL, M. & N., 256 Bambra-road, South Caulfield. One commercial goods vehicle (L/C. 32 cwt.) to operate within a 20-mile radius of own premises at South Caulfield as a "Tow Truck" for the purpose of lifting and carrying or towing and/or repairing wrecked or disabled vehicles—tools of trade, spare parts and materials incidental thereto.

CRAWFORD, I. P., 24 Coolabah-street, Mooroolbark. One commercial goods vehicle (L/C. 30 cwt.) to operate throughout the State of Victoria as a "Tow Truck" for the purpose of lifting and carrying or towing and/or repairing wrecked or disabled vehicles—tools of trade, spare parts and materials incidental thereto.

SCHUBERT, A. C. & H. M. (trading as Croydon Garage), 4 Croydon-road, Croydon. One commercial goods vehicle (L/C. 80 cwt.) to operate within a 25-mile radius of own premises at Croydon as a "Tow Truck" for the purpose of lifting and carrying or towing and/or repairing wrecked or disabled vehicles—tools of trade, spare parts and materials incidental thereto.

KLUN, A. J., White-road, Wonthaggi. One commercial goods vehicle (L/C. 27 cwt.) to operate within a 100 mile radius of the post office at Wonthaggi as a "Tow Truck" for the purpose of lifting and carrying or towing and/or repairing wrecked or disabled vehicles—tools of trade, spare parts and materials incidental thereto.

MELBOURNE TOWING SERVICE PTY. LTD., 169 City-road, South Melbourne. One commercial goods vehicle (L/C. 26 cwt.) to operate throughout the State of Victoria as a "Tow Truck" for the purpose of lifting and carrying or towing and/or repairing wrecked or disabled vehicles—tools of trade, spare parts and materials incidental thereto.

**A**PPPLICATIONS for renewal of licences as shown by persons listed hereunder to operate under the same terms and conditions from the expiry shown in each case.

ACCURATE SIGNS PTY. LTD., 188 Bay-street, Port Melbourne; D.A.45970/2; 21st May, 1966; 8 cwt.

ALFORD, J. T., Main-road, Bass; D.A.34979/1; 16th July, 1966; 116 cwt.

ALLANS MUSIC (AUSTRALIA) PTY. LTD., 276 Collins-street, Melbourne; D.A.12692/2; 14th July, 1966; 15 cwt.

BLACK, J. A., care of 103 Loongana-avenue, Glenroy; D.A.46682; 9th July, 1966; 104 cwt.

CALTEX OIL (AUST.) PTY. LTD., 185 William-street, Melbourne; D.A.791; 14th July, 1966; 10 cwt.

HYLAND, DAVID, & SONS PTY. LTD., 157 Salmon-street, Port Melbourne; T.D.A.39737/5; 7th July, 1966; 52 cwt.

HOGAN, W. J., 16 Grant-street, Bacchus Marsh; D.A.45941; 7th May, 1966; 68 cwt.

W. MCKNIGHT & SONS, PTY. LTD., 18 Doveton-street north, Ballarat; D.A.13665; 28th June, 1966; 9 cwt.

POULTRYMEN & FARMERS' TRADING CO. PTY. LTD., 696-710 Queensberry-street, North Melbourne; D.A.1847/8; 30th July, 1966; 113 cwt.; D.A.1847/9; 30th July, 1966; 113 cwt.; D.A.1847/10; 30th July, 1966; 114 cwt.

VIRGONA, G. (estate of), 30 Madden-avenue, Mildura; T.D.A.56067; 21st June, 1966; 120 cwt.

#### TOW TRUCK RENEWAL.

DAVIES, E. E. & G. A. (trading as Davies Motor Wreckers), 18 Elsworth-street, Ballarat East; D.A.34746/2, 5th June, 1966; 70 cwt.

#### RENEWALS WITH VARIATION.

GENERAL MOTORS-HOLDEN'S PTY. LTD., Box 161, Dandenong; D.A.27925/9; 1st July, 1966; D.A.27925/13; 1st July, 1966; Application to vary the conditions of licence Nos. D.A.27925/9 and D.A.27925/13 by deleting "30 miles" and adding in lieu "50 miles."

PELLNY, R., 2273 Dandenong-road, Springvale North; D.A.46710; 9th July, 1966; application to renew and vary the conditions of licence No. D.A.46710 by deleting "Fowler Road Construction Pty. Ltd." and adding in lieu "Monier-Reid Asphalt Pty. Ltd."

Notice of any objections should be forwarded to reach the Secretary of the Board not later than Wednesday, 22nd June, 1966.

Applicants are advised that it will not be necessary to appear on the hearing date specified above, unless advised in writing by the Board.

B. P. KAY,  
Secretary.

Exhibition Buildings, Rathdown-street, Carlton, N.3,  
8th June, 1966.

#### Transport Regulation Act.

#### TRANSPORT REGULATION BOARD.

#### HEARING OF APPLICATIONS.

**N**OTICE is hereby given that the following applications will be considered by the Transport Regulation Board at its offices at Rathdown-street, Carlton, at 10.15 a.m. on Wednesday, 29th June, 1966.

BELL-STREET BUS CO. PTY. LTD., 326 Bell-street, Preston. One commercial passenger vehicle with large seating capacity to be purchased to operate as an additional metropolitan route stage omnibus Route 6A (Pascoe Vale—Coburg—Heidelberg) under the same terms and conditions as licences already held in the applicants name.

HOLBOROW, W., and H. COLLINS (trading as Heidelberg—Eltham Bus Service), 37 Turnham-avenue, Rosanna. Application to operate metropolitan passenger service Route 87A (Heidelberg—Eltham—Research) as at present operated under M.O. licences held by the applicants with the following amendment to service:—To extend service on shopping days only from the corner of Lower Plenty-road and Turnham-avenue, via Lower Plenty-road, Waiora-road, Southern-road and Murray-road to Northland Shopping Centre; thence via the bus terminal stands within the centre returning to normal prescribed service via the same route. On journeys to Northland Shopping Centre, no pick up of passengers to occur after the corner of Grandview-grove and Lower Plenty-road and on journeys from the centre no set down of passengers to occur before the corner of Grandview-grove and Lower Plenty-road.

JACKMAN, A. J. & C. M., Bunbury-street, Cavendish. One commercial passenger vehicle (S/C 35) to operate under the same terms and conditions as licence No. T.S.241 subject to the cancellation of this licence in the name of A. J. Jackman.

MONSON, A. J., 284 Mount-street, Albury, N.S.W. Application to vary C.O. licences to amend time-table on the Albury—Corryong stage service to include a trip departing Albury 9.30 a.m. arriving Corryong 12.15 p.m.

PEELER, M. C., 516 Bluff-road, Hampton. One commercial passenger vehicle with large seating capacity to be purchased to operate as a substitute metropolitan stage omnibus on Route 118A (Moorabbin—Hampton).

REIDS BUS SERVICE, 252 St. Georges-road, Northcote. Application for permit authority to operate vehicle licenced No. M.C.19 free of charge for the carriage of employees only of Anthony Bearings Pty. Ltd., between Alphington Railway Station and Anthony Bearings Pty. Ltd. new factory premises Keon Park via Wingrove-street, Station-street, Darebin-road, High-street, Plenty-road, Bell-street, Albert-street, Boldrewood-parade, Strathmerton-street, Orrong-street, McMahon-road, Cheddar-road and Keon-parade to new factory premises at Dunstan-court.

#### Time-table (Monday—Friday).

Depart Alphington Railway Station 7.00 a.m.  
Depart Anthony Bearings Pty. Ltd., Keon Park 5.15 p.m.

(This application replaces that previously gazetted on 9th February, 1966.)

WATSON CAMERON & Co., Whyte-street, Coleraine. One commercial passenger vehicle (S/C 33) to operate in substitution for but not in addition to T.S. licensed vehicles in the applicant's name.

APPLICATION for renewal of licences as shown, by persons listed hereunder to operate under the same terms and conditions:—

BATES, O. E., 118 Johnson-street, Maffra; C.T.591, C.T.593.  
 BERBERICK, R. (Mrs.), 1 Adaleigh-court, Clayton; T.P.264.  
 BERTRAM, E. R., Box 15, Balmoral; T.S.47, T.S.258, T.S.386, T.S.447.  
 BOUNDY, J. J., 42 Alwyn-street, Mitcham; C.T.456.  
 CHEEP, W. A., 48 Darling-street, Echuca; C.T.244.  
 CLAYTON, R. C., care W. A. Cheep, 48 Darling-street, Echuca; C.T.429.  
 COON, L. J., Waubra; T.S.840.  
 DALTON, B. F., 148 Koroit-street, Warrnambool; C.T.29, C.T.535, C.T.541.  
 DORRINGTON, A., 110 Docking-street, Wodonga, C.T.445.  
 FERGUSON, S. V., 103 Stawell-street, Sale; T.S.587.  
 FOX, J. P., 22 Hoddle-street, Warrnambool; C.T.542.  
 FRASER, W. J., 12 Murray-street, East Colac; C.T.620, C.T.629.  
 GOLDSWORTHY, JOHN L., & Co. (trading as Kaniva Motors), Box 74, Kaniva; T.S.596.  
 HARVEY, L. C. & M. L., 15 Bowen-street, Echuca West; C.T.405.  
 HOSE, S., 32 Manifold-street, Colac; T.P.81.  
 MARTYN'S SERVICE PTY. LTD., 45 Vincent-street, Daylesford; C.O.811, C.O.813.  
 ROLLERI, E. R., Radium-avenue, Hepburn Springs; C.T.565.  
 RUSSELL, V. E. (Mrs.), 656 Bell-street, Pascoe Vale; T.P.221.  
 SMITH, R. W., Esplanade, Paynesville; C.O.775.  
 WEDGE, D. E., 94 Victoria-street, Cobden; C.O.231; C.O.766.  
 WATSON CAMERON & Co., Whyte-street, Coleraine; T.S.590.  
 YOUNG, C. F. W., 5 McDowall-street, Mitcham; C.T.524.  
 BEATTIE, N. G., 16 Arlington-street, Ringwood; M.T.1967.  
 DEPPELER, E. L., 4 Karoomba-avenue, Herne Hill, Geelong; U.T.701.  
 DUNN, N. H., Bonds-lane, Greenvale; M.T.1808.  
 ELIADES, C., 7 Acacia-street, Glenroy; M.H.1894.  
 ELLIOTT, C. F., 25 Little Myers-street, Geelong; U.T.700.  
 JACKSON, N. C., Flat 5, 186 Beach-road, Mordialloc; M.T.1184.  
 MCLEAN, A. R., 77 Saffron-street, Chilwell, Geelong; U.T.704.  
 MACARIO, S., 53 Saunders-street, West Coburg; M.T.1966.  
 NIANIAKOS, C., 31 Khartoum-street, Burnley; M.T.1972.  
 PARKER, G. L., 3 Bungalow-court, Gardenvale; M.T.476.  
 ROWE, H. L., 50 Crofton-street, Geelong West; U.T.703.  
 RUTLER, M. J., 19 Thompson-street, Belmont, Geelong; U.T.404.  
 STANBOROUGH, I., 10 Knight-avenue, Herne Hill, Geelong; U.T.702.  
 THEAR, R. J., 37 Zeally Bay-road, Torquay; U.T.705.  
 WOODTLI, J., 39 Jedda-street, Bell Post Hill, Geelong; U.T.639.

Notice of any objection should be forwarded to reach the Secretary of the Board not later than Wednesday, 22nd June, 1966.

Applicants are advised that it will not be necessary to appear on the hearing date specified above, unless advised in writing by the Board.

B. P. KAY,  
Secretary.

Exhibition Buildings, Rathdown-street, Carlton, N.3,  
Wednesday, 8th June, 1966.

LOCAL GOVERNMENT DEPARTMENT.

ORDER CONFIRMED.—SHIRE OF TAMBO.

THE Minister of the Crown administering the Local Government Act 1958, as amended on the 31st day of May, 1966, confirmed the Order hereinafter referred to in pursuance of section 514 of the said Act namely:

An Order of the Council of the Shire of Tambo made on the 19th April, 1966, directing the compulsory taking of the land described in certificate of title, volume 4941, folio 020, for the purpose of a site for a public hall.

R. J. HAMER,  
Minister for Local Government.

Local Government Department,  
Melbourne.

LOCAL GOVERNMENT DEPARTMENT.

ORDER CONFIRMED.—SHIRE OF MORTLAKE.

THE Minister of the Crown administering the Local Government Act 1958, as amended, on the 2nd day of June, 1966, confirmed the Order hereinafter referred to in pursuance of section 514 of the said Act namely:

An Order of the Council of the Shire of Mortlake made on the 17th May, 1966, directing the compulsory taking of the land described hereunder for road purposes:

All that piece of land being part of Crown allotments 34 and 35, Parish of Cobra Killuc, and containing 1 rood 27½ perches, the boundaries of which are as follows:— Commencing at the angle in the Government-road at the north-western corner of the said Crown allotment 35 and bounded by the southern boundary of the said road bearing 89 deg. 45 min. 358 feet; thence by a bearing 260 deg. 2 min. 363 ft. 3 in.; thence by a line bearing 236 deg. 53 min. 310 ft. 1 in. to the southern boundary of the Government-road; thence by the southern boundary of the Government-road bearing 48 deg. 37 min. 346 feet to the point of commencement.

R. J. HAMER,  
Minister for Local Government.

Local Government Department,  
Melbourne.

SHIRE OF WOORAYL.

ROAD DEVIATION ORDER.

PURSUANT to the provisions of sections 522 and 526 of the Local Government Act 1958 the Council of the Shire of Woorayl hereby directs that the land in the Parish of Koorooman indicated by hatching on the diagram hereunder, which has been purchased, taken or acquired by it, shall be a public highway on and from the date of publication of this order in the Government Gazette and declares that such land shall be a public highway in lieu of the land indicated by cross-hatching on the said diagram.

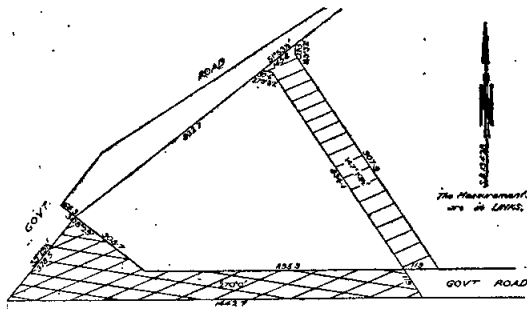

Dated the 13th day of May, 1966.

The common seal of the President, Councillors and Ratepayers of the Shire of Woorayl, was hereunto affixed this 13th day of May, 1966.

(SEAL) JAMES HAW, President.  
A. R. ASHENDEN, Councillor.  
K. G. BRYDON, Secretary.

Confirmed by the Governor in Council, 31st May, 1966.  
—J. COLQUHOUN, Clerk of the Executive Council.

LOCAL GOVERNMENT DEPARTMENT.

ORDER CONFIRMED.—SHIRE OF TAMBO.

THE Minister of the Crown administering the Local Government Act 1958, as amended on the 31st day of May, 1966, confirmed the Order hereinafter referred to in pursuance of section 514 of the said Act namely:

An Order of the Council of the Shire of Tambo made on the 19th April, 1966, directing the compulsory taking of the land described in certificate of title, volume 4941, folio 020, for the purpose of a site for a public hall.

R. J. HAMER,  
Minister for Local Government.

Local Government Department,  
Melbourne.

BARLEY MARKETING ACT 1958.

GILBERT LAWRENCE CHANDLER, Minister of Agriculture, do hereby appoint Thursday, the 11th day of August, 1966, as the day for the holding of an election of a representative of growers of barley in Victoria on the Australian Barley Board, and do further appoint Monday the 4th day of July, 1966, as the day for nominations of candidates to be lodged with the Returning Officer, Mr. H. E. Job, Department of Agriculture, Treasury Gardens, Melbourne, C.2.

Nominations will close at noon on nomination day.

G. L. CHANDLER,  
Minister of Agriculture.

1st June, 1966.

Health Act 1958.

VICTORIA—DEPARTMENT OF HEALTH.

**NOTICE TO ATTEND FOR RADIOLOGICAL EXAMINATION.**

To all persons aged twenty-one years and over enrolled or resident in the Subdivision specified hereunder in the State Electoral District of Scoresby.

TAKE notice that you are required to attend at a Department of Health X-ray unit sited in the public street at or as near as possible to the main entrance to the premises specified in this notice, at any time between the hours specified on one of the days specified and during the period specified in respect of those premises, and thereat to submit yourself to radiological examination of the chest for the purpose of ascertaining whether you may be suffering from pulmonary tuberculosis. If you have had a Chest X-ray within the last twelve months and for that reason do not wish to be examined now, you should attend the unit as directed and submit particulars of the previous examination.

SPECIFIED SUBDIVISIONS, PREMISES, PERIODS, DAYS AND HOURS.

Subdivision.	Premises.	Period.	Days.	Hours.
Croydon	Romari's Milk Bar, cr. Bayswater and Canterbury roads, Bayswater North	Monday, 20th June, 1966, and Tuesday, 21st June, 1966	Monday, 20th June, 1966 Tuesday, 21st June, 1966	From 2 p.m. to 9 p.m. From 10 a.m. to 12.30 p.m. and 2 p.m. to 9 p.m.
	(1) Public Hall, Mt. Dandenong-road	Tuesday, 21st June, 1966, to Wednesday, 29th June, 1966 (inclusive)	Tuesday, 21st June, 1966	From 11 a.m. to 12.30 p.m. and 2 p.m. to 9 p.m.
	(2) Joyfit Salon, 93 Railway-place, Croydon		All other days during the period except Saturday, Sunday and Public Holidays	From 10 a.m. to 12.30 p.m. and 2 p.m. to 9 p.m.
	At Both Centres			
	Eastfield Pharmacy, Lucille-street, Cheong Park	Wednesday, 22nd June, 1966, to Friday, 24th June, 1966 (inclusive)	Wednesday, 22nd June, 1966	From 11 a.m. to 12.30 p.m. and 2 p.m. to 9 p.m.
			All other days during the period except Public Holidays	From 10 a.m. to 12.30 p.m. and 2 p.m. to 9 p.m.
	Mooroolmart Self Service, Paul-street, Mooroolbark South	Monday, 27th June, 1966, and Tuesday, 28th June, 1966	Monday, 27th June, 1966 Tuesday, 28th June, 1966	From 11 a.m. to 12.30 p.m. and 2 p.m. to 9 p.m.
	Public Hall, Kilsyth	Wednesday, 29th June, 1966, to Friday, 1st July, 1966 (inclusive)	Wednesday, 29th June, 1966	From 11 a.m. to 12.30 p.m. and 2 p.m. to 9 p.m.
			All other days during the period except Public Holidays	From 10 a.m. to 12.30 p.m. and 2 p.m. to 9 p.m.
	Green's Pharmacy, Montrose	Thursday, 30th June, 1966, and Friday, 1st July, 1966	Thursday, 30th June, 1966 Friday, 1st July, 1966	From 11 a.m. to 12.30 p.m. and 2 p.m. to 9 p.m.
	Blue Moon Trading Co., Wandin North	Thursday, 30th June, 1966, and Friday, 1st July, 1966	Thursday, 30th June, 1966 Friday, 1st July, 1966	From 11 a.m. to 12.30 p.m. and 2 p.m. to 9 p.m.
	Seville Hall, Seville	Monday, 4th July, 1966	Monday, 4th July, 1966	From 2 p.m. to 9 p.m.
	Dorward's Milk Bar Mt. Evelyn	Monday, 4th July, 1966, to Wednesday, 6th July, 1966 (inclusive)	Monday, 4th July, 1966 All other days during the period except Public Holidays	From 2 p.m. to 9 p.m. From 10 a.m. to 12.30 p.m. and 2 p.m. to 9 p.m.
Doolan's Pharmacy, Mt. Dandenong	Monday, 4th July, 1966	Monday, 4th July, 1966	From 2 p.m. to 9 p.m.	
Olinda Electrics, Olinda	Tuesday, 5th July, 1966, and Wednesday, 6th July, 1966	Tuesday, 5th July, 1966 Wednesday, 6th July, 1966	From 11 a.m. to 12.30 p.m. and 2 p.m. to 9 p.m.	
Public Hall, Silvan	Thursday, 7th July, 1966	Thursday, 7th July, 1966	From 11 a.m. to 12.30 p.m. and 2 p.m. to 9 p.m.	

NOTE.—Any person to whom this notice applies and who without reasonable excuse fails to comply with the requirements of the notice shall be guilty of an offence, and shall be liable to a penalty of not more than Forty dollars.

Dated this eighteenth day of May, One thousand nine hundred and sixty-six.

KEVIN BRENNAN, Chief Health Officer.

ORBOST SEWERAGE AUTHORITY.

BY-LAW COVERING SPECIAL RATE FOR THE YEAR ENDING 31ST DECEMBER, 1966.

THE Orbost Sewerage Authority in pursuance and exercise of the powers conferred by the Sewerage Districts Act doth hereby make the following Rating By-Law.

"The Orbost Sewerage Authority doth hereby make and levy a Special Sewerage Rate of four (4) cents in the dollar on the nett annual value of all rateable properties within its declared Sewerage District boundaries.

Such rate is made and shall be levied upon the occupiers or owners of the said rateable properties for the year

commencing on the 1st day of January, 1966 and shall be payable on the 21st day of July, 1966 at the Office of the Authority."

Resolution for the passing of this By-Law was agreed to at a meeting held on the 10th day of May, 1966 by the said Authority and the Common Seal of the Orbost Sewerage Authority was thereunto fixed.

(SEAL) K. E. G. MOORE, Chairman.  
L. SPINK, Secretary.

Approved by the Governor in Council, 31st May, 1966.  
—J. COLQUHOUN, Clerk of the Executive Council.

## STATE RIVERS AND WATER SUPPLY COMMISSION.

LICENCES TO DIVERT WATER AND CUT RACES PURSUANT TO THE PROVISIONS OF THE WATER ACT 1958.

THE Governor in Council has approved of the granting by the State Rivers and Water Supply Commission of licences as detailed hereunder for the term of years from the date specified in each case to the persons named in the following Schedule :—

## SCHEDULE.

Licence No.	Term of Licence and Commencing Date.	Name and Address of Person to Whom Licence is to be Granted.	Source of Supply.	Area Authorized to be Irrigated Per Annum.	Volume of Water Authorized to be Diverted Per Annum.
				acres.	ac. ft.
506	Five years from 1.7.65 ..	Royston Siddons, Heidelberg West	River Murray and Margooya Lagoon	250	750
517	Five years from 1.7.65 ..	Eric Charles Orton and Veronica Maude Orton, Nangiloc	River Murray ..	17	51
518	Five years from 1.7.65 ..	Ernest Pennington Smith, Nangiloc ..	River Murray ..	30	90
524	Five years from 1.7.65 ..	Ilario Cirillo, Mildura ..	River Murray ..	19	57
552	Five years from 1.7.65 ..	William Alexander Gadsen and Percy Lawrence Gadsen, Robinvale	River Murray ..	90	270
560	Five years from 1.7.65 ..	Cecil Leonard Clarke, Nichols Point	River Murray ..	6	18
569	Five years from 1.7.65 ..	James Hugh Bowring and Margaret Hilda Bowring, Nangiloc	River Murray ..	50	150
644	Five years from 1.7.65 ..	Harold Stowell Brooke, Benjeroop ..	Little Murray River	..	500
771	Four years from 1.7.66 ..	John William Denis Fountain, Pentel Island	Little Murray River	..	200
822	Four years from 1.7.66 ..	Doris Josephine Sharam, Swan Hill	Little Murray River	..	116
1169	Four years from 1.7.66 ..	Eric Ivor James, Swan Hill ..	River Murray ..	100	200
1170	Four years from 1.7.66 ..	Clifford Thomas James, Swan Hill ..	River Murray ..	100	200
2066	Four years from 1.7.65 ..	Leslie Vernon Austin, Glenhuntly ..	Ovens River (Yarrawonga Weir Backwater)	16	32
2067	Five years from 1.7.65 ..	Percival David Cross, Toolamba ..	Goulburn River ..	24	48
2068	Five years from 1.7.65 ..	Percival David Cross, Toolamba ..	Goulburn River ..	10	20
2069	Five years from 1.7.65 ..	Hugh Malcolm Gilmore, Alexandra ..	Goulburn River ..	15	30
2070	Four years from 1.7.65 ..	Lawrence William Rohde, Raymond George Rohde and Leonard William Rohde, Nyah West	River Murray ..	53	106
2085	Four years from 1.7.65 ..	Domenico Albanese and Giuseppe Albanese, Robinvale	River Murray ..	15	45
2086	Five years from 1.7.65 ..	William Leslie Sandford, Boorhaman North	Ovens River (Yarrawonga Weir Backwater)	13	26
2088	Four years from 1.7.65 ..	Eric Charles Orton and Veronica Maude Orton, Nangiloc	River Murray ..	17	51
2090	Four years from 1.7.65 ..	John Henry Armstrong, Narrung ..	River Murray ..	50	150
2091	Five years from 1.7.65 ..	Alexander Cross, Toolamba ..	Goulburn River ..	30	60
2092	Four years from 1.7.66 ..	Ronald Douglas Knight, Molesworth	Goulburn River ..	20	40
2093	Four years from 1.7.66 ..	Murray Dudley Vincent Smith, Seymour	Goulburn River ..	50	100

Office of the State Rivers and Water Supply Commission,  
Melbourne, 7th June, 1966.

G. W. LEWIS, Secretary,  
State Rivers and Water Supply Commission.

## STATE RIVERS AND WATER SUPPLY COMMISSION.

LICENCES TO DIVERT WATER, PURSUANT TO THE PROVISIONS OF THE WATER ACT 1958.

THE Governor in Council has approved of the granting by the State Rivers and Water Supply Commission of licences as detailed hereunder for the term of years from the date specified in each case to the persons named in the following Schedule :—

## SCHEDULE.

Licence No.	Term of Licence and Commencing Date.	Name and Address of Person to Whom Licence is to be Granted.	Source of Supply.	Area Authorized to be Irrigated Per Annum.	Volume of Water Authorized to be Diverted Per Annum.
				acres.	ac. ft.
2073	Four years from 1.7.65 ..	Richard Gilbert Armstrong, Gooramadda	River Murray (Browns Creek)	100	200
2074	Five years from 1.7.65 ..	John S. McNamara Pty. Ltd., Nagambie	Goulburn Weir Pool	100	200
2075	Four years from 1.7.65 ..	Geoffrey Angus Williams, Brimin ..	River Murray Ana-Branch	30	60
2076	Four years from 1.7.65 ..	Alan Henry White, Yarrawonga ..	River Murray (Lake Mulwala)	100	200

Office of the State Rivers and Water Supply Commission,  
Melbourne, 7th June, 1966.

G. W. LEWIS, Secretary,  
State Rivers and Water Supply Commission.

## STATE RIVERS AND WATER SUPPLY COMMISSION.

APPLICATIONS FOR LICENCES TO DIVERT WATER AND CUT RACES PURSUANT TO THE PROVISIONS OF THE WATER ACT 1958.

THE Governor in Council has approved of the State Rivers and Water Supply Commission not granting the applications as detailed hereunder for licences to divert water and cut races.

Application No.	Term of Licence Sought.	Name and Address of Applicant.	Source of Supply.	Area Sought to be Authorized to be Irrigated.	Volume of Water Sought to be Authorized to be Diverted Per Annum.
				acres.	ac. ft.
2121	Fifteen years from 1.7.63..	Peter Hargreaves Wilkinson, Piangil	River Murray ..	17	50
2473	Eight years from 1.7.65 ..	Eric Charles Bennett, Yarrowonga Roadside	Ovens River ..	20	40
2488	Eight years from 1.7.65 ..	Geoffrey Wilson Salter, Peechelba East	Ovens River ..	50	100
2728	Eight years from 1.7.65 ..	Antonio Mancuso, Porepunkah ..	Ovens River ..	30	60
2738	Eight years from 1.7.65 ..	Richard Dwyer, Moya Bernardine Daily and Joseph Eugene Daily, Myrtleford	Ovens River ..	30	60
2764	Four years from 1.7.65 ..	Norman Edward Stoeckel, Boundary Point	River Murray ..	100	300

Office of the State Rivers and Water Supply Commission,  
Melbourne, 7th June, 1966.

G. W. LEWIS, Secretary,  
State Rivers and Water Supply Commission.

## MONEY LENDERS ACT 1958.

IN accordance with the provisions of the above-mentioned Act the following is published for general information.

List of persons to whom Money Lenders' Licences have been issued for the year ending 30th June, 1966.

Name.	Authorized Name.	Authorized Address.	Date of Issue.
†Alliance Acceptance Co. Ltd. (R. N. Tonkin Appointee)	Alliance Acceptance Co. Ltd. ..	9th Floor, Bank of Adelaide Building, 267 Collins-street, Melbourne	5.4.66
†Australian Guarantee Corporation Ltd. (H. A. Smith Appointee)	Australian Guarantee Corporation Ltd.	261-263 Moorabool-street, Geelong	7.1.66
Brown, Lloyd George ..	Brown, Lloyd George ..	146 Burwood-road, Hawthorn ..	2.3.66
*Commercial and General Acceptance Ltd. (M. S. Forgan Appointee)	Commercial and General Acceptance Ltd.	Cnr. Gheringhap and McKillop streets, Geelong	18.2.66
*Commercial and General Acceptance Ltd. (M. S. Forgan Appointee)	Commercial and General Acceptance Ltd.	29-31 Tarwin-street, Morwell ..	22.2.66
*Commercial and General Acceptance Ltd. (M. S. Forgan Appointee)	Commercial and General Acceptance Ltd.	Room 7, MacAlister Court, MacAlister-street, Sale	1.3.66
*Commercial and General Acceptance Ltd. (M. S. Forgan Appointee)	Commercial and General Acceptance Ltd.	100 Elgin-street, Carlton ..	22.3.66
Commercial and General Acceptance Ltd. (R. G. Overell Appointee)	Commercial and General Acceptance Ltd.	Room 7, MacAlister Court, 21 MacAlister-street, Sale	11.1.66
*Craig, Davis Homes Pty. Ltd. (A. K. Viney)	Craig, Davis Homes P/L. ..	237 Rathdowne-street, Carlton ..	29.3.66
Esanda Limited (E. K. Robertson Appointee)	Esanda Limited ..	186 High-street, Maryborough ..	24.2.66
†Esanda Limited (E. K. Robertson Appointee)	Esanda Limited ..	146-148 High-street, Wodonga ..	15.3.66
Esanda Limited (E. K. Robertson Appointee)	Esanda Limited ..	485-489 Queensberry-street, North Melbourne	15.2.66
General Loans and Mortgages Finance Co. Pty. Ltd. (Betty Lang Appointee)	General Loans and Mortgages Finance Co. Pty. Ltd.	17 Euston-road, Hughesdale ..	29.4.66
Grant, James ..	Grant, James ..	Rutherford-street, Avoca ..	3.2.66
Marchris Investments and Finance Corp. Pty. Ltd. (B. W. Vassis Appointee)	Marchris Investments and Finance Corp. Pty. Ltd.	4 Dudley-street, West Melbourne	6.5.66
P. and A. Industrial Finance Pty. Ltd. (J. T. Harrison Appointee)	P. and A. Industrial Finance Pty. Ltd.	252-262 Sturt-street, South Melbourne	2.5.66
Promotions Pty. Ltd. (C. K. Cutting Appointee)	Promotions Pty. Ltd. ..	300 Little Collins-street, Melbourne	13.4.66
Seaboard Finance Co. Ltd. (P. H. Brown Appointee)	Seaboard Finance Co. Ltd.	79A Nicholson-street, Footscray ..	28.2.66
Seaboard Finance Co. Ltd. (P. H. Brown Appointee)	Seaboard Finance Co. Ltd.	Shop 27, 798 Pascoe Vale-road, Glenroy	3.5.66
Seaboard Finance Co. Ltd. (P. H. Brown Appointee)	Seaboard Finance Co. Ltd.	Mahoney's-road, Forest Hill ..	17.1.66
Seaboard Finance Co. Ltd. (P. H. Brown Appointee)	Seaboard Finance Co. Ltd.	48 Atherton-road, Oakleigh ..	3.2.66
Seaboard Finance Co. Ltd. (P. H. Brown Appointee)	Seaboard Finance Co. Ltd.	449 Sydney-road, Brunswick ..	12.1.66
Seaboard Finance Co. Ltd. (P. H. Brown Appointee)	Seaboard Finance Co. Ltd.	Cnr. Walker and Langhorne-streets, Dandenong	28.3.66
†Tour Finance Limited (L. C. Cooke Appointee)	Tour Finance Limited ..	156 Swanston-street, Melbourne..	17.3.66
†Traders Finance Corp. Ltd. (V. E. Walmsley Appointee)	Traders Finance Corp. Ltd. ..	261-263 Moorabool-street, Geelong	7.1.66

\* Transfer of Appointee.

‡ New Authorized Address.

State Treasury,  
Melbourne, C.2, 31st May, 1966.

W. WATTS,  
Registrar.

*Process Servers and Inquiry Agents Act 1958.*

## APPLICATIONS FOR LICENCES LODGED WITH CLERKS OF COURTS.

BY direction of the Chief Secretary, the subjoined lists of "new" applications for process servers and inquiry agents licences are published for general information.

Applicant.	Address.	Court.	Tentative Date of Hearing of Application.
<i>Process Servers Licences.</i>			
Boyd, Bernard Leslie .. .. .	9 Iris-court, Blackburn	Box Hill	24.6.66
Kernot, Allen David .. .. .	145 Swanston-street, East Geelong	Geelong	22.6.66
<i>Inquiry Agents Licences.</i>			
Kristensen, Erik Samuel .. .. .	23 Howard-street, Box Hill	Box Hill	24.6.66
Morfoot, George Walter .. .. .	Celtic Mercantile Agency, Suite 3, 106 Wellington-parade, East Melbourne	Box Hill	21.6.66

Attention is directed to the provisions of the above Act and regulations thereunder relating to the lodgement of objections to applications.

Chief Secretary's Office,  
Melbourne, 6th June, 1966.

E. L. RICHARDSON, Registrar.  
Process Servers and Inquiry Agents.

## DEPARTMENT OF MINES.

SUBJECT to any necessary excisions, &c., it is proposed to grant the following mining leases:—

- 8276, Mineral; William Arthur Vickery; 100 acres, Parish of Canabore.  
8324, Mineral; Alan Ford Gerity; 93a. 3r. 24p., Parish of Thologolong.  
8326, Mineral; Bernhard Striet; 16 acres, Parish of Canabore.  
8328, Mineral; Alan Ford Gerity; 40 acres, Parish of Canabore.  
8430, Mineral; William Hoggan Thomas; 4a. 2r. 16p., Parish of Buchan.  
8452, Mineral; Mobile Quarries (Vic.) Pty. Ltd.; 16 acres, Parish of Tanjil East.

## MINING LEASES GRANTED.

- 5621, Gippsland; David William Hamilton; 87a. 2r. 34p., Parish of Jimkee.  
5622, Gippsland; David William Hamilton, John Coyle, Albert Trevor Bruhn; 102a. 1r. 21p., Parish of Jimkee.  
8254, Mineral; George Milton; 188 acres, Parish of Buchan.  
8320, Mineral; Milton Ray Kluge, Norma May Kluge; 20 acres, Parish of Banu Bonyit.  
8334, Mineral; Robert Henry Webb, Lloyd Oliver Lehmann, Frank Leslie Bayle, James Robert Slatter; 6a. 3r. 20p., Parish of Boort.  
8356, Mineral; James Haig Greig; 99 acres, Parish of Banu Bonyit.  
8363, Mineral; John Findlay Edelsten, Ruby Edna Edelsten; 16 acres, Parish of Nypo.  
8369, Mineral; Alan Edwin Morrow, Arthur Robert Morrow, Brian Valentine Morrow; 8 acres, Parish of Curyo.  
8375, Mineral; David Christopher Debenham, William John Davies, John Davies, Charles Alexander Nicoll; 6a. 2r. 3p., Parish of Yanakie South.  
8403, Mineral; Walter Douglas Chisholm; 7a. 2r. 22p., Parish of Moranghurk.  
8408, Mineral; Martin Stoneware Pipe Limited; 9a. 1r. 39p., Parish of Ballarat.  
8426, Mineral; Filtration and Water Softening Proprietary Limited; 6a. 2r. 25p., Parish of Narracan South.  
8428, Mineral; New Northcote Brick Company Limited; 26a. 2r. 22p., Parish of Sandhurst.

## TAILINGS LICENCES GRANTED.

- 3440, Tailings Licence; P. J. and G. P. Clarke; at Eaglehawk.  
3462, Tailings Licence; The President, Councillors and Ratepayers of the Shire of Tullaroop; Township and Parish of Carisbrook (in lieu of 3220 Tailings Licence expired).  
3464, Tailings Licence; Albert William Trotter; Parish of Durdidwarrah (in lieu of 3398 Tailings Licence expired).  
3465, Tailings Licence; The Mayor, Councillors and Citizens of the City of Bendigo; at Bendigo (in lieu of 3241 Tailings Licence expired).

## APPLICATIONS FOR LEASES DECLARED ABANDONED.

- 8275, Mineral; William Arthur Vickery; 120 acres, Parish of Canabore.  
8372, Mineral; Roland Walton; 600 acres, Parish of Ludrik Munjie.  
8373, Mineral; Roland Walton; 540 acres, Parish of Wollonaby.

## APPLICATIONS FOR LEASES REFUSED.

- 8317, Mineral; David Horatio Hilbrick and Alan Proudlock; 53a. Or. 24p., Parish of Tanjil East.  
8329, Mineral; Albion Hamilton Henderson; 2 acres, Parish of Maryborough.  
8360, Mineral; Edwin David Deas; 15 acres, Parish of Goormadda.  
8415, Mineral; John Charles Dean; 20 acres, Parish of Sandhurst.

## MINERAL SEARCH LICENCES GRANTED.

- 717, Mineral Search Licence; Roland Walton; 1.7 square miles, Parish of Bogong North.  
738, Mineral Search Licence; John Gordon Antliff; 6 square miles, Parish of Bogong North.

## CONSENT GRANTED TO TRANSFER MINING LEASE.

- 7873, Mineral; From John William Henderson to Sandhurst Clay Supplies Proprietary Limited.

## EXPLORATION LICENCE GRANTED.

- 43, Exploration Licence; R. R. Mining Proprietary Limited; 270 square miles, Parishes of Malkara and Mowamba.

T. A. DARCY,  
Minister of Mines.

## MINING LEASE DECLARED VOID.

- 8155, Mineral; Sulphates Limited; 6 acres, Parish of Narracan South.

E. CONDON,  
Secretary for Mines.

## ERRATUM.

IN the notice by the Department of Mines of mining leases proposed to be granted, which was published in *Victoria Government Gazette* No. 39, dated 1st June, 1966, (page 2000), the number "8641" appearing at the beginning of the 5th item on the list in such notice should read "8461".

Teaching Service Act 1958 (No. 6391).

**ELECTION OF A MEMBER OF THE COMMITTEE OF CLASSIFIERS FOR THE TECHNICAL SCHOOLS DIVISION, EDUCATION DEPARTMENT.**

PURSUANT to the Teaching Service (Teachers Tribunal) Regulations, I hereby notify that I have conducted an election of a Member of the Committee of Classifiers for the Technical Schools Division, and I hereby declare that—

RONALD BARTON DEDMAN  
has been elected a Member of such Committee.

R. H. BIGGS,  
Returning Officer.

**TEACHING SERVICE ACT 1958.—SECTION 73.**

**PUBLIC SERVICE ACT 1958.—SECTIONS 55 AND 56.**

IT is hereby notified that a charge of being absent without leave from and including the 1st February, 1966, has been preferred against Miss Cheryll A. Curren, Teacher, Class IV., Primary Schools Division, Education Department, under Section 73 of the Teaching Service Act 1958 which applies to the Teaching Service the provisions of Sections 55 and 56 of the Public Service Act 1958, and that a registered letter asking her whether she admits or denies the truth of the charge (posted to her last known address, viz. 141 Beach-road, Mentone) has been returned unclaimed.

Unless the said Cheryll A. Curren admits or denies the truth of the charge, in writing, to the Tribunal by Sunday, the 26th June, 1966, she shall be deemed to deny the truth of the charge and the investigation thereof will be proceeded with on Monday, the 27th June, 1966, at 9.30 a.m. at the office of the Teachers Tribunal, Birdwood-avenue, South Yarra.

By order,  
G. FENNELL,  
Secretary.

Office of the Teachers Tribunal,  
South Yarra, 1st June, 1966.

**PUBLIC TRUSTEE ACT 1958 (No. 6350), SECTION 17.**

I HEREBY give notice that on the 18th May, 1966, the Public Trustee filed elections to administer the following deceased persons' estates in accordance with section 17 of the Public Trustee Act 1958:—

CAM, ALBERT HENRY GEORGE, late of 28 Mills-street, Heyfield, labourer, died 3rd February, 1966.

MAHER, HANNAH, late of 71 Duke-street, Richmond (in will called Dyke-street, Richmond), married woman, died 24th February, 1966.

MACKENZIE, MERVYN CHARLES, also known as Charles Mervyn Mackenzie, formerly of lot 11 Burke-road, Fern Tree Gully, but late of 118 Gipps-street, East Melbourne, waiter, died 27th September, 1964.

PRESCOTT, GARNET, late of 165 Nelson-place, Williamstown, light keeper and boatman, died 18th December, 1965.

RANDALL, HENRY BENJAMIN, formerly of Goldring-street, Richmond, Queensland, but late of Whitfield, Victoria, labourer, died 29th October, 1965.

I HEREBY give notice that on the 20th May, 1966, the Public Trustee filed elections to administer the following deceased person's estate in accordance with section 17 of the Public Trustee Act 1958:—

WARNER, CHARLES JAMES, late of 15 Canberra-street, Brunswick, gardener, died 14th February, 1966.

A. D. DUNCAN,  
Public Trustee.  
256 Flinders-street, Melbourne, C.1, 1st June, 1966.

**NOTICE.**

CREDITORS, next of kin, and others having claims against the estate of any of the under-mentioned deceased persons are required to send particulars of their claims to the Public Trustee, 256 Flinders-street, Melbourne, the personal representative, on or before the 12th August, 1966, after which date the Public Trustee may convey or distribute the assets having regard only to the claims of which the Public Trustee then has notice:—

ARNALL, ELSIE MARY SACKVILLE, formerly of 11 Morey-street, Burwood, but late of 50 Blyth-street, Parkside South, South Australia, widow, died 7th March, 1966.

BASSO, MODESTO, late of 115 Cardigan-street, Carlton, retired cleaner, died 7th March, 1966.

BLANCHFIELD, EDITH MAY, formerly Edith May Hall, formerly of Flat 1, 33 Brighton-road, St. Kilda, but late of Flat 4, 12 Maryville-street, St. Kilda, married woman, died 4th October, 1964.

BREW, JEAN, late of 18 Kensington-terrace, Beulah Park, South Australia, married woman, died 21st May, 1956.

BROWN, WILLIAM JAMES, late of 19 Queensberry-street, Carlton, retired theatre employee, died 4th November, 1965.

CAM, ALBERT HENRY GEORGE, late of 28 Mills-street, Heyfield, labourer, died 3rd February, 1966.

COMMON, THOMAS, late of 5 Chatsworth-road, East Prahran, clerk, died 8th March, 1966.

CRAIG, FRANK CALDWELL, late of 16 Marrawong-avenue, Rosebud, retired market gardener, died 10th February, 1966.

DILK, KAROLY, late of 28 Merbein-street, Pascoe Vale, mail officer, died 6th November, 1965.

FITZGERALD, HARRIETT, late of 101 Vine-street, Moonee Ponds, married woman, died 29th December, 1965.

FOLEY, CHARLES, late of 101 Vine-street, Moonee Ponds, jewel case maker, died 27th December, 1923.

FOLEY, CHARLES WILLIAM, late of 101 Vine-street, Moonee Ponds, secretary, died 3rd September, 1925.

GROAT, GEORGE ROSS, late of 88 Nelson-road, Box Hill, retired public servant, died 17th January, 1966.

HARGREAVES, BENJAMIN BERNARD, late of 269 Richardson-street, Middle Park, storeman, died between 16th January, 1966 and 20th January, 1966.

HICKEY, WILLIAM THOMAS, late of 26 Michael-street, North Fitzroy, barman, died 27th November, 1965.

KNUCKEY, ELIZABETH HILDA, late of 19 Foch-street, Box Hill, married woman, died 29th December, 1965.

MAHER, HANNAH, late of 71 Duke-street, Richmond (in the will called Dyke-street, Richmond), married woman, died 24th February, 1966.

MOWBRAY, CLARA LOUISA, in the will called Clara Louisa Moubray, formerly of 117 Hambleton-street, Middle Park, but late of Kew, spinster, died 3rd June, 1965.

MURPHY, LEONARD CHARLES, formerly of 9 Fordham-avenue, Camberwell, but late of 103 Eley-road, Box Hill South, clerk, died 5th February, 1966.

OUTCH, KENNETH JOSEPH, late of 10 Lovelace-street, Preston, retired public servant, died 7th March, 1966.

MACKENZIE, MERVYN CHARLES, also known as Charles Mervyn Mackenzie, formerly of lot 11, Burke-road, Fern Tree Gully, but late of 118 Gipps-street, East Melbourne, waiter, died 27th September, 1964.

PRESCOTT, GARNET, late of 165 Nelson-place, Williamstown, light keeper and boatman, died 18th December, 1965.

RANDALL, HENRY BENJAMIN, formerly of Goldring-street, Richmond, Queensland, but late of Whitfield, Victoria, labourer, died 29th October, 1965.

RICHARDSON, BERTIE PERCIVAL EVERARD ST. CLAIR, commonly known as Bertie Percival Richardson, late of 22 Stephenson-street, South Kingsville, retired winch driver, died 18th January, 1966.

ROBINSON, NORMAN LESLIE, late of 115 Hanmer-street, Williamstown, retired boilermaker, died 17th October, 1965.

TOBIAS, ROBERT KILLIAN, late of 9 Gillies-crescent, Traralgon, process worker, died 26th November, 1965.

WARNER, CHARLES JAMES, late of 15 Canberra-street, Brunswick, gardener, died 14th February, 1966.

WATCH, LULU, late of Wood-street, Preston, widow, died 23rd January, 1966.

WEEKS, RONALD GEORGE, formerly of 14 Creswick-street, Deepdene, but late of 281 Albert-street, Sebastopol, retired storeman, died 22nd March, 1966.

A. D. DUNCAN,  
Public Trustee.  
Melbourne, 1st June, 1966.

**HEATHCOTE WATERWORKS TRUST.**

**AUTHORITY TO OBTAIN BANK OVERDRAFT.**

HIS Excellency the Governor of the State of Victoria, by and with the advice of the Executive Council thereof, doth by Order made on the 7th day of June, 1966, authorize the Heathcote Waterworks Trust to obtain, in pursuance of the provisions of section 286 of the Water Act 1958 (No. 6413), an advance or advances during the year 1966 from the Commercial Bank of Australia Limited, Heathcote, by overdraft of the Trust's current account thereat, such overdraft not to exceed at any one time the sum of Five thousand dollars (\$5,000).

J. COLQUHOUN,  
Clerk of the Executive Council.  
At the Executive Council Chamber,  
Melbourne, 7th June, 1966.

LINDENOW WATERWORKS TRUST.  
AUTHORITY TO OBTAIN BANK OVERDRAFT.

HIS Excellency the Governor of the State of Victoria, by and with the advice of the Executive Council thereof, doth by Order made on the 7th day of June, 1966, authorize the Lindenow Waterworks Trust to obtain, in pursuance of the provisions of section 286 of the Water Act 1958 (No. 6413), an advance or advances during the year 1966 from the National Bank of Australasia Limited, Bairnsdale, by overdraft of the Trust's current account thereat, such overdraft not to exceed at any one time the sum of Two thousand five hundred dollars (\$2,500).

J. COLQUHOUN,  
Clerk of the Executive Council.

At the Executive Council Chamber,  
Melbourne, 7th June, 1966.

ORDERS IN COUNCIL.—(Series 1965-66.)

EDUCATION DEPARTMENT.

3448. One only portametric bridge for Footscray Technical College, \$750.00.—Electronics (Vic.) Pty. Ltd.
3449. One only microwave equipment for Gordon Institute of Technology, Geelong, \$487.50.—Watson Victor Ltd.
3450. One only copy camera 5 in. x 4 in. and enlarger for Gordon Institute of Technology, Geelong, \$1,128.00.—Hanimex Pty. Ltd.
3451. One only cathode ray oscilloscope for Preston Technical College, \$557.20.—Jacoby Mitchell & Co.
3452. One only display oscilloscope for Preston Technical College, \$1,132.00.—BWD Electronics Pty. Ltd.
3453. One only microwave cooker for Royal Melbourne Institute of Technology, \$3,076.00.—Hawker De Havilland Australia Pty. Ltd.
3454. One only kiln for Royal Melbourne Institute of Technology, \$514.30.—Combustion Furnaces and Incinerators Pty. Ltd.
3455. One only micro halogen and sulphur determination apparatus for Swinburne Technical College, \$1,210.00.—Townson & Mercer (Vic.) Pty. Ltd.
3456. Two only double beam oscilloscopes for Swinburne Technical College, \$1,376.00.—Ronald J. T. Payne Pty. Ltd.
- Approved by the Governor in Council, 31st May, 1966.—  
J. COLQUHOUN, Clerk of the Executive Council.

PUBLIC WORKS.

3457. Balwyn, State School No. 1026, extension of heating system, \$1,125.00.—Smith & Osborne Pty. Ltd.—(M.88862 "B").
3458. Benalla, High School, supply and installation of gas heating, \$2,050.00.—The Colonial Gas Association Ltd.—(N.E.96617.)
3459. Burwood, Technical School, special grant authorized by the Education Department towards the cost of construction of an oval at the school, \$2,730.80.—Burwood Technical School Council.—(N.E.46866.)
3460. Castlemaine, High School, construction of an access road, additional sum of \$4,665.40.—City of Castlemaine.—(N.W.58349.)
3461. Dederang, Police Station, supply and erection of a Phelan type "Plymouth" residence and office, \$15,169.25.—W. Phelan & Sons Pty. Ltd.—(N.E.277546.)
3462. Fairfield, Fairlea Female Prison, supply and delivery of a steam heated laundry drying tumbler, \$2,456.00.—British Engineering Pty. Ltd.—(N.W.93611.)
3463. Geelong, Gordon Institute of Technology, supply and installation of Silicon rectifier, \$1,472.00.—Fenton & Douglas.—(S.W.93766.)
3464. Inglewood, Police Station, supply and erection of a portable "Phelan" type sleupout, \$2,290.00.—W. Phelan & Sons Pty. Ltd.—(N.W.85483.)
3465. Melbourne, State Library, hire of scaffolding, \$3,137.00.—G.K.N. Building and Engineering.—(M.77773.)
3466. Niddrie, High School, special grant authorized by the Education Department towards the cost of construction of asphalt courts at the school, \$1,685.25.—Niddrie High School Advisory Council.—(W.80142.)
3467. Reservoir West, State School No. 4711, special grant authorized by the Education Department towards the cost of erection of a library and craft room at the school, \$9,595.00.—Reservoir West State School No. 4711 Committee.—(N.W.39232.)

3468. Reservoir West, State School No. 4711, special grant authorized by the Education Department towards the cost of gas heating of the library and craft room at the school, \$1,100.00.—Reservoir West State School No. 4711 Committee.—(N.W.85715.)

3469. Sunbury, Mental Hospital, supply of a steam heated pressure sterilizer, \$3,227.00.—A. E. Atherton & Sons Pty. Ltd.—(N.W.43520.)

3470. Sunvale, State School No. 4818, special grant authorized by the Education Department towards the cost of erection of shelter shed at the school, \$1,060.00.—Sunvale State School No. 4818 Committee.—(W.58184.)

3471. Various schools, supply of 174 step ladders, \$2,414.00.—Hercules Ladders Pty. Ltd.—(V.67070.)

3472. Wangaratta, High School, special grant authorized by the Education Department towards the cost of erection of tennis/basketball courts at the school, \$1,266.50.—Wangaratta High School Advisory Council.—(N.E.87698.)

3473. Wattle Park, State School No. 3841, special grant authorized by the Education Department towards the cost of erection of a library at the school, \$3,236.67.—Wattle Park State School No. 3841 Committee.—(N.E.87496.)

3474. Wodonga, Court House, supply of furniture as under:—

Tables, benches, bookshelf, witness stand and barrier, \$1,207.89.—N. A. Stewart & Co.

Seating forms and chairs, \$1,312.00.—Aristoc Industries Pty. Ltd.

(N.E.32835 "C".)

Approved by the Governor in Council, 31st May, 1966.—  
J. COLQUHOUN, Clerk of the Executive Council.

EDUCATION DEPARTMENT.

3475. One only chain and chisel morticing machine for Collingwood Technical School, \$1,693.60.—A. E. Supplies Pty. Ltd.
3476. Three only double ended pedestal grinders (\$332.00); one only circular rip saw (\$750.00); and one only disc and belt sanding machine (\$840.00) for Collingwood Technical School, \$1,922.00.—Northern Machinery Co.
3477. One only electric pottery kiln for Geelong East Technical School, \$602.70.—Mechanical Handling Pty. Ltd.
3478. Three only Mettler single pan balances for Gordon Institute of Technology, Geelong, \$810.00.—Watson Victor Ltd.
3479. One only pottery kiln with pyrometer and time clock, &c. for Morwell Technical School, \$490.00.—Mechanical Handling Pty. Ltd.
3480. One only direct current amplifier for Swinburne Technical College, \$208.30.—Townson & Mercer (Vic.) Pty. Ltd.
3481. Three only overhead projectors and accessories at \$217.05 each for Morwell Technical School, \$651.15.—Nairn Audio Visual Activities.
3482. Two only stabilized power supply units for Morwell Technical School, \$292.00.—H. B. Selby & Co. Pty. Ltd.
- Approved by the Governor in Council, 31st May, 1966.—  
J. COLQUHOUN, Clerk of the Executive Council.

STATE ELECTRICITY COMMISSION.

3510. For the supply of eight front-end loaders for briquette distribution and general construction work, to Specification No. 65-66/350, \$53,600.—Tutt Bryant (Vic.) Pty. Ltd.
3511. For the re-erection of a vehicle shelter at Transport Workshops, Fishermen's Bend, to Specification No. 65-66/345, \$9,920, plus items at Schedule rates.—R. & J. Norton.
3512. For the supply of two 200-h.p. Leyland trucks for the replacement of existing high mileage vehicles in metropolitan area, to Quotation No. 4149, \$21,365.—The Leyland Motor Corporation of Australia Pty. Ltd.
3513. For the supply and laying of bricks in the Melbourne and metropolitan area for a period of two years, to Specification No. 65-66/287, at Schedule rates.—J. W. & E. G. Green.
3514. For the supply and laying of bricks in the Melbourne and metropolitan area for a period of two years, to Specification No. 65-66/287, at Schedule rates.—P. H. Childs Pty. Ltd.
3515. For the supply of ready mixed concrete for Melbourne and metropolitan area for a period of one year, to Specification No. 65-66/360, at Schedule rates.—Blue Metal Quarries Pty. Ltd.



3516. For the supply of ready mixed concrete for Melbourne and metropolitan area for a period of one year, to Specification No. 65-66/360, at Schedule rates.—Albion Reid Pty. Ltd.

3517. For the supply of ready mixed concrete for Melbourne and metropolitan area for a period of one year, to Specification No. 65-66/360, at Schedule rates.—Bayview Quarries Pty. Ltd.

Approved by the Governor in Council, 17th May, 1966.—  
J. COLQUHOUN, Clerk of the Executive Council.

#### CONTRACTS ACCEPTED.—(Series 1965-66.)

##### PUBLIC WORKS.

3483. Hawthorn, Swinburne Technical School, supply furnace, \$1,640.00.—Electro Chemical Engineering Pty. Ltd.  
3484. Geelong West, "Ariston" Teachers' College Hostel, supply bedspreads, \$1,501.90.—Supertex Industries Ltd.  
3485. Benalla, Technical School, supply furniture, \$5,486.00.—Bera Cabinet Works Pty. Ltd.  
3486. Dookie, Agricultural College, supply oven ranges, \$3,412.00.—Overseas Corporation (Aust.) Ltd.  
3487. Dookie, Agricultural College, supply steam kettles, \$2,466.00.—J. Curtin & Son, Pty. Ltd.  
3488. Dookie, Agricultural College, supply steam cookers, \$4,040.00.—Anderson & Ritchie Pty. Ltd.  
3489. Bundoora, Larundel Mental Hospital, supply electric grill, \$1,027.50.—E.G.A. (S. Cunningham) Pty. Ltd.  
3490. Warrnambool, Mental Hospital, supply oven, electric, \$1,180.00.—Thermo Radiant Oven Sales Pty. Ltd.  
3491. Williamstown, Technical School, supply machine tools, \$6,282.82.—McPherson's Ltd.  
3492. Williamstown, P.W.D. Dredging Depot, supply steel pipes, \$1,130.00.—Toorong Steel Construction Pty. Ltd.  
3493. Melbourne, Probate Duties Office, supply and install shelving, \$3,686.90.—Brownbuilt Ltd.  
3494. Melbourne, Therapy School, supply refrigerated cabinets, \$2,710.00.—Ahearn Main & Stoit Pty. Ltd.  
3495. South Yarra, National Herbarium, supply cupboards, \$4,570.00.—Bera Cabinet Works Pty. Ltd.  
3496. Hawthorn, Swinburne Technical School, supply tables, benches and cupboards, \$1,543.10.—Kennett Bros. & Rayner Pty. Ltd.  
3497. Werribee South, Werribee Foreshore, supply and deliver stone, \$4,000.00.—D. L. Starbuck Pty. Ltd.  
3498. Reservoir, Keon Park Technical School, supply lathes, \$7,650.00.—Demco Machinery Co. (Vic.) Pty. Ltd.  
3499. Queenscliff, Foreshore Queenscliff, supply and deliver stone, \$6,715.00.—A. W. Pett.  
3500. Coburg, H.M. Pentridge Prison, supply and deliver steel, \$2,605.30.—Dominion Reinforcements Pty. Ltd.  
3501. Nunawading, Vermont High School, supply lathes and equipment, \$1,270.76.—McPherson's Ltd.  
3502. Nunawading, Vermont High School, supply lathes and equipment, \$1,155.10.—Frank Vial & Sons Pty. Ltd.  
3503. Collingwood, Technical School, supply and install tables and cupboards, \$2,068.00.—Bera Cabinet Works Pty. Ltd.  
3504. Werribee, State Research Farm, supply beds, divan, \$1,215.00.—Herman Heetal.  
3505. Mont Park, Mental Hospital, supply machine, planing and thicknessing, \$1,116.00.—McPherson's Ltd.  
3506. Flemington, Travancore Developmental Centre, supply lockers, bedside, \$1,463.00.—Namco Furniture Contract Division.  
3507. Ascendale, Technical School, supply furniture, \$1,968.90.—Kennett Bros. & Rayner Pty. Ltd.  
3508. Flemington, Travancore Developmental Centre, supply and lay vinyl sheeting, \$1,326.00.—A.A.A. Floor Coverings.  
3509. Ballarat, Mental Hospital, supply kitchen equipment, \$1,528.70.—E.G.A. (S. Cunningham) Pty. Ltd.

MURRAY PORTER, Minister of Public Works. 3.6.66.

##### VICTORIAN RAILWAYS.

160. Manufacture, supply and delivery of disc wheels at \$77.51 each (C.62946).—Bradford Kendall Ltd.  
161. Excavation, cartage, placing and compaction of approved filling for filling of bridge openings to track formation level at Langwarrin at \$1.10 per cubic yard (C.62955).—Roche Bros. Pty. Ltd.  
162. Painting and cladding the extension to roofed goods loading area known as No. 5 Shed—Melbourne Goods Depot, for an amount of \$21,142.00 (C.62970).—F. Wilson.

By order of The Victorian Railways Commissioners,  
W. WALKER, Secretary for Railways.  
Melbourne, 3rd June, 1966.

No. 40.—5058/66.—2

## APPOINTMENTS AND RESIGNATIONS

### APPOINTMENTS.

THE Lieutenant-Governor as Deputy for His Excellency the Governor of the State of Victoria, by and with the advice of the Executive Council thereof, has, by Orders made on the 31st day of May, 1966, been pleased to make the under-mentioned appointments, viz.:—

#### CHIEF SECRETARY'S DEPARTMENT.

##### Electoral Registrar (Acting).

GEORGE LEO CHAMBERLAIN  
to be Electoral Registrar (Acting) for the Caulfield, Caulfield East, Malvern East and Malvern South Subdivisions of the Electoral District of Caulfield, and for the Darling, Malvern and Malvern West Subdivisions of the Electoral District of Malvern, to take effect on and from the 18th May, 1966, during the absence on leave of Clive Edward Gustav Warmbrunn.

#### MINISTRY OF HEALTH.

##### Member of Committee of Management of Hospital.

WALTER DOUGLAS GREBERT  
to be a Member of the Committee of Management of Latrobe Valley Community Hospital, pursuant to Proviso (a) of section 48(1) of the Hospitals and Charities Act, for a further period of three years ending 17th June, 1969.

#### LAW DEPARTMENT.

##### Commissioners for Taking Declarations, &c.

JOHN POWELL WILLIAMS, 2 Vermont-avenue, Corio,  
WALTER JOHN McCLEAN MITCHELL, 915 Glenhuntingly-road, Caulfield South; and  
GEOFFREY MYIEL CAWSEY, Flat 7, 72 Grey-street, St. Kilda,  
to be Commissioners for taking Declarations and Affidavits pursuant to the provisions of the Evidence Act 1958, to resign upon removing from the neighbourhood of the addresses stated.

REX KELVIN GERVASONI, and  
JOSEPH COX, care of Department of Crown Lands and Survey, Public Offices, Melbourne; and  
JOHN HENRY BIRD, care of Department of Agriculture, Victoria, Public Offices, Melbourne,  
to be Commissioners for taking Declarations and Affidavits pursuant to the provisions of the Evidence Act 1958, to refrain from charging fees and to resign upon ceasing to occupy their present positions; and  
JACK PURKESS WALTERS, care of BP Refinery (Western-port) Pty. Ltd., Crib Point,  
JOHN ANDREW WAUCHOPE, care of CML Fire and General Insurance Company Limited, 654 Bourke-street, Melbourne; and  
MARDEN FREDERICK JAMES TRENER, care of Victorian Dairy Products Board, 406 Lonsdale-street, Melbourne,  
to be Commissioners for taking Declarations and Affidavits pursuant to the provisions of the Evidence Act 1958, to resign upon ceasing to occupy their present positions.

##### Justices of the Peace.

BRENDON THOMAS CONNOR, 353 Edwardes-street, Reservoir; and  
ALAN DAVID CREE, 290 Keilor-road, North Essendon, to keep the Peace in the Central Bailiwick of the State of Victoria;  
JAMES HENRY MITCHELL, 15 Alexander-avenue, Wendouree,  
to keep the Peace in the Southern Bailiwick of the State of Victoria;  
ALLAN EDWIN ELSHAUG, Wyndham-street, Newstead, to keep the Peace in the Midland Bailiwick of the State of Victoria; and  
ROY WILLIAM FRANCIS COOPER, Milltown,  
to keep the Peace in the Western Bailiwick of the State of Victoria.

#### PUBLIC WORKS DEPARTMENT.

##### Wharf Manager.

First Constable RALPH EDWARD YOUNG, No. 12041, to be Wharf Manager at Mallacoota and Gipsy Point, as from 31st May, 1966, to carry out that portion of Part II. of the Marine Act 1958, which relates to the management of Public Wharves, and to be an officer under section 19 of such Act to levy and collect wharfage rates thereat, at a remuneration of \$25.00 per annum, vice First Constable Neil William Cameron, No. 12026, transferred.

DEPARTMENT OF THE TREASURER.  
Receiver of Revenue.

ROBERT NEIL HOLLIS  
to be Receiver of Revenue, Shepparton, vice J. J. Caven, relieved.

DEPARTMENT OF WATER SUPPLY.  
Member of Management Committee.

CYRIL JOHN MICHELSEN  
to be a member of the Kimbolton Recreational Area Management Committee, subject to the provisions of the Water (Kimbolton Recreational Area) Regulations 1966.

J. COLQUHOUN,  
Clerk of the Executive Council.

At the Executive Council Chamber,  
Melbourne, 31st May, 1966.

APPOINTMENTS.

HIS Excellency the Governor of the State of Victoria, by and with the advice of the Executive Council, thereof, has, by Orders made on the 7th day of June, 1966, been pleased to make the under-mentioned appointments, viz.:—

DEPARTMENT OF WATER SUPPLY.  
Waterworks Trust Commissioners.

GEOFFREY GORDON CUZENS,  
to be a Commissioner of the Marysville Waterworks Trust for a period from the date hereof until 16th June, 1968, subject to the provisions of the Water Act.

WILLIAM JOSEPH DOVE  
to be a Commissioner of the Timboon Waterworks Trust for a period of four years from the date hereof, subject to the provisions of the Water Act.

ALFRED THOMAS SPARKE  
to be a Commissioner of the Warburton Waterworks Trust for a period of four years from the date hereof, subject to the provisions of the Water Act.

J. COLQUHOUN,  
Clerk of the Executive Council.

At the Executive Council Chamber,  
Melbourne, 7th June, 1966.

Stock Diseases Act 1958.

APPOINTMENT OF INSPECTORS OF STOCK.

THE Public Service Board, in exercise of its powers, has by certificate dated 12th May, 1966, appointed the under-mentioned officers of the Department of Agriculture as Inspectors of Stock, Department of Agriculture, under the provisions of Part I. of the Stock Diseases Act 1958, without additional salary:—

JOHN CHRISTOPHER BANFIELD, Experimental Officer.  
MATTHEW BARRY WHITE, Veterinary Research Officer.

FRANK M. READ,  
Director of Agriculture.

RESIGNATIONS.

THE Lieutenant-Governor as Deputy for His Excellency the Governor of the State of Victoria, by and with the advice of the Executive Council thereof, has, by Orders made on the 31st day of May, 1966, accepted the resignations of the persons named hereunder of the offices mentioned, viz.:—

CHIEF SECRETARY'S DEPARTMENT.

BERTRAM HENRY GOULD, Superintendent, Grade I, as a Licensing Inspector for the purposes of the Licensing Act 1958, to date from and inclusive of the 28th May, 1966.

LAW DEPARTMENT.

ALAN DAVID CREE, as a Commissioner for taking Declarations and Affidavits, pursuant to the provisions of the Evidence Act 1958.

CLIFFORD SCHOFIELD MALLALIEU, from the Commission of the Peace for the Northern Bailiwick of the State of Victoria.

ROY WILLIAM FRANCIS COOPER, from the Commission of the Peace for the Southern Bailiwick of the State of Victoria.

J. COLQUHOUN,  
Clerk of the Executive Council.

At the Executive Council Chamber,  
Melbourne, 31st May, 1966.

ORDERS IN COUNCIL

DEPARTMENT OF CROWN LANDS AND SURVEY.

At the Executive Council Chamber, Melbourne, the thirty-first day of May, 1966.

PRESENT:

The Lieutenant-Governor as Deputy for His Excellency the Governor of Victoria.

Mr. Reid | Mr. Porter  
Mr. Hamer | Mr. Manson.

UNUSED ROADS CLOSED.

THE Lieutenant-Governor as Deputy for His Excellency the Governor of the State of Victoria, by and with the advice of the Executive Council thereof, doth hereby direct that, in pursuance of the provisions of section 349 of the Land Act 1958, the unused roads referred to hereunder be closed, viz.:—

Parish of Bumberrah, County of Tambo, being the road indicated by hachure on plan hereunder.—(B.99(\*) (H.029025).

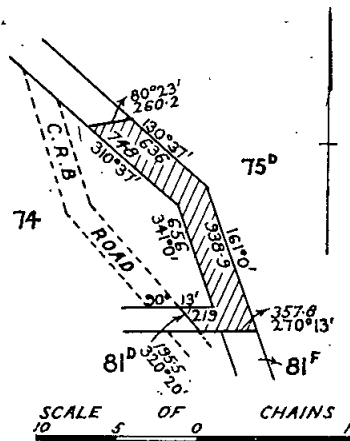

Parish of Murgheboluc, County of Grant, being the road indicated by hachure on plan hereunder.—(M.280(D) (Misc.3654).

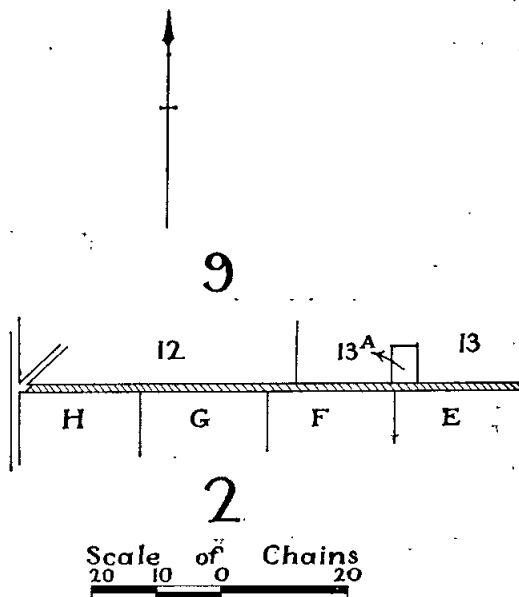

City of South Melbourne, Parish of Melbourne South, County of Bourke, being the road indicated by hachure on plan hereunder.—(M.333<sup>(2a)</sup>) (Misc.3708).

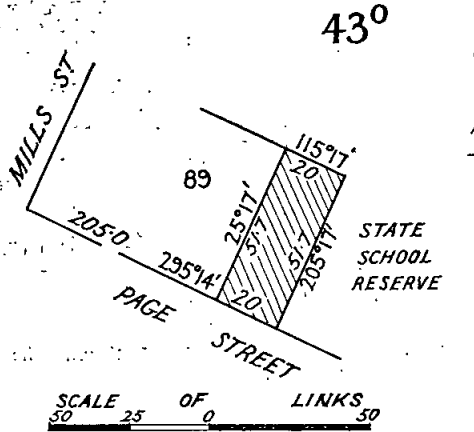

And the Honorable James Charles Murray Balfour, Her Majesty's Minister of Lands for the State of Victoria, shall give the necessary directions herein accordingly.

J. COLQUHOUN,  
Clerk of the Executive Council.

DEPARTMENT OF CROWN LANDS AND SURVEY.

At the Executive Council Chamber, Melbourne, the thirty-first day of May, 1966.

PRESENT:

The Lieutenant-Governor as Deputy for His Excellency the Governor of Victoria.

- |           |             |
|-----------|-------------|
| Mr. Reid  | Mr. Porter  |
| Mr. Hamer | Mr. Manson. |

LANDS TEMPORARILY RESERVED AS SITES.

THE Lieutenant-Governor as Deputy for His Excellency the Governor of the State of Victoria, by and with the advice of the Executive Council thereof, doth hereby, in pursuance of section 14 of the Land Act 1958, reserve temporarily from sale, from being leased and from having a licence granted in respect thereof, and also except from occupation for mining purposes under any miner's right, the lands hereinafter described:—

TOOLLEEN.—Site for Public Recreation, 1 acre 3 roods 5 perches, Township of Toolleen, Parish of Toolleen, County of Rodney, as indicated by hachure on plan hereunder.—(T.98<sup>(4)</sup>) (Rs.2801).

RECREATION RES.

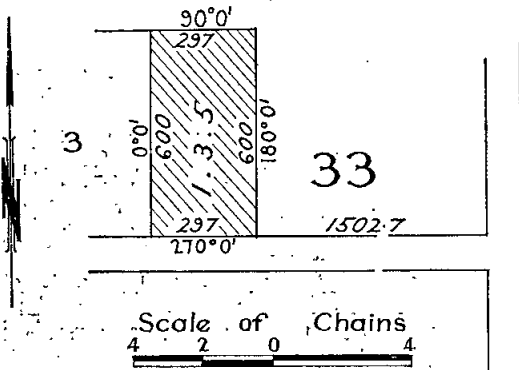

KEELBUNDORA.—Site for Mental Hospital purposes, 11 acres 35 perches, Parish of Keelbundora, County of Bourke, as indicated by hachure on plan hereunder.—(K.25<sup>(6)</sup>) (Rs.1436).

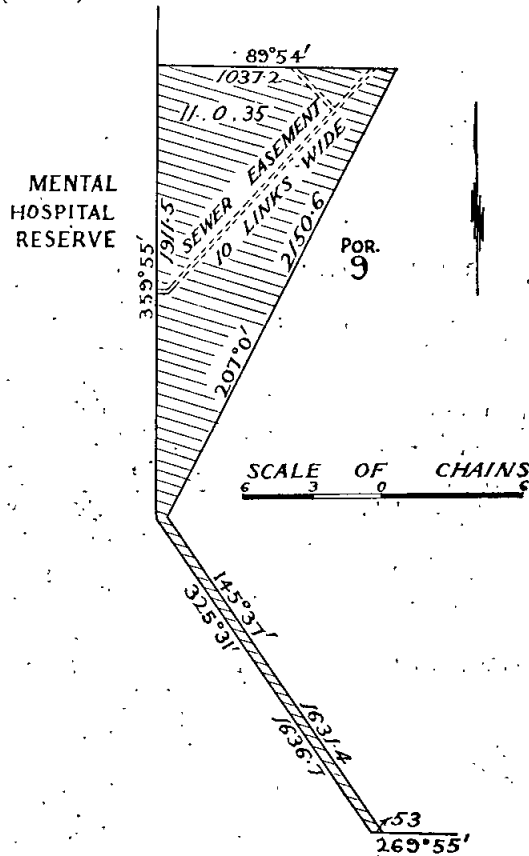

And the Honorable James Charles Murray Balfour, Her Majesty's Minister of Lands for the State of Victoria, shall give the necessary directions herein accordingly.

J. COLQUHOUN,  
Clerk of the Executive Council.

DEPARTMENT OF CROWN LANDS AND SURVEY.

At the Executive Council Chamber, Melbourne, the thirty-first day of May, 1966.

PRESENT:

The Lieutenant-Governor as Deputy for His Excellency the Governor of Victoria.

- |           |             |
|-----------|-------------|
| Mr. Reid  | Mr. Porter  |
| Mr. Hamer | Mr. Manson. |

LAND PERMANENTLY RESERVED.

THE Lieutenant-Governor as Deputy for His Excellency the Governor of the State of Victoria, by and with the advice of the Executive Council thereof, doth hereby, in pursuance of section 14 of the Land Act 1958, reserve permanently from sale and from being leased and from having a licence granted in respect thereof, the land hereinafter described:—

DART RIVER.—Crown lands forming the bed of the Dart River and 100 links from each bank from its source to its junction with the Mitta Mitta River, as defined by the description published in the Government Gazette of 27th April, 1966, which is required for Public purposes.—(C.99858.)

And the Honorable James Charles Murray Balfour, Her Majesty's Minister of Lands for the State of Victoria, shall give the necessary directions herein accordingly.

J. COLQUHOUN,  
Clerk of the Executive Council.

## COUNTRY ROADS BOARD.

At the Executive Council Chamber, Melbourne, the  
thirty-first day of May, 1966.

## PRESENT:

The Lieutenant-Governor as Deputy for His Excellency  
the Governor of Victoria.

Mr. Reid	Mr. Porter
Mr. Hamer	Mr. Manson.

DECLARATION OF A DEVIATION FROM THE  
STRATHFIELDSAYE-ROAD IN THE SHIRE OF  
STRATHFIELDSAYE.

WHEREAS by sections 21 and 58 of the *Country Roads Act 1958* (No. 6229) it is amongst other things enacted that when the Country Roads Board under the provisions of the *Country Roads Act* has by Resolution declared a deviation to be a main road the said Board may also declare that such deviation shall be in lieu of any existing road or part thereof named in such Resolution and that on publication in the *Government Gazette* of the Order confirming such Resolution the existing road or part thereof shall cease to be a main road or be discontinued as provided in the Resolution: And whereas the said Board has by Resolution declared the deviation on the land described in the First Schedule to such Resolution to be a main road and has also declared that such deviation shall be in lieu of the part of the existing road being the land described in the Second Schedule to the said Resolution: Now therefore the Lieutenant-Governor as Deputy for His Excellency the Governor of the State of Victoria by and with the advice of the Executive Council thereof doth hereby confirm the said Resolution.

Resolution for Declaration of a Deviation of a Main Road  
under the Country Roads Act.

Whereas the land the site of the road the course of which is below set out was taken by the Board under the provisions of the *Country Roads Act 1958* for the purpose of constructing such road deviation which road deviation has now been laid out and formed on the same: And whereas the said Board (being the Country Roads Board incorporated under the said Act) thinks that the road aforesaid is fit to be used as a public highway such Board at a meeting now holden acting under the authority conferred upon it by sections 21 and 58 of the said Act doth by this present Resolution hereby declare the said road deviation the course of which is described in the First Schedule hereto with the commencing and terminating points thereof respectively specified to be part of a main road within the meaning and for the purposes of the *Country Roads Act 1958*: And the said Board doth also declare that such deviation shall be in lieu of the existing road or part thereof described in the Second Schedule hereto.

## FIRST SCHEDULE.

## Shire of Strathfieldsaye.

2. *Strathfieldsaye-road* (15802).—All that piece of land in the Parish of Eppalock, the boundaries of which are as follow:—Commencing at a point on the western boundary of allotment 8A, section 12 of the said parish, distant 337 deg. 23 min. 482.1 links from the southern angle of the said allotment; thence by lines bearing respectively 337 deg. 23 min. 522.9 links, 328 deg. 40 min. 167.1 links, 137 deg. 5 min. 163.7 links, 139 deg. 7 min. 465.5 links, 128 deg. 30 min. 509.8 links, 110 deg. 22 min. 505 links, 99 deg. 48 min. 619.5 links, 270 deg. 0 min. 901.3 links, 290 deg. 22 min. 401.1 links and 308 deg. 30 min. 546.4 links to the point of commencement—which said piece of land is particularly delineated and shown coloured red on survey plan numbered 7112, lodged in the office of the Country Roads Board.

## SECOND SCHEDULE.

## Shire of Strathfieldsaye.

2. *Strathfieldsaye-road* (15802).—All that piece of land in the Parish of Eppalock, the boundaries of which are as follow:—Commencing at the southern angle of allotment 8A, section 12 of the said parish; thence by lines bearing respectively 90 deg. 0 min. 524.2 links, 110 deg. 22 min. 287.1 links, 270 deg. 0 min. 860.2 links, 337 deg. 23 min. 730 links, 128 deg. 30 min. 207 links and 157 deg. 23 min. 482.1 links to the point of commencement—which said

piece of land is particularly delineated and shown coloured blue on survey plan numbered 7112, lodged in the office of the Country Roads Board.

The common seal of the Country Roads Board was hereto affixed, at Kew, this twenty-third day of May, One thousand nine hundred and sixty-six, in the presence of—

(SEAL)	I. J. O'DONNELL, Chairman.
	F. WEST, Member.
	C. C. LIDDELL, Acting Secretary.

And the Honorable Murray Victor Porter, Her Majesty's Minister of Public Works for the State of Victoria, shall give the necessary directions herein accordingly.

J. COLQUHOUN,  
Clerk of the Executive Council.

## COUNTRY ROADS BOARD.

At the Executive Council Chamber, Melbourne, the  
thirty-first day of May, 1966.

## PRESENT:

The Lieutenant-Governor as Deputy for His Excellency  
the Governor of Victoria.

Mr. Reid	Mr. Porter
Mr. Hamer	Mr. Manson.

DECLARATION OF THE WIDENING OF WINCHELSEA-  
DEAN MARSH ROAD IN THE SHIRE OF  
WINCHELSEA.

WHEREAS by section 21 of the *Country Roads Act 1958* (No. 6229) it is amongst other things enacted that when the Country Roads Board under the provisions of the *Country Roads Act* has taken the land necessary for constructing the road or deviation or widening it shall as soon as it thinks such road or deviation or widening is fit to be used as a public highway by Resolution declare the road or deviation or widening to be a main road or part thereof and that upon publication in the *Government Gazette* of the Order of the Governor in Council confirming such Resolution such road or deviation or widening shall thereupon be a main road or a part thereof within the meaning of the said Act: And whereas the said Board has by Resolution declared the road on the land described in the Schedule to such Resolution to be part of a main road: Now therefore the Lieutenant-Governor as Deputy for His Excellency the Governor of the State of Victoria by and with the advice of the Executive Council thereof doth hereby confirm the said Resolution.

Resolution for Declaration of the Widening of a Main Road  
under the Country Roads Act.

Whereas the land the site of the road the course of which is below set out was taken by the Board under the provisions of the *Country Roads Act* for the purpose of widening the main road aforesaid which widening has now been laid out and formed on the same: And whereas the said Board (being the Country Roads Board incorporated under the said Act) thinks that the widening aforesaid is fit to be used as part of a public highway such Board at a meeting now holden doth by this Resolution hereby declare the same as described in the Schedule hereto with the commencing and terminating points thereof respectively specified to be part of the main road within the meaning and for the purposes of the *Country Roads Act*.

## SCHEDULE.

## Shire of Winchelsea.

8. *Winchelsea-Dean Marsh road* (18308).—All those pieces of land in the Parish of Yan Yan Gurt, the boundaries of which are as follow:—

- (a) Commencing at the south-western angle of allotment 73c of the said parish; thence by lines bearing respectively 7 deg. 14 min. 272.2 links, 14 deg. 27 min. 787.9 links, 41 deg. 2 min. 856.2 links, 47 deg. 43 min. 168 links, 222 deg. 27 min. 675.6 links, 207 deg. 26 min. 674.7 links and 192 deg. 13 min. 710.7 links to the point of commencement.
- (b) Commencing at the south-western angle of allotment 76A of the said parish; thence by lines bearing respectively 360 deg. 0 min. 1,639.3 links, 179 deg. 33 min. 1,639.3 links and 270 deg. 0 min. 13 links to the point of commencement.

- (c) Commencing at a point on the western boundary of allotment 76A of the said parish, distant 360 deg. 0 min. 1,639.3 links and 359 deg. 29 min. 440.3 links from the south-western angle of the said allotment; thence by lines bearing respectively 359 deg. 29 min. 877.3 links, 48 deg. 29 min. 819.9 links, 223 deg. 13 min. 495.7 links, 203 deg. 56 min. 550.0 links and 184 deg. 28 min. 558.7 links to the point of commencement—

which said pieces of land are particularly delineated and shown coloured red on survey plans numbered 8144 and 8145, lodged in the office of the Country Roads Board.

The common seal of the Country Roads Board was hereto affixed, at Kew, this twenty-third day of May, One thousand nine hundred and sixty-six, in the presence of—

(SEAL) I. J. O'DONNELL, Chairman.  
F. WEST, Member.  
C. C. LIDDELL, Acting Secretary.

And the Honorable Murray Victor Porter, Her Majesty's Minister of Public Works for the State of Victoria, shall give the necessary directions herein accordingly.

J. COLQUHOUN,  
Clerk of the Executive Council.

#### COUNTRY ROADS BOARD.

At the Executive Council Chamber, Melbourne, the thirty-first day of May, 1966.

PRESENT:

The Lieutenant-Governor as Deputy for His Excellency the Governor of Victoria.

Mr. Reid	Mr. Porter
Mr. Hamer	Mr. Manson.

#### ORDER APPROVING OF WIDENING AN EXISTING MAIN ROAD IN THE SHIRE OF YACKANDANDAH.

WHEREAS the Country Roads Board constituted under the Country Roads Act 1958 (No. 6229) has represented to His Excellency the Governor in Council that it appears to it desirable that the existing Huon-Kiewa road in the Shire of Yackandandah (declared to be a main road under the said Act which declaration was confirmed by the Order in Council published in the Government Gazette of the 30th March, 1958, on page 1081) should be widened by the said Board: And whereas the said Board in accordance with the requirements of section 19 of the said cited Act has caused to be prepared a map, plan and estimate showing the points between which and on and through what land the said widening is proposed to be made and the cost of acquiring the land: And whereas on an inspection of the said map and plan and a consideration of the said estimate His Excellency the Governor in Council is satisfied that there are funds legally available for acquiring the land: Now therefore be it known by this present Order that the Lieutenant-Governor as Deputy for His Excellency the Governor of the State of Victoria with the advice of the Executive Council thereof doth hereby approve of the said road being widened, that is to say:—

All those pieces of land in the Parish of Tangambalanga, the boundaries of which are as follow:—

- (a) Commencing at a point on the western boundary of allotment 14, section 7, of the said parish, distant 16 deg. 3 min. 2,915.9 links from the south-western angle of the said allotment; thence by lines bearing respectively 16 deg. 3 min. 132.1 links, 37 deg. 14 min. 219.8 links and 209 deg. 18½ min. 346.3 links to the point of commencement.
- (b) Commencing at a point on the north-western boundary of allotment 15, section 7, of the said parish, distant 37 deg. 21 min. 1,149.2 links from the western angle of the said allotment; thence by lines bearing respectively 37 deg. 21 min. 798.5 links, 41 deg. 49 min. 139.5 links, 216 deg. 33½ min. 382.7 links and 219 deg. 1 min. 555.2 links to the point of commencement—

which said pieces of land are particularly delineated and shown coloured red on survey plan numbered 10439, lodged in the office of the Country Roads Board.

And the Honorable Murray Victor Porter, Her Majesty's Minister of Public Works for the State of Victoria, shall give the necessary directions herein accordingly.

J. COLQUHOUN,  
Clerk of the Executive Council.

#### COUNTRY ROADS BOARD.

At the Executive Council Chamber, Melbourne, the thirty-first day of May, 1966.

PRESENT:

The Lieutenant-Governor as Deputy for His Excellency the Governor of Victoria.

Mr. Reid	Mr. Porter
Mr. Hamer	Mr. Manson.

#### DECLARATION OF A DEVIATION FROM THE MIRBOO SOUTH-ROAD IN THE SHIRE OF MIRBOO.

WHEREAS by sections 21 and 58 of the Country Roads Act 1958 (No. 6229) it is amongst other things enacted that when the Country Roads Board under the provisions of the Country Roads Act has by Resolution declared a deviation to be a main road the said Board may also declare that such deviation shall be in lieu of any existing road or part thereof named in such Resolution and that on publication in the Government Gazette of the Order confirming such Resolution the existing road or part thereof shall cease to be a main road or be discontinued as provided in the Resolution: And whereas the said Board has by Resolution declared the deviation on the land described in the First Schedule to such Resolution to be a main road and has also declared that such deviation shall be in lieu of the part of the existing road being the land described in the Second Schedule to the said Resolution and that such part of the said existing road shall be discontinued: Now therefore the Lieutenant-Governor as Deputy for His Excellency the Governor of the State of Victoria by and with the advice of the Executive Council thereof doth hereby confirm the said Resolution.

#### Resolution for Declaration of a Deviation of a Main Road under the Country Roads Act.

Whereas the land the site of the road the course of which is below set out was taken by the Board under the provisions of the Country Roads Act 1958 for the purpose of constructing such road deviation which road deviation has now been laid out and formed on the same: And whereas the said Board (being the Country Roads Board incorporated under the said Act) thinks that the road aforesaid is fit to be used as a public highway such Board at a meeting now holden acting under the authority conferred upon it by sections 21 and 58 of the said Act doth by this present Resolution hereby declare the said road deviation the course of which is described in the First Schedule hereto with the commencing and terminating points thereof respectively specified to be part of a main road within the meaning and for the purposes of the Country Roads Act 1958: And the said Board doth also declare that such deviation shall be in lieu of the existing road or part thereof described in the Second Schedule hereto and that such part of the said existing road shall be discontinued.

#### FIRST SCHEDULE.

##### Shire of Mirboo.

2. Mirboo South-road (10802).—All those pieces of land in the Parish of Mirboo, the boundaries of which are as follow:—

- (a) Commencing at the western angle of allotment 70 of the said parish; thence by lines bearing respectively 92 deg. 57 min. 82 links, 61 deg. 19 min. 336.7 links, 214 deg. 47½ min. 224.5 links, 189 deg. 38 min. 201.3 links and 316 deg. 17 min. 311.9 links to the point of commencement.
- (b) Commencing at a point on the eastern boundary of allotment 70E of the said parish, distant 349 deg. 38 min. 200.5 links and 309 deg. 9 min. 711 links from the south-eastern angle of the said allotment; thence by lines bearing respectively 300 deg. 51 min. 344 links, 337 deg. 2 min. 417.4 links, 136 deg. 17 min. 209 links and 142 deg. 33 min. 516 links to the point of commencement.
- (c) Commencing at the south-eastern angle of allotment 70E of the said parish; thence by lines bearing respectively 169 deg. 38 min. 245.9

links, 341 deg. 51½ min. 254.5 links, 355 deg. 33 min. 138.5 links, 337 deg. 44 min. 108.6 links, 129 deg. 9 min. 65.5 links and 169 deg. 38 min. 200.5 links to the point of commencement.

- (d) Commencing at an angle in the western boundary of allotment 79b of the said parish formed by the intersection of lines bearing 153 deg. 53 min. and 179 deg. 51 min.; thence by lines bearing respectively 150 deg. 25 min. 455.4 links, 157 deg. 12 min. 251.0 links, 306 deg. 7 min. 278.0 links, 330 deg. 35 min. 197.0 links and 359 deg. 51 min. 292.0 links to the point of commencement.
- (e) Commencing at a point on the western boundary of the existing Mirboo South-road through allotment 79 of the said parish, formed by the intersection of lines bearing 125 deg. 18 min. and 163 deg. 0 min.; thence by lines bearing respectively 163 deg. 0 min. 332.6 links, 330 deg. 49 min. 472.1 links and 125 deg. 18 min. 162.9 links to the point of commencement.
- (f) Commencing at the intersection of the eastern boundary of the existing Mirboo South-road through allotment 79 of the said parish, with the southern boundary of the said allotment; thence by lines bearing respectively 360 deg. 0 min. 246.9 links, 347 deg. 38 min. 242.2 links, 327 deg. 44 min. 595.3 links, 131 deg. 5 min. 218.6 links, 148 deg. 31½ min. 365.8 links, 150 deg. 45 min. 206.3 links, 186 deg. 23 min. 596.1 links, 351 deg. 41 min. 142.7 links and 360 deg. 0 min. 100.0 links to the point of commencement.
- (g) Commencing at the intersection of the western boundary of the existing Mirboo South-road through allotment 105 of the said parish, with the northern boundary of the said allotment; thence by lines bearing respectively 171 deg. 41 min. 271.3 links, 202 deg. 55 min. 140.3 links and 2 deg. 13 min. 398.0 links to the point of commencement.
- (h) Commencing at an angle in the eastern boundary of the existing Mirboo South-road through allotment 105 of the said parish, formed by the intersection of lines bearing 354 deg. 21 min. and 28 deg. 35 min.; thence by lines bearing respectively 168 deg. 48 min. 246.1 links, 186 deg. 8½ min. 116.5 links and 354 deg. 21 min. 359.0 links to the point of commencement.
- (i) Commencing at an angle in the eastern boundary of the existing Mirboo South-road through allotment 105 of the said parish, formed by the intersection of lines bearing 169 deg. 46 min. and 208 deg. 10 min.; thence by lines bearing respectively 349 deg. 46 min. 271.3 links, 146 deg. 0 min. 135.1 links and 190 deg. 1 min. 157.4 links to the point of commencement.
- (j) Commencing at an angle in the western boundary of the existing Mirboo South-road, through allotment 105 of the said parish, formed by the intersection of lines bearing 320 deg. 42 min. and 18 deg. 27 min.; thence by lines bearing respectively 140 deg. 42 min. 238.9 links, 120 deg. 12 min. 402.5 links, 161 deg. 44 min. 113.3 links, 284 deg. 26 min. 122.4 links, 320 deg. 29 min. 171.6 links, 312 deg. 6 min. 297.2 links, 326 deg. 56½ min. 158.4 links, 6 deg. 29 min. 377.2 links, 72 deg. 39¼ min. 559.7 links, 60 deg. 24½ min. 151.1 links, 57 deg. 58½ min. 76.0 links, 190 deg. 8 min. 134.9 links, 253 deg. 0 min. 334.5 links, 238 deg. 40 min. 421.6 links and 198 deg. 27 min. 217.9 links to the point of commencement.
- (k) Commencing at an angle in the eastern boundary of the existing Mirboo South-road, through allotment 105 of the said parish, formed by the intersection of lines bearing 198 deg. 27 min. and 140 deg. 42 min.; thence by lines bearing respectively 18 deg. 27 min. 126.2 links, 58 deg. 40 min. 18.6 links, 185 deg. 25½ min. 124.5 links, 144 deg. 41 min. 204.8 links, 300 deg. 12 min. 66.5 links and 320 deg. 42 min. 165.7 links to the point of commencement—

which said pieces of land are particularly delineated and shown coloured red on survey plans numbered 10244, 10245, 10246 and 10247, lodged in the office of the Country Roads Board.

## SECOND SCHEDULE.

## Shire of Mirboo.

2. *Mirboo South-road* (10802).—All that piece of land in the Parish of Mirboo, the boundaries of which are as follow:—Commencing at an angle in the eastern boundary of the existing Mirboo South-road, through allotment 105 of the said parish, formed by the intersection of lines bearing 77 deg. 36 min. and 0 deg. 0 min.; thence by lines bearing respectively 257 deg. 36 min. 138.8 links, 21 deg. 54½ min. 281.4 links, 152 deg. 30 min. 66.3 links and 180 deg. 0 min. 172.5 links to the point of commencement—which said piece of land is particularly delineated and shown coloured blue on survey plan numbered 10247, lodged in the office of the Country Roads Board.

The common seal of the Country Roads Board was hereto affixed, at Kew, this twenty-third day of May, One thousand nine hundred and sixty-six, in the presence of—

I. J. O'DONNELL, Chairman.  
F. WEST, Member.  
C. C. LIDDELL, Acting Secretary.

And the Honorable Murray Victor Porter, Her Majesty's Minister of Public Works for the State of Victoria, shall give the necessary directions herein accordingly.

J. COLQUHOUN,  
Clerk of the Executive Council.

## HOSPITALS AND CHARITIES ACT 1958, SECTION 65.

At the Executive Council Chamber, Melbourne, the thirty-first day of May, 1966.

## PRESENT:

The Lieutenant-Governor as Deputy for His Excellency the Governor of Victoria.

Mr. Reid	Mr. Porter
Mr. Hamer	Mr. Manson.

## AUTHORITY FOR SALE OF LAND BY GOULBURN VALLEY AMBULANCE SERVICE.

WHEREAS Goulburn Valley Ambulance Service, an association incorporated under the *Hospitals and Charities Act 1958*, and hereinafter called "the association" is the owner of certain land known as 17 Park-street, Seymour, and more particularly described in the Schedule hereto:

And whereas the said land is at the present time held by the Union Fidelity Trustee Company, of 100 Exhibition-street, Melbourne, as trustees for the association:

And whereas no part of the said land is reserved or set apart for the purposes of the association:

And whereas the majority of the members of the committee of management of the association desire that the said land be sold:

And whereas the Hospitals and Charities Commission after inquiry has reported that it would be advantageous to the association if the said land were sold:

Now therefore the Lieutenant-Governor as Deputy for His Excellency the Governor of the State of Victoria, by and with the advice of the Executive Council of the said State, by virtue of the powers conferred on him by section 65 of the *Hospitals and Charities Act 1958* and all other powers enabling him in that behalf, hereby revokes the Order published in the *Government Gazette* dated the 6th April, 1966, at page 1073, consenting to the sale of the said land to Geoffrey Hine Kenihan and Glenda Joy Kenihan, and in lieu thereof hereby consents to the sale of the said land freed and discharged from all trusts affecting the same to Geoffrey Hine Kenihan, journalist, and Gloria Joy Kenihan, married woman, both of 33 Gordon-crescent, Seymour, for the sum of \$9,100, and directs that the proceeds of the sale be applied towards the cost of the new ambulance station at Seymour.

## SCHEDULE.

All that piece of land being lot 62 on plan of subdivision No. 12230, lodged in the Office of Titles, and being part of Crown allotment 3, section V., Township and Parish of Seymour, County of Anglesey, and being the whole of the land described in certificate of title, volume 5400, folio 948.

And the Honorable Vance Oakley Dickie, Her Majesty's Minister of Health for the State of Victoria, shall give the necessary directions herein accordingly.

J. COLQUHOUN,  
Clerk of the Executive Council.

## AGRICULTURAL COLLEGES ACT 1958 (No. 6194).

At the Executive Council Chamber, Melbourne, the  
thirty-first day of May, 1966.

## PRESENT:

The Lieutenant-Governor as Deputy for His Excellency  
the Governor of Victoria.

Mr. Reid	Mr. Porter
Mr. Hamer	Mr. Manson.

IN pursuance of the powers conferred by the *Agricultural Colleges Act 1958* (No. 6194) and all other powers him thereunto enabling, the Lieutenant-Governor as Deputy for His Excellency the Governor of the State of Victoria, by and with the advice of the Executive Council thereof, doth hereby amend the Order in Council made on the 27th October, 1964, appointing members of the Advisory Committee constituted under the said Act for a period of three (3) years as follows:—

For the words "Superintendent of Agricultural Education" there shall be substituted the words "Chief of Division of Agricultural Education".

And the Honorable Gilbert Lawrence Chandler, Her Majesty's Minister of Agriculture for the State of Victoria, shall give the necessary directions herein accordingly.

J. COLQUHOUN,  
Clerk of the Executive Council.

## WARRAGUL WATERWORKS TRUST.

At the Executive Council Chamber, Melbourne, the  
seventh day of June, 1966.

## PRESENT:

His Excellency the Governor of Victoria.
Mr. Chandler   Mr. Rossiter.

## EXTENT OF WATERWORKS DISTRICT INCREASED AND APPROVAL OF PLAN OF PIPE-LINE.

UNDER the powers conferred by the Water Act and all other powers enabling him in that behalf, His Excellency the Governor of the State of Victoria, by and with the advice of the Executive Council of the said State, doth hereby:—

(a) declare, order and direct that the extent of the Waterworks District of the Warragul Waterworks Trust be increased by adding to the same the land comprised within the boundaries described in Portion I of the Schedule hereto, and as on and from the date hereof, the extent of such District shall be and be deemed to be increased accordingly; and

(b) approve the accompanying plan showing the site of pipe-line as described in Portion II of the said Schedule.

## SCHEDULE.

## Portion I.

## Extent of Waterworks District Increased.

Commencing at the northernmost angle of Crown allotment 31C, Parish of Drouin East, County of Buln Buln; thence south-westerly along the north-western boundary of the said Crown allotment 31C a distance of 450 links; thence north-westerly by a line at right angles to the said north-western boundary of Crown allotment 31C across a road and through Crown allotment 20b a distance of 300 links; thence north-easterly and north-westerly by lines parallel to and distant 300 links north-westerly and south-westerly from the south-eastern and north-eastern boundaries of the said Crown allotment 20b and by a line being the continuation thereof across a road to a point on the south-eastern boundary of the Warragul-Noojee Railway Reserve; thence north-easterly along the said south-eastern boundary of the Warragul-Noojee Railway Reserve to its intersection with a line parallel to and distant 300 links easterly from a line on the western boundary of Crown allotment 20A of length 937 links and bearing north 5 deg. 51 min. west; thence southerly by the said parallel line across a road, through Crown land and the said Crown allotment 20A to its intersection with a line parallel to and distant 400 links northerly from a line on the southern boundary of the said Crown allotment 20A of length 1,518 links and bearing north 84 deg. 0 min. west; thence easterly by the said parallel line to its intersection with a line parallel to and distant 700 links easterly from the said line on the western boundary of

Crown allotment 20A of length 937 links and bearing north 5 deg. 51 min. west; thence southerly by the said parallel line through the said Crown allotment 20A and across a road to a point on the northern boundary of Crown allotment 32B; thence westerly along the said northern boundary of Crown allotment 32B to its north-western angle; thence by a line across a road to the northernmost angle of Crown allotment 31C being the point of commencement.

## Portion II.

## Site of Pipe-line.

The site of the pipe-line being a strip of land 50 links in width being 25 links on each side of the centreline of the said pipe-line commencing at a point in Crown allotment 126C, Parish of Jindivick, County of Buln Buln being a point on the centreline of the Trust's existing main pipe-line and approximately 1,300 links south-westerly from the intersection of the centreline of the said main pipe-line with the north-western boundary of the said Crown allotment 126C; thence south-easterly by a line at right angles to the centreline of the said main pipe-line through the said Crown allotment 126C, the Tarago River Reserve and the Warragul-Noojee Railway Reserve to a point on its south-eastern boundary being a point on the boundary of the Waterworks District as described in Portion I.

All of which boundaries and lands are shown on a plan approved by the Governor in Council and deposited in the office of the State Rivers and Water Supply Commission, Melbourne.—(Corres. 64/349/16.)

And the Honorable Thomas Anthony Darcy, Her Majesty's Minister of Water Supply for the State of Victoria, shall give the necessary directions herein accordingly.

J. COLQUHOUN,  
Clerk of the Executive Council.

## BENDIGO SEWERAGE AUTHORITY.

At the Executive Council Chamber, Melbourne, the  
seventh day of June, 1966.

## PRESENT:

His Excellency the Governor of Victoria.
Mr. Chandler   Mr. Rossiter.

## EXTENT OF SEWERAGE DISTRICT INCREASED.

UNDER the powers conferred by the Sewerage Districts Act and all other powers enabling him in that behalf, His Excellency the Governor of the State of Victoria, by and with the advice of the Executive Council of the said State, doth hereby declare, order and direct as follows:—

That the extent of the Sewerage District of the Bendigo Sewerage Authority be increased by adding to the same the land comprised within the boundaries described in the Schedule hereto and as on and from the date hereof the extent of such District shall be deemed to be increased accordingly.

## SCHEDULE.

Commencing at the north-eastern angle of Crown allotment 34C, Parish of Mandurang, County of Bendigo, being a point on the boundary of the existing Sewerage District; thence westerly along the northern boundary of the said Crown allotment 34C to a point in line with the western boundary of Crown allotment 89, section 18, Parish of Sandhurst; thence northerly by a line across Wesley-street and along the said western boundary of Crown allotment 89 and by a line being a continuation thereof across Crown allotment 89A to a point on its north-western boundary; thence north-westerly by a line across Lockwood-road to the southernmost angle of Crown allotment 34M; thence north-westerly along the south-western boundary of the said Crown allotment 34M and by a line being a continuation thereof across a road to a point on the southern boundary of Crown allotment 34F; thence easterly and northerly along the said southern and the eastern boundaries of Crown allotment 34F to the southernmost angle of Crown allotment 34H; thence north-easterly along the south-eastern boundaries of the said Crown allotment 34H and of Crown allotments 15C and 15B to a point on the boundary of the existing Sewerage District; thence generally southerly and westerly along the boundary of the existing Sewerage District to the point of commencement.

All of which boundaries are shown on a plan approved by the Governor in Council and deposited in the office of the State Rivers and Water Supply Commission, Melbourne.—(Correspondence No. 63/3747/83.)

And the Honorable Thomas Anthony Darcy, Her Majesty's Minister of Water Supply for the State of Victoria, shall give the necessary directions herein accordingly.

J. COLQUHOUN,  
Clerk of the Executive Council.

#### SWAN HILL WATERWORKS TRUST.

At the Executive Council Chamber, Melbourne, the seventh day of June, 1966.

PRESENT:

His Excellency the Governor of Victoria.  
Mr. Chandler | Mr. Rossiter.

#### AMENDMENT OF ORDER.

UNDER the powers conferred by the Water Act and all other powers enabling him in that behalf, His Excellency the Governor of the State of Victoria, by and with the advice of the Executive Council of the said State, doth hereby amend as follows the Order in Council made on 18th January, 1966, and published in the *Victoria Government Gazette* dated 19th January, 1966, authorizing the Swan Hill Waterworks Trust to obtain an overdraft for the year 1966 from the English, Scottish and Australian Bank Limited, Swan Hill, under the provisions of section 286 of the *Water Act 1958* (No. 6413).

For the expression "such overdraft not to exceed at any one time the sum of Ten thousand pounds (£10,000)" there shall be substituted the expression "such overdraft not to exceed at any one time the sum of Thirty-five thousand dollars (\$35,000)".

And the Honorable Thomas Anthony Darcy, Her Majesty's Minister of Water Supply for the State of Victoria, shall give the necessary directions herein accordingly.

J. COLQUHOUN,  
Clerk of the Executive Council.

#### STAMPS ACT 1958 (No. 6375).

At the Executive Council Chamber, Melbourne, the seventh day of June, 1966.

PRESENT:

His Excellency the Governor of Victoria.  
Mr. Chandler | Mr. Rossiter.

HIS Excellency the Governor of the State of Victoria, by and with the advice of the Executive Council thereof, doth by this Order, made pursuant to section 131C of the *Stamps Act 1958* (No. 6375), revoke the declaration made on the 19th July, 1960, and published in the *Government Gazette* of the 20th July, 1960, declaring certain persons to be "approved vendors" for the purposes of subdivision (14) of Division 3 of Part II. of the *Stamps Act 1958* in so far as the said declaration refers to the under-mentioned person—

164. Supreme Finance Company Pty. Ltd.

And the Honorable Arthur Gordon Rylah, Her Majesty's Acting Treasurer for the State of Victoria, shall give the necessary directions herein accordingly.

J. COLQUHOUN,  
Clerk of the Executive Council.

#### HOUSING ACT 1958.

At the Executive Council Chamber, Melbourne, the seventh day of June, 1966.

PRESENT:

His Excellency the Governor of Victoria.  
Mr. Chandler | Mr. Rossiter.

#### CLOSING OF ROADS AND EXTINGUISHMENT OF EASEMENTS AND RESTRICTIVE COVENANTS.—CITY OF PRAHRAN.

WHEREAS by virtue and in exercise of the power contained in the *Housing Act 1958* (No. 6275), Housing Commission has recommended to the Governor in Council

that the roads, easements and restrictive covenants described in the Schedule hereto be closed and extinguished:

Now therefore His Excellency the Governor of the State of Victoria, in the Commonwealth of Australia, by and with the advice of the Executive Council of the said State, doth in pursuance of the powers conferred by the said Act and upon such recommendation, consent and by this Order hereby close and extinguish such roads, easements and restrictive covenants.

#### SCHEDULE.

All roads set out within and any easements and restrictive covenants affecting that piece of land situate within the municipality of the City of Prahran, being parts of Crown portions 34 and 35, Parish of Prahran, and being the land bounded by a line commencing at a point on the northern alignment of Malvern-road, being the intersection thereof with the eastern alignment of Bray-street; thence northerly by the eastern alignment of Bray-street and the eastern alignment of Grant-place to the intersection of the said eastern alignment of Grant-place with the southern alignment of Simmons-street; thence easterly by the said southern alignment of Simmons-street to the intersection thereof with the western alignment of Surrey-road; thence southerly by the said western alignment of Surrey-road to the intersection thereof with the northern alignment of Malvern-road; and thence westerly by the said northern alignment of Malvern-road to the point of commencement.

And the Honorable Lindsay Hamilton Simpson Thompson, Her Majesty's Minister of Housing for the State of Victoria, shall give the necessary directions herein accordingly.

J. COLQUHOUN,  
Clerk of the Executive Council.

#### STATE ELECTRICITY COMMISSION ACT 1958 (No. 6377).

At the Executive Council Chamber, Melbourne, the seventh day of June, 1966.

PRESENT:

His Excellency the Governor of Victoria.  
Mr. Chandler | Mr. Rossiter.

WHEREAS His Excellency the Governor of the State of Victoria, by and with the advice of the Executive Council thereof, has this day consented, pursuant to the provisions of the *State Electricity Commission Act 1958*, to the State Electricity Commission of Victoria raising by way of loan the sum of Eighty-six thousand two hundred dollars (\$86,200): And whereas His Excellency the Governor is satisfied that a sufficient proportion of the loan to be raised will fall due and be repaid in each year during the currency of the proposed loan: Now therefore it is directed, pursuant to the provisions of section 91 (3) of the said Act, that it shall not be necessary to provide a sinking fund in connexion with such loan.

And the Honorable Arthur Gordon Rylah, Her Majesty's Acting Treasurer for the State of Victoria, shall give the necessary directions herein accordingly.

J. COLQUHOUN,  
Clerk of the Executive Council.

#### MELBOURNE AND METROPOLITAN TRAMWAYS ACT 1958 (No. 6311).

At the Executive Council Chamber, Melbourne, the seventh day of June, 1966.

PRESENT:

His Excellency the Governor of Victoria.  
Mr. Chandler | Mr. Rossiter.

WHEREAS His Excellency the Governor of the State of Victoria, by and with the advice of the Executive Council thereof, has this day consented, pursuant to the provisions of section 28 of the *Melbourne and Metropolitan Tramways Act 1958*, to the Melbourne and Metropolitan Tramways Board raising by way of loan an amount not exceeding One hundred thousand dollars (\$100,000): And whereas His Excellency the Governor is satisfied that a sufficient proportion of the loan to be so raised will fall due and be repaid in each year during the currency of the proposed loan: Now therefore it is directed, pursuant to



the provisions of section 28 (6) of the said Act, that it shall not be necessary to provide a sinking fund in connexion with such loan.

And the Honorable Arthur Gordon Rylah, Her Majesty's Acting Treasurer for the State of Victoria, shall give the necessary directions herein accordingly.

J. COLQUHOUN,  
Clerk of the Executive Council.

### LANDS DEPARTMENT NOTICES

#### APPROACHING LAND SALES.

SALES of Crown lands, in fee-simple, will be held at the under-mentioned places and dates, viz.:—

	No. of Gazette.
Casterton.—Thursday, 14th July, 1966	.. 38
Dartmoor.—Thursday, 14th July, 1966	.. 38
Foster.—Saturday, 9th July, 1966	.. 37
Hamilton.—Friday, 15th July, 1966	.. 40
Heathcote.—Friday, 24th June, 1966	.. 37
Melbourne.—Wednesday, 29th June, 1966	.. 37
Rushworth.—Friday, 24th June, 1966	.. 37
Warmambool.—Wednesday, 29th June, 1966	.. 38

#### SALE OF CLOSER SETTLEMENT LAND BY AUCTION.

Kyabram.—Tuesday, 5th July, 1966	.. 38
Rochester.—Tuesday, 5th July, 1966	.. 38

#### SALE OF CROWN LAND BY AUCTION.

The land will be offered for sale in fee-simple, and subject to the provisions of the Land Act and Regulations thereunder.

The upset price is the sum at which bidding will start, and no bid below that sum can be accepted. The highest bidder at or above that sum shall be the purchaser, subject to signature of contract and any necessary payment.

#### TERMS:

A deposit of at least 12½% of the purchase price must be paid at the sale, either in cash or by cheque.

The residue is payable in half-yearly instalments, in accordance with the following scale, or may be paid off at any earlier time.

\$40 and under, 6 instalments.
Over \$40 and not exceeding \$100, 8 instalments.
Over \$100 and not exceeding \$200, 10 instalments.
Over \$200 and not exceeding \$400, 12 instalments.
Over \$400 and not exceeding \$600, 14 instalments.
Over \$600 and not exceeding \$800, 16 instalments.
Over \$800, and not exceeding \$1,000, 18 instalments.
Over \$1,000, 20 instalments.

Interest at the rate of 5% per annum is payable with all payments of residue, and is computed for each instalment from the date of sale to the date of such payment. Additional interest is charged if any instalment is not paid on or before the due date.

If paid off within 30 days of sale, no interest is payable.

#### FEES, ETC.:

Also payable at the sale, in addition to the deposit, are the survey fee and, if applicable, the valuation of improvements (if purchaser be not the owner thereof).

#### Payable with balance of purchase money—

Crown Grant fee—	
50 acres and under	.. \$3
Over 50 acres	.. \$4
Purchase money \$10 or under	.. \$2

Assurance Fund contribution.—One cent for each multiple of \$5. (This is a fund established to guarantee the validity of freehold titles.)

Transfer of interest prior to completion of payment may be allowed on payment of \$2 fee and subject to stamp duty.

If unable to attend personally, a prospective purchaser may arrange for another person to bid as his agent.

Attention is drawn to section 95, Land Act 1958, which provides that the purchaser shall be deemed to be the owner for the purposes of other Acts; also to an amendment to the Local Government Act providing for Government roads in certain circumstances, to be declared "private streets" thus making the purchaser liable to contribute to the cost of street construction.

J. C. M. BALFOUR,  
Minister of Lands.

Office of Crown Lands and Survey,  
Melbourne, 8th June, 1966.

**HAMILTON.**—Sale (No. 11827) of Crown land in fee-simple by auction, will be held at the LAND OFFICE, STATE PUBLIC OFFICE, THOMPSON-STREET, HAMILTON, on FRIDAY, 15th JULY, 1966, at half-past TEN o'clock a.m. To be conducted by K. C. GITTINS, Land Officer, Hamilton.

#### Lot 1.

PARISH OF BESSIEBELLE, COUNTY OF NORMANBY.  
In the centre of the Parish.

Upset price \$640 the lot. Survey fee \$67.75.

Area 319a. 3r. 12p., allotments 54 and 54A. Valuations of improvements, \$9,252 (fencing, sheds and land improvement) (K. I. Siemering).—(J.32213.)

#### COMMON ABOUT TO BE ABOLISHED.

IN pursuance of the provisions contained in the Land Act 1958, notice is hereby given that it is the intention of the Governor in Council to abolish the common hereinafter mentioned, viz.:—

The following Notice was published 1° on the 18th May, 1966, pursuant to Order of the 10th May, 1966.

The United Municipal and Goldfield Common of Clunes proclaimed as such by the Governor in Council on the 14th September, 1863, is about to be abolished.—(Rs.398.)

J. C. M. BALFOUR,  
Minister of Lands.

#### PROPOSED PERMANENT RESERVATION OF LAND AS A SITE.

IN pursuance of sections 14 and 21 of the Land Act 1958, notice is hereby given that it is the intention of the Governor in Council to reserve permanently from sale, from being leased and from having a licence granted in respect thereof the land hereinafter described:—

The following Notice was published 1° on the 1st June, 1966, pursuant to Order of the 24th May, 1966.

NAR-NAR-GOON (MARYKNOLL).—Land proposed to be permanently reserved as a site for Cemetery purposes, also excepted from occupation for mining purposes under any miner's right, 2 acres, 1 rood, 7 perches, Parish of Nar-nar-goona, County of Mornington, as indicated by hachure on plan hereunder.—(N.11(\*) (Rs.8608.)

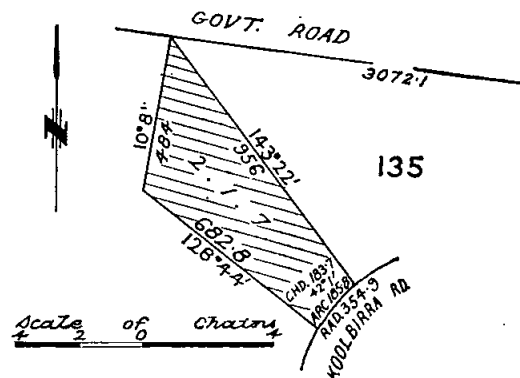

J. C. M. BALFOUR,  
Minister of Lands.

#### PROPOSED REVOCATION OF TEMPORARY RESERVATION OF LAND BY ORDER IN COUNCIL.

IN pursuance of the provisions of the Land Act 1958, notice is hereby given that it is the intention of the Governor in Council to revoke the temporary reservation of land by Order in Council hereunder referred to, viz.:—

The following Notice was published 1° on the 18th May, 1966, pursuant to Order of the 10th May, 1966.

BALLARAT.—The temporary reservation by Order in Council of the 8th July, 1878, of 4 acres 3 roods 39½ perches of land in the Parish of Ballarat as a site for Quarry and for affording access to Water.—(B.126(11) (Rs.8637).

J. C. M. BALFOUR,  
Minister of Lands.

**PROPOSED REVOCATION OF TEMPORARY RESERVATION, AND THE WITHHOLDING FROM SALE, LEASING, AND LICENSING, OF LAND BY ORDER IN COUNCIL.**

IN pursuance of the provisions of the Land Act 1958, notice is hereby given that it is the intention of the Governor in Council to revoke the temporary reservation, and the withholding from sale, leasing, and licensing, of land by Order in Council hereunder referred to, viz.:

The following Notice was published 1° on the 8th June, 1966, pursuant to Order of the 31st May, 1966.

**NUNAWADING.**—The temporary reservation and the withholding from sale, leasing and licensing by Order in Council of the 11th December, 1882, of 10 acres, more or less, of land in the Parish of Nunawading, as a site for a Quarry.—(N.79<sup>(6)</sup>) (Rs.1564).

J. C. M. BALFOUR,  
Minister of Lands.

**PROPOSED REVOCATIONS OF TEMPORARY RESERVATIONS OF LANDS BY ORDERS IN COUNCIL.**

IN pursuance of the provisions of the Land Act 1958, notice is hereby given that it is the intention of the Governor in Council to revoke the temporary reservations of lands by Orders in Council hereunder referred to, viz.:

The following Notices were published 1° on the 8th June, 1966, pursuant to Orders of the 31st May, 1966.

**BALROOTAN.**—The temporary reservation by Order in Council of the 12th January, 1885, of 5 acres of land in the Parish of Balrootan, as a site for a Cemetery and the temporary reservation by Order in Council of the 5th June, 1917, of 3 acres 16 perches, in two parts as an extension thereto, are about to be revoked so far only as the portion containing 3 perches, indicated by hachure on plan hereunder, is concerned.—(B.646<sup>(2)</sup>) (Rs.6157).

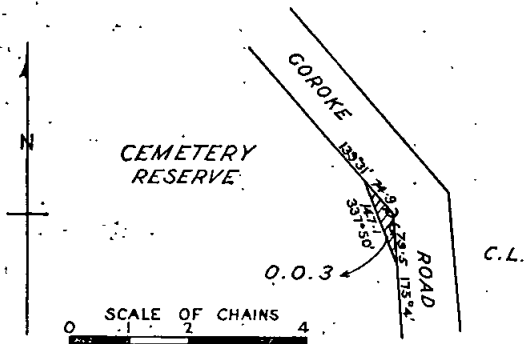

**SALE.**—The temporary reservation, by Order in Council, of the 6th June, 1956, of 92 acres of land in the Township of Sale, as a site for Public Park and Public Recreation, revoked as to part by various Orders, is about to be revoked so far only as the portion containing 29 perches, more or less, indicated by hachure on plan hereunder, is concerned.—(S.239<sup>(8)</sup>) (Rs.1321).

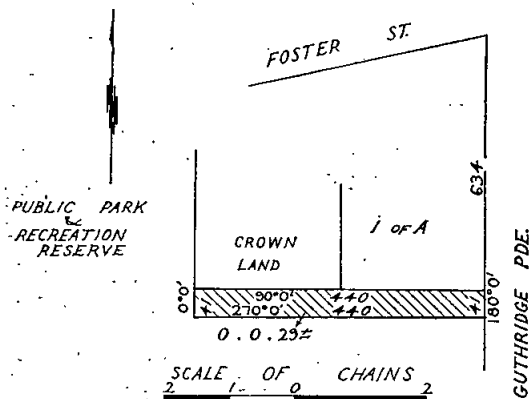

**TARRA TARRA.**—The temporary reservation by Order in Council of the 28th August, 1906, of 1 rood 24 perches of land, in the Parish of Tarra Tarra, as a site for a Public Hall.—(T.69<sup>(3)</sup>) (Rs.4840).

**TARRA TARRA.**—The temporary reservation by Order in Council of the 28th August, 1906, of 9 acres 2 roods 19 perches of land, in the Parish of Tarra Tarra, as a site for Public Recreation.—(T.69<sup>(3)</sup>) (Rs.4840).

**TRAWALLA.**—The temporary reservation by Order in Council of the 3rd March, 1915, of 13 acres 3 roods 21 perches, of land in the Parish of Trawalla, as a site for Water Supply and Public Recreation, is about to be revoked so far only as the portion containing 25 perches, more or less, indicated by hachure on plan hereunder, is concerned.—(T.140<sup>(2)</sup>) (Rs.295).

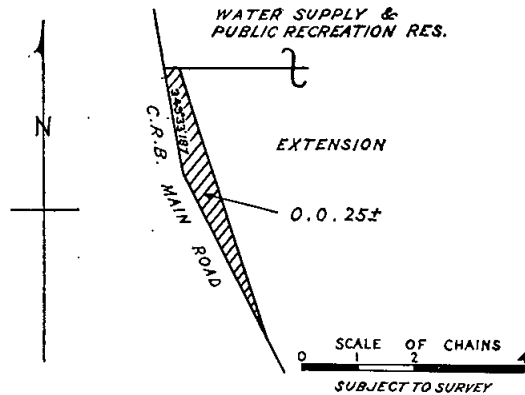

**TRAWALLA.**—The temporary reservation by Order in Council of the 3rd November, 1890, of 102 acres 3 roods 29 perches of land, in the Parish of Trawalla, as a site for Water Supply and Public Recreation, revoked as to part by Order in Council of the 6th October, 1908, is about to be revoked so far only as the portions containing 8 perches, more or less, indicated by hachure on plan hereunder, is concerned.—(T.140<sup>(2)</sup>) (Rs.295).

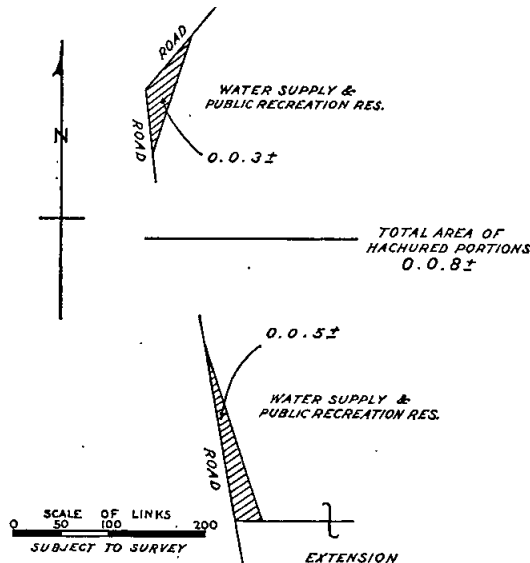

J. C. M. BALFOUR,  
Minister of Lands.

**REGULATIONS FOR THE CARE, PROTECTION AND MANAGEMENT OF THE MUNICIPAL AND PUBLIC PURPOSES RESERVE (CURTIS-STREET) BALLARAT.**

WHEREAS by section 218 of the Land Act 1958 the Minister of Lands is empowered to make Regulations as to any land which under the provisions of that Act or of any other Act relating to Crown lands has been reserved for any public purpose whatsoever and which has not been conveyed to or vested in trustees: And whereas certain Crown lands in the Township of Ballarat East were reserved for Municipal and Public Purposes by Order in

Council, dated the 30th October, 1962 and the 30th November, 1965: And whereas such lands (hereinafter called "the Reserve") have not been conveyed to or vested in trustees; And whereas it is expedient that Regulations for the care, protection and management of the Reserve and for other purposes connected therewith should be made: Now therefore I, James Charles Murray Balfour, Her Majesty's Minister of Lands in and for the State of Victoria, in pursuance of the powers aforesaid, do hereby make the following Regulations for or with respect to the Reserve:—

The Reserve has been placed under the control of the Ballarat City Council as the Committee of Management with power and authority to enforce the following Regulations:—

## REGULATIONS:

1. No person shall damage or destroy any property or light fires within the Reserve.
2. No person shall throw stones or missiles of any kind within the Reserve.
3. No person shall climb on any portion of any building, balustrade, or property within the Reserve or jump over any fence or hedge therein.
4. No person shall affix or interfere with any placard, bill, notice or marking of any kind on any building, structure, post, tree, constructed surface or anything within the Reserve.
5. No person shall enter or travel over the Reserve with or on a motor car, motor cycle, bicycle or other vehicle except on such portion therein provided for wheeled traffic and the driver of such motor car, motor cycle, bicycle, or other vehicle shall be guided and directed and shall abide by any notice, post or sign or marking or barrier that shall have been made or erected for the purpose of traffic guidance, control or direction.
6. No person shall drive any motor car, motor cycle, bicycle or other vehicle within the Reserve recklessly or at such a speed or in a manner dangerous to the public or likely to cause any damage to anything within the Reserve.
7. No person or persons except as hereunder provided shall park any motor car, motor cycle, bicycle or other vehicle within the Reserve, except completely within the marked spaces provided for such car parking.
8. No person shall spit or expectorate on the paths or seats or any wall, structure or property within the Reserve.
9. No person in an intoxicated state or who is disorderly or is not decorously dressed shall enter or remain in the Reserve and no person shall commit therein any nuisance or any indecent or offensive act.
10. No person shall remain within the Reserve or in any property therein when lawfully directed to leave the same by any bailiff of Crown lands or member of the Police Force or authorized Officer of the Committee.
11. No person shall hawk, or sell or offer for sale within the Reserve any goods, fruit, or merchandise or anything or solicit or gather money therein without the authority in writing of the Committee.
12. No person shall give out or distribute any hand bills, placards, notices, advertisements, books, pamphlets or papers in the Reserve without the authority in writing of the Committee.
13. No person shall litter the Reserve by scattering or throwing down hand bills, placards, notices, advertisements, books, pamphlets or papers or place them on any vehicle within the Reserve.
14. No person shall bring into the Reserve any dog unless securely held by a chain, cord or leash.
15. No person shall bring in or allow to remain in the Reserve any horse, cow, sheep, pig or goat and any such animal found therein shall be liable to be impounded or destroyed.
16. No person shall make or cause to be made any violent outcry, noise, disturbance or sound or shall play upon any musical instrument or noisy instrument or sing within the Reserve without the authority in writing of the Committee.
17. No person except on lawful occasions may enter any enclosed area or any garage or shed or other structure within the Reserve.

Given under my hand at Melbourne on the 1st day of June, 1966.

JIM BALFOUR,  
Minister of Lands.

Every person who contravenes or fails to comply with these Regulations shall, in accordance with the provisions of section 218 of the *Land Act 1958*, for each offence be liable to a penalty of not more than Ten dollars, and every person who contravenes or fails to comply with any such Regulations, and who, after he has been warned by any bailiff of Crown lands or by any member of the Police Force, does not desist therefrom may be forthwith apprehended by such bailiff or member of the Police Force and taken before some justice to be dealt with according to law and shall be liable to a penalty of not more than Twenty dollars.

## REGULATIONS FOR THE CARE, PROTECTION AND MANAGEMENT OF THE YARRA BANK ROAD PUBLIC PARK RESERVE, SOUTH MELBOURNE.

WHEREAS by section 218 of the *Land Act 1958* the Minister of Lands is empowered to make Regulations as to any land which under the provisions of that Act or of any other Act relating to Crown lands has been reserved for any public purpose whatsoever and which has not been conveyed to or vested in trustees: And whereas certain Crown lands in the Parish of South Melbourne and described in a notice published in the *Government Gazette* of the second day of March, 1966, were reserved as a site for a Public Park: And whereas such lands (hereinafter called "the Reserve") have not been conveyed to or vested in trustees: And whereas it is expedient that Regulations for the care, protection and management of the Reserve and for other purposes connected therewith should be made: Now therefore I, James Charles Murray Balfour, Her Majesty's Minister of Lands in and for the State of Victoria, in pursuance of the powers aforesaid, do hereby make the following Regulations for or with respect to the Reserve:—

The Reserve has been placed under the control of the South Melbourne City Council as the Committee of Management with power and authority to enforce the following Regulations:—

## REGULATIONS:

1. The Reserve shall be open to the public all day and all night free of charge.
2. No person shall in or on the Reserve—
  - (a) use the Reserve for any purpose except that of a public park;
  - (b) offend against decency as regards dress, language or conduct or speak or behave in an offensive or noisy manner, or be in a state of intoxication;
  - (c) play any ball, athletic or unlawful game.
3. Except as otherwise provided in these Regulations, no person shall—
  - (a) suffer any animal owned by him or in his charge to be in the Reserve, provided that "animal" shall not include a dog so controlled by a leash or cord as not to interfere with the convenience or enjoyment of any person in the Reserve, or to cause damage or injury to the Reserve or to any person or thing therein.
  - (b) ride or drive any vehicle, including any bicycle, in the Reserve;
  - (c) remove, uproot, pluck, interfere with, deface, damage or destroy any property or thing belonging to or under the control or management of the Committee, including anything growing in or on the Reserve;
  - (d) light any fire in or discharge any fireworks or throw anything in or into the Reserve;
  - (e) deposit or leave any litter in the Reserve except in a receptacle provided by the Committee for the purpose, or spit on the Reserve or on anything therein;
  - (f) obstruct, hinder or interfere with any person employed in the Reserve, or interfere with the convenience or enjoyment of any person therein.
4. (i) Except as otherwise provided in these Regulations, no person shall in the Reserve without the consent of the Committee in writing, first had and obtained—
  - (a) hawk, sell or offer for sale or advertise any goods or other article;
  - (b) solicit or gather money or other things;
  - (c) in any manner exhibit or give out any advertisement, placard, handbill or other notice or any book or paper;
  - (d) erect any tent or structure of any kind;
  - (e) speak publicly or take part in any public meeting or public entertainment or like assemblage;

(ii) The Committee may in writing at any time withdraw, cancel or annul any such consent.

5. Any person found committing a breach of any of the provisions of these Regulations shall state his name and place of abode when required so to do by any officer or employee of the Committee or any other person authorized by the Committee in that behalf or when so required by any bailiff of Crown lands or by any member of the Police Force.

6. Notwithstanding anything in these Regulations contained, no person employed by or acting with or under the authority of the Committee shall, by reason of performing or abstaining from any act in the due course of his lawful duties on behalf of the Committee in the Reserve, be deemed to have contravened or failed to comply with these Regulations.

Given under my hand at Melbourne on the 1st day of June, 1966.

JIM BALFOUR,  
Minister of Lands.

Every person who contravenes or fails to comply with these Regulations shall, in accordance with the provisions of section 218 of the *Land Act 1958*, for each offence be liable to a penalty of not more than Ten dollars, and every person who contravenes or fails to comply with any such Regulations, and who, after he has been warned by any bailiff of Crown lands or by any member of the Police Force, does not desist therefrom may be forthwith apprehended by such bailiff or member of the Police Force and taken before some justice to be dealt with according to law and shall be liable to a penalty of not more than Twenty dollars.

#### COMMITTEES OF MANAGEMENT OF RESERVES.

##### APPOINTMENTS.

NOTICE is hereby given that, in pursuance of section 221 of the *Land Act 1958*, the following appointments of Committees of Management of reserved Crown lands have been made by the Minister of Lands:—

##### "COMBIENBAR PUBLIC RECREATION AND PUBLIC HALL RESERVE."

Stephen Keith Farmer, William Michael Shiels, Leo Stanislaus Dennis as a Committee of Management for a period of three (3) years of the land in the Parish of Combiensbar temporarily reserved by Orders in Council dated the 20th July, 1925 and the 22nd December, 1953, as a site for Public Recreation and Public Hall.—(Corres. Rs.3150.)

##### "DUNOLLY RACECOURSE AND RECREATION RESERVE."

Harry Raven, William Kenneth Richards, Leonard George Watts, John Kenneth Richards, William George Kick, as a Committee of Management for a period of three (3) years of the land permanently reserved by Order in Council dated 22nd May, 1917, as a site for a Racecourse and Recreation Convenience or Amusement of the People in the Parish of Dunolly and known as the "Dunolly Racecourse Reserve".—(Corres. Rs.1542.)

##### "GENOA RIVER BRIDGE RESERVE."

The Council of the Shire of Orbost as the Committee of Management of the portion of the Reserve for Public Purposes in the Parish of Maramingo as is coloured red on plan M/10/12/46 with Lands Department correspondence Rs.8038 and known as the "Genoa River Bridge Reserve".

This appointment is in lieu of all previous appointments in respect of the said land which are hereby revoked.—(Corres. Rs.8038.)

##### "HOLLANDS LANDING PUBLIC PURPOSES RESERVE."

Gordon Baxter Dugan, James Robert Stewart, Gregor Scott Cox, Ronald Blandford, Leslie Joseph Blanks, Richard Laurence and Kevin Albert Maher as a Committee of Management for a period of three (3) years of the reserved Crown land in the Parish of Bengworden South indicated by red colour on plan B/20.7.55 attached to Lands Department Correspondence C.96151 and known as the "Hollands Landing Public Purposes Reserve".—(Corres. C.96151.)

##### "HORDERN VALE—GLEN AIRE MEMORIAL HALL AND RECREATION RESERVE."

Alexander Roy Marriner and Russell Henry Larnach in the place of Terrence Arthur Lowan and David John Denney (both resigned) as members of the Committee of

Management for a period ending the 12th October, 1968 of the land in the Parish of Otway temporarily reserved by Order in Council of the 15th May, 1956, as a site for a Public Hall and Recreation and of the land reserved by Order in Council dated the 6th July, 1965, as an extension thereto and together known as the "Horderm Vale—Glen Aire Memorial Hall and Recreation Reserve".—(Corres. Rs.1705.)

##### "KOONDROOK RACECOURSE AND RECREATION RESERVE."

Maxwell Francis Hird, Beryl Annie Campbell, Edward Ernest Hollingworth, Herbert Henry Richard Chick, Arthur Molin, Reginald Nicholas Penglase and Gilbert Arthur Burnett as a Committee of Management for a period of three (3) years of the land temporarily reserved for Racecourse and Public Recreation in the Parish of Murrabit and known as the "Koondrook Racecourse and Recreation Reserve".—(Corres. Rs.813.)

##### "LLANELLY PUBLIC HALL AND RECREATION RESERVE."

Stanley Mitchell, Harry William John Douglas, George Hamilton Alexander, Noel William Alexander, Eric Reginald Eugene Green, Leslie Benjamin Dale, Donald William Clark, Kenneth George Clark, Robert Alexander Gray, Russell James Leech, as a Committee of Management for a period of three (3) years of the land in the Township of Llanelly, Parish of Tarnagulla, temporarily reserved by Order in Council dated the 15th January, 1963, as a site for Public Hall and Recreation and known as the "Llanelly Public Hall and Recreation Reserve".—(Corres. Rs.8196.)

##### "MOONDARRA RECREATION RESERVE."

J. T. Macklin, Robert Leslie Ingram, W. C. Mickan, H. Thomas, R. K. Smith, J. P. Oliver and Clarence H. Rawson as a Committee of Management for a period of three (3) years of the land in the Township of Moondarra temporarily reserved by Order in Council dated the 20th January, 1914, as a site for Public Recreation.—(Corres. Rs.585.)

##### "SERVICETON RECREATION RESERVE."

Laurie Fryar, Lionel Merrett, Edgar David Tink, John Ronald King, Harry Roy Colwill, Ian Basil Merrett, Percy Arthur Grosser, Roger John Alexander, Augustus Clive Stimson and Leslie Gordon Miles as a Committee of Management for a period of three (3) years of the land temporarily reserved by Order in Council dated the 24th April, 1928, as a site for public Recreation in the Parish of Leeor and known as the "Serviceton Recreation Reserve".—(Corres. Rs.3643.)

##### "SUTTON GRANGE RECREATION RESERVE."

William Edward Penno, Eric Edward Davis, Stephen Searle Barty, William Bertram Broad and William Joseph Byrne as a Committee of Management for a period of three (3) years of the land temporarily reserved by Order in Council dated the 4th July, 1906, as a site for Public Recreation in the Township of Sutton Grange and known as the "Sutton Grange Recreation Reserve".—(Corres. Rs.4926.)

##### "TAGGERTY MECHANICS' INSTITUTE AND FREE LIBRARY RESERVE."

Norman Leslie Williamson, Owen William Hughes, William Charles Lakin, Victor Roland Davie, William Gray, Eric Kingford Wightman, William T. Purcell, Pamela Birtchnell, Harold E. Tonkin, Harold Birtchnell and Peter William Kerr as a Committee of Management for a period ending the 15th August, 1968, of the land in the Township of Taggerty temporarily reserved by Order in Council dated the 17th May, 1898, as a site for a Mechanics' Institute and Free Library and by Order in Council dated the 26th March, 1957, as a site for Public purposes.

This appointment is in lieu of all previous appointments in respect of the said land which are hereby revoked.—(Corres. 4795, 7556.)

##### "VAUGHAN AND GLENLUCE MINERAL SPRINGS RESERVE."

Reginald John Langdon, George Nathaniel Woods and Edward David Woods (as representatives of the Castle-maine Chamber of Commerce) Harold Alfred Slingo (as

representative of the Castlemaine R.A.C.V.) Stanley Frank Wickham, James Michael Sheehan and Joseph Thomas (as representatives of the Castlemaine and District Development Committee) Leslie Joseph Stevens (as representative of the Citizens of Campbells Creek) William Robert Allen (as the representative of the Citizens of Yapeen) Allen Nokes (as representative of the Citizens of Fryerstown) all for a period of three (3) years together with Helen Hope Vellacott and Sylvester Larsen Farrell (for so long only as they are Councillors and the elect of the Council of the Town of Castlemaine) and John Powell and Leonard Mein (for so long only as they are Councillors and the elect of the Shire of Newstead) as a Committee of Management of the reserved Crown lands in the Parish of Fryers, which are indicated in red and blue colours on the plan marked F/6/3/49

with Lands Department correspondence No. Rs.3188, and known as the "Vaughan and Glenluce Mineral Springs Reserve".—(Corres. Rs.3188.)

"YARRABY RECREATION RESERVE."

Lynnton Charles Maple, Raymond James Cockfield, Claude Henry Maple, Ian Kirby Watson and Verner Lancelot Watson as a Committee of Management for a period of three (3) years of the land temporarily reserved by Order in Council, dated the 14th December, 1922, as a site for Park and Recreation purposes in the Township of Towan and known as the "Yarraby Recreation Reserve".—(Corres. Rs.2669.)

ALAN J. HOLT,  
Secretary for Lands.

3rd June, 1966.

Land Act 1958.

LICENCES UNDER THE LAND ACTS DECLARED VOID.

NOTICE is hereby given that the Licences in the Schedule hereunder have been Declared Void for the reason specified in each case.

District.	Corr. No.	Name of Licensee.	Section of Land Act under which Licensed.	Parish.	Allotment.	Section.	Area.	Annual Rental.	Reasons for voiding.
							A. R. P.	\$	
Northern	1584/86	J. Munro ..	86	Tarrengower ..	1	C 1	18 2 27	0.25	Non-payment of rental
Melbourne	02126/129	Oliver-Davey Glass Co. Pty Ltd.	138	City of South Melbourne, Parish of Melbourne South.	33A	D	0 1 8 $\frac{1}{16}$	13.36	Surrendered
Northern	1570/86	W. R. Morgan ..	86	Franklin ..	53	14	20 0 0 $\pm$	0.25	Surrendered

Department of Crown Lands and Survey,  
Melbourne, 3rd June, 1966.

J. C. M. BALFOUR,  
Minister of Lands.

TENDERS

PUBLIC WORKS DEPARTMENT

TENDERS will be received at Public Works Department, Treasury-place, Melbourne, until TEN a.m. on dates shown and for purposes mentioned hereunder.

Particulars and tender forms available at Contracts Office, Room 7, Building Division, Parliament-place and at places indicated in brackets hereunder.

Abbreviations in brackets mean:—W.O.—Inspector of Works Office; P.S.—Police Station; C.S.—Consolidated School; H.E.S.—Higher Elementary School; H.S.—High School; S.S.—State School; T.S.—Technical School.

Tenders to be submitted on the Department's printed Tender Form and will not be received by telephone. All tenders must be on a "Firm Tender" basis. The lowest or any tender will not necessarily be accepted.

Address tenders to the Minister of Public Works, and endorse the envelope containing the tender "Tender for .. closing Tuesday,

No preliminary deposit is required with any tender, but a successful tenderer will be required to pay a deposit for any accepted tender of \$5,000 or over.

Tuesday, 14th June, 1966.

Building, Electrical and Mechanical Works.

Aberfeldie.—Internal and external repairs and painting, S.S. 4220.

Armada.—Renewal of water service, Frank Tate House, Dandenong-road.

Ballarat East.—Internal repairs and painting, S.S. 1998. (W.O., Ballarat.)

Brighton.—Improvements to out-office facilities, S.S. 1542. (Amended Specification.)

Bullioh.—Repairs and painting, S.S. 2495 and Residence. (W.O., Wangaratta; S.S., Bullioh.) (Re-advertised.)

Burnley Gardens.—Compressed air services, Agriculture Department.

Collingwood.—Roof repairs, Technical School.

Cowes.—Renovations, S.S. 1282 and Residence. (W.O., Korumburra; S.S., Cowes.) (Re-advertised.)

Dhurringile.—Repairs and painting, S.S. 3944 Residence. (W.O., Shepparton; S.S., Dhurringile.)

Echuca East.—External repairs and painting, S.S. 2667. (W.O., Shepparton; S.S., Echuca East.)

Eltham East.—Erection of four additional class-rooms, S.S. 4897.

Eltham East.—Extension of plenum heating, S.S. 4897.

Eltham East.—Electrical installation in additions, S.S. 4897.

Essendon.—External renovations, High School.

Fern Tree Gully.—Repairs and internal painting, Technical School.

Frankston.—Painting and repairs, Residence, High School. (H.S., Frankston.)

Frankston.—Electrical installation, additional Science Wing, &c., High School.

Geelong.—Provision of toilet facilities, Storeyard-Depot, Public Works Department. (W.O., Geelong.)

Hamilton North.—Renovations, S.S. 2035 and Residence. (W.O., Hamilton.)

Hawthorn.—New concrete fire escape stairs, Burwood Teachers' College Hostel, Paterson-street.

Kaniva.—External repairs and painting and internal renovations of Infants' School, Consolidated School. (W.O., Horsham; C.S., Kaniva.)

Korweinguboora.—Repairs and painting, S.S. 2016 and Residence. (W.O., Ballarat.)

Kotupna.—Re-blocking, repairs and painting, &c., S.S. 1999 and Residence. (W.O., Shepparton; S.S., Kotupna.) (Re-advertised.)

Kyabram.—Erection of new toilet block, Court House. (W.O., Shepparton; P.S., Kyabram.)

Miners Rest.—New out-office block and installation of septic tank, S.S. 1739. (W.O., Ballarat.)

Monterey.—Electrical installation Stages one and two, High School.

Mont Park.—Erection of Occupational Therapy Building, Mental Hospital.

Mont Park.—Installation of steam heating for new Industrial Therapy Building, Mental Hospital.

Mont Park.—Installation of steam heating and hot water to new Industrial Therapy Building, Larundel Mental Hospital.

Mornington.—Renovations, "Sutton Grange", Tanti-avenue. (P.S., Mornington.)

Murchison.—New garage and external repairs and painting, S.S. 1126 and Residence. (W.O., Shepparton.)

Myrtleford.—Repairs, renovations and painting to various buildings, Tobacco Research Station. (W.O., Benalla; R.S., Myrtleford.)

Nathalia.—New fence, repairs and painting, Residence, Kosdaht-street, High School. (W.O., Shepparton; H.S., Nathalia.)

Newport.—Repairs and painting, S.S. 113.  
Port Fairy.—Repairs and painting, Fisheries and Wildlife Branch Residence, Villiers-street. (W.O., Warrnambool; Fisheries and Wildlife Branch, Port Fairy.)

Purnim West.—Repairs and painting, garage, &c., Residence, S.S. 2905. (W.O., Warrnambool; S.S., Purnim West.)  
Rushworth.—Re-blocking, new garage and repairs and painting, Residence, S.S. 1057. (W.O., Shepparton; S.S., Rushworth.)

Scoresby.—Supply and installation of refrigeration system for five cool rooms, Research Station. (Amended Specification.)

Seymour.—Repairs and painting, S.S. 547. (W.O., Alexandra; S.S., Seymour.) (Amended Specification.)  
Shepparton.—Supply and installation of sump pumps, S.S. 4943. (W.O., Shepparton.)

Stanhope.—Renovations and additions, Police Station. (W.O., Shepparton; P.S., Stanhope.) (Amended Specification.)

Strathmore.—Soundproofing windows, High School.  
Warrenheip.—Internal and external renovations, S.S. 1591, and Residence. (W.O., Ballarat; S.S., Warrenheip.)

Warrong.—Repairs and painting, S.S. 1937. (W.O. Warrnambool.)

Werribee.—Drain for effluent from sheep shed and septic tank, Research Station. (W.O., Geelong.)

Whorouly South.—Class-room extension, re-blocking, repairs and painting, S.S. 4208. (W.O., Wangaratta; S.S., Whorouly South.)

Yarram.—Connexion to town sewerage, renovating and repainting, Court House. (W.O., Traralgon; P.S., Yarram.)

Yea.—Internal and external renovations, Residence, High School. (W.O., Alexandra; H.S., Yea.)

**Furniture and Furnishings.**

Melbourne.—Supply and lay vinyl tiles, William Angliss Food Trades School.

Mont Park.—Supply of 50 Geriatric Chairs, Mental Hospital.

Mont Park.—Supply of 50 Geriatric Chairs, &c., Larundel Mental Hospital.

Portsea.—Supply and fix curtains, "Marlborough House", Mental Health Authority.

**Site Works.**

Clayton.—Asphalting, concreting, drainage, retaining walls, landscaping and associated work, Monash Secondary Teachers' College.

Gravel Hill.—Provision of new asphalt paving, asphalt repairs, concrete works and associated works, S.S. 1566. (W.O., Bendigo.)

Keon Park.—Asphalting, drainage and concreting, &c., S.S. 4739.

Red Cliffs.—Repair and resurfacing of access road, replacement of concrete and associated works, High School. (W.O., Mildura.) (Amended Specification.)

Royal Park.—Earthworks, roadworks, concreting and drainage works, "Turana", Reception and Classification Centre.

Sunshine West.—General site works, High School.  
Various.—Asphalting, &c., Gowrie Park, S.S. 4806 and Jacana, S.S. 4839.

**Miscellaneous.**

Dandenong.—Maintenance cleaning, period 1st July, 1966, to 31st May, 1969, Social Welfare Department, District Office, 309 Thomas-street.

Port Melbourne.—Supply and delivery of five (5) tray body trucks (7-ton capacity), Public Works Department Depot, Salmon-street.

Port Melbourne.—Supply of one (1) 25-ton capacity low-loader and one (1) heavy duty prime mover, Public Works Department Depot, Salmon-street.

Various.—Chimney sweeping period, 1st July, 1966, to 30th June, 1967, Public Works Department, Melbourne and Suburbs.

**Tuesday, 21st June, 1966.**

**Building, Electrical and Mechanical Works.**

Agnes.—Internal and external repairs and painting, Residence, S.S. 3043. (W.O., Korumburra; S.S., Agnes.)

Bendigo.—External and internal repairs and painting, Teachers' College. (W.O., Bendigo.)

Beverly Hills.—Erection of eight additional class-rooms and library, S.S. 4813.

Beverly Hills.—Electrical installation in additional class-rooms, &c., S.S. 4813.

Beverly Hills.—Mechanical services in new wing, S.S. 4813.

Boort.—Electric pump and pressure cylinder, High School. (W.O., Swan Hill and Bendigo.)

Boronia.—Repairs and painting, Residence, S.S. 4081.

Braybrook.—Renovations, Cleaner's Residence, S.S. 1102.

Burwood.—Repairs and painting, Technical School. (Amended Specification.)

Eastmoor.—Repairs and painting, S.S. 4790. (Amended Specification.)

Elingamite North.—Repairs and painting, S.S. 4551. (W.O., Warrnambool; S.S., Elingamite North.)

Elwood.—Erection of two class-room Science Wing, High School.

Elwood.—Electrical installation in additional Science Wing, High School.

Footscray.—Additional staff toilets, Girls' Secondary School.

Footscray.—Renovations to floors, &c., S.S. 253.

Glenroy.—Extension of mechanical services, Technical School.

Heatherton.—Renewal of window sashes, Nurses Home, Sanatorium.

Horsham West.—Repairs and renovations, S.S. 4691. (W.O., Horsham.)

Ivanhoe.—Additions and renovations, Girls' Hostel.

Menzies Creek.—New shelter pavilion, repairs and painting, S.S. 2457 and Residence.

Mirboo North.—Internal and external repairs and painting, Residence, S.S. 2383. (W.O., Traralgon; S.S., Mirboo North.)

Monterey.—Mechanical services, High School.

Mont Park.—Electrical installation for Industrial Therapy Unit, Mental Hospital.

Mont Park.—Supply and erection of steel-framed hay shed, Janefield Mental Hospital.

Mount Clear.—Repairs and painting, Residence, S.S. 427. (W.O., Ballarat; S.S., Mount Clear.) (Re-advertised.)

Mount Waverley.—New shelter pavilion and fuel shed, repairs and painting, S.S. 3432.

Port Welshpool.—Repairs and painting, Residence, S.S. 3375. (W.O., Korumburra; S.S., Port Welshpool.) (Re-advertised.)

Preston.—Gas heating service, Police Station.

Red Cliffs.—Erection of brick office building, Lands and Survey Department. (W.O., Mildura.)

Red Cliffs.—Electrical installation, District Office, Lands and Survey Department. (W.O., Mildura.)

Red Cliffs.—Supply and installation of evaporative cooling unit, hot-water service and drink water cooler, District Office, Lands and Survey Department. (W.O., Mildura and Bendigo.)

Rushworth.—Internal renovations, Residence, S.S. 1057. (W.O., Shepparton; S.S., Rushworth.)

Spotswood.—Various repairs, renovations and painting, S.S. 3659.

Sunbury.—Alterations and additions to boiler house, Mental Hospital.

Werribee South.—Internal and external renovations, Residence, S.S. 3913.

**Site Works.**

Fairhills.—Surface and underground drainage, asphalt, gravel and concrete pavement and associated work, S.S. 4906. (Re-advertised.)

Maryborough.—Construction of concrete cover over drain approximately 320 feet long and 5 feet wide and associated works, Technical School. (W.O., Maryborough and Bendigo.)

Ringwood North.—Asphalting, concreting and gravelling, drainage and associated work, S.S. 4120.

Tottenham.—Asphalting, gravelling and associated works, Technical School.

**Miscellaneous.**

Port Melbourne.—Supply and delivery of two (2) pneumatic-tired wheeled tractors, complete with all-weather cabins, front-end loader attachments, tractor-drawn grader blades and tractor-drawn tipping trailers, Public Works Department Depot, Salmon-street.

**Tuesday, 28th June, 1966.**

**Building, Electrical and Mechanical Works.**

Albion.—Internal and external repairs and painting, S.S. 4265.

Alexandra.—Internal and external repairs and painting, Residence, High School. (W.O., Alexandra; H.S., Alexandra.)

Bairnsdale.—Cantilever bus shelter, Road Block, Agriculture Department. (W.O., Bairnsdale.) (Re-advertised.)

Carlton.—Installation of heating and hot-water services to Office Block, St. Nicholas Hospital.

Casterton.—Concrete water tank and additional water supply, High School. (W.O., Hamilton; H.S., Casterton.) (Re-advertised.) (Amended Specification.)

Corryong.—Re-blocking and renovations to original section, Consolidated School. (W.O., Wangaratta; C.S., Corryong.)

Costerfield.—Erection of out-office and installation of septic tank, S.S. 1187. (W.O., Bendigo; S.S., Costerfield.)

Dandenong.—External and internal renovations, High School. (H.S., Dandenong.)

Dimboola.—External renovations, Residence, 178 Lloyd-street, High School. (W.O., Warracknabeal; H.S., Dimboola.)

Frankston.—Extension of mechanical services, High School.

Geelong.—Repairs and painting, S.S. 4398. (W.O., Geelong.)

Glen Devon.—Erection of eight (8) additional classrooms, S.S. 4914.

Glen Devon.—Electrical installation in additions, S.S. 4914.

Glen Devon.—Plenum heating in new wing, S.S. 4914.

Glenroy.—Electrical installation in new Girls' Section, Technical School.

Keon Park.—Connexion to sewer, Technical School and Residence. (Re-advertised.)

Kerang.—Erection of brick veneer Police Office. (W.O., Swan Hill and Bendigo.) (Amended Specification.)

Lang Lang.—Connexion to sewerage, S.S. 2899. (S.S., Lang Lang.)

Lilydale.—Repairs and painting, High School.

Melbourne.—Soundproofing windows of Radio School, provision of two new fan chambers, Royal Melbourne Institute of Technology. (Re-advertised.)

Mont Park.—Erection of two Staff Amenities Blocks, Janefield and Larundel Mental Hospitals.

Myrtleford.—Renovations, new garage and extensions, Residence, Consolidated School. (W.O., Benalla and Wangaratta; C.S., Myrtleford.)

Myrtleford.—Evaporative coolers in leaf storage barn No. 2, Research Station. (W.O., Wangaratta.)

North Park.—Repairs and painting, S.S. 4787.

Pascoe Vale.—New brick toilet block, S.S. 3081. (Re-advertised.)

Poowong.—External painting and repairs, Consolidated School. (W.O., Korumburra; C.S., Poowong.) (Re-advertised.)

Port Melbourne.—Supply and erection of structural steel framework, concrete footings and floor, Mines Department, Cook-street.

Silvan South.—Additional toilet accommodation, S.S. 4259. (S.S., Silvan South.) (Re-advertised.)

Upper Yarra.—Renovations, provision of new laundry, Residence, High School.

**Furniture and Furnishings.**

Mont Park.—Supply of 320 metal bedside lockers, Larundel Mental Hospital.

**Site Works.**

Bairnsdale.—Site works, including asphalt paving and repairs, concrete paving and drainage, High School. (W.O., Warragul, Traralgon and Bairnsdale.)

Dandenong North.—Asphalt paving and repairs, &c., S.S. 4723.

Mirboo North.—Asphalt paving and repairs, S.S. 2383. (W.O., Warragul and Traralgon.)

**Miscellaneous.**

Preston.—Supply of electrical equipment, Technical College.

**NOTICE.**

**THE PUBLIC WORKS DEPARTMENT GIVES NOTICE THAT**

Leith & Bartlett Pty. Ltd.,

Directed by Architects, Engineers, and Town Planners, 458 St. Kilda-road, Melbourne, S.C.2,

On behalf of

**THE MINISTER FOR PUBLIC WORKS,**

advise that further to advertisements calling for the registration of Tenderers appearing in the Press during February, 1966, documents for the NEW CIVIL AND CRIMINAL COURTS BUILDING, CORNER WILLIAM AND LONSDALE STREETS, MELBOURNE, including the major sub-contracts, are now available at the office of the Architects, and Public Tenders are invited accordingly.

Tenders for the General Contract close 14th June, 1966.

M. V. PORTER,  
Minister of Public Works.

Public Works Department,  
Melbourne, C.2, 6th June, 1966.

**PUBLIC SERVICE NOTICES**

No. 1623.

Public Service Act 1958, Section 39.

**REGULATIONS.—PART IV.—SALARIES AND INCREMENTS.**

THE Public Service Board, in pursuance of the powers conferred by the Public Service Act 1958, hereby amends its Regulations as shown below :—

**FIRST SCHEDULE.**

**PROFESSIONAL DIVISION.**

Amount of Salary Assigned to Offices in Class "A1".

Office.	Yearly Rate of Salary.
DEPARTMENT OF AGRICULTURE.	
<i>Delete—</i> Senior Veterinary Research Officer .. .. .	8,480
<i>Add—</i> Deputy Chief of Division of Animal Industry..	7,992

F. E. CAHILL, Chairman.  
V. P. SCULLY, Secretary.

Office of the Public Service Board,  
Melbourne, 20th May, 1966.

No. 1624.

Public Service Act 1958, Section 50.

**REGULATIONS.—PART IV.—SALARIES AND INCREMENTS.**

THE Public Service Board, in pursuance of the powers conferred by the Public Service Act 1958, hereby amends its Regulations as shown below :—

**FIFTH SCHEDULE.**

**TEMPORARY EMPLOYEES.**

**DEPARTMENT OF HEALTH.**

**MENTAL HYGIENE.**

Designations of Positions and Rates of Salaries.

Designation of Position.	Yearly Rate of Salary.£	
	Minimum.	Maximum.
<i>Delete—</i> Case Aide (Female) . . . . .	\$ 1,904	\$ 2,048
<i>Add—</i> Case Aide (Female)— Junior—		
Under 16 years of age .. .. .		882
At 16 years of age .. .. .		966
At 17 years of age .. .. .		1,010
At 18 years of age .. .. .		1,104
At 19 years of age .. .. .		1,202
At 20 years of age .. .. .		1,464
Adult .. .. .	1,904	2,048

£ Annual increments shall be in accordance with those prescribed by Sub-Regulations 83 (2) and 83 (3), provided that in the case of the position of Assistant (Male), Administrative, the annual increments shall be in accordance with those prescribed by Part D of the Third Schedule.

This Regulation shall have effect as on and from the 24th March, 1966.

F. E. CAHILL, Chairman.  
V. P. SCULLY, Secretary.

Office of the Public Service Board,  
Melbourne, 30th May, 1966.

No. 1622.

## PUBLIC SERVICE ACT 1958.

THE Public Service Board, in pursuance of the powers conferred by the Public Service Act 1958, hereby amends the Public Service (Public Service Board) Regulations as follows:—

## PART V.—ALLOWANCES.

## DIVISION II.—OVERTIME AND STAND-BY ALLOWANCES.

## Water Supply Department.

Regulation 107 (1).

In paragraph (b) under the heading Senior Reservoir Keepers, Reservoir Keepers, Grades I, II, and III, immediately before the word "Eildon" insert the word "Bellfield,".

F. E. CAHILL, Chairman.  
V. P. SCULLY, Secretary.

Office of the Public Service Board,  
Melbourne, 30th May, 1966.

## PUBLIC SERVICE OF VICTORIA.—VACANCIES.

APPLICATIONS will be received by the Public Service Board up to Wednesday, the 22nd June, 1966, from persons employed in the Public Service of Victoria, who are eligible and qualified for appointment to the under-mentioned positions:—

## ADMINISTRATIVE DIVISION.

## Class "C2", State Superannuation Board, Treasury.

Yearly Salary.—\$4,280, minimum; \$4,560, maximum.

Duties.—To carry out special investigations as directed; to assist in the planning and implementation of the Supplementary Pensions Scheme and to arrange for and conduct the interviewing of Pensioners.

Qualifications.—To have made substantial progress towards a degree in an appropriate University course and to have administrative ability.

## Class "C2", Office of Housing Commission, Treasury.

Yearly Salary.—\$4,280, minimum; \$4,560, maximum.

Duties.—Under the direction of the E.D.P. Manager, to be in charge of the data preparation and control section; to be responsible for the processing and control of all input into the computer system; to organize the collection of data for new computer applications.

Qualifications.—Ability to control staff and to organize the work of the section; a knowledge of the Commission's accounting system and of data processing equipment would be an advantage.

## Class "C1", Public Solicitor's Office, Law Department.

Yearly Salary.—\$3,680, minimum; \$3,960, maximum.

Duties.—To prepare Briefs for the defence in cases committed for trial in the Supreme Courts and Courts of General Sessions and Appeals in Courts of Appellate Jurisdiction. To assist the Officer in Charge of the Criminal Law Branch as directed.

Qualifications.—Ability to conduct interviews, a sound knowledge of Criminal Law and Procedures and the Law of Evidence. Experience in the Criminal Jurisdiction adequate for the discharge of the said duties.

## Assistant Audit Inspector, Class "C1", Audit Office, Premier's Department.

Yearly Salary.—\$3,680, minimum; \$3,960, maximum.

Duties.—To conduct audits throughout Victoria and to perform examination duties as directed by the Auditor-General.

Qualifications.—Substantial progress in the study of accountancy. Auditing or general accounting experience.

## Class "C1", Water Supply Department.

Yearly Salary.—\$3,680, minimum; \$3,960, maximum.

Duties.—Under the direction of the Chief Divisional Engineer to be responsible for the administrative and accounting duties for the Wimmera-Mallee and the Mallee Irrigation Divisions.

Qualifications.—A good knowledge of the Water Act and the Commission's accounting procedure especially in relation to expenditure control, plant hire and maintenance programmes for urban and waterworks districts.

## Class "C", Education Department.

Yearly Salary.—\$3,026, minimum; \$3,320, maximum.

Duties.—To arrange for the medical examination of members of the Teaching Service and applicants for appointment; to deal with reports submitted by the School Medical Officers.

Qualifications.—To be an adult with at least three years' experience; ability to conduct correspondence and interviews. A knowledge of the Superannuation Board's requirements relating to medical examinations is desirable.

## Class "C", Maternal and Child Welfare Branch, Department of Health.

Yearly Salary.—\$3,026, minimum; \$3,320, maximum.

Duties.—Supervision of the correspondence and medical records section of the School Medical Service, maintenance of staff records and verification of accounts; liaison with the Education Department in connexion with teaching service medical examinations.

Qualifications.—To be an adult with at least three years' service; experience in dealing with correspondence and staff matters; a good knowledge of the Public Service Acts and Regulations and the Public Accounts and Stores Regulations.

## Class "C", Probate Duties Office, Law Department.

Yearly Salary.—\$3,026, minimum; \$3,320, maximum.

Duties.—To receive and file applications for Probate and Letters of Administration, Caveats and withdrawals thereof, re-Seals, &c., and check filing fees; to answer lesser queries raised by the Registrars; to relieve the Officer in Charge of Small Estates; to have charge of office stores and attend Court when required.

Qualifications.—To be an adult with at least three years' service; a knowledge of the Administration and Probate Act 1958, the Rules of the Supreme Court (Probate) and Supreme Court Office Fees Regulations under the Supreme Court Act 1958; ability to deal with the public.

## PROFESSIONAL DIVISION.

## Architect, Classes "B1", "A", Office of the Housing Commission, Treasury. (Two vacancies.)

Yearly Emolument.—\$4,760, minimum; \$5,714, maximum.

## Position No. 1.

Duties.—Under the direction of the Chief Architect, to prepare preliminary drawings and contract plans, details, specifications, reports and estimates, and assist in the planning of housing estates. Generally to supervise a section of the draughting staff.

Qualifications.—A qualified Architect, preferably with experience in house and multi-story flats design, and housing estate planning.

## Position No. 2.

Duties.—Under the Senior Architect (Supervision) to supervise building construction for the Commission; to control and direct supervisory personnel, District Works Officers and Clerks of Works.

Qualifications.—A qualified Architect with wide practical experience in supervising building construction particularly of a residential nature and in organizing the activities of supervisory personnel.

NOTE.—Separate applications must be submitted for these positions.

## Conservation Officer, Classes "C", "C2", Soil Conservation Authority, Premier's Department.

Yearly Emolument.—\$3,380, minimum; \$4,760, maximum.

(Commencing salary will be determined according to experience.)

Duties.—To supervise landholders on soil conservation measures; to carry out surveys for contour layout; to assist in the carrying out of soil conservation works.

Qualifications.—A Degree in Agricultural Science of the University of Melbourne or an approved equivalent; a good knowledge of the characteristics of the use of land, experience in the practice of agriculture and a knowledge of the principles and application of soil conservation methods.

NOTE.—Applications are also being invited for this position in the Technical and General Division.



## TECHNICAL AND GENERAL DIVISION.

**Senior Prison Officer, Cooriemungle Prison Farm, Prisons Division, Social Welfare Branch, Chief Secretary's Department.**

*Yearly Salary.*—\$3,018, minimum; \$3,228, maximum.

*Duties.*—To assist the Governor of Cooriemungle Prison Farm in the control and management of the Prison; to act as Officer in Charge, when required; to perform other such duties as directed including those of storekeeper, or to fill any position of equivalent rank as directed.

*Qualifications.*—To have passed the prescribed examination for promotion; to have a satisfactory record of service, the qualities of leadership required of a senior officer in the management of staff and prisoners, and the experience and ability to assume responsibility; ability to act as storekeeper when required.

**Conservation Officer Assistant, Soil Conservation Authority, Premier's Department.**

*Yearly Salary.*—

Junior—at 17 years of age, \$1,214;  
at 18 years of age, \$1,500;  
at 19 years of age, \$1,710;  
at 20 years of age, \$1,942.

Adult—\$2,810, minimum; \$3,228, maximum.

*Duties.*—To advise landholders on soil conservation measures; to carry out surveys for contour layout; to assist in the carrying out of soil conservation works.

*Qualifications.*—A Diploma of a recognized agricultural college or an approved equivalent; a good knowledge of the characteristics of the use of land, experience in the practice of agriculture and a knowledge of the principles and application of soil conservation methods.

NOTE.—Applications are also being invited for this position in the Professional Division.

**Jury Pool Supervisor, Sheriff's Office, Law Department.**

*Yearly Salary.*—\$2,914, minimum; \$3,018, maximum.

*Duties.*—To be in attendance at the Jury Pool at all times and to attend to the requirements of the Jurors in the Pool.

*Qualifications.*—To be of good personality, and to preferably have had Court experience, particularly in regard to Jury Trials.

**Assistant (Male), Grade III., Office of the Public Trustee, Law Department.**

*Yearly Salary.*—\$2,736, minimum; \$2,810, maximum.

*Duties.*—To make searches in the Office of Titles and Registrar-General's Office as directed; to lodge dealings and instruments in such offices and compute and pay all necessary fees thereon; to lodge instruments for the opinion of the Comptroller of Stamps; to make searches of land under the General Law.

*Qualifications.*—A good knowledge of the practice of the Office of Titles, Registrar-General's Office and the Office of the Comptroller of Stamps and of fees payable under the Instruments Act, Transfer of Land Act and Property Law Act; satisfactory experience in making searches under the General Law.

NOTE.—To be eligible to apply for this position, temporary employees or officers of the Technical and General Division, other than Assistants (Male), must have passed the Board's examination for registration for appointment as Assistant (Male), Grade I., Technical and General Division.

**Machineman (Register), Stamp Duties Office, Treasury.**

*Yearly Salary.*—\$2,736, minimum; \$2,810, maximum.

*Duties.*—To impress stamp duty on the various classes of instruments chargeable under the Stamps Act.

*Qualifications.*—To be efficient with figures. Experience in the operation of cash register type machines and familiarity with the classes of instruments presented for stamping would be an advantage.

**Estate Officer (Male), Grade I., Office of the Housing Commission, Treasury.**

*Yearly Salary.*—\$2,662, minimum; \$2,810, maximum.

*Duties.*—To perform Housing Estate duties in respect of a section of a district including revenue collection, interviewing tenants regarding rental arrears, advising tenants on matters affecting

their tenancy, and inspecting and reporting on dwellings and various phases of estate management.

*Qualifications.*—To be educated to Intermediate Certificate Standard and able to make investigations and prepare reports. Experience in dealing with the public and capable of handling public moneys; a car driver's licence.

NOTE.—After completing three years' satisfactory service as Estate Officer, Grade I., will be eligible for progression to Estate Officer, Grade II. (\$2,914–\$3,018).

**Assistant (Male), Grade II., Office of the Chief Commissioner of Police, Chief Secretary's Department.**

*Yearly Salary.*—\$2,590, minimum; \$2,662, maximum.

*Duties.*—To examine prosecution briefs for correctness of charges, and to record details of briefs. To compile statistics of prosecutions for certain traffic offences and of cancellations of drivers' licences by Courts.

*Qualifications.*—A good knowledge of the Motor Car Act, Transport Regulation Act, and the provisions of the Crimes Act which affect drivers of motor vehicles.

NOTE.—To be eligible to apply for this position, temporary employees or officers of the Technical and General Division, other than Assistants (Male), must have passed the Board's examination for registration for appointment as Assistant (Male), Grade I., Technical and General Division.

**Youth Officer (Male), Youth Welfare Division, Social Welfare Branch, Chief Secretary's Department. (Twenty-one vacancies.)**

*Yearly Salary.*—\$2,368, minimum; \$2,590, maximum.

*Duties.*—To assist in the care, supervision and treatment of youth trainees.

*Qualifications.*—Ability to acquire and apply a knowledge of modern methods of care and treatment, and of the instructions and procedures of a Youth Training Centre; preferably, experience in youth work. To have passed the examinations prescribed under Regulation 34 (4) of the Public Service (Public Service Board) Regulations and be between the ages of 21 and 47 years.

**Mechanic, Winlton Youth Training Centre, Social Welfare Branch, Chief Secretary's Department.**

*Yearly Salary.*—\$2,258, minimum; \$2,554, maximum.

*Duties.*—To assist in the care and maintenance of the grounds, buildings, fittings and equipment at Winlton.

*Qualifications.*—A qualified metal tradesman with general experience in workshop maintenance.

**Ranger, Water Supply Department.**

Three vacancies at Ouyen.

Three vacancies at Hopetoun.

Two vacancies at Murtoa.

*Yearly Salary.*—\$2,294, minimum; \$2,444, maximum.

*Qualifications.*—A knowledge of the water requirements and competent to control and regulate the supply of water by channel to landholders; a good knowledge of mechanical equipment used on sand cleaning and other work associated with channel maintenance; ability to carry out repair work to such structures of such nature as are provided on a supply channel system. Sufficient clerical ability to prepare time books for men engaged on works. A knowledge of the Manual for Field Staff is necessary and experience in Urban Retention Works would be desirable.

NOTE.—The successful applicants for two of the positions at Ouyen will be required to occupy the official residences provided and vacation of the residences will not be permitted without the express approval of the Water Supply Department. A rental of 10 per cent. of total emolument less \$72.60 a year will be charged. Occupancy will be subject to a formal tenancy agreement being entered into. Particulars are available from the Water Supply Department.

No accommodation is available for the remaining positions.

Separate applications must be submitted for these positions.

**Attendant, Public Offices Reserve, Public Works Department.**

*Yearly Salary.*—\$2,294, minimum; \$2,406, maximum.

*Duties.*—To assist in control of parking of motor vehicles in the Public Offices Reserve, and to direct the public as to location of the various Government Departments.

*Qualifications.*—To be of good address and tactful in dealing with the public.

**Motor Truck Driver, Tuberculosis Branch, Department of Health.**

*Yearly Salary.*—

Junior—at 18 years of age, \$1,500;  
at 19 years of age, \$1,710;  
at 20 years of age, \$1,942.

Adult—\$2,186, minimum; \$2,406, maximum.

*Duties.*—To drive X-ray vans and other vehicles as required and to ensure that regular maintenance is undertaken; other duties as required.

*Qualifications.*—A licensed driver with experience in driving trucks up to 5 tons capacity and ability to handle departmental vehicles towing X-ray caravans. To be capable of handling heavy X-ray equipment and preferably to have a good knowledge of roads throughout the State.

**Chauffeur, Departmental, "Winlton", Youth Welfare Division, Social Welfare Branch, Chief Secretary's Department.**

*Yearly Salary.*—\$2,186, minimum; \$2,330, maximum.

*Duties.*—To act as Chauffeur at "Winlton" Youth Training Centre; to ensure that the vehicles are maintained in a safe and serviceable condition; and to perform other general duties as directed by the Superintendent.

*Qualifications.*—A licensed and experienced driver with a good mechanical knowledge of motor cars.

**Chauffeur, Departmental, Department of Labour and Industry.**

*Yearly Salary.*—\$2,186, minimum; \$2,330, maximum.

*Duties.*—To drive a Departmental motor car; to be responsible for its regular maintenance, and to keep records as required.

*Qualifications.*—A licensed and experienced driver with approved experience in motor car driving; ability to effect minor repairs.

By order,

V. P. SCULLY,  
Secretary.

Office of the Public Service Board,  
Melbourne, 7th June, 1966.

**PUBLIC SERVICE OF VICTORIA.—VACANCIES.**

(TEMPORARY APPOINTMENTS.)

APPLICATIONS will be received by the Public Service Board up to Wednesday the 22nd June, 1966, from persons who are qualified for appointment to the under-mentioned positions:—

**Field Officer, Irymple, Department of Agriculture.**

*Yearly Salary.*—

Junior—At 18 years of age, \$1,704,  
at 19 years of age, \$1,912,  
at 20 years of age, \$2,146.

Adult—\$2,914, minimum; \$3,228, maximum.

(Commencing salary will be determined within this initial range according to experience, but advancement is not limited to the maximum quoted.)

*Duties.*—To assist the entomologist at the Plant Research Laboratory, Irymple, with laboratory and field investigations of insect problems of crops in the Mildura Irrigation Area and to conduct other duties as required.

*Qualifications.*—A diploma of an Australian Agricultural College or its equivalent.

NOTE.—Field Officers are eligible for appointment to the position of Field Officer, Senior, salary range \$3,546–\$3,864 and on passing a qualifying examination for appointment to the Professional Division, as Experimental Officer \$3,734–\$4,466.

**Motor Mechanic, Burnley Horticultural College, Department of Agriculture.**

*Yearly Salary.*—\$2,258, minimum; \$2,554, maximum.

*Duties.*—To be responsible for the care and maintenance of mechanical equipment and motor vehicles; to assist in the supervision and practical instruction of students in the Mechanics and Crafts branch at the College; other duties as required.

*Qualifications.*—To be an experienced motor mechanic and, preferably, to have had some experience in electric arc and oxy-acetylene welding; ability to control students.

**Commercial Artist (Female), Visual Education Centre, Northcote, Education Department.**

*Yearly Salary.*—\$2,012.

*Duties.*—To assist generally in the production of charts, film strips, and booklets, including mounting, frame editing, captioning, some illustration.

*Qualifications.*—To have completed a commercial art course at an approved technical school, and at least one year's experience in the trade as Commercial Artist. Knowledge of lettering of black and white illustration for process reproduction. Experience in making colour separations would be an advantage.

By order,

V. P. SCULLY,  
Secretary.

Office of the Public Service Board,  
Melbourne, 7th June, 1966.

**PUBLIC SERVICE OF VICTORIA.—VACANCIES.****DEPARTMENT OF HEALTH.****MENTAL HYGIENE BRANCH.****TECHNICAL AND GENERAL DIVISION.**

APPLICATIONS will be received by the Public Service Board up to Wednesday, the 29th June, 1966, from persons employed in the Public Service of Victoria, who are eligible and qualified for appointment to the under-mentioned positions.

**Charge Nurse (Female). (Three vacancies.)**

*Yearly Salary.*—\$2,564, minimum; \$2,772, maximum.

2 vacancies—Hobson Park Hospital, Traralgon

*Duties.*—To take charge of a ward in a Psychiatric Centre and to assist in the training of Student Nurses and others.

*Qualifications.*—A current practising certificate for Mental Nursing.

NOTE.—The successful applicants will be required to work an 8 hour roster.

1 vacancy—Janefield Colony.

*Duties.*—To take charge of a ward and to assist in the training of Student Nurses and others.

*Qualifications.*—A current practising certificate for Mental Deficiency Nursing.

NOTE.—Separate applications must be submitted for these positions.

**Cook (Male), Grade I, Mont Park.**

*Yearly Salary.*—\$2,186, minimum; \$2,294, maximum.

*Duties.*—To assist in preparation, cooking and serving of meals for patients and staff, and cleanliness of kitchen.

*Qualifications.*—A knowledge of and experience in large quantity cooking.

**Kitchenman, Mont Park.**

*Yearly Salary.*—\$1,940, minimum; \$2,186, maximum.

*Duties.*—To assist Cooks generally in preparation of vegetables and other foodstuffs. Attending to cleanliness of kitchen.

*Qualifications.*—Some knowledge of cooking is desirable.

By order,

V. P. SCULLY,  
Secretary.

Office of the Public Service Board,  
Melbourne, 7th June, 1966.

## PUBLIC SERVICE OF VICTORIA.—RECLASSIFICATIONS

THE Public Service Board has raised the classification of the under-mentioned offices as shown, and appointed thereto the respective officers named hereunder.

Office and Former Classification.	Revised Classification.	Duties.	Qualifications.	Officer Appointed.
<b>ADMINISTRATIVE DIVISION.</b>				
<b>LAW DEPARTMENT.</b>				
<i>Office of the Public Trustee.</i>				
Class "C2"	Class "B"	To prepare and lodge income tax returns in respect of estates of deceased persons, trusts, mental patients, infirm persons and agencies and to check the respective assessments; to supervise all legal advertising and the dissection and allocation of monthly advertising accounts to the appropriate ledger accounts	A qualified Accountant with a good knowledge of the Income Tax Assessment Acts and of the practice and procedure of the Income Tax Department	Crowe, E. R.
<b>PROFESSIONAL DIVISION.</b>				
<b>DEPARTMENT OF CROWN LANDS AND SURVEY.</b>				
Draughtsman Class "C1"	Senior Photogrammetrist, Class "C2"	To assist in the planning for, and to carry out, stereotriangulation; to plot large scale maps for engineering projects	Experience in numerical photogrammetry; ability to make precise observations and to plot from aerial photographs with modern photogrammetric equipment	O'Brien, K. L.
<b>CHIEF SECRETARY'S DEPARTMENT.</b>				
<i>National Gallery.</i>				
Assistant, National Gallery, Class "C"	Assistant Curator of Prints and Drawings, Class "C1"	To assist the Curator of Prints and Drawings and to administer the Department in the absence of the Curator; other duties as directed	A University degree in Fine Arts. A knowledge of the history of drawing and the making of original prints and of the techniques employed by artists in these fields. Experience as a lecturer and in cataloguing, storing and displays of prints and drawings	Preston, H. H.
<b>TECHNICAL AND GENERAL DIVISION.</b>				
<b>LAW DEPARTMENT.</b>				
<i>Office of Titles.</i>				
Draughtswoman, Grade I., Grades F9-F13 inclusive	Grade II., Grades F15-F20 inclusive	To have charge of the register of proclamations of Public Highways, Street Names and Closed Government Roads; to have charge of the Permanent Mark Index ( <i>Survey Co-ordination Act 1958</i> ); to perform other draughting duties as directed	To be a competent penwoman with a good practical knowledge of the recording systems throughout the Office of Titles; to have had experience in the draughting sections of the Branch	Nunn, Beverley J.
<b>PUBLIC WORKS DEPARTMENT.</b>				
Draughtsman, Grade III., Grades 34-39 inclusive	Grade IV., Grades 41-44 inclusive	To prepare under direction, plans, specifications and estimates of mechanical installations and services in all types of public buildings	A sound technical training in mechanical engineering together with several years' drawing office experience in plant design and lay-out, particularly in relation to heating, hot water supply, air conditioning steam plant and refrigeration	Wallek, E. I.
Draughtsman, Grade III., Grades 34-39 inclusive	Grade IV., Grades 41-44 inclusive	Under general supervision, prepare sketch plans, working drawings, details and specifications for alterations, extensions and maintenance works of both major and minor nature on Government buildings and institutions	A suitably qualified architectural draughtsman with a good knowledge of architectural work and maintenance requirements for all types of Government buildings, and appropriate experience in the preparation of plans and specifications for that type of work.	Sobolewski, K.
Draughtswoman, Grade III., Grades F25-F34 inclusive	Grade IV., Grades F36-F38 inclusive	Under general supervision to prepare sketch plans, working drawings, specifications and details, make field inspections, reports and estimates for important building projects and guide subordinate staff as required	At least four years' experience in architectural draughting and preparation of specifications, to have completed a substantial portion of an approved Technical School course, and have experience appropriate for the efficient discharge of the duties	Mountford, Eleonora R.

PUBLIC SERVICE (PUBLIC SERVICE BOARD) REGULATION 52.—VACANCIES.

THE Permanent Heads of the Departments shown have recommended the officers named hereunder for appointment to the under-mentioned vacancies.

Office and Classification.	Duties.	Qualifications.	Officer Recommended for Appointment.		
			Name.	Classification.	Date of Classification.
<b>ADMINISTRATIVE DIVISION.</b>					
<b>EDUCATION DEPARTMENT.</b>					
Class "C" ..	To assist the Estates Officer in the purchase and disposal of school sites and residences; to be responsible for keeping the branch expenditure and sites register	To be an adult with at least three years' service; ability to conduct correspondence and interviews; to be experienced in the preparation of site plans	Luzza, K. ..	Class "C" ..	14.2.64
<b>PROFESSIONAL DIVISION.</b>					
<b>LAW DEPARTMENT.</b>					
<i>Office of Titles.</i>					
Senior Draughtsman, Class "C2"	To be responsible to the Superintending Draughtsman for the control of an Auxiliary Group and to assist and relieve the Section Leader Draughtsman as required; to carry out the examination of Transfers, New Plans of subdivision, and other surveys	A good knowledge of the practical application of survey with experience in Transfer Dealings and other Office procedure under the transfer of Land and cognate Acts	Hawkes, E. C.	Draughtsman, Class "C1"	9.12.65
<b>PUBLIC WORKS DEPARTMENT.</b>					
Draughtsman, Class "C1"	Under general supervision prepare sketch designs, working drawings, specifications, details and estimates, make field inspections and reports for important structural projects and guide subordinate staff	At least four years' draughting experience appropriate for the efficient discharge of the duties, and to have completed a substantial portion of an approved Technical School course	Kelly, M. N. ..	Draughtsman, Class "C1"	1.1.64
<b>TECHNICAL AND GENERAL DIVISION.</b>					
<b>WATER SUPPLY DEPARTMENT.</b>					
<i>Werrimull.</i>					
Senior Works Inspector, Grades 37-39 inclusive	Under direction, to supervise and control the construction, operation and maintenance of water supply works in the districts administered from the Werrimull office; to supervise the distribution of water; to control labour, materials, equipment and plant on charge to the Centre and to be responsible for the field records of their operations	Experience in the distribution of water in channel systems for domestic and stock purposes and in the control and management of urban reticulation systems. A sound knowledge of the maintenance of domestic and stock channels in the Mallee particularly in connexion with sand drift control. Ability to manage large numbers of men, horses and mechanical plant	Dexter, T. A. ..	Works Inspector, Grades 35-37 inclusive	27.3.66

Appeals against such recommendations should be lodged with the Secretary to the Public Service Board not later than Saturday, the 18th June, 1966.

Office of the Public Service Board,  
Melbourne, 7th May, 1966.

By order,  
V. P. SCULLY,  
Secretary.

PUBLIC SERVICE OF VICTORIA.

SPEED TESTS FOR SHORTHAND WRITERS AND TYPISTS (FEMALE).

AT the tests held on the 21st May, 1966, the under-mentioned candidates passed at the required standards:—

TEST AT 120 WORDS A MINUTE.

METROPOLITAN CANDIDATES.

CHIEF SECRETARY'S DEPARTMENT.

*Institute of Applied Science.*

Manallack, Ruth Victoria.

LAW DEPARTMENT.

*Crown Solicitor's Office.*

Searle, Robyne Joy.

*Office of the Public Trustee.*

Austin, Maureen Margaret.

TEST AT 100 WORDS A MINUTE.

METROPOLITAN CANDIDATES.

DEPARTMENT OF AGRICULTURE.

Bear, Judith Anne.

CHIEF SECRETARY'S DEPARTMENT.

*Chief Secretary's Office.*

Wallace, Sandra Lorraine.

*Social Welfare Branch.*

Kellett, Lesley Beth.

## EDUCATION DEPARTMENT.

Perry, Jennifer Therese.

## LAW DEPARTMENT.

Crown Solicitor's Office.

Aram, Dorothy deLacey (Mrs.).

Office of the Public Trustee.

Beatty, Janette Lee.

## HEALTH DEPARTMENT.

Maternal and Child Welfare Branch.

McCormack, Margaret Mary.

## MENTAL HEALTH AUTHORITY.

Harris, Ruth Alison (Mrs.).

Taaff, Lynette Dorothy.

## TREASURY.

Office of the Housing Commission.

McGregor, Jennifer Therese.

## COUNTRY CANDIDATE.

TRANSPORT REGULATION BOARD.

Snowball, Robyn Elizabeth.

By order,

V. P. SCULLY,

Secretary.

Office of the Public Service Board,  
Melbourne, 7th June, 1966.**PRIVATE ADVERTISEMENTS**

## BENDIGO SEWERAGE AUTHORITY.

THE Bendigo Sewerage Authority, having made provision for carrying off the sewage from each and every property which or any part of which is within the Sewerage Area hereinafter described, doth hereby declare that on and after the 1st day of June, 1966, each and every property which or any part of which is within the said Sewerage Area, shall be deemed to be a seweraged property within the meaning of the Sewerage Districts Acts.

The boundaries of the Sewerage Areas hereinbefore referred to are—

## SEWERAGE AREA NO. 242.

Commencing at a point on the boundary of Seweraged Area No. 140, being the intersection of the northern prolongation of the western boundary of Crown allotment 54, no section, Parish of Sandhurst, County of Bendigo and its intersection with the said Seweraged Area No. 140 boundary; thence generally southerly across a Government road known as Strickland-road to the northernmost corner of Crown allotment 54, and along the western boundaries of Crown allotments 54, 53, 52, 51, no section, to the south-western corner of Crown allotment 51; thence generally easterly along the southern boundary of Crown allotment 51 to its south-eastern corner; thence generally northerly along the eastern boundaries of Crown allotments 51, 52, 53, 54 and the northern prolongation of the eastern boundary of Crown allotment 54 across Strickland-road to its intersection with the Sewerage District Boundary; thence generally north-westerly along the Sewerage District Boundary and the boundary of Seweraged Area No. 140 to the point of commencement.

By order of the Bendigo Sewerage Authority.

T. R. FLOOD, Chairman.

1919

H. A. MOORS, Secretary.

## CHELSEA SEWERAGE AUTHORITY.

PURSUANT to section 119 (2) of the *Sewerage Districts Act 1958* (No. 6368), notice is hereby given of the intention to construct sewers to provide for properties situated in portions of the area bounded approximately by Chelsea-road, Scotch-parade, Bondi-road, Genoa-avenue, Brixton-avenue, The Fairway, Mascot-avenue and Port Phillip Bay.

Particulars are shown on maps (as amended) which are open for inspection at this office between the hours of 9 a.m. to 12 noon and 1 p.m. to 4 p.m. on week-days other than public holidays.

1932

F. J. WALSHE, Secretary.

## GEELONG WATERWORKS AND SEWERAGE TRUST.

PURSUANT to section 60 (2) of the *Geelong Waterworks and Sewerage Act 1958* (No. 6263) notice is hereby given of the intention of the Trust to construct sewers to provide for properties in and adjacent to:—

Bonsey-road, Highton; Shire of South Barwon.

McCurdy-road, Herne Hill; Shire of Corio.

Tahara-street, Hamlyn Heights; Shire of Corio.

Tanner-street, Breakwater; City of Geelong.

Calvert-street, Bell Park; Shire of Corio.

Ising-street, Newcomb; Shire of Bellarine.

Pavo-street, South Belmont; Shire of South Barwon.

And more particularly as shown on maps which are open for public inspection at the Trust's Offices, Rynie-street, Geelong, between the hours of 9 a.m. and 4 p.m., daily from Monday to Friday.

Dated this 2nd day of June, 1966.

1935

B. C. HENSHAW, Secretary.

NOTICE is hereby given that Tomasetti & Son Proprietary Limited has applied for a lease under the provisions of section 134, *Land Act 1958*, for a term of 50 years from 27th August, 1966, of allotment 18, section 59, City of Port Melbourne, Parish of Melbourne South, containing 0 acres 3 roods 32 perches as a site for a warehouse and offices.

NORRIS, COATES & HEARLE, solicitors, 422 Collins-street, Melbourne. 1948

NOTICE is hereby given that the Royal Melbourne Yacht Squadron has applied for a lease under section 134 of the *Land Act 1958*, for a term of 21 years, in respect of an area of 1½ acres approximately of Crown land of West Beach at St. Kilda, in the Parish of Melbourne South, as a site for amusement and recreation (boat yard).

1694

O. A. MEIK, Commodore.

NOTICE is hereby given that Gunnensen Nosworthy Limited has applied for a lease under section 134, *Land Act 1958*, for a term of 50 years from 18th September, 1966, of allotment 6b, section 59, City of Port Melbourne, Parish of Melbourne South, containing 3 acres 2 roods 21 perches, as a site for wholesale merchandising and storage and for fabricating purposes. 1914

## NOTICE OF INTENTION TO APPLY FOR A LICENCE TO DIVERT WATER AND CUT RACE (RE-ISSUE) FROM THE RIVER MURRAY (BILLABONG), AT IRAAK.

I HEREBY give notice that I intend to apply for a licence empowering me to divert water for a term of fifteen years to the extent of 42 acre-feet per annum at a maximum rate of 4 acre-feet per day of 24 hours for the irrigation of a market garden, being part of allotment 8, section L.P.9767, Parish of Carwarp, and to occupy certain Crown lands for works of diversion, and to cut a race thereon.

Any objection to such application must be forwarded, in writing, to reach the State Rivers and Water Supply Commission, Melbourne, before 7th July, 1966, being 30 days from the first publication of this notice.

DAVID CHARLES GOULLET.

Nangiloc Post Office, via Red Cliffs, Victoria. 1906

## NOTICE OF INTENTION TO APPLY FOR A LICENCE TO DIVERT WATER AND CUT RACE (RE-ISSUE) FROM THE RIVER MURRAY, AT NICHOLS POINT.

I HEREBY give notice that I intend to apply for a licence empowering me to divert water for a term of 4 years to the extent of 9 acre-feet per annum at a maximum rate of 1 acre-foot per day of 24 hours for the irrigation of 3 acres, being part of allotment 2, section 5a, Parish of Mildura, and to occupy certain Crown lands for works of diversion, and to cut a race thereon.

Any objection to such application must be forwarded, in writing, to reach the State Rivers and Water Supply Commission, Melbourne, before 25th June, 1966, being 30 days from the first publication of this notice.

WILLIAM FREDERICK CHARLES VEIT.

River-road, Nichols Point Post Office. 1907

**NOTICE OF INTENTION TO APPLY FOR A LICENCE TO DIVERT WATER AND CUT RACE (RE-ISSUE) FROM THE RIVER MURRAY, AT IRAAK.**

I HEREBY give notice that I intend to apply for a licence empowering me to divert water for a term of fifteen years to the extent of 78 acre-feet per annum at a maximum rate of 2 acre-feet per day of 24 hours for the spray irrigation of 26 acres of citrus and vegetables, being part of allotment A, section 7, Parish of Carwarp, and to occupy certain Crown lands for works of diversion, and to cut a race thereon.

Any objection to such application must be forwarded, in writing, to reach the State Rivers and Water Supply Commission, Melbourne, before 30th June, 1966, being 30 days from the first publication of this notice.

GERALD ESHTON ROMAINE CALLENDER.

Iraak Post Office, via Carwarp, Victoria. 1908

**NOTICE OF INTENTION TO APPLY FOR A LICENCE TO DIVERT WATER AND CUT RACE FROM THE GOULBURN RIVER, AT THORNTON.**

I HEREBY give notice that I intend to apply for a licence empowering me to divert water for a term of three years to the extent of 20 acre-feet per annum at a maximum rate of 2 acre-feet per day of 24 hours for the irrigation of 10 acres of pasture, being part of allotments 31 and 31A, Parish of Thornton, and to occupy certain Crown lands for works of diversion, and to cut a race thereon.

Any objection to such application must be forwarded, in writing to reach the State Rivers and Water Supply Commission, Melbourne, before 26th June, 1966, being 30 days from the first publication of this notice.

JUDITH M. PORTER (Mrs.).

Bon-street, Alexandra. 1927

**NOTICE OF INTENTION TO APPLY FOR A LICENCE TO DIVERT WATER AND CUT RACE FROM THE GOULBURN RIVER, AT THORNTON.**

I HEREBY give notice that I intend to apply for a licence empowering me to divert water for a term of four years to the extent of 50 acre-feet per annum at a maximum rate of 2.5 acre-feet per day of 24 hours for the irrigation of 25 acres, being part of allotment 19, Parish of Eildon, and to occupy certain Crown lands for works of diversion, and to cut a race thereon.

Any objection to such application must be forwarded, in writing, to reach the State Rivers and Water Supply Commission, Melbourne, before 2nd July, 1966, being 30 days from the first publication of this notice.

DOUGLAS JAMES NICHOLAS.

"Wymarong", Thornton, Victoria. 1910

**NOTICE OF INTENTION TO APPLY FOR A LICENCE TO DIVERT WATER AND CUT RACE (RE-ISSUE) FROM THE RIVER MURRAY, AT WHARPARILLA.**

I HEREBY give notice that I intend to apply for a licence empowering me to divert water for a term of fifteen years to the extent of 50 acre-feet per annum at a maximum rate of 5 acre-feet per day of 24 hours for the irrigation of 25 acres of lucerne, being part of allotment 161A, Parish of Wharparilla, and to occupy certain Crown lands for works of diversion, and to cut a race thereon.

Any objection to such application must be forwarded, in writing, to reach the State Rivers and Water Supply Commission, Melbourne, before 7th July, 1966, being 30 days from the first publication of this notice.

SELBY POWER.

132 Glenferrie-road, Malvern. 1911

**NOTICE OF INTENTION TO APPLY FOR A LICENCE TO DIVERT WATER AND CUT RACE (RE-ISSUE), FROM THE RIVER MURRAY, AT NANGILOC.**

I HEREBY give notice that I intend to apply for a licence empowering me to divert water for a term of fifteen years to the extent of 30 acre-feet per annum at a maximum rate of 2 acre-feet per day of 24 hours for the irrigation of 10 acres, being part of allotment 2, section L.P.31214, Parish of Carwarp, and to occupy certain Crown lands for works of diversion, and to cut a race thereon.

Any objection to such application must be forwarded, in writing, to reach the State Rivers and Water Supply Commission, Melbourne, before 6th June, 1966, being 30 days from the first publication of this notice.

EDWARD THOMAS WIFFEN.

Box 78, Red Cliffs, Victoria. 1926

**NOTICE OF INTENTION TO APPLY FOR A LICENCE TO DIVERT WATER AND CUT RACE (RE-ISSUE) FROM THE RIVER MURRAY, AT PIANGIL.**

I HEREBY give notice that I intend to apply for a licence empowering me to divert water for a term of fifteen years to the extent of 40 acre-feet per annum at a maximum rate of 3 acre-feet per day of 24 hours for the irrigation of 6 acres of vines, furrow irrigation and 14 acres of various market garden, some spray irrigation, being part of allotment 147b, Parish of Piangil, and to occupy certain Crown lands for works of diversion, and to cut a race thereon.

Any objection to such application must be forwarded, in writing, to reach the State Rivers and Water Supply Commission, Melbourne, before 1st July, 1966, being 30 days from the first publication of this notice.

L. MASE.

Box 41, Piangil, Victoria. 1909

**NOTICE OF INTENTION TO APPLY FOR A LICENCE TO DIVERT WATER AND CUT RACE (RE-ISSUE) FROM THE RIVER MURRAY, AT NICHOLS POINT.**

WE hereby give notice that we intend to apply for a licence empowering us to divert water for a term of fifteen years to the extent of 6 acre-feet per annum at a maximum rate of 1/2 acre-foot per day of 24 hours for the irrigation of 2 acres of vine fruits, being part of allotment 8, section 6, block F, Parish of Mildura, and to occupy certain Crown lands for works of diversion, and to cut a race thereon.

Any objection to such application must be forwarded, in writing, to reach the State Rivers and Water Supply Commission, Melbourne, before 3rd July, 1966, being 30 days from the first publication of this notice.

ALLAN FRANCIS PITT.

BERYL ELAINE PITT.

Pate-street, Nichols Point. 1994

**NOTICE OF INTENTION TO APPLY FOR A LICENCE TO DIVERT WATER AND CUT RACE (RE-ISSUE) FROM THE CARWARP CREEK, AT IRAAK, VICTORIA.**

I HEREBY give notice that I intend to apply for a licence empowering me to divert water for a term of fifteen years to the extent of 45 acre-feet per annum at a maximum rate of 9 acre-feet per day of 24 hours for the purpose of irrigation of 15 acres, being part of allotment 9767, sections 2 and 6, Parish of Carwarp, and to occupy certain Crown lands for works of diversion, and to cut a race thereon.

Any objection to such application must be forwarded, in writing, to reach the State Rivers and Water Supply Commission, Melbourne, before 2nd July, 1966, being 30 days from the first publication of this notice.

IDA LILLIAN JOHNSON.

Iraak, via Carwarp, Victoria. 1995

**NOTICE OF INTENTION TO APPLY FOR A LICENCE TO DIVERT WATER AND CUT RACE (RE-ISSUE) FROM THE RIVER MURRAY, AT BUNDALONG.**

I HEREBY give notice that I intend to apply for a licence empowering me to divert water for a term of fifteen years to the extent of 80 acre-feet per annum at a maximum rate of 4 acre-feet per day of 24 hours for the irrigation of 40 acres of orchard and pasture, being part of allotments 1 and 2, Parish of Bundalong, and to occupy certain Crown lands for works of diversion, and to cut a race thereon.

Any objection to such application must be forwarded, in writing, to reach the State Rivers and Water Supply Commission, Melbourne, before 5th July, 1966, being 30 days from the first publication of this notice.

ESTATE OF ALEXANDER M. MACPHERSON.

"Bundawonga", Yarrowonga. 1996

**NOTICE OF INTENTION TO APPLY FOR A LICENCE TO DIVERT WATER AND CUT RACE (RE-ISSUE) FROM THE RIVER MURRAY, AT WHARPARILLA.**

I HEREBY give notice that I intend to apply for a licence empowering me to divert water for a term of fifteen years to the extent of 200 acre-feet per annum at a maximum rate of 10 acre-feet per day of 24 hours for the area of 100 acres of pasture, being part of allotments 6, 7, 7A and 8, section A, Parish of Turrumberry North, and to occupy certain Crown lands for works of diversion, and to cut a race thereon.

Any objection to such application must be forwarded, in writing, to reach the State Rivers and Water Supply Commission, Melbourne, before 8th July, 1966, being 30 days from the first publication of this notice.

ADRIANIUS DIKMANS.

Tongala. 1937

NOTICE OF INTENTION TO APPLY FOR A LICENCE TO DIVERT WATER AND CUT RACE (RE-ISSUE) FROM THE RIVER MURRAY, AT TORRUMBARRY.

I HEREBY give notice that I intend to apply for a licence empowering me to divert water for a term of fifteen years to the extent of 147 acre-feet per annum at a maximum rate of 7 acre-feet per day of 24 hours for the irrigation of 49 acres, being part of allotment 48, section D, Parish of Patho, and to occupy certain Crown lands for works of diversion, and to cut a race thereon.

Any objection to such application must be forwarded, in writing, to reach the State Rivers and Water Supply Commission, Melbourne, before 4th July, 1966, being 30 days from the first publication of this notice.

RAYMOND STANLEY WILLIAMS.

Torrumbarry. 1937

NOTICE OF INTENTION TO APPLY FOR A LICENCE TO DIVERT WATER AND CUT RACE (RE-ISSUE) FROM THE RIVER MURRAY, AT WEMEN.

I HEREBY give notice that I intend to apply for a licence empowering me to divert water for a term of fifteen years to the extent of 180 acre-feet per annum at a maximum rate of 4 acre-feet per day of 24 hours for the irrigation of 60 acres of trees, vines, vegetables, pastures and cereal crops, being allotment 3, Parish of Wemen, and to occupy certain Crown lands for works of diversion, and to cut a race thereon.

Any objection to such application must be forwarded, in writing, to reach the State Rivers and Water Supply Commission, Melbourne, before 4th July, 1966, being 30 days from the first publication of this notice.

R. C. CONNELL.

Wemen. 1937

CITY OF BOX HILL.

BY-LAW No. 123.

Dog Fees By-law.

A By-law of the City of Box Hill made under the Dog Acts and numbered 123 for fixing registration and other fees thereunder and for repealing By-law No. 103.

IN pursuance of the powers conferred by the Dog Acts and of any and every other power it thereunto enabling the Mayor Councillors and Citizens of the City of Box Hill orders as follows:—

- (1) This By-law shall be known as the Dog Fees By-law.
- (2) By-law No. 103 of the City of Box Hill is hereby repealed.
- (3) The following fees and amounts are hereby fixed pursuant to the Dog Acts:—
  - (a) For registration pursuant to Section 6 of the Dog Act 1958 as amended by any Act. One Dollar.
  - (b) For particulars of any registered dog or for the name of the registered owner thereof or for a certified copy of the receipt mentioned in Section 12 of the Dog Act 1958 as amended by any Act. Twenty-five Cents.
  - (c) Amount payable to the Registration Officer pursuant to sub-section (4) of Section 15 of the Dog Act 1958 as amended by any Act for the reclaiming of a dog under that section. One Dollar.
  - (d) Amount payable to the Registration Officer pursuant to Section 16 of the Dog Act 1958 as amended by any Act for the cost of keeping a dog. One Dollar.
- (4) This By-law shall apply to and have operation throughout the whole of the municipal district.

Resolution for passing this By-law agreed to by the Council of the City of Box Hill on the Fourth day of April 1966 and confirmed on the Thirtieth day of May 1966.

The corporate seal of the Mayor Councillors and Citizens of the City of Box Hill was hereunto affixed in the presence of—

(SEAL) S. G. DEWAR, Mayor.  
REGINALD H. L. SPARKS, Councillor.  
1900 A. N. WALLS, Town Clerk.

CITY OF BOX HILL.

BY LAW No. 124.

Noise By-law.

A By-Law of the City of Box Hill made under Section 197 of the Local Government Act 1958 numbered 124 for—

- (a) Controlling and regulating the use of premises with a view to preventing objectionable noises at unreasonable times.

IN pursuance of the powers conferred by the Local Government Act 1958 and by every other act or power enabling it in that behalf the Mayor Councillors and Citizens of the City of Box Hill order as follows—

1. This By-Law shall be known as the Noise By-Law.
2. In this By-Law unless inconsistent with the context or subject matter—

“Council” means the Council of the City of Box Hill.

“Instrument” means any instrument device or thing whatsoever capable of making or being used for making sound or noise and without affecting the generality of the foregoing includes any loud-speaker amplifier broadcasting set wireless receiving set television set gramophone piano player piano or other instrument or device.

“Municipal District” means the municipal district of the City of Box Hill.

“Premises” includes vacant land.

3. No person shall in or upon any premises use or operate or cause or permit the use or operation of any instrument or any machinery or plant in such manner as to cause any objectionable noise at any unreasonable time.

4. This By-Law shall apply to and have operation throughout the whole of the municipal district of the City of Box Hill.

5. Any person guilty of a wilful act or default contrary to the provisions of this By-Law shall be liable to a penalty of not less than \$10.00 nor more than \$40.00 and to a further penalty of not more than \$10.00 each for each day on which such offence is continued after a conviction or order of any Court.

Resolution for passing this By-law agreed to by the Council of the City of Box Hill on the Second day of May One thousand nine hundred and sixty-six and confirmed on the thirtieth day of May One thousand nine hundred and sixty-six.

The corporate seal of the Mayor, Councillors and Citizens of the City of Box Hill was hereunto affixed, in the presence of—

(SEAL) S. G. DEWAR, Mayor.  
1901 D. M. YOUL, Councillor.  
A. N. WALLS, Town Clerk.

CITY OF BOX HILL.

By-Law No. 122.

Sewerage By-law.

A By-law of the City of Box Hill made under Section 197 of the Local Government Act 1958 and Numbered 122 for—

- (a) regulating sewerage and drainage
- (b) providing for the health of the residents in the Municipal district and against the spreading of contagious or infectious diseases and
- (c) suppressing nuisances.

IN pursuance of the powers conferred by the Local Government Act 1958 and of any and every other power it thereunto enabling the Mayor Councillors and Citizens of the City of Box Hill orders as follows:—

1. This By-law may be known as the Sewerage By-law.
2. In this By-law unless inconsistent with the context or subject matter—

“Act” means the Melbourne and Metropolitan Board of Works Act 1958.

“Board” means the Melbourne and Metropolitan Board of Works.

“Sewer” means a sewer constructed by the Board pursuant to Part III. of the Act.

3. At any time
  - (a) After the Board shall have laid sewers in any Street or part of a Street and caused pursuant to sub-section (1) of Section 160 of the Act a general notice to be given that the Board has made provision for carrying off the sewerage of each and every property which or any part of which abuts on such Street or part of a Street in which Sewers have been so laid and

- (b) Before the Board has by a further general notice given pursuant to sub-section (2) of Section 160 of the Act ordered as in that sub-section provided

the Council may cause to be served on the owner of each and every property which or any part of which abuts on the said street or part of a street if there are any houses or buildings on such property notice in writing requiring him within such time as is specified in such notice to make all necessary applications to the Board for the purpose of providing for such property such proper water closet or water closets drains appliances apparatus and connexions with such sewer as may be prescribed by Regulations of the Board.

4. Within six months after having received the approval of the Board thereto or within such further time as the Council may allow such owner shall provide for such property such proper water closet or water closets drains appliances apparatus and connexions with such sewer as may be prescribed by Regulations of the Board.

5. Any person guilty of a wilful act or default contrary to this By-law shall be liable to a penalty of not less than £5.0.0 nor more than £20.0.0 and any person guilty of a continuing offence against this By-law shall be liable to a penalty of not more than £5.0.0 for each day on which an offence against this By-law is continued after a conviction or order by any Court.

6. This By-law shall apply to and have operation throughout the whole of the Municipal District.

Resolution for passing this By-law agreed to by the Council the Fourth day of April 1966 and confirmed the Thirtieth day of May 1966.

The Common Seal of the Mayor, Councillors and Citizens of the City of Box Hill was hereto affixed in pursuance of a Resolution of the Council and in the presence of—

(SEAL) S. G. DEWAR, Mayor.  
REGINALD H. L. SPARKS, Councillor.  
1902 A. N. WALLS, Town Clerk.

#### CITY OF BRIGHTON.

LOAN NO. 66.

*Notice of Intention to Borrow the Sum of \$10,000 for Permanent Works and Undertakings.*

NOTICE is hereby given that the Council of the City of Brighton proposes to borrow the sum of \$10,000, secured by a charge over the general rates of the municipality, such sum is to be raised by the grant of a mortgage, in accordance with the provisions of the *Local Government Act 1958*.

1. The maximum rate of interest that may be paid is 5.75 per cent. per annum.

2. The purpose for which the loan is to be applied is—  
Extension and Development of Wilson Recreation Reserve, including land acquisition costs—\$10,000.

3. The period of the loan shall be twenty years.

4. The moneys borrowed shall be repayable by providing out of municipal funds 40 half-yearly instalments of approximately \$423.93 each, including principal and interest, on the 1st day of September and the 1st day of March in each year during the currency of the loan. The first instalment shall be payable on the 1st March, 1967.

5. Such moneys borrowed shall be repayable to the Commonwealth Savings Bank of Australia, North Brighton.

The plans and specifications and the estimate of cost of the proposed works, and a statement showing the proposed expenditure of the moneys to be borrowed, are open for inspection at the Municipal Offices, Boxshall-street, Brighton, during office hours.

A. C. G. DEGARIS, Town Clerk.

Municipal Offices, Boxshall-street, Brighton, 6th June, 1966.  
1928

#### CITY OF ESSENDON.

BY-LAW No. 175.

*Nuisances By-law.*

A By-law of the City of Essendon made under section 197 of the *Local Government Act 1958* and numbered 175 for maintaining the good rule and government of the Municipality.

IN pursuance of the powers conferred by the *Local Government Act 1958* and of any and every other power it thereunto enabling the Mayor, Councillors and Citizens of the City of Essendon orders as follows:—

1. This By-law shall be known as the Nuisances By-law.

2. No person shall on any premises owned or occupied by him burn or cause or permit to be burned any substance in such manner or to such an extent as shall cause such quantities of smoke to be emitted from the said premises as will cause a nuisance to any other person upon any other land or upon any public highway.

Resolution for passing this By-law agreed to by the Council of the City of Essendon, on the 7th day of March, 1966, and confirmed on the 4th day of April, 1966.

The corporate seal of the Mayor, Councillors and Citizens of the City of Essendon was hereunto affixed, in the presence of—

(SEAL) C. D. ALLISON, Mayor.  
1903 E. A. REVELL, Councillor.  
K. LISTER, Town Clerk.

#### CITY OF GEELONG WEST.

LOAN NO. 54.

*Notice of Intention to Borrow the Sum of \$30,000 for Permanent Works and Undertakings.*

NOTICE is hereby given that the Council of the City of Geelong West intends to borrow the principal sum hereinafter mentioned on the credit of the municipal revenues of the Mayor, Councillors and Citizens of the City of Geelong West by the grant of a mortgage in accordance with the provisions of the *Local Government Act 1958*, and notice is hereby further given—

(a) That the amount of the principal sum which it is proposed to borrow is \$30,000.

(b) The maximum rate of interest that may be paid is 5.62500 per centum per annum.

(c) The moneys borrowed and interest thereon are to be repayable by 20 half-yearly instalments each of approximately \$1,981.68 on the 1st day of October and the 1st day of April in each year, and the place at which such moneys are to be repayable is the Commonwealth Bank Melbourne. The first instalment shall be payable on the 1st day of October, 1966.

(d) The purposes for which the loan is to be applied are Council's contribution towards Geelong and District Memorial Swimming Centre Appeal.

(e) The loan is to be liquidated by appropriation out of the municipal fund.

(f) The plans, specifications and estimate for the cost of such works, and the statement showing the proposed expenditure of the money to be borrowed, are open for inspection at the office of the Council, 153 Pakington-street, Geelong West, during office hours.

Dated the 1st day of June, 1966.

1923 R. J. HAMMETT, Town Clerk.

#### CITY OF GEELONG WEST.

NOTICE OF INTENTION TO ACQUIRE LAND COMPULSORILY.

*To All Whom It May Concern.*

WHEREAS the Council of the City of Geelong West deems it expedient to exercise its powers of taking land compulsorily for the work or undertaking mentioned hereunder.

Notice is hereby given as follows:—

1. The Council intends to acquire all that triangular piece of land being part of Crown portion 5 of section 8, Parish of Moorpanyal commencing at the point of intersection of the southern side of Waratah-street Geelong West with the western side of Askew-street bounded on the north by Waratah-street bearing westerly from the commencing point 31 ft. 3 in. or thereabouts; thence by a line bearing south-easterly to a point on the western side of Askew-street distant 31 ft. 3 in. or thereabouts southerly from the said point of intersection and thence on the east by Askew-street bearing northerly 31 ft. 3 in. or thereabouts to the commencing point to be used for road purposes.

2. A copy of the plan of survey of such land and a schedule of the owners thereof are deposited at the Town Hall, Geelong West, and are there available for inspection by all interested parties during office hours free of charge for the period of 40 clear days from the date of publication of this notice in the *Government Gazette*.



3. The Council hereby requires all persons affected by the said proposal to set forth in writing addressed to the Town Clerk, Town Hall, Geelong West within 40 clear days from the date of publication aforesaid all objections which they may have to the taking of the said land.

4. At the ordinary meeting of the Council next after the expiration of the said 40 clear days the Council will consider any such objection and any person so objecting as aforesaid may appear before the Council in support of such objection.

Dated the 1st day of June, 1966.

By order of the Council,  
1941 R. J. HAMMETT, Town Clerk.

**BOROUGH OF QUEENSCLIFFE.**

LOAN No. 20.

*Notice of Intention to Borrow the Sum of \$12,000 for Permanent Works and Undertakings.*

NOTICE is hereby given that the Council of the Borough of Queenscliffe proposes to borrow the sum of Twelve thousand dollars, secured by a charge over the general rates of the municipality, such sum to be raised by the grant of a mortgage, in accordance with the provisions of the *Local Government Act 1958*.

1. The maximum rate of interest that may be paid is 5.625 per cent. per annum.

2. The purpose for which the loan is to be applied is:—

(a) Drainage works .. .. .	\$2,000
(b) Council proportion, paving and channeling works .. .. .	10,000
	\$12,000

3. The period of the loan shall be ten years.

4. The moneys borrowed shall be repayable by providing out of the municipal fund twenty half-yearly instalments of \$792.67, including principal and interest on the 1st day of March and the 1st day of September, during the currency of the loan. The first instalment shall be payable on the 1st day of March, 1967.

5. Such moneys shall be payable at the C.B.C. Savings Bank Ltd., Melbourne.

The plans and specifications and the estimate of the proposed works and a statement showing the proposed expenditure of the moneys to be borrowed, are open for inspection at the Town Hall, Queenscliff.

1904 D. F. DREW, Town Clerk.

**SHIRE OF ELTHAM.**

NAMING OF ROAD.

NOTICE is hereby given that the unnamed Government road which abuts the southern boundaries of lots 25 to 28 inclusive on Plan of Subdivision No. 56756, bounded at its eastern end by Eltham-Yarra Glen road and at its western end by the railway reserve, has been named Coleman-crescent.

1943 M. B. WATSON, Shire Secretary.

**THE SHIRE OF LILLYDALE.**

NOTICE OF INTENTION TO TAKE LAND COMPULSORILY.

WHEREAS the Council of the Shire of Lillydale deems it expedient to exercise its power of taking compulsorily the land delineated and hatched on the map at the foot hereof for the work or undertaking of providing same as a place of public resort or recreation: And whereas the Council has caused to be prepared a map and other papers setting out the general description of the work or undertaking for which the land proposed to be taken is to be used the description of the land proposed to be taken and the names of the owners or reputed owners lessees or reputed lessees mortgagees and occupiers of that land so far as those names are known to or can be ascertained by the Council: And whereas the said map and other papers are deposited at the office of the said Council at Lillydale and are and shall be open for inspection by all persons interested at all reasonable hours for the space of 40 clear days after the publication of this notice in the *Government Gazette*: Now notice is hereby given to all persons affected by the proposed taking of the said land to set forth in writing addressed to the

Council or the Shire Secretary within 40 clear days of the publication of this notice in the *Government Gazette* all objections which they may have to the taking of the said land.

**PART OF CROWN PORTION 13**  
(Part Lots 9 & 10 L.P.818C)

**PARISH OF MOOROOLBARK**

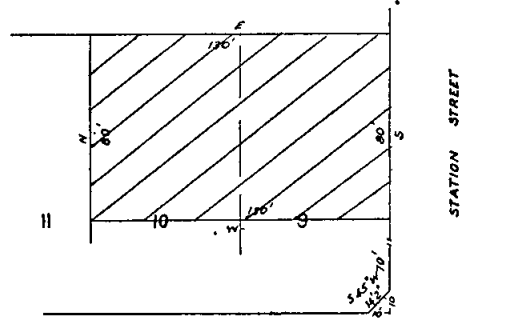

CHARLES STREET

Dated the 30th day of May, 1966.

By order of the Council,  
1945 T. H. COWLEY, Shire Secretary.

**THE SHIRE OF LILLYDALE.**

NOTICE OF INTENTION TO TAKE LAND COMPULSORILY.

WHEREAS the Council of the Shire of Lillydale deems it expedient to exercise its power of taking compulsorily the land delineated and hatched on the map at the foot hereof for the work or undertaking of providing same as a place of public resort or recreation: And whereas the Council has caused to be prepared a map and other papers setting out the general description of the work or undertaking for which the land proposed to be taken is to be used, the description of the land proposed to be taken and the names of the owners or reputed owners lessees or reputed lessees mortgagees and occupiers of that land so far as those names are known to or can be ascertained by the Council: And whereas the said map and other papers are deposited at the office of the said Council at Lillydale and are and shall be open for inspection by all persons interested at all reasonable hours for the space of 40 clear days after the publication of this notice in the *Government Gazette*: Now notice is hereby given to all persons affected by the proposed taking of the said land to set forth in writing addressed to the Council or the Shire Secretary within 40 clear days of the publication of this notice in the *Government Gazette* all objections which they may have to the taking of the said land.

**PART OF CROWN PORTION 13**  
(Part Lots 9 & 10 L.P.818C)

**PARISH OF MOOROOLBARK**

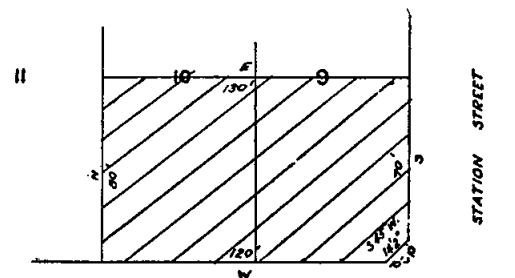

CHARLES STREET

Dated the 30th day of May, 1966.

By order of the Council,  
1946 T. H. COWLEY, Shire Secretary.

## SHIRE OF NEWHAM AND WOODEND.

## BY-LAW No. 36.

A By-law of the Shire of Newham and Woodend made under Section 93 of the *Health Act* 1958, and numbered 36, for fixing the limits inside which it shall be unlawful to keep swine or any pig sty.

IN pursuance of the powers conferred by the *Health Act* 1958, the President, Councillors and Ratepayers of the Shire of Newham and Woodend order as follows:—

1. By-law No. 32 is hereby repealed.
2. This By-law shall come into full force and effect immediately after its publication in the *Government Gazette*.
3. No person shall keep or permit or suffer to be kept any swine or any pig sty within the limits of the area to which this By-law applies as described in clause 7.
4. The proper officer of the Council shall have the power to enter into or upon any premises, yards or lands at any reasonable hour for the purpose of carrying out the provisions of this By-law.
5. Every person who does not do anything directed to be done or does anything forbidden to be done by or under this By-law shall be guilty of an offence against this By-law.
6. Every person found guilty of an offence against this By-law shall be liable to a penalty of not more than Twenty pounds, and in the case of a continuing offence to a further daily penalty of not more than Five pounds.
7. This By-law shall apply to and have operation throughout the following part of the municipal district, that is to say:—

Within the Township area of Woodend, and such parts of the parishes of Newham and Woodend, as depicted on the attached plans.

Resolution for passing this By-law No. 36 was agreed to by the Council on the 7th day of December, 1965, and was confirmed on the 1st day of February, 1966.

The common seal of the President, Councillors and Ratepayers of the Shire of Newham and Woodend was hereunto affixed, in the presence of—

GILBERT GORDON, President.  
(SEAL) A. C. ANDISON, Councillor.  
N. M. SMITH, Secretary.

Submitted to the Commission of Public Health on 13th April, 1966.—A. T. GARDNER, Secretary, Commission of Public Health.

Approved by the Governor in Council, 3rd May, 1966.—  
J. COLQUHOUN, Clerk of the Executive Council. 1929

## SHIRE OF RODNEY.

## LOAN No. 58.

*Notice of Intention to Borrow the Sum of \$20,000 for Permanent Works and Undertakings.*

NOTICE is hereby given that the Council of the Shire of Rodney proposes to borrow the principal sum of Twenty thousand dollars on the credit of the municipal revenues of the President, Councillors and Ratepayers of the said Shire, such sum to be raised by the grant of a mortgage in accordance with the provisions of the *Local Government Act* 1958.

1. The maximum rate of interest that may be paid is 5½ per centum per annum.
2. The purposes for which the loan is to be applied are:—  
Purchase of mechanical street sweeper and road-making plant.
3. The period of the loan shall be five (5) years.
4. The moneys borrowed shall be repayable by providing out of the municipal fund ten half-yearly instalments of \$2,314.79 each, including principal and interest on the first day of March and the first day of September, during the currency of the loan. The first instalment shall be payable on the first day of March, 1967.
5. Such moneys shall be repayable at the Commercial Bank of Australia Ltd., Tatura.

A statement showing the proposed expenditure of the moneys to be borrowed is open for inspection at the Shire Office, Tatura.

1944

R. PERRY, Shire Secretary.

## SHIRE OF SOUTH BARWON.

## NOTICE OF CHANGE OF STREET NAME.

NOTICE is hereby given that in pursuance of the powers conferred by the Local Government Act, the Council of the Shire of South Barwon at a meeting held on the 17th day of May, 1966, did resolve to make the following alteration in a street name:—

*Old Name; New Name; Location.*

Karann-street; Highfield-drive; between Heyers-road and Karana-avenue, Grovedale, on plan of subdivision No. 57879.

E. T. CORNISH, Shire Secretary.

Shire Hall, Belmont.

1920

## SHIRE OF SWAN HILL.

## LOAN No. 40.

*Notice of Intention to Borrow the Sum of \$100,000 for Permanent Works and Undertakings.*

NOTICE is hereby given that the Council of the Shire of Swan Hill proposes to borrow the principal sum of \$100,000, secured by a charge over the general rates of the municipality, such sum to be raised by the grant of a mortgage, in accordance with the provisions of the *Local Government Act*.

1. The maximum rate of interest that may be paid is 5½ per cent. per annum.
2. The purpose for which the loan is to be applied is—  
Electricity Supply Extensions at Robinvale.
3. The period of the loan shall be fifteen years.
4. The moneys borrowed shall be repayable by providing out of the municipal fund 30 half-yearly instalments of \$5,019.84 each, including principal and interest, on the 1st day of September and the 1st day of March during the currency of the loan. The first instalment shall be payable on the 1st day of March, 1967.
5. Such moneys shall be repayable to the Commonwealth Savings Bank of Australia, Melbourne.

Plans and specifications and estimate of cost of the proposed works, and a statement showing the proposed expenditure of the moneys to be borrowed, are open for inspection at the office of the Council of the Shire of Swan Hill, at Beveridge-street, Swan Hill.

J. D. LAURITZ, Shire Secretary.

6th June, 1966.

2001

## SHIRE OF SWAN HILL.

## LOAN No. 41.

*Notice of Intention to Borrow the Sum of \$50,000 for Permanent Works and Undertakings.*

NOTICE is hereby given that the Council of the Shire of Swan Hill proposes to borrow the principal sum of \$50,000, secured by a charge over the general rates of the municipality, such sum to be raised by the grant of a mortgage, in accordance with the provisions of the *Local Government Act* 1958.

1. The maximum rate of interest that may be paid is 5½ per cent. per annum.
2. The purpose for which the loan is to be applied is—  
Electricity Supply Extensions at Robinvale.
3. The period of the loan shall be fifteen years.
4. The moneys borrowed shall be repayable by providing out of the municipal fund 30 half-yearly instalments of approximately \$2,510 each, including principal and interest, on the 1st day of September and the 1st day of March during the currency of the loan. The first instalment shall be payable on the 1st day of March, 1967.
5. Such moneys shall be repayable to the Commissioners of the State Savings Bank of Victoria, at the office of the said Commissioners, corner of Elizabeth and Bourke streets, Melbourne.

The plans and specifications and the estimate of the cost of the proposed works, and a statement showing the proposed expenditure of the moneys to be borrowed, are open for inspection at the office of the Council of the Shire of Swan Hill, at Beveridge-street, Swan Hill.

J. D. LAURITZ, Shire Secretary.

6th June, 1966.

2002

## SHIRE OF VIOLET TOWN.

LOAN NO. 19.

*Notice of Intention to Borrow the Sum of \$44,000 for Permanent Works and Undertakings.*

NOTICE is hereby given that the Council of the Shire of Violet Town proposes to borrow the principal sum of Forty-four thousand dollars on the credit of the municipal revenues of the President, Councillors and Rate-payers of the said Shire, such sum to be raised by the grant of a mortgage in accordance with the provisions of the *Local Government Act 1958*.

1. The maximum rate of interest that may be paid is 5.75 per cent. per annum.

2. The purpose for which the loan is to be applied is the construction of a Memorial Hall, Supper Room, Kitchen, Meeting Room and Library, Cowslip-street, Violet Town.

3. The period of the loan shall be twenty years.

4. The moneys borrowed shall be repayable by providing out of the municipal fund 40 half-yearly instalments of \$1,865.27 each, including principal and interest on the 1st day of May and the 1st day of November, during the currency of the loan. The first instalment shall be payable on the 1st day of May, 1967.

5. Such moneys shall be repayable to the National Bank Savings Bank Limited, Melbourne.

The plans and specifications and the estimate of the cost of the proposed works and a statement showing the proposed expenditure of the moneys to be borrowed are open for inspection at the office of the Council of the Shire of Violet Town, at Violet Town.

1905

B. C. REES, Shire Secretary.

## SHIRE OF WARRACKNABEAL.

LOAN NO. 26.

*Notice of Intention to Borrow the Sum of \$5,300 for Permanent Works and Undertakings.*

NOTICE is hereby given that the Council of the Shire of Warracknabeal proposes to borrow the principal sum of \$5,300 secured by a charge over the general rates of the municipality, such sum to be raised by the grant of a mortgage in accordance with the provisions of the *Local Government Act 1958*.

1. The maximum rate of interest that may be paid is 5½ per cent. per annum.

2. The purpose for which the loan is to be applied is aerodrome development.

3. The period of the loan shall be fifteen years.

4. The moneys borrowed shall be repayable by providing out of the municipal fund half-yearly instalments of approximately \$266.05 each, including principal and interest on the 1st day of March and the 1st day of September during the currency of the loan. The first instalment shall be payable on the 1st day of March, 1967.

5. Such moneys shall be repayable to the Commissioners of the State Savings Bank of Victoria at the office of the said Commissioners, corner Elizabeth and Bourke streets, Melbourne.

The plans and specifications and the estimate of the cost of the proposed works and a statement showing the proposed expenditure of the moneys to be borrowed are open for inspection at the office of the Council of the Shire of Warracknabeal.

S. FELL, Shire Secretary.

Dated 31st May, 1966.

1917

## SHIRE OF WARRNAMBOOL.

LOAN NO. 11.

*Notice of Intention to Borrow the Sum of \$12,198.00 for Permanent Works and Undertakings.*

NOTICE is hereby given that the Council of the Shire of Warrnambool proposes to borrow the principal sum of Twelve thousand one hundred and ninety-eight dollars, secured by a charge over the general rates of the municipality, such sum to be raised by the grant of a mortgage, in accordance with the provisions of the *Local Government Act 1958*.

1. The maximum rate of interest that may be paid is 5 9/16 per cent. per annum.

2. The purpose for which the loan is to be applied is for the purchase of plant as set out hereunder:—

One road grader with Windrow eliminator complete.

3. The period of the loan shall be eight years.

4. The moneys borrowed shall be repayable by providing out of the municipal fund half-yearly instalments of approximately \$955 each, including principal and interest, on the 1st day of March and the 1st day of September during the currency of the loan. The first instalment shall be payable on the 1st day of March, 1967.

5. Such moneys shall be repayable to the Commissioners of the State Savings Bank of Victoria, at the office of the said Commissioners, corner of Elizabeth and Bourke streets, Melbourne.

The plans and specifications and the estimate of the cost of the proposed works, and a statement showing the proposed expenditure of the moneys to be borrowed, are open for inspection at the office of the Council of the Shire of Warrnambool, at the Shire Office, 99 Fairy-street, Warrnambool.

Dated: 2nd June, 1966.

2000

A. F. PONTING, Shire Secretary.

## SHIRE OF YEA.

NOTIFICATION OF PROPOSAL FOR THE CONSTITUTION OF A RIVER IMPROVEMENT TRUST.

NOTICE is hereby given that the Council of the Shire of Yea acting on its own behalf and at the request of the Shire of Broadford has made application to the Minister of Water Supply for the constitution of a River Improvement District under the control of a River Improvement Trust to carry out and maintain works on sections of the King Parrot Creek, Strath Creek, Carver's Creek and Kangaroo Creek.

The application and general plan and description have been forwarded to the Minister and have been deposited for inspection at the Shire Office, Broadford and the Shire Office, Yea, and at the Head Office of the State Rivers and Water Supply Commission, 90 Orrong-road, Armadale, S.E.3, and also at the Office of the Minister.

1794

F. F. BERKERY, Shire Secretary.

NOTICE is hereby given that the partnership heretofore subsisting between Gordon Henry Mardon Allingham and Brian Alfred Wendt, carrying on business as Commercial Photographers, at 436 St. Kilda-road, Melbourne, under the style or firm of Allingham-Wendt, has been dissolved as from the 25th day of May, 1966.

Dated the 25th day of May, 1966.

GORDON H. M. ALLINGHAM.  
B. A. WENDT.

L. E. Penttila, LL.B., solicitor, 867 Sydney-road, Moreland, N.13. 1952

NOTICE is hereby given that the partnership heretofore subsisting between Eric Horatio Bond, Trentyn Bond and Roy Thomas Lockman carrying on business as electrical retailers, at 96 Koormang-road, Carnegie under the style or firm of Magnetic Electrix, has been dissolved as from the date hereof. The said business will be continued by the said Roy Thomas Lockman, in partnership with Ronald Francis Lockman who will carry on business at the same address under the said name of Magnetic Electrix.

Dated the 30th day of May, 1966.

ERIC HORATIO BOND.  
(By his Attorney).  
NELLIE ELIZABETH BOND.  
ROY LOCKMAN.  
R. F. LOCKMAN.  
TRENTYN BOND.

Maddock, Lonie &amp; Chisholm, solicitors.

Melville &amp; Melville, solicitors.

1956

NOTICE is hereby given that the partnership heretofore subsisting between Lawrence Charles McInerney and Allen Joseph Millay, carrying on business as Milmac Panels at the rear of 601 Keilor-road, Niddrie, has been dissolved as from the 1st day of June, 1966.

Dated this 1st day of June, 1966.

1963

L. C. MCINERNEY.  
A. J. MILLAY.

NOTICE is hereby given that the partnership heretofore subsisting between the undersigned Stanley John Burke, of Curdie-street, Cobden, Hazel Florence Burke, of Curdie-street, Cobden, Eveline Muriel Belcher, of 16 West-garth-street, Northcote and Ronald Franklyn Pitcher, of 406 Lonsdale-street, Melbourne, carrying on the business of General Merchants, at 77 Curdie-street, Cobden, under the firm name of Stanley Burke & Co., has been dissolved

by mutual consent as from the 26th day of April, 1966. All debts due to and owing by the said late firm will be received and paid by Stanley Burke and Co. Pty. Ltd., which company will carry on the said business at 77 Curdie-street, Cobden.

Dated this 26th day of May, 1966.

S. J. BURKE.  
H. F. BURKE.  
R. F. PITCHER.  
EVELINE MURIEL BELCHER.

1976

**NOTICE** is hereby given that the partnership heretofore subsisting between us the undersigned, Oswald Victor Moll, and Delia Elsa Moll, both of Nhill, in the State of Victoria, nurserymen, carrying on business at Nhill aforesaid, under the style or firm of "Delvic Florist and Nursery", has been dissolved by mutual consent as from the 20th day of May, 1966. All debts due and owing by the said firm will be received and paid by the said Oswald Victor Moll, and Delia Elsa Moll, who have disposed of the said business to Cecil Lester Carr Thompson, plasterer, and Sophie Agnes Thompson, married woman, and Donald Lester Thompson, nurseryman, all of Nhill aforesaid, who will continue to carry on the said business under the same name.

Dated the 20th day of May, 1966.

O. V. MOLL.  
D. E. MOLL.

Witness—C. C. PALMER.

1918

In the matter of **AMALGAMATED MOTELS PTY. LIMITED.**  
**WINDING-UP** Order made the 2nd June, 1966.

Name and address of liquidator: Reginald Wilfrid Ellis, of care of David Fell & Co., 360 Collins-street, Melbourne.

HEDDERWICK, FOOKES & ALSTON, solicitors for the petitioner.

1972

In the matter of **ALBERT STREET MEDICAL CENTRE LIMITED.**  
**WINDING-UP** Order made the 2nd June, 1966.

Name and address of liquidator: Reginald Wilfrid Ellis, of care of David Fell & Co., 360 Collins-street, Melbourne.

HEDDERWICK, FOOKES & ALSTON, solicitors for the petitioner.

1973

In the matter of **CECEC (TOORAK) LIMITED.**  
**WINDING-UP** Order made the 2nd June, 1966.

Name and address of liquidator: Reginald Wilfrid Ellis, of care of David Fell & Co., 360 Collins-street, Melbourne.

HEDDERWICK, FOOKES & ALSTON, solicitors for the petitioner.

1974

The *Companies Act 1961*.—In the matter of **MARYBOROUGH THEATRES PTY. LTD.** (in Liquidation); and in the matter of *The Companies Act 1961*.—Notice of Meeting of Creditors and Members in Creditors' Voluntary Winding Up.

**NOTICE** is hereby given that in pursuance of section 272 of the above Act, a Meeting of creditors and members of the above-named company will be held at our offices, 20 Collins-street, Melbourne, on 4th day of July, 1966, at 12.30 p.m., when we will lay before the meeting an account of our acts and dealings and of the conduct of the winding up of the above-named company during the course of the liquidation.

Dated this 1st day of June, 1966.

WARNOCK, WHARTON & BIGNELL, as agents for the liquidator.

1977

*Companies Act 1961*, Pursuant to Section 272 (2).

**OHIO DEVELOPMENT CORPORATION (AUST.) PROPRIETARY LIMITED** (IN VOLUNTARY LIQUIDATION).

**NOTICE** is hereby given that the Final Meeting of the shareholders of Ohio Development Corporation (Aust.) Proprietary Limited will be held at the office of Cape Development Pty. Ltd., 196 Williams-road, Toorak, on Wednesday, 27th July, 1966, at 12 o'clock noon for the purpose of having an account laid before it showing how the winding up of the company has been conducted and the property of the company has been disposed of and to pass a Resolution to destroy the company's books and papers pursuant to section 284 (3) (b) of the *Companies Act*.

1978

N. W. GLUCK, Liquidator.

*Companies Act 1961*, Pursuant to Section 272 (2).

**ARK RUBBER HOLDINGS PTY. LTD.** (IN VOLUNTARY LIQUIDATION).

**NOTICE** is hereby given that the Final Meeting of the shareholders of Ark Rubber Holdings Pty. Ltd. will be held at the office of Felt & Textiles of Australia Ltd., 8 Nicholson-street, Melbourne, on Monday, 18th July, 1966, at 12 o'clock noon, for the purpose of having an account laid before it showing how the winding up of the company has been conducted and the property of the company has been disposed of and to pass a Resolution to destroy the company's books and papers pursuant to section 284 (3) (b) of the *Companies Act*.

1979

R. A. BERRY, Liquidator.

*Companies Act 1961*, Pursuant to Section 272 (2).

**S. M. GOODMAN PTY. LTD.** (IN VOLUNTARY LIQUIDATION).

**NOTICE** is hereby given that the Final Meeting of the shareholders of S. M. Goodman Pty. Ltd., will be held at 7 Studley-avenue, Kew, on Monday, 18th July, 1966, at 8 p.m., for the purpose of having an account laid before it showing how the winding up of the company has been conducted and the property of the company has been disposed of and to pass a Resolution to destroy the company's books and papers pursuant to section 284 (3) (b) of the *Companies Act*.

1980

R. A. BERRY, Liquidator.

The *Companies Act 1961*, Pursuant to Section 272.

**GIANT CONFECTIONS PTY. LTD.** (IN VOLUNTARY LIQUIDATION).

**NOTICE** is hereby given that a Final Meeting of members will be held at the offices of the liquidator on Wednesday, 13th July, 1966, at 10 a.m., for the purpose of laying before the meeting the liquidator's account and to give any explanations thereof.

Dated this 3rd day of June, 1966.

P. C. SIMMONS, liquidator, 8th Floor, 150 Queen-street, Melbourne.

1981

*Companies Act 1961*.

**J. T. HADWEN PTY. LTD.**

**NOTICE OF MEETING OF CREDITORS OR CONTRIBUTORIES.**

**NOTICE** is hereby given that a meeting of the creditors of J. T. Hadwen Pty. Ltd., will be held in the General Meeting Room, Chamber of Manufactures, 368-374 St. Kilda-road, Melbourne, on Tuesday, the 28th June, 1966, at 10.30 o'clock in the forenoon, for the purpose of considering the company's affairs, the company having convened an Extraordinary General Meeting of its members to be held on the same day and for the purpose of considering and, if though fit, passing a Special Resolution that the company be wound up voluntarily.

Dated this 3rd day of June, 1966.

1982

J. HADWEN, Director.

**LAMBERT RECTIFIERS PROPRIETARY LIMITED.**

**NOTICE CONVENING FINAL MEETING PURSUANT TO SECTION 272.**

**NOTICE** is hereby given pursuant to section 272 of the *Companies Act 1961*, that a General Meeting of the members of the above-mentioned company will be held at 419 Lonsdale-street, Melbourne, on Wednesday, the 13th day of July, 1966, at 9 o'clock in the forenoon, for the purpose of having an account laid before them showing the manner in which the winding up has been conducted and the property of the company disposed of, and of hearing any explanation that may be given by the liquidator.

1985

NORMAN FRANK HENNING, Liquidator.

*Companies Act 1961*.

**THE UNITED PAPER BAG COMPANY OF AUSTRALIA PTY. LTD.** (IN VOLUNTARY LIQUIDATION).

**NOTICE CONVENING FINAL MEETING OF MEMBERS PURSUANT TO SECTION 272.**

**NOTICE** is hereby given in pursuance to section 272 of the *Companies Act 1961* that a General Meeting of the members of the above-named company will be held at the office of the liquidator, 25 Coventry-street, South Melbourne, on Friday, the 8th day of July, 1966, at 9.30 o'clock in the forenoon, for the purpose of having an account laid before them showing the manner in which the winding up has been conducted and the property of the company disposed of, and of hearing any explanations that may be given by the liquidator.

Dated this 6th day of June, 1966.

1942

JOHN W. KENNY, Liquidator.

Unclaimed Moneys Act 1962.

REGISTER of Unclaimed Moneys Held by—

Name of Owner on Books and Last Known Address.	Total Amount Due to Owner.	Description of Unclaimed Moneys.	Date when Amount first became Payable.
	\$ c		
<b>AUSTRALIAN EQUITY CORPORATION LTD.</b>			
Victorian Potato Growers Association, c/o D. Lindsay, Box 8, Berwick	10.50	Interest on Loan Moneys	30.6.64
Turner, George, 10 Farleigh-grove, Brighton .. .. .	62.50	" " "	
Johnston, James Dawson, "Mungala", Rye .. .. .	20.00	" " "	30.9.64
Clarke, Morton Stewart, Park-road, Fisherman's Bay, c/o P.O. Maianbar, N.S.W.	60.00	" " "	
Smith, Vera M., Orana Private Bag, Horsham .. .. .	13.50	" " "	31.12.64
Morton, Percy Herbert, 58 Liverpool-road, Croydon, N.S.W. ..	20.00	" " "	
Maskell, Bertha, c/o A. E. C. Treloar, 38 Grenfell-street, Adelaide, S.A.	22.19	" " "	
Merchant, M. L. (estate of), c/o I. M. Merchant, Beauty Point, Tasmania	13.15	" " "	2.11.64
1925			

The Companies Act 1961.  
**AUSTRALIAN MEDICAL EXPORT COMPANY PROPRIETARY LIMITED (IN LIQUIDATION).**  
 NOTICE CONVENING FINAL MEETING OF MEMBERS AND CREDITORS PURSUANT TO SECTION 272.  
 NOTICE is hereby given that in pursuance of section 272 of the Companies Act 1961 that a Meeting of the members and creditors of the above-named company will be held on the 13th day of July, 1966, at the office of Hall & Rose, 260 Queen-street, Melbourne, at 11 a.m. in the forenoon, for the purpose of having an account laid before them showing the manner in which the winding up has been conducted and the property of the company disposed of and of hearing any explanations that may be given by the liquidator.  
 Dated this 3rd day of June, 1966.  
 J. K. HALL, Liquidator.  
 Hall & Rose, chartered accountants, 260 Queen-street, Melbourne, C.1. 1966

Companies Act 1961.  
**GILMOURS MEATS PTY. LTD.**  
 NOTICE PURSUANT TO SECTION 254 (2) (b) OF THE COMPANIES ACT 1961.  
 NOTICE is hereby given that at an Extraordinary General Meeting of the members of the above-named company held on Thursday, the 26th May, 1966, it was resolved that the company be wound up voluntarily and at a meeting of creditors held on the same day pursuant to section 260, it was resolved that for such purposes, Bruce Edward Fordham, of 170 Toorak-road, South Yarra, chartered accountant, be appointed liquidator.  
 Notice is also given that after 21 days from this date, I shall proceed to distribute the assets. All creditors having any claims against the company should furnish particulars of same by that date, otherwise I shall proceed to distribute the assets, without regard to their claim.  
 Dated this 31st day of May, 1966.  
 BRUCE FORDHAM, Liquidator.  
 Bruce Fordham, chartered accountant, 170 Toorak-road, South Yarra. 1968

**PHOTO LITHOGRAPHERS PTY. LIMITED (IN LIQUIDATION).**  
 NOTICE OF FINAL MEETING.  
 NOTICE is hereby given that a Meeting of the members of Photo Lithographers Pty. Limited (in liquidation) will be held at Raleigh Park, Kensington, in the State of New South Wales, on Friday, the 24th day of June, 1966, at 11 a.m., for the purpose of laying before the meeting an account showing how the winding up has been conducted and the property of the company disposed of.  
 Dated this 30th day of May, 1966.  
 E. G. F. HORNE, Liquidator.  
 28, O'Connell-street, Sydney.  
 Best, Hooper, Rintoul & Shallard, 100 Queen-street, Melbourne. 1969

The Companies Act 1958.—In the matter of FLASH TAXI & AUTO SERVICE PTY. LTD. (in Liquidation).  
 NOTICE is hereby given that pursuant to section 210 of the Companies Act a Final Meeting of the creditors of the above company will be held at the offices of Kennedy, Smal & Middlemiss, 296-300 Little Lonsdale-street, Melbourne, on Wednesday, the 6th day of July, 1966, at 10.30 a.m.  
 Business.—To receive the liquidator's accounts.  
 Dated this 30th day of May, 1966.  
 EDWARD RONALD SMAL, Liquidator.  
 Kennedy, Smal & Middlemiss, 296-300 Little Lonsdale-street, Melbourne. 1967

Companies Act 1961.—Notice of Meeting—Creditors Voluntary Winding Up Pursuant to Section 260.—In the matter of JEDDA STYLES PTY. LTD., Sugden-place, Melbourne, Victoria.  
 NOTICE is hereby given that a Meeting of creditors of the above-named company will be held at Room 510, fifth floor, 342 Flinders-street, Melbourne, on Friday, 10th June, 1966, at 11 a.m., the company having convened a meeting of its members for the same day for the purpose of considering a Resolution that the company be wound up voluntarily.  
 Dated this 2nd day of June, 1966.  
 A. ROSENBERG, Director.  
 Bastian, Bent & Cogle, public accountants, Suite 18, 545 St. Kilda-road, Melbourne, S.C.3. 1938

In the Supreme Court.—1966 Coy. No. 7190.—In the matter of the Companies Act 1961 and in the matter of CROYDON DEVELOPMENTS PTY. LIMITED.  
 NOTICE is hereby given that a petition for the winding up of the above-named company by the Supreme Court was, on the 26th day of May, 1966, presented by Foodland Stores Proprietary Limited: And that the said petition is directed to be heard before the Court sitting at Melbourne, at the hour of 10.30 a.m., on the 24th day of June, 1966, and any creditor or contributory of the said company desiring to support or oppose the making of an order on the said petition may appear at the time of hearing by himself or his counsel for that purpose; and a copy of the petition will be furnished to any creditor or contributory of the said company requiring the same by the undersigned on payment of the regulated charge for the same.  
 The petitioner's address is Springvale-road, Glen Waverley.  
 The petitioner's solicitors are Messrs. Moule, Hamilton & Derham, of 224 Queen-street, Melbourne.  
 Moule, Hamilton & Derham, solicitors for the petitioner.  
 NOTE.—Any person who intends to appear on the hearing of the said petition must serve on or send by post to the above-named solicitors, notice in writing of his intention so to do. The notice must state the name and address of the person, or, if a firm, the name and address of the firm, and must be signed by the person or firm, or his or their solicitor (if any), and must be served, or, if posted, must be sent by post in sufficient time to reach the above-named not later than Four o'clock in the afternoon of the 23rd day of June, 1966. 1970

## The Companies Act 1961.

## S. S. HUMPHREYS PTY. LIMITED.

## NOTICE OF MEETING OF CREDITORS OR CONTRIBUTORS.

NOTICE is hereby given that a Meeting of the creditors of S. S. Humphreys Pty. Limited, will be held at the office of David Ting, solicitor, 224 Queen-street, Melbourne, on the 15th day of June, 1966, at 3 o'clock in the afternoon, for the purpose of considering the company's affairs, the company having convened an Extraordinary General Meeting of its members to be held on the 14th day of June, 1966, and for the purpose of considering and if thought fit passing a Special Resolution that the company would be wound up voluntarily.

Dated this 19th day of May, 1966.

1975 S. S. HUMPHREYS, Director/Secretary.

The Companies Act 1961.—In the matter of G. and J. MOTOR PANELS PROPRIETARY LIMITED, of Dandenong-road, Oakleigh.—Notice re Meeting of Creditors, Pursuant to Section 260.

NOTICE is hereby given that a meeting of creditors of the above-named company will be held at the Honorary Justices' Association, 34 Queen-street, Melbourne, on Friday, the 17th day of June, 1966, at 11.30 in the forenoon, the company having convened a meeting of its members for the same day for the purpose of considering a Resolution that the company be wound up voluntarily.

Dated this 6th day of June, 1966.

R. H. JOHNSTONE, Director.

C. P. Stephens, 20 Collins-street, Melbourne. 2006

The Companies Act 1961.—In the matter of KEN GRAY ADVERTISING PROPRIETARY LIMITED, of 12 Delos-street, Oakleigh.—Notice re Meeting of Creditors, Pursuant to Section 260.

NOTICE is hereby given that a meeting of creditors of the above-named company will be held at the Honorary Justices' Association, 34 Queen-street, Melbourne, on Friday, the 17th day of June, 1966, at 2 o'clock p.m. in the afternoon, the company having convened a meeting of its members for the same day for the purpose of considering a Resolution that the company be wound up voluntarily.

Dated this 6th day of June, 1966.

K. C. GRAY, Director.

C. P. Stephens, 20 Collins-street, Melbourne. 2007

## Companies Act 1961.

## J. &amp; D. GILCHRIST PTY. LIMITED.

AT an extraordinary general meeting of the members of J. & D. Gilchrist Pty. Ltd., duly convened and held at 346 Little Collins-street, Melbourne, on 1st June, 1966, the following Resolution was duly passed as a Special Resolution:—

"That the company be wound up voluntarily." and at a meeting of creditors held on the same day, pursuant to section 260, it was resolved that for such purpose, George Emery Thomas Christian, of 436 Toorak-road, Toorak, be appointed liquidator.

Dated this 3rd day of June, 1966.

2008 G. E. T. CHRISTIAN, Liquidator.

The Companies Act 1961.—In the matter of MAYWOOD-BELL PROPRIETARY LIMITED (in Liquidation).—Members Winding Up.

NOTICE is hereby given that at an Extraordinary General Meeting of members of the above company duly convened and held at 34 Queen-street, Melbourne, on the 2nd day of June, 1966, the following Resolution was proposed and passed as a Special Resolution:—

"Resolved by Special Resolution that the company be placed in liquidation as a Members Voluntary Winding Up pursuant to section 260 of the Companies Act 1961."

And the following Resolution was duly passed:—

"That Mr. Kenneth Albert Coleman, public accountant, of 409 St. Kilda-road, Melbourne, be and is hereby appointed liquidator of the company."

Dated the 7th day of June, 1966.

G. R. MOODY, Director.

Ken A. Coleman & Co., public accountants, 409 St. Kilda-road, Melbourne. 2010

## The Companies Act 1961.

EASYWEAR CONSOLIDATED PROPRIETARY LIMITED  
(IN VOLUNTARY LIQUIDATION).

NOTICE is hereby given that in pursuance of section 272 of the Companies Act 1961, a General Meeting of the above company will be held at the offices of Messrs. Morton, Watson & Young, Charter House, 4 Bank-place, Melbourne, on Monday, 11th July, 1966, at 12 o'clock noon, for the purpose of receiving the liquidator's final account of the winding up of the company.

Dated this 7th day of June, 1966.

2011 W. P. WATSON, Liquidator.

## The Companies Act 1961.

EASYWEAR HOLDINGS PROPRIETARY LIMITED  
(IN VOLUNTARY LIQUIDATION).

NOTICE is hereby given that in pursuance of section 272 of the Companies Act 1961, a General Meeting of the above company will be held at the offices of Messrs. Morton, Watson & Young, Charter House, 4 Bank-place, Melbourne, on Friday, 8th July, 1966, at 12 o'clock noon, for the purpose of receiving the liquidator's final account of the winding up of the company.

Dated this 7th day of June, 1966.

2012 W. P. WATSON, Liquidator.

## Companies Act 1961, Section 254 (2).

## WIMMERA MILK SUPPLY PROPRIETARY LIMITED.

## NOTICE OF RESOLUTION.

AT an Extraordinary Meeting of members of Wimmera Milk Supply Proprietary Limited, duly convened and held at 57 Wilson-street, Horsham, on the 31st day of May, 1966, the following Resolution was duly passed as a Special Resolution:—

"That the company be voluntarily wound up, and that Lawrence Allan Barber, of 57 Wilson-street, Horsham, be appointed liquidator."

Notice is also given that after 21 days from this date I shall proceed to distribute the assets. All creditors having any claims against the company should furnish particulars of same by that date otherwise I shall proceed to distribute the assets without regard to their claims.

Dated this 1st day of June, 1966.

L. A. BARBER, Liquidator, 57 Wilson-street, Horsham.

1931

## Companies Act 1938.

## MALEELA PROPRIETARY LIMITED.

AT an Extraordinary General Meeting of members of Maleela Proprietary Limited, duly convened and held at the company's property at Donnybrook-lane, Woodstock, on the 31st day of May, 1966, the following Special Resolution was passed:—

That the company be wound up voluntarily, and that William Anthony Tope, be appointed liquidator at no remuneration.

Dated this 1st day of June, 1966.

1924 W. A. TOPE, Liquidator.

The Companies Act 1961.—In the matter of MARIBYRNONG MIGRANTS CANTEN PTY. LTD.

NOTICE is hereby given that at an Extraordinary Meeting of the members of the above-named company, held on 31st day of May, 1966, it was resolved that the company be wound up voluntarily, and at a meeting of creditors, held on the same day, pursuant to section 260, and it was resolved that for such purpose, Everett Thomson Bent, of Suite 18, 545 St. Kilda-road, Melbourne, accountant, be appointed liquidator.

Notice is also given that after 21 days from this date I shall proceed to distribute the assets. All creditors having any claims against the company should furnish particulars of same by that date, otherwise I shall proceed to distribute the assets, without regard to their claim.

Dated this 31st day of May, 1966.

E. T. BENT, Liquidator.

Bastian, Bent & Cogle, public accountants, Suite 18, 545 St. Kilda-road, Melbourne, S.C.3. 1913

In the Supreme Court of Victoria (Coy. 7187).—In the matter of the *Companies Act 1961*; and in the matter of **ATLAS MEAT SUPPLY PROPRIETARY LIMITED**.—Advertisement of Petition.

**NOTICE** is hereby given that a petition for the winding up of the above-named company by the Supreme Court was on the 23rd day of May, 1966, presented to the said court by Spillane & Co. Pty. Ltd., a creditor of the said company. And that the said petition is directed to be heard before the court sitting at Melbourne, at the hour of 10.30 o'clock in the forenoon on the 30th day of June, 1966, and any creditor or contributory of the said company desirous to support or oppose the making of an Order on the said petition may appear at the time of hearing by himself or his counsel for that purpose; and a copy of the petition will be furnished to any creditor or contributory of the said company requiring the same by the undersigned on payment of the regulated charge for the same.

The petitioner's address is Metropolitan Meat Market, Courtney-street, North Melbourne.

The petitioner's solicitors are Messrs. H. L. Yuncken & Yuncken, of 443 Little Collins-street, Melbourne.

H. L. YUNCKEN & YUNCKEN.

**NOTE**.—Any person who intends to appear on the hearing of the said petition must serve on or send by post to the above-named solicitors, notice in writing of his intention to do so. The notice must state the name and address of the person, or if a firm, the name and address of the firm and must be signed by the person or firm or his or their solicitors (if any), and must be served, or if posted must be sent by post in sufficient time to reach the above named not later than Four o'clock in the afternoon of the 29th day of June, 1966, the day previous to the day appointed for the hearing of the petition. 2005

*Companies Act 1961*.—In the matter of **J. & R. L. DOYLE PTY. LTD.** (in Liquidation).

**NOTICE** is hereby given that a Third and Final Dividend is intended to be declared in this matter. Creditors who have not proved their debts by 29th June, 1966, will be excluded from the dividend.

Dated this 3rd day of June, 1966.

W. N. JOHANSON, Liquidator, National Bank Chambers, Pall Mall, Bendigo. 1998

**ALBERT EDWARD GREGORY**, late of Auckland, in the Provincial District of Auckland, in the Dominion of New Zealand, retired insurance agent, **DECEASED**.

**CREDITORS**, next of kin and others having claims in respect of the estate of the deceased (who died on the 8th of September, 1965), are required to send particulars of such claims to The Trustees, Executors and Agency Company Limited, of 401 Collins-street, Melbourne, on or before the 15th of August, 1966, after which date the company may convey or distribute the assets, having regard to the claims of which it then has notice.

**KIDDLE, BRIGGS & WILLOX**, solicitors, 400 Collins-street, Melbourne. 1971

**NORMAN JOSEPH JONES**, late of 23 Palmerston-place, Carlton, in the State of Victoria, retired storeman, **DECEASED**, intestate.

**CREDITORS**, next of kin and others having claims in respect of the estate of the above-mentioned deceased (who died on 3rd December, 1965), are required by the administratrix, Laura Myrtle Margaret Kelly, of 32 Lincoln-street, Richmond, packer, to send particulars to her, care of the under-mentioned solicitors, by the 19th day of August, 1966, after which date the administratrix may convey or distribute the assets, having regard only to the claims of which she then has notice.

**UPTON & ETTELSON**, solicitors, 100 Queen-street, Melbourne. 1983

Estate of **DOROTHY MAUD RINTOULL**, late of 2 Meadow-lane, Yalloom, in the State of Victoria, widow, **DECEASED**.

**CREDITORS**, next of kin and others having claims in respect of the estate of the deceased (who died on the 31st day of March, 1966), are required by the trustee, Alan Jack Francis, to send particulars to him, care of Ambrose, Riches & Co., solicitors, of Morwell, by the 15th day of August, 1966, after which date the trustee may distribute the assets of the estate, having regard only to the claims of which he then has notice.

**AMBROSE, RICHES & CO.**, solicitors, Commonwealth Bank Chambers, Morwell. 1984

**CREDITORS**, next of kin and others having claims in respect of the estate of Henry Angus Wilson, late of 6 First-avenue, Brunswick, retired head master (who died on the 21st day of April, 1966), are to send particulars of their claims to The Trustees, Executors and Agency Company Limited, of 401 Collins-street, Melbourne, by the 10th day of August, 1966, after which date it will distribute the assets, having regard only to the claims of which it then has notice.

**RUSSELL, KENNEDY & COOK**, solicitors, 401 Collins-street, Melbourne. 1986

**CLARA MARIA BROWN**, formerly of 21 Madden-grove, Kew, but late of 5 Horsley-street, Bentleigh, widow, **DECEASED**.

**CREDITORS**, next of kin and others having claims in respect of the estate of the above-named deceased (who died on the 2nd day of March, 1966), are required by the executor, The Equity Trustees, Executors and Agency Company Limited, of 472 Bourke-street, Melbourne, to send particulars to the above-named company by the 9th day of August, 1966, after which date the executor may convey or distribute the assets, having regard only to the claims of which the said company then has notice.

Dated the 6th day of June, 1966.

**OSWALD BURT & CO.**, solicitors, 178 William-street, Melbourne. 1987

**GEORGE BERTIE PICKERING**, late of 740 High-street, Reservoir, milk bar proprietor, **DECEASED**.

**CREDITORS**, next of kin and others having claims in respect of the estate of the above-named deceased (who died on the 8th day of November, 1965), are required by The Perpetual Executors and Trustees Association of Australia Limited, of 100-104 Queen-street, Melbourne, to send particulars of their claims to the said company by the 8th day of August, 1966, after which date it will convey or distribute the assets, having had regard only to the claims of which the company then has notice.

**NORRIS, COATES & HEARLE**, solicitors, of 422 Collins-street, Melbourne. 1988

**IDA FARMER**, late of 4 Bellaire-court, Toorak, spinster, **DECEASED**.

**CREDITORS**, next of kin and others having claims in respect of the estate of the above-named deceased (who died on the 8th day of March, 1966), are required by the executors, Hilda Hope, of 4 Bellaire-court, Toorak, widow, and National Trustees, Executors and Agency Company of Australasia Limited, of 95 Queen-street, Melbourne, to send particulars to the above-named company by the 8th day of August, 1966, after which date the executors may convey or distribute the assets, having regard only to the claims of which the said company then has notice.

Dated the 6th day of June, 1966.

**OSWALD BURT & CO.**, solicitors, 178 William-street, Melbourne. 1990

**GEORGE EWART STRINGER**, late of Yarra-street, Warrandyte, retired builder, **DECEASED**.

**CREDITORS**, next of kin and others having claims in respect of the estate of the deceased (who died on the 10th August, 1964), are required by Jack Graham Pendrell Stringer, of Research-road North Warrandyte, builder, the administrator to whom letters of administration with the will annexed, were granted on the 19th April, 1966, to send particulars to him in care of the under-mentioned solicitor by the 9th day of August, 1966, after which date the administrator may convey or distribute the assets, having regard only to the claims of which he then has notice.

**DUDLEY A. TREGENT, B.A., LL.M.**, solicitor, of 422 Collins-street, Melbourne, C.I. 1991

**NORAH ILEEN FISHER**, sometimes known as **NOREEN FISHER**, late of 220 Tooronga-road, East Hawthorn, widow, **DECEASED**.

**CREDITORS**, next of kin and others having claims in respect of the estate of the deceased (who died on the 13th day of December, 1965), are required by The Perpetual Executors and Trustees Association of Australia Limited, of 100-104 Queen-street, Melbourne, to send particulars of their claims to the said company by the 10th day of August, 1966, after which date it will convey or distribute the assets, having had regard only to the claims of which the company then has notice.

**W. H. FLOOD & PERMEZEL**, solicitors, 388 Bourke-street, Melbourne. 1992

**CREDITORS**, next of kin and others having claims in respect of the estate of Mary Ann Bray Morley, late of 34 Deepdene-road, Balwyn, in the State of Victoria, widow, deceased (who died on 24th day of September, 1965), are to send the particulars of their claims to The Equity Trustees, Executors and Agency Company, of 472 Bourke-street, Melbourne, by the 9th day of August, 1966, after which date it will distribute the assets, having regard only to the claims of which it then has notice. 1989

**CREDITORS**, next of kin and others having claims in respect of the estate of Leonard James Garland, late of Cobbannah, retired, deceased, intestate (who died on the 7th day of November, 1965), should send the particulars of their claims to the Union Fidelity Trustee Company of Australia Limited, of 100 Exhibition-street, Melbourne, by the 15th day of August, 1966, after which date it will distribute the assets, having regard only to the claims of which it has notice.

J. I. LANFRANCHI, solicitor, Bairnsdale. 1930

ERNEST ALFRED SMITH, late of 7 Summer-street, East Geelong, labourer, DECEASED, intestate.

**CREDITORS**, next of kin and others having claims in respect of the estate of the said deceased (who died 6th February, 1966, are required by the applicant for grant of letters of administration of the estate of Adeline May Smith, of 7 Summer-street, East Geelong, widow), to send particulars to her, care of the undersigned solicitors, by 10th August, 1966, after which date the said applicant may convey or distribute the assets, having regard only to the claims of which she then has notice.

WIGHTON & McDONALD, solicitors, 189-191 Moorabool-street, Geelong. 1940

**CREDITORS**, next of kin and others having claims in respect of the estate of Ronald Arthur Lloyd Murdoch, late of Lismore, in the State of Victoria, contractor, formerly farmer, deceased (who died on 10th January, 1966), are required to send particulars of their claims to The Union-Fidelity Trustee Company of Australia Limited, of 100 Exhibition-street, Melbourne, by the 10th August, 1966, after which date it will distribute the assets, having regard only to the claims of which it then has notice.

SEWELL & SEWELL, solicitors, Colac. 1951

**CREDITORS**, next of kin and others having claims in respect of the estate of James Kincaid Russell, late of "Barunah Plains," Hesse in the State of Victoria, pastoralist, deceased (who died on the 25th day of October, 1965), are required by the executors, Ronald James Kincaid Russell of "Kildean", Winchelsea, in Victoria, and David Kincaid Russell, of "Bochara Park", Hamilton, in Victoria graziers, and Leslie John Parker, of 17 Stephen-street, Newtown, Geelong, in Victoria, retired woolbroker, to send particulars of their claims to them, care of the under-mentioned solicitors by the 9th day of August, 1966, after which date they may convey or distribute the assets, having regard only to the claims of which they then have notice.

AITKEN, WALKER & STRACHAN, solicitors, 414 Collins-street, Melbourne, C.1. 1953

**CREDITORS**, next of kin and others having claims in respect of the estate of Jessie May Barber, late of 12 Ireland-street, Burwood, gentlewoman, deceased (who died on the 3rd day of October, 1965), are to send particulars of their claims to The Trustees, Executors and Agency Company Limited, at 401 Collins-street, Melbourne, by the 12th day of August, 1966, after which date the executors will distribute the assets, having regard only to the claims of which they then have notice.

J. M. SMITH & EMMERTON, solicitors, of 170 Queen-street, Melbourne. 1954

HAROLD HAMILTON DAYMOND, late of 178 Camberwell-road Camberwell, retired, DECEASED.

**CREDITORS**, next of kin and others having claims in respect of the estate of the deceased (who died on the 1st day of May, 1966), are required by The Perpetual Executors and Trustees Association of Australia Limited, of 100-104 Queen-street, Melbourne, to send particulars of their claims to the said company by the 10th day of August, 1966, after which date it will convey or distribute the assets, having had regard only to the claims of which the company then has notice.

W. A. PRENDERGAST & ROBINSON, solicitors, 406 Lonsdale-street, Melbourne. 1965

**CREDITORS**, next of kin and others having claims in respect of the estate of James Thomas Anderson, late of 21 Langdon-road, Caulfield, in the State of Victoria, gentleman, deceased (who died on the 24th day of September, 1965, and probate of whose will thereto was granted to Ethel Maud Bach, of 125 Lincoln-road, Essendon, in the said State, married woman, and The Union-Fidelity Trustee Company of Australia Limited, of 100 Exhibition-street, Melbourne, in the said State (formerly The Union Trustee Company of Australia Limited, of 333 Collins-street, Melbourne), in the said State, on the 19th day of May, 1966), are hereby requested to send particulars of such claims to the said company at its address as above on or before the 9th day of August, 1966, after which date the said Ethel Maud Bach, and the said company will proceed to distribute the assets of the said deceased amongst the persons entitled thereto, having regard only to the claims of which they shall then have had notice.

Dated the 7th day of June, 1966.

D. BRUCE TUNNOCK, CLARKE & CASEY, solicitors, of 452 Lonsdale-street, Melbourne. 1958

**CREDITORS**, next of kin and others having claims in respect of the estate of Arthur Ernest Sydney Smith, late of 300 Riversdale-road, Hawthorn, in the State of Victoria, retired cutter, deceased (who died on the 6th day of March, 1966), are to send particulars of their claims to Frederick Thomas Allen the personal representative, care of the under-mentioned solicitor, by the 16th day of August, 1966, after which day he will distribute the assets, having regard only to the claims of which he then has notice.

LACHLAN K. GARDINER, solicitor, 275 Bridge-road, Richmond. 1959

**CREDITORS**, next of kin and others having claims in respect of the estate of John Robert Manderson, late of 13 Welwyn-avenue, East Brighton, in the State of Victoria, manager, deceased, intestate (who died on 3rd August, 1961), are requested to send particulars of their claims to Winifred Hope Manderson, administratrix of the estate, care of the undersigned solicitors, by the 17th day of August, 1966, after which date the administratrix will distribute the assets, having regard only to the claims of which she then has notice.

SEWELL & SEWELL, solicitors, 422 Collins-street, Melbourne. 1960

**CREDITORS**, next of kin and others having claims in respect of the estate of Annie May Burton, late of 19 Beavers-road, Northcote, spinster, deceased (who died on the 8th day of January, 1966), are to send the particulars of their claims to The Perpetual Executors and Trustees Association of Australia Limited, of 100-104 Queen-street, Melbourne, by the 23rd day of August, 1966, after which date it will distribute the assets, having regard only to the claims of which it then has notice.

HENDERSON & BALL, solicitors, 430 Little Collins-street, Melbourne. 1964

**CREDITORS**, next of kin and others having claims against the estate of Bennie Simons, late of 345 North-road, Caulfield, in the State of Victoria, retired gentleman, deceased (who died on the 15th day of September, 1965), are required to send particulars of their claims to the executors of his will, Rachael Simons and Jewel Okno, care of the under-mentioned solicitors, before the 10th day of August, 1966, after which date the said executors will distribute the estate of the said deceased, having regard only to the claims of which they will have then had notice.

J. OKNO, PAPAS & CO., solicitors, of 390 Lonsdale-street, Melbourne. 1962

**CREDITORS**, next of kin and all other persons having claims against the under-mentioned person are required to send particulars thereto to Mary Noreen Pollard, care of R. P. Barrett & Son, solicitors, 473 Bourke-street, Melbourne, on or before the 8th day of August, 1966, otherwise they may be excluded when the assets are being distributed.

Name: Aileen Frances McGee, late of 497 Inkerman-road, East St. Kilda, spinster.

Date of death: 17th day of April, 1966.

R. P. BARRETT & SON, solicitors, 473 Bourke-street, Melbourne. 1957



JAMES CHARLES COLLINS, formerly of 274, but late of 472 Campbell-street, Swan Hill, in the State of Victoria, retired farmer, DECEASED (who died on the 24th day of August, 1965).

CREDITORS, next of kin and all other persons having claims against the estate of the deceased are required by the executors of the will, George Lawrence Collins and George Francis Lay, to send particulars to them, care of the undersigned, on or before the 3rd day of September, 1966, after which date they will distribute the assets, having regard only to the claims of which they then have notice.

GARDEN & GREEN, solicitors, 4 McCallum-street, Swan Hill. 1947

IDA MARY PASCOE, late of 42 Draper-street, Ormond, widow, DECEASED (who died on the 10th April, 1966).

CREDITORS, next of kin and all other persons having claims against the estate of the deceased are required by the executor of her will, Bruce Herbert Pascoe, of 349 High Street-road, Mount Waverley, accountant, to send particulars thereof to him, care of the under-mentioned solicitors, before 10th August, 1966, after which date he may distribute the assets of the deceased, having regard only to the claims of which he then has notice.

COLTMAN, WYATT & ANDERSON, solicitors, of 578 Bourke-street, Melbourne. 1961

JOHN ORLANDO KIELY, late of 18 Rodda-street, Coburg, council employee, DECEASED, intestate (who died on the 18th February, 1966).

CREDITORS, next of kin and all other persons having claims against the estate of the deceased are required by the administrator, Ronald Kiely, to send particulars of their claims to the administrator care of the undersigned solicitors, on or before the 10th day of August, 1966, after which date he will distribute the assets, having regard only to the claims of which he then has notice.

HOME, WILKINSON & LOWRY, solicitors, 401 Collins-street, Melbourne. 1993

*Trustee Act 1958.*

NOTICE TO CLAIMANTS.

PURSUANT to the *Trustee Act 1958*, creditors, next of kin and all other persons having claims in respect of the estate of any deceased person named below are required to send particulars to the legal personal representative or representatives at the addresses stated, after which date the representative or representatives will distribute the assets, having regard only to the claims of which notice has been received:—

William Cornelius Kinsella, late of 68 Ardmillan-road, Moonee Ponds, Victoria, clerk, deceased, who died on the 26th May, 1965.—Claims to T. A. Kennedy, of 509 Collins-street, Melbourne, Victoria, solicitor for the estate of the said deceased, by the 10th August, 1966. T. A. Kennedy, LL.B., solicitor, 509 Collins-street, Melbourne. 1955

Olive Clark, late of 58 Blandford-street, West Footscray, married woman, deceased (died on the 16th day of October, 1951). Claims to the executor, Arthur Clark, of 58 Blandford-street, West Footscray, retired engineer, care of John F. Carroll, of 4 Paisley-street, Footscray, solicitor, by the 10th day of August, 1966. John F. Carroll, LL.B., solicitor, 4 Paisley-street, Footscray. 2017

CREDITORS, next of kin and others having claims against the estate of Audrey Mary Robertson, late of 20 Lansell-crescent, Camberwell, secretary, deceased, are required to send particulars of their claims to the executor, Norman James Perkins, of care of the under-mentioned solicitors, on or before the 31st day of August, 1966, after which date the said executor will distribute the assets of the estate, having regard only to the claims of which he then shall have notice.

SACKVILLE, WILKS & CO., solicitors, 100 Collins-street, Melbourne. 2004

CREDITORS, next of kin and others having claims in respect of the estate of Janet White Curnow, late of 14 Beaumont-avenue, Canterbury, retired teacher, deceased (who died on the 2nd day of October, 1965), are required by the executrix, Amy Beatrice Woolhouse, of 19 Heatherbrae-avenue, Ringwood, widow, to send particulars of their claims to her by the 8th day of August, 1966, after which date the said executrix will distribute the assets of the deceased, having regard only to the claims to which she then shall have notice. 2003

CREDITORS, next of kin and others having claims in respect of the estate of Hannah Ada Smith, late of 11 Kendari-avenue, North Balwyn, spinster (who died on the 13th April, 1965), are requested to send particulars of their claims to the executrix, Effie Kirsteen Sinclair, care of the under-mentioned solicitors, on or before the 10th day of August, 1966, after which date she will distribute the assets, having regard only to the claims of which she then has notice.

McKEAN, PARK & COOPER, solicitors, 84 William-street, Melbourne. 2009

CARMELO CUTAJAR (also known as Charles Cutajar), late of 17 Cecil-street, Fitzroy, fumigator, DECEASED.

CREDITORS, next of kin and others having claims in respect of the estate of the deceased (who died on 27th December, 1964), are required by the administrator, Emanuel Carbone, of 760 Brunswick-street, Fitzroy, assistant fitter, to send particulars to him, care of the undermentioned solicitor, by the 9th day of August, 1966, after which date the administrator may convey or distribute the assets, having regard only to the claims of which he then has notice.

F. J. CORDER, solicitor, 470 Bourke-street, Melbourne. 2013

MICHAEL JAMES JOSEPH O'CONNELL, late of 15 Westbury-grove, East St. Kilda, retired public servant, DECEASED.

CREDITORS, next of kin and others having claims in respect of the estate of the deceased (who died on 10th April, 1966), are required by the executrix, Elizabeth Ann Corder, of 470 Bourke-street, Melbourne, solicitor, to send particulars to her, care of the under-mentioned solicitor, by the 9th day of August, 1966, after which date the executrix may convey or distribute the assets, having regard only to the claims of which she then has notice.

F. J. CORDER, solicitor, 470 Bourke-street, Melbourne. 2014

CREDITORS, next of kin and others having claims in respect of the estate of Thomas Henry Anthony Alexander (usually known as Thomas Henry Alexander), late of 196 Danks-street, Albert Park, gentleman, deceased (who died on the 22nd June, 1965), are to send particulars of their claims to The Trustees, Executors and Agency Company Limited, at 401 Collins-street, Melbourne, by the 11th August, 1966, after which date it will distribute the assets, having regard only to the claims of which it then has notice.

LEACH & THOMPSON, solicitors, 472 Bourke-street, Melbourne. 2015

CREDITORS, next of kin and others having claims in respect of the estate of Graeme David Luke, late of Glen Alvie, farm hand, deceased, intestate (who died on the 25th day of December, 1965), are to send particulars of their claims to David Luke, care of the undersigned, by the 3rd day of August, 1966, after which date he will distribute the assets, having regard only to the claims of which he then has notice.

BIRCH, ROSS & BARLOW, solicitors, Korumburra. 2016

CHARLES GILBERT, formerly of 727 Drummond-street, Carlton, but late of 7 Mair-street, Brighton, in the State of Victoria, pensioner, DECEASED.

CREDITORS, next of kin and others having claims in respect of the estate of the above-named deceased (who died on the 29th September, 1963), are to send particulars of their claims to the executors for the estate, Joseph Shatin and Stella Rothschild Shatin, both of 224 Queen-street, Melbourne, solicitors, by the 9th day of August, 1966, after which date the executors will distribute the assets, having regard only to the claims of which they then have notice. 1912

CREDITORS, next of kin and others having claims against the estate of Winifred Maud Lenna Weir (also known as Winnifred Lenna Maud Weir), formerly of "Glengarry", Central Springs-road, Daylesford, but late of "Alexander", Castlemaine, widow, deceased (who died on the 29th day of March, 1966), are to send particulars of their claims to The Union-Fidelity Trustee Company of Australia Limited, of 101 Lydiard-street north, Ballarat, by the 10th day of August, 1966, after which date the company will distribute the assets, having regard only to the claims of which it then has notice. 1915

**CREDITORS**, next of kin and others having claims against the estate of Thomas Daniel Shelton (also known as Thomas Shelton), late of Cochill's Creek, pensioner, deceased (who died on the 11th day of March, 1966), are to send particulars of their claims to The Union-Fidelity Trustee Company of Australia Limited, of 101 Lydiard-street north, Ballarat, by the 10th day of August, 1966, after which date the company will distribute the assets, having regard only to the claims of which it then has notice. 1916

In the Supreme Court of the State of Victoria.

**SALE BY THE SHERIFF.**

**ON** Friday, the 15th of July, 1966, at 10 a.m., at the Police Station, Sunshine (unless process be stayed or satisfied):—

All the estate and interest (if any) of Holdfast Holdings Limited, a company whose registered office is at 135 Rundle-street, Adelaide, as proprietor of an estate in fee-simple in the land described in certificate of title, volume 8064, folio 061, the land which is vacant is situated on the west side of Knight-avenue, Sunshine, approximately 405 feet north of Baldwin-avenue, Sunshine, and is known as lot 144 Knight-avenue, Sunshine.

Terms: Cash only.

DAVID J. JOHNSTON, Sherriff's Officer.

3rd June, 1966. 1949

In the Supreme Court of the State of Victoria.

**SALE BY THE SHERIFF.**

**ON** Monday, the 18th of July, 1966, at 10 a.m., at the Police Station, Lilydale (unless process be stayed or satisfied):—

All the estate and interest (if any) of C. Rouvalis, poultry farmer, of "Benerembah", Gruyere-road, Gruyere, as proprietor of an estate in fee-simple in the land described in certificate of title, volume 7783, folio 048 and volume 8544, folio 065, the property which is known as "Benerembah", Gruyere-road, Gruyere, consists of approximately 137 acres 12 perches and erected thereon is a dwelling house, cow bails, and other outbuildings.

Registered mortgages Nos. C.96384 and C.289891 affect the said estate and interest.

Terms: Cash only.

N. FROGLEY, Sheriff's Officer.

3rd June, 1966. 1950

In the Supreme Court of the State of Victoria.

**SALE BY THE SHERIFF.**

**ON** Wednesday, the 20th of July, 1966, at 10 a.m., at the Police Station, Yarraville (unless process be stayed or satisfied):—

All the estate and interest (if any) of Donald Alfred Arthur McDonald and Shirley June McDonald, engine driver and married woman respectively, both of 4 Marjory-street, Yarraville, as joint proprietors of an estate in fee-simple in the land described in certificate of title, volume 6402, folio 254, upon which is erected a dwelling house known as No. 4 Marjory-street, Yarraville.

Registered mortgages Nos. 1106417 and A.330635 affect the said estate and interest.

Terms: Cash only.

N. FROGLEY, Sheriff's Officer.

6th June, 1966. 1936

**IMPOUNDINGS**

**OXLEY**.—Impounded in Oxley Pound, from Bobinawah.

1 crossbred ewe lamb, V notch in right ear, no visible brand

If not claimed and expenses paid, to be sold on 20th June, 1966.

M. PERKINS,

1934—\$1.20 Poundkeeper.

**PAKENHAM**.—Impounded in Pakenham Pound.

1 roan cow, no visible brand

1 black and white poll steer, about two and a half years, no visible brand

1 black steer, white face, about eleven months, no visible brand

1 brown steer, about eleven months, no visible brand

If not claimed and expenses paid, to be sold on 22nd June, 1966.

H. SMITH,  
Poundkeeper.

2020—\$2.20

**SWAN HILL**.—Impounded in Swan Hill Shire Pound, at 1.30 p.m., on Wednesday, 25th May, 1966, from the Swan Hill Municipal Sale-yards.

1 red and white Hereford steer, no visible brand

If not claimed and expenses paid, to be sold on 20th June, 1966.

A. DUNSTONE,  
Poundkeeper.

1921—\$1.60

**UPWEY**.—Impounded in Upwey Pound, on 2nd June, 1966, from Mary-street, Emerald.

1 red Shorthorn cow, no visible brand

1 red Shorthorn calf, no visible brand

If not claimed and expenses paid, to be sold on 22nd June, 1966.

K. McMAHON,  
Poundkeeper.

2019—\$1.60

**WARRNAMBOOL**.—Impounded in Warrnambool Pound, on 1st June, 1966.

1 Jersey cow, two notches both ears, no visible brand

If not claimed and expenses paid, to be sold on 22nd June, 1966.

M. STONEHOUSE,  
Poundkeeper.

1939—\$1.40

**WHITTLESEA**.—Impounded in Epping Pound by Ranger.

1 light-brown Jersey heifer, no visible brand

2 black and white Friesian heifers, no visible brand

1 white heifer, no visible brand

2 black and white female goats, no visible brand

1 brown and white female goat, no visible brand

If not claimed and expenses paid, to be sold on 24th June, 1966.

W. HERD,  
Poundkeeper.

1999—\$2.00

**YARRA JUNCTION**.—Impounded in Yarra Junction Pound.

1 black and white bull, no visible brand

If not claimed and expenses paid, to be sold on 25th June, 1966.

M. BERUDE,  
Poundkeeper.

1922—\$1.40

*Subordinate Legislation Act 1962.*

**NOTICE OF MAKING OF STATUTORY RULES**

**I**N pursuance of the provisions of the *Subordinate Legislation Act 1962* and the Regulations made thereunder, notice is given of the making of the following statutory rules:—

No.	Motor Boating Act 1961, Section 15	Price.
152/1966.	Motor Boating (River Loddon) Authority Regulations 1966 .. ..	8c
	<i>Poisons Act 1962 (No. 6889).</i>	
153/1966.	Drugs of Addiction and Restricted Substances Regulations 1966 .. ..	28c
	<i>Police Regulation Act 1958.</i>	
154/1966.	Police (Amendment) Regulations 1966 .. ..	5c
	<i>Town and Country Planning Act 1961.</i>	
155/1966.	Town and Country Planning Board (Staff) Regulations 1964, Amendment No. 12 .. ..	5c
	<i>Local Government Act 1958.</i>	
156/1966.	Municipal Auditors Board Regulations 1966 .. ..	8c

No.	Price.	ACTS REPRINTED IN ACCORDANCE WITH THE AMENDMENTS INCORPORATION ACT 1958 (No. 6422)—continued.	No.	Price.
		<i>Education Act 1958.</i>		
157/1966. Education Department Regulations 1962 (Amendment No. 10)	10c		6250. Fertilizers Act 1958 (Incorporating Amendments up to No. 7142)	\$0.18
		<i>Local Government Act 1958.</i>	6916. Foreign Judgments Act 1962 (Reprint No. 1, including amendments made by Act No. 7332)	\$0.12
158/1966. Municipal Engineers Board Amending Regulations No. 1	5c		6251. Firearms (Incorporating amendments up to No. 6716)	\$0.22
		<i>Health Act 1958.</i>	6585. Forests (Pulpwood Agreement) (Incorporating amendments up to No. 6886)	\$0.15
159/1966. Infectious Diseases (Amendment) Regulations 1966	5c		6259. Gaols (Incorporating amendments up to No. 6651)	\$0.15
		<i>Agricultural Colleges Act 1958 (No. 6194).</i>	6265. Goods (Third Reprint—Incorporating amendments up to No. 7131)	\$0.28
160/1966. Agricultural Colleges (Amendment) Regulations 1966	5c		6270. Health (Incorporating amendments up to No. 6886)	\$1.45
		<i>Agricultural Colleges Act 1958 (No. 6194).</i>	6274. Hospitals and Charities (Incorporating amendments up to No. 6716)	\$0.35
161/1966. Agricultural Colleges (Cadets in Training) (Amendment) Regulations 1966	5c		6279. Instruments (Second Reprint—Incorporating amendments up to No. 6886)	\$0.38
		<i>Mental Health Act 1959 (No. 6605).</i>	6282. Justices (Incorporating amendments up to No. 6961)	\$1.12
162/1966. Mental Health (Salary Revision) Regulations 1966	5c		6283. Labour and Industry (Second Reprint—Incorporating amendments up to No. 7143)	\$0.75

Copies of these statutory rules may be purchased at the Sale of Publications Section of the Government Printing Office, located off Parliament-place, Melbourne, C.2. If ordered by mail, remittance should be addressed to "The Government Printer, Box 203, P.O., North Melbourne, N.1", and should include 5c extra for postage. If a credit account is held at this Office, no remittance is required with the mail order.

A. C. BROOKS,  
Government Printer.

ACTS REPRINTED IN ACCORDANCE WITH THE AMENDMENTS INCORPORATION ACT 1958 (No. 6422), AND FOR SALE AT THE SALE OF PUBLICATIONS BRANCH OF THE GOVERNMENT PRINTING OFFICE, MACARTHUR-STREET, MELBOURNE.

No.	Price.	No.	Price.
6189. Acts Interpretation (Incorporating amendments up to No. 7146)	\$0.15	6310. Melbourne and Metropolitan Board of Works Act 1958 (Incorporating amendments up to No. 7054)	\$0.85
6191. Administration and Probate (Second Reprint—Incorporating amendments up to No. 6920)	\$0.35	6312. Melbourne Harbor Trust Act 1958 (Reprint No. 1, incorporating amendments up to Act No. 7356)	\$0.48
6194. Agricultural Colleges Act (Reprint (No. 1)—Incorporating Amendments up to Act No. 7302)	\$0.12	6605. Mental Health (Incorporating amendments up to No. 7135)	\$0.45
6199. Apprenticeship (Reprint No. 1, incorporating amendments up to No. 7312)	\$0.25	6315. Metropolitan Fire Brigades (Incorporating amendments up to No. 6886)	\$0.28
6209. Boiler Inspection (Incorporating amendments up to No. 7072)	\$0.18	6317. Milk and Dairy Supervision (Incorporating amendments up to No. 6964)	\$0.40
6210. Building Societies Act 1958 (Incorporating Amendments up to No. 7125)	\$0.25	6318. Milk Board Act (Incorporating amendments up to No. 7093)	\$0.22
6218. Children's Court (Incorporating amendments up to No. 7084)	\$0.20	6324. Money Lenders (Incorporating amendments up to No. 6886)	\$0.25
6219. Children's Welfare (Incorporating amendments up to No. 6812)	\$0.25	6832. Motor Boating (Incorporating amendments up to No. 6961)	\$0.15
6220. Clean Air (Incorporating amendments up to No. 6886)	\$0.10	6325. Motor Car (Incorporating amendments up to No. 6867)	\$0.65
6222. Commercial Goods Vehicles (Incorporating amendments up to No. 6886)	\$0.18	6326. National Parks Act 1958 (Incorporating Amendments up to No. 7275)	\$0.15
6839. Companies (Incorporating amendments up to No. 7142)	\$2.25	6328. Nurses (Incorporating amendments up to No. 6716)	\$0.20
6839. Companies Act 1961 (Second Reprint—Incorporating amendments up to No. 7332)	\$2.32	6330. Partnership	\$0.15
6225. Co-operation (Second Reprint—Incorporating amendments up to No. 7083)	\$0.42	6889. Poisons (Incorporating amendments up to No. 7065)	\$0.35
6226. Co-operative Housing Societies (Incorporating amendments up to No. 7097)	\$0.40	6337. Police Offences (Incorporating amendments up to No. 7145)	\$0.82
6228. Country Fire Authority (Incorporating amendments up to No. 7065)	\$0.40	6338. Police Regulation (Incorporating amendments up to No. 7081)	\$0.45
6229. Country Roads (Incorporating amendments up to No. 6943)	\$0.40	6890. Probate Duty (Incorporating amendments up to No. 6970)	\$0.38
6231. Crimes (Incorporating amendments up to No. 6958)	\$1.32	6343. Process Servers and Inquiry Agents (Incorporating amendments up to No. 7126)	\$0.12
6236. Dog (Second Reprint—Incorporating amendments up to No. 7065)	\$0.15	6344. Property Law (Incorporating amendments up to No. 6867)	\$0.90
6242. Employers and Employés (Incorporating amendments up to No. 6740)	\$0.18	6349. Public Service (Incorporating amendments up to No. 6886)	\$0.28
6245. Estate Agents (Second Reprint)—Incorporating amendments up to No. 7134	\$0.38	6350. Public Trustee (Incorporating amendments up to No. 6961)	\$0.35
6246. Evidence (Incorporating amendments up to No. 6758)	\$0.35	6359. Road Traffic (Incorporating amendments up to No. 6999)	\$0.15
6249. Fences (Incorporating amendments up to No. 6550)	\$0.12	6359. Road Traffic (Second Reprint—Incorporating amendments up to No. 7332)	\$0.18
		6360. Rural Finance Act (Reprint (No. 1)—Incorporating Amendments up to Act No. 7328)	\$0.12

ACTS REPRINTED IN ACCORDANCE WITH THE AMENDMENTS  
INCORPORATION ACT 1958 (No. 6422)—*continued*.

No.	Price.
6846. Rural Finance and Settlement Commission Act 1961 (Reprint No. 1, incorporating amendments up to No. 7332) ..	\$0.20
6975. Sale of Land Act 1962 (Reprint No. 1, incorporating amendments up to No. 7332) ..	\$0.18
6363. Second-Hand Dealers ..	\$0.12
6367. Settled Land (Incorporating amendments up to No. 6505) ..	\$0.40
6368. Sewerage Districts Act (Reprint (No. 1) —Incorporating Amendments up to Act No. 7332) ..	\$0.62
6651. Social Welfare (Second Reprint—Incorporating amendments up to No. 7084) ..	\$0.35
6372. Soil Conservation and Land Utilization Act 1958 (Incorporating amendments up to No. 6961) ..	\$0.20
6375. Stamps (Second Reprint—Incorporating amendments up to No. 7142) ..	\$0.70
6375. Stamps (Third Reprint—Incorporating amendments up to No. 7359) ..	\$0.82
6377. State Electricity Commission (Incorporating amendments up to No. 7054) ..	\$0.50
6379. State Savings Bank (Incorporating amendments up to No. 6886) ..	\$0.42
6886. Subordinate Legislation (Incorporating amendments up to No. 6961) ..	\$0.15
6849. Town and Country Planning Act (Reprint (No. 1)—Incorporating Amendments up to Act No. 7276) ..	\$0.35
6399. Transfer of Land (Second Reprint—Incorporating amendments up to No. 7130) ..	\$0.52
6401. Trustee (Second Reprint—Incorporating amendments up to No. 6963) ..	\$0.42
6879. Unclaimed Moneys (Incorporating amendments up to No. 6961) ..	\$0.12
6653. Valuation of Land (Incorporating amendments up to No. 7019) ..	\$0.15
6413. Water (Incorporating amendments up to No. 7228) ..	\$1.42
6414. Weights and Measures (Including amendments up to No. 6918) ..	\$0.32
6419. Workers Compensation (Incorporating amendments up to No. 7063) ..	\$0.50

A. C. BROOKS,  
Government Printer.

PUBLICATION OF OFFICIAL MATTER.

ATTENTION is invited to the following procedure in relation to the publication of official matter in the *Government Gazette*:—

1. *Matter submitted to the Executive Council.*

Matters submitted to the Executive Council which requires gazettal will normally be published in the issue of the following week.

Where urgent gazettal is required, special arrangements should be made with the *Gazette Officer*, Room 9, first floor, Old Treasury Building.

Publication will be facilitated by the submission of carbon copies for the use of the *Gazette Officer*.

2. *Other matter.*

(a) All other matter duly certified by a responsible officer for publication should be lodged with the *Gazette Officer* not later than half-past Ten a.m. on Tuesday.

(b) Lengthy or involved notices should be forwarded several days before publication.

(c) Proofs, which will be supplied only when specifically requested or, at the direction of the *Gazette Officer*, should be returned promptly to avoid delay in publication.

(d) No additions or amendments to matter for publication will be accepted by telephone.

THE "VICTORIA GOVERNMENT GAZETTE".

SUBSCRIPTIONS.—The subscription, including postage, is \$5.50 per annum, or \$2.75 per half year, payable in advance.

Subscriptions are required for whole months, and must cover at least a half year.

Single copies are 10 cents, posted 15 cents. Subscribers do not receive the Acts of Parliament with the GAZETTE.

GAZETTES are held in stock for five years only.

PRIVATE ADVERTISEMENTS.—The charge for insertion is 20 cents per line single column, and 40 cents per line double column. The title forms one or more lines as a heading. On an average ten words make a line of single column. Every signature must likewise be counted as a line. The final words of a paragraph, though only portion of a line, must be counted as one line. Signatures (in particular) and proper names must be written very plainly in the text; ONE SIDE ONLY of each sheet of paper should be WRITTEN UPON.

All documents illegibly written will be returned unpublished, and where brands occur unprovided for by the ordinary letters of the alphabet, a worded explanatory description must be furnished.

THE VICTORIA GOVERNMENT GAZETTE is published on WEDNESDAY EVENING in each week, and Notices for insertion will be received by the Government Printer at or before ONE p.m. at ordinary rates, and late advertisements between ONE p.m. and FOUR p.m. at double rates on the day preceding the day of publication.

PAYMENTS.—Unless the advertiser has a credit account, all payments are required in advance. Remittances should be made by cheque, postal note, or money order payable to "GOVERNMENT PRINTER".

ADDRESS.—All communications should be addressed to "The Government Printer, Box 203, P.O., North Melbourne".

CONTENTS

	PAGE
Acts of Parliament on sale at the Government Printing Office .. .. .	2094
Appointments .. .. .	2061
Contracts .. .. .	2060
Erratum .. .. .	2058
Estates of Deceased Persons .. .. .	2059
Government Notices .. .. .	2050
Impoundings .. .. .	2094
Lands .. .. .	2069
Levee at Parliament House, Melbourne .. .. .	2045
Mining .. .. .	2058
Money Lenders Act 1958—Supplementary List .. .. .	2057
Notice of Making of Statutory Rules .. .. .	2094
Orders in Council—	
Acts—Land; Country Roads; Hospitals and Charities; Agricultural Colleges; Water; Sewerage Districts; Stamps; Housing; State Electricity Commission; Melbourne and Metropolitan Tramways.	2062 et seq
Private Advertisements .. .. .	2081
Proclamations .. .. .	2046
Public Holiday—Queen's Birthday .. .. .	2050
Public Service Notices .. .. .	2075
Regulations—	
Acts—Teaching Service .. .. .	2059
Resignations .. .. .	2062
State Rivers and Water Supply Commission .. .. .	2056
Tenders .. .. .	2073
Transport Regulation Board—Public Hearings .. .. .	2051
Waterworks Trusts .. .. .	2059